

Digitized by the Internet Archive
in 2008 with funding from
Microsoft Corporation





P
Technol
B

THE BUILDING NEWS

AND

ENGINEERING JOURNAL.

VOLUME ONE HUNDRED AND NINE.

JULY TO DECEMBER, 1915.

34724
2211

Published for the STRAND NEWSPAPER CO., Ltd., by E. J. KIBBLEWHITE, Managing Director,

AT THE OFFICE OF THE "BUILDING NEWS,"

EFFINGHAM HOUSE, ARUNDEL STREET, STRAND, LONDON, W.C.

Civil engineers: commissions for, 368; institution of, 527 (and E. de Vesian) 90, 108

Clark, J. J., Melbourne, the late, 308

Charnac and charphalte, 2

Charphalte and charnac, 2

Cleansing stone surfaces, 249

Clegg v. Manchester Athenaeum, 135, 137

Clergyman as Judas Iscariot, 378

Cleveland, Ohio: architects and builders, 221; group plan of buildings, 635

Closing order and liability for rent, 27

Clouting, Lieut. C. E., military cross for, 547

Clubs: BUILDING NEWS designing, 59 (awards) 374, 496; Burlington fine arts, 612

Colborne v. Ammanford church committee, 27

Collapse of business premises at Dewsbury, 633

Colleges: Bristol (Baptist) 664; Edinburgh (royal Dick veterinary) 546; Glasgow (royal technical) 310, 664; royal college of art, 84; University, W.C. (prizes) 52 (school of architecture) 25, 56; Wimpiege (agricultural, scandal as to) 340

Collier, Hon. John, exhibition by, 79

Colonial companies, income tax on, 56

Colour and arrangement in the home, 518

Column reinforcement, effect of, 257

Columns, concrete, reinforcing, 406

Commercial museum, Calcutta, 577

Commission, alleged secret, 516

Committees for civil engineers, 368

Committee on war damage, 604, 635

Comparative municipal statistics, 193

Competition and contracts, 700

Competitions: BUILDING NEWS designing club, 59 (awards) 374; co-operative premises (Plymouth) 168, 368, 373, 397, 410; cottages (Port Sunlight) 118; dwellings (Kings-town) 175, 231, 252; factory (Dutch East Indian, rubber) 38; garden city (Eisteddfod) 195; hall mark design, 168; hospital (Whitehaven, small-pox) 108; laying out park (Dublin) 606; libraries, free (Nottingham, branch) 251; library (Sacramento) 458; municipal buildings (Hastings, N.Z.) 339 (Stepney) 8; national, 83; offices (Dundalk county) 38, 80; Owen Jones, 80; park entrance (Philadelphia) 195; parliament houses (Cambrera) 108 (Ottawa) 8; prize of Rome (American) 224; regulations, R.I.B.A., 6; royal academy, 669; royal college of arts, 84; schools (Govan secondary) 742 (Leicester, Wyggeston grammar) 38, 168 (Tottenham) 25; sewerage (Doncaster) 80; society of arts (Le Neve Foster) 195; street intersection (New York) 38; town hall (Milford, Conn.) 168; town planning (York) 239, 307, 338, 378; travelling studentship (Alex. Thomson) 695; university (Perth, W.A.) 251

Completion of purchase of estate, 516, 576

Compressed air v. immersion for painting, 497

Concentrated loads, foundations for, 581

Conclusions, some, on housing our workers, 582, 604

Concrete: bridge, 81, 168; columns, reinforcing, 406; ferro, factory construction, 433; floor construction in Canada, 194; hydrated lime in, 277; paints to prevent electrolysis in, 338; percentage of water in, 338; reinforced construction (design of) 316 (efficient control in) 201 (L.C.C. regulation-) 31, 61, 89, 115 (paint in) 194 (shrinkage and time effects in) 338; repairing and patching, 4; sewers, reinforced, 405; sleepers, reinforced, 430; strength of influenced by temperature, 645; unfinished, protection of, 35

Conference, housing, Bristol, 258

Consecration crosses on churches, 36

Construction: bomb-proof, 438; building, Rivington's notes on, 318; emergency military hospital, 552, 558, 575, 634; factory, 169, 197, 225, 253, 433; fireproof, in New York, 79; reinforced concrete (design of) 316 (efficient control of) 201 (regulations) 31, 61, 89, 115

Consumption among shoe workers, 160

Contemporary architecture in India, 199

Contract, building, appeal, 51

Contracts: aliens', 378; competition and, 700; pre-war building lease, 644, 645, 664, 727; timber, Government, 368

Control of reinforced concrete construction, 201

Co-operation, architects', in town planning, 632

Co-operative premises, Plymouth, 168, 368, 373, 397, 410

Corrosion, metal bridge, causes of, 51

Cottage: repair of, a, 546; windows, height of, 577

Cottages: Blenheim, Clandon and Hatfield, 147; Bogner (cheap) 378; Denton Burn (aged workmen's)

427; Port Sunlight, 48; rural, child-ling plans for, 53, 90

Council schools, decorating, 167, 189

County offices, Dundalk, 38, 80

Courts, law, Durban, 107

Covenant in lease, breach of, 135

Coventry, housing in, 159

Crane v. South Suburban Gas Co., 632

Creaser v. Huthy, auctioneer's notice, 645

Crosses, consecration, on churches, 36

Crowds: provocative in bankruptcies, 290, 307; power to requisition land, 51, 81, 110

Crystal Palace, school of engineering, 742

Curves, practical method of tracing, 409

DACRE church, near Ullswater, 167

Dam, Ralph, Burslem, the late, 60

Dalkoth, sewage disposal at, 368

Damage, war: a national responsibility, 408, 604, 635, 728

Dartford housing scheme, 711

Date plaque, Val de Travers, 721

Davis, W. Galsworthy, the late, 528

Davis, Lieut. H. E., the late, 37

Davis, H. David, the late, 25

Davy, Sir J. Stewart, the late, 589

Dawson, J. H., Stamford, the late, 277

Decoration, architectural, the zodiac in, 727

Decorations: chartered accountants' institute, 429; Christ's hospital, school chapel, Horsham, 379, 410, 470, 695; for council schools, 467, 489

Defective: gangway, liability for, 488, 499, 516; street gully, 643

Delays in return of empties, 721

Delhi, cheese-paring economies at, 26, 664

Demarcation lines between building trades, 293, 721

Depton camp, picture for, Miss Macmillan's, 720

Derivation of French monuments, 487

Design, of reinforced concrete buildings, 316

Designing club, BUILDING NEWS, 59 (awards) 374, 496

Designs: BUILDING NEWS club, 59, hall mark, 168; national competition, 83; Plymouth co-operative premises, 373; royal college of art, 84; schools of architecture (architectural association) 37, 58 (University college) 56

Destruction of macadam streets, 743

Determining fineness of cement, 469, 613

De Vesian v. Institution civil engineers, 90, 108

Developments in manufacture and use of brick, 202

Dewsbury, collapse of premises at, 633

Dexter v. Alder-shot F.D.C., 606

Diary, architects and surveyors', 744

Dictionary of Essex, 380

Dilapidations, church laymen on, 79

Discounts in wallpaper trade, 487

Dismissal of a district surveyor, 138; of land valuation staff, 238, 398, 438, 467, 527, 607

Dispensary, Roscommon (tuberculosis) 277

Disputed use of sewerage outfall, 27, 397

Dissemination of epidemics, animals and, 167

District surveyors: and the L.C.C., 90, 138; association, history of, 497

Doncaster sewerage competition, 89

Doors, loophole, in factories, 225

Draughtsman not a workman, 429

Drink traffic, nationalisation of, 203

Dudley, artisans' dwellings for, 459

Dunblane cathedral, 204

Dundee: architect's libel action, 51; photographic survey, 340

Dutch photographs at the Camera club, 344

Duty, increment value, 307

Dwellings: Dublin, 194; Dudley, 159, in Ireland, rural, 702; Kingstown, 175, 231, 252; Prabhdy (Rodney road, Walworth) 176 (Summer Street, Southwark) 107; of Scotland, broch, 605; sanitary inspection of, 633; Walsand, 427

Dyeworks industry, Huddersfield, 468

EARTHWORKS, ancient: at Chalton, 457; destruction of, 370

East Riding antiquarian society, 174

Eating, fresh air and, 145

Ecclesiological societies, St. Paul's, 52, 457; Scottish, 437

Economies by H.M. office of works, 368

Economy: and public buildings, 36, 337; expert advice on, 409; false (in building) 193 (in road construction) 664 (of houses) 202; government, 586, 604; in road maintenance, 547; in sanitation depicted, 173

Edinburgh architectural association, 37, 633

Effects of column reinforcement, 257

Efficient control of reinforced concrete construction, 201

Egypt: ancient architecture of, 150, 611; exploration fund, 633

Eighteenth century Irish houses, 111

Electric lamp company's litigation, 701

Electrolysis in concrete, paints to prevent, 226

Elevator, grain, Manchester, 379

Elizabethan oak room from Leigh hall, 86

Elkott, Samuel, Caversham, the late, 719, v. Biggs, 516, 718; v. C. P. Roberts and Co., 488, 496, 516

Ell, John, Manchester, the late, 614

Emergency: building and the war, 415; caissons, 611; military hospital construction, 557, 589, 575, 634, 741

Emery, Burkett J., Birmingham, the late, 589

Employment committee, professional, 6

Empties, delays in return of, 721

Engineer a practical idealist, 665

Engineering: for architects, 435, in institution's volunteer engineer corps, 304; school, Crystal Palace, 742

Engineers' and the war, 385, 397; civil (commissions for) 368 (institution of) 527 (do and E. de Vesian) 90, 108; society of, 397, 695, 717; water, institution of, 576

England and Scotland, town building in, 488

English: Lieut. Eric, the late, 332; timber, before, during, and after the war, 674

Ennis, building appeal from, 606

"Enormous" profits of speculating landlord, 693

Epidemics, animals and dissemination of, 167

Escapes, fire, access to, 429

Essex: dictionary of, 380; main roads in, 109

Estate, completion of purchase of, 516, 576

Examinations: art (Board of Education) 350; R.I.B.A., 3, 114, 157, 705; science regulations, 310

Exchange, royal, Glasgow, 743

Exhibitions: artists' rifles' pictures (Longton) 527; artists' war relief, 60, 113; Belgian artists, 26; Bradford (loan) 547; Bristol, 109; Burlington fine arts club, 612; Gillingham landscapes, 79; Dutch photographs at Camera club, 314; International societies, 378, 435; Liverpool (autumn) 167, 409; London salon of photography, 79, 316; north-west, Glasgow, 577; Old Newcastle-on-Tyne, 720; Panama-Pacific, San Francisco, 145, 318; photographs of Rheims cathedral, 58; portraits by Purley Lewis, 527; royal photographic, 200; royal society British artists, 435; royal society printers in water colours, 495; sketches at Camera club, 56; society of Scottish artists, 696; Toynebe art club, Whitechapel, 165; Willesden Green (palace of industry) 193; Williams, Miss Margaret, works by, 665

Ex-borough surveyor and alderman fined, 606, 642

Experiments, temperature, at Lahore, 468

Expert advice on economy, 409

Exploration fund, Egypt, 633

Export, Government certification of cement for, 526

Extension of war emergency acts, 611, 645, 664, 693

Extra copies, alleged secret commission on, 516, 718

Extravagant private street works, 165

FACTORIES and workshops: Dutch East-India (rubbish) 38; Ipswich (Christ church clothing) 694; lighting of, 257

Factory construction: ferro-concrete, 433; loads on stanchions and girders, 197; north light, roofs, 253; staircases and loophole doors, 225; various systems of, 169

Fair, trades, Nottingham, 430

False economy: in building, 193; in road construction, 664, of houses, 202

Fawcett, Mark, the late, 641

Federal council of Australian architects, 78

Federation, national: building trades employers, 60, 167, 174; Scottish building trades, 428

Fellowship, peasant arts, 519

Fenwick's skull for H.M. Abbey, 277

Ferro-concrete factory, 433

Ferry rights at Twickenham, 108

Finance Act, case law under, 586, 604

Finch, R. E., city of London engineer, 136

Fineness of cement, determining, 406, 613

Fire: escapes, access to, 429; prevention committee, British, 146 (warnings by) 377

Fireproof construction in New York, 79

Fittings, sanitary, in working class houses, 437

Flaps, cellar, liability for, 496

Flats, landlord's liability as to, 613, 645

Flats, landlord's liability as to, 613, 645

Flats, M. v. H. P., liability of, 613

Flooding, of the River Trent, 194

Floor construction, in Canada, 194

Floor, concrete, in the factory, 433

Flow in sewers, 606

Ford, Dean of St. Mary's, 272

Foreign: non-ferrous metal, in institutions, 370, 409

London, Gwynne, 718; 718; v. C. P. Roberts and Co., 488, 496, 516

Form, art history, 718; 718; v. C. P. Roberts and Co., 488, 496, 516

712; architectural, form, in accord in, 606

Fort, Roman, Amphipolis, 194

Fortune, C. R., Bath, the late, 614

Forty years' retrospect, 1915-1916

Foundations for construction of, 194, 199

Font of beauty, 194

Fontaine, drinking, Park, 194, 199

Fox v. Barry, breach of contract in lease, 173

Fracture, law of, 194, 199

Free libraries, Nottingham, branch, 251

Freemasons' hall, extension of, 194

Freight, Canterbury, 577 (Henry's name) 199

French: architects, sympathy with in German visitation, 111; art, and the war, 350; monuments, destruction of, 457; Sir John, and the Artists' Rifles, 743

Fresh air and eating, 145

From mansion to man-of-war, 674

Furniture sketches, 150, 617

GALLERIES: national, safety of treasures, 717; national, portraits, 136; late, new works for, 48

Gateway, defective, liability for, 488, 499, 516

Garden city, Listed-off competition, 195; pavilion, club designs, 173

Gardens, old and new, 318

Gas, Light and Coke Co., 108

Gateway, Abbey, Bristol, 604

Gauging the flow in sewers, 116

Genes, German imitation, 195

General post office extension, 137

Generating station, Birmingham, 194

German: imitation genes, 107; visitation, sympathy with, French architects, 111

Gibson, Lieut. E. H., the late, 614

Gill, F. J., Birmingham, fatal accident to, 488

Girders: insecurely fastened, 207; loads on, 197

Glasgow: building contract appeal, 195; housing conditions and rents on, 198; institute of architects, 437; removal of Falshaw stocks, 26, 221, 606; road, reduced, 606, 610, 614; water extension scheme, 602; workmen's dwellings co., 642, 692, 693

Godfrey v. Godfrey and others, 643

Golden age of walnut oak, 115

Government: certification of cement for export, 526; contracts (for timber) 38 (in American building materials) 293; economy, 586, 604

Grain elevator, Manchester, 379

Grammar school, Leicester (Wyggeston) 108

Grass round roots of trees, 231

Great seals, London as illustrated on, 499

Greater London arterial roads in, 26; survey of, 169

Green royalties on town planning, 704

Greenock, overcrowding in, 173

Green's classes on advertising, 278

Green E. Adolph, Serjeant, the late, 617

Grey, George, Wooler, the late, 49

Grover v. Hopkins, 27

Growth of land in, 614

Guildhalls: Hovey in Arden, 270; Westminster (Middlesex) 242, 291

Gully, defective, appeal as to, 613

Gutters, road, breakers in, 728

Gwydyr Forest, felling of, 965

HADDINGTON, the Skimmers' Close, 369

Haddingtonshire, water supply, 427

Halfax, as a commercial centre, 78; church, sketches of, 92

Hall mark design, 168

Halls: Belfast (Presbyterian) 719; Cleveland, O. (city) 635; Edinburgh (Sandeman) 743; Freemasons' (extension) 221; Leigh, Essex, oak room from 86; New York (city) 370; picture, ventilation of, 699

Roxley, 379; Sheffield, two 17th century, 250; Toynebe, at Poplar, 173

Hammersmith, survey of, 721

Handbook of patent law, 166

Harmonious accord in architectural form, 699

Harrison and Gregory, Liverpool, in the, 129

Harv v. Roger, 643, 645

Hay, J. Murdoch, Liverpool, the late, 437

Haywards, Ltd., 28

Health Society, National, 728

Heavy penalties for resuming work, 718

Health Society, National, 728

Heavy penalties for resuming work, 718

Table of contents for the left column, listing various topics and page numbers.

Table of contents for the middle column, listing various topics and page numbers.

Table of contents for the right column, listing various topics and page numbers.

Table of contents for the right column, listing various topics and page numbers.

INDEX TO ILLUSTRATIONS.

Index to illustrations for the left column, listing building names and page numbers.

Index to illustrations for the middle column, listing building names and page numbers.

Index to illustrations for the right column, listing building names and page numbers.

THE BUILDING NEWS

AND ENGINEERING JOURNAL.

Effingham House.

CONTENTS.

Strand, W.C.

The Fount of Beauty	1
The Value of Texture in Architecture	2
"Clarmac" and "Clarphalte"	2
Repairing and Patching Concrete	4
The London County Council	4
R.I.B.A. Examinations	5
Corrente Calamo	6
Our Illustrations	8
Building Intelligence	25
Obituary	25
Professional and Trade Societies	25
Our Office Table	26
Chips	27
Legal Intelligence	27

Trade Notes	28
Correspondence	28
Intercommunication	28
Latest Prices	29
Meetings for the Ensuing Week	30
To Arms	30
Tenders	30
List of Competitions Open	31
List of Tenders Open	31
Statues and Memorials	31

Northward Antofagasta and La Paz	32
Chili and Bolivia Railway. Mr. Arnold M.	32
F.R.I.B.A., Architect.	
Stepney Municipal Buildings, Arbour Square,	32
Commercial Road, East. First printed	32
1910, by Messrs. W. Frazer Grant and J. E.	32
Leathart, Architects. Second printed	32
1915, Messrs. Ambrose Poynter, F.R.I.B.A., and	32
George H. Wenyon, Licentiate R.I.B.A., Architects.	32
Elevations and plans.	
Portsea Island Gas Company's New Chief Offices and	32
Show Rooms, Portsmouth. View and plan. Mr.	32
Victor Wilkins, Architect.	
The Pasteur Institute of Burma, Rangoon, India.	32
Mr. E. J. Fuller, F.R.I.B.A., Architect.	

OUR ILLUSTRATIONS.

The New Parliament House, Ottawa, Canada. View and Plan. Design by Messrs. Clyde Young, F.R.I.B.A., and H. S. East, A.R.I.B.A., Architects.

THE FOUNT OF BEAUTY.

Nature, the fount and origin of all inspiration of all the arts, is a fitting and necessary subject of study by the architect, and not only in architectural detail and enrichment. "Proportion," whatever we may understand by the term, is a matter of eye education, giving power to originate and design in beautiful ratio and harmonious contrast of dimension. Such education, if based on architecture solely, is gained at second hand. By study of natural beauty we tap a source. Since the architect is, more than ever, as well as a practical planner and constructor, the supervisor of manifold arts and crafts, he surely needs to base his knowledge and appreciation of the beautiful on a sound foundation. In his practical, everyday business he has to advise on every handicraft concerned in beautiful building. Of all such, notable examples doubtless exist; but the whole of them are insignificant when compared with the infinite store of natural beauty. And since the ornamental and decorative in each art and craft have been evolved, originally, from the study and observation of natural form, it would seem well that, instead of confining ourselves to man-made precedent, we should go to the fountain-head for motive and inspiration.

That from precedent we may, by toil and industry, build up a store of form-knowledge, is no doubt true. That this is not the best course preparatory to design seems suggested by the consideration that somewhere at some time or epoch the forms that we now admire in rich and beautiful architecture have been, insensibly at times perchance, deduced from Nature and the natural. We may see clearly enough the result of too confined attention to old architectural form. The study of the letter of Classical architecture still further bound up ancient method in "orders," and the Gothic revival led to "parallels"; whereas the true designer pitches set orders and exact parallels out of the window, and, for weal or woe, gives us of his own. Every designer worthy of the name brings forth as from a refining furnace, and not as from a warehouse. To be able to do this, he must acquire powers founded on the patient study and analysis of natural beauty, exalting the "taste," giving skill to the hand, and judgment to the eye. These powers cannot be acquired if we confine our study to building. By so doing we should risk failure and go shadow-grasping, losing the real and substantial by our neglect to go to the fount and origin of beauty.

Take a particular instance. In one variety of Gothic capital the stalks of the floriations that adorn the bell and curve below the abacus are gracefully disposed—

not strictly, but approximately, as radiants about the axis of the column. Now, if we decide to study the graceful arrangement of the stalks of this order merely from precedent, we shall get a very limited range of example; whereas, by extending our survey into the domain of Nature, we get an infinity of suggestion; for, not to mention trees and flowers, every tuft of grass exhibits pseudo-radiant lines. Again, assume that these particular capitals have in the course of years been perfected to a certain plane of beauty, and that it is desired to make a further advance and produce yet more beautiful examples: in this case no precedent exists. As it seems fairly clear that unless we put something into our brains we cannot take anything out, further progress in the design of these capitals comes, perforce, to a standstill. We need to put in before taking out, not necessarily the same thing, but something milled and refined, something that we should never be able to bring forth without first mentally digesting suitable raw material, if we may so call it.

But, since every tuft of grass exemplifies quasi-radiation after the manner of our particularised Gothic capital, by reverting to an earnest and analytical inquiry of Nature, we may increase our knowledge of the principles governing graceful divergence, and in this way become empowered to make the required advance in design. We thus vastly extend the field from which we garner information, in a way impossible otherwise, though we haunt every church and cathedral in search of precedent. And we get information at first hand. In our wonderful world there is an infinity of inspiration in design, of actual suggestion to those willing to seek out causes. Mere inspection and admiration cannot greatly assist. It is everyone's business to wonder and admire; it is the duty of the designer to search out principle. By so doing he learns the art of conventionalising. Restricting study to old example seems to lead to copyism, apparently because we accumulate set form instead of gaining insight into principle. We need not a mental stockroom, but converting machinery whereby the elements of the beautiful may be built up from a sound basis with new grace and interest; not a barn, housing and delivering unthreshed harvestings, but a vigorous and relentless thrasher—a mill, with grit-stones and winnow. We do not want a trunk-full of Gothic chapters, but a headpiece of our own, the seeing eye, true understanding, and an intellect trained to break down the old and construct anew from the primordial and elemental; and it is difficult to see how we are to come at this, except that we seek to learn from Nature.

It may be that we suffer nowadays from the plethora of example; for universal travel, the camera, and profuse illustration have deluged us with precedent from every quarter of the globe. Yet, wanting principle, we remain dumbfounded and ineffective in our endeavours to give interest and novelty to our designs, we are driven in sheer perplexity to building bare brick walls, and pile up gaunt blocks of squared stone and marble, seeking to excuse our poverty of imagination by the plea of "simplicity." That which the designer needs, given trained eye and skill of hand, is not form to copy, but inspiration; and we may as reasonably look for so much as this in rude rock and mountain crag as in polished building stones.

The study of Nature for design purposes must be large and generous. We shall not from the observation of a tulip learn how to proportion a column. It is the whole mental and ocular education and training that counts—the sum of infinitesimals. No one knows exactly what specific studies gave him the power to proportion well. We may learn directly of tulip or narcissus in decorative design; but in proportioning, which in architecture is nearly equivalent to, and synonymous with, the whole act of designing, we draw, insensibly, from a well of acquired information the accumulated treasure of a life's observation and inquiry. Our studies, therefore, cannot be on too broad lines. No doubt, we may often glean suggestion direct. The whole earth teems with elegant form; but such opportunities are special and particular, and on the whole not helpful to that general study of cause and effect which stimulates and rouses the latent faculty of design. There is as little excuse for copying Nature as for copying precedent; indeed, the attempt is vain, since Nature will not be directly copied. Even the artist must resort to strategy.

From the study of building we learn construction and variety of constructive method, and if content to copy, also architectural form; while, by the exercise of reason, we may so modify and remodel an old device that a certain degree of novelty is imparted to that which otherwise is mere repetition of the time-old. Skill, however, is here to be understood as necessary—a consideration that lends support to the idea that a more general study than that of architecture solely is necessary to the making of an architect; for it is scarcely possible to conceive of anyone adding novel interest to, while preserving the beauty of, long-existent form, unless hand and eye have been previously trained and a certain grasp of principle acquired.

We must either be content to remain copyists or launch out into independent

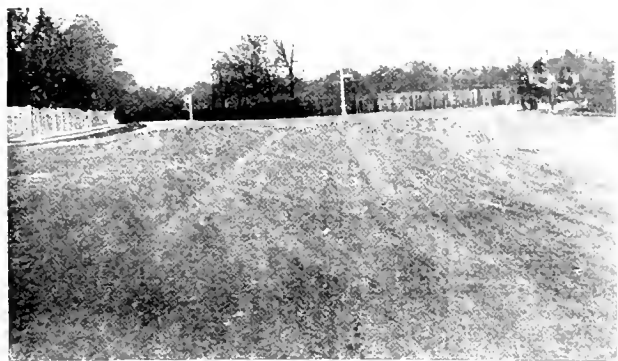

SCOTT'S LANE, BECKENHAM.



SCOTT'S LANE, BECKENHAM.



DORSET STREET, MARYLEBONE.



DORSET STREET, MARYLEBONE.



LORDSWOOD ROAD, BIRMINGHAM.



HEARSALL LANE, COVENTRY.



VALKYRIE AVENUE, WESTCLIFF-ON-SEA.



LENNARD ROAD, FENGE.

SOME ROADS AMONGST MANY LAID WITH "CLARMAC."

of Trinidad Lake asphaltum, and other essential materials. The asphaltum blocks are melted on the site and the surface covered and the mastic is laid down in slabs by experienced workmen, who use rollers which ensures the maximum adhesion, and obviates the formation of air bubbles so generally noticed when the surface is effected by steam rollers. The surface carpeting can be applied on a rough or a smooth surface, whilst the latter is most successful and upon old concrete, asphaltum, etc. The demand for this material is steadily increasing for a number of years, as it is strong, and durable, and does not wear, because it meets the requirements of all officers of health, and is regarded as being the most satisfactory pavement extant. It is manufactured under the supervision of Messrs. W. & A. Clark, Royal, Ltd., by the Trinidad Asphalt Co., Limited, Trinidad, and is the product of the renowned Trinidad Asphalt Co., which has been used by architects and engineers for lining drains, gullies, and for damp courses for three-quarters of a century. The experience of the firm in the application of asphaltum is a guarantee of the excellence of the asphaltum for road surfacing.

REPAIRING AND PATCHING CONCRETE.

Wet Method.—The surface of the old concrete is thoroughly roughened, cleaned, and drenched with water, and covered with a cement grout. Then the new concrete is mixed to a sloppy consistency and applied, being held in place till set by forms, as required.

From the reports received, it appears that many successes and many failures have followed this method. Where it has been successful, that result probably has been due to painstaking care and expense having been employed in the preliminary cleaning and thorough wetting of the old concrete surface before the new concrete is applied.

Moderately Dry Method.—The surface of the old concrete is thoroughly roughened, cleaned and drenched with water, and powdered with cement or painted with cement grout, after which the new concrete is applied and thoroughly tamped against the old surface. Generally, such patches are kept moist by sprinkling them with water for several days. The same comment applies here as to the wet method.

Dowel Method. This is a modification of the two preceding methods, and is generally used for other than horizontal surfaces, although it may be applied to the latter. The new concrete may have any consistency to meet the particular conditions or the ideas of the engineer in charge; but usually a fairly wet concrete is used. This method involves drilling holes and setting dowels in the old concrete, with projecting ends to be driven into the new concrete. Sometimes steel bars or metal fabric are connected to these dowels to further ensure permanency of the patch.

This method can be made uniformly successful, but cannot be applied always. Where any considerable mass of new concrete is to be attached to old concrete, this is the only safe method to pursue.

Wedge Method. This method includes the cutting out of defective concrete in such a manner as to render if the surrounding good concrete, so that the new concrete will be held in place when set, by the shape of the cutting edge of the old concrete.

The difficulty of undercutting concrete so that the cutting edges is too great to make this method applicable in ordinary cases; and even where a considerable depth of new concrete is to be put in, such undercutting cannot be done successfully, as concrete will be liable to break as to leave sharp, clean edges.

Steam Method. This is a method of cleaning the surfaces of old concrete preparatory to putting on a patch of new, or of covering the top of a rough concrete floor before applying the "finish coat." The

surface of the old concrete is brushed as clean as possible with stiff brushes, and then gone over at least twice with a steam jet. An ordinary piece of 1-inch gas pipe makes a very satisfactory jet nozzle. This short length of pipe is connected to a steam hose so that it can be moved about readily. The steam is supplied by the boilers of the mixer or hoisting engines. The steam will clean and heat the concrete surface, leaving it perfectly dry; so it is important to drench the surface thoroughly with water after cleaning with steam. In cold weather it is found advantageous to use hot water. Immediately after the surface is thoroughly cleaned and drenched, the new concrete is applied.

Excellent results have followed the use of this method of cleaning; but it is essential that the surface of the old concrete be thoroughly drenched with water after using the steam jet, otherwise the new concrete will not adhere to the old.

Cleaning with Acid.—This method includes the washing of the surface of the old concrete with a solution of hydrochloric (muriatic acid) (one part acid to two parts water), after which the surface must be washed carefully and thoroughly to remove any free acid.

This is a very commonly applied method of cleaning old concrete surfaces preparatory to placing new concrete against them, and is considered by many the only safe treatment to use, especially in cases where a "finish coat" is to be put on after the concrete base is set.

THE LONDON COUNTY COUNCIL.

At the meeting yesterday (Tuesday) afternoon the Building Act Committee submitted a series of fresh regulations with respect to buildings wholly or part of reinforced concrete. They reminded the Council that on November 21, 1911, regulations were prepared in this matter. These regulations were prepared after consultation with the Royal Institute of British Architects, the Institution of Civil Engineers, the Surveyors' Institution, the Concrete Institute, and other associations and committees interested in the matter. After prolonged negotiations with the Local Government Board a revised draft of the regulations was prepared, and the Council on June 24, 1913, made regulations in accordance with this draft. The amended regulations were submitted to the Board for allowance, and in accordance with the provisions of the Act the four institutions before-mentioned were informed of the Council's intention to apply for the allowance of the Board. Further negotiations have taken place with the Board and the institutions, and numerous suggestions for modifications in the regulations have been received. The committee think that a large number of these suggestions might be adopted, and they have accordingly prepared and now submit a revised set of regulations. The Local Government Board has stated that in its opinion the regulations as now amended might properly be allowed, and the Royal Institute of British Architects has placed on record its opinion of the great value of the regulations to architects not only in London, but throughout the whole of the Empire. The regulations as now amended are less onerous than those made on June 24, 1913, and more in line with the regulations made on November 21, 1911. If as the result of experience gained during the next few years it should be found that alterations are desirable, there should be no difficulty in modifying the regulations. The committee therefore recommended:

- (a) That the resolution of June 24, 1913, making regulations with respect to the construction of buildings wholly or partly of reinforced concrete and with respect to the use and composition of reinforced concrete in such construction, and the further resolution of July 1, 1913, confirming the same, be rescinded.
- (b) That, pursuant to the provisions of section 23 of the London County Council (General Powers) Act, 1909, regulations with respect to the construction of buildings wholly or partly of reinforced concrete and with respect to the use and composition of reinforced concrete in such construction, be made.
- (c) That notice be given to the Royal Institute of British Architects, the Surveyors' Institution, the Institution of Civil Engineers, and the Concrete Institute, of the Council's intention to apply to the Local Government Board for allowance of the regulations specified in the foregoing resolu-

[Faded text, likely bleed-through from the reverse side of the page. The text is illegible due to low contrast and blurring.]

tion (b), and that notice be advertised in daily newspapers and technical papers circulating in London. (d) That, on the confirmation of the regulations specified in the foregoing resolution (b) and after the expiration of one calendar month from the date of the appearance of the advertisements specified in the foregoing resolution (c), the necessary steps be taken to obtain the allowance of the regulations by the Local Government Board, and that the Board be asked to fix a date on which the regulations shall come into force.

The Building Act Committee also reported as to the action taken by them during the past three months, and observe that the total length of new streets sanctioned was one-third mile only. 1,226 notifications were received with regard to structures alleged to be in a dangerous state. In accordance with the provisions of Part IX. of the London Building Act, 1894, a survey was made in each case. In 125 cases it was found that the structures were not in a dangerous condition, and consequently no further action was necessary. In 1,101 cases notices were served upon the owners requiring the removal of the danger. In order to secure compliance with the Council's notices, it was necessary in some cases to obtain orders from magistrates, and in fifty-six cases in which such orders were not complied with the committee arranged for the Council's contractors to take down the dangerous portions of the structures. As a temporary expedient they arranged for forty structures to be shored up or hoarded in by the Council's contractors. Surveys were made of ten structures which were alleged to be in a dilapidated or neglected condition. Proceedings were commenced for obtaining the demolition or repair of five structures. In two cases they arranged for structures to be demolished in default of compliance by the owners with orders made by magistrates.

It was decided to contribute one-third of the estimated cost, £450, of a proposed widening at the junction of Bermondsey Wall and Flockton Street, by the addition to the public way of part of the site of the Golden Fleece public-house. Bermondsey Wall is a continuation of Rotherhithe Street, various widenings of which have been executed by the Council and the borough council in co-operation. By the improvement the width of Bermondsey Wall at the part in question will be increased for a distance of 24 ft. from 12 ft. to 24 ft., and that of Flockton Street for a distance of 60 ft. from a minimum width of 9 ft. to a general width of 11 ft.

The Education Committee reported as to the progress made with the scheme for the reduction of accommodation in classrooms in elementary schools to maxima of forty places in senior departments and forty-eight in infants' departments during the first triennial period ended March 31 last. They drew attention to the fact that the works completed during the year ended March 31 last, and the works in the builder's hands on that date, were undertaken before the issue of the Treasury minute with regard to the restriction of capital expenditure owing to the war. In connection with the scheme, which is to be completed within a period of fifteen years from March 31, 1915, the Council on July 23, 1912, agreed (a) to complete certain new schools, enlargements, and adaptations, and to remodel or rebuild certain old schools within three years from March 31, 1912; (b) to complete the modernising of certain schools within five years from March 31, 1912; (c) to commence the structural work in connection with the modernising of certain schools within five years from March 31, 1912; (d) to reduce the accommodation of 1,000 classrooms to the new maxima within five years from March 31, 1912; and (e) to provide 24,000 school places in each triennial period by means of new schools and the enlargement or improvement of existing schools. In connection with the scheme, steps are being taken to deal with the problem of "noisy" schools. Owing to unforeseen circumstances it has been necessary to make certain variations in the three years' programme, and on March 31, 1915, this included the following works:—The erection of twelve new schools, the enlargement of fifteen existing schools, the adaptation as elementary schools of three pupil teachers' centres or secondary schools, and the modernising of twenty-three existing schools. During the three years under review

six schools (3,688 places) have been completed; three schools (3,504 places) will probably be completed by the end of the summer holidays, 1915; one school (996 places) will be completed in November, another school (1,480 places) in December, and the remaining school (996 places) early in 1916. In the case of twelve other schools (3,084 places) the work of enlargement has been completed; the work will be completed shortly in the case of two others (443 places); and the enlargement of the remaining school (463 places) will probably be completed by the end of the summer holidays, 1915. Two of the adaptations (507 places) have been completed, and the remaining case will probably be completed by the end of July, 1915. Of the twenty-three schools specified for completion by March 31, 1915, sixteen have been finished: in two cases the modernising will probably be completed shortly, in one case by the end of the summer holidays, 1915, and in three cases by Christmas, 1915. With regard to the remaining school, one section of the work had been completed. Of the twelve schools the modernising of which is to be completed by March 31, 1917, a tender has been accepted in four cases (the Haverstock Hill, Grafton Road, Winchester Street, and Wolverley Street schools); plans have been approved in three cases (the Pritchard's Road, St. Paul's Road, and Burrage Grove schools); in one case (the London Fields school) plans are under consideration; and in the remaining four cases plans are not yet in hand. Of the ten schools the modernising of which is to be commenced by March 31, 1917, in two cases (the Victoria and Southampton Street schools) a tender has been accepted; in three cases (the Sumner Road, the Neckinger, and Webb Street schools) plans have been approved; in one case (the Jessop Road school) plans are under consideration; and in the remaining four cases plans are not yet in hand. 995 classrooms in existing schools, previously recognised for more than forty or forty-eight children, have been replaced by classrooms with accommodation within the new maxima, either by modernising old schools, carrying out minor structural alterations, or writing down the accommodation. There will, therefore, remain only five classrooms to be replaced or written down by March 31, 1917, in order to comply with the agreement with the Board of Education. Of the 24,000 permanent school places (including those in the "minimum" programme) which the Council undertook to provide by March 31, 1915 (the end of the first triennial period), 14,339 places had been completed at that date, whilst tenders had been accepted for proposals involving a net addition of 10,059 further places. In addition to the places referred to above, the Council had at March 31, 1915, decided on the provision of 66,342 new places, of which 6,690 were in the contractors' hands. In the case of twenty-eight noisy schools, steps have been taken to overcome the difficulties arising from the noise of traffic. In the case of sixteen other schools steps will be taken. In fourteen cases it does not seem possible to take any action, or it has not been considered necessary to do so.

Mr. Thomas Nibbt, the city engineer, has been appointed to the dual offices of city engineer and master of works to the Glasgow Corporation.

The new infectious diseases hospital built by the Rural District Council of Easington at Thorpe, near Easington, at a cost of £12,600, has been formally opened. The architect was Mr. Hugh T. D. Hedley, of Sunderland, and the contractors were Messrs. Christopher Brown, Limited, of West Hartlepool.

We regret to hear that our old correspondent Mr. Harry Hems, of Exeter, has suffered a great bereavement in the death of his wife after forty-seven years of happy married life. Mrs. Charlotte Presswell Hems, who had been in ill-health for the past three years, died at their residence, Fair Park, Exeter, on the 29th ult., aged 75 years. The funeral took place in Exeter Cemetery on Saturday. Mr. Hems, we are sorry to learn, has himself been in indifferent health for some time with sclerosis of the spinal cord, making walking without support impossible and writing a matter of difficulty.

R.I.B.A. EXAMINATIONS
THE FINAL ALTERNATIVE PAPER
DESIGNS.

INSTRUCTIONS TO CANDIDATES.
1. The drawings, which should preferably be on uniform sheets of paper not larger than Imperial size, must be sent to the Secretary of the Board of Architectural Education, Royal Institute of British Architects, 9, Conduit Street, W., on or before the dates specified below.

2. Each set of drawings must be signed by the author, and his full name and address, and the name of the school, if any, to which the drawings have been prepared, must be attached thereto.

3. All designs, whether done in a school or not, must be accompanied by a declaration from the student that the design is his own work, and that the drawings have been wholly executed by him. In the preparation of the design the student may profit by advice.

4. Drawings for subjects (a) are to have the shadows projected at an angle of 45° in line, monochrome, or colour. Drawings in subjects (b) are to be finished as working drawings. Lettering on all drawings must be of a clear, scholarly, and unaffected character.

SUBJECT XXII

(a) The Entrance Façade to a Tube Railway Station in a Main Thoroughfare.—The total width of the façade available for both approaches and exits to be 40 ft. The upper part is to be let off as offices with separate entrance and staircase.

Drawings.—A plan to 1/2 in. scale, showing the arrangement of booking offices, etc., and an elevation and section of the façade to 1/2 in. scale.

(b) A Co-operative Stores in a small village of 300 inhabitants, to be managed by a resident salesman. The shop, to be built on the south side of the village street, should be portioned off into groceries, provisions, and drapery, the latter with a top light. There should be considerable store-room, accommodation in connection. The salesman to have a living room, kitchen and usual offices, three bedrooms and bathroom.

Materials. Brick and tiles, with rough-cast if desired.

Site.—A corner site with chief frontage 54 ft. to main road, and a small lane at the side.

Drawings.—Plans of each floor, one section and two elevations, with one detail. 1/2 in. scale, of portion of front elevation.

SUBJECT XXIII

(a) A School Chapel to accommodate 250, of whom 150 are boys. Gallery at west end for organ and choir. Vestry for clergy and choir. Entrance porch, or narthex, with way up to gallery. Screen under gallery shutting off entrance from chapel.

Drawings.—Plan and two elevations to 1/2 in. scale, cross section and one bay longitudinal section to 1/2 in. scale.

(b) A Doctor's House (detached), to be built in stone on a corner site, say, 80 ft. by 200 ft., in the main road of a provincial town, such as Stamford.

Accommodation.—Separate entrance for patients; consulting and waiting rooms near the kitchen part of the house. Front and back stairs. Good drawing room and dining room, five ordinary bedrooms, with one dressing and two bathrooms, and usual offices; one bedroom for a resident patient; with bathroom adjoining, and small bedroom for nurse. A study or morning room is optional. The house is to be set back from the road on both frontages. A small garage without living accommodation is desired.

Drawings.—1/2 in. plans and two elevations and one section and a small block plan.

SUBJECT XXIV

(a) The accompanying plan shows a large house built in 1810, standing 110 ft. back from a main road now much used by motor traffic. The owner is greatly inconvenienced by noise and dust, and desires to enclose his forecourt in order to shut off these nuisances as far as possible. He has need of a studio for wood and metal work, an organery for

Currents Calamity.



...committee, the members of which are prepared to give applicants the benefit of their personal experience and advice, with a view to finding some solution to the applicants' difficulties. The idea is that of personal service, and the Professional Employment Committee has been fortunate in securing the co-operation of Messrs. Henry T. Hare, F.R.I.B.A., Gerald C. Horsley, F.R.I.B.A., and Pam Waterhouse, F.R.I.B.A., who form the advisory committee, and to whom will be referred any applications received by the Professional Employment Committee, of the kind indicated. The Professional Employment Committee of the Architects' War Committee loses no opportunity of turning to good account any circumstances which may assist it in providing paid work for architects who are in distress owing to the War. An instance of this occurred when the "Clan Grant" was sunk by the "Emden," and with her Professor Geddes' collection of drawings en route for Madras to illustrate his lectures on cities and town planning. On hearing of the disaster the committee at once set a number of architects at work to replace the drawings lost, from Professor Geddes' original notes, and the news that the work was in hand was cabled to him. It seems from a communication recently received from Professor Geddes, expressing his appreciation of the work accomplished by all concerned, that the cable crossed his letter asking for the help which had been given already in anticipation. In the meantime the Professor had been carrying on as best he could with Indian plans and such European scraps as he could muster. He was not only delighted but surprised at the quantity as well as the quality of the exhibits sent out to Madras, where the first Cities and Town Planning Exhibition was held. This exhibition was attended by representatives of most of the sixty-five towns and cities of the presidency, which roughly compares in population and extent to the United Kingdom. Their leading citizens and professional men, engineers, and others attended, and for the latter there were held practical classes in connection with the improvements in progress. Something of the same kind will be done in Bombay and Calcutta, and in this way the cities are being reached, and in some instances more fully than is the case as yet at home. Professor Geddes expresses the hope that the assistance which the committee has rendered to him is but a phase of that wider co-operation which is so desirable towards the renewal of cities, whether those destroyed by war abroad or those deteriorated in peace at home, and we are sure he will not be disappointed.

The sixty-eighth annual general meeting of the Builders' Benevolent Institution will be held at Kohn Noor House, Kingsway, W.C., on Wednesday week, July 21st, when Mr. George Holland, the president, will take the chair. A numerous attendance of all friends is very desirable. Like all other institutions of the kind, the Builders' Benevolent Institution is feeling the pressure of the times very severely and much more so than some, owing to the fact that the industry it serves has been more sorely tried by the war than any other. It is, therefore, most necessary that a special effort should be made this year to succour the victims of the hard fight we are all making to keep going till the better days dawn which we believe are in store for us, when prosperity will be best deserved by those who have held out helping hands to those who have succumbed in the hard struggle.

...committee, the members of which are prepared to give applicants the benefit of their personal experience and advice, with a view to finding some solution to the applicants' difficulties. The idea is that of personal service, and the Professional Employment Committee has been fortunate in securing the co-operation of Messrs. Henry T. Hare, F.R.I.B.A., Gerald C. Horsley, F.R.I.B.A., and Pam Waterhouse, F.R.I.B.A., who form the advisory committee, and to whom will be referred any applications received by the Professional Employment Committee, of the kind indicated. The Professional Employment Committee of the Architects' War Committee loses no opportunity of turning to good account any circumstances which may assist it in providing paid work for architects who are in distress owing to the War. An instance of this occurred when the "Clan Grant" was sunk by the "Emden," and with her Professor Geddes' collection of drawings en route for Madras to illustrate his lectures on cities and town planning. On hearing of the disaster the committee at once set a number of architects at work to replace the drawings lost, from Professor Geddes' original notes, and the news that the work was in hand was cabled to him. It seems from a communication recently received from Professor Geddes, expressing his appreciation of the work accomplished by all concerned, that the cable crossed his letter asking for the help which had been given already in anticipation. In the meantime the Professor had been carrying on as best he could with Indian plans and such European scraps as he could muster. He was not only delighted but surprised at the quantity as well as the quality of the exhibits sent out to Madras, where the first Cities and Town Planning Exhibition was held. This exhibition was attended by representatives of most of the sixty-five towns and cities of the presidency, which roughly compares in population and extent to the United Kingdom. Their leading citizens and professional men, engineers, and others attended, and for the latter there were held practical classes in connection with the improvements in progress. Something of the same kind will be done in Bombay and Calcutta, and in this way the cities are being reached, and in some instances more fully than is the case as yet at home. Professor Geddes expresses the hope that the assistance which the committee has rendered to him is but a phase of that wider co-operation which is so desirable towards the renewal of cities, whether those destroyed by war abroad or those deteriorated in peace at home, and we are sure he will not be disappointed.

...committee, the members of which are prepared to give applicants the benefit of their personal experience and advice, with a view to finding some solution to the applicants' difficulties. The idea is that of personal service, and the Professional Employment Committee has been fortunate in securing the co-operation of Messrs. Henry T. Hare, F.R.I.B.A., Gerald C. Horsley, F.R.I.B.A., and Pam Waterhouse, F.R.I.B.A., who form the advisory committee, and to whom will be referred any applications received by the Professional Employment Committee, of the kind indicated. The Professional Employment Committee of the Architects' War Committee loses no opportunity of turning to good account any circumstances which may assist it in providing paid work for architects who are in distress owing to the War. An instance of this occurred when the "Clan Grant" was sunk by the "Emden," and with her Professor Geddes' collection of drawings en route for Madras to illustrate his lectures on cities and town planning. On hearing of the disaster the committee at once set a number of architects at work to replace the drawings lost, from Professor Geddes' original notes, and the news that the work was in hand was cabled to him. It seems from a communication recently received from Professor Geddes, expressing his appreciation of the work accomplished by all concerned, that the cable crossed his letter asking for the help which had been given already in anticipation. In the meantime the Professor had been carrying on as best he could with Indian plans and such European scraps as he could muster. He was not only delighted but surprised at the quantity as well as the quality of the exhibits sent out to Madras, where the first Cities and Town Planning Exhibition was held. This exhibition was attended by representatives of most of the sixty-five towns and cities of the presidency, which roughly compares in population and extent to the United Kingdom. Their leading citizens and professional men, engineers, and others attended, and for the latter there were held practical classes in connection with the improvements in progress. Something of the same kind will be done in Bombay and Calcutta, and in this way the cities are being reached, and in some instances more fully than is the case as yet at home. Professor Geddes expresses the hope that the assistance which the committee has rendered to him is but a phase of that wider co-operation which is so desirable towards the renewal of cities, whether those destroyed by war abroad or those deteriorated in peace at home, and we are sure he will not be disappointed.

The case which we report in our last column elsewhere, in which one of the City magistrates very properly convicted for failure to report to the district surveyor the nature of measures being taken to prevent the consequences of an air raid on an important building, should be heeded by all property owners, and by those employed by them. All will agree that any such work should only be undertaken under the direction of the architect of the building, or in his absence by some other competent architect, and that notice should be given to the district surveyor. There is always risk when additions of any kind are made to a building by those unacquainted with the nature of any of its parts. There is always danger to adjoining owners when those not so acquainted are allowed access to buildings except under due supervision. We have little doubt that the magistrate, in the case referred to, took care to assure himself of the competence of the firm engaged, and think he was justified, on that and other accounts, in imposing a nominal penalty. But in any future cases of default we take it for granted there will be no disposition to minimise precautions which in these days of danger and difficulty are more incumbent on all of us than ever in the interests of public safety.

The proceedings of the Town Hall Committee to be submitted to the Manchester City Council to-day contain the correspondence which has passed between a special sub-committee and the city surveyor (Mr. T. de Courcy Meade) relating to certain employees in his department who were dismissed by him because there was not work for them. They themselves represented that they had been dismissed because they had declined to enlist as soldiers, and they appealed to the Town Hall Committee. A sub-committee was appointed to investigate. On June 4 the sub-committee sent a letter to the chairmen of various committees stating the circumstances in which the city surveyor had dispensed with the men's services, and asking if suitable work could be found for the men in another department. In reply, the several committees appealed to said they could not find any suitable work. The sub-committee, therefore, recommend that the suggestions contained in their report dated May 12 be approved. The report of May 12 states that the sub-committee had fully considered the matter, and had conferred with the Lord Mayor in the presence of the city surveyor. At the outset the city surveyor admitted that he had made a mistake when he gave two men seven days' notice to leave instead of submitting the matter in the form of a recommendation to the Town Hall Committee. "Your sub-committee," the report of May 12 proceeds, "are of opinion that in substance the alternative that was offered to these men was enlistment or dismissal, especially in view of (a) the city surveyor's letter to the staff, (b) his reports to the committee, and (c) to the fact that these men refused to enlist, while all those who enlisted and those who are ineligible for enlistment have been retained in the corporation service. They are further of opinion that there is not sufficient work in the city surveyor's department to justify the retention of the services of the whole of the men who did not enlist, and that the staff should be reduced, and that the services of the three men in question can be dispensed with on this ground." With regard to the staff under the Town Hall Committee, they did not think that any

one of the three men in question should be retained on the staff, and they recommended that the staff should be reduced to the number of men who had enlisted. The committee's report was approved, and that the notice to two of the men be confirmed, and that a month's notice to the third man be given terminating his service with the corporation. An amendment was moved that two of the men, with the approval of the city surveyor, be reinstated, and this was carried.

A big deal in London property has just been effected with the sale, for the sum of close on £250,000, of the freehold of the Arundell Estate, in the vicinity of Piccadilly Circus, with frontages to Shaftesbury Avenue and Coventry Street, and embracing an area of 34,500 ft. Included in the property is one of the few surviving relics of the Georgian period to be seen in the streets of the Metropolis—a well-known silversmith's—which displays an inscription informing the passer-by that Lambert's are "Goldsmiths and Silversmiths to their Majesties (George III. and his Consort) and to her Royal Highness the Duchess of Kent." Mr. R. M. Phillips, of 97, New Bond Street, who has effected the deal, states that the disposal of the estate foreshadows another improvement in the scheme of alteration which has been going on in the region of Piccadilly Circus. Other property may be involved at a later date, but the plan, so far as it can be explained at present, is to raise on the site a building which will provide "a combination of pleasure and entertainment, with all the comforts of a palatial hotel and restaurant." Arundell Street, which runs through the centre of the block to Panton Square, derives its name from the Lords Arundell of Wardour, a title perpetuated in another well-known thoroughfare near by. On the Coventry Street side of the property there is a frontage of 117 ft., while in Shaftesbury Avenue, and close to the Trocadero, the extent is 105 ft.

A useful paper on the effective illumination of streets was read on the 30th ult. by Mr. Preston S. Millar at Dear Park, Md., U.S.A., to a joint session of the American Institute of Electrical Engineers and the American Illumination Society, which appears in the July Transactions of the first-named body. The paper mentions the dependence of effectiveness in street lighting upon municipal appropriations and efficient lamps, but discusses more particularly those aspects of effectiveness which are dependent upon skillful utilisation of the light to produce the most effective illumination. There are included a classification of streets, a statement of the objects of street lighting and the elements of vision under street-lighting conditions. The paper emphasises three considerations which are sometimes neglected in street lighting discussions; namely, the silhouette effect, specular reflection from street pavements, and glare. The remainder of the paper is given over to a presentation of the variables upon which the effectiveness of street illumination depends, and upon the influence which each feature of the installation exercises through these several variables. As a part of this discussion illuminating efficiency values for the several modern street illuminants are given. The appendix includes statistics and photographs of some very recent installations which illustrate the latest trend in street lighting.

Mr. G. F. Pepler, of the Local Government Board, has been appointed to the post of borough engineer and surveyor in succession to the late Mr. J. Rish, Duxford, at a salary of £500 a year, rising to £750. Mr. Roseveare has been since 1912 borough engineer of South Smethals and was previously chief assistant engineer of Birmingham.

Mr. H. St. John Bidwell, borough engineer of the Local Government Board, held an inquiry at Penrith borough yesterday, in connection with an application by the Sake Rural District Council for permission to borrow £200 for sewerage works, amounting to £200 for sewerage works, and disposal purposes for the construction of sewers of Penrith Borough Without, Warrington, and Warrington.

The City and County Department of Health, are preparing a hearing before the chief officer of whom when it is to be seen that the hearing apparatus are installed in the City. A considerable amount of damage will be done by the blowing up of boilers due to faulty installation, and the by-law is intended to make it possible for the City authorities to control and valves in hot water systems are fitted properly, so as to guard against the danger of explosions.

The rural district council of Hamble, which has recently applied to the Local Government Board for approval of a new drainage scheme for the Templewarrick area, is the first rural council to reach this stage in a drainage proceeding. The governing factor of the scheme has been the provision of a wide new road to form a by-pass to the Leeds to Selby road, avoiding the present narrow, and in places tortuous, village street. The work of preparation and advising the council was originally entrusted to Messrs. Pepler and Allen, who have carried the scheme through. Mr. F. L. Thompson having taken Mr. Pepler's place on the appointment of Mr. Pepler to the Local Government Board staff.

Mr. G. F. Pepler, of the Local Government Board, has been appointed to the post of borough engineer and surveyor in connection with an application by the Sake Rural District Council for permission to borrow £200 for sewerage works, amounting to £200 for sewerage works, and disposal purposes for the construction of sewers of Penrith Borough Without, Warrington, and Warrington.

Woodwich Borough Council on Wednesday appointed Mr. L. S. Roseveare, M.B.E.C.E., to the post of borough engineer and surveyor in succession to the late Mr. J. Rish, Duxford, at a salary of £500 a year, rising to £750. Mr. Roseveare has been since 1912 borough engineer of South Smethals and was previously chief assistant engineer of Birmingham.

Mr. H. St. John Bidwell, borough engineer of the Local Government Board, held an inquiry at Penrith borough yesterday, in connection with an application by the Sake Rural District Council for permission to borrow £200 for sewerage works, amounting to £200 for sewerage works, and disposal purposes for the construction of sewers of Penrith Borough Without, Warrington, and Warrington.

The City and County Department of Health, are preparing a hearing before the chief officer of whom when it is to be seen that the hearing apparatus are installed in the City. A considerable amount of damage will be done by the blowing up of boilers due to faulty installation, and the by-law is intended to make it possible for the City authorities to control and valves in hot water systems are fitted properly, so as to guard against the danger of explosions.

The rural district council of Hamble, which has recently applied to the Local Government Board for approval of a new drainage scheme for the Templewarrick area, is the first rural council to reach this stage in a drainage proceeding. The governing factor of the scheme has been the provision of a wide new road to form a by-pass to the Leeds to Selby road, avoiding the present narrow, and in places tortuous, village street. The work of preparation and advising the council was originally entrusted to Messrs. Pepler and Allen, who have carried the scheme through. Mr. F. L. Thompson having taken Mr. Pepler's place on the appointment of Mr. Pepler to the Local Government Board staff.

Our Illustrations.

NEW STATIONS AT NORTH ANTOCAGASIA AND LA PAZ FOR THE CHILE AND BOLIVIA RAILWAY COMPANY.

The new railway stations which are being erected by the Chile and Bolivia Railway Company will, by reason of their being erected during the war, be of a particularly interesting character. The smaller ones will be erected entirely in reinforced concrete and with Dutch style garrises. The various styles of garrises and other special fittings are shown in Messrs. H. S. and H. J. L. ... The elevations which we have reproduced today are now at the Royal Academy Exhibition. Mr. Arnold Mitchell, F.R.I.B.A., of Haverley Square, W., is the architect.

STEFANIA MUNICIPAL BUILDINGS AND R. SQUARE COMMERCIAL ROAD EAST PRELIMINARY DESIGNS.

Today we give a review of the preliminary designs for these new buildings, submitted by the architects of the design competition, Messrs. Briggs, Wood and Carter, of Liverpool. Today we reproduce the first and second preliminary designs. The £100,000 preliminary scheme by

... and the ground floor contains the committee room, waiting-rooms for passengers and natives, dispensary, vaccine, operation, store, record and ... the meteorological department, laboratories being specially well lighted by large windows facing north, and ... Rooms for steamers, centrifuges, ... photography, and washing ... Mr. E. J. Pullar, F.R.I.B.A., of Rangoon, is the architect, and the principal contractors for the work were Messrs. Ryan and Mundy, of Rangoon, ... the plumbing and sanitary work Messrs. Gears and Grogg, of Rangoon, were employed.

THE NEW PARLIAMENT HOUSE, OTTAWA, CANADA.

Our illustration shows the competitive design submitted by Messrs. Clyde Young and H. S. East for the proposed Departmental and Courts Buildings at Ottawa. This drawing is now on view at the Royal Academy. The Courts building is arranged as a separate block in the centre of the S. front of the Departmental buildings being grouped on the E., W., and N., the

ing stoves, general stores and strong rooms. There are rooms for the ventilating and heating plant, and also for the high-pressure gas plant. Further there is a large cycle store, approached from the outside by a slope adjoining the staff entrance, where accommodation is provided for the bicycles belonging to the outdoor staff. The ground floor is divided into showrooms and general offices. The main entrance is approached through a circular porch on the principal corner. Model rooms have been designed to exhibit the various gas appliances. All the screens, enclosures, fittings, and desks are carried out in mahogany, and the scheme of lighting in the general offices will be by the semi-indirect system of lighting. The staff entrance and cycle slope to basement are situated at the rear of the general office. The main staircase out of the showroom leads to a large square hall on the first floor. On this floor is a demonstration hall for lectures, directors' rooms, and rooms for the general manager, secretary, and their staff. The board room is panelled throughout in mahogany. The back part of the first floor, which is served by a separate staircase situated at the rear of the building, is planned to accommodate the automatic collectors' staff and additional offices and main staff lavatories. The caretaker's quarters are situ-

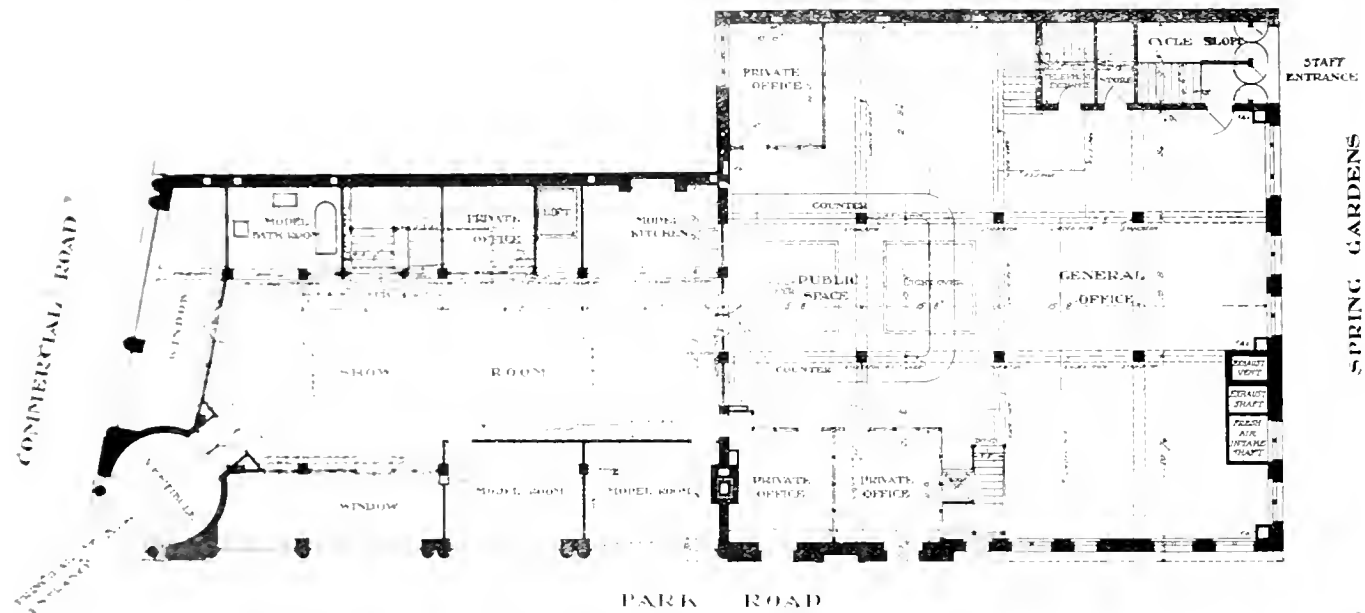

PORTSEA ISLAND GAS COMPANY'S NEW CHIEF OFFICES AND SHOWROOMS. Mr. VICTOR WILKINS, Architect.

Messrs. W. Frazer, Engineer, and J. R. L. ... Messrs. A. ... F.R.I.B.A., and ... F.R.I.B.A., of ... The design of the building is of a ...

PASTEUR INSTITUTE OF BURMA, BANGKOK.

The Pasteur Institute of Burma, Bangkok, is a building of considerable interest, and is one of the most modern and well-planned buildings in the city. It is situated in the heart of the city, and is a fine example of modern architecture. The building is designed to house the laboratory and offices of the institute, and is a fine example of modern architecture. The building is designed to house the laboratory and offices of the institute, and is a fine example of modern architecture. The building is designed to house the laboratory and offices of the institute, and is a fine example of modern architecture.

... of these, being the tower ... On the S. front of the Departmental buildings, the principal features have been arranged to centre with the streets leading up Wellington Street. Formal gardens are laid out between the cliff and the buildings on the E. and W., also between the Departmental and Courts buildings. A free ... treatment has been ... suitably ... of the buildings, and in no ... of the buildings is about twenty ... We illustrated Mr. E. ... for these same buildings ... Our plate was ... also hanging in the Architectural Gallery at the Royal Academy this season.

PORTSEA ISLAND GAS COMPANY'S NEW CHIEF OFFICES AND SHOW ROOMS, PORTSMOUTH.

The new building, now nearing completion, is situated in a prominent corner position on the ... of the company ... at the ... square at Portsmouth. The building is built of Portland stone, and Welsh granite is used for the roof. The basement is provided with showrooms for gas cook-

ated on the second floor. Messrs. Sabey and Son are the general contractors. Mr. Victor Wilkins, of York Buildings, Adelphi, is the architect.

The death is announced of Mr. A. G. Joass, borough surveyor, Dingwall.

A new Council school at Hidhops Stones, Penistone, built at a cost of £1,675, has been formally opened. The contractor was Mr. D. Brearley, of Deepcar.

The Lynton Rural District Council have decided to apply to the Local Government Board for sanction to borrow £4,000 for laying a sewer from Forest Park Hotel to the disposal works near Brockenhurst.

The annual U.S. National Conference on City Planning was held at Detroit, Michigan, on June 7, 8, and 9. The programme was based chiefly on original research work, which has been conducted by the Conference during the past year on fundamental subjects of city planning.

Good progress is being made in the reconstruction of the Bristol Cattle Market, which was rendered necessary in consequence of the acquisition by the Great Western Railway Company of part of the site for the purposes of extending their station accommodation at Temple Meads. The financial arrangements between the corporation and the railway company have now been completed.



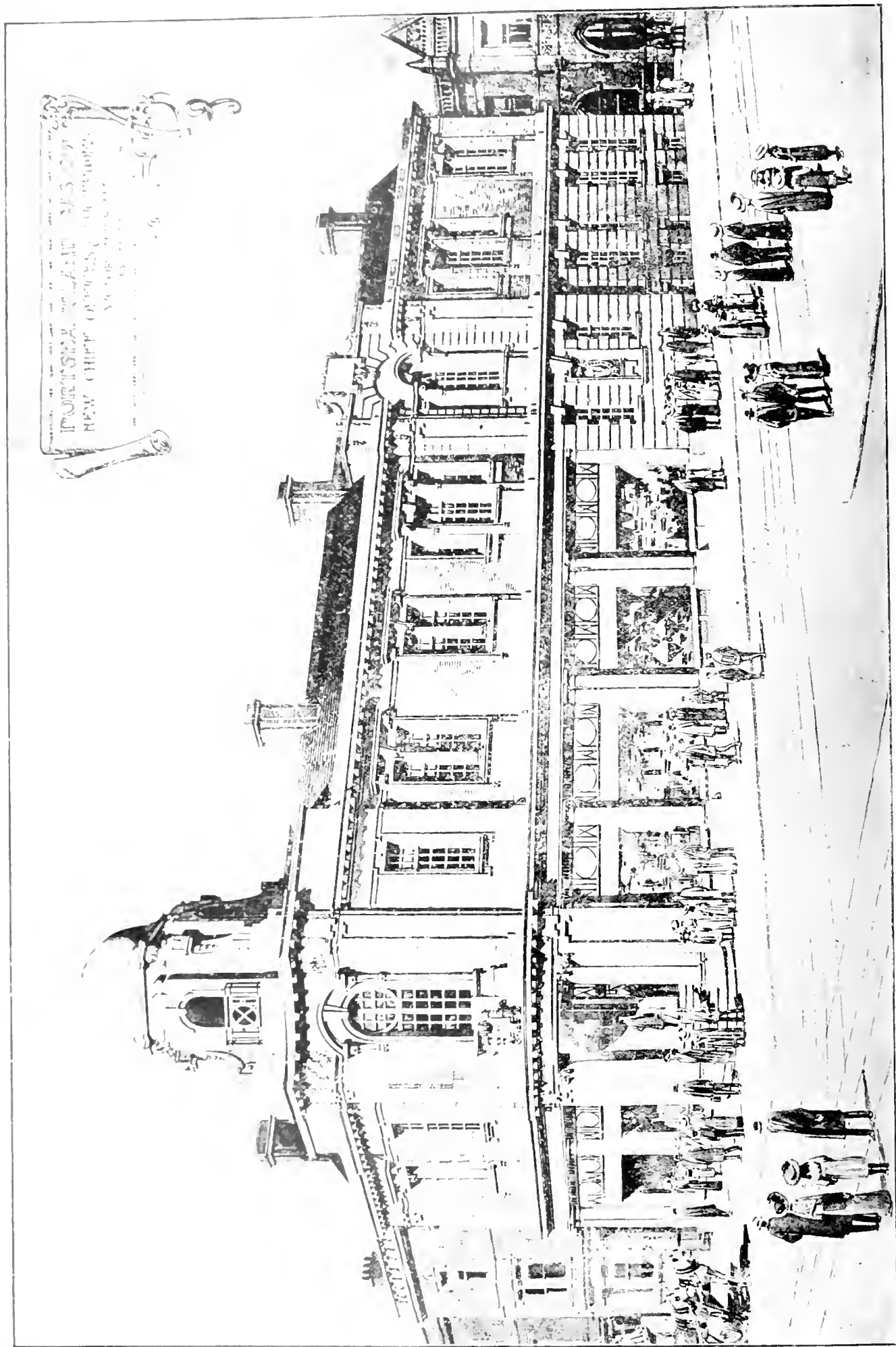

PORTSEA ISLAND GAS COMPANY'S NEW CHIEF OFFICES AND SHOWROOMS, PORTSMOUTH.—Mr. VICTOR WILKINS, Architect.

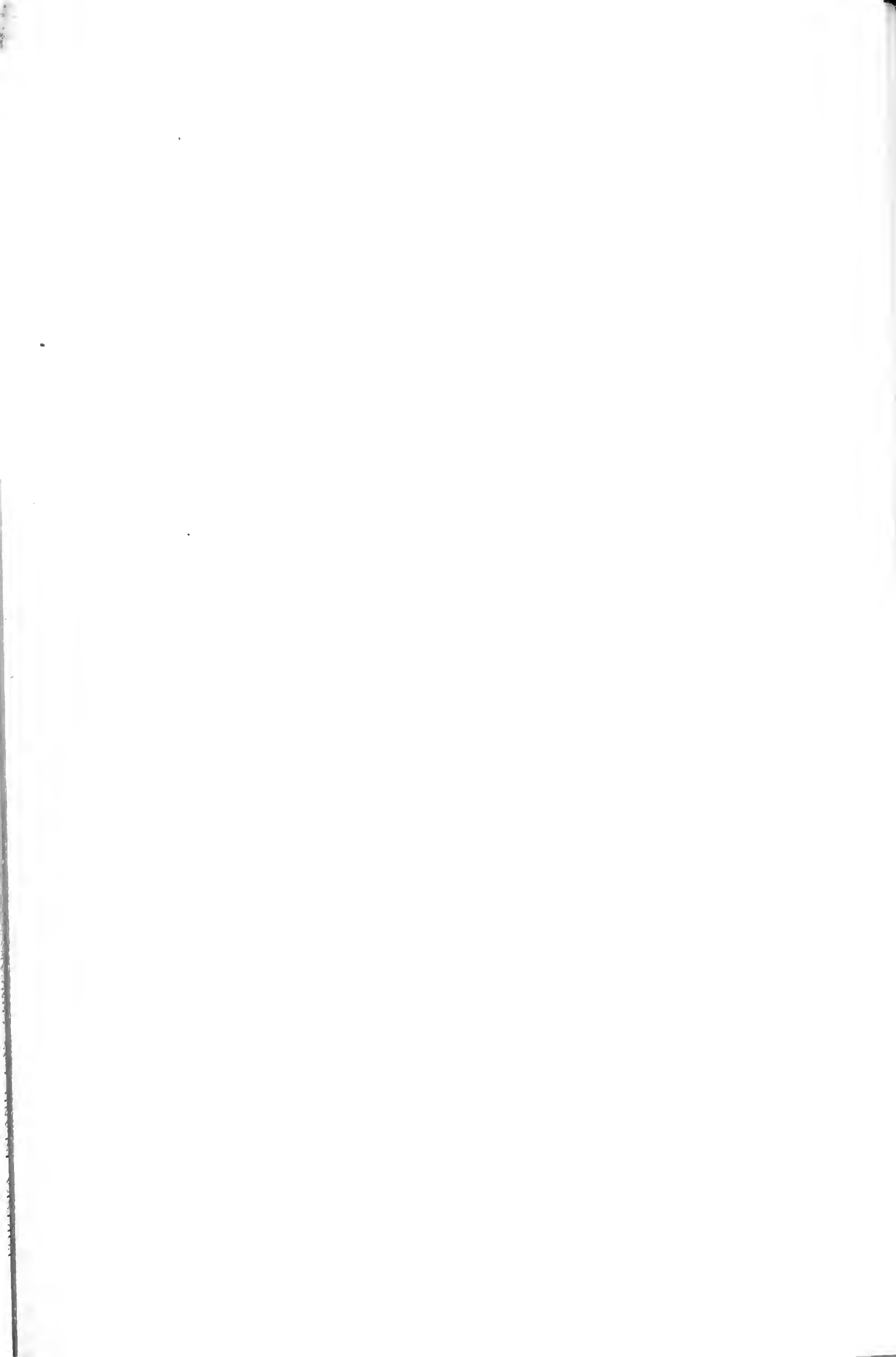

STEPNEY MUNICIPAL BUILDINGS

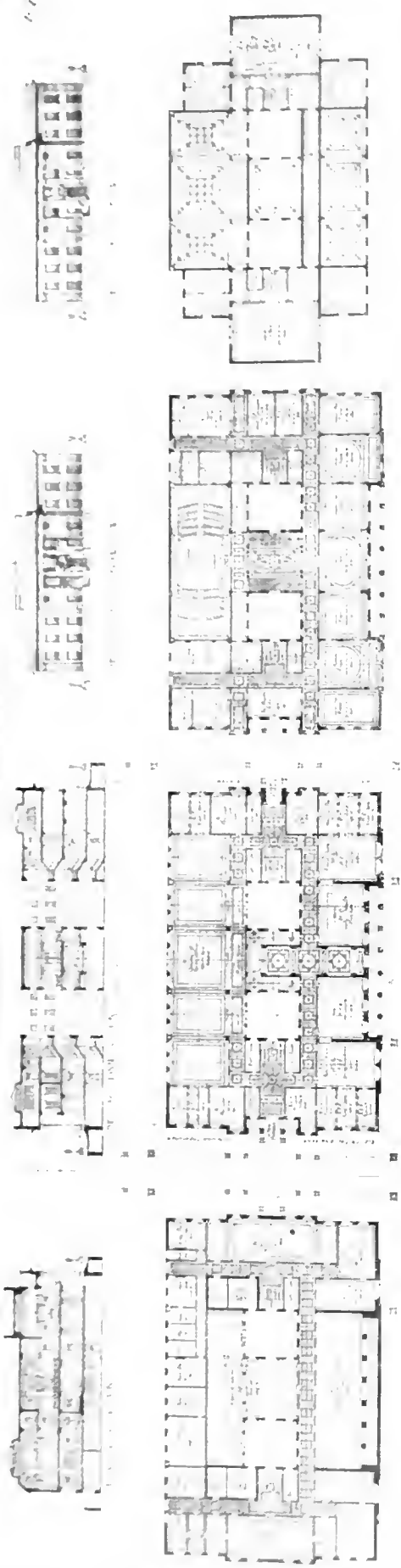

THE GRAND FLOOR PLAN

THE FIRST FLOOR PLAN

04

STEPNEY MUNICIPAL BUILDINGS

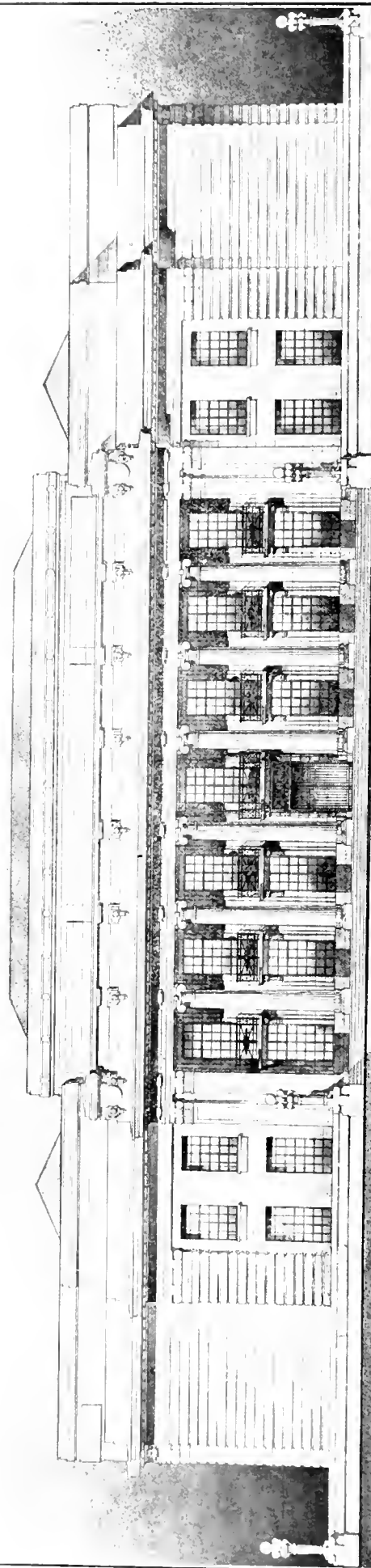

DESIGN PLACED THIRD

THE DESIGN FOR THE MUNICIPAL BUILDINGS, ARBOUR SQUARE, E.

THE SECRET OF THE DESIGN

75 SECOND PREMIAED DESIGN, STEPNEY MUNICIPAL BUILDINGS, ARBOUR SQUARE, E.

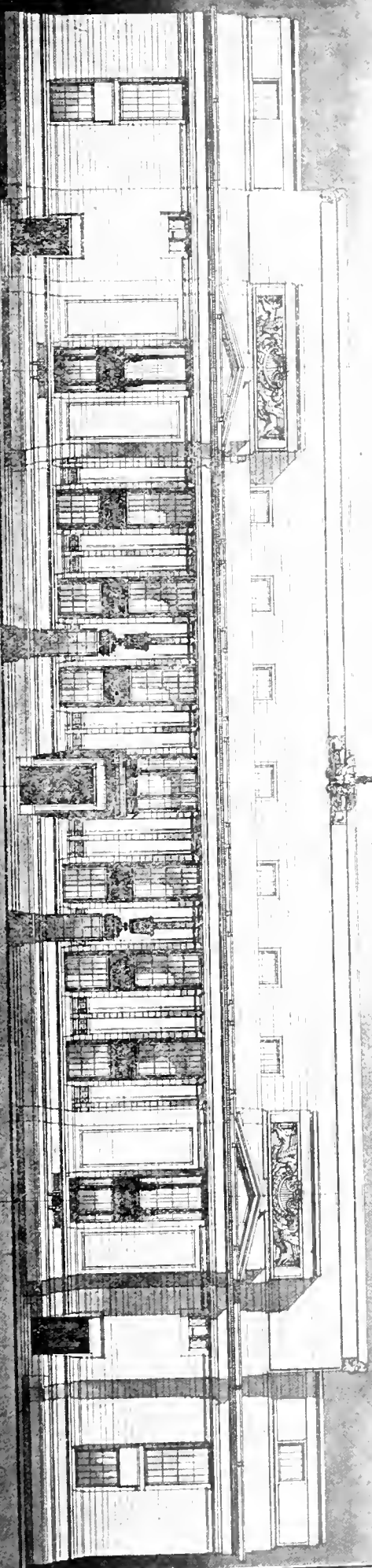
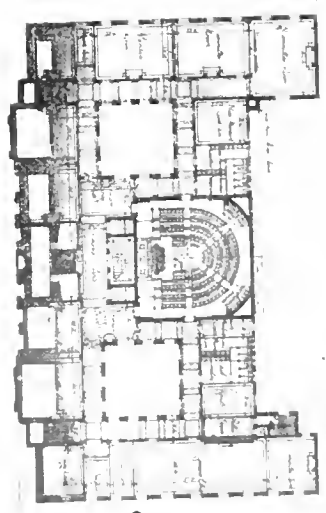
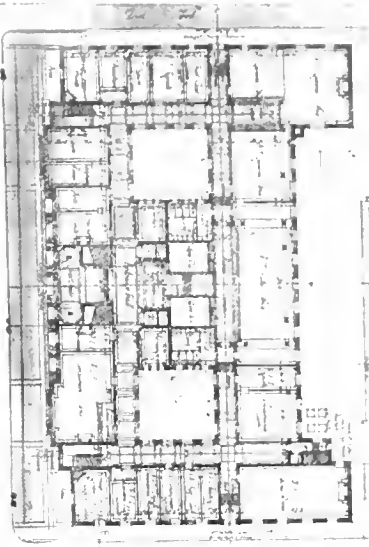

SOUTH ELEVATION: 5 and 6

DESIGN PLACED SECOND.

£100 FIRST PREMIAED DESIGN, STEPNEX MUNICIPAL BUILDINGS, ARBOUR SQUARE, E.
Messrs W. E. Dawson, Gwynne and T. P. T. Architects

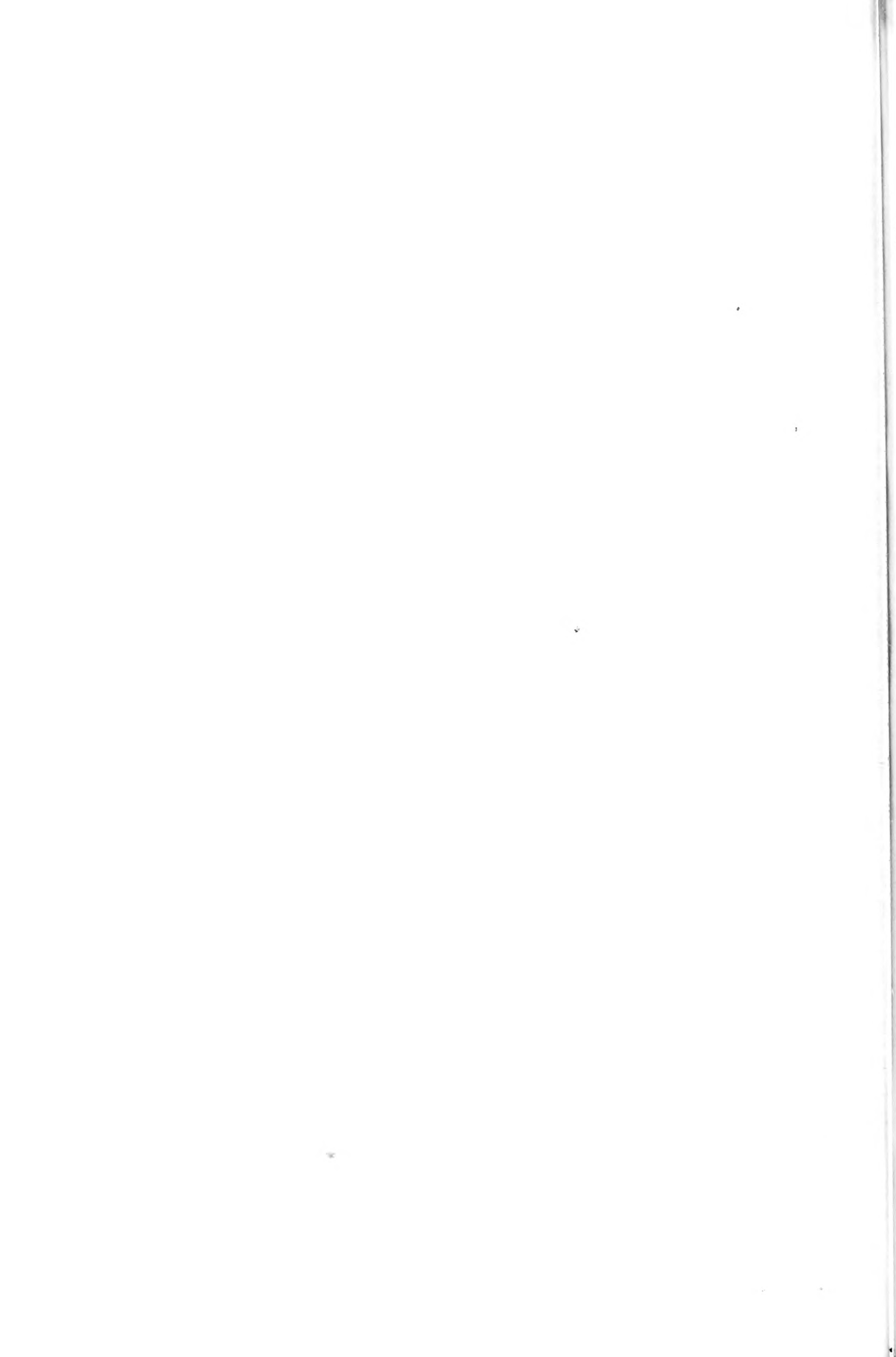

THE BUILDING NEWS, JULY 7, 1915.

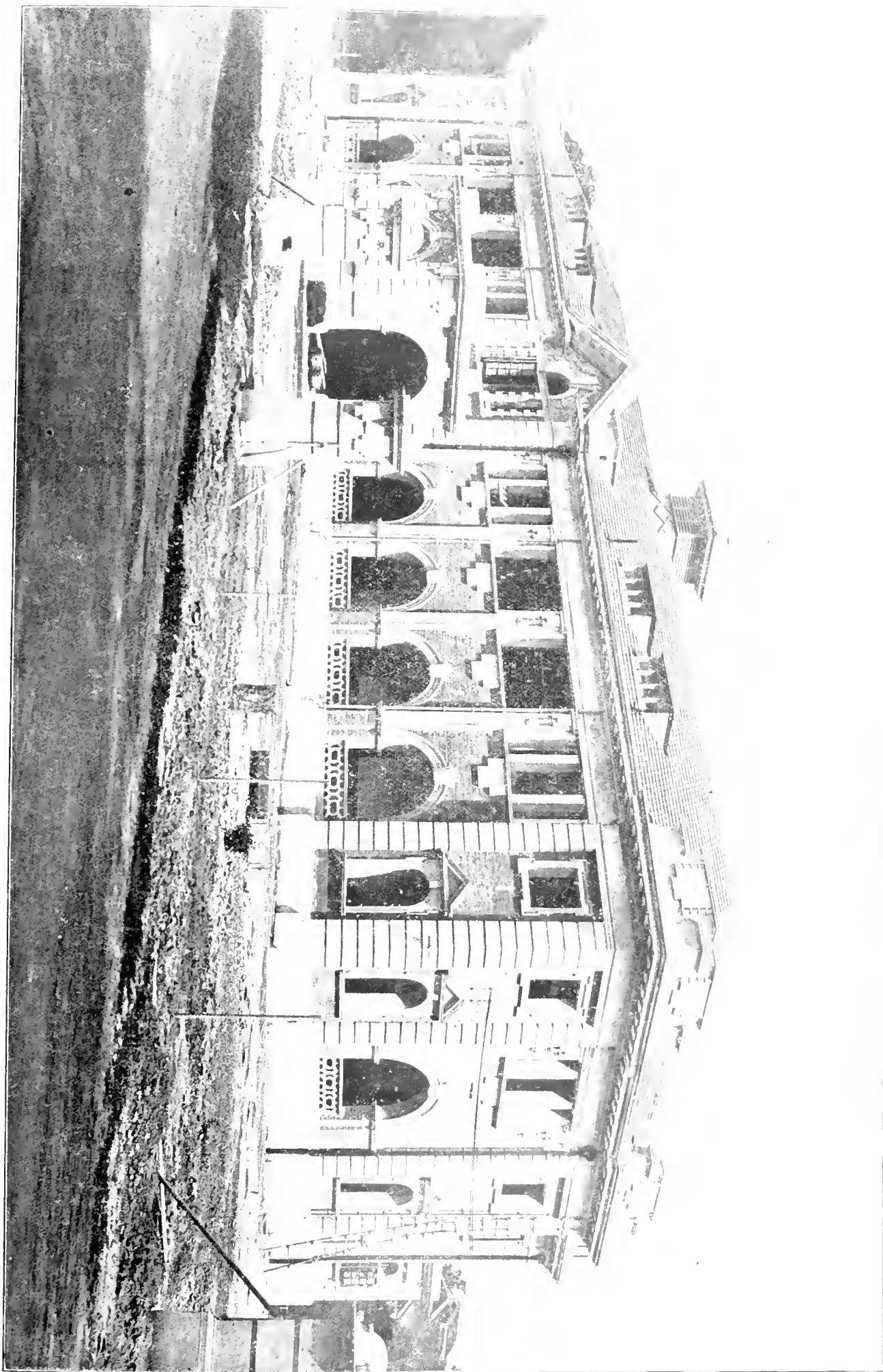

THE PASTEUR INSTITUTE OF BURMA, RANGOON, INDIA.—Mr. E. J. PULLAR, F.R.I.B.A., Architect.

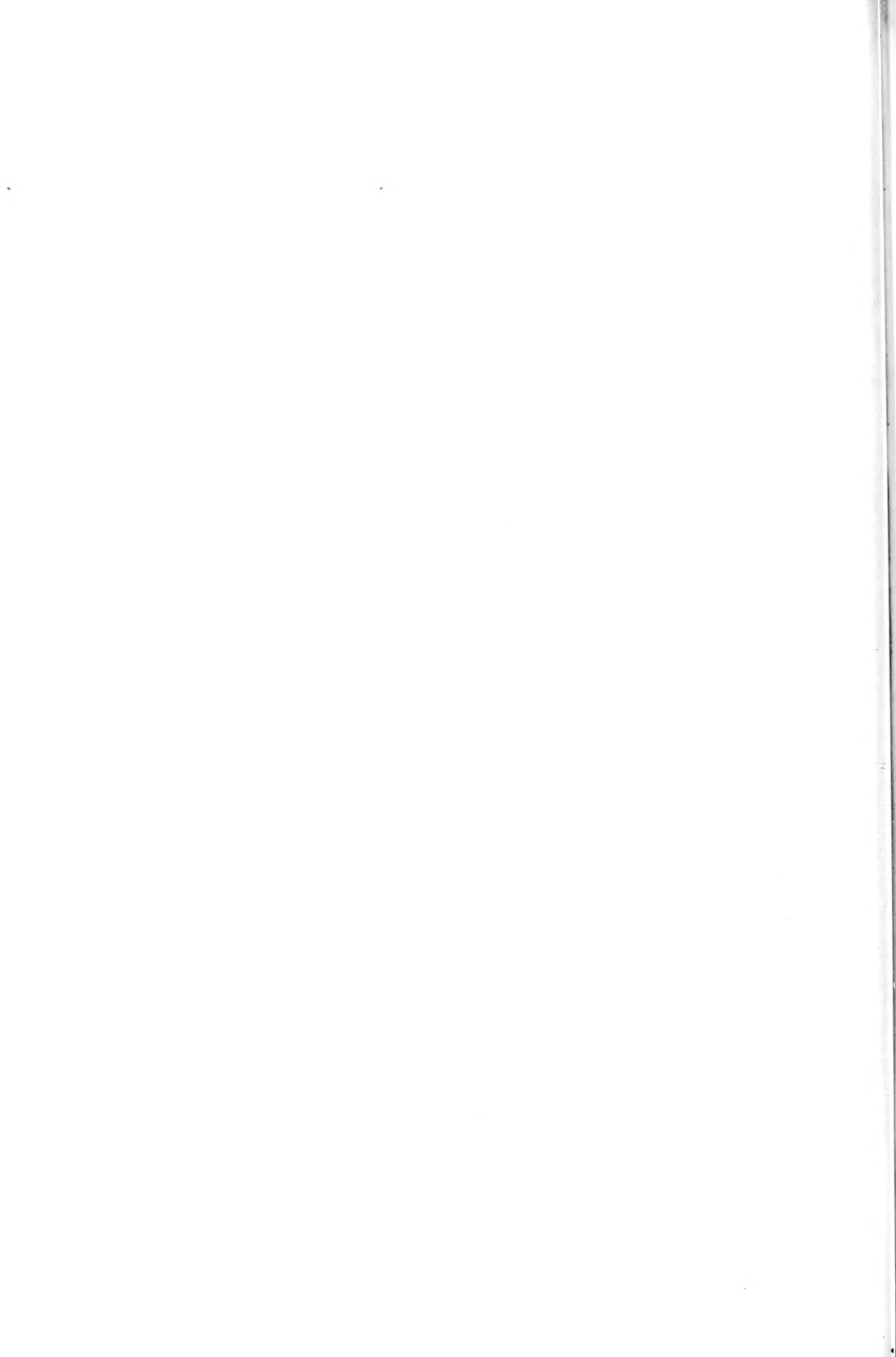



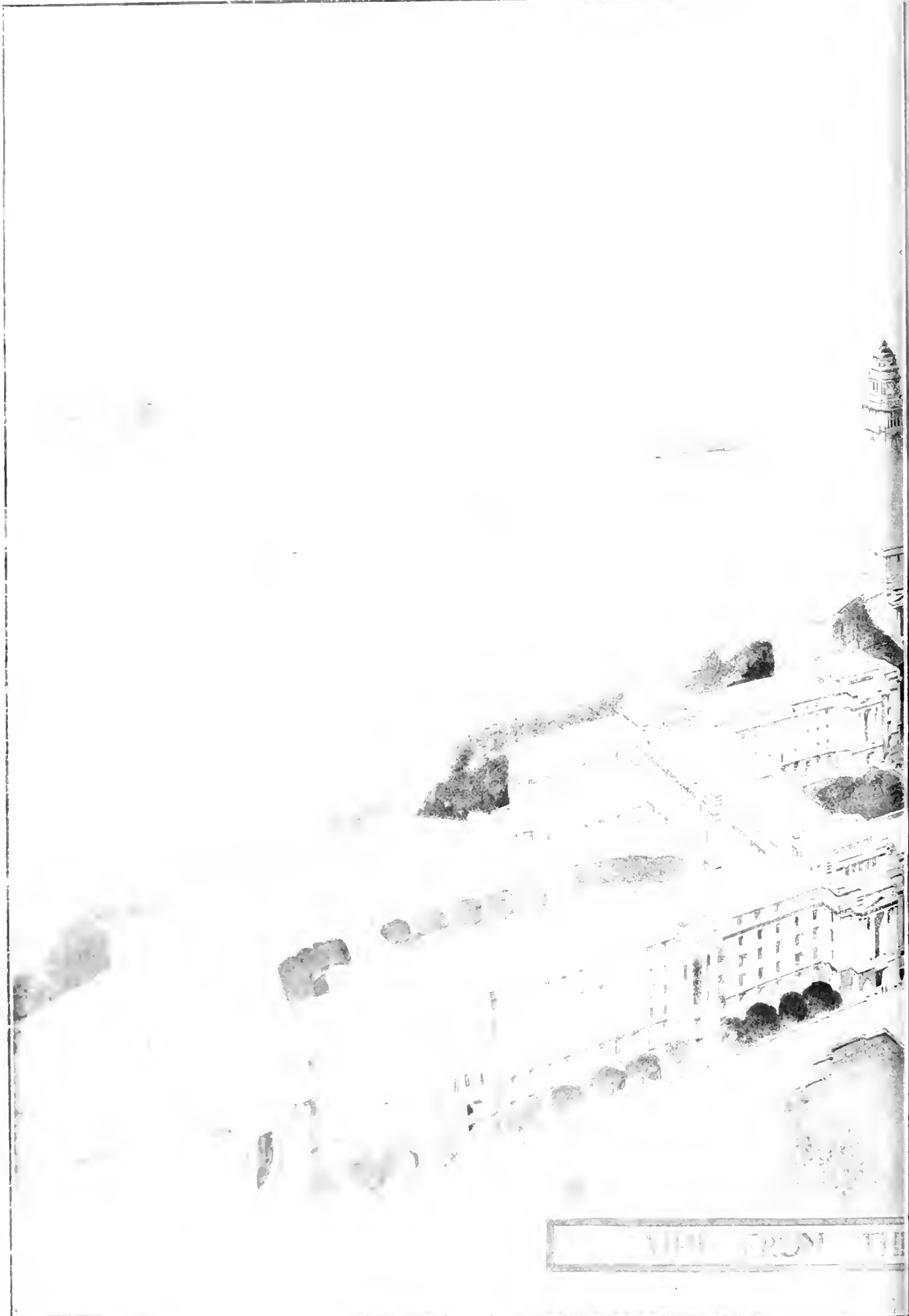

VIEW FROM THE

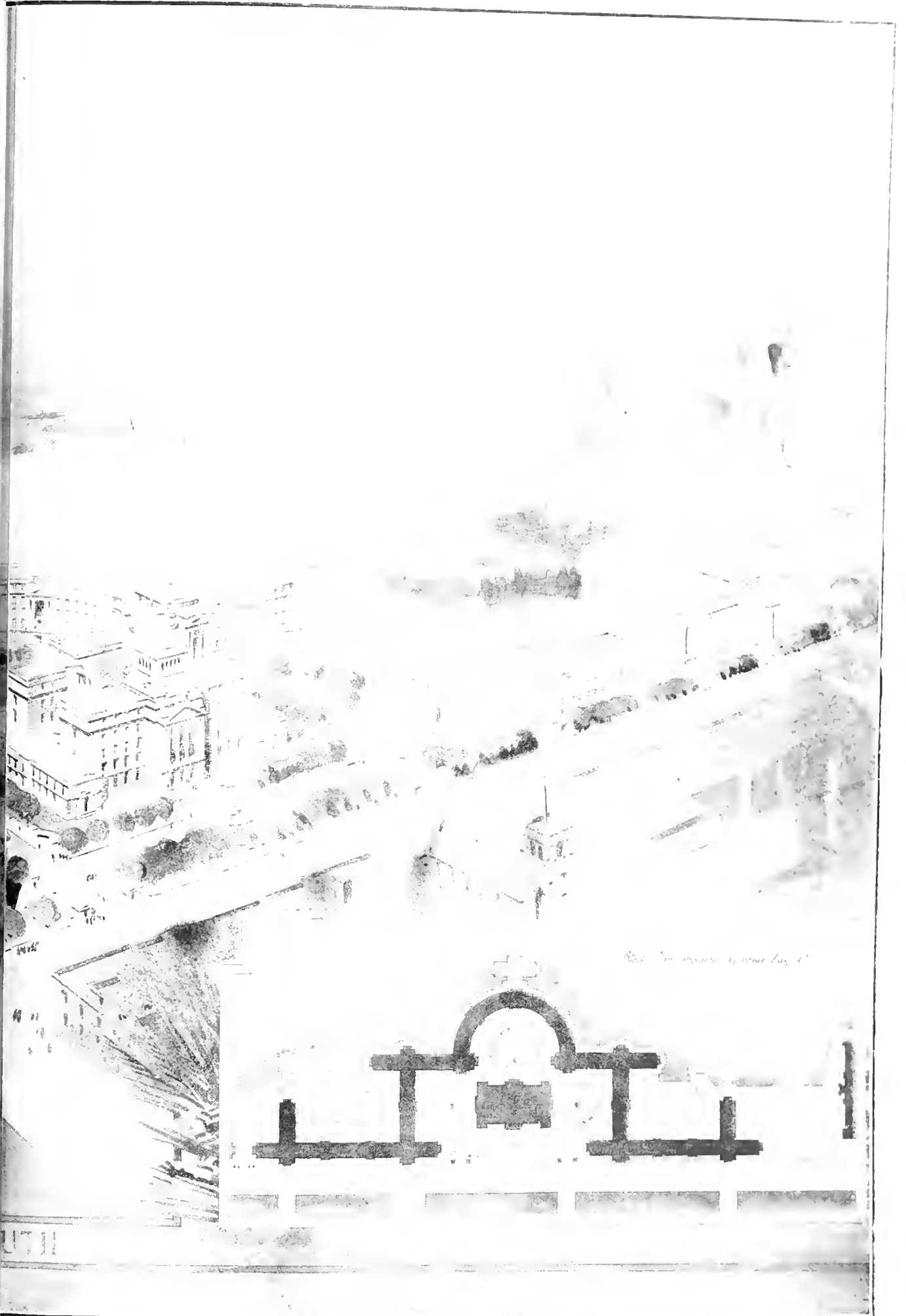

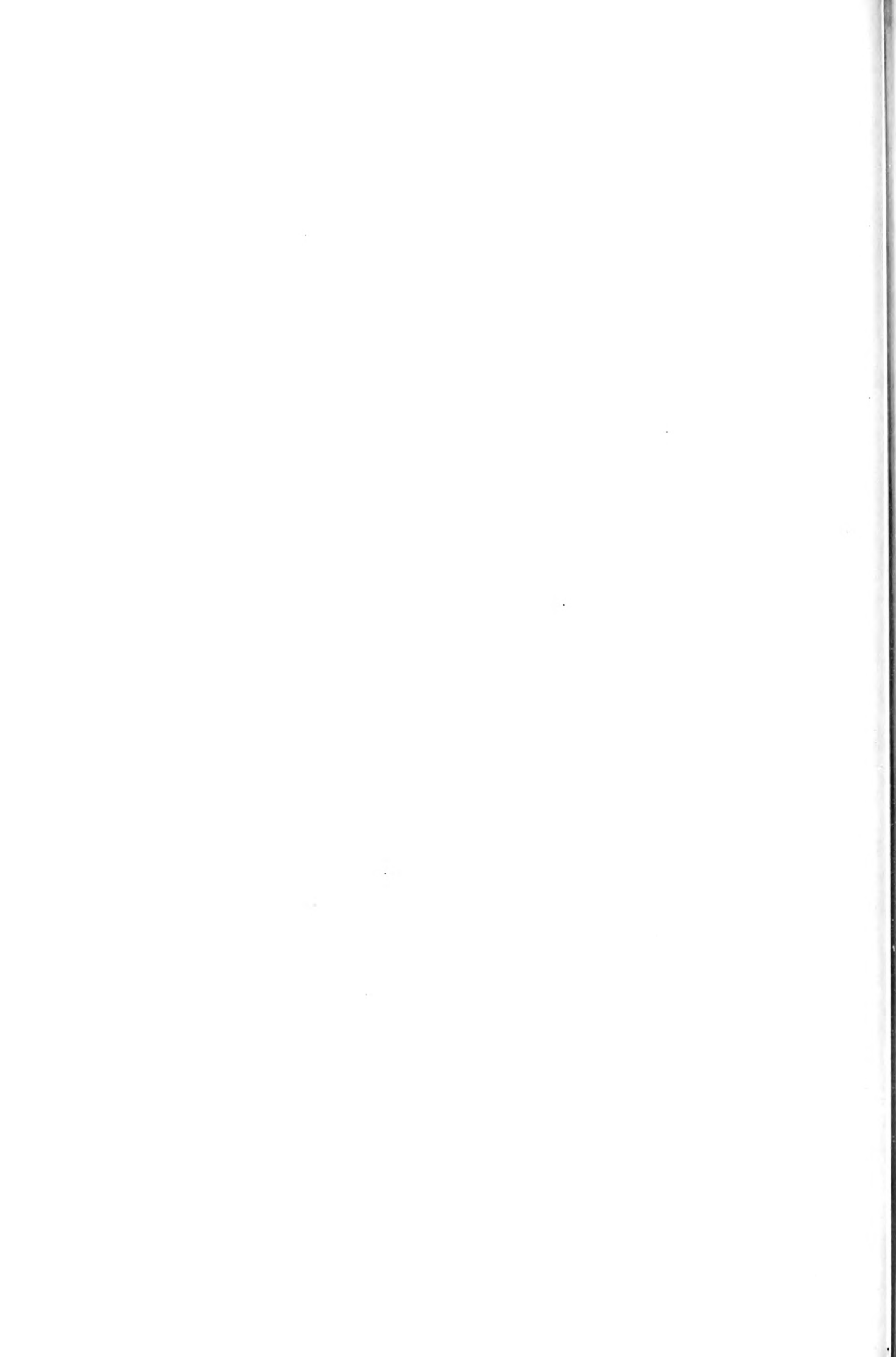



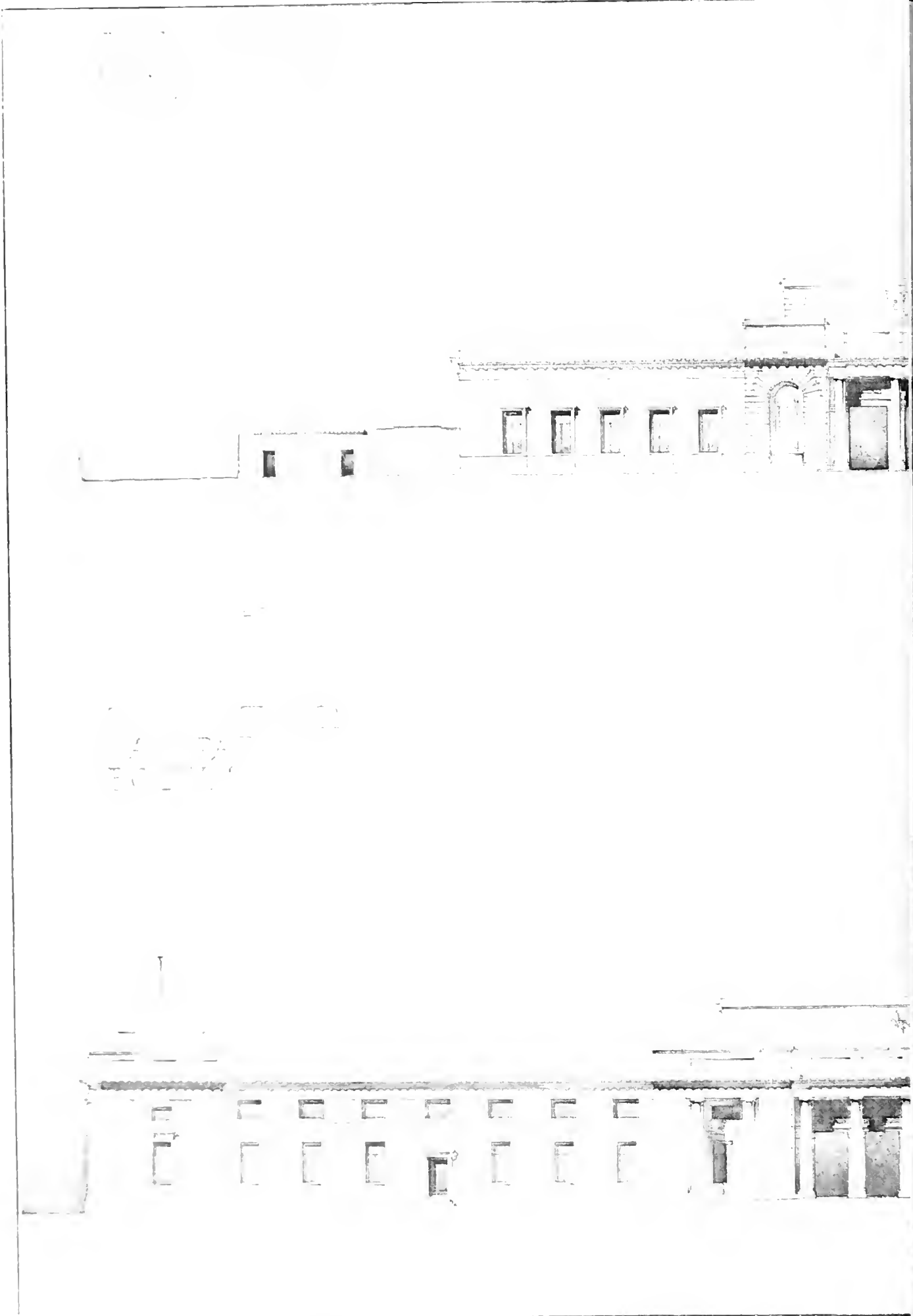

SECTION NORTH YARD, ANTOLOGIA, AND LA PAZ FOR THE

JULY 7, 1915.



LI AND BOLIVIA RAILWAY COMPANY. -Mr. ARNOLD MITCHELL, F.R.I.B.A., Architect.

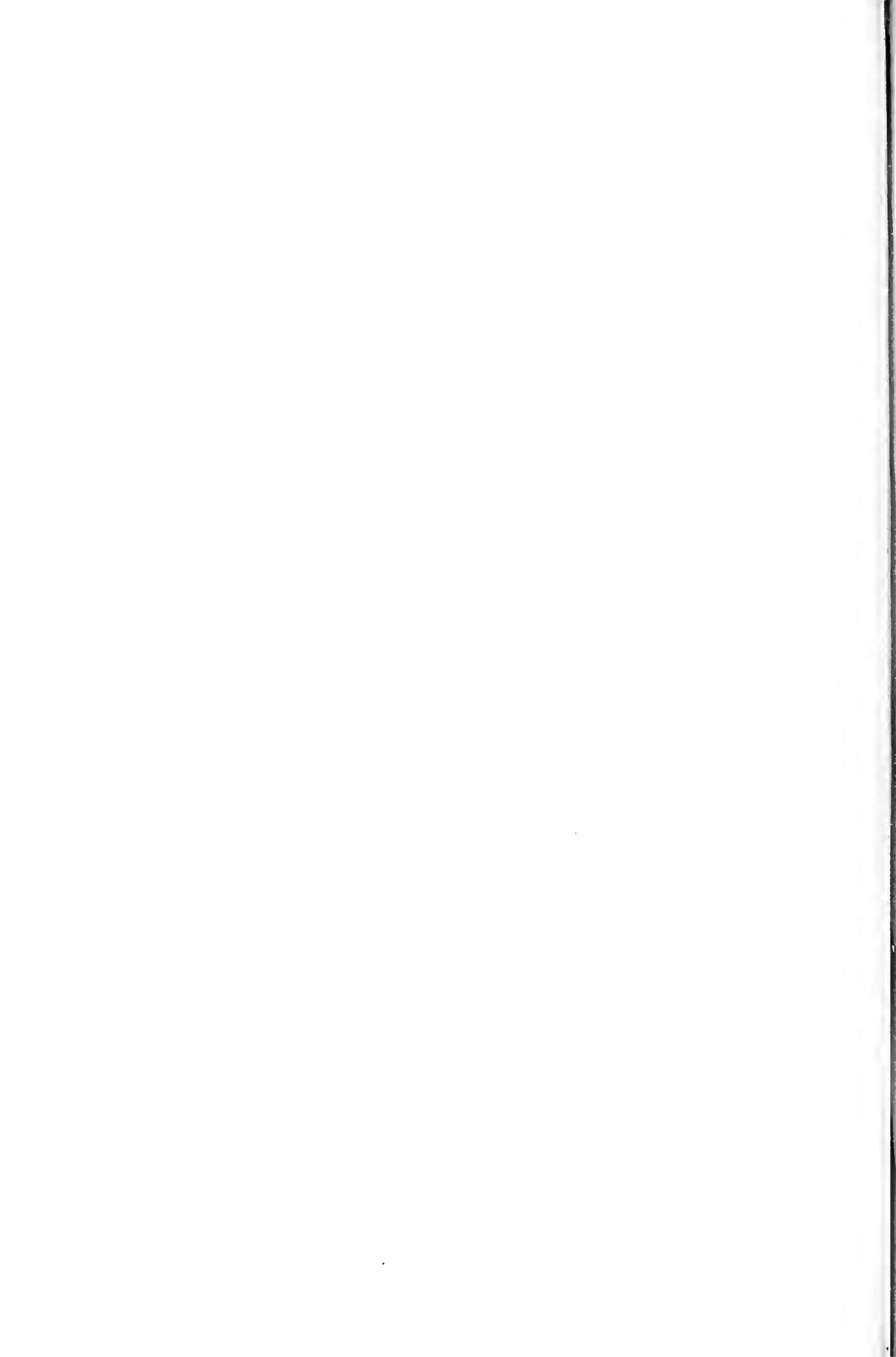

Building Intelligence.

BLOOMSBURY.—A new synagogue is in course of erection in Alfred Place, Bedford Square, from plans by Mr. Claude W. Ferrier, of Waterloo Place, Pall Mall. In addition to the main synagogue on the ground floor, there will be a small synagogue in the basement for daily services, rooms for meetings and for the secretary and ministers, and a residence for the caretaker. The main synagogue, including the ladies' gallery, seats 600 persons. Upholstered tip-up seats are provided, and a full complement of retiring rooms. The construction is of a fire-resisting character throughout, and the front elevation is in Portland stone. The foundation contract is in the hands of Messrs. Ford and Walton, Ltd., of Kilburn. Mr. R. H. Kellond is the clerk of works.

EDGBASTON.—With Masonic ceremonial the foundation stone was laid on Saturday of the new church which the parishioners of St. Augustine's, Edgbaston, are erecting to the memory of St. Germain at the junction of Portland and City Roads. The new church has been designed by Mr. E. F. Reynolds, in competition with twenty-one other Birmingham architects, and accommodation will be provided for 700 worshippers. The plan is set out with the customary arrangement of nave and aisles, the church being entered by two western porches and by an additional door at the east end of the north aisle. On the south side of the chancel is the organ chamber, and on the north side the morning chapel. On the east of the chancel is a semi-circular apse, covered with a semi-dome, beneath which the altar will be placed. Behind the apse is an entrance leading to the choir vestry and clergy vestry. The length of the church from the west wall to the end of the apse is 128 ft., and the width across the nave and aisles 56 ft. The columns supporting the arches on each side of the chancel will have Swedish green marble shafts, with white marble caps and bases; and the columns between the aisles and nave will be of Shap granite, with Portland stone caps and bases. The roofs will show massive trusses and purlins, and it is intended to decorate these timbers with patterns in colour. The walls and porches will be plastered and left bare until it is possible to add their decoration of fresco painting and model plaster work. It is hoped that the walls of the apse will eventually be panelled with marble, and the semi-dome covered with mosaic. The floor under the seats will be laid with wood blocks, and the aisles and chancel will be of red quarries, grey stone, and green slate, laid in decorative patterns. Externally the walls will be of grey brick, with red-brick angles to the piers. Stone is introduced in the window frames and copings, and in decorative patternwork in the gables, and there will be seven stone panels carved with figures in low relief. The roof will be covered with Italian tiles, and a bell turret will rise above the ridge of the roof. The church is to be completed by March next year.

STANFORD STREET, S.E.—The King George Hospital, in Stamford Street, S.E., the largest and one of the best-equipped of its kind in London, is complete, and was opened for inspection on Wednesday last. The building, which has been equipped by easy stages, was originally destined for his Majesty's Stationery Office. It is six floors in height, is divided into sixty-five wards, and contains 1,650 beds. The building was erected from plans by, and under the supervision of, Mr. R. J. Allison, F.R.I.B.A., of H.M. Board of Works. The original contractors for the whole of the work were Messrs. Perry and Co., Ltd., of Bow, E. The alterations to serve as a hospital have been executed by the Director of Barrack Construction from plans by Mr. Edwin T. Hall, F.R.I.B.A., of Bedford Square. The block has a frontage of 323 ft. to Cornwall Road, and a depth of 189 ft., with an average height above pavement of 79 ft. The construction is of reinforced concrete, the floor slabs being 3½ ins. thick and calculated for a weight of 2½ cwt. per sq. ft.; the windows are provided with steel sashes. The premises were fully illustrated in our issue of December 6, 1912.

COMPETITIONS.

TOTTENHAM.—The following awards have been made for the Elementary Schools, Tottenham:—First premium, Mr. A. Jessop Hardwick, F.R.I.B.A., Eagle Chambers, Kingston-on-Thames; second premium, Mr. Arnold Mitchell, F.R.I.B.A., Hanover Square, W.; third premium, Messrs. R. H. Spalding, F.R.I.B.A., N. Toller Myers, A.R.I.B.A., and Ernest G. Theakston, F.R.I.B.A., King Street, Cheapside. Mr. Leonard Stokes acted as assessor. Fourteen designs were sent in by the thirteen invited architects.

UNIVERSITY COLLEGE, LONDON.—In connection with the work of the session 1914-15, the following awards have been made in the School of Architecture at University College:—

- DEPARTMENT OF TOWN PLANNING.
 Lever Prizes in Town Planning, A. G. Wood
 H. N. Fisher
 L. H. Shattock
 Lever Prizes in Architecture, H. N. Fisher
 E. Roehner
 Town Planning—Certificate, H. N. Fisher

OBITUARY.

We regret to announce the death on Wednesday last, at his residence, 52, Portsdown Road, Maida Vale, W., of Mr. Henry David Davis, F.R.I.B.A., formerly senior partner in the firm of Messrs. Davis and Emanuel, architects, 2, Finsbury Circus, E.C. Mr. Davis was in his seventy-seventh year. He was a member of the firm from 1870 until 1898, when he retired. He joined the Royal Institute of British Architects as an Associate in 1872, became a Fellow seven years later, and was placed on the list of Retired Fellows in 1905. His partner, Mr. Barrow Emanuel, M.A., J.P., died in February, 1904, aged sixty-four. Among the many works carried out by the firm were the important blocks of chambers and offices known as Salisbury House, and Finsbury Pavement, in connection with the rebuilding of the Finsbury Circus Estate of the Bridge House Committee; several synagogues, including those in Upper Berkeley Street, W., Stepney Green, Maida Hill (Spanish and Jewish), and Hampstead; the City of London School, Victoria Embankment (gained in competition); Portsmouth Grammar School; Thorn-gate Memorial Hall, Gosport; the concert pavilion on the Clarence Esplanade Pier, Gosport; the Jewish Cemetery, Golder's Green; various blocks of offices in the City, including those of Messrs. Ashurst, Morris, Crisp, and Co.; premises of the Imperial Continental Gas Association; extensive alterations to East Cliff Lodge, Ramsgate, for the late Sir Joseph Sebag Montefiore, and to Castle Hill, Englefield Green, for the late George E. Raphael; the Freeman's Almshouses in Fern-dale Road, Brixton, for the City Corporation; almshouses in Mile End for the Jewish Charities; offices of the Jewish Board of Guardians in Middlesex Street, E.; London Joint Stock Bank, Wood Street, E.C.; the Yarrow Convalescent Home for Children, Broadstairs (illustrated in our issue of August 2, 1895); the laying-out of the Kidderpore Estate at Hampstead; Meistersingers' Clubhouse, St. James's Street, S.W.; large blocks of workmen's dwellings for the East End Dwellings Co. at King's Cross, Bethnal Green, White-chapel, and Columbia Market; and many large warehouses in various parts of London. Mr. Davis was in indifferent health for some years before his death. He leaves a widow and one daughter.

Dr. William Robert Ware, Professor Emeritus of Architecture of the Columbia University, whose death we briefly announced in our issue of a fortnight since, died June 9 at his home in Milton, Mass., in his eighty-fourth year. He graduated from Harvard in 1852. Until 1881 he applied himself to the pedagogy of architecture, at the same time working as an architect in Boston, Mass. During that period he was Professor of Architecture at the Massachusetts Institute of Technology and the Lawrence Scientific School. In 1881 he went to New York and joined the Faculty of Columbia, being retired as Emeritus Professor twelve years ago. Professor Ware was one of the commission that designed the

buildings of the P. S. A. He was a Fellow of the Royal Academy of Arts and Society of Architects, an Honorary Corresponding Member of the Institute of British Architects. He conferred the degree of LL.D. in 1906.

Particulars are just to hand of the death of Sergeant Gordon Smart, of the 1st Buffs Yeomanry, which occurred in the Royal Hospital at Burham on Wednesday last. The deceased, who was thirty-two years of age, was the second son of the late Mr. J. C. Smart, R.S.A. He served through the African South African War with the Buffs of Cambridge's Yeomanry, and on the outbreak of the war last August he immediately gave up his profession as an architect at Burham to join the Yeomanry again. He was mentioned in despatches by the General of the Division for conspicuous colours, and by way of an engagement in Flanders, and was promoted to the rank of sergeant. On Saturday, June 19, Sergeant Smart got leave of absence for seventy-two hours, and went to Burham to spend them. He seemed very overstrung, and it was thought that he was suffering also from the effect of German gas. He became very ill almost as soon as he had arrived at Burham, was removed to the military hospital there, became unconscious, and died on Wednesday.

Mr. David Adamson, retired builder, Innerleithen, lost his life through a shooting accident on Wednesday last. Mr. Adamson retired from business as a builder in Edinburgh a number of years ago, and went to reside in Innerleithen, where he was a generous supporter of all schemes which needed help in the town. He took an active part in the affairs of the town, and was a town councillor.

PROFESSIONAL AND TRADE SOCIETIES.

ROYAL ARCHEOLOGICAL INSTITUTE.—The annual meeting of the Institute was held at Burlington House on Wednesday. Sir Henry Hoare, President, occupied the chair, and, in moving the adoption of the report, stated that the Institute had had another year of successful life, and had never been more prosperous than it was now. Mr. A. Hamilton Thompson was appointed vice-president in the place of Mr. Mill Stephenson, and the following were elected members of the council: The Rev. D. H. S. Cramage, the Rev. E. S. Dewick, M. S. Gausepp, Dr. Philip Norman, Mr. H. Ploymman, and Professor E. S. Prior, F.R.I.B.A. Professor G. Baldwin Brown read a paper entitled: "Was the Anglo-Saxon an Artist?" He said that there was a sufficient body of valid evidence that the Anglo-Saxon possessed an artistic capacity quite on a level with that of his Continental contemporaries, and there was no real foundation for the popular prejudice which regarded him as a rather clumsy, boorish creature, who had to subsist the needy foreigner to do his artistic work for him. It might be considered that all beautiful cases were to be given in favour of the foreigner, but there still remained a mass covering almost the whole Anglo-Saxon period, the tomb furniture, including the Kentish inlaid jewels of the pagan epoch, the ring of Ethel-Smith, and the Durham embroideries of a later time, not to mention the ornamented manuscripts, the native origin of which had never been in doubt. If the Gospels of Lindisfarne be handed over to Celtic scribes, it was impossible to withdraw from native Anglian brains and fingers a large share of the responsibility for the Ruthwell and Bewcastle crosses. These were things that "cannot be spoken against."

Mr. Percy Heaton has received instructions from the rural district council of Preston, Lancs., to prepare a scheme for a new water main and the erection of a water tower to hold 40,000 gallons.

The corporation of Birmingham accepted, with thanks, at their meeting yesterday (Tuesday) the gift from Mr. Alexander M. Chance and the subscribers of an area of 33,611 square yards of land adjoining Worley Park for the extension of that open space.

Our Office Table.

W. Mr. J. H. ...
V. Mr. ...
M. Mr. ...
S. Mr. ...
H. Mr. ...
C. Mr. ...
P. Mr. ...
W. Mr. ...
L. Mr. ...
R. Mr. ...
G. Mr. ...
B. Mr. ...
K. Mr. ...
I. Mr. ...
M. Mr. ...
P. Mr. ...
A. Mr. ...
R. Mr. ...
C. Mr. ...
H. Mr. ...
L. Mr. ...
E. Mr. ...
D. Mr. ...
S. Mr. ...
J. Mr. ...
B. Mr. ...
N. Mr. ...
O. Mr. ...
T. Mr. ...
F. Mr. ...
G. Mr. ...
I. Mr. ...
H. Mr. ...
M. Mr. ...
P. Mr. ...
R. Mr. ...
S. Mr. ...
T. Mr. ...
V. Mr. ...
W. Mr. ...
X. Mr. ...
Y. Mr. ...
Z. Mr. ...

state; it, with the county West Hartlepool and partly in the district of Hartlepool, Mr. ... the borough engineer, said ... 1,210 acres of land within ... 1,122 acres in the rural ... Stranton, Seaton, and ... The land generally was suitable, ... proximity to large industrial ... the development of estates, and ... there was a great future for the ... to questions by Mr. Jeyons, ... Durham County Council, Mr. ... there were 1,216 unoccupied ... West Hartlepool in 1911, as com- ... 515 in 1901, but in the inter- ... years a great wave of depression ... the whole country, and West ... suffered as other places. Mr. ... of the county council did not want ... to a town planning scheme, ... could suggest for the Board's con- ... in the event of their approving of ... scheme, that the rural authority should ... by way of representation on ... responsible authority. Mr. Jeffries, for ... rural district council, submitted that, ... regard to the fact that the rural ... had been stationary for twenty ... years, there was no need for a town-planning ... Mr. Foster also opposed on behalf ... of the Greatham Parish Council. The owners ... of Tarstall estate desired to be excluded ... from the scheme, and Lord Eldon objected ... to the scheme on the ground that the time was ... out ripe. Mr. Tilly said his clients, Messrs. ... W. Gray and Co., recently bought ninety ... acres of the land included in the scheme. Their ... attention was to build a garden city ... for workmen employed at the proposed new ... shipyard, and it would be a great hardship ... if their plans were affected by the scheme.

M. Paul Lambotte, Directeur des Beaux-Arts de Belgique, has arranged at the Goupil Gallery an exhibition of paintings, sculpture, and other works of art (including modern Flemish lace, leather-work, and embroidery) by Belgian artists. Among the paintings are a landscape triptych, by M. Leon Frederic, and works by Madame Alice Renon, M. Fernand Khnopff, and M. Alfred Delaunois. Two galleries are filled with an exhibition of old Flemish towns (oil paintings and original etchings), by M. Julien Celas. The names of these quaint, old-world cities are on every lip, though some of them have practically ceased to exist. Thus we have "Maison de Pauvres, Nieupoort destroyed," "Vulle Cour a Lierre," "Jour de Marche, Malines," showing the cathedral, with its magnificent unfinished tower, and "Matin a Nieupoort." M. Celas, an etcher especially achieves success in his pictures of winter, of which the best are "Le Hamon sous la Neige," "Le Petit Marche en Hiver," "Sour d'Hiver au Beguinage de Lierre," and "Le Degel, Bruges." Wisely he has not attempted to raise the havoc of the war, which has practically wiped out of existence many of these Flemish towns and villages. The public will, we trust, second M. Lambotte in his efforts to relieve the necessities of his Belgian art brethren.

Writing in "The Nineteenth Century and After" on the effect of six months' war on the timber supplies of England, Mr. E. P. Stedding asks whether we are making full use of the opportunity which the shortage in timber supplies is affording us, and, further, whether we are considering the forestry problem in the new aspect in which the war presents it. Much is being done by the Boards of Agriculture, both English and Scottish, in the direction of drawing the attention of proprietors of woods to the possibilities presented by this unique opportunity for clearing out woods of poor development, which have suffered irretrievably from wind or snow damage; and, secondly, in encouraging planting promising young woods of well selected material as pit wood. Some proprietors, he said the position at once. The question now is: Is there not some danger that the supply being held up too long by anticipation of a still further rise in price? The opportunity is without parallel. Iron brackets for supporting the roofs of mine work-

ings are more expensive, but, provided they can be recovered for further use, they can be made to pay; and by offering an extra inducement by way of pay the men are being persuaded to recover them. Once the initial difficulty of introduction and recovery of these props is surmounted the managers are unlikely to go back to the wood prop, and the market for this article will be proportionately lessened at a juncture when, with the advance in British forestry, it is most important that it should be maintained.

Further, is it not time that a decision should be arrived at as to the percentage of the available plantable land in the country which should be maintained under woods in the interests of the community as a whole? It is known that there are several million acres of plantable land which could be made to produce a proportion of the materials now imported. Incidentally, the woods would also give rise to flourishing industries, such as pulp mills, furniture and toy factories. The Blue Books of the Forestry Commissions have pointed out that town labour was useless for planting and general forestry work, as the townsman could not handle a spade or stand the hard work and climatic conditions entailed by forestry operations. This plea was true at the time. It is a question now, however, whether large planting schemes could not be put into force at the conclusion of the war. Numbers of soldiers might be induced to take to forest work, and planting on a large scale could be undertaken.

In the report of the progress of the Ordnance Survey to March 31, 1915, it is stated that the publication of the 1:2,500 survey of Ireland was completed on August 31, 1914. This survey was begun in 1887, and thus took twenty-seven years to execute. The area of Ireland is 32,400 square miles, and the average out-turn per annum was 1,200 square miles. The total cost was £1,400,000, and the average cost per annum was £51,850, and per square mile £43. These figures include the cost of all field work and of the levelling, of printing, and publication of both 1:2,500 maps and 6-in. maps, and the delineation of boundaries and sites of antiquities. During the year experiments were continued with a view to the production of a new type of 2-in. map.

The editor of *Indian Engineering* expresses regret that the designs by Messrs. E. Landseer Lutyens and Herbert Baker for the Government House and the two Secretariat Buildings at New Delhi have been cut down for economical reasons. Our contemporary urges that the principal buildings in the new capital ought to be worthy of their purpose. As it is, the edifices are to be faced with red and white Agra sandstone, but no one would have complained if the material had been marble. There is no doubt that the effect of the buildings in marble would have been greatly enhanced, but the cheaper material having been chosen, it seems unnecessary to mar the effect by further economies.

The Bill creating the State Board of Architects and providing for regulation and examination of all architects practising their profession in the State of Florida has passed the Senate, and, having been passed by the house formally, has been certified to that body as notice of completion of legislative action on it. It now goes to the governor for signature. Before passage the Bill was amended so as to make 20 dol. instead of 25 dol. the license, and further amended so as not to apply to buildings costing less than 5,000 dol.

It has been announced that the Dominion Government will continue the construction of all public works under contract in Canada. Apart from the war, the total expenditure of the Canadian Dominion will reach 200,000,000 dollars for the year, while the war expenditure will mean an addition of 100,000,000 dollars. The programme for the current year includes an expenditure upon public works of 25,000,000 dol. on railways and canals of 27,000,000 dol., and on capital account and works of harbour commissioners of over three and a half millions. Since the outbreak of the war the Dominion has made every effort to minimise unemployment in Canada by maintaining its programme of public works, including the I.R.C. terminals at Halifax, the

Welland Canal, the Quebec Bridge, the Northern Territories and Hudson Bay Railroad, and terminal elevators and harbours at Halifax, St. John, Quebec, Montreal, Toronto, Hamilton, Port Arthur and Fort William, Vancouver, and Victoria.

"Masonry," by Professor Malverd A. Howe (London: Chapman and Hall, Limited, 6s. 6d.), is an American work dealing concisely with natural building stones, artificial materials, stone masonry, brick and hollow-tile work, concrete, and railway work. It is mainly meant for help in courses of instruction of those where little time is given to the subject. In regard to quarrying by machinery, American quarry owners seem considerably ahead of us, and some of them who do not know it might read the volume with advantage.

The strength of sand-lime brick, states the *Canadian Engineer*, depends upon a firm bonding of the sand grains through the agency of lime. A mixture of sand and lime is pressed into bricks, which are then subjected to the action of steam under pressure for several hours. A chemical union takes place between the lime and the quartz of the sand, forming hydrated calcium silicate. The sand used should not be too coarse. That passing through a twenty-mesh screen and composed of grains ranging in size down to minute particles is desirable. In other words, the sand grains should be so graded in size as to leave very little interstitial space. The strongest bricks are made from sharp sand which is free from inert minerals, such as clay, iron oxide, mica, etc. The clay and iron oxide are particularly objectionable, since they are liable to mask the grains of quartz and thus prevent the union of the lime and quartz. Ten per cent. of clay substance should be set as the extreme limit. Feldspar is less objectionable, but in large proportions is undesirable, as it reduces the strength of the brick.

CHIPS.

The urban district council of Llanfrecifa have appointed Mr. M. R. Jones, of Abergele, as surveyor and inspector.

Mr. Thomas Nisbet has been appointed to the joint offices of master of works and city engineer by the Glasgow Corporation.

The Local Government Board have given their sanction to an application by the urban district council of Surbiton for permission to borrow £4,875 for sewerage works.

Alderman Owen Ridley, of Cwelly House, Craven Road, Reading, formerly head of Ridley and Sons, timber merchants, and twice Mayor of Reading, died on April 28, aged 77, leaving £60,496.

The city council of Sheffield have made application to the Local Government Board for sanction to prepare a town-planning scheme for Hillsborough, Malin Bridge, Stannington, and Crookes.

The Tolhurst Memorial Roman Catholic Church at Northfleet has been formally opened. The new building forms a striking feature on the hill, and has been erected from the designs of Mr. G. Gilbert Scott by Mr. J. B. Lingham. The contract amount, including the tower, was £6,436, but the actual cost reached £8,000.

At the last meeting of the Stepney Borough Council the Finance and Parliamentary Committee presented lengthy reports on the application by contractors for increases in their respective contract rates. In connection therewith they presented an estimate of £7,334. A long discussion ended in the reports being adopted.

Extensive renovations and additions to Newlyn East Church of England School have been carried on during the past few months at an outlay of about £1,000. The roof of the old school has been remade, and five new Boyle ventilators and five fresh windows put in. The architect was Mr. C. King, F.R.I.B.A., Plymouth.

The opening to traffic of the Leuk-Leukerbad line, the latest of the Swiss mountain railways to be constructed, took place on Monday. The construction of this new electric line, just over 6½ miles long, was begun in 1912. It is mainly a tourist line, leading from Leuk, a station on the main Simplon line, to the winter resort of Leukerbad (Loèche-les-Bains). It has cost £120,000 to construct.

LEGAL INTELLIGENCE.

MIR RAID PRECAUTIONS.—PROSECUTION UNDER THE BUILDING ACT.—At the Guildhall, on July 4, Mr. Walter Wheeler, of the firm of Wheeler and Sons, engineers, of Victoria Gardens, Notting Hill Gate, appeared to answer two summonses under the London Building Act, 1911, for having failed to serve a building notice on the district surveyor before beginning certain work on the roof of the North British Assurance Company, and for having cut into certain chimney shafts and flues for a purpose other than that sanctioned by Section 64. The defendant admitted that no notice was given, but said he was of opinion that as the work was in connection with precautions against hostile air raids no notice would be required. Mr. John Todd, the district surveyor, said it was an extremely difficult matter for him to deal with. The work of protecting City buildings and financial houses must be given the utmost consideration by every person. This was not the only case he had to deal with, but he had refrained from his duty in prosecuting in other cases in the public interests and on the principle that no mere breach of the Building Act should prevent anyone in the City from doing what was reasonable to safeguard their property against air raids. He was not going to enforce the law in respect of any mere technical contravention of the Act, but he felt that it would be only good cricket on the other side if they would give him every opportunity to see what was going on.—Sir John Baddley said that under the circumstances he would only impose a nominal penalty of 5s. and costs.

CONTRACTOR v. CHURCH BUILDING COMMITTEE.—In the King's Bench Division, on June 29, before Mr. Justice Atkin, mention was made of the action of Mr. A. J. Calborne, builder and contractor, of Bristol and Swindon (suing through his trustee in bankruptcy) against the Rev. J. W. Jones and the Building Committee of the Annanford Church to recover £2,540, the balance due in respect of the erection of the new church at Annanford, Mon. Plaintiff alleged that the defendants, through their architect, Mr. W. D. Jenkins, had acted wrongfully in determining the contract. The defendants set up a counter-claim for damages, and said they were entitled to determine the contract owing to delay on plaintiff's part. This was denied.—His Lordship held his reserved judgment given on June 8 (and published in our issue of the 16th ult.) that the contract was wrongfully terminated, and also gave judgment in plaintiff's favour on the counter-claim.—Mr. Morton, K.C., for the plaintiff, now said the parties had been unable to agree as to the amount due to plaintiff. After hearing counsel's arguments, his Lordship said the best thing would be for the parties to appoint a quantity surveyor. Unless they agreed within seven days to give him a name he should ask the President of the Surveyors' Institution to name a gentleman, and he (his lordship) should nominate him.

GROVER v. HOPKINS.—A CLOSING ORDER AND LIABILITY FOR RENT.—Before his Honour Judge Scully at the Watford County Court, last week, the adjourned hearing took place of a case in which H. Grover, Upton Road, Watford, sued James Hopkins for two quarters' rent of a house in Cassio Road. It was stated that the premises had been closed by an order of the local authority owing to their condition. At the first hearing Mr. S. J. Ellis, for the plaintiff, admitted that it was a hard case, but Mr. Grover, who held the premises under a lease, was in a similar position. There was no agreement on the part of the landlord to repair. His Honour now said that he wanted further information as to the ground on which this house was condemned.

Mr. Ellis said that the damp course was defective through neglect. Plaintiff explained that the stuff used in the damp course was not as it should have been. The stuff allowed to be used would not last more than a certain number of years.—Mr. Ellis. The damp course was made with material which was all used by the urban district council when the house was built. This material was not now at all used, the council had some other approved material. He also said that the wall above the damp course was heaped up with earth. Mr. Matthew Arnold, on behalf of defendant, said that he did not admit that. A reply was made by the proveyor-tenor. His Honour said that he would take evidence on this, as it was a very material point. Plaintiff said that he was the lessee of the house in Cassio Road, and he submitted it to be demolished by an agreement dated August 22, 1911. Defendant had not given up possession of the house, but was not in possession.—Mr. Ellis said that the house was closed by an order issued in July, 1913.

His Honour said he was not prepared to make an order for the return of the deposit. A reply was made by the proveyor-tenor, that he had taken possession of the house and that he was not prepared to return the deposit. He said that he was not prepared to return the deposit because the house was in such a state of disrepair that he could not take possession of it. He said that he was not prepared to return the deposit because the house was in such a state of disrepair that he could not take possession of it. He said that he was not prepared to return the deposit because the house was in such a state of disrepair that he could not take possession of it.

Mr. Ellis said that the damage to the house was caused by neglect on the part of the landlord. His Honour said that he would take evidence on this, as it was a very material point. Plaintiff said that he was the lessee of the house in Cassio Road, and he submitted it to be demolished by an agreement dated August 22, 1911. Defendant had not given up possession of the house, but was not in possession.—Mr. Ellis said that the house was closed by an order issued in July, 1913. The plaintiff said that he was not prepared to return the deposit because the house was in such a state of disrepair that he could not take possession of it. He said that he was not prepared to return the deposit because the house was in such a state of disrepair that he could not take possession of it. He said that he was not prepared to return the deposit because the house was in such a state of disrepair that he could not take possession of it.

MABLETHORPE AFFIRMATION.—An agreement to give to the Mayor of Mablethorpe, Lincolnshire, the sum of £12,750 for the purchase of a certain piece of land in Mablethorpe, Lincolnshire, was affirmed by the court. The agreement was made between the Mayor and the defendant. The court held that the agreement was valid and should be affirmed. The sum of £12,750 was ordered to be paid to the Mayor for the purchase of the land. The court also held that the defendant was liable for the costs of the proceedings.

London, having 2 years' course, having been... Mr. Jeeves a... Mr. Dyce followed... of the... The... was awarded in... course... and the proceedings...

SUB-CONTRACTOR v. BUILDER.
BATES v. MILLER. In the Court of Appeal, N. 1012, 1915. Mr. Justice Rowlatt, Mr. Justice Wainwright, and Mr. Justice Buckley. Plaintiff, James Bates, 10, White Horse Road, Whitechapel, London, E. 1. Defendant, James Miller, 24, St. George's Street, Whitechapel, London, E. 1. The plaintiff was a sub-contractor engaged by the defendant to build a house. The defendant was a builder. The plaintiff was a sub-contractor engaged by the defendant to build a house. The defendant was a builder. The plaintiff was a sub-contractor engaged by the defendant to build a house. The defendant was a builder.

"SWELLED BRICKS." A point of interest in the building trade arose in a case the hearing of which was concluded on July 1 in the Liverpool County Court, before his Honor Judge Shird. The case was one in which the plaintiffs, the Royal Naval Sanitary Pipe and Brick Company, of St. Helens, sought to recover from Messrs. David Roberts, Son, and Co., Limited, of Liverpool, the cost of a quantity of bricks which had been supplied to the latter in February, last, under the term of "swelled bricks." The defendants had entered into a contract with the plaintiffs for the delivery by the latter of a quantity of "swelled bricks," and in pursuance of this contract the plaintiffs had supplied to the defendants bricks of varying thicknesses which had been burned in their kilns. These bricks, upon delivery, had been rejected by the defendants on the ground that they were entitled to receive only burnt bricks of the standard size. The case for the plaintiffs was that under the term "swelled bricks" they were entitled to deliver bricks which had been burnt in their kilns. On the other hand, however, it was contended by the defendants that the universal custom in the brick trade was that, unless otherwise specified, an order for "swelled bricks" meant the ordinary common burnt bricks which had been so supplied in the past. The contention they also supported by a number of expert witnesses.

THE SCREEN IN NEWCASTLE CATHEDRAL. A competition for the design of a screen in the Cathedral, Newcastle, on Saturday, to commemorate the Year of Queen Victoria's 70th Anniversary, was held. The design of the screen will be decided by the design of the year of Queen Victoria's 70th Anniversary. The design of the screen will be decided by the design of the year of Queen Victoria's 70th Anniversary.

Witness held there was no danger in those days, and knowing the people of Newcastle, he did not think it was likely to happen. Mr. W. H. Wood, architect, submitted that the alteration, and stated it would be of architectural advantage and architecturally essential to this group. Mr. Dickenson, stating the legal aspect of the matter, quoted Lord Penzance's judgment in reference to the Exeter pinnacles, and said it may be used into a question of fact for the Chancellor to decide whether the proposed alteration was likely to be a subject of superstitious reverence or not. He stated that similar ornaments have been recently sanctioned for St. Luke's and St. Gabriel's Churches, both in Newcastle-on-Tyne. The Chancellor replied that this was a different matter, as the cathedral should be a sort of pattern to the diocese. At the close of the arguments the Chancellor stated he would take some time to think the question over. He hoped to be able to find that he did not consider the law too strong for them.

TRADE NOTES.
 Under the direction of Mr. F. H. Overmann, F.M.S.A., Boyle's latest patent "Air Pump" ventilator has been applied to Styal Church, Cheshire.

The Bolton new schools have flat roofs over the verandahs, and we learn that the education architect is constructing these flat roofs with waterproofed cement concrete. We understand that Puddled cement roofs are being increasingly specified.

The shares of Haywards, Limited (a private one) are all held by the directors and a few members of their families; the widow of a former director, Mr. D. McInnes; and two or three members of the staff, all British, whilst the company gives employment to some 200 British workpeople and staff in London, Manchester, and Scotland, and a considerable proportion have gone to the war.

The business of Pritchett's and Gold, Limited, manufacturers of storage batteries, has been amalgamated with that of the Electrical Power Storage Co., Limited, the title of the amalgamated company being Pritchett and Gold and Electrical Power Storage Co., Limited. In order to provide the necessary accommodation for the increased staff, larger offices have been taken at 82, Victoria Street, London, S.W. The telephone No., "Victoria 3131," and telegraphic address, "Accidulated, Sowest, London," remain as heretofore.

The Great Central Railway Company have just issued their new Guide to Health and Holiday Resorts. Within an attractive cover is included a description of the various resorts, and interesting information is given regarding climatic advantages, bathing facilities, sports and entertainments, also a list of hotels, boarding houses, and country lodgings, schools, etc. The book has been entirely re-written, and anyone contemplating a short or long holiday, either at the seaside or in the country, should obtain a copy, which will be sent free on application to the G.C. Publicity Dept., 216, Marybone Road, London, N.W.

The old-established business of Messrs. Bart and Potts, Limited, of York Street, Westminster, wholesale ironmongers and manufacturers, will in future be carried on by Mr. William Potts, Mr. A. J. Hewlett, Mr. F. J. Osborne, and Mr. A. J. Collins, under the style of Bart and Potts, Collins and Co., at 47, York Street, Westminster, and the Lambeth Ironworks, Ethelred Street, S.E. Mr. Potts is a grandson of one of the founders of the firm, and has been responsible for the manufacturing part of the business for a number of years. Mr. Collins is well known as buyer and manager of the ironmongery department, whilst Mr. Hewlett and Mr. Osborne have both been instrumental in building up the reputation the firm have gained for their iron and gunmetal castings and window work.

Correspondence.

HAYWARDS, LIMITED.
 To the Editor of THE BUILDING NEWS.
 Sir,—We beg to inform you that, with the consent of the Board of Trade, the name of this company has been altered to "Haywards, Limited, by which title it should be known and addressed in future. Our Mr. Wm. Eckstein and his family are English of several generations back, and he has served many years in the Public Works Department of India; but it has been suggested by several of our principal clients that, owing to the present state of public feeling in connection with the war, the retention of his name in the firm may mislead some of our correspondents and cause them to imagine there is some German interest in the business. As a matter of fact, the firm is entirely a British one, founded in 1783, registered as a joint stock company in 1896, and it has no connection, directly or indirectly, with any German or Austrian interests.

All the business of the company will be conducted as heretofore, and various contracts for Government work are being carried out, but inquiries and orders will be attended to with all care and promptitude.—Yours faithfully,

Haywards, Limited,
 GEO. F. PITTAR, Director.

187 to 201, Union Street,
 Borough, London, S.E.
 [Not one of the countless clients of Haywards, Limited, is, we know well, in the least likely to have fancied there was anything German about the firm or Mr. William Eckstein, who is one of the most typical Britons living. May the change herald increased prosperity, and add, if possible, new customers among those who might not have known it.—Ed. B.N.]

Intercommunication.

QUESTIONS.
 [11312].—CONCRETE BRIDGE.—Sketch of reinforced concrete bridge to carry 15-ton roller. Inquiry will be obliged if some reader would show a

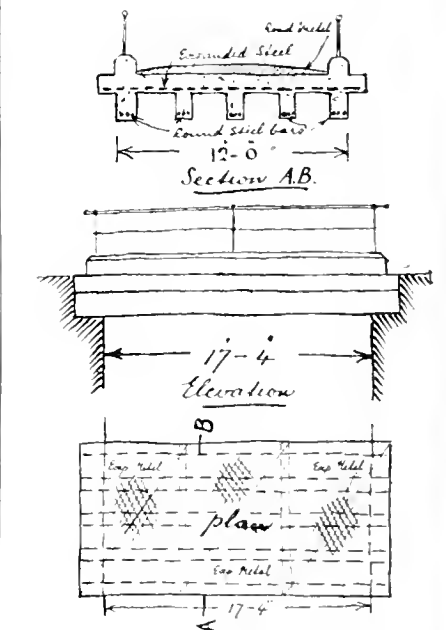

good simple formula for calculating thickness of slab, and depth and breadth of ribs; also diameter of steel bars, etc.—Bombard.

Mr. John White Alexander, till recently president of the United States National Academy, and himself a skilled artist, died on June 1, aged 53 years. His great regret, expressed but a short while before his death, was that he had not been successful in securing during his term as president a site and permanent home for the National Academy.

LATEST PRICES.

N.B.—All prices must be regarded as merely approximate for the present, as our usual sources of information are in many cases failing us.

TIMBER.

Owing to stoppage of supplies all prices have advanced considerably.

IRON.

Table listing prices for Rolled Steel Joists, Wrought-Iron Girder Plates, Steel Girder Plates, Bar Iron, good Staffs, Do., Lowmoor, Flat, Round, or Square, Do., Welsh, Boiler Plates, Iron—South Staffs, Best Snedshill, Builders' Hoop Iron, Galvanised Corrugated Sheet Iron, Cast-Iron Columns, Cast-Iron Stanchions, Rolled-Iron Fencing Wire, Rolled-Steel Fencing Wire, Cast-Iron Sash Weights, Cut Floor Brads, Corrugated Iron, 24 gauge, Galvanised Wire Strand, B.B. Drawn Telegraph Wire, Galvanised—0 to 8, 10, 11, 12, B.W.G., £10 10s., £10 15s., £11 0s., £11 5s., £11 15s., Cast-Iron Socket Pipes, Wrought-Iron Tubes and Fittings, Gas-Tubes, Water-Tubes, Steam-Tubes, Galvanised Gas-Tubes, Galvanised Water-Tubes, Galvanised Steam-Tubes.

OTHER METALS.

Table listing prices for Lead Water Pipe, Lead Barrel Pipe, Lead Pipe, Tinned inside, Lead Pipe, tinned inside and outside, Composition Gas-Pipe, Lead Soil-pipe, Lead, Common Brands, Lead Shot, Copper sheets, Copper, British Cake and Ingot, Fin, English Ingots, Do., Bars, Pig Lead, Sheet Lead, Genuine White Lead, Refined Red Lead, Sheet Zinc, Old Lead, Fin, Cut nails.

* For 5 cwt. lots and upwards.

SLATES.

Table listing prices for Blue Portmadoc, Blue Bangor, First quality, Permanent Green, Eureka unfading green.

BRICKS.

(All prices net)

Table listing prices for First Hard Stocks, Second Hard Stocks, Mild Stocks, Picked Stocks, Facings, Pressed Wire Cutts, Red Wire Cutts, Best Farnham Road, Best Red Pressed Ruabon Facing, Best Blue Pressed Staffordshire, Ditto Bullnose, Best Stourbridge Fire-bricks, 2 1/2 n. Best Red Arc, Facing Bricks—Plastic, Acerrington Best Red Plastic Facing Bricks, Ditto Second Best Plastic, Ditto Ordinary Secondary Bricks, Ditto Plastic Engineering Bricks, Sewer Arch Brick, Chimney Bricks, Ditto ditto through and through, Beaded, Oval and Bevel Jamb; Octagons; 2 1/2 and 3/4 radius Bullnose; Stock patterns, Acerrington Air Bricks, Ditto ditto.

Table listing prices for Acerrington Chamber Arches, 3 course deep 3 1/2" soffit, per foot opening, 4, 5, 6, 3, 4, 5, 6, Net free on rail, or free on boat at works.

GLAZED BRICKS.

HARD GLAZES (PER 1,000).

Table listing prices for White, Ivory, and Best, Salt Glazed, Buff, Cream, Other, Second, Best, Seconds, & Bronze, Colours, Stretchers, Headers, Double Stretchers, Double Headers, One side and two ends, square, Two sides and one end, square, Splays and Spouts, Plinth and Hollow Bricks, Stretchers and Headers, Double Bullnose, Round Ends, Bullnose Stops, Rounded Internal Angles.

MOULDED BRICKS.

Table listing prices for Stretchers and Headers, Internal and External Angles, Sill Bullnose, Stretchers, and Headers, Majorca or Soft Glazed Stretchers and Headers, Compass bricks, circular and arch bricks, Camber arch bricks, Stretchers cut for Closers and Nicked Double Headers.

Table listing prices for Thames Sand, Pit Sand, Thames Ballast, Best Portland Cement, Ground Blue Liass Lime.

Exclusive of charge for sacks.

Table listing prices for Grey Stone Lime, Stourbridge Fireclay.

STONE.

Table listing prices for Red Mansfield, Darley Dale, Red Corshill, Clacshurn Red Freestone, Ancaster, Greenhill, Beer, Chilmark, Nine Elms, Hard York, Do. 6 in. sawn both sides, landings, random sizes, Do. do. 3 in. slab sawn two sides, random sizes.

Table listing prices for Bath Stone, waggons, Pabblington Dept., Ditto, Nine Elms Dept., Best Stone, delivered in waggons at Seaton Station, Ditto, delivered at Nine Elms Station, Portland Stone, in random sizes, delivered on road waggons at Pabblington Dept., Nine Elms Dept., Fimlico Wharf.

TILES.

Table listing prices for Plain red roofing tiles, Hip and Valley tiles, Broseley tiles, Ornamental tiles, Hip and Valley tiles, Kitchen red, brown, or bunnet, ditto Edwards, Ornamental ditto, Hip tiles, Selected "Perfection" roofing tiles, Plain tiles, Peabody's, Ornamental ditto, Hip tiles, Valley tiles, "Rosemary" brand plain tiles, Ornamental tiles, Hip tiles, Valley tiles, Staffordshire Hanley Reds, bundled tiles, Hand made sand-faced, Hip tiles, Valley tiles, "Hartshill" brand plain tiles, sand-faced, Pressed, Ornamental ditto, Hip tiles, Valley tiles.

OILS.

Table listing prices for Rapeseed, English pale, per ton, Ditto, brown, Cottonseed, refined, Olive, Spanish, Seal pale, Coconut, Cochin, Ditto, Ceylon, Ditto, Mauritius, Palm, Lagos, Ditto, Nut Kernel, Olive, Sp. m., Lubricating, U.S., Petroleum, refined, Tar, Stockholm, Ditto, Archaugal, Linseed Oil, per gal., Baltic Oil, Turpentine, Putty (Genuine Linseed Oil), Pure Linseed Oil, "Stonry" Brand.

GLASS (IN CRATES).

Table listing prices for English Sheet Glass, Fourths, Thirds, Fluted Sheet, Hartley's English Rolled Plate, Figured Rolled and Repoussé.

VARNISHES, Etc.

Table listing prices for Pine Pale Oak Varnish, Pale Copal Oak, Orange Copal Oak, Superfine Pine Elastic Oak, Pine Extra Hard Church Oak, Superfine Hard drying Oak, Fine Elastic Carriage, Superfine Pale Elastic Carriage, Fine Pale Maple, Finest Pale Drab Copal, Extra Fine French Opal, Egg-shell Flattening Varnish, White Copal Enamel, Extra Pale Paper, Best Japan Gold Size, Best Black Japan, Oak and Mahogany Stain, Brunswick Black, Best Black, Knotting, French and Brush Polish.

The Rochford Rural District Council have granted an honorarium of £25 to Mr. A. C. Mudge, their inspector, for his services as architect in connection with the Great Stour bridge housing scheme.

The new arcade and municipal buildings at Aberavon, built at a cost of £15,000, have been formally opened. The work has been carried out by Mr. Morgan Cox, contractor, of Aberavon, from the designs of Mr. James Roderick, borough engineer.

An Indiana Masonic home is about to be erected at Franklin, Indiana, under the direction of the Indiana Grand Lodge of Masonry, at a cost of about \$200,000. Plans for the home have been completed by Mr. Herbert Foltz, a local architect.

MEETINGS FOR THE ENSUING WEEK

WELLS. A. I. ... MEETINGS FOR THE ENSUING WEEK ...

TO ARMS

TO ARMS ... THE ARMS ...

MENTION WORK

MENTION WORK ... THE MENTION WORK ...

ADVANCE GUARD

ADVANCE GUARD ... THE ADVANCE GUARD ...

ATTENDANCE AT DRILLS AND PARADES

ATTENDANCE AT DRILLS AND PARADES ...

ATTENDANCE AT CAMP

ATTENDANCE AT CAMP ... THE ATTENDANCE AT CAMP ...

BATTALION COMPETITIONS

BATTALION COMPETITIONS ... THE BATTALION COMPETITIONS ...

DRILLS AND PARADES

DRILLS AND PARADES ... THE DRILLS AND PARADES ...

RESULTS

RESULTS ... THE RESULTS ...

SEARCH DRILLS

SEARCH DRILLS ... THE SEARCH DRILLS ...

SCHOOL OF ARMS

SCHOOL OF ARMS ... THE SCHOOL OF ARMS ...

STATION

STATION ... THE STATION ...

OGILVIE & CO.

Mildmay Avenue, ISLINGTON, N. EXPERTS in HIGH-CLASS JOINERY. ALTERATIONS & DECORATIONS.

FOR Olivers' Seasoned Hardwoods,

WM. OLIVER & SONS, Ltd., 129 Bunhill Row, London, E.C.

TENDERS.

Correspondents would in all cases oblige by giving the addresses of the parties tendering at any rate, of the accepted tender; it adds to the value of the information.

ASHFORD, EAST KENT. For alterations to the Ham Street drainage works, for the rural district council.

Headland, C. J., Deal (accepted) 4281 0 0

ASHFORD. For repairs to the children's home at M... for the Ashford Board of Guardians.

Boyd, J., accepted 4180 0 0

BREATHLE ROAD, SE. For the supply of lead pipes and rain-water leads required at the new County Hall, for the London County Council.

Boyd, J., accepted 4180 0 0

BRIGHTON, SE. For the work of painting and decorating the Council schools.

Boyd, J., accepted 4180 0 0

BRIGHTON. For supply of electrical fittings, for the Guardians.

Boyd, J., accepted 4180 0 0

BROWSBILLS. For tar-spraying about 35,000 super-yards and tar-grouting about 5,000 super-yards of road, including the provision of materials, plant, tools, heaters and labour for spraying and grouting, for the Brownhills Urban District Council.

Boyd, J., accepted 4180 0 0

CARDIFF. For the erection of the first houses on the Welsh Rhym Garden Village, Salsp, 124 0 0.

Boyd, J., accepted 4180 0 0

DEATH. For the erection of a shed, 51 yards by 70 yards, at Gatehead Mills, Dolph, near Oldham.

Boyd, J., accepted 4180 0 0

EXETER. For supply of 160 ft of 14 in. cast-iron 122 water-piping and valves, for the City of Exeter.

Boyd, J., accepted 4180 0 0

GLoucester. For the construction of three houses in Lavender Road, W. of St. John's Town End, Gloucester.

Boyd, J., accepted 4180 0 0

GLoucester. For the construction of three houses in Lavender Road, W. of St. John's Town End, Gloucester.

Boyd, J., accepted 4180 0 0

GLoucester. For the construction of three houses in Lavender Road, W. of St. John's Town End, Gloucester.

Boyd, J., accepted 4180 0 0

GLoucester. For the construction of three houses in Lavender Road, W. of St. John's Town End, Gloucester.

Boyd, J., accepted 4180 0 0

LAWES. For supply of granite and screenings, delivered at Lawes Station, for the town council.

St. Keveneg Stone Co., Helston, Cornwall, 600 tons Cornish granite, 14s. 6d. per ton; 150 tons fine screenings, 14s.; 150 tons coarse screenings, 13s. 3d. (accepted)

LONDON. Tenders accepted for the following works to schools for the Education Committee of the London County Council.

Lowisham County Secondary school for Girls, Forest Hill, heating, Vaughan, T. W., and Co. (1914), Ltd. 11,050 10 0

Bethnal Green, N.E. Wolverley Street, heating, May, J. and F., 589 0 0

Hackney, S. County Secondary school, South Hackney, electric lighting, Alpha Manufacturing Co., 562 1 0

Wandsworth, Derham Road, electric lighting, Alpha Manufacturing Co., 357 15 0

London, S. Sibbon Street, electric lighting, Vaughan, T. W., and Co. (1914), Ltd., 306 4 0

Hampstead, Netherwood Street, enlarging boiler-room, Bovis, Ltd., 257 0 0

Woodwich Plum Lane, heating, Davies, F., 230 0 0

Southwark, W. Walder Street P.D., gas-lighting, South Metropolitan Gas Co., 193 10 0

Hackney, S. Upton House, industrial, heating, Padovkar and Sons, 158 0 0

Newington, W. "John Ru kin", air-washing screens, Stride and Co., Ltd., 119 0 0

LONDON, E. For the work of economiser tubes at the refuse destructor works, for the Poplar Borough Council.

Economiser, Ltd., including cost of erection recommended for acceptance 4360 0 0

Luton. For fitting the two boilers at the baths with a patent smoke-consuming and coal-saving apparatus, for the corporation.

Johnson, Economiser and Smoke Consumer, Ltd. (accepted) 472 10 0

NORTH WOODWICH. For the supply and erection of a Lancashire boiler at North Woolwich pumping-station, for the London County Council.

Spicer, Putman and Co., Ltd., Wakefield 11,100 0 0

Galloways, Ltd., Manchester 970 0 0

Yates and Thom, Ltd., Blackburn 969 0 0

Tillot Bros., Hollinwood 955 0 0

Daniel Adamson and Co., Ltd., Dukinfield 955 0 0

Linkers, Ltd., Hyde 912 0 0

Ruston, Proctor and Co., Ltd., Lincoln 858 0 0

Clayton, Son and Co., Ltd., Leeds 823 0 0

Linker, Shenton and Co., Ltd., Hyde (accepted) 780 0 0

PENANG. For erection of a new Constitutional club at Twyn-y-fald, Pungam, Mon., for the Twyn-y-fald Constitutional Club Co., Ltd.

Mr. D. J. Thomas, M.S.A., architect 12,557 0 0

Walters and Son, Bristol 2,553 1 0

Davies, L. J., and Co., Bargoed 2,365 0 0

Evans, W. H., and Co., Cardiff 2,252 19 0

Green, F., Blackwood 2,250 0 0

Hodds, F. F., Caerphilly 2,218 0 0

Davies and Lloyd, Senghennydd 2,210 0 0

Morgan, A. S., Newport 2,195 13 1

Perkins, J. B., Pontllanfraith 2,030 0 0

Jones, R., Caerphilly (accepted) 2,009 3 3

James, L., Hengoed 2,000 3 3

SHEFFNESS. For work at the Hippodrome, Messrs. Morgan and Buckingham, Norwich, architects.

Accepted tenders: Croth and Son, Norwich, fibrous plaster and decoration 4525 0 0

Mann, Egeton, and Co., Ltd., Norwich, electric lighting and ventilating 193 10 0

Pank and Son, Norwich, heating 169 0 0

SOUTH HACKNEY. For installing electric light at the County Secondary school, South Hackney, for the London County Council.

The Titan Lift Co., Ltd., 9-11, Eagle Street, Bolton 4749 0 0

Weston, G., and Sons, Ltd., 155, Finchurch Street 497 8 6

Hawkins, A., and Sons, 125/8, London Road, Southwark 564 0 0

Alpha Manufacturing Co., Harberson Road, Ballon (accepted) 562 1 0

STANMOOR. For the construction, supplying, and fixing a boiler at their pumping station at Burrow Bridge, 1 mile from Athelney Station, for the Stanmoor District Drainage Board.

Mr. W. Lunn, M.E.E., 65, Wombledon Road, Bridgewater, engineer: Wills, W., and T., Ltd., Bridgewater (accepted)

STIVENAGE. For supply of about 800 tons of 1 1/2 in. to 2 in., 1 in. to 1 1/2 in., 1 in. to 1 1/2 in. clean granite chippings and dust, for the Stevenage Urban District Council.

Emberby and Stoney Stanton Granite Co., Ltd., Emberby, Leicester, 1 in. to 2 in., 12s. 5d.; 1 in. to 1 1/2 in., 12s. 5d.; chippings, 9s. 6d. and 11s. 9d.; dust, 8s. (accepted)

TIERNEY. For the supply of four six-ton end-tipping wagons, for the county council.

Fleming and Co., Glasgow (accepted) each 475 0 0

THE BUILDING NEWS

AND ENGINEERING JOURNAL.

Effingham House.

CONTENTS.

Strand, W.C.

The London County Council Regulations for Reinforced Concrete Construction	31	Causes of Metal Bridge Corrosion	51
The London County Council	34	Legal Intelligence	51
Protection of Unfinished Concrete	35	Our Office Table	52
Correspondence	35	Meetings for the Ensuing Week	53
Currente Calamo	36	Chips	53
Professional and Trade Societies	37	Latest Prices	54
Obituary	37	To Arms	54
Our Illustrations	38	Tenders	ix.
Competitions	38	List of Competitions Open	x.
Building Intelligence	51	List of Tenders Open	x.
		Trade Notes	xii.

OUR ILLUSTRATIONS:

New Head Office for the British Diamond & Gem Insurance Co., Limited, Royal Exchange Avenue, E.C. View and plan, Mr. Arthur H. Moore, A.R.I.B.A., Architect.
 Church of St. Augustine, Gillingham, Kent. Interior looking east. Mr. Temple Moore, F.R.I.B.A. Architect.
 Tunstall Court, Sittingbourne, Kent. Elevations and plan. Mr. Walter H. Bierley, F.S.A., Architect.

THE L.C.C. REGULATIONS FOR REINFORCED CONCRETE.

On July 6, 1915, the London County Council, under the authority conferred on them by Section 23 of the L.C.C. (General Powers) Act, 1909, formally made draft regulations with respect to the construction of buildings wholly or partly of reinforced concrete. The preparation, consideration and discussion of these regulations appears to have progressed steadily and continuously from August, 1909, when the L.C.C. (General Powers) Act came into operation, up to July, 1915.

It is generally known that whereas the Council are required by law only to give notice to certain Technical Institutions of their intention to apply to the Local Government Board for allowance of the regulations, the Council have nevertheless consulted the Technical Institutions at all stages of progress.

The intermediate drafts that have been available appear to show that at some stages the criticism has been in the direction of greater stringency and at other times in the direction of greater elasticity in the use of the material. It is a remarkable fact that the net result of all the criticism has justified a reversion towards the standard of stability of the draft first submitted to the Technical Institutions.

For ordinary beams and pillars, and for concrete mixed in ordinary proportions, the final standard of stability coincides with the Council's initial standard; but in the case of slender pillars and richer mixtures of concrete the amendments would appear to be in the direction of somewhat greater caution.

Considering the extent to which the regulations have been discussed in the technical Press and at the committee meetings of the Technical Institutions, and the efforts which have been made to make a consistent and harmonious whole out of suggestions, which must, by the necessities of the case, often have been mutually contradictory, we are of opinion that the Council are to be congratulated on having made regulations which appear to meet the requirements of both the designer and those who are required to supervise the design or the actual execution of the work.

The standard of stability would appear to be in accord with the best general practice, and no impossible ideal has been set up in the requirements as to the ultimate strength of the concrete.

We note that the formulæ are given in more than one form, and useful approximations to the results demanded are added where possible.

The regulations are also drafted so as to give encouragement to scientific

methods of design. Take, for example, the bending moments on beams. The designer is free to follow any one of three courses:—

- (1) To arrive at the maximum bending moment by a simple rule which does not discriminate between the ratio of the dead to the superimposed load.
- (2) To arrive at the maximum bending moment by a simple equation which does take into account the ratio of the dead load to the superimposed load.
- (3) Notwithstanding anything contained in the previous rules, beams may be designed for the exact positive and negative moments which will occur at every cross section, whether all the spans be loaded or alternate or any of the spans be unloaded.

This affords sufficient latitude for every practical purpose.

The question of a variable modular ratio is one to which we specially invite our readers' attention. It is obvious that the richer the concrete the stronger it is and the nearer its elastic modulus approaches the elastic modulus of the steel. Therefore, the ratio of the two moduli must vary with variations in the strength or proportions of the concrete. It is sometimes urged that a variable modular ratio brings complexity into the calculations, and the regulation may be criticised on these grounds. On the other hand we have seen some of our contemporaries object to a fixed modular ratio. However, seeing that the variable modular ratio is introduced in such a manner that *mc* is constant, it follows that variations in the proportions of concrete will not have that effect on the position of the neutral axis which might be expected in the first instance. The modular ratio is varied in such a manner that the calculations will be simplified rather than made more complex.

It should be realised that designers need not use the long orthodox rules for the resistance moment of beams if they will calculate, once and for all, the values of *Q* for their favourite mixture of concrete (vide Regulations 87 and 88). If this is done, the calculation of the resistance moments of reinforced concrete beams is scarcely more complex than for a simple timber beam.

We are glad to see this question at last so crystallised that this construction can be utilised in London, and a well-considered set of regulations given as a guide. The more one considers the question, their initiation and the subsequent sifting they have undergone, the more obvious becomes the courage and patience of those who have brought these rules

within the reach of all. We give them fully, and are certain that their careful consideration will facilitate the use of this system of construction as it should be employed in London, under the direction of competent designers, assisted by regulations which bear the visible impress of technical skill unhampered by tendencies to create difficulties which are sometimes characteristic of the official mind.

THE LONDON COUNTY COUNCIL REGULATIONS FOR REINFORCED CONCRETE CONSTRUCTION.*

PART I.

GENERAL.—REINFORCED CONCRETE DEFINED.

1. The term "reinforced concrete" as occurring in these regulations shall mean concrete which is reinforced by metal so combined therewith that the metal will (a) be sufficient to take up all the tensile stresses; (b) assist in the resistance to shear; (c) assist in the resistance to compression where necessary.

SCOPE.

2. These regulations shall apply only to the construction of buildings of reinforced concrete in which the loads and stresses are transmitted through each story to the foundations by a skeleton framework of reinforced concrete or partly by a skeleton framework of reinforced concrete and partly by a party wall or party walls.

SKELETON FRAMEWORK.

3. The skeleton framework of reinforced concrete of a building; together with the party wall or party walls (if any) upon which such framework bears shall be capable of safely and independently sustaining the whole dead load and the superimposed load bearing upon such framework and party wall or party walls, calculated in accordance with the data hereinafter contained.

FLOORS, STAIRS, ROOFS, ETC.

4. All floors, stairs, landings, and other portions of a building carried by a reinforced concrete framework shall be constructed throughout of incombustible materials, and be carried upon supports of incombustible materials; nevertheless, all internal stairs and landings may be constructed of fire-resisting materials, and nothing in this regulation shall prevent the use of wood framing, boarding and battens in the construction of roofs.

ELECTRICAL CURRENTS.

5. No part of the reinforcing metal in a building shall be used for conducting electrical currents.

NOTICES AND PLANS.

6. In the case of the erection of a new building of reinforced concrete or the making of any addition or alteration or the carrying out of other work under the provisions of these regulations, the like notice shall be served upon the district surveyor as is re-

* Sub-headings and italic cross references do not form part of the regulations.

pared to be served by Part XIII of the Land & Building Act, 1894, and such notice shall be accompanied in the case of a new building by plans and sections of sufficient detail to show the construction thereof, together with a copy of the calculations of the loads and stresses to be provided for and particulars of the materials to be used; and should such plans, sections, calculations or particulars as originally furnished be not in sufficient detail, the person depositing the same shall furnish the district surveyor with such further plans, sections, calculations or particulars as may be reasonably necessary for the aforesaid purpose, and in the case of an alteration or addition or other work as aforesaid by such plans, sections, calculations and particulars as may be reasonably necessary.

PART II.

DATA TO BE USED FOR THE PURPOSES OF THESE REGULATIONS.

Fl. and R. of Loads.

DEAD LOAD DEFINED.

7. The dead load of a building shall consist of the actual weight of walls, floors, stairs, landings, roofs and all other permanent construction comprised in such building.

SUPERIMPOSED LOAD DEFINED.

8. The superimposed load in respect of a building shall consist of all loads other than the dead load.

LOADS.

9. In calculating the loads on foundations, pillars, piers, walls, framework, beams and other constructions carrying loads in buildings, the superimposed load shall be estimated as equivalent to the dead load set forth in the regulations following, and numbered 10 to 24, both inclusive.

FLOOR LOADS.

10. For a floor the estimate shall be made in accordance with the table immediately following:—

For a floor intended to be used for the purpose of—	Equivalent dead load in pounds per square foot
Domestic buildings not hereafter specified	70
Other similar purposes	70
Asylum wards	80
Common lodging house bedrooms	80
Hospital wards	80
Hotel bedrooms	80
Warehouse yards	80
Other similar purposes	80
Counting houses	100
Offices	100
Other similar purposes	100
Art galleries	100
Chapels	100
Churches	100
Classrooms in schools of buildings not being dwelling houses so used	100
Lecture rooms	100
Meeting rooms	100
Musical halls	112
Public assemblies	112
Public concert rooms	112
Public library reading rooms	112
Rath-houses	112
Theatres	112
Workshops	112
Other similar purposes	112
Ball rooms	150
Dinner halls	150
Other similar purposes	150
Similar floors subject to vibration	150
Book-rooms at libraries	224
Wine-rooms	224
For every floor in a building of the warehouse class except open floors as are intended to be used for any of the purposes aforesaid not less than	224

LOADS ON STAIRS AND LANDINGS.

11. For stairs and landings the superimposed load shall be estimated as equivalent to a distributed dead load of at least 120 pounds per square foot, but each step shall be designed to support a concentrated load at its point of contact not less than 300 lb.

LOADS ON ROOFS.

12. For a roof the plane of which inclines upwards at a greater angle than twenty degrees to the horizontal, the superimposed load which shall for this purpose be deemed to include wind pressure and weight of snow and ice shall be estimated at 25 lb. per square foot of sloping surface normal to such sloping surface, or for the case of such roof

13. For all other roofs the superimposed load shall be estimated at 50 lb. per square foot measured on a horizontal plane.

GREATER LOADS.

14. If the superimposed load on any floor, landing, stairs or roof is to exceed that hereinbefore specified for such floor, landing, stairs or roof, such greater load shall be provided for with an equivalent margin of safety.

LOADS NOT OTHERWISE SPECIFIED.

15. In the case of any floor or roof intended to be used for a purpose for which a superimposed load is not specified in these regulations, the superimposed load to be carried on such floor or roof shall be provided for with an equivalent margin of safety.

ROLLING LOADS.

16. In cases where a rolling load actuated by mechanical power is to be provided for such rolling load shall be taken as equivalent to a static load 50 per cent. in excess of the actual rolling load. The positive and negative bending moment at every cross section due to every position of the rolling load shall be properly provided for.

PARTITIONS.

17. Partitions and other structures superimposed on floors and roofs may be included in the superimposed load, provided the weight of the partition or other structure per square foot of base does not exceed the permissible load per square foot of floor or roof area. Partitions and other structures of greater weight shall be specially provided for.

ANGLE OF DISPERSION.

18. For calculating the resistance moment the angle of dispersion of a point load through hard filling and concrete shall not be taken at more than forty-five degrees from the vertical.

LOADS.

19. For the purpose of calculating the total load to be carried on foundations, pillars and walls in buildings of more than two stories in height, the superimposed loads for the roof and for the floor of the topmost story shall be calculated in full, but for the floors of the lower stories a reduction of the superimposed loads shall be allowed as follows:—

For the floor of the story next below the topmost story a reduction of 5 per cent. of the superimposed load on the floor of that story, as calculated in pursuance of the foregoing regulations, shall be allowed; for the floor of the next story 10 per cent. of the superimposed load on the floor of that story similarly calculated; and so on by increments of 5 per cent. per story till the reduction amounts to 50 per cent. It shall be taken at 50 per cent. per story for all floors below.

20. No such reduction as aforesaid shall be allowed in the case of a building of the warehouse class.

Wind Pressure.

21. All buildings shall be so designed as to resist safely a horizontal pressure equivalent to a static pressure of not less than 20 pounds per square foot of the whole projected surface normal to the direction of every wind.

For pressure on panels of external walls see regulation 130.

22. All structures or attachments whatsoever in connection with a building, including towers or other parts which extend above the roof, flat, or gutter adjoining thereto, shall be so designed as to resist safely a horizontal pressure equivalent to a static pressure of not less than 40 lb. per square foot of the whole projected surface normal to the direction of every wind.

Working Load.

23. The working load shall include the superimposed load and the dead load inclusive of the weight of the beams, slabs, pillars, or other members, and any plastering, tiles, mosaic, granite or other similar finishing materials.

Weight.

24. For the purposes of calculation, the average weight of reinforced concrete, together with any finishing materials as aforesaid, shall be taken at not less than 144 lb. per cubic foot measured over finished surfaces.

Ratio of Span to Depth of a Beam.

25. For the purpose of determining the ratio of span to depth of a beam, the effective depth of the beam shall be taken.

26. The effective depth shall be measured from the compressed edge of the structural concrete to the common centre of gravity of the tensile reinforcement.

27. The ratio of the span of a beam to its effective depth shall not exceed the lesser of the two following ratios:—

$$20 \cdot \frac{\text{tensile stress in regulation 43}}{\text{actual maximum tensile stress}}$$

or

$$20 \cdot \frac{\text{compressive stress in regulation 42}}{\text{actual maximum compressive stress}}$$

28. The length of a cantilever shall not exceed five times the effective depth at the bearing.

Bending Moments.—Effective Span.

29. For the purpose of ascertaining the bending moments on a beam or on a slab, the effective span and the whole load on the effective span shall be taken into account in the calculations.

30. In the case of non-continuous beams or slabs, the effective span shall be taken as the distance between the main vertical sides of the piers, pillars, or walls, plus the effective depth of the beam or slab at the supports, or the span between the centres of the necessary bearing surfaces, whichever may be the lesser.

31. In the case of continuous beams or slabs the effective span shall be taken as the clear span plus the effective depth of the beam or slab, or the length between the centres of the supports, whichever may be the lesser.

FIXED ENDS DEFINED.

32. A beam or slab shall be deemed to have fixed ends when its ends are sufficiently secured to other parts of the construction having such rigidity as will maintain the neutral planes of the beam at the ends in their original positions and directions under all variations in the incidence and intensity of loading.

MAXIMUM MOMENTS.

33. The bending moments to be provided for at every cross-section of a beam or of a slab shall be the maximum positive and negative moments at such cross-section. Such maximum bending moments shall be calculated in a manner consistent with regulations 34, 35, 36, 37, and in accordance with regulations 38 and 39.

34.—BEAMS WITH ENDS FREE OR FIXED.

Notation for bending moments.

- B = bending moment.
- b = breadth,
- l = length of effective span.
- W = total weight or working load.

Load.	Supports.	Value of B to be provided for.
Concentrated free end of cantilever	at Cantilever.	$B = -Wl$ at fixed end.
Uniformly distributed	Both ends free	$B = -\frac{Wl}{2}$ at fixed end.
Concentrated centre	Both ends freely supported	$B = \frac{Wl}{4}$ at centre.
Uniformly distributed	Both ends freely supported	$B = \frac{8}{12} Wl$ at centre.
Concentrated centre	Both ends fixed	$B = \frac{8}{12} Wl$ at centre.
Concentrated centre	Both ends fixed	$B = -\frac{Wl}{12}$ at ends.
Uniformly distributed	Both ends fixed	$B = -\frac{8}{12} Wl$ at ends.
Uniformly distributed	Both ends fixed	B at centre shall not be taken at less than the numerical value of B at the ends.
Uniformly distributed	One end fixed, one end freely supported	$B = -\frac{Wl}{8}$ at fixed end.
Uniformly distributed	One end fixed, one end freely supported	$B = \frac{Wl}{14}$ at 2 of span from the free end.

CONTINUOUS BEAMS.

Notation for Bending Moment.

- 35 B = bending moment.
- 35.—B = bending moment.
- l = length of effective span measured between the centres of supports. (See regulation 31).

W = total weight or working load. (Superimposed and dead loads.) (See regulation 23).

W_d = total deadweight per span.

W_s = total superimposed weight or load per span (uniformly distributed).

The total bending moment (B) to be provided for at every cross section shall be the algebraic sum of the bending moments due to the superimposed and dead loads respectively.

Maximum bending moments due to variations in the incidence of distributed loads over approximately equal spans.

Near Middle of End Span.	At Support Next to End Support.
$+ \frac{W_s l}{10} + \frac{W_d l}{12}$ or approximately $+ \frac{W l}{10}$	$- \frac{W_s l}{9} - \frac{W_d l}{10}$ or approximately $- \frac{W l}{10}$
At the Middle of Interior Spans.	At Other Interior Supports.
$+ \frac{W_s l}{12} + \frac{W_d l}{24}$ or approximately $+ \frac{W l}{12}$	$- \frac{W_s l}{9} - \frac{W_d l}{12}$ or approximately $- \frac{W l}{10}$

36. Notwithstanding anything in regulation 35, beams may be designed for the exact positive and negative bending moments which will occur at every cross-section whether all the spans be loaded or alternate or any of the spans be unloaded.

BENDING MOMENTS ON SLABS.

37. (a).—Bending moments on slabs supported by, fixed at, or continuous over four edges, shall be calculated as for beams.

(b) When reinforced with mesh reinforcement or reinforced in two directions at right angles to each other, the load assumed to be carried in each direction may be apportioned as follows:—

Proportion of load assumed to be carried in the direction of the breadth of the slab—

$$= \frac{1}{1 + \left(\frac{b}{l}\right)^4} \times \text{total load on slab.}$$

Proportion of load assumed to be carried in the direction of the length of the slab—

$$= \frac{1}{1 + \left(\frac{l}{b}\right)^4} \times \text{total load on slab.}$$

Provided that when the length of a slab exceeds twice its breadth the whole load shall be assumed to be carried in the direction of the breadth of such slab.

MOMENTS OVER SUPPORTS.

38. The maximum area of steel required to take the negative bending moment at any support shall be carried without reduction across the centre of that support. (Also see regulation 35.)

VARIATIONS OF LOADING.

39. To allow for variations in the incidence of the loading on contiguous spans of continuous beams or slabs, the bending moments to be provided for at every cross-section shall be the maximum positive and negative moments at such cross-section, whether all the spans be loaded or alternate or any of the spans be unloaded.

CONDITIONS OF LOADING NOT OTHERWISE SPECIFIED.

40. For every condition of loading not specified in these regulations, the bending moment for beams or slabs shall be calculated so as to give an equivalent margin of safety.

REINFORCEMENT AT POINTS OF CONTRA-FLEXURE.

41. Reinforcement shall be carried beyond the points of contraflexure under any condi-

tion of loading, by a length at least equal to half the effective depth of the beam.

Working Stresses.

42. (a). Also see regulations 145, 148, 156, 157, 158, 159, 162. Except as further provided for in pillars, the permissible working stresses in concrete shall not exceed the following:

Proportion by Volume.	Pounds per square inch.		Pounds per square inch.
	Cement Sand.	Coarse Material.	
V 1	1	3	600
V 2	2	2	600
V 3	3	1.5	600
V 4	4	1.2	600
V 5	5	1	600
V 6	6	0.8	600

Stresses in Concrete	Pounds per square inch.
Direct compressive stress. (See Regulation 100.)	1000
Extreme flexural compressive stress in beams	1000
Shearing stress	60
Grip or adhesion between concrete and steel	100
Bars hooked at both ends	60
Grip or adhesion between concrete and steel bars otherwise effectively anchored at the ends	60
Tensile stress	nil

(b) The values of the permissible compressive stress in pounds per square inch for intermediate proportions may be estimated from the following equation—

$$c = 990 - 50 V$$

where V equals the volume of the sand plus that of the coarse material, per volume of cement, each measured separately and including the voids proper to each material.

If V is less than 5, the stresses in the last column shall not be exceeded.

(c) The values of the shearing stress shall not exceed one-tenth of the direct compressive stress for any given value of V.

STRESS IN STEEL.

43. The permissible working stress in the steel shall not exceed the following:

Stresses in mild steel complying with the British Standard Specification.	Pounds per square inch.
Compressive stress	m times the stress in the concrete immediately surrounding the steel (the value of m being obtained in accordance with Regulation 54). See also Regulations 61 and 62.
Tensile stress	16,000

44. Provision shall be made to prevent the steel from being stressed due to eccentricity of loading.

COMBINED STRESS.

45. The term "combined stress" used in these regulations shall mean the resultant of all the stresses due to any one or more causes.

46. Neither the steel nor the concrete shall be subjected to combined stresses which exceed the permissible working stresses.

CONNECTIONS.

47. All connections in or between reinforced concrete members shall be designed and arranged so that the stresses which come upon them shall be within the limits allowed by these regulations.

HOOKS AND ANCHORS.

48. (a) All tensile and shear members shall be hooked or otherwise effectively anchored at each end.

(b) Hooks at the ends of bars shall be in a U form, and shall have an inner diameter of at least four times the diameter of the bar; or when the hook fits over a main reinforcing bar, the diameter of the hook may be equal to the diameter of such bar. The length of the straight part beyond the end of the curve shall be at least four times the diameter of the bent bar.

(c) When the bars are anchored at each end by means other than a hook complying with paragraph (b) of this regulation, the anchorage shall be bent up to a right angle from the centre line of the bar. The width across such anchorage shall be at least three times the normal diameter of the anchored bar. (Also see regulation 139.)

Grip Length.

49. The grip length or adhesion length of a bar embedded in concrete shall be measured along the bar from the beginning of the curve of the hook or the nearer end of the other form of anchorage.

50. The grip or adhesion length shall be sufficient to keep the stresses within the limits set out in regulation 42, except for web reinforcement complying with regulations 43 (b) and 67.

51. For the purpose of ascertaining the necessary grip or adhesion length in the case of a bar having mechanical bond the perimeter of the bar may be measured over the transverse projections, provided:

(a) That the transverse projections are not further apart (centre to centre) than twice the normal diameter of the bar;

(b) That the height of such projections above the normal surface of the bar shall be at least 1/10th of the diameter of the bar.

MODULAR RATIOS.

52. The term "modular ratio" shall mean the ratio of the elastic modulus of steel to the elastic modulus of the concrete.

53. The elastic modulus for steel in tension or compression shall be taken at thirty million pounds per square inch. See regulation 80 (c).

54. The modular ratio for steel in concrete shall be taken as follows:—

For beams	9,000
For pillars with the minimum of hooping or binding	9,000
For pillars with more than the minimum of hooping or binding	9,000

Where c = permissible compressive working stress given in regulation 42 and i = increased stress given by regulation 115.

PART III

BEAMS

55. The term "beam" shall include any beam, girder, lintel, cross-member, or cantilever, or any other similar member carrying transverse loads.

DIAMETER OF BARS.

50. The least diameter or thickness of the longitudinal bars in beams shall not be less than one quarter of an inch.

51. All other reinforcements in beams shall be at least one eighth of an inch in diameter or thickness.

SPACE BETWEEN BARS.

52. There shall be a distance of at least one inch horizontally and one half inch vertically between the bars in beams except at joints or at points where the bars are in direct contact and transverse to one another.

53. The distance between the bars of the tensile reinforcement in a beam shall not be greater than six times

WRING.

54. Wring used in beams for the purpose of holding bars in position shall not be regarded as reinforcement.

COMPRESSIVE REINFORCEMENT.

55. In cases where the compressive resistance of the concrete is taken into account the stress in the compressive reinforcement may be taken at an amount not exceeding m times the stress in the concrete at the same distance from the neutral axis on condition that

a. The compressive reinforcement is anchored by bars extending at least through a depth equal to the arm of the resistance moment.

b. The anchors are spaced not further apart (centre to centre) than a distance equal to the arm of the resistance moment, and not further apart (centre to centre) than 16 times the least diameter of the anchored bar. (Also see regulations 89 and 90.)

56. In cases where the compressive resistance of the concrete is not taken into account the stress in the compressive reinforcement may be taken at 15,000 pounds per square inch on condition that—

a. Sufficient steel is provided to take up the whole of the compression.

b. The compressive reinforcement is anchored laterally and vertically by anchors not further apart (centre to centre) than 6 inches and not further apart (centre to centre) than 8 times the diameter of the anchored bar.

c. The anchors shall be passed round or hooked over both the compressive and the tensile reinforcement.

HOOPED CORE.

57. In cases where the concrete in compression is hooped at the ends of a beam, the stress within the hooped core, for the distance of one quarter the span of the beam at each end, may be taken at the same value as for a core in a pillar similarly hooped. In this case the compressive stress in the concrete outside the hooping shall not be taken into account in estimating the compressive resistance.

SHEAR OR WEB REINFORCEMENT.

58. The vertical shear taken by the concrete only will be calculated on the compressed area of the web or on the web area to a depth equal to the arm of the resistance moment of the beam. The intensity of the shearing stress shall not be greater than the values given in regulation 42.

59. Where the vertical shear is taken by the concrete only, in accordance with regulation 42, the ends of 50 per cent. of the bars of the tensile reinforcement shall be inclined across the neutral plane of the beam, and shall be carried through a depth equal to the arm of the resistance moment, or the ends of the bars shall be carried through twice the arm of the beam. See regulations 60 and 61.

60. If the beam stress at any cross section is taken at a value m times the stress in the concrete alone, is in excess of the maximum shearing stress, the whole beam shall be provided for by the tensile reinforcement alone or web reinforcement, or in combination with the compressive stress in the web, but in no case shall the ratio $\frac{S}{b \cdot d}$ exceed three times the shearing stress given in regulation 42, and where

b = mean breadth of the rib of a tee beam or the breadth of a rectangular beam;

d = effective depth of the beam;

S = total vertical shearing force at any cross section.

(Also see regulation 84.)

61. Shear or web reinforcement shall—

(a) Be spaced according to the distribution and intensity of the shearing stresses, but the distance from centre to centre of the shear or web members at any part of the beam shall not exceed a length equal to the arm of the resistance moment.

(b) At least extend from the centre of the tensile reinforcement to the centre of pressure in the concrete under compression.

(c) Be passed under or round the tensile reinforcement or be otherwise secured thereto.

(d) Be hooked at both ends, in the same manner as for tensile reinforcement, or equally effectively anchored.

62. Tensile reinforcement which is inclined across the neutral plane of a beam, and which is carried through a depth equal to the arm of the resistance moment may be taken as shear or web reinforcement.

63. The shear or web reinforcement may be regarded as anchors under the regulations 61 and 62, provided it complies therewith.

(To be continued.)

THE LONDON COUNTY COUNCIL.

At their meeting yesterday (Tuesday) afternoon, the London County Council formally confirmed, as required by Section 23 (3) of their General Powers Act, 1909, the regulations with respect to the construction of buildings wholly or partly of reinforced concrete and with respect to the use and composition of reinforced concrete in such construction, made at their meeting last week, referred to in our last issue, pp. 4, 5, and also above, in this number. The Building Acts Committee reported that they had had under consideration the question of the position of Mr. J. D. Mathews, district surveyor for the district of Stoke Newington, who was appointed by the Metropolitan Board of Works in 1874. In November, 1914, the committee interviewed Mr. Mathews, who was then seventy-six years of age, and formed the opinion that his retirement should not be long delayed. In order that he might have an opportunity of making any necessary arrangements, the committee suggested that he should submit his resignation to take effect as from November 30, 1915. Mr. Mathews had not, however, adopted that suggestion, and the committee now felt, therefore, that they had no alternative but to recommend the Council to dispense with his services as from the date mentioned. They recommended "That the services of Mr. J. Douglass Mathews, district surveyor for the district of Stoke Newington, be dispensed with as from November 30, 1915." They had also had under consideration the question of the position of Mr. F. Wallen, district surveyor for the district of St. Pancras, South. Mr. Wallen was appointed by the Metropolitan Board of Works in 1878, and is now eighty-four years of age. The committee interviewed Mr. Wallen in November, 1914, and were satisfied that it was desirable in the public interest that he should be relieved of his duties. In order that he might have an opportunity of making any necessary arrangements with a view to retirement, they suggested that he should appoint a qualified deputy forthwith and should submit his resignation to take effect from November 30, 1915. Mr. Wallen had appointed a deputy, and the committee agreed to the appointment on the understanding that it will continue for so long as Mr. Wallen remains district surveyor, but not after November 30, 1915. Mr. Wallen had not, however, submitted his resignation, and they felt, therefore, that it was incumbent upon them to recommend the Council to dispense with his services as from the date mentioned. They recommended "That the services of Mr. Frederick Wallen, district surveyor for

the district of St. Pancras, South, be dispensed with as from November 30, 1915."

Owing to the demands of the military authorities, the contractors have not been able to complete the Council's last order for motor appliances for the Fire Brigade. The Fire Brigade Committee submitted an estimate of £25,665 for the purchase of ten motor fire-engines, seventeen motor fire-escapes, and a motor-lorry, pointing out that it has become increasingly apparent that the efficiency of the Fire Brigade must be maintained at a high standard during the period of war. The Fire Brigade Committee added that in view of the conditions arising out of the war they had decided that no building work at fire-stations involving capital expenditure, except works already in progress, shall be proceeded with until further order. This decision involves the postponement of the extension of the Euston station, of the building of a new station in substitution for the Tooley Street station, and of the enlargement and improvement of the Kennington station. They had also given instructions that the usual painting work at fire-stations is not to be carried out during the current financial year, that only repairs which cannot be deferred are to be executed, and that certain proposed works of a minor character at fire-stations are not to be put in hand at present.

No proposals are to be submitted to the Council for the construction of new tramways, and the Highways Committee recommended that application be made to Parliament for an extension of the time allowed for the construction of the junction lines from Farringdon Road into Clerkenwell Road, from Battersea Park Road into Battersea Bridge Road, from Southcroft Road into Mitcham Road, the tramways in Bridge Road, Hammersmith, and the junction line from the Broadway, Hammersmith, into Bridge Road. The Improvements Committee reported negotiations with the Hammersmith Borough Council with regard to (i.) the proposed formation of a new road between Old Oak Road and Old Oak Common Lane; (ii.) the continuation of such road by the addition to the public way of land partly outside the county belonging to the Goldsmiths' Company; and (iii.) the widening of Old Oak Common Lane south of Ducane Road. The total cost of the works involved in the execution of (i.) and (ii.) is estimated by the borough council at £1,565, and the cost of the works necessitated by the third improvement is estimated at £550, making a total of £2,115. The Ecclesiastical Commissioners are prepared to give up the land required for (i.) and (iii.) and to contribute £400 towards the cost in the case of (i.). On this basis the cost of the improvement may be estimated at £1,515. The borough council states that the work is one of urgent public necessity, and the Ecclesiastical Commissioners are very anxious that the work should be completed before next winter. The committee recommended the Council to contribute £1,000 towards the cost of the improvements which will thus be effected forthwith on the basis of no payment being made by the Council until after the conclusion of the war, with interest at the rate of 4½ per cent. on the date of completion of the improvement.

Mr. Courtenay Clifton held a Local Government Board inquiry at Hadleigh, West Suffolk, on Monday, into an application by the Cosford Rural District Council for sanction to borrow £1,200 for a housing scheme.

The directors of the Ulster Publichouse Trust Co. have opened a large new hall at the Templetown Arms, Templepatrick, to be called "St. Patrick's Barn." All the old features of an Ulster barn, including an external staircase, have been preserved and every modern accommodation added. The builders were Messrs. Kirkpatrick Bros., of Muckamore.

Mr. W. O. Meade-King, an inspector from the Local Government Board, held an inquiry at the Town Hall, Wednesbury, last week, respecting an application by the town council for sanction to the borrowing of £1,350 on account of the extensions of the municipal offices and public baths and the erection of new education offices. The application was unopposed.

TIMBER IN BRITISH NORTH BORNEO.

The Government of British North Borneo is taking steps for a general survey of the timber possibilities of the country, and, for the purpose of estimating the amount available and classifying it into the various kinds suitable for export, Mr. D. M. Matthews, an American forestry expert, formerly in the Forestry Service of the Philippines, has been employed. According to a report by the United States Consul at Sandakan, Mr. Matthews began his duties in December, 1914, and is now proceeding with the work of classification.

North Borneo is covered with forests. On account of the dense vegetable growths of all kinds in the tropics, the word "forest" is seldom used; instead, the word "jungle" is commonly applied. In British North Borneo the entire coastline is an unbroken jungle of nipa palms and mangrove trees, but the higher ground is covered with many kinds of forest trees, particularly rare hardwoods, which it is the intention to convert into timber for export. These hardwoods are of many kinds, and can be used for many purposes.

A peculiar feature of several best-known woods is the dual formation—a soft outside of a few inches covering a heart of hardwood, usually black. Several trees have sand-coloured and reddish woods—very similar to the so-called California redwood.

The most valuable of all Borneo timber is billian, or ironwood. This is an extremely hard timber, sand-coloured when newly cut, but it darkens with age. It is so heavy that it sinks in water, and for that reason cannot be rafted down the rivers. About 2 in. of the outside of the tree is soft and worthless, but the inside can be used for almost any practical purpose where a strong, solid, and durable wood is required. It is particularly in request for building purposes in the tropics because it is ant-proof.

Another valuable hardwood is russak or selangan batu. This is a dark sand colour and has many of the properties of billian wood, though it is not so heavy nor does it take so high a polish. Billian is more like reddish-brown ebony, if the description may be allowed. Russak is used for general building purposes, but is preferred for posts and piles for wharves, beams for houses, and all kinds of heavy framework. It is an admirable wood for interior finish in halls and churches, for wainscoting and panel woodwork. The supply is practically unlimited.

The next common timber is sirayah, or redwood, a comparatively soft wood, very similar to California redwood. Sirayah puteh is a whitewood closely resembling American yellow pine. Sirayah proper is so easily worked that it is in very common use. For all building purposes which do not require hardwood sirayah is in great demand.

A very valuable timber is known by the local name of urat mata. It is a dark-red colour, grained, not dissimilar to American mahogany, and much desired for shipbuilding, masts, and planks. It is very durable, and impervious to ants and other insects. The Malays prefer this wood for the bottoms of their boats.

Greeting is a wood closely resembling Indian ebony, though the black inside is sometimes relieved by streaks of brown or red. It may be used for all fancy and decorative purposes, including furniture, though it is almost as heavy as billian. Greeting is a good imitation of English black oak, and might even take the place of walnut. In a new country it is the first wood to disappear.

Another wood similar in texture and grain to greeting is rungas, a dark-red wood with a black stain. The heart is a beautiful dark red. Two or three inches of the outside are soft and worthless, but the inside has all the qualities of the most desirable hardwood. It is durable, impregnable to insects or the elements, and takes a high polish. It is not so heavy as billian or urat mata, as it floats. This wood is not found in forests, but grows as isolated trees. It is found all over Borneo.

Other timbers valuable to the export trade are camphor wood, mirabow, and chindana. These woods all have a more or less agree-

able scent, and are fine grained and durable. They are in great demand in Hong Kong for the inside finish of wardrobes, chests, bureaux and all wooden furniture intended to contain clothing. These woods are also adapted for fine building purposes and furniture. In the tropics they are used for stairways, doors, window-frames, and finishing work generally.

The cost of procuring timber is not great. The system in vogue near Sandakan is to fell the timber, using Chinese coolies, and raft it down rivers to the bay, where it is loaded into lighters, which go alongside the big steamers and discharge.

It is claimed that the supply of nearly all kinds of timber in British North Borneo will last hundreds of years. At present two companies only are engaged in the export timber trade. The entire supply goes to Hong Kong.

PROTECTION OF UNFINISHED CONCRETE.

The use of concrete during the winter months has always been attended with more or less danger, and opinions are divided as to the advisability of placing concrete in freezing weather. Mr. Leonard C. Wason, president of the Aberthaw Construction Company, of Boston, Mass., in a paper read before the Boston Society of Civil Engineers, gives a number of interesting items which he has found during his experience in that line. It seems to be generally considered that concrete laid in winter months will be exactly as good as that laid in summer—and possibly more so—if the necessary precautions to protect it are taken.

The aggregates must be free from frost when mixed. A live steam pipe should be shoved into the sand pile, the escaping steam heating it and removing all frost. The same may be done with the stone; but a canvas should be thrown over the top of the pile to retain the heat, which more readily escapes. When a considerable amount of heating is provided for in advance, steam pipes are laid on the ground, and stone as received is dumped upon them. Then there is a canvas thrown over to prevent storms getting into the pile, and to retain the heat. The frost is thus easily and economically removed.

Salt is frequently used in the water to lower its freezing point. It is seldom worth while to heat the water itself. Little care need be used to prevent mass concrete from freezing, as the frost will usually only strike to a depth of about one inch. Buildings are inclosed with tarpaulin tied on to an outside staging, and the inclosed space is heated with salamanders burning coke. Sometimes it is possible to use steam.

Frost is removed from work by the use of salt and steam; and if the concrete surface is left rough, it is common to sprinkle the top surface with salt to prevent freezing. In winter it is very common to put the finish on as a separate operation, after the building is enclosed, and not as an integral part of the construction, on account of the danger of freezing. After it is put on, it must be kept from freezing for the first 48 hours.

The expense of protection against the weather is not very great, and good results can be so surely guaranteed that it is not usual to discontinue work on account of cold weather.

Occasionally it is necessary to make some provision for the protection of the men. Shelter or wind shields are built in front of the benches where carpenters are making up forms, as well as around the men at the concrete mixer, whose work does not necessarily keep them warm. Where excavation is going on in the open, it is expedient to have a building with a good fire, in which the men can warm themselves when necessary, and on a few jobs it has proved to be wise to provide hot coffee free in these shelters.

The corporation of Dudley have decided to purchase fifty-five acres of land at Burnt Tree from Lord Dudley, at a cost of £14,000, for the purpose of a housing scheme. The matter has been before the town for twenty years. It is proposed to provide fresh dwellings, so as to give opportunity for closing the existing overcrowded and insanitary two-room and three-room tenements in the borough.

Correspondence.

PULPITS FOR ENGLISH CHURCHES.

To the Editor of THE BUILDING NEWS.

SIR, This admirable book, of which the first book was ably reviewed in THE BUILDING NEWS for June 25, 1914, is a most interesting and it may be pointed out that the book is amongst post-Reformation and pre-Reformation is said therein to exist at St. Stephen's Exeter.

The pulpit in that edifice is of stone (oak), and was designed and placed in situ fully half a century ago by the late Mr. Edward Aspinwall, architect of Exeter.

The unfortunate mistake seems to have been copied from "Pulpits" in "English Church Furniture," page 139, by J. Charles Cox, LL.D., F.S.A., and Alfred Harvey, M.B., published in 1907, wherein St. Stephen's Exeter, is also erroneously included amongst the West-country churches containing pre-Reformation pulpits. Yours,

Exeter. S. J. SNOWELL.

SOUTHWARK CATHEDRAL.

SIR, Your note in this week's issue on the work to the altar screen which was dedicated on Monday is in some respects not quite accurate, and a few further particulars may be of interest. The fine altar screen erected in 1520 by Bishop Fox was early in the eighteenth century almost wholly covered by a wooden altar-piece. This was removed early in the last century, when the canopies and other projecting features of the screen were found to have been cut back, flat, presumably to allow for the woodwork.

The whole screen was very carefully restored by Wallis in 1855. His methods were, however, rather more drastic than we could wish nowadays, and there is not very much of the original stonework of the canopies, shafts, etc., now remaining. It seems clear that the three niches immediately over the altar, in the bottom stage, were added by Wallis. The recent work to the screen has been to reconstruct this entire part on lines which such evidence as there was suggested, assisted by the treatment of the corresponding space in such similar screens as those at Winchester and St. Albans.

A large recess was formed above the altar for the tabernacle panel, and is now filled with a rich dorsal and frame, while above are a row of small niches containing figures of the Apostles. The corbel, carrying the shaft in the central niche above, was also redesigned to suit this new work. The two steps to the altar were pushed back, so that the altar now stands against the stonework of the screen. This work was carried out by Messrs. Farmer and Brindley. The two new figures of Henry I. and Edward VII. fill the outer niches of the bottom stage, and are the work of Messrs. T. and E. N. Jollis, who also carved the other figures in the screen.

C. M. ORDING-SMITH.

2, Dean's Yard, Westminster, S.W.1.
July 10, 1915.

Plans have been prepared by the borough surveyor of Aidershot, Mr. F. C. Lewis, for an additional block at the isolation hospital.

The Castlebar Asylum Committee have adopted plans by Mr. R. M. Butler, F.R.I.B.A., Kildaro Street, Dublin, for adding new pavilions, tubercular sanatorium, and bakery to the institution, at an estimated outlay of over £27,000.

Private Edwin Froelrick Warth died at Alexandria on June 25 from wounds received at the Dardanelles. Born in India in 1883, he was the youngest son of Dr. H. Warth, formerly of the Indian Geological Survey, and now residing at Arneliffe, Forest Road, Moseley. After filling important posts in Manchester and Liverpool he went to Las Palmas in the spring of last year to take up an appointment on the waterworks survey, but gave up this post in September and returned home to join the Forces. He applied for a commission; but, impatient at delay, enlisted as a private, his commission as lieutenant being received after he was wounded.

Currente Calamo.

Lord Middleton's zeal for economy in the Civil Service, which the House of Lords endorsed so readily last week, may or may not be according to knowledge as regards Labour Exchanges, of which we have never had much opinion, and which at present must be soft jobs for all engaged in the task of finding employment for 'out of works'. But with regard to the expenditure on public buildings he probably forgets that it is nearly always the truest economy. We can call to mind no Government or municipal building erected of late years which has been undertaken until the necessity for it was so patent and the proof so evident that it would be cheaper to build than to house the staffs in separate and not infrequently distant quarters, the rents for which far exceeded the interest on the sum spent on the new structure, to say nothing of the delay caused in work and injury to the health of the workers. It is, for instance, at the present time a task involving some research to hunt out the various departments of the London County Council, who, except the principal officers, are located in more than fifty different offices. The makeshifts of the Post Office, again, are as unfavourable to despatch as could well be imagined, and from other branches of the Civil Service the same cry comes almost every day. One might as well denounce the outlay on the various camps absolutely needful for our new armies as cavil at building of offices for the various agencies created during the past few years which have transferred to the State and the municipalities work of all kinds that has grown a hundredfold.

There was an equal division in the House of Lords last Friday, not only on the particular merits of the income-tax appeal, but also on the application of previous decisions of the House. The question was whether the Egyptian Hotels, Limited, whose office is situated in London, were liable to pay income tax, under Case I. of Schedule D, upon the whole of their profits, or under Case V., upon a sum not less than the full amount of the actual sum remitted to Great Britain. The company said their Egyptian business was managed by an Egyptian board of directors, independent of the board in London, and of every general meeting of the company not held in Egypt. The Crown contended that the company was resident in the United Kingdom, that the head seat and directing power were situated in England, and that the ultimate control of the company, which resided in its general meetings, was at all times exercised in Great Britain. Mr. Justice Horridge agreed with the Crown, but this decision was reversed by the Court of Appeal. Equal division in the House of Lords resulted. Following the practice of the House in such circumstances, the decision of the Court of Appeal was allowed to stand. Lords Loreburn and Parmoor thought the appeal ought to be allowed, and considered that the principles to be applied had already been settled in *Colquhoun v. Brooks* and the *Sun Paulo Brazilian Railway Company v. Carter*. Lord Parmoor, with whom Lord Loreburn concurred, adopted Lord Watson's reading of the effect of the *Colquhoun* decision, that every interest in the profits of trade belonging to a person who was within the meaning of the Act resident in the United Kingdom must be charged under the first case of Schedule D if the trade was carried on, either wholly or in part within Great Britain, or Ireland, and

was chargeable under the fifth case if the trade was exclusively carried on in any of his Majesty's dominions outside the United Kingdom. In the present case Lord Parmoor thought there was evidence that the directors of the respondents had not only the power to deal with all general financial arrangements of the company, but also exercised the power. Lord Parker, with whom Lord Sumner concurred, and whose opinion prevailed, said the important point in the *Colquhoun* case was not whether the partner had power to interfere with the trade or business, but whether he had so in fact interfered during the period for which the Crown alleged that he was assessable under Case I. In the present case, Lord Parker said, there was an absence of any act done or directed by any person resident here in participation or furtherance of the business operations in Egypt from which the profits and gains in question arose.

The dismissal by the City Surveyor of Manchester, Mr. T. de Courcy Meade, M.Inst.C.E., of three members of his staff, referred to on this page last week, was again the subject of prolonged discussion by the City Council last Wednesday. The report which the Town Hall Committee presented was summarised in our last issue. It showed that the majority of the committee refused to take the view of their Special Committee of investigation that the dismissal of these men could be justified on the ground that there was no work for them to do in the City Surveyor's department; and as the sub-committee failed to find work for them in any other department it was resolved by a majority of the committee that two of the men, "with the approval of the City Surveyor, be reinstated." The statement made by Mr. Derwent Simpson, the chairman of the committee, in presenting the report last Wednesday, indicated that those who voted for this resolution regarded the dismissal of these men as a form of industrial conscription, or compulsory enlistment. The whole question of the action and responsibility of the City Surveyor in the matter was raised by an amendment to delete the words "with the approval of the City Surveyor," moved by Mr. Swales. If, said Mr. Swales, the City Surveyor had really been desirous, as he said he was, of cutting down the expenses of his department, he might have begun by suggesting a reduction of his own salary, which now stood at £1,400 per year. He said it was obvious that the City Surveyor had made a great blunder. He had now told the committee that he could find work for these two men, and it was with that fact in mind that the committee inserted the words under discussion. The chief object of those who supported the amendment in the Council was obviously to express their disapproval of what they considered to be an attempt of an official to use his power in order to force employees of the Corporation to enlist. A second point of criticism was that the Town Hall Committee, in view of the City Surveyor's threat of resignation, were afraid to "say anything to him." Sir Thomas Shann and Alderman Wilson took what they described as a more charitable view of Mr. Meade's conduct, and, while admitting that he had taken too great a responsibility upon himself, contended that he had acted solely in the interests of economy. The amendment to leave out the words "with the approval of the City Surveyor" was carried by a vote of thirty-five against twenty-five. If that had ended the discussion the intention of the Council would have been perfectly clear. But a

second resolution was carried referring the question back for further consideration. Mr. Cook, who moved the amendment, did so on the simple ground that he objected to "two able-bodied pensioners on the ratepayers' fund," which, he said, would be the position if these men were reinstated. The whole subject will therefore come up again at the Council meeting to-day.

Up to this date only two churches are known in England to have more than a complete set of external crosses upon their walls. One of these is the church of Ottery St. Mary, in South Devon, where a thirteenth cross is found, possibly in honour of St. Paul; the other church is at Canington, near Bridgnorth, where there are no less than seventeen crosses on the outside, probably the result of two consecrations. Crosthwaite Church to-day is the only church known to exist with the twelve crosses as symbols of the Twelve Apostles upon the outside walls, and, according to a correspondent of the *Manchester Guardian*, we owe the discovery of this unique fact to Mr. F. C. Eeles, of Edinburgh, who has discovered during the past month that, in addition to the six consecration crosses that were known to exist on the exterior of the south wall, there are six other crosses hidden beneath the rough-cast on the jambs of the windows on the north wall. The whole set of crosses probably dates from 1554, in which year there were inserted Marian windows in the fourteenth-century walls. The use of consecration crosses on sacred buildings has a long history. In the Pontifical of Egbert, Archbishop of York, A.D. 732-766, the bishop is directed to make crosses with his thumb dipped in chrism on the walls of the church. For consecration crosses according to the Roman use twelve red crosses were painted on the four internal walls of the church at equal distances, with twelve branches of iron to hold twelve large candles. By the English use it was required that, in addition to the twelve internal crosses, there should be twelve crosses painted on the outside walls as well. Towards the end of the fifteenth century the crosses are ordered to be within circles, and in the early part of the sixteenth century orders were given to the bishop not only to anoint the crosses with chrism but to cense them as well. Whilst the crosses on the south walls at Crosthwaite are of a normal height from the ground, 7 ft. 6 in., they vary in height on the north wall, the sculptor having apparently chosen a more important or harder stone in the window jambs. It was probably Dr. Aldrich, of Carlisle, who would be the consecrating bishop at that time, who used the English use for the consecration of the church notwithstanding the fact that Queen Mary was on the throne. Mr. Eeles has also discovered beneath the plaster in the interior of the church seven other consecration crosses, some of them enclosed with a black line and two of them picked out with black paint. One consecration cross was previously known to exist, so that there are eight now in the interior. The other four were probably wiped out of existence when the splay of the windows were redressed in 1844.

Careful scientific investigations are being carried out in Queensland in accordance with the Rights in Water Act. The State has been divided into two divisions one lying north of the Central Railway, and the other to the south. Each division is under the control of an assistant hydraulic engineer,

who has a district engineer stationed at Winton and Charleville respectively. Under the district engineer in the southern division are three hydraulic surveyors with working staffs, two bore-drain surveyors, two bore inspectors, and three overseers. In the northern division are two hydraulic surveyors, two levelers, two bore-drain surveyors with field staffs, and two bore inspectors. Amongst other things, these officers are obtaining altitudes and particulars about existing bores, the proper seatings of castings, the proper construction of new bores, and making the necessary inquiries respecting trust areas. The problem respecting the diminution of flow is also being carefully investigated, and in one district the rate of fall has been observed to be as much as 7 ft. per annum; 124 bores that have been specially observed show that during the last fifteen years there has been a decrease of 40 per cent. in the aggregate flow. The Act was passed in 1910, and the following year was occupied very largely in preparing for work. In 1912 the first Interstate Artesian Water Conference was held in Sydney, and since that time Queensland has been working steadily with the object in view. Five water trust areas have been constituted, and bores have been sunk by the Government, while twenty-two trust areas have been constituted, and work is being pushed on with the necessary bores and bore-drains. In connection with the five completed areas 156 miles of bore-drains have been provided, watering about 385,000 acres, at a cost of less than a penny an acre. The twenty-two areas on which work is in progress will water approximately 2,250,000 acres.

When Mark Twain in his early days was editor of a Missouri paper, a superstitious subscriber wrote him saying that he had found a spider in his paper, and asking him whether that was a sign of good or bad luck. The humorist wrote him this answer and printed it:—

“Old Subscriber: Finding a spider in your paper was neither good luck nor bad luck for you. The spider was merely looking over our paper to see which merchant is not advertising, so that he can go to that store, spin his web across the door, and lead a life of undisturbed peace ever afterwards.”

The death is announced at Fernleigh, Crawley Down, of Mr. William Orrin, who was for many years a surveyor to the East Grinstead Rural District Council.

The partnership hitherto subsisting between A. J. Wileman and F. B. Gange, builders and contractors, at Nottingham Road, Loughborough, Leicester, under the style of Wileman and Gange, has been dissolved.

Approval has been given by the Local Government Board to the preparation of a town planning scheme for the Beulah Hill district of Croydon. The Board suggested at the same time that authority should be sought to prepare similar schemes for other unbuilt areas in the borough.

The City Council of Nottingham have reconsidered their determination to abandon the provision of public baths in three districts, and have decided to proceed with the Basford scheme, land in Noel Street having been purchased at a considerable cost as a site for the new establishment, while a street widening will also be effected.

At the last meeting of the town council of Loughborough, Leicestershire, the waterworks engineer reported the failure of registered waterworks plumbers to obtain cards from the waterworks department before proceeding with work connected with the water services. One man had carried out ten jobs without first obtaining cards for the work. It was resolved, after some discussion and a division, that the plumber in question be prohibited from carrying out any work for a period of two months.

PROFESSIONAL AND TRADE SOCIETIES.

EDINBURGH ARCHITECTURAL ASSOCIATION AT STIRLING.—The annual excursion of the Edinburgh Architectural Association took place on Saturday week to Stirling and Keir House, Bridge of Allan. The party first visited Stirling Castle by permission of H.M. Office of Works and the military authorities. Dr. Thomas Ross acted as leader, and Mr. W. S. Menzies clerk of works. Queen Anne's Gateway and King James IV.'s Gateway were described in passing. The Palace was first visited, and Dr. Ross stated that the grotesque statues and figures were probably the work of French masons brought over by King James V. Stirling parish churches were next visited by permission of the Town Council. In the afternoon, the mansion and gardens of Keir were visited by permission of Colonel Stirling of Keir. Mr. Balfour Paul, architect, and Mr. James Rodger, factor, conducted the party over the new chapel, the library, dining and reception rooms.

WAR TROPHIES FOR MUSEUMS.—The annual conference of the Museums Association was opened on Wednesday at the Victoria and Albert Museum, South Kensington. Sir Cecil H. Smith, Director of the Museum, welcomed the members. The president, Mr. E. R. Dibdin, curator of the Walker Art Gallery, Liverpool, said he thought the present dangers to the national treasure-houses were understood, and guarded against as far as possible, by those who had national collections, both public and private, in their charge. Dr. F. A. Bather, of the Natural History Museum, South Kensington, gave an address on "Museums and the War." Mr. W. Ruskin Butterfield, of Hastings, in a paper on "Museums and the National Cause," said that the War Office must have accumulated a large amount of material and appliances captured from the enemy or found on the battlefields. If the War Office and the Admiralty were willing to co-operate with museums it would not be difficult to arrange for the exhibition of it. Mr. E. Howarth, Sheffield, said that he had desired to set up a collection of munitions and shells, but the War Office had refused their sanction. Mr. J. H. Charlton Deas, Sunderland, said that they had been unable to secure any relics of the bombardment of West Hartlepool for the museum. There were plenty of fragments of shells, and there had been a great demand for them, so that when the supply ran short local tradesmen had to manufacture them. The museum had not even got the shell that came through the library roof, for a workman who was working there appropriated it. The proposal to utilise museums for exhibits of munitions and war history subjects was supported by many other speakers, including the curator of Warrington Museum. In the course of a discussion on Thursday on "Museums in Relation to Education," Mr. J. A. Green, Professor of Education at Sheffield University, said that for the student the museum should be an encyclopaedia and book of reference. The labels on the specimens were rarely skilfully done, and to the uninstructed they carried no message. In his opinion the authorities responsible for the museums did not spend enough money on printing, and he advocated the distribution among teachers of a little book dealing with the educational side of the museum. A well-organised museum should be the most popular and useful institution in a town. Mr. H. Bolton, of Bristol, remarked that at one time the museum was nothing more than a curiosity shop, but it had now moved forward and had taken its stand nearer the University College than the elementary school. Mr. Woodhough, Ipswich, complained that Mr. Carnegie had crippled museums by stipulating that the whole penny under the Libraries Act should go to the library.

NORTHERN SANITARY INSPECTORS' ASSOCIATION.—Nearly forty surveyors and inspectors connected with the various public authorities, and members of the North of England Centre of the Sanitary Inspectors' Association, paid a visit to Shotley Bridge on Saturday week and inspected the new sewerage disposal works which are being constructed by the

Benlie Bridge Local Board, on the old wood Farm. The party was accompanied by Mr. Walling, of the firm of Messrs. G. and W. Walling, Newcastle-on-Tyne, and for the new sewerage Mr. Walling is responsible. Blackhill, to the north of Shotley Bridge, works, which cover an area of 25 acres, which 25 acres are reserved for other purposes. Mr. J. G. R. Ross, of the County health department, presided. A general meeting of the members was held subsequently at the Crown Hotel, Shotley Bridge, Mr. George Edwards, Lynton, president, being in the chair.

OBITUARY.

Hendrik Willem Mesdag, the well-known Dutch marine painter and monument painter of other painters, died at his home, De Laan van Moerdervoest, The Hague, on Friday night, aged 84 years. His museum of modern Dutch art, presented to the Dutch nation in 1905, is the resort of all cultivated visitors to The Hague. Yet, although all his life a lover of painting, Mesdag was 55 before he left his father's banking business to make it a profession. His wife was also 55 before she took the brush in hand, yet lived to achieve a reputation with it almost as great as his. Both were born in Groningen, the birthplace of Josef Israels; he in 1851, she three years later, and they married in 1856. Two of his seascapes are hung at the Luxembourg—"The Smoking Sun," acquired in 1888, and "Before the Storm," in 1890, and in the Rijks Museum at Amsterdam is his "Shore at Scheveningen."

Second-Lieutenant Hugh Frederic Davies, 1-5th Regiment (T.F.), whose death was reported on Friday, aged 25, the youngest son of Mr. John Davies, of Chester, was an assistant architect in the service of the Liverpool Corporation. On the outbreak of war he enlisted as a private, and on October 24 was given his commission. He was mentioned in Sir John French's despatches of June 22 last. He was a relative of the late Major Hale, V.C., C.B., and was killed in action in Flanders on July 3.

Mr. Douglas Thomas, junr., of the firm of Messrs. Parker, Thomas and Rice, architects, Boston, Mass., was killed in an automobile accident while in Baltimore, on June 10. Mr. Thomas was only forty-four years old. He graduated in 1895 from Johns Hopkins University, and later studied both at the Massachusetts Institute of Technology and in Europe.

We regret to learn that Mr. Joseph Mason, managing director of the Safety Tread Syndicate, of 15, Barbican, E.C., passed away on Friday evening last. He was the original patentee of the Mason's Patent Spur Treads, so well known and used all over the world. He had governed the syndicate in the capacity of managing director since its inception in 1895, and the directors and staff feel that they have suffered an irreparable loss. His death has caused great sorrow among both his personal and business friends. The end was very sudden and quite unexpected. Although Mr. Mason had been away from business since November last through a severe illness, he recovered sufficiently to take up his residence at the seaside, and, valetent; up to the day before his sudden death he was in communication with the firm, and his last letter stated how well he was feeling. The funeral takes place to-day (Wednesday) at the Sutton Cemetery, Brixtlewell.

The foundation stone of a Congregational school church at Sealand, Chester, has been formally laid. Mr. F. Gilbert Smith, of Prestatyn, is the architect.

The Erith Urban District Council are considering a report prepared by the electrical engineer for extensions to the electricity undertaking. The scheme will involve an expenditure of £20,000.

The road between Newhaven and Seaford, which is narrow, with bad corners at six points and in a poor state of repair is to be replaced by the military authorities with a new highway, as far as two sections are concerned, while the existing thoroughfare will be widened to 22 ft. in the third section, between Bishopstone and Seaford.

Our Illustrations.

NEW HEAD OFFICES FOR THE BRITISH DOMINIONS GENERAL INSURANCE CO., LTD., ROYAL EXCHANGE AVENUE, E.C.

This building is now in course of erection and covers a site lately occupied by Nos. 2, Royal Exchange Avenue, and 19, 20, and 21 Finch Lane, E.C. The inset view, from a drawing by the architect, is of the frontage to Royal Exchange Avenue. The plan given shows the ground floor, comprising entrance vestibule, lobby and staircase hall, with marble-lined walls and modelled plaster friezes, domed ceilings, etc. A passage similarly treated leads to an entrance from Finch Lane. In the staircase well is an electric passenger lift, with wrought-iron enclosure and stair railing, with cast decorative panels. The underwriting room will be panelled in figured Italian walnut with waxed finish, and will have a plaster modelled ceiling, frieze

Chatham, in the diocese of Rochester. The complete church will seat 750 people. The erection of the first portion, including the chancel, chapel, vestries and three bays of the nave, has lately been commenced, and is arranged to accommodate 500 worshippers. The shape of the site necessitated a long narrow plan. The nave is 93 ft. in length, with a tower at the west end and one aisle only on the north side. The chancel is 57 ft. long, also with an arcade on the north side only, opening into a large choir aisle which is arranged as a chapel. The church is to be built of brick, plastered inside and faced on the outside with Kentish rag. Weldon stone is used for the external stone dressings. The roofs will be covered with Westmoreland slates. Mr. Temple Moore, F.R.I.B.A., of Well Walk, Hampstead, is the architect.

TUNSTALL COURT, SITTINGBOURNE, KENT.

This house, of which we give elevations and plans, is an attempt to combine some of the symmetry and stateliness of an Early

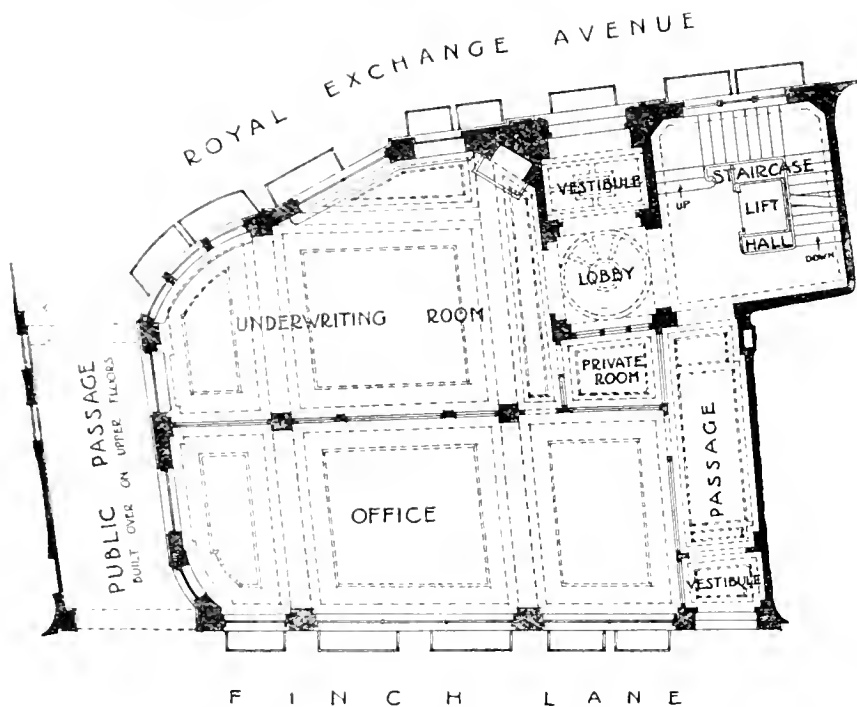

GROUND FLOOR PLAN

HEAD OFFICE FOR THE BRITISH DOMINIONS GENERAL INSURANCE COMPANY, LIMITED, ROYAL EXCHANGE AVENUE, E.C.

Mr. A. H. MOORE, A.R.I.B.A., Architect.

and beams. This ceiling, etc., will be repeated over the office adjoining. The upper floors, which extend over the public passage, contain additional office accommodation, and on the second floor is the board room, panelled in oak with modelled plaster frieze and ceiling. The top floor contains the lavatories and resident caretaker's apartments. The basement contains additional office accommodation and strong rooms, and the sub-basement the heating chamber, coal and storage. A vacuum cleaning outfit is installed throughout the building. Owing to rights of light by opposite owners, the building will be faced externally with Doulton's white "Carrara" ware. The roofs will be covered with green Westmoreland slates with asphalt-covered flats. The structure is of steel framing with ferro concrete floors, roof and staircases. The architect is Mr. Arthur H. Moore, A.R.I.B.A., of 11, Dowgate Hill, Cannon Street, E.C., and the general contractors are Messrs. Patman and Forberingham, Ltd.

ST. AUGUSTINE'S CHURCH, GILLINGHAM.

This perspective is now at the Royal Academy Exhibition. It shows the interior of a new Parish Church of St. Augustine, to be built on the hill at Gillingham above

Georgian house with modern comforts and convenience, and every possible facility for economising labour. The living rooms all face so that they obtain the maximum of sunshine and variety of views. The "wet department," viz., the sinks, lavatories, baths, w.c.'s, are all together on the north side of the house, so as to simplify the drainage, etc. The outer walls are 20 ins. thick, including a 2-in. cavity. The outer facing is of 2-in. thick red hand-made Tudor bricks of broken colour, and the roofs are covered with red hand-made sandfaced tiles. The entrance doorway is of Portland stone. The interior is treated with character in a simple and quiet manner. The house has been built from the designs of Mr. Walter H. Brierley, architect, York. Mr. W. L. Grant, architect, Sittingbourne, acted as local representative. The builders are Messrs. West Brothers, of Rochester.

A church of St. Patrick is in course of erection at Newport, Ireland, from plans by Mr. R. M. Butler, F.R.I.B.A., of Kildare Street, Dublin. The church is Irish Romanesque in style, and measures 150 ft. by 80 ft. It is being built of local red sandstone. The contractors are Messrs. John Sisk and Son, of Cork.

COMPETITIONS.

A MODEL STREET INTERSECTION.—Out of a total of 200 competitors for prizes offered by the New York Municipal Art Society for the best architectural solution of the intersection of an avenue and a street—the society having in mind the congestion of traffic at Fifth Avenue and Forty-second Street, N.Y., as an example—Mr. John Floyd Yewell, of 120, Regia Street, Peekskill, N.Y., won the first prize of \$300. Messrs. James Ambrose Thompson and Ernest Lewis, of 101, Park Avenue, New York, won the second prize of \$200, and Mr. Calvin Kiessling, with Mr. Herbert E. Davis, of 175, Fifth Avenue, the third prize of \$100.

DUTCH EAST INDIAN RUBBER FACTORY.—H.M. Consul-General at Rotterdam (Mr. E. G. B. Maxse, C.M.G.) reports that the Council of the International Association for Rubber Cultivation in the Netherlands East Indies is organising an international competition for (1) a plan for a complete rubber estate factory principally for the making of "crepe," and (2) a plan for a complete rubber estate factory principally for the making of "smoked sheet." Both plans are to be drawn up in such a way that at first the capacity of the factory will amount to 100,000 kilogs. of dry rubber per annum, which by three extensions can be increased to 250,000 kilogs. The projects should be accompanied by a detailed description of the factory and of the way in which the competitor considers the product should be treated, and also of the necessary machinery. Projects may be made in English and should be sent in before March 1, 1916, either to the office of the Association, 13, Kneuterdyk, The Hague, or to the office of the "Algemeene Vereeniging van Rubberplanters ter Oostkust van Sumatra" at Medan (Deli). For the best project a prize of 1,500 florins is offered, and a prize of 500 florins will be given for the second best project. Prizes will be awarded before June 1, 1916, by a committee appointed by the Association, who reserve the right to make no award of the prizes if in their opinion the designs sent in are unsuitable. The conditions can be seen at the Board of Trade Office, 73, Basinghall Street, E.C.

LEICESTER.—Twenty-three designs have been submitted for the new Wyggeston Grammar school, Leicester, in competition. The drawings are in the hands of the assessor for adjudication, but it is uncertain when the official notification of the award will be made known. Premiums of £100, £75, and £50 are offered for the three best designs, and the assessor appointed is Mr. George Widdows, F.R.I.B.A.

LOUTH, IRELAND.—The award of the assessor, Mr. William A. Scott, F.R.I.A.I., A.R.H.A., A.R.I.B.A., in the Louth County offices' competition, has not yet been settled. Nineteen sets of designs have been received, and the plans will be on view in the Council Chamber, Court House, Dundalk, after the umpire's choice is made. The result may be expected shortly.

The hospital of St. John, Crumlin Road, Belfast, is being enlarged under the direction of Mr. W. J. Moore, Royal Avenue, Belfast.

The urban district council of Audley, Staffs, have approved the plans of Messrs. Whitehead and Eales, engineers, for the sewerage of the Chapel Street area, at an estimated cost of £1,500.

M. Henri Gaudier Brzeska, a sculptor of great promise and ability, who was killed at Neuville St. Vaast after two promotions for his gallantry, was a French citizen, but most of his sculpture was done and exhibited in London. Several examples of it were to be seen at the recent Exhibition of Vorticist Art at the Doré Gallery.

Wednesbury Town Council have received an intimation that the Local Government Board do not think they would be justified at present in sanctioning the application by the corporation for power to borrow £5,340 for the erection of twenty-four artisan dwelling-houses. They regret that the carrying out of the scheme must be postponed. The decision places the corporation in a somewhat awkward position, as not only has the land been acquired, but a number of the houses have actually been erected.



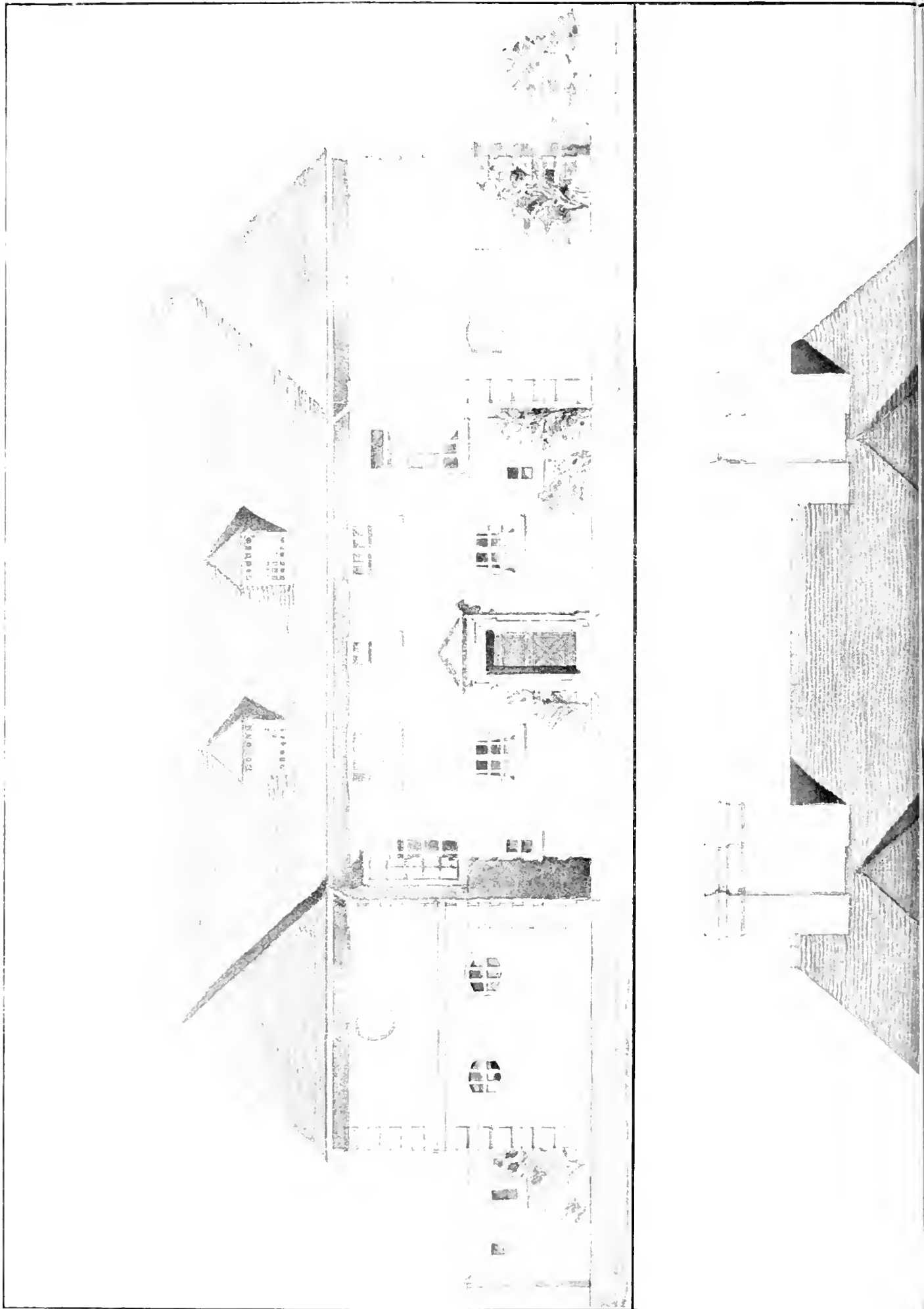

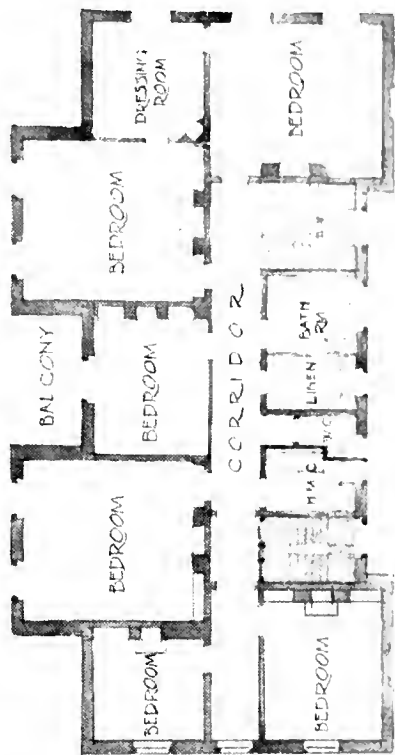
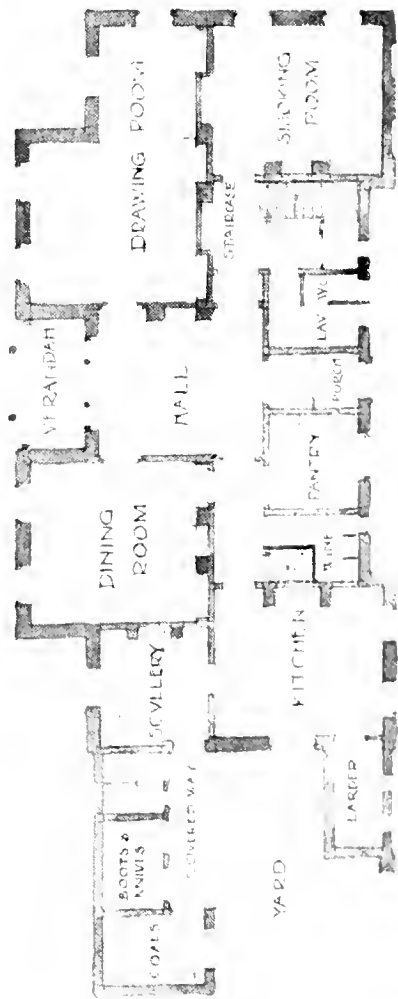
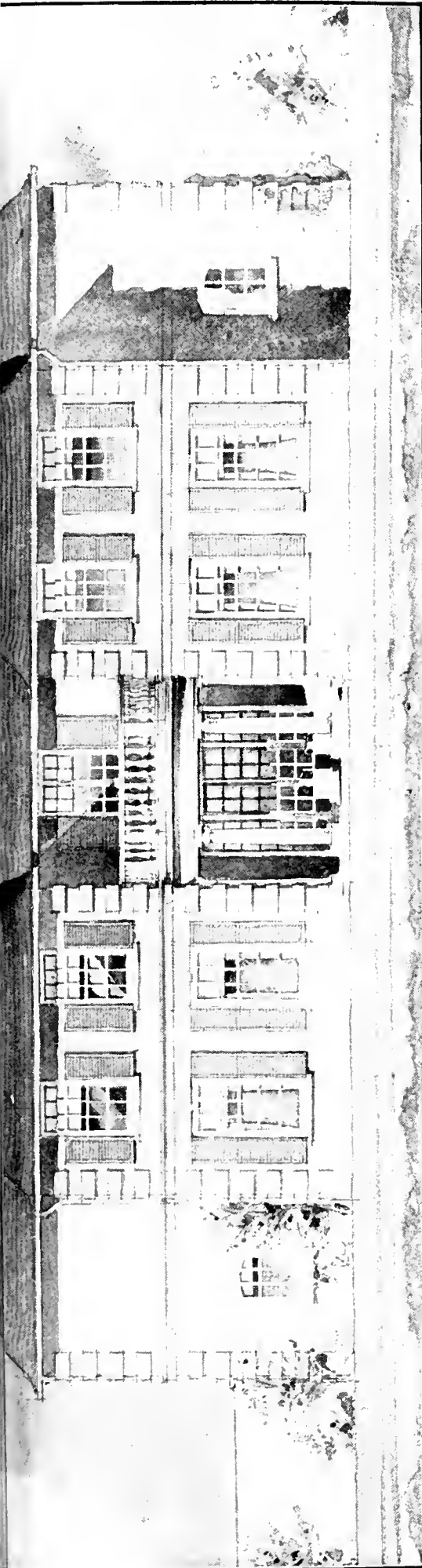

FLOOR PLAN

SETTINGBOURNE

Frank Lloyd Wright
Author of 'The City of Tomorrow'





THE BUILDING NEWS, JULY 14, 1915.

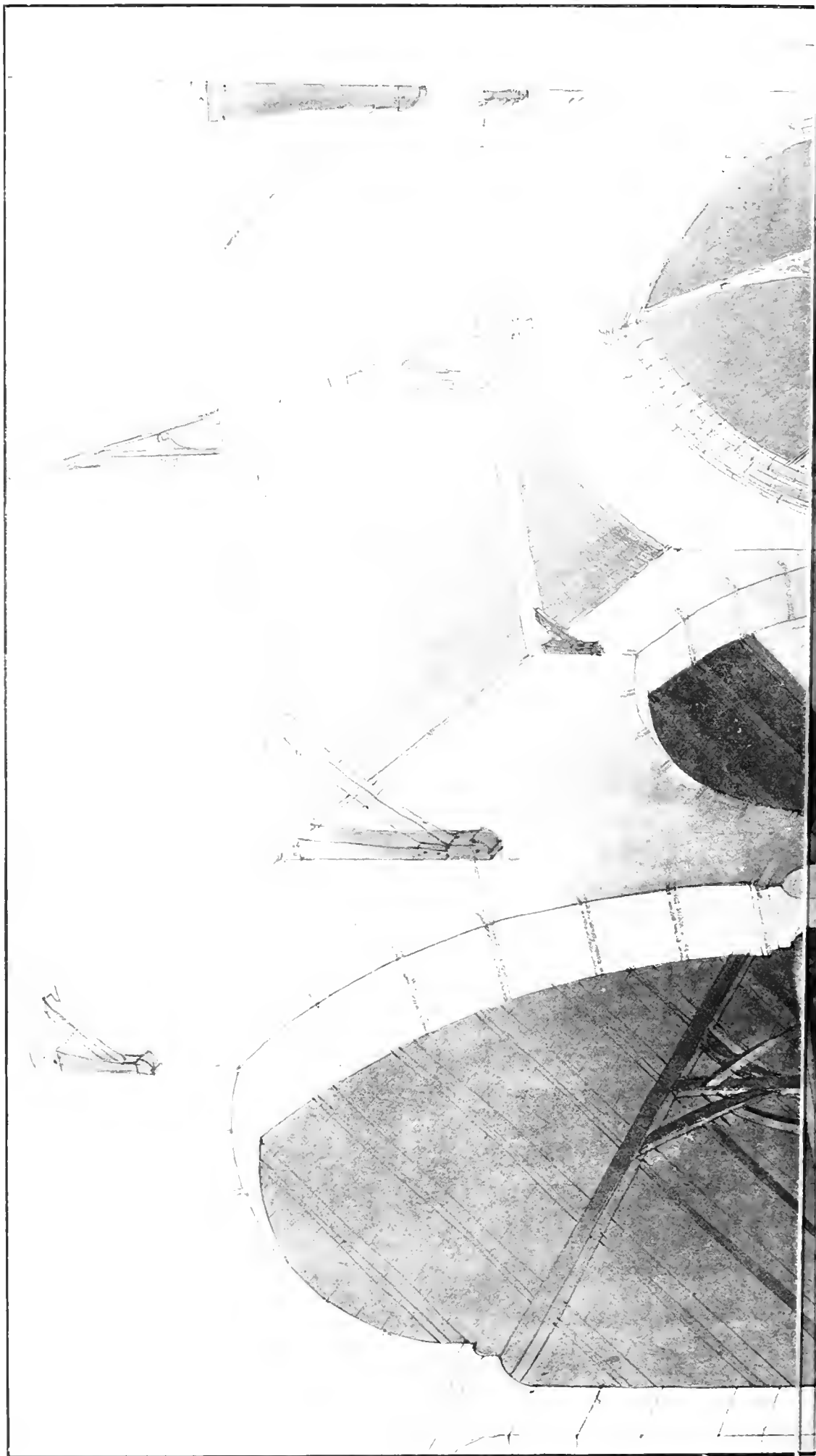

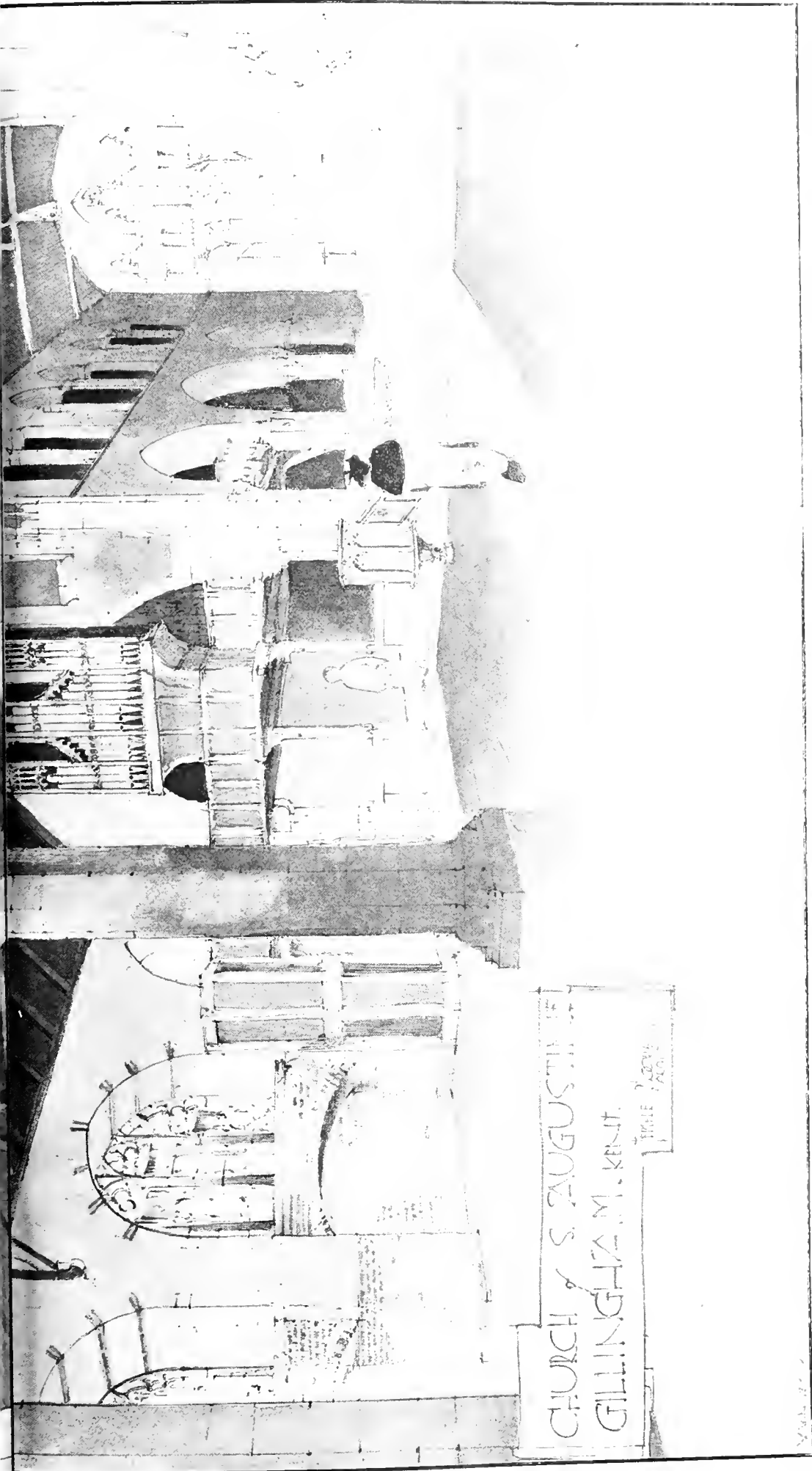

CHURCH OF ST. AUGUSTINE
GILLINGHAM, KENT.

W. G. 1882

CHURCH OF ST. AUGUSTINE, GILLINGHAM, KENT. INTERIOR, LOOKING EAST. MR. TRENKLE, M.A., F.R.I.B.A., ARCHT.

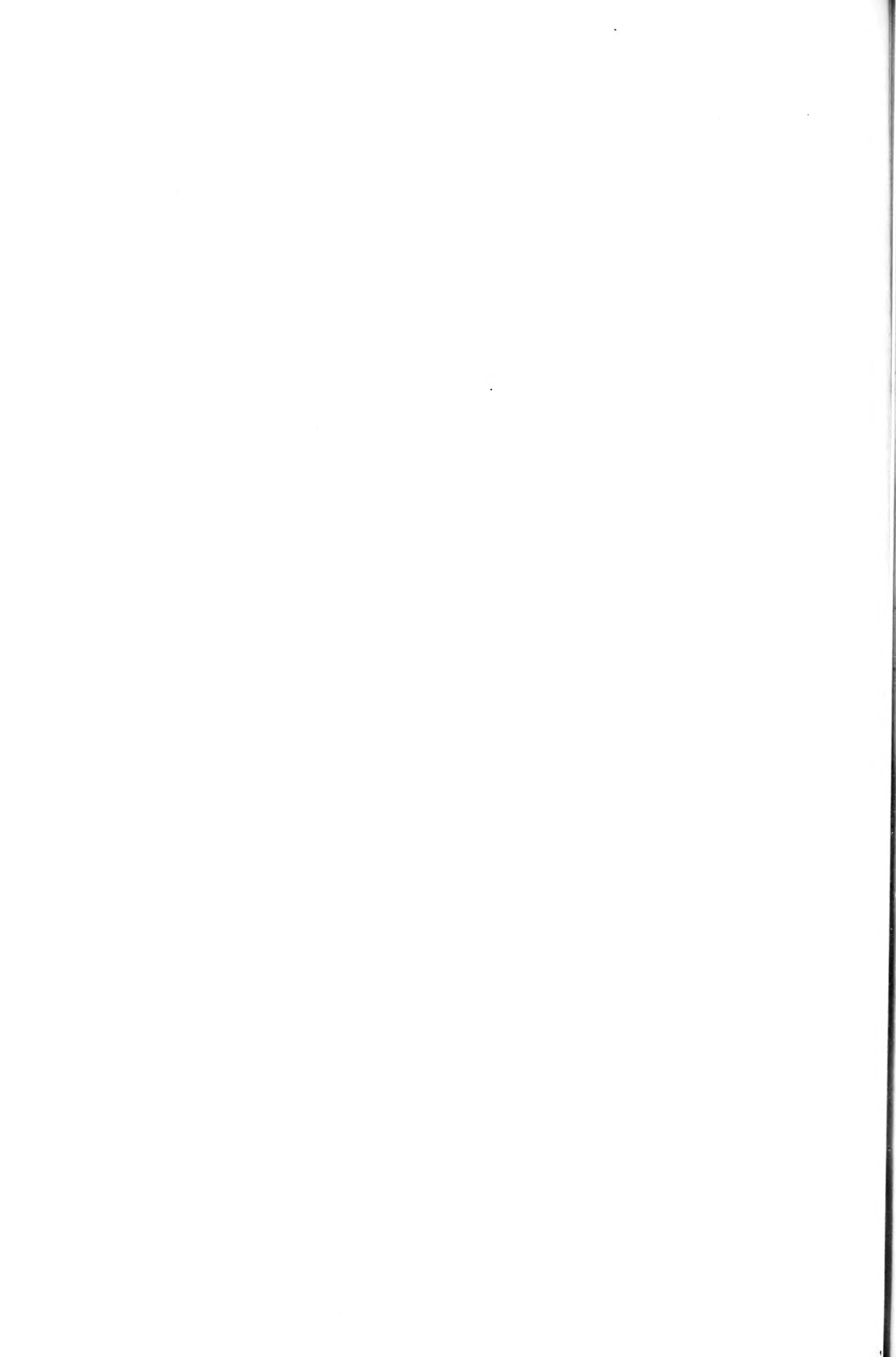





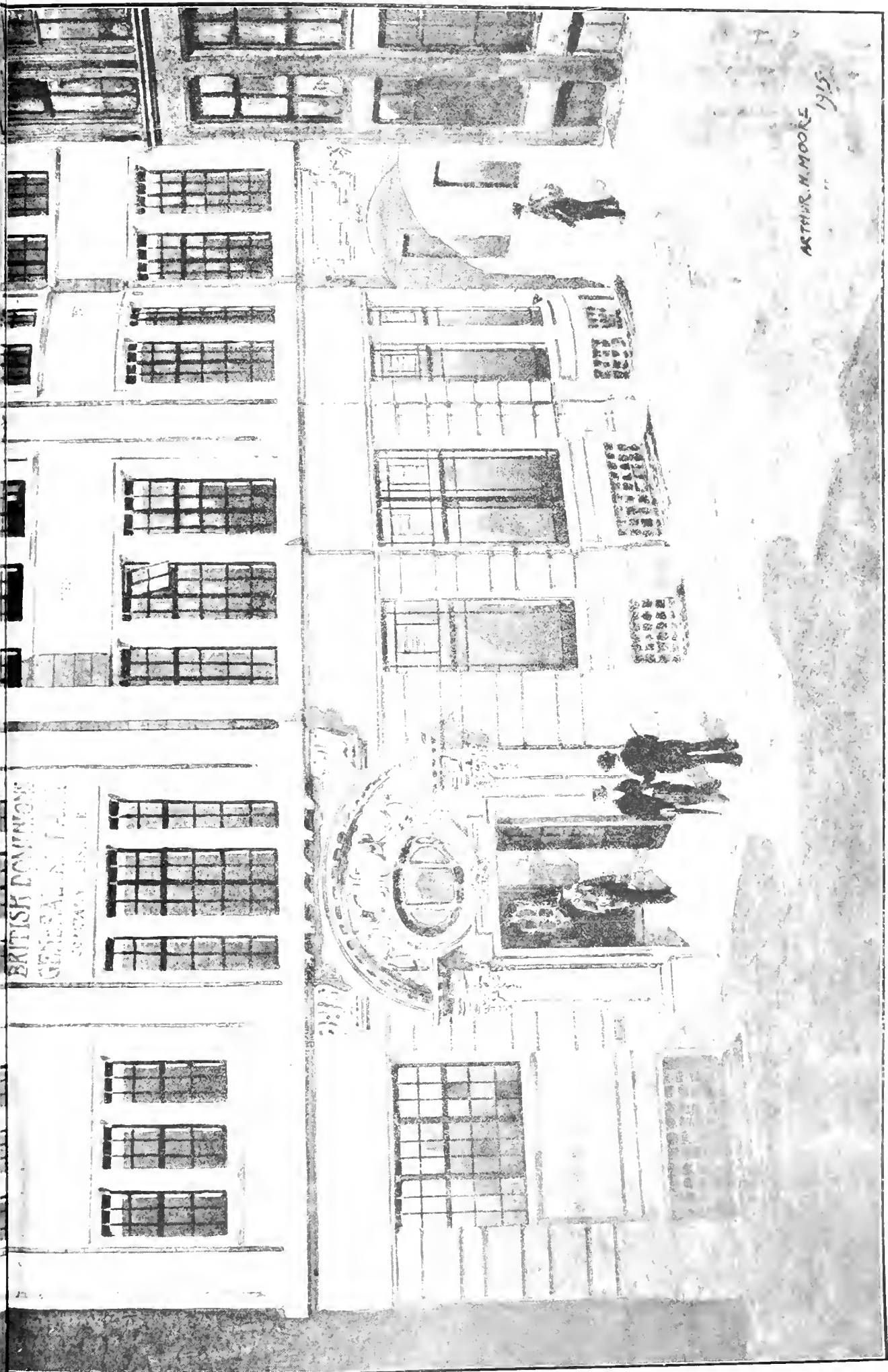

ARTHUR M. MOORE
1915

BRITISH DOMINION
GENERAL INVESTMENT
CORPORATION

NEW YORK CITY THE BRITISH DOMINION GENERAL INVESTMENT CORPORATION LIMITED ROYAL AVENUE, F.O.C. ME. A. 1. THE NEW YORK AREA, A. 1. 1915

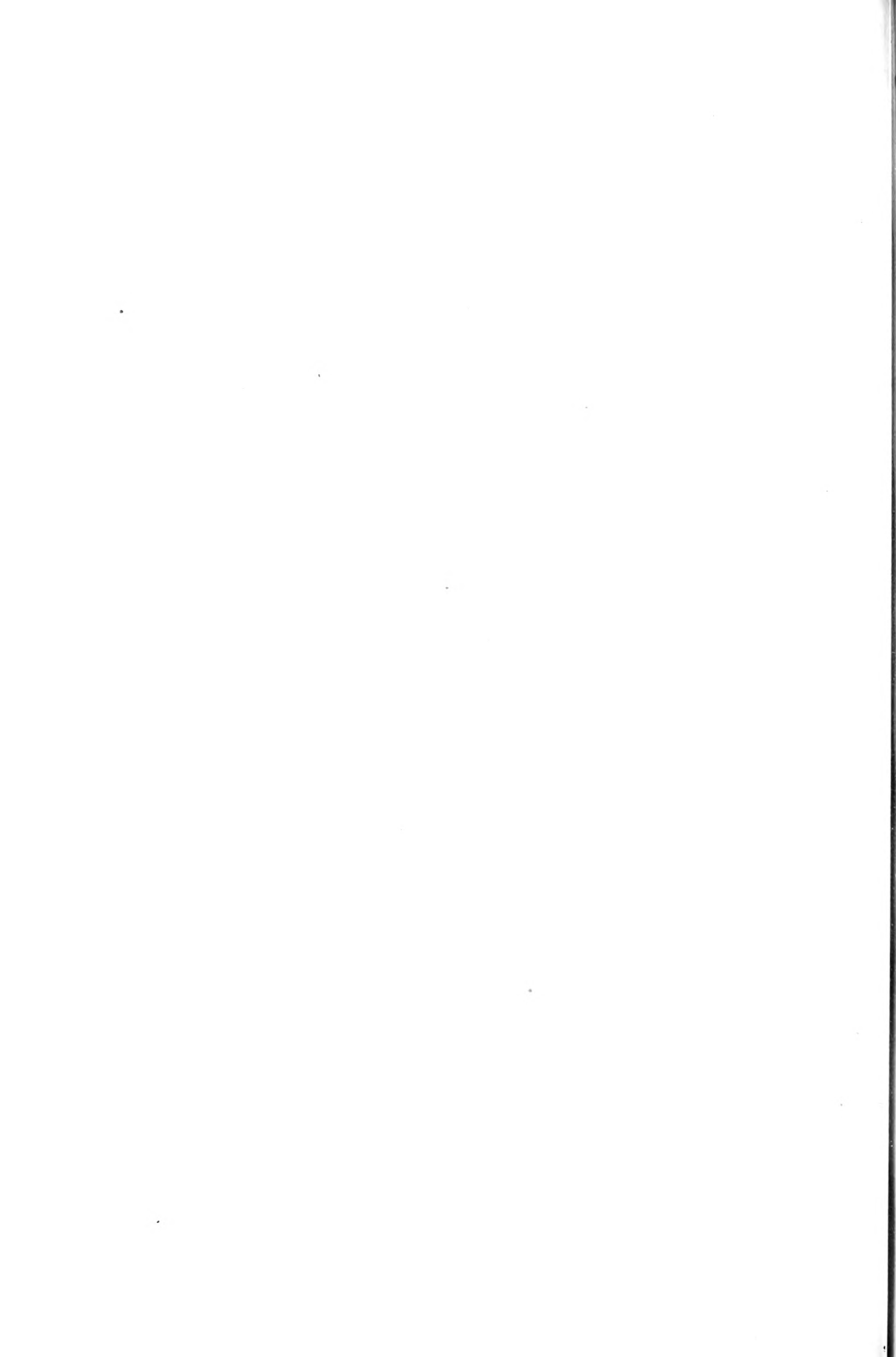

Building Intelligence.

GLASGOW.—The North British Railway Company have entered upon a scheme of improvements at Queen Street Station, Glasgow, which will involve an expenditure of about £40,000. A new parcels department is being erected, with a public entrance in North Hanover Street, for outward parcels, and an exit is also being provided for delivery vans for inward parcels. The inward parcels will be raised by elevators from the various platforms to an overhead roadway, along which they will be conveyed to the vans. After the parcels departments are transferred to the new offices the present offices at the corner of West George Street and Queen Street will be rebuilt, and a new entrance provided to the station. The offices of the goods manager and the engineer, at present situated in this building, will be removed to what was formerly the Royal Hotel, on the north side of George Square.

WESTMINSTER CATHEDRAL.—The chapel of St. George and the English Martyrs in Westminster Cathedral is to be dedicated to the everlasting memory of officers who fall in the war. The decoration of the chapel will be carried out in marble and mosaic in the style followed in the adjoining chapel of Holy Souls, and simple memorial tablets will record the names of the officers who are killed in action, together with their regiments and the dates of their death. Work is also to be started at the cathedral on the great tympanum of the entrance, the only important feature outside the building which now remains to be finished.

CAUSES OF METAL BRIDGE CORROSION.

Discussing, before the Engineers' Society of Western Pennsylvania, the protection of metal structures, Frederic H. Fay, of Fay, Spofford, and Thorndike, consulting engineers, Boston, pointed out that the corrosion of metal bridges is due principally to one or more of four causes. These are exposure to locomotive gases; exposure to sea water; exposure to surface water leaking through bridge floors; overstress of the metal, by which corrosion has been hastened.

The condition of frequent wetting by salt water, followed by exposure to the atmosphere, is a severe test. The Neponset bridge, built in 1877, was a small two-leaf trunnion bascule draw span with wrought-iron girders. The counter-weighted ends of the girders were immersed in salt water whenever the bridge was open at high tide. These girders were painted frequently, usually with red lead, and they continued in service thirty-two years, until the bridge was rebuilt.

Laboratory experiments have shown that steel stressed beyond its elastic limit will rust more rapidly than steel which is not overstressed. This seems to be borne out by experience in certain cases of highway bridges carrying constantly increasing street railway loads. When heavy cars have been put in service over these structures the outstanding legs of the flange or seat angles immediately under the stringers have been found to rust very rapidly—much faster than the metal at each side of the stringer.

The foundation-stone of a new Wesleyan church has been formally laid at Wincanton. Mr. A. Brocklehurst, of Manchester, is the architect, and Messrs. Bird and Pippard, of Yeovil, are the contractors. The outlay will be £2,000.

The urban district council of Stone, Staffs., have this week decided not to purchase the gas and electricity undertaking offered to them by a local supply company for £38,100 and to withdraw from all negotiations, and from all further steps towards the promotion of a Bill for the acquisition of the works.

At a meeting of the Northern District Committee of Ayrshire County Council at Kilwinning on Thursday, it was intimated that Mr. Roderick McDonald had been appointed road surveyor for the whole district. The appointment was carried at a special meeting by 14 votes to 12. The amendment favoured two surveyors, as formerly.

LEGAL INTELLIGENCE.

CROWN'S POWER OF REQUISITION OF LAND.—No Right to Compensation.—On the 7th inst., in the King's Bench Division, Mr. Justice Avory gave judgment on a petition of right presented by an aerodrome company raising the important question whether the Crown could commandeer premises and land for military purposes without granting any compensation.—The aerodrome company by their petition contended that they were entitled to receive compensation for their aviation ground and premises having been taken over for military purposes. They did not dispute the right of the military authorities to acquire the property compulsorily. The Crown submitted that the aerodrome had been acquired under military necessity, and that the petitioners were not entitled to compensation. It was said that the Crown claimed no right or interest in the land against the petitioners. When the case was before the Court during the previous week it was not reported, as for military reasons it was thought inadvisable to mention the locality. The judge now intimated that there was no objection to the decision being reported.—Mr. Justice Avory said he had come to the conclusion that his Majesty, by virtue of his war prerogative through his representatives was, in existing circumstances, entitled to take possession of the land and premises without making compensation. In addition the regulations under the Defence of the Realm Act conferred on competent naval and military authorities during the continuance of the war absolute and unconditional power to take possession of land and buildings, and do any other act interfering with private property for the public safety or the security of the Realm. That enactment repealed any right to compensation if it existed at any time under the earlier Acts. The petitioners had failed to establish any right in law, and there would be judgment for the Crown. The petitioners were, however, entitled under the conclusions of the Royal Commission of Inquiry of March 31 to apply for compensation in respect of direct or substantial loss sustained by them through interference with their property and business. There were reasons in the correspondence which induced him to make no order as to costs.—Leave to appeal was refused.

DUNDEE ARCHITECT'S LIBEL ACTION.—R.N. for Pursuer, in Cause—J. H. Langlands v. J. Leng and Co., Ltd.—In the Second Division of the Scottish Court of Session, the Lord Justice-Clerk and Lords Johnston and Guthrie on Saturday disposed of a reclaiming note for James Henry Langlands, architect, Cumment, Kingennie, near Dundee, in his action against John Leng and Co., Ltd., proprietors of the *Dundee Advertiser*, for £3,000 damages in respect of alleged slander. The pursuer, who is the architect under the Dundee School Board, complained of statements which appeared in the *Dundee Advertiser* in connection with proceedings which took place at a meeting of Dundee School Board when the extension of Harris Academy was under consideration. The defendants denied slander, and repudiated the interpretation put by the pursuer on their comments. Lord Anderson in the Outer House dismissed the action as irrelevant, with expenses. The Division allowed the pursuer to amend his record, and after this had been done, recalled the Lord Ordinary's interlocutor, and approved of an issue for the trial of the action. No expenses were found due to or by either party. The Lord Justice-Clerk said that the Court were of opinion that there must be an issue, and that the terms of it should be as follows:—It being admitted that on or about the 7th day of October, 1914 the defendants printed and published in their newspaper, the *Dundee Advertiser*, an account of a meeting of the School Board of Dundee headed "School Board Plight," in terms of Schedule I, hereto annexed, and a relative article headed "Dundee School Board and its Architect," in terms of Schedule II, hereto annexed—whether said account and article, or part thereof, are of and concerning the pursuer, and falsely and calumniously represent that the pursuer had in his position of architect to the said Board acted corruptly for his personal benefit, or make similar false and calumnious representations of and concerning the pursuer, to his loss, injury, and damage. Schedule I contains the account of the meeting, and Schedule II, the article referred to. Counsel for the Pursuer—Mr. Watt, K.C. and Mr. Paton. Agents—Maxwell Gill, and Pringle, W.S. Counsel for the Defendants—Mr. Sandeman, K.C. and Mr. Lippe. Agents—Alex. Morrison and Co., W.S.

GLASGOW BUILDING CONTRACT APPEAL.—In the House of Lords on Tuesday,

Wednesday, and Thursday in 1915, Lord Chancellor and Lord Alton of Liverpool and Wrenbury heard the appeal from the Scottish County Investment Company, 57, Victoria Street, Glasgow, from a judgment of the First Division of the Court of Session affirming an action by the Lord Ordinary Lord Hender against the builder, Dixon Street, Glasgow, for the payment of £653 as balance alleged to be due under a contract for work in connection with the erection of four tenements in Glasgow Road, North Kelvin-side. The appellants alleged that the work was done in breach of contract in various respects, and the question in the appeal was whether the respondent was in breach of his contract, and, if so, whether he was entitled, notwithstanding the defence of the balance of the contract price. Considerable discussion took place as to the difference between the laws of Scotland and England in regard to breaches of contract in such circumstances. Their Lordships announced at the close of legal arguments on Thursday that judgment would be reserved.

THE MEASUREMENT OF TIMBER CARGOES. His Honour Judge S. and gave judgment on Wednesday in the action brought at the Liverpool County Court, the hearing of which lasted three days, in which the owners of the steamer Erik, a Copenhagen firm, claimed £194 from the Ship Canal Portland Cement Manufacturing Company, Ltd., of Ellesmere Port, balance of freight on a cargo of staves carried from Archangel to Ellesmere Port. His Honour found that the method of measuring the cargo adopted by the defendants was more accurate and reliable than that of the Customs Fund, who measured for the plaintiffs, and that the ship carried 269 standards as against the 419 set up by the plaintiffs.—Judgment was given for the defendants, with costs.

THE VALUE OF LINCOLNSHIRE LAND. Mr. John D. Wallis, F.S.I., an Official Referee under the Finance Act, 1909-10, has given his decision in the appeal of "Austen v. Commissioners of Inland Revenue," which he heard at Lincoln on June 5, relative to the valuation of land at Swinshead, near Boston, for the purpose of estate duty. The appellant was Mr. Edward L. Tennant Austen, and the question for decision was the market value of a total area of 1,102 acres as at the death of the Rev. J. M. Austen on May 24, 1909. For the appellant it was stated that the land was sold for £33,500 on November 1, 1915, and the value of £40,970 placed on it by the Land Valuation was therefore excessive, being apparently influenced by the price of £47,150 realised at the subsequent resale. Evidence was called on behalf of the appellant to show that there had been a considerable appreciation in the value of land in Lincolnshire since the Small Holdings Act came into operation, and the resale figure had been reached by virtue of the land being split up. Mr. Gerald Ewe, F.S.I., of 8, Oxford Street, Nottingham, superintending valuer of the Eastern Division, said the basis of his valuation was what a person in the open market would pay, not what an expert would advise him to give. If Mr. Austen had had local advice in 1909 there was no reason why he should not have obtained £47,000 then, and witness would not admit that £47,000 was the top price that could be got. The Referee has fixed the value at £40,970, the appellant to pay the costs incurred by the Commissioners.

Mr. D. Bell, surveyor to the Wundesham Urban District Council, has had his salary increased by £45 per annum.

Mr. Donald Reid, burgh surveyor and sanitary inspector of Wick, has been appointed burgh surveyor of Inverkeithing.

The town-planning scheme of the burgh council of Dunfermline, which has been in preparation for three years, is now ready for presentation.

The town council of Middleton, Lancs., resolved at the last meeting that the draft scheme for the town-planning of Alkington Estate, as now amended, be approved, and forwarded to the Local Government Board and to Messrs. Popler and Allen for their information.

The corporation of Sutton Coldfield formally inaugurated on Thursday a refuse destructor, the work being executed under the supervision of Mr. J. H. Thwaites and Mr. W. A. H. Chury, borough engineer. The destructor has three cells with a grate area of 75 square feet and a cremation capacity of 45 tons of refuse per twenty four hours. The cost was £5,500.

Our Office Table.

The annual exhibition of drawings at the School of Architecture, Liverpool University, was opened on Wednesday last at Liberty Buildings in that city. The display is, as was to be expected, smaller in number than usual, but the standard of draughtsmanship is high. The principal exhibits are the competitive drawings for the travelling scholarship offered by the British School of Architecture at Rome and for the Sir William Lever prize. The School of Rome subject was a design for a "Palace of Justice," and that sent in by Gordon Hemm, of Heaton Chapel, near Stockport, arrests attention on account of its striking ground plan. As the scholarship has been suspended owing to the war, the designs in this section, which are all of high merit, will be put into another competition. Mr. Hemm's cubicle contains also a number of cathedral and abbey sketches, and a measured drawing of the Free Trade Hall at Manchester. For the Lever prize (the subject being a railway terminal hotel and station), Lime Street, Liverpool, was selected as an ideal site, and the drawings suggest a North-Western station extension on lines harmonious with St. George's Hall. Vincent Hall's design has been placed first, and that of A. B. B. Jopling second. A series of designs are shown for a national memorial to Lord Roberts, by H. Gregory and others. The work of F. O. Lawrence and R. G. Dixon has special interest because they are the first two students to be admitted to the degree of "B.Arch." (Bachelor of Architecture), which supersedes the former B.A., with honours in architecture. A young Belgian student, Hemil Hofman, who has just diverted his attention from Gothic to Classic design, shows good progress in his new line. Among his measured work is the Lyceum, Bold Street, Liverpool. He has joined in the general competition for a pump-room with dome, a subject which, together with that of premises for a fine art dealer, has evoked much meritorious work. Other subjects for designs set in the school are those for a country residence, a golf club-house, and a cricket pavilion.

A series of a dozen original pen-and-ink sketches by Mr. Arthur Comfort of various features of the Mid Fifteenth-Century parish church of Halifax has been purchased by the Education Committee of that borough for the permanent collection of local views in the Bank Field Museum, Halifax. There is a crude engraving of the south side of the church, says Dr. T. W. Hanson in the *Halifax Chronicle*, in Watson's History and a much later and wretchedly drawn steel engraving of the same view by Adamthwaite. About 1824, John Horner drew on stone an exterior and interior view, which drawings were issued hand coloured. Shortly afterwards an unknown artist executed a lithograph of the south exterior. In 1839-40, Wm. Moor published four views of various parts of the interior. Somewhat earlier was the drawing on copper by Thos. Taylor, which was re-issued in 1876 in connection with Leyland's paper on the parish church by the Yorkshire Architectural and Topographical Society. Albert Gilbert's painting, 1887, is both poor and incorrect. Two years ago F. O. Ellis, who has now enlisted, issued a sketch in which the tower looms in the distance.

This year the National Art Collections Fund has not been able to put forward any great effort, but it has steadily continued its valuable activities. The beautiful ironwork grille for the tomb of Margaret Combes of Richmond and Derby, in the north aisle of Henry the Seventh's Church, which was removed by Wyatt Lang's alterations in 1822, has been restored to Westminster Abbey, and replaced round the tomb. It was discovered in the possession of a firm of art dealers, and purchased for the sum of £400. A small tempera painting on canvas by William Blake, entitled "Bathsheba at the Bath," is accompanied by drawings by Hogarth for his "Industry and Idleness," and a Roman drawing of St. Mark's are among the

other gifts which the Fund has presented to national collections.

An interesting discovery has been made during the rebuilding of Wargrave Church, which was set on fire by suffragettes in 1914. In restoring the tower it was found that the present casing of red brick is a covering or casing of the original Norman tower, which is a very fine example of Norman masonry, and, in the opinion of experts, one of the best discovered up to the present time. There is no record of the date of the casing of the tower, or by whom the work was done, but the treatment suggests that it was in the reign of either Henry VII. or Henry VIII. There has also been discovered a number of interesting vaults under the chancel, of which no mention is made in the church records.

The Cathedral of Arras, wilfully destroyed by fire by the Germans on Wednesday last, was built on the site of the church of the Abbey of St. Vaast, or Vedast, in the second half of the eighteenth century, and was a heavy structure of no architectural merit. The reconstruction was begun in 1755 and was brought to a stop by the Revolution of 1789. The works, resumed in 1810, were completed in June, 1855. It was a pseudo-classical cruciform edifice with a nave of half-a-dozen bays, a choir of three bays, both with aisles, and semi-circular apse, out of which six chapels open, and transepts also each of three bays. The nave, choir and transepts, which had barrel vaults, were separated from their aisles by colonnades of Corinthian columns, and at the west end was a gallery housing a large organ. In the west aisle of the north transept was a large baptistery, in which various coloured marbles were employed with fairly good effect. Till the beginning of the war the cathedral contained several good paintings and monuments and two Early Flemish triptyches, all formerly in the Abbey of St. Vaast. A small view of the interior of the cathedral nave, looking East, appeared in our issue of January 15, 1911, p. 61. The old Gothic cathedral, one of the finest in the north of France, was a much larger edifice, wantonly destroyed in the eighteenth century on the allegation being made that it was in an unstable condition.

How to find sufficient housing accommodation for war workers is becoming an increasingly difficult problem in Sheffield. Numerous letters have been received by the corporation authorities from both workers and employers asking that the problem should be taken thoroughly in hand. Seventy per cent. of the applicants for houses on the corporation's model dwellings estate at High Wincobank Estate certify themselves as being armament workers. The town clerk has been instructed to bring these facts to the notice of the Local Government Board and the Minister of Munitions, together with statistics as to the overcrowding of existing houses, with an intimation that, in the opinion of the Estates Committee, an overwhelming case has been made out for the erection by the corporation at the earliest possible date of an even larger number of working-class dwellings than is comprised in a scheme now before the Local Government Board; and that as the existing shortage has been intensified by the importation of a large number of workers on munitions of war, and the demolition of houses in connection with extensions of works, it is desirable that the requisite consent of the Government departments to the necessary loan be given at once. The town clerk has also been instructed to inform the Local Government Board that unless steps can be taken to remedy the shortage the corporation will find it difficult to carry out to the full extent the duties imposed upon them with regard to the closing and demolition of insanitary property.

Mr. Reginald Brown, M.Inst.C.E., engineer and surveyor to the Southall-Norwood Urban District Council, writes asking for information from surveyors of other towns relative to the regulations for the admission of liquid trade wastes into sewers. The percentage of flow due to wastes, their nature and preliminary treatment, the basis of pay-

ment made to the local authority by manufacturers, and the extent to which trade liquors interfere with the purification of sewage, are among the points whereupon Mr. Brown, whose address is the Town Hall, Southall, Middlesex, seeks information, and, when tabulated and edited, will evidently be of great value to municipal engineers generally.

The Executive Council of the United Operative Plumbers' Association of Great Britain and Ireland, at a special meeting held at Newcastle-on-Tyne, expressed approval of the action of the Plumbers' Company in appealing to the registered plumbers of the United Kingdom to place their services, so far as practicable, at the disposal of the Government for the execution of work connected with the supply of munitions of war, or other purposes for which their work might be required by the State, for the duration of the war. The Executive Council joined the Company in the appeal, and decided to extend it to all members of the association.

The following awards have been made in the Faculty of Engineering at University College, Gower Street, W.C.:—Archibald P. Head Medal and Prize, B. C. Drummond; Studentship in Heating and Ventilating Engineering, G. F. Mitchell; Engineering Diplomas, P. W. Baker (Mechanical), E. E. Barnard (Civil and Municipal), J. R. D. Bushell (Civil and Municipal), P. L. Capper (Civil and Municipal—with distinction), H. N. Charles (Mechanical), T. C. Chua (Civil and Municipal), B. C. Drummond (Mechanical—with distinction), H. Foad (Civil and Municipal), G. K. Pillai (Civil and Municipal), and S. L. Wong (Civil and Municipal).

"Plain and Reinforced Concrete Arches" (London: Chapman and Hall, Ltd.) is an American translation, by Professor D. B. Steinman, of Idaho University, of a German work by Professor J. Melan, which is probably well known to many readers, but of which, so far as we know, no English rendering has before appeared. The principle of the Melan arch is fully explained, and all data has been converted from metric to English units.

Part IV. of Volume VII. of "The Transactions of St. Paul's Ecclesiastical Society" has just been published (by Harrison and Sons, 45, Pall Mall), price 5s. Two City churches in the neighbourhood of London Bridge, both rebuilt by Wren, those of St. Magnus the Martyr and St. Mary-at-Hill, are described by Mr. Philip Norman, LL.D., V.P.S.A.; Mr. H. P. K. Skipton contributes an interesting paper on "The Pilgrims' Way and the 'Pilgrim's Progress,'" in which he seeks to show that the scenery of the world-famous allegory was derived, not from the low hills of Bedfordshire, but from the bolder landscapes of Surrey. Guildford as the City of Destruction, St. Martha's Hill as the Hill of Difficulty, the iron furnaces of the Weald as the Valley of Humiliation, Dorking as Vanity Fair, and the Leith Hill range as the Delectable Mountains—these are among the identifications supported by the theory that the immortal tinker and dreamer preached in the villages about Guildford before his second imprisonment. Mr. Geoffrey Webb descants on "The Relation of Painted Glass to Other Colour Decoration in Churches"; the Rev. E. S. Dewick, M.A., F.I.A., writes an illustrated article on a Premonstratensian abbot's service book of the beginning of the sixteenth century.

During the months of April, May, and June the Road Board indicated additional advances to highway authorities, amounting in the aggregate to £109,905, of which £107,007 was by way of grant and £2,896 by way of loan. The advances made and indicated up to June 30, less indications cancelled, amount to £6,132,279. Of this total £4,685,753 is by way of grant and £1,446,526 by way of loan. The formal grants completed, with the approval of the Treasury, during the last quarter, amounting to £125,847, were applied as follows: Road crust improvements, £125,045; road widenings and improvement of curves and corners, £419; reconstruction and improve-

ment of bridges, £1,633; new roads and bridges, £1,050.

The annual report for 1914 of the Medical Officer of Health to the Borough of St. Marylebone, Dr. Charles Porter, barrister-at-law, has just been published. The population of the borough continues to diminish, owing to migration, demolition of houses, and the erection of business premises in their stead, and is now estimated at 112,892, against 117,844 revealed by the census of 1911. The birth-rate remains at 18.7, exactly as in 1913, and the death rate is also unaltered, being 14.9 per thousand. Efforts are being made by the borough council and a local health society for the prevention of infantile mortality. House to house inspections were carried out systematically, and as a result of friendly discussions a large number of reforms were effected by the owners. In six cases demolition orders were obtained. Two appeals against closing orders were heard by the Local Government Board. One of these, relating to flats in Dorset Buildings, New Street Mews, was dismissed; in the other a decision had not been given when the year closed. The number of overcrowded rooms and of underground dwellings were considerably fewer than in previous years, results of the active work done in the past. The report, of 96 foolscap pages, testifies to the efficient work done in the Sanitary Department of the borough by Dr. Porter and his colleagues.

Dissatisfaction has been expressed recently in Australia with the progress of the important railway under construction from Kalgoorlie, in Western Australia, to Port Augusta, in South Australia, which is designed ultimately to form part of a great east-to-west transcontinental line. The Commonwealth Minister for Home Affairs has now issued a report on the work, supplied by the engineer-in-chief. The construction of the line, which will be over 1,000 miles in length, has been proceeding from both ends. From the West Australian end the rails have been laid for 238 miles, the route has been permanently located for 260 miles, and a preliminary survey has been carried right up to the South Australian border. From the South Australian end rails have been laid for 245 miles, and the route has been permanently located for 428 miles. In each State telegraph lines have been erected for about 250 miles. Some idea of the magnitude of the work may be gathered from the fact that at the end of April last the expenditure on the line amounted to well over three millions sterling. In South Australia the construction of the earthworks is involving exceptional difficulties, and a certain amount of delay has been occasioned by the decision to ballast the line throughout its entire length. Rock-crushing machinery for this purpose has now been erected in both States. Rails are being laid at the rate of a mile a day, and it is estimated that the line will be completed towards the end of next year.

MEETINGS FOR THE ENSUING WEEK.

WEDNESDAY (TO-DAY).—Camera Club. Opening of Exhibition of Sketches by Members. (Closes on August 21.) 17, John Street, Adelphi, W.C. 11 a.m. to 5 p.m.

Royal Sanitary Institute. Provincial Sessional Meeting at Yeovil. Discussions on "Water Supplies to Rural and Small Urban Areas," to be opened by Dr. W. G. Savage, and on "Prevention of Minor Infectious Diseases," to be opened by Dr. A. E. Remmett Weaver. 11.15 a.m.

WEDNESDAY (JULY 21).—Builders' Benevolent Institution. Thirty-eighth Annual Meeting. Koh-in-noor House, Kingsway, W.C. 4 p.m.

A military hospital is to be erected at Huddersfield to accommodate 500 wounded soldiers. The cost, about £15,000, will be defrayed by voluntary subscriptions. The town council agreed on Friday to give the site, which will be on their estate at Royds Wood.

The Essex County Council have adopted plans for additions to the sanatorium at Black Notley, midway between Witham and Braintree, at an estimated cost of £4,486 9s. 11d. Tenders will be invited for the work as soon as the Local Government Board have approved the scheme.

CHIPS.

Mr. T. Richards, deputy surveyor, has been appointed surveyor to the Caerphilly Urban District Council.

At the last meeting of the Dublin Port and Docks Board it was stated that the corporation were about to spend £24,000 on repairing the north and south quays.

The Grange-over-Sands Urban District Council at their last meeting increased the salary of their surveyor (Mr. T. Huddleston, C.E.) from £250 to £275 per annum.

At the last meeting of Moffat Town Council, Mr. P. Grant McGregor, Bishopbriggs, Glasgow, was unanimously appointed burgh surveyor and sanitary inspector.

The old State Hall at Albany, New York State, is about to be remodelled to serve as a Court of Appeals, from plans by Mr. Pilcher, of Capitol Buildings, Albany, the State architect.

Mr. H. B. T. Wakelam, son of Mr. H. T. Wakelam, county surveyor of Middlesex and president of the Institute of Municipal and County Engineers, is gazetted as Second Lieutenant in the Royal Regiment of Artillery, R.H. and R.F.A.

The death is announced of Mr. Francis Wiswally, J.P., A.M.I.C.E., of Runcorn, a member of the urban district council and manager of the Manchester Ship Canal Company at Runcorn (Bridgewater Department). He was seventy-two years of age.

The new county council schools at Newbiggin have been opened. They provide accommodation for 738 scholars. The accepted tender was for £11,551. Mr. Martin Martinson was the architect, and the contractor, Mr. Stanley Miller, of Newcastle-on-Tyne.

The Doncaster Corporation Bill has received the Royal assent. The measure provides for municipal buildings at a cost of £30,000; an isolation hospital at £35,000; street improvements at £50,000; and the extension of the gasworks and mains at £65,000.

Mr. Thos. P. Collinge, borough engineer and surveyor of Mansfield, has been the recipient of a solid silver teapot from the officials on the occasion of his leaving to take up his new appointment as borough surveyor and waterworks engineer to the corporation of Roth-rham.

The Streets and Plans Committee of Middlesbrough Corporation have approved generally the alternative scheme of the borough engineer, Mr. S. E. Burgess, for laying out the Saltwells Estate, and have appointed a committee to confer with the land-owners on the subject.

The following officers in the Architects' Department, London County Council, have recently been killed in action:—Lance-Corpl. A. E. W. Chappell, Queen's 24th London Regiment, T.F.; Lance-Corpl. J. Carey, a piper in the London Scottish; and F. H. Stanton, 12th Battalion, London Regiment, the Rangers.

The Merthyr Corporation Housing Committee have decided to invite tenders for erecting 160 houses at Gellifaflog, so that the cost may be considered when formal application is made to the Local Government Board for sanction to a loan. The estimate of the borough architect (Mr. Thackeray) is £220 per house and a total cost of £40,000.

The new schools presented to the parish of St. Anne, Stanley, Liverpool, by Mr. Thomas Fenwick Harrison, were formally opened by the donor in the presence of a very large gathering on Saturday. The buildings accommodate 900 children, divided into three departments of 300 each—boys, girls, and infants. The class-rooms each hold fifty children. A roof playground is provided. The architects were Messrs. G. Bradbury and Sons, of Cook Street, Liverpool.

The estimates on maintenance account for the current year of the London Education Committee were reduced at the last meeting by a further sum of £90,000, bringing the total reduction on last year's estimate to £400,000. The largest item in this further reduction was £66,000 for the painting and cleaning of schools, and there was also a reduction in the amount for window cleaning by contract. During a discussion on the proposed reductions, Mr. Warburg ridiculed the idea that educational efficiency was being affected if painting was deferred. As for window-cleaning, the contractors had difficulty in finding the men, and it was patriotic to help to prevent the drain on the men of the nation. The reduction was merely in the number of cleanings. The committee's proposals were adopted.

The London County Council Corporation Bill was read a third time in the House of Commons on Thursday.

New works estimated to cost £100,000 are to be erected in Derby Road, Huddersfield, Messrs. J. and R. Mosley, being the contractors.

The urban district council of Gillingham secured the sanction of the Local Government Board to a loan of £5,734 for works of various kinds.

The Road Board have sanctioned a grant of £3,367 towards the Devon County Council's proposed new road schemes, the total estimated cost of which is £7,979.

A new social club has been formally opened at Rhymney. Mr. W. R. Jackson, of Rhymney, was the architect, and Messrs. H. Davies and Co., of Bargoed, were the contractors. The cost was £1,400.

The Northamptonshire County Council on Thursday, rejected, by thirty votes to thirteen, the recommendation of the education committee to raise a loan of £750 for the erection of a boot and shoe institute.

Mr. A. O. Harpur, surveyor to the Caerphilly Urban District Council, has resigned his appointment on account of failing health, and Mr. T. H. Richards, deputy surveyor, has been appointed his successor.

At Southampton yesterday (Tuesday) Mr. A. W. Brightmore held a Local Government Board inquiry as to an application from the Corporation for sanction to borrow £14,000 for a water tower to be built near the Common.

New offices for the weights and measures department of the Cardiff Corporation erected in Womanby Street were opened last week. The building has been erected at a cost of £1,370 from the designs of the city engineer, Mr. W. Harpur.

Chelmsford Town Council has received the sanction of the Local Government Board to the borrowing of £1,500 for pumping plant at Admirals Park waterworks, and £341 excess expenditure in connection with wood block-paving in three streets.

On Sunday last the Roman Catholic Archbishop of Liverpool solemnly opened the new Church of St. Paul, West Derby. This church has been built and completely furnished out of a sum of £10,000 bequeathed by the late Mr. William Leeming for that purpose. The architecture is Gothic, from the designs of Messrs. Pugin and Pugin, and the building is of red sandstone. The altars are of alabaster, with marble panels, and the spacious nave and aisles will afford ample accommodation for the Catholic population of the neighbourhood.

The final accounts in connection with the erection of the Usher Hall, which was a gift to the city of Edinburgh, have been submitted to a corporation committee. The cost of the site, building, and furnishings amounts to £144,984. The estimated money in hand from capital and interest is £134,466. Thus there is an excess of expenditure of about £10,400. The Usher Hall is built from plans by Mr. Howard H. Thomson, of Leicester, selected in competition and illustrated in our issues of July 29, 1910; August 4, 1911; and March 16, 1914.

A Local Government Board inquiry will be held at the City Hall, Dublin, to-day (Wednesday) into the application of the corporation for sanction to loans of (1) £39,350, (2) £22,075, and (3) £6,000, for the purpose of erecting working-class dwellings in 1, Crabb Lane and (2) Boyne Street, and 3) for widening and improving Lower Liffey Street. Another inquiry will be held in the same building on Friday next into the application of the corporation for sanction to a loan of £12,940 for the purpose of erecting working-class dwellings on the M. Coffey estate and St. James's Walk, Rind.

Mr. Cuthbert Rodham Morris, of Gwyer House, North Curry, near Taunton, whose death occurred there on Tuesday night in last week, is believed to have been the oldest auctioneer in the West of England, for he commenced business on his own account no less than sixty-three years ago—in 1852 when he was barely twenty-one years of age. In course of time he took into partnership his two sons, Messrs. C. W. and R. S. Morris, and his son-in-law, Mr. J. G. Beard, who remained connected with the firm. Deceased was president of the Western Committee's Tenant Right Valuers' Association in 1903, while for thirteen years he was a member of the Somerset Drainage Commission.

TO ARMS!

4th Battalion "Architects" Central London Regiment Volunteers.

RECRUITING

Recruits are greatly needed for the Regular Territorials and Volunteers. Intending recruits should apply to Battalion Headquarters, where they will be advised as to the branch of the Service for which they are best suited.

ORDERS FOR THE WEEK BY LIEUTENANT-COLONEL A. W. WARDEN

37- MUNITION CAMP

All members of Muniton Sections, who are unable to hold their own, are invited to proceed to Camp this weekend. Members are fully required in connection with this work will be notified by their Section Commanders.

38- ATTENDANCE AT CAMP

The general training of the Corps, including Brady Building, School of Arms, etc., etc., will be continued in Camp. Full attendances are, therefore, essential.

Members, other than those detailed for Muniton Work, who desire to sleep in Camp for week nights, should notify the Quartermaster at Camp, not later than the first post on Thursday morning of each week. Those men should report themselves to the orderly Officer on arrival in Camp.

Hours of Parade for men not sleeping in Camp: Saturday 4 p.m., and Sunday 10.15 a.m., at Camp in all cases.

A few names are still required of members able to sleep in Camp during the week, not necessarily for the whole period. Applicants should state for what period they are available.

39- POSTAL ADDRESS AT CAMP

4th Battalion C.R.V. Camp, Summer Gardens Road, East Chelsea.

40- SUMMER CAMP July 21 to August 16

Owing to the arrangements now made as to Muniton Work, the Summer Camp will be held at Thames Ditton instead of Walmer, as previously announced. The Muniton Camp will be extended as necessary between the dates of Saturday, July 31, and Monday, August 16, and the ordinary training of the Corps will continue. It is hoped that all members will attend this Camp for at least one week, and names should be sent at once to the Adjutant's Office. The cost will not exceed 50s. per week.

41- RIFLE COMPETITIONS

The teams for the competitions will be selected in Camp.

42- SOCIAL MEETING

Members are reminded of the Social Meeting this evening, Wednesday, at the Gallery of the R.I.B.A., No. 6, Cannon Street, W., when Miss Lena Ashwell has kindly consented to address the Corps, and relate some of her experiences with the troops in France. Members of the Corps should attend in uniform.

43- COMMITTEE MEETING

The Meeting of the Civil and Military Committee, announced for Wednesday, 14th inst., at Headquarters, 7.15 p.m., has been postponed to Wednesday, 21st inst.

44- ATTENDANCE AT DRILLS AND PARADES

In accordance with the resolution passed at the recent General Meeting, all members must attend at least one parade every week, and alternative Saturdays or Sundays at Camp for general training.

45- DRILLS AND PARADES

All drills and parades will be held as usual.

46- RECRUITS

A number of recruits are required to replace those recently joined the Regular and Territorial Arms, or who have obtained commissions. Application should be addressed to the Adjutant's Office.

47- BULLET DRILLS

A. Coy., Deal's Yard, 5.15 to 7.15 and 6.15 to 8.15, Wednesdays and Fridays.

B. Coy., Dulwich College, Mondays 8 to 10, Thursdays 6 to 8 p.m.

C. Coy., Now being formed. Drill ground and miniature range, Central Electric Supply Company's Generating Station, Lodge Road, St. John's Wood, N.W.

D. Coy., Mercer's School, Tuesdays and Thursdays, 6.45 p.m.

48- SCHOOL OF ARMS

As usual at Millbank School, Erasmus Street, W., on Thursdays, Tuesdays, 6 to 8 p.m.

49- TRANSPORT SECTION

Names are required of a few members to be specially trained in Transport Work. Application should be made to the Adjutant's Office.

CORRESPONDENCE

Enquiry forms of new members and all correspondence not relating to recruiting for the Army or to military matters, must be addressed to the Adjutant, 10, Conduit Street, W.

Correspondence regarding recruiting for the Army and payment of subscriptions, and accounts, should be addressed to the Paymaster at Battalion Headquarters.

BATTALION HEADQUARTERS

10, CONDUIT STREET, W. (MINSTER, S.W.)

By Order, I. R. GUTHRIE, Adjutant.

The Corporation is now for the widening of the Bridgegate in Glasgow involves the removal of the Bridgegate United Free Church, and the future of which is a stone pulpit of the east end.

LATEST PRICES.

N.B.—All prices must be regarded as merely approximate for the present, as our usual sources of information are in many cases failing us.

TIMBER.

Owing to stoppage of supplies all prices have advanced considerably.

IRON.

Table listing various iron products and their prices per ton. Includes items like Rolled Steel Joists, Wrought Iron Girder Plates, Steel Girder Plates, Bar Iron, Good Stails, etc.

Table listing various iron products and their prices per ton. Includes items like B.B. Drawn Telegraph Wire, Cast-Iron Socket Pipes, Wrought-Iron Tubes and Fittings, etc.

OTHER METALS.

Table listing various other metals and their prices per ton. Includes items like Lead Water Pipe, Lead Barrel Pipe, Lead Pipe, Composition Gas-Pipe, Lead Soil-pipe, etc.

SLATES.

Table listing various slate products and their prices per 1,000 of. Includes items like Blue Portland Slates, Blue Banzor, First quality, etc.

BRICKS.

Table listing various brick products and their prices. Includes items like First Hard Stocks, Second Hard Stocks, Mild Stocks, Picked Stocks, etc.

GLAZED BRICKS.

Table listing various glazed brick products and their prices. Includes items like White, Ivory, and Salt Glazed, Buff, Cream, Other, etc.

MOTTLED BRICKS.

Table listing various mottled brick products and their prices. Includes items like Stretchers and Headers, Internal and External Angles, etc.

STONE.

Table listing various stone products and their prices. Includes items like Red Mansfield, Darley Dale, Red Corshill, etc.

THE BUILDING NEWS

AND ENGINEERING JOURNAL.

Effingham House,

CONTENTS.

Shilling Plans for Rural Cottages 53
 Sketches at the Camera Club 56
 A Sculptor's Photographs of Rheims Cathedral before and after the Bombardment .. 56
 School of Architecture Exhibition, University College 56
 Architectural Association Prize Works Exhibition 57
 Prize Distribution at the A.A. School of Architecture 58
 Building News Designing Club.—A Garden Pavilion 59
 The National Federation of Building Trades Employers of Great Britain and Ireland .. 60
 Obituary 60
 Artists' War Relief Exhibition 60
 The London County Council Regulations for Reinforced Concrete Construction 61

Building Intelligence 62
 Water Supply and Sanitary Matters .. 62
 Professional and Trade Societies 63
 Our Illustrations 63
 Curiente Calano 63
 Our Office Table 79
 Competitions 80
 Trade News 80
 Chips 80
 Trade Notes 80
 Parliamentary Notes 80
 Meetings for the Ensuing Week 80
 Intercommunication 81
 Legal Intelligence 81
 To Arms 82
 Latest Prices 82
 Tenders 83

Strand, W.C.

List of Competitions Open
 List of Tenders Open
OUR ILLUSTRATIONS
 L.C.C. Trade School for Girls, Lime Grove, Hammersmith, W. View and plans. Mr. W. L. Bayly, F.R.I.B.A., F.R.B.A., M.I.C.E., superintending Architect to the London County Council.
 Five houses in Prignal Lane and Greenway Garden, Hampstead, N.W. Views and plans. Mr. Cyril A. Farry, Architect.
 Building News Designing Club. A Garden Pavilion. Views, plans, sections, and elevation. Selected designs. First design by "September Morn." Second design by "Wallbrake."
 Detail of Octagon to Tower, Church of St. Mary, Whitechapel, Messrs. John Madland and H. Hardwicke Langston, Joint Architects.

SHILLING PLANS FOR RURAL COTTAGES.

We pointed out on page 430 of our last volume, and indicated there several previous occasions on which we had already shown how failure had followed the attempts of local authorities to build rural cottages from stereotyped plans, giving out contracts for such—especially in Ireland—to builders evidently unacquainted with local needs, and without proper architectural supervision. We are glad to see the Society of Architects have taken this matter up in connection with a report of the Advisory Committee of the Board of Agriculture and Fisheries, which we briefly noticed on page 286 of our issue of March 5 last. That Advisory Committee consists of Mr. Christopher Turnor (the chairman), and Mr. Cecil Harmsworth, Mr. Raymond Unwin, Mr. Lawrence Weaver, and Mr. C. E. Varnell. Working drawings of the designs given are to be had at a shilling or eighteenpence a sheet, and the specifications in each case at one penny. Twenty-three types of cottages are shown.

As the Society of Architects have pointed out in the remonstrance which the secretary has addressed to Lord Lucas, the President of the Board of Agriculture, the report contains a warning against the indiscriminate use of standardised designs, points out that an important factor in economy is competent supervision during erection, and states that in many cases "consultation with the builder" will enable economy to be effected without sacrifice. There is no reference in the report to the desirability of retaining an architect's services, and the natural inference is that such services are unnecessary and can be dispensed with.

Would it not, ask the Society of Architects, have been in accordance with proper and safe practice, and to the advantage of the public and in the best interests of the Board of Agriculture and Fisheries, if this report, most useful in itself, had been accompanied by a definite reference to the necessity of retaining an architect's services in order that the object which the Advisory Committee have in view may be fully attained? Local authorities, public bodies, and private building owners are already too prone to endeavour to eliminate the architect whenever possible, and one result of the publication of the report will be to accentuate this tendency and to make it possible that the said plans and specifications may be so used that the object of the Advisory Committee will be defeated.

Lord Lucas seems to have turned the letter of the Society of Architects over to the Advisory Committee for explanation, and Mr. Christopher Turnor's reply has been forwarded to the Society. It seems

to us to evade altogether the point of the Society's remonstrance. This is the reply:—

27th May, 1915.

To the President of the Board of Agriculture and Fisheries.

My Lord.—The substance of the Society of Architects' objection to the report of the Advisory Committee on Rural Cottages seems to be contained in the following paragraph of their letter:—

"There is no reference in the report to the desirability of retaining an architect's services, and the natural inference is that such services are unnecessary and can be dispensed with."

Considering that the sample specification in the report requires the whole of the works to be carried out "under the direction and to the satisfaction of the architect or employer's agent," thus assuming the services of a skilled supervisor, the committee hardly think that the inference drawn is derived from the report.

The committee would further draw attention to pars. 4 and 5, which lay stress on the need for the exercise of care and taste and for adapting the type of designs to the local materials and the building traditions, with a view to bringing the building into harmony with the surroundings; to par. 19, which emphasises the need for careful planning of the cottages; and to par. 31, which speaks of the importance of a careful lay-out plan with a view to prevent the spoiling of our villages and hamlets by the building of incongruous houses in unsuitable positions.

They do not think these paragraphs suggest that the committee wished to encourage the dispensing with the services of a skilled advisor.

The view which is strongly expressed in the letter from the Society of Architects, that the report may have the effect of causing less cottages to be designed by architects, is not shared by the committee. Only a very small proportion of the cottages now built are designed or supervised by any professional expert. The committee believe that this is because so few people realise how important are the many questions involved in cottage design, and how difficult it is to find a satisfactory solution within the available resources; and they anticipate that their report, by drawing attention to all these matters and showing that cottage design needs careful study if it is to be well done, will have the effect of inducing far more owners and authorities to take skilled advice than to dispense with it.

With reference to the suggestion that there should be in the report a recommendation to employ an architect, the committee, when they considered the points were met with the planning of cottages comes within their duties. Both surveyors and estate agents carry out this work, and many of them have made a special study of it. Indeed, only a limited number of architects have given as much attention to this class of work as have many members of the other professions mentioned. In these circumstances, while the committee sympathise with the view that cottages should be designed in all cases by those fully qualified to do the work, they do not feel that it is their function to determine that none but architects are so qualified, in face of the claims and practice of the other professions mentioned.

The committee have endeavoured to make clear the importance which they attach to good planning and good design; they cannot believe that this can be otherwise than beneficial to the architectural profession. In the majority of cases, where the plans issued are made use of without skilled advice, they think it may be safely assumed that no architect would have been employed had these particular plans not been available.—Yours obediently,

(Signed) CHRISTOPHER TURNOR.

The Council of the Society of Architects say in their rejoinder thereto that their observations on the report were made in the interests of architects, and not on behalf of the members of other professions or other skilled advisers. They point out that the requirement of sample specification contained in the appendix to the report that the whole of the works is to be

carried out under the direction and to the satisfaction of the architect or employer's agent is beside the mark, and such reference is lessened in value by the alternative mention of the employer's agent, whom it would be unsafe to assume in every case would be skilled in the planning and designing of cottages. It is added that the chairman of the Advisory Committee admits that only a very small proportion of cottages are built or superintended by any professional expert, and the Council deprecates the alleged suggestion that it is the function of the Advisory Committee to determine that only architects are qualified to design cottages in face of the claims and practice of other professions to do similar work.

What was suggested by the Society of Architects was that it is desirable that an architect's services should be retained, and not that members of other professions experienced in that particular class of work shall be prevented from doing it. If the building owner prefers to consult them. The fact remains that the Advisory Committee in its report does not specifically express the view that the building owner should retain skilled professional advice of any kind. Certainly it refers to the desirability of "consulting a builder," but that appears to be in connection with securing economy by way of supervision; and, surely, the Advisory Committee hardly wishes to convey the impression that a builder is necessarily a skilled professional adviser on questions of planning and design? The chairman of the Advisory Committee, in the concluding paragraph of his letter, confirms the Council's views that the issue of the plans may lead to their use without skilled professional advice, and the suggestion that no architect would have been employed had these particular plans not been available seems to us an untenable one. The main points raised by the Council were:—First, that the Advisory Committee had not suggested the desirability of retaining an architect's services in carrying out its recommendations; and, secondly, that the precedent set by the Board of Agriculture and Fisheries in this matter was unfortunate from a professional, that is to say, an architectural, point of view. Most certainly, the Council's observations on the report still hold good, and injustice has been done to the architectural profession by the publication of the report in its present form by a Government Department. That perhaps is a small matter! But the housing of the rural workers of the nation deserves more intelligent comprehension than it has received so far by the Board of Agriculture's Advisory Committee if Lord Lucas's reply fairly gauges that committee's capacity!

SKETCHES AT THE CAMERA CLUB.

The committee of the Camera Club may be congratulated upon the success of their bold experiment in inviting a display of sketches by members. Each exhibitor was restricted to half a dozen frames, and the committee have evidently made a careful selection from the pictures submitted. The outcome justifies the expectation that many of our leading experts with the camera have attained their reputations as a result of being able to compose a good picture, and have an eye for colour harmony, and no little technical skill in draughtsmanship. A good, if limited and somewhat unequal output of work, chiefly in water-colour, is on view on the club-room walls at 17, John Street, Adelphi, W.C. The best work of those sent in by Mr. Marcus Adams is "A Street in Jerusalem." Mr. H. J. A. Bowden, now a captain on active service, sends a clever rendering of "Le Quay Vert, Bruges"; he has chosen the picturesque aspect looking along the canal westwards, with the steep Horse Bridge in the foreground, and to the right, peering above the rearward walls of the Palais de Justice and the Hotel de Ville, is the crown of the Belfry Tower. Another excellent sketch from the same hand shows "The Sand Dunes near Ostend" from the marsh behind. Of Captain Bowden's three sketches in the village of Witley, near Haslemere, that of the old vicarage and adjoining cottages and the twelfth century church with its central oak-shingled spire, is the most attractive. Mr. Charles H. L. Emanuel contributes some impressionist views of the Cornish "St. Ives" and of "Pilchard Boats" in the bay, and also two works in silver repousse, of which the better is the tier of superposed houses at "Montreuil." A penchant for effects of evening light and rain reflections is evident in the exhibits of Mr. E. T. Holding; in No. 21, "The Valley of the Teign, South Devon," the space given to the sky, for the display of cumuli clouds, and in order to convey the impression of a wide expanse of moorland landscape, is disproportionate; and the same excess in sky scope is visible in his "Waxham, Norfolk." Mr. F. J. Mortimer, whose name we associate with fine photographs of rolling billows and ships scudding under close-reefed canvas, shows some colour schemes for magazine covers and programmes, and drawings in black and white of a French type for comic papers. Mr. Donald Macalister, now a Lieutenant in the 19th Battery, Royal Garrison Artillery, has three exhibits, the best being a sketch in greys, browns, and greens of a formal old-world garden at Chideock Manor, Dorset, the foreground being provided by a fountain basin, having in the centre a large stone bowl supported by three herons. The hon. secretary of the London Salon of Photography, Mr. Bertram Park, is represented by half a dozen boldly executed panels in oil colour from his sketch-box. Perhaps the most attractive work in the exhibition is that in black and white sent in by Mr. C. H. Hewitt, head of the Photographic Department at the Regent Street Polytechnic, who proves himself an architectural draughtsman of considerable ability. No. 33, "Caudebec en Caux," depicts the well-known Flamboyant pined masonry of the church spire rising over the houses of the main street. Next to it is a sketch in the market place at Wells, Somerset, looking over the fountain towards the two Medieval gateways in the close, with the central and south-western towers of the Cathedral rising above the roofs of the old shops and

houses between. Another careful drawing is a view from the north transept into the massive Norman nave of the Church of St. Cross, Winchester; near by is one of the delicate thirteenth century pillars against a broken pier in the south transept at "Notley Abbey," in fine contrast to the bulky circular shaft and scalloped capital of a Late Norman pier at "St. Bartholomew's, Smithfield." Mr. Alexander Keighley shows some Italian landscapes, vigorously rendered in monotype. Mr. Eustace Calland has been sketching on the banks of the Lake of Geneva; his "Gliion Sur Montreux" has a background of serrated Alpine peaks enhanced in effect by the water below; and No. 46, limned in the same neighbourhood, portrays the village, and detached by heaving clouds are mountain masses looming against the sky-line, an entrancing atmospheric effect very familiar to all visitors to the shores of Lac Lemman. Of the works of Mr. Walter Thomas the best is "Early Morning, Cornwall," a vision of a line of inhospitable granite cliffs viewed over a foreground of angry sea.

A SCULPTOR'S PHOTOGRAPHS OF REIMS CATHEDRAL BEFORE AND AFTER THE BOMBARDMENT.

An exceedingly interesting and exceptionally fine assemblage of large photographic pictures and studies illustrative of "The Glory that was Reims" is now on view in the Leicester Galleries, Leicester Square. The views were all taken by the cathedral sculptor, who has had charge of the statues and carvings of this church during the past twenty years prior to and since the Germans wrecked the building. The walls and screen of the gallery are devoted to the display of 113 subjects, but the entire series actually numbers 200 pictures, the remainder being shown in the folio or on the table in a second room.

The prints include general and detailed views of the building from different standpoints showing the church before the bombarding took away the roof and battered the windows and walls, besides smashing much of the sculpture. Several more recent photographs depict the fabric as it stands now, including bird's-eye views looking down on to the top of the nave groining left open to the sky and roofless. The northern portal of the west front in its denuded condition, No. 88, is a particularly well lighted and artistic photograph, the debris in the foreground adding much to its pictorial effect, "sad and sorry" as the destruction wrought on so grand a masterpiece must for ever be. No. 3, taken from the north-west, shows the cathedral of Reims in all its glory, with the pride of its western portals intact—perhaps the noblest example of Early Gothic in the whole of France, with its twin towers 267 ft. high.

A grand set of detail photographs, each 23 ins. long (Nos. 11, 12, 15, 16, 22, 23, 26, and 27), add much to the copious illustration of the iconography of the great porches, and these again are further elucidated by special studies of individual figures or parts, such as the pair of prints, No. 8 and No. 40, of "La Vierge de la Visitation," the former detail illustrating the lovely features of Our Lady and St. Catherine (more advanced in years), both modestly draped in a sculpturesque style almost Greek in the manner of its refinement. No. 17 of "Notre Dame de Reims," of which M. Rodin speaks in such unmeasured praise, shows the crowned head of "the Queen of Heaven," and the full length of the

infant Christ held on her arm. This exquisite statue has been badly mutilated by the German shells.

It is not easy to select special prints for notice where there are so many, and all so very good, but No. 6 for its subject—the Tympanum of the "Romanesque Portal"—has attracted much attention with its carved responds and angel filled semi-circular arch under which, in a recessed canopy panel, are seated the Blessed Virgin and Child. The set of three pictures hanging in situ 42, 43, and 44, furnish perspective pictures of the three great west portals. Nos. 49 and 85 are devoted to gargoyles. The first shows King David seated playing on the harp above the grotesque sort of rhinoceros with its metal-like treated snout. The second print illustrates in sharp perspective a series of cattle, with the lead lining of the troughs in their bodies neatly dressed over the masonry on top of each beast. The big heads of SS. Peter and Paul (62 and 66), from "The Portal of the Last Judgment," are immensely decorative and fine, and so are the caryatides of the west front. The interiors of the church, such as No. 7, of the northern transept, with the organ over the doorway, are very valuable as illustrations of the beauties now gone. Many readers will be glad to hear of this exhibition, which will remain open during August.

SCHOOL OF ARCHITECTURE EXHIBITION, UNIVERSITY COLLEGE.

An exhibition of students' work, done during the session of 1914-15, is on view this week up to Saturday next, the 24th inst., at 5 o'clock, in the school attached to the University buildings in Gower Street. All who are interested are admitted free of charge. We illustrated the new premises and studios specially erected for the School of Architecture not so long ago, and this is the first entire session held in this new building since its completion. This has not been a very propitious year, owing to the war, for the normal conduct and consequent success of any school devoted to the arts of peace. Professor F. M. Simpson's experience, however, has not been singular; on all sides we hear of young men having to leave their class-rooms and studios. This, therefore, must not be overlooked, though we are far from saying that this display is marked by indifferent merit or paucity in the amount of work accomplished even if brilliance in design may, perhaps, be said to be conspicuous by its absence. The average standard has, nevertheless, been maintained, and a highly creditable show is now made. The principal events recorded are the results of two competitions for prizes given by Sir William Lever for the encouragement of town planning, the scheme being divided into two stages under the newly founded Department for the study of this subject. No. 1, a scheme for a central railway station on the Surrey side of the Thames, and No. 2, for the "architectural development of a portion of the above." In the premier contest Mr. A. G. Wood is awarded the first prize of £15, and Messrs. H. N. Fisher and L. H. Shattock are bracketed as equal, the money prize being £10. The winners in the second competition are not by any means identical with the first, as Mr. H. N. Fisher takes the £15 prize, Mr. Ignace Reicher the £10 prize, while Mr. A. G. Wood has an hon. mention.

There appears to be some discrepancy between the station buildings' plans shown to the smaller scale on the town

planning lay-out scheme, and the plans worked out presumably as an architectural development to a much bigger scale. The portions thus amplified in neither case seem actually to correspond. The shapes of the block of buildings in the second stage appear to bear no reference to the planning of the station included in the first stage. The drawings are hung at the extreme ends of the great studio, very far apart from each other, and, therefore, are not easy to compare.

The station chosen by the winning competitors is intended to be built at Waterloo, an ideal problem formulated without regard to finance, and entailing several changes of enormous magnitude. It would hardly be possible to describe these designs in detail, except at great length, for which we have no space. Mr. A. G. Wood has conceived a very interesting and ingenious proposal for rearranging not only the station itself, but the contiguous railway system of lines and new approaches which would necessitate another bridge over the Thames from the Temple, the other two ways being from Waterloo Bridge and from Hungerford Bridge, all three roads being brought into a Grande Place fronting the station, the quadrant train tracks being behind Stamford Street and York Road. St. George's Circus would be reached by an inclined continuation of Waterloo Bridge Road going seemingly through a subway and emerging a good way down south, beyond the limits of the station rendezvous. We need not discuss this project further save to add that the scheme as such is quite worthy of the first place. Messrs. Fisher and Shattoch deal with the same problem rather differently, while some of the other town planning competitors have chosen Victoria Station or the G.W. Avenue island site at Shepherd's Bush, the King's Cross improvement, or the N. circular road at Hendon, much adroitness being displayed and serious solutions being fairly well aimed at, considering the early position of this Town Planning Department now in vogue at University College.

The most ambitious part of the exhibition is devoted to the enlarged designs for the railway station buildings, and it is a matter of regret that Mr. Wood happens to have come in third. Mr. H. N. Fisher's plan is accorded the prize, and it deserved this distinction. Waterloo Station, according to his scheme, would present an enormously long façade, the building being a detached rectilinear parallelogram, with a central entrance in front and secondary entrances at either return end. The chief portals consist of three semi-circular archways, with iron and glass weather pents projecting level with the springing course, and having a clock attached in the middle co-ordinate with the tympanum of the central opening. All this is very American in manner. There are three doorways to each arched span. Above the arcade rises an hotel with an Ionic colonnade of nine bays set between two pilastered pavilions, and finished off with an inconsequential-looking and shaped blocked skyline. Low side wing buildings extend right and left, with the attic-like plain walls and the semi-circular iron-framed roofs of the pair of big waiting-rooms well recessed behind the frontage-line. Each end of the whole frontispiece terminates with pilastered tower-like blocks, having similar archways below leading to the Customs departments. The ground stage is in keeping throughout, but it does not go well with the super-structure, which looks stilted. The plan is well lighted, and in many respects well thought out. The great central booking-hall encloses a particularly spacious ticket-office for the main lines services, the tube and suburban four ticket offices being in small square

places, one at either corner of this big enclosure. The waiting-halls, right and left, measure 206 ft. by 76 ft. each, with lofty proportions to match. Two wide, long corridors run the entire length of the building, and have cross exit doors, two in each flank, at the ends of the front restaurants. A pair of inquiry offices are placed in each corridor, with columned halls intervening behind them and set between the two big waiting-halls and booking-office. No seating accommodation is indicated on the plan, and we look in vain for the essential conveniences for travellers and their waiting friends. Restaurants, smoking-rooms, and ladies' toilet-rooms face the Grand Place, and men and women's lavatories (not suitable for closets) measure 45 ft. by 32 ft., with windows adapted for one room only. These are placed next the Concourse of the station, along which main side come the luggage and minor waiting-rooms, amply large enough, perhaps, for everyday needs without the big halls. At the ends are passengers' corridors and exits from the main lines. The company's station officials' offices are situate far apart at the ends of the building on the first and upper floors, cut off from each other rather seriously some hundreds of feet away. The entrances to the hotel are put on either end of the station entrance vestibule, which figures 136 ft. by 40 ft., so that all hotel visitors have to more or less mix with the traffic on going in and coming out, with their bags and baggage interfering with the hurrying public.

Mr. Ignace Reicher, who wins the second prize, has given his building a distinctly foreign appearance, with its vast semi-circular arches leading to the booking-office, set in the midst between two projecting wings, and measuring 60 ft. by 36 ft., with galleries round. Columned café and restaurant rooms flank this body of the premises, with adjacent waiting-rooms and such-like all crudely laid out, with a departure vestibule in front of the booking-hall and Concourse platforms at the ends of the premises, right and left for arrivals, far away from the ticket-procuring places. On the main Concourse are two four-square detached blocks of buildings, consisting of waiting and retiring rooms. The elevation is poorly and heavily coloured. There is a fairly good detail, but the figures for sculpture are indifferently drawn. No hotel is attached to this station.

There are only two other designs, Mr. A. G. Wood's being given an Hon. Mention. His is by far the better of the pair; indeed, we prefer his scheme to the plan placed second. Architecturally, it is more English, consistent, and refined. A fifth elevation in pencil is shown, but seemingly it has no plan, for none is exhibited.

The "first year's students' work we thought commendable, and we noticed some almshouses and homes for the aged in a Georgian style by Messrs. H. W. Cash and C. C. Nauth-in, the latter's work being based upon the well-known Blackheath type of similar housings. The post-office at Wells is shown carefully measured up and plotted, also a good sheet of pen-and-ink details of the chapel door, Greenwich Hospital, but the authors names of these drawings were obscured.

A memorial, erected by subscription, to the late Dr. Mungle, physician, who for over twenty years practised in Kinross and district, has been unveiled at Kinross. The memorial consists of a drinking fountain, surmounted by a bronze portrait bust of Dr. Mungle, which was designed and executed by Mr. John S. Rhind, sculptor, Edinburgh, and is erected on a site at the corner of Graham Street and Swansacre.

ARCHITECTURAL ASSOCIATION PRIZE WORKS EXHIBITION

On Friday last the annual awards were announced and the collection of students' drawings exhibited to public view in the Royal Architectural Museum, Tattenhoe Street, Westminster, as the result of the year's course in the London School of Architecture. The display, at first so numerous as heretofore, is certainly very reassuring, and though a good number, including some of the more brilliant men, have been called away on military duty, the work done in their absence is workman-like and highly creditable, judging by this present exhibition. The prizes awarded are not given for any individual competition design upon which a special effort is concentrated, but are taken in recognition of the merit displayed by the winners throughout the whole session. Sustained effort is in this way encouraged in accordance with the system inaugurated long ago at the Architectural Association, and we need hardly say it has always had our warm approval.

THE A.A. TRAVELLING STUDENTSHIP

is taken by Mr. Wilfred C. von Berg, a gentleman of Dutch extraction resident at Croydon, but who has recently left the school to join the English forces. The subjects of his designs, common to the whole of the students in the third-year course, are those set from time to time by the master, Mr. Robert Atkinson, F.R.I.B.A., or perhaps by the assistant-master in this grade, Mr. L. H. Bucknill, A.R.I.B.A. These problems necessarily are varied, and not necessarily of a *tour de force* character, though perhaps more than often of rather a monumental kind, as, indeed, seems inevitable. The reserve displayed by Mr. von Berg is one of his essential merits, and the reason, perhaps, of his success; while his draughtsmanship is excellent, based on the Parisian model. The triumphal arch he submits has a bronze equestrian group of six horses in a chariot surmounting the composition, which displays a pair of trophies on the face of the main walls. The Lord Roberts Memorial consists of a truncated obelisk of elegant outline and detail. The arched courtyard shown for an Italian palace steers clear of marked originality which too frequently degenerates into the bizarre. The entrance proposed for a museum has twin columns of a Composite order, with bronze doors and standard lamp-like bronzes flanking the portal. Another ambitious project is the plan of a council house, with division lobbies at the sides and a members' hall behind the council chamber. Coming down to more mundane matters, Mr. von Berg has designed a small country house having a large common or living room, with a loggia opening into the garden, and the dining-room leading out of the living-room—an excellent idea to save service and space, provided the meal-place is not too large and is really more like an alcove. This plan suffers from insufficient light to the common room, which is sacrificed to the façade, so as to obtain breadth. The result is somewhat stilted elevationally, and the landing is wasteful. The exterior is in stock bricks, with red vertical divisions, presumably "Georgian." Mr. G. B. Tubbs' house on the other wall is a more practical scheme, if we except his dark store out of the kitchen, with no ventilation, and object to the size of the bathroom, considering the restricted narrow shape of one of the bedrooms. The dining-room in this plan is a separate apartment. Before ending with Mr. von Berg's set, we may allude to his venetian flag-staff sketch, with the rams' heads round the metal base and swags on each

face below. The cemetery tomb set in a tree above is not exhilarating, with the pair of arms at the ends of the plinth. The memorials of the departed should rather aspire to indicate life eternal and express at least a hope in futurity. So many monuments look like refrigerators.

THE JARVIS STUDENTSHIP of £40 is deservingly awarded to Mr. C. J. Brandon, who is represented by a capital set of drawings, not perhaps quite so accomplished in style as those by Mr. von Berg, but workmanlike and neat. His over-strewn bridge connecting two public buildings is quiet and unpretentious, and this quality also is observably in the bridge set for a public square stream, though perhaps some of these latter designs on view are apt to approach the commonplace. Mr. Brandon's elevation for an art-dealer's shop and street facade in stone is well thought out. The swags over the doorways would be better away. The Andrew Ouyver prize of £5 5s. is taken by Mr. F. P. M. Woodhouse, whose work is distinctly creditable. His time study for a brick-burner's room in front of a big courtyard is worth naming, done as it was without help, and we rather prefer his art-dealer's street front with the marble treatment on the ground floor round the shop, and we like the iron balcony over, below the three-arched windows on the first floor.

Mr. J. C. C. Bruce over-emphasises the length of his lintel or hidden garder above the shop opening by including both the side doors into the one wide-spaced space which he divides up with bronze uprights, adding some horizontal bars which dwarf the effect where more height is wanted. The upper handling of this front is on the right lines. The Italian palace courtyard by Mr. G. B. Tabbs is one of the best and the street front sent by Mr. C. Reixa is studied on old 18th Century lines, though the big spandrel window on the second floor might make many difficulties inside, above the triple lights below, divided by Ionic columns. Mr. G. B. Tabbs is more spirited than some with his bridge having an Italian pavilion or covered way very open at the sides. His cemetery tomb sketch is fetching and forcible, but the trees suggest a site in a vast park where land is of no moment. The pretentious baldachino for a cathedral high altar by Mr. T. C. Evans is too ambitious, not to say a bit out of hand, with its twisted columns and gilt roocco canopy very out of drawing.

IN THE SECOND YEAR CLASS

Mr. A. Hodges carries off with *gloria* the Howard Collis prize of £15 15s. His banqueting-hall overlooks a formal garden and marble-enclosed pool, with rather attenuated columns to the side verandahs. The study of a courtyard after Mansart and the court of a French chateau are very praiseworthy on right lines of study. His thatched cottage is pleasing, but whether a compact and almost cube-shaped cottage is suitable for thatching seems doubtful, the material suggesting a haystack or a long, rambling, quaint sort of building. Mr. W. P. Wigglesworth is a clever student with an excellent design for the dining hall in a park, though it is no doubt over-rich with the range of statues above the parapet and columns between the windows. The Italian Renaissance composition of an arch showing Santa Maria della Salute at Venice beyond in the distance makes a good drawing for a student's trial. We noticed Mr. G. A. Galsworthy's chateau front of XVII. date, with the arched entrance, all well studied on precedents. Mr. P. M. Hill's

French dining-hall design in brick and stone has end pavilions breaking the roof, but they scarcely project enough for that. The orangery by Mr. W. E. de Souza and another by Mr. P. E. V. Mauger deserve attention, but Mr. Hodges's orangery is the best, and his details are workmanlike. The Entrance Scholarship drawings by Mr. J. L. Shepherd admit him to the school, and so does the winning of the Banister Fletcher Scholarship by Mr. Jean Godwin.

PRIZE DISTRIBUTION AT THE A.A. SCHOOL OF ARCHITECTURE.

The annual meeting for the distribution of the prizes gained by the students of the Architectural Association School of Architecture was held at 13, Taitton Street, S.W., on Friday afternoon. Mr. H. Austen Hall, F.R.I.B.A., the President of the Association, occupied the chair, and owing to the depletion of the school by war conditions, there was a much larger number of old members of the Association and friends of the students (including about a dozen ladies) than of young men.

In opening the proceedings, the President remarked that since they met for a prize distribution twelve months ago much that was then unexpected had happened, and their School of Architecture had been greatly affected by the war. At the very outbreak of hostilities, early in August, they lost by recruiting for our new forces four masters and about fifty students out of the seventy then on the roll. Fresh students came in during the session; but many of these and others of those who remained were drawn away by the recruiting officers in the next room, so that they were now reduced to five-and-twenty, none of whom were eligible for service on one ground or another. Some of those still with them had tried three or four times, but without success, to enlist. The year had thus been one of exceptional worry to all concerned for its usefulness and success, and they had furthermore a difficulty in arranging lecture courses on account of the absence of masters and the constant diminution of and changes in the students. Under the unprecedented circumstances, the quality of the work that had been turned out was remarkable. The standard and character of the work had been well maintained; the masters and men had alike set themselves to their studies with determination, and the Council were gratified, nay delighted, with the outcome, and thankful to Mr. Robert Atkinson, head-master, and his capable staff for what had been accomplished. Some of the masters and men had been granted commissions in the Army, and others had as loyally served their King and country in the ranks. There was a sad side to the subject in the casualties reported. From their first-year men, Mr. R. W. Wilson had been killed, from their second-year students Mr. J. D. S. Orbell was reported wounded and missing, and the Hon. Anthony Methuen was wounded; from their third-year class Mr. H. A. Ryan and Mr. J. H. Jacob were wounded, and two members of the evening school, which he might incidentally mention had been necessarily suspended during the war, Mr. T. W. Donald and Mr. H. D. Ainsworth, had been killed. Addressing himself to the students present, the President continued: The great object of all study is to reveal truth, and to you as students it is also to obtain a standard of judgment and of comparison, whereby to carry on, at a high level of thought, the art of your day. You who come into our school here are surrounded from the first day of your entrance into the school with the presentation of the finest known works of architecture. You have in the masters who direct your studies men who are enthusiasts, men who put their work before everything else. It is not surprising, therefore, if you find enthusiasm comes easily to you, and, above all, if it comes soon. Those of us who have had these advantages are fully aware of the incalculable value they will be to you, and through you to the development of architecture in this country. Most earnestly would I say to you. Do not be discouraged by those who criticise the tendency in modern design, and throw their theories like red herrings across your path. Have absolute confidence in your teachers

and in yourselves, and do the best that is in you. On the foundation of the culture you are acquiring the future of your art will be sure. Your ceaseless efforts must be to express the highest conception of design you have yet received, and to accept no lower standard than the best in whatever work you undertake.

Mr. H. M. Fletcher, hon. secretary, read the following list of prizes and studentships, awarded by the Council, which were distributed to the students by Mrs. Austen Hall.

FIRST YEAR: First Prize, value £1 10s., V. J. Wenning; Second Prize, value £1 1s., H. E. Mills. Prize for Greatest Improvement, Volume of A.A. Sketch Book, F. A. McEvoy. Special Prize, Volume of A.A. Sketch Book, W. B. Lancer.

SECOND YEAR:—"Howard Collis" Travelling Studentship, value £15 15s., A. Hodges. Second Prize, value £3, W. P. Wigglesworth. Prize for Greatest Improvement, value £2, W. E. de Souza. Master's Prize, F. W. Haindrie. Special Prize, volume of A.A. Sketch Book, P. V. E. Mauger. The Association Two-Year Course Certificate is awarded to the following students:—G. R. Galsworthy, F. W. Haindrie, A. Hodges, P. M. Hill, P. V. E. Mauger, W. E. de Souza, and W. P. Wigglesworth.

THIRD YEAR:—A.A. Travelling Studentship, value £25 5s., W. C. Von Berg. Andrew Oliver Prize (value £5 5s.) and President's Prize (value £5 5s.), F. P. M. Woodhouse. Book Prize, value £5, F. Reixa. Book Prize, value £2, N. F. C. Day. Master's Prize, J. C. C. Bruce. Master's Prize, G. B. Tabbs. Vacation Prize, value £1 1s., F. P. M. Woodhouse. Vacation Prize, value £1 1s., C. J. Brandon. "Jarvis" Scholarship, value £40, C. J. Brandon. Special Prize, two volumes A.A. Sketch Book, L. H. Hutton.

FOURTH YEAR:—Special Prize, value £5, R. A. Duncan.

A.A. Essay Prize, value £10 10s., T. C. Evans. A.A. Entrance Scholarship, value £52 6s., J. L. Shepherd (Charterhouse).

"Banister Fletcher" Studentship, value £25 5s., Jean Godwin.

The following have been recommended for Third Year Certificates of Exemption from the R.I.B.A. Intermediary Examination:—N. F. C. Day, G. B. Tabbs, F. P. M. Woodhouse, and F. Reixa.

Mr. Ernest Newton, A.R.A., P.R.I.B.A., in proposing a vote of thanks to Mr. Austen Hall, said he feared that Mr. Hall, in giving him that privilege, thought that as President of the Royal Institute he not only ought to be able to speak with authority on the future of architecture and the aims to be pursued in teaching students, but that it was his duty to do so. Unfortunately, election to the chair at 9, Conduit Street did not carry with it in his case a gift of tongues or prophecy. He had seen in his lifetime so many movements all of which were said to be destined to be permanent, but which had had their day and passed away, but at the risk of appearing to shirk his task of pronouncing *ex cathedra* on a subject which all of them thought about and which none of them considered they had yet solved, he should confine himself to a few general remarks. Was he not right in assuming that vaguely they had in their minds that some form of Classic was the right thing for large monumental buildings? For churches they balanced between a Classic and a Gothic form, according to their temperament. In designing houses they left themselves the greatest latitude. That in itself should be enough to show that architects now in practice had by no means made up their own minds. Speaking for himself, his admiration for the teachers of architecture who would keep their heads and pursue a definite aim amidst this confusion knew no bounds. They had to teach composition, construction, and the forms and features of every known style from the Parthenon to the buildings of the nineteenth century, which architecture had been so much "revived" as to be practically moribund. One often saw in modern Classical buildings certain radical errors which he was sure were never acquired at the Architectural Association. For instance, a building of several stories which was merely a nest of smallish rooms of moderate height was often treated like a temple with columns and entablature complete. Let them examine the plan, and they would see how perversely ingenious the architect had been

in getting windows for his rooms behind the entablature. Now surely all would agree with him that however fine the proportions and delicate and learned the details of such a building might be, it was wrong as architecture. Then, again, this same type of building would have charmingly designed features, pavilions, pediments, and so forth, apparently marking something in connection with the plan, but comparison with that plan would show that they were merely stuck on as part of a composition. A.A. students would never do that when they were entrusted with the edifices of the future. They would always, he was sure, cast their buildings in a gracious mould and make their composition express the purpose of the fabric. He was sure that students at 18, Tufton Street were taught to analyse all the features of the various buildings on which they based their essay designs, and were made to understand that those features belonged only to that particular building where they occurred, or to one of a like nature, and ought not to be annexed, as part of the designer's stock-in-trade as an architect, to appear in all the buildings he might be called upon to design in the future. Another point was that modern buildings generally had as many features to the square inch as old ones had to the square yard—even more sometimes. It was a great art to leave out—not because one did not know what to put in—but because one did not want to put it in. In designing a building, the indiarubber was often a more useful and valuably ally than the pencil. He had not touched upon the influence that material must have upon design, nor had he alluded to the necessity for grappling with a problem and solving it fairly and squarely without tricks and subtleties. Even if the result was ugly, it would at least be true. As for the study of modern planning, that was a chapter by itself, and he must not venture to refer to it in a vote of thanks. There must, for instance, be a best arrangement for all the departments of municipal buildings, just as there was for the parts of a ship—the right kind of entrance, the best position for the council chamber, and so on. If all this could be standardised, what a simple task a competition would be! All that the architect would have to do would be to perfect perfection. When one considered how much there was for an architect to learn, it was almost incredible that anyone should have the courage to begin. Indeed, to be serious, there must be something in the discipline of an architect's training that made for courage and a sense of duty. Some sixteen hundred members of the profession had given up all their prospects as architects to become soldiers, and no doubt before next session opened many more would have followed their gallant example. Many architects had already died for their country, but no one who died for his country had lived and died in vain. They could not tell what the future had in store for them, whether next year there would be any prizes and prize-giving, but that afternoon the front was engaging their attention, and in very cordially proposing a vote of thanks to Mr. Hall he was to be allowed also to congratulate the prizewinners.

Mr. Arthur Keen, past-president, seconded the vote of thanks. As a member of the Board of Education he had examined the testimonies of study submitted by candidates, and had been impressed by the high standard of the designs sent in from the Tufton Street School and by the capable grasp of the problems shown by the students. The quality of the A.A. School work reflected the greatest credit on the teaching of Mr. Robert Atkinson and of his assistants. He felt that their headmaster was the right man in the right place. Students who loyally and industriously worked in the School were laying a very good foundation for a successful career in future years.

In memory of his late wife, Dr. Godfrey Lowe has given to St. Peter-at-Gowt's Church, Lincoln, an oak altar table, which has been made by Mr. C. R. Lucas, builder, Sibthorp Street, Lincoln, in keeping with the design of some of the late Mr. Hodgson Fowler's work in the chancel.

BUILDING NEWS DESIGNING CLUB.— A GARDEN PAVILION.

On the whole possibly "September Morn" presents the more attractive and picturesque design. His drawings are set out well on the sheet of paper, and the building bespeaks its purpose unmistakably. We also must give him credit for the superiority of his perspective sketch, because in a competition of this kind among students a recognition of draughtsmanship ought to obtain its due. We would rather select a good building indifferently drawn than a poor building merely adroitly delineated in a chic sort of manner. The general rule, however, is that good drawing and good design synchronise. We are not likely to place too much stress upon draughtsmanship per se, neither are we overlooking the painstaking care displayed in the execution of the geometrical elevations submitted by "Walbroke." He is mostly workmanlike, and neatness induces accuracy of detail. Qualities of this sort are highly praiseworthy and indispensable. The treatment and manner or style distinguishing the proposal placed second, if not exactly of a high order, bears comparison in many ways with the design sent in by his confrère "September Morn." Hence some diffidence in arriving at our ultimate selection for the premier place, not that we doubt this decision as a proper conclusion. Some may question its rightness and others may consider we had little choice, which is true enough. In some particulars the layout of "Walbroke's" façades is preferable, specially in the spacing of the west end, where the arched opening more consistently forms part of the sturdy rusticated plinth. The casual fashion of the arch treatment adopted by the other designer is not altogether happy. At the same time, "September Morn" has realised our intention by making the long side of this summer house overlook the lake, which is, of course, its principal prospect. The conditions are distinct enough. They provide that the approach to the pavilion is to be on the land side, with a way down to the boat shelter under the entrance steps. No mention whatever is made of the land end. The building properly ought to present its main façade to the east, to be viewed from the owner's house over the water. The pavilion, in fact, is considered as part of the property in question. By thus setting out the boathouse alongside of the shore of the lake a much wider creek is insured than could be possible when the waterway is reduced by its contiguity with the much more restricted end of the building. The conditions mention an environment of willow trees, common to such a site, close to the pond. The "pictures" of both these designs avoid such specified ambrosial details. "Walbroke's" perspective in this respect looks derisive, and the foreshore as shown might be mistaken for the rag end of a litter heap or perhaps a bit of a disused slate quarry. By locating the building the wrong way round about with reference to the lake he has made his scheme somewhat irrelevant.

Undue importance must not be attached to incidental matters such as pictorial draughtsmanship. Still we cannot refrain from acknowledging that neither of these perspectives precisely display the eagerness proper to a "sketch," and all sketches ought to be artistic, even if only roughly so. It is too common a fault with many that they set up to be "artistic" without being artists. The word "artistic" has been tabooed by architectural professors who reckon themselves authorities beyond a doubt, and the term for that reason by a certain cult is banned. No other word, however, actually expresses what is intended. Success depends upon the artist being possessed of his subject before it can come off, and the work must not express a trifling mood, however slight in execution the work may be. It must have some true grit about it and evince a force compelling its expression. "September Morn," limited by his conventions and laboured effort in design, has yet to comprehend architectural relevance and dignity in composition. Correctly speaking, he fails by non-attention to detail. Thus he gives us nondescript windows instead of mullioned windows bargained for. The spacing of his lights is not in conformity with what is customary to expect, and when he does employ mullions the result falls short of

any improvement upon the ordinary way of setting out window openings. A window in the middle of the bay and a mullion modified his proportions and added character, thus justifying itself. The fenestration in "Walbroke's" scheme is in a more consistent. "September Morn" brings the importance of another item, viz., where the chimney in the back elevation rises above the broad and quoined fire-place breast projecting between the two doorways. The mullion emphasises the position by breaking round, as it must do, to preserve the full section throughout. This solitary smoke flue in consequence appears to be stuck on, and looks paltry and thin, set up in this mean, awkward fashion. By omitting to include a back elevation "Walbroke" fails to show his method of managing this same little ticklish detail so conspicuous on the "off side" of his building. The end elevation submitted by him does, however, include a stone-topped ramp, pediment, or something of that kind to ease off the architectural lines, but as to how this is actually to be done we are left to conjecture. We have noticed the inconclusiveness displayed by the elevations of the design which we have put first. For instance, the author has not made it clear whether the brick facings really run through to the reveals of the windows or not. He has been at some pains to show the headstones and sills in rather an ostentatious or, shall we say, emphatic manner, and so the inference would be that masonry dressings to these openings are intentionally omitted. If this be so, the upper and lower blocks of stone would suggest a spotty effect in execution, and particularly so should white stone be used for the lintols and sills, and the difference of colour happen to be intensified by employing strong and self-assertive red bricks for the walling. The importance of texture materials is frequently overlooked, and not enough care is taken in setting out the proportions of solids to voids in architectural conceptions. These deductions may doubtless be elementary, but certainly architects seldom realise their consequence, and likewise omit to avoid the objectionableness of spotty masonry or of fussy detail. Faults like these result from a want of native artistic sense. Party colourings are considered handsome, and vulgar contrasts appeal to the ignorant, who know no better, but architects ought to do so. The colour blind are hopeless whatever pretensions they make to capacity in designing.

The pair of doorways in the pavilion by "September Morn" are not in accord with the dignity of the double set of steps and terraced approach. The effect seems inconsequential, and by starting the stairways close up to these openings the result is not only awkward, but positively dangerous. The boathouse landing stages provided in this design look more serviceable and furnish better access to the boats, which in consequence are less cramped for room than in "Walbroke's" shelter, with its "art w" "end on" allowance of space. The latter scores a point, however, by sliding his iron gates back, right and left, on the main face of the plinth wall. His competitor has saved himself the fag of thinking out such incidental requirements, and he also has not bothered to show how the projecting external face of his plinth comes in relation to the extrados member of his arch where the set-off dies on to the segment of the opening. These minor details and various things serve to constitute the pros and cons about these designs creating the doubts already alluded to in ascertaining their relative merits in this little contest. The proportions and general effect of the roofs and clock towers tell in favour of "September Morn." With this conclusion the parapet to the elevation submitted by "Walbroke" has a direct concern. The absence of rainwater heads and down pipes scores, on the other hand, against the scheme which we put first. An eaves guttering is drawn by "September Morn," but he rests content and we are uninformed as to how the water gets its discharge. Carelessness of this kind is blameworthy. Big stack pipes and deep cesspool heads to match, figure in "Walbroke's" drawing, and we suppose the tubes turn in through the wall above the

plans, by the use of water into boat house plan. The interior treatments, so far as we can gather from the sections of these two plans, may be taken, on the average, as about equal, and we reckon, both are rather ineffective and uninteresting. The symmetrical repetition of the windows in the second plan of building might be expected to insure a more dignified result, as the other plan leaves too little wall space for the windowing. We are disappointed with both proposals in this respect, and the ceilings, of which the conditions made a special note, are very poor. The circular disc in the middle of "Walbrooke's" ceiling is common-place and out of accord. Access to the clock is secondary, provided for in each scheme, with space for the bells and chiming gear.

This is the concluding subject of our Club's work for 1914-15, and although the problem was the easiest proposed during the past annual session, the number of designs submitted happens to be by far the smallest ever known since the Building News Designing Club commenced about forty years ago. For this time of the year the proposal was reasonable enough, but owing to "the emergency period" through which things are passing an abnormal abatement in the work of the members was only to be expected. Their energies have naturally enough been diverted from the pursuit of the arts of peace to the patriotic task of helping forward the defence of hearth and home. In so far as this particular competition for a Garden Pavilion is concerned, though "the spring tide has been torn out of our season," the situation was saved by the receipt of the two capital schemes sent in by "September Morn'" and "Walbrooke," whose well-sustained endeavours to the last merit unstinted approbation, seeing that they both made time to compete notwithstanding their many other engagements.

The following is a copy of the conditions issued for the guidance of members: A Garden Pavilion at the end of a lake, which also is to form a shelter for small rowing-boats, the approach to boat-house being formed by a small creek flanked by willow-trees, which do not encroach upon the level site, the shore being 4ft. above the water-line. The floor of the pavilion to be 5ft. above the ground, and reached by stone steps, the treatment architecturally to be Georgian, in red brick and stone. Quiet dignity in design is required, and the roof, covered with green slates of graduated sizes, is to show, and a simple clock turret, with chimers, may rise from the ridge, and be covered with lead. The size of the pavilion inside to be 30ft. by 15ft., with a fireplace, and below, a fuel store of small dimensions to be provided. Inside the walls of the pavilion to be panelled in oak, and a decorative plaster ceiling is intended, with frieze, but not too ornate. The windows to be mullioned in stone, and have metal casements. The boat shelter to have wrought-iron gables above the water line, and small mooring timber stage at the back inside, with approach from the land side under the pavilion steps. Ssde 4ft. to the inch. Two plans, three elevations, and one section, with perspective sketch, taken from the lake side. The building will face east, and can be seen over the water from the house to which the property belongs. The accompanying drawings suffice to indicate the attractive character of this undertaking, which lends itself to a pretty inventiveness by affording scope for the imagination and display of unassuming taste without unduly taxing effort or calling into requisition very much specialisation. However, like most simple things, a garden pavilion is not quite so easy a subject as would appear at first sight. Such an occasional and monumental structure demands a degree of reserve coupled with a cultured appreciation of architectural attainments.

The site, as regards to the uses of the building, is in sympathy with its immediate surroundings. The view, itself is so small that it requires to be handled in a big way without being ostentatious. All straining after novelty of forms and style has to be avoided, and not trifling with the inherent detail is allowable. Such a formula may be reckoned, perhaps, as ideal, and we do not claim that the designs now put forward exactly or even

approximately reach that standard. Both the competitors rank very closely, and considering the plans on their merits a perspicuous decision was hardly likely; indeed, as we have said, some difficulty occurs in stating reasons for a preference in favour of either.

THE NATIONAL FEDERATION OF BUILDING TRADES EMPLOYERS OF GREAT BRITAIN AND IRELAND.

The half-yearly general meeting of this federation will be held at the Masonic Hall, Great George Street, Leeds, on Wednesday, the 28th inst., at ten in the forenoon, to deal with the business mentioned on the agenda.

1. Notice calling the meeting.
2. Minutes of last annual meeting, held January 27, 1914, and business arising, if any.
3. Welcome to representatives from colonial and foreign federations.
4. Report.—In accordance with decision of a former meeting, a short interim report will be submitted to the meeting and published in the N.F. Record.
5. Consider recommendations from yesterday's council on the following matters:—

- (a) Report on apprenticeship question.
- (b) Report on contract conditions with local authorities.
- (c) Resolutions of the National Board of Conciliation.—

1. "That this board, recognising the difficult position in which both employers and workmen in the building trade find themselves, in consequence of the high cost of materials on contracts taken before the war, and of the high cost of living in consequence of the war, recommends that the National Federation take into consideration the position with a view, if possible, of employers granting some special assistance, where circumstances may justify it, to their workmen before winter comes in, and that the reply of the federation be considered at a special meeting of this board to be held in Yorkshire on July 29."
2. "That the United Builders' Labourers' Union be admitted to membership of the conciliation boards wherever working rule agreements exist between branches of the N.F.B.T.E. and the United Builders' Labourers' Union, subject to the approval of the parties at present affiliated to the scheme."
3. "That the Electrical Trades Union be admitted to membership of the conciliation board wherever working rule agreements exist between branches of the National Federation of Building Trades Employers and the Electrical Trades Union, subject to the approval of the parties at present affiliated to the scheme."

- (d) Reference from conference on proposed national scheme for demarcation committees.—"That the scheme as amended be recommended to the approval of the various parties, with a request that a return of the result be made in time for the October meeting of this board."
- (e) Application from the Bricklayers' Society (London Order) for readmission to the conciliation scheme.
- (f) Any other recommendations from the executive council.
6. Next meeting.
7. Such other business as may be presented by the president.

Provisional Programme.—Tuesday, July 27, 10 a.m.—Meeting of the Administrative Committee, at the Masonic Hall, Great George Street, Leeds. 2.30 p.m.—Executive Council meeting same place. 8 p.m.—Reception by the President of the Yorkshire Federation to representatives of E.C. and G.M. and their ladies. Wednesday, July 28, 10 a.m.—General meeting at the Masonic Hall. 1.30 p.m.—Luncheon to members and their ladies.

The headquarters of the gathering will be at the Queen's Hotel, City Square, close to station, where a special tariff has been arranged for members.

ARTISTS' WAR RELIEF EXHIBITION.
An exhibition of pictures and drawings is being arranged by the Imperial Art League and the Royal Institute of British Architects jointly, to be held in the Galleries of the Royal Institute in Maddox Street, for the benefit of painters and architects who are suffering from the effects of the war. It will be opened on Wednesday, July 28, and will remain open for some weeks after that date. As far as the Royal Institute is concerned, it is proposed to divide the exhibits into two classes: (a) Works given to be sold for the benefit of the War Relief Fund of the Architects' Benevolent Society (these may be works by the donor or by any other artist); (b) works by architects sent to be sold for their own benefit. No distinction will be made in the catalogue. All architects,

therefore, who have saleable water-colour, pen-and-ink, or pencil drawings or etchings are invited to send them to be sold either in class (a) or class (b). All works should be distinctly marked (a) or (b). A small percentage will be deducted from all sales to cover expenses. As the time for making the necessary arrangements is very short, and the number of drawings for which space can be found cannot yet be ascertained, it may not be possible to hang all that are sent in; but it is proposed to remove drawings when they are sold and to hang others in place of them, in order to show and sell as many as possible. Exhibitors are asked to send to Mr. Harry Redfern, the hon. secretary, 9, Conduit Street, W., a list of the drawings they propose to submit, with the prices to be asked. Drawings illustrating buildings in Belgium or Northern France would be likely to find purchasers. All works not sold will be returned to their exhibitors.

OBITUARY.

The death is announced at the age of 70 of Mr. Lewis Sheppard, who was in practice as an architect in Worcester from 1876 until 1905, when he retired. He built and restored many churches in the Midlands, enlarged the Grammar School at Bromsgrove, and restored, after a disastrous fire, the Elizabethan mansion of Severn End, the seat of the Lechmere family. His last work was to plan the Laslett Almshouses in the city of Worcester. He was succeeded in his practice by his elder son, Mr. George Lewis Sheppard, A.R.I.B.A., of Worcester and Folkestone, now on active service with the Royal Engineers.

Mr. Ralph Dain, retired architect, died on July 11, at his residence, Liverpool Road, Burslem, within eleven days of his 86th birthday. Mr. Dain had lived in Burslem for over sixty years and had planned some important public buildings in Leeds and Manchester, as well as many in the Potteries. He was one of the oldest freemasons in Staffordshire.

Captain George Pigrum Bowie, L.R.I.B.A., 5th Batt. 1st Canadian Contingent (Vancouver) fell in action on July 7, aged 54. He was the eldest son of Mr. and Mrs. A. H. Bowie, of 9, Bernard Gardens, Wimbledon, and was in practice when the war broke out as an architect at 705, Bank of Ottawa Buildings, Hastings Street West, Vancouver. He joined the Royal Institute of British Architects as a Licentiate in 1911.

The death is announced of Mr. Gerard Wight, of Melbourne, who for many years was a Fellow of the Royal Victorian Institute of Architects. A Victorian by birth, he was born in 1860; educated in Melbourne, and in 1886 took his degree as M.C.E., in the Melbourne University. Prior to taking his degree, he was engaged in survey work on the railway line to Ballarat via Bacchus Marsh, under Mr. Cussen (now Judge Cussen), and was afterwards articled to Messrs. Smith and Johnson, architects, of Melbourne. In 1885 he won the first prize for the design for the Merri Creek Bridge, which was afterwards built under his supervision. For some years he was in partnership with Mr. Wm. Lucas, architect, carrying on business under the name of Wight and Lucas. In 1891 he went to Europe with his late principal, Mr. Johnson (who became, subsequently, the President of the Institute). Mr. Wight's last important work was the Geelong Church of England Grammar School, for which he and Mr. Phillip Hudson had gained the first prize in a public competition, and the work just completed was carried out under their joint supervision. For many years Mr. Wight held a seat on the Council of the Royal Victorian Institute of Architects, and in 1912 he was elected President. In conjunction with Messrs. Henderson and Little, he also represented the Institute upon the Faculty of Engineering at the Melbourne University. He had been unwell for the past year, and died suddenly on May 8, at his residence, Church Street, Hawthorn. He was unmarried.

The parish church of the Mumbles, Glam., is being restored at an estimated cost of £11,000.

THE LONDON COUNTY COUNCIL REGULATIONS FOR REINFORCED CONCRETE CONSTRUCTION.*

(Continued from page 34.)

Splays and Brackets at Ends of Beams and Bracketed Work.

70. Where the end of a beam is splayed for the purpose of increasing the resistance moment, such splayed work shall not be calculated at a greater angle than 30 degrees from the horizontal.

BRACKETS.

71. In cases where bracketed work in reinforced concrete is provided in the structural design to carry loads, and to act as a cantilever, it shall be reinforced sufficiently to provide for the stresses due to such loads.

SLABS.—EFFECTIVE DEPTH.

72. The effective depth of slabs shall be measured from the compressed edge of the constructional concrete to the centre of gravity of the tensile reinforcement. In the case of floor slabs the effective depth shall not be less than three inches.

DIAMETER OF BARS.

73. The least diameter or thickness of independent reinforcing bars in slabs shall not be less than one quarter of an inch.

WIRES.

74. The wires under tensile stress in connected mesh and similar reinforcement in slabs shall be at least one-tenth of an inch in diameter or thickness.

SPACE BETWEEN BARS.

75. There shall be a distance of at least one inch between bars in slabs except at joints and at points where the bars are in direct contact and transverse to one another.

76. All meshed reinforcement shall be of such dimensions as will enable the coarse material in the concrete to pass easily through the meshes of such reinforcement.

77. The maximum distance between bars or strands of the tensile reinforcement in slabs shall not be greater than 12 inches, and not more than twice the effective depth of the slab.

DISTRIBUTING BARS.

78. In cases where independent reinforcing bars are provided in one direction only, distributing bars shall be provided on the top of the lower tensile bars at right angles thereto. Such distributing bars shall not be further apart than 18 inches, and shall have an aggregate cross sectional area of at least 0.08 per cent. of the effective cross sectional area of the slab; or the diameter of each of the distributing bars shall be at least 1-16th of the effective depth of the slab, and the pitch of the distributing bars shall be not greater than four times the effective depth of the slab.

WIRING.

79. Wiring used in slabs for the purpose of holding bars in position shall not be regarded as reinforcement.

RESISTANCE MOMENTS.

80. The resistance moment of reinforced concrete construction under transverse loads shall be determined by formulas based on the following assumptions—

- (a) All tensile stresses shall be taken by the steel.
- (b) The strain in any layer or fibre is directly proportional to the distance of that layer or fibre from the neutral axis.
- (c) The tensile elastic modulus of steel shall be assumed to be equal to the compressive elastic modulus of that material. (See regulation 53.)
- (d) The elastic moduli of the concrete remain constant within the limits of the working stress.
- (e) The stress-strain graph is a straight line.
- (f) The anchorage, together with the grip between the concrete and steel, is sufficient to make the two materials act together.

* Sub-headings and italic cross references do not form part of the regulations.

† NOTE.—Five inches is the least thickness for fire-resisting floors in the principal Acts.

NOTATION FOR BEAMS AND SLABS.

- 81.—
- A = area of tensile reinforcement, in square inches.
- a = arm of the resistance moment, in inches.
- B = bending moment of the external loads and forces.
- b = breadth of rectangular beam in inches, or breadth of the flange of a tee beam in inches, or breadth of slab in inches.
- c = permissible compressive working stress, at the extreme edge of the concrete in compression, in pounds per square inch.
- d_c = total depth of slab in inches.
- d = effective depth of the beam or slab in inches.
- e = distance from the compressed edge of the constructional concrete to the common centre of gravity of the tensile reinforcement.
- E_c = elastic modulus of concrete in compression.
- E_s = elastic modulus of steel in tension or compression.
- l = length of the effective span of a beam or slab.
- m = $\frac{E_s}{E_c}$ = modular ratio. (See regulation 54)
- n = distance of the neutral axis from the compressed edge of the constructional concrete of the beam or slab, in inches.
- n₁ = $\frac{n}{d}$ = neutral axis ratio, i. e., n₁ = d = n.
- p = percentage of tensile reinforcement = 100r.
- Q = qualifier in the equation R = Q b d².
- R = resistance moment generally.
- R_c = resistance moment of the internal stresses in the beam or slab in terms of the permissible compressive working stress.
- R_t = resistance moment of the internal stresses in the beam or slab in terms of the permissible tensile working stress.
- r = ratio of A to b d, i. e., r = $\frac{A}{b d}$ and A = r b d.
- s₁ = slab depth ratio = $\frac{d_c}{d}$.
- t = permissible tensile working stress, in tensile reinforcement, in pounds per square inch.
- t₁ = ratio of the tensile stress in the steel to the compressive stress at the extreme edge of the concrete under flexure = $n \left(\frac{1}{n_1} - 1 \right)$.
- W = total weight, or working load.

Beams and Slabs.

BREADTH OF FLANGE.

82. For the purpose of computing the resistance moment of a tee beam, the breadth of the flange shall not be taken at more than—

- (a) One-fourth of the effective span of the tee beam;
- (b) The distance between the centres of the ribs of the tee beams;
- (c) Twelve times the thickness of the slab;

whichever is the least.

(Also see regulations 45 and 46 as to combined stresses in beams, slabs, and other members.)

83. In the case of T (ell) beams the breadth of the flange shall not be taken at more than four times the thickness of the slab, provided that where the moments due to the eccentricity of the compression are adequately provided for, the width may be increased, but not beyond one-half of that allowed for T (tee) beams.

BREADTH OF RIB.

84. The minimum breadth of the rib of a T (tee) or T (ell) beam shall not be less than one-third the depth of the rib below the slab. (Also see regulation 66.)

85. Rectangular beams shall be secured against buckling whenever the length of the beam exceeds 20 times the least width thereof, or whenever the length of the beam exceeds 30 times the least width measured from outside to outside of the outermost longitudinal reinforcement.

SLAB REINFORCEMENT.

86. When a part of a slab is taken as forming part of a tee beam, the reinforcement in the slab transverse to the beam must cross the full breadth of the portion of the slab forming the flange of the tee beam.

NEUTRAL AXIS WITHIN THE SLAB.

87. In the case of slabs, rectangular beams and tee beams reinforced in tension only when the neutral axis is within the slab, i. e., tee beams in which r is less than

$$\frac{s_1^2}{2m(1-s_1)}$$

(a) The position of the neutral axis shall be obtained from the equation—

$$n_1 = \sqrt{(m^2 r^2 + 2m r) - m r}, \text{ or}$$

$$n_1 = m r \left[\sqrt{\left(1 + \frac{2}{m r}\right) - 1} \right]$$

$$n = \left[\sqrt{(m^2 r^2 + 2m r) - m r} \right] d$$

(b) The mean compressive stress in the concrete be taken at $\frac{c}{2}$

(c) The arm of the resistance moment shall be obtained from the equation—

$$a = d - \frac{n}{3}, \text{ or}$$

$$a = d \left(1 - \frac{n_1}{3}\right), \text{ or}$$

approximately, for tee beams, $a = d - \frac{d}{3}$

(d) The tensile resistance moment at every cross section shall be at least equal to the bending moment at that section and shall be obtained from the equation—

$$R_t = t A \left(d - \frac{n}{3} \right), \text{ or}$$

$$R_t = t A d \left(1 - \frac{n_1}{3} \right), \text{ or}$$

$$R_t = t r b d^2 \left(1 - \frac{n_1}{3} \right)$$

$$R_t = Q b d^2 \text{ where } Q = t r \left(1 - \frac{n_1}{3} \right)$$

(e) The compressive resistance moment at every cross section shall be at least equal to the bending moment at that section and shall be obtained from the equation—

$$R_c = \frac{c}{2} b n \left(d - \frac{n}{3} \right), \text{ or}$$

$$R_c = \frac{c b d^2}{2} n_1 \left(1 - \frac{n_1}{3} \right), \text{ or}$$

$$R_c = Q b d^2 \text{ where } Q = \frac{c}{2} n_1 \left(1 - \frac{n_1}{3} \right)$$

NEUTRAL AXIS INTERSECTING THE RIB.

88. In the case of tee beams, reinforced in tension only when the neutral axis intersects the rib, i. e., tee beams in which r is greater than—

$$\frac{s_1^2}{2m(1-s_1)}$$

(a) The position of the neutral axis shall be obtained from the equation—

$$n_1 = \frac{s_1^2 + 2m r}{2(s_1 + m r)}$$

(b) The mean compressive stress in the concrete shall not be taken at more than

$$\left(1 - \frac{s_1}{2n_1}\right) c$$

$$\frac{c m r (2 - s_1)}{s_1^2 + 2m r}$$

(c) The arm of the resistance moment shall be where

$$a = d \left[1 - \frac{n}{3} \left(\frac{3 + 2}{2n_1 + s_1} \right) \right]$$

$$a = d \left[\frac{s_1^2 + 4m r s_1^2 - 12 m r s_1 + 12 m r}{6 m r (2 - s_1)} \right]$$

$$\text{or approximately } a = d - \frac{d}{2}$$

(d) The tensile resistance moment at every cross section shall be at least equal to the bending moment at that section, and shall be obtained from the equation

$$R_t = t A a, \text{ or}$$

$$R_t = t b d^2 \left[\frac{s_1^4 + 4m r s_1^3 - 12 m r s_1 + 12 m r}{6 m (2 - s_1)} \right]$$

or $R = Q/b$ where

$$Q = \left[\frac{s_1^2 + 4mrs_1^2 - 12mrs_1 + 12mr}{6m(2 - s_1)} \right]$$

The compressive resistance moment at every cross-section shall be at least equal to the bending moment at that section, and shall be obtained from the equation

$$R = c \left(\frac{1}{2n_1} \right) i d_1 r$$

$$R = c \left(\frac{1}{2n_1} \right) \left[\frac{s_1^2 + 4mrs_1^2 - 12mrs_1 + 12mr}{6(s_1^2 + 2mr)} \right]$$

or $R = Q/b$ where

$$Q = \left[\frac{s_1^2 + 4mrs_1^2 - 12mrs_1 + 12mr}{6(s_1^2 + 2mr)} \right]$$

COMPRESSIVE REINFORCEMENT.

89. In sections reinforced in compression due allowance shall be made for the depth of the compressive reinforcement from the compressed edge of the beam.

90. The equations in Regulations 87 and 88 may be used in conjunction with Regulation 61 when the compressive reinforcement is located at or near the centroid of compression in the concrete.

BEAMS SUPPORTING OTHER BEAMS.

91. In the case of a beam supported at its end by a transverse beam—

a. Longitudinal bars of the supported beam shall be continued across to the further side of the supporting beam, and the ends of the bars shall be hooked.

b. The whole shear shall be provided for by the tensile resistance of the shear or web reinforcement acting in conjunction with the compressive stresses in the web.

c. Provision shall be made to resist any torsion in the supporting beam, and to resist any negative bending moments on the supported beam, but the positive bending moments on the supported beam shall be calculated on the assumption of ends being freely supported.

92. At the ends of beams supporting transverse beams the bars shall be so arranged as to give the same margin of safety as required by Regulation 91.

NOTES ON DRAWINGS OR DIAGRAMS.

93. Notes shall be added to the drawings or diagrams of all beams and pillars showing the loads which have been provided for.

PART IV.

PILLARS AND OTHER STRUTS.

94. The term "strut" when used in these regulations shall be deemed to include any compression member at any angle.

95. The term "pillar" when used in these regulations shall be deemed to include any pillar, pier, post, column, detached support, or any other vertical compression member.

96. Pillars shall be designed on the assumption that the concrete and the vertical bars are shortened in length in the same proportion.

RATIO.

97. In calculating the strength of a pillar the maximum ratio of length to gyration radius or the maximum ratio of length to effective diameter shall be taken.

LENGTH.

98. The length shall be measured between the lateral supports, irrespective of any splayed work in excess of that allowed as part of the beam by Regulation 70.

EFFECTIVE DIAMETER.

99. The effective diameter shall be measured to the outside of the outermost vertical reinforcement, and shall be measured in the direction of the lateral supports which determine the length of the pillar.

REINFORCEMENT BINDING.

100. All pillars shall be provided with vertical and lateral reinforcement.

101. Each pillar with rectilinear laterals binding shall have at least four lines of vertical reinforcement throughout its entire length.

102. Each pillar with curvilinear laterals binding shall have at least six lines of vertical reinforcement throughout its entire length.

103. The least diameter of rectilinear laterals (binding) shall not be less than 3-16ths of an inch.

104. The least diameter of curvilinear laterals (binding) shall not be less than 1/8 in.

105. (a) The pitch of the laterals (binding) shall not exceed 6-10ths of the effective diameter of a pillar of any part of its length or sixteen times the diameter of the least vertical bar.

(b) At the ends of a pillar for a length equal to one and a half times the effective diameter the pitch of the laterals (binding) shall not exceed 5-10ths of such effective diameter.

106. The lateral reinforcement (binding) shall be firmly secured at each end.

107. The volume of lateral reinforcement (binding) shall not be less than 0.5 per cent. of the volume of the hooped core.

VERTICAL BARS.

108. The diameter of vertical bars shall not be less than 1/2 in. or greater than 2 ins.

109. The total cross-sectional area of the vertical reinforcement in any pillar shall not be less than 1.0 per cent. of the area of the hooped core.

JOINTS.

110. Joints in the vertical reinforcement of pillars shall only be made at or adjacent to a floor level or other point of lateral support.

111. In all joints in the vertical reinforcement there shall be provided an overlap at least equal to twenty-four times the diameter of the upper bar.

In cases where there may be tension in the pillar, the ends of the bars shall be formed as required by Regulation 48.

RECTANGULAR PILLARS.

112. In the case of rectangular pillars in which the ratio between the greater and the lesser diameter exceeds one and a half, the cross-section of the pillar shall be subdivided by cross-ties, and the number of vertical bars shall be such that the distance between the bars along the longer side of the rectangle shall not exceed the distance between the bars along the shorter side of the rectangle.

NOTATION FOR PILLARS, STRUTS, AND OTHER COMPRESSION MEMBERS.

- 113 —
- A = effective area of pillar, i.e., the area bounded by the lateral reinforcement (binding) measured to the inside of the hooping.
- A₁ = cross-sectional area of one bar of the binding or lateral reinforcement.
- A_v = area of the vertical reinforcement.
- c = permissible direct compressive stress. (See regulation 42.)
- d = effective diameter. (See regulation 99.)
- f = form factor, depending upon form or type of binding or laterals. (See table in regulation 118.)
- g = gyration radius of the area [A + (m - 1) A_v] about an axis passing through the centroid of the area.
- i = increased stress permissible in the core of a pillar suitably hooped.
- l = actual length of the pillar as defined in the regulation numbered 98.
- m = modular ratio = $\frac{F_s}{E_c}$. (See regulation 54.)
- P = permissible load or pressure on pillars with both ends fixed and with a ratio of virtual length to gyration radius not exceeding 45. (See first column of figures in regulation 122.)
- p = percentage of volume of binding or lateral reinforcement with respect to the volume of hooped core in any given length of pillar = $100 V_1$.
- pb = pitch of the binding or lateral reinforcement.
- s = spacing factor depending upon the spacing or pitch of the binding or laterals. (See table in regulation 118.)
- V₁ = volume ratio or ratio of the volume of binding or lateral reinforcement to the volume of the hooped core in any given length of pillar. (See regulations 116 and 117.)
- r = virtual length of the pillar, strut or other compression member for different conditions of the ends. (See regulations 122 and 124.)

FIXED ENDS.

114. A pillar or other strut shall be deemed to have fixed ends when the ends are sufficiently secured to other parts of the construction having such rigidity as will maintain the axis at the ends in its original position and direction under all loads less than the crippling load.

(To be continued.)

Major General Peter Pierce L. O'Connell, for many years an executive engineer in the Public Works Department of the North-East Provinces, has died at Bromley, Kent, aged eighty-eight. He retired so far back as 1878.

Building Intelligence.

WESTBURY PARK, BRISTOL.—The Right Rev. Dr. Forrest Browne, as Commissary for the Bishop of Bristol, consecrated on Sunday week the east end of St. Alban's Church, including the chancel and a chapel dedicated to St. Oswald. The western portion of the church, consisting of nave, north and south aisles, and transepts, was completed in 1909. The work at the east end now nearing completion consists of the choir and sanctuary, a chapel on the south side, and vestries for choir and clergy on the north. The external stonework is in Brently limestone. Internally the chancel and chapel are lined with ashlar work. The total length of the building is 150 ft. and the width across the transepts 75 ft., the height to the apex of ceiling of chapel being 37 ft. above the chancel floor. The reredos in the chapel is of Beer stone. The total cost has been about £13,000. It is hoped in the near future to complete the tower at the north-east corner, the height of which will be 86 ft. above ground level. The contractors were Messrs. Pittard and Sons, Unity Street, Bristol, and the architects Messrs. E. G. Rodway, A.R.I.B.A., and C. F. W. Dening, F.R.I.B.A., Gaunt House, Orchard Street, Bristol.

WEYMOUTH.—At a meeting of the Weymouth Town Council the Advisory Committee reported that they had accepted the tender of Messrs. Pattinson and Sons, Limited, of 50, Parliament Street, Westminster, for the erection of 115 houses on the Pye Hill estate for the sum of £32,722. For the erection of thirty tenements on the Granville Road estate the tender of another firm was accepted, but on the tender being withdrawn Messrs. Pattinson were approached, and they agreed to take over the contract for £6,445. The Pye Hill scheme was subsequently reduced from 115 to 96 houses, and the contract price brought down to £27,024. Each house or tenement is provided with a bath, and has hot and cold water supply. It is the intention of the committee that the houses on each estate shall be lighted by electricity if arrangements can be made.

PROFESSIONAL AND TRADE SOCIETIES.

NOTTINGHAM AND DERBY ARCHITECTURAL SOCIETY.—On Friday, July 16, about twenty members accepted the invitation of Mr. W. V. Betts, architect to the Nottingham Co-operative Society, to inspect the steel construction and fireproof flooring at their premises now being erected in Parliament Street, Nottingham. Mr. Betts explained the plans and drawings and then conducted the party over the building. The front in Parliament Street will be in buff terra-cotta with large display windows. At the conclusion of the visit, the president of the society, Mr. Harry Gill, complimented Mr. Betts on his carefully thought out building, and thanked him for so fully describing the points of construction.

WATER SUPPLY AND SANITARY MATTERS.

BALLYMENA.—In order to increase and improve the water supply to the town of Ballymena, derived from mountain springs some eight miles distant, it was recently determined to construct an additional 7-in. cast-iron main 4,800 yards in length from the storage reservoir to the filters. The pipes will be cast in three thicknesses, which will be tested after being laid to static heads of 450 ft., 600 ft., and 700 ft. respectively. Owing to the high velocity of flow in the main, pressure relief valves are provided on the up-stream side of the various sluice valves. Messrs. James Ross and Sons, of Belfast, have taken the contract at £5,097, the engineers for the extension being Messrs. Swiney and Croasdale, M.M.Inst.C.E., of Belfast.

The town council of Dartmouth have approved the recommendations of the Water Committee with a view to carrying out suggestions in the report of Dr. St. George Mivart, Local Government Board inspector, with respect to the water supply.

Our Illustrations.

FIVE HOUSES IN FROGNAL LANE AND GREENAWAY GARDENS, HAMPSTEAD, N.W.

These houses, grouped together, are both commodious and picturesque. The sketches reproduced herewith are on view at the Royal Academy Exhibition this year. The buildings occupy a well-wooded and exceptional site in a very favourite part of Hampstead. Mr. Cyril A. Farey is the architect, and the owner, Mr. George W. Hart, of "The Drive," Hampstead, has erected all of these residences. We quote as an item of general interest the prices allocated for each house. The first perspective on the top left-hand corner of the double page inset plate represents "Erskine House," Greenaway Gardens, and herewith in the text we reproduce the ground and first-floor plans. The setting out is somewhat original, centring round an octagonal hall with a vista from the front door. The staircase window on the west lights the hall, and the roomy loggia is a useful feature in the lay-out. Purple and brown stock bricks are used, with red dressings and tiled roofs. The situation is on the crest of the hill, and the balanced front is of Queen Anne character. The kitchen premises are well isolated and on the other side of the house is a garage. The dining-room measures 24 ft. by 18 ft., the drawing-room 24 ft. by 21 ft., and the library 18 ft. by 15 ft. There are four bedrooms on the first

side of the plan page is shown the lay-out of this house. The fine position is taken advantage of in the contrivance of the rooms, which are insured the maximum of sunshine. The plan is disposed on broad lines, simply managed, with the entrance set well back from the road and the reception rooms get a view of the garden at the rear. Brick treatment is adopted, much being made of bold chimneys. The drawing-room is 27 ft. by 20 ft., library 18 ft. by 15 ft., and the dining room 22 ft. by 16 ft. Five bedrooms occupy the first floor and two maids' rooms are in the roof. The price is £3,575, with a ground rent of £46. The last perspective to the right hand of our illustration is an effective sketch of "Greenaway Corner." The plans will be found to the top left-hand of our single page. A view of Froggnal Lane is commanded from this spot midst some very handsome old trees in an ideal position facing south-west. The north and east winds are screened by rising and well timbered grounds beyond. The comparatively small size of this house is distinguished by spacious apartments, commodiously considered. The dining-room scales 23 ft. long by 15 ft., facing west, and having a garden door in the north wall. The drawing room is figured 25 ft. by 15 ft., with a due south aspect. The library is 16 ft. by 12 ft. The hall is a wide corridor and the staircase is obscured from observation from the main entrance. There are seven bedrooms and a pair of bathrooms. Space remains in the ample garden for a garage

accommodation has been provided. The first floor. Wash-house, room, room, 22 ft. by 12 room and passage, central hall, front and model kitchen, pantry, dining hall, 22 ft. room, administration, 10 ft. by 10 ft. store. Mezzanine between ground and first floor. Lavatories. First floor. Study, 12 ft. by 10 ft., embroidery, dressmaker, 10 ft. by 10 ft., English class room, and a sitting room for the staff. Second floor. Millinery, 12 ft. by 10 ft., English class room, assembly hall, and a store for materials. The whole of the roof has been planned to secure a much sunlight as possible, having regard to the use of the respective rooms. The external walls are faced with red sand-faced bricks; the window openings have steel casements with lead panes. The roofs are constructed with fir common rafters, oak purlins and principals, and are covered with red sand-faced tiles. The principals are exposed to view. The floors are constructed of steel and concrete, and generally are finished with deal boarding, the laundry wing, kitchen, and dining hall having wood block flooring. The internal walls are plastered, and the classrooms and trade rooms have a wood dado 3 ft. 6 in. high. The kitchens and the laundry wing have a glazed tile dado 5 ft. high. The warming of the building is by steam radiators. Behind the radiators are inlets for the admission of fresh air, and near the ceiling level are gratings communicating with air ducts. The foul air is extracted by means of electrically driven fans. The external staircase at the southern end of the

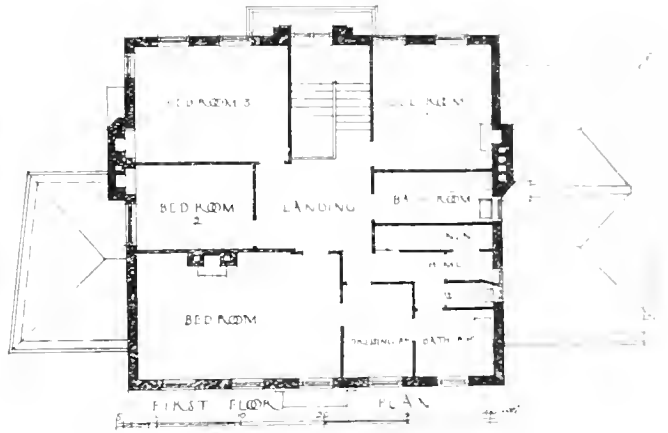
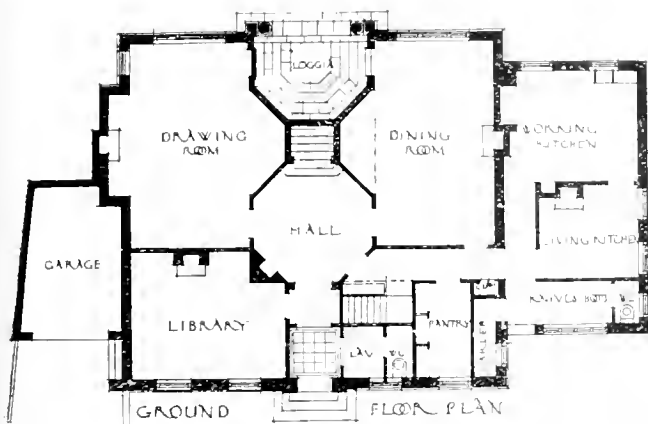

ERSKINE HOUSE, GREENAWAY GARDENS, HAMPSTEAD.

floor and three more above. The price is £3,650, with £50 ground rent. The right-hand top view shows "Tramore" in Froggnal Lane. Its plans are set forth on the upper right-hand corner of the single-page sheet of plans. This is not really a large house, but contains some adaptable facilities, such as either a big drawing-room or a billiard room and general lounge. The dining room, 21 ft. by 15 ft., accommodates a party without crowding, and has direct service. There are plenty of cupboards. Five bedrooms and two bathrooms on the first floor, with the servants' quarters above. The double-fronted exterior is in variegated red bricks, somewhat similar in treatment to the house already named. The price is £3,300, with £42 ground rental. "The Corner Chimney House," Froggnal Lane, occurs on the lower left corner of the inset page of views, and the two main floors figure in the lower corner to the right of the single page illustration. The contrivance is not common and a picturesque group is the result. The angle-set porch leads to an octagon, with the staircase facing the entry. The drawing-room, 26 ft. by 15 ft., is very sunny and projects in front, the best bedroom and bathroom en suite being placed over same. The dining-room, figures 22 ft. by 15 ft., and the library 18 ft. by 12 ft., looking towards the road. There are eight bedrooms and a garage. The price is £2,975, and a ground rent of £38, for which there is a fair-sized garden. The middle picture represents "Varley's," in Greenaway Gardens. At the bottom left

£3,200 is the price, and a ground rental of £50.

DETAIL OF OCTAGON TO TOWER, CHURCH OF ST. MARK, WHITE-CHAPEL, E.

The pinnacles and upper part of the octagon surmounting the tower of this church were exceedingly crude and unsightly, and, having become dilapidated, it was decided to take down the overhanging portions and other parts which appeared dangerous, and erect thereon a structure more in character with an ecclesiastical building. We reproduce the working drawings. The encasing of the tower has been carried out. The additions begin from the stone weathering which terminates the rectangular brick buttresses at the four corners of the tower, the central brick octagon remaining as formerly. The upright posts and cusped stays at the angles of the octagon, also the lantern and traceried corona surmounted with pinnacles and cusped openings, are all in teak. Mr. John Medland and Mr. H. Hardwicke Langston were joint architects for the work. Messrs. Harris and Wardrop were the contractors.

L.C.C. TRADE SCHOOL FOR GIRLS, LIME GROVE, HAMMERSMITH.

This building is partly three stories high and partly one story. The latter, which forms the northern wing, has been built with the external walls of sufficient thickness to carry an extension of the same height as the central block. The school is for training girls in various trades, and the following

building affords an alternative means of escape in case of fire. The building has been designed by and carried out under the supervision of the superintending architect to the London County Council, Mr. W. E. Riley, F.R.I.B.A., R.B.A., M.I.C.E., the contractors being Messrs. W. Lawrence and S. G. The design and plans constitute, we think, one of the most successful examples of the schools erected by the London County Council, and certainly the most economical advantage of the system of construction adopted has been obtained without any sacrifice of legitimate architectural effect.

A GARDEN PAVILION.

The description of these designs for a garden pavilion submitted in connection with the Building News Designing Club will be found in our Reference's report on another page.

A new police station is being built at Bishopsgate, Kent, at a cost of £6,500. The architect is Mr. James F. Johnson, F.R.I.B.A., Brandon Chambers, Hammersmith.

The urban district council of Farnham have received the general approval of the Local Government Board for the borrowing by the Council of £15,240 for works of sewerage and sewage disposal.

Mr. J. K. Lancashire, I.C.S., who is on special duty in connection with town planning, has visited Ootacamund to confer with the Government of Madras on town planning matters generally, and on the lines of action to be taken. The Sanitary Commissioner of Madras is also taking part in the conference.



HOUSES IN FROGNAL LANE AND GREENAWAY GARDENS HAMPSTEAD.

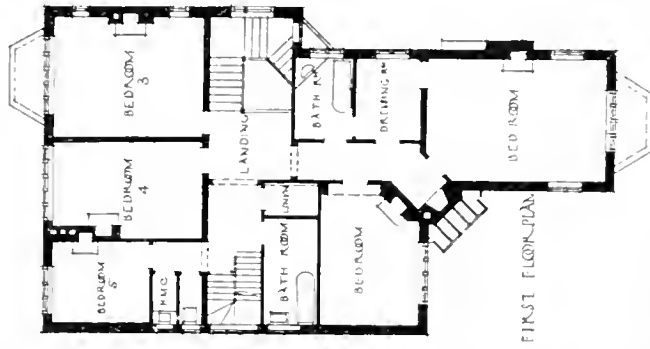
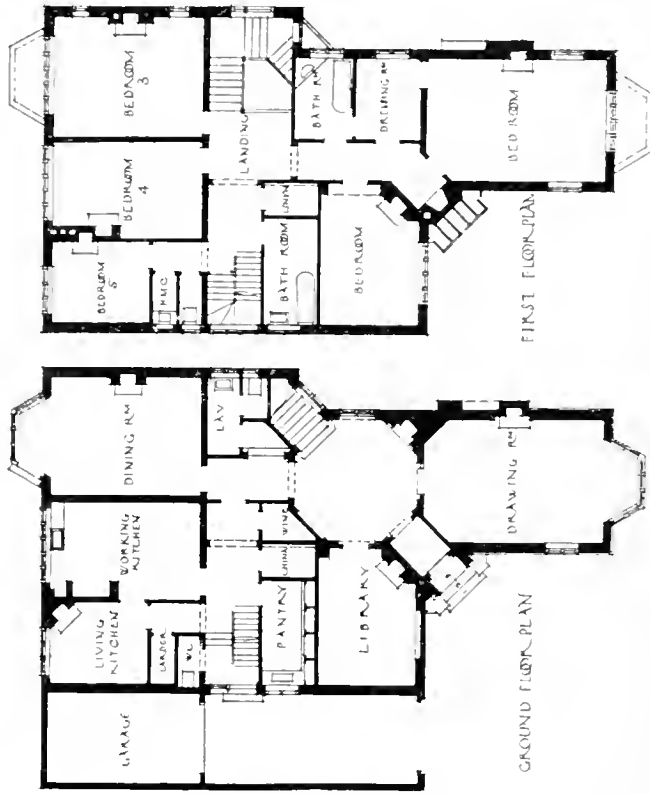
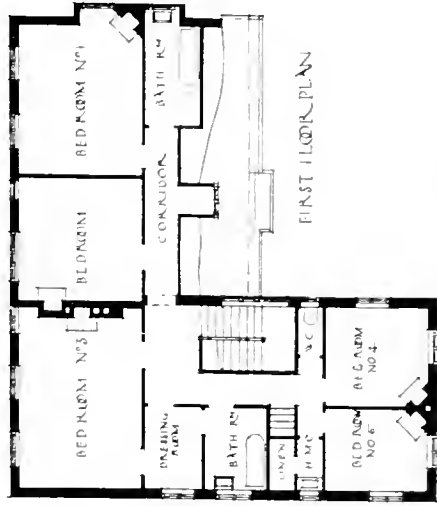
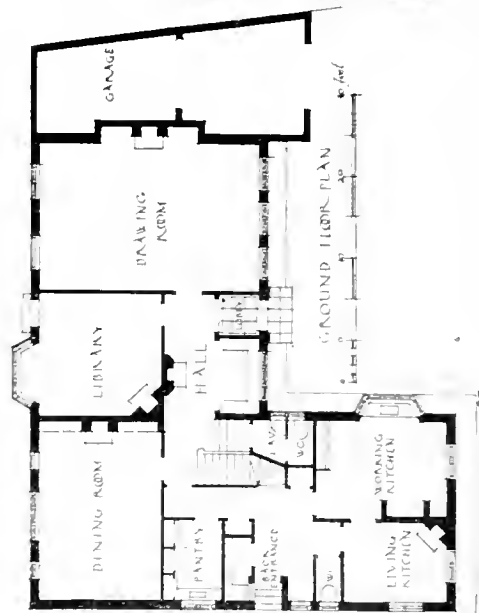

M^S CYRIL A. FAREY ARCHITECT 1915

FOUR HOUSES IN FROGNAL LANE AND GREENAWAY GARDENS, HAMPSTEAD, N.W.

(Plans reading from Left to Right:—"Greenaway Corner," "Tramore," "Varleys," and "Corner Chimney House.")

Mr. CYRIL A. FAREY, Architect.

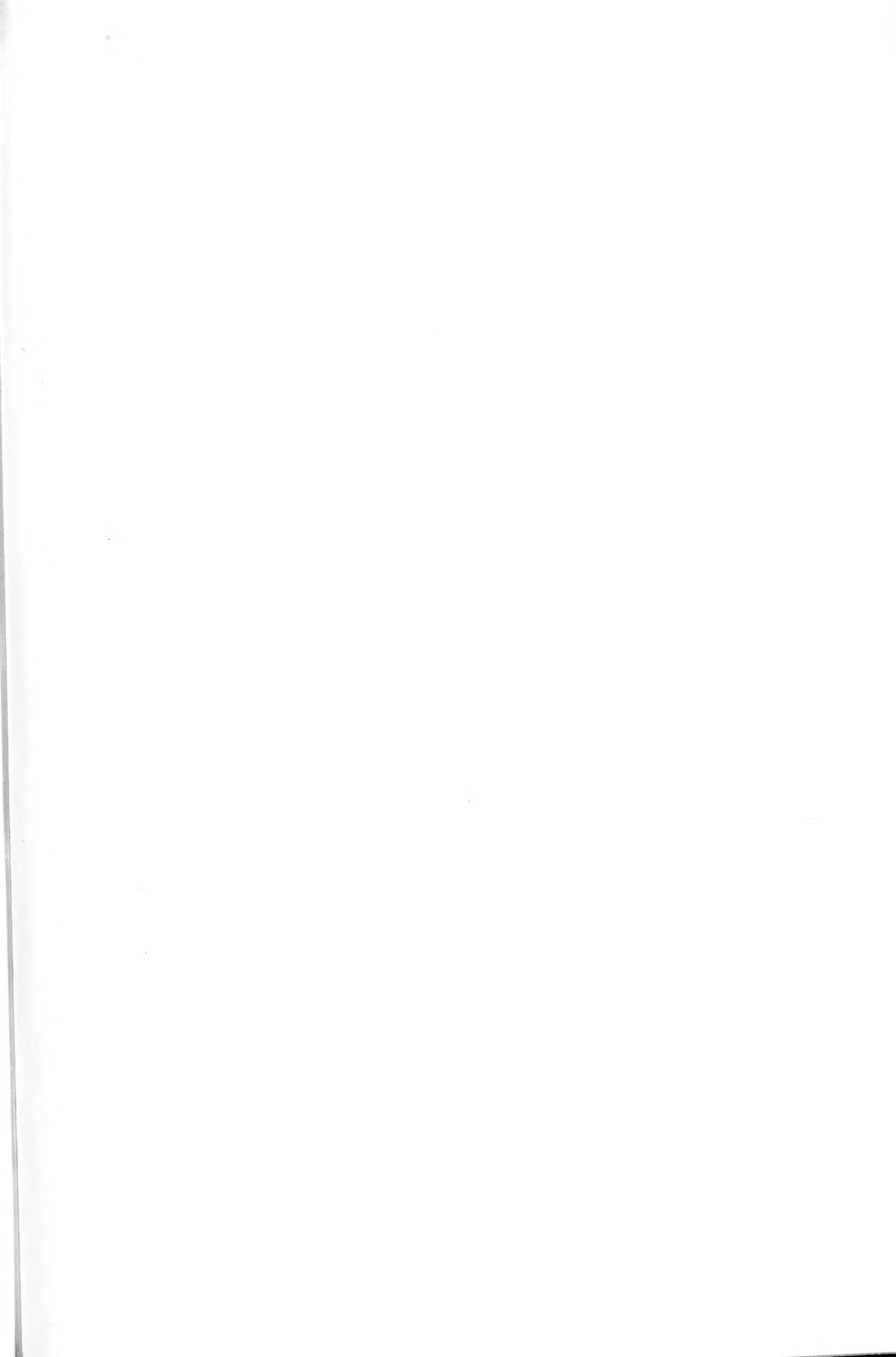

PLACED FIRST

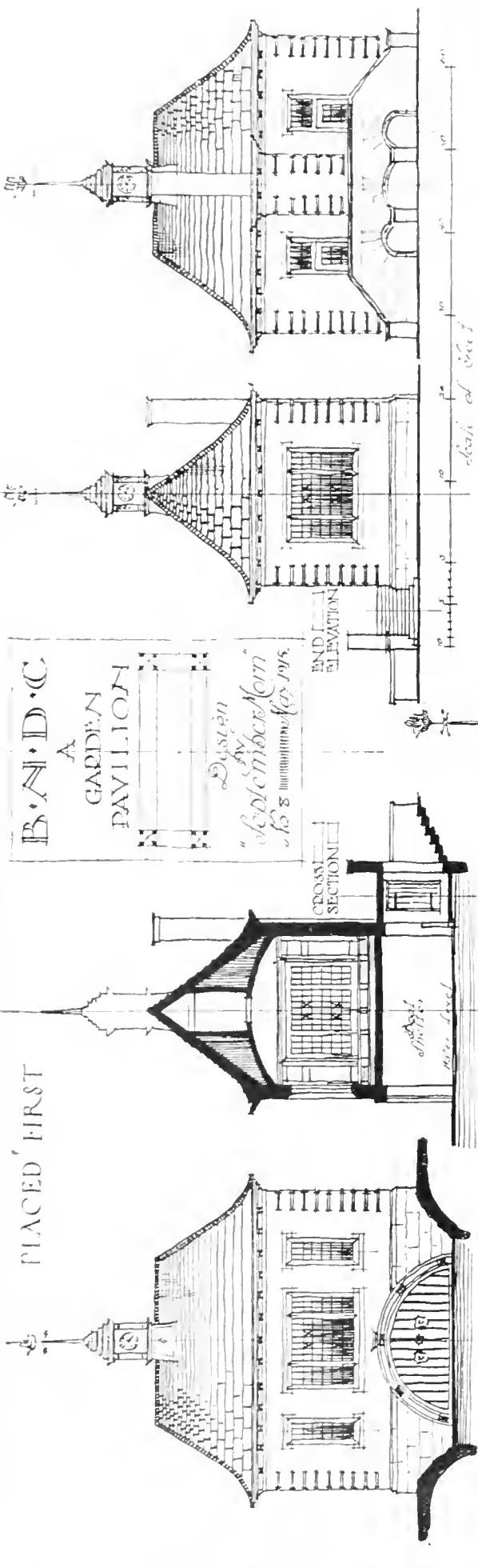

ELEVATION TO LAKE

BACK ELEVATION

CROSS SECTION

END ELEVATION

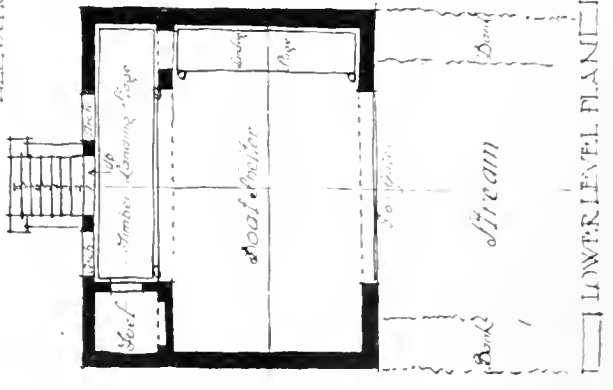
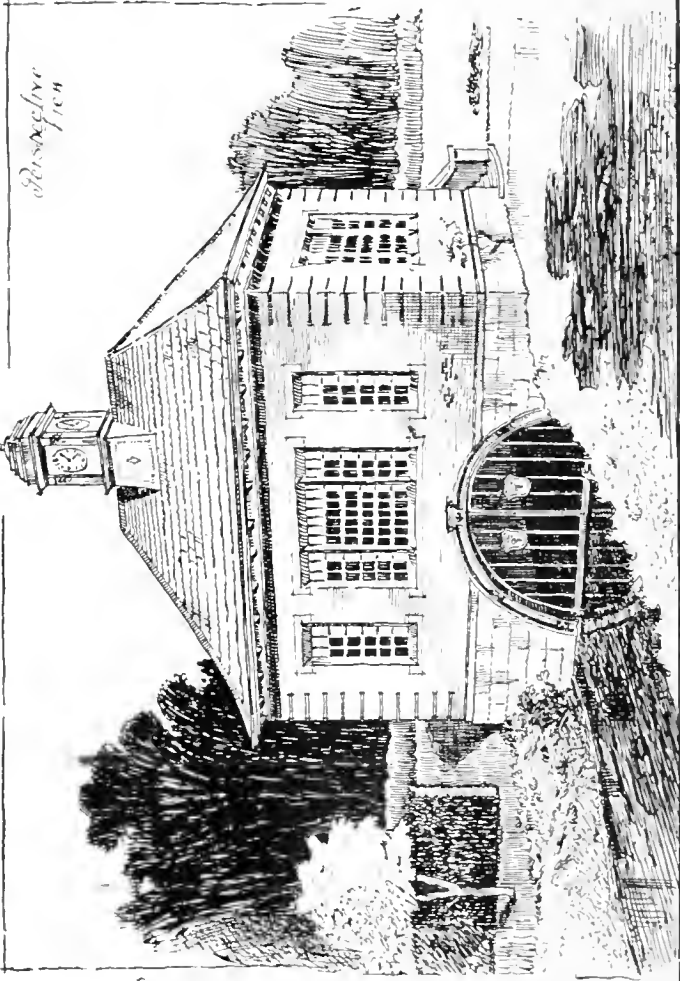
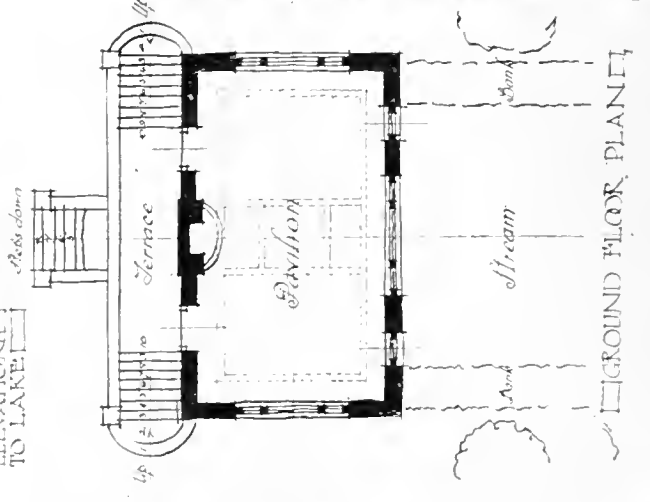

"BUILDING NEWS" DESIGNING CLUB. A GARDEN PAVILION.—Design by "SEPTEMBER MORN," placed first,

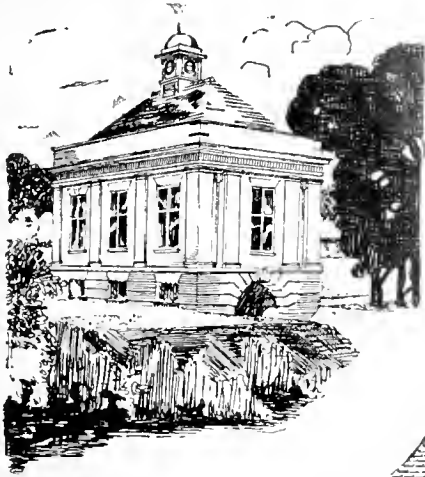

View from S.E.

DESIGN
FOR A
GARDEN
PAVILION
by
WALBROKE

SECTION
A.B.

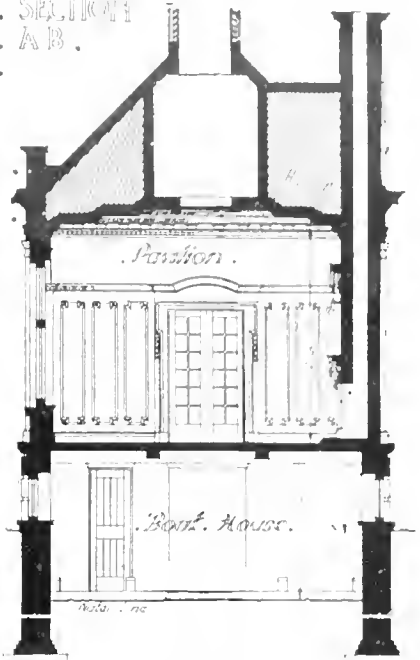

. BNDC .
. Subject H .
. May 15 .
SOUTH ELEVATION .



PLACED SECOND

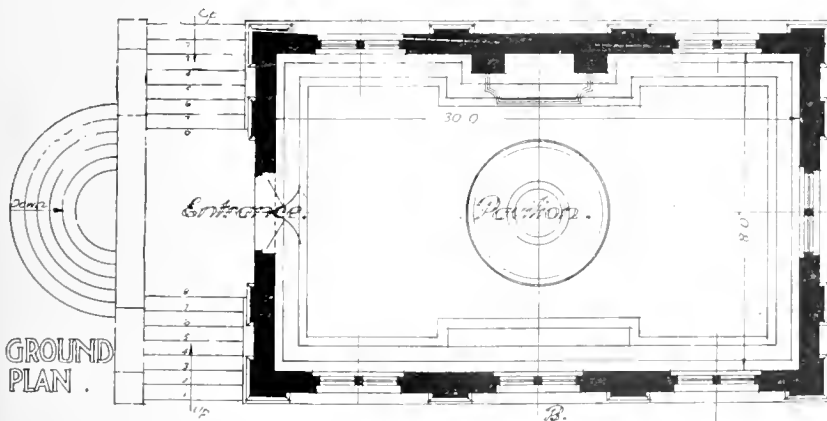
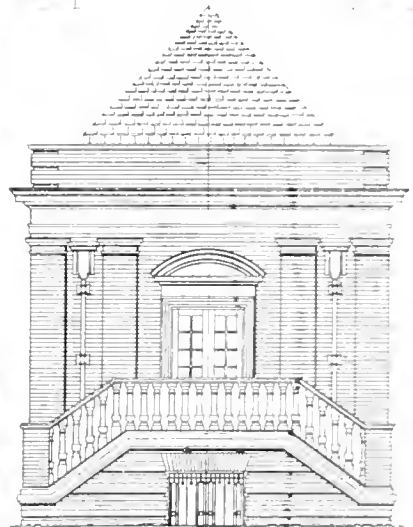

GROUND
PLAN .

WEST
ELEVATION .

BASEMENT
PLAN .

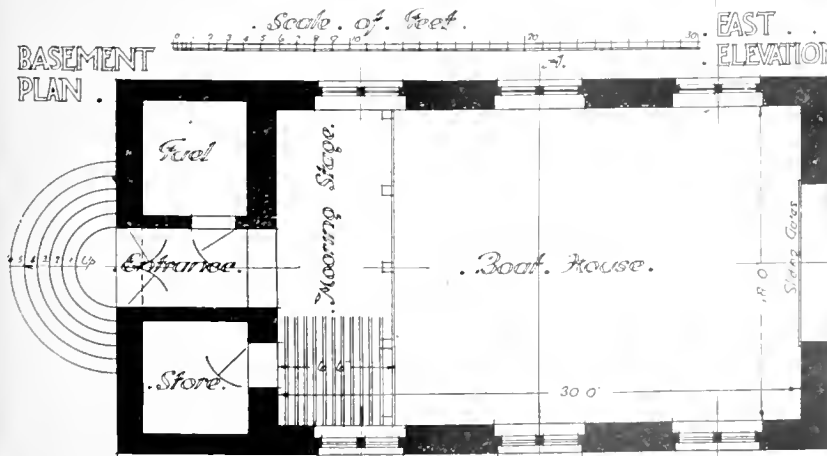

EAST
ELEVATION .

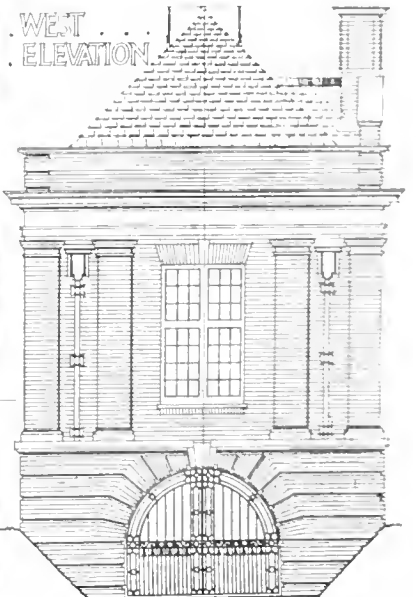



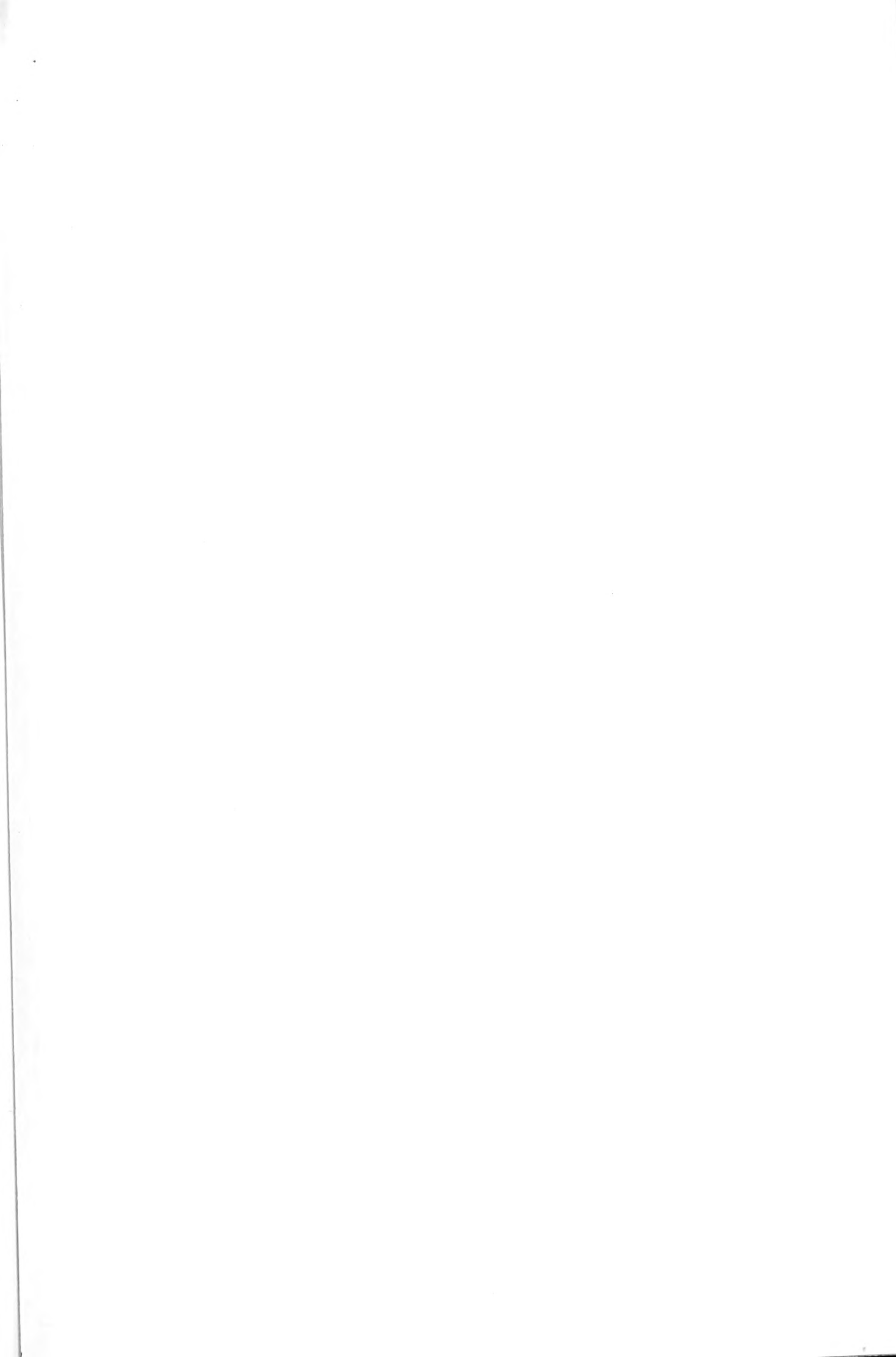

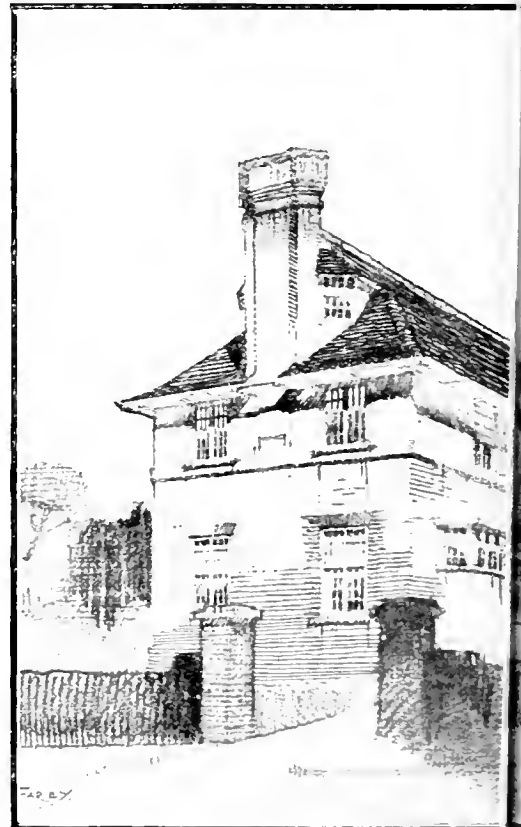

FIVE HOUSES IN FROGNAL LANE AND GREEN

Erskine House. Tramore. Corner Chimney House

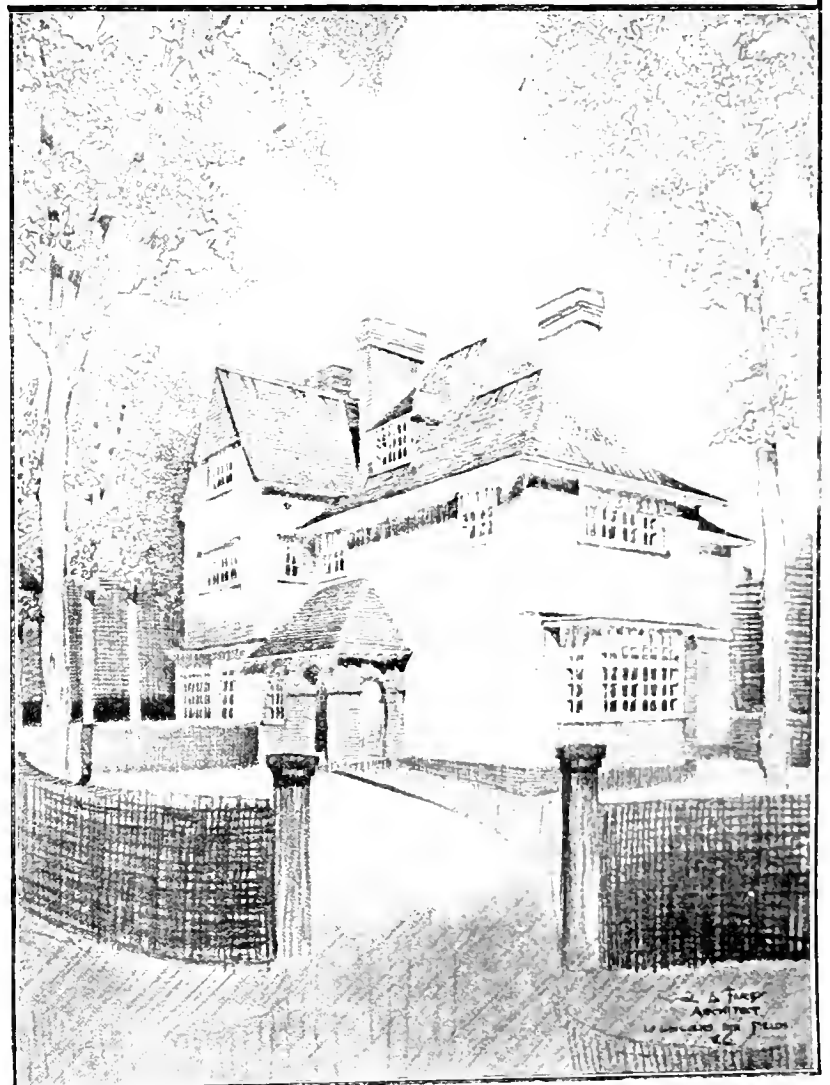
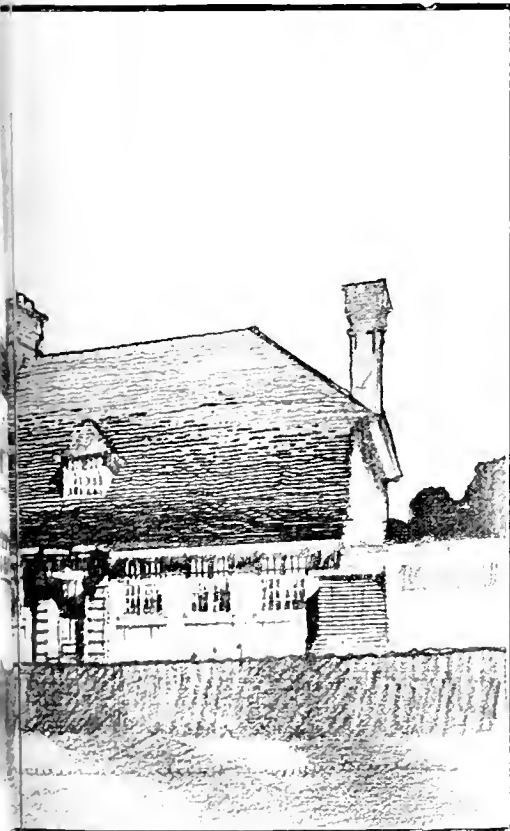
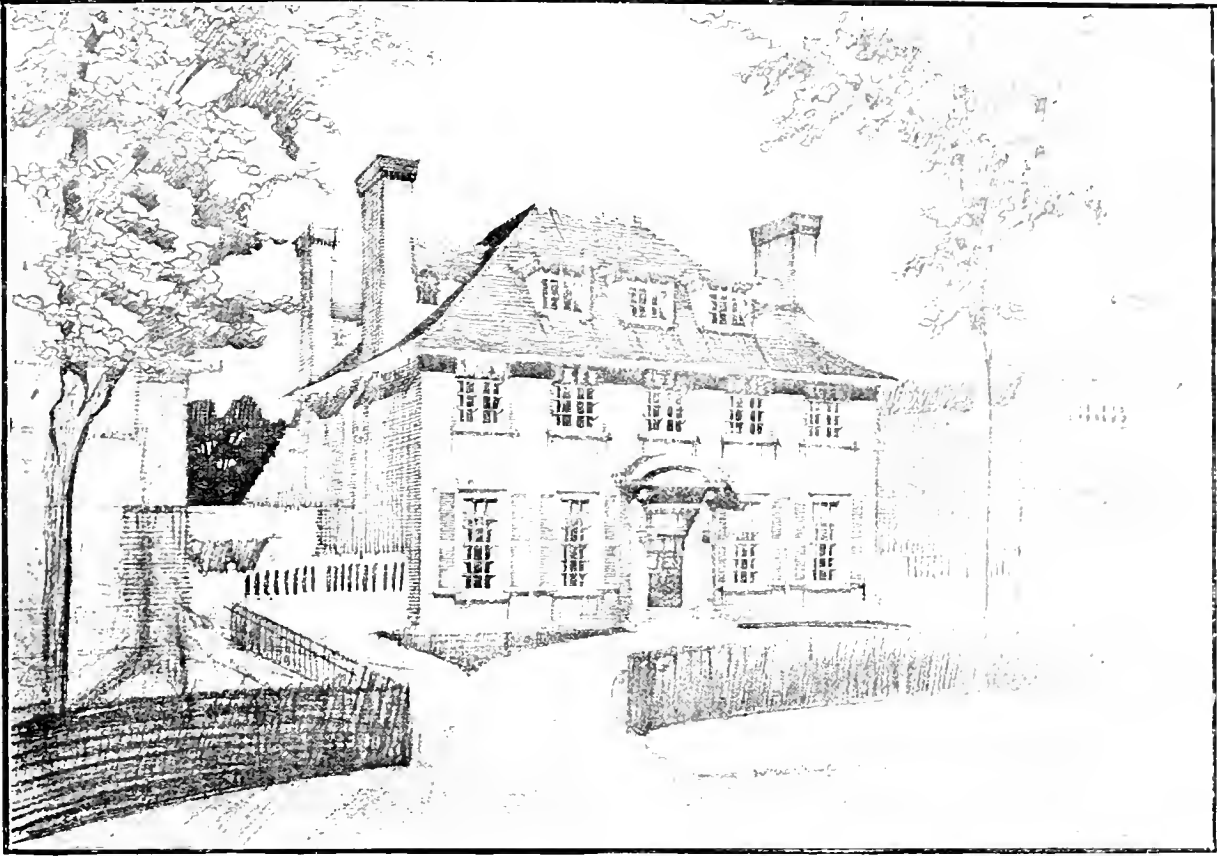

GARDENS, HAMPSTEAD.—Mr. CYRIL A. FARLY, Architect.
(“Greenaway Corner,” and “Greenaway Corner,” reading from left to right)



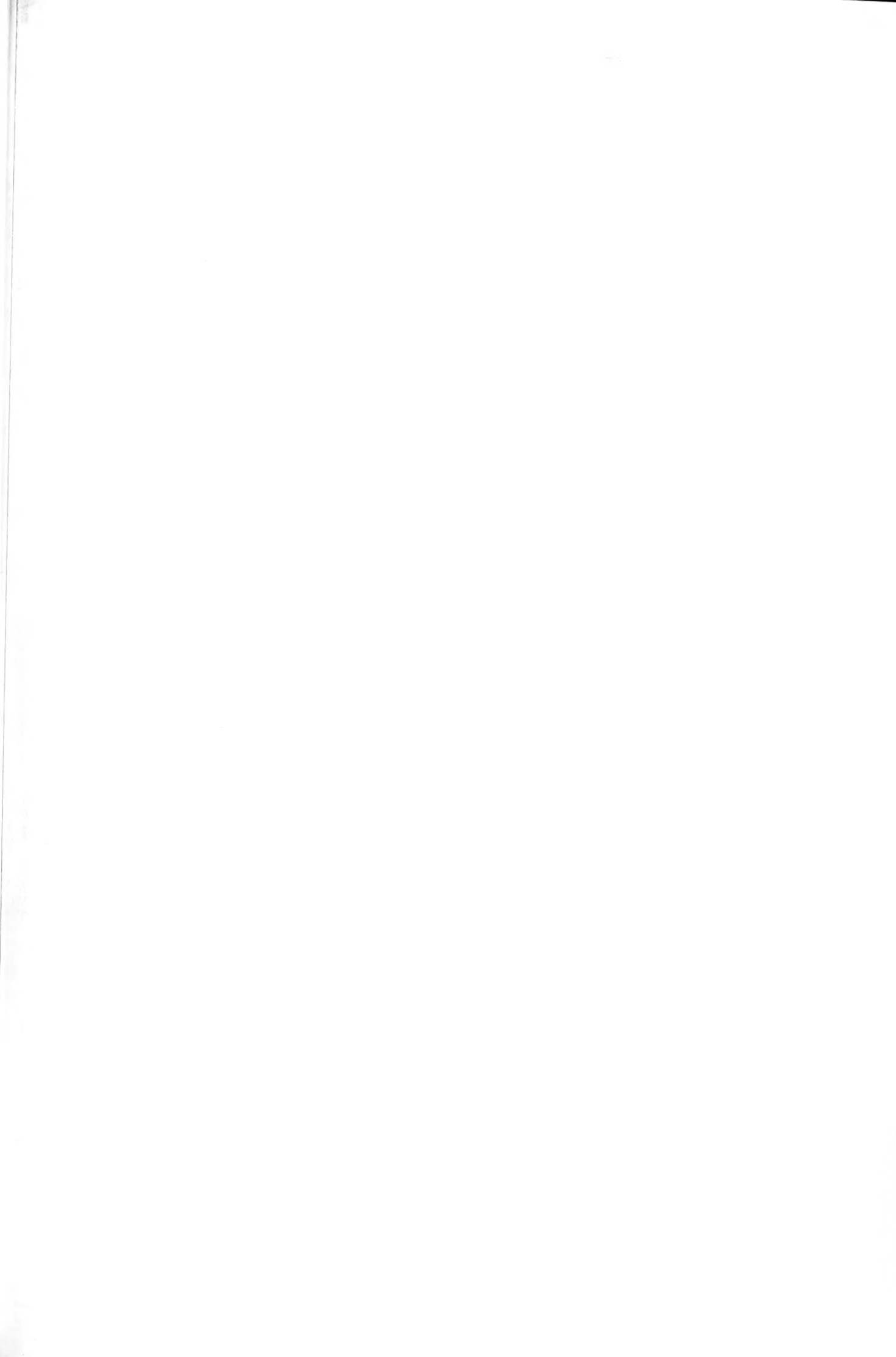

FIRST FLOOR PLAN



SECOND FLOOR PLAN

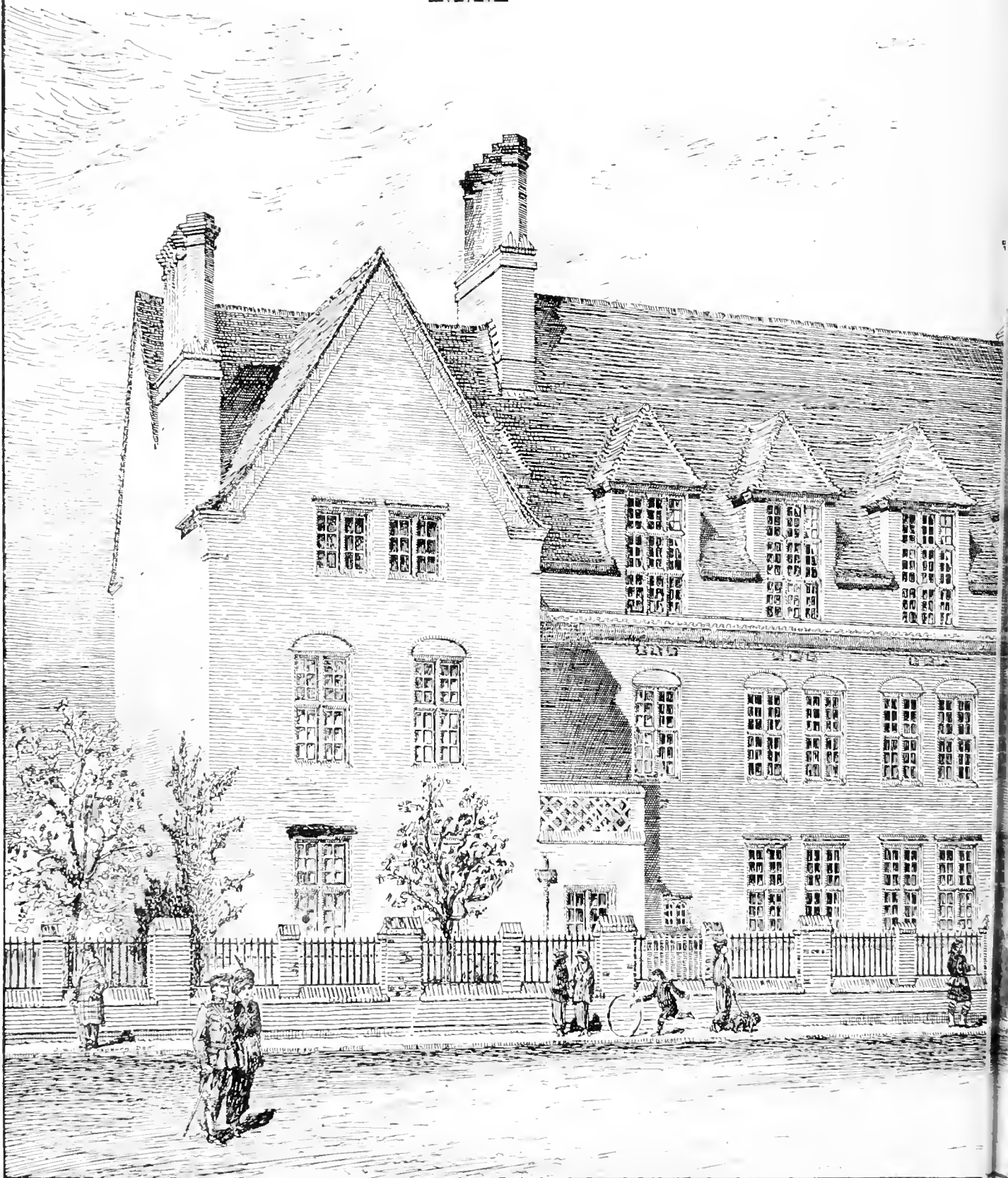

L.C.C. TRADE SCHOOLS FOR GIRLS, LIME GROVE, HAMMERSMITH.—Mr. W. E.

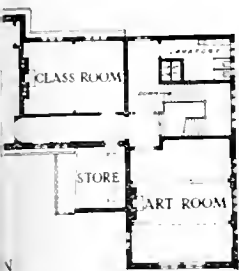

GROUND FLOOR PLAN.

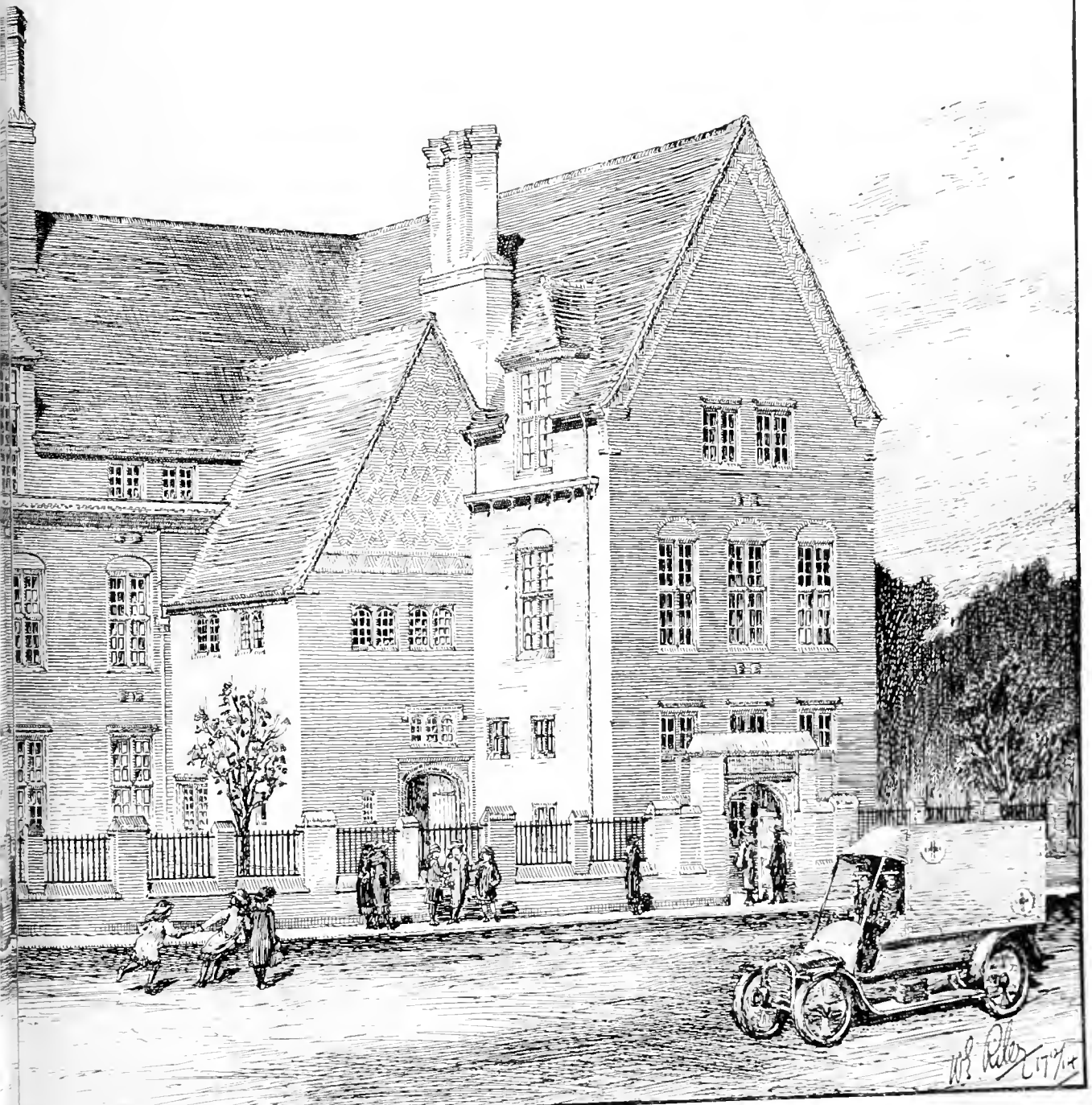
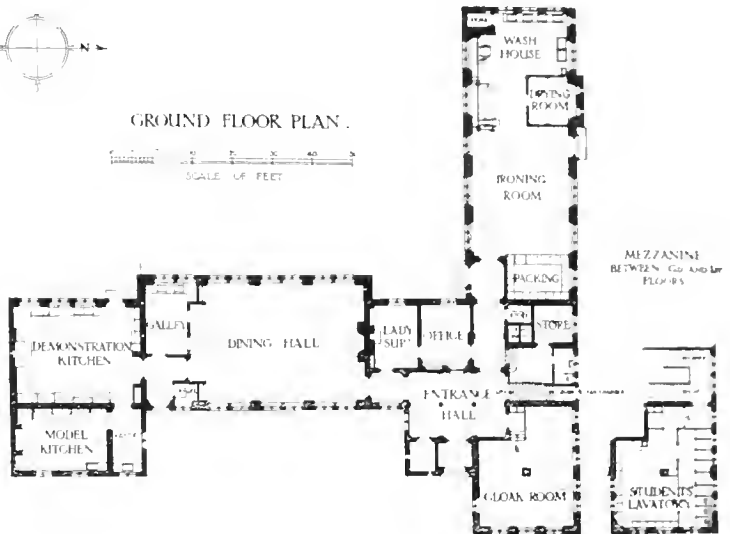

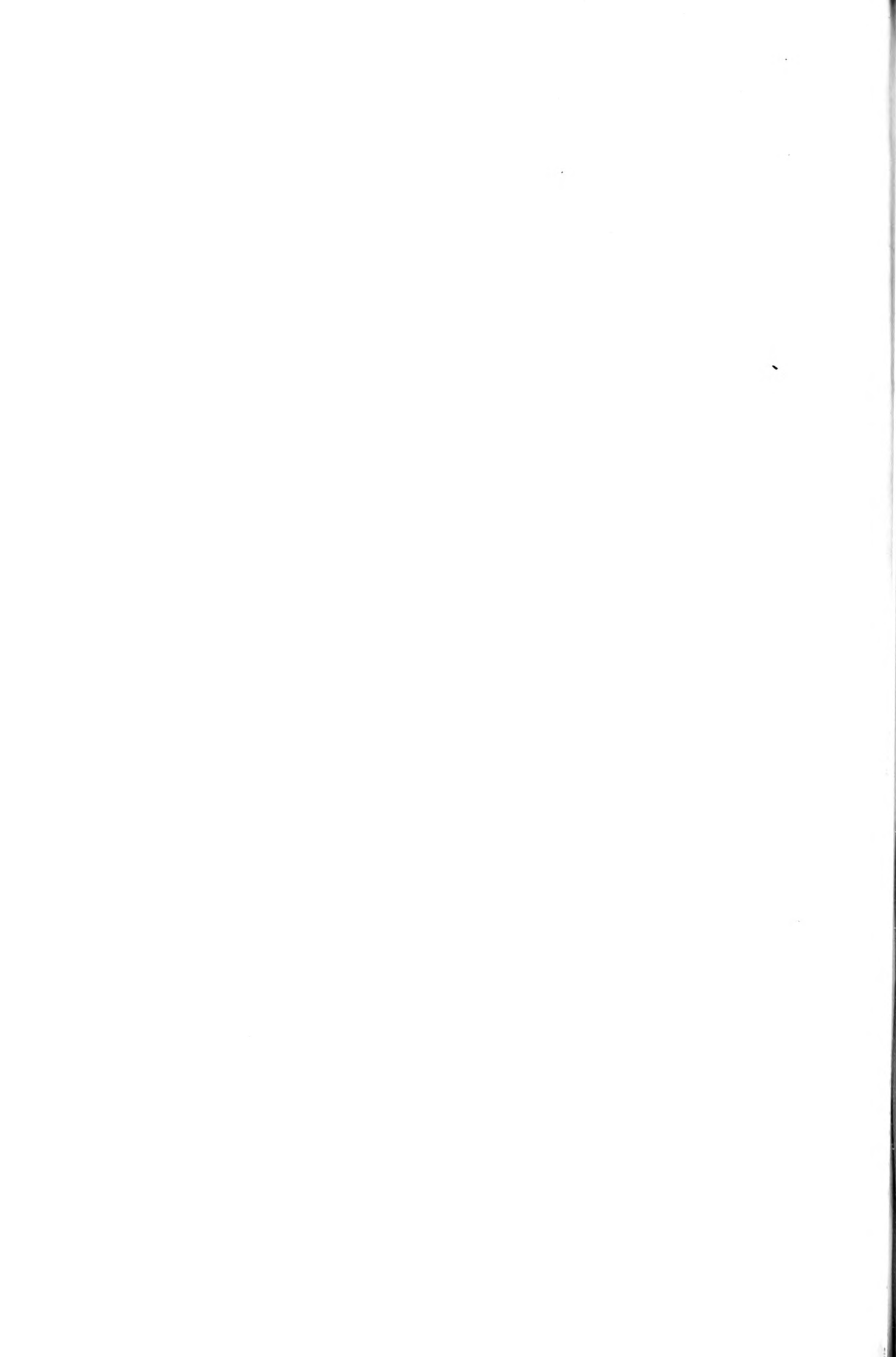

CHURCH OF S. MARK, AT WHITECHAPEL.
ADDITIONS TO LANTERN OF TOWER.

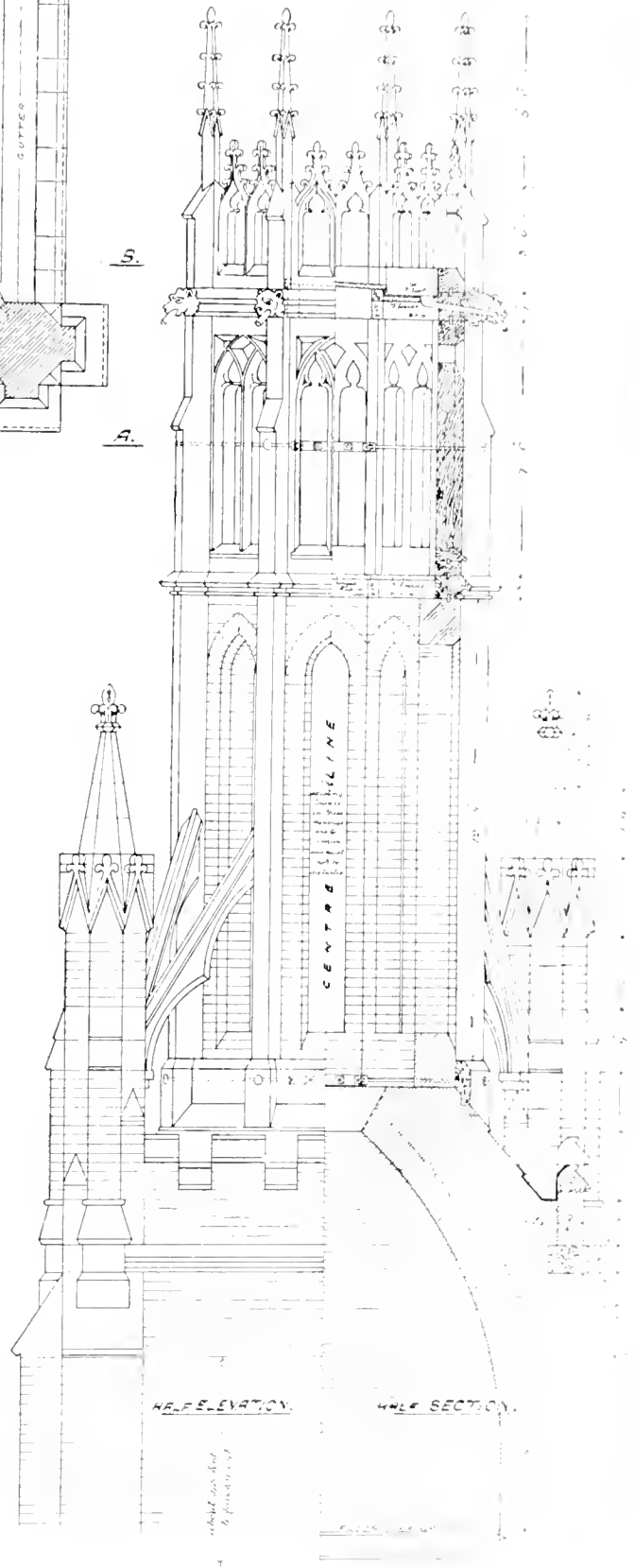
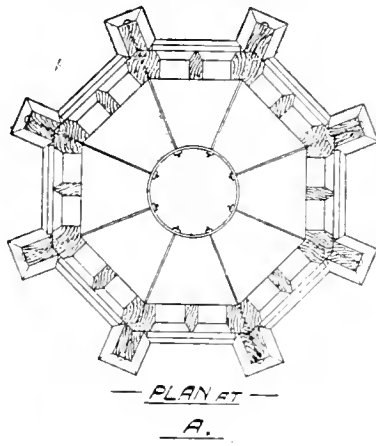
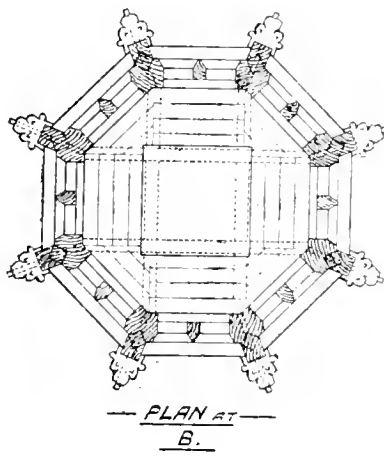
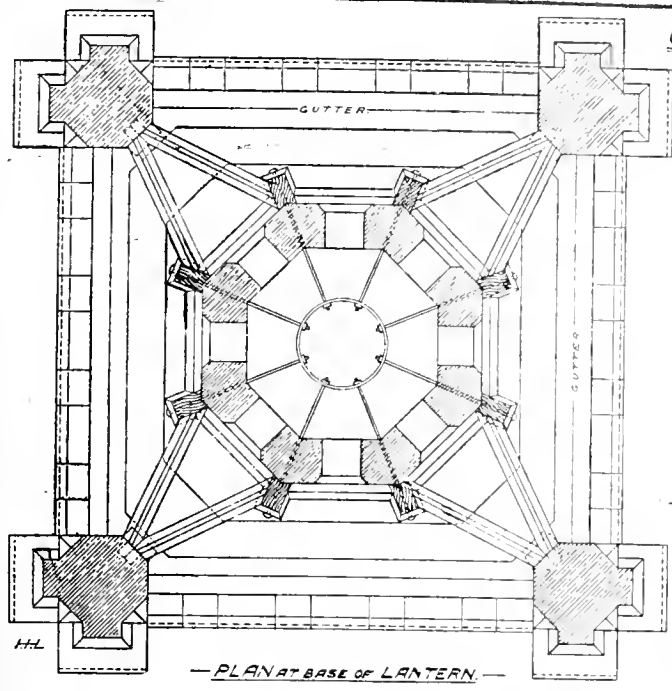

WORKING DRAWING BY JOHN MEDLAND & HARDWICKE LANGSTON ARCHITECTS

DETAIL OF OCTAGON TO TOWER, CHURCH OF ST. MARK, WHITECHAPEL. E.

Currente Calamo.

The Federal Council of the Australian Institutes of Architects has at last been formed after an interval of fourteen years since its first attempt to bring the architects of the States together in 1901. There are six States in the Commonwealth, and each has its own Institute of Architects. The States vary greatly in size, as do the Institutes. New South Wales and Victoria rank as the two larger Institutes, whilst Tasmania is the smallest. It, therefore, was to be anything like equality of representation upon the Federal Council, it became necessary that each State should have an equal number of representatives, and equal voting powers. The idea of the formation of the Council is to be carried out at the conference of the Presidents of the State Institutes, held in Melbourne last year. At the invitation of the Institute of Architects of N.S.W., a further conference was arranged, to meet in Sydney in November last. To this Sydney conference, each Institute sent two representatives, and the principle of federation, rather than union, was agreed upon, as a working basis. The general resolutions of the conference, having subsequently been laid before the various Institutes, the policy which had been adopted was affirmed by the Institutes. A further conference was held in Melbourne last April, and the following resolution was unanimously adopted, and upon which the Council was constituted:—"Whereas it was resolved at a conference of representatives of the State Institutes, held in Sydney in November, 1914: That it was desirable to form a Federal Council to represent the State Institutes of the Commonwealth, and this being concurred by the respective Institutes, the said Federal Council is hereby constituted."

Having been only constituted, the first business was the election of the president, and the secretary and treasurer. Mr. A. W. Anderson, the President of the Institute of Architects of New South Wales, was unanimously elected the first President, and Mr. W. Newman (N.S.W.), the Secretary and Treasurer. It is obvious that both these officers must belong to the same State, otherwise the administrative work, when the Council is not in session, would be very difficult. The members of the Council are to be appointed by the Councils of their respective Institutes, the term of office being twelve months. The Councils of the States chosen from the State in which the Federal Council is sitting are empowered to appoint substitutes to take the place of any of their representatives who may be unable to attend the Federal Council. In order to provide for a majority of the States transacting the business of the Council, the quorum shall be composed when five or more States are represented; but each State shall, at all Council meetings, be entitled to two votes. In order to provide the necessary funds for carrying on the work of the Council, the Council is empowered to levy upon the per capita dues of membership of each State Institute. Victoria has just paid the due of £200 per member, as its quota for the current year. The objects for which the Federal Council is established are:

1. To represent the profession in the Federal Council.

2. To bring about uniformity in Australian architectural practice generally, the views of the profession being taken into due consideration, and its integrity and independence to be preserved, and its interests to be promoted.

The powers and powers of the Council are to be defined by the Council.

1. Matters of Federal interest.

2. Matters affecting two or more Institutes.

Any question which may be referred to the Federal Council by any Institute. The ruling of the Council shall be final and binding on the State Institutes.

The annual meeting shall be held during April or May, in such State as the Council may decide. Audited balance-sheets, and an annual report shall also be presented. We understand that Adelaide is chosen for the meeting in 1916.

After framing the constitution under which the Federal Council will work, the Council settled down to the consideration of conditions of competitions, and issued a lengthy code, showing the guiding principles to be embodied in future competitions. The aim is that there shall be clear instructions to competitors, the minimum of work in the preparation of the designs, fair and reasonable prizes, which shall not be merged into the commission of the successful competitor, together with obtaining professional advice during the adjudication. Another subject dealt with by the Council was the scale of professional charges. There are still those who tell Australians that 5 per cent. is the standard fee of the British architect. But, as is remarked, if anyone will refer to the "Kalendar" of the R.I.B.A., he will find a long list of items which are not included in the 5 per cent. charge; and it is contended that the British architect, with his 5 per cent., comes off much better than his Australian brother with his 6 per cent. The Federal Council has, therefore, carefully dealt with the problems of remuneration, and, whilst laying down a model scale, has left some of the final determinations to the various State Institutes. Other matters were dealt with in a business-like fashion, which augurs well for the future of the Federation, to which we very heartily wish success in every respect.

Since the war broke out many fresh business contracts of service have been entered into for the purpose of arranging to "carry on" during the war, usually with reduced salaries. The legal position of the parties to these old and new agreements is sometimes not easily determined. The recent case of *Ragzow v. Scougall and Co.*, heard on July 16, is, therefore, of some interest to the building and other trades, in which such fresh arrangements have been made for the duration of the war. In this instance the plaintiff, by a written agreement of August, 1915, entered into the service of the defendants for two years at a certain salary, with a proviso that, if the business should be discontinued during that period, the agreement should come to an end. When the war began defendants thought of shutting down their business. Then the plaintiff made a fresh agreement with the defendants, as did other employees of the firm, by which he accepted a lower salary for the duration of the war, with a proviso that, when it ended, the old agreement should revive and be effective. He went on at the reduced salary until last February, when he claimed payment at the old rate, and, this being refused, he sued for the excess. In the City of London Court he got a judgment in his favour on the technical ground that there had been no consideration for reducing his salary. Now, on appeal, the High Court has emphatically reversed that ruling. The judges there held that the new agreement was quite clear and binding, as it provided for carrying on at a lower salary while the war lasted, and also for the revival of the

old agreement and the old terms when the war was over. So a perfectly fair and just arrangement was supported and backed by the law, and the plaintiff will have to pay all the costs of this ingenious plot to do what the judge called a dishonest thing.

One thing is certain about the State scheme for insurance against damage done by enemy aircraft and by bombardment from the sea, and that is unless it is seriously modified it will fail. The bombardment phase of it does not apply to ninety nine hundredths of the country, because it includes only damage done from the sea; but the fact that the anti-air damage premium for private houses is to be as high as is charged on the ordinary fire insurance policy is sufficient condemnation to the ordinary citizen. Ordinary fire danger is always with us, the Zeppelin peril at the worst is relatively remote, and to charge the like premium against the risk of each is to feed the fire insurance companies and court failure. There are other limitations also which render the scheme futile in our opinion; and, speaking generally, it seems another characteristic attempt to solve the problem of giving nothing for something so ingeniously contrived in connection with the National Insurance Act.

"She may go to Halifax and not come back again," ran the tag of an old music-hall song in our gilded youth, though why the advisory permission was granted remained one of the many mysteries we have never solved. Probably because the well-wisher knew the lady would never leave Halifax if once she got there. That, anyhow, is likely to be the resolve of all readers of the excellent and informatively illustrated handbook, "Halifax: A Commercial and Industrial Centre," just issued by Messrs. Sells, Ltd., at the Sign of the Sundial, 166-169, Fleet Street, E.C., at 2s. 6d., post free 2s. 10d. Its perusal will make it as clear as crystal that this ancient and thriving town, with its varied prosperous activities in trade and commerce, offers one of the most advantageous locations in the three kingdoms for new works, or extensions of old ones, and any architect, builder, or land agent might do far worse in these none-too-busy times than run down for a day or two and explore the district in the interest of clients watching for opportunities. The interest of the volume is enhanced by the illustrations of some of its beauty spots, and by those of some excellent residences which its residents and others have had the good taste to build.

Mr. J. Robinson, sanitary inspector at Watford, has had his salary increased from £220 to £250 per annum.

The salary of Mr. J. H. Castle, town surveyor of Gough, has been increased by the Urban District Council by £50 per annum.

Lieut. Ralph G. Dinwiddie, R.N., son of Mr. Thomas Dinwiddie, F.R.I.B.A., F.S.I., has been promoted to rank of commander in his Majesty's Fleet.

Mr. Doyle, town surveyor, has resigned his position under the Athlone Urban District Council, having been appointed county surveyor of Longford.

By unanimous votes, both in the Council and in the general meeting of members at Melbourne, the name of Franz Jaffe has been removed from the rank of Hon. Follow upon the roll of membership of the Royal Victoria Institute of Architects, as that of an enemy alien.

The City Engineer of Worcester has submitted to the Corporation a report on the best means of washing the gravel on the surface of the primary filters, and for alterations and works at the sewage farm, at an estimated cost of £2,000. He estimates the annual cost of washing the gravel at £1,000. The matter is still under consideration.

Our Office Table.

A collection of landscapes and architectural studies by the Hon. John Collier is now to be seen in the Leicester Galleries, Leicester Square. These water-colours are very diverse, both in subject and character, garnered from different places, and including a series of detailed studies of buildings from Thebes and other parts of Egypt. Judging from the date of one of them these pictures appear to have been made during a tour in 1885. Every feature is drawn with keen technical recognition and unfeigned appreciation as exemplified by the artist in the interior view of a characteristic colonnade from Denderah (5), also the Temple of Edfou (23), and by two sketches of the Great Temple of Philae (9 and 27). Equally well rendered and of another type architecturally, but not less elaborate in ornamentation, appears the Mosque of Cordova and the Courtyard of Lions in the Alhambra (20 and 22). More freedom of handling, as might naturally be expected, is evidenced by Mr. Collier's charming subject of the outer walls of Carcassonne, the capital of the Department of Aude, in France, showing the conical roofed circular corner tower on the ramparts (14) with the fertile country beyond, wide of Toulouse. Another sketch of the same turret occurs in the interior of the walls (21). At home in the west the artist has given us water-colours of Salcombe and Saundersfoot harbours, as well as Woolacombe Sands and a garden in Devon. All these are marked by contrast, of course, to the orange trees in the garden of Lindaraja or in the spring scene at the Villa Serbelloni, from whence we get also an autumn piece (25), and "A Winter Study at Murren" (19), which hangs near the last. Probably most of these exhibits represent work done during the leisure of bygone years.

The sixth exhibition promoted by the members of the London Salon of Photography will be held at the Galleries of the Royal Society of Painters in Water-Colours, 5a, Pall Mall East, S.W., from Saturday, September 18, to Saturday, October 16. The exhibition will remain open daily (Sundays excepted) from 10 a.m. to 6 p.m. The private view will be held on Friday, September 17, from 3 to 6 p.m. An innovation has been introduced this season by the committee. All pictures may be submitted to the Salon, both from Great Britain and from abroad, unframed and, if necessary, unmounted. The Salon committee will see that the prints are suitably mounted if accepted, and in all cases will be shown under glass. Exhibits can thus be sent safely and cheaply in packages by parcels post, and the result ought to be that the committee will receive the best available work of the year from which to select a display.

At the meeting of the London County Council yesterday (Tuesday) it was reported that reductions in the maintenance votes for the current financial year amounting to £156,747 had been made by the various spending committees of the Council, and all the committees were instructed to consider and report on possible further reductions. The Council on March 7, 1911, sanctioned expenditure not exceeding £20,000 for the acquisition from the South-Eastern Railway Company of a portion of Nos. 9 and 10, Strand, required for widening the road to a width of about 80 ft. The price to be paid was recently the subject of an appeal by the Council to the Court of Appeal, and the settlement is being effected at £18,550, in accordance with the findings of the Court. The Housing Committee reported that a group of twenty-six cottages on the Norbury estate, providing accommodation for 166 persons, are nearly completed. Inclusive rents for the cottages have been fixed as follows: Four rooms, bathroom, and scullery, 10s. 6d. a week; four rooms and scullery, with bath, 9s. 6d. a week; three rooms and scullery, with bath, 8s. to 9s. a week; three rooms and scullery, 8s. 6d. a week.

Facilities were courteously given at the end of last week by the Liverpool Cathedral

authorities to Freemasons associated with the West Lancashire Provincial Library to visit the Latham Memorial Chapter House, recently roofed. The architect (Mr. Gilbert Scott) considerably left to the chief sculptor, who happens to be a member of the craft, the detailed decoration of the Chapter House, which already presents a large proportion of the Masonic features to be embodied. Several of the leading Biblical characters associated with the building of King Solomon's Temple are recognisable among the statuettes visible through the scaffolding, while the working and emblematic tools used by masons, operative or free, have been floridly entwined. The common gavel is encircled by the thistle, this being part of an elaborate scheme embracing the lily and the rose in a novel form of architectural treatment.

The Bribery and Secret Commissions Prevention League, Incorporated, now possesses records of exactly 102 convictions under the Prevention of Corruption Act, which came into force on January 1, 1907. The list may not include all the cases, as no official record is kept for the United Kingdom. In thirteen instances terms of imprisonment have been imposed. The maximum fine has been imposed eleven times, and the fines have exceeded, in the aggregate, £2,000, while the costs imposed by the Court, when stated, have averaged about £10. The reports of the 102 cases show twenty-seven cases connected with canteens, Army or Navy purchases, etc., thirteen attempts to bribe the police, ten instances of bribery concerned with trade secrets, seven with weighing and packing; and it has been proved that bribes have been offered to, among others, solicitors (two), a doctor, a borough surveyor, a clerk to a board of guardians, a county council inspector, a town council officer, an insurance assessor, a mercantile marine officer, a motor expert, the hon. secretary of a miniature rifle range, professional footballers (four), and to one woman cook. The persons convicted include twelve manufacturers (automatic machines, blouses, boots, bottles, chemicals, guns, textiles, typewriter supplies), nine merchants (coal, hay and straw, metal, timber), eight shopkeepers (butchers, dairymen, fishmongers and fruiterers, grocers), six commercial travellers, five clerks, four persons driving motors (attempting to bribe the police), and three motor agents and repairers, four persons connected with the cinema film industry (one of them the owner of a picture theatre), six betting men, eight labourers, carmen, etc., and a solicitor (convicted on two charges), an actor, a boarding-house manager, a builder, an emigration agent, a farmer, a hotel valuer, a metal broker, a restaurant keeper, etc. There have been three appeals against convictions, each of which was unsuccessful. In the period under review there have been, of course, many other convictions for bribery under the Public Bodies Corrupt Practices Act, the Licensing Acts, the Customs Laws, the Merchant Shipping Act, and the Common Law.

At the meeting of the Canterbury House of Laymen, held last week, Lord Parmoor presiding, the vice-chairman, Chancellor P. Vernon Smith, submitted the report of the Committee on Dilapidations, containing a number of recommendations. As amended, the first was: "That the House is not prepared to approve of the provisions of the Draft Bill for amending the Ecclesiastical Dilapidations Acts, 1871 and 1872 (and for other purposes) which substitute for the existing system a central authority." Approval was given to a provision for the compulsory survey of the buildings of a benefice every five years, and a number of other provisions which it was felt might be grafted upon the existing Acts, and it was resolved that in every diocese the Diocesan Board of Finance should make grants in aid of dilapidations or for paying the surveyors' fees or salaries, or the other costs of administering the Acts. It was further resolved that diocesan surveyors should be paid by salary.

A third edition of Thomas Holloway's little manual of "Leveling and Its General Application," published in 1896, and revised by H. T. Tallack, is issued by Messrs. E.

and F. N. Spence, Haymarket, London, E.C.4.

The handiest means of sending a telephone message to order a telephone call has been issued by the General Patent Application Company, Ltd., of 2, Central Buildings, 11, Hill Street, Westminster, London, W.1. (No. 10,444), and enclosed in a paper slip, one on the side of every reader's instrument. The neatly bound book is attached to the hand front in alphabetical arrangement of subscribers' names and numbers, rendering instant reference easy, and is provided with a series of slips to receive the message. At the top centre is suspended a perforated card for the inscription of the message. The whole occupies little wall space and is as ornate as it is a decorative as it is a practical indispensable.

The following short list gives, according to a Pittsburg newspaper, the total number of church edifices built in the United States area during the seventeenth century, which have escaped the destroying hand of time, and the more destructive neglect and indifferent attitude of man: St. Lawrence's, Springfield, Va., 1632, a brick building of which Joseph Bridger was the architect; the Ship Meeting House, so called because it was built of ships' timbers, at Hingham, Mass., 1691; the Quaker Meeting House at Flushing, 1692; "Gloria Dei," Swedish, Philadelphia, 1697; Trinity, Wilmington, 1671; and the Dutch Reformed Church at Oakland, N.J., both built of stone in 1698.

A draft of a new ordinance to govern fire-proof construction of buildings in New York City, prepared by a committee of the Board of Aldermen, with Mr. B. P. Miller as expert, contains the following rule for determining the safe carrying capacities of concrete slab floors: "The gross load in pounds per square foot of floor space shall not exceed the product of the depth in inches of the reinforcement below the top of the slab, by the cross-sectional area in square inches per foot of width of the tensional steel, divided by the square of the span in feet, all multiplied by the following coefficients: When cinder concrete is used 14,000 if the reinforcement is not continuous over the support, 18,000 if the reinforcement consists of rods or other shapes securely hooked over or attached to the supports, and 26,000 if the reinforcement consists of steel fabric continuous over the supports; and when stone concrete is used, 30,000 and 40,000 respectively." The rule is a portion of a revision of the city's building code, now in progress.

A new Constitutional club has been formally opened at Rhyl. The architect was Mr. A. Crumpton, and Mr. W. Rickersgill was the builder.

Mr. George Culling, J.P., member of the Norfolk County Council, and past chairman of the Swaffham Urban District Council, who has for the last five-and-thirty years been in business at Swaffham as a builder and plumber, died last week, aged fifty-eight years. He held many public offices in North West Norfolk.

The relative merits of cast iron and vitrified stoneware pipes for house sewer drains have been exhaustively investigated for a year by Mr. A. C. Shaver, chief sanitary engineer of the City Government of Pasadena, Cal. Judgment is in favour of the cast iron pipe. The conclusion arrived at is that cast iron pipes can be made proof against the acids and can be the own out of a large number of materials, whilst the stoneware, though not acid proof, nor justify the risk of having to tear up the entire sewer to clean it.

The Great Central Railway Company has made arrangements to facilitate subscriptions by its employees to the new 4 Per Cent War Loan, and thus enable the smallest investors to acquire this excellent Government stock on exactly the same terms as the capitalist. Then the subscriptions reaching £5 or multiples of £5, the sum can be converted into War Loan Stock, and the necessary stock certificate will then be issued. This effort on the part of the leading railway company to encourage thrift, and directly benefit the country, is very commendable, especially when it bears in mind the number of trained men who have already been released for active service.

COMPETITIONS.

DUNDALK, IRELAND.—The new Louth county offices, Dundalk, competition, restricted to architects in practice in Ireland, has been settled and we give the assessor's report. The winners of the competition, Design No. 14, are: Messrs. O'Callaghan & Webb, F.F.R.I.A., 31, South Frederick Street, Dublin. The design placed second is the work of Messrs. Batchelor, A.R.H.A., and Hicks, F.F.R.I.A., 86, Merrion Square, Dublin, and the design placed third, No. 15, is that of Mr. Thomas J. Cullen, 25, Saint's Street, Dublin. The award of the assessor has been approved and accepted by the committee. The plans are now being exhibited in the Council Chamber, Court House, Dundalk. The cost was limited to £200, exclusive of fittings, furniture and equipment. The style of the building had to harmonise with the Court House, Dundalk, a building with Doric portico of considerable merit, which adjoins the site, and Irish materials were to be specified. The selected architects have to prepare a perspective of their design forthwith showing the entire scheme. The following is the award of the assessor, Professor W. A. Scott, F.R.I.A., A.R.I.B.A.:

45, Mountjoy Square, Dublin, July 8, 1915.

LOUTH COUNTY OFFICES.

Dear Sir, I beg to report that I have examined the nineteen designs submitted in competition for the new county offices for County Louth, to be erected at Dundalk, and place the designs as follows:

- (1) The design No. 14.
(2) The design No. 12.
(3) The design No. 15.

The design I place first is straightforward and a good solution of the problem, while the architectural treatment is the best of the designs submitted, having regard to the conditions of matching the old building and as to the cost.

The lighting of the judges' room in the courthouse is not unduly curtailed. A reconsideration of the arrangement of the staircase is desirable, and this competitor should submit a modified plan accordingly.

The design No. 12 is a good second. I commend the arrangement of the council chamber, committee-room and lobby, and also the staircase. The ground plan would have been improved by a direct entrance to the staircase hall.

The congested area at the public convenience is a defect, but the width and lighting of the courtyard is good.

The architectural treatment is not of the same quality as the planning.

The design No. 15, which I place third, presents a good plan, but the width and lighting of the courtyard is not so good as in the pre-nominated designs. The office near the entrance are not well proportioned. The committee rooms are rather remote from the council chamber, if these apartments are to be used in course.

The architectural effect of this design would be better than that of the second pre-nominated design, but would not harmonise so well with the existing building.

I think it right to direct attention to the high standard to which the greater number of the designs have reached.

The sealed envelopes which accompanied the competitive designs I shall submit to your committee when they consider this my award. Yours faithfully, W. A. SCOTT.

DONCASTER.—The borough surveyor, Mr. F. O. Kirby, has completed the draft conditions for the proposed competition for the sewerage and sewage disposal scheme, and the Council of the Institution of Civil Engineers will be requested by the corporation to nominate the assessor.

OWEN JONES PRIZES.—In this competition for designs for furniture and carvings, open to students in Schools of Art, the prizes have been awarded this year by the examiners of the Board of Education to the following candidates:—John B. Baswell, School of Art, Nottingham, for a design for a chair; George Alec Curran, Frederick W. Hillier, Broad Weir School of Art, Bristol, for designs for the fireplaces; William H. Williams, School of Art, Manchester, for designs for painted chairs; John H. Rowe, School of Art, Dudley, for a design for a school building; Harry Brocklehurst, School of Art, Middlesfield, for designs for a school; Harold Gutzger, School of Art, Manchester, for a design for a painted chair. The examiners who judged the designs submitted report that generally the standard of merit is equal to that of last year, and that there is a slight improvement in the design of chairs. While a considerable number of designs show a real cleverness in the treatment of the given examples, the designs, as a whole, have not been in-

teligently studied, there are some which are original in treatment and at the same time adhere to the principles laid down by Owen Jones.

Trade News.

WAGES MOVEMENTS.

Toesing Plumbers' Wages.—The operative plumbers recently gave their employers notice for an advance in wages of one penny per hour, 2d. to 11d. According to agreements the question came before the Conciliation Board, who were unable to come to a decision. At the unanimous request of the Board, Mr. S. E. Burgess, borough surveyor of Middlesbrough, undertook to act as arbitrator. He has now given his decision to the effect that the wages remain unchanged. Mr. Burgess pointed out that the request was for an advance of wages, not a war bonus, and he had considered the question on those lines. The decision affects Middlesbrough, Stockton, and the Hartlepoons.

TRADE NOTES.

The British Reinforced Concrete Engineering Co., Limited, intimate that they have (since July 20) removed from their premises at 82, Victoria Street, Westminster, S.W., to 1, Dickinson Street, Manchester, where larger and more convenient offices have been secured in close touch with their works at Trafford Park, Manchester.

In the desire to avoid purchasing any article that has the slightest appearance of German origin or manufacture the public are apt to conclude that unless the commodity they feel inclined to buy has a thoroughly English name it must necessarily come from Germany. This prejudice has even occasionally affected an article like "Ronuk" Floor Polish, which is English from "top to bottom," and it may be interesting to explain the derivation and meaning of the word "Ronuk." When this famous polish was first invented the owners were anxious to get a thoroughly unique name for it, and a retired army officer, who had been much in the East, suggested "Ronuk," which is derived from a Persian word meaning beauty, splendour. The owners were much struck with the peculiarity of the word, and our readers can see there is not the shadow of a shade of connection with Germany.

Messrs. McNeill and Co., Limited, of Bantull Row, E.C., tell us of important inquiries for their slag wool consequent on the appearance in THE BUILDING NEWS of their advertisements illustrating the various types of hostile aircraft. This series of advertisements have proved conclusively that topical events may with advantage suggest good subjects for technical as well as everyday advertising.

MEETINGS FOR THE ENSUING WEEK.

WEDNESDAY (To-Day).—Builders' Benevolent Institution. Thirty-eighth Annual Meeting, Koh-i-noor House, Kingsway, W.C. 4 p.m.

WEDNESDAY (July 28).—National Federation of Building Trades Employers. Semi-Annual Meeting, Masonic Hall, Great George Street, Leeds, 10 a.m.

PARLIAMENTARY NOTES.

THE MALL IMPROVEMENT SCHEME.

—On a vote of £32,000 for the improvement of the approach to the Mall being applied for in the House of Commons on Thursday night, Mr. Pringle expressed the view that it would be most undesirable to expend money on this work at present.—Mr. Beck (Vice-Chamberlain of the Household) stated that no unnecessary work of any kind was being carried on in connection with this scheme. The cost was being shared by the Westminster City Council, the London County Council, and the Government. One of the bargains which were necessitated by the improvement was the purchase of the premises of the Phoenix Insurance Company, and the sum it was estimated to be £76,000. A third of this was to be borne by the Government. The Phoenix Company had agreed to take what was due to them from War Stock, instead of cash.—Mr. Lord James moved as an amendment the reduction of the vote by £7,000. The third of £76,000 was not quite £22,000, and the Government, without having the £7,000, would have an ample margin left.—Mr. Beck said a bargain had been entered into by this House last year, and it was not becoming of the House to go back on the bargain. No money would be spent on any unnecessary work.—The vote was agreed to.

CHIPS.

Mr. John Graham, Down, Co. Down, has commenced the erection of the new offices for the Great Northern of Ireland Railway Company, at Sheriff Street and Common Street, Dublin.

The Tees Valley Water Board, Middlesbrough, have ordered the preparation of plans for the construction of a reservoir at the top of Ormesby Bank for a water supply to certain Cleveland villages.

At Wincanton, yesterday (Tuesday), Mr. P. M. Crosthwaite held a Local Government Board inquiry into an application by the rural district council for sanction to borrow £3,500 for works of water supply.

The county council of Derbyshire have received the sanction of the Local Government Board to the borrowing of £6,000 for the extension of Penmore Hospital, and £1,600 for a secondary school at Ekeston.

The dissolution is announced of the partnership which has hitherto subsisted between G. Henderson and H. Brown, architects and surveyors, at Acresfield, Bolton, Lancaster, under the style of Henderson and Brown.

The urban district council of Fareham, Hants, have received a letter from the Local Government Board, expressing approval generally of the scheme for sewerage and sewage disposal works. The estimated cost is £15,240.

In our Chip on p. ix, last week concerning Mr. C. J. Innocent's paper on the ruined hall at Thorpe Salvin, read before the Hunts Archaeological Society, the name of the sixteenth-century builder of the mansion was given as Henry Sandford instead of Heryc Sandford.

The Council of the Auctioneers' and Estate Agents' Institute, 34, Russell Square, Bloomsbury, W.C., are desirous of obtaining a complete list of those members who are now serving with His Majesty's Forces. Members are asked to forward to the secretary their names, with rank and unit.

Mr. R. W. Furniss, architectural assistant in the Birkenhead borough surveyor's department, has been appointed by the Health Committee of that corporation clerk of works in connection with the proposed sanatorium at Thingwall, at a salary of £130 a year, plus travelling expenses.

The corporation of Dundee have approved the changes in the plans for the pavilions at the King's Cross Hospital suggested by the architectural inspector of the Local Government Board. The council will proceed with the work when the approval of the Treasury to the expenditure is obtained.

The interment took place at Birkdale Cemetery, on Friday, of Mr. Albert Wright, one of the best-known builders in the district. It is estimated that deceased, who was sixty-eight years of age and leaves a widow, was responsible for the erection of 30 per cent. of the modern villa residences in Southport and Birkdale.

The new Public Building at Brantford, Ont., was opened recently. The building consists of four floors, and cost approximately \$300,000. It is occupied by the Post Office, Customs, Inland Revenue, and Indian Affairs Departments. The contractors were P. H. Sissord and Sons, and the work was carried out under the supervision of Mr. C. W. Hall, the architect. Mr. J. Graham was clerk of the works.

Only one objector attended the inquiry, conducted by Mr. A. W. Brightmore, D.Sc., M.Inst.C.E., Local Government Board inspector, to the application of the Southampton Corporation for sanction to borrow the sum of £24,000 for the provision of a water tower in connection with the waterworks undertaking, held at the Municipal Offices, Southampton, on Tuesday, in last week. Mr. E. C. Rodda, the waterworks engineer, explained the proposals.

An annex to the district offices of the Prudential Assurance Company in Belfast is completed. The exterior is Neo-Grec in style, the columns being of Newry granite and the other stone of Portland. The entrance hall, in which the walls are lined with majolica tiles, leads into the general office, which is some 30 ft. square. The flooring is of black and white marble, while the dado is of dark-stained wood. A suite of compartments opens off the general office. The structure was designed by the company's architect, Mr. Paul Waterhouse, M.A., F.R.I.B.A., London, with Messrs. Young and Mackenzie as local architects, the builders being Messrs. Courtnay Brothers, Belfast.

Intercommunication.

REPLIES.

[13142.]—CONCRETE BRIDGE.—I trust the following will be of service to "Bombard":—Bending moment about the middle and at the supports of a beam or slab with both ends fixed and a single concentrated load at the centre:

$$B = \frac{Wl}{6}$$

Bending moment on a beam or slab with one end fixed and one end freely supported, and the load uniformly distributed

$$\text{At the fixed end } B_r = \frac{Wl}{8}$$

$$\text{About the middle } B_c = \frac{Wl}{10}$$

Bending moment on a beam or slab with both ends fixed, and the load uniformly distributed:

$$\text{At the ends } B_r = \frac{Wl}{12}$$

$$\text{About the middle } B_c = \frac{Wl}{12}$$

Bending moment on a continuous beam or slab of three or more spans, and the loads uniformly distributed. End spans, about the middle and at the inner support:

$$B = \frac{Wl}{10}$$

Intermediate spans, about the middle, and at supports.

$$B = \frac{Wl}{12}$$

Bending moment on a continuous beam or slab of two spans, and the load uniformly distributed:

$$\text{About the middle of spans } B_c = \frac{Wl}{10}$$

$$\text{At the central support } B_r = \frac{Wl}{8}$$

Reaction on adjoining support from intermediate spans in continuous construction:

$$R = .6W$$

The bending moments upon square or rectangular slabs with load uniformly distributed and supported on

LEGAL INTELLIGENCE.

SEWERAGE CONTRACT APPEAL. In the King's Bench Division on Wednesday, Justices Darling and Coleridge heard an appeal by the Tipton Urban District Council in connection with the Tipton sewerage case from a decision of the Official Referee in favour of Mr. Arthur John Plowdrill, who had sued them as assignee of a contract between the council and Messrs. Thompson and Farley, and had obtained judgment for £431 and costs. They claimed to recover the money in respect of a balance of the contract price alleged to have been wrongfully deducted on account of charges paid by the District Council to the Birmingham Canal Company for drawing off the water while sewer pipes were laid across the canal. The Official Referee came to the conclusion, after hearing evidence and arguments for six days, that the plaintiff was entitled to £206 on his original claim and £225 on an amended claim. Mr. Disturnal, K.C., on behalf of the Tipton Urban District Council, said the case arose out of a contract made on September 24, 1912, between Messrs. Thompson and Farley and the council, and Mr. Plowdrill was the assignee of the obligations and benefits under that contract, which was for the construction of sewers in the council's district. The sewers had to cross the Birmingham Canal in three places, and, for this purpose, it was necessary that the canal should be emptied. The Birmingham Canal Company charged the district council for the time the canal was empty. The contract and bills of quantities stipulated that the contractor should provide certain sums for these canal crossings and be responsible for them. The district had paid £700 in respect of those canal crossings, and Mr. Plowdrill had paid nothing. In the settlement of accounts between the parties the engineer to the council deducted a portion of this £700 from Mr. Plowdrill's bill and certified for the balance which he was paid. Mr. Plowdrill then sued for the amount so deducted, and also although he had not paid it he sued by an amendment for the

THE CROWN'S POWER TO TAKE POSSESSION LAND. In the Supreme Court of Appeal in Westminster, the Lord Chief Justice, Master of the Rolls, and Lord Justice Darling and Walter Lawrence, J., considered an appeal from a decision of the Official Referee in favour of Mr. Arthur John Plowdrill, who had sued them as assignee of a contract between the council and Messrs. Thompson and Farley, and had obtained judgment for £431 and costs. They claimed to recover the money in respect of a balance of the contract price alleged to have been wrongfully deducted on account of charges paid by the District Council to the Birmingham Canal Company for drawing off the water while sewer pipes were laid across the canal. The Official Referee came to the conclusion, after hearing evidence and arguments for six days, that the plaintiff was entitled to £206 on his original claim and £225 on an amended claim. Mr. Disturnal, K.C., on behalf of the Tipton Urban District Council, said the case arose out of a contract made on September 24, 1912, between Messrs. Thompson and Farley and the council, and Mr. Plowdrill was the assignee of the obligations and benefits under that contract, which was for the construction of sewers in the council's district. The sewers had to cross the Birmingham Canal in three places, and, for this purpose, it was necessary that the canal should be emptied. The Birmingham Canal Company charged the district council for the time the canal was empty. The contract and bills of quantities stipulated that the contractor should provide certain sums for these canal crossings and be responsible for them. The district had paid £700 in respect of those canal crossings, and Mr. Plowdrill had paid nothing. In the settlement of accounts between the parties the engineer to the council deducted a portion of this £700 from Mr. Plowdrill's bill and certified for the balance which he was paid. Mr. Plowdrill then sued for the amount so deducted, and also although he had not paid it he sued by an amendment for the

BUILDERS' RIGHT OF APPEAL FROM A KING'S BENCH JUDGMENT. Attorney-General v. Knowles. In the Lancaster Chancery Court on Friday Vice-Chancellor Stewart Smith, K.C., heard this action when the Attorney General for the County Palatine of Lancaster, at the relation of the Corporation of Darwen, asked for an injunction to restrain the defendants, John Knowles, Robert Knowles, and Walter Knowles, builders, Darwen, from continuing to build two houses at Knowlesby Street, in that Borough. Mr. Sutton said the action arose under the Darwen Corporation Act, 1887, which conferred powers upon the corporation with regard to the paving of new streets and the erection of new buildings. The defendants built two houses before the street was laid out, and proceedings were taken in the police court, and a small fine was imposed by the Darwen justices. The defendants appealed to Quarter Sessions, which quashed the conviction of the justices, and the case was then taken to the Court of King's Bench. That Court upheld the decision of the justices. The Vice-Chancellor is final. Mr. Sutton said the plaintiffs held the decision of the King's Bench was binding upon the defendants, and probably the Court would not think it right to differ from the Court of King's Bench. After that decision, Mr. Sutton added, the Court of Quarter Sessions formally confirmed the decision of the justices, and the defendants paid the fine. The corporation then understood that the matter was settled, but the defendants, since then, afterwards, gave notice that they were going to proceed with the building of the houses, and the Attorney General for the County Palatine of Darwen, instituted these proceedings to restrain them. At the close of arguments the Vice-Chancellor said he would consider the matter and give judgment as he hoped, shortly.

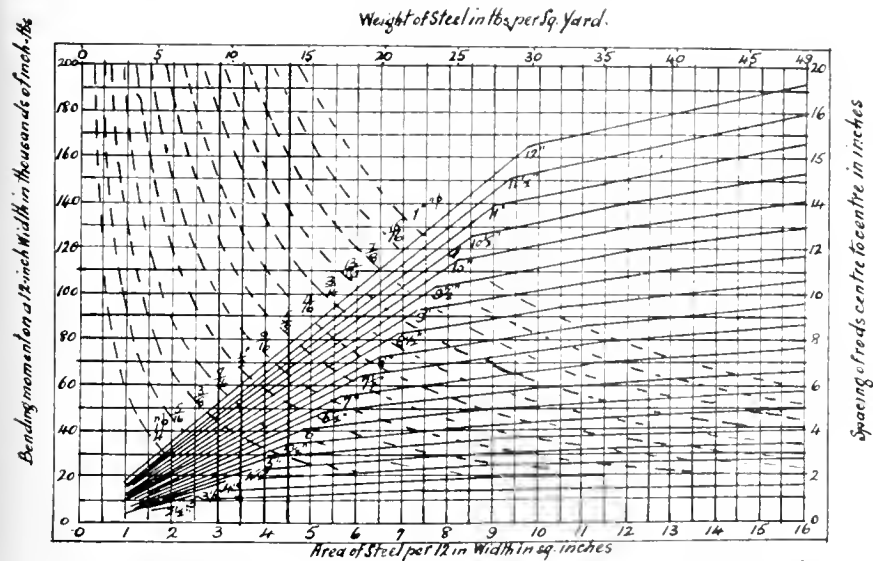

Diagram. For calculating reinforcements in slabs. Based on limiting stresses of 600 lbs. per sq. in. in the concrete, and 16,000 lbs. per sq. in. in the steel. The full lines are for slabs of effective depth stated, i.e., 12" = 12 ins. depth from top of concrete to centre of steel. The overall depth must be increased to allow for at least 1/2" cover of concrete to the steel, so that the total thickness of a 12" in. slab would be about 13 ins. The dotted lines show sizes of round rods the spacing of which is given on the right hand vertical scale.

four edges, and reinforced in two directions at right angles to each other, should be determined as for slabs reinforced in one direction only, with the load reduced, however, by multiplying it by the following factors:

For the shorter span—i.e., breadth—

$$Fb = \frac{1}{1 + \left(\frac{b}{l}\right)^4}$$

For the longer span—i.e., length—

$$Fl = \frac{1}{1 + \left(\frac{l}{b}\right)^4}$$

Where *b* = breadth or shorter dimension and *l* = length or longer dimension.—James Bromley, Rothwell Estate Office, Miller Arcade, Preston, Lancs.

sums provided in the contract which he had agreed to pay to the canal company. Although he had not paid a penny, the Referee not only awarded the amount deducted, but the amount provided in the contract. Mr. A. A. Hudson, K.C., in support of the Referee's finding, argued that the urban district council had incurred liabilities with which Mr. Plowdrill had nothing whatever to do, and after the canal was crossed the district council entered into onerous agreements with the canal company. Eventually their Lordships allowed the appeal as to £225, but affirmed the decision of the Official Referee in regard to the balance of £206. Judgment was entered accordingly, with no order as to costs.

The Board of Trustees of Delaware College, Newark, Del., have accepted the offer of Mr. Frank Miles Day, of Philadelphia, of donations to the college buildings, amounting to over \$225,000.

Mr. William Arthur Mason, of 31, Colborne Row, Birmingham, surveyor and valuer, whose death took place on April 5, has left estate of the amount of £17,435. His executor, Mr. J. R. Reynolds, of 11, in Frederick Road, and the goodwill of his business and other furniture.

An exhibition by the various architectural societies of the Pacific coast has been opened in San Francisco. The collection comprises examples from nearly every town and city of importance in California, as represented by upwards of three hundred individuals and firms.

TO ARMS!

4th Battalion "Architects" Central London Regiment Volunteers.

Recruits are urgently needed for the Regulars, Territorials, and Volunteers. Intending recruits should apply to Battalion Headquarters, where they will be advised as to the branch of the Service for which they are best suited.

ORDERS FOR THE WEEK BY LIEUTENANT COLONEL A. W. WARDEN. Officer for the week: C. S. Bach. Next for Duty: L. R. Guthrie.

REGIMENTAL INSPECTION.

Sunday, July 25, 1915. All members, including recruits, must attend. Dress: Drill order with haversacks and water bottles. Members of Munition Shifts 1 to 4 inclusive will parade at camp as ordered. Remainder parade by the Langham Hotel, Portland Place, W., at 2 p.m. Munition Shifts from camp will rendezvous there. Applications for leave must be received at the Adjutant's Office, 10, Conduit Street, W., not later than this evening, July 21.

MUNITION CAMP.

All members of Shifts 1-4 parade at camp, Saturday, 24th inst., 3 p.m. (train, 2.2 Waterloo), for week end, unless ordered to the contrary. Shifts for duty, week-end commencing Saturday, 31st, shifts 5- inclusive.

Members other than those detailed for munition work who desire to sleep in camp for week-end should notify the Quartermaster at camp, not later than the first post of Thursday morning of each week. These men should report themselves to the Orderly Officer on arrival in camp.

Hours of parade for men not sleeping in camp:— Saturday, 3 p.m. (train Waterloo, 2.2 p.m. for Hampton Court) and Sunday, 11.15 a.m. at camp in each case. (Train, Waterloo, 10.10 a.m.)

A few names are still required of members able to sleep in camp during the week, not necessarily for the whole of the period. Applicants should state for what period they are available. Postal Address of Camp—4th Battalion C.L.R.V., Camp, Summer Garden, East Molesey.

SUMMER CAMP. July 31—August 16.

Names must be received at the Adjutant's Office not later than Friday next, the 23rd inst. All members are expected to attend for one week at least. Company and Platoon Commanders lists of men attending should be forwarded to the Adjutant at Camp by first post Saturday morning next. The cost will not exceed 20s. per week.

BATTALION COMPETITIONS.

Entries in writing should be forwarded to the Adjutant at Camp by next Saturday morning at latest.

DRILLS AND PARADES.

All drills and parades will be held as usual.

RECRUITS.

A number of recruits are required to replace those recently joined the Regular and Territorial Armies, or who have obtained commissions. Applications should be addressed to the Adjutant's office.

RECRUIT DRILLS.

- Company Officers are reminded that they must detail the necessary N.C.O.s as instructors. "A" Coy: Dean's Yard, 1.15 and 6.15 Wednesdays and Fridays. If wet, the drills will be held at Millbank School. "B" Coy: Dulwich College, Mondays, 8 to 10 Thursdays, 9 to 8 p.m. "C" Coy: Now being formed. Drill ground and miniature range, Central Electric Supply Company's Generating Station, Lodge Road, St. John's Wood, N.W. "D" Coy: Moor's School, Tue-days and Thursdays, 6.45 p.m.

SCHOOL OF ARMS.

As usual, at Millbank School, Erasmus Street, Westminster, on Tuesdays, 6 to 8 p.m.

CORRESPONDENCE.

Enrollment forms of new members and all correspondence not referring to recruiting for the Army or to financial matters, must be addressed to the Adjutant, 10, Conduit Street, W.

Correspondence regarding recruiting for the Army should be addressed to the Recruiting Officer at Headquarters.

BATTALION HEADQUARTERS.

10, CONDUIT STREET, WESTMINSTER, S.W.

By Order, L. R. GUTHRIE, Adjutant.

The London County Council Tramways and Improvements Bill, including a scheme for laying tramways along Mansell Street to Tower Hill, was considered last week by a Select Committee of the House of Lords, presided over by the Marquis of Bristol. The principal opponents of the Mansell Street scheme were the Corporation and the Port of London Authority. In the result the Select Committee rejected the proposal, thereby reversing the decision of the House of Commons Committee.

The circumstances surrounding the death of Mr. Stephen Coates, a well-known Middlesbrough builder and contractor, who was killed on the railway at Ormesby Station on Thursday, were investigated by a Middlesbrough jury on Friday night. Evidence was given that Coates had suffered from insomnia and had been very depressed. A signalman said that Mr. Coates got on the footway and deliberately fell down, but put his head on the line when a general train was approaching. A witness of sufficient, which was temporarily insane was not called.

LATEST PRICES.

N.B.—All prices must be regarded as merely approximate for the present, as our usual sources of information are in many cases failing us.

TIMBER.

Owing to stoppage of supplies all prices have advanced considerably.

IRON.

Table listing iron prices: Per ton, Per ton. Rolled Steel Joists, English, £9 12 6 to £9 17 6. Wrought Iron Girder Plates, 9 15 0 to 10 0 0. Steel Girder Plates, 9 15 0 to 9 17 6. Bar Iron, good Staffs, 6 5 0 to 8 10 0. Do., Lowmoor, Flat, Round, or Square, 22 0 0 to 0 0 0. Do., Welsh, 5 15 0 to 5 17 0. Boiler Plates, Iron—South Staffs, 8 0 0 to 8 15 0. Best Suedshell, 9 0 0 to 9 10 0. Angles, 10s., Tees 20s. per ton extra. Builders' Hoop Iron, for bonding, £12 5s. to £12 15s. Ditto galvanized, £19 to £19 10s. per ton. Galvanized Corrugated Sheet Iron—No. 18 to 20, No. 22 to 24. 6ft. to 8ft. long, inclusive, £13 0 0 to £13 10 0. Best ditto, 13 10 0 to 14 0 0. Per ton. Cast-Iron Columns, £6 17 6 to £8 10 0. Cast-Iron Stanchions, 6 17 6 to 8 10 0. Rolled-Iron Fencing Wire, 8 5 0 to 8 10 0. Rolled-Steel Fencing Wire, 7 5 0 to 7 10 0. Galvanized, 8 15 0 to 6 5 0. Cast-Iron Sash Weights, 6 0 0 to 6 5 0. Cut Flt or Brads, 10 15 0 to —. Corrugated Iron, 24 gauge, 16 0 0 to —. Galvanized Wire Strand, 7 ply, 14 5 0 to —. 14 B.W.G.

Table listing B.B. Drawn Telegraph Wire, Galvanized—0 to 8, 9, 10, 11, 12, B.W.G. £10 10s. to £11 15s. per ton. Cast-Iron Socket Pipes—3 in. diameter, 46 15 0 to 47 2 6. 4 in. to 6 in., 6 10 0 to 6 12 6. 7 in. to 24 in. all sizes, 6 17 6 to 7 2 6. [Coated with composition, 5s. Cd. per ton extra. Turned and bored joints, 5s. per ton extra.] Iron—Cold Blast, Lillieshall, 80s. Od. to 127s. 6d. Hot Blast, ditto, 87s. Od. to 97s. Od. Wrought Iron Tubes and Fittings—Discount off Standard Lists (f.o.b. plus 2½ per cent.)—Gas-Tubes, 67½ pc. Water-Tubes, 66½ pc. Steam-Tubes, 60 pc. Galvanized Gas-Tubes, 55 pc. Galvanized Water-Tubes, 51½ pc. Galvanized Steam-Tubes, 45 pc.

OTHER METALS.

Table listing other metals: Per ton, Per ton. Lead Water Pipe, Town, £32 10 0 to —. Country, 33 10 0 to —. Lead Barrel Pipe, Town, 3 10 0 to —. Country, 34 10 0 to —. Lead Pipe, Tinned inside, Town, 34 10 0 to —. Country, 35 10 0 to —. Lead Pipe, tinned inside and outside, Town, 37 0 0 to —. Country, 38 0 0 to —. Composition Gas-Pipe, Town, 35 10 0 to —. Country, 36 10 0 to —. Lead Soil-pipe (up to 4 in.) Town, 35 10 0 to —. Country, 36 10 0 to —. Over 4 in., £1 per ton extra. Lead, Common Brads, 17 17 6 to £18 12 6. Lead Shot, in 28lb. bags, 24 15 0 to —. Copper sheets, sheathing & rod, 102 0 0 to 103 0 0. Copper, British Cake and Ingot, 90 10 0 to 91 10 0. Tin, English Ingots, 162 0 0 to 163 0 0. Do., Basis, 163 0 0 to 164 0 0. Pig Lead, in Lewt. Pigs, Town, 23 0 0 to 24 0 0. Sheet Lead, Town, 32 0 0 to —. Country, 33 0 0 to —. Genuine White Lead, 37 10 0 to —. Refined Red Lead, 31 0 0 to —. Sheet Zinc, 115 0 0 to —. Old Lead, against account, 22 0 0 to —. Tin, 9 10 0 to —. Cut nails (per cwt. basis, ordinary brand), 0 14 0 to —.

* For 5 cwt. lots and upwards.

SLATES.

Table listing slates: in. in. £ s. d. per 1,000 of 1,200 at r. stn. Blue Portmadoc, 20 x 10, 12 12 6 to —. 16 x 8, 6 12 6 to —. Blue Bangor, 20 x 10, 13 2 6 to —. 29 x 12, 13 17 6 to —. First quality, 20 x 10, 13 0 0 to —. 20 x 12, 13 15 0 to —. 16 x 8, 7 5 0 to —. Eureka unfading green, 20 x 10, 15 17 6 to —. 20 x 12, 18 7 6 to —. 18 x 10, 13 5 0 to —. 16 x 8, 10 5 0 to —. Permanent Green, 20 x 10, 11 12 6 to —. 18 x 10, 9 12 6 to —. 16 x 8, 6 12 6 to —.

BRICKS.

(All prices net.)

Table listing bricks: £ 15 0 per 1,000 alongside, in river. First Hard Stocks, 1 11 0. Mild Stocks, 1 9 0. Picked Stocks for Facings, 2 5 0. Plettons, 1 14 0. Pressed Wire Cuts, 1 18 0. Red Wire Cuts, 1 14 0. Best Fareham Red, 3 12 0. Best R d Pressed Ruabon Facing, 5 0 0. Best Blue Pressed Staffordshire, 3 15 0. Ditto Bulfnose, 4 0 0. Best Stourbridge Fire-bricks, 4 0 0. 2½ n. Best Red Accrington Plastic Facing Bricks, 4 10 6. 3½ n. Accrington Best Red Plastic Facing Bricks, £2 10 0. Ditto Second Best Plastic ditto, 2 2 6. Ditto Ordinary Secondary Bricks, 1 11 3. Ditto Plastic Engineering Bricks, 1 17 6. Sewer Arch Brick, not more than 3½ in thickest part, 2 0 0. 3½ Chimney Bricks fit for outside work, 2 6 0. 3½ ditto ditto through and through, 2 0 0. 3½ Beaded, Ovolo and Bevel Jambes; Octagons; 2½ and 3½ radius Bullnoses; Stock patterns, 3 7 9. Accrington Air Bricks, 9" x 2 course deep, each, 0 0 6. Ditto ditto 9" x 1 course, 0 0 6.

Table listing Accrington Camber Arches: 3 course deep 4½" soffit, per foot opening, 0 1 3. 4 " " " " " " " " " " 0 1 8. 5 " " " " " " " " " " 0 2 1. 6 " " " " " " " " " " 0 2 6. 7 " " " " " " " " " " 0 2 1. 8 " " " " " " " " " " 0 2 11. 5 " " " " " " " " " " 0 3 6. 6 " " " " " " " " " " 0 4 6. Net free on rail, or free on boat at works.

GLAZED BRICKS.

HARD GLAZES (PER 1,000).

Table listing glazed bricks: White, Ivory, and Best. Salt Glazed. Buff, Cream, Other Second. Best. Seconds. & Bronze. Colours Colours. Stretchers—£12 7 6 to £10 17 6. Headers—11 17 6 to 10 7 6. Quoins, Bullnose, and 4½ in. Flats—15 17 6 to 14 17 6. Double Stretchers—17 17 6 to 16 7 6. Double Headers—14 17 6 to 13 7 6. One side and two ends, square—18 17 6 to 17 17 6. Two sides and one end, square—19 17 6 to 18 7 6. Splays and Squints—17 7 6 to 15 7 6. Plinth and Hollow Bricks, Stretchers and Headers—5d. each, 4d. each, 6d. each, 6d. each, 5d. each. Double Bullnose, Round Ends, Bullnose Stops—5d. each, 4d. each, 6d. each, 6d. each, 5d. each. Rounded Internal Angles—4d. each, 3d. each, 5d. each, 5d. each, 4d. each.

MOULDED BRICKS.

Table listing moulded bricks: Stretchers and Headers—8d. each, 8d. each, 8d. each, 8d. each. Internal and External Angles—1 2 each, 1 2 each, 1 2 each, 1 2 each. Sill Bullnose, Stretchers, and Headers—5d. each, 4d. each, 6d. each, 6d. each, 5d. each. Majolica or Soft Glazed Stretchers and Headers—£22 17 6. Compass bricks, circular and arch bricks of single radius 46 per 1,000 over above list for their respective kinds and colours, exceeding 9 in. by 4½ in. 1s. 2d each. Stretchers cut for Closers and Nicked Double Headers, £1 per 1,000 extra.

* These prices are carriage paid in full truck loads, to London Stations. Thames Sand, 7 6 per yard, delivered. Pit Sand, 7 0. Thames Ballast, 6 0. Best Portland Cement, 36 0 to 41 0 delivered. Ground Blue Lias Lime, 21 0 per ton delivered. Exclusive of charge for sacks. Grey Stone Lime, 13 6 to 14 0 delivered. Stonbridge Fireclay in sacks 27s. Od. per ton at rail, way station.

STONE.

Table listing stone: Red Mansfield, in blocks, per foot cube, £0 2 4. Darley Dale, ditto, 0 2 3. Red Corshill, ditto, 0 2 2. Cleseburn Red Freestone, ditto, 0 2 0. Ancaster, ditto, 0 1 10. Greenhill, ditto, 0 1 10. Beer, ditto, 0 1 6. Chilmark, ditto (in truck at Nine Elms), 0 1 10½. Hard York, ditto, 0 2 0. Do. do. 6 in. sawn both sides, landings, random sizes, per foot sup., 0 2 8. Do. do. 3 in. slab sawn two sides, random sizes, 0 1 3. All F.O.R. London.

tion for its judiciousness and refined Greek character, which in Leeds would seem to lack as Broderick's famous : with a. This museum has four galleries and a portico all in stone and looking in the money proposed would provide for. A book prize is accorded to Mr. Cuthbert B. Stewart, of Newcastle-on-Tyne, for a block of almshouses set out in a quadrangle with a dining hall. This subject is very like one of the advanced students' schemes on view this year at the Royal College of Art; so much so, in fact, that both appear to be the result of the same instructions. But this may be a mere coincidence. Mr. Stewart puts the almshouses' bedrooms on the first floor, and the colonnaded cloister or verandah in front must darken the ground-floor rooms, add much to the cost, and prove very draughty for the aged to sit out under. There is much waste of space in the roofing, which is covered with red tiles, but would seem to be pretty in execution. Mr. Percy Whitehead, from the same school, gets a similar prize for an elementary school and a fireplace. "Commendation" is the limit of recognition devoted to Mr. Stanley E. Ridger, of the Armstrong College, Newcastle-on-Tyne, for a garden pavilion, shown by a taking yellowish pasted view sketch of a loggia and solid-looking side summer-houses, or tool places, which appear to make up a pleasant scheme backed by trees. The "measured drawings" are not much more exhilarating than these architectural designs, but Mr. William N. Spence, of Dublin, shows a workmanlike set of Trinity College Chapel in that city, giving plans and details of a type of building for which Dublin is so famous, and which is now much in fashion. We need not allude to the other few things in this immediate above devoted to architecture; indeed, that art is so insufficiently represented that to fill the wall and two side screens other things follow on. Before proceeding to the gold and silver medal works, we made a note or two at the far end of the big north gallery on some decorative interior work by Mr. Arthur E. Harvey, of Hackney Institute, for the interior of a ballroom in a country house. It proposed a Late Classic panelling for the mural treatment with pedimented over-doors and panel emblazoned with heraldry over the fireplace, of which features details are given. The capital ceiling in plastering has a cove with foliations in the corners beyond the mitres, and in the centre of its lengths. All very good of its kind on old lines. This thoroughness is worth much more than a book prize, even if the fireplace is rather flat in design. At least it is reserved and in scale. Mr. Percy B. Hindson, of the Storey Institute, Lancaster, only scores a book prize for his decoration drawings of a dining-room and furniture, including a fairly successful sideboard, a carving chair and a smaller *meuble*. There is also a view of the room in water-colour and sets of plans showing the lay-out. We hardly think it is wise not to recognise such a standard of work, giving only a book—not that we reckon the design too highly; still, there is a limit.

There are this year seven gold medals, 58 silver medals, 163 bronze medals, 334 book prizes, and 1,422 commended designs in the Exhibition. The modelled figure from the rule of a man, somewhat recalling the Quot. Thrower, admirably wins a gold medal. It is by Mr. George W. Bedford, of Leeds, who has imparted to it a fine swing generally and good pose of the head in particular, the figure excellently modelled in its detail. The Jewelry Class, as we have already

intimated, is strong this year, and the Camden School of Art, Islington, is once more singled out for a gold medal. It is given to Miss Dorothy Ballantine for a cloisonné and gold and silver necklace with coloured enamel pendant, harmonious in scale and tone throughout, though, perhaps, lacking merit in its design, and undistinguished by much special inventiveness of idea. The judges in this section are Messrs. Nelson Dawson, R.E., Alexander Fisher, R.B.S., and George B. Heming, the same examiners who almost invariably have decided these awards for some years, and nearly the same words were repeated in their report this time as those printed in 1912, when a gold medal was given to Miss Dorothy Munro, of the Camden School, for a Scotch-like enamelled cloak clasp. Last year four silver medals went to the same Islington school, besides a bronze one for jewelry. On the present occasion Mr. Wilfrid L. Vinson of this school takes the jewelry silver medal (29) for a pendant and chain in gold and silver set with stones. We think the pendant is rather bizarre in effect and overdone by its attachments. A bronze medal is won by Miss Cecilia Adams, of Belford Park, from the Central School of Arts and Crafts, Cambridge, for two necklaces; one in gold having a pendant with a Mediaeval castle set about with jewels and foliage beautifully executed, and with an idea of its own, and the other in enamelled links of a delicate chain and carrying a moonstone drop pendant wrought about with ideal settings. In the same showcase, and as a centre to the other two exhibits in the place of honour, is an exquisitely rich necklace in gold and enamel, blue and white, interspersed with ball chains in enamel, bearing an engraved swivel pendant illustrative of personalities of the contemporary "Dance" set in a jewelled and foliated frame by the same lady (374), and for this work a book prize was thought appropriate. Miss Dorothy Hollam, also from the Peckham Road School, has a bronze medal for an enamelled plaque not particularly interesting. When competitors send in a group or set of similar works of art with a view to recognition on their merits in the same class, it seems unreasonable to divide them up so as to give two minor prizes in lieu of one substantial reward, especially when the rule "b" precludes the successful student from receiving more than one of the same class prizes. It looks like giving with one hand and taking back with the other, particularly when the asterisk is added signifying that the competitor is not qualified, no matter what his or her skill may be, to receive any prize as recommended by the examiners. There is no quibble for which some plausible excuse may not be found, and this, perhaps, is one of such.

A gold medal is well won by Mr. G. Rayner Hoff, of Nottingham, for a modelled design for a plaster panel over a theatre or opera-house proscenium. The work is rhythmic in the progression of the low-relief figures, with an exquisite reserve and power of grouping, flatly handled, with horses at the tail-end of the procession. Miss Gwen White, of Marybone Polytechnic, for a stained wood dressing case, scores a gold medal by her accomplished handicraftsmanship, though the unpires reckon the opaque pigment here used detracts from the vivacious colour displayed by her work last year, when they gave her a gold medal for a triptych, which we then favourably noticed. This year's medal can-

not be taken by this lady. Mr. David Evans, of Manchester, sends a "Roll of Honour" frame in oak, carved with laurel leaves in a distinguished way, which fully merits the gold medal accorded. The work evinces a knowledge of old work and traditional manner, while the author has impressed his personality in an original and crisp handling, adding illuminated heraldic shields in the head of the frame. This is quite one of the best things in the Exhibition. Mr. L. R. Squirrell, of Ipswich, takes a silver medal for delightful studies and etchings of old houses and sheds, and Mr. Fred C. Jones has a like reward for fine book illustrations of "Gulliver's Travels" (Bradford 13). We are much taken with a glazed pottery figure of a woman in green and dark brown purple robe, from Hanley School by Mr. Joseph Bension, whose work is of great interest in colour and modelling, for which he wins a silver medal. Miss Grace Ashmore, in the same case and from the same school, is represented by her bronze medal Piping Shepherd on a Rock, in pottery. Miss Gertrude Green has a Japanese-like figure of like kind for which a book prize is given, and the penguins by Mr. Lionel Peters, of Greenwich, are "commended." The figure studies from the nude this year are not so brilliant as usual; but Miss Constance Carver, of Leicester, has a silver medal for a direct and well-shaded-in graphic back view of a man vigorously drawn, and Miss Dorothy Bunn, of Birmingham, has fine shaded heads from the life. The stained glass is exceedingly well displayed this year, but the wall-paper designs are puerile. Miss Doris Boulton, of Deptford, sends some excellent coloured lithographs, for which she won a bronze medal.

ROYAL COLLEGE OF ART STUDENTS' WORK EXHIBITION, 1915.

Notwithstanding the fact that this is the smallest show which we have ever seen since the Royal College of Art was established, the Board of Education has not yet made up its mind as to how the prizes and studentships are to be allocated, or, indeed, whether the prizes will be awarded at all. There may be a good reason for this delay, but even if competitors are few this season, there is all the more reason, surely, to encourage participants by business-like conduct on the part of those at the head of affairs. Officials with comfortable posts possibly care little how much often depends upon some individual student's comparative success or otherwise negligence. Indeed, our inquiry only elicited a pained surprise at our wonder of the hesitancy of the Board.

The private view of the exhibition was last Friday, and it is now open to the public in Exhibition Road, behind the Science Schools in the Royal College of Art. If small, the exhibition has the merit of being compactly arranged all on one floor and within compass, but otherwise the advantage is small, too, because there is not much of it, considering what the cost to the country just now is when money is so badly needed for more serious business; not that we are blaming the professors and officials, for, obviously, without the class attendances, there can be no material for production in proportion to the outlay.

Taking the architectural exhibits in the order of their hanging, having little else to guide us, we begin with one of the Royal Institute of British Architects, "Testimonies of Study." In other art centres these studies turn up, and it may be said in a correct way, but, for all that, it is

not easy to apportion what share the many and various professors and staff have to do with such evidences of equipment on active individual service. A first year "specialising" design (No. 25) is by Mr. H. St. J. Harrison, the subject being a monument to Lord Roberts. The structure is set upon a raised platform with an equestrian figure of the great soldier seated in front of a tower surmounted by a group of "Victory," driving a chariot of three horses. Steps go down on all sides save where the ugly raking wall at the rear stops them off. An open loggia forms the base of this tower, and above its rusticated base with the pedimented openings on all four sides, the walls are devoted to military trophies suggested by the French Renaissance type of ornamentation, and wreaths adorn the attic stage with swags drooping on either hand. The figures are most indifferently depicted.

Nos. 26, 28, 31, 33, 37, and 39 are more or less correctly termed designs for "A National Art Library," and seemingly proposed as one wing of a bigger scheme for spending public money when, perhaps, the war is done with. Mr. Harrison (No. 26) shows a long block of building with reading and index rooms flanking a central cortile or vestibule, and this above stairs has magazine alcoves, the stairs being at the extreme ends of the premises, to fit in, as we suppose, with the adjacent or ultimate additions. The stairs really are not exclusive to this National Art Library. The façade in this case has coupled columns between semi-circular arched windows having disc niches above them for the busts of great men, and surrounded by wreaths or garlands to give a due solemnity. The cupola in the middle of the structure has a very stilted and meaningless look, speaking as we can only do for the library, for it is that alone with which we are now concerned. There is a lantern story below the dome, with windows of lofty proportions. Perhaps this scheme is as good as any, though the mansard roof is not very pleasing, and the lighting is insufficient with the projecting bookcases dividing the rooms quite properly into bays, but tending, of course, to obscure the light in the centre of these lofty apartments with florid coffered ceilings above a very heavy cornice. The detail sheet is restless in draughtsmanship; otherwise for a "first-year advanced class student," the design is commendable, even if the elevations sadly want a good plinth, which is a bad fault.

Nos. 30-32 are by Mr. J. C. Taylor, of the Upper Division school. His design for the art library is not so amply illustrated, and has no complete plan, but a careful study is figured on a separate sheet for the tympanum of the central pediment, with the figures much better put in than usual. The sheet of details, too, is good in this respect. The Ionic caps have coarse-looking volutes. The segmental-headed windows in the rusticated plinth part of the façade suggest a lack of light behind the foliated grills, which are intended to give protection, perhaps, and add an interest to these comparatively poor sort of openings. The roof, being flat pitched, is hidden by the balustraded parapets. The coupled columns are rather hackneyed, and so is the Italianlike treatment of windows, such as the late E. M. Barry rather fancied. It is notable because of the professorial fuss about advance and tall talk about Art in Architecture, and it looks odd to find contemporary professors' pupils reckoned in the same category as those of Professor E. M. Barry. Possibly this result is due to the fatal effect of trying to be merely "scholarly," a word used really when a design appears to possess no virile merit.

The paucity displayed by the treatment adopted in No. 29 by Mr. J. S. Knook is largely due to a thin line of brown ink draughtsmanship and the wide-spaced row of single-fluted Doric columns. The pedimented windows with neat architraves set between this colonnade are refined, and in reality would work out well in execution having more breadth of walling, which is no small gain. The square heads of this fenestration would insure more light. We much prefer the cupola in this design to that of No. 26, but, internally, the dome would be quite dark, unless a skylight is intended at the crown of the structure, and which, indeed, may be intended between the upper and the lower domes. This, however, is not clearly set out. The author has shown a quiet scheme of colour decoration in reds and blues. The galleries to the reading-rooms come above the windows, and there appears to be no top light. The remark of the Judges in the National Competition, which we have quoted in our notice of that exhibition, as to the sections not properly showing the intended construction of a building, certainly equally applies to the students of the Royal College of Art, if we take these drawings as evidence.

No. 35, by Mr. M. C. Oliver, is architecturally indifferent, being devoted to a fulsome decorative scheme. No. 37 likewise is made unduly subservient to its colour adornment, which evidently is the main idea of its author, Mr. T. C. Eastwell. The design marked 39 is the work of Mr. J. Nixon, who limits his proposal to decoration almost entirely. We presume he is not "specialising" in architecture, as some are said to be. His ornamentation is much too ambitious for even a National Art Library. Mr. G. C. Styles represents the "Advanced Upper Division" of the School by his monument to Lord Roberts (No. 24). It consists of a short panelled obelisk-like erection, having tomb-like recumbent figures of Egyptian females stuck up on end tilted against the inclined plane on the cardinal faces of the "obelisk." The detail is coarse, and soldiers in contemporary khaki range at the angles on guard in close order of single file, crowded together to give room for an enormous panel with brahminagian lettering for the word "Roberts," in case we should forget. This is, however, a capital set of sepia-washed drawings. In No. 22 Mr. Styles furnishes a design for a public library, if we read the sections correctly. The drawings are unfinished in pencil. Massive columns of the Ionic order are employed singly, with big windows between them in two ranges to amply light both floors, one being the gallery level of very lofty apartments with flat ceilings well treated. The building has a substantial plinth pierced by square windows to the ground story. A very flat and fussy pediment marks the middle of the façade, and there is rather a clumsy look about the scheme, which is hardly done justice to by the detail study exhibited, though it is capital from the "scholarly" standpoint, which has its limitations. It would be a poor criticism to describe a poet's work by such a term. Mr. Styles shows a set of almshouses, with a dining hall schemed seemingly upon conditions similar to a corresponding proposal, obtaining a Book Prize in the National Competition, by Mr. C. B. Stewart. The College of Art design, No. 22, by Mr. Styles, is in an expensive stone treatment of Jacobean character, well worked out in that respect, but having a very indifferent plan and internal w.c.'s opening out of the bed-rooms. Convenient, no doubt, for old folks; but they are apt to be very dirty in their habits, and, anyhow, the arrangement is not sanitary, seeing that the lobbies have

no direct ventilation, and are lit by a separate lighting system. The appointments are not very good, and the inmates, evidently, will be obliged to take all their meals there, and wash, whether sculleries and wash-houses be there. Such a foundation will be a very seriously-endowed charity for the aged, infirm, and staff.

Two over-elaborated designs are shown. No. 11, by Mr. J. S. Lawson is overdone but ingenious. No. 13, by Mr. W. J. Knight, merits the same remark, and both in a way, perhaps, are clever. Mr. Lawson's Lord Roberts' Memorial Chapel is quite praise-worthy (p. 7, and 20). Some excellent studies are being in the room of existing and historic types of design done by the students of the "Lower Division." These include Greek ornament, bronzes, and reliefs. There is to be also shown a "Library Study" of medieval foliage from Lincoln Cathedral.

In the Sculpture School, as usual, very capital work is to be seen, and a series of casts show a recumbent figure of a nude girl variously treated from the same model, the difference structurally being in the way in which the extended arm is managed. Mr. C. T. Wheeler leaves the hand outstretched unsupported. Mr. J. A. Floyd uses a book as a prop, which seems needed in sculpture, and Miss Jessie M. Riding uses a crouching monkey for the same object, gaining a suggestion of contrast, for the beauty of her figure is very attractive. Mr. W. S. Wilkinson's figure rests her hand on a vase. The attenuated legs of this model are to be noted. Mr. R. T. Cotterill shows in No. 15 a modelled design for a mantelpiece, rather capable, with a restrained note about the work and a figure panel over the fireplace. The unfinished composition for a similar subject, by Mr. C. W. Smith (14), is, however, much more suggestive with the curved in lines of the main cornice to the room in which the chimney-piece is to be placed. The usual arts and crafts are represented by much that is excellent and much that seems inconsequential and over-elaborated, but the glazed pottery seems equal to the standard of past years. The etchings shown in the gallery beyond Professor Lethaby's room are interesting, but somehow this year are less impressive than on the last occasion. Some clever and inimitable character studies are on view by Mr. George Behler, the "Punch" artist, to liven up the room.

The School of Painting includes decorative and other renderings of the stories of Shahrazad and the Merchants' Story of the Jinns, of the Ladies of Bagdad, and of the History of King Younan, all very clever, no doubt, if a trifle far fetched for contemporary needs, and this, presumably, should be the aim of the Royal College of Art in studying the art schools of the country. Perhaps subjects for training are of secondary importance, but the designs are as good as many of their subjects.

A convent and seminary are to be built at Kild of the Grange Co. Dublin, the designs of Messrs. W. H. Barry and S. J. Sulloek Street, Dublin.

The Corporation of Sheffield have decided to proceed without delay with the progress for covering the city with an Exchange Street, a street which will run into the river Don at Birk Street, and be of 120 yds. The work has a bearing on the contemplated new market scheme, and is part of the Exchange Street and Farnival Road widening operations. Rigid economy is being exercised in its execution, and it is expected that it will be completed for an outlay of £9,000. The plans and particulars in connection with the scheme were prepared by Mr. C. F. Wike, the city engineer, and the work is being carried out under his supervision.

THE ELIZABETHAN OAK ROOM, LEIGH HALL, ESSEX.

This Hall dates from 1561, and was always celebrated for the oak panelling and carved oak work within its walls. The Elizabethan Oak Room from Leigh Hall, Essex, is now in London. As the accompanying note states, the room can be reinstated according to the original plan given, but the chimney-piece and panelling could, of course, be adapted to another plan. We understand that the room has been temporarily erected in London, under the direction of Mr. Mark H. Judge, A.R.I.B.A. It can be viewed on application to him at 7, Pall Mall.

Essex is not a county particularly favoured by the collector or connoisseur; indeed, on



TOP OF PILASTER.

almost every ground, it is the Cinderella among English counties, unduly overlooked both for its own special features and its contents. In this last respect the panelling from Leigh Hall here illustrated is important enough to correct what is only too common a view of the county's claims to consideration, and will serve to show what may still be sought for without invariably overworking districts of a more brilliant reputation to the art hunter.

Leigh Hall, now demolished, dated from 1561. Its architectural interest resided in its wealth of oak work, and the very fine carving of that. The work belongs to a period which is the most interesting point in the development of the English Renaissance, where we find—*for styles of architecture are no more to be bound by kings and queens than any other art*—Elizabethan merging into Jacobean. The nature of the work is such as to recompense the genuine artlover for the absence of any definite historical connection with the Hall, or Mansion House as it originally was known. The manor of Leigh does, however, under surprisingly diverse forms of the name, go back to the beginnings of our history: it figures in Domesday; records occur in the reign of Edward II., and its later history is associated with such names from English history as Rich. Warwick, Bolingbroke, the manor passing from the last named to other members of the St. John family. The town of Leigh lies in the vicinity of Southend, and has given us many naval heroes and voyagers—Sir Richard Haddock, Whittaker, Andrew Battel. Camden remarked upon the "lusty seamen" with which the "pretty little town" was stocked. It may be of interest to refer in passing to the "Collectanea Spectantia Manerium de Leigh," six volumes of manuscripts, as yet unpublished, in the library of the Essex Archaeological Society.

Turning now to the oak room itself, which can be completely reinstated in all its original features, the beautiful preservation of the wood is perhaps what first strikes us. The condition of the panelling is splendid, the soundings being striking testimony to the quality of the joiner's work. The design of

the panels, together with the carving throughout, and the culminating feature of the chimney-piece, give the room a real importance, best appreciated by a comparison with other examples of this period, like the two "oak rooms" in the Victoria and Albert Museum. One of these was removed from a house at Bromley-by-Bow formerly known as the "Old Palace," dating from 1606. As set up in the museum the panelling is slightly rearranged, with parts renewed. The room measures 23 ft. by 20 ft. 6 in., and the panelling is square throughout. The Leigh Hall room has a length of 35 ft. and a width of 25 ft. 5 in., and the apt-to-be monotonous effect of square panelling is relieved by a charming use of diamond panels above a more complex geometrical design formed by the superimposition of simple rectangles.

The vertical divisions so essential to the aspect of a large room are provided by characteristic pilasters, the precisely cut ornament on which is testimony to the hardness of the oak. This is oak treated as the Greeks treated marble. The panelling is completed by a carved frieze below the final cornice,

in the right place, a minor echo of which we perceive in the subsidiary points of the rooms occupied by the pilasters, the whole being held together by the surrounding frieze.

Panelling in such extent and of such a high standard, in so fine a condition, as Leigh Hall has provided us with, will become more in request as it becomes more difficult to obtain. The love of a "panelled room" seems to be inherent in our nature. It is interesting to remember that the panelling of Elizabethan times and downwards was only a reversion to the original practice of covering the walls with wainscot, which had given way to tapestry wall-hangings, and we can see a reflection of the play of fancy so easy to be indulged in with tapestry when the idea of oak panelling came to be fully developed. It coincides with the rise of English furniture, and panelling should really be considered as a link between the purely architectural form of a house and the intimate embodiment of life which alone can give a meaning to each individual room.

So regarded, we shall find that the peculiar charm of an old English interior is to be

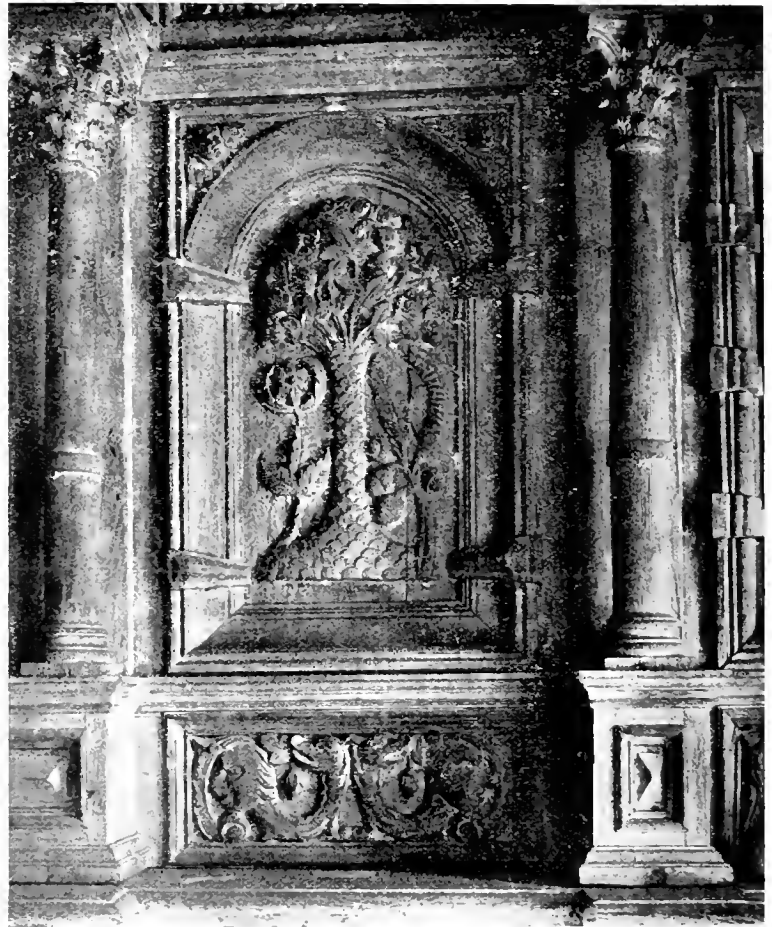

PART OF CHIMNEY-PIECE.

broken up by grotesque heads over each pilaster, which have almost a Norman vigour and much of that noble quality of the true grotesque on which Ruskin was so emphatic. There is no dado, and the panelling is extended down to the floor, the height from floor to cornice being 9 ft. 6 in.

Further detail of the room is hardly necessary, except a reference to its chief feature, the chimney-piece. This is an integral part of the room, with a more than usual architectural character. The fireplace is always the nucleus of the English home, and the elaboration we find invariably bestowed on it is only the natural consequence of this importance persisting throughout all styles and periods. Too often we find it indeed overdone, not quite in harmony with the rest of the room, as though it were something imported that did not really belong there. But there is no mistaking the unity achieved in the Leigh Hall room. It is a composition in which we find not fancy run riot, but just the right concentration of elaborated detail

explained by a sense of what in the Renaissance of Italy would seem but an unjustified violation of the spirit of a particular style. In Italy interior and exterior are dominated by the same rigidity, the actual coldness which seems the setting necessary to Italian warmth of sentiment. Unrelieved, this deliberate austerity must ever fail to satisfy the ineradicable English nature seen underplaying every current of our architecture. Even where English reserve has flown to the Italian expression for its outer mask, its inherent love of freedom and healthy vigour was not to be denied in the intimacy of the home life, and so we find the early English joiner indulging in variations on the "orders" which the mason would hesitate to follow. Function and nature of material must always be the prime factors in determining the enduring qualities of architecture, factors which must justify the craftsman in the degree of departure from recognised standards, in precisely how far he may experiment with the expression of a certain dignity of character.

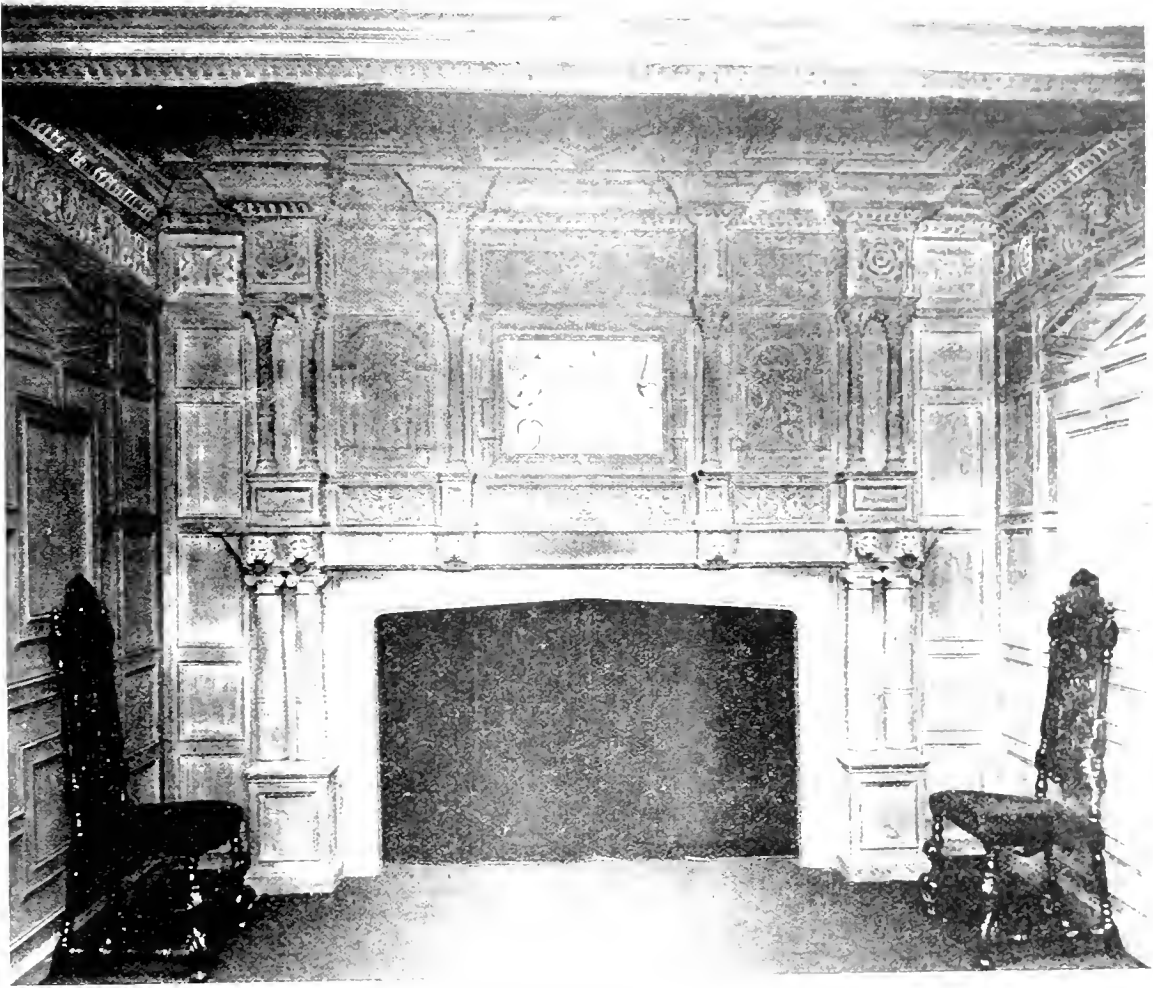

THE CHIMNEY PIECE.

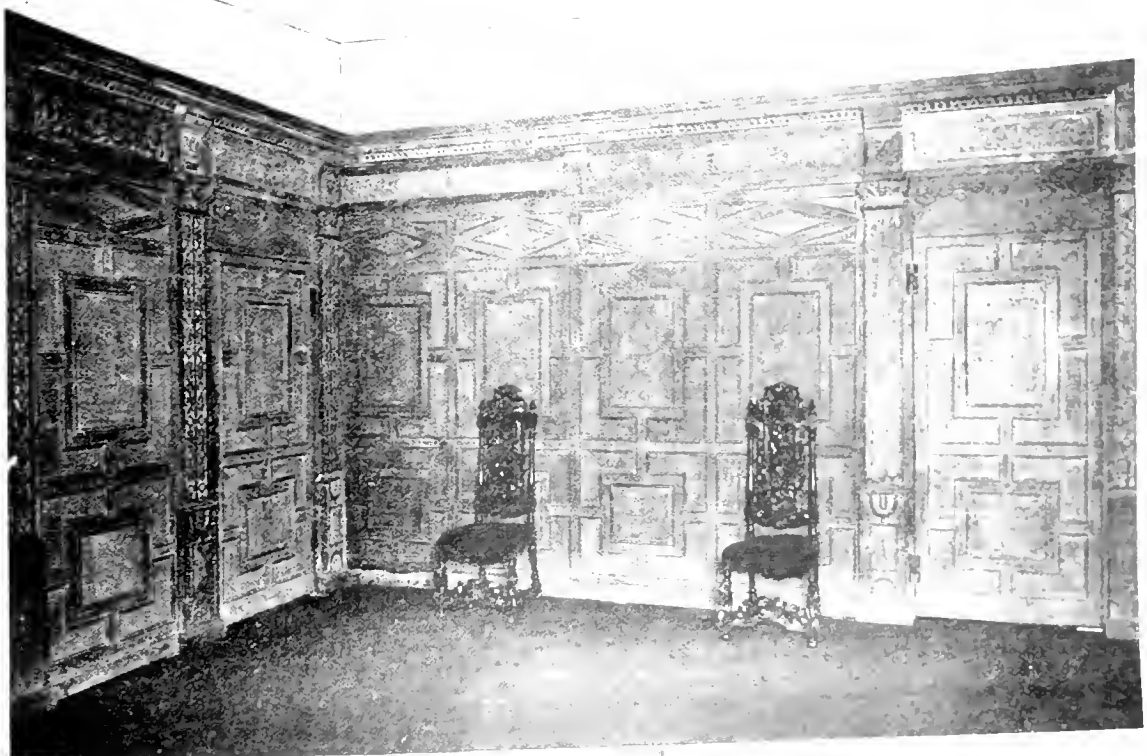

AN ANGLE OF THE ROOM FROM LEIGH HALL, ESSEX.

a well-earned propriety of demeanour, underlying the English character. If certain aspects of the house are asked to conform to certain conventions, all the more can this conformity be released in other, more personal aspects, and we shall take joy in finding that there is after all something a little more tolerant of natural impulses behind the reserve which the English character so loves to assume.

Take only the chimney-piece from Leigh Hall, and the irresistible fascination of the "architecture" which in any other connection would be grotesque parody. Here, the Corinthian columns are like rapid sketches of something actually seen abroad, and all the more convincing than orthodox Classic models based merely on some "Parallel" of the orders, faithful enough reflections of Vitruvius or Palladio but wanting the personal touch, the sense of a personal feeling

pensioners died. The institution is greatly indebted to those old friends of the charity who so generously supported the treasurer's appeal last November: the amount received saved the Committee from realising any invested capital, and so retained the financial position acquired during the past sixty-eight years. The Committee tender their hearty thanks for their kind assistance to the trustees (Mr. F. J. Dove, Mr. Frank May, J. P., Mr. Thos. F. Rider, Mr. T. Stirling and Mr. T. J. Bolding), and to the honorary auditors (Mr. J. T. Bolding and Mr. Hubert S. Ward, F.C.A.). The Committee are informed that Mr. George R. Holland will kindly consent to act as president for the coming year.

The report was adopted on the motion of Mr. Frederick Shingleton, M.V.O., seconded by Mr. Frank May.

cluding salaries, rent, advertising, stationery and postage, had been reduced from £261 7s. 6d. to £222 10s., and the net result was that the balance on deposit current account and with secretary was reduced from £794 10s. 6d., at which it stood last year, to £521 13s. 11d. The total income from all sources was £2,600 18s. 7d., against £2,928 14s. 4d. The Chairman concluded with an earnest appeal for additional subscriptions to meet the difficult situation that would surely ensue in the building trade before long.

Mr. May moved that the balance-sheet and statement of accounts be received and adopted, and this having been seconded by Mr. Shingleton, was carried unanimously.

On the motion of the Chairman, seconded by Mr. May, Mr. George R. Holland was re-elected as President, the Chairman expressing a hope that they would speedily see him in

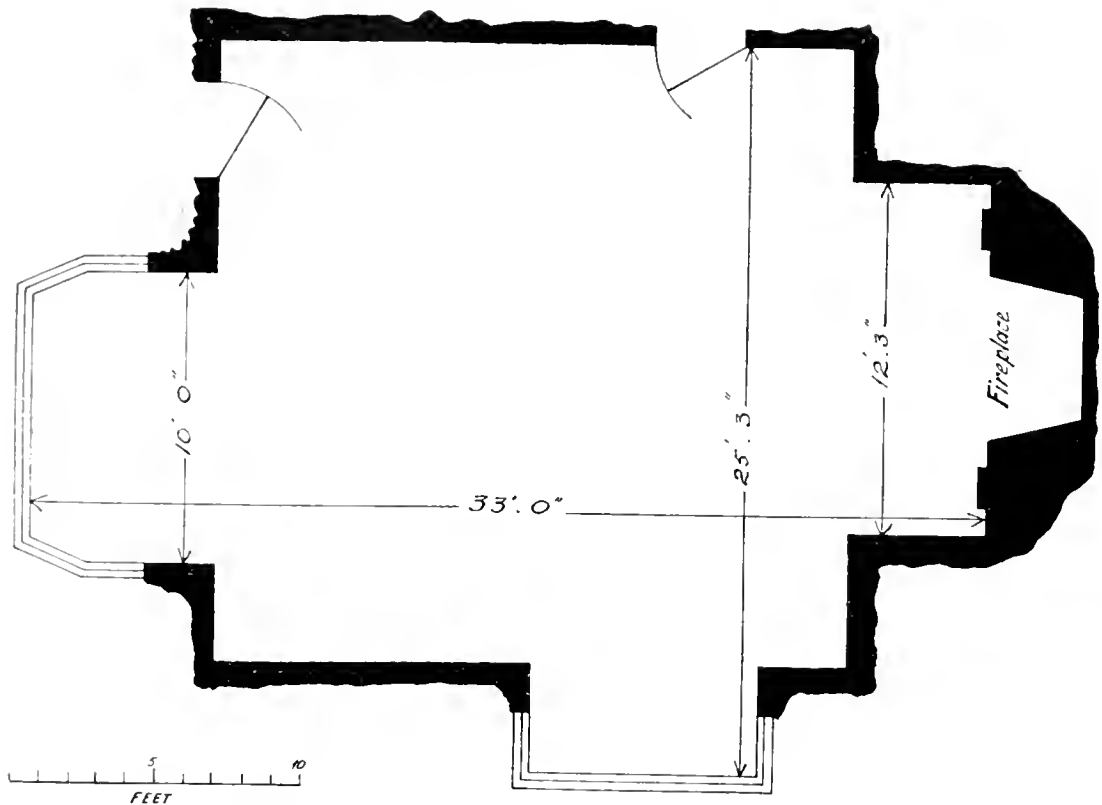

PLAN OF THE ROOM FROM LEIGH HALL, ESSEX.

for the thing done, without which art is merely reproduction of what has been done already, sacrificing what an interpretation gains.

IAN IVOR.

BUILDERS' BENEVOLENT INSTITUTION.

The sixty-eighth annual meeting of this deserving charity was held on Wednesday afternoon at Koh-i-Nor House, Kingsway, W.C. In the absence of the president, Mr. George R. Holland, who is at the front, Mr. John Bolding, past president, was called to the chair.

The annual report of the Committee of Management was read by the Secretary, Mr. Thomas Costigan. The Committee expressed their deep regret at the continuance of the war, and wished to mark their appreciation of the action of the president and the members of the Committee who were serving in his Majesty's Forces. The report continued: The past year has been an exceptionally trying one for this charity, as it, in common with other institutions, has experienced the loss of much support in consequence of the numerous appeals made to meet national needs. The Committee deplore the death of Sir Arthur Charles Lucas, Bart., who for many years was a generous contributor to this institution and one of the trustees. During the past year two men and four women have been added to the pensioners' list, which now includes 27 men and 15 women. During this period five male

The Chairman next submitted the annual balance-sheet and statement of accounts, which had been carefully scrutinised and audited by Mr. Hubert S. Ward and himself. He went through the details seriatim item by item, comparing them with those of last year, and pointed out that, considering the exceptional circumstances, the institution had well maintained its position, although he felt that there ought to be a much more general response from members of the trade, and that the number of subscribers and donors ought to be larger. The annual subscriptions last year, £368 16s., only showed a falling off of less than £10 on the previous year's amount, £378 8s., but owing to the decision to abandon the annual dinner the donations showed a serious diminution. The deficit was reduced by a response of nearly £100 to an appeal sent out by the treasurer, Mr. Frank May, but even then they only received in donations £589, against £835 18s. last year. The two sources of current income, subscriptions and donations, thus totalled £1,057 16s., against £1,265 6s. 2d. last year. The interest on dividends, £751 18s. 4d., was the same as last year, less the additional income-tax deductions: two pensions, amounting to £7 12s. 6d., had been refunded, and they still had the Ingle legacy, £567 13s., on deposit, awaiting the appointment of additional trustees. Turning to the expenditure side, the amount of pensions and burial moneys paid was £1,356 14s. 8d., against £1,872 17s. 4d. last year. The expenses of management, in-

full health and strength at the head of the committee.

On the motion of Mr. Frederick Higgs, seconded by Mr. Carter, Mr. May was re-elected as treasurer, with hearty thanks for his successful efforts by circular to increase the funds of the institution.

The Chairman said the next business was to elect eight members of committee in place of those retiring by effluxion of time. He suggested that the retiring members be re-elected, and that he put the names separately.

Mr. J. Chessum asked before the names were given that the number of attendances for the past year of all members of committee be read out. There were some who had not been more than once or twice to the monthly meetings, and in the past a member put in an appearance for the first time for twenty years. No one present recollected him, and the Chairman had to ask how it was he had come there. To send invitations to such members was a waste of the secretary's time, of stationery and postage, and he moved that all who had failed to attend more than twice in the year be struck off the committee.

Mr. Northcroft and Mr. F. Higgs expressed sympathy with Mr. Chessum's outspoken remarks.

The Secretary read a list of the committee, and opposite many names were recorded "attendances nil" and "once" or "twice."

The Chairman said there was another side to the question. No fewer than fifteen mem-

bers of the committee were past-presidents, who retained their seats *ex-officio*, and many of them were well advanced in years. No doubt it was necessary to have a live committee, but these gentlemen had contributed generously and still gave liberal aid, and even if these left the routine of committee work to younger men, the trifling sum expended on postages brought in a large return.

Mr. Northcroft moved, and Mr. Higgs seconded, a motion that the secretary write to the members who had failed to attend committee meetings, reminding them of the fact, and that no further action be taken till next year.

This was agreed to, Mr. Chessum's motion being withdrawn, and the following eight retiring members of committee were re-elected *en bloc*: Mr. H. Arthur Bartlett, Mr. T. Hall, Mr. B. Hannen, Mr. H. Holloway, Mr. J. W. Lorden, Mr. J. C. Nicholson, Mr. F. G. Rice, and Mr. William Shepherd.

The hon. auditors, Messrs. J. T. Bolding and H. S. Ward, were re-elected, with thanks for past services, on the motion of Mr. Shingleton, seconded by Mr. T. Stirling; and votes of thanks to the committee of management and the trustees brought the proceedings to a close.

THE LONDON COUNTY COUNCIL.

At Tuesday's meeting of the London County Council a report was submitted by the Improvements Committee recommending that Earl Grey's option on the crescent site in Aldwych and the Strand be extended until 1917. The option price was £5,000 a year for taking a lease for ninety-nine years at a rent of £50,000 a year, or buying the freehold at £1,500,000. The committee have treated the past year on the moratorium principle and have extended the option.

The Local Government Committee reported that they have authorised the destruction of documents relating to the late Works Department. "These documents," they observed, "cannot have any bearing on questions that may arise as to the general working of the late department, and the space is needed for storage of records of permanent value."

The same committee stated that they had considered whether the work in connection with the ground plan and the 6-in. map of London should be proceeded with at the present time, and also the whole question of the continuance of the work. They arrived at the opinion that the value of the ground plan to the Council justifies its being kept up to date. The necessity for the separate publication of the 6-in. map will disappear now that the Council has prepared the municipal map. This map will be kept up to date, and the cost will become a general establishment charge.

The General Purposes Committee recommended that, on the understanding that the Council accepts no responsibility in the matter, Mr. W. E. Riley, the architect of the Council, be permitted to advise the governors of the North-Western Polytechnic as to modifications of the plans and specifications of the North-Western Polytechnic with a view to the erection of the building at a cost within the amount at their disposal being proceeded with at an early date.

The Commissioners of His Majesty's Works have inquired whether the Council would be willing to undertake the maintenance and management of the new Government housing estate at Well Hall, Woolwich, which has been provided for the accommodation of munition workers. The estate, which is about 100 acres in extent, will comprise altogether some 1,300 houses, and the gross rental is estimated at £37,000 a year. About 800 houses are completed, or are on the point of completion, of which about 100 are occupied, and the remainder will be finished shortly. The Housing Committee recommended that the Council accept the responsibility, and that the estate be managed on the lines of the Council's cottage estates.

THE LONDON COUNTY COUNCIL REGULATIONS FOR REINFORCED CONCRETE CONSTRUCTION.*

(Continued from page 62.)

FORMULÆ.

115. In a pillar with fixed ends the stress in the concrete in the area bounded by the lateral reinforcement shall not exceed

c , in a pillar with the minimum of hooping or binding,

i , in a pillar with more than the minimum of hooping or binding, where

$$i = c [1 + fs V_1]$$

116. The required ratio of the volume of binding or lateral reinforcement to the volume of the hooped core may be obtained from the equation

$$V_1 = \frac{i - c}{c f s}$$

117. The value of V actually provided, in either round or square pillars, may be ascertained by direct measurement or from the equation—

$$V_1 = \frac{4 Ab}{d p^2}$$

118.—TABLE SHOWING THE VALUE OF f_s .

Form of lateral reinforcement or binding.	Form factor, f_s .	Spacing of laterals throughout the length of the pillar (in terms of diameter of hooped core).	Spacing factor, s .	Value of f_s .
Helical (curvilinear on plan).....	1.0	0.2 d or less	32	32
Helical do.	1.0	0.3 d	24	24
Helical do.	1.0	0.4 d	16	16
Circular hoops	0.75	0.2 d	32	24
Circular hoops	0.75	0.3 d	24	18
Circular hoops	0.75	0.4 d	16	12
Rectilinear	0.5	0.2 d	24	12
Rectilinear	0.5	0.3 d	16	8
Rectilinear	0.5	0.4 d	8	4
Rectilinear	0.5	0.5 d	0	0
Rectilinear	0.5	0.6 d	0	0

119. Notwithstanding any other provision in these regulations the increased stress in the concrete of pillars shall not exceed one-third of the ultimate compressive resistance at four months as given in regulation 159.

120. The working stress in the vertical reinforcement shall not exceed m times the stress in the concrete. (See regulation 54.)

121. The permissible load or pressure on pillars with both ends fixed and with ratios not exceeding those in the first column of figures in regulation 122 shall be obtained from either of the equations—

For Pillars with the minimum of hooping or binding

$$P = c [A + (m-1) Ar]$$

For pillars with more than the minimum of hooping or binding—

$$P = i [A + (m-1) Ar]$$

122. For pillars the permissible load or pressure shall be obtained from the following table—

For the maximum ratio of virtual length to gyration radius	r	45	54	63	72	81	90
For the maximum ratio of virtual length to effective diameter for square pillars	r	15	18	21	24	27	30
For the maximum ratio of virtual length to effective diameter for round pillars	r	12	15	18	21	24	27
Permissible load	P	0.8 P	0.6 P	0.4 P	0.2 P	0.2 P	Nil

For other ratios higher than those in the first column of figures the stress shall be proportional to the above.

STRUTS.

125. Struts shall be subject to all the rules applying to pillars, and the combined stresses at any part shall not exceed the permissible stresses for pillars of like ratios. (See regulations 44, 45, 46.)

AS TO CONDITIONS OF ENDS OF STRUTS AND PILLARS.

124. For the different conditions of the ends of pillars and other struts mentioned in the

following table, the permissible stresses shall be ascertained by using the appropriate value of i of the virtual length in the formulae of regulation 115 with regulations 121 and 122.

Condition of axial ends.	Virtual length, i .
Both ends fixed in position and direction.....	0.5 l
One end fixed in position and direction, the other end fixed in position but not in direction.....	0.7 l
Both ends fixed in position but not in direction.....	1.0 l
One end fixed in position and direction, the other end not fixed in position and direction.....	1.25 l
One end not fixed in position and direction.....	1.5 l

ARCHES. (ALSO SEE REGULATIONS 44, 45, 46.)

125. In the case of arches or other similar constructions the combined stresses at any part shall not exceed the permissible stresses set out in regulations 42 and 43.

PART V.

WALLS.

126. Where the dead loads or superimposed loads of, or upon, a building are transmitted to the foundations by a series of reinforced concrete pillars, beams, arches, or other constructions designed and constructed in accordance with these regulations, any external enclosing walls of reinforced concrete between such pillars may be of any thickness not less than four inches provided that such enclosing walls are designed and constructed in accordance with these regulations to resist

any loads and pressures they may have to carry.

127. In any case where any wall or part of a wall is intended to support vertical loads or resist lateral pressures, it shall be of such thickness as may be necessary to keep the stresses within the limits prescribed by these regulations for the construction of pillars, beams, and other members.

128. When portions of the external walls between the reinforced concrete pillars and beams are constructed of brickwork, stonework, or plain concrete, such portions of walls shall be of a thickness not less than $\frac{1}{2}$ in. for the topmost 20 ft. of their height and not less than 13 in. for the remainder of their height below such topmost 20 ft.

When such portions are constructed of hollow blocks, the blocks shall conform to the following requirements

(a) The aggregate thickness, including any cavity, shall be at least 8 $\frac{1}{2}$ in., measured at right angles to the face of the wall.

(b) The sides shall be at least 2 in. thick.

(c) The ends and any interior partitions shall be at least 1 in. thick.

(d) The clear unsupported span of any part of any side, end, or interior partition shall not be more than four times the least thickness of such part.

(e) The aggregate thickness of the material shall be at least 6 in., measured at right angles to the face of the wall.

Provided that a less thickness shall be allowed in any case in which, under the London Building Act, 1904, such less thickness is prescribed, and provided that in any case in which an external wall or portion of an external wall is not supported or carried or secured by the reinforced concrete skeleton framed construction within the limit of height and length prescribed by the First Schedule of the London Building Act, 1904, for the purpose of determining the thickness of walls, such external wall or portion of external wall shall be of a thickness not less than that prescribed by such schedule.

FACING.

129. All walls and facing materials shall be incombustible and shall be securely connected

* Sub-headings and italic cross references do not form part of the regulations.

The applications of the town council of Newport, Mon., for leave to borrow £6,950 for road widening and £1,493 for the purchase of a site for a destructor have been sanctioned by the Local Government Board.

to the pillars, beams, floors, and other contiguous parts of the reinforced concrete construction.

PRESSURE ON PANELS.

130. Each panel in any external wall shall be designed to resist safely a horizontal pressure equivalent to a static pressure of at least thirty pounds per square foot assumed to be acting uniformly over the area of one panel from either side. (See regulations 21 and 22.)

OPENINGS.

131. The aggregate area of openings in external walls constructed in accordance with these regulations shall not exceed in a wall of any story above the ground story two-thirds of the whole area of such wall, and the aggregate width of such openings in such a wall shall not exceed three-quarters of the whole length of such wall.

PARTY AND DIVISION WALLS

132. Party walls and division walls constructed in reinforced concrete in accordance with these regulations shall be of such thickness as may be necessary to comply therewith, but in no part shall such walls be of less thickness than 8 inches.

133. Provided that any such party wall between a building constructed in reinforced concrete and a building of the warehouse class constructed in accordance with the Rules of the London Building Act, 1894, or as a steel-framed building, shall not be in any part less than 15 inches in thickness.

MORTAR.

134. All brickwork, stonework, and plain concrete shall be executed in Portland cement mortar. The mortar shall be in accordance with the Council's by-laws from time to time in operation.

PRESSURE ON BRICKWORK.

135. The pressure on any brickwork supporting reinforced concrete work shall not exceed the following—

Brickwork.	Tons per square foot.
Blue brick in cement mortar	12
Hard brick (including London stock) in cement mortar	8
Ordinary brick in cement mortar	5

RATIO OF HEIGHT TO THICKNESS.

Such brickwork shall not have a height without proper lateral supports of more than six times its least thickness, but any such brickwork with proper supports may have a height between such lateral supports not more than twelve times the least thickness of such brickwork. Such thickness shall in no case be less than thirteen and a-half inches.

PART VI FOUNDATIONS

136. The pressure of foundations on the natural ground shall not exceed the following—

Nature of ground.	Tons per square foot.
Natural bed of soft clay or wet or loose sand	1
Natural bed of ordinary clay or conchoidal sand	2
Natural bed of compact gravel, London blue clay, or chalk	4

137. The pressure on plain concrete in foundations shall not exceed twelve tons per square foot. The plain concrete shall be in cement and its quality shall be at least equal to that required by the Council's by-laws from time to time in operation.

PART VII PROTECTION

138. The cover shall be measured from the outer surface of the concrete to the outer surface of the metal reinforcement.

139. The end cover to be provided beyond the anchored end of a bar coming within the provisions of regulation 43 (b) shall not be less than 2 inches and not less than twice the normal diameter of the bar to be covered.

140. The cover of any vertical bar in a pillar shall not be less than 1½ inches and not less than the diameter of such vertical bar.

141. The cover of any longitudinal bar in a beam shall not be less than one inch and not less than the diameter of such longitudinal bar.

142. The cover of tensile, compressive, shear or any other reinforcement in slabs shall not be less than one half-inch, and not less than the diameter of the bar to be covered.

143. The cover of any reinforcement in other members shall not be less than one inch and not less than the diameter of the bar to be covered.

(To be continued.)

Correspondence.

SHILLING PLANS FOR RURAL COTTAGES.

SIR, The Society of Architects has very properly, I think, addressed the "Board" on the subject of its report and batch of drawings and specification, which are published at the price of 1s. 6d.; specification in detail, one penny; and full-size working drawings of window details, one shilling.

The idea of the Board and of its technical advisers (members of the R.I.B.A.) seems to be on the lines of "every builder of a cottage his own architect," and, in trying to defend itself against the criticism of the Society of Architects, it indulges in that form of casuistical reply to which one is so well accustomed just now within the walls of the House of Commons.

There is much to say on this particular form of depriving architects of work, and I venture to ask, through your columns, Mr. Raymond Unwin, F.R.I.B.A., and Mr. Charles E. Vandell, A.R.I.B.A., two of the architects engaged in this matter by the Board, to favour your readers with their view of the matter.—I am, Sir, your obedient servant.

WM. WOODWARD, F.R.I.B.A.,
15, Southampton Street, Strand, W.C.,
July 24, 1915.

SIR,—Under the above heading in your issue of the 21st inst., you set forth exception that has been taken by the Society of Architects to the report of the Advisory Committee of the Board of Agriculture and Fisheries on the subject of rural housing; and you give the reply of the Committee's chairman and your own views.

At the moment I cannot again go through the Committee's report in detail, but some months ago I carefully perused it with much satisfaction, as being, in my opinion, very sound and the most helpful contribution to the solution of a matter of national importance that had come under my notice. I know nothing of the correspondence between the Society of Architects and the Board of Agriculture and Fisheries beyond what is given in your article above referred to, and sincerely hope that the Society has welcomed the report as I do, and has only as a matter of detail taken exception to the fact that the employment of an architect is not therein urged; otherwise, bearing in mind the national importance of the matter and the great value of the report, I venture to think the society has taken a somewhat narrow and class-interested view of a matter calling for broad-minded and generous treatment.

As an architect, surveyor, and land agent with a varied and, mostly, country practice, I stand to lose as much as most by such a report if its effect be to lessen the employment of professional assistance in such matters as rural housing; but be that as it may, I wholeheartedly welcome it for the reasons I have stated. With others I (as an architect) often regret the crudities in cottage design, often perpetrated by landowners and their agents, are not obviated by the taste and skill of the architectural profession; but where such is called in the temptation of going beyond this often proves irresistible, and beautification is given which adds to expense. Everybody wishes that such could be afforded; but its deletion is less vital than the provision of accommodation at rock-bottom price, and landowners and their agents, who are sometimes more closely in touch with the hard facts of cost, etc., should, as I have done, find the report both inspiring and helpful. If they can afford the refinements that should result from an architect's advice, so much the better; but the more pressing and primary consideration is accommodation, and I urge this fact more strongly than I should have a year ago, as

the expenditure on this war must mean simpler and rougher conditions for most of us in most directions—perhaps first in housing.

Seldom do I trouble the Press with my views, and I choose you for this infliction as yours is the only architectural paper that I have taken continuously during the last nearly twenty-five years.—I am, Sir, yours faithfully,

R. E. BRINKWORTH, F.S.I., M.S.A.
Bath, July 25, 1915.

ACTION AGAINST THE INSTITUTION OF CIVIL ENGINEERS.

ELLIS DE VESIAN v. THE INSTITUTION.

SIR,—In view of the full report which was given in your issue of June 16 of the proceedings in the action of our client, Mr. John Stuart Ellis de Vesian, against the Institution of Civil Engineers, we trust that you may see your way to give equal prominence to the result of our client's appeal to the Court of Appeal against the decision of Mr. Justice Neville of June 9 last, refusing the injunction asked for, namely, that the defendant and its president might be restrained until the trial of the action or further order from proceeding on their resolution to expel our client from membership of the Institution. This appeal came before the Court of Appeal on the 19th instant, and occupied the court during the greater part of two days, and resulted in the court unanimously reversing the decision of Mr. Justice Neville and deciding that our client was entitled to the injunction asked for until the trial of the action.

This results in restoring to our client his full rights, for the time being, as a corporate member of the Institution of Civil Engineers, but, as very little publicity is likely to be given to this particular aspect of the case in the Press, we would ask you to make it prominent by inserting this letter in your next issue.—Yours faithfully,

ELLIS DE VESIAN AND Co.
8, Old Jewry, E.C.

DISTRICT SURVEYORS AND THE L.C.C.

SIR,—In your journal of the 14th inst., you mention, among the proceedings of the London County Council, the report of the Building Act Committee, that they recommended the Council to dispense with my services, as well as those of another district surveyor, as from November 30 next.

The legality of the proceedings is, I believe, still in question in another case, and I had received and agreed to the postponement of any question as concerns myself whilst awaiting the decision of the court, I having, with the Council's consent, appointed my deputy with full powers, in accordance with Section 132 of the London Building Act, 1894. You will see, therefore, that at present I retain my official position.—Yours faithfully,

FREDERICK WALLEN, F.R.I.B.A.,
District Surveyor for St. Pancras South.
96, Gower Street, W.C., July 20, 1915.

Official information has been received at Lockerbie that Lieutenant Robert Douglas, previously reported wounded, has died from his wounds. Lieutenant Douglas, who was forty-two years of age, was the only surviving son of Mr. John Douglas, land steward, Murrayfield, Lockerbie. He was in business as an architect in the town, and leaves a widow and three children.

The Baptist Church trustees have approved plans for the conversion of an existing chapel in Manchester Road, Barnoldswick, into a Sunday school for the accommodation of 500 scholars, at an estimated cost of £1,600. This will necessitate the building of a new edifice, a site for which has already been purchased, with a frontage to Manchester Road. Plans for the new church (estimated to cost £6,500) are now under consideration.

In consequence of the resignation of Mr. M. R. Jones, as surveyor and inspector of nuisances, the Abergyle Urban District Council have considered the question of appointing a successor. It was urged that for the present there was no necessity to appoint a successor, and that the salary should be saved. A motion to this effect was carried, the appointment being deferred indefinitely. An amendment was moved, but defeated, that the appointment be deferred until after the war.



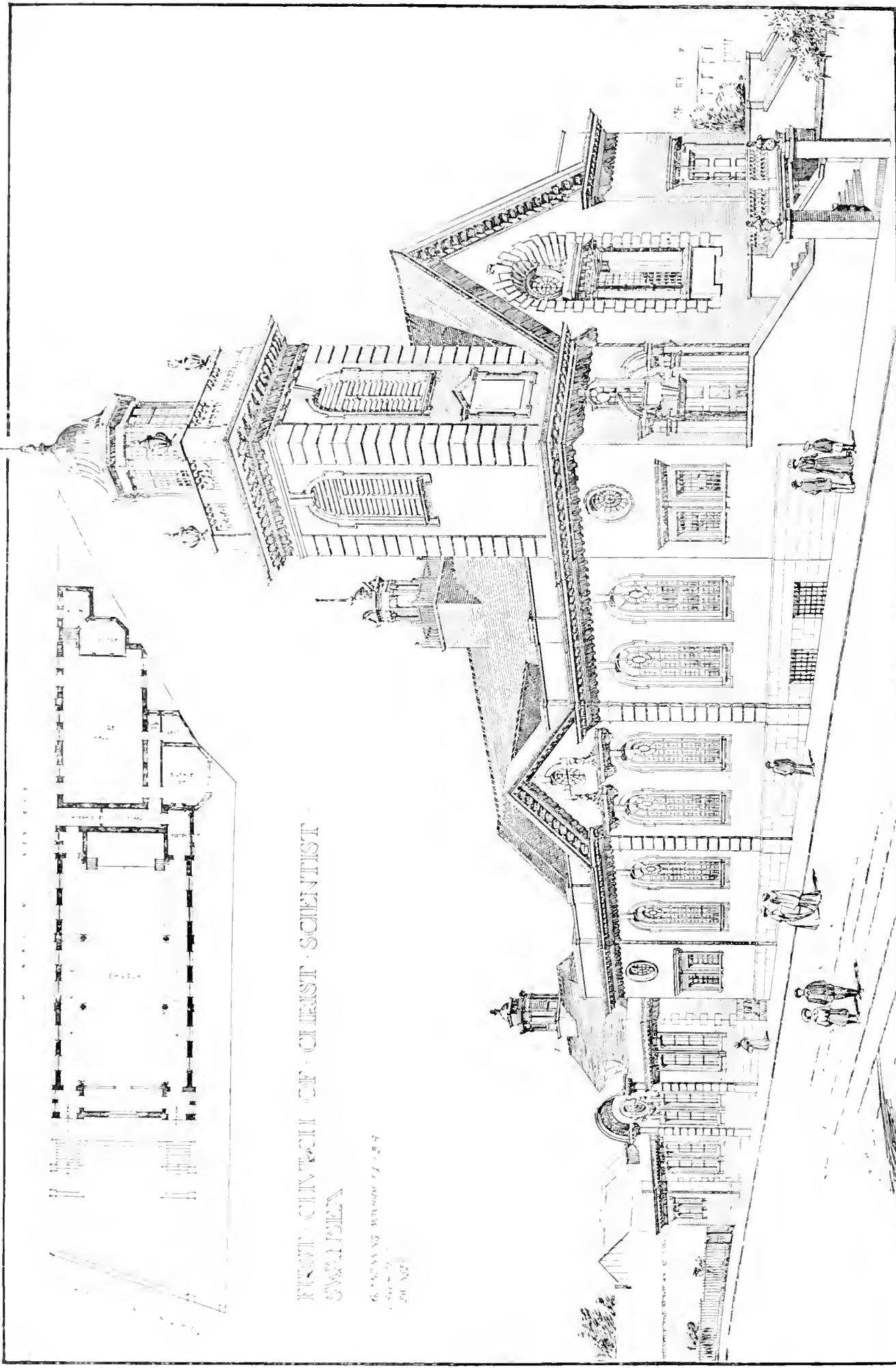

FIRST CHURCH OF CHRIST SCIENTIST
SWANSEA

6, 8, 10, 12, 14, 16, 18, 20, 22, 24, 26, 28, 30, 32, 34, 36, 38, 40, 42, 44, 46, 48, 50, 52, 54, 56, 58, 60, 62, 64, 66, 68, 70, 72, 74, 76, 78, 80, 82, 84, 86, 88, 90, 92, 94, 96, 98, 100, 102, 104, 106, 108, 110, 112, 114, 116, 118, 120, 122, 124, 126, 128, 130, 132, 134, 136, 138, 140, 142, 144, 146, 148, 150, 152, 154, 156, 158, 160, 162, 164, 166, 168, 170, 172, 174, 176, 178, 180, 182, 184, 186, 188, 190, 192, 194, 196, 198, 200, 202, 204, 206, 208, 210, 212, 214, 216, 218, 220, 222, 224, 226, 228, 230, 232, 234, 236, 238, 240, 242, 244, 246, 248, 250, 252, 254, 256, 258, 260, 262, 264, 266, 268, 270, 272, 274, 276, 278, 280, 282, 284, 286, 288, 290, 292, 294, 296, 298, 300, 302, 304, 306, 308, 310, 312, 314, 316, 318, 320, 322, 324, 326, 328, 330, 332, 334, 336, 338, 340, 342, 344, 346, 348, 350, 352, 354, 356, 358, 360, 362, 364, 366, 368, 370, 372, 374, 376, 378, 380, 382, 384, 386, 388, 390, 392, 394, 396, 398, 400, 402, 404, 406, 408, 410, 412, 414, 416, 418, 420, 422, 424, 426, 428, 430, 432, 434, 436, 438, 440, 442, 444, 446, 448, 450, 452, 454, 456, 458, 460, 462, 464, 466, 468, 470, 472, 474, 476, 478, 480, 482, 484, 486, 488, 490, 492, 494, 496, 498, 500, 502, 504, 506, 508, 510, 512, 514, 516, 518, 520, 522, 524, 526, 528, 530, 532, 534, 536, 538, 540, 542, 544, 546, 548, 550, 552, 554, 556, 558, 560, 562, 564, 566, 568, 570, 572, 574, 576, 578, 580, 582, 584, 586, 588, 590, 592, 594, 596, 598, 600, 602, 604, 606, 608, 610, 612, 614, 616, 618, 620, 622, 624, 626, 628, 630, 632, 634, 636, 638, 640, 642, 644, 646, 648, 650, 652, 654, 656, 658, 660, 662, 664, 666, 668, 670, 672, 674, 676, 678, 680, 682, 684, 686, 688, 690, 692, 694, 696, 698, 700, 702, 704, 706, 708, 710, 712, 714, 716, 718, 720, 722, 724, 726, 728, 730, 732, 734, 736, 738, 740, 742, 744, 746, 748, 750, 752, 754, 756, 758, 760, 762, 764, 766, 768, 770, 772, 774, 776, 778, 780, 782, 784, 786, 788, 790, 792, 794, 796, 798, 800, 802, 804, 806, 808, 810, 812, 814, 816, 818, 820, 822, 824, 826, 828, 830, 832, 834, 836, 838, 840, 842, 844, 846, 848, 850, 852, 854, 856, 858, 860, 862, 864, 866, 868, 870, 872, 874, 876, 878, 880, 882, 884, 886, 888, 890, 892, 894, 896, 898, 900, 902, 904, 906, 908, 910, 912, 914, 916, 918, 920, 922, 924, 926, 928, 930, 932, 934, 936, 938, 940, 942, 944, 946, 948, 950, 952, 954, 956, 958, 960, 962, 964, 966, 968, 970, 972, 974, 976, 978, 980, 982, 984, 986, 988, 990, 992, 994, 996, 998, 1000

THE FIRST CHURCH OF CHRIST SCIENTIST, WALTERS ROAD, SWANSEA.—MR. GLENNING MOXHAM, F.R.I.B.A., ARCHITECT.

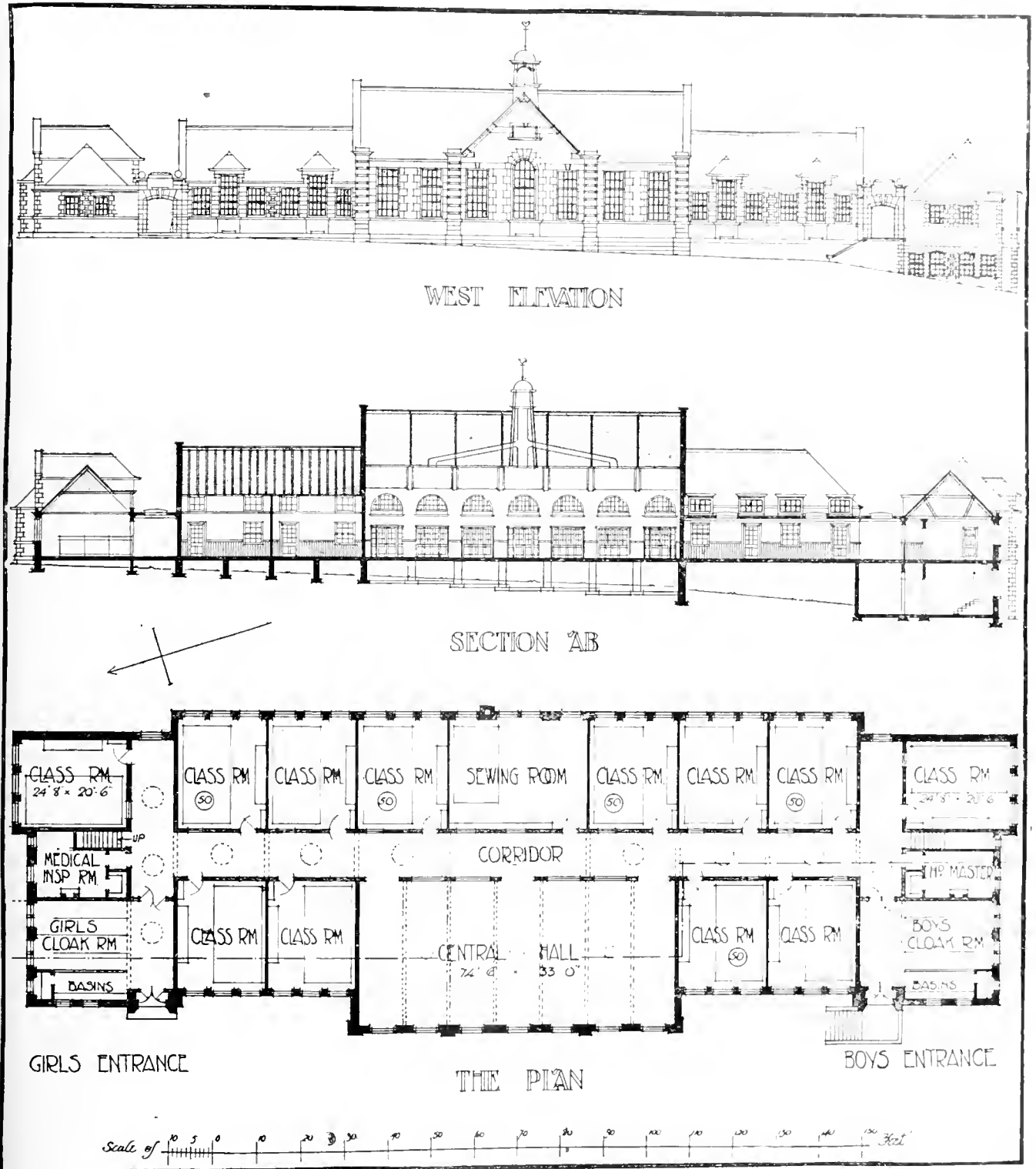

KIRKCALDY AND DYSART SCHOOL BOARD: BLAIRHILL SCHOOL (SELECTED DESIGN).
Mr. WILLIAM WILLIAMSON, F.R.I.B.A., Architect.

This is one of the pair of schools at Kirkcaldy, for which Mr. William Williamson, F.R.I.B.A., was chosen architect in competition. We illustrated the larger one in the BUILDING NEWS for February 5 last, with a good scale copy of its plan, as carried out at Pathhead. To-day's illustration shows the Blairhill School, now completing its erection by the same authority, and giving accommodation for 600 pupils. Each class has direct "through" ventilation. The school is being built in stone. The plan, elevation, and section

reproduced clearly show the capital and economic arrangements, also how the site allows room in a lower ground story at the south end.

The London Electric Railway Companies' Facilities Bill has been read a third time in the House of Lords and passed.

The new arcade and municipal buildings at Aberavon, built at a cost of £15,000, have been formally opened. The work has been carried out by Mr. Morgan Cox, contractor, of Aberavon, from the designs of Mr. James Roderick, borough engineer.

Mr. H. Chubb has resigned his position as surveyor to the East-Korrier Rural District Council.

The salary of Mr. W. Newton, surveyor to the Hawarden Rural District Council, has been increased by £50 per annum.

The German cement industry continues to fare badly. The Besching Portland Cement Company, which paid a dividend of 5 per cent. for 1913, has a loss of 122,622 marks for 1914. Under the circumstances the company has transferred its allotment, excepting a small balance, to another South German company, subject to a remuneration, which is expected to leave a small profit.

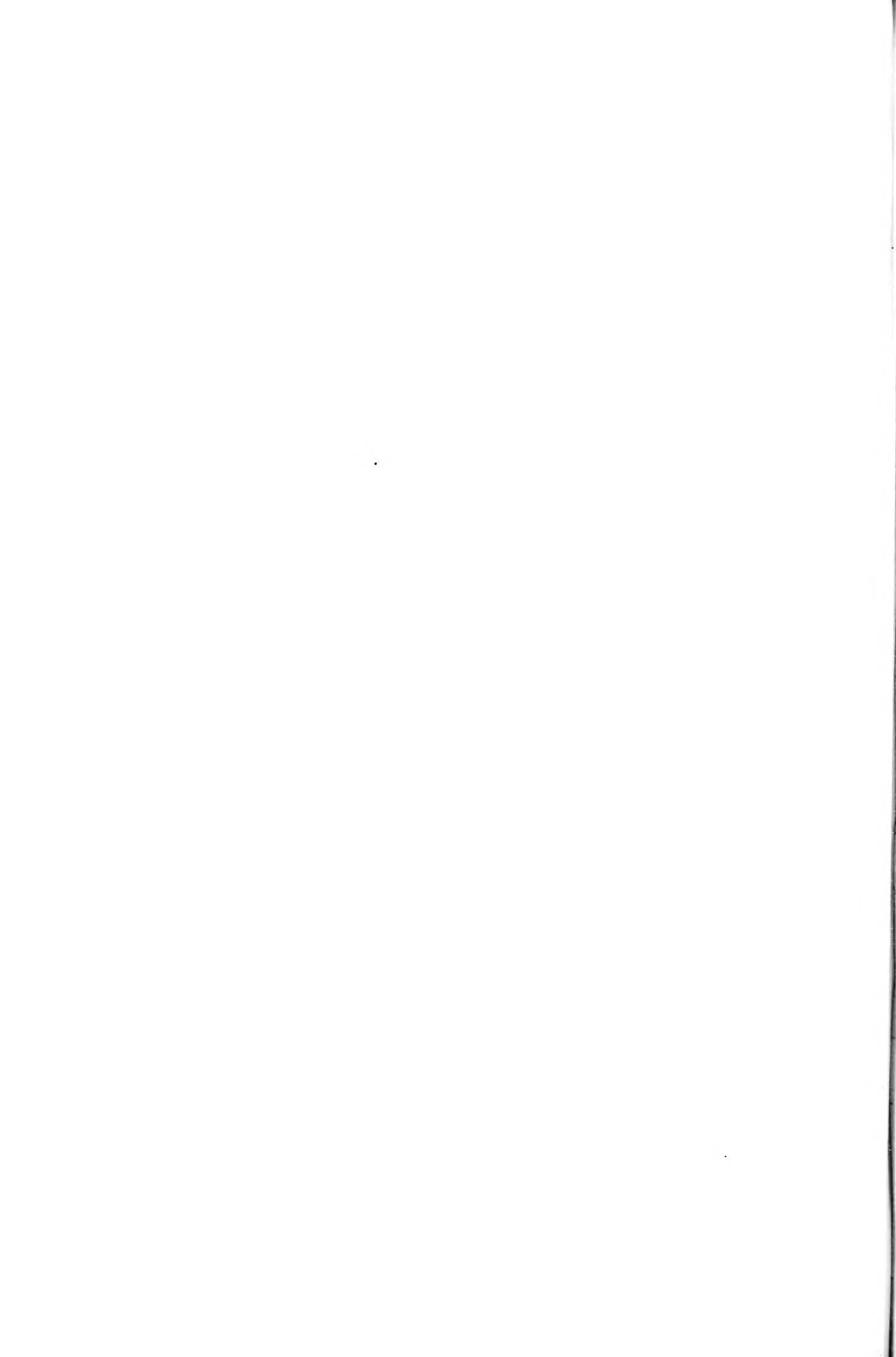

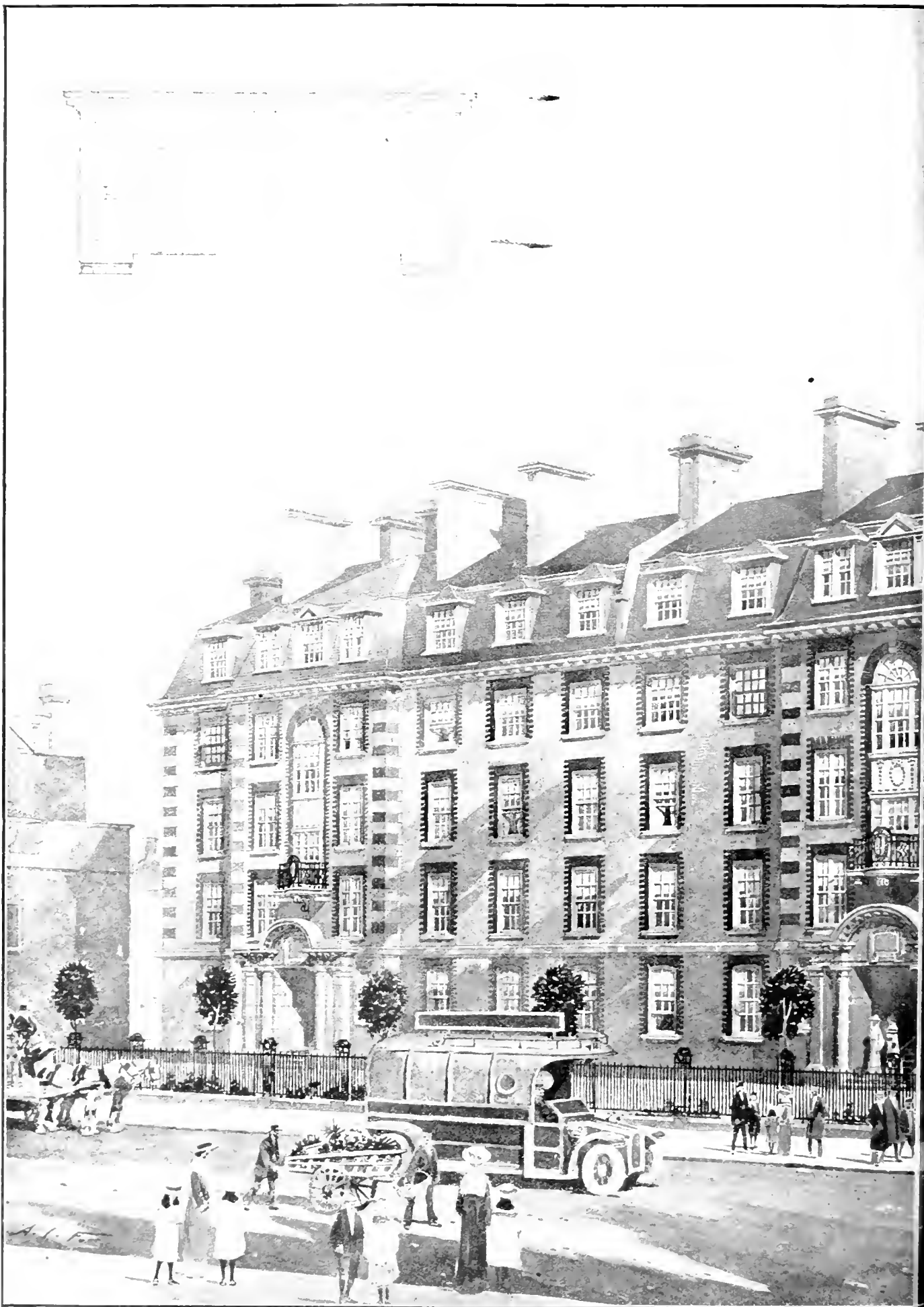

PEABODY DONATION FUND, WORKING CLASS DWELLINGS, REICHS
Mr. Viet

JULY 28, 1915.

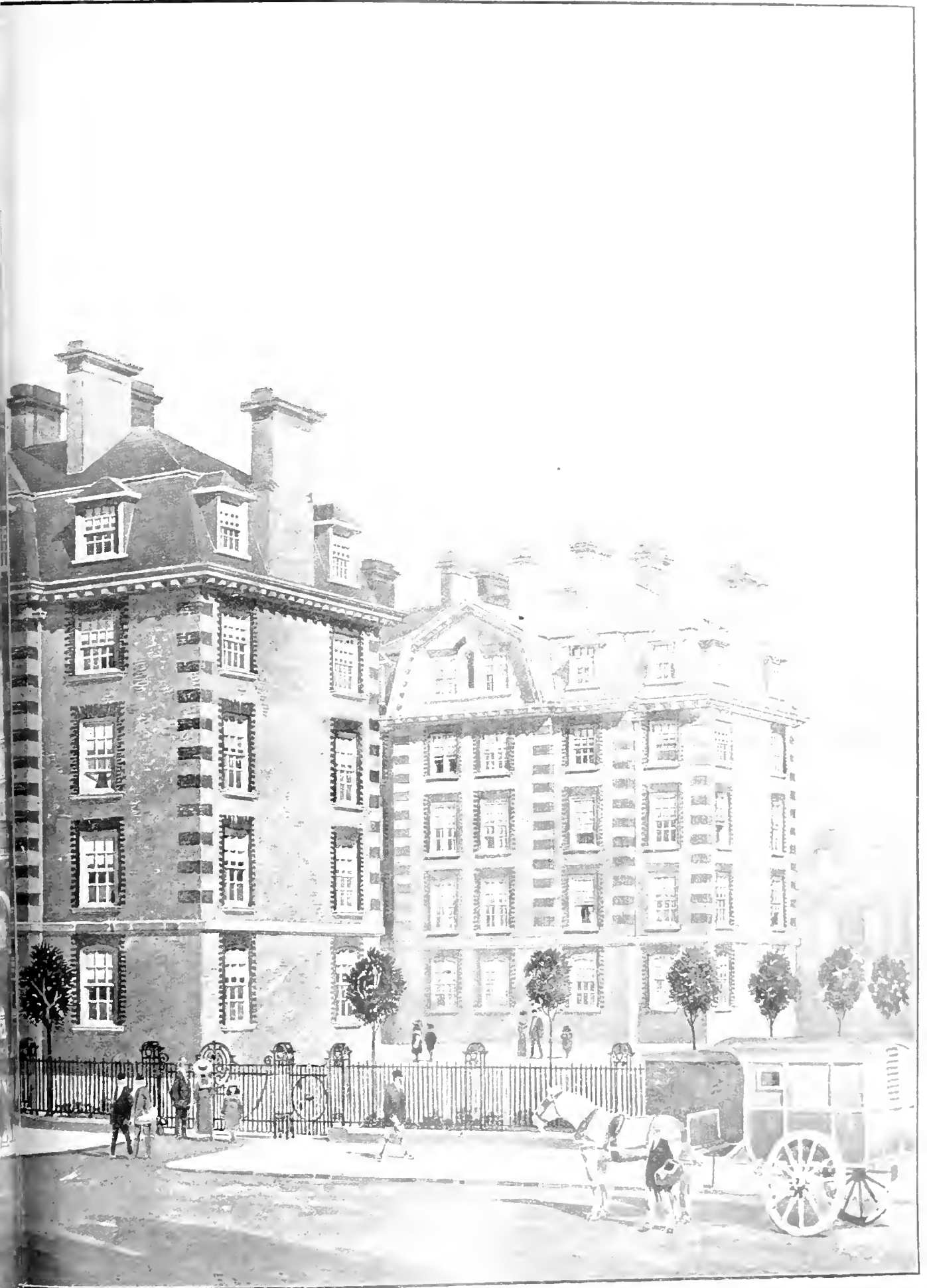

FOR THE CITY CORPORATION, SUMNER STREET, SOUTHWARK. S.E.
[Name], Architect.

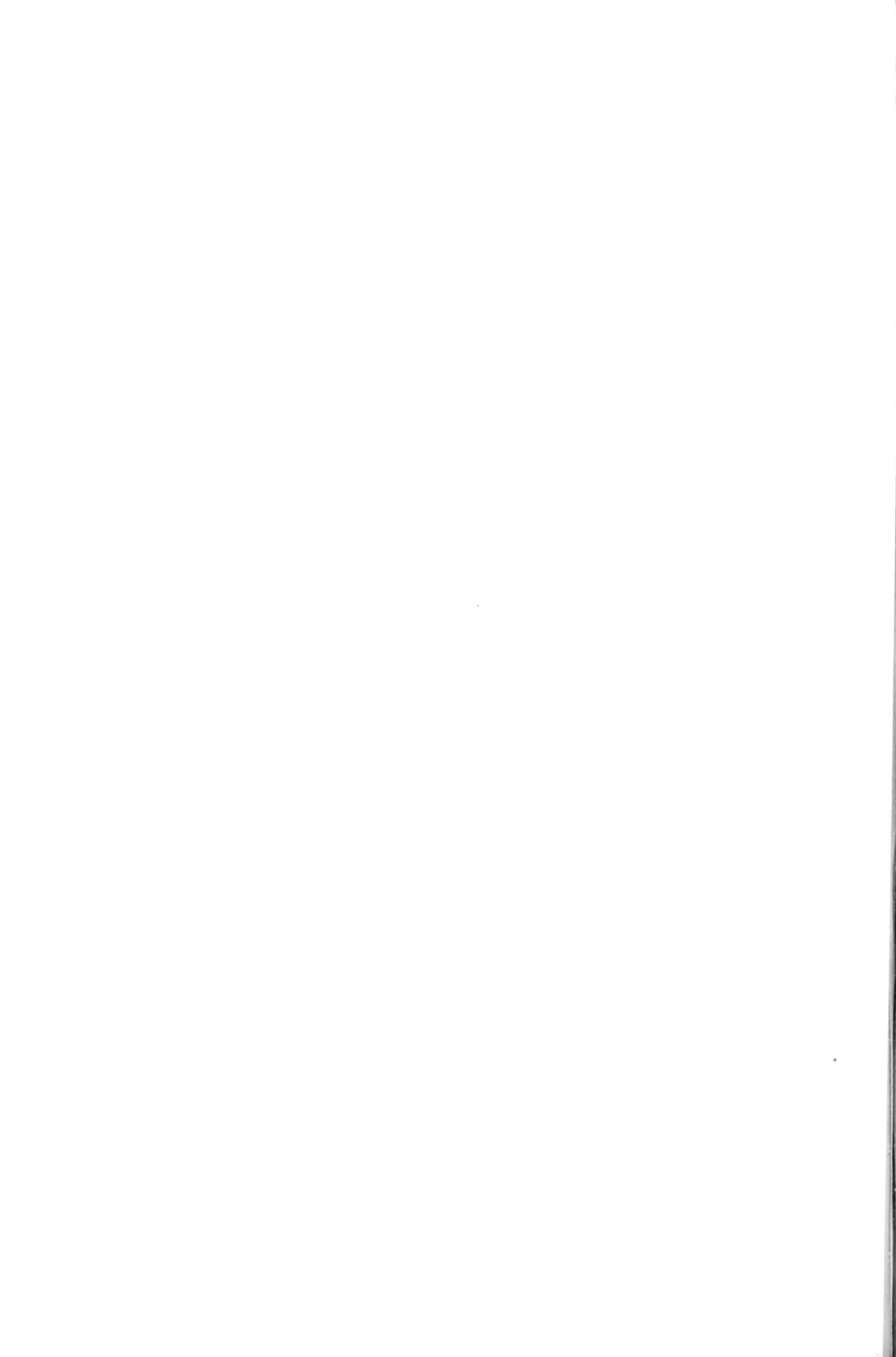



THE BUILDING NEWS. JULY 28, 1915.

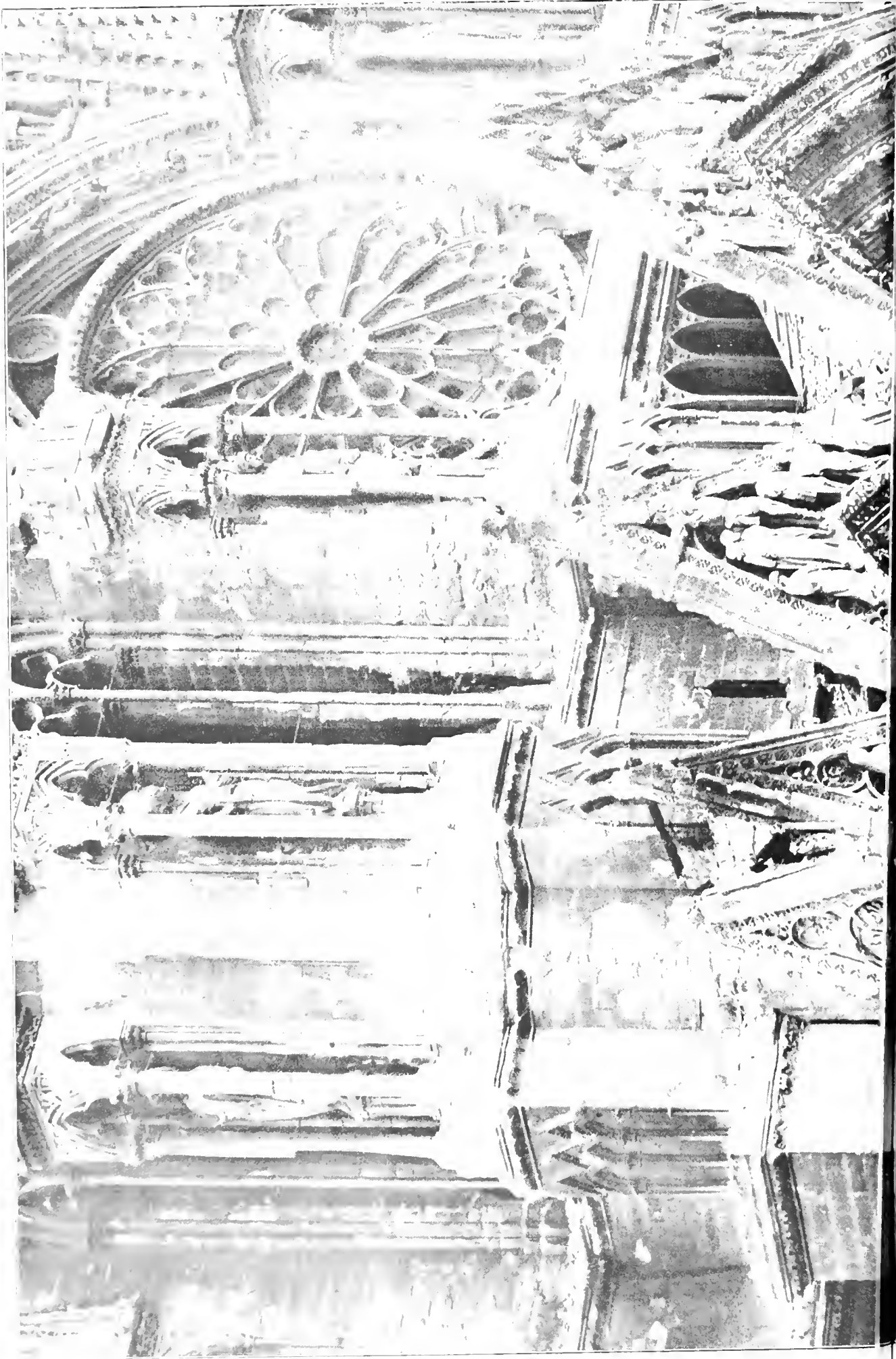

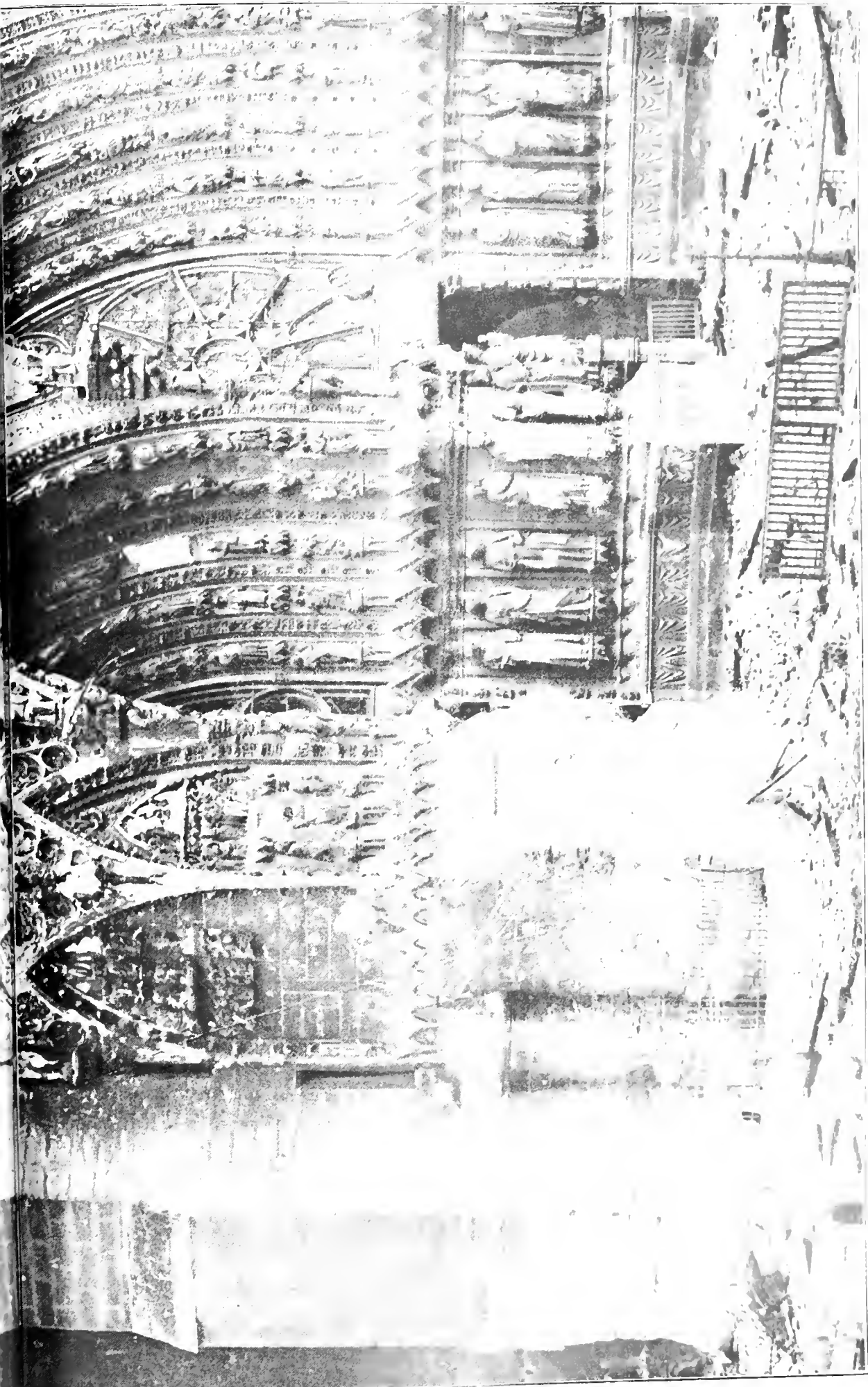

THE PORTALS OF ST. PETER'S CATHEDRAL AFTER THE FIRE WHICH DESTROYED THE INTERIOR OF THE CHURCH IN 1823. THE VIEW IS FROM THE INTERIOR OF THE CHURCH.

LIBRARY
MAY 12 1915
UNIVERSITY OF TORONTO



THE BUILDING NEWS, JULY 28, 1915.

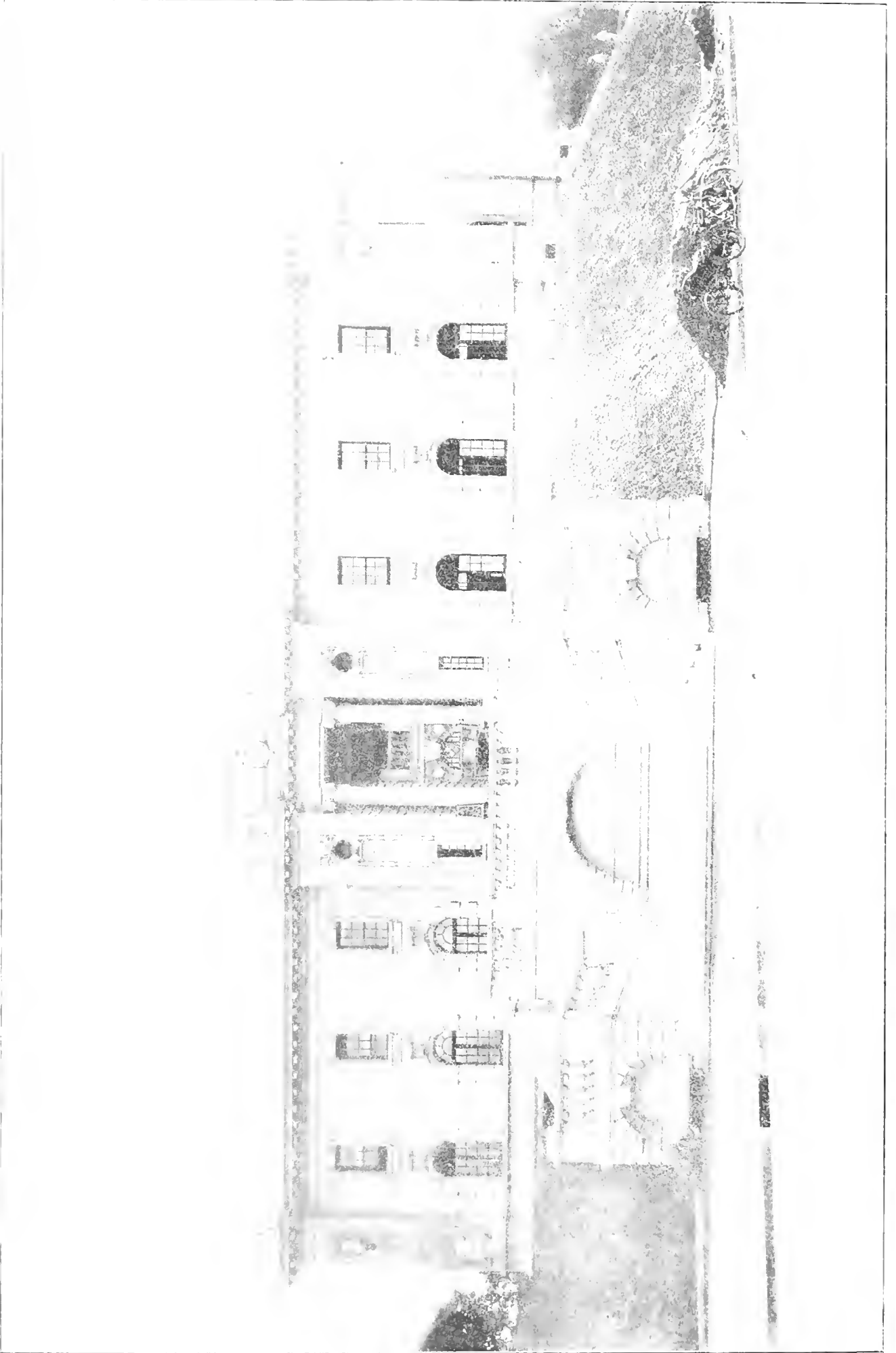

MISS JENNIFER GORDON'S BUILDING WITH THE GARDEN COURSE



Photo J. Atkinson, Johannesburg.
THE NEW LAW COURTS, DURBAN, FOR THE UNION GOVERNMENT OF S. AFRICA.

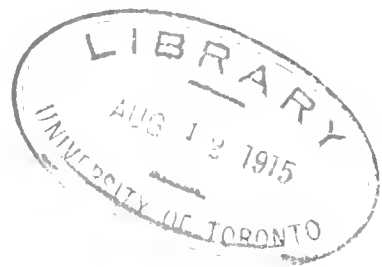

Our Illustrations.

RHEIMS CATHEDRAL PORTALS AFTER THE BOMBARDMENT.

Fergusson says, "Rheims is perhaps the most beautiful structure produced in the Middle Ages." The fine photograph printed herewith to-day, showing the west front after its bombardment, was taken by the sculptor who has had charge of the sculptures and ornamentation of this great historic church for the past twenty years. The picture gives an excellent idea of the havoc wrought to the great portals by the German shells, and, as Anatole France exclaims, the outrage is "infamie immortelle," making its authors "execrable à tout l'Univers pensant." The view is taken looking towards the façade from the N.W. We have chosen it from the collection of some two hundred similar photographs forming the exhibition now open at the Leicester Galleries, Leicester Square, W. Our readers' attention was directed to this display in the BUILDING NEWS last week, when some particulars were given descriptive of the exhibition, which includes enlargements of many exceptionally artistic and well-defined studies of the more famous statues and groups of figure carvings, as well as a large series of notable details of the architectural elaboration of the fabric itself, which is not only one of the most exquisite cathedrals of its date in the whole of Europe, but ranks as the third in size in France, Amiens and Chartres alone surpassing Rheims in scale and magnificence of design. The first attack upon it took place on September 17 and 19 last, when the shells falling on the church set fire to the roof, burnt part of the western towers, and shattered the windows and sculpture. The fusillade was renewed in November, and repeated last February, as well as during the month of July. A Commission was appointed by the French Minister of Education to investigate the state of the structure in the autumn of 1914, and photographs were taken as records illustrative of the condition in which the building was then found. Messrs. Ernest Brown and Phillips have prefaced their handy little catalogue of this exhibition of photographs with a quotation from the Commissioners' report. Before reproducing this paragraph we may mention that the pamphlet alluded to is presented to every visitor to the collection, and also add that the proceeds will go to the credit of the French Relief Fund. The admission charge is one shilling. The catalogue is interspersed with seven reduced reproductions of typical examples of the prints, including a general exterior view and also an interior of the Cathedral, so that the brochure is very useful for reference. The same series of photographs is being shown simultaneously in the Musée des Arts Decoratifs of the Louvre, Paris. A smaller collection, which was lately on view by the Medici Society in London, served to enlighten many on the character of the desolation wrought by the Germans at Rheims, but this assemblage is by far the finest yet on view to public inspection in the Metropolis. The Commissioners' report, just referred to, says, "Although disfigured in its lines and in the details of its decoration, the Cathedral of Rheims still stands. Its stout construction has resisted the shock of the projectiles. The roof of the building can be restored, the masonry repaired, but the sculpture can never be replaced, and the Cathedral will bear profoundly the mark of vandalism which has surpassed imagination." On October 15, the bombardment was renewed, and repeated during the end of November and again in February this year. Another attack was made about July 16, and may occur again at any time in the near future. Dr. Capitan, member of the "Commission des Monuments Historiques," has enumerated the further deplorable damage done since the official report to which we have alluded was presented to the Government in Paris. The defence made by the Germans of their acts of vandalism is, of course, futile, and the following declaration

of the Vice-Chancellor of the Archbishopric of Rheims is representative. "In the name of His Eminence, the Cardinal Archbishop of Rheims, and in my own name, I offer to the most formal denials to the improbable German report. No bombardment on the towers, nor batteries on the court in front of the building, in no circumstances, nor any possible troops at any moment, was directed against the Cathedral. The whole population was being evacuated." M. De Cassé, Minister of Foreign Affairs; M. Anatole France, M. Emile Houellebecq, Léopold, a General of Police, Instruction, and Mr. Hilaire Belloc have also protested to the same or similar effect. On the site where the present cathedral stands, St. Neaise erected a church 400 A.D., the year when the four authorised gospels, as printed in the English Bible, were compiled in their present form. Till the ninth century this church remained intact, but about 820 A.D. Archbishop Ebbo founded the new cathedral, and Rumbold, architect to Louis I., was sent by that monarch to assist in the building, which was finished in 862 A.D. A great fire destroyed the fabric in 1210, but within two years the existing structure was begun, and Archbishop Aubert de Humbert laid the foundation-stone. Jean d'Orbais was the designer of its plan. The first architect who succeeded him was Jean de Coup. He in turn was followed by Caucher, and many more architects more or less known to fame took up the work as time went on. The consecration of the choir was celebrated in 1241 A.D., the erection of the rest of the Cathedral being continuous till 1481. A terrible fire happened in that year when the upper parts of the church were badly burned, the towers of the transepts being entirely consumed, or, as records say, "reduced to ashes." Thirty years were devoted to the work of reparation under an army of artificers. The fabric escaped further harm, and remained substantially intact from the early days of the sixteenth century till the great European War. The plan of Rheims Cathedral measures 466 ft. in length and 96 ft. in width, the height being 122 ft., and these dimensions tally nearly with Amiens and Chartres. The building is laid out on the lines of a Roman cross, with consummate skill as regards the poise of its parts and with reference to solids and voids. The west front is embellished by 550 statues illustrating incidents from the Passion of Our Lord, the life of the Virgin Mary, and scenes from other subjects, not forgetting to name the "Crucifixion," of a classic term, or properly be applied to such supporting Medieval figures as those at Rheims, which are spoken of by a recent writer as being beyond the *genre* of Rodin or Mestrovic. Bernarde de Saisons describes the florid great west "rose window," which is 40 ft. in diameter, and till the Germans bombarded the Cathedral it was entirely filled with beautiful glass of late thirteenth century date. "The Gallery of the Kings" above this window is formed by a row of colossal figures set in the niches extending the whole width of the elevation. In the middle of "Baptism of Clovis" is represented flanked by the Monarchs of France. The western towers are 257 ft. high. There should have been six towers to this Cathedral according to the architect's original design, but the four terminating the two transepts have never been really completed. The Kings of France were consecrated at Rheims, and Clovis, when he was the Archbishop, anointed the Sovereign of his day with the miraculous oil preserved in the Sainte Ampoule, brought by a sacred dove, according to the legend. Two views of the Church of St. Remi at Rheims, with a leading article, appeared in the Building News for October 16 last year, when we published a photograph of the Founder's Tomb of modern date in that Abbey Church, and giving at the same time several particulars of the Abbatial buildings, and the Archbishop's Palace, as well as of the Cathedral, with a few notes on its surroundings. Viollet le Duc, it will be remembered, had charge of Rheims Cathedral for many years, and he carried out much work of reparation there, renewing a good many things which some architects would have much preferred if he had left untouched

the original fabric. The Cathedral of Rheims is a masterpiece of Gothic architecture, and its west front is one of the most beautiful in the world. The building was severely damaged during the bombardment of 1914-15, but the main structure remains standing. The west front, which is the most important part of the building, was almost completely destroyed. The towers of the transepts were also damaged, and the roof of the choir was burnt. The damage was so severe that the building was considered to be in a state of ruin. However, the French Government has decided to rebuild the cathedral, and the work is now well advanced. The new building will be built on the same site as the old one, and will be in the same style as the original. The west front will be rebuilt in the original style, and the towers of the transepts will also be rebuilt. The roof of the choir will be replaced by a new one, and the interior of the cathedral will be restored to its original condition. The work is expected to be completed in a few years. The cathedral is a great work of art, and its restoration will be a great benefit to the city of Rheims. The building is a masterpiece of Gothic architecture, and its west front is one of the most beautiful in the world. The building was severely damaged during the bombardment of 1914-15, but the main structure remains standing. The west front, which is the most important part of the building, was almost completely destroyed. The towers of the transepts were also damaged, and the roof of the choir was burnt. The damage was so severe that the building was considered to be in a state of ruin. However, the French Government has decided to rebuild the cathedral, and the work is now well advanced. The new building will be built on the same site as the old one, and will be in the same style as the original. The west front will be rebuilt in the original style, and the towers of the transepts will also be rebuilt. The roof of the choir will be replaced by a new one, and the interior of the cathedral will be restored to its original condition. The work is expected to be completed in a few years. The cathedral is a great work of art, and its restoration will be a great benefit to the city of Rheims.

THE FIRST CHEMISTS' SCIENTISTS' BUILDING.
The building has been designed by Walter R. G. and is a fine example of modern architecture. It is a four-story building with a central tower and a large entrance. The building is located in the City of London and is a landmark of the area. It was designed by Walter R. G. and is a fine example of modern architecture. It is a four-story building with a central tower and a large entrance. The building is located in the City of London and is a landmark of the area.

PEABODY DONATION FUND WORKING CLASS DWELLINGS, SUMNER STREET, SOUTHWARK.

By an arrangement between the Corporation and the Peabody Donation Fund these dwellings are shortly to be completed in Sumner Street, Southwark, to accommodate the people of the working class who will be displaced by the improvement of the St. Paul's Bridge scheme. The building will consist of four blocks, each of three stories in height. The construction is proposed to be built of London brick and sand faced bricks to be used for the window sills, door and window frames, and door and window openings. The roof will be of wrought iron. A central staircase will be provided for 60 sets of flats, each of three and four rooms, 40 sets of one and two rooms, and in addition, 10 sets of one and two rooms, and a small shop. A detached scullery, and water closets, are also provided. The building will be built on a plot of 10,000 sq. ft. and will contain 100 flats. The flats will be arranged in a row, and will be of the following sizes: 10, 11, 12, 13, 14, 15, 16, 17, 18, 19, 20, 21, 22, 23, 24, 25, 26, 27, 28, 29, 30, 31, 32, 33, 34, 35, 36, 37, 38, 39, 40, 41, 42, 43, 44, 45, 46, 47, 48, 49, 50, 51, 52, 53, 54, 55, 56, 57, 58, 59, 60. The flats will be arranged in a row, and will be of the following sizes: 10, 11, 12, 13, 14, 15, 16, 17, 18, 19, 20, 21, 22, 23, 24, 25, 26, 27, 28, 29, 30, 31, 32, 33, 34, 35, 36, 37, 38, 39, 40, 41, 42, 43, 44, 45, 46, 47, 48, 49, 50, 51, 52, 53, 54, 55, 56, 57, 58, 59, 60. The flats will be arranged in a row, and will be of the following sizes: 10, 11, 12, 13, 14, 15, 16, 17, 18, 19, 20, 21, 22, 23, 24, 25, 26, 27, 28, 29, 30, 31, 32, 33, 34, 35, 36, 37, 38, 39, 40, 41, 42, 43, 44, 45, 46, 47, 48, 49, 50, 51, 52, 53, 54, 55, 56, 57, 58, 59, 60.

Currente Calamo.

As last yesterday week the covering was removed from Mr. Rodin's impressive bronze group, "The Burglers of Calais," in the Victoria Palace Galleries without ceremony. The group is well worthy of the reputation of its sculptor, and fully synchronises with the contrast between the clement intervention of one of the most lovable of England's Queens and the absence, hitherto, of any such manifestations on behalf of mercy on the part of the spouse of the modern embodiment of all that is barbarous in warfare. Whether the brave burglers, even after the lengthy siege the French had so gallantly endured, were quite as forlorn as M. Rodin represents them we have before ventured to doubt. That the group, the figures of which are about life-size, is mounted on a base far too high is certain. Compare the effect with that of the three times as large as life-size of the statue of Richard Cœur de Lion in Palace Yard and its modest but quite sufficient pedestal. Possibly the idea is to prevent the irrepressible London archon from effecting a closer acquaintance with the figures—a hopeless endeavour, if one may judge by the daily to-be-witnessed evolutions of the Boy Scouts and their less picturesque but proximately pushful, postprandial pals of the dinner-hour, whose bareheaded performances transform the sphinxes which flank Cleopatra's Needle into centaurs.

Dearer gas means lower dividends. The Gas Light and Coke Company intimates the payment of one for the past six months at the rate of £4 4s. per cent. per annum. That is the lowest for a long many years. Ending eleven years in December, 1907, £4 8s. was paid, but from then, with cheaper gas, there was a gradual improvement to £4 17s. 4d. in June, 1914. Last December it dropped to £4 15s. 4d. Early last year the ordinary stock was quoted £107½; by last July it had receded to 93; and at the present time it is round about 80. Why not pipe-line gas to London from the pit's mouth and sell a lower grade gas for heating at, say, 1s. per 1,000 and leave lighting to the electric undertakings? We should all use it then, and London would be smokeless.

On this page of our issue of June 16 we reported the refusal of Mr. Justice Neville on June 10 to make any order on the application of Mr. J. S. E. de Vestan for an injunction to restrain the Institution of Civil Engineers from interfering with his rights as a member of that institution, or with his enjoyment of the use and benefit of the institution, and from acting upon or enforcing a resolution of the council of the institution purporting to expel him from membership, and from omitting his name from the register or list of members of the institution, and from announcing that he had been expelled from or had ceased to be a member of the institution. Mr. Justice Neville was of opinion that there had been no irregularity in the judicial proceedings of the council, and he declined to make any order on the motion. The appellant thereupon appealed, and the appeal was heard on July 20 before the Master of the Rolls, Lord Justice Pickford, and Lord Justice Warrington. The Master of the Rolls said that the appellant was only entitled to an injunction until the trial of the action. There were points of difficulty, and of some importance, in the case, and it was more satisfactory that a decision

on these should be reserved until the trial, when evidence would be adduced in the usual way and discovery would have been obtained. There was no use in discussing these points at present. An injunction until the trial of the action would not hurt the defendants, and would prevent the plaintiff from being in any way injured pending a final decision. The Court would therefore grant an injunction until the trial. Lord Justice Pickford and Lord Justice Warrington concurred.

At the meeting of the Town Hall Committee of the Manchester Corporation last Wednesday the question of the reinstatement of two men in the City Surveyor's Department was again considered. The matter was supposed to be settled three or four weeks ago, when the committee decided in favour of the men going back to work with the approval of the City Surveyor, but the Council, at its meeting on July 7, called for further consideration of the subject. The committee decided on Wednesday last to find the men some employment and to recommend that they be paid as from the time they were discharged to the present.

We heartily congratulate Mr. Hammerton, the Thames waterman who has saved the public from the monopoly the Earl of Dysart claimed of the ferry rights at Twickenham. He well deserves to be associated hereafter with other humble but spirited champions of public right whose memory is cherished by all who value it, and the courage which has maintained it against usurpers in high places. Epping Forest was saved by a poor forest woodman, who sixty years since stood boldly up to one of the lords of the manor, not that the liberal backing of the City of London should be forgotten, which spent £25,000 in costs during the fifteen years' battle that ensued. Similarly Timothy Beck, a Hampton Wick cobbler, in George the Second's time, is gratefully remembered for his stubborn opposition of the action of Lord Halifax, then Ranger of the Park, who tried to close it to the people.

A valuable paper by Dr. A. Maxwell Williams, M.D., B.Sc., the Medical Officer of Health to the City of Edinburgh, in the July issue of *The British Journal of Tuberculosis* (London: Baillière, Tindall, and Co., 8, Henrietta Street, W.C. 1s. 6d.), will well repay careful perusal. Dr. Williams, after a careful analysis of the health conditions of his own city, arrives at the conclusion we have always maintained that the right method of attack on tuberculous disease must be along the line of improved housing conditions. Here are his points:—

1. Pulmonary tuberculosis is a disease which in 70 per cent. or 80 per cent. of cases occurs in houses of three rooms and under; the number of cases is larger in two-roomed houses than in three; larger in houses of one room than in two; and the number of cases of tuberculous disease increases almost in direct proportion to the number of small houses in any district or ward of a city.

2. That since the year 1882 the number of deaths from tuberculosis has shown a rapid and steady decrease, and a like statement applies to the general death-rate and the death-rate from other forms of infectious disease.

3. That this decrease has been taking place quite apart from, and irrespective of, any special effort to deal with the condition other than the preventive measures which have been carried out in the ordinary march of public health administration.

4. That the establishment of sanatoria and dispensaries, while useful aids in carrying on a general crusade against this form of disease, are not of themselves likely to be attended by markedly beneficial results in the absence of other definite preventive measures.

5. That preventive measures centre largely in the housing question, and that, irrespective of cost, there is an urgent need, in the light of our present-day knowledge, of dealing more effectively than has hitherto been the case with congested areas, dense foci of population, and insanitary dwellings.

Had we spent half the money that has been wastefully devoted to National Insurance on healthy housing, we should have had ten times the value for it. For beyond all question, as Dr. Williamson says, "If statistics prove anything, they prove to the hilt that the disease originates and thrives in direct proportion to the unsatisfactory nature of the house and its surroundings; and they prove invariably that an improvement on these conditions is followed, as by the law of cause and effect, by an immediate fall in the tuberculosis rate."

OBITUARY.

We greatly regret to learn that Mr. Allan Whitfield, of Whitfield's Safe and Door Co., Oxford Street, Birmingham, died on the 14th inst., after a long illness. The business will be carried on under the same management, and we are sure the wide consideration so well deserved in the past will be continued in the future to this, one of the oldest and most enterprising firms in the kingdom, and second to none as regards its reputation for its well-known specialities.

We regret to hear that Mr. James Willing, head of the well-known firm of advertising contractors, of 125, Strand, passed away at his residence, Rock Hall, Teddington, on Monday evening, the 26th inst., at the age of seventy-seven. Up to a fairly recent period Mr. Willing took an active interest in municipal affairs, having at one time been chairman of the assessment committee of the City of Westminster. He was a prominent Freemason, being a member of many lodges, including the "Willing," which was named after him, and the "Strand," of which he was the oldest founder, and he was a liberal supporter of the Masonic institutions and an officer of the Grand Lodge of England. He leaves three daughters and one son, and his cheery presence and general bonhomie will be missed by a very wide circle of friends. The funeral will take place on Friday at Hampstead Cemetery at noon.

COMPETITIONS.

CANBERRA.—The Australian Minister of Home Affairs states that he will shortly revive the competition for designs for the Federal Parliamentary buildings at Canberra. The competition will be confined to the British Empire. The Minister added that this competition was only for Parliamentary and not for administrative buildings. Asked as to what the prizes would be, the Minister said they had not been fixed, but he expected that they would be the same as previously fixed—viz., £2,000 first, £1,500 second, £1,000 third. The Minister said a lot of work was being done at the capital, and he thought there was quite sufficient for the next six months.

WHITEHAVEN.—The borough surveyor, Mr. E. E. Stiven, as assessor, has selected for the purposes of a joint small-pox hospital for the borough and several adjoining urban and rural areas the design prepared by Mr. H. Irving Graham, of Harrington. The estimated cost of the scheme is £3,500.

TRADE NOTES.

Mr. J. Craddock Perkin, F.R.I.B.A., has removed from 131, Queen Victoria Street, E.C., to No. 62, Moorgate Street, E.C., and his new telephone number is London Wall 2955.

WATER SUPPLY AND SANITARY MATTERS.

OLDHAM WATER SUPPLY.—An important addition was made on Wednesday to the Oldham water supply, when the new filtration works at Castleshaw were formally opened. It is estimated that an additional 90 million gallons a year will now become available for supply purposes.

The Rural District Council of Doncaster have resolved that a town-planning scheme for the Carcroft area be carried out by the council, with the co-operation and assistance of the Adwick-le-Street Urban District Council.

Our Office Table.

By the recent death of Mrs. Sale, of Holt, Worcestershire, the water-colours bequeathed by her husband, the Rev. J. C. Sale, who died in 1897, have come into the possession of the Department of Prints and Drawings at the British Museum, and are now on exhibition in King Edward's Galleries. They include two sketches by Turner, "Glacier des Bossons, near Chamounix," and "A Storm at Venice"; "View on the Dee," "Flocks," "The Vale of Clwyd," "Beeston Castle," and "Stepping-stones at Bettws-y-Coed," by David Cox; and examples of W. J. Muller, P. de Wint, William Callow, James Holland, and Egon Lundgren, and other well-known artists.

A start was made last week with the civic survey of Greater London, under the scheme drawn up as a professional war relief measure by certain architectural and kindred bodies, and approved by the Government Committee. Several men have been employed on the work already, and a further number of the 150 eligible in London took up their duties on Monday. Greater London, South Lancashire, and South Yorkshire were the three areas mentioned by the Government Committee in making a preliminary grant of £1,000 at the end of June, and a beginning will be made as soon as possible in Manchester, Liverpool, Leeds, Sheffield, and other places in those areas. Mr. H. V. Lanchester and his co-directors for the different areas have just completed the general details of the survey programme. The maps and diagrams which are to record in the most accessible manner the entire life and interests of the communities will be grouped in seven sections, and considerable ingenuity has been necessary in scheming the colours which are to show at a glance the physical vital, density, recreative, industrial, traffic, and housing characteristics of the areas. The seven groups referred to cover physical features, mortality, population, public and private recreative opportunities, classification of industrial, residential, and transport occupations within the areas, traffic and relative areas of streets, buildings, and open spaces. The hon. directors for the three areas are:—Greater London, Mr. A. R. Jemmett, F.R.I.B.A.; South Lancashire, Professor Abercrombie, A.R.I.B.A. (Liverpool University); South Yorkshire, Mr. H. S. Chorley, F.R.I.B.A. (Leeds).

In an address at the recent annual meeting of the American Federation of Arts in Washington, Mr. Charles R. Ashbee, M.A., F.R.I.B.A., speaking as an English architect and art worker, deplored the effect of the war on British industrial art. He said that just before the war he had worked out a plan by which a labourer's cottage could be designed and built for a thousand dollars, just the amount that it costs to fire a 16-in. gun. Now no cottages are built and millions of money are shot away on the battlefields. Mr. Ashbee's workshops are all closed, three of his workers are at the front, a fourth is drilling cavalry, another is learning to drop bombs from an aeroplane, and another, "the best enameller in England," is making cartridges.

A conference was held on Tuesday in last week at King's College, when several Belgian experts expressed their views upon the future reconstruction of their country. The chair was occupied by M. Borbonx, Secretary and member of the Belgian Chamber of Representatives. Dr. Horta, architect and director of the Ecole des Beaux Arts, Brussels, stated that in the work of reconstruction in Belgium there would be needed a small number of expert directors. It would be necessary to study the character of Belgium and the Belgians in all their perfections and imperfections. He suggested that a committee of the burgomasters should be called to enable re-building to be undertaken, not from sentimental grounds, but from the practical standpoint of supplying in the best manner possible the needs of modern industries and agriculture. He also proposed that besides the highways for commerce, new roads should be built near the railway lines for the use of

motors. Town-planning should be studied, but its theories should be put into practice with the utmost discretion. Mrs. H. D. Acland, hon. secretary of the Belgian Repatriation Committee, urged that our national duty to Belgium would not cease with the departure of our Belgian refugees.

Mr. P. J. Sheldon, the county surveyor of Essex, in his annual report, states that main roads, exclusive of those under contract with urban authorities, cost for upkeep and improvements £115,472. A principal item was tar-painting, 3,511,523 super. yds. having been treated at an average cost of 15d. per yard. The year's expenditure was considerably less than the estimate, owing to the difficulty, through the war, of obtaining granite, but the result had been that the general condition of main roads had distinctly lowered, and this, he feared, would seriously affect the roads for some time to come. No ordinary road crusts could stand the strain imposed by the exceptionally heavy vehicles now in use during such a winter as the past one, and the sooner this was recognised the better, and more stringent regulations made as to the weights that might traverse the highways. Owing to the war it had been possible to spend only £108,310 of the anticipated amount of £173,920 under the scheme of resurfacing to cost £576,890 in five years.

"Stability of Masonry," by Ernest H. Sprague, A.M.I.C.E. (London, Scott Greenwood and Son, 8, Broadway, E.C., 4s.), is a useful manual of earth and water pressure on walls and other structures, both from the graphical and mathematical points of view. Prominence is naturally given to the former. The volume is based on lectures given by the author at University College and the Westminster Technical Institute, and includes ninety-two illustrations and three folding plates.

The energetic campaign for the extension of the lumber export trade of British Columbia has directed attention to the timber resources of the province, their present development and prospects. In an interview, the Hon. W. R. Ross, Minister of Lands, said that because they needed reliable information in order to manage their forests intelligently he began a forest survey in 1912, and a very considerable area had already been covered. The figures obtained gave something definite to go upon. Besides the eight and one-third million acres under timber license, a million acres under old timber leases, a million acres of deeded timberland, three-quarters of a million acres held under railway grants, the Crown timber reserve, created in 1907, was very considerable. In the coast forests a solid third was Douglas fir, which was the finest all-round wood in the world; over one-fifth was cedar, and there was an immense stand of Western hemlock. The world was now beginning to realise what Western hemlock was. Our pulp and paper mills had gone great things with it already, but the big uses of this wood were only just beginning. The development of the lumber business was just a matter of transportation. The Province had developed a fine system of railway transportation inland; so far, they had not done the same seawards. If the lack of sea-going tonnage that was stifling the export lumber trade were supplied, there would follow an expansion in the lumbering business and activity in every form of commerce.

After charging debenture stock interest and sinking fund, transferring £40,000 to general depreciation reserve account and £2,000 to barge and rolling stock depreciation account, the net profit of the British Portland Cement Manufacturers, Limited, for the year to April 30 last amounted to £146,375. A dividend of 5 per cent as recommended on the ordinary shares for the year, against 7 per cent for the previous year, while the "carry forward" is £70,767, against £64,522 brought in. A year ago £40,000 was allocated to general depreciation, and £11,755 written off preliminary expenses. The year under review, embracing nine months of the war, opened with a normal demand for Portland cement and a reduction in manufacturing costs resulting from the improvements effected at the various works. With the outbreak of

war the demand for cement rose to an extent which was not anticipated, and a serious shortage developed. The supply of fuel and materials, which are essential for the manufacture of cement, rose to an extent equal to the demand, resulting in a considerable decrease in output. The price of cement in the open market, while the great majority of the manufacturing, particularly in the north, was but partly met by the Government in the selling price.

PROFESSIONAL AND TRADE SOCIETIES.

ARCHAEOLOGISTS AND THE RESTORATION OF DEERHURST CHURCH.—The annual meeting of the Bristol and Gloucestershire Archaeological Society was held at the Guildhall, Gloucester, on Wednesday, the president, Mr. C. E. Keyser, F.S.A., being in the chair. The hon. secretary, Mr. A. E. Hurry, read the report, which stated that certain archaeological discoveries had been made at Bristol and Churchdown. The report made the following reference to Deerhurst Church, near Tewkesbury:—"In September last the vicar and churchwardens of Deerhurst Church obtained a faculty authorising the rebuilding of the apse and the consequent alteration of the 16th century pews on the north, east, and sides of the communion table. In view of the fact that the church is one of the very few left in which this arrangement of pews has been allowed to remain, strong protests were raised by members of the society and others against the proposed alterations."

BRISTOL SOCIETY OF ANTIQUARIES.—The second excursion of the season, under the auspices of this society, took place on Saturday, the 17th inst., when a visit was paid to Banwell Parish Church and the ancient camps and Bone Caves in the vicinity. At the church, the Rev. C. S. Taylor acted as guide. Mr. Taylor stated that it was agreed that a church stood upon the site since 885. The chancel screen, a masterpiece in wood-carving, with elaborate fan tracery, was erected in 1520, and the old register records that £700 was paid to the carver. Attention was directed to the fine timbered roof, with its stained plaster panels to represent wood. The stone pulpit, with its delicate tracery, supported on a slender octagon stone pillar, is an item of note. Above hangs a richly ornamented oak sounding-board, erected in the reign of James I.

SOMERSET ARCHAEOLOGICAL SOCIETY.—This society held its sixty-seventh annual meeting at Taunton on Tuesday in last week. Mr. A. F. Somerville, who presided, said that there had been no excursions during the year owing to the war. The council's annual report, presented by Mr. St. George Gray, secretary and curator, stated that the membership was 95, a decrease of nineteen, the first since the new century began. There were twenty-five new members, but losses by death had been heavy, and the war had caused some resignations. The deficit on the general account was £124. There had been no falling off in the quantity of museum specimens, and much valuable work had been accomplished. The report was adopted on the motion of the Dean of Wells, Dr. Robinson, who said it showed the thoroughly high character of the society, and the quality of the centre of its work, the Castle Museum, Foul Wicliffe, was a most interesting incident.

YORKSHIRE GEOLOGISTS' TOUR.—The Yorkshire Geological Society made a tour through the Widdow Valley on Saturday, under the leadership of the Rev. J. May of Leeds. Mr. J. E. B. Peck, F.R.S., was the party leader. The party journeyed by train to Airedale, where they were met by a carriage, by which the remainder of the trip was made. The route taken was via Beaufort, where the parish church, an interesting example of Saxon architecture, was visited, to the Lindby Wood Reservoir, Swinsty Hall, a sixteenth century building, which belongs to the Leeds Corporation, was also visited. It is one of the best examples of Elizabethan buildings in Yorkshire, and is in its original state. Luncheon was provided by the Lord Mayor at the Waterworks Lodge, and the party, after inspecting some of the works, returned to Leeds by train.

THE BUILDING NEWS

AND ENGINEERING JOURNAL.

Effingham House,

CONTENTS.

Eighteenth-Century Irish Houses	111
Painters', Sculptors', and Architects' War Relief Exhibition	113
R.I.B.A. Examinations	114
The London County Council Regulations for Reinforced Concrete Construction	115
Some American Methods of Gauging the Flow in Sewers	116
Currente Calamo	135
Our Office Table	136
Obituary	137
Legal Intelligence	137
Building Intelligence	138
Trade News	138

Lat-st. Prices	139
Tenders	140
List of Competitions Open	M
List of Tenders Open	M

OUR ILLUSTRATIONS.

Eighteenth-Century Irish Houses, Beaulieu, Co. Louth, and Cashel Palace Hall, Tipperary, from "Georgian Mansions in Ireland," by Messrs. Thomas C. Sadler, M.A., and Page L. Dickin-son, F.R.I.A.I.
The London City and Midland Bank, Ltd., Metropolitan Branch, Wolverhampton. View and plan. Messrs. Cousins, Peacock, and Bewlay, Architects.

Strand, W.C.

The Saxon Crystal, R.I.B.A. Exhibition, 1915. A water-colour by Miss M. W. S. Architects.
First Premium of 1914. St. George's, London. Site-Plan, Bromley, Kent. Estate, Part of the Plan for Messrs. Lever Brothers. View and elevation. Mr. Ernest G. Lacey, M.A., F.R.I.B.A., Architect.
Business Premises, Watling Street, Newington, Tyne, for Messrs. W. H. Smith and Sons, Ltd. and plan. Messrs. Marshall and Faulkner, Ltd., Architects.
Y.M.C.A. New Premises, St. Helen Road, Southampton. View and Plans. Mr. Robert G. Maxwell, F.R.I.B.A., Architect.

EIGHTEENTH-CENTURY IRISH HOUSES.

(WITH ILLUSTRATIONS.)

Dublin is pre-eminently famous for its Georgian architecture, and several eminent representatives of the fine arts and learned bodies in the city founded "The Georgian Society" a few years ago for

Subsequently, however, having devoted four handsome volumes to Dublin, the committee turned their attention to the wider field, including some of the more notable mansions scattered about the four Provinces.

Architects generally know next to nothing of these fine old Hibernian treasure homes; indeed, we are given to

only alternative was a collection of about a dozen of the chef-d'œuvres, while the lesser specimens had to be omitted. Thus it came about that the last volume issued by the Georgian Society, published in 1913, was devoted to a few imposing country seats of the Irish gentry. Excellent pictorial illustrations were obtained, together with their historic par-

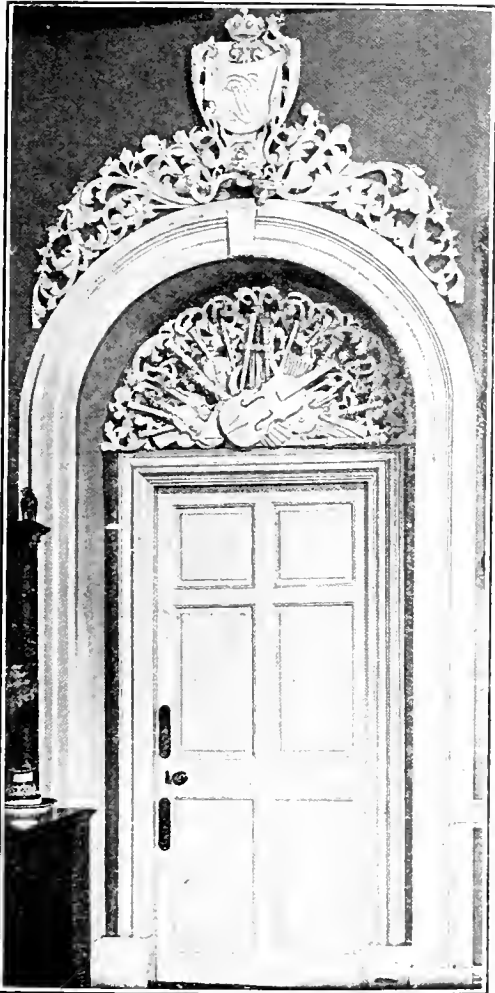

BEAULIEU, CO. LOUTH.—DOORWAY IN HALL.
From "Georgian Mansions in Ireland."



BEAULIEU, CO. LOUTH.—DOORWAY IN HALL.
From "Georgian Mansions in Ireland."

the express purpose of collating an authentic and copiously illustrated record of the best Georgian domestic work in Dublin. At the outset little idea was entertained of attempting a survey of the country houses of Ireland, mainly built though they were during this epoch. There was no intention either of covering the ground occupied by the historic decorative work of the Hanoverian period in other parts of the country.

understand that a half-impression prevailed among the organisers of this special scheme, when it was decided to devote their fifth book to Irish country houses, that the available material would be inadequate. As a matter of fact the project incurred an inspection of as many as three hundred Georgian houses of different sizes. The editors were unable to cope with such a number of buildings, consequently their

particulars which add value to the publication. Its practical utility is further enhanced by some information concerning two hundred and seventy houses included in the original survey instituted by the society. The volume to which we direct attention today certainly well fulfils the initial object of the society, including as it does a good few of the typical Georgian houses left

untouched by the committee. Domestic buildings of secondary importance are frequently much more suggestive than grander structures, and therefore this new book will be welcomed.

Some of the buildings previously dealt with, as above stated, should here be enumerated, or it might appear that the author had overlooked the richest Georgian examples in Ireland when arranging their material for the work just published in Dublin. The society having given these big places, there was no occasion for illustrating them again. The first to be named is the palatial seat of Castletown, near Celbridge, Co. Kildare, being the earliest stone-built residence in the Classic style erected in Ireland. The buildings comprise a four-square central block with lateral wings connected by segmentally planned colonnades. The composition presents a refined monu-

the Mid-Victorian period, when new windows were inserted, but the house still well retains its 18th Century character and merits the space given to its illustration as a leading example of its time. The ornate saloon, with its somewhat pretentious organ case, suggests the effect of over-elaboration, and is lacking in dignity. Newbury Hall, in the same county, is particularly interesting because of its construction in red brick. The arrangement of the plan consists of big wings with intermediate buildings joining them up to the central or crowning block. Powerscourt House, Co. Wicklow, and Castletown, in Kilkenny, are likewise amply illustrated. The last-named is singularly fine, comprising a middle composition of the typical Late Renaissance kind with arcaded verandahs terminating in tall, opulent-looking pavilions having ogee-shaped roofs. Much suggestive detail

most part they are very characteristic, and are still rich in good paintings and plate, often containing exceedingly good 18th Century workaday furniture as distinguished from show pieces, for the cabinet work of Ireland is marked by much excellent style of its own. Old Irish furniture is distinctive, mostly well-finished, and it will bear comparison with English contemporary productions. This supplementary but otherwise complete volume, though primarily intended to be a context to those which the Georgian Society brought out, will be valued for its own sake, quite apart from their five former books. In size, style, and binding the work is uniform with them. The authors, Messrs. Thomas U. Sadleir, M.A., M.R.I.A., and Page L. Dickinson, M.R.I.A.L., acknowledge in their preface an indebtedness to the Rev. J. P. Mahaffy, C.V.O., the Provost of Trinity College,



CASHEL PALACE, TIPPERARY: CARVING ON STAIRCASE.

From "Georgian Mansions in Ireland."

mental extensive façade in the Italian manner. The "Long Gallery," common to earlier mansions, is more than 100 ft. in extent, and a lordly feature is made of the "Grand Hall," besides which there is a very spacious staircase hall in keeping with the rest. No plans of the building are furnished, and this absence of plans materially reduces the architectural value of all these publications of the Georgian Society. Russborough Court, in County Wicklow, has a similar lay-out, extending, however, to greater magnificence, being 700 ft. long, measuring out to out. All the elevations are faced with wrought stone, and the design is attributed to Bindon and Castle, well-known architects of their day. The estate is hard by Blessington. The mansion has a beautiful saloon, and is remarkable for the great variety of its mantel-pieces. Summerhill, Co. Meath, is of a similar type, quite as important in scale, and well worthy of its architect, Richard Castle, who commenced its erection in 1731. The proportions are more lofty than usual, making an exceptionally fine building. Some eight years later the same architect was engaged by the Duke of Leinster to recast his pre-Georgian mansion Carton, his famous seat near Maynooth, Co. Kildare. Further alterations were made to this place during

abounds, and the excellent doorways of elegant proportions add to its charm. The house was built between 1767 and 1770 from plans by David Ducart, the architect. The Marino, Co. Dublin, supplies the only measured plan included in this Volume V., published by the Georgian Society. In their previous books restricted to Dublin, more plans are provided, the most important being those printed in Volume IV. of Leinster House, accompanied by sections to scale nicely drawn and reproduced.

The Georgian town residences in Dublin no longer remain in the occupation of the rich, for whom they were built, while in some streets only their shells stand intact. In the majority of instances these long-neglected mansions are used for housing the distressed poor. About the better parts of the city similar sometime opulent residences are utilised by institutions, or have been converted into hotels or adapted to office requirements. The country houses of Ireland, on the contrary, have been more fortunate, being very largely maintained in their original status notwithstanding "Castle-Rack-rent" stages and various ruination difficulties incidental to their chequered history. These historic homes do not always possess many valuable curios, but for the

Dublin, for his sympathetic co-operation as President of the Georgian Society in furthering the production of this publication, for which they alone are responsible. The volume cannot fail to be recognised as a standard work on the subject. Mr. Dickinson served as joint hon. secretary of the society, and consequently had the whole business before him. His partner, in his professional practice, Mr. R. Caulfield Orpen, R.H.A., has lent a hand by contributing some cleverly-free pen-and-ink sketches, interspersed in the text, and more marginal illustrations are added by Messrs. L. Giron and J. Haughton. Mr. Milford Lewis, the well-known architectural photographer, of Dublin, who supplied most of the views and details of ceilings and other decorations for the illustrations issued by the Georgian Society, has been also retained for the same work in this book, besides executing all the copper engravings from his own photographs. We have been permitted to reproduce those given by the Dublin University Press, the printers of the whole series in question. The book contains eighty full-size plates, besides twenty smaller drawings in the letterpress. The buildings represented are Abbey Leix, Beaulieu, Bessborough, Caledon, Cashel Palace, Castle Ward,

Curraghmore, Desert Court, Furness, Palatten Hall, Turvey, Belgard, Castle Upton, and Heywood. The last-named house possesses an exceptionally handsome Georgian punch bowl used by the notorious "Hell Fire Club." The cup was made in London by Anthony Nelme and bears the Hall-mark of 1700. It is illustrated to a good scale. Some drawings by Robert Adam are also reproduced in the final pages of the volume.

Our inset plate to-day comprises the entrance front of Beaulieu and an interior of the hall, from which an heraldic carving is shown in detail. We add here a pair of doorways in this apartment for the sake of their elegant enrichments. From Cashel Palace the hall is photographed, and added to this there is a smaller illustration of the carving on the string of the staircase landing. Prior to printing particulars of the subjects depicted in their book, the authors have devoted a chapter to an informative essay on the "Development of Georgian Architecture and Its Application to Irish Requirements." When these 18th Century dwellings were built, English architects were very often imported to design and carry out their execution. No genuine Tudor-dated mansion exists in the whole of Ireland, and the only exception of that period is furnished by the house of the Ormonders at Garrick-on-Suir, while very few houses are to be found which can rightly be called Jacobean. Irish fortified castles, still very numerous, were long retained for use after the English had abandoned the erection of that earlier class of buildings altogether.

Beaulieu, in Co. Louth, lies between Drogheda and the sea-shore. The house is reckoned the earliest of its kind erected in Ireland carried out in stone, with red-brick dressings, the bricks being of Dutch manufacture. The bold eaves and dormers bespeak the Caroline period, to which the property belongs. The hall is an exceptionally good one for such a residence, rising as it does through two stories. It is the more notable for the admirable Early 18th Century pierced wood carvings, which we have previously mentioned. The door cases have bold, deep architraves of the style of the last quarter of the seventeenth century, and some of the ceilings much resemble Jacobean plaster work. The staircase is a capital Mid-Georgian example. The Tichborne family was long associated with Beaulieu, and the great treasure shown to visitors is the famous portrait by Sir Joshua Reynolds of Lord Rokeley, Archbishop of Armagh, of whom Sir Joshua painted five portraits. The charm of Beaulieu is its well-balanced dignity and unpretentious, homely look, though, strictly speaking, the Georgian style in Ireland was exotic, being the architecture of an English garrison; but, all the same, some of these houses are so Irish in character as to wear almost a foreign appearance to English eyes.

Cashel Palace, in Tipperary, has for long been occupied as the Episcopal home of the holder of the Protestant See. The house is hard by the famous Rock of Cashel, where King Donal Mor O'Brien built his great cathedral in 1169 and fitted it in between the Round Tower and Cormac's Chapel, both of which buildings were already in possession of the Rock. The noble chapel, "that perfect flower of Irish architecture," like the earliest churches of Ireland, had its orientation fixed by the position of the rising sun on the festival of Beltane on May 1. The orientation of Cashel Cathedral, now long since in ruins, was taken from the sun's

point of rising on the feast of St. Patrick the dedication being, May 17, and in this way King Donal magnanimously worked in his building and devising a regulated orientation. Cashel Palace is a commodious two-storied building carried out in red brick with limestone dressings. Much of its homely character and style is due to its range of dormers. The roomy hall is panelled in red pine and has bold Corinthian columns, as seen in the illustration. The staircase occupies a hall of its own and typifies its Early Georgian origin, worked out richly with twisted balusters. The bedrooms preserve their original windows and broken architraves to the doorways, while the mantels differ in their detail, all dating about the year 1810. The mansion itself was erected in 1730 by Dr. Theophilus Bohm when he was Archbishop of Cashel. Of the remainder of the houses so well represented in this book, we have only space to mention Caledon, a white-stone building distinguished by much decorative finish of a high class inside. Curraghmore, Co. Waterford, occupies a splendid position in the delightful valley of the Suir. Ranking as it does among the best in Ireland, it is so genuinely Georgian that the building on the garden side might easily be mistaken for some English country seat. The kernel of its structure is a modernised castle belonging to the class of mediæval strongholds built by the Barons. This has been faced up in its towering form after the manner akin to the François Premier or French Renaissance, rising between much lower flanking buildings to the front sides, and these wings represent the stern pure Georgian type of the strictest simplicity. The ceilings and handsome chimney-pieces form perhaps the chief architectural merit of Curraghmore. Desert Court, built in blue limestone, has bold terraces and stately gardens disposed in a handsome fashion, worthy of this dual home. Lord Desert owns some very fine cabinets and other choice old furniture. There is a noble staircase in the house, quite worthy of its setting.

Florence Court, likewise freely photographed in this volume, is palatial in scale, with wide and arcaded wings in accord with so splendid a mansion. It is the finest Mid-Georgian place in Ulster, and is chiefly remarkable for its extraordinarily free and fanciful plaster ornamentation, said to be French. Some claim this work as that of native craftsmen, which is probably correct, because there was a local school of clever plasterers at Waterford well-known for their skill in following the style perfected by the Brothers Adam. Furness is comparatively modest in size, but is distinguished by special points of its own. Platten Hall represents a type much imitated nowadays by English and Scottish architects when affecting the mannerisms of the less pompous form of the "Late Renaissance." The dining-room, here so well shown, is specially admirable, true to style and boldly panelled in oak, with a refined white and grey marble chimney-piece; the whole apartment being adaptable as it stands to present-day taste. The book contains a few contemporary and other portraits, including Romney's exquisite painting of Lady Arabella Ward at Castle Ward, the seat of Viscount Bangor.*

At Lowestoft an inquiry was held on Thursday before Mr. H. Shalford Bidwell, respecting an application by the corporation to the Local Government Board for leave to borrow £7,500 for works of sea defence.

* Georgian Mansions in Ireland. By Thomas V. Sadleir and Pace L. Dickinson. Printed for the Authors at the Dublin University Press by Ponsonby and Gibbs, 1915. Dublin. £1 1s. net.

PAINTERS' AND ARCHITECTS' ASSOCIATION WAR RELIEF EXHIBITION

The Artists' and Architects' Association War Relief Exhibition, which is being held at the Royal Academy, has opened its doors to-day. The exhibition is a most interesting one, and is well worth a visit. It is a collection of works of art, including paintings, drawings, and sketches, which are being sold for the benefit of the war. The exhibition is a most interesting one, and is well worth a visit. It is a collection of works of art, including paintings, drawings, and sketches, which are being sold for the benefit of the war. The exhibition is a most interesting one, and is well worth a visit. It is a collection of works of art, including paintings, drawings, and sketches, which are being sold for the benefit of the war.

Not a few painters and architects well known for their skill and facility with the pencil, pen, and brush are conspicuous by their absence, but this perhaps may be readily accounted for by their not having been personally applied to; indeed, we are aware that this was partly the case, but the oversight possibly was quite unintentional. The result is none the less to be regretted whatever the cause, seeing that some of our best men are not represented. The collection on the whole, nevertheless, is highly creditable, and certainly draws interest, even if the impression at first sight is that many of the exhibitors belong to the work of past days. There may, indeed, be critics who will argue that the collection "includes a few many old staggers," but after all very few of the sketches and drawings in the exhibition seem to be the serious work of a professional boy and on the walls of the exhibition hall actually belong to the past, and are the past work of the past, and are not us.

There are, however, a few very good things to be seen in the exhibition, and these are the hanging pictures, which are of a great gallery as they are of a great gallery. The exhibition is a most interesting one, and is well worth a visit. It is a collection of works of art, including paintings, drawings, and sketches, which are being sold for the benefit of the war. The exhibition is a most interesting one, and is well worth a visit. It is a collection of works of art, including paintings, drawings, and sketches, which are being sold for the benefit of the war.

of his excellent spouse, both strongly drawn with a close knowledge of big cats and their varying moods. Miss Eva Ross (Mrs. S. H. Vedler) is rich in the colour-scheme of her Stroh wedding-party before the vestibule of a stone-built Oriental temple. Its warmth is a good foil to the next adjoining seascape in moonlight, by Mr. Alex. Maclean, whose work is one of the pleasantest in the room. There is a lack of brilliance in Mr. Harold Speed's smaller study (No. 12) of "A Capri Bay," with the dead, deep waters of the rock-bound pool devoid of all reflection of the shore. One of the largest, if not the biggest exhibit is "The Storm: Its Burst of Passion Spent," given by Mr. A. Caruthers Gould, and showing a village among the hills illumined by a rainbow effect bravely handled in an impressionist way, with water-logged flats in the front of the picture, distraught as it is by the elements, tellingly painted in oils, making a handsome gallery picture.

Mr. Frank Calderon, with his modest "Shelter," adds a foil to this storm scene by showing a ploughman and two tired horses enjoying refuge under the trees during a passing shower, so nicely and capably depicted. Mr. David Murray, R.A., is the generous contributor of "In the Heart of the Highlands," a fine example of his masterly skill, and Mr. Arthur Hacker, R.A., shows an oil sketch of a brown field, group of trees, and a woman at work, called "Hoing." Sir Ernest A. Waterlow, A.R.A., graces the gallery with a large oil-painting of "A Dorset Mill-stream," having a row of poplars in front and farmstead to the rear alongside of the stack-yard. The whole thing is delightful, almost like a Constable in its manner and tone. "Fountains Hall from the Gardens" is not an architectural subject as here rendered in Mr. John Lavery's dashingly done and highly capable impressionist study of the flower-beds, terraced lawn, cut yews, and topiary work. Architects would never recognise the great Jacobean mansion near the Cistercian's Abbey mins from this picture, as the house serves merely as a foil to the graphic confusion of flowers and foliage, which at a distance looks wonderfully real in this offhand dash of colour brains, as Sir Joshua said, being mixed with the paint.

Very different to the last-named is the "Moorland Pasture" sent by Mr. J. Curtis Michie, A.R.S.A., a lovely-toned big sky scene, well mellowed by time, amidst the open country, where two oxen and a woman give a personal interest. "Loch Shiel" is another Scotch mood, suggesting a more airy effect in water colour, with some "fingers" homesteads looking thoroughly sleeping, by Mr. A. K. Brown, R.S.A., whose work needs no introduction here. "The Wolf's Tail," "In Disgrace," is leaving away the stormy rain in an oil submitted by Mr. S. George Hans. The oil in the latter's cap is lovely in tone, every vivid note. It is curious to note the last named landscape that the cow put in vermillion or nearly so, and yet it looks quite right owing to Mr. Brown's touch and sense of values. The blue "The Blue Light" day at "Canadal Bay," by the same painter, is most captivating, and shows a big landscape of Windsor as seen from the meadows at Eton Wick. Mr. Herbert J. Spill, A vast expanse of sky merges in a long, dark line of the horizon. "The Allegory," by Mr. J. J. Salmon, R.A., is decorative, showing a boat and the "Grinning Sea," with the sun peeples on a sunny shore, and is, I believe, by Mr. Lionel F. South, A.R.A., is figured by a boy and

woman, suggesting a story which enriches the gallery. "The Ice Maiden," in blues and cold tints, the work of Mr. T. C. Gatch, is beautiful and vastly more than a study of the nude; while "Sweet September" furnishes a truly English pastoral, with the orchard and embowered cottages by the banks of a river. It is thoroughly and artistically painted by Mr. E. W. Waite. The telling ideal of "The Eye of the Storm," shown by Mr. Tom Mostyn, is Rembrandt-like in breadth, showing the snow-peaks beyond the valley, where the wind-brushed shrubs in the gleaming light up the middle picture beyond the hush under the forest trees.

On the screens, Sir Aston Webb, R.A., has a gateway from Bruges next a circular bastion tower and conical roof with its lantern stage, near by the "Late and Flat" pediment over the archway in stone. Two other water-colours, by the late Alfred Waterhouse, R.A., from Rome and Quimper, are to be welcomed as an evidence of his capacity as a colourist equalled by very few of his contemporaries. Sir Ernest George, A.R.A., shows several of his beautiful etchings, and the most typical of his sketches here seen is that of the great portals of St. Trophime, Arles, drawn with every appreciation of the statuary, the whole being lightly washed, with good results. The timbered front over the fishing-tackle shop in "A Street in Exeter" is another typical sketch by Sir Ernest George. One of the smaller gems of the gathering is a pair of storks so eminently characteristic of the late H. Stacy Marks, R.A. (220), also so true in all his renderings of bird-life. Mr. W. Walcot shows several of his masterly etchings of architectural compositions, but his *chef d'œuvre* is a powerful study of the great portal of the modern Palace of Justice at Brussels. Mr. Andrew N. Prentice does himself and his subjects justice in "A View in Skye" and "View in Perugia," a pair of pleasing little water-colours. We were much taken with the old square at Semur, France; the brilliant sunshine midst cold colourings in a narrow way at Chatillon, Val d'Aosta, with its arched side entries, as drawn by Mr. E. Guy Dawber. Mr. Ed. Warren sends a delicate pencil sketch of a florid Gothic oriel, "The Eckes Fenster, Nurnberg," so rightly rendered. Rheims Cathedral is drawn in elevation by Mr. Arnold Mitchell, and dated 1886, and the same architect shows similar big fronts of Lichfield and Wells Cathedrals, all carefully and tellingly realised as to their elaboration of iconography. Mr. Curtis Green is fully represented, and his most telling drawing is the "West Portal, Cremona." He also supplies a pen sketch of Fountains Hall, which gives a very different impression to the painting, already mentioned, by Mr. John Lavery, A.R.A. (24). Mr. S. D. Althead's "Kent Farm" and "Marsh Side, Revalers," show no little capacity as a water-colour sketcher, and Mr. Phen Spens sends "The Ruins of St. Cloud After the Commune." Mr. Raffles Davison's work is on view several times, but the gem of his series is a small dashed-in ivory coloured seascape, "After George Shelfield." Mr. Alfred Yeates, Mr. Herbert Wigglesworth, Mr. Barclay Nixon, and Mr. J. J. Joss send water-colours, one and all capital in their own direction. Amongst the most delightful is "Bromeswell Heath, Suffolk," with westward winds, rolling clouds, and the mill by Mr. H. Woods. The "Lincolnshire Church" on the crest of the hill, by Mr. H. S. East, hangs worthily near the last named, "Sculling," by Mr. H.

Heathcote Statham, looks sadly out of drawing, with little knowledge of boats and the sea resembles a hayfield on a very choppy dry.

R.I.B.A. EXAMINATIONS.
PRELIMINARY.

The Preliminary Examination, qualifying for registration as Probationer R.I.B.A., was held in London, Bristol, and Manchester, on June 8 and 9. Of the 80 candidates admitted, 56 were exempted from sitting, and the remaining 44 examined, with the following results:—

Centre.	Examined.	Passed.	Relegated.
London	27	18	9
Bristol	8	5	3
Manchester ..	9	5	4
	44	28	16

The passed and exempted candidates—numbering together 64—are as follow:—

Atcheson, Henry Maynard, 4, Buxton Road, Brighton, Albion, Frederick William Harforth, 39, Marchills Avenue, Chapeltown Road, Leeds; Anderson, George, St. Giles' House, Norwich; Avelley, Max Heriot, Nevil Cuthbert, 25, St. John's Road, Clifton, Bristol; Ayers, William Cecil, 77, Ryan Street, W. Bowling, Bradford; Barber, Norman Arthur, Vicarage Avenue, Derby; Bateham, John Ambrose, 56, Con-tantine Road, Hampstead; Bennett, Harvey Ernest, 5, Douro Villas, Cheltenham; Benson, Christopher Augustus, "Cartlett," 47, Pentre Street, Grangctown, Cardiff; Booth, Harry Ernest, 29, Sydney Street, Brighton; Brown, Charles Robert, 2, Poidvent Place, Colchester; Burkitt, Cecil, 3, Westbourne Road, Barnsbury, N.; Byrom, Richard, 223, Tottington Road, Elton, Bury, Lancs.; Chaudhuri, Agra Kumar, "Lakham," Clarence Road, Clapham Park, S.W.; Cross, Walter Edward, 132, Richmond Road, Dalston, N.E.; Davies, David Owen Harris, 81, Calabria Road, Highbury, N.; Evans, Leslie Maurice, 21, Forster Street, Ashted, Birmingham; Fieldsend, Henry, Mason's Arms, Ackworth, Pontefract; Fisher, Nancy Cooper, Kirk Villa, Church Row, South Ascot; Goldthorp, Alfred Reginald, 30, King Cross, Holfax, Yorks.; Green, Allan, 3, Denby Mount, Oakworth, near Keighley; Hardy, Ernest Harold, 21, Belle Vue Road, Wandsworth Common, S.W.; Harris, Samuel George Stanley, "Mons," Constitution Hill Road, Parkstone, Dorset; Harvey, James Maegregor, 8, Beaumont Gate, Downhill, Glasgow; Haywood, Algar Arthur Newton, 15, Farm Street, Mayfair, W.; Holliday, Albert Clifford, Parkfield, Gildersome, Leeds; Hollingsworth, Christopher Raymond, Manor House Offices, Barnsley; Honeyman, James Maclaren, H.M. Office of Works, 3, Parliament Square, Edinburgh; Hughes, Eleanor Katherine Dorothy, Beafield, Hengist Road, Bournemouth; Jepson, Reginald, Irceton House, Rose Hill Street, Derby; Jones, Colin Lancelot, Oakfields, Cwmbran, Newport, Mon.; Kelly, Stephen Stanislaus, Walmer, Sutton, Co. Dublin; Lawrence, Fredk. Orchard, 1644, Aigbunth Road, Liverpool; Lawrence, Henry Matthew, 22, Marston Street, Tannworth, Loughborough; Lewis, Ernest Wansley, "Kia-Ora," Icen Road, Weymouth; Marshall, Thomas Leslie, "Oban," Hills Road, Cambridge; Meild, Henry Alexander Nesbitt, The Vineyard, Abingdon; Morgan, William Thomas, Queen's Hotel, Castle Street, Maesteg, Glam.; Morrow, Leslie George, "Brent Lodge," Berkhamstead; Napier, James, c/o J. Burnet and Son, 239, St. Vincent Street, Glasgow; Noble, Charles, 9, Parsonage Road, Withington, Manchester; Papworth, Henry William, 5, Gall Road, March, Cambs.; Peever, George Henry William, "Caradol," Perry Street, Greenfields, Shrewsbury; Pite, Horace Victor Walter, 13, Elm Grove Road, Ealing; Rogers, George Reynold Hubert, 17, Brynmill Crescent, Swansea; Rose, Kenneth Woodhouse, The Mount, Halesowen; Schofield, Herbert Walter, 20, Haldane Road, Fulham, S.W.; Shaw, Robert Philip, 26, North Bridge Street, Bathgate, Linlithgowshire; Slater, Cyril, Municipal Offices, Babington Lane, Derby; Somerset, Douglas Forbes, Public Works Dept., Suva, Fiji; Stevenson, James, Gateside, Ayr, N.B.; Stribling, Herbert James, 80, High Street, Slough, Bucks.; Tamner, Charles Puget, 110, St. George's Terrace, Jesmond, Newcastle-on-Tyne; Taylor, George Swan, 49, Buisnessey Road, Kirkcaldy, N.B.; Trehearne, Abraham, 13, Shelone Terrace, Briton Ferry, W. Vale, Christian Courtenay, Park House, Exeter; Waddear, Arnold, Laburnham House, Pool Street, Bolton; Ward, Frank Vaughan, P.W.D., Suva, Fiji; Ward, Victor Ernest, "Scarcroft," Westeros, Swansea; Westgarth, Silas, "Allensford," Cathedral Road, Cardiff; White, Frances James, Bannadon, West Avenue, Exeter; Williams, Alun, "Brynhaedog," Ogmore Vale, Glam.; Yardley, James Howard, Rathmore, Stourbridge.

INTERMEDIATE.

The Intermediate Examination, qualifying for registration as Student R.I.B.A., was held in London, Bristol, and Manchester, from June 4 to 11. Twenty-one candidates entered, with the following results:—

Centre.	Examined.	Passed.	Relegated.
London	13	5	8
Bristol	3	2	1
Manchester ..	5	2	3
	21	9	12

The passed candidates are as follow, the names being given in order of merit.—

P.—Probationer.

Philp, Arthur Thomas [P. 1913], 34, Alderney Street, S.W.; Francis, Bernard Thomas [P. 1912], "Michigan," Watling Hill, St. Austell, Cornwall; Johnson, Henry Andrew [P. 1911], The Vicarage, Great Harwood, Blackburn; Warwick, James Guy [P. 1912], 103, Park Road, Peterborough; Todd, Harold Edgar [P. 1912], Hart's Cottage, Almonby, near Bristol; Bonister, Harry [P. 1914], 65, Edith Grove, Fulham Road, S.W.; Wincham, Goodman George [P. 1911], 13, "Shydake," Calvert Avenue, Bethnal Green, N.E.; Metcalf, Harry [P. 1913], 173, Shear Brow, Blackburn; Ems, James Albert [P. 1905], 14, Nightingale Square, Wandsworth Common, S.W.

The number of failures among the relegated candidates was as follows:—

A. Principal Styles and General History of Architecture, 1; B1. Simple Applied Construction, 8; B2. Theoretical Construction, 8; C1. Historical Architecture: (a) Greek and Roman, 2; (b) Byzantine and Romanesque, —; (c) French and English Gothic, —; (d) Italian, French, and English Renaissance, —; C2. Mathematics and Mechanics, 1; C3. Design, 5.

EXEMPTIONS FROM THE INTERMEDIATE.

The following Probationers, having produced satisfactory evidence of their training and qualifications, were exempted from sitting for the Intermediate Examination, and have been registered as Students:—

Dey, Berendra Nath [P. 1913], 36, Ottago Street, Glasgow (Government C. E. College, Sibir); Dhama, Bhanwar Lal [P. 1913], Consulting Architect's Office, Benbay (University of Allahabad); Ford, Thomas Francis [P. 1912], 36, Hanover Park, S.E.; Goulay, William [P. 1913], 2, Balmoral Terrace, Queen's Park, Glasgow (Glasgow School of Architecture); Hardy, Thomas Charles [P. 1913], 15, Carmichael Place, Langside, Glasgow (Glasgow School of Architecture); Honeyman, James MacLaren [P. 1915], H.M. Office of Works, 3, Parliament Square, Edinburgh (Glasgow School of Architecture); Lawrence Frederick Orford [P. 1915], 164, Aigburth Road, Liverpool (Liverpool University); Louy, Ethel [P. 1913], 11, Ladbrooke Terrace, W. (King's College); Napper, James [P. 1915], c/o J. Burnet and Son, 239, St. Vincent Street, Glasgow (Glasgow School of Architecture); Shaw, Robert Philip [P. 1915], 26, North Bridge Street, Bathgate, Linlithgowshire (Edinburgh College of Art and Heriot Watt College).

In accordance with the special concession granted by the Council to Probationers on military service who are candidates for the Intermediate Examination and whose Testimonies of Study have been approved, the following were also exempted:—

Barlow, Smith [P. 1911], "A" Company, Army Service Corps, Aldershot, Berry, Harold [P. 1913], "Knebworth," Station Road, New Barnet (Queen Victoria Rifles); Burleigh, Harold [P. 1911], 7, Priory Road, West Hill, Hastings (University of London O.T.C.); Daniel, Thomas Llewellyn [P. 1909], Bryn Dovey, 37, Craunbrook Park, Ilford (Royal Naval Air Service); Eaton, Alexander Robert Charles [P. 1904], 203, Neville Road, Forest Gate, E. (Bedfordshire Regiment); Hall, Daniel Carly [P. 1911], Prudential Buildings, Leeds (Army Service Corps); Hall, Herbert James [P. 1913], 104, Cornerswell Road, Penarth, S. Wales (Glamorgan Yeomanry); Hall, William Basil [P. 1909], 33, Carlingford Road, Hampstead, N.W. (Royal Fusiliers); Hope, William [P. 1908], 37, Beverley Terrace, Cullercoats, Northumberland (St. John's Ambulance Brigade); Hunt, Reginald [P. 1911], The Honestad, Summingswell Road, Oxford (Oxford and Bucks Light Infantry); Jarvis, Harold Edgar [P. 1911], 62, Blacker Road, Birkby, Huddersfield; Larkin, Horatio Edward Arthur [P. 1914], 71, Peel Street, Kensington, W. (13th County of London Territorials); MacKenzie, Frederick Wheatley [P. 1908], 20, Oakwood Gardens, Seven Kings, Essex (Middlesex Regiment); Mansfield, Roland Edward [P. 1912], "Tonquay," Tonquay Drive, Leigh-on-Sea, Essex (Royal Engineers); Martindale, Christopher James Fawcett [P. 1904], Moor Side, Garden City, Carlisle (Royal Engineers); Mercer, John Frederick Lees [P. 1911], 11, Park Mount, Revdgate, Blackburn (Royal Engineers); Ramsden, Eric Alfred [P. 1912], 27, Hyde Terrace, Leeds (West Yorks Regiment); Reed, William James [P. 1912], 11, Theresa Street, Blaydon-upon-Tyne (Royal Naval Air Service); Rees, Frederick William [P. 1911], 1, Lin Park Road, Pontypridd (Royal Engineers); Shields, George Darnley [P. 1912], 258, Otley Road, Bradford (Royal Engineers); Smith, Arthur [P. 1909], 19, West Hill Road, Luton, Beds (Royal Engineers); Taylor, John Alexander Chisholm [P. 1909], 29, Ouch Street, Oldham (10th Bn. Manchester Regt.); Wharf, Henry Francis [P. 1913], 106, Coltman Street, Hill (East Yorks Regiment); White, Raymond Charles [P. 1913], 6, Bierton Hill, Aylesbury, Bucks (Royal Bucks Hussars); Williams, Percy James [P. 1911], "Carno," Carmarthen (Welsh Regiment); Wood, Thomas Spencer [P. 1913], Hawthorne House, Handsworth Wood (Royal Field Artillery).

FINAL AND SPECIAL.

The Final and Special Examinations were held in London from June 24 to July 2. Of the 52 candidates examined, 27 passed, and the remaining 25 were relegated. The

successful candidates, given in alphabetical order, are as follows:—

Adams, Percy Joe [S. 1911], Larnoo St. Woodside Road, Woodford, Essex; Andrew, Herbert [S. 1912], 56, Whiteknights Hill, Belsara, Phoenix-shah Parkdon, Special; 6, Highbury Place, Highbury, N.; Bennett, James [S. 1911], c/o Messrs. J. E. Burnet and Son, 19, St. Vincent Street, Glasgow; Bruce, Reginald [Special], 21, Hoddinhurst Avenue, North Finchley, N.; Catbridge, Edgar Gooding [S. 1908], 46, Christchurch Street, Ipswich; Duncan, Alexander McLaughlan [Special], Raboy, Lango, Dumbarton-shire; Francis, Eric Carwardine [S. 1911], 14, St. Andrew Mansions, Dorset Street, W.; Fyfe, James Stimpson [S. 1913], 147, Humberstone Road, Ecclesall, Sheffield; Gommman, John Henry [S. 1909], c/o Messrs. St. Venus and Grogson, 37, Avonmore Street, S.W.; Loewth, Sidney Harold [S. 1913], 67, Downs Park Road, Hackney Downs, N.E.; MacLaurin, Robert William [Special], 8, Mucklenburgh Street, W.C. (Ankland), N.Z.; Melburn, Percy Hayman [Special], 8, Mucklenburgh Street, W.C. (Melbourne); Mitchell, Carl Hawthorn [S. 1911], c/o Messrs. Aky, Curran and Sons, Ltd., 21, 5, Upper Thames St., E.C. (Ankland, N.Z.); Munson, Ernest Paul Brauder [S. 1912], 27, Upper Phillimore Place, Kensington, N.W.; Chas. Edman [S. 1911], Rectory Farm, Ekington, Sheffield; Pace, Charles Lancelotti [S. 1907], 8, St. George's Street, Primrose Hill, N.W.; Reiva, Thomas [S. 1908], Gloucester, Erwood Road, Lyenshine, Manchester; Robertson, Manning Purdin [S. 1911], 50, Norfolk Square, W.; Robinson, Alfred Douglas [S. 1909], The Abbey, Thorpe-le-Soken, Essex; Sayer, Harvey Robert [S. 1905], 3, Baylock Road, West Marlands, Southampton; Takakoshi, Kenzo, 100, Brompton Road, S.W.; Turner, Albert Isaac [S. 1909], 65, Wilmington gardens, New Barking, Essex; Walker, Harold Frederick [S. 1913], 13, New Street, Dorset Square, N.W.; Waidrop, James Hastie [Special], 8, Mucklenburgh Street, W.C. (Melbourne); Williams, Enoch [S. 1905], 30, Canada Road, Cardiff; Young, William Cecil [S. 1909], 19, King's Drive, Beaton Moor, Stockport.

Under a special Regulation this gentleman, being a foreign subject and not eligible for membership, will be granted a Certificate.

The number of failures among the relegated candidates in the final examination was as follows:—

A. Design, 12; B. Construction—(D) Foundations, Walls, Roofs, etc., 17; (E) Iron and Steel, 19; C. Hygiene, 19; D. Properties and Uses of Building Materials, 9; E. The Ordinary Practice of Architecture, 13; F. The Thesis, 3.

THE FINAL DESIGNS APPROVED.

The Board of Architectural Education announce that the designs submitted by the following students have been approved:—

SUBJECT XXI.

(a) DESIGN FOR A BANDSTAND IN A PUBLIC PARK. Brandon, C. J.; Hutton, L. D.; H. Traumer, F.; Duttall, J. A.; Kellock, A. D.; Tibbs, G. B.; Day, N. F. C.; Munzaga, G.; Wilkinson, F.; Dunsen, R. A.; Reiva, F.; Woodhouse, F. G.

(b) DESIGN FOR A HOSTEL FOR MALE STUDENTS ON A DETACHED SUBURBAN SITE. Sauter, M. C.; Vanden, G.; Taylor, R. V.; Wilson, J.

THE LONDON COUNTY COUNCIL REGULATIONS FOR REINFORCED CONCRETE CONSTRUCTION *

(Concluded from page 90.)

PART VIII.

MATERIALS AND TESTING.

Cement

144 All cement used shall be Portland cement of slow setting quality and shall be in accordance with the British Standard Specification from time to time in operation.

145 The quantity of cement shall be determined by weight, and ninety pounds shall be deemed to be the equivalent of one cubic foot.

146 The sand shall be clean and gritty. It shall be composed of hard siliceous grains, or of materials permitted under regulation 150. It shall be free from clay or any animal, vegetable, or bituminous matter.

147 All sand shall pass through a test three sixteenths of an inch square measured in the clear.

148 The sand shall be separated from the coarse material before the materials are measured.

Coarse Material

149 The term "coarse material" means all the ingredients of the concrete except the sand, the cement, and the water.

150 The coarse material shall consist of clean flumes or pit-ballast or gravel, hard stone, such as granite, basalt, trap rock, or other hard and equally suitable material.

* Sub-headings and italic cross references do not form part of the regulations.

151 The coarse material shall be tested by the following methods:—

152 The coarse material shall be tested by the following methods:—

153 The coarse material shall be tested by the following methods:—

154 The coarse material shall be tested by the following methods:—

155 The coarse material shall be tested by the following methods:—

156 The coarse material shall be tested by the following methods:—

157 The coarse material shall be tested by the following methods:—

158 The coarse material shall be tested by the following methods:—

159 The coarse material shall be tested by the following methods:—

160 The coarse material shall be tested by the following methods:—

161 The coarse material shall be tested by the following methods:—

162 The coarse material shall be tested by the following methods:—

163 The coarse material shall be tested by the following methods:—

164 The coarse material shall be tested by the following methods:—

165 The coarse material shall be tested by the following methods:—

166 The coarse material shall be tested by the following methods:—

167 The coarse material shall be tested by the following methods:—

168 The coarse material shall be tested by the following methods:—

169 The coarse material shall be tested by the following methods:—

170 The coarse material shall be tested by the following methods:—

171 The coarse material shall be tested by the following methods:—

172 The coarse material shall be tested by the following methods:—

173 The coarse material shall be tested by the following methods:—

174 The coarse material shall be tested by the following methods:—

175 The coarse material shall be tested by the following methods:—

PLACING

164. The concrete shall be placed in its final position before initial set has taken place.

In the case of beams, pillars, and walls, the thickness of the layers of loose concrete shall not exceed three inches before ramming.

As soon as possible after mixing, the concrete shall be properly rammed into the moulds in such a manner and under such conditions as will secure a compact mass, without voids and of the greatest possible density for the proportions used.

Steel

165. All metal reinforcement shall be of steel which shall comply with the British Standard Specification for structural steel for bridges and general building construction from time to time in operation.

166. All metal for reinforcement shall be cleaned of all scale, dust and loose rust, immediately before depositing the concrete.

167. Butt or scarf welding shall not be employed in any tensile reinforcement.

168. The builder or other person directing the work to be executed shall, for the purpose of due supervision of the construction of the building, furnish the district surveyor with reasonable proof as to the quality of materials to be used in such construction, and shall make any tests which shall be reasonably necessary.

TESTS AND TESTING.

169. If at any time during the construction or within two months after the completion of the reinforced concrete construction it is found necessary to test any part of such construction by reason of any sign of weakness or faulty work appearing in the construction, the builder or other person causing or directing the work to be executed shall make such tests, and, if the tests show the work to be faulty, it shall be reconstructed and reinstated in accordance with these regulations.

170. The total deflection of beams or slabs freely supported and uniformly loaded and subject to the permissible working stresses shall not exceed 1-600th of the span when the span is twenty times the effective depth, and shall be in proportion for other ratios of span to depth, and for other conditions of ends and stress and loading.

171. The superimposed test load on any floor, roof, or other structure shall be not more than one and a-half times the superimposed load for which such floor, roof, or other structure has been designed. The superimposed test load on any beam, slab, or other similar member which has been exposed to frost during the first week of hardening, shall be not less than one and a-half times the superimposed load for which such floor, roof, or other structure has been designed.

172. Loading tests shall not be made until the expiry of ninety days from the date of laying the concrete.

PART IX.

FORMWORK OR CENTERING.

173. For the purpose of these regulations, the terms "Formwork" or "Centering" shall include all forms, moulds, sheeting, shuttering, planks, poles, posts, shores, struts and strutting, ties, uprights, walings, and all other temporary supports to the concrete during the process of setting.

174. The formwork or centering shall be of such dimensions and so constructed as to remain rigid during the laying, ramming, and setting of the concrete.

175. The vertical strutting shall be maintained continuous through the lower stories to the foundations or to other floors or beams which are sufficiently set to afford the required support without injury to the construction.

176. All form work or centering shall be removed without shock or vibration.

177.—Before the formwork or centering under any beam or floor slab is removed the

pillars below such beam or floor slab shall be partially stripped so that the pillars may be examined on all sides.

PART X.

WORKMANSHIP.

178. All reinforcement shall be placed and maintained in the position shown on the drawings.

179. The concreting in any member shall be carried out as continuously as possible.

180. Where work has to be recommenced on a surface which has hardened, such surface shall be well hacked, swept clean, thoroughly wetted, and covered with mortar composed of equal volumes of cement and sand.

DRY WEATHER.

181. Concrete laid during dry weather shall be protected against too rapid drying. During the first week of hardening it shall be kept damp by means of wet sacking or other methods or by watering daily (Sundays and holidays included).

COLD WEATHER.

182. Concrete shall not be laid when the temperature is below 4° Centigrade (39° Fahr.), and shall be protected when necessary.

FROST.

183. Concrete or mortar which has been frozen shall not be used.

184. The concrete or mortar in any beam, slab, strut, or other similar member which has been exposed to frost during the first week of hardening shall be removed, or such members shall be tested as provided for in regulations 169 to 172.

CUTTING.

185. No cutting for piping or any other purpose shall be done which would reduce the strength of any part of the structure below the standard required by these regulations.

STRIPS AND BLOCKS.

186. Blocks or strips of hard wood, coke breeze, or other equally fire-resisting material may be embedded in the concrete and used solely for fixing purposes, provided that—

(a) they do not reduce the strength of any part of the structure below the standard required by these regulations;

(b) the area of such blocks or strips at any given cross section is not included in the calculated compression area of any beam, slab, pillar, or other constructional member.

INLAID MATERIALS.

187. Soft wood or other equally combustible material shall not be embedded in the concrete.

OVERLAID MATERIALS.

188. Wood or other combustible materials may be placed on or over the surface of the concrete provided that any voids or hollow spaces between the combustible and incombustible materials be filled up with materials of an incombustible nature.

New offices are being built for the Great Northern of Ireland Railway Co. at Sheriff and Common Streets, Dublin. The contractor is Mr. John Graham, Dromore, co. Down.

The city corporation of Edinburgh has agreed to sell to Messrs. Redpath, Brown, and Co., Limited, an area of 17 acres of land at Gorgie, formerly part of the markets, for the erection of new works and artisans' houses.

Mr. Robert Forster, divisional road surveyor, Alston, who joined the Westmorland and Cumberland Yeomanry, has received a commission as second lieutenant in the 11th Battalion of the King's Own Yorkshire Light Infantry.

At Leyton on Thursday, Mr. A. W. Brightman, an inspector under the Local Government Board, held an inquiry as to the application from the Urban District Council for sanction to borrow £1,175 for purposes of the electricity undertaking.

The foundation stone of the new church of St. Margaret, Scotswood, was laid last week on a site at the junction of Denton Road and Armstrong Road. The church when completed will provide accommodation for 550 persons, and will cost £5,500. The architects are Messrs. Hoeks and Charlewood, Newcastle-on-Tyne.

SOME AMERICAN METHODS OF GAUGING THE FLOW IN SEWERS

In designing new relief or intercepting sewers and sewage treatment works it is becoming a more common practice to gauge the flow of sewage in existing sewers. The measures adopted by a number of cities in sewer gauging were described recently by *Engineering and Contracting* as discussed before the Boston Society of Civil Engineers.

The Massachusetts State Board of Health uses a comparatively simple and inexpensive type of recording gauge. It is described substantially as follows by Edward Wright, Jr.

The gauge is used mainly for measuring sewage at disposal works where the sewage passes over a weir, although it has been used in the measurement of stream flow and in the measurement of the flow of trades and wastes where it is possible to install weirs.

The gauge, Fig. 1, consists of a copper float to which a rod and pencil are attached, and a cylindrical drum, which is caused to revolve by an ordinary clock mechanism. The float rod engages in two brackets which are provided with roller bearings. The paper upon which the diagram is indicated is wrapped around the drum and held in place by pins at the top and bottom and by rubber bands. The elevation of the starting point in relation to the crest of the weir is obtained by means of a hook gauge. The actual head on the weir is indicated.

The moving parts of the gauge are constructed of brass, and while corrosion starts in very rapidly, the gauge is so constructed that little or no difficulty ensues from this cause in its operation. The clock is so constructed as to run seven or eight days, and except when weather conditions interfere, the gauge will run without attention for this length of time.

Owing to the great amount of moisture which at times rises from the sewage in the tanks where the edge has been used, it has been found impossible to produce a pen-and-

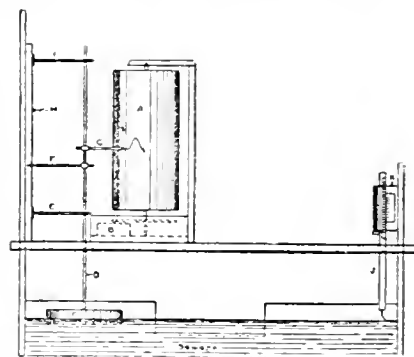

FIG. 1.—Automatic gauge used by Massachusetts Board of Health.

A, Revolving drum covered by paper that receives the record; B, clock; C, float; D, float rod; E, braces for float rod; F, finger, engages slide in upright; H, G, pencil, bears against paper on drum (A); J, hook gauge rod; K, hook gauge block and vernier.

ink diagram, and, in fact, the moisture rising at certain sewage disposal works has been so great that the paper would be torn by the pencil, and to overcome this the very best quality of paper has been used.

The most remarkable feature about this gauge is that its cost, exclusive of the weir, is only about \$25 or \$30, which includes about \$4 for the clock mechanism.

The gauge is very sensitive and, in fact, the effect of matters rising with gas in the sewage in the measuring tanks under the float has frequently been indicated. Most of the inaccuracy is due to the floating matters in the sewage, which displace the float and tend to clog the weir.

The flow of the sewage at the sewage disposal works at Marlboro, Mass., is measured by means of a trapezoidal or Cippoletti weir, placed in a channel leading to the sedimentation tanks. The sewage enters the screen chamber through a long cast-iron pipe siphon, passes through a coarse bar screen, and along a channel 7 ft. wide to a trapezoidal weir. The crest of this weir is 2 ft. long and the sides have a batter of 1 in 4.

The crest of the weir is set 18 in. above the floor of the channel. The weir itself is made up of 6-in. by 3½-in. by ½-in. steel angles bolted together and set in concrete. The inner edge or crest is planed to a true, sharp edge. The depth of flow over the weir is measured either directly by hook gauge or rule, or by means of a recording gauge of the Bristol type. This description is by Frank A. Marston.

The original plan provided a cast-iron pipe well, with connection to the channel a few feet above the weir, in which the diaphragm was suspended. The recording gauge was fastened to the wall of the screen house. After operating the plant for several months it was found that considerable sludge and scum collected in the diaphragm well and proved to be objectionable, although it may not have had any serious effect on the diaphragm or on the operation of the recording gauge. Because of this collection of scum the diaphragm was removed from the well and was suspended in the channel itself, which arrangement has proved more satisfactory.

The average depth of flow is obtained from the circular chart by the use of a circular planimeter, and the quantity discharged by the trapezoidal weir is computed from the following formula:—

$$Q = 3.266 2.5 L h^{3/2}$$

Q = quantity in cu. ft. per second.

L = length of crest of weir = 2 ft.

h = head on crest in feet.

In the design of the plant, the possibility of using a Venturi meter or some other form of measuring apparatus was considered, which would obviate the necessity of constructing an open channel with its attendant difficulties due to the deposition of solid matter, but it was felt that the city would not be justified in going to additional expense for this purpose.

The trapezoidal form of weir was chosen because of the great variation in flow to be measured. During dry weather single daily flows have been recorded as low as 150,000 gallons in twenty-four hours, and during the spring flow has reached as high as 2,500,000 gallons in twenty-four hours for a single day.

In studying the operation of the plant, it was found desirable to know the number of doses discharged by the automatic siphon from the dosing tank each day, and to obtain this information Mr. George A. Stacy, the Superintendent, installed another Bristol gauge in the dosing tank. This new gauge has operated in a more satisfactory manner than the other, perhaps partly due to the fact that the diaphragm is immersed in settled sewage. The charts obtained from this new gauge have been satisfactory and of considerable value.

They show the rise and fall of the sewage level in the dosing tank, and are used not only as a check on the quantity of sewage, but especially to determine the quantity applied to the various filter beds.

After about one year's service, a new rubber diaphragm was installed in the screen chamber gauge. The old diaphragm appeared to have been attacked by something in the sewage, possibly sulphides, which partially rotted the rubber.

From the beginning of the operation of the recording gauge in the screen chamber, the attendant has kept daily readings of the depth of flow over the weir, measured directly at a point a short distance above the weir. The attendant was instructed to take these measurements at approximately four o'clock each afternoon, and from the data thus obtained it has been possible to check the readings of the recording gauge and to fill in the records for the periods that the gauge was out of commission.

A number of daily records were selected as being representative of the variations in flow, and from these a curve was plotted showing approximately the percentage which the four o'clock p.m. rate of flow is of the average for the entire day for varying rates of flow. By means of this curve the average daily flow was estimated, having as a basis a single measurement made at four o'clock in the afternoon. The results have been reason-

ably close and furnished a fair check on the working of the gate. The Marlboro sewerage system is largely on the separate plan, so that the variation in flow of sewage throughout the day is quite regular for certain average flows.

The experience with this type of record gauge at Marlboro, although somewhat adverse, is not of a sufficiently serious nature to prevent the gauge being used in other places. The experience seems to point out, however, that it is very important that the gauge be thoroughly tested at the factory before it is installed, and that every precaution be taken to make sure that the tube connecting the diaphragm with the recording gauge be absolutely air tight. It is also of advantage to have the diaphragm immersed in as nearly clear water as possible, although the gauge has operated successfully in what might be called thick sludge. Apparently, septic sewage has some action on the rubber of the diaphragm, requiring its renewal perhaps once a year, but this can be easily done by a man of average mechanical ability and should not be a source of serious trouble. Where a slight leak does occur in the pressure tube or in some other part of the mechanism, it is exceedingly hard to locate and much harder to remedy. On the whole, the records obtained in Marlboro have been very valuable, and experience seems to justify this type of instrument as against a more expensive type, under the conditions at this particular plant.

The engineering department of Newton, Mass., maintained sewer gauging apparatus at three of the connections of its sanitary sewer system with the metropolitan trunk sewer near the Charles River for a period of about a year during 1902 and 1903. These gauges are described as follows by Edwin H. Rogers:

The gauges were in the form of a weir, with apparatus to measure the depth of flow, consisting of a float and a connection therefrom which registered the rise and fall of the sewage on a perpendicular revolving drum operated by clockwork. No reduction gear was used, the actual rise and fall being recorded. The drums revolved once a week, requiring the renewal of the record chart every seven days.

The weirs were located in manholes of the sanitary sewers, and as their crests were raised from 1 to 2 ft. above the invert sewers, they proved more or less of an obstacle to the discharge of the solid matter in the sewage, retaining a considerable amount of sludge which had to be frequently removed.

Considerable difficulty was experienced in the maintenance of the clocks, principally on account of the dampness which rusted out the hair-springs in their escapements and also tended to promote the growth of mildew in the works in such quantities as to stop them within a month, even though they were entirely enclosed in brass boxes.

The results obtained were in the main satisfactory, owing principally to the care exercised to keep the apparatus in suitable working condition.

In 1906 to 1908 attempts were made by the department to record the flow in three of the main surface drains of its separate sewer system for the purpose of obtaining data relative to the run-off of storm water. In one drain a weir was constructed with automatic registering apparatus, but was a failure, owing to the sand and other wash from the streets interfering with the operation of the apparatus.

In another instance a float was installed in a chamber beside the drain and connected with the invert of the drain by an inverted siphon.

Owing to the amount of rise and fall of the flow it was necessary to use reduction apparatus between the float and the register chart.

This method of measuring the flow could not be considered a success, partly on account of the pipe connection between the drain and the chamber being clogged with sand and other materials, and partly from the difficulty of calibrating the chart for different depths of flow in the drain. The drain was laid on a 3 per cent. grade and the flow through it caused apparent fluctuations in the float chamber which vitiated the attempts to obtain accurate records.

It was found that the use of a float in a 12 in. diameter drain was not a satisfactory gear with a 12 in. diameter drum. The float and drum were made of brass, and the float was 1 in. in diameter and 1 ft. in length. The drum was 1 ft. in diameter and 1 ft. in length. The float was not collected in the drain, but was housed outside of the drain, thus avoiding difficulty in the drain. This apparatus was in operation for several weeks, but results for several months.

A self-recording gauge was installed in conjunction with the other gauges at the drains.

The element of time in the measurement of the flow in the drains is a factor in the derivation of the average flow, and it is important that the element of time be closely synchronized with the element of time to environment in the drains. A system of electric clocks was installed.

After a considerable sum of money had been expended, it was decided that the records obtained did not appear to justify the further expense of maintenance and operation of the gauges were discontinued.

Various methods have been used for the measurement of the flow in the drains.

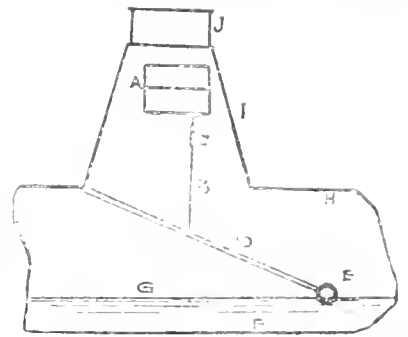

FIG. 2.—Water stage register used in Brooklyn sewers.

sewers, and these methods are here described by Edwin J. Fort.

Of the several methods employed at Brooklyn the most successful have been the use of the self-recording water stage register and the knife-edge weir.

The self-recording water stage register referred to may be used in all sizes of sewers for domestic flow or storm water run-off. By using this method the hydraulic gradient of the flow is obtained by observation and measurement, as is also the cross-sectional area of the sewer for the depth of the flow. The value of *u*, in Kutter's formula, is determined mainly by the exercise of judgment on the part of an experienced observer, in the absence of experimental data. Kutter's formula for velocity is then applied and this means the quantity of flow is obtained.

Weir measurements are used in exceptional cases, especially where the entire flow of a drainage area or district can be weired in the out fall trunk sewer.

The gauge and weir, the description of which follows, have been used in experimental work of this character in a number of drainage areas in this borough, and the results have been quite satisfactory.

Objection may be made that the determination of the value of *u* is liable to some error, but even if this were true, since the greatest care should be exercised in the value of *u*, as mentioned above, the information furnished, thus far, is of such a nature that the error in designing sewers, if any, would be compensated for by the result.

The equipment used to measure the flow in sewers from the run-off of storm water consists of two forms of gauging apparatus, water stage registers, and knife-edge weirs. A water stage register described by Fort consists of a float (A) in a chamber (B) which is connected to the sewer by an inverted siphon. The float is connected to a drum (G) which has a recording chart (F) on its surface. The drum is operated by a gear mechanism (H) which is connected to the float.

Fig. 2 shows a diagram of the water stage register. A water stage register placed in a sewer will record the flow in a manhole (B). A rubber gasket (C) is used to seal the transmission gear of the register. A lead counter-weight (D) is attached to one end of the

ribbon to keep it in tension so that the motion of the float arm will be transmitted to the recording device; D, an adjustable float arm to which the other end of the ribbon is attached; E, a copper ball float; F, represents the inner bottom of a 42 in. sewer; (G) the normal flow line; H, the inner top of sewer; I, the manhole, and J, the head.

The gauges are calibrated by raising the float 0.5 ft. at a time, and noting the value of the movement on the recording device. In this way calibration curves and scales are drawn.

When installing a gauge, the sewer in which it is to be placed is carefully measured, and a curve plotted showing the value of Q for all depths of flow. The gauge is then placed in position, the ribbon attached to the float arm and counter-weight, a blank record placed on the drum and the pen inked and pressed down on the record ready for recording. The ball float is then placed 0.5 ft. from the bottom of the sewer, the position of the pen and the elevation of the float ball being recorded on the blank record; the float ball is raised 5.0 ft. more and the new position of the pen and elevation float recorded. This operation is repeated until the float ball has reached the inner top of the sewer. The elevations are then corrected for the depth of water required to float the ball. By comparing this record with the Q curve, a scale is made so that it will give the value of Q for any position of the pen on the record.

The height of a flood wave is shown on a well sanded vertical flood stick by the sand being washed off as high as the water rises. This gives a very sharp line for the height of the wave, and is of advantage in determining the slope.

The use of the weir is well illustrated by a concrete example; one of our problems was to determine the infiltration and the maximum and minimum flow of sewage for a large district, the population of which was about 177,671.

To obtain the desired information a weir was used, and the flow automatically gauged during the entire day and night for each day of the week.

The weir used was located in the outfall sewer, or outlet flume, and belonged to the sharp-crested type, with end contractions suppressed. The crest length measured 25.84 ft., and the height 2.17 ft. The head on the crest when not affected by storm or snow water varied from .362 ft. at 4.30 a.m. on Fridays to .543 ft. at 3.05 p.m. on Tuesdays.

The device for recording the heads consisted of an automatic water stage register placed over a "basin" pit located just outside the channel and about 16 ft. up-stream from the weir crest. The pit was connected with the flume by means of a 3-in. iron pipe, 3 ft. long, laid on the floor and perpendicular to the side of the approaching channel. The zero for the register was determined by means of a hook gauge and a Y level. The correction for slack motion of the register was determined by the hook gauge to be $\frac{1}{2}$ of 1 per cent.

Bazin's formula, $Q = MLD \sqrt{2GD}$, for suppressed weirs with velocity of approach, was used to plot the results of the investigation. It is suggested, however, that Hamilton Smith's formula, $Q = 3.29 LH^{3/2}$, for weirs of great lengths, may give more accurate results.

The total mean flow for twenty-four hours as indicated by the gauge records was 1,125,000 gals. The total amount of water supplied to the district gauge, according to information received from the Water Department, was 17,767,000 gals. The total amount of ground water infiltration a day was 77,670 gals.

Saving in one way sometimes involves expense in other ways that more than offsets the prospective gain. The president of a Canadian construction company states that in one case the saving of concrete by reducing the size of columns on successive floors was \$2.30 per column. On the other hand, the increase in floor cost was \$5.70 per column, entailing a loss of \$3.40 per column. This is a very good example of why it is cheaper to use the same size columns on successive floors than to reduce the dimensions. One way to avoid frequent changes in column sizes is to vary column reinforcement in successive stories.

Our Illustrations.

NEW Y.M.C.A. BUILDINGS, SWANSEA.

The new Y.M.C.A. buildings erected at Swansea on the site of the old Longlands Hotel, St Helen's Road, were designed by Mr. Glendinning Moxham, F.R.I.B.A., Swansea. The materials used externally were thin red local bricks and Portland stone. Internally all floors were of steel and concrete construction. The woodwork was chiefly of selected oak. The plans below the perspective show the ground and first floors of these extensive premises.

SANDSTONES, CAMBERLEY.

This house is now in course of erection for Colonel W. J. C. O'Shaughnessy. It stands amidst pines, on an elevated site adjoining the Camberley Heath Golf Links, commanding extensive views of the surrounding country. Externally the house is being built in hand-made sand-faced bricks, supplied by Messrs. Thos. Lawrence and Sons, of Blackwell, with Monk's Park stone to the entrance door and window over, and to the steep columns and cornice. The roof is to be covered with hand-made sand-faced antique tiles. The woodwork is to be painted white. Internally it is proposed to carry out the main staircase, the panelling in the hall, and the floors of the best rooms in oak. The principal fire-places are being specially made to the architect's designs, based on genuine examples of fire-places of this period, in keeping with the style of the house. Mr. Jonathan Corbett, of Bagshot, is the general contractor, and Mr. H. Reginald Poulter, of Camberley, is the architect. A lodge has already been erected at the drive entrance.

LONDON CITY AND MIDLAND BANK, METROPOLITAN BRANCH, WOLVERHAMPTON.

This building, designed by Messrs. Cossins, Peacock, and Bewlay, of Birmingham, for the Metropolitan Bank before the absorption of that company by the London City and Midland Banking Company, occupies one of the most prominent sites in Wolverhampton, immediately adjoining the Art Gallery. The basement and the ground floor are almost entirely given over to banking requirements, and the two upper floors are arranged for offices for letting purposes. The banking hall walls are panelled in mahogany to a height of 10 ft., and the fittings are carried out in the same material, the floor of public space being paved with a Siberian green and Breche rose marble. The ceiling, which is divided up by beams supported on columns, is finished in enriched plaster. The exterior of the building is executed in Darley Dale stone.

SAXON CRYPT, REPTON CHURCH, DERBYSHIRE.

This water-colour sketch has been sent us by Mr. William Swindell, of Derby, in further illustration of this famous crypt following upon our correspondent's request for drawings on page 654 of our last volume. Mr. Harry Gill, M.S.A., of Nottingham, lent a smaller photographic view and a plan of the crypt, which we gave in our issue for June 16 last, accompanied by several interesting particulars not furnished by our previous contributor. The crypt measures about 13 ft. square and the four detached columns are 12½ in. in diameter and nearly 6 ft. 6 in. tall. The sketch shows on the right one of the type approaches which occur on either hand, forming a communication with the church. The styte to the left is now built up, and the vestries occur above. The monument seen in Mr. Swindell's drawing at the far end has now been removed, and we believe stands under the tower at the west end of the nave. We can recall no drawing of this crypt, illustrated elsewhere, in any architectural work. Repton is in the postal district of Burton-on-Trent.

FIRST PREMIAED DESIGN FOR SEVEN COTTAGES AND SHOP, BROMBOROUGH PORT ESTATE, PORT SUNLIGHT.

This design for these cottages was awarded the first premium by Mr. Geoffrey Lucas, F.R.I.B.A., the assessor in the competition promoted by Messrs. Lever Bros.,

Ltd., just lately. The following conditions had to be observed: That the cost should not exceed £1,500 for the group, £200 per cottage, and £100 in addition for the shop. The sites were set out 80 ft. deep, and the widths were left to the competitors to decide, with a minimum of 17 ft. The position of the group was to be a corner site. The scheme illustrated shows the treatment suggested for the four corners of two cross roads forming a shopping centre or square. Strict economy in planning was essential, as the living room had to provide an area of not less than 170 sq. ft. and the scullery 100 sq. ft., and the height from floor to floor was to be 9 ft. 9 in. Back yards approached from back roads were to be provided, divided by brick walls. The materials to be used externally are rough cast over stock brickwork with red facing bricks where shown, sand-faced tiles for the roof covering, and elm boarding in the gables. A plinth of smooth trowelled cement, tarred 2 ft. above ground, runs round the block on three sides. The shop front is suggested for general use, but the designs would have to be individually varied in detail according to the various trades to be provided for. The architect is Mr. Ernest G. Theakston, F.R.I.B.A., 36, King Street, London, and Wendover, Bucks.

NEW PREMISES FOR W. H. SMITH AND SON IN WATERLOO STREET, NEWCASTLE-ON-TYNE.

These new premises, which are being erected, will present several new features in warehouse construction. The whole scheme is being carried out under the superintendence of the building and estate department of W. H. Smith and Son, of which Mr. F. C. Bayliss is the manager, and the architects are Messrs. Marshall and Tweedy, 17, Eldon Square, Newcastle. The front elevation to Waterloo Street will be stone, with iron panels and steel window frames. There are two main entrances—one for goods and one for offices and showrooms. The basement is approached by means of a sloping way at back of building, as well as by stairs, lifts, and elevators. The contract for the main structure and foundations has been placed with Mr. Thos. Clements, Newcastle. White glazed bricks will be used in the basement. The floors and staircases will be carried out in ferro-concrete by Messrs. Melville, Dundas, and Whitson. The steel girders and columns will be provided by Messrs. Redpath, Brown, and Co., of Edinburgh. The steel windows and iron panels will be supplied by the Crittall Manufacturing Co., Baintree. Oak block floors will be carried out by Messrs. Hollis Brothers, Hull. Electric lifts and conveyors are being provided, and everything which will make for the general comfort and convenience of their customers and staff has been embodied, for it is realised that environment itself is an important adjunct to the progress of the individual as well as the business. There will be quite a new feature in the doorway, from which some interesting developments may be expected. The whole scheme has been worked out with the idea of providing increased facilities in every direction for prompt and regular despatch, for which the firm and its Newcastle house are noted. With the further provision of adequate means for displaying, warehousing, and dealing with books, stationery, fancy goods, and the many varied classes of stock, the new premises, when completed, will be the embodiment of purpose and of all that is best in an up-to-date wholesale business. By this means Mr. W. H. Manning, the manager, and his staff—to whose energy and ability the growth of the business is due—will be able to continue even more effectively the policy of adequate service and satisfaction, on which success so much depends.

The City of London Corporation decided on Thursday to acquire the freehold and leasehold interests in various properties in Cloth Fair at amounts in most cases considerably below those originally asked by the claimants. The Corporation also agreed to purchase for £5,922 the interests of the Vintners Company in Nos. 67 and 68, Leadenhall Street, in connection with the work of widening there in progress.



BUSINESS PREMISES WATERLOO STREET:

NEWCASTLE ON TYNE
for Messrs W. H. Smith and Son

MARSHALL & TWEEDY
ARCHITECTS 88
NEWCASTLE-ON-TYNE.

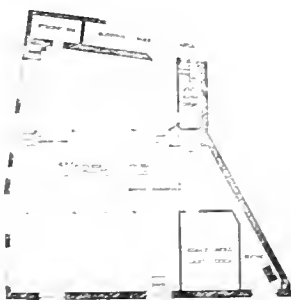

BASEMENT FLOOR

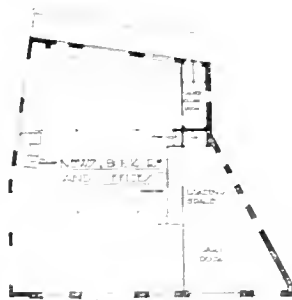

GROUND FLOOR



FIRST FLOOR



SECOND FLOOR

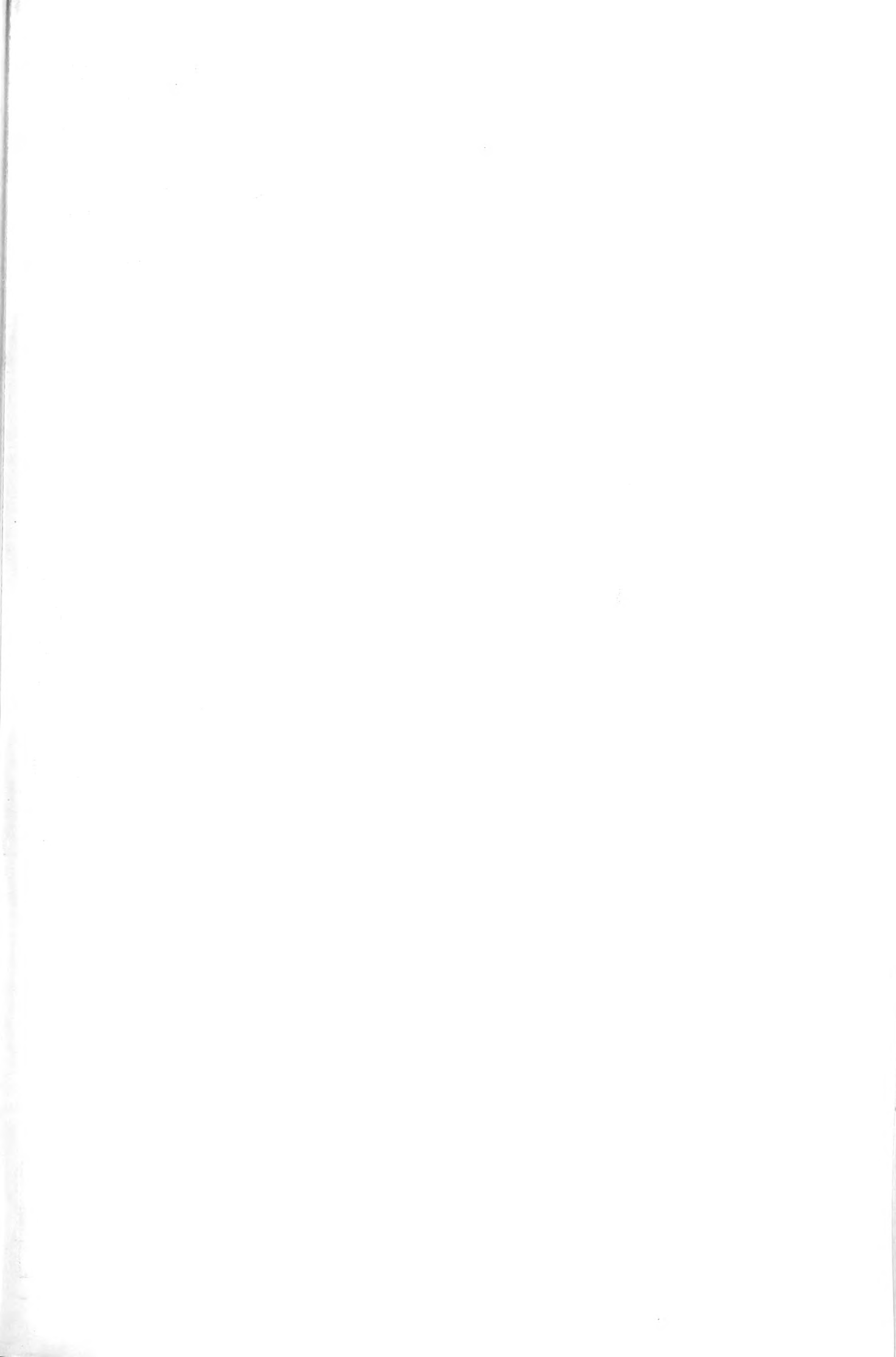

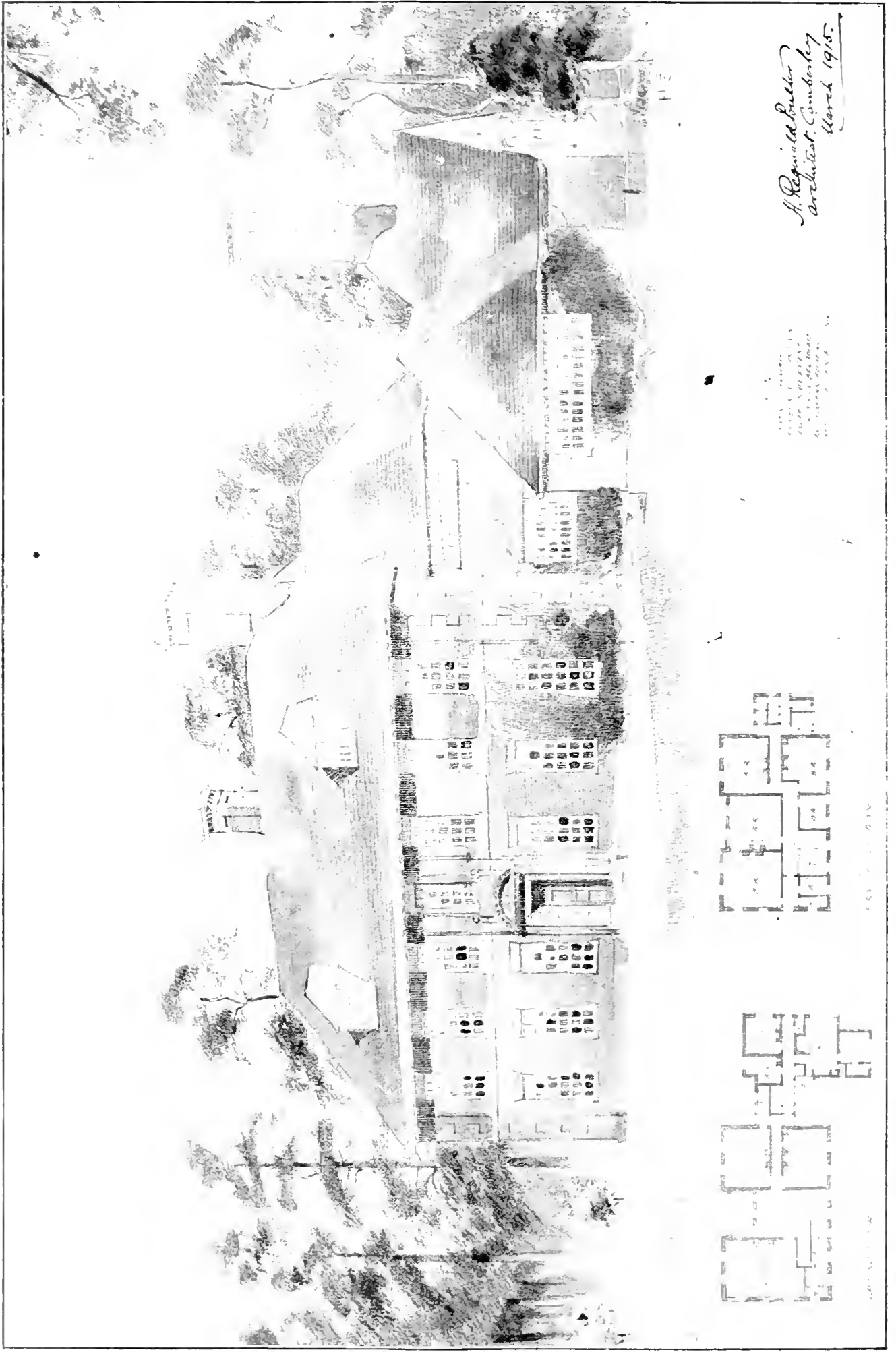

H. Reginald Butler
Architect, Camberley
March 1915.

Scale
1/4" = 10'
1/8" = 5'

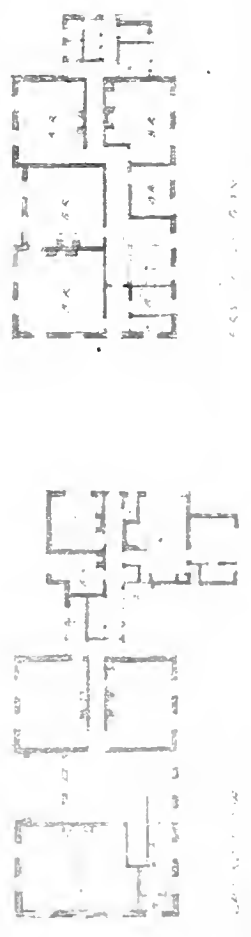

"SANDSTONES" CAMBERLEY.



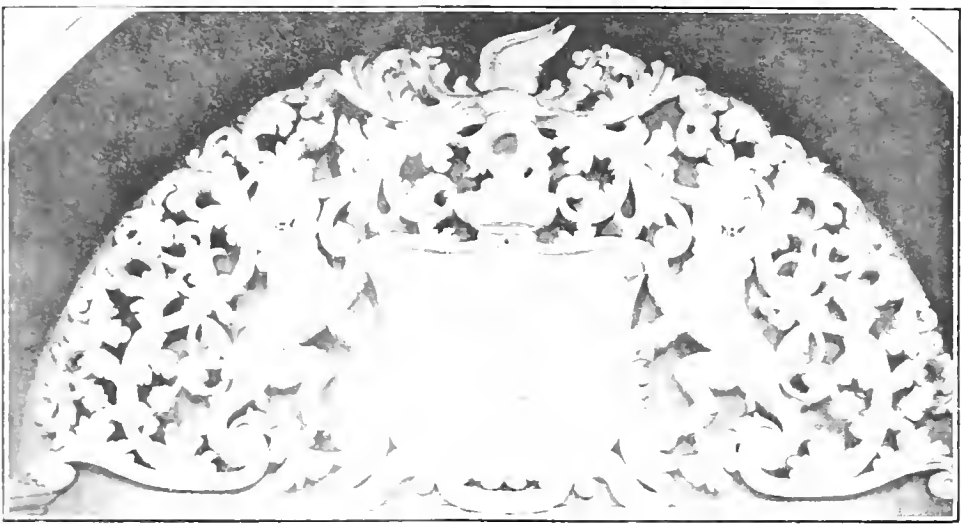

THIRTEENTH CENTURY FISH HOUSES, BEAULIEU, CALIFORNIA, AND
BY MISS T. S. U. SAGGER.

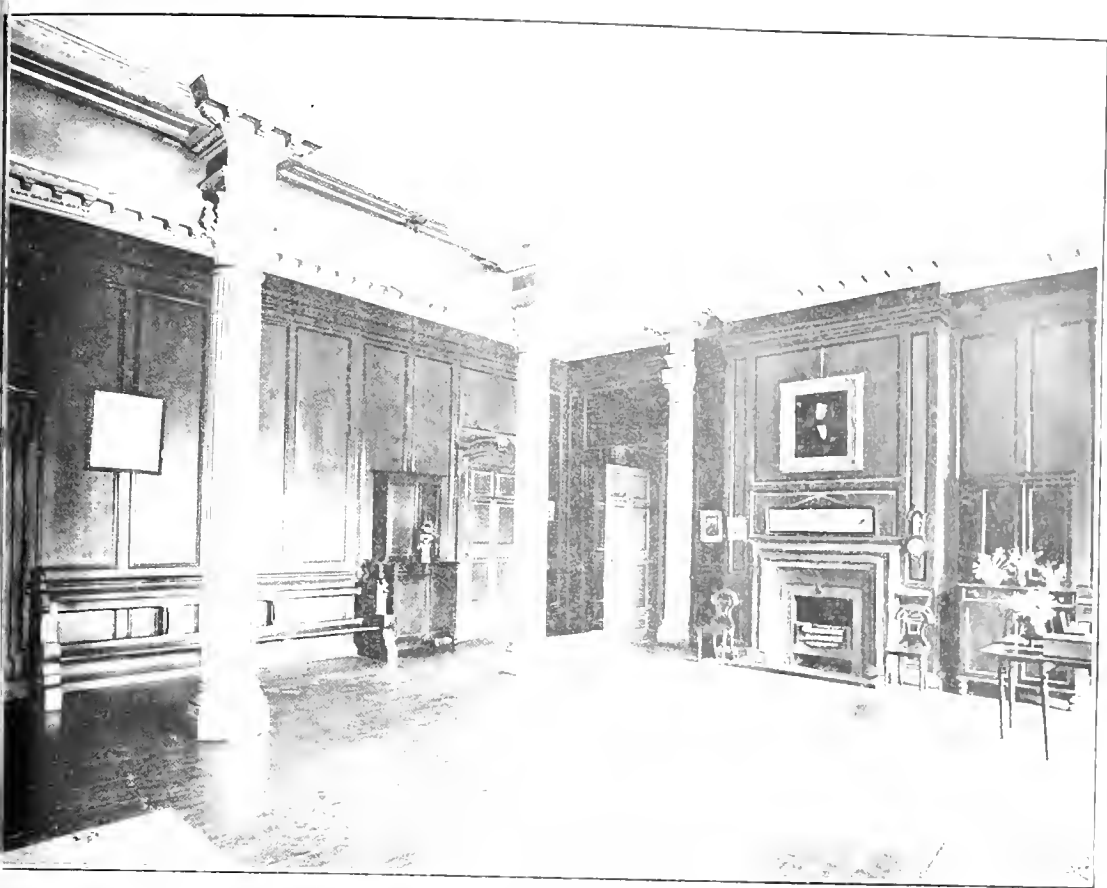

PALACE HALL, TIPPERARY. FROM "GEORGIAN MANSIONS IN IRELAND."
PAGE L. DICKINSON, F.R.I.A.I.





THE BUILDING NEWS, AUGUST 4, 1915.



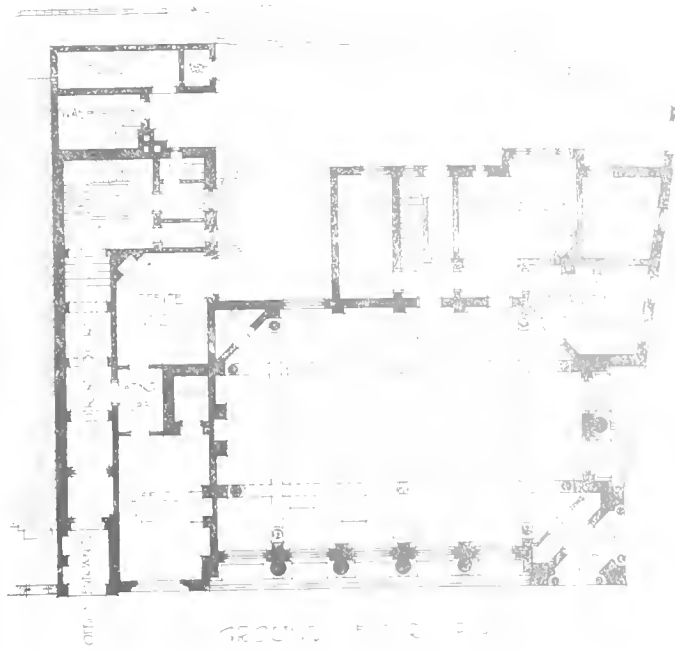

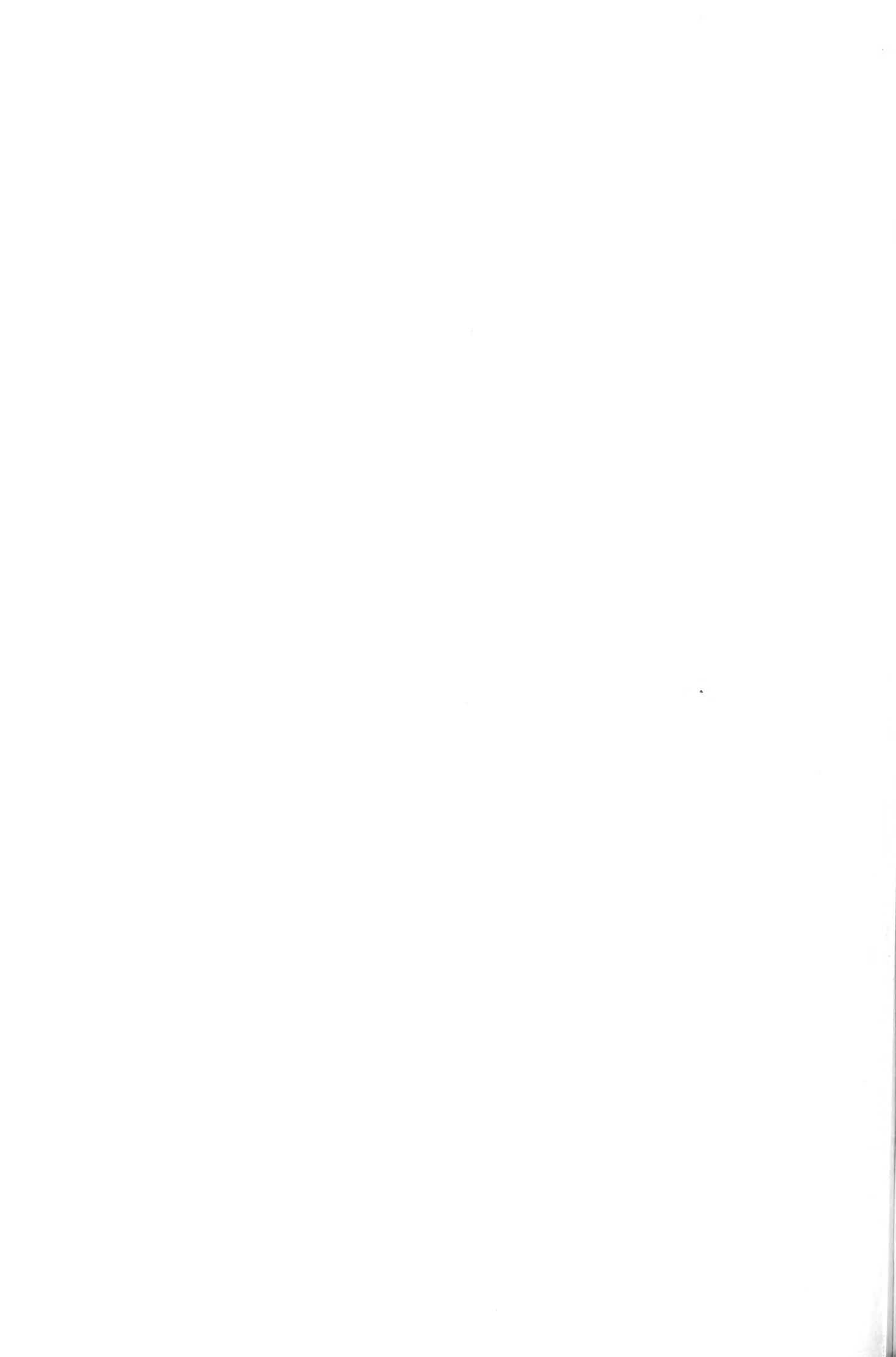

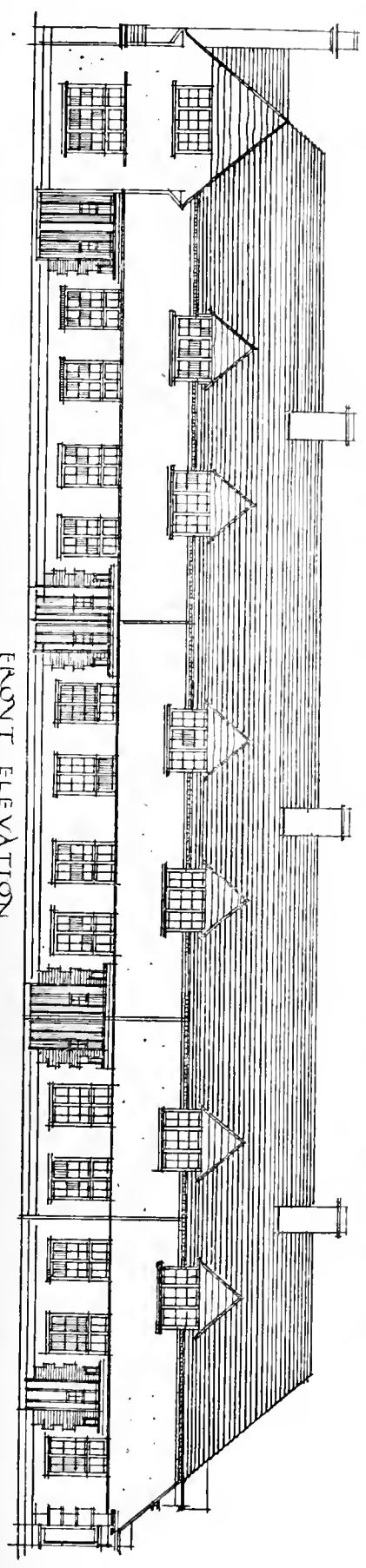
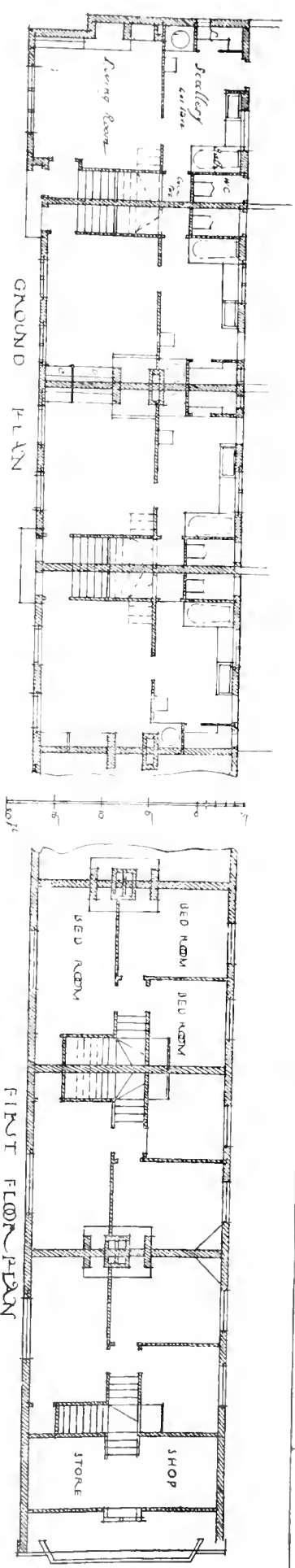
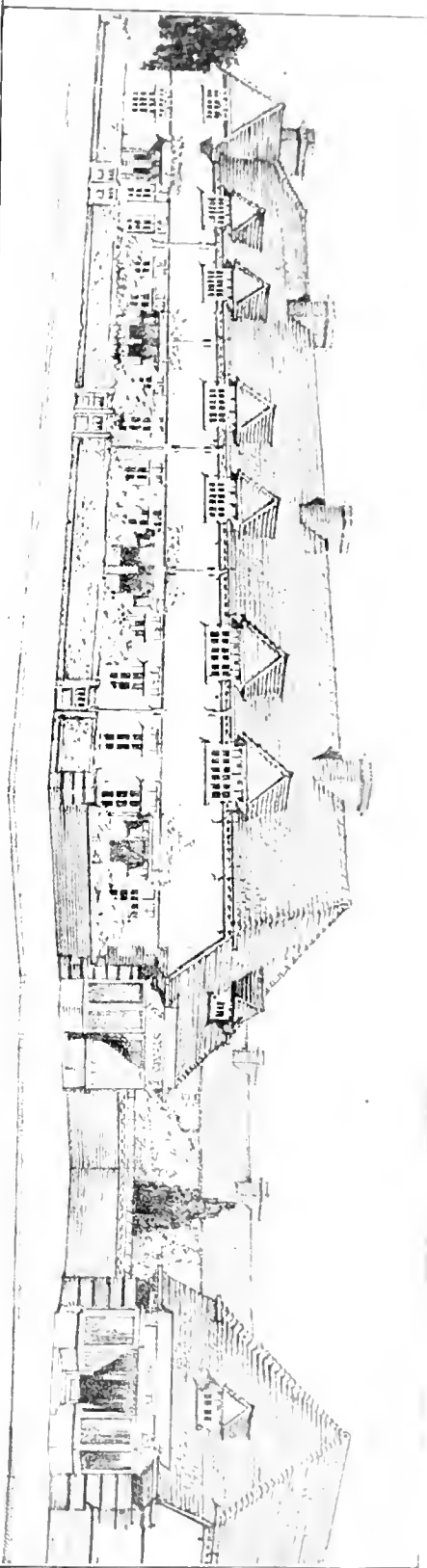

FIRST PRIMITATED DESIGN FOR SEVEN COTTAGES AND SHOP, BROMBOROUGH PORT ESTATE, PORT SUNLIGHT, FOR MESSRS. LEVER BROS.—MR. ERNEST G. THEAKSTON, F.R.I.B.A., Architect.



· NEW · PREMISES
for the · Y.M.C.A. ·
· SWANSEA ·

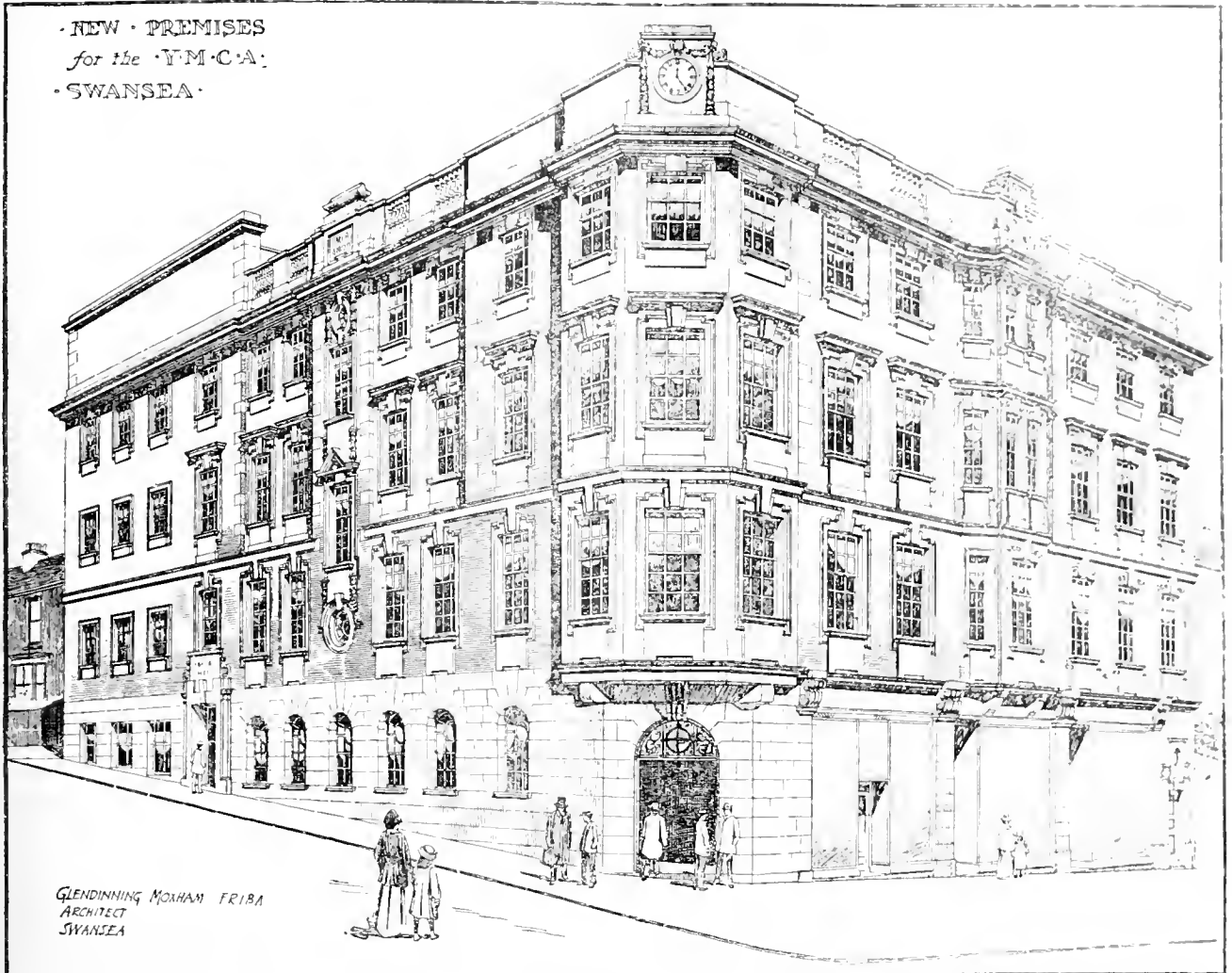

GLENDINNING MOXHAM FRIBA
ARCHITECT
SWANSEA

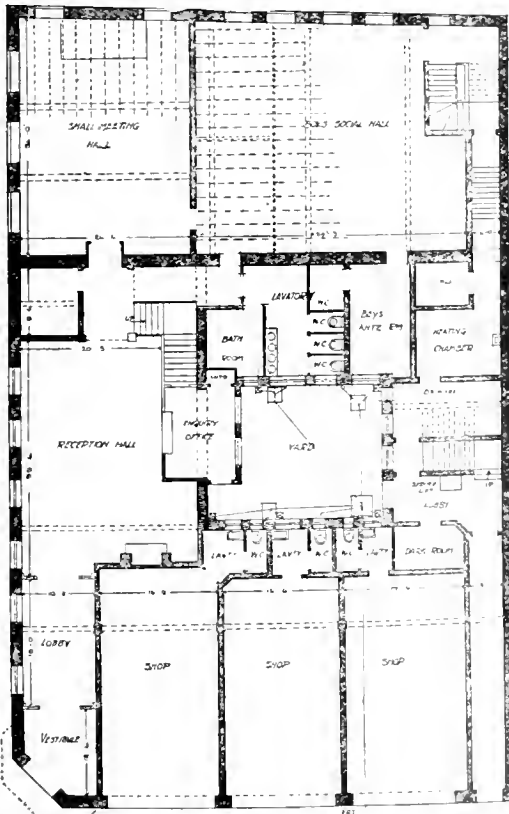

GROUND FLOOR PLAN

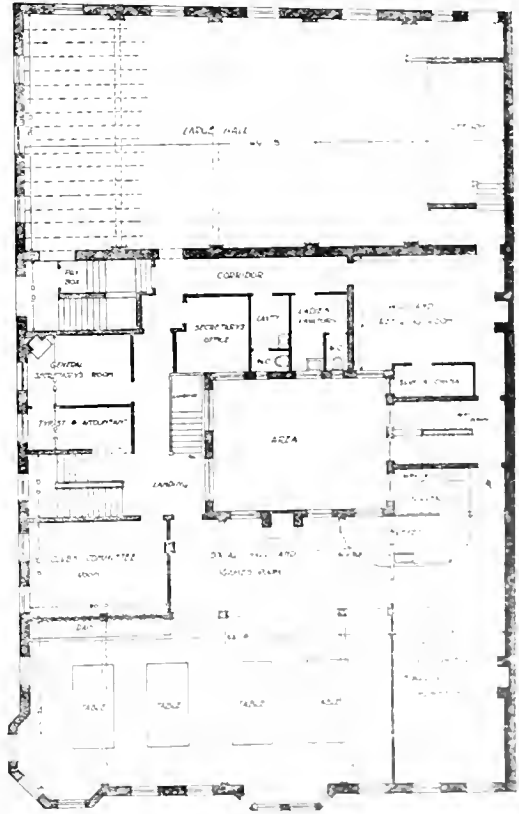

FIRST FLOOR PLAN

Y.M.C.A. NEW PREMISES, ST. HELEN'S ROAD, SWANSEA.
MR. GLENDINNING MOXHAM, F.R.I.B.A., ARCHITECT.



valuable timbers lie between the eastern seaboard and the Great Dividing Range, which runs, roughly, parallel to and 200 miles from the coast. At about the 21st parallel of south latitude a spur runs westward nearly to the South Australian border, and tears on its crests and slopes much valuable timber. Forests are also found on the Darling, Johnstone, and Gilbert Ranges. The principal eucalypts are ironbark, grey, spotted, and red gum, blackbutt, and turpentine; Moreton Bay, brown and Bunya Bunya trees represent the conifers; and red cedar, cypress, tulipwood, rosewood, red bean, and black bean are among the brush timbers of the plain. On the extensive plateau west of the Divide there is but little timber, and towards the vast basin of the interior the low ridges and banks of the short water-courses bear a growth of stunted eucalypts, such as the gimlet gum, the desert she-oak, acacias, and mallee. The chief supply of mill timber (eucalypts, Moreton Bay pine, etc.) is in the southern coastal region, from the New South Wales border as far north as Gladstone. In the regions between Rockhampton and Ingham the supply is not so plentiful, but northward of the latter town the red cedar, gum pine, and black bean are luxuriant. Large supplies of these valuable trees are found on the Barron Valley reserves, and in other localities between Ingham and Port Douglas. Inland from this zone of heavy forest is another, less densely timbered, bearing cypress and other pines, ironbark, and acacias. In the south-western regions of the State the cypress pine flourishes.

Sir Edward Carson may be serious in demeanor, but he is a master of the art of repartee. During one case in which he appeared he had more than one passage-at-arms with the judge, who finally drew attention to a discrepancy between the evidence given by two of Sir Edward's principal witnesses—one of whom was a carpenter, and the other a tavern-keeper. "That's so, my lord," instantly retorted Sir Edward. "Yet another case of difference between the Bench and the Bar."

At the meeting on Wednesday of the Bristol Dock Committee, a draft specification and contract drawings for a footbridge across the south end of Portishead Dock were approved, and the engineer was authorised to invite tenders for the work.

A beginning is to be made with the work of converting the Hulme Barracks site at Manchester into an open space. A special estimate of the Parks Committee for levelling ground and other works, at a cost of £350, will be considered at the meeting of the Manchester City Council to-day (Wednesday).

The municipality of Montreal North have accepted plans for a main drainage scheme drawn up by Mr. F. C. Laberge, of Montreal, and have awarded the contract for the work to Mr. J. Chartier, Montreal, at the price of \$127,500. The drains, which are to be constructed of concrete, will run the entire length of the town, and will discharge into the Back River at two points, the pipes being carried 60 feet into the river.

Halesowen Rural Council discussed on Wednesday the appointment of a district surveyor in succession to Mr. G. H. Dallow, who is leaving to take up a position at Much Wenlock. The General Purposes Committee recommended that the position be advertised at a salary of £150 a year, £50 per annum more than has been paid to Mr. Dallow. A motion was brought forward that the Council make temporary arrangements for carrying out the work until the conclusion of the war, the mover being of opinion that they would get a much better value for the money at the close of the war than they would at the present time. The voting being equal, the chairman gave his casting vote for the committee's recommendation that a fresh appointment be proceeded with.

Our Office Table.

Fresh regulations for technical schools, schools of art, and other forms of provision of further education in England and Wales came into operation on Monday last, and can now be purchased through any bookseller from Wyman and Sons for 2d. They show the conditions of grant specially applicable to the various schools and classes. There are very few modifications from previous arrangements, one being under evening schools, No. 54, D, providing that the Board of Education may pay an instalment of the estimated grant in advance of the final payment. As to the endorsement of certificates, a new rule, No. 59, enacts that "(a) Examinations upon the courses of study as set out in the syllabuses must be held in each year of the course. These examinations must be held by the teachers, with whom must be associated for the examinations in the last year, and if desired, for those in earlier years, an external assessor or assessors. The board may exceptionally approve other arrangements for examining students taking senior part-time courses. (b) If an advisory body has been established for the school or for any particular course, members of that body should be associated with the teachers and assessors in the award of certificates or diplomas." 65, D, provides that "No addition may be made without the Board's consent to the record upon any endorsed certificate or diploma."

The programme of the Department of Technology of the City and Guilds of London Institute for the session 1915-16, containing regulations for the registration, conduct, and inspection of classes and examination of candidates in technological subjects has just been published. As compared with former years there are several alterations in the arrangements. The conditions governing the award of full technological certificates to painters' and decorators' work, cabinet-making, book-binding and embroidery have been modified, and the lists of works of reference have been revised and brought up to date. About eighty subjects are comprised in the examinations. The programme of 394 pages contains full syllabus of the various subjects, and is published at 9d. net by Mr. John Murray, Albemarle Street, W.

The fifty-eighth annual report of the Trustees of the National Portrait Gallery states that the plans prepared last August by H.M. Office of Works for the much-needed extension of the gallery have, with minor changes, been accepted. These provide for a single gallery along the Orange Street frontage, practically in a line with the existing building. Some difficulty was experienced in adjusting the floor levels of the proposed new building to those of the present galleries. The trustees were aware that equality of floor levels was a cardinal principle in the construction of all modern museums, and in accordance with their representations the Office of Works produced new plans, which were examined and formally approved by the Board in February, 1915. The number of visitors during 1914 was 119,928, a decrease of 16,503 upon the total of the previous year.

The West Bromwich Town Council discussed on Wednesday the question of the Mayer's Green housing and improvement scheme. On account of the demolition of houses in carrying out a public improvement, the Council must, under the Housing of the Working Classes Act, 1905, undertake a housing scheme. The Sanitary Committee reported that the Local Government Board required the erection of twenty houses on a site or sites to be approved by them, and according to plans also to be approved by them. The scheme has to be carried out within twelve months from its approval by the Board, but it was very doubtful whether the Board would require the scheme to be executed within that period. The committee recommended that the scheme be carried out, stating that particulars as to site, kind of house, and rental would be

submitted later. An amendment was proposed that the scheme should be postponed until after the war. Mr. Bell said the condition of things in the Mayer's Green area was absolutely a disgrace to the town. Some of the people were living rent free in hovels which should have been demolished years ago. The amendment was lost by 6 votes to 9, and the report was adopted.

The British Vice-Consul at Bangkok (Mr. H. Fitzmaurice) reports that the bulk of the cement now imported into Siam comes from Denmark and French Indo-China. Recently, however, a firm at Bangsue, near Bangkok, commenced the manufacture of cement, and the annual output of this new works is estimated at 120,000 barrels or 20,000,000 kilograms. (about 44,092,000 lb.), a quantity very nearly equal to the average importation of cement into Bangkok during the last five years. The British Vice-Consul adds that if this local factory is able to produce the quantity and quality of cement its promoters expect (as to which some doubt is expressed), and at the same time to compete in price with the cheap cement now imported from French Indo-China, the importation of cement into Siam may practically cease.

At the meeting on Wednesday of the Corporation of Birkenhead Alderman Solly, chairman of the Parliamentary Committee, gave the council some information regarding the town planning schemes for the Oxtou, Cloughton, and Rock Ferry districts. Those residents who had inquired concerning the scheme had been satisfied with the information given them. Long before the work began a decision was taken to "town plan" the districts mentioned for the protection of property, and books of reference were prepared at a cost of £200. If the council had not proceeded with the serving of notices on owners and residents affected the expenses incurred would have been rendered useless. By town planning the council could settle how many houses should be erected per acre. By serving the notices the districts were protected from any danger of being spoiled and their amenities were preserved.

At the meeting on Thursday of the City Court of Common Council, Mr. Ernest Edward Finch, M.Inst.C.E., M.R.San.Inst., for the past half-dozen years Chief Assistant in the Engineer's Office, was unanimously appointed Chief Engineer of the City at a commencing salary of £800 a year, the appointment to date from Christmas, 1914. Mr. Finch, formerly Chief Assistant Engineer of Bermondsey, and then Borough Engineer of Bethnal Green for six years, was appointed Chief Assistant in 1909, and since then the Corporation has paid over £800,000 in settlement of compensation claims in connection with the widening of Fleet Street, Bishopsgate, and Leadenhall Street, the work being carried out by the engineer's staff.

In his annual report to the City Council of Bristol, Mr. L. S. McKenzie, A.M.I.C.E., states that the number of new houses erected within the civic boundaries during the year is only ninety-eight—the lowest on record, while the number of void houses remains practically the same as the previous year. The small number of new houses is doubtless largely attributable to the scarcity of labour and the abnormally high price of materials. Nothing definite has been accomplished in the direction of town-planning, but the question of arterial roads has been under consideration.

The fact that the war has shut off the Russian and Baltic wood supplies has turned the attention of timber buyers to the resources of British Columbia in this respect, and the Trade Commissioner of the Canadian Trade and Commerce Department has arranged an exhibition at 87, Union Street, Glasgow, in order that commercial men may have an opportunity of seeing what British Columbia can produce. The principal woods British Columbia has for export are the giant Douglas fir, Columbia spruce, the red cedar, and the hemlock, and all four are to be seen, treated in a variety of ways which serve to

show the numerous purposes to which the timber of the province may be turned. The natural woods are shown, and also samples of the timber when it has been dressed, stained, and varnished, and utilised as doors, panels, cornices, etc. The uses of the woods for street paving, barrel-making, and flooring are also demonstrated, and a number of photographs are on view descriptive of the logging operations carried on in the province and the manufacturing and shipping capacity of export mills. The opening of the Panama Canal has reduced the shipping distance from British Columbia by about half.

The "Strand Magazine" for August contains a well-illustrated article on "The Value of Observation in War," by Mr. Frederick G. Cooke, M.S.A., of the Eastbourne Volunteer Training Corps. The paper is substantially the admirably suggestive lecture on the same subject delivered at 9, Conduit Street, W., before the Central London Regiment of Volunteers, and fully reported in our issue of May 14 last. The author demonstrates in some new photographs how by besmirching and mottling his uniform and modifying the stiff outlines of his service cap a sniper may adopt protective coloration when in the field almost as effectual as that of the feathered snipe from whom he derives hints. Mr. Cooke writes us:—"It was through your publishing my address last May that I got into communication with the editor of the 'Strand Magazine.'"

The Council of the University of Liverpool have just issued the prospectuses of the School of Architecture and Department of Civic Design for the ensuing session. The School of Architecture is under the charge of Mr. C. H. Reilly, M.A., F.R.I.B.A., the Roscoe Professor, assisted by Mr. L. P. Abercrombie, M.A., A.R.I.B.A., Lecturer in Building Construction, and Mr. L. B. Budden, M.A., A.R.I.B.A., assistant lecturer and student instructor. Mr. Giles Gilbert Scott, F.R.I.B.A., is the Reader in Ecclesiastical Architecture, and the subject of Greek Art is taken by Professor R. C. Bosanquet, M.A., F.S.A. The autumn term begins on October 5, in the Department of Civic Design. Mr. L. P. Abercrombie is the lecturer, Mr. T. H. Mawson deals with Landscape Design; Mr. J. A. Brodie, the city engineer of Liverpool, and Mr. H. E. L. Martin, B.Sc., with Civil Engineering; Dr. E. W. Hope with Civic Hygiene; and Mr. H. Chaloner Dowdally, B.C.L., an ex-Lord Mayor of the city, with Civic Law. This department, founded in 1909, was the first school in this country exclusively designed to meet the need of students who wish to study town-planning.

OBITUARY.

Quebec has lost a well-known architect in the person of Mr. Rene Lemay, who died at his summer residence at Cape Rouge recently. During his active career Mr. Lemay contributed extensively to Quebec's architecture, and many of the modern edifices which are monuments to the commercial expansion of the ancient capital were planned by him. Among the buildings which he designed are the Merger Building, the Dominion Fish and Fruit Building, Quebec Technical School, Caisse d'Economie, St. Roch's, the Lindsay Building, and the new St. Patrick's Church, besides other splendid buildings throughout the province, including Chicoutimi Cathedral. The late Mr. Lemay represented St. John's Ward in the City Council for six years, and he was a former President of the Dominion Association of Architects.

The death took place on Thursday morning of Mr. James Ramsden, builder and decorator, at his residence, The Elms, Walmersley Road, Bury, Lancs. He was a well-known man, and last year was president of the North-Western Master Builders' Federation.

An isolation hospital is about to be built at Ely at the joint cost of the town and rural districts councils. Mr. S. J. Wearing, A.R.I.B.A., of Norwich, is the architect, and Messrs. Parren and Son, of Earith, Hants, have taken the contract at £5,223.

LEGAL INTELLIGENCE.

ARCHITECTS' ACTION AGAINST MANCHESTER ATHENÆUM. At the Manchester Assizes, on the 20th ult., Mr. Justice Atkin, sitting without a jury, began the hearing of an action brought by Messrs. Charles Clegg and Son, architects and surveyors, Economic Buildings, Manchester, against Mr. H. Stafford Golland, hon. secretary of the Manchester Athenæum (sued on behalf of the officers and members of the institution) to recover sums amounting in the aggregate to £721 for work done and services rendered. Mr. Acton and Mr. Jordan appeared for the plaintiffs, and the defendant was represented by Mr. Atkinson, K.C., and Mr. Brocklehurst.—Mr. Acton said there were also associated with the plaintiffs in the action Messrs. Hurrell and Taylor, quantity surveyors, Manchester. The Athenæum was an institution in the city, devoted to artistic, literary, and intellectual pursuits. In July, 1912, Mr. Golland consulted the plaintiffs with a view of removing the hall from the top to the ground floor of the building. Messrs. Clegg were of opinion that it could be done, and that it would be necessary to prepare plans and take out quantities. The wish of the Athenæum authorities was that they should only have one firm to deal with for the purpose of payment, and Messrs. Clegg, therefore, made arrangements with Messrs. Hurrell and Taylor for the work they would have to do. Terms were arranged on the basis fixed by the Royal Institute of British Architects, and Messrs. Clegg prepared sketch plans. Various alterations were suggested by the committee of the Athenæum, and these were made in the sketch plans, which were obviously distinct from working plans. There was a suggestion that the Manchester Corporation should buy the building, but this was not carried out. Amended sketch plans were finally passed by the corporation, and the members of the Athenæum at a meeting resolved to proceed with the work. Messrs. Clegg then prepared sectional working plans, and Messrs. Hurrell and Taylor took out the quantities. It appeared that Messrs. Clegg's original approximate estimate was £17,000, but this was greatly increased by the alteration suggested, by tests as to the foundations of the building, and other matters, and the lowest tender was £29,000. This was reduced in consultation with the plaintiffs to £21,177, some of the more expensive items being cancelled. Ultimately, however, the Athenæum authorities decided that owing to the war they would not proceed with the work. The plaintiffs thereupon sent in their bills of charges. A sum of £310 had been paid, but the defendants disputed liability to the extent of £721, which the plaintiffs now sought to recover. At the close of counsel's statement the judge suggested that all the parties were men of position in Manchester, and the case appeared to be one in regard to which an arrangement might with advantage be arrived at.—Mr. Acton said the plaintiffs were quite prepared to leave it to the judge. They only sought to recover what was fair. The judge's suggestion was, however, not adopted.—Mr. Charles Theodore Clegg, one of the plaintiffs, who was called on Tuesday, said the charges made were in accordance with those recognised by the Royal Institute of British Architects, of which his firm were members. The suggestion that the Corporation of Manchester should buy the Athenæum building was not carried out, and the alterations to the building which the directors proposed were abandoned by the Board on account of the war. If eventually the changes should be carried out the directors would have the advantage of the work done by his firm, and by Messrs. Hurrell and Taylor, the quantity surveyors. When following the instructions of the defendants, he invited tenders for the work. He thought the lowest received, which was £29,000, was too high. The highest tender was £34,000. Thereupon he and Mr. Hurrell made a series of suggestions with a view to reducing the cost, and ultimately they got a tender for £21,350. For all that they charged nothing. His first estimate of £17,000 was not misleading, having regard to the proposals he was then asked to consider.—Cross-examined, the witness said he was instructed to get on with the quantities, and that involved the necessity of preparing working plans. The contractor he was relying upon was the instructions given to him originally, after being called in to act as architect—namely, 5 per cent and 2½ per cent for the quantities, which the defendants agreed to in writing. His original agreement was that he should prepare sketch plans, and if anything was done in the matter he should be the architect at the terms mentioned.—Mr. Atkinson: Do you say that when you were instructed to prepare quantities that amounted in your mind to instructions to pre-

pare a sketch of what was to be done?—Yes. It was plain and clear from the contract that these gentlemen were not to charge themselves to any expense without a pretty definitely what it was. They wanted to have an idea of it. What their obligations to you was in connection with the scheme?—Yes. In further cross-examination the witness said he knew there were two parties to the Athenæum, one wanted to proceed with the work and the other did not. Mr. Golland told him it was important to win over the opposition, that the board should be able to do so before then a definite figure beyond what the Athenæum would not be allowed. That definite figure could not be arrived at until the estimate had been obtained. He did not remember saying to Mr. Golland that he was prepared to offer special terms. The plans he prepared for submission to the corporation would do for working drawings. Mr. J. W. Hurrell, Brazenose Street, Manchester, quantity surveyor, Mr. A. G. Murgatroyd, architect, Manchester, and Mr. J. W. Beaumont, architect, Manchester, gave evidence as to the reasonableness of the charges made by the plaintiffs. Mr. Atkinson, for the defence, submitted that his clients took no step in the matter without making a special contract with the architect as to what the cost would be, and it was before him to quote the terms of the Royal Institute of British Architects, and to say that formed part of the contract. The defence understood that the costs to which they would be put were covered by the original charges. One had to consider the persons one was dealing with, who did not know about these matters.—The Judge: Amongst the arts and crafts at the Athenæum, is not architecture one?—Mr. Atkinson: It is only a club, they have nothing to do with architecture there. The Judge said quantities could not be got out until plans were prepared. Mr. Atkinson: We have a very good set of plans here, prepared for the corporation. If it was necessary, additional counsel, to have special plans for getting out quantities and working from the plaintiffs ought to have told the board so, but there was not a syllable about it. Mr. H. Stafford Golland, hon. secretary of the Athenæum, described the negotiations with Mr. C. Clegg, and said he told him that the fullest extent to which the directors of the Athenæum could go was £20,000, and it was doubtful whether they could go to that limit. They put the plaintiffs' estimate for £17,000 together with his reports as to the carrying out of the work. There was strong opposition to the scheme in the institution. The witness gave his version of conversations with Mr. C. T. Clegg during the progress of the negotiations, in which he differed materially from the evidence with regard to them given by Mr. Clegg. He had not the faintest idea, he said, that in addition to the charges they had already made, the plaintiffs intended to charge the Athenæum with the cost of preparing working drawings and making a survey. He had no idea they were under any liability beyond £25,000. On Wednesday, witness, in further examination by Mr. Atkinson, said nothing would have persuaded his board to go beyond £17,000 for the work proposed, and Mr. Clegg assumed a member of the board that the scheme could be carried out for that sum. When he gave Mr. Clegg instructions to get out the quantities so far as he was concerned he had no idea that they were giving him instructions which involved the board in an expense of 2½ per cent for working drawings, not the quantities. Witness did not make suggestions that the new hall should be lined with oak, or that certain tiles should be used. Mr. Atkinson asked before him such suggestions, and the witness replied: "That would be very nice, but you must remember you must keep to the estimate of £17,000." He said that the witness, when the tender of £29,000 was received, the witness had an interview with Mr. Clegg, who was, he thought, a quantity surveyor, and said the amount of the tender. At a later interview Mr. Clegg said that Mr. Hurrell, the quantity surveyor, was in consultation with the plaintiffs, and that the cost of the work was £21,177. The witness asked why he was not asked to take out quantities, and Mr. Clegg replied that he had no idea that Mr. Clegg intended to make the Athenæum responsible for the work, but to have been too extravagant. Mr. W. M. Brocklehurst, member of the board of the Athenæum, said he knew that the limit which the plaintiffs would demand for the scheme was £20,000. He had discussed it on more than one occasion with Mr. Clegg, particularly with regard to the new lecture hall. The witness had no idea that he was making the institution liable for more than 1½ per cent, for the quantities. In reply to Mr. Acton, the witness said he saw the

diff. (2) between the plans submitted to the corporation and the working drawings. Mr. G. Noel, Mr. W. Fletcher, and Mr. H. Furber, directors of the Athenæum, all said, in evidence, that they understood the 1½ per cent. would cover everything. Mr. Justice Atkin, in giving judgment, said in the absence of any express agreement between the parties there could be no dispute that the remuneration which the architects were entitled to receive would be 2½ per cent. upon the amount of the lowest tender, and, in respect of alterations and other work, the usual professional terms. The real defence in the case was that the defendants had always been anxious to know he forehand what the limit of their expenditure was going to be, that before they decided to go on and obtain tenders for the work they tried to find out how much they had to pay the architect, and that they understood the sum they would have to pay him was 1½ per cent. upon the lowest tender. It was for the defendants to make out that there had been a special contract. In order that working plans might be prepared it was necessary that quantities should be taken out, because it was utterly impossible that original sketch plans would suffer. He was satisfied that in the absence of proper plans no quantities could be taken out that would be of the slightest value. He found that Messrs. Clerg were entitled to recover the sum that they claimed, namely, 2½ per cent. upon the lowest tender of £21,177 and 1½ per cent. in regard to the quantities, together with some other charges, including the charge for the survey. He disallowed an item with regard to assisting to procure a mortgage. The total claim allowed was £22 2s. 7d. From this amount there had to be deducted £310 5s. already paid, leaving the amount for which he gave judgment, £21 17s. 7d. In answer to Mr. Atkinson, the judge said he did not think he should grant a stay.

CROSS CLAIMS BY ARCHITECT AND BUILDERS. His Honour Judge Moss sat for seven hours at Wrexham County Court on July 29 to hear an action brought by Alderman Edward Hughes, trustee for Lewis Brothers, builders, Wrexham, against John Henry Swains n, architect, Wrexham, for the payment of £27 15s. 7d., balance due in respect of a residence built for him by Lewis Brothers. Defendant counter-claimed £169 odd for delay in executing the work, and alleged defective work. Defendant had paid £120 on the claim into court, and plaintiff had paid £15 into court, with a denial of liability. It appeared that in April, 1911, Lewis Brothers agreed to build a house for Mr. Swainson at £225. They were to complete it in five months, but the time was extended six weeks when the contract was signed in August. The house was not finished until April, 1912, and the builders stated that the delay in completing the work was due partly to the indiscretion of the architect as to what he required, partly to changes and additions to the work not originally provided for, including an extra room, and partly to a strike, which caused delay in the delivery of tiles. Mr. Pryse Lewis, one of the builders, said it was impossible to complete the work sooner, owing to the alterations made by the defendant, who was building the house for him. f. The work could have been completed within the time stated if they had had a reasonable architect who knew his own mind. Evidence was given by independent witnesses as to the satisfactory nature of the work done. Defendant gave evidence to the effect that owing to the delay in completing the house he had to stay at an hotel and to incur additional expenses. He did not do anything to prevent the completion of the work within the period provided by the contract. He had to exercise extended vigilance of the job for twenty-four weeks. This would not have been necessary if the work had been executed with energy and expedition by the builders. The hearing was adjourned to September 11.

BUILDING HOUSES WHERE THE STREET IS UNDEFINED ATTORNEY-GENERAL v. KNOWLES. At the Lancashire Chancery Court, on the 25th ult., the Vice-Chancellor, Mr. Stewart Smith, K.C., gave judgment in this case. It was an action in which the Attorney-General of the County Palatine of Lancaster, at the relation of the Corporation of Darwen, sought an injunction to restrain the defendants, Messrs. John Robert and Walter Knowles, builders, Darwen, from continuing to build two houses in Knowles Street, Darwen. Mr. Sutton and Mr. Reby were counsel for the Attorney-General, and Mr. W. W. McKenzie, K.C., and Mr. Rutherford appeared for the defendants. The defendants, it was alleged, in building the houses, had contravened the provisions of

the Darwen Corporation Act of 1887, one clause of which provided that before property could be built the street must be defined. The corporation proceeded against them under the Act, and they were brought before the borough justices and a small fine imposed. An appeal against the decision of the justices to Quarter Sessions was successful, the conviction being quashed. The matter was then taken to the Court of King's Bench, which reaffirmed the decision of the justices. The defendants then gave notice that they intended to proceed with their building, and the Attorney-General, on the appeal of the corporation, instituted proceedings for an injunction. The Vice-Chancellor said that in their defence the defendants asserted that the judgment of the Court of King's Bench was wrong. Notwithstanding that assertion, he felt bound to follow and give effect to it. The defendants having been shown to have been guilty of a breach of statutory duty, and of intending to continue to commit such breach, the Attorney-General was entitled to the injunction he sought to restrain the commission of the breach. The result was that he would make a declaration in the terms of the statement of claim. If the defendants were willing to give an undertaking he would not grant an injunction, but if they felt they were unable to do that an injunction would follow. Mr. Sutton said the corporation felt that as this was the first case of the kind they had had it would be a guide to their conduct in other cases that were likely to arise within the borough. They thought the matter was very important, and they preferred to have the injunction.—The Vice-Chancellor: I think you are entitled to it on my judgment, and I must grant the injunction. The defendants will pay the costs of the action. The injunction was granted accordingly.

LIVERPOOL CORPORATION v. SEWERAGE CONTRACTOR.—In the Chancery Division, on Thursday, Mr. Justice Eve granted an application on behalf of the Liverpool Corporation for an order to restrain, until the trial of an action, William Muirhead and Co., Limited, contractors, of London, from interfering with the plaintiffs in the exercise of their right to take possession of the sewerage work which the defendants had contracted to carry out at the northern outfall of the city sewerage system.—Mr. Maughan, K.C., on behalf of the Corporation, said the motion was upon an order agreed to by the contractors. The Corporation, in May, 1914, invited tenders for the construction of a northern outfall sewer, and a contract was entered into between the Corporation of Liverpool and William Muirhead and Co., Ltd., contractors, for its construction. The defendants commenced the work, and were not proceeding in such a way as to give satisfaction to the Corporation, and a question arose as to whether, in the opinion of the engineer, under Clause 45 of the contract, they had exercised due diligence and made such due progress as to enable the work to be completed within contract time. That question was submitted to the engineer, and on the 22nd inst. he gave a certificate pursuant to the contract that the contractors had not exercised due diligence as to enable the contractor to be completed. Notice had been given by the Corporation that they were to enter upon the work, and the defendants had replied that they were going to resist the Corporation taking possession in the Court. Thereupon the plaintiffs issued a writ and notice of motion for that day.—His Lordship granted the interim injunction as stated, costs to be costs in the action.

DISMISSAL OF A DISTRICT SURVEYOR BY THE L.C.C.—On Wednesday last in the High Court before Mr. Justice Rowlatt, Mr. Robert Pledge Notley applied for a declaration that the resolution of the London County Council of March last purporting to dismiss him from his office as district surveyor for Bethnal Green was illegal and void, and further claimed an injunction to restrain defendants from enforcing the resolution. The defendants claimed power to dismiss, and alleged that the plaintiff, who was seventy-five, had become disabled by age from fulfilling his duties. Counsel said there was no previous decision on the point, and the case affected others.—The judge gave judgment for the defendants, being of opinion that there was no question that the defendants did not exercise their proper discretion.

The urban district council of Farnham have obtained sanction to the borrowing of £15,240 for works of sewage disposal.

A theatre is to be built at a cost of over £100,000 sterling in Monroe Avenue, at Grand Rapids, Michigan. The architect is Mr. Lee Decamp, of Grand Rapids.

Building Intelligence.

DEPTFORD. The new set of slipper baths erected for the Deptford Borough Council at the junction of Stockholm and Hilderston Roads have been formally opened. The entrance is at the corner of Stockholm Road and Hilderston Road, and gives direct access to an octagonal hall, adjoining which are a waiting-room and office and store. Accommodation is provided for eighteen baths, all of which are placed on the ground floor, the cubicles being tiled from floor to ceiling, with a view to keeping down the cost of maintenance. On the first floor, a flat containing a living-room, two bedrooms, and a kitchen-scuttery is provided for the superintendent, while the basement is utilised for accommodating the boiler, fuel, and storage of hot water. The baths were designed by Messrs. Joseph and Smithem, of Queen Street, Cheapside, and erected by Messrs. W. S. Barton and Co., of Chancery Lane, W.C.

PAISLEY ABBEY.—The first part of the Abbey restoration at Paisley has been completed, and was informally opened on Thursday last. This is the cloisters, the money for the rebuilding of which was provided by Mr. and Mrs. A. F. Craig. Sir Charles Bine Renshaw, Bart., chairman of the restoration committee, who was accompanied by other members, mentioned that the work had been carried out to the plans and under the supervision of the architect, Mr. McGregor Chalmers. He congratulated him and Mr. Taylor, the builder, on the successful completion of their work.

Trade News.

WAGES MOVEMENTS.

BRIDGWATER.—An adjourned private meeting of the Bridgwater Conciliation Board has been held, under the presidency of Mr. Charles Doughty (barrister-at-law, appointed by the Board of Trade), to consider the question of wages and rates of pay of men employed in the brick, tile, cement, and timber trades in the town and district. There was again a large attendance of employers and employees, and after a conference lasting several hours, a satisfactory settlement was arrived at, advances of varying degrees being made to the employees, both in regard to day and piece work.

TRADE NOTES.

Under the direction of Mr. Reginald T. Longden, architect, Boyle's latest patent "air-pump" ventilator has been applied to the Chapel, Bottom House, near Leek.

Mr. G. T. Kingston has been appointed by the Elbow Court of Sewers, Spalding, to the position of surveyor, in place of his brother, Mr. W. Kingston, who has resigned the office.

A Local Government Board inquiry will be held at Erlam, near Manchester, to-morrow (Thursday) into an application by the urban district council for sanction to borrow £15,900 for works of sewage disposal.

Lieutenant John Harley, M.A. (Oxon.), 15th Worcestershire Regiment, born in 1880, who was killed in action in the Dardanelles on June 4, had for some years been engaged on historical research work at the Record Office and had recently been made a Fellow of the Society of Antiquaries. On the outbreak of war he gave up his work and enlisted in the Artists' Rifles.

Mr. Egerton Swartwout, architect, 244, Fifth Avenue, New York, has prepared plans for a memorial monument to be erected at the grave of Mrs. Mary Baker G. Eddy, founder of the Christian Science Church, in Mount Auburn Cemetery, Lansborough, Mass. A fund of 110,000 dols. has been raised for the erection and maintenance of the memorial.

At a meeting of the Bristol United Trade Committee of Carpenters and Joiners, held last week, the following resolution was adopted: "That this committee is of opinion that all public works, such as schools, etc., which have already been sanctioned, but temporarily stopped owing to the war, should be put in hand forthwith, in order that the distress which at present prevails in certain sections of the building trade may be relieved."

LATEST PRICES.

N.B.—All prices must be regarded as merely approximate for the present, as our usual sources of information are in many cases failing us.

TIMBER.

Owing to stoppage of supplies all prices have advanced considerably.

IRON.

Table listing various iron products such as Rolled Steel Joists, Wrought-Iron Girder Plates, Cast-Iron Columns, and Galvanised Corrugated Sheet Iron, with prices per ton.

Table for B.B. Drawn Telegraph Wire, Galvanised, listing prices for different gauges and lengths.

Table for Cast-Iron Socket Pipes, listing prices for different diameters and lengths.

Table for Iron products including Cold Blast, Lillieshall, and Wrought-Iron Tubes and Fittings.

OTHER METALS.

Table listing various other metal products such as Lead Water Pipe, Lead Shot, Copper sheets, and Tin, with prices per ton.

SLATES.

Table listing various slate products such as Blue Portmahon, Blue Bangor, and Permanent Green, with prices per 1,000 of slates.

BRICKS.

Table listing various brick products including First Hand Stock, Second Hand Stock, and Facing Bricks, with prices per 1,000.

Table for Accrington Camber Arches, listing prices for different sizes and depths.

GLAZED BRICKS.

Table listing various glazed brick products such as White, Ivory, and Salt Glazed, with prices per 1,000.

MOULDED BRICKS.

Table listing various moulded brick products including stretchers and headers, with prices per 1,000.

Text providing details for those prices are arranged in full truck loads to London Stations, including Thames Sand and Pit Sand.

Table for Grey Stone Limestone, listing prices per yard delivered.

STONE.

Table listing various stone products such as Red Mansfield, Barley Dale, and Cleburn Red, with prices per cubic foot.

Text indicating prices are for London.

Table listing various tile products including Plain Tiles, Hip and Valley Tiles, and Ornamental Tiles, with prices per 1,000.

TILES.

Table listing various tile products including Plain Tiles, Hip and Valley Tiles, and Ornamental Tiles, with prices per 1,000.

OILS.

Table listing various oil products such as Rapeseed, Cottonseed, Olive, and Lard, with prices per ton.

GLASS IN GRATES.

Table listing various glass in grate products such as English Sheet Glass and Fluted Sheet, with prices per square foot.

VARNISHES, ETC.

Table listing various varnish and paint products such as Fine Pale Oak Varnish, Copal Varnish, and White Copal Varnish, with prices per gallon.

OGILVIE & CO.

Telephone: WALTON 188.
Many flats connected with the estate of W. H. BASCHELLEN & CO., of Bunhill Row.

Mildmay Avenue, ISLINGTON, N.
EXPERTS in HIGH-CLASS JOINERY.

ALTERATIONS & DECORATIONS.

ESTIMATES FREE

FOR **Olivers' Seasoned Hardwoods,**

W. M. OLIVER & SONS, Ltd.,
129, Bunhill Row, London, E.C.

TENDERS.

Correspondents would in all cases oblige by giving the addresses of the parties tendering at any rate, of the accepted tender; it adds to the value of the information.

ACTON.—For sundry painting work and repairs at various schools, for the Acton Urban District Education Committee:—
Rothschild school—(external):—
Daley and Co. £231 0 0
Ferris Bros. 225 10 0
Ferris, W., and J. 214 0 0
Stocking and Son 200 0 0
Poore (accepted) 187 15 0

Acton Infants' schools:—
Daley and Co. £76 0 0
Ferris Bros. 57 6 0
Ferris, W., and J. (accepted) 49 0 0
Poore (accepted) 454 10 0
Daley and Co. 50 0 0
Ferris Bros. 40 0 0
Ferris, W., and J. (accepted) 37 10 0

BARROW.—For supplies in connection with forced draught, for the town council. Accepted tenders:—
Chimney:—
Thompson, J., Ltd. £430 0 0
Ash hopper:—
Morris, H., Ltd. (exclusive of hopper) £259 0 0
Meter:—
British Thomson-Houston Co. £24 0 0
Fan:—
Davidson and Co. £205 0 0

BATTERSEA.—For the supply of meters, for the Metropolitan Water Board. Accepted tenders:—
1-in. and 1/2-in. "Imperial" positive water meters:—
Beck and Co., Ltd. (less 5 per cent.) £4,375 0 0
1-in. and 1/2-in. "Empire" meters:—
National Meter Co. £1,937 0 0

BATTERSEA.—For the supply of 12,900 firebricks, 25-centers and 25 fire tiles, for the Metropolitan Water Board:—
Sankey, J. H., and Son (accepted).

BATTERSEA.—For the supply of steel shafting for meter shop, for the Metropolitan Water Board:—
Smith and Grace, Screw Boss
Palley Co. (accepted) £173 0 0

BATTERSEA.—For the supply of travelling cranes, for the Metropolitan Water Board:—
Morris, Herbert Ltd. (accepted) £434 2 0
(Three tenders accepted.)

BATTERSEA.—For the supply of soft wood blocks, dressed, 3 in. by 5 in. by 4 in., required in connection with the establishment of central station, for the Metropolitan Water Board:—
Burnett, Sir W., and Co., Ltd. (accepted) £465 0 0
(Six tenders received.)

BATTERSEA.—For glazing central station (steel tees, bars, lead covered, 24-in. centres), for the Metropolitan Water Board:—
Haywood, W. H., and Co. (accepted) £128 16 10
(Five tenders received.)

BATTERSEA.—For asbestos slating, same building:—
Matthews, E., and Co. (accepted) £118 0 0
(Three tenders received.)

BATTERSEA.—For steel sashes (segmental-headed, 12-in. rise, 7 ft. 6 in. wide by 12 ft. 6 in. to top of crown, 1/2-in. sashes for same building:—
Haywards, Ltd., Union Street,
Borough, S.E. (accepted) £52 10 0
(Three tenders received.)

BATTERSEA.—For removal of parts of No. 2 economiser at the electricity station, for the Battersea Borough Council:—
Green, E., and Sons, Ltd. £512 0 0
(Recommended for acceptance.)

BRIGHTSWALE.—For construction of footpath, Shortwood Street, for the urban district council:—
Jackson, W. £433 0 0
Allen, M. J. 385 0 0
Wymor, W. G. 748 6 0

BRIGHTSWALE.—For various stores and supplies for the Electric Bus Committee. Accepted tenders:—
Fishbait and nuts:—
Guent, Keen, and Nettlebolls, Ltd.
Fangbolts:—
Phenyl Bolt and Nut Co.
Tarpaulins:—
Dallin Bros. and Son.
1 1/2-in. oil canvas conveyor belt:—
Gwell and Eastern Rubber Co.
"Traffic" plan:—
Messrs. R. Wilkins and Son.

BRISTOL.—For electrical supplies, for the Corporation Electrical Committee. Accepted tenders:—
Alternating Current Meters:—
British Westinghouse Electric and Manufacturing Co., Ltd., Manchester £1,329 0 0
Arc Lamp Carbons:—
Olive Arc Lamp Co., Ltd., Woolwich £765 0 0
Joint and Junction Boxes:—
Sykes and Sugden, Ltd., Huddersfield £508 15 9
Direct Current Meters:—
Farrant, Ltd., London £365 9 6
Fuse Boxes:—
Lacey, W., and Co., Ltd., Oxford £148 12 6

BROADWAYS.—For supply of granite, for the urban district council:—
Brooke's, Ltd., 188, 2d. per ton (accepted tender).

BROWNHILLS.—For the laying and construction of a 9 in. stoneware pipe sewer, at Bad Lane, Walsall Wood, for the Brownhills Urban District Council. Mr. J. H. Shaw, engineer and surveyor:—
Cutral, Lewis and Martin, Icknield Port Road, Birmingham £798 0 0
Martin and Element, Woodlands Street, Smethwick 771 17 0
Lewis and Tipton, Great Tindall Street, Birmingham 694 17 5
Thorpe, W., Hollywood, near Birmingham 629 2 0
Jackson, C., Waterloo Street, East Tipton (accepted) 588 16 6

CANNOCK.—For the supply of 150 larger and 30 smaller desks, for the Education Committee:—
Midland Education Co., Birmingham, accepted, at 15s. 6d. and 11s. 6d. each respectively.

CLIFTON.—For construction of an additional septic tank at the North Riding Asylum at Clifton, for the North Riding County Council:—
Birch, W., and Sons, Ltd., York (accepted) £596 18 3

COLWYN BAY.—For the construction and completion of extension to Victoria Park, Colwyn Bay, for the owner, Mr. J. M. Porter, F.S.I., Estate Office, Colwyn Bay, surveyor:—
Mitchell, F., and Son, River Place, City Road, Manchester £916 1 7
Shepherd, W., and Son, Milkstone, Rochdale 696 0 0
Lumb, W. (successor to Anderton and Co.), Woodlands, Old Colwyn 680 0 0
Pritchard, R. O., Bryn Dedwydd, Conway 567 11 2
Rowlands, R., Bod Ivor, Rhw Bank Avenue, Colwyn Bay 545 11 11
Hughes and Co., Back Sea View Terrace, Colwyn Bay (accepted) 499 13 1

COWES.—For repairs to Gurnard Bridge, for the Isle of Wight County Council. Mr. S. R. Cocks, county surveyor, St. Thomas Street, Ryde, I.W.:—
Quinton, G. P., Carisbrooke Road, Newport £37 13 0

DARTON.—For enlargement of Gawber churchyard, for the Darton Urban District Council:—
Taylor, E., Darton (accepted) £128 0 0

EAST HAM.—For cleansing and whitewashing the latrines and urinals at 19 schools and for internal repairs, painting, and sundry work at Hartley Avenue school, for the East Ham Education Committee:—
Hartley Avenue school repairs:—
Jarman, E., 6, Knapp Road, Bow £350 0 0
(Cleansing latrines:—
Jarman, E., 6, Knapp Road, Bow 194 0 0
(Accepted.)

EBBW VALE.—For painting external woodwork and ironwork of their 64 houses at Council Street, for the Ebbw Vale Urban District Council. Mr. T. J. Thomas, town surveyor:—
Inge, F., Swindon £115 10 0
Phillips, D., Newport 89 0 0
Astop, A., Ebbw Vale 80 0 0
Mortimer, T., Ebbw Vale (accepted) 48 10 0

ERITH.—For the construction of foundations for the new electricity generating station at Portobello for the corporation:—
Goslin, G. and R. (accepted) £5,725 0 0

ERITH.—For the erection of Munitions Factory No. 119, for Vickers, Ltd., Erith. Accepted tenders:—
Builder work:—
Borman, Long, and Co., Middlesbrough.
Steelwork:—
Gunning, G. H., and Son, Erith.

FARNHAM.—For repairs to ledge and chapel at Farnham cemetery, for the Joint Burial Committee:—
Goddard and Son (accepted) £64 16 0

FERMOY.—For improving the water supply, etc., of the workhouse for the guardians:—
Donald Hayes, Fermoey (accepted) £2,329 16 0

FERMOY.—For improving the water supply and sanitary and lavatory arrangements in the workhouse for the guardians. Messrs. Coughlan and Tierney, Fermoey, engineers:—
Hayes, D., Fermoey (accepted) £2,329 16 0

GLASGOW.—For special track work, for the Tramways Committee. Accepted tenders:—
Loran Steel Co. and E. Allen and Co.

HAMPTON.—For providing points and crossings in connection with coal unloading and transporting plant, Hampton and Kempton Park, for the Metropolitan Water Board:—
Kerr, Stuart and Co., Ltd. (accepted) £57 10 0
(Three tenders received.)

LANCASTER.—For alterations to property at the rear of George Street, Thurnham Street, and Robert Street, Mr. R. Jackson, L.R.I.B.A., Lancaster, architect. Accepted tenders:—
Mason work:—
Ward, R., Golgotha Road £378 0 0
Joiner work:—
Bill and Riley, Greaves Road 131 15 0
Plumber work:—
Barrow, S., Edward Street 129 19 1
Plasterer work:—
Cross and Sons, King Street 67 0 0
All of Lancaster.

LONDON.—For the supply of 2-in. and 6-in. Siemens' meters, complete with automatic valves and lead connections for by-pass meters, for the Metropolitan Water Board:—
Laidlaw, R., and Sons, Ltd., Edinburgh (accepted) £175 0 0

LONDON, E.C.—For relaying with stone the carriageways of (a) Queenhilth and (b) Padding Lane, for the City Corporation:—
Anderson, G. J. (accepted for both) £359 2s. 6d. (a), £315 4s. 6d. (b).

LONDON, N.—For installing heating apparatus in connection with the rebuilding of the Winchestr Street school, for the London County Council:—
Deane, E., and Beal, Ltd., 3, Monument Street, London Bridge £745 0 0
May, J. and F., 33, Whetstone Park 729 12 0
Unsign'd 693 10 0

BRIGHTSIDE FOUNDRY AND ENGINEERING CO., LTD., 28, VICTORIA STREET 649 0 0
PALOWKAR AND SONS, 90-91, QUEEN STREET 638 0 0
YETTON AND BROCKETT LTD., MUTTON ROAD, SOUTHWARK 620 0 0
CANNON, W. G., AND SONS, LTD., 107, LONDON ROAD 612 0 0
VAUGHAN, T. W., AND CO. (1914), LTD., 22, CROSS STREET, ISLINGTON 548 10 0
(Architect's estimate, £590.)

* Recommended for acceptance.

LONDON, E.—For extending the heating apparatus in connection with the enlargement of Redman's Road school for the London County Council:—
Brightside Foundry and Engineering Co., Ltd., 28, Victoria Street £295 0 0
Simmonds, W., and Co., Frederick Street, Stratford 279 0 0
Norden, L., 117, Hampton Road, Forest Gate 274 0 0
Sneecal and Co., 66, Hatton Garden 269 7 0
Watkin, W., and Son, 313, High Road, Wood Green 264 10 0
Thames Bank (Blackfriars) Iron Co., Ltd., Upper Ground Street 261 5 0
Yetton and Brockett, Ltd., Mutton Road, Southwark 260 0 0
Palowkar and Sons, 90-91, Queen Street (unsigned) 253 0 0
Cannon, W. G., and Sons, Ltd., 107, London Road* 212 0 0
* Recommended for acceptance.

LONG CLAWSON.—For the construction of 9-in. and 6-in. sewers at Long Clawson, for the Melton Mowbray Rural District Council. Mr. G. E. Fryer, Thorpe Road, Melton Mowbray, surveyor:—
Hayes, F., Liverpool £381 17 9
Chamberlain, C., Barclay Street, Leicester 380 7 4
Clarke, E., Melton Mowbray 376 9 9
Wade, C., Luddenden Foot 376 0 0
Shardlow, J., Leicester 342 16 0
Barry, W., Ratcliffe-on-Trent 340 4 3
Palmer, A. E., Glenfield, Leicester 336 0 0
Emery and Co., Birmingham 316 6 0
Clarke, W. G., and Co., Grantham 315 0 0
Margerson and Co., West Bridgford, Nottingham 303 19 7
Sikes, A., Nottingham 298 14 0
Burnett, R., Huckling 272 0 0
Doubleday, Waltham, Leics. (accepted) 239 10 4

MOUNTAIN ASH.—For painting and colouring schools, for the education committee. Mr. W. H. Williams, Mountain Ash, architect:—
Duffryn boys' girls' and infants' schools, cookery, and home-making centres and school clinic:—
Lloyd, G. H., Mountain Ash £215 15 0
Cezzarw girls' and infants' schools (interior):—
Jones, G. T., Aberdare 179 0 0
Treborth boys' school (interior):—
Cadywan, P., Pontypridd 69 0 0
Christow mixed school (interior):—
Jones, E., Pontypridd 55 10 0
Amyshwl mixed school (interior):—
Ferris, W. J., Pontypridd 35 15 0
Clarence Street infants' school (exterior):—
Lloyd, G. H., Mountain Ash 30 15 0
Abertal mixed and infants' schools (exterior):—
Jones, J., Cilfandd 26 10 0

NOTTINGHAM.—For the internal cleaning, painting, and papering of their several scattered homes in the city, for the guardians:—
Bee, W., 15, Lamas Street, Nottingham (accepted) £82 0 0

RICHMOND.—For repairs to schools, for the education committee. Accepted tenders:—
Work at county school for boys:—
Speckley and Smith £69 15 0
Work at county school for girls:—
Morris, W. D. and Co., Ltd. 64 10 0

THE GERMAN VISITATION, SYMPATHY WITH FRENCH ARCHITECTS.

The following letter, signed by the president of the Institut Royal, has been addressed to the president of the Societe des Architectes allemands par le Gouvernement, Paris.

June 1, 1915.

Sir, We, the members of the Council of the Royal Institute of Architects, beg you to receive the cordial greetings of our colleagues of the Societe des Architectes allemands par le Gouvernement, our professional brethren, and you, our countrymen, and with the kindest remembrance of the wanton destruction of your monuments by so many examples of French barbarism, of which such as the Cathedral of Reims were the proof by the whole civilized world, and by setting the whole possible history of the ravages of this war.

It is a pleasure to express in terms of liberation the feelings which are not only British, but of every country of our continent have received the same feelings of sympathy and indignation of the ravages of this war.

It is a pleasure to mention that there is another country which has suffered from the ravages of this war, and that is the country of France, and that the Government of this country has ordered the British Government to carry on the war, and that the Government of this country has ordered the British Government to carry on the war, and that the Government of this country has ordered the British Government to carry on the war.

Very truly yours, J. H. B. A. SOCIETE DES ARCHITECTES ALLEMANDS PAR LE GOUVERNEMENT.

A letter in the same terms, but signed by the Societe des Architectes Français, Paris, has also been received.

The following is a translation of the letter from the Societe des Architectes Français, Paris, 22 June, 1915.

A Monsieur le Président de l'Institut Royal des Architectes Français, Paris.

Monsieur le Président, Les membres du Conseil d'Administration de la Societe des Architectes Français ont le plaisir de vous adresser, au nom de nos collègues de l'étranger, les cordiales salutations de sympathie et de solidarité que nous vous adressons dans ce moment de crise.

Nous sommes convaincus que la République Française, par son courage et son patriotisme, sera victorieuse de la barbarie allemande, et que la paix sera rétablie dans le monde.

Très respectueusement, J. H. B. A. SOCIETE DES ARCHITECTES ALLEMANDS PAR LE GOUVERNEMENT.

Monsieur le Président, vous et les membres de votre honorable Société, à l'expression de nos sentiments de sympathie et de solidarité.

JACQUES HERMANT.

(S. members of the members of Council, etc. follow.)

Societe Centrale des Architectes, Paris, 22 June, 1915.

Monsieur le Président et Très Honoré Collègue, Au nom du Bureau et du Conseil de la Societe Centrale des Architectes, nous venons vous adresser nos cordiales salutations et notre témoignage de sympathie et de solidarité.

Le monde entier a été pénétéré d'indignation en voyant les crimes de barbarie de la barbarie allemande, et nous sommes convaincus que la République Française, par son courage et son patriotisme, sera victorieuse de la barbarie allemande.

Très respectueusement, J. H. B. A. SOCIETE DES ARCHITECTES ALLEMANDS PAR LE GOUVERNEMENT.

Monsieur le Président, vous et les membres de votre honorable Société, à l'expression de nos sentiments de sympathie et de solidarité.

JACQUES HERMANT.

The following is a translation of the letter from the Government of the Reich, signed by the President of the Reich, Berlin, 22 June, 1915.

The Reichstag, Berlin, 22 June, 1915.

The Reichstag, Berlin, 22 June, 1915.

The Reichstag, Berlin, 22 June, 1915.

The Reichstag, Berlin, 22 June, 1915.

TRAVEL NOTES IN ITALY.

What is the charm of Italy? That such a charm exists to very many is undoubted. When once you have come under the spell of this romantic land, the deep longing to return will seize at most unexpected moments. The sight of a Roman urn, a Madonna, a majolica replica, or the smell of cypress or stone pine in a hot sun will be sufficient to recall memories of sun-baked walls, of vineyards, cypress avenues, white towers, way-side shrines, and the teeming and picturesque life of the roadway.

Some few years ago a party of us spent some months in the larger towns of Italy, and, being the charm still upon us, we arranged another visit, intending to spend our time in some of the smaller centres; and with this object in view landed at Naples at the end of January last year. Propitious circumstances led to our arrival at the very season of which our previous trip terminated, so that knowledge of the seasons was completely lacking.

NAPLES.

The climate of Naples during February was, unfortunately, foggy frosts at night were scarcely visible, and sets of early falling were visible. Comfortably settled, and enjoying the famous bay, we renewed acquaintance with the wonderfully interesting streets of Naples, explored the ancient city with its straight, narrow, team-tracks and of gateways, surrounded and overgrown by the old, but more recent, buildings, and admired the fine effect of the cypripal and arched trees, forming walls of greenery in the Piazza Minopoli, and the fascinating National Gardens, on the sea front, in which we recognised many Australian gums and sheoaks, and watched the crowded traffic in the Chiaia. As it was the season, Naples was crowded with visitors. Bettoloni's Terrace was filled each day for afternoon tea with an interesting sun-pollion crowd well worth studying.

A pleasant trip from Naples is to take the train from the Torretto through the huge grotto or tunnel, and then along the coast past the ironworks to Pozzuoli, a dirty and most interesting spot. Here St. Paul landed on his voyage to Rome, and the old dock is well worth visiting for those in search of the picturesque. Solfatina is easily reached by carriage or by walking from Pozzuoli. The guide conducted us over the glistening bed of the crater by a devious path, avoiding the numerous boiling mud springs. The ground sounds hollow underfoot, and when a light is applied to the sulphurous vapour issuing from cracks and rents in the ground, the smoke issues from other rents hundreds of feet away, and even from parts of the crater cliffs high above our heads. Flocks of sheep and goats were grazing on the edge of this inferno, and the bamboo huts of the shepherds were erected within a few feet of the boiling springs. The whole of this district is dotted with ruined Roman buildings, many buried by the numerous volcanic disturbances. The ancient Temple in Pozzuoli, which is approached through a bath-house, shows the signs of submergence under the sea, and is now again sinking below sea level.

We spent a long day driving round the Bay of Baie, crawling into decorated, smoke-blackened tombs scattered among vineyards looking down on the beautiful bay in which Agrippina was drowned, descending into the great vaulted water cistern on Cape Messina, from which the Roman Fleet was watered, entering the mouth of the underground passage that connected Cumae with Lake Avernus. The district is a museum of ancient remains, and appears to be in the hands of private owners, who use decorated vaults as stables and storehouses, and expect a few centners from visitors.

Returning to Naples: The Castle Nuovo, with its handsome carved entrance gateway and its bronze doors, is approached through military stores. Obtaining permission from the sentry, we passed into a yard among

A paper read at the Royal Victorian Institute of Architects by Mr. Percy Kerfoot. A fine display of slides illustrating the paper were shown by Mr. C. A. Cowper-Kelk.

piles of empty shells, transport waggons, and other warlike stores, and had time to examine the carvings of the towers, representing scenes from the war with Spain, while a small boy went in search of the guide. When he appeared, armed with an enormous key, he pointed out the panels of the bronze doors representing incidents in local history. The heavy bronze has in one place been broken by a round shot, which is still embedded in the door. The inner court of the castle is crowded with military waggons, arranged in a very haphazard manner. The guide, with his enormous key, unlocks the chapel door and conducts us round the various historical and family monuments. A very fine circular, open, newelled staircase leads up to the private apartments; a narrow, steep stairway also leads down to the dungeons, which are reserved to the last. The guide shows the decapitated trunks, in their coffins, of two victims to the Spaniards' fury, and explains that they were preserved by being embalmed in sea water. He then lifted the lid of a third rough wooden coffin, in which is the mummy of a strangled cardinal, still wearing his vestments. The awful look of horror, the gaping mouth and twisted hands and feet are as realistic as when the unfortunate wretch perished hundreds of years ago. The guide, to relieve the situation, so fraught with horror, gave the withered, leathery flank a playful slap as he closed the lid, and asks us if we are "Contento." We assured him of our complete satisfaction, and only longed for the open air, in which to forget his dungeons and their horrors.

The Old Church of the Carmine, situated just behind the Porta Capuana, near the ancient harbour of Naples, is one of the most picturesque in the town. At the time of our visit a horse fair was being held at the very doors, and we had some difficulty in dodging the heels of the stallions which were being offered for sale. Outside, the church has an imposing tower of black and white marble. The greasy, heavy leathern curtain that hangs at all church doors in Italy in winter has to be pushed aside, and we are in a beautiful mellow interior, Baroque in style, glowing with dull gold. Long rays of wintry sunshine, heavy with dust motes, shine through the clerestory windows, lighting up shrine and statue. Here and there, amid the general gloom, the poor of Naples are here at their devotions. Matins are being sung, bells toll, the organ peels out, while we follow intricate passages into the chapel behind the altar, where, standing among a crowd of kneeling devotees, we are shown the miracle-working picture of Saint Bueno. We walk back from the Carmine, through some of the wonderful streets of the old town, and are particularly pleased with the street of the artificial flower workers, whose wares are shown in the open street, giving it a most festive appearance. It was carnival time, and, meeting a crowd of students, our ladies were well sprinkled with confetti.

AMALFI AND RAVELLO.

One day we had a discussion as to the composition of the characteristic smell of Naples. Some said wasting coffee and stable; others, humanity; all agreed that the predominating noise was the ceaseless braying of the humble donkey. From Naples, a rapid trip to Capri, Sorrento; thence by the famous roadway along the Gulf of Salerno to Amalfi. Here we rested at the monastery high on the cliff above the bay, celebrated in Longfellow's poem. The old cells are converted into bedrooms, the refectory is used as a dining-hall, the chapel remains, and a portion of the cloister. The vine terraces and lemon orchards, with the water cistern and cemented aqueducts, are maintained as of old. In the hanging woodland above the gardens we were pleased to find the first or hids, wild violets, and daisies, and other signs of spring. It is hard for the visitor to realise that Amalfi was an important Medieval republic, and a bustling commercial port at the time of the Crusades. At present the town is crowded into a small space between two headlands, at the mouth of a mountain stream. The houses climb the cliffs on either hand, and are approached by intricate, uneven passages.

The cathedral, backed against the cliff, and approached by a high flight of steps, is almost buried by the surrounding buildings. Two ancient castles dominate the headlands, and the whole, as viewed from the city square, is most picturesque. The ancient city lies submerged under the blue waters of the Gulf, and the fishermen still hear the church bells ring for matins and vespers as they float above the submerged towers. We slept well in our cells, notwithstanding the fact that a portion of the monastery has been carried away by a rock-fall from the cliffs, the seat of which is plainly visible.

All who take this route should visit Ravello from Amalfi. As the road is very steep, some of our party walked up by the old mule track, through romantic scenery. The track follows a mountain stream, and passes through vineyards and chestnut woods; the banks were purple with crocus. At one spot we saw how the immense labour of building the terraces for the vines was accomplished. The whole available population was at work—men, women, boys, and girls—all carrying stones or soil. Only by such a combined effort could such an amount of work be finished. About 10d. a day is a labourer's wage, I believe, in these parts.

Ravello is superbly situated, over 1,500 ft. above sea-level, and overlooks miles of coast-line. We felt we could almost throw the proverbial biscuit into the Gulf from the terrace of the Hotel Belle Vue. The padronna, hearing we were from Melbourne, was delighted to show us a photograph of her uncle's house in "San Kild," Melbourne. The contrast of this photo with our surroundings was striking. Ravello, stone built, ancient, deserted, side by side with St. Kilda's bijou villa. The cathedral contains the well-known inland mosaic pulpit, supported by polished shafts, on bases resting on the backs of lions and lionesses, and also some curious Scriptural mosaics. Many of the palaces in Ravello have marble columns at their entrances removed from the ruins of Paestum. The Ruffillo Palace, the garden terrace of which is one of the sights of Italy, bears a tablet erected by the inhabitants of the district to the generosity of the Gibson-Carmichael family, who at one time resided here. An incident of the road was characteristic. One of the ponies, beautiful little creatures from Sardinia, lost a shoe. The driver produced a spare one and a handful of nails, and with a spanner as a hammer proceeded to make good the defect; and a botched job it was. But there being no option, we had to complete the journey in this uncomfortable manner.

ROME.

Rome is too large a subject to touch in a discursive paper. The huge Victor Emmanuel monument dominates the Capitol. "Time, alone," as an Italian gentleman explained, "can pass a true criticism of such a stupendous work." Most lovers of the ancient condemn this work as disappointing and in bad taste; but Rome has survived many building periods, and its great charm is as an historical reference to great national movements; and the new memorial will pass into the future as one of these, built by the State to catch the eye of an emotional people, in competition with the great Church memorial on the Vatican Hill. It has failed to eclipse the work of Michael Angelo, both in utility and in grandeur.

Architects in Rome must have an interesting time, as it is a rare thing to open foundation trenches without finding evidence of earlier construction, and occasionally sculpture and jewelry of great value is unearthed. The authorities of Rome are waking up to the fact of the great value of the historic remains their city contains, and are taking steps to protect them from injury. Unfortunately, in some cases this care has erred in taste. The beautiful little round Temple in the ancient cattle-market has been surrounded with rockeries somewhat after the St. Kilda Road pattern. Personally, I much preferred the litter of straw and picturesque groups of contradini which I knew of old.

Rome was indulging in the usual epidemic of strikes during our visit. The cabmen struck against the regulation fares, and received an increase. Still, even with this addition, we found it often more economical

to patronize a motor omnibus than to take the tram. The Metro, or city street car, is the Government's chief objection to the municipality. At the time of our expedition the shops closed for a day or three days, and roads met, in the morning, some 100,000 men with the military uniforms, were marching down. But, save for a riot on August 2, confined only to the tourists, and the "Badeker" which is quite sufficient passport to open the ranks of double guards, and fixed bayonets, who were stopping all other traffic. From Rome, a delightful day trip was made by electric tram across the Campagna to the towns on the slope of the Alban Hills. A good service of cars leaves Rome from the vicinity of the Stazione de Termini. In a short time we find ourselves traversing the undulating slopes of the Campagna, "so beautiful as to fill one with melancholy," as an Italian friend remarked. Monuments and ruined aqueducts stand out against the wonderful purple distances of the hills. Shepherds clothed in goatskin breeches, with the long hut on the outside, looking uncommonly like ancient satyrs, attended their flocks, the temporary huts of bamboo reminding us of Indian wigwags. The tram line follows the road to Frascati, and the whistle has to be frequently sounded to warn the sleeping driver of a picturesque wine cart which has strayed between the rails. After some ten miles of this journeying, the line leaves the open Campagna and ascends between vineyards in which are mounted guns with wide bell mouths, for shaking up storm centres in the heavens before the hail can descend and ruin the crops. The tram divides, one branch going to Frascati, famous for its villas, gardens, and wine. From Frascati a delightful trip may be made to Tusulum, and I would advise good walkers to go on foot, as the views all the way up to the mine are delightful. The right-hand branch of the tram runs to Albano, where we get a fleeting glimpse of the beautiful crater-lake; and then on to Genzano, some twenty miles from Rome. Genzano is described in "Badeker" as a poverty stricken village, without attractions; but to sit in the central piazza, and watch the women carrying water in copper buckets to their homes, is worth the visit. Two types are very noticeable—a fair haired, fair complexioned type, supposed to show the northern blood of Charlemagne's warriors, are mixed with the smaller, vivacious, dark skinned Italians.

Our objective in Genzano is the Lake of Nemi. Climbing the steep street, accompanied by a crowd of archins, each anxious to earn a soldo, we reach the gate of the Palazzo Cesario; but before admittance is granted, we must interview the lordly major-domo at the Palace adjoining. We enter our names in the visitors' book, the gates are unlocked, and we are as free of these beautiful gardens as if we owned them. This is a delightful feature of Italy, the way one is welcomed and shown over private property. It sometimes leads, however, to awkward moments, as when some over-zealous guard leads one into a dining-room in which the rightful owners are sitting down to dinner. Awkward for the visitors, alone, as Italian manners seem equal to all occasions. The winding paths of the Palace Garden lead through hanging woodlands down to the shifting levels of the lake, 400 ft. below. We spent hours wandering in this sylvan solitude, undisturbed, picking wild violets and porcupisus in the woods, searching unsuccessfully for the ancient artificial outlet built by the Romans, and still maintaining the lake at a uniform level. The journey back to Rome in the evening light, with the floating dome of St. Pietro growing ever larger and more distinct before other features are distinguishable, is an experience long to be remembered.

Our last drive in Rome was to the Station San Pedro, outside the walls, behind the Vatican Hill. We felt, as we waited for the train, that our Italian journeyings were starting in earnest. Here were no guides, no interpreters, no tourists, but ourselves, as we waited in a crowd of rustic-looking people with large market baskets, for the slowly coming train. At last a shout from a small boy in the crowd, which is taken as a warning by the crowd, is itself seems to be a warning to the crowd, and ourselves: "Eccolo"

the train, and we were off. The train was a fine one, and we were in good luck. The train was a fine one, and we were in good luck. The train was a fine one, and we were in good luck.

The train was a fine one, and we were in good luck. The train was a fine one, and we were in good luck. The train was a fine one, and we were in good luck. The train was a fine one, and we were in good luck. The train was a fine one, and we were in good luck.

The train was a fine one, and we were in good luck. The train was a fine one, and we were in good luck. The train was a fine one, and we were in good luck. The train was a fine one, and we were in good luck. The train was a fine one, and we were in good luck.

From Viterbo we went to the ruins of Ferentino. These have been well preserved, and are a most interesting sight. The ruins of Ferentino were utterly destroyed by the earthquake of 1172, and the only remains are the ruins of a few houses, and a shepherd attending his sheep. The ruins of Ferentino are a most interesting sight, and are a most interesting sight. The ruins of Ferentino are a most interesting sight, and are a most interesting sight.

Another excursion in the Valley of the Saccara, charming Viterbo, led to the ruins of Otricoli, situated on a rocky outcrop, on the cliffs of which served as a natural fortification, as appears from the remains of the towers. The ruins of Otricoli are a most interesting sight, and are a most interesting sight. The ruins of Otricoli are a most interesting sight, and are a most interesting sight.

The ruins of Otricoli are a most interesting sight, and are a most interesting sight. The ruins of Otricoli are a most interesting sight, and are a most interesting sight. The ruins of Otricoli are a most interesting sight, and are a most interesting sight.

and I, by the way, I go to Assisi to see the famous Giotto's "St. Francis Preaching to the Birds" and a long wait at Teramo for a train of little interest. You can trust the "Assisino," or porter, to look after you. I say "Give him a lira, and he takes you to your train, finds you a seat, makes sure of your luggage, and, in our expectations, is to be trusted."

ASSISI

Scrupulously by a drive of some three or four miles from the station across a dusty plain, and then a steep climb up to the rosy-pink city clinging like a swallow's nest to the top of Mount Subasio. The chief interest here is, of course, the connection with St. Francis, and the great church—or, rather, churches—for there are two—one super-imposed upon the other—called after his name. The frescoes of the lower church, which recede one back, again and again, to their study, are the chief attraction to tourists, but the rest of the town is well worth exploring, and the surrounding country is most beautiful. We were amused hearing an American, who had just arrived, and "done" the churches, remark to his companion: "We can't get out of this place till to-morrow morning."

A hot walk of about four miles by mule track (not possible for motors, thank heaven!) up the bare, glistening slopes of Mount Subasio brings us to the hermitage of the Canon, 2,500 ft. above sea-level. It was St. Francis of Assisi's habit to retire here for meditation and prayer. A small monastery was built on the edge of the ravine, and a small park enclosed. After the heat and fatigue of the climb it was delightful to rest in the shade. An aged brother drew cool water from the well, and provided refreshing wine for us as we sat on the parapet of the courtyard, enjoying the extensive view. The rock bed of St. Francis is shown, also many of his personal relics. There is a most charming modern statue in the park, under the tree where St. Francis blessed the birds, of the saint and his feathered friends. We were sorry to leave Assisi, after a visit of a week; but Easter was approaching, and we had engaged to spend that season in Florence, so, hiring a two-horsed carriage, we drove with all our luggage some sixteen miles across country to Perugia, the towers of which, dimly in the line of the setting sun, had rightly beamed us during our stay in Assisi.

PERUGIA

is a town of great interest, and most important to the student of painting, as only here can Umbrian art be properly studied. Built on the top and slopes of a hill, the views over the surrounding country are impressive. Those interested in architecture should look up the Oratorio of San Bernardino, a magnificent polychrome work, in which marble and terra-cotta are employed; to the right of the Oratorio is a deserted church, used as a mill-race. The forges, seen in the dim religious light, and the smoke-blackened walls are most picturesque. A young mechanic invited us in to see Grottos (Jottos) Frescos. It was evidently a standing joke of his, which he immensely enjoyed; but we were not quite so green, and we all laughed together.

The youth of these hill towns of Italy have a pastime suited to their environment. Large discs of wood, about the size of a cheese, are bowled down the curving roads which wind the hills, and it is rather alarming to meet a flight of discs bounding down the slope. I tried my hand at throwing one, but it soon ended its course in the gutter.

FLORENCE

at Easter is most interesting, not only the ceremony of the town itself, but those in the city and the District are quaint and beautiful, but would require an evening to themselves.

Siena

is an interesting centre for a long visit. The climate is delightful, very different from Florence, which is so very fine in every way. A number of the modern improvements, especially the express electric cars that traverse the city streets, often pulling right along side the old fronts to pass a pair of the magnificent old and Tuscan draught-oxen, harnessed in a wicker-work ox-wagon. The

"were" was (a man in the form of a wolf) still haunts the streets at night, plunging into the Fountain of Fontebranda at the first streak of dawn, in the belief of the more ignorant of the citizens. The visitor receives nothing but kindness from the fine-looking people. The sitting tower of Palazzo Pubblico, over 300 ft. in height, one of the noblest in Italy seen from one of the dark and narrow streets in the full flash of sunset will never be forgotten. Sodoma's picture of "The Scourging of Christ," in the Belle Arti, impressed me more, I think, than any picture I have seen. The simple technique and use of line in this fragment is mastery, and the finest thing in the Accademia collection.

VIA REGGIO.

We rested some weeks in Via Reggio, an Italian watering place on the Ligurian Sea, and enjoyed sea-bathing and sand-baths. The sands are strongly impregnated with iodine, and so are recommended for rheumatism. At Via Reggio there is a prosperous ship-building business going on, most interesting to anyone connected with construction. The raw material for the ships is grown in the adjoining oak and pine forests; the logs are cut to the docks, and there cut to timbers or planks by sawyers, cutting the curved timbers from natural grown trees, the top sawyer following one line, the bottom sawyer another, thus getting the proper shear. The pine plank is also sawn so as to follow the natural curves of the trees, and the curves all seem to come in somewhere in the construction. Of machinery there is little or none. Ropes, canvas, sails, boats, iron work, are all being made near the same spot. The Via Reggians are very proud of their ships, and well they may be, as they are beautiful specimens of naval architecture, sound and well built. As they say if a seaman is drowned: "If Antonio had only sailed in one of our ships he would not have been wrecked." From Via Reggio we visited

THE FAVORS CARRARA MARBLE QUARRIES. By the courtesy of the Marble Quarries Railway Co., a special carriage was attached to one of the trains, leaving Carrara for the quarries, high on the mountains. The line ascends by a series of zigzags, and fine views of the plains are obtained as we rise higher and higher. Below us it looks as if the whole population of the Carrara valley had their washing out to dry; but we are told by the courteous official who accompanies us that the white dots are blocks of marble waiting to be sawn into slabs. The sawing is largely done by water-power, and the mills line the mountain torrents. After ascending some thousands of feet, the line enters a dark tunnel, and then we again emerge into daylight. What a change! Instead of the green squares of the cultivated plain, the white towns and villages, the distant blue Ligurian Sea, there is a mountain valley of dazzling whiteness. Large stacks of marble blocks line the railway ready for transportation. The slopes and cliffs above us as far as we can see up to the vivid blue Italian sky are covered with glistening white spalls and chippings of marble, down which, on rough skids, large blocks are being lowered by crowds of men with heave ropes. The spoil from one quarry overflows another, and endless are the lawsuits in consequence between the different owners. There is a proposal to erect overhead transporters to convey the rubbish to the sea, there to be used in building a much-required breakwater. But want of co-operation between the quarry-owners has so far stood in the way of realisation. Leaving this station, still ascending, we pass through a long tunnel into another and higher valley, where the same scene is repeated. While our train of trucks is being loaded by overhead travellers, we are taken into a quarry in which a huge mass of stone has been blown down by powder and is ready to be cut up into blocks. The good stone in the cliffs is in irregular masses, surrounded by disintegrated stone which is worthless. This accounts for the huge accumulations of small and rubbish. Electric power is supplied from generating stations on the other side of the gorge, and a good deal of quarrying by winnowing, with sharp sand, is done. Our stay

in the valley is punctuated by warning blasts on horns, followed by heavy detonations, which reverberated from the cliffs. While the train is being loaded we adjourn to a little inn under the shelter of a projecting cliff; it is pleasant to retire from the heat and glare into this humble hostelry, where biscuits and a sweet fruity wine are served, while the padrone shows us his portrait by Sargent, who spent some weeks here fascinated by the scene. The railway company convey over 1,000 tons per day to the coast, and there is also a large traffic by ox-wagon from the valleys not served by the railway. The company's representative told us that blocks of marble at present in Rome, conveyed there in ancient times, are far beyond the capacity of the railway to handle. It is not known how they were removed from the quarries; but once on the sea beach the sand was dug away round them, and in the dock thus formed a ship was built outside the block of stone, which was then floated to sea. The blocks were Imperial property, and the ships were labelled A.C.F., and could demand assistance from any other vessel encountered on the voyage. This has passed into a local proverb, A.C.F. meaning "to get something for nothing."

These notes have covered some of the places visited during our journeyings in this most delightful land, where we received nothing but kindness and courtesy from the people, and which we left with regret and the hope to visit again.

PERSHORE ABBEY.

The vicar of Pershore (the Rev. F. R. Lawson) has issued a report on the work accomplished in connection with the reparation of Pershore Abbey.

In 1912 the removal of ivy from the south transept disclosed serious mischief, and further examination showed danger of settlement in the west wall, while the tower itself showed signs of giving to the west. A committee was formed and issued an urgent appeal, and the work of repair was begun. The transept wall (the vicar reports) has been well repaired, the larger and more ancient cracks being filled with fresh stone; the smaller, but newer and more perilous, ones by "grouting" with liquid cement. Two large flying buttresses now support the tower from its western side, and have given it stability. Before this work was completed, in July, 1913, an inspection of the decorated vaulting of the presbytery was made from a platform, and from above under the roof. Very grave peril was discovered, some of the work being almost ready to fall. The great tie-beams of the roof had rotted at their ends, had slipped from the wall-plates, and were bringing a heavy burden upon the stone vaulting.

By the architect's advice the church was closed for worship. His report, received later in July, showed that about £2,000 was required for absolutely necessary repair; further, that it might be found necessary to add additional flying buttresses to the presbytery, and to underpin the south wall of the transept; work requiring fully another £1,000.

A county committee was formed to organise funds, a contract was accepted, and work began in October upon the roof. The tie-beams were either renewed or spliced, and put back upon the wall-plates; the worn-out lead of the outer covering was replaced by reinforced concrete. Early in January last year scaffolding was erected under the whole of the presbytery vaulting, and its careful repair was carried on. No new stone was used, and except for some damage to one of the larger bosses, the whole of the beautiful work was found unharmed, made secure, and given a cleansing which has made its loveliness more apparent than before. Some minor repairs included the re-glazing of the cloister windows, which were in a bad condition, and better glass has brought a fuller light upon the vaulting. The repair of the vaulting was so thorough that it was not found necessary at present to add extra flying buttresses to the walls, and as the cracks in the south transept wall showed no signs of movement, the underpinning could also be postponed until danger threatened. On May 18, 1914, the Abbey Church was reopened, the Bishop of Worcester

dedicating the new works and the repairs to the old.

The accounts of the Reparation Fund show that £5,459 9s. 11d. was raised in less than two years, and that the work has cost £3,450 8s. 8d. The balance of £9 1s. 3d. will be applied to the replacing in the Abbey, near the west door, of a late Norman font, which for centuries belonged to the Abbey. It was cast out some eighty years ago to make way for a larger and newer one, and given away to a gentleman at Kempsey. His descendant, Sir R. C. Temple, however, has given it back, and it will shortly resume its proper place and sacred use.

THE GOLDEN AGE OF WAINSCOT OAK.

The golden age of wainscot oak, remarks a writer in the *Timber Trade's Journal*, may be pictured in its bud or bloom during the latter half of the seventeenth and the first half of the eighteenth century, when its use was largely influenced by Sir Christopher Wren and King William III. (1689-1702). The former has left this impression with us in the interior of his London churches, and the latter, hand in hand with him, in Hampton Court Palace. Here we have the opinion of a practical man who flourished in the City a century ago: "The wainscot oak in the old houses in the country was mostly English oak, there was not much Dutch or Riga wainscot before the reign of William the Third. I think Sir Christopher Wren introduced a great deal of it in this country in his time; he was building for a Dutch king; therefore, it was natural he should use it." (John Armstrong, before the Committee of Timber Duties, 1835).

"Dutch wainscot," which he placed first, was the finest wood that Europe or the world has ever produced. It was obtained in the sawn or converted form, and quartered to 17 in. a century later than Wren and William's time, and, what appears to have been forgotten, had its natural floatage and outlet in the Rhine. Riga, Memel, and Dutch wainscot, in the log form only, were then rated as inferior. Here be it known that the word *wainscot* implies a board, not a log.

In the evidence of Henry Warburton, Esq., M.P. (who succeeded his father in 1808 as a "wholesale foreign timber dealer" and "yard-keeper" in London, and conducted that business until 1831), we have the following: "Formerly most of the wainscot used in this country came from Holland or Ostend. It is cut from logs that are brought down the Rhine, and which grew principally, I believe, on the country adjoining the Moselle. The windmills by which it is cut are principally at Westzaam and Zaandam, near Amsterdam, but there are others near Rotterdam."

There was a "standard board," the unit of the Dutch sawn wainscot trade, and every detail hung upon it. The length was 12 ft., its other dimensions about 11½ x 1 in., which possibly meant 12 super. feet of 1-in. wood in a newly cut board. In 1757 such a board, computed or otherwise, could be imported into London, all charges paid, for *three shillings and three pence*, which included barely 6d. duty (about 3½d. per ft. superficial), a rate that obtained until 1785, when the duty was advanced to 10d. This, hitherto protective in favour of colonial woods, was then swelled for revenue purposes. By 1803 the same wainscot board under like pressure cost 7s. 4½d. to import, out of which 2s. 11d. went for duty, bringing the price up to nearly 7½d. per ft. In 1814, nearing the end of the long war, the import cost stood at 11s. 4½d., carrying a duty of 6s. 4d. From 1757 to 1814 the board costing 5s. 3d. had increased two hundred and forty-five per cent.

During all the above years there was not a penny duty imposed on wood from our colonies, or, indeed, not until 1821. European oak was thus strangled, and the hardwood trade was largely turned into mahogany, cedar, and American or Canadian oak. This handicap accounts for the solid mahogany doors we see in our old-fashioned houses, and the same wood in church and chapel fittings of our fathers

True, there was a duty drawback on Dutch wainscot and other duty-paying woods was used in *Established* churches, but not a penny in other churches and chapels.

ARCHITECTS AND THE NATIONAL WAR REGISTER.

The Executive and General Purposes Committee of the Architects' War Committee have been considering in what way architects can most effectively promote the objects which the Government seek to obtain by the formation of the National Register.

They strongly recommend all architects, when filling up their registration forms, to insert information under the following heads in answer to the questions asked under Clause 4 (1) (c) of the National Registration Act:—

1. State in what branches of construction you have specialised.
2. Give particulars, as briefly as possible, of the more important works on which you have been engaged as architect or otherwise.
3. Give particulars of any personal experience you may have had:
 - (a) In the organisation of workers;
 - (b) in the control of workers.
4. State what you could do if given an opportunity of rendering professional service to the Government:
 - (a) *Paid Work*.—State whether you could offer your entire services continuously, or, if not, what portions of your time you could offer (days or hours per day).
 - State whether you could go to any locality, or, if not, in what district you could work.
 - State whether you are prepared to go away for short periods.
 - State what scale of payment you would be willing to accept.
 - (b) *Voluntary, unpaid work*. State what portions of your time you could offer and in what district you could work.

Note. (b) is merely a suggestion in case it is desired to offer gratuitous service.

FRESH AIR AND EATING.

The New York Commission on Ventilation has recently made a report on one more phase of the investigation which they have been carrying on with so much thoroughness for the past two years. Their earlier work shows that people can remain in an unventilated room for several hours without there being any direct effect upon the pulse, blood pressure, body temperature, respiration or metabolism, provided the temperature of the room is kept down. Their latest results, however, show that lack of ventilation very decidedly influences us in a way in which most of us certainly do not want it to, namely, in our desire to eat.

In order to carry on this part of the general study the commission divided the number of people on whom the experiments were conducted into five groups, only one group being under investigation at a time. Those in the first three groups were young men and those in the last two, young women. Each group of these scientific aids remained in the room, which is used in all the ventilation experiments, for a period of several hours, five days a week, for several weeks. On half of the days the room was well ventilated. On the other half there was no ventilation. On all occasions the temperature and humidity were controlled so that they were the same throughout the experiment.

After the people had been in the room for a period of from two to three hours each day a luncheon was served to them. How tempting a meal was placed before them the commission fails to report. Neither do they record whether individual idiosyncrasies were favoured, but without doubt the menu was first class. All food was weighed and its value in calories recorded before each meal. What was left over over 50 meals were eaten, one half of them in fresh air and the other half in vitiated air, with the result that on "unventilated days" less food was consumed than on "fresh air days." Furthermore, the records indicated a pushy offer of vitiated air upon the plate increased the longer the experiment continued.

AMERICAN BUILDERS' WEEK AND PANAMA-PACIFIC INTERNATIONAL EXPOSITION.

The American Builders' Week, which is being celebrated in San Francisco during the month of August, is a most interesting and important event in the history of the building industry in this country.

The purpose of this week is to bring together the representatives of the building industry from all over the country, and to give them an opportunity to discuss the progress of the industry and to discuss the various problems which are confronting it. The week is being held in San Francisco, which is the site of the Panama-Pacific International Exposition, and its location is most convenient for the representatives of the industry from all over the country.

No such opportunity has ever before been afforded to the American Builders' Week, of promoting harmony and brotherly love among the members of the industry, and of securing the best results from the interchange of ideas and information.

The assembling of all the representatives of the building industry from all over the country to participate in this week of activities cannot fail to promote a better understanding of the progress of the industry, and to secure a more intimate acquaintance with the technical and business matters which are so vitally important to the success of the industry.

Actively interested as builders are in the upbuilding and development of our cities and towns, these visitors to San Francisco this year will have a unique opportunity of viewing the greatest exposition of exquisitely beautiful exhibits that has ever been held in the City by the Golden Gate. The renowned world over for its progress and hospitality, they will find what is beyond doubt, the most up-to-the-minute modern city in the world.

From a mass of ashes, ruins, and complete desolation which covered over four square miles in April, 1906, a new city has arisen. A new San Francisco, the "Queen of the West," and she stands today as a worthy monument to her local builders, the members of whom are now cordially inviting their brethren and all who build, to come and view the finished work, to share their hospitality, and to contribute by their presence to the joy and success of American Builders' Week.

We learn that a strong general committee embracing representatives from all branches of the building business in San Francisco, with numerous sub-committees, are actively engaged in making the necessary arrangements to insure the success of this great gathering of builders. Invitations to attend are being sent to every Builders' Exchange and similar organisations in the country and to the building press.

It may be mentioned that the San Francisco builders are receiving the good news regarding the Exposition authorities, who are extending a special invitation to builders to attend the Exposition during American Builders' Week.

It may also be stated that the Builders' Week is being celebrated in San Francisco, which is the site of the Panama-Pacific International Exposition, and its location is most convenient for the representatives of the industry from all over the country.

We are pleased to state that the information may be obtained from the Publicity Committee, American Builders' Week, 110, Jackson Street, San Francisco.

News of the building industry in this country is being published in the *Building News*, a weekly journal published by the American Builders' Association, 110, Jackson Street, San Francisco.

The *Building News* is a weekly journal published by the American Builders' Association, 110, Jackson Street, San Francisco. It contains news of the building industry in this country, and is a most interesting and important event in the history of the building industry in this country.

BEAUTIFYING OUR STREETS

By Prof. A. A. STOURHEON.

In the logical development of a town the necessities are first fixtures for lighting, standards for carrying wires and signboards, mail and fire alarm boxes, receptacles for waste, benches, shelters and waiting stations, drinking fountains for man and beast, kiosks for vending and advertising, public conveniences, entrances for sub-surface structures, bridges and elevated structures. All of these utilities must, of course, be treated decoratively so as to be agreeable in form and to harmonise in scale and character with their surroundings. In many cases the original useful purpose is merged in the decorative, and certain of them as fountains, for instance, exist for the latter only. In the next class may be put such conveniences as ramps and steps, retaining walls, bridge approaches and waterside constructions generally, city gateways, park enclosures, towers for beacons or bells, clocks and sundials, bandstands and pavilions, which present an even more natural appeal for artistic treatment. Then there are all the resources of nature, the plantation of mass and surface, the green of the tapis vert with the glow of the parterre, and the sparkle and tinkle of water.

Then come the purely ornamental features, in which art and sentiment join hands to add the highest touch of grace to the street picture, varying in a wide range between the boulder bearing an inscription and the triumphal arch or the many-figured group. Finally, above all, there is the embellishment of the buildings, private or public, which line the streets or occupy open spaces, and make or mar them. This phase of the subject is outside the scope of this paper, but I may say that if buildings are to enter into the decorative scheme of the streets they should at least be visible. It is sad to think how much of the possible effect of fine buildings is never realised on account of our long, narrow streets and the rigid adherence to the rectangular block. For buildings, as for monuments, a short vista gained by cutting off or turning a street or broadening it into a decorative place is necessary. I come from a place which glories in the possession of several fine avenues 122 ft. wide, giving unusual opportunities for architectural effect. One of them is notable as being the longest street in the world. But although running nearly straight for 825 miles, it turns as it crosses another principal avenue, and is faced on the latter by a fine building, which therefore has its full effect. Perhaps I should add in another category those embellishments for which former times give no precedent, which are the most obtrusive and insistent of all, and from which the most enlightened society has so far been unable to protect itself—the advertisements. I will say only that the State which finds a remedy for this outrageous evil, which renders nugatory all beauty in our streets, deserves a reward equal to that of the man who conquers cancer or typhoid.

There are no rules for designing street features except those applying to other works of art. The book of suggestion is wide open in the aspect of foreign cities and towns. When we turn its pages we find an astonishing variety in the choice of motive, in treatment, and in placing. Every problem of treatment and adjustment has its own special conditions and its own best solution by which the object shall be related most agreeably to its purpose and site and surroundings to give it individuality and distinction. To pass about the Grand Boulevards and along the great east-and-west axis of Paris—one of our most common mental promenades—gives a most complete exposition of the subject. We see the monument, the column and obelisk, the architectural setting of sculpture, the group and equestrian statue, the fountain and pool, the triumphal arch and the city gate, the decorative avenue leading up to a monument or building, open places of various sorts, the splendid building enhancing and being enhanced by its surroundings, the careful use of the green of nature, the colour of flowers and the flow of water, the variety of effects of changing angles of view, the terraces and balustrades and ramps and bridges.

Even without a culture and love of beauty for its own sake, and basing our plea on a lower plane, we should accomplish more if we could convince our authorities of the money value of civic art. Just as many foreign products command a high price purely for the element of beauty of design in them, so a beautiful street or square or bridge or building or monument raises the value of real estate in the vicinity, while a city which, as a whole, is organised on attractive lines draws people and business enterprises to itself, has its fame carried far and wide by every chance visitor, and recoups itself directly and indirectly for the outlay many times over. Beauty as an asset convertible into real estate values and tax returns is recognised by most foreign cities not yet sufficiently by ours. As soon as our people realise this they will, of course, hasten to invest in public art.

BRITISH ART AND WAR.

We endorse entirely some very wise cautionary remarks offered by the *Connoisseur*, in its last issue, which should be taken to heart by those who may not have seriously considered the possibilities it refers to, the occurrence of which would be disastrous:

"Taking one thing with another, the artistic position occupied by England at the beginning of the present war is analogous to that held by her at the end of the eighteenth century. Her art commands profound respect abroad as well as at home, and in several departments of it—engraving, domestic architecture, and the production of furniture and ceramic ware—she leads the world. This position has been built up during a hundred years of comparative peace; for though war has occurred, no echoes of the actual fighting have penetrated across the sea to England. Now, as in the great French war, the struggle is raging at our gates; it is straining the resources of the country to the utmost, and personal as well as national economy is urgently demanded. Unfortunately, one of the economies which impose the least self-denial on the majority is the cessation of the purchase of objects of art. But this, far from conserving the resources of the country, tends in the long run only to diminish them. The creation and the conservation of the beautiful together form a vast industry or which both the present and the future commercial success of the nation largely hinges. The artists who create art, and the dealers and collectors who accumulate the treasures of the past, originate the artistic taste which governs the design of textiles, pottery and porcelain, metal-work, and the thousand and one wares which are not merely mechanical productions. Weaken and vitiate this source, and the future of half the industries in the country is jeopardised. Something like this actually occurred during the French war, and art to a great extent became commercialised; its destinies fell from the control of the people who practised and understood it, into the hands of people who were more interested in making it a pecuniary success. One can see this exemplified in the transfer of publishing from the hands of engravers to individuals who had no technical knowledge of the art. The brothers Boydell, the brothers Ward, Green, Smith, and many other of the leading eighteenth-century print-sellers, were all practical engravers. The close of the war saw their businesses either extinct or belonging to laymen. The result was a general decline in the art of engraving. A similar decline may be traced in almost every other branch of art and artistic industry.

The taste of the country, which reached its nadir in the mid-Victorian epoch, has gradually been restored to its former level, with immense benefit to the trade of the country.

Now, unless we are careful, there is every danger of another decline in English taste. The people who have devoted their lives to the pursuit and study of art must receive adequate support, or else, as in the case of their predecessors, their efforts will be brought to a standstill, and, when the war is over, a new generation arise ignorant

of artistic tradition and deficient in artistic knowledge.

In some respects the situation is far more perilous than before, because, though the country was exhausted in the Napoleonic struggle, it was less affected than any other of the great nations. At the present time the wealthiest country in the world is not taking part in the struggle at all, and unless the British public can give support to art dealers, it seems likely that a large portion of the treasures they have accumulated will be transferred to the other side of the Atlantic.

It must be remembered that money spent in British art is not money lost to the country, but remains here to the benefit of the whole nation. Artists and art dealers have more than borne their share in the great struggle, and many have already given their lives for their country, and it is the country's duty and for the country's profit to help those who remain in the task of upholding the cause of English culture."

THE BRITISH FIRE PREVENTION COMMITTEE.

The activities of the British Fire Prevention Committee during the first week of the war have naturally been redoubled, and the ordinary public, which it is only fair to admit has been praiseworthy vigilant, and prompt to suppress outbreaks, is perhaps hardly fully aware of the debt it owes to this voluntary association of willing workers.

Specially, amongst much else, the Committee has devoted itself to:—

1. Fire Survey Force.—At the outbreak of war the Committee formed a special fire survey force of 100 surveyors to undertake at short notice any fire surveys required by the Government in an honorary capacity. Over 900 establishments taken over for war emergency work all over the country were surveyed by this force with a total of over 40,000 beds. Latterly re-surveys are made in cases of special fire risk.

2. Fire Warnings.—The Committee's warning service embraced the preparation and free issue of a large number of public "fire warnings" in connection with the war emergency, disseminated by the Committee in the form of posters, circular letters, or as notices. The special classes of risk under review, for which special notices were issued, embraced hospitals, convalescent homes, refugee hostels, schools, billets, factories, and farms, for each of which a separate form of warning was prepared, whilst air craft hazards were dealt with on general lines. The total issue of posters, etc., exceeds 200,000.

3. Fire Service Force.—The Committee's special fire service force, organised by the Committee at the outbreak of the war, and comprising ex-fire brigade officers and firemen, was originally brought into such a form as to make 500 firemen readily available for mobilisation in sections within forty-eight hours.

The Arabian lamp designed by the German Emperor for the tomb of Saladin, in Damascus, has been handed over by the German Consul with full ceremony. The Kaiser promised the lamp when he visited Syria in 1893.

Two recent acquisitions by the Trustees of the National Gallery are now on exhibition at Trafalgar Square. They are: (1) *Winter at Dordrecht, by Aelbert Cuyp*; (2) *The Mouth of a River*, by Simon de Vlioger. Both were purchased out of the fund bequeathed by Mr. C. E. Mackerell from the Huntingfields Collection.

At Ayr Sheriff Court last week William Galloway, architect, Craigie Cottage, Troon, admitted failing to obscure an indoor light in his dwelling. He was only in temporary residence at Troon, and he pleaded ignorance of the regulations, as he had only recently returned from Africa. A fine of £5 was imposed.

In a paper by Mr. Marcel Gillicaux on "Lining shafts with concrete Z-blocks," read last Saturday before the Mining Institute of Scotland, it was urged that in addition to being cheap, this method saved a temporary lining, and enabled the shaft fittings to be placed in their permanent position as the sinking proceeded. From a technical standpoint, the method gave a perfectly homogeneous lining, and was really essential in all cases where the ground was friable.

Our Illustrations.

WORKMEN'S COTTAGES, BLENHEIM, HATFIELD, AND CLANDON.

These cottages, of which we give plans and views, were designed by Mr. Arnold Mitchell, F.R.I.B.A. Those at Blenheim have been erected both in brick and tile and in stone

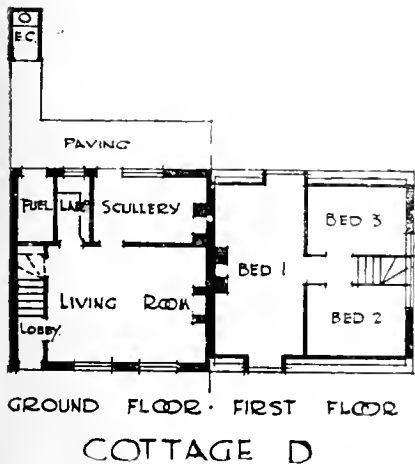
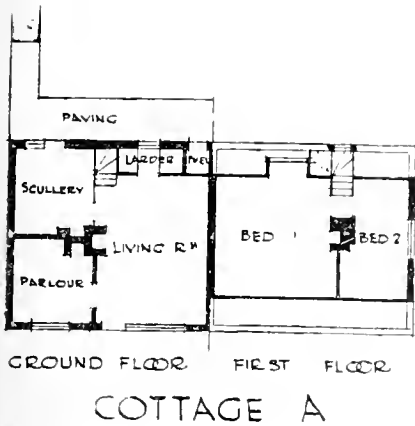

COTTAGES AT HATFIELD, BLENHEIM, AND CLANDON.

Mr. ARNOLD MITCHELL, F.R.I.B.A., Architect.

and tile. In each case the cost was £220 per pair, the water supply, shared between eight cottages, costing about £40 additional. At Hatfield the pair of cottages were erected by a local builder at a total cost of £275, in brick and tile. The standard of accommodation exactly corresponds with that laid down by the Departmental Committee. The brick and tile mansard-roof cottages in Surrey have similar accommodation, and cost £300 the

pair. In concrete, they have been put up at a prime cost of £250.

CITY OF BIRMINGHAM BATHS FOR WOMEN, KENT STREET.

These buildings have been designed by Messrs. Cossins, Peacock, and Bewlay, architects, of Birmingham, with a view to harmonise as far as possible with the original

on all sides of the bath, 6 ft. wide, paved with special ribbed concrete tiles. Dressing rooms are provided along each side of the bath, and at one end with lockers and club room, etc. A spectators' gallery has also been provided over the dressing room, both sides and at each end, with two separate stair-ways leading from the central lobby and main entrance corridor. Nine first-class

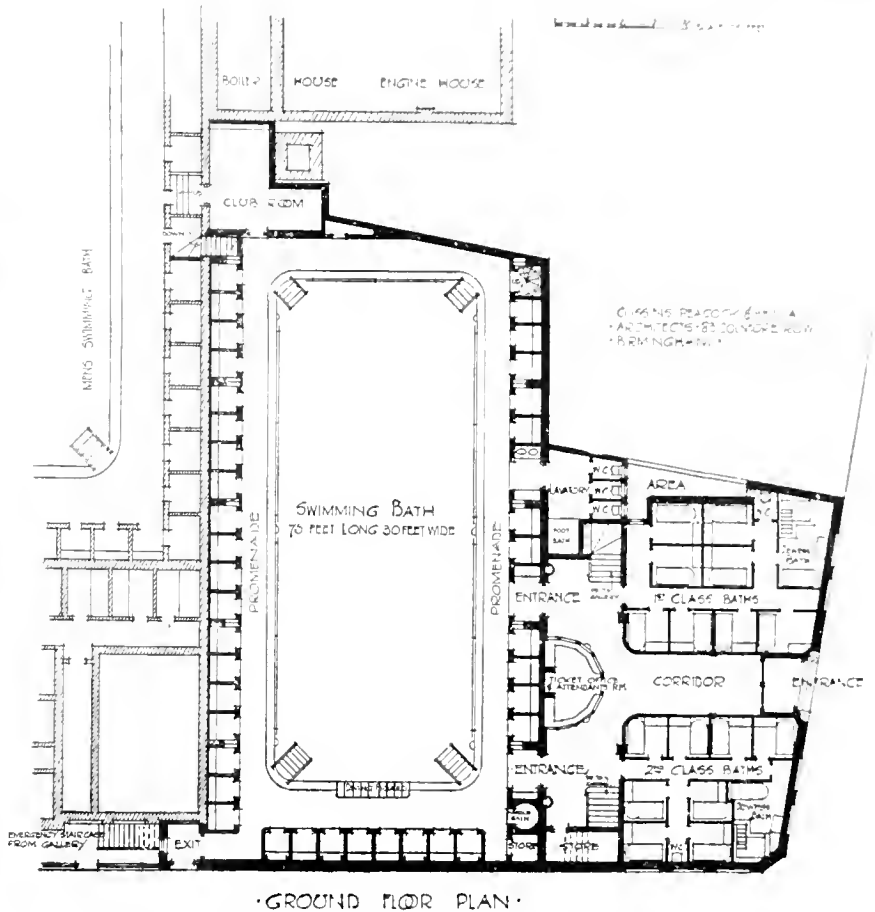

Messrs. COSSINS, PEACOCK, and BEWLAY, Architects.

structure, of which they form an extension. The external walls are faced with Black Country bricks set in white mortar, and the window dressings, cornices, and balustrades, etc., are carried out in Empire stone. The new buildings provide one large swimming bath, 75 ft. in length by 50 ft. in width, the floor of which is constructed with a gradient of 4 ft. 6 ins. at the shallow end and 7 ft. at the deep end. There are promenades

and nine second-class private baths are provided on each side of the main entrance, with ticket office and attendant's room between the two departments. The internal walls throughout are lined with glazed bricks, the scheme of colour being silver grey and white, with green Carrara for all moulded work. The floors of the slipper baths, passages, and the main entrance corridor are laid in terrazzo paving, and the floors of the dressing rooms, etc., of the swimming bath are treated in a similar manner. The walls and bottom of the swimming bath are constructed in concrete, reinforced with steel bars and lined inside with white glazed bricks. The floor of the gallery is also constructed in reinforced concrete and paved with terrazzo paving. We give a plan and elevation, as well as a general photograph of the exterior of the buildings, and also an interior of the swimming bath.

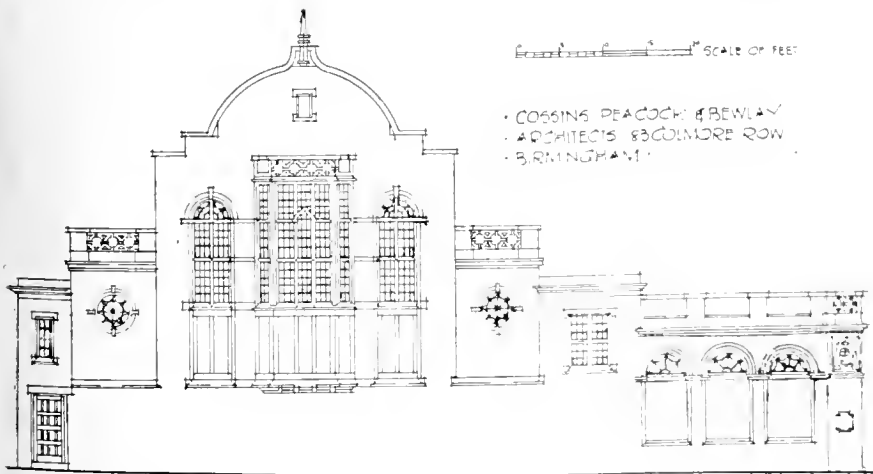

ELEVATION TO KENT STREET
CITY OF BIRMINGHAM BATHS FOR WOMEN.

RESTORATION OF PREMISES, WOOD STREET, STRATFORD-ON-AVON.

This work has recently been executed by Mr. William Hyatt. A preliminary photograph shows the front as it appeared before the work was commenced, with a screen of cement-rendered studding on the same plane as the projecting top story. Between this screen and the original timber front (now exposed) was discovered another front of rough cast (probably dating back to beginning of the nineteenth century), but following the gallery line of the original front. The new shop windows are arranged under positions of the original beams, which adds about 4 ft. 6 in.

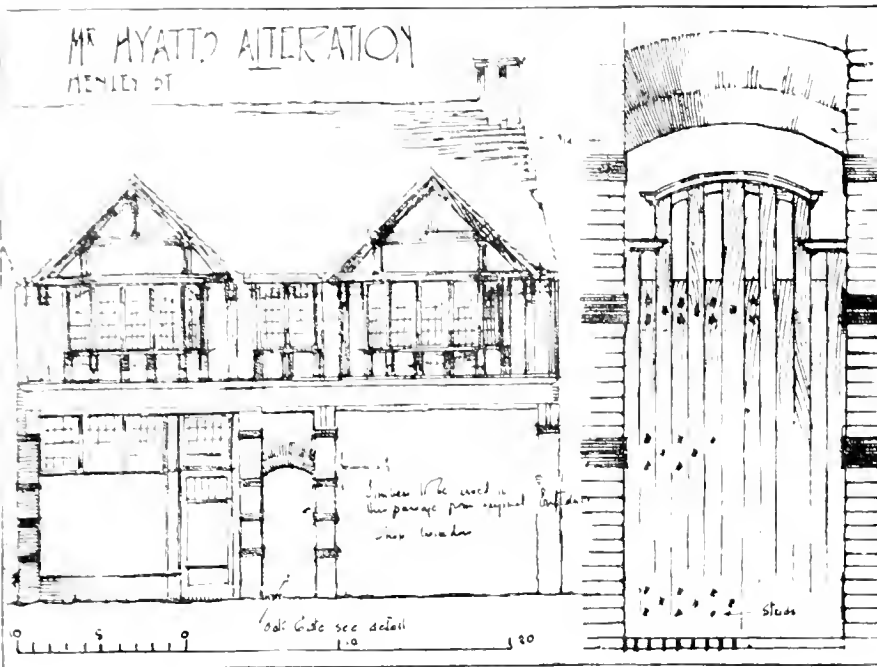

known by the Museum authorities, who, therefore, can afford no account worth repeating here. Mr. Scott Lawson, who made this capital sheet of drawings reproduced today, also says he is unable to supply more information than that afforded by his measured details, which he has been good enough to place at our disposal for illustration in the BUILDING NEWS.

THE BUTCHERS' ROW, YORK.

"The Shambles" at York, also well known as "The Butchers' Row," forms one of the most antique and picturesque parts of the city. Domesday records tell that the Earl of Morton had fourteen mansions (holdings) and two stalls in the Butchery and the Church of St. Crux. The latter stood at the south end of the Shambles, otherwise Butcher's Row. The fabric of this church was only removed for the widening of the Pavement some twenty years ago. Architecturally, however, the building was considered one of the finest churches in the city. A small mission-house has been built near the site of this ancient structure, and in this new building some few remains from St. Crux are preserved, including the tomb and helmet of the Duke of Northumberland, who was beheaded on the Pavement, August, 1572.

GORDON HEMM.

to the width of the pavement. All the windows are new, but are placed as nearly as possible in the original window openings. The timbers, internally as well as externally, have been exposed, and present several fine ceilings, the timbers everywhere being found in an excellent state of preservation and of good scantlings. Very little timber was required for the restoration and replacements, and this, when needed, was provided from premises pulled down at the rear. The roof was stripped of modern tiles laid some years ago, and replaced by old tiles. Messrs. John Harris and Sons, of Stratford-on-Avon, carried out the work, under the supervision of Mr. Francis W. B. Yorke, Licentiate R.I.B.A., 5, New Street, Birmingham, and Stratford-on-Avon. We give a plan and sketch sections, with elevation of the rear frontage in Henley Street, and detail of new timber gate.

WAREHOUSE AND WORKS FOR MESSRS. WEINBERG, CHEETHAM, MANCHESTER.

These works, which are for the manufacture of waterproof clothing, cover an area of about 6,000 sq. yards on the ground floor. The building has a basement under half this extent. The interior of the premises throughout is faced with glazed brick, the ceiling is covered with fibrous plaster slabs, and lighted with patent steel bar glazing. The construction of the roof is on the Warren girder principle and fireproof throughout. The external elevation will be faced with best red pressed brick and stone-faced Raabon terra-cotta. The offices and showrooms on the ground and first floors in the central part of the front of the building will be elaborately treated in marble, wood-block floors, oak woodwork, and patent cement panelling. The lighting is by electricity in every part, and the heating by low-pressure hot water. The works will accommodate about 1,000 workpeople. Mr. Joseph Sun-
ter, of St. Ann's Square, Manchester, is the architect.

OLD FRENCH CABINET IN THE EDINBURGH ART MUSEUM.

The plaster replica of this fine 15th century French oak cabinet, shown in the architectural part of the Victoria and Albert Museum, South Kensington, gives but an indifferent idea of the beauty of the original piece, which is to be seen at Edinburgh. This London copy is misleading inasmuch as it entirely fails to do justice to the delicacy of the workmanship or to the texture of the cabinet work, and the cast, of course, has none of the charm peculiar to the incised black lacquer and floral designs on the three circular panels on the upper part, consequently the effect is lost. Few particulars about the cabinet are given, and nothing is

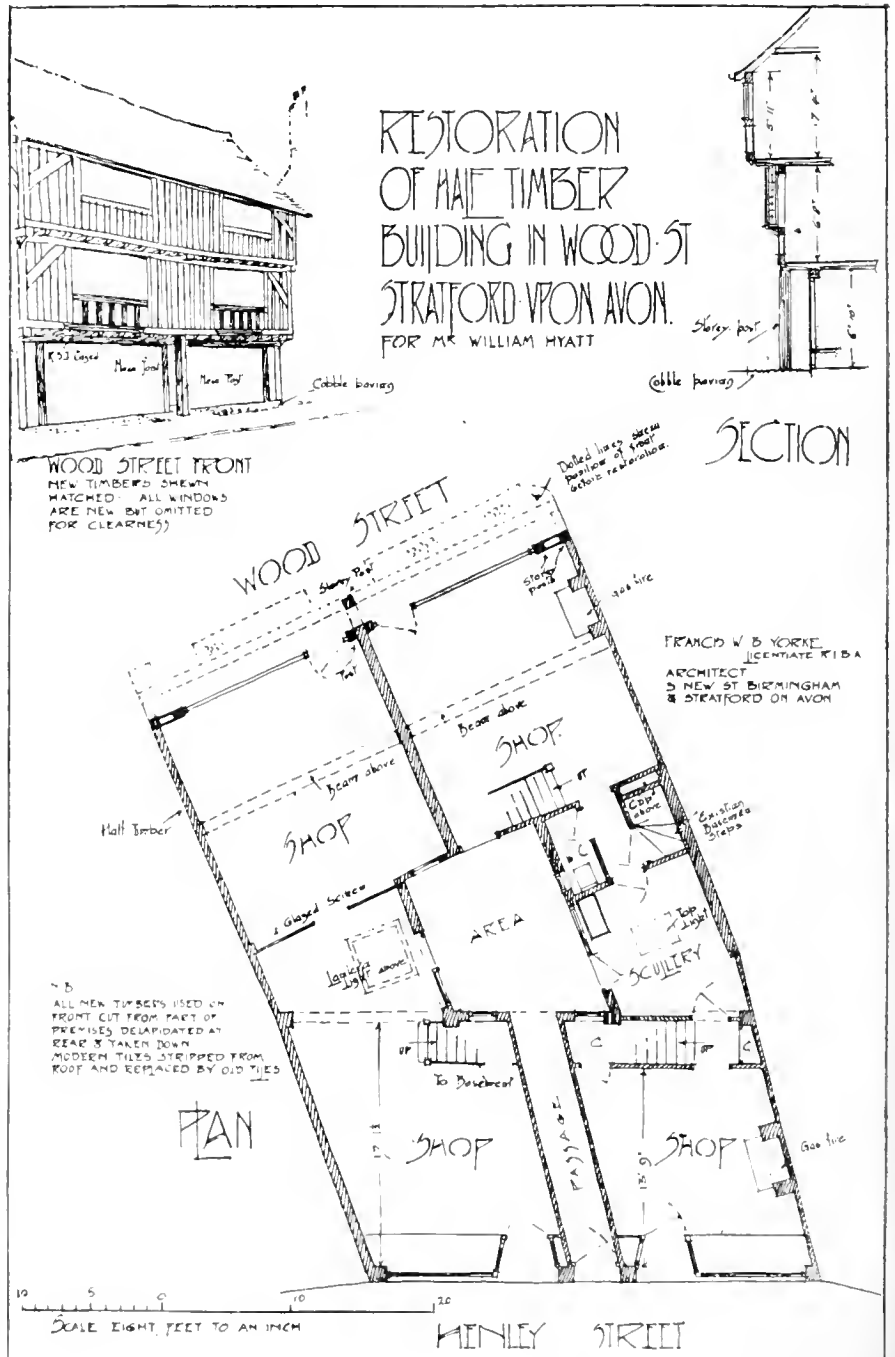



OLD FRENCH CABINET (16TH CENTURY), NOW IN THE EDINBURGH ART MUSEUM.

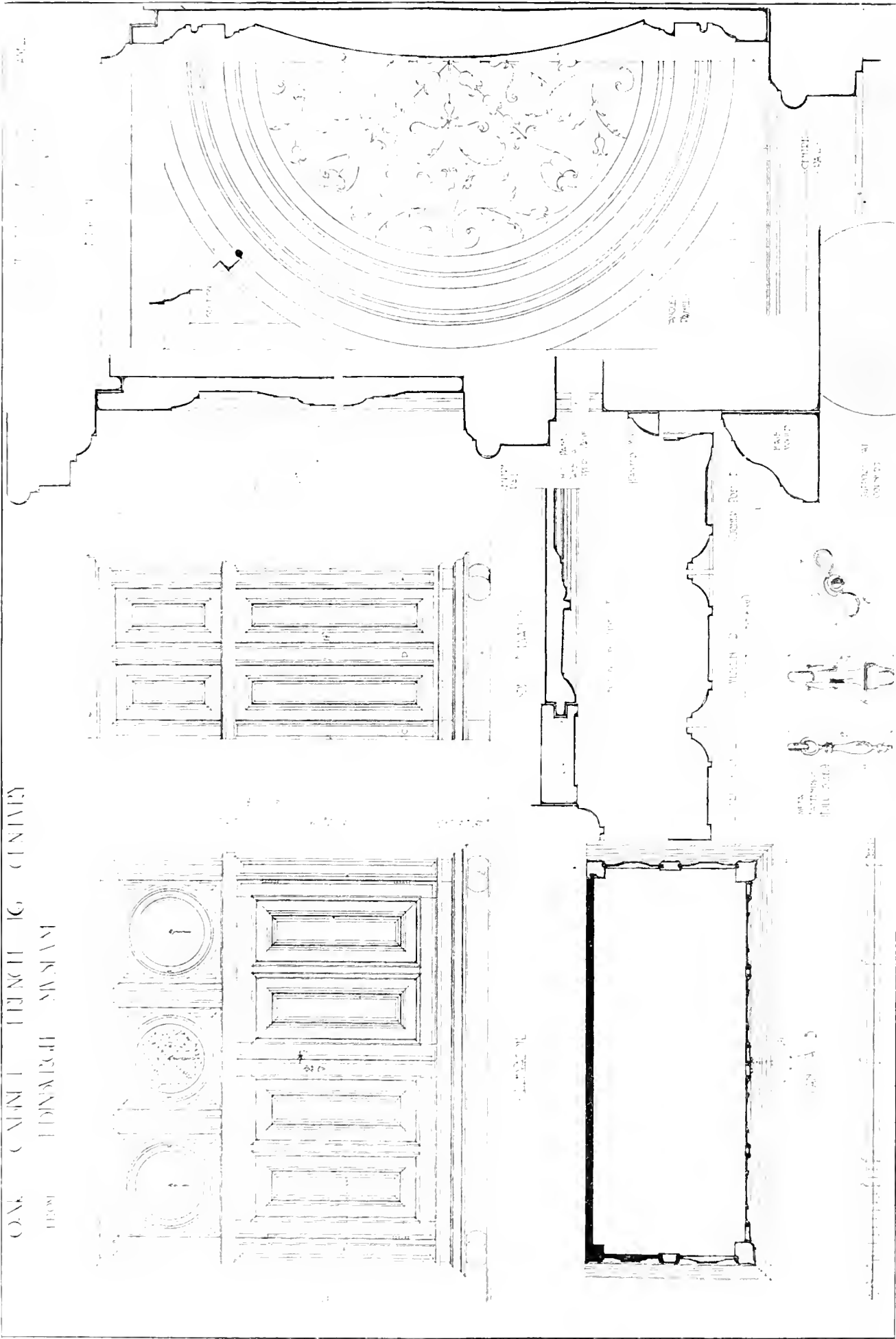

OLD FRENCH CABINET (16TH CENTURY), NOW IN THE EDINBURGH ART MUSEUM.—Measured and Drawn by Mr. SCOTT LAWSON.



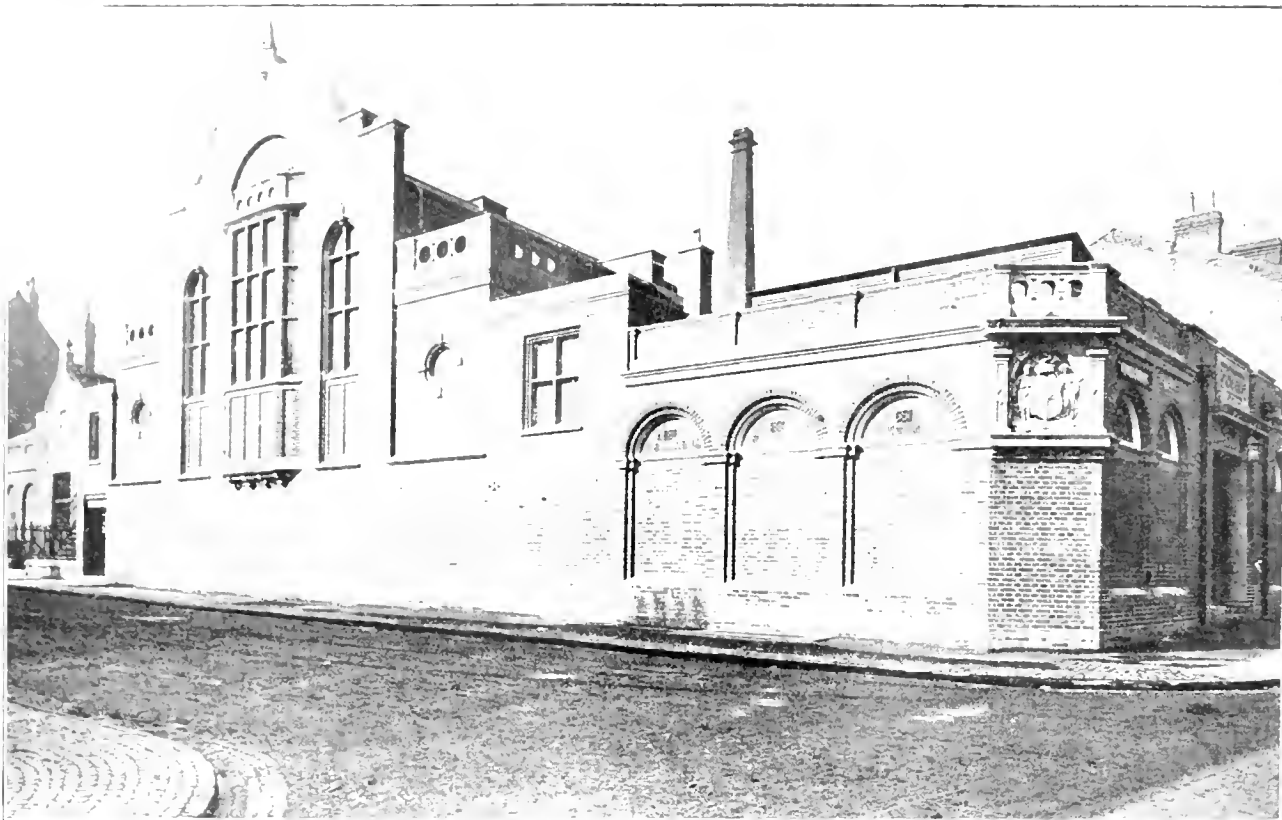
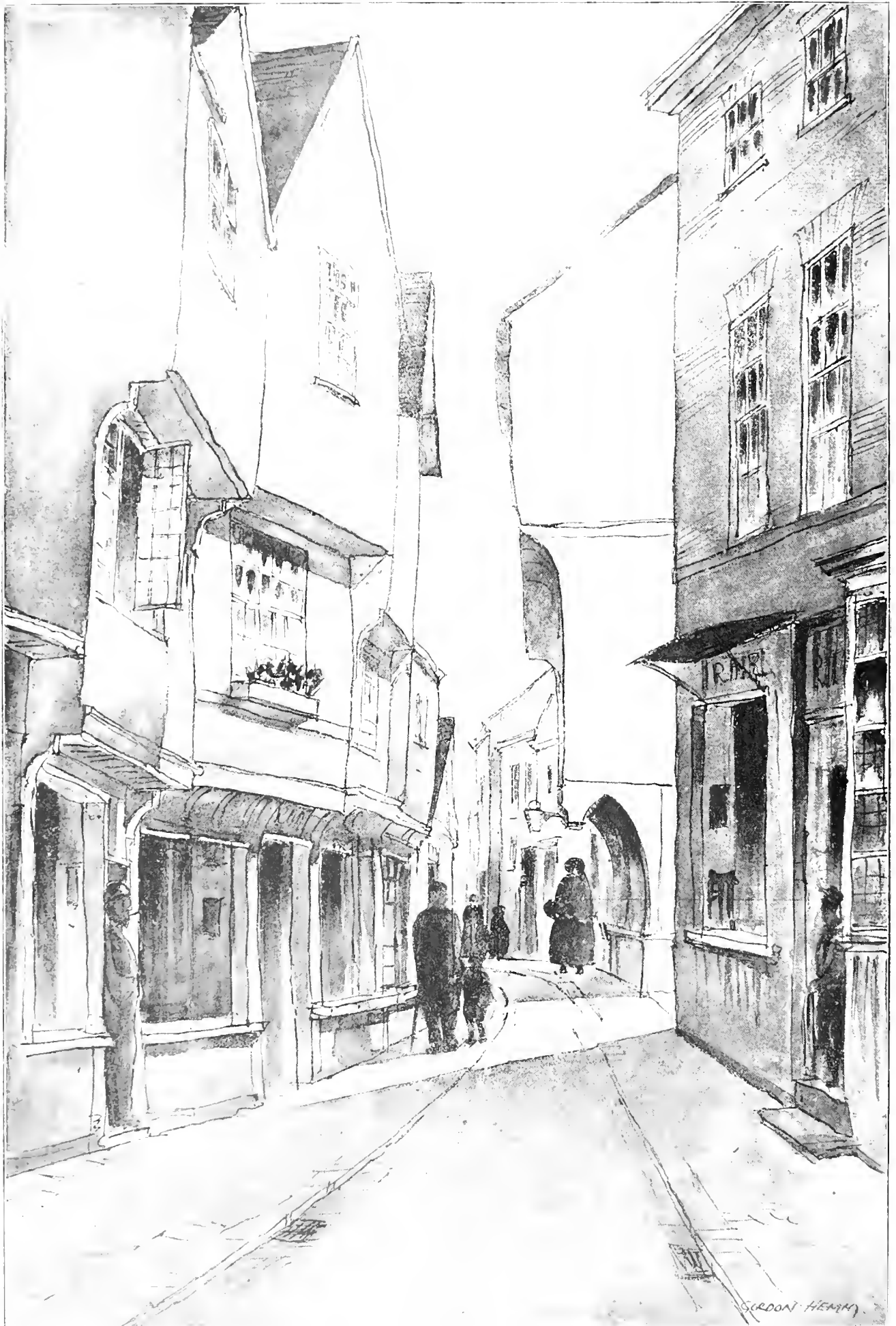

FIG. 10. BATHS FOR WOMEN, KENT STREET, BIRMINGHAM.
Messrs. C. W. P. PROCK and BIRLEY, Architects.





THE BUTCHERS ROW, YORK.—Sketched by Mr. GORDON HEMM.



WORKMEN'S COTTAGES. WETHEIM, HATHFIELD, AND CLAYTON.
MR. A. J. M. F.R.I.B.A., ARCHT.

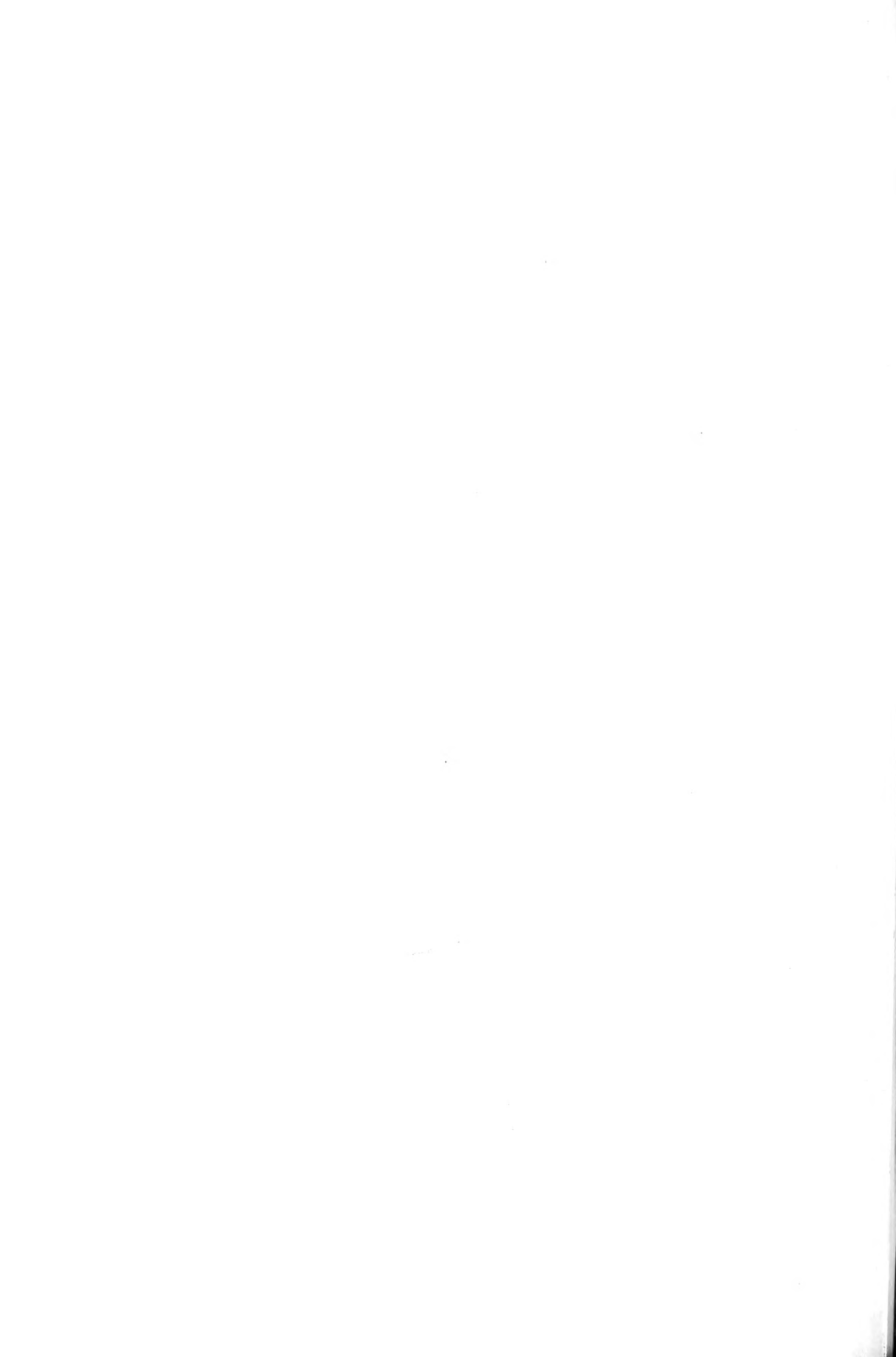

·PREMISES WOOD ST.
·STRATFORD-ON-AVON·
·BEFORE AND AFTER RESTORATION·
FRANCIS W. BYORKE ARCHITECT

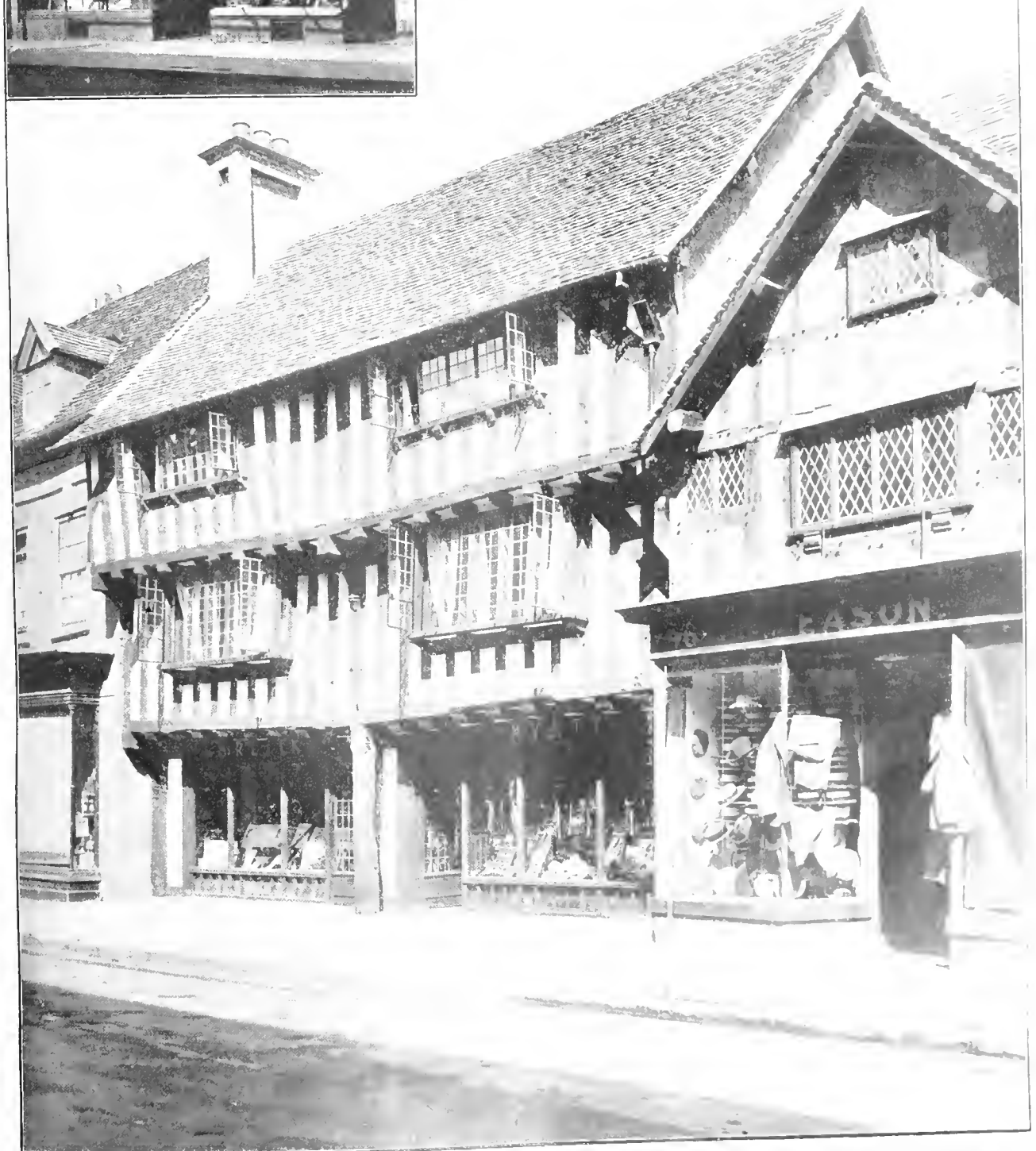



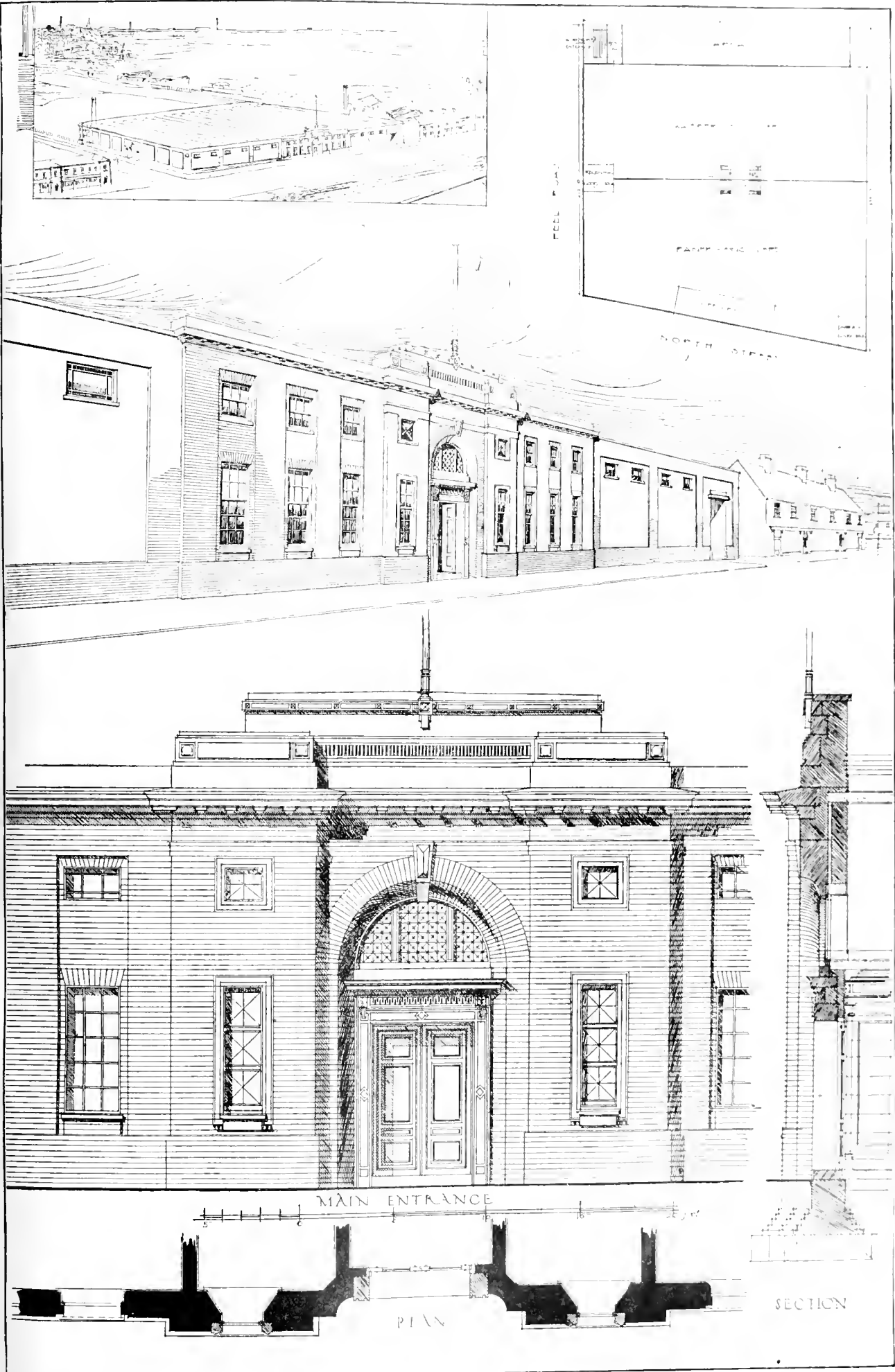

WAREHOUSE AND WORKS, CHEETHAM, MANCHESTER, FOR MESSRS. WEINBERG.
Mr. JOSEPH SUNLIGHT, Architect.





THE BUILDING NEWS, AUGUST 11, 1915.



J.A. SWAN



WOMEN'S COLLEGE, BLENHEIM HAVELDE, AND CLAXTON, W. VA. M. C. I. 1911



COMPETITIONS.

LEICESTER.—Mr. George H. Widdows, F.R.I.B.A. the assessor employed by the Education Committee of the Leicester Corporation, has made his award as follows from the twenty-three sets of designs submitted by local architects for the Wyggeston Boys' School, which will be erected on land fronted by Regent and Victoria Roads, Leicester: First prize, Mr. Howard H. Thomson; second prize, Messrs. G. Lawton Brown and Percy C. Jones; and third prize, Messrs. Stockdale Harrison and Sons. The Secondary Schools' Sub-committee have recommended that Mr. Howard Thomson be instructed to proceed with the preparation of detailed plans and drawings with a view to carrying out his design with certain modifications suggested by the assessor.

MILFORD, CONN.—A recent competition for a school architect for the proposed building has resulted in the selection of Messrs. Tracy and Swartwout, 244, Fifth Avenue, New York City. The *American Architect* has the result as a splendid vindication both of the fairness and the practicality of the Institution's rulings. The award committee seem to have been blundering in their justice—more from want of the right to want of heart, as usual—when the Connecticut Chapter of the Institute stepped in. Six architects had been invited, all Institute men. The first obstacle to the competition was encountered when it was discovered that the building committee had no power delegated to it by reason of which it could not enter into a contract with the winning architect for the preparation of plans for the building, or the supervision of the erection of the proposed building. The Committee on Competitions of the Institute thereupon announced that it would be obliged to withhold its approval of the proposed competition. The local committee at this juncture gave unmistakable indications of impatience at the delay, and all hope of conducting a proper competition seemed to be lost. Renewed activity on the part of the Connecticut Chapter, however, resulted in the delegation of the necessary powers to the committee before unfavourable action had been taken by it. A second obstacle arose in the discovery that no actual appropriation had been made to complete even a part of the proposed building, and a hurried conference was called at which were present the chairman of the Institute Committee, the chairman of the Local Committee, and the president of the Connecticut Chapter. Being finally assured of the entire good faith of the local committee and that the omission amounted to merely an error of form, the first step was at length obtained, and the competition held with the result as announced.

PLYMOUTH.—The date for sending in designs for the proposed new premises for the Plymouth Mutual Co-operative and Industrial Society is September 14, not December 14, as mentioned in our list of Competitions Open during the past three weeks by a clerical error. Intending competitors who have applied for and received the Conditions have no objection to this.

PRIZE FOR A "HALL MARK" DESIGN.—At a convention held early in June in Toronto, the Canadian Manufacturers' Association gave much attention to the made-in-Canada movement which received the hearty approval of the convention, and it was decided to have a design embodying the phrase "Made in Canada" copyrighted, with the right reserved to a committee of broad representation composed of men, with authority granted permission to use the design as a prize for the most appropriate design according to reports from Commissioner Julius B. Deane of Toronto.

Intercommunication.

REPLIES.

1314.—CONCRETE BRIDGE.—There is no simple formula for calculating the strength of the bridge shown in the sketch given on p. 125 to carry a steam roller. "Bombard" should employ an engineer for the job, as reinforced concrete works require to be very carefully calculated. For instance, the loads on each wheel and on the roller must be known, also the tread of the wheels and the roller, the gauge of the wheels, and the wheel base; the sizes of the beams must be assumed in proportion to the span to arrive at the weight of the bridge. The bending moments and shearing forces for different positions of the steam roller will have to be found, allowances will have to be made for shock on and deflection of the beams; their moments of inertia must be calculated, and the stresses in compression and tension found. The quality of the concrete will have to be considered, and considerable steel in a diagonal direction will be required in the beams to take the shear.

The quiet and others in need of similar information may advantageously consult a very valuable series of "Notes and Data," which was specially prepared for and given in "The Architects' Compendium and the Contractors' Compendium" for 1914 and 1915, published by the Compendium Publishing Company, 214-220, Bank Chambers, 329, High Holborn, W.C., and from which the correspondent whose reply appeared on page 51 of our issue of July 21 took his information without a word of acknowledgment. It is due to ourselves—but much more to the Compendium Publishing Company—to mention this, and to apologise for our own involuntary cooperation in this unwarrantable appropriation. We may add that of all the similar notes on the subject we are familiar with this series is in many respects likely to be of the most service to the architect and engineer in need of the information furnished therein.

TRADE NOTES.

The borough engineer of Plymouth has reported that on the flats over dressing-rooms at Plymouth Hoe swimming baths he adopted the powder Pullo, and is very pleased with the results.

Under the direction of Mr. F. W. Parson, architect, High West Street, Gateshead-on-Tyne, Boyl's latest patent "Air-Pump" ventilator has been applied to Gateshead secondary school.

The extensive cabinet-making works of Messrs. Waring and Gillow at Liverpool were destroyed by fire early last Sunday morning.

Instead of renewing the wood paving in Holland Road, Kensington, on a new foundation, an experimental weight distributing road crust is to be laid down.

Two stained-glass windows are shortly to be placed in St. Nicholas's Church, Wallasey, in memory of the late Mr. Fred J. Harrison, the patron and benefactor of the church.

To perpetuate the memory of Colonel Sir William Carrington, late Comptroller of the King's Household, facilities have been granted for the erection of memorials in the ancient Parish Church at Moulsoe, Buckinghamshire, the burial place of the family.

The Germans are erecting a monument in Gotha showing a Taube monoplane on a pedestal of red marble 6 ft. high. In front is seen a German soldier in fighting attitude, and the two sides of the pillar show Paris and Dover where Taubes have operated.

The *New York Herald* says that Mr. Rockefeller has purchased for £18,750 the Linton Aphrodite. This statue, which is attributed to Praxiteles, was the subject of much controversy in 1890, when the Metropolitan Museum experts rejected it on the ground that it was not an antique work at all.

At the meeting of the Metropolitan Asylums Board last Saturday a recommendation to the effect that the offices of the Board should be insured against damage caused by aircraft was rejected, as also was an amendment seeking to extend the insurance to the whole of the Board's property, the value of which was stated to be about £3,250,000. The premium required was £3,000.

Since the outbreak of the war the Star and Garter Hotel, the famous hostelry on Richmond Hill, has been used as a barracks for the Army Service Corps. It is now about to be fitted up as a hospital for disabled soldiers. The pile of buildings, which form a landmark for many miles up the river, is being purchased, it is believed, by the auctioneers and house agents of this country with a view to handing them over to the Queen ready for the purpose indicated.

TO CORRESPONDENTS.

We do not hold ourselves responsible for the opinions of our correspondents. All communications should be drawn up as briefly as possible, as there are many claimants upon the space allotted to correspondents.

It is particularly requested that all drawings and all communications respecting illustrations or literary matter, books for review, etc., should be addressed to the Editor of the BUILDING NEWS, Effingham House, 1, Arundel Street, Strand, W.C., and not to members of the staff by name. Delay is not infrequently otherwise caused. All drawings and other communications are sent at contributors' risks, and the Editor will not undertake to pay for, or be liable for, unsought contributions.

**Drawings of selected competition designs, important public and private buildings, details of old and new work, and good sketches are always welcome, and for such charge is made for insertion. Of more commonplace subjects, small churches, chapels, houses, etc.—we have usually far more sent than we can insert, but are glad to do so when space permits, on mutually advantageous terms, which may be ascertained on application.

When favouring us with drawings or photographs, architects are asked kindly to state how long the building has been erected. It does neither them nor us much good to illustrate buildings which have been some time executed, except under special circumstances.

Telephone: Gerrard 1291.

Telegrams: "Timeserver, Estrand, London."

NOTICE.

Bound copies of Vol. CVII. are now ready, and should be ordered early (price 12s. each, by post 12s. 6d.), as only a limited number are done up. A few bound volumes of Vols. XXXIX., XLI., XLVI., XLIX., LIII., LXI., LXII., LXIV., LXV., LXVI., LXVII., LXVIII., LXIX., LXXI., LXXII., LXXIII., LXXIV., LXXV., LXXVI., LXXVII., LXXIX., LXXX., LXXXI., LXXXII., LXXXIII., LXXXIV., LXXXV., LXXXVI., LXXXVII., LXXXVIII., LXXXIX., XC., XCI., XCII., XCIII., XCIV., XCV., XCVI., XCVII., XCVIII., XCIX., C., CI., CII., CIII., CIV., CV., CVI., and CVII. may still be obtained at the same price; all the other bound volumes are out of print. Most of the back numbers of former volumes are, however, to be had singly. Subscribers requiring any back numbers to complete volume just ended should order at once, as many of them soon run out of print.

Handsome Cloth Cases for binding the BUILDING NEWS, price 2s., post free 2s. 4d., can be obtained from any Newsagent, or from the Publisher, Effingham House, 1, Arundel-street, Strand, W.C.

TERMS OF SUBSCRIPTION.

One Pound per annum (post free) to any part of the United Kingdom; for the United States, £1 6s. 0d. (or 6dols. 30c. gold). To France or Belgium, £1 6s. 0d. (or 3fr. 30c.). To India, £1 6s. 0d. To any of the Australian Colonies or New Zealand, to the Cape, the West Indies, or Natal, £1 6s. 0d.

**Our Direct Subscription Agents for Australia are Messrs. E. T. Kibblewhite and Co., Printers and Publishers, 19, York Chambers, 105, Liverpool Street, Sydney, New South Wales; for Japan, The Maruzen Co., Ltd., 11-16, Nishibashi Tori Sancho, Tokyo; who will receive Subscriptions at £1 6s. 0d. per annum on our account. Copies of the paper will be sent by us direct to the subscribers' address.

**The special rate to Canada is £1 3s. 10d. = 5dols. 90c. for 12 months, and 11s. 11d. = 2dols. 90c. six months. Our Direct Subscription Agents for Canada are Messrs. Sells, Ltd., 302, Shaughnessy Buildings, McGill Street, Montreal, who will receive Subscriptions, £1 3s. 10d. per annum, on our account.

Cheques and Post-office Orders to be made payable to THE STRAND NEWS PAPER COMPANY, LIMITED, and crossed London County and Westminster Bank.

RECEIVED.—S. M. and S., Ltd.—H. E. W.—R. B. and Sons—K. E. C.—C. J. and Co.—C. A. A., Ltd.—W. C. Co., Ltd.—T. and J.—V. de T. A. Co., Ltd.—W. H. S. and Son—W. and S.—R. L. C. and Co., Ltd.—L. H.—R. P. C. Co., Ltd.—C. C. D. and Co.—W. H. S.—G. G. S.—F. F. Co.—H. C. and Co.—D. and Co., Ltd.—R. C. and C. Co., Ltd.

REX.—Yes.

T. R. J.—Thanks, please send.

FEFER.—We believe it still exists.

DISPUTE.—The extra seems to us a reasonable one. 2/6.

DILATIONS.—We incline to think the decision of the House of Lords on which we commented last week relieves you of any such obligation.

POST FILE TO YOUR DOOR.—The interruption of regular and punctual transit and unavoidable shortage of labour in the distributive facilities of the news trade is causing much disappointment to readers of our own and similar journals. Wherever this is so and difficulty is experienced in obtaining THE BUILDING NEWS punctually on Wednesday morning, we will send a copy POST FREE direct to any reader's address on receipt of 1s. 4d., the amount of the quarterly subscription. Readers away on holiday, or in camp, can also have single copies sent them POST FREE to any address on receipt of four penny stamps.

THE BUILDING NEWS

AND ENGINEERING JOURNAL.

Effingham House.

CONTENTS.

Strand, W.C.

Various Systems of Factory Building ..	163
Hydrated Lime and Ordinary Lime ..	17
Occidental Architecture in Japan ..	17
Length of Portland Cement Kilns ..	17
The Longest Raek-Railroad in the World ..	17
Japanese Oak ..	173
Economy in Sanitation Depreciated ..	17
Correspondence ..	16
Professional and Trade Societies ..	173
Corrente Calamo ..	17
Our Illustrations ..	17
Obituary ..	173

...m. Office ..	17
Building Intercourse ..	17
Competitions ..	17
Water Supply ..	17
Trade Notes ..	17
To Arms ..	17
Latest Prices ..	17
Tenders ..	17
List of Tenders ..	17

Advt. A ..	17
Advt. B ..	17
Advt. C ..	17
Advt. D ..	17
Advt. E ..	17
Advt. F ..	17
Advt. G ..	17
Advt. H ..	17
Advt. I ..	17
Advt. J ..	17
Advt. K ..	17
Advt. L ..	17
Advt. M ..	17
Advt. N ..	17
Advt. O ..	17
Advt. P ..	17
Advt. Q ..	17
Advt. R ..	17
Advt. S ..	17
Advt. T ..	17
Advt. U ..	17
Advt. V ..	17
Advt. W ..	17
Advt. X ..	17
Advt. Y ..	17
Advt. Z ..	17

OUR ILLUSTRATIONS

Church of St. Barnabas, North Finchley, Vicar of St. Barnabas, North Finchley, and plan, Mr. J. S. M. W. H. Wood, F.R.I.B.A.

VARIOUS SYSTEMS OF FACTORY BUILDING.

The architect about to plan a factory or works needs to give particular heed to instructions; for the whole building and occupants when complete constitute in truth a kind of machine, whereof the workers are the motile organs and the structure the framing wherein motion takes place. He should either very carefully study the particular methods of work or manufacture, or listen very attentively to the instructions of his clients. In work of this nature the planner is naturally very much under direct dictation by men having the special business "at their finger tips." Rightly, workers are under careful protection of the State, and, consequently, special Acts greatly affect planning. The

principles of economical beam construction. In Fig. 1, to divide the span A into two parts, as B, will make a very considerable difference in the cost of steelwork, in the case of heavily loaded floors. As a rule, in factory planning, with multiple floors to carry heavy loads, increase of total support area, within reason, reduces costs, since large spans involve great increase of weight of metal in girders. Moreover, we should, if engaged on work immediately to be carried out, remember the trying times in which we now live. The building trade is depressed, business firms are, especially where engaged with constructional steelwork, operating under great difficulties, in part owing to the enormous demand for steel for war purposes. Plainly, we cannot bridge a great void with any kind of chance girder, but we may, where spans are moderate, and well within the outside size of stock rolled joists, find it possible to get some quite suitable section other than that we might in preference select. Thus, by a judicious reduction of span, considerably economising in first cost of the building, we not only save engineers' work at a time of extreme stress and pressure, but may get delivery of sections where others may be practically unobtainable. The designer of a building requiring much steel must at the present time keep quite an open mind as to the sections he will use. Bearing, too, on this question, is the matter of type of support, for while cast columns need patterns, since we can seldom hope to find anything of this nature suitable in stock, stanchion construction permits of cutting from stock lengths; and here, again, we may, in what is practically a famine time for steelwork, find, if not exactly the section preferred, something that will well answer the purpose. In architects' work at the present time the brightest field is perhaps factory and works construction and addition, so that it may be useful to point out how a little revision of details of proposed construction may facilitate progress with the work.

The choice of general type of building construction rests between ordinary mixed brick and steel, Fig. 1, and B, Fig. 3, genuine steel-framed construction, Fig. 3, A, with more or less reinforced concrete and genuine *in loco* ferro-concrete. A time like the present, with an extraordinary demand for steel and virtual congestion in every engineer's shop and shortage of skilled mechanics, should favour a system like ferro-concrete, employing little steel and that with little or no skilled labour. In weighing these matters the type of building must be considered. As a rule, concrete construction is not suitable for buildings of one story, such as engineering shops, like Fig. 4, and munitions factories. When works are of the heavy ground-floor type, such as

for the industries mentioned, or for motor-car factories, and when steel is cheap and plentiful, first cost is studied by building brick walls and providing steel roof trusses. The advantage of reinforced concrete construction is only apparent in buildings of several stories. The cheapest and most quickly erected method of factory structure is that of light steel sections for vertical posts, light steel roofs and enclosure of sheet galvanised iron, such as has been often used for power houses and for miscellaneous industries, and this type is suitable where there is some urgency but not great enough to demand temporary wood framing. Various fireproof substitutes have of late years been produced as substitutes for galvanised iron which, under the best conditions, is very short-lived. Steel joists for posts spaced in by each

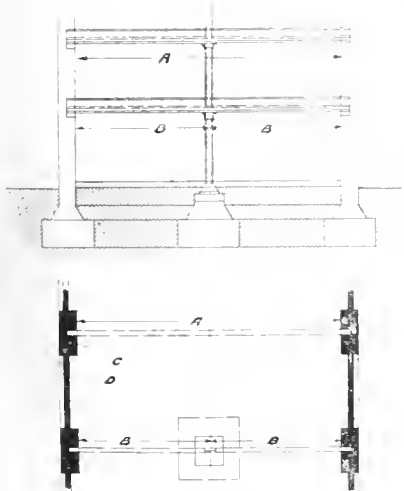

FIG. 1.

whole proposition in factory planning is commercial; generally the greatest floor area for the least money. It is not so much what will look well, architecturally, but what will work well, facilitating maximum production at least cost, after duly satisfying all demands of central and local authorities and by-laws.

The factory planning which is demanded of the architect is a maximum of works accommodation for money outlaid; the greatest area for practical work with the least obstruction; but the cutting down of total area of supports is not always in harmony with economy in first cost. Large spans add to expense of construction. To economise we need moderate spans and more supports, so that although the general demand is for as much unobstructed floor space as possible, unless it is considered worth while to secure floor-area free from obstructing pillars, the centre supports must be provided in harmony with basic

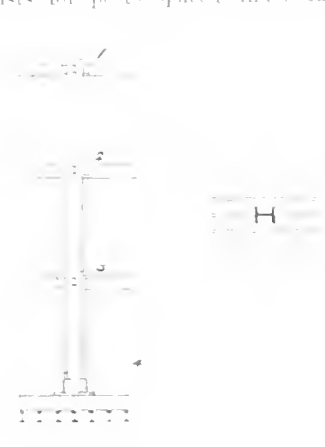

FIG. 2.

roof truss, with joists of some width lighted, and with suitable fireproofing and walling enclosure. For the cost and cheapest method where despatch of construction is important.

Taking the ordinary substituted system of brick walled factory and works construction, this may be either of the steel skeleton or of the brick wall type, where the girders can be made wide, as in Fig. 1. In this latter case, as a proposition of the present time, Fig. 1, the girders should be of some suitable kind of section, and not wholly between wide wall plates. Where not here, it will be less than 12 in. wide work, which is the best for the purpose, cut down section work, and not 12 in. between weight supporting posts, Fig. 2. For ordinary construction of two or three floors, with no iron end girders, and Fig. 2, i.e. the extra stanchions for brick walls; but for factories, piling up story upon story, nothing is more suitable than

work in steel framing, Fig. 3, A, a system of building that gives a "tie," not present in the case of mixed construction. And it cannot be said that ferro-concrete is so suitable for very many stories, if there are many joists, for the deduction from floor areas at the lower stories becomes a serious matter. It is not yet shown that ferro-concrete is a nostrum—a remedy for all shortcomings in older building construction methods. The truth seems to be that for ferro-concrete the work requires to be suitable. For certain special constructions, as for certain moderate-sized factories, where no doubt nothing is more satisfactory; and it seems certain that a plain shell of reinforced concrete may be put up in the neighbourhood of 40 lb. per cubic foot, even lower figures having been suggested. What the immediate future of *en bloc* ferro-concrete for works, factories, and warehouses may be is not easy to forecast. It is said that an innovation, apparently superseding all types, actually does so; but it takes its fitting place, competitive and older methods surviving. Neither the ancient bricks-and-mortar method, nor the modern steel structure, has been yet swept away. Rushed-up jobs and factories are often required in a fever of haste, and for such ferro-concrete is not suitable, for its ultimate strength is a matter of time, whereas we may load up girders and steel joists as soon as they are bolted in position and all ready below for taking up the load. There is always this obvious benefit in pure steel construction. Again, it should in fairness be noted that to compare the area required by a reinforced concrete pillar with a rolled steel stanchion of, say, H section, the area taken up by this latter is not the net metal or its cross-section in square inches, but the rectangle of its flange by web and flange depth. Viewing matters in this light, the solid steel column is the greatest saver of valuable floor area.

For the attachment of brackets carrying power shafting, undoubted advantages and great convenience attend genuine steel-frame building. Where the factory is heavily equipped with machines, and new ones frequently added the girders and stanchions may be anywhere drilled for new brackets. In the immediate future there would appear opportunity for all varieties of factory construction. Although we may not adopt ferro-concrete *en bloc*, yet the roofs, bresssummers, stairs, and landings are often most suitably made of concrete, reinforced, and the success of the system of reinforcing has stimulated ingenuity in detail, and a stratum of steel netting, or a few steel rods, is now good practice where not long since we should have put an array of relatively heavy steel joisting. For fire-resisting warehouse and factory construction, simple steel reinforced concrete is highly suitable.

In London, the substantial factory building is an affair of brick-and-mortar exteriors and steel interiors, steel structure preferably being used as isolated points of support. In this class of work economy results from careful repetition, planning in equal bays, and equal spans, the work of construction required in the shops, and the work of the erection on the job being thereby considerably simplified; again, as tending to reduce the first cost of factory building, by using as many equal-sized equal-section, similarly connected stanchions and joists as possible, thus securing expeditious machining and drilling on the erection. Further, in the matter of stanchion design, the use of a single section, such as a 10 in. by 6 in. R. S. J., consistently from the upper floor downwards, with extra riveted plates to

give increased power as the load increases in the lower floors, as in Fig. 2, simplifies design and tends to keep down costs. At the present time, it may be that this practice, which has often been carried from basement through many stories, may not be so conveniently practical as some diversity in sizes and sections. We had best take what we can get. Timber is dear, and steel-construction is hindered by the war. Those having immediate concern with works and factory buildings might

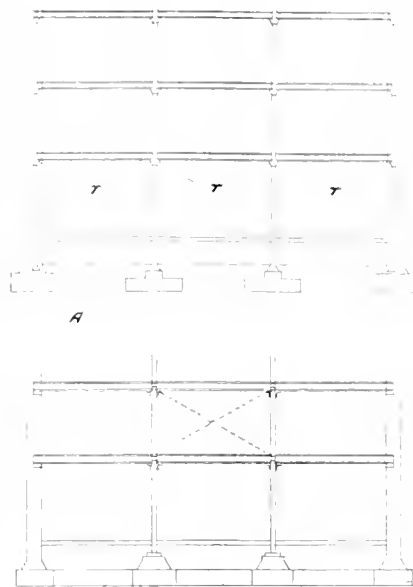

FIG. 3.

do worse than first carefully ascertain how the war has affected steel constructional engineering, and find how, before designing and calculating, what are the most available sections.

The work of the designer of factory or warehouse for heavy loads, to be constructed with all regard to first cost, whether in concrete, steel, or of ordinary building construction, commences, or early necessitates, calculations for stresses and loads. The simplest procedure is to start

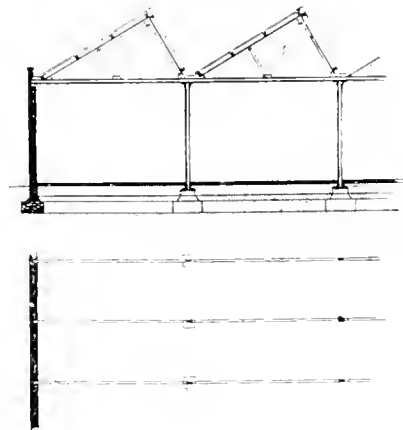

FIG. 4.

from the roof and work downwards, bringing out the net weight of superimposed mass at the several points of support, as 1, 2, 3 in Fig. 2, at each floor level, finding the ultimate stress on the lowest stanchions (at 4), piers or columns, and so the pressure upon foundations at 5. In genuine steel framing tied throughout and having all independent of brick and stone walling, the total load is the sum of that upon each lowermost stanchion, and for calculations such construction is the simplest. The whole load is the construction itself plus the legally imposed, or the "superimposed" load—as so many cwt

per super. foot—all as detailed in the Building Acts, where is allotted a certain ratio of slenderness for steel stanchions. Economy is promoted by getting evenly-distributed loads upon stanchions and pillars. Very considerably more metal is required in steel props, not having balanced loading, or, in other words, not having equal stresses all round the axis of the prop. Not many architects trouble themselves with the details of steelwork in these days of close specialisation; but there accrues a certain advantage in making a careful estimate of loads and stresses whilst plans are *in embryo*; for, if such plans be made finished drawings, the sizes of girders, joists, and stanchions or pillars will be correctly drawn from the first, and in the despatch and urgency with which such buildings will be erected, the draughtsman's work will be facilitated.

The weight calculations when brought to ground level give the load on brick piers or on stanchion base-plates (4, Fig. 2) and knowing, or assuming, the nature of the soil and its power to sustain weight, the area of concrete or grillage foundations (as Fig. 2) can be determined. Unless, therefore, we start away and determine all stresses from the time when the plans are settled and right for completion, we cannot do more than hazard suitable foundation design. In genuine steel-framed buildings a special importance attaches to stanchion foundations. The whole stability of such structures is based on unyielding points of support. If any point sinks, a series of eccentric stressing occurs which may be disastrous. The whole theory of homogeneous steel building construction is based on efficient "tie." We, and our forefathers, have so long in ordinary building construction completely ignored this that we may be apt to miss its importance where a great array of joists and stanchions is concerned.

If we have drawn out a works plan with sections, showing all accessory features, and have decided the thickness of walls in accordance with by-laws, the work of making these calculations may be commenced, and this needs reference to the controlling building Acts. The correct time for making these calculations is when the general plans are wholly approved by the client.

HYDRATED LIME AND ORDINARY LIME.

By E. W. LAZELL, Ph.D.*

Everyone is familiar with the fact that when quicklime is treated with water a violent action takes place, the lumps of lime break up, heat is generated, steam is given off, and after the action is completed a paste or putty remains—the ordinary lime putty used for mortar. The fact that quicklime has changed its form from dry lumps to a wet paste and that heat has been generated prove that a chemical reaction has taken place, or that quicklime has combined chemically with water. It is a scientific fact that when any chemical change or reaction occurs exact amounts of the material are involved. In the chemical change which takes place when lime is quenched with water definite amounts of lime and water are involved; in slaking lime an exact amount of lime unites with an exact quantity of water, forming an exact amount of hydrated lime, and it differs from the original quicklime, and if water is present to satisfy the calcium oxide (lime), then a dry powder will remain. This powder is hydrated lime, and it differs from the original quicklime and from pulverised lime in its behaviour towards water. When water is added to hydrated lime no heat is generated, nor does the material slake, thus indicating that water has no further chemical action on the hydrate.

What is Hydrated Lime?—Hydrated lime of commerce is the dry powder resulting from

* Chemical Engineer, Portland, Ore. From *Concrete-Cement Age*.

the treatment of lime with sufficient water to satisfy the chemical requirements of all the calcium oxide.

Necessity for Exact Proportions of Lime and Water.—In the foregoing, emphasis has been laid upon the fact that precise amounts of lime and water react chemically. In other words, 1 lb. of lime requires a certain definite amount of water to form a perfect hydrate. If too little water is used in quenching the lime in the process of manufacture, the lime will be burned in slaking, and free lime, or lime which is not combined with water, will be present in the hydrate, rendering the material unsound. Plaster made from such hydrated lime will later pop and pit, due to the gradual slaking of the free lime; the mortar made from such unsound hydrate generally works tough and non-plastic. The free, uncombined lime when present to any considerable extent will dry out the mortar, rapidly decreasing its strength and causing it to crumble. Free lime in hydrated lime is a dangerous ingredient, and one which will always give trouble.

If too much water is used in the preparation of hydrate the material will be damp and wet, rendering it difficult to handle.

Obsolete Methods of Manufacture.—In the past three methods were used to produce hydrated lime:—

(1) Small pieces of lime were placed in a basket and immersed in water for a few minutes, until slaking began, when they were withdrawn and placed in a heap in order to conserve the heat and prevent the escape of the vapour; the material swelled, cracked, and became reduced to a dry powder.

(2) Lumps of lime were placed in a heap and wetted at intervals until the mass was equally moistened throughout. The slaking proceeded as in the first instance.

(3) Small pieces of lime were exposed to the air for a number of months, and the lime absorbed both water and carbon dioxide from the atmosphere, falling to a dry powder. The powder consisted of dry sub-carbonate of lime containing about 10 per cent. to 11 per cent. of water.

These three methods of dry-slaking lime were crude, and unless the greatest care was exercised the resulting product contained particles of unslaked lime. The hydrate produced by these methods was generally short and possessed poor sand-carrying capacity; in fact, hydrated lime made by any of the above methods was suitable for use in agriculture only, and such hydrate should not be confounded with hydrated lime manufactured by modern methods.

Modern Methods of Manufacture.—The modern method of manufacturing hydrate depends upon the addition of a definite amount of water to a predetermined amount of lime. By no other method is it possible to produce a hydrate which will contain sufficient combined water to satisfy the demands of the calcium oxide (lime) present. It is of the utmost importance that all the calcium oxide be in combination with water, otherwise the hydrate will be unsound and unsuitable for building uses. That all the lime be satisfied with water will be insisted upon in any specification which may be drawn for hydrated lime to be used in the building trade, and it is vital for each manufacturer to recognise that the formation of hydrated lime involves a chemical change requiring the presence of exact amounts of lime and water. Since the process is chemical, it requires the same careful supervision as any other chemical process—such as the manufacture of Portland cement. The production and use of hydrated lime have been more retarded by the manufacture of only partly hydrated lime than from all other causes. Any method of manufacturing hydrated lime continually to produce a perfect product must be based upon weighing the lime used and measuring the amount of water added.

Advantages of Hydrated Lime from the Standpoint of the Manufacturer.—One of the great difficulties in connection with the manufacture of lime is the perishable quality of the product. Lump lime cannot be stored for any length of time without deteriorations, thus making the operation of the plant dependent upon the season and the whims of

the weather. Kilns must be fired up, lumps of down, or put out according to the season of the year and the condition of the weather. The unevenness of operation results in a high unit cost. Since hydrated lime can be stored in bins in a manner similar to cement, it is possible to make the operation of the plant more nearly continuous, thereby introducing economies in the manufacture and reducing the cost. The manufacture of hydrate also means a more extended market, as hydrated lime can be used for a number of purposes for which quicklime is not suitable.

Advantages to the Dealer.—Three principal advantages to the dealer are the ease in handling, less deterioration of the product, and the freedom from fire risk. These three facts alone should convince the dealer that it is more economical to handle hydrated lime.

Use of Hydrated Lime.—In general it may be stated that hydrated lime is suitable for any use in the building trade to which lump lime can be put, and it would appear that as soon as the material comes into general use, its advantages will be found to far out weigh any disadvantages. The use of hydrated lime does away with the necessity of slaking lime to a paste, thus saving the space required for the slaking bed as well as the labour of slaking. By the use of hydrate it is possible to proportion the mortar so as to have exact quantities present, since this form of lime comes into the market in convenient packages of known weight. This point is always appreciated by the architect and engineer, as it is a well-known fact when lump lime is used as much sand as possible is added, with the result that the mortar is lean and possesses little strength.

Mortar Made from Hydrate Stronger than that Made from Slaked Lime.—In June, 1910, the writer presented the results obtained from an extended series of tests on mortars made from both hydrated lime and lump lime to the American Society for Testing Materials. One of the most important conclusions drawn from these investigations was that the mortar produced from hydrated lime was stronger than that produced from the corresponding lump lime slaked to a paste. This conclusion was to be expected, since it is possible to manufacture hydrated lime by mechanical means under good chemical control which is more thoroughly slaked than it is possible to slake lump lime on the job.

Practically all those who have investigated the strength of lime mortars have recommended the use of hydrated lime in place of lump lime. In Bulletin No. 50 of the U.S. Bureau of Standards the following statement is made: "The proportion of impurities in hydrated lime is generally less than in the lime from which it is made. In building operations hydrated lime may be used for any purpose in place of lump lime, with precisely similar results. The consumer must pay the freight on a large amount of water, but the time and labour required for the slaking are eliminated, and there is no danger of spoiling it either by burning or incomplete slaking. For all building purposes hydrated lime is to be preferred to lump lime. By its use the time and labour involved in slaking may be saved, and the experience of the labourer is eliminated as a factor in the problem."

If the use of hydrated lime in the building trade is to be increased, this can be brought about only by the manufacturers of hydrate preparing and marketing only such material as is sound and contains no free lime. There is an increasing demand for hydrate for use in concrete to render the material more plastic and dense. Hydrated lime can be advantageously used in all cement plaster and stucco to make them work smoothly and give a more pleasing colour. In all these uses the soundness of the hydrate is the paramount requirement. No one would think of using unsound cement—why, then, should they expect to use unsound hydrate?

The market for hydrated lime is present, and a concerted action on the part of the lime manufacturers to exercise the care necessary to make a thoroughly hydrated lime will result in a more extended use of the material. It is to be hoped that the manufacturers will direct their energies along this line.

THE IMPERIAL ARCHITECTURE OF JAPAN

BY H. H. K. [Name obscured]

It is a well-known fact that the architectural period of the Meiji Restoration in Japan, or what is known as the first period of the adoption of Western architecture, is the most important in the history of Western architecture in Japan, since the capital has been almost entirely rebuilt in this respect. The objects of the buildings in Tokyo and elsewhere during the Meiji Restoration at the beginning of the 19th century as they were built specially for the use of foreigners they cannot be taken in the same important sense as representative buildings. This is further emphasized by the fact that the Japanese never attempted to imitate them.

The construction of buildings in Western style did not commence until after the Restoration. One of the first of these buildings was the First Bank, which was erected in 1872; and this was followed by the construction of the new House of Assembly in 1875, since burnt down, and the House of Affairs Department building was constructed in 1875. These were built by Japanese architects and for the Japanese, and may, therefore, be taken as typical of the first period of Western architectural influence in Japan, covering the first fifteen years of the Meiji period.

Other buildings were erected at about the same time under the direction of foreign experts, one of which was Shimbashi station, completed in 1871; while other buildings in foreign style arose along the Ginza, which is the main thoroughfare of Tokyo. These were after plans by an architect named Wordsworth, who also constructed the British Embassy, erected in 1873. The Russian Embassy, planned by a Mr. Melby, was built in 1874, and the German Embassy in 1877 and the Naval Academy in 1878. The building for the Tokyo Foreign Office was erected in 1879 and the Peers' Club in 1881, the architect for the latter being Dr. Josiah Conder. Most of the foreign architects employed in constructing foreign buildings in Tokyo were not really architects, being for the most part engineering experts who turned their hand to the planning of buildings, with the exception of Dr. Conder and a French architect named Binville. Dr. Conder came to Japan in 1875 as a teacher at the Imperial University, which position he held until 1895. The Imperial Museum and the Navy Departmental building are the work of his brain. He has educated many Japanese architects, and is still a professor emeritus of the Imperial University.

During this first period of Western architecture in Japan there were very few native experts in the art of constructing foreign buildings. But during the second period, which lasted from about 1872 to 1895, the pupils of Dr. Conder began to mature, and had a decided taste of the styles of the Gothic and the Renaissance, those being the types they had studied at school. There was no attempt at originality, but they simply followed the designs they had been taught how to draw. Many of these architects, however, developed into real authorities on architectural matters. Some of them, such as Tatsuno, Kawamura, and Utsunomiya, met respectively in 1877, 1878, and 1880, at a day, and especially to the study of architecture, and they met to discuss the sentiment buildings of the Meiji period. The Fifteenth Baron, the Prince of Arima, and the Emperor Hirohito, and the Imperial Household Agency, Dr. Witmar, the Department of Education, and Commerce, the Ministry of Finance, and the Tokyo Police Department, were after plans by Dr. Tatsuno in 1895.

The materials used varied a good deal. For instance, the Imperial Hotel, of wood plastered on the outside, with some portions of brick, the architecture being in Renaissance

same style. The Department of Agriculture and Commerce is the same style and finish, in three stories, but is of brick covered with plaster. The Tokyo Prefectural Building is of brick faced with stone. The Bank of Japan, one of the finest buildings in Tokyo, is all of granite, the style being Italian Renaissance. The Tokyo Engineering College is in Gothic style and constructed of brick with grey stone facings. These two buildings are regarded as masterpieces of Japanese architecture during the Meiji era.

The third period of foreign architecture in Japan may be said to extend from the year 1895 to the year 1905. During this period there was a marked development of skill among native architects, with a tendency to independence and originality. One of the most typical buildings of this time is the Mitsui Bank, which was planned by Dr. Yokokawa in 1902, and the Imperial Crown Prince's Palace at Akasaka by Dr. Katayama in 1907. The Mitsui Bank building is of yellow brick on a steel frame, the first steel frame in Japan, Dr. Yokokawa being one of the first Japanese architects to go abroad and make a study of steel in architecture. It is in Renaissance style. The Akasaka Palace is in the style of Louis XIV., with steel frame, filled with brick, and stone outside. The design was taken from the famous palace at Versailles.

From the year 1905 onwards a new period may be said to have begun in Japanese use of Western architecture. From this time our native architects began to display some degree of self-consciousness. They had by this time taken in and digested the achievements of the great architects of the world, and felt a freedom that enabled them to go on without restraint to produce something of their own. They were no longer beholden to models. The development of resources for building materials also had something to do with the improvement in architectural designs, especially the employment of reinforced concrete in wall construction. Most of the new buildings of this period are steel frames filled with reinforced concrete. There seems to be no special thought given to new styles or designs, the weight of consideration being confined to new materials of construction. Styles of architecture in this period are marked by Austrian and German influence, mixed with Japanese ideas. The new gate in front of the Imperial University, which was completed in 1912, marks this period of conflicting ideals. It is a mixture of iron, stone and brick; foreign materials worked up into Japanese style, the design being by a Japanese architect named Yamaguchi, the suggestion coming from Baron Hamano, then president of the institution. It will long stand as a monument to those who made desperate efforts to depart from established models. The Metropolitan Police Bureau, built after plans drawn by Drs. Tatsuno and Fukunoka in 1911, as well as the Red Cross Society building by Dr. Tsumaki in 1912, not to mention the beautiful Mitsui building by Dr. Yokogawa in 1911, are all representative of the fourth period of Western architecture in Japan.

The Metropolitan Police Bureau is a modified Renaissance style, revealing many native ideas. It is 270 ft. by 253 ft., with a central dome and tower rising 100 ft. The Red Cross Society's building near Shiba Park is in German Renaissance style, of brown brick faced with stone, the frame being steel. The new Mitsui building is also in Renaissance style with steel frame, but the design shows American influence. It is a six-storied office building, the first one after the American manner.

It will be inferred from what has been said that the Meiji era was one of imitation and study of Western architecture; while the Taisho era promises to be a period of originality and remarkable development, combining the best in various western countries with designs of purely Japanese evolution. Every year sees large new buildings being erected in Tokyo for business purposes, their forests of steel, with men like mites climbing over them, reminding one of what is constantly seen in any progressive Western city. *Japan Magazine*.

LENGTH OF PORTLAND CEMENT KILNS.

EDISON PATENT 802,631 HELD VOID.

A report of an appeal to the U.S. Circuit Court of Appeals from the District Court of the United States for the Southern District of New York is reported in the *Official Gazette* of the United States Patent Office of August 5. It is of some interest this side, as dealing with what is or what is not novel in the construction of Portland cement kilns. The action was brought by Edison *et al.* against the American Portland Cement Works. The following is the text of the judgment delivered by Judge Cox, the Circuit Judge:—

At the time application was filed, December 5, 1902, Portland cement was produced by burning a mixture of cement, rock, and limestone in long rotary kilns lined with fire-brick and maintained at a slight angle, the heat being produced by the combustion of pulverized coal. A stack was connected at the upper end of the kiln to permit the escape of smoke. These kilns for some years prior to 1902 had been of the standard length of about sixty feet with an internal diameter of about five feet. The patentee admits that longer kilns had been suggested for the dry process, but he asserts:—

"I am not aware that such kilns have been practically utilized or any advantages discovered therewith over the standard sixty-foot kilns."

The specification contains seven pages of description, but it is thought that the only important improvement suggested or claimed is the lengthening of the kiln without proportionately increasing its diameter. This is the idea which is constantly asserting itself in the specification and the claims.

Claim 2 will sufficiently describe the alleged invention. It is as follows:—

"A cement-burning apparatus for dry material, comprising a tubular kiln, upward of one hundred feet in length and more than twelve times the internal diameter thereof, means for rotating the same, means for creating a combustion zone within the kiln near its lower end, and means for introducing cement material into the kiln at its upper end, substantially as set forth."

The kiln must be upwards of one hundred feet in length, and, as Judge Holt points out, a kiln half an inch more than one hundred feet would infringe and a kiln half an inch less than one hundred feet would not infringe. The record shows kilns in the prior art over one hundred feet in length, and, as before stated, the patentee admits that kilns over sixty feet have been suggested, though he is "not aware that such kilns have been practically utilized."

There is a dispute on the facts regarding these prior kilns, and therefore we find it unnecessary to discuss them, for, in the view we take of the situation, it may be conceded that Edison was the first to make a kiln over one hundred feet in length. The question is, Did it require an exercise of the inventive faculties to do this? Was it not rather an improvement due to the natural evolution of the art? It was not an improvement which a poor man could attempt. The experiments and the structures necessary to make the experiments successfully would involve a considerable outlay of money which would make it impossible for him to test his theories, no matter how implicitly he might believe in them. The skilled mechanic, with years of experience and unlimited resources at his command, could make the experiments and enlarge the kiln to meet the increasing demand for Portland cement.

The great demand for this product in recent years, which has steadily increased, created the necessity for larger kilns. As this demand grew, the kilns were increased in length from fifteen feet by progressive additions until at the date of the patent here were many kilns sixty feet in length. No one pretended that it required invention to do this. It was a mere matter of construction. In the same way the stone-crushers were made larger as the demand for good roads became insistent, the oil-tanks increased in size with the increase of petroleum,

and elevator-bins grew larger with the increased traffic in corn and wheat. We are not at all convinced that any better or different result is reached by the long kiln than by the short kiln. They both produce equally good cement, and the only real difference is the one which occurs as a matter of course—viz., that a large machine will produce more product than a small one. But it did not require invention to make the machine longer or larger so long as the only result is to produce a larger output. As pointed out by the trial judge, if mere elongation be patentable, then each builder as he added an additional foot to the original fifteen-foot machine would have been entitled to a patent. But it is argued that a better result is obtained by the patented kiln because the increased distance from the upper end of the kiln down to the point of the combustion enabled the mixture in the calcining zone to be subjected to a longer application of heat, thus driving out the carbon dioxide before the combustion zone is reached. We agree with Judge Holt in thinking that the relative operation of these zones depends largely upon the method adopted by the operator. Judge Holt says:—

"The evidence satisfies me that in kilns of all sizes whether the action in the calcining zone overlaps the action in the combustion zone depends very largely upon the operation of the kiln. The operator can introduce at will a longer or shorter blast; he can revolve the kiln more slowly or more rapidly; he can feed into the kiln a larger or smaller amount of cement material; and it depends largely upon the manner in which the kiln is operated whether the calcining process is substantially completed before the material is subjected to the heat in the combustion zone, and the best results obtained generally."

It is true that Edison made a longer step than any one person before him, but others were bound to reach the advanced position, although more time might have elapsed before that consummation was reached.

In short, we are convinced that the enlargement of the kiln was sure to come sooner or later, as the growth of the business demanded. With the increase in length would come the proper increase in diameter and the other necessary changes which any skilled mechanic would know how to make. We find it unnecessary to add further to the opinion of the district judge.

The decree is affirmed with costs.

THE LONGEST RACK-RAILROAD IN THE WORLD.

A prime favourite among American tourists this year is the ascent of Pike's Peak, in Colorado. One train leaves the lower terminus late in the afternoon and reaches the summit in time to witness the gorgeous spectacle of the setting sun, and, spending the night at the Summit Hotel, one is able to view the equally enthralling dawn of another day. One of the most popular trips is the Sunrise Excursion, which, leaving the lower terminus at midnight, lauds the travellers at the crest in time to see the sun creep over the eastern horizon. This special service has developed to such a degree that the entire equipment of the railway has to be impressed to cope with the crowds.

The road is only opened early in June, and its continuance depends on the severe snows which set in early in the fall. On the upper five miles there is frequently snow falling in July, and the road is occasionally blocked, as the snow packs very hard in the upper exposed regions. Clearing out the snow is a difficult operation, as there is no mechanical appliance which can cope with the frozen layers of snow and ice. Trenches are cut in the solid mass and blocks about nine feet square are transferred to a flat car. The train with a load of blocks runs back along the line until a ravine is reached. The blocks are then slid off the car and sent tumbling down the mountain side.

The rack-rail system in use comprises a rack made of Bessemer steel, with the teeth cut from the solid mass of metal. It is built up in lengths of 80 inches. The rack-track comprises two of these rails laid side by side

centrally between the outer metals, and set about 1½ inches apart. The rack-rails are so laid that the joints of each length do not come in line, while the teeth of one is brought opposite the space between two teeth of the other. This secures an even bearing at all times, and is conducive to smooth travelling.

The railway measures a little over 30 miles in length, and the gradient is 844.8 feet per mile, the highest grade being 25 in 100. The sharpest curves are 16 degrees, that is, of a radius of 358 feet. A large portion of the rails and rack are anchored to the solid rock; 146 of these anchors are used throughout its entire length. The highest point on the mountain is 14,147 feet above sea level. The railroad is the longest rack-railroad in the world.

JAPANESE OAK.

Considerable prejudice seems to exist in some quarters against Japanese oak on the alleged ground that it shrinks and swells when exposed to rain and sun. The matter has occupied considerable space recently in the *Timber Trades Journal*. One writer in the last issue says the prejudice is produced not by consumers but by timber merchants who do not hold stocks of the wood. However that may be, we do not know, but the opinion expressed in the columns of our contemporary by Professor Percy Groom, M.A., D.Sc., B.Sc., F.L.S., of the Imperial College of Science and Technology, is probably that which will carry most weight, and we therefore reproduce it. Prof. Groom says:—"Being engaged on an investigation concerning the structure and swelling or shrinkage of timbers, I was interested in the allegation, quoted by your correspondent 'Quercus,' in reference to Japanese oak, that, 'owing to its porous character, it is very liable to swell and shrink when exposed to rain and sun.' On the Continent the view largely prevails that increased porosity decreases swelling and shrinkage. This view is not justified when applied to utterly different kinds of woods, but is generally, if not always, correct when applied to different samples of the same kind. It would, therefore, be of interest to know of any case whatsoever in opposition to this last statement. It is to be presumed that the idea promulgated in the letter of 'Quercus' is that the numerous pores allow the easy entrance and exit of water, and thus readily lead to considerable changes of volume. Such an assumption would be entirely premature, as the 'pores' (vessels) of the oak heart wood are plugged with obstructive bodies, which oppose powerful resistance to the passage of water through the wood. Quite another matter is the tacit assumption that Japanese oak has greater porosity than other commercial oaks. This character is gauged by the dry weight of the wood, and in the absence of numerous weighings I can only express a doubt as to whether the average porosity of Japanese exceeds that of other commercial oaks."

The last "News Sheet" of the Bribery and Secret Commissions Prevention League, Incorporated, obtainable at 9, Queen Street Place, E.C.1., contains, among other interesting matter, a report of the recent Military Court of Inquiry into the conduct of the British Empire Committee and its relations with Mr. Devereux and his Hutting Contract.

The Public Health Committee reported to the last meeting of the Aberdeen Town Council that they had before them a letter from the Local Government Board in regard to the erection of a tuberculosis sanatorium, stating that if the local authority had not already acquired a site, they should postpone proceedings for that purpose. If the local authority had acquired a site, but had not accepted any contract for the erection of the buildings on the site, they should not enter into any undertaking that would commit them to further capital expenditure, and should postpone building operations. Where, however, contracts had been entered into for the whole or part of the work, the above restrictions would not apply. It was stated that the council had not made any arrangements for acquiring a site or erecting a sanatorium.

ECONOMY IN SANITATION DEPRECIATED.

Discussion at the annual general meeting of the North-Eastern Centre of the Sanitary Inspectors' Association, in Leeds last Saturday, revealed a wide divergence of opinion as to the interpretation to be put upon the recent circular of the Local Government Board, which emphasised the necessity for economy.

Mr. Anderson, Middlesbrough, expressed the opinion that in the immediate future there would not be much progress in the stamping out of tuberculosis. For one thing, he said, the flower of our manhood was away at the front, whilst another disadvantage was that the Government had taken all the sanatoria they could lay their hands upon for the use of wounded soldiers, and those who required treatment in such institutions were laying to go back to the dark hovels and insanitary areas.

Then, too, there was a wave of economy passing over the country. "We are told," said the speaker, "to do nothing but what is absolutely necessary; not to repair dilapidated property, nor to put the owners to this and that expense. The Local Government Board tell you that—perhaps not in so many words, but local committees do not neglect to impress that upon you."

Mr. Cass, of Hull, deprecated the Local Government Board supporting that idea. "I dread to think," he said, "what the result will be when our men, strained in nerve and muscle, come back from the front to insanitary homes."

Some of the speakers expressed surprise that the Local Government Board circular should have been interpreted in this way.

Mr. Hailstones, of Birstall, declared that the Board stated distinctly that in the matter of nuisances and for purposes of health expenditure should go on.

Mr. J. C. Dawes (chief sanitary inspector at Kighley), who read a paper on the influence of applied sanitary science on the incidence of tuberculosis, remarked that what ever else might be said about the Germans they knew how to treat the class of people who were habitually dirty and a danger to the community. These people were sentenced to do scavenging work for a short period, and the scavenging badge was the badge of disgrace. As it was a German method, there might be some difficulty in obtaining its establishment in this country, but he thought it might be adopted, perhaps in some modified form, with advantage.

Mr. T. Pridgin Teale, of Leeds, who presided over the meeting, was re-elected president of the Centre.

The Vienna Town Council has decided to employ women as city scavengers. About three fourths of the men employed on this work have been drafted into the ranks, and a further depletion of their ranks is impending.

The foundation work has been started for the new theatre which the St. Denis Theatre Co., Limited, are going to erect on St. Denis Street, Montreal, at a cost of 300,000 dol. The architects are Messrs. Barrett, Blackader, and Webster, of Montreal, and the contractors Messrs. Nerepis Bros. Co., Limited, Montreal. The building is to be 205 ft. by 110 ft. in dimensions, of brick and steel construction.

At the last meeting of the Uppingham Rural District Council it was reported that notices served from 1912 to the end of 1914 in respect to improvements being made to some sixty properties under the Housing Act had not been complied with. Several of the houses were absolutely past repair, and there were no signs whatever that the owners would, whether in a position to do so or not, carry out the extensive alterations or reconstruction of these cottages.

The Dumbarton Building Society intend to go on with a building scheme which will include eighteen terrace cottages similar to those already erected at Silvertown, and four blocks of tenements similar to Beechwood Terrace. These are to be erected on the Overton estate between Silvertown and Dumbarton East Station. There is a big demand at present for houses of these types, and many local workmen are increasing their subscriptions to the Building Society, as they will everywhere, we believe, recognizing that a man's own house is a better investment than most.

Correspondence.

THE HOUSE-OWNERS' BILL.
 The House-Owners' Bill, introduced in the House of Commons on August 11, 1915, is a measure which is expected to give rise to a considerable amount of discussion. The Bill is designed to enable local authorities to acquire houses for the purpose of providing a supply of houses for the use of the public, and to enable them to let these houses to the public at a reduced rate of rent. The Bill is expected to be passed by the House of Commons on August 18, 1915.

In Yorkshire we have seen a generation before the eyes of our youth the present ephemera of a man's life—economise and save our money, but do it in the house we live in. The result is that more people in Leeds, and Bradford, own their own houses—their own better citizens than in any other part of the size of the Empire. Our local Council will lend money at 4 per cent, and they will build now to let at less than 5 per cent. It is equally true—economy to pay 5 per cent to a building society for your own house to save 5s. a week in any other way. Property revaluation that has come to our door has refugees have come to Britain. Many of those remained and have taught us the refinements such as the woollen manufacture. Let the Belgian refugees teach us to make cheap window glass—one of the few articles in the building trade which will depreciate in value from present prices. Many refugees will remain in this country, and will to provide housing accommodation.

On the other articles in the old paper I am not so competent to pronounce upon. But it is difficult to ascertain what economy arises by eating your dinner in a jacket instead of in a dinner jacket, and I do not object to the proposal to economise in washing. No doubt some saving would be effected by going to bed earlier; but surely the best way to secure that is by passing some Day of Saving Bill.

What is required for the practice of true economy is some temporary relaxation of legislative laws and trade union by-laws, which press so onerously on capital and labour, especially on the employment of male or female refugees, who should be enabled to earn their own living in their own way, and who may not get adequate returns for their insurances and taxes. No one wants to see permanent advantage of the local nature of which all ranks have to subscribe to, and to arms, but it is a relief to see the Government to devise some temporary expedient. W. H. WOOD, Queen Square, Harrogate, Leeds, August 12, 1915.

The paving, sewer, and water works committees of the Metropolitan Board of Works for the year ended 31st March 1915, have spent £21,053.

At the Red Cross Art Exhibition, held at M. F. C. Gallie, R.F.S., Kilmacdonagh, Dublin, on August 11, 1915, the Northants Red Cross Committee has received £26 10s. donated by the public.

At a meeting of the Board of Trustees of the Tower Company, held on August 11, 1915, the proposed scheme for the reconstruction of the tower was discussed by the Board. The Board has decided to accept the scheme, and to raise the necessary funds by a new issue of debentures. The Board has also decided to appoint a committee to manage the scheme, and to report to the Board at a future meeting. The Board has also decided to accept the offer of the Government to purchase the tower at a price of £11,275.

PROFESSIONAL AND TRADE SOCIETIES.

EAST RIDING ANTIQUARIAN SOCIETY. The second excursion of the summer session of the East Riding Antiquarian Society was held on Tuesday week. Londesborough was first visited. The Rev. Arthur A. R. Gill, addressing the members, said he did not intend to enter into the question whether Londesborough was the ancient Delgovitia, but certainly a portion of a Roman road was visible at the bottom of the lake in Londesborough Park when the water was drained off some twenty years ago. This was probably part of the road from Malton to the Humber. Londesborough may also have been the site of the summer palace of the Kings of Northumbria and the scene of the preaching of St. Paulinus to King Edwin in the beginning of the 7th century. Londesborough came into the possession of the Clifford family by the marriage of Margaret Bromflete, the daughter and heiress of Lord Vesey, to Lord Clifford, generally known as "Butcher Clifford," who is said to have slain the Duke of Rutland after the battle of Wakefield in 1460. The interesting brass to this Lady Margaret Clifford, who after the death of her first husband married Sir Lancelot Threlkeld, and was buried in Londesborough Church, was shown. She was the mother of the Shepherd Earl, though it is not known where he is buried, but his wanderings had given us perhaps the finest lyric that Wordsworth ever wrote. Londesborough remained in the Clifford family till the failure of the male line by the death of Henry, fifth Earl of Cumberland, in 1643, when it passed to the second Earl of Cork and first of Burlington by the marriage of a daughter. From the Boyles it passed by the marriage of a daughter in 1743 to the Cavendishes, till it was sold by the sixth Duke of Devonshire to George Hudson, the railway king, and was finally purchased by Lord Londesborough. The park was laid out by Richard Boyle, the third Earl of Burlington, the patron and friend of Pope. The old Hall was pulled down in 1819, and only some vaults remain. The two lower stages of the western tower of the church are Early English. On the whole the church may be said to be Early English with later additions and alterations. The chancel, the burial-place of the Burlingtons, was visited. There are hung four funeral banners of the Burlingtons and two funeral helmets. The very fine Norman south nave door, with its sundial and Saxon cross, was admired. Tea was kindly provided by the rector, the Rev. A. G. and Mrs. Bazshaw, and afterwards Burnby was visited, where Mr. Gill spoke on the history of the parish and church, in which he said he had no belief that Burnby was the site of the great battle of Brunaburgh. The west door of the church is Norman, and the little bell turret has apparently some genuine old Norman work recast in modern form. There are three very large and fine sedilia, which are said to have come from the neighbouring Augustinian Priory of Warner. The plain circular Norman font, with its later inscription, was admired. On the floor of the sanctuary is a stone dated 1676, to the memory of Major Ralph Waterhouse: "Quem Mars non potuit mors permit."

"Death with his dart took him away

Whom sword nor cannon could once slay.

Would any know the reason why?

Both one and other all must die."

By a window on the north side of the chancel is a bit of old glass, evidently a crest, a shield.

NATIONAL FEDERATION OF BUILDING TRADE EMPLOYERS.—In our report last week, on page 167, it was stupidly stated that the 69th half-yearly report recorded a further decrease in membership. It is some consolation for having to correct this error that in spite of our bad times the membership of the Federation is still increasing, as well as the beneficial scope of its activities.

NOTTINGHAM AND DERBY ARCHITECTURAL SOCIETY.—The Thorot Society, in conjunction with the Nottingham and Derby Architectural Society, found much in the older part of the parish church

to interest them when they made an excursion to West Bridgford on Wednesday, August 11. Mr. Harry Gill said that the earliest written reference to the church was in the Taxation Roll of Pope Nicholas IV., but there was unmistakable architectural evidence that part of the present work was executed at least 100 years earlier. This evidence was to be found in the lower part of the rubble walling, which was of skerry or water-stone, obtained most probably from the Mapperley hills. Windows indicated 13th Century work, or as early even as the reigns of Richard I. or John. During the reign of Edward III. (1327-1377), village churches throughout the land were enlarged or rebuilt to meet the needs of the more elaborate ritual then in vogue. Bridgford Church was not pulled down, but was transformed by the addition of larger windows and the introduction of a rood screen and loft and other internal adornments. The stone altar, built into the eastern wall and destroyed at the Reformation, was replaced in Elizabeth's reign by an oak Communion table. This was still in use in the side chapel, and the church also possessed a paten bearing the hall mark of 1564-5. The crudeness of the figures on the screen set up about 1380 suggested that the work was that of the village carpenter or mason. This was what made the church particularly interesting—that it was not built under monastic influence or by a trained band of itinerant craftsmen, but by village workmen under the direction of the squire. Speaking of the effigy known as the "stone man," which has now found a resting-place in the new morning chapel, Mr. Gill said that beyond the fact that at the close of the 18th century the figure was set upright to mark the boundary of the manor, near the junction of Melton Road and Loughborough Road, its history was unknown. There was strong presumptive evidence that it was intended to represent Sir Robert Luttrell, lord of the manor early in the 14th century, whose widow was known to have presented an acolyte to the rectory in 1315. Externally, the charm of the old church was now somewhat overshadowed, but interest might still be aroused by the tracery of the eastern windows, the grotesque gargoyles, the carved stone in the south face of the tower, and a collection of 18th-century headstones in the graveyard, obtained from the Swithland slate quarries in Leicestershire. After tea the company proceeded to St. Peter's Church, where Mr. Robert Evans, F.R.I.B.A., said it was disappointing to find no mention of the building in Domesday Book. The foundation deed of Lenton Priory was the first record we had, in 1100. The south arcade was the oldest portion, and was a fine example of the Early English period, probably about 1180. There were no signs of Norman work, and in the various phases of restoration no Norman remains had been found. The original stone staircase to the old rood loft was one of the most interesting features. The north arcade was a much mutilated example of Early English work—probably about the end of the 14th century. The chief damage was caused to it by the erection of galleries, which were removed in 1887. Touching upon the work of restoration, for the completion of which funds are much needed, Mr. Evans remarked that five centuries' exposure to rain and sun had left its mark upon the tower and spire, but fortunately the men who selected the stone of which it was built did so wisely, and if succeeding generations were alive to their trust we might expect it to remain a landmark for many years to come. Originally the spire was crocketed, but ninety years ago the crockets were sawn off by a mason named Philip Wooton. The apex of the spire had for many years looked new, being of a lighter colour than the rest of the stonework. This part of the spire had been a source of expense and anxiety for 200 years. In 1789 Robert Wooton, of Kegworth, rebuilt four yards of the spire and refixed the weathercock. He played a good many pranks at the top of his ladders, including beating a drum and drinking a bottle of ale in the sight of thousands of people on a market day. He died in the debtors' prison. In 1825 the cock fell on to the nave roof,

the stonework having perished. The present works of repair and renewal were long overdue. There was no mortar in the joints of the spire masonry within two inches of the face, and a great many of the joints were without any mortar, the rain driving through, with the result that the joints had become very wide through the perishing of the stone. The stonework at the apex, which was cracked and badly weathered, had now been entirely removed and rebuilt in Derbyshire stone of a colour and composition more closely resembling the original stone. The walls of the tower were about 3½ ft. thick at the ringing chamber level, and stones as large as 3 ft. 8 ins. long were used in their construction. The four pinnacles crowning the four angles of the tower evidently became badly decayed a long time ago and were restored, but these in turn became dangerous, and the remains were taken down and placed in the churchyard. The pinnacles that had now been placed in position followed the lines of the old ones and were 7½ ft. in height. In the tower there was a well-constructed groined ceiling, and in the centre was a covering on which were depicted the emblems of St. Peter.

ROYAL PHOTOGRAPHIC SOCIETY.—The sixtieth annual exhibition of this society will be held at the Gallery of the Royal Society of British Artists, Suffolk Street, Haymarket, from Monday next, the 25th inst., till October 2. The exhibition, which is international in character, will be open daily from 11 a.m. till 6 p.m., and on Tuesdays, Thursdays, and Saturdays till 10 p.m. As in former years, an attractive programme of lantern lectures is arranged to be given on Tuesdays, Thursdays, and Saturdays, at 8.30 p.m., as follows:—

Tuesday, August 24.—"Romanesque and Gothic Doorways," by C. H. Dedman, Chairman—A. Herbert Lisett.

Thursday, August 26.—"A Ramble Round Hampstead, with Historical Notes on the Old Town," illustrated by Paget colour slides, by H. Hardwick, Chairman—F. Martin-Duncan, F.R.M.S.

Saturday, August 28.—"A Northern Cathedral," by E. W. Harvey Piper, Hon. M.S.A. Chairman—G. Lamley, F.R.G.S.

Tuesday, August 31.—"How Animals Express Their Feelings," by F. B. Kirkman, Chairman—F. F. Renwick, A.C.G.I., F.C.S.

Thursday, September 2.—"The Attractions of the London Suburbs," by A. H. Blake, M.A. (All the slides for this lecture will be supplied by the School of London Photography.) Chairman—F. F. Renwick, A.C.G.I., F.C.S.

Saturday, September 4.—"The Romance of High-speed Photography," by Lieutenant Adolphe Abrahams, R.A.M.C. (Fellow), B.A., M.D., B.C., M.R.C.S., M.R.C.P. Chairman—W. L. F. Wastell.

Tuesday, September 7.—"Some Ground-nesting Birds," by E. J. Bedford, Chairman—Chas. H. Oakden, F.R.S.A.I.

Thursday, September 9.—"Canterbury Cathedral," by R. P. Howgrave Graham, Chairman—Alvin Langdon Coburn.

Saturday, September 11.—"Huns of the Insect World," by F. Martin-Duncan, F.R.M.S., Chairman—A. Herbert Lisett.

Tuesday, September 14.—"Through the Dolomites to Venice," by Chas. H. E. West, F.S.I. Chairman—Ernest Marriage.

Thursday, September 16.—"Bird-watching with Field Glass and Camera," by Oliver G. Pike, F.Z.S. Chairman—W. L. F. Wastell.

Saturday, September 18.—"A Loon in London," by W. L. F. Wastell, Chairman—F. T. Hollyer.

Tuesday, September 21.—"An Hour with the Microscope," by Dr. Geo. H. Rodman, Chairman—Alvin Langdon Coburn.

Thursday, September 23.—"Notes from my Indian Diary," by Miss H. R. Levy, Chairman—D. Cameron Swan, F.S.A. Sec.

Saturday, September 25.—"Some Village Homes and Cots" illustrated with Colour Slides, by Arthur E. Morten, Chairman—H. Esselrich Corke, F.R.H.S.

Tuesday, September 28.—"Mont Saint Michel, the Abbey of the Arch-Angel and its Sea-girt Town," by H. W. Fincham, Chairman—A. Herbert Lisett.

Thursday, September 30.—"Gloucester Cathedral," by Henry W. Bennett, Chairman—J. C. Warburg.

Saturday, October 2.—"Bird Life on a Hertfordshire Estate," by W. Bickerton, F.Z.S., Hon. M.B.O.C. Chairman—W. B. Ferguson, K.C., M.A.

Currents Galamo.

A somewhat curious situation, reminding the *Irish Builder*, has arisen in connection with the advertisement of the Kingstown Urban Council to architects inviting them to submit their names for appointment in connection with a scheme of working-class dwellings. The remuneration offered was 2½ per cent. upon the outlay, no payment whatever to be made in the event of the work being abandoned. The Royal Institute of Architects asked the Council to receive a deputation, who laid their views before the Housing Committee. The Urban Council subsequently revised their terms, offering 5 per cent. upon the first house of a scheme and only 2 per cent. upon the remainder, and promising very vaguely to consider a claim for money expended by the architect, should the scheme be abandoned. The Institute thereupon asked its members not to apply for the position, or if application had already been made to withdraw it. Nevertheless, at the last meeting of the Council it was announced that eleven Irish and eight English applications had been received. At the meeting it was argued that there had been a technical error in connection with the matter by reason of the terms having been decided by the committee and not by the Council. It was therefore decided to adjourn the appointment. It is extremely regrettable that the Council of Kingstown should go out of their way to cut down architects' modest remuneration to such an extent as to debar qualified members of the Institute from submitting their names. It can hardly be supposed that this is likely ultimately to be to the advantage of the ratepayers.

We are now able to confirm the statement we published last week with regard to the acquisition of the Star and Garter Hotel as a permanent home for disabled soldiers and sailors. The Queen has accepted the offer of the Auctioneers' and Estate Agents' Institute, and proposes to hand the gift over to the Red Cross Society if the committee of that society will equip and maintain the building. The property, which cost over £80,000, is being purchased for £21,500. The hotel at present contains about 100 bedrooms and magnificent reception rooms. A feature of the estate is its beautiful terraces, gardens and grounds, facing south-west, and the building is eminently suitable for a permanent home for paralysed and totally disabled soldiers and sailors. The moneys collected will be devoted to the purchase of the property. The necessary alterations, equipment and maintenance, on the handing over of the building by the Queen, will be undertaken by the British Red Cross Society, and any sum received in excess of the purchase-money required will be given to the British Red Cross Society for the above purposes. The annexe will be opened in about three months, but extensive alterations are necessary to the main building.

The ground floor will accommodate about 135 beds, and it is proposed that these beds (and these beds alone) should be occupied by the absolutely helpless. The reasons for this arrangement are obvious. By means of a series of special exits all the beds can be moved rapidly into the open in the event of fire. Each bed will be provided with large wheels on ball-bearing joints so that a nurse, single-handed, can with ease draw a bed out of the building. By a like arrangement the beds can be taken into the garden over the Thames so that on every suitable occasion the patient can spend some hours in the open air. The first floor will be given up to dis-

abled men, and the second and third floors will be given to the women or children of the disabled men. The remaining floor will be given to the paralysed and totally disabled men. A series of rooms will be devoted to guests, not to the type of visitor who patronised the hotel in the days of its glory, but to the relatives of patients in the wards. These men will wish to see their friends, but when these friends have come from a distance their visits will of necessity be short, unless they seek lodgings in the town. It is proposed that each man should have the privilege of inviting a relative or friend to stay with him for a week end or for two or three days. The garden, as is well known, is superbly placed on the steep crest of Petersham Common. It is proposed to make here a Garden City for paralysed soldiers. There will be a little street with cottages and bungalows, each with one good room capable of accommodating some four beds. The houses will be warmed and will be occupied by patients the whole year through. The Soldiers' Garden City will accommodate some fifty patients, so that the total number of helpless men who can find a home, either in their hotel or in their village, will be about 185. Gifts in money or kind are solicited. The latter, for sale within the London area, may be forwarded direct to Knightsbridge Hall, No. 217, Knightsbridge, which Mr. J. Charlton Humphreys has lent to the Institute for the purpose of warehousing and selling such. Notice of despatch should also be sent to the secretary of the Institute at 34, Russell Square, W.C.

The announcement of the removal of Toynbee Hall from Whitechapel to Poplar is followed by the news that the Passmore Edwards Settlement in Northern Bloomsbury has become a women's institution. Mrs. Humphrey Ward, the hon. secretary, who announces the change, explains that it is due to the urgent demand for the whole-time help of educated women in many social fields. The settlement was a product of the social forces of the early 'nineties, and in the purpose of its founders stood as a concrete symbol of enthusiasm for humanity independent of the support and sanction of orthodoxy. The building was given by our Chairman, the late Mr. J. Passmore Edwards, and was opened in 1897. It stands in Tavistock Place, and the playground covers part of the garden of Tavistock House, the last London residence of Charles Dickens. It was illustrated by us in our issues of August 9, 1895, July 3, 1896, and October 19, 1900, and the architects were Messrs. A. Dunbar Smith and Cecil Brewer, whose designs were selected by Mr. R. Norman Shaw. There Mrs. Ward started her vacation schools for the children of the neighbourhood, which, with the classes for defective children and the play evenings, may be regarded as one of the distinctive contributions made by this settlement to the common stock of civil service.

The Guardian complains that a conspicuously bad example of absolutely unnecessary interference with old work has recently taken place at Charlton Kings, Gloucestershire, where the old sundial termination of the Churchyard Cross has been removed and placed on a new base further away, while the old shaft has been surmounted by a new imitation Gothic model. Another case is alleged to be that of the south doorway at Etkin's Church, Yorks, which has been en-

larged and the old doorway left in situ. The *Guardian* also complains that the old sundial termination of the Churchyard Cross at Charlton Kings, Gloucestershire, has been removed and placed on a new base further away, while the old shaft has been surmounted by a new imitation Gothic model. Another case is alleged to be that of the south doorway at Etkin's Church, Yorks, which has been enlarged and the old doorway left in situ.

The Rochdale Housing Association, Huddersfield, returns a report for the last twelve months which is a most interesting document. There are some 1,000 houses in the association, chiefly through the gift of the Government and Rochdale Council. The object of the association is to provide a permanent home for the most hopeful, but not the most fortunate, of the occupants of the town. Perhaps the most hopeful fact in the report is that which describes the efforts of the association to get the trade unions and the various societies of the town to co-operate in the formation of a "Public Utility Society" for Rochdale, to build houses for the workers, using their surplus funds for the purpose and obtaining from the Government, as they may do, an advance of two-thirds of the capital required for any approved scheme. The further large falling off in the supply of new houses in Rochdale during the last twelve months emphasises the need of a move in this direction, and we congratulate Rochdale on the activities of the association. The formation of similar vigilance councils in many other towns is as greatly to be desired.

In his annual report on the health of the burgh of Greenock for 1914, Dr. William S. Cook, the medical officer of health, states, with regard to the dearth of houses in the burgh suitable for the labouring and artisan classes, and the consequent overcrowding and the difficulty and delay in directing the proper remedies under the Housing Acts, that there has been little appreciable improvement during the year. Dr. Cook further remarks that it is a great misfortune that the proposed scheme for building two apartment houses and a small proportion of one apartment houses on a central site was delayed during the spring and summer owing to the Local Government Board requiring the consent of the European War, as this has led to a serious delay and handicapped the solution of the most urgent part of the housing problem in Greenock, namely, the provision of shelter for families at present occupying houses scheduled under the Housing Acts. These houses are utterly unfit to live in, and the occupants are placed in conditions such as to be dangerous to themselves and the community. The corporation should build proper houses for the poorer classes, and at the same time do everything in its power to stimulate and encourage private building for the benefit of the artisan class, and to try to pay a nominal rent. Dr. Cook's opinion after careful consideration is that the best way to do this would be to purchase a portion of the unproductive sites in the town, and to build on these sites the great advantage to be derived by these schemes through the sale of the surplus, providing the consent of the Local Government Board may be obtained by the strictest supervision of the building process, and relaxing the building by laws, providing for cheaper street construction, and generally providing for more economical development would go far to encourage builders to set up houses suitable for artisans.

Our Illustrations.

CHURCH OF ST. BARNABAS, NORTH FINCHLEY.

This new church consists of a nave, 94 ft. long and 37 ft. wide; aisles, partly 12 ft. wide and partly 6 ft. wide, and of same length as the nave; chancel, of apsidal form at east end, 35 ft. long and 26 ft. wide; morning chapel, 40 ft. long and 16 ft. wide; organ case, at clergy and choir vestries, with reading screen between, so that the two can be made into one large room, for parish meetings, etc. The nave and chancel are of lofty proportions, with traceried clerestory windows and open timbered and panelled roofs of arched form, and there are handsome arcades with stone piers and richly moulded arches dividing the nave and chancel from the aisles and morning chapel. A projecting baptistery and angle turrets, with lofty traceried windows between, and gabled porches, form the principal features at the west end of church, facing Holden Road. The aisles are more than usually lofty, the wide portions being covered with leaded roofs, carried by arched timber principals. The general style of the church follows that known as the "Decorated" period of Mediaeval work. The windows and other dressings externally are of Welton stone, and the walls generally are faced with red brick, relieved by stone bands and gable copings, and the roofs, where

Son, contractors, of Dulwich, from the designs of Mr. W. H. Wood, F.R.I.B.A., successor to the late Mr. C. Hodgson Fowler, F.S.A., of Durham and Newcastle-on-Tyne. The plan shows the general lay-out of the building.

"SEFTON," WEYBRIDGE.

The perspective by Mr. B. A. Poulter shows this house which has recently been erected for Mr. W. Shakespeare at Weybridge. The building is finished with rough-cast, and the roofs are of dark tiles made by Mr. Warner, of Twyford. The external woodwork is of oak. On the west front there is a large balcony and verandah with a fine view over the flat country near Chobham. The windows have iron casements and are filled with leaded lights. Internally the work is very simply treated, the best rooms having stone fireplaces and beamed ceilings. A little decorated plaster work has been introduced, which was executed by Mr. G. P. Bankart. The house is heated throughout by radiators, in addition to fires. The work, including the gardens, has been carried out by Mr. W. G. Tarrant, of Byfleet. Messrs. Tubbs, Messer, and Poulter, of Charing Cross House, Craig Court, Whitehall, S.W., are the architects.

PEABODY BUILDINGS, RODNEY ROAD, WALWORTH.

These dwellings have been erected on an island site in Rodney Road, Walworth, S.E., for persons of the working

supply to scullery sink. The tenants can obtain a constant supply of hot water from a tap arranged in a convenient position in the courtyard. There is store and workshop accommodation for the use of the superintendent and porters for doing any small immediate repairs. The buildings are of fire-resisting construction throughout. The lighting is by gas supplied to the tenants through slot meters. Gas is also used for the courtyard lighting. The buildings were designed by Mr. Victor Wilkins, surveyor to the Peabody Donation Fund. The general contractors were Messrs. W. Cubitt and Co., 258, Gray's Inn Road, W.C.

OBITUARY.

Mr. Frank Bramley, R.A., died on Tuesday, at Hope House, Chalford Hill, aged fifty-eight. He was one of the best-known members of the group of artists known as "the Newlyn School." Born near Boston, he studied at Lincoln and in Antwerp, and began exhibiting at the Academy in 1884. It was four years later that he produced "A Hopeless Dawn," his first popular success. The canvas was bought under the terms of the Chantry Bequest, and now hangs in the Tate Gallery. From 1885 to 1895 Mr. Bramley worked at Newlyn, near Penzance. In 1900 he settled at Grasmere. Among his best known pictures were "For of Such is the Kingdom of Heaven" (1891) and "While there is Life there is Hope" (1896). He was elected an Associate of the Royal Academy in 1894 and R.A. in 1911. He was a gold medallist of the French Salon, where he frequently exhibited.

Mr. Alfred Usher Soord, the well-known portrait painter, died at his residence, "Cranmere," New Bushey, Herts., on the 10th inst., following an attack of pneumonia. Born at Sunderland in 1863, Mr. Soord received his early training at the York Institute School of Art, and later studied under Sir H. V. Herkomer at Bushey. He exhibited several noteworthy pictures at the Royal Academy, the Paris Salon, and in the provinces. "The Lost Sheep," perhaps his most popular work, has been reproduced in thousands, both in this country and in America. The repositos in the private chapel at Oxford House, Bethnal Green, was also the work of Mr. Soord.

The Sanitary Inspectors' Association will hold its next meeting at Lichfield on Saturday, August 23.

Renovations are being carried out at the Presbyterian Church, Ballyclare, under Messrs. Watt, Tulloch, and Fitzsimons, architects, Belfast. The church is to be reopened on September 5.

The death is announced of Mr. T. Elliott, borough surveyor of Enniskillen, at the advanced age of eighty-two. Mr. Elliott had been many years connected with Enniskillen. He was a member of the Architectural Association of Ireland since its revival, and was its oldest member.

By request of Colonel Cradock, now at the front, brother to the late Admiral Sir Christopher Cradock, friends and relatives of those who went down with him on H.M.S. "Good Hope" in the battle off Coronel, Chile, are invited to inspect the memorial tablet, designed by Mr. W. S. Weatherby, F.R.I.B.A., which is to be erected in the family parish church, in Yorkshire, at 74, Baker Street, W.

The British Fire Prevention Committee has issued a special Farmers' Fire "Warning," pointing out certain precautions that should be taken by farmers or estate owners, more particularly in the matter of ricks and stacks. The "Fire Warning" has been published as a small free poster, and may be obtained on written application (with large-size stamped and addressed envelope enclosed) from the Registrar, the British Fire Prevention Committee, 8, Waterloo Place, Pall Mall, London.

The Lord Mayor, aldermen, and citizens of Manchester were fined £3 last Wednesday, on a charge of "neglecting to comply with an order made upon them on September 13, 1899, to abate a nuisance caused by the omission of black smoke from a chimney on their premises," the chimney referred to being at the Mayfield Baths, Store Street. The proceedings were taken by the Sanitary Department of the Corporation.

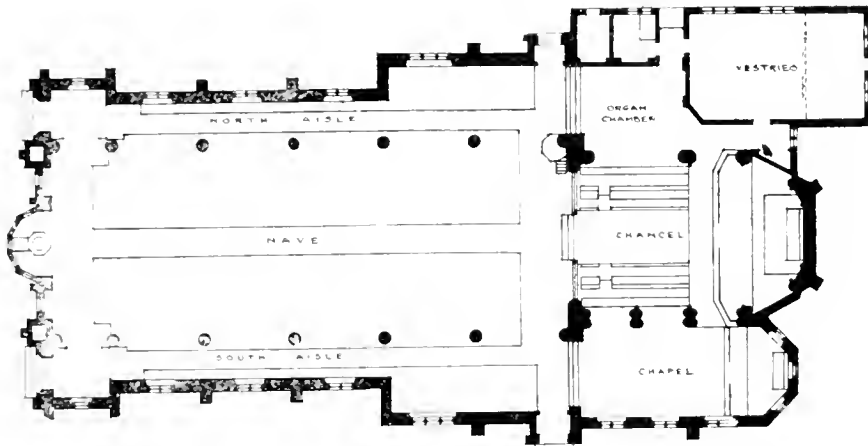

CHURCH OF ST. BARNABAS, NORTH FINCHLEY.

Mr. J. S. ALDER, Architect.

not of lead, are covered with rough red hand-made tiles. The inside stonework is of Bath stone. The accommodation provides for 750 persons. The cost has been about £3,600. The architect is Mr. J. S. Alder, of 1, Arundel Street, Strand; and the builders are Messrs. John Bentley and Sons, of Waltham Abbey. We have chosen two photographs of the building showing the interior, and one of these we reproduce to-day. A series of similar views of the church were taken by Mr. Richard Moreland *en amore*, and as the work of an accomplished amateur photographer his prints are of unusual interest, particularly as no attempt has been made by the artist to tamper with the limitations of the camera, depending instead upon the legitimate use of untinted photography and to the ability of selecting well-composed pictures in the points of view of each particular subject. This judgment is of the greatest importance, and Mr. Moreland, as a water-colour painter, is singularly successful in this respect, in striking contrast with more pretentious work of the professional photographer.

ST. BARNABAS' VICARAGE, DULWICH.

The Lord Bishop of Southwark conducted the office for the benediction of this house, just completed. The building is of red sand-faced bricks, with red hand-made tiles on the roof. The doors, window frames, and large boards are of oak. The vicarage is connected to the church by a cloister formed of oak framing filled in with concrete panels and with flat asphalted roof. The work has been carried out by Messrs. Mitchell and

classes. The dwellings consist of ten blocks, and are five stories in height. The blocks at the rear of the site are similar in their arrangements to those forming the frontage group, as shown on the plan below the view on our double-page plate. The elevations are built of red sand-faced bricks with Luton brick base, artificial stone dressings, and slated roofs. The gates and railings are of wrought iron. Accommodation has been provided for 179 self-contained one-, two-, three-, and four-roomed tenements, each tenement having in addition its own entrance lobby, scullery, and w.c. There has been provided, free of charge, for the use of the tenants, a detached building, comprising a steam-heated laundry, bath-house, and shelter, occupying the centre of the site. Coal stores are also provided in this detached building where tenants can obtain coal from the Fund at a low rate all the year round. The charge of 1d. per week is made for the use of the perambulator sheds and bicycle sheds. All the staircases, w.c.'s, bath-house, and laundry have the walls tiled. Each living room has a dresser and ventilated meat larder and cupboard as a combined fitting, and all the bedrooms have a wardrobe cupboard. The one-room tenements are provided with both these fittings. Hanging space is provided in addition in a recess in the entrance lobby. In each scullery there is a deep white glazed fireclay sink with teak draining board, coal bunker to take 3 cwt. of coal, portable washing copper, and gas cooking stove. The living-rooms have the latest pattern portable ranges and hot water

GROUND PLAN

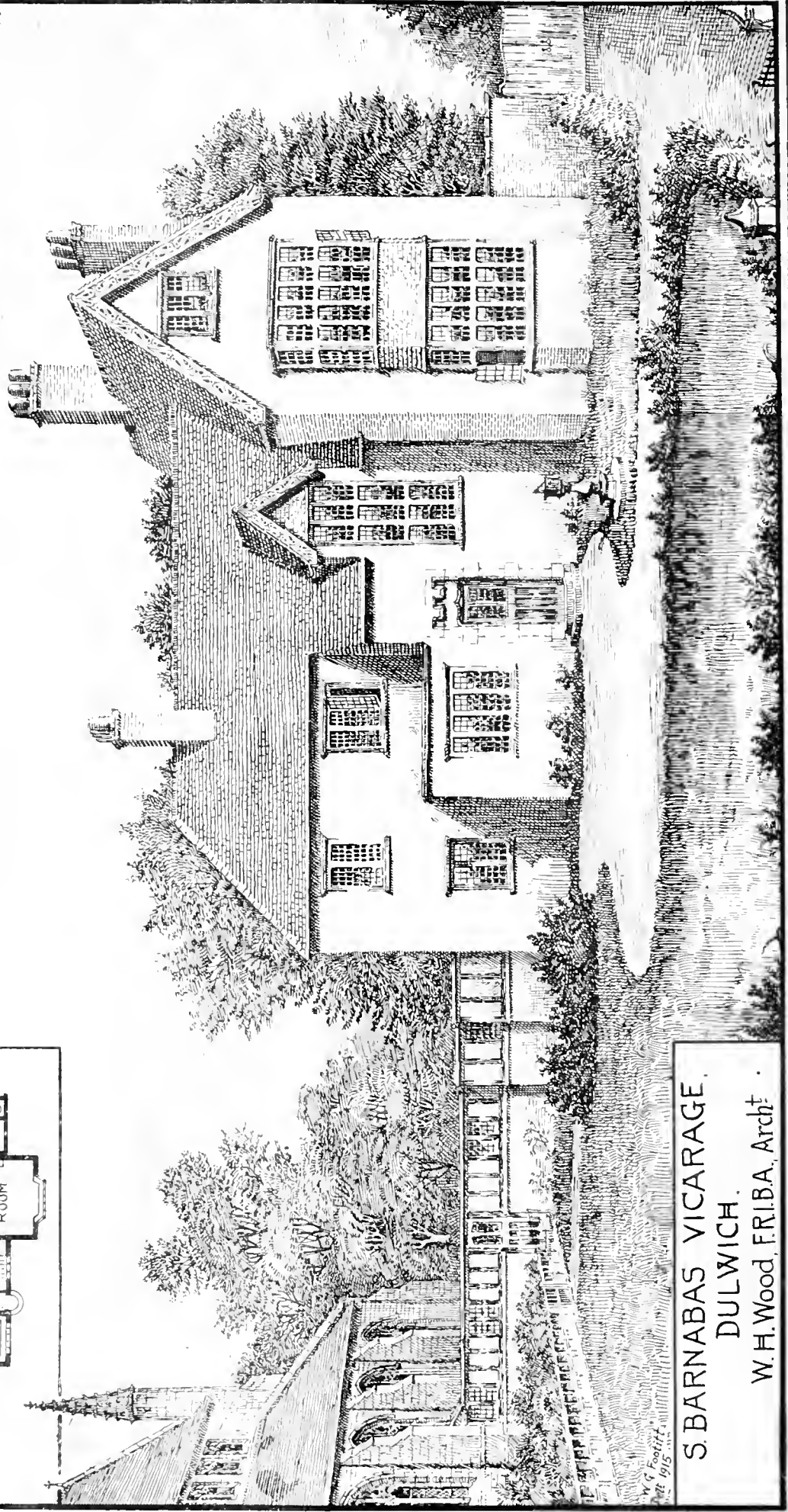
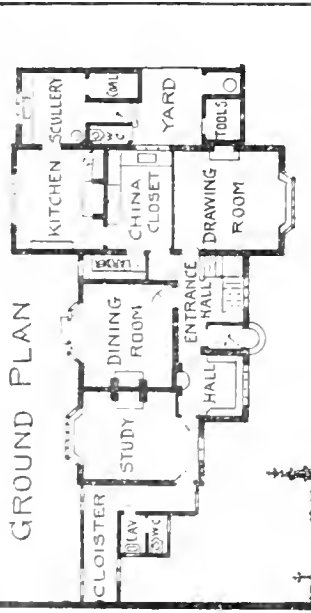

S. BARNABAS VICARAGE,
DULWICH.
W. H. Wood, F.R.I.B.A., Archt.

W. H. Wood
1915



SECTION "WEYBRIDGE"

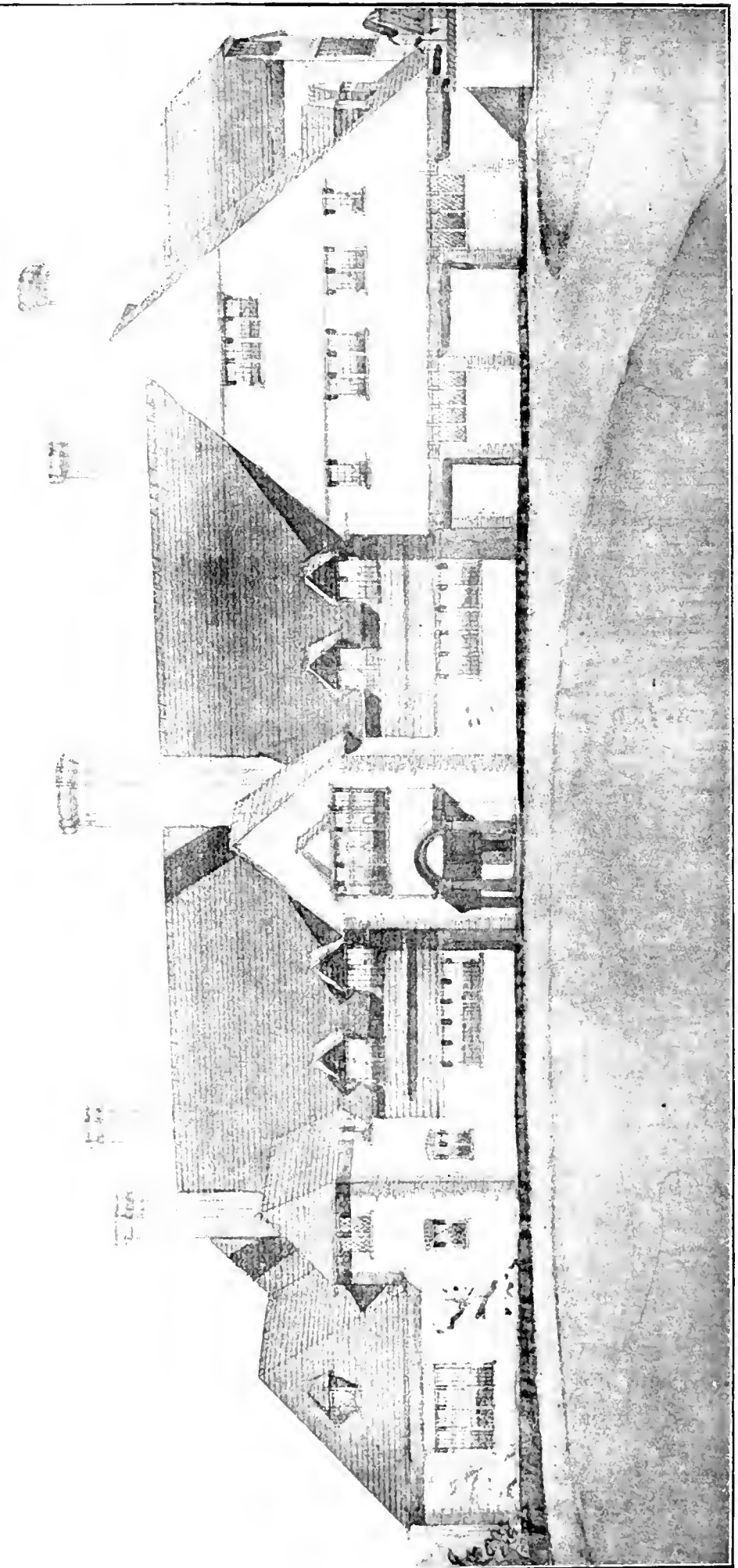

SECTION "WEYBRIDGE" VIEW OF ENTRANCE FRONT.—Messrs. Tubbs, Messer, and Poirer, Architects.



BRANCH OFFICE FOR THE COMMERCIAL UNION ASSURANCE COMPANY, PILGRIM STREET, NEWCASTLE-ON-TYNE. Messrs. MARSHALL and TWLEDY, Architects.

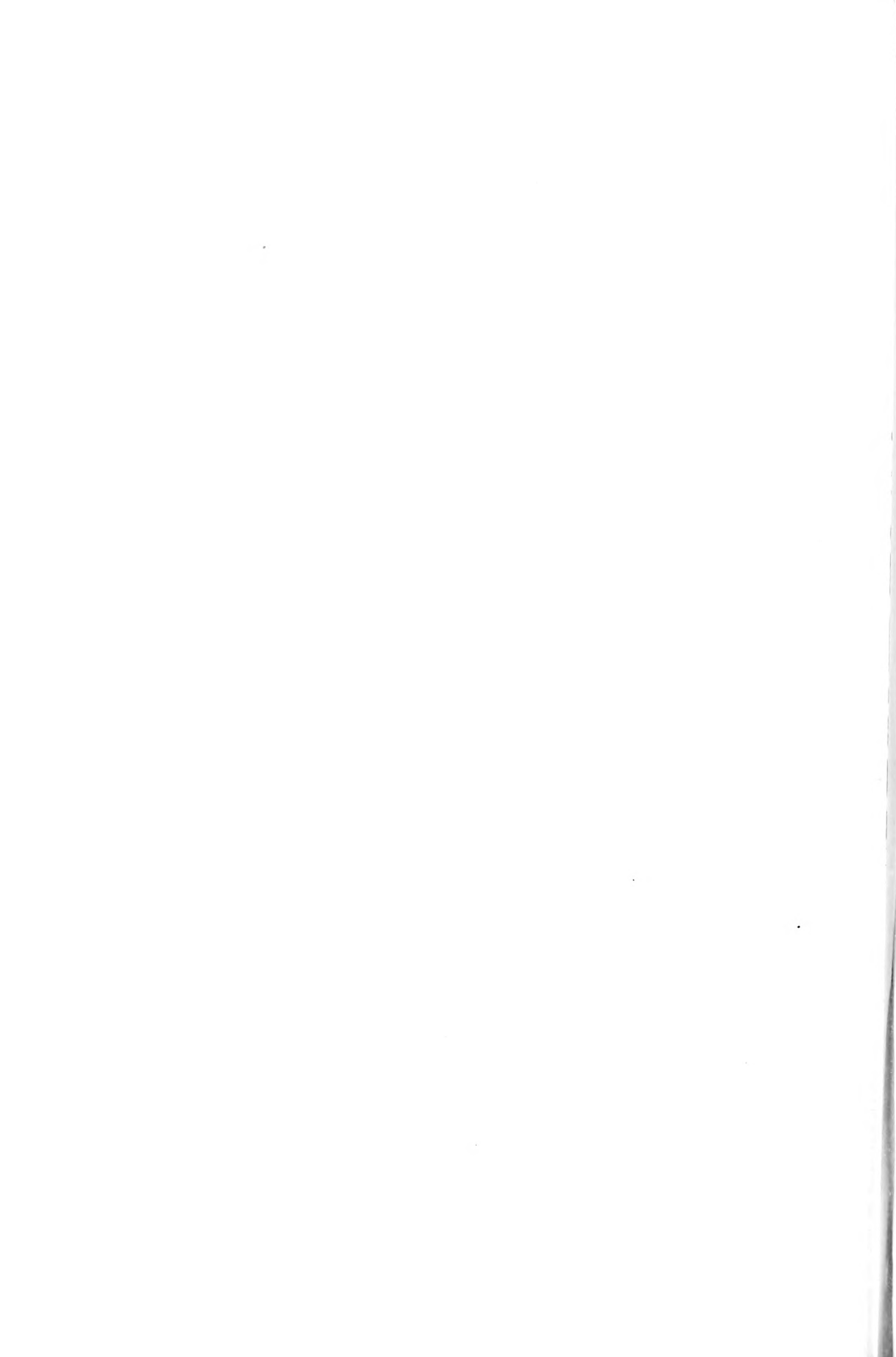

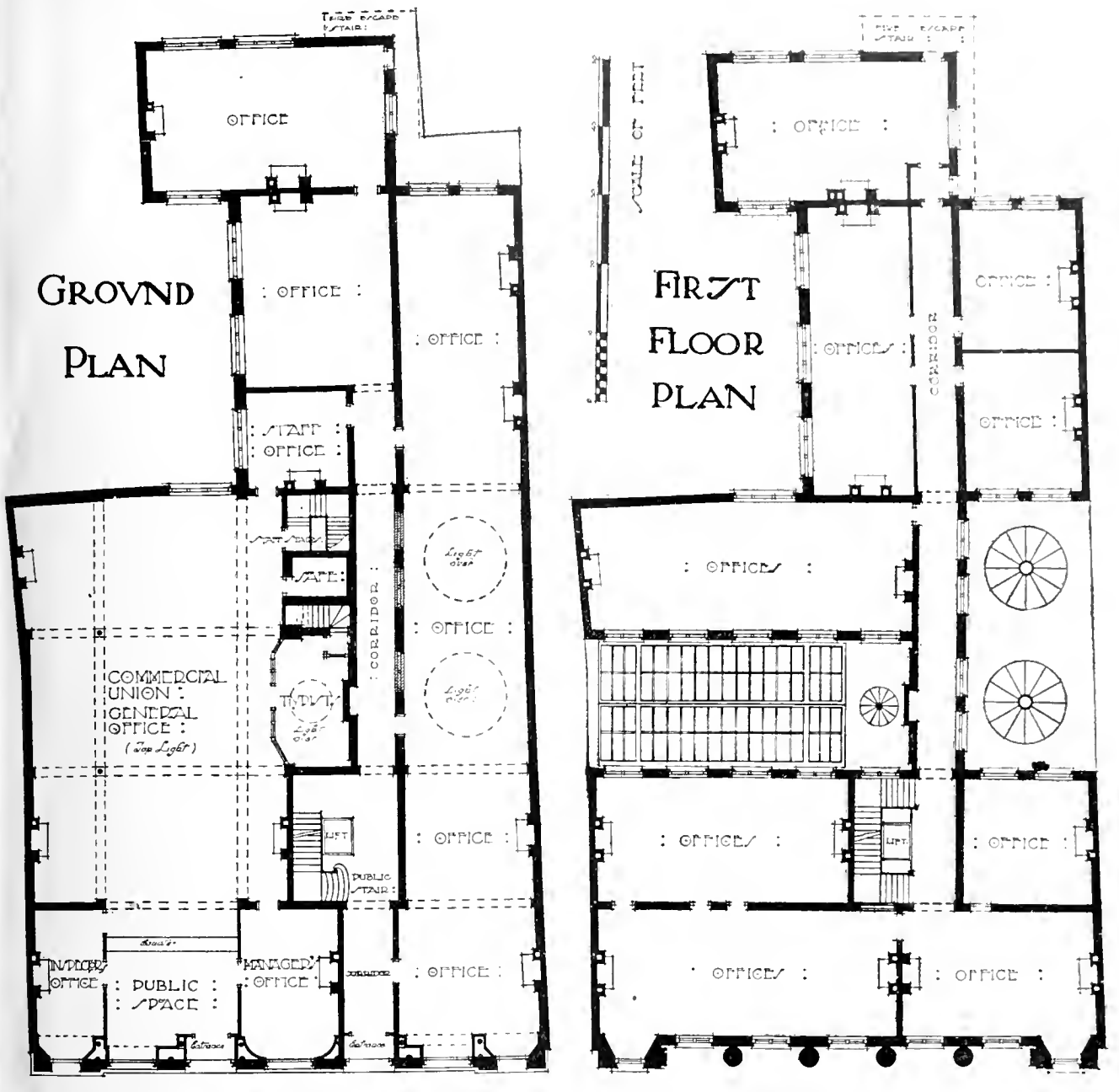

BRANCH OFFICE, THE COMMERCIAL UNION ASSURANCE COMPANY, PILGRIM STREET, NEWCASTLE-ON-TYNE.—Messrs. MARSHALL and TWEEDY, Architects.

COMMERCIAL UNION ASSURANCE CO., LTD.'S NEW BRANCH, PILGRIM STREET, NEWCASTLE-ON-TYNE.

The new branch office for the Commercial Union Assurance Company, which is in course of erection in Pilgrim Street, Newcastle, has been designed by Messrs. Marshall and Tweedy, architects, 17, Eldon Square, Newcastle. The elevation to Pilgrim Street will be Daruley Quarry stone; the base up to ground floor sills will be of Aberdeen red granite. The whole of the facings in areas and basement are of Lumley white glazed best quality bricks, the rear walls and gables being of white unglazed bricks. The whole of the floors will be of ferro-concrete, and the surface of same covered with Jarrah wood blocks, the corridors and staircases with marble and terrazzo. An express passenger lift, installed by Messrs Waygood, Otis and Co., communicates with each floor. The Commercial Union will occupy part of the ground

floor, and they will have a separate entrance from the street. Their offices will be fitted with oak panelling and handsomely decorated fibrous ceilings. The staff lavatories and cloak rooms are in the basement; owing to the slope of the site from front to back these will be entirely out of the ground, thus avoiding areas. The contract for the foundations has been carried out by Mr. Thos. Lumsden, Jarrow, and the superstructure is now being proceeded with by Mr. Alex. Pringle, of Gateshead. All contracts for steel windows and all interior fittings have been placed. The clerk of works is Mr. Bourn.

At a meeting of the Downham Urban District Council on Tuesday week, it was decided after much discussion to raise the salary of the surveyor (Mr. J. M. Jackson) from £50 to £65 per annum.

The Penzance Town Council have resolved that £51 should be spent in converting the old Guildhall in the market house into a public hall, which it is reckoned will bring in from £100 to £150 a year.

Wages advances are announced by the Executive of the Amalgamated Society of Carpenters and Joiners to have been conceded at Chester-le-Street, Omagh, Elgin, Birtley, Greenock, Glongarnock, Kilbirnie, Glossop, Timbridge Wells, Nantwich, Worthing, and Sandbeck.

The condition of Monksilver Church has given rise to anxiety in consequence of a report by Mr. Bligh Bond that immediate steps involving considerable expense must be taken to save the fabric from collapse. A sum of about £80 has been raised, representing less than a third of what is required.

The Bishop of Bangor is urging his clergy not to spend money on new buildings at the present time, or on "what might be called church luxuries." For instance, no one had a right to order an organ for his church during the war, and nothing should be spent in church decorations.

A housing scheme promoted by the Briton Ferry Urban District Council has been successfully completed at a cost of £16,000. In spite of abnormal conditions, the original estimate was only exceeded by £14, and the surveyor (Mr. H. Alex. Clarke) has been congratulated by the council on his successful carrying out of the scheme.

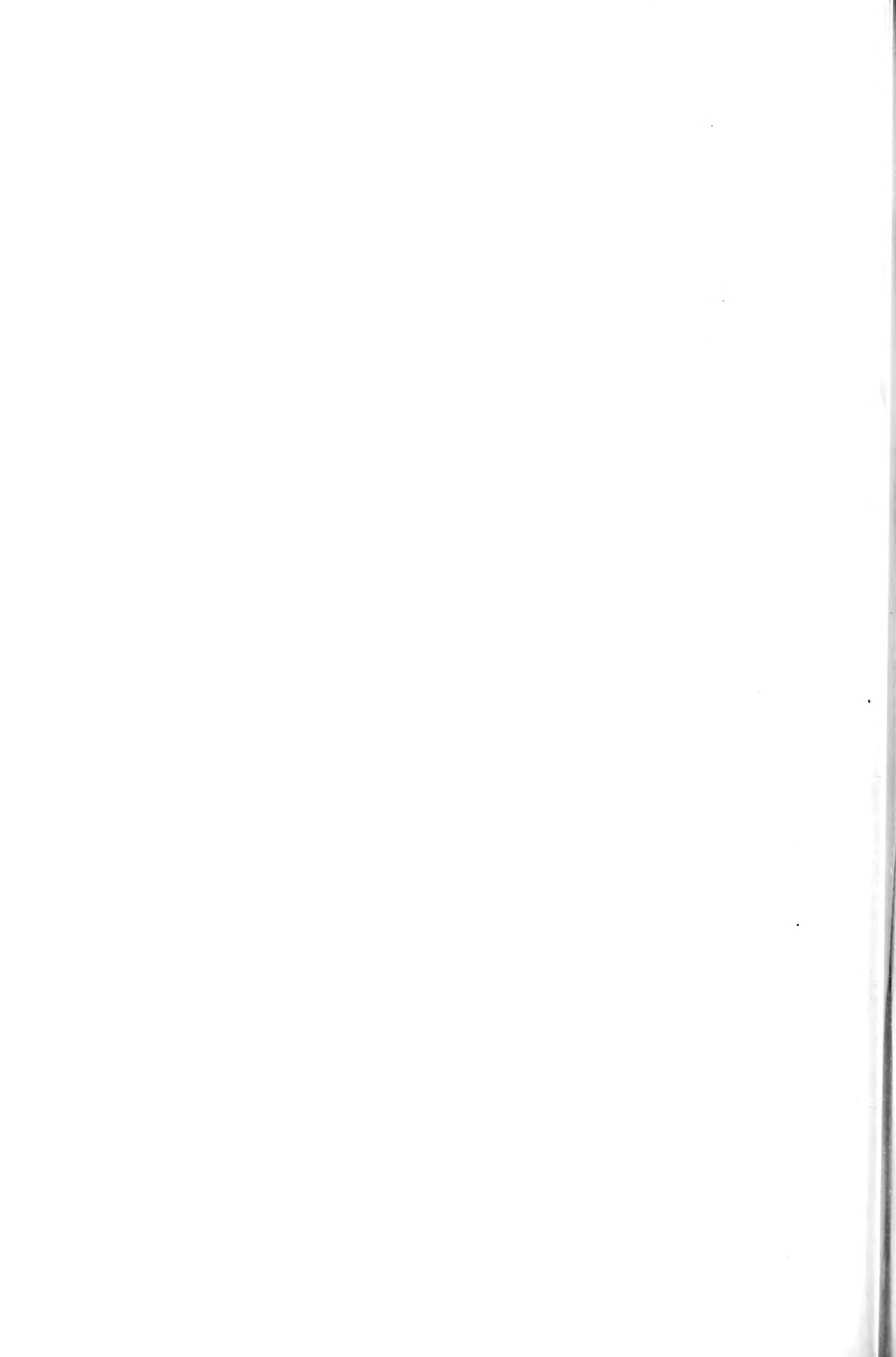



THE BUILDING NEWS, AUGUST 18, 1915.

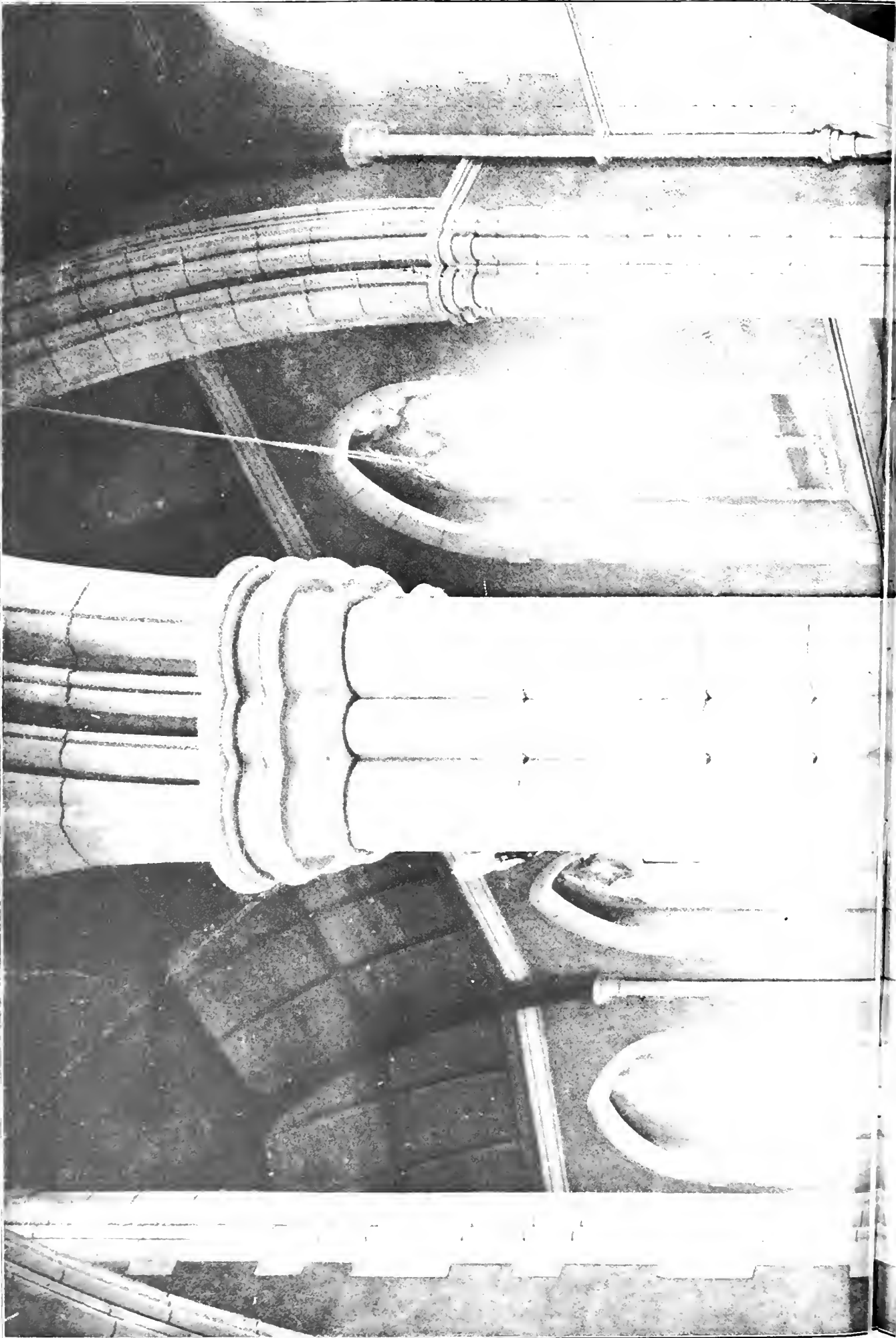

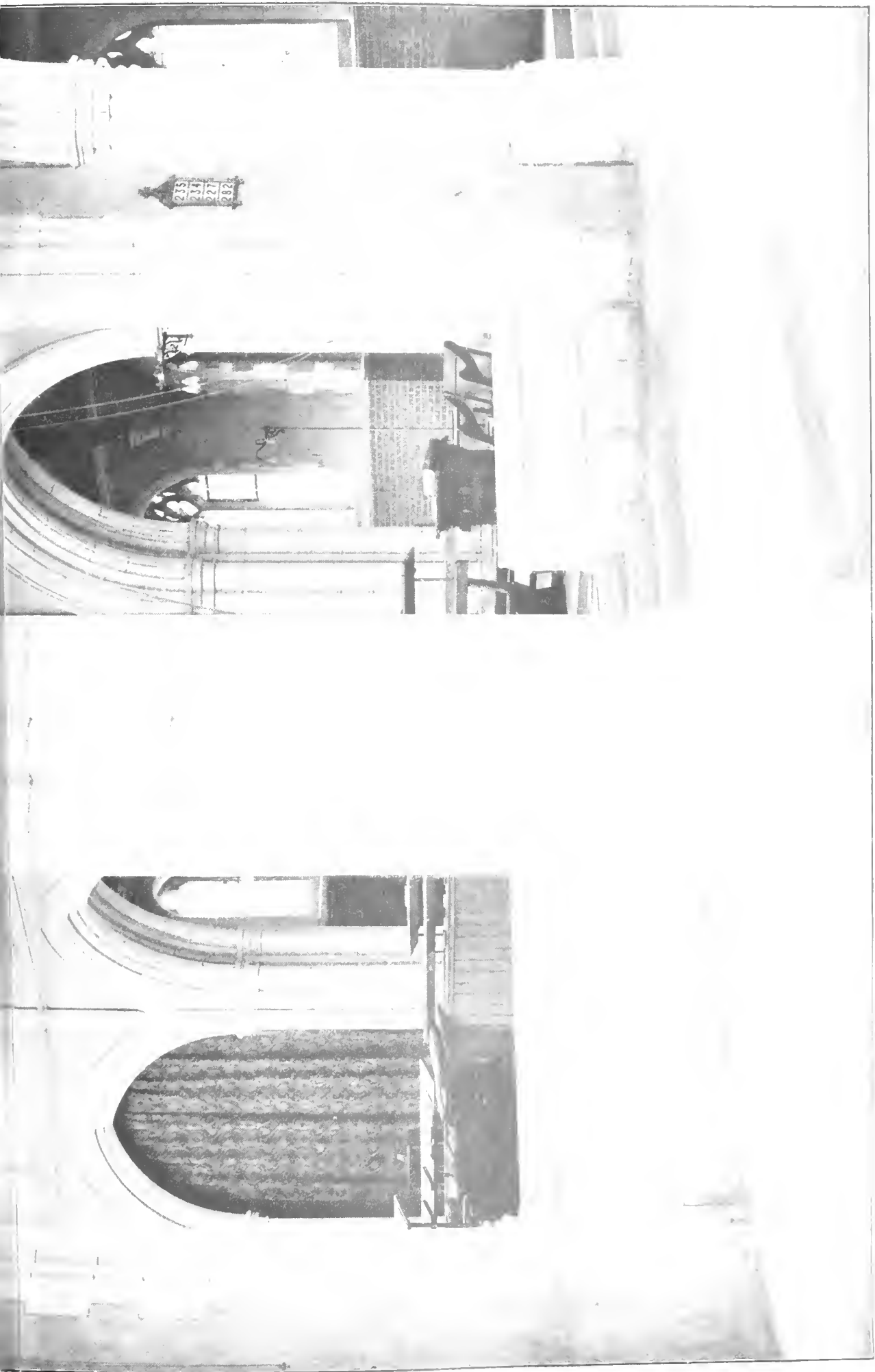

CHURCH OF THE HOLY TRINITY. VIEW OF NAVE FROM NORTH TRANSEPT BALCONY.

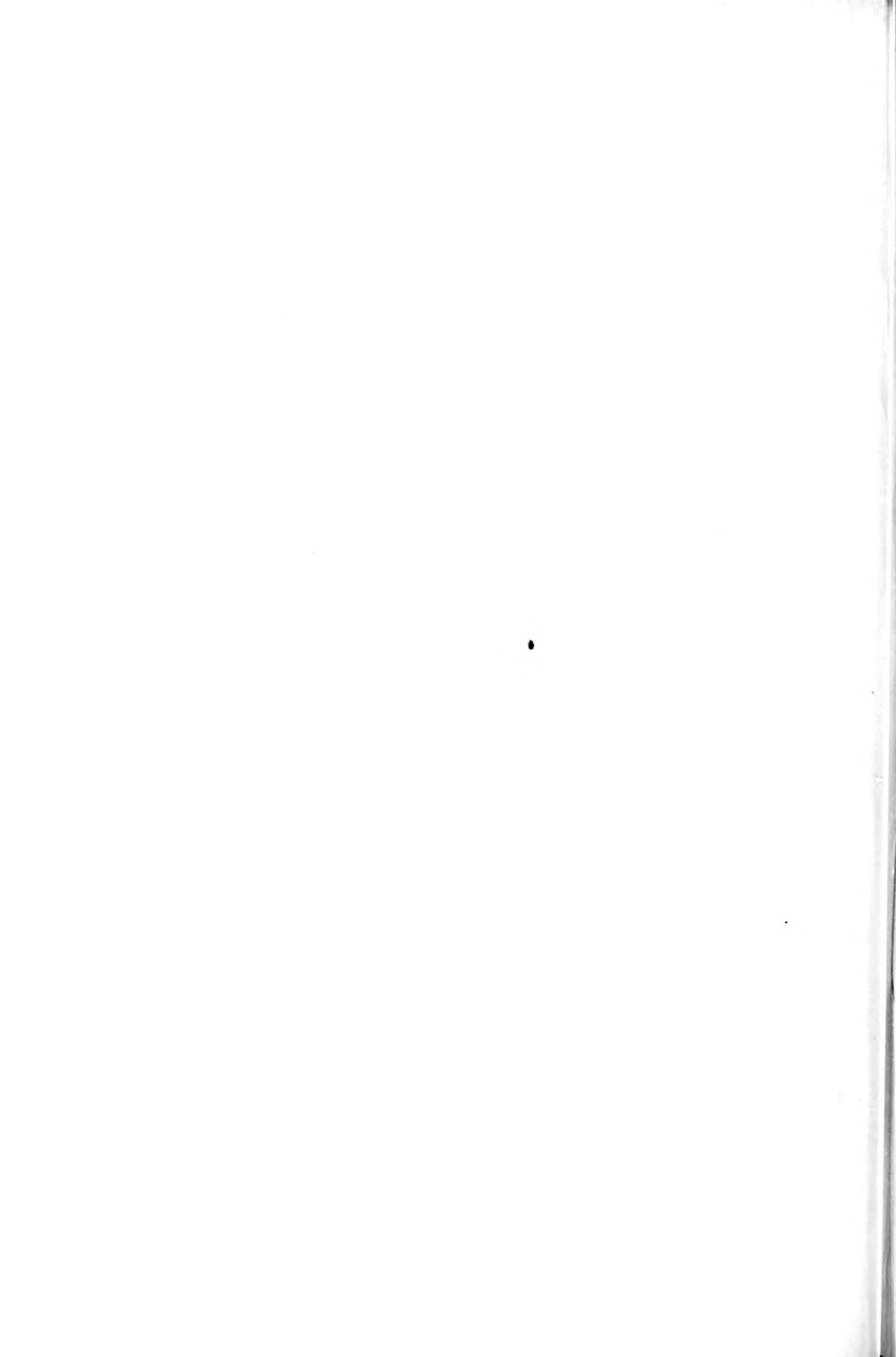

LIDB - 1818
T.M.
1970

PEABODY TRUST
BLOCK BUILDINGS
RODNEY ROAD, NEW NORTH
S. 1897

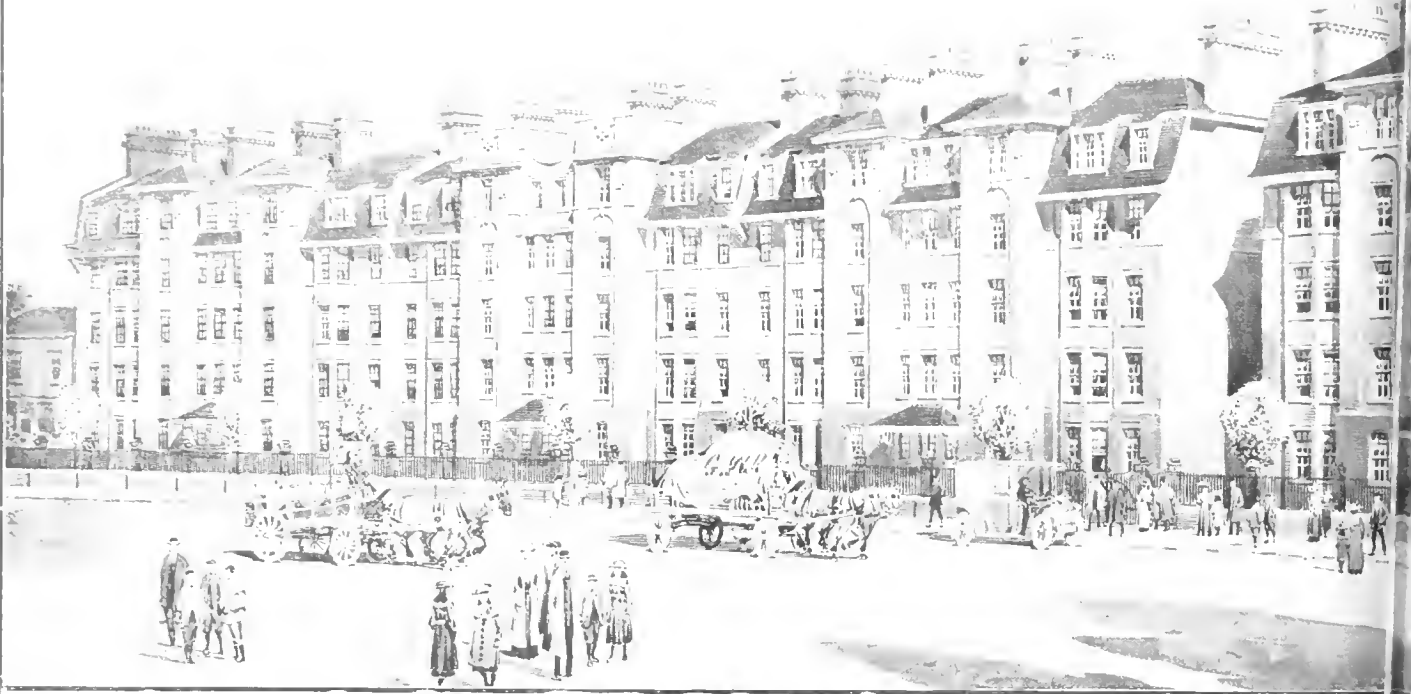

PEABODY TRUST BLOCK BUILDINGS, RODNEY ROAD



D, WALWORTH, S.E.—Mr. VICTOR WILKINS, ARCHT.

B. C. K. and F. at corner of Block A



Our Office Table.

Sir Edward Poynter last Thursday formally presented M. Eglise Rombaux's statue, "Le Premier Matin," to the trustees of the National Gallery on behalf of the subscribers to the fund in the Sculpture Gallery of the Royal Academy. The gift was accepted on behalf of the trustees of the National Gallery by Lord Plymouth, who announced that it is to be placed in the Tate Gallery. M. Rombaux was unable to be present as he is in Brussels. Sir Edward Poynter said that £865 5s. had been collected for the purchase of the statue in three weeks from 265 subscribers, of whom 150 were artists, and the remainder art lovers and writers on art subjects of all shades of opinion. M. Rombaux had put on his splendid work the modest price of £800, and the remainder of the money subscribed would be given to the fund for the relief of distressed Belgian artists. Sir Edward paid a high tribute to the Belgian school of sculpture and to M. Rombaux in particular. Of "Le Premier Matin" he said:—"It is a work magnificent not only in design and expression, but in that profound and masterly knowledge of the human figure and its capabilities of beauty, which is the characteristic of the great masters of the great schools of Greece and Italy; and these qualities it displays in the highest degree, the sense of form being as refined as it is colossal in conception." M. Paul Lambotte, the Belgian Director of Fine Arts, said the gift assumed the character of a symbolic act of homage paid by British artists to Belgian art.

In the spring of 1917 a "Palace of Industry" will be opened in which to hold two fairs, every spring and autumn, in which will be exhibited the main industries of the Empire. The site chosen is Willesden Green. Forty-four acres of land have been taken, and the buildings will be three times the size of Olympia. There will also be extensive pleasure grounds attached. Only wholesale manufacturers and their agents will be allowed to show their products, and admission to see them will be limited to traders and other possible customers by ticket. Each "Industries of the Empire Fair" will be run on the same lines and for the same object—the pushing of trade—as the Leipzig Fair. It will last three weeks, and invitations to visit it will be sent broadcast throughout the Allied and neutral countries. In the summer months it is proposed to hold a show of a more popular kind illustrating the scenery and natural advantages of all the countries in the Empire.

The principal Bavarian Art Societies have issued a joint appeal to the public to sacrifice artistic copper, brass, and nickel objects for the Fatherland. The circular says: "Intelligent public bodies can doubtless find monuments unworthy of the personage or event commemorated, which would yield great quantities of metal which the Army now so greatly needs; and further, cemeteries might sacrifice a large number of monuments to such a sacred purpose." We could very well spare a few here for similar use!

Mr. H. T. Chapman, the county surveyor of Kent, has just published his annual report, from which it appears that the total length of main roads in Kent under the direct control of the county council is just over 600 miles. The actual cost of maintenance, painting, and improvement work carried out during the year ended May 31 last. Mr. Chapman says, was £158,202 13s. 11d., an increase in outlay on the previous twelve months of £248 8s. Towards this expenditure £38,756 was received in the account year from the Road Board. A total of £54,636 17s. 10d. was expended upon painting, widenings, kerbing, channelling, paving and drainage works, and represented 1.0 per mile. The total cost of tar-painting carriageways amounted to £27,053 11s. 11d., 942,480 gallons of tar being used, the area treated being approximately 52 million superficial yards. There was also 20,224 gallons of tar used in the repairing of footpaths. The payments for tar alone represented £11,365 7s. 11d., the average price

paid per gallon being 2.7d. The total quantity of material used upon the roads under direct control was 143,401 tons or yards. The average price per ton for granite macadam, exclusive of haulage, was 11s. 5.47d., as compared with 10s. 11.54d. in the previous year, being an increase of 6.13d. Of the material used 50,962 tons consisted of granite macadam and 26,766 tons of Kentish rag tarred macadam. The cost of supervision, including county surveyors' and clerks' salaries, and maintenance of motor cars, was £3,499 13s. 11d., being equal to 2.3 per cent. upon the expenditure of £149,413 4s. 6d. Expenditure on improvements during the year amounted to £27,583 10s. 11d. The total Road Board grants received during the year amounted to £51,316. Mr. Chapman refers to the damage caused to macadam roads by the constant watering carried out by urban authorities, which is most destructive and seriously increases the cost of maintenance.

The *Daily Telegraph* comments pertinently on some of the complaints about false economy it is receiving. The effect of the war on the building trade is the subject of one correspondent's letter. He recalls the recommendations of the Parliamentary War Savings Committee, and mentions in particular the recommendation that "No one should build a house to reside in for himself or herself." "Inferentially," he comments, "it may be assumed that it is quite right to build a house for your friend's occupation, but not for yourself. Be that as it may, the folly of putting forward any suggestion tending to discourage the general public from investing in house-building, when fully appreciated, cannot be too strongly condemned. The building trade employs as many hands as any other trade in the country. Seventy-five per cent. of the money spent on a house is paid for labour. It cannot be suggested that money so spent goes out of the country, and the increased production of dwelling-houses is admittedly one of the great needs of the present day." It is added that if the economy doctrines now being inculcated are carried out in their entirety, the result in the building trade will be that "all over the country numbers of men who have been in regular employment for many years will be suddenly thrown out of work."

In their fifth annual report, the Road Board state that during the year ended March 31 last applications were made for £2,001,264, of which £1,541,684, or 77 per cent., was for improvements of road crusts, and £208,190, or 10.4 per cent., for widenings, diversions, and improvement of gradients, curves, and corners. The decrease of £592,541 in the amount applied for was probably due to an intimation given to the highway authorities that the Board were not prepared to continue making grants during the war to the same extent or on the same basis of distribution as in previous years. The receipts credited to the Road Improvement Fund during the year amounted to £1,620,974, and the net payments after deducting £93,266 for loans repaid were £1,386,175. Grants amounting to £1,698,884 and loans amounting to £482,418 were made. After the outbreak of war the Board undertook at the request of the Army Council to arrange for the construction at the cost of the Council of certain new roads, and to arrange with highway authorities for improvements in public roads, mainly at the cost of the Council, which were required for military purposes. The total estimated cost of the last-mentioned works was £475,669, to which the Army Council contributed £383,070, the Highway Authorities £30,591, and the Road Board £62,008.

As one of the useful series of pamphlets entitled "Indication of Houses of Historical Interest in London" the County Council have published a handbook relating to Holywell Priory and the site of the Theatre in Shore-ditch, and giving the results of careful investigations on the subject undertaken by an official of the Council, Mr. W. W. Braines. Notwithstanding the fact that Shakespeare is known to have been connected at one time with the theatre, its exact site has never

hitherto been determined with accuracy. As a result of Mr. Braines' inquiries to Records and Museum, however, the fact arrived at the conclusion that the theatre was situated within what was formerly the Precinct of the ancient Priory of Holywell. In due course a tablet will be erected on the spot to commemorate the fact, but owing to the necessity of restricting expenditure nothing will be done in the matter at the present.

The London County Council's first issued, at 5s. net, through Messrs. P. S. King and Son, Ltd., Vol. I of a Comparative Municipal Statistics, for 1912-13, giving full particulars regarding the municipal life of sixteen great towns in the United Kingdom during the years dealt with. The resident of London, Birmingham, Liverpool, Manchester, Sheffield, Leeds, Bristol, Newcastle, Cardiff, Swansea, Glasgow, Edinburgh, Dundee, Aberdeen, Belfast, or Dublin can find out just how his city stands in relation to the others, in the matter of area, population, occupations of the people, pauperism, drainage, wages, rates, prices paid by the working classes, parks, crime, education, tramways, gas, water and electricity supplies. An illuminating introduction is contributed by Sir Laurence Gomme, till recently clerk to the council. Taking the year under survey, London had to pay 66s. 11.9d. per head for her general municipal services. The six next greatest English towns escaped with an average of about 47s. each. Education cost 8s. 6d. a head more in London than the average for the other six towns; police about 4s. 6d. a head more. It is shown that there is a slight general increase in the cost of any given service per head as the size of the town increases. There is a tendency for the cost of nearly all services to reach a minimum in towns of about 90,000 population, though the cost of gas and water services tends to decrease as population increases even above that figure. The cost per head in towns of 250,000 and over considerably exceeds that in towns of fewer than 250,000. The increase of the cost of administration, owing to the size of the towns, is found to be affected by the question of site values.

It is stated that the action of the Berkenhead Corporation in serving notices on the owners and occupiers of Oxtou and Cloughton respecting a town planning scheme for those areas is not in any way a breach of the policy of "municipal economy during the war." The serving of the notices involved a cost of only about £5, but the process served the purpose of preventing a pre-war expenditure of some £200 being rendered useless. The effect of what has been done is to avoid the possibility of any part of the districts being spoiled by the whim of individual owners pending the making of the contemplated order. The only question at the forthcoming Local Government Board inquiry will be whether or not the Board will allow the Corporation to prepare a scheme of town planning, and no further expense is likely to be incurred until long after the end of the war.

In consequence of the restriction of building work by public bodies and the refusal of loans for housing purposes by the Public Works Loans Board, a statistical report has been issued by the National Associated Building Trades Council showing, approximately, the number of men of military and non-military age still likely to be affected by any general stoppage of employment in the building trade. Men nineteen years and over total 1,148,369, of whom there are eligible by age for service 865,098. Not eligible by age, 283,771.

The hearing of the charge of manslaughter against Mr. Alexander Montagu Pyke, managing director of the Cambridge Circus Kinematograph Theatre, Ltd., Charing Cross Road, and Mr. Lionel Grant, the chief engineer, was concluded last Friday at Mornington Street. The charge arose out of a fire at the theatre in which a workman named James Powley was burnt to death. It was stated that there was stored at the theatre a ton of old films which had been obtained by Mr. Grant and Mr. Pyke, who were going to supply them to Pathé Frères. At the pre-

Mr. Pyke was given as to the sum of £65 to Grant for trial. Mr. Frampton submitted evidence to justify Mr. Pyke's conviction for trial. The Magistrate seemed to him that the case was stronger against Grant than against Pyke. The case against Pyke was given as to allowing the film to be shown. He thought there was a doubt, and that under the direction of a judge should be a further negligent steering was sufficient to amount to manslaughter. Defendants reserved their defence, were committed for trial, bail being allowed as before.

The effect of the war has been felt at the Royal Academy, as elsewhere, but the attendances at the summer exhibition, which closed on Saturday night, have, it is said, exceeded expectations. The customary lantern slide series, which in normal times mark the opening of the exhibition, were this year abandoned, and the only public function has been the formal presentation to the trustees of the National Gallery of M. Ramboux's statue, "Premier Matin," for the nation, which took place on Thursday last in the sculpture gallery. In all 1,926 pictures have been on view this year, compared with rather more than 2,000 last summer. No decision has at present been arrived at as to the holding of a winter exhibition.

The tower of Woolwich Building, New York, the highest "sky-scraper" in existence, is now seen by night as well as by day. An installation of electric projectors renders every architectural detail visible from the roof of the main building to the crow's nest, or lantern, which forms the sixtieth storey. For this purpose 600 lamps, each of 250 watts, similar to those used on motor-cars, are used. They are of the new gas-filled type, and while some throw their rays upwards from the gables of the roof on to the sides of the tower, others shine down from the tower top itself, these being hidden by an ingenious system of screens. The surmounting lantern contains twenty large lamps giving together 45,000 candle-power, and by means of diffusing glass and an automatic dimmer, the intensity is constantly varied from a dazzling brilliance to a deep red glow.

The oldest bell in the diocese of Liverpool is said by the *Liverpool Daily Post* to hang in Roby Church. The bell is the tenor of the old ring of four in Huyton Church, and when the Huyton peal was increased to six, as the bell in question was not to be a tone and quality to harmonize with the new bells, the vicar and churchwardens presented it to Roby, where a tower was built for its accommodation. This was in 1346. The present church dates from 1275. The bell is believed to be the only pre-Reformation bell in the diocese. There is a local tradition that it is of Spanish manufacture, but this is erroneous, for it is certainly of Nottingham make, probably by Richard Selwoke. It is 40 in. in diameter. It bears the inscription: "See-Bedietie, I S P, A D, 1512." The lettering is Gothic, but the numerals are Arabic, a very early use of such figures on bells, only two earlier being known to exist in England. The 5 in the date is in the shape of the letter "h." This form of the numeral was first used by Gower in 1400, or thirty-two years before the bell was cast at Nottingham. The 5 indicates a number of archaic taste, for the present form of the numeral came into general use in 1500, and has been commonly employed ever since.

In connection with a factory building which has just been erected at Windsor, Ont., the method of floor construction is of more than passing interest. The walls of the structure are of brick, while the floor is of concrete, the latter being on a level with the concrete foundation. Below the floor level is a 5-ft. thick gravel bed, which is laid as follows: A dam of sand is built around an area of convenient size and this area is flooded with water and the gravel sprinkled with it. The height was raised in this manner 1 ft. over the entire area of the building, and the operation was repeated until the desired 3-ft. thickness of gravel bed. The point is made that the result of this method of washing the

gravel a very hard fill was secured. On top of this is a covering of maple flooring fastened to sleepers embedded in the concrete.

The suggestion has often been made that steel should be painted before being embedded in concrete, with the idea of protecting the metal from corrosion. An investigation of this proposal has been conducted by Mr. H. A. Gardner, of the Institution of Industrial Research at Washington. One of the results brought out was the statement that painting may have a distinctly prejudicial effect. One serious objection to the use of paint in reinforced-concrete is its interference with the natural adhesion bond between the steel and the concrete. It is true that painted surfaces may be improved by being coated with crushed quartz or fine sand, but even then the presence of the paint is objectionable because it is interposed between two materials capable of entering into chemical combination, resulting in the formation of a rust-resisting compound which adds very greatly in the efficiency of the bond.

A process of rust-proofing steel and iron is being promoted by Henry C. Barnes, engineer and metallurgical chemist of Barnes' Metallurgical-Chemical Laboratories, 411, First Street, Jackson, Mich. The process was developed in 1903, and several English factories were equipped for treating metal parts by it. The treatment consists of boiling the parts to be rust-proofed in a combination of chemicals for from fifty minutes to two hours, depending on the depth of rust-proof coating required and the size and bulk of the articles to be treated. The equipment required consists of an iron tank of a size necessary to accommodate the products to be treated, and a few utensils. The tank may be heated by steam or by any other heat. The cost of the treatment, including chemicals, heat and labour, is less than one cent a pound for small articles, averaging five to the pound, and the cost decreases in proportion to the increase of weight and bulk of the material treated. It is claimed that iron and steel, both wrought and cast, can be rendered permanently rust-resisting, and that it imparts a black matt finish to the metal, thus providing an attractive colouring and rust-proofing in one process. The treatment is well suited for articles to be painted, as it furnishes a ground impervious to rust and chemical action, and effectually prevents peeling of paint due to these causes.

The restoration of the North Luffenham parish church tower is entrusted to Mr. S. F. Halliday, of Stamford, and the summit of the spire has been removed preparatory to rebuilding.

At the quarterly meeting of the Hants County Council, held at Winchester, it was reported by the Education Committee that only five out of thirty-two recommendations for school repairs would be carried out owing to the war, whilst the contracts on painting and re-decorating the schools had been cut down from £3,500 to £1,700. It was, however, decided to build a school for girls and infants in Station Road, Sholing, at an estimated cost of £9,540.

At Avonmouth the dockers' canteen which has been erected close to the dock gates was opened on Saturday by Lord d'Abernon. The premises, which have cost £5,000 to build, are semi-permanent in character. Over the timber framework supporting the walls light steel work is fixed, and this is clothed with cement. The lower part of the wall is covered with steel plates, painted green, to form a dado, while the upper part and the ceiling are white. The floor is of concrete, and electric light is provided for artificial illumination. The canteen has been put up in four weeks by Messrs. Perry and Co., Ltd., of Bow, E.

While engaged in making an opening in the wall of Albasdony, adjoining Old Friars, Richmond Green, which has been used as a Red Cross hospital for some months, the workmen discovered an old plaster wall, which appears to be part of the interior wall of the Convent of Observant Friars, which was built in 1499, and on which was a coloured fresco of floral design in excellent preservation. A section of the fresco is being submitted to experts by the local librarian, Mr. Barkas. The convent, which was occupied by the Franciscans of the Grey Friars, covered a large area adjoining the old palace, on the site of which Maid of Honour Row and other residences now stand.

Building Intelligence.

BELFAST.—Operations have been commenced in connection with the demolition of the Theatre Royal, the site of which is to be utilised for the erection of a picture house on a large scale. Messrs. Warden, Ltd., the owners of the Theatre Royal, intend to erect a building which will bear comparison with any other structure of the kind in the United Kingdom. The plans have been prepared by Mr. Crewer, who designed the Royal Hippodrome, and the contract has been let to Messrs. H. and J. Martin, Ltd., of Belfast. The whole of the ground floor will be devoted to stalls, with upholstered chairs, and there will be a large and well-equipped circle. Accommodation will be provided for an audience of about 1,500. It is expected that the building will be ready about Christmas.

DUBLIN.—Artisans' dwellings for the corporation of Dublin on the Church Street and Beresford Street area are shortly to be commenced by the contractors, Messrs. Fraser and Co., Gloucester Street. This scheme involves the clearing away of nearly four acres of slums, which portion of the work has just been finished by the corporation themselves. The total number of houses to be erected on this area is 146, made up as follows:—24 four-roomed, 94 three-roomed, and 28 two-roomed, the respective frontages being 15 ft., 14 ft. 4 in., and 15 ft. All the streets bounding this scheme are to be considerably widened, and provision has been made for the laying out of a playground, an ornamental shrubbery with fountain in front of the church, sand pits, seats, etc.

GIANTS' CAUSEWAY.—New schools were opened on the 4th inst. at Giants' Causeway. The building was designed by Mr. Cluff Williams Ellis, of London. The body of the hall can be divided into two sections, and the gallery can be utilised for social functions. The exterior is enhanced by a spire with a bell, and in the entrance there is a marble tablet, and in front of the gallery a bust of the late Lord Macnaghten. The building contract was carried out by Mr. John Carson, Ballymena, and the heating by Messrs. J. McCandless, Ltd., Coleraine.

PLATT BRIDGE.—The new Moss Lane Council School is opened to-day. The arrangement of the schools is on the pavilion principle, the central hall being placed in the centre, with the classrooms radiating therefrom. No classroom has direct access to the central hall. The exterior has been kept severely plain, as, apart from the site suggesting a plain structure, it was considered wise by the committee, in place of useless external ornament, to have an up-to-date interior, with the latest and best sanitary and other fittings. The buildings are faced with "grey" bricks, relieved with red quoins, string courses, and bases. The roofs are covered with slates, and the stonework throughout is red sandstone. The central hall is a lofty and well-proportioned room 40 ft. long and 22 ft. 6 in. wide. The school is divided into two departments—mixed and infants. The mixed department provides accommodation for 250 children, and contains five classrooms—one for 60, three for 50, and one for 40 children. The infants' department provides accommodation for 200 children. The department contains four classrooms—one for 60, two for 50, and one for 40 children. In addition, there are head teachers' rooms on the ground floor, and on the upper floor two assistant teachers' rooms, store rooms, and lavatory accommodation. Messrs. Massey Bros., of Enfield Street, Wigan, were the contractors, their sub-contractors for the work being:—Masonry, Mr. E. Orrell; plumbing, Mr. E. Popleston; plastering, Messrs. W. and I. Moorby; decorating, Messrs. Dawber and Cheetham; Mr. A. Platt, of Hindley, acted as clerk of works. The schools, the builder's contract for which amounted to £6,050, have been erected from plans and quantities prepared by Mr. Herbert Wade, of Birley Street, Blackpool, who, a few years ago, designed the Argyle Street Schools for the council.

LATEST PRICES.

N.B.—All prices must be regarded as merely approximate for the present, as our usual sources of information are in many cases failing us.

TIMBER.

Owing to stoppage of supplies all prices have advanced considerably.

IRON.

Table listing various iron products such as Mild Steel Joists, Wrought Iron Girder Plates, Steel Girder Plates, Bar Iron, and Cast Iron Columns with their respective prices per ton.

Table listing B.B. Drawn Telegraph Wire, Galvanised Sheet Iron, Cast Iron Sash Weights, and other iron-related items with prices.

OTHER METALS.

Table listing various metals and alloys including Lead Water Pipe, Lead Barrel Pipe, Lead Pipe, and other metal products with prices per ton.

SLATES.

Table listing different types of slates such as Blue Portland, Blue Banner, and First Quality with prices per 1,000 at railway station.

BRICKS.

(All prices net.)

Table listing various types of bricks including First Hard Stocks, Second Hard Stocks, Mild Stocks, and other brick varieties with prices per 1,000.

GLAZED BRICKS.

HARD GLAZES (PER 1,000).

Table listing glazed bricks with different colors and finishes such as White, Ivory, Buff, Cream, and others with prices per 1,000.

MOULDED BRICKS.

Table listing moulded bricks including stretchers and headers, internal and external angles, and other specialized brick shapes with prices.

STONE.

Table listing various types of stone such as Red Mansfield, Darley Dale, and other stone varieties with prices per foot cube.

Table listing Bath Stone and Portland Stone with prices per foot cube, including details about delivery and location.

TILES.

Table listing various types of tiles including plain red roofing tiles, hip and valley tiles, and other tile varieties with prices per 1,000 or per doz.

OILS.

Table listing various oils such as Rapeseed, Olive, and other oil products with prices per ton or per gallon.

GLASS (IN CRATES).

Table listing different types of glass including English Sheet Glass, Fourths, and other glass products with prices per 32oz or 63d.

VARNISHES, Etc.

Table listing various types of varnishes and finishes such as Fine Pale Oak Varnish, Copal Oak, and other varnish products with prices per gallon.

A memorial stone has been placed in Hawarden Churchyard on the grave of the late Lieut. W. G. Gladstone, Lord Lieutenant of Flintshire, and M.P. for Kilmarnock Boroughs, who was killed in action in April last.

THE BUILDING NEWS

AND ENGINEERING JOURNAL.

Effingham House.

CONTENTS.

Strand, W.C.

Factory Construction.—Loads on Stanchions and Girders 197
 Contemporary Architecture in India 199
 The Royal Photographic Society's Exhibition .. 200
 Training in the Methods of Teaching Building Subjects 200
 The Efficient Control of Reinforced Concrete Construction 201
 Town Planning in South Australia 201
 Developments in the Manufacture and Use of Brick 202
 Currente Calamo 202
 Our Illustrations 203
 Our Office Table 221
 Obituary 222
 Statues and Memorials 222

Correspondence 222
 Building Intelligence 223
 Trade Notes 223
 Legal Intelligence 223
 Competitions 224
 Professional and Trade Societies 224
 Chips 224
 To Arms! 224
 Meetings for Raising Week 224
 Latest Prices 224
 Tenders 224
 List of Competitions Open 224
 List of Tenders Open 224

Contemporary Architecture in India—Agricultural College Students' Hostel, Poona; Mr. G. Wittet, Architect. Science Institute, Gujarat College, Ahmedabad; Mr. G. Wittet, Architect. Civil Court House, Jabalpur; Mr. H. A. Crouch, F.R.I.B.A., Architect. Post Office, Agra; Mr. John Begg, F.R.I.B.A., Architect. Mount Abu Residence—Staircase in Hall; Mr. John Begg, F.R.I.B.A., Architect.
 Dunblane Cathedral. Details of West Front. Measured and drawn by Mr. J. Scott Lawson.
 Selected Design. Small-pox Hospital, Whitby, Leven. Plans, Elevations, Sections, and View. Mr. H. Irving Graham, Architect.
 Week-end Cottage, Gower, near Swansea. Views and plans. Mr. Glendinning Moxham, F.R.I.B.A., Architect.

OUR ILLUSTRATIONS.

Jubé, Dixmude, Belgium, XV. Century. (Demolished by the Germans.)

FACTORY CONSTRUCTION.—LOADS ON STANCHIONS AND GIRDERS.

Part IV. of the London County Council (General Powers) Act, 1909,* contains regulations controlling the structural design of framed steelwork, such as required in modern factory and workshop construction. The Act enforces roofs and floors of certain minimum strength. So-styled "superimposed" loads must be provided for: thus the total load is that of the structural parts themselves plus the superimposed loads, as in the case of a warehouse type floor of, say, 2,500 superficial feet, divided by girders into 10 ft. bays. The superimposed load allowance is here 2 cwt. per foot super., so that 5,000 cwt. is to be provided for in addition to the actual weight of flooring itself, which, if it weighs $\frac{3}{4}$ cwt. per foot super., adds 1,875 cwt.; or dead and super-imposed load = 6,875 cwt. These rules obviously do not affect ground or one-story buildings which have directly earth-borne loads on floor. Load calculations are most conveniently commenced from the roof. The pressures being accumulative, floor below floor, this is the natural way to perform the operation of estimating the stresses put upon and sections necessary for girders, joists, and stanchions.

For roofs, those of greater inclination than 20 degrees with the horizontal are required to be suitable for a superimposed load, "which for this purpose shall be deemed to include wind pressure" of 28 lb. per foot super. measured over the sloping surface, while flat roofs come under the low-pitched rule of 56 lb. per square foot "measured over a horizontal plane."

Roof calculations are thus simple for straightforward plans. Our assumed building of 100 ft. x 25 ft. must allow for dead load—the roof structure itself—and 56 lb. per super. foot. Assuming the roof to weigh the same as a floor, the total load to be carried by the roof girders is $56 + 84$ lb., or 140 lb. per foot super. and on each intermediate bay $\frac{140 \times 2,500}{10}$

=over 312 cwt., say 15½ tons, which is a great deal less than a warehouse type floor load; and on this account the uppermost stanchions in all steel-framed buildings require, by comparison with the uppermost floor stanchion, a very light steel section. For practical convenience in making attachment, as in the case of

the scantlings of timber roof trusses, a larger section than satisfies theory may be adopted.

We have had in mind a construction free of stanchions, the girders spanning the void of 25 ft. This is a very simple

proposition, for if all floors carry equal loads the sizes of beams and their weights per foot run are similar. So far, therefore, as girders are concerned only two different sections are required, one for roof and one for all floors. The accumulation of pressures is in the brick wall-

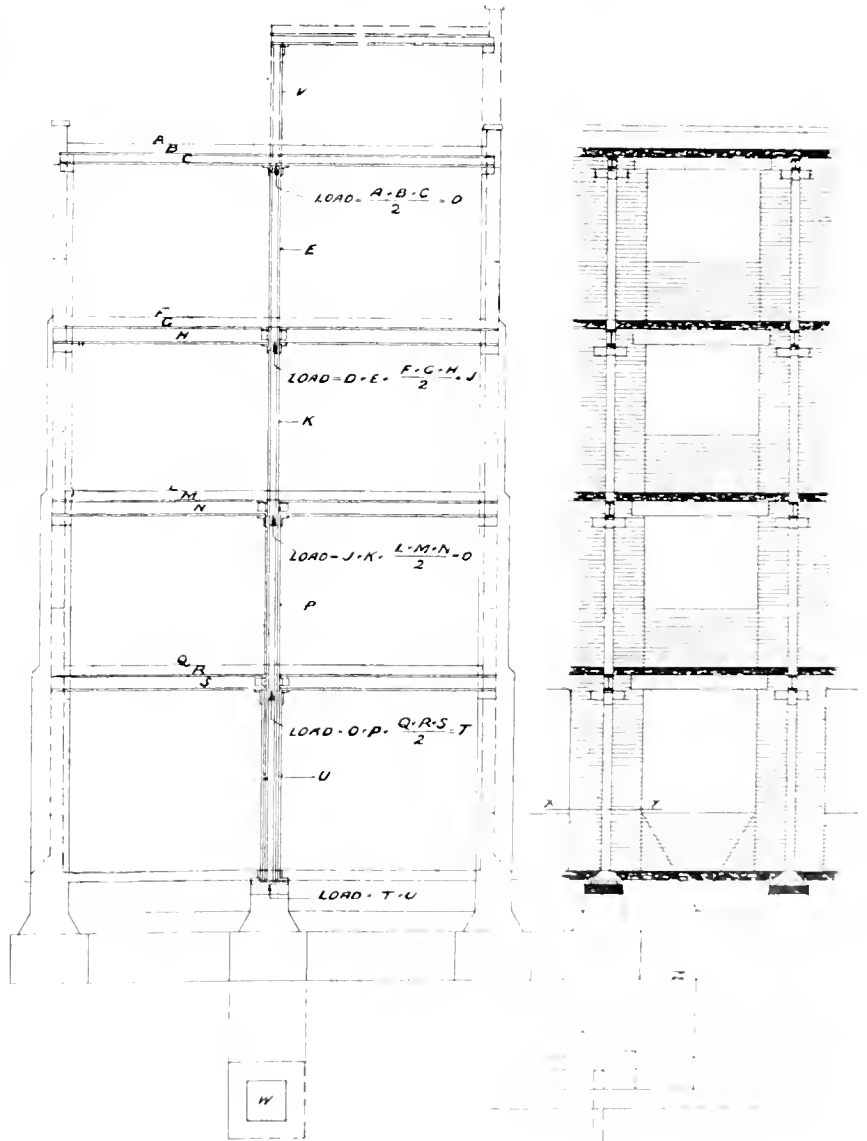

* Readers will bear in mind, of course, that the new regulations of the London County Council with regard to Reinforced Concrete were passed by the Council on July 6 last and that the Local Government Board is about to fix a date for their coming into operation. They affect nothing stated in this article, but should be carefully studied by all interested. They have been given in our issues of July 14, 21, 28, and August 4.

in ground floor level must be in some part curtailed, unless we arrange piers buttress fashion, which might not be convenient, and not apparently a valid recourse under the regulations. We note here a point in pure steel-framed construction and brick piers reinforced with

stanchions, that is, that which would normally be a wall.

Let us assume a case of four floors, and let us take the total pressures applied to the piers are to be (1) the full, (2) the first, second, and third floors, and (3) the piers, etc. As we have taken a case without spandrels and stanchions, the whole load at intermediate bays, i.e., where end walls do not form part of the load, is concentrated on the piers, and the stress in the brickwork will be greatest at the level of the ground floor window sills, as at X-Y in the diagram. Below this the stress on the brickwork naturally decreases, as indicated, if there is solid walling between the piers, but if, as shown, with 9-inch screen walls, the practical method would be to consider the stress decreases only below floor-line. In any case, it is easy to distribute load on foundations at Z, with economy in concrete. The Act quoted regulates these pressures as five, eight, and twelve tons per square foot respectively on ordinary, on hard, and on blue brick, all in cement mortar. Having arranged the wall to be in due accord with regulations as to thickness in 4 1/2-inch multiples, for height and length, we must cut out the window space, leaving sufficient area to meet the requirements of the Act. As there are few buildings in which window area is not important, the indications here are plainly for the auxiliary steel stanchions and genuine framed steelwork throughout. In some cases it might be a fine matter between, say, blue brick and steel, and we need to weigh pros and cons. The nature of consistent steel construction would appear an attraction in favour of such method of building. There may be something more of mere sentiment often in this than of hard matter of fact. The complete steel framing is plainly first in respect to tie, but as we endeavor to point out in our diagram B, Fig. 5, in our article on "Various Methods of Factory Building," where there are, ranging axially with pier centres, two or more stanchions properly connected to girders, the tie here is good still, and the auto-stability, as it might be termed, of solid vertical brick walls satisfies all demands merely by providing for carrying dead weight, i.e., omitting, as superfluous, "tie" as it is understood by the steel framer; but there is obviously a point where we must revert to complete steel designing, basing our reason in the argument that, without such, skyscrapers would be impossible. In other words, where large window area is demanded below, a point is reached in lofty buildings where integral steelwork, with complete tie by plate, rivet, and bolting, is a necessity.

In the case assumed, and considering intermediate bays, where cross-walling does not interfere with the calculations, the total load of 1,390 tons brings, say, 1390 / 20 = 69.5, say 70 tons on each pier, being with blue brick in cement mortar, say 6 super. ft. of brickwork to be in accordance with the laws. The wall of cross-section being 100 ft. long and, say, 50 ft. high, and must have at base a width of 27 ins. or three blocks. To be correct, we must add the weight of girders to carry the 500 cwt. of one bay, say, if 25 ft., we cannot well afford less than say, 112 lbs. per ft. of weight of total channel and flange plate. With a 2 ft. girder, this would add, say, one and a half tons of weight at each bay, but with a 3 ft. girder a number of seventy tons. With 2 ft. 3 in. walls we shall

need piers 3 ft. wide, allowing 7 ft. window voids, which, for our assumed factory warehouse type building, suggest blue brick as satisfactory, with no special call for external steel stanchions. Let us double the height. We may then use 2 ft. 7 1/2 in. piers of total length not less than one-quarter the length of wall. We may, for these approximations, call the load at level of ground floor sill-line (X-Y) double our former figure, or 140 tons on each pier, neglecting girders. As we are compelled to make at least 25 ft. of pier in 100 ft. walls, we get an area of 2 ft. 7 1/2 in. x 2 ft. 6 in., which will be insufficient for 140 tons, which needs 140 / 12 = 11.67, say, 12 super. ft. We shall need,

in blue brick, some 5 ft. in length of pier on ground story, which leaves 5 ft. windows, suggesting that for so many stories steel wall allow much better lighting of the ground floor premises. Light is the gain by use of steel, and it is plainly all important in factory planning. Light, too, may be gained by the not generally economical recourse of increasing the bay dimension. It appears demonstrated that, in modern practice, any such many-storied warehouse-type floored building would, so far as the important point of light on lower floors is concerned, be more advantageously constructed of homogeneous steelwork with complete tie.

We will take one bay of a building, as in the diagram on previous page, and consider the loads in part carried by an intermediate stanchion dividing the span from back to front walls into two. The load upon the stanchion, E, is plainly one-half that of the sum of the dead and superimposed roof loads plus the joist carrying the concrete; while the load upon each third floor pier head is this latter amount halved. The load is transmitted by the stanchion and piers to the third floor level. We add to the load on the stanchion its own weight. When we say that the load is on the stanchion, it is well to explain that the prop has to be arranged to carry such load, with a suitable factor of safety; for the load, A, in diagram, is the legal "superimposed" load of 56 lbs. per foot super., and is non-existent, excepting when, as in a heavy fall of snow, some portion of the potential load is placed actually on the roof. The stanchion, E, however, must be of such strength as is suited to withstand the whole load, as stipulated, together with the fabric of the roof. In the same way the "superimposed" floor loads, F, L, and Q, together with the "dead" loads, must be adequately sustained by the series of stanchions. To arrive, finally, at the pressure upon the template under the lowermost stanchion, we take into account the loading as set out on the diagram. It is plainly the sum of one-half the total weight of dead and superimposed floor and roof loads, and of the stanchions of an intermediate bay. The result is a structure suited to carry the full superimposed floor loads of 2 cwt. per square foot which is required for buildings of the warehouse class. In buildings not of this class, where of more than two stories in height, certain reductions may be made and are scheduled in the Act. Let us assume a load on the lowermost stanchion headplate of fifty-five tons. If we are to use blue brick in cement, at twelve tons per square foot allowable pressure we need 12 superficial feet in the lower pier. In practice one would put at least 2 ft. 3 ins. by 2 ft. 3 ins. piers, and must spread the footings and provide a bearing on the earth of area suited to its foundation quality. The Act regulating these matters provides for

certain pressures upon certain earths, and this is a point which in reality needs a knowledge of the site and subsoil before any decision can be made. The scheduled list allows, per square foot, one ton on soft clay or wet, loose sand, two tons on natural clay or confined sand, and four tons on compact gravel, blue clay, or chalk. According to the Act, therefore, from one to four tons per square foot may be placed upon earth, according to its nature as judged, if need be, by the authorities. If we were building on the poorest soil, the best recourse is a raft-like steel-and-concrete grillage; on a thoroughly sound bottom, ordinary cement concrete. In the former case our foundation must spread to an area in feet equivalent to the tons of pressure—the load, or fifty-five tons above estimated; and even the two-ton basis needs a considerable spread of concrete, or 27 1/2 super. ft., and the footings must swell out in number in suitable accord, in practice say, 5 ft. 6 ins. square of concrete of a suitable depth.

It should be noted that there is a further advantage in reducing span, because less load coming on the exterior girder-ends, the area of the piers may be reduced. From this results easy gain in window space. Our calculations and estimates have been exceedingly rough and approximate, but the general trend shows the kind of work required by the designer of quite plain many-storied warehouses and factories. And it cannot be said to be anything but simple and elementary until complicated and irregular plans are encountered with irregular stressing of steel stanchions and unbalanced loads. In the simple illustration given we have a balanced loading of the stanchions. If we introduce stanchions into walls, or as V, in the diagram, all such are unequally loaded, and under such conditions the strength of the stanchion must be increased from two to two and a-half times that required for balanced loading. But it is plain that stanchions well pinned into solid brick walls receive support from such walls. Stanchions in exterior walls are placed with their plane of maximum "radius of gyration" across the wall—in simple English, the flanges are parallel with the wall. Hence the steel prop is strengthened in the direction of its greatest weakness.

Unless we are building in a country of potential earthquake shocks there is no reason for hastily deciding to provide a complete steel framing even for comparatively large buildings. Given sound, adequate walling, a design embracing central or interior framing tied with rivet, bolt, and plate, with exterior girder-ends on felt and stone templates, would even seem to present certain advantages. It is a real saving in cost where, whether steel wall-stanchion or not, a wall of certain specified thickness relative to height and length has to be provided. Interior girders, joists, and stanchions, if, as said, more than two in line, form with cleats and plates ample tie, such that allowing in imagination the exterior girders to project unsupported—except as cantilevers—all conditions of equilibrium are met by roving plumb walls to catch up the ends of the beams. They give a practically direct downward thrust by virtue of the elastic packing above the templates. There is no irregular stressing. This is not the case when the girders are secured to exterior free-standing stanchions, which are then the subject of unbalanced forces. With scientific steel design interiorly, such a building satisfies all demands of stability. It is, with securely bolted-up girders and stanchions, a different affair from the ill-

ried structure of twenty-five years back, with its cast-iron columns and joists and girders on brackets bolted, in country blacksmith's fashion, with one or two inefficient bolts. The argument assumes sound, plumb walls upon enduring foundations. If we miss this, then, when a length of wailing subsides, irregular stresses are communicated throughout the series of tied stanchions and girders of the interior construction.

CONTEMPORARY ARCHITECTURE IN INDIA.

(WITH ILLUSTRATIONS.)

The Agricultural College Students' Hostel at Poona, erected from the designs of Mr. G. Wittet, consulting architect to the Government of Bombay, accommodates 120 inmates connected with the college with which it is associated. The main building contains the students' rooms, while the dining-rooms, cook rooms, bathrooms, and the like form detached blocks at the rear. The work was carried out in local grey trap and the roof covered with red Mangalore tiles. The total cost was Rs. 1,60,181, giving a rate of annas 5.92 per cubic foot.

The Science Institute Gujrat College, Ahmedabad, comprises on the ground floor the physics and natural history departments, while the upper floor is occupied by chemistry. Two well-equipped lecture theatres are located at the back. Local red brick is used for the walling, with dressings of white Hemnagar stone, Mangalore tiles being employed for the roof covering. Adjoining this block of buildings is the Sir George Clarke Library, since undertaken, as well as a new bungalow for the principal of the college in the same compound. Mr. G. Wittet is the architect of the institute.

The Civil Courthouse, Jubbulpore, in brick and stone, has a carriage porch leading to a cloistered verandah on the front side, the treatment of its arcade being similar to that shown in the photograph here given of the back view. The treatment is very English in style, with the mullioned windows. Mr. Henry A. Crouch, F.R.I.B.A., Consulting Architect to the Government of Bengal, is the architect.

The Post Office, Agra, is also completed, and its designer, the Architect-in-Chief to the Indian Government, Mr. John Begg, reports his satisfaction with the way in which the building work has been carried out from his designs. It is his opinion that in general appearance the building realises his intentions as being "successful in grouping and mass and in scale of detail." Some modifications in the lower part of the central dome have been carried out with good results prior to its final finishing.

We have also to-day chosen the photograph of another of Mr. John Begg's works in order to illustrate the staircase in the hall of the Mount Abu Residency. We have, however, no particulars of the building, which certainly serves to illustrate the versatility of the architect.

These undertakings figure among some thirty-two plates, chiefly reproduced from photographs, and forming the illustrations of the official annual report issued by the Office of Public Works in India for the year ending with 1914. The letterpress is written mainly by Mr. Begg, as architect to the Indian Government. Our choice of subjects is to be taken as fairly representative of the type of architectural adoption now in vogue in India under his supervision, aided by the provincial architects at the present time. Certainly these samples are among the best in point of design produced during the twelve months

covered by the limits of this architectural review of the year's doings. The average merit of the majority of these Indian buildings is comparable with similar enterprises at home. They are certainly diversified, and this quality, of course, is largely due to the particular purposes for which the designs were made. The collection does not include any big undertakings of outstanding interest. We look, however, in vain for an evidence of any concerted scheme for the evolution of modern building on fresh lines under local conditions following upon historic traditions or as marking the employment of new or

new materials. It may be said, perhaps, that some lack of unity of idea and comparability of design is shown by the building. The memorial church at Maymyo, by the late H. Swinton Morris, F.R.I.B.A., is represented by an interior having semi-circular arches in a brick arcade, with piers to match and bold cushion-shaped capitals. The venture of an official architect in ecclesiastical building is marked by boldness and a breadth of manner expressed in a moderately suitable and modern way in civil building lines. The exterior, perhaps as less in accord with a place of worship as



MOUNT ABU RESIDENCY STAIRCASE IN HALL.

Mr. J. BEGG, F.R.I.B.A., Architect.

local materials, in different districts. Possibly such an ideal is not now possible, and facility of transporting building materials from long distances may account for the likeness of character seen in not a few of these public buildings, in which the architect employed appears to be able to Europeanise most things, though now and again we remark notable exceptions to this tendency. For instance, Mr. John Begg has made a good attempt in the Agra Post Office to illustrate a combination of Eastern forms with European precedents, the whole purpose being controlled by a determination to meet contemporary requirements in a practical and architectural manner. This also is observ-

distinct from preaching principles considered. Colonel Sir Swinton Morris, K.C.I.E., now somewhat settled in England, built largely for the Government in India. He favoured the traditional style in a manner familiar to the member his considerable experience of this kind, as P. V. V. W. has done during a long period of years. The Medical College Hospital, Lucknow, in its crests and turrets, and in its Indian detail, is one of the best of his designs. The new Law College, Alahabad, also from his hand, is large and imposing, and Sir Swinton Morris designed the King Edward Memorial, Ajmer. The Gwalior Residency, if hardly conceived

on the same precedents, exhibits an attempt to assimilate types of that combine, and successfully scores in making an advance on the contemplated adaptation line towards developments. This last-named building differs essentially from ideals worked for by the younger generation of architects. We do not say which is preferable, and a comparison would be invidious. In our personal judgment, a dead style can never be brought into line with living aspirations and as a provision in the future. Mr. John Begg has done much in that direction, and much more remains to be accomplished.

THE ROYAL PHOTOGRAPHIC SOCIETY'S EXHIBITION.

The sixtieth annual exhibition of the Royal Photographic Society, which opened on Monday at the Suffolk Street Galleries, Pall Mall, suffers from the absence of Continental work, but is a representative display of British camera art of the present day. The collection is arranged in sections embracing pictorial, scientific, technical, colour, professional, and trade work, the last class having found re-admittance, possibly owing to the stress of war conditions, after an absence extending over several years.

As usual, the largest room, the lecture hall, is devoted to the pictorial section, numbering over 170 exhibits, and here the latest impressionist efforts are hung side by side with untouched work. Nos. 1 and 2, bromoids by George Brown, have both been taken in Durham City, the first being a view in Framwellgate Street, with the central tower of the cathedral peering down upon the pantiled roofs and yellow, rough-cast walls of the low cottages on the left, and the second shows the Abbey Mill on the wooded bank of the River Wear, with the south-west tower of the cathedral above. Two admirable, straightforward representations of Rheims Cathedral before its bombardment are contributed by the veteran artist, Frederick H. Evans. No. 5 depicts the richly carved west portals surmounted by the huge rose window, and No. 8 is an interior view, the point selected being athwart the nave and south aisle, so as to emphasise the deep band of figure carving on the capital of the arcade support. No. 11, "Through the Centuries," a bromide by R. H. Lawton, is a peep into the south-west transept of Ely Cathedral. Close by is a fine bromoid by R. Perkins, "Old Amsterdam," a view along a canal to a sturdied church. Studies in which the problem of introducing the nude figure into idyllic landscape is solved with fair success are submitted by H. Y. Simmons (Nos. 19 to 24); one of the best of these is the first, "Amorion," showing a male figure reaching for a wreath just beyond his grasp. No. 29, "A Northern Height," by F. W. Jackson, is a clever selection of a point where dark fir trees and a sandy pathway combine in an effective and well-contrasted landscape. In No. 32, "Evening on Derwentwater," by F. Humpherson, on the other hand, the chance of scene on this beautiful lake might easily have been bettered by the inclusion of one of the islands, or some of the bolder mountains. The time and labour expended in deciding upon the happiest or most characteristic viewpoint are well utilised by the pictorial artist. Of a very different character to the last is "Hamlet in Bermuda, by Moonlight," by Karl Strauss, No. 40, where the dark waters of the harbour throw up the brilliant, lighted houses beyond and the trees as silhouettes against a murky sky. A 2 1/2 character study is the bromide,

"The Knife Grinder," by H. W. Fincham.

Among the eccentric studies of still life, demonstrating the catholicity of the hanging committee which accepted them, must be noted Nos. 48, 49, and 50 mere collections of "cellos, warming pans, and other miscellaneous and incompatible odds and ends, devoid of arrangement or selection. No. 99, looking across the nave of "St. Pierre, Chartres," is a noteworthy photogravure, and of another type but equally attractive is a forest scene in bromide, No. 103, by A. G. Buckham. Whittly always yields picturesque bits to the camerist, and in No. 104, a bromide, G. B. Clifton has scored by going down to the river's brink at low tide overhung by steep tiers of fishermen's cottages. Two bromides, interiors of St. Bartholomew the Great, attract attention, Nos. 112 and 148, by William H. Collins and R. H. Lawton respectively; the former taken in the ambulatory, and giving a fine effect of shadow and sunlight, is the better picture. H. Essenhigh Corke has this year forsaken his flowers in natural colours, and gives two crowded London scenes in Nos. 123 and 124, "Lower Thames Street" and "Covent Garden." One always looks for the bold and impressionist work of Alvin L. Coburn, and this year he has three brilliant portraits, an interior of "Munition Works," No. 131, and large prints entitled "Peace"—sheep under cumuli clouds—and "War," a battleship half-obscured by smoke. Dr. E. Stevens gives us in No. 133, "Santa Maria Della Pace, Lago di Como," a characteristic scene on that beautiful lake; and near by are two other North Italian scenes, also in oil pigment, by John H. Gear, Nos. 137 and 138. Fred Judge is not so felicitous as usual in his selection of aspect in his bromoid transier, "Peterborough," No. 144, showing the north-west tower and pinnacles from the entrance to the Deanery. An attractive bromide is No. 164, "A Westmorland Landscape," by W. L. Shand, and this section is brought to an excellent close with the platinotype "Sunlight on Lincoln Minster," No. 172, by Victor E. Morris.

Few exhibitions are complete without a view of the unfinished fourteenth century church tower of Dordrecht, as seen across the harbour, and this item, well portrayed, is supplied in G. B. Clifton's contribution, No. 136. Among the portraits the best is the only exhibit by Furley Lewis, No. 165, "A Polish Patriot," a striking and sympathetically treated character study of Ignace Paderewski, in platinotype. Among the transparencies in other rooms in Sections II. and III. are some fine exhibits, notably No. 411, "The Cloister Arches, St. Albans," by F. H. B. Smith; some dexterous copies of water-colour drawings by W. L. F. Wastell, Nos. 490 and 491; and the autochrome slide, No. 502, "The River in Autumn," for which the medal has been awarded by the council to J. Walton Lee, of Dulston-on-Tyne.

TRAINING IN THE METHODS OF TEACHING BUILDING SUBJECTS

A course of instruction has been recently completed at the Municipal College, Bournemouth, for teachers of building subjects engaged in technical schools. The course was specially arranged by the Board of Education for part-time or full-time teachers having sufficient experience to profit by attendance at the course, which consisted of full-time instruction extending from August 2 to 14 inclusive, dealing with the selection of subject matter and the method of its presentation for a student's first-year course of lessons in a technical school. Thirty teachers

were enrolled and completed the course, these gentlemen being selected from a list of applicants from all parts of the country.

Until recent years, isolated class instruction in any selected subject was common, with the result that students did not have time or opportunity to obtain a sufficient grounding in scientific principles to enable them to bring their knowledge to bear directly on problems arising in their advanced studies. The method of grouping classes in recent years has partially overcome this difficulty by enabling teachers to frame "courses" of instruction specially suited to the needs of particular groups of students, one of the more important of these being the "building trades group." Accepting the principle of grouped courses as fundamentally good, the present need is to make these courses efficient in the selection of subject matter, the treatment of such matter to bear directly on the main subject of the group without diminishing the prospect of obtaining fundamental knowledge, and to correlate the work of grouped classes intimately with each other, and with the processes, practice, and professional work of the industry.

The method of dividing the grouped course instruction for convenience of handling and of approaching the problems selected for consideration at this special course may prove interesting.

To ensure thoroughness of treatment in the short time available, it was decided to restrict the series of lectures and demonstrations in this case, to work suitable for a student of building entering upon a first-year course of study in a technical school, or the assumption that his preparatory education was sufficient to equip him for the work. This preparatory education for evening students has for some time been receiving careful attention throughout the country, and in the near future should cease to hamper the introduction of this particular technical course.

The subject matter of the course was conveniently treated under three heads, viz.:—Building Construction and Drawing, Building Mathematics and Geometry, and Building Science. Particular emphasis was placed throughout on the necessity, for and opportunities of correlating these sections. In addition, the careful planning of the course at this stage was thoroughly considered, in order to prepare the student for more advanced work at a later stage.

Generally, the assumption was made that the subject-matter of the course lectures was known to the teachers in attendance, and it was thus possible to deal with the selection and arrangement of class examples and with the problems of class instruction presenting themselves constantly to the teacher.

In considering building construction and drawing the lecturer impressed the necessity for most careful training in draughtsmanship in the early stages, for an acknowledgment of drawing as the best means of communication between the designer and the craftsman or constructor, for the elimination of the false from constructional detail, and a consideration of design in order to avoid the ugly or undesirable. He showed the need for a study of the properties of materials, and of the principles of mechanics, in order to appreciate, as the work developed, the principles involved in the selection of materials and in truthful construction.

The lecturer on mathematics and geometry of building attacked the problem of providing a really suitable course of work for building students erected on a sound basis, yet treating the subject in an atmosphere of its own. The lectures were developed from this point of view, and the treatment of the combined subjects everywhere bearing closely upon practical builders' problems was much appreciated. Free use was made of numerous demonstration models, many of which were quite original, and thus, by appeal to the eye, the common difficulties due to the more abstract methods of approach were largely overcome.

In building science the lecturer in charge had considerable difficulties to face, because experienced teachers are only beginning to realise the possibilities and importance of

this branch of study. The general impression felt by all concerned was that an excellent start had been effected in the development of a real "science of building." While the chief concern at this stage was the preparation of a student for work in later years, a close connection between elementary science and the builders' problems was noticeably maintained throughout the course, and much interesting experimental work was accomplished.

It is felt that this course—the first of its kind—has been a distinct success; the enthusiasm of the student teachers was obvious, and it is hoped that the measure of success of this experiment in providing training for building teachers will be continued and developed in future years. It would appear to foreshadow the reorganisation and improvement of technical teaching in this branch of work, and should go far to prove the value of and necessity for special training in order to produce a body of capable men, ready and able to attack the problems of builders' education thoroughly and scientifically.

The conduct of the course was supervised by Mr. Hugh Davies, H.M. Inspector of Building Subjects.

The lecturers in charge of the three divisions of the subject were:—Building Construction and Drawing: Mr. W. R. Jaggard, F.R.I.B.A., lecturer in building and architecture at the Northern Polytechnic Institute, London. Building Mathematics and Geometry: Mr. F. E. Drury, F.I.S.E., M.C.I., head of the Department of Building and Civil Engineering, Royal Technical Institute, Salford. Building Science: Mr. J. Leask Manson, B.Sc. Eng. (Lond.), M.R.S.I., A.M.C.I., head of the Building Trades Department, Municipal Technical School, Leicester. Mr. W. Munn Rankin, M.Sc., headmaster of the Department of Science and Technology at the Municipal College, Bournemouth, acted as local secretary for the course.

THE EFFICIENT CONTROL OF REINFORCED CONCRETE CONSTRUCTION.*

A number of casualties have attended construction in concrete. A sudden collapse of a portion of a reinforced concrete building in a large city, attended with loss of life of workmen, generates in the public mind a fear of concrete construction; and a prospective builder is likely to resort to a less permanent and less fitting style of building because of the uncertainty. He knows that a concrete building is serviceable and permanent after the cement has set, but he fears the risk arising during construction.

Structural engineers, on the other hand, know that the percentage of failures is small, and the accidents to be avoidable.

Dangerous conditions in reinforced concrete construction arise from (1) inadequate designs; (2) defective materials, and (3) unfavourable weather conditions and lack of care under those conditions.

All of these elements may be, and are, controlled in the larger cities by building codes and active inspection. For instance, in the city of Chicago, which has an unusually efficient and watchful building department, there have been no serious failures of reinforced concrete buildings under construction. In this city designs are checked over very carefully to see that they conform with the conservative practice established by the building code of that city.

It is in the smaller cities, that are not large enough to demand permanent buildings, but without building codes, that the most dangerous conditions obtain.

The building codes are thought to be too conservative by some designing engineers of companies interested in the sale of materials. For instance, while these codes generally permit 16,000 lb. stress per sq. in. upon ordinary reinforcing steel, some designers will increase this to 20,000 lb. where the code does not prevent, and under circumstances where the sale of the material depends upon a low total price.

Many buildings have been erected under designs that are not conservative and yet have given good service. Their construction

has been under favourable conditions with reference to cement, sand, weather conditions, and skill of workmen; and the lack of factor of safety in design has been counterbalanced by the increased factor of safety in materials.

Codes, however, must recognise average conditions. The architect or structural engineer of commercial firm supplying material, who has drawn upon the factor of safety in design, and then has met unexpected conditions in the materials—weather conditions, etc., and has a failure on his hands, is certainly in a weak position.

The larger number of failures of concrete buildings occur during the late fall when the low temperature and wet weather prevent the cement from hardening properly. At this time, too, the owner is anxious to get into the building. Every one is in haste; forms are struck before the concrete is hard enough to support the floors above; the roof, which is often the weakest part of the design, is being covered with cinders into which the rain seeps. Instead of weighing 45 lb. per cubic ft., the weight of these cinders may run up to 100 lb. per cubic ft. Then, too, the plumber may seriously overload a portion of the floor with piles of pipes, may even remove a form support. Under these conditions it is no wonder that failures occur. In the presence of these unfortunate failures a designer who has furnished a conservative design is in a strong position.

The writer has investigated and made reports upon several failures in which it has been necessary to criticise the design. In some of these cases the architect has originally made a conservative design with sufficient materials and proper connections. The sales engineer of a company supplying steel has afterwards prevailed upon the architect and owner to allow a substitute design. The latter is shaved down to the lowest limit, involving high stress in steel, short laps for bond, and defective continuity. While the substitute design will save in the cost of steel, the per cent. saved on the cost of the entire building is usually small, and will not justify the risk of the entire structure.

While recognising the fact that methods of construction and dimensions of structures proceed partly upon experience and the desire for economy, the writer urges that, in the case of reinforced concrete, designs should follow building codes and the report of the conservative practice as fixed by the joint committee on concrete and reinforced concrete which has recently been adopted by the American Society of Civil Engineers and the American Society for Testing Materials.

The standard designs of some of the constructing companies are also reliable and conservative. A special mention might be given to the Kahn standards of the Trussed Concrete Steel Co., Detroit, and those of the Corrugated Bar Co., Buffalo, for the dimensions of beams and girders of ordinary floors and roofs.

The codes, however, are naturally behindhand in respect to the newer forms of construction, such as the so-called "flat slab" design.

In construction with new materials the tendency is to follow forms that have been developed for old materials. Thus the first reinforced concrete building used the old wooden construction of girders, floor beams, and slabs between the latter.

In another line the first railway coaches were patterned after stage coaches.

Reinforced concrete, however, is continuous, like the old constructions.

The flat slab designs omit girders and floor beams. There is a continuous slab over the entire floor, and it rests upon and is monolithic with the expanded heads of the columns.

The steel is disposed in either a four way system or a two-way system.

These constructions are usually patented. Advantages are—(1) the better lighting of the room, (2) the increased head room, (3) decreased story height, (4) more simple installation of sprinkling systems, (5) simpler form work, and (6) a construction more in keeping with the material.

The construction is generally considered more suitable for loads up to 500 lbs., and

columns reaching up to 24 ft. than for larger loads and wider spacing. When the panel becomes rectangular instead of square, the long side should not exceed the short side more than $\frac{1}{3}$ part.

The depth of slab should be at least $1\frac{1}{30}$ the span between column centres.

The design of the expanded head of the column needs attention. It should be stiff.

The steel is in the bottom of the slab at the centre of the panel, and passes up to the top of the slab near the quarter point of the span.

The steel that passes from one panel to another should lap well over into the next span at least 60 diameters beyond the edge of the column cap. And where both bars are counted upon as reinforcing over the column, they should keep well up in the top of the slab over the column, and run 60 diameters beyond the quarter point of the span.

The amount of steel should be about the same in the various patented arrangements for given loads and spans.

Over the column head, the amount of steel should be sufficient to resist an external bending moment equal to $1\frac{1}{15}$ W.L. for interior square panels; where W = total load, live and dead, on panel; L = span centre to centre of column along direct line.

TOWN PLANNING IN SOUTH AUSTRALIA.

Considerable attention has in recent years been given to the question of town planning, both by the Government and municipal authorities in South Australia. The opening up of all parts of the State for agriculture has had the effect of stimulating secondary industries in and around the metropolises, with the consequent development of the residential areas; and the need for the systematic arrangement of the suburbs, with the provision of open spaces, has become increasingly pressing. Definite steps have previously been taken by the Government, and a conference of representatives of suburban corporations and district councils was convened to consider the subject. This resulted in the formation of a committee for the purpose of having some co-ordination in the action to be taken by the municipalities.

Besides the proposal to submit a Bill in the coming session of Parliament, the Government have purchased a 300-acre block of land, so that a scheme for the formation of a model settlement may be carried out as an example to those concerned. The area secured is about four miles from Adelaide, and can be served by an extension of the existing railway. It is at present being used by the Commonwealth Defence Department.

The Attorney-General (the Hon. J. H. Vaughan), who is also Minister for Pleasure Resorts, made the following statement in regard to the matter:—

"Careful consideration will be given to the basis of allotment, and we shall endeavour to adopt the system of tenants' co-partnership, which has proved so successful in England. In the past it has been the practice to throw a reserve into the centre of a community, and say that a town has been planned. Thus, only those whose residences abut on the reserve enjoy its benefits. That will not be done in the case of the new model. Areas will be set apart in different localities, so that the number who will derive pleasure from having their homes on the borders of reserves will be greatly increased. This is not only a practical demonstration of said system, a plan which differs from that upon which all our suburbs have been designed. Instead of a monotony of straight roads meeting one another at right angles, I have endeavoured that it is possible to produce curves and breaks which will lend beauty to the scheme, thus sacrificing economy of space. It will be my aim, not simply to attract the class of resident, for we hope to see 1,000 persons, but a few hundred pounds alongside these 1,000 run into four figures. At present the military authorities are in possession of the land, and they will, of course, remain until they have no further use for it. In the meantime surveys will be made; but until the Defence Department is no longer in need of the area, nothing further can be done in connection with the scheme of settlement."

*By W. K. Hatt, in the *Ohio Architect*.

DEVELOPMENTS IN THE MANUFACTURE AND USE OF BRICK.

By W. D. ALLEN.*

In the very early ages of mankind, burned clay was first used and was used to house and serve man. It is intended to go into the history of the development of the craft of brick-making. We will take burned clay ware that we find on the present market for construction purposes, and see if we can eradicate some of the abuses and create a clearer apprehension of some of the causes and effects that tend to curtail the use of this best of all fireproof material.

Under the heading "Brick" we have a great variety, which I will divide as follows:—First, common building brick; second, face brick; third, paving brick; fourth, fire brick.

Common brick are made by several processes, viz.: (a) slop or water-slipped soft mud brick; (b) sand mould, soft mud brick; or "Auger," "plunger machine," wire cut, or stiff mud brick; (c) dry pressed brick; (d) hammer machine, semi-dry clay brick.

(a) Slop or water-slipped brick are only manufactured in a small way, and therefore need not be considered.

(b) Sand mould brick are manufactured by hand, either by a striker or moulder. The clay is prepared (tempered with plenty of water) and delivered on a table. The striker cuts a wedge-shaped slice off, large enough to fill a little more than the mould, and casts it into the mould with force enough to fill the corners and edges. The clay must strike the bottom of the mould first, then spread and fill from bottom to top to avoid wiping off the sand which has been deposited on the mould before coming to the striker, otherwise it will not be possible to get the brick out of the mould, which usually holds six bricks. After the moulds have been filled, the caps or clauds are struck off with a strike-stick, which is taken from a water trough and thrown back to be added to the next mould or brick. The sand mould brick are also manufactured "by hand" by a moulder. This process is used when clay is fat or sticky and does not leave the mould freely. The moulder cuts off enough clay to equal about a brick and a half, and rolls it in sand forming a pointed claud, which is cast the same as described above, except that the caps are cut off by a wire box. Sand mould brick to-day are nearly all machine-made, and they are an improvement on the hand-made product. Clay used is usually taken from the surface deposits. The brick when burned weigh from 4 to 4½ lb., and are of a more or less porous nature. Canadian standard brick weigh less than most of the American manufacture, owing to the panel or frog which is moulded into the flat or bottom side of the brick. Sewer, face, common and fire brick are manufactured by this process.

(c) Auger machine or wire-cut brick are manufactured from plastic clay with just enough moisture to cause the clay to work into shape. Some machines mould the clay stiff enough to pack or pile eight high without losing their shape. Shales and surface clay are used. The fat clays take much less power. The brick are very dense, and weigh from 5 to 6 lb. Paving, sewer, face and common building brick are manufactured by this process.

(d) Dry pressed brick are made of surface and shale clays. The clay must usually be worked and dried and then ground into a fine state. This ground clay or dust contains about seven ounces of water per brick, and is fed into the machine, where it is subjected to enormous pressure. In some districts common building brick are manufactured by this process.

(e) Hammer machine brick are made by a machine that tamp the clay into the mould, in most the same manner as a quartz stamp mill. These machines are only used, I believe, in the St. Louis, Mo., district, and doubtless they will soon disappear.

THE USES OF BRICK.

We will come to the uses of brick. Most modern buildings have sufficient strength to carry all the load required of them in ordi-

nary building. Your local engineer will determine and pass on all questions of this nature. There is little room to doubt the strength of a brick which has been built into a twelve or fifteen-story skyscraper, and found not wanting. Such a brick will or should be accepted for stores, warehouses, dwellings and structures requiring less pressure. Where concentrated loads are to be carried on piers, or at ends of steel beams, clinker brick or paving brick should be used. Brick laid up in lime mortar make a good wall, but when laid in mortar cement, a wall is produced that is nearly indestructible and will stand for generations. In cold climates, such as prevail in Western Canada, the architect and builder must keep in mind the power of the various kinds of brick to resist cold. A porous body will absorb and conduct much less cold or heat than a solid or dense body; therefore in selecting the brick for building a wall for a dwelling where the walls are only 9 in. and 13 in. thick a porous brick will make a much warmer house. The same applies to blocks, stores and apartments, where steel or reinforced concrete are used. The curtain walls are light, and therefore must be built with brick that will be as nearly non-conductive as possible. The old-fashioned stone house, the new concrete house, and the wall built of vitrified street pavers are all the best cold conductors it is possible to select, and if these materials must be adopted, then the best backing or lining should be used to ensure a warm building. A stone or concrete wall should be lined on the inside with porous hollow brick, to which at least 25 per cent. sawdust has been added, and burned out, producing a fireproof body much like cork. The plastering may be applied directly on these brick, and no bad effects will be produced in the coldest weather. Walls finished with water-coloured kalsomine have stood season after season in kitchens and laundries when this method of construction has been adopted.

The old method of furring or strapping the walls and lath and plastering is not as effective, as it is found nearly impossible to keep the air in the room from coming into contact with the wall and forming frost or dampness, which in turn forms mould or must, which, when dried out, forms dust, which permeates the rooms and is the cause of much sickness. Many cases of hay fever, tuberculosis, rheumatism, and kindred ailments can be traced to damp houses. Damp, cold houses are not caused—as many believe—by the moisture passing through the walls, but by the walls becoming cold or hot, and then having hot or cold air coming in contact with them, causing the moisture in the air to condense and deposit drops of water, much as a glass pitcher will do when filled with cold water on a humid day. In building a block, warehouse, or home, as much and more care should be exercised in selecting the brick for the different parts of the work as is used in selecting material for any other part of the building.

A freight depot or warehouse might require a vitrified paving brick to stand the hard knocks, and keep clean of soot and dirt in a down town district. A stable would have to be built better and with more care—as to the ability of the structure to keep dry—than perhaps any other building. The large amount of moisture thrown off by a stable full of horses, just in from heavy work, will condense on the walls of a concrete, stone, or solid brick wall, but when lined up with porous, hollow brick or tile this is almost, if not entirely, overcome. For a dwelling-house a faced brick, more or less porous, that will keep clean and ripen in appearance by age, is preferable to a more dense or water-proof brick, and when backed up with a porous hollow brick or block it will produce a dry, warm house that will save fuel, do away with draughts, and be a joy to the owner all his life. Speaking of draughts, often in a house where windows and doors are airtight there is a constant draught in cold weather, caused by the heated air of the room coming in contact with the cold, solid wall. The cool air settles to the floor and is drawn towards it, causing a draught

that is very disagreeable and apt to cause colds and ill-health to the occupants.

In conclusion, this slogan should be adopted by all builders: "The best is not too good."—*Canadian Contract Record*.

Currente Calamo.

Mr. Tennant, the Under-Secretary for War, is seldom happy in his replies to queries about his department. The instance given by Mr. Stankey Peach in his letter on another page is, however, one of the most flagrant. Mr. Tennant recently stated that the offer of the Royal Institute of British Architects to assist the department "was not received until May, 1915, when the greater part of the work of erecting wooden huts for the troops had been finished; hence comparatively little advantage could be gained by the War Department availing itself of the offer." Our own readers have, of course, already concluded that this statement was untrue, knowing, as they do, that the offer was made on September 11, 1914. They have possibly imagined that, maintaining its reputation as a branch of the Circumlocution Office, it forgot or neglected to accept the offer till the need was past. This is not so, as Mr. Peach's letter makes clear. On September 23, 1914, a letter was received from the War Office acknowledging the receipt of the letter and stating that "the Army Council much appreciates the patriotism which has prompted the offer, which has been noted for future use." Why was the offer not utilised? Will somebody ask Mr. Tennant that when Parliament reassembles, if only to elicit another of his informative replies?

Mr. Ernest Newton, P.R.I.B.A., emphasises in a letter to the *Times* the disastrous idleness of the Parliamentary War Savings Committee's recommendation that "No one should build a house for himself at this time," and that "Decorations and enlargements should be cut down as much as possible." As he points out:—

"To stop all but absolutely necessary building would no doubt keep money in the pockets of those able perhaps to afford a modest and prudent expenditure in house building, decorating, and furnishing, but it would entirely deprive of all means of livelihood a very large number of people beyond military age and with no aptitude for munition making or other definite war work, even if it could be found for them. These men must inevitably become a burden on the community, and, consequently, what is saved in one direction is lost in another. Almost everyone connected, directly or indirectly, with building work already finds his income greatly reduced; indeed, in some cases the vanishing point is almost in sight, and it work of this nature ceases entirely complete ruin is inevitable."

That matters little, possibly, to well-salaried placemen who seem to have little to do but indite these fatuous recommendations to "economy" which is no economy, but really penny-wise and pound-foolish blindness. No calling has sent more men to the colours than that of architecture proportionately to its numbers, and no great group of industries adds more remuneratively to the solid wealth of the nation than those connected with building. On all sides the need for our work is urgent—more so than for many years past—and to stop it and turn hundreds of thousands of willing workers into paupers, and thus increase the heavy burdens borne by the rest of the community, is egregious folly. Even half bankrupt Austria—so a Vienna telegram stated not many days since—is raising money to keep architects and sculptors at work on the public buildings and monuments of the capital, while our own "economists" are doing their best to penalise an industry which at the beginning of the war it was distinctly promised should be encouraged wherever possible.

Most of the disputes in the building trades and those fought out with the greatest acrimony have arisen on the question as to what work should be executed by men in branches or affiliated unions, such as the bricklayers and carpenters and joiners, and work by men in outside branches, including the plumbers and plasterers. For a considerable period efforts have been made by the National Conciliation Board to frame regulations which shall be mutually acceptable to building trade employers and to the various trade unions, settling the lines of demarcation between trades, so as to obviate quarrels of this character. The negotiations, which have not as yet been understood, the support of the National Federation of Building Trade Employers and of the leading unions, have been so far crowned with success that the draft proposals have been sent out to the master builders and the unions for their consideration. If they are mutually agreed upon they will be brought before the National Conciliation Board at its meeting on Monday, October 11. A portion of the proposed regulations has appeared in some of the daily papers this week, but it is incomplete, and, without its context, hardly comprehensible. For the present, and probably till after October 11, the full details are not likely to be published at any rate, authoritatively.

A case of some interest to the building trades, which in many ways seem the scapegoats of law and order just now, has just been decided in the Court of Criminal Appeal. The appellant, a bricklayer, was sentenced at the Middlesex Sessions to nine months' hard labour for having, as was alleged, house-breaking implements in his possession at night. He was, it seems, found in possession of a large chisel and a screw-driver, and he complained on appeal that the onus was thrown on him at the trial not only to prove that he was in lawful possession of the tools, but that he did not intend to use them unlawfully. The Court quashed the conviction, holding that the onus could not and should not have been thrown on the appellant. Mr. Justice Bailhache very sensibly remarked that if a bricklayer going home late at night with his tools could be called upon to account for his possession of them, the trade was one to be avoided, for every bricklayer in such a position was liable to be locked up.

While discouraging work at home, the Government, moreover, seems to be sending a good deal abroad. The Canadian *Contract Record*, in its issue of August 4, says the report is that the British Government has been negotiating for the purchase of all kinds of portable structures to be taken to Northern France and Belgium to replace temporarily the dwellings, churches and schools which have been laid low in that ravaged territory. A large Brooklyn firm has been mentioned in connection with one of the most important contracts which are to be awarded; but the requirements are on such a huge scale that Canada cannot fail to receive a share of the business and a considerably greater share of subsequent orders of the kind. It is said that the contracts now pending include one for the construction of 20,000 portable houses—the largest single contract ever given for buildings of this type. Entire cities and towns are being created from them to house the refugees made homeless by the high tide of the German advance into France. The buildings are to be so constructed that they can be set up quickly upon their arrival in France. Shipment is to begin early in the fall if the contract goes through.

It is not surprising that the Government should be so anxious to provide temporary dwellings for the refugees in France, as the country is now being overrun by the German advance. The Government has been negotiating for the purchase of all kinds of portable structures to be taken to Northern France and Belgium to replace temporarily the dwellings, churches and schools which have been laid low in that ravaged territory. A large Brooklyn firm has been mentioned in connection with one of the most important contracts which are to be awarded; but the requirements are on such a huge scale that Canada cannot fail to receive a share of the business and a considerably greater share of subsequent orders of the kind. It is said that the contracts now pending include one for the construction of 20,000 portable houses—the largest single contract ever given for buildings of this type. Entire cities and towns are being created from them to house the refugees made homeless by the high tide of the German advance into France. The buildings are to be so constructed that they can be set up quickly upon their arrival in France. Shipment is to begin early in the fall if the contract goes through.

The subject of the House of the Working Classes is a subject of the utmost importance. In the past, housing legislation in this country has been largely the result of public opinion. Our legislators have overlooked the fact that the state ought to take over the responsibility of housing the most part of the population. The state should not only be responsible for the housing of the most part of the population, but it should also be responsible for the housing of the most part of the population. The state should not only be responsible for the housing of the most part of the population, but it should also be responsible for the housing of the most part of the population.

The House of the Working Classes is a subject of the utmost importance. In the past, housing legislation in this country has been largely the result of public opinion. Our legislators have overlooked the fact that the state ought to take over the responsibility of housing the most part of the population. The state should not only be responsible for the housing of the most part of the population, but it should also be responsible for the housing of the most part of the population.

Our Illustrations.

CONTEMPORARY ARCHITECTURE IN INDIA.

A description of the illustrations printed in this sheet will be found in the second article in this week.

WEEK-END COTTAGE, GOWER NEAR SWANSEA.

This drawing shows the exterior of the exterior of a small week-end cottage designed to be built at Gower near Swansea. The plans explain the accommodation provided. The materials to be used are specified and the facing tiles for roof and walls are shown for all external walls. The architect is Mr. Glendinning Moxam, F.R.I.B.A., Swansea.

SMALLPOX HOSPITAL, WHITEHAVEN.

(SELDEN HOUSES.)

The accompanying sheet of illustrations illustrating the chosen design for a hospital, showing that it is mainly necessary to give a plan by way of description. The architect is Mr. H. Irving Gurnard, of Ebor Bar, Harrington, Cumberland. The ward provides for twelve beds, equally divided between male and female patients. The construction is rough-cast in cement or brick, with a plaster dressing to the interior surfaces of the pavilion. The roof is covered with Welsh slates. Each patient has a room of 12 ft. x 12 ft. of lined with a bedstead, a washstand, a room with a sink, a table, a chair, and a small cupboard for the patient's personal effects. The windows are of the double-hung type, with a view of the sea. The hospital is situated on a hillside, and the view is very fine. The architect is Mr. H. Irving Gurnard, of Ebor Bar, Harrington, Cumberland.

WATERWORKS, BIRMINGHAM.

A plan of the waterworks at Birmingham, showing the layout of the buildings and the water supply system. The architect is Mr. H. Irving Gurnard, of Ebor Bar, Harrington, Cumberland.

in the right-hand tower corner of our plate. The estimate for this part of the premises is set out on p. 161, but if reinforced concrete is used a considerable saving would be effected in the cost of the scheme as a whole.

DUNBLANE CATHEDRAL, PERTH SHIRE, SCOTLAND. MEASURED DRAWING OF THE W. FRONT.

Our last illustrations, in our issue of December 1, 1914, of this famous Scotch cathedral, comprising double and single page photographic plates, were of the new and ornate oak stalls, "altar" screen and organ case, carried out from the designs of Sir Robert Lormer, A.R.S.A. Our earliest drawings of the church, specially worth reference, appeared on May 20 and in October, 1870, from the masterly pen of the late Edward Francis C. Clarke, showing the west facade and south aisle, recording the work as it then stood in comparative ruin. Mr. J. S. Gibson, F.R.I.B.A., also lent us a view from his sketch-book representing the interior of the nave of Dunblane looking west, in the BUILDING NEWS for July 24, 1885, which, of course, was long prior also to the restoration. Mr. William Ferguson, of Glasgow, published in our pages an exterior view of the west front on December 15, 1878. Sir R. Rowand Anderson, LL.D., re-roofed the nave and restored the cathedral about twenty years since, and furnished us with a most interesting account of the history and description of the building when we devoted a double page to the accurate plan which the architect had made and a general view of the church as reinstated by him, see BUILDING NEWS for December 1, 1893. The Mural Memorial erected to the Stirlings of Keir on the east wall of the north aisle of the nave was designed by the same veteran Scottish architect in 1912, when we reproduced a photograph of the work on March 22 that year. To-day we are able to give a double page of measured drawings of the elegant frontispiece of Dunblane Cathedral delineated by Mr. J. Scott Lawson, of the Royal College of Arts. Dunblane Cathedral occupies the site which is intimately associated with the introduction of Christianity into Scotland when Blaauw visited the North of Great Britain from Ireland at the end of the sixth or beginning of the seventh century. The monastery of the Culdees was founded by him, and he became their abbot and bishop. Four centuries later Bishop Clement has left a record of the sadly decayed condition of this very early Scotch church at Dunblane, which had then for some while suffered in competition with the Culdees' newer monastic foundation at Muthill, and thus the ancient mother church stood verging on the brink of ruin. Clement was a Dominican, and in 1253 he became Bishop of the Diocese, and from that time the turning point in the history of Dunblane was reached. It is his building which still is more or less preserved for the edification of all students of architecture. The see had much to contend with in those days; at last the church authorities acknowledged the Earls of Strathern and their feudal claims, but its records testify to many phases of political trouble and also neglect of the cathedral, while contests raged now and again between the rival factions of Ecclesiastical order, and then came Protestant inroads, though "the Popish roof" remained on the walls of the choir. The nave for ages was left open to the weather and the sky, having no roof whatever. The church, as we know the building consists of a choir, 80 ft. long by 23 ft. wide, having on the north side of it a long, a-like apartment of two floors, the lower one being vaulted, and a nave of the north and south aisles, 129 ft. long by 55 ft. broad, and divided into eight bays. A tower rises on the south side opposite the fifth bay, counting from the west, 22 ft. square and 97 ft. high, surmounted by a slate spire over 210 ft. tall. The building is, with the exception of the lower two-thirds of the tower, of one period, and is the structure erected by Bishop Clement, who ruled over the Diocese from 1253 to 1255 A.D. The earlier part of the tower belongs to the church of St. John's, Father of the Faith found in such a ruined and decayed condition. It may belong to a tower of an early part of the twelfth century. The two square tower stands in

no relation to any part of the cathedral, and no structural indications exist to show what position it occupied relatively to the early building, of which it formed a part. The top part of the tower belongs to the end of the fifteenth century. The west end has always been greatly admired. The vesica window in the apex has been made famous by a poetical, but most inaccurate, description of it by Ruskin, in his Edinburgh lecture. There being no vaulting to the aisles, there is no triforium. The clerestory comes immediately above the nave arches. There is a passage in the thickness of the wall, and the inside face consists of a series of moulded arches two to each bay of the nave arcade and richly moulded, but only about half of the series being filled with tracery. The outside or west window face corresponds with the internal treatment of the design, but the mullions and tracery are quite plain. The aisle windows are all alike except the end ones and the east, which are divided into four lights, the others having five. There can be no doubt that every care was taken by Dr. Rowand Anderson to carefully repair and retain all that could be preserved of the old fabric, and his restoration has most certainly saved the cathedral from becoming a heap of ruins, for it might well have collapsed at any moment, owing to its neglected state when he took up the repairs. Mr. Lawson sends us the following notes as to the subject of his excellent drawing, which, of course, shows one of the finest parts of the cathedral: On the ground floor the western doorway is deeply recessed with a series of shafts and arch mouldings of the first pointed period of design flanked by an acutely pointed blind arch on each side with trefoil head within it. This lower stage is surmounted by three lofty, pointed windows all of equal height, and each divided with two lights by a central mullion, and having the arched head filled in this central window by a cinquefoil, the side lights being finished with quatrefoils. These windows are enclosed with a label moulding having caryd terminals, which have weathered badly. The piers and arches have plain triple splays, and the opening in the arched heads are cut out like the windows of the clerestory. A passage similar to the clerestory one runs round at the west end with an inner arcade of clustered shafts and mouldings all corresponding. In the internal arcade the three arched heads are filled with cinquefoils. The gable is occupied by an elegant vesica piscis to which Ruskin directs particular attention in the reprint of his Edinburgh lectures.

JUBÉ, DIXMUDE, BELGIUM. (DEVOLISHED BY THE GERMANS.)

This exquisite and highly ornate 15th Century screen, one of the most beautiful in Belgium among Flemish masterpieces of applied design and Gothic workmanship, has been destroyed by the German vandals during their wanton devastation in Flanders. We are indebted to the Rev. Ernest Geldart, of Dorking, for the loan of the accompanying photographic illustration now reproduced. Much less open in its design than our English Rood screens, and in this respect also differing from examples of the more usual French Jubé, such as that in Limoges Cathedral, it has rather more the character of the Greek Iconostasis so familiar in Eastern churches. The custom of drawing a veil round Christian altars crystallised during the Middle Ages into the very general practice of setting up structural screens, built of stone or timber, while in Spain, particularly, wrought iron and metal formed the material largely employed. This Jubé at Dixmude is not without Spanish influence, judging by its elaborate Plateresque character and mannerism. The use of enclosures and screens in churches naturally led to grand and imposing erections, and from them arose the term chancel, implying a screened-in place or sanctuary. The ciborium or baldachin generally met with in the churches of Italy over altars, and having richly embroidered hangings suspended either as dossils or between the columns as veils, served the same object, facilitating provision for the reservation of the sacrament. The Jubé at Dixmude ranked among the most remarkable of its kind and was exception-

ally rich in its detail. The rood, however, had for a long time been absent. The central figure in the screen itself represents the Majesty of the Godhead of the Risen Lord, who is depicted in the midst supported by adoring angels. The choir organ, which was added later, rose, as the photograph shows, above the Jubé, and it had a wooden gallery of still later date, extending right and left of the organ. The word Jubé primarily meant a pulpit or ambon or a reading desk or place, more commonly designated the rood loft, in some instances taking the form of a narrow gallery, positioned for the greater part in the usually accepted situation between the nave and the choir. In France the term became to be applied in this wider sense from the first words uttered by the Gospeller, be he abbot, bishop, or merely the celebrating priest—"Jubé Domine benedicere." The reason why the Gospel was read from so elevated a position was definitely given by Pope Innocent III: it is that the ministers who proclaim the Evangel of the Gospels should go up on high, as said the prophet Isaiah, "Super montem excelsum ascende tu, qui Evangelizas Sion, exalta in fortitudine vocem tuam." The screen when complete, therefore, had a platform usually about 6 or 8 ft. wide, from whence the laity were addressed, and for the most part it was here the Gospel was recited, at least on Festivals during the celebration of the High Mass, this signification being participated in and understood by the entire congregation worshipping in the nave. "The Lenten veil," suspended on the Western face of chancel screens, shut off the choir of the building for a different purpose when the veil separated the priests from the people thus temporarily. The Anglo-Saxon pontifical provided for this, and in their small churches in those days a curtain was stretched across the commonly quite narrow chancel, and so the draperies were easily adjusted. At Salisbury there exists the remains of a winch, used to haul up a much bigger veil, which indicates the position adopted in that fine 13th Century cathedral, and we fancy there is also a similar record existing in Durham Cathedral. This Jubé at Dixmude stood, till the Germans smashed it up, in a perfect condition, unaltered since its erection in the time of the Spanish occupation of the Low Countries, except that the organ had taken the place of the Rood itself, and this accounts really for the absence of that usually essential feature as mentioned in the earlier paragraph of these few descriptive notes.

While excavations were being made on the north side of the Abbey Churchyard at Dunblane there has been discovered the foundations of an old wall, about 2 ft. in depth and of equal thickness, faced with hewn stones, about 50 ft. in length.

A Carnarvonshire correspondent points out that while galvanised iron has gone up to about double its price before the war, slate can be bought to-day at the same rate as twenty years ago. He suggests that slate cisterns are now more economical than those constructed of galvanised iron.

The Secretary of State for India has appointed the undermentioned gentlemen to be assistant engineers in the Indian Public Works and State Railway Departments: G. F. Balfour, Datt Dev, X. N. Farrell, F. H. Hogshaw, H. G. Jackson, Mian Muhammad Khan, J. L. Roy, L. St. Clare Rundlett, and J. Woodside.

The council of the Union Jack Club have purchased, for £9,500, land on the north side of their premises in Waterloo Road, S.E., on which an extension of the club for soldiers and sailors will be built. The existing institution was erected in 1907 from plans by Mr. H. B. Measures, F.R.I.B.A. and this cost £85,000.

Second Lieutenant William Stewart Colleen, 6th Royal Inniskilling Fusiliers, who was officially reported on Monday to have been killed while serving with the Mediterranean Expeditionary Force, was a son of Mr. Joseph Colleen, of Homestead, Dundrum, Dublin. He was educated at the Methodist College, Belfast, and Cambridge University, and was in business with his father in the firm of Colleen Brothers, builders. He was twenty-six years of age.



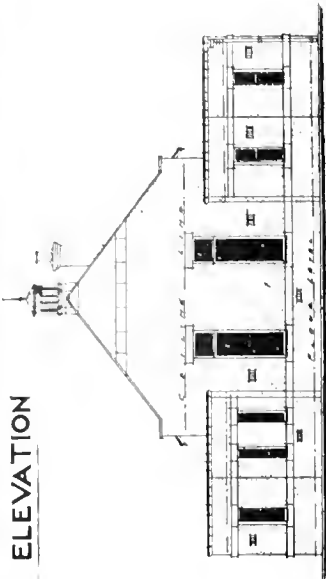
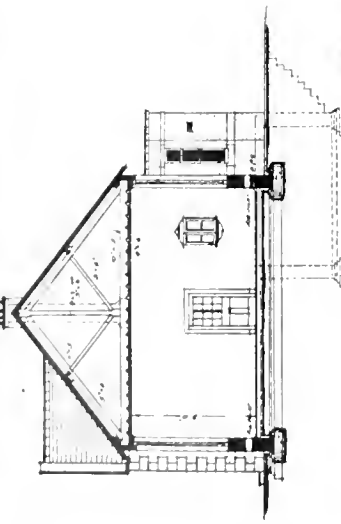
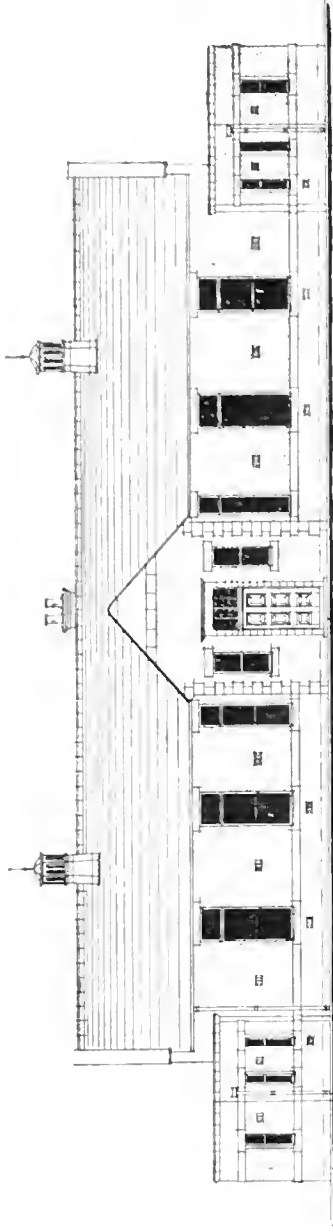
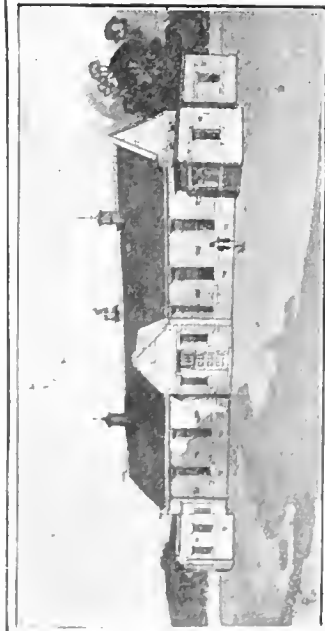

FRONT ELEVATION

SECTION A.A.

SIDE ELEVATION

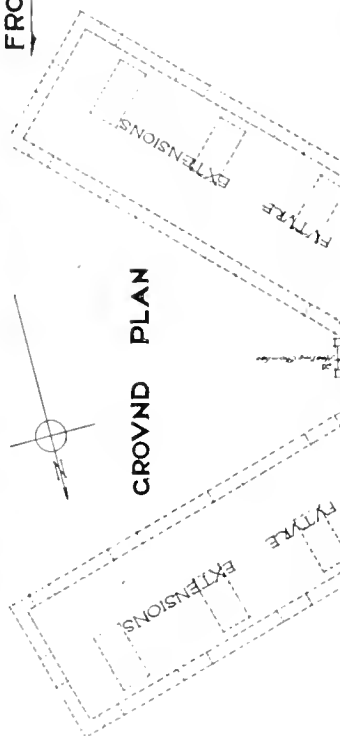

GROUND PLAN

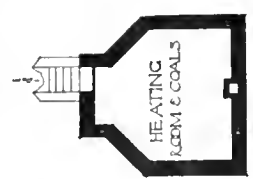

HEATING ROOM & COALS

PLAN

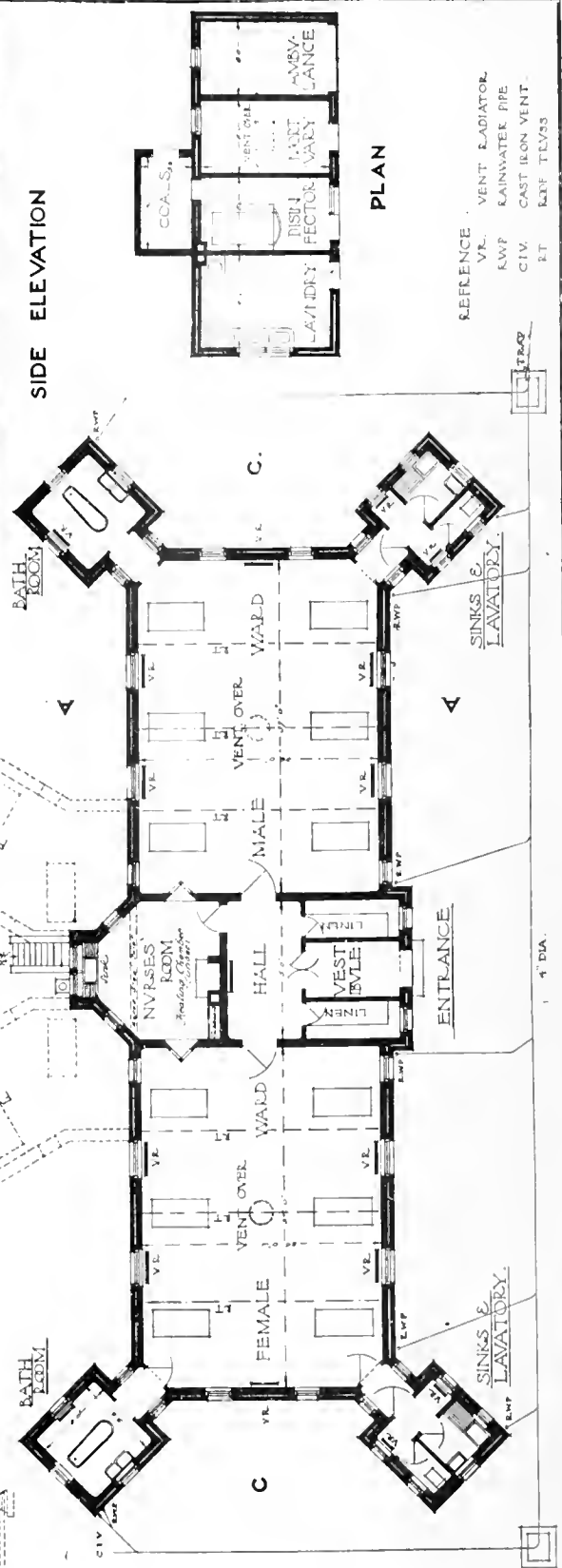

**SMALLPOX
HOSPITAL
WARD
PAVILION**

- REFERENCE.
- V.V. VENT. RADIATOR
 - R.W.P. RAINWATER PIPE
 - C.I.V. CAST IRON VENT.
 - E.T. RIVE TILTS



WINDMILL CHURCH
WEST SIDE

SECTION AND ELEVATION OF WEST SIDE
J. H. St. John

INTERIOR DETAIL - 4' x 11' - 6" SECTION
ELEVATED FROM FLOOR TO TOP OF ARCH

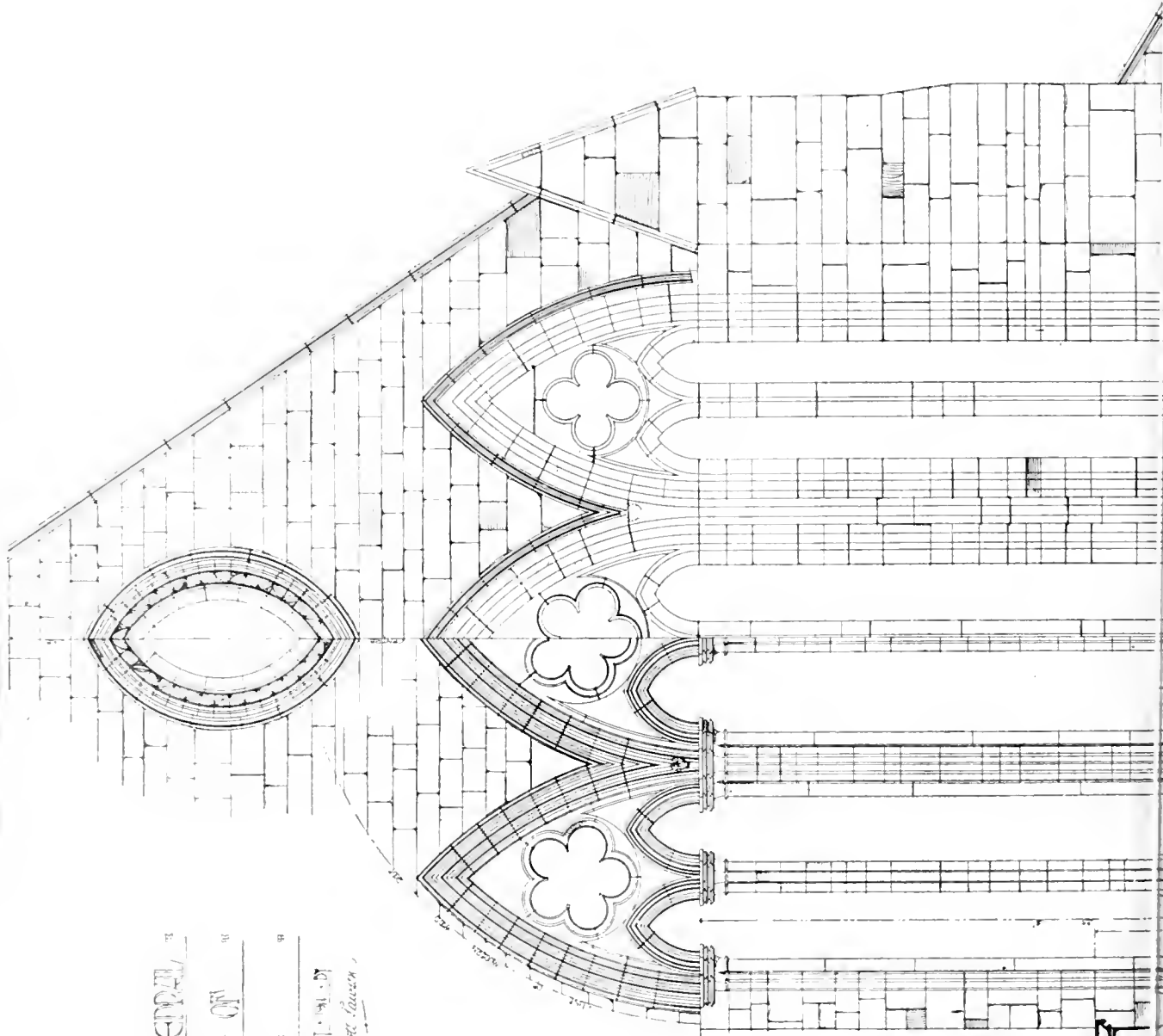
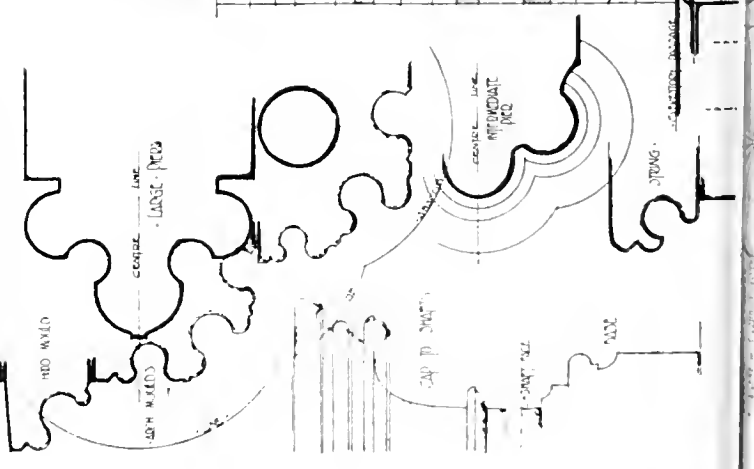

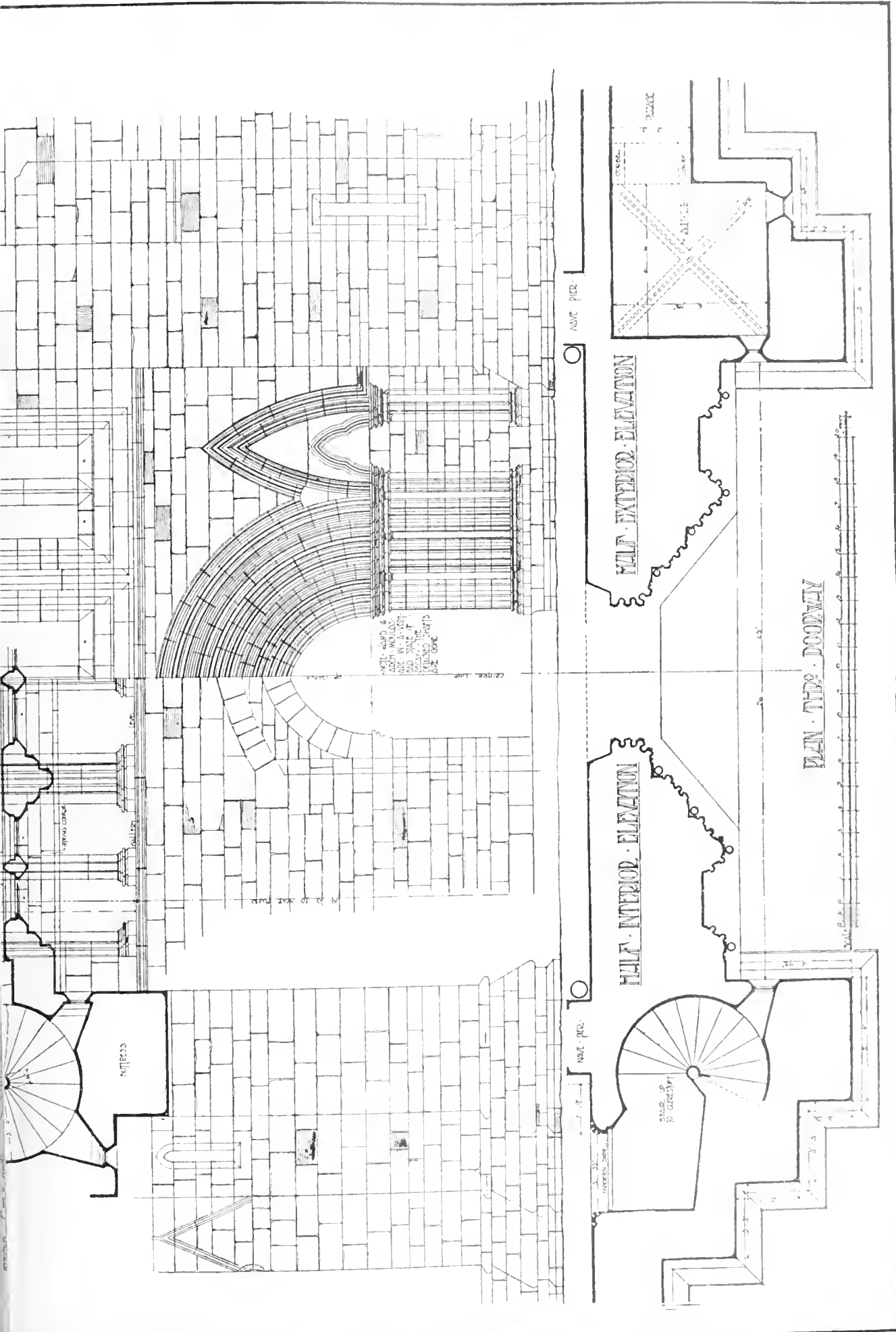

DUNBLANE CATHEDRAL, PERTHSHIRE, SCOTLAND. DETAIL OF THE WEST FRONT.—Measured and Drawn by Mr. J. SCOTT LAWSON.

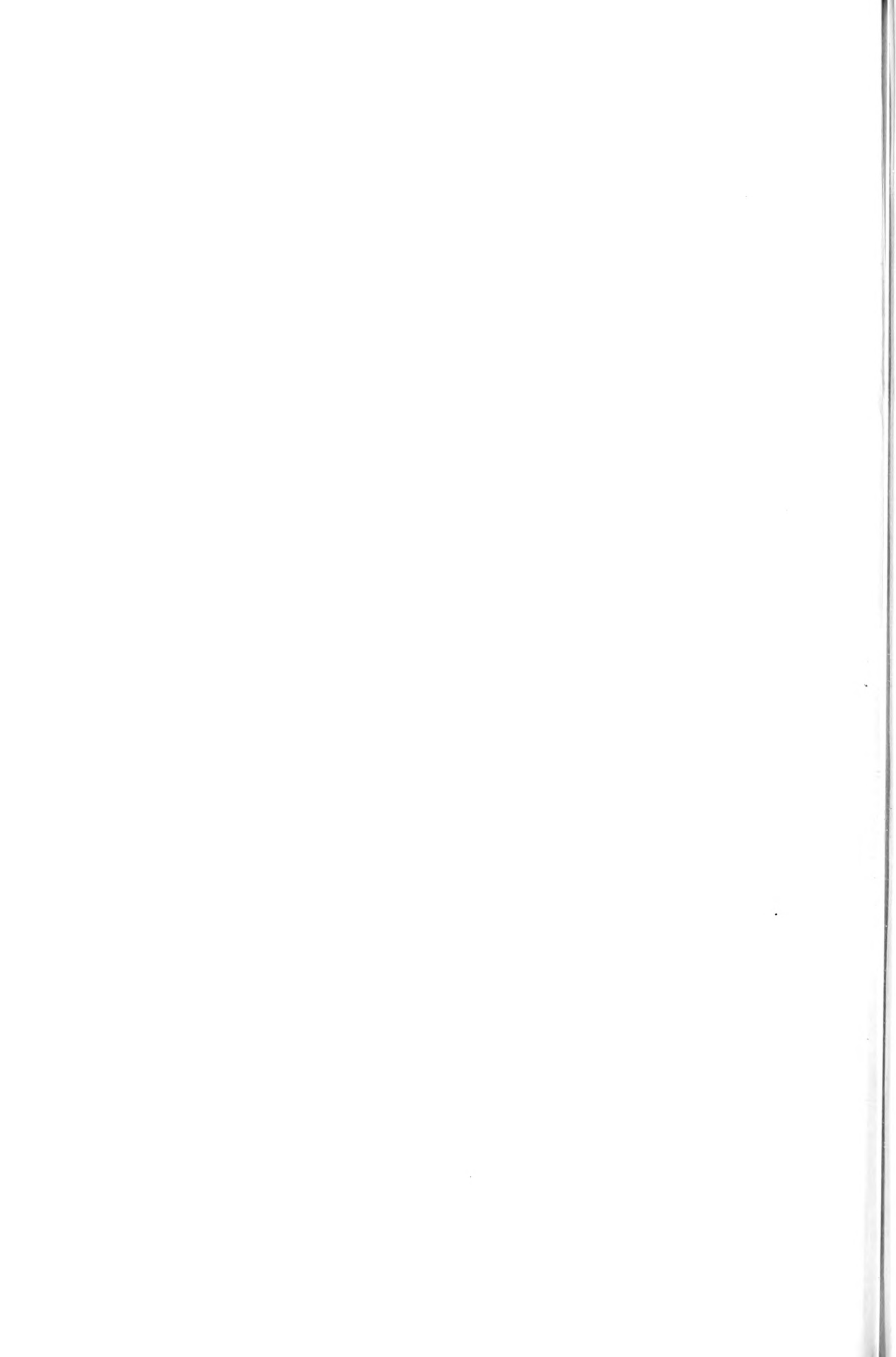

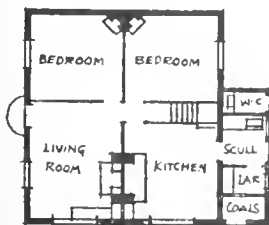
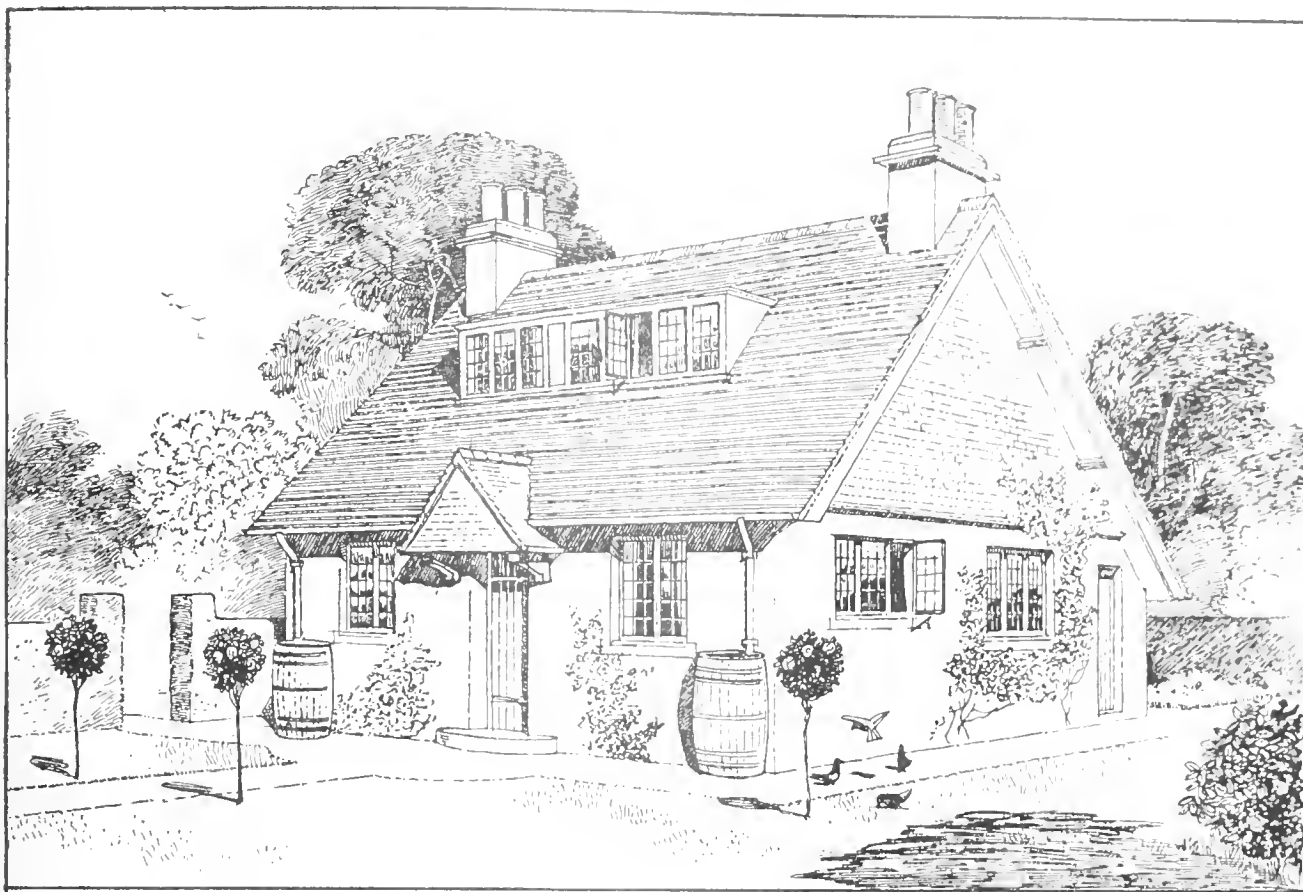

· GROUND · PLAN ·

WEEKEND · COTTAGE AT
GOWER NR SWANSEA

· Glendinning · Moxham · F.R.I.B.A.
· Architect · Swansea ·

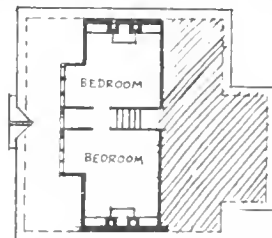

· FIRST · FLOOR · PLAN ·

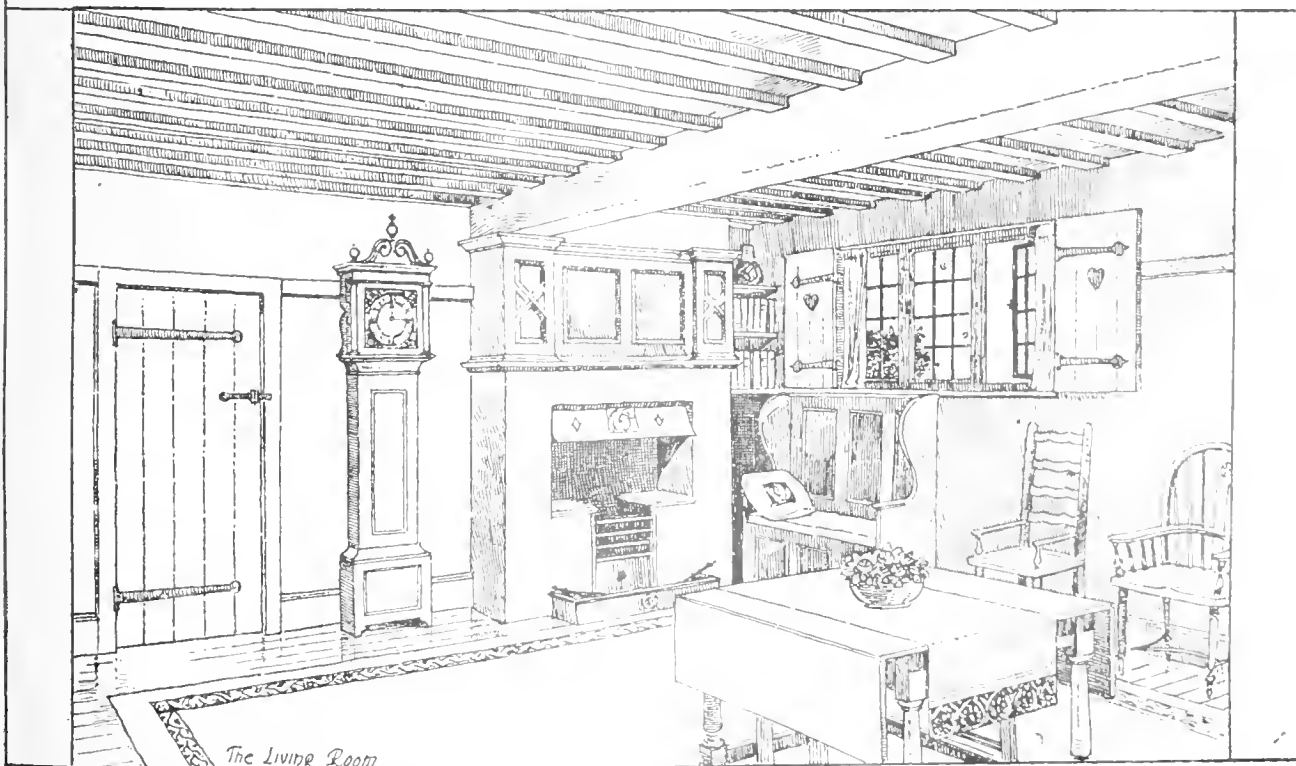

The Living Room

WEEK-END COTTAGE, GOWER, NEAR SWANSEA.
Mr. GLENDINNING MOXHAM, F.R.I.B.A., Architect.

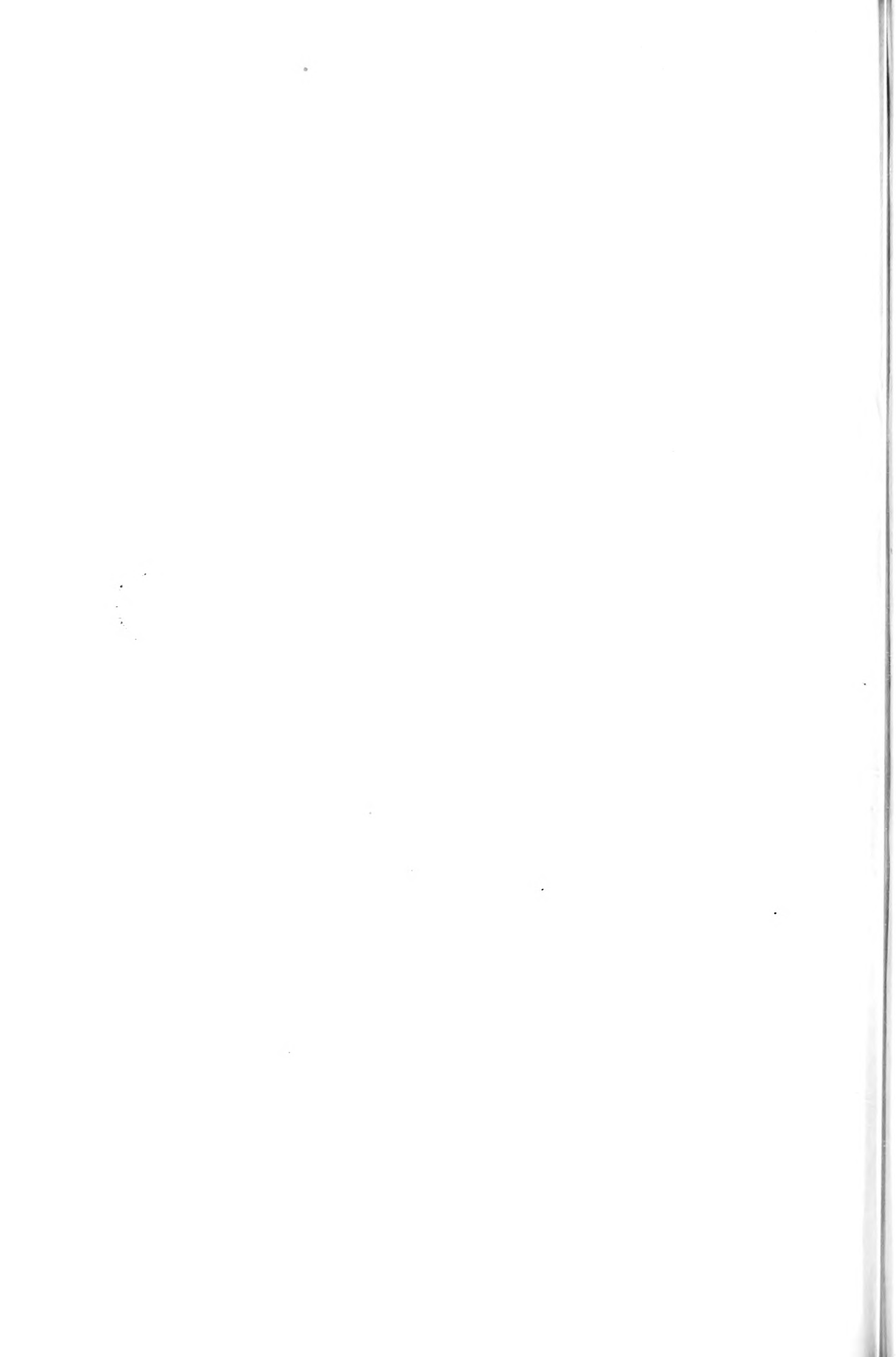



AGRICULTURAL COLLEGE STUDENTS' HOSTEL, POONA.

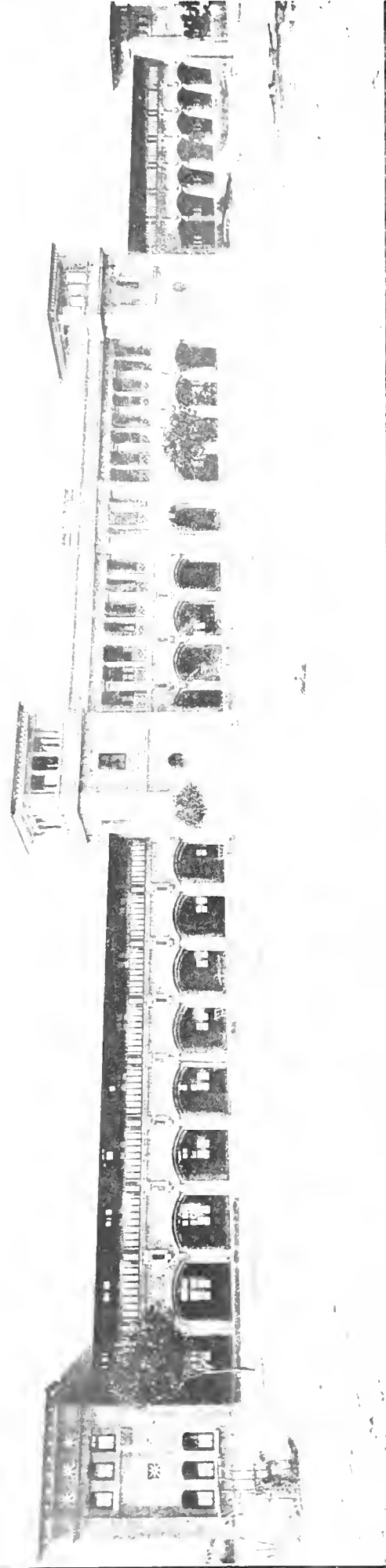

SCIENCE INSTITUTE, GUJRAT COLLEGE, AHMEDABAD.

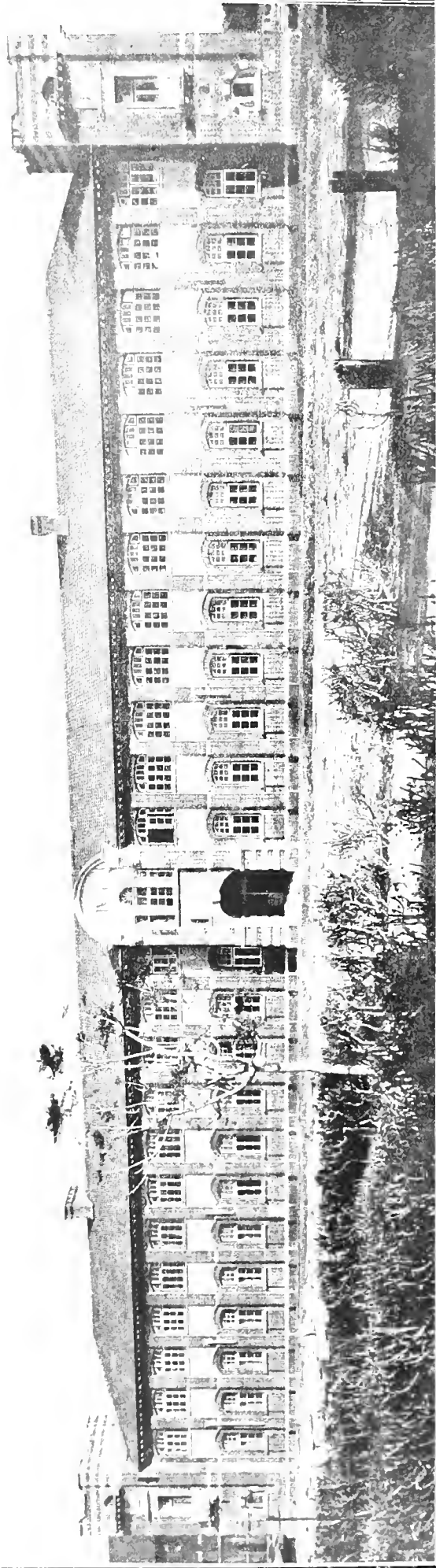

CIVIL COURT HOUSE, JUBBULPORE.

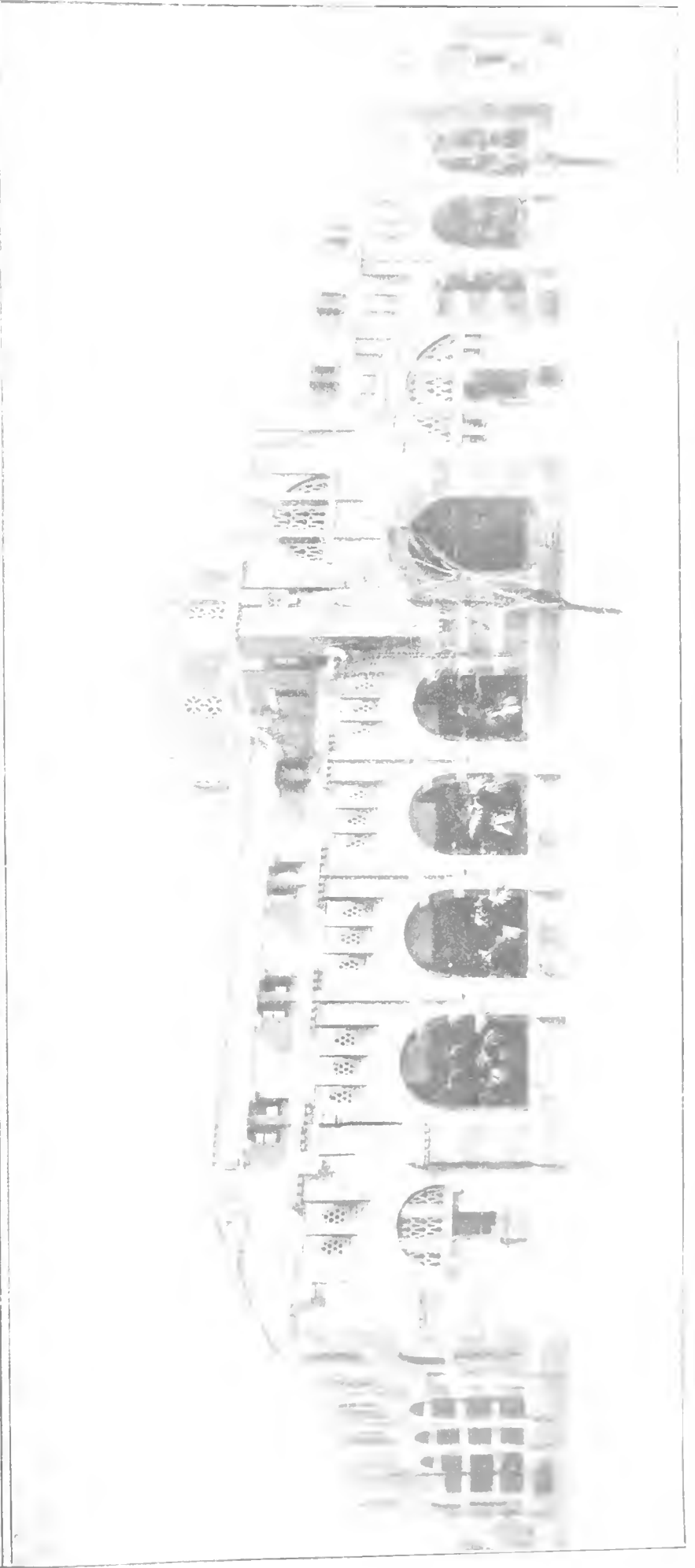
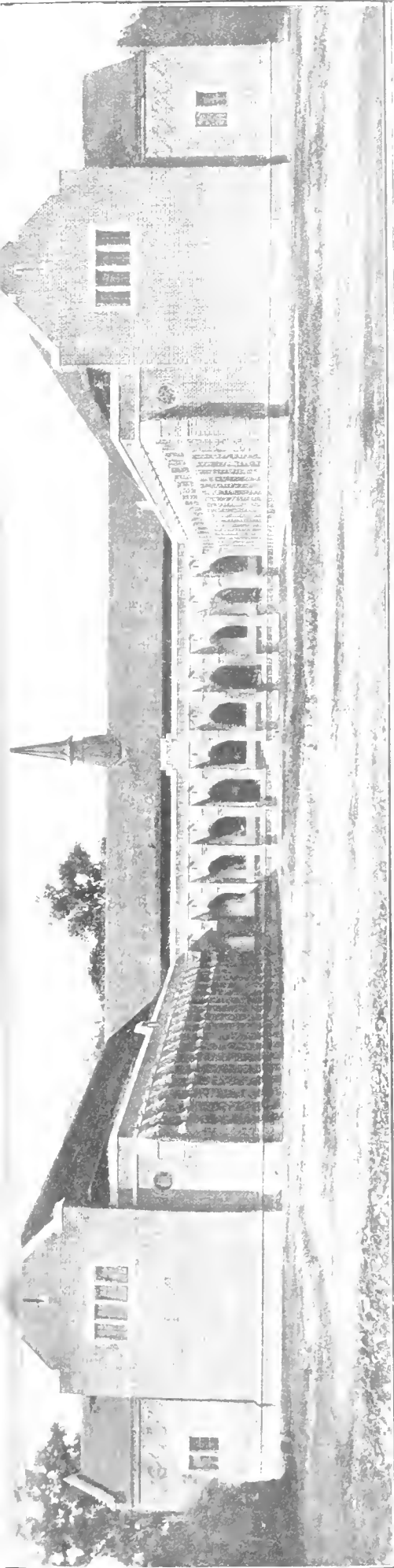





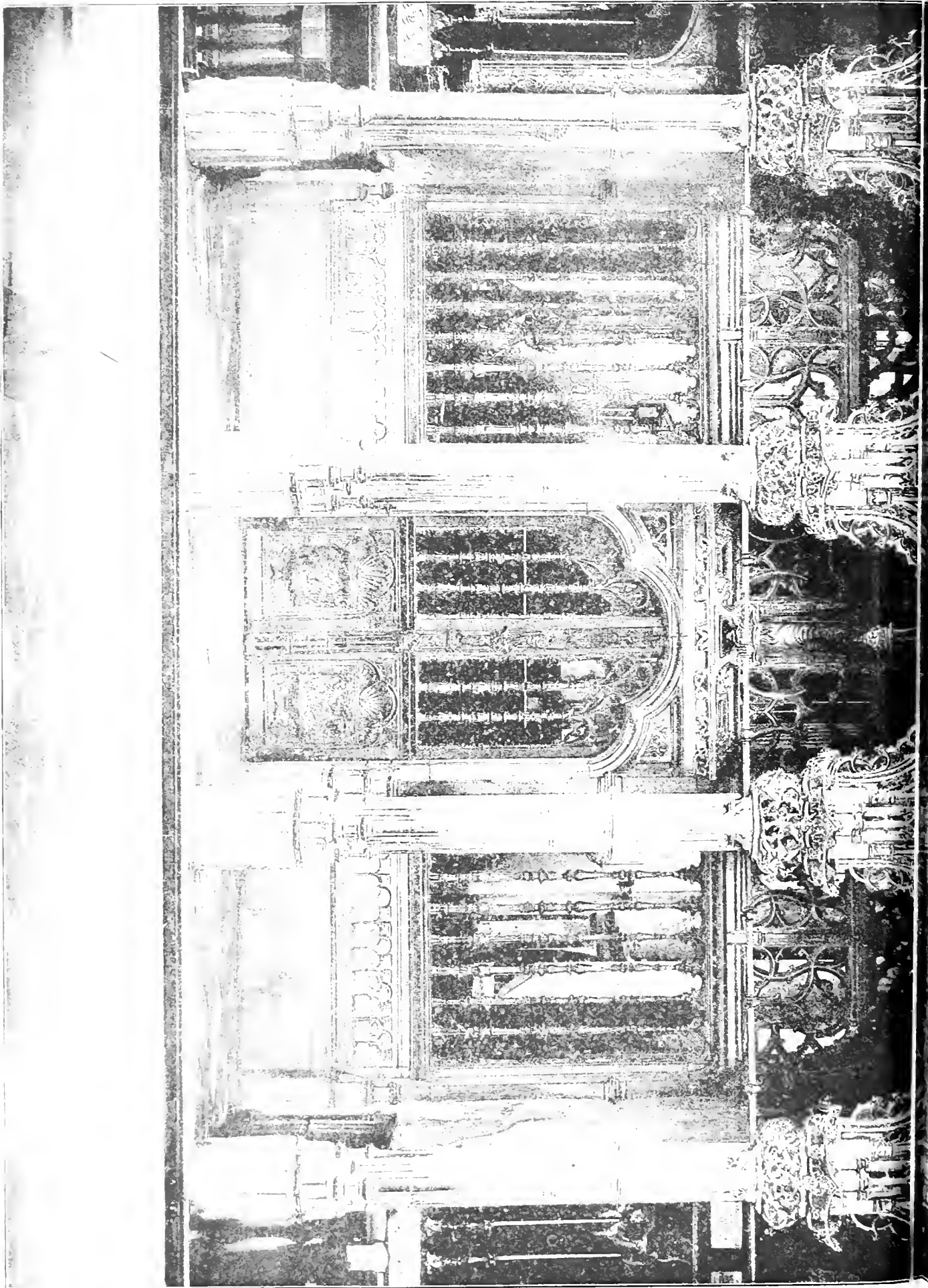

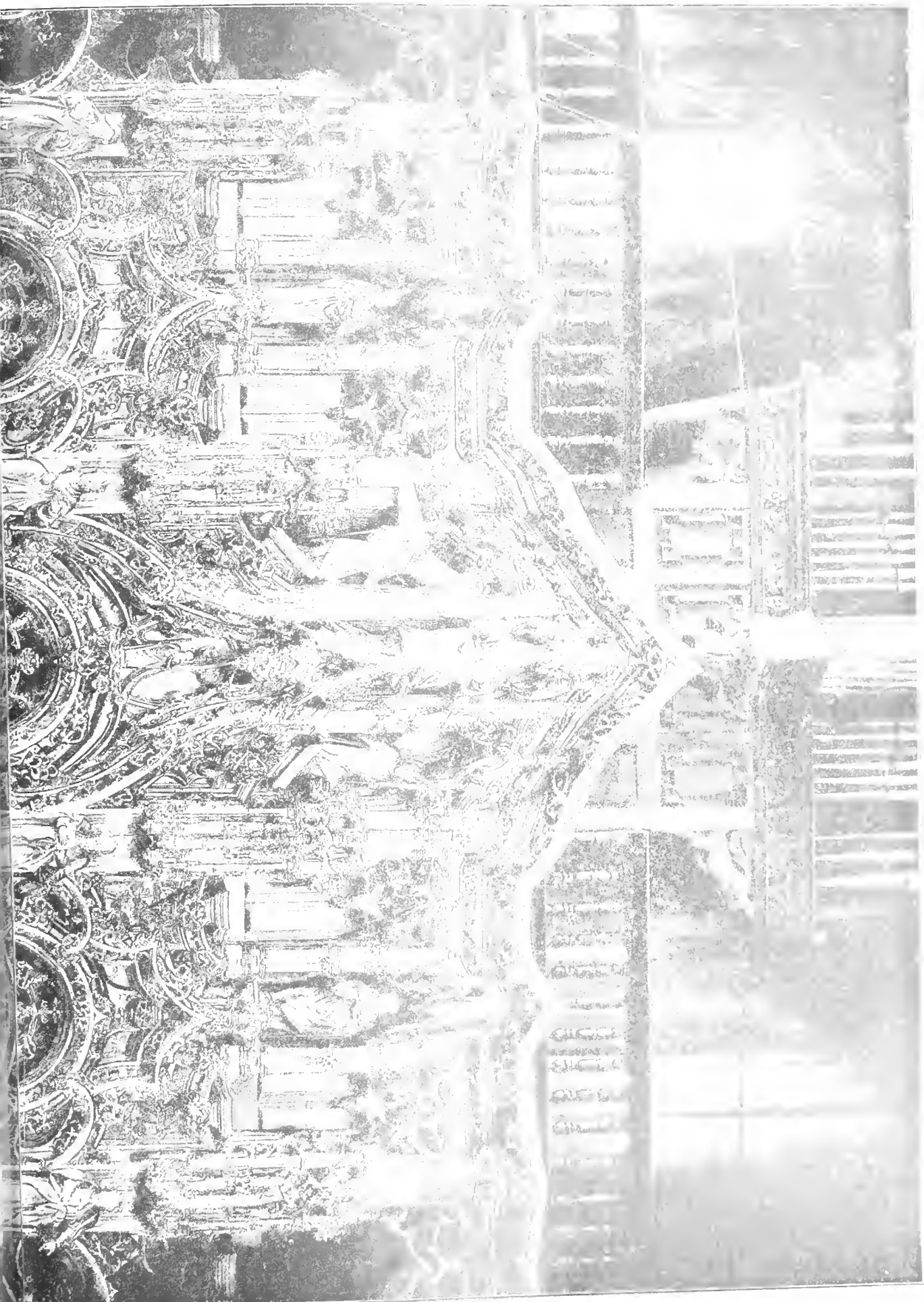

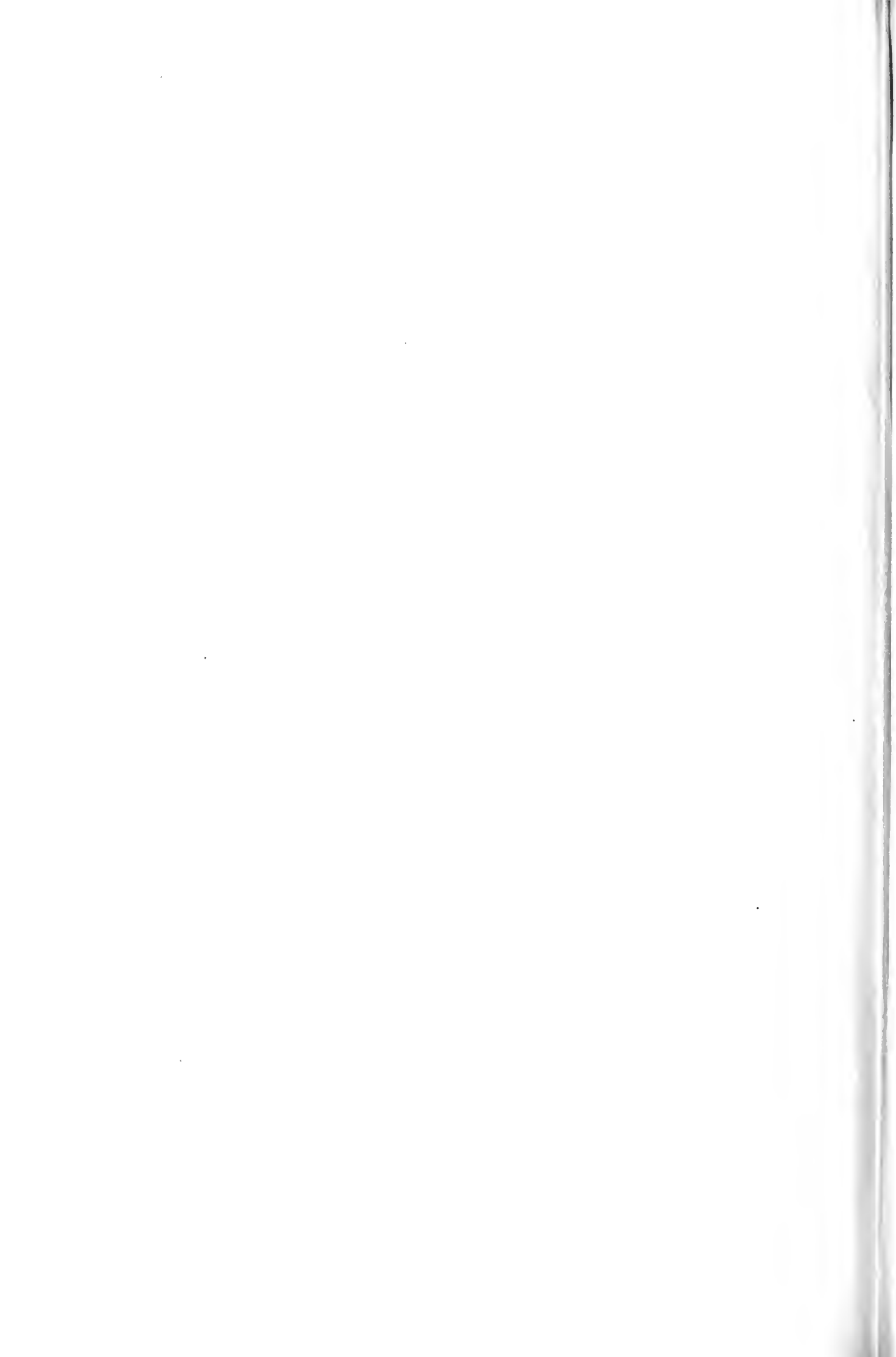

Building Intelligence.

BURTON HASTINGS.—The parish church at Burton Hastings, near Nuneaton, is to be restored. The edifice, which is in the Early English style, anciently belonged to the Monastery of Nuneaton. It is proposed to put all the stonework into good order, to execute repairs to the windows, to strengthen the tower and porch, to take off the present roof of the chancel, and substitute a new barrel roof, and to effect many other necessary alterations and additions. The work will probably cost £921. It is hoped eventually to put the bells in order, to erect a chancel screen and a new pulpit at a cost of £240, thus making the total outlay about £1,160. It is further proposed to reseat the church, either with chairs or with benches.

LLANDUDNO.—The police headquarters at Llandudno were removed on Wednesday to the new Police-building and Petty Sessions House which has been erected in Oxford Road, near the railway station. It contains a charge-room, parade-room, and other accommodation for the police, and cells for prisoners, with two courtrooms on the first floor, a large room for petty sessions, and a smaller room for occasional courts. There is also a residence for the police inspector. The cost of a little extra land in order to plan the police inspector's house to face Vaughan Street, which some day will be an important thoroughfare, where it would face westwards, would have been about £100. By a majority of one or two the committee refused to sanction this additional expenditure of £100, and so the occupants of the inspector's house, probably for hundreds of years to come, have been condemned to live in sunless rooms with an ugly outlook.

TRADE NOTES.

Messrs. Robert Hammond and Son, 64, Victoria Street, Westminster, regret to announce the death of their senior partner, Mr. Robert Hammond, on the 5th inst. It is the intention of the firm to carry on the practice under the old name and at the above address. Pending the return to civil life of the junior partner, Captain R. W. Hammond, now on active service, Messrs. Prece, Cardew, Snell and Rider have kindly undertaken to execute, on behalf of the firm, all work now in hand and any future work which may be entrusted to the firm.

Messrs. C. Jennings and Co., timber and plywood importers, general woodworkers, 952, Pennywell Road, Bristol, draw our attention to the fact that they have boats just arrived with spruce, birch, red and white timber. They will be pleased to answer inquiries in regard to timber, plywood, or woodwork of any kind, either manufactured or otherwise.

Boyle's latest patent "air-pump" ventilators have been adopted for the swimming bath at St. Paul's Schools, Hammersmith, London, W.

The roofs and floors at the Faringdon police station have been given a waterproofed cement treatment. We understand that the result of the Pudloed work was very satisfactory.

The death is announced of Mr. John Ritchie, builder and contractor, Dunblane.

The corporation of Colchester have appointed Mr. A. G. Wheeler as assistant surveyor and Mr. A. G. Andrews to the position of draughtsman and building surveyor.

The Bishop of Peterborough has dedicated the Lady Jane Grey memorial window, a new vestry, and other alterations and additions to the parish church of Newtown Linford, near Leicester. The cost of the new window has been borne by Mrs. Grey, and that of the new communion rails, reredos, carved oak panels, and screen at the west end by Mr. T. W. Everard. The vicar raised funds for the restoration of the organ.

At the last meeting of the Clyde-bank Dean of Guild Court, John Brown and Co., Limited, shipbuilders and engineers, applied for permission to form a new street off Clyde Street, and also to erect seven tenements in Clyde-streets and the new street, at an estimated cost of £12,000. The plans were passed. These tenements form part of a comprehensive scheme of housing which Messrs. Brown have undertaken for the accommodation of their workmen. Eight tenements are at present in course of construction in Clyde Street.

LEGAL INTELLIGENCE.

ACTION BETWEEN BUILDER AND SUB-CONTRACTORS.—At Newcastle-on-Tyne County Court, before His Honour Judge Greenwell, on Wednesday, George Greener, builder, and contractor, and Messrs. Greener and Sons, at Newcastle, were brought on an action against William Charlton, builder, trading as William Charlton and Sons, Cawkerock, to recover the sum of £243, as due in respect of timber used and prepared for the erection of some houses for the Stella Coal Company, for which the plaintiff was subcontractor for joinery work. The defendant counter-claimed for £54, a claim that he had had to expend that amount by reason of the plaintiff's neglect to complete his contract. Mr. E. Meynell was for the plaintiff, and Mr. H. S. Mundahl for the defendant. Mr. Meynell said that plaintiff had done the joinery work at several houses which the defendant was erecting to the order of the Stella Coal Company. Plaintiff was subcontractor to the defendant, and a dispute arose between them as to putting up frames and parting in front of the houses. Plaintiff declined to do this work because it was not in the defendant's specifications, on which he had contracted, and as a result of the dispute defendant took the contract out of Greener's hands. Greener now claimed £47 7s. 8d. for timber which he left on the defendant's site, and which had been used by him, and also £50 for timber which had been specially prepared for the houses. Defendant's counter-claim alleged that the plaintiff had overpaid £19 6s., that £192 had already been expended towards the completion of the contract which the plaintiff had not fulfilled; that the sum of £76 was estimated to finish the work, and that £43 had been deducted from the price of the houses because of the plaintiff's failure to comply with the specifications. Defendant also counter-claimed for £13, which appeared to be outside the contract in dispute. Greener gave evidence in support of his claim, and declared that any deviation he had made from specifications was made with the consent of Charlton. Mr. Mundahl said the defendant was quite willing to pay for whatever timber he had used that was the property of the plaintiff, but defendant had by no means the quantity alleged by the plaintiff. He admitted owing the sum of £29 13s. 6d. on that item. With regard to the material in plaintiff's workshop it appeared to be largely of unsuitable measurements for the work, and, in any event, should be the subject of nominal damages only. Mr. Mundahl stated that defendant's counter-claim arose because the plaintiff would not complete the contract. Judgment was given for £56 6s. 11d. on the claim, and for £61 12s. 2d. on the counter-claim. Each side undertook to pay its own costs.

AN INSECURELY FASTENED GIRDER.—At Nuneaton the North Warwickshire coroner (Dr. C. W. Hille) held an inquest on the 17th inst. on the body of William Carr (50), erector's labourer, Leicester, who was fatally injured on July 16 by a falling girder at a new needle factory in course of erection at Nuneaton. Alfred James Russell said he was in charge of the erection of ironwork in connection with the factory roof, and deceased was working with him. Some girders had been put in position, and they were painting them. These girders were supported by stanchions. In order to do the painting sprags had to be removed and afterwards replaced. While deceased was removing a sprag he accidentally pulled the girder from its position with his other hand, and two girders knocked witness and Carr from the platform. Witness was fast beneath the girder, but deceased was not; his injuries, however, were such that he could not move without assistance. Witness believed the accident would have been avoided if the girder had been fastened. The Coroner: Did you work to the plan of the architect? Witness: Yes. Either extra support or the fastening together of the girders with fish plates would probably have prevented the accident. The Coroner said that in the absence of the architect, he was not going to say whether he was right or wrong. There was something left undone which should have been done to make the workmen perfectly safe in their work. They either should have been more supports or the girders fastened together with fish plates. The jury returned a verdict of "Accidental death."

DUNFREMLINE BUILDING BY LAWS CONTRAVENED.—Mr. Dea of Council, W.S., represented R. S. B. & Co. of Tyle Country, Leith, at Dunfermline Division of Guild Court on Wednesday in connection with a contravention of the Act by laws in respect of permitting the use of a wooden hut which had not been approved by the burgh engineer. It

was found that the building was erected in contravention of the Act, and the court ordered the defendant to demolish the building and to pay the costs of the proceedings.

INFRINGEMENT OF BUILDING BY LAWS.—At R. S. B. & Co. v. R. S. B. & Co., the court found that the defendant had infringed the building by laws by erecting a building without a certificate, and the court ordered the defendant to pay the costs of the proceedings.

TRADE MOVEMENT.

LEEDS.—There was a strike of the builders' labourers in Leeds on Monday. The men demand the payment of a weekly bonus of 2 per cent., which the masters are not prepared to grant.

The County Council of Bedford have appointed Mr. F. W. Smart as deputy city surveyor.

The Hertford Rural District Council have approved the scheme submitted by Messrs. Balfour and Sons for a water supply. The Board held at an estimated cost of £170,000.

The corporation of Cheltenham have acquired the local gasworks, and intend to build a new gasholder of 2,000,000 ft. capacity, and estimated to cost £20,000.

Additions made to the isolation hospital at Billerica, Essex, at a cost of £20,000, have been formally opened. Mr. Hugo R. B. was the architect and Messrs. Harris B. was the contractors.

Mr. J. F. Hawkins, county surveyor for Berkshire, has received a commission from the Royal Engineers as temporary captain of the staff of General Gibbon, R.E., and is about to proceed to the Mediterranean.

New buildings, to cost about £250,000, will be erected for Delaware County, New York State, Delaware. These buildings are the gift of Mr. Pierre S. du Pont, president of the du Pont Powder Company.

Mr. Joseph Mallon, of Great Yarmouth, has been appointed waterworks engineer to the Weymouth Urban District Council, in succession to Mr. R. W. Maffell, who has taken up a similar appointment at Bournemouth.

A church of St. John the Baptist, in the course of erection at Blandford, Dorset, by Lane, Wandsworth, T. and Co., of Messrs. Home and Wheeler, of Bath, Somerset, under the contract of Messrs. D. B. & Co., of Colchester, Essex, is being built.

The corporation of Dunfermline have appointed Mr. John A. Wilson, of Messrs. W. & A. Stewart, of Glasgow, as engineer and architect, and Mr. James G. G. as architect, for the building of a new school in the town.

The corporation of Peterborough have appointed Mr. J. W. S. as engineer and architect, and Mr. F. G. as architect, for the building of a new school in the town.

Messrs. A. R. & Co., of Newcastle-on-Tyne, have been appointed to erect a new school in the town.

Mr. W. D. & Co., of Newcastle-on-Tyne, have been appointed to erect a new school in the town.

COMPETITIONS.

THE AMERICAN PRIZE OF ROME. Mr. C. Grant La Farge, Secretary of the American Academy in Rome, has announced the following awards in the annual competition for the Rome prizes:—The Fellowship in Architecture was awarded to Philip T. S. ... of Columbia University and Georgia School of Technology. The Fellowship in Painting was awarded to Russell Cowles, National Academy of Design, New York. The Fellowship in Sculpture was awarded to Joseph E. Renier, National Academy of Design, New York. The Fellowship in Landscape Architecture was awarded to Edward G. Lawson, Cornell University.

PROFESSIONAL AND TRADE SOCIETIES.

BRITISH ARCHAEOLOGICAL ASSOCIATION IN THE ISLE OF WIGHT.—The seventy-second annual Congress of the British Archaeological Association was held in the Isle of Wight during last week, with headquarters at Ryde. A reception was given by the Mayor of the borough, Mr. John L. Barton, on Wednesday evening at the Royal Pier Hotel as an inaugural function, and among the guests were the President of the Association, Mr. Charles E. Keyser, M.A., F.S.A., and the hon. secretaries (Mr. G. W. C. Bennett and Mr. A. W. Coke). The Mayor, in welcoming the guests, said the last visit to the Island of the Association was in 1855, when, by a strange coincidence they were at war with Russia.—On Thursday about fifty members of the Association, in conjunction with the Hampshire Field Club and Archaeological Society, visited Christbrooke Castle, the official residence of the Governor, Princess Henry of Battenberg, with Mr. Percy G. Stone, F.S.A., F.R.I.B.A., as guide. They afterwards proceeded to the ancient church of St. Mary's, where Mr. Stone explained the leading features to them. The Roman villa in the Vineage grounds was shown by Mr. J. H. Greenfield. Afterwards they proceeded to Newport, where they were welcomed by the Deputy Mayor at the Guildhall. Here the Newport Corporation charters, dating back to the reign of Henry II., and other records and curiosities were inspected, after which the party visited Newport parish church, the foundation-stone of which was laid by Prince Albert. In the evening, after dinner at Ryde, the Presidential address was delivered by Mr. C. E. Keyser. Mr. G. W. Chesatt, F.G.S., exhibited some of the most interesting specimens of Island flint implements from his collection, including the Tribachate implement, which is probably unique.—On Friday the members proceeded by motor from Ryde to the "Kings' Town" of Brading, with its ancient stocks and whipping-post, its bull ring and its historical church, rich in monuments. The Roman villa near by, with its well-preserved mosaic pavement, described by the custodian, Mr. George Cox, was a source of considerable interest to members, who afterwards proceeded via Shanklin and Ventnor, and through the romantic inlets to Blackgang, with its remarkable chimneys, and thence on to Wootton, to inspect one of the many fine manor houses of the island, existing on the way back Kingston and St. Andrew's Churches and Northcott, the beautiful residence of Mrs. Disney Lamb.—On Saturday morning the members went to Quarr Abbey, where Mr. G. W. Cole gave a talk at the lecture of the notes, as shown by the operations which took place in 1691. A pleasant drive over the downs then brought the party to Arretton Church, which, although not a cathedral, is still full of interest to archaeologists, its interior being architecturally the finest in the island. The Jacobean manor house near by was also inspected, and the Congress terminated with a visit to Newchurch Church, an edifice of great antiquity.

CHIPS.

Mr. T. Thomas, chief assistant to the city engineer of Hull, has been appointed deputy city engineer. The urban district council of Cannock have under consideration a proposal for the widening of Uxbridge Street. The urban district council of Llantarman, Mon., have approved of the plan and estimates for sewerage of the district of Cwmbran prepared by Mr. A. Gordon Jones, their surveyor. The Sewers Commissioners, Sessions House, Dartford, have appointed Mr. William Scott Willton, assistant engineer, as engineer to the Commissioners, in succession to the late Mr. C. Huntzger. The chairman of the Ilkley Urban District Council has formally opened the electricity generating station erected to supply Ilkley urban district and the Middleton township, the scheme having cost £21,000. The sanitary department of the Corporation of Oldham are vigorously conducting an inspection of houses, and so far have found 210 in a dirty condition, ten overcrowded, and 680 structurally defective out of 2,769 inspected. The death has taken place at Carmarthen of Mr. Daniel Phillips, Pieton Villa, who was for twenty-five years road surveyor for the western division under the Carmarthenshire County Council. He retired fifteen years ago. A Wesleyan soldiers' hall was opened at East Boldon on Wednesday. It has been erected at a net cost of £475, by Mr. Davidson, builder, of Boldon, who undertook to execute the contract without profit to himself. The Greenock Corporation Electricity Committee recommend an increase of £100 to the salary of the engineer, Mr. Frank H. Whysall. Mr. Whysall was appointed a year ago, and his first financial report shows a surplus of about £10,000. Mr. Henry David Davis, F.R.I.B.A., aged 76, of Port-down Road, Maida Vale, W., formerly a senior partner in the firm of Messrs. Davis and Emanuel, architects, of 2, Finsbury Circus, E.C., left net personalty £21,596, and a gross sum of £18,647. Mr. W. J. Goode, for the past two years surveyor and sanitary inspector at Buckfastleigh, and one of the sanitary inspectors under the Totnes Rural District Council, has been appointed surveyor and sanitary inspector to the urban district council of Street, Somerset. Further constructional work, the Agent-General for the Province of Quebec states, is promised at the Port of Montreal, such as the extension of the harbour, the improvement of the waterway, and the construction of dry docks, dockyards, and of a branch line to link Montreal with the National Trans-continental Railway. The Treasury intimates that during the war no loans can be granted under the Small Dwellings Acquisition Act to enable workmen to buy their own houses, declaring that loans for such purposes cannot in existing circumstances be considered to be in the public interest. The Act has practically become a dead letter. The Road Board have informed county councils that while they propose to make grants towards the cost of road crust improvements which are immediately required, unless special circumstances can be shown the grants will be on a considerably reduced scale, and will only be made in the case of important roads, the improvement of which cannot properly be postponed. At Prince Rupert, British Columbia, a dry dock has been built, and will be ready for business this month. It has cost £300,000, part of which will be borne by the Dominion Government, the greater share, however, being paid by the Grand Trunk Railway Company, the terminal port of whose new Trans-continental line is Prince Rupert. The dock consists of three units, with a total capacity of 20,000 tons. All of them are interchangeable, and when necessary they will be joined to hold a boat of about 600 ft. in length. To alleviate the great distress the war has brought to architects, designers, sculptors, and other professional men, the Vienna City Council have resolved to carry out work which will furnish them with moderate remuneration and at the same time add to the attractiveness of the city. As a beginning, artistic drinking fountains will be erected in the grounds of the new schools and in the children's playing spaces in the public parks and gardens. For the first of these, in the Schubert school, the council has appropriated a sum equivalent to £230.

TO ARMS!

4th Battalion "Architects" Central London Regiment Volunteers. Events are urgently needed for the Regulars, Territorials, and Volunteers. Intending recruits should apply to Battalion Headquarters, where they will be advised as to the branch of the service for which they are best suited. ORDERS FOR THE WEEK, BY LIEUT.-COL. A. W. WARDEN. Officer for the week, G. H. Parker. NOTE. The attention of all members is drawn to Routine Orders 14 to 17. Any member not receiving a copy is requested to notify the Adjutant's Office. GENERAL PARADES. Saturday, 25th inst., 3 p.m., at Hampton Court. Train 2.2 Waterloo. Sunday, 29th inst., 10.20 a.m., at Boreham Wood. Train St. Pancras 9.30. CAMP. Members desiring to sleep in camp for week-ends should notify the Quartermaster at camp not later than the first post on the Thursday of each week. These men should report themselves to the Orderly Sergeant on arrival in camp. MENTION WORK. The attention of members is drawn to circular letter dated 16th inst., to which an immediate reply is desired. COMMITTEE MEETING. A meeting of the Civil and Military Committees is called for 7.15 p.m. this evening (Wednesday), at Battalion Headquarters. A full attendance is requested. SCHOOL OF ARMS, DRILLS AND PARADES. All as usual. RECRUIT DRILLS. "A" Coy., Dean's Yard, 5.15 and 6.15 Wednesdays and Fridays. If wet, these drills will be held at Millbank School. "B" Coy., Dulwich College, Mondays, 8 to 10 p.m., Thursdays, 6 to 8 p.m. "C" Coy., Boreham Wood and Elstree District Headquarters, A.A. Athletic Ground, Boreham Wood. For full particulars, apply to Alan Potter, Esq., Grey Gables, Boreham Wood, Herts. "D" Coy., Movers' School, Tuesdays and Thursdays, 6.45 p.m. CORRESPONDENCE. Enrolment forms of new members and all correspondence, not referring to recruiting for the Army or to financial matters, must be addressed to the Adjutant, 10, Conduit Street, and regarding recruiting for the Army to the Recruiting Officer, at Battalion Headquarters, and regarding accounts and subscriptions to the Paymaster, W. R. Hughes, 17, Ditchwood House, E.C.

By order, L. R. GUTHRIE, Adjutant. BATTALION HEADQUARTERS, 15, TUFTON STREET, WESTMINSTER, S.W.

MEETINGS FOR THE ENSUING WEEK.

THURSDAY.—Royal Photographic Society's Exhibition, "A Ramble Round Hampstead, with Historical Notes on the Old Town," by H. Hardwick. Suffolk Street Galleries, Pall Mall, S.W. 8.30 p.m. FRIDAY.—Royal Photographic Society's Exhibition, "A Northern Muster," by E. W. Harvey Piper, Hon.M.S.A., Gallery of the Royal Society of British Artists, Suffolk Street, Pall Mall, S.W. 8.30 p.m. Sanitary Inspectors' Association. Meeting at Lichfield.

Mr. M. A. Robinson, city surveyor of London-derry, has had his salary increased by £200 a year.

The death is announced of Mr. Thomas Elliott, for over a quarter of a century borough surveyor of Enniskillen.

The Marquis of Bute proposes to expend £250,000 in additional siding accommodation and in further hydraulic plant and other equipment at the Bute Docks, Cardiff.

The foundation stone of the new physiological building of the Welsh National School of Medicine has been formally laid in Newport Road, Cardiff. Sir Wm. James Thomas, of Ynys-hir, has given over £60,000 to the school fund.

Mr. Herbert C. Snewin, Hampstead Hill Gardens, N.W., eldest son of the late C. B. N. Snewin, timber merchant, Back Hill, Hatton Garden, and Putney Hill, died on the 17th inst. at a nursing home in Mandeville Street, W.

The wedding took place at St. Mary's Church, Frome, on Tuesday in last week, of Mr. Henry George Blomfield, I.C.S., elder son of Mr. Reginald Blomfield, R.A., ex P.R.I.B.A., of 51, Frognal, Hampstead, and Point Hill, Rye, and Miss Frances Blomfield Crutwell, elder daughter of Mr. Percy Wilson Crutwell, of Northcote, Frome. The ceremony was performed by the vicar (the Rev. C. G. Glynn-Jones) in the presence of a crowded congregation. The wedding was of a quiet character, owing to the war, and there was no reception.

Messrs. Cornhill Label and Co., of Sheffield, are now engaged on extensive works, costing over £250,000, and employing 300 men. The Corporation of Nottingham have agreed to lease a site of 150,000 sq. ft. for a period of six months beyond the expiration of the lease.

The purpose of the Act is the insurance of the safety of the worker. All plans of the factory must be laid with this ultimate end in view. It is but part of a scheme that the requisite fireproof or incombustible iron fire-escape, and the necessary stairs, are provided. They have to be in suitable positions. One is possible in buildings, solid in appearance, the square on plan, but tend to reveal their true character—parallel—when the general arrangement is a stair case at one end and one about the middle of the building. In this case the satisfactory or hardware enclosed stairs may be conveniently placed centrally, and in this position may serve the lavatories. But from the fire-escape may take a central position, since the natural trend of planning is for lavatory accommodation to group towards one end, having regard to the convenience of drainage. Whatever the general arrangement, the principle is to fairly distribute the stairways about the premises, affording as great an opportunity as possible for all workers in emergency. It is essential in planning to remember that the regulations are, in a sense, tentative. Although certain requirements are scheduled and details, as of stairs construction, clearly set out, the whole of the planner's work is liable to be set aside; hence the wisdom of ascertaining, at the earliest possible moment, whether his plans are satisfactory.

The idea in the minds of the framers of the Act, as to safety against fire in factories, evidently centred about a fireproof staircase. They certainly had in view, as the first consideration, an "incombustible" staircase. This, therefore, should receive the architect's first consideration. What there may be demanded in addition to this depends chiefly on the individual character of the proposed building and its surroundings. An easy and obvious way of escape on to neighbouring premises is generally viewed by the authorities as a great advantage, and the existence of such greatly modifies the matter of factory staircase provision. Nowadays, however, the exterior fire-escape stairs are very generally required. If no third staircase is needed, the factory floors will have an escape at either end—by the solid brickwork fireproof stairs and by the exterior iron staircase. Where the external fire-escape staircase is used for inter-communication—i.e., in addition to being merely an emergency fitting—the regulations demand non-slipping treads. It may be required that both, and in some cases all, staircases run up to the roof. We show this arrangement in our sketch, as an example, although in a building having but one upper floor it is not likely that such will be required. Where the plan is needed, a bulkhead of the kind indicated, usually having, for economy's sake, the roof cut away, merely leaving sufficient head room over the last flight, is general practice. It is shown of fireproof construction, having concrete flat roof with steel reinforcement. As to thus, the regulations set out that staircases should have an iron and concrete ceiling where they are not carried up above the roof, or where, being carried up above the roof, they are liable to attack by fire from an adjoining structure. In the sketches there is provided an emergency door opening out to the flat, connected with the main roof over factory.

Such a staircase as our drawings show is a structure conforming to regulations, because (1) the walls are of brickwork; (2) the stairs are of incombustible material, within the limit as to maximum number in flight, and having 3 in. minimum thickness in portion of tread and

riser; (3) a brick newel-wall supporting steps; (4) handrailing iron at newel wall ends; (5) fire-lobbies of fireproof material; (6) doors opening outwards. It is, further, lighted and ventilated, as required, by windows. Inasmuch, however, as the authorities consider each new proposed factory as an individual scheme, and judge all points on merits, all details of emergency fire arrangements for

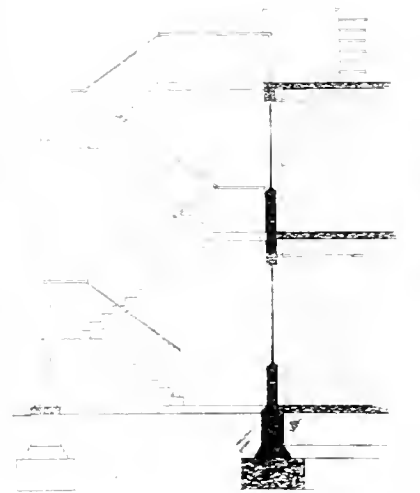

FIG. 2.

factories are best submitted. The practice will save time and delay in rearranging details to suit the experts, since, as we have said, to rearrange staircases in industrial buildings may seriously affect the whole planning.

Fig. 2 is a diagram of a fire-escape staircase. It is provided by the Act that such shall rest on "dead bearings," i.e., must be supported direct from earth, as by walls or stanchions. The sketch

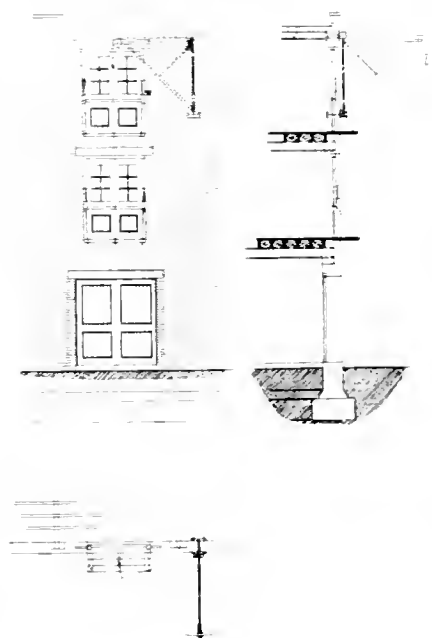

FIG. 3.

shows a stanchion upon stone template with suitable foundation. It carries one end of the steel cranked strings, the other ends being pinned into the factory walls. The building has ground and first floor and flat roof; and although the escape to the roof would not, in most cases, be here required, we show the arrangement as illustration for a many-storied building. In constructing the staircase the iron treads of stairs must be solid or with

not more than 3-in. perforations, and a close type of riser is required. The iron handrail must be supported by balusters not more than 6 in. apart. Doors off the landings must open outwards, and not, when open, obstruct the stairway. The drawing shows an emergency escape ladder from factory roof to adjoining premises, a way of escape from fire to which the authorities attach considerable value when considering proposed arrangements.

LOOPHOLE DOORS

are a necessary feature in many-storied factories and warehouses. They must be designed with reference to the most ready manner of hauling and delivering material. Fig. 3 is a sketch plan, elevation and section of a factory with first and second floor loophole doors and a jib-crane. The hinged flaps are 2 in. thick, with strong wrought-iron straps and chains, and are hooked back to door frames, which should be strongly attached to walls by wrought-iron straps built in. Long bar handles, bolted to the door frames afford hold for men supervising the hauling. A wooden cleat is often provided for ropes, and, in the case of many stories, a wood friction-roller to prevent the chain chafing the window head. The doors are hung in two parts, and have a water-bar to the sash-framed portions. The jib-crane is supported and swings in two bearing blocks bolted to the wall, the chain passes through into the building, and the haulage may be by hand or power, hydraulic gear being the most suitable.

THE A.B.C. OF HERALDRY.

The close connection of Heraldry with architecture has always been evident to the cultured, and no competent architect will fail to acknowledge the debt of his own art to the Noble Science as a means of architectural enrichment. Not always, perhaps, has he used his opportunities wisely, or rightly understood them, as some of the freaks of the Gothic revivalists perpetrated half a century since bear witness; but these extravagances after all were few, and in some cases due to the fact that the architect responsible was content to instruct the various art-workmen that such and such a shield was to be placed in this or that position, or that so and so's badge, cognizance, or motto was to be blazoned or carved here or there, when he ought to have known and made clear exactly the Heraldry he wanted displayed. In other cases doubtless he overdid it, utterly ignoring the elder Pugin's caution, "Don't work it to death!" Again some of us were so certain that Heraldry was part and parcel of Gothic architecture that when the Classic revival set in something like a settled conviction that Heraldry was out of place in Classic buildings led to neglect of the Science and its resources. There was surely no justification for that. If Heraldry is really of use—to put it on the lowest ground—to express facts in connection with the art and life of our modern times, it is as safe and wise to use it now as ever, if only we abide by the sound principles of the heralds of the golden age of Heraldry, and ignore the vain conceits of the formalists who during the decadence which lasted from the sixteenth century down to the middle of the nineteenth. There is no lack of good examples left to us, and the architect who will study them and familiarise himself with the alphabet of the Science will find it well worth his while. If he desires to give historic character to his public buildings Heraldry will enable him to associate with his work the benefactors, statesmen, potentates, and

... effects which give the painter conventionalised the lion, the better the decorative effect. Whenever an attempt is made to draw a symbolical or heraldic lion true to nature failure results. It is quite impossible to do justice to the real animal in the limited space and under the restricted conditions imposed upon the artist in heraldry, and consequently strong conventionalising is necessary.

More yet it is to be observed that the more the painter conventionalises the lion, the better the decorative effect. Whenever an attempt is made to draw a symbolical or heraldic lion true to nature failure results. It is quite impossible to do justice to the real animal in the limited space and under the restricted conditions imposed upon the artist in heraldry, and consequently strong conventionalising is necessary.

That there should be a revival in many directions—in leadwork, plaster, and carved work—in the decorative use of Heraldry, we, of course, agree with Mr. Rothery, and we are sure his book will help. By the courtesy of the publishers we reproduce three of the illustrations, one showing an Armorial chimney-piece at Tattershall Castle; another an Armorial aster, and another an Armorial plaster

magnificence of effect, seated, as it is, on the rising point of a sandstone rock at the apex of a narrow peninsula formed by the windings of the River Wear. The masses of grey masonry are flat and austere in outline, but a crown of three broad and beautifully in-proportioned towers, together with a cluster of steep pinnacles flanking the gables of the wide eastern chapel, impart to the edifice a regal and unmistakably English aspect. Immediately to the north of the cathedral church, but separated by a broad open space, the huge keep and long level line of lofty bastioned parapets of a castle frown upon the rapid and shallow stream beneath, contrasting in their bare severity with the rugged and well-wooded cliffs in the foreground. As we gaze upon the group, a veritable union of Church and State, from the railway line upon the opposite bank of the river we realise that here has been a frontier settlement on an important military position.

As cathedrals go, the history of Durham is a short one, extending over but 920 years, but the cathedral is in the line of succession of a much more ancient and extensive see, first of Northumbria and then of Bernicia. The present church is the third built on Dunholme, and was begun by Bishop William de St. Carleph in 1095. At his death, six years later, the choir, with its three apses, the transepts and eastern bays of the nave had been built. The choir was completed by 1104, the walls of the nave had been erected by 1128, and five years later the stone vault had been added to it. Between 1170 and 1175 Bishop Hugh Pudsey, foiled in his attempt to build an eastern Lady-chapel beyond the apses by the occurrence of fissures in the walls and foundations, constructed the unique Galilee chapel between the west front and the cliff verge, and more than sixty years later, between 1242 and 1278, the eastern apses were removed and replaced by the noble eastern transept known as the Chapel of the Nine Altars. The western towers, raised to roof level in the days of Stephen, were carried to the present height early in Henry the Third's reign, and the central tower was several times recased or reconstructed, the lower story to the ringers' gallery having been repaired, if not rebuilt, about 1470, and the upper story added twenty years later. Just a century before that work of completion, in 1390, Bishop Skirlaw began the rebuilding of the Norman clusters, a work which was not finished for eight-and-twenty years. Few other important changes were made in the cathedral till the time of the Restoration. From the first, all the vaults had been of stone, and the chief alterations were to secure better lighting and at the same time to bring the tracery of the windows into the fashion of the day. To Bishop Cosin, appointed by Charles II., we were indebted for the magnificent font cover and the stalls, and to his dean, Dr. Sudbury, for the conversion of the monks' dormitory into a library. Cromwell had utilised the choir in 1650 for the housing of Scottish soldiers taken at Dunbar, with the result that the old stalls and other fittings were burned or smashed by the interned men, and seven years later the wooden spires which added so greatly to the picturesque and imposing character of the western steeples were demolished, never to be re-

* The following illustrations of Durham Cathedral have appeared during recent years in the BUILDING NEWS:—Plan of minster and monastic buildings (by late Rev. Mackenzie E. C. Walcott), March 3, 1876; plan of cathedral, May 16, 1884; photographic view from W.N.W., October 24, 1890; in the close, looking towards central tower (from a water colour by Charles Dixon), September 1, 1893; nave, looking east, photograph, March 4, 1887; south arcade of nave, measured drawing by John H. Taylor under supervision of James Ryan, December 20, 1907; elevation of the bay of nave (by S. T. H. Parkes), October 23, 1885; in Galilee Chapel to S.W. (photograph by George Bankart), January 29, 1899; arcade, west side of north transept (photograph by Henry W. Bennett), December 20, 1907; in the sanctuary to east, from photograph, August 3, 1888; Bishop Hatfield's throne and tomb (sketch by Joseph Pennell), February 10, 1888; double page of measured drawings (by Ryan Watson), February 8, 1907; Chapel of the Nine Altars (measured drawing of eastern wall by S. W. Aldford, of Sunderland), February 28, 1913; double tracery in north window of the Nine Altars Chapel, December 29, 1905.



ARMORIAL PLASTER CEILING, SIZERGH CASTLE, WESTMORLAND.

design, for it springs out of the design and appears essential to it. This secret of good design also characterises much of the Renaissance work of the early and middle periods; and it was possessed to quite a remarkable degree by our own masters of carving and plastering craftsmanship.

In early heraldic work, whether seen in carving or illumination, there is a boldness of tone in design, an easiness in the treatment of detail, which makes for diversity and artistic effectiveness. At one unfortunate period of armorial evolution this conventionalisation was regarded as an error, and an attempt was made to return to nature, while conforming to the strict rules of the 17th Century heralds. This failure of the nineteenth century is well illustrated by the unbelonging realism in the story that once upon a time an old country coach painter visiting London was taken to see the lions at the Tower, and presently regarded the town by these as lions. "These lions," he cried, "No, no! I've seen painting lions in all kinds of positions in the coats of arms of the noblest nobles and I ought to know what a lion is like." Now, in heraldry the heraldic lion is not a beast in creation, but it conveys the idea of the proud "King of beasts" and preserves the ancient tradition

ceiling at Sizergh Castle, Westmorland. There are a good many others which will equally interest the architect and the art-worker.

A NORTHERN CATHEDRAL

At the exhibition of the Royal Photographic Society, in the gallery of the Royal Society of British Artists, Suffolk Street, Haymarket, S.W., a lantern lecture on "A Northern Cathedral" was given by Mr. E. W. Harvey Piper, Hon.M.S.A., on Saturday evening last. Mr. G. Lamley, F.R.G.S., F.R.P.S., occupied the chair, and in introducing the lecturer remarked that for at least fourteen or fifteen years past Mr. Harvey Piper had given them at the Society's Exhibition a discourse on the architectural characteristics and historical incidents of some great English cathedral.

The opening sentence of the address, which was illustrated by between eighty and ninety photographic slides, showed that the edifice to be described would be Durham. "Beautiful in situation, the joy of the whole earth," as the lecturer remarked, the Benedictine Minster Church of Christ, the Virgin Mary, and Saint Cuthbert. Its position is unrivalled in England for stern splendour and

placed. The evil genius of Durham was the blatant and ignorant self-styled "architect," James Wyatt, who, after he had wrought irreparable mischief at Salisbury, Hereford, and Lichfield, was called in here to advise Bishop Shute Barrington. Wyatt pared down the external masonry, obliterating its original vigour and ornamentation, removed tracery and stained glass from most of the windows, and rebuilt doorways and pinnacles in a debased form of Churchwardens' Gothic. He devised, and his successor Morpeth carried out, the mutilation of the incomparable chapter-house, and only by the protests of John Carter was Wyatt prevented from removing the Galilee chapel in order to provide a drive for the bishop from the Castle to the western doorway. Anthony Salvin, who rebuilt the keep of the Castle and restored the cathedral choir in the late forties of the last century, was but little better informed than Wyatt, and the earlier work by the late Hodgson Fowler, say the dozen years from his appointment in 1864 until his restoration and refitting of the edifice, completed in the summer of 1876, was by no means free from blame. But Fowler grew in grace, in taste, and in discretion with the widening of his archaeological and ecclesiastical knowledge, and during the last four-and-thirty years of his long career as architect to the fabric proved a zealous and well-informed conservator of its highest interests. It was an interesting fact that Mr. Edward R. Robson, who preceded Mr. Fowler as architect to the Dean and Chapter, resigning in 1864 on his removal to Liverpool, and subsequently acting for many years as architect to the London School Board, was still living in retirement, having attained an advanced age.

Looking at the plan, it appeared at first sight one of the double-transepted or patriarchal cruciform type of English cathedral, such as we possessed at Canterbury, Lincoln, Salisbury, and Worcester, but lacking the eastern projection of a Lady-chapel, which seemed to be tacked on to the western front. The choir was of the usual four bays of the larger English Benedictine churches, such as we see at Ely, Norwich, Peterborough, St. Albans, and Winchester; there were short transepts with eastern aisles, as in the last-named cathedral, and an all-inadequate nave of eight narrow bays, with cloisters and the buildings of a Benedictine monastery in the usual position, south of the nave. In dimensions, Durham ranks sixth among English churches, being a little less in area than Ely or Westminster Abbey, and considerably more spacious than Salisbury.

Mr. Harvey Piper then proceeded to conduct the audience on a tour around and through the cathedral, elucidating the various features described by throwing simultaneously upon the lantern screen behind the platform drawings by John Carter, 1785; G. F. Robson, 1828; John W. Billings, 1832; and C. Clement Hodges, and photographs by Messrs. Edwin R. Bull, W. Ellison, T. W. Freshwater, J. Patterson Gibson, W. H. Hirst, J. W. Hodges, Mark Holloway, T. M. Grose Lloyd, Newton and Co., Photochrome Co., James Valentine, G. W. Wilson, and other experts in architectural camera work. The cathedral and castle, as depicted from the opposite bank of the Wear were shown from various standpoints, and it was remarked that the view from the south-west, with the abbey mill and weir in the foreground, had, perhaps, been more often sketched, painted, and photographed than any other combination of buildings and landscape scenery in the United Kingdom. Another excellent prospect, but lacking the river, is that from the south-east gained from St. Oswald's Churchyard, and a third, of which advantage had been taken by Mr. George Brown in a beautiful bromoil print (No. 1) on view in the lecture-hall, was half-way down Framwellgate Street. From the opposite bank of the river looking W.N.W. a comprehensive idea of the general grouping of the building, its towers and chapels, is obtained. The central tower owes much of its effectiveness and power to dominate the landscape to the addition made in 1490 of the

beltry stage, which, as the lecturer has behind him, is the only one of the almost dis-everted. The central tower of the thirteenth century is, however, the third in height among the crowning of cathedrals, was disfigured, the tower of St. Albans, by a casing of plaster, and this was removed in 1659, under the advice of Sir Gilbert Scott, who, by the way, was never admitted to the Dean and Chapter, as is erroneously stated in most guide-books. The lecturer suggested that if the lower portion of the central tower were opened out, it would possibly be revealed, as Mr. W. D. Caroe had found during the repairs to the Bell Harry tower of Canterbury, that much Norman or Early English worked masonry existed beneath the outer shell. The broad western towers are, like those of Wells, although not to the same extent, boldly projected beyond the aisle walls, and a piquant contrast is provided by the arcaded surfaces of the Early Thirteenth Century upper stories to the massive treatment of the Norman bases. Pusey's Galilee Chapel is kept so low as not to obscure the lighting of Carileph's nave through the elegant although incongruous window cut through the west wall by Abbot Fosseur.

Passing round to the south side, the Monks' (or, as it is now called, the Dean's) Kitchen, built by Abbot Fosseur in 1379, is seen to be in perfect preservation; it is an octagonal building of stone with central chimney, and greatly resembles the equally well known one at Glastonbury, also constructed for a Benedictine abbot, some four or five years earlier. Passing into the cloister garth, it was remarked that it was the third built on the site, the work of Bishops Skulaw and Langley, in the thirty years 1390-1420. The ignoble tracery in the unglazed panes was one of the numerous local memorials to Wyatt's meddling. In the centre is the stump of a former lavatory of marble, which, carried before the Dissolution a number of brass spouts discharging water and overhead a dove-cote tower. Excavations made between this fountain and the north walk of the cloisters in 1905, by the late Mr. Hodgson Fowler, disclosed the foundations of a Norman cluster of smaller dimensions. Nearby, and apparently extending under the south aisle of the nave, were other foundations, which were not followed up, but which were conjectured to be those of the White Church of Aldham. On the west side of the cloisters is the monks' dormitory, reconstructed and refitted in Charles II.'s reign by Dean Sudbury, under Bishop Cosin, as a library. Among the objects preserved here, and shown on the screen, were a panel containing Early English carved figures, the richly carved head of a twelfth-century cross, both in stone and a Saxon carved capital, probably from the White Church, discovered during recent excavations. Beneath the dormitory is a crypt, or, rather, undercroft, having richly ribbed vaulting carried on short cylindrical shafts, of the same period as the more extensive one at Fountains. The east walk of the cloisters opens into the reconstructed Chapter House, originally the largest in this county. It was built by Bishop Rufus in 1140, but in 1799 the Dean and Chapter employed one Morpeth to demolish the apsidal east end, throw the space this gave into the Dean's garden, and build up lath and plaster walls to afford a more comfortable meeting room for the chapter. Fortunately, John Carter had made in 1785 careful drawings of the house, and under the direction of Hodgson Fowler it was rebuilt on the old foundations in 1890-5, as a memorial to Bishop Lightfoot, the cost being £5,600. On digging over the site, sufficient fragments of arched, window jambs, corbels, vaulting ribs, and keystones were found for a reproduction of Carter's sketches, instances of which, together with the truncated room and Fowler's new work, were successively thrown on the screen, and also one of the stone thrones at the east end, in which every bishop from Pusey to Barrington had been enthroned, and which was preserved almost intact. Proceeding to the east side of the cathedral, the grotesque, but sizeable, knocker on

the east door, which was designed by Charles Cosin, was shown. The lecturer mentioned that the original proposal was to cover the nave with a wooden ceiling, such as we see in the contemporary Benedictine churches of Ely, Peterborough, and St. Albans, for the corbels on which the vaulting shafts are carried are clearly inserted in the wall as afterthoughts. The transverse arches over the nave are slightly pointed, an early example of the use of this form; but the diagonal ribs are segments of circles. In the nave triforium passage are rudimentary flying buttresses, large arches of masonry in the roof being employed to uphold the outside wall at a high level and transmit the thrust to a pier against the external wall at the triforium floor level. A later development was to carry the arch from the pier to the outer wall as the flying buttress so familiar in Canterbury, Westminster, Norwich, and elsewhere. Turning back to the Galilee, it was seen that the masons employed by Cardinal Langley in strengthening the four arcades with two additional columns to each pier so closely followed the mouldings of 1175 that it was not easy to detect the new work except by the different texture and hue of the fresh stones. Bishop Cosin's nave stalls and choir screen, carrying the case of Father Schmidt's organ, which replaced a medieval screen, were destroyed in 1845 by Salvin. The choir screen was replaced in 1876 by the present one by Hodgson Fowler, which probably looked effective as an architect's design, and has but three faults unfitting it for its position—the style, Advanced Decorated, an exotic at Durham; the material, shining alabaster, equally exotic; and the clumsy

Entered in the margin of the text, the lecturer drew attention to the fact that the harm in its treatment of the nave is the most complete and perfect Norman nave in England, although a little handicapped by its lack of length. Cosin's nave is, in the loftiest, largest, and most magnificent example of its class, and also the contemporary stalls in the choir, exhibits a design a delightful blend of Perpendicular and Jacobean details. For thirty years it was relegated to an obscure position in the north-western tower, but was repaired to its rightful position at the restoration of 1876. It houses a tawdry pseudo-Norman font, executed fifty years ago, and the lecturer suggested that it would be well if the Dean and Chapter could persuade the Mayor of Pittington, near Durham, to return Cosin's marble chalice, with shallow fluted bowl, to the minister from whence it was ejected forty years ago. The arcades of Durham nave are supported by clustered piers and massive circular columns alternating; the latter are variously ornamented with deeply incised patterns of vertical flutings, chevrons, and lozenges, each opposite pair being treated alike, and in the choir and transepts a spiral device similar to that on a pair of columns in Norwich nave was to be found. As to the channelling here and at Waltham Abbey and Lindisfarne, it had been hotly debated by archaeologists and practical masons as to whether they were incised before or after the shafts were erected. So far as Durham was concerned, the point might be regarded as settled, for close inspection had demonstrated that the deep grooves were cut through the stonework irrespective of the masonry joints, rendering it certain that the carvers wrought upon them after the masonry was set up. The triforium and clerestory are kept comparatively low in relation to the nave, and thus contribute to the good proportioning. One of the most interesting features of Durham nave is its quadripartite vault, erected between 1123 and 1133, and the earliest of these high stone roofs of great span (with the exception of the transepts here). It is evident that the original proposal was to cover in the nave with a wooden ceiling, such as we see in the contemporary Benedictine churches of Ely, Peterborough, and St. Albans, for the corbels on which the vaulting shafts are carried are clearly inserted in the wall as afterthoughts. The transverse arches over the nave are slightly pointed, an early example of the use of this form; but the diagonal ribs are segments of circles. In the nave triforium passage are rudimentary flying buttresses, large arches of masonry in the roof being employed to uphold the outside wall at a high level and transmit the thrust to a pier against the external wall at the triforium floor level. A later development was to carry the arch from the pier to the outer wall as the flying buttress so familiar in Canterbury, Westminster, Norwich, and elsewhere. Turning back to the Galilee, it was seen that the masons employed by Cardinal Langley in strengthening the four arcades with two additional columns to each pier so closely followed the mouldings of 1175 that it was not easy to detect the new work except by the different texture and hue of the fresh stones. Bishop Cosin's nave stalls and choir screen, carrying the case of Father Schmidt's organ, which replaced a medieval screen, were destroyed in 1845 by Salvin. The choir screen was replaced in 1876 by the present one by Hodgson Fowler, which probably looked effective as an architect's design, and has but three faults unfitting it for its position—the style, Advanced Decorated, an exotic at Durham; the material, shining alabaster, equally exotic; and the clumsy

proportions. The pulpit erected at the same period is also a terrible example of inharmonious style, materials, and proportions. Looking along the transepts from south to north, Abbot Fosser's elegant six-light window of 1365 in the north wall, and Chantrey's kneeling figure of Bishop Shute Barrington, 1826, the patron of Wyatt, were noted, and the scene shifted into the choir. Here, again, the problem of the vaulting had aroused long and bitter controversy, but examination of the masonry would demonstrate without possibility of dispute that when the Chapel of the Nine Altars was added the eastern bay of the choir and parts of the choir aisles were remodelled in the new fashion, the beautiful blend of Early English merging with and into the Decorated style, and that a new vault of this character was constructed over the entire choir and the eastern chapel. This new chapel and the reconstruction it involved were in progress between 1242 and 1278. In the four or five years ending in 1380 two important additions to the finishing and ornamentation of the choir, which had added greatly to its interest and beauty, were in progress, the ponderous episcopal throne or tribune, with tabernacle work and trestle-cusped canopy, built by Bishop Thomas de Hatfield, who fought at the siege of Calais and the Battle of Neville's Cross, and which had recessed within it the prelate-warrior's own altar tomb, constructed in his lifetime; and the rather wiry open screen between the high altar and St. Cuthbert's tomb, built at the cost of John Lord Neville of Raby, of Bedfordshire church stone, worked in London and transported thence by sea and rivers. Opposite the Hatfield throne and tomb, just east of the northern choir stalls, there has been erected a cenotaph altar tomb and effigy to Dr. J. B. Lightfoot, commentator and divine; the memorial of black and white marble is similar in style to that to Hatfield, but is more elaborate in character. Designed by the late Sir Edgar Boehm, it was completed after his death by Mr. Alfred Gilbert. Bishop Cosin's beautiful choir stalls and organ case, constructed in 1632-70 by James Clement, of Durham, in a blending of Tudor and Jacobean detail, were exhibited on the screen from a drawing by J. W. Billings as they appeared before Anthony Salvin destroyed the return stalls and Father Schmidt's organ case and threw the choir open to the nave, and as they now appear after being restored and set back by Hodgson Fowler, who also designed the new divided organ cases.

Turning eastward, the audience were invited in the imaginary perambulation of the edifice to descend a couple of steps behind Neville's altar screen into the elegant and spacious Chapel of the Nine Altars. The only other extension of like character (except the much later one at Peterborough) is the like-named chapel at Fountains Abbey*, built by Abbot John of Kent between 1220 and 1247, and therefore in course of completion during the first four or five years of the Durham chapel was being constructed. A view into the roofless ruins of the Fountains chapel showed a similar plan, with in each case wide lancets in the walls above an elaborate trifolled and moulded arcade, and in the eastern wall three bays each containing three windows, beneath each of which was formerly an altar; but whereas in the earlier Cistercian example lofty circular columns, centrally placed, once supported the vault, here at Durham the sexpartite vault is carried over the chapel without intermediate piers. The great height of the Durham chapel, the abundant lighting, the slenderness of the freestone and Frosterley marble window shafts and vaulting ribs, and the elegant bell-necked foliage capitals all contribute to the refinement and beauty of effect of Thomas de Moises' work. The huge rose window in the eastern gable, although deprived of its original tracery and stained glass by the detested Wyatt, still added by its fine proportions much to the magnificence

of the interior. The most interesting feature of the interior was the great feretory of St. Cuthbert, which occupied a great part of the western wall. Unfortunately the Jacobean screens erected around it, replacing the gorgeous shrine destroyed after the Reformation, were swept away by Salvin, leaving a bare rectangular tomb. The relics of St. Cuthbert removed from the innermost coffin of the saint in 1827, including his stoles and a girdle, his bracelet, pastoral cross of gold, oaken and silver altar tablet, and ivory comb, were now exhibited in the Library Museum. The outer coffin of oak, constructed in 1542, and of which a photograph was shown on the screen, was transferred at the time of the exhumation to the kitchen of Durham Castle, where it still remained. The lecturer suggested that it would be a gracious act on the part of the custodians of the coffin, probably the council of Durham University, to restore this valuable relic to the Dean and Chapter, since its most appropriate resting place would be on the saint's tomb. Below the elegant north window of this church is the statue of Bishop William van Mildert, the last of the earl-bishops and the benefactor to the university, who is shown by the sculptor, John Gibson, as attired in bob-wig and lawn shoes, and seated with a closed book in his hand. The concluding views showed details of the arcading, a capital, the rose window, and vaulting, and the lecturer quoted from *Marmion*, Scott's eulogy on the Grey Towers of Durham now carved on a panel upon the Prebends' Bridge in the city:—

Yet well I love the mixed and massive piles,
Half church of God, half castle 'gainst the Scot;
And long to roam those venerable aisles
With records stored of deeds long since forgot.

PAINTS DESIGNED TO PREVENT ELECTROLYSIS IN CONCRETE.*

The use of a paint as a protective covering for reinforcing steel against damage by electrolysis has often been proposed, but the writer is not aware of any tests having been made to determine a type of coating best adapted for this purpose.

Paints having a high insulating value are generally those drying with a high gloss, which is apt to prevent proper bonding, a fact which has undoubtedly prevented a general use of this protection. A method for overcoming this objectionable feature was developed by these experiments.

Corrosion Causes.—It may be well to review briefly the causes of corrosion in reinforcing steel for the benefit of those not thoroughly familiar with the subject.

The ordinary forms of iron corrosion have been found to be due to auto-electrolysis, the presence of segregated impurities being responsible for differences in potential at certain areas, which set up galvanic action and cause solution and the formation of rust at the positive nodes. A similar but more rapid action takes place when an electric current is passed through an iron anode immersed in an electrolyte, such, for instance, as salt water. When damp cement contains an embedded iron anode the cement acts as an electrolyte, and the same rusting action takes place, regardless of the fact that concrete contains sufficient lime to inhibit corrosion when no electrical currents are present. With the electrolytic change of metal into oxide comes an increase in volume of the products of reaction, and there is developed an enormous expansive force of mechanical pressure, which is sufficient to crack the strongest forms of concrete.

Engineers are active in their endeavours to prevent high-voltage currents from running wild, but this fact does not justify a disregard of precautions against stray currents.

Preparation of Specimens and Methods of Testing.—The tests were made on two series of specimens as follows:—

1. Rods $\frac{1}{2}$ in. by 12 in., painted two coats and embedded in concrete cylinders.
 2. Rods $\frac{3}{4}$ in. by 12 in., embedded as anodes in cylinders of concrete.
- All cylinders were $3\frac{1}{2}$ in. by 8 in., of cement mortar 1:2. The moulds were re-

moved in two days, and the cylinders aged from one month.

Tests on Series 1 were made by immersing the lower 2 in. of the specimens in water, connecting them in parallel, and passing through them a direct current at 30 v.

Observations were made for one week, when small cracks began to show near the bottom on a few specimens.

The specimens were then immersed to within 1 in. of the cylinder tops, the current turned on, and observed for ten days. Cracking was shown by every cylinder carrying an appreciable amount of current, the fracture starting at the anode.

Wherever the protecting film broke down the increased passage of current resulted in rapid corrosion of the steel, followed by the expansion and bursting of the concrete cylinder.

Series 2 were tested by placing them in individual earthen jars containing sheet-iron cathodes coiled around, but not touching, the cylinders. The jars were filled with water to within 1 in. of the top of the concrete.

The cylinders were connected in Series 1, and current passed at 30 v. for 240 hours, when seven specimens developed cracks. The voltage was increased to 55 v., and continued for sixty hours.

Observations on Tests.—In the specimens in which cracking occurred the anodes showed considerable rust, the paint coatings having been broken down. On the cathodes in Series 1 the paint coatings were still intact, although some had apparently been affected by moisture and the hydrated lime in the wet concrete, chalky surfaces being shown.

The coatings on anode and cathode bars which were embedded in cylinders which did not crack and which carried little current, were in a good state of preservation.

Bonding Tests.—In order to determine the comparative bonding strength of rods coated with the various paints a duplicate of Series 2 was made, with the exception that the rods were placed flush with the bottom of each cylinder. At three weeks the specimens were placed on an iron block drilled with a 1-in. hole and tested in a Riehle² testing machine. Some paints that proved to be good insulators failed to show bonding strength, and *vice versa*. When painting rods in order to overcome the objection to using paints which dry to a gloss surface and prevent proper bonding, these coatings were dusted while tacky (not wet) with sharp particles of sand, which formed a rough surface, assuring a good bond. The corrosion of metal embedded in concrete structures, by stray currents of high voltage, is often productive of serious effects. The use of properly made paints upon such metal constitutes a safeguard that should not be neglected by the engineer. Such paints may be prepared from the following substances:—

The vehicle should contain:—
Boiled or bodied oils or products which dry to a fairly saturated film.

Oils which dry by semi-polymerisation rather than oxidation.

Oils which dry to a flat rather than a highly glossed surface.

The solid portion should contain a percentage of:—

Pigments which are coarse, and which, therefore, tend to form films having a rough surface.

Pigments which are inert, and which do not act as conductors of electricity.

The painted metal should be "sanded," if possible.

Mr. F. H. Tulloch will hold a Local Government Board inquiry to-day (Wednesday) at Skelmersdale into an application by the urban district council for sanction to borrow £2,000 in order to provide a new gas-holder and condenser.

Sixteen new houses have been erected under the Housing of the Working Classes Acts by the Llandudno Urban District Council. The contract was let to Mr. Luther Roberts in November last, and all the houses have been occupied by tenants this week. During the past eighteen years the council have erected 67 houses at the total cost of £15,712. The council have in their possession land in King's Road on which 27 additional dwellings can be built.

* See measured drawings of the Nine Altars Chapel at Fountains Abbey and plan of entire establishment, by Ernest Woodhouse, in the BUILDING NEWS for September 16, 1898.

* Abstract of paper by Henry A. Gardner, Assistant Director of the Institute of Industrial Research, Washington, D.C.

cases of the leafy potato, and the four trees were cut down in the plantation. A few years later the father planted a row of chestnuts along the side of the park. The holes made were not filled up, and there was no breaking up of the soil, and consequently though the trees are old, the growth has been very slow. Six or eight years ago it was decided to put a new bridge over the lake at the end of the chestnut avenue, and this necessitated a gradual raising of the drive as it approached the bridge, and the consequent digging and replanting of the first trees in the newly raised ground, at the sides of the lake. All with it might have been expected to have young fancy tree aged about twenty years would have died, and the trees which they killed their sap was exhausted, yet so great has been the strength of them of growing in what is called "old" trench ground that it has been found that many saplings cut in the chestnut avenue and in the water garden are now large trees with wider spreading canopies than the original ones.

OBITUARY

Mr. James P. Gibson, F.R.I.B.A., died on August 27, 1915, at the age of 82 years. He was born in 1833, and was the son of James Gibson, Esq., of London, and his wife, Mary, daughter of James Gibson, Esq., of London. He was educated at the University of Cambridge, and was a member of the Senate of the University. He was a member of the Royal Society, and was a Fellow of the Royal Institution. He was a member of the Council of the Royal Society, and was a member of the Council of the Royal Institution. He was a member of the Council of the Royal Society, and was a member of the Council of the Royal Institution. He was a member of the Council of the Royal Society, and was a member of the Council of the Royal Institution.

Mr. James P. Gibson, F.R.I.B.A., died on August 27, 1915, at the age of 82 years. He was born in 1833, and was the son of James Gibson, Esq., of London, and his wife, Mary, daughter of James Gibson, Esq., of London. He was educated at the University of Cambridge, and was a member of the Senate of the University. He was a member of the Royal Society, and was a Fellow of the Royal Institution. He was a member of the Council of the Royal Society, and was a member of the Council of the Royal Institution. He was a member of the Council of the Royal Society, and was a member of the Council of the Royal Institution.

Our Illustrations.

A MODERN INTERIOR EXECUTED WITH OLD MATERIALS.

Mr. Murray Adams Acton,* the artist of the Royal Academy drawing, has sent us the following particulars of the work which he has carried out in France, as shown. The original, in water colour, is particularly bright and transparent, being most effectively tinted in clear washes.—“It is not an everyday occurrence to find a client that proposes to build, possessing the necessary amount of appreciation to enable one to carry out this particular type of interior. The house in question was in France, the design suggested and carried out practically as shown in this sketch, every room on the ground floor being treated in a similar manner. An old 17th Century farmhouse had been condemned on the site, but as this was fairly well furnished with massive oak beams, old stone, etc., that had formed part of the original structure, one's object, naturally, was to preserve as much of the old material as possible. This was done, as will be seen in the accompanying drawing, the interiors of the new building being left to their effect upon their extreme simplicity and restraint throughout. The high quality of the ornament selected for the new decorated features was sufficiently good to denote the style. The walls were white, the beams, with small additions, were painted in position almost in the same condition just as they were when taken out of the old house, also the wooden floors, and in some cases the coloured tiles of the floor were re-used, with excellent result. Nothing can be found more effective and pleasing as a setting for old furniture than the simplest form of interior treatment possible, and in the fireplaces in this instance an abundance of old fire dogs and grate backs were fortunately collected.”

A STREET VIEW IN WORCESTER.

Worcester contains, of course, many old houses and several genuine timber framed buildings. They are especially numerous in Friars Street, New Street, and Lich Street. One of the most interesting is a large structure in Friars Street, supposed to have been an ancient hostelry. Another old house worth seeing stands at the corner of Choir Street and the Shambles. In the Old Corn Market is “King Charles’s House,” with the inscription, “Love God, honor ye King,” over the doorway. This curious half-timbered house originally extended round the corner into New Street, but a portion has been modernised. In the Tything, at the White Ladies, are traces of an ancient nursery, bearing the name, with a few remains of the chapel. In Sibbury, opposite the Talbot Inn, is an old house bearing date 1642. The Trinity House, or Queen Elizabeth’s House, stands in the Trinity, and some years ago was removed and rebuilt further back several yards to facilitate passing traffic. It is an interesting building, with an open gallery, in which, tradition states, minstrels performed when Queen Elizabeth visited the city.

GORDON HEMM

LE PREMIER MATIN

M. Eugène Rombeaux has kindly sent us a photograph of his magnificent marble statue, which, thanks to his liberality and the quick response of the subscribers who responded to it, is to remain permanently in England, a treasured testimony for long years to the good relations of the Belgian and British peoples, as witnessed to-day by the memory of the sacrifice of the former and by the determination of the latter that, so far as is humanly possible, the sacrifices Belgium has made shall be made good and her independence maintained. In our review of this year’s exhibition of the Royal Academy on p. 516 of our issue of May 7 last we said the “equal” of this statue has been rare at any exhibition for many years, and we trust it will

not be left by a printer’s error the name of Mr. M. A. Acton is accurately given on the last page of the book.

not leave England.” We rejoice that our hopes have not been disappointed. On p. 195 of our issue of August 18 we recorded the presentation of the statue to the Trustees of the National Gallery on August 12 at the Royal Academy, and we again reproduce the well chosen words of Sir Edward Poynter:—“It is a work magnificent not only in design and expression, but in that profound and masterly knowledge of the human figure and its capabilities of beauty which is the characteristic of the great masters of the great schools of Greece and Italy; and these qualities it displays in the highest degree, the sense of form being as refined as it is colossal in conception.”

ST. JAMES’S CHURCH, WEST STREATHAM.

The chancel, chancel aisle, organ chamber, and vestry shown by the perspective view we illustrate complete the church. These have been carried out by Messrs. J. Garrett and Son, contractors, of Balham Hill, from the designs of Mr. W. Samuel Weatherley, now of 15, Buckingham Street, Strand. The external facings are dark Cromborough stocks, and the stone, both external and internal, Monk’s Park, from the Bath stone firms, works and fixed by them. The internal wall faces are plastered, the lower part being paroled in oak. The reredos, sedilia, chancel seats, communicants’ desks, etc., are also in oak. The flèche is of teak, the spirette covered with lead.

THE MIDDLESEX GUILDHALL, BROAD SANCTUARY, WESTMINSTER, S.W.

A double-page perspective view of this excellent building appeared in our issue for February 5, 1911 when the County Council adopted the design prepared by Mr. J. S. Gibson, F.R.I.B.A., of the firm of Messrs. Gibson, Skipwith, and Gordon, of 5, Old Bond Street, W. In working out the scheme Mr. Gibson was assisted by the county engineer, Mr. H. T. Wakelam. To-day we publish the two chief plans of the new building as executed, and among our inset plates will be found a pair of good photographs lent us by the architects in illustration of the County Sessions Courts, known as Court No. 1 and Court No. 2. The frontage of the building towards Broad Sanctuary measures 102 ft. long, and to Little George Street it figures 161 ft. Portland stone has been used for the frontages.

A COUNTRY INN, SHERBORNE, DORSET.

It is the good fortune of few engaged upon the erection of licensed premises to have the opportunities here presented—a charming town, a good frontage, and clients who desired something different from “the ordinary,” and good old materials obtained from the former building. The external walls are of old stone with Bath stone dressings, the roofs covered with old tiles, and the old oak beams re-used in construction of the first floor and visible in the principal apartments beneath. The work has been recently completed, Messrs. F. Bartlett and Co., of Yeovil, undertook the general building and carpenter work. The architect is Mr. Edward C. H. Maidman, Licentiate R.I.B.A., of Sherborne.

Mrs. Mary Vicat-Cole, widow of the late George Vicat-Cole, R.A., and mother of Mr. Rex Vicat-Cole, also a landscape painter of great ability, died on Friday last at 9, Campden Hill Square, W., in her eighty-eighth year.

The reopening of St. John’s Church, Newport, Isle of Wight, after reseating, which has cost about £250, took place on Thursday afternoon. There have been several additions to the church furniture, including an eagle lectern, altar rails, and a pulpit rail all executed in brass.

The ancient Guild House at Henley-in-Ardun was purchased last year by Mr. W. J. Fieldhouse, lord of the manor, whose object was to rescue the building from further deterioration. The Guild House has been repaired and renovated, and the land at the back cleared of some uninteresting buildings, in place of which there is to be an old-world garden.

Mr. J. S. Gibson, F.R.I.B.A., died on August 27, 1915, at the age of 82 years. He was born in 1833, and was the son of James Gibson, Esq., of London, and his wife, Mary, daughter of James Gibson, Esq., of London. He was educated at the University of Cambridge, and was a member of the Senate of the University. He was a member of the Royal Society, and was a Fellow of the Royal Institution. He was a member of the Council of the Royal Society, and was a member of the Council of the Royal Institution. He was a member of the Council of the Royal Society, and was a member of the Council of the Royal Institution.



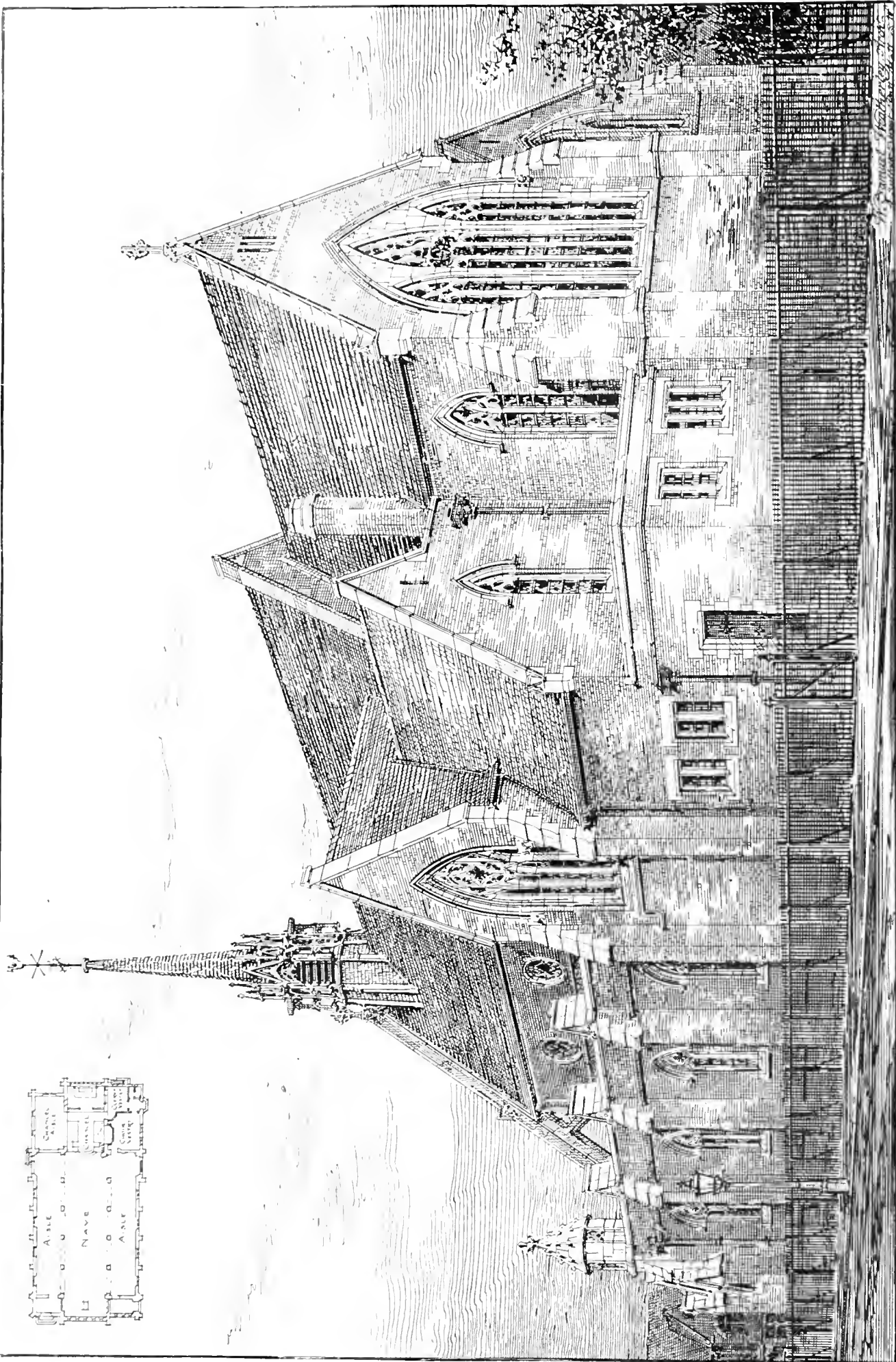

ST. JAMES'S CHURCH, WEST STREATTHAM, S.W. COMPLETION OF THE EAST END.—Mr. W. SAMUEL WEATHERLEY, F.R.I.B.A., Architect.



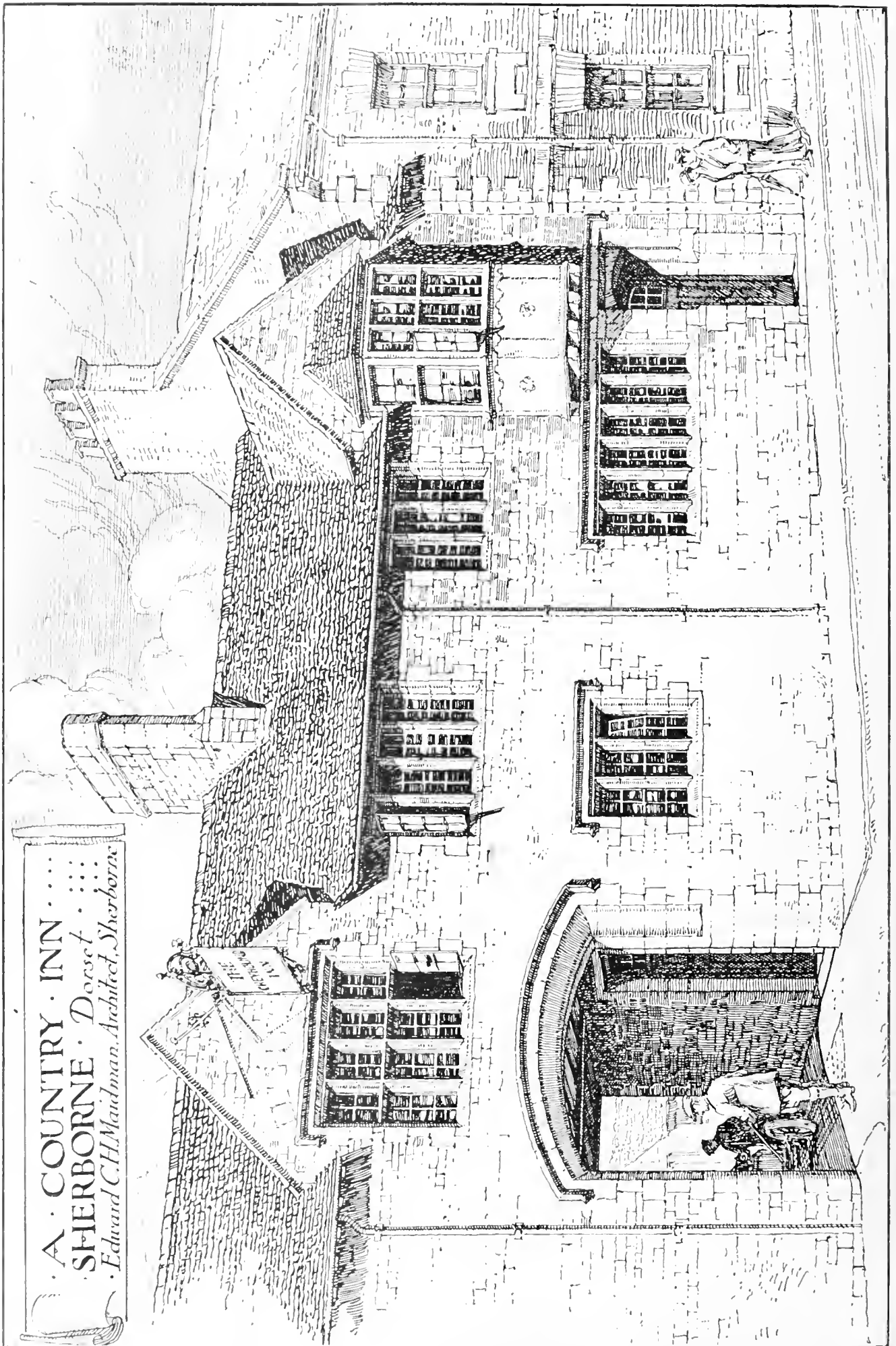

A · COUNTRY · INN · · · · ·
· SHERBORNE · Dorset · · · · ·
· Edward C.H. Maichman, Architect, Sherborne

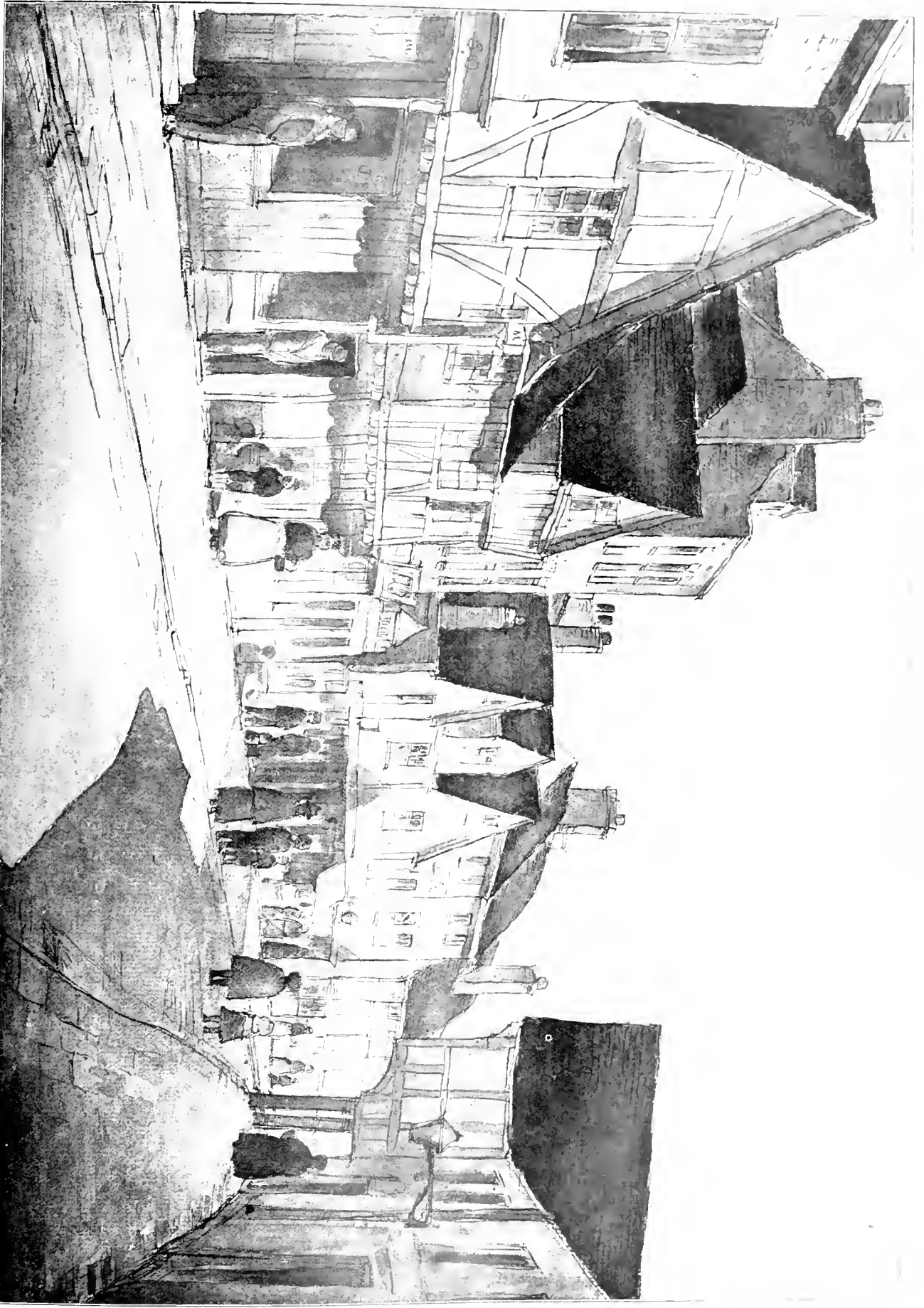

A STREET VIEW IN WORCESTER.—Sketched by Mr. GORDON HEMM.



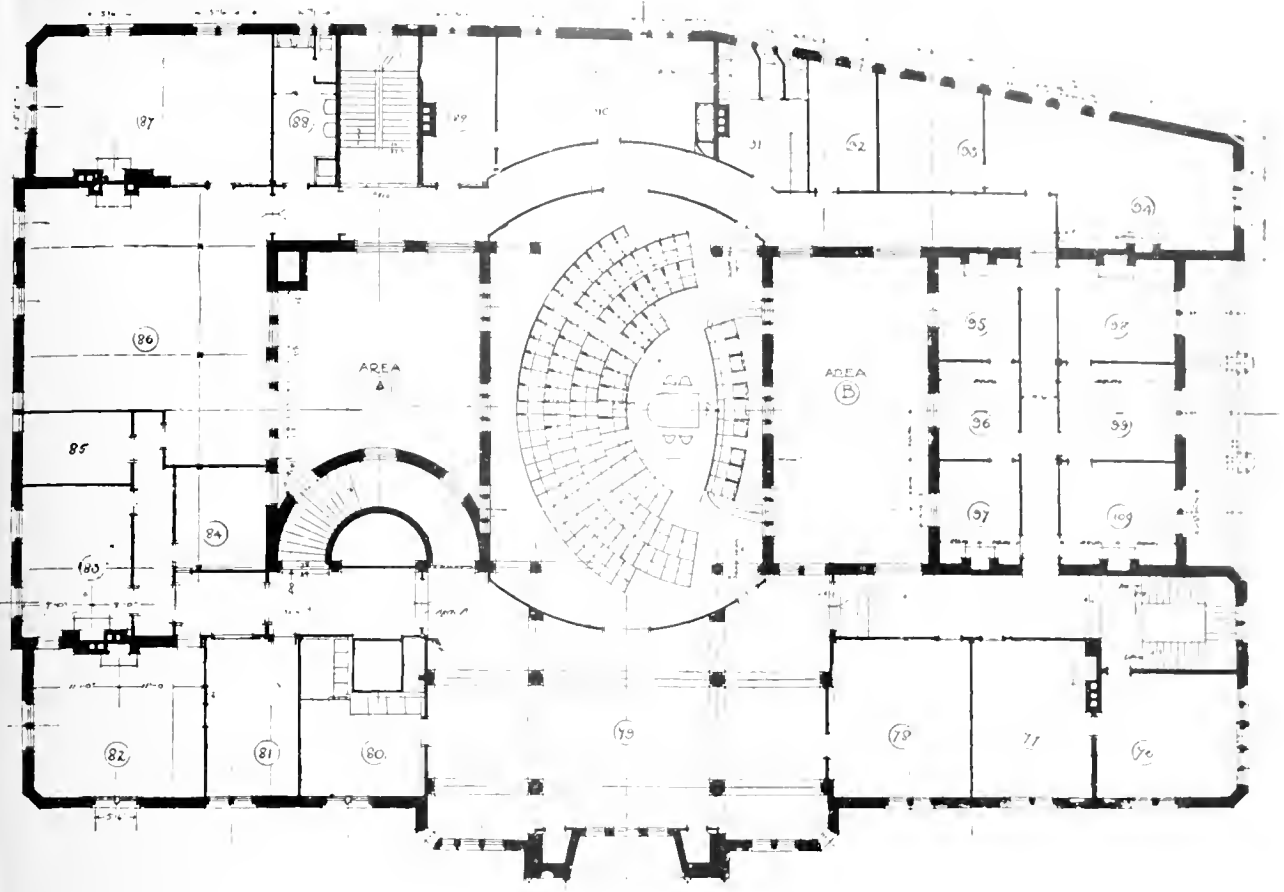

SECOND FLOOR PLAN

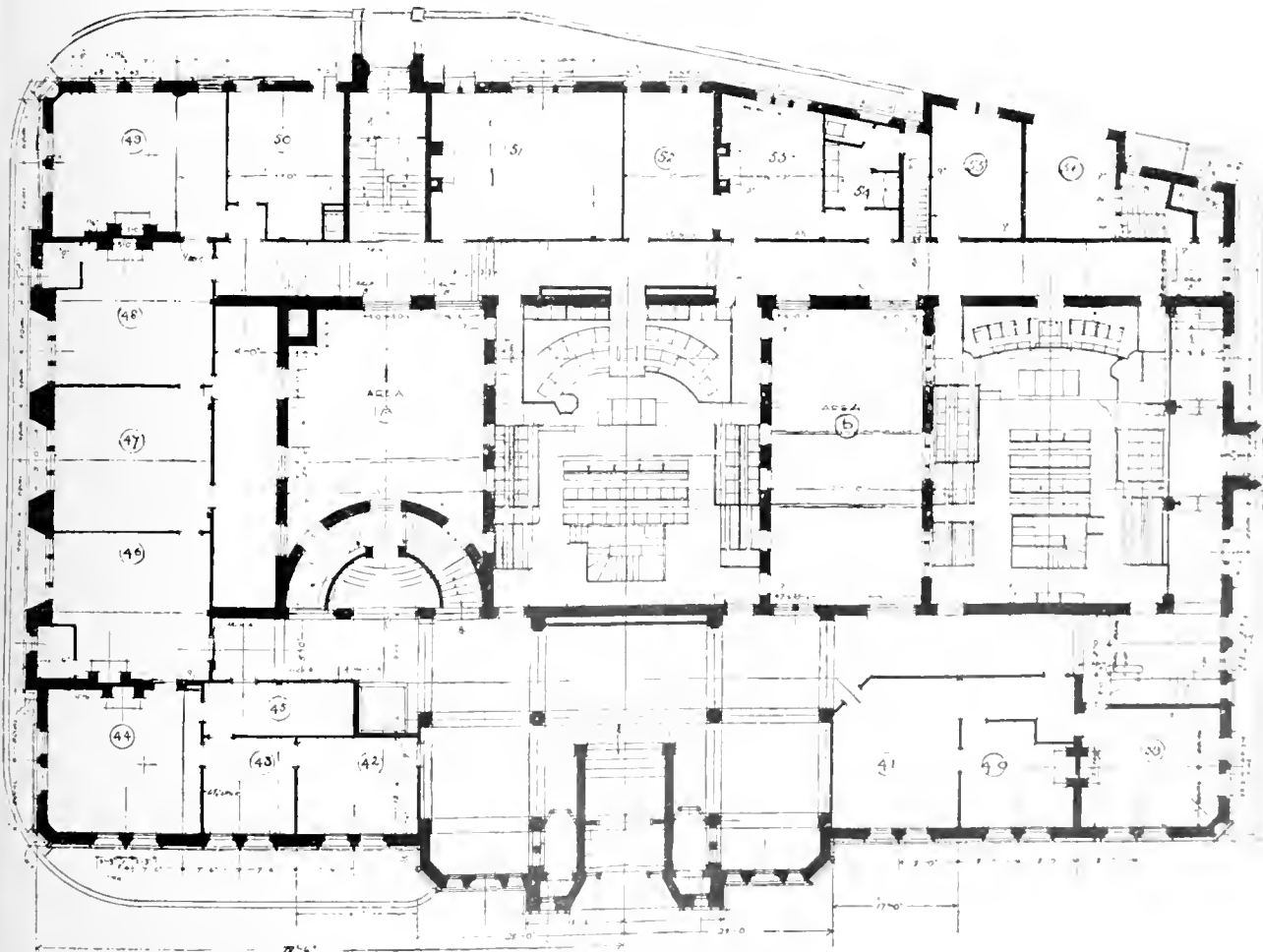

GROUND FLOOR PLAN





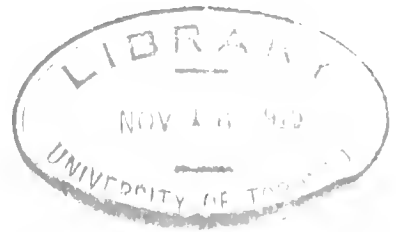



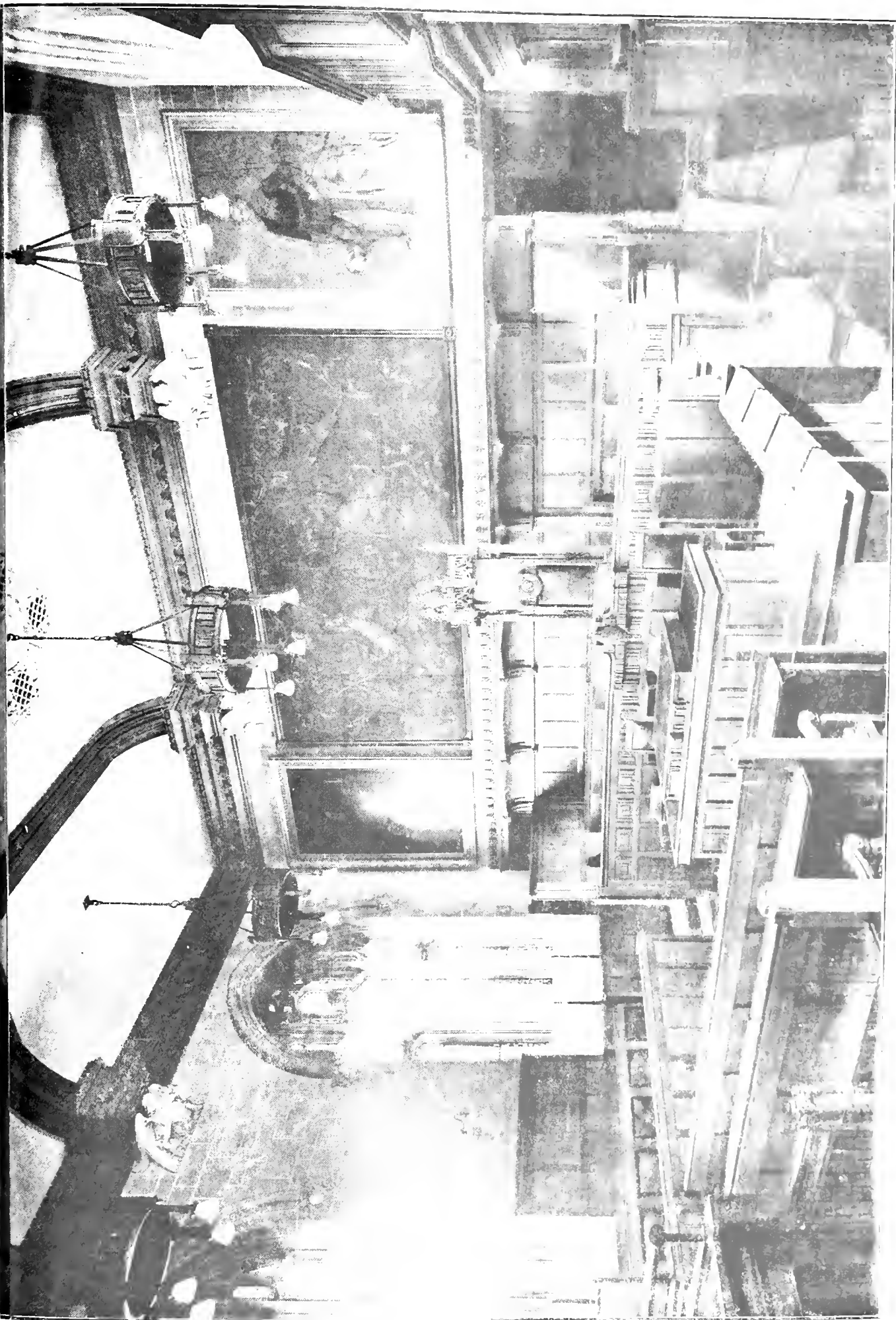









PROFESSIONAL AND TRADE SOCIETIES.

INCORPORATED SANITARY ASSOCIATION OF SCOTLAND. The forty-first annual congress of this association will take place at Glasgow to-day (Wednesday), to-morrow and Friday. Nearly all the burgh and county authorities throughout Scotland were represented. The proceedings will open this evening with the annual business meeting, followed by a lecture in the Masonic Hall, West Regent Street. The lecture is by Dr. R. M. Buchanan, bacteriologist to the Corporation of Glasgow, and the subject is, "Pests and Bacteria in Disease." Sir Hugh Sney Stewart, Bart., will preside. To-morrow morning County Councillor Lambie, convenor of the Public Health Committee of Lanark County Council, will deliver his presidential address. For the first papers will be read on "Malaria," "The Care of the Health of the Country," "Methods of Tinting Vermin in Buildings," and "Refuse Bins on Fire." On Friday, the concluding day, there will be further papers on "Sanitary Provisions in Scottish Town Planning Schemes," "Planning of Houses for the Working Classes," "Economic Dieting in Time of War," "The Effect of the War on the Duties and Responsibilities of Local Authorities in Scotland," and "The Training of Nurses in Local Authority and Poor-Law Hospitals and Their Relation to the General Study of Nurses." All the papers will be open for discussion by the members of the congress.

ROAD SURVEYORS OF SCOTLAND.—At the thirtieth annual meeting of the Road Surveyors of Scotland, held in Aberdeen, Mr. Peter Clark, Dundee, was appointed president; Messrs. A. Forbes, Dumfries, and W. L. Gibson, Dundee, were elected vice-presidents; and Mr. Allan Stevenson, Ayr, was appointed secretary and treasurer, for the ensuing year. At the outset of the proceedings Mr. James Watson, Strathaven, the retiring president, occupied the chair, and in the course of an address mentioned that seven members of the association were serving with His Majesty's forces. The chair was afterwards taken by the newly-appointed president, Mr. Clark. Discussions took place on several questions of interest to the members, amongst the topics being the possibility of securing uniformity in the system of keeping road accounts, the economics of road surfacing, and the best way of obviating the difficulties frequently met with in the filling up of opened road tracks. It was resolved that the next meeting of the association be held in Glasgow in August, 1916.

TWO SEVENTEENTH CENTURY SHEFFIELD HALLS.—The Humber Archeological Society recently visited two Sheffield houses, Carbrook Hall and Attercliffe Hall, with the old Attercliffe Chapel, which, with the exception of the cathedral, is the oldest ecclesiastical edifice in Sheffield. The former has for the past ninety years been used as a licensed house, and was described by Mr. J. R. Wigfull, A.R.I.B.A., Carbrook Hall, dates, he showed, from the time of Stephen Bright, whose father, Thomas Bright, of Bradbury, settled at Carbrook about the beginning of the seventeenth century. Stephen built or enlarged the hall, where, on the back of one of the fireplaces, are still to be seen his initials and the date 1623. He was bailiff of Hallamshire and lord of the manor of Eccleshall. In the seventeenth year of Charles I. he was granted arms as "a person of £1,000 a year estate, of credit and respect in the affections of the gentry, and of extraordinary merit." He died in 1642, and was succeeded by his son, Sir John Bright, who took an active part in the Civil War, rising to the rank of colonel in the Parliamentary Army. He was appointed Governor of Sheffield Castle after its surrender, and afterwards Governor of York. The original panelled room, said Mr. Wigfull, was once the principal apartment of the house, and has, no doubt, of many a conference during the Civil War. The panelling is of an elaborate design. At one end of the room is a richly carved mantel, in the upper part of which is a panel said to represent Wisdom trampling upon Ignorance, the latter represented by a skeleton.

while Wisdom is typified by a figure in a long robe. Above this room is another of great interest. The chapel dates from 1630. It was originally 66 ft. from east to west and 30 ft. from north to south, together with an aisle on the north side, but it was considerably reduced in size in 1837. The cost of building it was £104, and the ground on which it stood—though of much smaller area than that which now surrounds it—was bought for only £3 3s. For many years the chapel was allayed to remain in a dilapidated condition, but about ten years ago it was repaired and again adapted for service, while at the same time the city council took charge of the graveyard and laid it out as an open space. According to Mr. C. Paul, what remains of Attercliffe Hall is now used as a dwelling house, and is situated on Attercliffe Road, just past the junction of Old Hall Road. Dr. Gatty states that the hall was demolished in 1863 by Mr. Robert Hadfield, but (said Mr. Paul) recent investigations by Mr. C. R. Vine and Mr. Ward, of Attercliffe, show that the doctor was not strictly correct. The hall can claim greater antiquity than its Carbrook neighbour. It was the seat of the Spencers, and William Spencer was born there in 1591. His son William became a lieutenant-colonel in the Parliamentary Army. After the collapse of the Commonwealth he obtained a free pardon from the Crown, and was confirmed in the possession of his estates. He invited one of the ejected clergy of 1662, Richard Frankland, to set up his academy at the hall, and the Rev. Timothy Jollie also carried on his school there. The present remnants of the hall are supposed to have been the academical rooms. In one, which was probably the lecture room, is a plaster motto over the fireplace reading, "Whatever thou dost take in haunde thinke of the ende and seldom so shalt thou offend." The rooms contain some very interesting plaster work. The Spencers parted with their Attercliffe possessions some time before 1810. Afterwards the premises were occupied by a firm of spade and shovel manufacturers.

The Secretary of State for India has sanctioned the appointment of a Chief Conservator of Forests in the United Provinces.

The Ham Hill Stone Quarries, which Messrs. Marchant and Co. offered for sale by auction on the 19th ult., were subsequently disposed of by private treaty at a very satisfactory figure.

The session for 1915-16 of the Architectural Association School of Architecture will open on Monday, September 27. The annual meeting of the association itself for the delivery of the presidential address will be held on Monday, November 8.

After being extended and rebuilt, the Mile End New Town Synagogue, Dunk Street, was opened on Sunday. The structure was first erected in Dunk Street, Mile End New Town, in 1865, and it has now been reconstructed at a cost of over £1,000.

A new council school at Tynywern, Tre-Thomas, built at a cost of £10,500, has been formally opened. The designer was Mr. J. Bain, architect to the Monmouthshire Education Committee, and the contractor Mr. R. W. Moon, Newport, Mon.

Additions are being carried out at the premises of the Ulster Banking Co., Limited, at Phillamore. The building contract has been taken by Mr. James Lees, Great George's Street, Belfast, and the architects are Messrs. Blackwood and Jury, MMR.J.A.I., 41, Donegal Place, Belfast.

The rural district council of Wantage have adopted a scheme for the sewerage of the village of Harwell. A system of land treatment will be adopted, and the storm water will be separated from the sewage. The present sewers, which are defective, will be used solely for surface water, and new sewers be laid throughout the parish for sewage.

Information has been received by the Secretary of the Glasgow School of Art that Professor Eugene Bourdon, Director of the Glasgow School of Architecture, now serving as captain on the staff of the French Army, was gazetted on August 4 last (order of July 30) as a Knight of the Legion of Honour. Captain Bourdon's military services only are mentioned, but it is known that his civil services as Professor and Director of the School of Architecture appear also on the nomination.

Correspondence.

OUR ANCIENT CHURCHES.

To the Editor of the BUILDING NEWS.

Sir,—In the course of a lecture on "Romanesque and Gothic Doorways," delivered by Mr. C. H. Dedman at the Royal Photographic Society's exhibition, he referred to the great risk of damage and destruction by accident to ancient churches, particularly in the Eastern Counties.

After the raid upon Scarborough the local authorities issued requests for photographs of buildings showing their condition prior to receiving injury, and received but a poor response. Yet there are thousands of photographers, both professional and amateur, in the country willing and even anxious to make records at the present time, if they were allowed to do so. In view of the fact that restrictions are necessarily placed upon out-of-door photography at the present time, permits would have to be granted by the War Office or police authorities. If such permits were granted loosely there might be a danger of giving facilities to alien enemies resident in the country, but this danger can readily be guarded against by requiring references from the applicants to the officials of the many photographic societies throughout the land. Personal knowledge of the applicant would be a sine qua non, and the permits would be granted only for special work in specified places.

Our well-known abbeys, minsters, and cathedrals have probably been photographed from every point of view, and records of details secured, though many of these photographs have in the course of time been lost. The smaller ancient churches up and down the country, however, have not received the same attention, although they contain priceless relics of the past, which could not be restored in the absence of large-scale photographs.

In some instances a single door, a window, or a few capitals are all that remain of the ancient work, and these should be copied on a scale large enough to show the tool marks. No expense to the country would be incurred, but the co-operation by the Government, the clergy in charge, and the photographer is necessary, and the work should be undertaken at once.—I am, yours faithfully,

J. McINTOSH, Secretary, the Royal Photographic Society of Great Britain.

35, Russell Square, W.C., August 25.

[We could help occasionally to ensure permanent record if architectural amateur photographers who know what is worth reproduction sent us photos.—Ed., "B.N."]

LEGAL INTELLIGENCE.

SUB-CONTRACTORS v. CONTRACTORS.

—Judge Cunn has held a special sitting at Coventry County Court to hear an action brought by George Nichols, Limited, who were sub-contractors for the plastering, to recover £23 16s. from Kelley and Sons, builders, who were the contractors for the building extensions at Coventry and Warwickshire Hospital in 1912-14.—Eventually plaintiffs were given judgment for £78 17s. 1d.

Mr. James Zeno Sloan, for the past few years assistant surveyor for Co. Down and stationed at Newtownards, has been granted a commission in the Royal Engineers.

Mr. Samuel F. Hynes, F.R.I.B.A., Cork, has prepared plans and specification for works to be carried out at Lisheen church, near Arghadown, County Cork, for the Rev. Jas. O'Sullivan, P.P., tenders for which work have already been sent in.

The death has occurred of Mr. William Macdonald, carpenter contractor, Inverness, who was well known and esteemed in building trade circles throughout Scotland. For several years he was president of the Inverness Branch of the Builders' Federation, and he held a similar position in the Scottish Federation. He took a warm interest in Celtic matters, and was one of the earliest members of the Inverness Gaelic Society, of which he was a vice-president. He carried out extensive contracts in many parts of the Highlands and Islands. Mr. Macdonald, who was unmarried and a native of Glenurquhart, was about sixty years of age.

COMPETITIONS.

NOTTINGHAM.—The competitive designs for the three new branch libraries which are to be built in Nottingham when circumstances permit are now on exhibition to the public at the School of Art in that city. Under the terms of the Carnegie gift the Public Libraries Committee proposed to establish new libraries at Highbury Road for Bulwell, on Nottingham Road for Basford, and in Bruce Grove for the Meadows district. Architects engaged in practice in Nottingham were invited to submit designs and plans, and, in all, some fifteen competed, some among them submitting the necessary plans for all three buildings. Mr. J. Alfred Gotch, F.S.A., F.R.I.B.A., of Kettering, who was appointed assessor, has made his award as follows:—Highbury Road, Bulwell: 1, Messrs. L. Bright and Thoms; 2, Mr. W. H. Higginbottom. Bruce Grove: 1, Mr. F. W. C. Gregory; 2, Messrs. J. Howitt and Son. Nottingham Road: 1 and 2, Messrs. Sutton and Sons. Messrs. L. Bright and Thoms estimate the cost for the Bulwell library at £3,430, Mr. Gregory's estimate amounts to £3,425, and Messrs. Sutton's (first premiated) to £3,400. In each case the buildings are of one story, and the plans provide for general reading-room, a juvenile reading-room, a lending library, and certain administrative apartments. The designs submitted all round represent a very high standard of architectural skill, but no attempt has been made, since it was not desired, to provide anything else than substantial and efficient buildings. Wealth of architectural ornamentation which would necessarily have involved a considerable additional expense was not sought, and the competitors kept themselves well within the bounds of the specified instructions.

PERTH, W.A.—In connection with the erection of the permanent buildings of the University of Western Australia two prizes of a hundred guineas and twenty-five guineas respectively were offered for the two best designs for the laying out of the University's grounds at Crawley Park, Perth, W.A. A large number of designs were sent in, and the following awards have now been made by the Board of Adjudication:—First prize, H. Desbrowe-Annear, Melbourne, Victoria; second prize, H. W. Hargreave, Perth, W.A. The design submitted by Messrs. J. Cheal and Sons, Limited, Crawley, Sussex, has, in addition, been granted an honourable mention.

TRADE NOTES.

Boyle's latest patent "Air-Pump" ventilators have been applied to Messrs. S. Fletcher and Son's new factory, Wood Street, Ilkeston. We understand that the architects for the Middleton Sanatorium have adopted the powder Pudlo for the waterproofing medium, and, in addition, have specified its use in a large training college.

The Birmingham Engineering Co., Ltd., have decided to build a munitions factory on the Cawney Bank estate at Dudley.

The little church of St. Andrew, Pillmoor, in the East Riding, was reopened by the Bishop of Beverley after restoration, the works including a new organ and a stained-glass window containing a figure of St. Andrew.

A faculty has been granted by the York Consistory Court to the rector and churchwardens of Stokesley to remove the present chancel roof and to re-roof the same with a new oak roof, re-using, where possible, the old slates.

Through the efforts of the Florida Association of Architects a law creating a State board of examiners of architects and providing for the licensing of architects, similar to the Illinois law for the same purpose, has passed both houses of the Florida Legislature.

The Board of Regents for New York has appointed the following architects as members of the board for the registration of architects, provided for under Chapter 454 of the Laws of New York, 1915:—Arnold W. Brunner, Manhattan; D. Everett Waid, Manhattan; William B. Bannister, Brooklyn; A. L. Brockway, Syracuse; and E. B. Green, Buffalo. Under the law the fee for registration is \$25, to be paid to the State Board of Regents.

Building Intelligence.

MANDABAWN.—The building of the new Catholic Church at Mandabawn, near Cootehill, Co. Cavan, has now been completed. The building, which stands on the site of the old chapel, is, says the *Irish Builder*, Early Gothic in style, and is designed with nave, aisles, and square apse, from plans prepared by Mr. J. J. McDonnell, J.P., architect, M.R.I.A., 27, Chichester Street, Belfast. The lighting of the nave is from each end by tall lancet windows, arranged in triplets, and by two light windows in each bay of the aisles, the windows being filled with leaded glass. The nave and aisles are divided into five bays on each side by tall columns having moulded bases and caps. The ceilings are treated in fibrous plaster with moulded pitch-pine ribs and cornices, the roof principals and other joinery work of the church being of similar material. The cost of the new church has been over £3,000.

CHIPS.

The new central council school at Haslingden, built at a cost of £19,500, has been formally opened.

The Denbighshire County Council have appointed Mr. J. S. Williams, of Denbigh, as assistant to the county surveyor for main roads for the western division of the county.

The mediæval bridge of four spans in stone, which spans the river Dove on the Uttoxeter and Derby road about one mile from Uttoxeter, has just been widened. The cost has been over £5,300 and the contractor was Mr. Thomas Godwin, of Hauley.

Captain John Miller, 6th Royal Welsh Fusiliers, who was killed in action on August 16 at the Dardanelles, was on the permanent engineering staff of Messrs. Guinness and Co., of Dublin, and was a prominent member of the Engineering and Scientific Association of Ireland, of which he was president at the time war was declared.

Messrs. J. and M. Clarke, of Clanbrassill Street, Dublin, are at present erecting an addition to the nuns' choir at St. Clare's Convent, Harold's Cross, from the designs of Mr. P. J. Munden, architect, Trinity Street, Dublin. The leaded lights and carved stone work are being executed by Messrs. Earley and Co., Camden Art Works, Dublin.

The band of workmen engaged in excavations at Pompeii have made some interesting discoveries. The frescoes decorating the triclinium of a recently dug-out villa in what is known as the "Avenue of Tombs" have turned out to be remarkably fine and in wonderful preservation. The frescoes comprise five separate pictures on themes familiar to those acquainted with household decorations at the famous Roman resort and the colouring of the newly-found frescoes is of unusual brightness.

The Stainland Urban District Council are being urged by the West Riding County Council to proceed with the preparation of a housing scheme under the Housing of the Working Classes Act. The County Council point out that in the urban district there is a great shortage of five-roomed houses, and on the Registrar-General's standard of overcrowding there were sixty-two cases at the last census affecting a population of 457. The Stainland Council has replied that the matter will be taken into consideration at a favourable opportunity.

At the last meeting of the Sheerness Urban District Council on Tuesday, a letter was received from the Local Government Board stating that their application for a loan of £5,000 was a generally satisfactory proposal in ordinary circumstances, but the council's proposed enlargement of the refuse destructor not being regarded as of pressing necessity, they could not see their way to sanction the loan at present. This decision was regarded by the council as unfortunate, as the destructor enlargement is part of the water scheme, the existing boiler being required for the air-compressing plant to be set up at the supplementary bore-hole at Sheerness East, which is to be the third source of supply, and has already been proved equal to an estimated capacity of 12,000 gallons per hour. It was resolved to lay more facts before the Local Government Board with a view to securing the loan forthwith.

The Local Government Board have sanctioned a loan of £225,000 for the purpose of a supplementary water supply in Bedford, Northamptonshire. The works include a water turbine, and works have been started by the urban district council, who are proposed to place the matter before the Board at an early date if possible.

The borough engineer of Kington has devised a scheme for the improvement of the town economically. He proposes to lay out the experimental length of roadway, including the wood and converting it to a concrete road. The existing roadway is of bituminous concrete, even with a wearing surface carpet of concrete on the pavement.

The erection of the new St. Columba's Church, at Llangunhaun, is now well advanced. The cost is estimated at £4,000. The church will accommodate about 300 people and will be fitted with a modern interior, including a north-south chancel, and north arcade, with a porch at the future north aisle and also a vestry and a set of bells. Mr. W. D. G. G. F.S.A., F.R.I.B.A. of Westminster, is the architect.

A cross, ornamented with a relief of the life of the Blessed Virgin, has been erected in Rothwell, Leicestershire, in the memory of the Baroness Aylesbury, who died at Grasside on December 12, 1897. The cross is of white Sicilian marble of the height of 10 ft. 6 in. in height. Mr. R. G. B. sculptor, Newcastle-on-Tyne, executed the work from designs by Messrs. H. S. and J. Charlowood, architects, of Mansel Street, Newcastle.

The Bradford Corporation are considering ways and means of cutting down the expenditure on the lower pressure water supply undertakings as the Nidd Valley Waterworks and the Esholt sewage disposal works, of the nature of absolute necessities, cannot be abandoned without serious loss to the community, but several projects, some of them authorised, but not actually in progress, have been shelved. These include the proposed new secondary school at Bolling Hall, the extension of the Thackley Open-air School, the new elementary school at Low Moor, the residential school at Thackley for delicate children, and extensions at other schools.

Mr. J. J. McDonnell, J.P., architect, M.R.I.A., 27, Chichester Street, Belfast, has been appointed by the Local Government Board as the architect for the design of the isolation hospital at 8 minutes, near Chichester.

The Local Government Board have sanctioned the appointment by the Council of the Public Health Committee, of Mr. J. J. McDonnell, J.P., as inspector of nuisances at a salary of £2,000 per annum.

Mr. G. C. Vernon Ingham, of Plymouth, has been appointed by the Local Government Board as the architect for the design of the Westhampton as an architect for the design of the isolation hospital at 8 minutes, near Chichester.

The Johannesburg Municipal Council have instructed their engineer to prepare plans and specifications for the installation of a fuel-burning plant at the abattoir, at an estimated cost of £7,500.

Correspondence between the War Office and the Sanitary Inspectors' Association states that the military authorities are not granting commissions to sanitary inspectors or officers who do not hold medical qualifications.

A subcommittee of the Greenock Corporation have under consideration a scheme for the provision of hot dwellings for people engaged at the R.N. torpedo factory, the suggested accommodation being for 500 persons.

The annual exhibition in connection with the Royal Glasgow Institute of the Fine Arts will be opened on Saturday, September 26, at the Lord Provost, and that day is also reserved for the private view. Vanishing dates September 22, and the Press day, September 27 and 28.

The Local Government Board have sanctioned a loan of £225,000 for the purpose of a supplementary water supply in Bedford, Northamptonshire. The works include a water turbine, and works have been started by the urban district council, who are proposed to place the matter before the Board at an early date if possible.

The borough engineer of Kington has devised a scheme for the improvement of the town economically. He proposes to lay out the experimental length of roadway, including the wood and converting it to a concrete road. The existing roadway is of bituminous concrete, even with a wearing surface carpet of concrete on the pavement.

The erection of the new St. Columba's Church, at Llangunhaun, is now well advanced. The cost is estimated at £4,000. The church will accommodate about 300 people and will be fitted with a modern interior, including a north-south chancel, and north arcade, with a porch at the future north aisle and also a vestry and a set of bells. Mr. W. D. G. G. F.S.A., F.R.I.B.A. of Westminster, is the architect.

A cross, ornamented with a relief of the life of the Blessed Virgin, has been erected in Rothwell, Leicestershire, in the memory of the Baroness Aylesbury, who died at Grasside on December 12, 1897. The cross is of white Sicilian marble of the height of 10 ft. 6 in. in height. Mr. R. G. B. sculptor, Newcastle-on-Tyne, executed the work from designs by Messrs. H. S. and J. Charlowood, architects, of Mansel Street, Newcastle.

The Bradford Corporation are considering ways and means of cutting down the expenditure on the lower pressure water supply undertakings as the Nidd Valley Waterworks and the Esholt sewage disposal works, of the nature of absolute necessities, cannot be abandoned without serious loss to the community, but several projects, some of them authorised, but not actually in progress, have been shelved. These include the proposed new secondary school at Bolling Hall, the extension of the Thackley Open-air School, the new elementary school at Low Moor, the residential school at Thackley for delicate children, and extensions at other schools.

The late Mr. J. Eastwood, builder, of Dartmouth, died of personality amounting to £1,250.

The town council of Aberdeen have adopted plans by their architect, Mr. John Rast, for a new fish market in Market Street.

The late Mr. Ormerod Whitaker, of Oak Bank, Colne Road, Burnley, slater and contractor, who died on January 10, left a net estate of £30,634, with £51,854 gross.

The town council of Kingstown, County Dublin, have agreed to appoint Mr. J. Robson, architect, for the erection of artisans' dwellings, Nos. 1, 2, 3, and Mr. R. Donnelly, architect, No. 4.

Mr. Edward Stead, A.M.I.C.E., county surveyor for Somerset, has joined the Royal Engineers. In the meantime the duties of the county surveyor will be carried out by the assistant surveyor, Mr. Folland.

A new school institute at Clifton, near Workington, built at a cost of £17,000, has been formally opened. The architect was Mr. C. C. Birtney, of London, and the contractor Mr. Thomas Johnston, of Workington.

Mr. H. J. Bambury, builder, formerly of Carlisle Road, Newport, Mon., has died at Sydney, New South Wales. Mr. Bambury had built a large number of working class houses in Newport, and left for Australia a few years ago.

Mr. Joseph Mallett, of Great Yarmouth, has been appointed waterworks engineer and collector of rates. His former Urban District Council, transferred to Mr. R. W. Macfarlane, who has been appointed waterworks engineer at Great Yarmouth.

Bristol Health Committee have decided to appoint Mr. J. W. Kirley, at present chief inspector of nuisances, as consulting inspector at a salary of 25s. a week. Mr. Kirley has been in the service of the Health Committee for forty-two years.

A council school at Platt Bridge, near Wigan, built at an outlay of over £6,000, has been formally opened. Mr. H. Wade, Barley Street, Blackpool, was the architect, and Messrs. Massey Bros., Enfield Street, Wigan, were the contractors.

Mr. J. R. MacLeod, who has done excellent work for the city of Montreal as townways and railways engineer, has been appointed chief of the sewers department, in succession to Major Stuart Howard, retired on a pension. Mr. MacLeod will combine the two offices.

The cost of sewage treatment last year in the borough of Bury, Lancs., worked out, according to the manager's report, at £5 0s. 8d. per annum, gallons, against £2 15s. 7d. the previous year, the cost per head of population being 15.23d., as compared with 12.69d. last year.

The death has occurred at the front of Lance Corporal Barney, son of Mr. J. Bailey, surveyor to the Spalding Urban District Council. He was almost instantly killed whilst fixing wire entanglements. The deceased acted as surgeon for several years to the Holbeach Urban District Council.

The Bristol Docks Committee formally sanctioned at the last meeting a proposal submitted through the Board of Trade from the Western, Caledonian, and Portseahead Light Railway Company to construct a landing stage and other works on the foreshore of the River Yeat at Wick St. Lawrence.

Mr. W. W. E. Fletcher, Local Government Board inspector, held an inquiry at Hadley, Suffol., on Tuesday in last week respecting the application of the county council for authority to borrow £800 for the purchase of five acres of land as a site for an isolation hospital. There was considerable opposition to the proposal.

The town clock placed in Airdrie on Tuesday evening last week of Mr. John Frew, retired contractor, father of the Provost of the burgh. Mr. Frew was 65 years of age, carried out many important works. One of his sons, Mr. John Frew, sanitary inspector, is in Llandudno, Wales.

The Finance Committee for the Taxation of Land Values and the Executive of the Scottish Land Value Taxation of Land Values have arranged to hold a private conference of their members to be held in Glasgow on Friday and Saturday next. The object of the meeting is to consider the immediate relation of the taxation of land values to the present conditions of the building industry, and in particular to the effect of the land value movement on the building industry in the forthcoming year.

Extensive additions are about to be made to the Electricians' Hotel, Longroyd Bridge, Huddersfield from plans and designs by Messrs. J. B. Abbey and Sons, of that town.

Acting on the principle of rigid economy for local authorities, the Treasury has refused to sanction a Poplar paying loan of £4,726 and a Bournemouth scheme to instal machinery for the crushing of refuse.

The partnership hitherto existing between J. Huggott and F. J. Huggott, builders, contractors, and ironmongers, at Station Road, Belmont, Surrey, under the style of Joseph Huggott and Son, has been dissolved.

The Tuberculosis Committee of the County Council of Tyrone have accepted the tender of Mr. Isaac Copland, Belfast, at £2,750, for the erection of a pavilion, and another tender, at £2,015, for alterations to Dungannon House.

Mr. John Sweeney, formerly district engineer for the Department of Public Works, Ottawa, at Winnipeg, has succeeded Mr. C. H. Mathewson as resident engineer for the Department on the Toronto harbour improvement board.

Mr. A. G. Drury, an inspector of the Local Government Board, recently held an inquiry into an application of the Huddersfield Corporation to borrow £26,050 for the construction of relief sewers to the river Colne from the Fartown and Birkby districts.

The rural district council of Eastbourne have appointed Mr. William Walker, at present surveyor and inspector of nuisances to the Cuckoo Rural District Council, as district surveyor, at a salary of £200 a year, to include travelling expenses. Mr. Walker has held his present appointment for seven years, prior to which he served under the Mayfield Rural District Council for two years.

The Board of Control of the State of Florida, at Hotel Mason, Jacksonville, have received tenders for the construction of the Negro Building and Hospital Building for the State School for the Deaf and Blind at St. Augustine. The plans were prepared by Messrs. Edwards and Sayward, architects, 655, Candler Building, Atlanta.

The Imperial Trade Correspondent at Toronto (Mr. F. W. Field) reports that a large company operating a departmental store in that city has decided to build a warehouse at Regina, Saskatchewan, at an estimated cost of 150,000 dol. (about £30,800). A company operating large departmental stores at Toronto and Winnipeg has also decided to erect a factory at Hamilton, Ontario.

The corporation of Belfast proposes to build 252 workmen's houses, and of these 162 have been built, leaving a balance of 90 yet to be erected. The accommodation provided by the new houses consists of a large kitchen, scullery, two upstairs rooms, and a yard. The floors of the kitchen and scullery are tiled, the yards are built of concrete, and the fronts of the houses are of perforated brick. The new streets are wide and paved with pebbles, and the back passages are all 40 ft. wide, and will be either concreted or tar-macadamed.

A suggestive paper contributed to the recent annual meeting of the American Concrete Institute by Mr. N. C. Johnson dealt with micro-photography as applied to the examination of concrete, with the object of obtaining better knowledge of the structure of the material itself. A fact particularly mentioned by the author was that all specimens of concrete examined by him possessed a surprisingly large quantity of unhydrated cement, a feature he attributes to the difficulty in diffusing the water completely during the process of mixing. The voids revealed by the microscope also emphasise the importance of scientific grading.

The work of electrifying the Lancashire and Yorkshire Railway Company's line between Victoria Station, Manchester, and Bury is steadily proceeding. With the exception of the section from Queen's Road to Victoria Station the "third rail" has been laid along the entire length. Much of the rolling stock is also ready at the Newton Heath works. October or November is unofficially mentioned as about the date of opening. The power station at Clifton Junction will not be ready until the end of the year, but arrangements have been made for obtaining a supply of electricity from the Manchester Corporation. The district covered by the proposed new electrical service includes Woodlands Road (Cheetham), Higher Crumpsall, Heaton Park, Prestwich, Whitefield, Stand, Radcliffe, and Bury. There is also a short branch of electric service from Bury to Holcombe, a moorland district.

The Leek Board of Guardians are about to enlarge their isolation hospital at Tinster's Wood. Mr. J. Moss, of Milton, Staffs, is the builder.

At Cyma, near Neath, Glam., a joint isolation hospital will shortly be built from plans by Mr. J. C. Rees, M.S.A., Parade Chambers, Neath.

A Roman Catholic recreation hall is about to be built at Passage West, County Cork, from plans by Mr. J. F. M'Mullen, M.R.I.A.L., of South Mall, Cork.

H.M. Commissioners of Public Works are about to enlarge the post office at Dundee, the existing premises being quite inadequate to modern requirements.

The corporation of Ipswich are applying to the Local Government Board for sanction to borrow £8,760 for providing sub-stations in connection with their electric supply undertaking.

The order constituting a Drainage Board for the Derwent Valley has been confirmed. An area of about 10,000 acres has been scheduled in the neighbourhood of Wressle and Bubwith.

Stirling Town Council has decided to defer till after the war the execution of the St. Mary's Wynd improvement scheme, estimated to cost £15,000, and involving the clearance of a slum area.

The Public Service Stores Tender Board of Wellington, New Zealand, have accepted the tender of Messrs. P. R. Bailie and Co., at £1,951 for the supply of 120 miles run of twin-twisted rubber-insulated wire.

Alterations and additions are about to be made to the old Tabernacle Chapel in Elder Street, Bridgend. Mr. P. J. Thomas is the architect, and Mr. R. Jones, jun., of Coychurch, has taken the contract at £1,030.

Mr. J. T. Dewhurst has resigned his appointment as sanitary inspector and assistant surveyor to the Ruislip-Northward Urban District Council, and the council have appointed Mr. W. L. Carr, engineer and surveyor to the council, as chief inspector of nuisances. For the present no assistant inspector of nuisances will be elected.

The Glasgow Corporation are about to widen two overhead bridges carrying Pinkston Road over the Caledonian and North British Railways and two other overhead bridges carrying Balmore Road over the same railways in connection with the augmented water supply now being provided. The plans have been prepared by Mr. J. R. Sutherland, of John Street, Glasgow, water engineer to the corporation.

A site has been selected for the Ontario Government Hospital at Orpington, Kent. The hospital will contain 1,040 beds, and will primarily be used for acute cases among the wounded men of the Canadian contingent. The cost of construction and equipment will be borne by the Ontario Government, subject, on completion, to a grant made by the War Office. A beginning has been made, and the work will be pushed on without delay.

At a meeting of the district committee of the Middle Ward of Lanarkshire on Friday, the desirability of making application to the Local Government Board of Scotland for authority to prepare a town-planning scheme in respect of land lying in the parishes of Cambuslang and Old Monkland was under consideration. The extent of the area included in the scheme is 5,616 acres. After considering the whole proposal it was unanimously resolved to make the application to the Local Government Board.

H.M. Commissioners of Public Works are reports that, according to the local Press, negotiations for the purchase of a site for new freezing works at Wanganui have recently been completed. Not less than £100,000 will be invested in the site, buildings and plant. The works are being planned to deal with 4,000 sheep and 100 head of cattle daily. Building operations are to be commenced as soon as possible, and it is expected that the works will be ready for business in August, 1916.

The Conway and Conway Bay Joint Water Supply Board have accepted the tender of Messrs. J. Bryon, Ltd., of Bury, Lancs., at £2,750, for a steel girder bridge over the River Conway at Maenan, and midway between Llanwrst and Taly-Cafu, to carry a new water-main, and the tender of Mr. B. Lumb, at £2,895, for the supply of the 15-inch cast-iron pipes required for the crossing. The engineer is Mr. C. F. Farrington, M.I.C.E., of Trinity Square, Llandudno, who succeeded to the appointment a few months since on the death of his father, Mr. T. B. Farrington.

the designer, but the angle gives $2\frac{1}{8}$ -in. width for the bolt holes. At the head of the principals there is a plain cut $\frac{3}{8}$ -in. plate. At the back of the principals are 5 in. by 5 in. cleats—pieces sawn off steel angle, drilled and riveted to principals and bolted to the timber purlins, which are shown 6 in. by 4 in. to carry 1-in. boarding and light asbestos sheets. If the sheets are to a steel length, the purlins must be spaced to suit the size of sheets. We leave the covering of the long slope of roof to the choice of the reader. If galvanised iron, light Z steel purlins will suffice. The matter of completing the roof now concerns the ridge, the gutter, and the glazing of the steep side. We show a section suited to

roofs and stone templates to catch up the free ends of the tie-beams and ties, and to carry purlin-ends, etc. To provide a galvanised iron walling, horizontal steel members must be framed between the exterior stanchions, and spaced according to the size of sheet adopted. In this case the brickwork of the structure will be confined to stanchion foundations and a suitable plinth to the iron walls. Something very light will be all that is here necessary, the real foundation being under the exterior stanchions, which take all the load. It should be noted that a structure composed of a number of bays, on the system shown in the sketch has not the natural "tie" of a two-storied

which is formed the "road" for the traveller. It is no great matter if the crane means nothing more than a couple of steel joists carrying a kind of enlarged hand-pulley block; but for heavy work, which is not here contemplated, but such as is required in, say, a foundry, quite special care is needed, because the carrier and its burden brings concentrated load upon the centre of the girders bracketed from stanchion to stanchion, while the stanchions themselves are eccentrically stressed.

A concrete floor is shown, but for engineering shops it is hard to beat solid wood-block flooring, both on account of its good foothold and because there is less

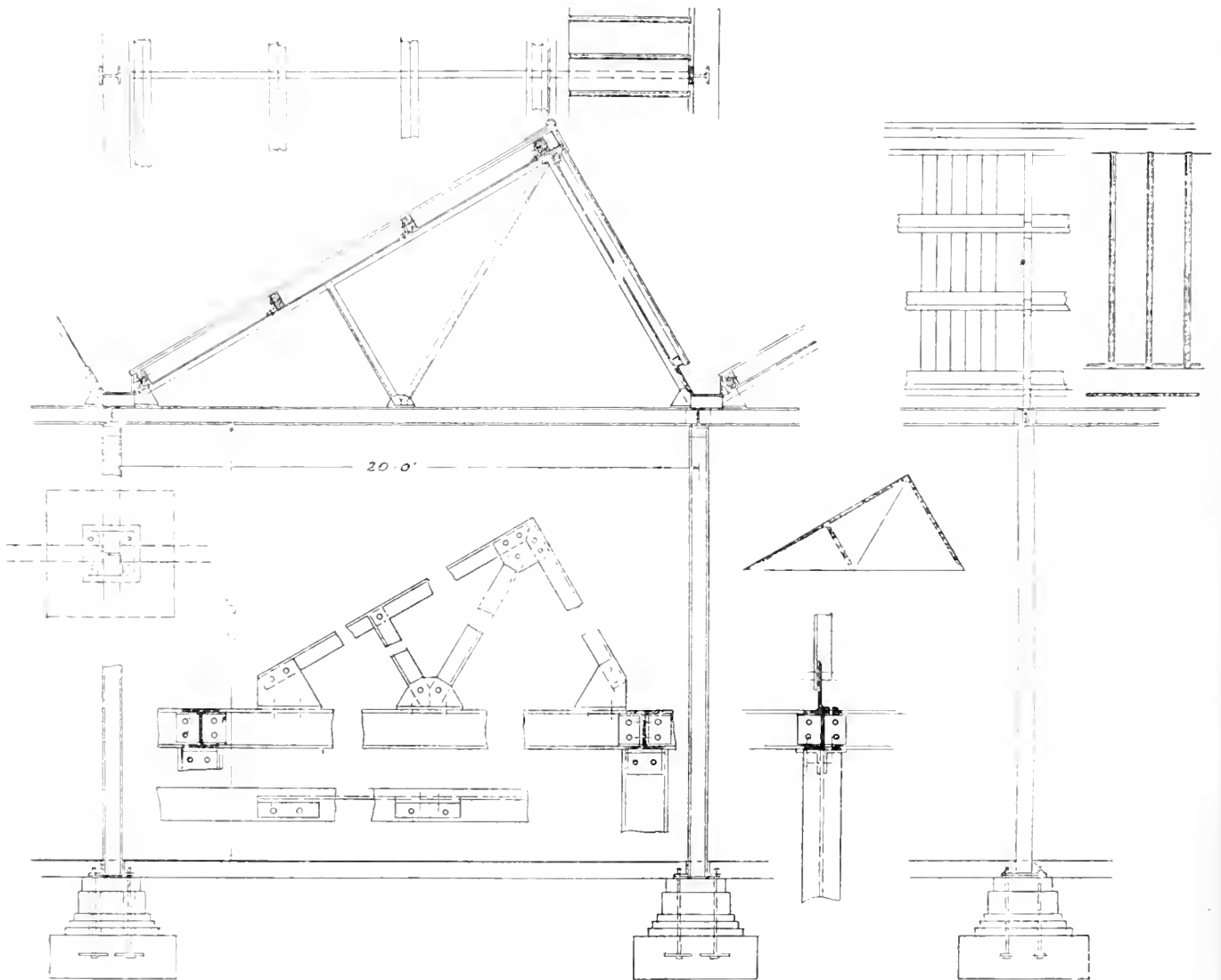

DETAILS OF A NORTH LIGHT ROOF.

a cast-iron gutter, it lead be adopted, the necessary bearing-beams and drips must be framed, with outlets to w.p.'s, which, where required, must run down beside stanchions. In the construction of the ridge, the rough-boarding is carried up to a full and the space on the other side of ridge is boarded against the related timber that holds the upper ends of the glazing bars, so that the lead can be dressed over the whole and down on to the glass. Ordinary skylight bars and putty can be used, but nowadays, on a number of the patent glazing bars is advantage as, and general practice, the bars are carried below by a longitudinal timber, and water runs direct into the valley gutter.

If the roof is to have brick external walls, they will have gable-ends to stop the

building, being comparable to a table and its legs, the strength of the whole being in the attachment of the legs. The strength in the design shown resides in the bolting at the stanchion heads. Strong brick exterior walls add to stability. Where such do not exist, the exterior stanchions might well be strutted to the horizontal steel sections.*

The proposals do not contemplate travelling cranes. Such would be best served by auxiliary, shorter stanchions connected by several riveted plates to the roof supports, and carrying joists on

* Since this was written, and the sketch completed, we have added the anchor-bolts, etc., to stanchion foundations as shown. The table legs to the floor. Genuine base plates are arranged, riveted by angles cut gussetwise, 44-in. flues could be left in the brick pier, and grouted before bedding stone template, a carefully holed for 1-in. bolts.

risk of accidental injury to perhaps delicately machined castings. The bases of the stanchions are below floor level, leaving the least obstruction to space. Where the kind and location of machine-tool is definitely known, suitable concrete foundation should be put down, with anchor-bolts to secure the machines.

A great variety of industries, works, etc., have adopted this north-light roof. It may be modified and produced with variety of detail. We have chosen the form seeming the most suitable for engineering and manufacturing premises generally. At the present time many industrial concerns have had to increase their premises, or hold in view possible increase of works area. Our plans show the simplest and most economical scheme for urgency in providing new works for

light duty, and one that can be carried out with ordinary steelwork, such as at the present time is likely to be procurable by the builder, where elaborate constructions may entail some delay and difficulty in delivery.

MODERN WARMING SYSTEMS.

The present dearth of fuel will probably induce many lovers of the extravagant and wasteful open fire to realise that the time has come to supersede it by less costly and more efficient means of heating. Gas and electricity offer no real advantages. The latter may, some day, and then no one will dream of dedicating an altar in every living room to the demons of dust and smoke; but, as yet, the cost of electricity is prohibitive. Gas is little cheaper, and will probably advance still further in price; and with it there is always the increased danger of fire, and of explosion—for which all insurance offices do not compensate when it occurs in adjoining premises. Gas, moreover, is destructive to books, pictures, and metal work. Its ease of installation is its recommendation to most people, but the apparent low cost thereof is very soon far more than compensated for in the ordinary private house by the adoption of hot-water heating. It is an established fact that with a properly designed and installed low-pressure hot-water warming apparatus eight average sized rooms can be warmed healthily and adequately throughout the day at the same cost as that of two open fires. Of the boon to the housekeeper following the cessa-

In the private house comfort and regard for more hygienic surroundings call for something better than a half warmed and "stuffy" room in which to spend the dull winter evenings. The result of this movement is shown by the rapidly increasing number of houses and mansions installed with central heating apparatus, either completely replacing or acting as an auxiliary to the open grate fire, in order that a more even distribution of heat can be obtained.

With a modern heating boiler practically all the heat generated by the combustion of the fuel is utilised, only sufficient being

allowed to escape up the chimney to create the necessary draught. The question of appearance has also been carefully studied, and radiators can now be obtained in many graceful designs, both in the plain and ornamental finish, while with suitable enamels or bronzes they can be made to harmonise completely with their surroundings, and in this respect alone are really an acquisition in any home. The necessary pipes for the conveyance of the hot water to and from the radiators can also be laid out of sight or rendered quite inconspicuous; moreover, the scientific development of central heating has made possible the use of smaller sizes of pipes.

At Oxford the Bodleian Library, the home of many of the most valuable books in the world, is warmed by means of a "Norris" low pressure hot water system, and also remembers that with regard to the nature of a

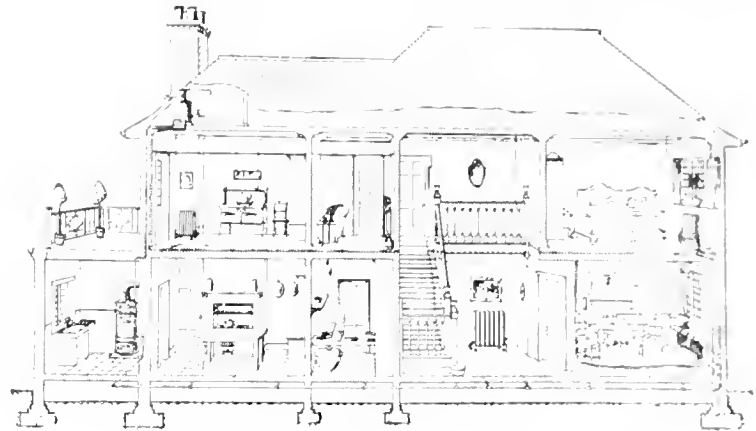

A Low Pressure Warming System in a House without Basement.

allowed to escape up the chimney to create the necessary draught. The question of appearance has also been carefully studied, and radiators can now be obtained in many graceful designs, both in the plain and ornamental finish, while with suitable enamels or bronzes they can be made to harmonise completely with their surroundings, and in this respect alone are really an acquisition in any home. The necessary pipes for the conveyance of the hot water to and from the radiators can also be laid out of sight or rendered quite inconspicuous; moreover, the scientific development of central heating has made possible the use of smaller sizes of pipes.

For stores, shops, and all buildings of any pretensions to size a central heating apparatus is the only reliable and efficient method

light is allowed in this building, it may be taken as an official confirmation of our statements regarding the safety of this warming system. The new underground book stores consist of two floors under the roadway and lawn in front of Radcliffe Camera, and are capable of storing about two million books. Ventilation is provided by means of large inlet and extractor fans driven by an electric motor; the air first passing through a screen to purify it and then being conveyed through ducts to the necessary points. In cold weather the air is passed through a heater, thus the stores are ventilated and warmed at the same time.

Low-pressure hot water is universally recognised by the fire insurance companies as a safe and effective method of heating, and generally more favourable terms of insurance

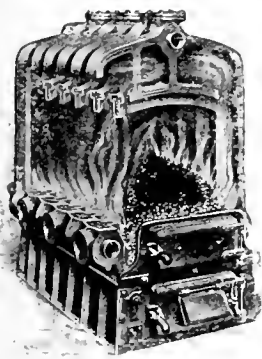

Broken View of Sectional Boiler.

tion of the ceaseless work of keeping the stoves going, and cleaning the rooms—of the saving in the laundry bills, and the end of damage to fabrics and furniture none have an adequate conception who have not been emancipated from the thralldom of the fireplace.

It is necessary, of course, that intelligent knowledge should govern the selection of a suitable heating apparatus, as systems which offer advantages under certain conditions may fail to do so under others. Moreover, the architect—while insisting on economy and efficiency—will rank appearance, especially in the home, as of equal importance. He will find guarantees for all three if he adopts the suggestions embodied in an informative brochure issued by Messrs. F. A. Norris and Co., of 11 and 12, St. Andrew's Hill, Queen Victoria Street, which they will send free on application.

As they point out, the difficulty of combining economy, efficiency, and appearance has been successfully overcome by the low pressure hot water and steam systems of heating. The former is most generally in vogue in this country on account of the comparatively small variation in temperature of the atmosphere, and is especially suitable for warming private residences, hotels, public buildings, churches, schools, etc. Steam heating can often be employed with advantage in factories, workshops, etc., where a supply of exhaust steam may be available, and in large buildings where long runs of piping are necessary; also in places where the apparatus is used intermittently, as it is possible with a steam system to raise the temperature in a building very quickly when required.

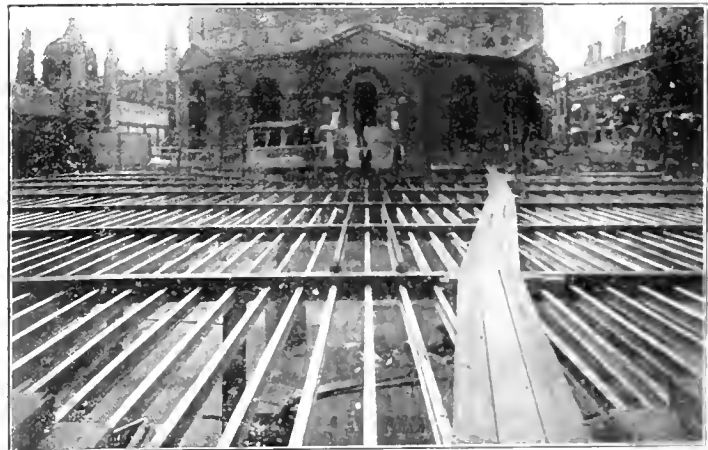

Beneath the steel joists which support the roadway and lawn are the underground Book Stores of the Bodleian Library, heated and ventilated by a "Norris" System. Radcliffe Camera, in the background, also has a "Norris" Warming System.

to employ to keep the building uniformly warm and comfortable. The results obtained are decreased fuel and labour expense, cleaner stocks and interior furnishings, and absence of fire risk. To these advantages must, of course, be added the maintenance of an inviting and comfortable atmosphere which lends so much to the attractiveness of business premises, and helps in no small measure towards their success.

The large and increasing number of business and public buildings which are being

are obtainable where this method of Ventilation can be secured by fitting ordinary direct radiators with baffle plates, when the air is admitted to the room through the wall at the back or through the floor immediately beneath the radiator, as illustrated.

Another method is known as the "indirect" system, for which a special type of radiator is manufactured, this usually being enclosed and suspended from the basement ceiling, a cold air duct leading from the

...of the ... the bottom ...

FACTORIES AND OFFICES.

In a modern factory it is desired to ...



Showing Radiator fixed in Fireplace.

the ... and maintain the temperature ...

The ... of its comparative slowness in heating ...

In factories where exhaust steam can be obtained from the power plant it may be utilized for warming.



Bear and Dyson School, Oxford University.

When ... systems are used, coals can be ...

Natural ... are given in the ...

THE WORK OF THE TRADES TRAINING SCHOOLS.

The report and awards of the judges on the work done at the Trades Training Schools of the Worshipful Companies of Carpenters, Joiners, Painter Stainers, Plasterers, Tylers and Bricklayers, and Wheelwrights, at 153, Great Titchfield Street, Port and Place, W., have just been published. The endeavour of the management of the schools, of which Mr. H. Phillips Fletcher, F.R.I.B.A., F.S.L., is the director, is to improve the technique of each craft by instructing men who actually earn their living by their labours therein.

The Alexander Howard Medal and £2 in books or tools (these prizes are in every case given in books or tools of the value stated) has this year been awarded to G. Austin for an excellently executed honours board in English oak. Certificate and 15s., W. S. Hales; certificate and 10s., J. Dipple. The handicraft awards were:—Silver medal and £2, H. G. Howe; certificate and £1, E. C. Owen; certificate and 15s., W. Chance. In Masons' work the judges were of opinion that in future the exhibits should be executed on a larger scale and the joints shown. The awards were:—Baister Fletcher Medal and £2 in books or tools, Herbert George Bush; certificate and 30s., Henry Joseph Maibach; certificate and £1, Richard Sherman; certificate and 15s., Frederick James Moore. In the Painters' Class there was a marked improvement in the quality of the work.

Violent colouring was avoided and more care taken in the preparatory processes; the examples of graining were quiet in colour, and showed care and skill in the execution; while the specimens of signwriting exhibited a distinct improvement on that of previous exhibits. The awards were:—Silver medal and £1, Edward Leander; bronze medal and £1, William Bedford; certificate and 15s., E. Fowler; certificate and 10s., L. Harlow; certificate and 10s., W. Giddins. In the Plasterers' Class the judges experienced some difficulty in separating the prize-winners, so uniform was the work:—Silver medal and 15s., Thomas McDonnell; bronze medal and 15s., Alfred Austin; certificate and 15s., James Donovan; certificate and 15s., John Laver; certificate and 10s., Stanley Thresher; certificate and 10s., Walter Pettit. The Plumbers' Class maintained the excellent record of past years, the prize-winners being as follows:—Silver medal and £1, Albert Henry Briffett; silver medal and 10s., Alfred Grefley; silver medal and 10s., William Parsons; bronze medal and 15s., Charles Lamburn; certificate and 15s., Charles Porter; certificate and 15s., Henry James Briffett; certificate and 15s., Percy Harris. The Smiths' Class also maintains the previous high standard—Special prize of £2, Harry Collins; special silver medal and £1 (former recipient of silver medal), Harold Pound; bronze medal and £1 (presented by the Blacksmiths' Company), S. Jones; certificate and 15s., S. Blake. Considerable promise was displayed in the Stone Carvers' Class, the awards being:—Bronze medal and £1, Arvid Phillips; certificate and £1, Reginald Phillips; certificate and £1, William Cooke; certificate and £1, F. C. Legge.

In the Tyllers' Class, again, the judges were ... The awards were:—Special prize of £2, ... of first prize, Alfred Harlow; special prize of £2, ... F. R. B. Legg; certificate and £1, Herbert Hart; certificate and £1, William Whorner. In the Tyllers and

Bricklayers' Class, a high standard of excellence was maintained, no works falling below the average submitted in recent years. The silver medal and £1 went to Albert Henry Smith, and the silver medal and 15s. to George Henry Wilnot; special prize of £2 (former recipient of silver medal), Geo. John Reynolds; certificate and £1, Alfred Hurst; certificate and £1, Geo. Wm. Billinghurst; certificate and £1, James Walsh; certificate and £1, Joseph Henry Grove; certificate and 10s., Frances Geo. Bond; certificate and 10s., George Wiles; certificate and 10s., Harry Wiles.

The exceptional demands made by the war has affected the Wheelwrights' Class more than any other in the school, and the work has been produced entirely by apprentices of between fifteen and nineteen years of age. Notwithstanding this, the quality of the work is well maintained. The certificate and 30s. went to W. H. Dawar, a certificate and £1 to F. Mitchell, the master's prize of £1 to G. Packham, and a certificate and 10s. to M. Ellis. The exhibits in the Woodcarvers' Class were mostly of an elementary character, and the awards were as follows: Certificate and £2, James Shirley; certificate and £1 (given by Joiners' Company), Frederick Devisse; certificate and £1, Harold Crow; certificate and £1, Thomas Waltham; certificate and £1, Hugh Clittham; certificate and £1, Ernest Brock; certificate and 10s. (given by Joiners' Company), Sidney Lett.

The work done in the Wiremen's Class is of a practical nature, and does the exhibitors great credit. The awards are: Senior Division—Certificate and £1, A. E. Darlow; special prize of £1 (former recipient of first prize), A. Jordan; certificate and 7s. 6d., A. V. Morgan; certificate and 5s., G. Hastings; certificate and 5s., H. Rickards. Junior Division—Certificate and 15s., P. Doody; certificate and 10s., F. Goodge.

The new session of the whole of the classes commences on one of the days in the week after next, opening Monday, the 20th inst. They are held in the evenings, beginning at 7 or 7.30, and the fees are very moderate, being uniformly 3s. per term for apprentices and 5s. (or in the solitary case of woodcarvers, 6s.) for a lults.

ANCIENT MONUMENTS IN WALES.

The sixth report of the Royal Commission on Ancient Monuments in Wales and Monmouthshire mainly deals in continuance with the inspection of the monuments of Merionethshire and Pembrokeshire. It is remarked that much of the latter county lies within the military protected area, and "the necessary restrictions upon the movements and occupations of civilians have slightly retarded the progress of the work of the Commission."

During the year the Commission issued a volume on the ancient monuments of Denbighshire, practically completed that dealing with those of Carmarthenshire, and completed the inspection of the monuments of Merionethshire. They also finished the task of examining the title schedules and maps of the entire Principality.

The Commissioners declare that there can be no two opinions regarding the importance of farm and field names to the Welsh archaeologist. The fact that the Welsh place-names are being rapidly replaced by English names, so that the local lore which is often enshrined in the former is in danger of being lost, was in itself a sufficient reason for the undertaking.

Continuing their policy of visiting the principal monuments, the Commissioners made special tours of inspection to the counties of Merioneth and Pembrokeshire during last year, and they remark that they are convinced that these visits had considerably effect in quickening the interest of residents, and in quickening their sympathy of local opinion, in favour of the preservation, not merely of the large and valuable monuments, but of those smaller and less imposing remains which are always in danger of removal or destruction.

Mr. W. D. Bliss, A. R. C. S., architect and surveyor, Bodwey, L. F. £5 35s.

THE VALUATION OF NONCONFORMIST CHAPELS

Mr. C. Hewetson Nelson, of Liverpool, has rendered a public service in obtaining a memorandum from the Board of Inland Revenue as to the position of Nonconformist chapels under the Finance Act, 1910. The inquiry arose out of a proposal to value the Wesleyan Church at Wallasey. Mr. Hewetson Nelson ascertained that there appeared to be no specific exemption of churches under the Finance Act, 1910, but that, on the contrary, Section 6 of the Act provided that where land was held by a permanent trust (such as is the case with most churches) it should be valued once every fifteen years, and the increment value duty collected thereon.

At Mr. Nelson's request, Mr. Arthur Henderson, M.P., the President of the Board of Education, kindly undertook to obtain the opinion of the Treasury, and in the course of a fortnight forwarded the following memorandum prepared by the Board of Inland Revenue:—

"Mr. Nelson is under a misapprehension as to the purpose of the valuation. The scheme of valuation set up by Part I. of the Finance (1909-1910) Act, 1910, is a general one. It embraces all land in the United Kingdom, both that which in its present ownership and condition falls within the scope of the Land Valuers' duties and that which does not. Much land which is at present within the scope of exemptions may, on account of some future change of condition, become liable to increment value duty, and the original valuation would then, of course, become an essential factor in the calculation of duty. No increment value duty or other land value duty is, of course, chargeable on a church held by or on behalf of the Wesleyan Connexion and occupied and used for its purposes, though increment value duty might become payable in the event of a sale."

In reply to this memorandum Mr. Nelson drew Mr. Henderson's attention to the fact that the memorandum did not state:—

1. Whether churches held on permanent trusts came within Section 6 of the Act; and

2. Whether churches came within the exemptions of Section 37 as "property appropriated for charitable purposes."

To these inquiries Mr. Henderson has obtained the under-mentioned note from the Board:—

"Notwithstanding that a Wesleyan trust falls within the provisions of Section 6 of the Finance (1909-1910) Act, 1910, property held by such a trust would be exempt from increment value duty on the periodical occasions for collection of that duty, provided that the conditions for exemption under Section 37 of the Act be fulfilled. In any normal case church purposes would be charitable purposes within the meaning of that section."

At the last meeting of the city council of Winchester approval was given to a scheme for the further widening of Bridge Street, from No. 29 to Chesselhall Street, in accordance with military requisitions. An application will be made to the Road Board and the county council for a grant towards the cost, which is £11,711s.

A few carvings and paneling have been dedicated at St. Thomas's Church, Penkull, Staffs. The work was carried out by Messrs. Meiklejohn and Sons, Stoke-on-Trent, from designs by the two churchwardens, Messrs. A. R. P. Piercy and J. Arfon Jones, both of whom are architects. The carving was being executed and presented to the church by Mr. Meiklejohn, senior, now in his eightieth year.

At the last meeting of the Shipston-on-Stour Rural District Council it was reported that the actual work on the contract for Shipston sewerage amounted to a cost of £5,167 16s. 6d., and that the estimate was exceeded by about £79, and the Joint Committee recommended the council to apply to the Local Government Board for sanction to a loan of £50,000 to meet this. The Joint Committee also recommended the council to apply for sanction for a loan of £27,500 for carrying out the work on connections with the new sewers, so that no delay could be caused when the council were in a position to deal with that matter. The report was adopted.

Currente Calamo.

The "explanations" by the officials of the reasons for the dismissal by March next of 1,700 of the temporary men on the staff of the Land Valuation Department may satisfy the comparatively few people who believe that when this Government gives place to another the "refreshing fruit" of their labours are likely to be utilised by their successors any more profitably to the nation than heretofore; but it is rather hard on the men under present circumstances. Before the war there were 4,000 of them engaged, and we doubt very much whether, as it is stated, 97 per cent. of the valuations have been made. We doubt still more whether much of the £125,000 we are told is to be saved by turning them adrift is ever likely to appear on the credit side in future Estimates. However, "economy" is the order of the day in all that concerns the professional workers. There is no need of their votes in Parliament, where the four-hundred-pounders must still be given full pay for half time, and little outside where war bonuses and increased wages are being so generously distributed at the cost of the taxpayer. For them the sole consolation is that discharges are as "automatic" as successive strikes of Welsh miners who have so mastered the secret of coercing the Government, and whose successive defiances of all attempts to keep them to their engagements will doubtless continue to extort concession after concession while their friends at court and their German sympathisers calmly contemplate our fast vanishing coal output!

The special Housing Conference held at Bristol last Saturday rightly emphasised the fact that the housing question is more urgent than ever, and that it must be recognised that it is a national and not a mere local matter. It is always difficult, and frequently impossible, to move local authorities in the matter. They are afraid of the rates rising or they say so, ignoring the fact that few other forms of outlay yield so good a return, and add lastingly to the solid capital of the town or district wise enough to perceive it. We have long recognised that an Imperial need demands Imperial help, and that this would encourage private enterprise and stimulate municipal activity more than anything else. Mr. Ammon, of the Fawcett Association, urged that Government should advance from the National Exchequer sums equal to 20 per cent. of the amounts sanctioned by the Local Government Board for housing schemes. It would be a good investment, but the State will never move till the workers recognise that only united pressure will compel it to do for Englishmen what they are being taxed for to do for Irishmen. Ireland, as he insisted, has not been side-tracked by all kinds of shibboleths as have English workers, and it only needs persistency to induce legislators, who will do nothing till they are obliged, to frame some such measure as the Irish Labourers Act.

The *Connoisseur*, in a second sound article on art and national economy, drives further home some excellent reasons why if the sacrifice of art will weaken the country during its mighty struggle, then art should be fostered, and those who can still afford to support it should do so to the best of their ability. The question at issue is whether the expenditure on the productions and wares of artists, art craftsmen, designers, and dealers could be transferred to other objects during the present crisis with advantage to the nation. The result of such procedure would be to drive some

art-workers into retirement, and others not so advantageously situated into lay employments. The amateur economist will say, "So much the better: the younger men can join the Army or Navy, while the elders and those otherwise incapacitated from active service may become munitions makers." As it is, however, the first part of this programme has already been largely carried out. The younger men have volunteered for the front as eagerly as those belonging to any section of the community. Many a career which might have been crowned by immortal fame has ended in a nameless grave amidst the lowlands facing the English Channel, or on the steep hill-slopes overlooking the Hellespont. Of the elder men, some have already been compelled for a time to sacrifice their artistic knowledge, gained during years of study, and turn to work which could be as efficiently performed by any hack office clerk. The majority still try to maintain their positions, hoping that with the support their wealthier patrons can still afford to give them they may hold out until the end of the war. What will happen if they fail in their endeavours? Dealers will suffer: close up these various galleries and shops, and the result will be ruin to most of their proprietors, a heavy loss to property owners, and a substantial decrease of Government revenue. Repeat the process throughout the country, and the loss to the community will be enormous. One of the most profitable methods of wealth creation is in the employment of the higher forms of art. Commodities almost valueless in themselves are converted by the hand of the artist into something rare and precious. A strip of canvas and a few ounces of pigment are transformed into a beautiful picture; a block of stone into a fine statue; some fragments of clay and silica into a delicate piece of porcelain; a few lumps of wood tend to become more valuable with time, and by accumulating them we are adding to the national savings as much as if we put by the purchase-money for them in the savings bank. Interrupt such service by setting their producers to the industrial labour more perfectly executed by people whose ability rises to no higher office, and the country is impoverished rather than strengthened. National economy is essential, but it must be a wise and discreet economy rather than a blind and partial parsimony. There are certain directions in which large savings may be advantageously made.

A case of some interest incidentally to some of our readers which was heard in the Chancery Division before Mr. Justice Sargant on June 16, 17, 18, and July 14 last, is fully reported in "The Illustrated Official Journal (Patents)" of the 1st instant. On September 7, 1906, Letters Patent (No. 19,949 and No. 19,949a, of 1906) were granted to William Hervey Brown for, respectively, "Improvements in bond ties for walls and the like" and "Improvements in bonds for securing facing constructions to concrete columns." On March 4, 1908, Letters Patent (No. 4,953, of 1908) were granted to the same patentee for "Improvements in and relating to bond ties for walls and the like," as a patent of addition to the patent No. 19,949, of 1906. A petition for the revocation of the patents No. 19,949 and No. 19,949a, of 1906, and another petition for the revocation of the patent No. 4,953, of 1908 were presented by the Expanded Metal Company, Limited. On the last mentioned petition an order was made by consent for the revocation of the patent. The first-mentioned petition (with a petition for the re

vocation of a patent No. 13,624, of 1903) came on for hearing on July 28, 1914, before Mr. Justice Warrington. On the third day of the hearing, it was stated to the Court that the parties had agreed to the dismissal of the petition on terms, and an order was made accordingly (31 R.P.C. 397). On January 7, 1915, a summons was taken out by Robert Newbald Kay, who asked that it might be declared:—(1) That the applicant, as the solicitor employed by the patentee in his opposition to the petition, was entitled to a charge upon the patents No. 19,949 and No. 19,949a, of 1906, and the whole of the interests therein of the several respondents to the application, including the interests of them, or any of them, in or under an indenture, dated December 20, 1907, and made between the patentee of the one part and Richard Johnson, Clapham and Morris, Limited, of the other part (being a sole and exclusive licence under the two patents, amongst others), and any royalties or moneys receivable under or by virtue of the indenture, and upon any other property recovered by, or preserved for, the respondents to the application, or any of them, in the petition or the opposition to or defence thereof, for the taxed costs, charges, and expenses of the applicant of, or in reference to, the petition, as such solicitor as aforesaid. (2) That it might be referred to the taxing master to tax the costs as between solicitor and client, including the costs, charges and expenses of the applicant of and in reference to the petition, and his costs of and incidental to the application. (3) That the amount of the taxed costs, charges and expenses (including the costs of the application) might be raised and paid to the applicant by a sale of the patents, including the interests of the respective respondents in or under the indenture of December 20, 1907, and the other property (if any) so preserved, and that until payment, and also in the meantime pending the hearing of the application, the whole of the premises should stand charged as aforesaid. After a lengthy review of the whole circumstances, Mr. Justice Sargant said: "In the result, I dismiss the summons, and I am afraid that I must dismiss it with costs." Leave, if necessary, to appeal was given, and a stay of execution was granted until August 1, and then, if notice of appeal was given, until the hearing of the appeal.

Among the sculptured stones which are about to find a permanent home in the new museum at Whithorn is the "Inscriptive Stone Pillar," which had its more modern position about a quarter of a mile from the burgh, on the road to the Isle of Whithorn. Its position there, however, according to a correspondent of the "Scotsman," was wholly capricious, it having been brought from the Mains Farm, which is partly within the precincts of the burgh, and where in all probability it served the purpose of a burgh boundary mark, as other stones can be traced in the environs—uninscribed, however—performing a like function. It is of great antiquity. The stone is of the hardest variety of the prevailing rock of the district, and it is of parallelogram form. Its height, measured from the greensward level, or eight above ground, is 3 ft. 2 ins., and its breadth 3 ft. 10 ins., the broad side being 1 ft. 6 ins. and the narrow 9 ins. The hieroglyphic figure upon the stone consists of two concentric circles, of which the interior is 1 ft. 6 inches and the exterior about 1 ft. 2 ins. $\frac{1}{2}$ diameter. Within the inner circle is inscribed a cross, formed of lines drawn

double like a cross, extending to exhibit four distinct double concentric lenses, of which two, placed end to end, make a diameter, the four thus forming two diameters, passing at right angles to each other through the centre of the circle. The two concentric circles stand upon a sort of pedestal made of two lines drawn double, which are distant from each other at the base, or widest part, 6 ins., and at the top, or narrowest part, where the concentric circles rest, about $\frac{1}{2}$ ins. The height of this pedestal is 8 inches, which being added to the other or largest circle (1 ft. 2 ins.), makes the whole height of the hieroglyphic figure 1 ft. 10 ins. Under the concentric circles, and partly across the pedestal, are the words *Locus Petri Apostoli*. The last two words present no difficulty, and the common people style the stone that of the Apostle Peter, but the first is not a little puzzling. From what has been brought to light of late years, however, the original inscription upon the stone seems to have been—*Hic est locus Petri Apostoli*—"Here, or this is the place of Peter the Apostle." When it is understood that in such inscriptions *locus* is frequently translated as if it were *sanctus*, the meaning of the sentence appears obvious, the translation thus being, "Here, or this is the Church of the Apostle Peter." This stone, probably, originally marked one of the Chapels of Ease Cruggleton, Isle of Whithorn, Kirkmadrine, Kirkmadrine, etc.—to the renowned monastery at Whithorn, erected in the reign of David I. There is a hole at the top of this stone 8 inches deep and two inches in diameter.

Mr. Walter H. Whitear, who last year showed by presumptive evidence in the *Athenaeum* that Samuel Pepys was born at his father's house in St. Bude's parish, and that the house abutted on the churchyard, but thought its exact situation would probably never be determined, now writes to the same journal that he thinks that, with as much certainty as is possible after the lapse of time, the site was that now occupied in Salisbury Court by the White Swan public-house and the restaurant adjoining on its south side; and an interesting confirmation is that the measurement of the two frontages together is forty feet, and that the site of the back portion in the churchyard is that now occupied by Nos. 9 and 10, St. Bride's Avenue. Soon after the Great Fire, a body of Commissioners was appointed to supervise the rebuilding of the City, and of these, three were instructed to make a survey of the devastated ground and the properties involved. The original MS. surveys of Oliver and Mills, two of the Commissioners appointed, are happily still extant, and are in the Guildhall Library in five large volumes. Of the importance of these unique records it is impossible to speak too highly, and their value in research like this is priceless. From their giving the names of the owners of the adjoining properties one is enabled to piece together the plan, and reconstruct it as a whole. Some of our own readers who may have occasion for ordinary business reasons to seek similar information will do well to note this.

The risks of sketching without a permit should be borne in mind, especially during this holiday time, and only if it would be well if the Home Office could define prohibited areas more clearly. The valued contributor Mr. A. W. Bennett, F.S.A., to whom our readers are indebted for some of the most beautiful illustrations to have published, was

clearly instructed to do so. Bennett's sketches make a most interesting study, and are well worth a perusal. The sketches are of course not intended to be taken as a guide, but rather as a study of the various methods of construction. Bennett's sketches are of the most interesting kind, and are well worth a perusal. Bennett's sketches are of the most interesting kind, and are well worth a perusal.

COMPETITIONS.

CITY OF YORK TOWN PLANNING COMPETITION. The terms of the competition are under consideration by the Council of the Society of Architects with a view to amendment. Members are requested to communicate with the Secretary before entering for the competition.

ARCHAEOLOGICAL.

THE ROMAN FORT AT AMBLESIDE, WINDERMERE. The annual meeting of the Cumberland and Westmorland Antiquarian and Archaeological Society was held at the Roman Fort, Ambleside, on Friday, when Mr. R. G. Cloughwood gave an interesting report of the work of exploration during this year. At the end of last season it was discovered that beneath the second century fort lay another dating from the century before, and this year's digging had been devoted to exposing this earlier fort. Whereas the later fort lay east and west, the earlier lay almost north and south across the eastern end of the site, projecting beyond it some sixty feet to the north. It was defended by a double ditch, varying in width from 25 ft. to 40 ft., according to the distance between them, and 4 ft. or 5 ft. deep. In the Eastern ditch were ditches oak timber was found, which suggested that a palisade was also used. Inside these defences was a rampart, whose foundations, consisting of a strip of hard stone paving, had been discovered in several places. The rampart itself was cleared away by the builders of the later fort. The north end of the early fort, projecting beyond the limits of the later fort, had received most attention this year. Between the fort and the middle roadway, on the inner side of the ditches, was found a pavement thickly covered with charcoal, which might represent the floor of a galley. Several trenches had been dug on the other sides of the early fort, to fix its limits, and a certain amount of pottery, believed to belong to the first century, had been discovered. One large Samian dish, found in the bottom of the early ditch, was almost complete. Two bronze coins had been found, one of Domitian, the Emperor under whom the early fort was probably built, and one of Antonine, an Emperor of the second century, also a fourth century silver coin in a well belonging to the later fort.

A HOUSE WITHOUT NAILS.

A specimen of the architecture and building abilities of George Washington is a brick house, still standing, in good repair, which was built by the father of his country in 1790 at Glasgow, Barron County, Kentucky, although it was in Fairfax County, Virginia, when it was built.

The building says the *Scientific American* (U.S.A.) is a residence constructed by General Washington for the use of General Spotswood, who was then in Virginia at that time. General Spotswood was by nature a very particular person, and had become a millionaire. The building of solid brick, 30 ft. high, and the roof was of half-inch, 2 in. thick, oak shingles, not and laid with dovetail joints. The roof was hand drawn, and the shingles were thick, and fastened with wooden pegs.

There is not a single nail in the entire building, for nails were not introduced at that time. The glass windows, which were imported from France, as was the marble in America, and many of the original panes are still doing duty, but the action of the weather has had the effect of wearing them away, until they are now little thicker than a sheet of paper.

Our Illustrations.

ST. ANDREW'S CHAPEL, EXETER CATHEDRAL.

This illustration shows a measured drawing of St. Andrew's Chapel, which is situated in the north choir aisle of Exeter Cathedral, and is opposite to and corresponding with that of St. James' Chapel in the south choir aisle. It was Marshall's work, originally, like its fellow chapel, but substitute for one of the old apsidal chapels of the Norman choir. Stapledon imitated the renovations so as to make it parallel to Brouncker's restored chapel of St. James'. The detached shafts are clearly indication of the earlier bishop's work. The choir contains an upper chamber wherein among the archives are Leofric's will, with everything wrought poetry, MSS. of Roger Bacon, and the Fabian Rolls; also the "Exon Domesday

and the ashlar work. The total length of the building is 150 ft. and the width across the transept is 75 ft.; the height to the apex of ceiling of chancel being 57 ft. above chancel floor. Miss Margaret J. Chilton, R.B.A., has designed and executed the stained glass in the south transept window, and the stained glass windows of the chapel are by Messrs. Powell & Lloyd. Mr. Herbert J. Read, of Exeter, executed the pinnacles in the chapel, which is of Beer stone. The sedilia and piscina are the gift of Mrs. Griffin, as is also the marble flooring to the sanctuary. The pulpit is the gift of Canon Hitchcock. The marble flooring is by the Marble Mosaic Co., stone and wood carving by Mr. Lewis Small, of Bath. The total cost of the building has been about £13,000. It is hoped in the near future to complete the tower at the north-east corner, the height of which will be 70 ft. above the ground level. The contractors were Messrs. Pittard and Sons, Unity Street, Bristol, and the architects Messrs. E. C. Rodway, A.R.I.B.A., and

overlooking and having an entrance into the garden. A library has been arranged to the right of the main entrance, and on the left there is a large social or drawing room, which will be used for dances, concerts, etc. A door from this room leads out to the garden. There has also been provided on this floor the office and the waiting room, matron's sitting room, and two private retiring rooms, also lavatories, cloak room, and service room. There are twenty-seven bedrooms on the first, second, and third floors, and twenty-six on the fourth floor, giving a total accommodation for ninety-seven residents after deducting ten bedrooms for the staff, the servants' bedrooms having been arranged on the fourth floor. Each bedroom floor has three bathrooms, two lavatories, and three w.c.'s, a housemaid's closet, and two linen stores. Situated at the end of the corridor is a staff staircase. This staircase will also serve as an additional staircase for the residents from any floor in case of fire, and the street can be reached direct.

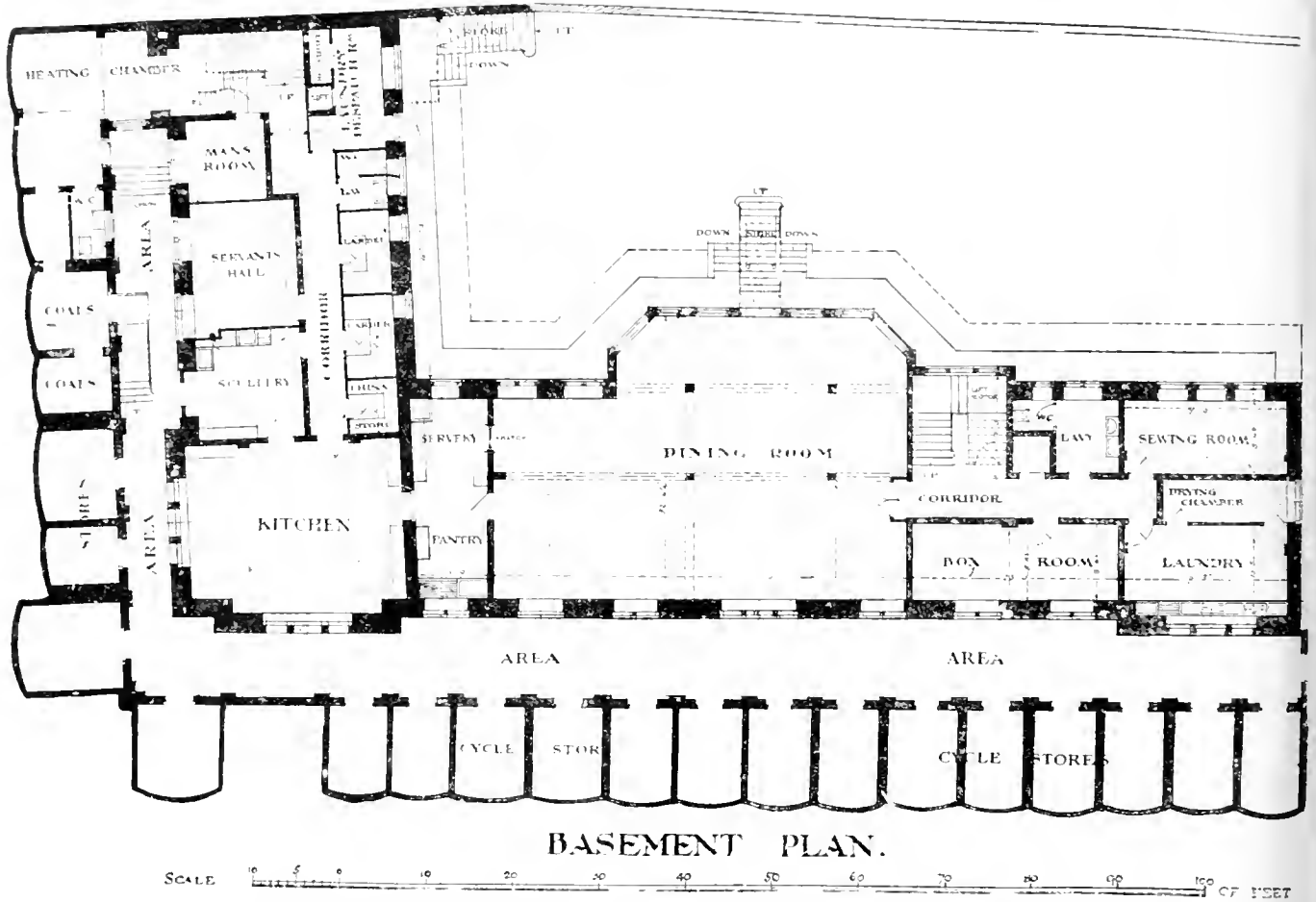

NUTFORD HOUSE, BROWN STREET, W.—Mr. VICTOR WILKINS, Architect.

Book of Hours, "Liber Pontificalis" and the diocesan "Ordo of Services" have been arranged for the interior use. The chapel, originally founded before St. Andrew's Cathedral, dated 1305 is an order of Buton's that country services should be held here for Andrew of Kilkenny, late dean, and others. Among the names we find that of Henry de Kilkenny, who was at the time of Buton's order still living and canon of the Cathedral.

WALTER W. HITCHINS.

ST. ALBAN'S CHURCH, WESTBURY PARK, BRISTOL.

The western portion of the church, consisting of nave, north and south aisles, and transepts, was completed in 1909. The work at the east end now nearing completion, consists of the choir and sanctuary, a chapel on the south side, and vesties for choir and organ on the north. The external stone is of the Bristol limestone, with dressings of Monks Park Bath stone. Internally the nave and chancel are lined with Bath

C. F. W. Deane, F.R.I.B.A., Gaunt House, Orchard Street, Bristol.

HOME FOR EDUCATED WOMEN WORKERS, NUTFORD HOUSE, BROWN STREET AND NUTFORD PLACE, W.

This building, of which we give a view and three plans, is being built as a residential club for educated women workers. It is situated in Brown Street and Nutford Place, W., and will give accommodation as follows.—In the basement, a large dining-room and kitchen, scullery and offices adjoining. On this floor there is also the servants' hall, laundry despatch room, heating chamber, coals and cycle stores. A sewing room, laundry, and drying chamber for the use of the residents have been arranged, together with a large box room, and lavatory accommodation for bath residents and staff. There are service lifts from the servery and laundry despatch room to the upper floors. On the ground floor, directly opposite the main entrance is the lounge, with windows

The elevations are Georgian in style, with a mansard treatment of the roof. The walls are faced with purple brown Chesham bricks and stone dressings. The windows are varied in some cases by light red brick dressings, and these, with a heavy modillion cornice, combine to give a Georgian character to the edifice. The building has been designed by Mr. Victor Wilkins, architect, 12, York Buildings, Adelphi, W.C.

MESSRS. GOSSAGE AND SONS, LTD.'S NEW OFFICES, WIDNES, LANCS.

The staircase hall and board of directors' room fireplace furnish the two views given by the accompanying plate. A plan and a pair of photographs of the general central office and of the board room appeared in the BUILDING NEWS for April 23 last, when we printed several particulars concerning the work. Messrs. Charles W. Harris and Laurence Hobson, A.A.R.I.B.A., of Liverpool, are the architects who designed and superintended the execution of the buildings, which cover a considerable area.



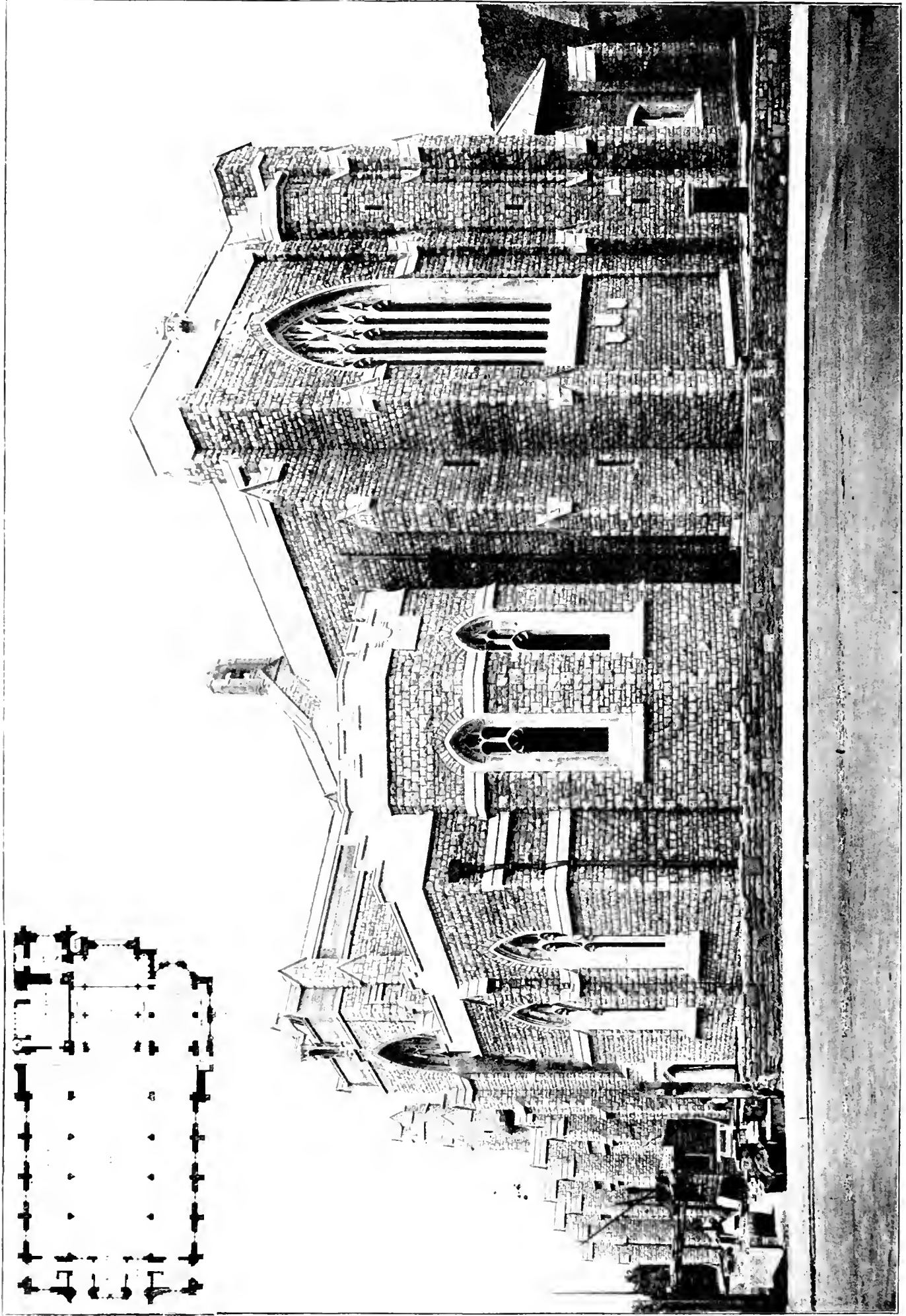

Mr. F. Bromhead, Clifton, Photo.]

ST. ALBAN'S CHURCH, WESTBURY PARK, BRISTOL.—Messrs. E. G. Rodway, A.R.I.B.A., and C. F. W. Dening, F.R.I.B.A., Architects.



ST ANDREWS CHAPEL EXETER CATHEDRAL.

NOTES

THIS CHAPEL ST
CHOIR AISLE IS PS
BISHOP BRONSCO
WAS COMPLETED
(1308-1326)
IN THIS CHAPEL
AND TWO PISCINA
ONE TO EACH AL
THE EXCHEQUER
KEPT MANY VAL
OVER THE CHAPE

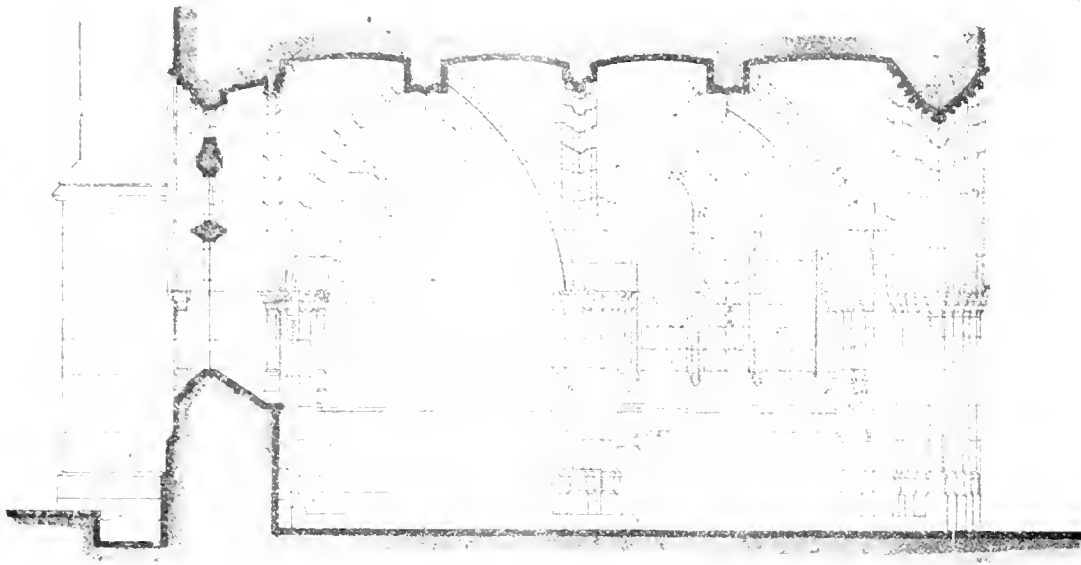

SECTION A.A.

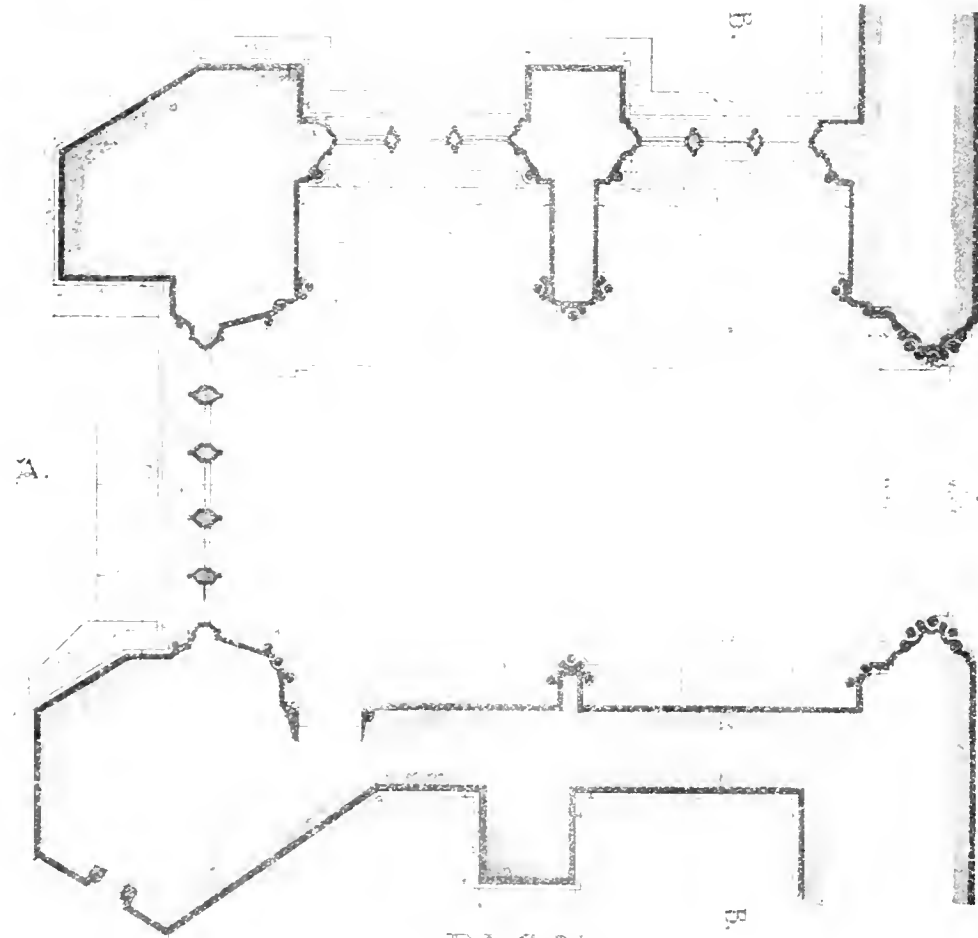

PLAN.

NORTH AISLE OF CHOIR.

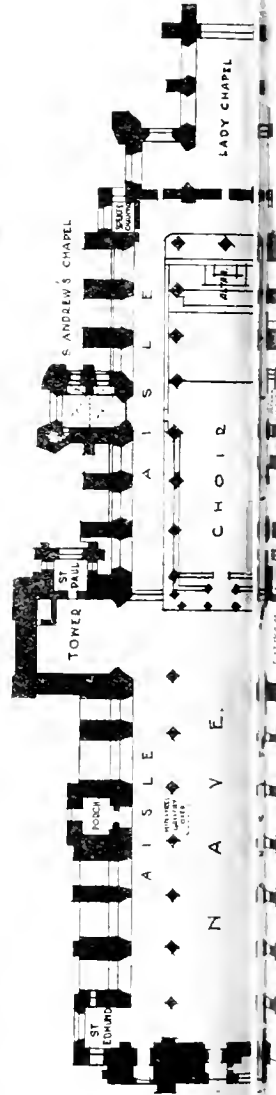

EXETER CATHEDRAL

Scale of

NOT

SCALE

FEET

IN THE NORTH
THE WORK OF
7-1230] AND
STAPLEDON

RE: TWO ALTARS
CRENCENCES

WHICH ARE
RECORDS, LIES

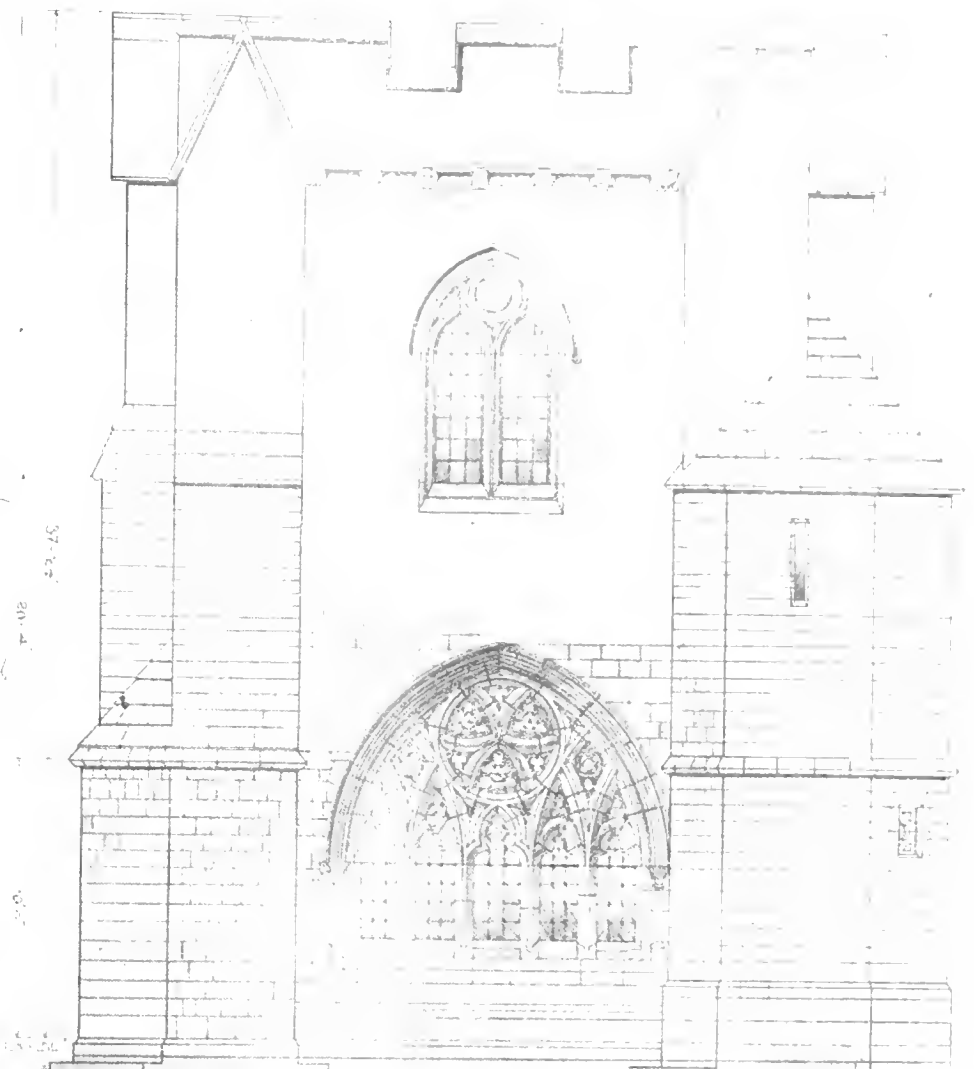
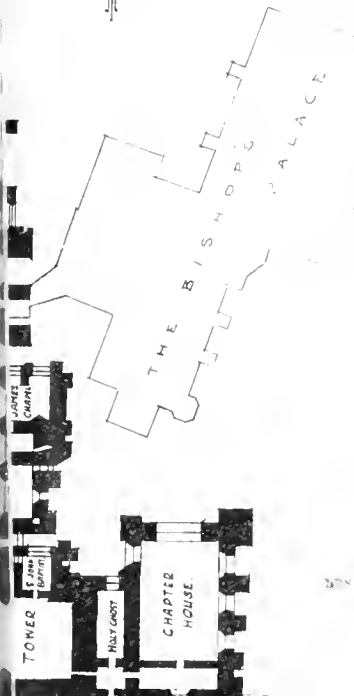
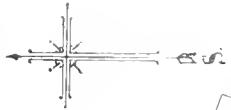

NORTH ELEVATION

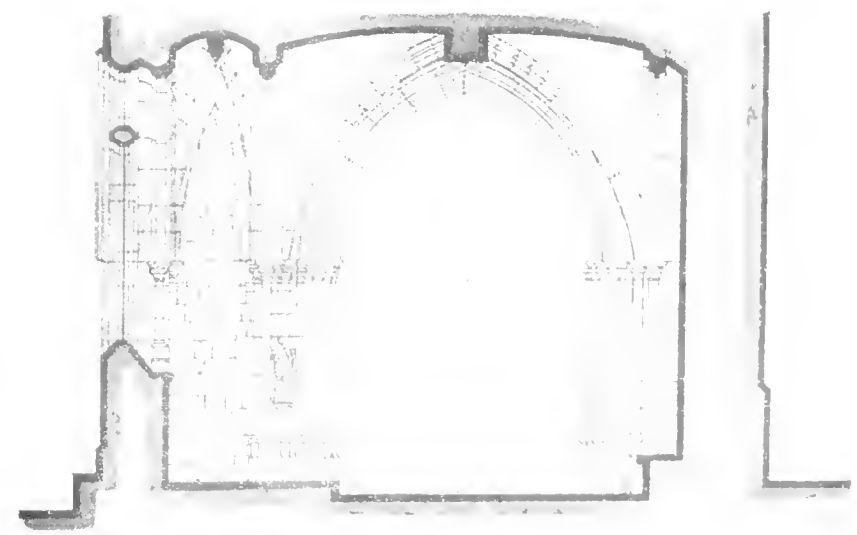

SECTION BB.

MEASURED AND DRAWN BY:-

Walter W. Hitchins

0 FEET.



NUTFORD HOUSE BROWN STREET

W.

VICTOR WILKINS
ARCHITECT

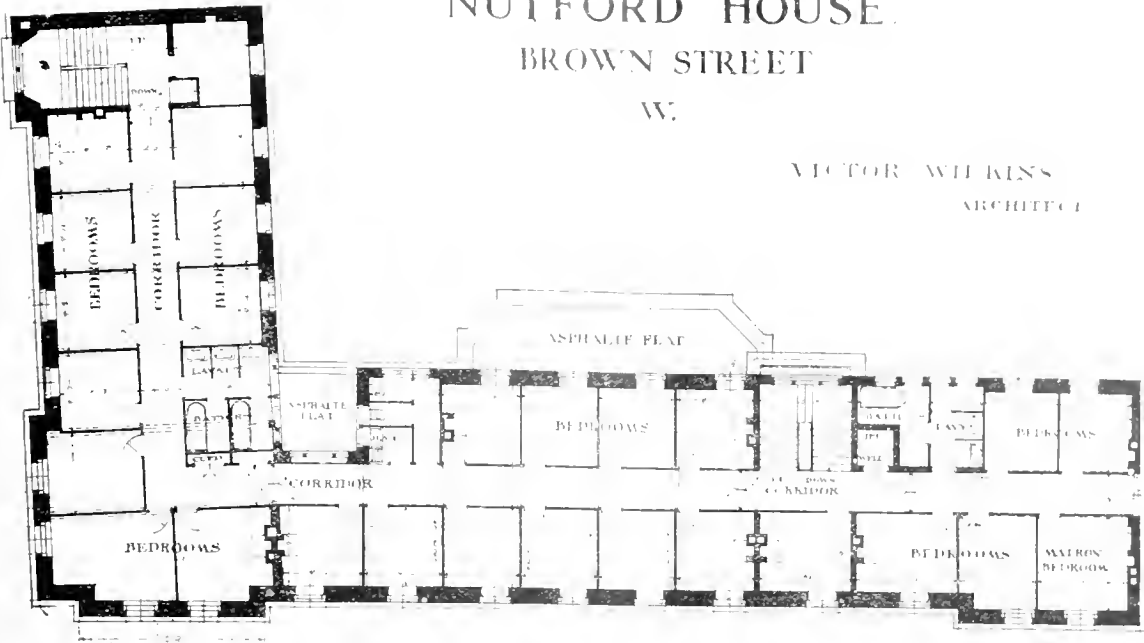

FIRST FLOOR PLAN

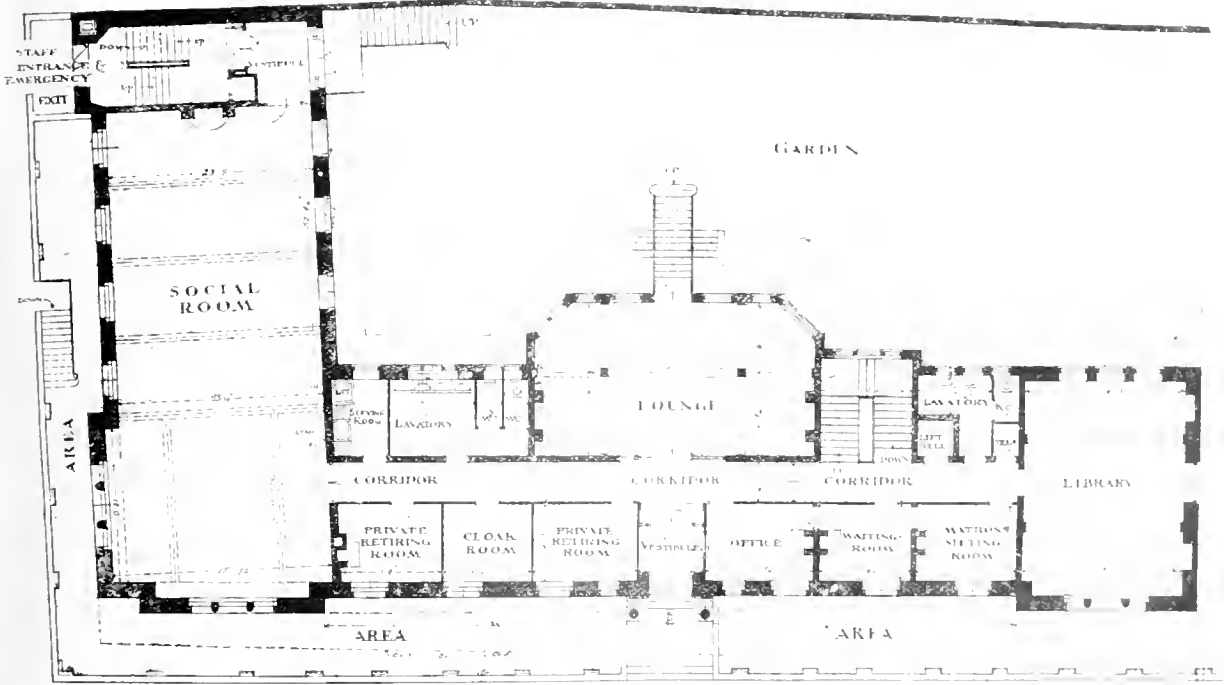

BROWN STREET

GROUND PLAN

SCALE 10 5 0 10 20 30 40 50 60 70 80 90 100 FEET







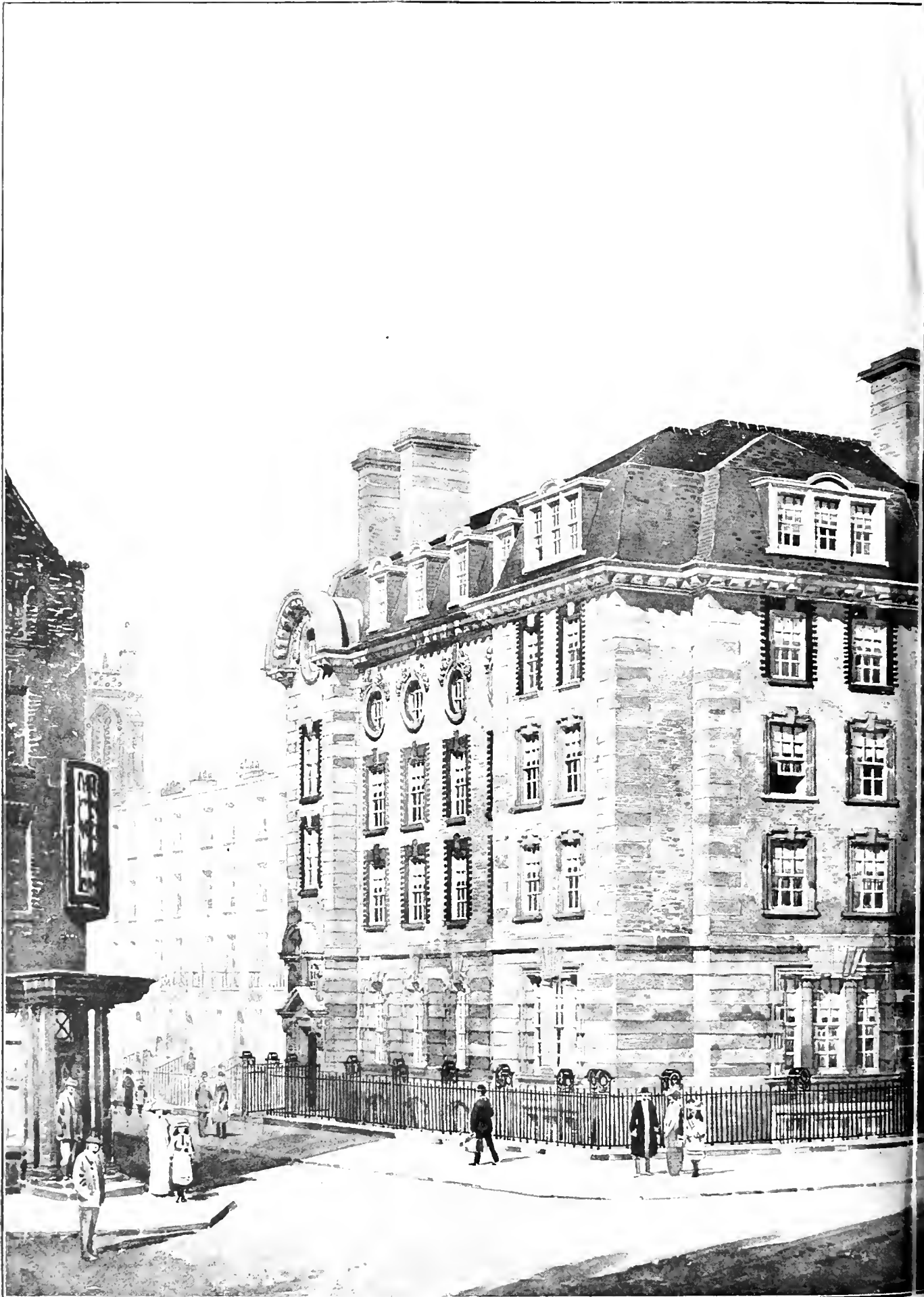

HOME FOR EDUCATED WOMEN WORKERS, NUTFORD HOUSE, BRONX



STREET AND NUTFORD PLACE, LONDON. W.—Mr. VICTOR WILKINS, Architect.

HYDRATED LIME IN CONCRETE.

Results to be secured by the use of hydrated lime incorporated in the concrete mixture are set forth by Robert S. Edwards, consulting and chemical engineer, of Portland, Oregon, in a paper recently published in the Los Angeles *Builder and Contractor*.

Hydrated lime is now widely used in this country for mixing with concrete to make the concrete dense and moisture-proof. The addition of small percentages to the mix is immediately effective in promoting plasticity throughout the mass, thereby rendering the concrete more homogeneous and keeping it so during transit, before placing. After placing concrete which contains hydrated lime its subsequent spalling in the form is greatly facilitated, and the thorough covering of all steel reinforcing rods is more perfectly accomplished. In fact, concrete mixed with a small percentage of hydrated lime seems to fall almost automatically into place.

The proportion of plasticity and homogeneity which small percentages of hydrated lime give to concrete cannot be secured in any other way at so little added expense for the material used. On many large reinforced concrete buildings which are being constructed in the United States to-day the concrete is mixed at one or two central mixing plants, which are generally located on the ground or in the basement of the building. After mixing it is dumped into carriages and elevated, then distributed through galvanized iron pipes or chutes to the various parts of the building. It is a well-known fact that Portland cement, when mixed with water, is not very plastic, some brands of cement being extremely non-plastic; and while the mixture for reinforced building construction is a rich one (generally 1 : 2 : 4), yet even so it is sometimes very difficult to secure sufficient plasticity in the concrete to insure its being elevated, poured, and distributed without considerable sticking and clogging of the pipes, attended with more or less separation of the aggregate.

The use of hydrated lime as a void filler in concrete mixtures, and for rendering concrete mixtures more water tight, dates back several years. Numerous tests show that a replacement of from 10 to 15 per cent. of cement by hydrated lime in rich mixtures does not decrease the compressive strength of the concrete after three to four months' time, and ultimately increases the strength and performance of the concrete. It apparently makes a but little difference as to its action as a void filler whether the hydrate is manufactured from a dolomitic or high magnesian lime or a high-calcium lime, it being necessary only to have a product which contains no free lime or unslaked particles. The proper hydration or dry slaking of lime reduces it to a finer degree of sub-division than can be accomplished by any mechanical means.

The amount of water required to convert the dry hydrated lime into a plastic paste varies from 59 to 70 per cent. of the weight of the lime; while to obtain a mortar of similar consistency with Portland cement an addition of 25 to 39 per cent. of water is required.

Unlike Portland cement, however, the addition of water to hydrated lime does not create any chemical reactions; simply a lime paste is formed, which holds its excess water for a long time. Even the addition of small quantities of hydrated lime, amounting to 10 or 15 per cent., to the weight of cement used in concrete mixtures the hydrate, which has absorbed a large amount of water, corresponding to its weight, is thoroughly disseminated throughout the concrete mass; and, owing to its fine plastic condition, it is forced immediately into places in the concrete which the cement cannot reach.

Concrete so mixed, on leaving the mixer, flows more readily into place, and the coarse aggregate has much less tendency towards segregation in the concrete mass. In other words, the extreme finely divided condition of the moistened hydrated lime paste has increased to a marked degree the covering or spreading quality of the cement, and reduced to a similar marked degree the friction between particles of fine and coarse aggregate.

This answers the question: "Why does hydrated lime benefit concrete?" The action is purely a mechanical one, and can be compared to the oiling or greasing of a shaft or

ball joint, or to the use of a thin layer of oil on the end of a bolt. In forming large pieces of concrete, the use of a ready solution of this problem of hydration means for keeping the body of the concrete thoroughly poured, until the lower setting cement hardens, more scientific.

From a study of the foregoing data it is evident that small percentages of hydrated lime when added to concrete mixtures in small quantities will accomplish the following:

1. Rendering of the concrete highly plastic and homogeneous, thus producing dense and uniformity in the finished concrete. This condition adds much to the life and efficiency of the road, because of the uniform resistance to wear and other stresses.

2. Keeping a certain amount of excess moisture in the concrete while setting.

3. Rendering the concrete mass more nearly water tight and thereby preventing the alternate wetting and drying out of the finished concrete.

4. In large pieces of work the above properties given to concrete by hydrated lime would materially reduce the labour in spreading and bringing the concrete to a uniform surface, which is of great importance in paving work.

OBITUARY

We regret to learn that Mr. J. H. Dawson, the late managing director and one of the founders of the Stan-life Estates Co., Ltd., stone merchants, quarry proprietors, and nurserymen, of Stancliffe, Darbydale, passed away on the 30th ult., at the age of fifty-seven, after a long illness.

Lieut. Hugh Arnold, of the 8th Northumberland Fusiliers, was recently killed at the Dardanelles. He was the second son of Mr. C. P. Arnold, for many years a partner in the firm of Crawley and Arnold, solicitors to the E. J. S. Trust, Coombe, Bucks, and was a nephew of Sir Thomas Graham Jackson, Bart., R.A. Born in 1872, and educated at Eastbourne and at Eton College, after studying at the Staff Schools he became a worker in stained glass and a well-known member of the Art Workers' Guild. He was responsible for the letterpress of a book on stained glass of the Middle Ages in England and France. He was married and leaves a wife and three young children to mourn his loss. Mr. H. F. Traylen, A.R.C.S., of Stamford, writes: "Among the many losses to art sustained by us in this terrible war the name of Hugh Arnold will live in the front rank. As a stained glass artist he held a name and reputation second to none. He had the proud distinction of being among those whose work was chosen to represent the modern English school of stained glass painting at foreign exhibitions. His strong line, straightforward representation of the subject in hand, and his artistic clearness made no doubt that he would make a good soldier, and his death at the Dardanelles has proved it. Locally he had a great reputation. He entirely executed the window in the west end of the south aisle of St. George's Church, Stamford, two windows in the chancel of Edith Weston Church, and a large fine light window in Groby Church, Leicestershire. His great delight was in hand-painted glass, and his work in this manner has been in the Church House, Boston, Herts. His methods were entirely original, though taking his inspiration from Early 14th Century work. The painting of the windows in Browne's Hospital Chapel, Stamford, is evidence of his hand artistic gifts, and he held a firm reputation."

A new hospital for the Prudential Assurance Company at 11, Abchurch Lane, South Wharf, Chelsea, R. O., is being constructed by Messrs. R. O. G. and Co., the contractor.

The new house built at Edmonton is to be erected by Messrs. J. L. & Co., and is to be built on a plot of 200 ft. by 100 ft. and will cost £25,000.

New plans for the Prudential Assurance Company at 11, Abchurch Lane, South Wharf, Chelsea, R. O., are being prepared by Messrs. R. O. G. and Co., the contractor. The work is being carried out by Messrs. J. L. & Co., and is to be built on a plot of 200 ft. by 100 ft. and will cost £25,000.

Our Office Table.

Mr. H. F. M. ...

Mr. H. F. M. ...

Mr. R. C. ...

Lord Alendale has presented to the Abbey a repaired skull of a ...

At their last meeting the ...

The Treasury recently decided to ...

er that the shell of the building would suffer from depreciation if kept unfinished through the winter. At the meeting of the corporation on Thursday a letter was received from the Local Government Board refusing to grant a loan for the alteration and improvement of the Springfield Estate at inland recently purchased for £15,500, for a sanatorium for consumptives. The Board have also returned the plans for the sanatorium with a request that certain modifications, in the way of curtailment, should be made when sanction to proceed with the scheme is forthcoming.

The Society of Australia, the official organ of the Institute of Architects of New South Wales, Queensland, South Australia, West Australia, and Tasmania, publishes in the States a portrait of the new president of the West Australian Institute of Architects, Mr. M. F. Cavanagh, and also several illustrations taken from some buildings designed and erected by Mr. Cavanagh in collaboration with his brother, Mr. J. C. Cavanagh. The buildings include the Central Fire Brigade Station, the Redemptionist Monastery, the Commercial Bank (the first portion which was erected by Mr. H. Trigg), and the Convent Parochial School, Perth. The design for the Fremantle R.C. Church is another of the firm's works; also the P. & O. Hotel, the Esplanade Hotel, and the Grand Hotel, the Orphanages at Glendalough and Clontarf, Baird's Arcade, the R.C. Archbishop's Palace, the Christian Brothers' College, the Fremantle Fire Station, and several others. Mr. Cavanagh studied in London, passed the R.I.B.A. examination in 1888, and was made a Fellow of the Royal Institute of British Architects in 1895, but after giving his subscription for twenty years he has allowed his active membership to lapse, but re-entering into private practice he was made architect-in-chief of the Public Buildings in South Australia.

A large rain gauge was placed last year by the City Corporation on the roof of their mortuary in Golden Lane, and the rain water from a square area of surface is collected monthly and analysed. As the result of the examination on 16th March, the City Medical Officer states that in the month of December last the average amount of deposit registered as falling in the City amounted to 54½ tons avoirdupois, of that mass of dirt nearly 54 tons were sand, and included sulphate of ammonia and chlorine, while 2½ tons were insoluble and consisted of tar, carbon, and grit. Nausea-fog has as yet been tested. The examination is being continued.

Students of Structural Design who have been admitted by V. I. I. bearing that title, by Professor Horace B. Thayer, will welcome V. I. I. London, Constable and Co., Ltd., 168, who deals with a variety of simple structures, including beams, girders, viaducts, trusses, buildings, stand pipes, and elevator tanks. Many concrete examples are given, with copious illustrations, and the various subjects are ably treated, theoretically and practically. Some examples of American terra-cotta are illustrated in the chapter on high office buildings.

Mr. A. C. J. Green is resuming his classes this season of advertising and salesmanship. He will be well appreciated last year by many readers who had probably little idea of the magnitude of these matters concern the building and engineering trades. The courses are held in London are very nominal, and those interested will get all further particulars on application to Mr. Green, at 10, Grosvenor Gardens, near Roupell. The courses will be held at the High Middleton Commercial Institute, Clerkenwell Green, London, on Tuesday evening, August 17th, starting on the 23rd inst., and at the Cassell and Bond Commercial Institute, White Street, South Hackney, on Wednesday evening, August 18th, commencing on the 29th inst. Both courses are very accessible, and will be of great benefit to those many thousands in the building and engineering trades who appreciate it.

The new book, "The History of the City of London," by Mr. H. W. Bassett, of Faverley House, 27, St. Mark's Place, Faversham, is published by the London and South-Eastern Railway Co., at 2s. 6d.

PROFESSIONAL AND TRADE SOCIETIES.

CAMBRIAN ARCHAEOLOGICAL SOCIETY. The Ven. Archdeacon Thomas presided at the annual meeting of the Cambrian Archaeological Society held at Shrewsbury on Tuesday in last week. There was a large and representative attendance. The report of the committee stated that it was unanimously agreed, owing to the continuance of the war, to postpone the society's annual excursion. A grant of £5 was recommended for excavations at Llanthony Abbey and £20 for excavations at the Roman city of Fricomum, near Shrewsbury. A special grant of £25 had been made to the Prince of Wales's Fund. The committee had decided to publish the series of MS. notebooks of Feuton's "Tour in Wales," now in the possession of the Cardiff Library.—The Chairman moved the adoption of the report. Mr. T. E. Morris, London, in seconding the motion, said in regard to the votes for excavations, he would be very glad if in future the association could persuade the owners of the soil where excavations were made to hand over any finds to museums. He regretted to say that during the last twenty-five or thirty years most of the objects of interest so discovered had gone, and no one knew where. It could be seen from the reports of the commissioners on ancient monuments in Wales that a good many objects of interest in the Principality had been lost, and he hoped in making their grants they would urge that the objects discovered be preserved in some institution.—Mr. H. J. Gardner, Margate, supported Mr. Morris's suggestion.—The Hon. Mrs. Bulkeley-Owen asked if the meeting suggested that interesting finds should be placed in the Welsh Museum or the National Library of Wales. They did not want such discoveries to go out of Wales. Mr. Gardner said he did not want them to go out of Wales.—The report was adopted.

THE SOCIETY OF ARCHITECTS.—The following are the house list nominations for officers and Council for the ensuing session, 1915-16: President, *E. C. P. Monson, F.R.I.B.A., F.S.I., London; Vice-Presidents, *Edwin J. Sadgrove, F.R.I.B.A., London, and *A. Alban H. Scott, M.R.San.Inst., London; Past Presidents, *Albert E. Pridmore, F.S.I., London, and *Percy B. Tubbs, F.R.I.B.A., London; Hon. Secretary, *E. J. Partridge, F.S.I., Richmond, Surrey; Hon. Treasurer, *J. Herbert Pearson, London; Hon. Librarian, *Gilbert A. Harrison, Oxford; Council (18 seats, 21 nominations): *Henry Adams, M.Inst.C.E., London; George Barnes, London; *P. M. Beaumont, A.M.I.C.E., Maldon, Essex; J. A. Bowden, London; *B. D. Cancellor, Winchester; Edward Cratney, Newcastle-on-Tyne; G. E. Deacons-Lewis, Aberystwith; Charles Dunch, London; *Herbert O. Ellis, London; G. Blair Imrie, London; *T. Stewart Inglis, London; *Col. F. Seymour Leslie, R.E. (retired), Woolwich; W. H. Lockton, A.M.I.C.E., Newark-on-Trent; *F. G. Moscrop-Young, London; *George H. Paine, London; *Charles E. Salmon, London; *Noel D. Sheffield, London; *Alfred J. Taylor, Bath; *B. R. Tucker, M.R.San.Inst., London; *Thomas Wallis, London, and Victor Wilkins, London. (An asterisk * signifies proposed re-election; a dagger † proposed change of office.) Additional nominations for Council and officers may be made by any three members who shall send in their nomination, properly signed, to the Council before the first day of October, and the names of such nominees shall be incorporated with the list proposed by the Council, which shall be arranged alphabetically. The ballot papers containing the complete list of names will be issued in advance of the special general meeting on October 14 to members who are not under any liability to the Society.

The great spiral tower which forms the central feature of the main front of the Victoria Tower at Ottawa has been leaning forward for some years, and now, on the advice of an engineer from New York, it is to be demolished and rebuilt on fresh foundations. The tower was built between 1902 and 1908 at a cost of £2,000,000 sterling.

LEGAL INTELLIGENCE.

DISPUTED USE OF A SEWERAGE OUTFALL.—The case of Wapentake of Ouse and Derwent Drainage Commissioners v. Fletchers (Shipley), Limited, came before Mr. Justice Low in the Vacation Court on Wednesday on a motion by the plaintiffs for an interim injunction. Mr. T. Terrel, K.C., for the plaintiffs, said that the object of the injunction was to restrain the defendants continuing a certain outfall which they had recently constructed, whereby sewage and other foul matter flowed from the defendants' works into the Cherry Orchard drain of the plaintiffs' system of drainage. Mr. Robertson, for the defendants, asked that the matter should be allowed to stand over for a fortnight, to enable his clients to file evidence in reply to the plaintiffs' affidavits. He explained that the defendants had to obtain an engineer's report, and that this must necessarily take some time. In the meanwhile the defendants were willing to give an undertaking to have the drain secured and cleaned at the point where the effluent entered. Mr. Justice Low directed that the evidence should be furnished by the defendants to the plaintiffs at Selby by Monday, and that the motion should come on for hearing to-day (Wednesday).

MANITOBA PARLIAMENT BUILDINGS: ALLEGED CONSPIRACY WITH CONTRACTORS.—Sir R. P. Roblin, former Premier of Manitoba, with Mr. W. H. Montague, Mr. J. H. Howden, and Mr. G. R. Coldwell, all members of the late Conservative Government of Manitoba, have been arrested on a charge of conspiring to defraud in permitting the contractors for the new Parliament buildings to draw large sums of money for work not performed, and collusion to increase the prices under contract. The arrests are only technical, as the accused consented to appear in Court without compulsion. All four were released on £10,000 bail each. It will be remembered that on May 12 the investigations of the Royal Commission appointed to inquire into charges made by the Opposition in connection with contracts for the new Parliament buildings, led to the resignation of Sir R. Roblin's Government. In the general elections on August 6, 40 out of 49 seats were carried by the Liberals.

THE RISKS OF SKETCHING.—Mr. Alexander Wallace Rimington, F.S.A., R.P.E., the well-known etcher and water-colour artist, of Pembroke Crescent, London, was charged at Beaumaris Police Court on Saturday with a breach of the Defence of the Realm Act by making a sketch of a section of the Menai Straits without having a permit. Admitting the offence, he pleaded ignorance of the fact that he was sketching in a prohibited area. He produced income-tax, rent, and rates receipts, together with a British Museum reading ticket and an old passport, to prove his identity and his British nationality. In view of the great uncertainty as to areas in which sketching was prohibited, he begged the Bench to communicate with the Home Office in order to get such areas clearly defined by authority.—The Bench dismissed the case, but said the police were justified in their action, and begged Mr. Rimington not to repeat the offence.

The Eastbourne Rural District Council have appointed Mr. William Walker, of Cannock, district surveyor.

The parish church of Burton-Hastings, near Nuneaton, is about to be restored and reseated at an outlay of £1,150.

New Council schools are to be built at Wyggestown, Leicester, from plans by Mr. Howard H. Thompson, of the latter borough.

The testing of the Upper Medway, on the completion of the Conservancy Board's improvement scheme, took place on Tuesday last week, when a barge 75 ft. in length, and laden with 120 tons of ballast, was towed up the river to Tonbridge by the steam tug "Keston." The craft, accompanied by a motor-launch, left the All Saints' Horseway at Maidstone, the boundary of the Upper Medway Conservancy Board, at 8 a.m., and entered the Tonbridge Town Lock some eleven hours later.

The mystery surrounding the disappearance of Mr. Harold E. West, late assistant surveyor to the city council of Canterbury, has at length been solved. Mr. West was compelled by a breakdown in health to resign his position under Mr. A. C. Turley at Canterbury, and went to his father's house at Wexhambreux on August 16. He disappeared from there on the 23rd, and no trace of him was discovered until Thursday night, when his body was recovered from the Lesser Soud River three miles from his home.

Correspondence.

ARCHITECTS AND THE WAR OFFICE.

To the Editor of THE BUILDING NEWS.

Dear Sir,—My attention has been drawn to a letter in your issue of August 25, headed "More War Department Inaccuracies," signed by Mr. C. Stanley Peach, in which certain charges of inaccuracy are brought against Mr. Tennant, M.P., Under-Secretary for War, in a reply to a question addressed to him in Parliament.

In your Editorial column you comment on this.

The reason for the alleged inaccuracy is that whereas Mr. Tennant stated that the offer of the Royal Institute of British Architects was made in May, Mr. Peach points out that the offer was made in the previous September.

As a matter of fact there were two offers made. The first (in which the President R.I.B.A. did not appear) was made by the Architects' War Committee, who in September, 1914, offered to his Majesty's Government "an assurance of the loyal and energetic support of the profession in any direction which may be found practicable and desirable," leaving the Government "to indicate what form of assistance would be of most value." This letter was acknowledged on September 23, 1914. It was thought that the best way to take advantage of this offer was to obtain the names of gentlemen who would be willing to serve under the War Office, and such a list was asked for and obtained.

The offer, however, to which Mr. Tennant referred in his reply was a subsequent one, and went much further than the above. Mr. E. Newton, president of the Institution, called at the War Office on May 13 and there laid a definite scheme before the authorities. This scheme begins as follows:—"In the first month of the war the R.I.B.A. made a general offer of assistance to the War Office and to other Government Departments in all matters in which its special qualifications might be of service. This offer was accepted in general terms and, since that date, all requests which have been received from the War Office for advice in connection with architectural and engineering appointments have been promptly dealt with. It is now suggested that the War Office might make a more extended and systematic use of the R.I.B.A. organisation." Then followed a detailed description, illustrated with maps, of how the R.I.B.A. could assist the War Office. Copies of these were at once circulated to all commands in the British Isles, showing how responsible officers could take advantage of the proposals.

Now in considering the accuracy of Mr. Tennant's statement, it is necessary to consider the terms of the question. The member who made the enquiry asked: "Whether early in the war the President of the Institute of British Architects submitted plans for wooden huts, and offered the services of a number of qualified architects and surveyors, and if full advantage was taken of the offer of such plans and services with beneficial results?"

It will be observed here that specific reference was made to the President of the R.I.B.A., and it appeared therefore that the question had reference to the second and not the first offer of service.

Mr. Tennant's reply was: "The President of the R.I.B.A. offered the services of the Institute in its corporate capacity to assist in any work carried out by the War Department. This offer was made in May, 1915, by which time the greater part of the work was finished and hence comparatively little advantage would be gained by the War Department availing itself of the offer. No plans for wooden huts were submitted early in the war by the President. A number of qualified architects and surveyors have offered themselves for service under the War Department, and after careful examination of their qualifications, several of these have been selected. At the beginning of the war the President of R.I.B.A. was asked to send

in the names of a table men, and several of these have been given employment."

It will, I think, be seen that Mr. Tennant's answer was accurate. Although he did not specifically allude to the earlier offer, he indicated that it was not ignored, by the latter part of his answer. The offer of the Institute in its corporate capacity was not made until Mr. Newton's visit of May 13. Yours truly,

R. H. BRADY.

War Office, London, S.W., August 31.

SLEAFORD CHURCH, LINCOLNSHIRE, AND THE S.P.A.B.

To the Editor of THE BUILDING NEWS.

SIR,—In your issue of 18th ult., in "Currente Calamo," there is a quotation from the *Guardian* on the subject of unnecessary interference with old work, instancing "Sleaford Church, Lincolnshire, where carving which had lost its defined outline owing to decay has been renewed in stone, to insert which old stones which were still performing their structural duty were removed. This work, it is satisfactory to note, has now been discontinued owing to the interference of the church authorities."

I have been engaged at Sleaford. The carving referred to was so perished that another winter's storms would have obliterated it beyond recall. The carving was carefully copied before it was impossible to do so, only such new stones being inserted as were absolutely necessary. The statement in the last paragraph is untrue, and I am authorised by the church authorities to state that "the work was stopped simply because our Building Fund was temporarily exhausted, but after the war we have every intention of completing the work." The other statement is:—"The south door of Tickhill Church, Yorks, has been entirely renewed, though the stonework was nowhere so badly affected as to be of danger to the structure." I have also been, but only during the last year, engaged in superintending some very conservative reparation at this church; during that period the south doorway has not been touched.

Whilst all must sympathise with the expressed motives of the S.P.A.B., one must regret that their efforts are sometimes stultified by unfortunate methods of procedure. Their ideas of protection are in direct conflict with the advice issued by the R.I.B.A. addressed to promoters of restoration.

I think that in making statements such as those referred to the S.P.A.B. should at least be sure of their facts, and also pay a little respect to the opinions of those who also have spent their lives in the study of ancient buildings, and yet venture to differ from them in technical details.—I remain, Sir,

W. H. WOOD, F.R.I.B.A.

20, Collingwood Street,
Newcastle-on-Tyne.

The Essex Archaeological Society has just sustained a loss by the death, in his eighty-fourth year, of the Rev. James Wright Kenworthy, for twenty-seven years the vicar of Braintree, and latterly a resident of Colchester.

Mr. Thomas Astell, timber merchant, of Astell Bros., Limited, Bedford, who died on May 23, left estate valued at £13,548 0s. 2d., with net personalty £3,263 13s. 5d. Mr. Thomas John Astell and Mr. Charles Astell, timber merchants, his sons, are the executors.

Three temporary wards, each 134 ft. by 22 ft. and 11 ft. in height, and accommodating 40 patients each, have been added to the rear of the East Suffolk and Ipswich Hospital, Anglessea Road, Ipswich. Mr. H. Munro Cauty, A.R.I.B.A., Batten Market, Ipswich, was the architect, and Messrs. W. G. Fisk and Co., of the same borough, were the builders.

There was opened on Friday, for through traffic between Leith and Portobello, the new road which was rendered necessary by the scheme of the North British Railway Company, which had for its purpose the formation of additional lines for the development of the mineral fields of the Lothians. The new thoroughfare is 50 ft. wide against an average of 30 ft. formerly, and runs on a higher level, giving a more attractive view of the Firth and the Fife Hills on the north, and of Arthur's Seat and Calton Hill and the Pentlands on the south. The roadway is surmounted by a two-span bridge, in lieu of the former level crossing.

Building Intelligence.

MANCHESTER. The new grain elevator to be brought into use at the Victoria Dock, Ship Canal Company, at the Victoria Dock, will not be fully equipped with machinery for some weeks. The new elevator is a building, like the other erected at 1, 2, and 3 Wharf, of 30,000 tons capacity, and is capable of handling grain at the rate of 1,200 tons per hour. It is a reinforced concrete building with steel window frames and floor, comprising 260 storage bins and 100 storage bins, as well as distributing, weighing and loading out floors and machinery for cleaning the grain. The structure is 190 ft. high, 235 ft. long, and 165 ft. wide. The equipment includes six receiving elevators and six discharging or shipping elevators, each of these being provided with an automatic scale capable of weighing 200 tons of grain per hour. There are also automatic scales for weighing and soiling, machinery for loading into carts or railway wagons, and for the discharge into coasting vessels or barges. The elevator is built at the east end of No. 9 Dock. It has subways on both sides of the dock, in which run band conveyors arranged so that during the time general cargo is being dealt with portable elevators and conveyors will be used for discharging parcels of grain from vessels to the granary.

THE GUILD HALL, HENLEY IN ARDEN. On Thursday, without ceremony, the doors were opened to the public of Henley's old Guild Hall, whose existence was practically unknown to the inhabitants of the little town until the work of restoration was taken in hand. Stucco hid the external timber and laths and plaster covered oak beams and rafters. The building was left off in tenements, and the Warwickshire County Council had made an order for its demolition. The Lord of the Manor, becoming the owner of the site, determined to restore it as far as possible to its original appearance. This has been done upon lines suggested by Mr. Alfred Redway. Exterially it now presents the appearance of a half-timbered building. Part of the ground floor is occupied as bank premises, and the remainder is at present tenanted. The front of the building is adorned with the escutcheons of the founder and several other former lords of the manor. A stair-case leads up to the guild room, a lofty apartment overlooking the main street. This guild room up to a year ago was partitioned off for bedroom purposes, while the old oak beams at rafters were hidden from view by a low plaster ceiling. The oak woodwork now disclosed is a principal feature of the hall, and is still in a fairly good state, though eaten away here and there. The flooring of the same wood has been renewed in keeping with the style of the place. The stained glass window in the little apartment known as the Lord of the Manor's room, contains a representation of St. Anthony and the arms of the Suffices, Earls of Dudley.

STATUES AND MEMORIALS.

VICTORIA EMBANKMENT. A bronze medallion of the late Sir W. S. Gilbert, 1836-1911, somewhat similar to that erected to the memory of Sir Walter Besant, has been placed in position on the river bank of the Victoria Embankment, facing Clerkenwell District Railway Station. It has been executed by Sir George Frampton, R.A. Beneath the head of the statue are the figures of Comedy and Tragedy. About 200 yards eastwards, in the Embankment Gardens, is the bust of Gilbert's great-grandfather, Sir Arthur Sullivan.

TRADE NOTES.

Boyle's latest patent "Air-Cast" rough-casting has been adopted at All Souls College, Oxford. Rough-casting on brickwork is considered an innovation in these districts provided with a local building stone. For the ninety brick-dwelling houses erected at Bradford under the city architect, water-proofed cement rough-cast was adopted. We understand the city architect has also specified a large quantity of Puddlo for the rough-casting on the Grassington Sanatorium.

The new Technical School, Grey Friars Road, Doncaster, will be opened by the Mayor tomorrow (Thursday).

A new Wesleyan chapel, near Hayes Street, Uxbridge, has been formally opened. Mr. W. Harborough, of South Bermondsey, was the builder.

The Treasury has refused to sanction the raising of a loan of £10,500 by the Guildford Town Council for the erection of forty cottages for working men.

A group of Council schools is being built in Ryland Road, Erdington, Birmingham. The contract was taken at £22,420 by Messrs. Harper and Sons, of Blackheath, Warwickshire.

At a meeting of the Sewage Committee of the Bradford Corporation on Wednesday it was announced that the Local Government Board had declined to sanction any further loan in connection with the Esholt tunnel scheme. The contract, which is for over £190,000, was let last year to Messrs. Best and Sons, Limited, and a good deal of the preliminary work has been done.

The current issue of the Architectural Association Journal reports the total number of members of the association serving with the Forces as 567. All former students of the school will be interested to learn that Second-Lieutenant H. P. G. Maule has now received a staff appointment as "water adviser" to the Army Corps, i.e., the whole three divisions, "somewhere in France."

The marriage arranged between Lieutenant P. Hubert Boulnois, R.N., and Miss Lucy Boase, took place yesterday (Tuesday) afternoon in the Catholic Apostolic Church, Dundee. Lieutenant Boulnois, who is in command of a submarine "somewhere off the coast of England," is a son of Mr. H. Percy Boulnois, M.I.C.E., of the Local Government Board, and formerly city engineer of Liverpool.

A movement to secure the passage of a uniform State building law is now being carried on in Massachusetts. A special committee of the Boston Chamber of Commerce has appointed a sub-committee with Mr. C. H. Blackall, a Boston architect, acting as chairman, the purpose of this committee being to gather data and direct the Chamber's attitude toward a Bill now pending in the Legislature.

Theodore Sington, who was at one time an architect in practice in England, and latterly a writer of articles for the Press, of Lime Grove, Old Trafford, has been sentenced to six months' imprisonment with hard labour by the Manchester City magistrates under the Defence of the Realm Act. Sington is an elderly man, the son of German parents who had become naturalised in this country. The charges against him had reference to articles sent to an American journal, published monthly in Boston.

Major G. T. Hurst, M.S.A., of the 5th (Natal) Mounted Rifles, Durban, has returned from late German, now British South-West Africa, where he was engaged with his regiment in assisting General Botha to alter the colour scheme of the map. His criticism on the architecture there, where it existed, is, "that it is too awful for words and typifies the coarseness and aggressiveness of the German Colonial character, swinish with hardly a redeeming feature."

Lieutenant Henry Fawcett Garrett, B.A., of the 6th East Yorkshire Regiment, who was killed in action on the 22nd ult. in the Dardanelles, was a member of the well-known family of engineers and agricultural implement makers, of Airedale, and was thirty years of age. After leaving Pembroke College, Cambridge, he became an artist, and he executed some decorative wall paintings at Winchester and elsewhere. Shortly before the war his design for the memorial to Canon Barnett, at Whitechapel, was selected by the committee, and he was engaged upon it when the war broke out.

Work has been started on a three-story bank building for the Merchants' Bank at Granville and Pond Street, Vancouver, which will cost \$175,000. It will occupy an area of 50 ft. by 104 ft. The banking chamber will be 20 ft. in height from floor to ceiling. Above that there will be two floors of offices, and the whole structure will be equal in height to five ordinary stories. Gray marble will be used throughout, and dull steel instead of brass will be used to carry out the grey colour scheme. The plans have been drawn by Messrs. Somervell and Putnam, Ltd., architects, of Vancouver, and the contractors are Messrs. Purdy and Henderson, Ltd., Vancouver.

TO ARMS!

4th Battalion "Architects" Central London Regiment Volunteers.

Recruits are wanted for the Regular, Territorial, and Volunteer Battalions. Those who apply to Battalion Headquarters should advise a friend to whom they will refer, who they will attend to.

ORDERS FOR THE WEEK, BY LIEUT. COL. A. W. WARDEN. Officer for the week, J. J. Castell. Next for duty, G. H. Prosser.

GENERAL PARADES.

Weekend camp at Thom's Dutton, Saturday and Sunday, September 11 and 12. Contingent from 6 a.m. to 10 a.m. at Thom's Dutton. Those who are requested to bring their own kit, including their own camp kit, to be ready for the parade on Saturday morning, 11.15 a.m. Train, 10.10 a.m. Waterloo. Members attending camp to send in their names to the Quartermaster before Thursday morning next.

MENTION WORK.

The mention of members is again drawn to the attention of the Battalion, to which an immediate reply is desired.

DRILLS AND PARADES.

"A" Company, Drill, miniature range, Gas Light and Gas Co., 10, Monck Street, W.C.2, Monday, 7.30 a.m.

Wednesday, Company parades, 5.15 to 7.15 and 6.15 to 8.15, at Dean's Yard, W. Minster. If wet these parades will be held at Millbank School. Notice will be posted in vestibule at Headquarters.

Thursday, Signaling. See orders from Acting Battalion Quartermaster.

"B" Company, Miniature range and Company parades, at "A" Company. See orders at local Headquarters.

"C" Company, See orders local Headquarters, Pavilion, V.A. Athletic Ground, Boreham Wood.

"D" Company, Platoon and section drill at Mervyn School, Holborn, on Fridays and Thursdays, 6.15 p.m. Company parades, Wednesday, at Dean's Yard.

SCHOOL OF ARMS.

Millbank School, instruction in bayonet fighting, gymnastics, physical drill, boxing and single sticks, on Tuesdays, from 6 to 8 p.m.

REGIMENTAL DRILLS.

"A" Company, Dean's Yard, 5.15 and 6.15, Wednesday and Friday. If wet, the drills will be held at Millbank School.

"B" Company, Dulwich College, Monday, 8 to 10 p.m. Thursday, 6.15 to 8 p.m.

"C" Company, Boreham Wood and Elstree District, Headquarters, V.A. Athletic Ground, Boreham Wood. For full particulars apply to Alan Potter, Grey Gables, Boreham Wood, Hert's.

"D" Company, Mervyn School, Tuesday and Thursdays, 6.45 p.m.

CORRESPONDENCE.

Special attention of members is drawn to the fact that correspondence should be answered by return. If this is not attended to the other work of the corps is immensely increased. Enrollment forms of new members and all correspondence not referring to recruiting for the Army or to financial matters must be addressed to the Adjutant, 19, Conduit Street, W., and regarding recruiting for the Army to the Recruiting Officer, at Battalion Headquarters, and regarding accounts and subscriptions to the Paymaster, W. R. Hughes, 22, Doshwood House, E.C.4.

By order,

L. G. GUTHRIE, Adjutant.

BATTALION HEADQUARTERS,

18, TILTON STREET, WESTMINSTER, S.W.

MEETINGS FOR THE ENSUING WEEK.

THURSDAY.—Royal Photographic Society's Exhibition, "The Canterbury Cathedral," by R. P. Hoagrave, Graham, Southold Street, Gallery, Haymarket, S.W., 8.30 p.m.

FRIDAY (Sept. 10). Institution of Municipal Engineers, V.A. at the Oldham Corporation Waterworks, at Delph, 8 P.M.

The new church of St. George in South Place, Finsbury, has a new spire, completed in 1914, which is a masterpiece of the work of the architect, Mr. G. G. Scott, of Manchester in Oct. 1914.

The urban district council of Redbury has just elected Messrs. D. Balfour and J. S. Newbery. The latter is a member of the works committee.

The sub-committee of the Defence Council have recommended the purchase of a new type of machine gun, the Vickers, for the use of the Royal Artillery.

Mr. J. W. O'Brien has been elected K.C. for the County of London, in the City of Westminster, in the election of 1914.

The House of Commons has passed the Bill for the amendment of the law relating to the jurisdiction of the Admiralty in respect of ships.

The House of Commons has passed the Bill for the amendment of the law relating to the jurisdiction of the Admiralty in respect of ships.

LATEST PRICES.

Merely applicable to the present, and not to be taken as a guide for the future. The usual sources of information are the London and Liverpool Markets.

LIMBER.

Owing to the high price of timber, the following prices have advanced since the last issue.

IRON.

Table with 2 columns: Item and Price. Items include Rolled Steel Joists, Wrought Iron Order Plates, Steel Grid Plates, Bar Iron, and Boiler Plates.

Galvanised Corrugated Sheet Iron.—No. 14 to 24, 2 1/2 to 2 3/4, 2 1/2 to 2 3/4, 2 1/2 to 2 3/4, 2 1/2 to 2 3/4, 2 1/2 to 2 3/4.

Table with 2 columns: Item and Price. Items include Cast Iron Chimneys, Cast Iron Stanchions, Rolled Iron Fencing Wire, and Galvanised Wire Strand.

Cast Iron Socket Pipes.—3 in. diameter, £7 5 0 to £7 12 6; 4 in. to 6 in., £7 0 0 to £7 2 6; 7 in. to 24 in., £7 6 0 to £7 12 6.

Table with 2 columns: Item and Price. Items include Iron, Cold Blast, Lilleshall, Hot Blast, and Wrought Iron Tubes and Fittings.

OTHER METALS.

Table with 2 columns: Item and Price. Items include Lead Water Pipe, Lead Barrel Pipe, Lead Pipe, and Lead Soil Pipe.

Table with 2 columns: Item and Price. Items include Lead, Common Brands, Lead Shot, Copper sheets, and Sheet Lead.

I BUY SCRAP METALS

ARTHUR P. COLLINS, Snow Hill, BIRMINGHAM

Buyers of Scrap Metals, Iron, Brass, Copper, Lead, Tin, Zinc, and other metals.

STATES.

Table with 2 columns: Item and Price. Items include Blue Portland Cement, Blue Portland Cement, and Portland Cement.

Fareika	m.	n.	£	s.	d.	per 1,000 of
Green	20	10	15	17	6	1,200 at r. stn.
"	20	12	18	7	6	"
"	18	10	15	5	0	"
"	16	8	10	5	0	"
Permanent Green	20	10	11	12	6	"
"	18	10	9	12	6	"
"	16	8	6	12	6	"

BRICKS.

(All prices net)

First Hard Stocks	£1 15 0	per 1,000 alongside, in
Second Hard Stocks	1 11 0	" "
Mild Stocks	1 9 0	" "
Pricked Stocks for		delivered at
Facings	2 5 0	raily station.
Flettons	1 14 0	" "
Pressed Wire Cuts	1 18 0	" "
Red Wire Cuts	1 14 0	" "
Best Farclum Red	3 12 0	" "
Best Red Pressed		" "
Ruaben Facing	5 0 0	" "
Best Blue Pressed		" "
Staffordshire	3 15 0	" "
Ditto Ballnose	4 0 0	" "
Best Sturbridge Fire-		" "
bricks	4 0 0	" "
2 1/2 in. Best Red Accrington Plastic Facing Bricks	4 10 6	Net, delivered in full truck loads in London.

5 1/2" Accrington Best Red Plastic Facing Bricks	£2 10 0	Per 1,000
5 1/2" ditto second Best Plastic ditto	2 2 6	"
Ditto Ordinary Secondary Bricks	1 11 3	"
Ditto Plastic Engineering Bricks	1 17 6	"
Sewer Arch Brick, not more than 3 1/2 in thickest part	2 0 0	"
3 1/2" Chimney Bricks fit for outside work	2 6 0	"
3 1/2" ditto ditto through and through	2 0 0	"
3 1/2" Beaded, Ovolo and Bevel Jamb; Octagons; 2 1/2 and 3/4 radius Bullnoses; Stock patterns	3 7 6	"
Accrington Air Bricks, 9" x 2 course deep, each	0 0 6	"
Ditto ditto 9" x 1 course	0 0 3	"
Accrington Camber Arches—		"
3 course deep 4 1/2" soffit, per foot opening	0 1 3	"
4 1/2" " " " "	0 1 8	"
4 1/2" " " " "	0 2 1	"
5 1/2" " " " "	0 2 6	"
6 1/2" " " " "	0 2 1	"
7 1/2" " " " "	0 2 11	"
8 1/2" " " " "	0 3 6	"
9 1/2" " " " "	0 4 6	"

Net free on rail, or free on boat at works.

GLAZED BRICKS.

HARD GLAZES (PER 1,000).

White, Ivory, and Best.					
Salt Glazed.	Buff, Cream, Other	Second			
Best.	Seconds. & Bronze, Colours.	Colours.			
Stretchers—					
£12 7 6	£10 17 6	£13 7 6	£17 17 6	£12 7 6	
11 17 6	10 7 6	13 7 6	17 7 6	11 17 6	
Quoins, Bullnose, and 4 1/2 in. Flats—					
15 17 6	14 17 6	17 17 6	21 7 6	15 17 6	
Double Stretchers—					
17 17 6	16 7 6	20 17 6	24 7 6	17 17 6	
Double Headers—					
14 17 6	15 7 6	17 17 6	21 7 6	14 17 6	
One side and two ends, square—					
18 17 6	17 17 6	21 17 6	26 7 6	18 17 6	
Two sides and one end, square—					
19 17 6	18 7 6	22 17 6	26 17 6	19 17 6	
Splays and Squints—					
17 7 6	15 7 6	21 17 6	24 17 6	17 7 6	
Plinth and Hollow Bricks, Stretchers and Headers—					
5d. each	4d. each	6d. each	6d. each	5d. each	
Double Bullnose, Round Ends, Bullnose Stops—					
5d. each	4d. each	6d. each	6d. each	5d. each	
Rounded Internal Angles—					
4d. each	3d. each	5d. each	5d. each	4d. each	

MOULDED BRICKS.

Stretchers and Headers—					
8d. each	8d. each	8d. each	8d. each	8d. each	
Internal and External Angles—					
1 2 each	1 2 each	1 2 each	1 2 each	1 2 each	
Sill Bullnose, Stretchers, and Headers—					
5d. each	4d. each	6d. each	6d. each	5d. each	
Maple or Soft Glazed Stretchers and Headers					
£22 17 6					
Quoins and Bullnose					
27 17 6					
Compass bricks, circular and arch bricks of single radius 4 1/2 per 1,000 over above list for their respective kinds and colours					
Camber arch bricks, any kind or colour, by 1/2 in. ls. 2 1/2 each					
Stretchers cut for Crosses and Nicked Double Headers, £1 per 1,000 extra.					
These prices are carriage paid in full truck loads to London Stations.					
Thames Sand	7 6	per yard, delivered.			
Put Sand	7 0	" "			
Thames Ballast	6 0	" "			
Best Portland Cement	36 0	to 41 0	per ton, delivered.		
Ground Blue Lias Lime	21 0	per ton, delivered.			
Exclusive of charge for sacks.					
Grey Stone Lime	13 6	to 14 0	per yard, delivered.		
Stoubridge Fire-clay in sacks 27s. 0d. per ton at railway station.					

STONE.

Red Mansfield, in blocks	per foot cube	£0 2 4
Barley Dale, ditto	"	0 2 3
Red Corshill, ditto	"	0 2 0
Closeburn Red Freestone, ditto	"	0 2 0
An aster, ditto	"	0 1 10
Greenhill, ditto	"	0 1 10
Beer, ditto	"	0 1 7 1/2
Onlmark, ditto on truck at Nine Elms	"	0 1 10 1/2
Hard York, ditto	"	0 2 0
Do. do. 6 in. sawn both sides, landings, random sizes	per foot sup.	0 2 8
Do. do. 3 in. slab sawn two sides, random sizes	"	0 1 3

* All F.O.R. London.

Bath Stone—Delivered in railway trucks at Westbourne Park, Paddington (G.W.R.), or South Lambeth (G.W.R.)	per foot cube	0 1 7
Delivered in railway trucks at Nine Elms (L. & S.W.R.)	"	0 1 8 1/2
Delivered on road waggons at Nine Elms Depot	"	0 1 9 1/2
Portland Stone—Brown Whitened in random blocks of 20 ft. average, delivered in railway trucks at Westbourne Park (G.W.R.), South Lambeth (G.W.R.), or Nine Elms (L. & S.W.R.)	"	0 2 5 1/2
Delivered on road waggons at Public Wharf or Nine Elms Depot	"	0 2 6 1/2
White Basebed—2d. per foot cube extra.	"	

TILES.

Plain red roofing tiles	s. d.	Delvd. at ry. stn.
Hip and Valley tiles	42 0	per 1,000
Broseley tiles	3 7	per doz.
Ornamental tiles	50 0	per 1,000
Hip and Valley tiles	52 6	"
Ruabon red, brown, or brinded (ditto Edwards)	4 0	per doz.
Ornamental ditto	57 6	per 1,000
Hip tiles	60 0	"
Valley tiles	4 0	per doz.
Selected "Perfecta" roofing tiles Plain tiles (Peake's)	3 0	"
Ornamental ditto	46 0	per 1,000
Hip tiles	48 6	"
Valley tiles	3 4 1/2	"
"Rosemary" brand plain tiles	48 0	per 1,000
Ornamental tiles	50 0	"
Hip tiles	4 0	per doz.
Valley tiles	3 8	"
Staffordshire (Hanley) Reds or brinded tiles	42 6	per 1,000
Hand-made sand-faced	45 0	"
Hip tiles	4 0	per doz.
Valley tiles	3 6	"
"Hartshill" brand plain tiles, sand-faced	45 0	per 1,000
Pressed	42 6	"
Ornamental ditto	47 6	"
Hip tiles	4 0	per doz.
Valley tiles	3 6	"

OILS.

Rapeseed, English pale, per tun	£28 15 0 to £29 5 0
Ditto, brown	26 15 0
Cottonseed, refined	29 0 0
Olive, Spanish	39 10 0
Seal, pale	21 0 0
Cocanut, Cochin	46 0 0
Ditto, Ceylon	42 10 0
Ditto, Mauritius	42 10 0
Palm, Lagos	32 5 0
Ditto, Nut Kernel	35 0 0
Oleum	17 5 0
Sperm	30 0 0
Lubricating, U.S.	per gal. 0 7 0
Petroleum, refined	0 6 1/2
Tar, Stockholm	per barrel 1 6 0
Ditto, Archaengel	0 19 6
Linsed Oil	per gal. 0 2 6
Baltic Oil	0 2 9
Turpentine	0 3 0
Putty (Genuine Linsed Oil)	per cwt. 0 9 6
Pure Linsed Oil	0 9 0
"Stority" Brand	0 9 0

GLASS (IN CRATES).

English Sheet Glass: 15 oz.	21 oz.	25 oz.	32 oz.
Fourth	51d.	53d.	7d.
Third	53d.	64d.	81.
Fluted Sheet	5 1/2	6 1/2	—
Hartley's English Rolled Plate	3 1/2 in. 3 1/2 in. 3 1/2 in.	3 1/2 in. 3 1/2 in. 3 1/2 in.	3 1/2 in. 3 1/2 in. 3 1/2 in.
White.	5d.	6 1/2d.	6 1/2d.
Tinted.	5d.	6 1/2d.	6 1/2d.
Reoussine	5d.	6 1/2d.	6 1/2d.
Figured Rolled	5d.	6 1/2d.	6 1/2d.

VARNISHES, Etc.

Fine Pale Oak Varnish	per gallon.	£0 3 6
Pale Copal Oak	"	0 10 0
Omnifac Copal Oak	"	0 10 0
Supertine Pale Elastic Oak	"	0 12 0
Fine Extra Hard Church Oak	"	0 10 0
Supertine Hard-drying Oak, for seats of churches	"	0 14 6
Fine Elastic Carriage	"	0 12 9
Supertine Pale Elastic Carriage	"	0 16 0
Fine Pale Maple	"	0 10 0
Finest Pale Durable Copal	"	0 18 0
Extra Fine French Oil	"	1 1 0
Eggshell Flattening Varnish	"	0 18 9
White Copal Enamel	"	1 4 9
Extra Pale Paper	"	0 12 0
Best Japan Gold Size	"	0 10 0
Best Black Japan	"	0 16 0
Oak and Mahogany Stain	"	0 9 0
Brunswick Black	"	0 8 0
Berlin Black	"	0 16 0
Knottin	"	0 10 0
French and Brush Polish	"	0 10 6

The firm is announced of Mr. John McKissack and Son, architects, 63, West Regent Street, Glasgow. He had been in professional practice in Glasgow for fifty years, and had designed many churches and other important buildings in Glasgow and the West of Scotland. For about two years Mr. McKissack has been laid aside by ill health, the practice being carried on by his son and partner, Mr. James McKissack.

TO CORRESPONDENTS.

We do not hold ourselves responsible for the opinions of our correspondents. All communications should be drawn up as briefly as possible, as there are many claimants upon the space allotted to correspondents.

It is particularly requested that all drawings and all communications respecting illustrations or literary matter, books for review, etc., should be addressed to the Editor of the BUILDING NEWS, Elingham House, 1, Arundel Street, Strand, W.C., and not to members of the staff by name. Delay is not infrequently otherwise caused. All drawings and other communications are sent at contributors' risks, and the Editor will not undertake to pay for, or be liable for, unsought contributions.

*Drawings of selected competition designs, important public and private buildings, details of old and new work, and good sketches are always welcome, and for such no charge is made for insertion. Of more commonplace subjects, small churches, chapels, houses, etc.—we have usually far more sent than we can insert, but are glad to do so when space permits, on mutually advantageous terms, which may be ascertained on application.

When favouring us with drawings or photographs, architects are asked kindly to state how long the building has been erected. It does neither them nor us much good to illustrate buildings which have been some time executed, except under special circumstances.

Telephone: Gerrard 1291.

Telegrams: "Timeserver, Estrand, London."

NOTICE.

Bound copies of Vol. CVIII. are now ready, and should be ordered early (price 12s. each, by post 12s. 9d.), as only a limited number are done up. A few bound volumes of Vols. XXXIX., XL., XLVI., XLIX., LIII., LVI., LXI., LXII., LXIII., LXIV., LXV., LXVI., LXVII., LXVIII., LXIX., LXXI., LXXII., LXXIII., LXXIV., LXXV., LXXVI., LXXVII., LXXVIII., LXXIX., LXXXI., LXXXII., LXXXIII., LXXXIV., LXXXV., LXXXVI., LXXXVII., LXXXVIII., LXXXIX., XC., XCI., XCII., XCIII., XCIV., XCV., XCVI., XCVII., XCVIII., XCIX., C., CI., CII., CIII., CIV., CV., CVI., and CVII. may still be obtained at the same price; all the other bound volumes are out of print. Most of the back numbers of former volumes are, however, to be had singly. Subscribers requiring any back numbers to complete volume just ended should order at once, as many of them soon run out of print.

Handsome Cloth Cases for binding the BUILDING NEWS, price 2s., post free 2s. 4d., can be obtained from any Newsgate, or from the Publisher, Elingham House, 1, Arundel-street, Strand, W.C.

TERMS OF SUBSCRIPTION.

One Pound per annum (post free) to any part of the United Kingdom; for the United States, £1 6s. 0d. (or 6dols. 30c. gold). To France or Belgium, £1 6s. 0d. (or 33f. 30c.). To India, £1 6s. 0d. To any of the Australian Colonies or New Zealand, to the Cape, the West Indies, or Natal, £1 6s. 0d.

*Our Direct Subscription Agents for Australia are Messrs. E. T. Kibblewhite and Co., Printers and Publishers, 19, York Chambers, 105, Liverpool Street, Sydney, New South Wales; for Japan, The Maruzen Co., Ltd., 11-16, Nishibashi Tori Sanchome, Tokyo; who will receive Subscriptions at £1 6s. 0d. per annum on our account. Copies of the paper will be sent by us direct to the subscribers' address.

**The special rate to Canada is £1 3s. 10d. = 5dols. 80c. for 12 months, and 11s. 1d. = 2dols. 90c. six months. Our Direct Subscription Agents for Canada are Messrs. Sells, Ltd., 302, Shaughnessy Buildings, McGill Street, Montreal, who will receive Subscriptions, £1 3s. 10d. per annum, on our account.

Cheques and Post-office Orders to be made payable to THE STRAND NEWSPAPER COMPANY, LIMITED, and crossed London County and Westminster Bank.

ADVERTISEMENT CHARGES.

The charge for Competition and Contract Advertisements, Public Companies, and all official advertisements is 1s. per line of Eight Words, the first line counting as two, the minimum charge being 5s. for four lines.

The charge for Auctions, Land Sales, and Miscellaneous and Trade Advertisements (except Situation Advertisements) is 6d. per line of Eight Words (the first line counting as two), the minimum charge being 4s. 6d. for 50 words. Special terms for series of six insertions or more can be ascertained on application to the Publisher.

SITUATIONS VACANT AND PARTNERSHIPS.

The charge for advertisements for "Situations Vacant" and "Partnerships" is One Shilling for Twenty-four Words, and Sixpence for every Eight Words after. All Situation Advertisements must be prepaid.

SITUATIONS WANTED.

Advertisements not exceeding Thirty Words, inclusive of name and address, are inserted under the heading "Situations Wanted," free of charge.

Rates for Trade Advertisements on front page and special and other positions can be obtained on application to the Publisher.

REPLIES TO ADVERTISEMENTS.

Replies to advertisements can be received at the Office, Elingham House, 1, Arundel Street, Strand, W.C., free of charge. If to be forwarded under

THE BUILDING NEWS AND ENGINEERING JOURNAL.

Effingham House.

CONTENTS.

Strand, W.C.

Temporary Military Hospital Wards 283
The Address in the Engineering Section of the
British Association 285
Canterbury Cathedral 288
Load Tests on Brick Piers 289
Legal Intelligence 290
Corrente Calano 297
Megalithic Monuments 308
The L.C.C. School of Building at Brixton 308
Obituary 308
Building Intelligence 309
Water Supply and Sanitary Matters 309
Trade Notes 309

Correspondence 309
Our Office Table 310
To Arms! 310
Rabchester Museum of Antiquities 311
Latest Prices 311
List of Competitions Open XI
List of Tenders Open XI

The Middlesex County Guildhall, Broad Sanctuary, Westminster, S.W. Portion of the Roof in the Council Chamber, and View of Throne and Bench in County Session-Court No. 2. Messrs. J. S. Gibson, Skipwith, and Gordon, Architects.
Billiard-room, "Crow Clump," Weybridge. Messrs. Tubbs, Messer, and Poulter, Architects.
St. Michael's Church, Mill Hill, N. View and Plan. Mr. J. S. Alder, Licentiate R.I.B.A., Architect.
Library and Art Gallery, Shrewsbury Schools. View and Plan. Messrs. Forsyth and Maule, F.F.R.I.B.A., Architects.
House, Hampstead Heath. Mr. Gilbert C. Waterhouse, Architect.

OUR ILLUSTRATIONS.
The New Offices of the Mutual Life Assurance Company, Waterloo, Ontario, Canada. New Premises. View of Main Entrance and General Office. Mr. Frank Darling, F.R.I.B.A. (Royal Gold Medalist, 1915) (Messrs. Darling and Pearson), Architect.

TEMPORARY MILITARY HOSPITAL WARDS.

The problem of providing additional hospital accommodation has been one of the most pressing of the war. In the case of one great London hospital, a solution has been found in the provision of temporary wards in the open spaces between the permanent blocks. We are indebted to Mr. Percivall Currey, the architect of St. Thomas's Hospital, for the present information and the accompanying plans and section of one of the new wards provided at this institution.

At St. Thomas's accommodation has been found for 332 beds for patients and 40 for orderlies, in six temporary wards, erected by the War Office under Mr. Currey's supervision. It will be seen from our block plan of the hospital, Fig. 1, that the temporary wards are generally of the same length as the permanent wards, extending from the main corridor to the loggia that connects the ward pavilions on the river frontage. Single wards of two rows of beds accommodate 30 patients, the double wards having the number of beds indicated on the block plan, which shows the temporary buildings cross-hatched, it being noted that the baths and sanitary accommodation are, in all cases, excepting the 80-bed ward, arranged between the columns of the open loggia.

The cross section of a 66-bed ward, Fig. 2, and a plan, Fig. 3, are given herewith. It will be seen that two 20-ft. wards are thrown into one, excepting that a central screen 5 ft. 3 ins. high is arranged, and are roofed with collar-beam roofs, carried by the side walls and a fir girder upheld by steel stanchions. The height of the wards is 12 ft. 6 in. to the ceiled collars, and 10 ft. 6 in. to the heads of the quarter-partition walls, giving about 750 cubic ft. space per bed. Between every bed is a window with double hopper-type opening sashes, so that the wards approach nearly to the reputed ideal hospital ward—the open air—and have perfect ventilation, being excellently lighted. They are undoubtedly a model of their kind, and should be carefully studied by all interested in the problem of providing additional temporary hospital accommodation.

The whole of the wards are framed of timber, with 4-in. by 2-in. quarters, and in. by 3-in. heads and ceils. They are erected upon brick and concrete foundation. About 3 ft. of ground is excavated, and one foot of concrete laid, with 9 in. of brickwork under the main walls, and 4-in. sleeper walls. As indicated, there are three cross-sleeper walls carried right up to the underside of the floor. Where the ward buildings cross the area next to the main corridor, they are carried on

timber girders strutted up from the area pavements. Here are arranged the servery, linen-room, and sisters' room. Central doors connect the main corridor conveniently for the hospital and medical staff. It will be observed that the wards and the structure over the area completely fill the interval from corridor to loggia and buttress and add stability to the whole construction.

Blocks of concrete, as our section indicates, are provided as foundation to the

out in 1-in. rebated linings, with deal sills and light transomes, both the upper and lower sashes falling back, with hopper-type cheeks of 3-ply board, the lower sash being rather restricted in the opening for the reason that the inter-bed space is necessarily restricted, and the 30° opening of the upper sashes would be inconvenient in spite of the fact that under each window is a small table, which forms a natural fender for attendants and others by the patient's bedside.

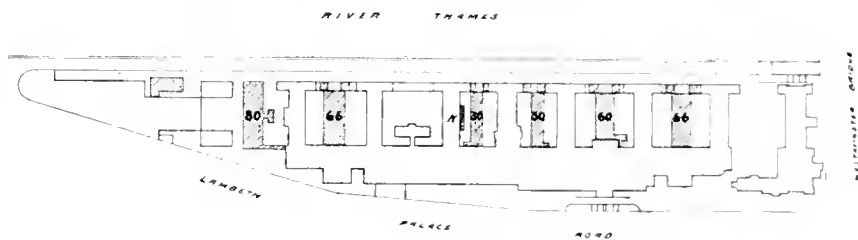

FIG. 1.—BLOCK PLAN, ST. THOMAS'S HOSPITAL.

steel stanchions, which are 4 in. by 3 in., with base-plates, and are bolted by angle-plates to the 9 in. by 4 in. fir girder at the junction of the roofs. The rafters and collars are 4 in. by 2 in., with 7 in. by 2 in. ridge-piece; and the floor joists are 6 in. by 2 in. upon 4 in. by 3 in. plates, with 1 in. grooved and tongued boards. We give these details in full because, when called upon to provide temporary

Externally, the walls are covered with asbestos slabs in two lengths, nailed to the posts—a stock 3 ft. width just fits between the windows; but to make out, under the windows, a certain amount of sawing of the stock slab has been necessary. To keep water out at horizontal joints a narrow double-sided zinc angle is run behind the upper and appears above the lower sheet. Similar material

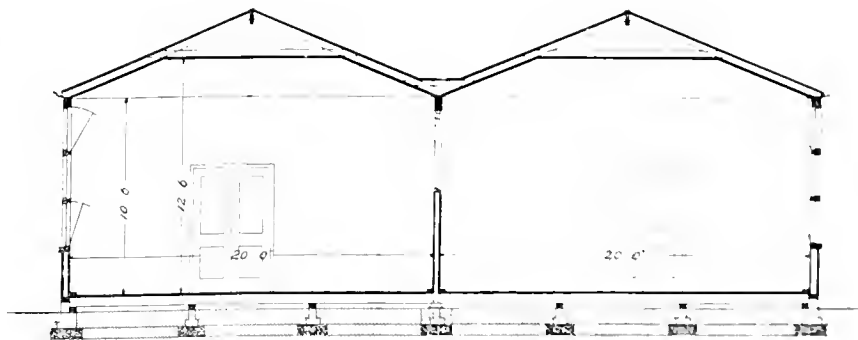

FIG. 2.—CROSS SECTION OF CORRIDOR.

structure, the architect—by custom having in mind details suitable for permanent building—may be often in some doubt and hesitation as to scantlings and dimensions. These details show what scientific disposition of a little material can accomplish.

Internally, the walls are covered with fibrous plaster slabs, which have been dis-tempered in a pleasant and restful shade of green. The window openings are made

covers the roofs, but in the form of Roman tiles, with ridges and hips of the same, while the valley gutters are laid in rubberoid.

The partition dividing the two wards is of 2-in. plaster slabs, with deal capping, forming a dwarf wall that fits snugly between the stanchion flanges. There is no doubt that the throwing of the two wards into one greatly assists in ventilation, there being a larger total volume of

air and a better and more controllable general air movement. For heating the wards, gas radiators are employed, with flues carried through the walls and above

The sanitary accommodation and the baths are arranged as shown on the plan, with walling in 2-in. slabs. The baths and lavatory water supplies are all from

the actual wards. The sanitary accommodation and the baths are arranged as shown on the plan, with walling in 2-in. slabs. The baths and lavatory water supplies are all from

The beds, of military size, 6 ft. 6 ins. by 2 ft. 6 ins., are spaced 6 ft. apart. From two of the interspaces, as shown, are arranged emergency exits. From the loggia, patients can pass on to the hospital terrace, which naturally forms, with its charming river views, a pleasant place for convalescents. The building, cross-hatched, on the extreme left of the block plan is a temporary hut for the accommodation of forty orderlies. Near by, in a basement of the medical schools, are further temporary quarters, mess-room, baths, etc., for eight sergeants.

The contract for erecting the wards was let to Mr. J. Carmichael, and it is almost literally true to say that the ink was scarcely dry upon the contract than the ground was out, urgency and despatch being the order of the day. The total cost has been £9,765 for 372 beds, including the forty beds for the hospital orderlies above referred to, and works out at a little over £26 per bed. The amount includes the cost of all fittings to lavatories, etc., complete, and also about £350 for new kitchen plant and utensils. Naturally, the addition of 372 beds to the hospital proves a strain on the normal kitchen department. The cooking for the temporary wards is effected in a special kitchen, K on the block plan. This serves the whole of the wards. At the same time, the serveries are equipped with a gas stove, boiling pan, and other conveniences.

We have personally inspected these new wards, and heartily recommend any hospital or institution or local authority to carefully examine the buildings. Unfortunately, we are faced with the necessity for yet further provision for the care of wounded. In Mr. Currey's designs the architect who may be entrusted with work of this nature will find an admirable model, and there are necessarily many little details of arrangement needing careful study. On these depend the comfort of the patients. A visit to St. Thomas's, too, may assist to bring cheer to the men who have been brought low in their devotion to their country.

Mr. Alexander Muir, sometime mason and builder, of Glasgow, of Dean Villa, 58, Aytoun Road, Pollokshields, who died on February 10 last, aged 90 years, left personal estate in the United Kingdom valued at £9,027, of which £7,716 is Scottish estate.

At the annual meeting of the Harlow Trust of Carnarvon, Mr. Alfred Richards, the chairman of the Finance Committee, replying to inquiries as to whether there were any indications of a revival in the slate trade, expressed his regret that there were none, nor were there any hopes of an improvement until after the war. The Government were prohibiting building schemes on the part of public bodies, and for private speculators he did not know of any worse enterprise than building.

At St. Nicholas Cathedral, Newcastle-on-Tyne, the judgment has been read of the Chancellor of the Diocese, Lieut.-Colonel Errington, M.A. in the application of the vicar and churchwardens of the Cathedral Church in regard to the completion of the rood screen by altering the shape and dimensions of the cross and placing upon it the figure of Our Lord crucified. The Chancellor granted the faculty, confirming the erection of the screen, which had been erected in 1888 without a faculty. He agreed that the existing figures of SS. Mary and John were out of place, and should be removed. The vicar (Canon Gough) intimated that he should carry the case further. The Chancellor seemed to forget that at Chester Cathedral they had just erected upon its rood a huge figure of Our Lord on the Cross, and a figure of St. Mary and St. John, while at Wells Cathedral they were doing precisely the same thing.

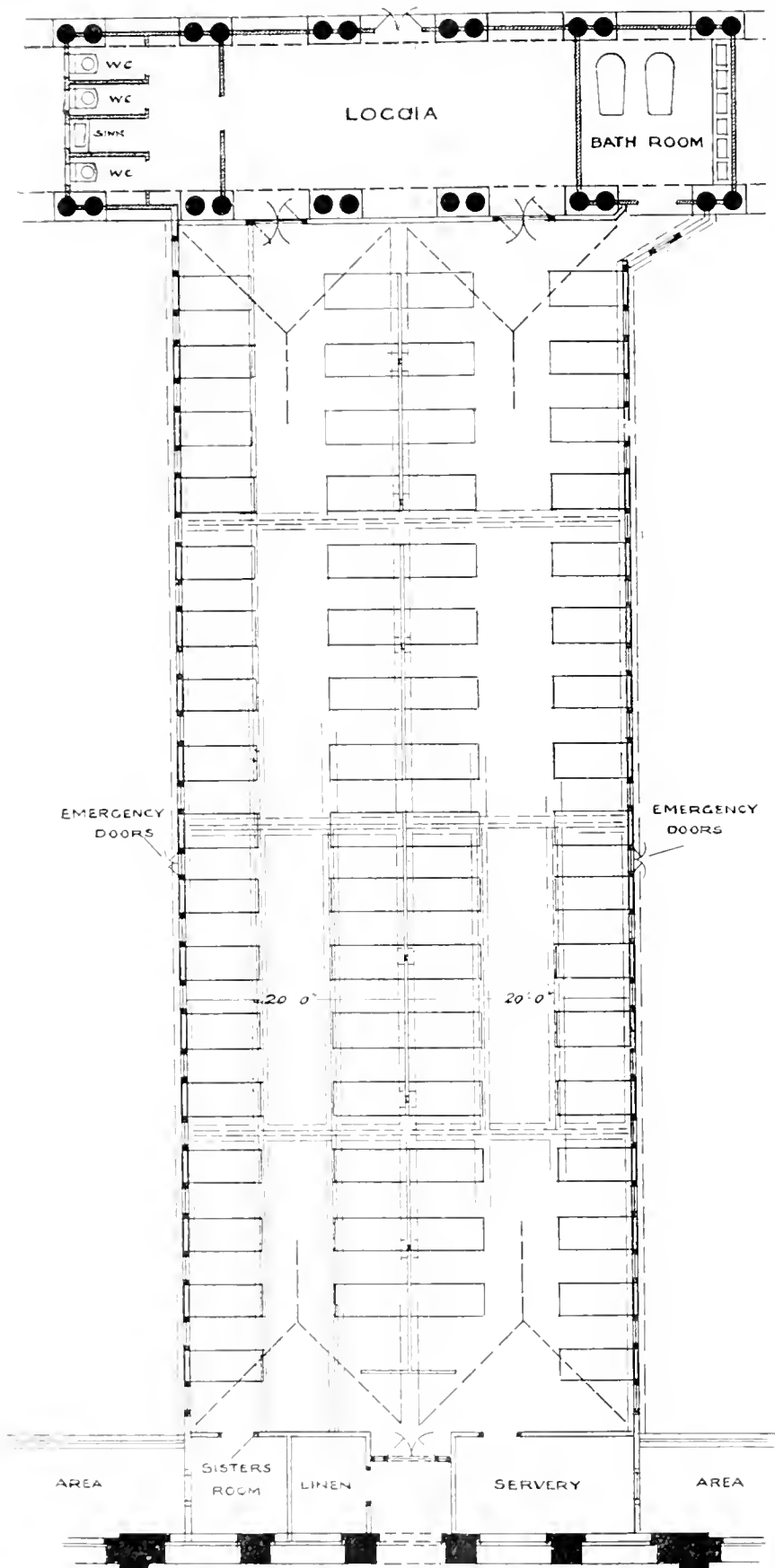

CORRIDOR

FIG. 3.—PLAN.

the gable end. The space between ground and floor is ventilated by air-bricks, and felt damp-course laid to all brick walls and to sleeper walls.

the hospital hot and cold-water mains, the drainage being also connected to the hospital drainage system. Between the sanitary and baths enclosures a screen

THE ADDRESS IN THE ENGINEERING SECTION OF THE BRITISH ASSOCIATION.

By PROF. H. S. HELE-SHAW, F.R.S.

The fact is the time is not an ordinary one, for the war which a year ago cast its shadow over the meeting of the British Association in Australia has, as the months have passed by, gradually unfolded the most terrible page in the history of the world.

It is terrible not merely because of the frightful slaughter which has taken place, and which will yet take place, owing, on the one hand, to the gigantic armies employed, and, on the other, to the nature of modern warfare. A predecessor in the chair, one who has left many marks of his genius on the peaceful engineering works of the country, Mr. Hawksley, commented about fifty years ago on "the unhappy necessity of devoting so much of the science and skill of members of the Association to the defence of the homes of the people of this great nation." He further remarked, with great prophetic insight: "War is no longer carried on by means of mere animal courage and brute force; on the contrary, we perceive, much to our amazement, I believe, that the highest branches of mechanical science and the most refined processes of the mechanical arts are resorted to by the modern warrior for the purposes of offence and defence. And we are taught by the logic of the facts that the modern soldier must cease to remain a passive machine, but, on the contrary, must henceforth be trained as a skilled labourer, if not, indeed, as a skilled artisan."

I do not think, however, that either Mr. Hawksley or anyone else could have anticipated what refinements of skill and science would be brought to bear, not merely on the destruction of the human species, but of those ancient edifices of beauty which cost hundreds of years to build, and which cannot be replaced, or even the loss of those great works of engineering in the form of bridges and other structures which, though doubtless replaceable, represent the accumulated wealth of mankind. All this does not constitute, however, the worst feature of the war which is still raging. I do not know which will hereafter stand out in the blackest light: the callous disregard by our enemy of the recognised laws which have governed warfare amongst civilised countries hitherto, of which the recent murder of a defenceless submarine crew in neutral waters is an example, or the fact, of which there is now abundant and overwhelming proof, that this country, while animated only by peaceful intentions, was itself the real object and ultimate aim for the destructive effort of our enemy.

Fortunately, we now all know that our determination at any cost to ourselves to stand by our treaty obligation to a weaker country was really a fateful moment in the history of our Empire. Had we then failed, such failure would have spelled our own doom.

This is not the place to dwell at any length on this subject; but I cannot help pointing out that the whole attitude of scientific and professional men in this country at the beginning of the war shows how little they realised the real nature of what was before us. Thus my own predecessor, after the war had begun, in his presidential address in Australia, used the words: "The discoveries in pure science and their innumerable applications to practical ends are ever a potent factor working for the common good." The truth is that the great majority of us did not realise to what uses science would be put in the mutilation and destruction of our fellow creatures.

Still, we are told by soldiers that practically any applications of science constitute legitimate warfare, and that the only way to escape from destruction ourselves is to employ all the resources of science in our own defence.

It is on these grounds that the meeting of the British Association for the Advancement of Science has been held this year, because science is proving such an all-important factor in the present war.

The mere holding of this meeting, however, with a vague sort of idea that science is

associated with war, does not seem to most of us to meet the real needs of the case. The decision to hold the meeting was made in March, i.e., six months ago. Since that time the nation has awakened to the fact that matters have become very much more serious, and we sorely needed the solemn warnings of our responsible statesmen to enable us to realise this. We see our toe turning every resource towards the active prosecution of the war and bringing in the aid of every man towards that end. If the result were a small matter, we might pursue our way, as we did at first, with the fatuous cry, "Business as usual"; but day by day it is brought home to us that the Hymn of Hate, childish though it may seem, really represents the serious mind and deadly intention of our enemy. When I say this I know there are exceptions, and it is gratifying to find that at least one German guest of the British Association acknowledged in print the generous manner in which the German guests were treated in Australia after the war broke out, even being given a passage home.* This and much else warns us that our failure in this war means the loss of what has been built up in so many centuries, and what we value above all other things—viz., our freedom; and that this loss would be accompanied by atrocities and degradation beyond the most savage happenings of the past. It behoves us all, then, who are members of it to show that the British Association, which has rendered such great services to the country in the past, can bear its share of the burden to-day.

Remembering how soon we forgot that black December week fifteen years ago, and the lurid indication from the German Emperor that he and his people had the will to destroy us then, if not the power, and how swiftly we relapsed into national ease at the end of the Boer War, it behoves every man who can do so to take his share in making ready for the terrific struggle Germany is certain to put up in the arts and manufactures.

Now, when we look closely into the causes of Germany's great advance, we can learn lessons which we have been culpably slow to take to heart. Although there are other causes, first and foremost, and overshadowing all others, is the determined and whole-hearted organisation of German industry. I see it recently stated that the scheme above referred to (the Victoria Falls scheme) was lost to this country because the industrial banks of Germany backed their own manufacturers, and this is no doubt partly true. As I have already quoted, Germany's power in war is admitted to be her mechanical organisation, and the organisation of every material and engineering force to that end. Just as striking, if not more so, is her organisation for the arts of peace, and I lately heard a very shrewd man of affairs express his amazement at Germany's entrance into war when by peacefully pursuing the way she was going she would have dominated the world commercially in a few years' time, and, in the words of the speaker, might in many manufactures have made as practically bankrupt. It is undoubtedly in the matter of scientific organisation, even more than the organisation of science, that Germany has achieved such wonderful results, and it is therefore in this direction that we must leave no stone unturned if we wish to have any chance of holding our own in the future. I will indicate a few of the matters in which there is ample scope for doing useful work in the above direction.

EDUCATION.

A sign of the times is the inclusion of an Education Section in an association for the advancement of science. This has not been done on the narrow ground of improving the teaching of science in schools, but because it is now recognised, and this none too soon, that the whole problem of education must be treated in a scientific manner.

When the subject of engineering education is mentioned we are apt to think only of the

training of such engineers as have been considered in a recent report, issued by the Institution of Civil Engineers, and to exclude, as that report purposely does, the training of our artisans and workmen. We certainly do not connect the idea at all with the training of the artisan himself. As a matter of fact, while high scientific training of the professional engineer and manufacturer is of vital importance, the proper education of the men whom he will have to control is scarcely less so. The latter education may not be of the same kind, but it is just as vital to the country, and its present condition is a serious evil.

A well-known American, in the "General Electric Review," writing on the "Individual and Corporate Development of Industry," points out that theoretically the aim of both employer and employee is the same—namely, the efficiency of industrial production to increase the return of the investment in labour and in capital. Unfortunately, however, as he remarks, "the relations between the two have frequently been hostile industrial warfare over the distributions of the returns rather than cooperation for the increase of financial returns of both parties."

One of the most humiliating things of the present war has been the mutual relation of the two in this country in what is probably the most critical period in our history. I will say more later on this subject, but there is no doubt the subject of industrial education needs earnest consideration. Take the first, the education of the professional man—the class, for instance, joining such institutions as the Civil, Electrical, or Mechanical Engineers; we find in one respect a most satisfactory progress as to what is insisted upon before such men are allowed to join one of these bodies. All such institutions now demand technical diplomas or university degrees, and, in addition, satisfactory evidence of practical training. But to prevent injustice to the man who may be self-taught, they hold examinations conducted by recognised men of standing in scientific and technical subjects. Great as this progress has been in recent years, there is a great deal to be done. In the first place, professors and teachers of engineering and technical subjects have to deplore the miserable previous training of a large number of students. It seems still to be a common idea that if a boy is unable to make any decent progress in the usual school subjects, he can be sent to a technical school if he is useful with his hands, under the pathetic impression that the success of the engineer depends upon his hands rather than upon his head; and the first year or two at a technical school or college is thus taken up with a work that ought to be done at a secondary school. It is not fair to put all the blame upon the school, for I have known students coming from the classical side of such a school with no knowledge of science, and very little of mathematics, who have taken the highest places in the engineering course, and, after entering their practical work, have rapidly risen in the profession; and this was because such men had been well trained to apply their mind to any subject and had a sound foundation upon which to build. This only shows that a good student will always rise to the top, and does not prove that the present school system is the best for an average boy, or makes him work as hard as, for instance, the corresponding school in Germany does. A large number of thinking men are convinced that our whole education system seriously needs reform. I say this not merely in reference to scientific education and technical training, but to the whole attitude of mind of the young of all classes of the community towards the serious work of life when they leave school. I will allude to this under another heading later on. In the matter of education and its bearing upon technical training, we have, then, a good deal to learn from Germany. There are some things that we think are quite as good, if not better, in this country, but there is no reason why we should not try to find a way to adopt the better features of education from our enemy, and, while retaining independence of thought and originality, inculcate firmer

* I regret to say this forms a striking contrast to the brutal treatment meted out in many cases to British visitors in Germany.

discipline, for there is surely a happier medium in this matter.

There is one matter which calls for remark before I pass from this subject. I see in the report above alluded to there is a great divergence of opinion concerning the wage earning value of highly technical students. Here, again, is a matter which in itself is worth a very careful discussion. The question depends first upon the student himself, next upon the kind of training he has had, and then upon the nature of the work he is expected to do. The blame in not getting the best results from a well trained student is very often due to the employer, and our section might do something to bring professors and employers into closer touch; both employer and professor may have something to learn from each other.

In leaving this subject I cannot help point out what important continuation schools are to be found in the meetings and discussions of the younger members of various engineering societies, and how much a young engineer learns in the preparation of a paper. Anyone who is accustomed to take the chair at such meetings will bear witness to the excellent outlay of money represented by the award of prizes and medals for such work. Many men to my knowledge have got jobs through thus showing acquaintance with a special subject or originality of thought.

RESEARCH.

If there is one thing more than another which the British Association can be congratulated upon, it is the work which it has done in the matter of research, and it is very interesting to go back to the earliest days, more than eighty years ago, and to see how, in very different days from the present, research in all branches of science was encouraged, and what a potent factor the various meetings have been, not only in actually fostering the work of research itself, but in obtaining the recognition which is accorded to-day. Amongst other things, the National Physical Laboratory stands largely to its credit, as having been first powerfully advocated at one of its meetings. This section has not been behind the others, and at the present moment there are three Research Committees—viz., those on Gaseous Explosions, Compound Stress, and Impact. The work of the first of these is so valuable that its results have been published all over the world.

To-day there is a more general recognition of the importance of research, and the recent institution by the Government of a committee for the organisation and development of scientific and industrial research is the latest indication that the nation is beginning to realise its importance.

So far from all this making our work less necessary, there is all the more reason why we should have a permanent Committee of Research, because one of the intentions of the new Government committee is to utilise the most effective institutions and investigators available, and the statement is made that one of the objects of the Government Research Committee is to select and co-ordinate rather than originate, and that one of its chief functions will be the prevention of overlapping between institutions and individuals engaged in research. The Government committee in question is only dealing with the organisation in England, Wales, Scotland, and Ireland. Now, the great advantage possessed by this association is the fact that it includes not only Great Britain and Ireland, but all the colonies, and, indeed, one of the three researches above mentioned is being carried out in Australia. Another research of the association is being carried out in Cyprus; and work is also being done in such places as Jamaica and Egypt. It is more important, therefore, than ever that the British Association work in research should go on, as, since its members are drawn from all parts of the British Empire, its influence should be correspondingly great.

There is another reason for research being a subject of a permanent sub-committee, and that is that suggestions for new work are more likely to be matured, and work of an advisory nature made more practical than is possible at one annual meeting.

There is yet one more reason, which is that, although we have made some progress, we are still far behind Germany in the organisation of research. There is no doubt that our students and scientific men are quite capable of conducting researches, but the training for this is like the training for the officers of an army; it cannot be done hastily, and, indeed, men themselves cannot be obtained for this purpose without years of preparation. All such work must be done as a factor in the reorganisation of our manufacturing and commercial resources in the great struggle that lies before us.

There is one subject which affects both education and research, and might be a matter to be reported on by our committee. It is very rarely that a professor is both a good teacher and gifted with the power of original research. Even when a professor or lecturer is so gifted, however, it is almost impossible for a man really to devote himself properly to research and at the same time undertake the duties which are attached to a professorial chair. Why not face this subject boldly, even relieve the bad lecturer (there are men who admit their failure in this respect) of a certain amount of his work, provided he is doing well in research; or for the man who can do both well, see that he not only has efficient assistance, but even more—that he is given the opportunity of devoting long periods (for instance, alternate years) entirely to research.

There are numerous other questions which would come up under this heading, and which could be usefully dealt with by our committee.

There is one more subject that we might consider, and that is a better differentiation of researches on purely industrial work, such as are often of a most profitable nature to the professor or research student, and those which are of a purely scientific character. While it is only right that every successful research, even if conducted at the expense of a public body, should bring solid return as well as fame to the worker, some steps should be taken as to the fair and equitable distribution of the proceeds. I see that one of the proposals of the new Research Committee is that discoveries by institutions, associations, bodies, or individuals in the course of researches aided by public money shall be "made available under proper conditions for the public advantage." If the discovery is patentable, I assume, it would be protected at home and abroad, unless we wish to spend public funds as much for the benefit of foreign trade rivals as for ourselves. This is one of the many matters in connection with which a British Association committee might from its cosmopolitan character render great service.

STANDARDISATION AND THE METRIC AND DECIMAL SYSTEM.

One of the favourite jibes at this country is our supposed utter want of system in regard to our standards and systems of measurement generally. With regard, for instance, to the decimal system, it is frequently stated that thirty or forty countries have adopted the metric system, while only three retain the inch as a standard. It must be remembered, however, that the population and wealth of the three latter are at least equal to, if not greater than, all the others, though this does not really prove anything, except the difficulty of the subject, and that there is a great deal to be said for both sides. In the report of the Decimal Association last April the hope is expressed that one of the changes for the better arising from the war will be a reform of our weights and measures. No class of the community would be affected more closely than the engineer, and engineers cannot fail to be interested in the question as to whether the general and immediate adoption of the metric system would or would not be a valuable means of assisting British firms in their competition with Germany and Austria in countries where that system is in vogue. Although it is very unlikely that a wholesale change is imminent, it is certain that the metric system is gradually spreading, and in the United States and Australia very strong forces are on foot to bring about a change to that system. The

British Association has over and over again had the subject before it, and our committee might be of service in making a report on the present state of the matter.

One thing is certain: the Committee might be of assistance in recommendations which would bring into line all British engineers in duplicating tenders for countries which have the metric system.

Coming to standardisation, here we have more ground for satisfaction. The Engineering Standards Committee during the last ten years has done a work which is quite equal to that in any other country of completing standardisation of all important matters in engineering, and, moreover, has secured the recognition of these standards in all public contracts. As giving some indication of the range of this work, it may be said that there are more than sixty committees for dealing with every conceivable engineering matter, from bridges, ships, and locomotives, down to electric lamps. One of the last of these committees, dealing with the automobiles, has eleven sub-committees, many of which have already completed their work. It is almost impossible to do justice to the extraordinary achievement of bringing order out of what was apparently hopeless chaos, and to the benefit of the British engineering industry of this work, largely due to the energetic secretary, Mr. Leslie Robertson. We may justly pride ourselves that this section was a pioneer of standardisation, by taking up the subject of small screws, its work being taken over ultimately by the Standardisation Committee.

There is yet work to be done, however, and one matter of great importance would be to get a universal standard of temperature for instruments of measurement other than zero. A temperature, for instance, of about 62° F. would make steel rods' measures more practically workable than at present.

In connection with the subject of temperature and standardisation, I recently came across a statement by the General Secretary of the International Electrotechnical Commission ("Journal," January, 1915) that the want of uniformity in the rating and testing of electrical machinery has been a serious evil, and he goes on to say: "The German standardisation rules, for instance, which, through well-organised and combined effort on the part of the German makers, had, previous to the war, become widely recognised on the Continent of Europe, as well as in many countries to which British machinery is exported, by permitting a higher temperature rise than is considered good technical practice in Great Britain, certainly have not assisted the British maker in foreign markets."

EXHIBITIONS AND MUSEUMS.

In recent years a large number of commercial exhibitions have been held of all branches of machinery, and it is satisfactory to note that one of the features of such exhibitions has been the holding of scientific lectures and the inclusion of the exhibition of scientific instruments and apparatus, and also exhibits showing the relation of scientific experiments to engineering work. In some of the privately organised exhibitions with which I have been associated myself the scientific men have been invited to take part when the general lines had been settled on which the exhibition was to be run, and thus we had comparatively little influence. I have thought from time to time that it would be well if a permanent committee of such a body as the British Association existed which could exert more direct influence, chiefly, of course, by reports and recommendations. The managers and organisers of such exhibitions would value assistance of this kind, and, in return, would listen to suggestions which might materially add to the scientific value of such an exhibition. I know from experience that a British exhibition is a most important means of promoting British industry, for the number of inquiries that come from all parts of the country and from all parts of the world show how much interest well-organised exhibits arouse, and what long distances people will travel to attend such an exhibition. A machinery exhibition was to

have been held in London, the date of the opening being a week or two after the date at which the war began, but was, of course, not held. This exhibition was to have been Anglo-Dutch, and though organised by private enterprise, was even in advance bringing in touch the consumers and manufacturers of the two countries. The "Beama Journal" quoted recently an American magazine in which the writer was advocating the support of a permanent Commercial Museum for industrial purposes, and this is what he said: "We produce a surplus of manufactures that must be sold. Our manufactured exports have about doubled in ten years—in truth a cause for satisfaction, and yet we have not accomplished enough. . . . We have only made a beginning, considering what we can do and will be forced to do in the future. . . . Manufacturers must compete with old-established nations in the market they seek to invade." It is noteworthy that this museum, which is really a permanent exhibition, is a very complete organisation, containing, amongst other things, science laboratories.

It is sad to think that the great hopes held out of the Imperial Institute by the President of this Association, Sir Frederick Abel, at the meeting held in Leeds in 1890, have not been altogether fulfilled. The President expressed the belief that, amongst other objects, the Institute would combine "the continuous elaboration of systematic measures tending to stimulate progress in trades and handicrafts, and to foster the spirit of emulation amongst the artisan and industrial classes." It may be a very fitting time to bring forward the whole question, because it has often happened that an excellent scheme, which has somewhat languished, has upon its revival at a later time, when its importance was better realised, been crowned with success.

Another matter which might be considered is the question of departmental museums at the technical schools and universities throughout the country. The organisation of these is simply a matter for the enterprise of the individual professor in each department. The museums in the engineering department of the colleges with which I have been associated were very much appreciated by the students, who constantly were the means of securing fresh specimens, and, after they have left the college, continued to contribute articles of great interest, such as fractures, corrosions, boiler-plates, models, etc. This matter might be handled in a much more systematic manner, and possibly a report from our Committee, with a recommendation to the proper quarters, would be of use.

PATENTS AND PATENT LAWS

This subject is well worthy of the consideration of the proposed committee, since progress in engineering, certainly on the mechanical and electrical sides, is largely dependent upon invention, which is not likely to be seriously undertaken without adequate protection, not entirely for the inventor, but also for those who really make the invention practical by means of capital and business support. A great deal of nonsense is talked and written about inventors, as if they were a special class of being, generally mad, and always impossible. Some inventors are both, but the fact is, most engineers spend their lives seeking new ideas and devising new methods of carrying them out; in short, in inventing. It is of the greatest importance that every step should be taken to encourage sound invention, and to see that anything of value is secured for this country. Of course, every invention worth anything is immediately known in other countries, but I need not argue to this Section that the country which actually produces the inventions is at a great advantage, quite apart from the royalties payable on foreign patents. The foundation of the Munitions Invention Panel is a step in the right direction, and will doubtless be followed later on by Government Committees for peace inventions. Such committees or Government departments dealing with various industries will be assisted by suggestions from a body like this. Take for instance, the present state of colonial

patents; in the few years one Commonwealth patent has been made to cover the whole of Australia, instead of varying, as of old, several patents, with different regulations and fees, for each separate colony. South Africa has not yet conferred a similar boon upon inventors, and we might do something to expedite this desirable innovation. But this touches the much wider question of Colonial Patent Laws as a whole. These are all different, and differ from those of the Mother Country. It would be a splendid thing if we could bring about a conference leading to unification of these diverse patent laws, and have one comprehensive patent law for the whole Empire.

There are many other matters; for instance, the question of extending the time of secrecy in the provisional patent. The "close" time in patents was the act of Chamberlain, and is a splendid legacy of that great man; but for really many important patents the close time allowed is not enough.

Another matter is one in which the German system has certain advantages—viz., in having two classes of patents. One of these is the patent "proper," which is only granted after the most severe search and criticism, and holds the usual period when granted. The other is a secondary patent, granted for the shorter term of five years, and is given for one of the hundred and one minor improvements and devices which, though of real value, only constitute small modifications in detail, and not new applications of principle.

Having previously spoken of German ways pretty plainly, I should like to say here that I believe the suspicion of injustice to British and other foreign applicants by the German Patent Office is to a great extent, if not altogether, unfounded. It is doubtless true that German manufacturers, in common with most of us, would like to avoid paying royalties, and it is, moreover, a common belief in this country that there is an advisory committee of manufacturers associated with the German Patent Office. This view is supported by such statements as in the prospectus of the Deutsche Maschinenfabrik, which runs as follows:—"With the present-day competition every firm is compelled to protect its new designs by means of patents, and watch that no other patents are granted which would seriously effect (*sic* affect) it." Notwithstanding an utterance like this, my own experience and that of others is that if the stringent rules of the German system are observed, any valid application is granted, the motto which appears to guide the officials being: "We will be just, but we cannot afford to be generous."

There are other matters, such as the question of giving wider powers to our Comptroller to refuse to grant where novelty is less than microscopic. Here again the German system of demanding that some definite principle is applied to produce some definitely new effect might to some extent be followed, especially in view of the constant accumulation of published devices, some patented and others not.

ORGANISATION.

This, I venture to think, is by far the most important question of any I have raised, and I will go so far as to say that I believe it to be the all-important one, as it practically embraces the others. If you do not agree with me, I feel sure it is because we do not understand the same thing by the word "organisation." When you speak of organisation to most people they immediately seize upon some small feature which may be to them of more immediate interest. It may be the general arrangement of their accounts, their system of storekeeping, of dealing with their workmen, of the sales department, or any other minor details. If you take this narrow view of organisation, you will, of course, at once say that a scientific man has very little to do with it, and, indeed, the manufacturer, as a rule, thinking of his work's organisation, scents the idea that a man of science can either know or have anything to say about it which is of any value.

Let me therefore take the dictionary definition. To organise is to "arrange or consti-

tute the separate parts, even bringing a special function, etc. office, or relation with respect to the whole." If we accept this definition, it is no matter of fact, we must, there is no question as to the all-important nature of organisation, for you will notice there are two outstanding things, the first "interdependent parts," and the second term "relation to the whole." This subject of organisation really includes the whole of industry. It includes science and its relation to manufacture, it includes the relations between the employer and employee; it includes the workman, and his attitude towards new devices, labour saving appliances, and output; it includes the whole question of the supply of raw materials, and even the sale and delivery of the finished article. Taking these different features, is there any doubt that the man of science in this country can hold his own, and more than hold his own, with that of any other? The history of invention is quite enough to give a final answer to this question. Again, the British employer and man of affairs has always shown himself individually in the forefront of enterprise; as for the workman himself, he is admitted, in the matter of intelligence, physical endurance, and skill, to have no superior; while with regard to materials for manufacture, and the power of delivering goods, it need scarcely be said that the British Empire, if we take it as a whole, is the richest country in the world in raw materials, and its means of delivery of its goods is expressed by the enormous preponderance of its mercantile marine.

When we come, however, to these interdependent parts and their relation to the whole, it is there that we find the weak joint in the armour. It is in this respect that Germany can teach us a striking lesson in the arrangement of these interdependent parts with respect to the whole. From the top to the bottom the whole forces of their industries are so thoroughly organised that they get all that is humanly possible out of the various factors. I do not limit this merely to the wonderful organisation of any works, like Krupp's, or the Deutsche Maschinenfabrik, or hundreds of other works; but I include the organisation of all the Government departments, together with the banks, the railways, and the shipping, so that every facility is afforded for the world commerce of the German Empire.

Taking only one of these details, I remember when at Liverpool, and the battle of the Manchester Ship Canal was being fought, what facts came out as to the difficulties in the transhipment and handling of goods. The late Mr. Alfred Holt, for instance, was one of the most earnest in pointing out that the want of co-operation and organisation in getting goods from our manufacturing centres was adding largely to their cost, and actually exceeded the cost of transporting these goods across the ocean. In Germany, on the other hand, the Government steps in, and, by means of special differential rates gives the manufacturer every facility, and the lowest possible rates for obtaining raw material and delivering the finished goods to all parts of the world. It was this organisation that not only rendered Germany so formidable a rival in times of peace, but makes her so powerful in war.

This co-ordination in Germany is carried out in every industry in a way we generally have little idea of. For instance, the other day, at a deputation to the Government, Mr. Runciman remarked that the difficulty of connecting the manufacturers with the commercial staffs in this country is deep seated, but perhaps not altogether incurable. Further, that the manufacturer must realise what he can get from the universities, and that university must know what the world requires. Dr. Foster, the treasurer of the Chemical Society, also said that "the Germans were so imbued with the need of pursuing modern and efficient methods of education in applying science to industry that they hold in contempt a country which notoriously neglects such processes"; and he attributed this contempt as partly contributory to their cheerfulness in entering into war with us.

Now, while these remarks are undoubtedly true, they are only a part of the truth. The

civil is far wider than in any special application, for, as the German knows perfectly well, there are innumerable individual cases of organisation in this country of equal efficiency to any in his country, and he is glad enough to learn from special cases. Let us take one and I do so because it shows that the man of science is capable of industrial and manufacturing organisation, if he turns his mind to it. I refer to the case of the firm of Barr and Stroud, Limited. As you know, the founders of this firm were originally colleagues in the Yorkshire College—the former, Professor Barr, occupied the presidential chair of this section three years ago, and they together invented a range-finder. Now, whatever the merit of this range-finder, it is safe to say, like every other important invention—for instance, the Parsons turbine—that the invention alone would have stood a small chance of coming into practice. In fact, to make the invention, as a rule, the beginning of the difficulty. Professors Barr and Stroud, however, set to work to carry their invention into practice, and did so with such effect that their works, which began on quite a small scale, rapidly grew. The first part of the new works was opened with about ninety hands, all told, in 1904. In the course of ten years it has increased to such an extent that there are now 1,700 employees. Those of us who have visited the works at Glasgow know the almost perfect way in which the whole arrangements are made, not merely for the scientific side, but for the comfort of the men, including the working dress, which in itself becomes a uniform. It gives some idea of the scientific side to know that there are at the present moment twenty-three men with high university qualifications, most of them with university degrees, and many of them men who were absolutely the first on the college list in the final examinations. This industry is another illustration of the lead given to Germany by this country, because the Barr and Stroud range-finders were brought out before any of the German range-finders of the kind now being made, the Germans having followed in their lines and copied them in many respects. I have enlarged upon this, because I cannot help pointing out that the Barr and Stroud range-finders have had no small effect in the marvellous precision of our naval guns, and it will no doubt pass through your minds what we owe to private enterprise, which started the manufacture of the turbines, range-finders, guns, and other naval features, when we think of such battles as those off Heligoland or the Falkland Islands.

The other day Field-Marshal von Moltke stated, and there is no reason to disbelieve him, that, great as was the storage of ammunition and shells before the war, the enormous demand far exceeded all expectation, and Germany found herself for a time in the same plight as her enemies; but he further stated that Germany's emergence "from this dangerous position was largely due to the extraordinary organisation, which included not merely the adaptation of their factories for munition purposes, but capacity for work of the people, and the patriotic spirit of the German workmen."

THE RELATION OF EMPLOYERS AND WORKMEN.

This brings me to consider what is probably the most serious feature in our national life to-day, which I have already alluded to under the heading of education—viz., the relation of employer and workman. It is hopeless, as long as there prevail such ideas as seem to do at present, to think of any sound organisation of our industrial system taking place, because the interdependent parts are not arranged with respect to the whole; they can never be arranged until we change radically. Now, as one who has served an apprenticeship, who has taken his money weekly from a tin box with hundreds of other men, who has been a member of the Amalgamated Society of Engineers (in fact, was working as an engine fitter when a Whitworth scholarship made a college career possible), I am the last man to put this evil down entirely to the working man. I know individually he is just as capable of patriotism as any other class. Get him by himself, even the men whose strikes have

caused such despondency in the minds of our Allies, and who have seriously jeopardised the very existence of the country, and you will find (except in the sort of case to be found in all classes of society) that he, as an individual, is willing to make sacrifices and, if necessary, to give himself for his country. The truth is that the cancer which is eating the heart out of our industrial life is due to an entirely wrong attitude of mind. For instance, however much we may sympathise with men who see a loss of employment in the introduction of labour-saving machines, some means should be found by which they can share the benefits to the State and to their employers by the introduction of such machines.

Again, the questions of piecework and overtime must be seriously considered by the State, and not allowed to become the subject of disastrous disputes. Once more there is the question of a standard wage. It is against the eternal laws of Nature to try and keep living beings at one dead level of equality and merit—i.e., it is against the law of the survival of the fittest. The trade unions have a great opportunity of placing their country and themselves in a leading position amongst nations if they will courageously grapple with a great problem by recognising degrees of merit and corresponding degrees of payment. These are a few of the many matters which must be dealt with in the immediate future.

The matter of labour disputes is so serious as to demand plain speaking. It must be admitted that there are many employers and companies which, to satisfy themselves and their shareholders, extort the largest possible dividends and pay the smallest possible rate of wages, and do so apparently without the slightest idea that the men and boys under them are capable of education and personal influence. Can it be wondered, then, that men under these conditions are willing enough to listen to the orator who merely appeals to their fighting instincts, and to join in the game of grab as against the employer? On the other hand, strikes have occurred when employers have honourably carried out their obligations and undertakings, and the men have shamefully departed from an agreement made by their chosen leaders, throwing over the leaders the moment they have fancied it to their own selfish interests to do so, and without a single thought of their duty to the community as a whole.

We have recently seen the Prime Minister and other leading statesmen struggling, sometimes in vain, to bring large bodies of men to a reasonable state of mind. Is not this (and I speak without the slightest reference to party questions) a case of Nemesis overtaking us for having in so many cases pondered to the selfish instincts of large bodies of men in order to secure their votes, instead of steadily telling them unpalatable truths?

There was recently an intensely interesting article by the late Professor Friedrich Paolsson, previously Professor of Philosophy in Berlin University, published in the "Educational Review," of New York. In this article, the subject of which was "Old and New-fashioned Notions about Education," he pointed out that the whole of our educational system was going wrong, and that we could not escape the conviction that a tendency towards weakness and effeminacy was its chief trait. His three mottoes were, Learn to obey, Learn to apply yourself, Learn to repress and overcome desires; and he remarked with great truth under the first heading: "He who has not learned to do this in childhood will have great difficulty in learning it in later life; he will rarely get beyond the deplorable and unhappy state that vacillates between outward submission and uproarious rebellion."

Is not one of the first things the reform of our educational system?

The other day a writer in the "Saturday Review" said, with great truth, that "what Great Britain is suffering from acutely and dangerously at the present time is the absence of discipline," and a neutral writer in the *Times* remarked as follows:—"The uniformity of German effort, due doubtless to their myriads of well-organised, machine-

like minds, though it renders them excessively tiresome people to dwell among in peace time, enables their Government to extract every ounce of energy in the conduct of a war." He further went on to say that the British Empire "could not have been created by minds like these, but it should not be forgotten that in the concentration necessary to national effort in a struggle like this the German system of self-subservience to the State has enormous advantages."

One of the tasks to which the British Association might bend its energies with the greatest benefit to the country is to bring about a reform of our educational system, so that while we do not kill individual enterprise and freedom of thought, which have contributed so largely to the political organisation and constitution of the British Empire, of the value of which we have had such wonderful evidence from our colonies and dependencies during this war, we seek to implant in the minds of young and old those ideas of discipline and service to the State the want of which so seriously threatens the successful organisation of our industrial life.

CANTERBURY CATHEDRAL *

A lecture on this building, illustrated by about eighty lantern slides, was delivered at the Royal Photographic Society's Exhibition, Suffolk Street Galleries, on Thursday evening, by Mr. R. P. Howgrave Graham, F.R.P.S., M.I.E.E. Mr. Alvin Langdon Cohn occupied the chair.

The lecture was limited to the main structural features of the existing cathedral church, and it was explained that with its two great crypts, its double transepts, and the Trinity Chapel and corona beyond the choir, it afforded a subject wide enough to need considerable compression in the available time, even if the numerous important tombs and the extensive monastic ruins were ignored. The slides shown formed part of a collection of 580 photographs taken by the lecturer, illustrating the Cathedral and Benedictine Monastery of Christchurch, and Mr. Graham introduced them by pointing out how the unique interest and value of the buildings were enhanced by the remarkable preservation of a series of records which enable us to date the more important parts within a few years and to follow the great rebuilding of 1174-1184, after the devastating fire of the previous summer, so closely that walls, columns, and vaulting can even be dated month by month. The history of the building operations was developed chronologically, and after a few words about the Saxon and Norman

* The following illustrations of Canterbury Cathedral have appeared in THE BUILDING NEWS during recent years:—Ground plan of monastic buildings and cathedral (by Lieut. Rev. Mackenzie E. C. Wallcut, March 3, 1876; chapter house, north transept, nave and central tower from cloisters (drawing by T. H. Curry), December 2, 1881; in the cloisters (drawing by G. N. Stevenson), September 24, 1890; do. (by E. Winbridge), March 4, 1870; 15th Century doorway to cloisters (National Silver Medal drawing by Harry P. Clifford), March 8, 1895; Norman staircase to registry (sketch by Maurice B. Adams), October 18, 1872; do. (sketch by J. W. Twist), September 12, 1890; infirmary arches and other ruins of monastic buildings (sketches by Leonard Martin), December 27, 1889; central tower from Park Entry in the Close (drawing by Joseph Pennell), February 10, 1883; south transept (sketch by T. H. Curry), December 21, 1881; do. (by Laurence M. Angus), June 3, 1900; carved boss in south porch vault, lion with protruding tongue (device of the Black Prince), August 27, 1900; oak pulpit in nave (by late G. F. Bodley, R.A.), January 1, 1897; tomb of Hales family in south nave aisle (Pugin drawing by J. J. Joass), January 24, 1890; perspective of north arcade and aisle of choir compared with that of Sens Cathedral (drawings by W. Samuel Weatherley), June 29, 1877; do., looking east (from photographs), June 2, 1911; the late I. Oldrad Scott's organ case, south side of choir, April 4, 1884; pavement in front of Becket's shrine, Trinity Chapel (measured by late F. C. Desham), March 1, 1872; tomb of Henry IV., and Joan of Navarre and of D. de Henry Wootton (drawing by F. W. Richardson), June 26, 1886; tomb of Edward the Black Prince (by F. W. Richardson), January 10, 1876; memorial to Archbishop Temple, by W. D. Carie and F. W. Pomeroy, photograph, September 29, 1905; Archibishop Simon de Meopham's tomb, St. Anselm's Chapel (measured drawings by Arthur Keen), March 4, 1881; iron grille in St. Anselm's Chapel (measured drawing by G. A. T. Middleton), May 20, 1898; in the crypt (sketch by Leonard Martin), December 7, 1889; half a dozen carved capitals in crypt (drawings by J. Dunkin), January 7, 1881.

work at the west end of the crypt, the main part of the Norman crypt was described and illustrated by a series of excellent photographs, attention being drawn to the fact that alternate pairs of columns had sculptured capitals and plain shafts, those between them having nearly plain capitals and shafts ornamented with spirals or scrolls. The existence of unfinished sculpture on one of the capitals is a most interesting proof that much—perhaps all—of the carving was done after the completion of the crypt, and suggests the intention to enrich the whole series. The lecturer pointed out how much architectural skill and energy in the south-eastern corner of England was associated with the Abbey of Bec, in Normandy, whence came Lanfranc, who built the first Norman Cathedral at Canterbury; Anselm and Ernulph, who rebuilt the choir and gave us the crypt as we now see it; and their friend Gundulph, to whom we owe the White Tower of London, St. Leonard's Tower at Malling, and other work at Malling and Rochester. In 1174 occurred the terrible fire so graphically and humanly described by the monk Gervase, and whether or no this caused the cessation of the work in the crypt, it marks the inception of the work in the crypt, it marks the inception of grand and new ideas carried out by William of Sens for the monastery. The restrictions imposed by the conservatism of the monks, who demanded that every fragment of old masonry uninjured by the fire should be utilised afresh, forced William to cramp his genius in order to avoid the destruction of certain chapels remaining untouched by the fire. A view of the choir looking north-east, and illustrating the curious construction of the choir due to the retention of the projecting chapels of St. Andrew and St. Anselm, was followed by one of the interior of Sens Cathedral (1143-68), taken from a similar viewpoint, and the remarkable resemblance in the two piers with foliated capitals and the system of vaulting showed the influence of Guillaume on the work in his native city. Guillaume's fall in 1178 from the scaffolding at the east end of the choir, and the continuation of his work by William the Englishman, give us a distinctively English eastern crypt and the Trinity Chapel and corona above, and these show incomparable delicacy and refinement, combined with a touch of Classic feeling which harmonises wonderfully with their semi-Gothic constructional principles. Such grand work left little needing to be done, and perhaps small financial resources for building during the Early English and Decorated periods, to which belong only minor features, such as a doorway, a unique screen, and a fine window in St. Anselm's Chapel, the last two being nearly as exactly dated as the work of the two Williams. Late in the Decorated period, however, is the exquisite bridal chantry of the Black Prince, with its beautiful bosses, but this is built into the Norman transept of the crypt, and has no constructional significance. The nave, carried out by Prior Chillenden, in the Early Perpendicular style, was fully illustrated, and this Prior's somewhat martistic but very businesslike proceedings were emphasised by a slide showing his portrait in a vaulting boss, where he appears as a severe, hard-headed, and somewhat unimaginative man. The central tower, dating from the close of the fifteenth and the first few years of the sixteenth century, is a wonderful example of perfect Gothic work, built at a time when old conceptions were in the melting-pot, and such art was rapidly decaying; it is, indeed, curious that Prior Sellyng, one of the moving spirits of Renaissance thought, seems to have been responsible for the design and part of the execution of this tower, which was conservatively repaired a few years ago under the direction of Mr. W. D. Caroe. The lecturer gave illustrations of the exterior and of the buttressing arches introduced to strengthen the tower-piers, and concluded his lecture with a few remarks on modern works of restoration at Canterbury, good and bad.

Mr. Pearson, the borough surveyor of Marlborough, has accepted the post of estate agent to Sir Audley Neeld, Bart.

LOAD TESTS ON BRICK PIERS.

At a recent meeting of the National Brick Manufacturers' Association an interesting paper based on an investigation now being conducted in Pittsburgh by the U.S. Bureau of Standards, in order to determine the physical properties of large piers when tested to destruction, was presented by Messrs. J. H. Griffith and J. G. Bragg, members of the staff of the Bureau. It is of interest to mention that Prof. A. V. Bleiminger, the well-known ceramic chemist, who has addressed several meetings of brickmakers in Canada, acted in an advisory capacity throughout the investigation.

So far, more than twenty-two piers have been tested.

As nearly as possible each pier was 30 in. square by 12 ft. high, except two piers, which were built 5 ft. high. Each pier averaged 44 courses. The joints were about 5-16 in. thick. The qualities of brick used, kinds of mortar, ages of piers and results of tests are tabulated below. Three typical styles of bonding were selected for test—header every other course, every fourth course and every

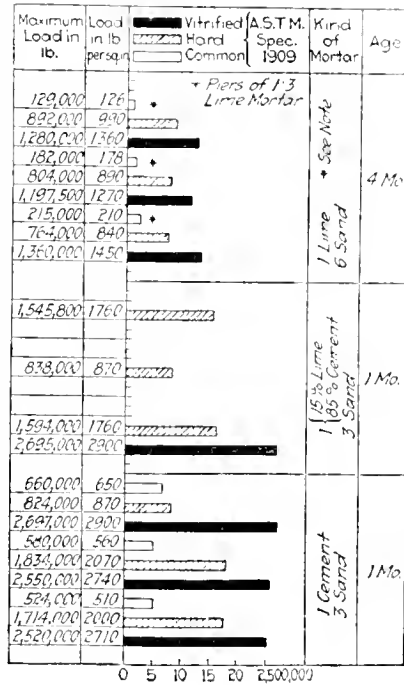

seventh course; thus there were three types of bonding for each set of piers. One of the 5-ft. piers had steel-mesh reinforcing placed in every horizontal joint; the other, every four courses; but the results obtained were inconclusive (see Conclusion No. 7).

METHOD OF TEST.

Each pier was constructed in the laboratory on a steel plate 1 in. thick, levelled on the floor. The plate surface which was to rest on the base of the testing machine was planed. A plate 1 1/2-in. thick, with eye-bolts for crane connections, was laid on the top of the finished pier, connected with the base-plate by four vertical rods, so that the piers could be filled easily and set in the testing machine without injury. The top plate was removed after the pier was in place. The pier was levelled, the top covered with a thin coat of plaster of Paris, and the head of the machine brought down, squeezing out superfluous material. The pier was then left for several hours to allow the plaster to set. Measurements of compression were made at several corners, as were also transverse measurements and strains between bricks.

As shown above, bricks laid in cement mortar stood up best. Cement-lime mortar gave almost as good results. Piers using lime mortar were only about one-half as strong as those with cement; but it should be noted that vitrified brick laid up in lime mortar withstood a pressure of more than 1,400 lb. per sq. in. The weakness of these piers was caused mainly by an almost entire

lack of penetration of the lime into the interior, rather than by a special efficiency of lime mortar when properly aged.

CHARACTERISTIC FAILURE OF PIERS.

At about three-fourths maximum load vertical haircracks began to appear. With continued loading the piers broke up into vertical laminations. This condition was induced by the bending of the individual bricks, causing them to split transversely. The bending is the result of non-uniform bearing proceeding from lack of homogeneity of texture in the pier, in an individual brick or in the mortars.

The progressive action of this cracking is most interesting. Sometimes very early in the test small haircracks formed in the upper or lower surface of a brick, usually just under or near the vertical joints, and widened at the surface as the load increased. Finally, subdued sounds were heard, which increased in volume until, in the case of vitrified and hard-burned brick laid up in lime mortar, a succession of popping sounds occurred frequently increasing until the sound became a loud "bubbling" in the final stages. When a brick split, the ones above and below tended to do the same, until the structure became a succession of strips, and failed either by spalling out in large masses or as a group of thin, isolated columns.

The following are the main conclusions reached in the investigation:—

- (1) The strength of piers under vertical loading bears a close relation to the kind of brick used and the quality and age of the mortar.
- (2) The low strength of piers laid in lime mortar is attributed in the main to insufficient ageing, with a consequent lack of a proper carbonation of the mortar.
- (3) Experiments seem to indicate that the strength of a pier is largely independent of the course bonding. The real function of bonds is to maintain a certain integrity and monolithic action of the masonry against initial strains induced through setting and "drying out" of the mortar rather than to give any great increase of vertical strength.
- (4) The elastic limit of the piers laid up in cement and cement-lime mortar was approximately one-half the maximum load.
- (5) Piers fail through a tendency to separate into vertical strips caused by bending failure in the individual brick produced by unequal distribution of the vertical load over the cross-section. This is aggravated by ineffective shearing and adhesive strength of the mortar.
- (6) A high modulus of rupture of the brick is more desirable than superior crushing strength. Higher modulus of rupture would be realised in practice by increasing the thickness of the bricks or by laying them on edge.
- (7) A further study of the action of steel-mesh reinforcing in the horizontal joints is recommended in order to ascertain the load efficiency of piers having an outer shell of hard brick with an inner core of softer brick. This construction would be useful where a high-grade brick is not easily obtainable.

Exterior work is progressing rapidly in the erection of the First Church of Christ Scientist at Winnipeg, for which the Fox Garry Construction Company are the general contractors. The architects of this building are Messrs. Gordon and Over, of Winnipeg.

The Grand Jury at the City of Montreal Court has thrown out the bill against Montreal Mayor (41), managing director of the City of Montreal (Cross Cinema, and Board of Health 22), who, as reported in our issue of August 14, p. 135, were committed by the Montreal Superior Court on a charge of the manslaughter of William James P. Alva. The case arose out of a fire which occurred in the Cross Cinema.

A boys' department has been added to St. Joseph's Roman Catholic School, Swansea. It is part of a larger scheme of building the schools of the parish, the old ones having been condemned some years ago and will accommodate in all 360 boys. It was built at a cost of £6,000 to the plans of Mr. G. E. T. Laurence, 22, Buckingham Street, Adolph, and the builders are Messrs. David Davis and Sons, Cardiff.

Our Illustrations.

NEW LIBRARY AND PICTURE GALLERY, THE SCHOOLS, SHREWSBURY.

This building, situated upon the rising ground and known as Kingsland, overlooking from the south-west the River Severn and the town of Shrewsbury, will form another link in the chain of school buildings which crowns the ridge. One of the main purposes of the building is to house the famous collection of rare books, and it will, ultimately, also contain a bequest of valuable water colour paintings of the English School. The plan comprises a wide entrance-hall, at one end of which are placed the reading-room and the picture-gallery, at the other, isolated by fireproof doors, the library, whose size and proportions are regulated by the inclusion of 17th Century bookcases from the old school building in the town. A librarian's room, store, and strong-room for the storage of the more valuable books complete the accommodation. The design of the building is based upon the Jacobean tradition of the old school buildings, and is carried out in Grinshill sandstone and 2-in. hand-made red facing bricks, of varied shades of colour. Notable features are the bay window to the reading-room and the two colonnades to the south and north of the hall, forming respectively a porch and a loggia, from which latter the magnificent view across the river may be enjoyed. The roofs are supported by oak trusses, whose timbers contribute largely to the interest of the interior of the building. Red hand-made tiles, laid with "swept" valleys, form the roof covering, finishing with a half-round ridge tile, while the gable ends are coped, and terminate in moulded stone finials and projecting kneelers. The windows are filled with leaded glass, with a large number of opening casements; wrought-iron stanchions, with foliated heads, preventing unwarranted intrusion through the windows of the library, are also provided. The picture-gallery is lighted solely by means of two ranges of dormer lights close to the ceiling level, the gable-end being, therefore, devoted to a decorative feature, formed of niches in which replicas of two 17th Century figures on the old school building will be placed. These niches, with their enclosing pilasters and entablature, all executed in Grinshill sandstone, surmount the foundation-stone laid by H.M. the King at his visit to Shrewsbury last year. Warming and ventilating radiators keep the temperature inside constant, but the reading-room has, in addition, a large recessed fireplace, whose projecting stack forms so prominent a feature in the illustration. Moulded brick cappings, curved horns, weathered base and offsets, add interest to the work. Care has been taken, by keeping the joints of the stone quoins irregular, and by using, for the walling, a struck joint pressed in with the thumb, to give a soft surface texture to the building. The cost of the work will be approximately £5,500. The architects are Messrs. Forsyth and Maule, F.F.R.I.B.A., 309, Oxford Street, W., and the general contractor is Mr. Henry Price, Welsh Bridge, Shrewsbury. The drawing here reproduced was shown at the Royal Academy this year.

ST. MICHAEL'S CHURCH, MILL HILL, N.W.

This new church is to be erected on a site in Flower Lane, adjoining the Hartley Memorial Hall, built by the same architect. The church will consist of nave 91 ft. long and 26 ft. wide, aisles 30 ft. by 14 ft. wide, chancel 20 ft. by 25 ft., morning chapel 39 ft. by 14 ft., organ aisle, clergy and choir vestries, and suitable porches at entrances. There will be clerestory windows, but the aisles and chancel will be lofty and have timbered roofs of same height as the nave and chancel, and the side windows will be large and kept high up so as to secure good lighting to the nave and chancel. The stone arcade walls between nave and chancel and the clerestory side of chancel will be of light proportions and slightly moulded. It is intended to erect a tower at north-west corner of nave,

next Flower Lane, as shown in the view. The window and other dressings externally will be of Weldon stone, the walls faced with red and purple bricks, relieved by stone bands and copings, and the roofs will be covered with red hand-made tiles. The inside stonework will be of Bath stone. Accommodation will be provided for 750 persons. The architect is Mr. J. S. Alder, Licentiate R.I.B.A., of 1, Arundel Street, Strand, W.C.

BILLIARD-ROOM, CROW CLUMP, WEYBRIDGE.

A view of this house from the gardens appeared in our issue for June 9 last, from the original shown at this year's Royal Academy. On July 10 last year the plans and entrance side of the house were illustrated. We now give a view of the billiard-room, with its angle-nook and hooded fireplace. All the woodwork is in oak and other hard timber. Mr. W. G. Tarrant, of Byfleet, is the builder, and the architects are Messrs. Tubbs, Messer, and Poulter, of Craig's Court House, Charing Cross, S.W.

THE MIDDLESEX COUNTY GUILDHALL, BROAD SANCTUARY, WESTMINSTER, S.W.

To-day we give two interior photographs of this building. That to the left illustrates part of the roof of the Council Chamber, and the other shows the throne and bench of the County Sessions Court No. 2. Two plans of this building appeared in the BUILDING NEWS of September 1, when interiors were published of the County Sessions Courts Nos. 1 and 2, together with a brief description of the building, which is erected on the detached site next the Westminster Hospital and facing the Houses of Parliament and Westminster Abbey. Messrs. J. S. Gibson, Skipwith, and Gordon, of Old Bond Street, W., are the architects. An exterior perspective appeared in our issue of February 5, 1911.

THE NEW OFFICES OF THE MUTUAL LIFE ASSURANCE COMPANY, WATERLOO, CANADA.

This handsome Canadian assurance office has been built at Waterloo, Ontario, from the designs of the Royal Gold Medallist of the R.I.B.A. for 1915. Mr. Frank Darling, F.R.I.B.A. (Messrs. Darling and Pearson), The building is monumental in character, and admirably adapted to its purpose. The photographs may be taken as typical of others, and representing Mr. Darling's style at its best. We hope shortly to publish two others of similar buildings erected in other parts of Canada by the same architect. The marble work was carried out by Messrs. P. Lyall and Sons, of Montreal. Messrs. Doulton and Co., of Lambeth, executed the terracotta of the great portal shown. The ornamental plastering was done by Mr. R. C. Dancy, of Toronto. Messrs. Jos. McCausland and Son, also of that city, were employed on the painting, while Messrs. J. S. Scott, of the same address, were entrusted with the woodwork.

HOUSE, HAMPSTEAD HEATH.

This house and chauffeur's cottage is erected on the high ground on the Hampstead Garden Suburb. The garden adjoins a large wood, and from the front the view is uninterrupted over the Heath, for which reason the garden room was provided. The bricks externally are Chesham greys, with dressings in reds from the same kilns. The timber framing is in oak with trowelled plaster panels. The tiles to roof and tile hanging are red hand-made sand-faced Bedfordshire tiles. The woodwork is painted white throughout, except the motor house doors and front door, which are bright green. Mr. Gilbert C. Waterhouse is the architect.

The tender of Mr. John Hunt, South Wharf, Cleveland Road, Gosport, has been accepted by the Admiralty for new block of buildings for the accommodation of the sick berth staff at Haslar Hospital, which is a gift from the Canadian ladies to the Mother Country.

A cross is to be erected in the churchyard of St. Mary and John, Cowley, Oxon, as a memorial to the late Rev. R. M. Benson. The cross will be built from designs by Mr. J. M. Comper. It will stand about 21 ft. high, and at the top of it there will be a crucifix with figures of St. Mary and St. John on either side. The cost will be about £300.

LEGAL INTELLIGENCE.

ADMIRALTY CONTRACT AT ROSYTH—QUESTION OF CROWN PREROGATIVE.—Judgment has been given by Lord Anderson in the Bill Chamber of the Scottish Court of Session at Edinburgh in a case the appellants in which were the Lord-Commissioners of the Admiralty. They appealed against a deliverance given by William Dunlop, Glasgow, on the sequestrated estate of Andrew Blair, public works contractor, Glasgow. The Commissioners, in May, 1914, entered into a contract with Mr. Blair for the execution of storage works at Rosyth at a cost of £7,651, and before the contract was completed the contractor was sequestrated. At the date of the sequestration the contractor had executed work to the value of £2,771 19s. 10d., and had been paid £1,800. The trustee declined to carry out the contract, and the Commissioners entered into a new contract with another contractor to complete the work for £6,280, making a total of £9,051 19s. 10d., representing a total increase of £2,020 19s. 10d., which, less the sum due to the contractor—£971 19s. 10d.—made the net extra cost £1,049, which amount, the Commissioners claimed, was the damages they sustained through the failure of the contractor and the trustee of the sequestrated estate to implement the contract. For this sum of £1,049 the appellants, as representing the Crown, claimed preferential ranking in the sequestration. The trustee admitted the claim to an ordinary ranking, but he rejected the claim in so far as it was made to a preferential ranking. Lord Anderson has refused the appeal, affirmed the deliverance of the trustee, and found the Crown liable in expenses. His Lordship said, in his judgment, that the appellants maintained their right to preferential treatment on the following grounds: That the Crown had an inherent right, by way of prerogative, to a preferential ranking; and that there was no provision in the recent Bankruptcy Act of 1913 which abrogated or modified that prerogative of the Crown. Regarding the first point, the appellants founded, on a decision of Lord Cullen in the case of the Lord Advocate v. Galbraith, in which his Lordship held that the Postmaster-General was entitled to a preferential ranking in a sequestration for the amount of a telephone rent. His Lordship was unable to agree with Lord Cullen's reasoning. His Lordship took that view because the principle was inequitable; the alleged prerogative was hostile to the general policy of the Bankruptcy Acts, which aimed at equal treatment of all creditors in the matter of the distribution of the estates of a bankrupt. But assuming that Lord Cullen's judgment was sound on the foregoing point, his Lordship was against the appellants on the second branch of their argument—that the provisions of the Bankruptcy Act of 1913 had neither modified nor abrogated the alleged Crown privilege. He held that Section 118 of the Bankruptcy Acts of 1913 implicitly abrogated any such alleged prerogative. In this result his Lordship was fortified by the consideration that his judgment determined that on this point the law of Scotland was the same as that of England.

A mission hall is about to be built at Blaenavon in connection with St. Paul's Church. The architect is Mr. G. A. Treharne, of Aberdare.

In response to the special appeal for funds to meet the deficit of the Architectural Association many fresh donations have been sent in, bringing the total receipts of the fund to a little over £310.

Mr. A. E. Brookes, the surveyor to the Durham County Council, has been instructed by the Government to act as engineer-in-chief in the construction of the whole of the new military roads on Salisbury Plain. Prior to going to Durham Mr. Brookes acted as surveyor to the Cornwall County Council.

A verdict of suicide while temporarily insane was returned at a Sunderland inquest on Thomas Henry Lackenby, a sculptor, who resided in an attic at 9, King Street, Sunderland. A sister of deceased said that for some time past he had been very depressed, and done very little work. He was found lying on the floor dead with a tube from the gas bracket between his lips. The gas had been turned on.

At a meeting of the Town Improvement and Streets Committee of Newcastle-on-Tyne Corporation on Wednesday the city engineer presented a report on a census of uninhabited premises taken on August 24, 25, and 26. The figures were:—Self-contained houses, 30; flats, 2; houses and shops combined, 12; doubtful if fit for habitation, 76; total 175. When the last census was taken, in May this year, the total was 193.



*The Schools, Shrewsbury
New Library, Reading Room
& Picture Gallery*

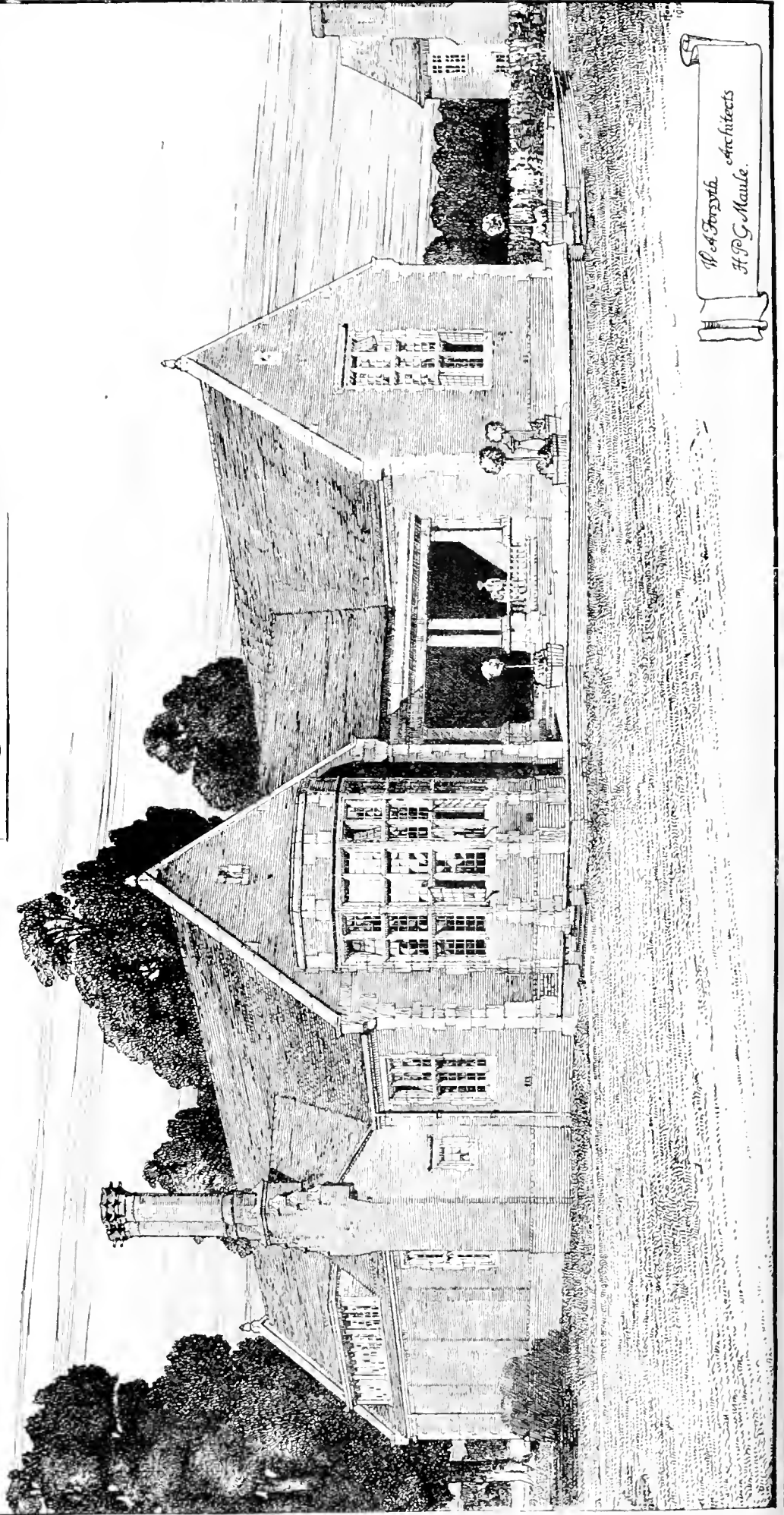
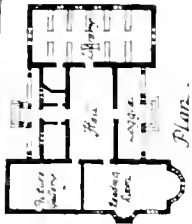

*H. A. Forsyth Architects
H. P. & Maule.*



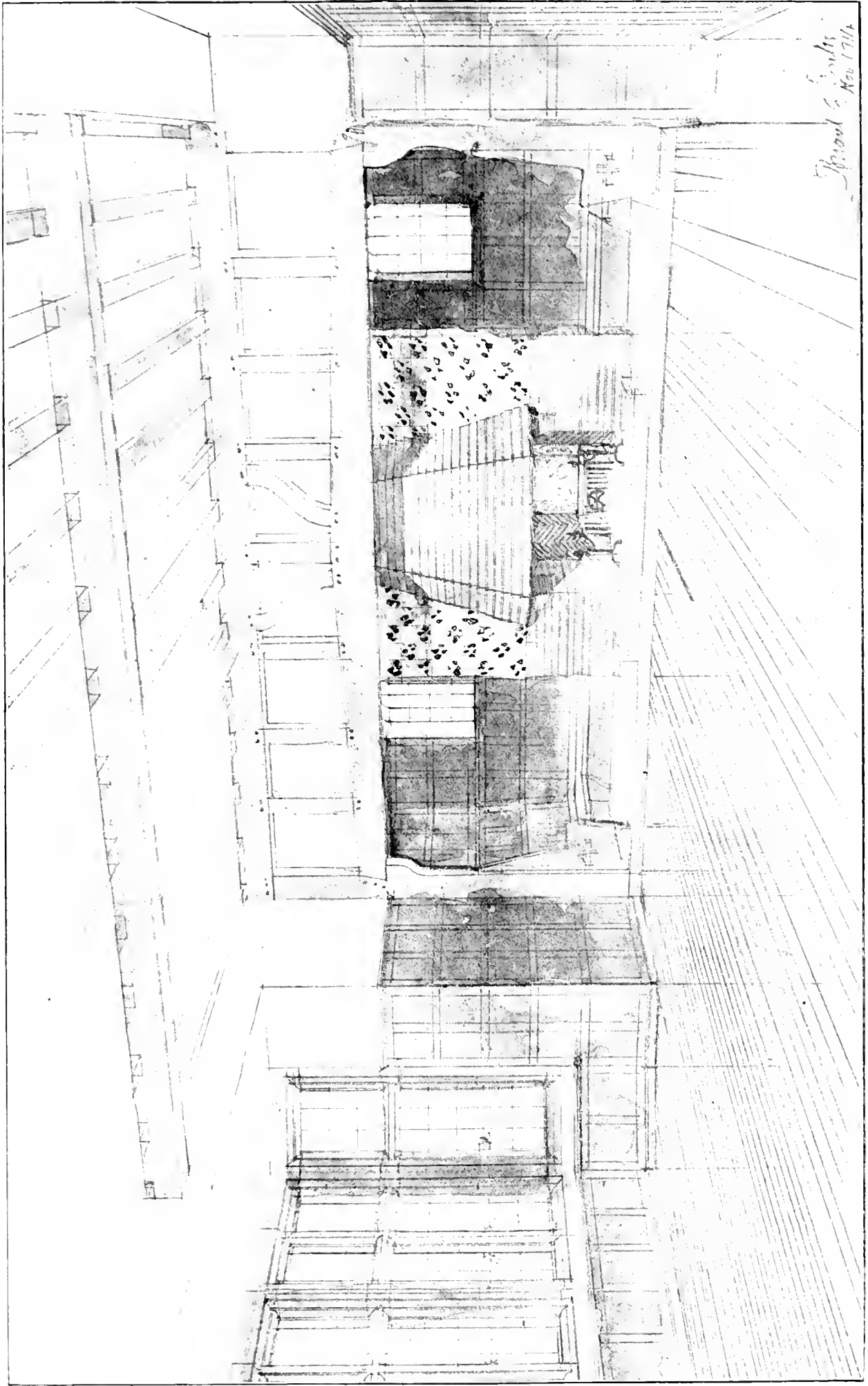

THE BILLIARD ROOM, "CROW CLUMP," WEYBRIDGE, SURREY.—Messrs. TUBBS, MESSER and POTTER, Architects.

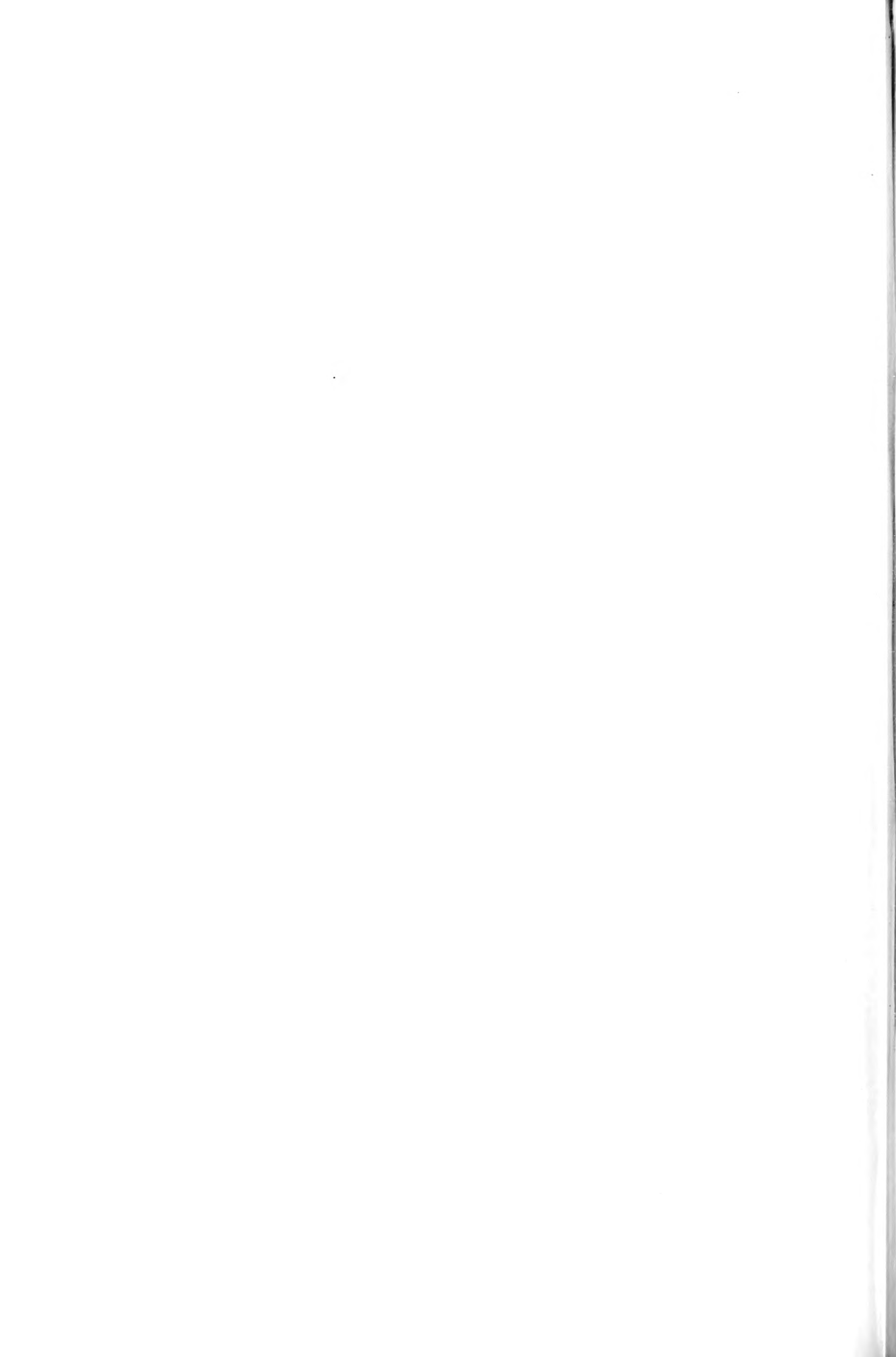

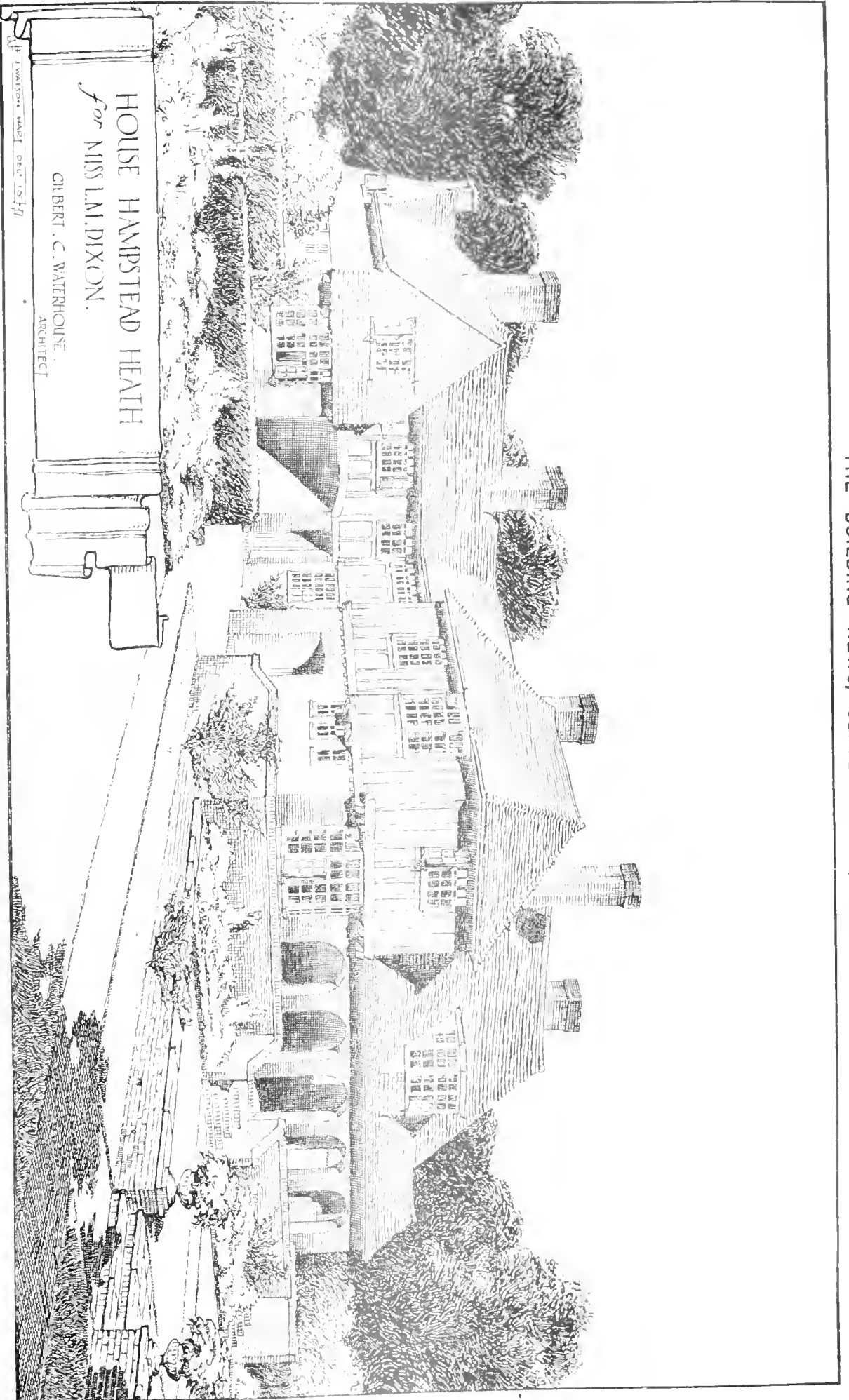







NEW OFFICES OF THE MUTUAL LIFE ASSURANCE COMPANY, WA
Mr. FRANK DARLING, F.R.I.B.A. (Royal Gold Medal)



UNIVERSITY OF TORONTO, ONTARIO, CANADA: GENERAL VIEW OF THE PORTICO AND MAIN ENTRANCE
(1915) (Messrs. DARLING and PEASE, Architects)







THE MIDDLESEX COUNTY GUILDHALL, BROAD SANCTUARY

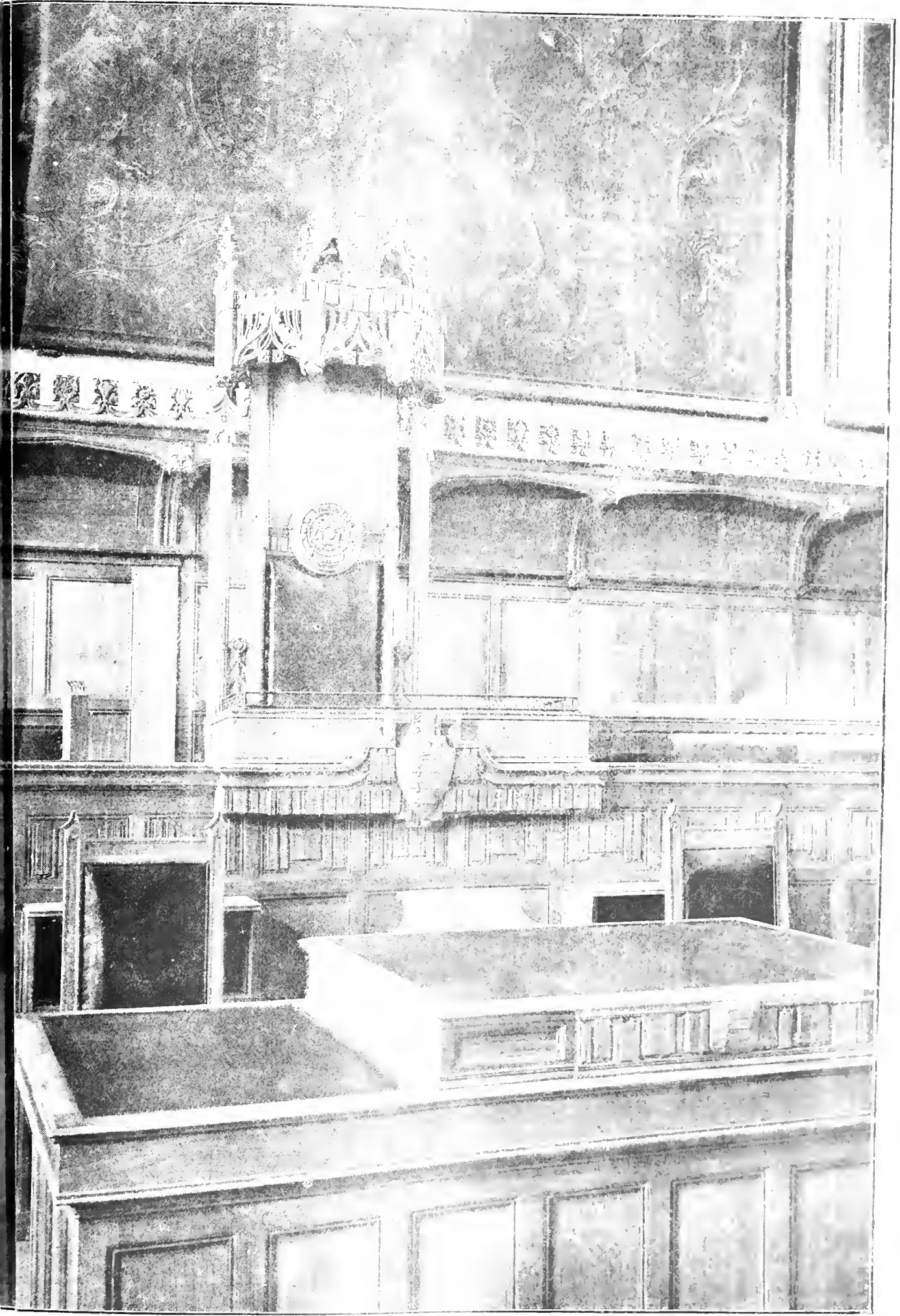

THE ONE AND ONLY COURT HOUSE IN THE CITY OF ST. LOUIS, MO. COURTESE OF THE ARCHITECT, MESSRS. J. S. GARDNER & COMPANY, ARCHITECTS, ST. LOUIS, MO.



Current Calamity.

Now is the winter of our discontent, with competitions generally very unlikely to be made glorious summer by this sun of York, which shines as dubiously as old Sol himself through the autumnal morning mists, on the prospects of competitors in the town-planning scheme that the city is about to engage in. No one knows who the assessor is to be, or if an architect is to assist him. For £175—the amount of the three premiums—the corporation demands the right to use all or any of the designs thus appropriated. The work asked for is very considerable, and of the kind that demands much time and brings little fame, and the hundred pounds offered is preposterously inadequate. The time fixed for delivery of the designs is insufficient. Unless the conditions—for which, by the way, every competitor has to deposit ten guineas—are materially amended, competitors are not likely to get fairly treated, and the city of York is almost certain not to get a scheme worth carrying out.

Of all the addresses at the British Association meeting last week, we think that of Prof. H. S. Hele-Shaw, which we give elsewhere, was the most timely just now. It is useless to ignore the fact—we of the engineering and building trades know it already too well—that when the war is over the labour problem will demand solution with an urgency more terrible than that of the Sphinx of old. It is hopeless, as Prof. Hele-Shaw says, to expect the machinery of our industrial system ever to work well again while the interdependent parts are not arranged, and never can be arranged till we change them radically with respect to the whole. The canker which is eating the heart out of our industrial life is due to a wrong mental attitude. It is no use blaming either side. There are employers and companies as deaf to the rightful claims of the men and boys they exploit as there are shameless departures from fair bargains with honourable employers by men who have thrown over their own leaders the moment it seemed to serve their interests to do so, without a thought of their duty to the community as a whole. We know *why* this is! The politicians have pandered to the selfish interests of those who could finance parties on the one hand, and to those of the masses who have the vote on the other; and we who have let them are pursued deservedly by a Nemesis we cannot escape unless we insist that truth shall be told, at whatever cost and however sternly, to Labour and Capital alike.

An appeal involving a claim to a Crown prerogative has been decided at Edinburgh by Lord Anderson. The case arose out of an Admiralty contract at Rosyth. Before the contract was completed the contractor's estates were sequestrated, and his trustee declined to carry on the contract. The Admiralty employed another contractor to finish the contract at an extra cost of £1,049, and for that sum they claimed a preferential ranking on the contractor's sequestrated estates. The trustee admitted the claim to ordinary ranking, but rejected it in so far as made for a preferential ranking.—Lord Anderson refused the Admiralty's appeal, and sustained the trustee's deliverance. The appellants were found liable in costs. His Lordship said that it was part of the common law of England that the Crown possessed that prerogative which might be asserted in the

distribution of a sequestrated estate. That was also the law of Ireland. It was contended that the doctrine of Crown prerogative as applicable to all kinds of debts had been introduced into the law of Scotland by the Act of Queen Anne. His Lordship did not agree with that contention, but in any event he held that the Bankruptcy Act, 1913, impliedly abrogated any such alleged prerogative.

While our own Local Government Board is cold-shouldering building in all directions Germany, according to an American correspondent quoted by the *Literary Digest* in the last issue to hand, is making a national matter of it. Even the news of the new Lille-Warsaw express, making in 30 hours the trip from front to front, is somewhat overshadowed by the report that the city fathers of Berlin have just authorised an issue of bonds to the amount of \$75,000,000, to be spent upon public improvements throughout the city, such as new subways, parks, new schools, and playgrounds. Incredible as this seems, at a time when many Germans are declaring their country to be fighting with its back against the wall, and to be the desperate victim of a conspiracy to starve, stifle, and crush its peaceful non-combatants into submission, we are given the definite testimony of the Lord Mayor of Berlin in corroboration as follows:—"At the beginning of August, immediately after the outbreak of war, things looked quite different. It was as if the whole business organisation, so to speak, held its breath. But that was merely a momentary pause. Then all at once we got our bearings and adapted ourselves to the new conditions. And in a few weeks the whole social organism, public and private, was again in full working order. In the first few days the number of unemployed rose from 20,000 to 60,000, a fact that clearly indicates the confusion that at first was prevalent."

That, we are assured, is the practical working out of the German principle—to keep on working at everything as in time of peace. Berlin is building two large underground lines which are to be under municipal control. In addition to these building operations within the town, there are others beyond the real area of the city itself. The new western harbour of Berlin is a gigantic undertaking of this nature. It is now almost complete. The larger part of the project, which has cost 40,000,000 marks, has been completed since the war. This harbour is intended to take up the immense traffic created by the Berlin-Stettin Canal. This is the so-called Great Ship Canal, which will make the city of Berlin, as it were, a Baltic port. A not less important building is the great market-hall in the north-west quarter, which will be the largest hall in the world, and will cost 25,000,000 marks.

The claim of the Commissioners of Inland Revenue for increment value duty to the amount of £45 is still being pressed, unfairly and hardly we think. The claim against Mrs. Walker is based, as readers will remember, on the interpretation of the Increment Value Duty sections of the Finance (1909-10) Act, 1910, as interpreted by the White Paper instructions, and as, in effect, upheld by the House of Lords in the Lumsden case, namely, that Increment Value Duty is collectable where the property has been sold for more than it is worth at the time, in the opinion of the valuing authority, although there has

been no change in the value of the land—a conclusion admitted to be in no contradiction of the pledges of Mr. Lloyd George and the Law Officers of the Crown when the Bill was brought into the House, contrary to the understanding of the country at the General Election which followed the rejection of the original Bill by the House of Lords, and opposed to the intentions of the Parliament which ultimately passed the Act. This was fully recognised by the late Government, and remedial legislation was promised (see page 260). In June, 1913, in reply to a question put by Mr. Roys as to the delay in hearing the Lumsden case, the then Attorney-General, Sir Rufus Isaacs, stated that the matter involved in the appeal, that is to say, the question of the levy of Increment Duty when there was no rise in the value of the site, would be discussed in Committee on the Revenue Bill, to be introduced later in the Session, "and," he added, "the result of the discussion might render it unnecessary to proceed further with the appeal." The Government, realising that the country was left behind them in this attempt to levy duty out of builders' and other occasional profits, had evidently determined to remedy the injustice by a clause in the Revenue Bill. In due course the Bill was introduced, and it contained a clause providing a partial remedy. After some negotiation the Chancellor of the Exchequer agreed to a clause which provided, in effect, that in the case of property which consisted of land with a building or buildings upon it, no Increment Duty would be chargeable unless there was in fact a rise in the value of the bare land. The Bill was withdrawn owing to a contentious clause affecting agricultural land site-value deductions.

Mr. Lloyd George promised to re-introduce it early last year. Nothing was done, and meanwhile the Lumsden case got to the Lords, and there opinion being equally divided the Crown got a judgment. On July 23, 1914, Mr. Asquith, in reply to Mr. Chamberlain, stated that the Government was prepared to introduce and pass that Session a one clause Bill giving the promised relief to those who were affected by the Lumsden decision, including, surely it must have been meant, Mr. Lumsden himself, the most notable sufferer, and other victims, such as Mrs. Walker. Nothing was done, but Mr. Lloyd George gave his personal pledge on behalf of the Commissioners of Inland Revenue that no further claims of a similar character would be made. In spite of this the Revenue Department brought Mrs. Walker before the House of Lords, and obtained a judgment against her practically similar to that of Lumsden's—thus on the strength of the judgment in Lumsden, by which the House of Lords was bound, overruling the judgment which Mrs. Walker had obtained in her favour against the Crown in the Valuation Appeal Court in Edinburgh. It was admitted in the Lords that Mrs. Walker's case came first, and had the court been as equally divided about that as they were about Lumsden's, judgment must have been given for Mrs. Walker. Yet in spite of all, this the Commissioners of Inland Revenue are still pressing a water-torture pound of flesh!

The Royal Institute of the Architects of Ireland have awakened to their responsibility in regard to questions pertaining to the ancient monuments of Ireland, and have given practical effect thereto by appointing a small sub-committee to deal with such matters. Mr. Patrick J. Lynch, M.R.I.A., F.R.I.A.I., of Northbrook Road, Leeson Park, Dublin, has consented to act as honorary secretary to the sub-committee.

MEGALITHIC MONUMENTS.

The subject of megalithic monuments and their dispersal, in which Professor G. Elliot Smith, entered a debate at the British Association's meeting in Dundee in 1912, was resumed last week at Manchester in an address which he gave on the influence of ancient Egyptian civilisation on the world's culture. The theses which he submitted were that the essential elements of the ancient civilisations of India, Further Asia, the Malay Archipelago, Oceania, and America were brought in succession to each of these places by migrants, whose Oriental migrations on an extensive scale began as trading intercourse between the Eastern Mediterranean and India some time about 3000 B.C., and continued for several centuries; that the highly complex and artificial culture which they spread abroad was derived mainly from Egypt not earlier than the twenty-first Dynasty, but also included many important accretions and modifications from the Phœnician world around the Eastern Mediterranean, from East Africa and the Sudan, Arabia, and Babylonia; that, in addition to providing the "cavea" which stimulated the development of the pre-Aryan civilisation of India, the cultural stream to Burma, Indonesia, the eastern littoral of Asia, and Oceania was in turn modified by Indian influences; and that, finally, the stream, with many additions from Indonesia, Malanesia, and Polynesia, as well as from China and Japan, continued for many centuries to play upon the Pacific littoral of America, where it was responsible for planting the germs of the remarkable pre-Columbian civilisation.

The reality of these migrations and the spread of culture was substantiated and dated by the remarkable collection of extraordinary practices and fantastic beliefs which the ancient migrants distributed along a well-defined route from the Eastern Mediterranean to America. He submitted that these were responsible for stimulating the inhabitants of the coast to adopt mummification, to build a great variety of megalithic monuments, to make idols, to worship the sun, to adopt tattooing, massage, and other practices, to practise weaving linen, and the use of precious stones and metals, to adopt definite metallurgical methods, as well as mining, and the use of intensive agriculture, associated with irrigated irrigation, to adopt certain phallic ideas and practices, to use the swastika symbol, to "comparing, to hold certain beliefs regarding the heavenly twins," to practise magic, and to display a special aptitude for skill and daring in maritime adventures, as well as to adopt a number of curiously arbitrary features in boat-building.

Mr. W. J. Perry, in a contribution to the discussion, cited a series of facts which, he held, pointed to the conclusion that the search for better forms of material wealth led the founders of the megalithic culture to those areas where they were to be found, and the presence or absence of the desired form of wealth determined that of megalithic influence.

THE L.C.S. SCHOOL OF BUILDING AT BRIGHTON.

We have several times drawn attention to the excellent work that is being done at the L.C.S. School of Building at Ferndale Road, Brighton, and again remind readers that there is a boy, a boy, which a boy can better start with his preparation for his life's work than in any other way, which, thanks to the generosity of the London County Council, is being taught in a staffed and equipped, and well-ventilated, and easily a commodious a hundred boys.

Readers interested should visit the school and make themselves acquainted with the various classes. In the Building Construction Class, each boy is given a scale, from blackboard diagrams, and is instructed by the teacher, every day, in the construction of an ordinary building, and thus establishes a firm basis of knowledge. For the second and third years, the instruction is developed to the extent of making full sets of drawings of buildings, and freehand drawing of buildings is taught by Mr. Herbert

Davies Richter, decoration is similarly inculcated; and colour is likewise dealt with by Mr. A. R. H. Jackson, A.R.C.A.; and other leading members of the staff are Mr. H. F. Murrell, A.R.I.B.A., Mr. G. P. Penham, A.R.C.A., and Mr. Allan Graham, A.R.I.B.A.

Theory is well seconded by practice in the shops, in which the boys carry out practical work in their chosen trades. Our contemporary the *Decorator*, in its August issue, gives an extremely interesting account of a recent visit to the school, when Mr. C. E. Wilkinson, the president of the London Association of Master Decorators, conducted a representative body of members over the building, and indicated more especially the trend and scope of the curriculum for boys who have chosen to become decorators. The first year's work includes Building Construction, workshop practice, the study of materials, workshop arithmetic and mathematics, experimental mechanics, geometrical and plane drawing and lettering, freehand drawing of building details, and other studies of contemporary history and literature bearing on the arts.

The excellent illustrations of the lads actually at work given by the *Decorator*, and the details of plaster decoration and other examples, are very interesting. At the present time one of the larger rooms is being wholly decorated by the students from a simple design, and the decoration of the whole of the upper floor by the boys is to follow.

OBITUARY.

We regret to record the death of Mr. William Henry Lynn, of Belfast, which occurred on Sunday last, at the age of 86. Mr. William Henry Lynn was President of the Royal Institute of Architects of Ireland from 1886-9. He was the architect of Chester Town Hall, with the adjacent market front; the Clark Halls, with the bridge adjoining them, at Paisley; new municipal buildings at Barrow-in-Furness, and the public library buildings at Belfast. These were mostly won in competition. In 1861 he was awarded the first premium for the Houses of Parliament and Government offices at Sydney, New South Wales. He was placed second in the Plymouth Gmudhall competition, and he took the third premium in the competition for the Glasgow municipal buildings. His design for the Birmingham new buildings to be connected with the town hall was disqualified owing to a technical point, but his scheme was acknowledged as by far the best submitted. As partner of the late Sir Charles Lanyon up to 1872, he carried out a great many public buildings in Ireland, including the Queen's University of Belfast, for which institution he has only just lately carried out extensive additions won in competition as recently as 1910, when (October 14) we illustrated his plans for this considerable undertaking. The whole of the drawings for the work were made by himself personally unaided, a remarkable feat for one so advanced in years. Lord Dufferin invited Mr. Lynn to advise on vast contemplated improvements in Quebec, and amongst other works a Voisageal residence (a new chateau, St. Louis) for the Governor-General of Canada, to be erected in the citadel. Mr. Lynn was joint architect for the new cathedral at Belfast with the late Sir Thomas Drew, R.H.A., but subsequently he arranged so that his friend and partner in this undertaking should carry on the work alone, and this was done. We gave a portrait of the deceased in our issue for January 17, 1890. For many years Mr. Lynn was an active member of the Architectural Association Excessions. He was an exceedingly capable draughtsman, working with a mastery of thought and extremely and most deservedly popular within his confines.

One of the oldest practising architects in Victoria, or, probably, in Australia—Mr. John James Clark, died at the residence of his son, St. Kilda, Melbourne, on June 25, at the age of seventy-seven, after a comparatively short illness. His body was buried at the Melbourne General Cemetery on the following day, the Council and mem-

bers of the Royal Victorian Institute of Architects being present at the funeral. Mr. Clark was born in Liverpool in 1838, and was educated at the Collegiate Institute in that city. Sailing for Australia in the Martin Luther, he arrived in Melbourne in 1851, the following year, at the age of thirteen, entering the Public Works Department. After serving for five years, he visited Europe to study its public buildings. On his return, in 1858, he was appointed officer-in-charge of the Treasury Buildings, Collins Street, Melbourne, which he resigned at the age of twenty-one. Between 1861 and 1878 was a period of great activity in the Public Works Department, and Mr. Clark was concerned with the designing and carrying out of many of the large State buildings, amongst which were the Government Printing Office, Customs House, Public Offices, Bendigo, the Mint Administrative Offices, Government House, various asylums and gaols, whilst he detailed and was in charge of Messrs. Smith and Johnson's design for the Melbourne Law Courts, concluding this last work seventeen months after retiring from the Government, with compensation, at the age of forty. From 1879 to 1881 Mr. Clark practised privately in Melbourne, in which latter year he joined his brother in partnership in Sydney. The firm was successful in carrying off prizes for town halls, the principal of which was the Brisbane Town Hall. In 1883 he was appointed Government architect for Queensland, the principal work being the supervision of the public offices (now known as the Treasury Buildings), for which building his firm had previously been awarded second prize in a public competition. In 1886 he resumed private practice in Brisbane, and three years later, with his son, took a nine months' trip through America, Great Britain, and Europe. In 1896 he went into the Public Works Department, West Australia, hospital and asylum work being entrusted to him. Retiring from this service, his son joined him in partnership, and the firm practised in Perth till 1899, when they returned to Brisbane for three years, afterwards resuming practice in Melbourne. The works carried out were mainly won in competition—viz., City Baths (Melbourne), Maitland Hospital (N.S.W.), National Mutual Buildings (Ballarat), Carlton Refuge, Women's Hospital (Melbourne), Auckland (N.Z.) Town Hall. Mr. Clark was appointed architect to carry out the Melbourne Hospital, his design having been placed second in a previously-conducted competition. This work—his last—is about nearing completion. Mr. Clark was very successful in competitive work. Out of 47 competitions entered, he won 24 first, 12 second, and 2 third places, a total of 38 scores out of 47 entries. He was a skilled landscape artist in water colours, having studied under Buvelot, and from 1877 to 1889 he was as much absorbed in this branch of art as in architecture itself. Some years ago he was elected a Fellow of the Royal Victorian Institute of Architects, and for some time occupied a seat on the Council, being appointed Vice-President for a number of years.

Mr. George Lister Sutcliffe, F.R.I.B.A., formerly of Heptonstall, Leeds, died on Sunday at 25, Cannon Place, Hampstead, in his 51st year. He joined the Royal Institute of British Architects as an Associate in 1891, becoming a Fellow twenty years later. The funeral service will take place at Rosslyn Hill Chapel, Hampstead, to-morrow (Thursday), at noon.

Lieutenant George Leonard Cheesman, of the 10th Hampshire Regiment, who was killed in Gallipoli on August 10, aged 31, had been since 1906 a Lecturer in Ancient History at Oxford University. Mr. Cheesman took a warm interest in the Roman Wall, and also in the excavations of Roman remains at Corbridge and elsewhere, and in the elucidation of ancient Roman inscriptions. He was a member of the Council of the Society for the Promotion of Roman Studies.

The "Premier Minut," by M. Egade Rombloux, which was purchased by subscription for the nation, and was illustrated in our pages on the 1st inst., is now placed on exhibition in the Tate Gallery, Millbank.

Building Intelligence.

ENGLEFIELD GREEN.—Princess Christian opened on Saturday and handed over to the War Office the new military hospital which has been erected on the outskirts of Windsor Great Park at Englefield Green, providing accommodation for 120 patients. The general construction has followed the lines of the Red Cross Hospital at Netley. The floor of each ward is extended 8 ft. beyond the front wall, so that through doors in the centre the beds can be wheeled out and, if desired, left there during fine weather under a covering of striped canvas stretched across two steel poles. The six pavilions, each containing twenty beds, are planned in a semi-circle facing the south. Behind these are arranged twenty-two other buildings for the staff and general administration.

GARLICKHITHE, E.C.—The Lord Mayor and the Sheriffs attended in state on Sunday morning at the reopening, after restoration, of St. James's Church, Garlickhithe. The building is one of the old riverside churches near Mansion House Station, which was consumed, as an inscription states, "by the late dreadful conflagration, A.D. 1666," and was rebuilt by Wren between 1676 and 1683. The elegant stone lantern of the tower, which projects from the centre of the west front, forming a porch, is known as "Wren's Lantern." Richard Steele was sometimes a worshipper at the church, and his impressions are recorded in the *Spectator*. One of the chief objects of interest in the church is the altarpiece, a picture of "The Ascension," by Andrew Geddes, which has been cleansed and restored.

HULL.—A colony of 120 rest homes, erected in the western suburb of Hull out of a legacy of £200,000 left by Dr. Lee, was opened on Friday. Apart from the cost of the site and buildings over £100,000 will remain to endow the homes. The homes are built on a site of 6½ acres, with frontages to the Anlaby Road and Pickering Road. The blocks are arranged in a quadrangle, and each block contains accommodation for eight inmates, four upon the ground floor and four upon the first floor. Upon the south side of the site stands conspicuous a central block, which contains a general room 50 ft. by 25 ft., panelled in oak and furnished. This is to be used as a reading-room and a library. In this block is also provided the board-room, a room for the medical man, and a room set out exactly as the dining-room of the late Dr. Lee, in Pryne Street.

Mr. G. Spur, an assistant surveyor at Pontefract, has been appointed to succeed Mr. G. H. Dallow as surveyor to the Halesowen Rural District Council.

A new Congregational church at Highroadwell, Halifax, built at a cost of £4700, has been formally opened. Messrs. Glodinning and Hanson, of Albany Chambers, Halifax, were the architects.

A Baptist school chapel has been opened at Hawksbridge, Oxenford, Yorks. The architect was Mr. Herbert E. Illingworth, A.R.I.B.A., East Parade, Leeds, and the outlay has been £2,100.

The Maghull Epileptic Homes Committee have decided to add a fresh building at a cost of £15,000 to adjoin the Henry Cox Home in Smithy Lane, Maghull, and plans have been passed by the Maghull Parochial Committee.

Mr. R. Barry Parker, F.R.I.B.A., the consulting architect to the First Garden City, Limited, has left Letchworth for a few weeks for Portugal, having been called upon to advise the municipality of Oporto upon a town planning scheme for that city.

Last Saturday the Dewar Memorial drinking fountain, erected by subscriptions in the Abercorn Gardens, Portobello, was unveiled in memory of Dr. Dewar. The structure is 14 ft. high, and has been carried out in grey Aberdeen granite, with a bronze portrait of the famous doctor on one side of the body of the monument, which is surmounted by a pediment standing on balls at the corners. The inscription occurs in a similar panel on the other face, the fountains being at either end. The design was chosen in open competition from 100 proposals submitted. The sculptor is Mr. T. Currie Bell, Synod Hall, Edinburgh.

WATER SUPPLY AND SANITARY MATTERS.

GLASGOW WATER EXTENSION SCHEME. It has been reported to the Glasgow Corporation by the Parliamentary Bills Committee that in conjunction with the proposed Corporation Water Order, which provides for the inclusion of the River Turk in the Leith Katrine water area, arrangements have to be made whereby the Earl of Moray is to receive £5,250, and the Crown authorities £22,000 in toll of their dams at the Royal Forest of Glen Fulas. A report on the scheme states that a supply of at least 15,000,000 gallons daily, over and above compensation on water, will be obtained, and for this quantity the estimated cost of the works is moderate. The Corporation secures in perpetuity the entire solum of the new lake, extending to over 300 acres, and a belt of land round the lake for present and future requirements. In the compensation to be paid, viz., £32,500, is embraced the ground for dam, reservoir, landings, wayleaves, servitudes, temporary use of land for railway and sidings, and all claims incident to the proprietor for disturbance of game, loss of shootings, and interference with remaining lands, as also the claim of the Crown for interference with the Royal Forest of Glen Fulas. The compensation is not payable until Whitsunday, 1917.

THE WATER SUPPLY OF LONDON. The twelfth annual report of the Metropolitan Water Board, just issued, shows that the funded debt on April 1 last amounted to £48,840,892 with £1,402,052 of interest, and in addition annuities and rent charges amounting to £7,900, or a total of £1,477,582 equivalent to 3.9d. per thousand gallons supplied. The net water rental received by the Board during 1914-15 was approximately £2,935,400, or an increase of £22,090. The percentage of collection for the half-year ended March 31 last in respect of domestic supplies and fixed charges was 94.4, being the same as for the corresponding period last year. The audit of the Board's accounts for the year ended March 31, 1914, showed a certified deficiency of £15,355 as against an estimated deficiency of nearly £105,000. This satisfactory position was attributable to the fact that the income exceeded the estimates by about 70,000, due to the favourable conditions of the summer of 1913 to a further reduction in allowances for empty premises, and to savings under the head of pumping and distribution charges. The Board's staff numbers 923 officers including 53 women, 3,189 workmen and others on weekly wages, and 116 service staff on weekly wages, or a total of 4,223, with an aggregate salary list of £173,943. The Board's supply (direct and in bulk to adjacent undertakings) during 1914 was 89,420 million gallons of water, or a daily average of 245 million gallons. The grand total volume is equivalent to 399.2 million tons of water. The Thames furnished 58.5 per cent., the Lee 23.1 per cent., and the wells, etc., 18.4 per cent. of this total. The total estimated population supplied by the Board at the close of last year was 6,744,247.

TRADE NOTES.

Boyle's latest patent, "Air-Pump" ventilator, has been applied to Naas Presbyterian Church, Ireland.

The cult of fresh air is gradually extending to bathing. It is interesting to know that an open-air swimming bath has recently been constructed in Lister Park, Bradford. The cement flat roofs over the dressing-rooms have been made wet-repellent by the water-proofing powder Pullo.

The death is announced of Mr. David Walter Henderson, builder, Quarrypark, Ecclefechan. Mr. Henderson carried out many large building contracts in the South of Scotland.

At Oadby, near Leicester, Mr. A. W. Brightman, an inspector under the Local Government Board, has held an inquiry into an application by the urban district council for sanction to borrow £4,600 for the sewerage of the Wigston Road district and the extension of the sewage disposal works. It was stated that the present arrangements for the disposal of sewage by lateral irrigation had proved quite unsuitable. A scheme has been prepared by Mr. W. Bell, the council's surveyor, and Mr. E. G. Mawley, M.Inst.C.E., the borough engineer of Leicester, acting as consulting engineer, to deal with the sewage by means of perforating filters, and the council had unanimously approved the plan. In preparing the scheme attention was also paid to the probable growth of the district.

Correspondence.

JACOBAN OAK BENCH SILENCING CHURCH, SUSSEX.

To the Editor of the Building News.
SIR,—I have just returned from a visit of 2 or 3 of many years to the other side of the interval, the church of Jacoban, near Lewes. It was built in 1672, and is a fine example of Jacoban architecture, which formerly characterised the buildings of the beautiful New Forest, and is now very properly regarded as a relic of the past. Upon this loss of seating accommodation the building has been very judiciously provided with new pews, and a very good service has been done during the time spent in the restoration. The organ was a great improvement to the living in 1870, and has since been of many years' standing. I should like to see an interesting old Jacoban church, and I believe to this building. I have seen the vestry and all the other parts of the church, but nowhere could I find any record of the church. Possibly the year of the building may have given rise to a confusion in the museum, if it is not to be found in the records. It would be interesting to hear of the result of the sale of the church, and if it is to be drawn by Mr. Maurice B. Aldrich, as mentioned in *The Building News* for February 22, 1915, 1872, so there can be no mistake as to its identity. Can any reader tell what has happened to it?—I am, etc.,
September 11, 1915. A SUSSEX MAN.

The parish church of Milltown, County Down, is about to be repaired and altered, from plans by Mr. J. V. Bodman, Bank Chambers, Belfast.

Mr. G. L. Pepler, of the Local Government Board, held an inquiry at Grimsby on Wednesday into an application by the Grimsby Rural District Council for authority to prepare a town planning scheme.

A new Council school at Berrweg, near Llangollen, built at a cost of £27,000, has been formally opened. The architects were Messrs. Shaylor and Ridge, of Clive Chambers, Salisbury, and Mr. Isaac Jones, of Hatfield, was the contractor.

Mr. Edmund Leonard, an inspector of the Local Government Board, will hold an inquiry at Carlisle to-day (Wednesday) into an application from the city council for sanction to borrow the sum of £9,582 for the provision of workmen's dwellings.

In the finished iron and steel trades of the North of England the prices of several sections have been advanced 1s. per ton. Common iron bars are now £11 1s., mild ship plates £11 10s., steel sheets (single and double) £11 15s., to £12, steel strip £10 15s., and cast iron bars £11 15s.

Mr. John Wilson, of Orchard Vale, Bexley side, Brent, passed away on Saturday last. The deceased, who was seventy-two years of age, was for many years borough engineer and surveyor of Bacon, and subsequently from 1882 to 1912 he represented Lewell Ward on the town council. He has left a widow and several sons and daughters.

Parliamentary power will be sought in a session for utilising for lighting purposes the surplus of power the falls of Leighton Buzzard, Bedford, and of the Stanton near Ludlow, Shropshire, above the falls will carry the water to places lower down. Mr. F. C. Stevens is the consulting engineer, and Mr. P. J. M. Andrew, Shropshire Engineer, is superintending the work, with Mr. B. Winslow as secretary. The project has been subscribed by the promoters of the Leighton Buzzard Canal and the Leighton Buzzard Canal. Engineers are now making the site of the necessary canals and of the lines of the power.

Lieutenant James Dixon, of the Royal Regiment, who was killed in action at the Tannenberg on August 2, was a brilliant and energetic officer, and had little to say of his military career. He was a very able and energetic draughtsman, and was a very successful draughtsman in various art competitions to Egypt during the last few years. Although still in his early twenties he had worked for the Egyptian Government, and for the Egypt Exploration Fund, with Professor Naville and Mr. Peppi at Abydos, and with Mr. Wellcome on the Sudd, and his handiwork may be seen in the publications of these expeditions.

Our Office Table.

Major H. Phillips Fletcher, F.R.I.B.A., F.S.I., M. H. S. S. H. S. S. of New Bridge Street, E.C. 4, the surveyor to the Carpenters Company and the director of the Trades Union, has been awarded the Croix de Guerre, on the recommendation of Admiral Darrigault, of the French Mediterranean Squadron. His name has also appeared in the Ordres du Jour, the French equivalent of being "mentioned in dispatches." The Major has been specially sent to the Aviation Maritime as military observer, and for the last four months has been making aerial reconnaissances of Turkish positions from the coast, and dropping bombs on munition factories in Asia Minor, Syria, and Arabia.

Mr. J. Landfear Lucas inquires as to the present whereabouts of a well-known carved stone which was embedded in the front of 52, Newgate Street until these premises were pulled down in 1663. The stone is mentioned in the "Survey of London and Middlesex," Vol. III., Pt. 1 (Nightingale, 1815); by John W. Archer, 1851, in "Vestiges of Old London"; and in "The History of Signboards," by Larwood and Hotten, 1866. The two last-named authors give an illustration. The carving represents Adam and Eve, with the date 1669, and initials at the top of the stone "I.S." Eve is shown handing an apple to Adam, and a tree, round the stem of which the serpent is winding, occupies the centre. A writer in "Notes and Queries" has made inquiries at the Guildhall and British Museums without result. The carving exactly tallies with the arms of the Fruiterers' Company, and it is suggested that the premises may have been the property of the company, since it was the custom to mark houses, etc., with panels showing the owner's arms.

The Board of Education intimates that the Regulations and Syllabuses which governed the Examinations in Science and Technology held in 1915 will continue in force for 1916. In the prefatory note to the volume of Regulations and Syllabuses for Examinations in Science and Technology, 1915, the Board announced their intention to discontinue those examinations at a date to be subsequently announced. The Board now desire to give notice that after 1916 they will no longer hold Lower General Examinations in any subjects of science and technology. The Higher General Examinations will for the present be continued. The conditions governing the award of scholarships, exhibitions, etc., in science in 1917 will be announced in due course. The time-tables of the examinations to be held in 1916 will be issued shortly.

The Calendar of the Royal Technical College, Glasgow, handsomely bound in purple, with a perspective of the new college buildings, erected at a cost of £400,000, from the designs of Mr. David Barclay, F.R.I.B.A., of St. Vincent Street, Glasgow, as a front-piece, has just been published. The 120th session of the college will open on Tuesday, the 26th inst. The School of Architecture is under the superintendence of a Joint Committee on Architecture, representatives of the college, and of the Glasgow School of Art. The Glasgow Institute of Architects have been consulted regarding the correlation of office apprenticeship with the course of study provided by the School of Architecture, and the Council of the Institute have expressed their concurrence in, and issued to the members a recommendation in favour of the alternative schemes of study arranged, under which attendance at the School of Architecture is combined with the service of an office apprenticeship. The work of the School prepares for, and exempts from part of the Final Examination of the R.I.B.A. The courses of study provided by the Glasgow School of Architecture are given in both the Royal Technical College and the School of Art. The complete course of study leads to a Diploma, and is the normal course for day students. A restricted portion of the same, called the Certificate course, although of lesser requirement and arranged for students who cannot give the time required for the Diploma course, will yet pro-

vide a fairly sufficient education. The whole Certificate course qualifies for the Senior Certificate; the junior division of this course, for a Junior certificate. The fees are: Full day, ten guineas per annum; half-day, five guineas per annum; evening classes, two guineas per annum. A Diploma course in Building, extending over three sessions, has been instituted at the College, with the object of providing for students a thorough knowledge of Building Construction.

The directors of the University of Pennsylvania Museum announce that Dr. Clarence L. Fisher, Curator of the Egyptian Section of the Museum and the leader of the Eckley B. Coxe, jun., expedition to Europe, has unearthed a great temple at Memphis, Egypt. The temple, it is estimated, is of the period of Rameses II., and was erected more than 3,000 years ago. While no definite data can be given out at this time, Egyptologists are inclined to believe that the temple is one that was built by Seti I., and that it is the one described by Herodotus.

The annual report of the Newcastle-on-Tyne City Engineer, Mr. W. J. Steele, for the year ended March 31, 1915, states that the estimated population of the city is 271,525, and the number of inhabited houses and flats 50,945. The number of dwellings erected during the year (each flat being counted as a separate dwelling) has been 163, compared with 111 in the previous year, which was the lowest recorded since 1882. The number of unoccupied premises of a habitable nature has further declined. In February, 1914, there were 356, and in February, 1915, there was only 152, which is about $\frac{1}{4}$ of 1 per cent. of the total number of houses in the city. The estimated cost of new buildings for which plans were approved during the year was £396,392, compared with £491,373 in 1914. In twenty-four streets the carriageway was resurfaced with tar macadam, the total area laid being 34,728 square yards. The approximate total length of highway now maintained is 254 miles, the cost of maintenance per mile being about £128. The house refuse amounted to 94,561 tons, and is equivalent to 6.96 cwt. per head of the population, or 37.12 cwt. per house, the cost of collection and disposal being 22.03d. per head of the population, or 9s. 9.41d. per house. The street refuse amounted to 42,128 tons, and is equivalent to an average of 166 tons per mile of highway cleaned. In the Ouseburn Valley 72,514 loads of material were deposited in the embankment forming Road No. 2 under the Corporation Act, 1904, and its vicinity; 27,852 loads were deposited by the corporation and 44,662 loads by private individuals. The total quantity deposited during the previous year was 51,403 loads.

For those who contemplate a change of residence the "Homestead," issued by the Great Central Railway for the special purpose of enabling house-seekers at once to decide how far they can live out of town, will be found most useful, as not only are the season ticket rates given, but a full description of each place is included, also useful local data such as rates in the pound, water, cost of gas, population, altitude, subsoil, etc., is also stated. Special articles are contributed by well-known authorities on "Where Shall We Live, and Why?" "Golf and the Choice of a Home," and "The Homestead Country: Its Literary and Historical Associations." The book is profusely illustrated, and produced in quite a superior style. Copies can be obtained free on application to the G.C.R. Publicity Office, 216, Marylebone Road, London, N.W.

The Michigan State law regulating the practice of architecture came into operation on August 24. The usual restrictions for the practice of architecture are enacted, and further it is permitted that any builder may draw plans for himself, or for any building that is being erected under his supervision. Architects who have practised prior to February 5, 1915, who can show satisfactory evidence of character and competency, can obtain a licence on application.

The County Council of Surrey have granted the surveyor, Mr. A. Dryland, two months' leave of absence to recuperate after severe illness.

TO ARMS!

4th Battalion ("Architects") Central London Regiment Volunteers.

Recruits are urgently needed for the Regular, Territorial, and Volunteers. Intending recruits should apply to Battalion Headquarters, where they will be advised as to the branch of the service for which they are best suited.

ORDERS FOR THE WEEK BY LIEUT.-COL. A. W. WARREN.

ENTRENCHING.

Special Parade. To-night, 15th inst., at Dean's Yard, Westminster, 6.15 p.m. Members desiring to offer their services must attend this parade; no later opportunity of volunteering can be given.

PARADES.

At Camp, Thames Ditton, Saturday and Sunday, 18th and 19th inst. Parade, Saturday, 3 p.m. Sunday, 11.15 a.m. (train 10.10 a.m., Waterloo). A number of fatigues are required on both days. The remaining tents will be struck on Sunday. Accommodation can be provided for a few men only on Saturday night. Members desiring to avail themselves should at once inform the Quartermaster, telephone 999, Brixton.

DRILLS AND PARADES.

"A" Company. Tuesdays, Miniature Range, Gas Light and Coke Co.'s premises, Monck Street, Westminster, 5 to 8.30 p.m.

Wednesdays, Company parades 5.15 to 7.15 and 6.15 to 8.15, at Dean's Yard, Westminster.

Thursdays. Signalling. See orders from Acting Battalion Signalling Sergeant Cheadle.

"B" Company. Miniature Range and Company Parades as for "A" Company. See orders at local headquarters.

"C" Company. See orders local headquarters, Pavilion, A.A. Athletic Ground, Boreham Wood.

"D" Company. Platoon and Section Drill at Mercers' School, Holborn. Tuesdays and Thursdays, 6.45 p.m. Company parade Wednesdays at Dean's Yard.

SCHOOL OF ARMS.

Special Note.—After date of these orders, the School of Arms will be held at new drill headquarters, Chester House, Eccleston Place, Westminster. Instruction in bayonet fighting, gymnastics, physical drill, boxing and single-sticks on Tuesdays from 6 to 8 p.m.

RECRUIT DRILLS.

"A" Company. Dean's Yard, 5.15 and 6.15, Wednesdays and Fridays.

"B" Company. Dulwich College, Mondays, 8 to 10 p.m. and Thursdays, 6 to 8 p.m.

"C" Company. Boreham Wood and Elstree district. Headquarters, A.A. Athletic Ground, Boreham Wood. For full particulars apply to Alan Potter, Grey Gables, Boreham Wood, Herts.

"D" Company. Mercers' School, Tuesdays and Thursdays, at 6.45 p.m.

CORRESPONDENCE.

Special attention of members is drawn to the fact that correspondence should be answered by return. If this is not attended to the office of the work of the Corps is immensely increased. Enrolment forms of new members and all correspondence not referring to recruiting for the Army or to financial matters must be addressed to the Adjutant, 10, Conduit Street, W., and regarding recruiting for the Army to the Recruiting Officer at Battalion Headquarters, and regarding accounts and subscriptions to the Paymaster, W. R. Hughes, 146, Dashwood House, E.C.

By Order,

L. R. GUTHRIE, Adjutant.

BATTALION HEADQUARTERS.

18, TUFTON STREET, WESTMINSTER, S.W.

Under the provisions of the Spenborough Amalgamation Order, Mr. Clifton Lund is retiring from the surveyorship of the Cleckheaton district, which he has held for seventeen years.

At Wembley, yesterday (Tuesday), Mr. A. W. Brightmore, of the Local Government Board, held an inquiry into an application from the urban district council for power to borrow £12,071 for the extension of the sewage disposal works.

The cost of the conversion of the grand stand on the racecourse at Blackpool into a temporary hospital is estimated at £25,000, and will be borne entirely by the War Office, the Blackpool Corporation's contribution being the preparation of the plans, the letting of the contracts, and the supervision of the work.

Messrs. Kerner-Greenwood and Co. have sent us a chart showing important tests made by the Japanese Imperial Government. They experimented with several waterproofers, and it was proved that "Pudlo" gave the best results against percolation. Further, the test with neat cement (not waterproofed) and a mixture of three parts of sand to one part of pudlo cement proved the latter to be much more waterproof than neat cement, the exact figures being an absorption of 21 mmmes against 23 mmmes of water. The chart will be sent to any applicant, together with the last of the series issue of "The Charm of Lynn," the business side of which deals principally with drainage work. Address Messrs. Kerner-Greenwood and Co., Ann's Square, King's Lynn.

RIBCHESTER MUSEUM OF ANTI-QUITIES.

In the North Lancashire village of Ribchester on Friday Dr. Haverfield declared open the newly built museum of Roman antiquities, in which are now placed some of the later relics found at this old Roman station. The museum has been placed under the guardianship of the National Trust. A numerous party of members of the British Association in attendance at the Manchester meeting were present, many having motored over the twelve miles from Preston. Sir Frank Forbes Adam, chairman of the council of Manchester University, presided. Dr. Haverfield said that at Ribchester they had the remains of a Roman fort such as was called a castellum. It was by the castella that the Romans held disturbed areas, especially on frontiers. Britain was an quiet area, and from Chester to Carlisle, from the Vale of York to Tyneside, so far as the hills went, forts were placed at strategic points, joined by a network of roads. Some of these forts were along the Roman Wall. A few were north of it; many guarded the land south of it. They were all much the same—square or oblong in outline, three to six acres in area. They were purely military. Strategically, the use of these forts rested on the assumption that the enemies of the Empire would only attack in small bodies, and that under the then conditions the attack was weaker than the defence. In the end the system broke down. The enemy arrived in hordes, the isolated forts fell one by one, and the frontiers had to be set back. Of such forts North Britain contained perhaps fifty or sixty, not necessarily all in use at once. Faint vestiges of one still stubbornly survived in a corner of Manchester; another, larger and more important, was there in Ribchester. It guarded a crossing of the Ribble from north to south. It guarded also the entrance to the Ribble estuary, and the passage up the valley inland, and the low hills by which one could penetrate the Pennine range from Blackburn to Todmorden, to Skipton, to Ribbleshead—all three easy passages. It was built possibly by Agricola, but more probably, Dr. Haverfield thought, four or five years before Agricola came to Britain, and it was held, with various reconstructions, till the very end of the Roman period. It was large and strong, but little was left of it now; one large piece, indeed, had been washed bodily out by the Ribble. In a field just west of the churchyard a grass-grown bank and mound marked its former western limit. Here some useful excavations were made twenty years ago by Professor Garstang. More lately Miss Greenall, in building her house, discovered parts of the headquarters building, right in the centre of the fort, and coerced her architect into preserving them in situ, and encouraged excavation. Professor Anderson, of Manchester, and Mr. Donald Atkinson had been able recently to recover the plan of the headquarters building nearly whole. There was a little more to do some day.

The urban district council of Cleator Moor have obtained the consent of the Local Government Board to the borrowing of £7,000 for the purchase of land and the erection of working-class dwellings under the Housing of the Working Classes Act.

An equestrian statue of Dick King, who saved Natal by his famous 600 miles ride from Durban to Grahamstown, when the former town was besieged by the Boers in May, 1842, was unveiled on August 14 on the Esplanade at Durban by the Mayor.

On the occasion of his retirement from the Bucks County Asylum service, Mr. Edwin Field, the engineer and clerk of works, has been presented by the members of the Visiting Committee, present and past, and the officers and staff of the asylum, at Stone, near Aylesbury, with a purse of gold and a barometer.

During some excavations at Minster, in the Isle of Sheppey, a Roman coin was found, which has been identified at the British Museum as a coin of Hadrian, who was Emperor from A.D. 117 to A.D. 138, and built the wall extending from the Solway to the Tyne. There is proof of the Roman occupation of Sheppey from Roman bricks found in Minster Abbey Church and in the abbey wall.

LATEST PRICES.

N.B.—All prices must be regarded as merely approximate for the present, as our usual sources of information are in many cases failing us.

TIMBER.

Owing to stoppage of supplies all prices have advanced considerably.

IRON.

Table listing various iron products and their prices per ton. Items include Rolled Steel Joists, Wrought-Iron Girder Plates, Steel Girder Plates, Steel Sheets, Steel Strip, Basic Bar, Bar Iron, Cast-Iron Columns, Cast-Iron Stanchions, Rolled-Iron Fencing Wire, Rolled-Steel Fencing Wire, Cast-Iron Sash Weights, Cut Floor Brads, Corrugated Iron, Galvanised Wire Strand, B.B. Drawn Telegraph Wire, Cast-Iron Socket Pipes, and various gas and steam tubes.

OTHER METALS.

Table listing various other metal products and their prices per ton. Items include Lead Water Pipe, Lead Barrel Pipe, Lead Pipe, Composition Gas-Pipe, Lead Soil-pipe, Lead, Common Brands, Lead Shot, Copper sheets, Copper, Tin, Pig Lead, Sheet Lead, Genuine White Lead, Refined Red Lead, Sheet Zinc, Old Lead, and Tin.

I BUY SCRAP METALS

ARTHUR P. COLLINS, Snow Hill, BIRMINGHAM. Phone Central 1029. Bakers: The National Provincial Bank of England Ltd., Bennett's Hill, Birmingham.

SLATES.

Table listing various slate products and their prices per 1,000 of 1,200 at r. strn. Items include Blue Portmadoc, Blue Bangor, and First quality.

Table listing various roofing materials and their prices per 1,000 of 1,200 at r. strn. Items include Eureka un-faling, Green, Permanent Green, and others.

BRICKS.

Table listing various brick products and their prices per 1,000. Items include First Hard Stocks, Second Hard Stocks, Mild Stocks, Picked Stocks, Facing Bricks, and various other brick types.

GLAZED BRICKS.

Table listing various glazed brick products and their prices per 1,000. Items include White, Ivory, and Salt Glazed, Buff, Cream, and Other Colours, and various other glazed brick types.

Bath Stone—Delivered in railway trucks at Westbourne Park, Hammersmith (G.W.R.) or South Lambeth (G.W.R.) per foot cube	0	1	7
Delivered in railway trucks at Nine Elms, L.A.S.W.R.	0	1	8½
Delivered on road wagons at Nine Elms Depot	0	1	9½
Lortiana Stone—Brown Whitelid in random blocks of 20 ft. average, delivered in railway trucks at Westbourne Park (G.W.R.), South Lambeth (G.W.R.) or Nine Elms L.A.S.W.R.	0	2	5½
Delivered on road wagons at Fulham Wharf or Nine Elms Depot	0	2	6½
White Basebed—22. per foot cube extra.			

TILES.

Plain red roofing tiles	42	0	per 1,000	ry. sq. ft.
Hip and Valley tiles	3	7	per doz.	
Brossiey tiles	50	0	per 1,000	
Ornamental tiles	52	6		
Hip and Valley tiles	4	0	per doz.	
Reason red, brown, or brindled ditto (Edwards)	57	6	per 1,000	
Ornamental ditto	60	0		
Hip tiles	4	0	per doz.	
Valley tiles	3	0		
Selected "Perfecta" roofing tiles—Plain tiles (Peaks)	46	0	per 1,000	
Ornamental ditto	48	6		
Hip tiles	3	10	per doz.	
Valley tiles	3	4		
"Rosemary" brand plain tiles	48	0	per 1,000	
Ornamental tiles	50	0		
Hip tiles	4	0	per doz.	
Valley tiles	3	8		
Staffordshire (Hanley) Reds or brindled tiles	42	6	per 1,000	
Hand-made sand-faced	45	0		
Hip tiles	4	0	per doz.	
Valley tiles	3	6		
"Hartshill" brand plain tiles, sand-faced	45	0	per 1,000	
Pressed	42	6		
Ornamental ditto	47	6		
Hip tiles	4	0	per doz.	
Valley tiles	3	6		

OILS.

Rapeseed, English pale, per tun	£28	15	0 to	£29	5	0
Ditto, brown	26	15	0	27	5	0
Cottonseed, refined	29	0	0	30	0	0
Olive, Spanish	39	10	0	40	0	0
Seal, pale	21	0	0	21	0	0
Cocoonut, Cochin	46	0	0	45	10	0
Ditto, Ceylon	42	10	0	43	0	0
Ditto, Mauritius	42	10	0	43	0	0
Palm, Lagos	32	5	0	33	5	0
Ditto, Nut Kernel	35	0	0	35	10	0
Oleine	17	5	0	19	5	0
Sperm	30	0	0	31	0	0
Lubricating, U.S.A. per gal.	0	7	0	0	8	0
Petroleum, refined	0	0	6½	0	0	6
Tar, Stockholm, per barrel	1	6	0	1	10	0
Ditto, Archangel	0	19	6	1	0	0
Linseed Oil, per gal.	0	2	7			
Baltic Oil	0	2	10			
Turpentine	0	3	2			
Purty Genuine Linseed Oil, per cwt.	0	9	6			
Pure Linseed Oil	0	9	0			
"Stority" Brand	0	9	0			

GLASS IN CRATES.

English Sheet Glass: 15 oz.	21 oz.	25 oz.	32 oz.
Fourths	5½d.	5½d.	7d.
Thirds	5½d.	6½d.	8d.
Fluted sheet	5½d.	6½d.	
Hartley's English Rolled Plate	3½d.	3½d.	4½d.
Figured Rolled	4d.		6d.
Berossine	4d.		5½d.
Red Sheet	3½d.		

VARNISHES, Etc.

Fine Pale Oak Varnish	£0	8	6
Pale Copal Oak	0	10	0
Omnifar Copal Oak	0	10	0
Superfine Pale Elastic Oak	0	12	0
Fine Extra Hard Church Oak	0	10	0
Superfine Hard-drying Oak, for seats of churches	0	14	6
Fine Elastic Carriage	0	12	9
Superfine Pale Elastic Carriage	0	16	0
Fine Pale Maple	0	10	0
Finest Pale Durable Copal	0	18	0
Extra Fine French Oil	1	1	0
Eggshell Flattening Varnish	0	18	9
White Copal Enamel	1	4	9
Extra Pale Paper	0	12	0
Best Japan Gold Size	0	10	0
Best Black Japan	0	16	0
Oak and Mahogany stain	0	9	0
Brunswick Black	0	8	0
Berlin Black	0	16	0
Knott's	0	10	0
French and Brush Polish	0	10	6

On Tuesday last week the new schools at Castle-town were formally opened by Cardinal Logue. The schools were erected by Mr. Mayhew from plans prepared by Messrs. W. H. Byrne and Sons, Dublin, and cost about £47,000.

The Herts County Council have adopted plans by Mr. W. J. Taylor, of Winchester Castle, their architects, for the reconstruction of the bridge at Welham carrying the Winchester Railway over the main road over the river Moen.

TO CORRESPONDENTS.

We do not hold ourselves responsible for the opinions of our correspondents. All communications should be drawn up as briefly as possible, as there are many claimants upon the space allotted to correspondents.

It is particularly requested that all drawings and all communications respecting illustrations or literary matter, books for review, etc., should be addressed to the Editor of THE BUILDING NEWS, Effingham House, 1, Arundel Street, Strand, W.C., and not to members of the staff by name. Delay is not infrequently otherwise caused. All drawings and other communications are sent at contributors' risks, and the Editor will not undertake to pay for, or be liable for, unsolicited contributions.

Drawings of selected competition designs, important public and private buildings, details of old and new work, and good sketches are always welcome, and for such no charge is made for insertion. Of more commonplace subjects, small churches, chapels, houses, etc.—we have usually far more sent than we can insert, but are glad to do so when space permits, on mutually advantageous terms, which may be ascertained on application.

When favouring us with drawings or photographs, architects are asked kindly to state how long the building has been erected. It does neither their nor us much good to illustrate buildings which have been some time executed, except under special circumstances.

Telephone: Gerrard 1291.
Telegrams: "Timeserver, Estrand, London."

NOTICE.

Bound copies of Vol. CVIII. are now ready, and should be ordered early (price 12s. each, by post 12s. 9d.), as only a limited number are done up. A few bound volumes of Vols. XXXIX., XL., XLVI., XLIX., LIII., LVI., LXII., LXIV., LXV., LXVI., LXVII., LXVIII., LXIX., LXXI., LXXII., LXXIII., LXXIV., LXXV., LXXVI., LXXVII., LXXIX., LXXX., LXXXI., LXXXII., LXXXIII., LXXXIV., LXXXV., LXXXVI., LXXXVII., LXXXVIII., LXXXIX., XC., XCI., XCII., XCIII., XCIV., XCV., XCVI., XCVII., XCVIII., XCIX., C., CI., CII., CIII., CIV., CV., CVI., and CVII. may still be obtained at the same price; all the other bound volumes are out of print. Most of the back numbers of former volumes are, however, to be had singly. Subscribers requiring any back numbers to complete volume just ended should order at once, as many of them soon run out of print.

Handsome Cloth Cases for binding the BUILDING NEWS, price 2s., post free 2s. 4d., can be obtained from any Newsagent, or from the Publisher, Effingham House, 1, Arundel-street, Strand, W.C.

TERMS OF SUBSCRIPTION.

One Pound per annum (post free) to any part of the United Kingdom; for the United States, £1 6s. 0d. (or 60s. 30c. gold). To France or Belgium, £1 6s. 0d. (or 33f. 30c.). To India, £1 6s. 0d. To any of the Australian Colonies or New Zealand, to the Cape, the West Indies, or Natal, £1 6s. 0d.

Our Direct Subscription Agents for Australia are Messrs. E. T. Kibblewhite and Co., Printers and Publishers, 19, York Chambers, 105, Liverpool Street, Sydney, New South Wales; for Japan, The Maruzen Co., Ltd., 11-16, Nishiba-hi Tori Sauchome, Tokyo; who will receive Subscriptions at 41 6s. 0d. per annum on our account. Copies of the paper will be sent by us direct to the subscribers' address.

The special rate to Canada is £1 3s. 10d. = 54s. 80c for 12 months, and 11s. 11d. = 30s. 60c. six months. Our Direct Subscription Agents for Canada are Messrs. Sells, Ltd., 302, Shaughnessy Buildings, McGill Street, Montreal, who will receive Subscriptions, £1 3s. 10d. per annum, on our account.

Cheques and Post-office Orders to be made payable to THE STRAND NEWSPAPER COMPANY, LIMITED, and crossed London County and Westminster Bank.

ADVERTISEMENT CHARGES.

The charge for Competition and Contract Advertisements, Public Companies, and all official advertisements is 1s. per line of Eight Words, the first line counting as two, the minimum charge being 6s. for four lines.

The charge for Auctions, Land Sales, and Miscellaneous and Trade Advertisements (except Situation Advertisements) is 6d. per line of Eight Words (the first line counting as two), the minimum charge being 4s. 6d. for 50 words. Special terms for series of six insertions or more can be ascertained on application to the Publisher.

SITUATIONS VACANT AND PARTNERSHIPS.

The charge for advertisements for "Situations Vacant" and "Partnerships" is One Shilling for Twenty-four Words, and Sixpence for every Eight Words after. All Situation Advertisements must be prepaid.

Advertisements not exceeding Thirty Words, inclusive of name and address, are inserted under the heading "Situations Wanted," free of charge.

Rates for Trade Advertisements on front page and special and other positions can be obtained on application to the Publisher.

REPLIES TO ADVERTISEMENTS.

Replies to advertisements can be received at the Office, Effingham House, 1, Arundel Street, Strand, W.C., free of charge. If to be forwarded under cover to advertiser, an extra charge of Sixpence is made. (See Notice at head of "Situations.")

Advertisements for the current week must reach the office not later than 3 p.m. on Tuesday. Front-page advertisements and alterations or stop orders for serial advertisements must reach the office by first post on Monday to secure attention.

RECEIVED—Rev. F. S. S.—E. J. P.—Van A. and Co.—L. and N.W.R. Co.—A. Ltd.—G.—E. R. R.—B. S. Co., Ltd.—J. H. and Co.—C. P. Co., Ltd.—E. S. Co., Ltd.—J. B.

RISKA, Yes.
PHILIP J.—Thanks, no.

H. P. L.—At the usual date. 2. No.
J. S. H.—We take your own solicitor's view.

CONCRETE—The original patent must have expired long since. Possibly some "improvement" has been patented since.

POST FREE TO YOUR DOOR.—The interruption of regular and punctual transit and unavoidable shortage of labour in the distributive facilities of the news trade is causing much disappointment to readers of our own and similar journals. Wherever this is so and difficulty is experienced in obtaining THE BUILDING NEWS punctually on Wednesday morning, we will send a copy POST FREE direct to any reader's address on receipt of 4s. 4d., the amount of the quarterly subscription. Readers away on holiday, or in camp, can also have single copies sent them POST FREE to any address on receipt of four penny stamps.

A new Congregational church is to be built at Bilton from the plans of Mr. A. A. Gibson, of Harrogate.

A new United Free church in Dumbarton Road, Dalmuir, has been formally opened. The cost was £4,700.

New Council schools at Glynlyfdwy, Merionethshire, erected at a cost of £3,000, were opened on Tuesday in last week. The architect is Mr. Howard Jones, of Borth.

The Housing Committee of the Herts County Council have approved provisionally of plans for the erection of 100 cottages. The prices range chiefly from £175 to £210 per cottage.

Alterations and additions are about to be carried out at the Tabernacle in Elder Street, Bridgend. Mr. P. J. Thomas is the architect and Mr. R. Jones, jun., of Coychurch, is the builder.

Plans have been passed by the Dean of Guild Court of Kilmarnock for a ham and bacon warehouse in Woodstock Street for the Scottish Co-operative Wholesale Society. The probable cost is £7,000.

The Fyde Water Board is about to undertake the construction of three reservoirs at Balhead, near Clitheroe. The cost will exceed £2,000,000, and the enterprise will give employment to 600 navvies.

A new Board school built in Calder Street, Govanhill, Glasgow, for the Govan Parish School Board, has been formally opened. The architect was Mr. Andrew Balfour, F.R.I.B.A., Mains Street, Glasgow.

The Wilberfoss and Thornton Level Drainage Board have instructed Messrs. Fairbank and Sons, engineers, of London, York, to examine the upper watercourses in the district and submit a report to the board.

Telephone DALSTON 1388.

OGILVIE & CO.

Many years connected with the late firm of W.H. LASCELLES & CO., of Bunhill Row.

Mildmay Avenue, ISLINGTON, N.

EXPERTS in HIGH-CLASS JOINERY.

ALTERATIONS & DECORATIONS.

ESTIMATES FREE.

FOR **Olivers' Seasoned Hardwoods,**

APPLY TO—**WM. OLIVER & SONS, Ltd.,**
129, Bunhill Row, London, E.C.

TENDERS.

* Correspondents would in all cases oblige by giving the addresses of the parties tendering—at any rate, of the accepted tender: it adds to the value of the information.

BELFAST.—For building a house in Linden Gardens, for Mr. William Lorrimer. Mr. R. S. Hill, Wellington Place, Belfast, architect.—Potts, Robert, Belfast (accepted).

BLAIRGOWRIE.—For carrying out extensive improvements and alterations to a factory on the Haugh:—Watson and Sons, Perth (accepted).

THE BUILDING NEWS AND ENGINEERING JOURNAL.

Effingham House.

CONTENTS.

Strand, W.C.

The War and Emergency Building	313
The Sky-scraper	314
The London Salon of Photography	316
Problems in the Design of Reinforced Concrete Buildings	316
The Panama-Pacific International Exposition, San Francisco	318
The Dewar Memorial Drinking Fountain, Portofino	315
Rivington's Notes on Building Construction	315
The New Parliament Buildings for Manitoba	319
Obituary	319
Our Illustrations	319
Currente Calamo	319
The Percentage of Water in Concrete	325
Shrinkage and Time Effects in Reinforced Concrete	325
Building Intelligence	329

London	313
San Francisco	318
Portofino	315
Manitoba	319
Obituary	319
Illustrations	319
Currente Calamo	319
Concrete	325
Intelligence	329

Strand, W.C.	313
London	313
San Francisco	318
Portofino	315
Manitoba	319
Obituary	319
Illustrations	319
Currente Calamo	319
Concrete	325
Intelligence	329

THE WAR AND EMERGENCY BUILDING.

With timber supplies restricted, prices high and tending to advance, it is more desirable than ever to consider the scope that may exist for temporary building in other material than wood. Apart from the question of first cost there may be occasions where a more solid form of structure may prove best suited to specific duty. Among systems of construction suited to rapid building is that of light steel stanchions filled in between with some thin and inexpensive panelling, as brick flat, on-edge, or concrete slab. Of these, if ob-

tainable, a thin waterproof slab offers advantages. Brick panelling would no doubt often prove convenient, but it would entail some exterior waterproofing, or cover, such as cement stucco, and, to promote equable temperature, interior plaster with air space.

On these general lines we shall consider the construction of temporary buildings suited to the present emergency. Our sketch shows a building on this system. In the case of a quite temporary structure, the stanchions would be very light, and the panelling very thin, either 4½-in. brickwork, or 3-in. brick-on-edge, or, say,

2 in. of wood 10 in. wide, or 1 in. of cast-iron, as we have seen in the case of necessary temporary buildings in the rain.

It is to be intended for a building, whereas we cannot cover the temporary work, space quarters near the coast, 11 ft. 6 in. apart, we only need stanchions in each roof truss, say at 10 ft. centres. In normal times we can never say 100 ft. by 20 ft. by means of one light steel roof trusses for £27, or less. Adding 22 stanchions at the cost, say, of £25, including all cutting, riveting, and connections and bolts, nothing more in the way of steel would be needed, since piling and window would fit in between the stanchions and give longitudinal stability to walls, leaving the matter of cross stability to some means of holding down the stanchions to earth, or tying the heads of roof trusses, or a combination of these methods; for we cannot, as when dealing with substantial brick walls, of ordinary thickness, rely upon the walling to resist wind pressure.

Our suggestions generally refer either to half-brick walling, brick on edge, or concrete slab. Taking the first, the 4-in. bricks should fit snugly between the flanges of the stanchions. For a 20 ft. span the steel roof truss would weigh say 4 wt., and allowing for lead and wind

or 4,224 lbs., this would represent the weight upon each stanchion; but the steel reinforces the wall, and the wall supports the steel, so that if we can assume that the post is held firmly upright, we can do with a very light section. Still, we are considering brick flat, as more convenient in fitting between the flanges, a 5 in. by 4½ in. section would suggest itself.

We are holding primarily to a wall as economical a structure as possible. As therefore, we are only venturing on a strength test, the main question is the question of wind pressure, as of rain, since, for the thin, the type of panelling might be well suited to expansion tests, experiencing the full stress of wind forces. If nothing occurred to cause a tendency for the thin wall to overturn, the weight of roof and a half might be carried, and it is some of the main points of the wall, if panelling is used, that will probably be the truss, and the stability of the building will depend on the stability of the stanchions, and the stability of the stanchions as well as the stability of the structural stresses of the trusses to the stanchions, which will be a matter over the other. If the main part of structure is panels, in the case of truss to stanchion held, which would be a case, must be sufficiently powerful to require this

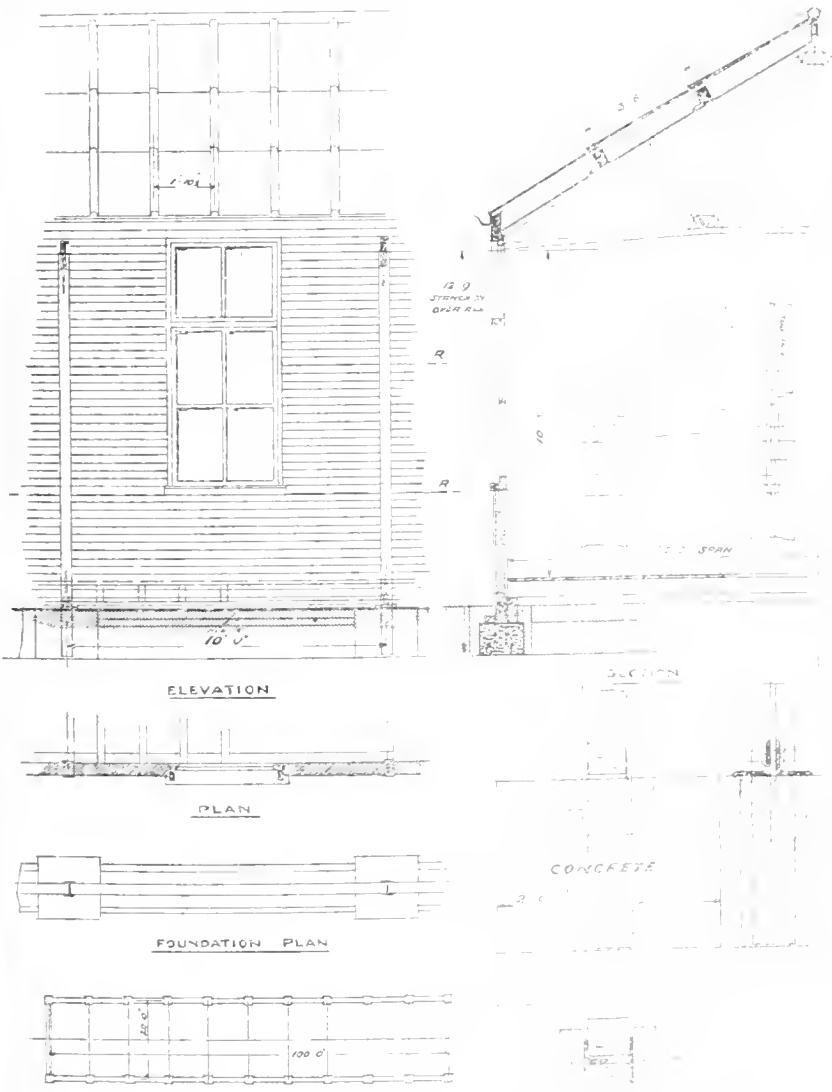

TEMPORARY IRON BUILDING WITH PANEL FITTINGS.

tion; if the stability depends on stanchion connection to earth, this resistance must be broken down before the building is wrenched. In ordinary cases, no doubt, a roof truss shoe, well bolted to a stanchion-head, provides all resistance needed; but where we wish to cut down the weight of steel as much as possible, it is advantageous to well anchor the post to the earth. In emergency building, and for temporary building, we should, with shortage of skilled labour, endeavour to avoid elaborate design and work, as in base-plates, anchorage, and head plate connections, seeking to keep all labour on steel work to cutting to lengths and simple drilling and riveting. We may effect this object in ground anchorage of stanchions, avoiding real base plate construction, by proceeding much on the old gate post principle, bedding the stanchion ends in concrete blocks. The concrete could be laid with recesses ready for the posts, and these latter being plumbed and secured as soon as, or soon after, the recess is grouted, the concrete grips the steel; and if the general foundation is homogeneous concrete, to overturn the stanchion we must overturn the foundation, or cause a rupture, neither of which is a likely event, excepting in a country of tornadoes. The stability of hollow, barn-like structure of the type sketched is greatly assisted where the foundation grips the post.

These considerations are to the point, because we desire to keep down cost of construction to the utmost. We do not wish to put a pound of unnecessary steel, in these days, in temporary or emergency building, nor to use superfluous walling material, and as regards this latter point, we may argue that inasmuch as rain may penetrate $4\frac{1}{2}$ in. of brickwork, 2 in. of walling material would be as good as $4\frac{1}{2}$ in., since in either case we must do something to make the structure waterproof. Hence we might consider that 2-in. of material, such as slab, would fit into 3-in. by 3-in. H stanchions, weighing $8\frac{1}{2}$ lb. per foot, and, stiffened to some extent by the rebated or grooved walling in cement mortar, suffice to carry less than two tons of load, even if—for orthodox, permanent construction—the 3-in. by 3-in. be outside the generally accepted ratio of slenderness. With a real grip on foundation and an efficient tie above, the steel post is greatly strengthened. Again, when an efficient roof truss sits squarely upon a stanchion head, the resultant stress may be said to partake of the nature of a balanced or "concentric" load.

The foregoing sketch was prepared to illustrate generally the considerations we have suggested, and to form a basis for argument rather than of insistence. The drawing shows stanchions set 10 ft. apart centre to centre, and it may be worthy of remark that we might employ steel in this manner, and yet, with some very light woodwork, compressed asbestos sheets as walling. The idea may be carried out either in brick panelling or some suitable form of slab, and in the event of a yet more advanced price of scantling timber, be found suggestive. We need, however, to remember that steel is in urgent demand, and greatly advanced in price. For this reason we have suggested that the stanchions should be as light as possible; and since, in this particular panel construction, they should be regarded not so much as true pillars, but as wall stiffeners, much, indeed, as reinforcement, we have suggested that the full value of the steel should be obtained by seeing that the posts are securely anchored to the ground. The scheme was sketched to scale for $4\frac{1}{2}$ in. brickwork and 5-in. by $4\frac{1}{2}$ in. posts as stanchions. Tak-

ing a building or shed 100 ft. by 20 ft., we may compare this with the timber-framed method. We will assume 10 ft. walls, stanchion construction on the one hand and quartering on the other. Putting an extra steel post at each end, the whole number of stanchions is twenty-four. Allowing that the quarters in a temporary timber framed building are 1 ft. 6 in. apart, there would be some 80 c. ft. of timber in 4 in. by 2 in. posts, as against, say, 5,800 lb. steel in 5-in. by $4\frac{1}{2}$ in. stanchions, giving these extra length to bed well in concrete, as a simpler system of ground fastening than genuine base-plates and anchor bolts, and more suitable where unskilled labour is involved. Taking that which would appear to be the limit in constructive lightness, 3-in. by 3-in. H stanchions and 2-in. grooved and tongued concrete slabs, the steelwork would be reduced to less than half, say 2,900 lb. As to roofing, there is considerable timber in a roof with each pair of rafters tied by a collar. Taking the 100 ft. by 20 ft. proposal, and allowing, for temporary construction, say 1 ft. 6 in. between one rafter centres, there would be some 120 c. ft. of 4-in. by 2-in. rafter and collar, as against the nine light steel trusses. It is true that with the arrangement shown in our sketch there are purlins, pole-plates, and ridge-piece to the extent of about 100 c. ft., which somewhat alters the outlook. In comparing, therefore, a collar-beam roof and one with light steel trusses, we must bear in mind the expense of purlins. A way out, possibly—and we are endeavouring to omit all superfluous timber—would be the employment of Z steel purlins, say $8\frac{1}{2}$ lb. to the foot. Light steel offers many advantages in purlin construction, where timber is dear. Inasmuch as that cleats are required to secure wood purlins, whilst drilling the principals for these we might make provision, with no more labour, for fastening the Z steel to the truss.

The sketch discards any more elaborate means of fixing steelwork than by cut angle-pieces or plain sawn plates. The stanchion is shown bedded in concrete, the cross-hatching on detail being a suggestion for leaving a sinking in the concrete block, to be finally grouted, the exact position in building being located, and the post plumbed, by means of angle-pieces riveted to the web, and taking bearing on concrete finished to a true and level surface. To connect the stanchions to the trusses in place of the ordinary shoe are shown two cut-plates, which are riveted to the feet of principals and tie-beams and bolted to the web of H stanchions. As drawn to scale, and as designed, no doubt in place of suggesting a temporary structure, it might be considered suited to quite permanent work and of superfluous strength. Structure of this nature, and no stronger, has been found extremely useful in ordinary commercial building, and would be found particularly so where firms have, in emergency, as to fill urgent contracts, to suddenly extend their premises. The sketch is put forward rather to be suggestive, and the remarks above made as to wind-pressure, stanchion and panel construction and strength bear upon the point of how to reduce steel to a minimum rather than as referring to the design and details shown. To reduce cost it is necessary to gain correct ideas on the method of construction, and to get the utmost out of every pound of steel we must see that it is secured in the best manner.

The roof trusses would be $\frac{1}{2}$ -in. steel only, with $\frac{1}{2}$ -in. bolts and rivets, where in permanent work we should use $\frac{3}{8}$ -in. steel; and in place of $2\frac{1}{2}$ -in. angles and bars,

say, 2-in. only; and connections and angle-pieces in $\frac{1}{4}$ in. in the roof and $\frac{3}{8}$ in. in fish-plates and angles to stanchion connections and quasi base-plates. The panelling is shown in brick flat, and where there are no windows might be reinforced, as suggested at R.R. The window is in deal rebated linings, with deal sill transom and stops against the underside of the pole-plate, which finishes the walling and gives a fixing for the gutter. Since the weight of the roof is chiefly upon the stanchions, and there is little upon the wall itself, very little wall foundation is required, but a larger block of concrete is shown in which to embed the stanchion ends.

With timber at present prices, and the uncertainty as to the future, and assuming steel procurable even at present enhanced prices, it is possible that there would not be a very great difference in the cost of erecting similar sized buildings in 4-in. by 2-in. timber framing and in the method shown and one or the other of the panel materials discussed. But it would be necessary to use and dispose steelwork with the utmost economy. We advance this opinion with caution, but as it is well to look ahead and consider all suitable methods we have put forward a practical alternative to timber. It should be remembered, too, that there are many uses to which steel and slab construction can be put, apart from those immediately attendant upon or the result of war.

THE SKY-SCRAPER.

As yet the sky-scraper is not an institution in England. Remembering the extremely high value of land in the City of London and in some of the other leading towns in the kingdom, and the natural tendency of late years on the part of most leading business concerns to run an office, or at any rate have an address, in the capital, wherever else located, it is a matter for congratulation that the authorities have resisted the desire to add story to story skywards in Babel-like fashion. For the great disadvantage to the community of high office buildings is sufficiently obvious. They detrimentally exclude sunlight and air from the streets; they prejudicially increase the congestion of traffic; they almost render impossible efficient fire-protection; and they overtax the sewer and water systems, quite adequate to the smaller population of the same area. Architecturally they are eyesores, of course, but that fact has not hindered their erection in America, and it may not here if Commerce, freed for some years to come from German competition and encouraged by the prospects of as long a peace as succeeded the final crushing at Waterloo of Napoleon's project of pan-European domination, redoubles her efforts to repair the losses of the present and to lay the nations under willing because beneficial tribute to British merchants and manufacturers.

On the other hand, if local authorities are obdurate, and Government departments still determined to keep builders and architects idle till the awful total of the war bill is liquidated, many of them will have to seek a living elsewhere when they return to civil life, and will need to learn a little more about the construction of sky-scrapers as well as other structures for which we have little need here. Admitting all their disadvantages just mentioned, it is probable that the community does benefit to some extent by anything that promotes the concentration of business, and it is certain that the ground landlord gets far higher rents—just as he does here when single houses

are turned into flats. Nowhere, probably, have these considerations so overridden all others as in New York, where floor has been piled upon floor till a maximum of fifty-five stories and a height of 775 ft. has been reached, as in the case of the Woolworth Building, which towers like a giant above its competitors, and reduces ordinary four and five storied buildings such as we are familiar with to the appearance of rabbit hutches by comparison.

As owners and builders successively sought to outdo each other in America, it soon became evident that the ordinary construction, in which exterior walls carry their own weight and some of the adjacent floor load, the rest being borne by iron or steel columns, became impracticable. The wall thickness insisted on by local authorities became so great that more and more of the space available for renting became absorbed. Windows had to be narrower and narrower to conserve the strength of the walls, and hence light became more and more poorly distributed; and if the unit-bearing capacity of the ground under the footing was low, more and more costly work became necessary properly to distribute the pressure over the soil. This led to the adoption of what is known as cage construction, on which all loads, including the weight of the wall, are carried at each floor level by the steel, and by which therefore weight-carrying walls are practically eliminated from the sky-scraper. It follows—at least, in American practice, whether or no time has yet sufficiently tested the theory—that windows may be used for almost the whole of the exterior wall area without danger to stability, and it is claimed that such structures are hurricane and earthquake proof to a greater degree than ordinary buildings. Possible rapidity of construction is another advantage gained. In America an old building is demolished and a new one of twenty-five stories completed on its site in a year. The reduction thus effected on the loss of site and increment value and the interest on the money spent in building is thus very materially reduced.

The increased depth of foundation demanded by such tall structures, of course, means much excavation, and if more than 5,000 cubic yards have to come out the steam shovel is employed. Shoring of undermined adjacent walls is also a heavy item, and in unstable ground the foundations of neighbouring buildings have to be renewed. The principal types of foundation are continuous, masonry footing, raft footing, piles, or caissons. The first method is not recommended, as considerable thickness of concrete is required properly to distribute pressure, and centres of gravity of applied loads and footing area are not likely to coincide. The second is not often used. Formerly piers were often made of stone or concrete, but seldom nowadays, except for small footings; for others the method is too costly. A grillage or raft footing has advantages, and so, of course, have piles, especially concrete ones, which are now very extensively used. The caisson type of foundation is, perhaps, the best of all. It is really a large single pile, round or square, made of brick or concrete. The method favours a larger pressure on the bottom of the footing, since the caissons may be driven with but a bare clearance. A large column will carry more per unit area than a small one; perfect contact with bearing area is assured; injury beyond inspection or repair is avoided, and there is less danger to adjoining buildings. Of the two methods of sinking the caissons the hydraulic is the cheaper. A pipe, usually of steel, open at each

end, is sunk by jets around the lower edge, and by weights placed on top. The dirt is excavated after bottom is reached and masonry built up inside, and on the top of the masonry a grillage is laid to receive the column base. In cases where the soil has not sufficient stability to resist the rush of water as the caisson is pumped out, the more costly pneumatic caisson must be used. With this a transverse bulkhead about eight feet from the bottom of the chamber forms a working chamber, and on the top of this is laid the masonry, an opening being left to the chamber below. A double valve forms an air-lock, which allows the passage of workmen and material. The caisson is forced down by the weight of the pier above, aided by the excavation of the material in the working chamber, in which air pressure is maintained to keep out water and silt. As soon as the rock is reached it is levelled, and the working chamber filled with masonry. The grillage is similar to that used with the hydraulic caisson.

The columns for the exterior walls are necessarily quite near the property line, and, to avoid trespass, the American architect and engineer favour the cantilever girder, designed and built much like the ordinary plate girder. With the cantilever, however, shear is of more importance than moment, hence those parts which in a plate girder carry shear receive special attention. Sometimes the cantilever girders have more than two supports, thus securing the advantages and the disadvantages of continuous beams, which the American engineer seeks to avoid. As regards the columns generally, and the beams, stringers, tie-rods, etc., there is little difference from those employed here. Floors, of course, receive special attention, brick, terracotta, tile, and concrete, and steel, well protected by one or the other, being usually employed. The ordinary floor with the fire-trap wooden joist is out of the question, although wood is often used on the top of the floor, in spite of the fact that it will not survive a fire. Terracotta, in hollow blocks, forming an arch, set in cement, are more typical than any other floor, flat and segmental arches being both used. The latter is the stronger type, and allows a longer span, and is favoured in warehouses and similar buildings. Probably the flat arch would be more effective if the joints were radial, which they seldom are, owing to the additional cost. Combination floors, which are really reinforced concrete floors with terracotta fillers to lessen weight, find some favour. A floor known as the Roebbing is also in demand. It is said to have advantages over expanded metal, instead of which it uses a woven wire supported by rods. Many other systems are in vogue, some of which hardly seem to fulfil the requirements which should be rigidly demanded by the architect. These are: Strength to bear the live load and its own dead weight safely; resistance to temperature of 1700 Fahr. for four hours while thus stressed, and ability to withstand fire streams after. In only less degree the floor should be agreeable to stand on, have good acoustic top and bottom surfaces, so as to be sound-proof as far as possible, be light in weight, durable, and economical.

Roofs are of only less importance than floors. Wood should never enter into their construction, as protection against exposure fires is indispensable. Tile roofs are fairly common, consisting of several layers of felt on which tiles are embedded in cement. Slate is sometimes used instead of tile. Asphalt, tar and gravel, brick set on edge, or Portland cement on felt, and tin and copper are used. If the

last two are employed, care has to be taken not to place either in contact with concrete, or terra-cotta, on account of the corrosion.

The cornice is not favoured. Its architectural advantage is recognised, but structurally it is disliked. It is much exposed to flames, and it is an eccentric load on the columns. Wind-bracing is of the highest importance. In addition to its principal function, it gives stiffness to the structure, and American builders maintain that, if properly designed, it will resist earthquake shocks, and that all high buildings should be so designed that the addition of wind to other loads should not cause stresses more than 25 per cent. in excess of ordinary values.

Specifications for high buildings do not seem to us to err on the side of stringency. It is true, no doubt, that there is little vibration, and that the live load seldom reaches the maximum. Under average circumstances it is said the live load varies from 10 to 40 lb., and it is considered safe to specify from 60 to 150 lb. per square foot. But high authorities have insisted that a selected crowd of people might weigh as high as 181 lb. per square foot. In view of this, live load should hardly be reduced below 75 lb., and 100 lb. seems safer. Certainly where machinery is installed to any extent the floors should be designed for a live load of not less than 150 lb.

From a very practical text book by Prof. Horace B. Thayer, recently published in this country by Messrs. Constable and Co., Limited, which we have already recommended to our British readers, and to which we are indebted for some of the facts gleaned herein, we take the following points in which the specification for the steel frame of an average high office building should differ from ordinary minimum requirements.

Dead Loads.—Dead loads shall be checked in all cases from architect's and contractor's cross-sections and details.

Live Load for Floors.—The live load on first floor shall be taken as 100 lb. per square foot plus a concentration of 5,000 lb. any where. Use same values for remaining floors, except that 80 is substituted for the uniform load.

Live Load for Flat Roofs.—The live load on a flat roof shall be taken as 50 lb. per square foot.

Live Loads for Pitch Roofs.—The live loads on pitch roofs are to have the same values as for flat buildings.

Live Loads for Columns.—The live load on the columns consists of uniform loads on floors and roofs as specified above; this to be taken at its full value on column in story below, 25 per cent. of same, two stories below, 16 per cent., three stories below, and so on. Maximum reduction, 50 per cent.

Wind Loads.—The wind pressure on exterior walls shall be taken as 50 lb. per vertical square foot acting in any horizontal direction.

Loads for Footings.—Footings shall be designed for dead loads plus 20 lb. per square foot for all floors. If dead plus live as reduced for columns plus wind exceeds twice the allowable bearing values as given below, all areas must be proportionately increased.

Allowable unit stresses in lb. per sq. in.

Medium Steel—Tension on net section, 16,000; compression on gross section, length in inches.

16,000—90 least radius of gyration in inches.

Shear on shop rivets, pins, and gross sections of webs, 12,000; shear on field rivets and bolts, 9,000; bearing on shop rivets and pins, 24,000; bearing on field rivets and bolts, 13,000; bending on pins, 24,000; other flexural stresses, 16,000.

Allowable compression on wall masonry: Brickwork, lime mortar, 100; brickwork, Portland cement mortar, 150; concrete Portland cement, 3 sand, and 6 stone, 250; stone masonry, first class, 250.

These values may be increased 5 per cent. for local bearing on bulky masonry as in foundations.

Allowable values in compression direct or flexural, reinforced concrete:—1 Portland

cement, 2 sand, 4 stone, 500; 1 Portland cement, 1 sand, 5 chuder, 200.

Footings areas shall be designed for the following values:—

Foundations.—On soft clay, 15; wet sand, 15; ordinary clay, 50; dry clay, 45; dry sand, 50; coarse sand, 60; gravel, 75; hardpan (cemented gravel), 15.

Combinations.—Above values are for dead plus live, for combinations including wind, all wind stresses may be increased 25 per cent, except for footings, which will be governed by the rule given under the heading "Designs for Footings".

Deflection Limit.—Beams will possess sufficient strength to carry their loads including the dead weight of walls without any assistance from the masonry. So loaded deflections shall not exceed 1/250th of the span.

THE LONDON SALON OF PHOTOGRAPHY.

The annual exhibition of the London Salon of Photography, which was opened on Monday at the galleries of the Royal Society of Painters in Water Colours, 5a, Pall Mall East, is of great excellence and value, and will well repay a visit. The Salon aims at showing only that class of work in pictorial photography in which there is evidence of personal artistic feeling and execution, and it has the support of many accomplished amateurs in this and other countries who strive after a synthesis of truth rather than the mechanical reproduction of facts. The scheme of hanging is a novel and effective one: there are no frames, but each photograph is pinned to the wall, which is then covered in with large sheets of glass. Robert Demarchy shows some interesting experiments in the use of bromid transfer on stone, including No. 2, "Rouen," illustrating half-timbered houses in a dark, paved alley, beyond which is the fourteenth-century church; and No. 4, a bridge on "The Seine, Paris." The canals and bridges of Bruges are the subject of several pictures, notably No. 5, by Miss Francesca Bostwick; 32, by Charles Job; and 328 by T. H. B. Scott. No fewer than seven prints, all of great excellence in selection, viewpoint, and lighting, are sent by a well-known Glasgow architect and amateur photographer, James McKissack; they include "In the Days of Peace," No. 43, hay-makers loading a wagon in a field, their labours hastened by the threatening storm-clouds overhead; No. 25, "La Lieutenantance, Hainaut," and the south portal of "St. Jacques, Lisieux," No. 123, and two or three seascapes. Direct representations of the west portals of "Rheims, 1899," and the level line of battlements of "Durham Castle," as seen from the Wear-side below, are given by Frederick H. Evans in Nos. 133 and 137, who also sends an admirable picture of "Rye," No. 111, as seen from Winchelsea across the marshes, on which a few isolated sheep and stunted bushes beside the dykes convey an idea of wide and dreary spaces. Sunlight and shadow are contrasted in the interior of "The North Transept, Peterborough," No. 82, contributed by W. A. Clark. The picturesque S inside village of Cruddehosen, Caux provides as usual several striking subjects, among which are the view along the main street, with the apex of the church, No. 96, by Peter W. Gibb, and No. 122, the doorway of the Flamboyant church, by John H. Anderson, who falls into the common error of styling the edifice the "Cathedral." A telling picture of "The Victoria Memorial," with a leaf of the new palace gates to the right, is shown by Hector Marchant, No. 156, and next to it is a reproduction, in colour, of "Orford Church," No. 157, by J. L. Tucker. Fred Judge, of Hastings, sends several bromid transfers

in successive printings, in which colour has been superposed. The subjects are varied—sylvan landscapes, country scenes, and portraits. James N. Doolittle, of San Francisco, contributes three interesting illustrations of the buildings of the Panama Pacific Exposition now on view in that city, in Nos. 122, 126, and 132, and Miss Jessie T. Banfield, also of San Francisco, makes a good picture out of "The Rotunda, Fine Arts Building," at the same exhibition, in No. 304. Castle Acre Priory and "The Wharf at Lincoln" are well portrayed by Bertram Cox in Nos. 276 and 277. A. H. Blake has been to Kensington Gardens for the subjects of his excellent works, Nos. 265 and 270. John La Farge's gateway to the "Chapels of St. John the Divine, New York," is shown in a photograph by Miss Blanche C. Hungerford, No. 320; she also obtains some picturesque effects from the suspension chains of "Brooklyn Bridge," in Nos. 273 and 274. A tenuous column in the south aisle of "Avria Cathedral" is contrasted with the massive piers and quadripartite vaulting above in J. R. H. Weaver's work, No. 310. Among the best of the Swiss scenes are "Curling at Kandersteg," No. 248, by Ward Muir; "The Lauterbrunnen Valley," No. 246, by Miss Constance H. Ellis; and "On the Brenner Pass," by John Keane. Several of the portraits challenge attention, notably the seated figure of "The Prime Minister," a dignified one of "The Lord Chief Justice," and "The Minister for Munitions," in khaki, all by Walton Adams (Nos. 230-2); that of James McKissack, No. 55, by Dan Dunlop, and of F. H. Evans, No. 110, by J. R. H. Weaver. Easily first among the seascapes are the fine contributions of F. J. Mortimer.

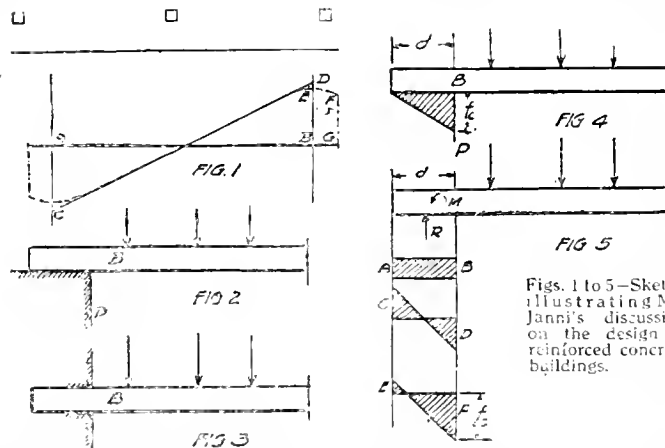

Figs. 1 to 5—Sketch illustrating Mr. Janni's discussion on the design of reinforced concrete buildings.

PROBLEMS IN THE DESIGN OF REINFORCED CONCRETE BUILDINGS.

Points of special interest to designing engineers are contained in a discussion (in *Concrete Cement Age*) of the queries propounded below. The subjects are taken up in order by Mr. A. C. Janni, who is consulting engineer for the New York Central, and by Mr. A. M. Wolf, principal assistant engineer, Condrom Company, structural engineers, Chicago.

1. Is it right to consider beams entering wall columns as continuous or partially continuous?
2. Should the effect of eccentric loading on columns be considered?
3. If a beam enters a wall column and is considered to be continuous or partially continuous, what effect does it have upon the eccentric loading of the columns?
4. If a column is avowedly eccentrically loaded and no provision for this is made in the design, should we consider entering beams as freely supported or consider them as continuous or partially continuous because of the monolithic nature of the construction?

By MR. JANNI.

1. In general, a beam entering a wall column, or any other quasi-rigid long support, may be considered as continuous, or partially continuous, according to the conditions of the supported end of the beam.

If the supported end of the beam has such a length that the allowable adherence between the concrete and the reinforcement in this supported end is at least equal to the tensile stress in the steel arising out of the assumption of continuity, it is clear, then, that the assumption of a continuous beam for the end of a beam entering a wall column is legitimate.

It should be borne in mind, however, that no matter what the assumption is with respect to that supported, a certain part of the adherence between concrete and steel in the supported end of the beam must withstand the shear in the beam. This fact, at first, seems in contradiction with theory, and a few words of explanation are perhaps necessary.

Let us suppose that in Fig. 1 A B is a beam supported at both ends and uniformly loaded; the shear diagram will be given by the line C D.

As in any section of the span the adherence between the longitudinal steel reinforcement and the concrete is proportional to the vertical shear in that section of the beam, it is plain that on the right of B, as well as on the left of A, the reinforcement should not have any tendency to slip, as there is no vertical shear in any cross-section of the supported ends of the beam.

Tests, however, show that, while for limited efforts the theoretical formula holds good, this is not the case with higher stresses, even far below the breaking-point of the beam.

The above phenomenon, apparently in contradiction of theory, finds its explanation in the fact that the modulus of elasticity of the concrete is not constant, but diminishes with the increasing stresses; so that, starting from a certain value of stress, the concrete begins to loose gradually its grip on the steel, which

then finds a new position of equilibrium extending its tensile action behind the vertical lines of supports.

The dotted line in the figure below should represent the diagram of shear. Incidentally it may be seen that the maximum actual shear is smaller than the theoretical one.

As said before, a designer, in assuming the hypothesis of the continuity of a beam entering a wall column, should take care first of the amount of shear shown by the diagram B E F G, and afterwards satisfy himself whether or not the remaining part of the allowable adherence is enough to withstand the moment due to the fixed end assumption.

Mechanical devices such as deformed bars, hooked ends properly made, etc., are, in a general way, good means of insuring the fixedness of that part of the reinforcement of the beam on the supports, while the vertical reinforcement of the column passing through the supported end of the beam ensures its quasi-rigid connection.

Similar remarks may be made regarding the assumption of a partially continuous beam.

2. The effect of eccentric loading on columns is an important condition of equilibrium, which should be investigated by the designer.

A column with eccentric loading is under the action of axial compression and bending; and specially for long spans carrying heavy live loads the compressive maximum stress may reach important values, the tensile stress in the steel doing likewise.

3. A wall column being a column rigidly connected with the wall, no matter what the assumption of the beam entering the wall column may be, it has no appreciable effect upon the column itself.

In connection, however, with the idea of a beam and its supports, there is a certain point in the design of a beam entering a column, or a wall column, which is often overlooked by some designers; the point referred to is the investigation of stresses upon the support of a beam, arising out of the various assumptions made concerning the supported end of it, or, in other words, out of the reaction of the support.

A few words on this subject may not be amiss.

Let Fig. 2 represent the case of a beam with a supported free end, and Fig. 3 the case of a beam with a supported fixed end. The distribution of the compression upon the support P, in Fig. 2, which is indeterminate, should be assumed, for the sake of safety, to vary according to a straight line, as shown in Fig. 4, the maximum compression f_c being by:

$$f_c = 2 \frac{R}{b \cdot d}$$

where R = total reaction, b = width of beam, d = length of the supported end of beam.

The case shown in Fig. 3 is never fully realised in practice; but the investigation of the stresses upon the support P should always be made.

This case may be represented as in Fig. 5, the reaction R being a compression and M the moment.

The diagrams to which each of these reactions give place are shown in Fig. 5: AB being the diagram due to the vertical reaction R (compression) and CD being the diagram due to the moment M.

Adding those two diagrams together, the total diagram EF is obtained, which gives the maximum f_c , the value of which can be given also by the expression:

$$f_c = \frac{1}{b \times d} R + 6 \frac{M}{d}$$

where the letters have the same meaning as above.

4. A column, which, being eccentrically loaded, has been designed disregarding such condition of loading, is a defective unit of construction, the conditions of equilibrium of which can hardly be improved by assumptions regarding the beams supported by it.

The assumption of a freely supported beam, while it is rightly made for the sake of safety, with respect to the beam itself, cannot be upheld with respect to its support, especially when this support is a column whose reinforcement extends vertically through the end of the beam and above it.

The prevented movement of the supported end of the beam during its deflection gives place to a moment, no matter whether or not the designer in his assumption took care of it.

Even if the reinforcement of the column does not extend in the beam end and above it (which would be another serious mistake), the friction between the top of the column and the bottom of the supported end of the beam is such that it would tend to deflect the column toward the span, during the deflection of the beam.

In either case, therefore, a bending moment is developed at the top of the column, which should have been taken care of.

The other two assumptions, namely, continuous and partially continuous beams, which are more proper for a beam entering a column, while they would result in economy, would not improve the conditions of the equilibrium of the column.

By Mr. Wolf.

In the writer's opinion it is right and proper to consider beams entering wall columns as continuous or partially so, the degree of continuity depending mainly upon the number of spans in the building parallel to the beam in question, the reinforcement of beam and the size and location of column, that is, whether the latter is in an upper or a lower story.

The degree of continuity to assume in beams cast monolithic with columns is dependent upon so many conditions that exact rules are impossible of formulation.

For example, a beam may be built monolithic with a wall column, but so little steel provided for negative moment at the column that when loaded the beam cracks at the top and the continuity is entirely destroyed, and the beam becomes practically a simple span. It is apparent, then, that to have continuous action steel must be provided in the top of the beam to care for the stresses developed. Just how to arrive at the amount of reinforcement necessary is a subject regarding which much has been written, and as a result we have some bending moment formulas covering average conditions and which give safe results, and have been used to a considerable extent, and, in addition, are recommended by the Joint Committee. These are $Mwl^2/12$ at centre and at support for interior spans truly continuous, and for end spans, $Mwl^2/10$, at centre and adjoining support of end spans for both dead and live load under favourable conditions of fixity. For beams and slabs continuous moment is usually taken as $wl^2/8$ at central support and $wl^2/10$ near middle of span. (These moments, of course, being for uniformly distributed loads.)

A beam is said to be fixed at both ends when the tangent to the elastic curve is horizontal over each support. Now, a beam framing into a large lower story exterior column which is relatively very stiff and unyielding will, if properly reinforced, be very nearly fixed, and it is evident that if steel is provided for a moment of $1.10 wl^2$ over the supports and the centre the construction will be safe, for a coefficient of $1/12$ applies to a fixed beam, and $1/8$ to a simple beam, 1.10 being an average of the two coefficients.

Taking the opposite case of a slender top story exterior column supporting a roof beam, it is evident that the conditions are by no means so favourable for continuous action, for more or less bending is sure to take place in the column, and the conditions of support approach those of a simple beam. For this reason, then, little or no continuous action should be depended upon in exterior beams of roof construction where light columns are used. Here again the judgment of the designer must be used in determining just what moment coefficient to use.

Some designers argue against reinforcing a continuous beam over the support for the full negative moment in accordance with the formulas given above, which are for beams with a constant moment of inertia, for the reason that the negative moment can be reduced by making the beam stiffer in the middle, or, in other words, designing for an increased bending moment at the centre and a reduced moment over the supports. It has been generally accepted, however, from studies by Samuel E. Thompson and others, that it is in general uneconomical to design a reinforced concrete beam stiffer in the middle than over the support. Sometimes, in order to comply with city building ordinances, it is necessary, in order to economise as much as possible, to design beams which tend to act as continuous for a lesser moment over the support than at the centre, as called for by ordinance, thus making allowance for the increased stiffness of the beam at the centre. Thus, for instance, if by ordinance a moment of $wl^2/8$ is specified at midspan for continuous beams, the steel over the support should be $6/10$ of that at centre to have the beam act as somewhat continuous, and, at the same time, be as economical as possible in the use of steel. This practice is often followed, but truly continuous action is not obtained, even if the safety of the structure is not endangered. For truly continuous action to develop, it is necessary that the member be designed for the maximum theoretical

moment which occurs over the support for uniform loading, and for a number of continuous spans the formula $Mwl^2/12$ is $wl^2/12$. Now, if less steel than is required by the above formula is placed over the support, the steel will be overstressed and cracks will tend to develop.

Some building ordinances condemn this practice by stating that the sum of the centre moment and that over support should be $1.9 wl^2$, and that at least one-third of this to fulfil the requirements of a moment equal to $1.18 wl^2$ shall be used over the support. Such recommendations have caused uneasiness and commercial designers to become "expert jugglers" of moments, making them whatever seem best to suit their needs. In fact, more faulty designs can be traced to this practice than to any other one cause.

It does not require much demonstration to prove that continuous action cannot be obtained by using a centre moment of $1.9 wl^2$ and a moment of $1.18 wl^2$ over the support (as the total moment of $1.6 wl^2$ requires). In such a case the steel over the support will be greatly overstressed, and cracks will occur over the supports, and the beam approach the condition of a simple beam, provided, of course, that the ends are supported. Finally, it can be said that it is impossible to obtain any desired distribution at centre and supports by the simple variation of reinforcement. The laws of mechanics govern these things, not the whims and desires of the designer.

The effect of eccentric loading on columns should be considered, but to arrive at a mathematically correct solution of the problem is practically impossible, on account of the number of variables which must necessarily be considered. Ordinarily, in buildings where the extent of the live load is very definite it will generally be found satisfactory to reduce the unit stress in exterior columns to, say, $3/4$ or $2/3$ of the average unit stress used for interior columns, depending upon the type of construction, for to compute the stresses due to eccentricity for the great variety of conditions of loading which might occur is not justifiable. In structures in which a definite condition of live load is to be maintained at all times the effect of eccentricity should be carefully looked into. The best treatment of the subject of eccentric loading considerations on columns, in the writer's opinion, is found in "Reinforced Concrete Design," by Faber and Bowie.

When a beam centres a wall column and is considered to be continuous or partially so, the result is that additional bending is thrown into the column, or, in other words, the eccentricity is increased, and provision should be made therefor in the design of the column.

In regard to the last question, this has practically been answered in the foregoing. If a beam is considered as freely supported and designed as such (there is no reinforcement placed in top of supports), the eccentricity on columns will not be so great as if the beam is designed as continuous, or partially so. Therefore, if no provision is to be made in column to care for the bending due to eccentricity, the beam should not be designed as continuous, or partially continuous at the support. This, however, is not good or economical design, for it would probably, in most cases, require a more steel to design beams as continuous and to strengthen the columns to care for the eccentric load imposed, than to design the beams as simply supported and not strengthen the columns. Reinforced concrete, from its very nature, tends to act as monolithic or continuous, and therefore, wherever possible, advantage should be taken of this characteristic, for this is the distinguishing mark of the most advanced reinforced concrete design.

At a meeting of the town council for Marlborough, four candidates for the office of borough surveyor and inspector of nuisances were interviewed. By seven votes to four Mr. N. E. Spence, at present engineer, surveyor, and inspector of nuisances to Hartshorne and Seals Rural District Council, was elected.

THE PANAMA-PACIFIC INTERNATIONAL EXPOSITION, SAN FRANCISCO.

The vast exhibit palaces, which contain more than 400,000 displays, are being eagerly inspected by the visitors. From the thundering Palace of Machinery, with its giant engines, pumping plants, dynamos, printing presses, and Linotype machines in action, through the vast Palace of Transportation, where the earliest types of locomotives contrast with the Great Mogul engines of the present day, where sections of large oceanic liners are seen in contrast with tiny models, into the great Palace of Agriculture, where threshing machines, harvesting machines, reapers, sowers, are beheld in operation, into the Palace of Food Products.

Wherever practicable, machinery is shown in operation, and all steps in the processes of production are illustrated. A giant laundry, operated by latest methods, a knitting machine, a broom factory, a fire hose factory, a coin-stamping machine are among the many operating plants in the Palace of Manufactures.

There are upon the grounds no less than fifty-four moving picture shows, wherein are daily displayed, without charge, in the exhibit palaces and in State and national pavilions well-selected and attractive scenes revealing the activities of the various states and countries. Lectures accompany many of the displays, and the visitor is enabled to enjoy scenes from Argentine, China, Japan, the Philippines, the Netherlands, Cuba, Sweden, and forty-three other lands, while cinematographs of important works, such as the Panama Canal, the New York State Lock Canal, the manufactories of the great corporations of the United States are displayed without charge.

The free pyrotechnics at night, which are part of the spectacular illumination of the Exposition, draw thousands of visitors to the marina upon the shore of San Francisco harbour. Here thunder and lightning are simulated with a vividly realistic effect, and a giant battery of forty-eight searchlight projectors, with 2,600,000,000 candle power, throw shafts of coloured light upon great jets of steam or clouds of smoke liberated high in the heavens. The brilliant shafts are visible at a distance of sixty miles from the Exposition grounds.

In the Persian exhibit in the Palace of Manufactures many bits of old pottery, pieces of ancient armour, silver bric-a-brac, and woven rugs are on exhibition. In the Royal pottery collection are 150 pieces with a total value of not less than a quarter of a million dollars. This includes the celebrated Bowl of Contemplation, 99 years old, and one that could not be duplicated by any collector. The famous Persia rugs represent every possible school of weaving and embroidery. There are velvets, broads, and cashmeres of every century from the ninth to the twelfth. There is the cloth of gold of the fourteenth century, including one that shows Adam, Eve, the tree of life, the cypress, and the apple, a rare bit of embroidery that has been sought by every collector in the world, but which still remains in the possession of the Shah of Persia. The Royal rug of camel's wool that has been used but once each year during the past two centuries, during the Royal reception, is on exhibition.

The Balkan States, which, in their struggles for independence, have been the theatre which have revolved many international conflicts, display a collection of garments, hand woven and embroidered by the Balkan peasants. There are numerous examples of decorative art, including many curbs and fabrics made by the children in the Royal School of Roumania, as well as a set of table dishes and glass ware used 100 years ago at State dinners. The famous Prince Starza actually used many of these himself, and it is said that the glass ware is of a kind that has never been duplicated, or even successfully imitated. There is a hammered silver set that was used by the Bulgarian royal families.

The substantial English representation at the Exposition includes machinery, automo-

bile parts, textiles, pottery, and the like. Located in the Palace of Manufactures is the Dickens china ware, bearing characteristic Dickens scenes, with excerpts from the novels. Royal Doulton ware and Devon pottery, bits of bric-a-brac, jars, vases, lamps, and Jasper ware are displayed.

In the Italian Pavilion, in the Italian section of the Palace of Varied Industries, and in the Palace of Manufactures is a display of one of the two finest collections of laces in the world. There is a point de Venice tablecloth of the fourteenth century, valued at 15,000 dol.; a Burano lace scarf of the thirteenth century, with a foundation of tulle and a border of Rosselina lace; and a tealoth of the seventeenth century, representing Raphael's painting of the Twelve Hours in point de Venice and filet; a small lace cushion top, about 20 by 30 ins., depicts Botticelli's "Spring," and is valued at 400 dol. Another beautiful tealoth represents Guido Reni's "Aurora." In addition, Italy displays many valuable bronzes, marbles, specimens of carved furniture, painted velvets, silks, hats, musical instruments, motor-cars, wines, and food products. A large and beautiful collection of modern Italian sculptures by many of the foremost sculptors of the day is displayed in the Palace of Manufactures. These include the famous statue, "Christ Emerging from the Pagan Temple," by Professor Raffaello Romanelli; "The Fountain with the Frog," by the same sculptor; "Napoleon at Moscow," by Professor Vanetti; "The Pompeian Girl and Algerian Girl," "Maternal Love," and other striking groups. The beautiful Italian pavilions, which won the grand prix for foreign pavilions at the Exposition, is always crowded with eager and enthusiastic sight-seers. In the pavilion, which is in reality not one but eight interconnecting structures grouped around Italian courts, one finds the architecture of typical cities at the height of the Italian Renaissance.

Switzerland, which, although a neutral nation, has 350,000 men in arms guarding her borders, exhibits the chief watchmaking companies of the Republic, as also hundreds of displays illustrating the household handicrafts. The Berner Woodcarvers' Association of Murrigen has an exhibit of the wares which the Swiss, in their winter nights, have learned to execute.

The displays of the Scandinavian nations, Norway, Sweden, and Denmark, are shown in a pavilion in characteristic architecture. The art exhibit of Norway occupies five rooms devoted to painting and sculpture, and two rooms to graphic art. The Norwegian Pavilion is filled with dioramas and panoramas portraying the scenic charms of the country, the northern fiords, the lofty spruce-clad mountains, the fishing industry; and there are many models of ships of the fleet of merchant steamers which carry the traffic of the kingdom. Duplicates in miniature of ancient war craft used by the berserkers of early days and ancient galleys.

Another European display of extraordinary interest is that of the French Republic. This is largely portrayed in the French National Pavilion, although France has made an elaborate display of art works in the exhibit palaces, including the Palace of Fine Arts, and is notably represented with her wines, her machinery, and laces in the Palace of Manufactures. One of the interesting exhibits in the latter palace is a new type of rapid firing gun now employed by the Legions of France. In the French Pavilion are many priceless relics and antiques, as well as displays of modern commercial art, the latter including remarkable exhibits of life-size models, draped in the latest Parisian fashions. Included in the French display are models of the famous French dolls, priceless Gobelin tapestries of Louis XIV., relics of Rohambau, Lafayette, Balzac, Victor Hugo, and other French notables. The four great tapestries which, with many modern tapestries, are in the Pavilion belong to a suite of eleven, the cartoons for which were the works of Le Brun, the great painter who was appointed to take charge of the Gobelin factory in the reign of Louis XIV. They were made between

the years 1668 and 1683, and represent different scenes in the life of Alexander the Great, the conquests of the wild tribes of Asia being the theme of the scenes, a theme which lends itself to graphic portrayal because of the slaves, elephants, and mighty, though crude, implements of war employed at that time.

In the Netherlands Pavilion, with its giant towers rising far into the air and surmounted by many flagstuffs, fishing scenes in Holland are reproduced in panoramas and dioramas. Models of railway cars, of steamships, displays of tin and rubber and sugar from the Netherlands' opulent possessions in the East Indies, together with illuminated dioramic scenes with alcoves, from which the sight-seer may gaze down upon apparently distant fields dotted with tiny factories, great irrigation flumes; while nearer, as though upon the edge of some frowning cliff, is seen the tropic foliage of the country, and further away rise the lofty mountains indented by ricefields that rise like steps in terraces up their precipitous sides. One is here borne into a far country, into the Orient of spices, of rich mines, and vast plantations, with all its fascination and strange life.

Portugal is represented by an attractive pavilion; and Belgium, through the co-operation of France, has a great section entirely its own in the French national pavilion. Spain is represented with many priceless paintings and works of art, and in the commercial section by her wines, tapestries, and valuable antiques.

THE DEWAR MEMORIAL DRINKING FOUNTAIN, PORTOBELLO.

Last week (on page 509) we gave some particulars of this memorial to Dr. Dewar, which has just been erected in the Abercorn

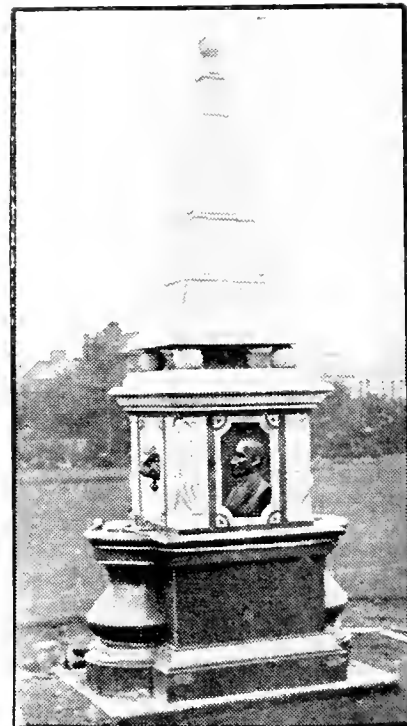

Gardens, Portobello, from the design of Mr. T. Currie Bell, Synod Hall, Castle Terrace, Edinburgh. We now give a view of the monument, which is carried out in grey Aberdeen granite, and has a height of 14 ft.

RIVINGTON'S NOTES ON BUILDING CONSTRUCTION.*

No text-book of our time has so deservedly enjoyed so continuously the high position at once taken by it when the first edition of this manual first appeared, some forty years since. It exactly met its purpose, which was to help students preparing for the examination in building construction held by the Board of Trade at South Kensington.

* Rivington's Notes on Building Construction, New Edition. Part I. and II., 7s. 6d. each. (London Longmans, Green, and Co.)

but its popularity, through that and many subsequent editions, among architects, builders, and the various members of the trades interested has been unequalled.

Naturally, after the lapse of ten years, during which changes in building construction have revolutionized methods of construction it was felt that more than mere revision was needed to bring the work up to date. Under the editorship of Mr. W. Noble Twelvetrees, therefore, the whole has been re-written by well-known architects and others. New chapters on Building Regulations, Damp and Sound-Resisting Construction, Steel Skeleton Buildings, Reinforced Concrete and Brickwork, Concrete Blocks, and Fire-Resisting Construction have been introduced, and an appendix contains selected examination questions from papers set by the R.L.B.A. and other educational bodies. There are 484 illustrations.

Part I. contains eighteen chapters devoted to subjects demanding attention before a building is commenced, and to forms of construction by means of which structures of different types are carried up from foundation to roof level. Part II. deals first with roofs and then with various branches of domestic engineering and sanitary equipment.

The subject matter is no longer based on a single course of study, but "a purely logical sequence" is followed in arranging the order of the subjects treated. Mr. Reginald Blomfield, R.A., contributes an introduction, in which, while emphasizing the value of practical knowledge, he points out that such a foundation, though indispensable, is only part of an architect's training, and that the student must never forget that architecture must include in its purpose the appeal to the imagination and the aesthetic sense.

The list of contributors includes Mr. W. E. Riley, the superintending architect to the London County Council; Mr. W. Douglas Caröe; Mr. Brook Kitchin, the architect to the Local Government Board; Mr. H. V. Lanchester, Professor Beresford Pate, Mr. Herbert Phillips Fletcher, Mr. Matt Garbutt, Mr. W. Kaye Parry, Mr. A. W. S. Cross, and others.

THE NEW PARLIAMENT BUILDINGS FOR MANITOBA.

The Royal Commission appointed to investigate the charges made in regard to the new Parliament buildings at Winnipeg for Manitoba issued an important interim report on August 24. The buildings were erected from plans by Mr. F. W. Simon, of Liverpool, in conjunction with Mr. Boddington, and in July, 1913, the contract was let to Messrs. Thomas Kelly and Sons. In July last an allegation that the contractors conspired with members of the late Government to obtain over-payments was the subject of an action brought before Chief Justice Mathers by the Attorney-General, and led to the appointment of a Royal Commission, with Chief Justice Mathers as Chairman, the other members being Sir Hugh John Macdonald and Judge D. A. Macdonald. The interim findings of the Commission were made public on the 25th ult. The Commission unanimously found that there was a "fraudulent scheme or conspiracy" entered into prior to the letting of the contract, and that the scheme or conspiracy was formed for the purpose of getting a campaign fund out of extras on the contract. The report names Thomas Kelly, George R. Coldwell, and Sir Rodmond Roblin as partners to the scheme in its inception, and states that "at least some of Kelly's sons," Dr. R. M. Simpson, V. W. Horwood, James H. Howden, ex-Attorney General, and Dr. W. H. Montague, ex-Minister of Works, later on became parties to and acquiesced in the plot. The Commission further found that Thomas Kelly was fraudulently overpaid \$892,098 10c., that steel contracts were inflated, and that the caisson foundations should have cost less than the piles for which they were substituted. The Commission state that they find all of the charges made by the Hon. A. B. Hudson on the floor of the Legislative Chamber, and in the memorial presented to the Lieutenant-Governor, have been fully proven. In connection with connivance in a scheme for keeping a witness

named William Salt "on holiday" in the United States, the Commission names George R. Coldwell, V. W. Horwood (Provincial Architect), Dr. R. M. Simpson, James H. Howden (Attorney General), W. A. Elliott (Chief Inspector of Buildings), M. G. Hook, and Harry W. Whittle, K.C. The report is particularly drastic with regard to James H. Howden, whom it accuses of making many untrue statements under oath with regard to various sums of money involved in his testimony. It finds that he helped G. R. Coldwell to raise \$10,000 to keep William Salt away from Winnipeg. For the \$21,900 expended on Salt's "holiday" Dr. R. M. Simpson was the financial agent.

As to the contractors, the Commission find that Thomas Kelly and Sons were informed of certain contemplated changes in the plans before tenders were due. That the tender put in by the Peter Lyall Company, being the only one received by the Department of Public Works on July 2, 1913, within the time allowed, was on that day either shown to Thomas Kelly, or its contents were made known to him, and on the following day a tender was received from Kelly's firm for \$5,250 less than the Lyall tender. "All the circumstances point to Sir Rodmond Roblin as the person through whom or by whose authority Thomas Kelly obtained this advance knowledge of the Lyall tender."

"That a fraudulent scheme or conspiracy formed before the contract was entered into to obtain from the extras an election fund was afterwards continued and carried out. For this purpose Dr. R. M. Simpson, V. W. Horwood, the provincial architect, and, at least, some of the other members of Thomas Kelly and Sons became parties to and active participants in carrying it out, in addition to those by whom the original conspiracy was formed. There is no direct evidence that J. H. Howden, the Attorney-General, was a party to the conspiracy at its inception, but his subsequent conduct convinces us that he early became a party to it. We believe that Dr. Montague, for some time after he became Minister of Public Works, did not become a party to the fraudulent scheme entered into by his colleagues, but that he was informed of its existence and purpose by Dr. Simpson in January or February, 1914, and that he then became a party to it." The Commission continue that they find that the contractors, Thomas Kelly and Sons, were paid by the Government five sums of money amounting to a total of \$892,098 10c.; that in three of these cases, the north wing steel contract for \$531,100, the south wing grillage for \$215,000, and the superstructure steel for a southern central portion and dome for \$802,650, Sir Rodmond Roblin and Kelly and Sons well knew that prices were inflated by the inclusion therein of large sums for an election fund, while there had been no plans prepared for the dome and no honest estimate of the steel required could be made. Further, "That Sir Rodmond Roblin and Dr. Montague, some time after October 18, 1914, and before January 1, 1915, fearing the consequences which might result from the discovery of the aforesaid \$802,650 contract, destroyed the Order in Council passed on July 4, 1914, authorising the execution of said contract and the several copies thereof, together with the said contract and every proof and record known to them by which its existence could be traced. That Dr. Montague agreed with the contractors, Thomas Kelly and Sons, to recoup them out of the dome construction to the extent of \$75,000, at least, for the loss they sustained in the destruction of the destroyed contract, and that he sent Mr. Horwood to Chicago in company with Thomas Kelly to arrange with Mr. E. C. Shankland to increase the weight of steel in the dome, plans then being prepared by him to the extent necessary to accomplish this purpose; that Mr. Horwood did so arrange with Mr. Shankland, who did increase the weight of the steel as required. That the steel plans for the dome prepared by E. C. Shankland were overloaded to the extent of 467 tons, representing a possible overpayment to the contractors of upwards of \$30,000. That the Government agreed to pay the said E. C. Shankland five per cent. on the contract price of the dome to be erected from

his plans, and on December 25, 1914, paid him \$15,000 on account. This was more than double what his remuneration would have been, based upon the necessary tonnage of steel in dome at reasonable prices. That during the session of the Public Accounts Committee in March, 1915, W. A. Elliott, the chief inspector, at the request of V. W. Horwood, certified the yardage of concrete on the last three applications for payment in respect of the caissons, and William Salt, also at Horwood's request, altered his records of the depth of the caissons for the purpose in each case of deceiving the said committee, and that in each case Mr. Horwood acted on the instructions of Mr. Coldwell. That when Mr. Horwood and Mr. Coldwell found that William Salt would not falsely swear to the accuracy of the said altered depths of the caissons, he was by them sent out of the province beyond the reach of the said committee, and was paid large sums to remain beyond the jurisdiction of your Commissioners." Finally, the Commission find that after giving the contractors credit for all work done and the value of materials on the site and of steel fabricated but not delivered until the work was stopped in May last, the said contractors were overpaid to the extent of \$701,995 59.

The preliminary investigation as to the charges of conspiracy against Sir R. Roblin and Messrs. Montague, Howden, and Coldwell, ex-Cabinet Ministers, opened at Winnipeg on Friday. Mr. Horwood, the provincial architect, stated that Mr. Coldwell told him to be guided by Dr. R. M. Simpson, president of the Conservative Party, so that a campaign fund might be raised from the money expended on the new Parliament buildings. He gave details of amounts which were added to various contracts, aggregating six figures, and he declared that Dr. Simpson dictated the sums needed.

The work of construction at the Parliament buildings has been resumed under the direct supervision of Mr. F. W. Simon, F.R.I.B.A., Liverpool, whose plans were successful in the competition, but who was not allowed to take charge by the late Government.

OBITUARY.

The death took place, suddenly, on Saturday, of Mr. George Grey, of Milfield, Wooler, a well-known north country land agent. He was born at Milfield in 1851, and was educated abroad and at Cheltenham College. The late Mr. Grey had the oversight of many large estates, including those of Earl Grey, the Marquis of Waterford, the Hon. F. W. Lambton, Sir F. D. Blake, and the trustees of the Blackett Ord Estates. He was a justice of the peace for Northumberland, having been appointed in 1886, and was chairman for many years of Glendale Board of Guardians and of Glendale Rural District Council. He was a member of the Northumberland County Council for the first six years after its institution.

We regret to announce the death, at the comparatively early age of 44, of Mr. Graham Nicholas, F.R.I.B.A., of Pilgrim House, High Street, Lymington. Mr. Nicholas, who joined the Royal Institute of British Architects as a Fellow in 1906, passed away at his residence on Sunday week after a long illness. His remains were cremated at Woking on Wednesday last.

Mr. Philip Arthur Cawte Wilkinson, L.R.I.B.A., of Craven House, Kingsway, W.C., died very suddenly early on Monday morning at the flat he occupied at 64, Gloucester Place, Baker Street, W. Mr. Wilkinson, who was 52 years of age and unmarried, was the third son of the late Mr. Philip Wilkinson, F.R.I.B.A., of Grenville Place, N.W., with whom, after having served his articles with Messrs. Wimpering and Arber, he was associated in practice for many years in Lincoln's Inn Fields. His practice lay chiefly in domestic work and in surveying. He had been a member of the Architectural Association since 1884, and joined the Royal Institute of British Architects as a Lieutenant four years ago. The cremation will take place at Golder's Green to-morrow (Thursday).

Our Illustrations.

BOARDROOM, CANADIAN BANK OF COMMERCE: HEAD OFFICE AND BANKING ROOM, UNION BANK OF CANADA, TORONTO, ONT.

These two notable commercial buildings erected in Toronto are excellent examples of the work designed by Mr. Frank Darling, F.R.I.B.A. (Royal Gold Medallist, 1915), and carried out by Messrs. Frank Darling and John A. Pearson, the well-known architects, of Toronto. We selected this pair of photographs now reproduced from the series of views placed at our disposal by Mr. Darling on the occasion of their exhibition at the Royal Institute of British Architects a short time since, when the Royal Gold Medal was presented to him in recognition of his ability and for the high character of his buildings. The top picture on the accompanying plate illustrates the Board-room of the Canadian Bank of Commerce, Head Office, Toronto. The oak panelling, which lines the apartment, was carried out by Messrs. J. C. Scott and Co., and the decorations were done by Messrs. Jos. McCausland and Son, both firms being in Toronto. The lower photograph shows the interior of the Banking room of the Union Bank of Canada, Toronto. Messrs. Wright and Co. executed the ornamental plastering. The bronze work was furnished by the Architectural Bronze and Iron Works, Toronto, and the Lautz Company of that city were employed for the marble work. All the executants belong to Toronto.

"PEMBURY RIDGE," PEMBURY, KENT.

The views we publish show the entrance and garden fronts of a simple country house planned to give comfortable rooms and easy service. It was designed by Mr. W. Henry

White, F.R.I.B.A., of No. 14A, Cavendish Place, Cavendish Square, London, W., and the building is now being erected by Messrs. G. and F. Penn, builders, of Pembury, Tunbridge Wells. The ground-floor story is finished on the outside with white rough-cast, and the upper story is hung with red sand-faced tiles, the roof also being covered with similar tiles. The gardens have been laid out to the architect's designs.

A MOSQUE DOORWAY, CAIRO.

With regard to the drawing of the Mosque Doorway, Cairo, I am sorry I am unable to give any particulars of the mosque—except that it is near the old city gate, known as the Bab Zuweilah, and is one of the lesser of the many Carrene mosques. It is typical of a great many doorways, colour being used freely in the shape of tiles, mosaics, and different marbles. It is still used, and has been kept in very good repair by the "Comité de Conservation des Monuments de l'Art Arabe." The drawing is a lithograph done on transfer paper from one of my water-colours, and after the drawing was on the stone some further work was done upon it.

W. J. PALMER-JONES.

CHURCH OF ST. MICHAEL AND ST. GEORGE, HESWALL, CHESHIRE.

The site for this church is on the crest of a hill sloping steeply towards the east, and advantage has been taken of this to place the vestries, church-room, and some class-rooms beneath the eastern portion of the church. The plan has been arranged on the passage aisle principle, with a wide nave and chancel (32 ft.) and a side chapel. The altar will be in view of practically the whole congregation. There is no chancel arch, but the junction of the chancel and nave is marked by wider piers, with niches for statues of Saint Michael and Saint George. It is proposed to erect the eastern portion of the church first, but not until peace is declared. The walls are to be

of local red sandstone, the roofs covered with grey Welsh slates, and the floors paved with oak blocks. The drawing was hung at the Royal Academy. Mr. R. T. Beckett, of Chester, is the architect.

THE OLD MILL HOUSE, FITTLEWORTH, SUSSEX.

The Old Mill at Fittleworth is well known to artists, its quiet grey stone walls and simple shape harmonising with the twin bridges near by. The accompanying drawing was in this year's Royal Academy exhibition. The Mill House itself and its adjacent cottages were marred by more modern additions and by the sheds and stables which were the necessary if ugly adjuncts of the various activities of the owner. When two or three years ago the Mill became the property of the late Sir Frederick Mirrielees it was decided to re-front the Mill House, to alter its internal arrangements somewhat, and to add to the accommodation. The modern brick front was replaced with a simple front of Pitkingdean stone. A large hall with covered way and porch were planned to link the house and cottages in one composition. The narrow central staircase was removed to make way for a long living room in the old front of the house, and replaced by a wide circular stair with solid oak winding steps and a solid brick newel. This staircase is placed in the angle between the hall and living room, and opens into the garden entrance vestibule in the internal angle. The overhanging upper story of the back part of hall is hung with old tiles of a fine rough surface. The roof has also been covered with old tiles. The chimneys are of narrow bricks and stone. The windows have mullions of Pitkingdean stone, with iron casements and leaded lights. The fireplaces are open-hearth fires of very simple design. English oak was used for the moulded beamed ceilings in the living room and hall, as well as for the framing of the roof to covered way and porch. The doors are also of English oak, with moulded boards and square ledges. The general contractor was Mr. Job Luxford, of Forest Row, Sussex. The unnecessary sheds were removed during the progress of the work, and the garden is now being formed with a simple terrace, linking the new lawn to the old garden on the higher ground in rear. The whole forms a group of considerable interest. Mr. L. Rome Guthrie, A.R.I.B.A., is the architect.

LATE 17TH CENTURY ENGLISH BRICKWORK FROM A HOUSE AT ENFIELD NOW PULLED DOWN.

This sheet of details was measured and drawn by Mr. Walter W. Hitchins, of Reading University College, from the front of this old building as now rebuilt in the large architectural gallery of the Victoria and Albert Museum, South Kensington. The house formed part of the brick front which was previously a celebrated school at which the poet John Keats, the composer Edward Holmes, and the writer C. Cowden, were educated. Quite apart, therefore, from its special value as a piece of historic building in brickwork, the example is one of particular interest. The bricks are of light red colour and are soft handmade ones set with fine joints. The rich carvings were executed in situ, irrespective of the joint courses. The sections of the mouldings add value to the general elevation of the portal.

Mr. H. Wood, the deputy city engineer of Norwich, has received a commission as Lieutenant in the Royal Engineers.

The new Technical College at Doncaster, opened last week, has cost £15,000, and was erected on the site of the old Vicarage from plans by Mr. W. P. Schofield, A.R.I.B.A., Park Row, Leeds. The contractors were Messrs. Paul Rhodes and Co., also of Leeds.

The Church of the Sacred Hearts, Talbot Road, Blackpool, was solemnly opened on Sunday week, after restoration at a cost of £4,000. Other improvements are the enlargement of the organ gallery, the division of the organ, and a new stained-glass window. The work has been carried out by Messrs. J. Fielding and Sons, of Blackpool.

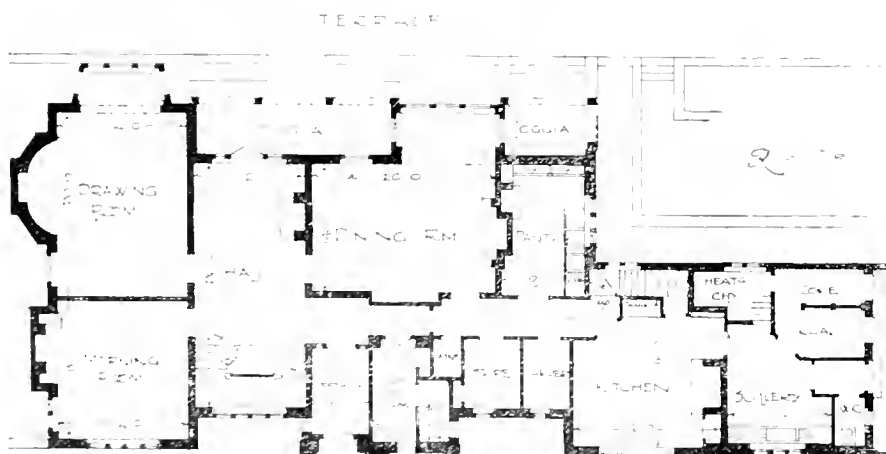
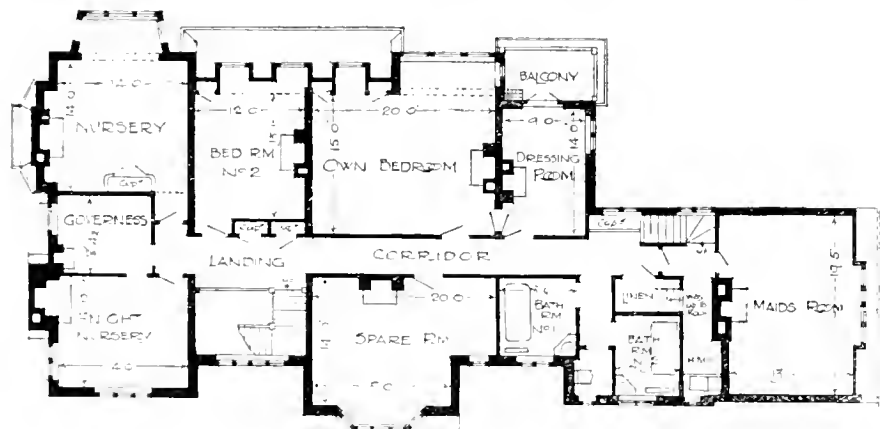

"PEMBURY RIDGE," PEMBURY, KENT.

Mr. W. HENRY WHITE, F.R.I.B.A., Architect.

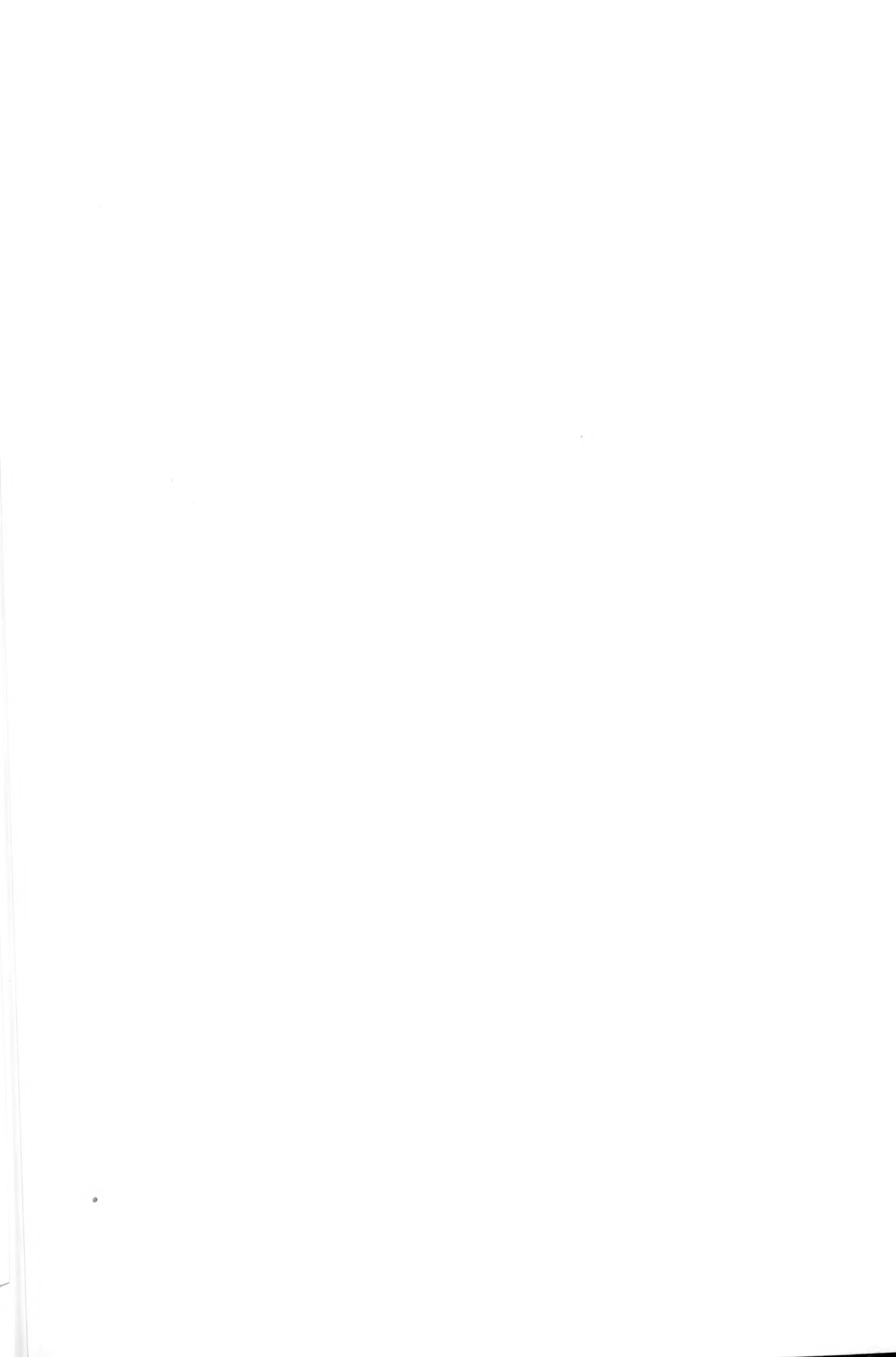

Church of St Michael & St George Hesselall

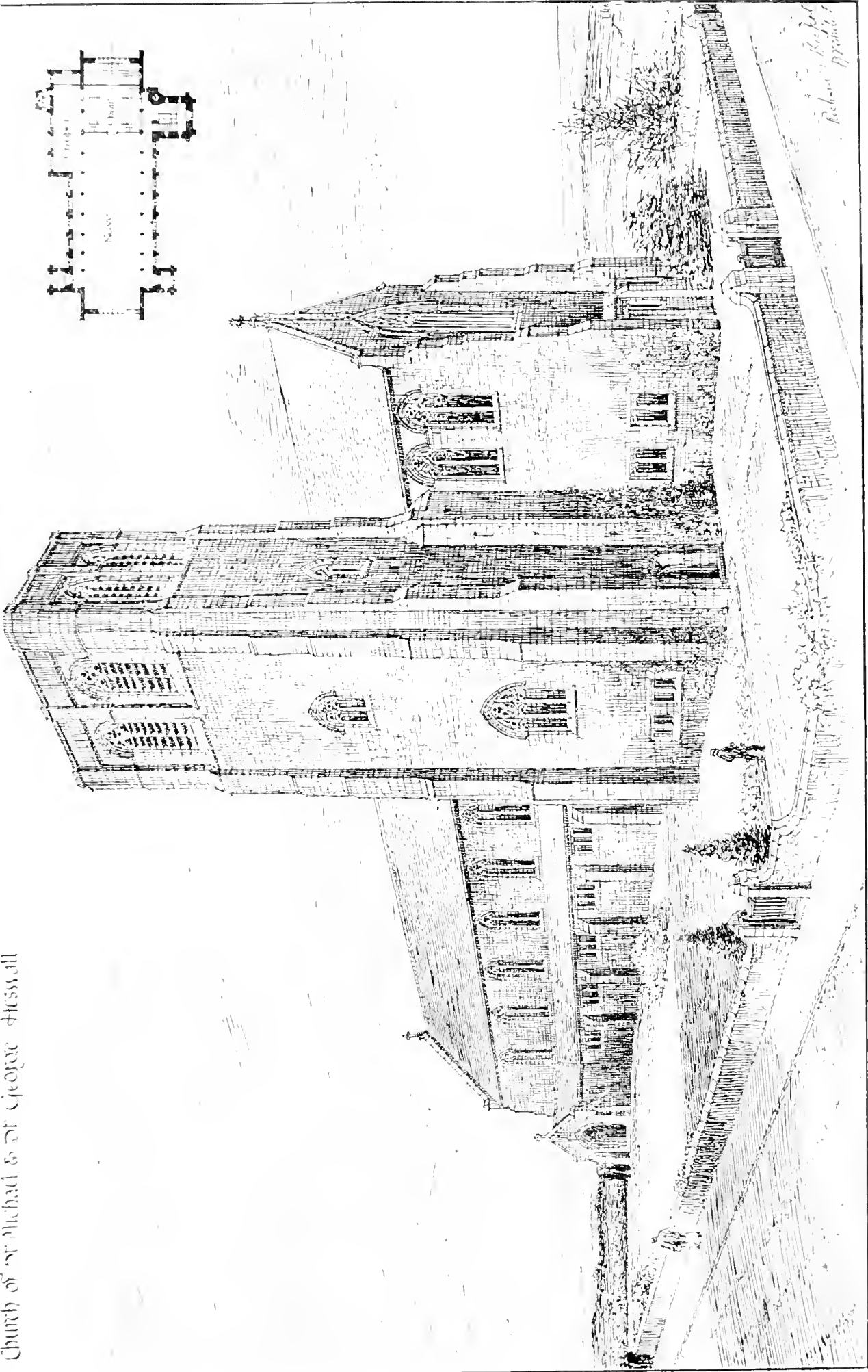

CHURCH OF ST. MICHAEL AND ST. GEORGE, HESWALL, CHESHIRE.—MR. RICHARD T. BECKETT, ARCHITECT.

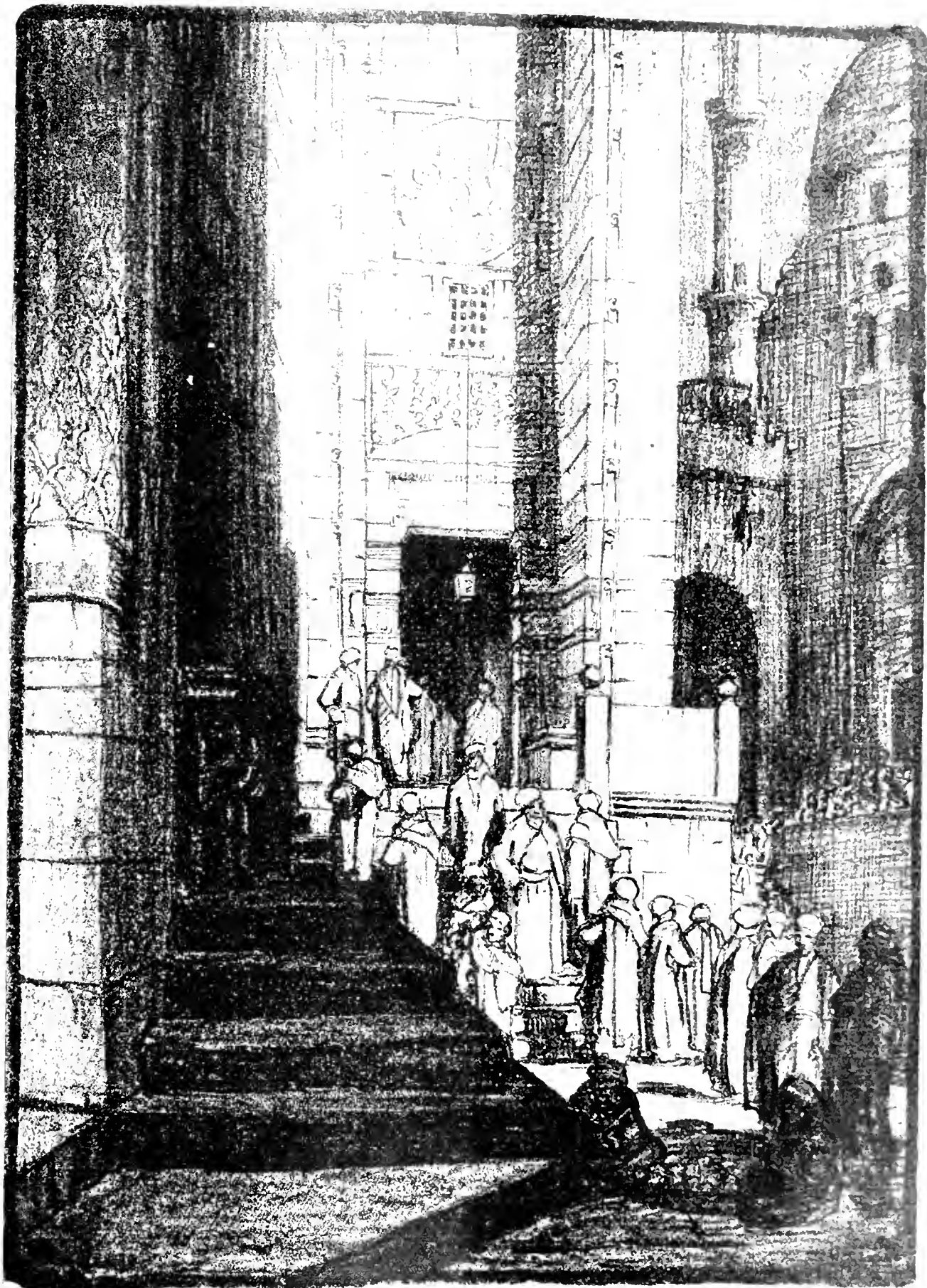

A MOSQUE DOORWAY CAIRO.

A LITHOGRAPH FROM THE ROYAL ACADEMY EXHIBITION.
By MR. W. J. PATER-SONS, Architect.

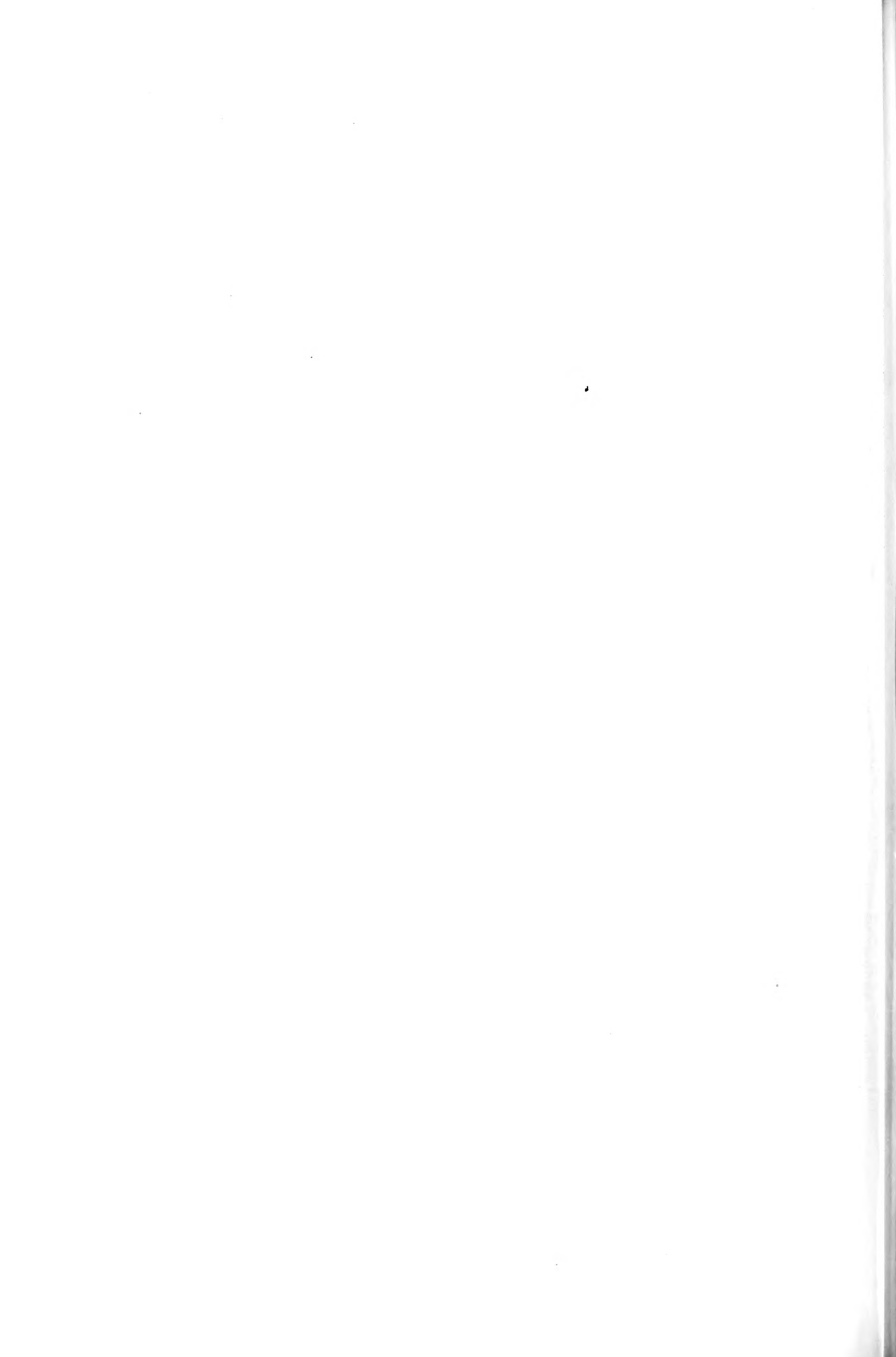

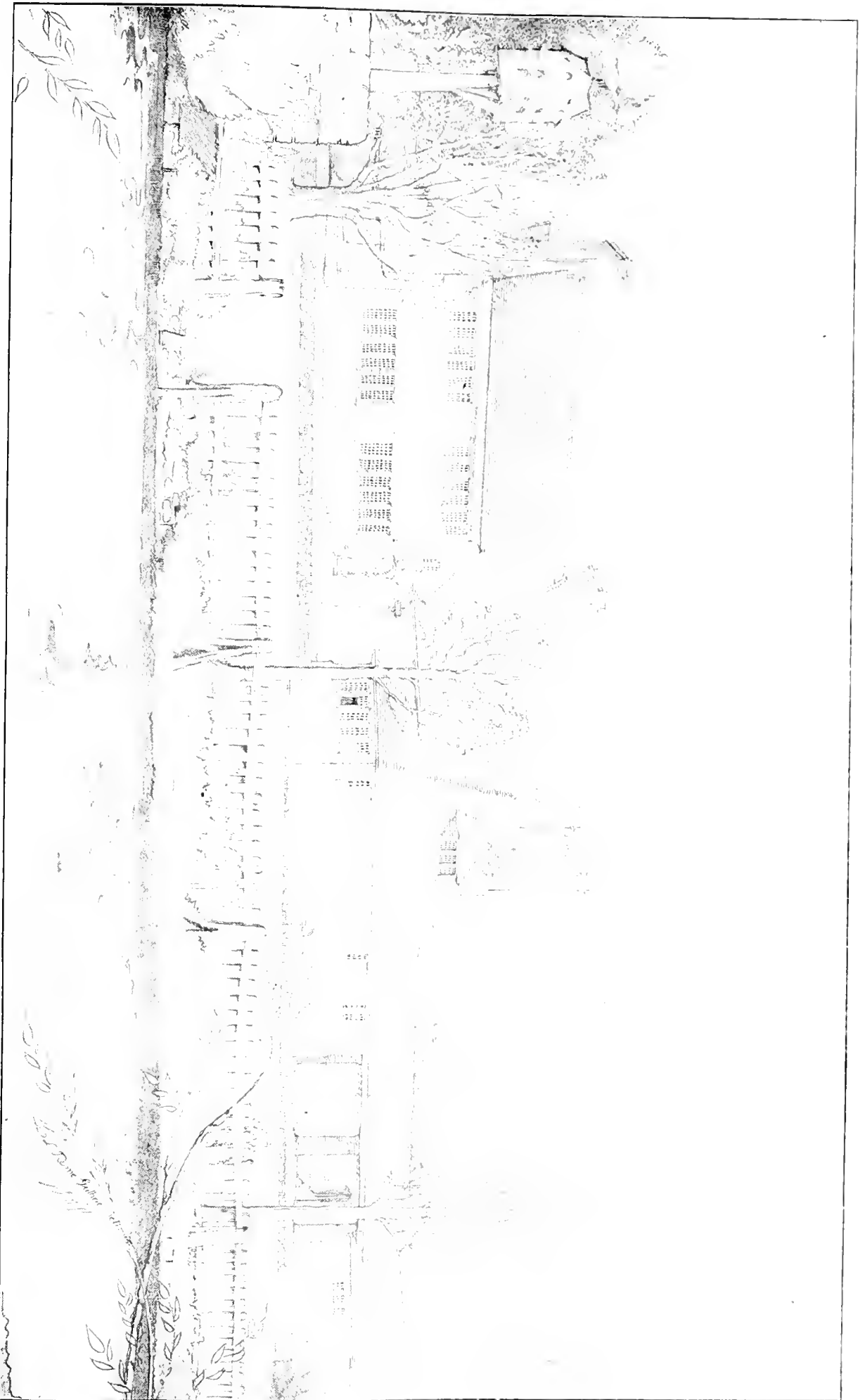

THE OLD MILL HOUSE, FITTLEWORTH, SUSSEX.—Mr. L. ROME GUTHRIE, A.R.I.B.A., Architect.

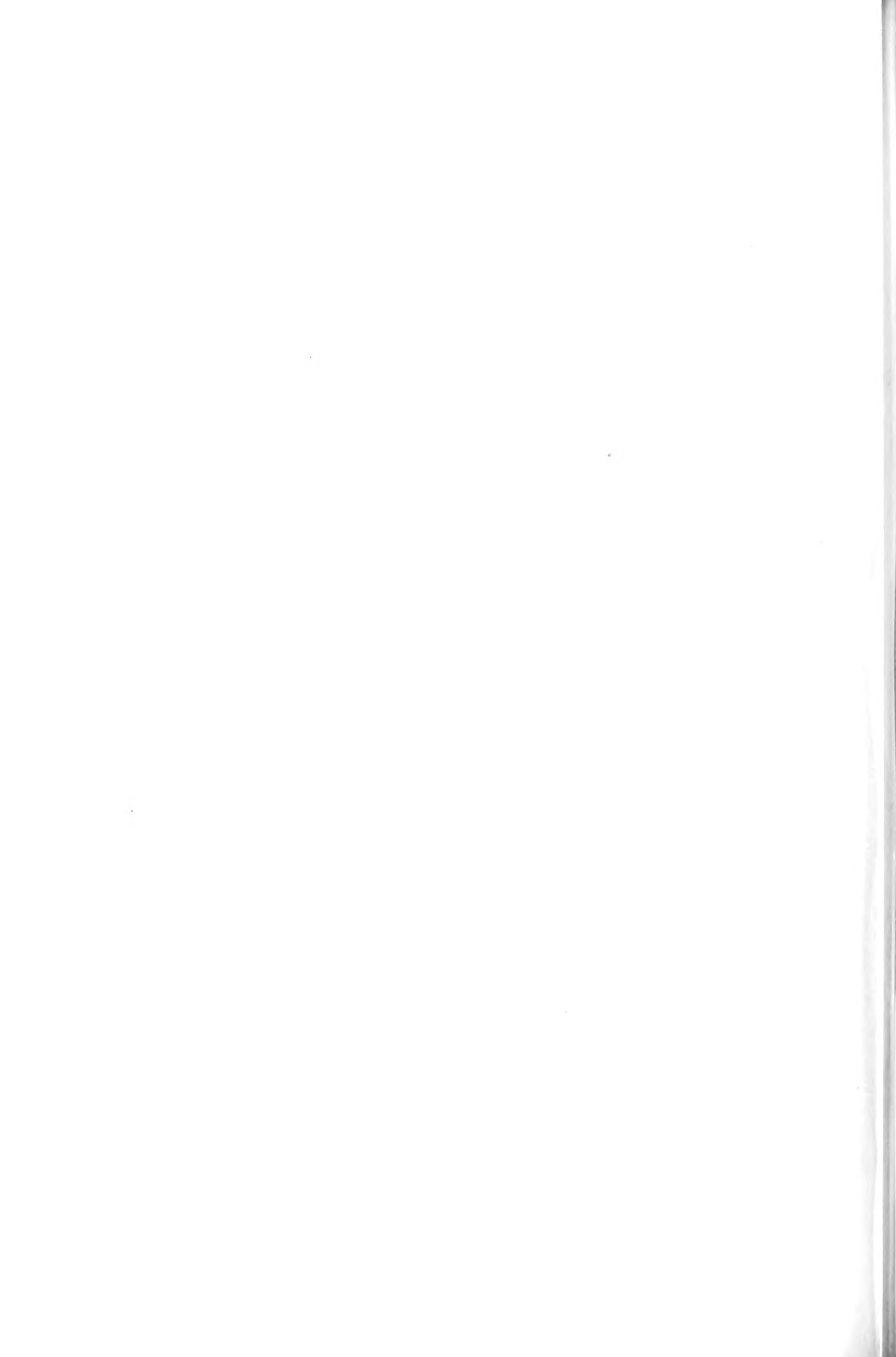



THE BUILDING NEWS, SEPTEMBER 22, 1915.

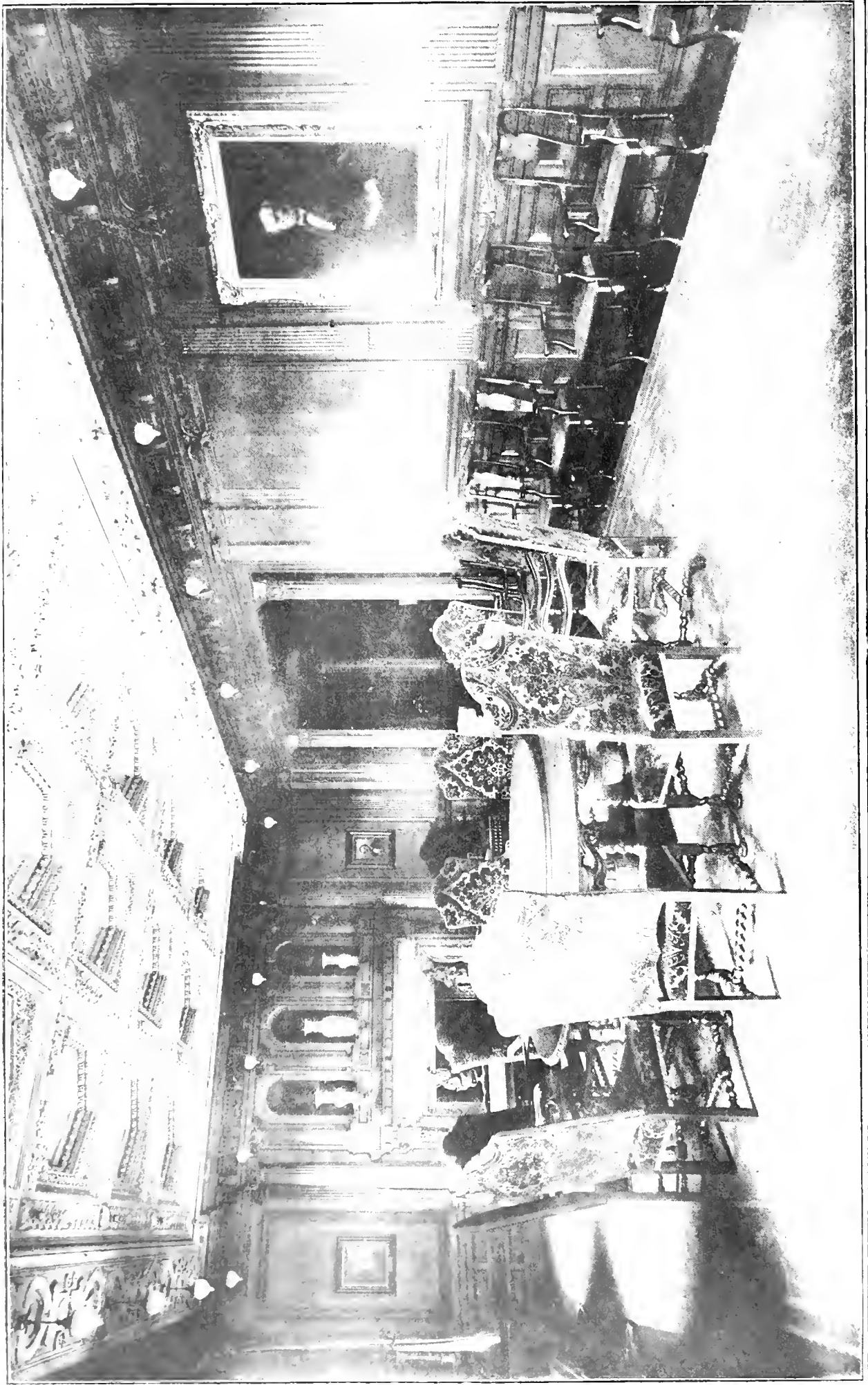

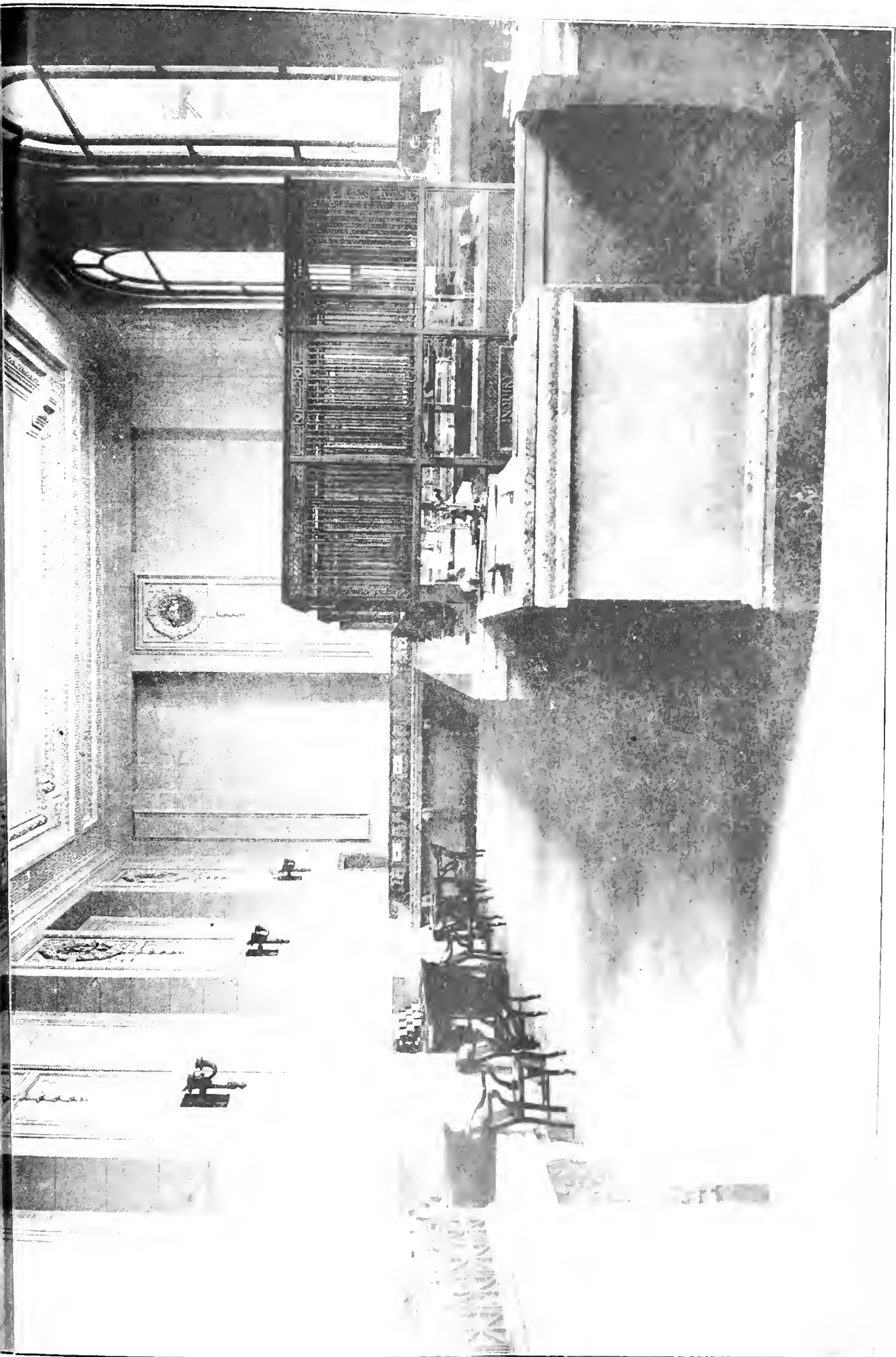

HOUSE OF COMMONS, OTTAWA, CANADA. THE HOUSE OF COMMONS, OTTAWA, CANADA. THE HOUSE OF COMMONS, OTTAWA, CANADA.





THE BUILDING NEWS, SEPTEMBER 22, 1915.

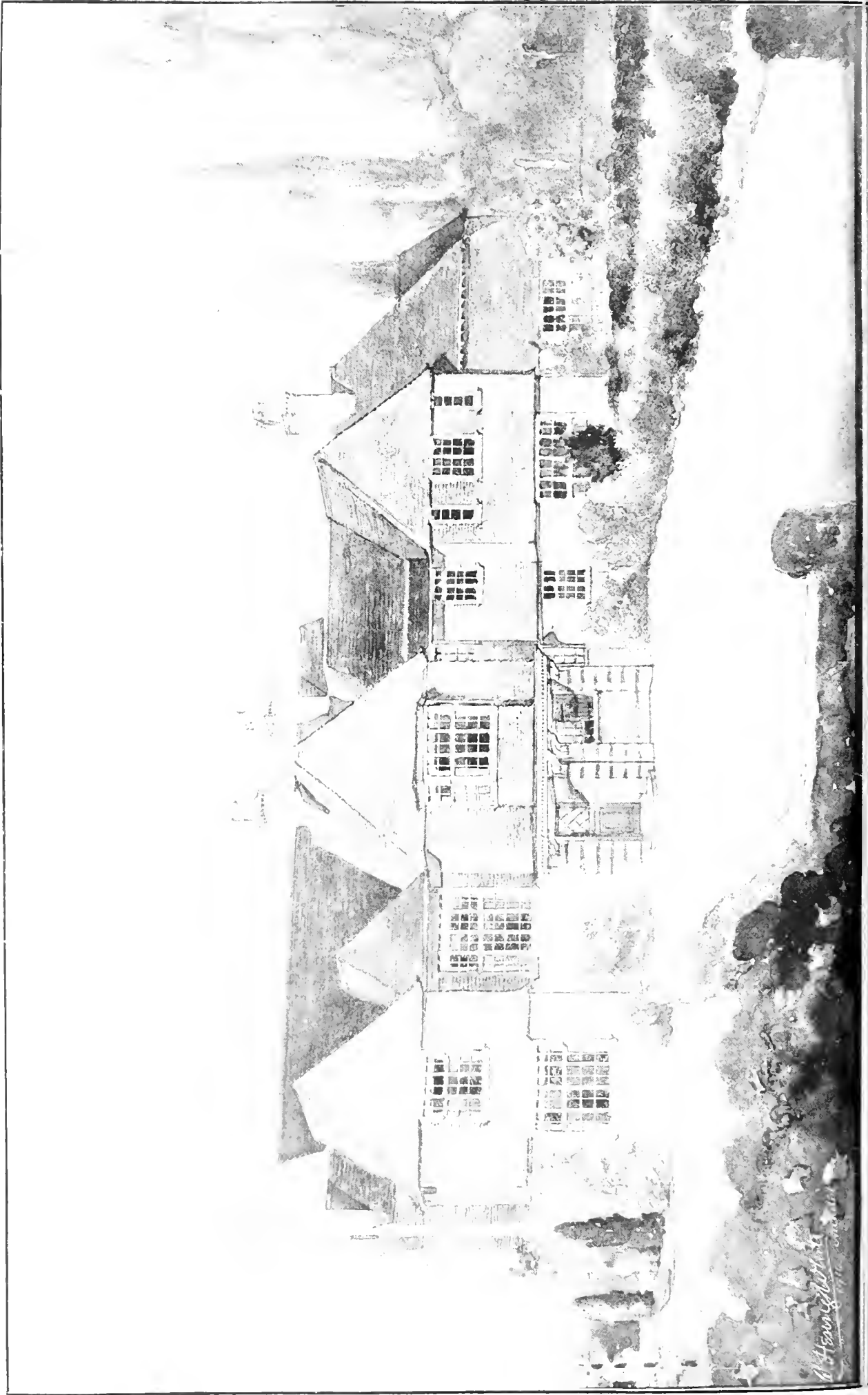

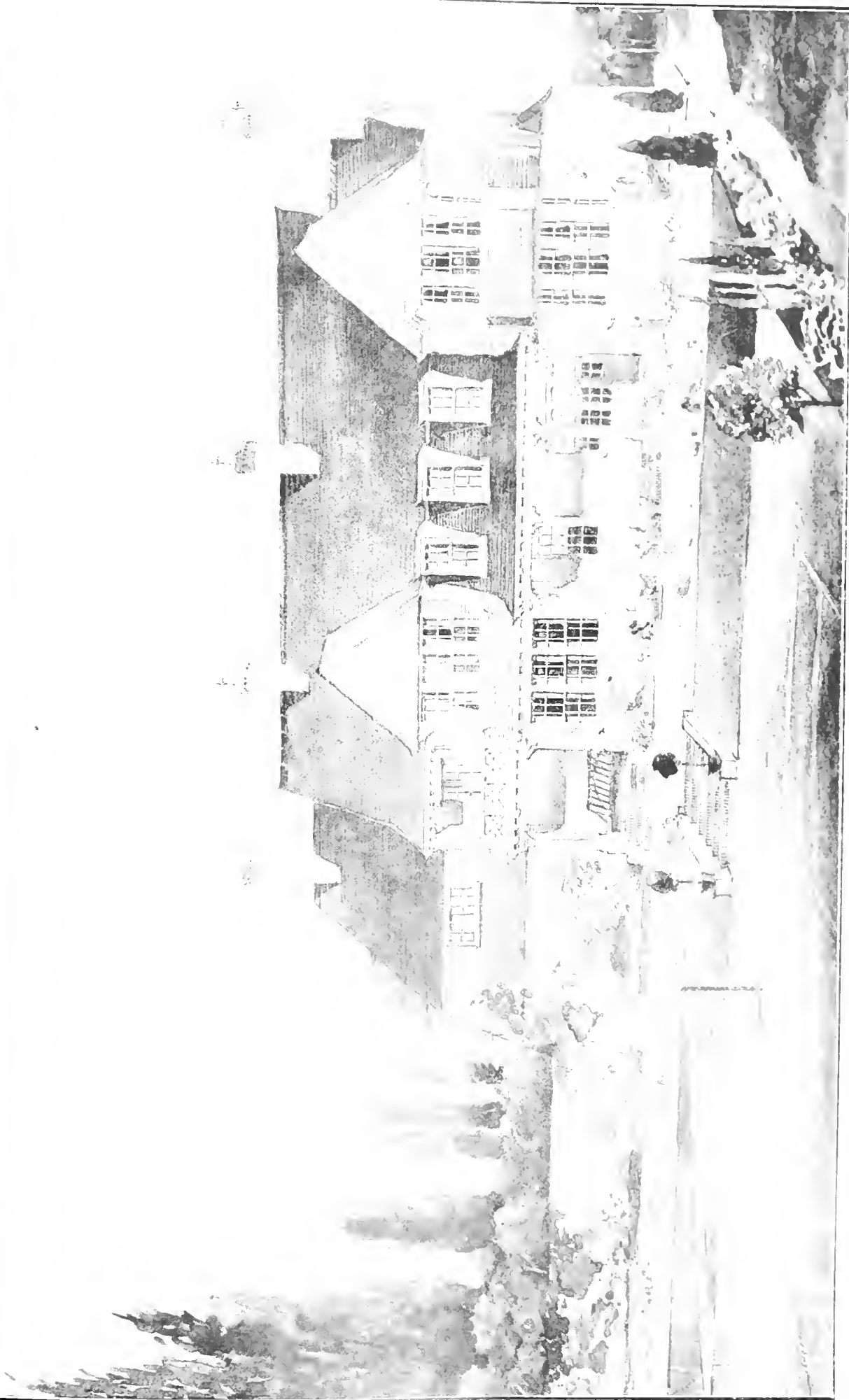

PLUMBING SHOP, PLEMBURY, KENT. MR. W. H. WOOD, F.R.I.C.A. V.



Currente Calamo.

Readers have been acquainted in notes on this page in past numbers of the circumstances with regard to the scandal that has arisen in connection with the contracts for the erection of the New Parliament Buildings for the province of Manitoba at Winnipeg, of which Mr. F. W. Simon, F.R.I.B.A., was the architect, and whose design was illustrated in our issue of September 22, 1912. As we intimated on this page in our issue of April 30 last a Royal Commission was then appointed to investigate the charges made by the Opposition, and on another page to-day will be found the Royal Commission's interim report. The charges are found to be substantially true, and there is said to have been fraud and much overpayment since the contract was let to Thomas Kelly and Sons over three years ago. The overpayments amounted to \$701,093 59c. Unfavourable inferences are drawn from the actions of G. D. Coldwell, J. H. Howden, Thomas Kelly, V. W. Horwood, Dr. R. M. Simpson, W. A. Elliott, M. G. Hook, and Harry Whitla, K.C. It will also be seen that the preliminary investigation of the charges against three ex-Cabinet Ministers commenced last Friday, and that work has been resumed under the direction of Mr. F. W. Simon.

A change with regard to the contract for the new head offices of the Metropolitan Water Board, in Rosebery Avenue, appears to be contemplated. On the agenda of the meeting held last Friday a Report of the General Purposes Committee appears as follows:—"At the special meeting of the Board held on August 27 last, we presented a report (Board Minutes, page 347) with reference to the contract for the erection of the new head offices in Rosebery Avenue, and recommended, for reasons stated, that notice should be given to determine the contract. Our recommendations were referred back with authority to take counsel's opinion or such other steps as might be necessary to enable us to present a further report. Since that occasion the building contractors and Messrs. Rice and Son, a well-known firm of London builders, have approached us with a suggestion that the contract should be transferred to that firm. If this were agreed to, Messrs. Rice and Son would at once assume control of the works, pay any sums due to the sub-contractors, remove charges on the existing contract, and reorganise the building contract so as to complete the structure within eighteen months from the date of transfer. As, however, Messrs. Rice and Son find that some of the prices in the bills of quantities are unremunerative in the conditions that now prevail and would, in fact, entail a loss, they stipulate that various sums amounting in the aggregate to £4,132 should be added to the contract price of £110,004. The fact that it has been considered desirable to submit the proposed transfer for our consideration confirms the view contained in our last report that the present arrangements are not working satisfactorily. It, therefore, being obvious that a rearrangement is desirable, we are advised by the architect that the Board could not in such circumstances have the building completed otherwise upon as favourable terms as the ones proposed, and, after a careful review of all the circumstances, we recommend them for the Board's acceptance, subject to the immediate execution by the parties concerned of a formal document to be prepared by the Board's

solicitor, which, amongst other things, would contain a suitable indemnity by the new building contractors protecting the Board from claims made by the present contractors or persons claiming through them.

"The proposed addition to the contract price will still leave that sum under the amount, including mahogany, of the second lowest competitive tender, viz., that of Mr. J. Carmichael, in £116,082, and less than Messrs. Rice and Son's competitive tender of £117,659 8s. 8d. We have made inquiries as to the status of Messrs. Rice and Son, and find them to be a firm of high repute in the London building trade, their senior partner, Mr. F. G. Rice, being a past president of the London Master Builders' Association and president of the Institute of Builders. The Board now hold the sum of £6,040 in respect of retention moneys under the contract. Under the terms of the proposed transfer, and subject to the satisfactory completion of the contract, this sum would ultimately become payable to Messrs. Rice and Son, but meanwhile, with additions thereto in respect of future work, would be retained by the Board as security against the assignees of the contract just as it has hitherto been against the present contractors. We have forwarded the necessary estimate to the Finance Committee, and recommend: "That the estimate of £4,132, to be submitted by the Finance Committee, be approved; that subject to the solicitor taking all necessary steps for the Board's protection, the Board do assent to the transfer to Messrs. Rice and Son of Messrs. Heath and Son's contract for the erection of the new head offices in Rosebery Avenue, E.C., subject to the terms set out in the foregoing report; and that the seal of the Board be affixed to all documents in the matter requiring the same." The report of the Finance Committee is to the following effect: "The Finance Committee, having considered in its financial bearings the above estimate, submit the same as chargeable to capital account." We are informed, on inquiry, that further consideration of the matter was postponed.

Numerous expedients are being devised by the clerks and surveyors to local authorities to meet the awkward situations evolved by the decision of the Local Government Board and the Treasury to cancel sanctions already granted for executing urgently needed building and engineering works. In several cases, notably the police station at Reigate and county council offices at Dundalk, the assessors' decisions had been adopted in competitions, in which many architects have fruitlessly expended much labour, time, and money in endeavouring to solve problems, and the successful man has the mortification of learning that the entire enterprise is abandoned "until after the war"; in many others contracts have been entered into with builders. These will involve the councils in considerable and absolutely unremunerative losses, and they will be well advised if they negotiate with the aggrieved architects and contractors to make the best terms possible rather than sink more of the ratepayers' money in fruiting and always unsatisfactory lawsuits.

The rise in rents in many towns is seriously pressing all householders. It is, of course, in no small degree due to the shortage of houses, and, very slightly, to rising rates. This was emphasised last week at a meeting held in Manchester to inaugurate a "plan of campaign" among householders generally,

with the view of obtaining a reduction in Mr. Mellor, the secretary of the Salford Trades Council, declared emphatically that a thousands of householders have been paid a much greater extent than is suggested by the mere statistics. Taking the average rate throughout the city at 3s. 6d. a week would cover the landlord's outlay of a house rented at 5s. Yet in almost every case the minimum increase is 3d., which means a return of 17s. a year for about 3s. 6d. extra on the rent. For example, a house rented at 11s. 6d. an increase of 1d. would impose on a large family of five, whereas 3d. would be sufficient for a landlord. Thus, for an additional expenditure of about 11s. 6d. a year, an increase of less than 52s. is received by the landlord in higher rents. "It has to be remembered," he added, "that many people have not shared in war bonuses, increased wages, and higher rents, and the greatly increased cost of living cannot be paid without much hardship." It must be remembered that the silent sufferers of the professional classes will get little redress while the Government stops building.

At a meeting of the Birtley Parish Council last Wednesday, Mr. B. Bolam reported that he had been officially informed that a certain firm which was at present erecting large works in the township would in the near future be employing 6,000 workpeople, for whom housing accommodation would have to be provided. A Local Government Board inspector had recently visited Birtley, and had stated that at least 500 houses would have to be built almost at once, as a commencement. No builder could think of building houses on a speculative basis at the present time, as they cost 35 per cent. more than a year ago. He, therefore, moved that they ask the Chester-le-Street Rural District Council to build a reasonable number of houses, for which he had every reason to believe the Local Government Board would provide all necessary facilities. Mr. A. S. Bolam, in supporting, said a Local Government Board inspector had been at Chester-le-Street that day, and he had informed a representative of the Urban Council that the Local Government Board would favourably consider the question of lending money for the erection of 500 houses at Chester-le-Street for this purpose on favourable terms. The resolution was agreed to. So, if the application is granted, and the facts are truly stated, the ratepayers will have to pay the difference between the cost now and that for which, in all probability, private enterprise would have supplied the need had it not been for war and strikes.

The dispute about the Gladstone Memorial site at Edinburgh, to which we referred on this page in our issue of August 11, seems still unsettled. At a previous meeting, the town council had agreed to offer a site at Saughton Gardens, but last week, by a majority of 27 to 11, the matter was disapproved of. The Lord Provost, however, revealed that if the Prince's Street site had been selected, with the statue being placed in Prince's Street, it would have been unanimously accepted. The town council had done everything they possibly could. It did not lie with the town council to say where the statue was to be put. They had given a site each time it had been asked, and he was quite sure the citizens freed them from any blame. It was entirely the fault of the sculptor and the President of the Royal

Sir, I am glad that this statue had to go to the country instead of an urban site. He is a great deal of trouble in connection with this matter, and he urged them to get it out of Bath. Rose asked where the statue was just now, and how much it cost to get it to the city for lying where it was. The Lord Provost replied that the statue, having the intervention of Sir M. Mitchell Thomson, was lying in the Caledonian Railway yard, carefully packed away. No doubt the committee would have to pay demurrage charges. It had been there for six weeks or more. The Town Clerk said the committee would have to decide was simply a matter of disapproval of the minutes. Mr. Lorne MacLeod asked if it was not a question for the Works Committee, which would be in possession of the Princes Street with the statue lying there. The Lord Provost: I am very imperative on that. Mr. Lorne MacLeod: So that we are really determining the statue is to be placed in Saughton. The Lord Provost: The Treasurer M. Michael asked the question a fact that since the Lord Provost is present in the Memorial Committee, and had rejected the Princes Street site, and accepted the Saughton site, and had communicated that fact to the Lord Provost. The Lord Provost: That is right. Treasurer M. Michael: Then all we have to do is to approve or disapprove of Saughton. And the majority, as before said, promptly disapproved.

Sketchers must really be careful. Mr. Thomas Ross, architect, 6, Coburg Place, Edinburgh, appeared before Sheriff Armon Haunay at Cupar last week, charged with having made a sketch at Burntisland showing Burntisland harbour, the Firth of Forth, and the vessels lying in the harbour. The Fiscal said accused was a very respectable man, and there was no suggestion that he had made the sketch with any ulterior motive. He seemed to have a great fancy for sketching old castles. Accused said it was purely the beauty of the scene which he was sketching. It was not an architectural drawing. He asked that the sketch, which had been retained by the police, should be returned to him, as some of the details were of value to the Royal Society for the Preservation of Ancient Monuments. The Sheriff said it was necessary that a permit should be taken out. One never knew when sketches might be of value. He had seen that the German aviators flying over the Gulf of Finland had been much aided by sketches which the Kaiser had made when on a visit to the Tsar. He imposed a modified fine of 5s., and directed that the sketch should be returned to accused.

By a printer's error last week it was stated on this page that the deposit asked of competitors in the York town planning scheme was ten guineas. It should have been five guineas.

At a public dinner at St. George's, Garrison College, Westwood, on Saturday morning, Brigadier-General T. F. Budge, invited two prominent pillars of the community, the late General Sir Henry Brack, and the other commemorating the 100th anniversary of the dedication of the church.

The Municipal Corporation housing scheme, so far as the 150 houses projected, is proceeding well. Mr. W. Hargreaves, the city engineer, is preparing a general town planning scheme, but these are largely dependent upon a boundary extension scheme, and will not be considered until after the war.

THE PERCENTAGE OF WATER IN CONCRETE.

In a paper read before the Connecticut Society of Engineers, results are given of a series of careful tests made to determine the effect of varying the percentage of water in concrete.

Although the percentage of water has a direct bearing upon the strength of concrete, it is the exception rather than the rule that the engineer concerns himself with the question of mixing beyond seeing that the proper proportions of sand, stone, and cement are used and the contractor is generally allowed to mix these materials as he thinks fit. In preparing the specimens for his tests, the author found it necessary, when making mixtures containing more than 27.5 per cent. of water, to increase the proportions 10 per cent. in order to fill the moulds. This indicates an increase in density which was obtained at a loss of strength. However, in some cases this is highly desirable. Often bulk and impermeability are the two requisite features. In reinforced concrete structures a moderately wet mixture is far more practical than a dry one; but it must not be forgotten that the use of wet mixtures increases the cost of materials. An increase in density means a corresponding increase in raw materials. The additional water weakens the concrete, and, therefore, a richer mixture or lower unit stresses must be used. The former is preferable, for the beams and columns in concrete building are always heavier than the corresponding members of steel or wooden structures. If a wet mixture is used, the engineer should be cautious in permitting the removal of the forms at an early date. In some of the tests the wet mixtures were very slow to develop their strength. The use of such consistencies in practice would necessitate extreme care. It might be a month or more before the forms could be struck with any security. The question of consistency is not altogether a laboratory question. The increased cost of materials due to the use of wet mixtures may be more than balanced by the saving in placing; but the engineer should bear in mind that consistency has a direct relation to strength, and if he permits a wet mixture he should provide the same in his design.

SHRINKAGE AND TIME EFFECTS IN REINFORCED CONCRETE.

In the extensive investigations of the properties and behaviour of reinforced concrete that have been made in recent years very little has been done in establishing the effects of loads sustained for long periods of time. This seems the more remarkable in view of the fact that a progressive sagging or cracking has been noticed in many structures. That these changes have not received more attention in the past is probably due to the suspicion of poor construction or inadequate design that is usually raised at the suggestion of such behaviour, a suspicion unfortunately too often justified.

In the tests cited in a bulletin of the University of Minnesota it has been found that certain changes do take place that are chargeable neither to poor construction nor inadequate design, but rather to the nature of the material itself—its tendency to shrink and yield under load. It is in recognition of the importance of these changes that this bulletin is issued; for, while no attempt is made even to suggest a solution to the problems presented by these shrinkage and time effects, it is felt that the facts presented are of sufficient importance to warrant their publication. With materials and mixtures used in these tests it is safe to predict a shrinkage of from three-fourths to one inch or more in 100 ft. when exposed to the ordinary dry air of a heated building. The yielding of the concrete under compressive stress with time, a phenomenon similar to the yielding of ductile metals when stressed beyond the yield point, is greater as the unit stress is greater and seems to go on indefinitely. In these tests the deformation due to yielding was found to be from three

to five times that produced immediately upon the application of the load.

A few of the possible results that may be looked for where these twin changes are in progress are suggested. The production of cracks in floors, ceilings, and partitions, even though in no sense indicating a structural weakness, is an undesirable feature. And in certain places with some types of structures or details cracks might leave the reinforcement accessible to moisture and thus prove a source of danger. Sagging of the structural framework may cause the bending of doors in positions, a feature that is both expensive and annoying. The tilting of columns by the unequal shrinkage in the different floors might be a source of high bending moments and column stress. But of far more importance than these may be mentioned the two following possible effects, both of which might in certain instances, be of serious consequence:—

First, the continued yielding of the upper fibres of a beam, coupled with the gradual breaking down of the concrete in tension, may result in a progressive destruction of the bond from the centre toward the supports, similar to that occurring with the progressive loading of a beam as shown by Mr. D. A. Abrams (Bulletin 71, University of Illinois). Also the drying-out incident to this large shrinkage movement may assist in this destruction of the bond.

Second, the possibility of high stresses in the longitudinal steel of compression members seems to be the most important conclusion to be drawn from these tests. The time yielding of the concrete under stress, combined with the excessive shortening due to shrinkage, may result in deformations from five to fifteen times those expected from the ordinary calculations. In columns of the ordinary ratio of vertical steel in which no allowance has been made for spirals, the resulting steel stress is probably well within the elastic limit, but in those columns designed on the assumption of large loads being carried by the hooping the steel stresses may approach dangerously near the yield point.

Mr. Lionel Williams, of Torquay, has been appointed by the urban district council of Buckfastleigh to the position of surveyor and sanitary inspector.

In the City of London Sheriff's Court on Wednesday, Messrs. T. and A. W. Norris, builders and decorators, Old Street, E.C., were awarded £75 damages against Mr. T. W. Hancock, of Berwick Villa, Langdale Road, Hove, in respect of certain statements which, it was alleged, reflected on the plaintiff's business probity.

A number of paving-stones have arrived at Middlesbrough for shipment to America to be used in repairing the portico at George Washington's old home at Mount Vernon. A committee of ladies from nearly every State in the Union have undertaken to maintain the home of the first President of the Republic, and it was their desire to have the restoration carried out with stones from the quarry at Whitehaven that supplied the original building.

Hutton Castle, Berwickshire, and adjoining properties belonging to Lord Tweedmouth, were offered for sale in Edinburgh on Wednesday by Messrs. Curtis and Henson, of London. The property is 4,615 acres in extent and the rental is £5,000. There was no purchaser for the property as a whole, and it was then offered in six lots. The first lot, comprising Hutton Castle and estate of 162 acres, was sold for £23,000, the name of the purchaser not being disclosed.

An institute provided by the Young Men's Christian Association for the benefit of the men of the Royal Navy and of those employed in the service of the Government at the Rosyth Naval Base was opened on Friday by Lady Beatty, wife of Vice-Admiral Sir David Beatty. The institute is of temporary character, and will be replaced later on by a more substantial building. It has been erected to plans by Lieutenant Stewart Kaye, Dunfermline, by Messrs. J. and R. Watson, Edinburgh. The main hall is 155 ft. by 30 ft., and there is a platform at the west end. The building is of timber framing, with weather-boarding outside and lined inside, with red rubberoid roofing. Heating is provided for by the installation of anthracite stoves, and the lighting is by electricity.

Building Intelligence.

DANYCOED.—The Red Cross Hospital, Danycoed, near Swansea, is being prepared for the reception of wounded soldiers. The residence is being adapted for this purpose, and will accommodate, with the addition of open-air wards, sixty-five patients. The architect for this work is Mr. Glendinning Moxham, F.R.I.B.A., Swansea, who has made a special feature in connection with this Red Cross hospital. The outside wards are being adapted either as open-air wards or closed-in wards at a moment's notice, and it is believed that when these wards are complete they will form a model for other military Red Cross hospitals. The work generally is being carried out by Messrs. J. and F. Weaver, contractors, Swansea.

GALASHIELS.—A well-equipped range of public baths and a public park and children's playground have been presented to the burgh by Mr. and Mrs. A. A. Dickson. The baths (of which Mr. John Hall is the architect) have a frontage to Wilderhaugh of about 80 ft., and are faced with rock-faced red freestone, with a rusticated entrance doorway. The rest of the building is of brick, rough cast, with cement. In the plunge bathroom there are six plunge baths, and there is also a spray bathroom with footbath sprays. The swimming pond is situated in a hall 92 ft. by 53 ft., the pond itself measuring 75 ft. by 35 ft., and varying in depth from 7 ft. to 3 ft. All the usual appliances are provided—dressing-boxes, diving ladders, trapeze-rings, spring-boards, water-shute, polo-posts, etc., the water being steam-heated before entering the pond. The other accommodation includes a laundry, with washing-machine, hydro extractor, and drying closets, and office accommodation for the staff. The playground and park, which extend to an acre, are being laid out with a shelter, rockeries, shrub-eries, and with seats, swings, and a seaside sand-pit.

NEWCASTLE-ON-TYNE.—On Saturday Bishop Ormsby dedicated the recent additions to St. Aidan's Church, Newcastle, which include the north and south porches and the lower portion of the tower, forming a baptistry, which is carried up to the level of the ringing room floor. A five-light window at the west end and a smaller window on the south side of the tower greatly add to the efficient lighting of the church. The new work is in conformity with the rest of the church, of 15th Century type, built with hammer-dressed stone throughout, with ashlar dressings. The church was commenced in 1838, and it was dedicated by Bishop Wilberforce on December 15, 1889. The recent work has been carried out in accordance with the original design of the late Mr. W. S. Hicks by the present firm of Messrs. Hicks and Charlewood, architects, of Newcastle. The builder is Mr. G. H. Mauchlen, also of Newcastle.

SHREWSBURY.—At the last meeting of Shrewsbury Town Council the Housing Committee reported on the cost of the Wingfield Gardens housing scheme, and also submitted a new housing scheme to provide 100 houses for the working classes of the borough. The total cost of the first scheme, which provided sixty-three houses, and of which Mr. A. E. Williams was the architect, was £13,616, and, owing to the adoption of the instalment system of repayment, there was a deficiency on the first year of £114. The new scheme submitted is in Castle Fields, and will connect up several streets already in existence. Plans and estimates prepared by the borough engineer, Mr. A. W. Ward, were submitted by the committee. Provision is made for houses rented at from 4s. 6d. to 7s. 6d. per week. The total cost, including land and sewerage, is set down at £22,030, and it is estimated that there will be a total annual income of £1,300, and after meeting all annual payments there will be a credit balance of £26 7s. 3d. Alderman Deakin, in moving the adoption of the report, said there was very great shortage of houses in the town. Some of the results of that shortage were that rents had gone up, and

hundreds of working men were paying more than a quarter of their wages in rent, and others were living in insanitary dwellings. After some criticism the report was adopted.

LEGAL INTELLIGENCE.

E. J. JONES TRADING AS JONES BROS., OF KENSINGTON. A meeting of creditors of Mr. Edward Jones, builder, of Oakwood Court, Kensington, who had traded as Jones Bros., was held at the Court of Bankruptcy on September 15. The gross liabilities were stated to be £303,127, and the assets, as valued by the debtor, £205,624. Failure is ascribed to pressure by mortgagees and inability to realise. Mr. F. S. Salaman was appointed trustee.

The late Mr. McArthur, Edward Fitt, of Oxford Road, Reading, builder and contractor, left £25,789.

The first completed section of the Church of the Holy Trinity, situated at the junction of Merryleigh Road and Bloomhall Road, Newlands, Glasgow, has been formally opened. The cost of the portion completed is a little over £7,000.

An altar, erected in reparation for the outrages committed in Belgium by the German Army, was unveiled on Sunday in St. Saviour's Roman Catholic Church, Lewisham. It is built of marble, and its construction was superintended by Mr. Claude Kelly, of Oxford Street, W.

At Chertsham, on Saturday, a brass was unveiled in the College Chapel and a life-size portrait in the College library to the memory of Dr. Edward Adrian Wilson, who perished with Captain Scott in the Antarctic expedition. The portrait of the explorer was painted by Mr. Hugh Riviere and hung in this year's Royal Academy.

Mr. A. D. Parham, who has been appointed as an architectural assistant in the Public Works Department of Ceylon, has just commenced his duties. He will start on the salary of a district engineer—£300 per annum. The new officer will be an additional assistant to Mr. A. Woodson, the other assistant being Mr. E. W. Bartholomew.

The Great Northern Railway Company are about to begin the construction of the first section of their authorised new railway from their tramway branch at Waltham-on-the-Wold to their main line at High Dyke, four miles south of Grantham. The total length of the railway is twelve miles, with a branch of one mile. The section to be first undertaken will be that between High Dyke and Stanbury.

A new Council school has been erected on Crown Road, Dereham, for older boys and girls. The school, which provides accommodation for 200 children, is a red brick structure, having roofs covered with red Roman tile. The architect is Mr. J. E. Burton, of Norwich, and the contractor Mr. R. Shanks, of Chertoris. The school has been constructed on an open site, and all the classrooms have window-facing south.

The splendid new buildings of King's College for Women, Campden Hill Road, Kensington, are almost ready for the students. They are Early Georgian in style, and are built of red sand-faced bricks, with Portland cement dressings. The buildings are grouped round a central quadrangle, and have cost over £100,000. The architects are Messrs. H. Percy Adams and Holden, whose plans and designs were illustrated in our issue of August 1, 1915.

Pioneer-Sergeant W. J. Warman, 7th South Staffords, formerly a builder and contractor in Lichfield Street, Walsall, has been killed at Gallipoli. Quartermaster-Sergeant E. Walker has written stating that part of the battalion was had got off, and Sergeant Warman was shot dead whilst trying to find his way back to the British lines. Mr. Warman came to Walsall from Cardiff, and leaves a widow and four children, who are now living in Darlaston Road, Wodnesbury.

The Premier of British Columbia, Sir Richard McBride, recently opened at Vancouver the Marine Drive, constructed at a cost of \$500,000, and one of the finest drives on the Pacific Coast. The Premier stated that within ten years he expected to see the Marine Drive connected with the head of Howe Sound and Spanish Bay. The two new bridges, which span the Capilano River, which are constructed of the Capilano River, were built by Messrs. Naylor Brothers at a cost of \$43,000. The larger structure is 355 ft. long, with approaches of 436 ft. When completed, the new Marine Drive will be some thirty miles long.

COMPETITIONS.

HASTINGS, NEW ZEALAND. An open competition for a municipal building, instituted by the Corporation of Hastings, N.Z., the first premium has been awarded to Messrs. Stanley Hill and A. G. Gairdner, architects practising at that town. The estimated outlay is £14,050.

STATUES AND MEMORIALS.

KING EDWARD MEMORIAL. A competition in the Mansions House of the Corporation of the King Edward Memorial Park, Aldershot, Sir Vezey Stirling, president of the competition, that the fund amounting to £27,250, which £72,000 had been expected to be raised from the Corporation of the St. John's Memorial as a public park for the East End of London. It was not considered a particularly even desirable, because of what he considered the river wall during the war, owing to the increased cost of materials and the amount of labour. The plans, however, submitted by Part of London Authority, at 1, West End, London, with at the earliest opportunity, Mr. B. and Mackenall, R.A., who has been engaged to deal to execute the sculpture, and Mr. King Edward for erecting a Waterloo Park, the site now occupied by Lord Strathmore, a train figure, reported that the plans would be ready for casting in bronze at the close of the year.

TRADE NOTES.

Boyle's latest patent "Air Pump" valves have been applied to the board meeting of the Penitentiary Parish Council, Malden.

East Kerrier Rural District Council, appointed Mr. S. T. Macnell, of Helston, as their surveyor, at a salary of £4,000 per £100, a year.

The foundation stone of a new Roman Catholic school in Holy Saviour's parish, Nelson, Lancs, has been formally laid by Messrs. W. T. Cunson and Son, of Manchester, are the architects. The cost is estimated at £25,000.

A lecture on the history and architecture of the Church of St. Bartholomew, the Great, Smithfield, will be given on Saturday, October 9, and repeated on October 16 at 2.5 p.m. No tickets are required, but a collection will be made to defray the heavy cost of removing Robert's tomb from Zappin's house.

The sewage disposal works belonging to the urban district council of Stalybridge, has just been rendered more efficient by the construction of a grit tank with a capacity of 250,000 gallons and other improvements carried out under the direction of Mr. J. N. Nield, A.M.I.C.E., of Bradford, consulting engineer at Stalybridge.

The death is announced, at the age of eighty-five, of Mr. Fredrick Smallock, R.A.W.S. (retired), who in the latter half of the nineteenth century was a well-known painter of figure pictures. He was a frequent exhibitor to the Royal Academy and the Grosvenor Gallery. By a painting in oils he is represented in the Manchester Art Gallery and by another in the Royal Cornwall Institute at Truro.

At the last meeting of the Irvine and District Water Board at Kilwinning a letter was read from the Scottish Command agreeing to the terms offered by the Board for a water supply to Garles Camp and it was remitted to the manager to arrange for the work being carried out at once. The Public Works Loan Board have sanctioned a loan of £50,000 to meet the cost of the new filtering plant installation and the pipe from Monoch to the filters.

The following wash is recommended as effective water-proofing for cisterns, silos, and similar structures. A stock solution is made of 1 lb. live, 5 lbs. alum, and 2 quarts of water. A quantity of this solution is added to a bucket of water and 10 lbs. of cement, making a paint like mixture to be applied with a brush. This same modification of the Sylvester process and depends on the precipitation with the pores of the concrete of insoluble alum silicate and alum hydrate, or both together.

There has been erected in the little public cemetery of Lyme Regis an imposing memorial to the victims of a crew of the submarine Formidable, which was torpedoed by a German submarine last January. The memorial, which takes the form of a granite Celtic Cross on three massive bases, stands immediately over the graves of six of the nine men who died from exposure as the result of the gale in which they were buffeted about in their boat for twenty hours after leaving the battleship.

Our Office Table.

At the last meeting of the City Council of Bristol a discussion arose on a proposition by a member to determine, on December 31, the appointment of Mr. Girdlestone, for nearly thirty years the docks engineer, as consultative engineer to the Docks Committee, at £7,500 per annum. Mr. Girdlestone, the mover avowed had nothing to do, as the present docks manager was quite capable to perform his duties; to close the engagement at the end of this year would be, he contended, too generous, as Mr. Girdlestone was appointed in 1876 at £300, and for many years received £1,200 per annum. In the course of the debate it was explained that when Mr. Girdlestone received his appointment as part of a scheme of reconstruction recommended by a special committee, he was told that while the committee or the Council had no right to make a life appointment, he might accept the assurance that it was intended to be a lasting one. There were strong complaints that this fact was not disclosed to the Council when the appointment was made, and the explanation did not alter the attitude of many members towards the resolution. An amendment to refer the matter to the Docks Committee to reconsider the position was defeated, and when the resolution was put to the vote it was defeated by the narrow majority of three, the numbers being 21 for and 24 against.

At a recent meeting of the Committee of Management of the Dundee Free Library Mr. A. B. Crichton said it was proposed to have an exhibition of the prints secured in connection with the photographic survey which has been completed by the Dundee and East of Scotland Photographic Association of Dundee at the beginning of the twentieth century. The town council, he explained, had advanced about £200 to the members of the association who had made the survey. Glasgow was forming such a collection, but they were paying thousands of pounds for it. The Dundee collection consisted of about 2,000 prints in duplicate. It was intended to bind the photographs into volumes, one set to be kept in the Charter Room at the Town House and the other in the Albert Institute. The committee agreed to grant the use of one of the galleries for the free exhibition of the collection, which in years to come will possess great historical interest.

The prospectus of the Manchester Municipal School of Technology, giving particulars of the part or time courses in municipal and sanitary engineering, architecture, and building for the ensuing session, has just been published. The principal of the school is Mr. J. C. Maxwell Garnett, M.A., and the vice-principal Mr. J. P. Wrapsen, A.B.C.S.I., B.A., M.Sc., and the secretary and registrar Mr. H. Williams. Mr. J. Radcliffe, M.Sc., is the head of the municipal and sanitary engineering department, Mr. Archibald C. Deane, M.A., A.R.I.B.A., is the professor of architecture, Mr. J. Lindsay Grant the lecturer in architecture, and Mr. W. L. Foster, M.S.A., the lecturer in building construction. The various courses begin on Monday week, the 27th inst.

The *Manitoba Free Press*, published at Winnipeg on August 30, states that a refund of \$2,500.00 cents was received two days since from the Manitoba Department of Public Works for overpayments to contractors made by the late provincial government. An investigation by the present Minister of Public Works into the accounts for the Agricultural College showed that in one contractor's case there had been three distinct duplicate payments in connection with extras on one building. One duplicate payment was for \$4,602.25 cents and for \$5,370.60 cents, and a third for \$1,629. When these overpayments were pointed out to the contractors, they not only admitted this, but made a refund amounting to \$9,101.60 cents. Their explanation was that in at least one case they debited the overpayment, and called the attention of the department to it, but had not returned the cheque, as they claimed

another bill against the Government on a second contract still unsettled.

The city of Winnipeg has just adopted a by-law limiting the height of buildings. Its provisions were formulated by a joint committee representing a number of organisations, architectural, town planning, real estate, and building, and it was passed without opposition from any quarter. It provides that no building shall exceed one and three-quarters times the width of the street, nor in any case be more than 138 ft. high, nor contain more than twelve stories. Cornices, roofs and parapets are included in these heights, but the roof may be covered with a roof garden, and pent houses, etc., one story high, set back 20 ft. from the street, may cover 25 per cent. of the roof area. Towers, with restrictions as to area and position, may be 500 ft. high. Winnipeg has three main streets, each 132 ft. wide. On these the limitation of twelve stories would make the ordinary commercial building about 165 ft. high, while for department stores, requiring high ceilings, 198 ft. is allowed for twelve stories, which is only one and one-half times the width of the street. Practically all other streets are 66 ft. wide, so that the rule would give a limit of height of 115 ft. 6 in., or about eight stories.

A report has just been issued by the United States Geological Survey showing that the value of brick and tile produced in the United States during the year 1914 was less by \$15,707,935 than the production of 1913, a falling off at the rate of nearly 10 per cent. in one year. The value of common brick produced in 1914 shows a loss, as compared to 1913, of \$6,365,233, or more than 11 per cent. in one year. It was the worst year in the recorded history of the department, the records going back to 1903 inclusive. In addition to the drop in the quantity produced, there was a drop in price—the average falling from \$6.20 per thousand in 1913 to \$6.12 per thousand in 1914. Face-brick production fell off in value to the extent of about \$324,515 as against 1913. This is a loss of only 3 per cent., and shows that face-brick withstood the pressure of competition and hard times better than its less aristocratic brother-in-clay. Paving-brick is the only important clay product that increased its output in 1914, the gain being \$362,345, or a little less than 5 per cent. better than 1913. Fire-brick sustained a loss of \$4,199,575. The value of the 1914 output was \$16,427,547, while that of 1913 was \$20,627,122. This is close to 21 per cent. The diminution is due to the almost complete stagnation of the iron and steel industries during the early months in the year.

Mr. H. Fitzmaurice, the British Vice-Consul at Bangkok, reports that the bulk of the cement now imported into Siam comes from Denmark and French Indo-China. Recently, however, a firm at Bangsue, near Bangkok, commenced the manufacture of cement, and the annual output of this new works is estimated at 120,000 barrels, or 20,000,000 kilogs. (about 44,092,000 lb.), a quantity very nearly equal to the average importation of cement into Bangkok during the last five years. The British Vice-Consul adds that if this local factory is able to produce the quantity and quality of cement its promoters expect (as to which some doubt is expressed), and at the same time to compete in price with the cheap cement now imported from French Indo-China, the importation of cement into Siam may practically cease to exist.

At the last meeting of the York City Council the estates committee recommended that the corporation should contribute £150 to the purchase of a house in Bootham to expose a round tower on the Abbey wall, provided that the property be conveyed to the corporation free of cost, and on condition that they be not requested to pull it down for five years, the corporation meanwhile receiving the rents. Councillor Shipley moved an amendment to refer the matter back, protesting against the expenditure of public money on a matter of this kind when economy was urged on all hands. If this house were pulled down it

would cost another £150 to build up the gable of the adjoining house. That would mean that they would have to spend £300. Alderman Birch seconded. He did not think the house was worth £400, and it was built on land that had probably been pinched. The amendment was defeated by 26 votes to 18, and eventually a picturesque circular tower will be revealed to view.

MEETINGS FOR THE ENSUING WEEK

THURSDAY AND FRIDAY.—Iron and Steel Institute. Autumn Meeting at the Institution of Civil Engineers, Great George Street, S.W. 10.30 a.m.

FRIDAY (Sept. 24).—Glasgow Architectural Craftsmen's Society. Presidential Address by Robert Moon Wright. College Buildings, Glasgow. 7.45 p.m.

Town Planning Institute. Opening Address by Raymond Unwin, F.R.I.B.A., President, 92, Victoria Street, Westminster. 8 p.m.

SAURDAY.—Institution of Municipal and County Engineers, South-Eastern District Meeting at Bognor. Paper on "Bognor Municipal Undertakings," by Oswald A. Bridges, Surveyor, 11.30 a.m. Visits to the various works (new housing scheme, new sea-defence scheme, site of new sewage works, hospital and underground convenience) described in the paper. 3 p.m.

Royal Photographic Society's Exhibition. "Some Village Homes and Cottages," by Arthur E. Morton, Suffolk Street Galleries, Haymarket, S.W. 8.30 p.m.

TUESDAY (Sept. 28).—Royal Photographic Society's Exhibition. "Mont S. Michel, the Abbey of the Archangel and its Seagirt Town," by H. W. Fincham, Suffolk Street Galleries, Haymarket, S.W. 8.30 p.m.

Mr. Andrew Warren, the borough surveyor of Totnes, having been refused permission to enlist by the corporation, has accepted a commission in the Territorial Cadet Corps at Totnes.

Mr. George Ley Pearce Butler has died at his residence, Oaklands, Lichfield Road, Four Oaks, in his 79th year. Mr. Butler was a Darlaston man, and formerly carried on an extensive business as builder and contractor.

A new pavilion, erected for the accommodation of scarlet fever patients at the burgh hospital, Motherwell, N.B., at a cost of about £3,600, was formally opened last week. It consists of two wards of ten and twelve beds respectively, with five one-bed side rooms—in all, twenty-seven beds with a space of 2,000 cubic feet for each. The walls have been constructed of corrugated iron on a brick foundation in order to minimise the risk from underground workings.

From returns obtained by the American Railway Bridge and Building Association, it appears that of fifty-four leading railways in the United States and Canada only thirteen have not made use of reinforced concrete. The mileage of the forty-one systems on which this material is employed amounts to 138,784 miles, the reinforced concrete structures in use comprising arch bridges, trestle bridges, arch and box culverts, hollow and solid bridge abutments, bridge piers, decking slabs, retaining walls, and city subways.

One of the recent Canadian developments in the way of builders' hardware is a screwless hinge, which has two steel projections on each end. On the end next to the door stop there is a straight steel projection that enters the wood, and on the other end of the hinge there is a clamp projection that enters the door casing. These projections or hooks counteract and offer the same resisting and holding force that the screw offers to the hinges. Besides doing away with the use of nails and screws, the statement is made that it gives the hinge a much neater appearance than those of ordinary construction.

At Grimsby Mr. George L. Pepler, an inspector of the Local Government Board, has held an inquiry into an application by the rural district council for sanction to prepare a town-planning scheme to deal with an area of 5,865 acres of land, of which 1,955 acres are under the jurisdiction of the Glanford Brigg Rural District Council. The Earl of Yarborough, the principal landowner affected (2,359 acres), regards the scheme as essential for the proper development of the place. The town clerk of Grimsby said that the corporation was most concerned that proper and adequate road communication should be made between Grimsby and Immingham.

LATEST PRICES.

N.B.—All prices must be regarded as merely approximate for the present, as our usual sources of information are in many cases failing us.

TIMBER.

Owing to stoppage of supplies all prices have advanced considerably.

Table with columns: Item, Per ton, Per ton. Includes Rolled Steel Joists, Wrought-Iron Girder Plates, Steel Girder Plates, Steel Sheets, Steel Strip, Bar Iron, Do., Lowmoor, Flat, Round, or Square, Do., Staffordshire Crown, Boiler Plates, Iron—South Staffs, Best Suedshill, Angles, 10s, Tees 20s, Builders' Hoop Iron, Galvanised Corrugated Sheet Iron.

Table with columns: Item, Per ton, Per ton. Includes Cast-Iron Columns, Cast-Iron Stanchions, Rolled-Iron Fencing Wire, Rolled-Steel Fencing Wire, Cast-Iron Sash Weights, Cut Floor Brads, Corrugated Iron, Galvanised Wire Strand, B.B. Drawn Telegraph Wire, Cast-Iron Socket Pipes.

Table with columns: Item, Per ton, Per ton. Includes Wrought-Iron Tubes and Fittings, Gas-Tubes, Water-Tubes, Steam-Tubes, Galvanised Gas-Tubes, Galvanised Water-Tubes, Galvanised Steam-Tubes.

OTHER METALS.

Table with columns: Item, Per ton, Per ton. Includes Lead Water Pipe, Lead Barrel Pipe, Lead Pipe, Composition Gas-Pipe, Lead Soil-pipe, Lead, Common Brands, Lead Shot, Copper sheets, Copper, Tin, Pig Lead, Sheet Lead, Genuine White Lead, Refined Red Lead, Sheet Zinc, Old Lead, Tin, Cut nails.

I BUY SCRAP METALS

ARTHUR P. COLLINS, Snow Hill, BIRMINGHAM. Phone: Central 1020. Telegrams: "Metalis, Birmingham. Bankers: The National Provincial Bank of England Ltd., Bennett's Hill, Birmingham.

SLATES.

Table with columns: Item, £ s. d., per 1,000 of. Includes Blue Portmadoc, Blue Bangor, First quality, " "

Table with columns: Item, £ s. d., per 1,000 of. Includes European roofing, Permanent Green, " "

BRICKS.

Table with columns: Item, £ s. d., per 1,000 of. Includes First Hard Stocks, Second Hard Stocks, Mild Stocks, Picked Stocks, Facing Bricks, Plettons, Pressed Ware, Red Wire Cuts, Best Farman Red, Best Red Pressed, Rubben Facing, Best Blue Pressed, Staffordshire, Ditto Bullnose, Best Stonebridge Fine-bricks, 2 1/2 in. Best Red Ac-crimington Plastic Facing Bricks.

Table with columns: Item, £ s. d., per 1,000 of. Includes Ac-crimington Best Red Plastic Facing Bricks, ditto Second Best Plastic ditto, Ditto Ordinary Secondary Bricks, Ditto Plastic Engineering Bricks, Sewer Arch Brick, Chimney Bricks, Beaded, Ovolo and Bevel Jambs, Ac-crimington Air Bricks, Ac-crimington Chamber Arches.

GLAZED BRICKS.

Table with columns: Item, £ s. d., per 1,000 of. Includes White, Ivory, and Best, Salt Glazed, Buff, Cream, Other, Best, Seconds, & Bronze, Colours, Stretchers, Headers, Quoins, Bullnose, Double Stretchers, Double Headers, One side and two ends, Two sides and one end, Splays and Squares, Plinth and Hollow Bricks, Double Bullnose, Rounded Internal Angles, Multiple Bricks, Stretchers and Headers, Internal and External Angles, Sil Bullnose, Majorica or Soft Glazed Stretchers and Headers, Compass bricks, Cauber arch bricks, Stretchers cut for Closets and Nicked Double Headers.

Table with columns: Item, £ s. d., per 1,000 of. Includes Best Portland Cement, Ground Blue Lias Lime, Grey Stone Lime, Stourbridge Fireclay, Bath Stone, Plain red roofing tiles, Hip and Valley tiles, Broochy tiles, Ornamental tiles, Hip and Valley tiles, Random red, brown, or brimled, ditto Edwards, Ornamental ditto, Hip tiles, Valley tiles, Selected "Perfecta" roofing tiles, Ornamental ditto, Hip tiles, Valley tiles, "Rosemary" brand plain tiles, Ornamental tiles, Hip tiles, Valley tiles, Staffordshire (Hanley) Reds or brimled tiles, Hand-made sand faced, Hip tiles, Valley tiles, "Hartsill" brand plain tiles, sand faced, Pressed, Ornamental ditto, Hip tiles, Valley tiles.

TILES.

Table with columns: Item, £ s. d., per 1,000 of. Includes Plain red roofing tiles, Hip and Valley tiles, Broochy tiles, Ornamental tiles, Hip and Valley tiles, Random red, brown, or brimled, ditto Edwards, Ornamental ditto, Hip tiles, Valley tiles, Selected "Perfecta" roofing tiles, Ornamental ditto, Hip tiles, Valley tiles, "Rosemary" brand plain tiles, Ornamental tiles, Hip tiles, Valley tiles, Staffordshire (Hanley) Reds or brimled tiles, Hand-made sand faced, Hip tiles, Valley tiles, "Hartsill" brand plain tiles, sand faced, Pressed, Ornamental ditto, Hip tiles, Valley tiles.

OILS.

Table with columns: Item, £ s. d., per ton. Includes Rapeseed, English pale, Ditto, brown, Cottonseed, refined, Olive, Spanish, Seal, pale, Cocoanut, Cochim, Ditto, Ceylon, Ditto, Mauritius, Palm, Lagos, Ditto, Nut Kernel, Oleme, Sperm, Lubricating, U.S., Petroleum, refined, Tar, Stockholm, Ditto, Archangel, Linseed Oil, Baltic Oil, Turpentine, Putty (Genuine Linseed Oil), Pure Linseed Oil, "Stouty" Brail.

GLASS IN CRATES.

Table with columns: Item, £ s. d., per 1,000 of. Includes English Sheet Glass, Fourths, Thirds, Plated Sheet, Hartley's English Rolled Plate, Figured Rolled, Reponsine, Rolled Sheet.

VARNISHES, Etc.

Table with columns: Item, Per gallon. Includes Fine Pale Oak Varnish, Pale Copal Oak, Orange Copal Oak, Superfine Pale Elastic Oak, Fine Extra Hard Church Oak, Superfine Hard-drying Oak, Fine Elastic Carriage, Superfine Pale Elastic Carriage, Fine Pale Maple, Finest Pale Durable Copal, Extra Fine French Oil, English Flatting Varnish, White Copal Enamel, Extra Pale Paper, Best Japan Gold Size, Best Black Japan, Oak and Mahogany Stain, Brunswick Black, Berlin Black, Kottmuller, French and Brush Polish.

STONE.

Table with columns: Item, £ s. d., per foot cube. Includes Red Mansfield, Darley Dale, Red Corshill, Closeburn Red Freestone, Ancaster, Greenhill, Beer, Chitmark, Hard York, Do. 6 in. sawn both sides, landings, random sizes, Do. 6 in. slab sawn two sides, random sizes.

The Sutton trustees have decided to apply part of their trust fund to the erection of about 250 workmen's houses at Basington, near Bristol. At the last meeting of the Arlethoath Dean of Guild Court plans were submitted by Messrs. M. C. Thomson and Co., Ltd., and were approved, for an extension to their factory at Wardmill Works. The additions will comprise a fresh block 90 ft. by 35 ft. The architect is Mr. Hugh Gavin.

TO CORRESPONDENTS.

We do not hold ourselves responsible for the opinions of our correspondents. All communications should be drawn up as briefly as possible, as there are many claimants upon the space allotted to correspondents.

It is particularly requested that all drawings and all communications respecting illustrations or literary matter, books for review, etc., should be addressed to the Editor of the BUILDING NEWS, Edinham House, 1, Arundel Street, Strand, W.C., and not to members of the staff by name. Delay is not infrequently otherwise caused. All drawings and other communications are sent at contributors' risks, and the Editor will not undertake to pay for, or be liable for, unsought contributions.

*Drawings of selected competition designs, important public and private buildings, details of old and new work, and good sketches are always welcome, and for such no charge is made for insertion. Of more commonplace subjects, small churches, chapels, houses, etc., we have usually far more sent than we can insert, but are glad to do so when space permits, on mutually advantageous terms, which may be ascertained on application.

When favouring us with drawings or photographs, architects are asked kindly to state how long the building has been erected. It does not matter how nor is much good to illustrate buildings which have been some time executed, except under special circumstances.

Telephone: Gerrard 1291.

Telegrams: "Timeserver, Strand, London."

NOTICE.

Bound copies of Vol. CVIII are now ready, and should be ordered early (price 12s. each, by post 12s. 9d.), as only a limited number are done up. A few bound volumes of Vols. XXXIX., XLII., XLV., XLIX., LI., LIII., LXI., LXIII., LXV., LXVII., LXVIII., LXIX., LXXI., LXXII., LXXIII., LXXIV., LXXV., LXXVI., LXXVII., LXXIX., LXXX., LXXXI., LXXXII., LXXXIII., LXXXIV., LXXXV., LXXXVI., LXXXVII., LXXXVIII., LXXXIX., XC., XCI., XCII., XCIII., XCIV., XCV., XCVI., XCVII., XCVIII., XCIX., C., CI., CII., CIII., CIV., CV., CVI., and CVII may still be obtained at the same price; all the other bound volumes are out of print. Most of the back numbers of former volumes are, however, to be had singly. Subscribers requiring any back numbers to complete volume just ended should order at once, as many of them are run out of print.

Handsome Cloth Cases for binding the BUILDING NEWS, price 2s., post free 2s. 4d., can be obtained from any Newsagent, or from the Publisher, Edinham House, 1, Arundel Street, Strand, W.C.

TERMS OF SUBSCRIPTION.

One Pound per annum (post free) to any part of the United Kingdom; for the United States, £1 6s. 6d. (or 6dols. 30c. gold); to France or Belgium, £1 6s. 6d. (or 33fr. 20cs.); to India, £1 12s. 6d. To any of the Australian Colonies or New Zealand, to the Cape, the West Indies, or Natal, £1 6s. 6d.

Our Direct Subscription Agents for Australia are Messrs. E. T. Kibblewhite and Co., Printers and Publishers, 19, York Chambers, 105, Liverpool Street, Sydney, New South Wales; for Japan, The Maruzen Co., Ltd., 114-1, Nombashi Tori Sanjome, Tokyo; who will receive subscriptions at £1 6s. 6d. per annum on our account. Copies of the paper will be sent by us direct to the subscribers' address.

The special rate to Canada is £1 3s. 6d., 5dols. 75c. for 12 months, and 11s. 11d. 2dols. 00c. for 6 months. Our Direct Subscription Agents for Canada are Messrs. Sells, Ltd., 302, Shaftesbury Buildings, McGill Street, Montreal, who will receive subscriptions at £1 18s. 6d. per annum, on our account.

Cheques and Postal Orders to be made payable to THE STRAND NEWSBEE COMPANY, LIMITED, and crossed London County and Westminster Bank.

ADVERTISEMENT CHARGES.

The charge for Competition and Contract Advertisements, Public Companies, and all official advertisements is 1s. per line of Eight Words, the first line counting as two, the minimum charge being 5s. for four lines.

The charge for Auctions, Land Sales, and Miscellaneous and Trade Advertisements (except Situation Advertisements) is 6d. per line of Eight Words (the first line counting as two), the minimum charge being 4s. 6d. for 50 words. Special terms for series of six insertions or more can be ascertained on application to the Publisher.

SITUATIONS VACANT AND PARTNERSHIPS.

The charge for advertisements for "Situations Vacant" and "Partnerships" is One Shilling for Twenty-four Words, and Sixpence for every Eight Words after. All Situation Advertisements must be prepaid.

SITUATIONS WANTED.

Advertisements not exceeding Thirty Words, no name of name and address, are inserted under the heading "Situations Wanted," free of charge.

Rates for Trade Advertisements on front page and special and other positions can be obtained on application to the Publisher.

REPLIES TO ADVERTISEMENTS.

Replies to advertisements can be received at the Office, Edinham House, 1, Arundel Street, Strand, W.C., free of charge. If to be forwarded under cover to advertiser, an extra charge of Sixpence is made (see Notice at head of "Situations.")

Advertisements for the current week must reach the office not later than 3 p.m. on Tuesday. Front page advertisements and alterations or stop orders for serial advertisements must reach the office by first post on Monday to secure attention.

RECEIVED: L. F. Co., Ltd.—W. C. W. H. S., and Son, W. F. S., and Co., Ltd.—F. E. P., Ltd.—S. H. B., Ltd.—W. Bros.—Dr. K. ROMEO, Acc.

ZEPPO, Thanks, etc.

J. R. S.: Yes, if you mean a measured drawing.

P. C.: You can see some very good samples of art metal door furniture, and all British made, at Kaye's, 93, High Holborn, W.C.

GREEN: The best system for your purpose is the Simplex led glazing made by Grover and Co., Ltd., Wharf Road, City Road, N. There is no lead, iron, or putty used with it.

M. B. (Cheltenham): Illustrations of the arms of the cities and boroughs of England and Wales are given in a volume of election statistics published by Robert (Dean and Son, Fleet Street, E.C.). Municipal coats of arms, more particularly the modern ones, are often crude, unartistic, and unforlorn. Many have been assumed without official authorisation. A list of the mottoes of municipalities, universities, and City companies is given in Jerk's Reference Book, pp. 807-10; but it is incomplete. Among the omissions we observe that of Ipswich.

POST LETTER TO YOUR DOOR.—The interruption of regular and punctual traffic and unmanageable shortage of labour in the distributive facilities of the news trade is causing much disappointment to readers of our own and similar journals. Wherever this is so and difficulty is experienced in obtaining THE BUILDING NEWS punctually on Wednesday morning, we will send a copy post free direct to my reader's address on receipt of 4s. 6d. the amount of the quarterly subscription. Readers away in holiday, or in camp, can also have single copies sent them post free to any address on receipt of four p. m. stamps.

TO ARMS!

4th Battalion ("Architects") Central London Regiment Volunteers.

Recruits are urgently needed for the Regulars, Territorials, and Volunteers. Intending recruits should apply to Battalion Headquarters, where they will be advised as to the branch of the Service to which they are best suited.

ORDERS FOR THE WEEK BY LIEUTENANT-COLONEL A. W. WARDEN.—SPECIAL PARADE

Wednesday, 22nd inst., the Corps will parade at new Drill Headquarters, Chester House, Lech-ston Place, S.W., 7.15 to 7.45 and 8.15 to 8.45.

GENERAL PARADE.

Tuesday, 25th inst., at the new Headquarters, Chester House, Lech-ston Place, at 3 p.m.

DRILLS AND PARADES.

"A" Company—Tuesdays, Miniature Range, Gas Light and Coke Company's premises, Monk Street, Westminster, 5 to 8.30 p.m.

Thursdays—signalling at Chester House. See orders from Acting Battalion Signaling Sergeant Chubb.

"B" Company—Miniature Range and Company Parades as for "A" Company. See orders at local Headquarters.

"C" Company—See orders local Headquarters, Pavilion A.A. Athletic Ground, Boreham Wood.

"D" Company—Platoon and Section Drill at Mercer's School, Holborn, Tuesdays and Thursdays, 6.45 p.m.

SCHOOL OF ARMS.

Special note.—After date of these orders the School of Arms will be held at new Drill H.Q.'s, Chester House, Lech-ston Place, Westminster. Instruction in bayonet fighting, gymnastics, physical drill, boxing, and single sticks on Tuesdays from 6 to 8 p.m.

RECRUIT DRILLS.

"A" Company—Chester House, 5.15 and 6.15 Wednesday and Friday.

"B" Company—Dalwich College, Mondays 8 to 10 p.m. and Thursdays 6 to 8 p.m.

"C" Company—Boreham Wood and Elstree district Headquarters A.A. Athletic Ground, Boreham Wood. For full particulars apply to Alan Potter, Gray Gables, Boreham Wood, Herts.

"D" Company—Mercer's School, Tuesdays and Thursdays, 6.45 p.m.

CORRESPONDENCE.

Special attention of members is drawn to the fact that correspondence should be answered by return. If this is not attended to the office work of the Corps is immensely increased. Enrolment forms of new members and all correspondence not referring to recruiting for the Army or to financial matters must be addressed to the Adjutant, 10, Conduit Street, W., and regarding recruiting for the Army to the Recruiting Officer at Battalion Headquarters, and regarding accounts and subscriptions to the Paymaster, W. R. Hughes, 146, Doshwood House, E.C. By Order,

I. E. GUTHRIE, Adjutant
BATTALION HEADQUARTERS,
15, TEFION STREET, WESTMINSTER, S.W.

The opening meeting of the twentieth session of the Glasgow Architectural Craftsmen's Society will be held at the Royal Technical College, Glasgow, on Friday evening at 7.45 p.m., when Mr. Robert Moor Wright will deliver his presidential address.

FOR

Olivers' Seasoned Hardwoods,

APPLY TO—

W.M. OLIVER & SONS, Ltd.,

120, Bunhill Row, London, E.C.

TENDERS.

*Correspondents would in all cases oblige by giving the addresses of the parties tendering—at any rate, of the accepted tender; it adds to the value of the information.

BATTERSEA.—For the supply of creosoted softwood blocks for flooring the central buildings of the Metropolitan Water Board:—

Bart, Boulton, and Haywood, Ltd. £387 10 0
(Accepted; seven tenders received.)
For flooring materials at same buildings:—
King and Scarborough £212 0 0
(Accepted; five tenders received.)

BARNES, S.W.—For the supply of wrought-iron unclimbable fencing at Barnes reservoir, for the Metropolitan Water Board:—

Bayliss, Jones and Bayliss, Ltd. (accepted) £274 17 6

BEDDINGTON.—For the supply and erection of a steam pumping engine, Hanford Mill pumping station, for the Bedfordshire Urban District Council:—

Evans, J., and Co., Ltd., Cnlwell Works, Wolverhampton (accepted).

PREST.—For providing a covered way from nurses' home to the pavilion at the institution, Deming, for the tuberculosis committee, Messrs. Kaye, Parry, and Ross, architects:—
McKenna and Sons (accepted) £247 10 0

BETHNAL GREEN, N.E.—For the supply of electric lamps, for the guardians. Accepted tenders:—

Metal-filament lamps:—
Pope's Electric Lamp Co., Ltd., 700 at 1s. 3d. each.
Tantalum lamps:—
Drake and Gorham, Ltd., 309, at £19 8s. 6d.

CHOBHAM.—For the construction of a new footbridge over River Bourne, for the Chertsey Rural District Council. Mr. C. G. Atkinson, P.A.S.I., M.I.M. and C.E., engineer and surveyor:—

Monro and Co., London £85 0 0
Burrows, W., Chobham 49 11 6
Allman, G., Adlestone 48 0 0
Warren, Parker and Co., Bafflet 39 19 0
Herring and Son, Chertsey 38 12 9
(Accepted.)

FINSBURY, E.C.—For installing heating apparatus at the Winchester Street School, for the London County Council:—

Deane, L., and Beal, Ltd., 3, Monument Street, London Bridge £745 0 0
May, J. and F., 39, Wheatsheaf Park 729 12 0
Unsigned 693 10 0
Brightside Foundry and Engineering Co., Ltd., 28, Victoria Street, 649 0 0
Palvokur and Sons, 90-91, Queen Street 608 0 0
Yall and Brickett, Ltd., Minton Road, Southwark 620 0 0
Cannon, W. G., and Sons, Ltd., 107, London Road 612 0 0
Voughan, J. W., and Co. (1914), Ltd., 22, Cross Street, Islington 548 10 0

HARGRAVE.—For repairs to roof at the winter gardens for the town council:—

Standard Patent Glazing Co., Bow-bury (accepted) £430 16 2

HULMEAD, N.B.—For alterations and repairs to dwelling-house. Mr. W. Davidson, Ellon, architect. Accepted tenders:—

Carpenter work:—
Sutherland, C., Hattenerook, Whittrashes £43 0 0
Slater work:—
Macdonald, C., and Sons, Dyce 13 18 0
Mason work:—
Burnett, Alex., and Co., Inverurie 9 18 0

HINDLEY.—For excavating, concreting, and brickwork at the gas-works, for the Hindley Urban District Council, Mr. H. O. Tummins, engineer:—
Lomas, H. and F., Platt Bridge, Wigan (accepted) £145 0 0

LONDON.—For the execution of plumbing work in the southern district during six months, for the Metropolitan Water Board:—
Jones, J. (accepted)

[An extension of existing contract, but on an increased schedule of prices, averaging 25 per cent.]

LONDON, E.C.—For constructing an external iron staircase to the crypt at the Guildhall, for the City Corporation:—

Norris and Co. £153 9 0
Nash and Co. 188 0 0
(Recommended for acceptance.)

OAKDALE.—For erection of a Baptist Sunday school at Oakdale Model Village, near Blackwood, Mon. Mr. A. F. Webb, Blackwood, architect:—

Lloyd and Hopkins £1,098 0 0
James, S. 1,086 0 0
Lewis, F. and R. 1,006 0 0
Walters Bros. 952 0 0
Jones, R., Caerphilly (accepted) 925 0 0

THE BUILDING NEWS

AND ENGINEERING JOURNAL.

Effingham House.

CONTENTS.

The Protection of Buildings Against Aerial Bombs	345
Dutch Photographs at the Camera Club	344
Mont S. Michel, the Abbey of the Archangel, and its Sea-Girt Town	345
The Artists' Rifles	347
Associated Portland Cement Manufacturers (1900), Ltd.	347
Malvern Priory Church	348
The Professional Classes Relief Fund—Christmas in-Wartime Sale	348
Obituary	348
Currente Calamo	348
Our Illustrations	349
National Competition, Examinations in Art, and Awards in Art, 1916	350
A Year's Building in Glasgow	367

Correspondence	367
Professional and Public	368
Competitions	368
Water Supply and Sanitary Matters	368
Parliamentary Notes	368
Building Intelligence	369
Trade Notes	369
Statues and Memorials	369
Clubs	369
Our Office Table	370
To Correspondents	371
To Arms	371
Meetings for the Ensuing Week	371
Latest Prices	372
Tenders	375
List of Competitions Open	375
List of Tenders Open	375

Strand, W. C.

OF ILLUSTRATIONS

The Editor's Room, "Daily Chronicle," 101, F.C. for the United News paper, Limited, Messrs G. Reymond Farrow, A.R.I.B.A. (London), S. E. Turner, Architects	368
Some Model and Travelling Student Trip Section in Italy. Interior of Santa Annunziata, Florence, and the Villa di Papa Giulio, Rome. In Architect. Drawn by Mr. Alck G. Horsnell, Some Modelist and Tete. Prisoner	369
"The New House" Airie Gardens, Campden Hall, W. View and Plan. Mr. H. M. Fletcher, M.A. Cantab, F.R.I.B.A., Architect	371
Overway, Tibbald, Surrey. View and plan. Mr. H. M. Fletcher, M.A. Cantab, F.R.I.B.A., Architect	371
William and Mary Bantons, From Fritton Manor, Banbury, Oxon, and other pieces of Old English Furniture drawn by Mr. W. J. White	375

THE PROTECTION OF BUILDINGS AGAINST AERIAL BOMBS.

It is certainly time to think seriously about this matter, as all will agree who have visited the devastated districts in London everybody knows of but nobody must mention. The first idea that presents itself in the way of protection against aerial bombs takes the form of horizontal strata of steel netting. In diagram Fig. 1 are

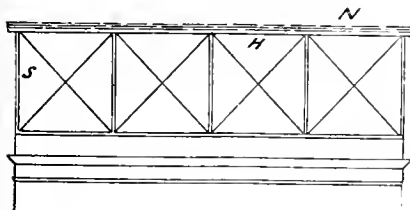

FIG. 1.

stanchions, S, carrying beams, H, that support several layers of steel lattice, N. A suitable bearing upon copings, etc., must be found for a sole-plate, the stanchions riveted and bolted up, with, say, diagonal strutting as indicated. The netting offers a more or less elastic reception to a falling body. The possible methods of resisting impact seem to resolve themselves into the armour-plate method, the elastic netting, and the earthworks system, as used in defence against gun and rifle. To meet mere impact the principle of elastic reception seems sound. A man may jump from the roof of the Crystal Palace into a net—we have ourselves witnessed the feat—and receive no hurt. The stanchions in Fig. 1 are assumed to be rigid, and the netting firmly held, but this latter might conceivably be loosely held and so offer an

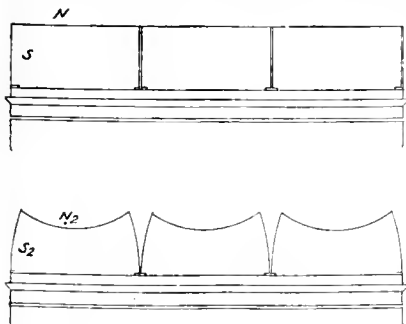

FIG. 2.

increased "give" to any falling mass; and the idea suggests itself (Fig. 2) that in place of rigid stanchions such might be arranged to yield somewhat, as diagrammatically indicated, so that the original position of stanchions S, holding netting N, might on impacting force assume posi-

tions such as S₁ N₁. Somewhat similarly, the netting N, Fig. 3, stretched over rollers, R R, in the frame, F, is kept taut by springs, SS, and on impact of mass at N₂ the netting gives much as in the case of the aerobol jumping from a height into a rope net. Again, following the elastic idea, in Fig. 3, the assumed bomb-proof platform, B, is directly supported by helical springs, H H, descending with gradually increased resistance, as indicated at B₁, on impact of falling mass. In this last example of elastic reception for a falling body the impact is met in a manner very similar to that in which recoil forces are absorbed in modern guns.

The next idea is associated with the principle on which military earthworks are constructed. The employment of earth or sand in sufficient layer is an obvious recourse, and must be esteemed one of the most practical. The projectile is arrested by a braking action, gradually—if we magnify infinitesimals for easier mental conception of what occurs per short time

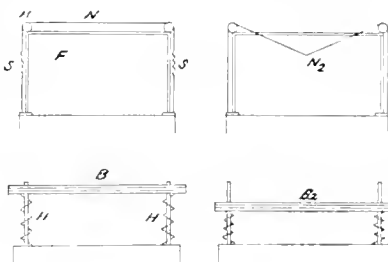

FIG. 3.

interval—compacting the earth and in part losing energy by conversion into vibration and agitation among earthy particles. Fig. 4 shows two rows of sand-bags, S, supported by strong steel mesh or netting, N. If the top of a building has many and varied eaves, as suggested in the diagram, such a bomb-resisting platform would need to be raised up on stanchions, such as indicated, finding suitable bearing on copings, etc., and, in this case, a considerable weight of sand would have to be provided for. The stanchions are secured to suitable longitudinal bearers, or sole-plates, and diagonally struted, with beams carrying suitable strong steel mesh or lattice.

However interesting it may be to speculate on special elastic systems of receiving falling bodies, such an arrangement as sketched in diagram Fig. 4 strikes one as practical. In providing such a protective covering for a building, the points of support for stanchions would have to be carefully selected, and the whole designed to support the dead load of sand, etc., and an assumed force

of impact. The stanchions, plates, beams, etc., would be riveted and bolted up so as to form a suitable framing to receive one or more layers of strong steel lattice.

On these general lines Fig. 5 is a suggestion for a bomb protecting covering for a theatre. Stanchions are carried on suitable sole-plates on the copings, etc.,

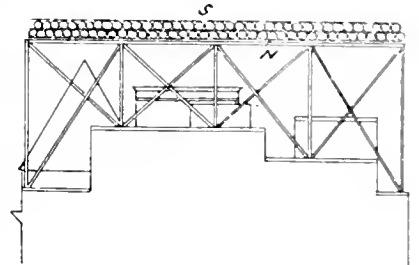

FIG. 4.

and lattice girders, L, suggest themselves to bridge over at right angles to the line of section as taken to represent, in diagram, the theatre auditorium, T. The girders and beams, it is suggested, would uphold one or more layers of stout steel netting, N, to carry a sufficient depth of sandbag defence, S, against impact. Sand is a cheap material to provide for the purpose. At somewhat greater cost, but well repaid by its many advantages, we should suggest slag-wool, the fire-resisting product of waste from blast furnaces. Quite incombustible, it presents a means of resisting fire outbreak. Where sand-bags are provided for receiving impact, they should have some adequate protection from rain, in order that the material may not be washed away. Although in the sketches shown in Figs. 4 and 5 the

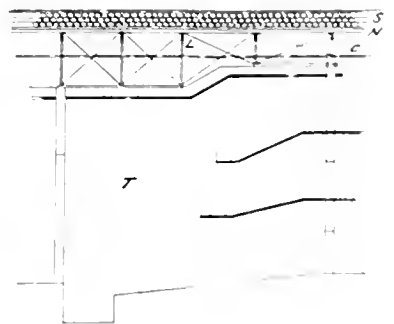

FIG. 5.

main idea is to convert the energy of impact into sand packing, condensing, disturbance, and agitation, it is conceivable that some elastic support might be arranged for the bomb-proof slag-wool or sand platform. Slag-wool saves in weight,

... which this ... used, it ... energy-absorbing ... tightly packed, the best ... principle involved.

When, therefore, we have reviewed and ... special devices for ... platforms, it would ... most practical idea is ... and this seems to be ... suitable steel posts ... supporting a layer of steel ... upon which rests the slag-wool ... In arranging for ... roof covering, the first ... to ascertain the points ... carrying the platform, and ... distribute the weight by means of careful placing of ... steel supports. Obviously the ... must be absolutely ... must be as nearly as possible ... and, in passing, the idea of ... water spray or "sprinklers," ... quenching installation, ... impact upon the platform ... to be distributed ... the bomb-resisting ... and, assuming a partial rupture ...

If the first line of defence, a further layer ... steel lattice might form a kind of subsidiary defences catcher. Where a strong concrete slab roof exists it suggests itself that such might be covered ... and some way above this, possibly, a plain but strong stratum of steel meshing. If we accept the principle of earthworks defence, assisted by a measure of elasticity, as the simplest, most suitable, and most effective means of arresting an aerial bomb, resisting explosive force, and quenching possible fire outbreak, the mere protection against impact is a question for experts, who would be able to lay down the needful strength and depth and details of protection on the general assumption of a mass of certain assumed weight falling under the constant accelerating force of gravity for an assumed number of seconds. From these data an estimate of the needful strength in the steel construction and netting could be made.

Under this general system of bomb-proofing buildings, the stanchion construction would be strong and rigid, well tied, stayed, and braced, because it seems essential that the base supporting the slag-wool mass should hold intact under any impulsive force that might be communicated to the beams by way of the strata of the bomb- and fire-resisting material. That the platform itself, carrying the netting and the fireproof energy-absorbing material, might be sustained by some form of elastic springs seems a possible improvement; but it would appear essential that the main steel framework, necessary, no doubt, as a rule, to carry the bomb-proof platform above the various upper features of a building, should be of such strength as to remain intact under all stress and circumstance. It is conceivable, possibly, that a defence might be designed to suffer, designedly, a certain distortion, the partial wrecking of the defence saving the object to be defended. A bicyclist, having a "spill," and anxiously examining his machine for damage, may take heart if he discovers that the handle-bar is turned round in its socket. Such an eventuality generally means no damage to the bicycle; for the reason that the force of impact is absorbed by the work of turning round the handle-bar against a considerable frictional resistance. Again, as bearing upon the same idea, some years back a man, carrying a chimney stack, lost his "wheel," and fell through a slate roof ... received little injury, and if we were to look at the posi-

tion, to another light, he did not injure the ground, because his impact was mainly absorbed in smashing the roof. It would be preferable to suffer the destruction of a defence if by so doing we saved the building.

The individual is advised to resort to the basement. He might reinforce his basement premises. Fig. 6 shows a stratum of slag-wool, S, between light netting, N, and held up by one or more layers of strong steel lattice, sustained by a few steel joists and stanchions wedged

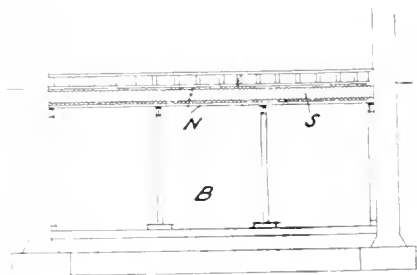

FIG. 6.

up from the basement floor, B; and, in Fig. 7, we are thinking of a fireproof theatre-curtain, S, unrolled from drum D, over roller, R, and shielding a whole house-front, or over windows, as S; but inasmuch as brick walls stop scattered debris, it seems to result that any nervous houseowner might put isolated window screens, S, as protecting vital parts, and offer all that any such general curtain as S might accomplish. After reviewing the various theories above put forward, it would seem that all that might be necessary can be accomplished with slag-wool and steel netting. Discarding as not obviously adaptable or practical purely elastic means of bomb-catching, we arrive at the conclusion that stout steel framings carrying strong steel lattice covered with slag-wool are practical means of protection. We need the right kind of steel

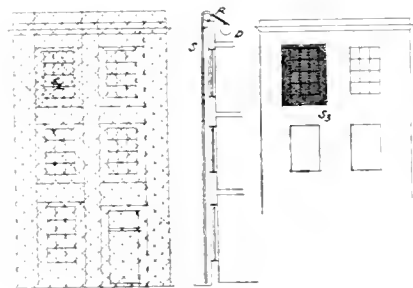

FIG. 7.

netting and the right kind of slag-wool, a material liable to variation in quality. The first requisite is that it should be absolutely free from combustible elements. McNeil's slag-wool is a suitable material, of the highest repute, perfectly incombustible, and peculiarly adapted for the present duty. The slag-wool is lightly compacted and sustained over voids by very strong steel lattice. From the suspended steel netting we gain elasticity; from the slag-wool that condensing and packing action characteristic of bullet-stopping in earth; so that the combination is most excellently suited for the reception and absorption of impulsive force, while, moreover, slag-wool is the best-known protection against fire and heat transference.

Mr. William MacDonald of the surveyor's office, has been appointed borough surveyor and sanitary inspector for Aberfeldy.

DUTCH PHOTOGRAPHS AT THE CAMERA CLUB.

A select and very interesting collection of photographs by members of the Netherlands Club, brought together by the secretary, Mr. F. L. Verster, of Amsterdam, is on view at the Camera Club, 17, John Street, Adelphi, W.C. The subjects are varied—all-lighted courtyards, in Old Amsterdam (no fewer than seven exhibits are shown under this title), peasant girls and women with white head-dresses and ample petticoats and skirts, maids at work in scrupulously clean kitchens, tulips and roses, farmyards, canals and fields, all provide topics. One of the best pictures is No. 3, a gum bichromate by J. Zeegers, a courtyard opening into a narrow lane in Amsterdam, which has the effect of a fine photogravure. No. 1, "Veere," shows a fourteenth-century village church with stumpy western tower finished with a flat cupola; in front of this is an irregular line of grey cottages, and on the common in the foreground are a woman and children, their faces turned from the camera in natural attitudes. "The Shepherdess," No. 4, by Adrian Boer, is a woman with a couple of milch goats in an avenue reminiscent of Hobbema's masterpiece in Trafalgar Square. The same artist photographer shows some clever gum prints of rural landscapes in Nos. 12, 14 and 16. Rembrandtesque effects of illumination of a single feature in an Amsterdam street by a street gas-lamp are obtained by J. Huysen in Nos. 9 and 10, who dexterously manages to evade the technical difficulty of the intense glare of newly fallen snow on roadways and roofs in his No. 5, "A Dutch Village." A well-composed picture is "Refugees," No. 15, a gum print by A. S. Weinberg. Crouching beside a ruined house in the rain a woman tightly holds her child, while far to the right, across a desolate flat landscape, is seen the tower of a village church. A similar subject has been selected by H. Berrsenbrugge in "Brabant." Here the velvet-like texture of the brickwork in the cottage sets off the impressionist character of the fields to the right. Of the three costume portraits by R. Polak, Nos. 20, 21 and 22, the best is the first-named, the head of a woman wearing an elaborate white linen cap and gophered ruff of Elizabethan dimensions, and pearl pendant. Two bromoids of "Bruges," by J. Huysen, Nos. 27 and 44, give unfamiliar aspects of the city, and an attractive bromoil by B. Zweers, No. 31, one of two in Rome by this photographer, is a felicitous rendering of the "Porta Maggiore." Of the kitchen interiors by G. C. Kooyker, No. 39, a servant girl ironing, is the best; near by is "Washing Day," No. 34, by A. B. Slier, who, in No. 35, "Old Amersfoort," makes a taking picture of the church steeple of that stagnant old-world town on the Eem. Among the still life photographs, each as direct, clear and well-defined as the drawings in a botanical guide, are "Double Tulips," No. 2, by J. Zeegers, and "Leaves," No. 45, by G. C. Kooyker. The exhibition, which will well repay a visit, will be open every day from 11 till 5 until October 23.

H.M. the King, as Emperor of India, has made a permanent loan to the Victoria Memorial Building at Calcutta, built from the designs of Sir William Emerson, past-president, R.I.B.A., two of his Oriental oil paintings of great value and interest, the subject of one being "Shah Zameen, King of Oude, Receiving Tribute," painted by Robert Home, and the other "Nawab Walajah Mahomed Ali of Arcot," by G. Willson. The dimensions of these works of art are 96 by 62 and 95 by 57 inches respectively. The pictures are expected to arrive in Calcutta very shortly.

MONT S. MICHEL, THE ABBEY OF THE ARCHANGEL, AND ITS SEAGIRT TOWN.

At the Royal Photographic Society's Exhibition in the gallery of the Royal Society of British Artists, in Suffolk Street, Haymarket, S.W., yesterday (Tuesday) evening an interesting lecture on the abbey and town of Mont S. Michel,* on the eastern verge of the Normandy coast, was given by Mr. H. W. Fincham. The chair was occupied by Mr. A. Herbert Lisett, F.R.P.S. The address was illustrated by one hundred and twenty admirable slides from photographs, taken by the lecturer, by special permission of M. Enlart, on the recommendation of M. Paul Gout, the Government architect to the fabric.

Robert Louis Stevenson said:—"Mankind was never so happily inspired as when it made a cathedral. . . . 'Tis the best preacher itself, and preaches day and night; not only telling you of man's art and aspirations in the past, but convicting your own soul of ardent sympathies, or rather like all good preachers, it sets you preaching to yourself and every man is his own doctor of divinity in the last resort." To-night I want to show you some photographs I have made and tell you something about one of the most picturesque of these sermons in stone—Mont S. Michel, the Abbey of the Archangel. And while I show you some pictures of its varying aspect from the bay, I will give you a very brief account of its history. It stands in the great bay of Cancale off the coasts of Normandy and Brittany, and is easily reached by crossing from Southampton in one of the fine boats of the London and South-Western Railway to the French port of St. Malo, and thence by rail to Pontorson, where we change on to a light railway, and after a few miles run to the coast we cross the three miles of embankment built over the sand and alight just outside the fortifications at the foot of the rock. Long before any buildings appeared upon the rock it was known to the Romans, who called it Mors Jovis, standing in the Forest of Scissy, about three miles from the sea. Constant erosion and subsidence with, tradition says, an earthquake drove the coast line back until the forest disappeared, and the rock stood alone, surrounded by the sea, which at low tide left bare miles of dangerous quicksand, so that the rock became known as Mont S. Michel "in periculo maris," or, in peril of the sea. Tradition tells us how, early in the eighth century, the Archangel appeared to Aubert, the Bishop of Avranches, and ordered him to build a sanctuary on the rock in his honour, and in the autumn of the year 709 the Abbey was started with twelve canons in residence. This original building lasted until 992, when much rebuilding took place, and the Abbey was enlarged. And so through the centuries the Abbey continued to grow, and thousands of pilgrims brought wealth and fame to the monks. Here on the north side we see the face of the rock covered with a little wood, the sole remaining relic of the ancient Forest of Scissy. Towering above it we see the building of the 13th century, which to this day has been known as "The Marvel," so wonderfully has it grown up from the rock, and such beautiful halls does it contain. At the foot of the wood we see a little building which covers the well of St. Aubert, which until the seventeenth century yielded the only water supply to the Abbey, and was reached from above by a fortified staircase. The Abbey buildings themselves were strongly fortified, but as the little town grew at its foot and the aggressive Englishmen were ravishing the neighbouring coast and constantly threatening the Mount, it

was necessary to strengthen the town. In the fourteenth and fifteenth centuries the long range of bastions and towers which you see at the foot of the rock were constructed, with their battlements and strongly guarded gateways, and the town was a strongly fortified place. And so its many enemies, including the English, who long maintained a vigorous siege, were never able to capture this little town or the Abbey above. Having not respected the picturesque aspect of the rock from a distance, let us take advantage of the low tide to ramble round its foot and examine the fortifications before we enter the town. And at the south-west corner we see the Tower of the Windmills, where the abbot ground his corn and kept the main store of the provisions of the monastery. The large square building was erected as a barracks, when the great Revolution having driven out the monks, the whole place was turned into a prison. At the western point of the rock adjoining the barracks stands the Gabriel Tower, with its many wide-mouthed embrasures for cannon and a little stone sentry box, now used as a lighthouse, overhanging the battlements; in the middle of the tower is a hollow shaft for the purpose of carrying off the fumes of gunpowder. And in the deeply shadowed angle of the wall is a strongly guarded little sally port, from which the defenders could issue and take in the rear any enemy attacking the walls. As we turn to the south we come upon the little Chapel of St. Aubert perched high upon a great rock, its only approach being a flight of stone steps from the sandy beach, and entirely inaccessible at high tide. When St. Aubert started to build his church upon the summit he was much troubled by a great rock too large to remove, and which obstructed the commencement of the work. But one day the Archangel appeared in the guise of a little child, and with one lift of his bare foot sent the rock hurtling down to the sands below, and this chapel was built on the top of it in memory of the deed, and possibly to prevent any more such dangerous flights. From the little platform at the top of the steps we are able to look into this miniature chapel. When St. Michael ordered Aubert to build the church on the rock the Bishop expressed considerable reluctance to make a start, and the Archangel, to convince him that it would be dangerous to delay the job, touched him on the head with his finger and made a great hole in his skull. This settled the matter, and the Bishop set to work at once. At Avranches Cathedral across the bay there is still preserved with great veneration the skull of St. Aubert, and you can see the hole where the Archangel's finger entered. The curious thing about it is that however the hole was made it shows clearly that the owner of the skull lived for many years after, for you can distinctly see the thickening of the bone around the edge of the hole as nature tried to repair the damage. From the rock of St. Aubert's Chapel we reach the north side of the mount, with its little wood growing down to the water's edge, and looking out across the bay to the north we see another rock somewhat smaller than the Mount known as Tombelaine. As the tide recedes we can walk across the hard sand the bare two miles which separate the rocks. Care must be taken over this walk, for when the tide turns it rushes across the sand with marvellous speed, the sands become quick, and there is little hope for anyone who should be caught in this way. But having reached the rock we scramble to the summit, and here we find the remains of the fortifications which the English built and used as their headquarters during the many years of the fourteenth and fifteenth centuries when they were trying, without success, to capture the Mount. Returning from Tombelaine, we turn the eastern corner of the Mount close to the North Tower, the most picturesque of the many towers which stand at intervals along the massive wall of the town. All along the top of the walls you will notice how the English coats are corbelled out, increasing the depth of the walk on the walls, and forming what are known as machicolations, for between each stone corbel is a slot open above, through which the defenders could pour molten lead, boiling oil, café au lait, or any other attractive fluid upon the heads of

besiegers attacking the town. Still walking westward we approach the Bay Gate, the largest and most important gateway, and beyond it is the Bay Tower, the last of the towers of the town, which is reached by a gallery of arches, the entrance to the gateway. Here we see the remains of a wall, washed by the incoming sea, and a little piece of Tombelaine away in the distance. You see how the narrow channel has come right on to the wall, and that many of them form a peacock's pattern on their back doors. Another bit of the wall, flanked by the Tower of Liberty and topped by the pleasant little Hotel of the White Tower, with its saloon level with the top of the wall, where one can sit at dinner and eat up the many lights and shades of the golden sands, and as the sun goes down see the shadow of the rock creep right across the green meadow. And then we come to two towers close together, the Tower of the King and the Arcade Tower. These towers are elevated in height by two or three modern causeways, which here are about 20 ft. above the level of the sand; which, although it gives a constant access to the Mount, is causing the sand of the bay to silt up so rapidly that in a few years the Mount will be standing in green fields instead of being in the peril of the sea. I understand that the French Government have at last recognised this danger, and intend to remove a portion of the dune, in order that the sea may again circulate right round the rock.

And now we have arrived at the outer gate of the town, known as the Aunee. At high tide the sea washes right up into this gateway, and one has to enter the town in a boat. On the rocks above a great boulder sticks out in a threatening manner, although it has been so for many centuries. It is called La Gire, and to this day the fishermen of the Mount salute the stone as they go out to sea, and again on their safe return with their catch. Passing through the gate, we turn to see the little guard-house up the steps, and the embattled wall on the right from which guns could cover the entrance to the town. This gateway was closed by a massive oak door, hinged at the top so that when lowered its weight would be a great assistance in its defence. On our right as we enter the gate we pass two curious old guns, which are called the Little Michaels. On June 17, 1434, the English, under the Earl of Somerset and Lord Scales, with 400 men attacked the Mount, but after a terrible fight they were driven off and left behind them these two great cannon, of which the Montois are still very proud. But a few yards further on we come to the Barbican, or Boulevard Gate, the second of the three gates which guard the entrance to the town. Here every visitor, be he pilgrim or soldier, beneath the rank of a Prince of France had to leave all arms he carried before he could approach the last defence of the entrance. This third gate is known as the Gate of the King, and it was very strongly fortified; before it was a moat and drawbridge, and then it had an iron portcullis, which still hangs in the arch, while above a covered passage had machicolations down which the defenders could pour unpleasant fluids upon the heads of those attacking the gate. The moat is now filled up, and on either side are the hotel buildings of the Pontal Company, once kept by the Widow Pontal. This is the most popular and expensive hotel in the street there are several small and comfortable hostels still carrying the old signs of the middle ages, such as The Swan, The White Cross, The Three Sannets, The Friary, The Golden Sword, and The White Sheaf. Some of these have the advantage of the drawing-rooms being on the very wall, and a few of them can pass you an ample glass of the wine which old Madame Pontal was so long famous. Passing through this last gate we enter the only street of the town, and turn to see the inner side of the great gate, with its guard room above, now used as the Communal School and for the meetings of the town council. On the left is an interesting half-timbered house, beneath which is the first flight of steps to the ramparts. And we see

* Illustrations and plans of the Abbey and Mount of S. Michel, by the late Viollet-le-Duc, appeared in the BUILDING NEWS for July 14 and August 4, 1871, and a plan of the Mount, a sketch of entrance to the churchyard, and general view by L. J. Jackson, in our issue of July 25, 1894; a double-page sheet of sketches, by Francis Masey, in that for October 14, 1887; La Grande Porte, a drawing by W. S. Betts (accompanying a description of a visit to the Mount by the Society of Architects Sketching Club), April 8, 1910; the Crypte d'Aquilon, from a photograph, September 23, 1892; measured drawing, photograph, and details of cloisters, June 17, 1910; sketch of a crocket from the cloisters, by A. J. Knott, April 8, 1910; and drawing of a leaf capital in the Salle des Chevaliers, by G. A. T. Middleton, September 28, 1906, p. 424.

the tower is a wall and a picture gallery. The tower is called the Tour de la Couronne, and is one of the watch-towers of the town. The street of the town contains many interesting medieval houses and hostels, with their old signs still projecting across the path. Apart from the hotels, the only business done seems to be the sale of souvenirs to the visitors and pilgrims. And many of the shops have for centuries contained the sale of beads and shells and other objects of piety to the crowds of strangers who pass between them. During the day in the holiday season there may be four or five hundred visitors, but with the departure of the last train at six o'clock they are nearly all gone, and the little town of 200 inhabitants is very quiet indeed. What they do in the winter I cannot say, for as all the laundry work goes to Pontorson they can't live as some of the seaside towns are supposed to do by taking in each other's washing. At the shops sell the pilgrim's badge of a metal scallop shell with a figure of St. Michael upon it; but the principal article nowadays is the picture postcard. As the street climbs the rock it narrows like a deep ravine until one can almost touch both sides at once. There is a little hostel which has hardly changed at all since it was built in the fourteenth century. Its interior is most picturesque, and in the dusk of the evening you can see perhaps a score of fishermen and women sitting round a long table with basins of "côte-au-pot," while a woman is tossing améchettes at an enormous stone fire place, with a log fire on the low open hearth. The flickering firelight and the deep, dancing shadows have an effect which is quite Rembrandtesque. The ancient parish church, dedicated to St. Peter, stands halfway up the street, with its chancel carried on an arch projecting over the path. It is an interesting old church of the fourteenth century, and contains some quaint tombs, all carved in the local granite; these are very simple in character, just the deceased's name in bold capitals, with a date, or a chalice and cross standing up about half an inch high, the remaining surface of the stone being sunk below. Here also is the Black Madonna that used to be in the crypt of the Abbey Church, the successor of the statue that miraculously escaped the great fire of 1112. A passage under the chancel leads up to the little churchyard, and close by is the house in which lived Tiphane de Rignenal, the accomplished wife of the great defender of Brittany, Bertrand du Guesclin. This house, although much restored, is very picturesque, and stands in a charming garden perched on a shelf of the rock.

Now we will take a little ramble along the top of the town wall, and climbing the steps by the King's Gate we pass on to the ramparts, where we can look down into the street, and on the left we see the little Tour de la Couronne, and the steep pitched roof of the Tower of the Arcade. The Tower of the Arcade still retains its ancient roof and massive timbers, and the only light comes through the little embrasures and loopholes in the walls. This is a part of the public walk around the walls, and as there is no public lighting of any kind on the rock, it gets very dark in here quite early in the evening. If the visitor takes a walk after dark he is furnished with a paper lantern with a candle in it, which he carries on the end of a stick, which does not help you much as you stumble up and down the many flights of steps which branch off the main street. Here we see the little covered way above the Gate of the King, which hid and protected the defenders while preparing the molten lead and boiling oil which they poured through the machicolations at their feet on to the attackers of the gate below. All the large towers appear to have been modelled similar to the Tower of the Arcade, and here inside the Great Tower we see the upper room now bare to the sky, but still containing a great fireplace round which the guard must have spent many a carousal on wintery nights while the French watched the Mount from the Island of Tombelaine across the bay. You can see the corbels in the wall which carried the roof timbers, and the walk goes on to the top edge of the wall above.

Here from the top of the North Tower we look down on to the Great Tower, and the length of wall between, and here we can see the inside and outside of the machicolations. If you look closely on the path against the wall you can see a row of slots, each of which opens straight down the wall between the corbels on the outer side. Here the old houses are built close against the wall, the other side being in the street two or three stories below. High up on the rock we can look down on to the top of the Gabriel Tower, and beyond we see the little river Cosneson, with its granite embankment, running away inland and forming the boundary between Normandy and Brittany. In the old days this river ran round the east side of the rock, and so included Mont S. Michel in Brittany; now that the river has changed its course the Mount stands in Normandy. From another point we look down on to the town with its charming old houses and little gardens wherever they can obtain a foothold on the solid granite of the rock. Every one of the little gardens is very fully cultivated, and the many granite walls are covered with fruit trees which bear splendidly, owing to their complete protection from the north. And turning we see l'Avancée Gate, with the fishermen's boats awaiting the arrival of the tide. Every cranny of the rock gives a hold to a profusion of wild flowers and shrubs, which cover with glowing colour the warm-toned granite which crops out between. Nestling under the wall of the Abbey is the ancient Auberge, the haunt of the hired soldiers of the middle ages, brought in to assist the monks in their defence of the Mount. The sign of the inn is "La Trui qui File," or, "Now that Spins," an ancient sign somewhat akin to our "Pig and Whistle." July 4 is the great festival of the coronation of St. Michael, and as the Abbey Church has long been desecrated and unused, a solemn mass is celebrated on a piece of waste ground close to the Abbey wall. It is attended by all the clergy for many miles round, and pilgrims come in crowds. At this one there was present the Archbishop of Bourges, with four bishops and some hundreds of priests. After the mass there was a grand procession all round the walls and up the street. The previous night, the eve of the festival, there was another procession after dark, and everyone carried a paper lantern on the end of a stick. The effect was most picturesque, with the many banners and long row of swinging lights as the choir and pilgrims marched along singing "Ora pro nobis, bon S. Michel." All the hotels were crowded, as each village priest brought with him his old lady housekeeper and several of his most important parishioners, and a curious lot of Norman and Breton peasants they are. On the morning of the festival the most ramshackle old vehicles came across the sands from all directions loaded with peasants from the neighbouring villages all bent on getting a blessing from the great archbishop. The suisse, or bundle, at the head of the procession is a most gorgeous individual in a crimson uniform and golden sword-sash, carrying a silver mace and a great golden halberd; then come the choir, with banners of Joan of Arc and St. Michael, incense and candles. The inhabitants of the town decorate their houses with green boughs and flowers. In the little wood on the north side of the rock the ground ivy spreads over the rocks in close grown masses, and this is torn up and hung in the fronts of the houses like curtains. Festoons of flags are hung across the street, and as the procession slowly wends its way up the steep street the whole appearance is very charming. The principal figure is the Archbishop of Bourges, a great personage, and the pilgrims flock to kiss his hand and receive his blessing as he passes by. Turning from the last of the procession as it passes us on the ramparts of the Great Tower, we look up to the Abbey towering high above the houses of the town; on the right is the eastern end of the building called the Marvel, and then we see the many-buttressed church with its tall and graceful fleche, and in front is the dwelling of the abbot. From the North Tower we see the Marvel alone, and the great flight of steps

which lead up to the entrance to the Abbey. This is its north eastern end, and you see the tall windows which light the three stories of wonderful halls it contains. From the north west we see the opposite end of the Marvel, with the walls which are the beginning of a great chapter house which was never built. The three arches in the wall of the top story are in the cloister, and the middle one was to be the door into the proposed chapter house. The gabled building just below the great tower is one of the dormitories of the monks. I am not showing you any plans of the buildings this evening, because it would require a great many to show the arrangement at various levels, and they become very complicated; but these two sections give us a very good idea of the way the buildings cluster around the rock. The Abbey itself was strongly fortified long before the town walls were built. This long flight of steps is its only access, and this is protected by the terrace above. I found it very amusing on a hot afternoon sitting in the shadow of the wall, to watch the amazement of the fat old Frenchwomen who, after toiling up the steep street, turned the corner and saw this great flight of steps between them and their goal. They would stop and puff awhile, and then bravely struggle on in blissful ignorance of the hundreds more steps to be climbed before they reached the top of the rock and the Abbey church. As we near the top of the steps we pass through the Gate of the Barbican, and the actual entrance to the Abbey rises before us. This is called the Châtelet, a tall building flanked by two massive cylindrical towers. It was built by Abbot Pierre le Roy about 1390, and it marks an earlier entrance known as Belle Chaise. The Châtelet, was closed by a heavy portcullis, the machinery for which still exists in the room above the arch. The military governor, who was a separate official to the abbot, was always getting into trouble on the ground that he vexatiously shut the gate too early in the evening and opened it too late in the morning. The entrance hall, or Salle des Gardes, is a fine hall with an enormous fireplace, round which the soldiers of the guard must have spent many a jovial evening in the old days with a great log fire roaring up the chimney. The steps lead up from the hall to the passage to the Almonry, and in the other direction to the long flight of steps to the abbot's house and church. The guides who conduct the visitors over the Abbey have a waiting-room immediately behind this fireplace; they are officials of the French Government, and although they are not above accepting a tip, the whole place is open to visitors every day without any charge. This little passage leads to the Almonry in the bottom story of the Marvel, and here the visitors assemble while waiting for the official guides; but as I am the guide this evening we turn from the Salle des Gardes to the great steps which separate the abbot's buildings from the church and monastery. The bridge you see was a short cut from the abbot's house to the crypt of the church, and so by a spiral stair direct into the choir. This bridge is about the last of the many fortifications protecting the Abbey, for you see it is machicolated in the same manner as the ramparts. The abbot's house and other offices are in a tall range of buildings on the left of this passage, quite distinct from the rest of the buildings; it contains many fine rooms, most of which are in a bad state of ruin, and filled with rubbish and debris, only a few of the upper rooms being in use as the dwellings of the guides attached to the Abbey. On the next landing we see an ancient fountain, and a curious mass of the actual rock sticking up through the pavement. There are several of these masses of projecting rock in various parts of the earlier buildings, and one wonders whether the monks attached some peculiar sentiment to them, as there is no apparent reason why they should not otherwise have cleared them away. On the next flight of steps we reach the cistern of the Almonry, a great stone tank built to hold the rainwater from the roofs for use when besiegers made it too risky to get water from the well of St. Aubert at the foot of the

rock. The covered bridge you see was a direct approach from the abbot's house to the choir of the church. At this level we can pass into the earlier buildings of the monastery. And we pass directly into the little Chapel of St. Martin. This is early 12th Century work, and although on its outer side it is lit by a little window, and also in its eastern apse, its north side is still the solid rock which rises considerably higher as it tapers to the summit. On the north side is the twin chapel dedicated to St. Symphorien, and much of its southern wall is natural rock, and against it we see a rough lump projecting as we saw it near the cistern of the Almonry. These steps lead up from the chapel we have just left, and here again we see how the rock has been allowed to remain, although it blocks a large portion of the stairway. At this level are a number of massive arches and passages which formed the Chapel of Our Lady Underground, and much of the masonry is of an extremely early date. It was here that the earlier monks were buried in shallow graves cut in the solid rock and in quicklime to ensure their rapid dissolution. Here you see clearly the early character of the masonry which, if not the work of St. Aubert himself, can be but very little later. Here also was the Chapel of the Thirty Candles, and the chroniclers speak of it as the berceau, or cradle, of the Abbey. The reason of the great height of the arches is to obtain a level platform for the buildings above. In one of these passages are the prison cells of the Abbey, some of the most awful dungeons it was possible to devise, and said to be the work of that prince of dungeons, Louis XI. Here are two cells side by side, known as La Jumelle, or twins; this outer door encloses a kind of lobby, and the two cells you see beyond each have a tightly fitting door, and when they are closed not a gleam of light can enter, and very little ventilation, and yet prisoners have lived in them for years at a stretch. I had, of course, to photograph them by magnesium light so that you could see the interior. Here is another, called the Iron Cage, although it is mostly of wood, with a great iron shackle still bolted to the floor in its further corner. Here a revolutionary pamphleteer named Duborg was imprisoned in 1745, and died a raving lunatic in a year and twelve days. Close by is this enormous wheel, which was used by the monks to haul up the stores from the granary at the foot of the rock. It was worked by several men walking inside, and thus winding up the rope you see on the axle, this pulled up a wooden sledge. The sledge sliding up this stone inclined plane, called the Poulain; this has rebates on the outside edges in which the runners of the sledge fitted, and so kept it in position. Near the wheel is the Chapel of St. Stephen, which you see is of early 13th Century architecture, with a very graceful vaulting springing from carved corbels on the wall. There are traces here of some interesting fresco painting of the same date as the building. This chapel was used by the novices of the Benedictine monks, and a vaulted chamber below was their dormitory. From a small door in a corner of the Chapel of St. Martin we saw just now we enter the crypt beneath the choir of the church. It is called the Crypt of the Great Pillars, a most appropriate name, for the pillars are truly great and many. At first sight the great diameter of the columns leads one to think that the crypt is of early date, but it is really quite late, being the work of Abbot William d'Estoutville, before 1450. Its massiveness is owing to its having to carry the great weight of the choir above. Notice how the vaulting ribs die into the columns without any capitals as we would expect to find in England. The play of light in this crypt gives some very beautiful effects as the sunshine moves round the rock as the day advances.

(To be continued.)

The corporation of Huntingdon have decided to proceed forthwith with the erection of forty artisans' dwellings on a site at Stoney Cross, adjoining the late Militia Barracks.

THE ARTISTS' RIFLES.

The chief work of the Artists' Rifles is to train officers. The fact is not so well known as it might be. No Territorial corps has a finer history. For nine years in succession they proved themselves, at the Royal Naval and Military Tournament, the champions in bayonet fighting, first of the Auxiliary and afterwards of the Territorial Forces. In 1905 it was suggested that the winners of the Navy and Army bayonet fighting competition should have a special combat with the winners of the Auxiliary Forces competition—the Artists. The Artists won.

They landed in the firing line in France last autumn. Sir John French then took them back to Headquarters to form a School of Instruction. The men were gazetted to different regiments in the firing line and distinguished themselves as officers. Eleven members of the corps have been mentioned in despatches, and seven have been awarded the Military Cross for "conspicuous gallantry and devotion to duty," whilst all have gained the praise of their superior officers.

The total number of commissions gained by members of the Artists exceeds 1,600, and out of this number over 500 have been gazetted to Regular regiments. At the start (according to Sir John French's despatch of February 2, 1915) the training school in France was able to turn out officers at the rate of 75 a month. This has since been increased to 100. It must be remembered that these men are gazetted from the School of Instruction alone, and that many commissions are gained by men in England before they ever get to France.

The Third Battalion of the Artists' Rifles is in training at a picturesque Essex camp under Lieut. Colonel Shirley, an Instructor at Sandhurst for five years, assisted by a staff of officers many of whom have been on the Western front during the early months of the campaign. The men go through an extremely interesting course. There are special courses in Field Engineering, Signalling, Map Making, and the Machine Gun, under experts in the different subjects. The men live as ordinary soldiers do, and the "fatigue" work of the corps is carried out entirely by them. Practically all the officers and all the N.C.O.'s have been through the ranks of the Artists.

The corps is open to educated men of all professions and pursuits. The connection between the Architectural profession and the Artists is well known, and there are members known in art, music, literature, commercial men, engineers, famous sportsmen and men from overseas who in pre-war days were prospectors, miners, ranchers, and fruit-farmers. At the corps' headquarters in Duke's Road, Easton, the recruits are prepared for camp life. There are capable officers and N.C.O.'s, and the newly-enlisted man is quickly versed in the art of drilling.

The stay in London is quite brief, but by the time the recruit joins the battalion in camp he knows all the rudiments of drill and is able in a short time to delve further into the mysteries of a soldier's training. The camp is never unpleasantly overcrowded, for the obvious reason that men are constantly being gazetted to other regiments. It is a difficult matter to regulate the supply and demand, but Colonel Shirley has apparently succeeded to a high degree. No man receives useless training, and so soon as he is efficient he is permitted to take his departure in order to accept a commission. Trained as a soldier first and as an officer afterwards, he becomes a man who is sought after by Commanding Officers with vacancies in their commissioned ranks. The name "Artist" is a magic word: it is the "open sesame" to many a military door that would otherwise be closed. And it is only natural. Out in France and in the Dardanelles artist-officers are winning honour for themselves and honour for their regiments, and their men will follow them anywhere, for an Artist appreciates a soldier's difficulties and knows exactly what he has to endure.

T. HAROLD HUGHES, A.R.I.B.A.

From the Journal of the Royal Institute of British Architects.

ASSOCIATED PORTLAND CEMENT MANUFACTURERS, 1906, LTD.

The report of the directors, submitted to the shareholders at the annual meeting of the company, held at the Winchester House, 94, Broad Street, London, E.C. 4, on August 17, 1915, states that the balance sheet forwarded at June 30, 1914, was £151,570 1s. 3d., the profit attributable to us, which amount to £20,654 3s. 6d. for repairs and other charges amounting to £155,711 3s. 6d. making £207,222 11s. 11d. from which have been deducted directors' and trustees' fees £2,000, amortisation of mortgage and other interest £222,555 11s. 5d. depreciation and sinking funds £51,291 17s. 4d., making £276,596 18s. 7d. and leaving £328,655 3s. 4d. An interim dividend on the preference shares to December 31, 1914, was paid on March 31, 1915, amounting to £62,829 16s. 8d. and leaving a balance of £265,855 7s. 4d., which the directors recommend should be appropriated as follows:—To the general reserve and depreciation account, £50,000; to the payment of a final dividend on the preference shares to July 30, 1915, at the rate of 5% per cent. per annum, amounting to £62,829 16s. 8d., making £112,829 16s. 8d. and leaving to be carried forward £153,025 11s. 4d.

The company's operations in all departments have been seriously affected by the war conditions which prevailed during practically the whole period covered by the accounts, with the result that the profit earned shows a great reduction on that of the previous year. For reasons directly attributable to the war the demand for cement was considerably reduced, while the manufacture was conducted under difficulties due to the same cause. Cost of production increased, and although as time went on the selling price was raised, this was in respect to new business and did not affect the major portion of the year's trade. Consequently the directors consider that the results are as satisfactory as could reasonably have been expected. They recommend the payment of the dividend on the preference shares at its due date on the 30th inst.

Although, having regard to the general state of business, a satisfactory return was made during the past year by the company's investments, the directors record with regret that quite apart from the acute political disturbance in Mexico which has affected all enterprise in that country, the works abroad in which the company is interested are suffering increasingly from the adverse conditions brought about by the war, and their aggregate production has been greatly curtailed. The South African works, however, are now running on a commercial scale, and the directors are able to report that the local conditions in that country are so far satisfactory that steps are being taken to increase substantially the productive capacity of the plant.

Provision has been made in the profit and loss account for the annual instalments required for the redemption of the debenture stocks, as well as for sundry other charges for depreciation and sinking funds. These items amount in all to £51,261 17s. 4d. The directors recommend that, in addition to this, a sum of £50,000 be carried to the general reserve and depreciation account, bringing the amount of that account to £435,000. The total charge for the year for depreciation and sinking funds will therefore amount to £101,261 17s. 4d.

First mortgage debenture stock to an amount of £20,584 was redeemed and cancelled during the year, bringing the total redemption of that stock to June 30 last to £230,550.

Of the second debenture stock £26,100 was also redeemed and cancelled, making the total redemption of that stock to June 30 last £49,541. The discount and other expenses connected with the issue of this stock stood at £174,623 6s. 1d. in the company's books at June 30, 1914. It has been thought well to liquidate this amount by an appropriation from reserves accumulated in past years out of revenue by the operation of the sinking funds of the debenture stocks.

MALVERN PRIORY CHURCH.

The architect to the Ecclesiastical Commissioners, Mr. W. D. Caroe, M.A., F.S.A., in a report on the fabric of Malvern Priory Church on the 500th anniversary of its foundation will be commemorated to-day (Wednesday) states that a great deal of money has been laid out upon works of repair which have worn badly. A true knowledge of the methods of medieval masonry, to the soundness of which methods we owe in the main the extraordinary permanence of our ancient churches, is far to seek among the majority of today's craftsmen, and was seldom in part of the equipment of even our most distinguished Victorian restorers. The greater amount of the decayed stone belongs to work of the last century. There are, fortunately, only a few points where the structure needs strengthening. Weak places exist chiefly in some of the cracked Norman pillars of the nave, and in two long fissures starting in the Norman wall over each of the first pillars from the west end, and extending up into the later work above. The unequal composition of the pillars has helped in the cracking of the walls above. Over and above the superficial decay, which extends over a large area of the surface, some of the buttresses have cracked considerably, and must be dealt with.

Mr. Caroe adds that the security of the windows is of first importance when they sustain so much invaluable glass. At present the protection of the glass is dealt with in a very haphazard and unsightly manner, and the glazing of the north choir clerestory is in a somewhat precarious condition. Mr. Caroe's examination of the tower leads to the conclusion that no grounds whatever exist for refraining from ringing the bells, provided they are hung in a properly designed frame and some cracks in the tower walls are made sound. He anticipates that an expenditure of £2,146 will be sufficient. Of this sum £591 is exclusively set aside for the proper protection of the ancient glazing, quite apart from the necessary repair of the stonework of the windows. It is proposed to effect the repairs year by year until the fabric is in a thoroughly sound condition, and to appeal for annual subscriptions to a fabric fund.

THE PROFESSIONAL CLASSES RELIEF FUND. CHRISTMAS-IN WARTIME SALE.

We appended on p. 251 of our issue of September 1 for help for the Architects' Committee of the Professional Classes Relief Fund, which is organising a Christmas-in-Wartime Sale at the Albert Hall in the second week of December of Christmas gifts to the men at the front and to friends at home, the proceeds of which will be devoted to the relief of the professional classes who have been so sorely hit by the war, and we desire to urge all who are able to lose no time in co-operating. No money is asked for, but articles which the Committee can sell for five shillings each, such as knitted goods, needlework of all sorts, all articles pertaining to the various handicrafts, games, toys, and woodwork, jans, sweets, neckles, plum puddings, etc. A full list of the articles desired, and all other particulars, may be had by application to the Gifts Secretary, Professional Classes War Relief Fund, 13 and 14, Prince's Gate, London, S.W.

There will be a series of prize competitions in connection with the exhibition. Special prizes will be given for the best presents for Class (a) the fighting forces, Class (b) the wounded, Class (c) British prisoners of war. Prizes to the value of £5, £3, and £2 will be awarded for those three articles and each of the above classes which are adjudged to be the most suitable and the best made.

There is also a special prize competition for the wounded. Three special prizes of £5, £3, and £2 will be awarded for the article under any class made by wounded soldiers which are adjudged the best, any disability of the competitors being taken into consideration by the judges.

As at least 10,000 articles are required wider circulation can be ensured if everyone who reads this will tell their friends all about it and get them to help too.

OBITUARY

A architect, artist, archaeologist, and writer of considerable ability has passed away in the person of Mr. John Tavenor Perry, late of John Street, Adolph, and The Grove, The Biltons, Kensington, who died on Thursday last at 3, Burlington Gardens, Chiswick, aged seventy-five years. He was a favourite pupil of the late Professor T. Hayter Lewis, and on the retirement of the Professor, continued to carry on his practice in the same offices in partnership with his fellow pupil, Mr. Reed. Messrs. Perry and Reed executed extensive structural alterations at the Albion, in Leicester Square, and after its destruction by fire rebuilt the theatre on novel principles, the first serious attempt made to construct a place of amusement wholly of fire-resisting material. The firm also built the north wing of University College, Gower Street, in continuation of the work of Professor Lewis; Peter Jones's drapery establishment at Chelsea; the Chapter Hall, schools and vestry at the Chapel Royal, Savoy, buildings on the Salisbury estate, Strand, and schools for the Deans and Chapters of Rochester and Worcester. As surveyors to the Union Assurance Office the firm executed many works of reinstatement as well as branch offices, including those for the company in the Wilhelmstrasse, Berlin. Mr. Tavenor Perry was awarded in 1864 the Instituto Silver Medal for drawings, and the following year became the first holder of the Pugin Studentship. Among the drawings from his pen reproduced in our pages was one depicting the tower walls in the great church of Prenzlau in the Uckermark, which appeared in our issue of September 22, 1905. Widely read, widely travelled, and possessing keen powers of observation and a retentive memory, Mr. Perry wrote many papers on architectural and antiquarian topics, and frequently lectured in earlier years before the Royal Institute of British Architects and the Architectural Association. Quite recently he adduced specious, but to some of us unconvincing, arguments in support of the proposition that the Church of St. Bartholomew the Great, Smithfield, originally terminated in a square east end, and that Sir Aston Webb had insufficient authority for his formation of an apse with ambulatory on the lines of the chapel in the White Tower, but the evidences of the bases of pillars *in situ* were too strong for his theory. We gave Mr. Perry's portrait in our issue of July 4, 1890.

Mr. Henry Charles Pullin, L.R.I.B.A., Quarendon Street, Parsons Green, S.W., of the R.I.F.E. Brigade, was until recently stated to be missing, but is now reported to have been killed in action on April 26. Aged 46 years. Mr. Pullin served a four years' term of articles with Mr. F. B. Wade, F.R.I.B.A., and remained in his office as assistant for six years. He afterwards assisted other architects, chiefly in London and Brighton, and did competition and other small works on his own account.

A verdict of accidental death was returned at an inquest at Marylebone on Thursday on the body of Philip Arthur C. Wilkinson, fifty-two, architect, of Craven House, Kingsway, who was killed by falling from the roof of a house in which he was a boarder at Marylebone. Evidence was given by Mr. H. W. Wilkinson, deceased's brother, Mr. C. W. Turner, and others. The late Mr. Wilkinson, who, in addition to his professional practice, had a substantial private income, was a special constable in the Marylebone Division, and before retiring at night had been in the habit of going on to the roof of the house from his bedroom. It was on the occasion of such a visit that the accident occurred which resulted in his death.

The Local Government Board have given authority for the preparation of four further town-planning schemes under the Housing Town Planning Act, 1909. Schemes are authorised to be prepared by the corporations of Craydon, Mansfield, and Nottingham, and the urban district council of Seaton Delaval, and relate to areas of about 800, 3,300, 500, and 2,400 acres respectively.

Currente Calamo.

Taken as a whole, the Budget does credit to Mr. McKenna, whose businesslike exposition last week was a welcome contrast to Mr. Lloyd George's gassy and prolific Budget speeches, which left the House of Commons tired out with endeavouring to find out what was meant. Mr. McKenna has taken front rank in the Cabinet at a bound, much as Mr. Gladstone did in the fifties, when he was called on to mend the holes in the nation's moneybags made by the Crimean War. May it be Mr. McKenna's good fortune to start us all by-and-by on the return road to solvency and prosperity with some such a series of Budgets as those Gladstone shaped, and with as good results! Having said this, and at the risk of seeming ungracious, we must have a few grumbles. It would have cost little to put builders on the same level as the rest of the taxpayers, as Mr. Lloyd George and Mr. Asquith promised should be done—we mean, of course, with regard to the increment duty which has been so unfairly levied in the Lumsden and Walker cases. The other mistake is the abolition of the halfpenny postage rates on postcards and newspapers. It will bring comparatively little into the Treasury, but will harass many trades. It will, of course, delight the postal authorities, who are reactionary by nature, and unamenable to grace; and who might have contented themselves with the restrictions of the penny letter rate to one ounce, to which we have little objection, so bored is everybody with the big parcels of circulars and samples crowded in on us by the latitude given by the four-ounce limit.

In the course of the trial for conspiracy in regard to the contracts for building the new Parliament Buildings at Winnipeg for Manitoba, now being heard, and in which are indicated Sir Rodmond P. Roblin, ex-President of Council; Dr. W. H. Montague, ex-Minister of Works; Mr. James H. Howden, ex-Attorney-General; and Mr. George R. Coldwell, another Cabinet Minister, counsel for the Crown announced last Wednesday that further charges will be preferred. Mr. V. W. Horwood, the provincial architect, the first witness in the preliminary investigation of the charges, underwent a severe cross-examination at the hands of Mr. E. F. B. Johnson, of Toronto, but he adhered to his previous statements. Referring to some alleged inaccuracies in a speech made by Dr. Montague in the Legislature defending the contracts that are the subject of the present charges, witness declared that Dr. Montague asked him to write a letter taking the blame for the incorrect statements made.

The scheme of temporary assistance for architects whose practice has fallen off owing to the war, devised by the Council of the Royal Institute of British Architects, and already experimentally adopted in London, is being applied to South-West Lancashire. To each architect employed the task will be assigned of preparing for an allotted area a series of ordnance maps, in order to demonstrate from available data the density of population, the infantile mortality, the general mortality, the mortality from specific diseases, the amount of local and through traffic, the proportion and distribution of open spaces, the places of outdoor and indoor recreation, as well as the vacant or convertible sites suitable for artisans' dwellings.

playgrounds, terraced parks, factories, and road widening. By a correlation of the plans, especially, for example, those relating to Manchester and the contiguous group of boroughs, a county scheme of town-planning and supplementary arterial roads will be prepared in anticipation of combined action, with the support of the Roads Board, soon after the close of the war. The harmonising of the many conflicting or isolated schemes long in embryo will be essayed, and independent suggestions, as far as practicable, incorporated. By this means it is hoped to promote economy and efficiency, and to save time when county expenditure on a large scale can be undertaken.

The machinery of the University of Liverpool's department of civic design in the School of Architecture has been requisitioned to be the centre for organisation, and Professor Patrick Abercrombie is acting as technical director. The founder of the school (Sir William H. Lever, Bart.), Vice-Chancellor Dale, Professor C. H. Reilly (architecture), Associate-Professor J. A. Brodie (civic engineering), Professor E. W. Hope (civic hygiene), Mr. H. Chaloner-Dowdall (civic law lecturer), and others officially associated, or to be associated, with the school, will certainly lend their aid. The school has given a signal lead to work of the kind in contemplation by the pioneer plans of Professor Adshhead and its yearly competitions for schemes of city reconstruction and improvement. In the lectures delivered semi-publicly before the Liverpool Engineering Society, Mr. Brodie and other experts have outlined schemes of road traffic which depend for their development on a county continuance of the new highways formed or projected in the city area. Professor Abercrombie has addressed all the South Lancashire urban authorities on the subject of immediate co-operation in the contemplated town-planning, and he is receiving favourable replies.

Mr. William Woodward's letter in another column is another grave indictment of some of the workers in our own industries. We fear there is no doubt that the eminent authority he quotes is an unbiassed and accurate observer. That similar shameful slanders are in great part responsible for the sickness and hardships endured by our soldiers seems but too likely, if the report of the special correspondent of the *Times* as to the behaviour of thousands of men employed during the past nine months on Salisbury Plain for the new army is well-founded. Of the still urgent need for more accommodation for the troops who are badly overcrowded in some parts we have, ourselves, personal knowledge. The *Times* correspondent says:—

"Take first the need for economy. When the construction of a certain camp which lies over a hill some distance from the railway was begun the Government bought up for the purposes of transport a large number of farm wagons. The price paid for the wagons could hardly be described as a competitive one, but they had not been long in use when it was found that the steepness of the road to the camp made horse transport undesirable. Tractor engines were then hired for the work at a price 60 per cent. higher than would be asked in normal times. These engines drawing heavy loads quickly ruined the road, and repeated repairs have cost the local authorities nearly £40,000. Now, when the camp is practically completed, work has been started on a light railway which will connect it with the main line. People are asking why the railway could not have been built at the outset. While there is discontent upon this matter, feeling runs highest over the apparent waste of money incurred in the building of huts for the troops. It was admitted in Parliament early this year that much of the labour employed on this work was of an unsatisfactory character, and if one-half the stories I have heard of idleness and a determination to make an easy and well-paid job last as long as possible are true, then the labour engaged has

remained in a state of idleness, and its inefficiency has been a serious loss to the country.

We are assured that the worst slackers are uneducated men of no ordinary age, and that their laziness is extreme. He saw himself groups where one man worked and several others looked on and loitered while he leisurely earned through his job. Study young fellows pushed wheelbarrows or carried planks with almost indolent swiftness. He continues:

"A farmer upon the land near by the huts have been erected told me that the men engaged on the job were very few in the evening. It was quite a common practice among them to turn up for work in the morning and then, when they had done their day's work, to go home, and when they were supposed to be working, and when they were being paid for working. They are detached in small gangs, and they have not been enough taken to look after them, owing to the scarcity of labour, too, they don't care very much for the farmer. Half a dozen men were observed taking a nip one day, and when they were hauled from the hedge-bottom they and they were tried and had done enough. The matter was looked at. Another farmer told me of two carpenters from Scotland who were hired to do the work here, and they give you all day to do on both's work here, and you get a handful of money for doing it. The 17-year-old son of one of his men came home after his first day on the work and said that he had been in trouble because he took off his coat. I heard of one instance of exaltation over the easiness of the job which brought well-merited punishment. A labourer remarked that the war was the best thing that ever happened and the Kaiser was the best friend they had. A Fern hand disagreed with him and kicked him down."

And while all this is going on, the winter is approaching, and men will die of disease presently, as they did last winter and spring, whom we shall want badly at the front by and by, and we shall have plausible explanations in Parliament, and the usual assurances that it was all unavoidable—as long as the nation will accept them, and pay through the nose for bad management and the shameful treachery of clackers to their fellow men whose exemplary devotion to the Empire and the Homeland they are too cowardly to emulate and too lazy to second.

Last winter made us familiar with "Jack Johnsons," "Black Marias," and a whole vocabulary of humorous nomenclature for German shells and for the topography of the trenches, from the outer line, or "drawing-room," to the inner line, or "reception room," and the grim "dormitory" in the rear where the dead are buried. Possibly it was an architect or a decorator who first called a body belt "the dado round the dining-room." Among the various comestibles that find their way into the dining-room "torpedoes" stand for sausage rolls and "shells" for twopenny meat pies. In training camps plenty of satire flies about if the cakes are smaller than usual—as, for example, "This is not up to chest measurement," or "This is below standard height." "Somewhere in France" (says the *Manchester Guardian*) it became the custom to call French matches "Asquiths," because you have to "wait and see" what happens when you strike one.

"I like a bit of ham and bacon as well as anybody, but it is the first time I have known of an architect being called in to build piggeries," said Alderman Binns, at the Knaresborough Guardians meeting, on Friday, when it was decided to pay a fee of three guineas to Mr. Illingworth for plan and specification for new piggeries on the workhouse farm. Let us hope Binns will never have to eat his ham and bacon as a welcome guest of the Guardians. If misfortune drives him to the workhouse with the rest of us, he will soon learn to appreciate the superior flavour of the product of pigs provided with properly planned piggeries.

Our Illustrations.

THE EDITOR'S ROOM: DAILY CHRONICLE OFFICE, E.C.

The room in which the editor of the Daily Royal Academy, London, sits, is a most unusual piece of architecture. The apartment is situated on the top of the best period of the Little King in Renaissance. It is planned to a rectangle of 8 ft. 6 in. in quartered oak, with a tiled and waxed, the frieze at the top of the panel for future mural decoration consisting of the centre of the plaster ceiling, starting in a large bay light, glazed with sand-blasted Flemish patterned glass. At night the scene is illuminated from below by a series of dispersed electric lights, giving a very soft and pleasing light. The ceiling is a richly headed window, formed of a series of arched one wall. The method of lighting is by large faulights above and the window is fitted with space over these windows is added in the rooms of paper, toned down by the panelling. The floor and ceiling fittings are in oxidised silver. The furniture is specially designed by the architects to match the room, and keeping all the details of a simple and harmonious character. The object aimed at in carrying out this room has been to give an effect of dignity and comfort befitting the directorship of a great newspaper, without losing sight of the requirements of an office and work of administration. The decorations and furniture were executed by Messrs. Robersons, Ltd., of 85, Knightsbridge, S.W. The electric fittings are by Messrs. Varsity; the floor furniture and metal work by Messrs. Gwynn, Cheng and Co., Ltd. Messrs. G. Reginald Farrow and S. R. Turner are the architects.

SOANE MEDALLIONS AND TRAVEL-LING STUDENTSHIP SKETCHES IN ITALY.

THE VILLA DI PAPA GIULIO, ROME; DI VIGNOLA, ARCHITECT.

Barozzio Giacomo, besides being an eminent architect, was a brilliant engineer, and is better known universally as di Vignola. On almost equal terms he represented with Palladio the academic and retrograde taste of his time, and both these architects are rightly accounted leaders of the school with which their names are associated. Notwithstanding his strong predilection for books and a fancy for rigid architectural rules, Vignola displayed considerable taste. He was not actually a letter man, and so kept clear of becoming a slave to his texts. His work, indeed, was distinguished by a marked originality. Moreover, he succeeded in impressing his imaginative conceptions with no little freshness of manner, while he observed a more strict compliance with propriety in design than prevailed among his followers who flourished so abundantly during the ensuing century, when architects, in emulating fashion, threw overboard control with all its principles of decorum, and consequently their productions degenerated into the Baroque. The lambent architectural vogue of to-day, commonly designated the "Free Classic Movement," has tended to the revival of Vignola's methods, and this tendency has been encouraged by the recent predominance of a cult of schoolmen and pedagogy in studios occupied by professional tuition classes. Students are inclined to be on the alert for precedents, and copies are sought for as recapitulations. Vignola's works in this way appear to be laid under contribution for the time being, if not as the goal of achievement. The well-known Villa di Papa Giulio, which Vignola designed for Pope Julius III. (1550-1555), and built in Rome, is for these purposes, perhaps, one of his best buildings, by presenting admirable suggestions as a model of an available type, and it ranks in that respect better than some of Vignola's more ambitious and distinguished undertakings. Every impartial student of architecture must recognise the charm of its grand cortile, finely laid out with the handsome semicircular colonnade which so ably distinguishes the larger Casino,

...the composition, being worked out in the Grand Manner" so continually insisted on by contemporary professors of our schools. This admitted merit of imposing order in the design of this example is well enhanced by the disposition of the plan and of the court, which helps to emphasise the balance and importance of its architectural contrivance. Very much neglected nowadays, the Villa di Papa Giulio is a building which became somewhat disastrous, its glory having departed, and so it stands in striking contrast to the time when its palace was celebrated by its Papal splendour and circumstance. The inner wall, of a certain, as may still be seen, was handsomely decorated in the Pompeian style. Two fine apartments, possessing exceedingly striking ornamental ceilings, occupy the ground floor. The details of the structure throughout are in keeping with its general conception, and are characteristic of the capable artist who here, as elsewhere, exhibits the influence of Michael Angelo, and in his domestic work particularly Vignola, obviously imitated the designs of Peruzzi in Rome. The accompanying admirable sketch of the Villa di Papa Giulio has been lent us by Mr. Allick G. Horsnell, Some Medallist and The Prizeman of the Royal Institute of British Architects. It formed part of the series of foreign studies which this artist made when holding the Smeaton Travelling Studentship. The committee considered these drawings so highly that the Council was induced, when the studies were submitted for approval, to agree to their exhibition to the members of the Institute, and in consequence the whole set was recently shown in the big gallery at Conduit Street. There can be no question as to their thoroughness and highly interesting character, and we have been allowed to make a selection for publication in the BUILDING NEWS, where they will be much appreciated by our readers.

The Villa di Papa is reached by way of the Ponte Mole and proceeding to the left of the Tiber for about a mile and a half past the Aqua Acetosa (with its famous wellhouse designed by Bernini in 1616, and from thence turning to the right and passing along the road which leads through the vineyards on either hand and so on towards the long vaulted gateway, called the Arco Oscuro, forming the immediate approach to an open space where this building by Vignola stands on a spacious site extending its frontage along the left side of the piazza. Barozio Gaeffler, who was born in 1507, died in 1573. His name of Vignola resulted from his father having taken refuge in the obscure village of Vignola, near Modena, where the boy was brought up, and it was not till he was 28 years old that he went to try his fortunes in Rome. The young architect soon became recognised under Papal patronage. He built the famous Porta del Branchi at Bologna during the pontificate of Pius IV. He was made chief architect to Julius III., and succeeded Michael Angelo as architect to St. Peter's at Rome. Vignola directed the reconstruction of the aqueduct Aqua Virgo, built 45 B.C. We do not propose to give a list of his many works, but it will be remembered that Vignola designed the great pentagonal Palace of Capranica near Viterbo, and he was the architect of the now destroyed ducal palace of Piazzola. The Porta del Popolo in Rome was his work, and the late Charles Garnier, the well-known Paris architect, who was awarded the first Royal gold medal in 1856, ascribed to Vignola the design of the palace of the Farnese Palace. Vignola likewise supervised what has been employed by Michael Angelo, Bernini, and some of his master's designs have been attributed to Vignola.

INTERIOR OF THE CHURCH OF SANTA MINATO, FLORENCE.

We also reproduce on the same double page plate an interior sketch of the beautiful church of Santa Minato, Florence. The drawing belongs to the same series already published, and shown by Mr. Allick G. Horsnell at the summer at the Royal Institute of British Architects. This building was founded by a member of the Florentine family who suffered from the third century under Diocletian and was destroyed by the ravages of which Michael

Angelo erected in 1592 on this same spot the city was enabled to defy "the united powers of Pope and Caesar." Who that remembers Florence does not remember well the San Minato in Monte, towering on its lofty eminence above the city, and visible along the Lung Arno from the Ponte alle Grazie to the Ponte alla Carraja, and the enchanting views of the Valley of the Arno as seen from the marble steps of the ancient church, and the old, dismantled fortress defended by Michael Angelo against the Medici, and the long avenue of cypresses, and the declivities robed in vineyards and olive grounds between the Gate of San Minato and the lofty heights above? It has been pointed out that the facade of this church resembles that of the church of S. Maria Novella. Now the interior is employed as a sort of Campo Santo for Florence. Ancient frescoes cover the side walls; the roofs of timber, and in the apse is a Greek mosaic representing the Christ with the Virgin and St. John on one side, and on the other St. Minato wearing a regal crown and mantle, and holding the Greek cross. In front of the lofty raised choir is the picturesque chapel built in 1448 by Michelozzo for Piero de' Medici. The pictures it contains are attributed to Spinello Aretino, and here the miraculous crucifix of St. Giovanni Gualberto was at one time preserved. Above the steps of the choir are an exquisitely wrought screen and pulpit. The door to the right leads to the sacristy, built in 1387 by Nerozzo degli Alberti, and decorated with frescoes illustrating the story of St. Benedict, by Spinello Aretino. At the end of the nave on the left is a chapel built by Antonio Rossellino for Cardinal Jacopo of Portugal, with his tomb of 1427. Though only 26 at the time of his death, he had received a Cardinal's hat from Pope Calixtus III., and had been appointed Ambassador from the Florentine Republic to the Court of Spain. St. Minato may be approached from the Porta Romana by the enchanting drive of Le Colle with its ever-varying views. The pavement in St. Minato was illustrated from a Pugin Studentship drawing by S. G. Follett in our issue of January 15, 1909, and from another set of Pugin drawings by William Dawson in our numbers for March 18 and April 15, 1904. The pulpit was shown from a National drawing by Robert Atkinson in the BUILDING NEWS for February 22, 1907.

"OVERWEY," TILFORD, SURREY

We reproduce the architect's Royal Academy drawing of this house, which stands on rising ground over the River Wey, with a fine view across Frensham Common and the open heather country to Handhead beyond. The nature of the site, sloping sharply down from north to south, dictated the long narrow plan, and we show both the main floors. The drawing-room was an addition to the original scheme, in which the hall formed the principal sitting-room, with a large window for the westward view over Tilford village. The walls, which are hollow, are set out of the exposed position, are faced with local stock bricks of a varied purple-brown colour, and the roofs are covered with thick hand-made tiles from the Nyewood kilns. The verandah is of oak, and the builders were Messrs. Goddard and Sons, of Farnham and Dorking. Mr. H. M. Fletcher, M.A. Cantab., F.R.I.B.A., of 2, Gray's Inn Square, is the architect.

"THE NEW HOUSE," AIRLIE, GARDENS, W.

This house has lately been built on a site at the southeast angle of Airlie Gardens, formed by the junction of Camden Hill Road and Camden Hill. The walls are faced with brick and Portland stone. The basements for the basement are of a deep purple, and were supplied by Messrs. Tucker and Sons, Ltd., of Loughborough. Those for the upper part came from Messrs. Thomas Lawrence and Sons, of Bracknell. The general wallings are of rough brownish bricks, with smother dark red bricks for window dressings. The roof is covered with Westmoreland slates of varied green-grey tones, supplied by Messrs. Ames and Hunter. The architect is Mr. H. M. Fletcher, M.A. Cantab., F.R.I.B.A., of 2, Gray's Inn Square, and

the builder Mr. F. G. Mater, of Putney. The plan, which is particularly interesting, is figured on the separate illustration page with the plans of "Overwey," Tilford, Surrey. This perspective was exhibited this year at the Royal Academy.

A WILLIAM AND MARY HAUTBOIS, FROM FRITWELL MANOR, BANBURY, OXON, AND OTHER OLD PIECES OF ENGLISH FURNITURE

These examples of Old English furniture need no explanation. They are all genuine pieces, and have somewhat recently been exhibited in London. The oak chest, or hautbois, consists of three long and two short drawers, with secret drawer above, on a handsome stand fitted with three drawers on baluster legs and shaped stretcher rails supported on ball feet. The brass furniture is original. The piece is 5 ft. 6 in. wide. The remainder of the sketches on the sheet represent Chippendale furniture, all typical, restrained in detail, and good in form.

NATIONAL COMPETITION, EXAMINATIONS IN ART, AND AWARDS IN ART, 1916.

In view of the urgent need for national economy and other circumstances arising out of the war, the Board of Education find it necessary to give notice of the following changes in their arrangements for the National Competition, Examinations in Art, and Awards in Art, 1916:—

NATIONAL COMPETITION.

1. The Board will not hold a National Competition in 1916.

EXAMINATIONS IN ART.

2. The Board hope to be able to hold the Examinations in Art as usual, and have issued regulations for 1916 accordingly. They desire, however, to give notice that it may prove necessary at a later date to suspend the examinations. In that event they will endeavour to give as long notice of the change as possible.

AWARDS IN ART.

3. The interim regulations for scholarships, exhibitions, free studentships, and other awards in art applicable to the year 1914 are provisionally continued in force subject to the following modifications:—

(a) The Royal Exhibitions, National Scholarships, free studentships, and local scholarships to be awarded in 1916 may be restricted to numbers less than those stated in paragraph 1 of the regulations.

(b) The Board may find it necessary to restrict the number of new Local Exhibitions in Art to be added under the provisions of chapter ii. of the regulations.

(c) The award of Princess of Wales' Scholarships may be suspended for 1916, or, if continued, will be made on conditions to be announced later.

(d) The Board will not hold short courses of instruction in art at the Royal College of Art in 1916.

(e) The grants in aid of visits to museums and centres of art instruction will be suspended until further notice.

SPECIAL EXAMINATION.

4. The Board desire to take this opportunity of giving notice that at some future date after the conclusion of the war they propose to hold one further special examination for the benefit of candidates who had almost completed the requirements for the art class teachers' certificate and the art master's certificate when the old regulations expired. Provision will be made for the re-examination of:—

(a) Persons who were examined in 1914 in subjects necessary to complete an art class teachers' certificate or an art master's certificate, as the case may be, but failed in one or more of those subjects;

(b) Persons who, having the art class teacher's certificate, were examined in 1914 in drawing from the life or drawing from the antique, and have obtained, then or previously, at least a second class in each of these subjects.

The detailed arrangements will be announced in due course, and at least three months' notice will be given of the special examination.



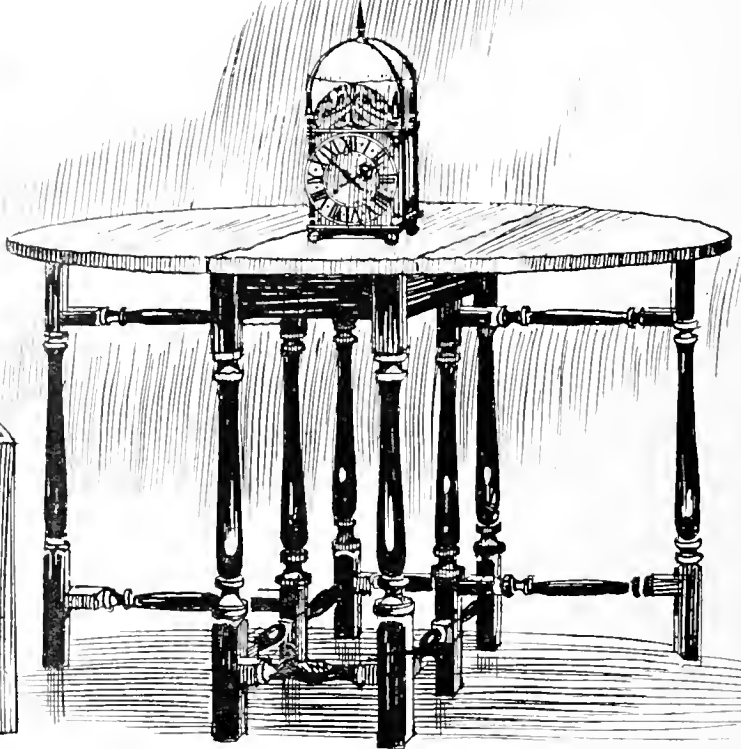
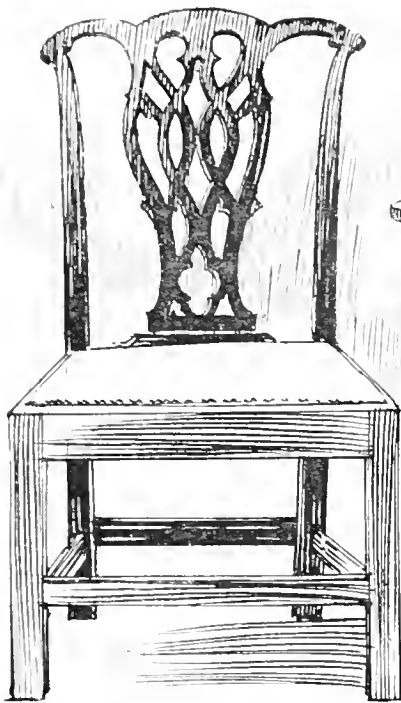

CHIPPENDALE CHAIR & GATELEG TABLE

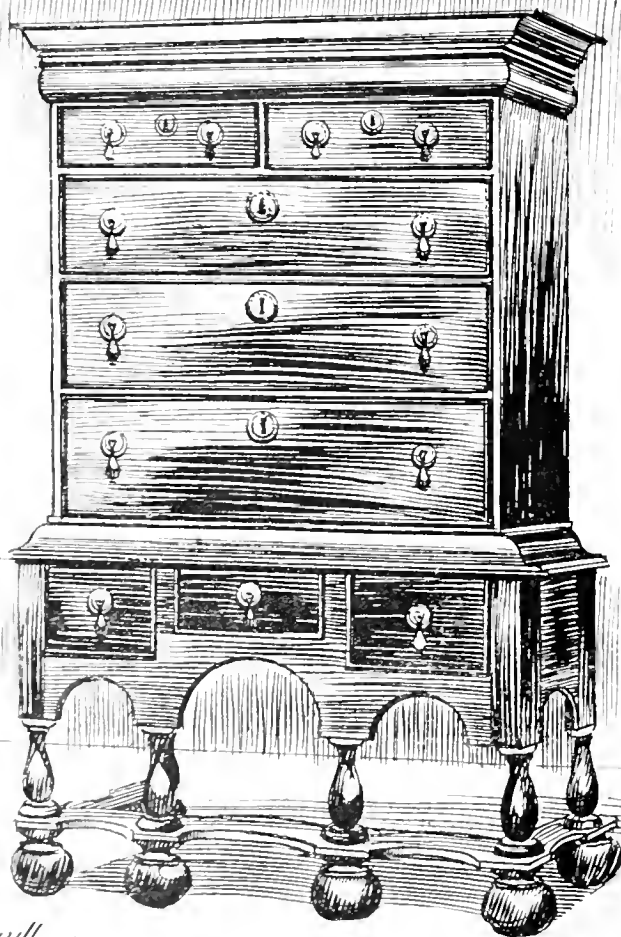

WILLIAM & MARY
CHEST

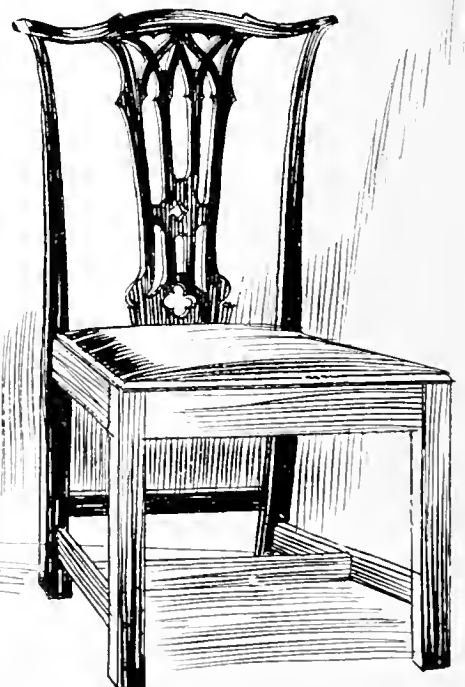

CHIPPENDALE CHAIR

W. J. Willis, del.

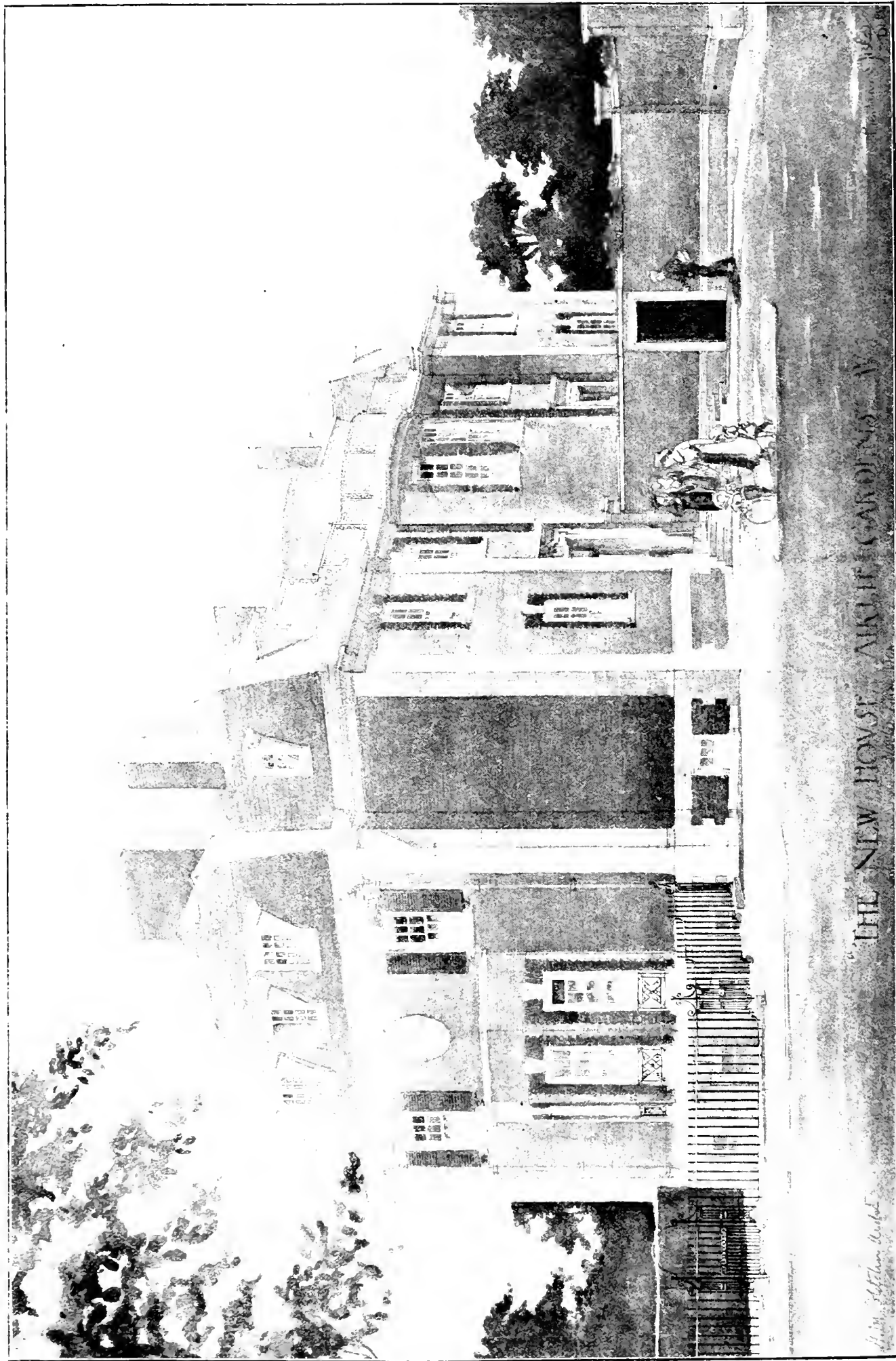

"THE NEW HOUSE," AIRLIE GARDENS, CAMPDEN HILL, W.

Mr. HENRY M. FLETCHER, M.A. Cantab., F.R.I.B.A., Architect.

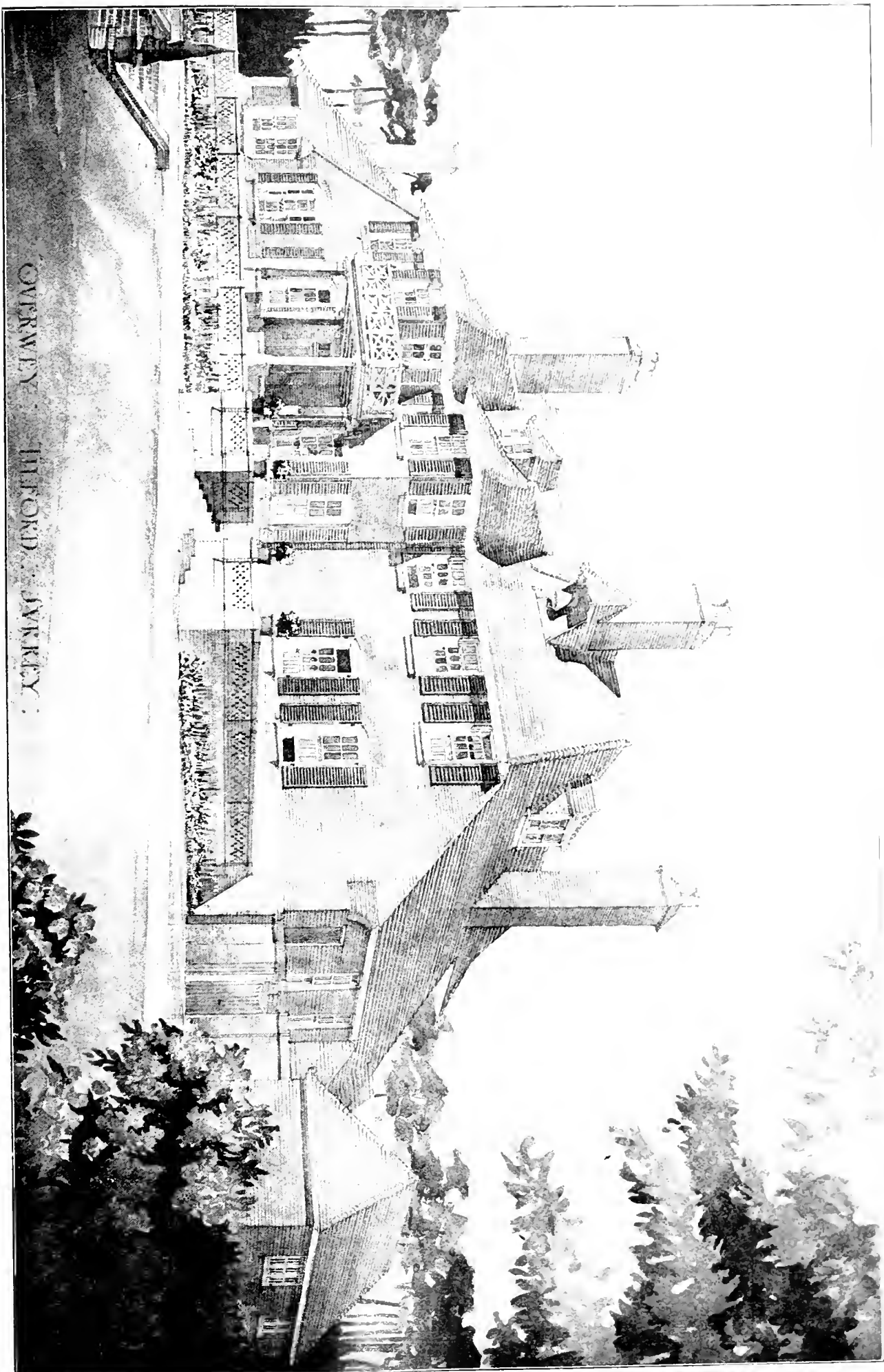

OVERWEY, TILFORD, JARKEY :

“OVERWEY,” TILFORD, SURREY. MR. HENRY M. FLETCHER, M.A.Cantab., F.R.I.B.A., Architect.



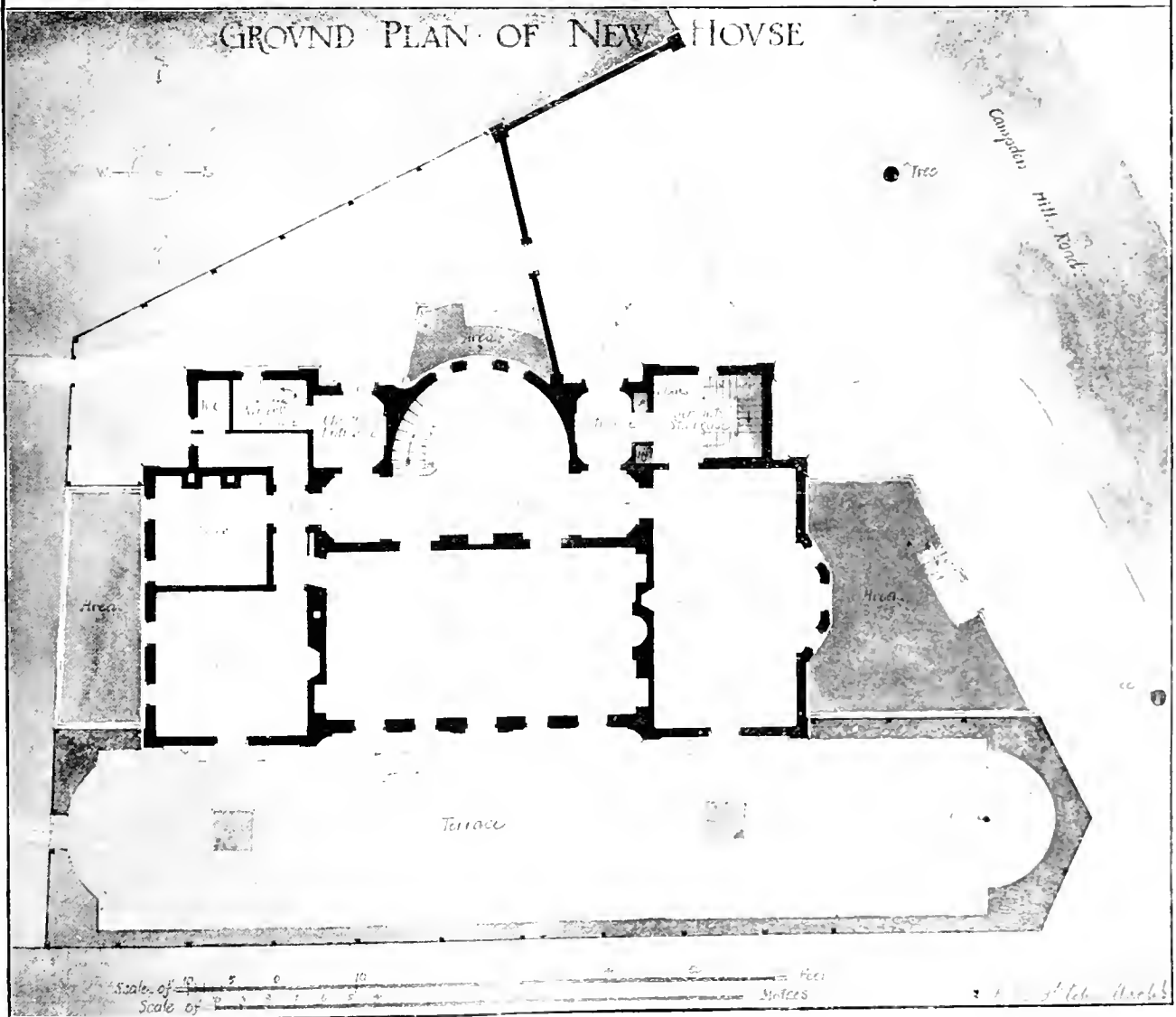
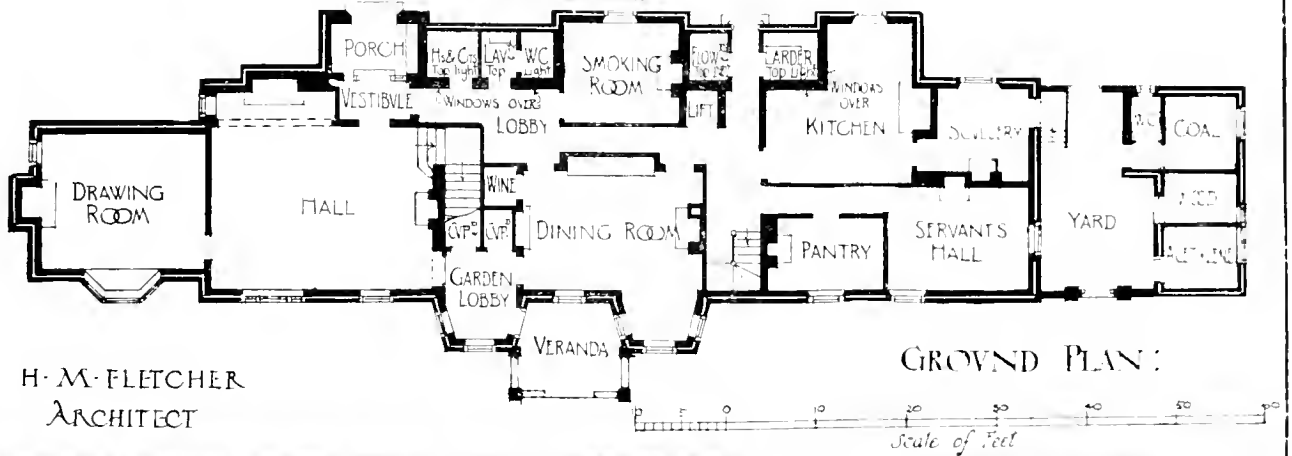
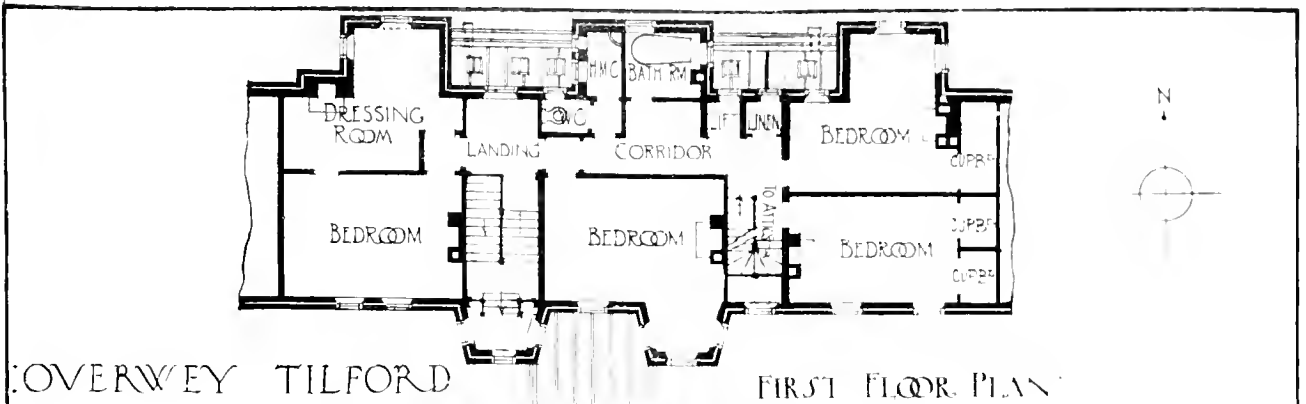

"THE NEW HOUSE," AIRLIE GARDENS, CAMPDEN HILL, W.—Mr. H. M. FLETCHER, Architect.





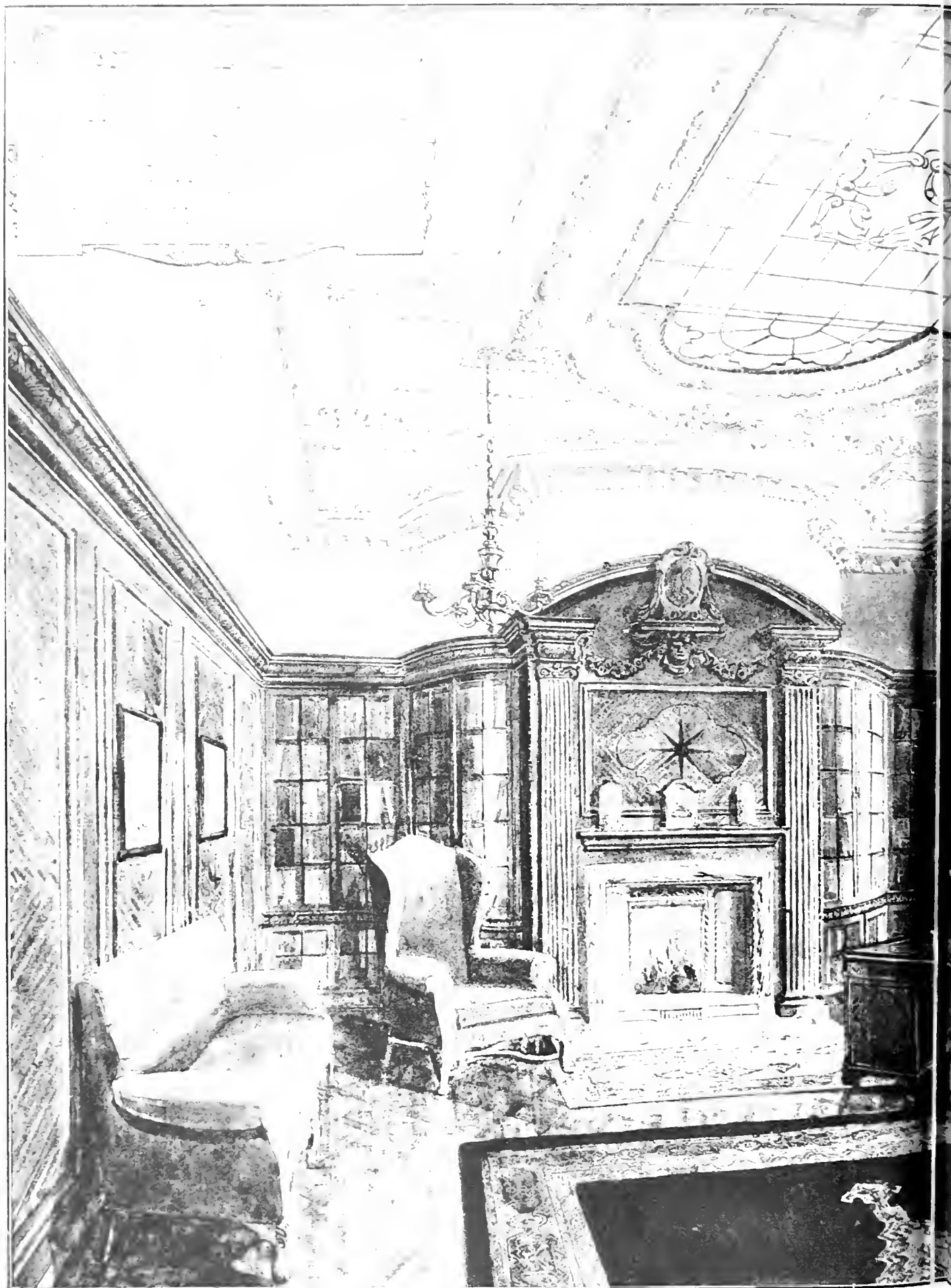

THE EDITOR'S ROOM. "DAILY CHRONICLE" OFFICE, E.C.; FOR THE UNITI .

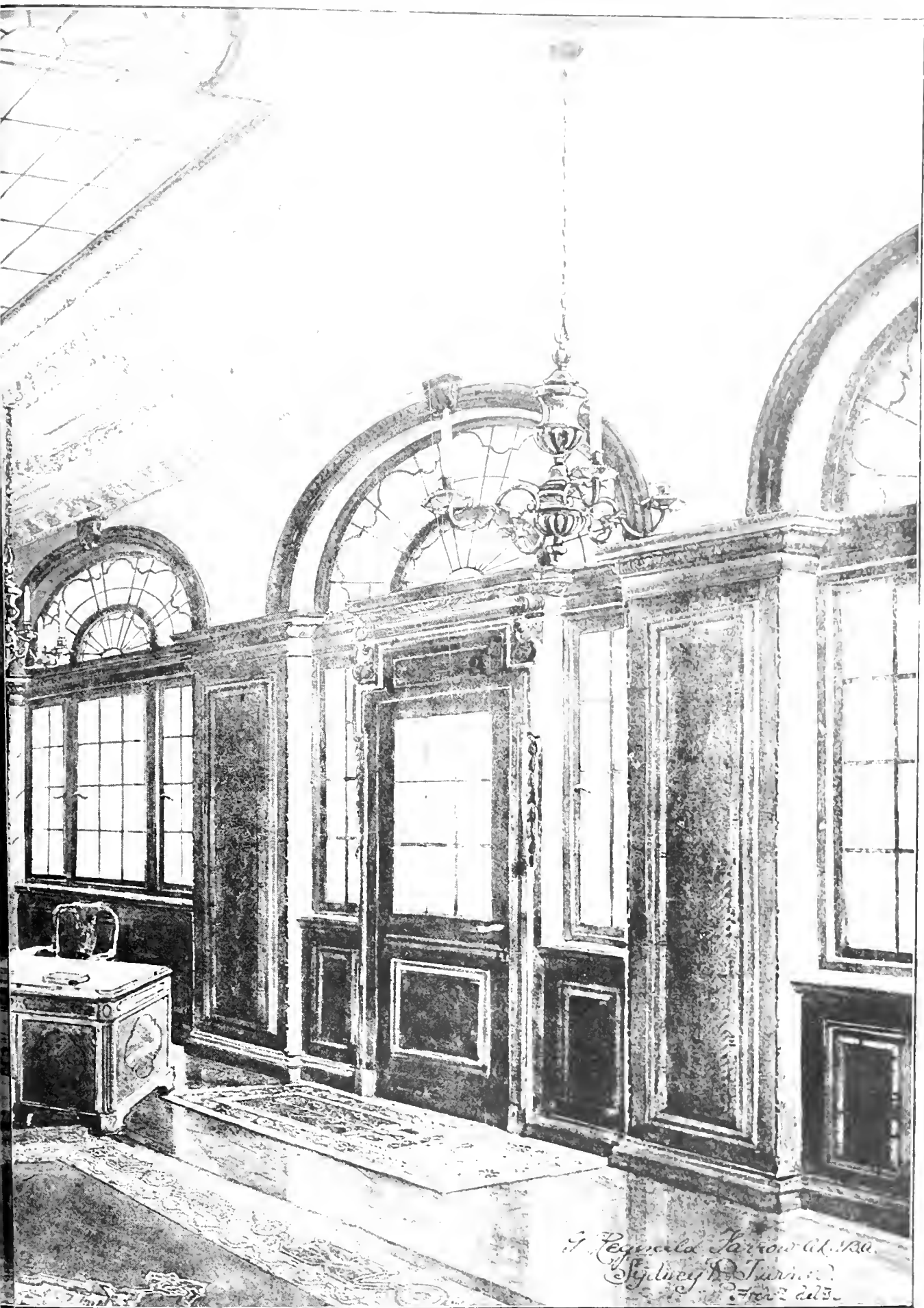

G. Reginald Farrow A.R.I.B.A.
Sydney D. Turner
1915



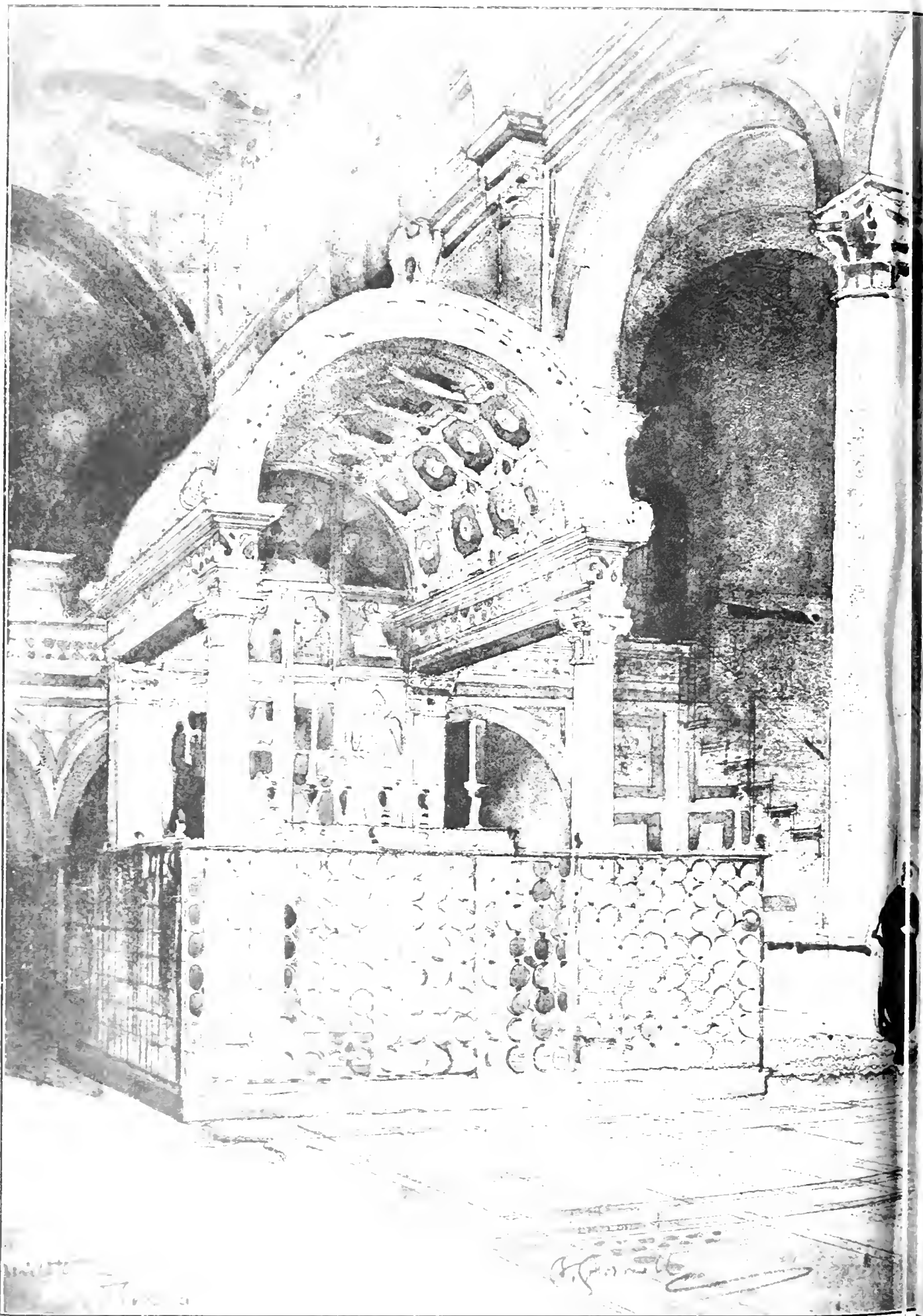

LIBRARY OF THE UNIVERSITY OF TORONTO
SOME MEDALLION AND TRAVELLING STUDENTS



THE VILLA OF LIVIA IN ROME. DE VON A. V. 16



PROFESSIONAL AND TRADE SOCIETIES.

R.I.B.A. SESSIONAL PAPERS, 1915-16. The programme of the forthcoming session of the Royal Institute of British Architects is as follows:—The following:

- "Notes on the Ministry for Architecture and the Ministry of Architecture," by Professor W. R. Lethbridge.
- "The War Hospital in France," by Mr. J. H. P. Barker.
- "The Housing of the Labouring Classes," by Mr. J. H. P. Barker.
- "The Works of Philip Webb," by Mr. W. R. Lethbridge.
- "The Study of Plans and Plans in the History of the Construction of Buildings," by Edward W. Lutyens.
- "A Building Act for London," H. D. Sargent.
- "The Urban," by Professor A. B. Rowlandson.
- "The English Domestic Architecture from 1700 to 1850."

R.I.B.A. COUNCIL APPOINTMENTS FOR STANDING COMMITTEES.

The following appointments to the four standing committees have been made by the Council:—Royal Institute of British Architects: Mr. Barker, 51, 171, H. P. Barker, Downing, Harry Redfern, Harry Sur, Raymond Upton, W. A. Webb, *Literature*; H. G. Johnson, A. R. Jennett, Herbert A. Satchell, H. H. Wigglesworth, C. E. Saver, *Finance*; W. G. Barr, Alan E. Mundy, Sydney Peck, F.S.A., W. Gilbee Scott, W. Henry White, *Science*; Ernest Flint, O. Barn C. H. S., N. O. Searle, C. E. Varn-dell, Herbert A. Welch.

PROPERTY PROBLEMS IN LIVERPOOL.

The Liverpool Property Owners' Association met at the Law Rooms in that city on Friday, and tentatively discussed two interesting questions. Alderman Taggart presided over a large attendance. The Chairman and Mr. G. B. Daniels reported on the waiting of a deputation upon the Estate Committee of the Liverpool Corporation. The object was to secure equitable treatment with regard to dilapidations on houses held under corporation seventy-five years' leases in such neighbourhoods as the southern side of Islington, Pitt Street, Park Lane, and Kempston Street. In each case the original lessee had signed covenants for houses at that time occupied by high-class tenants, some being of the "merchant prince" type. Under numerous successive lessees the property had gradually changed in character, and was now largely used, for example, as workshops for foreign cabinet-makers. The contention of the deputation was that to strictly enforce covenants requiring the houses to be restored to their original condition of interior decoration would be both unjust and most wasteful, seeing that workshops at low rents and not superior residences at high rents were in the specified areas in demand. If the present lessees were not equitably treated it was probable that the property would pass into the hands of "men of straw," a contingency not desirable in the interest of any of the parties concerned. The Estate Committee, however, had realised the situation, and a satisfactory arrangement was anticipated. On the subject of the increased rate of interest demanded since the issue of the 4½ per cent. War Loan for mortgages, it was resolved that where "undue" interest was demanded the Federation of Associations of Property Owners be asked to bring the matter before Parliament with a view to legislation.

At present Lochlyle Parish Church is being demolished preparatory to being rebuilt, and an interesting discovery has been made. In the foundation-stone was found a tin box, in which was a glass jar containing two local newspapers dated June 29, 1855, a small phial of oil and one of wine.

At the meeting on Thursday of the School Board for Glasgow the Property Committee called attention to the additions to be made to Alan Glen's School. The committee had examined contractors' schedules for the work, which involved a total sum of £17,476. Along with the Master of Works, they had, in consultation with the architects, gone over the specifications, and by cutting off unnecessary frills achieved a saving of £3,237 without altering the essential arrangements. The report was

COMPETITIONS.

PLYMOUTH.—Ninety six sets of designs have been submitted for the new and extensive buildings to be erected by the Plymouth Mutual Co-operative and Industrial Society, Limited, on the fine open site, bounded by Courtney, Raleigh, and Frankfort Streets, in Plymouth, opposite the present premises of the Society. The drawings will be exhibited in the Co-operative Luge Hall, but the date for that has not yet been decided. Prémiums of £75, £50, and £25 will be awarded. Mr. Paul Waterhouse, M.A., F.R.I.B.A., is the assessor. The proper display of goods in the ground floor windows is an essential part of the function of the building, and any idea that the architectural style should ignore this purpose will be entirely discouraged. This condition makes the problem particularly interesting, as the premises are to accord with the best modern practice of shop architecture. Cost is to be an important element in deciding the competition, but no sum is fixed and no price per foot cube is stipulated. We hear that the estimated outlay is between £90,000 and £100,000. Red brick and Portland stone are suggested as the materials, added to fireproof construction.

WATER SUPPLY AND SANITARY MATTERS.

PERTH.—At an early date the town council will consider a report by the special water and sewage committee as to the water supply and sewage disposal questions. The estimated cost of the various water schemes reported on is as follows: Bertha scheme No. 1, £101,000; Bertha scheme No. 2, £26,000; Stormontfield scheme, £105,250; and Water of May scheme, £192,500.

SEWAGE DISPOSAL WORKS AT DALKEITH.—The condition of the rivers North and South Esk has occupied the attention both of the Midlothian County Council and the borough authorities for a number of years. The Bonburgh burn, which runs through Bonnyrigg and Dalkeith, was until recently used by both towns as a main sewer, and in view of this it was at first thought that a joint scheme of sewage purification might be convenient. But at Dalkeith, where the joint works would have been situated, it was found difficult to get suitable ground of sufficient area, and it was deemed advisable to act independently. Bonnyrigg had little difficulty in finding an excellent site, and the works there were completed some time ago. A site for the Dalkeith scheme was eventually secured at Newmill, on the Newbattle estate of the Marquis of Lothian. In some respects the site is ideal, being convenient for the road and the river, with suitable levels and an open gravelly soil. With the completion of the Dalkeith operations a large volume of sewage which reached the Esk will now be purified. Messrs. Gilbert Thomson and Ferguson, civil engineers, Glasgow, designed and supervised the works; and Mr. John Monteith, Dalkeith, was the contractor. The estimated cost was £9,350, exclusive of the cost of land and wayleaves.

Mr. William Willett the younger, of The Cedars, Camden Park, Chislehurst, Kent, head of the firm of Willett and Co., builders, Chelsea and Hove, the promoter of the Daylight Saving Bill, who died on March 4, aged 58, left £557,150.

Glasgow City Council has remitted to a Special Committee to consider and report as to the necessity for, and the expediency of, the corporation building, upon ground belonging to it, or upon suitable ground to be purchased or leased, dwelling-houses of not less than one room and kitchen, with bathroom.

Mr. Thomas Moulding, M.I.C.E., the city engineer of Exeter, reports to his corporation that in the two years ended March 31 last 13½ miles of road were repaired in Exeter, the stone used amounting to 18,637 tons. During the same period 2½ miles of roads, covering an area of 295,466 square yards, were tar-sprayed at a cost of £1,264.

At the last meeting of the Gelliger Urban District Council Messrs. Wilcox and Ruikes, engineers, submitted plans and specifications for the construction of a sewer in the Culla and Derri Valleys to link up with the main trunk sewerage scheme for the Rhymney Valley now in progress. It was decided to write to the Local Government Board asking if it would send on the cost of preparing the plans and specifications.

PARLIAMENTARY NOTES.

COMMISSIONS FOR CIVIL ENGINEERS.—Asked by Mr. Watt whether an application was made in July by his Department to the Institution of Civil Engineers, to procure for them officers for the Royal Engineers who had a knowledge of heavy construction work, Mr. Tennant has stated that the facts were substantially accurate. The result had been that nineteen gentlemen had already received commissions in the R.E., and the consideration of the qualifications of others was proceeding, with a view to the filling of further vacancies which might occur.

ECONOMIES BY H.M. OFFICE OF WORKS.—Mr. Harcourt, First Commissioner of Works, has informed Sir E. Cornwall that the whole of the Votes taken for the Office of Works for 1915-16 had been carefully reviewed on the basis that nothing was to be done that was not absolutely necessary, that was, for reasons of health, to avoid actual deterioration of buildings, or to allow of the efficient working of departments. Practically all new works not subject to running contracts had been postponed. The reductions applied to all departments except the Convalescent Hospital at Osborne, where obviously no economy was possible. By this action it was hoped to save about £250,000 this year and a further saving of over £500,000 on next year's Estimates.

THE GOVERNMENT'S TIMBER CONTRACTS.—In the House of Commons on Thursday Mr. C. T. Neeldham asked the First Commissioner of Works whether, having regard to the special conditions in the new Government contract for building work in respect of the compulsory purchase of supplies of timber from His Majesty's Office of Works, it is the intention to take over all the existing stocks of timber in the merchants' hands? If not, what is the reason for the condition that timber must be bought from His Majesty's Office of Works, thus excluding the competition by timber merchants and importers? And, why must contractors take delivery of timber as and where it lies, in view of the existing close relations of the Government and the railways?—Mr. Harcourt replied: The answer to the first question is in the negative. The answer to the second is that the object of the contracts is to benefit the taxpayer by restricting the sphere in which private profit operates, and by extending, with that object, the arrangement under which any department supplies certain classes of timber to the War Office. The answer to the third question is that the arrangement was judged most convenient. I may add that, in view of the urgency of this particular requirement and the heavy demands on Government stock for other needs, it is proposed to arrange that those stocks are only to be drawn on for this purpose by certain contractors near defined ports of entry, and that other contractors will obtain their own supplies.

The Passmore Edwards Museum at Newton Abbot, which was gutted by fire on Thursday, when a valuable collection of antiquities and geological and mineral specimens was totally destroyed, was built, together with the adjoining Technical Schools (which also suffered from the flames), from designs by the late Mr. Sylvanus Trevail, and was illustrated in our issue of July 3, 1902.

The death has taken place at Brighton of the "golden dustman," Mr. Charles Marrell, of Blackfriars Bridge Wharves, contractor for the removal of dust to many London boroughs and district councils, including the City of Westminster, Southwark, Lambeth, Richmond, Mortlake and Wimbledon. Mr. Murrell succeeded to his father's business in Bermondsey as a coal merchant and street and house refuse contractor, and eventually removed about 250,000 tons of refuse every year.

The forty-fifth autumn exhibition at the Wilker Art Gallery will be opened on October 9, and continue open until Saturday, January 8 next. This year's collection of pictures is representative of the art movement of the day, besides having several novel features of special interest. Prominent among these is the collection illustrating modern Belgian art. An effort has been made to provide a representative collection, including examples of some of the great artists of the immediate past, such as Baron Henry Leys, Alfred Stevens, P. J. Clays, and Henriette Romer. The customary "one-man" room this year is devoted to Burmese pictures by Mr. Gerald Festus Kelly. There is a special collective exhibit by the Royal Society of Miniature Painters, and for the Black and White Room a very representative selection has been obtained, a special feature being made of the etchings of Mr. James M. Boy.

Our Office Table.

Mr. Ernest Bell, the well-known publisher, has issued a volume on the "Architecture of Ancient Egypt," which will be published by his firm, Messrs. G. Bell and Sons, Limited, York House, Portugal Street, Kingsway, London, W.C., next week. The main object of this volume is to give, in a manner adapted to general readers, a connected historical outline of the architecture of the ancient Egyptians, from their earliest dynastic period; and to show in the light of recent research to what extent it forms a place in the general history of the art. Some of the parts so given of the later periods, to which a large proportion of the existing remains are due. About 180 illustrations, maps, and plans, will, it is hoped, give the book some interest to travellers, as a supplement, so far as the chief architectural monuments are concerned, to the indispensable handbooks.

The Iron and Steel Institute at the autumn meeting held on Thursday at the Institution of Civil Engineers, dealt without hesitation with the problem of alien members. Subject to confirmation at the annual meeting in May next, a new rule was adopted providing that in the event of a state of war existing between this and any other country, all members, honorary members, and honorary vice-presidents who are subjects of such enemy country shall cease to be members, but shall be eligible for election after the war. Another rule adopted gave the council absolute authority to remove the name of any member from the list of members.

Stuttgart, which was treated by French aviators to a visit on Wednesday morning last, is pleasantly situated in the little valley of the Neckar, about a couple of miles above the confluence of that stream with the Neckar. The palace which was bombarded was begun in 1746, but was not completed until 1806, when the status of the Grand Duke of Wurtemberg was raised by Napoleon to that of King. It is a dull Baroque edifice of free-stone with two projecting wings in shape of an plan, of three stories and an attic, the central grand entrance being surmounted by a huge gilt crown. The palace contains 565 apartments. The large square in front is planted with trees, and contains two circular fountains, and in the centre a tall round Corinthian column of white stone surmounted by a winged figure of Victory. On the opposite side of this square, facing the palace, but in the Schlossstrasse, is the great railway station, which also received attention from the French airmen.

In recent years not a few picturesque and ancient bits of Haddington have disappeared before the march of improvement, and one of the most interesting is now in process of demolition in the removal of the old Skimmers' Close in Han Ligate. The buildings, constituting what was a most picturesque close of tiled roofs and harled walls, stretched from Han Ligate to the River Tyne. They were full of quaint interiors, with low roofs and walls, apparently clustered together on the principle of a puzzle for later days of advanced public health ideas. In their time they had served many purposes. Within the memory of old inhabitants they were occupied as an old hostelry known far and near as the "White Swan." The sign was doubtless drawn from the Tyne swans, a supposition which is lent out by the following quaint couplet which embellished the house: "As swans do like the water clean, Step in here and drink good beer." Many a jovial burghal and other gathering was held in the old premises. The locality obtained the name of the Skimmers' Close through being connected with works where skimmers were long employed. Lately the place had been in use for lodging for use purposes and dwellings of a poor class, and was largely in a tumble-down condition.

The Birkenhead Corporation's scheme for erecting working-class houses and flats on the Gilbrook estate, at the north-end of the borough, was the subject of an inquiry at the Town Hall on Tuesday evening in last week, conducted by Mr. Courtenay

Clifton, M.Inst.C.E., an inspector of the Local Government Board. The Town Clerk stated that the sum proposed to be borrowed in connection with the scheme was £68,500, and under the Housing Act there had already been expended £50,000. The desire of the council to proceed with a more comprehensive scheme than any hitherto undertaken had been intensified in recent years owing to the falling off of private building which followed the passing of the Finance Act and to the very rapidly increasing industrial population due to a large accession of work in connection with Messrs. Cammell, Laird's, which was the principal labour-employing firm in the borough. There was no doubt that even before the beginning of the war the supply of small houses fell considerably short of the demand, and this position had been accentuated within the last twelve months. The corporation at the same time had in mind that to some extent the accession of population might be temporary. The site intended to be used for the housing scheme was a portion of the unsold land on the Gilbrook estate, acquired in 1845, consisting of nearly eight acres, including street sites. In May, 1914, the Health Committee formulated a scheme for erecting 200 houses at the north end, 100 houses in a central area, and 100 at the south end. The present scheme was the first instalment of that proposal. Plans for the houses to be erected on the Gilbrook site were prepared by Mr. T. Taleisin Rees, Dr. Sydney Marsden, medical officer of health, spoke of the necessity of providing a large number of working-class dwellings in the borough, and observed that 80 houses had been demolished at the north end. Mr. T. T. Rees, F.R.I.B.A., of Birkenhead, gave details of the scheme. No opposition was offered to the application.

The Committee on Ancient Earthworks and Fortified Enclosures, in connection with the Congress of Archaeological Societies, in their annual report state that, in regard to the entrenching, hutting, and other work going on all over the country, no complaints have been received of damage or destruction of ancient earthworks by those engaged in constructing modern ones. That the soldiers were alive to the possibilities of their work was shown amusingly by some North Country officers employed in the Midlands, who carved and set up epigraphic records of their trenching in imitation of Roman inscriptions. The war has caused the suspension of archaeological work in many parts of the country. The committee express their regret that Balsham (or Heam Dyke and the Devil's Dyke, in Cambridgeshire, are still being used as chalk quarries, and that the destruction of the great hill fortress of Penmaenmawr continues. Bosence, the only earthwork in West Cornwall, which has yielded an appreciable quantity of Roman remains, and many other earthworks in the county, are suffering gradual destruction through ploughing, and the destruction of Lee Hill Camp, a loose rampart in Yorkshire, continues by stones being carted away.

In recording an oration service by the Bishop of Birmingham in St. James's Church, Ashsted, a correspondent of the *Guardian* writes:—"A hundred and twenty years ago Ashsted was a pleasant suburb of Birmingham, in which the wealthiest citizens lived, and among them a notable physician, Dr. John Ash. He can claim the gratitude of generations of Birmingham people, as having been the main cause of the founding of the General Hospital. On his death his large private house was turned into a church. The whole of the interior was removed, some new windows were inserted, galleries were built, and the result was an ugly, but useful, building that seated some thirteen hundred people. There have been two fairly thorough restorations since its adaptation to the purposes of worship, and now there are hardly any marks left of its origin, apart from a few windows which show unmistakable signs of the dwelling-house."

"The Practical Design of Steel framed Sheds," by Albert S. Spencer (London: Constable and Co., Limited, 10s. 6d. net), is a useful addition to the by no means scanty literature on the subject, in that it does

recognise that mere proficiency in the design of the various units is not un seldom gained at the sacrifice of due regard to the units as a whole. It is entirely true, as the author says, that the bad effect of the contrary is visible in present drawing-office practice, and we hope his book will recall the advisability of preparing more coherent and consistent drawings, and the payment of more attention to the stability of the structure as a whole. Mr. Spencer has also our sympathy with his attempt to offer a rational solution of the difficulty of providing fixity for stanchion bases, which, with reasonable care, may be safely adopted, and which, in our judgment, is far better than ignoring the problem, as most of the text-books do, or suggesting solutions which, on the face of them, are commercially impracticable.

The ninety-third report of the Commissioners of Woods, Forests, and Land Revenue has been issued, and states that, exclusive of land let for building purposes, the Crown property under their charge extends to 346,935 acres, of which 69,103 acres are under the growth of timber. The income amounted to £272,350, and the expenditure to £192,157, the corresponding figures for the previous year being £750,519 and £185,660. The area of agricultural lands under the Commissioners at the end of March last was 75,375 acres, an increase of 860 acres, attributable to the purchase of the Dymock Estate in Gloucestershire and of estates in Lincolnshire. The area converted by the Crown into small holdings within the year was 584 acres, bringing the area so converted since the policy of encouraging the creation of small holdings and allotments on Crown land was inaugurated nine years ago up to 7,827 acres. During these nine years there have been erected on these 7,827 acres 87 new cottages and 70 new sets of farm buildings; 43 cottages have been substantially altered and improved, and the homesteads and buildings which were on the farms divided into small holdings have been remodelled to fit them for the use of 92 smallholders. In order to meet urgent requirements of the military authorities large quantities of fuelwood for the Expeditionary Force in France and Flanders were supplied from New Forest and the Wood Distillation Works, Dean Forest, and a small quantity from Tintern Woods. Charcoal burning was carried on in New Forest, Bere, Parkhurst, and Alice Holt Woods, Dean Forest, and Highmeadow, and Tintern Woods, and large quantities of charcoal supplied for use in the trenches. Increased quantities of pit timber have been sold from Dean Forest and Tintern Woods. It is intended to use Dean Forest, about 18,700 acres, and the Highmeadow, Abbotswold, and Clearwell Woodlands, as a forestry demonstration area. A school for forest students and an office for the deputy surveyor and director, Mr. L. S. Osmaston, are being erected, and the school for woodmen students at Parkend has been extended.

French Artists and the War is the subject of one of the opening exhibitions of the autumn season at the Leicester Galleries, Leicester Square. Among those contributing appear such famous names as Forain, Steinlen, Leandre, Hermann-Paul, and Willette; but perhaps the most novel feature will be a number of sketches sent direct from the front by artists now serving in the trenches. This exhibition will open on October 2, and on the same date a series of fifty war cartoons, entitled "The Kaiser's Garland," by Mr. Edmund J. Sullivan, will be shown in these galleries.

In 1908 there were discovered in the archives of the New York Historical Society the original drawings by John McComb from which the New York City Hall was erected. While the exterior of this notable building has withstood the hand of vandals in all of the more important features, the interior has not been so fortunate, says the *American Architect*. Every passing administration had, up to recent years, worked its will until little, if anything, was left of the finely designed interior detail that was as correct in its essential qualities as is that of the exterior. The fortunate recovery of these working drawings made it possible to set about the correct restoration of the interior and to replace the

garish and poorly executed work that had found lodgment there with an exact replica of the original. Through the generosity and public spirit of Mrs. Russell Sage, funds were provided some three years ago for a complete restoration of the Governor's Room on the second floor. This work was executed, under the direction of Mr. Grosvenor Atterbury, and completely fulfilled the expectations of those who had the project in charge. A second instalment of restoration, also under the direction of Mr. Atterbury, has just been finished. Under the supervision of the Municipal Art Commission there has been going forward for some time a complete overhauling of the City Hall, with the intention to restore it, as far as possible, to its original state. The Mayor's office, reception room, and that part in the easterly wing on the first floor has been completed.

At the meeting on Saturday of Bettwsy coed Urban District Council a letter was read from Private W. O. Hughes, the sanitary inspector, who recently joined the Army, applying that half his salary as the council's inspector be paid during the war, as he had to keep a widowed mother. Mr. Faichney: We made him an offer of £10 per annum during the war, but he refused it and left without any arrangement being arrived at. The Chairman: We have thousands of men in the trenches, in France, and the Dardanelles who are fighting for their country without any other remuneration than their wages as soldiers. Why should Hughes be paid more than the others? The times are too hard to pay for nothing. It was decided to repeat the offer of £10 per annum during the war.

In the Journal of the Royal Institute of British Architects there is published this week a sixteenth list of members, licentiates and students who have joined H.M. forces for the period of war, the total to date being 45 Fellows, 334 Associates, 165 Licentiates, and 212 Students. There are also given the following particulars of architects who have been wounded:

Albert E. Kirk, F.R.I.B.A., lieutenant-colonel commanding 7th Bn. West Yorks Regiment. Wounded in the trenches in France on August 28. In hospital in London and progressing favourably.

Cecil Grellier, student, 2nd Lieut., 10th Bn. Hampshire Regiment. Wounded in Gallipoli on August 10. In hospital at Alexandria and progressing favourably.

Basil White Ridley, student, Captain, 7th South Lancashire Regiment. Wounded in the trenches in Flanders on September 3. Now in England and going on well.

Geoffrey William Ridley, A.R.I.B.A., Lieut., 4th Royal Sussex Regiment (brother of Capt. B. W. Ridley above mentioned). Wounded in the Dardanelles on August 15 and sent home. Recovering, and hopes to return to the front very shortly.

Robert William Pite, student, name-corp., R.E. (son of Mr. W. A. Pite, F.R.I.B.A.). Seriously wounded in Gallipoli on August 7. In hospital at Cairo.

Sub-Lieutenant Aldersey Ducken, L.R.I.B.A., of the R.N.V.R. Drake Battalion, died on the 12th inst. while on service.

A picture house is to be built at the corner of Caledonian Street and Dumbarton Road, Dabnuir, from plans by Mr. William Inglis, architect, West George Street, Glasgow.

Mr. Arthur Race, borough engineer and surveyor, Barrow-in-Furness, has been appointed to a similar post at Blackburn at a salary of £800 a year, in succession to Mr. W. Stubbs, retired. There were fifty applicants for the post.

The work begun in 1913 for the electrification of the London and South-Western Railway suburban lines within fifteen miles of Waterloo Station is nearly completed, and the section from Waterloo, via Southfields, to Wimbledon, and thence by the circular route through Kingston and Richmond to East Putney, will be ready for traffic in two or three weeks. The Shepperton section will be opened at the same time. These will be followed by the Hounslow loop line and the Hampton Court and Claygate branches. The length of these routes is about forty-seven miles.

TO CORRESPONDENTS.

We do not hold ourselves responsible for the opinions of our correspondents. All communications should be drawn up as briefly as possible, as there are many claimants upon the space allotted to correspondents.

It is particularly requested that all drawings and all communications respecting illustrations or literary matter, books for review, etc., should be addressed to the Editor of the BUILDING NEWS, Elingham House, 1, Arundel Street, Strand, W.C., and not to members of the staff by name. Delay is not infrequently otherwise caused. All drawings and other communications are sent at contributors' risks, and the Editor will not undertake to pay for, or be liable for, unsought contributions.

Drawings of selected competition designs, important public and private buildings, details of old and new work, and good sketches are always welcome, and for such no charge is made for insertion. Of more commonplace subjects, small churches, chapels, houses, etc., we have usually far more sent than we can insert, but are glad to do so when space permits, on mutually advantageous terms, which may be ascertained on application.

When favouring us with drawings or photographs, architects are asked kindly to state how long the building has been erected. It does neither them nor us much good to illustrate buildings which have been some time executed, except under special circumstances.

Telephone: Gerrard 1291.
Telegrams: "Timesover, Strand, London."

TERMS OF SUBSCRIPTION.

One Pound per annum (post free) to any part of the United Kingdom; for the United States £1 6s. 0d. (or 6dols. 30c. gold); To France or Belgium £1 6s. 0d. (or 3fr. 30c.); To India, £1 6s. 0d. To any of the Australian Colonies or New Zealand, to the Cape, the West Indies, or Natal, £1 6s. 0d.

Our Direct Subscription Agents for Australia are Messrs. E. T. Kibblewhite and Co., Printers and Publishers, 19, York Chambers, 105, Liverpool Street, Sydney, New South Wales; for Japan, The Maruzen Co., Ltd., 11-16, Nishiashi Tori Sancho, Tokyo, who will receive Subscriptions at £1 6s. 0d. per annum on our account. Copies of the paper will be sent by us direct to the subscribers' address.

The special rate to Canada is £1 3s. 10d. = 5dols. 80c. for 12 months, and 11s. 11d. = 2dols. 60c. six months. Our Direct Subscription Agents for Canada are Messrs. Sells, Ltd., 302, Shaftnessy Buildings, McGill Street, Montreal, who will receive Subscriptions, £1 3s. 10d. per annum, on our account.

Cheques and Post-office Orders to be made payable to THE STRAND NEWSPAPER COMPANY, LIMITED, and crossed London County and Westminster Bank.

ADVERTISEMENT CHARGES.

The charge for Competition and Contract Advertisements, Public Companies, and all official advertisements is 1s. per line of Eight Words, the first line counting as two, the minimum charge being 5s for four lines.

The charge for Auctions, Land Sales, and Miscellaneous and Trade Advertisements (except Situation Advertisements) is 6d. per line of Eight Words (the first line counting as two), the minimum charge being 4s. 6d. for 50 words. Special terms for series of six insertions or more can be ascertained on application to the Publisher.

SITUATIONS VACANT AND PARTNERSHIPS.

The charge for advertisements for "Situations Vacant" and "Partnerships" is One Shilling for Twenty-four Words, and Sixpence for every Eight Words after. All Situation Advertisements must be prepaid.

SITUATIONS WANTED.

Advertisements not exceeding Thirty Words, inclusive of name and address, are inserted under the heading "Situations Wanted," free of charge.

Rates for Trade Advertisements on front page and special and other positions can be obtained on application to the Publisher.

REPLIES TO ADVERTISEMENTS.

Replies to advertisements can be received at the Office, Elingham House, 1, Arundel Street, Strand, W.C., free of charge. If to be forwarded under cover to advertiser, an extra charge of Sixpence is made. (See Notice at head of "Situations.")

Advertisements for the current week must reach the office not later than 3 p.m. on Tuesday. Front-page advertisements and alterations or stop orders for serial advertisements must reach the office by first post on Monday to secure attention.

RED. H. and G. H. C. C. E. W. C. G. and Son, B. E. F. R. W. and Co. C. P. K. and Co. L. J. T. A. W. A. and Co. W. G. F. W. J. B. G. and Co. P. Y. O. Co. Ltd. C. W. H. C. B. Ltd. W. S. C. C.

R. G. H. Yes.
DATA.—Please send.

D. P. E.—Little demand just now.
S. S.—There are some very good classes near you at the City of London College, Moorfields, E.C.

A TIMELY REMINDER. Architects, builders, and others are reminded that the BUILDING NEWS is now published on Wednesdays instead of Fridays, at 2 a.m., and that it should be obtainable early in the day anywhere. If delay occurs it can be posted direct from the office on receipt of a quarter's subscription, or single copies can be similarly sent to readers in camp or moving about the country.

J. R. S.—We prefer flange joints for large gutters. They are a little dearer than sockets, but well

... ..
... ..
... ..
... ..
... ..
... ..

TO ARMS!

4th Battalion "Architects'") Central London Regiment Volunteers.

Recruits are urgently needed for the 4th Battalion, Territorial and Auxiliary. Information regarding should apply to Battalion Headquarters, where they will be advised as to the branch of the Service in which they are best suited.

ORDERS FOR THE WEEK BY LIEUTENANT COLONEL A. W. WARDEN, COMPOSITE MILL, LING.

A meeting of the Civil and Military Committee is called for 7.15 this evening (Wednesday) at Battalion Headquarters, 4, Tottenham Court Road.

GENERAL PARADE.

Saturday, October 2, at new Drill Headquarters, Chester House, Euston Place, at 2 p.m.

INTERLACING.

Members who have volunteered for this work receive written instructions regarding hour of parade, etc.

DRILLS AND PARADES.

"A" Company, Tuesdays, Manufacture Range, Gaslight and Coke Company's premises, Monk Street, Westminster, 7 to 8.30 p.m.

Wednesdays, Company Parades, 5.15 to 7.15 and 6.15 to 8.15 at new Drill Headquarters, Chester House, S.W.

Thursdays, Signalling at Chester House. See orders from Acting Battalion Signalling Sergeant, Chelsea.

"B" Company, Manufacture Range and Company Parades as for "A" Company. See orders at Local Headquarters.

"C" Company, See orders local Headquarters.

Parade "A" Athletic Ground, Boreham Wood.

"D" Company, Platoon and Section Drill at "Merers" School, Holborn, Tuesdays and Thursdays, 6.45 p.m. Company Parades, Wednesdays as for "A" Company.

SCHOOL OF ARMS.

Drill Headquarters, Chester House, Euston Place, S.W. Instruction in bayonet fighting, gymnastics, physical drill, boxing and single sticks on Tuesdays from 6 to 8 p.m.

RECREAT DRILLS.

"A" Company, Chester House, 5.15 and 6.15 Wednesdays and Fridays.

"B" Company, Dulwich College, Mondays 8 to 10 p.m. and Thursdays 6 to 8 p.m.

"C" Company, Boreham Wood and Elstree District, Headquarters, "A" Athletic Ground, Boreham Wood. For full particulars apply to Alan Potter, Grey Gables, Boreham Wood, Herts.

"D" Company, "Merers" School, Tuesdays and Thursdays, 6.45 p.m.

CORRESPONDENCE.

Special attention of members is drawn to the fact that correspondence should be answered by return. If this is not attended to the other work of the Corps is immensely increased. Enrollment forms of new members and all correspondence not referring to recruiting for the Army to financial matters must be addressed to the Adjutant, 29, Conduit Street, W., and regarding recruiting for the Army to the Recruiting Officer at Battalion Headquarters, and regarding accounts and subscriptions to the Paymaster, W. B. Hughes, 136, Doshwood House, E.C. by Order.

L. R. GUTHRIE, Adjutant.

BATTALION HEADQUARTERS,

18, TITTON STREET, WESTMINSTER, S.W.

MEETINGS FOR THE ENSUING WEEK

THURSDAY Royal Photographic Society's Exhibition, "Glenister Cathedral," by Henry W. Bennett, Suffolk Street Gallery, Haymarket, S.W. 8.30 p.m.

A mission hall is about to be built in Blaenavon in connection with St. Paul's Church from plans by Mr. G. A. Treheron, of Aberdare.

Since the passing of the Education Act, 1914, a sum of £1,668,349 13s. 1d. has been expended in providing school accommodation and equipment in Leeds.

The North-Eastern Railway directors have decided not to appoint a docks engineer, in succession to the late Mr. Charles Watson, at present, Mr. Charles F. Bengough, the chief engineer of the company, will for the time being take charge of the dock engineering work, in addition to his own work.

A Hull firm of architects sent in a bill for £49 10s. for plans prepared but not carried out to the Driffield Board of Guardians. The guardians offered fifteen guineas in settlement. The firm replied they would accept twenty guineas, and this compromise was agreed to in settlement of the charges for plans and specifications. A guardian remarked that the plans would never be carried out in the lifetime of present members.

LATEST PRICES.

N.B.—All prices must be regarded as merely approximate for the present, as our usual sources of information are in many cases falling as.

TIMBER.

Owing to stoppage of supplies all prices have advanced considerably.

IRON.

Table listing iron products such as Rolled Steel Joists, Wrought Iron Under Plates, Steel Girder Plates, etc., with prices per ton.

Table listing iron products such as Cast-Iron Columns, Cast-Iron Stanchions, Rolled-Iron Fencing Wire, etc., with prices per ton.

Table listing iron products such as Cast-Iron Socket Pipes, Wrought-Iron Tubes and Fittings, Gas-Tubes, etc., with prices per ton.

OTHER METALS.

Table listing other metal products such as Lead Water Pipe, Lead Barrel Pipe, Lead Pipe, etc., with prices per ton.

I BUY SCRAP METALS

ARTHUR P. COLLINS, Snow Hill, BIRMINGHAM. Central 250. Telegram: Metals Birmingham. Bankers: The National Provincial Bank of England, Ltd., Bennett's Hill, Birmingham.

SLATES.

Table listing slate products such as Blue Portmahoe, Blue Bangor, First quality, etc., with prices per 1,000 sq. ft.

Table listing brick products such as Eureka unfaling green, Permanent Green, etc., with prices per 1,000 of 1,200 at r. stn.

BRICKS.

Table listing brick products such as First Hard Stocks, Second Hard Stocks, Midd Stocks, etc., with prices per 1,000 alongside.

GLAZED BRICKS.

Table listing glazed brick products such as White, Ivory, Buff, Cream, etc., with prices per 1,000.

MOULDED BRICKS.

Table listing moulded brick products such as Compass bricks, Majolica or Soft Glazed Stretchers, etc., with prices per 1,000.

STONE.

Table listing stone products such as Red Mansfield, Darley Dale, Red Corsehill, etc., with prices per foot cube.

Table listing stone products such as Bath Stone, Portland Stone, White Basebed, etc., with prices per foot cube.

TILES.

Table listing tile products such as Plain red roofing tiles, Hip and Valley tiles, Broseley tiles, etc., with prices per 1,000 or per doz.

OILS.

Table listing oil products such as Rapeseed, Olive, Seal, Cocoa nut, etc., with prices per ton or per barrel.

GLASS (IN CRATES).

Table listing glass products such as English Sheet Glass, Fourths, Thirds, etc., with prices per 100 sq. ft.

VARNISHES, Etc.

Table listing varnish products such as Fine Pale Oak Varnish, Pale Copal Oil, etc., with prices per gallon.

Mr. Osmond Cattlin, assistant borough surveyor of Holborn, has been gazetted as lieutenant in the London Sanitary Company of the R.A.M.C. (T). Doncaster Rural District Council have decided to make application to the Local Government Board for authority to prepare a town-planning scheme with respect to lands and premises comprising portions of the parishes of Arnthorpe and Kirk Sandall, having a total area of 4,560 acres.

and inoffensive, but those to Raleigh Street and Frankfurt Street show an excess of glass and iron treatment which is unadvised for, and surely a judicious competitor introducing a little more mass might have been adopted. This is, however, a well-thought-out scheme with many good points to recommend it.

THE £50 PREMIATED DESIGN.

The main individuality which characterises design No. 10, by Mr. H. S. East, of Gray's Inn, awarded £50, is the radiation of the internal walls to tally with the converging lines of Raleigh Street and Frankfurt Street. This is an arrangement which cannot be said to look well on paper, and in view of the endless obliquities involved, it certainly would not work out satisfactorily in practice. The departments, too, in some cases are rather badly cut up, notably the drapery and furnishing, but the restaurant is well managed on the second floor, with practically no waste space. The elevations show a continuous ground floor of plate glass with narrow metal uprights, devoid of a vestige of masonry and surmounted by a series of piers and arches running through two stories, filled in with iron windows. A cornice and brick blocking course over this is crowned by a two-story mansard roof-line thickly studded with dormers, suggesting that the building is divided into three distinct portions in a not over-pleasing manner; but the elevations to the area have had much care and thought expended on them, and many other details have been very well considered.

THE £25 PREMIATED DESIGN.

Messrs. Frank Bethell, M.S.A., and C. M. Swannell, of Broad Street, London, have secured the third premium of £25, with design No. 27. These architects have approached the problem from quite a different standpoint, and provide a great circular staircase and light well, with areas on each side. The shops present ample opportunities for the display of goods, but there is a falling-off in the arrangement of the basement and stores, whilst the upper floors make doubtful solution of the problem. The elevations also are lacking in the restraint necessary for such a building; they do not convey the "business" idea embodied by the winner, the Neo-Grec on which their scheme is based, with a suspicion of Rococo in its lines, being somewhat unpalatable.

Before passing on to a few of the other 92 designs submitted it may be remarked that many of the competitors appear to have lavished their best efforts on the Raleigh Street South elevation, apparently because the assessor, merely for convenience, suggested this front for the detail drawing. This was clearly on account of size only—the important elevations, if either need emphasis, are those facing Frankfurt Street and Courtney Street.

With reference to the remaining designs, the names of the competitors were not disclosed, and they can only be referred to under their distinguishing numbers; access to them, moreover, was extremely difficult owing to the fact that they are at present huddled together in a small room. It is therefore more than probable that some of the better ones could not be seen; but among the visible ones No. 12 stood out strongly with a very well worked out refined Classic treatment and a nicely designed green tile roof. The basement railway is well arranged, although possibly the lighting is not perfect. The restaurant floor is also excellently well disposed, and the elevations are of quite exceptional merit, the show space being ample, and the moulds of support, especially not encroaching unduly, creating a feeling of security. It is rather

difficult to understand why this design was overlooked in making the awards, as it appears to be amply deserving of a premium.

Other designs which struck us as being worth more attention were Nos. 4, 2, 50, 25 (with a good double slope to counteract the trouble of vans meeting from different directions), 96 and 95; but in the absence of any information as to the authors' names, further criticism would be somewhat pointless, and impossible of identification by our readers.

"BUILDING NEWS" DESIGNING CLUB.

AWARD OF PRIZES FOR SESSION 1914-1915.

The record of our Designing Club has been continuous since it was started forty years ago, and even during the present war time its work has proved an almost unqualified success. The numbers of our competitors naturally fell somewhat short of those of previous years, and, for obvious reasons, towards the close of the session 1914-5 competitors failed to reach the high level invariably maintained hitherto in normal times. Business could not be "as usual" with so many students, assistants, and young architects fighting for their country or gone on active service. But we are able to say that in spite of this depletion in numbers the standard of merit, which has all through our Club's career distinguished the designs submitted, has been upheld, for the contests month by month were each excellent and showing sustained effort against odds. Eight subjects were set in the following periodical sequence, and each subject was illustrated in the order of the dates enumerated after the titles of the subjects, as printed in the following table:—October, 1914—A, "Gatehouse in a Street" (illustrated November 20, 1914). November, 1914—B, "A Small Market House" (December 18, 1914). December, 1914—C, "Headquarters and Drill Hall for a Country Town" (January 22, 1914). January, 1915—D, "A Small Labour Exchange" (March 5, 1915). February—E, "A Co-operative Hostel for a Garden Suburb" (April 2, 1915). March—F, "A Small Social Club for Airmen and their Friends" (May 28, 1915). April—G, "Church Christ Scientist" (June 16, 1915). May—H, "A Garden Pavilion and Boat-house" (July 21, 1915).

In these competitions "September Morn" submitted designs each time, and also always scored a place—twice first, four times second, and twice third—thus gaining 32 marks. "Wallbroke" was once first, twice second, and three times third, scoring 20 marks. "Penwith" runs him closely by taking the first place twice, once second, and once third, giving a record of 13 marks. "Why" was twice first and twice fifth. "Bournemouth Queen" stood once second, once fourth, and once fifth. "Thistle" and "Kitch" both won "first place" on one occasion, but their names do not occur again among the premier ranks. "Tonnelier" we thought would have done better, judging by his evidence of ability, but somehow he only figures third once and fifth once. "Thistle" joined in one competition, and then he took the first position, like a flash in the pan.

This tabulation decides the results, and it is evident that the awards must stand as follows:—

First prize of £10 10s.: "September Morn"—Mr. H. W. Smith, care of Mr. E. W. Allfrey, M.A., 57, High Street, Oxford.

Second prize of £5 5s.: "Wallbroke"—Mr. W. Brooke, care of Messrs. R. Castle and Son, architects, London City and Midland Bank Chambers, Cleecheaton, Yorks.

Third prize of £5 5s.: "Penwith"—Mr. J. Clark, care of Messrs. Cowell and Dreyatt, architects, Leonard's Chambers, Penzance.

Hon. mention is awarded to "Why" and "Bournemouth Queen."

Cheques for prizes, after verification, will be forwarded about October 30. Any alterations in the addresses of the prize-winners are, meanwhile, to be sent to the Editor.

MONT S. MICHEL, THE ABBEY OF THE ARCHANGEL, AND ITS SEA-GIRT TOWN.*

(Concluded from last week, p. 347.)

The eastern apse of the Crypt of the Great Pillars is deeply recessed, and has two windows with raised window seats. The door by the side leads down into a large hall which was the Justice Chamber of the abbot, but at present its fine timber roof is hidden by a flat ceiling put in when the Abbey was a prison, and the room is full of rubbish. On the north side of the rock, at about the same level as the substructures, is this fine crypt of the North Wind, as it is called. It was built by Abbot Roger II. soon after a great fire which destroyed much of the Abbey in 1112. It was used as the Almonry until the large one was built in the Marvel. The capitals and bases of the columns have a rugged simplicity and directness about them which is particularly charming, and at the further end you can see another mass of the original rock still left above the floor for no apparent reason. Much of the right hand wall in this crypt is the native rock cut to a flat face, against which the massive piers which carry the vaulting are built, and the stairs we see lead up to the room above, called The Promenade. This was the original cloister of the same date as the crypt below. Very different to any other cloister we know, this is but just one long gallery, with high windows looking away over the sea to the north. It consists of two aisles about 97 ft. in length. The columns originally supported a wooden roof which carried the floor of the dormitories above, and this graceful vaulting was added about a century later. The caps of the columns are carved with plain bold leaves, with the exception of one near the middle of the room. And on this one the carver-monk has done his best to perpetuate his idea of a twelfth century Mr. Nobody. And now we have arrived at the top of the great flight of steps to a platform level with the floor of the church. This platform, from which we can get a grand view southward, is called the Saut-Gualtier, or Walter's Leap. Walter was a young sculptor, who, in a fit of madness, threw himself down the rock from the parapet here. Here is the south door of the church at the western end of the nave. It is of the 13th Century, with a deeply moulded arch, the tympanum of which once held a carving of St. Michael slaying the dragon. Just round the corner is the great western platform, beneath which is the Chapel of Our Lady Underground. This west front of the church was built in 1776. The church had extended three bays more to the west, but they were taken down owing to their ruinous condition; and here, in what had been the floor of the western nave, were found the graves of two of the earlier abbots, one of whom, Robert de Torigni, did so much for the building of the Abbey. And here was buried that Duke Conan of Brittany who refused to do homage to Duke William, so that he, with Harold and his followers, set off to the Mount to punish him, with the result that many of his knights were lost in the quicksands, as we see portrayed in the Bayeux tapestry. Entering the west door we look along the whole length of the church to the east. The nave is now of four bays, three of which have the top of the rock immediately below the pavement. This nave is very early in date, for it was begun by Abbot Hildebrand II. in the year 1025. The church is no longer used, and while it was part of the State prison it was robbed of its monuments, screens, and other decorations which we expect to find in every great church. So that as we stand in the chancel we see that we have only the bare walls and an uninterrupted floor space. The great piers at the crossing which carry the tower were built in 1058. The nave was never vaulted in stone, and the present wooden waggon vaulted roof is of quite recent date. As we look along the nave arcading it has quite a familiar appearance, being very similar to

* By H. W. Fincham: a lecture, illustrated by 120 photographs by the author, delivered at the Exhibition of the Royal Photographic Society in the Suffolk Street Gallery, Haymarket, S.W., Sept. 28, 1915.

several of our Norman cathedral naves, but we must remember that it is nearly 100 years earlier than most of our great Norman churches. The piers, simple, with a great vaulting shaft running up the face of each to the roof. The triforium is small and heavy, and in the clerestory we have one simple round arched window in each bay. Up in the triforium we see how each bay is divided into two round arches with a central pier, and again subdivided with a little round column and simply carved caps. The south aisle of the nave looks quite homelike to an Englishman, and this picture would do almost equally well for the south aisle of Ely nave; the vaulting is almost identical, but instead of the great round columns we have here a square pier with a half-round

until 1211 that the choir was completed. It has a very noble effect with its lofty arches, and the fine and many lines of the mouldings running right round the arches without any capitals such as we should find at home. The triforium is not by any means a blind story, and the clerestory is very high, and its windows are as graceful as can be. This photograph picture shows us the capital of one of the great piers of the tower of 1093, and by its side we see the beautiful detail of the triforium. Although the material is the hard granite used all over the building, this tracery is as finely wrought as if it had been cut in a fine soft stone. The choir aisle runs entirely round the apse, forming an ambulatory from which a number of little chapels open out. Here you see the

They are varied such as the fine soft stone of Caen, and have been richly carved. It is one representation of the Expulsion from the Garden of Eden, with the Serpent, the human form, looking from the tree. And the other represents the Resurrection. We see our Lord rising from the grave, as they rise from the grave, while the broken arch and the Dove, as a dragon, represents the fall of the world. In a south chapel dedicated to Our Lady of Pity is a panel of the four Evangelists, writing the Gospels; on the right St. Matthew has a charming little angel, holding his inkpot; the next, St. Luke, holds his own inkpot, while his winged bull takes no interest in the business; the third, St. John, has his eagle minding the ink, while on the left St. Mark has no inkpot, and either uses a fountain pen or borrows an occasional dip from one of the others. Almost the only other object left behind at the clearance is this beautiful rack across the entrance to the east chapel. It is very delicately carved in oak of Late Gothic or almost Renaissance character. The gates are very rich in carving with shields of the see and some of the abbots. This great bell, which blocks up a large portion of the east chapel, was given to the church by Karg de Rebanbourg, a German baron, when Louis XIV. made abbot in 1703. It was specially used to guide the pilgrims and fishermen across the sands in foggy weather. This telephotograph shows us the apex of the vaulting of the apse, the boss of which is carved with the Royal Arms of France, surrounded with the collar of the Saint Esprit; then we have a representation of St. Michael slaying the dragon; and the lower shield bears the arms of the Abbey, with the fleur de lis of France and the scallops of Brittany. We will now visit that grand building on the north side of the rock, which from its earliest time has been known as The Marvel, so wonderfully has it grown up from the rock, and such magnificent halls does it contain. It consists of three floors, each of which is divided into two halls. This western room of the bottom story is the cellar of the monastery, and dates about 1120; it has been called the Montgomerie in memory of a dark deed that happened here in 1591. The Abbey was being besieged by the Huguenots, under the Sieur de Montgomery. He had bribed an inmate of the Abbey to admit his soldiers by hauling them up to this room by means of a great wheel, similar to the one I showed you just now, but which was used on this side to haul up water from the well of St. Aubert. On the night of the Feast of Michaelmas, when the monks were chanting their office, the besiegers crept up the face of the rock and were hauled up in twos and threes to this room, where they were quietly led within and stabbed to death. Seventy-eight of the Huguenots thus went to their doom, one only being kept alive, by name Rablotiere. At last Montgomery, hearing no noise of fighting above, became anxious, and cried out if all was well. The Governor led Rablotiere to the wheel, and promised him freedom if he would entice the others up, but the brave man shouted down that they were betrayed, and the horror-stricken Huguenots hurried away. It is pleasant to know that the Governor, touched to the heart by this splendid act, gave Rablotiere his life and freedom. The eastern hall is the Amory; here the monks daily dispensed food and alms to poor pilgrims. You see it is a fine vaulted hall of two aisles divided by well-proportioned columns, and, like the cellar, it dates from the early part of the twelfth century. Here the present day pilgrims wait for carts for the guides, and while away the time in addressing postcards which they carry off at a counter at the end of the hall. The second story is also divided into two, the eastern half being the Guesten Hall. The work is approximately of the last decade of the twelfth century, and is much more airy and graceful than the hall below. Unfortunately, at the time of my visit the hall was being restored, and was filled with scaffolding. At one end of the hall are two enormous fireplaces side by side, which must have been very welcome to the guests arriving on a wintry day. This picturesque passage con-



MONT S. MICHEL, FROM THE SOUTH.
(From a photograph by Mr. H. W. Puchan.)

shaft on each face. And all the time we must remember that this is about eighty years earlier than Ely Cathedral. On the right of this picture we have a little chapel on the east side of the south transept, which at one time held many relics of St. John the Evangelist; and then we look along the south aisle of the choir, with its vaulting of the latest period of Gothic architecture. The north transept is of the same style as the nave, but the window is of the 13th Century, and the circles in the head show that tentative feeling towards some means of lightening the upper part of the window, the result of which we shall see in the beautiful Flamboyant windows of the choir. The old Romanesque choir fell down in 1421, and this present choir was a long time building. They had first to construct the Crypt of the Great Pillars below, and it was not

great number and richness of the mouldings of the piers, which split up and form the ribs of the vaulting without any break whatever. In the south ambulatory we see the beautiful bases of the piers very high, as we get them in our own Late Gothic, with the horizontal mouldings intersecting the bases of the many deeply cut shafts, which, like a great bundle of reeds, go to make up each of the great piers of the choir. Against the middle pier we see a holy water stoup, not an after thought, but designed and built into the pier while the work was rising. In the little chapel we see the vaulting ribs dying into the wall without any of the vaulting shafts such as we should find in England. Although practically the whole of the decorations of the church have disappeared, there are still left in one of the northern chapels two carved panels of Renaissance character.

Wester Hall, with the western wall some floor. This is known as the Hall of the Knights of St. Michael. The Knights of St. Michael gave them this room as their resting place. It consists of four finely decorated bays, divided by three rows of columns, which are as majestic as can be imagined. The Hall of the Knights, one of the grandest in the world. On the north wall, between the windows, are two large niches, which, filled with blazing candles, have looked very noble. See the graceful treatment of the vaulting and the fluted shafts rising from the top of the great pyramidal chimney. The pictures to be obtained in this wonderful hall are endless, and this one gives you an idea of the beautiful lighting effects one gets as the setting sun streams in at the western windows. Before the creation of the Knights of St. Michael this hall was the Scriptorium, where the artist monks worked at those gloriously illuminated missals and service books which were used in the churches, and which are now the prizes of the millionaire collector. Here in detail is one of the capitals of the columns, and when we remember that they are wrought in hard and coarse granite, we wonder at the skill of the carver who produced such graceful work in such a difficult material. On the north side are delightful balconies, corbelled out from the wall, where the monks could look out over the top of the little wood and away out to Tombelaine and the open sea. And now we have arrived at the top story of this marvelous building; the eastern half is this great hall, the Refectory, or dining hall of the monks. It was not vaulted in stone as the others were, for there is no weight above to carry, and vaulting would greatly increase the weight on that below. The lighting of the hall is most brilliant, although its many windows, tall and narrow, are almost invisible, being placed on the outer face of the wall; here on the left is the pulpit, an important item in the Refectory. For here a monk read from the Lives of the Saints or some other holy book while his brethren dined. This was intended to prevent their thoughts being led away to worldly things, but probably the drone of the reader only helped to cover the inevitable chatter of a large dinner party. The Refectory opens immediately into the Cloister, a courtyard 21 ft. by all the many windows of the Mount, one of the most perfect and beautiful cloisters in the world. This really wonderful cloister was built between the years 1220 and 1225. The arcade consists of two parallel rows of columns and arches which alternate with or overlap each other, and are connected by diagonal ribs forming a triangular vaulting which is unique and most beautiful in design. The cloister garth, instead of being of grass-grown earth, is a granite floor, covering the Hall of the Knights immediately below. This view of the north walk gives you some idea of the beauty of the alternating arcade which on the inner side is covered with the most delicate and charming carving it is possible to imagine. It is here that we find the only departure from the use of the local granite, for this arcade is all carved in the soft and fine-grained Caen stone, about the only material possible for such delicate work. The roof is a simple barrel vault in wood, doubtless for the need of keeping the masonry at this great height as light as possible. This north walk has a row of small and simple one-light windows set deeply in the thickness of the wall, which look away over the vast expanse of sands and the open sea. The outer walls are all of granite, and the arch mouldings of the arcading upon them are of singular depth and beauty, considering the hardness of the material. The small door in the corner is that of the Chartria or Monument Room; it is now a little museum of interesting objects found about the Abbey, and contains beautiful vestments, rings, and chalices from the graves of the earlier abbots. In the south walk, against the wall of the church, are the lavatories of the monks, and the square holes in the lower part were for the ceremonial feet washing on Thursdays, and especially on Holy Thursday, when the

about washed the feet of all the monks, and here he also washed the body of a deceased monk before its burial. In the west walk is the door which was intended for the Chapter House which I told you was contemplated on the west side of the Marvel, but never built. There are three very richly moulded arches, and they would have made a most imposing entrance to a great Chapter House. They are now filled with glass, and we can look down and wonder at the boldness of the conception which proposed to carry up the masonry nearly 500 ft. from the base of the rock. Standing at the south-east angle we look along the arcading at the charming effect of the alternating columns and the delightful vaulting ribs between them. The columns and caps are of a kind of red marble called granitelle from a quarry on the main land near by, and were presented by the abbot of the old and celebrated Abbey of Luzerne, to whom the quarry belonged. These columns and capitals are, as you see, quite simple and plain, and so help to throw into great relief the beautiful work in the pinnacles above. Every spandrel between the arches is most richly carved in the highest possible relief, and here opposite the Refectory door was a crucifix, now much mutilated, but on either side is a beautiful mass of foliage, the nearest one is a lovely vine with the vine tender in its midst. The cornice is filled by richly carved bosses or paterae, every one different, and of most charming conception. Originally this wonderful carving was all richly painted and gilded, of which faint traces are still to be seen; but my own opinion is that we prefer to see the stone in its natural creamy-white colour. Opposite the door of the proposed Chapter House is a throned figure of Christ with censuring angels, and up in the cornice are four little beads, where the carvers, in the pride of their work, have commemorated their portraits, and in another part they have carved their names. It is pleasant to think that they each undertook the carving of a walk, and we can see how their striving to emulate each other has resulted in this magnificent display of the very finest carving of the thirteenth century. These next three sides show still more of the varied and beautiful ornaments carved upon the spandrels, and the row of little rose-like bosses above. The relief is as high as possible, and the undercutting is so complete that one wonders how some of the petals stand against the wind that whistles through the Cloister, and yet here it is after nearly seven centuries. Look in the cornice where the carver, tiring for a moment of regular shaped ornaments, has popped in that charming little owl, and in another place is a fine sea anemone with all its tentacles displayed and twisted into a circular pattern. The outside roof covering of the Cloister is of glazed tiles in alternating bands of black and yellow, modern, but said to be a faithful copy of the original tiling. Above we see the end of the north transept of the church and the great Romanesque tower. A telephoto picture of the east end of the church shows us the forest of pinnacles which cap the buttresses of the apse, and the many flying buttresses which carry the weight of the vaulting over the roofs of the aisle channels to the outer walls. Standing on the roof of the chapels we can see at close quarters these graceful flying buttresses which rise above us in three stages; one of these at the top of the picture carries a little staircase to the upper roof. Its charming open work triangular parapets has given it the name of the Escalier Dentelle or Lace Staircase. I wish I could show you more of it, but although I made several rather perilous climbs across the roofs to get a good viewpoint for the camera, I quite failed, and the best pictures of it were taken from a scaffold 12 or some years ago. Another telephotograph shows us the detail of the graceful fleche or spire which caps the great tower; this is of wood covered with lead, and is all modern work, being completed in 1899 from the designs of the architect, M. Petitgrand. Right on the summit stands this magnificent figure of St. Michael slaying the dragon. Nearly 14 ft. in height, it is made in beaten copper from the design of the eminent French

sculptor, M. Frémiet, and it stands 500 ft. above the level of the sands. And now on the highest ramparts let us look over the 100 square miles of the bay and watch the setting sun. The tide is low, and the river Couesnon, with the little streams of water running off the sands, make a wonderful pattern of curving lines, while the sun lights up the great expanse of the bay until the whole is like a blazing oval. An old custom was that no one was allowed to enter the church at night, as they believed that the angels met there and sing in the choir at midnight, while their effulgence illuminated the place. And one summer night as we strolled across the sands and saw the church standing out dimly against the midnight sky, we watched the long windows of the choir slowly lighting up until every pane was a blaze of brilliance, and one could almost think they heard the angels singing. Of course, it was but the rising moon reflected on the glass, while the wind hummed across the sand; but we could well understand how such a scene would appeal to the pilgrims trudging along in peril of the ever-changing quicksands.

And now that you have seen my pictures of this wonderful rock and the glorious Abbey of the Archangel, I think that you will agree with my quotation from Robert Louis Stevenson, that "mankind was never so happily inspired as when it built a cathedral," and that no more impressive site for such a building could be found as this little splinter of a rock in the midst of the great bay.

TOWN PLANNING AT SALFORD.

Mr. George L. Pepler, representing the Local Government Board, sat at the Town Hall, Salford, on Wednesday last, to hear the application of the borough corporation for permission to put into power the Housing and Town Planning Act of 1909.

Mr. L. C. Evans, Town Clerk, appeared for the corporation, and the scheme was strongly opposed on behalf of the Manchester Ship Canal Company, the Trustees of Booth's Charity, the Lancashire and Yorkshire Railway Company, and various landowners.

Mr. Evans said that the corporation were anxious to put the town-planning scheme into operation, and the land they proposed to include covered about 2,290 acres. It was situated in various parts of the borough, and was all land likely to be developed.

Mr. F. W. Platt, building surveyor to the corporation, in support of the application, said that had the Salford Corporation had the powers they now possessed forty years ago, Salford would have been a very different place. Apart from secondary streets, the main thoroughfares would have been made much wider and the people would have enjoyed three times the breathing-space they had to-day. Mr. Platt explained that since the opening of the Ship Canal there had been a considerable growth in the building of property, especially warehouses and workshops, and when normal times were reached again a much bigger growth was anticipated. On the Crescent area, where property belonging to the Booth's Charity was situated, there were some thirty-four different owners, and for uniformity alone it was necessary that the corporation should enjoy the powers given by the Act. This was once a residential district, but in course of time it would be all occupied by warehouses. In the north the development would be of a residential character.

The borough engineer, Mr. E. B. Martin, said the corporation was most anxious to assist landowners, and no obstacle would be put in the way of developing any of the plots. In other towns, he had found that owners had benefited considerably by the provisions of the Act.

For the opposition, Mr. Wallis, land agent and valuer to the Ship Canal Company, contended that the land belonging to the company, and shown on the plan, was already developed. The Canal Company had powers of their own, which he contended ought not to be interfered with.

THE BRITISH FIRE PREVENTION COMMITTEE'S FIRE WARNINGS.

We have from time to time called attention to the various "fire warnings" that have been issued by this committee in connection with the war emergency, but it does not seem to be generally understood that they can be obtained gratuitously within reasonable limits, nor are the various types of "warnings" available apparently known as well as they should be.

The "fire warnings" obtainable in poster form, printed in red, 8 in. wide, are as follows, and the reference number must be given in all communications regarding them:

For military and auxiliary military hospitals (No. 10).

For private hospitals, convalescent homes and hostels (No. 11).

For hospitals taking Belgian wounded: in French (No. 11a), in Flemish (No. 11b).

For Indian hospitals and depots: in Punjabi (No. 11c), in Urdu (No. 11d).

For refugee hostels (No. 12): in French (No. 12a), in Flemish (No. 12b).

For farmers (No. 14).

For troops billeted (No. 15).

For works and factories engaged on Government orders (No. 16).

For elementary and secondary schools, re air raids (No. 20).

For public schools and boarding schools, re air raids (No. 20a).

Re fires due to air raids (No. 17), for householders, etc.

Re fires due to air raids (No. 17a), as to dealing with incendiary bombs, etc.

All Government departments and military authorities receive the supplies of the "warnings" free.

Supplies of any "warning" are issued free to police forces upon the written request of the chief constable. Applications from constables or special constables connected with such forces cannot be considered.

A suitable number of copies of "warnings" No. 10, 11, 11a-11d, or 17a are obtainable free from the British Fire Prevention Committee by officers, doctors, or matrons of naval, military, auxiliary military, Red Cross, or St. John hospitals and civil hospitals or convalescent homes taking military patients, upon written application addressed to the registrar at 8, Waterloo Place, London, S.W., giving the full name of the institution, the number of beds contained, and the postal address.

Local authorities and school or refugee committees—as also the clergy and headmasters or headmistresses—requiring "warnings" No. 20 and 20a (for schools) or Nos. 12, 12a, and 12b (for refugees) will receive a suitable number of copies free upon written application to the registrar, giving the full name and postal address of the institution for which they are required, the number of pupils or refugees, subject to their enclosing a large-sized, addressed, and properly stamped envelope for despatching the necessary posters.

Factory owners, estate owners, farmers, shopkeepers, and householders requiring copies of the British Fire Prevention Committee's "warnings" must similarly enclose large-sized stamped and addressed envelopes for reply, but only receive a strictly limited number. Their communications cannot be attended to unless the return stamped and addressed envelope is provided, and in any case they are only dealt with in rotation of application after the requirements of the authorities have been met.

All communications as to "warnings" should be in writing addressed to the registrar, the British Fire Prevention Committee, 8, Waterloo Place, London, S.W., and not by caller or telephone. Over a quarter of a million posters have already been issued by the committee gratuitously.

FIRES DUE TO AIR RAIDS.

Don't wait until a fire occurs to find the best way out in the dark. Think of a way out beforehand.

Buckets of water (supplemented where feasible by ordinary hand pumps) are recommended as the most suitable and economical fire appliances, and, where oil or spirit is

used, also some buckets of sand. All buckets should be kept filled ready for use.

Pitchers and other minor household vessels should be kept filled ready for use, and where there are baths, wash tubs, etc., these should be kept filled so that a supply of water may be available independently of the water mains. Where there are garden utensils, such as syringes, garden pumps, etc., they should be readily accessible.

On no account should money be expended on powder extinguishers (tubes), glass hand grenades, or similar types of minor fire appliances at present being hawked about, and if provided they should not be relied upon.

Spirits or extinguishers containing carbon tetrachloride or similar chemicals, which are liable to form noxious gases, are unsuitable.

If portable liquid chemical fire extinguishers are desired, they should be of two or three-gallon capacity, and a written warranty should be obtained that they comply either with the specifications of the Board of Trade, H. M. Office of Works, the Metropolitan Police, or of this Committee, these specifications being mainly intended to prevent accidents from bursting.

Occupants should know how to use the available fire appliances efficiently.

Ascertain the quickest means of obtaining assistance from the fire brigade and police; post up the necessary particulars, nearest fire alarm, etc., on the ground floor, and do not

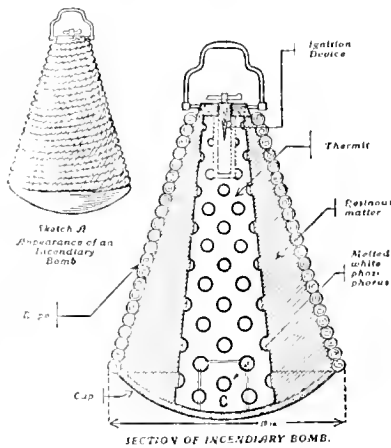

fail to notify any outbreak of fire immediately.

The ordinary explosive bombs employed by the enemy rarely cause a fire *per se*, but where a building is injured or collapses, fires are frequently caused by open lights or fires, etc., and their spread is assisted by escaping gas from broken mains or arcs from broken electric cables.

Fires thus caused indirectly by explosive bombs can, as a rule, be dealt with as ordinary fires in their incipient stage. Any gas or electrical supply not cut off prior to the outbreak should, if possible, however, be cut off at the earliest possible moment.

The incendiary bombs employed by the enemy readily fire buildings and their contents owing to the fierce nature of the flames and the molten metal generated by the chemicals used.

Fires caused by incendiary bombs may be prevented from spreading, regardless of the high temperature generated at the actual seat of the outbreak, if water be promptly applied in fair bulk, force and continuity, say, from a series of buckets energetically thrown, or hand pumps vigorously worked. Sand or loose soil similarly thrown might be useful in the absence of water, but would not have the necessary cooling effect. The application of single buckets of water, single shovels of sand, etc., would be comparatively valueless, a concentration of the available liquid first-aid appliances being required to obtain the necessary result.

In order to deal with fires from incendiary bombs, their make should be understood, and the following describes one of the types frequently used:—

The bomb, as a rule, is conical, of 10 inches diameter at the base, corded round, and has a metal handle at the apex (see A).

The base of a flat cup, on which a pierced metal funnel is fitted having a 2 1/2 inch diameter and handle fitted at the top.

The funnel is generally filled with Thermit which, upon ignition, generates intense heat and by the force of the concussion has taken the form of molten metal of the extraordinary high temperature of over 5,000 Fahr. The molten metal is spread by the concussion.

Outside the funnel is a padding of a highly inflammable or resinous material bound on with an inflammable form of rope. The resinous material creates a pungent smoke.

There is generally some melted white phosphorus in the bottom of the cup which develops nauseous fumes (see C). In some cases celluloid chippings are added and occasionally a small quantity of petrol.

The fumes from bombs are generally pungent. When poison gas is used it is often irritating and has a peculiar smell. A simple form of respirator that will cover the nose as well as the mouth, and can be readily damped, should be kept handy. Such a respirator can be made of a pad of cotton waste contained in gauze to tie round the head, the gauze to be of sufficient depth to also protect the eyes. The Metropolitan Police recommend that the cotton waste should be saturated in a strong solution of soda. Firemen and others whose duty it is to attend incendiary fires would do well to carry simple respirators in their uniform.

Further useful instructions are given in Warning 17a, which, as we have said above, can be obtained free from the Registrar of the Committee at the address given above, and should be posted conspicuously in every building in the Kingdom where danger is apprehended.

THE CASE FOR TOWN PLANNING.

This volume, intended for the use of councillors, officers, and others engaged or interested in the preparation of town planning schemes, contains the complete text of the schemes passed by Parliament for the Quinton, Harborne and Edgbaston, the East Birmingham, and the Ruislip-Northwood schemes, together with a complete explanation of the last mentioned scheme, supplied by the chairman and clerk of that council; a complete set of the forms and notices to be used by the officers of local authorities in all stages of town planning administration, together with the text of the Town Planning Procedure Regulations, both for England and Wales and Scotland; the annotated text of the Act, and the rules as to the Compulsory Purchase of Land.

A detailed description of the various stages of town planning administration follows: one hundred pages of the book have been devoted to this, and the following points are considered:—Section I. The preparation of the *prima facie* case for application to the Local Government Board for permission to prepare a scheme; II. The points to be considered in close detail when permission to prepare a scheme has been given by the Local Government Board, and the work of actual preparation has been placed in hand; III. The cost of a town planning scheme; IV. Co-operation with owners and the adoption of owners' plans; V. The preparation of the maps of the scheme; VI. The final stages of a town planning scheme; and VII. The administration of the Act in Scotland.

A history of the town planning movement, occupying a hundred pages, is followed by a consideration of various special points, including the fundamental principles of town planning, the desirability of town planning from the point of view of the landowner and the land developer, the cost of land development under town planning schemes, the cost of cottage building under town planning schemes, the possibilities of providing cottages for workmen under town planning schemes, the growth of the garden suburb movement and of public utility (or co-partnership) societies, the effect of town planning legislation on housing finance, municipal action in regard to the development of estates and the building of houses by muni-

"The Case for Town Planning," £79 pages, 4to (National Housing and Town Planning Council, 41, Russell Square, W.C. 15s. net.)

capacities, public utility societies and private enterprise, and the case for obligatory planning in urban and rural areas.

Upwards of forty illustrations are included in the book, including copies of maps No. 1 and No. 3, prepared in connection with actual schemes.

Currente Calamo.

Anything off the Budget is so much to the good, and we are not disposed to find fault with Mr. McKenna's remission of the plate-glass duty, especially as it saves us the trouble of analysing a sheaf of protests against the proposed duty of 9s. 6d. per cwt., which have gone to the waste paper basket. In this case it seems that the monopolist of the trade here was a Tariff Reformer, and that he as comfortably shed his own opinions as any Free Trader would, when they conflicted with his personal interests! It is perfectly true, of course, that most of our plate-glass comes from Belgium. It is equally true that more of it might and ought to be made here if makers were more enterprising. There is a field in this industry which is well worth the attention of capitalists who will spend time and money on up-to-date methods and make their existence known. Till then, we suppose, the Tariff Reformer will swear imported plate-glass is "raw material," as we all should if our own pet corn was crushed by the Protectionist boot.

There seems some likelihood that the conditions of the York Town Planning Competition will be amended, at any rate in some particulars, on the lines of the suggestions submitted by the Society of Architects. It will be remembered that the main lines embodied in these were:—That the deposit paid should be refunded to architects who decide not to compete, and that ordnance maps, etc., should be supplied to competitors free of charge; that the name of the assessor or assessors should be made known at once, and that the jury system of assessing should be adopted; that the premiums should be increased, and the successful competitor be employed on the present and future schemes at adequate fees, and that other competitors whose ideas are utilised should be properly remunerated. Although the council have not barred the competition, they anticipate that the views they have expressed and the action they have taken will commend themselves to the members. We hear that the deposits will be refunded, an assessor appointed at an early date, and Clause 14 amended by the omission of the author's *nom de plume* on the drawings. So far the premiums have not been increased, but the society's further communication on this point is still under consideration.

The Bankruptcy Report for the whole of last year gives a total of 215 failures of builders through the court and under deeds, as compared with 296 in 1913, showing a decrease of 81. Perhaps the most surprising thing is that there were so many builders left who thought it worth while to call their creditors together. Then it should be noted that the new Bankruptcy Law came into force on April 1, 1914, so that for eight months of last year conditions were different. Again, the Emergency Legislation, owing to the war, prevented many creditors from proceeding with their petitions, who were held up accordingly; though, of course, debtors could always make

themselves bankrupt, and the improved procedure under deeds of arrangement afforded the best facilities for a winding up to go on again. People are now wanting houses at about £50 a year very generally, while flats, at fair rentals, can be let before they are finished. Meanwhile the Government and the local authorities, in their strange perversity, discourage building. There is land everywhere ripe and ready for development, and there are builders willing to risk the high wages and prices; but capitalists are still shy of financing, and so private enterprise is stagnant. Old houses are fetching better rents than ever, and property all round is rising in value during this close time for builders.

There are numbers of interned enemy aliens still carrying on their business as usual in our midst, and, doubtless, doing so in the building trades. It may seem startling to the man in the street that a prisoner of war here can legally enter into contracts and make valid agreements, which, if necessary, he can enforce by action in our courts. Yet the judgment of Mr. Justice Younger in the important case of *Schaffenius v. Goldberg* (September 29) makes these points quite clear. The plaintiff had agreed to finance the defendant, a picture-frame maker, up to £500, with a view to his manufacturing their mouldings, of which the plaintiff was to have the exclusive supply. The plan was to capture German trade in this market, which, before the war, had controlled 98 per cent. of the whole output. They fell out in some way, and when the plaintiff was interned on July 1, the defendant refused to deal any longer with him as an enemy alien. Then plaintiff sued for damages for breach of contract, and defendant raised the point that plaintiff, being an enemy alien, and a prisoner of war, could not maintain an action in our courts. The judge held that, as he could legally enter into this agreement, he could also enforce it through the law. The Act against enemy trading only applied where this was done in an enemy country, which alone gave enemy character to the dealing. The plaintiff had a right to trade here, where he had acquired a commercial domicile, and his internment did not affect his civilian's right to make contracts, and, consequently, to enforce them in our Law Courts.

The new lighting regulations in London have led to a great rush for dark blinds, and many people have had much difficulty in getting either the blinds or the men to put them up. The increasing use of casement curtains in place of Venetian blinds means that many people have had to go to considerable expense in making provision to meet the police requirements, for casement curtains are of little use in screening lights. It is possible for householders with electric light to put on slipshades which throw the light down and prevent an outside glow, but where gas is used this cannot be done effectually or safely, nor can it in shop windows. As offenders can be fined any amount up to £100, the comparatively small expenditure to provide blinds for a fairly small house is an insurance likely to prove profitable, and should not be neglected.

The winter art exhibitions this year will mostly be held as usual. The Royal Academy have several suggestions before them, one being to exhibit a number of French pictures, including some from the Luxemburg. The International Society will open its exhibition on the 16th instant, and Mr. John

Lavery, Mr. William Strang, and other well-known members will be represented. Some of the portrait busts which M. Mestrovic, the Serbian sculptor, has done in England will be shown there, including the busts of Mr. Thomas Beecham and Lady Cunard. It was the International Society that first introduced M. Mestrovic's art generally to the London public, although some of his work had previously been shown in the art gallery of many of the Earl's Court exhibitions.

Bognor appears to have scored as regards the erection of cheap, decent cottages, according to a paper read at the South-Eastern District meeting of the Institution of Municipal and County Engineers by Mr. Oswald A. Bridges, the surveyor to the council. They are let at 4s. 6d. per week, and contain living-room, scullery, pantry, coals and water-closet on the ground floor, and three bedrooms on the first floor. The amount granted by the Local Government Board for the erection of this block of cottages was £150 each, but the lowest tender received was £179 2s., and the council therefore decided to do the work departmentally, and it was satisfactorily carried out for less than the estimated sum. Sixteen cottages of the same type were next built in two blocks in the same road by direct labour, but, owing to the extra foundations required in difficulties met with on the site, and the war breaking out before the completion of the work, the cost rose to £160 per cottage, for which an excess loan was granted by the Local Government Board. The council were fortunate in securing the land upon which these houses have been built at the low price of £5 10s. per plot of 15 ft., with a depth of 100 ft. The cottages are of decent elevation, with neatly paved forecourts, and it seems a pity that, "owing to a change in the policy of the local authority," no more are to be erected "for a time."

Whitechapel Parish Church, where a German bomb rendered innocuous, as we are reminded by the *Manchester Guardian*, has been presented to the rector for preservation as a memorial of the war, possessed a still more incongruous ecclesiastical ornament two centuries ago. In 1710 Dr. Welton, the High Church and Jacobite rector of Whitechapel, wished to be revenged on White Kennett, the Whig pamphleteer, who had received high preferment for his political apostasy. So he persuaded Sir James Thornhill to paint an altar-piece of the Last Supper in which Kennett, arrayed in full canonicals, was made to represent Judas Iscariot. That there might be no mistake the artist painted even the large black patch Kennett wore to conceal a scar, and Welton wrote beneath the portrait, "This is Judas." All London flocked to laugh at the libellous picture, until the Bishop intervened and ordered the removal of the altar-piece, which was afterwards re-erected in more decorous form at St. Alban's Abbey.

Some time ago a special committee of Glasgow Corporation were appointed to consider claims for alterations in contracts or prices in consequence of the war. About fifty applications for increases of various kinds have been considered, but the majority have been refused, and the remainder continued for further consideration.

In connection with the Deeping water supply scheme it has been reported to the rural district council of Spalding that water has been tapped at a depth of 343 ft., and there is an overflow amounting to 40,000 gallons a day. It is stated that the water was of good quality, and that the needs of the neighbourhood can now be met.

Our Illustrations.

ADDITIONS TO ROWLEY HALL, STAFFORD.

This house is now nearing completion, and the accompanying plans show the extent of the considerable additions which have been made to the buildings. The walls are of Hollington stone, and the roofs are covered with Dolemaen slates. We also give a view of Rowley Hall and an elevation of the entrance front facing north. The general contractors are Messrs. T. Lowe and Sons, Burton-on-Trent, and the architects are Messrs. Woolfall and Eccles, F.F.R.I.B.A., 60, Castle Street, Liverpool.

HOLNEST CHURCH RESTORATION, DORSET.

With the exception of the nave, which is of comparatively recent date, this interesting

for the work is Mr. Edward C. H. Mudman, Lic.R.I.B.A., of Sherborne, Dorset, whose drawing we reproduce to-day.

HISTORIC BUILDINGS IN BELGIUM DEMOLISHED BY THE GERMANS.

These sketches from Ypres were made by Mr. Robert C. Kennard, of Kilburn, when resident in Belgium before the invasion of the Germans, whereupon, as he says, Ypres became "a war storm spot, and now the whole of the beautiful little town is in ruins," so the subjects of our illustrations have in all probability been demolished with the rest of the architectural treasures of the place.

THE MERGHEINCK "MUSEUM," YPRES.

This may be hardly the right name to use or call it a museum, and yet no other word quite expresses its use. The house formerly belonged to a rich burgher of Ypres, and it was furnished in the most exquisite taste, possessing also very fine pictures, tapestries,

It is a remnant of the Ypres that once had a population of 200,000 with 4,000 homes at work. Previous to the war Ypres had a population of 16,000.

LLOYDS BANK, ST. JAMES'S STREET, S.W.

This building was designed in accordance with the requirements of the Crown authorities in such a way that it might form part of a complete scheme from King Street to Ryder Street, and from St. James's Street to Bury Street, when the properties on either side of the bank come to be rebuilt. The materials used are Portland stone, with Westmorland green slate and lead ridge for roof, the entrance doors and banking hall windows being of bronze. The vestibules and banking hall are treated in marble and bronze, with teak doors and fittings. The architects were Messrs. F. W. Waller, F.R.I.B.A., and N. H. Waller, M.A., Lic.R.I.B.A., of 17,

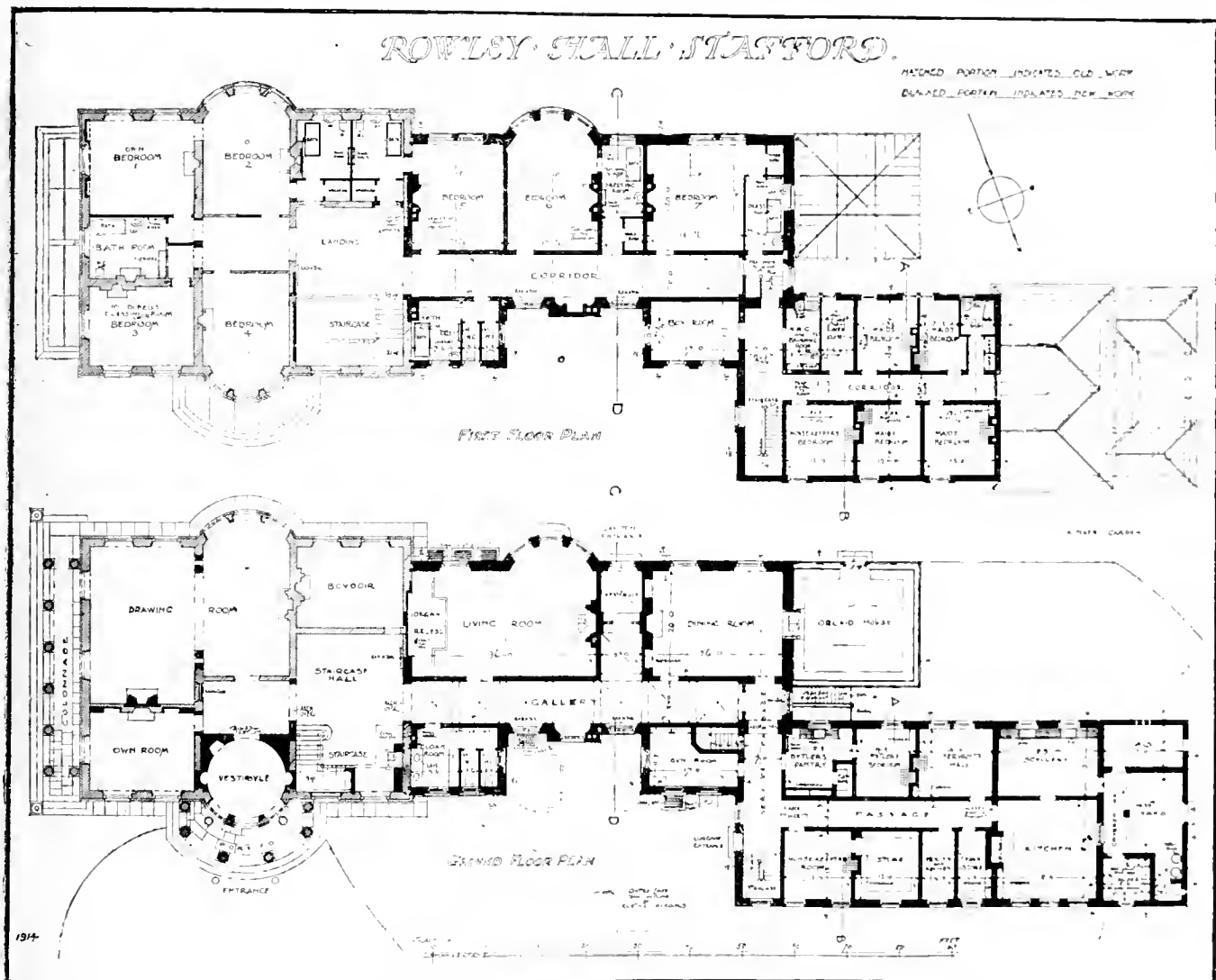

(Messrs. WOOLFALL and ECCLES, F.F.R.I.B.A., Architects.)

little country church in Dorsetshire, within a few miles of Sherborne on the Dorchester Road, is of the Perpendicular period of architecture. As the small sketch plan indicates, the building consists of a nave with north aisle with a barrel-plastered roof. The raison d'être of the restoration is occasioned by the insufficient strength of the north wall of the nave to uphold its present lead-covered roof. It is proposed to rebuild the wall to an increased thickness, adding stability to the buttresses and rebuilding the existing windows in slightly altered positions to improve the lighting, adding also a small new window near the pulpit. An old country practice is to be resorted to in regard to the lead from roof in order to meet the financial difficulty: as the aisle roof is stone-covered, the nave will be treated in the same way to enable the cost of the repairs being partially met by the sale of the old lead. The architect

and carpets, besides choice furniture and china. The garden also was most attractive, being laid out in harmony with the same period as the house, and set off with fountains and architectural features all in accord. People were freely admitted on introduction to see the collection, and practically the arrangement of the whole of its interesting interior was made the subject of attraction. The entire house, both externally and internally, was typical of an excellent example of a wealthy burgher's house of the early part of the eighteenth century.

CORNER OF THE GRAND PLACE, YPRES.

This second sketch forms part of the group of buildings adjoining the elaborate and famous historic Cloth Hall. The archaic colonnade forms part of the Town Hall, whilst the building adjoining, some is part of a series of houses with seventeenth-century gabled ends,

College Green, Gloucester, and the general contractors Messrs. Trollope and Colls, of Pimlico, S.W. We gave a double-page showing a detail view of the south vest corner of the block on June 7, 1912, with a descriptive note. Our illustration to-day is from the original shown at the Royal Academy.

DECORATIONS OF THE SCHOOL CHAPEL, CHRIST'S HOSPITAL, HORSHAM, SUSSEX.

These two tempera panels form part of a most interesting series of historic paintings forming a notable scheme of mural decorations, just now completed, or nearly so, by Mr. Frank Brangwyn, A.R.A., for the enrichment of Christ's Hospital School Chapel, near Horsham, Sussex. The panels are placed round the chapel above the oak stalls, each panel being separated by the shafts supporting the roof. When the whole

in situ they will have the effect of... The plan of the scheme consists of blues, old red, and warm grey, but the effect is of a blue sky extending along the top of all the pictures, and so binding the whole thing together. To give the effect desired the scale of the figures, colours, etc., have been carried out in each panel. They are light in key, so as to give lightness to the walls. We are indebted to the artist for the loan of the photographs reproduced. Others will follow, illustrating further designs, next week and in succeeding numbers. The subjects given to-day represent the Martyrdom of St. Stephen, "Lord, lay not this sin to their charge," and the Arrival of St. Paul at Rome. "He thanked God and took courage." Their splendid scheme of colour, which is characteristic of Mr. Brangwyn's masterly compositions, is handled in a thoroughly broad and decorative manner. This essential quality of colour, however, with its relative value of tones, can scarcely be conveyed by any monochrome illustration, and photography, of course, has its limitations, which are well understood. This being recognised when examining these excellent photographs, it goes without saying that to be enabled to thoroughly appreciate the work of the painter a visit to Housham is obviously necessary. These reproductions, nevertheless, will be valued by all who are more or less familiar with Mr. Brangwyn's beautiful designs, both at home and abroad. The present architect of the school chapel and the adjacent extensive range of educational buildings at Housham is Sir Aston Webb, R.A., but the late Mr. Ingress Bell was for many years joint architect with him. We gave their competition design on June 22, 1894, and a bird's-eye view of the whole group of buildings appeared in THE BUILDING NEWS October 22, 1897, the day prior to the foundation stone being laid by the late King Edward VII. when he was Prince of Wales.

Mr. Jean Williams, surveyor to the Abertillery Urban District Council, has had his salary increased by £55 to £371 a year.

Mr. Charles Newell, C.E., Dungannon, assistant county surveyor for Tyrone for the past six years, has received an appointment as First Lieutenant in the Royal Engineers.

The 50th anniversary of a Baptist church, which is finally laid at Bentley, near Doncaster, the architect is Mr. H. E. Illingworth of Leeds. The cost will be £1,750.

Mr. L. J. Stevens, assistant surveyor to the Haverhill Urban District Council, has been granted permission by his council to take up a commission in the Kent Fortress Engineers.

The rural district council of Doncaster have decided to apply to the Local Government Board for a grant to improve a town-planning scheme with a view to the purchase of 4,560 acres in the parishes of Airedale and Kirk St. Paul.

Yesterday, Tuesday, a Local Government Board inquiry was held at Pombroke into an application by the corporation for permission to borrow £1742 for water supply works, including the construction of works in the parish of Carew.

The death has taken place in Glasgow of Mr. Archibald McFarlane Stanton, an Associate of the Royal Scottish Academy. He abandoned business to study art and executed the Dunn Memorial Fountain at Paisley, the statue of Lord Kelvin, unveiled two years ago in Kelvin Grove Park Glasgow, and the statue of Mrs. Elder at Govan.

The installation meeting of the Society of Architects, Lodge of Freemasons, will be held at the Harbour Restaurant on Wednesday, November 11, at 5 p.m. Members of other lodges who would like to attend are invited to accompany us with the secretary, at 25, Bedford Square, W.C. The Worshipful Master Elect is Mr. Herbert W. Lee, and of Newell, Trow.

A new church of St. Nicholas has been built in Hesse-Cammon, near Hull. It provides seating accommodation for 70 persons, and has a lofty tower at the west end. The architect was Mr. Jean Elson, F.S.A., F.R.I.B.A., of Parliament Street, Hull. The church is named in King Edward VII. has been built at a cost of £5,000, borne by Mr. and Mrs. Christopher Pickering, who have also provided a group of England home for forty orphan children at Hesse.

A DICTIONARY OF ESSEX.

Year by year the south-western area of Essex becomes more densely inhabited by the overflow from the metropolis, and the number of people who are interested in the county is steadily increasing. Mr. G. Worley has written a little work on the ecclesiastical and antiquarian features of Essex, arranged in two sections, relating to the archdeaconries of Essex and Colchester respectively, and in each of these short notes dealing with the parishes are arranged alphabetically. The author remarks that, with the exception of the remains at Colchester, Hadleigh and Castle Hedingham, there is scarcely a stone left in Essex of the strong fortresses which the Norman barons erected throughout the country. Neither can the county boast of any cathedral churches of that period, unless the famous Abbey at Waltham may be quoted as an example. But the Norman builders have left abundant evidence of their activity in many of the parish churches, where, however, they have not hesitated to appropriate such ready-made materials as they found to hand in the Roman tiles which they have incorporated in their walls and towers. A few fragments of Saxon work are here and there imbedded in structures of the twelfth and thirteenth centuries, and, as the author suggests, doubtless in churches built after the loyalist Saxon workmen were employed in the work of building. If we look for magnificence of structure we still find it in the county at Coggeshall, Thaxted, Saffron Walden and elsewhere, in the Perpendicular style. Mr. Worley remarks:—

The peculiar charm of the Essex churches does not lie in the exhibition of any given style in its purity, so much as in the intermixture of one with another in a whole which is seldom displeasing, and always instructive as an historical lesson, even where we have to regret the acts of vandalism committed at every stage by innovators on work done before them. It would be an interesting study for an antiquary of leisure to trace the sources of the various materials employed in Essex church-building, and the means by which they were brought to their destination. On the Kentish border, for instance, we find abundant use made of the ragstone which occurs in the neighbouring county, and could easily be conveyed by water. An exception which seems to prove the rule is the fine 15th Century tower at South Weald, built entirely of Kentish rag, and said to be unique in its position so far from the coast and the usual means of conveyance. In common with the other eastern counties, Essex can show a good deal of flint in its church-walls, where there is also an abundance of the conglomerate known as "pudding-stone," presumably taken from the beach-deposits. Purbeck marble is not unknown in grave-stones, fonts, piscinae, and decoration. But the scarcity of building-stone in the county itself will account for a more extensive use of timber than elsewhere, conspicuously in roofs, porches, and bell-towers. In the notable case of Greenstead the nave-walls consist entirely of the bisected trunks of forest-trees, and at Shenfield the arcade between the nave and north aisle is an admirable imitation in oak of 15th Century stonework. The nine square miles of almost unbroken woodland which survive in Epping Forest, and the adjacent fragment of Hainault remind us of the time when the whole interior was covered with trees, a refuge in warfare, and an inexhaustible source of industry in peace. Brick appears in the Tudor period in the churches at East Hendon and Little Chignal (otherwise significantly called Black Chignal) being built of that material throughout, while brick towers are seen as prominent landmarks at Inzeston, Fryern, and other places.

The author briefly describes the remains of the more important pre-Reformation religious houses still to be found in the county. The recent selection of St. Mary's Church, Chelmsford, as the Cathedral of the new diocese, and the boundaries of the East Anglian sees as fixed by the Order in Council of April 7, 1914, are referred to. A useful bibliography of works of the architecture and ecclesiology of Essex is given, but in view of the separation of the parishes in the two archdeaconries a sketch map of the county would have added immensely to

"Essex: A Dictionary of the County, mainly Ecclesiastical." By G. Worley. 166 pages. Cloth bound. 5s. net. London, G. Bell and Sons, Ltd.

the value of the volume. A few illustrations would have been acceptable, and although we are now halfway between the taking of the censuses it would have been helpful and an inexpensive matter of compilation to have inserted after the name of each parish the number of the population as ascertained in April, 1911.

OBITUARY.

We regret to learn that Captain Douglas Carmichael, B.A., of the 9th Battalion, Rifle Brigade, was killed in action in Flanders in the action of September 25. Captain Carmichael, who was only twenty-one years of age, was the elder son of Mr. and Mrs. James Carmichael, of Redclyffe, Streatham Park, S.W. He was educated at Leys School and Jesus College, Cambridge, and passed out of the University with honours. He had just entered his father's business at Trinity Road, Wandsworth, when the war broke out. He obtained a commission as second lieutenant from the Officers' Training Corps in September of last year, was promoted to First Lieutenant in October, and to Captain in March last, being placed in charge of the machine-gun section. Colonel W. Villiers Stuart writes to his father:—"Douglas was killed on September 25 in action near Belle Waarde Farm. His bravery is a byword in the division. He fought that day with infinite courage. I have no words and no one else could find any to express his magnificent bravery. I shall never see a soldier like him again; it is quite impossible that anyone so fearless could be found. He carried four lines of trenches with his company under a most desperate artillery and machine-gun fire, and when masses of Germans came against him, by his wonderful personality he kept his men, now reduced to a handful, in good spirits, and led them again and again to the attack. He was wounded early in the day, about 5 a.m., but made nothing of it. He was killed instantaneously by a bullet in the forehead as he was once more leading a bomb charge." Mr. Carmichael has also received a letter from Sergeant W. Walker, machine-gun section, who writes:—"He was in command of the attack on the morning of the 25th, and right well did he lead us until he was hit in the leg. Then we pushed forward alone, as he refused to have any assistance; but just after I saw him hopping on one leg towards the next line of German trenches under a murderous fire. Your son was still in command, absolutely refusing to be taken back. Your son was killed with a machine-gun, and I was twice wounded at the same time. It was instantaneous, and his last words were, 'For God's sake, boys, hold them back.' He earned the V.C. fifty times over."

We also regret to hear that Mr. Henry Holloway, of Burntwood Grange, Upper Tooting, and of Messrs. Holloway Brothers, Bridge Wharf, Grosvenor Wharf, Pimlico, sustained a similar bereavement on the same day, his third son, Captain Bernard Henry Holloway, B.A., of the Royal Sussex Regiment, having been killed in the same engagement. Captain Holloway, who was twenty-seven years of age, was also educated at Leys School and Jesus College, Cambridge. He was not a member of his father's firm.

A vestry, 45 ft. by 20 ft., is about to be added to St. James's Church, Southampton, from plans by Mr. Nesbitt, architect, of Southampton.

The opening of a new elementary school at the small hamlet of Marishes, near Pickering, took place on Wednesday. The school accommodates sixty children, and cost £552. The walls are of red bricks and rough-cast. Mr. William Gamble, of Barterworth and Nawten, was the builder.

A group of twenty-two residential flats have been built in Recorder Road, off Prince of Wales' Road, Norwich, as a memorial of the late Right Hon. James Stuart, M.P., by the Misses Colman. They are of red brickwork, with stone dressings, and are sixteenth-century Dutch in style. Messrs. Edward Boardman and Son, of Norwich, were the architects.

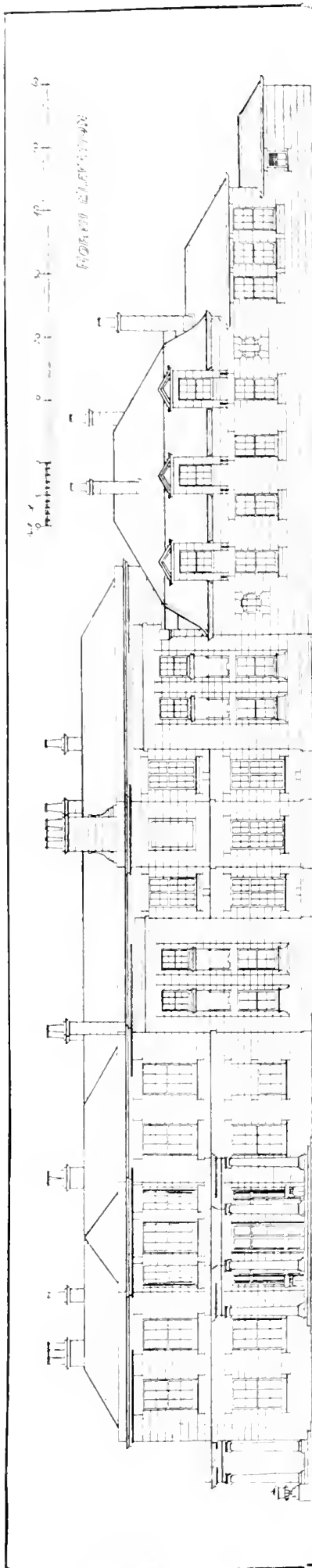

ROWLEY HALL STAFFORD
ADDITIONS

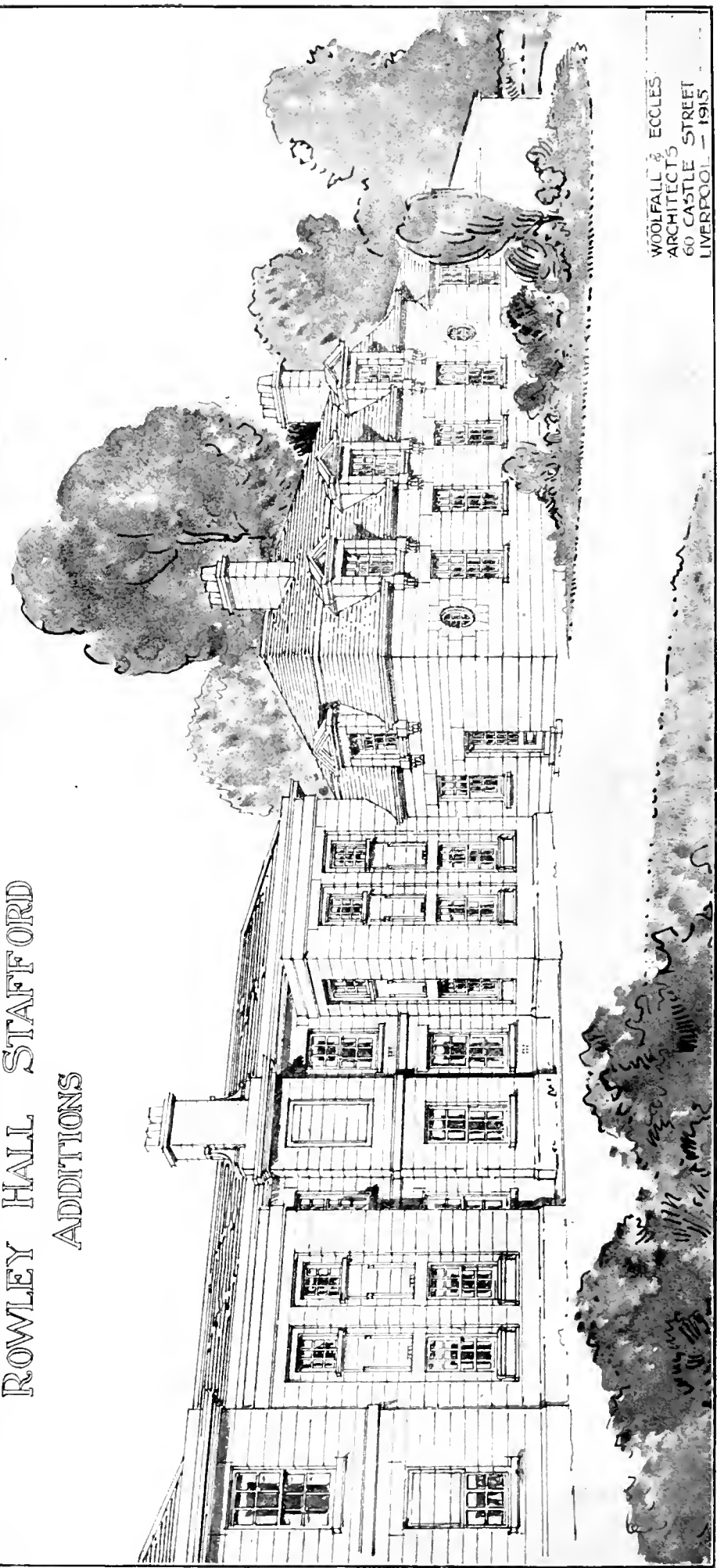

WOOLFALL & ECCLES
ARCHITECTS
60 CASTLE STREET
LIVERPOOL - 1915

ROWLEY HALL, STAFFORD: ADDITIONS IN COURSE OF COMPLETION. Messrs. Woolfall and Eccles, F.F.R.I.B.A., Architects.

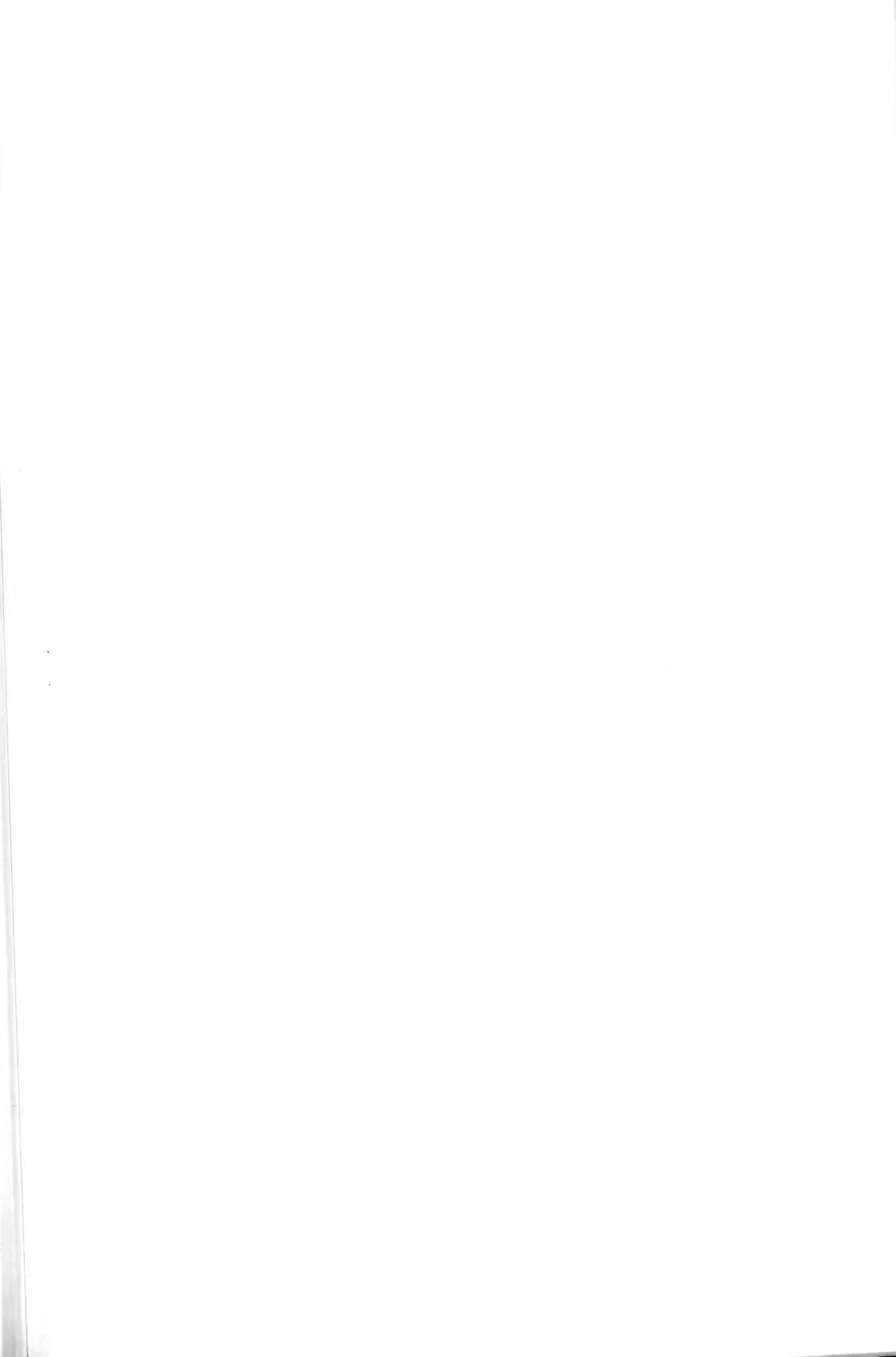

THE BUILDING NEWS, OCTOBER 6, 1915.

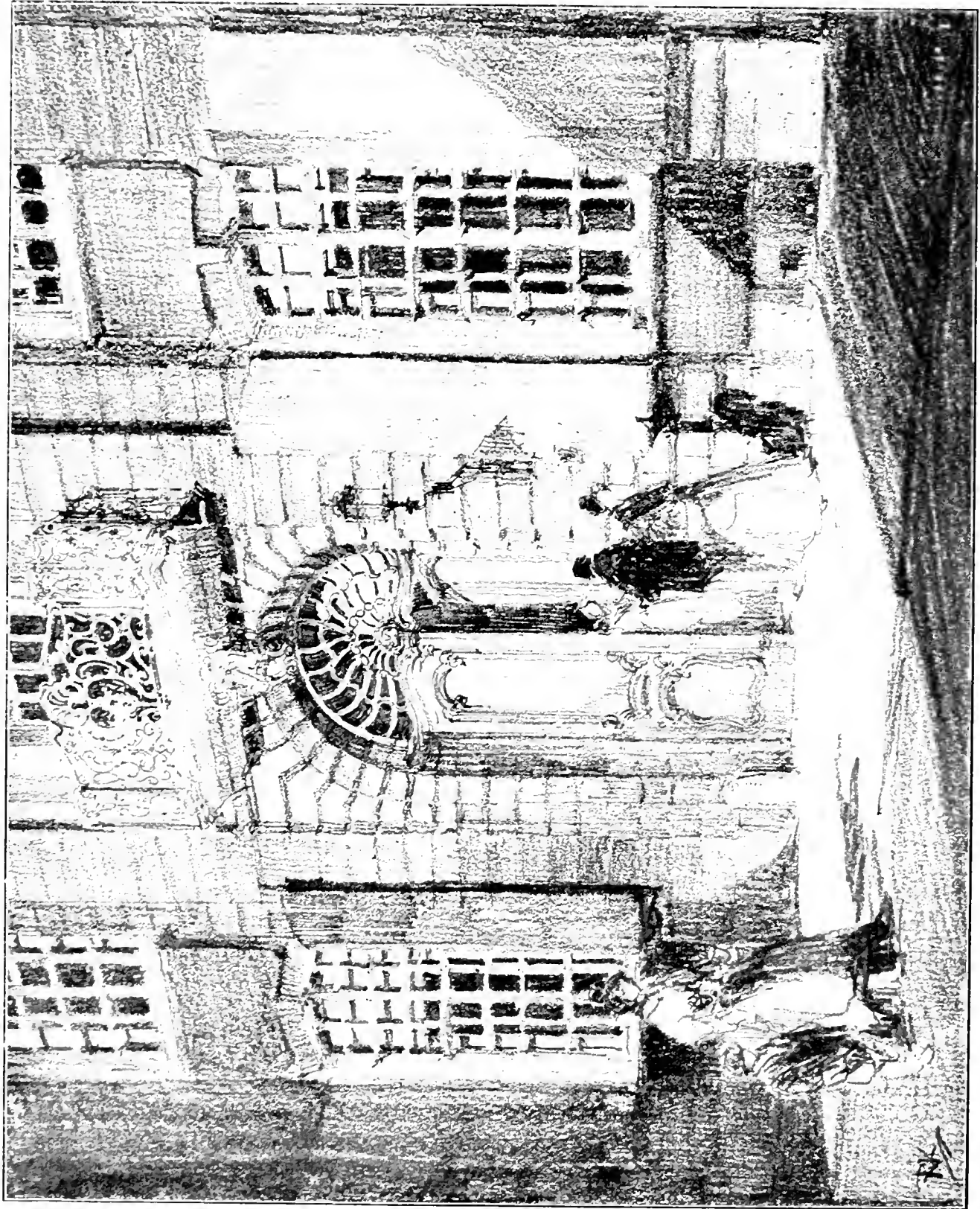

HISTORIC BUILDINGS IN BELGIUM DESTROYED BY THE GERMANS: THE MERGUELINCK "MUSEUM," YPRES.
Sketched by Mr. ROBERT C. KENNARD.



THE BUILDING NEWS, OCTOBER 6, 1915.





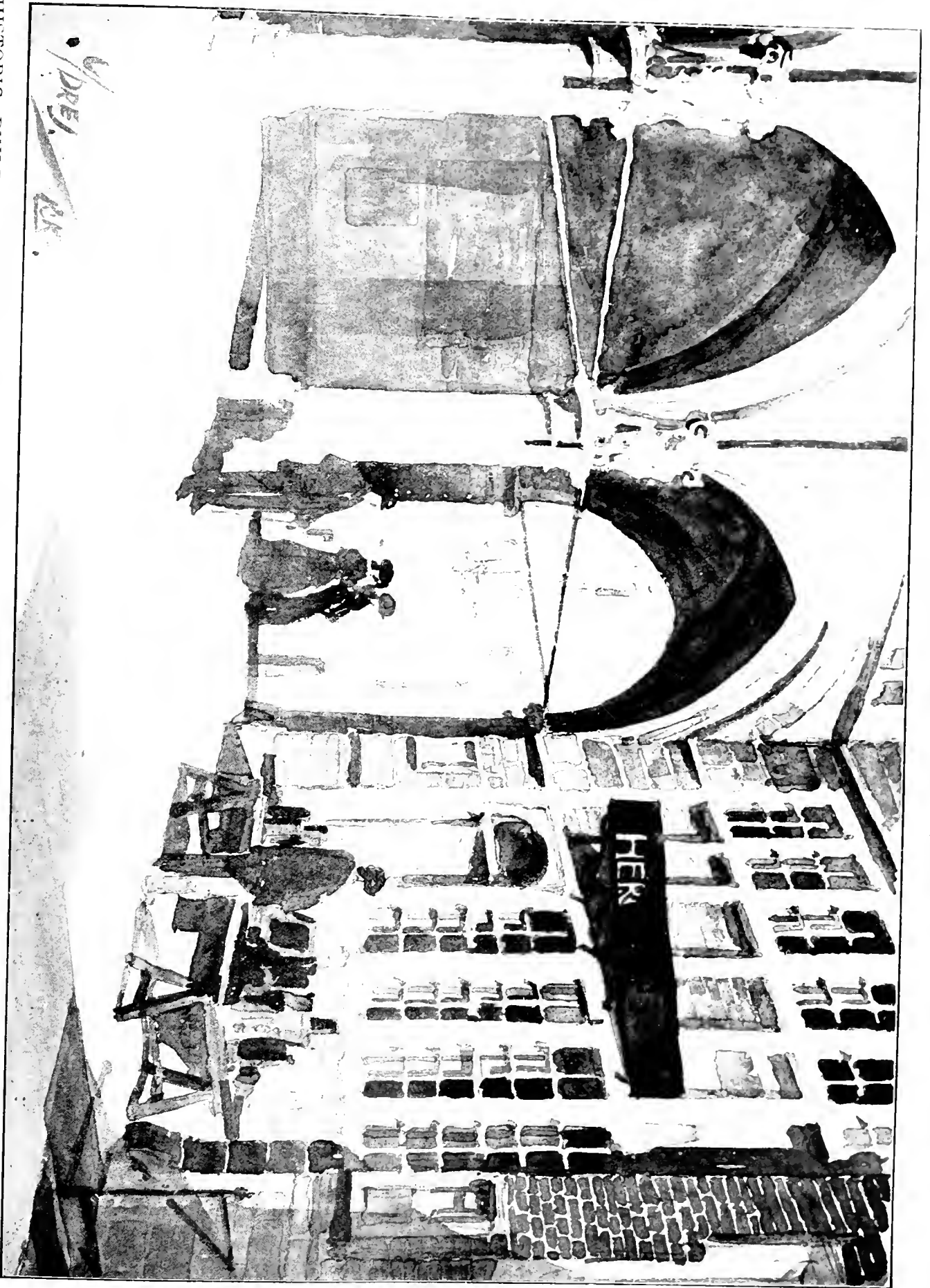

W. DREY.
L.R.

HISTORIC BUILDINGS IN BELGIUM DESTROYED BY THE GERMANS: A CORNER OF THE GRANDE PLACE. V.P.P.R.S.





MESSRS. LLOYDS' NEW BANK, ST. JAMES'S STREET, S.W.—5575



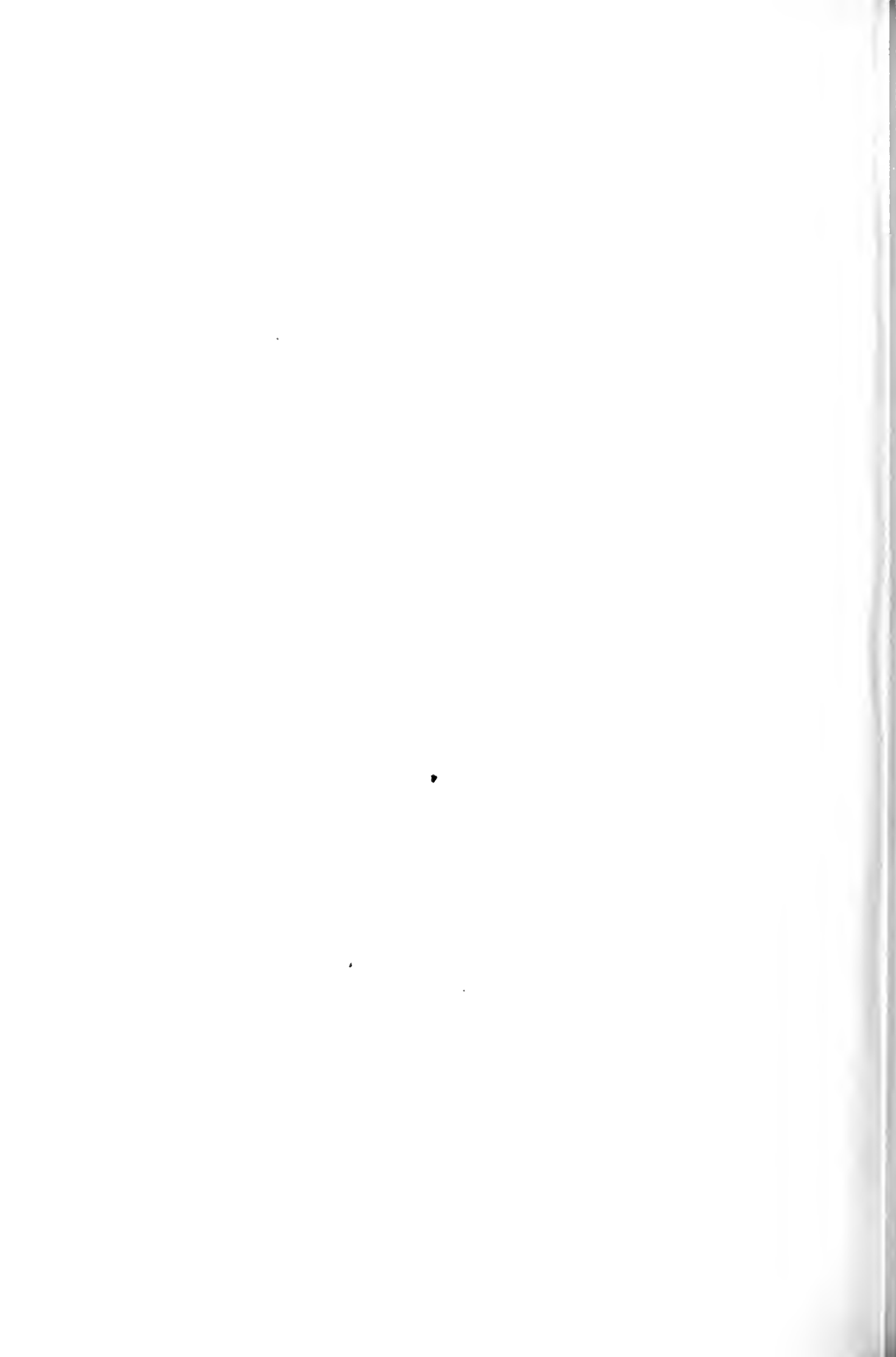

LEGAL INTELLIGENCE.

ANCIENT LIGHTS.—On Wednesday, in the Chancery Division, the adjourned motion for an injunction to restrain Messrs. John Barker and Sons from erecting a building in Townwell Fold, Wolverhampton, so as to cause a nuisance or illegal obstruction to the plaintiff, Mr. S. W. Page, in the enjoyment of certain ancient lights in his buildings at No. 30, Lichfield Street, came on for hearing before Mr. Justice Younger. It was admitted that the plaintiff's lights were ancient lights, and the Judge ordered the motion to stand over till the trial, the defendants to be at liberty to carry up their wall so far as necessary to complete the roof, but not exceeding three feet over the present height, they undertaking to abide by any order the Court might make at the hearing as to pulling down or altering anything erected by the defendants since September 15.

ARCHITECT v. MILLOWNERS.—Litigation has been in progress between the Ross Spinning Company, Bacup, and Mr. A. A. Stott, of the firm of Stott and Sons, who were the architects of the mill. The litigation was in the nature of writs demanding payment of calls, Mr. Stott being a shareholder in the company to the extent of £7,500. Mr. Stott entered a counter-claim against the company demanding £12,207 for services rendered under an alleged agreement of September, 1906. The action should have come on at the Manchester Assizes, but for the convenience of the parties was ordered by the judge to be tried at the Imperial Hydro, St. Annes, by Mr. Arthur J. Ashton, K.C., as referee. The action was part heard when a settlement was reached by which Mr. Stott and his firm withdrew all claims against the company and the company abandoned their claim against Mr. Stott in respect of the calls. Mr. Stott was to release to the company the whole of his shareholding amounting to £7,500 and give up all papers relating to the mill in his possession. The sum of £300 which Mr. Stott had paid into court was to be equally divided between the parties, and the parties were to pay their own costs and half the costs of the referee. These terms were subsequently embodied in an award made by the referee.

DISPUTED USE OF A SEWERAGE OUTLET.—In the Vacation Court on Wednesday, before Mr. Justice Younger, the case of the Wapentake of Ouse and Derwent Commissioners and Fletchers (Shipley), Limited, was again mentioned, it having been standing over for negotiation. We reported the case in our issue of September 8, p. 278. Plaintiffs claimed an injunction restraining the defendants from continuing the use of an outfall recently constructed, which it was alleged allowed sewage and other foul matter from defendants' works to flow into the Cherry Orchard drain of the plaintiffs' system of drainage. Mr. H. Terrell, K.C., for plaintiffs, said there had been negotiations between the parties, but no agreement had been come to. The defendants had built certain works and cottages, and were pouring the sewage direct into the plaintiffs' drain. Defendants said they had not caused a nuisance, and were prepared to move all the sewage in expectation of a drainage system which had not been carried out by the local authority from motives of economy. Plaintiffs now suggested that without prejudice to the legal rights of the parties defendants should agree to an undertaking until the trial or further order to cleanse and scour the Cherry Orchard drain, so far as the same was fouled by the sewage or effluent coming from the defendants' sewers or cottages, and to remove any obstruction to the free and natural flow of the drain caused by such sewage or effluent being discharged therein, pending construction by the local authority of their intended drainage scheme for Barlby, when they would forthwith connect with the proposed main drain. Costs to be costs in the action. Mr. Mathew, K.C., or defendants, asked his lordship to reserve his costs, because his case was that the motion was quite misconceived. He agreed to the undertaking suggested on the clear understanding that he offered it merely as a matter of peace, and without prejudice to defendants' rights. He objected to the words in the undertaking "fouled by sewage or effluent coming from defendants." After some discussion it was agreed to retain all the words objected to with the exception of the word "effluent," and the case stood over for speedy trial, costs being reserved.

WREXHAM BUILDING DISPUTE.—At Wrexham County Court, on Wednesday, his Honour Judge Moss delivered judgment in an action brought by Edward Hughes, accountant, alone Road, Wrexham, trustee of Lewis Bros., builders, Wrexham, against J. H. Swainson,

architect, Wrexham. Plaintiff claimed £227 15s. 7d., balance due under a building contract and for extras. There was a counter claim of £109 14s. 6d., which included a penalty of £120 for delay in completing the work, and there was an alternative claim for damages amounting to £69 3s. 3d. His Honour said with the exception of one or two small items plaintiff's claim was substantially admitted, and the issue had been as to whether defendant could set off against the claim the sum of £109 claimed by way of counter claim. Messrs. Lewis Bros. built a house for Mr. Swainson. The tender was sent in and accepted on defendant's specification and quantities. It was admitted that in the course of the work defendant made many alterations from the plan of the building, which delayed the work. An order for new work was given after the time limit had actually expired. He held that defendant was not entitled to the penalty he claimed for delay, and his claim for damages was altogether too remote, and it seemed as if it was an afterthought. He was alluding to the hotel expenses, loss of interest, etc., which in law defendant could not possibly sustain. With regard to defendant's claim in respect of the painting work, his Honour said the contract provided for the calling in of an umpire in case of dispute. This was not done. Defendant summarily handed over the painting work to a third party, which he was not entitled to do. Therefore he was not entitled to claim the difference between the price he paid for painting and the price set down in the contract. Defendant's claim of £22 17s. 6d. in respect of the builders' failure to do the work was grossly exaggerated. The correspondence showed that in respect of this item on February 25 defendant only claimed £7 10s. But this was not the only answer to it. The builders were bound to keep the building in proper repair for six months after completion. During this period the architect made certain complaints, and the builders did the work. After the expiration of the six months following the completion of the building, and until the defendant was threatened with proceedings, there was nothing in the correspondence to show that he complained as to the various defects in respect of which he claimed. He had come to the conclusion that the plaintiff was entitled to the amount for which he sued, and that the set-off defendant had endeavoured to raise failed. Judgment was then entered for plaintiff, with costs and allowances.

PROFESSIONAL AND TRADE SOCIETIES

SOCIETY OF ENGINEERS.—On the 4th inst., at a meeting of the Society of Engineers (Incorporated), Mr. Sydney G. Turner, A.M. Inst. C.E., barrister-at-law, read a paper entitled "Law and Engineering—Some Points of Contact." The general object of the author was to show that in almost every branch of engineering practice the provinces of the engineer and the lawyer overlap, and to advocate the establishment of some periodical meeting, open to the members of both professions, at which subjects of common interest could be discussed. In the section dealing with municipal engineering, the special topics selected were sewerage and drainage, and the execution of works of private street-improvement. In regard to the former, the decision of the House of Lords in the case of the Wood Green Urban District Council v. Joseph was discussed; and in regard to the latter the author dealt more particularly with the duties of the engineer in connection with the apportionment. In the section dealing with water engineering, the question of underground supplies was suggested as a subject for discussion.

The Red Cross Fund which is being raised by members of the Timber Trades Federation has now reached £3,520.

For the erection of a convalescent home at Grange-over Sands, Lanes, the Workmen's Club Union has voted £20,000.

Mr. G. A. T. Middleton, A.R.I.B.A., the first secretary of the Society of Architects and a past vice-president, has been elected an honorary member of the society in recognition of his services to the society and the profession, more particularly in the cause of registration. Mr. Middleton's health is, unfortunately, such that he is compelled for the present to take a complete rest from all professional engagements.

COMPETITIONS.

PLYMOUTH.—The competition for a city six design submitted for the new building to be erected by the Plymouth Mutual Cooperative and Industrial Society, 10, Cornbury Street has been thus settled: First prize £100 given to the design submitted by Mr. Paul Waterhouse, M.A., F.R.I.B.A., 16, Messrs. James T. Hulday and Charles Paterson, A.R.I.B.A., and C. George Azote, L.R.I.B.A., No. 13, John Dalton Street, Manchester. The first premium of £75 is accorded to the design submitted by Mr. H. R. Gardner, L.R.I.B.A., 10, Regate Road, Leatherhead, Surrey. The second prize of £50 is given to Mr. Herbert S. East, A.R.I.B.A., 14, South Square, Gray Inn, and the third premium of £25 to Mr. Frank Bethell, M.S.A., and C. M. Stannell, A.R.I.B.A., Broad Street Buildings, E.C. A review of the competition designs can be found in our first article this week.

A hospital for wounded soldiers is about to be built at Combe Park, Bath, by Messrs. R. Wilkins and Son, of Bishop Street, Bristol, as the builders.

A cinematograph hall is to be erected in Commercial Road, Stepney, from plans by Messrs. Adams and Coles, of Craven Street, Charing Cross.

A convalescent home for men is about to be built at Doganwy, near Hlanddudha, from plans by Mr. H. A. Brown, F.R.I.B.A., of Brazenose Street, Manchester.

The Bollingborne Rural District Council have appointed Mr. G. R. Burbridge as surveyor, at a salary of £110 a year, in succession to Mr. Roper, retired.

The streets committee of the Parlington Corporation have resolved to prepare a town-planning scheme as soon as the town clerk and borough surveyor can find a staff.

The new public baths in Marketgate, towards the east of which Mr. Carnegie contributed £7,000, have been formally opened. The plans were by Mr. Hugh Gavin, of Arleoth.

The annual conference of the Sanitary Association will be held at Carpenters' Hall, London, Wall, E.C., on the 26th, 29th, and 30th inst., under the presidency of Sir James Craighero-Browne, M.D., F.R.S.

A Salvation Army hall in Parker Street, Whiteinch, N.B., has been formally opened. The plans were by Messrs. John Hamilton and Son, St. Vincent Street, Glasgow, and the builders were Messrs. Marshall and Ritchie.

At the meeting of the urban district council for Wolstanton, North Staffs, it was reported that tenders had been received for altering a bridge in Knutton Lane varying in amount from £22 5s. to £100. It was decided to invite fresh tenders.

Mr. C. G. Bolam, estate agent for the Duke of Buccleuch at Dumfries, has retired after thirty-six years of service. He has served as agent under three dukes. On behalf of the tenants on the Dumfries estate Mr. Bolam has been presented with a silver teapot, cream jug, sugar basin, and other dishes, a W. Loan bond, and an easy chair.

At the Venerable Bede's Church, Gresham, on Sunday, a stained glass window, erected by her husband and family to the memory of Elizabeth Tennent, was unveiled by the vicar. The window, designed and executed by Messrs. Thompson and Snee, Bankwell Lane, Gateshead, is at the north end of the church, and consists of two lights and three panels of antique glass.

The death occurred, on Saturday, of a man done in Burslem, of Mr. William, of Burslem, J.P. The deceased, who had been in failing health for some time, was formerly well known as a builder and contractor, having been some years ago. He resigned his position as a man on the Stoke-on-Trent Police Force in October, 1914, and was previously an inmate of the old Burslem Gaol.

At a meeting of Inverkeithing Parish Council on Friday night, Provost Finlayson read the following letter from Mr. Alexander Campbell, contractor for H.M. Dockyard, Rosyth: "Every day there have been persistent rumours that our contract here is nearing completion, and that the services of a large number of men are being dispensed with. Instead of dismissing men, we are busily recruiting, as we have not sufficient to carry on our work according to the national requirements. We cannot find out the origin of these mischievous and untrue rumours. In all probability the work will continue for many years."

Correspondence.

LAURENCE BAK BENCH, STEYNING.
CHURCH, SUSSEX.

The Building News.

Sir, Having read with some amusement the article in "A Sussex Man" which appeared in your issue of the 10th inst., I feel compelled to point out:-

1. That I became Vicar of Steyning in 1912, and not, as he states, in 1872.

2. That there has been no Jacobean church at Steyning since I have been vicar. As far as I can ascertain from the oldest parish records, no such thing has gone to the ground.

3. That "The Jacobean bench" referred to in "A Sussex Man" refers has neither been presented to a "museum" nor "housed" in the vicarage, but it may interest this gentleman to know that on my induction to Steyning thirty-three years ago I speedily discovered that the church had highly benefited by the late vicar, but *not the vicarage* from the vicar's hands.

4. That "A Sussex Man" oblige me with his name and also an illustration of this "historic" stall. Yours truly,

ARTHUR CONGREVE-PRIDGON.

Steyning Vicarage, September 27, 1915.

TEMPLES OF STONEHENGE AND MAGH SLECHT.

Sir.—Although the ancient temple of Stonehenge forms part of the Amesbury estate belonging to the late Sir Edmund Anson, it has been sold for £6,000 at public auction, and inquiries will be pleased to know it is now included under the Ancient Monuments Act and the new owner is merely its custodian for the nation. Fortunately, its exact position is definitely defined and beyond all question, as the stones are in situ, unlike that of the Hiberno-Keltic ancient temple of Crom Cruach, surrounded by twelve sub-idols, situated at Magh Slecht which was destroyed by St. Patrick, about which much controversy has taken place. But it is now conclusively ascertained to be situated in the level plain of Ballymagauran, in the parish of Templeport, barony of Tullyhaw, Co. Cavan, and entirely the patrimony of the MacGaurans or McGovern's, so "Onamasticon Gaedelicum Eborac et Tribuum Hibernia et Scotia an Index, with identification to the Gaelic names of places and tribes, by the Rev. Edmund Hogan, p. 550, 1910," a work of great erudition and invaluable to the historical student.

JOSEPH HENRY MCGOVERN.

L.R.I.B.A.

L. Liverpool, September 29, 1915.

HOUSING AT LETCHWORTH.

Sir.—The housing problem is not solved even in garden cities. Here in Letchworth there is a great shortage of small houses and cottages, owing chiefly to the great influx of Belgian and other munition workers. One of the chief cottage companies—the Garden City Tenants, Limited—has seized the opportunity to raise rents on an average of 9d. a week, while others have had to do the same, so that the present tenants find it hard to bid against the Belgians for the houses which they wish to remain in. The rents in the new parts during the last few years have been so enormous, thus one cottage which had been built for £150 in 1912, was first let at 5s. 10d. a week, and now it is 10s. plus rates. The rents of the company's cottages were built before the war and in the cost of building materials of half years ago.

The tenants, being strongly organized, the sub-tenants, and the council, all refused to pay the increased rents, but they are in line with the tenants of other parts, who are represented by the chairman of the tenants' association, who feels that the attitude of the tenants is wrong in raising rents at the present time.

The "Garden City Tenants" are also to their credit, as they have managed to build 160 cottages since the Local Government Board have been in existence.

J. C. TICKELL.

Letchworth.

"STOFFA DI ITALIANO."

SIR, You may possibly be able to use the enclosed verses. They were sung at a recent banquet here, when the Architects' Chapter entertained the artists and sculptors engaged in decorative work at the Exposition. Am sorry I cannot say who wrote them.

It is some twenty-seven years ago since I last met you. You may, however, have possibly noted my work in all of the quantity system in the United States. It will come "some day." With best wishes, Yours faithfully,

G. ALEXANDER WRIGHT.

554, Pine Street, San Francisco, Cal.

"We are sure it will, and in no small degree owing to the good work of an old friend, whom we are delighted to hear from. Ed. "B.N.""]

"STOFFA DI ITALIANO."

Time: CHRISTOPHER COLUMBUS.

It long to you about some men whose names are known to history. Their works are copied right and left by men of great sophistry. Architects, both young and old, bow down to them quite fitly. Their names, you know, all end in "O"—they come from sunny Italy.

CHOIRS.

Mike Angelo, Palladio, Vitruvius, and San Gallo. They wouldn't do a thing if they heard us sing, "Stoffa di Italiano."

Among the class of famous men was one who's named Vitruvius. He could draw the Orders up-side-down, while rowing his gondola. San Gallo, too, could do this trick, likewise the Lombardo. But it gave him the gout, when he found out he wasn't the only dago.

(Chorus.)

Palladio, you must know, gave these men a great surprise.

When, on Della Sante, he designed a volume of most gigantic size, Brambascchi's name shone out to fame when he built the Palazzo Pitti.

But, alas and alack! if he came back, he'd find one in every city.

(Chorus.)

Another famous man you know, who built the great Saint Peter. And they do tell he did it well and didn't try hard, either.

O Mike, you know you were not slow to adopt Brambascchi's plan. With your glorious dome, you paralysed Rome, and became a famous man.

(Chorus.)

So, if you want to design in the classic line and draw your steeple right smart. Lay in a stock of balustrades, festoons, and eggs and darts.

Scrape all you can from Lay-troobloy, Buhlman and Bagnonday.

Then a song and dance in the Renaissance will come to you quite easy.

CHORUS TIME: TIFFERAY.

It's a long way back to the office, It's a long way to go; We're all here for a time to-night. To meet the artists, you know say goodbye to the drawing-board. And farewell to square. It's a long way back to the office, For my heart's right here.

Lieutenant R. B. Angus, R.E., late of the Executive Public Works Department and 17, Victoria Street, S.W., was killed at the Dardanelles on September 22.

The first section of the restoration of the parish church of Newton St. Cyres, near Exeter, has just been completed at an outlay of over £1,000. The architects were Messrs. Harcourt and Sons, of Exeter.

A tuberculosis hospital has been built on May Hill for the Greenwich Borough Council. Mr. Alfred Roberts, of Greenwich, is the architect, and Messrs. William Mills and Sons, of Westcombe Park, are the contractors.

The vicar and churchwardens of St. Mary's, St. George's, have received a report from Mr. A. E. Lloyd Owsel, of Dana Chambers, St. George's, as to the state of the spire and tower of the parish church. He writes that the spire had expanded by 6 in. that cracks have expanded during the last five years, and that a serious movement is in progress. He estimates the cost of the repairs urgently needed at £15, while further works must eventually be carried out.

PARLIAMENTARY NOTES.

LAND VALUATION STAFF REDUCED.

The Chancellor of the Exchequer, replying to Mr. Currie and Sir J. Rolleston, said: The stage which has been reached in the original valuation of land under Part I. of the Finance (1913-14) Act, 1914, renders it possible to dispense with the services of a number of the temporary valuation staff, and the reduction in numbers is being effected, so far as possible, by selecting for discharge men of military age. There is no intention of replacing the officers now being discharged. The number of Valuation Office officials whose employment under the Board of Inland Revenue terminated between March 1 and September 1 is 1,437. The number of new appointments in this period is 12. The number of the effective valuation staff on September 1 was 2,620, the salaries amounting to £411,150. Valuation Office premises to the rental value of £2,800 have either already been given up or will be given up at an early date. The number of officials employed on September 1 in the land values branch of the Inland Revenue Department was fifty-six, their salaries totalling £9,570.—Mr. Watt: May we take those figures as indicating that the Government have abandoned the taxation of land for the future?—The Chancellor of the Exchequer: No.

TRADE NOTES.

The "Boyle" system of ventilation (natural), embracing Boyle's latest patent "air-pump" ventilator and air inlets, has been applied to the board-room at the Miller General Hospital, Greenwich.

We learn that additional plant has recently been installed in the Harrogate electricity station, and that after excavations had been made there was trouble with running water. Pudlo was then incorporated in the cement as a water-proofing medium with excellent results. Although there is a stream in close proximity, the interior of the building is perfectly dry.

A new Wesleyan chapel at Lydden, Kent, has been formally opened. Mr. S. Watson, of Caversham, Reading, was the architect.

At Bootle new premises for the Millom Co-operative Society, Limited, have just been opened. The builder was Mr. L. Fairclough.

The town council of Luton have received the sanction of the Local Government Board to the borrowing of £2,000 for additional pumping plant at their sewage disposal works.

A Local Government Board inquiry was held at Sheerness on Friday before Mr. H. S. Bidwell into an application by the urban district council for sanction to borrow £6,750 for works of additional water supply to the town.

The new town hall at Omagh, erected at a cost of £4,000, has been completed. The frontage of the buildings is 47 ft., and they extend back a distance of over 160 ft. The main assembly hall, which is 85 ft. long, 37 ft. wide, and 23 ft. high, will accommodate over 600 persons.

There have been completed twenty-nine workmen's dwellings, arranged in three blocks, which the corporation of Newcastle-under-Lyme started shortly before the outbreak of war. The scheme has been carried out by Mr. A. A. Pattison, the borough surveyor, from plans prepared by Mr. Frank Emery.

A memorial to the late Miss Braddon was unveiled at Richmond Parish Church, Surrey, on Monday by the novelist's youngest grandchild, Miss and Master Maxwell. The memorial is a bronze portrait in relief, on a circle of laurels and oak. It is the work of Mr. John E. Hyett. It is next to that of Edmund Keane.

Mr. J. H. Chubb, of Peury, who passed away on Thursday evening at the age of sixty-six years, went to the borough many years ago as surveyor under the old Highway Board, and in 1895 became surveyor to the rural district council. An ardent Freemason, he was a member of Lodge Three Grand Principles, Peury, and held provincial honours.

At St. Anne's Church, Upperton Gardens, Eastbourne, Mr. Harry George Lay, A.R.C.B.A., son of Mr. C. W. Lay, The Laurels, Wellingborough, was married the other day to Miss Violet Peppercorn, daughter of the late Rev. A. T. Peppercorn and Mrs. Peppercorn, of Stoke Prior, Leominster. The ceremony was performed by the Rev. J. W. Peppercorn (brother of the bride).

Building Intelligence.

GREAT TOWER STREET, E.C.—The office of Christ's Hospital was transferred last week from Aldersgate Street to 26 and 27, Great Tower Street, a site which came into the possession of the governors under the will of John Fowke in 1686. From the designs of Mr. Arthur Blomfield, with Messrs. Howell Williams, Limited, as builders, there have been erected premises in the Queen Anne style, the predominant material being red brick of cheerful hue faced with stone. The ground floor, which is approached through a wide hall, contains, in addition to the general office, separate rooms for the chief clerk and deputy clerk, a telephone room, a waiting room, a typing office, and the receiver's office. In the basement are strong rooms and general storage accommodation. Below is the heating apparatus. A lift connects the ground floor with the upper portions of the building. On the first floor is the Court Room, extending east and west the full width of the premises. It is panelled in oak, and at each end has been affixed a stained-glass window, one showing the arms of Edward VI., Charles II., and George V., and the other those of the Hospital itself, the City, and Sir Richard Dobbs. On the same floor are the treasurer's room, the committee room, and a waiting room. A mezzanine floor contains the caretaker's quarters, and above are two rooms, in which the entrance and competitive examinations of the two schools will be held. The historical pictures, sculptures, and other treasures have been removed to the new offices.

LIVERPOOL CATHEDRAL.—It is now beginning to be possible, says a correspondent of the *Guardian*, to gauge the importance of the addition of the first great transept to the choir, the fabric of which has been for some time practically complete. As the cathedral emerges into view seen by one approaching Duke Street along Hope Street from the Philharmonic Hall, the two ends of the transept already thrust themselves up finely, and give a breadth and massiveness to the building which help the imagination to picture its appearance when the huge central tower, second transept, and nave shall fill out the site. Whether any of us will live to look on this vision is another question. A party of Freemasons lately visited the Lathom Memorial Chapter House, which the Masons of Lancashire are presenting to the Diocese. It is a lofty octagonal building with a basement room beneath the Chapter-room. The stained glass is to be done at the Merton Abbey Works, and the subjects, as for the stone carving, are being chosen with special reference to the masons' craft. One of the windows is to represent the Dedication of the Temple of Solomon.

LONGFLEET, DORSET.—The church of St. Mary, Longfleet, near Poole, has been reopened after enlargement at a cost of £6,000. The architect was Mr. H. Kendall. The area of the church has been increased by 1,400 ft. In addition to the new nave and its aisles, there are north and south transepts, clerestory windows, chancel, organ chamber, and vestries. The new nave is in architectural keeping with the style of the remainder of the structure. It has been constructed of Purbeck stone, with stone dressings, the inside being faced with random rubble, Purbeck piers, with dressings of stone. A tiled roof has been substituted for a slate one. The heating is by means of radiators, and electric light is installed. The north transept is fitted up as a side-chapel for weekday services, and an oak screen separates the vestry from the church. Although a gallery has been dispensed with, there is accommodation now altogether for between 600 and 700 people.

The question whether a draughtsman is a workman within the meaning of the Munitions Act, and therefore liable to all the restrictions and privileges conferred by the Act, was decided in the affirmative by the chairman of the Newcastle-on-Tyne Munitions Tribunal on Wednesday.

CHIPS.

Mr. James Blakely has been appointed surveyor of Portland, and has succeeded the late Mr. William W. Jones.

Mr. E. H. Camp has been appointed surveyor to the Hackney Urban District Council, and has been granted a certificate of qualification in the Royal Engineers.

Mr. W. J. Edinger has been appointed by the Urban District Council of Aldersgate to the position of surveyor and sanitary inspector in succession to Mr. M. R. Jones.

A convent is to be built at Killeshil Grange, Co. Dublin, from designs by Messrs. W. H. Byrne and Son, of Suffolk Street, Dublin. The contractor is Mr. James Kiernan.

In spite of the large number of painters and sculptors who have enlisted, the International Society has decided to hold its autumn exhibition, and the private view is fixed for Saturday, the 10th inst.

A new theatre at Langley Moor, County Durham, built at a cost of £3,000, has been formally opened. The architect was Mr. J. A. Robson, and Messrs. Walton Bros., of Crook, were the contractors.

Mr. Edward Williams, surveyor to the Criccieth Urban District Council, having joined H.M. forces, Mr. M. Williams (his father) has been appointed to the vacancy. He had held the position before for many years.

With a view to the augmentation of the water supply recommendations to construct a reservoir for Treunage and another for Penwithick are being considered by the water committee of the rural district council of St. Austell.

The Dean of Guild Court for Johnstone, N.B., have approved plans submitted by Messrs. William Paton, Limited, Clark Street, for a new roof, boilerhouse, and chimney stack, which is to be 120 ft. high. These are the first parts of more extensive alterations which will be carried out at the works.

Owing to the incursion of munition workers, a serious scarcity of houses has arisen at Weymouth, and the workers complain that landlords are unduly exploiting the war conditions. The town council, with the help of a free grant of £10,000 from Government, are erecting a large number of dwellings.

The scheme adopted by the corporation of Croydon in June last for increasing the water supply at a cost of £250,000 has been suspended owing to the war. In arriving at this decision the borough council were influenced by the enormous expense of the passage of a contested Bill through Parliament.

The marble busts of the King and Queen by Sir George Frampton, R.A., presented to the City Corporation by Alderman Sir Edward Cooper and Alderman Sir Charles Wakefield, were formally unveiled at the Guildhall on Wednesday by the Lord Mayor. Both busts have been exhibited at the Royal Academy.

The entrance hall of the Whitechapel Art Gallery is to be completed in accordance with plans by the architect of the building, Mr. C. Harrison Townsend, F.R.I.B.A., but the execution of the mural decorations, designed by Mr. H. F. Garrett, who is serving with the forces at the front, will be postponed until the artist's return.

Mr. Wm. Coleman, contractor, and a member of the Keighley Town Council, was prosecutor, on Wednesday last week, when Daniel Hanley, plasterer, was charged with larceny as a servant. Mr. Coleman deposed that on August 10 he advanced 2s. 6d. as a "sub." to Hanley, and then gave him £4 12s. 6d. with which to purchase some laths. The man never came back. Hanley was sent to goal for three months.

The late John Lindsay, ironmaster, of Gargunnoch Ironworks, Coarbridge, left £1,400 for the erection of a statue of the great Sir William Wallace in Glasgow, with the inscription, "Erected by John Lindsay, Greenfield Cottage, Gargunnoch, as a tribute of admiration to the memory of Sir William Wallace, who was betrayed by Menteith." The Glasgow Town Council, however, have resolved not to grant a site nor to accept custody of the statue if erected, and now the heirs of Mr. Lindsay are claiming before the Scottish Courts in Edinburgh that the bequest has failed and falls to them. On the other hand, the trustees contend that the bequest has not failed, that a site can be obtained, and that some archaeological society can be found to take charge of the statue. The Glasgow Corporation and the Lord Advocate are called as parties to the action for any interest they may have.

The Edinburgh Department of Works and Plans is preparing the plans for the new school at Broomfield, which was delayed last year. The estimated cost is £200,000. J. J. Witter, of Edinburgh, is the architect.

At Wigan on Tuesday last week, J. P. M. Croftwhite, on a petition under the Local Government Board, held an application for an application by the corporation of Wigan for a borrow of £300 for the electricity undertaking.

The Local Government Board have given their sanction to the Sheffield Corporation to borrow £152 for financing sixty-seven houses on the High Windbank estate, and instructions have been given for the work to be put in hand.

A joint Red Cross hospital for Merthyr and Aberdare, built at Treynon, has been formally opened. Mr. Thomas Robert K. L.R.I.B.A., of Ashbrook House, Aberdare, was the architect, and Messrs. J. Morgan and Son, Limited, also of Aberdare, were the builders.

The new church of St. Alban at Llanely, built at a cost of £12,000, has been formally consecrated. Mr. E. M. Bruce Vaughan, F.R.I.B.A., of Dumfries Place, Cardiff, was the architect, and Messrs. Brown, Thomas, and John, of Llanely, were the contractors.

The Mayoress of Huddersfield formally opened on Monday the new military hospital which has been built on the Royds Hall estate on a site given by the corporation. The building will accommodate 500 wounded soldiers, and has cost for erection and equipment £24,000.

At a meeting of the Glasgow City Council on Thursday the general finance and statute-labour committees jointly recommended that the salary of the city engineer and master of works be in future fixed as from June 1 last at £1,000, and that the question be reserved when the war is over.

The proposed sewerage scheme for the parish of Coates is estimated to cost from £5,000 to £35,500. Although it entails sewerage under the canal at considerable depth, the scheme is on the gravitation principle throughout. The scheme will be put in hand by the Rural District Council as soon as conditions are favourable.

The Governor-in-Council has sanctioned an application from the Commissioners of the Howrah Municipality for a loan of Rs. 1,000,000 from the Government of India, bearing interest at the rate of 4 per cent. per annum, and repayable in forty equal half-yearly instalments, for the Howrah waterworks improvement scheme, which is estimated to cost Rs. 16,75,000.

The Right Hon. T. W. Russell, M.P., has opened the Colgan Hall and new technical and agricultural schools at Cardonagh, County Donegal. The entire cost of the building was about £4,000. Mr. W. J. Doherty, 12, Castle Street, Londonderry, was the architect, Mr. Michael Sweeney, also of Derry, the contractor, and Mr. J. Donaghy carried out the plumbing and gas lighting.

Messrs. Marsh and Peter, architects, £2, Thirteenth Street, Washington, have been selected to prepare plans for the preparatory school of the Georgetown University on a tract near Washington, D. C. The group will consist of administration and school buildings, dormitories, chapel, refectory, gymnasium, athletic fields, power house, garage, and stable. The estimated cost is 500,000 dollars.

The Stoke-on-Trent Board of Guardians at their meeting last week, unanimously gave permission to the architect and surveyor of the union, Mr. A. R. Peary, Peary, L.R.I.B.A., of High Street, Stoke-on-Trent, to accept a commission in the Royal Engineers. In reply to a question, the chairman said that Mr. Peary would receive his salary, less the tax of his rank, whilst serving with the Forces.

The village church at Buntford, near Stroud, on Avon, has a memorial to the crew of the great South Polar expedition on the ship of a stained glass window, which was unveiled last week. The four light window depicts Captain Scott and his four companions taking farewell of the last supporting party, Captain Scott finding the flag left by Amundsen within a few miles of the Pole; Captain Oates leaving the shelter of the tent to die, and the search party crossing a cairn over the bodies of Captain Scott, Dr. Wilson, and Lieutenant Bowers. The upper part contains a representation of "The Great Sacrifice."

Our Office Table.

The annual exhibition at the Royal West of England Academy in Queen's Road, Bristol, was opened yesterday (Tuesday) and is perhaps the best display yet shown there. Among the works of interest are "A Venetian scene by David Murray, R.A.," "A Day in October," "Scanty Pastures," by Claude Hayes, R.I.; "A Little Mother," by Arthur Hacker—a girl saying grace at the table with two small brothers, "Charles II. introducing Barbara Palmer to the Queen at Hampton Court, 1662," and "The Herring Season, Great Yarmouth," both by Edgar Bundy, A.R.A. "On a Suffolk Waterway," a low lying country with a river and towing path, by Bertram Priestman, R.B.A., is an intense contrast to R. G. Goodman's "A South African Landscape," in which the distant hills are garishly coloured. Near by is "A Fallen Idol," by the Hon. John Collier. T. C. Gatch has four canvases hung, of which the more attractive are "The Flag" and "The Flight." "La Cage Aux Amours," by Charles Sims, A.R.A., is very effective, and one of the best of the water colours is Sir Ernest Waterlow's "A Lock on the Ouse."

In a letter to the Royal Geographical Society, Sir Aurel Stein described his detailed survey last winter of the Turfan depression in the north-eastern corner of Chinese Turkestan, and his series of archaeological investigations in the ruined town of Idikut-shahri. The systematic clearing of the deeper strata brought to light interesting remains in the shape of fresco pieces, fragments of painting on paper and cloth, stucco reliefs, illustrating Buddhist art at Turfan. He also recovered manuscript remains in the Uigur, Tibetan, Chinese, and Manchu scripts, a hoard of metal objects, and a large number of coins, which enabled him to fix with approximate accuracy the date of its deposit in the time of the Sung dynasty about the 10th century. In numerous rock-cut caves once used for Buddhist worship in the picturesque Toyuk, Sir Aurel found some fine fresco paintings and stucco reliefs. At another site he explored an ancient burial ground containing tomb chambers cut in hard sandstone, in which were found many Byzantine and Sassanian coins, and also brocades and other decorative fabrics showing designs usually associated with Persian work of Sassanian times.

The installation meeting of the Renaissance Lodge of Freemasons, which was founded mainly by the members of the London Association of Master Decorators, was held at the Waldorf Hotel on Monday. The outgoing Master was Mr. Arthur S. Jennings, the editor of our contemporary *The Decorator*, who, after inducing his successor into the chair, signalled the completion of his year of office by presenting the lodge with a banner which we hope to illustrate in our next issue. It has been most handsomely worked in embroidery in the studio of Mr. Arthur Wilcock, the designer, and for purity of design as an example of Renaissance work can hardly be excelled. The new Master of the lodge is Mr. Archibald Campbell, well known as a partner in the firm of Messrs. Campbell and Christmas, and the officers for the year include Messrs. E. W. Wighwick, Senior Warden; E. E. Anderson, Junior Warden; J. J. Honychurch, Treasurer; Chas. E. B. Kibblewhite, Secretary; T. A. Hall and C. Ives, Deacons; H. Price, Director of Ceremonies; Lieut. Col. Duncan, Assistant Director of Ceremonies; J. Cayley, Almoner; J. Wood, Organist; C. Harrison, Assistant Secretary; G. Colley, Inner Guard; W. Falkner, John Lewis, H. S. North, Stewards; and H. Passenger, Tyler.

The third programme of War Lectures under the Chadwick Trust will be given as follows:—Professor D. Noel Paton will lecture on "Food in War-time," at the Hainstead Central Library, on October 4, 11, and 18, at 8.15 p.m.; Dr. R. O. Moon will lecture on "Typhus in Serbia," at the Royal Society of Medicine, on October 20 and 29, and November 3, at 5.15 p.m.; Mr. A. S. von Siedl will lecture on "Emergency

Military Hospital Construction," at the Royal Institute of British Architects, on November 10, at 8.15 p.m.; and Mr. W. E. Riley, F.R.I.B.A., superintending architect to the London County Council, on "Some Conclusions on Housing Our Workers," at the Royal Sanitary Institute, on November 17, at 8.15 p.m.

A practical method of tracing some useful curves, by Arthur Hindhaugh Shield, M.Inst.C.E., is reprinted from the Proceedings of the Institution of Civil Engineers, and is published at its office, Great George Street, S.W. While the method described is not mathematically correct, it is sufficiently accurate for most practical purposes, and has been used by the author for many years in the general work of an engineer's office. With ordinary care and skill a parabola, hyperbola, or logarithmic curve can be drawn with the same approach to accuracy as a circle is drawn with the usual drawing instruments. Further, it can be drawn much more quickly and more neatly than by determining points in the curve by computation, or by intersections and subsequently tracing the curve through these points. The usefulness of this method is not confined to the drawing office, but is also applicable to setting out on the ground the cubic parabola $y = cx^3$ used for transition curves on railways, and to the production in patterns, templates, or stencils of curves for artistic and other work. It is a well-known principle in art, having its origin in nature, that a curve is more beautiful than a straight line, and a curve which continually changes its curvature is more beautiful than a curve of uniform curvature. Such a line of changing curvature can readily be given to a bracket by setting it out on the pattern or template by the method given for $y = \frac{c}{x}$ or any similar curve, and will be much better in appearance than the usual approximation by arc of circles. The paper is illustrated by nine diagrams.

"An Introduction to Applied Mechanics," by E. S. Andrews (Cambridge University Press, 4s. 6d.) is a welcome departure from the methods of some of the older textbooks, which give the student too much applied mathematics, and many of the modern ones, which neglect the proper explanation of mechanical principles in the eagerness to discuss their engineering application. The author has striven, and we think successfully, to present the elementary principles of mechanics in clear terms, basing his treatment more on graphical conceptions than on purely mathematical analysis, and then to show the application of those principles to the simple problems of engineering and architecture. A number of simple experiments are given; principally, and advantageously, those which need only the simplest apparatus.

The foremen employed on barrack construction by Messrs. Sykes and Son, Ltd., of 10, Essex Street, Strand, W.C., were entertained to dinner at the King's Head Hotel, Richmond, Yorks, on the 23rd ult. Mr. Alfred Gee, the managing director, who presided, in replying to the toast of the firm, stated that it had been in existence for just over 150 years, and dealt with all the trades in turn. "We start with the levellers," he said. "They give us a fair and square start, and may we always act on the square and keep a level balance. The excavators start the building and also perform the last rites on us. May we therefore, all through, drive a straight furrow. The concretors give us a sure foundation; the steel erectors a substantial framework, without which which we should be like a man without ribs, or a lady without corsets. The bricklayers fill all in and give shape to the building. The carpenters and felters finish and straighten things up, they give us a good straight floor to walk on, and may we always walk straight. The plasterers coat the walls smoothly; the plumbers let the water in, and help to keep us clean; the drainlayers remove all that would otherwise offend; the painters contrive to cover up a multitude of sins; all through the timekeepers keep us all up to the

scratch; and the general foremen keep their eyes on everything." In conclusion, he explored everyone not to forget the "Tomnies," who are doing so much for us, to strive to give them good, sound homes with all the speed we are capable of. The foremen representing the trades responded with good effect.

TO ARMS!

4th Battalion ("Architects") Central London Regiment Volunteers.

Recruits are urgently needed for the Regulars, Territorials, and Volunteers. Intending recruits should apply to Battalion Headquarters, where they will be advised as to the branch of the Service for which they are best suited.

ORDERS FOR THE WEEK, BY LIEUTENANT-COLONEL A. W. WARDEN.

GENERAL PARADE.

Saturday, 9th inst., at new Drill Headquarters, Chester House, Eccleston Place, at 3 p.m. Uniform parade.

ENTRENCHING.

Members who have volunteered for this will receive written instructions regarding hour of parade, etc.

WORKING PARTIES.

New Drill Headquarters.—Parties are required each evening commencing at 6 p.m. Volunteers should immediately communicate with Platoon Commander G. H. Parker at Chester House, Eccleston Place, S.W.

DRILLS AND PARADES.

"A" Company.—Tuesday, miniature range, Gas Light and Coke Company's premises, Monck Street, Westminster, 5 to 8.30 p.m.

Wednesdays.—Company Parades, 5.15 to 7.15 and 6.15 to 8.15, at Chester House, S.W.

Thursdays.—Signalling at Chester House. See orders from Acting Battalion Signalling Sergeant Cheadle.

"B" Company.—Miniature range and Company Parades as for "A" Company. See orders at local headquarters.

"C" Company.—See orders at local headquarters, Pavilion, A.A. Athletic Ground, Boreham Wood.

"D" Company.—Platoon and Section Drill at Chester House, Tuesday and Thursday, 6.45 p.m. Company Parades, Wednesdays, as for "A" Company.

SCHOOL OF ARMS.

Drill Headquarters, Chester House.—Instruction in bayonet fighting, gymnastics, physical drill, boxing, and single sticks on Tuesday from 6 to 8 p.m.

RECRUIT DRILLS.

"A" Company.—Chester House, 5.15 and 6.15 Wednesdays and Fridays.

"B" Company.—Dulwich College, Mondays, 8 to 10 p.m., and Thursdays, 6 to 8 p.m.

"C" Company.—Boreham Wood and Elstree District Headquarters, A.A. Athletic Ground, Boreham Wood. For full particulars apply to Alan Potter, Grey Gables, Boreham Wood, Herts.

"D" Company.—Chester House, Tuesdays and Thursdays, 6.45 p.m.

CORRESPONDENCE.

Special attention of members is drawn to the fact that correspondence should be answered by return. If this is not attended to the office work of the Corps is immensely increased. Enrolment forms of new members and all correspondence not referring to recruiting for the Army or to financial matters must be addressed to the Adjutant, 10, Conduit Street, W., and regarding recruiting for the Army to the Recruiting Officer at Battalion Headquarters, and regarding accounts and subscriptions to the Pavmaster, W. R. Hughes, 146, Dashwood House, E.C.

By Order.

L. R. GUTHRIE, Adjutant.
BATTALION HEADQUARTERS,
15, TUFTON STREET, WESTMINSTER, S.W.

MEETINGS FOR THE ENSUING WEEK.

FRIDAY.—Junior Institute of Engineers. "A Grinding Problem," by A. J. Simpson, 39, Victoria Street, Westminster, 8 p.m.

Glasgow Architectural Craftsmen's Society. "Old World Belgium, with a Postscript," by James Lochhead, F.R.I.B.A., 8 p.m.

MONDAY (Oct. 11).—Junior Institution of Engineers. "Modern Foundry Practice," by J. Rawlinson, 30, Victoria Street, Westminster, 8 p.m.

Victoria and Albert Museum. "Medieval and Renaissance Architecture," by Banister F. Fletcher, F.R.I.B.A., 4.30 p.m.

THURSDAY (Oct. 14).—Society of Architects. Special Meeting to receive Report of Scrutineers on Ballot for Officers and Council, 28, Bedford Square, W.C., 6.30 p.m.

British Museum Lectures, "Architecture of Ancient Egypt," by Banister F. Fletcher, F.R.I.B.A., 4.30 p.m.

FRIDAY (Oct. 15).—Town Planning Institute. "The Planning, Design, and Arrangement of Railway Terminals," by James Crossland, Lie R.I.B.A., 92, Victoria Street, S.W., 8 p.m.

A Roman Catholic church of St. Patrik has been completed at the junction of Cemetery and Bath Roads, Heckmordwike. The cost was between £3,000 and £4,000.

LATEST PRICES.

N.B.—All prices must be regarded as merely approximate for the present, as our usual sources of information are in many cases failing us.

TIMBER.

Owing to stoppage of supplies all prices have advanced considerably.

IRON.

Table listing prices for Rolled Steel Joists, Wrought-Iron Girder Plates, Steel Girder Plates, Steel Sheets, Steel Strip, Basic Bars, Bar Iron, good Staffs, Do., Lowmoon, Flat, Round, or Square, Do., Staffordshire Crown, Boiler Plates, Iron—South Staffs, Best Snedshill, Builders' Hoop Iron, Galvanised Corrugated Sheet Iron, Cast-Iron Columns, Cast-Iron Stanchions, Rolled-Iron Fencing Wire, Rolled-Steel Fencing Wire, Cast-Iron Sash Weights, Cut Floor Brads, Corrugated Iron, Galvanised Wire Strand, B.B. Drawn Telegraph Wire, Cast-Iron Socket Pipes.

OTHER METALS.

Table listing prices for Lead Water Pipe, Lead Barrel Pipe, Lead Pipe, Lead Pipe, Composition Gas-Pipe, Lead Soil-pipe, Lead, Common Brands, Lead Shot, Copper sheets, sheathing & rods, Copper, British Cake and Ingot Tin, English Ingots, Do., Bars, Pig Lead, Sheet Lead, Genuine White Lead, Refined Red Lead, Sheet Zinc, Old Lead, Tiu, Cut nails.

I BUY

SCRAP METALS

ARTHUR P. COLLINS, Snow Hill, BIRMINGHAM. Phone: Central 1029. Telegrams: "Metalse, Birmingham." Bankers: The National Provincial Bank of England, Ltd., Bennett's Hill, Birmingham.

SLATES.

Table listing prices for Blue Portmadoc, Blue Bangor, First quality, and other slate types.

Table listing prices for Eureka Portland Cement, Permanent Green, and other cement types.

BRICKS.

Table listing prices for First Hard Stocks, Second Hard Stocks, Mild Stocks, Picked Stocks, Facing, Fletton, Pressed Wire Cut, Red Wire Cut, Best Fareham Red, Best Red Pressed Raabon Facing, Best Blue Pressed Staffordshire, Ditto Bullnose, Best Stombridge Fire-bricks, 2 1/2 in. Best Red Accrington Facing Bricks, 3 1/2 Accrington Best Red Plastic Facing Bricks, Ditto Second Best ditto, Ditto Ordinary Secondary Bricks, Ditto Plastic Engineering Bricks, Sewer Arch Brick, Chimney Bricks, Ditto ditto through and through, Beaded, Oval and Bevel Jamb; Octagons, 2 1/2 and 3/4 radius Bullnoses, Stock patterns, Accrington Air Bricks, Accrington Chamber Arches, and various other brick types.

GLAZED BRICKS.

Table listing prices for White, Ivory, and Salt Glazed, Buff, Cream, Other Second, and Bronze Colours, and various other glazed brick types.

MOTTLED BRICKS.

Table listing prices for Stretchers and Headers, Internal and External Angles, Sill Bullnose, Majolica or Soft Glazed Stretchers and Headers, Compass bricks, Camber arch bricks, Best Portland Cement, Ground Blue Lias Lime, Grey Stone Lime, and Stoubridge Fireclay.

STONE.

Table listing prices for Red Mansfield, Darley Dale, Red Corshill, Closeburn Red Freestone, Ancaster, Greenhill, Beer, Chilmark, Hard York, Do. do. 6 in. sawn both sides, Do. do. 3 in. slab sawn two sides, and Bath Stone.

Table listing prices for Bath Stone, Plain red roofing tiles, Hip and Valley tiles, Broseley tiles, Ornamental tiles, and various other tile types.

TILES.

Table listing prices for Plain red roofing tiles, Hip and Valley tiles, Broseley tiles, Ornamental tiles, Staffordshire (Hanley) Reds or brimled tiles, Hand-made sand-faced, Hip tiles, Valley tiles, Hartshill brand plain tiles, sand-faced, Pressed, Ornamental ditto, Hip tiles, Valley tiles.

OILS.

Table listing prices for Rapeseed, English pale, Ditto, brown, Cottonseed, refined, Olive, Spanish, Seal, pale, Coconut, Cochinn, Ditto, Ceylon, Ditto, Mauritius, Palm, Lagos, Ditto, Nut Kernel, Oleine, Sprm, Lubricating, U.S., Petroleum, refined, Tar, Stockholm, Ditto, Archangel, Linsed Oil, Baltic Oil, Turpentine, Putty (Genuine Linsed Oil), Pure Linsed Oil, "Stority" Brand.

GLASS (IN CRATES).

Table listing prices for English Sheet Glass, Fourths, Thirds, Fluted Sheet, Hartley's English Rolled Plate, Figured Rolled, Renoussine, Rolled Sheet.

VARNISHES, Etc.

Table listing prices for Fine Pale Oak Varnish, Pale Copal Oil, Omnifac Copal Oil, Superfine Pale Elastic Oak, Fine Extra Hard Church Oak, Superfine Hard drying Oak, Fine Elastic Carriage, Superfine Pale Elastic Carriage, Fine Pale Maple, Finest Pale Durable Copal, Extra Fine French Oil, Eggshell Flattening Varnish, White Copal Enamel, Extra Pale Paper, Best Japan Gold Size, Best Black Japan, Oak and Mahogany Stain, Brunswick Black, Berlin Black, Knotting, French and Brush Polish.

The Ichen Urban District Council are about to build an isolation hospital at a cost of £3,122, and propose to pay for it out of revenue by instalments spread over five half-years.

Mr. Graham C. Awdry, of the firm of Messrs. Foster, Wood, and Awdry, of 35, Park Street, Bristol, has been appointed diocesan surveyor for the Archdeaconry of Bristol; and Mr. W. A. H. Masters, of 42, Cricklade Street, Swindon, has been appointed diocesan surveyor for the North Wilts Archdeaconry.

TO CORRESPONDENTS.

We do not hold ourselves responsible for the opinions of our correspondents. All communications should be drawn up as briefly as possible, as there are many claimants upon the space allotted to correspondents.

It is particularly requested that all drawings and all communications respecting illustrations or literary matter, books for review, etc., should be addressed to the Editor of the BUILDING NEWS, Elingham House, 1, Arundel Street, Strand, W.C., and not to members of the staff by name. Delay is not infrequently otherwise caused. All drawings and other communications are sent at contributors' risks, and the Editor will not undertake to pay for, or be liable for, unsought contributions.

*Drawings of selected competition designs, important public and private buildings, details of old and new work, and good sketches are always welcome, and for such no charge is made for insertion. Of more commonplace subjects, small churches, chapels, houses, etc., we have usually far more sent than we can insert, but are glad to do so when space permits, on mutually advantageous terms, which may be ascertained on application.

When favouring us with drawings or photographs, architects are asked kindly to state how long the building has been erected. It does neither then nor us much good to illustrate buildings which have been some time executed, except under special circumstances.

Telephone: Gerrard 1291.

Telegrams: "Timeserver, Etrand, London."

NOTICE.

Bound copies of Vol. CVIII. are now ready, and should be ordered early (price 12s. each, by post 12s. 9d.), as only a limited number are done up. A few bound volumes of Vols. XXXIX., XL., XLVI., XLIX., LIII., LXI., LXII., LXIV., LXV., LXVI., LXVII., LXVIII., LXIX., LXXI., LXXII., LXXIII., LXIV., LXXV., LXXVI., LXXVII., LXXIX., LXXX., LXXXI., LXXXII., LXXXIII., LXXXIV., LXXXV., LXXXVI., LXXXVII., LXXXVIII., LXXXIX., XC., XCI., XCII., XCIII., XCIV., XCV., XCVI., XCVII., XCVIII., XCIX., C., CI., CII., CIII., CIV., CV., CVI., and CVII may still be obtained at the same price; all the other bound volumes are out of print. Most of the back numbers of former volumes are, however, to be had singly. Subscribers requiring any back numbers to complete volume just ended should order at once, as many of them soon run out of print.

Handsome Cloth Cases for binding the BUILDING NEWS, price 2s., post free 2s. 4d., can be obtained from any Newsagent, or from the Publisher, Elingham House, 1, Arundel-street, Strand, W.C.

TERMS OF SUBSCRIPTION.

One Pound per annum (post free) to any part of the United Kingdom; for the United States, £1 6s. 0d. (or 60s. 30c. gold); to France or Belgium, £1 6s. 0d. (or 33l. 30c.); to India, £1 6s. 0d. To any of the Australian Colonies or New Zealand, to the Cape, the West Indies, or Natal, £1 6s. 0d.

*Our Direct Subscription Agents for Australia are Messrs. E. T. Kibblewhite and Co., Printers and Publishers, 19, York Chambers, 105, Liverpool Street, Sydney, New South Wales; for Japan, The Maruzen Co., Ltd., 11-16, Nishibashi Tori Sanchoe, Tokyo; who will receive Subscriptions at £1 6s. 0d. per annum on our account. Copies of the paper will be sent by us direct to the subscribers' address.

*The special rate to Canada is £1 3s. 10d. = 50s. 50c. for 12 months, and 11s. 11d. = 20s. 90c. six months. Our Direct Subscription Agents for Canada are Messrs. Sells, Ltd., 302, Shaughnessy Buildings, McGill Street, Montreal, who will receive Subscriptions, £1 3s. 10d. per annum, on our account.

Cheques and Post-office Orders to be made payable to THE STRAND NEWSPAPER COMPANY, LIMITED, and crossed London County and Westminster Bank.

ADVERTISEMENT CHARGES.

The charge for Competition and Contract Advertisements, Public Companies, and all official advertisements is 1s. per line of Eight Words, the first line counting as two, the minimum charge being 3s. for four lines.

The charge for Auctions, Land Sales, and Miscellaneous and Trade Advertisements (except Situations Advertisements) is 6d. per line of Eight Words (the first line counting as two), the minimum charge being 4s. 6d. for 50 words. Special terms for series of 12 insertions or more can be ascertained on application to the Publisher.

SITUATIONS VACANT AND PARTNERSHIPS.

The charge for advertisements for "Situations Vacant" and "Partnerships" is One Shilling for Twenty-four Words, and sixpence for every Eight Words after. All Situation Advertisements must be prepaid.

SITUATIONS WANTED.

Advertisements not exceeding Thirty Words, inclusive of name and address, are inserted under the heading "Situations Wanted," free of charge.

Rates for Trade Advertisements on front page and special and other positions can be obtained on application to the Publisher.

REPLIES TO ADVERTISEMENTS.

Replies to advertisements can be received at the Office, Elingham House, 1, Arundel Street, Strand, W.C., free of charge. If to be forwarded under cover to advertiser, an extra charge of Sixpence is made. (See Notice at head of "Situations.")

Advertisements for the current week must reach the office not later than 3 p.m. on Tuesday. Front-page advertisements and alterations or stop orders for serial advertisements must reach the office by first post on Monday to secure attention.

RECEIVED—H. A. C.—I. C. S.—A. W.—W. W. and Son, K. E. C. W. W. S. Co.—H. H. S. Co.—I. W. S.—W. P. T. and Co., Ltd.—I. B. D.—B. S. A. Co.—J. B. R., Ltd. P. and Co.—C. Bros.—J. D. and Son—H. M. E. Co.

Losen, No.

F. R. A.—Please send.

AMAVIS.—There is no charge.

No SLACKER—Glad to hear it, but facts are facts.

J. E. T.—We take your solicitor's view, but have no time to do what you ask.

A TIMELY REMINDER.—Architects, builders, and others are reminded that the BUILDING NEWS is now published on Wednesdays instead of Fridays, at 2 a.m., and that it should be obtainable early in the day anywhere. If delay occurs it can be posted direct from the office on receipt of a quarter's subscription, or single copies can be similarly sent to readers in camp or moving about the country.

FOR

Olivers' Seasoned Hardwoods,

APPLY TO—

WM. OLIVER & SONS, Ltd., 120, Bunhill Row, London, E.C.

TENDERS.

*Correspondents would in all cases oblige by giving the addresses of the parties tendering—at any rate, of the accepted tender: it adds to the value of the information.

ABERDEEN.—For furnishing new hospital, for the asylum committee of the Aberdeen City District Board of Control:—

Allan, J., and Co., Union Street, Aberdeen (accepted).

ABERDEEN.—For construction of new lavatory, Justice Mill Lane, for the town council. Accepted tenders:—

Table with 2 columns: Tenderer Name and Amount. Includes Plumber work (Blaker, J. and Son, Bon Accord Street, £203 16 0), Tile and plaster work (Sellar and Co., 116, John Street, 120 4 6), Mason work (Took, J., and Son, 42, Holburn Road, 105 2 11), Carpenter work (Hill, A., 21, Mid Stocker Road, All of Aberdeen, 84 15 6).

AUSTRALIA.—For the supply and delivery of schedule quantities of steelwork for cattle grids and cattle and dog stops, for the Commonwealth. Accepted tenders:—

Table with 2 columns: Tenderer Name and Amount. Includes Port Augusta requirements (Doming, Long and Co., £84 16 2), Fremantle requirements (Dorman, Long and Co., 260 8 7).

BALFOURGOTH.—For external painting of the workhouse, for the guardians:—

Table with 2 columns: Tenderer Name and Amount. Includes Beatty, J. J. (46 5 0), Rogers, E. (accepted) (37 9 0).

BARNSELY.—For electric lighting work at Agnes Road schools, for the borough education committee:—

Table with 2 columns: Tenderer Name and Amount. Includes Broley, E., Barnsley (accepted) (472 0 0).

BLYTH.—For erection of a teachers' private room at the Beside girls' and infants' schools, for the Blyth Education Committee:—

Table with 2 columns: Tenderer Name and Amount. Includes Waddle, R. S. (457 17 6), Sampson, J. and W. (54 11 0), Kelsy and Dover (52 5 0), Crook Bros. (39 15 3), Robson, J. J. (accepted) (37 18 6).

BRISTOL.—For the supply of 7 1/2 paper-insulated, lead-covered and armoured main cable, for the docks committee:—

Table with 2 columns: Tenderer Name and Amount. Includes Johnson and Phillips, Ltd. (accepted).

BRECKENRIDGE.—For erecting a bellard-room at the Temple's Institute, West Church Street. Accepted tenders:—

Table with 2 columns: Tenderer Name and Amount. Includes Mason work (Dawson, O., West Church Street, 100 0 0), Carpenter work (Murray, A., Blandford Street, 100 0 0), Slater work (Barelay, J. and Son, Commercial Rd, 100 0 0), Plumber work (Campbell, J. and T., Commercial Road, 100 0 0).

BRISTOL.—For electric lighting work at Agnes Road schools, for the borough education committee:—

Table with 2 columns: Tenderer Name and Amount. Includes Painter work (Dunne, J., West Church Street, 100 0 0), Painter work (Dunne, J., West Church Street, All of Bucks, 100 0 0).

BURTON.—For supply of two feeder pillars and four poles, for the urban district council:—

Table with 2 columns: Tenderer Name and Amount. Includes British Insulated and Helsby Cables, Ltd. (accepted) (4207 0 0).

EVESHAM.—For the erection of a caretaker's cottage at the sewage works, for the corporation. Mr. H. S. Harvey, borough surveyor:—

Table with 2 columns: Tenderer Name and Amount. Includes White, W., Hampton (4230 10 0), Eyles and Co. (228 0 0), Hill and Co. (205 0 0), White, P. A. (199 10 6), Walters, F. (150 18 6), Knox, J. (accepted) (174 0 0).

HASLINGDEN.—For electric lighting erecting shops, machine shops, etc., for Messrs. S. S. Scott and Co., Haslingden:—

Cramp, A. M., Haslingden (accepted).

HUDDESFIELD.—For alterations and additions to the Electricians' Hotel, Longroyd Bridge, Huddersfield. Messrs. J. B. Abbey and Son, District Bank Chambers, Market Street, Huddersfield, architects. Accepted tenders (total 4090 17s. 3d.):—

Mason work:—Graham, R., Lockwood. Joiner work:—Mellor, A., and Sons, Armitage Building.

Plumber work:—Hale, S., High Street. Plasterer and slater work:—T. B. Tunncliffe, West Parade.

Painter work:—Sykes, G. A., Paddock. Electricians:—Senior and Co., Marsh. Concretor:—J. E. Dyson, Lindley.

All of Huddersfield.

ISLINGTON, N.—For supply of 12,300 creosoted yellow deal blocks, for the Islington Borough Council:—

Gabriel, T., Sons, and Barbons, Commercial Road, Lambeth (accepted) (4122 17 4).

LONDON, S.W.—For the linking up of the two electric supply undertakings, for the Battersea and Fulham Borough Councils:—

Henley's, W. T., Telegraph Works Co., Ltd., London, E.C. (accepted) (45,541 0 0).

MUDSTONE.—For providing new showcases at the museum, for the town council:—

Table with 2 columns: Tenderer Name and Amount. Includes Corbens (444 0 0), Elmore and Sons (32 8 0), Cox Bros. (accepted) (31 16 0).

MUDSTONE.—For the re-erection of the Week Street Congregational Church, which was destroyed by fire:—

Table with 2 columns: Tenderer Name and Amount. Includes Elmore and Son (45,565 0 0), Barden and Head (5,490 0 0), Wallis, G. E., and Sons, Ltd. (5,447 0 0), Corben, R., and Co. (accepted) (5,394 0 0).

MELBOURNE, AUSTRALIA.—For supply of structural steelwork for Victoria Barracks:—

Table with 2 columns: Tenderer Name and Amount. Includes Dorman, Long, and Co. (accepted) (41,123 0 6).

RICHMOND, SURREY.—For alterations at the Grove Road institution, for the guardians:—

Table with 2 columns: Tenderer Name and Amount. Includes Soole and Son (4965 0 0), Eldridge and Sons (888 0 6), Speechley and Smith (provisionally accepted) (733 0 0).

ROSTREYOR, CO. DOWN.—For sewerage works at Rostreyor, for the Killeel Rural District Council:—

Table with 2 columns: Tenderer Name and Amount. Includes Lightbody, H., and Sons (accepted) (479 10 0).

SYDNEY, N.S.W.—For the supply and delivery of girder plates for collars for 72-in. main, for the Metropolitan Board of Water Supply and Sewerage:—

Table with 2 columns: Tenderer Name and Amount. Includes Stewarts and Lloyds, Ltd. (42,669 0 0) (Accepted in lieu of R. W. Cameron and Co.).

TWICKENHAM.—For works in connection with the making-up of Cambridge Road (section 3), for the urban district council:—

Table with 2 columns: Tenderer Name and Amount. Includes Adams, T., Wood Green, N. (4957 17 1).

YEovil.—For supply of scholars' dual desks for the central junior school, Yeovil, for the Yeovil Education Committee:—

Table with 2 columns: Tenderer Name and Amount. Includes Wake and Dean, Ltd., Yatton (accepted).

Varying sizes to 24-in. high, 13s. per desk. Larger size desks, 16s. 6d. per desk.

The new open-air school for tuberculous children, built at a cost of £2,880 on the Mount Vernon estate, Barnsley, has been formally opened. Mr. E. W. Dyson was the architect.

A stained-glass window has been dedicated in Slipton Church, Northants, to the memory of Anna Frances Collins, wife of Canon Collins. The window is by Messrs. Heaton, Butler, and Bayne, Garrick Street, W.C.

The death occurred on Saturday, at the age of sixty-six, of Mr. Arthur Sessions, a well-known Cardiff builder and contractor, and for many years a member of the City Corporation. He was a native of Gloucester, and belonged to an old Quaker family.

The Monaghan Rural District Council recently advertised for an architect or engineer under the Labourers' Act. Mr. Hugh McCague, a working mason, was appointed, on the ground that in the view of the majority Mr. McCague was a practical man. The Local Government Board for Ireland has now refused to sanction the appointment.

The United States Government is considering a series of road experiments, the results of which are to be used to determine an engineering formula for vehicle taxation, based on the road destructive effect of all types of vehicles. The aim is to obtain a universal formula on which to base taxation, that a uniform tax may be established, each vehicle being levied so much per year according to the amount of damage, i.e., road wear, it causes, so that sufficient money will be available to build highways of the standard now required by the newer and faster traffic.

THE BUILDING NEWS AND ENGINEERING JOURNAL.

Effingham House,

The Influence of Aerial Warfare on Architecture	303
Messrs. Beckett's Bank, Doncaster	304
The London County Council	304
Reinforced Concrete Sewers	305
The Photography of Church Interiors	305
Modern Building Tendencies in the Central United States	306
Reinforcing Concrete Columns to Carry Additional Stories	306
New Apparatus for Determining Fineness of Cement	306
The Renaissance Masonic Lodge Room	307
Testing Buildings for Settlement	307
Obituary	306
Correspondence	308

CONTENTS.

The Art of Jolly	308
Currents of Opinion	309
Our Illustrations	309
Building Intelligence	309
Water Supply and Sewerage Matters	309
Professional and Trade Societies	309
Trade Notes	309
Legal Intelligence	309
Clubs	309
Our Other Table	309
For Arms	309
Meetings for the Ensuing Week	309
Latest Prices	309
For Correspondents	309
Tenders	309
Last of Competitions Open	309
List of Tenders Open	309

Strand, W.C.

OUR ILLUSTRATIONS

Bl. ...	309
Messrs. Beckett's Bank, Doncaster	304
The London County Council	304
Reinforced Concrete Sewers	305
The Photography of Church Interiors	305
Modern Building Tendencies in the Central United States	306
Reinforcing Concrete Columns to Carry Additional Stories	306
New Apparatus for Determining Fineness of Cement	306
The Renaissance Masonic Lodge Room	307
Testing Buildings for Settlement	307
Obituary	306
Correspondence	308

THE INFLUENCE OF AERIAL WARFARE ON ARCHITECTURE.

A fortnight ago we offered hints likely to be of use under present circumstances for mitigating the effects of bombs on existing buildings. But it is evident that war in the air is a factor to be reckoned much more seriously with by architects in the future. Special conditions and unforeseen circumstances have always produced specific types of architecture. The emblettlement, the moat and drawbridge, keep, machicolation, and portcullis were the outcome of ancient warfare. The Swiss chalet roof is the defence against the avalanche. Not so long ago we were all discussing start-off platforms on our roofs to accommodate the then novel aeroplane. We may have in the near future to regard turrets and gables as mere "peace fixtures," clearing, in time of war, the roofs for action, outspanning bomb-proof nets, and letting down debris screens.

Either the future building must be bomb-proofed on some permanent lines resulting

over his house, but he elects to hazard his life and pay the Government 5s. per cent. He will therefore smile at us if we conjure up visions of buildings like up-ended battleships or Eddystones heavily manclad, and refuse to believe that we shall be driven to

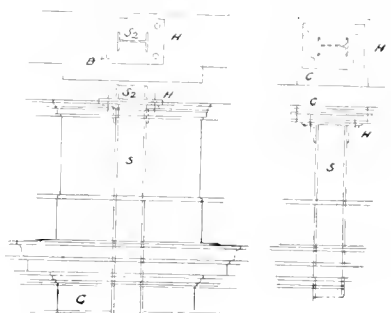

FIG. 2.

earth like hunted foxes. The concern of his architect, therefore, is likely to be rather with quasi-temporary devices than with permanent and radical amendment of design and construction.

But in the near future, as we have said more will be asked of us when designing new buildings. It would be, structurally, quite easy, even if it involved a little extra expense, to arrange either our array of strong steel and girder tie beams differently, or to devise better support from foundation to eopings. Our general system of steel-framed construction well lends itself to some method of forming sockets and baseplates for stanchions for a bomb-proof gantry, designed by experts at the same time as the main building is planned by the architect. At present in general planning we arrange for a comparatively light roof. In planning on the assumption of aerial warfare, we should arrange the supports of sufficient increased strength for emergency duty, and see that the steel framing was efficient and that any impulsive stresses were properly received

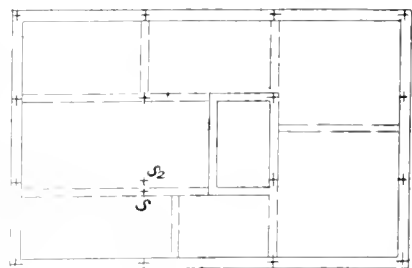

FIG. 3.

and distributed. There are portending advantages in the quasi-elastic horizontal bomb-resisting screen, because whereas this might be arranged—as by means of strong vertical dwarf screens—to prevent the reflex of debris upon adjoining premises, where we

provide a steep-pitched, arm-plate roof we may no doubt divert, harmless to ourselves, hostile missiles, but, accidentally, since the angle of rebound would be approximately the same as that of incidence, blow off our neighbour's roof. Hence it appears to us regulations in this matter would be desirable from authorities.

It is possible, therefore, that the influence of aerial warfare upon building design may be partial only, and may dictate the adoption of permanent anchorage for emergency fittings—means to which, in time of war, actual defensive devices could be secured, whether in the form of armour-plate roof covering or wall-screen, or as an array of eyelets or base-plates where-to may be at once bolted suitable stanchions and bomb-proof covering. Fig. 1 is a plan and superimposed elevation of the upper part of a building, showing an ordinary arrangement of steel framing; but instead of the stanchions stopping at the ceiling level of the uppermost story, they are continued up as permanent construction to the eoping level,

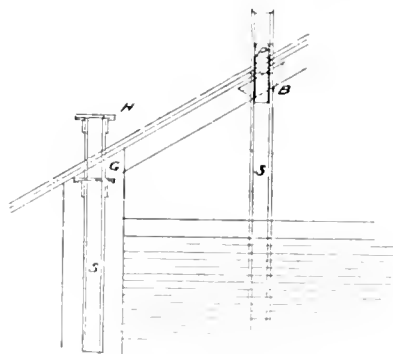

FIG. 4.

there having baseplates all ready to bolt the stanchions indicated, as temporary defensive fittings, to carry the beam shown above roof level, thus forming an outline of the steel framing necessary to take a bomb-proof platform. Fig. 2 shows the balustrade and coping to enlarged scale. The stanchion, S, continued above the girder, G—where, say, in the ordinary manner of building it would stop—runs through the blocking course, and finishes with a head plate, H, at the level of the coping. This has holes for bolts, B, etc., ready to securely and with emergency stanchions, S. A corresponding one could be fitted to maintain the baseplate, etc., without deterioration; or the baseplate could be at the lower surface of the coping stone, as shown in the alternative section on right hand of diagram. In this case the length of coping, C, would be treated much with the same idea that we form straight-pitch in brickwork. It would preserve the baseplate and be removed on emergency. On this system the nature of the special planning required by the architect might be put haphazardly. Let Fig. 3 represent the plan of a proposed building, the crosses in-

in the modification of architectural planning and construction, or we must rig up temporary defences. Can temporary defence be considered all-sufficient and as effective as the more radical amendment of constructive method? Must we have steep-pitched roofs, more than 40 degrees to the normal, of genuine armour-plate, with steel framing and principals after the model of the ribs of a ship, and generally strengthen our steel construction? Or can we still trust to sand and slag-wool and stout steel netting? Or must we burrow in the earth and live like moles, ringing up the lift-man rather to take us below than above?

In potential fire outbreak we have a permanent factor of danger; yet we do not, by any means, live in fire-proofed buildings. We risk structural injury and insure against financial loss. A man might now conceivably construct a bomb-proof platform

deating stanchions. All as planned would, let us suppose, suit a scheme of defence, excepting in the case of S. We might say that some slight modification of arrangements, as moving S to S₂, is the work and thought demanded of the architect to enable possible future building protection to be securely and economically provided. At times, it is conceivable, some support directly over a pitched roof might be required. In Fig. 4 a suggestion is made that stanchions, S, might be permanently built into walls, finished as H or as G or B, in which event small parts of the roofing would require to be removed when bolting up emergency stanchions. At P the suggestion is for a fish-plate connection. It would seem that, under the general scheme, the matter of arranging support for emergency stanchions above a roof is a comparatively small affair if foreseen in planning.

If it can be shown that the best protective method is likely to be based on such lines as we have last suggested, then the modification of architects' plans will be a comparatively small matter; but our impression is that more will be required of us at an early date, at any rate in the design of buildings of national and public importance.

MESSRS. BECKETT'S BANK, DONCASTER.

This illustration represents the new security work recently built by the Ratner

Safe Co., Ltd., from designs and under the supervision of Mr. W. H. Brierley, F.S.A., F.R.I.B.A., county architect of York. The builder's work was carried out by Mr. W. Anelay, of Doncaster, who made himself responsible for all the concrete walls, interwoven with steel girders, etc., on a special principle designed by the Ratner Safe Co., Ltd.

It is also interesting to record that in a fire caused by a recent visitation of hostile aircraft there were four Ratner safes, all of which preserved their contents perfectly.

In addition to the magnificent strong-room, illustrated above, we are informed that the Ratner Safe Co., Ltd., have recently completed the following important contracts:—

A triple steel and girder strong-room of exceptional design for the Huddersfield branch of the West Yorkshire Bank; two steel strong-rooms made on the same special twelve-corner bent principle as Ratner safes, for the new Durham Miners' Hall, Durham; and a massive steel safe deposit—designed to contain 2,068 small safes—for Messrs. Selfridge and Co., Ltd., the well-known London stores.

Naturally, the war has caused a pause in the placing of such orders as the foregoing, but, nevertheless, Messrs. Ratner tell us that, owing to the number of their staff who have joined the Forces, they have found it as much as they can do to keep pace with the orders they are now receiving from the Government, bankers, and private buyers. Since the outbreak of hostilities they have received orders for some 700 safes for Army use, and there are now considerably over 200 of their special "Paymaster Safes" on board H.M. battleships. Only last month 140 Ratner safes were ordered for the War Office.

and Son, architects, London City and Midland Bank Chambers, Cleckheaton, Yorks.

Hon. mention is awarded to "Why" and "Bournemouth Queen."

Cheques for prizes, after verification, will be forwarded about October 30. Any alterations in the addresses of the prize-winners are, meanwhile, to be sent to the Editor.

THE LONDON COUNTY COUNCIL.

The meetings of the London County Council were resumed yesterday (Tuesday) after the summer recess. The Finance Committee recommended that sanction be given to the borrowing by the Lewisham Borough Council of £1,577, repayable on the annuity system within sixty years, for the purpose of a contribution towards the cost of street improvements in Bromley Road, London Road, Devonshire Road, Waldram Road, Stanstead Road, Catford Hill, and Catford Road, now being carried out by the Council. The expenditure was wholly incurred before March 31 last, and the Treasury raise no objection to the borrowing.

The General Purposes Committee reported that Mr. Herbert Edwin Bailey, of the unestablished staff in the Architect's Department, a private in the 5th Battalion Seaforth Highlanders (Rossshire Buffs), has been killed in action.

The same Committee reported that Mr. Cyril S. Cobb, Chairman of the Council in 1913-14, who bore the entire expense for providing the Council with a coat of arms, has intimated his desire to present to the Council a banner embodying their coat of arms, and the Rev. E. E. Dorling has been consulted as to the design. Recommending that the offer be accepted, the General Purposes Committee pointed out that there are many occasions of purely municipal importance when the flying of the national flag at the central office of the Council is inappropriate—events such as the anniversary of the first meeting of the Council, and ceremonial occasions when no member of the Royal Family is present.

The Education Committee reported that Mr. G. Gummer, head of the art department of the Shoreditch Technical Institute at Hoxton, has submitted his resignation, having obtained a position as inspector under the Board of Education. They recommended that Mr. B. C. Hastwell, lecturer in art at the Islington Training College, which was closed at the end of the summer term, 1915, now be transferred to fill the vacancy at Shoreditch at his present fixed salary of £320 a year. They further recommended that means of escape from fire be carried out at the premises of the Cordwainers' Technical College, Bethnal Green, at a cost of £315, these works being absolutely necessary. It was reported that the building of a new school in Cork Street, North Camberwell, for which Messrs. J. Marsland and Sons are the contractors, is approaching completion.

The Building Act Committee reported that the Local Government Board has allowed the regulations made by the Council on July 6 last under section 23 of the London County Council (General Powers) Act, 1909, with respect to the construction of buildings wholly or partly of reinforced concrete and with respect to the use and composition of reinforced concrete in such construction. The Board has fixed January 1, 1916, as the date upon which the regulations shall come into operation.

The Improvements Committee recommended the Council to let on a 99 years' lease to Messrs. Perry and Co., at a rent of £200 a year, a site at the corner of Horseferry Road and Dean Bradley Street. The site has an area of about 4,050 square feet, with frontages of about 48 feet to Horseferry Road, 103 feet to Dean Bradley Street, 50 feet to Romney Street, and 105 feet to Carpenter Street. The condition is made that in the event of Carpenter Street being closed, the lessees are to have half the width of Carpenter Street included in their lease without further payment.

The Parliamentary Committee reported that the London County Council (Tramways and Improvements) Bill, 1915, has been considered by a Select Committee of the House of Lords, presided over by the Marquis of

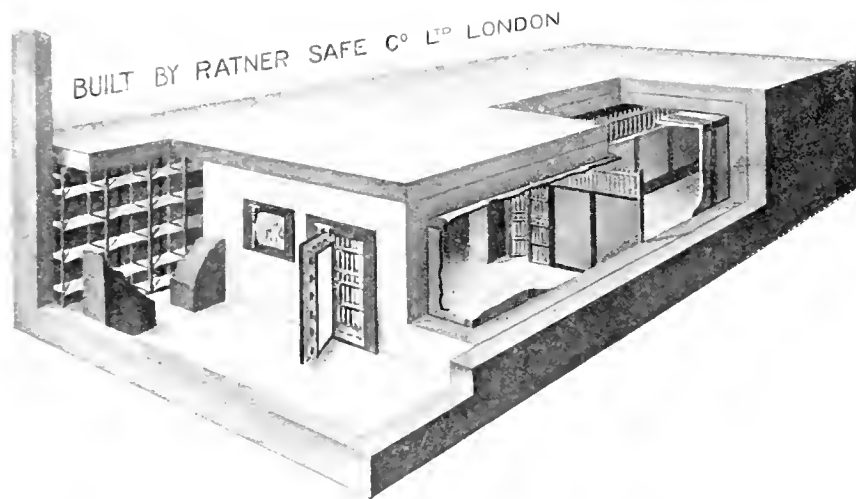

SECURITY WORK BY RATNER SAFE CO., LTD., IN MESSRS. BECKETT'S BANK, DONCASTER.

Safe Co., Ltd., from designs and under the supervision of Mr. W. H. Brierley, F.S.A., F.R.I.B.A., county architect of York. The builder's work was carried out by Mr. W. Anelay, of Doncaster, who made himself responsible for all the concrete walls, interwoven with steel girders, etc., on a special principle designed by the Ratner Safe Co., Ltd.

It will be seen that the room is built with a patrol all round, which on two sides is used for the storage of books, the entrance being guarded by an additional strong-room door. The roof is of double formation, being specially strengthened to take the floor of the bank. The doors are constructed of a patent combination of metals, designed especially to resist every known means of attack, including the oxy-acetylene blow pipe, having a thickness of at least $\frac{3}{4}$ inches over the locks and other vital parts.

The construction is such that it would seem that the contents could not, under any circumstances, suffer damage at the hands of burglars or through the ravages of fire, or even bombs from a Zeppelin. As to the latter risk, which is one that merits the most serious consideration of all having the custody of valuables, Messrs. Ratner point out that all strong-rooms should have their

"THE BUILDING NEWS" DESIGNING CLUB.—AMENDED AWARD, 1914-15.

The decision of our referee announced on page 374 of our issue of October 6 has been challenged with regard to the respective positions of the second and third prize-winners; and, we find, rightly.

On a recount we find that "Walbroke" Mr. W. Brooke, care of Messrs. R. Castle and Son, architects, London City and Midland Bank Chambers, Cleckheaton, Yorks) was wrongly credited with having scored first place on one occasion. The positions, therefore, of "Penwith" (Mr. J. Clark, care of Messrs. Cowell and Drewitt, Lennard's Chambers, Penzance) and "Walbroke" must be reversed, as "Penwith's" record is 18 points against "Walbroke's" 14 points.

The prize-list will therefore stand as follows:—

First prize of £10 10s.: "September Morn"—Mr. H. W. Smith, care of Mr. E. W. Alfrey, M.A., 57, High Street, Oxford.

Second prize of £5 5s.: "Penwith"—Mr. J. Clark, care of Messrs. Cowell and Drewitt, architects, Lennard's Chambers, Penzance.

Third prize of £5 3s.: "Walbroke"—Mr. W. Brooke, care of Messrs. R. Castle

Bristol. Tramways Nos. 2 and 2a, commencing at the existing terminus at Aldgate, passing through Mansell Street and across Tower Bridge Approach, and terminating by a single loop line round Trinity Square, together with the reconstruction of a short length of the existing tramway in Whitechapel High Street, which had been passed by the House of Commons, were again strongly opposed and were rejected. The Home Office report contained criticisms of tramways Nos. 4 to 4c (Mare Street to Terrace Road and Church Crescent, Hackney) and of the proposal for the reconstruction of the existing tramways in Grange Road, Bermondsey. The Bill was re-committed, but after hearing evidence from the police and from the Council's official, both schemes were passed. There were no petitions against the remaining parts of the Bill.

The Building Act Committee stated that they had consented, under Section 142 of the London Building Act, 1894, to the appointment of deputy district surveyors in twenty cases. In order to fill temporary vacancies for district surveyors the committee had appointed Mr. A. G. Morrice, district surveyor for Streatham East, to be interim district surveyor for Streatham West; Mr. W. R. Davidge, district surveyor for the district of Lewisham, to be interim district surveyor for the district of Woolwich; Mr. H. T. Bromley, district surveyor for Whitechapel, to be interim district surveyor for Bethnal Green West; and Mr. E. W. Knight, district surveyor for Bromley, to be interim district surveyor for Poplar All Saints. Each of the appointments dates from October 1, 1915, and will continue during the pleasure of the Council. The committee adopted the course of appointing existing district surveyors temporarily to these positions, as they thought it unwise to recommend the Council to appoint any new district surveyors during the war. 1,002 notifications have been received during the recess with regard to structures which were alleged to be in a dangerous state. In 115 cases it was found that structures were not in a dangerous condition, and consequently no further action was necessary. In 887 cases notices were served upon the owners requiring the removal of the danger. In order to secure compliance with the Council's notices it was necessary in some cases to obtain orders from the magistrates, and in thirty-six cases in which such orders were not complied with the committee arranged for the Council's contractors to take down the dangerous portions of the structures. As a temporary expedient they arranged for forty-eight structures to be shored up or hoarded in by the Council's contractors.

REINFORCED CONCRETE SEWERS.

The results of tests recently made upon reinforced concrete pipe for sewers by Mr. A. T. Goldbeck, assistant engineer of the testing laboratory, Bureau of Surveys, Philadelphia, are described in a paper presented to the American Concrete Institute. The author's conclusions are as follows:—

1. Reinforced concrete pipe, when properly made and properly cured, is very satisfactory for the construction of sewers.
 2. The use of a concrete cradle greatly increases the stiffness of the pipe, and reduces the load under which initial cracking takes place.
 3. For sections of the size tested and for smaller sections, the placing of the reinforcing near the inner face throughout the entire circumference seems to be justified.
 4. The matter of curing should be very carefully controlled, as much stronger pipe will result if care is taken to keep them thoroughly wet, preferably for a period of two weeks.
- Finally, the manufacture of concrete pipe should be much superior to that of ordinary construction. Not only should the quality of the available material be carefully investigated, but density tests should be made in order to combine these materials in such proportions as to produce the densest possible concrete. Density and elastic strength are absolutely necessary for good concrete sewer construction.

The Hawarden memorial to the late Mr. V. G. C. Gladstone, M.P., will take the form of the replacement in the parish church of the roof beam, cross and figures.

THE PHOTOGRAPHY OF CHURCH INTERIORS.

Churches may be divided into two classes. There is the church that is the design of one man, and forms a complete work of art in itself, such as St. Paul's, St. Peter's, and numerous smaller churches among which Wren's are prominent. Then there is the church that has grown up by instalments, as it may be expressed, where various architects have had a say in the design at different periods, and that possibly represents the various types of design that prevailed during four or five centuries. Many such examples exist in our old abbey churches and minsters, and in most cases these can only truthfully be described as collections of works of art, not as complete works in themselves. This peculiarity must be allowed for when photographing or sketching such buildings, but it will be sufficient for us to confine our attention to the former class, which are complete in themselves and not confused by the additions of various periods.

One obvious way in which a church differs from a private house is that it forms practically one chamber alone, and is not cut up into a multitude of small portions, but if we compare this one large chamber with other erections that are similarly units by themselves we find very important differences. The church has one definite point of focus which governs the whole of the design, whereas the private large chamber, be it ball-room, picture gallery, or what not, has no such focus. The focus point in a church is the altar, and in a well-designed church the whole design is controlled by the purpose of leading the attention to and fixing it upon the altar. In a church interior the altar fulfils the same purpose as the point of interest in a well-composed picture, while, further, just as a picture is arranged by the painter to represent the subject as seen from some one particular view point, so the church is designed from one particular view point, from which point alone can we see exactly what the designer wished us to see; that is, the design at its best. To put all this into other language, we may say that while the private ball-room will have no one special point of interest, and will be designed as far as possible so as to look equally well from any where, the church has one dominant point of interest, and also has one particular view point from which the design as a whole looks at its best.

Inasmuch as the whole of the interior cannot be seen from one point, it follows that there are subordinate points of view from which parts of the whole should be studied, but if the photographer does not know the general principles of church design he is never likely to hit upon the best points, while in some cases mistaken ideas and prejudices will cause him deliberately to avoid them.

There are three general principles by which the architect is guided in the attempt to compel attention to be focussed on the altar, all three being also more or less the same as those which serve as guides to the picture painter. In a really fine, well designed church it will be noticed that many horizontal lines are introduced, all leading apparently towards the altar. Also that the design becomes more refined and more ornate as it nears the altar end, and, finally, that the two sides of the church symmetrically correspond, so that neither possesses special interest to attract the vision from the centre focus. The one point from which all these features is most manifest is the central west door of the church, which is also the main point of view from which the church as a whole was designed to be seen. In some cases the view from this point is so striking that the church looks like a different building to any one who has only seen it before from inferior stand-points. St. Paul's is a case in point, and it can truly be said that anyone who has never entered St. Paul's by the great central west door has never really seen St. Paul's at all. Unfortunately, opportunities of doing so are rare, and even in minor churches there is

often difficulty in getting the west door opened, while entering a narrow aisle and walking round the view point does not give at all the same impression.

This is the best view that an architect can see for, and in order to get it as a first impression he will often pay the verges handsomely for the privilege of getting the west door opened, but it is, as a rule, the last view that the photographer will present him with, and when the photographer does produce it it is generally found that he has spoilt the effect by making his exposure, not from the west door but from some point well to one side of it, thus destroying the perfect symmetry and knocking out one third of the emphasis that the designer tried to produce. Some photographers have a foolish prejudice against symmetry at all, not being able to realize that in some cases, though not in all, perfect symmetry is an ideal condition. In the palatial ball-room, designed to look well from anywhere, we do not want a symmetrical view, because it will divide the interest and spoil the picture. In the church view from the west we do want it, because it helps to concentrate the interest on the one right point, whereas anything that detracts from perfect symmetry diverts the interest and spoils the concentration. In some Continental churches the symmetry is obviously spoilt by the importation of large and ornate pulpits on one side of the nave. These are often very fine things by themselves, but their effect in detracting attention from the main point of interest is very marked. When no such disturbing feature exists a remarkable effect can sometimes be obtained if we take up various points of view at the west end of the church. On walking from one side to the other, looking east all the time, it may be noticed when we reach the central position that the general design of the building seems to come together, with a snap as it were, and becomes complete. The effect is like that sometimes obtained when searching for the best point of view in a landscape. Suddenly, at one place, everything looks perfect, though at other places some defect in the composition is quite noticeable.

The west door is the principal point of view for the design as a whole, but as we advance up the church new points are reached from which smaller parts of the design are seen. The altar becomes more and more prominent as we approach it, and claims attention on its own account, wherefore we are no longer so dependent on other factors for emphasis. Moreover the design is becoming more ornate as the simplicity of the nave is left behind us, and a too symmetrical view may soon tend to scatter interest by the elaboration of detail on all sides. At the west end the opposing sides of the nave are of simple design, and symmetry has no disadvantages, whereas at the east end the design may be too elaborate to render perfect symmetry advisable. There is, however, usually one good view point at the centre of the top of the chancel steps, this being another point of view specially considered by the architect.

In the transepts symmetrical views should generally be avoided, the design being very often non-symmetrical, while there is no special point of interest in focus. The eastern transept walls are generally designed to be seen from the nave, and therefore in conjunction with the chancel. The western walls, on the other hand, are often designed to be seen together with the nave from the east, and are then much more simple. Sometimes the walls are designed in unison, but there is usually little interest in either transept, and there is no specially designed view point. Cross views showing the merging of the design of chancel or nave into that of the transepts will, however, generally be of interest to architects.

Views looking west, away from the altar, are usually devoid of any special interest. A view from the immediate front of the altar will, however, often be of considerable interest from the purely architectural point of view.

Practically what the architect wants is the important view from the west door showing the general design and the way everything tends to lead attention to the altar, and a

* From a valuable article in the *British Journal of Photography*, which we commend to the attention of our own readers, to whom we are often indebted for photographs which we could sometimes wish were capable of better reproduction.

Correspondence.

MISSING JACOBAN OAK BENCH, STEYNING CHURCH, SUSSEX.

To the Editor of THE BUILDING NEWS.

SIR.—I hasten to apologise for saying Mr. Pridgen was inducted to Steyning in 1879. The Clergy List gives this date as the year of his ordination, and also records the fact that three years subsequently he was appointed to the cure of Steyning. The publication on my pages of the sketch of the missing carved bench in question occurred, therefore, ten years prior to his incoming in 1882. I do not happen to know exactly when the ugly deal galleries and box-like pews were removed from this church, but, if my memory serves me rightly, I saw there a few weeks ago the name of the vicar (when this clearing out took place) inscribed in clear, conspicuous lettering on the wall of the south aisle, and it was this inscription which gave me the impression that it might have been put up as a memorial to a beneficent departed parish priest who had helped to improve the building by disencumbering the beautiful arcade of the Puritan galleries, the removal of which I so approvingly mentioned. Whoever the architect employed may have been—and I have no notion whom he was—he certainly ought to have looked after the preservation of this quaint old seat if it then existed in the church; but Mr. Pridgen, who I now gather was vicar at the time, doubts if it ever did exist, and he adds that after full inquiry he can find no one left in the parish who remembers anything of the kind. This is quite likely, for ordinary folks know so little of such things and perhaps care less. The bench was only a sample of Sussex vernacular work, but art nowadays has receded away from life.

I find you published an article on page 222 of your journal for September 20, 1872, which is descriptive of a visit by the British Association to Steyning on August 17 that year, when the writer says he was met by the vicar, the Rev. T. Matfield. General particulars as to the styles and dates of the church are furnished and mention is made of this oak seat as being poked away in the tower. The illustration of it, which I previously alluded to, will be found in your issue for February 25, 1872.

In corroboration of the above I see that in the following number (March 1, 1872) a well-known correspondent of THE BUILDING NEWS at that time, Mr. W. E. Potter, wrote confirming what Mr. Maurice B. Adams had directed attention to (when his drawing appeared about the neglected condition of this interesting bench-ended settle. Mr. Potter, however, roundly blamed the Sussex Archaeological Society for allowing such negligence. Really the parson and churchwardens were primarily at fault, as they are the legal custodians of all trustee property owned by their parish church. However, Mr. Potter apparently had some experience of archaeologists, and he suggests that the use of such bodies "seems to consist in occasionally going to look at antiquities and eating a good dinner." In Sussex, so rich in old buildings and works of art, they treated such things with indifference and neglect for long years, and he names specially Hastings Castle. By way of a similar example of wanton disregard of old church furniture Mr. Potter tells when visiting Guestling Church, in the same county, to see the famous Flamboyant or Flemish richly traicord and ornamented oak chest, which is illustrated in Parker's "Glossary," he discovered that it had been "recently destroyed," and he found the only single remaining panel, "like our friend at Steyning, stowed away in the tower." Not even the oldest inhabitant in Guestling, I'll be bound, could now testify, if inquired of by the vicar, that such a chest ever existed. It has gone for aye! I may refer to one very notable case of this sort, because it concerns the magnificent lectern at Detling, in Kent, perhaps the most beautiful piece of church furniture of its kind in England. It is still in a fine state of preservation. During the last century, and quite likely about the time

when the Gothic chest at Guestling was broken up and the Jacobean settle at Steyning went astray, the churchwarden of Detling, finding himself in need of funds, carted away this lectern, and it was subsequently found in a dealer's store at Maidstone. From thence it was fortunately recovered and reinstated in Detling Church. The rector told me about this, and he knows how to estimate such things held in trust for the parish and the Church as a whole.

Steyning Church is illustrated in Britton's "Ancient Architecture in England," and by Mr. F. L. Griggs in "Sussex Highways and Byeways," "The Brotherhood Hall" in "Churches Street," Steyning, figures in THE BUILDING NEWS for September 20, 1872, from the pen of Mr. Maurice B. Adams. The windows shown by his sketch to the first floor have since been removed, vastly to the improvement of the external appearance of the building, which is uncommonly picturesque. The now dirty whitewash applied to the old Sussex brickwork round about the arched entrance is a sad disfigurement and most objectionable. I do not know who is responsible, but someone with a little enterprise might get this washed off and the Brotherhood Hall brushed up a bit, but not restored or modernised, like "the old post office" at the other end of the town.—I am, etc.

October 8, 1915. A SUSSEX MAN.

WAR DAMAGE A NATIONAL RESPONSIBILITY.

SIR.—The Government insurance scheme which has made the individual citizen responsible for war damage is so manifestly unjust that we may reasonably hope that it will soon be abandoned.

The Army and Navy are maintained for the defence of the citizens and their property. In so far as they fail to give complete protection the community as a whole should compensate those who suffer damage, whether they be freeholders, leaseholders, house-holders, or lodgers.

Prior to the Government insurance scheme, sufferers from air raids and bombardments on the East Coast were, properly, compensated out of national funds, on the same principle that residents of a police district are compensated for damages resulting from failure of the authorities to give complete protection in the case of riots.

The Riot (Damages) Act, 1886 (49 and 50 Vic., C. 38), provides in Section 2 as follows:—

"Where a house, shop, or building in any police district has been injured or destroyed, or the property therein has been injured, stolen, or destroyed, by any persons riotously and tumultuously assembled together, such compensation as hereinafter mentioned shall be paid out of the police rate of such district to any person who has sustained loss by such injury, stealing, or destruction; but in fixing the amount of such compensation regard shall be had to the conduct of the said person, whether as respects the precautions taken by him or as respects his being a party or accessory to such riotous or tumultuous assembly, or as regards any provocation offered to the persons assembled or otherwise."

This question of war damage seriously affects the whole community, and if not dealt with in an equitable manner will add to the necessary evils of the war untold suffering on the part of those citizens who happen to be hit by the enemy in their attack on the nation. Once recognise that war damage is a national responsibility, and it becomes clear that all insurance schemes are out of place, and that an Act should be passed for compensating all citizens injured in the person or estate by the enemy.—Yours, etc.

MARK H. JUDGE AND SON,
Architects and Surveyors.

7, Pall Mall, S.W., October 9, 1915.

[We entirely agree, and said so some months ago. See our remarks on p. 78 of our issue of July 21 last.—Ed., "B.N."]

A receiving order was made on the 30th ult. in the case of Ernest Schaufelberg, Lombard Street, E.C., architect.

THE ARTISTS' RIFLES.

The following appears in the current issue of the *A.A. Journal*:—

I have received a letter from Lieut.-Colonel May, C.B., the Commanding Officer of the 1st Battalion, Artists' Rifles, in which he says: "You probably know that on arrival in France" (in November last) "the Artists' Rifles were given the task of training and supplying young officers to the British Army, especially Regular units. I send you a roll showing you what the Corps has done in this direction which may interest you, and from which you will see that we have supplied 1,500 young officers (some to every Regular Infantry Regiment in the British Army) besides Machine Gun Instructors and others, so that I think we may feel that the 50 years of preparation has been justified." Colonel May says he gets "splendid accounts" from the C.O.'s of his men, and they all ask for more. The roll is most interesting, as it contains the names and rank, etc., of those members of the Corps who have been appointed officers, and I have had a copy sent to the office of the A.A., where it may be seen by any of our members.

As many of our members are in the Artists' Rifles (a number which will no doubt be largely increased during the war), I think the readers of the *Journal* will like to know of the good work the Corps is doing in France.

The intensely interesting notes by Lieut. W. H. Ward, published in the last issue of the *Journal*, and his account of his meeting with a brother "Artist" at "Anti-Krupp Villa" in the trenches, give one a good idea of the spirit of the men in the old Corps.

GERALD C. HORSLEY,
Past President.

P.S.—Copies of the pamphlet (6d. each to cover expenses) can be obtained on personal application at any Orderly Room of the Artists' Battalions or by remitting cost to the O.C. Administrative Centre at the Regimental Headquarters.

Second-Lieutenant F. G. Sainsbury, architect and surveyor, of Friar Street, Reading, has been selected by the War Office for the Royal Engineers, and is now in France supervising defence works.

A brass tablet erected to the memory of Captain H. R. S. Pulman has been fixed in the vestibule of the Council Chamber at Westminster City Hall, Charing Cross Road, and will be unveiled by the Mayor to-morrow (Thursday) afternoon.

At the urban council's office, Northallerton, on Wednesday, Mr. P. M. Crosthwaite, C.E., an inspector under the Local Government Board, held an inquiry into the further application for an additional sum of £10,000 in respect to the expenditure on the new water-works at Osmotherley, in the area of the rural council. Mr. E. Sandeman, the water-works engineer, outlined the new works and mentioned details of the expenditure, together with the unexpected difficulties which had arisen which necessitated the further borrowing powers.

By ballot the members of the Amalgamated Society of Engineers have decided to secede from the General Federation of Trade Unions, and the requisite six months' notice has been given by the Executive Committee. The A.S.E. has a membership of 200,000, of whom 20,000 are abroad. The ballot figures were: For secession, 16,075; against, 14,259. Mr. Young, the general secretary of the society, gives as the reason for the secession that "the numbers no longer wish to belong to a financial federation like the General Federation of Trade Unions, but wish to build up a fund of their own."

Mr. Hubert Hall, F.S.A., Assistant Keeper of the Public Records, in the course of a lecture on Monday night at the London School of Economics, Clare Market, W.C., on the archives of England and Wales, remarked there was a great opening during the war for the employment of women as archivists. He hoped to see at least one woman in every office for the preservation of public records. Sir Laurence Gomme, who presided, said that the local records of this country were as valuable as the national records. In the sixties the records of Weymouth were discovered in an auctioneer's catalogue, but fortunately the sale was stopped. It was distressing that so many public authorities continued to neglect the valuable documents in their possession.

Currente Calamo.

Great lawyers seem to us strangely unacquainted sometimes with stubborn facts, which are palpable to most of us, whether we are landlords or tenants. Among other suggestions to the Government how to tax us more, Sir Edward Clarke, K.C., says in a letter to the *Times* of Saturday last:—

There is another matter connected with the income-tax to which I should like to refer. It is one in which the State is deprived of payments which it is by law entitled to receive. As the law stands, the tenant who pays an annual rent . . . is entitled, and indeed bound, to deduct income-tax, but in the enormous majority of private transactions he keeps the money himself and never pays it over to the Treasury.

As mere tenants we should really be obliged to Sir Edward Clarke if he will introduce us to a good landlord who will allow us to deduct income-tax from our rent without production of the tax-collector's receipt, and at the same time tell us how we can then "keep the money"!

One may perhaps wish the various Metropolitan borough councils a little common sense in their endeavours, at the very proper suggestion of the Office of Works, to arrange equality of lighting. The differences lately have been ludicrous. We live on a boundary road of two boroughs, lit by gas, which, when the trees are in leaf, is always badly lit. One has extinguished half the lamps and coloured the rest dark green. The other sticks to whitewash. The mere man in the street has been asking himself for months whether the end aimed at might not have been achieved by simply turning down the gas, instead of burning a full flame and then obscuring it! The whole thing has been ridiculously overdone, and the conclusion of the Office of Works that 75 per cent. of the lamps in side streets should be lit, and that the reduction in main road lighting has been excessive, might with advantage have been arrived at sooner.

The Government and the municipalities seem to have been smitten with the beauty and profit of teaching other people to practise frugality. Some of our mentors, we fancy, must chuckle to themselves as they hum the refrain of the old song:—

By studying economy
We live like a lord!

Anyhow, the first and indispensable item of their propaganda seems to be to spend other people's money on "Expert advice and assistance." One instance is furnished by the proceedings at a recent meeting of the Devon County Council, when the following resolution was moved by one of the members:—

That with a view to lighten the burdens of the ratepayers, a committee be appointed to consider whether the expenditure of the county council can not be reduced, and to report thereon.

The committee to consist of nine members of the council and three members selected by the nine from outside the council. The three to be appointed by virtue of their experience in public and other business.

The committee to have power, if they consider such expenditure necessary, to spend a sum not exceeding £100 in obtaining such expert advice and assistance as they may deem of value to them.

The resolution was defeated, and "Devon, glorious Devon" is to be congratulated on its common sense, or was it that the hundred pounds was not enough to share round?

The presidential address of Mr. J. G. Read, at the Auctioneers' and Estate Agents' Institute opening meeting of the session on Friday last, should reassure property owners who are wisely declining to swell the ranks of panic-stricken sellers. That this is so is evident from the diminution in sales during the last five months of 1914, which only

totalled £148,426, as against £1,718,205 in the first seven months of that year. Now is the time to buy for all who can afford to wait during the transition period that will follow the end of the war. Then we are certain values will improve, and more than regain their previous level. In the meantime, of course, auctioneers and estate agents are sharing our own bad times, though probably to nothing like the same extent, as their activities cover the field of management of property, unlike those of the architect and builder, which cease with the completion of the building.

The German trade-mark forgers are at their old game again. A slight telegraphic blunder, the change of one letter into another, and, by consequence, of one word into another, has been the indirect means (according to Reuter's Agency) of disclosing a clever scheme initiated with the double purpose of securing trade profit and of disseminating lies in foreign countries. Switzerland and other neutral countries are naturally open doors to the whole world. So these counterfeited goods go to neutrals, who not merely sell to other neutrals in South America and many British Colonies, but are to-day sending over German goods which are being sold in London disguised under counterfeited trade marks. The forgers are, of course, quite secure from legal proceedings owing to the present condition of affairs, and there still seem to be buyers about, even in our own industries, who are none too particular, if the counterfeited article can be had at a cheaper figure. We are watching the matter, and may have more to say about it shortly.

The Executive Committee of the Star and Garter scheme have wisely decided to abandon their original intention to adapt the existing hotel for the proposed Soldiers and Sailors' Home. After the most careful consideration it was, of course, found that by the erection of an entirely new building on the existing site the Home could be made to provide many more beds at a cost per bed not exceeding the sum originally anticipated for the alterations. It was therefore obviously more economical to rebuild than to adapt the old building, and the plans of the new building are now being settled by the Committee of the British Red Cross Society, with the approval of her Majesty the Queen. In the meantime the annexe is being fitted up as a temporary hospital, and when the new building is completed the annexe will be rebuilt, thus forming a complete scheme, the details of which will be published shortly.

The Liverpool Autumn Exhibition was opened on Saturday at the Walker Art Gallery. The expenses connected with it are being met through the generosity of a Liverpool citizen, and the proceeds from admissions are to be given to the Liverpool branch of the Red Cross Society. Other receipts will be available for the purchase of works for the Gallery. Gallery II. of the exhibition has been given up this year to a collection of modern Belgian pictures and sculpture, and another to pictures of Burmese subjects by Mr. G. F. Kelly. In addition, there are some smaller special exhibits, including those of the Royal Society of Miniature Painters. In the large gallery, Room VII., the chief pictures are Mr. Orpen's "Western Wedding," Mr. Shannon's "Princess Mary," and Mr. Maurice Goeffenhagen's "Woman by a Lake," the last-named a loan by the Chantry Trustees. The principal landscapes are those

by Messrs. Cameron, David Murray, G. Houston, Oliver Hall, and T. Minge. The dominant works in the first gallery are Mr. Arnesby Brown's "Cattle in the Fields," and the "Deserted Quarry," by Mr. Wilson Steer. There are good displays of water-colours by Messrs. Frank Reynolds and Cameron, and etchings by Messrs. J. McBay, F. S. Unwin, and others.

Very late in the day, Mr. Thackeray Turner, Chairman of Committee of the Society for the Protection of Ancient Buildings, replies to the letter of Mr. W. H. Wood, F.R.I.B.A., of Newcastle-on-Tyne, which appeared in our issue of September 8, p. 279, in which Mr. Wood defended his restoration of the churches of Sleaford and Tickhill from the criticisms made in the current report of the society. With regard to Sleaford, Mr. Turner says the society holds to its opinion that the "careful copying of the carving," which Mr. Wood describes as having been done, is the type of restoration to be resisted. The society now, "hears with regret from Mr. Wood that the work has been temporarily stopped only from want of funds, and that it is intended to complete it after the war. With regard to Tickhill, the report contained two photographs showing the south porch before and after 'restoration.'" Mr. Wood says that during the period in which he has superintended the reparation of the church, that is during the last year only, the south doorway has not been touched. This may well be, says Mr. Turner: "No particular date was mentioned in the report nor the name of any architect." So that the restoration denounced is apparently a matter of ancient history.

We are pleased to learn from the October issue of the *Journal* of the London Society that the efforts made by Mr. Arthur Crow, F.R.I.B.A., the district surveyor for Finsbury, and other members of the council of that society, to preserve Wren's church of St. Vedast, Foster Lane, have been so far successful that, in the event of the suggested road from Newgate Street to Liverpool Street being found necessary and practicable, it will be possible to form the road without materially interfering with either the use or the appearance of the church. The new building about to be erected on the site of the old Post Office is to be placed farther north than was originally intended, thus leaving a space between it and the buildings in Cheapside. The result of this will be that the view of the church spire from Newgate Street will be preserved, and the need for the destruction of the church avoided, if at any time the new road becomes necessary. The Corporation of the City of London have reconsidered the question of the traffic requirements at this busy corner, and St. Martin's-le-Grand is to be widened to 80 ft. in lieu of 70 ft. as originally proposed, and the western end of Cheapside is to be widened to 95 ft. This is mainly done in order to provide for the increased traffic which it is anticipated will result from the construction of the proposed St. Paul's Bridge, should it ever be built. The officials of the City Corporation evidently believe that the bridge is to be an accomplished fact, since leases of properties acquired on the route are being renewed for twelve months only, with henceforth a tenancy determinable quarterly.

Two interesting letters by architects protesting from different viewpoints against the building of St. Paul's Bridge appear in the

Mr. P. B. ... demands the reconsideration of ... the ground that there is ... between Blackfriars and ... He points out that the ... with any proposal ... by the Traffic Branch of the ... is not part of a comprehensive ... south thoroughfare, and that ... approach road south of Southwark ... has been designed as a complement ... of the proposed bridge has obvious ... defects. The level at one side of ... higher than the other, each arch ... approaches the south side, is of less ... than its neighbour, and nearly every ... would be out of adjustment. Even by such questionable expedients, there remains insufficient length to get a proper ... to Southwark Street, consequently the southern viaduct is made to bend east ... to gain a few feet. On the north again the bridge just misses the Cathedral, although there seems little reason why it might not have been in alignment. Where a viaduct bridge is really needed, he says, at Charing Cross, Mr. A. E. Richardson's objections to the scheme are that it would, by its oblique alignment, destroy the amenities of St. Paul's and of the river itself.

Commenting on these letters, the editor of the *Builder* remarks: It is an open secret that this bridge was conceived in unseemly haste by the Bridge House Trustees, at a time when they had large funds at their disposal with no fixed destination. Fearing that their coast was being watched for spoliation, they promptly devised this outlet, and already, we believe from current rumours, regret it. The trustees might have made themselves famous for ever, had they taken charge and given up, as they could in their discretion, the fetish that their funds must be spent within the City boundary, and devoted themselves to a new road bridge at Charing Cross instead. Such a bridge was seen to be necessary as long ago as 1846, when Mr. Pennethorne advocated it in connection with his scheme for central reconstruction; and to-day it is such an obvious and urgent need that we can only suppose that the existence of the railway bridge has prevented its realisation. That all traffic from the West End should be forced to cross via Westminster or Waterloo Bridges, both out of line with the general direction of traffic, shows how long suffering the London public really is.

Unparagoned scenes were witnessed at a special meeting of the Monaghan Rural Council, on Monday, says the *Irish Builder and Engineer*. Over forty men were attended, and Mr. Hugh McCague, stone mason, Drumahaire, Monaghan, was for the second time within a month elected by twenty-one votes to eight as engineer to the Rural Council under the Local Acts and Sanitary Acts. The Local Government Board, it is remembered, was lately successful in his appointment owing to his not possessing the necessary qualifications, as defined in Art. 10 of the Regulations O. No. 1912. His services have again been obtained, as stated, on a demand of the Board. The chairman, Mr. James McGuire, J.P., refused to put the motion proposing Mr. McCague at Monday's meeting and the election, which was taken by Mr. James L. G'ahill, a prominent member of the Council. A cry has thus arisen, and

the further action of the Local Government Board is awaited with much interest in Monaghan and district.

Mr. Redmond P. Roblin, the ex-Premier of Manitoba, and Dr. Montague, ex-Minister of Works, Mr. Howden, ex-Attorney General, and Mr. Goldwell, another Cabinet Minister, were committed for trial on Friday on the charge of conspiracy to defraud the Province of Manitoba in connection with the erection of the Parliament buildings.

"Wind Stresses in the Steel Frames of Office Buildings" is the subject of the most recently published Bulletin of the University of Illinois. The increase in the price of land in large cities has made it necessary to build high buildings in order to get a large rentable floor space on a small parcel of land. The type of building generally used is known as the steel-skeleton building. In this type of building the live and dead loads, including the weight of the walls, are carried by a system of beams and girders to columns and are carried by the columns to the footings. In high buildings the horizontal shear due to the wind load is very large; and, since it is usually impracticable to put diagonal braces between the columns, it is customary to make the steel frame rigid enough to resist the horizontal shear by virtue of the stiffness of the columns and girders. The exact determination of the stresses in a steel frame due to a horizontal shear is one of the problems of structural engineering which remains to be solved. While the writers realise that the method of determining these stresses presented in the Bulletin is based upon assumptions which are not exactly true, they believe that the method is more accurate than the methods ordinarily used. The Bulletin can be had in this country of Messrs. Chapman and Hall, Ltd.

Forty-eight new cottages erected at Harton, near South Shields, for old miners and their wives by the Durham Aged Mine-Workers' Homes Association, were formally opened on Saturday afternoon. The architect is Mr. J. H. Morton, F.R.I.B.A., of South Shields.

The new wing which has just been added to the F.N.F. Hospital, Botanic Avenue, Belfast, has been opened by the Marquis of Londonderry. The building contract was carried out by Mr. William Dowling, under the supervision of Mr. R. J. Calwell, architect, Scottish Temperance Buildings, Belfast.

Another new picture theatre has been commenced in Upper Sackville Street, Dublin. The hall will be 160 ft. by 28 ft. and 26 ft. in height. There will be a tea lounge and offices in the front having a depth of 50 ft. The interior of the building will be finished in polished mahogany. Mr. T. F. Macnamara, Great Brunswick Street, Dublin, is the architect, and Messrs. H. and J. Martin, Grand Canal Street, are the contractors.

New elementary schools at Shilidon, County Durham, were opened on Saturday afternoon. They consist of three departments, providing 366 boys, 405 girls, and 400 infants, and in addition there will be accommodation for cookery, housework, laundry, and handicraft. The site cost £1,210, and the cost of the building was 13,843, making a total of £15,053. The cost per head, excluding cookery, laundry, etc., would be £16 14s. 1d. The architect was Mr. Rushworth, and the contractors Messrs. Makepeace and Vaux, of Trimdon Colliery.

Saturday was the seventy-fourth anniversary of the consecration of Christ Church, Clifton, which has been described as one of the finest Victorian examples of the Early English style in Bristol. The original cost, including the site, was about £10,500. In 1358-59 the tower and spire 212 ft. in height were added, according to the original design, at a cost of £2,400. In 1535 north and south aisles were added at a cost of £3,000 after litigation, several influential residents being of opinion that the additions, if carried out, would irreparably destroy the beauty of the edifice.

Our Illustrations.

BLACKSOD BAY RAILWAY TERMINUS STATION IN THE HARBOUR, MAYO, CONNAUGHT, IRELAND.

We give to-day an interior of the station hall or concourse, with an exterior perspective and plan, reduced, on a separate sheet, with the entrance elevation of this station, which has been designed to be built on a reef of rock projecting into Blacksod Bay, and to be a terminus for the Transatlantic traffic. The largest liners are able to berth at the end of this reef, which is the occasion for the railway station being so placed. The construction of the building is intended to be carried out in reinforced concrete. The main feature is the concourse, which forms a waiting-place between the platforms and the harbour. The interior perspective shown by our double-page plate was included in the Royal Academy Exhibition this year. The architects are Messrs. E. B. Hoare and M. Wheeler, F.R.I.B.A., of Portman Street, Portman Square, W.

DECORATIONS OF THE SCHOOL CHAPEL, CHRIST'S HOSPITAL, HORSHAM, SUSSEX.

Last week we commenced a series of illustrations of the decorative panels of the Fathers of the Church, which have been painted in tempera as a frieze round the chapel of Christ's Hospital School, near Horsham, by Mr. Frank Brangwyn, A.R.A. To-day we give two more of the subjects, viz., St. Paul Shipwrecked, "so it came to pass that all escaped safe to land," and the Conversion of St. Augustine at Milan, A.D. 387. "Take read! Take read!" With our previous reproductions a brief description of the scheme was printed and the uniformity of the individual panels, as subordinate to the whole decorative conception, renders no further particulars necessary. We hope at the end of the set of plates to give a view of the chapel showing the decoration in its entirety.

THE PLYMOUTH CO-OPERATIVE AND INDUSTRIAL SOCIETY'S NEW PREMISES COMPETITION.

SELECTED DESIGN.

To-day we publish the two main elevations of the chosen design. The upper one shows the chief front to Courtenay Street, and the lower one faces Raleigh Street West. The ground and first floor plans now given clearly show the difficulty with which the competitors had to contend in dealing with the right-of-way into the basement of the building to enable vans and motors to descend and circulate, besides providing a rendezvous for the reception and delivery of goods. The other difficulty to be remembered in discussing the elevational treatment of the premises architecturally was, of course, the requirements of the Co-operative Society, above all other considerations, to allow ample uninterrupted window space for display of goods on the street level. The architects of the chosen design, with this idea, advanced the ground-floor glass fronts by nine inches in projection of the superincumbent masonry, as a counterfoil to the apparent inadequate support to the superstructure; this glazed screen was introduced standing out in advance of the stanchions carrying the upper floors. In the elevations this difference of face, of course, does not show, but actually in execution the authors think it will well realise their intention. Taking the selected plans as a whole, Messrs. James T. Halliday and Claude Paterson, A.A.R.I.B.A., conjointly with Mr. C. Gustave Agate, F.R.I.B.A., of 14, John Dalton Street, Manchester, as the joint architects chosen, have certainly most satisfactorily solved all the difficulties presented.

The first meeting of the Birkenhead Corporation since July was held on Wednesday, when it was officially reported that not a single plan had been submitted for approval to the improvement committee during the last three months. There is practically, it is stated, no building in progress in the borough.

BLACKSOD BAY.

THE HARBOUR TERMINUS IN THE HARBOUR, MAYO, IRELAND.—Messrs. E. B. HOARE and M. WHEELER, F.F.R.I.B.A., Architects.

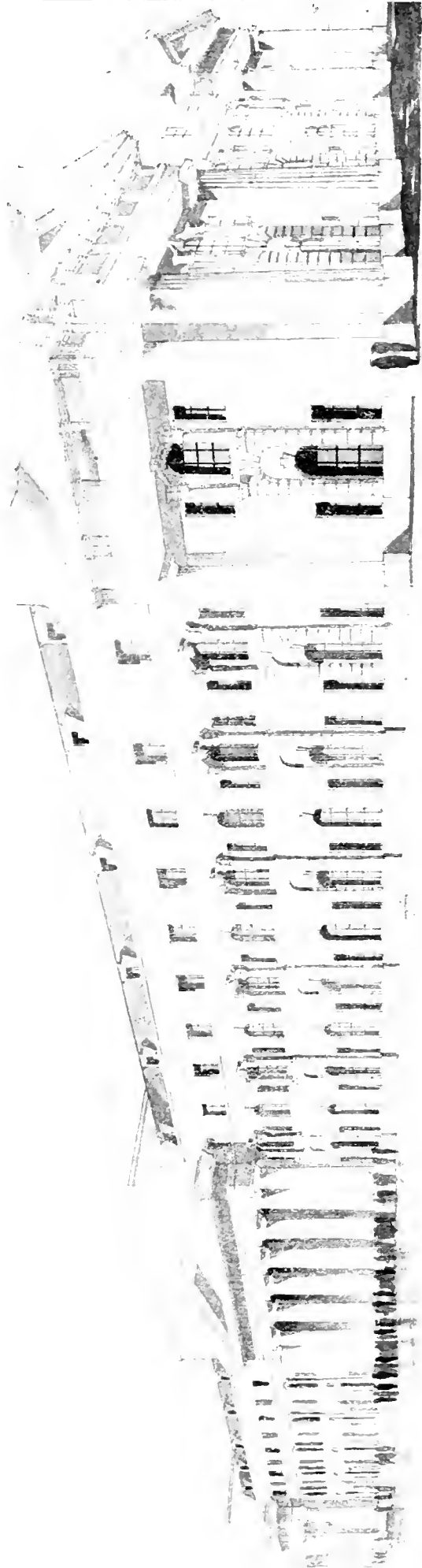

*E. B. Hoare
M. Wheeler*

F. 1030/15

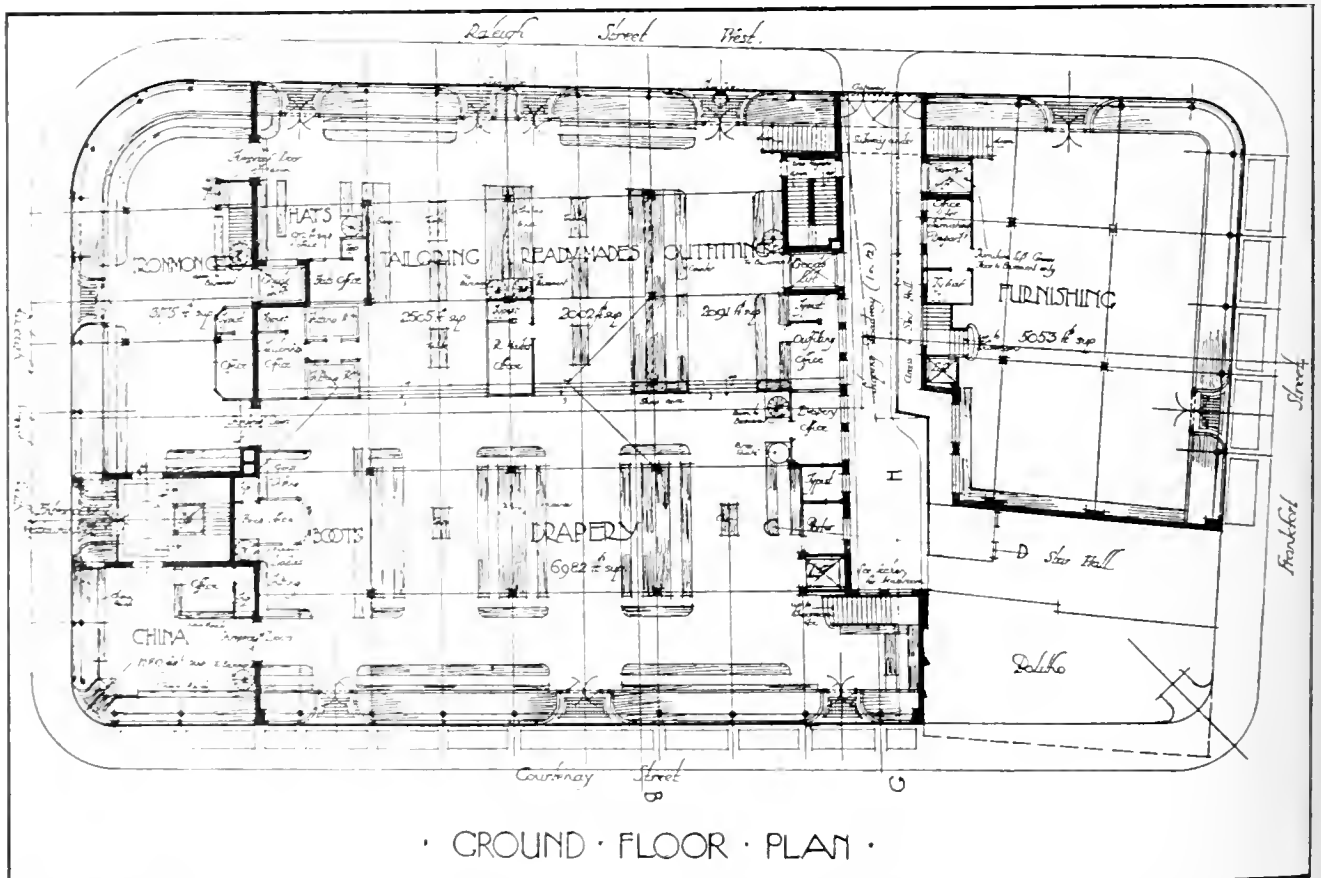
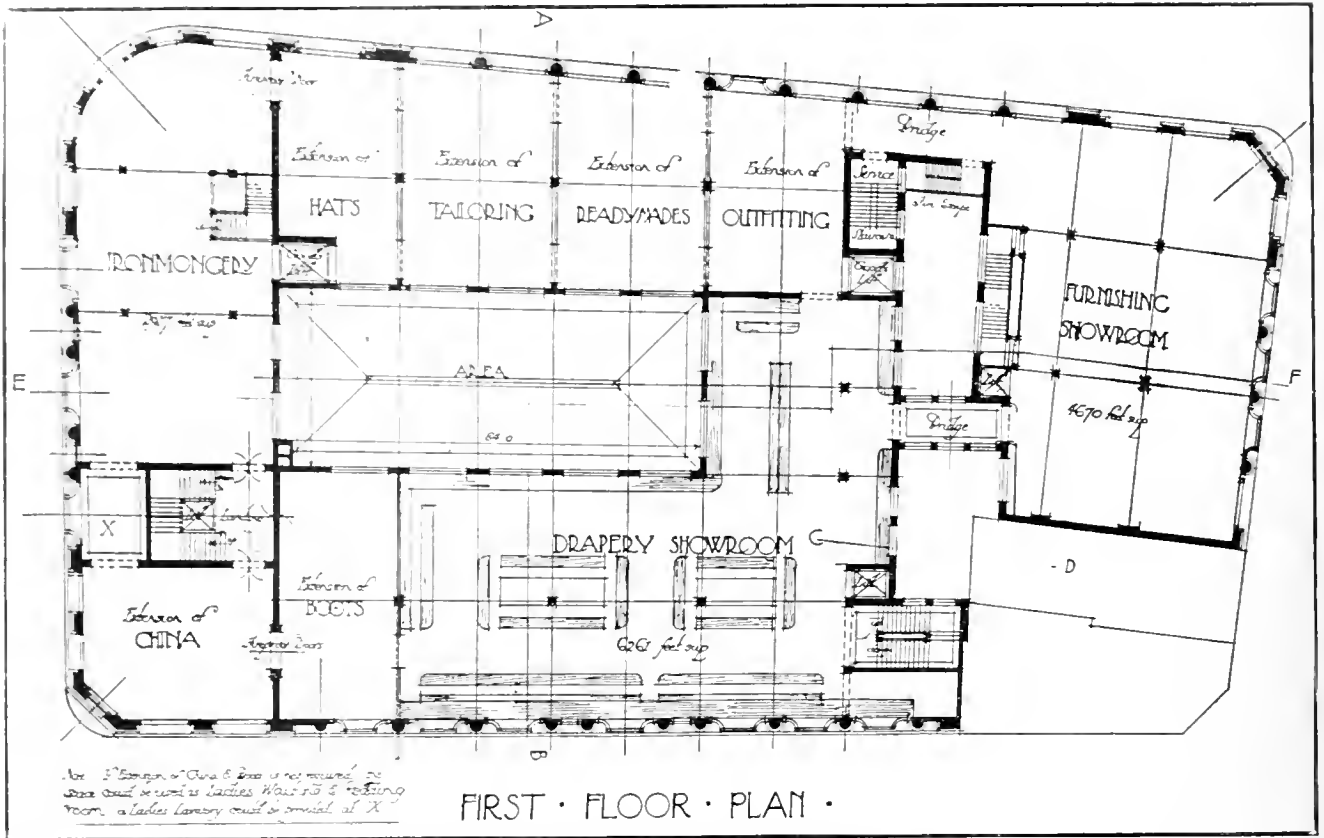

H. H. K. P. 1
PLYMOUTH MUTUAL CO-OPERATIVE AND INDUSTRIAL SOCIETY'S PREMISES:
SELECTED DESIGN.

Messrs. HALLIDAY and PATERSON and C. GUSTAVE AGATE, Architects.

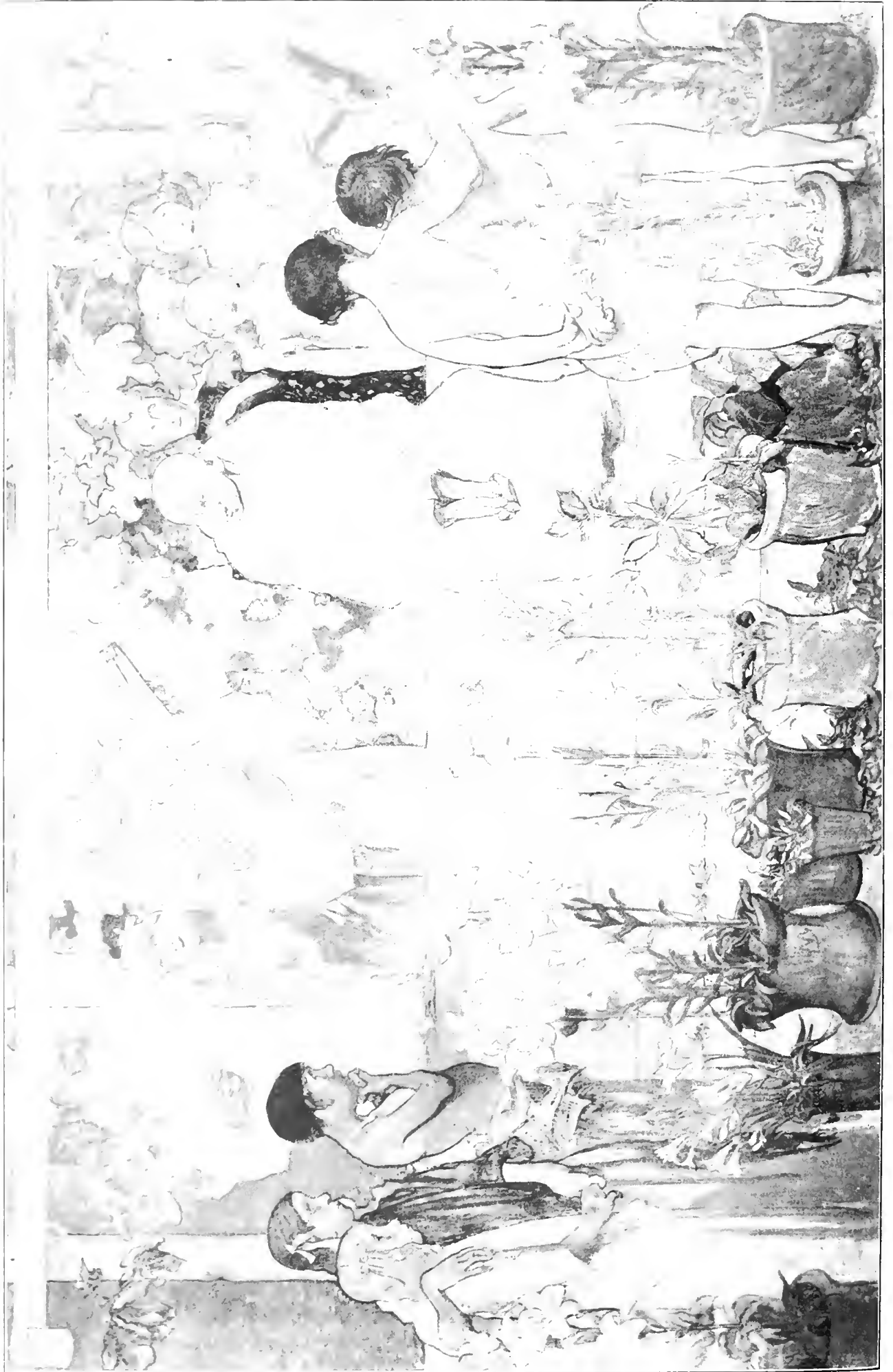



DECORATIONS OF THE CHAPEL, CHRIST'S HOSPITAL, HORSHAM, SUSSEX.—BY MR. FRANK BRONKHORST, A.R.A. (See page 100.)



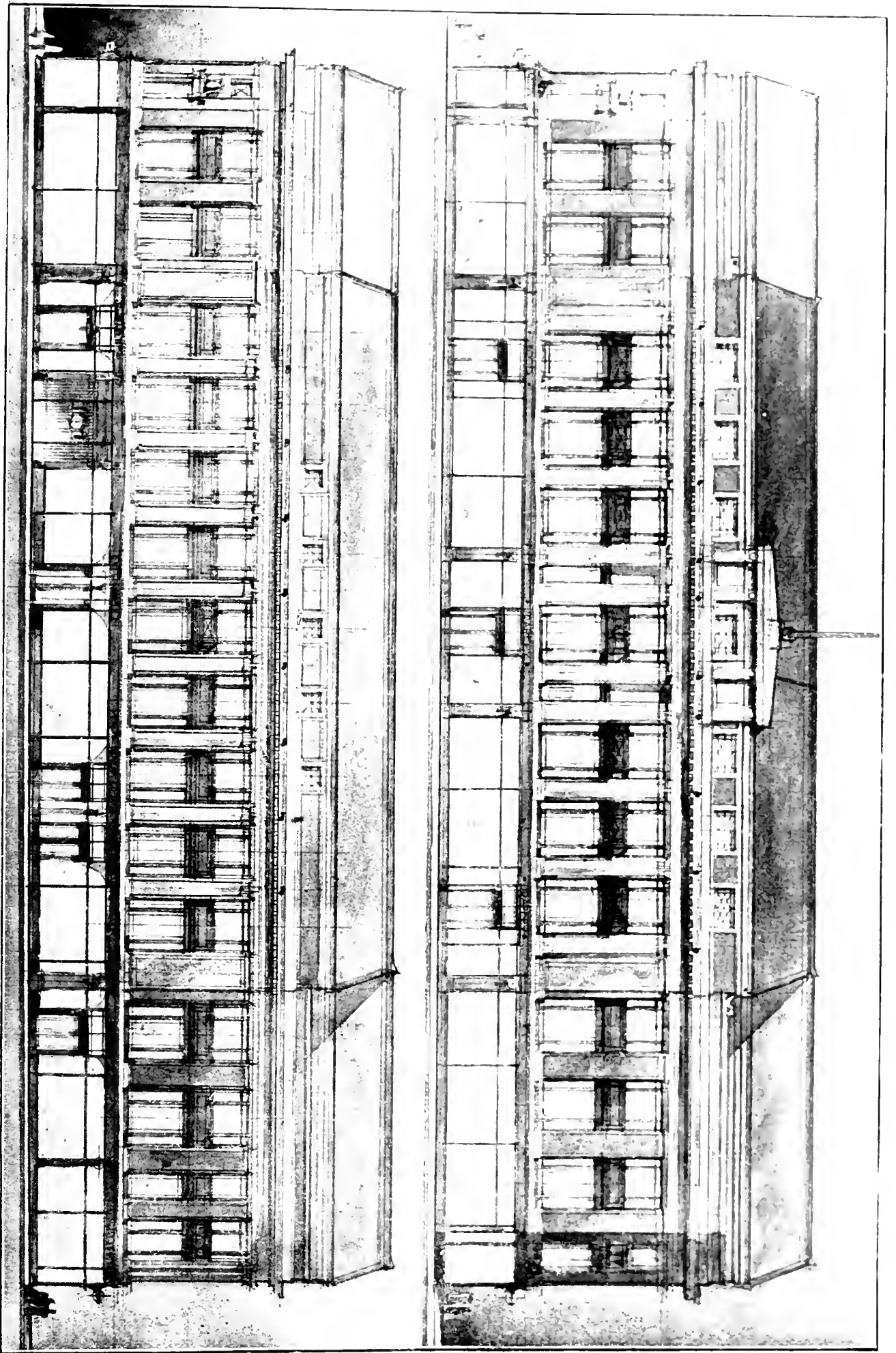

H. Hawkins Photo.

PLYMOUTH MUTUAL CO-OPERATIVE AND INDUSTRIAL CO-OPERATION SOCIETY





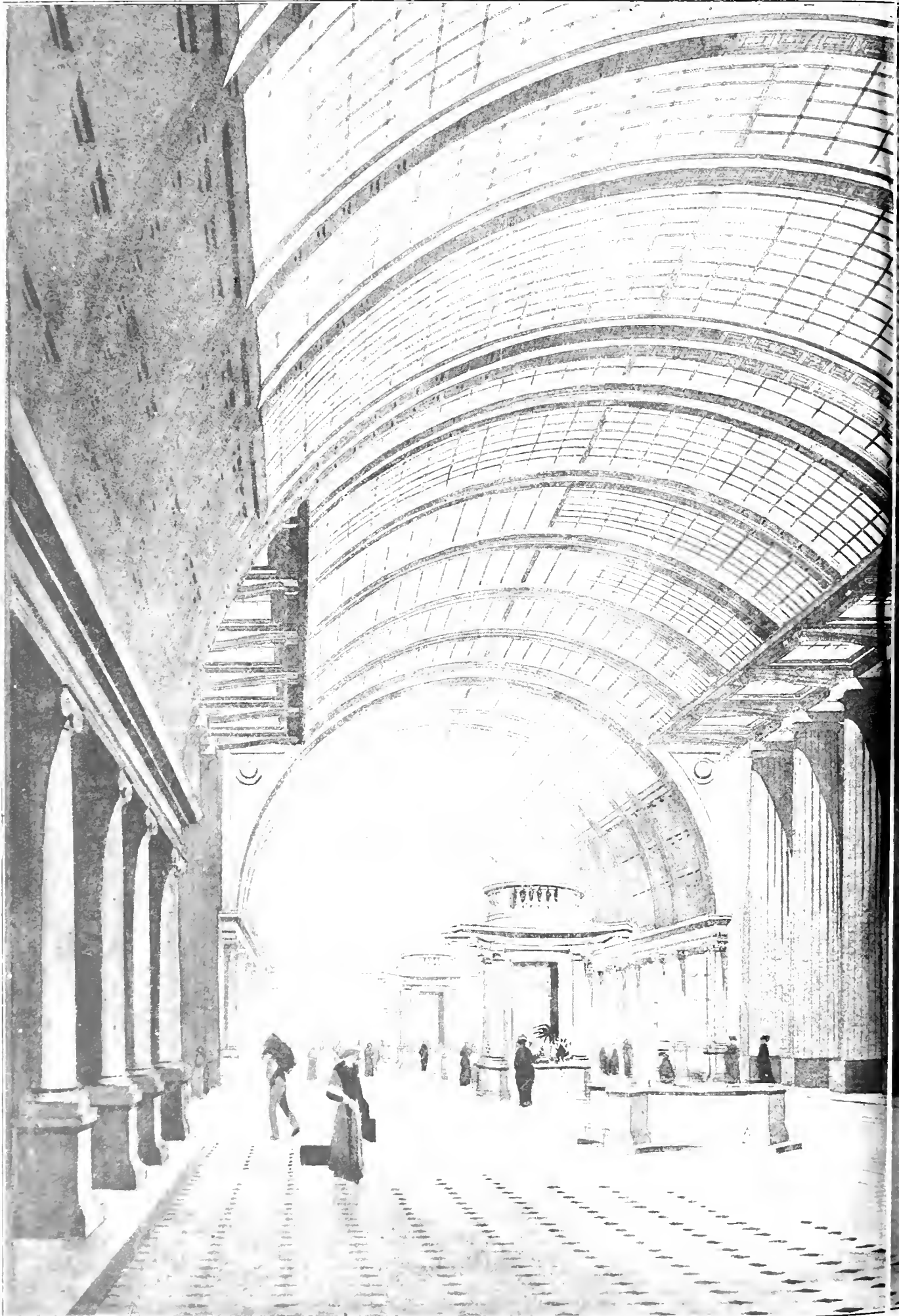

PLACES OF THE RAILWAY TERMINUS IN THE HARBOUR. INTERIOR OF

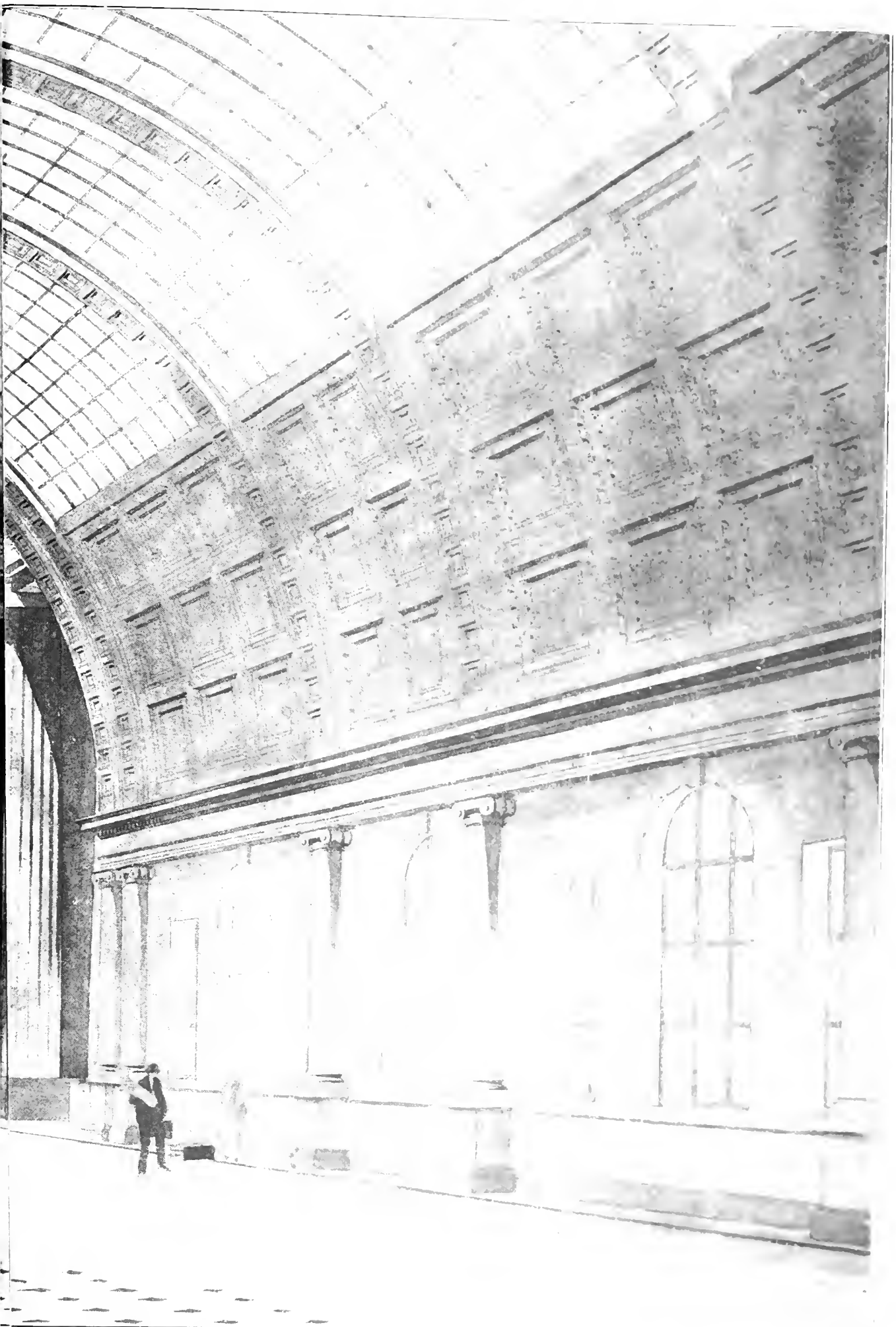

STATION HALL.—Messrs. E. B. Hoyt and M. Whittier, F.F.R.I.B.A., A.S.



PROFESSIONAL AND TRADE SOCIETIES

INSTITUTE OF HYGIENE. A lecture "The Use and Abuse of Light" was given by Mr. Leon Gaster at the Institute of Hygiene on Thursday. Until recently, the author remarked, the lighting of shops had been futile and wasteful in the extreme. A Government Committee had found that misdirected light was a cause of curvature of the spine and other diseases in children. On the other hand, bad light caused shortness of sight, and glare was equally harmful. Nowadays reflections were made with such precision that it was possible to throw the necessary amount of light just where it was required. In factories there should be adequate lighting—a reasonable degree of constancy and uniformity of illumination over the necessary area of work but an avoidance of direct and horizontal glare; and there must be the utmost care in the placing of lights, so as to obviate the casting of extraneous shadows on the work.

ROUND THE WORLD IN WAR TIME. Mr. W. T. Oldrieve, F.R.I.B.A., who has just arrived home after a tour round the world, undertaken on his retirement from the post of principal architect to H.M. Office of Works at Parliament Square, gave a lantern lecture on Wednesday night in Morningside Baptist Church, Edinburgh. Amongst the more important ports visited on the voyage were Cape Town, New Zealand, Australia, and the South Sea Islands. The lecture, which was profusely illustrated by beautiful views—chiefly from photographs taken by Mr. Oldrieve himself—was most interesting, a result contributed to in no small degree by Mr. Oldrieve's accompanying explanatory remarks. A pathetic interest attached to several pictures which he showed of Samoa, including as they did views of Robert Louis Stevenson's house and grave. In connection with the war, Mr. Oldrieve had something to say about British destroyers, aeroplanes, and British and Japanese cruisers that he saw while on his tour. Speaking of the effects of the war, Mr. Oldrieve said that we here ought to be most grateful for our comforts and the extent that we were able to keep on the normal course, as it was not so in some places where he had been recently. One thing that struck him while on his journey was the tremendous enthusiasm for our cause. Our Government had made a great stand for the cause of truth and liberty. In New Zealand especially, it seemed to him, they had grasped the situation even in a more thorough way than we had here at home.

ROYAL INSTITUTE OF THE ARCHITECTS OF IRELAND.—An ordinary meeting of the council was held at the institute rooms, 31, South Frederick Street, Dublin, on Monday, October 4, at 11 a.m. The President, Mr. R. Caulfield Orpen, B.A., R.H.A., was in the chair, and there were also present: Messrs. L. O'Callaghan, H. Allberry, F. Hayes, G. P. Sheridan, W. A. Scott, G. L. O'Connor, C. A. O'Connell, W. Kaye-Perry, A. E. Murray, R. M. Butler, A. G. C. Millar, and F. G. Hicks (hon. secretary). Before proceeding with the business of the meeting the President proposed the following resolution:—"The council of this institute desires to place on record its sense of the great loss the institute and the profession of architecture generally has sustained in the death of Mr. W. H. Lynn, president of the institute in the years 1886-87-88. Mr. Lynn, during a long life devoted to the practice of the profession of his adoption, designed many important public and domestic buildings, which, both in Ireland and England, testify to his masterly qualifications." The minutes of the previous meetings of the council were read and signed. The result of the ballot for election of members was reported by the scrutineers, and the following gentlemen were elected:—Mr. W. S-dzwick Keating, Mr. William J. Doherty, and Mr. G. Hemingway Yeoman. A special meeting of the council was arranged to discuss the question of architects' fees generally.

SCOTTISH NATIONAL BUILDING TRADES FEDERATION.—The twenty-

first annual meeting of this federation was held on the 4th inst. in the Trades House, Glassford Street, Glasgow. Representatives were present from all centres in Scotland, including Edinburgh, Aberdeen, Dundee, Dunfermline, Kirkealdy, Stirling, Kilmarnock, Ayr, Greenock, Dumbarton, etc. Mr. George Lyall, Junior (Aberdeen), president, occupied the chair. Prior to the business of the meeting the delegates were accorded a welcome by Bailie McKechnie, D.L. In its annual report the board states:—"The activities of the federation have during the past year been carried on under the most unfavourable conditions. In common with many other industries, the building trade throughout the country has been seriously affected by the war. Notwithstanding the national crisis, the organisation of the federation has been strengthened, and much important work has been accomplished. Notable progress has been made in securing regulations of entering into and carrying out contracts for building works in Scotland, and for a Scottish mode for the measurement of building works. The regulations, it is hoped, will shortly be finally adjusted. Preliminary rules for measuring work applicable to all trades and the mode of measurement for carpenter and joiner work have now been established. Long-standing grievances will have been terminated, and to Sir George Askwith, the Chief Industrial Commissioner, great credit is due. Altogether he has already presided over nine conferences, most of which have lasted from early morning till late at night, and exercising the utmost skill and patience in adjusting differences. Questions dealing with the reinstatement of apprentices serving with the Army after the war and the employment of non-union labour were fully discussed at the meeting. Office-bearers for the ensuing year were appointed as follows:—President, Mr. Henry H. Spittal, Glasgow; senior vice-president, Mr. Edward Bruce, Edinburgh; junior vice-president, Mr. George Rose, Kilmarnock; and a board of eighteen members. Secretary and treasurer, Mr. Thomas Ferguson, solicitor, 125, George Street, Edinburgh.

WAR VALUES OF REAL PROPERTY.—The Auctioneers' and Estate Agents' Institute of the United Kingdom held its first meeting of the session of 1915-16 on Friday night, when Mr. J. George Head delivered his presidential address. This dealt entirely with war values of real property. After analysing influences affecting the matter, Mr. Head summarised the conclusions arrived at as follows:—"That owing to the upheaval of our lives in all these respects (economical, domestic, and financial) the property market is depressed, and prices have fallen to such an extent that the question is no longer 'What will the property fetch?' but 'Can we find a buyer?' That the revival will come not immediately with the arrival of peace and the improvement in trade, but after an interval, when profits have eased the money market, reduced the demand for capital, and having been saved, are ripe for investment. That values, although much above the prices now obtainable, will be lower at the conclusion of the war than they were before, owing to the demand for capital in other spheres, the abundance and cheapness of gilt-edged securities, and the high rate of interest caused by these conditions. That present values should be calculated not at panic prices, but with relation to the lowered figures likely to prevail during the transition period, by deducting therefrom a sum sufficient to allow for accumulation of interest during the duration of the war, and a further sum for contingencies. That this transition period of depression may be expected to last some years, according to the analogy presented by previous wars. That during the period of transition (given a rest from new disturbing influences) prices will gradually rise, and that after it has passed they will regain and probably surpass their previous altitude. The situation (the speaker thought) is one which calls for grave attention and some anxiety, but not for despondency, and certainly not for panic. We are passing through a serious crisis; but storms have been weathered before by the ship of our island State, and favouring winds will again fill the sails and waft it to a prosperous haven.

Trade News.

WAGES MOVEMENTS.

BIRMINGHAM.—Builders' labourers in the Birmingham district are to receive a war bonus of a halfpenny an hour. This decision has been arrived at as a result of negotiations between the Birmingham Building Trades Employers' Association and the National Union of Builders' Labourers. The bonus will be paid as from October 24, and will continue for three months after peace has been declared. The masters have offered the bonus to all sections of the building trade having an agreement with their association, and it has been accepted by the labourers and the navvies. The other sections have the offer under consideration, and in all probability it will be accepted by the men.

BRADFORD.—The dispute arising out of the demand of the Bradford builders' labourers for an advance in wages has been settled. The men have been granted one-halfpenny per hour advance, and the question of other conditions has been left to be determined by the Board of Conciliation.

TRADE NOTES.

A public swimming-bath has recently been erected in Barrow-in-Furness. We understand the borough engineer adopted the powder Pudo for waterproofing the same.

Boyle's latest patent "Air-Pump" ventilator has been applied to Bawdsey Church, Suffolk.

The members of the London and Middlesex Archaeological Society will pay a visit to Tottenham on Saturday next, and will be shown over the parish church and Bruce Castle by Mr. W. J. Bennett, librarian of the Tottenham public libraries.

Mr. T. L. Hustler, borough engineer of Shore-ditch, who has been appointed a lieutenant in his Majesty's Forces, has been presented with a service sword and a full camp kit, as a mark of esteem from the officials at the town hall.

At a meeting of the Newbiggin Urban District Council on Thursday night a block plan was submitted by the agent for the Cresswell estate, showing sites for 323 houses proposed to be built in the Bull Field, Woodhorn Lane, Newbiggin. The council decided to give general approval of the plans subject to certain alterations.

Mr. John Gill, city surveyor of Bangor, has submitted a report to his council showing that he had during the twenty-four weeks ending September 9, effected the following savings:—Main roads, £35 2s. 8d.; highways, £57 9s. 9d.; lighting and wages, £60 11s. 9d.; gas, £75; pleasure grounds, £6 6s., in addition to a sum of £63 saved by deferring the making up of Gorad Road, the total saving in the twenty-four weeks being £297 10s. 4d.

The scaffolding around the magnificent Perpendicular tower of St. Stephen's Church, Bristol, has recently been removed, and the work of the restoration is practically completed. The architects were Messrs. Paul and James, of Bristol, and the contractors Messrs. Cowlin and Sons, of the same city. The outlay has exceeded £3,000. At some future day the south porch will be similarly repaired.

The passion for economy may be carried too far. The Stamford Board of Guardians having been informed that the lightning conductor on the chimney stack at the workhouse was out of repair, discussed with great length at their last meeting the question of accepting or rejecting a tender for its renovation amounting to £3 10s. Eventually it was decided that the risk of injury by lightning was so small that in the interests of the ratepayers the old rod should be taken down and not replaced.

Mr. A. G. Temple, F.S.A., the Director of the Guildhall Art Gallery, has now completed the rearrangement of the pictures in that collection. Nearly 1,000 works are now displayed in the galleries, but there are many others which for want of space cannot be hung, and are now placed in various committee-rooms and lobbies in the Guildhall itself. Recent additions now exhibited in the galleries include Frank Holl's "The Lord Hath Given, the Lord Hath Taken Away," a bequest of Mr. F. C. Paul, of Reigate; a portrait of Lord Mayor Cubitt, by Sir W. Boxall, given by Lord Ash-ton; and a water-colour drawing of Rheims Cathedral as it was just before the war, by Mr. H. C. Brewer.

LEGAL INTELLIGENCE.

ACCESS TO FIRE ESCAPES.—A recent fire in Manchester, in which a man lost his life by jumping through a window, has called attention to the fact that some employers of labour in that city are not keeping clear the entrances leading to the fire escapes. The Manchester Sanitary Department have issued warnings to forty or fifty firms in regard to the matter, and have intimated that unless the means of escape in case of fire are kept in proper condition prosecutions will follow. Two cases against employers were heard at the Manchester City Police Court on Wednesday, and the evidence showed that in one case the doors leading to the escape on two floors were either fastened or obstructed with goods, and that in the other case the door on one floor was barred with pieces of wood. Mr. Pickford, who prosecuted, said Section 14 of the Factory and Workshops Act provided that where escapes had been erected it became the duty of the owner to see that the escapes were maintained in proper condition and that the means of access to them were free from obstruction. The Stipendiary Magistrate imposed a fine of £3 in the one case and of £2 in the other.

ARBITRATION AS TO SPITALFIELDS MARKET.—Spitalfields Market having been acquired compulsorily by the City Corporation under an agreement, dated December, 1914, from Mr. Robert Horner, an arbitration was opened on the 5th inst. at the Surveyors' Institution to decide the purchase price. Mr. C. A. Russell, K.C., was the arbitrator, and the counsel were Mr. Balfour Browne, Mr. Upjohn, and Mr. Landers on behalf of Mr. Horner, and for the Corporation Mr. E. H. Lloyd, Mr. Vesey Snow, and Mr. H. C. Munroe. Mr. Balfour Browne explained that the lease of the market, which had a charter dating from 1682, and certain other properties with the market franchise were acquired for £2,500 a year by Mr. Horner in 1875, and in his hands the market was greatly improved. In 1882 he got a new lease of eighty-four years at £5,000 a year, one of the conditions being that he should spend at least £55,000 on remodeling the markets. Various Parliamentary Bills were promoted by the London County Council and the City Corporation to acquire the market. In 1901 the City Corporation offered £350,000, but Mr. Horner's minimum was £400,000. In 1904 he offered to sell his rights and property for £600,000, but subsequently withdrew the offer. In addition to the value of the market, which occupied 2½ acres, there was much property. The arbitration is being continued.

DRAUGHTSMAN NOT A "WORKMAN."—Professor Tillyard presided over a sitting of Coventry Munitions Tribunal on Friday, with Messrs. T. Hancock and W. H. Dexter (Rugby) as assessors. The case of John A. Northfield, draughtsman, Old Manor House, Silbourne, who complained that the certificate of leaving was unreasonably withheld by Messrs. Willans and Robinson, Limited, Rugby, raised, the chairman said, a new point—whether a draughtsman was a workman within the meaning of the Munitions Act. Applicant produced a letter from the Ministry of Munitions, in which it was said:—"I am directed by the Minister of Munitions to reply to your letter of August 1 respecting the position of draughtsmen and their salaried employees, as distinct from workmen, with regard to leaving their employment and obtaining other engagements elsewhere. . . . The Minister is advised that the term 'workman' should be construed in its ordinary sense as meaning a person who, substantially, does his work with his hands, i.e. at all events, by physical exertion." There on the further question, whether Northfield was engaged on munitions, and Mr. Briggs, representing the company, said the engines on the plans of which applicant was working, were sold almost exclusively to armament firms. When Northfield had been offered more responsible work elsewhere. The chairman said the decision of the Court was that applicant was not a workman within Section 7 of the Act, and a statement would be made that no certificate was necessary for him.

LYNNE HARRISON AND GREGORY, LIVERPOOL.—A meeting was held in Liverpool on the 5th inst. of the creditors of Mr. William Harrison, of Southport, and Mr. Ebenezer Little Gregory, of Liverpool, who acted as Harrison and Gregory, timber merchants, Greenland Street, Liverpool. The Official Receiver said the joint liabilities amounted to £12,448 18s. 1d., and the net joint assets to £5,605 10s. 7d. Mr. Louis Nicholas was appointed trustee with a committee of inspection.

CHIPS.

The Bishop of Southwark dedicated on Wednesday the new mission church of St. James's, Nine Elms, Putney.

A waste warehouse is about to be built at Dumb Mills, Finsbury, for the Corporation of Bradford, from plans by their city architect.

The Local Government Board has sanctioned a loan to the Urban District Council of Hendon of £1240 for the purchase of a motor fire-engine.

A new manual book for Galowhill School, Rutherglen, has been formally opened. The architect was Mr. Walter R. Watson, Bath Street, Glasgow, and the cost was over £1200.

The renovation of the woodwork and other fittings in the parish church of Little Gidding, near Peterborough, has just been completed, having been carried out by Messrs. Hampton, of London.

At the meeting of the Council of the Institute of Civil Engineers, held on September 29, a silver salver was presented to Mr. Horace Boot, past president, on the occasion of his recent marriage.

The Union bridge over the Basingstoke Canal at Purbright is about to be rebuilt for the Guildford Rural District Council from plans by the engineer, Mr. J. Anstel, of Commercial Road, Guildford. The new bridge will be of steel decking with concrete abutments.

At Wednesday's meeting of Derby Town Council it was reported that, through an indiscretion on the part of the then youngest engineer-in-charge, who has now left their service, the new steam turbine at the power station had sustained damage which would cost £60 to repair.

At the Royal Academy the lectures to students on anatomy will be delivered by Professor Arthur Thomson, M.A., F.R.C.S., LL.D., at 4 p.m. on Wednesdays and Fridays, October 15, 16, 20, 22, 27, and 29, and November 10, 12, 17, and 19. The lectures on painting, sculpture, architecture, and chemistry are postponed until further notice.

Mr. Albert P. Sturt, of St. Helens, Lancs., has been appointed building and sanitary inspector to the Egham Urban District Council in place of the late Mr. W. J. Simpson. Mr. Sturt was formerly an assistant in the office of Mr. W. Menzies, the Egham surveyor of highways, but for some years past has had the management of two large estates in Lancashire.

The Parsik tunnel, which will be the longest railway tunnel in India, had been bored through on September 10 from end to end. The tunnel is for the new alignment of the Great Indian Peninsular Railway, and is situated between the Thana and Paksi railway stations, twenty-two miles from the Victoria terminus. This new line will effect a saving between Bombay and Kalyan Junction of three miles. The tunnel is 4762 feet in length, and will be laid with double broad-gauge lines.

At the meeting on Wednesday of the Liverpool City Council the water committee recommended that steps be taken to obtain a provisional order for the construction of a third pipe line of supply from Lake Vyrnwy. The recommendation was opposed on the ground that it would ultimately commit the city to an expenditure of between £7,000,000 and £8,000,000, and the additional water might not be needed for ten years. Eventually the recommendation was withdrawn for further consideration.

At the last meeting of the Marches or Rivers Committee, the city surveyor, Mr. F. de Courcy Meade, reported that Mr. Gilbert Hart, a member of the committee's main drainage staff and now a temporary second-lieutenant in the 173rd (Tunnelling) Company of the Royal Engineers, had been awarded the Military Cross for conspicuous gallantry and skill in France. The Rivers Committee passed a resolution congratulating Lieutenant Hart on the honour that had been conferred on him.

A new rood screen, designed in the Perpendicular style, has been placed in the parish church of Wellingbourne. The screen is divided into six bays with moulded and carved posts, and tracery heads, having a vaulted coffer, ornamented with carved patera at the intersections of the ribs. The rood left over is enclosed with panelled and traceried fronts upon a moulded and carved cornice from which rises the Great Rood, with floriated terminations charged with the emblems of the Four Evangelists supported on a raised tribune with the accompanying figures of St. Mary and St. John, all relieved with gold.

Professor Healy, the well-known landscape and for over thirty years a resident of Boston, died in that city on Tuesday in the week.

A new book of 110 pp., 25 plates, published by Messrs. Thomas and T. Co., Ltd., at Warwick, and Woking, Avebury, from plans by Mr. Hugh Gwyn.

Mr. F. Tuckey has tendered his resignation as highways surveyor to the Hinkley Rural District Council in order to take up a similar position at Uttoxeter in a month's time.

Mr. A. P. Housay, former engineer of Hartlepool, has been appointed surveyor and architect to the education authorities, and has had his salary increased by £50 per annum.

The partnership hitherto subsisting between J. Lawden and J. H. Heaver, architects and estate agents, at Temple Street, Birmingham, under the style of Lawden and Heaver, has been dissolved.

In view of the heavy arrivals expected next season, the Port of London Authority have decided to erect sheds at the Royal Victoria and Albert Docks sufficient to accommodate 50,000 to 60,000 bales of wool.

The Nairnshire County Council have decided to consult Messrs. Walker and Dugan, engineers, Aberdeen, with regard to the condition of the Caydor and Fornightly bridges, damaged by the recent flooding.

Mr. William Mitchell Aitken, of Hope Terrace, Edinburgh, late of Messrs. Mackintosh, Burn, and Co., architects, builders, and contractors, Calcutta, who died on May 12, has left £62,453, exclusive of real estate.

The John Dawson Memorial Sanatorium at Lincoln has just been opened. It was planned by Mr. F. Taylor, of the city engineer's department, and accommodates thirty-five patients. Mr. F. W. Horton, of Lincoln, was the builder.

Mrs. John Crosfield, of Bryn Eithan, Colwyn Bay, has unveiled a marble bust of her late husband, Mr. John Crosfield, in the Town Hall, Warrington. The bust, which is the work of Mr. Henry Pogram, A.R.A., is the gift of the Crosfield family to the town.

Plans for the erection of a new school on the Orchard House site have been submitted by the Tottenham Education Committee to the Board of Education for approval. Mr. G. E. Laurence, A.R.I.B.A., Buckingham Street, Adelphi, W.C., is the architect.

Good progress has been made on the erection of the First Church of Christ, Scientist, on River Street, Winnipeg, and the exterior work is nearing completion. The architects are Messrs. Jordan and Over, of Winnipeg, and the general contractors the Fort Garry Construction Company.

Captain N. H. L. Matear, 2nd Battalion, Royal Warwickshire Regiment, the only son of Mr. Hiram A. Matear, F.R.I.B.A., North John Street, Liverpool, has been killed in Flanders. Captain Matear was originally gazetted to the Royal Engineers, but was transferred to the Royal Warwick. He was very severely wounded last winter, but returned to duty in May.

The Corporation of Northampton recently applied to the Local Government Board for permission to raise a loan of £5,750 for works of sewage disposal at Kingshorpe, and the draining of 405 acres outside the borough boundary. At the inquiry held last week the inspector pointed out the futility of such applications at present. As an alternative he suggested proposals for temporary expedients costing from £500 to £400.

The Dalnair West of Scotland Estate Company, Limited, have received permission at Clydebank Dean of Guild Court to erect eighteen tenements, consisting of 120 workmen's dwelling-houses at Dalnair. The cost is estimated at £30,000. This firm has at present 250 houses in course of construction, the entire number being part of a scheme for the housing of the employees of Messrs. William Beardmore and Co., Limited, Dalnair.

General approval was expressed at the last meeting of the Nottingham City Council of the plan proposed to attract fresh industries to the city. The establishment of a small department of the council, to be run at a maximum cost of £500 a year, to make a properly organized and systematic effort to secure new works, may very probably prove one of the most profitable undertakings on which the council has ever entered. A special official is to be appointed for two years at a salary of £250 a year to devote his whole time to watching the formation of new companies and the development of industries, so that the promoters may be promptly and adequately informed of the advantages which Nottingham can offer.

Our Office Table.

Mr. J. S. Simpson, F.R.I.B.A., read a paper on "The Exhibition at University College, London, 1914, Constantinople, and the Exhibition at Constantinople and Brussels," at the meeting of the Society on Tuesday, October 27. Address will be by letter, which will be sent to the Secretary of the Society, and will be enclosed on application, enclosing a stamped envelope.

A committee of Glasgow Corporation has been appointed to recommend that a model factory similar to the exhibition field factory, and at other continental cities, should be built in Glasgow early next year. The committee enable manufacturers to show, to the public, what goods can be made in this country which have not been supplied by foreign goods. The proposal is that the fair should be held in one of the city halls, so that the factory constructed buildings would be used for the purposes of the exhibition.

The Town Council of Wednesbury have been busy dealing with the difficulties which were placed by the Local Government Board having refused to sanction the erection of twenty-four houses, after they had completed the site and the erection of the houses had been completed. It is stated that, as a result of negotiations, the contract for the purchase of the land was rescinded and the vendor had to give up a portion of the land, to be used by the council as an open space. The council carried out the proposal to construct a new road, and an approach to the new building site. The contract for the erection of the houses also to be rescinded, but the council proposes, after the war, and subject to the consent of the Local Government Board, to purchase for £1,760 the eight houses which have been erected.

At the last session of the Dean of Guild Court, Mr. Paton, Messrs. Ralph W. Stewart and C. G. Scottish Central Rubbers, were presented plans for an extension of the premises in Elgin Street. The town planning committee reported that the proposed buildings should be erected on ground which, under the existing scheme, was earmarked for other purposes. The Town Planning Committee, however, were quite willing that the plans should be passed, subject to the consent of the Local Government Board and the Earl of Elgin, who was the superior of the land. Mr. Currie Macbeth, solicitor, pointed out that very great prejudice might be done to the burgh in the future through the elastic provisions of the town planning scheme. If the scheme were adopted, the land which was dedicated for other purposes could be utilised for other purposes, and the land which was dedicated to works areas might be used for that purpose, no matter what the conditions might alter. Subject to the approval of the Local Government Board and the Earl of Elgin, the plans were approved. Dean of Guild Irvine observing that, in any event, he thought the ground earmarked for that use was unsuitable for other purposes.

At the meeting of the City Council of Manchester, held on Wednesday, the Lord Mayor presented the report of the committee appointed in November, 1914, to inquire into the charges that members of the council had used their position to influence officials of the council to transact their private interests. The committee reported that they could only assist in two instances, in which it was suggested, it appeared, that undue influence had been exercised by a member of the council. That member was Mr. John Harrison. It was stated that he had sought to induce the council to recommend the use of local granite blocks made from clay in substitution for the addition to shale bricks, in the case of large work, then being specified for

A similar allegation was suggested in Mr. Harrison's relation to the city surveyor's deputy in the engineering department. The committee, in the first case, found that Mr. Harrison was indiscreet and committed an error of judgment. They did not, however, consider he was actuated by any corrupt motive. In the second case they thought he "showed indiscretion but no corrupt motive." Mr. Harrison assured the council that he had no corrupt motive in anything he had said or done. In the development of the brick industry of Manchester thousands of pounds had been spent; it now stood second to none in the country, and he had tried to do the best he could for the trade. The report was adopted, and the matter ended.

During the months of July, August, and September, 1915, the Road Board indicated additional advances to highway authorities amounting in the aggregate to £38,667, of which £33,715 was by way of grant, and £4,974 by way of loan. The advances made and indicated from the constitution of the board up to September 30, 1915, less indications cancelled, amount to £6,170,966. Of this total £4,719,466 is by way of grant, and £1,451,500 by way of loan. The formal grants during the last quarter, amounting to £94,015, were applied as follows:—Road crust improvements, £88,781; road diversions, £705; reconstruction and improvement of bridges, £1,800; new roads and bridges, £2,727.

A writer in the *Commonwealth Engineer* describes the reinforced-concrete sleepers that have been laid in Adelaide, S.A., to carry tram rails. The sleepers used are reinforced in connection with a metal shoe, on which the rail rests. The shoes are connected with reinforcing rods, and these are strengthened by intervening braces. The whole forms a truss bridge, which in itself is very strong, and is further strengthened by the addition of concrete. The ironwork of the sleeper is placed in a mould, into which the concrete is poured, and the necessary tamping is done to ensure that every crevice is filled. The bottom of the sleeper has a concave surface, which is considered an improvement on the usual flat bottom, as it gives a better grip of the road bed. When the sleepers are laid the rails do not come in contact with the concrete, and all vibration is taken on the shoe. The initial cost per sleeper is considerably higher than in the case of wood or steel, but the durability is said to be immensely greater.

The discovery of walnut on the Pacific coast of Mexico is generally regarded as very important, since many have believed that walnut was a stranger to the woodlands of western and southern Mexico. Botanists have named it *Juglans mexicana*. A number of prospectors have reported three varieties of this walnut—white, red, and black—in great abundance. Of these the black is said to be the most valuable, as it is curly in grain, and as fine as the Circassian walnut from Asia Minor. It is susceptible of the finest polish, and seems metallic in its compactness. The region where this walnut grows is exceedingly rugged and wild. The forests are very dense and must have stood for centuries undisturbed by fire and axe. It is not unusual to find walnut trees from which cuts 80 ft in length and 4 or 5 ft in diameter may be obtained. It is believed that after the walnut in Arkansas and surrounding territory becomes more heavily exhausted, the Mexican walnut will find a ready sale, both in the United States and in Europe.

At the suggestion of a committee of the American Chemical Society, the United States Bureau of Standards has made an experimental study of the quality and purity of platinum anodes, such as crucibles, wire gauze, dishes, etc., and has developed a delicate thermo-electric test for platinum purity which permits a rapid estimate to be made of the amount of included foreign matter, such as iridium or iron, without injuring the article tested. This thermo-electric test is being generally adopted by large purchasers of platinum ware.

TO ARMS!

4th Battalion ("Architects") Central London Regiment Volunteers.

Recruits are urgently needed for the Regulars, Territorials, and Volunteers. Intending recruits should apply to Battalion Headquarters, where they will be advised as to the branch of the Service for which they are best suited.

ORDERS FOR THE WEEK BY LIEUTENANT-COLONEL A. W. WARLEN, GENERAL PARADE.

Saturday, 10th inst., at new Drill Headquarters, Chester House, Euston Place, S.W., at 3 p.m. Uniform parade.

ENTRENCHING.

Members who have volunteered for this will receive written instructions regarding hour of parade, etc.

DRILLS AND PARADES.

"A" Company—Tuesdays, Miniature Range, Gas Light and Coke Co.'s premises, Monck Street, Westminster, 5 to 5.30 p.m.

Wednesdays—Company Parades, 5.15 to 7.15 and 6.15 to 8.15 at Chester House.

Thursdays—Signalling at Chester House. See orders from Acting Battalion Signalling Sergeant Cheale.

"B" Company—Miniature Range and Company Parades as for "A" Company. See orders local headquarters.

"C" Company—see orders local headquarters, Pavilion A.A. Athletic Ground, Boreham Wood.

"D" Company—Platoon and Section Drill at Chester House, Tuesdays and Thursdays, 6.45 p.m. Company Parades, Wednesdays as for "A" Company.

SCHOOL OF ARMS.

Drill Headquarters, Chester House. Instruction in bayonet fighting, gymnastics, physical drill, boxing, and singlesticks on Tuesdays from 6 to 8 p.m.

RECRUIT DRILLS.

"A" Company—Chester House, 5.15 and 6.15, Wednesdays and Fridays.

"B" Company—Dulwich College, Mondays, 5 to 10 p.m., and Thursdays, 6 to 8 p.m.

"C" Company—Boreham Wood and Elstree District Headquarters, A.A. Athletic Ground, Boreham Wood. For full particulars apply to Alan Potter, Gray Gables, Boreham Wood, Herts.

"D" Company—Chester House, Tuesdays and Thursdays, 6.45 p.m.

CORRESPONDENCE.

Special attention of members is drawn to the fact that correspondence should be answered by return. If this is not attended to the office work of the Corps is unnecessarily increased. Enrolment forms of new members and all correspondence not referring to recruiting for the Army or to financial matters must be addressed to the adjutant, 10, Conduit Street, W., and regarding recruiting for the Army to the Recruiting Officer at Battalion Headquarters, and regarding accounts and subscriptions to the Pamphlet, W. R. Hughes, 140, Dashwood House, E.C.

By Order,

L. R. GUTHRIE, Adjutant,
BATTALION HEADQUARTERS,
18, TUFTON STREET, WESTMINSTER, S.W.

MEETINGS FOR THE ENSUING WEEK.

WEDNESDAY (Today)—Royal Academy. Introductory lecture on Anatomy. By Professor Arthur Thomson, M.A., F.R.C.S., L.L.D. 4 p.m.

Association of Engineers-in-Charge. Presidential Address by Frank Bailey, St. Bride's Institute, E.C. 8 p.m.

THURSDAY.—National Housing and Town-Planning Council. Annual Meeting, 41, Russell Square, W.C. 5 p.m.

British Museum Lectures, "Architecture of Ancient Egypt," by Banister F. Fletcher, F.R.I.B.A., 4.30 p.m.

Society of Architects. Special Meeting to receive Report of Scrutineers on Ballot for Officers and Council, 28, Bedford Square, W.C. 6.30 p.m.

FRIDAY.—Town Planning Institute. "The Planning, Design, and Arrangement of Railway Terminals," by James Crossland, F.R.I.B.A., 92, Victoria Street, S.W. 8 p.m.

Sheds and other additions are about to be built at Highfield Mills, Ossett, from plans by Messrs. Holton and Fox, of Corporation Street, Dewsbury.

St. Nicholas' Church, Ardtole, Ardglass, Co. Down, has recently been conserved by H.M. Board of Works, and its history and details noted by Mr. F. J. Bigger, M.R.I.A. Its full size and architectural details are now for the first time exhibited to the visitor. The remarkable feature of the building is the size of the east window. This has now been explained by the discovery of large fragments of stained glass with which the window was filled before it was ruined and destroyed. No old church in Ireland has provided such a store of early painted glass as has St. Nicholas of Ardtole. The doors and other features of the building are also well worthy of examination.

LATEST PRICES.

N.B.—All prices must be regarded as merely approximate for the present, as our usual sources of information are in many cases failing us.

TIMBER.

Owing to stoppage of supplies all prices have advanced considerably.

IRON.

Table listing various iron products like Rolled Steel Joists, Wrought-Iron Girder Plates, Steel Sheets, etc., with prices per ton.

Galvanised Corrugated Sheet Iron—

Table listing galvanised sheet iron specifications and prices.

Table listing various cast-iron and rolled-iron products like Cast-Iron Columns, Cast-Iron Stanchions, etc.

Table listing cast-iron socket pipes with diameters and prices.

Table listing wrought-iron tubes and fittings with standard lists.

Table listing gas and water tubes, both galvanised and steam.

OTHER METALS.

Table listing various other metals like Lead Water Pipe, Lead Barrel Pipe, Lead Pipe, etc., with prices per ton.

I BUY SCRAP METALS

RTHUR P. COLLINS, Snow Hill, BIRMINGHAM. Home: Central 1020. Telegrams: Metallac, Birmingham. Bankers: The National Provincial Bank of England, Ltd., Bennett's Hill, Birmingham.

SLATES.

Table listing slate products like Portland, Bangor, etc., with prices per 1,000 of a certain size.

Table listing Eureka and Permanent Green products with prices per 1,000 of a certain size.

BRICKS.

Table listing various brick types like First Hard Stocks, Second Hard Stocks, etc., with prices per 1,000.

GLAZED BRICKS.

Table listing glazed bricks in various colors like White, Ivory, Buff, Cream, etc., with prices per 1,000.

MOULD BRICKS.

Table listing mould bricks like Stretchers and Headers, Internal and External Angles, etc.

Table listing various types of stone like Red Mansfield, Darley Dale, etc., with prices per foot cube.

STONE.

Table listing stone products like Red Mansfield, Darley Dale, etc., with prices per foot cube.

Table listing Bath Stone products like Bath Stone, Bath Stone, etc., with prices per foot cube.

TILES.

Table listing various tile types like Plain red roofing tiles, Hip and Valley tiles, etc., with prices per 1,000.

OBS.

Table listing various oils and products like Rapeseed, Olive, Coconut, etc., with prices per ton.

GLASS (IN CRATES).

Table listing glass products like English Sheet Glass, Fluted Sheet, etc., with prices per square foot.

VARNISHES, Etc.

Table listing various varnishes like Fine Pale Oak, Pale Copal, etc., with prices per gallon.

The Kirkeby United Fire Insurance Co. decided to build a new church of 500 sittings on the main road at Dombarton, in proximity to the colliery. The funeral took place at Berkeley on Friday in last week of Mr. Edward Gregory, whose death occurred on the previous Friday at the age of ninety years. The deceased had for many years carried on the business of builder and timber merchant in Berkeley. For some years he had lived in retirement.

TO CORRESPONDENTS.

We do not hold ourselves responsible for the opinions of our correspondents. All communications should be drawn up as briefly as possible, as there are many claimants upon the space allotted to correspondents.

It is particularly requested that all drawings and all communications respecting illustrations or literary matter, books for review, etc., should be addressed to the Editor of the BUILDING NEWS, Effingham House, 1, Arundel Street, Strand, W.C., and not to members of the staff by name. Delay is not infrequently otherwise caused. All drawings and other communications are sent at contributors' risks, and the Editor will not undertake to pay for, or be liable for, unsought contributions.

*Drawings of selected competition designs, important public and private buildings, details of old and new work, and good sketches are always welcome, and for such no charge is made for insertion. Of more commonplace subjects, small churches, chapels, houses, etc.—we have usually far more sent than we can insert, but are glad to do so when space permits, on mutually advantageous terms, which may be ascertained on application.

When favouring us with drawings or photographs, architects are asked kindly to state how long the building has been erected. It does neither them nor us much good to illustrate buildings which have been some time executed, except under special circumstances.

Telephone: Gerrard 1291.
Telegrams: "Timeserver, Estrand, London."

TERMS OF SUBSCRIPTION.

One Pound per annum (post free) to any part of the United Kingdom; for the United States, £1 6s. 0d. (or 6dols. 30c. gold). To France or Belgium, £1 6s. 0d. (or 33f. 30c.). To India, £1 6s. 0d. To any of the Australian Colonies or New Zealand, to the Cape, the West Indies, or Natal, £1 6s. 0d.

*Our Direct Subscription Agents for Australia are Messrs. E. T. Kibblewhite and Co., Printers and Publishers, 19, York Chambers, 105, Liverpool Street, Sydney, New South Wales; for Japan, The Maruzen Co., Ltd., 11-16, Nishibashi-Tori Sanchoe, Tokyo; who will receive Subscriptions at £1 6s. 0d. per annum on our account. Copies of the paper will be sent by us direct to the subscribers' address.

*The special rate to Canada is £1 3s. 10d. = 5dols. 50c. for 12 months, and 11s. 11d. = 2dols. 90c. six months. Our Direct Subscription Agents for Canada are Messrs. Sells, Ltd., 302, Shaughnessy Buildings, McGill Street, Montreal, who will receive Subscriptions, £1 3s. 10d. per annum, on our account.

Cheques and Post-office Orders to be made payable to THE STRAND NEWSPAPER COMPANY, LIMITED, and crossed London County and Westminster Bank.

ADVERTISEMENT CHARGES.

The charge for Competition and Contract Advertisements, Public Companies, and all official advertisements is 1s. per line of Eight Words, the first line counting as two, the minimum charge being 5s. for four lines.

The charge for Auctions, Land Sales, and Miscellaneous and Trade Advertisements (except Situations Vacant) is 6d. per line of Eight Words (the first line counting as two), the minimum charge being 4s. 6d. for 50 words. Special terms for series of six insertions or more can be ascertained on application to the Publisher.

SITUATIONS VACANT AND PARTNERSHIPS.

The charge for advertisements for "Situations Vacant" and "Partnerships" is One Shilling for Twenty-four Words, and Sixpence for every Eight Words after. All Situation Advertisements must be prepaid.

SITUATIONS WANTED.

Advertisements not exceeding Thirty Words, inclusive of name and address, are inserted under the heading "Situations Wanted," free of charge.

Rates for Trade Advertisements on front page and special and other positions can be obtained on application to the Publisher.

REPLIES TO ADVERTISEMENTS.

Replies to advertisements can be received at the Office, Effingham House, 1, Arundel Street, Strand, W.C., free of charge. If to be forwarded under cover to advertiser, an extra charge of Sixpence is made. (See Notice at head of "Situations.")

Advertisements for the current week must reach the office not later than 3 p.m. on Tuesday. Front-page advertisements and alterations or stop orders for serial advertisements must reach the office by first post on Monday to secure attention.

RECEIVED—R. A. S. and Co.—L. M.—W. H. W. R. and Son—L. L. Co.—L. E. F. Ltd.—C. A. Co., Ltd.

J. M. S.—No.

F. G. H.—Kilby send.

B. S.—Very important, Oct. 13, 1915.

Dear Sir: Where was the paper read? We have not received it.

O. E.—The structural details might be altered, Mr. W. G. is open to spare for the point.

A TIMELY REMINDER—Architects, Builders, and others are reminded that the BUILDING NEWS is now published on Wednesdays instead of Fridays, at 2 p.m., and that it should be obtained as early in the day as possible. If delay occurs, it can be posted direct from the office, or sent at the advertiser's subscription, or single copies can be sent by air to traders in camp of moving in the country.

OGILVIE & CO.

Mildmay Avenue, ISLINGTON, N.
EXPERTS in HIGH-CLASS JOINERY.
ALTERATIONS & DECORATIONS.

FOR
Olivers' Seasoned Hardwoods,

APPLY TO—
WM. OLIVER & SONS, Ltd.,
129, Bunhill Row, London, E.C.

TENDERS.

*Correspondents would in all cases oblige by giving the addresses of the parties tendering—at any rate, of the accepted tender: it adds to the value of the information.

BIRROW-IN-FURNESS.—For lining the chimney and extension of flue at the electricity works, for the town council:—
Neal, J. (accepted) £206 0 0

BLACKWALL TUNNEL.—For the repair of the carriage-way paving of Blackwall Tunnel, for the London County Council:—

Coles, A. N., Ltd., Wandsworth	41,640 8 6
Adams, Thos., Wood Green	1,595 9 4
Mowlem, J., and Co., Ltd., Grosvenor Wharf, S.W.	1,281 8 0
Griffiths, W., and Co., Bishopsgate Street, E.C.	1,187 6 4
Manders, W., and Co., Leyton	1,130 17 2
Municipal Contracting and Engineering Co., Leyton	995 2 4
Anderson, G. J., Poplar	991 8 4
Wheeler, W. H., and Co., Ltd., New Kent Road, S.E. (accepted)	987 3 0
[Chief engineer's estimate, £1,000.]	

BRIDGINGTON.—For erection of a stable and cart shed on land in Bampton Short Lane, for the town council:—
Abel, I. and G. (accepted) .. 455 0 0

CENTRAL FINSBURY.—For installing heating apparatus in connection with the rebuilding of Winchester Street School, Central Finsbury, for the London County Council:—

Buono, E., and Bull, Ltd., 3, Monument Street, London Bridge	4,745 0 0
Mox, J., and F., 33, Whetstone Park	729 12 0
Unsett	693 19 0
Brightside Foundry and Engineering Co., Ltd., 28, Viotna Street	649 0 0
Palokkar and Sons, 99-91, Queen Street	628 0 0
Yetton and Brockett, Ltd., Mutton Road, Southwark	620 0 0
Cannon, W. G., and Sons, Ltd., 107, London Road	612 0 0
Vaughan, T. W., and Co. (1914), Ltd., 22, Cross Street, Islington (accepted)	548 10 0
[Architect's estimate, £500.]	

CHORLEY.—For supply of various materials, for the town council. Accepted tenders:—

Paving sets and kerbs:— Catterall, T. C., Anglezarke
Limestone and chippings:— Horrocksford Lime Co., Ltd., Clitheroe
Natural flags:—Brooks, J., and Sons, Hipperholme
Concrete flags:—Shap Granite Co., Ltd.
Broken granite:—Kernonmawr Granite Co., Ltd.
Earthware pipes:— J. Crankshaw Co., Ltd., Horwich

CLAPHAM JUNCTION.—For the reconstruction of the bridge carrying St. John's Hill over the London, Brighton and South Coast and South-Western Railways, for the London County Council:—

Wallis, G. E., and Sons, Ltd., Maidstone	£3,867 0 0
Playlar and Todd, Southampton	3,584 0 0
Charles Ward, Ltd., Chelsea	3,547 0 0
Garrett, John, and Son, Balham	3,393 0 0
Hollway Brothers (London), Ltd., Lambeth (accepted)	3,017 0 0
[Chief engineer's estimate, £2,000.]	

COYDON.—For repairs at the slaughter-houses, for the town council:—
Munell, R., Grant Road, Coydon £134 6 3
(Recommended for acceptance.)

DENMARK HILL, S.E.—For the supply of locks required at the Maudsley Hospital, for the London County Council:—
Babbis, Hart, and Co., Ltd. (accepted) £411 0 0

DEBBY.—For repairs to a steam turbine, for the electric lighting committee:—
Parsons and Co., Ltd. (accepted) 400 0 0

DEBBY.—For the supply of wood blocks, for the tramways committee:—
Millar's Trading Co. (accepted) 4136 0 0

DEBBY.—For the supply of copper wire, for the tramways committee:—
British Insulated and Helsby Cables, Ltd. (accepted) .. 459 0 0

DEBHAM.—For building a reinforced concrete retaining wall for the road bank of the Mickley Dyke, near the Grange, for the Driffield Rural District Council:—
Witty, W., North Fordingham (accepted).

DEUNDEE.—For the reinforced concrete superstructure of the new city hall, for the town council:—
Yorkshire Benninghough Contracting Co. (accepted) £25,355 0 0

EDINBURGH.—For supply of plant for new power station at Portobello, for the Edinburgh Town Council:—
Fraser and Chalmers, Erith (turbines and alternators, £23,251, and condensing plant, £7,611, accepted).

ERITH.—For supply of turbo-alternator, for the urban district council. Accepted tenders:—
Turbo-alternator and condensing plant:—
Fraser and Chalmers, Ltd., Erith £10,432 0 0
Extension of generating station:—
Friday, H., and Sons, Erith .. 1,420 0 0

GLASGOW.—For the electric wiring of the new tenements at Calton, for the corporation:—
Bonnet and Rutherford (accepted) £104 0 0

HALIFAX.—For the erection of garage, etc., at Hazelton Well Works, Messrs. Chas. F. L. Horsfall and Son, Lord Street Chambers, Halifax, architects. Accepted tenders:—
Mason work:—Pickles, T., Luddensfoot.
Joiner work:—Wadsworth, S., and Sons, Halifax.
Plumber, heating, and glazing work:—
Belton Bros., Halifax.
Plasterer and slater work:—
Baneroff, J., and Son, Halifax.
Contractual engineer work:—
Haywood, W. H., and Co., Huddersfield.
(Total amount of accepted tenders, £950.)

HALIFAX.—For the supply of plant, for the tramways and electricity committee. Accepted tenders:—
Water-tube boiler and super-heater:—
Babcock and Wilcox, Ltd. .. £2,949 0 0
Two water-cooling towers:—
Francis Corder and Engineering Co., Ltd. 2,450 0 0
Two unlined stokers:—
Underfeed Stoker Co., Ltd. .. 538 0 0

HAMPTON WICK.—For the supply of 5,000 wood blocks, for the urban district council:—
Bennett, W., and Co. (accepted), £10 4s. 6d. per 1,000.

HUNTINGDON.—For erection of 40 artisans' dwelling-houses on Stoney Close, adjacent to the late militia barracks, for the town council. Mr. O. W. Gillson, borough surveyor:—
Pattinson and Son, London .. £12,640 0 0
Benfield and Laxley, Oxford .. 11,125 0 0
Pryer, A. E., Bedford .. 10,000 0 0
Kidman and Son, Cambridge .. 10,090 0 0
Pearson and Wright, Huntingdon 9,660 0 0
Thompson, J., and Co., Peterborough 9,620 0 0
Bateman, A. J., Ramsey .. 9,487 0 0
Furness, T., Peterborough .. 9,173 0 0
Clark and Sons, Cambridge .. 9,085 0 0
Gutteridge and Sons, Peterborough 8,980 0 0
Bull, H. F., St. Neots 8,680 0 0
Shanks, R., Chatteris 8,600 0 0
Dwyer, O. P., Kettering .. 8,411 0 0
Thackray and Co., Ltd., Huntingdon 8,340 0 0
Allen and Son, Brampton (accepted) 8,276 0 0

J. HUNESBERG.—For supply of eight 100-kw. single-phase transformers, for the municipal council:—
Gould, R. H., and Co. (accepted) £803 0 0

LONDON, S.E.—For supply of wood blocks, for the Betmonsey Borough Council:—
£2,500 creosoted yellow deal blocks:—
Lee, J. B., and Son, Ltd., Gracechurch Street £9 10s. per 1,000
(Accepted.)

LOWER BIRLING.—For extending the sewer at Lower Birling, for the Malling Rural District Council:—
Perce and Son £119 0 0
Davison 105 0 0
Wilford, J., and Sons (accepted) 87 0 0

LUTON.—For the supply of 2-in. broken granite, for the town council. Accepted tenders:—
Enderby and Stoney Stanton Granite Co., Ltd. (12s. 4d. per ton).
Mountford Granite Co., Ltd. (12s. 6d. per ton).
Croft Granite Co., Ltd. (12s. per ton).

PORTLAND.—For effecting repairs to the sewer outfall at Chessell, for the urban district council:—
Jesty and Baker, Weymouth (accepted) £120 0 0

regulations stipulate that beams supported by other beams must be regarded as having "free" ends. Ferro-concrete structure, however, has little or nothing to do with true free ended beams or true rectangular beams; if it has, then it misses the beauty and economy of the system. All the main and subordinate beams in our sketch are, technically, "fixed," and are "continuous," designed to be moulded *in bloc*—i.e., as though the

which deals with the divergence in effect of loading at end and intermediate spans. Having had careful regard to these general rules and modifying circumstances, the bending moments may be obtained in inches and the formulae given in Part III applied to the design of beams having the necessary moments of resistance.

The economy of ferro-concrete construction largely results from the application of

in the rule following. No doubt the scree walling below the window-sill, if effectively connected and homogeneous, with beam, assists this latter; but in calculations this would be ignored, and the beam designed as an L-beam carrying its share of flooring and the screen walling.

In making calculations for a building such as our sketch shows, we should begin from the roof, which has to bear a superimposed load of 56 lbs. per foot super.

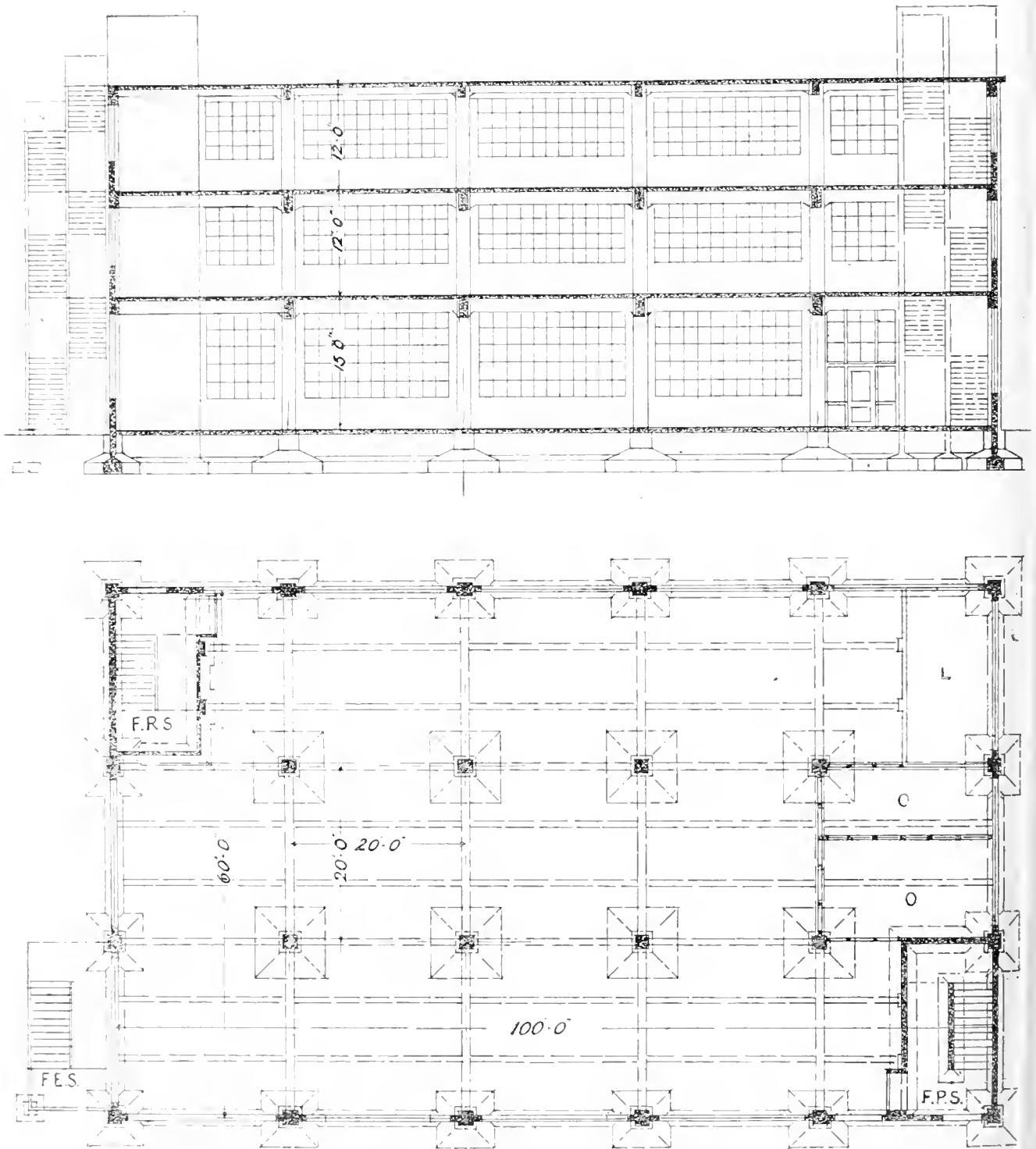

SUGGESTED DESIGN FOR A FERRO-CONCRETE FACTORY: GROUND PLAN AND SECTION.

when the beam is in a solidifying fluid. But it is pointed out that, in theory, and overlooking other considerations, that end bars are not so strong as intermediate, given equal spans and similar cross section to girders. On these points the regulations take note; so that, in addition to referring to the scheduled formulae of bending moments for various elementary conditions of loading, etc., in Rule 34, the designer must take note of Rule 35,

the T-beam principle, which views a large cross area of floor slab as available for taking up compressive stress; and this, which applies throughout our sketch proposals, excepting where L-beams are concerned, is a matter regulated by Rule 82. The wall beams carrying the margins of floors and screen-walls are L-beams, and the amount of floor slab allowable as compressive resistance is dealt with in Rule 83, the breadth of rib being further considered

in the case of six columns, the load admitted to the foundations is roof, and first floors with their superimposed loads, as included within a square of 2 ft. centred about the axis of the column together with the included parts of and secondary beams, and the total weight of the columns. Since the economy of ferro-concrete construction is greatly affected by the cost of "forms," should be simplified as much as possible.

or, more correctly, the design should be prepared bearing this important point in mind. Although calculations may show that an organic part—beam or column, etc.—should be of a different total breadth and depth of reinforced material, it is not absolutely necessary always to proceed on this plan, and in many cases real economy may result from putting a little extra concrete and reducing the steel. Thus, in ordinary practice, the columns shown in our sketch would diminish in cross area in upper floors. As a suggestion we have shown them of similar area as illustrating the principle of maintaining sizes to simplify "form" work. The steel reinforcement would be, of course, reduced, and more than in the proportion if the columns were designed of reduced area at higher positions.

A design must be suitable for ferro-concrete construction. The more simple and plainly rectangular the better for the form work; the more that part repeats in exactly similar form as to height, length and breadth, the less costly will be the timber framings and boxings, etc. We think that our sketch typifies the kind of structure most suitable. The plain rectangular construction is modified somewhat by the staircases and lift well, but apart from this the scheme seems highly suited. If more floors were added, the same superimposed loads being carried, and the same pitch of 12 ft. floor to ceiling being maintained, the total economy of reinforced concrete construction should be still better shown; and these considerations point to the reason why one would deem one-story buildings as well suited. Again, although a consistent mixture as 1, 2, and 4 may seem a best practice, economy may result from a poorer concrete in suitable parts—as, for example, in the upper columns of the porch, which, being maintained of similar cross area, this becomes unnecessarily great on the topmost story. Where great load is concentrated, as, say, 76 tons approximately, on the ground floor columns of our sketch, we may well employ the richest mixture—2, 2 and 4—under rule 42, allowing a compressive stress of 750 lbs. per square inch.

THE ROYAL SOCIETY OF BRITISH ARTISTS.

The autumn exhibition at Suffolk Street, though noticeably less rich in leading works, and numerically than in former years, is fairly representative.

Mr. J. H. Amschewitz shows one of the best portraits, "Elsbeth's Portrait" (33), a "Portrait Study" (146), and a somewhat rollicking Bacchanalian orgy, "Come Fill the Cup, and in the Fire of Sing, the Winter garment of Repentance a fling" (199). Mr. A. J. Bryce has a portrait of "Miss Walpole" (123), and another of "Senor Don Jose Garcia" (11), with two other pictures, "Demolishing the Zandstraat, Rotterdam" (186), and a "Spanish Gypsy" (207). Mr. H. D. Richter's two flower-pieces are good, "Roses" (155), and "Peony" (180). He also shows two other works, "In Hyde Park" (124), and "Scoria" (145). Mr. John Muirhead's "Meadow Lane, Highton" (126), is his best exhibit; "A Harvest Field, Houghton" (28), "The Pale Gate Pit, Houghton" (201), and "The Two Windmills, Port St. Croix, Brzes" (106), are all worth notice. Of those shown by Mr. E. A. Cox, the best is "An Artist and His Daughter" (127). Mr. Robert Morley is best represented by his "Autumn" (130), with its russet tints excellently rendered. Mr. Leonard Richmond has an impressive subject, "Rays of Light" (131), excellently conceived.

Mr. Francis Black's "On the Conway" (132) is the best of his three, but "The Lesser Orme, Llandulno" (181), and "Croesau, N. Wales" (202), will gratify all lovers of Welsh scenery.

Mr. Frank Brangwyn, A.R.A., R.P.E., the president, contributes five subjects, "Avignon" (21) we like best, but "On the Terrace" (25), "Milan" (26), "The Breaking Up of the Duncan" (255), and "The Old Mill, Dixmude" (234) are all worthy of him.

Mr. F. E. Hodge has three good portraits. "The Late Brigadier General Julian Hasler, killed in action April 27, 1915" (155), a "Lady in Fancy Dress" (151), and "Dunstan, Son of the Late A. C. Curtis, Esq." (215). Mr. A. Carruthers' two landscapes, "In Horner Woods, Somerset" (157), and "The Green, Barbery" (212), are among the best, and he shows two more, "The Lyn at Brendon" (1) and "The Vale of Aylesbury from Whitechurch" (18). Mr. W. E. Riley only sends one of his always-welcome seascapes this year, "The Tireless Tide" (88); his other subject is "The Chalk Road, Box Hill" (103). Two excellent seascapes are shown by Mr. Christopher Williams, "A Lonely Shore" (141) and "By the Sea" (135). Two very satisfactory portraits by Mr. Thos. F. M. Sheard are "Paula, Daughter of Stanhope Sprigg, Esq." (145), and "The Rev. Hope Gill, M.A." (149). "In the Days of Cicero" (222), by Mr. Walter, is good, and his "Entrance to the Doge's Palace, Venice" (224), is the best thing of its kind in the exhibition.

THE INTERNATIONAL SOCIETY OF SCULPTORS, PAINTERS AND GRAVERS.

The autumn exhibition of the International Society of Sculptors, Painters and Gravers at the Grosvenor Gallery is reasonably well up to the average, and there are not a few pictures of more than passing interest, and several of very real merit.

Mr. W. Nicholson sends two excellent Indian military portraits, "Duffadar Bar Singh" (1) and "The Viceroy's Orderly" (35), both fine specimens of the gallant men who are so nobly doing their share in the defence of the Empire, and adequately well rendered. His "The Bull" (75) is a fine study of its subject, and "Tiger Skulls" (80) is a noteworthy piece of artistic osteology. Of Mr. Louis Sargent's three contributions we like "Cart-hew Beach" (73) best. We do not care much for "The Sea" (78), a decorative cartoon. The nudes are doing nothing suggestive of their habitat, and they hardly are of sufficient interest in themselves to monopolise the picture.

Mr. Walter Sickert's only exhibit, "The Prussians in Belgium" (17), is somewhat of a misnomer. The man and woman might be of any decadent race, but scarcely less repulsive. Mr. John Lavery shows three portraits, "Mrs. F. A. König" (13), "The Right Hon. Winston Churchill" (22), and "Miss Jean Crombie" (51). Mr. Charles Shannon's "Autumn" (24) is a decorative subject, well embodying its title, but hardly up to his average. Mr. William Strang, A.R.A., has three interesting works, "A Café Bar" (4), "The Gypsy Girl" (26), and "In the Country" (38). One of the best works shown is Mr. William Rothenstein's only contribution, "A Little Boy Lost" (39). It tells its story well, and the structural adjuncts are excellently done. Mr. D. M. Cameron's "St. Andrew's—Early Morning" (2) is good; and would have been better with less sky. Mr.

Charles Ricketts' "Mintzuma Swathing to the Sun" (47) is good, and so is his "Aeolus and Galatia" (79). Mr. Daniel Veres-Smith sends well with a flourish his works, "The Spanish Student" (79), "The Chorus Girl" (71), and "Dinner Hour at the Angel" (115). Miss Freda Macdonald has a really nice exhibit, "A Garden" (54). Mr. Charles Hayward is entirely successful with his "Saint Francis Preaching Poverty, Chastity and Obedience" (133). His etching of "A Stormy Landscape" (283) is a good one.

Probably the general public would be more interested in Mr. Edmund Druce's clever caricatures, as expensively funny as they are models of good draughtsmanship. "Mr. Winston Churchill Looking for More Trouble" (183) is his first; the life as he timely offers the first fruits of his newly discovered artistic faculty to the somewhat "supercilious looking" director of the gallery. Mr. Edmund Druce has well earned a copyright of the many future chances his versatile subject is likely to afford him; like Lord John Russell's fold, Mr. Churchill having commanded the fleet to his own satisfaction, is as ready for anything ere the days come when he too will prefer to "rest and be thankful." Scarcely less happy are the conceptions of "Inspector James Pryde" (181), contemplating the ladders and flags in his landscape, or "Ivan Mestrovic" (184), working away at the toe of a statue many sizes larger than himself.

Among the water colours we liked "The Dining Room at 1, Dorset Street" (141), by Mr. W. B. Ranken; "Henry Regatta" (146), by Mr. William Monk; "Lamshouse" (150), by Mr. W. G. Bruckman; "Poppy" (206), by Miss Lily Blatherwick; and "Edgware" (211), by Mr. H. M. Livens.

There is not much sculpture of interest, Rodin's marble "Countess of Warwick" (41c) is lent by its owner, as are two heads of Lady Cunard by Ivan Mestrovic, one in bronze and the other in wax.

ENGINEERING FOR ARCHITECTS.

This is a very useful book, on a gilt edge, and well worth the study of British architects in the regrettable absence of such a text book this side based on our own trade handbooks. We have often insisted that there is no real use for an architect to go to specialists to design constructive details, or to decide on the size of beams, girders, and column sections.

He ought to be able to do this himself; and when he is, the results are considerable saving to his client, and much less risk of failure of the structure. There is, or ought to be, no mystery about the matter, for no knowledge of mathematics beyond simple algebra is necessary.

With that and such a book as this the solving of simple engineering problems is easy, and the design of structural members facilitated to such an extent that a general readers will gratefully realise, probably with some surprise.

The Arts and Crafts Exhibition Society selected as its president, to take the place of the late Mr. Walter Crane, Mr. Henry Wilson, who has for many years added to his work as an architect the practice of a civil engineer associated with architecture, and has taken part in ensuring the success of the Exhibition of British Handicraft in Paris, in the summer of 1914 and in Ghent the year before. Under the new president the Society is considering its action with regard to the future problem of British Artistic Industries, and their re-organisation to meet the new conditions which must arise after the war.

"Engineering for Architects." By Dr. Wm. Clinton Pond, M.A., Instructor of Architectural Engineering at Columbia University (London: Oxford University Press, 8s. 6d.)

LEGAL INTELLIGENCE.

BUILDERS' CLAIM AGAINST EXECUTORS OF LORD BURTON—Mr. Edward Pollock, one of the High Court official referees, commenced on Tuesday, in Court No. 2 at the Royal Courts of Justice, an action in which Messrs. Henry Wilcock and Co., church builders, 11, Regent Street, Wolverhampton, sought to recover the balance of £3,500 for building St. Chad's Church at Horninglow, Burton-on-Trent, for the late Lord Burton. The contract price for which was £19,559. The defendants in the action were Harriet Georgiana, Dowager Lady Burton, Rangenore, Burton-on-Trent; Mr. John Arthur James, Grafton Street, London; Mr. John Grotton, M.P., Elmstone Gardens, London; and Mr. John Lambuck, Stratford Road, Burton-on-Trent, joint executors under the will of the late Lord Burton. Mr. A. A. Hudson, K.C., with Mr. Disturnal, K.C., and Mr. Drysdale, appeared for the plaintiffs, and Mr. Leslie Scott, K.C., with Mr. Gibbons and Mr. Bettune, was for the defendants. The action involved an enormous mass of details, the pleadings occupying four bound volumes of from 250 to 400 pages each. Mr. Hudson, K.C., in his opening, said the claim was upon two certificates given by the architect under a building contract. In 1904 Lord Burton desired to build a church at his own expense, and the designs were made by the late Mr. George Frederick Bodley, R.A. The designs having been approved of, it became necessary to prepare estimates and other documents necessary to form a contract. Then it appeared that a Mr. Couchman, who apparently represented Lord Burton, desired to have his name inserted in the specification for the purpose of giving him power to supervise the work. Tenders were invited, and that of the plaintiffs, being the lowest, was accepted. Mr. Grover was the quantity surveyor who prepared the quantities for the purpose of the tenders. Various modifications in the plaintiffs' tender had to be made to bring the price down to the figure which Lord Burton was prepared to pay. Lord Burton had, in the meantime, prepared the foundation for the church by his own men independently of the plaintiffs, and this somewhat delayed the work. The contract was entered into in November, 1905, and the contractors were only able to start work in May, 1907. Directly after work was started difficulties arose with Mr. Couchman, who was engaged to Messrs. Bass and Co., as to the quality of the stone, and that on two or three occasions stopped the work. Mr. Cecil G. Hare, Mr. Bodley's partner, had the immediate charge of the work, and he disagreed with Mr. Couchman in his condemnation of the stone. These disputes resulted in difficulties and delays, as a fresh quarry had to be opened to procure the stone required. Not only did Mr. Couchman assume great powers in reference to the stone, but he also made considerable alterations in the plans. The church was entirely of stone, faced inside and out, and he gave extraordinary instructions as to how the work was to be carried out. He was an engineer, and the result was that it was an engineering instead of a church job. Matters were, however, smoothed over to an extent. Lord Burton died in February, 1909, and Mr. Pollock in October, 1909. After Lord Burton's death Mr. Couchman again raised difficulties, but ultimately the work was completed in May, 1910. It should have been finished in June, 1907. The contractors sent in a claim to the trustees for the interference so far as the condemnation of the stone was concerned, but with that part of the case the Court would not be troubled. Mr. Grover, the quantity surveyor, set up the work of valuation for the purpose of the extras, and they amounted to £1,749. Mr. Couchman had been invited by Mr. Grover to attend the valuation, but he did not appear to have done anything. Directly the valuation was made, however, Mr. Couchman began to raise difficulties again, and in the result, in April, 1911, the plaintiff obtained a certificate for £3,500 and upon that certificate the action was brought. It was not known from the correspondence that Mr. Couchman had taken upon himself the duties of quantity surveyor, but that knew how that disputes were occurring between Mr. Grover and Mr. Couchman, and between Mr. Grotton and Mr. Hare. It appeared that in the end Mr. Grover was induced to revise his valuation, and he reduced it from £7,126 12s. 6d. to £3,566 12s. 6d. The second valuation was made without any reference to Mr. Wilcock. In the meantime, plaintiff had been pressing for payment of the £3,517 certified by the architect, but not a penny of it had then been able to get.—Mr. Hudson, K.C., continued his opening speech on Wednesday,

nearly the whole of the day being occupied in reading correspondence between Mr. Couchman and Mr. Cecil G. Hare, the architect, and Mr. Couchman and Mr. Grover, the quantity surveyor. He remarked that Mr. Couchman appeared to have been tempted to interfere with the work of construction. Mr. Leslie Scott, K.C., for the defendants, objected to Mr. Hudson making slapdash observations, but said he would have something to say on that matter later on. In regard to the correspondence with Mr. Hare, Mr. Scott said he supposed that gentleman would be called by Mr. Hudson. Mr. Hudson said he was not going to call him, as he was defendants' witness. Mr. Scott said he would not call him. During the course of the action on Friday the learned Referee said it seemed to him that the position of the case was that defendants were entitled to show, if they could, that what were called "extras" really represented work done within the contract. Mr. Hudson, K.C., said he did not dispute that. The Referee said the defendants, on the pleadings, were not entitled to say that the work claimed to have been done was not done, and they could not say that those things claimed as extras were not authorised. Mr. Hudson said that those were his points. Mr. Gibbons said he agreed, except with regard to the second point. The Referee said in his opinion the question whether the work had been done or not had not been raised on the pleadings, the only paragraph which could have raised it having been struck out. Mr. Couchman, who was apparently there during the whole of the time, did not in his affidavit say that the work was not done. Mr. Gibbons, K.C., applied to be allowed to amend the pleadings. Mr. Hudson, K.C., objected, as the amendment would result in a further delay of the long-pending trial. The Referee said he felt bound to allow the amendment to be made upon conditions. After an adjournment, Mr. Gibbons said that having been unable to get into communication with either of the executors he was in the position of not being able to say whether or not he would be prepared to ask for the amendment. The case accordingly stood adjourned until Monday in next week, the 25th inst., upon the understanding that the defendants paid the costs of the day.

WOOD FLOORING CO. v. TRAVELLER.—Mr. Verey, one of the High Courts Official Referees, concluded on Friday the hearing of the action brought by Mr. William Barry Greger, trader in the Zeta Wood Flooring (Stratford) Company, against Mr. A. S. Horsford, a commercial traveller, of Victoria Road, Stechford, to recover £197 4s., balance of account for work done and materials supplied. The claim was admitted, but defendant counter-claimed damages for alleged breach of agreement, for loss of commission, and for the expense of several visits to London made by the direction of plaintiffs. The admission of the debt threw the onus of proof upon defendant, who alleged against plaintiff that he had failed to afford the necessary information to enable defendant to ascertain the amount of work done by him and the commission due. The Referee found there had been a settlement in September, 1913, and there had been no refusal to allow defendant to have access to the books. The defendant had failed to prove his case, and there would be judgment for plaintiff on the claim and counter-claim with costs.

Messrs. Carrere and Hastings, Boston, Mass., have completed plans for the chemical laboratory of the Johns Hopkins University at Homewood, Baltimore.

Mr. W. English, formerly water engineer at Terquay, now chief engineer to the Rand Water Board, has been elected as president of the South African Institution of Engineers.

The Postmaster-General has presented to the City Corporation for the Guildhall Museum a number of the Roman antiquities including various coins of Samian ware and fragments of Samian pottery and painted plaster—recently found at the site of the old General Post Office, St. Martin's Lane-Grand.

On Sunday week the Bishop of Winchester performed the consecration ceremony of St. Cuthbert's Church, Copnor, the fifth of the six new churches provided for out of the Bishop's £50,000 Portsmouth Six Churches Fund. The church cost £11,000, of which Mr. Heath Harrison, of Petersfield, gave £300, in addition to the organ and some unique panelling for the sanctuary. Mr. F. Starke Hall, M.A. A.R.I.B.A., of Bedford Square, W.C., was the architect.

Currente Calamo.

Probably the capriciousness of the effects of the bombs discharged over the "five areas" in last Wednesday's Zeppelin raid will have surprised most of us who have had the opportunities of examining the scenes of destruction more closely than the general public. It is difficult to say more without specifically pointing to instances of what we mean; but it is obvious that in any future attempts to modify construction with the view to rendering buildings bomb proof this will have to be taken into account seriously; and, moreover, that it will be as necessary to study the dangers to our roads, and the gas and electric mains, and other services beneath them, as well as those to our structures. As regards the latter the latest developments of German barbarism have suggested ideas which we shall endeavour to explain next week, which may be suggestively useful, and which we should be glad to see criticised by others. The matter is a pressing one, and might well engage the attention of architects and engineers and those who are responsible for invitations to them to communicate their ideas to the various professional institutions, the paper-lists of which, so far as we have glanced at them, scheduling not a few other things that can very well stand over till more tranquil times.

In a letter to manufacturers, Mr. Lloyd George says he is encouraging a scheme for giving a short course of training in technical schools to applicants who undertake to work whole time in munition factories on the completion of their course. He says:—"No attempt will be made to produce skilled engineers, and the training given will differ materially from the ordinary educational training given in technical schools in normal times. The whole object of the Minister is to have a certain number of people who would otherwise be entirely unskilled taught the use of tools, and to have them trained, as far as the equipment of the technical school permits, in performing a specific mechanical operation. Such men and women would still be at most semi-skilled workers, but they should be far more useful recruits in a munitions factory than workers who have never used a tool. Every effort will be made to select for training men of intelligence, and only those who are likely to make satisfactory munition workers will receive a certificate at the end of the course." The idea is rather vaguely stated, and as only men ineligible for military training are to be selected it would appear that they must be handicapped, either by age or physical disqualifications; but we must wait and see what the proposed "short course" is before saying more.

Several members of the House of Commons are determined to ventilate the grievance which has been caused by the recent decision of the Treasury to dismiss the whole of the temporary staff of land valuers. It is recognised that very little has reached the Exchequer as a consequence of Mr. Lloyd George's excursion into land-taxing in his Budget of 1909, while it has cost very much more than any resulting revenue has been worth. That, however, is not the fault of the temporary staff, all of them skilled men in the work and engaged under the implied understanding that the tax had "come to stay," and some quitting other positions in which they were established so as to secure what so many desire, a position under Government. As it is alleged that, in cases of which details can be furnished, unmarried men eligible for the

* An interior perspective of a church in St. Chad's, Horninglow, appeared in the BUILDING NEWS for June 2, 1905.

Army are being retained in this particular service, while married men ineligible for the Army have received notice of dismissal, the Financial Secretary to the Treasury is to be questioned on the whole matter.

Under the scheme for assisting architects and surveyors whose practice has been brought temporarily to a standstill owing to the war, to which we have previously referred, four applications for survey work have been granted in the Manchester district and one in Liverpool. The main objects of the Lancashire survey are—(1) To promote the health of the community, (2) to improve the commercial facilities of the county; these boons being primarily sought by means of more open spaces and better means of transport. The hon. director for Lancashire (Mr. L. P. Abercrombie) is being valuably assisted by Mr. Isaac Taylor (Manchester). The idea is a practical and timely one, and we heartily commend it to other authorities.

The trouble caused by landlords raising the rents in munitions areas, first heard of in Glasgow, has extended to London. Vigorous protests are being organised, and tenants' protection societies are being formed in many districts. Mr. Lloyd George's promise of an immediate inquiry and his statement that the Government will, if necessary, take powers to deal with the situation are not much believed in! Mr. James Rowlands, who raised the matter in the House, and has forwarded some details of increases to the Prime Minister, states that rents are being raised all round in the London munitions area—in some cases by as much as eightpence a week. The owners of a large estate in Canning Town have sent their tenants a demand for an extra sixpence a week, accompanied by a formal notice to quit. Tenants who make difficulties are being forced to leave to make way for more accommodating persons. At Dartford, where the housing problem is specially serious, Judge Parry has intervened on the side of the tenants by refusing to grant ejectment orders. He has laid it down that if landlords want to turn out tenants who are munition workers they must appear themselves and give their reasons. The plea of agents and owners in most cases is that they are compelled to raise the rents in order to meet the new Budget burdens. Others allege that mortgagors are raising the interest on mortgages, and then there is also the extra cost of aircraft insurance. At the bottom of the whole matter, of course, is the present dearth of houses all over the country.

An interesting and sensible proposal for honouring the fallen was made by Mr. George Kirby (the York Museum curator) in the course of a lecture last Wednesday. Mr. Kirby said the ordinary statue and tablet memorial should be superseded by designs conceived from a lofty patriotic impulse, and which would at the same time serve some useful purpose. He suggested noble buildings, suitable for advancing arts, sciences, chemistry, crafts, manufactures, machinery, and various other industries, as well as lecture and concert halls. They should be majestic in design and artistic in embellishment, selected from competitive designs suitable for local requirements. They should represent scenes and subjects of heroism and battlefield bravery, chiefly (for York) gallant deeds done by sailors and soldiers of York battalions and individuals. To advocate the provision of several small and useless memorials would be to throw away money. To erect temples of art would be worthy of the

loyalty and sacrifice of present-day citizens and meritorious memorials of the brave defenders who suffered for the honour of England, home, and Empire. We very heartily endorse the idea. Far better than frittering away funds on the stock memorials of the mason's yard, and other puerilities, would be the co-operation of all the art in the erection of really useful and creditable memorials of the appreciation by their fellow countrymen of the heroism and self-sacrifice of the Empire's heroes.

In yesterday's *Daily Telegraph*, in a timely and interesting article on "Voice Preserved," Sir Claude Phillips describes the precautions that have been taken to protect St. Mark's and the other treasures of the city, and trenchantly contrasts them with the apparent indifference of our own authorities to the possible fate of some of our own great monuments. What, he asks, have the guardians of Westminster Abbey done? In the centre of Henry VII.'s Chapel the great tomb of Henry VII. and his Consort, by Torrigiano, still remains utterly exposed, and it is, moreover, encircled with a veritable forest of most inflammable woodwork, in the shape of carved and fretted stalls, with all their accessories and the decaying banners which project from them. What the explosion of an incendiary bomb here would mean we leave to the imagination of our readers. It would very possibly entail the destruction not only of the whole chapel, but of the whole Abbey. And then there are in the choir of the main church tombs even more precious to England; a group of Royal sepulchres which are without parallel at present in Europe. Are we to attempt absolutely nothing to protect the Shrine of Edward the Confessor, the tombs, so precious artistically as well as historically, of Henry III., of Eleanor of Castile, of Edward I., of Philippa of Hainault, of Edward III., of Richard II., of Henry V., of William de Valence and Aylmer de Valence? Are we to look on impassive and inert, leaving it to Fate to decide whether a most precious heritage of the Anglo-Saxon race shall be utterly ruined and obliterated? Are we here again to be told to "wait and see" to await, it may be, some hideous catastrophe, some awful enveloping destruction by licking tongues of fire of all that we hold most precious, most vital as a record of our country's greatness?

He appeals forcibly to all interested, to all concerned, to make themselves heard. "Let them speak, even if there be no comfort in their words; let them speak, even if it be to confound us." Have the universities no word to say on such a subject as this; or the Royal Academy; or the corporate bodies of architects; or the British Academy; or the time-honoured societies for the promotion of art and science? Why do the Society of Antiquaries, the National Art-Collections Fund, the Burlington Fine Arts Club remain mute and officially unresponsive? How futile will their activities appear in the future if now, at this moment of supreme anxiety, held back by trivial considerations of routine and etiquette, they are content to look on as mere spectators while risks are run which may result in irreparable disaster. The men in authority who, through irresolution, through lack of courage to take the initiative and throw down merely conventional obstacles, fail to impose such drastic measures as the imminent danger calls for—these men, however high in place

and in the esteem of their fellow countrymen, will be held to have betrayed a most sacred trust, and their great refusal will be recorded against them, and for ever remembered in utterance by their brother."

Our Illustrations.

PAINTED DECORATION IN THE COUNCIL CHAMBER OF THE INSTITUTE OF CHARTERED ACCOUNTANTS, MOORGATE PLACE, E.C.

The pair of large figure panels, 2 ft. by 19 in., are painted on canvas banded on walls. The motif of the one opposite the door is "Science Bringing Order to Commerce"; of the one over the door, "The Triumph of Law." The architectural background is more or less a repetition of the architecture of the Council Chamber. Figures about life-size. The rest of the decoration is painted directly on the wall. The Cove at top is filled by the signs of the Zodiac. The four pendulines are in gesso—Justice, Prudence, Wisdom, and Truth. Over the bust of the Queen is a treatment of the Royal Charter of the Institute. The accompanying plate has been reproduced from the beautiful water colour shown at the Royal Academy Exhibition this year by the artist, Mr. George Murray, of 10, Girdlers Road, W.

EXHIBITION HALL, AUSTRALIA HOUSE, ALDWYCH AND STRAND, W.C.

The Exhibition Hall occupies the central portion of the ground floor. It is intended for the display of the produce from various States in the Commonwealth. The hall is in itself one of the exhibits, as its walls and floor are of Australian marble. Throughout the building Australian marble and woods are being employed in the interior finishings. A general plan of this important stone building, now advancing on all four sides, was given in *The Building News* on July 4, 1913, immediately prior to the laying of the foundation stone by the King. We also then gave a general perspective exterior view from the Strand, looking north west, where the Gladstone statue stands, on an island west of St. Clements Dane's Church. The architects are Messrs. A. Marshall Mackenzie, LL.D., A.R.S.A., F.R.I.B.A., and A. G. R. Mackenzie, F.R.I.B.A. The builders are Messrs. Dove Brothers. The section below the accompanying view of the Exhibition Hall is very interesting, as it shows the columned lantern rising through the floor above, with gallery round, giving light, and adding a fine architectural effect to this monumental interior, with its vaultings carried by detached columns and piers below a very massive entablature, in one consistent order throughout.

ST. PETER'S, ROME, FROM THE STRADA DELLA MURA

This charming pencil drawing by Mr. Fred Richards was hung on the line in the "Black and White Room" of the Royal Academy this year. It forms part of the set of illustrations of "Rome" in Messrs. Adam and Charles Black's "Artists' Sketch Book Series," and the high standard of these little handy and artistic volumes may be gauged by the merit of this example which we have reproduced from the original picture placed at our disposal by the owners of the copyright and the artist. The book devoted to "Rome" comprises twenty-four similar studies, all of which possess the quality of local atmosphere, and their accessories are fittingly subordinated. The subjects, without being over-embellished, have the charm of freshness of view quite unassumingly handled and delineated with precision without paandering to the popular parade of the ordinary guide-book. Each drawing is valuable as a portrait, and all are considerably more interesting than photographic reproductions. Notwithstanding their great reduction as compared with the original, the plates are capitally printed. The Basilica of St. Peter as seen from the Strada della Mura stands clear of the additions by Maderno and avoids his 17th Cen-

lary's recent colonnaded frontispiece which passes the façade as built in 1560 from the designs of Michael Angelo, overlooking the Piazza di S. Pietro. The dome was erected during his lifetime, but the lantern surmounting the great cupola remained to be finished after his death, and this was carried out in accordance with Michael Angelo's plans. The choir end of the cathedral appears still very much as he designed it, and a reference to a former illustration given by THE BUILDING NEWS of this front may be useful as showing the special treatment perhaps more clearly than the present study. We refer to the freely drawn pencil sketch lent us by Mr. Walter Keesey, A.R.C.A., when he was Travelling Student of the Royal College of Art. It appeared in our issue for August 25, 1911. The point of view he adopted was rather unusual, being chosen to illustrate the cupola and chapels as seen from the hill to the rear of the Pontifical Basilica, and for that reason the picture possesses a special interest. The capital little pocket book on "Rome," to which we are directing attention to-day, includes a sketch of St. Maria di Loreto from the Piazza Venezia. It will be remembered that there are two churches on the north side of this open space. That on the right, known as "Del Nome di Maria," was begun in 1507 by Antonio da Sangallo, junior. Trajan's Column, of course, comes into the picture though another plate is very fully devoted to its individual illustration, and necessarily shows the same church beyond. A very scholarly drawing is given of the Parthion, the only ancient building in Rome which is still in a perfect state of preservation. Its history is familiar, and readers will recall the eminent fact of its consecration as a Christian church by Pope Boniface V. in 609, after which time the structure was known by the ecclesiastical name of "St. Maria Rotonda." The Castle of St. Angelo, one of the most familiar objects in the city with its well known bridge approach, needs no more than a passing mention by way of alluding to another of Mr. Fred Richards' sketches, and as showing Bernini's statues of angels standing on the bastion piers. Though these figures in themselves are somewhat indifferent as examples of the plastic art, they really do look extremely fine in sharp perspective leading up to "Hadrian's Tomb," in contrast to which they furnish a befitting foil and serve to show the value of heroic sculpture. Plate 7 gives a river view of St. Peter's, and in the middle of the picture looms the spandrel toward the top of a rugged bridge over the Tiber. Its modern conformity is modernized with the surface of truth, by the touch of the artist's facile pencil. No. 9 is a charming sketch of the glitzy and the solemn facade of "The Unknown Temple" near the river, and we also admire very much the sketch of the windows of the Temple of Castor and Pollux, as sketched with accuracy and feeling by the draughtsman, which is but a minor fragment of one of the most beautiful designs of the Berninis. The Arch of Titus, though not represented with the *bona fides* of the draughtsman. In closing it may be set down that the noble gateway was dedicated to the memory of the high Emperor A.D. 81, and we have no doubt as to the skill of the artist in which the sketches are suggested under a singularly high effect of brilliant light and shadow. The outstanding features of the Temple of Minerva, known as Capua, and completed by Augustus, is the work of B. B. and one of the most famous architectural features for their massive proportions, and being this building and the temple of Castor and Pollux, and the Arch of Titus, perhaps the most important monuments of the Roman Empire. No doubt it is possible, and indeed probable, that the artist has not been able to reproduce the exact proportions for Plate 17. The sketch is used to assist the reader's eye at the subject of this temple, and it is to be hoped, when viewed with any fairness, and some of the details considered that an advantage

All the same it is very convenient to have ready to hand a few dates for reference on the spot, and these might quite well have been added to the index of plates without increasing the bulk of the volume, and so avoid the necessity of carrying about an ordinary "guide" in the pocket in addition to this sketch book.

SE. GABRIEL'S CHURCH, PLYMOUTH.

The nave and aisles of this church have recently been finished. The drawing shows the complete effect after the erection of the chancel. The site is a sloping and irregular one, which has permitted the erection of a large parish hall, as well as vestries beneath the main fabric. The staircases and approaches to the upper floor will form an item of interest in the whole scheme. The architect is Mr. W. D. Croc, M.A., F.S.A., F.R.I.B.A. The drawing now reproduced was in the Royal Academy this summer.

HISTORIC BUILDINGS DEMOLISHED BY THE GERMANS IN BELGIUM: AN OLD GABLED TIMBER HOUSE IN YPRES.

In our journal for October 6 last we gave two sketches made in Ypres and lent us by the artist, Mr. Robert C. Kemard, as illustrating examples of the characteristic architecture and old domestic buildings of that famous and beautiful, but now ruined, Belgian town. During the past year the place has been reduced almost to a veritable heap of ashes. Now only a few ruins are still standing here and there to emphasise the vandalism shown by the relentless bombardments of the cruel German invaders. Their wanton disregard for historic architecture and their murders of civilians, young and old alike, are abundantly manifest wherever their armies have gone. It is not necessary to say more on that self-evident page in the history of this war. In all previous wars in which the Germans have taken part they invariably, as in 1870, displayed a similar barbarity, though never before on so large a scale. We printed a few particulars about the subjects of Mr. Kemard's artistic and excellent studies before published as above mentioned. There is not much to add about this typical timber-framed old house, with its picturesque gable and overhanging stories. In all likelihood the building has entirely perished, and most probably it burned to the ground very quickly. The steps in front lead down to the entrance doorway, placed at a considerably lower level than the side walk. The artist says he knows nothing of the history of this house. The sketch depends entirely on its architectural character, which gives it much interest, though the effect of the building was by no means improved by the adjacent modern business premises, part of which necessarily comes in the picture.

LION'S HEAD WATER SPOUT FROM GARGENTI, SICILY.

In the National Museum at Palermo there is a special gallery, known as the Sala delle Metope, and in this room are housed most of the prime treasures of that exquisite and valuable collection. These chief d'œuvres comprise the famous Metopes from three of the Doric temples of Selinunte. All these examples belong to the earliest period of Doric sculpture, and the oldest of them must have been carved soon after the foundation of Selinus, i.e. 623. They are strongly conventional and stiff in treatment, but their chief interest consists, popularly speaking, in the fact of their being some of the most ancient attempts extant in competition, as well as striving after an expression of life and movement. In this same gallery are preserved several noble fragments of lions' heads and the like from Himeræ. We give to-day a fine fold detail drawing, executed on the spot in red chalk, showing a splendid water spout lion's head. It was sketched from the original now to be seen at Palermo in this room. This example was brought from Gargenti, where once stood the great Greek city of Agræus, founded by a colony from Gela, i.e. 522, and amidst the ruins of ancient structures there to-day may still be found the remains of a series of temples, and likewise the Tomb of Theron. The lion's head thus illustrated came from

one of these temples, and we are indebted to Mr. Alick G. Horsnell for this sketch. The same collection contains two celebrated Etruscan rams' heads in bronze from Syracuse. One and all of these things are powerful conceptions, bold in form, big in their sense of scale, and admirably suggestive for modern monumental buildings. They belong to the mythological family, "well worthy to carry Phryxus and Helle." This lion's head detail, on its merits as a design, will be much appreciated by our readers, because it is a beautiful specimen of fine conventional conception, based upon exactitude of treatment, at once recognised as being in direct contradiction to the feeble naturalistic limitations prevailing pretty generally till lately among modern sculptors and designers of architectural metal work, both at home and abroad.

The Madras Government have secured the services of Mr. H. V. Lancheester, vice-president R.I.B.A., for town planning. Mr. Lancheester is due in India this month, and has been engaged till March, 1916.

The Government have acquired the freestone quarries of Corsehill, Annan—the largest freestone quarries in the South of Scotland—which have been in the occupation of Messrs. Murray and Sons for fully forty years.

The seventeenth list of Members, Licentiates, and Students of the Royal Institute of British Architects who have enlisted in the Army or Navy for the period of the War gives a total to date of 45 Fellows, 339 Associates, 174 Licentiates, and 216 Students.

A report has been submitted to the Manchester Corporation Finance Committee on a scheme for the provision of cooling water at the new electricity generating station at Barton. Sanction has been received to the borrowing of £10,750 and £4,750 in connection with the new station.

The new buildings of Cheshunt College, Cambridge, were occupied last October, but on account of the war there was no formal opening ceremony. The Governors, however, have now arranged for an opening commemoration on Tuesday in next week, the 26th inst. The debt on the buildings now stands at about £4,500.

In connection with the opening of the Edinburgh College of Art for the winter session, it is announced that 202 members of the staff and students are serving with the colours, forty-one of whom hold commissions. A fair proportion have already seen service at the front, and of these twelve have been killed and seventeen wounded. One student who held a travelling scholarship is still interned in Germany.

The railway in Alaska which the United States Government is building runs from the deep-water port of Seward in Resurrection Bay to Fairbanks, a distance of 471 miles. The first seventy-one miles were built by the Alaskan Northern Railway Company, now defunct, and the Government bought that section for £3,200 a mile. The line is now being reconstructed, and it is hoped to open the first thirty-four miles this year. The dock that belonged to the Alaskan Northern Company will have to be largely rebuilt.

It was reported to the Metropolitan Water Board at the meeting on Friday that the work of laying an independent main from the Fortis Green reservoirs to the three engines at the new pumping station at Fortis Green, together with a sump pit and pipe chambers, and the laying of two 24 in. delivery mains to connect to the mains laid under the Great Northern Railway for future use on completion of the Fortis Green pumping station, has been completed at a total cost of £3,636 about £986 above the original estimates.

Recently Dr. H. T. Bidwell, M.Inst.C.E., Local Government Board inspector, held a public inquiry at the Council Chamber, Sheerness, into the urban district council's application for sanction to borrow the sum of £6,750 for purposes of water supply. The clerk of the council (Mr. V. H. Hallon) and the consulting engineer for the scheme (Mr. F. W. S. Stanton) gave exhaustive evidence on the technical details of the proposed works, which comprise the erection of buildings and machinery at Sheerness East, to render operative the bore-hole and settling tanks provided there under a prior loan of £3,000. This work, with other proposals, had already been the subject of applications to the Local Government Board for sanction, which was refused on grounds of economy.

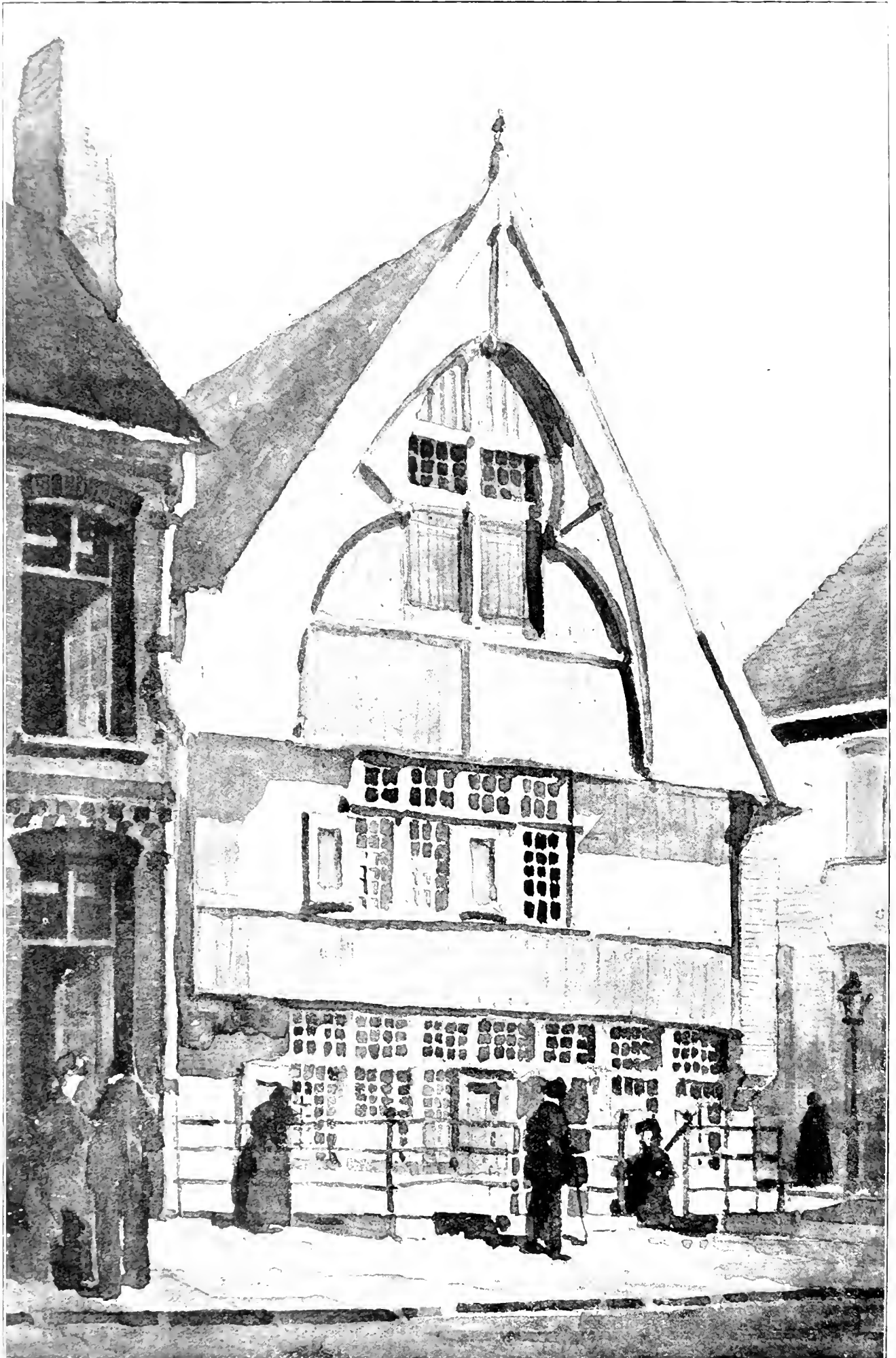

HISTORIC BUILDINGS IN BELGIUM, DESTROYED BY THE GE MANS: A TIMBER HOUSE IN YPRES. Sketched by Mr. ROBERT C. KENNARD.

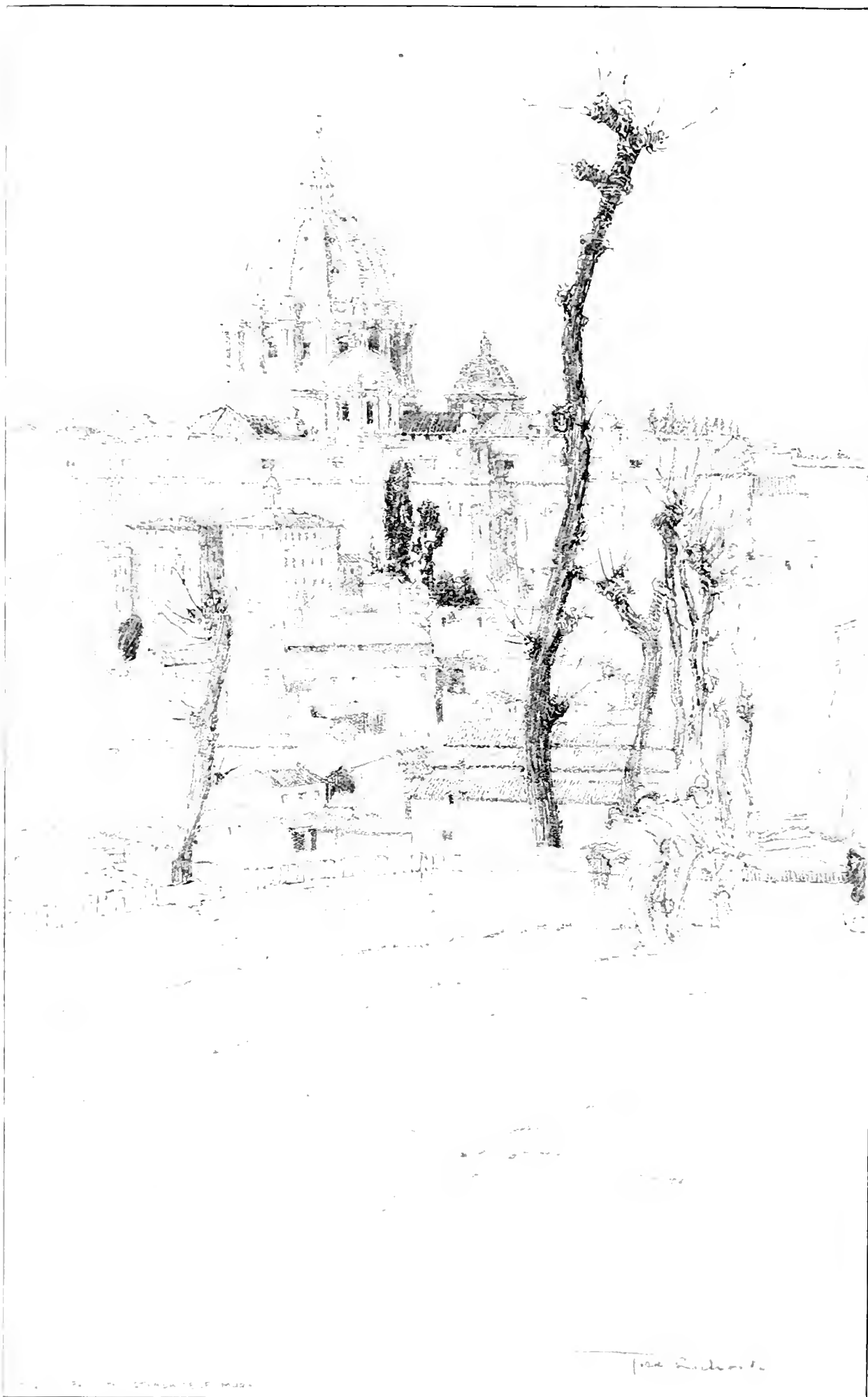

ST. PETER'S, ROME: FROM THE STRADA DELLA MURA.—Drawn by Mr. FRED RICHARDS.
From "Rome" Artists' Sketch-book Series. By permission of Messrs. A. and C. Black.

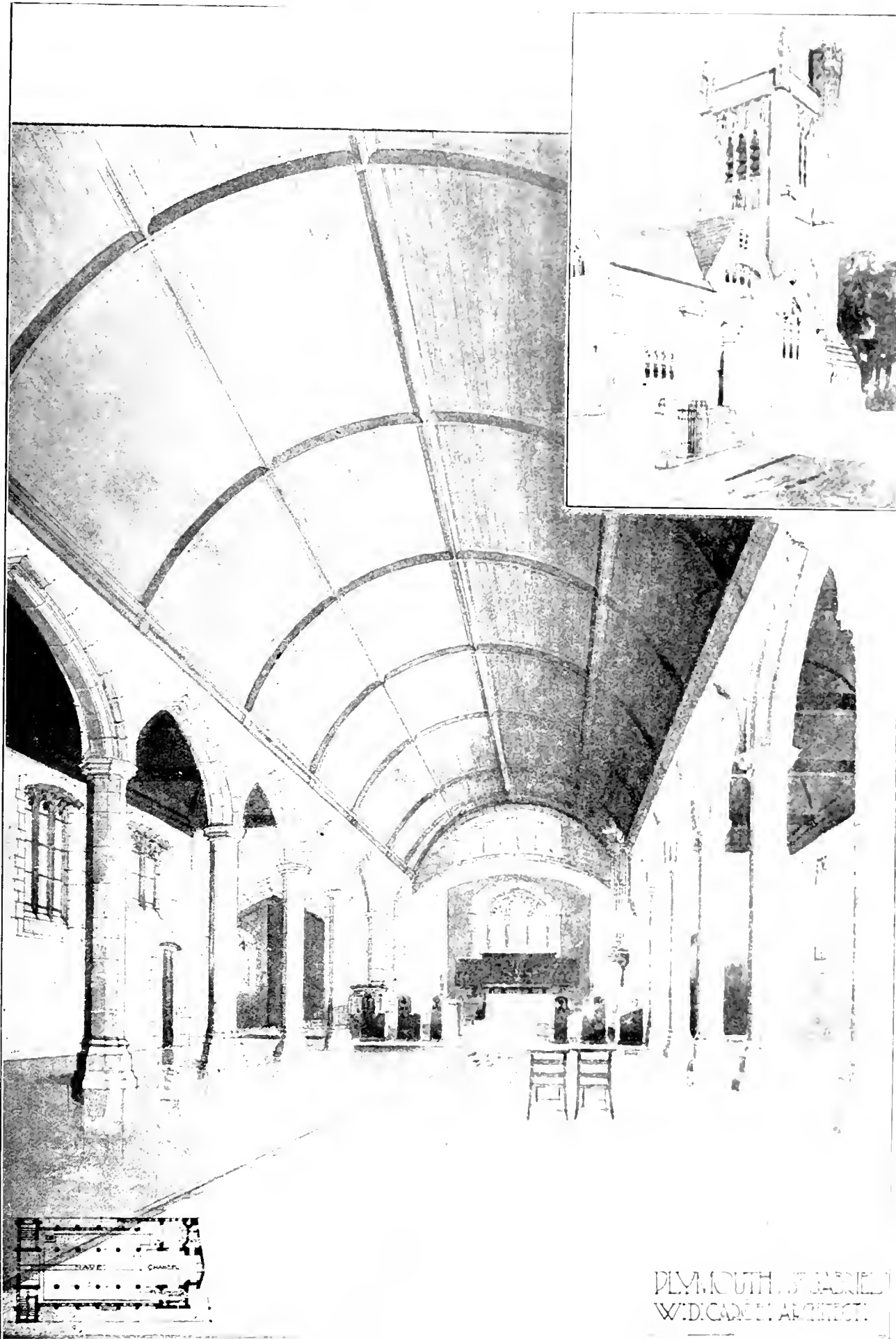

PLYMOUTH, ST. GABRIEL
W. D. CAROE, ARCHTCT.

CHURCH OF ST. GABRIEL, PLYMOUTH: INTERIOR LOOKING EAST.
Mr. W. D. Caroe, M.A., F.S.A., F.R.I.B.A., Architect.



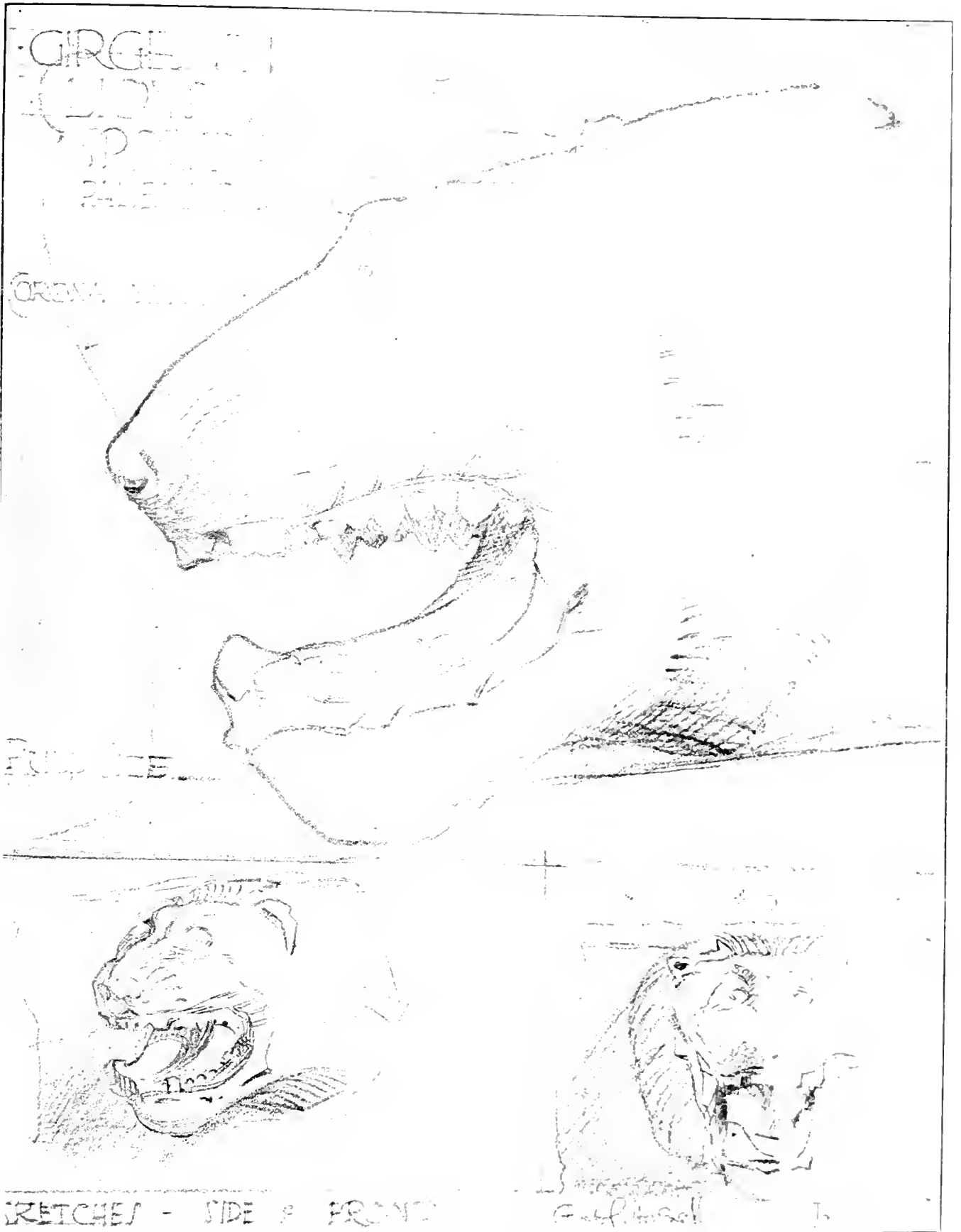

LION'S HEAD WATER SPOUT. FROM GIRGENTI, SICILY: SOME MEDALLION AND TRAVELLING STUDENTSHIP SKETCHES IN ITALY. By MR. A. G. H. ...





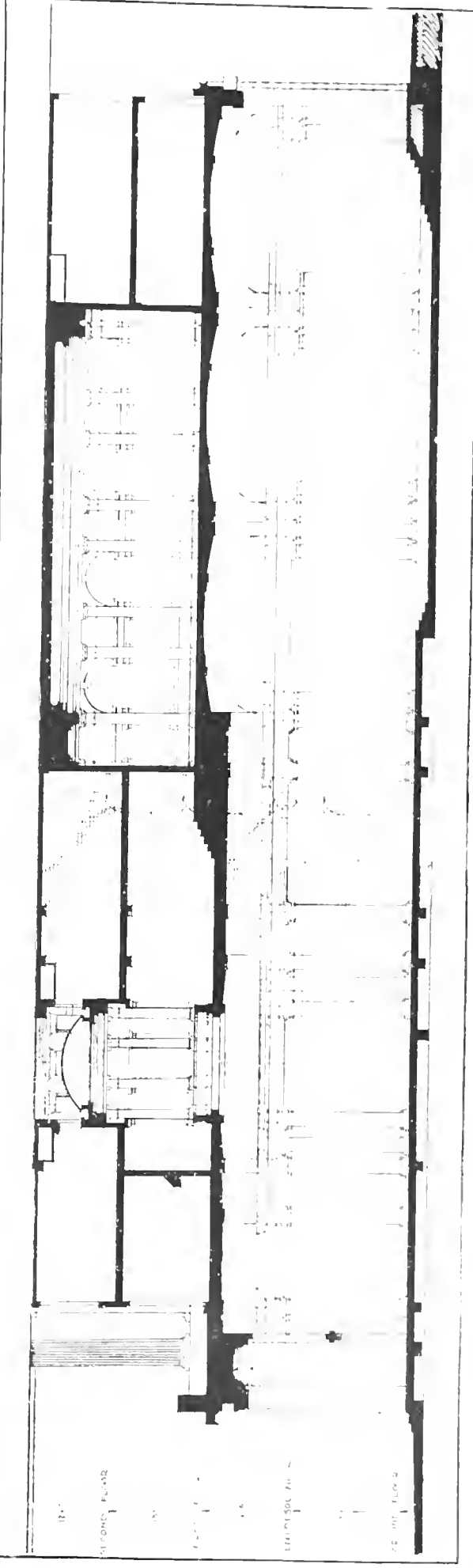

THE EXHIBITION HALL, AUSTRALIA HOUSE, STRAND, LONDON, W.C.; VIEW AND SECTION
 BY MR. A. MURRAY MURPHY, LL.D., A.R.S.A., F.R.I.B.A., and A. G. R. MACKENZIE, F.R.I.B.A., ARCHTDS.





THE BUILDING NEWS, OCTOBER 20, 1915.

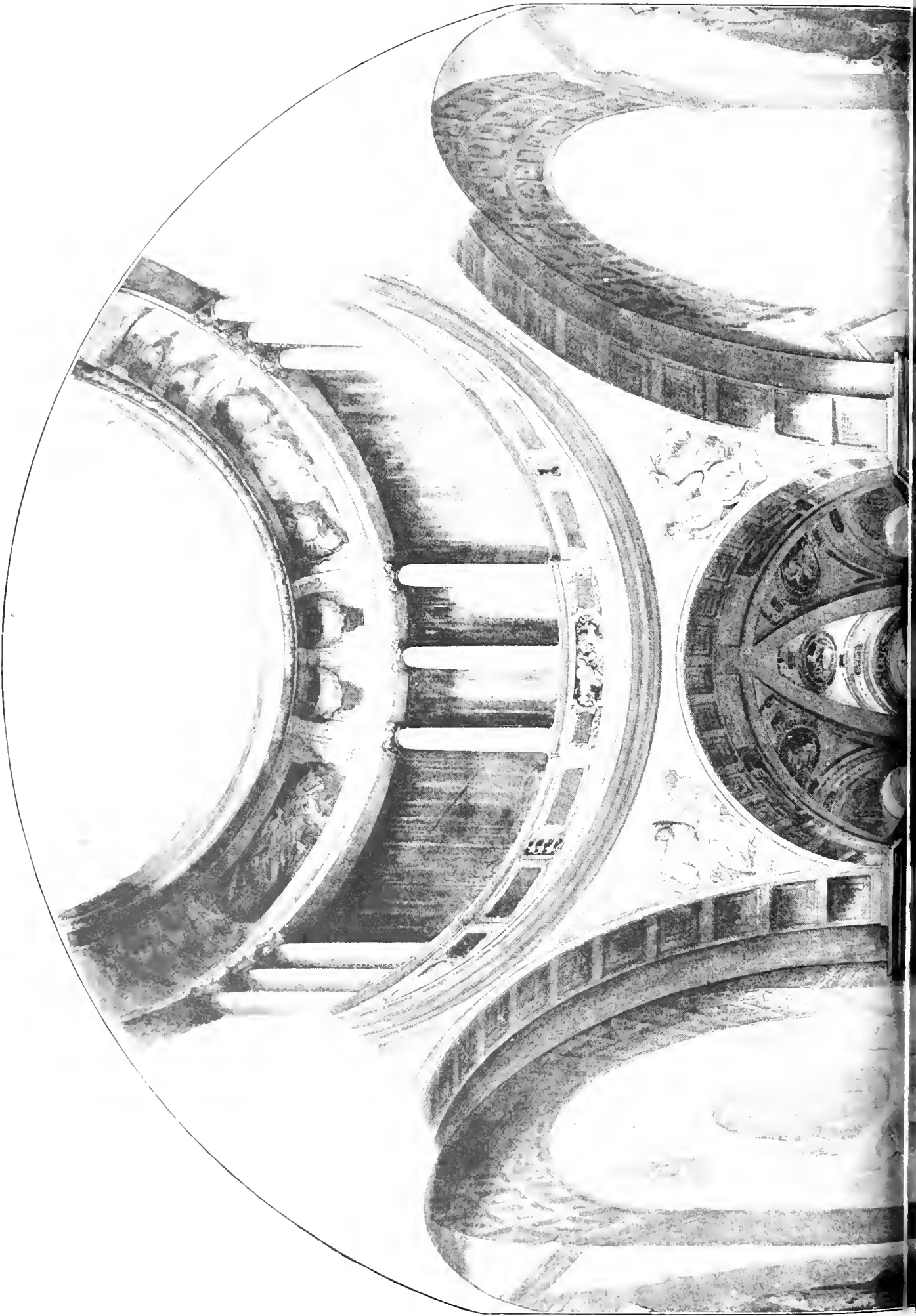

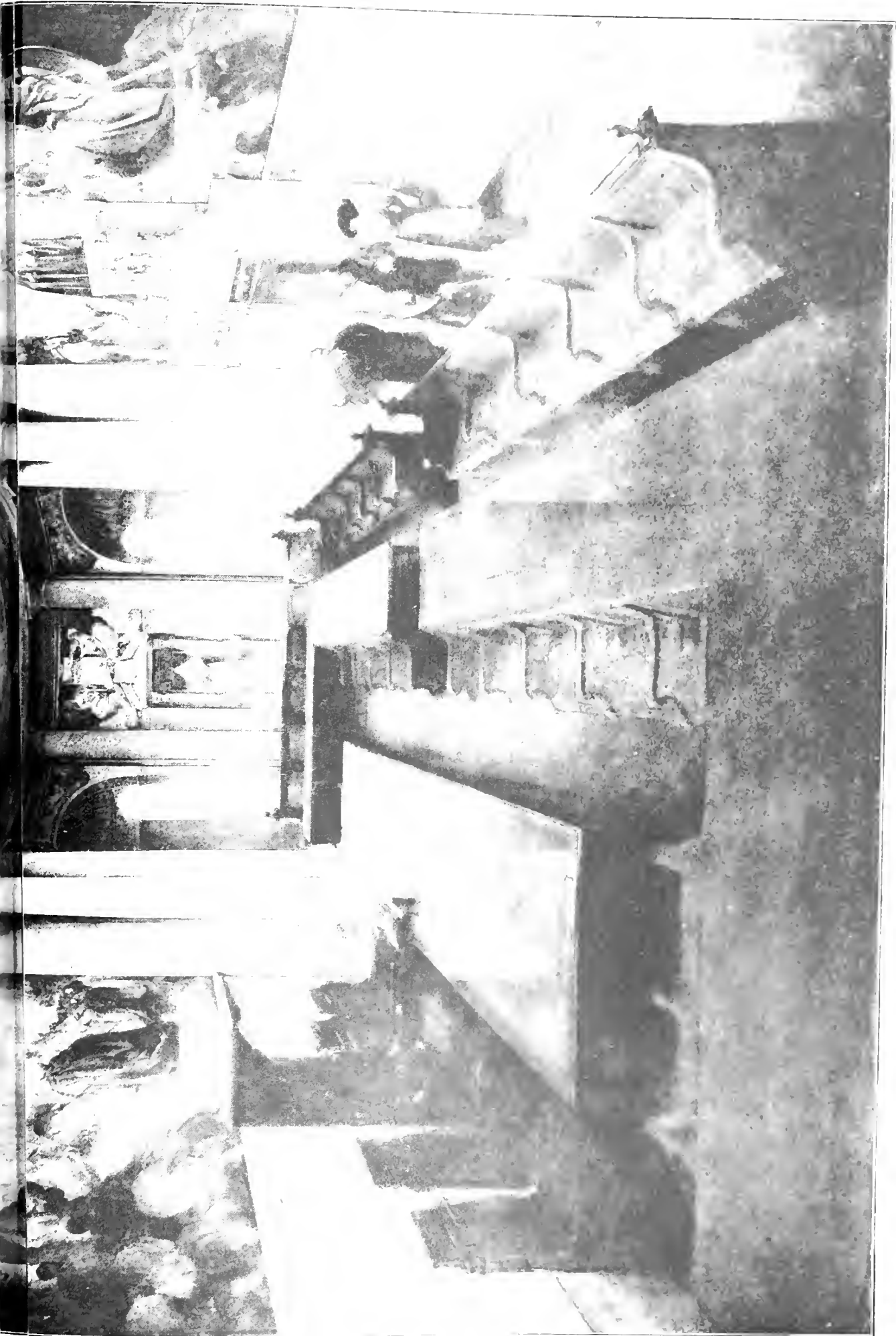

THE GREAT HALL OF CHARLES ACCORDING TO THE ARCHITECTURAL DRAWINGS OF THE ARCHITECT



PROFESSIONAL AND TRADE SOCIETIES

BRISTOL SOCIETY OF ARCHITECTS.—The opening meeting of the session 1915-1916 took place on October 11, when the president, Mr. Graham C. Awdry, F.R.I.B.A., held a conversazione at the Restaurant, 6, Royal Promenade, Clifton. In the mahogany room a collection of drawings submitted by members of the society in various architectural competitions was exhibited, and refreshments were served. An interesting and instructive address was delivered by the president, after which a programme was rendered in which the following took part:—Mr. C. G. Skinner, piano solos; Mr. Charles Bernard, piano solos; Mr. J. Foster Wood, F.R.I.B.A., readings; Mr. T. S. Davis, recitations; Mr. John Bevan, Lic.R.I.B.A., violin solos; Mr. H. J. Cavell, songs. A hearty vote of thanks to the president, proposed by Mr. W. S. Skinner, F.R.I.B.A., and seconded by Mr. T. H. Weston, F.R.I.B.A., was carried with acclamation. A most enjoyable evening was spent, and the proceedings terminated shortly after 9 p.m.

EARLY EARTHWORKS AT CHARLTON.—An examination of the scanty remains of a once extensive earthwork at Charlton has been made by the British Archaeological Association, by the courtesy of Sir Spencer Maryon-Wilson, Bart., the freeholder, and Mr. E. Gilbert, the lessee. A paper on the subject was read to the members on Thursday by Mr. F. C. Elliston Erwood, the director of the excavations, who pointed out that the remains constituted the only fragment of early earthwork in the County of London, and they were being gradually destroyed in order to obtain sand for casting and glass manufacture. The earthworks, which probably covered an area of 17½ acres, had now dwindled to about three acres, and had been reduced by at least one-half since Professor Flinders Petrie surveyed them in 1870. The remains indicated a quadrilateral enclosure surrounded by a double bank and ditch, crowning an eminence overlooking the Thames. The excavations revealed the existence of a settlement of Romano-British culture, the period of habitation ranging from the middle of the first to the middle of the second century. The objects found indicated a community dwelling in wattle and daub huts, engaged in agriculture, weaving, and perhaps metal-work. No evidence of military occupation was seen. Among the various finds were two coins of Claudius, two fibulae—one of second century type being enamelled in white and blue—loom weights, quern fragments, a supposed fire-bar, similar to but larger than those discovered in the Essex red hills, and a large quantity of pottery fragments of the first two centuries. These objects were on view, and also two complete vessels found on the site in the course of quarrying in 1906.

GLASGOW INSTITUTE OF ARCHITECTS.—The quarterly meeting of the Glasgow Institute of Architects was held on Wednesday last. Mr. John Watson, F.R.I.B.A., presided. The president explained the proceedings which had taken place in regard to regulations for contracts for building works in Scotland and stated that the proposed regulations issued by Sir G. R. Askwith would be considered at a conference to be held in Edinburgh to-day (Wednesday).

INTERESTING DISCOVERIES AT URICONIUM.—At the annual meeting of the Shropshire Archaeological Society at Shrewsbury, last Wednesday, an interesting report was given by Mr. Bushe-Fox, director of the excavation at the Roman city of Uriconium, Wroxeter, near Shrewsbury. Mr. Bushe-Fox said they had uncovered about two acres. There were the remains of many houses superimposed one upon another, the earlier ones of wattle and daub being similar to the half-timbered houses common in Shropshire in the present day. They dated back to between 75 and 120 A.D. One large dwelling-house had rooms heated with hot air, fine mosaic pavements in different colours, and hot, tepid, and cold bathrooms. One of the most striking points about this building was the

drainage system. From a large water main running down the street-side channels passed through the different houses, having mouths raised 7 in. or 8 in. above the level of the main. There were sluice-gates at intervals, so that when the water was raised in the main it flushed out the drains in the houses and carried everything away to the River Severn. The excavations already made proved almost conclusively that the town was abandoned about the year 595. They had not found any evidence that the end of the town was a massacre, nor that the town was burnt, as was generally supposed. Some of the objects found dated as early as 50 A.D. Among the many interesting objects found were hundreds of brooches, some beautifully made; a very fine clasp knife, carved bone; and two exquisite cameos.

MANCHESTER SOCIETY OF ARCHITECTS.—The Calendar of this incorporated society has just been published. It contains the annual report of the Council for the year 1914-15, which shows an aggregate membership of 271, viz., 113 Fellows, 111 Associates, and 42 Students, a decrease of one on the previous year. The syllabus is given of the School of Architecture in connection with the Victoria University of Manchester, which has as its director Professor A. C. Dickie, M.A., F.S.A., A.R.I.B.A.; on the Advisory Committee the society is represented by Mr. Pam Ogden, F.R.I.B.A., and Mr. F. B. Dunkerley, F.R.I.B.A. The opening meeting of the session of the society was held at Canada Chambers, 36, Spring Gardens, Manchester, on Wednesday evening. A collection of working drawings, lent by Messrs. J. Gibbons and Son, were exhibited, discussion being invited. The usual presidential address will not be delivered this year, the syllabus for the session being as follows:—November 10, Mr. J. B. Goss, F.R.I.B.A.; paper, "Athens and Some of the Isles of Greece." December 8, Mr. C. E. Elcock, F.R.I.B.A.; paper, "The Necessity for Proportion." January 12, Mr. James Brown; paper, "The Builders' Point of View." February 9, Mr. I. Budden, M.A., A.R.I.B.A.; paper, "Originality in Architecture." March 8, Mr. J. A. M. Hunter, Lic.R.I.B.A. The scheme of prize competitions for the session is left over for future consideration.

R.I.B.A. EXAMINATIONS: DISCONTINUANCE OF THE PRELIMINARY.—The Council of the Royal Institute give notice that the Preliminary Examination of candidates for Registration as Probationers will be held probably for the last time next month. The Regulations which will come into force after its discontinuance will be published as soon as possible.

R.I.B.A. PROBLEMS IN DESIGN.—The galleries of the R.I.B.A. not being available for exhibition in consequence of their being devoted to the work of the civic survey of Greater London, the Council of the Architectural Association has kindly offered accommodation for the bi-monthly exhibitions of the problems in design. The exhibitions will be held on the following dates at 13, Tufnell Street, Westminster:—November 5 to 15, 1915; January 10 to 15, 1916; March 6 to 11, 1916; May 3 to 13, 1916; July 10 to 15, 1916.

SANITARY INSPECTORS' MEETING IN NOTTINGHAM.—A meeting of the Derbyshire, Leicestershire and Nottinghamshire branch of the Sanitary Inspectors' Association has been held in the Guildhall, Nottingham. At the business meeting the war, both in relation to enlistment and sanitation, came in for careful consideration. The chairman, Mr. J. Tomlinson, Long Eaton, reported that 25 per cent. of the members of the Midland Centre had joined the colours. The necessity for a continued increase to his Majesty's forces, especially in regard to sanitary services, was fully appreciated, and although the members did not wish to appear unpatriotic, the feeling was evident that it would be economically and morally wrong to deplete the staffs of the local authorities to such an extent as to leave them unable to effectively carry out their duties. For the purpose of obtaining a clearer understanding as to the position of

the sanitary inspectors, it was resolved that the General Council of the association should make an appeal to the Local Government Board for a statement on the matter. After the meeting Chairman A. B. Gibbons, chairman of the Nottingham Corporation Housing Committee, gave a lantern lecture on housing, showing some of the slums, among others, the properties of which he had visited in the afternoon.

SCOTTISH ECCLIOLOGICAL SOCIETY.—On Saturday afternoon the Scottish Ecclesiological Society inaugurated the proceedings of the year by visiting two churches in the neighbourhood of Edinburgh. At Midrhill the party was received by the Rev. John MacBeth, B.D., minister of Newton, and conducted through to the Old Kirk of Newton. Mr. MacBeth gave an interesting account of this building, of which only the tower now remains. It was founded in the twelfth century in a spot where it should be out of sight of human habitation. After the Reformation it ceased to be a parish church, was deserted in 1563, and was authentically recorded to have so. By 1595 it was in a ruinous condition, and though afterwards repaired, it ceased to be the place of worship for the parish in 1742, when a new church was built. The old churchyard has been neglected upon, but a number of tombstones remain near the graves. A cordial vote of thanks to Mr. MacBeth was accorded, on the motion of Lord Guthrie. By permission of the Duke of Buccleuch, the society enjoyed a walk through the grounds of Dalkeith Palace. The trees were in full autumn beauty, and the fine views of the Esk and of the remains of the Caledonian Forest were greatly admired. The party was then met by the Rev. W. A. Dunnett, B.D., minister of Dalkeith, and conducted to the church, inspected the ruined chancel, and listened to a descriptive and historical account by Mr. Thomas Ross, LL.D. On the motion of Sir James B. Muir Paul, M.V.O., Dr. Ross was thanked for his services.

ST. PAUL'S ECCLIOLOGICAL SOCIETY.—The following meetings of this society will be held during the autumn at the Chapter House, St. Paul's, E.C.4., on Wednesdays at 8 p.m.:—October 20, "Monasticism in the Greek and Russian Churches," by the Rev. N. E. Robinson, S.S.J.E.; November 7, "The Oxford Movement and Its English Churches," by Clifton Kelly, F.R.H.S.; November 17, "Anchorite Cells," by Arthur D. Sharp; December 1, "Some Churches of North West Kent," by E. Rogers, F.R.S.; December 15, "Gare," by the Rev. R. W. Hayward, M.A.

THE NATURE OF THE ART OF PAINTING.—A lecture under this title was held on Friday evening by Mr. A. C. Brown before a large audience in the Metropolitan Art Gallery, Mr. Laurence Hayward presiding. The lecturer did not discuss the technical side of painting, but took painting as a means of illustrating the visual arts, and went on to give a definition of the great, the good, and the beautiful, his work, and to the help of Mr. Brown showed that, while the beauty of a picture must be represented to the eye, it is not the object of representation in itself, but that it was not great only by reason of the fact that it reproduced to the artist's mind what he recalled or memory of beautiful things. The work of the great artist was the result of his own contact with his own inner experience. Thus the beauty of the picture is much deeper than any imitation of nature could be, and was not the result of a casual memory of things seen. In painting things more precious than gold, and more closely connected with character and life, than what the artist represents. It is not anything which we had ourselves seen, and so, in looking at pictures, it is not to be clear our mind of previous scenes. It is a habit of constant, for instance, of painting a landscape to end a picture, and to find of what he had learned from other artists. The lecturer cited examples, as from Raphael, Michelangelo, and Rembrandt, to illustrate his thesis that behind mere representation there lay the idea inherent in the painter, dif-

personality, reflective of him self, and necessarily attractive to others, will make his work great.

THE SOCIETY OF ARCHITECTS. A special general meeting of the Society of Architects was held at 23, Bedford Square, on Thursday evening last. The President, Mr. E. C. P. Mounson, F.R.I.B.A., F.S.I., occupied the chair. The committee's report on the election of officers and council for the session 1915-16 was presented, showing the following result of the poll: President, E. C. P. Mounson, F.R.I.B.A., F.S.I., London; Vice-Presidents, Edward J. Salgrave, F.R.I.B.A., London, and A. A. Bay, H. Scott, M.R.S. Inst., London; Past Presidents, Albert E. Padmore, F.S.I., London, and Percy P. Tubb, F.R.I.B.A., London; Hon. Secretary, Edward J. Padmore, F.S.I., Richmond; Hon. Treasurer, Herbert Pearson, London; Hon. Librarian, Gilbert A. Harrison, Oxford; Members of Council, eighteen, twenty-one, and twenty-two. Honorary members: Henry Adams, M. Inst. C.E., F.S.I., London; George Baines, F.R.I.B.A., London; P. M. Beaumont, A.M. Inst. C.E., M.C.S., J. A. Bowden, London; B. D. Canham, Winchester; Edward Chatney, Newcastle-on-Tyne; George E. Dickens-Lewis, Abingdon; Hubert O. Ellis, London; G. Blain Irvine, London; T. Stewart Inglis, London; Col. F. Seymour Leslie, R.E. (retired), Weymouth; F. C. Moscrop Young, London; George H. Paine, London; Charles E. Salmon, Registrar, N. and D. Sheffield, London; Alfred J. Taylor, Bath; B. R. Tucker, M.R.S. Inst., London; and Thomas Wallace, London. An asterisk (*) signifies re-elected; a dagger † change of office. No observations being offered on the report, it was resolved that it be adopted and entered on the minutes. Votes of thanks were passed to the retiring members of the Council and to the Secretary and staff for their services. Five names of new members were announced.

THE SURVEYORS' INSTITUTION.—Owing to the effect of the war upon the number and standard of excellence of the competitors, the Council have decided not to offer the Institution Scholarships during the coming year, and the usual examination in January will, therefore, not be held. The following papers will, provisionally, be read at the ordinary general meetings held at the Institution on Mondays, at 8 p.m., during the first part of the session:—

- Nov. 8, 1915. . . . The President's Address.
- Nov. 22, 1915. . . . Case Law under the Finance Acts, by E. M. Konstant, Barrister-at-Law.
- Dec. 12, 1915. . . . English Timber Industries and the War, by M. C. Duchesne, Fellow.
- Jan. 12, 1916. . . . The New Statutory Office, by Mr. R. M. Kearns, Fellow.
- Jan. 24, 1916. . . . Practice in Assessing Disputations, by Mr. C. F. Slater, Fellow.
- Feb. 7, 1916. . . . Accepted Principles of Town Planning, by Mr. W. R. Davidge, Fellow.

The Local Government Board has, with the consent of the Treasury, sanctioned the borrowing by the Hull Corporation of £47,252 for war-works purposes.

On account of the difficulty in obtaining money from the Public Works Loan Board, Clydebank Town Council have decided to relinquish their municipal scheme of workmen's dwelling houses.

The new phthisis pavilion at the Iford Hospital, Heston, Chesham Heath, has been completed. The plans were prepared by Mr. H. S. Law, surveyor to the Urban District Council of Iford. The cost is estimated at £2,600.

The Clyde Navigation Trustees have agreed to provide the plan for the extension of the Glasgow Harbour, and now Glasgow, by the purchase of the adjoining farm land on the east bank of Renfrew Road, and laying off 100 acres of building sites, estimated at £250,000.

Arrangements have been made for the erection of a mission church on a site in Darby Road, Lambeth, Birmingham, to take the place of the St. John's Church, Tar Bank, which was destroyed recently in consequence of the bombing of the large works in the vicinity. The proposed construction as a place of worship is estimated at £120,000. Plans have been prepared for the erection of a building so arranged that it will serve as a temporary hall, and when the permanent church is completed be converted into a parish room. The estimated cost is estimated at £130,000.

Building Intelligence.

BRISTOL. — The reconstructed cattle market was opened on Thursday by the Lord Mayor of Bristol (Alderman Swaish). The reconstruction has been rendered necessary by the purchase by the Great Western Railway Company of two fifths of the site of the market for the purpose of extending their accommodation at Temple Meads Station. The work has been carried out from plans prepared in the City Valuer's office, and under the superintendence of Mr. Peter Addie and the members of his staff. The area purchased by the railway company is being walled off, and the remainder has been laid out as a sale ring, with the result that there is now covered accommodation than formerly. A new tavern and banking premises have been built, and also a covered sale ring and covered penning for cattle. At the sale ring a crescent shaped gallery provides accommodation for buyers or spectators, while in the front part of the building suites of offices for auctioneers have been arranged. A new covered penning for sheep is being built just inside the boundary wall of the railway company. The floors of the market are of concrete with roughened surface. The whole of the new buildings are of Cattybrook brick with Brossley tiles, and the contractors are Messrs. Walkerline, Limited, of Bristol and Ferby. The covered cattle penning is the work of Messrs. Garliner, Sons, and Co., Limited, of Nelson Street, Bristol; and Messrs. Stock and Collings, of the Albert Iron Works, St. Philip's, supplied and erected the cattle pens, sale ring, ornamental entrance gates, and stable fittings.

COMPETITIONS.

SACRAMENTO, CALIFORNIA. — The competitive plans for the Carnegie Public Library, to be built in Sacramento, Cal., were sent in on Monday in last week, the 11th inst. The City Commissioners appointed as the assessor their inspector of buildings, Mr. W. B. Rohl.

Mr. Albert D. Jenkins, the city land steward and surveyor, of Liverpool, has returned to duty after a prolonged illness.

The new Wesleyan day schools in Ribbleston Avenue, Preston, Lancs, built at a cost of over £4000, have been formally opened. Mr. F. Howarth was the architect.

The names of Mr. William Davidson, architect of Ellon, and of Mr. James Burnett, builder, of Drumoak, have been added to the Commission of the Peace for Aberdeenshire.

In connection with the northern relief sewer for Acton, W., an amended scheme, prepared by Mr. Binnie, has been referred to the Sewerage and Drainage Committee of the Urban District Council for their consideration. The cost is estimated at £40,000.

The foundation-stone of the new Church of the Blessed Sacrament, Copenhagen Street, Caledonian Road, N., will be laid by Cardinal Bourne on Saturday, October 30, at 3 p.m. A parish hall is in course of erection, and will be under the church. The church is to be ready for opening in the early part of next year.

Mr. W. J. Corker, clerk to the Omagh Town Council, has been granted a closing order in respect of houses in Castle Lane, which the medical officer of health, Mr. J. J. Todd, stated were damp, were without windows, and the sewage ran in open pipes at the doors, whilst the area all round the houses was a mass of filth and dirt.

The Cambridge University Press are issuing, as a commemorative work to his recent "Romanesque and Byzantine Architecture," Sir Thomas Jackson's "Gothic Architecture in France, England, and Italy." Many buildings that have suffered during the war, such as the Cathedral of Rheims, fall to be described and illustrated in his two volumes.

Mr. A. W. Brightmore has held a Local Government Board inquiry at Pembroke Dock with respect to an application of the town council for authority to borrow £1,742 for water-supply purposes, including the construction of new works in the parish of Carew. Particulars of the proposed works were given by the town clerk and the borough surveyor.

Trade News.

WAGES MOVEMENTS.

BIRMINGHAM. — Negotiations that have been proceeding between the master builders of Birmingham and the Amalgamated Society of Carpenters and Joiners have resulted in the employers agreeing to pay one halfpenny per hour as a war bonus to the operatives in Birmingham and district who are not receiving such a bonus or its equivalent. This will mean a weekly advance in wages of from 2s. to 2s. 6d., and by the concession, which comes into operation on October 24, from 7,000 to 8,000 men (bricklayers, carpenters, plasterers, masons, labourers, and navvies) will be affected. The arrangement will remain in force until three months after the war. Councillor Saunders, the secretary of the society, suggests that the workers should still press for the payment of a bonus of a penny per hour, and for the deletion of the clause "to terminate three months after the war." As we announced in our last issue, the employers have granted a similar bonus of 3d. per hour to the builders' labourers in the city.

CONTINUED DECREASE OF UNEMPLOYMENT.—In the trades compulsorily insured against unemployment—viz., building, works of construction, engineering, shipbuilding, vehicle-making, etc.—the percentage of unemployment at October 1 was 0.91, as compared with 5.11 a year ago and 3.45 two years ago. These figures relate to the whole of the United Kingdom, and include all unemployed workmen in the insured trades.

WAGES IN WAR TIME.—The Board of Trade Labour Gazette publishes an article on the advance in wages during the war. This states that the advance which began in 1910 and reached its culminating point in the first half of 1915 was followed by a decline in wages in the metal and mining industries and by a slackening in the advances in other industries. In the first seven months of 1914 the net effect of all the changes recorded was a decrease in wages of nearly £15,000 a week. After the outbreak of the war, however, owing to enlistments and an active demand for war requirements, employment became very good, and before the end of the year a considerable amount of overtime was being worked, and in several trades complaint was being made of a shortage of labour. Concurrently the prices of food and many other necessities rose. In these circumstances a movement began at the beginning of 1915 to raise wages. This movement, which in most cases took the form of bonuses, or of increases in rates of wages limited to the duration of the war, first became evident in the trades most directly concerned with the output of munitions and the transport of troops and supplies. From March onwards, however, it spread to nearly all the principal industries, and its effects have been far greater than those of any other upward movement in wages previously recorded. It is estimated that during the whole period under review about four and a-half million workpeople have had their rates of wages increased by over £750,000 per week. In the organised trades in which the numbers affected are ascertained by the department from the parties concerned in arranging the changes there have been increases reported amounting to £494,000 per week in the rates of wages of over 2,800,000 workpeople, an average of about 3s. 6d. per head.

TRADE NOTES.

Boyle's latest patent "Air-pump" ventilators have been applied to Allerton Wesleyan Chapel, Bradford, Yorks.

The Wholesale Co-operative Society's architect (Newcastle) reports that the water tower connected with the new West Hartlepool Co-operative buildings has been made watertight by using Pullock cement.

The Triforce College, Talgarth, which has been restored at a cost of £2,000, has been formally opened. Mr. Griffiths was the architect.

In consequence of the war, and of the need for economy in every direction, the construction of the new offices of the India Government in Karachi has been indefinitely postponed.

A new Church of the Covenant is to be built at the corner of Broadway and East 27th Street, Paterson, New York, at an estimated outlay of \$125,000. The architects are Messrs. Lee and Hewitt, of 1,123, Broadway, New York.

Our Office Table.

The Committee for La Maison de Dieu, 45, Salisbury Square, E.C.4., of which Mr. Douglas Pepler is one of the hon. secretaries, has started a fund to present wooden churches to Cardinal Mercier to take the place of the churches which have been destroyed in Belgium, and which cannot be rebuilt for a long time to come. It is proposed that these structures should be made by the Belgian refugees, and started either in Holland or France. They would be made in sections, bolted together, and used by the refugees in their temporary homes until the time came for them to return to their own country, when they could be re-erected on a concrete platform, and would last as long as they were wanted. Donations may be sent to M. M. de Wachter, Bishop's House, St. George's Road, Southwark, S.E.

Facilities for the study of designing in steel-work and reinforced concrete are provided on Thursday evenings at the L.C.C. School of Building. The advances made in structural engineering and the L.C.C. new regulations for reinforced concrete have created a growing demand for young engineers and architects with practical training in the theory and design of structures. The class is conducted by Mr. R. Graham Keevill, A.M.I.M.E., M.C.I., and affords opportunities to those desirous of instruction on practical lines.

According to the annual report of William Williams, Commissioner of the Department of Water Supply, Gas, and Electricity of the City of New York, for 1914, the Street Lighting Bill for 1915 will be \$400,000 less than for 1914. A goodly portion of the saving is said to have been effected by the use of nitrogen-filled tungsten lamps in place of the arc lamps. The former are being rapidly introduced all over the city. In fact, before the end of the year it is expected that 15,000 gas lamps will be replaced by the electric incandescent lamps. An interesting comparison between the relative cost of operating nitrogen-filled tungsten lamps and arc lamps is presented in the following figures: 300-watt nitrogen-filled tungsten lamps cost \$70.00 each a year to operate, while the 400-watt lamps cost \$77.00. The cost of operating arc lamps was \$85.00 each; reduction of \$5.00 having been effected in the course of the current year.

The City Council of Coventry met specially on Thursday to deal with the scheme, worked out by the Housing Committee, the Ministry of Munitions, and the Local Government Board, for the erection of 600 huts for munition workers on land near toke Heath, just outside the borough limits. The site of fifty acres will be purchased at £200 an acre. The cost is estimated at from £150,000 to £200,000, and the Ministry of Munitions will pay the corporation about 20 per cent. on what such a scheme would have cost at pre-war prices. Mr. Poole, chairman of the Council Housing Committee, said it might have been thought that the fact of so many men having gone forth as soldiers would have reduced the need for more houses, but that had not proved the case, and the trouble was greater now than at any other period. The houses to be erected were to be, in the first instance, for munition workers, and held by the corporation in the usual way; but the committee recognized that there must be quicker methods of erection than ordinarily prevailed, and that the corporation must have financial assistance from the Government. He urged the council that the scheme was to be by any means the last word in local house-building; but 600 permanent dwellings must be provided at once. The committee erected an alternative of temporary accommodation, on the ground of ultimate waste of their confidence that Coventry was going to be, in the future, a much more important armament centre that it had been hitherto. Mr. Grant said he thought the Government allowance should be on the basis of 33½ per cent. on pre-war prices, as at Dudley. Alderman Batchelor contended that provision should be made also for the 2,000 or 3,000 women about to come to

Coventry for armament work. The city council adopted the committee's recommendation. It is expected that the contractors will be at work in the course of a fortnight.

The Town Council of Dudley sitting in committee have formulated a report on an important scheme for providing artisans' dwellings at a total estimated expenditure of £100,000. The report states that the council had considered correspondence from the Local Government Board inviting the council to build at once 300 houses in the borough, subject to a grant-in-aid from an important Government Department representing a material part of the additional cost of building at the present time. They sent a deputation to confer with officials of the Board on the subject, with the result that a final offer of a free grant of 25 per cent. of the cost of the buildings and 10 per cent. of the cost of the necessary roads and sewers had been made to the council. The committee had accepted this offer, subject to the council's approval. The committee recommended that a housing scheme be prepared forthwith, with the assistance of the officials of the Local Government Board; that application be made to the Local Government Board for sanction to borrow the proportion of the cost of the scheme, including the land, to be borne by the council, and that application be made to the Public Works Loan Commissioners for a loan of the proportion of the cost of the scheme, including the land, to be borne by the council. It is proposed that the whole council in committee act as a Housing Committee for the purposes of the proposed scheme.

The Borough Engineer of Kensington has, says a writer in the *Engineer*, prepared a scheme to repair roads economically. Much road improvement is necessary, but municipalities will not be able now to secure loans for costly repaving schemes. The borough engineer some time ago experimented with a concrete carpet over the macadamised roads, and was delighted to find that it served its purpose admirably. The carpet not only spread the weight of the heavy modern motor-vehicle fairly evenly over the foundation of the road, but also did much to absorb shock. Now this process is to be adapted to certain wooden roads which are in bad condition. He proposes to deal with an experimental length of roadway by removing the wood and converting the foundations into a concrete road. The existing foundation will remain, but will be reinforced by a layer of bituminous concrete, over which a wearing surface carpet of concrete will be placed. It is computed that such a reinforced road will last as long as a completely new road, but the cost will be only one-third of a new road.

It is announced in a supplement to the *London Gazette* that the King has been graciously pleased to confer the Military Cross on Lieut. William Harold Hillyer, a student of the Royal Institute of British Architects and a member since 1901 of the Architectural Association, 3rd London Field Coy., R.E., T.F. (att'd. 171st Mining Coy.). "For conspicuous gallantry and devotion to duty in mining operations at 'Hill 60' near Ypres, between 2nd and 17th April, 1915. The task of completing and charging one of our mines was one of great difficulty and strain. Lieut. Hillyer worked and watched long hours at the end of a gallery 165 ft. long and 3 ft. by 2 ft. 3 in. in size, knowing that the enemy was countermining close by. His pluck and endurance were remarkable, and resulted in the successful explosion of the mine and consequent capture of 'the hill.'" Lieut. Hillyer, who was wounded at Festubert on May 12, was mentioned in Sir John French's dispatch of May 31 for gallant and distinguished service in the field, and has since been promoted Captain.

A Civic Arts Association has been formed, having for its first business the offering of prizes for suitable designs for the permanent memorials to be erected to those who fall in action. An exhibition will be organised of such designs. Committees will be appointed

to advise these committees to put a list of names and to bring them to the Council with suitable chairmen. The Association is taking the following scheme for consideration, in conjunction with our Alliance gift scheme in 1915, in the form of work by British citizens, and for presentation to the various authorities in the named districts. Support is invited which may take the form of contributions towards the general fund, or possibly of particular objects of the Association, or of an annual subscription of 5s. Among the names who have already promised their support are: Sir Edward Punter, P.R.A., K.C.V.O.; Sir Aston Webb, K.C.V.O., C.B., R.A.; Sir Wm. Goscombe John, R.A.; Frank Dicksee, R.A.; Sir F. Knigton, K.C.R.; Genl. G. N. Plunkett, Prof. Sir W. R. Letchford, Halsey Ricardo, Lord Henry Cavendish, B. L. Finck, M.P., Viscount Colclough, Sir G. F. Laking, Bart., and other influential people. All communications should be addressed to the Secretary, care of The Hon. Roche Keble Shuttleworth, 23, Prince's Gardens, S.W., and cheques should be made payable to the Hon. Treasurer of the Civic Arts Association.

Arithmetic for Carpenters and Builders by Professor R. Burdett Hale, London, Chapman and Hall, Limited, 5s. 6d. net, is practical; and those benefited will find they have learnt a good deal more than at times they have assimilated it, probably without knowing it.

"Practical Shop Mechanics and Mathematics," by Professor James F. Johnson (London, Chapman and Hall, Limited, 3s. 6d. net), are evidently based on actual shop practice, coupled with experience in technical and trade school teaching.

It is announced that no further consideration as to the site for the London University is to be given during the war.

By the demolition of old property at Carlisle in the neighbourhood of the Castle, some 27 ft. of the old city wall has been uncovered.

Professor Sidney Barwise has been elected President of the Association of Managers of Sewage Disposal Works for the year 1915.

New police buildings in Prescott Street, Liverpool, were formally opened on Monday. The building was designed by the municipal architects, and the contract was carried out by Messrs. Rimmer Brothers, builders, of Liverpool.

After spending £13,000 on their sewerage scheme, the urban district Council of Ystradgynlais have decided to stop the work until after the war. This step has been taken on the recommendation of the Local Government Board.

The rural district council of Abbeyleix have appointed Mr. M. Kelly as engineer for the carrying out of the eleven-year under the Irish Labourers Acts for the erection of cottages in the towns of Ballinakill, Derrin, and Rathdowney.

Mr. J. Brierley, divisional surveyor under the Sheffield city surveyor, who temporarily left the corporation service in June last to join the Army, has just been promoted to the rank of lieutenant in the engineering unit of the Royal Naval Division.

At Gull Bay, on the island of Tiree, in the Hebrides, a ferro concrete breakwater for the use of steamers has just been completed. It is solid for 571 ft. in length, and sheltered by a parapet wall, and beyond this an open water duct 250 ft. in length and 12 ft. in width extends into the sea. Mr. G. Wolfe Burnett was the engineer, and Messrs. Kerr, Moodie and Co., of Glasgow, were the contractors.

The tender of the firm of Messrs. Mackenzie Davison and Co. for the building of the new Municipal Offices in Karachi has been accepted by the managing committee of the corporation's acceptance. The cost of the building is nearly Rs. 20,000, but as against the original allotment of five lakhs, the sum has recently increased and now still further increased by Rs. 1,22,000 on account of the increased cost of building materials. The contract stipulates for the completion of the building within two years hence. We illustrate the original designs for the offices, by Mr. J. Cumming Wynnes, F.R.I.B.A., of Edinburgh, as selected in competition in our issue of January 15, 1911, and the materially altered revised edition by the same architect in our number for April 16 of this year.

CHIPS.

Sanitary District Council have sanctioned the plan of Mr. John Hawken, of St. Mary's, for a new church.

Mr. T. E. Owen, surveyor to the Conway Rural District Council, has been appointed surveyor to the Urban District Council of Llanidloes, Wales.

Plans submitted to the Ledbury Rural District Council at the last meeting that the sewerage scheme for the village of Colwall had been approved at a total cost of £2,620.

A valuation of £70 avens that while members of the Education Department staff have been dismissed the War Office staff have been engaging outsiders for valuation purposes.

The foundation stone of a new church at St. Andrew, Snelfold, has been formally laid. The cost will be £3,547. Mr. J. D. Webster, of Westbourne Road, Sheffield, is the architect.

The Methodist and P. Swick parish church at St. Andrew, Snelfold, has been formally opened. The church has been designed and carried out by the surveyor of Mr. A. Stevenson, of St. Andrew, Snelfold.

Mr. Charles Murrell, of Albon Road, Worcester, has been appointed contractor for the new school at St. Andrew and Lambich, who did on September 15, 1915, at £13,571 with net personalty of £2,500.

Mr. C. Temple, recently district engineer at Madhavpur, has been definitely appointed as sanitary engineer to the Government of Bihar and Orissa, in place of Mr. B. B. B. who has resigned his appointment.

The Worcester District Council has appointed Mr. A. P. S. of St. Helen's, as sanitary inspector and inspector of buildings. Mr. Smit was in the office of the surveyor to the Egham Council. Mr. W. Menzies, some years ago as a health officer's assistant.

A lifeboat station and concrete slipway are about to be built in the North Harbour, Fraserburgh, N.B., for the National Lifeboat Institution, from plans by the engineers to the institution, Messrs. Douglass, Lewis, and Douglass, of Victoria Street, S.W.

The new Worcester Council school in Stanley Road was recently opened by the Mayor of Worcester. The school has three departments, and the accommodation of the city up to 1,355. It was built from the designs and under the general guidance of Mr. G. Parker, the architect.

A series of designs for the famous French artist, Paul Gauguin, has been presented by the French Ministry of Fine Arts to Mr. Frank P. of the A.R.A. The designs were made by the artist in connection with the presentation to the French Government by Mr. Brangwyn of a complete set of designs.

The National Geographic Society of Washington, D.C., in making a survey of commercial geography of the various cities and towns of the United States, is including a comprehensive inquiry into the building trade in the country. The Builders' Exchanges of the country have been asked for information regarding the building industry in their localities.

The report of the Deputy Keeper of the Public Records in England, published on Monday, states that a large collection of original documents relating to Lord Ormonde had been deposited for the purpose of being calendared. They begin with the Anglo-Norman conquest and are of great historical value to the student of topography and family history.

A very fine collection of the York Minster cross has been completed. Mr. W. William H. of the Kalendar, Chester, taken from the remains found at Milbourn, near Bournemouth, and from a church within a few miles of the village of Candall. By a comparison the two remains have been proved to be parts of the one original shaft of a fine Anglo-Norman cross. The cross is being viewed as memorial of the late Mr. A. S. Lawson, and is being set up at Ruffly, near Bournemouth. On the east side are two subjects, one of King David playing before King Saul, and the other Samson carrying away the gates of Gaza. The other panels are filled with scenes of the life of Christ, and the uppermost panel, which is the most decorative, shows conventional foliage decorated with animal subjects, with a landscape in the foreground panel. The lower panels show a natural foliage and animals.

Messrs. Ramsden and Co. are about to rebuild Warth Mills, Duggle, Saddleworth, from plans by Mr. F. Thorpe, of Oldham.

The Madras Government have sanctioned £15,007 for constructing a pier at Tellicherry and also a wall for preventing the erosion of the beach by the sea.

The corporation of Chesterfield have received the sanction of the Local Government Board and the Treasury to a loan of £5,000 for providing electricity plant.

The local district council of Shrewsbury have resolved to prepare a town planning scheme for the district of Old Heath, abutting on the borough of Shrewsbury.

Operations on the new sewerage scheme for Lynton have been completed. Messrs. Ripley, Holt, and Co. were the engineers, and Mr. H. Preston was the contractor.

The highways and sewers committee of the urban district council of Goolle recommend that application be made to the Local Government Board for a further loan of £4,000 for works of sewerage.

The new home of St. Hugh's, Oxford, which was to have been occupied at the opening of Term, is not ready. The students will lodge awhile in Wyche Hall, which has for some time stood empty.

Mr. Joseph Ash, of Leamington and Birmingham, zinc manufacturer and galvanised iron roofing and tank manufacturer, director of the Birmingham Wagon Co., Smethwick, who died on August 1, left estate valued at £165,505.

Lieutenant Richard Newman Somerville, R.E., who was killed in France on the 9th inst., was the eldest son of Mr. R. M. Somerville, of Osborne Park, Belfast, for many years county surveyor of Cavan. He was educated at the Royal School, Cavan and graduated in arts and engineering at Trinity College, Dublin.

A conference of the urban district councils of Walton, Esher and the Dittons, and East Molesey has decided adversely to the suggestion of the Surrey County Council for the formation of a board of control over the river Mole. An alternative scheme for improving the course of the river and minimising flooding has been drawn up by the surveyors to the three councils, the estimated cost being about £5,000.

The Glasgow Corporation considered on Thursday the position relating to the increased house rents in the city. Proposals were made to petition Parliament and to hold a local inquiry, but by an absolute majority the Corporation agreed to forward to the Commissioner appointed by Mr. Lloyd George the whole representations and resolutions received by the corporation for his information.

Mr. Edward Leonard has held an inquiry on behalf of the Local Government Board into the application of the Carlisle City Council to borrow £9,532 for the purchase of land and the erection of workmen's dwellings. The town clerk, Mr. Collingwood, stated that there were no empty cottages in the district, and that a big influx of workers was anticipated in the near future. Dr. Beard, medical officer of health, and Mr. Marks, city surveyor, also gave evidence as to overcrowding, the latter stating that the proposed houses would probably be erected by direct labour.

The members of the Church Committee of Holbrook, East Suffolk, are contemplating making certain necessary improvements and alterations in the fabric of the church, and have requested Mr. E. Fearnley Bishop, architect, of Ipswich, to report upon the matter. He acknowledges that Holbrook Church at one time must have been really beautiful, but through long years of neglect it has gone down, and some of the modern work is very poor. A large sum must be spent upon the roof, which is in a bad condition. Mr. Bishop's report was considered, and eventually it was agreed to take up the matter again at the next monthly vestry meeting.

Colonel Porter, chairman of the Liverpool water committee, briefly reviewed at the last meeting the work of the past twelve months. During the year the total quantity supplied from all sources was 14,164,575,000 gallons, an increase on the previous year of 345,951,000 gallons. The average rate of consumption per day was 39,738,000 gallons. In accordance with suggestions received from the President of the Board of Agriculture arrangements had been made to reduce as far as possible the area of land to be planted on the Vyrway area during the season 1915-16. The reduced area to be dealt with would be sufficient only for the planting out of young trees which could not be kept longer in the nurseries.

TO ARMS!

4th Battalion ("Architects") Central London Regiment Volunteers.

Recruits are urgently needed for the Regulars, Territorials, and Volunteers. Intending recruits should apply to Battalion Headquarters, where they will be advised as to the branch of the Service for which they are best suited.

ORDERS FOR THE WEEK, by LIEUT.-COL. A. W. WARDEN.

GENERAL PARADE. Saturday, 23rd inst., at new Drill Headquarters, Chester House, Leekston Place, S.W., at 3 p.m. Uniform parade. A full attendance is particularly requested.

EXTRENCING.

Members who have volunteered for this will receive written instructions regarding hour of parade, etc. The Corps has been asked to carry on this work. Names of members prepared to assist are now required for week commencing Monday, 25th inst., and should be sent to the Adjutant's office, by first post Friday. The arrangements for billeting have proved very successful, and the work is of first-rate importance and very interesting.

DRILLS AND PARADES.

"A" Company.—Tuesdays, miniature range, Gas Light and Coke Co.'s premises, Monck Street, Westminster, 5 to 8.30 p.m.

Wednesdays.—Company Parades, 5.15 to 7.15 and 6.15 to 8.15, at Chester House, Eccleston Place, S.W.

Thursdays.—Signalling at Chester House. See orders from Acting Battalion Signalling Sergeant Cheadle.

"B" Company.—Miniature range and Company Parades as for "A" Company. See orders at local headquarters.

"C" Company.—See orders at local headquarters, Payton, A.A. Athletic Ground, Boreham Wood.

"D" Company.—Platoon and Section Drill at Chester House, Tuesdays and Thursdays, 6.45 p.m. Company Parades, Wednesdays, as for "A" Company.

SCHOOL OF ARMS.

Drill Headquarters, Chester House, Eccleston Place.—Instruction in bayonet fighting, gymnastics, physical drill, boxing, and singlesticks on Tuesdays, from 6 to 8 p.m.

RECRUIT DRILLS.

"A" Company.—Chester House, 5.15 and 6.15, Wednesdays and Fridays.

"B" Company.—Dulwich College, Mondays, 8.10 p.m., and Thursdays, 6 to 8 p.m.

"C" Company.—Boreham Wood and Elstree District, Headquarters, A.A. Athletic Ground, Boreham Wood. For full particulars apply to Alan Potter, Grey Gables, Boreham Wood, Herts.

"D" Company.—Chester House, Tuesdays and Thursdays, 6.45 p.m.

CORRESPONDENCE.

Special attention of members is drawn to the fact that correspondence should be answered by return. If this is not attended to the office work of the corps is immensely increased. Enrolment forms of new members and all correspondence not referring to recruiting for the Army or to financial matters must be addressed to the Adjutant, 10, Conduit Street, W.; and regarding recruiting for the Army, to the Recruiting Officer at Battalion Headquarters; and regarding accounts and subscriptions, to the Paymaster, W. R. Hughes, 146, Dashwood House, E.C.

By Order,

L. R. GUTHRIE, Adjutant.

BATTALION HEADQUARTERS, 18, TUFTON STREET, WESTMINSTER, S.W.

MEETINGS FOR THE ENSUING WEEK.

WEDNESDAY (To-day).—St. Paul's Ecclesiological Society. "Monasticism in the Greek and Russian Churches," by the Rev. N. F. Robinson, S.S.J.E., St. Paul's Chapter House, E.C. 8 p.m.

FRIDAY.—Junior Institute of Engineers. "Safety Precautions for Transmission Machinery," by W. V. H. Capps, 39, Victoria Street, S.W. 8 p.m.

Glasgow Architectural Craftsmen's Society. "The Rocks of Scotland" (illustrated), by David Chalmers, 8 p.m.

SATURDAY.—Institution of Municipal and County Engineers. North-Eastern District Meeting at Brixhous. "The Duties of a Municipal Engineer in the Present War," by S. Haywood, 2.30 p.m.

The Local Government Board have sanctioned a loan of £3,327 for a refuse destructor to the corporation of Newport, Mon.

Mr. H. Stringer Jardine, A.R.I.B.A., Turner Road, Dulwich, late of the 1st Battalion London Scottish, has been gazetted 2nd Lieut., 3rd 1st London Field Company, R.E.

Lieutenant E. Stanley Thornton, of the 6th Worcester Regiment, is reported to have been wounded in Gallipoli, and moved to hospital at Alexandria. He is well-known as a surveyor in Birmingham.

Members of the Architectural Association's School of Architecture will be gratified to learn that the late Master, Mr. H. P. G. Maule, F.R.I.B.A., formerly Company Sergeant-Major of the Hon. Artillery Company, has been given a commission and the post of Camp Commandant.

LATEST PRICES.

N.B.—All prices must be regarded as merely approximate for the present, as our usual sources of information are in many cases failing us.

TIMBER.

Owing to stoppage of supplies all prices have advanced considerably.

Table listing prices for IRON (Rolled Steel Joists, Wrought-Iron Girder Plates, Steel Girder Plates, Steel Sheets, Steel Strip, Basic Bars, Bar Iron, Do., Lowmoor, Flat Round, Square, Do., Staffordshire Crown, Boiler Plates, South Staffs, Beat Sneathill, Builders' Hoop Iron, Galvanised Corrugated Sheet Iron) and Cast-Iron Columns, Cast-Iron Stanchions, Rolled-Iron Fencing Wire, Cast-Iron Sash Weights, Cut Floor Brads, Corrugated Iron, Galvanised Wire Strand, B.B. Drawn Telegraph Wire, Cast-Iron Socket Pipes.

OTHER METALS.

Table listing prices for Lead Water Pipe, Lead Barrel Pipe, Lead Pipe, Composition Gas-Pipe, Lead Soil-pipe, Lead, Common Brands, Lead Shot, Copper sheets, Copper, British Cake and Ingot, Do., Bars, Pig Lead, Sheet Lead, Genuine White Lead, Refined Red Lead, Sheet Zinc, Old Lead, Tin, Cut nails.

I BUY SCRAP METALS

ARTHUR P. COLLINS, Snow Hill, BIRMINGHAM. Phone: Central 1023. Telegrams: Metalis Birmingham. Bankers: The National Provincial Bank of England, Ltd., Bennett's Hill, Birmingham.

SLATES.

Table listing prices for Blue Portmadoc, Blue Baogor, First quality.

Table listing prices for Enreka unfaling Green, Permanent Green, etc.

BRICKS.

Table listing prices for First Hard Stocks, Second Hard Stocks, Picked Stocks, Facing Stocks, Flattons, Pressed Wire Cuts, Red Wire Cuts, Best Fareham Road, Best Red Pressed, Raabon Facing, Best Blue Pressed, Staffordshire, Ditto Bullnose, Best Stourbridge Fire-bricks, 2 1/2 in. Best Red Acorn, Facing Bricks, Acornition Best Red Plastic Facing Bricks, Ditto Second Best Plastic, Ditto Ordinary Secondary Bricks, Ditto Plastic Engineering Bricks, Sewer Arch Brick, Chimney Bricks, Ditto ditto through and through, Beaded, Oval and Bevel Jamb; Octagons, Acornition Air Bricks, Ditto ditto, Acornition Camber Arches, 3 course deep, 4, 5, 6, 7, 8, 9, 10, 11, 12, 13, 14, 15, 16, 17, 18, 19, 20, 21, 22, 23, 24.

GLAZED BRICKS.

Table listing prices for White, Ivory, and Best, Silt Glazed, Buff, Cream, Other, Second, Best, Seconds, & Bronze, Colours, Colours, Stretchers, Headers, Quoins, Bullnose, and 4 1/2 in. Flats, Double Stretchers, Double Headers, One side and two ends, square, Two sides and one end, square, Splays and Squants, Plinth and Hollow Bricks, Stretchers and Headers, Double Bullnose, Round Ends, Bullnose Stops, Rounded Internal Angles, Moulded Bricks, Stretchers and Headers, Internal and External Angles, Sill Bullnose, Stretchers, and Headers, Headers, Compass bricks, circular and arch bricks of single radius, Camber arch bricks, Stretchers cut for Clovers and Nicked Double Headers, These prices are carriage paid in full truck loads to London Stations, Thames Sand, Pit Sand, Thames Ballast, Best Portland Cement, Ground Blue Lias Lime, Grey Stone Lime, Stourbridge Fireclay, Red Mansfield, Darley Dale, Red Corshill, Closeburn Red Freestone, Ancaster, Greenshill, Beer, Chilmark, Nine Elms, Hard York, Do. do. 6 in. sawn both sides, Do. do. 3 in. slab sawn two sides, random sizes.

STONE.

Table listing prices for Bath Stone, Portland Stone, Plain red roofing tiles, Hip and Valley tiles, Ornamental tiles, Hip and Valley tiles, Rubion red, brown, or brinded, ditto Edwards, Ornamental ditto, Hip tiles, Valley tiles, Selected "Perfecta" roofing tiles, Ornamental ditto, Hip tiles, Valley tiles, "Rosemary" brand plain tiles, Ornamental tiles, Hip tiles, Valley tiles, Staffordshire (Hanley) Red or brinded tiles, Hand made sand faced, Hip tiles, Valley tiles, "Hartshill" brand plain tiles, sand-faced, Pressed, Ornamental ditto, Hip tiles, Valley tiles.

Table listing prices for Bath Stone, Portland Stone, Plain red roofing tiles, Hip and Valley tiles, Ornamental tiles, Hip and Valley tiles, Rubion red, brown, or brinded, ditto Edwards, Ornamental ditto, Hip tiles, Valley tiles, Selected "Perfecta" roofing tiles, Ornamental ditto, Hip tiles, Valley tiles, "Rosemary" brand plain tiles, Ornamental tiles, Hip tiles, Valley tiles, Staffordshire (Hanley) Red or brinded tiles, Hand made sand faced, Hip tiles, Valley tiles, "Hartshill" brand plain tiles, sand-faced, Pressed, Ornamental ditto, Hip tiles, Valley tiles.

TILES.

Table listing prices for Rapeseed, English pale, Ditto, brown, Cottonseed, refined, Olive, Spanish, Seal, pale, Coconut, Cochinn, Ditto, Ceylon, Ditto, Mauritius, Palm, Lagos, Ditto, Nut Kernel, Oleine, Sperm, Lubricating, U.S., Petroleum, refined, Tar, Stockholm, Ditto, Archangel, Linsced Oil, Baltic Oil, Turpentine, Putty (Genuine Linsced Oil), Pure Linsced Oil, "Stority" Brand.

GLASS (IN GRATES).

Table listing prices for English Sheet Glass, Fourths, Thirds, Plated Sheet, Hartley's English Rolled Plate, Figured Rolled, Penonsine, Rolled Sheet.

VARNISHES, Etc.

Table listing prices for Fine Pale Oak Varnish, Pale Copal Oak, Omniflex Copal, Superfine Pale Elastic Oak, Superfine Hard-Church Oak, Superfine Hard-drying Oak, Fine Elastic Carriage, Superfine Pale Elastic Carriage, Fine Pale Maple, Finest Pale Durable Copal, Extra Fine French Oil, Eggshell Flattening Varnish, White Copal Enamel, Extra Pale Paper, Best Japan Gold Size, Best Black Japan, Oak and Mahogany Stain, Brunswick Black, Berlin Black, Knotting, French and Brush Polish.

Mr. Stephen MacDonagh, B.A., B.E., Lecturer at St. Joseph's College, Ballinasloe, has been appointed by the Leinster County Council as assistant county surveyor. At the Manchester Consistory Court a faculty has been granted to the vicar and wardens of St. Thomas's Church, Pendleton, for lengthening the chancel by a single bay, laying the new marble floors in chancel and sanctuary, providing oak panelling screen and panelling, and providing new vestry and porch.

TO CORRESPONDENTS.

We do not hold ourselves responsible for the opinions of our correspondents. All communications should be drawn up as briefly as possible, as there are many claimants upon the space allotted to correspondents.

It is particularly requested that all drawings and communications respecting illustrations or literary matter, by us for review, etc., should be addressed to the Editor of the BUILDING NEWS, Lillingham House, 1, Arundel Street, Strand, W.C., and not to members of the staff by name. Delay is not infrequently otherwise caused. All drawings and other communications are sent at contributors' risks, and we will not undertake to pay for, or be liable for, insurance contributions.

Drawings of selected competition designs, and that of public and private buildings, details of old and new work, and good sketches are always welcome, and for such a charge is made for insertion. Of more commonplace subjects, small churches, shops, houses, etc., we have usually far more sent than we can insert, but are glad to do so when space permits, on mutually advantageous terms, which may be ascertained on application.

When forwarding us with drawings or photographs, architects are asked kindly to state how long the building has been erected. It does neither their nor us much good to illustrate buildings which have been some time executed, except under special circumstances.

Telephone: Gerrard 1291.

Telegrams: "Times-Ver, Estrand, London."

NOTICE

Bound copies of Vol. CVIII are now ready, and should be ordered early (price 12s. each, by post 12s. 6d.), as only a limited number are done up. A few bound volumes of Vols. XXXIX, XL, XLV, XLIX, LIII, LXI, LXII, LXIV, LXV, LXVI, LXVII, LXVIII, LXIX, LXXI, LXXII, LXXIII, LXXIV, LXXV, LXXVI, LXXVII, LXXVIII, LXXIX, LXXX, LXXXI, LXXXII, LXXXIII, LXXXIV, LXXXV, LXXXVI, LXXXVII, LXXXVIII, LXXXIX, XC, XCI, XCII, XCIII, XCIV, XCV, XCVI, XCVII, XCVIII, XCIX, C, CI, CII, CIII, CIV, CV, CVI, and CVII may still be obtained at the same price, and the other bound volumes are out of print. Most of the back numbers of former volumes are, however, to be had singly. Subscribers requiring any back numbers to complete volume just ended should order at once, as many of them soon run out of print.

Handsome Cloth Cases for binding the BUILDING NEWS, price 2s., post free 2s. 4d., can be obtained from any Newsagent, or from the Publisher, Lillingham House, 1, Arundel-street, Strand, W.C.

TERMS OF SUBSCRIPTION

One Pound per annum (post free) to any part of the United Kingdom; for the United States, £1 8s. 1d. (or 60s. 30c. gold); to France or Belgium, £1 6s. 6d. (or 30s. 30c.); to India, £1 6s. 6d. To any of the Australian Colonies or New Zealand, to the Cape, the West Indies, or Natal, £1 6s. 6d.

Our Direct Subscription Agents for Australia are Messrs. E. T. Kibbwhite and Co., Printers and Publishers, 19, York Chambers, 195, Liverpool Street, Sydney, New South Wales; for Japan, The Maruzen Co., Ltd., 11-16, Nishibashi Tori Sanhome, Tokyo; who will receive Subscriptions at 41 6s. 6d. per annum on our account. Copies of the paper will be sent by us direct to the subscribers' address.

The special rate to Canada is £1 3s. 10d. = 50s. 8d. for 12 months, and 15s. 11d. 2dols. 90c. for 6 months. Our Direct Subscription Agents for Canada are Messrs. Seals, Ltd., 202, Shaftness Buildings, 206-611 Street, Montreal, who will receive Subscriptions at £1 3s. 10d. per annum, on our account.

Cheques and Post-office Orders to be made payable to THE STRAND NEWS-PAPER COMPANY, LIMITED, and crossed London County and Westminster Bank.

SITUATIONS VACANT AND PARTNERSHIPS

The charge for advertisements for "Situations Vacant" and "Partnerships" is One Shilling for Twenty-four Words, and Sixpence for every Eight Words after. All Situation Advertisements must be prepaid.

SITUATIONS WANTED.

Advertisements not exceeding Thirty Words, in lists of name and address, are inserted under the heading "Situations Wanted," free of charge.

Rates for Trade Advertisements on front page, and second and other positions, can be obtained on application to the Publisher.

LETTERS TO ADVERTISERS

Reply to advertisements can be received at the Office, Lillingham House, 1, Arundel Street, Strand, W.C., free of charge. If to be forwarded under cover to advertiser, an extra charge of Sixpence is made. (See Notice at head of "Situations.")

REMOVED: J. O. and Sons, Ltd., Sir W. H. B. and Co., Ltd., E. S. Co., Ltd., E. Col. J. A. A. K. G. Ltd., S. W. F. and Co., A. T. G. F. C. M. R. W. C. J. K. and Sons, Ltd., W. N. S. G. L. S. P. C. B. and Co., M. and Co., W. R. N.

THESE: The... and...
P...: Hardly worth while doing, in probability.

A. P. J.: The system is not one we should use. We should be far more concerned as regards the patent.
A. S. F. G. H. N.: There are cases at the different... at which you can work up for... examinations, and there are con-

who give private lessons some of whom advertise in these columns.

A. HOUTSHORDE. We do not think the council can be compelled to lay the sewer deep enough to drain the cellars, but in ignorance of their powers we cannot say more. The best course is for owners interested to combine and take advice from some competent local sanitary engineer, and if he is of opinion there is a good case, to appeal to the Local Government Board to order an inquiry.

A. TIMELY REMINDER. Architects, builders, and others are reminded that the BUILDING NEWS is now published on Wednesdays instead of Fridays, at 2 a.m., and that it should be obtainable early in the day anywhere. If delay occurs, it can be posted direct from the office on receipt of a quarter's subscription, or single copies can be similarly sent to readers in camp or moving about the country.

Mr. William Morris, M. Inst. C.E., V.D., late chief engineer to the Kent Waterworks Co., died on Thursday last at Buxton in his 80th year.

We regret to hear that Major Basil Edgar Baily, F.R.I.B.A., of the 7th Battalion Sherwood Foresters, and in practice at 43, Parliament Street, Nottingham, has lost his right hand as the result of being wounded in action at France. He is now progressing favourably in a London hospital.

The old oak bechern which was displaced in 1843, when an eagle bechern was given by "Certain College Prefect," has been restored to the chapel of Winchester College. It dates from 1686, and was made by one Howman, who is described in the College accounts for 1682-85 as "Howman fabro lignario."

Mr. J. W. Gilmour Wilson, chief assistant to his father, Mr. W. Gilmour Wilson, of Bloomsbury Mansions, Hart Street, W.C., F.R.I.B.A., who has been for six years a member of the London Scottish, has just received a commission as 2nd Lieutenant in the Mechanical Transport Division of the Army Service Corps.

By twenty-four votes to eight the corporation of Wolverhampton have approved of the payment of an honorarium of 350 guineas to Mr. E. A. V. Woodward, the borough water engineer, in recognition of his services in assisting in the passing of the Wolverhampton Corporation Water Act, in spite of strenuous opposition.

It was reported to last week's meeting of the Manchester Rivers Committee that Mr. Gilbert Harr, a member of the committee's main drainage staff and now a temporary second lieutenant in the 175th (Tunnelling) Company of the Royal Engineers, had been awarded the Military Cross for conspicuous gallantry and skill in France.

In the new hall of Spurgeon's Orphanage, Clapham Road, Stockwell, a three-light window in the transept, erected as a memorial to the Rev. Vernon J. Charlesworth, for many years the lecturer, will be unveiled tomorrow (Thursday) afternoon by the Rev. Thomas Spurgeon. The subject is the Good Shepherd, and the artists are Messrs. Morris and Sons, of Kennington.

The opening meeting of the session 1915-16 of the Royal Institute of British Architects will be held on Monday week, November 1, when the subscription portrait of Mr. Reginald Blomfield, R.A., past president, painted by Mr. J. J. Shannon, R.A., will be formally unveiled and presented to the Institute, and the opening address of the session will be delivered by Mr. Ernest Newton, A.R.A., the President.

The death at Stockton Bridge of Mr. Thomas Allen at the age of eighty-four removes a well-known ceramic artist from North Staffordshire. He received his artistic education at the National Art Training School at Marlborough House, and afterwards at the South Kensington Schools, and on the completion of his training he joined Messrs. Minton, and subsequently became art director at Messrs. Josiah Wedgwood and Sons', Etruria. He had lived in retirement at Stockton Brook for some years.

At the last meeting of the urban district council of Market Harborough it was reported that the surveyor, Mr. Herbert G. Coales, had prepared a plan in connection with a town-planning scheme. The clerk, Mr. H. Lindby, said the general idea of the scheme was that, if the land was scheduled for town-planning, (one) could say where roads could go and which part of the town could be used for building factories and which could be used for residential purposes, and they could limit the number of houses to the acre. The matter was adjourned to give the members an opportunity of looking into the plan.

FOR **Olivers' Seasoned Hardwoods,**
APPLY TO—**WM. OLIVER & SONS, Ltd.,**
120, Bunhill Row, London, E.C.

TENDERS.

*. Correspondents would in all cases oblige by giving the addresses of the parties tendering—at any rate, of the accepted tender; it adds to the value of the information.

BATTERSEA.—For providing and fixing revolving shutters at the Central Buildings, Battersea, for the Metropolitan Water Board:—
Dunston, Kerr and Co., ... £203 0 0
(Accepted.)

BATTERSEA.—For machine-made canvas fire-brigade hose for the Metropolitan Water Board:—
Angus, Geo., and Co., Ltd., ... £100 0 0
(Accepted.)

BATTERSEA.—For supplying pulleys and wall brackets at the Central Buildings, Battersea, for the Metropolitan Water Board:—
Smith and Grace (accepted) ... £175 10 0

BATTERSEA.—For the supply of gunmetal stop-cocks, and ferrules, for the Metropolitan Water Board:—
Woodhouse and Co., Ltd., ... £412 10 0
(Accepted.)

BATTERSEA.—For the supply of 110 yds. of taped and braded coals, 60 megohm grade, for the Metropolitan Water Board:—
Callender's Cable and Construction Co., Ltd. (accepted) ... £116 0 3

BRADFORD.—For supplies for the tramways department. Accepted tenders:—
Oxygen (three months):—

British Oxygen Co., Ltd., £1 5s. per 1,000 feet.
Gearwheels and pinion for motor-cars:—
Scholey and Co., Ltd., 200 tool-steel gears at £7 9s. each, and 200 tool-steel pinions at £1 5s. each.

PHIDGORTH.—For repairs and improvements to the stairway approach to the council chamber, for the corporation:—
Lay, T. E. (accepted) ... £115 0 0

CASTLETOWN BEEHAVEN.—For the lighting of the town by electricity, for the district council:—
Nugent, P. H., Bantry
(accepted) about ... £1,500 0 0

CHESHUNT.—For the supply of 2-in. broken Guernsey granite, for the urban district council:—
Griffiths, W., and Co. (accepted), at from 14s. 3d. to 14s. 11d. per ton, according to place of delivery.

DERBY.—For the provision of cloakroom fittings at the new secondary school for girls, for the education committee:—
Ratchiffe, J., and Co., Derby ... £172 0 0
(Provisionally accepted.)

DUSS.—For repairing Walcot Road, for the urban district council:—
Edwards and Co., Norwich ... £565 0 0
(Accepted.)

EASTBOURNE.—For alterations to 32, Hyde Gardens, for Mr. J. H. C. Coles, Mr. F. G. Cooke, Eastbourne, architect:—
Chapman, W. (accepted).

EASTBOURNE.—For alterations to Darley, The Avenue, for the Rev. Sir Peile Thompson, Bart. Mr. S. C. Seales, architect:—
Bambridge, G., and Son, Eastbourne
(accepted.)

HAMMERSMITH.—For repairs to boiler at Hammersmith station, for the Metropolitan Water Board:—
Beely, Thos., and Son ... £85 0 0
(Accepted.)

HILTON.—For painting the workhouse exterior, wood and iron work, for the guardians:—
Eddy and Sons (accepted) ... £48 0 0

KINSMOUTH.—For erection of proposed medical residence at Kinnegh, for the Cahirveen Board of Guardians:—
Jennings, W., Kilgarvan ... £1,300 0 0
(Provisionally accepted.)

LAMBETH, S.W.—For retriming, repairs, and decorations to manager's house, Providence Wharf, for the borough council:—

Collins, S. J., and Sons, 7, Clifton Street, Clapham	£225 5 0
Pierpoint, R. H., 106, Albert Road, Peckham	225 2 6
Daley, W., and Co., 58, Birch Grove, Acton	215 0 0
Peddie, E., 166, Hamilton Road, West Norwood	179 0 0
Finch and Co., 48, Dudley Road, Hford	176 10 0
Long, H., 81, Peckham Rye, S.E. 11ns., A. H., 36, Cannonale Street, E.C.	168 0 0
Truscott, R. J., 291, Romford Road, Forest Gate	167 15 0
Shaw, S., 58, Grange Park Road, Leyton	164 1 2
Jackson, H., 22a, Alfred Street, Bow	159 8 0
King, W., and Son, 3, Vauxhall Bridge Road, S.W.	147 0 0

(Acceptable work to be completed in four weeks.)

THE BUILDING NEWS AND ENGINEERING JOURNAL.

Effingham House.

A Bomb-Proof Building	463
The Engineer a Practical Idealist .. .	465
Maintenance, Materials, and Methods of Road Work	466
Daer Church, near Ell-water	467
The London County Council	467
The Dismissal of the Land Valuation Staff .. .	468
Temperature Experiments at Lahore .. .	468
The Medieval Architecture of the Wey Valley .. .	468
A New Industry for Huddersfield	468
The Street System in City Planning	469
Our Illustrations	470
Obituary	470
Corrente Calamo	487
Legal Intelligence	488

CONTENTS.

Professional and Trade Societies .. .	488
Correspondence	489
Our Office Table	489
Water Supply and Sanitary Matters .. .	490
Trade Notes	490
Chips	490
To Arms	490
Meetings for the Coming Week .. .	490
Latest Prices	490
Tenders	490
List of Competitions Open	490
List of Tenders Open	490

OUR ILLUSTRATIONS

New Central Offices, Rotherly Avenue, E.C., for the Metropolitan Water Board. Mr. H. Austen Ha FRIBA, Architect.	490
--	-----

Strand, W.C.

Decoration of the School Chapel, Christ Hospital, Horsham	488
St. Ambrose, Training the Choir in his Church at Milan, A.D. 485, and St. Augustine at 166th St., Turn, O. Land, by wrath from this people. By Mr. Frank Brangwyn, A.R.A. Sir Aston Webb, R.A., Architect.	488
King Edward Memorial Laetitia Hospital, Hastings. View and block plan. Messrs. John Saxon Snell and Stanley M. Spear, Architects.	488
Scene, Medals and Travelling Studentship Sketches, by Mr. A. G. Hornell, R.C.B. at Vernon, Eure, France.	488
Old English Furniture from Fritwell Manor, Banbury, Oxon, and elsewhere. Drawn by Mr. W. T. Willis.	488
Catholic Church and Priory, Southold, Suffolk. Plan and view. Messrs. Bened. C.S.S.S., and Bert Pies, Architects.	488

A BOMB-PROOF BUILDING.

Since we last dealt with this matter a fortnight ago, the results of the last Zeppelin raid in the "five areas" have sufficiently demonstrated the urgency of the necessity for modifying our future construction. We know, at any rate, what aerial bombs will do!

An aerial bomb, falling at K, Fig. 1, is endowed with destructive force of impact related to its mass and velocity. On ex-

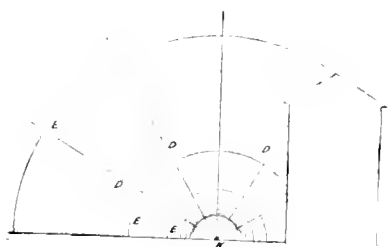

FIG. 1.

plosion it wrecks material and structure in contact. Presumably this force may vary inversely as the cube of the distance from the centre of explosion, as diagrammatically indicated at E, etc. The explosion scatters shell-contents and debris, as shown at D, etc., in rectilinear, radiant lines, obviously under ordinary projectile law. In addition, there is either chance fire, or such by design, as from specific incendiary bombs. Further, from solid objects, such as walls, there must be secondary, reflex air-concussive wave systems, no doubt capable, at times, of blowing in the glass of windows.

Assume an explosive bomb of, say, 50 lb. weight, falling from a height of some 4,000 ft. Under the constant acceleration of gravity, such a hostile missile will arrive at the earth's surface at a velocity of about 500 ft. per second. The kinetic energy—the impact or impulsive force, available for destruction—acquired through the fall, taking g 's the force of gravity = 32, and using the old formula $K = \frac{1}{2} m v^2$, will be $\frac{50 \times 500 \times 500}{2 \times 32}$, or

about 195,000 foot-lb., for our purposes in round numbers, 87 foot-tons. To oppose the mere impact of such a falling mass, we need more than a few slight sheets of wire netting.

We have heard that some of these hostile bombs weigh 2½ cwt. It is conceivable that such may be dropped from, say, a height of 10,000 ft., so the reader can estimate the force of impact. In Fig. 2 we give a diagram, from memory, of something we have seen in one of the "five areas," so officially described. A bomb impacted on the concrete roof C,

broke through this, and the concrete floor C₂ and appears to have impinged directly over a steel joist, J. This joist, we understand, was about 10 in. by 6 in., of ½-in. metal. About 1 ft. 6 in. to 2 ft. of that R.S.J. has vanished, as indicated at K; appears to have been wiped out of existence. The joist formed a lintel to an area window, and the explosion has disrupted the brickwork of the area walls a great deal more violently than approximately indicated in our sketch, besides greatly damaging adjoining buildings; and although our sketch may not exactly represent the premises where this bomb fell, the quite undisturbed brickwork here, and its complete disruption there, is in true accord with the peculiar, partial character of high explosive. In all the areas officially described, examples of the destructive forces to be met are numerous. In one a foot of concrete was perforated, and four or five feet of earth thrown out, roofs were blown off, holes made in solid granite in which one may put two fists, 1½ to 2-in. iron railings cut clean through, cubic feet of solid masonry dislodged, to say nothing of other evidences of immense explosive energy that it is the duty of the architect to consider.

When new problems of this sort are suddenly presented, only the empiric will instantly profess to suggest certain solutions; but we will endeavour to put forward some further suggestions. Before

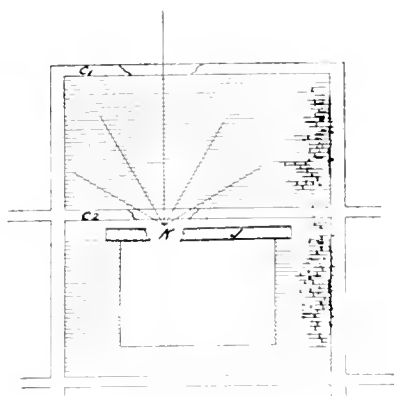

FIG. 2.

our examination of the latest results of great impact and high explosive forces, we might have hesitated to submit our sketch, Fig. 3, for discussion. We present the design now, however, for what it is worth. While ordinary stanchions, supporting netting, slag-wool, or sandbags may be the best possible expedients in regard to existing methods of construction, our sketch essays something entirely re-

modelled, assured and complete. Our suggestions are mainly inspired by consideration of certain natural phenomena. The earth is protected from meteoric bombard-

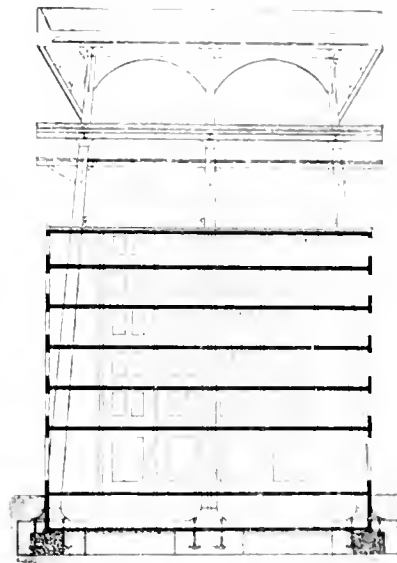

FIG. 3.

ment by its atmosphere. The high velocity of these celestial projectiles causes their destruction. Our proposal here is to seek to ensure a definite explosion of a bomb as high above the building as possible. In doing this we must guard against diverting destructive forces to neighbouring premises. But for this consideration, we might rely more on steep-pitched armour plate roofs. These would possibly shelve a bomb, but the missile would be discharged over adjoining roofs or into the street. The bomb must be caught directly, and the explosive forces rendered as harmless as possible. Reviewing these circumstances, we turn to Figs. 4 and 5. We have suggested already that the explosive energy must lessen, from its source of origin in a certain geometrical order. Therefore, a relatively slight removal from immediate contact with the explosion greatly reduces the destructive energy; the further that we can remove the point of detonation the less will be the destruction to the building. Fig. 4 shows a special detonating platform, P. The explosion should occur as far above a secondary platform, B, as may be practically possible, which should be of such a nature that it will resist the results of the explosion as the forces of such are diminished by the distance between the two stages. This we think a correct principle, when we consider the holes in thickly-concreted roads, which

appear to be the result of explosive force against solid resistance. It would seem that it is the *instantaneous* contact that renders high explosives so destructive. In Fig. 2 we should incline to consider the actual detonation and explosion to have taken place immediately above K, and regard the holes in the concrete, C, and U, as resulting from impacting force. A bomb-proof platform, then, must resist both the force of impact and the explosion if it is at a low level; but, if raised sufficiently high, its office might be to cause detonation and explosion, the secondary results of explosion being received by a lower staging. Assume that the platform, P, Fig. 4, is raised 500 ft. above B, then, once the explosion has been caused, we do not mind what wreckage occurs at this level, so long as the explosion wave (500 ft. below) is so reduced that we have only to deal with this lessened force plus the projectile emanations from the explosion. We must, however, have regard to neighbouring premises. In Fig. 4, say the explosion occurs at impact K. Debris and shell contents are showered down at D, etc., upon the bomb-proof platform, B; but at D miss this screen and are directed on to adjoining roofs. If now, in Fig. 5, side walls are erected round the detonating platform, debris from the explosion at K cannot be projected over adjoining premises at a lower angle than D₁, D₂. That something immensely strong is needed for this screen wall is evident to all who have seen the results of a bomb falling in a passage-way and bodily shifting a heavy stone plinth below massive iron railings. Figs. 4 and 5 we sketched some little time back; it was after witnessing various recent wreckage that we made sketch, Fig. 3. It may be thought extreme, we thought so ourselves until we considered the forces involved in Fig. 2. If indeed extreme, it may perhaps be reduced by calculation and design, so that the right mean may be discovered between obviously ineffectual efforts and that which attempts, possibly, superfluous strength and excess of precaution.

The general idea of Figs. 4 and 5 was a detonating platform, a bomb-proof plat-

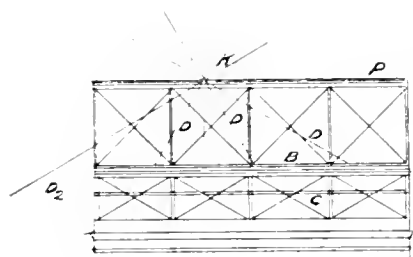

FIG. 4.

form, and a further air-catching net, respectively, in the diagrams, P, B, and C. The sketch, Fig. 3, proceeds on much the same lines, and assumes aerial warfare to have become a recognised factor influencing building construction, and carries such a weight of protective defence that separate steel plate riveted columns carry this load direct to foundations. We neglect, for the moment, destructive effect from bombs falling outside the building. Assuming the building 100 ft. square, five feet of sand would be a load, alone, of over 2,000 tons. As sketched, the steel columns necessarily trespass on the building space, being battered for stability. If erected plumb they could be enclosed in turn, in projections, and the construc-

tion could be such that the steel-riveted columns could be isolated, or insulated, from the actual building. The sketch, Fig. 5, was made before we had studied the effect of the bomb as shown in Fig. 2, wherein, the missile has penetrated a concrete roof and floor, and wrought some havoc upon a steel joist, the nature of which is not quite clear. If it sheered the steel, as appears possible, it exerted a force equivalent to a dead load of, say, 270 tons, in the face of this, and the clean holes in roof and floor, we must not trust to con-

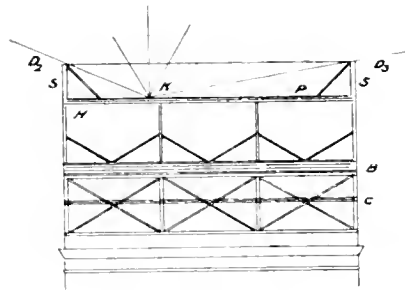

FIG. 5.

crete or steel to resist either impact or explosion; and we are driven back to the quasi-elastic means of receiving a falling weight, and to sand-packing; and hence, for the top platform in our sketch, Fig. 3, we would suggest steel netting, a layer of slag-wool over, and a very considerable depth of sand, the whole so designed that the bomb would have no chance of dropping on to any solid material whatever. The side-screen walls would restrain any scattering of debris over adjoining premises below a certain angle.

The sketch, being a development of the plea in Figs. 4 and 5, shows a lower platform to catch any debris from, and penetrating, the upper platform, and an additional steel netting below this. It seems plain that the amount of protection afforded would relate to the amount of braking resistance that would be brought upon the falling projectile; this is best accomplished with sand, which packs under the influence of a projectile. We would place the sand upon one foot of slag-wool, supported by strong lattice-steel netting, and would give the whole as much elasticity as possible. We inclined the steel columns for stability, but it seems possible that the out-setting of these supports to or near the exterior wall lines would leave a clear run for netting. Necessarily these are points open to much debate. That which a theoretical consideration would seem to demand is a strong hoop, free of supports over the building area, and so designed that the lateral stress from sudden depression of the elastic structure would be suitably resisted by the hoop. The instant when the tennis-ball strikes the racket must witness the conversion of the energy of impact into stresses tending to crush in the hoop; so that our main principle would seem to be a maximum of elasticity for the platform, and to prepare the hoop to adequately withstand the converted stress, equivalent to a side thrust upon the girders supporting the margins of the netting. It would seem, then, that cross girders should be absent. In practice it would, no doubt, be difficult to realise this ideal, and where this is so, we must bear Fig. 2 in mind, and protect as much as possible all steelwork. Short of greatly inclined armour-plate, it would seem hopeless to stop a bomb by means of solid material of any such moderate weight and thickness that it could be placed in some way above a building. The general idea seems rather to suggest a tubular girder, bearing in mind that, in addition to sup-

porting a load, we have to be prepared for cross strain; and as we cannot expect a bomb to fall in the centre of our elastic structure, we may see certain advantages in a design of platform that yields equally all over. The more science is brought to bear on this problem the less cumbersome and weighty, probably, need be the whole scheme of defence.

Fig. 5 shows the great mass of defensive material on the uppermost staging. In Fig. 6 this is provided at B, while P, so long as it causes detonation and explosion, may be as light as consistent with the provision of sufficient obstruction to cause such explosion. K is the point of impact and explosion. Circles 1, 2, 3, 4, and 5 suggest the decreasing effect of the explosion wave, which, if impact is at R, the distance K-E is the measure of the reduced forces acting at the level of the platform B. This, then, need but resist debris and shell contents. The impact, say, has partially destroyed P, but the explosion has obliterated the impulsive, destructive force. We have got rid both of this and the necessity for providing resistance to high explosive in immediate contact. The debris-resisting platform B shelters the building, as shown, within the lines D₁, D₂.

It must be remembered that the impact of 2½ cwt. falling say 10,000 feet is over 1,200 foot-tons. If we are to deal with this and with an immediately contacting high explosive, we require an upper staging after the lines of Fig. 3, with as great a depth of sand as possible, all needing immense strength in the supporting structure, while if we make the staging P, Fig. 6, act on the bomb as the concrete roof and floor in Fig. 2 presumably acted, we need something comparatively light. Before considering detail design we need to arrive at

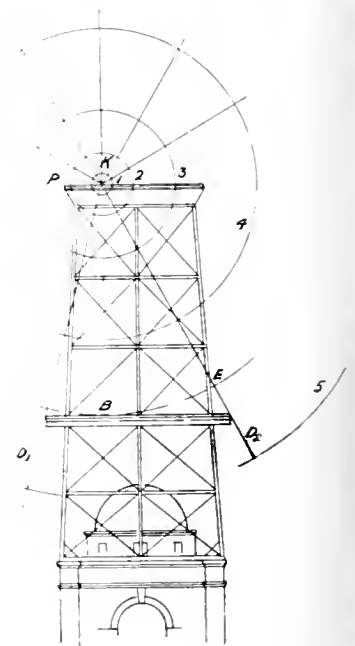

FIG. 6.

some general principle of arrangement, based upon sound theory.

We may learn much from Fig. 2. Obviously the bomb broke through the concrete by impact. In the space of, say, 1-80th second, it exploded, probably close to the steel joist. The evidences are the level, angle, and direction in which shell contents and debris have been scattered on to adjoining premises, and they bear eloquent testimony to the fact that while endeavouring to protect our own buildings we must have due regard to those of our neighbours.

THE ENGINEER A PRACTICAL IDEALIST.*

Let us turn in detail to various branches of our profession, and see if the practice of them is likely to be destructive of idealism. The Mosaic code of laws shows that the health of the Jewish population was a matter of such supreme interest that special legislation on that subject seemed warranted. The Greeks, and particularly the Romans, recognized fully the moral value of personal cleanliness, but it has been left to our country to show clearly, and on the basis of scientific study, the interdependence between sanitation and disease, sewerage and crime. Munsterberg has said, "Hygiene can prevent more crime than any law." Speaking before the Massachusetts Conference of Health Officials, Dr. Charles W. Eliot, President Emeritus of Harvard, addressed them, in part, as follows: "The progress of knowledge of preventive medicine made during the past fifty years, and in applications of that knowledge in social practice, has been the most cheerful phenomenon in the recent history of civilization. The new applications of physical forces—heat, light, and electricity, which mankind has learned to use in its conflict with nature—have proved to be highly beneficent in the field of preventive medicine. Civilized communities have been enabled to make their water supplies, food supplies, and drainage systems safe, and to contend with unexampled success against formidable pestilences, the common communicable diseases, and the bodily ills which attend urban life and the factory system."

SANITARY ENGINEERING: ACHIEVEMENT.

In this work of preventive medicine the sanitary engineer has borne his full share. As we read these inspiring words of Dr. Eliot our thoughts turn at once to that monumental work in sanitation carried out on the Panama Canal under the direction of General Gorgas, and with the hearty co-operation of the engineering staff. Under disheartening difficulties, and with sacrifice of personal comfort—yes, at the risk of their lives—the men laboured who made the Isthmus a place fit for the white man to live, and thereby made the construction of the canal, which means so much to mankind, possible. Honour, deserved honour, has come to him who directed this splendid piece of sanitary engineering; but I desire to put on record here the appreciation of this society for the men who stood by. Is it reasonable to suppose that the engineers who did this work, who made these sacrifices, were not the highest type of non-practical idealists?

We are called iconoclast engineers, utilitarians, non-respecters of tradition, antiquity, and picturesque. Iconoclasts? Yes; reformers usually are. Utilitarians? That, too, is an accusation we cannot deny, but is an act less noble for being useful? Non-respecters of tradition and antiquity? Again I plead guilty, if tradition stands for error, and antiquity for decay. Destroyers of the picturesque? A general denial cannot be uttered against this charge either, and in some cases, I am free to confess too little justification can be shown for the disregard of the picturesque. This is a point I shall touch upon more fully later, but with special application to the cases cited above and similar ones; what is picturesque but the seared condition of structures and their surroundings? What is this vaunted love of the picturesque, in many cases, but a selfish and thoughtless appreciation of surface appearances? Selfish and thoughtless, I say, because the few are willing to sacrifice the faith and happiness of a whole community, perhaps, in order that they may feast their eyes on narrow winding streets, on quaint gables, far-reaching eaves, small, arched windows, leaded panes of glass. They are taken in by the surface appearance of things. But little heed give they to the squalor and dirt, to misery and sickness existing in these picturesque quarters. Who, then, is the idealist—the man probing into the sore which has so little surface indication, finding its deep-seated seat, and skillfully using the knife,

or the man who, misled by these same facts, applies a surface dressing and allows the sore to eat into the body. To the thinking man the answer is simple. Perhaps you will grant now that at least one branch of engineering, sanitary engineering, and idealism are not only not incompatible, but that they are almost inseparable. And what I have shown somewhat fully for this branch of the profession can be shown as well for the many other branches.

IRRIGATION OPENS NEW TERRITORY.

Take irrigation engineering, for instance the possibilities of which are only beginning to be realized in this country. Is it likely that the men carrying out these works see in them but the piling of one stone upon another, the digging of so many feet of pipe? These black cast-iron wrought-iron cylinders stand for more than this to the true engineer. He realizes that with every water or drain pipe well laid he is bringing prosperity and happiness, health and vigor, where before existed poverty and misery, sickness, and languor. Perhaps the most wonderful instance on record in modern times of the far-reaching effects of irrigation engineering is found in Egypt. In an article on the regeneration of Egypt by the former librarian at Stanford, Mr. Woodruff, now professor of law at Cornell, he indistinctly and justly, I think, attributes a large share of the credit for this "new birth" to the work of the English engineers. Mr. Woodruff says, "The history of the English in the administration of Egypt for the past nine years is the record of the return to health, strength, and prosperity of a country that has been bled and starved almost beyond resuscitation. And yet there has been little romance in this restoration. It is chiefly a story of common sense, honesty, and straightforward hard work."

But we need not turn to foreign countries to find work of the irrigation engineer worthy of commendation. Our own Reclamation Service has made a record of which we may well feel proud. Here, too, the men, with loyalty and steadfastness, have given a service the value of which is not yet fully recognized. They are the men of whom Chief Engineer Davis said: "The chief tie to the service is not the matter of salary, but interest in their work and loyalty to it, and the belief that they are appreciated." Again I ask, is such work destructive of idealism, are such men lacking in ideals?

RAILROADS UNITE MANKIND.

In railroad engineering, think you that the men who through virgin forests and sandy deserts, through miasmatic swamps and rocky canyons across rivers and over mountains, carried the steel bands that now tie mankind so closely together, think you that these men were engaged in an occupation likely to kill their ideals? When the final balance is struck, I warrant that the debt will not be on the side of this grand army of peace of the present, as compared with the armies of war of the past and present, for deeds of ideal heroism, self-sacrifice, and devotion to duty. It seems like carrying coals to Newcastle to speak in an audience like this of what the railroads have done for all countries. For our own country especially, and more particularly for the Pacific slope. It was not so long ago since I read of the beginning of construction of the Trans-Siberian Railway, which now unites the Atlantic and the Pacific on the other continent. The Cape-to-Cairo Railway, too, has passed through the stages of its preliminary surveys and partial construction. What centuries of fighting could not accomplish these two roads will in time accomplish. The light of civilization will be spread on the Dark Continent, and its strong rays will burst the fetters and open the prison doors of suffering men and women in Russia. Who, then, is destructive of idealism the man whose work is a means, if but a humble one, of bringing his fellow beings into a freer contact with the wonders of creation, or he who, enveloped by the mantle of exclusiveness, hemoans this defiling contact?

ROMANCE OF BRIDGE BUILDING.

What bridge engineer has not been touched by the romance of his profession?

What engineer has not been touched by the romance of his profession? The Kip-Engs, too, in the Bridge Building, where they master the forces of nature, and where almost poetry is wrought into the work of the engineer as he levels a road. It was a long, long road, and it covered a storm, sudden freshets, death in every manner and shape, violent and unrelenting against the tape half freezing a mind that knows it should be busy on other things, drought, sanitation, finance, births, wedding, burial, and not in the village of twenty warring wastes; argument, expostulation, persuasion, and the blind despair that a man goes to bed upon, thankful that he is there at all, in peace in the gun case. Behind everything rose the black frame of the Kasin bridge, plate by plate, girder by girder, span by span, and each piece of it recalled Hitchcock, the all-round man, who had stood by his craft with-out faltering, from the very first to the last.

If I desire to show that in still another branch of engineering—the one of river and harbour improvement—there is nothing destructive of idealism, I need not go far for an illustrious example. What James B. Eads has done for the people living in the Mississippi Valley in opening up the mouth of the Father of Waters stamps him as one of the benefactors of mankind. For years he laboured and fought; removed mountains of obstacles, overcame prejudice, ignorance, and ignorance. Mr. Cathell, the staunch friend and principal assistant of Captain Eads on this momentous work, quotes him as saying, "I therefore undertake the work with a faith based upon the ever-constant ordinances of God Himself; and so certainly as He will spare my life and health for two years more, I will give to the Mississippi, through His Grace and by the application of His laws, a deep, open, safe, and permanent outlet to the seas."

ART AND THE ENGINEER.

I think enough has been brought before you now to show clearly that engineering is not destructive of idealism. That much refuted, there still remains the charge that engineering is destructive of, or at least in part responsible for, the decay of art. I propose to show that this statement also is false. Artist and romantic appear as accusers. Again they point backward and say: "See what the past has created; what have we that can be placed by its side?" Their eyes are blinded to the changed condition of things. They lack the sympathetic understanding of the complex problems of the life of to-day, and the materialistic solution of these problems does not appeal to their ideal of the beautiful. For the intelligent enjoyment and, more particularly, for the realism of any creation, there is needed at least a fair knowledge of the underlying principles of construction, be that work a symphony, a poem, or a bridge. It is true that a symphony or poem appeals much more readily to a large audience than does a bridge or a complicated piece of machinery; yet both the latter may be as much works of art as the former, a higher degree of development of the intellect being needed, however, to see and feel their beauty. Every engineering structure is the materialized idea of its function. The ideas underlying engineering works are often ideal ones, and the works themselves therefore can be idealized. When this is done the engineering structure becomes a work of art.

In all ages that which most truthfully and characteristically embodied in truth the representation of the life and the ideas of those times was deemed a work of art. He is the artist who expresses most faithfully what we think and feel. If such representation has not been had in our country, it is due, not for lack of raw ideas and materials, but for lack of science, pure and applied, and for lack of adequate assimilating power on the part of the would-be apostles of the beautiful.

THE ARTISTIC IN THE STRUCTURES OF THE PANAMA CANAL.

It is encouraging to note that the own Government in connection with the engineers of the Panama Canal sent the sculptor, Daniel C. French, and the landscape architect, Frederick Law Olmsted, to report on the

Extracts from the presidential address of Charles Marx, delivered at the Forty-seventh Annual Convention of the American Society of Civil Engineers in San Francisco on September 16.

half-gallon to the square yard, and on subsequent applications the amount varies from one-fifth to one-third of a gallon to the square yard. The asphalt contained in this oil forms a thin carpet on the macadam surface and not only prevents wear, but prevents distribution of dust. It has been found that the use of heavy oils, such as are known to the trade as "90 per cent. oils," assists in a satisfactory maintenance for only one or two years, after which the bituminous material has a tendency to crawl and become waxy. The lighter oils, having less body, do not have this objection. Refined tar is often used in the same manner as described above in the maintenance of macadam roadways, and often gives quite satisfactory results.

REPAIRS ON A BITUMINOUS BLANKET.

Repairs on a bituminous blanket or thin surface coat may be made by covering the section to be repaired with a thin coat of asphaltic oil or tar, as the case may be, and immediately covering with pea stone, fine gravel or coarse sand. This is assuming that the repairs consist of renewing comparatively small sections of the coating that for any reason may have disappeared. No general fixed method can be described for making repairs due to imperfect workmanship, the use of too much bituminous material, or the irregular distribution of material, each case having to be treated in such a manner as experience may show to be best. Ordinarily, renewals of bituminous carpets may be made by a repetition of the usual process of constructing such carpets, except that it is advisable always to use less bituminous material per square yard for renewal than was used in the original carpet.

So-called sand and oil-mixed road surfaces are either repaired or renewed by the addition of mixed material of the same quality and density as that used in the original surface.

Bituminous grouted or mixed macadam surfaces should not require early or frequent repairs or renewals if designed and constructed properly in the first instance. Should the necessity for repairs arise, however, they are ordinarily made by the removal of all disintegrated or imperfect portions of the surface, and substituting a mixture of bitumen and small broken stone, the mixture being made either by mixing previous to application or by spreading stone and filling the voids by pouring. In renewing bituminous macadam surfaces it is not generally necessary to break up or remove any of the existing surface; the new surface may be added by spreading directly over the old surface. If, however, the old surface in addition to having become worn thin is worn very irregularly, it is advisable to loosen up, scarify, re-shape and roll the old surface before adding the new surface material.

CEMENT-CONCRETE SURFACES.

The repair of cement-concrete surfaces is a comparatively new problem, as such surfaces have not been in use for many years, and such repairs as have been required have been due to imperfect workmanship or material. If the defects to be repaired consist of badly-disintegrated sections, they cannot be permanently repaired except by the removal of all material in the sections to the full depth of the surface, replacing with new and proper concrete. If the defects to be repaired are minor, however, and consist merely of small depressions, they may be repaired by filling the depressions with a bituminous mixture. When a cement-concrete surface becomes worn sufficiently to appear to require renewal, it is impossible to renew it by adding a new thin coat of cement-concrete mixture; therefore, it may be said that a cement-concrete surface cannot be renewed with the same type of surface, but must be entirely removed and a new section constructed. This would be expensive, however, and it appears that the proper method of bringing up an old concrete surface is to cover it with a bituminous-bound surface in place of a cement-concrete surface.

Block pavements of all kinds can be repaired or renewed only by the entire removal and replacement of the sections.

DACRE CHURCH, NEAR ULLSWATER.*

There are many old villages and hamlets in the caverns of the Lake District which are rather out of the beaten track of tourists, and are, therefore, not much visited; but they are well worth inspection, for all of them have their architectural remains, not to speak of their old customs and legends, the latter being given material support by quaint stories and signs of every conceivable form and shape.

One of these villages is Dacre, a quaint old world retreat, a few miles from Ullswater. The Castle, church, and houses still retain the vigour of their youth, so well are these northern structures able to withstand the ravages of time.

The Castle usually receives most attention from visitors, although there is nothing particularly noteworthy about it, except its antiquity.

The church, however, is extremely interesting, for although it has been extensively restored and repaired from time to time, it has lost nothing of its architectural value. It was originally a Norman structure, the chancel being now the only remaining portion of this date. The walls are constructed with a red sandstone in uncoursed rubble, the rest of the church being built with a white sandstone.

There is a small doorway in the south side of the chancel which appears to have been inserted at a later date, being transitional in character, as shown by the flat keystone, and the columns worked on the separate stones of the door jambs.

The latter was a step to making the column a separate feature, distinct from the jamb. The interior of the church is very interesting, much of its charm, however, being lost by the insertion of new varnished woodwork and dull drab red floor tiles.

There are many beautiful wall monuments; some within the sanctuary should command special attention as a specimen of the craftsman's work of the period 1709. They include a stone effigy of a knight, presumably Lord Dacre, from whom the name of the village is derived, and two other pieces of stonework with crude surface carving. The altar rail is of extreme age, and the baluster is a well-wrought piece of work.

Four peculiar stones in the churchyard, very much weathered, are said to be carvings of bears which were formerly on the Castle tower; and then there is underground masonry in the lower portion of the churchyard, which is pointed out as being the head of a vaulted tunnel leading to the Castle. All such quaint features of these old villages can only safely be presumed to have the significance attached to them by the local villagers, who are only too glad to talk to anybody seemingly interested in them. The writer was initiated into the key series of the symbols of Dacre Church by the village innkeeper, who was superintending the digging of new graves at the time. Possibly he was the verger of the church, in addition to his calling of Boniface.

Another village in the vicinity is Askham, perhaps the prettiest of all Lakeland villages, and well worth more than one visit to the architectural student.

Dacre lies about five miles to the north of Pooley Bridge, at the northern head of Ullswater, and Askham about five miles to the south.

BRIGHT FRASER, Student S.A.

Mr. C. H. Wollaston has been appointed Chief Engineer of Burma, in place of Mr. D. W. Aikman, transferred in a similar capacity to the Punjab.

Mr. D. J. Phillips has been accidentally killed whilst serving in the Naval Division at the Dardanelles. Prior to the outbreak of war he was engaged as a divisional surveyor under the West Suffolk County Council, and resided in Bury St. Edmunds. He was about twenty-seven years of age.

The first meeting of the session of the Birmingham and Midland centre of the Institute of Sanitary Engineers was held at the Exchange Restaurant, Birmingham, on the 18th inst., when the president, Mr. E. J. Harber, delivered an address on "The organising and work of the sanitary engineering profession."

* From the *Journal of the Society of Architects*. C

THE LONDON COUNTY COUNCIL.

At the meeting of the London County Council yesterday (Tuesday) afternoon, the Education Committee reported that the Professional Classes War Relief Council had asked that, with a view to finding work for artists in distress through the war, the walls of certain Council schools, to be selected by the Council, may be decorated with friezes and panels, the decorations to remain the property of the Council. It is proposed that the subjects and designs shall be supervised by an expert committee of artists, and submitted for approval to the Council before being carried out. In order that the work of the schools may not be interfered with, the friezes and panels will be executed away from the school buildings, and fixed during the school vacations. The Council will not be put to any expense in the matter. The committee recommended that the offer be accepted with thanks.

The Council was recommended by the Improvements Committee to consent to the postponement for another year to Christmas, 1916 of the demolition of the properties at Nos. 107, 103, and 109, Strand, part of the site which has been acquired by the Duchy of Lancaster for the widening of the Strand.

The Treasury having refused sanction to the capital expenditure involved in the reconstruction of the horse tramways between the West India Dock via Bunlett Road and Grove Road to Victoria Park and those in Grange Road, Southwark Park Road, and Rotherhithe New Road, Deptford, it was reported that it will be necessary to effect extensive repairs to the tracks in order to make the highway safe for vehicular traffic at an estimated cost of £6,250.

Some of the owners of property in the Tabard Street slum area, which is being cleared by the Council, refused to accept the compensation offered, and the disputed claims have been settled by arbitration. In one case, where £2,000 was claimed, the council offered £200. The arbitrator now awards the landlord £61 16s. In another case, where £625 was claimed and the Council offered £20, the arbitrator awards £5, this being for four hours.

THE DISMISSAL OF THE LAND VALUATION STAFF.

Mr. McKenna, the Chancellor of the Exchequer, received on Friday afternoon a deputation of the "retrenched" professional staff of the Land Valuation Department. The deputation, which was introduced by Mr. C. E. Price, M.P., the Liberal member for Central Edinburgh, consisted of delegates representing England, Scotland, and Wales.

Mr. Price, before introducing the speakers, gave a résumé of the case of the temporary professional staff, and urged that the dismissals would result in serious loss of revenue; and, further, that in view of commitments and promises held out it was the duty of the Government to find them new employment in other departments, where their services would be of value to the State.

Mr. Lamont, Manchester, dealt with the broad aspect of the case, and especially drew the attention of the Chancellor to the loss of revenue which would arise in estate duty alone, and also to the fact that the sales on which increment value duty was revealed could not be investigated, and that consequently a loss of revenue would result, as the depleted staff was inadequate for dealing with the work.

Mr. Crompton pointed out the hardship resulting to men in the department who had confidently relied upon promises made by responsible officials as to the security of their position, and urged upon the Chancellor to show every consideration to these men (eligible for military service). He referred to the desertion of treatment in the cases of men who, at the outbreak of war, were given permission to enlist, with the benefit of their civil pay (less 7s. per week) and a promise of reinstatement, and those who were refused such permission, and who were now dismissed without any consideration.

Mr. Agate, Manchester, declared that eligible military men were now at a disadvantage in consequence of the War Office

apparently men outside the department to lists of names and have been suitably filed by the architect department.

Mr. McKenna gave the delegates a patient hearing, discussed with them the various points raised, and promised to make further inquiries.

TEMPERATURE EXPERIMENTS AT LAHORE.

Under this title, Mr. W. S. Dorman, M. Inst. C.E., executive engineer in the Punjab Roads and Buildings branch of the Public Works Department, furnished a paper to the Punjab Congress of 1915. He mentioned that in the design for the new Government Press stress was laid on the necessity for keeping down the temperature of the machine room as far as possible, and it was, therefore, decided to carry out experiments with various roofing materials.

The building concerned was very suitable for the experiments, as there was a row of rooms, each 12 ft. by 8 ft., for the mental staff employed at the Press. These rooms were roofed with red eternit on battens with an eternit ceiling below; grey eternit on battens, and 1 on 2 in. boards; asbestos on battens; asbestos corrugated sheets on battens; and 22 B.W.G. corrugated iron sheets on 2 in. boards, with a 2 in. fibre cement ceiling on 2 in. boards without the ceiling, on 2 in. battens over 2 in. boards, on battens with the sheets painted with two coats of white corrugated paint, and on battens with the sheets unpainted. The observations were evidently made with great care by Mr. Dorman, and he arrived at the following results:—(a) In any ten-day period the maximum temperature seldom varied by more than 5 degrees. (b) The colour of the eternit tiles, grey or red, made no difference in the temperature. (c) The addition of an eternit ceiling below the rafters was of no advantage in reducing temperature. (d) The substitution of boards for battens below the eternit added Rs. 12,152 per hundred sq. ft., to the expense and reduced the maximum temperature by 2 degrees. (e) Asbestos corrugated sheets was double the cost of the asbestos roofing, and only 1 degree cooler. (f) Corrugated iron on battens was 1 or 2 degrees hotter than the asbestos corrugated sheets, and one-third the price. (g) Painting the corrugated iron white had no effect in reducing temperature. (h) The use of boards instead of battens under the corrugated iron reduced the maximum temperature, and kept the room from heating up so soon. (i) The addition of a fibre cement ceiling added largely to the cost, and was not worth the expense. (j) There was no advantage in having battens between the boarding and the corrugated iron sheets.

A second set of experiments were made with three-ply corrugated iron on 2 in. boards, with three-ply mahogany on 2 in. boards, with red polite tiles on battens and a 2 in. pine ceiling, with Roman tiles on battens, and with single Allahabad tiles on battens. These experiments confirmed the first set, and showed that as far as the temperature was concerned, there was very little difference in the materials tried. A port roof being obligatory, corrugated iron on boards was as good as any for all practical purposes, and it was decided to use this form of roof for the Press.

In the discussion, R. B. Mahar Ganga Ram said that in his opinion the coolest and most satisfactory roof was of mahogany with a ceiling, and 6 in. of washed mica over the ceiling. Mr. Dorman highly approved of the mahogany roof proposed by the Chief of the Public Works Department, and the use of stretches over the roof, and the use of a general Colonial Climate R.F. was another effective means of reducing temperature. *Indian Engineering.*

Under the title, Mr. W. H. L. R.I.B.A., architect, Bedfordshire, furnished a paper of £500,000, and the cost of the new St. Mary's Church, Guildford, Mr. L. C. B. says a short account of the building, and a technical description of the work of Sir Thomas Drew. Some years ago he presented a stained glass west window to the cathedral.

THE MEDIEVAL ARCHITECTURE OF THE WEY VALLEY.

In the course of an interesting paper read recently by Mr. E. Chapman before the London Natural History Society, the author says:—

The valley was so strongly held, and was so largely royal demesne, that the long struggle between Crown and Nobles left little mark upon it, but with the rise and decline of monasticism, and with the struggle between the church and state its history is closely linked. The documentary history of Surrey begins with a charter, probably a forgery, but a very early one, of Chertsey Abbey. The great monastic revival of the eleventh and twelfth centuries saw the reform of the Benedictine rule, and the foundation under an Englishman, Stephen Harding, of the Cistercian order. In 1128 the Bishop of Winchester brought over from France twelve monks of the new order, and gave them lands at Waverley by Farnham, where, under the renewed encouragement of successive bishops, they established a great abbey. The story of this abbey forms in itself a synopsis of the story of monasticism in England. We see the monks busy with their buildings, industriously cultivating the country side, raising great flocks of sheep on the neighbouring hills, entertaining great nobles and kings, for here in 1203 came John to spend four days of Holy Week, bringing with him two tuns of wine, no doubt to mitigate the severity of the Lenten fast, and here, in 1225, came the young Henry III., and was admitted to the confraternity in the chapter house. At this date the monks were in the midst of rebuilding; they were replacing their first Norman Abbey with a beautiful Early English structure. The new church was completed in 1250, and now the monks seemed at the height of their prosperity. In 1240 a young shoemaker charged with homicide took sanctuary with them, but after some months was seized by the king's orders and carried off to prison. The Abbot, after a vain appeal to the Papal Legate, turned to the king himself, producing the charters and privileges of his order, convincing him "that the precincts of abbeys and their estates were by apostolical authority exempted from the encroachments of all wicked and profane persons, and inviolable as the altars of churches." The shoemaker was restored to the monks, the officers who arrested him were condemned to ask pardon at the convent gates, and afterwards to be publicly whipped, "which sentence having been fully executed upon them by the Dean of the House and the Vicar of Farnham, they were absolved in form, and, having a sufficient penance enjoined them, were dismissed."

Now was this the only incident in the great struggle which the valley witnessed. Already in July, 1174, Henry II. had passed through Guildford on his swift penitential journey to Canterbury, after the murder of Becket, and in 1199 Ruald de Calva had founded, in honour of St. Thomas, the Austin priory of Newark at Ripley. The beautiful little church of East Clandon also dates from about this time and bears the same dedication.

Of the rise and development of mediæval architecture, the valley presents many interesting, but no very rich or famous illustrations. The district was not wealthy, and building materials were not of the best. But what a rural population could do with flint and chalk and Bargate stone, with tiles and Hursbam slabs, and with here and there a shaft of Sussex marble, was done. Of the ancient churches the outer walls are mostly of flint, and the interior arches very frequently of church a hard form of chalk. Lady boxes and delicate traceries were alike out of the question. But of simple and simple work, well adapted to its ends, much is left to us.

Of one-Compust building there is little remaining, but the strong rude towers of St. Mary's, Guildford, and of Compton have been added to this period with some confidence. Of the Norman period there are several interesting examples, including Compton, with its noble chapel above the vaulted sanctuary, and its very ancient screen, the

main structure of St. Mary's, Guildford, whose walls were enriched in the thirteenth century by paintings which remain, the royal keep of Guildford, and the tiny village church of Pyrford. Of Early English work the most notable remains are those of Waverley Abbey, the beautiful western doorway of Shere, and the great E. window of seven lights at Ockham. The architectural needs of the district do not seem to have undergone any great expansion in the fourteenth century. Here and there a fine new window was opened, as at Shere, but I do not recall any building wholly in Decorated work, and similarly the examples of Perpendicular work are mostly to be found in enlargements and modifications of older buildings. Then at the very close of our period, we see the needs of a new time finding satisfaction in two buildings, both instinct with the old Gothic beauty, the great manor house of Sutton, and the Grammar School at Guildford.

A NEW INDUSTRY FOR HUDDERSFIELD.

The directors of British dyes have, after long deliberation, decided definitely to set up great works in Huddersfield, in close proximity to those of Messrs. Read, Holliday and Sons, Limited, which they took over some months ago. Huddersfield will thus become the chief colour-making centre of the country, and its population and rateable value will be largely increased, as the company is expected to have 10,000 workers in its service. The Mayor and Corporation will undertake to make the trade effluent satisfactory to the river authority, as they already do. The directors considered the relative advantages of Manchester (Trafford Park), Selby, Leeds, Goole, Widnes, and Huddersfield, and eventually the choice lay between the last two named. The scale probably turned in favour of Huddersfield, no doubt owing to the proximity of Messrs. Read, Holliday and Sons' works, but also because the town can offer a large supply of good soft water, and is well situated for supplying all the Lancashire and Yorkshire textile districts. The company has acquired about 250 acres of land for buildings and yards, extending from the river Colne in Leeds Road up the Dalton Valley, and has let contracts amounting to some £250,000.

The housing problem which will be created at Huddersfield by the establishment of these works was discussed at a meeting of the Town Council on Wednesday. Alderman Smith, chairman of the Housing and Town Planning Committee, said that already the applications for houses exceeded the number of houses that the council had decided to build. Councillor H. Dawson said if only 5,000 men were employed at the British Dye Company's works it would mean an increased population of 25,000, with all that was necessary for them. He suggested that a special meeting of the General Purposes Committee should be called to consider the question. Councillor Jagger urged that in addition to corporation enterprise private builders should be encouraged to erect cottage property. Alderman Smith promised that the question should come before the General Purposes Committee.

The Council of the Surveyors' Institution have nominated Mr. Howard Martin, past-president, 27, Chancery Lane, W.C., as the representative of the institution on the Tribunal of Appeal under Sec. 176 of the London Building Act, 1894, to fill the vacancy caused by the death of the late Mr. Herbert T. Bishop.

At Broad-stall on the 18th inst. the Bishop of Derby took part in the celebration of the completion of the first stage in the rebuilding of the parish church, which was destroyed by fire, presumably the act of female suffragists, about eighteen months ago. The shell of the church has now been completely restored, and the tower has been made safe. Lighting and heating apparatus and seating accommodation are on order, and the church will be opened for divine service next spring. Before it can be restored to its condition before the fire, vestry and organ chamber, organ, bells, clock, chancel screen, pulpit, choir stalls, and other necessaries have to be procured. The total cost of the work is estimated at £11,000, towards which £8,050 has been secured, including £6,280 from the insurance company.

RAILWAY TERMINALS.

At the Surveyors' Institution on October 15, Mr. James Crossland gave a lecture, illustrated by lantern slides, on "The Planning, Design, and Arrangement of Railway Terminals." The common view, he said, was that a big railway station should be placed in the very heart of a town, but he thought that wrong, because it would generally be found that slums accumulated in the vicinity of large stations. It, therefore, a station was some distance from the centre, it led to decent development of the town from the station to the centre. A railway running through a town necessarily created a kind of barrier, and therefore it might just as well be a barrier between the residential and the factory areas.

He discussed the methods of bringing a railway into a town, on the ordinary ground level, above, or below, and expressed the opinion that if a railway could be brought in below the surface it was obviously the best. The advantages of having through stations instead of terminals were referred to, and the lecturer urged that architects, in designing a railway station, should strive to express a railway station, and not an hotel or a bank.

In conclusion, he dwelt on the design of small country stations, and by slides showed how, by simple design and an arrangement of foliage, these could be made to look very pleasing. Incidentally, he expressed the opinion that in large towns the right way to deal with traffic was to entirely separate the suburban from the main line traffic.

The discussion was opened by Mr. T. H. Mawson, who said that, as city planners, they must have some idea of the areas required for the probable traffic of a station they were planning which would provide for the growth of the town for twenty, thirty, or fifty years. This was necessary in order to avoid the constant alterations of stations and the expenditure of money which did not bring in any return, not to mention the upsetting of the plan of a town.

Mr. Davidge expressed the opinion that within the next twenty years the whole of the large railways running into London would have to reorganise their systems of arrangement of suburban traffic.

After having been closed for about six years the old Forby Cement Works, Frindsbury, have been re-opened by the Medway Standard Portland Cement Company, Ltd., and are now employing upwards of fifty men. Mr. John Clarke, for twenty-two years manager of the Artillery and Albion Works, Greenhithe and Shoreham, is in charge of the works.

At the last meeting of the Stafford Rural District Council a letter was read from the Road Board expressing their appreciation of the valuable services which Mr. Idiens, the council's surveyor, had rendered in connection with the construction and improvement of roads, and asking the consent of the council to make him some monetary payment. The council consented.

The funeral of Mr. William Francis Hile, of Little Bayham, Lamberhurst (clerk of works on the Bayham Estate), who died suddenly at the age of sixty-four, took place at Frant, on Monday, the Rev. E. S. Jose, chaplain to the Marquis Camden, conducting the service. The coffin was borne to the grave by members of the staff. There were numerous beautiful floral tokens, amongst the senders being the Marquis and Marchioness Camden.

Private Edgar James Edgar, younger son of Mr. James Edgar, of Cronkbourne Road, Douglas, Isle of Man, has been killed in action in the Gallipoli Peninsula. Private Edgar was just twenty-nine years of age. On finishing his education at the Douglas secondary school, he was articled as a pupil to Mr. A. E. Prescott, then borough surveyor of Douglas, and now of Eastbourne. After completing his articles, Private Edgar held several appointments in Canada, and later in the city surveyor's office at Sydney. At the outbreak of war he was an assistant engineer to the Public Works Department, New South Wales. He was appointed Second-Lieutenant in the Submarine Defence Force of Sydney Harbour. When the menace of an attack on the harbour was removed, he joined a signalling company as a private, and proceeded to the Dardanelles, where he met his death.

THE STREET SYSTEM IN CITY PLANNING.*

By NELSON P. LEWIS,†

There have been a few cases where important cities have been planned as a unit; where the administrative centre, the commercial, industrial, and residential districts, the lines of transportation and their terminals, have been laid out after careful study to meet conditions which could be confidently expected or to a large degree controlled. Washington is one of the most notable instances of such city planning. The city planner usually finds, however, that the beginning has already been made, a beginning which may prove a serious handicap or may, though less frequently, be an admirable nucleus for the larger plan. Most old cities have simply grown with very little planning. Comprehensive plans, where such have been prepared, are of comparatively recent date, and have had to adapt themselves as well as might be to the older portions of the towns as they were, and make designs for sections not yet developed conform with the haphazard growth which had already taken place. Plans of such cities, therefore, commonly consist of a number of separate designs more or less unrelated to each other, abutting upon the confused and uneconomic system of streets in the old town, which in most cases has persisted as the actual centre.

STREETS IN UNDEVELOPED SECTIONS.

In every city, however, there are large areas not yet developed and not even planned, where opportunities are presented to design a street system, the different parts of which will be properly located with respect to each other and to such modification of the system of the existing town as may ultimately be carried into effect. Too often these undeveloped sections are planned as if they were so many different urban areas unrelated to each other or to the original city, and too often the obvious blunders of the older sections are repeated in the new additions.

In nearly all cases where a street plan is to be devised, whether it be for a large area which can be treated almost as an entire city in itself, or for a smaller tract contiguous to the built-up portion of an important city, the first essential is an accurate plan of the existing roads showing their widths and the buildings fronting upon them. The old highways which serve to connect villages or centres of population have a good excuse for existence and serve a useful purpose; they lead where people want to go and are likely to be fairly direct. Their alignment may be somewhat faulty, their grade excessive in some places, and their widths inadequate in view of the fact that they will naturally become the main lines of traffic for the urban district which will include them. With such straightening and widening as may be deemed necessary and such changes in line as will reduce excessive grades, these old roads will be the logical basis of the street plan which is to be prepared. When they have been plotted, it will be obvious that additional roads will be needed, some to establish cross connections, others to give greater directness to the roads traversing the entire territory, others as bypasses around groups of buildings so located as to render the widening of some portions of the old roads unduly expensive, and still others to furnish lines of main drainage along the valleys through which the lateral sewers and subsidiary trunks must ultimately find their outlets.

While no one can predict with any certainty the precise manner in which any city will grow, the purpose of the preliminary design is to establish lines of least resistance which future development is quite likely to follow. The streets laid down in the plan will probably become the main arteries of traffic.

They will divide the territory into a series of irregular figures having three, four, or more sides, which sides may be a quarter or half a mile or more in length. The areas must be subdivided by secondary roads in the location of which regard should be paid wherever possible to property subdivision, to the possibility of some of them developing into main traffic roads, and to the avoidance of awkward junctions with the main roads already laid down, which would result in confusion of traffic. It is difficult to say how wide the primary and secondary roads should be made. The Royal Commission on London Traffic in its report, made some years ago after an exhaustive study, suggested the following widths: Main avenues 140 ft., first class arterial streets 100 ft., second class arterial streets 80 ft., third class streets 60 ft., fourth class streets 40 to 60 ft. This scale of widths may be somewhat over generous and might involve unnecessarily great cost.

Lastly will come the minor streets, which will serve almost entirely for access to dwellings. Their alignment and grades are of little importance. The chief concern is that they should be so laid out as to furnish ample light and air and discourage, if not prevent, a too intensive development with rear buildings in case the city ordinances do not prohibit this menace to health and decent living. To plan far in advance the precise location of these minor streets is not necessary, if it be not unwise. There is no reason why a street which is to be devoted to private residence should be long and straight. Among the most attractive features of a city are small residential areas treated in a distinctive way, each with a character of its own, which the visitor stumbles upon with agreeable surprise. If these minor subdivisions are planned at different times or by different persons, this variety in treatment is more likely to be realised. The important thing is that the skeleton should be created first.

While directness is desirable in the main and even the secondary streets, it does not follow that such streets should be perfectly straight; in fact, straight streets are seldom interesting. Neither need circumferential or curved streets be laid out with perfect symmetry. In studying a plan the slightest departure from symmetry is noticeable, but on the ground it cannot be detected. One can ride or walk along a boulevard following a sweeping curve and be unconscious of the fact that its radius is frequently changing.

Mr. George Elton Soding, Lance Corporal, Signalling Section, 7th Norfolk Regiment, elder son of the late John D. Soding, F.R.I.B.A., and grandson of the late Rev. E. D. Tindling, Canon of Gloucester, died in a London hospital on Saturday last from wounds received in action in Flanders, aged thirty three.

The Sutton Trustees have purchased Bromwell House Estate in Wick Road, Brighthelm, Bristol, where they propose to build 240 workmen's dwellings, at a cost of £75,000. As the trustees have been prohibited by the courts from spending any of their funds upon buildings until the close of the war, they will not be able to proceed with their scheme at once.

At the last meeting of Stirling Town Council it was reported that certain donors had intimated their willingness to supply a stained-glass window for the principal staircase leading to the council chamber in the new Municipal Chambers. A design, executed by Mr. Gillespie, architect of the buildings, has been accepted. The design represents King Alexander II, presenting to the Provost of Stirling the Royal Charter of August 13, 1226, by which he granted the burgesses of Stirling a weekly market, a guild, and other privileges.

The death has occurred after a short illness, at his residence, Menai Bridge, at the age of sixty-four, of Mr. Evan Parry, builder and contractor. Mr. Parry was a native of Menai Bridge, and succeeded nearly forty years ago to the extensive business carried on by his uncle, the late Mr. Richard Parry, and carried out many important building contracts, including several schools and chapels in the county, the National Provincial Bank, Menai Bridge, (Crisis the residence of Mr. J. R. Davies, D.L., and the Marquis of Annesley's estate office). He executed extensive structural alterations some years ago to Gallys, the residence of the late Colonel McCorquodale. Mr. Parry leaves a widow.

* Abstract of a paper presented last month before the International Engineering Congress at San Francisco.

† Chief engineer, Board of Estimates and Apportionment, New York City.

Our Illustrations.

NEW CENTRAL OFFICES, ROSEBERY AVENUE, E.C. FOR THE METROPOLITAN WATER BOARD.

These buildings have been in course of construction for some months. The competition drawings submitted by the six invited architects were all illustrated in the *Building News* for June 5, 1914, and the perspective here-with reproduced, showing Mr. H. Austen Hall's front part of the premises now in hand, was exhibited at the Royal Academy this season. It shows several alterations upon the original elevation, and by further study the details have been much improved, although the lay-out of the plans seems to have been substantially adhered to. The chimneys seen in the picture were absent in the sketch submitted in the competition. We published a block plan of the site and the two chief floors of the buildings, giving a fairly full description of this scheme, and pointing out the main essentials of the five other plans. Their architects were Messrs. Brown and Barrow, Messrs. H. T. Hare and H. S. East, Mr. Edwin Cooper, Messrs. Herbert O. Ellis and Clarke, and Messrs. E. T. Hall and Son.

DECORATION OF THE SCHOOL CHAPEL, CHRIST'S HOSPITAL, HORSHAM.

We commenced this series of tempera paintings, executed by Mr. Frank Brangwyn, A.R.A., illustrative of the Fathers of the Church, on Wednesday, October 6, and continued their illustration in the following number. To-day we give two more of the panels, which are, like the remainder, based upon a scheme of blues, warm gray, and old gold for the figure work, with a blue sky serving as a band round the chapel to bind the decorations together as a frieze above the top of the oak stalls, the bays being divided by the wall shafts carrying the roof. The subjects now given are St. Augustine at Ebbsfleet, "Funn, O Lord, Thy wrath from this people," and St. Ambrose Training the Choir in his Church at Milan, A.D. 385. Other subjects will follow.

KING EDWARD VII. MEMORIAL, EAST SUSSEX HOSPITAL, HASTINGS.

This hospital is being built on a site to the north of the existing hospital on the high ground. The present building is opposite to the pier, handstand, and promenade, and, therefore, does not enjoy the quiet necessary to an institution of this kind. It is seen that the hospital is designed on the ordinary pavilion system; it has to adapt itself to a very difficult site, which has a fall of nearly 60 ft. from west to east. The buildings will be entirely of brick, with a few stone dressings, the roofs to be covered with Westmoreland green slates. The design is by Messrs. John Saxon Snel and Stanley M. Spoor, architects, of Great James Street, Bedford Row, W.C. The drawing shown was at this year's Royal Academy exhibition.

PORCH AT VERNON, EURE, FRANCE.

SOANE MEDALLION AND TRAVELLING STUDENTSHIP SKETCHES BY MR. ALICK G. HORSNELL.

This excellent water colour sketch is handled in a particularly transparent way, and, architecturally, it makes a very suggestive drawing of a broad and rich piece of work. The study thus directly done is executed with knowledge and minimum effort. It is by Mr. Alick G. Horsnell, Soane Medallist and Tate prizeman of the R.I.B.A. The subject is the portal of the interesting church at Vernon, on the Seine. The building has a choir of the 12th Century, a nave of the 14th Century, with chapels added in the 15th Century. The work is thus very mixed in style and of distinct periods, which differ in detail. In the second chapel, on the left stands the tomb of Marie Maugrand and wife of Simon Hubert d'Harcigny. In the right aisle is a Resurrection group by Arrivabene Caracci. There are half a dozen tapestries of 17th Century date in the choir. The columns of the porch, as may be seen by the illustration, are extremely delicate in their fabrication, and are very freely undercut. The Tombe des Archives, one of the finest parts of the ancient fortifications of Vernon, Edward I. of England erected the castle of Vernon east of the right bank of the Seine. The stables alone are now left intact of the

Chateau de Bizy. This mansion was destroyed during the Revolution. It was the property of the Duc de Penthièvre. The original drawing was recently exhibited in the large gallery at Conduit Street with the rest of Mr. Horsnell's studentship sketches.

SOUTHWOLD CATHOLIC CHURCH AND PRESBYTERY.

This church is designed in the Late 15th Century style, of the same period as that of the ancient parish church of St. Edmund at Southwold. When it came to erecting this comparatively small church, it was necessary to consider in what way it should be treated in order not to compare unfavourably with the magnificent Mediæval church near by. The architects determined to make the whole of the sanctuary form the lower walls of the massive tower. The treatment is extremely simple, and a noticeable feature is that no buttresses are used. The walls internally are plastered and are to be panelled to a height of 7 ft. The contract for the whole building of the church was £5,000. The architects are Messrs. Benedict and Beart-Foss, of Great Marlborough Street, W. The drawing reproduced to-day was shown at the Royal Academy Exhibition this year. The plan, with the view, shows the arrangement of the presbytery with the church at the chancel end.

OLD ENGLISH FURNITURE.

The pair of 17th Century oak chests on legs drawn in the upper half of the accompanying sheet of sketches came from Fritwell Manor, Banbury, Oxon. Both pieces, singularly harmonious, though so different in size. The lower chest, from another private collection, differs in style, which is more akin to the Jacobean manner, with its pretty, simple patterned inlay and applied turned work. The Cromwellian chair is true to date and detail, and so is the Yorkshire chair from an old yeoman's house in the Wolds.

OBITUARY.

The death occurred at his residence, Carisbrooke House, Southey Street, Nottingham, on Monday in last week, of Mr. Richard Charles Sutton, principal of the firm of Messrs. Sutton and Sons, architects, of Bromley House, in that city. Mr. Sutton, who has died at the age of 81, was a pupil of the late Mr. S. S. Toulon, and afterwards established a large practice in his native city, where he built many churches, schools, warehouses, shops, and domestic buildings. For fourteen years, 1837-1901, he was a member of the Nottingham Corporation.

We regret to announce the death, which occurred on the 19th inst., at his residence in Tewit Well Avenue, Harrogate, of Mr. George Portram Bulmer, F.R.I.B.A., of the Leeds firm of Messrs. Henry Perkin and G. B. Bulmer, architects, City Chambers, Infirmary Street. Mr. Bulmer, who was sixty-four years of age, was a past-president of the Leeds and West Yorkshire Society of Architects, and had been a Fellow of the Royal Institute of British Architects since 1891. Among the Leeds buildings in the erection of which he was concerned are the head office of the Yorkshire Penny Bank, the National Provincial Bank, the United Counties Bank, the Scottish Union and National Insurance Buildings, the Union of London and Smith's Bank, Atlas Chambers, City Chambers, Cabinet Chambers, and West Bar Chambers. The funeral service was held in St. Peter's Church, Harrogate, on Friday.

Mr. Gordon Sanderson, a clever young architectural draughtsman and architect, has been killed in France, at the age of twenty-nine years. After serving some time in a London architect's office he went out to Egypt, and was engaged in Government work there. He went to Scotland, marrying an Edinburgh lady, and was over a year and a half in the office of Mr. J. B. Dunn, F.R.I.B.A., of Frederick Street, Edinburgh. Out of over a hundred and fifty applicants he was selected to fill an important post on the Archaeological Survey of India, having charge of the buildings of archaeological value in the United Provinces and the Punjab, with headquarters at Agra. He had the honour of showing H.M. the Queen over some of the temples round Agra on her In-

dian visit. Of commanding appearance and physique, being over six feet four inches in height, he had a charming personality, and was a very fine pen-and-ink and pencil draughtsman—a Phil May in architectural draughtsmanship. One of his earlier works was a charmingly-illustrated book on the "Yeoman Farmhouses of Yorkshire." He could illustrate the Indian temples with their filagree work in a remarkable manner. Although offered an A.D.C. appointment, he preferred to see some fighting, being in charge of the Machine-gun Section of the 2nd Gurkhas. Lieutenant-Colonel Boileau writes of him to Mrs. Sanderson:—"It is with the greatest sorrow that I have to write to you about your gallant husband. I was talking to him only about half an hour before he was wounded. He was as usual full of energy and keenness, and then unfortunately was wounded and removed from our midst about an hour afterwards. I do not think I ever knew a man who was so universally respected and beloved, and his cheery, brave spirit was a great asset to us. He took up machine-guns with that keenness that characterised all his actions, and he soon became an absolute expert. I am thankful to say he did not suffer at all, for he was unconscious when I saw him, and must have been so at once. May I offer you my deepest sympathy, for if we as a regiment deplore his loss, I know what sorrow it must be to you." Mr. J. B. Dunn, in sending particulars to us of Mr. Sanderson, says:—"It is sad to think such a very clever fellow should have been killed so young. . . . He was a fine young fellow, and a highly-skilled draughtsman." He was buried in the British Cemetery at Gorre, not far from Bethune.

Professor Vivian Byam Lewes, Professor of Chemistry at the Royal Naval College, Greenwich, and Chief Superintending Gas Examiner to the City of London, died on Saturday from an attack of double pneumonia. He arrived at Mold, Flintshire, on Tuesday in last week, and delivered a lecture under the auspices of the Educational Trust on "The Explosives used in the Great War." He was afterwards in a state of collapse, and was removed to Hafod, near Mold, the residence of Mr. William Buckley, Chairman of the North Wales Munitions Board, whose guest he was to be during his visit, and succumbed four days later. Professor Lewes was born in 1852, and was educated at University College, London. Among his published works are "Service Chemistry," "Acetylene," and "Liquid and Gaseous Fuel." He was a contributor of many papers to the Society of Arts, the Chemical Society, the Chemical Institute, and the Royal Society, and had lectured before the Royal Institute of British Architects and many other societies on the relative values of illuminants, and kindred subjects.

Mr. George Macfarlane, J.P., the oldest master builder in Manchester, and an ex-president of the Master Builders' Association of Great Britain and Ireland, died on Friday at his residence, Oxford Road, Manchester, in his seventy-seventh year. Mr. Macfarlane, who was a native of Perthshire, where he was born in 1839, went to Manchester in 1854, after spending a little time at Bolton. He began business a few years later as a builder. In 1876 he became a member of the Manchester Builders' Association, and, in due time, its president. In that capacity he took a leading part in the settlement of several labour disputes affecting the building trade. It was, however, in the work of the administration of the Poor-law that Mr. Macfarlane, outside his business activities, took the widest interest. He was elected a member of the Chorlton Board of Guardians, now the South Manchester Board—in 1901, and afterwards became chairman of the board, a position which he relinquished a few years ago. Mr. Macfarlane was an ardent advocate of the scheme for the amalgamation of the Manchester, Chorlton, and Prestwich Boards, and one of the principal witnesses who supported, at the Local Government inquiry, the proposal which has now come into operation. For many years Mr. Macfarlane was also a Governor of Henshaw's Blind Asylum. He had held high office in Freemasonry.

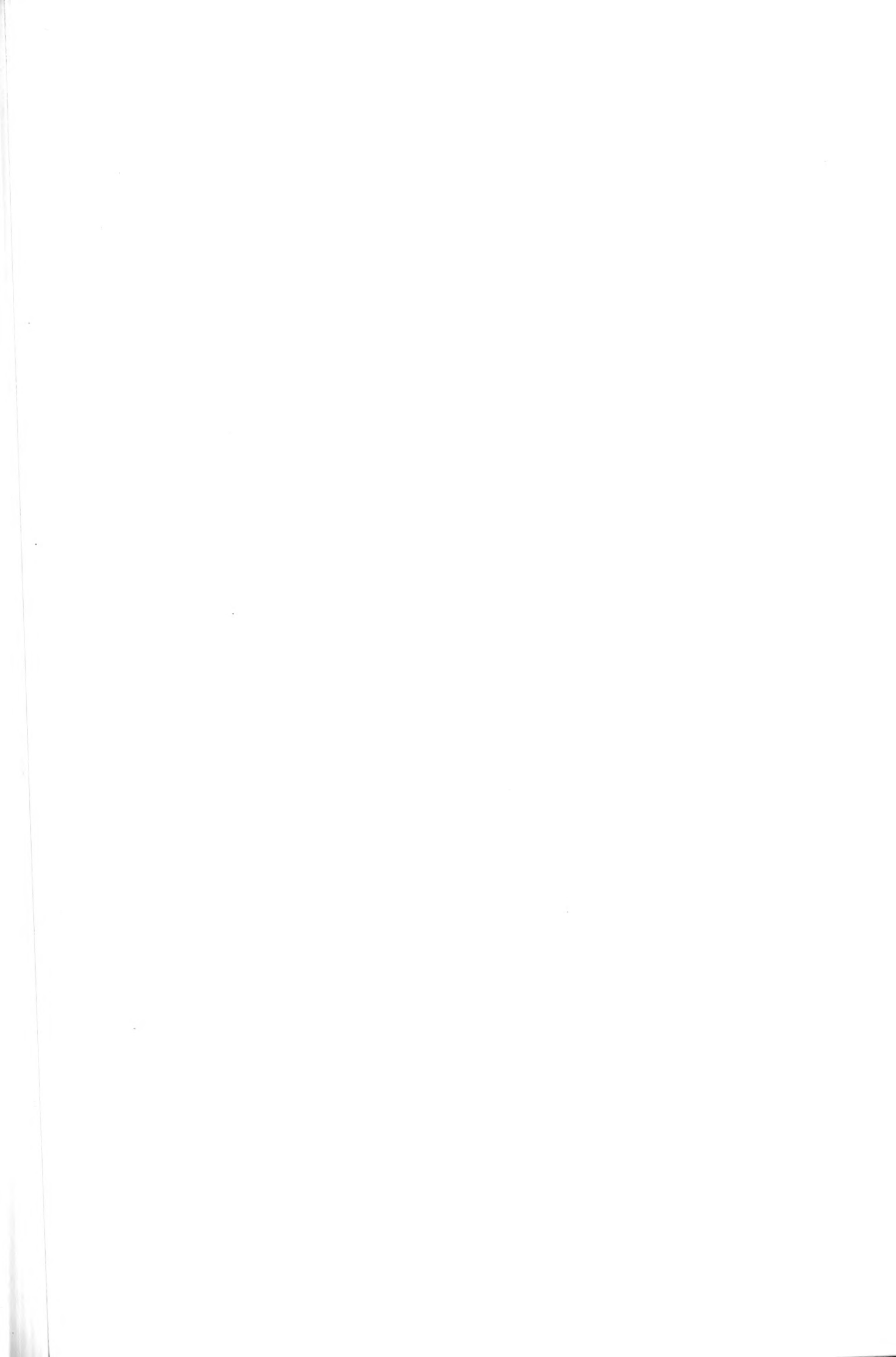

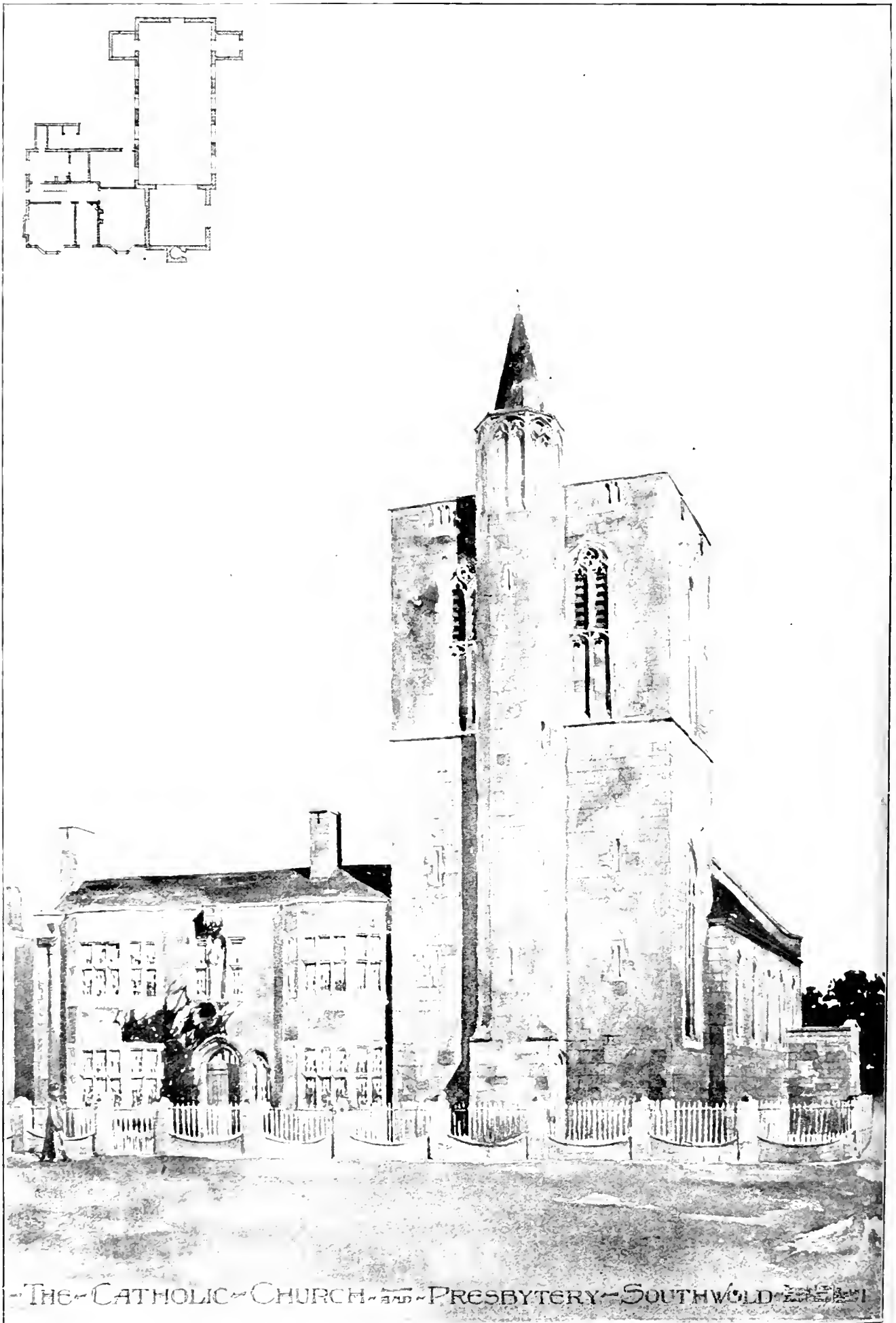

CATHOLIC CHURCH AND PRESBYTERY, SOUTHWOLD, SUFFOLK.
Messrs. BIRLTON, C.S.S., and BLAIR-FOSS, Architects.





PORCH AT VERNON, EURE, FRANCE: SOANE MEDALLION AND TRAVELLING STUDENTSHIP SKETCHES.—By Mr. ALICK G. HORSELL.

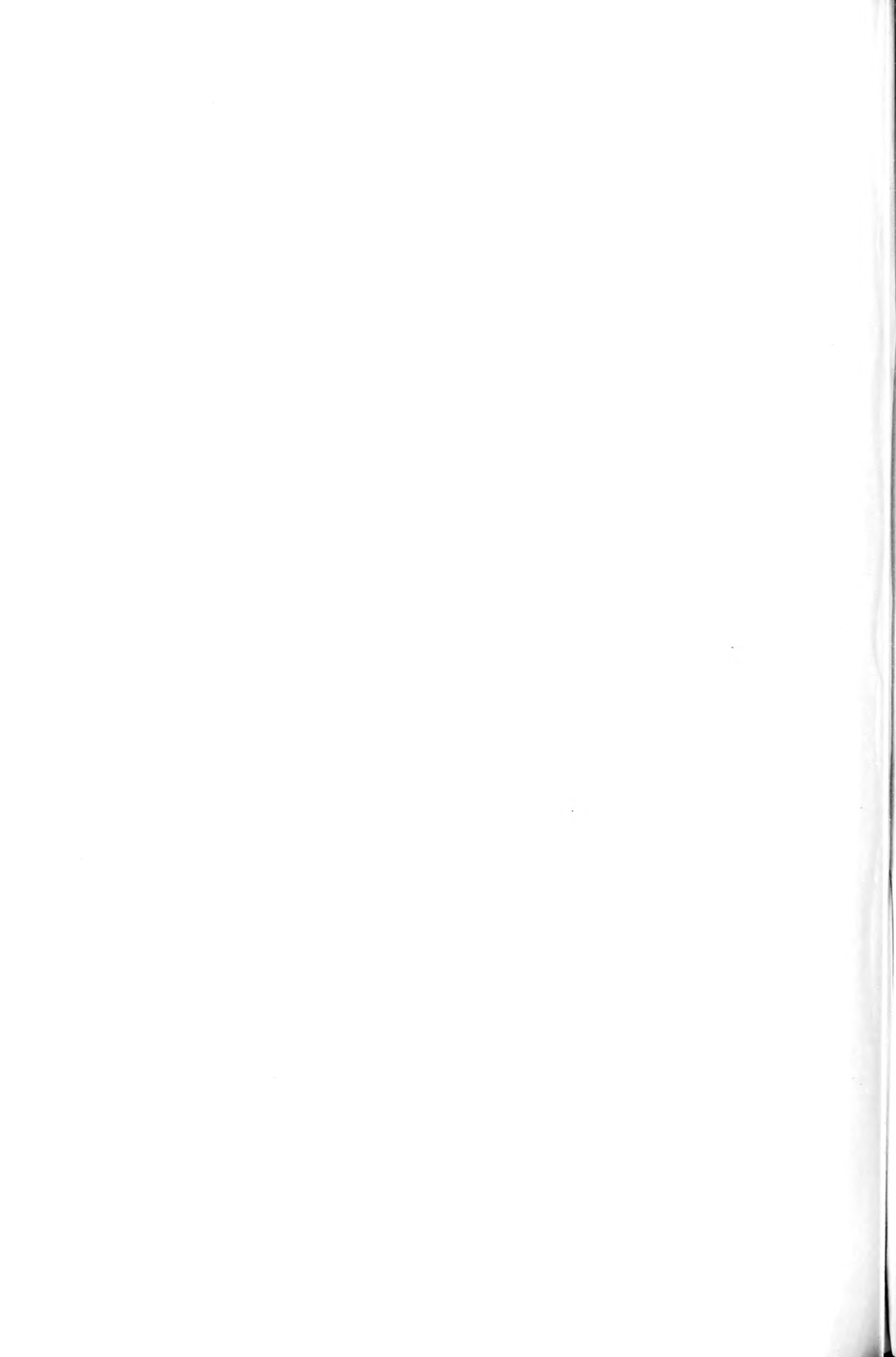

OLD ENGLISH
FURNITURE

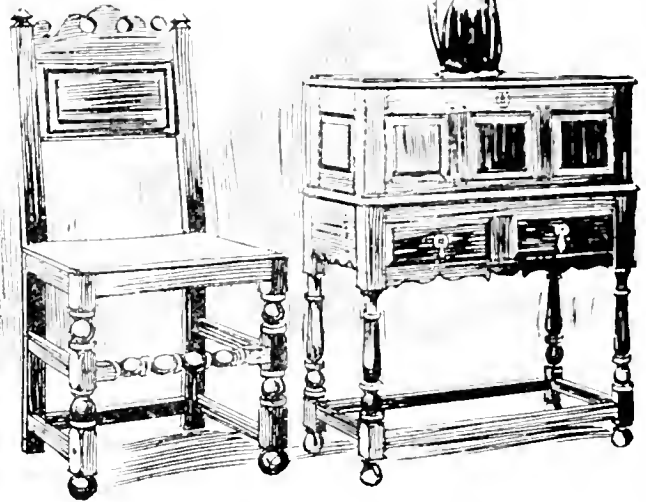
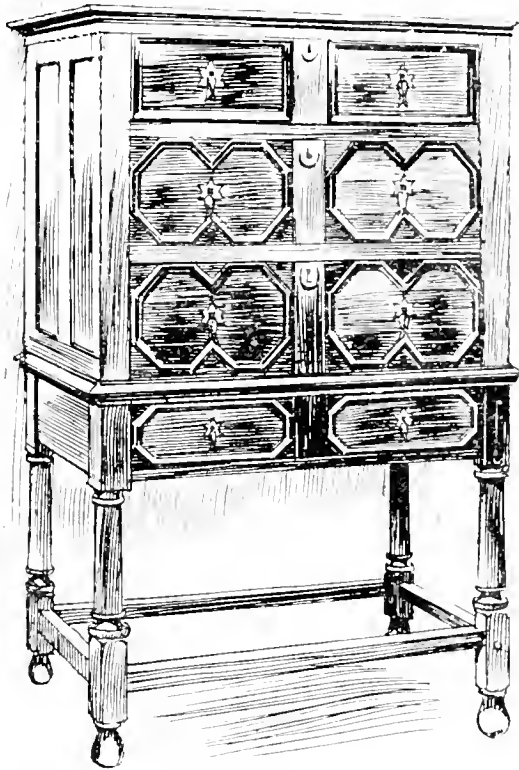

TWO 17TH CENTY OAK CHESTS
& A YORKSHIRE CHAIR

FROM
FRITWELL-MANOR
BANBURY-OXON-

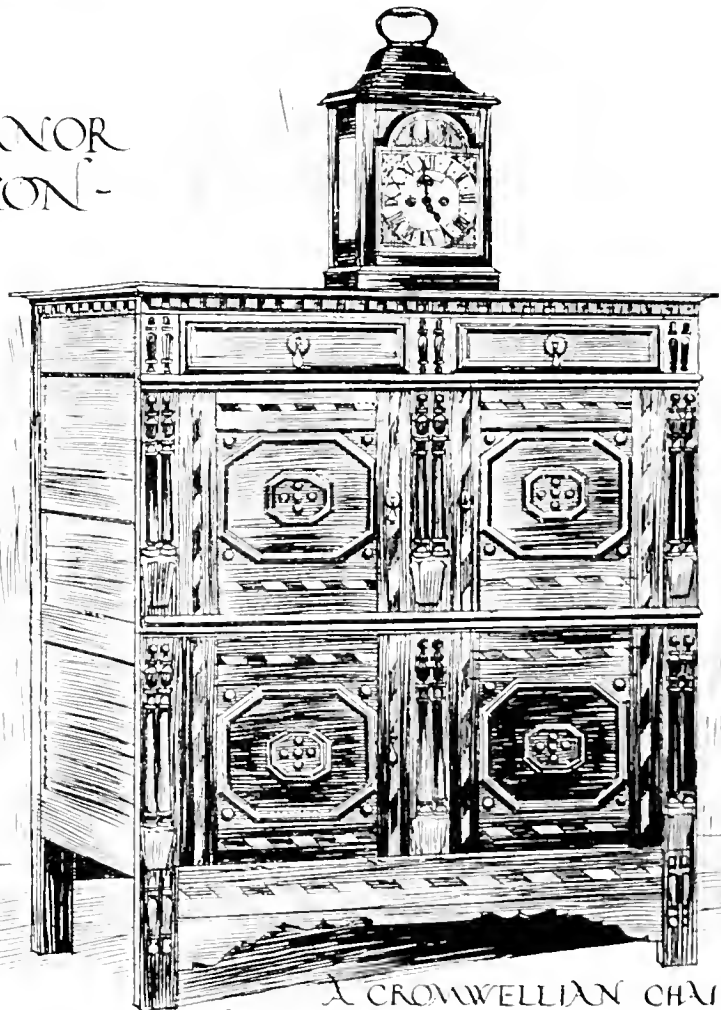
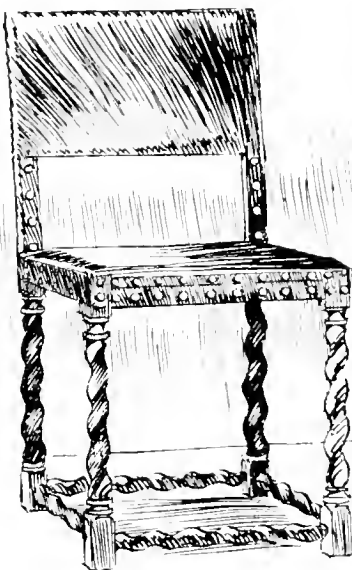

A CROWWELLIAN CHAIR
& INLAID OAK JACOBEAN CHEST

w. j. wills del







Paul Ladb. Phot. (4)

DECORATIONS OF THE SCHOOL CHAPEL, CHRIST'S HOSPITAL, HORSHAM.

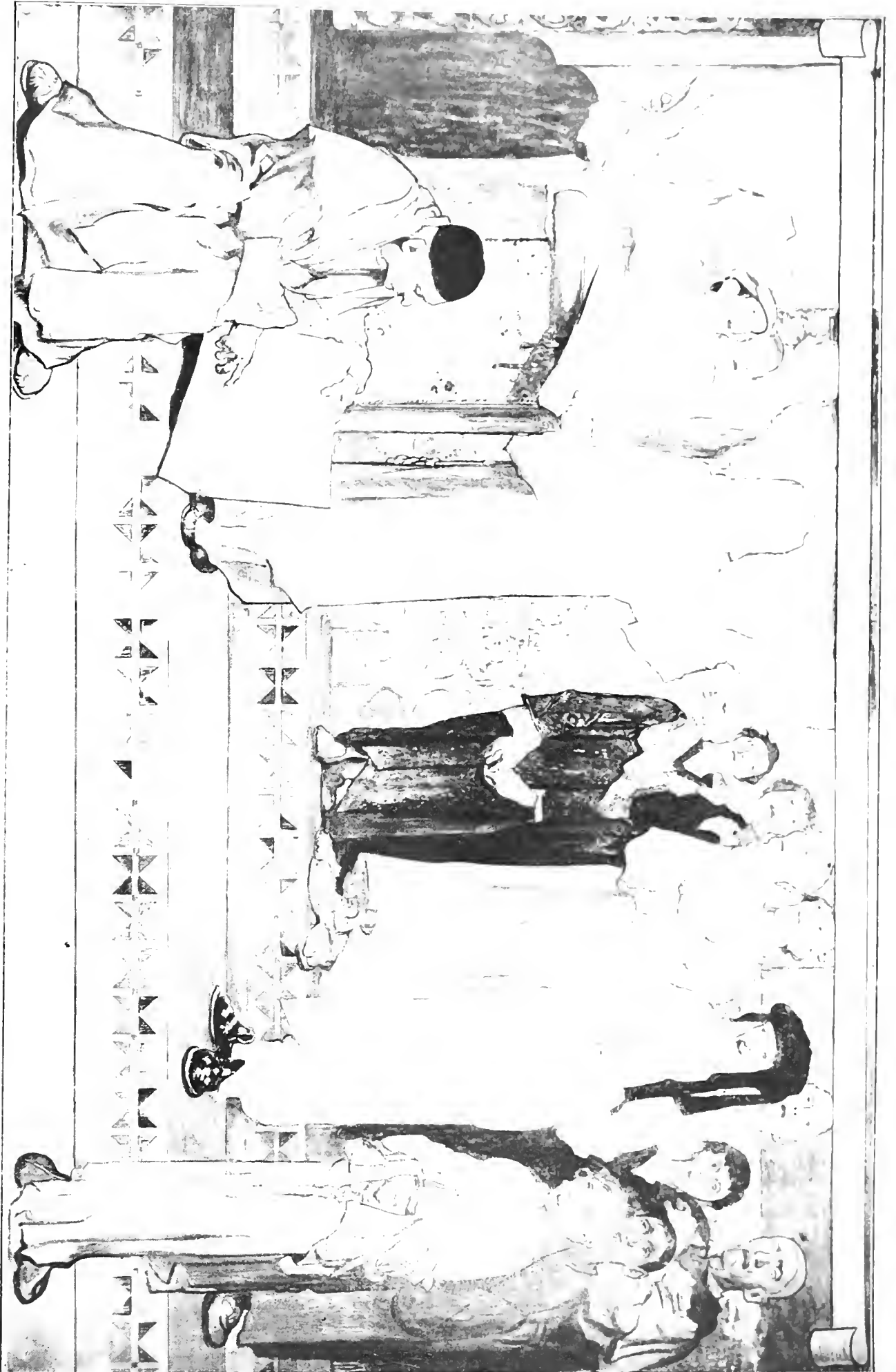

Paul Lamb Photo.

DEPARTMENT OF THE ARMY, GEORGE WASHINGTON UNIVERSITY, CHRISTIAN HOSPITAL, HONOLULU.

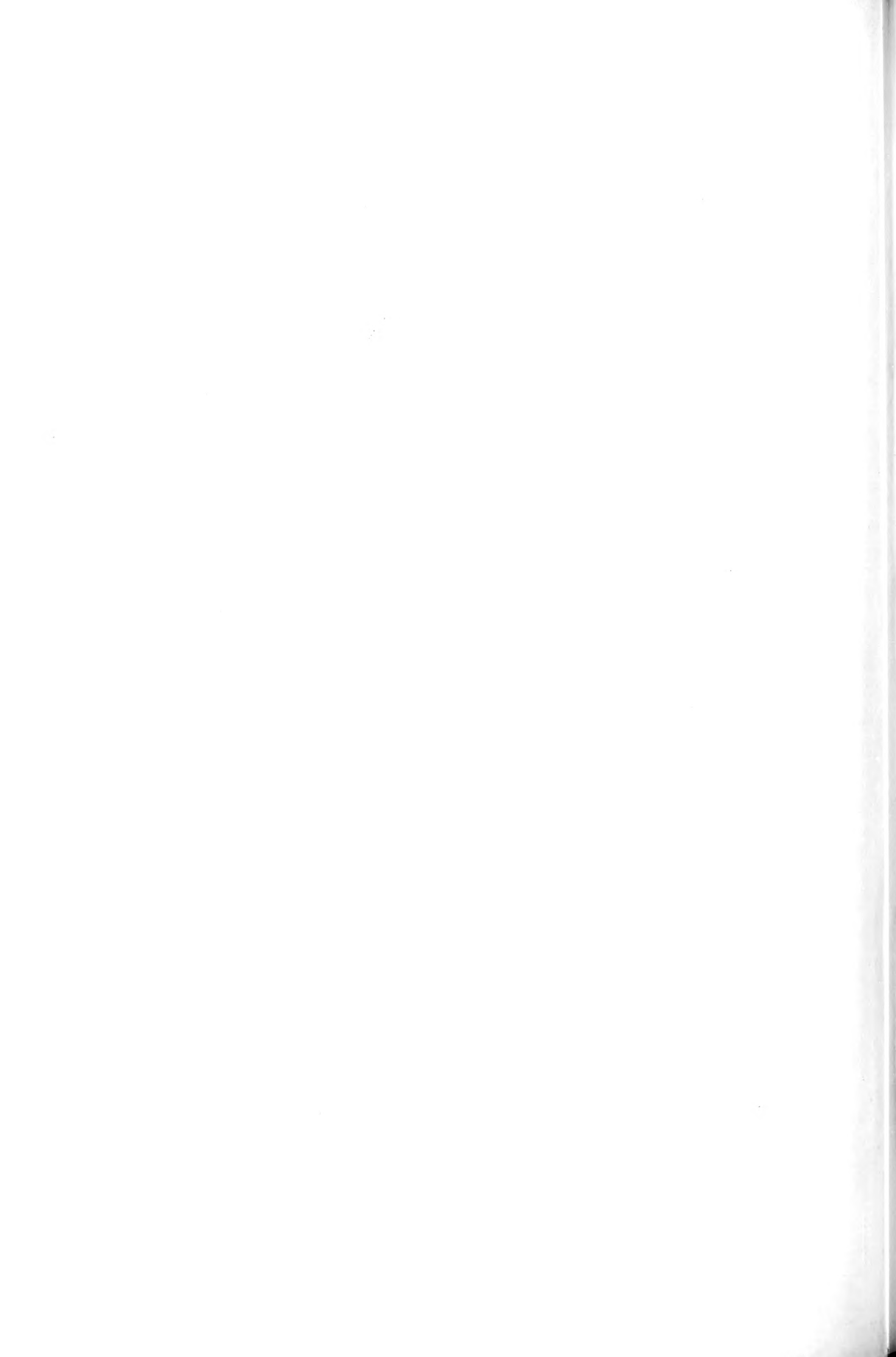



*Metropolitan Water Board
New Capital Office
Riverside Avenue London E.C.*

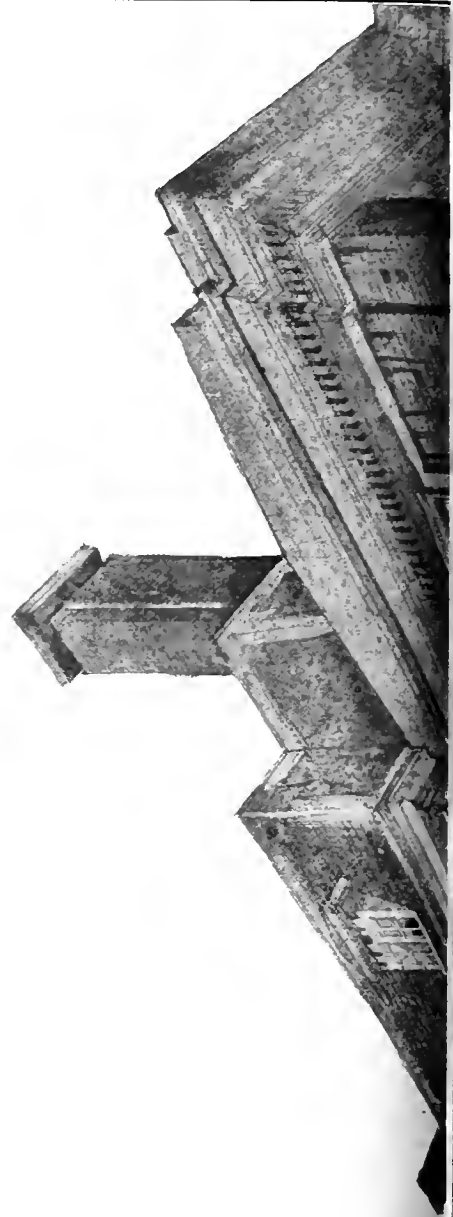

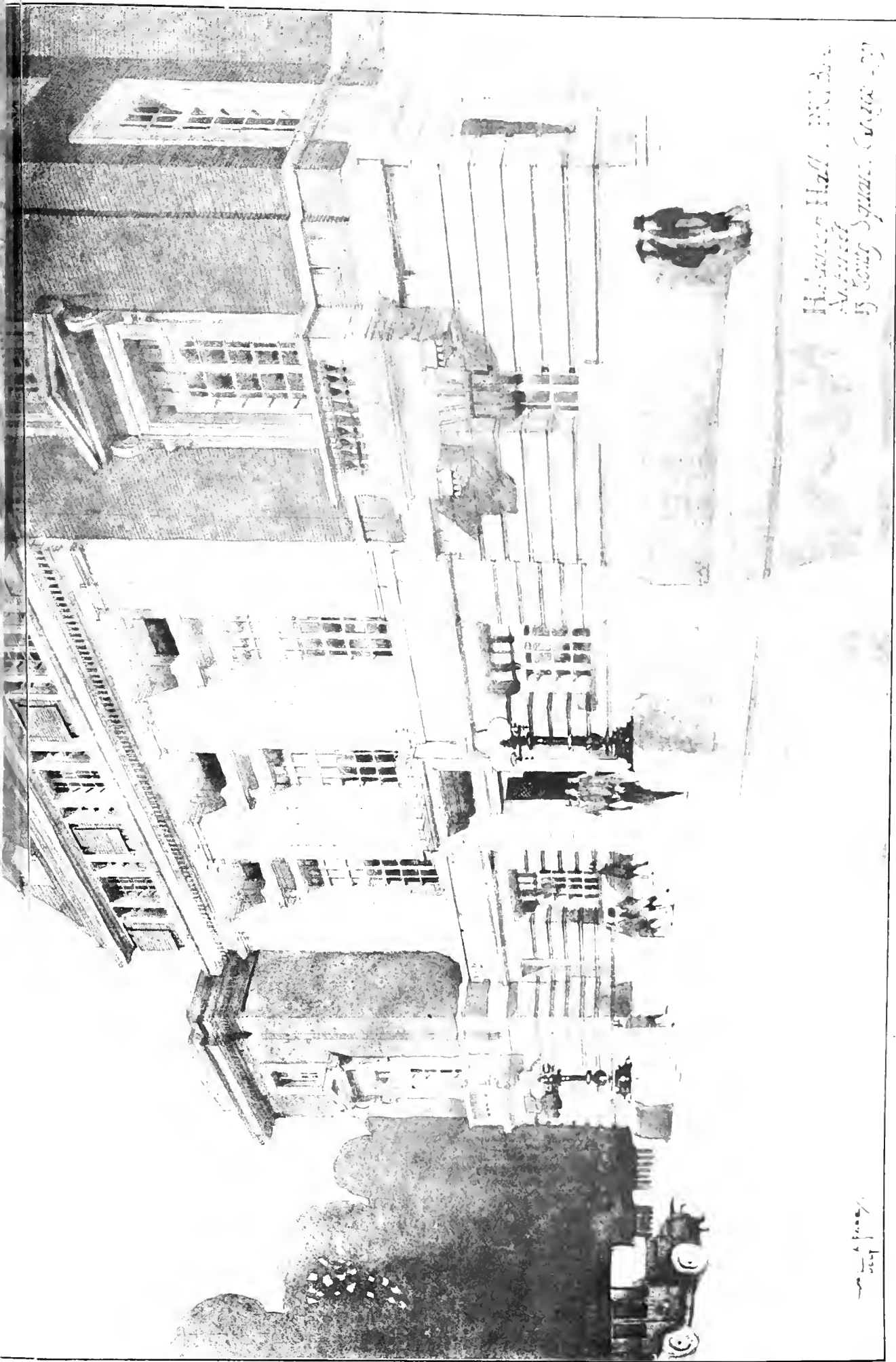

NEW CENTRAL OFFICES, ROSEBERY AVENUE, E.C.4, FOR THE METROPOLITAN WATER BOARD
MR. H. A. T. HALL, ARCHT. R.C.S.

Hobart Hall, 18, White
Avenue, London
15 Long Square, Cairo 1911

1911

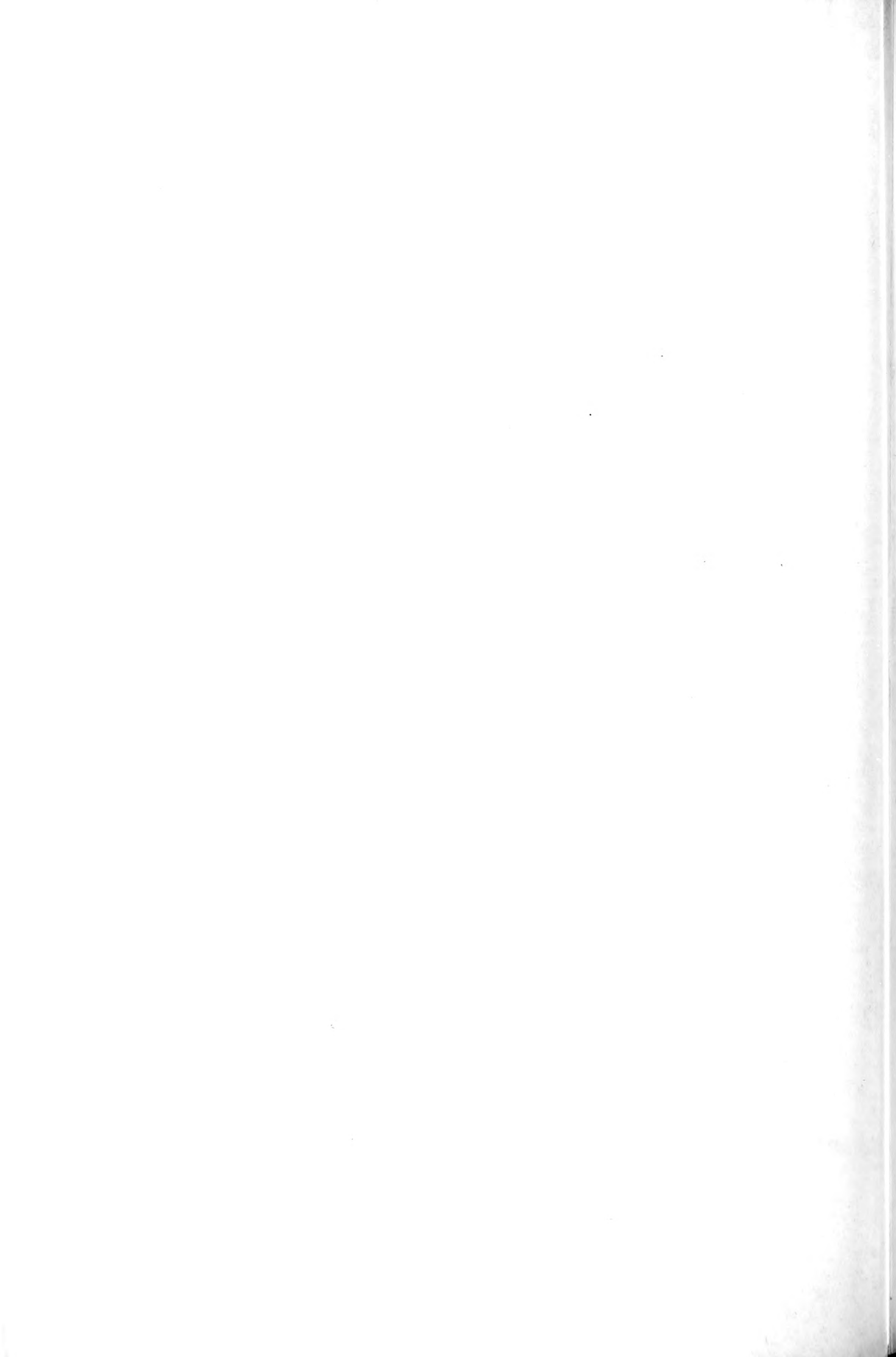

LEGAL INTELLIGENCE.

A BIRMINGHAM ARCHITECT FOUND DROWNED.—The Birmingham City Coroner Mr. Isaac Beasley held an inquest at the Victoria Courts on Wednesday into the circumstances of the death of Frederic John Gill, aged 55, an architect and surveyor, of 79, Watergate Road, Smethwick, who was found dead in the canal near Garrison Lane on the previous morning. Miss Florence Ellen Gill, the deceased's sister, with whom he lived, said he was in very good health. He had never mentioned his life. He left home on the previous Thursday to go to the office, and she had not seen him since. He had many a time stayed away from home for some days at a time, so that at first she was not specially anxious. He periodically gave way to drink, but had been a teetotaler for seven or eight months. Sometimes when he met a few friends he had a little too much to drink. The deceased's clerk, George Randle, said Mr. Gill came to the office on Thursday morning. He left about 11.3 to keep, witness believed, an appointment. He did not return. The body was discovered in the canal at 7.15 in the morning by two men who were walking along the towing-path about sixty yards from the Garrison Lane bridge. George Dallow said on Friday evening, about 9.15, he noticed a man walking up the lane in the direction of the canal. He seemed very much the worse for drink. The towing path there was often used by people as a short cut to get to Watery Lane. He believed the person he saw was the deceased. His dress appeared the same, as well as his general appearance. In reply to Mr. Sidney Vernon, who represented the relatives, a police witness said the path was a dangerous place for a man "who was not quite steady," especially as Friday night was very foggy. A doctor who examined the body said it had been in the water several days. Death was due to drowning. The jury returned a verdict of "found drowned."

AN ALLEGED DEFECTIVE GANGWAY, HEAVY DAMAGES.—**ELLIOTT v. C. P. ROBERTS AND CO. LIMITED.**—Mr. Justice Lush and a common jury heard on Thursday in the King's Bench Division, an action brought by Sidney Elliott, hot water engineer, Carley Street, Stepney, against C. P. Roberts and Co. Limited, builders, Tysson Street, Dalston Lane, to recover damages for personal injuries alleged to have been sustained through the alleged negligence of the defendants. On December 21 of last year the plaintiff was employed on the London County Council's School buildings in Brompton Road, Brompton, and while walking across a gangway formed of two planks, he fell and was severely injured. He suffered serious injuries, and is now paralysed. Plaintiff alleged that the defendants were guilty of negligence in not providing a safe and suitable gangway. The defendants denied negligence, and said the gangway was perfectly safe and suitable. The jury found for the plaintiff and awarded him £2,000 damages. Judgment was not entered pending arguments as to the legal liability of the defendants.

AN ARBITRATION AT BOUTHAM. At the last meeting of the Brantston Rural District Council a committee reported the result of the arbitration as to the charges under the contract for the sewerage of Boutham made by the contractor, Mr. Smith. It was reported that a bill of £31 for extras was sent in by Mr. Smith, and objections were made by the committee. Mr. Smith withdrew the account and sent in another for £115. Eventually the matter was referred to an arbitrator, Mr. Jesse Clegg, of Shefford, who awarded £115.36d. and ordered Mr. Smith to pay the cost £9.

BUNGALOWS AND BUILDING BY-LAWS.—Some of Seabank Farm, Moreton, was summoned before the Birkenhead county justices on Thursday for setting up a temporary building at Moreton, contrary to the provisions of the Public Health Acts Amendment Act. Mr. W. Greaves, J.P., for the Wirral Rural District Council said this was one of the well-known bungalow cases, and one where a hurried attempt had been made to get round not merely by laws, but by Acts of Parliament. On March 20 there was a case at Moreton station on a bungalow in a caravan. A team wagon came to receive it, and a man got on to the bungalow to the top of the wagon. Mr. Sheen, J.P., for the Council, went to the bungalow, and Mr. Alexander Kerr, J.P., for the defendant, was allowing another bungalow to be put on the land, and asking for the

name of the owner. Replies were given denying the erection of the bungalow, but it was found out later that the owner was the defendant. Notice was then given to Sheen that he had recently erected a building contrary to the Public Health Act. A reply was then received, not from Sheen, but from the solicitors to Mr. Kerr, the owner, stating that the building had been erected on Seabank Farm, but saying that the caravan there could be inspected by the Council in Birkenhead if the Council were prepared to pay the cost of the necessary hoists. The building (continued counsel) had a span roof, spouting, and gutters, a stove which was built out over the end of the wagon with a chimney, and at the other end there was a down spout which seemed to be much more suited to a permanent dwelling. The building had a garden in which were growing vegetables, and, in fact, there were all the amenities of a country dwelling. Mr. Shannon, surveyor to the Council, gave evidence as to the character of the structure, which, he said, was intended to be used as a bungalow and not as a caravan. For the defence, Mr. Dean argued first on the legal point that this structure was not a temporary building. They had had three summonses issued against them, one of which was for erecting a temporary building, and another for erecting a new building. It would be quite clear that if this structure was a new building it was not (under a legal decision) a temporary building. He objected to these alternative summonses. Briefly his point was that this structure was neither a new building nor a temporary one. It was purely and solely a caravan. He also raised the point that the Council had not given the necessary notice to the owner as to their intention to take proceedings, and therefore the case could not succeed against him. The Wirral Rural Council had tried to get at the bungalow owners on the ground of public health, and had failed. They had lost two cases in the High Court, and now came before the magistrates in order to secure a more favourable decision. The caravan in question complied with the law. It was a caravan and not a permanent building. Mrs. Sheen, wife of the defendant, said she always regarded the structure as a caravan, and not as a bungalow. Her husband had made an application to erect a bungalow, but permission was refused. Mr. A. Kerr, owner of the land at Moreton, said the caravan had been moved from one place to another to prove that it was mobile. The magistrates decided to convict. The structure was a temporary building within the meaning of the Act. They inflicted a fine of 20s. and defendant must also pay five guineas costs. The bench expressed the hope that some arrangement would be arrived at to avoid further litigation concerning the bungalow.

THE BUILDERS' CLAIM AGAINST EXECUTORS OF LORD BURTON.—In the Official Receiver's Court, on Monday, after an adjournment from the 15th inst., Mr. Edward Pollock again had before him the action of Messrs. Wilcock and Co., builders, Wolverhampton, to recover from the executors under the will of the late Lord Burton the sum of £3,795, balance of the cost of building St. Chad's Church at Horninglow, Burton-on-Trent, for the late Lord Burton, the contract price being £19,559, to which a certain amount was added for extras in the claim by the plaintiffs. The defendants in the action were Harriet Georgina, Dowager Lady Burton, Rangemore, Burton-on-Trent; Mr. John Arthur James, Grafton Street, London; Mr. John Gretton, M.P., Ennismore Gardens, London, and Mr. John Lambuck, Stanton Road, Burton-on-Trent, joint executors under the will of the late Lord Burton. Mr. A. A. Hudson, K.C., with Mr. Disturnal, K.C., and Mr. Drysdale, appeared for the plaintiffs, and Mr. Leslie Scott, K.C., with Mr. Gibbons, and Mr. Bethune, was for the defendants. We reported the earlier hearings of the action in our last issue, p. 450. The adjournment took place on the question of the defendants being allowed to amend their pleadings in regard to an allegation that work said to have been done as extras had not been done. The Referee decided to allow the amendment to be made on certain conditions as to payment of costs, and defendants' counsel being unable to accept the condition without consultation with the executors the case stood adjourned. On the re-assembly of the court, a consultation took place between the leading counsel in the case, and ultimately they succeeded in arriving at a settlement of the action. The terms were communicated to the Official Referee in his private room, but no announcement was made in court.

PROFESSIONAL AND TRADE SOCIETIES

ARCHITECTURAL ASSOCIATION RED CROSS VOLUNTARY AID DETACHMENT.—A second series of lectures on first aid is being arranged in connection with the above detachment. The course will consist of six lectures, and will be held at the Architectural Association on Monday evenings, commencing on November 1, at 6 p.m. The detachment is now supplying orderlies for various London hospitals, and further recruits are urgently needed. The work is purely voluntary and part-time only. Full particulars can be obtained from the Quartermaster, at 18, Tufton Street, Westminster, S.W.

BIRMINGHAM ARCHAEOLOGICAL SOCIETY.—Mr. J. A. Cossins presided on Wednesday night at the Midland Institute at the annual meeting of the Birmingham Archaeological Society. The report, which was approved, stated that the excavations at Uriconium had been discontinued for the present. The officers of the society were re-elected as follows:—President, Mr. J. A. Cossins; hon. secretary, Mr. Howard S. Pearson; hon. librarian, Mr. Francis B. Andrews, A.R.L.B.A.; hon. excursion secretaries, Messrs. Phillip B. Chatwin, F.R.I.B.A., and John Humphreys. Dr. Christopher Martin was elected on the committee in the place of Mr. W. Hobart Bird.

ROYAL INSTITUTE OF BRITISH ARCHITECTS.—At a meeting of the council of the Royal Institute of British Architects held on Monday, the 18th inst., it was decided, owing to the war and the exigencies of the lighting regulations, to cancel the programme of papers and to suspend altogether the evening meetings which had been arranged for next session. The president, however, will deliver the opening address on November 1 as already announced, but the meeting will be held at three o'clock in the afternoon instead of eight in the evening. General meetings will also be held during the session for the election of members and the transaction of the usual business of the Institute, the meetings to take place at three in the afternoon. At the meeting of November 1, the portrait of Mr. Reginald Blomfield, R.A., Past President, painted by Mr. J. J. Shannon, R.A., will be formally presented to the institute. It has also been decided that the hours during which the Institute Library will be open shall, until further notice, be from 10 a.m. till 6 p.m. instead of from 10 till 8 as hitherto.

TOWN BUILDINGS IN ENGLAND AND SCOTLAND.—The Archdeacon of Ely, Dr. William Cunningham, lectured to the members of the Royal Philosophical Society, Glasgow, on Wednesday night, on "Town Buildings in England and Scotland." He said that when he compared institutions of Scotland with those of England he came to the conclusion that, though there were many superficial resemblances, there were real differences between them. The main result was that, whereas in England there had been a great deal of influence from the Mediterranean lands in the town buildings both in Mediaeval times and the Renaissance, in Scotland the influence was largely derived from Flanders. The two different types both in England and Scotland were the monastic and the castle, which types represented the different reasons for a considerable population gathering together. Aided by lantern slides, Archdeacon Cunningham explained the contrast between the towns and the effect which the affairs of primitive times had upon their organisation.

The Bristol and District branch of the Auctioneers and Estate Agents' Institute of the United Kingdom held its fifth annual meeting at Bridgewater on Friday last. The president for the year is Mr. H. Mundy, Mr. John E. Pritchard being the honorary treasurer, and Mr. E. A. Young the honorary secretary. The meeting considered the question of offering Institute prizes for the 1916 examinations. A special meeting followed the general meeting to make further arrangements for the conduct of sales for raising funds for the purchase of the "Star and Garter."

Correspondence.

AFTER FORTY YEARS: A RETROSPECT.

Sir,—Forty years have passed since I first contributed to these pages, and the anniversary, with its many happy recollections, suggests a contrast between the conditions of to-day and October, 1875, in the architectural and building world.

At that period the Gothic revival had nearly spent itself, most of our cathedrals and churches had been restored, and rising architects were following the lead set by Norman Shaw, J. J. Stevenson, and other students of Dutch art of the beginning of the eighteenth century, and were endeavouring to revive the style of Queen Anne and the use of cut and moulded red brickwork. It was a time of commercial prosperity, and, therefore, of much building activity. Many towns were providing themselves with larger and more ambitious municipal offices, and numerous board schools were in course of erection, both in rural and urban areas. Two important measures aiming at the advance of sanitation and the solution of the housing problem—the Public Health Act and the Artisans' Dwelling Act—had just been passed, and had a marked influence on public opinion. Under the stimulus of the obvious growing prosperity of the middle classes, unrest showed itself among the working-class and labouring population, who demanded their rightful share in the advancing scale of domestic comfort. Many important buildings were in progress. George Edmund Street's Law Courts were beginning to show themselves above the ground level of the vast area cleared of slums, the most forward portion being the red-brick block facing Bell Yard and the base of the clock tower at right angles to old Temple Bar, which still obstructed the Strand. The National Gallery was being enlarged from Professor E. M. Barry's plans. Sir Gilbert Scott was putting the finishing touches to the Albert Memorial, hard by Captain Fowke was demonstrating how needless it was to commission an architect when a concert room of the dimensions of the Albert Hall was contemplated, and the Brompton boilers were being expanded. Alfred Waterhouse was showing the capabilities of red-brick and terracotta in the Natural History Museum, just being started, and was bringing to completion the Town Hall and Owens College at Manchester. Hul and Bickerdike were building for Newington Hall Christ Church, Westminster Bridge Road, Lockwood and Mawson had in hand for Messrs. Joseph Parker the City Temple, and Harring and Son the Memorial Hall in Farringdon Street. Buildings of another class were John Bedborough's Westminster Aquarium, Horace Jones's Markets at Smithfield and Billingsgate, and the reconstruction of the Alexandra Palace after its destruction by fire, all then in progress.

Architects were having a busy time, and it was beginning to reflect itself in their offices and in the professional societies. The great influx of the ambitious sons of builders and tradesmen into offices, where their parents hoped that they would have easy hours and an early competency, was beginning to awaken concern among the elder members of the profession, who, while gladly accepting premiums, gave less personal attention to pupils, and inquired with an appearance of anxiety where all these budding architects would find bread-and-butter.

The membership of the Royal Institute of British Architects was then comparatively small, and, as many leading members of the profession preferred to remain outside, its influence was not great. In October, 1875, the roster consisted of 293 Fellows, 290 Associates, 12 Honorary Fellows, and 9 "contributing members," in all 609, whereas at the date of last June's report the membership showed an aggregate of 4,641, of whom 857 were Fellows, 1,713 Associates, 54 Honorary Associates, and 2,017 Licentiates. At the date referred to Sir Gilbert Scott was serving for a third year as President, with Messrs. Henry Cusey, George Vulliamy, and John Woodhead (afterwards president) as vice-presidents, and F. P. Cockerell was the hon. secretary. C. L. Eastlake, the secretary, afterwards pitchforked by Lord Beaconsfield

at a meeting of the National Gallery, was distinguishing himself by endeavours to "improve the Press." The publication of the annual report was prohibited, and attempts were made to prevent the reporting of the presidential address efforts promptly squashed by Scott.

At the Architectural Association, which I met at 9, Conduit Street, the voluntary system of classes was being carried on with great energy and success, the membership very rapidly increasing, and proposals that the vigorous younger body should be absorbed in the Institute were rejected with spirit. Mr. F. Salmon Quilter, an architect with a good City practice, had succeeded G. H. Birch, the ecclesiologist, as president, with H. Cowe Boyes (a son of Anak in stature and proportionately well built) and H. L. Florence, a vice-president, and E. G. Hayes, as hon. secretary—all three afterwards in turn occupied the chair, and of them all only Mr. Florence survives. An energetic ex-officio member of committee, qualified for office as the teacher of a class, was one Aston Webb, who next year undertook the duties of hon. secretary, in succession was called to the office as vice-president and president, and then served in turn the like positions at the Institute, and as the most eminent architect of the day received high honours from three Sovereigns of England. It is interesting to note that two of the young men elected as members of the opening night of that session of the association were afterwards elected president—G. H. Fellowes Pryme and Leonard A. S. Stokes, and that the latter immediately followed Sir Aston Webb in the Institute chair. At that time the total membership of the Association was little over 600, against a total at the date of the last annual report of 1,485.

The BUILDING NEWS then, as always throughout its long career, was served by an able band of contributors. Many of these have passed away, and many more have renounced the ranks. For the moment you, Sir, whose service of fifty-two years dates back farthest of all of us, must miss some of the help so freely rendered, which, as you have often said, has made the BUILDING NEWS what it is. When the struggle in which so many of us are manfully bearing their part is finished, may it be yours and ours to rejoice together in the hour of victory, and may those that come after be able to say, "and the hand had rest forty years," throughout their our art flourished, and the BUILDING NEWS and all its friends and helpers with it.—I am, etc., F. STRAUVER.

WATER SUPPLY AND SANITARY MATTERS.

ABERDEEN WATER BILL. The Parliamentary Commission appointed to deal with Provisional Orders in Scotland opened an inquiry at Aberdeen on Friday into the application by the corporation for power to take an additional 3,000,000 gallons of water per day from the River Dee to meet the growing demands of the city, and to make provision for the erection of works for liming and storage of the water, in order to ensure the proper preservation of its purity. The cost of the scheme is estimated at £450,000. The opposition to the Bill is at the instance of the Dee District Fishery Board. Sir Thomas Burnett, Bart., of Leys, Sir Victor Mackenzie, Bart., of Glenmuick, and other proprietors of salmon fishing on the river, the principal objection being that the proposed abstraction of 3,000,000 gallons additional per day would seriously and injuriously affect the salmon fishings, and they ask the tribunal to make provision in the Order for compensation water being supplied. The inquiry is proceeding.

TRADE NOTES.

Boyle's latest patent "Air-Pump" ventilators have been applied to Wraynall Parish Church, Bristol.

In consequence of the expansion of their business, and in order to facilitate the output of orders, Messrs. F. McNeill and Co., Ltd., the well-known manufacturers of felt and slag wool, have removed their offices to Stonehouse, South Place, Finsbury, E.C., thereby enabling them to extend their factory in Bull-hill Row. It is worth recording that Messrs. McNeill and Co. have been contractors to the British Government for over twenty years, and their resources are such that they are in a position to supply 5,000 rolls of felt weekly.

Our Office Table.

An interesting proposal from the Provisional Classes War Relief Committee was discussed by the London Education Committee on Wednesday. The Council agreed that, with a view to finding work for artists and distress through the war, the walls of certain Council schools, to be selected by the Council, might be decorated with friezes and panels, the decorations to remain the property of the Council. It was proposed that the subjects and designs should be supervised by an expert committee of artists, and submitted for approval to the Council before being carried out. In order that the work of the schools might not be interfered with, the friezes and panels would be executed away from the school buildings, and fixed during the school vacations. The Council would not be put to any expense in the matter. Mr. G. E. Warburg proposed that the offer should be accepted. Mr. Gantley objected that the decorations should not be classed as art, but modern. For example, one of the Royal scholars had gained the V.C., and a painter depicting how he won it would surely be appropriate for his old school. Mr. Warburg said that he thought Mr. Gantley's suggestion worthy of careful consideration, and he undertook to bring it before the General Purposes Sub-Committee. The motion was unanimously approved.

A Yorkshire correspondent of the *Manchester Guardian* writes: "Splenium moss was once used as a builder's sundry, to give an ugly name to a beautiful thing. All along the border of the West Riding the old houses are roofed with grey stone slates. Moss was collected and forced into the joints of the slates. As the rain ran down the roof the moss absorbed the moisture, and the swollen moss made a water-tight joint. Besides serving this purpose, the rich green, velvety lines of moss bejewel the grey slates and make a pleasing picture worthy of being introduced by the architect of our garden cities. The old builders took especial pride in their roofs," continues the correspondent, "and added another touch of decoration that is worth following. Their fine stone chimneys and ridge stones were well pointed, and over each course of lime a local band of whitewash or even white paint was added, so that the pointing of the chimneys and the ridge is plainly visible from a distance. It is called seam pointing, and the black and white effect is most charming. The house-proud farmer has the white seams renewed every spring. I am told that the custom is quite local."

Sand is mixed with nearly all aggregate, remarks a writer in the *Contract Record* of Toronto, for the purpose of filling the voids. If enough sand is added to fill up the voids between the particles of aggregate added to fill the interstices between the sand, a much smaller quantity of cement is required than if the sand be omitted, while at the same time a stronger, heavier, and more impervious concrete is obtained. Sand of uniform size tends to weaken the concrete, as also very fine sand. Uniformity in size means a greater proportion of voids, and either a larger quantity of cement has to be used to fill up the interstices or some means employed to weaken the strength of the concrete.

The old church of St. Paul's, Halifax, N.S., is a standing testimony to the durability of timber. This ancient pile, which dates from 1750, is constructed of pine and oak, which were brought from Boston, Mass., within a few days of its being part of the British Empire. It is the mother church of the Church of England in America, and has frequently been termed "The Westminster Abbey of Canada." It is very richly and artistically decorated. It was built on the site of a church at the expense of the Crown by grants from His Majesty George II., and also by means granted to the King for the use of Government. The interior of the church, built of wood, contains a great wealth of mural tablets of great historical interest than can probably be found in any other church on that side of the Atlantic.

LATEST PRICES.

N.B.—All prices must be regarded as merely approximate for the present, as our usual sources of information are in many cases failing us.

TIMBER.

Owing to stoppage of supplies all prices have advanced considerably.

IRON.

Table listing various iron products like Rolled Steel Joists, Wrought-Iron Girder Plates, Steel Sheets, etc., with prices per ton.

Table listing Galvanised Corrugated Sheet Iron with prices per ton for different gauges.

Table listing Cast-Iron Columns, Cast-Iron Stanchions, Rolled-Iron Fencing Wire, etc., with prices per ton.

Table listing Cast-Iron Socket Pipes with prices per ton for different diameters.

Table listing Wrought-Iron Tubes and Fittings, Gas-Tubes, Water-Tubes, Steam-Tubes, etc., with prices per ton.

OTHER METALS.

Table listing various other metals like Lead Water Pipe, Lead Barrel Pipe, Lead Pipe, etc., with prices per ton.

I BUY SCRAP METALS

THUR P. COLLINS, Snow Hill, BIRMINGHAM. Agents: The National Provincial Bank of England, Ltd., Bennett's Hill, Birmingham.

SLATES.

Table listing various slate products like Portland Slates, Best Bangor, etc., with prices per 1,000 sq. ft.

Table listing Eureka unfeeling green, Permanent Green, etc., with prices per 1,000 sq. ft.

BRICKS.

Table listing various brick types like First Hard Stocks, Second Hard Stocks, etc., with prices per 1,000.

Table listing various brick types like Acerington Best Red Plastic Facing Bricks, etc., with prices per 1,000.

GLAZED BRICKS.

Table listing various glazed brick types like White, Ivory, and Salt Glazed, etc., with prices per 1,000.

MOULDING BRICKS.

Table listing various moulding brick types like Stretchers and Headers, etc., with prices per 1,000.

Table listing various stone products like Red Mansfield, Darley Dale, etc., with prices per foot cube.

STONE.

Table listing various stone products like Red Mansfield, Darley Dale, etc., with prices per foot cube.

Table listing Bath Stone, Portland Stone, etc., with prices per foot cube.

TILES.

Table listing various tile types like Plain red roofing tiles, Hip and Valley tiles, etc., with prices per 1,000.

OILS.

Table listing various oil products like Rapeseed, Cottonseed, Olive, etc., with prices per ton.

GLASS IN CRATES.

Table listing various glass products like English Sheet Glass, etc., with prices per 1,000 sq. ft.

VARNISHES, ETC.

Table listing various varnish and paint products like Fine Pale Oak Varnish, etc., with prices per gallon.

Mr. F. Oscar Kirby, borough surveyor of Doncaster, has obtained a commission in the Army. He will be attached to the Kent Fortress Royal Engineers, and is at present stationed at Gillingham, near Chatham.

The foundation stone of the new church of St. Saviour's, Great Moor, Stockport, has been formally laid. The architect is Mr. R. B. Preston, of Manchester, and the contractors are Messrs. R. Rathbone and Sons, of Atherton.

1. CORRESPONDENTS.

We cannot hold ourselves responsible for the opinions... All communications should be drawn up as briefly as possible...

It is particularly requested that all drawings and all communications respecting illustrations or literary matter, books for review, etc., should be addressed to the Editor of the BUILDING NEWS...

**Drawings of selected competition designs, important public and private buildings, details of old and new work, and good sketches are always welcome...

When favouring us with drawings or photographs architects are asked kindly to state how long the building has been erected...

Telephone: Garrard 1291.

Telegrams: "Timeserver, Strand, London."

NOTICE.

Bound copies of Vol. CVIII are now ready, and should be ordered early... A few bound volumes of Vols. XXXIX, XL, XLII, XLIII, XLIV, XLV, XLVI, XLVII, XLVIII, XLIX, L, LI, LII, LIII, LIV, LV, LVI, LVII, LVIII, LVIX, LX, LXI, LXII, LXIII, LXIV, LXV, LXVI, LXVII, LXVIII, LXIX, LXX, LXXI, LXXII, LXXIII, LXXIV, LXXV, LXXVI, LXXVII, LXXVIII, LXXIX, LXXX, LXXXI, LXXXII, LXXXIII, LXXXIV, LXXXV, LXXXVI, LXXXVII, LXXXVIII, LXXXIX, XC, XCI, XCII, XCIII, XCIV, XCV, XCVI, XCVII, XCVIII, XCIX, C, CI, CII, CIII, CIV, CV, CVI, and CVII, may still be obtained at the same price...

Handsome Cloth Cases for binding the BUILDING NEWS, price 2s. 6d., post free 2s. 4d., can be obtained from any Newsgator, or from the Publisher, Edinburg House, 1, Arundel-street, Strand, W.C.

TERMS OF SUBSCRIPTION.

One Pound per annum (post free) to any part of the United Kingdom; for the United States, £1 6s. 6d. (or 60s. 30s. 60s.); To France or Belgium, £1 6s. 6d. (or 30s. 30s.); To India, £1 6s. 6d. To any of the Australian Colonies or New Zealand, to the Cape, the West Indies, or Natal, £1 6s. 6d.

**Our Direct Subscription Agents for Australia are Messrs. E. T. Kibbwhite and Co., Printers and Publishers, 29, York Chambers, 105, Liverpool Street, Sydney, New South Wales; for Japan, The Maruzen Co., Ltd., 11-15, Nishi-Shinjuku San-cho-me, Tokyo; who will receive Subscriptions at £1 6s. 6d. per annum on our account...

**The special rate to Canada is £1 3s. 6d. = 50s. 15s. 12s. 6d. and 11s. 11d. = 24s. 6s. 6d. 6s. 6d. Our Direct Subscription Agents for Canada are Messrs. Sells, Ltd., 202, Shaftesbury Buildings, Market Street, Montreal, who will receive Subscriptions, £1 3s. 6d. per annum, on our account.

Cheques and Post-office Orders to be made payable to THE STRAND NEWSPAPER COMPANY, LIMITED, and crossed London County and Westminster Bank.

ADVERTISEMENT CHARGES.

The charge for Copying and Contract Advertisements, Public Companies, and all official advertisements is 1s. per line of Eight Words, the first line counting as two, the minimum charge being 5s. for four lines.

The charge for Auctions, Land Sales, and Miscellaneous and Trade Advertisements (except Station Advertisements) is 6d. per line of Eight Words (the first line counting as two), the minimum charge being 4s. 6d. for 20 words. Special terms for series of advertisements or more can be ascertained on application to the Publisher.

SITUATIONS VACANT AND PARTNERSHIPS.

The charge for advertisements for "Situations Vacant" and "Partnerships" is One Shilling for Twenty-four Words, and Sixpence for every Eight Words after. All Situation Advertisements must be prepaid.

SITUATIONS WANTED.

Advertisements not exceeding Thirty Words, including name and address, are inserted under the heading "Situations Wanted," free of charge.

Rates for Trade Advertisements on front page, and special advertising conditions can be obtained on application to the Publisher.

LETTERS TO ADVERTISERS.

References, when they can be received at the Office, Edinburg House, 1, Arundel Street, Strand, W.C., should be kept. If to be forwarded under cover to a particular firm, an extra charge of 8pence is made. (See Notice at head of "Situations.")

Advertisements for the current week must reach the office not later than 3 p.m. on Tuesday. Front page advertisements and alterations or stop orders for serial advertisements must reach the office by first post on Monday to secure attention.

T. M.—Yes.

R. G. D.—Thanks, no.

PREMIUM. No. You might write us again later.

H. R. G.—We know of no other address than that given.

MERCHANT.—1. There is no recognised limit. 2. Probably it may be as you say, but naturally these intimations are confidential.

A TIMELY REMINDER. Architects, builders, and others are reminded that the BUILDING NEWS is now published on Wednesdays instead of Fridays, at 2 a.m., and that it should be obtainable early in the day anywhere...

H.M. Office of Works propose to proceed with the enlargement and reorganisation of the post office at Dundee at a cost of £20,000.

Mr. H. J. Chapman, borough surveyor of Buckingham, has been appointed surveyor to the Hartshorne and Seals Rural District Council.

Mr. Thomas Owen, of Llanfihangel, Aberystwyth, has been appointed surveyor to the rural district council of Conway, out of twenty candidates.

Among those sentenced to death last week by a German court martial at Brussels for alleged espionage was M. Philippe Danco, an architect in practice in that city.

A new Council school in the garden suburb, Pengam, has been formally opened. The cost was over £8,000, and the contractor Mr. R. Jones, of Caerphilly.

Galloway, one of the prettiest suburbs of Leeds, is to be developed at the hands of the builder, the Local Government Board having made an order authorising the preparation of a town-planning scheme for the district. The corporation's scheme is expected to be ready shortly.

An inspector under the Local Government Board for Scotland will hold an inquiry at Newton, N.B., on November 15, into the application of the Middle Ward District of Lanarkshire for authority to prepare a town-planning scheme for the Newton, Carnyln, and Baillieston area.

At the meeting on Thursday of the town council of Glasgow a long discussion took place regarding a recommendation by a special committee with reference to the remuneration for the joint office of city engineer and master of works. Ultimately it was carried that the salary of £250 per annum at present paid to Mr. Nisbet as master of works be the salary paid to him for the combined office until after the war, and that thereafter the salary be £1,250 per annum.

The new church of St. Francis d'Assisi on Grace Street, Toronto, is nearing completion. The style is Italian Gothic of the thirteenth century. The auditorium will have a seating capacity of 350. A feature of the building will be a large number of stained-glass windows estimated cost \$5,000, illustrating the mysteries of the Rosary. The building, with out furnishings, is being erected at an expenditure of \$112,000. Mr. R. Sheehy, of Peterborough, Ont., is the contractor.

The Council of the Institution of Civil Engineers have just awarded for papers published in the Proceedings a Telford Gold Medal to Mr. James Forgie, New York; Telford premiums to Mr. J. B. Mason (Dunedin, New Zealand), Mr. Harold Berridge (Aden), Mr. C. R. White (London), and Mr. C. S. Carsehill (Rangoon, Vancouver), and the Trevithick premium to Mr. A. Paulsen (Leipzig, Denmark). The Indian premium for 1915 has been awarded to Mr. C. W. Anderson (Madras, India).

The opening meeting of the new session of the Engineering and Scientific Association of Ireland took place at the Royal College of Science, Upper Merrion Street, Dublin, on Monday last week, when a paper was read on "Applied Physics" by Mr. Arthur E. Porter, M.I.E.E., M.I.C.E.T. Mr. Porter fully dealt with the subject of ancient lights and case-law illustrations, his remarks by numerous diagrams. The paper was occupied by the president, Dr. P. C. Cowan, who referred to the death of the late Professor Christian John Miller, who was killed in action at the Dardanelles.

OGILVIE & CO. Telephone DALSTON 1288. Many years connected with the late firm of W.H. LASCLETT & CO., of Bunhill Row. Mildmay Avenue, ISLINGTON, N. EXPERTS in HIGH-CLASS JOINERY. ALTERATIONS & DECORATIONS. ESTIMATES FREE.

FOR Olivers' Seasoned Hardwoods, APPLY TO— WM. OLIVER & SONS, Ltd., 129, Bunhill Row, London, E.C.

TENDERS. Correspondents would in all cases oblige by giving the addresses of the parties tendering—at any rate, of the accepted tender: it adds to the value of the information.

BATTERSEA.—For the supply of new cast-iron rib segments in connection with the repair of Battersea Bridge, for the London County Council:— Fraser and Chalmers, Ltd., Erith 4575 0 0 Lilliehall Co., Ltd., Oakengates 455 0 0 Cochrane, J., Earrhall, near Glasgow 475 0 0 Potter, R., and Sons, Govan 575 7 6 Oakes, J., and Co., Alfreton 321 10 0 Stanton Ironworks Co., Ltd., Nottingham (accepted) 281 7 0

BATTLE.—For the haulage of 400 tons of broken stone, for the rural district council, Mr. H. Blackburn, surveyor. Accepted tenders:— Horse haulage:— C. R. H., Battle 480 0 0 Steam haulage:— Thomas, C. R. H., Battle 480 0 0

BLYTH.—For alterations and additions to the superintendent's lodge at cemetery, for the urban district council, Mr. E. Grieves, surveyor:— Simpson, J. and W. 4105 2 0 Kelsey and Dwyer 97 0 0 Waddle, R. S. 83 16 6 Cook Bros. 79 11 0 Robson, J. J. (accepted) 78 0 0 All of Blyth.

BLACK NOTLEY.—For enlarging the sanatorium at Black Notley, midway between Braintree and Witham, for the Essex County Council:— Brown, A., Braintree 685 0 0 (Accepted.)

BRAY.—For the supply of road metal, unbroken stone, and granite boulders, for the urban district council. Accepted tenders:— Whelan, F., Shankhill, Co. Dublin, broken stone 4s. 6d. per ton, unbroken stone 3s. 4d., tailings 4s. 8d. Brock, P., Ballycoons, Co. Dublin, granite boulders 4s. 9d. per ton.

CARRIBHILLY.—For reconstruction of the Picedilly Hotel, for the Pontypool United Breweries:— Howell, T. F., Cardiff and Caerphilly (Accepted.)

CAPE TOWN.—For the supply of low-tension feeder cable, joint boxes and disconnecting pillars, for the electric lighting department:— Telegraph Manufacturing Co. 44,875 0 0 S.A. General Electric Co. 4,810 0 0 Siemens, Ltd. (accepted) 4,667 0 0 Two disconnecting pillars:— Siemens, Ltd. (accepted) 172 0 0

DEPTFORD.—For installing heating apparatus at Clyde Street School, Deptford, for the London County Council:—

No. 1.—Two-pipe system:— James, D., Boyd and Co., Ltd., 129, Great Portland Street 41,551 4 6 Bright-Side Foundry and Engineering Co., Ltd. 1,350 0 0 Ferguson 1,355 0 0 Yelland and Brackett, Ltd., Munton Road 1,342 0 0 Buzes, J., 101-2, Borough Road, 1,300 0 0 Cannon, W. G., and Sons, Ltd., 157, London Road 1,240 10 0 Polawkar and Sons, 90-91, Queen Street (Architect's estimate, 41,125.)

No. 2.—Drop system:— Bright-Side Foundry and Engineering Co., Ltd. 41,325 0 0 James, D., Boyd and Co., Ltd., 129, Great Portland Street 1,362 12 6 Yelland and Brackett, Ltd., Munton Road 1,234 0 0 Buzes, J., 101-2, Borough Road, 1,150 0 0 Cannon, W. G., and Sons, Ltd., 157, London Road 1,149 0 0 Polawkar and Sons, 90-91, Queen Street 1,043 0 0 (Architect's estimate, 4,991.) Accepted.

THE BUILDING NEWS

AND ENGINEERING JOURNAL.

Effingham House,

The Survey and Repair of Bombstruck Buildings	493
The Royal Society of Painters in Water Colours	495
Royal Institute of British Architects	495
The "Building News" Designing Club, 1914-15	496
The District Surveyors' Association	497
Painting by Immersion and by Compressed Air	497
The Capital of the Canal Zone	497
Housing Conditions and Rents in Scotland	498
Corrente Calario	499
Correspondence	500

CONTENTS.

Our Illustrations	500
Obituary	505
Legal Intelligence	510
Water Supply and Sanitary Matters	517
Building Intelligence	517
Professional and Trade Societies	517
Trade Notes	518
Our Office Table	518
Clips	519
Latest Prices	518
Tenders	518
List of Tenders Open	518

Strand, W.C.

R.V. and Mr. J. J. Jose	HERBA
Church of St. Barnabas, North Finchley, A.C.	1915
Across the Choir, Photographed by Mr. Richard Mondland, Mr. J. S. Abbot, Architects	
New Picturehouse and Concert Hall, Worthing, Sussex, Two views and plans, Mr. Peter D. Stoddam, M.S.A., Architect	
Scene, Medallion and Travelling Student's Sketches in Italy. The Entrance to the Palazzo Terzi, Bergamo. Drawn by Mr. Victor Bonnell	
New Buildings, Comprising the Guild, Bromley, Essex, School, Worcester-shire, A.C., and plans, Mr. Arthur Bartlett, F.R.I.B.A., Architect	

THE SURVEY AND REPAIR OF BOMB-STRUCK BUILDINGS.

The air raids have made a good deal of work for builders, and of a kind presenting some quite special problems—rotably the peculiar injuries wrought by high explosives. The ravages of the incendiary bomb present no new conundrums, because repair in such cases is of a type with which we are, of course, familiar, presented as it constantly is in connection with ordinary fires. Of injuries to buildings caused by high-explosive bombs we have had unusual variety. They group themselves, of course, under the heads of structural damage and mere architectural disfigurements. The first-mentioned include disorganised and shattered brickwork and masonry, disrupted bricks and dislocated and fractured stones, smashed roofs and floors, and joinery splintered to match-wood. The latter class of injury is chiefly the result of shell contents and debris, causing eyesores upon façades and damage to architectural detail. The architect

substructure. The bomb fell between the railing and building indicated on the sketch, and although all was open and unconfined about the railing, the plinth, originally occupying the position



FIG. 2.

shown in the straight, strong lines on our plan, was shifted to a position indicated approximately by the dotted lines. First impressions, as we have said, may be deceptive. We made a rough sketch from memory (Fig. 2) of something we witnessed in one of the districts attacked, and put the double-headed arrow as an example and illustration of that which we thought might be preserved after pulling down the wrecked brick gable. To refresh our memory we again visited the spot, but failed to locate the premises. We think, however, that it was the left hand building shown in Fig. 3, and, if so, those who more carefully examined the structure no doubt found the whole front unstable, and dealt with it and the adjoining premises in the drastic manner indicated. Had we originally taken a lateral view of these premises, in addition to merely viewing from the front, we should have seen, as shown by the remaining

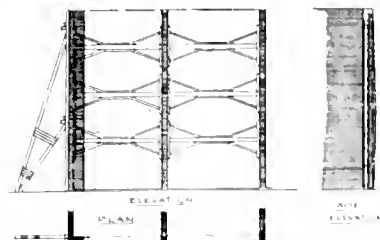

FIG. 3.

piece of front wall, that, as indicated in our side elevation, this wall was dangerously bulging. This, however, and our Fig. 4—a cracked wall and split angle pier—are obviously gross and evident in

juries, but the study of the results of shock evidenced to the eye are valuable as giving a clue to hidden flaws in structure. Both the damage shown in Fig. 3 and Fig. 4 must be considered the direct effect of high explosive, as distinct from injury by shell contents and debris.

As bearing upon direct shock, the case of Fig. 5 is instructive. The sketches are all given herewith approximately more or less to the actual occurrence and premises. The upper parts of the building shown in Fig. 5 were odd, but the lower story has a concrete floor over. As our diagram indicates, this substantial horizontal stratum assisted to preserve the lower part of the building. The whole of the brickwork above the concrete floor not actually blown down by the explosion needed to be cleared away. Where there exists such a strong floor as C, Fig. 5, some distance below a roof, and especially where there are several superimposed floors, we may look for sound work below. Where a bomb passes through even a slight roof, this obstruction seems sufficient to ensure detonation. The



FIG. 4.

instant of actual explosion apparently following very rapidly, the upper part of a building seems to suffer most from shock, and any such solid floor, as C, Fig. 5, has chiefly to resist the impact of shell contents and debris. Since it seems to be nearness to actual point of explosion that causes solid material and building construction to suffer from shock, such as is likely to produce structural unsoundness, these considerations may be worth bearing in mind when proceeding to survey damaged premises. Where, as in the case of an exterior explosion, a few yards from a strong modern building, the nearest point of attack for the explosion wave is overborne by a vast dead weight of material, this seems to enable the part immediately attacked to hold up steadily and homogeneously against concussion and vibration. We here, again, advance the opinion with reserve. It is not easy to conceive how some of the broken and splintered exterior walls can have remained quite free from injurious stress upon the construction as a whole.

Forces that will sheer solid masonry, lift off bodily entire roofs, and send a

alled upon to survey wrecked buildings and to specify and supervise repairs will do well to study carefully the effects of high explosive upon material and structure. Mere repair is comparatively easy, but the subtle and hidden effects of shock of explosion on the stability of structure needs care, otherwise reinstatements may be made upon unsound substructure.

Of the two kinds of repair work required—internal and external—as a rule, the one is the result of explosion actually at the premises, and the other is necessitated by externally falling bombs, as in the street. Strong modern buildings—their main organic parts, at any rate—seem well to withstand shock; but it will be judicious to assume this with caution. To discover damage not at once evident, and not obvious to the eye, should be the first aim of the architect in surveying premises for repair. We may, of course, well study the effects of obvious damage. Thus Fig. 1 affords a good example of the force of explosion—a strong and heavy iron railing plinth bodily severed, at about ground level, from the

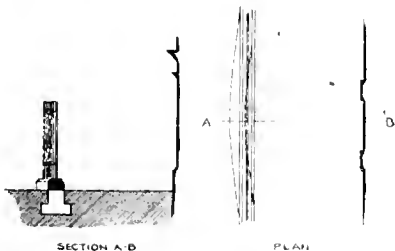

FIG. 1.

to high substantial buildings hundreds of feet away from the actual point of explosion. They are liable to convert sound brickwork and masonry into unreliable structures, prone to fail later if we again place heavy loads upon it. The main tendency of high explosive must be to break and, as in brickwork. In most instances, jointing would suffer. Given plumbness and squareness, on test, apparently indicating soundness, the signs of hidden weakness may possibly be best revealed in

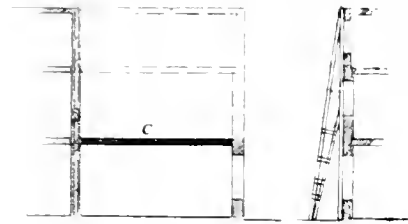

FIG. 5.

minute affections at joints. Except in special circumstances, foundations are unlikely to be disturbed; but in the worst cases everything will have to be cleared away to ground-line and the premises wholly rebuilt.

Shell contents, as distinct from the shock of the explosion wave, splinter and disfigure stone and granite façades and pulverise bricks. To appreciate the effect of projectile emanations from exploded bombs, we must give credence to the statement that the shrapnel contents of these shells are of chilled iron. It was represented to us on visiting the site of the damaged building illustrated last week that such chilled metal was found on the spot. This being so, it is not a matter of surprise that soft iron, such as railings, is cut through so cleanly and that the injury to dressed stone and granite indicates so violent an impact. How to repair the fronts of the many beautiful buildings disfigured in this way is one of the problems presented to the architect. Figs. 6 and 7 fairly represent the class of injury to be repaired. Much detail of the whole building is beyond repair in the sense that the whole feature requires to be reconstructed. One side of the arch pier, column and entablature, in diagram Fig. 7 might as well be rebuilt as repaired by patchwork. It needs at least ten new worked stones, and we should call this a quite mild example of many actual occurrences. In damaged brickwork, the injured bricks will need to be cut out and the bright new patchwork here and there accepted. In many instances,

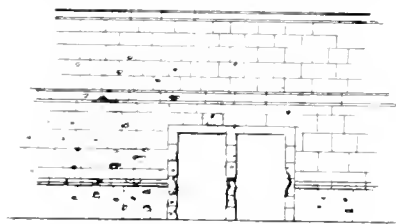

FIG. 6.

soft iron, notably soft-gauged work, are pulverised, and need entire reinstatement, even should the main walling prove sound.

Insurance worth the name should insure the exact replacement of things existing prior to the raid, and some very expensive builders' work is foreshadowed. Often, too probably, the uninsured premises will get a patchwork repair at the best, stones pieced in and at times holes made good in cement, but our ornate public and important private buildings cannot be treated in this manner. Jointing, in

stone work, must be considered one of the beauties of masonry, and, indeed, one of the most effective and expressive attributes of architecture. If, then, having an ornate façade, largely dependent upon stone jointing for its effect, we piece in a patchwork repair, we are spoiling its beauty. Such a necessity should certainly be obviated by insurance. Then, again, in the case of solid stone and granite fronts, constructed, as is often the case, of facing material right back to the steel stanchions—it may be to a depth of 20 in. reinstating, say, a 4-in. facing is not "making good" as before the aerial attack. An effective insurance claim will no doubt include both structural correspondence and architectural concord.

If Fig. 8 represents the two elevational views of the angle of an injured stone-fronted building, we may certainly piece in, as at A and B, and the repair will be structurally sound. But, as we have said, the beauty of regular-coursed masonry resides in its jointing, and this effect has been in part ruined by the discordant joints introduced by the pieced repair. Small injuries, of a fraction of an inch in depth, such as C, could no doubt be faced off as indicated; but to make good as before the damages at A and B necessitates drawing the damaged stones and replacing with blocks of similar size; and if D be a deep defacement in granite, it seems a little bit of a problem to

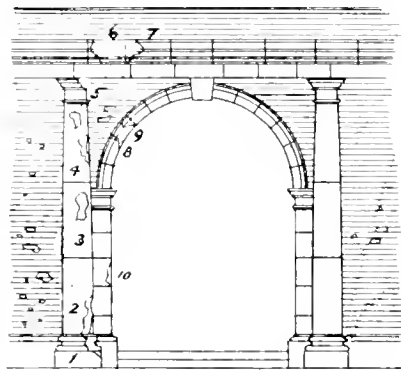

FIG. 7.

remove D and maintain sharp arrises on the surrounding blocks. Structurally, perhaps, a thin facing, in place of deep stones, would leave the structure practically as good as before, but it would certainly not be the state of things existent before the damage. Fig. 9 is an elevation of stone or granite work, of a solid order of workmanship, backing right on to the stanchions of the steel-framed construction. We may face back, say, 4 in. for repair to injury B, but, structurally, the work cannot be compared with that effected by drawing a stone, as at A. No doubt many compromises will be made by insurers, but it is plain that a deeply injured building can only be effectually repaired by withdrawal of damaged stones and replacement by blocks of similar size, similarly dressed. From "patriotic" motives, at a time when money is urgently needed for national purposes, we may be persuaded by insurance offices that 4-in. replacement is practically as good and substantial a repair as a new stone 20 in. deep, but we shall remain incredulous and unsatisfied.

A general clearance and a start *de novo* seem absolutely necessary in a great number of cases, repair being impossible. The peculiar partial effect of high explosives is, however, a circumstance indicating the possibility of saving much that otherwise one would consider, viewing the

destruction wrought in the immediately adjoining parts, certain to be rendered quite unsound. We have recently seen some hollow brick walls the subject of explosion not many yards distant. The explosion certainly pulverised the outer 4½-in. casing, but the backing appeared sound, the galvanised iron bonding ties standing out at sharp right angle, as originally set by the bricklayer. One would have expected the backing to have

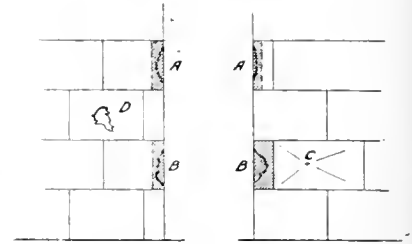

FIG. 8.

been blown in, if high explosive did not act in such curiously inconsistent fashion. Possibly the weakest part yields, and, so yielding, relieves the stress on another part; so that where a front wall may be blown out, the back wall may stand, and the general relief by blown-off roof, flying quarter partitions, and the throwing down of the front, may leave party walls sound. It will, however, be always well to view the whole with suspicion. Shock from high explosive is just that kind of stress that bricks and mortar and cemented masonry are least suited to withstand. Earthquake tremor is far less trying, and it has been demonstrated that well-tied steel-frame construction well resists seismic disturbance. Appearance, in estimating necessity of repair, should go for nothing. We have noted a granite pilaster to a shop front, greatly injured by impact from shell burst and debris thrown up by the explosion. Some 3 ft. of one arris was deeply scarred, and about 2 ft. on the other side injured, the pilaster being about 4 in. thick. To all outward appearance the central part of the pilaster—i.e., between the two points the subject of heavy impacting force—was as good as ever; but we doubt not that it would, on a slight blow, be found absolutely void of cohesion and strength.

Timber, as a rule, seems to withstand well concussive shock and vibration—no doubt owing to its semi-elastic nature. Whole roof slopes may be seen with rafters intact, blown clear of natural

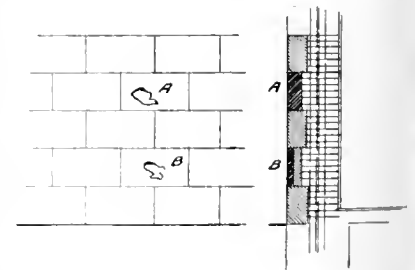

FIG. 9.

support. Window frames, too, seem to hold up remarkably well, as a rule, affording little hold to the explosion wave, and, moreover, possibly saved to some extent by the yielding of the glass. Doors suffer more damage than windows, and are blown forcibly away from frames and splintered. Taking, as it were, the place of glass, they offer a wide area of resistance, conducive to their destruction. Doors and joinery of like nature appear to need complete reinstatement, where often the apparently fragile window sashes may be repaired.

THE ROYAL SOCIETY OF PAINTERS IN WATER COLOURS.

The winter exhibition—the 165th of the Royal Society of Painters in Water Colours—is a good one. The group of twenty works by the late Comm. Walter Crane (173-192) alone is well worth the admission charge, including as it does several of the deceased artist's best efforts and some of his earliest. The majority are Italian scenes, and all sympathetically rendered. Of architectural subjects, "The Arch of Constantine" (177) and the "Arch of Titus" (182), both at Rome, will most interest our own readers.

Mr. Alfred Parsons, R.A., the President, sends four subjects—the "Old Arthur in South Wales" (3), "Lilies and Loosetrife" (9), "The Chimney Campanula" (28), and "Cardiff" (228), the floral beauties of the first three being done full justice to. Mr. Lionel Smythe, R.A., has an able and pleasing rendering of "A Young Gleamer" (4). Mr. Edwin Alexander, A.R.S.A., successfully devotes two contributions to birds—Woodcock" (5) and "Bullfinches" (49); his third is "The Desert—Egypt" (71). The majority of Sir Ernest A. Waterlow's contributions are Sussex scenes, but the eighth is a good view of "The Ogmore Valley, N. Wales" (135). Mr. Reginald Barrett sends a well-drawn "Holy Water Basin, from Siena Cathedral" (17), a charming "Evening Glow, Venice" (51), an "Entrance of the Grand Canal, Venice" (80), and "The Taj Mahal, from Agra Fort" (225), and "A Corner of a Venetian Palace" (229). Mr. F. Cayley Robinson is represented by his excellent design for a mural decoration for the Dublin Art Gallery, "The Landing of St. Patrick in Ireland" (84), and an "Autumn Evening in London" (251).

Mr. T. M. Rooke contributes some good architectural studies, "The Towers of All Souls, Oxford" (10), "The Choir, Southwark Cathedral" (102), "The Porch, Malmesbury Abbey" (108), "The Temple Church, London" (157), and "Westminster Abbey" (197). Mr. C. Napier Henry, R.A., may be well congratulated on "A Patrol Boat" (37), with its stormy sea. Very good also are "Wind on Shore" (92), "On Watch" (98), "A Mackerel Boat—The Run Home" (118), "Here She Comes" (146), and "The Torpedo Boat" (212). Mr. S. J. Lamorna Birch is to the fore with some of his always welcome West Country scenes. There are "The Junction of the Plym and Meavy, Shaugh Bridge, Devon" (56), "On Wigford Down, near Meavy" (56), "The Sketcher" (91), "The Rocky Plym" (195), and "A Devon-hire Cottage on the Tamar" (251). Mrs. Allingham sends four welcome floral pictures—"Roses in a Venetian Garden" (45), "Bluebells" (82), "In a Surrey Garden" (86), and a "Bit of Garden border—October" (166). Mr. Robert Anning Bell, A.R.A., has only one subject on the walls, "A Flight of Fairies" (156).

A fascinating group of ethereal visitors, Mr. Byam Shaw is fully up to his standard with "The Abbot's Niece" (22), "Illustration to the Boyhood of Akbar" (165), and "In Memory of Private Maurice Giffroy, 3rd County of London Regiment" (202). Miss Eleanor Fortescue Brickdale embodies the title suggests in "The Enchanted Prince" (100). Her four other contributions are "Evening" (109), a "Portrait of Mrs. Noel Buxton" (113), "The First week of Poycecks" (151), and "June is dead" (235).

Mr. W. J. Wainwright's only work, "Aaid of the Hostel" (145), modestly entitled "A Study," is one of the best things at the exhibition. Mr. G. Clansen, R.A., has two good sky studies, "Evening Sky" (94) and "A Summer Sky" (215).

London Bridge" (218) is perhaps the best of his other contributions. Of Scottish scenery, the best examples come naturally from Mr. D. Y. Cameron, A.R.A., A.R.S.A. They are the "Aval of Forth" (15), "Inverclyde" (50), "Uplands in Montroth" (147), "Spring" (211), "Balnpholzie" (232), and "The Stack" (250). Mr. J. C. Dollman's "Keeper's Cottage" (59) is excellent, and so are his "Sussex Summer" (116), "Gorse" (122), and "A Sussex Team" (220). Mr. Hughes Stanton, A.R.A., sends "A Stormy Evening" (41), and a pleasant view of "Hindhead, Looking Towards Haslemere" (61).

Among others which will deservedly be noted are Mrs. Laura Knight's "The Two Fishers" (67) and her "Bathing From the Shipway" (114), Mr. W. Russell Flint's "Three Damsels" (150), Mr. Charles Stan's "Bathers" (127), Mr. Henry Henshall's "His First Steps" (148), and Mr. J. W. North's two subjects, a "Water Mill in South Wales" (164) and "When Houses Were Built Round the Chimney" (a small farmhouse).

ROYAL INSTITUTE OF BRITISH ARCHITECTS.

The evening session of the Royal Institute of British Architects was held on Monday afternoon, in the western, or smaller gallery, at 9, Conduit Street, W. Among those present were the Past Presidents, Sir Aston Webb, R.A., Mr. Reginald Blomfield, and Mr. Leonard Stokes, and the visitors included several ladies.

ANNUAL ORDINARY MEETING.

A sombre note was struck at the outset of the proceedings by the announcements made by Mr. E. Guy Dawber, hon. secretary, who remarked that it was his sad duty to record the losses which the Institute had suffered since their last meeting. These losses were exceptionally severe, numbering no fewer than twenty members, including four Fellows, five Associates, eight Licentiates, and three Students. Nine among them were young men, who came forward to the call of duty to fight in defence of their country, and had perished on the battlefield. Their names were: Lance-Corporal Alexander Wingate, 9th Battalion, Highland Light Infantry; Captain George Pilgrim Bowie, 5th Battalion, First Canadian Contingent; Charles Henry Rowed Hemant Royal Naval Division a son of their steamed Fellow, Mr. Charles Hemant; Henry Charles Pullen, Rifle Brigade; Sub-Lieutenant Aldersly Deeken, Royal Naval Volunteer Reserve; all the above were Licentiates; Private Charles Joseph Newbery, 3rd Royal Fusiliers; Second Lieutenant James Bernard M. J. Walch, 2nd Queens Royal West Surrey Regiment; Edmund George Dawson, Frontiers; and Captain Frederick Henry Lawson, 5th Battalion, Northumberland Fusiliers, the last four named having been Students. He moved that there be recorded on the minutes an expression of the Institute's deepest sorrow at the loss of these gallant young heroes, and that messages of sympathy and condolence be conveyed to the bereaved relatives. The motion was put by the President and was agreed to.

Continuing, Mr. Guy Dawber further announced the death of Mr. George Bell, F.R.I.B.A., a Past President of the Glasgow Institute of Architects, and a former member of the R.I.B.A. Council, and Mr. George Bertram Bulmer, Fellow, Past President of the Leeds and Yorkshire Architectural Society, who had also served on the R.I.B.A. Council. With regard to Mr. Bertram Bulmer, he had the pleasure to announce that under his will the Architects' Benevolent Society, on the expiration of certain life interests, would benefit to the extent of no less than £5,000. He had further to announce the decease of George Henry Hunt, Graham Nicholas, George Lister Sutcliffe Fellows; Henry David Davis, retired Fellow; and Edwin Richard Hewitt, A.R.I.B.A.

Legation, Mr. George Bell, F.R.I.B.A., Mr. Gibson Hunt, R.I.B.A., Mr. J. W. North, F.R.I.B.A., Mr. Arthur Cecil Wood, F.R.I.B.A., and Mr. The President, Mr. E. Guy Dawber, in a cordial appeal to the members of the Institute to contribute to the fund.

Nearly every time that I have attended a meeting since I became President I have asked for funds to carry on the work that I have set on hand. In the absence of any employment there are not a few vacancies, and it is to the dwellers in the "fourth estate" that our appeal is made. I should like to be able to treble the amount subscribed so far. The sums that have been collected are promised are as follows:

- Prince of Wales, £1,000; Lord Curzon, £1,000; Viscountess Bess of Warwick, £1,000; Lady Curzon, £1,000; Lady Curzon, £1,000; Viscountess Curzon, £1,000; Viscountess Curzon, £1,000.

And in addition there is a considerable sum from sales of the Artists' War Relief Exhibition, which was opened by her Royal Highness Princess Louise in July, and remained open during August and September. The most important of the War Committee's schemes for dealing with unemployment is the Civic Survey. Throughout the war we have kept in touch with the Professional Classes Relief Committee, and this committee has helped architects' families by receiving their wives into the maternity home and assisting in the education of their children. It has also organised summer holidays for children and has helped in many other ways. In connection with this committee we have undertaken to help in a Christmas Sale at the Albert Hall, and a special committee has been formed for this purpose. We shall be glad to receive the names of ladies who are willing to make articles for this sale.

VOLUNTARY REGISTER OF ARCHITECTS.

The Selection Committee is now engaged in preparing a voluntary register of architects suitable for military, civil, or munitions work. It has been felt that the Government has not been able to make sufficient use of architects, as the information at its disposal was not sufficiently complete. It will be remembered that early in the war we made, through the Architects' War Committee, a general offer of service from the whole body of architects. When the war broke out an enormous amount of work suddenly fell on all Government Departments, and more especially on the War Office. Probably on this account our general offer of service did not receive as much attention as we hoped might have been the case, although we have been able to supply several men for responsible positions, but as this offer had been made by me as Chairman of the Architects' War Committee and President of the Royal Institute of British Architects, I thought it well to call at the War Office personally in May last and renew it in greater detail. The suggestions I then made were most courteously received, and I understand have since been circulated to all the commands in the British Isles. Mr. Stanley Peach, who, with Mr. Munby, has been most indefatigable and devoted an enormous amount of time to this branch of our activities, finds that even now the lists at the disposal of the Government are not sufficient, and that the only way in which we can best real service is to have names of all qualifications ready beforehand, so that the information required may be provided at once. I regret very much that some controversy should have arisen out of our offer, but as the object was, and is, to assist the Government by every means in our power, without anything in the way of controversy, such a line would be a waste of energy.

THE PROFESSIONAL FELLOWS. In addition to the Civic Survey, already alluded to, has been asked to be made, work of a very varied nature for 200,000 men, but there are, of course, certain cases where no suitable employment can be found, and in these cases the Architects' Benevolent Society and the Artists' General Benevolent Institution have given direct assistance. This committee has held its meetings at the premises of the Society of Architects, which has given the services of its staff for the pur-

War Service started a Loan Fund to raise money in various positions to tide over a

MEMBERS OF INCOME TAX

It has not been unkindly pointed out that the burden of income tax on those who are professional men has

A letter was addressed to the Revenue Office in August last calling attention to the fact that it would be impos-

many at intervals to pay the tax in years, basis, and suggesting that

possible to make the returns during the a tria year. The Institute

with the Institution of Civil Engineers at other bodies in sending a

of a similar kind to the Chancellor of the Exchequer. A certain

has been promised on professional incomes, but it hardly meets the

Architects are in the peculiar position of not only having to face

the war, but of having their means of livelihood still further reduced by the action

of the Government in stopping public building, and of the Government committee in recom-

ending the stoppage of all private building. In these circumstances we have a

claim to consideration, and a further letter has been written to the Chan-

ARCHITECTS ON SERVICE

The Architectural Association has con-

ductors of recruits to various branches of the service. Something like 850 men have

been added to the forces through its agency, and in many cases, where a special type of

work is required, the commanding officers have expressed great satisfaction with the

sent to them through the Architectural Association War Service Bureau. The Association is keeping in touch with all these

and is now asking for contributions of comforts for them. I hope everyone who

will spare something for this fund. Altogether we have serving in His Majesty's

Forces over 1,800 architects, including assistants, pupils, and students, and teachers of our technical schools. Last

November there were about 1,000. At that time nearly all these young men were in

training at home. Now most of them are abroad many have been wounded, and some

have given up their lives for their country.

THE URGENT NEED FOR MORE RECRUITS.

The end appears to be far off, and there is a very few of us who do not live in daily

and hourly anxiety as to the fate of those who are very dear to us. It is a weary

business waiting, but it is the lot of those who are too old to fight. Many of us, too,

have the added anxiety of vanishing incomes and increased cost of living and taxation: not as the character of the younger generation

is now being formed on the battlefield, the character of the older generation is also being put to the test. The situation is

majority of them are sound at heart and, if the right note is struck, will do their duty as those who have already gone have done theirs. We who are too old for a five military service must let them know that we realise all that we are asking of them. It is easy for us to say "Would I were a young man!" I hope we should all have gone; but none of us can realise the struggle of the man who hesitated to go at first, and is now asked for what has been well described as "3 o'clock in the morning courage." But the decision can no longer be put off. The time for choice is over. No one fit for his country's service has a right to live at ease and carry on his work protected by those who have not weighed the *pros* and *cons* but have seen only one path and have trodden it fearlessly. Many of these men have given up promising careers and good positions, and it is unthinkable that, now the need is so great, others should hesitate to make the same sacrifice.

OUR IMMEDIATE PROSPECTS.

It is hard, too, for some of us older men to sit still and not criticise this or that apparent act of omission or commission of the Government. Nearly everyone has somewhere in his secret recesses the conviction that he could do the work better himself, but let him remember that the slashing critic is often a very mediocre performer. We are passing through the accustomed phases. First, the light-hearted disdain of the enemy, the unreasoning certainty that everything is all right and that victory is ours merely by wishing for it. Then comes the second period, the period in which we are now, when there is a sort of uneasy feeling that we cannot go on in a nice comfortable optimistic everything-as-usual kind of way, that something has to be done, we don't quite know what, we are depressed without quite knowing why, and we begin to look about for scapegoats. But when we are tempted to be impatient, let us see what actually has been done in fifteen months. We have performed the miracle of raising, training, and equipping an immense army. We have entirely reorganised and immensely increased our munition factories. Germany has lost practically all her colonies, and all her ships have been driven from the seas. These many months of mutual anxiety and fierce fighting have consolidated the British Empire as nothing else could have done, have revealed to us the splendid character of our manhood, and given the lie to the croakers who declared that we were a decadent race. They have, too, tightened the bonds of friendship with our Allies—particularly with our great neighbour, France, a country especially dear to architects—and out of the great welter of war is emerging a clearer view of the immense issues at stake. I think, then, that it is our part to have a fixed and serene intention to be victorious, to remember the tremendous responsibilities of our Government, and to lighten those responsibilities by doing everything that we can to assist and support it, and so help to form a united public opinion resolute to do everything possible, and impossible, to bring the war to a victorious end.

I feel, ladies and gentlemen, that I owe you an apology for dwelling so much on the war and not at all on architecture. I will confess that I had intended merely to give a short account of what we were doing for our brother architects, but my pen has run away with me. After all, what is there really so important, except this great war? On that subject everything depends, and everyone can contribute something towards this result, not by morbid brooding, not by gloomy forebodings, but by realising its tremendous seriousness, understanding the sacrifices which must be made by us all, and by believing that victory is certain, if we as a nation bend our whole energies to the task, and shrink from nothing which will give us that victory, without which life would not be worth living.

PRESENTATION OF MR. BLIMFIELD'S PORTRAIT.

The President said he had now the pleasure of presenting to the Institute, on behalf of subscribers, Mr. J. J. Shannon's fine

portrait of Mr. Reginald Blomfield, a work which would be, he believed, one of the most appreciated of their valuable collection. Mr. Shannon had had an unusually difficult task. They all knew their late President had almost every aspect but that of repose. (Laughter and applause.) Mr. Shannon had had to suggest and convey to canvas a president full of movement, energy, and brisk decision, and he felt sure the members would realise that he had produced not only a fine picture, but what was familiarly called a "speaking likeness." On withdrawal of the curtains the portrait was revealed, in three-quarter face and kit-cat length, which was a noted feature of the old water-colour room at the Academy exhibition last summer.

Mr. Blomfield said he could not pronounce asure to the merits of the portrait, but was sure the Institute had obtained a good picture. He proposed a hearty vote of thanks to Mr. Newton for his address.

This was seconded by Mr. J. Alfred Gotch, who thought that perhaps the President took rather too gloomy a view of the amount of recruiting that was going on. Whatever might be the case in London, there seemed very few eligible men in the Eastern Midlands who had not yet offered their services.

In response to the motion, which was carried by acclamation, the President said he supposed every occupant of that chair felt surprised at being expected to play the part of "first old man." No one, he supposed, felt old until he was called upon to fill this kind of position, when he made a mental calculation of a very sobering kind. The war had added much to the responsibilities of the position, and had created all sorts of situations without precedent to guide one. But he found himself surrounded by friends who helped him to steer through these uncharted waters, and he trusted that when he handed over command to his successor it might be in times of calm.

THE "BUILDING NEWS" DESIGNING CLUB, 1914-15.

After due verification, the prizes awarded to the winners who submitted designs during the past session, as announced in our issue of October 15, have been despatched to their recipients as follows:—

First prize of £10 10s.: "September Morn"—Mr. H. W. Smith, care of Mr. E. W. Allfrey, M.A., 57, High Street, Oxford.

Second prize of £5 5s.: "Penwith"—Mr. J. Clark, care of Messrs. Cowell and Drewitt, architects, Lennard's Chambers, Penzance.

Third prize of £3 3s.: "Walbroke"—Mr. W. Brooke, care of Messrs. R. Castle and Son, architects, London City and Midland Bank Chambers, Cleckheaton, Yorks.

In reply to inquiries, we do not contemplate continuing the Club during the ensuing twelve months. It was founded for the benefit of the students and junior members of our profession, and the present time demands the whole service and self-sacrifice of all such. It is getting it, we are proud to say, in larger measure than from any similar club, and we are little likely to get much worth attempting from the very few whose place is in the ranks with their brethren, but who have not yet taken it.

New Wesleyan day schools in Ribblesden Avenue, Preston, Lancs., have just been opened. They were built from plans by Mr. F. Howarth, M.S.A., at a cost of over £4,000.

A set of carved oak altar rails, in a design adapted by Mr. C. M. Oldrid Scott from the carving of the Watching Gallery in the Saints' Chapel, was dedicated on Saturday in the nave of St. Albans Cathedral. They form a memorial to the late Mr. Charles Woollam, for twenty-six years a churchwarden for the Abbey parish.

The death was announced on Saturday of Corporal W. H. Marley, R.F.A., of Buttriss Road, Barry, Glam., killed in action in France. He was a son of Mr. W. Marley, of Barry, and was attached to Mr. W. E. Knapman, M.S.A., of that town, and joined the Society of Architects as a student in 1912. Corporal Marley enlisted in the R.F.A. on the outbreak of war, and has died on the field of honour in his twentieth year.

THE DISTRICT SURVEYORS' ASSOCIATION.

We briefly acknowledged the receipt last week, just as we were going to press, of an interesting account of the District Surveyors' Association, by Mr. Henry Lovegrove, F.S.A., (R.I.B.A.), a Past President and Hon. Secretary and Treasurer of that body. In twenty-four pages, it covers the main incidents of the history of the association, and gives many more or less brief notes about its members.

The association embraces the District Surveyors of Buildings appointed under the Acts since the passing of the Metropolitan Building Act in 1844, although Acts of Parliament regulating the construction of buildings existed many years before; in fact, after the great Fire had swept away the picturesque but insanitary old City of London, an Act was passed in 1667 giving the Corporation of the City power to appoint surveyors or inspectors. In 1725 the buildings law of the city was extended to include four large London parishes, viz., St. Pancras, St. Mary le Bone, Paddington, and Chelsea. The Act of 1844 was a more comprehensive Act, and gave the officers the title of District Surveyors, making provision for an examination to show that the surveyors were competent to perform their duties. The Metropolitan Building Act of 1855 repealed the former Act, and confirmed the district surveyors in their offices, and transferred their appointments to the newly created Metropolitan Board of Works.

The more elaborate Act and the many questions of law and procedure appeared to render necessary some special society where the district surveyors could meet for mutual assistance.

The first minute book records the sending out of a circular letter, dated January 20, 1845, calling a meeting at the London Coffee House, Ludgate Hill. At this meeting the following attended:—Mr. John White (in the chair), Messrs. C. R. Badger, George Aller, George Pownall, Robert Sibley, George Otch, H. E. Kendall, William Lovell, E. Foxhall, Charles Beachcroft, H. E. Kendall, junr., William Grelhier, T. L. Donaldson, F. C. Carpenter, George Aitchison, George Carter, John Blyth, Edward P. Anson, junr., Samuel Angell, Robert P. Browne, Richard S. Martyn, T. H. Wyatt, William Rogers, Jun. Mullins, W. Crawford Stow, James Howell, E. Woodthorpe, H. Baker, J. Collis, Charles Mayhew, E. N. Clifton, E. C. Hake-well, J. C. Christopher, Rawlinson Parkinson, and W. L. Donaldson, honorary solicitor.

In July, 1849, the members dined together for the first time.

In July, 1851, the death of Mr. White was announced.

Messrs. J. A. White and J. Jennings were elected members, having been appointed to North and South Marylebone respectively.

In January, 1852, it was decided to issue reports of cases. In April, 1853, a piece of plate was presented to Mr. R. Hesketh for valuable services rendered as hon. sec. In 1854 meetings were first held at 9, Conduit Street, Hanover Square, W. In January, 1858, Professor Donaldson, on behalf of the members, presented a handsome silver salver to Mr. Charles Fowler for his services as hon. sec. In January, 1875, a successful dinner was held, twenty-four members attended, with Mr. George Vulliamy and Mr. George Godwin as guests, and Mr. Edmund Woodthorpe in the chair. In April, 1883, Mr. C. Fowler received a silver loving cup and other articles in commemoration of his services as hon. secretary for twenty-one years. In 1884 the constitution of the society was altered, Mr. Edmund Woodthorpe being elected the first president.

Early in 1887, after a very severe contest, Mr. Thomas Blashill, F.R.I.B.A., F.S.A., was elected superintending architect to the Metropolitan Board of Works. He was born at Sutton-in-Holderness, near Hull, and after some time with an uncle, a land agent at Hereford, he entered the office of Mr. J. W. Perold and afterwards that of Mr. T. E. Knightley. In 1861 he commenced practice in Oldferry Chambers in partnership with Mr. C. Inslie. He was associated with Mr. William Hayward, engineer to the City, and

assisted in the construction of the Holborn Viaduct.

In April, 1887, Mr. Henry Lovegrove, D.S., for South London, Mr. R. Plimber, having been transferred to West Hamstead, was elected in his stead. In 1889 the London County Council took the place of the Metropolitan Board of Works. In December, 1893, the members were informed of the resignation of Mr. Thos. Blashill, superintending architect, and in March, 1899, Mr. William Edward Riley was elected superintending architect after a wide experience in architectural matters. For about twenty-one years he was in the service of the Government, the last three years as Assistant Director of the Works of the Admiralty, when he had the supervision of a very large number of important buildings. He is a Fellow of the Royal Institute of British Architects, a most indefatigable worker, and it is not generally known that he is an artist of considerable merit, and hon. treasurer of the Royal Society of British Artists. In July the members of the D.S.A. dined together, with Mr. Thos. Blashill and Mr. W. E. Riley as guests, when an illuminated address signed by all the district surveyors was presented to the former as a testimony of the high esteem in which he was held. In January, 1905, Mr. T. Blashill, the late superintending architect, died somewhat suddenly, to the great regret of a large circle of professional friends.

In February, 1905, the association was incorporated as the District Surveyors' Association (Incorporated), and the first meeting under the incorporation was held, the election of officers and other acts of the old body confirmed.

It is difficult to obtain particulars of district surveyors before the Act of 1844, but one name stands out from the rest, Charles James Matthews was elected to Augustus Pugin in 1819, and through his father's influence was elected surveyor for Bow, a post which he soon resigned, and, taking to the stage, became a famous comedian. When the 1844 Act was passed, many eminent architects held office, one being Mr. Cockerell, father of Professor Cockerell.

Prior to 1891, it was usual, on a vacancy occurring, for between thirty and forty prominent London architects to offer themselves, but since that time the candidates have usually been assistants, or young men who, from no fault of their own, have not seen their way to make a successful practice. Giving the whole time to the office, remarks, Mr. Lovegrove, is probably to the public advantage, but with the change there should have been some guarantee of a minimum income, with a pension on resignation. Through all the years since the District Surveyors' Association was founded, the Building Acts have been well administered, one or two members have been their own enemies and had to resign, none were ever charged with conduct unworthy of professional men, and no class of official stands so high in public esteem.

PAINTING BY IMMERSION AND BY COMPRESSED AIR.*

This book is the first on its subject, and as well thought out as it is greatly needed. The necessity of paint to many industries is paramount, and as universally recognised as we wish the desirability of applying paint in up-to-date fashion was. In America dipping and spraying have very largely superseded the brush and the man-machine, especially in connection with metal-work and engineering. Here, as yet, only the firms whose enterprise is the secret of their success and good standing have troubled themselves to instal a dipping or spraying plant, and have benefited, but the indications increase that ere long no factory will be complete without one, and to all wise enough to recognise this Mr. Jennings' book will be of the utmost service.

Dipping, of course, is no novelty as far as the principle goes. But recent improvements in the form and construction of the dipping

tank and its appendages, including hoists, hoists, etc., have so facilitated operation that speed and efficiency have been vastly increased. Of these many illustrations are given, together with a list of leading factories where they are in successful operation. One of the most simple but effective plants may be seen at the works of Messrs. Hayward's, Limited, Union Street, Borough, S.E., a firm better known to most of our own readers than many, and one the antiquity of whose productions is due only in a less degree to the initiative of its able and successful directors than to the foresight which has always anticipated all practicable improvements in the process of manufacture of its specialities. The plant consists of a shallow tank, in which iron and steel goods are dipped in horizontal position. The bottom is slanted, and the contents duly stirred from time to time. The principal goods painted are Hayward's lights, ubiquitous in every street of every city; their metal casements, scarcely less familiar; and their patent steel collapsible gates.

The older methods of painting by compressed air of the pump and kettle type were only partially successful, and attention, therefore, was directed to the concentric form of sprayer, now almost universally used, often to the astonishment of antiquarian observers, who are unable to understand how far superior is the result of the control of the paint by a suitably constructed spray than that achieved by the human hand and a hog's-hair brush. Many forms of air-sprays are shown, with their accessories.

With both dipping and spraying the saving of time as compared with hand painting is enormous in many cases the work can be done in one-twentieth part of the time it would take with the ordinary brush, and infinitely better. Failures, wherever they have occurred, have been found the result of the injudicious selection of one process or the other, or the defects of the paint used. These drawbacks are easily overcome by the exercise of a little common sense, and the means of doing so are explained at useful length by Mr. Jennings.

Altogether, the book is a unique one as regards subject and treatment. Many ably-written trade manuals are noticed almost weekly in these pages, but it is at rare intervals that we find advantageous and complete novelty so clearly demonstrated or with such convincing testimony.

THE CAPITAL OF THE CANAL ZONE.

Gary, Ind., and other made-to-order cities will find a sister in the new city of Balboa, which Governor Goethels, of the Canal Zone, is constructing at the Pacific entrance of the canal to be the capital of Uncle Sam's newest province. The administration building at Balboa, which will be the capital of the Zone, differs from similar buildings elsewhere in that it contains no legislative hall, the government being administered from the War Department at Washington, all the chief officials, according to executive orders, being officers of the Army and Navy.

The new administration building is of modern construction, concrete and steel being largely used. The building is fireproof throughout even to the office furniture, desks, tables, and book and filing cases being of steel.

Practically the entire town of Balboa will be of concrete, and to alleviate the glittering newness of the city a supervising horticulturist has been appointed to promote the "city beautiful" movement, both there and at all points along the canal. It is pointed out by the *Ohio Architect* that no other climate in the world offers better opportunities for the development of beautiful garden schemes. Plants, trees, and shrubs are being furnished free to the residents by the Government.

Mr. W. D. Caroe, F.S.A., F.R.I.B.A., has been offered, and has accepted, the appointment of honorary consulting architect to the diocese of St. David's.

At Southgate, the district church of St. Andrew, built in 1903, is about to be enlarged from 240 to 709 sittings, at an outlay of £26,679. The architects are Messrs. Barler and Kirk, of Buckingham Street, Strand, W.C.

* "Painting by Immersion and Compressed Air." By Arthur Seymour Jennings, F.I.B.D., London: The Managing Engineer Office, 93 and 94, Chancery Lane, W.C. 10s. 6d. net.

HOUSING CONDITIONS AND RENTS IN SCOTLAND.

At Glasgow Lord Hunter and Professor Scott, by their inquiry on behalf of the Secretary for Scotland into the increases of rents of small dwelling-houses in the industrial districts in Scotland.

Mr. Alexander Walker, the City Assessor of Glasgow, was the first witness examined. He gave figures revealing the fluctuation of rents in certain houses in the different wards of the city, and also showed that since the beginning of the war the number of vacant houses had greatly diminished. In regard to 17 selected houses, he stated that in the case of 155 there had been no increase in the rent since May, 1914. In 208 there had been increases ranging from 1d. to 5s. 4d. per month.

Mr. Walker Smith, M.Inst.C.E., Controller of Housing and Town Planning and Chief Engineer to the Local Government Board for Scotland, said there was no doubt that the standard of housing for the working classes of Scotland was by no means a high standard, and in many cases and in many areas the standard was distinctly bad. Contrasting English industrial parts with those of Scotland, he said that, like for like, the English working man had about 40 per cent. more house accommodation on the average, for which he paid an additional rental of only about 15 per cent. Private enterprise had been more or less stagnant in relation to the provision of working-class houses within the last seven years. As to the reasons given by owners for this stagnation, they were legislation, actual and feared, and increased cost of labour and materials—the cost having advanced generally from 20 to 25 per cent. Only when economic circumstances enabled owners to obtain increases in rents would private enterprise be automatically switched on again. The present building conditions in the West of Scotland did not permit of a solution on the normal process of evolution. The witness said housing difficulties were becoming extremely acute. Clydebank and Renfrew were more than full—they were overflowing, to the extent of about 16,000 workers at Clydebank, principally at the Harmer Shipbuilding Works, and about 5,000 workers from Renfrew, from the boiler-makers' and machine tool works there. He believed that at the present time the provision of permanent houses in the area neighbouring Glasgow was a physical impossibility. Neither the labour nor the time for the provision of houses could be found, and in any case the cost at the present time would render it financially impossible. The only place witness went on where any additional houses could be obtained in large numbers in the Clyde valley at present was in Glasgow itself, and these numbered only 8,947. It was common knowledge that a very considerable number of houses in Glasgow were unfit for habitation. The witness afterwards expressed the view that in the near future the whole of the existing accommodation must be taken up, and there would then be no open market in the ordinary sense of the term. He estimated the additional expenses property owners had to bear as a result of war conditions, and gave what he considered a fair adjustment of the rent of a £14 house. He allowed an increase for repairs and for the advance in interest, but held that insurance and collect on and management expenses were not affected. As to empty houses and bad debts, he thought that there should be some relaxation. The result of his calculations was that he estimated the total increase on a house of £17, rent and rates combined, at 18s. 9d., that was to say, 55 per cent. on the maximum payment, or 67 per cent. on the rental proper of £14.

Mr. Thomas Bruce, member of the Scottish Land Commission under the Finance Act, said the great fault of housing in Scotland was the scarcity of tenements, which last 150 years had come in their day, ultimately becoming seams. Local authorities were allowed to put up buildings which would fall to pieces in a few years this would solve the Scottish housing problem more than anything else. Witness would allow brick walls 14 inches in Scotland instead of stone walls 2 ft

thick, as at present. The heavy houses in Scotland accounted for dearer rents compared with England.

Mr. William Gillies, Dean of the Faculty of Procurators in Glasgow, dealt with the fluctuations in the value of heritable property in Glasgow, beginning with the boom in 1875. It was in 1910, he said, that they had the greatest number of unlet dwelling-houses in the area of Glasgow as it then existed, and not including Partick or Govan. Rents naturally tended to fall, and the rates were going up all the time. This caused in a good many instances that came under his notice no return at all to the property owner.

Mr. William C. Faulds, President of the Association of House Factors, said that in regard to property factored by him east of Glasgow Cross and north of the Clyde, increases had been intimated or were to be intimated varying from 10 per cent. to 5 per cent. on the assessed rental. Upon the gross rental, including rates, the increase varied from 12½ per cent. to 6½ per cent.

Mr. William Menzies, manager of the City Improvement Department of Glasgow Corporation, gave evidence as to the smaller houses owned by the Department.

Other witnesses declared that 10 per cent. increase on the net rental was imperative to recoup owners for the burden of increased rates and higher cost of money and repairs. It was stated that there is a complete house famine in certain Clydeside towns, while the margin in Glasgow is very small.

Witnesses stated that the War Loan at 4½ per cent. made lenders less eager to invest in property. Some demanded 5 per cent. All classes of tradesmen were benefiting from the higher wages. It was said that the only people who felt the pinch of living were warehousemen and salaried folks. Owners asserted that the increases made were justified.

Mr. Andrew McBride, who represented the Labour Party Housing Committee formed two years ago, deposed that as private speculators had practically ceased building, and that as many of the houses were admitted to be unfit for human habitation, they were in Glasgow within easy reach of a famine in houses. The standard of housing in Glasgow was below that of any other city, and per acre they were the most congested city in Great Britain, with 55 per acre, while Liverpool, the next worst city, had 45 per acre. They urged that at the earliest moment the town council should, on a definite and permanent plan, start building cottages in order to secure healthy houses for the citizens, and that for this purpose a loan free of interest should be taken from the tramway surplus. He held that it was impossible for private enterprise, either when the conditions are normal or under the present abnormal conditions, to build healthy houses at a rent which could be paid.

Baillie James Stewart, representative of Townhead Ward, a member of the Labour Party's Housing Committee since its foundation, also spoke as an opponent of private enterprise. Any loss, he held, ought to fall on the State and not on the municipality. In further evidence, witness admitted that there had been an increase in the cost of labour and material; but he submitted as against that that the repairs carried out just now were less than they were three years ago, and the amount expended on repairs would consequently not be so great.

The city surveyor of Glasgow stated that in his area there were only five unlet houses, compared with 1,200 five years ago. In three firms over 30,000 men were employed. The rents had risen, and some tenants had had to pay two advances this year. He did not agree with the landlords' plea regarding the extra cost of repairs. The advance in the rate of interest demanded by the bondholders was said to be half the reason for dearer rents; the cost of repairs accounted for the other half. In reply to Lord Hunter, witness stated that in order to return to pre-war rents the extra cost of labour and material would require to be considered.

Mr. George Boss, burgh surveyor, Clydebank, stated that in that burgh there were

at present 8,947 houses, which were almost entirely occupied by the working classes. In 1871 there were 105 inhabited houses, with a population of 816, and these figures gradually increased till in 1914 there were 8,730 houses and 44,741 of population. In 1910-11 there were 1,276 empty houses; in 1913-14 there were 218; and in 1915-16 the number was five. Building in Clydebank generally came in spurts. For example, between 1905 and 1908 almost 3,000 houses were built, and consequently the supply was above the demand. Messrs. Beardmore put up a lot of buildings, and speculative builders also came into the field. During the last two years only fifty houses were built, but since May, 1914, plans for 565 houses had been passed by the Dean of Guild Court. There was at present a big lot of building going on, and there was a large demand for houses, arising from extra work and more people being anxious to reside near their place of employment. A scarcity of houses always meant a tendency to increase rents, and that tendency had been showing itself recently. Increases had been put on rents of single apartment and room and kitchen houses of from 9s. to 10s. to about 50s., or about from 5 to 15 per cent. In some cases there had been two increases since the war started. The rates on owners and occupiers for the current year were lower than they had been for some years.

In answer to Professor Scott, the witness said that the expenditure on repairs during a period of five years was as low as 4 per cent. and as high as 25 per cent., but in some of those cases the property had not been repaired for twenty years.

Mr. James Steel, vice-president of the Glasgow Factors' Association, said that for some years the result of the excessive number of houses had been disastrous. Within the city the depression was not so acute as in Govan and Partick, where for some years proprietors, instead of receiving any return on their capital, were paying debit balances half-yearly. Witness offered instances of increased tradesmen's charges. Thirteen items usually found in bills for plumber work had risen from 32s. 2d. in 1905 to 49s. 5d. in 1913, and the present price was 66s. 1d. Then there was the interest on bond interest, and fully 95 per cent. of those he represented had borrowed money on their properties.

Mr. Archibald Speirs, president of the Glasgow House Owners' Association, said that from 1900 to 1905 rents remained practically stationary, and after that, owing to the over supply of houses, a fall took place, which had not yet been made good. In rents that were increased prior to the war they were only trying to get back a portion of the rent that had been previously reduced. Houses not let in ordinary circumstances had been let to a small extent, but there were still many houses in Glasgow unlet. Owners required 10 per cent. increase to put them in a position similar to that before the war. Mr. Samuel C. Eadie, builder, said that on the whole rents were rather lower than they were fifteen years ago. Subsequently evidence was submitted regarding the situation in Rutherglen and Greenock, the views of the respective parties being generally along the lines of evidence already reported.

A new church hall has been erected at Shelton, North Staffordshire, adjoining the Rectory grounds. The building contains a hall 60 ft. by 35 ft., with ante-rooms, secretary's office, men's club, parlour, kitchen, and is lighted by electricity. A bowling green and tennis court are included in the scheme. The contractor is Mr. Thomas Godwin, of Hanley, and the work has been designed by Mr. A. W. Moss, architect, Hanley.

The Westminster City Council on Friday decided, subject to the approval of H.M. Office of Works, to offer the large triangular paved island in St. Martin's Place, between the National Portrait Gallery, the Westminster Hall, and the end of Chandos Street, as a site for a memorial to Miss Cavell, to be executed by Sir George Frampton, R.A. The site is that on which the Gordon statue stood for a short time. Mr. Lewis Harcourt, ex-First Commissioner, has sanctioned the appropriation of the site for the purpose.

Currente Calamo.

The President's address at the opening of the eighty-second session of the R.I.B.A. on Monday was delivered to a small audience at 3.30 p.m., and the whole proceedings finished in less than an hour. Naturally Mr. Ernest Newton had little to say about matters that members usually look to the President or comment on. All will be glad to note that a further appeal has been made to the Chancellor of the Exchequer to deal fairly and honestly with those of us whose incomes are falling to zero, or have vanished altogether. Certainly, as Mr. Newton said, "relief" hardly meets the cases of those who have nothing to be relieved of, and whose present impecuniosity is due to the shortsighted eagerness of the Treasury to stop building operations, which it was promised by the Local Government Board could be encouraged. One hopes, almost against hope, that Mr. McKenna may realise that some of his colleagues elsewhere—architects have done to help the common cause. The President's summary thereof is familiar to our readers, and the record is a noble one. We trust his concluding appeal to all of us will hearten the feeble-minded and touch the hearts of the sickers. We are glad he endorses our own previous criticism of some of the methods of some of our authorities—notably those responsible for "the exasperating and dead appeal of the picture poster"!

Accidents will, or must, happen during building operations. When these affect those employed on the work compensation is payable under the present law, which practically amounts to an insurance. But when third parties suffer, who are neither in the service of the builder nor under a contract with him, difficult legal questions often arise. The latest example is the case of *Elliott v. C. P. Roberts and Co., Ltd.*, heard before Mr. Justice Lush and a common jury. The defendants were re-building a school for the L.C.C., and under their contract they were bound to provide a plant, etc., and afford facilities to any other tradesmen employed by the Council, including the reasonable use of any scaffolding. The defendants had control of the premises at the building. The plaintiff's case was that he was lawfully using a gangway on the job, made of two unfixed planks placed diagonally in an open space, with no fence or rail. The plaintiff had used this safely for six weeks, and the planks were obviously not fixed. Then he fell and was seriously injured. The jury found negligence by the defendant on the facts and gave plaintiff a verdict with £2,000 damages. But the judge reversed this on points of law and entered judgment for the defendants, the builders. As there was no contract between the defendant and the plaintiff the question was what they owed to him in law. The builders had allowed him to come on the job and use the gangway, but they did not invite him to do so. Holding there was no duty to provide a safe gangway as between the parties, the judge decided for the defendants. The case will go to the Court of Appeal, where we shall hope to get a clearer view of this very important practical point for builders and contractors and tradesmen.

Chain flaps, opening in the highway, have caused a good deal of litigation, but though the legal principles of liability may seem to be

settled, they are not so well applied in practice. In a recent case, *W. and J. Hodgson-Kingston, Receiving Clerk, Limited*, the facts were common and clear enough, but the lawyers differed widely. There a boy fell through a chain flap opening in the pavement and sued, through his father, for damages. The defendants were the owners of the place, which was a tied public house where they were delivering beer by means of a contractor engaged for that work. The plaintiff sued both the owners and the tenant, and the County Court judge decided against them both. But, on the owners' appeal, the High Court has now reversed this ruling, and so no one is yet made liable. The Court held that, as the defendants, the brewers, and owners of the premises, had engaged an independent contractor to do the cartage of their beer, they were not legally responsible. Certainly, the carter was not doing work on the surface of the highway which would necessarily be a public danger, and thus bring in the owners as liable. The plaintiff had sued both the owners and tenant, not adding the contractor, of whose existence he may not have been aware. But it would have cost no more to include him in the action and so brought it against the three as being liable, jointly or severally, in the alternative. If he was known this would have been the proper and the safe course to adopt. The carting contractor can still be sued if negligence can be shown against him. Obviously, someone should be liable in damages, unless, of course, it was all the boy's own fault!

In view of the part taken by the Society of Architects in the establishment of the first Atelier of Architecture in London by the Beaux Arts Committee, the following account of a similar movement in Sydney is of interest. Its inception and success appears to be entirely due to the single-handed efforts of its promoter and patron, Mr. Gordon S. Keesing, A.I.A., late of the Atelier Prevot, New York, and Atelier Gromont, Paris. In the course of an article published in "The Salon," Mr. Keesing says: "Realising the disabilities under which the more ambitious architectural students of Sydney labour as regards their studies, I evolved a scheme by which the regular functions of an Atelier are combined with the most important elements of a University course. I drew up the curriculum as a result of criticisms I heard whilst in England, of the work our students submitted for the R.I.B.A. examinations, as well as from the observations of local architects, and in addition from my own experience—having had the experience of being an Australian trained draughtsman in competition with the Atelier and University trained men of New York." The quick success which has met Mr. Keesing's endeavours justifies the methods he is employing, and the improvement which has been accomplished, in a few months, in the work of some of the members of the Atelier is surprising. The novelty to the students of the new methods, the suddenness with which they were being thrust upon them, and the different conditions which obtain in Australia from those existing in Paris, New York, or even London, where the first Atelier started with Paris-trained men among its members, all threatened to be insurmountable. Quite the contrary has happened. Some of the members frequently do quick "design" problems, which would gain a pass in the rather severe examination of l'Ecole des Beaux Arts. Some of their more finished work is above the average of that submitted at the bi-monthly

exhibition at the N. Y. Beaux Arts Society. Under a drawing of a vase, for example, been in existence for some time. The original members have a good deal of knowledge of the geography and history of architecture. The first year's studies consist of the following items: A sheet of plans in details, carefully drawn, inked in and coloured; a sheet of measured work, for the purpose of a detail of a feature, the whole being on, anyhow, sufficient to show the relation of the feature, must be included; a position, design and planning in each important style, finished in pencil and colour, and a number of additional problems giving freedom of design, plan, and construction; thus, class-work has the additional objective of developing speedy draughtsmanship, and each problem has to be finished in about twelve hours; fresh-hand sketches, lectures in history, design, and allied subjects. Mr. Keesing's only trouble is the lack of any supporting institutions, which devolves such a comprehensive curriculum on him single-handed.

With a much larger army in the field than we have ever had before, the percentage of disease is much smaller than in previous campaigns on foreign soil, owing to the excellence of the sanitary arrangements, and the efficiency of the medical staff. Sir James Crichton Browne, in his presidential address to the Sanitary Inspectors' Association, is responsible for the statement that if the sickness in the present war had been at the same rate as in the South African War in proportion to the number of troops engaged, we should have lost more than a million men from sickness. Our losses in killed, wounded, and missing, in all fields of operations, now total nearly half a million, or, to be precise, 495,294. Sir James contended not only that the power of sanitation had been conspicuously shown in relation to sickness in the field, but that it had also enabled us to send our troops abroad in a sound and efficient condition. Of the men who offered themselves for service in the first year of the war, one million were said to have been rejected—all born from eighteen to forty years ago, in the bad old sanitary days, as Sir James described them.

Dr. William Martin's interesting lecture last week to the British Numismatic Society on "London as Illustrated upon the Great Seals" will, we hope, second his desire to draw attention to a source of information, hitherto somewhat neglected, concerning the appearance of Stuart London, and by so doing lead possibly to the discovery of the original view of Old London from which the illustration on the Great Seals and similar pictorial efforts had been drawn. The earliest view shown on the screen was the wonderful cartographical attempt at portraiture by the well-known corporate Seal of the City of London, 1224, and pictures were also given of London and its vicinity as shown upon the Barcheston tapestry, and of the view occurring as an inset to the map of Houdius, to be seen in Speed's Atlas of 1609. From these there was a natural transition to the Australian portrait of James I., in which a panorama of London appears between the horse's legs. The lecturer then passed to the Great Seals, and showed a succession of plates from Charles I. to George I., where between the horse's legs panoramas of London occur, in which buildings such as St. Paul's and Lambeth Palace could be identified. It was noted that the horse shown on the seal of Richard Cromwell seemed to be exactly like the horse on which Charles I. is mounted at

In addition, by permission of the authorities, several medals were struck in London was depicted. These include the rare medal of 1633, commemorating King Charles's return to London after his capture at Edinburgh. If any of our readers should happen to possess seeds or medals with architectural subjects on them of great interest we should be glad to illustrate such, if favoured with photographs or drawings.

Mr. H. Percy Burns, M.P., presided over a meeting at the Whitehall Rooms on October 20, to consider the Government insurance scheme for war damage, when Mr. Mark II. Judge proposed the following resolution:— "That, in the opinion of this meeting, the Government scheme for insuring against loss of property by aircraft and bombardment, which has made individual citizens responsible for war damage inflicted on them by the enemy, is manifestly unjust; and it is hereby agreed to present a memorial to the Prime Minister urging the abandonment of the scheme, and 1. the adoption of an Act recognising national responsibility somewhat on the lines of the Riot (Damage) Act, 1886, or 2. revert to the policy adopted in connection with the Zeppelin raids on the East Coast and the bombardment of Scarborough and Hartlepool prior to the introduction of the insurance scheme, and compensate sufferers out of national funds, a condition of the withdrawal to be that the premiums already paid under the scheme should be returned." Mr. W. H. Southon seconded, and, after discussion, the resolution was passed unanimously. A committee was elected to prepare and present the memorial, and Mr. W. H. Southon, Southon and Robinson, 115a, Chancery Lane, W.C., was appointed hon. secretary. We trust support of this movement will be promptly given. A more ridiculous, unfair, and short-sighted course than that the Government has adopted could scarcely be conceived.

Readers who receive their copies by post direct from our office will notice that we are compelled this week and henceforth to pay a penny instead of a halfpenny postage on each copy, the rate having been fixed at 1000 by the Postmaster-General. We and others have pointed out to that official that an extension to 1000 would have met the needs of all handmade newspapers, but no attention to our representations has been manifested. It is no use grumbling at the Postmaster-General. He is simply in the grip of the Treasury, whose idea of good that seems to be to raise the Income-tax to ten shillings in the pound and then to awaken to the fact that we shall all be working at a loss, and that no "profits" will be available for assessment. Since the war commenced, at considerable sacrifice, we have kept the BUILDING NEWS intact as regards size, quality of paper, and the number of our illustrations. We shall still do so if our readers and advertisers support us. For the present, at any rate, we shall bear the additional postage charges ourselves, and our subscription rate will, as heretofore, be £1 per annum, post free, 10s. half-yearly, and 5s. quarterly. We mention this now because our subscribers renew their subscriptions. We are anxious to see a continuation of our determination that the flag flying are unrealised, we are anxious to reduce our size or the quality of our paper. We shall do neither, but we are sure that our readers and advertisers

Correspondence.

DEDUCTION FROM AND ADDITION TO PRICED BILLS OF QUANTITIES.

SIR,—Your account of the resolution come to by the Works and Stores Committee of the Metropolitan Water Board, given in your issue of the 20th, is quite interesting.

It shows how public bodies ignore generally accepted methods of carrying on business. For a considerable number of years it has been the practice of contractors tendering to alter the total amount as priced out by adding to it or deducting from it an amount, not as a rule any particular percentage, but a sum which might approximate to a percentage on the total of the estimate as made up in many instances by an estimating assistant in the office. The amount deducted depends in some cases on how anxious, or the reverse, the contractor is to get the work, and perhaps on his views as to the prices put down by the estimating assistant. No matter what the object in view may be, the custom prevails, and in many cases it has the following effect: that where alterations or variations are made in carrying out the work, the alterations have to be priced out at the original prices, paying no attention to the sum deducted at the end of the bills of quantities, and so the work done under items of alterations costs more than the original prices as reduced by the percentage. This may be all right for the contractor, but it is not fair to the client, who naturally expects to pay *pro rata* for any extra work or variations he may desire to carry out.

My object in writing you is to call the attention of members of the profession in general, and the Metropolitan Water Board in particular, to the fact that their proposed clause is not as clear as it might be.

I take it the object of every contract between employer and contractor is to make the obligations on either side as clear as possible, not an easy matter in a building contract; some may say that some particular form is "too hard" on the contractor, some others say a form does not sufficiently protect the employer, and so there can be no real agreement between the parties, and the result is a compromise.

A building contractor's business is always of an eminently speculative character; low prices necessary to get work sometimes mean loss, high price in tendering often means want of work. But, given a particular form of contract, no builder need accept it; he need not tender, and then both parties are satisfied more or less.

What, in my opinion, is required is a form of contract as fair as possible to both sides and set out in such clear language that there cannot be any mistake, even to the legal mind, as to what the meaning is. This, I do not think, is attained in the clause suggested to the Water Board.

In nearly every bill of quantities there are some "provisional sums," the amounts of which cannot, or should not, be subject to any deduction by way of percentage or otherwise, so to these the percentage should not apply, and this is the point which I think is not made clear in the clause suggested to the Water Board.

In my own practice I use the following clause, which I suggest is better and clearer than the one in question:—"Should the said schedule of quantities on examination show that the prices when carried out do not agree with the amount of the tender, or if any sum is added to or deducted, to add to or reduce the total of the amounts so carried out to the amount of the tender, such difference will be adjusted by a percentage, equal to such variation added to or deducted from the total of the variation account as the case may be, but the percentage or provisional sums shall not be subject to any alteration in amount due to any percentage added or deducted by the contractor."

The method in settling variations under this clause is as follows:—

Suppose a tender is received, the total of which is £1,000, which contains £100 of pro-

visional sums, and it is found on examination that the prices when carried out amount to £1,100, the first thing to do is to deduct the amount of the provisional sums, viz.: £100 from the total of £1,100. From the remainder (£1,000) £100 has been deducted by the contractor, which equals 10 per cent. This reduction applies to every item in the bill of quantities except provisional sums, and it would be deducted in one sum at the end of any variation account, after taking off the amounts of the provisional sums.

I hope I have made my system clear, and I should like the opinion of your readers as to whether it is clear, and what is of more importance, whether it is fair between the parties concerned.

Apologising for the length of my letter, I am, Sir, yours faithfully,

MAX CLARKE.

4, Queen Square, Bloomsbury, W.C.

RISE IN HOUSE RENTS AND MORTGAGE INTEREST.

To the Editor of THE BUILDING NEWS.

SIR,—The Land Union has had under consideration the policy of owners of small house property of raising their rents, and the tendency of mortgagees (particularly of that class of property) to increase the rates of interest upon mortgages created prior to the war.

As regards house owners, no one having any knowledge of the subject can deny that heavy burdens have fallen on them owing to the increase in the cost of repairs, extra premiums for insurances, and other causes, which in normal times would justify an increase of rent, but the Land Union has no hesitation in asking owners to refrain from raising their rents during this war, and it cannot too strongly condemn attempts to shift the burdens of personal taxation on to their tenants.

As regards mortgages, the Land Union recognises that money has become dearer since the war, that lenders are often borrowers themselves, the bank rate has risen, bankers charge higher rates of interest, and mortgagees, especially those who have lent money on small house property, are often themselves comparatively poor people.

Notwithstanding these facts, it considers the present time most inopportune to disturb existing mortgages or to raise the rate of interest, the consequent effect of which must be to cause a rise in rents or to give a plausible excuse for raising them.

The Land Union is therefore well aware that the course it advises will in some cases involve considerable sacrifice, but in these times sacrifices have to be made by us all.

On behalf of the council, I make an earnest appeal to the patriotism of house owners and mortgagees to abstain from raising rents and rates of interest now—a course which I am convinced is in the best interests of the whole country during this world-wide crisis.—I am, yours obediently,

DESBOROUGH,

Chairman of the Council.

The Land Union,
St. Stephen's House, S.W.

Our Illustrations.

NEW RESTAURANT, ZOOLOGICAL GARDENS, REGENT'S PARK.

The accompanying drawing from the Royal Academy shows a view of the new restaurant to be erected in the Zoological Gardens, Regent's Park. It is part of the scheme for the general improvement of the N.E. section of the Gardens, and will form one side of a spacious open piazza, with bandstand, lawns, etc., in front, giving ample room for all classes of visitors and for the fêtes and other public gatherings which are becoming increasingly popular at the Gardens. The building itself will be constructed of 2-in. bricks with wide joints and will accommodate a large number of the public both on the ground and first floors.

The wide verandah on the first floor is a feature of the design, and from it an extensive view of the Gardens and the park beyond will be obtained. Special accommodation has been provided for the Fellows, and the kitchens and service arrangements will be of the most up-to-date description, in order to deal with the large numbers of people who now frequent the Gardens. The construction was arranged for before the war, and it was intended to be opened this year, but it has been postponed to the present. Messrs. John Belcher, R.A., and J. J. Joass are the architects.

plaster and seating by Messrs. Wilson, Rae, Pixton and Co., Ltd., of London, while Messrs. David Rowland and Co., Ltd., were responsible for the ventilation. The picture-drome has been decorated in cream and gold, relieved with blue, the colour of the panels and seating being rose du barri. Mr. Peter D. Stonham, M.S.A., F.R.S.A.E., of Eastbourne and Bevil II, is the architect. The plans here reproduced show the somewhat unusual shape and capital arrangements of the premises, which are near the School of Art and not far from the Public Library and Art Gallery on the other side

were made in the 14th century. The cathedral is of secondary importance compared with the Church of S. Maria Maggiore, one of the most remarkable and well-known buildings of Romanesque date in black and white marble, very often described and illustrated, as by the late George Edmund Street, R.A., in his standard book on "The Brick and Marble of Italy." The drawing reproduced herewith shows the entrance to the Palazzo Terzi, from the crush of Mr. Alec G. Horsnell, Soane Medallist and Title Prize-man of the R.I.B.A., who kindly lent us this sketch.

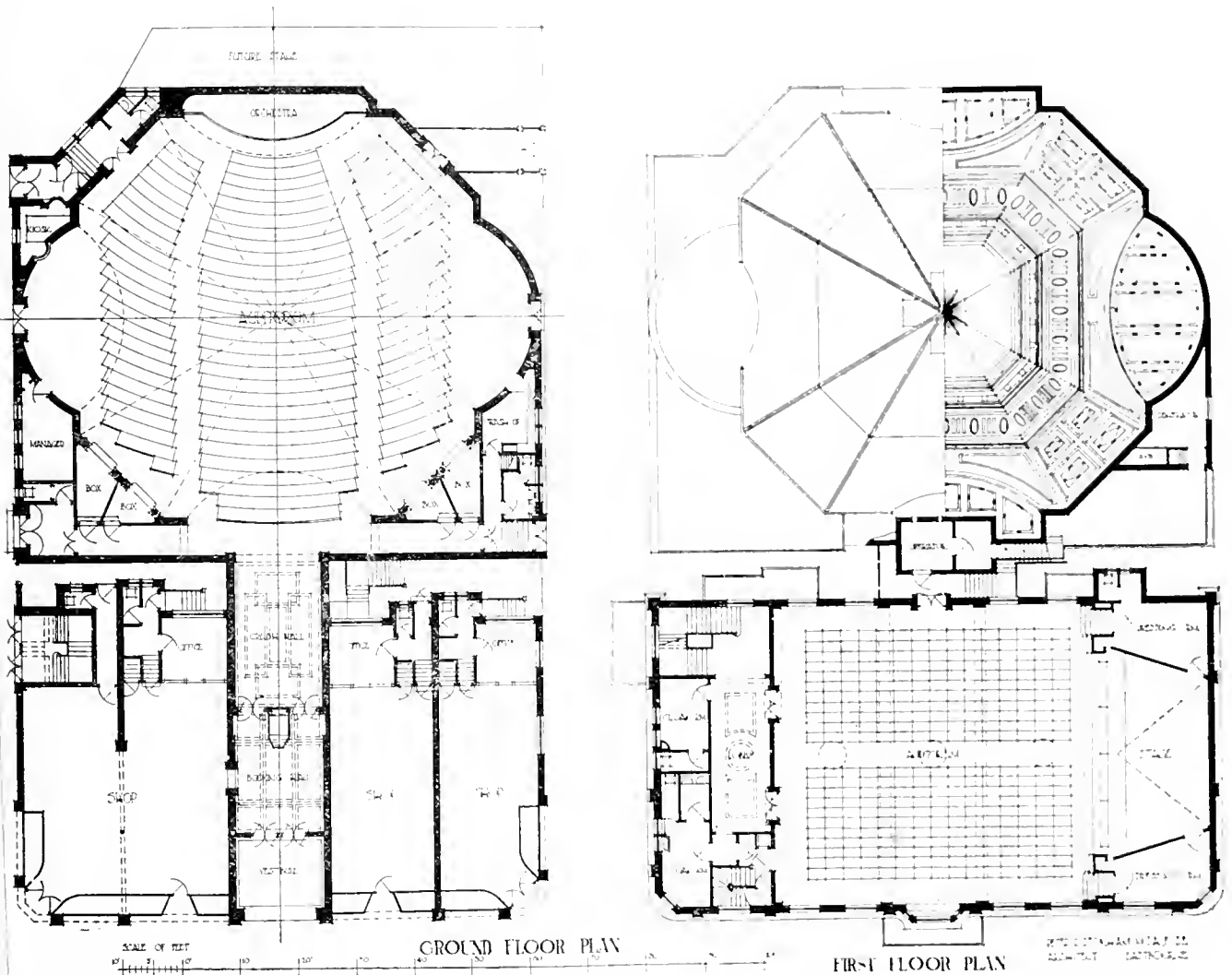

PICTUREDROME AND CONCERT HALL, WORTHING, SUSSEX: GROUND AND FIRST FLOOR PLANS.

Mr. PETER D. STONHAM, M.S.A., Architect.

CHURCH OF ST. BARNABAS, NORTH FINCHLEY.

We published the plan and some particulars of this building in our issue of August last, when a view of the apse from the north transept formed one of our double-page plates. To-day we give another of Mr. Richard Moreland's very fine photographs of the church, the subject being a view across the choir. Mr. J. S. Alder, of Tunnel Street, Strand, W.C., is the architect.

NEW PICTUREDROME AND CONCERT HALL, WORTHING, SUSSEX.

We give exterior and interior perspectives of a new picturedrome and concert hall just lately built at Worthing, in Chapel Street, the main road from the station to the pier. The picturedrome accommodates one thousand people, and the concert hall four hundred. The general contractors were Messrs. Fink Sandell and Sons, of Railway Aoroach, Worthing, the constructional steelwork was carried out by Messrs. Smith, Wiker and Co., of London, the fibrous

of the way. The site is a corner one, in the heart of the town, and very central, between East and West Worthing.

SOANE MEDALLION AND TRAVELLING STUDENTSHIP SKETCHES IN ITALY.

THE ENTRANCE TO THE PALAZZO TERZI, BERGAMO.

Bergamo is a delightful town, embracing a good deal of variety. The Città or upper part forms the aristocratic quarter, and the Borgo or the lower town is devoted to shops and commercial buildings. The principal objects of historical interest and architectural merit are within the immediate precincts of the cathedral. The bastions and gates of the city are planted round about with chestnut trees, and the walls are covered with snapdragon and scarlet valerian, walks being formed on the picturesque ramparts facing the mountains on the one side, and on the other the vast Lombard Plain, where mulberries grow in immense profusion. The Duomo was originally erected from the plans of Antonio Filarete, but many alterations

NEW BUILDINGS, COMPLETING THE QUAD, BROMSGROVE SCHOOL, WORCESTERSHIRE.

These buildings were finished this year. They consist of additions to the school-house in the shape of a new residence for the headmaster, with a new dining hall and sick-house block for the boys in his home, and quarters for servants. The buildings are kept low, to interfere with the sunlight as little as possible, and the sharp fall of the ground is utilised for the formation of cellars. The contractors were Messrs. J. and A. Brazier, of Bromsgrove, and the architect is Mr. Arthur Bartlett, F.R.I.B.A., of 11, Adam Street, Adelphi. The drawing from which this illustration was taken was exhibited in this year's Royal Academy.

The town council of Edinburgh have accepted with thanks the offer from Sir Robert Maule of a decorative panel for the council chamber.

The name of Mr. Joseph Parr, builder's merchant, has been added to the commission of the peace for the county borough of Bootle.

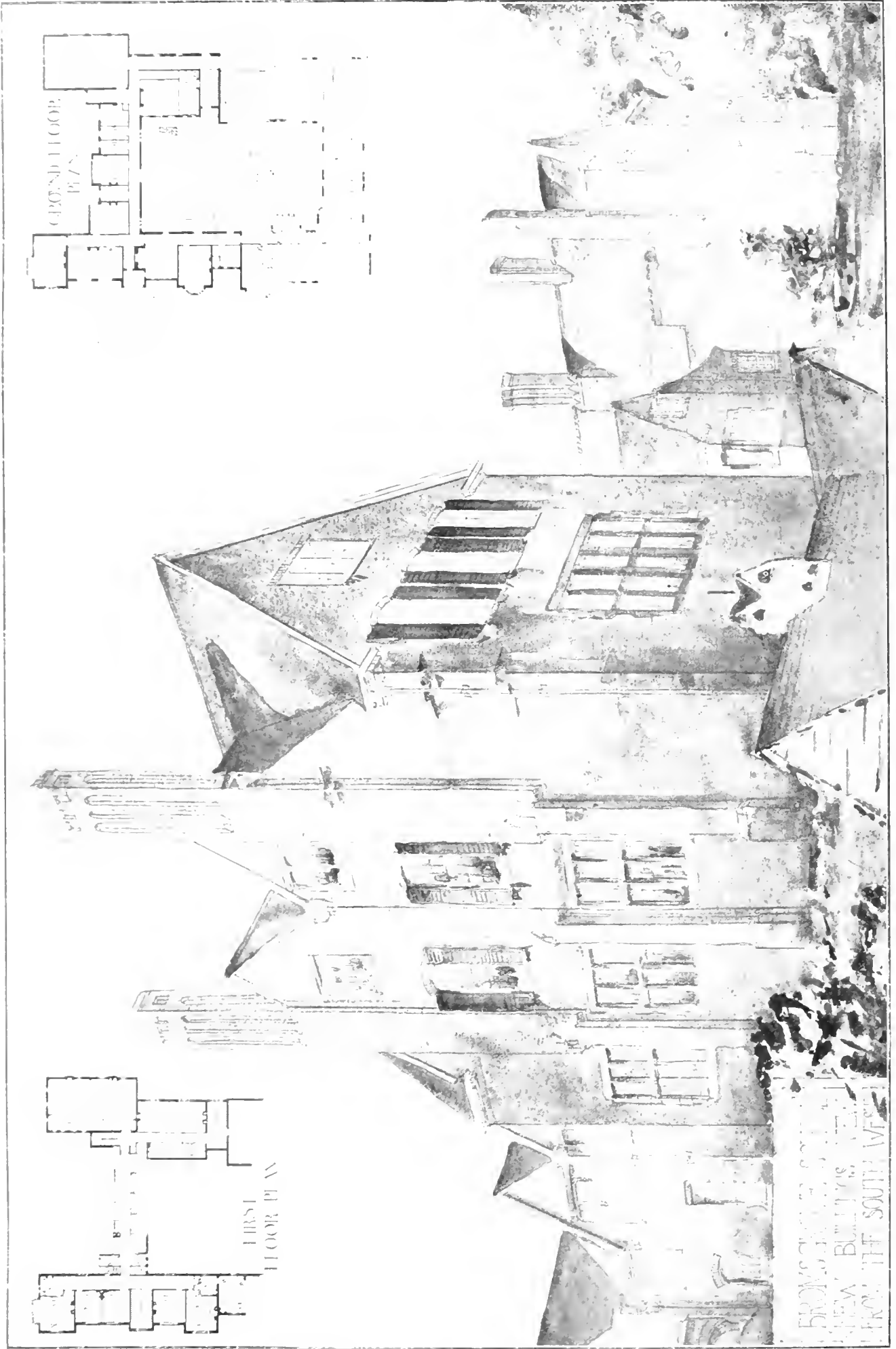

BROMSGROVE SCHOOL, WORCESTERSHIRE. NEW BUILDINGS VIEWED FROM THE SOUTH WEST

NEW BUILDINGS COMPLETING THE QUAD, BROMSGROVE SCHOOL, WORCESTERSHIRE.—Mr. ARTHUR BARTLETT, F.R.I.B.A., Architect.



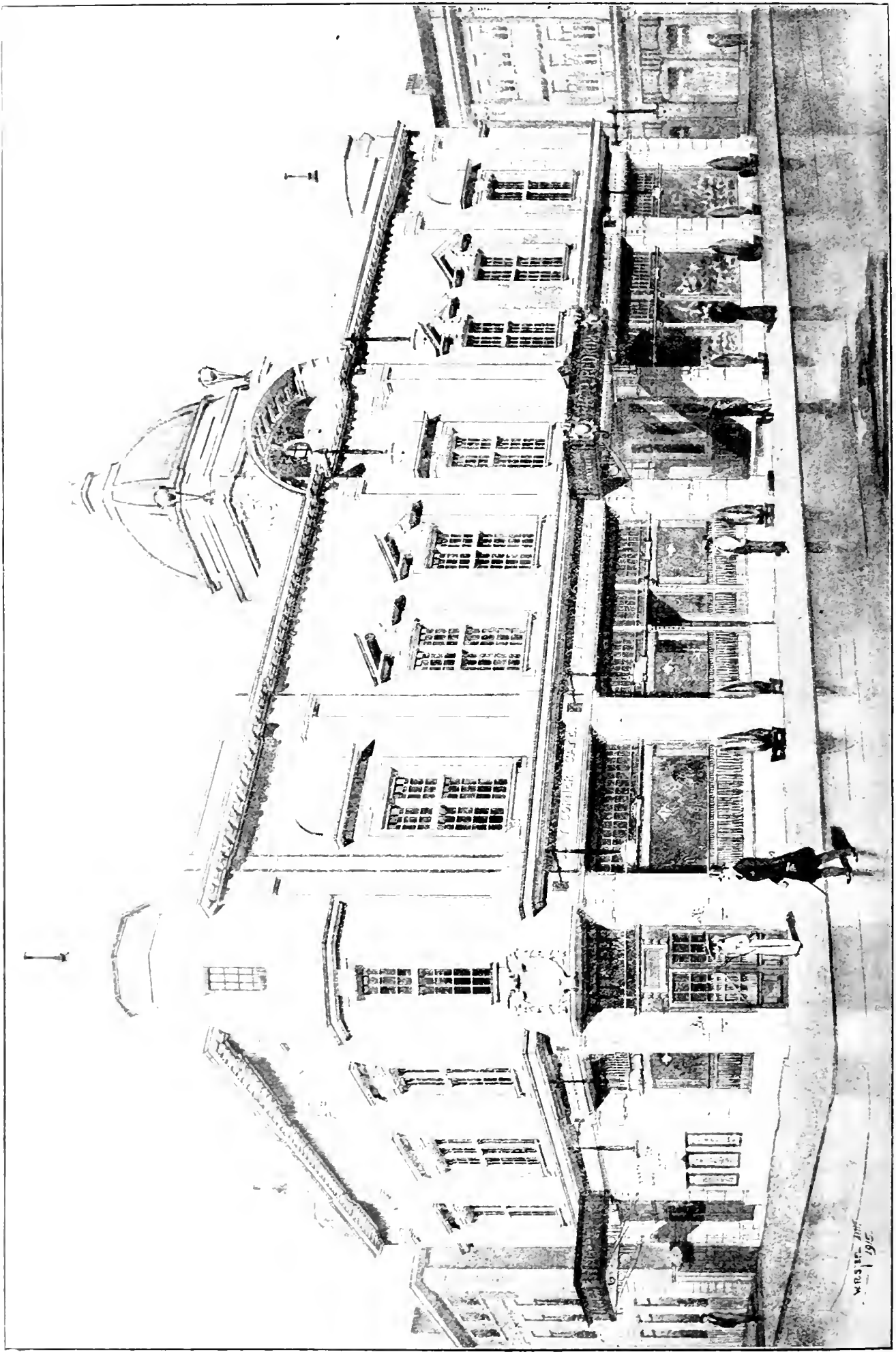

THE PICTUREDROME AND CONCERT HALL, WORTHING, SUSSEX.—MR. PETER D. STONHAM, M.S.A., Architect.

W.P.S. 2116
1915

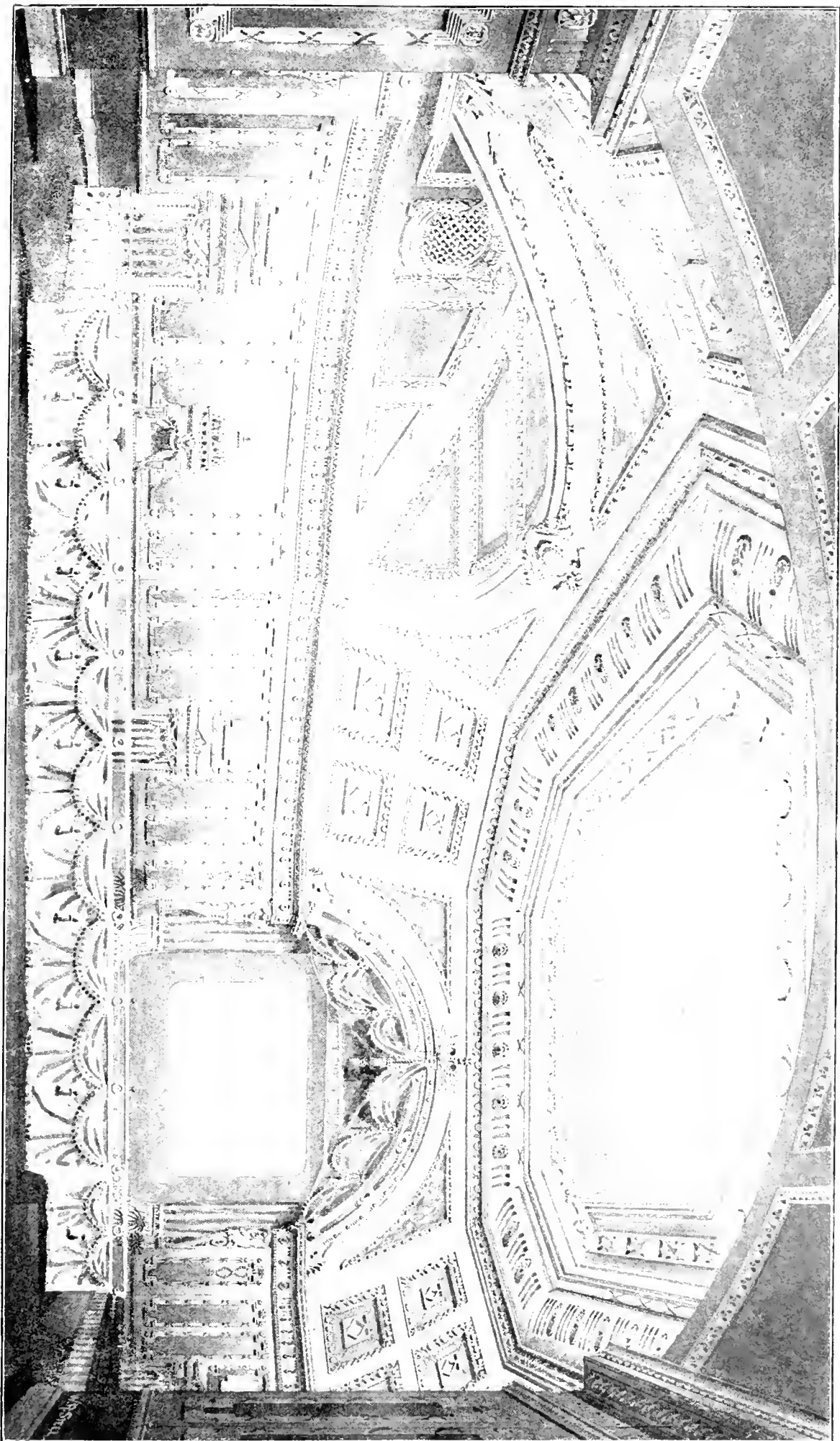

THE PICTUREDROME AND CONCERT HALL, WORTHING, SUSSEX.—MR. PETER D. STONHAM, M.S.A., ARCHITECT.

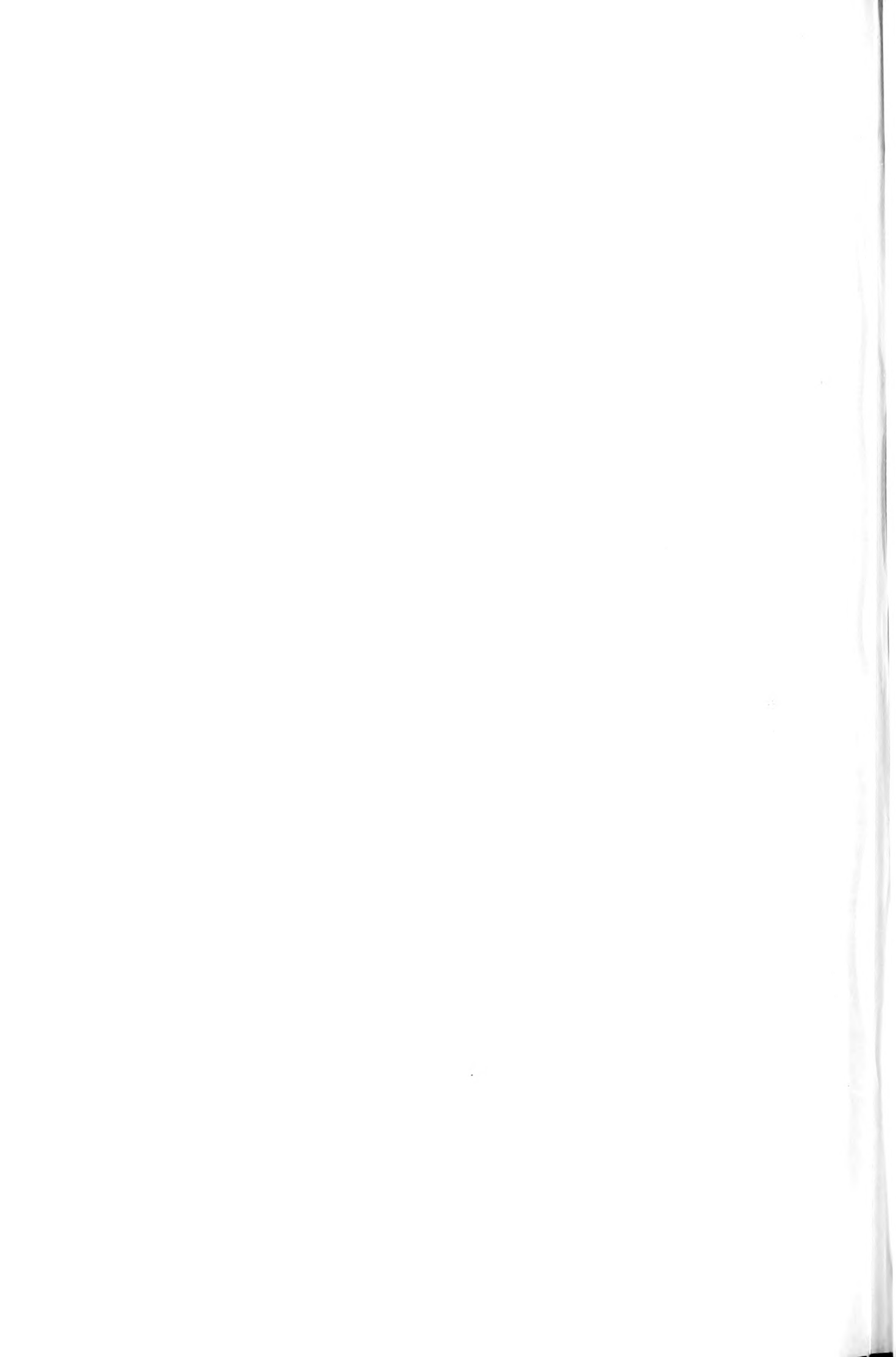

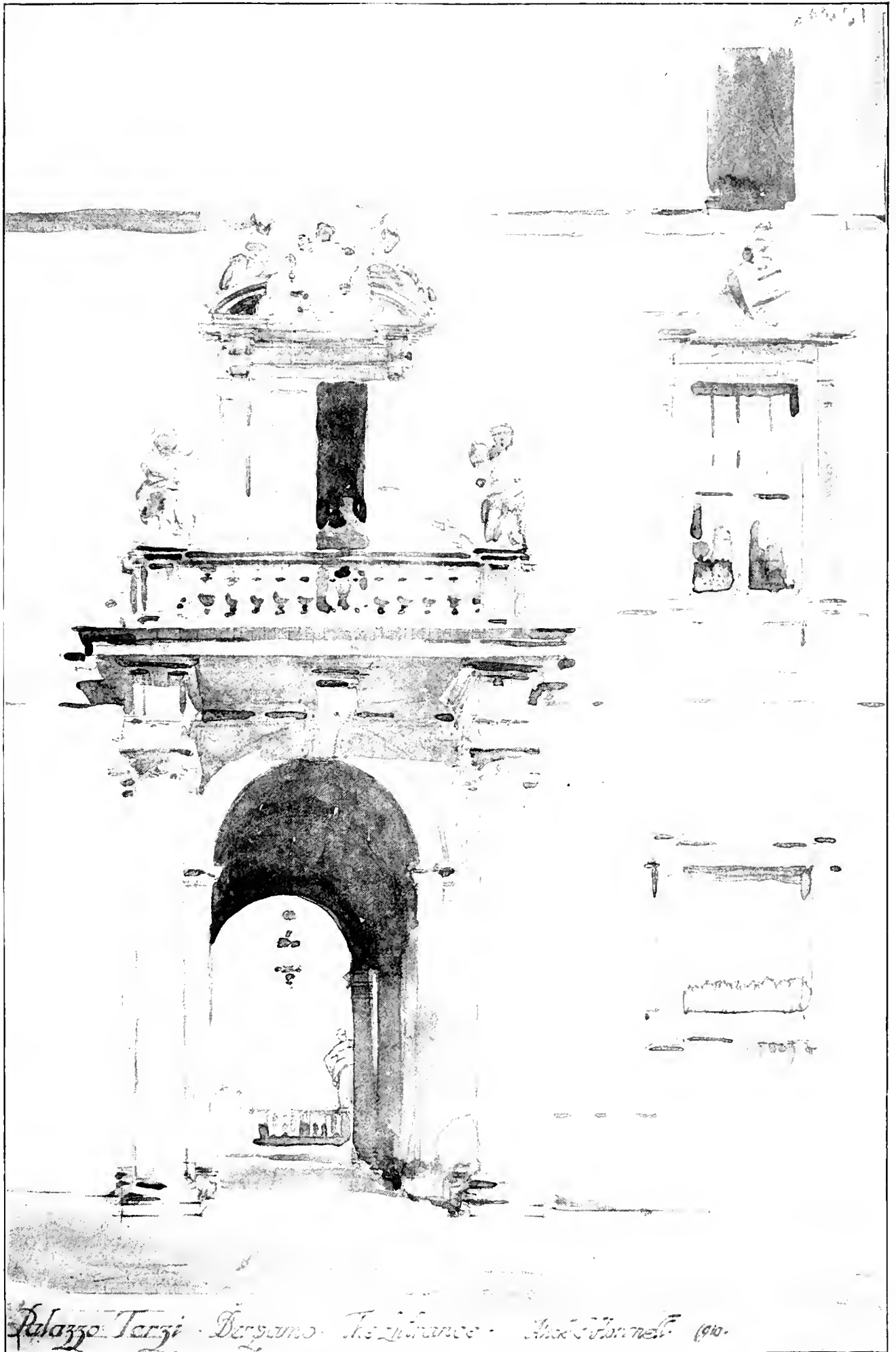

Palazzo Terzi Bergamo. The Entrance. Alick Horsnell. 1910.

PALAZZO TERZI, BERGAMO: THE ENTRANCE. SOANE MEDALLION AND TRAVELLING STUDENTSHIP SKETCHES IN ITALY.—By ALICK G. HORSNELL.

DIARY

18th Nov. (age 188) M.Y. ... R.I.B.A., prin ... of arts, Carac ... and ... estate ... seventy years ... work carried on ... was the construc ... of the ... Square ... H. C. Cochrane ... Architects ... with late ... 1902-9 ... of British ... His ... of the ... of Bath ... Bank ... Our ... in last week ... The deceased ... some ... from an in ... Mr. Fortune went to ... previously held ... Board of Works ... he was ap ... and street inspector. In ... a time surveyor, ... his salary, and ... surveyor. At ... his salary had been ... £225 per annum, ... had to pay certain ... During his tenure ... effected many ... in the city, particularly ... as T. Lampart's Buildings ... matter of sewage and ... Mr. Fortune took the ... years gone by ... plans ... of the ... Mr. W. H. Bell had brought ... 1914

Money at Fletcher Gate; Manyers Street, Dayles Road; Hammer, Loughborough, Sutton-in-Ashfield, Leicester, etc. In 1894 he took into partnership with his son, Ernest Richard Sutton, and in 1906 Mr. R. C. Sutton retired, the business being carried on by his son. He was a member of the City Council from 1887, and retired in 1901. He was a prominent Freemason, and one of the oldest members of the craft in the province. He was initiated into the Newstead Lodge (No. 47) in 1863, and twelve years later was appointed Worshipful Master. Among other offices which he filled was Prov., Grand Supt., of Works, Prov., Grand Treasurer, and Prov., Grand Warden. He was formerly a member of the Abbey Chapter. Mr. Sutton was twice married, and leaves a widow, two sons, and three daughters.

We regret to hear of the death of Mr. James Brady, one of the founders of the Clerks of Works Association in 1882, who has passed away after a long and painful illness, at the age of seventy-seven years. Mr. Brady was elected to serve upon the first committee of the association, and in September, 1883, was appointed managing editor and publisher of its *Journal*, and continued to hold that position with the exception of a two and a-half years' interval—until the end of 1909, when, through failing health and advancing years, he retired from its management. He continued to take an interest in the progress and welfare of the association to the end of his days.

LEGAL INTELLIGENCE.

BIRMINGHAM BUILDER'S AFFAIRS.

A meeting of the creditors of Albert Victor Hopkins, builder and contractor, 39, Thorp Street, Birmingham, was held on Friday at the Board of Trade Offices in that city. The debtor's statement of affairs showed gross liabilities amounting to £2384 10s. 10d., of which £1905 16s. 8d. was expected to rank for dividend; the deficiency was set at £1634 0s. 1d. The debtor alleged as causes of failure loss on contracts by the increase in wages and cost of material since the commencement of the war. The Official Receiver (Mr. A. S. Cully) stated that the receiving order was made on the 30th ult. upon the petition of a creditor. At the date of the receiving order five judgments amounting to £250 11s. 6d. were entered up against the debtor, and eight creditors, whose claims amounted to £342 13s. 3d., were suing. The debtor, who is thirty-eight years of age, stated that he commenced business in September, 1910, as a builder and contractor, without capital. He was financed by a friend, with whom matters were settled up in November, 1913, when a balance of £30 was found to be owing by the debtor, and which was still unpaid. The debtor alleged he was successful until the war commenced, when wages and material advanced to such an extent that his existing contracts resulted in heavy losses. Six months ago he entered into a contract to erect a post office at West Bromwich, which he alleged was a very beneficial contract, having regard to the price at which he had contracted for the supply of material. The debtor's interest in this contract was the most important matter connected with his affairs. It was voidable on the insolvency of the debtor and the meeting of creditors had been delayed in the anticipation that the debtor and his advisers would be able to form some scheme whereby the contract could be completed and the benefit therefrom accrue to the creditors in the shape of an acceptable dividend. Neither the debtor nor his advisers had however been able to get any sanction from the authorities having control of the contract, as to the attitude they would adopt. The debtor had kept proper books of account for the last three years, and balance sheets and profit and loss accounts had been prepared. They had included as assets estimated profits expected to be derived from current contracts, but which had not yet materialised. Mr. J. D. Kerr, 4, West Street, was appointed trustee.

BUILDER'S LIABILITY FOR GANGWAYS, ELLIOTT'S CASE. P. ROBERTS AND COMPANY, LIMITED. Suing in King's Bench Division, in February, Mr. Justice Lush decided in favor of the plaintiff, the verdict of a jury being that the defendants were liable for £2000 damages, and that the plaintiff was entitled to interest thereon. The case was brought by Sidney Elliott, for water damage done to his premises, 10, Cannon Street, London, by the defendants, P. Roberts and Company, Limited, builders of Trench Street, Dalston, to recover damages for

serious personal injuries. The hearing took place, as reported in our last issue, p. 488, on October 20, 21, and 22, when the jury gave judgment for plaintiff, assessing the damages at £2,000, but the learned judge reserved judgment on the legal issues raised. On December 21, 1914, the defendants were engaged in rebuilding a school at Bonner Road, Bethnal Green, under a contract with the London County Council, and the plaintiff was employed by the County Council to do certain work. While walking across a gangway formed by two planks, not fixed at either end and unprovided with fenced rail, the plaintiff fell, and received serious injuries, resulting in paralysis. The gangway had been used without accident for three months, and during six weeks plaintiff had crossed it many times each day. The plaintiff said the defendants were guilty of negligence in not providing a safe and suitable gangway. Mr. Moyssos, for M. Davies and Co., appeared for the plaintiff, and Mr. McCall, K.C., and Mr. Henderson for the defendants. Mr. Justice Lush, in his judgment, said that in his opinion the defendants were under no duty to the plaintiff to provide a gangway which was safe in fact, though they were under a contractual duty to the London County Council to afford facilities to any tradesman, including the reasonable use of any scaffolding. He did not see how a stranger to the contract between the defendants and the County Council could take advantage of it. The defendants were mere licensors, and the only duty they owed to the plaintiff was not to expose him to a concealed danger or trap. It was admitted by counsel for the plaintiff that there was no hidden danger or trap. He referred to the judgment of Lord Justice Phillimore in "Norman v. Great Western Railway Company" (1915) and "Smith v. London and St. Katherine Docks." As in his view there had been no breach of duty, he entered judgment for the defendants, with costs. It was intimated that there would be an appeal. Mr. McCall, K.C., applied that the sum of £200 which had been brought into court by the defendants should be paid out to them. Mr. Justice Lush made the order asked for.

CLAIM FOR COMPLETION OF PURCHASE OF AN ESTATE.—KECK v. FABER GELLETT AND KEEBLE THIRD PARTIES.—Mr. Muir Mackenzie, Official Referee, sitting at the Royal Courts of Justice, Strand, concluded the hearing on Wednesday of an inquiry as to the damages alleged to have been suffered by Mr. Thomas Charles Leicester Powys Keck, of Palliser Road, Baron's Court, by reason of the failure of the defendant, Major Walter V. Faber, M.P. for Andover, to complete certain agreements made in May, 1913, for the purchase from the plaintiff of the Stoughton Grange Estate and other property in Leicestershire, of which the plaintiff was tenant for life. The estate of 7,201 acres included the manor known as Stoughton Grange and the lands comprising Stoughton, Evington, Thornley, Bushby, Oadby, Great Stretton, Little Stretton, Houghton-on-the-Hill, King's Norton, Galby, Frisby, Billesdon, Burton, Overy, and Knighton. The purchase money was £251,700, of which only a deposit of £12,500 was paid by defendant, the balance being due six months later in November, 1913. Mr. G. J. Talbot, K.C., and Mr. H. T. Mould appeared for the plaintiff, and Mr. A. J. Rom, K.G., and Mr. W. J. Jeeves for the defendant and the third parties. The action was originally one for specific performance, but by a judgment of Mr. Justice Neville dated July 9, 1914, as the plaintiff had asked for damages in lieu of specific performance, the present inquiry was ordered. The judgment further directed that the deposits amounting to £12,665 paid by the defendant to the plaintiff on entering into the agreements should be forfeited, and ordered that the third parties should indemnify the defendant in respect of this liability under the judgment.—It was stated in evidence at the present inquiry that there was a great deal of dissatisfaction among the tenants, who could not get their titles. Public meetings were held, and a deputation attended before the Board of Agriculture. Much expert testimony was given as to the value of the property. At the close of the inquiry the Official Referee intimated that he would report his findings to Mr. Justice Neville, the Chancery judge who originally had the action before him.

PAYMENT FOR EXTRA COPIES AN ALLEGED SECRET COMMISSION?—At the Westminster County Court, before his Honour Judge Woodfall, the case of Elliott v. Escurvix, of the late T. Woodhouse Biere's was heard last Monday week, which raised the important point as to whether an architect is entitled to obtain payment from a contractor for additional copies over and above those provided in the R.I.B.A. scale—also as to how

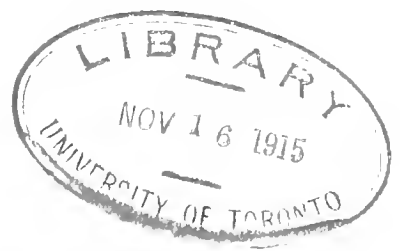

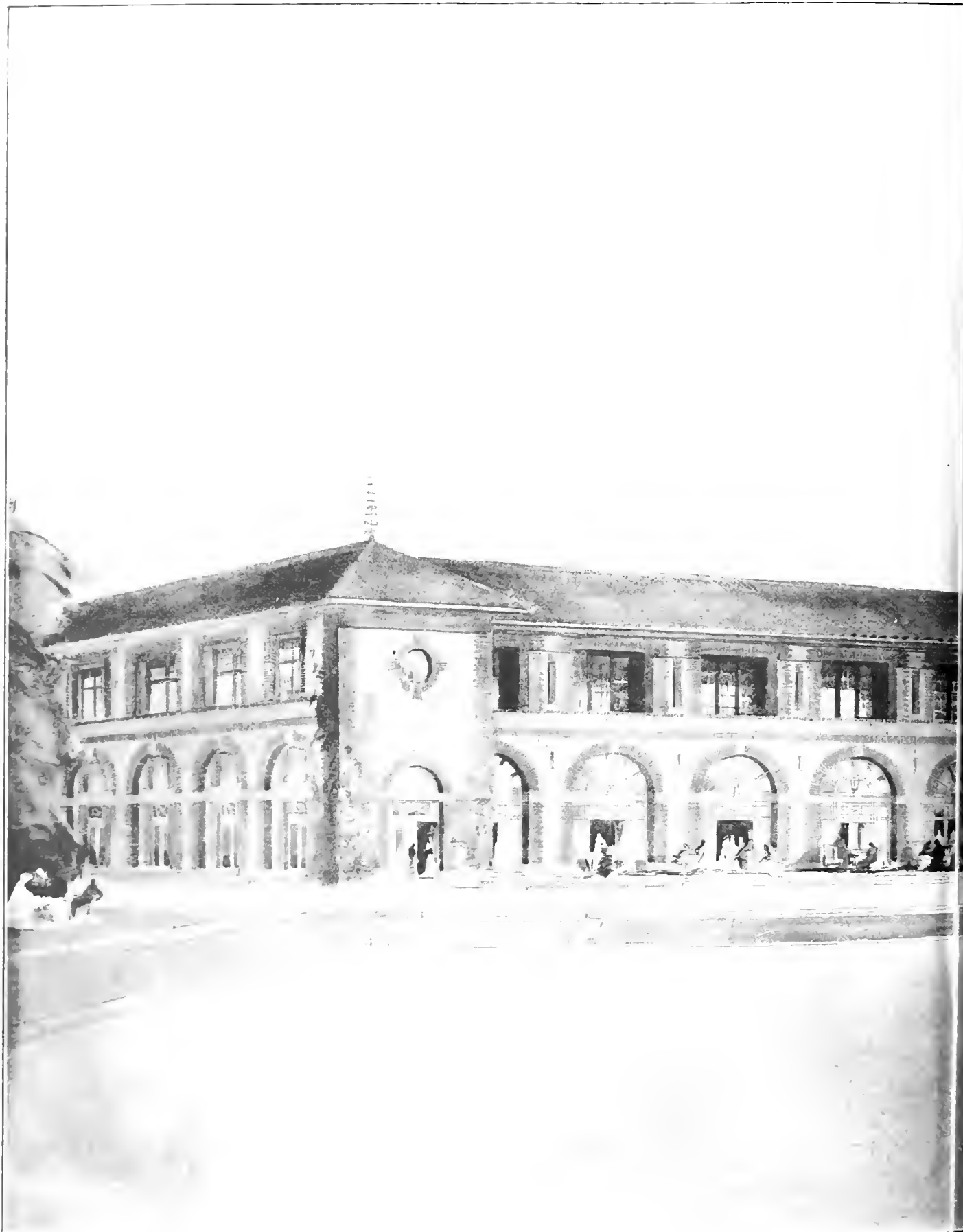

NEW RESTAURANT, ZOOLOGICAL GARDENS, REGENT'S PARK, LONDON

NOVEMBER 3, 1915.

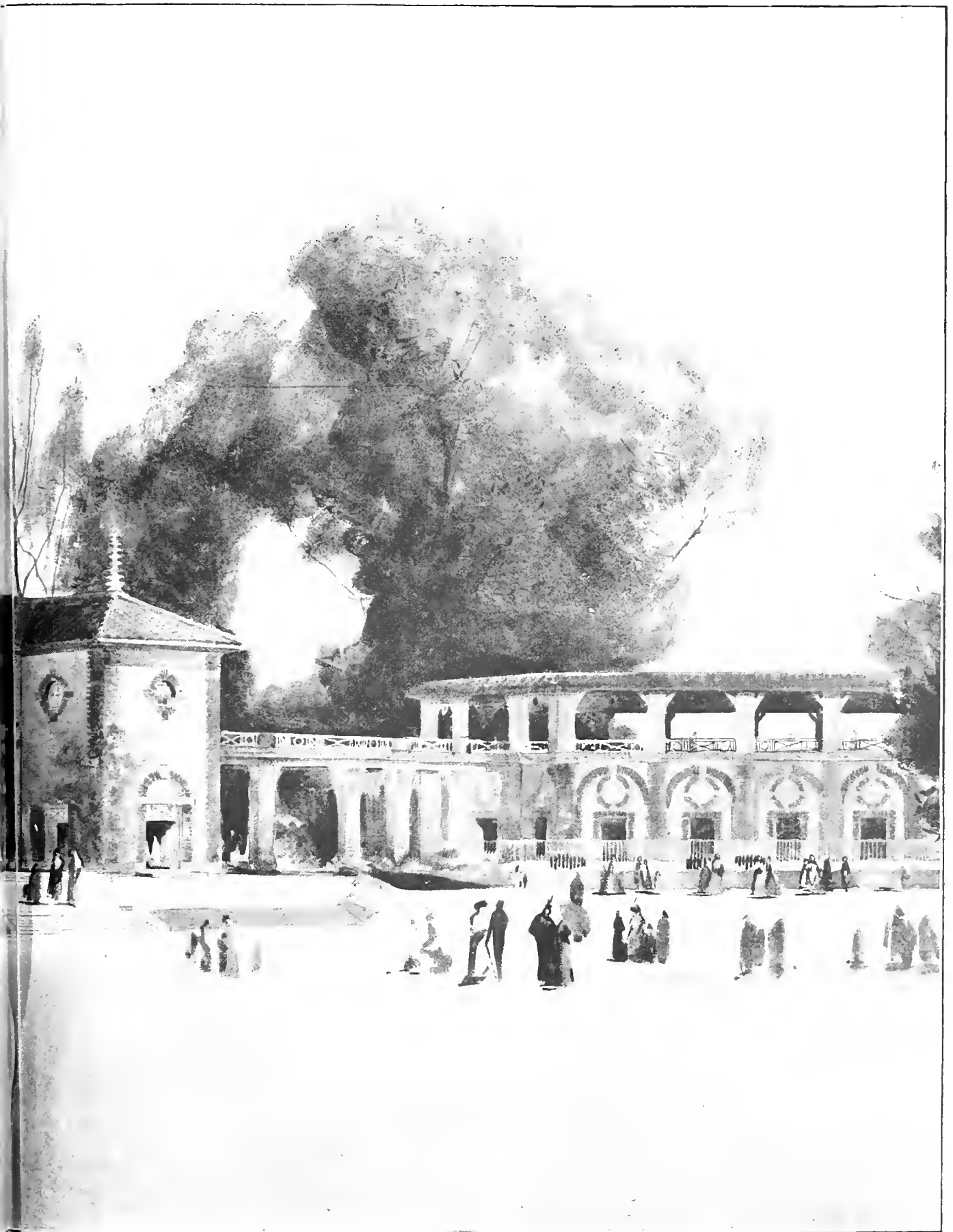

S. N. W.—The late JOHN BELCHER, R.A., and Mr. J. J. JOASS, F.F.R.I.B.A., Architects.





THE BUILDING NEWS, NOVEMBER 3, 1915.

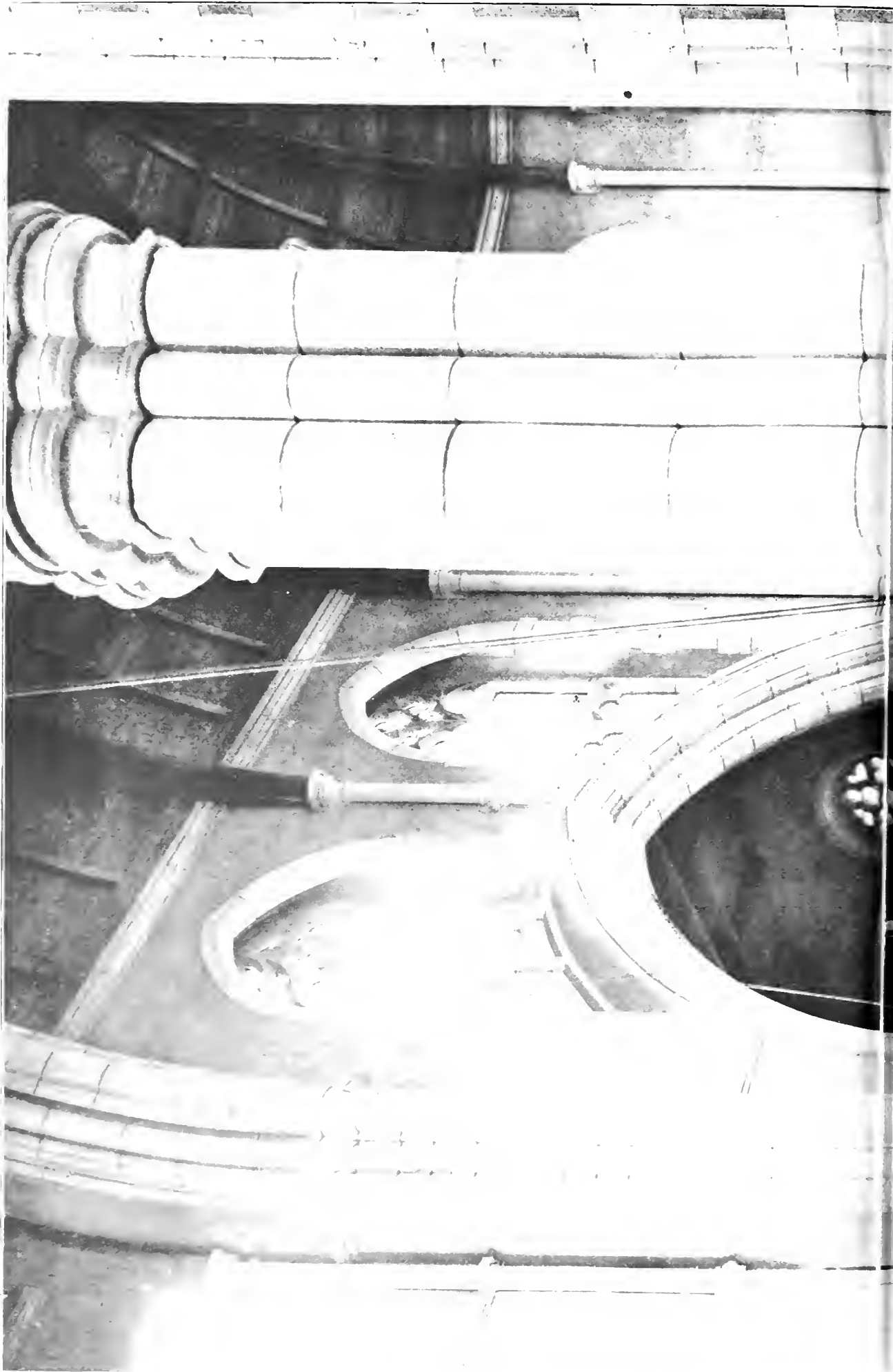

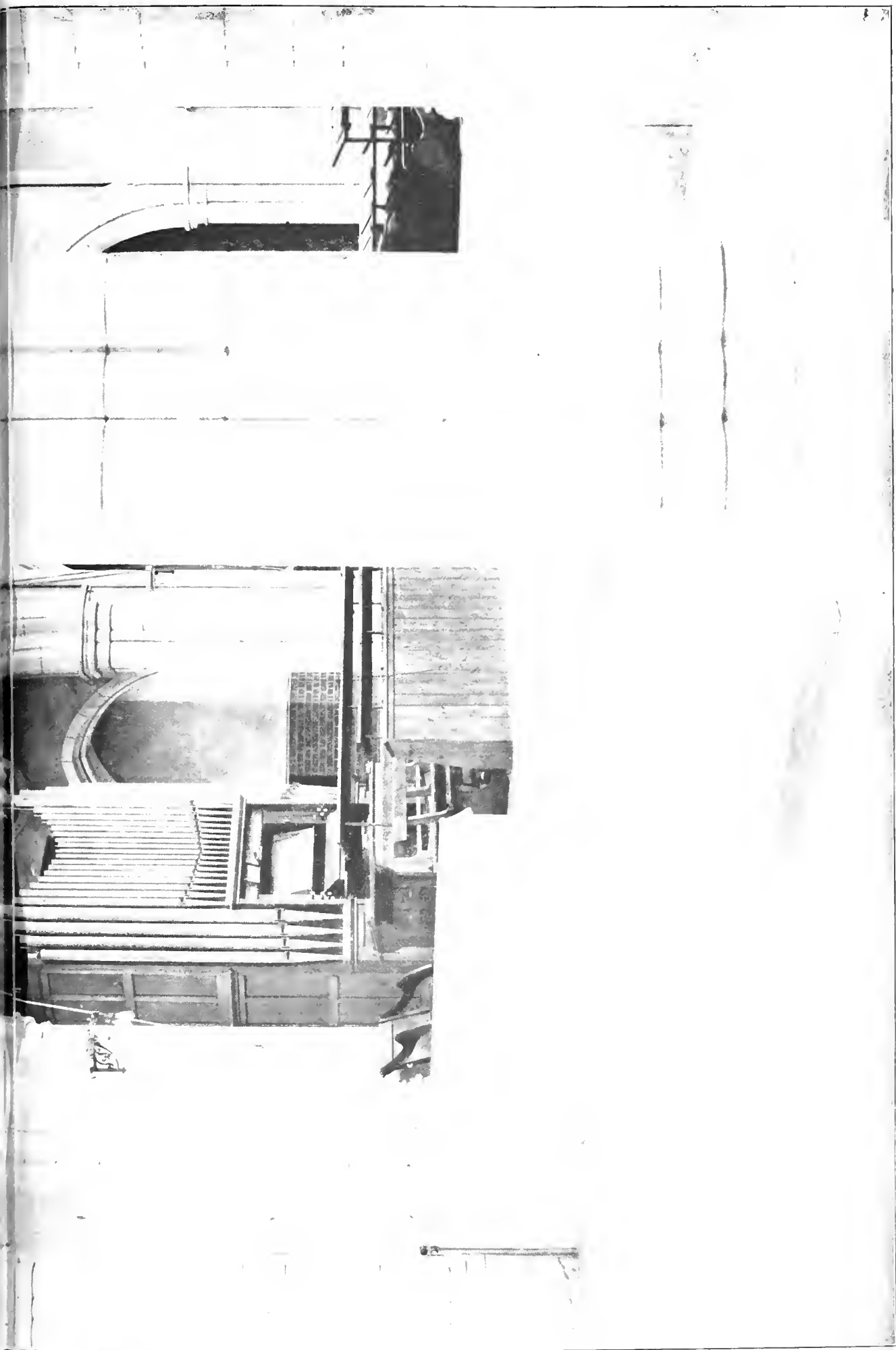

FIG. 1. INTERIOR OF ST. BARNABAS' CHURCH, NORTH FINCHLEY. VIEW LOOKING INTO CHOIR. MR. J. S. ARDREY, ARCHITECT.



far an architect can be deemed negligent in superintending the carrying out of works—when the time of maintenance has expired and no defects have been discovered. In December, 1912, the late P. Woodbridge Biggs received instructions from the plaintiff for the re-erection of a greenhouse at "Chalkpit," Maidenhead. The specification, drawings and forms of tender were prepared in the usual way, a tender of Messrs. Duncan Tucker, of Tottenham was accepted, and they, in accordance with the form of tender, paid a sum of three and a-half guineas for the extra copies referred above those provided for in the R.I.B.A. scale of 5 per cent. The plaintiff claimed that such payment was in the nature of a secret commission. From the cross-examination of the plaintiff it appeared that credit was given for the amount received, and also that he was informed of the same. The defendant (the executrix of Mr. Biggs) gave notice of special defence under the statute of William and Mary, saying that what was complained of by the plaintiff was a tort; this his Honour upheld. Another portion of the claim was that Mr. Biggs had acted negligently in passing certain work, but in the statement of claim the plaintiff had stated that the said architect had negligently and improperly issued his certificate, thereby complaining of the architect in his position of arbitrator, and in such an instance it was held that the decision in "Chambers v. Goldthorp" applied, and on this portion of the claim also his Honour gave judgment in favour of the defendant. During the course of the hearing his Honour asked why the present action had been brought. The proper way would have been to have dealt with it as a set-off to the action Mr. Biggs brought against the plaintiff. The plaintiff's answer to this in his cross-examination by Dr. Herbert Smith was: "Because we could not get the papers from Mr. Biggs"; but it was pointed out by Dr. Herbert Smith, the counsel for the defendant, that the papers the witness referred to were handed over on December 1, 1914, and the defence was not delivered until February, 1915. At the conclusion counsel for the defendant informed the Court that he had a full answer to the claims made by the plaintiff. Mr. Arthur Vernon, F.S.I., 11, Queen Victoria Street, and Mr. W. Woodbridge Biggs, F.S.I., F.I.A., Union Bank Chambers, Cary Street, were respectively the experts retained for the plaintiff and defendant.

WATER SUPPLY AND SANITARY MATTERS.

ABERDEEN WATER PROVISIONAL ORDER.—The Parliamentary inquiry concerning the Aberdeen Water Provisional Order for an improved and extended supply of water for the city of Aberdeen from the River Dee at Aberdein (referred to in our last issue, p. 489), was continued on Wednesday. Evidence was given by Sir Thomas Burnett, Bart. of Leys, Mr. William A. Carter, C.E., Edinburgh, and by Mr. R. W. Walker, C.E. The Commissioners, after being addressed by Mr. Horne, K.C., for the Dee Fishery Board, and Mr. Macmillan, K.C., for the Aberdeen Corporation, found the preamble proved, and did not find it necessary to insert any provision as to compensation. The adjustment of clauses took place on Thursday, and the Bill was ordered to be reported to the House.

The Oxford Corporation are about to spend £30,000 on the improvement of their roads.

Mr. William Lovell Mason, of Ambleside, architect and surveyor, who died on May 23, left estate valued at £4,750 15s. 9d. gross, with net personality £2,825 14s. 3d.

The new cottage hospital at Oakdale, near Blackwood, Mon., has been formally opened. The architect was Mr. Webb, of Blackwood, and the builders were Messrs. Lewis Bros., of Bargoed. The cost was £4,500.

The length of the railways of Canada was, on June 30, 1914, 30,795 miles, an increase of 1,492 in the previous twelve months. The capital spent during the year was 276,990,069 dols., and the total capital expenditure was 1,808,820,951 dols.

It was reported at the last meeting of the Somerset County Council that the Rhodyate Hill improvement had been completed at a total cost of £1,111, and that the Road Board had paid the balance of their grant. The estimated cost was £1,053, and the excess of £53 was attributed to the increased cost of labour and materials as between the date of the estimate and the completion of the work.

Building Intelligence.

CHESTERTON, STAFFS.—The informal opening of the extensions to the Bradwell Joint Isolation Hospital at Chesterton took place last week. The extensions, which have been carried out under the supervision of Messrs. A. R. Wood and Son, architects, of Tunstall, involved the repair and rearrangement of the existing buildings, the removal of some of the old blocks, and the erection of a new fever pavilion, steam laundry, administration block, and dis-lodge block, a fresh system of drainage, and the laying out of the grounds. The administration block comprises dining-room, nurses' sitting room, matron's room, waiting room, kitchen, with larders, and two floors above, used for bed rooms and bathrooms. The old house will provide the hearthroom, doctors' room, and scullery and bedrooms for the maids. The new steam laundry comprises a wash-house, ironing room, engine-house, boiler shed, steam-disinfecting room, and electric storage room. The general contractor is Mr. Paul Pemberton, of Tunstall.

DEAN'S YARD, S.W.—A new choir school has been built by the Dean and Chapter of Westminster on the west side of Dean's Yard, at a cost of about £30,000. The new building, which stands on the site of modern buildings where minor canons used to reside in the Collegiate style, is designed for thirty boys, as compared with twenty in the old school in Little Smith Street. On the roof there is a covered playground 106 ft. long. Besides a school-master's house, there is accommodation for two assistant masters, a matron, and a domestic staff. A residence for a minor canon is also included in the new buildings, which have been erected from the designs of Mr. Arthur G. Wallace, of Dean's Yard. The builders are Messrs. Holliday and Greenwood, of Millbank.

DORRINGTON, St. Edward's Church.—Dorrington, Salop, was reopened by the Bishop of Hereford last week, after the completion of improvements and an enlargement effected under the direction of Mr. Lloyd Oswell, of Shrewsbury. The chancel has been extended 8 ft., the vestry enlarged, new oak choir stalls supplied, a new organ chamber provided, and a new stone chancel arch erected in place of the old one of plaster and brickwork, the seats widened and improved, the heating arrangements improved, new umbrella stands to seats provided, the walls of the nave decorated with cream enamel, and the chancel floor laid with Broseley tiles. The builders were Messrs. R. Price and Son, of Shrewsbury.

MIDDLETON-IN-WHARFEDALE.—The Middleton-in-Wharfedale Sanatorium is to be opened on Wednesday afternoon in next week, November 10, by Alderman T. B. P. Ford, chairman of the West Riding Public Health and Housing Committee. The site, occupied by the buildings is a fairly level plateau, part of an estate which comprises 145½ acres. Two blocks of pavilions, each for twenty-five patients, have been completed, one being for women and one for men, and there are also shelters on the ground for twenty-five more patients of each sex, thus providing accommodation for 100 patients in all. To the north of these pavilions two more blocks are in course of erection. Each will be two stories in height, and each story will accommodate fifty persons. Between the blocks of finished and unfinished pavilions there is enough space on each side for a third block of buildings, each accommodating fifty sufferers, so that when these are completed there will be room for 300 patients. The electric lighting plant will illuminate all the institution. For the 100 beds now in use, the cost per bed, including land, buildings, furniture, and also the cost of conveying water for putting in the electric light for the laundry, etc., for the first 100 patients, comes to about £170, while, when the second 100 beds are completed next year, the cost will be about £162 per bed. Should

it be eventually decided to complete the design and accommodate 300 patients, the cost will be £156 per head. Towards this capital expenditure the Government is contributing three-fifths, leaving two-fifths of the basis cost of £150 per bed to be raised by the county council.

ROSYTH. Interesting evidence of the progress that has been made in meeting the housing needs at the Naval Base, Rosyth, was provided at the first statutory meeting of the Scottish National Housing Company, Ltd., held at 111, George Street, Edinburgh, on Wednesday last. Mr. John F. Findlay D.L., Master of the Edinburgh Merchant Company, chairman, who presided, stated that on September 1 last they were able to sign the first contract for the erection of houses at Rosyth. Since that date four other contracts had been entered into, and another one would be signed almost immediately. The effect of these contracts was that the company had already made arrangements for the erection of 292 houses. A considerable number of houses would be ready for occupation in the beginning of the year. In addition to these 292 houses actually constructed or in course of construction, plans, and preparations for a second lot of houses, 309 in number, were being rapidly matured, and schedules would be issued and contracts accepted for them before the end of this year. Some of the houses for which contracts had been made were in an advanced state of construction, and no fewer than ninety-nine houses had actually been begun. In some cases, the walls were up and rafters and tiles fixed, and in others the walls were up to the roof level. Concurrently with the arrangements for building those houses, arrangements were also in progress for the making of the necessary roads and sewers. Overtures had already been made to the company to undertake very similar work for the Government in other places. Replying to a question, the chairman said the type and size of the houses to be built were determined by the Admiralty.

PROFESSIONAL AND TRADE SOCIETIES

ARCHITECTURAL ASSOCIATION WAR SERVICE BUREAU: RECRUITING FOR THE ARMY.—We are informed that the Architectural Association War Service Bureau, which has already recruited nearly 1,000 men for the various specialised branches of the Service, is now endeavouring to raise 100 men for the 2d London Sanitary Company, R.A.M.C. (T.). The work required of members of the corps should specially appeal to members of the architectural and surveying professions and others with a good knowledge of sanitary matters. The secretary will be very glad to forward particulars of rates of pay, etc., to anyone sending a stamped and addressed envelope. The War Service Bureau is still open to assist all those connected with the architectural and surveying professions and building trades by supplying them with information and assisting them to enlist in those special branches of the Army where their professional training is likely to be of value. Men are also required for the Home Counties Divisional Artillery for Imperial Service, ages 19 to 38. Aptitude for map reading, etc., is an advantage. Arrangements will be made for parties of men enlisting through the bureau to be kept together.

NOTTINGHAM AND DERBY ARCHITECTURAL SOCIETY.—Although twenty-four members of the society are now serving the colours, there was a capital attendance at the opening meeting of the winter session held on Tuesday, October 26. The president, Mr. Harry Gill, M.S.A., entertained the members to tea, and by the courtesy of the City Library Committee and the contributors the premiated drawings of the branch libraries were on view. The president announced that death had claimed two former members of the society—Mr. R. C. Sutton, the father of their past-president, and Mr. Ralph Hemingway, a former hon.

in 1913-14. The first gift of twelve works included examples by Messrs. John Lavery, William Orpen, Charles Shannon, W. W. Russell, Oliver Hall, Ambrose McEvoy, and Gerald Kelly, to the latter of whom a special room has been given at the current exhibition at the Walker Art Gallery, Liverpool. The pictures now added are "An Interior" showing a doorway hung with a heavy purple curtain, by Mr. James Pryde; the second of the "Beggars of the Road"; Mr. William Strang's "Bank Holiday," a strongly headed group, hung in Gallery X, of the Royal Academy in 1912; Miss Flora Lion's portrait of her mother in black, entitled "The White Fan"; a landscape, "The Path by the River," by Mr. A. D. Peppercorn; and, in water-colour, Mr. A. W. Rich's "Shadwell Park." In addition there has been accepted a portfolio of coloured lithographs of dramatic war incidents in Belgium, done at the front by Mr. G. Spencer Pryse.

In spite of the war the Peasant Arts Fellowship, whose object is the encouragement of the hand industries of old, and finding a market for the output, has had a successful year, says the third annual report, the number of new members being gratifying. Classes of instruction in peasant arts, spinning, weaving, wood-carving, and so forth, are conducted under the auspices of the parent (the Peasant Arts) society. Miss Kate Sperling, the fellowship's teacher of spinning and weaving, is enthusiastic concerning the results of her first year's work.

The subject of "The Art Annual" (Virtue and Co.) this year is Mr. Henry Woods, R.A., whose Venetian pictures have given pleasure to so many people. Born at Warrington in 1846, Mr. Woods, while still very young, heard the clear call of art, and fortunately he was able to respond to it free from any serious interruption. Unlike many British artists he did not "drop into art" from some other profession. He began the study of art much in the same way as a young man studies law, medicine, or divinity. Art was to be his lifework, not a delightful hobby or a crutch to help to support him in his effort to master some other *métier*. His diligence and talent won for him a bronze medal in 1857, and a few years later he came to London with a scholarship from South Kensington. His draughtsmanship grew sure and strong, while he developed a distinct appreciation of character. Mr. Woods soon became known as an illustrator, and his subsequent career shows how much benefit he derived from his early training in connection with magazines and novels. This illustrated story of his life and achievements is told by Mr. James Greig.

Cardinal Bourne on Saturday laid the foundation stone of the new Roman Catholic Church of the Blessed Sacrament, which is being built in Copenhagen Street, Caledonian Road. The founder of the church, Commendatore Hicks, has given the site, church, presbytery, and parish hall.

The Archdeacon of Winchester, on Saturday, laid the foundation-stone of a new church which is to be built at Rudmore, Portsmouth, by the Winchester College Mission, at a cost of some £12,000, the total expenditure, including furnishing, being £18,000. Of this sum £15,000 has already been obtained.

The church of St. Bartholomew, St. Pancras, N.W., built in 1800, is now in a bad state of repair. There is extensive dry rot in the wood-work, and the rain penetrates through the main roof. It is proposed to renovate the structure from plans by Mr. F. C. Eden, of Gray's Inn Square, the estimate only being £1,760.

At the annual meeting of the Court of Governors of the National Museum of Wales at Cardiff on Saturday, it was stated that the position of the building fund caused anxiety, £54,000 was due to contractors, etc., to meet which £21,150 was available, leaving £32,850 to be raised. If half could be obtained from local sources the Treasury would provide the remainder. There was no power to stop or suspend building under the contract, and there was the possibility of a loss of £10,000 to £20,000 and the difficulty of a new contract to face. The architects are Messrs. Smith and Brewer, whose design, selected in competition, was illustrated by plans and elevation in our issue of January 5, 1912.

CHIPS.

New premises which have been built in Union Street, Larkhall, N.B., by the Larkhall Victualling Society have been formally opened. The architect was Mr. Wm. Baird, Main Street, Bellshill, and the cost will be fully £4,000.

A church of St. Thomas is to be built in the mining district of Maesycwmmwr, in the parish of Fleu de Lys, Mon. It will be seated for 500 persons, and is estimated to cost £5,170. The architects are Messrs. H. G. and P. V. Jones, of Hengoed.

Alderman Archibald D. Dawney, the principal of the well-known engineering and steel works at Bittersea and Cardiff, has been offered and has accepted the majority of the metropolitan borough of Wandsworth for the eighth year in succession.

Mr. Herbert Thomas Scoble, of The Dell, Twyford, near Winchester, and of Victoria Street, S.W., consulting engineer and surveyor, who was accidentally killed by a fall from the cliff at Bude, Cornwall, on August 24 last, left estate of the value of £6,501.

The new Spa sewage disposal works at Ossett, completed for the corporation at a cost of £11,859, were formally opened recently. The works were designed and carried out by the borough surveyor, Mr. H. Holmes, with direct labour.

At Shoeburyness yesterday (Tuesday), Mr. R. H. Becknell, an inspector under the Local Government Board, held an inquiry as to an application from the urban district council for sanction to borrow £2,000 for the enlargement of a sewage tank.

The city council of Gloucester resolved on Wednesday to apply to the Local Government Board for sanction to borrow a sum not exceeding £25,000 for providing the required high-tension generating plant, and also for defraying the cost of providing and laying special mains recently laid down.

The meeting-place and hour for the delivery of the Chadwick public lecture by Mr. Alfred Saxon Snell on Wednesday next have been altered. It will be given at the Royal School of Medicine, 1, Wimpole Street, W., at 5.15 p.m.; the subject, as already announced, is "Emergency Military Hospital Construction."

The Markets Department of the Manchester Corporation opened on Thursday two new rooms for cold storage, situated just under the wholesale fish market at Smithfield. They were designed by the city architect, Mr. H. Price, and add 23,750 cubic feet to the cold storage department, raising the total to 105,880 cubic feet.

At a cost of about £3,000, the Sleaford Urban District Council has provided a new water supply for the Ewerby district, and on Tuesday last the Earl of Winchilsea formally opened the water-tower and started the pumping-engines. The water is drawn from a bore on Evedon Hill, the site of which was given by Lord Winchilsea.

The new Roman Catholic church at Batley Carr, which was opened a few days ago by the Bishop of Leeds, will accommodate 320 people. It has been erected, at a cost of £1,752, from the plans of Mr. Edwin Simpson, architect, Marningham, Bradford. It supercedes a school-chapel, which will now be used exclusively as a school.

Having accepted a commission in the Royal Engineers, Mr. F. O. Kirby, the borough engineer of Doncaster, has resigned his position as hon. secretary to the North-Eastern District of the Institution of Municipal and County Engineers. Mr. W. E. H. Burton, of Wakefield, has been appointed as acting-secretary during Mr. Kirby's absence.

Extensions to the Girls' Industrial Home, Ipswich, which have been opened by the Bishop of Suffolk, comprise a large entrance hall, with matron's office, board-room, staff-room, store-room, class and sewing-room, schoolroom, three dormitories, staff bedrooms, and bath-room with four baths. Mr. Henry J. Wright, M.S.A., of Museum Street, Ipswich, is the architect.

The funeral of Mr. John Coates, formerly a well-known builder and contractor in Rochdale, who died on Sunday in last week, in his 70th year, at his residence, 400, Shawelough Road, Lowerfold, took place at the Rochdale Cemetery on Wednesday. In addition to the family mourners, a deputation, consisting of Alderman Taylor, Mr. T. Elyan Kershaw (secretary), Mr. John Fountain, and Mr. Joseph Whithead, attended, representing the Rochdale House and Estate Company, of which Mr. Coates was vice-chairman.

The urban district council of Epsom have approved plans submitted by Messrs. Smith and Munro, of Lincoln's Inn Fields, for Chases' cottages, for thirty cottages at Horton Hill to be built by Messrs. H. and F. R. H.

Having considered the question solely from the point of view of special war requirements, the Treasury have decided to grant the application for a loan for the erection of a hundred houses at Letchworth to accommodate the big influx of Belgian workers.

Following Sir George Frampton's generous offer to execute as a labour of love a statue of the late Miss Edith Cavell, judicially murdered by the Germans in Brussels, Mr. Henry Holiday offers to contribute the cartoon for a stained glass window. As he feebly suggests, the appropriate place for such a memorial would be Norwich Cathedral.

St. Peter's Church, Whitstable, at which the chancel was built in 1263 from plans by Mr. G. H. Fellowes Pryme, F.R.I.B.A., is about to be completed by the addition of a nave, on a less expensive scale than was originally proposed, from the same architect's designs. The nave will provide 457 seats, making in all 513 and is expected to cost £4,000.

The funeral took place on Wednesday in Warriston Cemetery, Edinburgh, of Mr. Robert Ferguson Laing, partner of the firm of Laing and Thorburn, slate-merchants, Quality Lane, Leith. Mr. Laing, who was sixty-one years of age, and unmarried, succumbed to an illness which has seriously affected him for several months past.

The standing joint committee of Renfrewshire have completed the erection of new police buildings at Giffnock, to serve the eastern division of the county. The scheme, which was rendered necessary by the inclusion of a large part of the county area within the boundaries of Glasgow, cost between £5,000 and £6,000. The Court Hall was used for the first time on Friday.

Plans were recently passed by Dunfermline Dean of Guild Court in connection with extensions at the Carnegie Swimming Baths. The alterations involve the demolition of several small dwelling-houses in Campbell Street. The Carnegie Dunfermline Trust decided on Friday to delay proceeding with the extensions meantime in view of the scarcity of dwelling-houses in the town.

Mr. John Hunter, managing director of the firm of Glasgow engineers and contractors, Sir William Arrol and Co., Ltd., has resigned his seat on the board of directors of that company, and has accepted the invitation of the Minister of Munitions to become Director of Factory Construction, in connection with the National Projectile Factories now being erected in various parts of the country.

A postmen's office in Kirk Street, Leith, built by H.M. Office of Works, Edinburgh, was opened on Saturday. Constructed of brick, with stone facings, the building consists of one story, and comprises a large hall, with inspector's office and other apartments. The hall, which is 65 ft. long and 48 ft. wide, has a gabled roof, and is well lighted. Messrs. Scott and Brown, Edinburgh, were the builders.

At a meeting of the executive of the Lord Roberts Memorial Committee, held in the City Chambers, Glasgow, on Wednesday, it was stated that the work in connection with the statue, which is to be a replica of the equestrian statue at Calcutta by the late Henry Bates, R.A., was nearing completion. In connection with the question of a site, it was decided to make representation to Glasgow Corporation on the subject.

The old timber Aekingsford Bridge, carrying the Epping and Aekingsford main road over Crispsey Brook, near Ongar, has just been reconstructed for the Essex County Council in ferro-concrete. The new bridge, designed by Mr. Percy J. Sheldon, M.Inst.C.E., the county surveyor, and carried out by Messrs. J. Garrett and Son, of London, is 31 ft. between parapets, whereas the prior structure was only 14 ft. wide, involving a serious narrowing of the roadway and a suppression of footpaths.

Last week the Bishop of Chichester attended at St. Leonard's Church, Turner's Hill, and dedicated a side-chapel, which has been fitted up as a memorial to the late Rev. C. R. Blaker, the first Vicar of the parish. Its east window has figures of St. Augustine of Canterbury and St. Richard of Chichester, whose respective faces reproduce those of Mr. Blaker and Bishop Durnford (who consecrated the edifice in 1895). Windows in the north aisle, in memory of members of the Martin family, were dedicated at the same service.

TO CORRESPONDENTS.

Contributors are responsible for the opinions... All communications should be sent to the Editor as early as possible...

Drawings of selected competition designs, imitations of private buildings, details of old architecture, and sketches are always welcome...

When forwarding us with drawings or photographs, contributors are asked kindly to state how long the copyright has been created...

Telephone: Gerald 1291.

Telegrams: "Timesriver, E-Strand, London."

NOTICE

Bound copies of Vols. XVIII, XIX, XX, XXI, XXII, XXIII, XXIV, XXV, XXVI, XXVII, XXVIII, XXIX, XXX, XXXI, XXXII, XXXIII, XXXIV, XXXV, XXXVI, XXXVII, XXXVIII, XXXIX, XL, XLI, XLII, XLIII, XLIV, XLV, XLVI, XLVII, XLVIII, XLIX, L, LI, LII, LIII, LIV, LV, LVI, LVII, LVIII, LIX, LX, LXI, LXII, LXIII, LXIV, LXV, LXVI, LXVII, LXVIII, LXIX, LXX, LXXI, LXXII, LXXIII, LXXIV, LXXV, LXXVI, LXXVII, LXXVIII, LXXIX, LXXX, LXXXI, LXXXII, LXXXIII, LXXXIV, LXXXV, LXXXVI, LXXXVII, LXXXVIII, LXXXIX, XC, XCI, XCII, XCIII, XCIV, XCV, XCVI, XCVII, XCVIII, XCIX, C, CI, CII, CIII, CIV, CV, CVI, and CVII may still be obtained at the same price...

Illustrations, Cash Cases for binding the BUILDING NEWS, price 2s. 6d., post free 2s. 4d., can be obtained from any Newsagent, or from the Publisher, Elingham House, 1, Arundel-street, Strand, W.C.

TERMS OF SUBSCRIPTION

One Pound per annum (post free) to any part of the United Kingdom; for the United States, £1.05; for France, 50s. gold; To France or Belgium, £1.05; To India, £1.6s. 6d.; To any of the Australian Colonies or New Zealand, to the Cape, the West Indies, or Natal, £1.6s. 6d.
Our Direct Subscription Agents for Australia are Messrs. L. T. Kiddlewhite and Co., Printers and Publishers, 14, York Chambers, 105, Liverpool Street, Sydney, New South Wales; for Japan, The Maruzen Co., Ltd., 11-15, Nishiochi, Tori Sanjome, Tokyo; China, see reverse page 78; at £1.6s. 6d. per annum in advance. Copies of the paper will be sent by air direct to the subscribers' address.
The special rate to Canada is £1.3s. 10d. = 55s. 8d. for 12 months, and 11s. 11d. 2d. 4s. 6d. in months. Our Direct Subscription Agents for Canada are Messrs. S. J. L. Ltd., 202, Spadina Street, Toronto, Ontario, Canada, who will receive subscriptions at 41s. 1d. per annum, on our account.
Orders and Payments.—Orders to be made payable to THE STRAND NEWS-LETTER COMPANY, LIMITED, and crossed London City and Westminster Bank.

ADVERTISEMENT CHARGES

The charge for Copying, and Contract Advertisements, Public Companies, and official advertisements is 1s. per line of 120 Words, the first line counting as two, the minimum charge being 2s. for 10 lines.
The charge for Auctions, Land Sales, and Miscellaneous and Trade Advertisements (except Special Advertisements) is 6d. per line of 120 Words. The first line counting as two, the minimum charge being 4s. for 10 lines. Special terms for series of advertisements can be arranged on application to the Publisher.
SITUATIONS VACANT AND PARTNERSHIPS.—The charge for advertisements for Situations Vacant and Partnerships is One Shilling for the first line, and Sixpence for every Eight Words thereafter. All such advertisements must be prepaid.

SITUATIONS VACANT

All advertisements not exceeding Thirty Words, containing names and address, are inserted under the heading "Situations Wanted," free of charge. For full Particulars, Advertisements on front page, and special conditions, particulars can be obtained on application to the Publisher.

REVIEWS OF ADVERTISEMENTS

Reviews of advertisements can be received at the Office of the Editor, 1, Arundel Street, Strand, W.C. 2R, on Thursdays. If to be forwarded under special conditions, an extra charge of 5s. per line is levied, payable at head of "Situations."

Advertisements for the current week must reach the office not later than 3 p.m. on Tuesday. Front

page advertisements and alterations or stop orders for serial advertisements must reach the office by first post on Monday to secure attention.

RECEIVED: J. B. G., A. A. W., B. F., A. N. and Co., Ltd., B. R. I. B., D. and Co., F. B. and Co., Ltd., F. and H. J. W., W. P. W. and W. A. S. A. Co., Ltd., F. H. Bros., F. B. B., R. F. W. and Son, H. R. Co., Ltd., B. O. Co., Ltd., P. B. and P. A. H. A. I. W.

A. J. N. No. 1, F. D. Thanks, y. s. MASON: Yes, it fairly brief.

The cleaning and disinfecting of the premises would have to be done by the owner or occupier on receipt of notice in writing from the clerk to the local authority, and if not so done within the time fixed by the notice, it would be carried out by the officers of the local authority, at the expense of such owner or occupier.

A TIMELY REMINDER. Architects, builders, and others are reminded that the BUILDING NEWS is now published on Wednesdays instead of Fridays, at 2 a.m., and that it should be obtainable early in the day anywhere. If delay occurs it can be posted direct from the office on receipt of a quarter's subscription, or single copies can be similarly sent to readers in camp or moving about the country.

A nave has just been added to the church of St. Pidem, Llanberis, Carnarvonshire, from plans by Mr. H. Harold Hughes, R.C.A., A.R.I.B.A., of Bangor. The expenditure was £1,600.

The church of St. Augustine, Bermuda-roy, erected in 1873, and enlarged in 1881, is to be repaired at a cost of about £1,200, under the supervision of Mr. A. Lloyd Edwards, architect, of Brockley, S.E.

Whilst many landlords are raising rents, the Metropolitan Industrial Dwellings Company, Ltd., has allowed 25 per cent. off the rent of 127 tenants who have gone to the war. The sum allowed amounted to £388 7s.

The Royal Assent was given by Commission on Thursday to the London County Council General Powers Act, the London County Council Tramways Improvements Act, and the Glasgow Water Supply O.P. or Confirmation Act.

The death is reported from Bromley, Kent, of Mr. W. H. Wheeler, M.L.C.E., formerly borough surveyor and harbour engineer of Boston, Lincolnshire. Mr. Wheeler was the designer of Boston Dock, and advised the present outfall of the River Whitham.

The Whitstable Urban District Council have found it necessary to apply to the Local Government Board for sanction to borrow another £5,725 for the sewerage scheme, making a total of £40,000. The increase is due to additions to the scheme and higher cost of material.

The death has occurred, at his residence, 10, Esplanade Place, Whitley Bay, of Mr. George Patton, aged 80 years. The deceased was a plumber and sanitary engineer, and had been in business in Bath Lane, Newcastle-upon-Tyne, since 1860, latterly in conjunction with his son.

At a meeting of Ecclesall Board of Guardians a letter was received from Mr. A. W. Kenyon, A.R.I.B.A. architect for the new children's hospital, stating that he had accepted a commission in the Royal Engineers, and would be obliged to take up duty in the South of England shortly.

The finance committee of the county council of Cornwall have received the sanction of the Local Government Board to the raising of £1,235 by loan for the purchase of the sanatorium site at Castle-on-Dunas, near St. Columb. The Board will refund to the council two-thirds of the total expenditure on building works.

The Rev. Rev. Bishop Ormsby, D.D., at tended St. Nicholas' Cathedral, Newcastle-upon-Tyne, on Thursday, and dedicated the Lady-chapel, the memorial erected to Mrs. Gough, widow of Canon Gough, Vicar of Newcastle. The memorial takes the form of oak panelling around the east end of the north aisle of the choir. The work has been carried out by Messrs. Ralph Hedley and Sons, from the designs of Mr. W. H. Wood, F.R.I.B.A., both firms of Newcastle.

The foundation-stone of the new Bethesda School, situated in Langer and Cavendish Roads, Felixstowe, was laid on Wednesday. Mr. R. J. Girling, surveyor, of Felixstowe, prepared the plans, and Mr. W. F. Cross is the builder. The school-chapel will be one story in height, built of red brick, with stone dressings, and with millioned windows of Gothic character. The large room will be 52 ft. by 25 ft. 6 in., with a wood block floor. At the end are two small class rooms.

TO ARMS!

4th Battalion ("Architects") Central London Regiment Volunteers.

Recruits are urgently needed for the Regulars, Territorials, and Volunteers. Intending Recruits should apply to Battalion Headquarters, where they will be advised as to the branch of the service for which they are best suited.

ORDERS FOR THE WEEK BY LIEUTENANT-COLONEL A. W. WARREN.

COMMITTEE MEETING. A meeting of the Civil and Military Committee will be held this evening (Wednesday), at 7.15, at the Officers' Mess, Chester House, Eccleston Place, S.W. A full attendance is requested.

GENERAL PARADE.

Saturday, 6th inst., at Drill Headquarters, Chester House, 3 p.m., for drill and bridging instruction. Uniform parade. Full attendance is particularly requested.

ENTRENCHING PARADE.

Sunday next, 7th inst., at Victoria Station, L.B. and S.C. Railway indicator board, 8.55 a.m. sharp. Uniform, haversacks, and water bottles. Middy rations to be carried. Return to town about 6.40. Railway vouchers will be provided and special train will be run by the railway company.

DRILLS AND PARADES.

"A" Company, Tuesdays, miniature range, Gas Light and Coke Co.'s premises, Monck Street, Westminster, 6 to 8.30 p.m.

Wednesdays, Company parades for drill and technical instruction, 5.15 to 7.15 and 6.15 to 8.15, at Chester House.

Thursdays, Signalling at Chester House. See Orders from Acting Battalion Signalling Sergeant Chadwick.

"B" Company, Miniature range and company parades as for "A" Company. See orders at local headquarters.

"C" Company. See orders local headquarters, Pavilion A.A. Athletic Ground, Boreham Wood.

"D" Company, Platoon and section drill at Chester House, Tue-days and Thursdays, 6.45 p.m. Company parades, for drill and technical instruction, Wednesdays, as for "A" Company.

SCHOOL OF ARMS.

Drill Headquarters, Chester House. Instruction in bayonet fighting, gymnastics, physical drill, boxing, and single-sticks, on Tuesdays from 6 to 8 p.m.

RECRUIT DRILLS.

"A" and "B" Companies, Chester House, 6.15 to 7.15 and 7.15 to 8.15, Mondays and Fridays.

"C" Company, Boreham Wood and Elstree District, Headquarters, A.A. Athletic Ground, Boreham Wood. For full particulars, apply to Alan Potter, Grey Gables, Boreham Wood, Herts.

"D" Company, Chester House, Tuesdays and Thursdays, 6.45 p.m.

NOTE.—For the present the School of Arms and Recruit Drills will be held jointly with the Engineering Institution, V.T.C.

By order, L. R. GUTHRIE, Adjutant. BATTALION HEADQUARTERS, 18, TUFTON STREET, WESTMINSTER, S.W.

MEETINGS FOR THE ENSUING WEEK.

WEDNESDAY (To-day).—Royal Archaeological Institute, "The Will of Master William Boune, Archdeacon of Leicester," by A. Hamilton Thompson, M.A., F.R.S.A. Society of Antiquaries' Room, Burlington House, W. 4.30 p.m. Institute of Sanitary Engineers, "Disposal of Night-Soil by Distillation," by James Menzies, Caxton Hall, Westminster, 8 p.m. Town Planning Institute, "Limited Owners and Town Planning," by J. S. Kirkett, M.A., 92, Victoria Street, S.W., 8 p.m. St. Paul's Ecclesiastical Society, "The Oxford Movement and its Effects upon Churches," by Clifton Kelway, F.R.Hist.S., St. Paul's Chapter House, E.C., 8 p.m.

FRIDAY.—Glasgow Architectural Craftsmen's Society, "A Modern Dwelling; Its Design, Construction, and Cost," by A. Davidson, D. Pringle, R. Anderson, and J. Muir, 7.45 p.m.

MONDAY.—Architectural Association, "The Military Hospital, Cambridge," by Dr. A. S. Shipley, F.R.S., President of Christ's College, Cambridge, 6 p.m. Surveyors' Institution, Presidential Address by John Henry Hanson, 8 p.m.

WEDNESDAY (Nov. 10).—Chadwick Lecture, "Emergency Military Hospital Construction," by A. Saxon Snell, A.R.I.B.A. Royal College of Medicine, 1, Wimpole Street, W., 3.15 p.m. Manchester Society of Architects, "Athens and Some of the Isles of Greece," by J. B. Gass, F.R.I.B.A., 6.30 p.m.

THURSDAY (Nov. 11).—Society of Architects, Members' Meeting for election of new members, 28, Bedford Square, 6 p.m.

The Dartford Urban Council propose to erect forthwith 72 houses in their district under the direction of their surveyor.

THE BUILDING NEWS

AND ENGINEERING JOURNAL.

Effingham House,

CONTENTS.

Strand, W.C.

War Service for All	521
The Surveyors' Institution .. .	522
The London County Council .. .	523
The Architectural Association ..	524
Housing Conditions and Rents in Scotland...	524
Logic in Architecture	525
Government Certification of Cement Intended for Export .. .	526
British Columbia Timber .. .	526
Currente Calamo	527

Our Illustrations	528
Obituary	528
Professional and Trade Societies .. .	545
Parliamentary Notes	546
Trade Notes	545
Trade Notes	545
Correspondence	546
Building Intelligence	546
Legal Intelligence	546
Statutes and Memorials	546
Our Office Table	547
Clips	547

Correspondents	548
To Arms	547
Latest Prices	549
Tenders	550
List of Competitions Open	541
List of Tenders Open	541

OUR ILLUSTRATIONS

New Cathedral, Colombo, Ceylon. Southwest view, South-east view, Interior looking east, and ground plan. Mr. Geo. H. Fellowes Payne, F.R.I.B.A., Architect.

WAR SERVICE FOR ALL.

The appeal of the Architects' War Committee, which we print this week, is a trumpet-call we desire to echo to the best of our ability. Not one reader who is not already on active service should fail to respond to it instantly. Lord Derby approves of it, and the War Office can hardly fail to take advantage of our response if that is prompt, complete, and pertinent.

As all readers know, lists compiled by the various architectural bodies show that at least 1,800 members of the profession are serving either as officers, non-commissioned officers, or privates. It is probable that this figure falls far short of the real number, as there is great difficulty in tracing members. According to the census, there are between 7,000 and 10,000 architects in the United Kingdom. Probably both figures include assistants.

The work of architects being of an intellectual character, and a great number being of the officer class, it seems to the War Committee desirable to classify members of the profession so that those who are suitable should receive commissions, and others who have the technical knowledge useful in various special branches in which their experience and technical training can be applied to assist the country should be advised which to join.

Hitherto it has been—and, in fact, it still is—difficult to obtain information of vacancies. Frequently such information has reached the Committee too late to do more than make one or two recommendations. From experience gained in filling such vacancies there is reason to believe that if complete lists, properly classified, were in hand, the Committee would be in a position not only to obtain more and better information, but the waste of men joining the Army from the profession could be to a great extent prevented, and the special knowledge possessed by architects could be directed into the proper channel and be used to its full extent. For instance, inquiries can be made in each district of commanding officers (to whom to some extent selection of officers is now delegated) to ascertain what vacancies they have or are likely to have, and to keep them informed of men whose names are on the list, and whom the Selection Committee, having interviewed, can recommend. It is found that the information in the National Register, although perhaps useful as a general guide, is not sufficient in the case of a profession of such versatile attainments and experience as that of architects, and fuller detail is essential.

The scheme has been working in a small unofficial and tentative way for some

time. From the results obtained the Committee are hopeful that, if now published as a general and official appeal from the War Committee and supported by the technical Press, it will be not only the greatest effort which the profession can make in the direction of National War Service, but also may be the means of finding suitable military employment for a large number of the profession of military age who have not yet joined the Army.

It has been suggested by the War Committee that we should publish the Information Form in place of one of our double illustrations, so that it will reach not only architects, but also members of the building trade. The Committee also express a hope that, as applicants are advised to keep a copy of the form sent in, they will buy two copies of this issue, although forms can be obtained at the Royal Institution of British Architects, the Society of Architects, the Architectural Association, and the allied societies.

The forms are based partly on Army Forms for Appointment of Officers to Temporary Commissions and Army Forms for Appointment of Officers to Territorial Forces. The information is directed to meet points which from experience we have found are required by applicants or necessary in order to make recommendations for appointment. The Committee also hope by means of these forms to be able to assist architects who enlisted early in the war to get promotion, which for some reason or other professional men do not get, although the promise was held out to them on joining that suitable men would be promoted from the ranks.

We may remind all that no offers of anything but whole-time service, anywhere, at home or abroad, can be considered. All applicants obtaining appointments will receive the ordinary pay attached thereto by the War Office or other authority concerned. Men thus rendering war service cannot expect to receive pay of a greater amount than would provide for the bare maintenance of the families of members of the professional classes, and it is unlikely that any appointments will be made at higher rates of pay for junior commissioned ranks than from seven shillings to four teen shillings a day, with certain allowances, except in rare instances in connection with which exceptional knowledge and qualifications will be indispensable.

For all ordinary work the technical training of architects, and their experience in organisation, render them specially eligible for work in all technical branches of the Service. As Royal Engineers, Fortress Engineers, in pioneer battalions, mining battalions, naval battalions, as inspectors of works, or in the

Mechanical Transport, Army Service Corps, Army Ordnance Corps, etc., they can hardly fail to render good service.

Expert knowledge of surveying, map-reading, use of the prismatic compass, sketching, ground and water works, road-making, repairs, timbering, scaffolding, and rough temporary work of all kinds will be most valuable. Mere routine and ordinary practice, particularly domestic and school work, will only be of service as far as construction is concerned. Knowledge of country pursuits, such as riding, shooting, and boating, will be advantageous, as also experience in forestry, rough timber, and underwoods, land drainage, horses, cattle, and meat. For inspectors of factories and works special knowledge of the processes of manufacture of iron, steel, canvas, paint, textile fabrics, all kinds of food, and of methods of conversion of all raw material into the necessaries of life, or means of destruction by explosion or fire, is wanted.

The Information Form we give elsewhere must be filled in, signed, and sent in at once to any one of the following centres which is most convenient to the applicant to be subsequently interviewed at. The envelope must be marked "W.S." on the top left-hand corner, and must be addressed to the secretary at that centre, as must all subsequent correspondence till the applicant is informed that he has been placed on a selected list, when further correspondence should be addressed to the London Centre.

CENTRES FOR RETURN OF FORMS AND INTERVIEWS.

- London.—The Secretary, War Selection Committee, Royal Institute of British Architects, 9, Conduit Street, Regent Street, W.
- Aberdeen.—Robt. G. Wilson, Esq., Hon. Secretary, the Aberdeen Society of Architects, 375, Union Street, Aberdeen.
- Belfast.—The Hon. Secretary, the Ulster Society of Architects, 9, Howard Street, Belfast.
- Birmingham.—F. Marston Eddland, Esq., Secretary, the Birmingham Architectural Association, 14, Temple Street, Birmingham.
- Bristol.—A. B. Bottrill, Esq., Hon. Secretary, the Bristol Society of Architects, Grafton House, Orchard Street, Bristol.
- Cardiff.—The Hon. Secretary, the South Wales Institute of Architects, 1, St. John's Square, Cardiff.
- Dublin.—The Hon. Secretary, the Royal Institute of the Architects of Ireland, 31, South Frederick Street, Dublin.
- Dundee.—William Salmon, Esq., Hon. Secretary, the Dundee Institute of Architects, 6, High Street, Dundee.
- Edinburgh.—John Wilson, Esq., 125, George Street, Edinburgh.
- Exeter.—Allan J. Pinn, Esq., Hon. Secretary, the Devon and Exeter Architectural Society, 5, Bedford Circus, Exeter.
- Glasgow.—C. I. MacLean, Esq., Secretary, the Glasgow Institute of Architects, 115, St. Vincent Street, Glasgow.
- Leeds.—The Hon. Secretary, the Leeds and West Yorkshire Architectural Society, 34, Prudential Buildings, Leeds.
- Leicester.—Clement Strutton, Esq., Hon. Secretary, the Leicester and Leicestershire Society of Architects, 4, Grey Friars, Leicester.
- Liverpool.—The Hon. Secretary, War Committee, the Liverpool Architectural Society, 13, Harrington Street, Liverpool.

justices and sheriff were to command all the inhabitants within the precincts of their office to be at the seaside with such instruments as they had or could get for making such works, under penalty of not exceeding ten days' imprisonment, without bail; and there were similar provisions as to landing places in other parts of the realm. This, it may be said, was a kind of "national service" with a vengeance, as by it personal service was commanded, subject to penalty and without reward, and it went on further, you will be interested to hear, to provide a power "to enter upon every man's ground, of what estate or degree he be of, and also to dig for and take materials for the said works, and this expressly without any manner of payment to be demanded, or any manner of action to be attempted in respect thereof."

After this, I understand, there were a number of statutes passed, as, in fact, there have constantly been right up to recent times, with the object of enabling the State to acquire specific lands for special purposes.

The earliest statute of the kind was passed in 1703, in the reign of Queen Anne, and between that time and the year 1803, to which I shall next refer, twenty-eight of such statutes were passed.

The chief point of interest for us in these statutes is that, generally speaking, in those up to 1845, when the Lands Clauses Act, with which you are all familiar, was passed, the lands in question, "to the end that the true and real value of the estates may be ascertained and the owners and proprietors thereof may have just and reasonable satisfaction," were vested in trustees in trust for the owners until compensation should be paid, and thenceforth in trust for the Crown, and commissioners were appointed to decide claims. Owners, if they wished, could have compensation settled by a jury to be summoned by the sheriff upon warrant from the commissioners—a provision which may be said to be the forerunner, as it were, of the procedure under the Lands Clauses Act, and which, since it passed, has usually been incorporated with the Acts in question.

THE THREATENED NAPOLEONIC INVASION.

At the beginning of the nineteenth century, however, as you will remember, there was the great impetus due to the apprehension of invasion by Napoleon, and we come to what may be said to be the first of the statutes of general application, which later came to be called Defence Acts. It is the statute of 45 Geo. III., cap 55, passed in the year 1803, and contains words which, on the authority of the present Master of the Rolls, contain a plain assertion of the prerogative right in its recital that "It is expedient that his Majesty should be enabled to exercise in the most effectual manner the powers by law vested in him for preventing and repelling an invasion of the United Kingdom by his Majesty's enemies, and that for such purposes provision should be made . . . to enable his Majesty to provide grounds which may be wanting for encamping his Majesty's armies and for erecting batteries, beacons, and other works which may be necessary for the public service; and also to provide for the indemnity (in certain cases) of persons who may suffer in their property by measures which may be taken for the defence and security of the country and annoyance of the enemy."

It then (among other matters), in case of actual or apprehended invasion, empowers the Crown to authorise county lieutenants, upon request from the military authorities, to order the removal or appropriation of anything which might be useful to the enemy or applicable to the public service, and in case of necessity to remove, destroy, or render useless any house, mill, bridge, or other building, or any matter or thing whatsoever and generally to do and act in the premises as the public service and the exigencies of particular cases should require. General officers were also authorised to survey and mark out any land required for the public service, and to treat and agree with the owners for the possession or use thereof during such time as the exigencies of the service should require. No lands, however, were to be taken without the

consent of the owners unless "the necessity" were certified by the lord-lieutenant or two deputy-lieutenants, or unless an enemy had actually invaded the kingdom. If no agreement were arrived at, two justices . . . might be required to give immediate possession by means of a warrant addressed to the sheriff. As to compensation in the case of houses, etc. destroyed, the Treasury were to appoint persons to assess compensation, and if their figure was not accepted, two justices might be called upon to settle an amount; while in the case of lands taken, two justices or two deputy-lieutenants were to issue a warrant to the sheriff to summon before them a jury to decide claims and settle compensation. It is to be noted that this statute appears only to have contemplated temporary use of land during an emergency.

In the next year a further statute was passed providing for absolute purchase of lands, but with substantially the same restriction on compulsion, substituting, however, "expediency" for "necessity," and in case of no agreement possession of lands could only be obtained if owners failed for fourteen days to accept what was offered to them, while in the matter of compensation an appeal from the decision of the jury was given to either side to bring the verdict before the Court of Exchequer for consideration, which Court might direct a common or special jury to be summoned for the next assizes to re-try the matter before a judge, this second verdict being final.

There was a further amending Act in 1809 of no great importance. Then, after a period in which a number of minor Acts, which are mainly special Acts for particular purposes of the kind to which I have already referred, or "vesting" statutes, we come to the Defence Act of 1842. This was chiefly a Consolidating Act, and, so far as I can ascertain, established no fresh precedent of interest to surveyors, its provisions in this regard being those of the Acts of 1803 and 1804, with which I have just been dealing, including the provisions for the protection of the owner to which I have already called attention, viz., consent save in exceptional cases, and a period of fourteen days for consideration as to whether the owner would accept the quantum of compensation after the same had been offered on behalf of the Crown.

LATER DEFENCE ACTS.

This Act, and other Acts amending it, or passed with like objects, and which raise no points of interest to us surveyors that have not already been covered, are known as the Defence Acts, 1842 to 1875. But it should be mentioned that in an Act passed in 1891 (the Ranges Act, 1891) it was provided that when any land was acquired under the Defence Acts the person, or authority acquiring it, may require the amount of compensation to be settled by arbitration instead of by jury.

In one of the Defence Acts (passed in 1860) it may be of interest to you to know that I found what in a sense may be called a provision for betterment in the case of prohibition against building upon a man's land, the tribunal being required to consider whether the agricultural value of the land affected was increased by drainage works carried out by the Secretary of State, or whether its available area was increased by the removal of hedges or ditches, and to take the same into account.

There were also in force in August, 1914, four measures known as the Military Land Acts, 1891 to 1913, for facilitating the acquisition or control of lands for various military or naval purposes, and the Military Manœuvres Acts, 1897 and 1911, but these, generally speaking, seem to have followed the lines of the Lands Clauses Acts as to acquisition of lands and compensation, and it does not seem to me necessary to do more than just refer to them.

Summarising these provisions as a whole we see that in the earliest days there was no provision whatever for compensation; that later came a period during which the Crown was subject to definite provisions and restrictions for the protection of owners as to compensation similar to, or the same as, those in the case of the compulsory acquisition of lands by subjects entrusted by Parliament with such powers. And lastly the matter

is now dealt with under Statutory Regulations in which, save so far as may be maintained in a general declaration of principle that interference should be limited to necessity, there is no provision or restriction in favour of owners, nor for payment of compensation as of right. Provision, however, has been made for such payment as of grace, the amount to be determined by a Royal Commission specially appointed to deal, fairly and reasonably with the matter.

Exercise of the powers conferred by these Acts of Parliament have necessitated the calling in of surveyors throughout the whole country, and thus provided work at a time when it has been most opportune and acceptable to the profession.

And now, gentlemen, the most important national problem and duty of to-day is for each and all of us to put aside every personal consideration, and to devote our untiring energies in whatever way may be nearest to our hand towards helping to bring this war to a successful and speedy termination with the full and deliberate determination that its conclusion must rest upon terms that will secure to our children a reasonable prospect of lasting peace, so that they may devote their thoughts and energies to the development of the many social problems and the improvement of the condition of life for the community generally which this war has interrupted.

THE LONDON COUNTY COUNCIL.

At the meeting of the London County Council yesterday (Tuesday) the Education Committee submitted a report recommending a reduction in the estimates for the current financial year of a net sum of £360,225. This included savings of £71,590 on painting and cleaning (nearly half the estimated amounts), £51,340 on buildings and furniture not chargeable to capital account, £26,520 on repairs to buildings, and £6,990 on furniture.

The Establishment Committee reported that Mr. W. A. Green, a senior assistant in the estates and valuation department, will attain the age of sixty-five years on the 15th inst. They recommended that, as his retirement from the service at the present juncture would cause inconvenience to the Council's service, Mr. Green be retained up to and including November 15, 1916, or the conclusion of the war, whichever be the earlier date. They further recommended that leave of absence without pay be granted to Mr. B. G. Amey and Mr. L. H. Cooke and Mr. J. Treman and Mr. J. Quiller, assistant foremen and inspectors of furniture and timber on the classified staff in the Stores Department, in order that they may undertake war contract work.

The Local Government Committee reported that they had considered the question of the desirableness of sinking a well for the supply of water to the new sessions house at Newington. Apart from practical difficulties, there were several objections to the proposal. Having considered the matter in all its bearings, the committee decided that it would be undesirable for a well to be sunk at the sessions house, and that the most satisfactory method of dealing with the water supply would be to arrange for a combined system of mains for the purpose of general supply and fire hydrant service. The committee further stated that, with the concurrence of the Finance Committee, they have notified the architect to issue from time to time certificates for advances to the contractors for the erection of the new sessions house to an extent not exceeding 50 per cent. of the value of materials which are ready for fixing in the building, such advances to be made generally on account of the contract and without prejudice to any liabilities and obligations of the contractors. The accounts will be adjusted from time to time as the work proceeds, and the issue of the certificates will be subject to the contractors complying with such conditions as may be prescribed.

Mr. Edward Warren, F.R.I.B.A., is holding the position of Lieutenant-Réserviste under the Croix Rouge Française at the Hôpital d'Arc-en-Barrois, in the Argonne District.

LOGIC IN ARCHITECTURE.*

By HARRY GILL, M.S.A.

"Our World has passed away
in wantonness or error,"

but thanks to the courage and steadfastness of the allied armies, and the devotion and self-sacrifice of the younger members of our Society, another, and let us hope, a more beautiful world will spring "phoenix-like" from the ashes.

Almost without exception the practice of architecture has been brought to a standstill by the war. It behoves us, therefore, to put this temporary surcease to advantage, and indulge in introspection such as we never could, or should be disposed to do, in the throes of normal times. This uncongenial task has been made all the easier seeing that political and religious controversies have been laid aside for the moment, and we can meet on common ground and speak our minds as comrades and Englishmen *sans peur et sans reproche*.

Under these peculiar circumstances, "Logic in Architecture" appealed to me as a topic worthy of consideration—using the word logic to mean the "science of reasoning" and architecture the "science of building."

I do not wish to infer that "logic" is the only or even the chief thing an architect should cultivate. When I think of the terrible pass to which the German nation has been brought by their dependence upon "logic" alone, I feel that it is necessary to remind ourselves, paradoxical as it may seem, that we must also have ideals which are often illogical, and we must also foster the spiritual side of our nature, which is often impractical, if we would make a real living success of our work.

But these are great themes of which I can only make passing mention in the limited time at my disposal, and therefore I confine my remarks chiefly to "logic."

Logic has been neglected of late, and we have been prone to follow the dictates of fashion, a dangerous guide where architecture is concerned; for fashion has led to unsound methods of construction and meaningless ornamentation.

If I criticise adversely the details of recent work, my own as much as any other, you will understand that I speak of the work for the work's sake only, and quite without any personal motive.

To many who commenced their training some fifty years ago, the Gothic revival came as a misfortune; for while I would yield to no one in my admiration for mediæval architecture, I feel that the Gothic revival was a mistake, because it was the revival of the outward forms without a true grasp of the inward spirit.

You have only to look round to see what this has done for us in modern ecclesiastical buildings, and more especially as exhibited in what for the sake of classification only I may call the Dissenting places of worship. Of how many of these conventicles ought it to be said, "Our Church at the front is as fine as an abbey. But seen from the rear 'tis remarkably shabby." But the gods see everywhere.

Let me repeat that I speak of the material fabric only, and no word of my criticism applies to individuals or sects.

The Presbyterians, who of all people should be the last to respect images of the saints, have placed over the chief entrance to their place of worship in this district a "little Gothic niche of nicest workmanship," which looks as though "it once had held the sculptured image of some patron saint looking down on all who entered those religious doors." When age has added its mellowing influence, will future generations believe that the iconoclastic spirit of our time deprived that niche of its occupant? For only on the assumption that it was intended to shelter a sculptured image can such a housing be justified.

If the Presbyterians could be outdone in this direction it would surely be by the Baptists; but the Baptists have put *two* niches

on the front of their new church, which again are meaningless unless intended for statuary.

In old time representations of the saints it was not unusual to depict them in the greatest act of their lives, St. Wilfrid giving freedom to a slave, etc. When this terrible war is happily over, I suggest that it might be appropriate to make these niches commemorative. On the one side we could have St. Lloyd George distributing rare and refreshing fruit to the English, and on the other the same saint devising iron rations for the Germans.

The buildings in which men worship nowadays are indeed a strange study, for do we not find that where faith is supported by appeal to reason, the architectural setting is frequently illogical and quite out of harmony with the scheme; but where the appeal is to authority and individual reasoning is discouraged, the architectural setting is logical and designed to give an uplifting influence. So that speaking of course on broad and general lines, we might say that the more logical the creed the less logical the architecture, when it ought to be vice versa.

I would say to the young architectural student, study ancient Gothic architecture by all means, but do not attempt to copy it. Remember that the methods of construction and the materials at our disposal are not so restricted as they were in the days of old when the craftsman had to choose either oak or stone. Let archaeology be your handmaid if you will, but do not make of it a fetish.

When we turn from the modern Gothic to modern Classical architecture, we find the details are more illogical still.

Whatever semblance of reason there may be in putting a key-block in a flat brick arch, it is surely a violation of principle to put a key-stone in the centre of a stone head or lintel. And yet this anomaly is a feature of modern design. If you study the brick buildings of the 17th and 18th centuries, you will find numerous instances where key-blocks have fallen out owing to settlement of the jambs or decay of material.

In recent buildings not only are key-blocks introduced in flat lintels, but they project so indignantly beyond the face of the wall as to become dangerous.

In my opinion, such buildings will in years to come be almost as great a menace to human life as Zeppelin bombs are to-day.

A key-stone in an arch is a structural necessity, but to use a structural necessity purely as an ornament is quite a different thing to the ornamentation of a structural feature, and there surely can be no justification for treatment which offends against all laws and rules of common sense.

Consider one of the most important details in Classical architecture—the Column. In the hands of the Greeks, the column was indeed a thing of grace and beauty. I wonder what would happen to the builders who lived B.C. if they could see what we "degenerates" euphemistically call a "rusticated" column.

The grace and dignity of a Grecian column is due to its perfect proportion and the subtlety of its entasis, and yet how often do we see these attributes destroyed by the senseless system which is sometimes adopted in modern work, of building up a column for part of its height, yea, and sometimes the full height, with alternate drums and cubes, until the graceful lines of taper and the effect of entasis are entirely obscured.

I am aware that the Queen Anne and Georgian architects who used this abomination claimed that "chiaroscuro" was the effect they aimed at; but if light and shade can be obtained only at the expense of the column, I, for one, would prefer shade to shadow, and I think the day is not far distant when our successors will wish to dress down these abortive columns to their true lines.

I know a modern building with supposed Doric pilasters at the angles. These pilasters are "rusticated" throughout their full height, so that the taper can be only fitfully seen in the wide sunk joints between each block, while the cap and base have to be searched for before they are seen at all. Although an architect with many years' experience, I felt it quite a feather in my

cap when I found out that these were really intended for pilasters. But will such work cause the public bosom to swell with pride at the prowess of the native genius?

Then, again, what liberties we have taken with the pediment! A broken pediment is claimed by some to be decorative treatment. For internal use, especially, when it is broken to admit a medallion or bust, it may be done with a semblance of reason. Even then it is a long remove from the sculptured tympanum of the Greeks; but to build a broken pediment with masonry can never be commended.

It surely is topsy-turvy logic to put a keystone where it is not needed, either for strength or appearance, and to omit the keystone from a pediment where it is needed, both for strength and appearance. To build a pyramid on its apex would not be more illogical than the attempt to give apparent support to a wide arch by dividing it into compartments with stone or brick mullions.

Why do we perpetrate these things? Is it not because, without stopping to think for ourselves, we follow "fashion" in architecture? We become imitators of one another instead of designers.

Our society is fortunate in having a copy of "Stuart and Revett's Antiquities at Athens," and the young architect could wish for no better studies, but they should only be used as the groundwork for a logical adaptation to modern needs.

Another very weak point in modern architecture, in my opinion, is the shorn and unfinished appearance of the cornice. A parapet wall, perforated with what one might call the "Union Jack pattern," which is very patriotic, but not pretty, and devoid of any sheltering coping, is very much in fashion just now. To me it gives the impression of the man who began to build without first having counted the cost, and who, consequently, had to leave off abruptly before the full height was reached.

I was taught that the top of a wall should always be protected with a projecting coping, and in such an uncertain climate as ours a projection is a logical necessity, quite apart from the question of appearance.

There is some difference of opinion as to how far the exterior of a building should reveal the interior arrangement of its component parts. In any case, I think it is illogical to design an elevation without regard to the plan.

An otherwise satisfactory building not far from here has its chief façade disfigured by the staircase string crossing the hall window. We all know how difficult it is to arrange the various levels of a staircase so as to work harmoniously with a symmetrical design; but to plan a staircase without incorporating it with the design can never be justified.

The other day I had occasion to look over a detached house. By standing immediately in front of it the upper story appeared to be in what is known as the half-timbered style. But the timbering! I asked myself, Is it structural? No. It could not be, for the timbers appeared only on the front face, and not on the returns. It was, therefore, applied art, so I asked myself, Is it decorative? I think that was the idea the builder had in his mind when he did it, but I could not find one pleasing line in it. The work was altogether illogical, and a sheer waste of money.

This is not a condemnation of any attempt to reproduce the timbered style of building. There are some who teach that timber buildings should be restricted to sites where timber abounds, and so on, and there was a time when such a practice was necessary. Stone buildings in a stone district, brick buildings in a clay district, and timber framing where neither stone nor brick was plentiful has produced some delightful results. But in these days, when every facility is given for carriage of material from one district to another, there is not the need to adhere to any traditional manner of building. In large towns and industrial centres especially any endeavour to relieve monotony is commendable.

But we must educate the public taste. We must convince men that a house need not

* The President's address at the opening meeting of the Nottingham and Derby Architectural Society on October 26.

Currente Calamo.

The interesting summary of the provisions of past Defence Acts given by Mr. J. H. Hanson in his presidential address at the opening meeting of the Surveyors' Institution on Monday night is a timely contribution to the information needed by all whose province it is to act for real property owners, whose obligations to the State have been so considerably revived by the war. They are, as the President said, undoubtedly drastic and far-reaching, and when it is remembered that compensation for all interference is a matter of grace and not of right, it will be understood that the services of surveyors will be in demand in ascertaining the amount likely to be paid and in obtaining it. Surveyors, therefore, are busier than architects and likely to be so for some time to come, though probably to nothing like the extent of their ordinary work. That, however, has not hindered their prompt response to the primal duty of all to-day—active war service. That nearly 1,400 members have as promptly responded to the call as those of our own calling and our brethren of the civil engineers is something all may be mutually proud of, and we are sure that no member of either profession will hesitate to follow the noble example set.

The President of the Institution of Civil Engineers, in his address at the opening meeting yesterday week, dealt at some length with the necessity for the better utilisation of our national resources, if the present generation is to sustain the huge burdens war is piling on to our backs when peace comes, leaving posterity as usual to pay off the phenomenal load of debt we are saddling it with. He confined his remarks in the main to the Iron and Steel Industries, Timber, Floods and Land Drainage, and the Land. Under each head Mr. Ross had, of course, the old tale to tell. Government indifference—except when action offers opportunities for nepotism in the interests of family connections or political partisans—and the lavishing of our resources on other nations, blinded us to the fact that our boasted "commercial prosperity" was a delusion so far as the welfare of the great mass of the nation was concerned. On every hand, of course, we hear of effort and inquiry and organisation, which is to end all this—generally followed by very proper protests from those concerned, that the men selected on committees and the like are in many cases round pegs in square holes; and little will come of it all except the spending of more money vainly. Every indication points to the conclusion that unless we find out within the next decade how to feed ourselves, house ourselves, and defend ourselves, the coming crash in Europe of the civilisation of the last fifty years will find us amongst its earliest victims.

All who can should not miss the interesting exhibition of pictures which four members of the Artists' Rifles are holding this week at The Club, Loughton. Their names are Lance-Corporal Edward Handley-Read, R.B.A., Private Gerald Ackerman, R.I., Private Edgar L. Pattison, and Private James Thorpe—all well-known artists who have from time to time exhibited in the Royal Academy. Private Thorpe, the black and white artist, is represented by a series of cartoons and black and white studies, many of which have already appeared in *Punch*, the *Bystander*, the *Tatler*, the *Graphic*, etc. Four of his car-

toons depict Major Sir Richard Rycroft, Captain Edge, Lieutenant T. H. Hughes (Artists' Rifles), and Mr. Arthur Morrison, the well-known writer, who appears as an "extra Special." Private Pattison's contributions include two etchings and several excellent water-colours. Private Ackerman is an old R.A. student, who won the Creswick landscape prize when he was twenty-four. Two of his pictures were in the Academy this year. His sketches on view are a series of water-colours, mostly sketches of the country in the neighbourhood of the camp and the Sussex Downs. Lance-Corporal Handley-Read's studies of the silver birch in the Forest are very good, and one entitled "Somewhere in France" was painted while the artist was at the officers' training camp at the front.

The individuality and distinctive characteristics of the subjects portrayed are admirably brought out in the fifty two portraits photographed by Mr. Furley Lewis, President of the Royal Photographic Society, and hung as a one-man show at the Camera Club, 17, John Street, Adelphi, W.C. The works are all by the platinum process, and exhibit considerable variety in pose, treatment, and lighting. All are successful pictures, even where the subject, as in No. 28, seems to have carelessly thrown himself back in an easy chair in an attitude that would be baffling to many experts with the camera. No. 5, a three-quarter length portrait of Mr. J. C. S. Munnery, A.R.I.B.A., one of the predecessors of Mr. Lewis in the presidential chair at 35, Russell Square, depicts that well-known architect, pipe in hand, and in a contemplative and genial mood. Another past-President of the R.P.S., Lord Redesdale, who has just delighted us with his reminiscences, is happily shown in No. 36; the veteran diplomatist is seen in top hat and frock-coat. In No. 14 Professor Patrick Geddes is limned full face, looking forward as if considering a fresh development in town-planning. Of the two portraits of Ignaz Jan Paderewski we prefer the full-face, No. 52, exhibited this summer at the Royal Photographic Society's display in the Suffolk Street Gallery, to that of the great violinist and Polish patriot seen in profile, No. 27, now shown, we believe, for the first time. No. 31, "The audience was small but sympathetic," is a back view of a player on the instrument; his sole auditor is a small boy carrying a toy horse. The familiar earnest expression, deep-set eyes, and short grey beard of Mr. John Burns are well portrayed in No. 32; and another fine character study is that of Prince Kropotkin (No. 3)—the benevolent aspect of the lofty forehead and broad bald head, spectacled eyes, and flowing beard is as unlike that of the typical revolutionary Socialist of high birth and social status as could be imagined. There are several ladies' portraits on the walls, the best and most charmingly posed, perhaps, being that of Mrs. Furley Lewis (No. 47), hung next to the busts of their little sons, Wentworth and Jack Lewis. The exhibition, which will well repay a prolonged visit, remains open until Saturday, the 27th inst.

Although leases, which word in law includes the usual tenancy agreements for three years, given by or to alien enemies continue binding during the war, a very pretty point arises where, as the premises let are in a prohibited area, the lessee or tenant cannot remain in occupation. Builders who so frequently let their new houses on these terms of three years are specially interested in this matter. In the recent case of "London and Northern

Estates v. Kish Schlesinger," a flat at West-cliff, which is part of Southend in Essex, and in a prohibited area under the Restriction Order, had been let by the plaintiffs to the defendant, who is an alien enemy, on an agreement for three years from March 25, 1914. There were the usual covenants as to the flat being used only as a private dwelling and against assigning or underletting it without the landlord's consent. In December last the defendant wished to terminate the tenancy, which the plaintiffs declined, but allowed him to try and let it, which he failed to do. The landlords had brought an action in the Mayor's Court, London, for a quarter's rent, due last Lady Day, and the judge there had held that the Restriction Order did not avoid the lease, as, although the defendant could not live in the house and the landlord could not let him remain, he could sublet it if he found a tenant. On appeal to the High Court this ruling has now been confirmed, the two judges holding that the State had not put an end to the lease or agreement, nor had the Restriction Order affected the term of years granted thereby and vested in the tenant. So the enemy alien remains liable for the rent of the flat until March, 1917, although he may not himself be allowed to live there. It is said there will be a further appeal, which will be watched with interest, because there are many other like cases awaiting decision in similar prohibited areas.

The invitation addressed by the Board of Inland Revenue to the officials of the Land Valuation Branch, permanent and temporary, to apply for appointments in the Income-tax Service, has caused the gravest concern amongst the surveyors in the latter department. An interview with the Board has already taken place on the subject, and a special general meeting of the surveyors has been held to consider the situation. They hold that to appoint temporary valuation officials in another department over the heads of the existing staff, all of whom entered by competitive examination, would be to rectify one injustice by creating one of larger dimensions, and at the same time would create a most undesirable precedent. It is urged that those transferred from the Land Valuation Department should, in justice, rank after the last assistant surveyor already on the Inland Revenue establishment. Mr. Montagu, Financial Secretary to the Treasury, has promised, in answer to questions by Mr. O'Grady in the House of Commons, to investigate the whole subject.

The urban district council of Haslemere have adopted a scheme for improvements at the sewage works estimated to cost £340. The alterations provide for a separation of the storm water from the sewage proper, and the existing bacteria beds will be utilised in the improvements, which include the installation of a new pumping plant.

Mr. H. G. Crothall, F.R.I.B.A., county architect of Middlesex, has voluntarily offered to his county council that, during the suspension of the works in connection with the proposed new sanatorium and the new lunatic asylum, his salary should be paid at the rate of £1,000 instead of £1,200 per annum, as authorised by the council in May last. The council have accepted the offer.

At the last meeting of Droitwich Rural District Council, a letter was read from the Local Government Board declining to sanction a loan for the purchase of land for housing schemes at Ombersley, Sneed's Green, and Curnal Green. The council had decided not to build in the near future, but desired to purchase the sites in order to be prepared with the necessary land should cottages be required after the war. It was decided to abandon the contract for the purchase of the sites, and to pay the vendor's expenses.

ARCHITECTS' WAR SERVICE FORM.

Fill in first and last names before filling in. Please write clearly and in the spaces provided for answers to each question.

Leave blank - but put "Yes," or "A little," or "No" where such answers apply: Do not say "I do not know" about to acquire proficiency in anything which is the subject of this form. If you offer this at the date of the offer of service (see next page) state "A heavy yes," or "A little, May, yes," as the case may be.

This space is reserved for the Report of the Committee of the Centre selected by the Applicant.

1. Name on National Registration Card

2. Name on Order under Lord Derby's Scheme (if any)

3. Surname (in capital letters)

4. Other names

5. Present address - Residence

Town

County

6. Temporary address

7. For correspondence

till (date)

8. Professional Architectural Society of which you are a member (if any)

9. Other Professional or Learned Society

10. Age

Height

Chest measurement

11. General health (state as Fair, Good, or Excellent)

12. Any physical defects? If so, give details

13. What dependants have you? Number of adults Children Ages
 (include partial dependants as $\frac{1}{2}$)

14. What was your School College

15. What are your diplomas or degrees?

16. Can you ride a horse?

17. Undertake animal management?

18. Ride a motor cycle } Do motor
 Drive a car } repairs

19. Do metal turning

20. Do any other skilled handicraft? (state nature of)

21. Do simple electric work?

22. Do military signalling?

23. Use a prismatic compass? Level? Other surveying instrument?

24. Make and plot a primary bench survey?

25. Speak foreign languages? (state which, and whether Slightly, or Fluently, or Technically)

26. Give name of any machine you have operated and for how long

27. Give name of any

28. Undertake any of the following

29. Are you or have you been engaged in any War Service?

If so, state whether Regular, Territorial, Voluntary or Civil

30. Give the date of your enlistment or appointment on joining?

31. Give the date of your retirement or discharge (if effected)?

32. Give the name of your commanding officer?

33. State the name of the medical certificate?

Societies' Name or Stamp.

Interviewed 191

Particulars given

Rec.

Ra.

Rec.

Ra.

Rec.

Ra.

Remarks

Signed

Dated



NEW CATHEDRAL, COLOMBO, CEYLON: VIEW FROM THE SOUTH EAST TOWARDS THE SEA.
Mr. G. H. FELLOWES PRYNNE, F.R.I.B.A., Architect.

COLOMBO CATHEDRAL CEYLON

GROUND PLAN

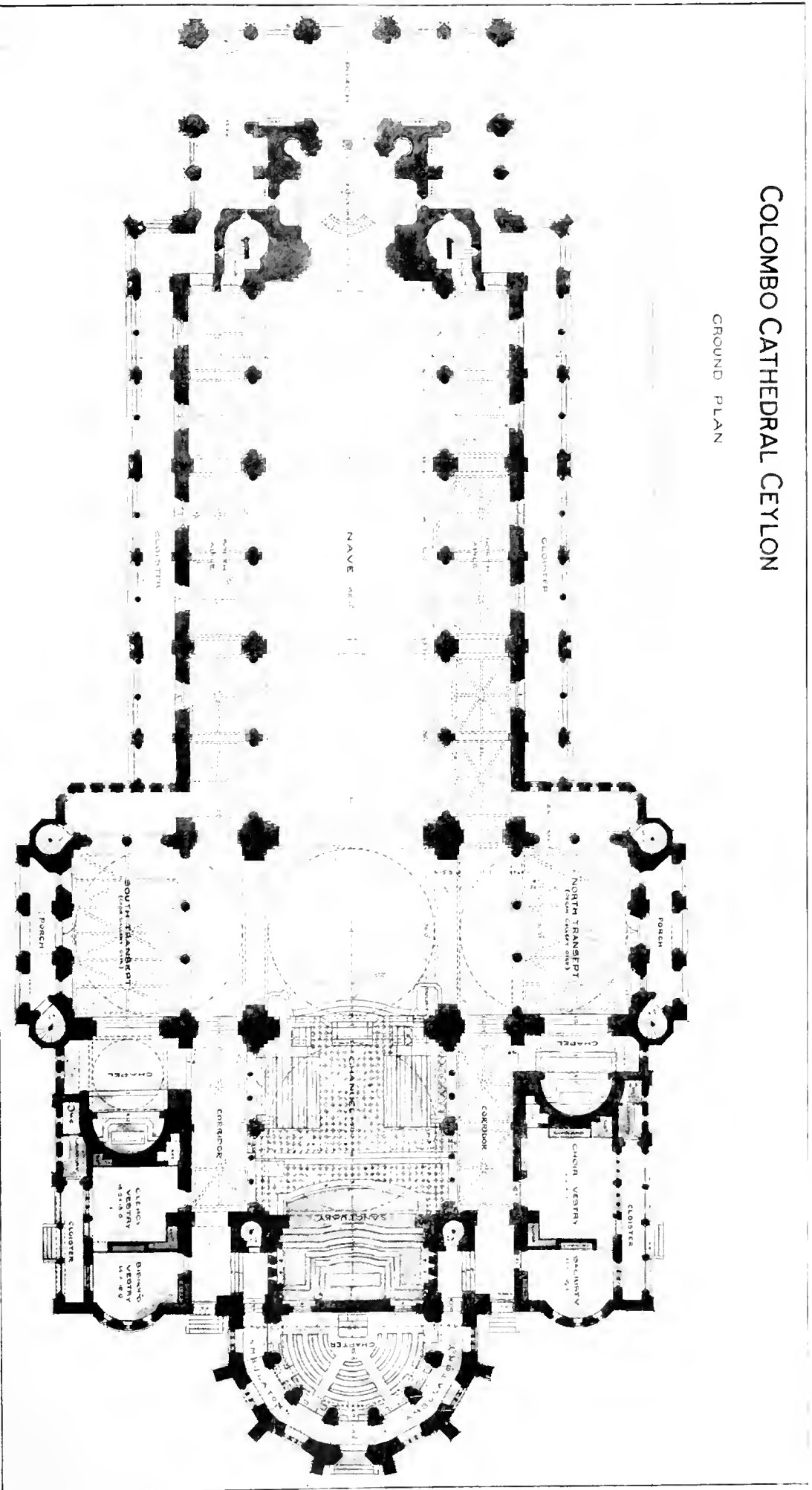

GROUND PLAN, COLOMBO CATHEDRAL, CEYLON.—MR. G. H. FELLOWS PRYNNE, F.R.I.B.A., Architect.

DETAILS OF PROFESSIONAL EXPERIENCE.

Put a cross in the spaces under headings in which you have had most experience, and a circle to those in which you possess less, but some proficiency.

	As Principal.	As Draughtsman.	As Clerk of Works or Outdoor Supervisor.
General Practice			
Business Premises			
Factories and Workshops			
Hospitals			
Schools			
Temporary Buildings.....			
Bridge Work.....			
Sanitary Work.....			
Municipal Engineering			
Civil Engineering			
Dilapidations			
Valuations			
Structural Steel Work			
Ferro-concrete			
Road Making			
Land Surveying			
Other Work, not included above, namely			

Put a cross in red ink in the space or spaces below applying to any service you would preferably undertake, and a circle in red ink in spaces for any second preference, your application being for junior commissioned rank or position as supervisor. Put a cross in black ink and a circle in black ink to indicate your first and second preferences respectively for any service in which you would enlist as a private or workman.

PRESENT OR FUTURE SERVICE YOU WOULD UNDERTAKE.

	At Short Notice after Nov. 30, 1915.	At Short Notice after Feb. 28, 1916.	At Short Notice after May 31, 1916.	At the Date offered under Lord Derby's Scheme.
Engineers, Naval Division.....				
Royal Naval Reserve				
R.N. Air and Anti-aircraft.....				
Royal Engineers:—				
Fortress (Territorial)				
Mining Battalions				
Navy Battalions				
Royal Artillery Machine Gun Corps.....				
Infantry				
Pioneer Battalions				
Equipment Section Flying Corps.....				
Army Service Corps.....				
Mechanical Transport.....				
Army Ordnance Corps.....				
Ordnance Department.....				
Royal Army Medical Corps.....				
Army Pay Corps				
Sanitary Companies				
Military (not necessarily in uniform):—				
Inspector of Works				
Surveyors (Billets, Dilapidations, Valuations)				
CIVIL EMPLOYMENT FOR MEN INELIGIBLE FOR MILITARY SERVICE.				
Practical Draughtsman				
Putting and Sanitary Work				
Inspector of Stores, Works and Factories				
Munition Supervisor or Workman				
Inspector of Stores, Works and Factories				

Signed by the applicant this
Signature

day of

191



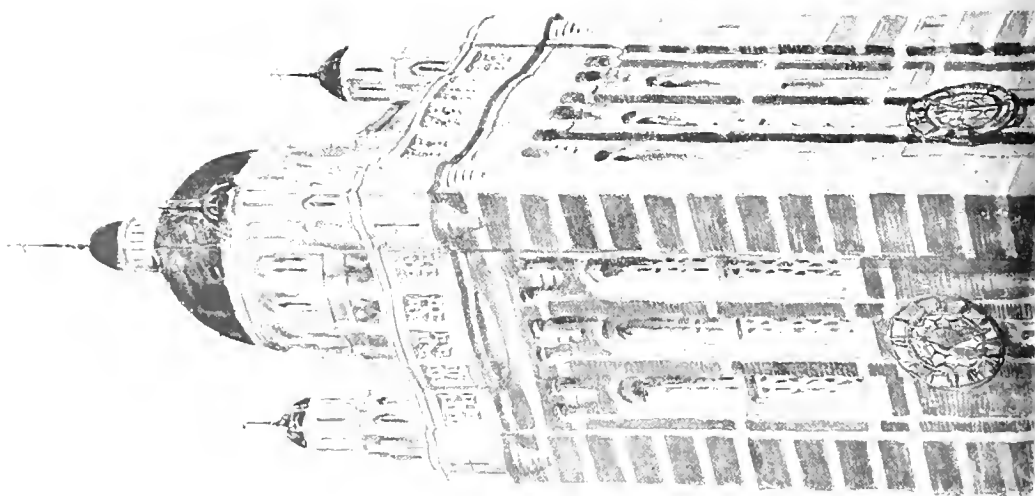

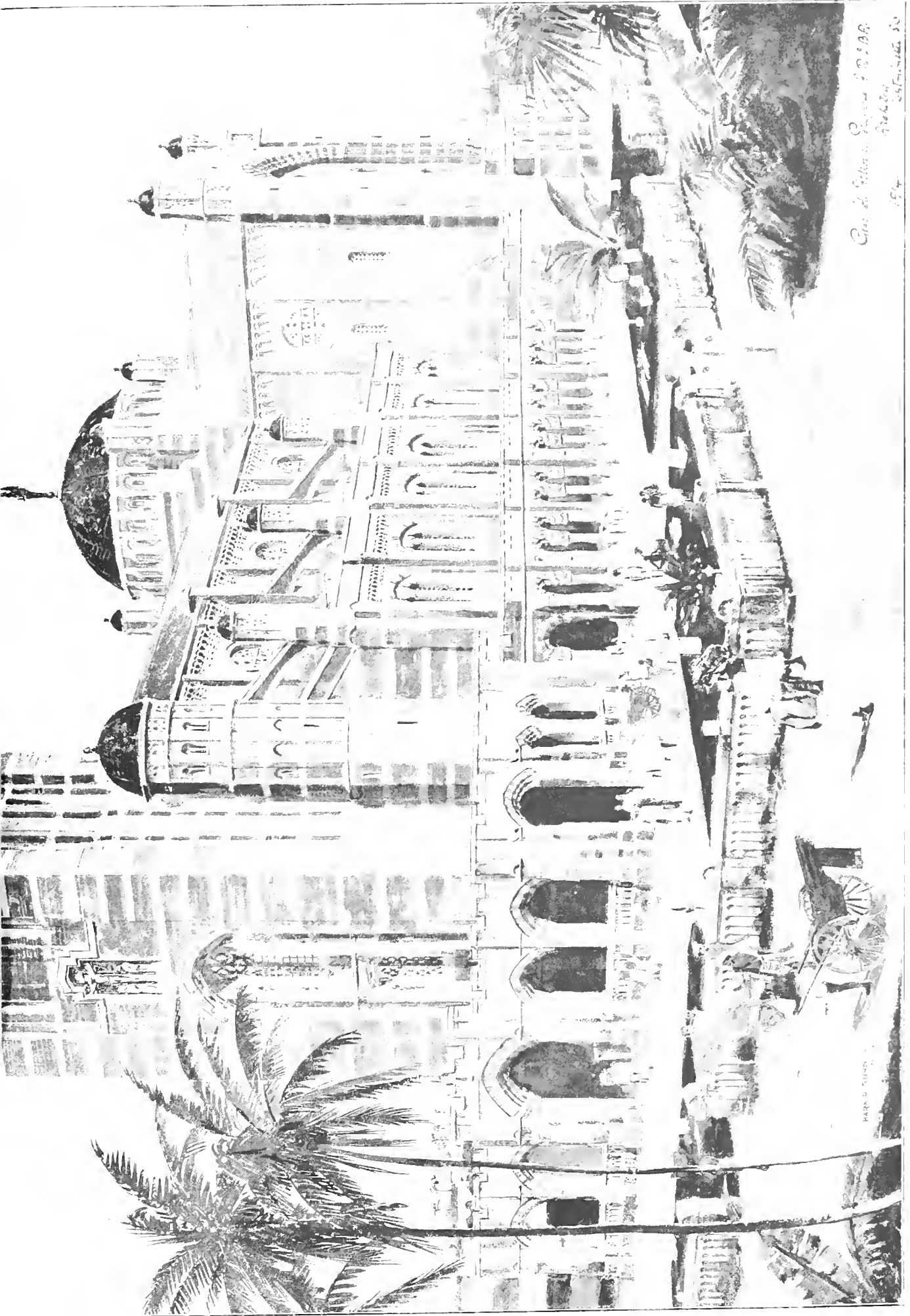

*Cath. de Colombo. Ceylon. P. B. 1848.
Publ. by
S. S. & Co. 50*

S.W. VIEW. NEW CATHEDRAL, COLOMBO, CEYLON. MR. G. H. FITZGERALD, PICTOR. F.R.S.E. & F.R.C.S.



THE BUILDING NEWS, NOVEMBER 10, 1915

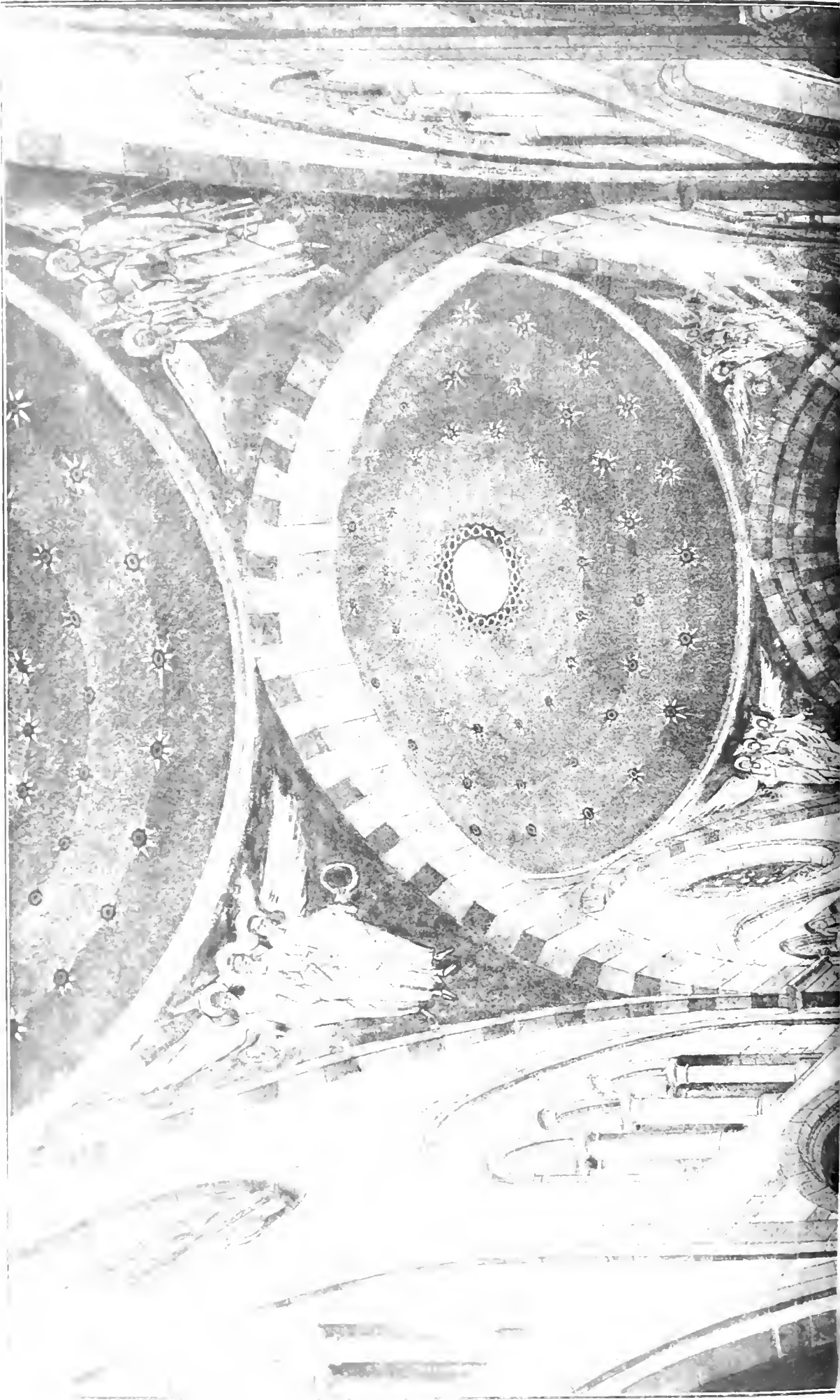

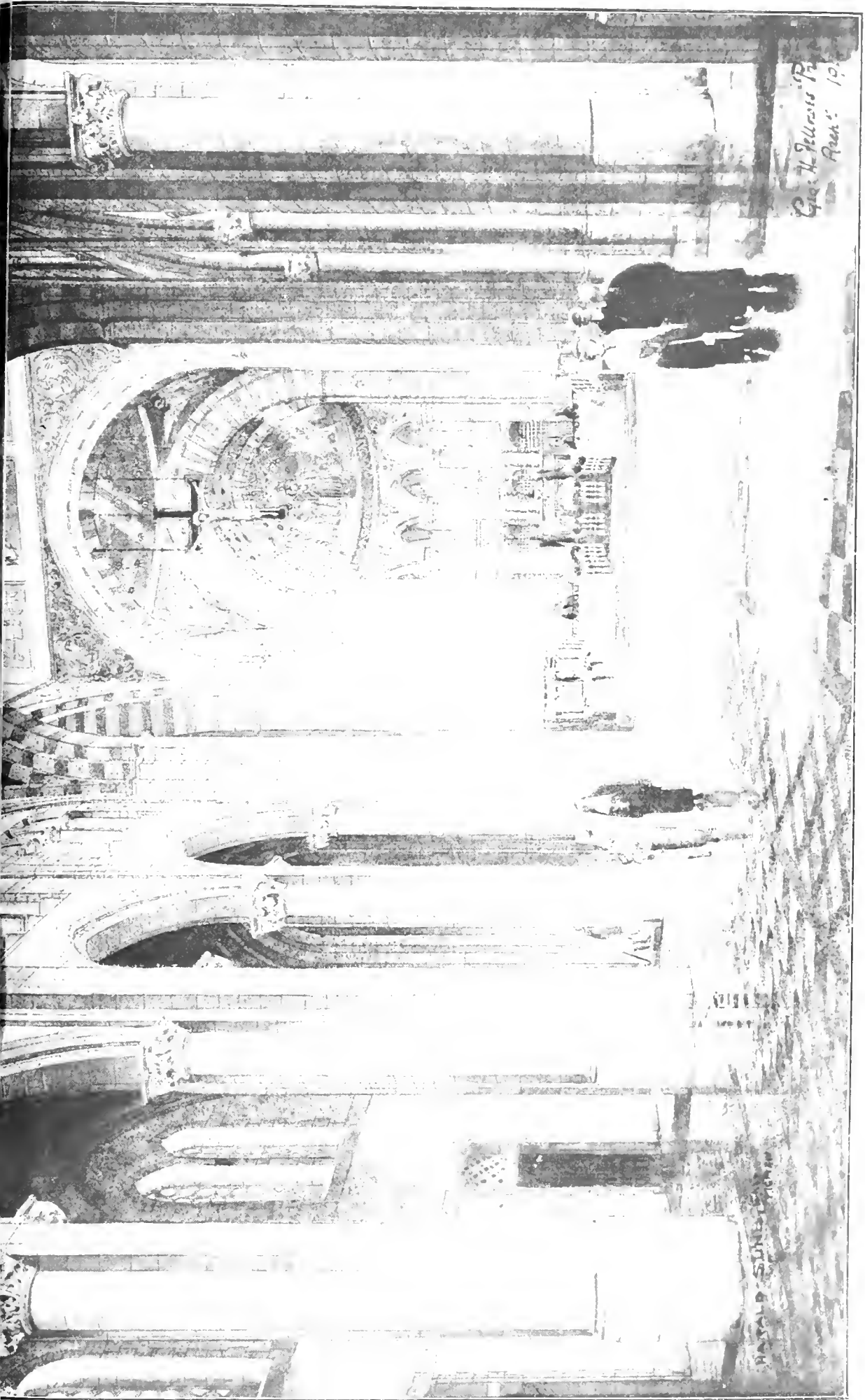

G. H. F. P. 1910
Arch: 10

INTERIOR. LOOKING EAST, NEW CATHEDRAL, COLOMBO, CEYLON. MR. G. H. F. P. PHOTOGRAPHER, F.R.P.H.A., V. 10.

PROFESSIONAL AND TRADE SOCIETIES

ARCHITECTURE AFTER THE WAR.

The desirability of doing everything possible to advance architecture in the Midlands was the chief subject dealt with by Mr. G. Salway Nicol, A.R.I.B.A., in his presidential address to members of the Birmingham Architectural Society on Friday night. The disturbance of war, he pointed out, could never be more than a temporary matter compared with the perpetual claims of architecture, and the success of our army and navy would once again leave us free to devote our energies to the development of the arts of peace. When that opportunity occurred, as most assuredly it would, it was of the utmost importance they should have a more definite idea of the course to be pursued than they had had in the past. Continual changing from one phase of design to another would lead nowhere. Recommending the younger members of the profession to support the Municipal School of Architecture, the President said it was from such a source as this that the founding of a traditional style of building might be expected. The finest buildings of the past were invariably the result of working for generations in the evolution of art on similar lines, and in spite of extended knowledge of the various styles it was quite possible by the foundation of definite schools of design to re-establish this principle. It was only by means of such a traditional style and the co-operation of the complementary arts of sculpture and painting that the finest results could be attained.

CIVIC SURVEYS AND TOWN PLANNING IN YORKSHIRE.—Representatives of various West Yorkshire towns attended a conference held at the Town Hall, Leeds, on Thursday afternoon, for the purpose of inaugurating a civic survey scheme similar to those which are in existence in London and in Lancashire. The object of the scheme is to collect in regard to different districts data which may be of use in the preparation of town-planning schemes, and incidentally it is to provide work for architects who are suffering as a result of the war. The schemes are supported by Government allowances from the Prince of Wales's Fund. It was decided to form a consultative committee, the members including the Lord Mayors of Leeds and Bradford; Ald. Jessop, of Huddersfield; Mr. Charles Lupton, of Leeds; Miss Unwin, of Shipley; Mr. M. E. Sadler, Vice-Chancellor of Leeds University; and the Medical Officers and Engineers of Leeds, Bradford, Wakefield, Dewsbury, Batley, and Spenborough.

EXCAVATIONS IN THE CRYPT OF ST. MARY-LE-BOW CHURCH.—In a paper read before the British Archaeological Association at their rooms in Russell Square on Thursday evening, Mr. F. Lambert described "The Excavation carried out by the Association in the Crypt of the Church of St. Mary-le-Bow, Cheapside." When Sir Christopher Wren rebuilt the tower of the church he found a Roman causeway, on which the foundations of the tower were laid. In the recent excavations a trench was dug along the east side of the crypt, along the line of Bow Lane. The first three or four feet down consisted of made earth; the next seven feet was a black peaty swamp, and at the bottom of this mass were two oak piles with planks which had been used to embank a stream running almost north and south across Cheapside. The question was whether that stream could be followed in any other part of London? He thought it could. The old idea that Moorfields was a primitive swamp had long been abandoned in favour of the more reasonable explanation that the swamp was caused by the Wallbrook, which used to flow through London Wall by means of culverts, one or two of which had been found. In late Roman times, or after the Roman excavation, these culverts were neglected, and became blocked up. The river, therefore, spread a considerable distance, and the swamp began to form, and found an outlet by passing underneath the foundations of the walls all the way along from Cripplegate to Bishopsgate, and so into the Thames. It was already known that a swamp existed under the east end of St.

Lawrence's Church, under the Council Chamber of the Guildhall, and under the Public Health Office of the Corporation in Basinghall Street, and he suggested that these were caused by a stream parallel to the Wallbrook, which, flowing south, had in turn caused the recently discovered swamp under Bow Church. By connecting these four places they got the line of flow. The presence of the swamp crossing the middle of Cheapside caused the Normans who built Bow Church to lay exceedingly massive and deep foundations. Mr. W. A. Cater, F.S.A., afterwards read a paper describing the medieval church and crypt of Bow.

ROCHDALE MASTER BUILDERS' ASSOCIATION.—A half yearly meeting of this association was held in the Masonic Hall, Oldham Road, on Wednesday evening. The president, Mr. T. S. Wilkinson was in the chair. After the disposal of the business of the meeting, Mr. Fred Greenwood's concert party provided an enjoyable entertainment. During the evening the five special prizes given by the association, and awarded by the education authorities to the successful Building Course students at the Technical School, were presented to the students by the president, who, after congratulating them on their success, advised them to continue to take full advantage of the educational facilities granted, and also to remember that whatever was worth doing at all was worth doing well. Mr. T. Howarth also delivered a short address in which he pointed out the necessity for and the value of strict attention to detail and thoroughness in every undertaking. The prizewinners were:—John L. Shepherd, 112, Church Street, Littleborough; Herbert V. Townsend, 14, Moss Street, Rochdale; Fred Crossley, 20, Newall Street, Littleborough; Fred Kershaw, 3, Penine Villas, Littleborough; and Harry Wild, 36, Rose Terrace, Shore Road, Littleborough.

ULSTER SOCIETY OF ARCHITECTS.—The October annual meeting of the members, associates, and students of this society was held at the society's rooms, 9, Howard Street, Belfast, on Friday, the 29th ult. The chair was occupied by the president, Mr. N. Fitzsimons, F.R.I.B.A., and amongst those present were Messrs. R. E. Buchanan, W. J. Gilliland, F.R.I.B.A., H. Seaver, B.E., F. H. Tulloch, F.R.I.B.A., W. C. Maxwell, A.R.I.B.A., Captain Ferguson, R.E., and T. W. Henry, M.S.A., hon. secretary. The report of the council regarding the alliance with the R.I.B.A., and its correspondence were submitted to the meeting and discussed, and the council was instructed to follow the matter up to a definite conclusion. The President reported on negotiations he had had with reference to a proposed memorial to the late W. H. Lynn, R.H.A. The proposal was discussed at some length, and referred back to the council for further development. The work of the Architects' War Committee was reported on and discussed by some of the members, and some suggestions were made as to its working with reference to War Office works. The scheme of the Central War Committee with relation to enrolment for national service was read from the correspondence of the War Committee of the Royal Institute of British Architects, and the members unanimously decided to support the scheme. Mr. Robert I. Calwell, of Donegall Square South, Belfast, was elected a member of the society by ballot. Messrs. H. Seaver and Captain Ferguson acting as scrutineers.

Mr. F. M. Williams, who has been docks marine manager at Southampton since 1902, has been appointed a justice of the peace for the borough.

Exterior additions are being made to the post office at Ballsbridge, Dublin, from plans by Mr. Andrew Robinson, of H.M. Office of Works, Dublin. The builder is Mr. E. B. McKee, of Belfast, and the outlay will be about £4,000.

Mr. Balfour, First Lord of the Admiralty, unveiled at Waterloo Place on Friday a statue, subscribed for by officers of the Navy, in memory of the late Captain Robert Falcon Scott, R.N. The statue, which is in bronze, and shows the explorer in his Antarctic costume, is the work of Lady Scott.

Trade News.

WAGES MOVEMENTS.

MANCHESTER AND SALFORD.—The Northern Building Trades Conciliation Board has conferred in Manchester to consider an application for an advance in wages made by the bricklayers, the joiners, the stonemasons, the wood-cutting machinists, and the builders' labourers. The board decided to grant the labourers an advance of a penny an hour and the skilled men an advance of a half penny an hour, making the labourers' wages 7½d and 8d (instead of 6½d and 7d) and the skilled men's wages 11d (instead of 10½d). This is an advance in the rate of wages—not a war bonus—and it applies to Manchester and Salford and the outskirts.

TRADE NOTES.

Boyle's latest patent "Air-Pump" ventilators have been applied to the Presbyterian Church, Limerick.

The storage benefit of a basement is often minimised through dampness. We learn that two such basements in Birmingham have now been successfully treated with a blue brick lining, the bricks being bedded with Padloot cement mortar.

A fire recently occurred at Wm. Morris and Co.'s, of Ruskin House, Rochester Row, Westminster, and was reported so extensively that the firm finds architects are withholding orders on the supposition that they cannot be carried out. The damage, however, was confined to the top story, which was being used as a drill hall. The "Ruskin House" works are proceeding uninterruptedly, and all inconvenience to output has been entirely overcome. Messrs. W. Morris and Co., whilst grateful to those friends who have so kindly sent their good wishes, hope that they may continue to receive orders, the execution of which will be absolutely unhampered.

Messrs. E. H. Shorland and Brother send us their new catalogue, No. 31, of their most recent warming and ventilating specialities. It contains illustrations and sections of their latest warm-air ventilating Manchester grate with patent hot-water boiler with intersecting flue, various designs of their well-known warm air ventilating patent Manchester grates, some having low fires, whilst others are shown fitted with vertical front bars, ventilating specialities, electric fans, and louvre roof ventilators to work in conjunction with same, patent hygienic inlet ventilators, sections of their warm-air ventilating patent Manchester stoves, which are in general use in hospitals, infirmaries, etc., and a list of a few hospitals where their patent Manchester stoves, etc., have been installed.

PARLIAMENTARY NOTES.

SAFETY OF NATIONAL GALLERY TREASURES.—Mr. Asquith, replying to Mr. Butcher, said: The question of the protection of the National Gallery has received the close attention of the Trustees and Director in consultation with experts. Many pictures have been removed from exhibition, and, in view of the special precautions adopted, the Trustees, after full consideration, have felt that they would not be justified in closing the Gallery. Mr. Butcher: Is it not the fact that there are many irreplaceable pictures still on the walls? Mr. Asquith: I have not been there lately.

A meeting of the suburban committee of the Midlothian County Council was held on Wednesday in the County Rooms, Edinburgh, when it was reported that, in contravention of the building bye-laws, the building of an addition of ten bedrooms at Craiglockhart Hydropathic was commenced without plans being submitted, and that on plans being subsequently sent in they were found not to conform in many respects with the requirements of the bye-laws. It was resolved to insist on the building being taken down and removed.

Lance-Corporal G. Ramsay Thomson, 12th Battalion Royal Fusiliers, son of Mrs. Thomson, West Grove, St. Cuthbert's Avenue, Maxwelltown, has been posted as wounded and missing since September 28. Mr. Thomson is a partner in the firm of Messrs. Crombie and Thomson, architects, Irish Street, Dumfries, and he enlisted into the Army immediately after the outbreak of war. The other partner in the firm, Captain W. F. Crombie, L.R.I.B.A., served in the Dardanelles with the 15th King's Own Scottish Borderers, and he was invalided home wounded some time ago.

Correspondence.

NEW LONDON AND RAILWAY STATIONS

The Building News.

Dear Sir, On October 27, in which I have the pleasure to inform the Town Council, I am made to say that the station should not be placed in the town, because it would be a nuisance and a committal of the town's name. This is a very important point, and I am sure that the Council will be satisfied with the plan being placed before them. I am, Sir, very respectfully,
Yours faithfully,
JAMES CROSSLAND,
Surveyor, London E.C.

JAMES CROSSLAND.

RESERVE FOR ARCHITECTS

The Building News.
Dear Sir, The War Committee, in their report, have recommended that the Government should provide a reserve for architects, to be used in the event of a general mobilization. This is a very important point, and I am sure that the Government will be satisfied with the plan being placed before them. I am, Sir, very respectfully,
Yours faithfully,
JAMES CROSSLAND,
Surveyor, London E.C.

THE REPAIR OF A COTTAGE

The Building News.
Dear Sir, The case of the repair of a cottage at Reddish, in which the plaintiff, Mr. J. O. Reed, of Bungalow, and Mr. Joseph Chapman, builder, Halesworth, brought charges for a and repairs to a cottage at Reddish. The plaintiff, Mr. J. O. Reed, of Bungalow, and Mr. Joseph Chapman, builder, Halesworth, brought charges for a and repairs to a cottage at Reddish. The plaintiff, Mr. J. O. Reed, of Bungalow, and Mr. Joseph Chapman, builder, Halesworth, brought charges for a and repairs to a cottage at Reddish.

LEGAL INTELLIGENCE

THE SPITALFIELDS MARKET ARBITRATION.—The prolonged inquiry into the amount payable to Mr. Robert Horner by the City Corporation for his leasehold interests in Spitalfields Market, which has been held before Mr. Charles A. Russell, K.C., at the Surveyors' Institute, Great George Street, has been brought to a close. Evidence on behalf of Mr. Horner was given by Mr. Daniel Watney, Mr. J. Statham Richards, Mr. W. P. Ryan, Mr. P. A. Monro, Mr. Howard Martin, and Mr. W. H. Payne, and other surveyors, and by Sir Alexander R. Spinning, Mr. F. W. Pexley, Mr. Leslie R. Vigors, Mr. Howard Chatfield Clarke, Mr. Sydney Perks, F.S.A., City Surveyor, Mr. W. S. Walker, and others for the Corporation. Sir Howard Crawford, the City Solicitor, announced that as the result of negotiations the Corporation had agreed to purchase the properties outside the market for £32,000. The arbitrator then awarded a further £252,000 for the acquisition of the market lease, making a total of £284,000. The claim was for £600,000, and the Corporation's valuation was £276,600.

ment of the Royal Institute of the Architects of Ireland, Adam F. Watson, F.R.I.B.A., President of the Society, South Yorkshire, and District Architectural Society, John Watson, F.R.I.B.A., President of the Glasgow Institute of Architects, Walter Gavey, F.R.I.B.A., Past President A.A., E. Guy Fowler, F.R.I.B.A., Past President A.A., Hon. Secretary R.I.B.A., H. E. Florence, F.R.I.B.A., Past President A.A., Harry T. Haro, F.R.I.B.A., Past President A.A., Gerald C. Horsley, F.R.I.B.A., Past President A.A., J. Archibald Lucas, F.R.I.B.A., Past President of the Devon and Exeter Architectural Society, Edmund Moxham, F.R.I.B.A., Past President of the South Wales Institute of Architects, Alexander N. Paterson, F.R.I.B.A., Past President of the Glasgow Institute of Architects, John Slater, F.R.I.B.A., Past President A.A., Ernest R. E. Sutton, F.R.I.B.A., Past President of the Nottingham and Derby Architectural Society, Percy B. Tyles, F.R.I.B.A., Past President, Society of Architects, Margaret E. Webb, Past President A.A.; G. P. K. Young, F.R.I.B.A., Past President of the Dundee Institute of Architects; Herbert Parker, F.R.I.B.A.; Walter Brody, F.R.I.B.A.; John Burnet, R.S.A., F.R.I.B.A., Vice-President R.I.B.A.; C. M. Arden Butler, Secretary of the Society of Architects, Basil Champneys, H. Chatfield Clarke, F.R.I.B.A., Past Vice-President R.I.B.A.; May Clarke, F.R.I.B.A.; Alfred W. S. Cross, F.R.I.B.A., Past Vice-President R.I.B.A.; Percival Curry, F.R.I.B.A., Hon. Secretary Architects; Benvenuto Scotti, G. Leonard Hingston, A.R.I.B.A.; H. M. Fletcher, F.R.I.B.A., Hon. Secretary A.A.; Walter S. A. Jackson, L.R.I.B.A.; E. Rome Guthrie, A.R.I.B.A.; T. Vincent Harris, F.R.I.B.A.; George Hubbard, F.R.I.B.A., Past Vice-President R.I.B.A.; T. G. Jackson, B.A.; A. R. Jannett, F.R.I.B.A.; Ralph Knott, F. S. Leslie, R.E. M.S.A.; Robert S. Lorimer, A.R.S.A., F.R.I.B.A.; Edwin I. Lutyens, A.R.A., F.R.I.B.A.; Tim MacAlister, Secretary R.I.B.A., Secretary of the Architects' War Committee, Ann E. Minby, F.R.I.B.A.; George H. Paine, M.S.A., Hon. Secretary of the Society of Architects; Sydney Perks, F.R.I.B.A.; Ernest T. Richmond, F.R.I.B.A.; Herbert Shepherd, A.R.I.B.A.; Alexander R. Spinning, F.R.I.B.A.; Henry Tanner, C.B., F.R.I.B.A.; Walter J. Tappin, F.R.I.B.A.; Paul Waterhouse, F.R.I.B.A., Vice-President R.I.B.A.; Thomas Wallis, M.S.A.; Wm. Woodward, F.R.I.B.A.; F. H. Wrench, L.R.I.B.A.; John E. Yerbury, L.R.I.B.A.; C. Stanley Peach, F.R.I.B.A., Hon. Secretary of the Architects' War Committee.

LEGAL INTELLIGENCE

THE REPAIR OF A COTTAGE. At Bowdler County Court on Tuesday, 11th inst. week, before the Deputy Judge (Mr. W. P. Exorslev), the case was resumed of Berne Henry Elijah Crane, painter, of Brampton, against William Smith, tenant, of Enfield. This case was first heard at the September Court. Mr. Gilbert was for the plaintiff and M. O'Connor for the defendant, who disputed a claim for £32 2s. 5d. balance account in respect to repairs to a cottage at Reddish. The plaintiff called Mr. J. O. Reed, of Bungalow, and Mr. Joseph Chapman, builder, Halesworth, to prove that his charges were for a and repairs to a cottage at Reddish. The plaintiff, Mr. J. O. Reed, of Bungalow, and Mr. Joseph Chapman, builder, Halesworth, brought charges for a and repairs to a cottage at Reddish. The plaintiff, Mr. J. O. Reed, of Bungalow, and Mr. Joseph Chapman, builder, Halesworth, brought charges for a and repairs to a cottage at Reddish.

STATUES AND MEMORIALS

MEDALLIONS IN WESTMINSTER ABBEY.—In Westminster Abbey medallions have been uncovered to perpetuate the memory of three famous scientists—Sir Joseph Hooker, Lord Lister, and Dr. Alfred Russel Wallace. The new memorials have been placed on the wall of the north aisle of the choir, beneath the organ, and the medallions which were already there have been rearranged. The bronze medallion of Charles Darwin is now at the end nearest to his last resting-place, and the fresh memorial to Dr. Russel Wallace, whose name is associated with that of Darwin in scientific work, has been placed next to it. The Wallace medallion is the work of Mr. A. Bruce Joy. Lord Lister's memorial, which is placed next to that of Dr. Wallace, was executed by Sir Thomas Brock. Other than the name, it bears no inscription. The tablet to Sir Joseph Hooker is lower on the wall, near the tomb of Lord John Thynne, below the tablet to Sir George Gabriel Stokes. The inscription is:—"Joseph Dalton Hooker, 1817-1911. Herbarium Scientia Paestantissimas." This monument is the work of Mr. Frank Bowcher.

Building Intelligence.

EDINBURGH.—The hoarding is being removed from around the front section of the Royal Dick Veterinary College buildings, in Summerhill Hope Park, of which the foundation stone was laid by the Marquis of Linlithgow, July, 1914, and this portion will be occupied after the Christmas holidays. The main buildings, which are Classic in character, form three sides of a courtyard, and in them are grouped separate departments for anatomy, chemistry, physiology, pathology, biology, materia medica, and obstetrics. Connected with the various departments there are seventeen laboratories and five lecture theatres, with adjoining preparation rooms, and a dissecting hall with accommodation for over sixty students. On the east side of the courtyard is a separate clinical department, where the practical work of the College will be carried on. In this department there are, in addition to loose boxes, stables, cow-byre, and sheep pens, five isolation and general wards for dogs and cats. The clinical block also contains two operating theatres for large and small animals respectively, "X" ray apartment, and room for pharmacy and surgical demonstrations. The college is being erected from plans by Mr. David M'Arthy, L.R.I.B.A., of Frederick Street, Edinburgh. Unfortunately, a financial crisis has arisen owing to the war, and an urgent appeal is being made for the £12,000 necessary for the completion of the building on a curtailed scale. About £50,000 has already been expended on the buildings.

WEST THURROCK HOUSING SCHEME.

—The Rural District Council of Orsett has recently built on two and a-half acres of land at West Thurrock fourteen cottages for the working classes, being half of a complete scheme of twenty-eight cottages, the building of the remaining half being postponed until the conclusion of the war. The accommodation in each case is as follows:—On the ground floor: Entrance lobby, out of which the stairs lead, living room, scullery, larder, coal store, and cupboard under stairs; on the first floor: Three bedrooms, with a cupboard over stairs. The cottages are semi-detached, each standing on a plot of land having a frontage of 26 ft. and a depth of 116 ft. The cost per cottage works out at about £175, including road, drains, and fences, but not land. After allowance for repayment of loan, insurance, repairs, empties, etc., in accordance with the Local Government Board's schedule, the cottages are self-supporting at a rental of 5s. 6d. per week each, including rates. Mr. F. J. Winter, M.S.A., of 2, Heygate Avenue, Southend-on-Sea, was the architect, and Mr. F. C. Stark, of Morris Avenue, Manor Park, the builder.

STATUES AND MEMORIALS

MEDALLIONS IN WESTMINSTER ABBEY.—In Westminster Abbey medallions have been uncovered to perpetuate the memory of three famous scientists—Sir Joseph Hooker, Lord Lister, and Dr. Alfred Russel Wallace. The new memorials have been placed on the wall of the north aisle of the choir, beneath the organ, and the medallions which were already there have been rearranged. The bronze medallion of Charles Darwin is now at the end nearest to his last resting-place, and the fresh memorial to Dr. Russel Wallace, whose name is associated with that of Darwin in scientific work, has been placed next to it. The Wallace medallion is the work of Mr. A. Bruce Joy. Lord Lister's memorial, which is placed next to that of Dr. Wallace, was executed by Sir Thomas Brock. Other than the name, it bears no inscription. The tablet to Sir Joseph Hooker is lower on the wall, near the tomb of Lord John Thynne, below the tablet to Sir George Gabriel Stokes. The inscription is:—"Joseph Dalton Hooker, 1817-1911. Herbarium Scientia Paestantissimas." This monument is the work of Mr. Frank Bowcher.

Mr. Dolan, assistant surveyor to the Roscommon Rural District Council, has resigned after fifty years' service.

Our Office Table.

An important loan exhibition of drawings, principally by artists of the British school, and almost entirely gathered from Yorkshire collections, is open at the present time in the Corporation Art Gallery, Bradford. Among the older British school, such men as Rowlandson, Romney, Gainsborough, Lawrence, Blake, Cotman, and Constable are represented. There is an even larger and more varied collection of modern work, which includes examples by Messrs. John, Rothenstein, Bone, Cameron, Strang, Clausen, and many others. Drawings by such Victorians as Ruskin, Madox Brown, and Alfred Stevens, and a few studies by important French artists like Puvion de Chavannes and Daubigny are also shown.

The urban district council of Frome received at their last meeting a suggestive report by Mr. F. W. Jones, their surveyor, on the question of true economy in road maintenance, which deserves a wider circulation than the governing body of that flourishing little Somersetshire town. Mr. Jones remarked that it was only fair to everyone concerned to realise that a wrong interpretation might be put on the word economy. Some people might think that a rigid cutting down of the stone allowance was economy, because, for the time, the stone bill was reduced. Such a policy, if carried too far, would only end in the ratepayers having to face a quadrupled expenditure. For if surface crusts were to be allowed to be worn through, the expense of renewing the sub-structure of the road must be enormously greater than the mere maintenance of the surface. And it was not to be forgotten that for transit purposes the roads to-day were being increasingly used to relieve the congested state of the railways, and it was important that the main arteries, at least, should be kept up to bear this increased traffic.

The damage done to the Church of Santa Maria in Nazaret (commonly called the "Church of the Scalzi"), in Venice, during the recent Austrian air raid appears to be irreparable. The architecture is of the Late Renaissance period. The chief artistic value of the church lay in the vault fresco by Tiepolo, which has been almost completely destroyed. The fresco was of the same period as the famous picture of the Carmine (1743-44). It represented the Virgin expelling the heresies from her house. Round about the Madonna, both above and below, were groups of angels. The fresco covered the entire vault of the nave. The bomb fell on the apex of the nave, bringing down almost the whole vault. Only fragments of the fresco remain on the parts of the vaulting which springs from the pillars. The rest lies in fragments on the floor of the church. Experts who have visited the church say that there can be no question of restoring the fresco.

We heartily endorse the Bishop of Worcester's sensible remarks as to the extravagant size of many memorials in our churches, in the current number of the *Worcester Diocesan Magazine*. The Bishop thinks that, in view of the sad fact that the war is likely to add greatly to the number of our tributes to the dead, it would be well that the clergy should make an effort to get the size of tablets and brasses reduced. "A small memorial in a church," says the Bishop, "has in it a beautiful idea, but large and pretentious monuments, which tend to occupy wall space and exclude poorer neighbours, are not suitable for the House of God. If this were pointed out to the relatives of the dead I am sure they would see the force of it, but, failing that, it might be possible that faculties should insist upon tablets of smaller dimensions."

The number of dwelling-houses certified as fit for human habitation in Manchester for the year ending October 31 is 415. This compared with 748 last year, 997 in 1913, 1,283 in 1912, 1,578 in 1911, 2,254 in 1910, and 2,344 in 1909. Divided into districts

the returns for this year show that 214 houses have been built in the Withington district, fifty-nine in Moston, forty-five in Rusholme, twenty-two in Levenshulme, twenty in Openshaw, sixteen in Crumpsall, thirteen in Clayton, eight in Cheetham, six in Newton Heath, five in Blackley, and one each in Moss Side and Ancoats. For many years Withington has headed the list. During the last seven years no fewer than 3,360 houses have been built in that district. Rusholme, Moston, Blackley, Cheetham, and Openshaw, generally in the order named, come next, but all the six districts show a great falling off in the last two or three years.

Second Lieutenant Charles Emerson Clouting, A.R.I.B.A. (of Sevenoaks), 1st Bat. Buffs (East Kent Regiment) has been awarded the Military Cross for conspicuous gallantry on the night of September 21, 1915, near Forward Cottage, when on patrol duty with Captain Colville, 1st Shropshire L.I. Capt. Colville was shot within fifteen yards of the German sap which they were reconnoitring, and, although Second Lieutenant Clouting endeavoured to drag him back, he was unable to do so. It was uncertain whether Captain Colville was still alive, and, after the return of the patrol, a rescue party was led back by Second Lieutenant Clouting. He found Captain Colville dead, and, recognising that numbers would be a source of danger, he sent all his party back except Sergeant Baker. These two crawled back under heavy fire, dragging the body with them. There was bright moonlight at the time.

The general report of the Survey of India for the year comprised between October 1, 1913, and September 30, 1914, has just been published. For topographical work a programme had been drawn up in 1905, comprising 1,821,600 square miles; of this, 356,244 square miles have been completed in the ten years, and 1,455,356 square miles remain to be completed. During the year under report 54,359 square miles have been completed at a cost of Rupees 14,48,508, being at an average rate of Rupees 26.6 per square mile. The work was done in three circles, designated respectively the Northern, Southern, and Eastern, and their rate costs, respectively, were Rupees 13.2, Rupees 27.2, and Rupees 39.5. Rate cost for the Eastern circle was naturally high as it included much inaccessible and otherwise difficult country in Assam and Burma. All the forest surveys were also carried out by topographical parties, the majority on a scale of two inches to the mile, some on the one-inch scale, and forest boundaries on the scale of four inches to the mile. Captains Bailey and Morshed of the Survey of India, after a six months' exploration of the Upper Brahmaputra, returned in November, 1913, confirming the belief that the Tsun-po and Brahmaputra are the same river. They have correctly located the great southerly bend in the course of the river, placing it about sixty miles further east than it was supposed to be, and also definitely establishing the fact suggested by Sir S. Burrard that the great Namcha Barwa Peak, 25,445 ft. high, lies in this bend. These two officers have succeeded in making a reconnaissance of 16,000 square miles of hitherto unknown country.

The Wallpaper Manufacturers Company paid 8 per cent. per annum on its ordinary shares for the nine years to 1906-7, but after that the dividend dropped to 4 per cent. Then for five years it stood at 5 per cent., but for 1913-14 it fell to 2 per cent., which was an interim distribution. Now the ordinary dividend ceases for the time being, and the preference dividend can only be paid by reducing the balance forward. The company has a debentured share capital of £1,095,621, but as this only takes the residue when the ordinary shares have had 10 per cent. paid on them, apparently it has yielded nothing in all the years named.

The rural district council of Crowland are about to construct a new road across Crowland Common to connect the north end of Renow's Drive with the road to Littleworth Station. The necessary land has been given by the owners, and the route is now staked out.

CHIPS.

Mr. John E. Dwyer, M.R.S.A., has been elected Master of the Grovers' Company.

Mr. D. Roberts, borough surveyor, has reported to the Lewes Town Council that the repair of the sewage culvert at Winterbourne has been completed at a total cost of £1,650.

Mr. A. P. Horsley, borough engineer of Hartlepool, has been appointed surveyor and architect to the Education Authority, and has had his salary increased by £50 per annum.

The Corporation of Leeds have received the sanction of the Local Government Board to prepare a town-planning scheme for the suburb of Gledhow over an area of 852 acres.

The new mission church at Charlburgh, designed by Mr. John Begg, F.R.I.B.A., consulting architect to the Government of India, was dedicated by the Bishop of Lucknow on October 15.

At Cardiff, on Monday, a Local Government Board inquiry was held by Mr. W. O. E. Meade King into an application of the council for leave to borrow £5,300 for the purposes of the fire brigade.

A new Wesleyan Church, on the Leek Road, Bottonhouse, Staffs., was opened last week. The architect was Mr. R. T. Longdon, of Leek, and the builders Messrs. J. Fielding and Sons, Alton.

Mr. Robert Wylie, architect and surveyor, Lord Street, Liverpool, died last week, at the age of eighty-one. He was for many years the Deputy Provincial Grand Master of Freemasons in South-West Lancashire.

It is proposed to build on the site of the rink in Westgate Street, Cardiff, a public hall seated for 4,000 persons. The architects to the syndicate are Messrs. Willmott and Smith, of St. Mary Street, Cardiff.

A new Primitive Methodist church and schools are about to be built at Salsbury from plans by Messrs. George Barnes and Son, of Clements Inn, Strand, W.C. The contract has been taken at £3,017 by Mr. J. Nichol.

Mr. W. C. Percy has been appointed borough engineer and surveyor of Burrow-in-Furness for a period of twelve months, in succession to Mr. Arthur Race, who has secured the borough surveyorship of Blackburn.

The late Mr. Thomas John Thompson, of Peterborough, senior member of the firm of John Thompson and Co., church builders and restorers, and son of the late Mr. John Thompson, J.P., left net personality £3,743—gross £10,697.

The eighteenth list of Members, Licentiates and Students of the Royal Institute of British Architects who have joined the Army or Navy for the period of the war gives a total to date of 45 Fellows, 345 Associates, 130 Licentiates, and 226 Students.

The death has occurred at Eastgate Seafood, of Mr. W. H. Maxey, builder and contractor, in his eighty-first year. He had carried on many church restorations in the district. Mr. Maxey, who was a widower, leaves two sons and three daughters.

A new decorative fresco, the gift of Sir Frederick Green, has been placed in one of the vacant panels at the Royal Exchange. The subject is "The Charter of Philip the Good of Burgundy," and the artist is Mr. E. A. Cox, formerly in the studio of Mr. Frank Brangwyn, R.A.

Lieutenant William Brian Mortimer, 2nd Durham Light Infantry, of The Debdale, Finedon, Wellingborough, artificial stone manufacturer, who was killed in Flanders on June 13, aged 39, second son of the late William B. Mortimer, of Hay Carr, Lancaster, left personality amounting to £24,500.

The Roman Catholic Church of the Most Sacred Sacrament and St. James in Copendagen Street, West 13-lington, of which the foundation stone was laid last week by Cardinal Bourne, is being built from plans by Mr. Robert L. Curtis. The building is in simple Romanesque style, and comprises a parish hall in the half basement, with the church immediately above, providing accommodation for about 250. The planning allows for a future extension. The church plan is a nave without aisles. The main façade is of purple bricks, with red-brick arches and dressings, and the roof is of red tiles. Artificial lighting will be by electricity, and the heating by radiators. The buildings are being erected by Messrs. E. Lawrence and Sons.

TO CORRESPONDENTS.

We do not hold ourselves responsible for the opinions of our correspondents. All communications should be drawn up as briefly as possible, as there are many claimants upon the space allotted to correspondents.

It is particularly requested that all drawings and all communications respecting illustrations or literary matter, books for review, etc., should be addressed to the Editor of the BUILDING NEWS, Elingham House, 1, Arundel Street, Strand, W.C., and not to members of the staff by name. Delay is not infrequently otherwise caused. All drawings and other communications are sent at contributors' risks, and the Editor will not undertake to pay for, or be liable for, unsought contributions.

*Drawings of selected competition designs, important public and private buildings, details of old and new work, and good sketches are always welcome, and for such no charge is made for insertion. Of more commonplace subjects, small churches, chapels, houses, etc., we have usually far more sent than we can insert, but are glad to do so when space permits, on mutually advantageous terms, which may be ascertained on application.

When favouring us with drawings or photographs, architects are asked kindly to state how long the building has been erected. It does neither them nor us much good to illustrate buildings which have been some time executed, except under special circumstances.

Telephone: Gerrard 1291.

Telegrams: "Timeserver, Estrand, London."

NOTICE.

Bound copies of Vol. CVIII. are now ready, and should be ordered early (price 12s. each, by post 12s. 9d.), as only a limited number are done up. A few bound volumes of Vols. XXXIX., XLI., XLVI., XLVII., LHI., LXL., LXII., LXIV., LXV., LXVI., LXVII., LXVIII., LXIX., LXXI., LXXII., LXXIII., LXXIII., LXXIV., LXXV., LXXVI., LXXVII., LXXIX., LXXX., LXXXI., LXXXII., LXXXIII., LXXXIV., LXXXV., LXXXVI., LXXXVII., LXXXVIII., LXXXIX., XC., XCI., XCII., XCIII., XCIV., XCV., XCVI., XCVII., XCVIII., XCIX., C., CI., CII., CIII., CIV., CV., CVI., and CVII. may still be obtained at the same price; all the other bound volumes are out of print. Most of the back numbers of former volumes are, however, to be had singly. Subscribers requiring any back numbers to complete volume just ended should order at once, as many of them soon run out of print.

Handsome Cloth Cases for binding the BUILDING NEWS, price 2s., post free 2s. 4d., can be obtained from any Newsagent, or from the Publisher, Elingham House, 1, Arundel-street, Strand, W.C.

TERMS OF SUBSCRIPTION.

One Pound per annum (post free) to any part of the United Kingdom; for the United States, £1 6s. 0d. (or 6dols. 30c. gold). To France or Belgium, £1 6s. 0d. (or 33s. 30c.). To India, £1 6s. 0d. To any of the Australian Colonies or New Zealand, to the Cape, the West Indies, or Natal, £1 6s. 0d.

*Our Direct Subscription Agents for Australia are Messrs. E. T. Kibblewhite and Co., Printers and Publishers, 19, York Chambers, 105, Liverpool Street, Sydney, New South Wales; for Japan, The Maruzen Co., Ltd., 11-16, Niombashi Tori Sanchoe, Tokyo, who will receive subscriptions at £1 6s. 0d. per annum on our account. Copies of the paper will be sent by us direct to the subscribers' address.

*The special rate to Canada is £1 3s. 10d. = 5dols. 80c. for 12 months, and 11s. 11d. = 2dols. 90c. for six months. Our Direct Subscription Agents for Canada are Messrs. Selis, Ltd., 302, Slaughtnessy Buildings, McGill Street, Montreal, who will receive subscriptions, £1 3s. 10d. per annum, on our account.

Cheques and Post-office Orders to be made payable to THE STRAND NEWSPAPER COMPANY, LIMITED, and crossed London County and Westminster Bank.

ADVERTISEMENT CHARGES.

The charge for Competition and Contract Advertisements, Public Companies, and all official advertisements is 1s. per line of Eight Words, the first line counting as two, the minimum charge being 5s. for four lines.

The charge for Auctions, Land Sales, and Miscellaneous and Trade Advertisements (except Situation Advertisements) is 6d. per line of Eight Words (the first line counting as two), the minimum charge being 4s. 6d. for 50 words. Special terms for series of six insertions or more can be ascertained on application to the Publisher.

SITUATIONS VACANT AND PARTNERSHIPS.

The charge for advertisements for "Situations Vacant" and "Partnerships" is One Shilling for Twenty-four Words, and Sixpence for every Eight Words after. All Situation Advertisements must be prepaid.

SITUATIONS WANTED.

Advertisements not exceeding Thirty Words, inclusive of name and address, are inserted under the heading "Situations Wanted," free of charge.

Rates for Trade Advertisements on front page and special and other positions can be obtained on application to the Publisher.

REPLIES TO ADVERTISEMENTS.

Replies to advertisements can be received at the office, Elingham House, 1, Arundel Street, Strand, W.C., free of charge. If to be forwarded under cover to advertiser, an extra charge of Sixpence is made. (See Notice at head of "Situations.")

Advertisements for the current week must reach the office not later than 3 p.m. on Tuesday. Front-

page advertisements and alterations or stop orders for serial advertisements must reach the office by first post on Monday to secure attention.

- A. C. Co.—G. R. and Son.—T. S.—G. and Son.—W. C. Co., Ltd.—V. de T. Co., Ltd.—T. and R. B., Ltd.—E. F. B. and Co.—E. and R., Ltd.—C. C. D. and Co.—D. and Co., Ltd.—R. I. C. and Co., Ltd.—W. and Co.—B. Bros.—P. C. Co., Ltd.—R. C. C. and Co., Ltd.—L. and R. J. and Co.—W. and O., Ltd.—I. and Son.—B. P. C. Co., Ltd.—R. B. and Son.—W. O. and Son.—J. M. and Son.—D. and Co.

VERBA.—Yes. J. L. A.—Please send. C. G. G.—We know nothing of them. STUDENT.—See our notice last week on p. 496.

TO ARMS!

4th Battalion ("Architects") Central London Regiment Volunteers.

Recruits are urgently needed for the Regulars, Territorials, and Volunteers. Intending recruits should apply to Battalion Headquarters, where they will be advised as to the branch of the service for which they are best suited.

ORDERS FOR THE WEEK BY LIEUT.-COL. A. W. WARDEN.

GENERAL PARADES.

There will be no General Parade on Saturday, 13th inst. Saturday, 20th inst., Uniform Parade at Chester House, 3 p.m.

NEW HEADQUARTERS.—OPENING MEETING. 24th inst., 7 p.m. All members are particularly requested to attend.

Working parties are still required every evening up till 7 o'clock and on Saturday.

ENTRENCHING PARADE.

Sunday next, 14th inst., at Victoria Station, L.B. and S.C., Railway Indicator Board, 8.55 a.m. sharp. Uniform, haversacks, and water-bottles. Mid-day rations to be carried. Return to town about 6.40. Railway vouchers will be provided and special trains will be run by the railway company.

DRILLS AND PARADES.

"A" Company, Tuesdays, miniature range, Gas Light and Coke Co.'s premises, Monck Street, Westminster, 5 to 8.30 p.m.

Wednesdays, Company Parades for drill and technical instruction, 5.15 to 7.15 and 6.15 to 8.15, at Chester House.

Thursdays, Signalling at Chester House, 6 p.m.

"B" Company, miniature range and company Parades as for "A" Company. See orders at local headquarters.

"C" Company. See orders local headquarters, Parkton A.A. Athletic Ground, Boreham Wood.

"D" Company.—Platoon and Section Drill at Chester House, Tuesdays and Thursdays, 6.45 p.m. Company Parades, for drill and technical instruction, Wednesdays, as for "A" Company.

SCHOOL OF ARMS.

Drill Headquarters, Chester House.—Instruction in bayonet fighting, Gymnastics, physical drill, boxing, and single sticks on Tuesdays from 6 to 8 p.m.

RECRUIT DRILLS.

"A" and "B" Companies.—Chester House, 6.15 to 7.15 and 7.15 to 8.15 Mondays and Fridays.

"C" Company.—Boreham Wood and Elstree District Headquarters, A.A. Athletic Ground, Boreham Wood. For full particulars apply to Alan Potter, Grey Gables, Boreham Wood, Herts.

"D" Company.—Chester House, Tuesdays and Thursdays, 6.45 p.m.

Note.—For the present the School of Arms and Recruit Drills will be held jointly with the Engineering Institutions Y.T.C.

By Order,

L. R. GUTHRIE, Adjutant. BATTALION HEADQUARTERS, 18, TUFTON STREET, WESTMINSTER, S.W.

MEETINGS FOR THE ENSUING WEEK.

WEDNESDAY.—Chadwick Lecture. "Emergency Military Hospital Construction," by A. Saxon Snell, F.R.I.B.A., Royal Society of Medicine, 1, Wimpole Street, W., 5.15 p.m.

Manchester Society of Architects. "Athens and Some of the Isles of Greece," by J. B. Gass, F.R.I.B.A., 6.20 p.m.

THURSDAY.—Christmas Fair, Architects' Committee, 9, Conduit Street, W., 4.30 p.m. Society of Architects, Members' Meeting for election of new members, 28, Bedford Square, 6 p.m. Auctioneers and Estate Agents' Institute. "War Risks to Property," by Sydney A. Smith, F.A.I., 34, Russell Square, W.C., 5 p.m.

FRIEDAY (Nov. 16). Institution of Civil Engineers. "The Punjab Triple Canal System," by Sir John Benton, K.C.I.E., M.I.C.E., 5.30 p.m.

WEDNESDAY (Nov. 17). Chadwick Lecture. "Some Conclusions on Housing Our Workers," by W. E. Riley, F.R.I.B.A., Royal Sanitary Institute, 8.15 p.m. St. Paul's Eccelesiastical Society. "Anchorite Cells," by Arthur D. Sharp, St. Paul's Chapter House, E.C., 8 p.m.

SAURDAY (Nov. 19). Glasgow Architectural Craftsmen's Society. "Wind Bracing for High Office Buildings," by George Maitby, 8 p.m.

...being built at Buncleoly, ... It is of stone, 30 ft. by 26 ft. ... Mr. Patrick Armstrong, of ...

...T. S. Phipps, M.A., F.R.I.B.A., ... of Fine Art at Cambridge, ... Tuesday afternoon the ... of Hermione lectures on "The ... of the Flemish Arts," at Alex. ... Dublin.

...The Boreas Docks Committee have authorized Mr. McKinnon, their engineer, to carry out the renewal of the foundation of the Boreas warehouse, east side, Avonmouth ... to provide an additional fire ... wharf, Portishead Dock.

...A ... being carried out at the head ... Provincial Bank, Royal Avenue, ... Architects, are Messrs. Watt, ... Fensimens, Wellington Place, and ... being carried out by Messrs. W. J. ... and Son, Ravenhill Road, also ...

...Mr. G. E. Matthews, surveyor, of Spalding, ... of the South Holland Drainage ... of Crowland and Cowbit ... given a captivity in ... Companies of the Royal ... of a score of drainage men from ... district have joined the companies. They will be sent early to France to ...

...Messrs. Gash and Co., of Capenhurst, the ... new workhouse infirmary ... Wednesday handed over to the ... of Guardians ... new building, which has just ... The members of the board ... thanks to the contractor, the ... Mr. Roberts, Mold, and Mr. Parry, ...

...The ... disposal works for the urban ... of Bingley, near Bradford, ... by Mr. H. ... the council's surveyor. They consist of ... to the existing sewage works ... The contractors were Messrs. ... of Bradford, and the outlay ... making a total expenditure on ... sewage disposal by the urban ... of £37,550.

...At ... of Guild Court plans ... for the erection at Rosyth of a ... 1,000 pupils, ... of about £20,000. It was ... that the building plans were ... a drainage plan, and a letter ... from the Scottish National Housing ... to the school ... to their ground at Rosyth. ... was adjourned in order that the ... of drainage might be settled.

...Among the wounded in action in the latest ... at ... A Ducks (son of the ... of the R.I.B.A., 9, Conduit Street, ... the 4th London Regiment, who is ... the ... severely; he is ... in England, and progressing ... Also, Major Charles Richard ... of the 4th Royal ... Arnold, Sibcock, ... of the 2nd South ... Regiment, formerly in the ... Rifles, ... at Smoolby, Knowle, ... good progress.

...On the ... of the Improvements ... Committee, the City Corporation ... The ... from the Queen ... Company, Limited, to ... and buildings of 51, 53, ... and 64, Leadenhall ... for 99 years at a rental ... The Court also ... City of London Real ... Limited to purchase ... and buildings of ... Leadenhall Street, and 3, 4, ... for £16,500.

...The ... at St. Fin Barre's ... has been built ... of ... W. ... A.R.A., the ... By Mr. W. H. Hill, ... under whose ... by Messrs. ... of ... with ... of ... of wrought ... The walls are ...

LATEST PRICES.

N.B.—All prices must be regarded as merely approximate for the present, as our usual sources of information are in many cases failing us.

TIMBER.

Owing to stoppage of supplies all prices have advanced considerably.

IRON.		Per ton.	Per ton.
Rolled Steel Joists, English.	£14 0 0	to	£15 0 0
Compound Girders, Ordinary Sections.	16 10 0	to	17 10 0
Wrought-Iron Girder Plates.	13 10 0	to	13 12 6
Steel Girder Plates.	13 15 0	to	13 17 6
Steel Sheets (Single or Double).	11 10 0	to	—
Steel Strip.	10 15 0	to	—
Basic Bars.	11 15 0	to	—
Bar Iron, good Staffs.	13 10 0	to	13 15 0
Do., Lowmoor, Flat, Round, or Square.	24 0 0	to	—
Do., Staffordshire Crown.	14 0 0	to	14 10 0
Boiler Plates, Iron—			
South Staffs.	8 0 0	to	8 15 0
Best Sneedhill.	9 0 0	to	9 10 0
2 1/2" x 1/2" Angles, 10s., Tees 20s., per ton extra.			
Builders' Hoop Iron, for bonding, £13 5s. to £13 15s.			
Do., Ditto galvanized, £20 to £20 10s. per ton.			
Galvanized Corrugated Sheet Iron—			
No. 18 to 20. No. 22 to 24.			
6ft. to 8ft. long, inclusive.	Per ton.	Per ton.	
gauge.	£20 0 0	to	£20 10 0
Best ditto.	2 10 0	to	21 0 0
	Per ton.	Per ton.	
Cast-Iron Columns.	£7 7 6	to	£9 0 0
Cast-Iron Stanchions.	7 7 6	to	9 0 0
Rolled-Iron Fencing Wire.	8 15 0	to	9 5 0
Rolled-Steel Fencing Wire.	7 15 0	to	8 0 0
Galvanized Wire Strand, 7 ply.	6 5 0	to	6 15 0
Cast-Iron Sash Weights.	6 5 0	to	6 15 0
Cat Floor Brads.	15 0 0	to	15 5 0
Corrugated Iron, 24 gauge.	16 0 0	to	—
Galvanized Wire Strand, 7 ply.	14 5 0	to	—
B.B. Drawn Telegraph Wire, Galvanized—			
0 to 8.	9	10	11
10 to 15.	£11 0s.	£11 5s.	£11 15s.
Cast-Iron Socket Pipes—			
3 in. diameter.	£7 5 0	to	£7 12 6
4 in. to 6 in.	7 0 0	to	7 2 6
7 in. to 24 in. (all sizes).	7 7 6	to	7 12 6
[Coated with composition, 5s. Od. per ton extra.			
Turned and bored joints, 5s. per ton extra.]			
Iron—		Per ton.	
Cold Blast, Lillieshall.	157s. 6d.	to	142s. 6d.
Hot Blast, ditto.	100s. 0d.	to	107s. 0d.
Wrought-Iron Tubes and Fittings—Discount off Standard Lists f.o.b. (plus 2 1/2 per cent.)—			
Gas-Tubes.	6 1 1/2	pc.	
Water-Tubes.	5 7 1/2	"	
Steam-Tubes.	5 3 1/2	"	
Galvanized Gas-Tubes.	5 0	"	
Galvanized Water-Tubes.	4 7 1/2	"	
Galvanized Steam-Tubes.	4 0	"	

OTHER METALS.

	Per ton.	Per ton.	
Lead Water Pipe, Town.	£31 10 0	to	—
" Country.	32 10 0	to	—
Lead Barrel Pipe, Town.	32 10 0	to	—
" Country.	33 10 0	to	—
Lead Pipe, tinned inside, Town.	33 10 0	to	—
" Country.	34 10 0	to	—
Lead Pipe, tinned inside and outside.	36 0 0	to	—
" Country.	37 0 0	to	—
Composition Gas-Pipe, Town.	34 10 0	to	—
" Country.	35 10 0	to	—
Lead Soil-pipe (up to 4 1/2 in.) Town.	34 10 0	to	—
" Country.	35 10 0	to	—
" [Over 4 1/2 in. £1 per ton extra.]			
Lead, Common Brands.	17 17 6	to	18 12 6
Lead, 4lb. sheet, English.	32 0 0	to	—
Lead Shot, in 28lb. bags.	24 15 0	to	—
Copper sheets, sheathing & rods.	103 0 0	to	104 0 0
Copper, British Cake and Ingot.	88 0 0	to	89 0 0
Tin, English Ingots.	156 10 0	to	157 0 0
Do., Bars.	157 10 0	to	158 10 0
Pig Lead, in lwt. Pigs, Town.	23 12 6	to	24 12 6
Sheet Lead, Town.	31 0 0	to	—
" Country.	32 0 0	to	—
Genuine White Lead.	38 10 0	to	—
Refined Red Lead.	38 0 0	to	—
Sheet Zinc.	110 0 0	to	—
Old Lead, against account.	22 0 0	to	—
Tin.	9 0 0	to	—
Cut nails (per cwt. basis, ordinary brand).	0 16 0	to	—
* For 5 cwt. lots and upwards.			

I BUY SCRAP METALS

ARTHUR P. COLLINS, Snow Hill, BIRMINGHAM.
 Phone: Central 1924. Telegrams: "Methers, Birmingham"
 Bankers: The National Provincial Bank of England, Ltd., Bennett's Hill, Birmingham.

SLATES.

	in.	n.	£ s. d.	per 1,000 of
Blue Portmadoc.	20	10	12 6	1,200 at r. sto.
"	16	8	6 12 6	"
Blue Bangor.	20	10	11 0	"
"	20	12	11 7 6	"
First quality.	20	10	11 0	"
"	20	12	10 12 6	"
"	16	8	5 10 0	"

	in.	in.	£ s. d.	per 1,000 of
Eureka unfading green.	20	10	15 17 6	1,200 at r. sto.
"	20	12	18 7 6	"
"	18	10	13 5 0	"
"	16	8	10 5 0	"
Permanent Green.	20	10	11 12 6	"
"	18	10	9 12 6	"
"	16	8	6 12 6	"

BRICKS.

(All prices net.)			
	£	s.	d.
First Hard Stocks.	22 0 0	to	per 1,000 alongside, in
Second Hard Stocks.	16 0 0	to	river.
Mild Stocks.	14 0 0	to	"
Picked Stocks for Facings.	2 15 0	to	delivered at
Flettons.	1 16 0	to	raily station.
Pressed Wire Cuts.	1 13 0	to	"
Red Wire Cuts.	1 14 0	to	"
Best Farcham Red.	3 12 0	to	"
Best R d Pressed Ruabon Facing.	5 0 0	to	"
Best Blue Pressed Staffordshire.	3 15 0	to	"
Ditto Bullnose.	4 0 0	to	"
Best Stourbridge Fire-bricks.	4 0 0	to	"
2 1/2 in. Best Red Ac-crington Plastic Facing Bricks.	4 10 6	to	Net, delivered in
			full truck loads
			in London.
			Per 1,000
3 1/2" Accrington Best Red Plastic Facing Bricks.	£2 10 0	to	
3 1/2" ditto Second Best Plastic ditto.	2 2 6	to	
3 1/2" ditto Ordinary Secondary Bricks.	1 11 3	to	
3 1/2" ditto Plastic Engineering Bricks.	1 17 6	to	
Sewer Arch Brick, not more than 3 1/2 in. thickest part.	2 0 0	to	
3 1/2" Chimney Bricks fit for outside work.	2 6 0	to	
3 1/2" ditto ditto through and through.	2 0 0	to	
3 1/2" Beaded, Ovolo and Bevel Jamb; Octa-gons; 2 1/2" and 3 1/2" radius Bullnoses; Stock patterns.	3 7 6	to	
Accrington Air Bricks, 3" x 2 course deep, each	0 0 6	to	
Ditto ditto 3" x 1 course deep.	0 0 3	to	
Accrington Chamber Arches—			
3 course deep 4 1/2" soffit, per foot opening.	0 1 3	to	
4 " 4 1/2" " " " " " "	0 1 8	to	
5 " 4 1/2" " " " " " "	0 2 1	to	
6 " 4 1/2" " " " " " "	0 2 6	to	
4 " 3" " " " " " "	0 2 1	to	
5 " 3" " " " " " "	0 2 11	to	
6 " 3" " " " " " "	0 3 6	to	
6 " 3" " " " " " "	0 4 6	to	
Net free on rail, or free on boat at works.			

GLAZED BRICKS.

HARD GLAZES (PER 1,000).			
	White, Ivory, and Salt Glazed.	Buff, Cream, Other Best. Second.	Best. Second.
Stretchers—	£12 7 6	£11 7 6	£13 17 6
Headers—	11 17 6	10 17 6	13 7 6
Quoins, Bullnose, and 4 1/2 in. Flats—	15 17 6	14 17 6	17 17 6
Double Stretchers—	17 17 6	16 17 6	20 17 6
Double Headers—	14 17 6	13 17 6	17 17 6
One side and two ends, square—	18 17 6	17 17 6	21 17 6
Two sides and one end, square—	19 17 6	18 17 6	22 17 6
Splays and Squints—	17 7 6	16 7 6	21 17 6
Plinth and Hollow Bricks, Stretchers and Headers—	5d. each	4d. each	6d. each
Double Bullnose, Round Ends, Bullnose Stops—	5d. each	4d. each	6d. each
Rounded Internal Angles—	4d. each	3d. each	5d. each

MOULD BRICKS.

Moulded Bricks.			
	8d. each	8d. each	8d. each
Internal and External Angles—	1/2 each	1/2 each	1/2 each
Sill Bullnose, Stretchers, and Headers—	5d. each	4d. each	6d. each
Majolica or Soft Glazed Stretchers and Headers.	£22 17 6	to	£27 17 6
Compass bricks, circular and arch bricks of single radius 4 1/2 per 1,000 over above list for their respective kinds and colours.	Not exceeding 9 in. by 4 1/2 in. by 2 1/2 in.	to	—
Camber arch bricks, any kind or colour.	—	to	—
Stretchers cut for Closers and Nicked Double Headers, £1 per 1,000 extra.	—	to	—
These prices are carriage paid in full truck loads to London Stations.	s. d.	to	Per ton.
Thames Sand.	7 6	to	per yard, delivered.
Pit Sand.	7 0	to	"
Thames Ballast.	6 0	to	"
Best Portland Cement.	36 0	to	41 0
Ground Blue Lias Lime.	21 0	to	per ton, delivered.
Exclusive of charge for sacks.			
Grey Stone Lime.	13 6	to	14 0
Stourbridge Fireclay in sacks 27s. Od. per ton at railway station.			

STONE.

	per foot cube	£	s.	d.
Red Mansfield, in blocks.	£0 2 4	to	—	—
Darley Dale, ditto.	0 2 6	to	—	—
Red Corsehill, ditto.	0 2 6	to	—	—
Cloeburn Red Freestone, ditto.	0 2 2	to	—	—
Ancester, ditto.	0 1 11	to	—	—
Greenshill, ditto.	0 2 0	to	—	—
Beer, ditto.	0 1 7 1/2	to	—	—
Chilmark, ditto (in truck at Nine Elms).	0 1 10 1/2	to	—	—
Hard York, ditto.	0 2 0	to	—	—
Do. do. 6 in. sawn both sides, landings, random sizes.	per foot sup.	0 2 8	to	—
Do. do. 3 in. slab sawn two sides, random sizes.	"	0 1 3	to	—
* All F.O.R. London.				

	£	s.	d.
Bath Stone—Delivered in railway trucks at Westbourne Park, Paddington (G.W.R.), or South Lambeth (G.W.R.) per foot cube.	0	1	7 1/2
Delivered in railway trucks at Nine Elms (L. & S.W.R.)	0	1	8 1/2
Delivered on road waggon at Nine Elms Depot.	0	1	9 1/2
Portland Stone—Brown Whit-bed in random blocks of 20 ft. average, delivered in railway trucks at Westbourne Park (G.W.R.), South Lambeth (G.W.R.), or Nine Elms (L. & S.W.R.)	0	4	5 1/2
Delivered on road waggon at Pimlico Wharf or Nine Elms Depot.	0	2	6 1/2
White Basebed—2d. per foot cube extra.			

TILES.

	s.	d.	Divrd. at
Plain red roofing tiles.	42 0	per 1,000	ry. sn.
Hip and Valley tiles.	3 7	per doz.	"
Brosely tiles.	50 0	per 1,000	"
Ornamental tiles.	52 6	per doz.	"
Hip and Valley tiles.	4 0	per doz.	"
Ruabon Red, brown, or brindled ditto (Edwards).	57 6	per 1,000	"
Ornamental ditto.	60 0	per doz.	"
Hip tiles.	4 0	per doz.	"
Valley tiles.	3 0	per doz.	"
Selected "Perfecta" roofing tiles: Plain tiles (Peake's).	46 0	per 1,000	"
Ornamental ditto.	48 6	per doz.	"
Hip tiles.	3 10 1/2	per doz.	"
Valley tiles.	3 4 1/2	per doz.	"
"Rosemary" brand plain tiles.	48 0	per 1,000	"
Ornamental tiles.	50 0	per doz.	"
Hip tiles.	4 0	per doz.	"
Valley tiles.	3 8	per doz.	"
Staffordshire (Hanley) Reds or brindled tiles.	42 6	per 1,000	"
Hand-made sand-faced.	45 0	per doz.	"
Hip tiles.	4 0	per doz.	"
Valley tiles.	3 6	per doz.	"
"Hartshill" brand plain tiles, sand-faced.	45 0	per 1,000	"
Pressed.	42 6	per doz.	"
Ornamental ditto.	47 6	per doz.	"
Hip tiles.	4 0	per doz.	"
Valley tiles.	3 6	per doz.	"

OILS.

	per ton	£	s.	d.
Rapeseed, English pale,	£28 15 0	to	£29 5 0	
Ditto, brown.	26 15 0	to	27 5 0	
Cottonseed, refined.	29 0 0	to	30 0 0	
Olive, Spanish.	39 10 0	to	40 0 0	
Seal, pale.	21 0 0	to	21 10 0	
Cocunut, Cochon.	46 0 0	to	46 10 0	
Ditto, Ceylon.	42 10 0	to	43 0 0	
Ditto, Mauritius.	32 5 0	to	33 5 0	
Palm, Lagos.	35 0 0	to	35 10 0	
Ditto, Nut Kernel.	17 5 0	to	19 5 0	
Oleine.	30 0 0	to	31 0 0	
Sperma.	0 7 0	to	0 8 0	
Lubricating, U.S.A. per gal.	0 6 3	to	0 6 6	
Petroleum, refined.	1 6 0	to	1 10 0	
Tar, Stockholm, per barrel.	0 19 6	to	1 0 0	
Ditto, Archangel.	0 3 1	to	—	
Linseed Oil.	0 3 4	to	—	
Baltic Oil.	0 3 8	to	—	
Turpentine.	0 3 8	to	—	
Putty (Genuine Linseed Oil).	0 9 6	to	—	
Pure Linseed Oil.	0 9 0	to	—	
"Stority				

OGILVIE & CO.

Mildmay Avenue, ISLINGTON, N. EXPERTS in HIGH-CLASS JOINERY. ALTERATIONS & DECORATIONS.

FOR Olivers' Seasoned Hardwoods,

WM. OLIVER & SONS, Ltd., 120, Bunhill Row, London, E.C.

TENDERS.

For alterations in all cases oblige by... accepted tender, it adds to the value of the material.

For... accepted.

For... accepted.

For... accepted.

For... accepted.

For... accepted.

For... accepted.

For... accepted.

For... accepted.

For... accepted.

For... accepted.

For... accepted.

For... accepted.

For... accepted.

For... accepted.

For... accepted.

For... accepted.

For... accepted.

For... accepted.

For... accepted.

For... accepted.

CROSSNESS, S.E.—For electric fittings and wiring... London County Council. Pearson, R.H. and J., Ltd., Notting Hill Gate, W. 4140 0 0. Toole and Mann, Ltd., Victoria Street, S.W. 13 0 0. Catcott, C.H. and Co., Salisbury Square, E.C. 130 0 0. Cox, H.J. and Co., Ltd., Westminster, S.W. 120 0 0. Taskley, W.C. and Co., Ltd., Kensington, W. 122 14 0. Lund Brothers and Co., Queen Victoria Street, E.C. 121 0 0. Lund Brothers and Co., Queen Victoria Street, E.C. 116 10 0. Fredegar, Ltd., Victoria Street, S.W. 100 0 0. Hargrave, A.V. and Sons, London Road, S.E. (accepted). 95 0 0. Solid draught tube (welded tube).

EASTHOVE.—For alterations to No. 5, Joynton Gardens. Mr. C. Crispold, architect. Harding, J., Esherborne (accepted).

EASTHOVE.—For alterations to premises in Old West Road, for Mrs. Harris. Mr. Stephen Box, architect. Radcliffe and Son, Eastbourne (accepted).

EAST ISLINGTON.—For providing a new boiler-room and installing a new steam boiler at the Forster School, East Islington, for the London County Council.

New boiler room.—Bates, Ltd., 4, Upper Berkeley Street, Portman Square, W. 476 0 0. Avon Larch and Sons, Lombard Street, E.C. 793 0 0. Griggs and Son, Court Road, E.C. 728 0 0. Bell, F., 31, Old Hill Street, Upper Clapton. 715 0 0. Price, C.R., 87, Belsomgate. 714 0 0. Maddison, W.J., Clerk on Street, Cannon Town. 678 0 0. Rome, E.A. and Co., Uxbridge Road, Hackney. 673 0 0. Stevens and Sons, 67, Crouch Hill. 669 0 0. Miles, A., Lower Edmonstone. 666 0 0. Mather, J.C., 88, Northampton Street. 627 0 0. Roberts, C.P. and Co., Ltd., 1, Tasson Street, Dalston. 596 0 0.

Providing and fixing steam boiler.—Deane, E. and Beal, Ltd., 25, Monument Street, E.C. 480 0 0. Cannon and Bedford, Stanbury Road, Peckham. 705 0 0. Cannon, W.G. and Sons, Ltd., 107, London Road. 439 0 0. Pearson, R.H. and J., Ltd., Notting Hill Gate. 647 0 0. Yetton and Brockett, Ltd., Munton Road, Southwark. 594 10 0. Paleykar and Sons, 90/91, Queen Street. 563 0 0. Brightside Foundry and Engineering Co., Ltd., 28, Victoria Street. 550 0 0. (Accepted).

EDINBURGH.—For supply of 400 tons of cast-iron pipes for the Edinburgh and District Water Trust. Manufacturers, Strang and Co., Ltd., Glasgow. (Accepted).

FULHAM, S.W.—For extension of operating room at military hospital, 181, Dunstan's Road, Fulham Palace Road, W. for the guardians. Mr. A. Savin Snell, F.R.I.B.A., 9, Bunting Street, Manchester Square, W., architect.—Small and Sons, 185, St. Johns Street, Clerkenwell. (Accepted) 429 0 0.

KEADBY.—For widening the old bridge at Keadby, for the county council at Lindsey. Roberts, C.E., Epworth. 4152 18 9. (Accepted).

KEITH.—For the building of a medical officer's residence at Keith, for the Gairdner Board of Guardians.—Denham (accepted). 41,700 0 0.

LONDON.—For the supply of electrical sundries to six asylums during five months, for the London County Council.—Goodwin, A.F. and Co. 4145 0 4. (Accepted).

LONDON.—For supply of (A) lead and (B) glass to six asylums during five months, for the London County Council.—A. B. Farthing, George and Sons. 4210 0 7. 4198 14 2. (Accepted for both).

LONDON, E.—For erecting a cold store for 250,000 chairs in a month and a sorting shed at the Royal Albert Dock, for the Port of London Authority.—Stirling, I., 1, 1st, E.C. 41, Glasgow (accepted).

LONDON, S.E.—For coating and repainting installation of the central car repair depot, third section, for the London County Council.—Beard, F. and Beal, Ltd., Monument Street, E.C. 41,890 0 0. Brightside Foundry and Engineering Co., Ltd., 28, Victoria Street, E.C. 1,819 0 0. Cox, W.G. and Sons, Ltd., 107, London Road, S.E. 1,78 0 0. Young, Austin, and Young, Leamington. 1,671 0 0. May, J. and F., 1, 1st, E.C. 1,597 0 0. Gray, Morgan, and Co., South London Road, W.C. 1,440 0 0. Standard Engineering Co., Ltd., Queen Victoria Street, W.C. 1,282 0 0. (Accepted alternately). 41,790 0 0. (Accepted for the complete).

MALDEN, ESSEX.—For providing and laying 245 lineal yards of cast-iron water-main in Station Road, for the town council. Mr. J. R. Swales, M.I.C.E.I., borough engineer.—Loy, H., Ltd., 39, Victoria Street, S.W. 4,269 10 0. Spalding, Sons and Co., Crescent Road, Heybridge. 175 0 0. Jackson, W., Forest Gate, E. 1 0 0 0. Emery and Co., Holbe Road, Aston, Birmingham (accepted). 144 0 0.

PARK PREWELL, NEAR BASINGSTOKE.—For electrical installation at the Park Prewell asylum, for the Hampshire County Asylum Visiting Committee.—Alger, R. and Sons, Newport, Mon. 4,228 75 3. Rashleigh, Phipps and Co., London, W. 22 78 0 0. Gallies, H.J., Brighton. 12,011 19 5. Cooper, C. and Co., London, S.W. 21,287 2 2. Nuneaton Electrical Contracting Co., Ltd., Nuneaton. 21,092 10 11. Stode and Co., London, S.W. 20,496 0 0. Crompton and Co., Ltd., London Wall, E.C. 20,421 12 4. Fox and W. Snow, Brixton, S.W. 19,504 0 0. Foot and Milne, Ltd., London, S.W. 11,985 0 0. Mann, Egerton and Co., Ltd., London, N.W. 18,860 0 0. Rawlings Bros., London, N.W. 18,451 0 0. Furze, W.J., and Co., Ltd., Nottingham. 18,418 16 6. Tyler and Freeman, London, W.C. 18,253 9 0. Edmundson's Electricity Corporation, Ltd., Westminster, S.W. 17,600 0 0. Davis, J. and Co., Ltd., Southampton. 17,578 0 0. Coates, W. and Sons, Belfast. 17,445 14 7. Hancock and Ryan, London, W. 17,124 19 0. Cox-Walkers, Ltd., Darlington. 16,490 16 0. Cash, H.J., 1st, E.C. 16,115 11 0. National Electric Construction Co., Ltd., London, E.C. 15,834 14 0. Hill, Upton and Co., 22, George Street, Oxford (accepted). 15,489 8 7.

SHADWELL, E.—For an extension of Messrs. Crompton and Thompson's factory, Denmark Street, Shadwell, Mr. W. Gilbert, 35, Broad Street Avenue, E.C., architect.—Gibbs, J., Cable Street, E. 4,780 0 0. (Accepted).

SHADWELL, E.—For erecting offices and workshops in Denmark Street, Shadwell, Mr. W. Gilbert, 35, Broad Street Avenue, E.C., architect.—Gibbs, J., Cable Street, E. 4,180 0 0. (Accepted).

SHOREDITCH, E.C.—For renewing and repairing zinc bars at the town hall, for the borough council.—A. B. C. Thomerson, C., 203, 205, Hackney Road, N.E. 475 479 487 0. Clark, J.A., and Son, 15, Goldsmiths' Row, N.E. 66 99 79 15. Hatley, E., and Son, 523, Old Street, E.C. 61 65 74 0. Recommended for acceptance. A—16-gauge zinc; B—24-gauge zinc; C—10-gauge zinc.

WANDSWORTH, S.W.—For the construction of surface-water drainage works at cemetery, for the borough council.—Lane, S. 4,710 0 0. (Recommended for acceptance).

WANDSWORTH, S.W.—For repairs to the dust destructor for chimney, for the borough council.—Bersted, E. and Co. (accepted). 476 0 0.

WEST HAM.—For the supply of cast-iron pipes at Abbey Mills pumping station, for the London County Council.—Clayton, Gooltellow and Co., Ltd., Blackburn. 4129 0 0. Sneepbridge Coal and Iron Co., Chesterfield. 75 18 0. Oakes, James, and Co., Ltd., Alfreton. 73 5 0. Staveley Coal and Iron Co., Ltd., Chesterfield. 64 1 7. Stanton Ironworks Co., Ltd., Nottingham. 65 12 8. (Accepted).

WEST HAM.—For supply of furnace tubes for boiler at Abbey Mills pumping station, for the London County Council.—Ruston, Proctor and Co., Ltd., Queen Victoria Street, E.C. 4147 0 0. Tansor, Shinton and Co., Ltd., Hyde. 129 0 0. Clayton, Sam and Co., Ltd., Leeds. 120 0 0. Tankers, Ltd., Hyde (accepted). 120 0 0. For offer of Tankers, Ltd., to supply furnace tubes for another boiler at Abbey Mills pumping station for 4129 was also accepted.

MALDEN, ESSEX.—For providing and laying 245 lineal yards of cast-iron water-main in Station Road, for the town council. Mr. J. R. Swales, M.I.C.E.I., borough engineer.—Loy, H., Ltd., 39, Victoria Street, S.W. 4,269 10 0. Spalding, Sons and Co., Crescent Road, Heybridge. 175 0 0. Jackson, W., Forest Gate, E. 1 0 0 0. Emery and Co., Holbe Road, Aston, Birmingham (accepted). 144 0 0.

PARK PREWELL, NEAR BASINGSTOKE.—For electrical installation at the Park Prewell asylum, for the Hampshire County Asylum Visiting Committee.—Alger, R. and Sons, Newport, Mon. 4,228 75 3. Rashleigh, Phipps and Co., London, W. 22 78 0 0. Gallies, H.J., Brighton. 12,011 19 5. Cooper, C. and Co., London, S.W. 21,287 2 2. Nuneaton Electrical Contracting Co., Ltd., Nuneaton. 21,092 10 11. Stode and Co., London, S.W. 20,496 0 0. Crompton and Co., Ltd., London Wall, E.C. 20,421 12 4. Fox and W. Snow, Brixton, S.W. 19,504 0 0. Foot and Milne, Ltd., London, S.W. 11,985 0 0. Mann, Egerton and Co., Ltd., London, N.W. 18,860 0 0. Rawlings Bros., London, N.W. 18,451 0 0. Furze, W.J., and Co., Ltd., Nottingham. 18,418 16 6. Tyler and Freeman, London, W.C. 18,253 9 0. Edmundson's Electricity Corporation, Ltd., Westminster, S.W. 17,600 0 0. Davis, J. and Co., Ltd., Southampton. 17,578 0 0. Coates, W. and Sons, Belfast. 17,445 14 7. Hancock and Ryan, London, W. 17,124 19 0. Cox-Walkers, Ltd., Darlington. 16,490 16 0. Cash, H.J., 1st, E.C. 16,115 11 0. National Electric Construction Co., Ltd., London, E.C. 15,834 14 0. Hill, Upton and Co., 22, George Street, Oxford (accepted). 15,489 8 7.

SHADWELL, E.—For an extension of Messrs. Crompton and Thompson's factory, Denmark Street, Shadwell, Mr. W. Gilbert, 35, Broad Street Avenue, E.C., architect.—Gibbs, J., Cable Street, E. 4,780 0 0. (Accepted).

SHADWELL, E.—For erecting offices and workshops in Denmark Street, Shadwell, Mr. W. Gilbert, 35, Broad Street Avenue, E.C., architect.—Gibbs, J., Cable Street, E. 4,180 0 0. (Accepted).

SHOREDITCH, E.C.—For renewing and repairing zinc bars at the town hall, for the borough council.—A. B. C. Thomerson, C., 203, 205, Hackney Road, N.E. 475 479 487 0. Clark, J.A., and Son, 15, Goldsmiths' Row, N.E. 66 99 79 15. Hatley, E., and Son, 523, Old Street, E.C. 61 65 74 0. Recommended for acceptance. A—16-gauge zinc; B—24-gauge zinc; C—10-gauge zinc.

WANDSWORTH, S.W.—For the construction of surface-water drainage works at cemetery, for the borough council.—Lane, S. 4,710 0 0. (Recommended for acceptance).

WANDSWORTH, S.W.—For repairs to the dust destructor for chimney, for the borough council.—Bersted, E. and Co. (accepted). 476 0 0.

WEST HAM.—For the supply of cast-iron pipes at Abbey Mills pumping station, for the London County Council.—Clayton, Gooltellow and Co., Ltd., Blackburn. 4129 0 0. Sneepbridge Coal and Iron Co., Chesterfield. 75 18 0. Oakes, James, and Co., Ltd., Alfreton. 73 5 0. Staveley Coal and Iron Co., Ltd., Chesterfield. 64 1 7. Stanton Ironworks Co., Ltd., Nottingham. 65 12 8. (Accepted).

WEST HAM.—For supply of furnace tubes for boiler at Abbey Mills pumping station, for the London County Council.—Ruston, Proctor and Co., Ltd., Queen Victoria Street, E.C. 4147 0 0. Tansor, Shinton and Co., Ltd., Hyde. 129 0 0. Clayton, Sam and Co., Ltd., Leeds. 120 0 0. Tankers, Ltd., Hyde (accepted). 120 0 0. For offer of Tankers, Ltd., to supply furnace tubes for another boiler at Abbey Mills pumping station for 4129 was also accepted.

The Surveyors' Institution Roll of Honour records the death, while on active service, of Lieut. R. J. Poynton, 2nd London Divisional Engineers, Royal Engineers. Mr. Poynton was a Professional Associate of the Institution.

THE BUILDING NEWS

AND ENGINEERING JOURNAL.

Effingham House.

Architecture by Synthesis	551
Emergency Military Hospital Construction ..	552
"Spralolite" and the Maseon Health spray r. .	555
The Old Churches of York	555
War Risks to Property	555
British Columbia Timber (<i>Continued</i>) .. .	556
Obituary	558
Currente Calamo	575
Professional and Trade Societies	576
Building Intelligence	576
Legal Intelligence	576
Correspondence	576
Trade News	577
Trade Notes	577

CONTENTS.

Our Office Table	577
Parliamentary Notes	577
Chips	578
To Arms!	578
Meetings for the Ensuing Week	578
Latest Prices	579
Tenders	580
List of Competitions Open	580
List of Tenders Open	580

Strand, W.C.

Leo Home, at Cusheurst, on Narrow Sites. Plans, elevations, and views. Mr. Edward J. May, F.R.I.B.A., Architect.	577
"Emergency Military Hospital Construction." Typical plans illustrating the "Chadwick" Lecture by Mr. A. Saxon Snell, F.R.I.B.A. The War Office model plan Hospital, Beachborough Park, Siamchelte. Mr. W. Henry White, F.R.I.B.A., Architect. Leicester Hospital; Messrs. Everard, Son, and Pick, Architects. Welsh Hospital, Netley; Messrs. Edwin T. Hall and Son, Architects. Norfolk and Norwich Hospital, Messrs. E. Boardman and Son, Architects. Imperial House on the occupation of the War Office, Westminster. View and plan, entrance vestibule, and detail of main entrance. Messrs. Henry Metcalf and Thomas R. Greig, Architects.	577

OUR ILLUSTRATIONS.

The Edith Cavell Home for Nurses, London Hospital. View and plan. Messrs Rowland Plunbe, F.R.I.B.A., and Partners, Architects.

ARCHITECTURE BY SYNTHESIS.

By the analytical method, we break down to elements; by synthesis, we build up from the same elemental parts. If architectural design is to be based on synthetic lines we must reconstruct from primordial atoms—of architecture. If we seek to evolve true grace and beauty we must break up the old, and from its ultimate, unchangeable parts produce anew by recombination. To attain success in design on these lines we need to establish a working hypothesis.

Ordinarily, we do not proceed on synthetic lines in design. The truth seems to be that fitness, while an obvious essential, assists us not one whit in evolving beauty or in adding novelty and interest to architectural composition. The problem is to discover, in architectural design, how this attribute of fitness for duty helps to produce elegant variety. What, then, are the true elemental parts? On superficial consideration we might consider them to be such entities as columns, string-courses, fluted pilasters, pillared doors, and arched windows. Are

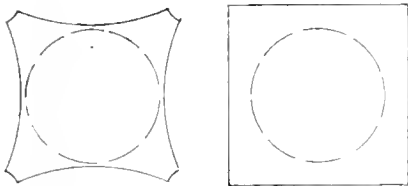

FIG. 1.

not such rather comparable to elementary molecules? A column is a composition of head, body, and base; a cornice is the massing of many unit parts into one feature. If we break up whole columns we find cylinders, or truncated cones, cubes, rectangular solids, and curvilinear and angular bodies. Now the square is an unchangeable; the cube was, is, and will remain a cube to all time. In designing a "rusticated" column, fitness, if a guide, is all against us. If we fall back on precedent we cease to operate as thinkers, and must open our formal copy-books for examples. We need sound theory respecting the elemental, which in architecture is plain rectangular, angular, or curvilinear form. We must cast all styles into the fining pot, taking therefrom the indestructible and unalterable components of building mass. These, common to all true styles, may be termed the atoms of architecture. It is evident that the cylinder and the truncated cone are such. The circle and part-circle are found profiling marble and stone in every country. Of all obvious facts the rectangle and rectangular mass are super-

basic in every mode of beautiful building. Equally, the juxtaposition of circle and rectangle is prime, elemental, and paramount in all refined and universally-esteemed architecture.

These considerations may suggest that the ultimate components of architectural



FIG. 2.

mass and form can be but few. Substantially, they are prime figures of solid geometry. Of such we must construct architecture by synthesis. These elemental, solid mass-forms should have the same significance for the architect that the square, circle, rectangle, angle and straight line have for the designer in the flat. Whereas, however, it really often seems to us that, in the view of the architect, perspective is something unnatural. Admitting that the reflection may seem strange, we yet record it, soberly. A Grecian Doric capital, on elevation, and the real feature as revealed in sun and shadow are two different affairs. Nevertheless, on plan, a certain parallel may

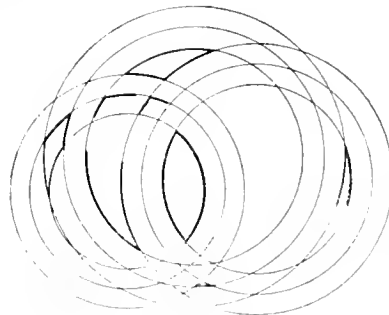

FIG. 3.

be instituted between the flat presentment and the actual effect in the solid; while the grace and beauty, the pre-eminent material liveliness of the so-called Roman Ionic, are clearly pre-shadowed in its plan. We see, in Fig. 1, the harmonious accord of circularly planned abacus to circular section of the column.

Equally, in the plan of the Doric capital, the square abacus is revealed as contrasting pleasingly with the circular, or circle-embraçed, horizontal profile of the fluted column. So far as the plan goes, the correlation of elemental square to elemental circle presents, in a certain measure, a parallel to the true, perspective effect; but whereas in the case of the Doric capital all that we see is a pleasing pattern of a square enclosing a circle, in actual presentation we get the soft rotundity of the columns opposed harmoniously to the rectangular abacus; and since every rectangular mass presents to the eye one of its solid angles as acute, or virtually so, such correlation of rotundity and acuteness affords, according to universal judgment of the refined in all ages, a pleasing object to the eye.

We have instanced simple forms that may be viewed as true, atomic parts of

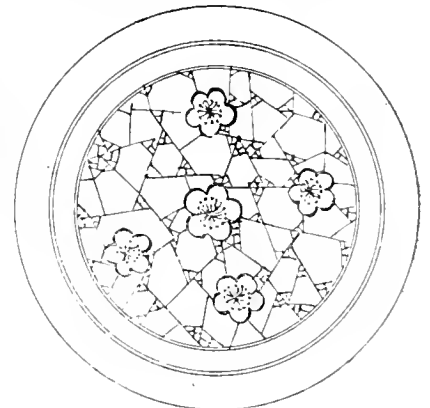

FIG. 4.

architecture. Plainly, the Doric abacus is an elementary form—rectangular mass rendered the more nearly primordial because founded, in plan, upon the square, an obvious, unchanging and unchangeable, fundamental and ultimate. No doubt we might be reasonably justified in viewing every rectangular mass, of whatever proportion, as atomic and elemental, or but little removed from such. The incidence of its variability, so far as respects proportion, need not be considered an obstacle. Whatever its relative dimension, it is a plain rectangular figure; and if we desire to gain some insight into the effect of disposing, grouping and co-ordinating rectangular solids we must study such, under natural aspect, in various circumstances and surroundings, variously placed and assembled.

If we wish to establish some helpful law or laws to guide us in harmoniously correlating elemental or atomic parts of

... we must first study the less...
 ... was relative to harmony in
 ... geometrical device. O.
 ... suggest the great fundamental
 ... every rainy day in every
 ... Every circle is in har-
 ... with every other circle,
 ... small, and every circle is
 ... with every variety
 ... by circular intersection.

In Fig. 2 we have such a series of
 ... those formed
 ... pond. At first glance we are
 ... with a consistently harmonious
 ... obviously that the
 ... and to lack foil; but further inspection demonstrates that
 ... this is by no means the case. The very
 ... name given by geometers—"caustic"—
 ... signifies something sharply opposed to the
 ... nature of the circle. Wherever
 ... circle is formed a figure with
 ... sharp cutting edge, a veritable
 ... of the philo-
 ... of egg-and-tongue—the smooth,
 ... opposed to the spiny, all produced from
 ... solely. This is of practical
 ... where a number of
 ... are grouped, as in a
 ... seen in perspective, at
 ... where circle strikes circle a
 ... formed, more or less acute,
 ... according to the distance apart of the

device, sketched in Fig. 4, represents
 ... on a backing of cracked
 ... indicating the break-up of winter.
 ... such an ornamental device,
 ... and reduce the principle to an elementary
 ... diagram, as in Fig. 5, we shall see that
 ... the enhancement of curve by
 ... straight line and angle. Our drawing is
 ... a matter of superficies; but, while re-
 ... regarding it, we may think of solid form,
 ... for we may equally employ the diagram
 ... to illustrate the perspective effect of the
 ... rectangular mass and the rotund in archi-
 ... tecture, and see, in the upper, sharp
 ... angle, square building mass projected
 ... against spherical dome. The basis of ulti-
 ... mate eye-effect in the flat ornament
 ... and in the perspective of solids, is sub-
 ... stantially identical. It is essentially the
 ... block, or rustication, projected against
 ... column drum. The rusticated column is
 ... a useful illustration, for it is obviously
 ... composed by alternating, ultimate,
 ... atomic parts of architecture—cylinder and
 ... cubic or quasi-cubic mass. If there be
 ... any true harmony in such rusticated
 ... columns, it is derived from the pleasing
 ... interplay of square and round; and what-
 ... ever we may think of such column treat-
 ... ment, there is an undoubted eye-pleasing
 ... effect and certainly no obvious discord.
 ... The whole conception is too elemental
 ... in basic form to create positive offence,
 ... and above these considerations is the fact
 ... that anything tending to add emphasis
 ... to constructionalism, as the chief and
 ... most typical expression in architecture,
 ... adds to interest, if not always to positive
 ... beauty.

The synthetic method of design in archi-
 ... tecture may not be attractive, but study
 ... on these lines would tend to ameliorate
 ... prevalent evil—the decorative treat-
 ... ment of basically ungraceful mass. We
 ... are ensured of a correct base or founda-
 ... tion, of pure outline and simple mass-
 ... formation, if our main lines of composi-
 ... tion are arranged in accordance with
 ... some principle. If we can trace back
 ... such humble means as rain-splash and briar-
 ... thorn, we can feel confident that our
 ... work, if not super-excellent, can yet never
 ... offend.

EMERGENCY MILITARY HOSPITAL
 CONSTRUCTION
 WITH ILLUSTRATIONS.

A Chadwick public lecture on "Emergency
 Military Hospital Construction" was delivered
 at the Royal Society of Medicine's premises,
 Wimpole Street, W., on Wednesday after-
 noon, by Mr. Alfred Saxon Snell, F.R.I.B.A.
 The hall was crowded, the audience including
 many architects and medical men, and not
 a few nurses. Mr. John Slater, B.A.,
 F.R.I.B.A., one of the Chadwick trustees,
 occupied the chair. The lecture was illus-
 trated by some seventy-five lantern views
 of temporary hospital plans, elevations, and
 sections, some of which are reproduced
 in this issue, and also by photographs of
 wards and grounds.

No one could study the question of hospital
 design and construction, observed the lecturer,
 without recalling the far-sighted genius
 of Sir Edwin Chadwick, the idealism
 of Sir Benjamin Ward Richardson, and
 the practical teaching and noble work of
 Florence Nightingale. In normal times they
 had in England, in addition to the purely
 civil and military establishments, a very
 large number of voluntary and public hospi-
 tals, sanatoriums, and infirmaries. In view of the great im-
 provement in the general health of the country
 in recent years, these buildings had not been
 always in full use. They might fairly, there-
 fore, be expected to deal with the casualties
 likely to arise at the first onset of an ordinary
 year. In a first-class war it was obvious,
 however, that very considerable additional
 accommodation would be required. That con-
 tingency had always been contemplated by
 the War Offices of all nations—even our own

To meet such an emergency, all kinds of
 large buildings would be requisitioned for
 conversion as temporary hospitals. Indeed,
 in this country, a number of buildings had
 been scheduled for this purpose long before
 the present war broke out. Whether all the
 buildings thus scheduled were the best
 possible for the purpose was a matter of
 opinion; certainly there were grave objec-
 tion to the employment of schools as
 hospitals, and a church or mission-hall was
 at the best ill-adapted for its new purpose.
 In this, the greatest war with which the world
 had ever been cursed, private individuals had
 come forward, with unexampled generosity,
 offering their fine houses and resources for
 the benefit of the wounded. The conversion of
 part of Woburn Abbey for this purpose by
 the Duchess of Bedford was but one instance
 out of many he might cite. The Germans,
 with immense thoroughness, specially pro-
 vided for the eventual occupation of all
 school buildings as emergency hospitals. We
 had never gone so far, since we, unlike the
 Germans, regarded war as an occasional and
 disagreeable necessity. Our habit of facing
 inevitable difficulties with imperturbable good
 humour, trusting to get through somehow,
 really amounted in its resourcefulness to posi-
 tive genius. Some weeks ago the lecturer
 inspected a small thirty-bed hospital at
 Willesden, improvised out of St. Matthew's
 Church Institute, where the main hall was
 utilised as a general ward, with three rows
 of beds, the platform, as an orderlies' retiring
 and general utility room, the committee room
 as an operating theatre, and other small
 apartments as kitchens, storerooms, and
 nurses' quarters. In every part of the build-
 ing all hospital rules were jubilantly
 ignored, but goodwill and humour prevailed
 among workers and patients alike. In addi-
 tion to the conversion of existing buildings,
 the War Office had also contemplated the
 erection of temporary emergency hospitals, and
 its staff had long since prepared detailed
 plans for temporary buildings, which would be
 erected at short notice, quickly and at compar-
 atively small expense. The scale of the present
 war was, however, so vast that many civil
 architects had been called in to assist the
 War Office by preparing schemes both for the
 erection of temporary hospitals and for the
 conversion of existing buildings for that pur-
 pose. It was inevitable that many of the
 plans so provided should have exhibited
 considerable variation from the War Office
 scale, both as regarded planning and con-
 struction, and these modifications were both
 instructive and interesting. The model plan
 issued by the War Office (shown at the foot
 of our double-page illustration in the centre
 of this issue) was, however, remarked Mr.
 Saxon Snell, very helpful; it provided a guide
 to the size, general arrangement, and relative
 positions of the various buildings required for
 a general hospital, and such information was
 obviously invaluable to an architect for a
 commencement of his work. Indeed, an
 architect might make the model plans the
 end as well as the beginning of his design,
 and it was conceivable that hard-worked
 officials at the War Office, to whom such plans
 had to be submitted, would welcome the civil
 architect's lack of imagination as relieving
 them from the necessity to criticise and
 analyse in a time of stress and hurry. But
 architects had not by any means confined
 themselves to adopting the model plans, but
 in most cases had introduced improvements
 and special modifications in their designs.
 The plans and designs he was exhibiting that
 evening showed quite a variety of solutions of
 the problem, all of which would repay close
 inspection and study. He was sure that these
 designs would influence those of all future
 hospitals, both temporary and permanent.
 One of the first of these hospitals, planned by
 an outside architect, was the *First Eastern
 Military Hospital at Cambridge—one in which
 the promoters did not hesitate to act on their
 convictions, not counting the cost. This
 hospital represented an act of faith and
 courage on the part of those who constructed
 it, among whom he must mention Colonel

Described in detail in a lecture delivered by Dr. A. E. Shipley, Master of Christ's Hospital, Cambridge, before the London Architectural Association and fully reported in our last issue, p. 524.

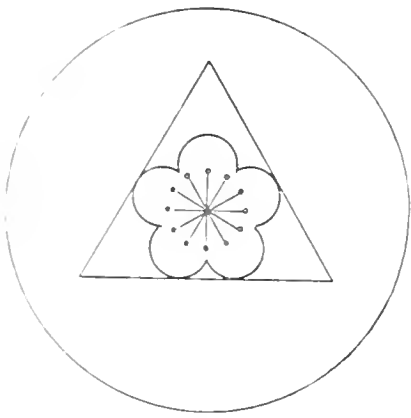

FIG. 5

... the same as the model plan...
 ... This scale, then, is not the
 ... of the
 ... of the architecture, and
 ... that its
 ... that
 ... the
 ... and
 ... as
 ... have indicated
 ... the
 ...

We do not here make new groups in
 ... and such as at all
 ... but, selecting
 ... other
 ... and
 ... of the
 ... at all
 ... of design,
 ... is of a
 ... and prin-
 ... enough. It
 ... with some
 ... in the
 ... device
 ... guiding
 ... similar lines of
 ... reference to
 ... the fundamen-
 ... of straight
 ... They
 ... King Hst-
 ... that
 ... have pat-
 ... of spring,
 ... very favour-
 ...

and Professor G. Sims Woodhead, and its architect, Mr. Charles F. Skipper, of Cambridge, both of whom knew that their principles were sound. It ought to be borne in mind that open-air wards, for use both in winter and in summer, were by no means novelties in this country. For instance, Dr. Philip Boobhyer, medical officer of health for Nottingham, had had several in his extensive district for a number of years, and in these every kind of disease, not excluding pneumonia, had been treated under every variation of temperature and climate with the greatest success. The value, from a health

under these conditions they preferred it to any other. Reverting to temporary hospital planning and construction, the lecturer pointed out that the nucleus in most cases was an existing hospital or large house utilised as administrative offices and staff quarters. The temporary ward blocks were erected in adjoining fields or gardens. The War Office model plans provided for a framing of timber, lined on the inside with boarding or plaster, and on the outside with corrugated iron. The roofs were also finished with corrugated iron. Such buildings were no doubt quickly erected, but aesthetically they left much to be

out that we should not be critical as to the finishing, nor expect to find any meticulous care displayed in the provision of rounded internal angles, nor even in the avoidance of dust ledges. Aseptic surfaces were not to be expected; sinks and lavatories were often supported on rough wooden frames, and fittings were not always fixed clear of the walls. They must not think lightly of architects because such commonplace rules of hygienic laws were ignored. The buildings were meant to be constructed quickly, and at very small cost, and such requirements were inconsistent with refinement in detail. One matter he

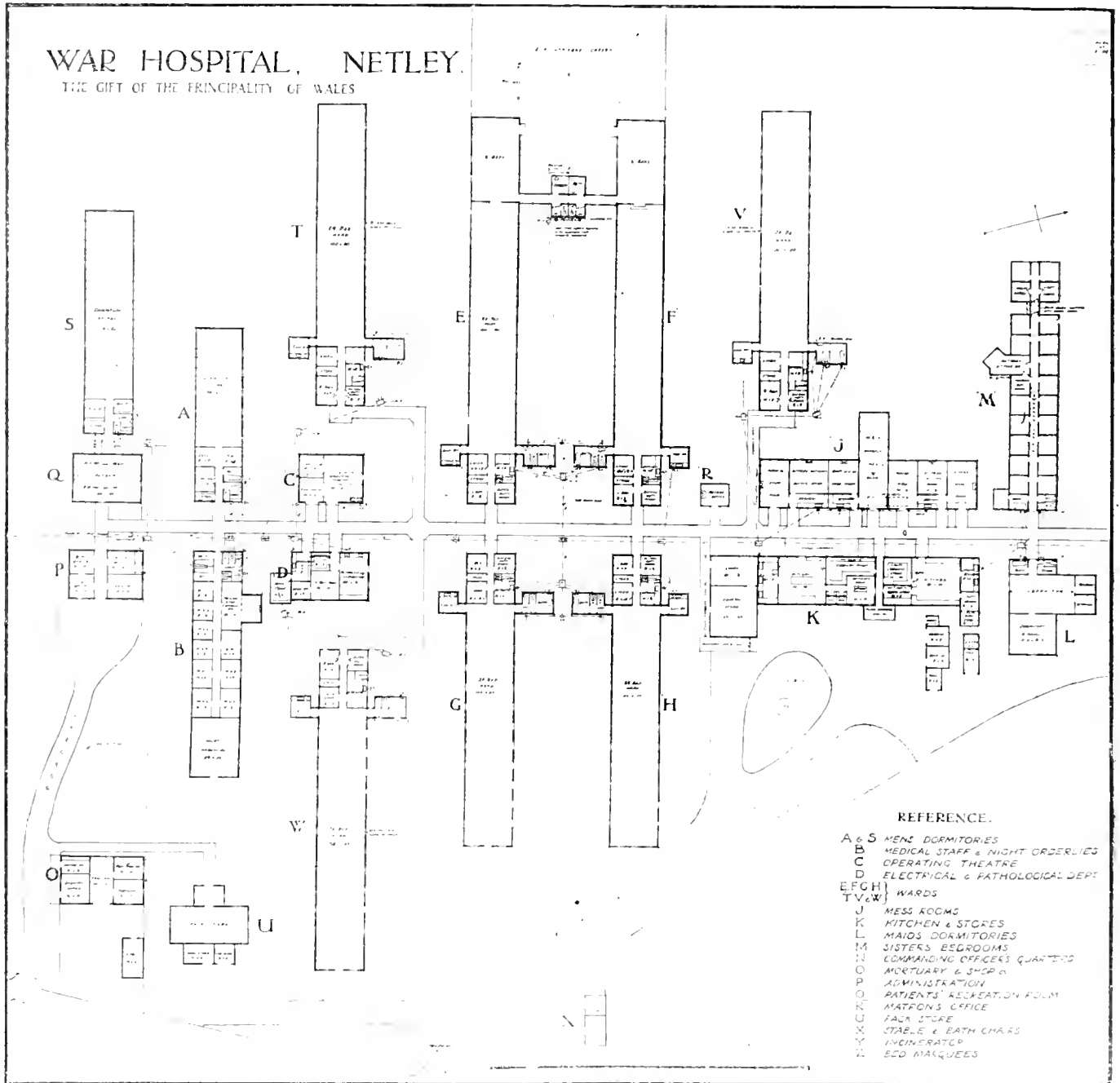

WELSH WAR HOSPITAL, NETLEY.—Messrs. E. T. HALL and SON, Architects.
Illustrating Mr. A. Saxon Snell's lecture on "Emergency Military Hospital Construction."

view-point, or roughly improvised buildings or sheds, which were practically open-air wards, had been advocated by Miss Florence Nightingale, Dr. Brocklesby, Sir John Pringle, and indeed as far back as 1759 by Dr. Guy. The main principles which formed the lines of all good hospital work were the importance of fresh air in abundance of sunlight, and of cleanliness in everything, from bedding to food utensils. Open-air wards had some disadvantages and inconveniences, the most serious being the way in which the staff were affected; but Dr. Boobhyer had testified that when once nurses had been induced to work

desired, and necessarily were noisy in case of rain. Timber framing, lined inside and out with asbestos sheets, was another method of construction, and such edifices had the merit of being much more sightly and no less fire-resisting. Ruberoid was employed on the roofs, and frequently the flooring was of tongued boards and wooden joists. Steam pipes, radiators, and hotways of earth were used for closed wards, but in open-air wards no heating whatever was provided, for it would be quite ineffective. Electric lighting was general. In the construction of these temporary buildings, Mr. Saxon Snell pointed

personally regarded as essential was the provision of a concrete bed under the ground floor, and he should adversely criticise its omission from any temporary buildings, and, further, aseptic principles and absolute cleanliness and smoothness of surface must be imperative in the operating theatre. The cost of temporary hospitals varied surprisingly, and was affected by many factors. It ranged from £20 to £70 per bed, whereas £500 per bed was a recognised round figure for permanent hospitals. The outlay was afforded by expenditure on site, the relative building wages of the district, the provision of staff quarters

Miss Richardson held that the time had gone by for great metropolitan hospitals in crowded districts. The aim would be to secure sites in rural districts affording plentiful fresh air and sunlight.

The Chairman remarked that much had been done, at very short notice, to provide temporary hospital accommodation for our wounded soldiers and sailors. It would be wise in future years to look ahead and provide temporary buildings in open spaces rather than to hastily adapt inappropriate buildings in the heart of London.

Mr. Saxon Snell, in acknowledging the vote of thanks, which was carried by acclamation, said he had not been convinced by Col. Hodgetts as to the merits of the butterfly form of ward planning.

"SPRAOLITE" AND THE MASCON HEALTH SPRAYER.

The necessity for the constant use of a powerful antiseptic to destroy the many germs which are always surrounding us is universally admitted, as it is well known that they become particularly harmful in a vitiated atmosphere. We have therefore much pleasure in drawing attention to "Sprao-lite," which is non-poisonous and leaves no stains and which clears the air of all harmful germs and smells, leaving a refreshing scent behind. This preparation, which is far more active than carbolic acid when tested against the typhoid germ, is made in eleven odours, pink may, pink carnation, jonquils, lavender, blush rose, pine violet, eau de cologne, magnolia, sweet pea, spinol, and sweet briar, all having antiseptic value of a high order. It can also be supplied odourless if desired. The best means of using "Sprao-lite" is by means of the Mascon Health Sprayer, which is illustrated herewith. This is light, strong, and portable, and gives a continuous, mist-like spray, consisting of air and liquid, readily floating through the atmosphere, absorbing the dust, killing germs, and rendering the air pure and health-giving. "Sprao-lite" and

the Mascon Health Sprayer are used in a very large number of the principal colleges, schools, Government offices, hospitals, sanatoriums, drill halls, sick rooms, factories, theatres, country mansions, banks, high-class cinemas, clubs, dance halls, infirmaries. In fact, in any place where the air is likely to get vitiated "Sprao-lite" will give instant relief. It clears away all smoke and unpleasant odours, and leaves the air pure and invigorating. A well-known bacteriologist reports: "I have tested 'Sprao-lite' for its germicidal efficiency in aqueous solution by the Rideal-Walker or drop method. I find that it has a carbolic acid co-efficient of 4-5, which indicates that under the conditions of the test 'Sprao-lite' has a germicidal efficiency four and a half times that of carbolic acid." "Sprao-lite," which has received the certificate of the Institute of Hygiene, is put on the market by Messrs. B. Maslin Bros., Spray House, 54, Clerkenwell Road, London, E.C.1, and should be in use in all institutions where the air is likely to become polluted from crowds or other causes.

Mr. William James Harding, a local sanitary engineer and builder, has been elected Mayor of Banbury. A sewage-disposal scheme for the borough, costing £40,000, is at present being carried out.

Mrs. Solomon D. Sassoon laid the foundation stone on Sunday afternoon of the new London Jewish Hospital, which is being erected on Stepney Green at a cost of £33,000. It will be the second Jewish hospital in England, there being one at Manchester.

Mr. John Evans, for the past twenty-seven years sanitary inspector under the Stafford Corporation, and previously for eight years a member of that body, died on Wednesday last in his seventy-fifth year. He took a prominent part in the work of the Sanitary Inspectors' Association.

THE OLD CHURCHES OF YORK.

"The Old Churches of York" was the theme of a lantern lecture delivered by Mr. George Benson before the members of the York Philosophical Society in the Tempest Anderson Hall on Monday evening in last week. Alderman Sir Joseph Sykes Rymer presided. The first church built in York, according to reliable data was, said the lecturer, founded in 627, when King Edwin, having embraced Christianity, erected a church in the street adjoining his palace, within the old Roman walled-in camp, which was the beginning of York Minster. Some five years later the King decided to carry out Gregory's project of an Archbishopric at York, and began to build a stone church—the earlier one being of wood—suitable for the needs of the province. Before the stone church was completed King Edwin fell in battle, and York was occupied by the pagan Cadwallon, who was eventually defeated by Oswald. King Oswald founded a new see on the isle of Lindisfarne, but he completed, however, at York the stone Minster which was now subject to Lindisfarne. It was not until 735 that York was made an Archbishopric, and the stone Minster became the mother-church of the province. About half a century later a new cathedral was built, the concrete foundation of which was laid bare during the last century. The second Church of York was probably built by the Archbishop in his own shire, the edifice now known as St. Mary's, Bishophill Junior. A portion of the west wall still existed and its thickness, materials, and workmanship proved its great antiquity. Three or four other churches apparently arose in York during the Anglian period. Some were probably built of timber and covered with thatch, and in the churchyards were stone sculptured slabs and crosses. York fell to the heathen Danes in 867, but Christianity revived under the glorious King Athelstan, who was a great benefactor to the Minster. Another revival took place under Edward the Confessor, when a tower was added to the Church of St. Mary Bishophill Junior, which was the oldest tower in York. In the Anglo-Danish period there were built St. Mary, Castlegate; St. Mary, Bishophill Senior; Christ or Holy Trinity, Micklegate; and St. Gregory; and on the other side of the river Holy Cross. During the interval of seventeen years between the great fire of 1069 and the Domesday Survey, the churches of St. Crux and St. Mary's, Castlegate, had been rebuilt, and new churches were erected to St. Andrew, St. Michael (Spurriergate)—where the curfew bell is still rung every night at eight—and to St. Andrew, St. Saviour, St. Martin (Coney Street), All Saints', Pavement, and St. Cuthbert. St. Olave's Church was unimpaired by the fire. Other churches built by the Normans were St. Helen, Stonegate; All Saints', Fishergate; St. Andrew's, Fishergate; St. Stephen, Walmgate; St. Michael (de-Belfrey), St. Denis and St. Nicholas, whilst St. Clement's Church arose on the Archbishop's land across the Ouse. Mr. Benson gave an interesting survey of the architectural features of the various old churches, Norman, Transitional, Early English, Perpendicular, and Georgian, as well as referring to the churches which were destroyed during the 14th, 15th, and 16th centuries. The two edifices of St. Andrew and Christ Church were now disused as churches. The nave of the former had been used as a school-furniture warehouse, and was now a mission room, while the chancel was used as a dwelling-house. St. Helen's, the only surviving church in York of the four dedicated to the mother of Constantine the Great was occasionally used for service. The churches of St. Maurice and St. Lawrence, except the tower, had been removed and new ones built, and that of St. Crux was a mission room. There were twenty-two ancient churches in York. They had a character peculiarly their own, being mostly small and of no great height, but each was worthy of careful study. The most conspicuous tower was that of All Saints', Pavement, which had been copied from the tower of St. Dunstan's, in Fleet Street, London. The finest of the York churches was that of St. Mary's, Castlegate, with its lofty spire. Many of the churches

were renowned for their painted Mediaeval glass. Many of the York churches had been mutilated for so-called street improvements. Churchyards had been added to the streets, and the adjoining church walls shorn of their buttresses, whilst chancels had been shortened or swept away. This damage to the ancient works of art in our streets was to be deplored, since the street improvement could have been as easily achieved by the setting back of inferior buildings on the opposite side of the road. The churches stood for lofty ideals, and as we passed them in our busy streets they silently reminded us of our duty to one another, and thus made their preservation the more desirable.

WAR RISKS TO PROPERTY.

On Thursday Mr. Sydney A. Smith (Messrs. Weatherall and Green) read a paper at the Auctioneers' and Estate Agents' Institute on war risks to property.

The lecturer remarked that he had not yet met with any ante-war insurance lease which provided in express terms for the contingency of war damage, although in the case of a property in the City of London which was let to a German firm in 1912 for a term of 21 years a request was made by the lessee during the negotiations that the leases should be determinable at three months' notice in the event of war with his country, which at the time was regarded as so absurd a suggestion that it was not given serious consideration. After referring to the terms of insurance offered by underwriters and by the Government, Mr. Smith went on to say that all difficulties which the fire offices experienced were referred to the War Risk Insurance Committee, and he believed that about 150 rulings had been given. In the settlement of claims the practice adopted under fire policies had been followed. No new principles of valuation of loss had arisen for consideration. If the loss could not be agreed with the loss surveyor or the Government, it was uncertain what remedy the insured would possess. The term in the policy "his Majesty's Government" was a vague description, and a lawyer would be in doubt whom to sue. Possibly some part of the Attorney-General or petition of right from the King might be needed. The author discussed the responsibility as between landlord and tenant for the reinstatement of aircraft or other war damage. Express covenants to repair and to maintain the property and so deliver it up would, it was thought, include this responsibility. Many lessees would resist the liability very strongly on the ground that the risk was never foreseen when the lease was made, but the action of the King's enemies would not override that which was a matter of positive contract. If the lessee were in terms excused from "inevitable accident" it was perhaps likely that a bomb risk would fall within the exception, and such clause operate to excuse him. Tenants who are not under covenants for the maintenance of the property still found the position unsatisfactory, as it was generally assumed that any tenant would in law be liable to continue to pay rent, even though the premises were rendered uninhabitable by enemy damage. The cost of insuring rent would be so small that it should never be neglected by tenants. There was an old law case dating back to 1647, *Jardine v. Jane*, in which it was held that a tenant was not excused from paying rent by the fact that he had been expelled from occupation by Prince Rupert's army. Under *Mark v. Cooper* (1727) a tenant was liable to pay the rent although the premises had been burned. Where mortgages were in existence before the war many mortgages had served their mortgagors with requests to effect insurance. Where a lease was near its end, particularly 99 years' lease, it seemed unfair that tenants should have to insure, the effect of which might be to present to the freeholders a new house at the end of the term. It would be very satisfactory if a record were to be kept of the damage which occurred from aircraft, with a view of presenting a bill to Germany at the end of the war.

Plans prepared by Mr. R. A. Herold, architect, for the new county hospital to be erected at Sacramento, California, shortly, have been adopted by the Board of Supervisors. The estimated cost of the buildings is \$400,000.

1. Strongest.—Douglas fir, longleaf pine. Size for size, these two average about equal in strength; weight for weight, Douglas fir is considerably stronger, because it is about 20 per cent lighter than longleaf pine.
2. Intermediate.—Western hemlock, western larch, loblolly pine, shortleaf pine.
3. Weakest.—Norway pine, tamarac.

DIMENSION TIMBER AND BOARDS.

Owing to its great strength, durability, lightness, cheapness, and the fact that it can be obtained in any size, Douglas fir is pre-eminently suited for all dimension material, beams, joists, scantling planks and boards needed for any purpose in any kind of building, whether exposed or not to the weather.

Western hemlock, because of its strength, lightness, and ease of working, is also excellent for dimension stuff and boards, though it is less durable than Douglas fir when exposed to the weather. Spruce boards are very suitable for inside uses where great strength is not required, being light, soft, and easy to handle. Western red cedar is not so generally used for common dimension material and boards, because Douglas fir and western hemlock are harder, stronger and cheaper. Cedar is, however, very useful in construction work wherever durability or light weight is the main consideration, as, for example, where wood is to be used in contact with the soil.

SHINGLES.

The western red cedar shingle is unexcelled as a roofing material. Nothing else compares with it for durability, cheapness, comfort and beauty.

Many instances are found in which the red cedar shakes (shingles split by hand), with which the early buildings in this province were covered, are in an excellent state of preservation after having been in service since the early "forties" and "fifties." In other instances shingles have remained in use after thirty to thirty-five years' service. Sawn cedar shingles, without paint or treatment, last from twenty to thirty years, according to the situation in which they are used, the general reason for repairs being the rusting-out of wire nails used in roofing. The use of zinc, copper, galvanized, or cut iron nails overcomes this difficulty and greatly lengthens the life of the roof. Zinc or zinc-clad nails are perhaps the best, price and durability considered.

Shingles sawn edge (or "vertical") grain will lie flat, and will not warp or twist even after years of exposure to the elements. British Columbia edge-grain shingles are the highest quality of shingle sold, and practically the entire output of the province is edge-grain material.

Dry light wood is almost a non-conductor of heat or cold. Western red cedar is one of the best natural non-conductors known, or commercially available, because it is unusually light, is by nature a dry wood containing no pitch, and is impervious to rain or wind. A western red cedar roof is cool in summer and warm in winter.

Very attractive architectural effects can be secured by the use of red cedar shingles. This is particularly to be noticed on the Pacific Coast, where the shingle is not only the predominating roofing material, but is also used with charming effect as an outside wall covering.

The remarkable durability of red cedar makes preservative treatment of the shingles unnecessary, but if desired, they can be easily stained or painted in any shade or colour, and beautiful colour schemes may be obtained in this way. Stains or paints can be applied with a brush to dry shingles after laying, by which means a superficial covering of the exposed part of the shingle may be obtained. Shingles can be more thoroughly treated by immersing in creosote at about the temperature of boiling water. Dry shingles should remain in this for about thirty minutes, but in the case of green material the time should be extended to an hour or more. Any of the common colours, ground in oil, can be mixed with the creosote.

British Columbia red cedar, in the form of bevelled siding, shingles, and trim, is an

exceptionally good interior finish for walls of buildings. Besides its natural durability, cedar bevel siding holds its form, is well manufactured, and takes paints and stains very satisfactorily. It nails easily without splitting, and is free from pitch. For the foregoing reasons, and because it is easy to work, has a straight and even grain, and is particularly suitable for turning, western red cedar is superior to any other wood of North-Western America for porch columns, balusters, and turned novelties.

Sitka spruce makes excellent siding, being sift, light, easily worked, free from pitch, with attractive grain, and taking stain and paint readily.

Douglas fir and western hemlock are also both suitable for siding, and the former wood is very widely used for this purpose.

WINDOW SASHES AND DOORS.

Douglas fir is used to a greater extent than any other wood by the sash and door manufacturers of British Columbia. In fact, most doors used on the Pacific Coast of America are made from Douglas fir. It is easily worked, presents a hard surface, is strong and durable. Even the clear and No. 1 grades, which are used in this work, are inexpensive, and there need be little or no waste in cutting out material. Edge-grain stock, which is easily obtainable, is used for the frames.

FLOORING.

All Douglas fir flooring is sawn edge-grain, and the hardness, wear, resisting qualities and ease of working of the wood, combined with its beauty of grain and ability to take a high polish, have led to its extensive use. It is very popular as a house floor on account of its beauty and cleanliness; it is especially attractive in the form of a parquetry floor. It is equally popular and in general use for factories, warehouse, and other places where it is subject to hard usage, because of its great strength, resistance to wear, and cleanliness. Western hemlock, when cut edge-grain, also makes an excellent flooring material. It finishes smoothly on account of the uniform texture of the wood, and it also wears evenly. It is not suitable for use in damp places on account of its tendency to warp under such conditions.

PANELLING FOR WALLS AND CEILING.

No form of interior finish compares with wood panelling for beauty, comfort, cleanliness and cheapness combined. It is generally used all through the Pacific Northwest, and is finding great favour wherever introduced elsewhere. The old-fashioned painted door is being replaced by doors with panels of slash-grained Douglas fir or hemlock, finished in the natural wood so as to bring out the full effect of the beautiful figuring. Plaster and paper-covered walls, partitions and ceilings are likewise giving way to wood panelling. The all-wood room gives the utmost in beauty and comfort. Unlike many other woods used for panelling, British Columbia woods, especially Douglas fir and western hemlock, can be finished in a great variety of ways. Many different coloured stains can be applied and dull or bright surface secured. Douglas fir is the favourite panel wood on account of its beautiful grain and figuring when slash-cut or veneer-cut, and because it takes stain so well.

Western hemlock makes a desirable interior finish, as it is easy to work, readily turned, and its straight, even grain makes it free from brashness and tendency to chip or splinter. It is one of the most ornamental woods for office or home interiors, takes stain readily, and is not easily dented. Western red cedar makes a very desirable interior finish because of its ability to hold its shape and retain a smooth surface. In its natural colour the wood somewhat resembles mahogany, although, of course, it is much softer and lighter. It has a distinctive silky finish and takes stain well. Slash-cut sitka spruce has an attractive grain or figuring, and the soft, silvery, easily worked wood is well adapted to panelling.

OTHER INTERIOR FINISH.

This includes all the minor kinds of interior finish, such as wainscoting, shelving, moulding, casing, baseboards, etc.

Douglas fir is in most general use because of its attractive grain, abundance, and cheapness. Western hemlock, sitka spruce, and western red cedar are all used, however, for different purposes in accordance with their respective qualities.

BRIDGE, TRUSS, AND TRESTLE TIMBERS.

Douglas fir is the standard timber for the construction of wooden bridges, trestles, etc., owing to its great strength and stiffness, durability, comparative lightness, the large dimensions in which it can be obtained, and its abundance and cheapness.

Western hemlock is also very suitable for purposes where the maximum of strength is not required. It is not quite as strong as fir, but is lighter, and, therefore, easier to handle. It is obtainable in large dimensions.

Western red cedar, because of its remarkable durability, is sometimes used in positions where ordinary wood quickly rots, such as sills or foundation beams in contact with the soil. Fir, hemlock, and spruce treated with creosote or other preservative are also used under such conditions. Where a heavy load is to be borne, Douglas fir and western hemlock are, of course, especially suitable because of their greater strength and resistance to compression.

PILING AND CRIBBING.

Douglas fir is most widely used for piling and cribbing. Its valuable qualities for these purposes are its very long, straight, slightly tapering trunk, its strength, resilience, and comparative durability. The wood is hard enough to penetrate most soils, and stands the hammering of the piledriver well. Only where hard subsoils are to be penetrated is it necessary to band the tops to prevent brooming and splitting.

Western hemlock, sitka spruce, and western red cedar also make good piling and cribbing. Hemlock is strong, and is durable if given preservative treatment. Sitka spruce is suitable for use where great strength is not required, and, like hemlock, is durable if treated. Western red cedar is naturally very durable, and is valued also for its light weight and excellent form, but its greater cost and lesser strength as compared with Douglas fir and hemlock restrict its use.

Teredos and other marine borers are the worst enemies of piling, and will attack nearly every wood that is not creosoted. Untreated piling lasts from three to six years. Creosoted Douglas fir piling has remained sound for twenty to thirty years in salt water on both the Atlantic and Pacific coasts of North America. Piling intended for permanent work should always be treated with a preservative or protected in some other way against marine borers. Creosoted piling and cribbing of all kinds can be obtained in British Columbia.

POLES FOR TELEPHONE, TELEGRAPH, AND POWER TRANSMISSION LINES.

Western red cedar is more widely used, suitable, and popular for poles than any other wood used without preservative treatment. This is because it best meets the requirements of great durability in contact with the soil, lightness, and suitable taper. Because of the great size to which the tree grows, poles can be obtained from it of greater length than in any other species of equal durability.

Douglas fir, western hemlock, and sitka spruce, though naturally less durable in contact with the soil than red cedar, meet every other requirement for poles. Durability and long life can be ensured in these species by treating the butt ends of the poles with some preservative, as creosote. Douglas fir is especially suited for positions where great size or strength are required. The largest and best wooden flag-poles are obtained from the fir forests of the Pacific slope. What will probably be the tallest pole in the world is the one to be presented by the lumbermen and Government of British Columbia to Kew Gardens. This flag-pole, which is now awaiting a ship capable of carrying it, is 2½ ft. long, 33 in. in diameter at the butt, and 12 in. at the top.

Our Illustrations.

THE EDITH CAVELL HOME FOR NURSES, LONDON HOSPITAL, WHITECHAPEL.

The building, which provides additional accommodation for nurses, is in course of erection in East Mount Street, Whitechapel. Considerable interest in regard to it arises from the fact that for Majesty Queen Alexandra, the consort of the hospital, has desired Lord Kinnaird, the chairman of the hospital, to name the "Edith Cavell Home" instead of designating it the "Alexandra Home," as originally intended. The building has a frontage of about 150 ft. to East Mount Street, with a return frontage of 47 ft. to Oxford Street, facing the Luckes Nursing Home. It consists of eight floors, including the basement, and has accommodation in separate rooms for 110 nurses, twelve sisters, and twelve servants. The basement, surrounded by wide areas, is well lighted, and contains the heating chamber, the accumulator room, the coal cellars, servants' rooms, together with a servants' sitting room, scullery, linen store, larders, bathrooms, and lavatory block detached. The ground floor contains, in addition to the sisters' and nurses' rooms, a large nurses' sitting-room and library, visitors' room, three bathrooms, and tearoom. The upper floors consist entirely of sisters' and nurses' bedrooms. Each of these rooms is provided with a fitted wardrobe, similar to the other nurses' rooms in the hospital. Each floor is provided with a hair washing room fitted with a special electric blower for the use of nurses in quickly cleansing and drying the hair, as fitted up in the older parts of the hospital. Each floor is also provided with a central staircase and large electric lift, also with a boot room, three bathrooms, and a detached lavatory block. There are also additional escape staircases provided at each end of the building. The attic floor is used as a box room, but it also contains separate iron lockers for the use of each nurse. The premises generally are constructed of non-combustible materials, the floors being composed of concrete carried by steel joists. The inside staircases are constructed of ferro-concrete covered with terrazzo mosaic, thus avoiding the use of hearthstone, which is found objectionable in practice. Hot-water radiators are provided throughout, with coal stoves in the sitting rooms, and the building is lighted by electricity. The room floors are covered with parquet on a prepared cement surface; the large sitting room and library is floored in oak. There is direct communication with the interior of the hospital by means of a covered bridge across East Mount Street, so that the whole of the main hospital buildings are approached without exposure to the weather. Architecturally the design of the building is very simple, being somewhat Georgian in character. The ground floor walling is faced with red bricks, and above that with mingled bricks. A small quantity of artificial stone is used for the dressings, and the roof is covered with green slates. The architects are Messrs. Rowland Plumble and Partners, and the work is being carried out by Messrs. Perry and Co., the contractors.

TWO HOUSES AT CHISLEHURST, ON NARROW SITES.

These two houses were designed for long narrow plots of land, and which had been left unoccupied and boarded as they are in the neighbourhood of gardens. The solution of the problem was found to be to throw the main part of the front, thus leaving the rear part open to the sitting-room, and to give the occupants their share of the garden by means of a good view from the front window of the houses. The houses are built over the front part of the plots, and the rear part is left open to the garden. The houses are built on the narrow plots, and the rear part is left open to the garden. The houses are built on the narrow plots, and the rear part is left open to the garden.

with white-painted 18th-Century paneling from Catharine Court, Tower Hill, lately pulled down. The paved path to the front door is some 70 ft. long, and the first part of the garden behind is laid out with stone-paved paths and forms a small rose garden. The builders were Messrs. T. Rider and Son, of Southwark and Chislehurst, and the drawings were hung in this year's Royal Academy. Mr. E. J. May, F.R.I.B.A., was the architect.

MILITARY EMERGENCY HOSPITAL.

These plans, grouped on one of our double-page illustration sheets to-day, together with the plan printed with our report of Mr. Alfred Saxon Snell's Chadwick's lecture on "Military Emergency Hospital Construction," page 552 *et seq.*, were chosen from the series of examples exhibited last Wednesday in Wimpole Street, W., at the Royal Society of Medicine on the occasion of this lecture. Mr. Snell alluded to all these hospitals, so there is nothing to add save to record their titles and architects' names:—The Queen's Canadian Military Hospital, Beechborough Park, near Shorncliffe, Kent; Mr. W. Henry White, architect—plan, block plan, and section. The 5th Northern General Hospital, Leicester, open-air wards; Messrs. Everard, Son, and Pjck, architects—plan of one ward, block plan, and detailed section. The Military Emergency Hospital Ward Office model plan—block plan, plan of ward, a general section showing spacing and detail section. Norfolk and Norwich Hospital Military Emergency huts—plan of ward, block plan, and sections. War Hospital for Wales, Netley—general plan; Mr. Edwin T. Hall (Messrs. E. T. Hall and Son), hon. architect.

IMPERIAL HOUSE, IN THE OCCUPATION OF THE WAR OFFICE, TOTHILL STREET, WESTMINSTER.

These premises have been recently completed, and are now occupied by the War Department. The building was designed as a block of professional offices and for commercial business, but is devoted to a different purpose, and one for which the accommodation is well adapted. The work is of steel frame construction, the main elevation to Tothill Street being faced with stone. The Dartmouth Street front is 170 ft. long. The design of the main front carries on the lines and general character of the adjoining building, Caxton House. A prominent feature is made of the entrance portico, with its very successful sculptured figures, by Mr. L. F. Roselieb, R.B.A. This portal is shown by a larger photograph. The architects are Messrs. Metcalf and Greig, Kingsway Chambers, and the general contractors were Messrs. Lorden and Son, of Tooting, S.W. The lifts are by Messrs. Waygood-Otis, Limited. A photograph is given of the vestibule. Below the general view of the building in Tothill Street we reproduce two plans showing the extent of the premises, which give an office area of 8,009 sq. ft. on the ground floor alone. The total area of the whole block, exclusive of corridors, is set down at 54,993 ft. super.

In view of present circumstances, the committee of the Surveyors' Institution have reluctantly decided that it will not be practicable to hold the usual Junior Meetings this session.

The alterations to the Grand Pump Room at Bath, which was re-opened on Monday in last week, have been carried out from plans by and under the direction of Mr. Alfred J. Taylor, M.S.A., of Bath, architect to the Baths Committee.

A stained-glass window in memory of the late Sir Alfred L. Jones has been inserted on the south side of the choir of Liverpool Cathedral. In the Lady chapel windows the leafage of the Tree of Life runs through them all, replacing any canopy work above or supporting structure below the figures. In the new window there is canopy work, but it frames only the group of figures and is itself set in the midst of unshaded glass, showing off the groups. The prevailing colour in the window is blue, and the scrolls in the two lights, referring to the window, are held by angels, as on the Lent and Advent frontal belonging to the Lady chapel.

OBITUARY.

Mr. George Morgan, 24, King Street, Carmarthen, died on the 5th inst., within a few hours of completing his eighty-first year. Mr. Morgan was one of the oldest architects in South Wales, and during the last fifty years designed a great many buildings in nearly every county in Wales, including Monmouthshire. He acted as architect to over twenty-eight school boards, and designed no fewer than eighty schools, both secondary and elementary, in Carmarthenshire and the adjoining counties. He was responsible for the planning of numerous Nonconformist chapels, one of the largest being at Newtown, Montgomeryshire. During the last thirty years he was associated with his eldest son, Mr. J. Howard Morgan, F.R.I.B.A., who continues the practice, and during that time many important commissions were undertaken, among them being Bush House, the Pembrokehire seat of Colonel Sir Thomas Meyrick, C.B.; Penrallt, Cardiganshire, for the late Mr. W. G. Reddie; Rhosygilwen for the late Mr. J. V. Colby; Cilwendeg for the late Mrs. Saunders-Davies; and other country residences. Bank premises were erected in various towns for the London and Provincial, Lloyds, and the London, City and Midland banking companies. Mr. Morgan is survived by three sons and four daughters.

The sanction of the Local Government Board has been given to loans to the Corporation of Derby of £1,927 for distributing mains and £2,043 for electric motors.

Sir H. A. Farrington will succeed Mr. C. E. Muriel as Conservator of Forests, Bengal, from January 3 next, when the latter proceeds on long leave preparatory to retirement.

The Kantuck Rural District Council have received the sanction of the Local Government Board for Ireland to the borrowing of £1,400 for the erection of labourers' cottages.

Mr. S. C. Brittingham, A.R.I.B.A., of Melbourne, has been promoted to the office of Acting Government Architect in the Public Works Department of Victoria. "Mr. Brittingham has been in the service of the State for many years, and his work has been characterised by marked ability," remarks the *Journal of the Royal Victorian Institute of Architects* in recording his promotion.

All points regarding the purchase by the Morpeth Town Council from the Countess of Carlisle of the town hall and other properties have been settled except the condition that no intoxicating liquor should be sold, distributed, or consumed on the premises. The council will take a plebiscite of the ratepayers on this point. The purchase money has been agreed at £4,500.

Mr. John Howard, of Brighton, has decided, as a memorial to Miss Cavell, the heroic nurse, to build at Brighton and endow twenty-four cottages, at a cost of £50,000, for the free use of trained hospital nurses who are unable to follow their calling. The cottages are to be built on land adjoining the convalescent home built and endowed by Mr. Howard at a cost of £40,000, and now used as a military hospital.

At Matlock on Wednesday, Mr. H. S. Bidwell held an inquiry on behalf of the Local Government Board with regard to the request of the urban district council for further powers to raise loans to continue and complete the sewerage scheme. By order of the Treasury the power to borrow a further £12,000 to go on with the scheme had been deferred pending a visit of an engineer to the works. It was explained that £45,000 was granted for the work, and £32,000 had been expended. A sum of £24,000 had been asked for, and the Local Government Board granted £12,000. If the scheme were stopped now it would mean losses all round.

The work of restoring Chichele College, Higham Ferrers, is now finished, the benefactors being the late Dr. John Crew and his brother Mr. Josiah Crew. The style of the architecture as well as the badge of Henry IV., which appears in the cornice on the south side, give the approximate date of its erection (1390-1400). Its original purpose was that of a Chantry Chapel—probably it is the Jesus Chapel mentioned in the old records in connection with the church. It certainly was never a refectory. Portions of the piscina and of the rood staircase remain in the south wall. The college was founded by Archdeacon Chichele, who was a native of Higham Ferrers.

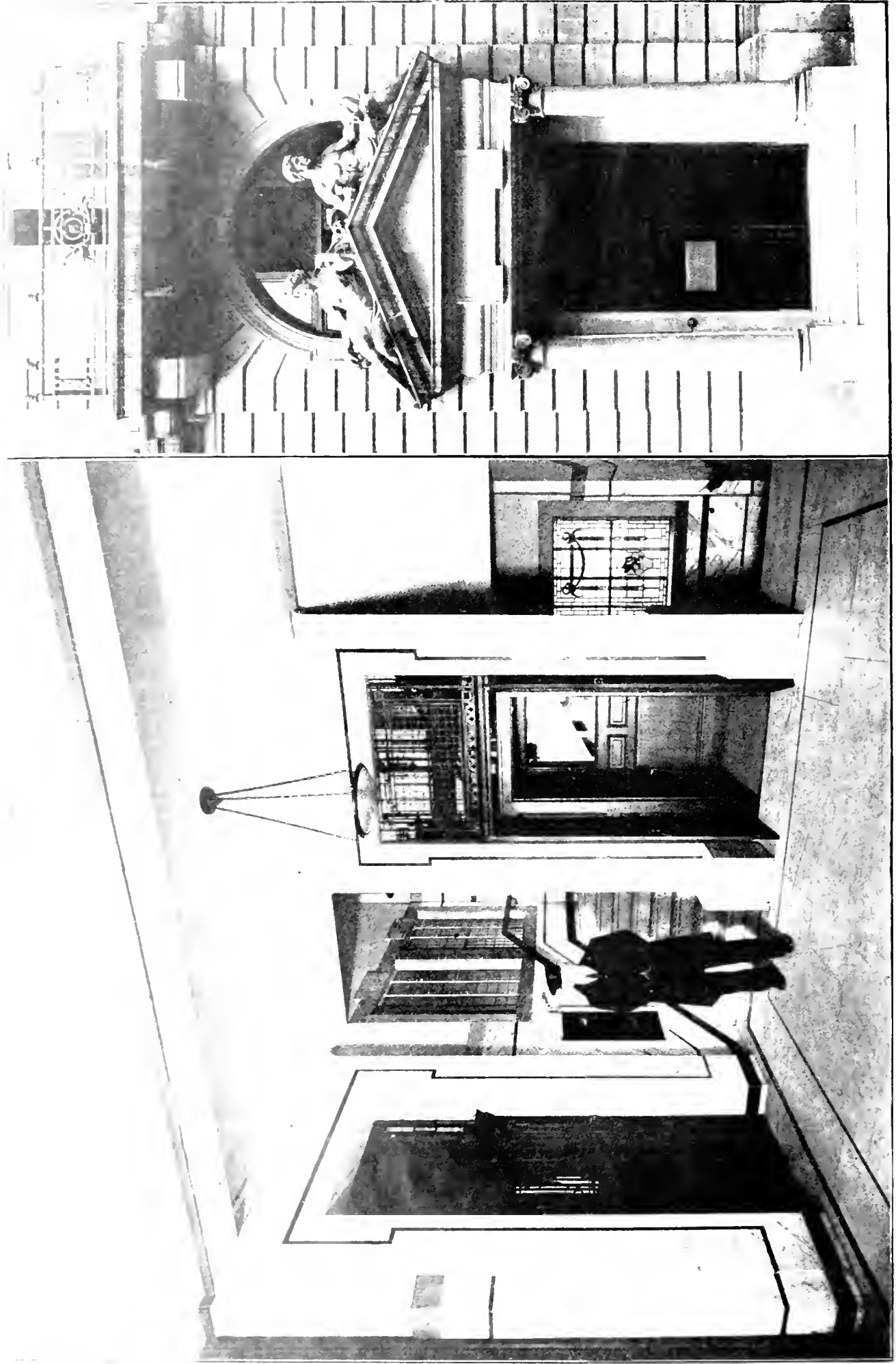

Tellie Camera Co., Photo

ENTRANCE VESTIBULE AND MAIN DOORWAY, IMPERIAL HOUSE, WESTMINSTER (OCCUPIED BY THE WAR DEPARTMENT).

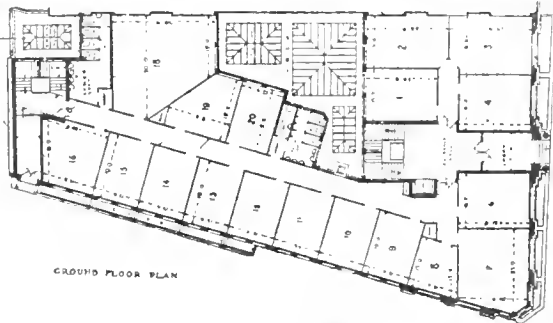

GROUND FLOOR PLAN

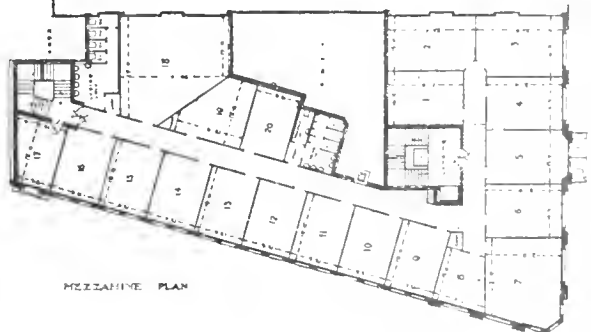

MEZZANINE PLAN

Tella Camera Co. Photo.

IMPERIAL HOUSE, WESTMINSTER (OCCUPIED BY THE WAR DEPARTMENT).
Messrs. HENRY METCALF and THOMAS R. GREIG, Architects.

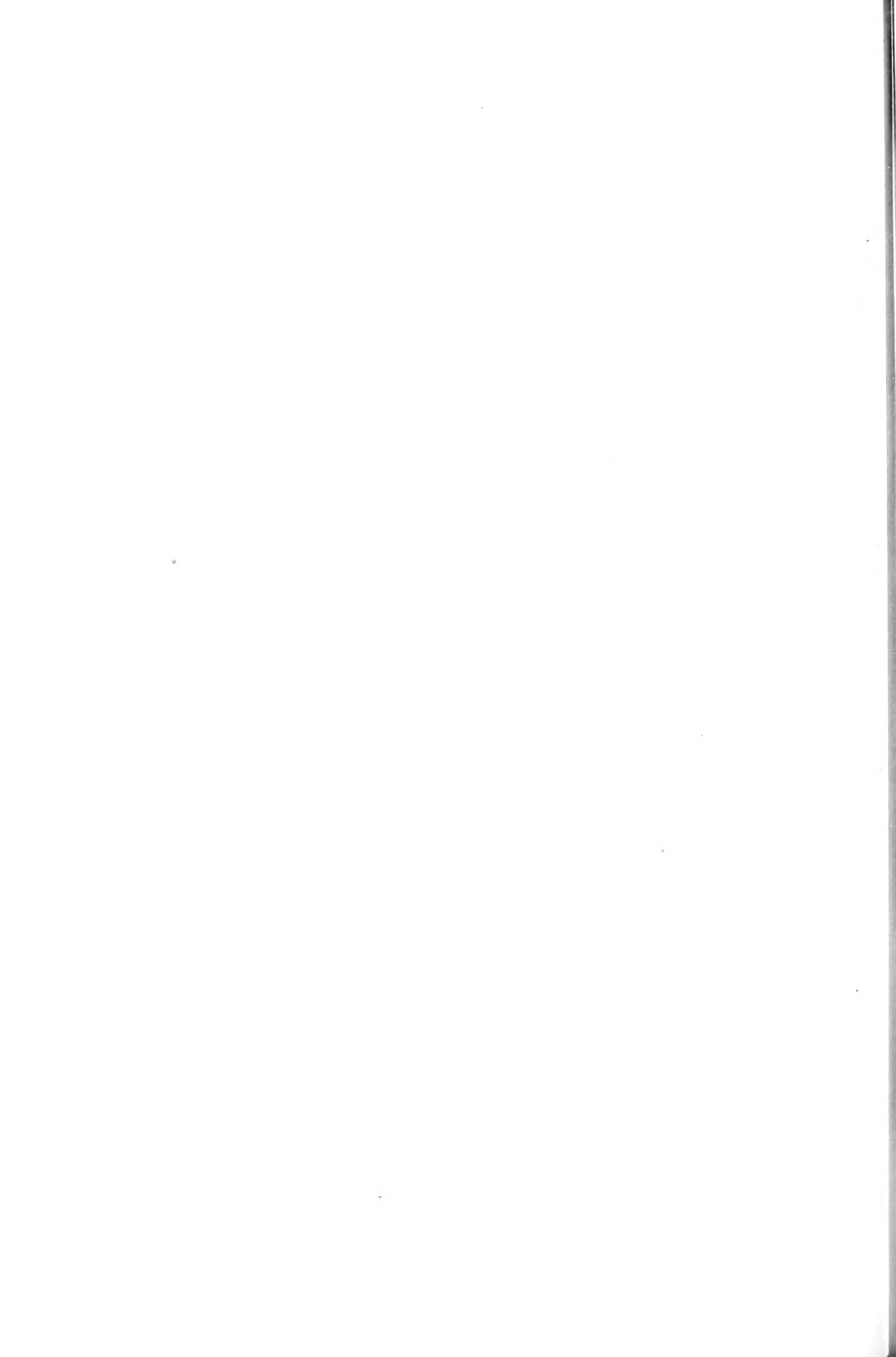

THE QUEEN'S CANADIAN MILITARY HOSPITAL,
BEACHDOROUGH PARK, SHORNCLIFFE, KENT.

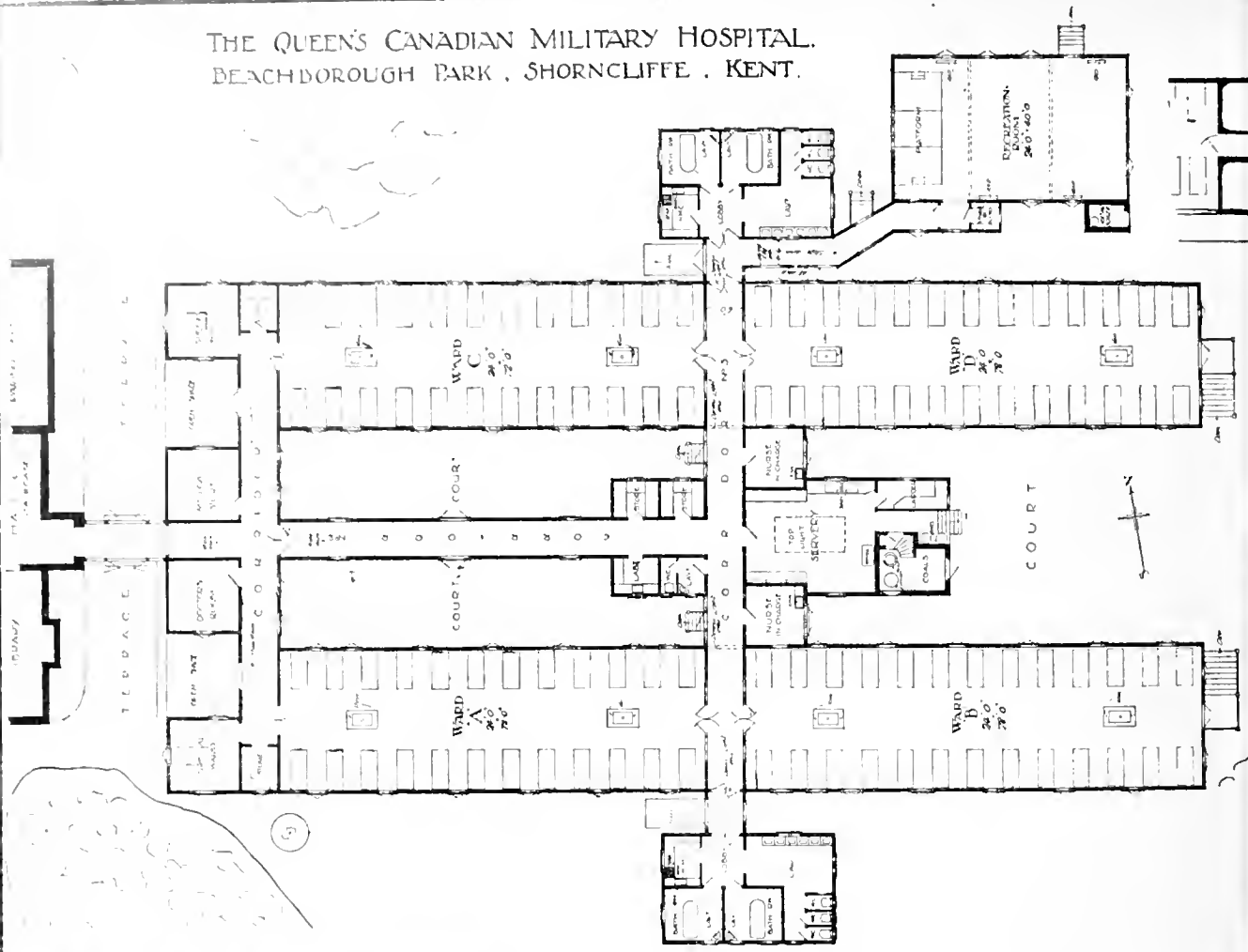

SCALE OF FEET FOR DETAIL

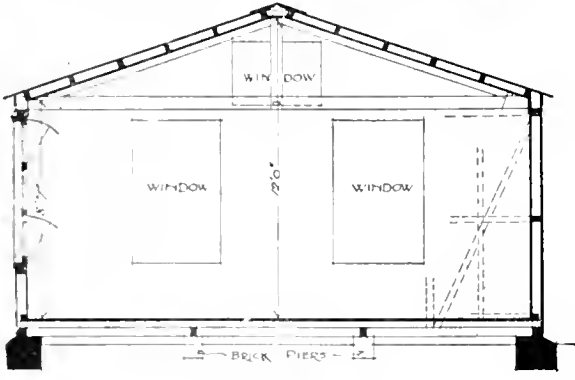

SECTION

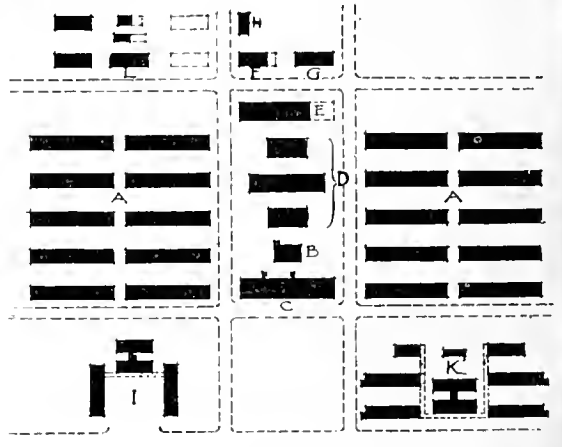
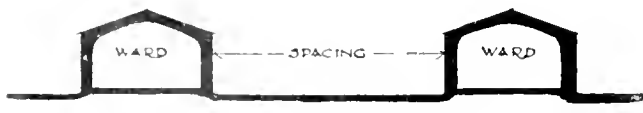

BLOCK PLAN
SCALE OF FEET



PLAN OF WARD BLOCK
SCALE OF FEET

- REFERENCE
- A WARD BLOCK
 - B OPERATING BLOCK
 - C ADMINISTRATION
 - D KITCHEN & DINING ROOMS
 - E HOSPITAL SUPPLY DEPARTMENT
 - F PACK STORE
 - G DISINFECTING BLOCK
 - H MORTUARY BLOCK
 - I OFFICERS QUARTERS
 - K NURSES QUARTERS
 - L R.A.M.C. UNIT

MILITARY EMERGENCY HOSPITALS.
WAR OFFICE MODEL PLAN

OPEN AIR WARDS

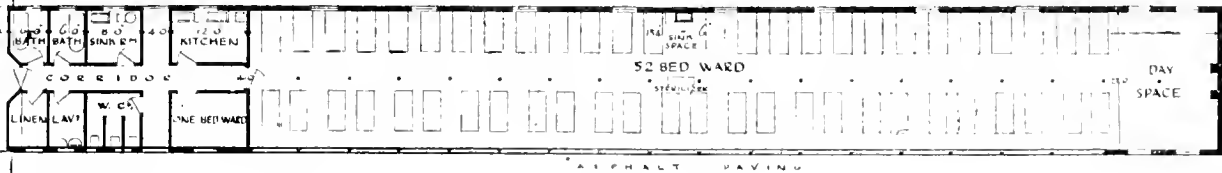

PLAN OF WARD

5TH NORTHERN GENERAL HOSPITAL LEICESTER

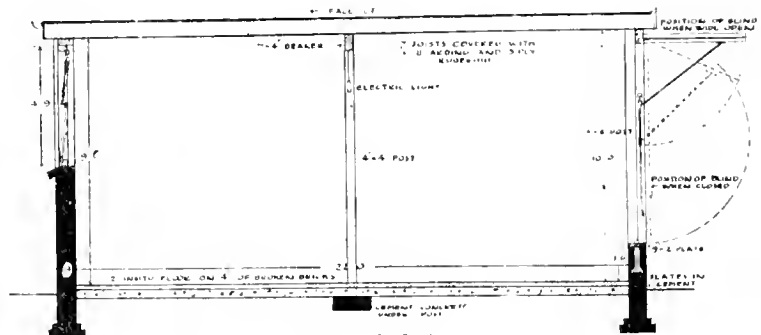
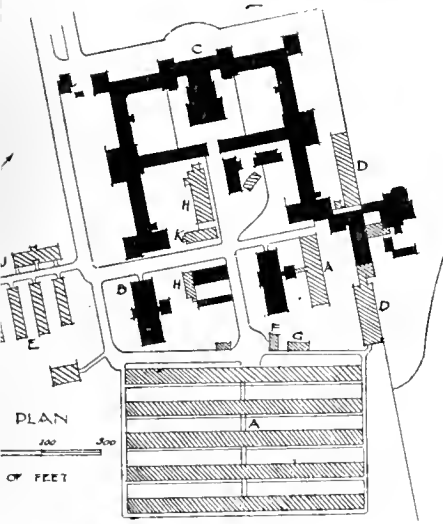

SECTION OF WARD

- REFERENCE
- A NEW WARD BLOCKS
 - B OPERATING THEATRE
 - C ADMINISTRATIVE
 - D NURSED QUARTERS
 - E ORDERIES
 - F OBSERVATION BLOCK
 - G BATHOLOGICAL
 - H STORES
 - J CANTEEN/ABLUTION
 - K CHURCH

MILITARY EMERGENCY HOSPITALS
NORFOLK & NORWICH HOSPITAL
TEMPORARY HUTS

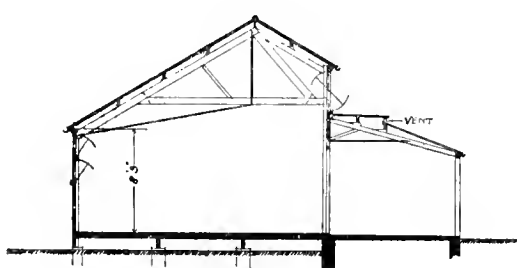
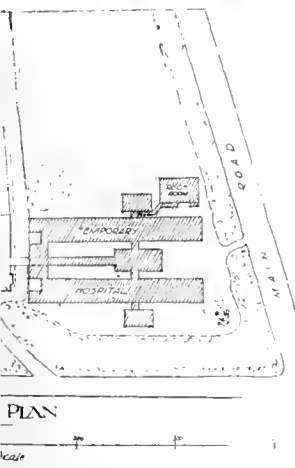

TRANSVERSE SECTION
SCALE OF FEET FOR SECTIONS

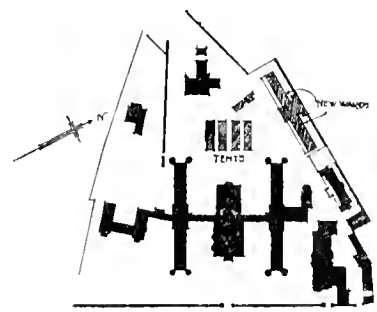

BLOCK PLAN
SCALE OF FEET

WOMEN'S CANADIAN
HOSPITAL
KENT

W. Henry White
ARCHITECT 1915

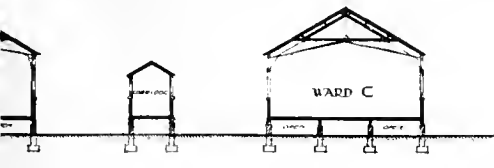

CROSS SECTION
OF WARDS A & C

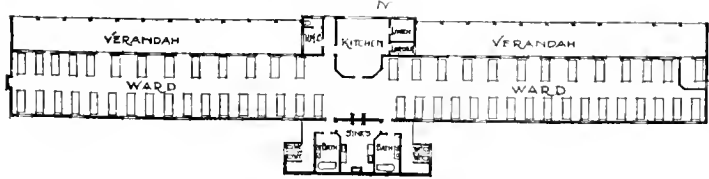

PLAN OF WARD
SCALE OF FEET

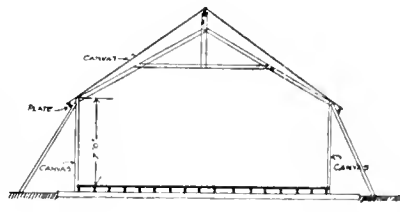

SECTION OF TENT WARDS

EDM. BOARDMAN & SON
ARCHITECTS
NORWICH





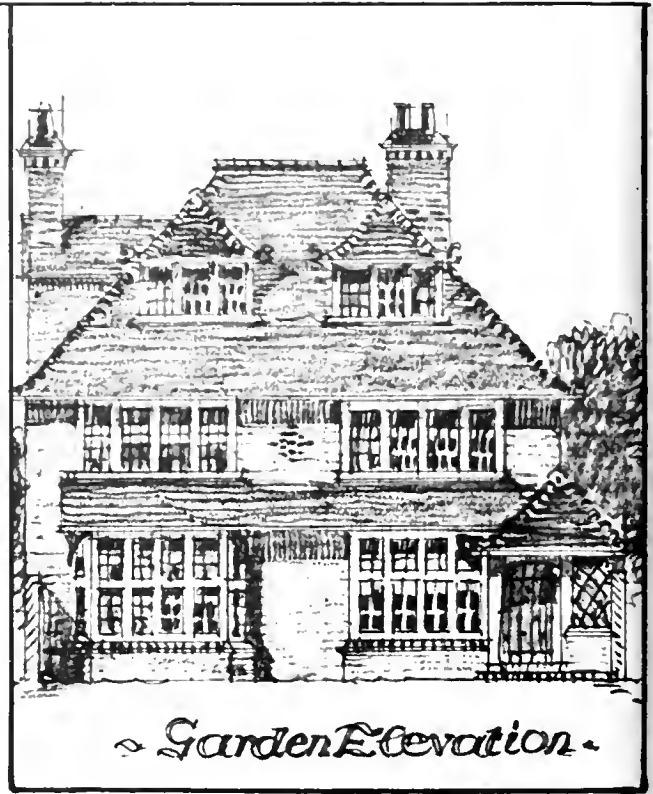
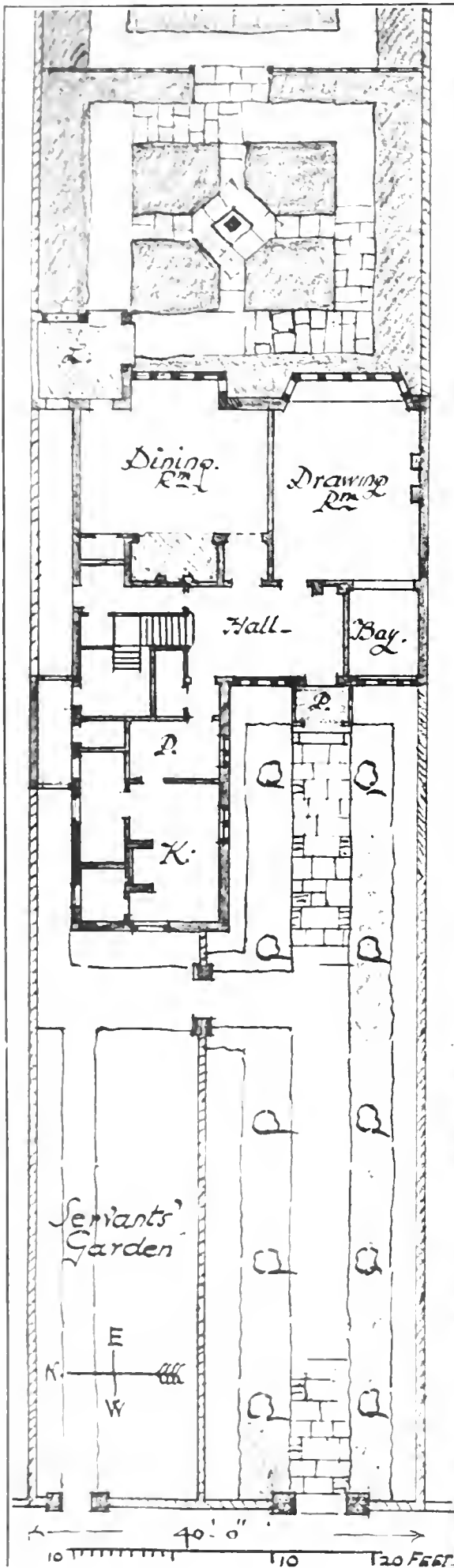

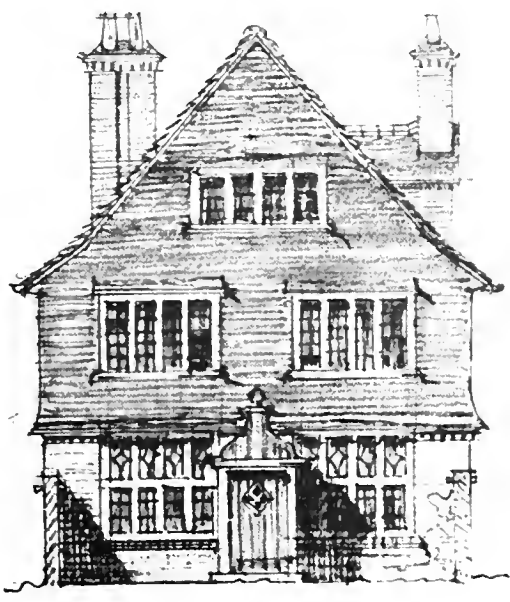

Garden Elevation

Proposed House at (nislehurst)

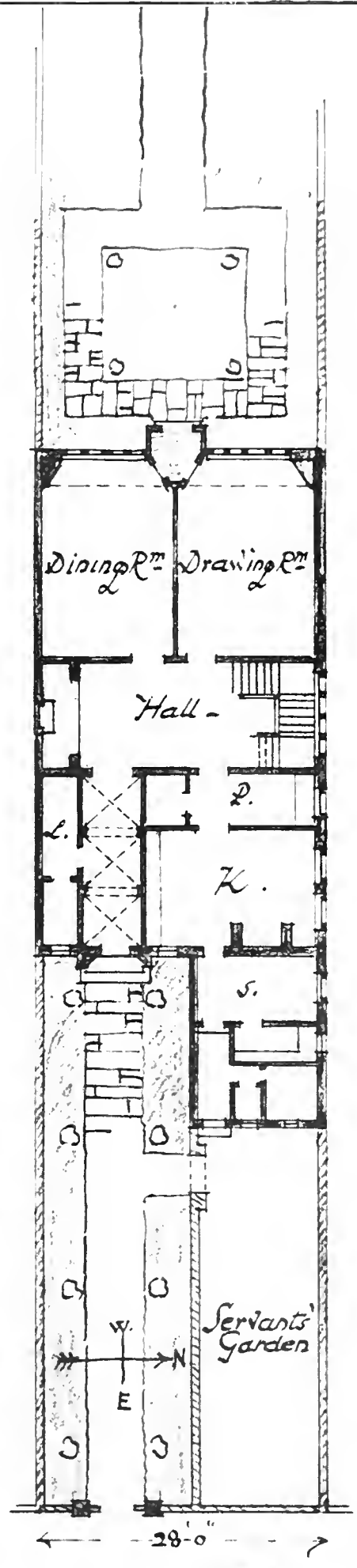

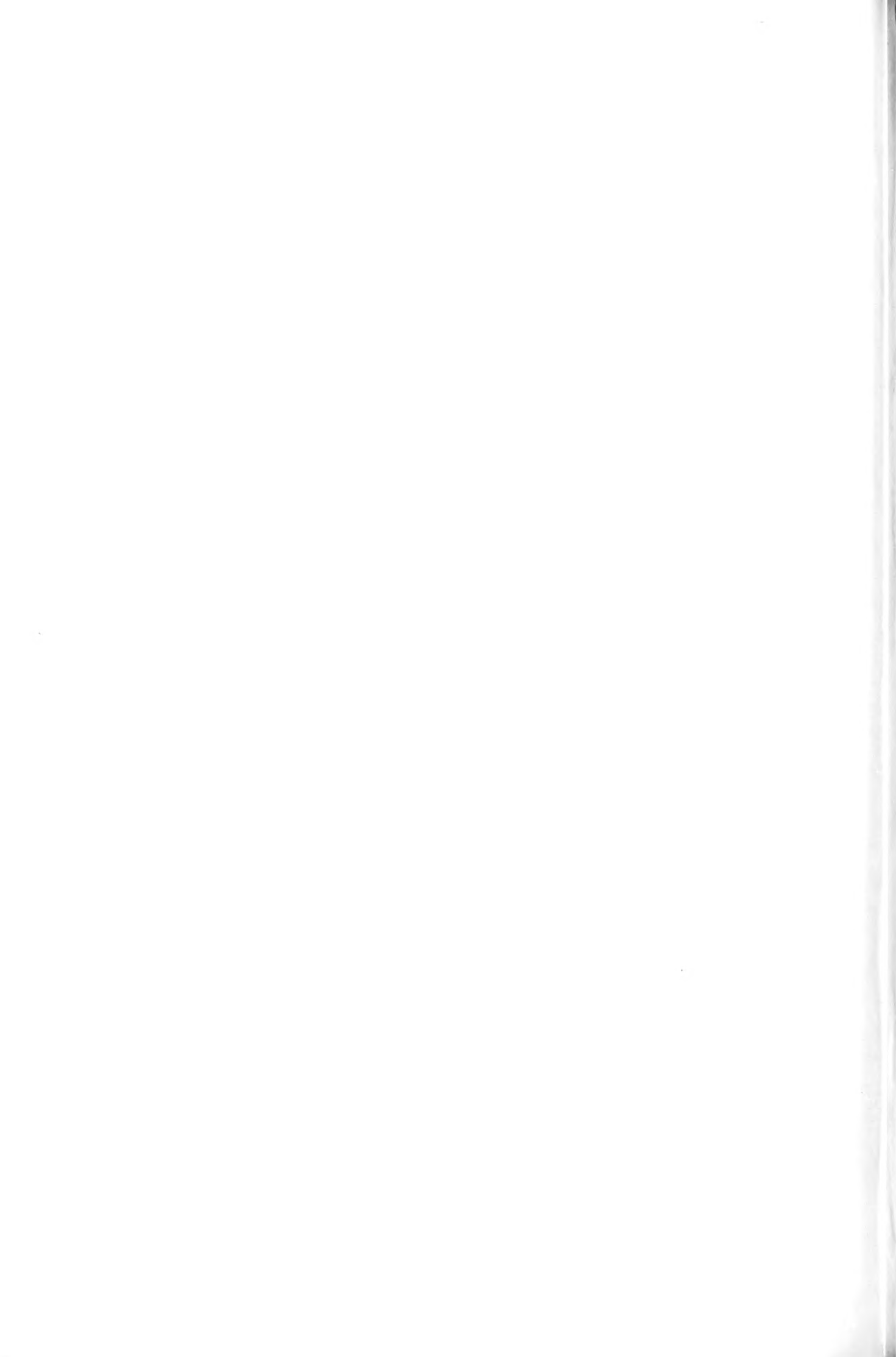

THE EDWIN CAMEL BUILDING



Rowland Plombe & Partners Architects 1915

C.F.W. del.

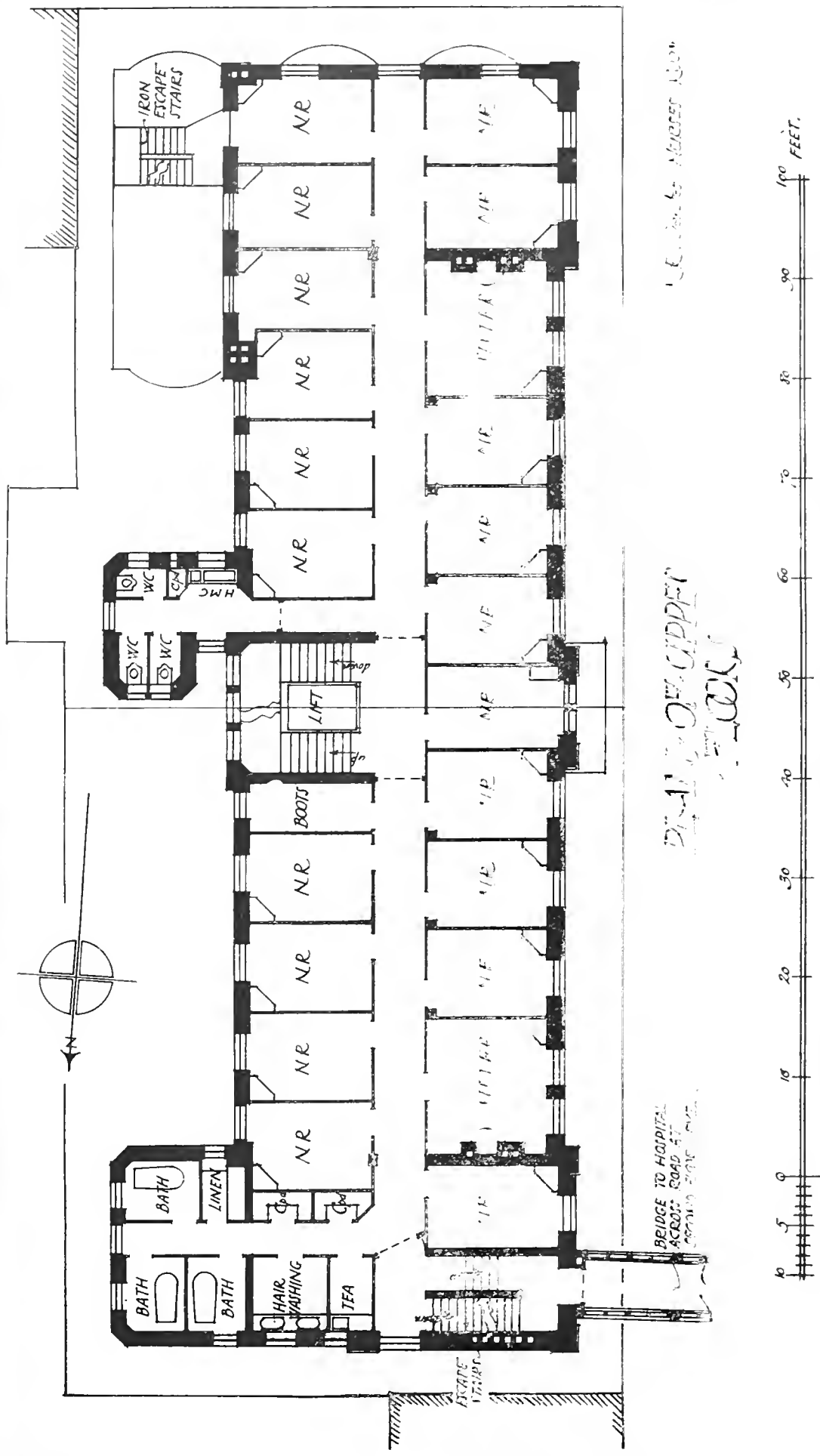

Edith Cavell Home

PLAN OF UPPER FLOOR

BRIDGE TO HOSPITAL ACROSS ROAD AT CORNER OF WHITECHAPEL

THE EDITH CAVELL HOME FOR NURSES, LONDON HOSPITAL, WHITECHAPEL, E.
Messrs. ROWLAND PLOMBE, F.R.I.B.A., and PARTNERS, ARCHITECTS.



Currente Calamo.

His own well deserved reputation, and that of his able father, doubtless sufficed to attract the crowded audience last Thursday at the rooms of the Royal Society of Medicine to profit by Mr. Alfred Saxon Snell's able Chadwick Lecture on Emergency Military Hospital Construction, which we are glad to be able to illustrate as fully as our space will permit. As in regard to other Departments of the Government, most of us, the War Office possibly excepted, have certainly been struck by the wide differences in cost of some of the hospitals built. We have come across no cases yet in which, as has been alleged with some of the huts, generous contributions to battalion funds are said to have been made by contractors, so that cannot account for it. Some of us also have wondered, perhaps, at the absence from the lists of architects employed of names of some who have been regarded as hospital specialists. Probably the War Office is unfamiliar with their existence. The whole subject is of the highest importance, and we incline to regret that the R.I.B.A., instead of closing down its meetings, did not secure temporary accommodation elsewhere, as the Chadwick Trustees had to, and fill the bill throughout the first half of the session with a series of papers thereon, in which fuller details still might have been rendered by the architects of the buildings concerned. They would have been appreciated. There were as many architects among Mr. Saxon Snell's hearers at Wimpole Street last Thursday as gathered to listen to their President at the R.I.B.A. meeting on Monday fortnight.

We have received from the Commonwealth of Australia a report by Mr. Walter Burnley Griffin, the selected architect and now "Federal Director of Design and Construction" of the proposed new capital, Canberra, accompanied by a preliminary plan. These were prepared two years ago, and readers are familiar therewith. We have also received a bulky budget of correspondence during the past two years between Mr. Griffin and the various officials of the Federal Government, from "Home Minister" downwards, from which it is evident that, as here at home, the traditions of the Circumlocution Office still prevail whenever an unfortunate architect is fair game for Jacks-in-office. Some of the letters are very funny, but Mr. Griffin seems to be holding his own so far as may be gathered from the following, dated June 18, 1915:—

The Honourable the Minister for Home Affairs,
Melbourne.

Sir,—I have had an opportunity of partially inspecting the file of correspondence laid upon the table of the House, and find that it largely comprises adverse representations and recommendations by departmental officers upon my work, with minutes by you, in relation to the whole of which I have had absolutely no previous knowledge. I am surprised that these should have been placed upon record without giving me the privilege of perusal, since you were entitled to know that there is an entirely different version.

Further, the file is incomplete. I could find none of the documents relating to the withdrawal of my chief assistant nor reference thereto.—Yours truly,

W. B. GRIFFIN,
Federal Capital Director of Design
and Construction.

"Incomplete or not, the present batch of letters fills 153 pages, and has cost the Commonwealth £75 to print. By the time Canberra is built it strikes us as probable that some weary chronicler will wind up the record with some such words as conclude John xxi. 25!

Up to June 30 of this year the expenditure on the building of Canberra amounted to

£691,201. This does not include the purchase of land. The heaviest outlay has been in connection with water supply, which has cost £196,000; on the power plant the expenditure has been £66,000; on buildings, £73,000; on roads and bridges, £91,000; and on the railway from Queanbeyan to Canberra, £35,000. In all, 363,660 acres of land have been compulsorily acquired, the gross revenue derived from the land amounting to £16,453. Work in the permanent nursery is now in full swing, and re-forestation is also in progress. The sewerage works are reported to be making excellent progress, and the Staffordshire kiln brickworks are approaching completion. A proclamation will shortly be issued, taking over sovereign rights over about 18,000 acres at Jervis Bay.

The committee of the Builders' Benevolent Institution has again decided to pass the annual dinner, which, in ordinary times, would have been held this month. The responsibility of providing the means to continue the payment of pensions devolves upon the treasurer, the president, Mr. George R. Holland (of Messrs. Holland and Hannen and Cubitts, Limited), being still away on his military duties. An earnest appeal to readers, therefore, is made to send a special donation to take the place of the amount they would have given at the annual dinner. The only reliable income of the institution amounts to £700 from investments, and an average of £300 from annual subscriptions. The yearly payments to pensioners are over £1,900. To make up this deficiency of £900, special effort is necessary, and donations should be sent at once to Mr. Frank May, the treasurer, at Messrs. Holland and Hannen and Cubitts, Limited, Hyde Street, Bloomsbury, W.C.

Builders often let, if they cannot sell, their new houses to newly married couples, who buy new furniture upon a hire-purchase agreement. Then there is the rent to be paid and the furniture instalments. When trouble comes the question is usually whether the landlord or the hire-purchase people shall first get the furniture. The recent case of Bence and Johnson v. Maple and Co., Limited, though not an example of this newness all round, shows what may happen in this race for the furniture. The plaintiffs, as landlords of a house at Hampstead, sued the defendants, who had sold some furniture on hire-purchase to the tenants, for trespass. It was clearly quite a near thing during the war. The plaintiffs, as landlords, had applied for leave to distrain, as is now necessary during the war, which the county court judge refused. Then they got a key, took possession of the house, and ended the tenancy, their smart agent carefully locking up the place, but leaving the furniture there and the front door on the latch. Thereupon Maple's people took their turn, got another key from the tenant by persuasion, went in, and cleared out all their hired furniture. There were some neat and knotty points of law in the case, one being as to whether the landlords could distrain after having put an end to the tenancy, as this would affect their damages. After a two days' hearing, with full arguments and summing-up, the jury found there had been a trespass, and gave £50 as damages. There were other findings, but the landlord's right to distrain was found too shadowy for argument, even by the lawyers. So the curtain fell on this comedy of errors, leaving the plaintiffs, as landlords, in possession of the house, with a judgment for £50, which will pay them the rent owing, while Maple's have got their hired furniture back

to sell again, and such instalments as were paid before the crisis. Still, as the landlords have judgment, with the costs of the action, they seem to have come off best in this legal scuffle. The tenant, indeed, remains, a sad vague figure of failure, in the background, but she can always tell and re-tell her dramatic little story of "The Two Latch-keys," and what happened to the landlords and the lawyers!

The Public Authorities Protection Act, 1893, was plainly and primarily intended to protect those authorities in doing their public duties. But corporations, councils, and the rest are always seeking to extend the scope of that statute for purposes of what may be called their private protection. It is satisfactory to find that, in the recent case of "Bradford Corporation v. Myers," this attempt has entirely failed. The judgment of the House of Lords, laying down first principles, will become a leading precedent, and so is of much interest to all contractors, builders, and others who have to do business with these public authorities. The corporation made their own gas, and so they had to sell their own coke. The case began in October, 1912, when the servant of the corporation, while delivering a ton of coke through the plaintiff's coal-hole in the pavement, broke his shop window. Plaintiff sued in the county court for damages, but did not do so until more than six months later. Then the corporation set up the technical plea that, as the action had not been brought within six months, they were exempted from liability under the Public Authorities Act. They succeeded in the county court; a Divisional Court of two judges was divided in opinion; then the Court of Appeal held that the Act did not apply; and now five Law Lords have confirmed this decision in favour of the original plaintiff and his claim for £17 2s. against the corporation. It is all very well to protect public authorities in the execution of their public duties under statute or otherwise; but when they take to making gas and selling coke on their own account this is a carrying-on of business and not the performance of a public duty. So they were held liable to this action for damages in the same way as would be any other trader whose servants were guilty of negligence.

A new church hall at Bolsover, built at the junction of the Mansfield and Creswell main roads at a cost of over £1,000, has been formally opened. The architects were Messrs. C. Robinson and Sons, of Chesterfield.

Mr. P. M. Crosthwaite, an inspector under the Local Government Board, held an inquiry at Battle yesterday (Tuesday) into an application from the urban district council for sanction to borrow £950 for works of sewage disposal.

Mr. Cuthbert Rodham Morris, of North Curry, near Taunton, agent to the Duchy of Cornwall Estates and head of Morris, Sons, and Peard, surveyors and auctioneers, who died on July 6, aged eighty-three, left estate of the value of £170,885.

The death was reported to the Metropolitan Water Board on Friday of Mr. W. Morris, for over fifty years engineer for the Kent district under the Kent Waterworks Co. and the Board. Since his retirement in January, 1909, Mr. Morris has been receiving a pension of £1,215 8s. per annum.

An open verdict was returned at the resumed inquest at St. Pancras on Saturday respecting the death of Norman Stuart Fergusson, aged twenty years, a cadet in the Inns of Court Officers' Training Corps, and formerly an architect's pupil residing at Cathedral Road, Cardiff. Dr. Frederick Womack, toxicologist, of St. Bartholomew's Hospital, stated that the cause of death was veronal poisoning. The jury returned a verdict accordingly, but added that there was no evidence to show for what purpose Fergusson took the veronal.

Trade News.

WAGES MOVEMENTS.

LEEDS JOINERS' BONUS.—Sir George Askwith has presided over an important conference, held at the Board of Trade Offices, between seven representatives of the Leeds Joint Committee of the Carpenters and Joiners' Society and six representatives of the Leeds Master Builders' Association. The subject under discussion was the claim for a war bonus made by the Leeds joiners, who number approximately 900. They have not yet been conceded any war bonus, and they have agitated for one during the last six months. Mr. Tom Heale, the senior Leeds society's delegate to the conference, stated in an interview that the decision of the conference was for a bonus of 2s. 6d. weekly, payable at the end of the first week after the close of the conference. This is the sum paid as a bonus for some months past to carpenters in the shop-fitting trade, and the men's representatives accepted the decision at once. The employers' representatives stated they would be compelled to submit the agreement to their association for approval.

TRADE NOTES.

Under the direction of Messrs. A. F. Scott and Son, architects, Norwich, Boyle's latest patent "Air-Pump" ventilator has been applied to the new Primitive Methodist church, Carcroft, near Doncaster.

In the construction of new houses much consideration is directed by the authorities towards the vital question of the health of the future inmates. Many old houses are condemned because the walls are saturated with water. We learn that a house well situated next a river at Bingley (Yorks.) has been made absolutely water-tight with a Pudloed cement rendering.

Messrs. D. Anderson and Son, Ltd., the makers of Rok and other roofing, whose announcement appears on page xvii., have a unique record in manufacturing and supplying roofing felts. They supplied roofing to the British War Office during the Crimean War, and from August, 1914, to the present time have supplied many thousands of rolls of different kinds of their roofing to the Government for use on huts, hangars, hospitals, munition factories, etc. Messrs. Anderson have had over sixty years' experience in the manufacture of roofing, and when it is considered that the enormous output of their works reaches the figure of 60,000 rolls a month, the reader will have some idea of the immense demand for their goods. Their new booklet is excellently illustrated with photographs of buildings erected throughout the British Empire, all of which are roofed with their famous Rok roofing. A copy will be sent to readers who apply by post-card to Messrs. Anderson and Son, Ltd., Lagan Felt Works, Belfast.

PARLIAMENTARY NOTES.

ROAD IMPROVEMENT GRANTS.—During the discussion in the Commons on Clause 41 of the Finance Act, which provides that the charge on the Consolidated Fund for road improvement grants shall cease, Mr. Molteno moved that instead of the grant being abolished it should be reduced to £300,000 per annum. Hitherto, he said, the payment had been from £1,500,000 to £1,750,000 per annum. The money, which came from the petrol and motor-car taxes, was necessary for road maintenance, especially as heavy road motor traffic had so increased owing to military requirements and to the fact that the railways were overburdened with traffic. He paid high tribute to the work of the Board, without which the main thoroughfares of the country would not have stood the strain of the past twelve months. Owing to the congested state of the railways it was absolutely necessary to maintain the roads in a good state of repair, otherwise the ordinary life of the country would be paralysed.—The Chancellor of the Exchequer said that the Road Board's funds amounted at present to over £3,000,000. The average expenditure in grants was about £400,000 a year, so that the existing funds would at that rate suffice for seven or eight years. Was it conceivable that the charge on the Consolidated Fund should be continued at present when the money would not be used?—Sir R. Adkins pointed out that owing to the increased wear of roads the Road Board grants had grown to £800,000 per annum.—The amendment was negatived, and the clause was duly added to the Bill.

Our Office Table.

A special company for training candidates for commissions in the Royal Engineers and other special branches of the Service has been formed by Colonel W. Shirley, of the 28th Battalion, The London Regiment (Artists Rifles), O.T.C. All applicants filling in the forms we published last week and willing to receive preliminary training in this corps should mark their forms "Will undergo training course." During training pay will be at Army rates for privates, with separation allowances on the usual scale.

The Governors of the Glasgow School of Arts propose to hold an exhibition of ancient and modern needlework, chiefly British, at the School of Art early next year. A committee of the Governors has been formed, and to this certain artists and connoisseurs have been co-opted. The scheme for the exhibition includes three divisions:—(1) Civil—articles of domestic use; the decoration of the house and personal adornment; (2) military—arms and accoutrements: flags and banners; heraldry; and (3) ecclesiastical. The committee desire that as far as possible the exhibition be confined to British productions, and ask owners of interesting examples to forward particulars of such to Mr. John M. Groundwater, the secretary, School of Art, 167, Renfrew Street, Glasgow.

The Brown Book of the Architectural Association of Ireland contains a portrait of the president, Mr. H. G. Leask, who delivered his opening address at the meeting of the association, held at 15, South Frederick Lane, Dublin, on the 4th inst. From the accompanying biographical note in the Brown Book we learn that the new president is three-and-thirty this month. He served his apprenticeship to his father, Mr. R. H. Leask, M.I.C.E.I., after which a practical experience in Keal's, a firm of Dublin ironfounders, and a short period in the Waterford drawing office was followed by two years with a past-president of the association, Mr. G. P. Sheridan, A.R.I.B.A. Mr. Leask then joined his father in partnership, but afterwards obtained a position on permanent staff of the Office of Public Works, first as assistant surveyor and latterly as chief draughtsman. He was hon. secretary of the A.A.I. in 1905-6 and 1909-10, and their president in 1911-12. Mr. Leask is an expert photographer as well as a facile draughtsman.

The Streets and Buildings Committee of the Corporation of York have received a letter from Messrs. De Burgh Bros., enclosing plans of a five-roomed cottage proposed to be built in Carrington Avenue, Poppleton Road, which complied with the building by-laws except as to height of window lights in bedrooms, which, in this case, they asked should be allowed to be 6 ft. 6 ins., as against 7 ft. 6 in. required by the by-laws. They stated that if the concession were granted, their client proposed to build fifty cottages in the street. The committee decided that application be made to the Local Government Board for an amended by-law whereby the minimum height required for at least one of the windows in a habitable room shall be 6 ft. 6 in., instead of 7 ft. 6 in., as at present, where the width of the street from building line to building line is not less than 50 ft.

At the installation meeting of the "Canterbury" Lodge of Freemasons, No. 1655, held at the Monaco Restaurant on November 9, Mr. F. J. Lennox Robertson, who is well known to our readers as the energetic secretary of Claridge's Asphalte Co., Limited, was inducted in the master's chair by Mr. George Frederick Ridley, the outgoing master. He afterwards invested his officers as follows:—The Rev. Arthur George Lennox Roberts, M.P.D.G., Chaplain, Argentine Republic, S.W.; Messrs. David Louis Strellett, J.W.; the Rev. John Farrington Downes, P.A.G.C.; Chaplain; Fredk. Conkling van Duzer, P.G.D.; Treasurer; Mytyl Madine Prichard, P.A.G.D.C.; Secretary; Harcourt Wm. Hanrott, S.D.; George Herbert Lennox Robertson, J.D.; Frederick T. Galsworthy, P.G.D.; Alfred McGregor Hughes, L.R.; Org.; Ernest Decimus Ponsford, I.G.; Arthur Ed-

ward Hall and Edward William Mitchell, Stewards; and J. H. McNaughton, Tyler. Amongst those present to witness the ceremony were Messrs. F. E. Bristowe, Grand Junior Deacon of England, F. W. Rogers, Chas. E. B. Kibblewhite, and L. E. Ellison, the last-mentioned being amongst the latest recruits to the British Army. A particularly pleasing feature of the evening was the fact that in the Senior Warden and the Junior Deacon of the Lodge the Master was investing his father and brother respectively.

The Government of India have decided to establish a permanent commercial museum in India. The museum will be located in Calcutta, and will be attached to and form part of the Department of Commercial Intelligence. The development of the museum must necessarily be gradual. It is intended that the museum should contain samples of the principal manufactures imported into India from all foreign countries with which there is any existing or prospective Indian competition, and also representative samples of the corresponding Indian manufactures. It will also contain samples of goods marketed in foreign countries which India might be in a position to supply. The samples exhibited will be supplemented by catalogues and price lists, which will be kept continuously up to date by printed statistics wherever possible.

"Valves and Valve Gears, Vol. II," by Prof. Franklin De Ronde Furman, M.E. (London: Chapman and Hall, Ltd., 3s. 6d.) deals with gasoline, gas, and oil engines on similar lines to those of Vol. I, in which steam-engines and steam turbines were treated.

"Mathematics for Machinists," by R. W. Burnham, M.A. (London: Chapman and Hall, Ltd., 3s.) is a simple and practical guide. Beginning with fractions, it gives in elementary form an explanation of the calculations most frequently occurring in the machine-shop, discouraging as far as possible the practice of using a formula mechanically, with no thought for its meaning. It will be of service to the majority of mechanics who have forgotten most of what they learned of mathematics at school or in a technical class.

A new church is to be built at Wallasey from plans by Messrs. Langford and McGovern, of North John Street, Liverpool.

The new municipal buildings at Maesteg have been formally opened. Mr. W. Gaylard, of Bridgend, was the contractor. The cost was £4,350.

A hall is about to be built in connection with the parish church of Seom, near Porth, as a memorial to the late Captain McCall, of the 1st Cameron's. Mr. Mackenzie, of Inverness, is preparing the plans.

The estimate of Messrs. W. F. Spencer, Cross Bank Works, Oldham, amounting to £42,700 has been accepted for the heating and hot water supply in the new offices of the Beyer Co., Ltd., now being erected from the plan and under the supervision of Messrs. Maxwell and Take, architects, 25, Brazennose Street, Manchester.

Bedford County Council have unanimously promoted the deputy county surveyor, Mr. F. W. Smart, to succeed the late Mr. W. H. Legg as county surveyor. Mr. Smart will receive a commencing salary of £400, rising by annual increments of £20 to £500 a year, with an allowance of £150 in respect of travelling expenses within the county.

At the meeting on Friday of the Metropolitan Water Board it was reported that the arbitrator's award in the proceedings between the Board and the Corporation of Hertford with reference to the Hertford sewage works amounted to £25,000. Incidentally, it provides for the conveyance by the Board of twelve acres of land at a price of £4,300. It was ordered by the Board to defer payment until six months after peace is declared. Meanwhile, 2 per cent. interest will be paid. On the recommendation of Mr. H. Austen H. J., the architect for the new head offices in Rosbury Avenue, it was agreed to expend an estimated additional sum of £350 in continuation of the filtered retaining wall adjoining the side of the offices, so as to allow access to be obtained to the ground floor of the building through a doorway in the west flank wall instead of through the area as originally planned.

CHIPS.

M. W. S. ... A. ... H. ... M. ...

TO CORRESPONDENTS.

We do not hold ourselves responsible for the opinions of our correspondents. All communications should be drawn up as briefly as possible, as there are many claimants upon the space allotted to correspondents.

Telegrams: "Limesurvey, E-Strand, London."

NOTICE.

Bound volumes of Vol. CXLII are now ready, and should be ordered early (price 12s. each) by post. A few bound volumes of Vols. XXXIX, XL, XLV, XLVI, XLVII, XLVIII, XLIX, L, LI, LII, LIII, LIV, LV, LVI, LVII, LVIII, LIX, LX, LXI, LXII, LXIII, LXIV, LXV, LXVI, LXVII, LXVIII, LXIX, LXX, LXXI, LXXII, LXXIII, LXXIV, LXXV, LXXVI, LXXVII, LXXVIII, LXXIX, LXXX, LXXXI, LXXXII, LXXXIII, LXXXIV, LXXXV, LXXXVI, LXXXVII, LXXXVIII, LXXXIX, XC, XCI, XCII, XCIII, XCIV, XCV, XCVI, XCVII, XCVIII, XCIX, C, CI, CII, CIII, CIV, CV, CVI, and CVII may still be obtained at the same price as the other bound volumes are out of print.

TERMS OF SUBSCRIPTION.

One Pound per annum post free to any part of the United Kingdom for the United States, £1.6s. 6d. for the Colonies, France or Belgium, £1.10s. 6d. for India, 41.6s. 6d. To any of the Australasian Colonies or New Zealand, to the Cape, the West Indies or Natal, 41.6s. 6d. Agents for Australia are Messrs. F. P. Kirby, Adelaide and Co., Printers and Publishers, 29, York Chambers, 155, Liverpool Street, Sydney, New South Wales; or Messrs. The Maruzen Co., Ltd., 111, Nishinashi, Tomi, Shinjome, Tokyo, who will receive subscriptions at 41.6s. 6d. per annum on our account. Copies of the paper will be sent by us direct to the subscribers' address. The special rate to Canada is 41.3s. 10d. for 12 months, and 11s. 11d. = 2dols. 99c. six months. Our Direct Subscription Agents for Canada are Messrs. Sales, 140, 142, Shaughnessy Buildings, McGill Street, Montreal, who will receive subscriptions, 41.3s. 10d. per annum, on our account. Cheques and Postal Orders to be made payable to THE STRAID NEWS-PAPER COMPANY, LIMITED, and crossed London County and Westminster Bank.

ADVERTISEMENT CHARGES.

The charge for Competition and Contract Advertisements, Public Companies, and all other advertisements is 2s. per line of 1,200 Words, the first line counting as two, the minimum charge being 5s. for four lines. The charge for Auctions, Land Sales, and Miscellaneous and Trade Advertisements (except Situation Advertisements) is per line of Eight Words for the first line, and not less than the minimum charge being 4s. 6d. for four words. Special terms for series of advertisements or more can be ascertained on application to the Publisher.

SITUATIONS VACANT AND PARTNERSHIPS.

The charge for advertisements for "Situations Vacant" and "Partnerships" is One Shilling per Faculty for Words, and 8 pence for every Eight Words after. All Situation Advertisements must be prepaid.

SITUATIONS WANTED.

Advertisements not exceeding Thirty Words, inclusive of name and address, are inserted under the heading "Situations Wanted," free of charge. Rates for Trade Advertisements on front page and elsewhere for positions can be obtained on application to the Publisher.

NOTICES TO ADVERTISEMENTS.

Requests for advertisements should be received at the office of the Publisher, House 1, Abchurch Lane, Strand, W.C. 2, before 4 p.m. If to be forwarded under cover to a business, an extra charge of 8 pence is made. (See Notice at head of "Situations.") Advertisements for the current week must reach the office not later than 3 p.m. on Tuesday. Front page advertisements and alterations or stop orders for advertisements must reach the office by 10 p.m. on the day previous to ensure attention.

TO ARMS!

4th Battalion ("Architects") Central London Regiment Volunteers.

Recruits are urgently needed for the Regulars, Territorials, and Volunteers. Intending recruits should apply to Battalion Headquarters, where they will be advised as to the branch of the service for which they are best suited.

ORDERS FOR THE WEEK BY LIEUT. COL. A. W. WARDLAW.

GENERAL PARADES. Saturday, 20th inst., Church House, 3 p.m. Uniform ready. Combined route march and drill with the L.F.V.C. There will be no general parade on Saturday, 27th inst.

ENRICHING PARADE. Sunday, 21st inst., at Victoria Station, 1.15, and S.W. Railway, indicator board, 8.55 a.m. Carried, training, gymnastics, and water bottles. Midday ration to be carried. Return to town about 6.10 p.m. Railway vouchers will be provided, and special trains will be run by the railway company.

LECTURES. A short course of lectures on Pioneer Work and Field Engineering generally will be commenced on Wednesday next, 17th inst., at 7 p.m., in the Sergeants Mess. The opening lecture will be by the Adjutant.

NEW HEADQUARTERS. The opening meeting originally arranged for the 24th inst. has been postponed to December 1, at 7 p.m. All members are particularly requested to attend.

DRILLS AND PARADES. All drills and parades will be as usual.

SCHOOL OF ARMS. Drill Headquarters, Chester House. Instruction in bayonet fighting, gymnastics, physical drill, boxing, and singlets, Tuesdays, 6 to 8 p.m.

RECRUIT DRILLS. "A" and "B" Companies, Chester House, 6.15 to 7.15 p.m. and 7.15 to 8.15 p.m. Mondays and Fridays. "C" Company, Boreham Wood and Elstree District, Headquarters, A.A. Athletic Ground, Boreham Wood. For further particulars apply to Alan Potter, Gray Gardens, Boreham Wood, Herts. "D" Company, Chester House, Tuesdays and Fridays, 6.45 p.m.

Note: For the present the School of Arms and Recruit Drills will be held jointly with the Engineering Institutions V.T.C. By Order, L. R. GUTHRIE, Adjutant.

MEETINGS FOR THE ENSUING WEEK.

- WEDNESDAY. ... FRIDAY. ... SATURDAY. ... MONDAY. ... TUESDAY. ... WEDNESDAY. ... THURSDAY. ... SATURDAY.

In the last case, Produce Bookers Co., Ltd., Olympia Oil and Cake Co., Ltd., Lords Leoburn, Atkinson, Parker, Sumner, and ...

FOR **Olivers' Seasoned Hardwoods,**

WAL. OLIVER & SONS, Ltd., 120 Bunhill Row, London, E.C.

TENDERS.

For the supply of materials for the construction of the new works...

For the supply of materials for the construction of the new works...

For the supply of materials for the construction of the new works...

For the supply of materials for the construction of the new works...

For the supply of materials for the construction of the new works...

For the supply of materials for the construction of the new works...

For the supply of materials for the construction of the new works...

For the supply of materials for the construction of the new works...

For the supply of materials for the construction of the new works...

For the supply of materials for the construction of the new works...

For the supply of materials for the construction of the new works...

For the supply of materials for the construction of the new works...

For the supply of materials for the construction of the new works...

For the supply of materials for the construction of the new works...

For the supply of materials for the construction of the new works...

For the supply of materials for the construction of the new works...

For the supply of materials for the construction of the new works...

PINEFLOVE. For supply of a pump and electric motor for the rural district council.

ROSEBY. For carrying out works of paving and kerbing in main roads, for the town council.

ROSEBY. For converting a cartshed into a store, for the town council.

ROSEBY AVENUE, L.C. For supply of brass receiver cases, for the Metropolitan Water Board.

SHEFFIELD. For the construction of foundations for turboalternator at Neepsend power station, for the city council.

STATIONERY. For supply of cable, for the urban district council.

WARMINSTER. For erection of a public convenience in East Street, for the urban district council.

WEST BROMWICH. For the supply of generating plant, for the Electricity Committee.

WYMEOUTH. For electric light installation at the municipal dwellings, for the town council.

WYMEOUTH. For electric light installation at the municipal dwellings, for the town council.

WYMEOUTH. For electric light installation at the municipal dwellings, for the town council.

WYMEOUTH. For electric light installation at the municipal dwellings, for the town council.

WYMEOUTH. For electric light installation at the municipal dwellings, for the town council.

WYMEOUTH. For electric light installation at the municipal dwellings, for the town council.

WYMEOUTH. For electric light installation at the municipal dwellings, for the town council.

WYMEOUTH. For electric light installation at the municipal dwellings, for the town council.

WYMEOUTH. For electric light installation at the municipal dwellings, for the town council.

WYMEOUTH. For electric light installation at the municipal dwellings, for the town council.

WYMEOUTH. For electric light installation at the municipal dwellings, for the town council.

WYMEOUTH. For electric light installation at the municipal dwellings, for the town council.

WYMEOUTH. For electric light installation at the municipal dwellings, for the town council.

WYMEOUTH. For electric light installation at the municipal dwellings, for the town council.

WYMEOUTH. For electric light installation at the municipal dwellings, for the town council.

WYMEOUTH. For electric light installation at the municipal dwellings, for the town council.

WYMEOUTH. For electric light installation at the municipal dwellings, for the town council.

WYMEOUTH. For electric light installation at the municipal dwellings, for the town council.

WYMEOUTH. For electric light installation at the municipal dwellings, for the town council.

WYMEOUTH. For electric light installation at the municipal dwellings, for the town council.

WYMEOUTH. For electric light installation at the municipal dwellings, for the town council.

WYMEOUTH. For electric light installation at the municipal dwellings, for the town council.

WYMEOUTH. For electric light installation at the municipal dwellings, for the town council.

WYMEOUTH. For electric light installation at the municipal dwellings, for the town council.

WYMEOUTH. For electric light installation at the municipal dwellings, for the town council.

WYMEOUTH. For electric light installation at the municipal dwellings, for the town council.

WYMEOUTH. For electric light installation at the municipal dwellings, for the town council.

WYMEOUTH. For electric light installation at the municipal dwellings, for the town council.

WYMEOUTH. For electric light installation at the municipal dwellings, for the town council.

WYMEOUTH. For electric light installation at the municipal dwellings, for the town council.

WYMEOUTH. For electric light installation at the municipal dwellings, for the town council.

WYMEOUTH. For electric light installation at the municipal dwellings, for the town council.

WYMEOUTH. For electric light installation at the municipal dwellings, for the town council.

WYMEOUTH. For electric light installation at the municipal dwellings, for the town council.

WYMEOUTH. For electric light installation at the municipal dwellings, for the town council.

WYMEOUTH. For electric light installation at the municipal dwellings, for the town council.

WYMEOUTH. For electric light installation at the municipal dwellings, for the town council.

WYMEOUTH. For electric light installation at the municipal dwellings, for the town council.

WYMEOUTH. For electric light installation at the municipal dwellings, for the town council.

LIST OF COMPETITIONS OPEN.

Nov. 30.—Housing and Town-Planning, York, for the Corporation Town-Planning Committee.

Nov. 30.—Bridge in Reinforced Concrete, over River Barrow, and for Kilkenny and Wexford County Councils.

March 1, 1916.—Dutch East Indian Rubber Factory.—Premiums, 1,500 florins and 500 florins.

LIST OF TENDERS OPEN.

BUILDINGS.

Nov. 17.—Engine House, Cropper's Hill Power Station, St. Helens, Lancs.

Nov. 17.—Two Hundred and Sixty-one Cottages, High Winobank, Sheffield.

Nov. 19.—Three Hundred Houses, in sections, Dudley.

Nov. 20.—Motor Garage at Mineral Water Factory, Sheerness.

Nov. 20.—Renovating old Llwynbrwydrau School, Llansamlet.

Nov. 25.—One Hundred and Fifty Workmen's Dwellings, Mossend, Hamilton.

Nov. 29.—Wagon Repair Shops at Adelaide Station, near Belfast.

Nov. 29.—Repairs and Materials (One Year), Lowlands Engineer District of Scottish Command.

Dec. 8.—Public Market, Artigas, Uruguay.

Dec. 14.—Pavilion, County Sligo Sanatorium, Cloonmahon House, Collooney.

No date.—Steel and Corrugated Sheeted Buildings, in South of England.

No date.—Two Chimney Shafts, Eastern Counties, Colimba.

ELECTRICAL.

Nov. 17.—Turbo-Alternator Plant, Manchester.

Nov. 17.—Switchboard Parts, Telegraph Instruments, and Ironwork, Brisbane.

Nov. 22.—Cable Testing Outfit, Sydney, N.S.W.

Nov. 30.—Power Station Plant and Equipment, Commonwealth Naval Dockyard, Cockatoo Island, Sydney, N.S.W.

Dec. 1.—Telegraph and Telephone Measuring Instruments, Brisbane.

Dec. 6.—Three-phase Transformers (33,000 volt) and Switchgear, Sydney, N.S.W.

Dec. 7.—Battery Material, Melbourne.

Mr. Lloyd George as Minister of Munitions has appointed Mr. Henry Holloway, the managing director of the well-known building firm of Mossis, Holloway Brothers, to be Director of Housing Construction...

Mr. John Hepper, J.P., F.S.I., for sixty-one years the principal of the firm of Hepper and Sons, auctioneers, of East Parade, Leeds, died from pneumonia on Sunday at his residence, Millbrook, Ilkley...

Messrs. Wilcox and Raikes, of Birmingham, have been instructed by the Urban District Council of Bishop Auckland to prepare plans and estimates for the intercepting sewer from Raby Cross to Wear Chare...

In an address given before the Delphian Cotery at the Cannon Street Hotel on Monday night, Mr. E. G. Culpin, hon. secretary, Belgian Town Planning Committee...

The death occurred at Ashover, Derbyshire on Monday, at the advanced age of 95, of Mr. John Sartees, at one time a well known landscape artist. For over twenty years Mr. Sartees had been blind...

The estimated cost of £17,000 for a new high pressure boiler, to be installed at the Municipal Station, Birmingham, has been published by the Birmingham City Council...

THE BUILDING NEWS

AND ENGINEERING JOURNAL.

Effingham House.

CONTENTS.

Strand, W.C.

Foundations for Concentrated Loads ..	581
Some Conclusions on Housing our Workers ..	582
The London County Council ..	585
Case Law under the Finance Act ..	586
Our Illustrations ..	589
Obituary ..	589
Corrente Calamo ..	601
Housing Problems in Bristol ..	602
Mathew Boulton's House at Soho ..	605
The Broch Dwellings of Scotland ..	605
Legal Intelligence ..	606
Competitions ..	606
Professional and Trade Societies ..	606
Trade Notes ..	606
Our Office Table ..	607

Building Intelligence ..	607
Parliamentary Notes ..	607
Clips ..	608
To Arms! ..	608
Meetings for the Evening Week ..	608
Latest Prices ..	609
To Correspondents ..	610
Tenders ..	610
List of Competitions Open ..	VI
List of Tenders Open ..	VI

Programme of the General Medical Council, Hallam Street, W. View and plan. Mr. Eustace C. Fry, A.R.I.B.A., Architect.
Some Medallion and Traveling Studentship Drawings in Italy. Church of La Madonna dei Miracoli, Brescia, and the Cortile, Palazzo Fava, Bologna. Sketched by Mr. Altek G. Horsnell, Medallist and Tite Prizeman.
Entrance Lodge, "Birdlocks," Fairford, Gloucester. Elevations and sections. Mr. E. Guy Dawber, F.R.I.B.A., Architect.
An Architect's House, Church End, Finchley. Exterior View, interior of back sitting-room, and two plans. Mr. H. S. East, A.R.I.B.A., Architect.

OUR ILLUSTRATIONS.

Cathedral Church of All Saints, Khartoum, Sudan. West front with Campanile, perspective view, and plan. Mr. Robert S. Weir, Architect.

FOUNDATIONS FOR CONCENTRATED LOADS.

Modern building operations constantly involve a concentration of heavy loads at points, especially in steel-framed construction; and inasmuch as it can be shown that the stability of such resides, primarily, in the security of its foundations, every care is needed to secure unyielding support for stanchions. In such a steel-framed building as is indicated in Fig. 1 any failure at any one point necessarily entails the setting up of injurious stresses in the whole framing; for secondary only to sure foundation, in steel building, is the matter of tie-joint connections—throughout the construction. If every post and beam is securely riveted and bolted, the whole work becomes homogeneous. Under these circumstances it is not possible to lower the level of any given point in any one vertical member without throwing abnormal stress upon the jointing. These considerations do not

this is so in spite of heavy walling, which is merely screen-work. True steel framing is a structure complete in itself, and although stanchions well enclosed in strong brick walls receive undoubtedly a measure of support from such walls, all such extraneous support is discounted in calculations. Our ordinary method of building with a self-contained, self-supporting steel skeleton is certainly not noteworthy for economy, where solid brickwork and masonry of quite sufficient strength to support all the free ends of girders and joists is arranged. Such construction has superfluous strength; but where we require the benefits of fireproof building, together with massive, ornate, and deeply-cut architecture, we have no recourse under present by-laws than to make practically a dual construction.

It follows that every fireproof floor, in a construction such as Fig. 1, represents a surface that should be a perfect plane, normal in every direction to stanchion axis. The accuracy and constancy of such plane depends on unvarying conditions in the substructure. Thus we have shown to be a matter attendant upon foundation and tie, first upon the one, secondly upon the other. It is well recognised that that construction which is accurately aligned and riveted and securely bolted can be put up at less cost than one of apparently greater strength, having deeper girders and heavier stanchions. In an extensive building, of a great number of stories, the amount of steel that can be saved by intelligent design and the best connections is considerable. Thus security and economy attend upon sure foundation, for it is this, and this alone, that enables the lighter section of steel to be employed in post and beam.

In the earlier days of steel joisting—the cast-iron column era—we depended upon solid concrete, brick base, and stone template, much as shown in Fig. 2; but the increase in loads, the finer concentration of weight on points, and tall buildings with floors and superimposed loads bearing only here and there, has caused this type of foundation to be, to a great extent, discarded, and introduced a kind of reinforced concrete foundation, in substance if not in design. It is plainly an advantage, and in many soils a vital necessity, not to carry foundations too low. We cannot, economically, greatly broaden concrete bases; that is to say, the method of spreading out for distributed load over a wider area is not consistent with the type of construction. The use of steel, in the form of H section, permits a great load to be spread over an area sufficiently large to come within the safe margin for soils. It must be remembered that the maximum loads on soil permitted in the

London district is not large. If we have to arrange to distribute 250 tons on soil bearing only 1 ton per foot, according to the views of authorities and enforced by law, we need an area of 250 super. feet. If we decide to make the foundation of simple concrete, we cannot put down a mass of 15 ft. by 15 ft. only a yard deep, but we can do something similar by employing the grillage system. This is the true apology for grill-type foundation. Let us take Fig. 2, and assume 300 tons upon the column base. To design a suitable depth of concrete is a more or less ephemeral, rule-of-thumb, practised-eyesatisfying matter. Take what data we may, the point is one demanding experience and judgment, as it has ever been with architects and engineers in dealing with foundation problems. But we have to take account of certain conditions and

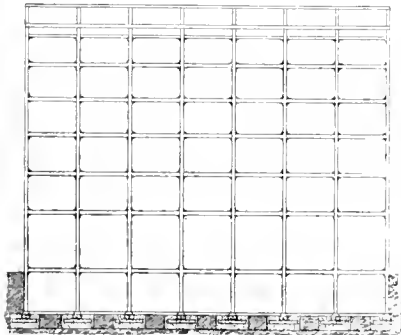

FIG. 1.

apply to ordinary mixed building construction, the stability of which depends largely on strong brick walls and cross walls. Settlements will cause unsightly cracks; but where such are slight they do not indicate serious danger, which, as a rule, only subvenes in cases of really untrustworthy foundations. Moreover, since the strength of steel framing, given secure foundations, is a matter of well-made connections, it results that economy of material succeeds upon good design and workmanship, for where this condition is observed lighter sections of steel can be employed and the total weight of the construction reduced. We cannot do this unless the points of support are rigid and unyielding.

It is important, therefore, to secure the stanchion base, in the sense that it may remain immovable in its designed position. In steel construction all the weight is concentrated and brought down to foundation by isolated stanchions, and

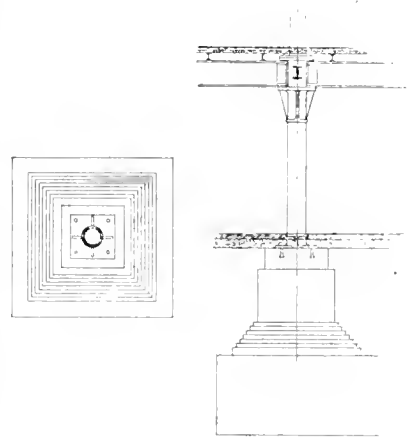

FIG. 2.

circumstances. First, the less the depth the less the cost, and the less the brickwork base of such a foundation mass, as indicated in Fig. 2. It may be that we could just comfortably arrange for legal loading of foundations by putting a broad footing immediately beneath the basement floor indicated. As drawn, we run down to a better bottom, assumed, but this not being always the result of deeper digging, indeed often leading from bad to worse, we may gain by maintaining a higher foundation level, both economy and safety, and be within the by-law at the same time. We might assume 3 tons per foot super, as a possible safe load for the level of foundation as drawn, requiring 100 super. feet of concrete and ten feet square for the mass shown. Assuming so much, let us further suppose that at the level of the top of the brick base the soil will bear one ton; we require 300 super. feet, or, say, 18 ft.

on easy terms led to abuses, and as artisans not employed at the Cadbury works were eligible as tenants, Mr. Cadbury founded a trust to take the concern over and use the income for further development, making the enterprise a question of supply and demand. The trust was enjoined to suppress all political and sectarian bias, and to allow intoxicants to be sold only where their suppression might create greater evils. When I was there the efforts were concentrated on getting something cheap and good enough to fulfil the terms of the trust, and the remarkable variety in the appearance of the early buildings was endangered, as the drift was then towards a rather dull exterior. The scheme at Cresswell mining village, Thornton Hough, and that at Port Sunlight were founded on the same idea of housing the worker in more cheerful and elevating conditions where the work in a central factory provided a fairly secure employment. The 140 acres of land, which were exclusive of the Sunlight soap factory, were purchased at about £240 an acre, and laid out with great skill. No road is less than 40 ft. wide, the main avenues have a width of 60 ft., and the natural formation is utilised in an artistic and effective manner. There were 25 acres which were overflowed each tide. These areas were dammed off, two bridges constructed to carry through important roads and avenues, and an excellent town-planning scheme designed and carried through. The recreative needs as well as the housing accommodation proceeded simultaneously. Schools, church, village halls, inn, dining-halls, institutes, and gymnasium, swimming bath, open air theatre, etc., were put in hand as the want was felt. When I visited the area, there were about 570 houses built and in occupation, and the cost had then reached the gigantic sum of £370,000. It is a wonderful evidence of broad-minded spirit that Messrs. Lever Brothers have never received or ever expected any direct return whatever from the sinking of this huge capital. The tenants were paying as rent the rates and taxes and the bare cost of maintenance of the houses. With trifling exceptions there are only two types of cottages: (a) what would be classified in London as a 4-room cottage, and (b) a 6-room (or locally called, parlour) house. Class (a) has a living room on an average about 15 ft. by 14 ft. 6 in., and a scullery and bath on the ground floor, and 3 bedrooms on the first floor, the smallest being generally without a fireplace and between 60 and 70 sq. ft. in area. The (b) class has on the ground floor a parlour ranging from 13 ft. 6 in. square to 18 ft. by 14 ft. 6 in., a kitchen about 13 ft. square, and a spacious scullery and bath. On the first floor are four bedrooms of good size. Class (a) were costing in 1902 £330 to build, and class (b) £550. It will be seen that none but merchant princes could carry through great and generous enterprises such as these.

WELL HALL.

Turning from private to public enterprise, the most recent large scheme is that of the Government at Well Hall. Approximately, the areas covered and to be built upon are 70 acres on the east and 30 on the west side of Well Hall Road. The tramway to Woolwich bisects them, the southern corner being 300 yards from Well Hall station, which should be a valuable asset when the houses are no longer required for the Arsenal workers. The areas are laid out with streets of 40 ft. and 30 ft. between the forecourt fences. The latter width is in contravention of the provisions of the Building Act, which prescribes a minimum width of 40 ft. It is curious that this somewhat retrograde step should have been taken by a Government Department, thus traversing an Act of Parliament which has regulated every new building scheme within the county for the past twenty years. The immense outlay which the ratepayers of London have met to improve the width of streets for the requirements of increased traffic and to open up closely-built areas would, it is thought, have given pause to such a scheme, and the number of houses to the acre (approximately twelve) did not compel the resort to such a policy. It should be noted

that the plea of Defence of the Realm obviates any challenge, but the provision of legalised space about buildings ought not to have been set aside by the creation of narrow streets without convincing reasons. There are on the east side sixty-five houses of the first class, 249 of the second class, 411 of the third class, and 212 of the fourth class; the latter are flats of the maisonette type. The first class accommodation consists of living-room, parlour, spare bedroom or dining-room, with scullery on the ground floor, and three bedrooms on the first floor, with the usual offices, and bathroom with hot and cold water. Class II. houses contain living-room, parlour, scullery, three bedrooms, and the usual offices, with bathroom. Class III. houses contain living-room, scullery, three bedrooms, and the usual offices, with bath. Class IV. are flats arranged in two-story houses, each flat consisting of living-room, scullery, two bedrooms, and the usual offices, with bath. The elevations are treated with skill, and great variety has resulted. The frontages are generous, as also is the provision for gardens. The construction and the materials employed are of the first class, but here again it is to be regretted that Parliamentary enactments on the employment of building materials should not have been observed. The adoption of weather boarding in instances where it has been used as an external covering to a building will, I submit, be conceded as obsolete. When timber of every kind was at a high price, it seems to require much weighty reason to have so employed this material, especially having regard to the heavy bill for maintenance which will be involved in the future. As a lesson to those who have to comply with strict financial equilibrium in all voluntary housing schemes, it is to be regretted that the financial phase of the problem cannot be made known and compared with the operations of other authorities, trusts, and companies.

COTTAGE HOUSING BEST.

Hitherto it has been contended that, except in the case of a minority before mentioned, the most rational method of housing where travelling facilities are available was to provide cottage accommodation. This should be far enough from the business centre to ensure that by reason of cheapness of site it would be possible without incurring financial loss to afford a reasonable amount of open space and sufficiency of accommodation, with the privacy which is probably the greatest asset in a home. With adequate transit to convey the worker cheaply and quickly to his employment, there can be little doubt of the superiority of the cottage over the block dwelling. Fresh air, change of scene, and easy access to the country must brighten the lives of the occupants of the cottages, and the removal of many sordid influences inseparable from town life cannot fail to produce a good effect not only on the health, but on the efficiency of the worker. The conditions under which accommodation has been recently required by the State are so exceptional as scarcely to constitute a fair test. The urgency of the need allows little time, and the state of the market for labour and materials almost eliminates consideration of cost. It is inevitable that cottages built in such circumstances should cost more, but the result of these conditions is that any doubt as to the relation of rent to capital cost might be disregarded. Such schemes in themselves are unconcerned with the problem which has troubled housing reformers for many years—viz., whether it is financially possible to house the worker on a rent which he can afford to pay, having regard to his income, and whether the State should subsidise those cases where, owing to lowness of wages, adequate accommodation cannot be provided on a sound financial basis. Where the Government provide the site and buildings and the worker also earns a wage considerably in excess of what he receives in peace time, these questions do not arise; but the reflection cannot be ignored as to what is to happen to such estates after the war, in the event of large numbers of men being no longer required for such work. The State may not need the estates, and it is to be doubted whether any purchaser at anything like the original price could make a sound investment of them.

THE BOUNDARY STREET SCHEME.

Economic considerations must be predominant in all normal housing operations, whether private or municipal, and the essence of the question is, how to build working class habitations which will pay their way, at a rent within the means of the occupant. My own experience is that the crux of the problem is the cost of the site, and thus the difficulty is most acute with housing in central districts. Cleared sites in such localities are seldom obtainable, and where sites have to be cleared to enable the population to be rehoused, the value of the land has had to be considerably written down in estimating the financial result of such schemes. Previously to the passing of the Housing Act in 1890, the late Metropolitan Board of Works sold land carrying a housing obligation to companies or trusts, all of which received a subsidy in the form of a "writing down" from the commercial value to "housing" value at which it was charged to purchasers. In the case of 30 such sites, the commercial value of which was estimated at £727,535, no less than £397,613, or nearly 55 per cent., was written off. Part I. of the Housing Act placed on local authorities the duty of preparing and carrying into effect schemes for the rearrangement and reconstruction of the streets and houses within unhealthy areas. The clearance of the notorious Boundary Street area, about 15 acres in extent, was the first scheme undertaken by the London County Council under these powers, and in this case the commercial value of the land was written down from £131,670 to £62,010. With a population of about 5,700, the death rate was over 40 per thousand in 1889, or nearly double that for the whole of Bethnal Green. The widest street was barely 28 ft. wide; no house possessed a front door; no repairs were ever carried out, and the neighbourhood was described as tenanted by heathens. Under the scheme formulated by the Council, the area is now approached by an avenue 60 ft. wide, leading to a central open space with a band stand. Tree-planted streets, 50 ft. wide, radiate from this centre to the limits of the area, and these are connected with the streets bounding the area by branch streets 40 ft. wide. Five thousand five hundred and eighty-four persons were rehoused in 1,069 tenements, 23 blocks of tenement dwellings being erected, and a smaller number of cottage dwellings half a mile away.

The gross rental of the estate for the year ended March 31, 1915, was £23,485, and the accounts show that after paying all maintenance and debt charges, sinking fund, etc., there is a surplus balance on the year of £1,403. The buildings are well occupied, the empties for the same period amounting to only £274, or 1.17 per cent. of the gross rental. The cost of the scheme and buildings was £337,535.

THE TABARD STREET SCHEME.

The largest area of clearance ever undertaken under the Housing Act is that which is now proceeding at the Tabard Street, Grotto Place, and Crosby Row areas, Southwark and Bermondsey. The total extent is 17 acres, and the number of persons of the working class to be displaced is 4,552. It will be noticed that the number of persons is smaller than in the Boundary Street area, but the insanitary condition of most of the property rendered it impossible to effect any real improvement by dealing with individual properties. The death-rate from 1903 was 36.8 per thousand, or more than twice that of Southwark (18.2), which again exceeded that for the whole of London—viz., 14.9. The number of vacant houses and tenements within a radius of one mile enabled provision to be made for supplying an urgent need for additional open space in the neighbourhood. By the scheme confirmed by the Local Government Board in March, 1912, accommodation is arranged on the area for only 2,580 persons, and the central portion, about five acres in extent, will be laid out as an open space. Rehousing accommodation will be provided in five-story balcony block dwellings, overlooking the open space, and twenty-five cottages will be erected on a detached

...the fact that the surplus at the end of each year was added to the capital, the particulars furnished were not sufficient to enable us to compare its financial operations with those of other dividend-paying companies.

SELF-CONTAINED DWELLINGS THE MOST DESIRABLE.

It is not, however, on account of financial considerations alone that every endeavour should be made to draw the industrial population from crowded centres to the spacious and healthier suburbs. A recent Departmental Committee has said that public opinion now recognises and demands that every working-class family should be provided with a self-contained dwelling of sufficient size to prevent overcrowding, and which admits of the separation of the sexes. A self-contained dwelling is defined as one which provides living accommodation with scullery and water-closet accommodation for the sole use of each family. Some of the difficulties which beset the provision of such accommodation in central districts have been indicated. In addition, there is the growing importance which is given to abundance of light and air, and there are signs that demands will be made for more hygienic construction in our buildings. The effect of the sun's rays in destroying microbes is admitted, and it is claimed that buildings should be so designed that the direct rays of the sun should penetrate through every part of all living rooms. I am strongly of opinion that an effort should be made in every case in which block dwellings are erected to dispose the blocks on the site in such a way that the maximum of sunlight would reach the habitable rooms. This might operate disadvantageously on the accommodation, but considering the limited sunlight particularly in winter in this country, it is essential that as much as possible should find its way into the living rooms.

FRENCH CRITICISM OF ENGLISH "MODEL" DWELLINGS.

At the Housing and City Development Congress held in Ghent in 1915, a French housing expert showed plans of dwellings which are described as model in various parts of England, and produced statistics to show that they are planned against many elementary principles in hygiene. The criticisms were levelled at the practice of enclosing common staircases and the exclusion of the very limited sunlight which this latitude affords in the darker portions of the year, but principally in connection with the want of cross-ventilation in the tenements. There was much reason in these criticisms, as there are numerous dwellings in London where it is impossible to get through ventilation between front and back rooms, the cross wall in many cases obstructing the passage of air. This matter is referred to in the London County Council's housing handbook in 1915, where it is stated that, although the Housing and Town Planning Act declares the erection of back-to-back houses to be unlawful, it does not prohibit the erection or use of a tenement house in which the tenements are placed back to back, if the medical officer for the district certifies that the tenements are so constructed and arranged as to secure effective ventilation of all habitable rooms in every tenement. The Housing Acts give no definition of back-to-back houses, but a reasonable definition would appear to be a house or letting having one central side only, with ventilation open to the external air. It states that the Council in 1911 had before it plans of a group of six dwellings proposed to be erected by the trustees of a philanthropic fund. On the basis of the above definition a large number of the tenements were back-to-back, and in any case the Council felt that the general provision of through ventilation to the intermediate tenements was unsatisfactory. The medical officer for the district issued the certificate required by the Act, and the Council could not therefore take any effective action. In addition to through ventilation, all staircases giving access to the room should have openings which cannot be closed on the two

sides back to front of the block, to afford efficient ventilation. Where balconies are employed they should in no case overshadow habitable rooms. I am loath to admit that in London there is always opposition to leaving the staircases open, but I am convinced that it is a correct and hygienic method of dealing with the ventilation of these buildings.

THE L.C.C. COTTAGE HOMES.

Financial and hygienic difficulties such as have been indicated do not arise in the construction of cottage homes, so many of which are being developed on the outskirts of our large towns. It may be interesting to compare the cost of a cottage at the County Council's White Hart Lane Estate, Tottenham, containing living-room, bedroom, scullery, and offices, with the same accommodation in block dwellings at the Bourne Estate, Holborn. At White Hart Lane the cost of land was £11 16s., roads and sewers £24 4s., and buildings £180, or a total of £216. At the Bourne Estate, the cost of land was £337 and the buildings £286 10s., or a total of £623 10s. It will thus be seen that a family could be housed at White Hart Lane for considerably less than the cost of land alone at the Bourne Estate. The municipal development of cottage estates on the outskirts of London has been carried out under Part III. of the Housing Act, which has been regarded as voluntary. The land charge is taken into account at purchase price, and the scheme must show financial equilibrium after bearing all capital charges.

Time will not permit a lengthy description, but it may be of interest to refer briefly to the development of these estates. The cottages are two-story buildings arranged in short terraces with spaces at intervals, and they are almost invariably set back 5 to 15 ft. from the fore-court fence. The schemes for development have been largely influenced by the following considerations—

- (1) Economy of land area and road construction in proportion to building.
- (2) The avoidance, as far as practicable, of deep external back projections in close juxtaposition, which tend to cause insanitary pockets and prevent the freer circulation of air currents along the backs of terraces of houses. The wholesale erection of these insanitary projections in close proximity to each other in many suburban estates is a reproach to the law which permits it.

TOTTERDOWN FIELDS ESTATE, TOTTING.

The first large scheme undertaken in London was the development of the Totterdown Fields Estate, Tooting, about six miles from Charing Cross and about three-quarters of a mile within the county boundary, on the main tramway route between Tooting and the central area. The estate, which is about 38½ acres in extent, was purchased in 1900 for £44 25s. the price being £1.150 per acre, a comparatively high figure for land for working-class cottages. The development of the estate has been completed, and in all 1,229 cottages and four shops have been built, with accommodation for 8,768 persons. The principal streets are 45 ft. wide, lined with plane trees, the other streets being 40 ft. wide.

THE NORBURY ESTATE.

The purchase of estates outside the county boundary is permissible under the Housing Acts, and the first to be acquired was the Norbury Estate, situate about two miles from Croydon and about seven miles from Charing Cross. About 17 acres have been developed, providing accommodation for 3,633 persons in 493 cottages, and the scheme approved for development of the remaining 11 acres of the estate provides for the accommodation of 1,869 persons in 264 cottages and two shops. The strain of finance during the war has so far prevented the completion of the last section of this estate.

WHITE HART LANE ESTATE.

The largest estate purchased for housing purposes by the Council is situate in Tottenham, Wood Green, and Edmonton. It is five miles north of the county boundary, about six and a half miles from Charing Cross, one mile from Wood Green station, and half a mile from Bruce Grove station. The estate

THE BOURNE ESTATE, HOLBORN.

The Bourne Estate, Holborn, is a typical example of a block dwelling scheme. It consists of a series of blocks of dwellings, each block containing a number of flats. The flats are arranged in a regular pattern, and the blocks are separated by narrow passages. The scheme was developed by the London County Council, and it is one of the largest and most successful of its kind in London. The flats are well lighted and ventilated, and the scheme has been a great success. The cost of the estate was £623 10s., and it has provided accommodation for a large number of persons. The scheme is a good example of what can be done in a central district of London.

THE BOURNE ESTATE, HOLBORN.

The Bourne Estate, Holborn, is a typical example of a block dwelling scheme. It consists of a series of blocks of dwellings, each block containing a number of flats. The flats are arranged in a regular pattern, and the blocks are separated by narrow passages. The scheme was developed by the London County Council, and it is one of the largest and most successful of its kind in London. The flats are well lighted and ventilated, and the scheme has been a great success. The cost of the estate was £623 10s., and it has provided accommodation for a large number of persons. The scheme is a good example of what can be done in a central district of London.

...the fact that the surplus at the end of each year was added to the capital, the particulars furnished were not sufficient to enable us to compare its financial operations with those of other dividend-paying companies.

consists of two sections quarter of a mile apart, the northern section containing 49 acres and the southern 177 acres. The purchase price for the property was £90,225, or at the rate of £400 per acre, the owner requiring that both sections should be taken. As the northern section would be difficult to develop for building purposes, the Local Government Board in 1911 consented to it being sold, but it has not yet been disposed of. Development of the estate has up to the present been confined to a wide strip of the southern portion, where roads and sewers have been constructed sufficient to enable about 43 acres to be covered, and on about 40 acres (including 3½ acres laid out as a public garden), 963 cottages have been erected, providing accommodation for 7,524 persons. The Local Government Board has consented to the provision of fourteen shops on the estate, and five have been erected on the Lordship Lane frontage. Administrative buildings have also been erected. The roads have been so planned that the majority of the blocks of cottages run north and south, and each frontage of the buildings therefore receives direct sunlight. At the junction of Aylfield and Risley Avenues the cottages have been arranged in angle blocks, with open spaces in front, and in other cases the arrangement is in shallow quadrangles, with open spaces bordering on the road. The estate garden is turfed for tennis and bowls and surrounded by raised terraces and flower gardens.

OLD OAK ESTATE, HAMMERSMITH.

The estate at Old Oak Common Lane, Hammersmith, is the most recent, and being perhaps on that account more interesting, may merit a more detailed description. It is situated about five miles from Charing Cross, and is bounded on the north by Wormwood Scrubs, an open space of about 215 acres. As the ground rises towards the west, extensive views can be obtained. The estate originally contained about 54½ acres, the purchase price being £29,858 (about £550 per acre), but the Great Western Railway Company subsequently obtained running powers for a new railway to cross the estate diagonally, and acquired nearly eight acres for this purpose, paying the Council £10,500 in respect of the land and the damage sustained by the estate. Development of the section west of the railway is now completed, except for a site temporarily occupied by a school. This section is about fourteen acres in extent. Five shops and 319 cottages and cottage flats have been provided, accommodating 2,231 persons. Of the cottages, 65 contain five rooms, scullery and bath, let at 11s. 6d. to 13s. per week; 105 have four rooms, scullery and bath, let at 9s. to 11s. per week; 106 have three rooms and scullery, at 6s. 6d. to 9s. 6d. per week; 27 are two-room flats, let at 4s. 6d. and 5s. a week; and 16 are one-room flats, let at 4s. a week. The Old Oak estate may be regarded as embodying the most recent developments in cottage housing in London, and in framing the scheme the policy adopted was to endeavour to meet the demands for smaller cottages, which can be let at rents within the reach of those earning 25s. to 30s. a week. It was thought that only a small number of the larger type of cottage, for which a rent of 11s. 6d. to 13s. a week is charged, should be erected, and that about one-third of the total number should be three-roomed cottages, to be let at rents ranging from 6s. 6d. to 9s. 6d. a week. The rents are inclusive of rates, taxes, and water supply. The needs of smaller families of the poorer classes requiring only one or two rooms were also considered, and as an experiment a limited number of tenements of one, two, and three rooms, at low rents, are provided. The smallest type of one-room cottage flat, with a separate scullery and water-closet, is let at a rent of 4s. a week. It is not thought that these one-room tenements are adapted to the requirements of married couples with young children, and therefore their occupation is restricted to old married couples or to two persons of the same sex. One person living alone or an adult with one young child are, of course, eligible as tenants. The scheme for the section east of the railway provides for the erection of 721 cottages and two shops (one designed for a baker and to be fitted with a modern bakehouse). This section will accommodate 5,330 persons. A school will be

provided on the estate, and a site has been reserved for the erection of a church by the Ecclesiastical Commissioners. It may be stated that up to now the development of this estate has met with the greatest success, a list having to be kept of prospective tenants waiting for the erection of the cottages. Some of the cottages have been allocated as the subject of an experiment for enabling the tenants to purchase leases of their houses.

The following table shows the result of the working of these estates for the year ended March 31, 1915:—

Estate.	Capital Expenditure to March 31, 1915.			Result of Year's Working.		Employs. Percentage on Gross Rentals.
	Land.*	Buildings.	Total.	Surplus.	% Gross Rental.	
Totterdown Fields (completely developed)	£ 77,614	£ 317,897	£ 395,511	£ 2,100	s. 8 3	7.14
White Hart Lane (partly developed)	55,086	214,536	269,622	1,472	7 1	6.85
Norbury (partly developed)	35,338	130,730	166,068	256	9 10	2.58
Old Oak (partly developed)	19,957	33,953	53,910	430	0 11	5.51

* Including charges for roads and sewage. † Including new cottages handed over on completion.

MAXIMUM WIDTH FOR ALL STREETS.

In the development of these estates every endeavour has been made to combine commercial and architectural success, and variety in planning and in treatment of the elevations has been consistently aimed at. I should wish to take this opportunity of emphasising one point in particular—that in no case has any street on the County Council's estate been constructed of less than the minimum width required by the local building act or by-laws, and in many cases the width has been voluntarily made considerably greater. One hears it persistently argued that by-laws are too arbitrary and extravagant, and that in streets which are not intended for heavy traffic, the minimum width required by the by-laws might be reduced. I am not of that opinion, as I consider that narrow streets become alleys where the free circulation of air is, to say the least, impeded. I venture to submit that the same criticism might be applied to some designs for laying out estates, which have been influenced by a praiseworthy desire to escape from the old-fashioned rectangular gridiron plan of the speculative builder. To secure a more artistic grouping of buildings, however, streets are formed of snake-like curvature and with squares or enclosed places to which one outlet only is provided. The comparatively direct street can be treated without monotony, and if a liberal width is assigned to it the avoidance of traffic difficulties which may hereafter arise is ensured. A plentiful supply of fresh air will probably prove more beneficial to the working man than a vista, and it should not be impossible to combine the two.

EVERY COTTAGE HAS ITS OWN GARDEN.

A feature of the County Council's estates is that each cottage has its own plot of ground at the rear. It may be a matter for argument whether the provision of an open space—of which examples may be found near London—for the common use of the tenants surrounding it is preferable to the backyard or garden. The latter may present problems in neatness and orderly appearance, and may not offer a view from the house windows equal to that of a well-kept open space, but the privacy of a back garden is undoubtedly regarded as a great asset by the tenants on the Council's estate.

NEGLECT OF LOCAL AUTHORITIES PROVIDED FOR BY THE HOUSING ACT.

The provision of accommodation under Part III. of the Housing Act, 1890, has usually been looked upon as entirely optional or voluntary on the part of the local authority. The Housing and Town Planning Act of 1909, however, provided for cases of default where four inhabitant householders of an area complained to the Local Government Board that the local authority have failed to exercise their powers where those powers ought to have been exercised. Before deciding that an authority have so failed, the Board must take

into consideration the necessity for further accommodation for the housing of the working classes in the district, the probability that the required accommodation will not be otherwise provided, any other circumstances of the case, and whether, having regard to the liability which will be incurred, it is prudent for the authority to undertake the provision of such accommodation. If, after holding a public inquiry, the board are satisfied of failure on the part of the local authority, the board may make an order directing the authority to carry out works to remedy the default. That these

powers have been of considerable assistance in securing the provision and improvement of cottage homes throughout the country can be seen from the last report of the Local Government Board, who have also shown much activity in the collection of general information as to housing conditions in England and Wales. Three years ago, in many rural districts, notifications were posted of public inquiries into the sufficiency of housing in the district. I am not aware of the official result of such inquiries, but in the same part of the country which I recently visited, and where I had noted the announcement of official inquiries, I was invited to make an inspection of an estate which is being built by a local landowner. This not only embraced the provision of first-class houses, orchards, a suitable area of ground for cultivation, with piggeries and poultry accommodation of the most modern type to each cottage, but the whole project was laid out in a workmanlike manner, on sound principles of town-planning. The estate was being dealt with in a completely voluntary spirit and for the workers' benefit, and this exemplifies one of the useful effects of that Act.

THE INEVITABLE CONCLUSION.

What inevitably must the conclusion be? I am sanguine enough to think that when you compare the value given from either an educational, a social, or an independent aspect, the proper way to house the workers, wherever it is practicable, is at the outskirts of the city or town, where convenient transit should be made a part of the scheme. I am aware that many will talk of the loss of time and expense in travelling, etc. I am going to add my opinion that the public would be healthier and better if they walked more. Apart from the question of land value, on which the accommodation is built, there is on the fringe of the county the further marked economy of the building works. Having the environment in mind and the physical and moral advantage to the family, which method do you think the great sanitary reformer Chadwick would have chosen? I have long ago concluded in my own mind that the weight of opinion must go with the suburban cottage, and I think I would have had his endorsement.

Mr. C. T. Adshead, F.R.I.B.A., inquired whether all the estates of the London County Council, and in particular the Caledonian Estate, Liverpool Road, were self-supporting.

Mr. Riley replied that they all paid a return on the capital outlay, varying last year from 2.58 per cent. on the Norbury Estate, which was only partially developed, to 7.14 per cent. at Totterdown Fields, where the land was completely covered.

Mr. Adshead said this was highly satisfactory. He had had some experience on the Kennington Estate of the Duchy of Cornwall, where they had expended nearly £10,000 on the rebuilding as two-storied cottages of

... as not subsidised, ... the capita- ... Sir William J. Collins, ... Chairman of the Chad ... the ... County Councils' housing schemes ... mutually destructive ... the ... were not re- ... more respectable class was ... the opera- ... and not self sup- ... the first he might reply that the ... population were ... remained in a ... What the County Council ... rebuilding the Clare ... seemed essential that the ... in the immediate ... the inhabitants of the dis- ... were actually transferred ... in the neighbour- ... Mr. Riley's outspoken remarks on ... in their ... deliberately disregarded ... of the London Building Act of ... in ... very narrow streets and in ... they were ... He had worked ... Mr. Riley since his ap- ... could testify ... sanitary reforms and in ... the skill he brought ... to his great, if ... of improvement.

In replying to the vote of thanks, which was accorded by acclamation, Mr. Riley observed that it was nearly seventeen years since he became architect to the Council, and from the very first he had benefited by the helpful advice, and perhaps still more helpful criticism, of their chairman.

Section 23 of L.C.C. General Powers Act, 1909, with regard to the construction of buildings wholly or partly of reinforced concrete and with respect to the use and composition of reinforced concrete in such construction have been allowed by the Local Government Board, and will come into operation on January 1 next. The committee added:—The question now arises as to the steps to be taken to comply with Section 23 (5) of the Act as to the publication of the regulations in the *London Gazette* after they are allowed. We are advised that the regulations must be published in full. Such publication will serve no useful purpose, and in view of the expense involved, which is estimated at £180, we have asked the Local Government Board whether in its opinion it would not be sufficient to advertise the fact that the regulations have been made and allowed, and that copies may be purchased at the Council's publishers. In reply, the Board states that it does not differ from the Council in regard to the utility of publication in extenso, but that, having regard to the language of the Act, it is unable to escape from the conclusion that such publication is obligatory upon the Council and is a condition precedent to the coming into operation of the regulations upon such day as the Board may fix. We have also suggested to the publishers of the *London Gazette* that they should utilise the type which is at present standing, the Council paying to the publishers any profits which would have been made by them had the regulations been published in the *Gazette* in the ordinary way, and in reply a letter has been received from H.M. Stationery Office regretting that the proposal cannot be entertained. It appears, therefore, that the regulations must be published in the ordinary way.

There is a provision of £40 in the votes for the current financial year, and a supplemental estimate of £140 is therefore necessary. We recommend—

That the supplemental estimate (No. 15) of expenditure on maintenance account of £140 submitted by the Finance Committee in respect of publishing in the *London Gazette* the regulations made by the Council on July 6, 1915, under Section 23 of the Local Government Act, 1888,

The Finance Committee, having considered in its financial hearings the above-mentioned estimate, submit the same as chargeable to maintenance account. The total expenditure involved in the publication, in the *London Gazette*, of the Council's regulations as to reinforced concrete is £180. The type of the regulations is standing, and at the request of the Finance Committee the Building Acts Committee endeavoured, but without success, to make arrangements whereby this type could be used, the regulations being issued as a supplement to the *Gazette*. The Finance Committee are strongly of opinion that the proposed expenditure, which both the Local Government Board and the Building Acts Committee admit will serve no useful purpose, is most difficult, in present circumstances, to justify, but in view of the legal necessity for advertising the regulations, and the failure of the efforts made to reduce the expenditure thereon, there appears to be no alternative but to submit the estimate.

Private Robert Theodore Morrison Walllie, 14th Battalion, London Scottish Regiment, who was an unestablished assistant in the subject's department L.C.C., has been missing for more than six months, and is presumed to have been killed in action.

Mr. W. C. Clifford Smith, M.Inst.C.E., the engineer to the Asylums Committee of the London County Council, recently suffered bereavement in the loss of his son Dudley. We now learn that another son, Harold, who went to the front in June, has been wounded by a bomb which burst at his feet, shattering the left foot and smashing the big bones in the leg. His left arm was also injured. His leg has been amputated above the knee and, unfortunately, later operations have been necessary.

The L.C.C. new regulations as to reinforced concrete construction were published in extenso in our issues of July 14, 21, and 28, and August 4 last, pp. 31, 61, 89, and 115, in present volume ante.

CASE LAW UNDER THE FINANCE ACT.

By E. M. KONSTAM (Visitor), Barrister-at-Law.

Before attempting to summarise the cases decided under the Finance Act of 1910, it may be as well to enquire for a moment what principles our Courts apply in interpreting statutes. It is not too much to say that most statutes are obscure. But the Courts, unless absolutely driven to it, are loth to think that they are meaningless, that they are passed in ignorance of previously existing law, that they are intended to disregard the practical realities of life, or that they are enacted for the purpose of committing injustice. Further, there is a rule that a statute must be construed according to what it says itself, and not by what was said about it in Parliament. Anybody who has ever had to wade through *Hansard* and read the Debates on a Bill, will at once appreciate the necessity for this rule. For all these reasons there has been invented an imaginary person called the "draftsman," who takes the blame of all the defects of the Act, but who is by courtesy supposed to know the facts concerning the subject in hand, to have just intentions, to be aware of the law as it stood before the Act was passed, and even (though this is a large assumption) to remember what was enacted in the last section but one, and in the definition clause.

When in the face of the language of the Act these flattering suppositions can no longer be made, when it becomes quite clear that the section is hopelessly unpractical or has been passed in order to work injustice, the "draftsman" is dropped out, and judge and counsel prefer to speak of "the Legislature in its wisdom"—a phrase which, I fear, is sometimes not meant to be taken literally. We shall find instances of all kinds in the cases decided under the Finance Act; some sections drawn with knowledge of practical realities, others in complete ignorance of facts, some drawn with a just intention, some clearly intended to be unjust, others "willing to wound and yet afraid to strike," in which the desire to commit injustice has not been expressed with precision.

Let us now examine the decided cases.

It will be convenient to take the principal cases decided under Part I. of the Act in the order of the Act itself; and in this way we may begin with the name of Lumsden, so inseparably connected with the increment value duty. I am quite ignorant of the motives which induced Mr. Lumsden to fight the case up to the highest Court in the country, but if his object was to show the inherent injustice of this duty, that object has certainly been attained, and radical alterations in its nature have been promised in consequence of the decision in this case. Perhaps if it had not been for the war, those promises might even have been fulfilled! But let us leave the region of speculation and come to facts. The case, which is reported (1913) 1 K. B., 346; 3 K. B., 809 (1914), A. C., 877, arose upon Section 2 (2) of the Act. Land with a building upon it was given in the provisional valuation an original site value, as on April 30, 1909, of £105. The property was sold in August, 1910, for £750, subject to a title of £33 capital value. It was found in the case stated by the Referee that if a fresh valuation of gross value was to be made as at the time of the sale that gross value would be £658. The full site value on the earlier date was £228.

The appellant contended that, for the purpose of calculating the deductions to be made from the consideration or purchase price, which is set up by Section 2 (2) (g) as the standard from which the site value on the occasion of sale is to be ascertained, the price realised plus the capital value of the title must be taken to be the gross value as at the time of the sale. The Revenue contended that for this purpose the true gross value must be ascertained by valuation. If Mr. Lumsden was right, there would be no increment value; if the Revenue were right, the duty was leviable on an increment value of £125.

Read at the ordinary general meeting of the Surveyors' Institution, held on Monday, November 22, 1915.

THE LONDON COUNTY COUNCIL.

At the meeting of the London County Council yesterday (Tuesday) afternoon the Finance Committee recommended that sanction be given to the Islington Borough Council for borrowing £5,455 for electric ty mains and to the Woolwich Borough Council for borrowing £4,700 for linking up the undertakings of the borough council and the South Metropolitan Electric Light and Power Company.

The Education Committee reported that the contracts entered into with Messrs. Patman and Fotheringham, Limited, for erecting the Vernon Square School, Finsbury Central; with Messrs. Brand, Pettit, and Co. for rebuilding the Woolmore Street School, Poplar; and with Messrs. J. Chessum and Sons, Limited, for erecting the Vallance Road Schools, Whitechapel, were nearing completion, and the contracts had applied for the release of retention money held by the Council in respect of the completed portions of the buildings. Subject to the Council agreeing to suspend the operation of a £112 order No. 295, the committee proposed to release for the three amounts of £575, £617, and £155 respectively. It was agreed that to be deducted from selected items for the construction of foundations for a third water turbine generator to be installed at the Greenwell generating station, and that an appointment of book-keepers in the accounts department of the transport department be arranged, and that the necessary orders be referred to the Electricity Generation Board.

The Parliamentary Committee reported that the London County Council General Powers Bill, 1914-15, the London County Council Finance Bill, 1914-15, the London County Council Transport Bill, 1914-15, and the London County Council

Motors Bill, 1915, have passed the Royal Assent. The first named measure has not only passed through the House of Commons, but has also passed through Parliament. It remains to be dealt with in the House of Lords, and is expected to pass without any serious hindrance. The transfer to the Council of the property and powers of the Visiting Committee under the Lumsden Acts, and other matters.

The Building Acts Committee reported that the regulations made in July last under

Taking all the Courts together, four of the judges were in favour of the Crown's contention and three in favour of Mr. Lumsden's. The result was that increment value duty is leviable upon the increase in value of a composite property consisting of land and buildings instead of on the increase in the value of the site alone; and as it has been agreed that this is a bad result from the point of view of public policy, there is little now to be gained by a discussion of the judgments delivered. But if those of the dissentient judges are read, it is difficult to avoid the conclusion that they were actuated by a desire to believe that the Legislature had not intended to enact the injustice of taxing a man on the increase in value of property due to his own exertions, and that its sole intention was to tax—justly, as some think—the unearned increment in the value of bare land. The majority of the judges, on the other hand, thought—(1914) A. C., 395—that Parliament must, on the literal construction of its language, be taken to have contemplated the possible taxation of either something more or something less than site value, strictly so-called."

The House of Lords, in "Inland Revenue v. Walker" (1915) A. C., 509, followed their former decision, although the special case as stated by the Referee was, perhaps, rather more favourable to the appellant than that in Lumsden's case. The purchase here was made by a sitting tenant, and their lordships held, further, that an additional sum of £180 included in the purchase-money could not be excepted in arriving at the consideration for the purposes of the calculation under Section 2 (2) (a). The Referee inferred that this extra sum had been paid by the purchaser to avoid being disturbed in his occupation of the premises; and although it is true that the House thought there was not sufficient evidence to support this inference, only one of the Lords appears to have decided against the deduction of this sum of £180, on the ground that even if the reason of its being paid had been established in fact, it was inadmissible in law. Unless, therefore, this point is concluded by Clay's case, with which I shall lead later, it appears to be still open.

In the case of "Hayllar v. Inland Revenue" (1914), 1 K.B., 528, Parliament was held, in Section 2 (3), though it had purported to provide for a substituted site-value in the case of a decline in value after a mortgage, to have enacted what was "almost illusory as a benefit to the owner." "It seems to me irrational and absurd, but the language is too strong," said the Master of the Rolls, and proceeded to hold that the amount of the actual mortgage debt must be taken as the gross value for the purpose of calculating the site-value as at the time of the mortgage, and of substituting that site-value for the site-value ascertained as on April 30, 1909. The true gross value at the date of the mortgage was, as everybody with experience of the management of land knows, probably about half as much again as the amount advanced on mortgage; and if a site-value based on the true gross value could have been substituted, the owner of the land might derive some real benefit from the provisions of Section 2 (3), which are supposed to protect him from paying an excessive increment duty in addition to suffering a depreciation of his property. As it is, the benefit enacted is "merely illusory." Did the "draftsman" intend that, or had he so little experience of transactions in land as to imagine that "the amount secured by the mortgage" generally represents the full market value? Neither alternative is creditable to "the Legislature in its wisdom."

The next duty in the order of the Act is the Reversion Duty, and the leading case upon it is that of Inland Revenue v. Marquess Camden (1914) 1 K. B., 641; (1915) A. C., 241. In this case the Courts strained the presumption of good intention almost to breaking point in favour of the "draftsman." They held, in short, that Parliament, if it was ignorant of the practice in connection with leases of land, or, if knowing that practice, it desired to enact a grave injustice, had not expressed that ignorance or that intention in sufficiently clear words to be effective.

The material passage from Section 13 is as follows:—"The total value of the land at the time of the original grant of the lease, to be ascertained on the basis of the rent reserved and payments made in consideration of the lease (including, in cases where a nominal rent only has been reserved, the value of any covenant or undertaking to erect buildings or to expend any sums upon the property)." Applying to these words a very usual canon of interpretation, that the specific mention of one alternative implies the definite exclusion of the other, it might be thought that the value of such a covenant or undertaking was intended to be excluded in every case where the rent reserved was more than nominal. And if anyone were to infer, say, from the curious drafting of Section 2 (3), remarked upon by the Court of Appeal in Hayllar's case, that the hand that drafted Section 13 was the hand of one who was not perfectly familiar with the course of transactions in land, such a captious critic might suppose that the draftsman when he was penning this section had recalled some vague reminiscence of a thing called "a peppercorn," sometimes paid by people who built buildings, and had proudly put his dangerous little piece of knowledge into a parenthesis.

But the Courts have fortunately taken a more serious, and no doubt a juster, view. They have held that the draftsman could not have been ignorant of the fact that in countless cases building agreements are entered into in the first instance, sums large or small are then expended on construction, and leases at rents by no means nominal are granted after the buildings have been erected; and they have held that the Legislature could not intentionally have committed such an ineptitude as to inflict a heavy penalty of additional reversion duty in such cases. Accordingly they have held that sums expended under a building agreement are "payments made in consideration of a lease" subsequently granted, even though the rent reserved in that lease is not nominal. When it is remembered that a building agreement is usually an agreement for a lease, and that by the definition in Section 41 "lease" includes an agreement for a lease, this result becomes somewhat remarkable.

Seven judges were unanimous in arriving at the conclusion just summarised; four out of the seven deemed it best to ignore altogether the existence of the parenthesis; while those who assigned a meaning to it at all said that it applies only where there is an agreement to spend money after the granting of the lease itself, and not where money has been spent beforehand. But this interpretation itself still leaves the parenthesis undisturbed where it does apply: thus where there is no building agreement, but only a lease with a covenant to erect buildings or incur expenditure in the future, that covenant will not be taken into account except where the rent reserved is a nominal rent. Certain *dicta* of their Lordships, however, leave it open to be contended that almost any rent below a rack-rent is a "nominal rent"; and more may be heard of that point in times to come.

One practical result of this case will be that it will in future be to the interest of the lessor, where the lessee contemplates erecting buildings or incurring expenditure, to grant an agreement for a lease in the first instance; and this not only in the case of ordinary house-building operations, but in the case of companies or firms about to erect large works; in fact, in the case of all new or expanding undertakings which are not upon freehold sites. Where there is likely to be further expansion, or a subsequent renewal of the lease, this course will be to the lessee's interest also. Industry will thus be penalised by having (often quite unnecessarily except for the reversion duty) to have to go through the cumbrous and expensive process of negotiating an agreement with the landowners twice instead of once. But perhaps I ought not to complain, for the profit will be to the lawyers.

Other points decided in connection with reversion duty are as follows:—The "value of the benefit" is to be ascertained only as laid down in Section 13 (2) ("Ramsden v.

Inland Revenue" (1913), 3 K.B., 580 (n)); in ascertaining that value no deduction is to be made because the lease is surrendered ("Inland Revenue v. Marquess of Anglesey" (1913), 3 K.B., 62); nor because it was granted upon the surrender of a previous lease ("Inland Revenue v. St. John's College, Oxford" (1915), 2 K.B., 621); the total value on the determination of a lease includes the licence value of a public-house ("Earl Fitzwilliam v. Inland Revenue" (1914), A.C., 753); a marriage settlement does not exempt from the payment of reversion duty under Section 14 (1) ("Inland Revenue v. Gribble" (1913), 1 K.B., 220).

The decision in "Inland Revenue v. St. John's College, Oxford," just referred to, is important with regard to the assessment of reversion duty where the lease is one of those periodically granted, according to the practice of many corporate bodies, upon surrender and the payment of a fine. In that case, when the previous lease was surrendered in 1896, it had twenty-six years unexpired. The lease surrendered in 1910 had been granted in 1896, at the rent reserved in the previous lease for a term of forty years on payment of a fine of £95 8s. What was in effect granted was an additional fourteen years' lease at the expiry of the original term. The fine had been calculated, putting the two guineas rent on one side, at two years' purchase of the annual value of the property; and two years is practically (according to Willick's Tables) the present value of a lease for fourteen years deferred twenty-six years. The Crown contended that the sum of £95 8s. was to be taken as a premium for a forty years' lease (as it nominally was) and reduced to an annual sum as if the property had been in hand when the lease was granted, which was not the case. Mr. Justice Rowlatt held that that contention was wrong, and that the College was right in saying that the total value at the grant of the lease in 1896 was to be calculated on a basis of adding to the rent reserved of £2 2s. the additional annual value of £47 14s. (half the fine which represented two years' purchase), these being in truth the payments made in consideration of the lease. The learned judge said that he had to apply the words of the statute "perfectly strictly, but so as to make them operate in a sensible way by reading 'payment' with regard to that for which the payment was made, and not by taking the payment as being made for the same thing in the case of an immediate term granted, and in the case of a deferred term granted upon the surrender of an existing lease." No one who understands these matters will be inclined to differ from that conclusion.

The cases as yet decided by the Courts in regard to the undeveloped land duty have been comparatively few. Among these that of "Southend-on-Sea Estates Company, Limited" (1915), A.C., 429, is, I think, the most recent and probably the most far-reaching. Section 17 (5) prevents the duty from being levied where agricultural land is held under a tenancy originally created before April 30, 1909; but if the landlord has power to determine, the duty becomes leviable as soon as he can exercise the power, whether he, in fact, does so or not. In numerous cases the Inland Revenue attempted to levy the duty where there was power to determine in case the land should be required for purposes of building, and so on, and sought to say that it was immaterial whether the land was really required for those purposes; if the power exists, they said in effect, and the landlord is the sole person to decide whether he shall exercise it, then he can at any time determine the tenancy, and he is liable for the duty. The Court of Appeal and the House of Lords have rejected that contention, and have held, where the right reserved was "at any time to resume possession for building or other purposes," that "other purposes" meant purposes of the same kind as building, and that if the landlord had no such purpose he had no power to determine, even though he might have power to form the purpose. Technically, no doubt, this was merely a decision upon the particular form of words

... those words were... are plainly agree... would not come... I do not... Revenue have sought to... in other cases since... would probably have...

... referred to minerals are... likely in the Act. It is... place to say what are... no definition to... Appeal Court... from the problem... "minerals" means all... apart from the sur... be worked, except those... and does not exclude... substances composing the... which are of the nature... of the "district" *Wystrach v. Inland Revenue* [1912], S.S.C. 1165. They held that felsite was a mineral, and that the Inland Revenue Commissioners had no power to treat (as they purported to do) certain minerals, not mentioned in the statute, as excepted from the scope of the mineral rights duty. These minerals included Bath stone, Portland stone, sandstone, and freestone; and I am at a loss to suggest upon what grounds the Inland Revenue Commissioners based this assumption of the dispensing power. The remarkable thing is that it should have been seriously defended in a court of law, not by the Commissioners, but by the taxpayer.

The mineral rights duty is assessed on the rental value, and where the right to work the minerals is let, the income-tax under Schedule A deducted by the lessee, is not to be included in the rental value; but the super-tax payable by the lessor is to be included. *Duke of Beaufort v. Inland Revenue* [1915], 3 K.B. 48. Payment for wages is included, even though those wages are for minerals got from the land of third parties. *Shawe Storey v. Inland Revenue* [1914], 1 K.B. 87.

The increment value duty charged upon minerals as an annual duty under Section 22 has been held to be leviable whether there has been an "occasion" under Section 1 or not. *Inland Revenue v. Sheffield and North Yorkshire Navigation Company* [1917], 1 K.B. 725. An appeal against this decision is now pending, but it may be pointed out that in view of the way in which Section 22 (3) is framed, it is at least very doubtful whether it can be intended to operate itself without reference to Section 1. The effect of this decision, if it stands, is to deprive the taxpayer of the advantage of a 10 per cent. reduction in the increment value duty in respect of all minerals the working of which had commenced after April 30, 1909, or which have been leased since then; and the increment value duty is charged on the value of the land unless on the occasion of a lease for fourteen years, or a death, or the statutory occasions applying to a number of cases which does not die.

Probably the most important case yet decided with regard to minerals is that of *Form v. Attorney-General* [1915], 1 K.B. 753, in which the effect of Section 25 of the Act. That section provides that minerals are to be treated in the general valuation as having no value unless the proprietor, or his assignee, has returned to the Commissioners a statement of the nature of the minerals and the proportion of them. It does not say that the value of the minerals is to be determined by the figure of value returned by the proprietor in his return to the Commissioners by the Inland Revenue, but that the parties value on them the value returned to the Inland Revenue. The Inland Revenue has, however, in the past, taken the proportion of value as the basis of the proportion of value returned to the Commissioners. It is not clear, however, whether the value of minerals must be determined by the value returned to the Commissioners, or whether the value of minerals is to be determined by the value returned to the Commissioners, or whether the value of minerals is to be determined by the value returned to the Commissioners, or whether the value of minerals is to be determined by the value returned to the Commissioners.

The Court refused the contention of the Crown, and held that Form 4 was not the return referred to in Section 25 (2) because it "was not a proper or intelligible mode of requiring a return of particulars respecting the minerals, and certainly did not treat them, as the Commissioners were bound to do, as a separate parcel of land." Mr. Justice Joyce, in delivering the judgment of the Court, referred to Form 6 as being possibly, with some slight modifications, the form applicable; so that if there is any case in which a proprietor, having a return called from him in Form 6, has assigned no value to the minerals, it is possible that the consequences aimed at by the Inland Revenue may ensue, but such cases must be very rare. The Commissioners have certainly been unfortunate in their drafting of Form 4, both in regard to that all-starred question in which they asked for the owner occupier's estimate of the annual value of his land, and in regard to the question concerning minerals. It is difficult to resist the conclusion that they were trying to trap the taxpayer into unconsciously making admissions damaging to himself, or to sympathise with them now that they have been hoist with their own petard.

Reference to the case of *Form 4 (Dyson v. Attorney-General)* [1911] 1 K.B. 410 brings us to the other cases decided with regard to the general valuation. That case itself is now, perhaps, ancient history, and need not be dwelt on. But there have been several cases of great importance decided upon the portentous Section 25. Everybody in this room is no doubt familiar with that section—if it is not presumptuous to use the word familiarity in relation to such a Frankenstein's monster—and I do not propose to add to the length of this Paper by reading it; but it is comforting that even so perspicacious a judge as Lord Aboulton was puzzled to know, as he said in *Inland Revenue v. Herbert* (1913), A.C. 325, at page 358, "for what reason the draftsman chose to express the definition (of full site value) in so peculiar a fashion." It is not too much to say that Clause 14, as it was when originally drafted, was a monument of illiteracy; and the draftsman who was brought in on the Report stage, like the second collaborator who is sometimes called in in the theatre to "pull the play together," seems to have re-written the section with some desire to give it a logical appearance; but the effect of his doing so has been, as decided by the House of Lords in the Scottish case just referred to, that in certain cases the assessable site value ascertained under Section 25 may be a minus quantity.

It was strenuously argued that the value of bare site could never be less than nothing; and that Parliament must have legislated in view of that obvious fact. The effect of the decision is that Section 25, in its main lines, has little to do with real life, and merely prescribes the solution of an academic problem.

The success of the Crown in this case is thus a much greater condemnation of the Act than its failure would have been. No doubt the object of its contending for minus site-values was to increase the amount leviable as increment value duty in the cases concerned. But it has gained that tactical victory at the cost of a strategical defeat.

Incidentally, two of the learned lords (pp. 355, 362) expressed views which are, at first sight, somewhat surprising as to the meaning of site value in Section 5 (5), which provides for a 10 per cent. reduction upon the collection of increment value duty. These views, which were not a part of the decision of the House, and are not in complete agreement with each other, have not, as I gather, been acted upon by the Inland Revenue, and I have not heard that any taxpayer has claimed the benefit of them; they were negatived in the Revenue Bill of 1914, which did not pass into law; but they show how difficult it is to interpret this Act so as to arrive at a practical result.

The basis of the calculation directed by Section 25 is the value of land "sold in the open market by a willing seller," and has been discussed in the cases of *Inland Revenue v. Clay and Buchanan* [1914], 3 K.B. 406, and of *Glass v. Inland Revenue*

(1915), S.S.C., 449. In the English case Lord Justice Pickford said, at pp. 478-9: "Sold in the open market" means sold in such a way that anyone wishing to purchase was able to do so, e.g., by auction or by putting the house into the hands of an agent to sell; and I think a willing seller means one who is prepared to sell, provided a fair price is obtained under all the circumstances of the case. I do not think it means only a seller who is prepared to sell at any price and on any terms, and who is actually at the time wishing to sell. In other words, I do not think it means an anxious seller. . . .

The gross value is not to be measured necessarily by the price given by a buyer who is peculiarly in need of the particular piece of property, but it seems to me clear that the fact of there being such a person in the market must have an influence on the value in the open market. Upon these principles, which must commend themselves to all who bring any experience of sales or valuations of land to bear upon the question, the Courts have held that where the trustees of a nursing home desired to extend the home by acquiring the house next door, and where a water board desired to acquire lands within their catchment area, the value to the trustees and the board was the market value of the house or land, and that it was not true to say that the market value was the value to outside purchasers with a mere pound or two added to represent the extra bid of the nursing home trustees or the water board.

Tenant-right, i.e., the value of unexhausted manure or tillages, is included in gross value and total value, and is not to be deducted as a matter personal to the occupier (*Inland Revenue v. Smyth* [1914], 3 K.B. 406); neither is the value of the land laid down in grass. The same decision, however, directed the value attributable to grass to be included in gross value, but to be deducted in "divesting" or arriving at full site-value. The meaning of "structure" in the divesting clause was considered, and the road in that case was held, from its construction, to be a "structure." Sea-walls and drainage dykes are not "buildings" or structures connected with buildings (*Waite's Executors v. Inland Revenue* [1914], 3 K.B. 196); nor are the dry stone walls which so familiarly replace hedges in many parts of the West and North of England (*Morrison v. Inland Revenue* [1915], 1 K.B. 716). The value of agricultural land for agricultural purposes does not include its value for sporting purposes (*Inland Revenue v. Hunter* [1914], 3 K.B. 425). The cases of *Smyth, Hunter, and Morrison* are still under appeal to the Court of Appeal, and the effect of the various decisions just summarised appears to have been to delay indefinitely the valuation of agricultural land.

A very similar effect has been produced upon the valuation of land developed by buildings by the decision in *Inland Revenue v. Whidborne's Executors* (1915), 2 K.B. 350, where deductions were allowed in respect of the appropriation of land for roads, and of the construction of roads in an ordinary building estate; and the deductions took the form of a single sum applying to each building plot, being the percentage of its total value attributable on April 30, 1909, to the dedication and construction of the roads. In face of the language of sub-section (4) it is difficult to see what legal contention the Crown could put forward against the allowance on principle of the deduction; and a perusal of the reported arguments of the Law Officers did not solve the doubt. That they felt the difficulty themselves is shown by the fact that their chief attack was directed against the form of the deduction. They failed both on the question of principle and on the question of form.

From this, I fear, somewhat dreary review of the cases decided under the Finance Act of 1910 a few salient points emerge: the increment value duty is, by the victory of the Crown in the Lumsden case, shown to be the convincing of most parties to work injustice in the case of the building industry, and thus to impose an additional fetter on the housing movement; the reversion duty is, by the refusal of the House of Lords in *Lord Camden's case* to believe in the unjust

intention which the language of Section 13 goes far to substantiate, much reduced in its possibility of yield; the increment value duty as regards minerals is in a state of flux; last and by no means least, the national valuation—the new Domesday Book—the inaugurator of the millennium—remains suspended because the Courts have held that certain sub-sections of Section 25 are capable of a practical application to agricultural land and to land covered with houses. The valuation machinery cannot proceed, because it has been held that the valuation must, in part at any rate, be made in the light of actual fact.—But a political truce now prevails in the country, and their will be no peroration to this paper.

Our Illustrations.

CATHEDRAL CHURCH OF ALL SAINTS, KHARTOUM, SUDAN.

Towards the end of the year 1913 an appeal was issued for funds to enable the committee to proceed with the erection of the tower, which still remains to be done in order to complete the building. A considerable sum had been guaranteed provided the remainder was forthcoming by October 1, 1914, but unfortunately the war came on, the flow of donations ceased, and the whole matter has been shelved for the time being. All the working drawings had been prepared by the architect, Mr. Robert Schultz Weir, in anticipation of the work being shortly proceeded with, and we illustrate in our present issue the architect's Royal Academy drawing from this year's exhibition. The tower will be detached from the main structure, but connected with it by a covered passage leading from the narthex to the lower stage of the tower, which is intended to form the baptistery. Above this would come the ringing chamber, approached by a staircase entered from the outside at the ground level and going up in one angle (as shown in the plan). Still higher comes the clock chamber, and above that again the lantern, open on the four sides. From this high position a good view would be obtained of the city, the junction of the White and Blue Niles just below, and Omdurman beyond. Owing to the treacherous nature of the subsoil special precautions are necessary, and a reinforced concrete foundation raft has therefore been provided for. The baptistery will be constructed internally of dressed coursed ashlar, and will be vaulted in stone. It will have an apse on the eastern side. The font will be placed central with the connecting passage, so that it can be seen from the narthex of the church, and open bronze grilles will be placed at the tower end of the connecting passage. The external face of the tower will be of random rubble, like the wall of the church, with dressed coursed corners and windows. These latter will be filled in with pierced stone slabs, glazed in the case of the baptistery and open above. The lantern will all be constructed of dressed stone. Access will be obtained to the storeys above the ringing chamber by means of iron ladders going up through the openings left in the floors for getting up the bells. These ladders will be easily removable. It is only proposed to have one large deep-toned bell, but the spare provided is sufficient for a peal, should a generous donor come forward to pay for one. A clock is provided for with a dial on each of the four faces. These dials would be illuminated at night by electric lights at the end of long bars sticking out below, and arranged so as to reflect the lights directly on to the dials. On the small pinnacles at the four corners of the top of the tower will be cut the sacred cyphers: IC-XC: YC-OY: 4C-ZC: NI-KA ("Jesus Christ: Son of God: Light of the World: Conqueror"). We gave a general view of Khartoum Cathedral on January 5, 1912, showing the building from the south-west, but without the tower. In an early issue we have arranged to publish the working details of this interesting piece of work, lent us by the architect for illustration.

PREMISES FOR THE GENERAL MEDICAL COUNCIL, HALLAM STREET, W.

The building is erected on a site formerly occupied by small dwelling-houses of no particular interest. The structure is of brick and steel with reinforced hollow tile floors. The front is faced with Portland stone. The ground floor contains the general offices, cloak-rooms, etc. The first floor is approached by separate staircases for the public and for members, and contains the council room and three rooms for committees or for consultation. The mezzanine floor gives access to the galleries at each end of the council room and to two committee rooms. The second floor contains the dining room, service room, lavatory, smoking room, and one committee room. The kitchens and caretaker's rooms are in the attic; the basement contains the storage rooms for registers and the heating cellars. The elevation to Hallam Street is developed from the plan, and shows a central feature of a wide segmental bow carried up from the ground to the top of the second floor. The large windows of the council room are divided by pilasters supporting figures representing the attributes to the functions of the council concerning the education and registration of the medical profession in Great Britain and Ireland. The emblem of medicine is carved in low relief above the centre window. The sculptured ornament above the entrance is replaced in execution by a relief representing the cult of Asklepios. The sculpture generally is the work of Mr. F. Lessore and his assistants: it is distinguished by great delicacy and refinement in execution. The general contractors are Messrs. Chiuichen and Co., who have employed as sub-contractors Messrs. D. G. Somerville and Co., Limited, 120, Victoria Street, S.W., for the floors and reinforced concrete; Messrs. James Boyd and Sons, 196, Great Portland Street, W., for the heating; Messrs. Burn Bros., 3, Blackfriars Road, S.E., for the sanitary engineering; Messrs. Gent and Hurley, 24, Belvoir Street, Leicester, for the electrical work; and Messrs. Waygood-Otis, Limited, 3, Falmouth Road, S.E., for the lifts and vacuum cleaner. The building is erected from the designs and under the superintendence of Mr. E. C. Freere, A.R.I.B.A. The illustration is from a drawing by the architect exhibited in the Royal Academy.

SOANE MEDALLION AND TRAVELLING STUDENTSHIPS DRAWINGS IN ITALY.

THE CORTILE, PALAZZO FAVA, BOLOGNA.

This palace, situate opposite the church of La Madonna di Galliera at Bologna, was built by Giov. Batt. Jardi in 1689, and still remains unfinished. The cortile is very handsome, and is adorned with the works of Carracci. The great hall is decorated with scenes from the history of Jason, the first work in fresco by Agostino and Annibale. In the adjoining chamber the Voyage of Æneas is portrayed by Lodovico. Other rooms are enriched by other subjects, including the Rape of Europa. The Story of Æneas, painted in opposition to a frieze by Cesi in the same apartment, was, it is said, the turning point in the history of Carracci. Details of the arcade on brackets in this cortile were published in our issue of November 11, 1898, p. 675.

CHURCH OF LA MADONNA DEI MIRACOLI, BRESCIA.

The rich cinque cento portico of this church is in the Corso Vittorio Emanuele, and it is the richest building of its kind in Brescia. The date of its erection is set down as 1480, and Lod. Boretta carried out the decorations of its façade, which was designed by Gian Gasparo Pedoni, of Cremona. Those of the interior are quite Venetian in character. The church contains some excellent paintings by Moretto. His beautiful picture of St. Nicholas presenting two school-boys to the Virgin is fully described by Mrs. Jameson in her "Sacred Art": "This is an application of the religious character of this saint to portraiture and common life which is highly beautiful and poetical. St. Nicholas is presenting the Virgin two orphans, while she looks down upon them from her throne with a benign air, pointing them out to the notice of the Infant Saviour, who is seated in her lap. The two boys,

orphans of noble family of Roncaglia, are richly dressed; one holds the mitre of the good bishop; the other the three balls." These drawings now reproduced on our plate form part of the series of sketches made during his Travelling Studentship tour by Mr. Alick G. Horsnell, Soane Medallist and Tite Prize-man. We illustrated, from a photograph, the main façade of the church in THE BUILDING NEWS for August 20, 1897.

ENTRANCE LODGE, "BURDOCKS," FAIRFORD, GLOS.

We give the working drawings of this pretty and commodious lodge, built some short time since, at the same time that the house was being erected. The work was carried out in local stone for the general walling and dressings, the stone slates being obtained from the Byford Quarries, Stow-on-the-Wold. The details will explain themselves, and an endeavour was made to treat the building symmetrically on all sides, as it is in a conspicuous position. A view of the house itself, with plan, will be found illustrated in the BUILDING NEWS for June 23, 1911, from the architect's drawing. The estate is about a mile from Fairford. The builders of the lodge and stables and shell of the house were Messrs. Sells Bros., of Fairford, and the architect was Mr. E. Guy Dawber, F.R.I.B.A., of London.

AN ARCHITECT'S HOUSE, CHURCH END, FINCHLEY, N.

This cottage-like home has been built for the architect's own occupation at a cost of about £550 on rather a narrow plot of ground, and economy both as to planning and materials was a prime consideration. The exterior walls are built of rough stones lime-whitened, and the roof is covered with sand-faced tiles. The chimneys are of picked stock brickwork. The interior is very plainly treated, with no cornices, but a good effect is obtained by the use of heavy picture rails. The recessed fireplace in the parlour has a long expanse of valuable tiles and long shelves over for china, etc. Messrs. Mallock and Parsons, of Gray's Inn Road, were the builders. All the chimney pieces, both wood and iron, were designed by the architect, Mr. H. S. East, A.R.I.B.A., of Gray's Inn. We give two photographs of the house and the pair of plans on one plate.

OBITUARY.

Sir James Stewart Davy, who was from 1905 to 1913 Assistant Secretary and Chief General Inspector of the Local Government Board, has died at his residence, Wintergreen Wood, Pyrford, in his sixty-eighth year. Sir James Davy was the son of Mr. John Davy, of Jamaica, and was educated at Uppingham School and at Balliol. In 1872, shortly after taking his degree, he entered the Poor Law service. In 1875 Mr. Davy was transferred to the Lancashire Poor Law district, and in 1876 he was appointed permanently as Assistant General Inspector. In 1878 he was appointed General Inspector for the East and West Riding of Yorkshire, and in 1886 was transferred to the Kent and Sussex district, where he remained until his appointment as Chief General Inspector in 1905. During these last nineteen years he was employed in many public inquiries. In 1905 he gave evidence before the Royal Commission on the Poor Laws, occupying six days, and though his suggestions were not all accepted, he was able to carry out many desirable reforms which they recommended. He was appointed a C.B. in 1902, and in 1911 he was created a K.C.B.

Mr. Burkett J. Emery, a member of the Birmingham Architectural Association, and a lieutenant in the Mid Birmingham Battalion, Royal Warwickshire, is reported "missing, believed killed." Reports from brother officers show that Lieut. Emery acquitted himself very gallantly, and, after being wounded, kept in charge of his section in the action, which occurred on or about October 12. Lieut. Emery's architectural works consisted of several factories and domestic buildings in the Midlands. He had been in practice at 109, Colmore Row, Birmingham, for about six or seven years.

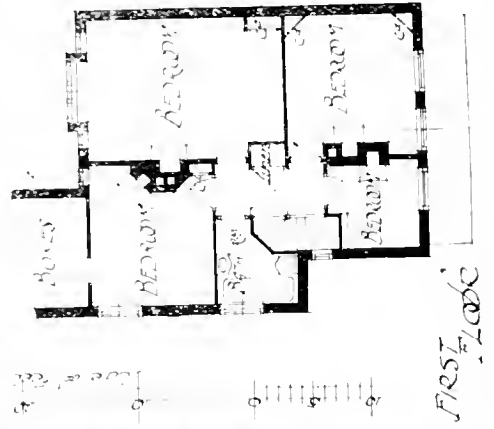
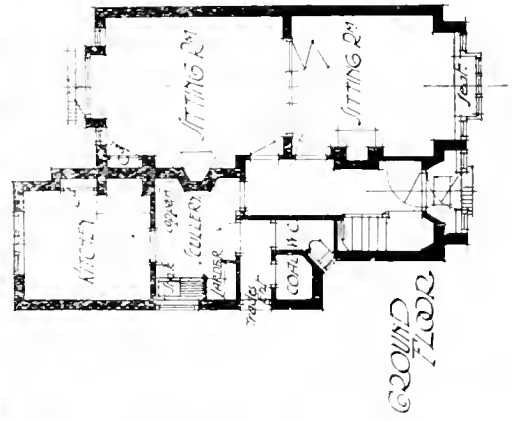
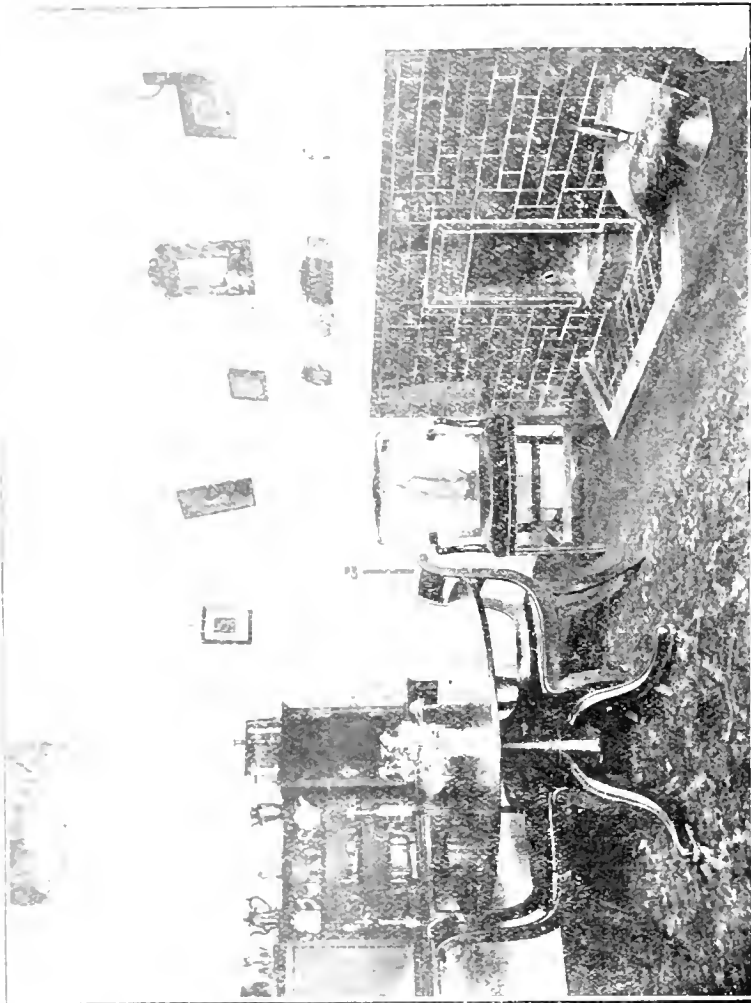

AN ARCHITECT'S HOUSE, CHURCH END, FINCHLEY.—Mr. H. S. EAST, A.R.I.B.A., Architect.

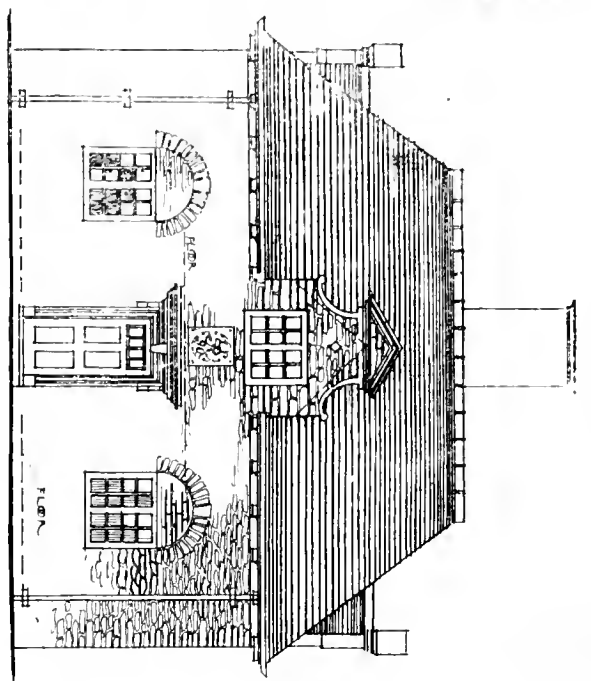

SOUTH ELEVATION

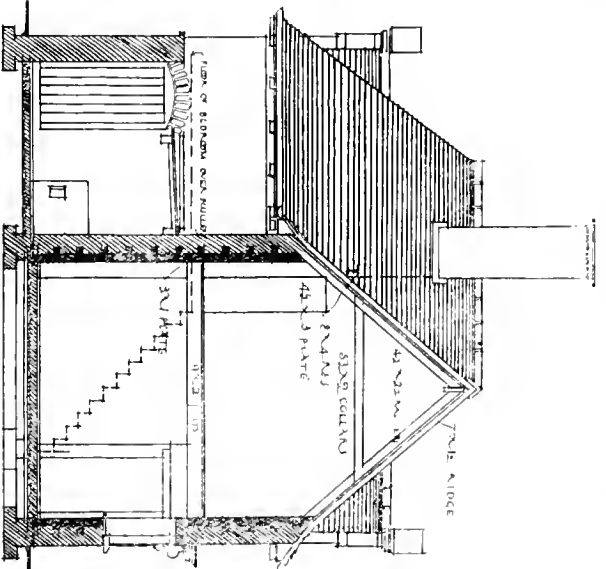

SECTION A-B
 0 5 10 15 20 25 30 feet

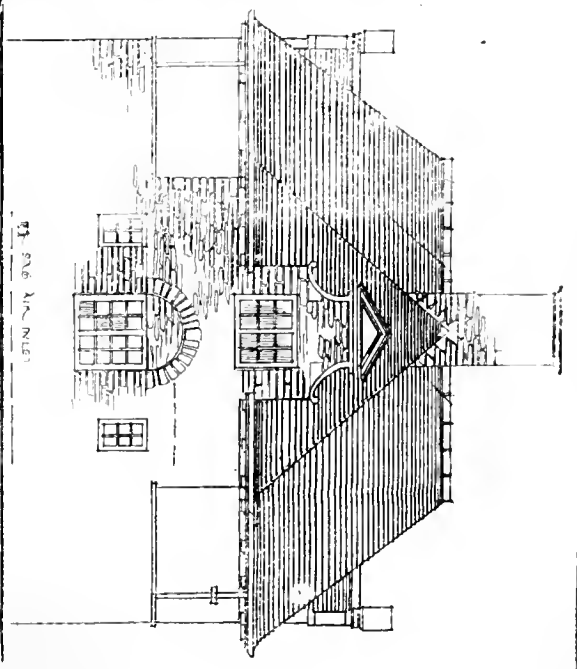

NORTH ELEVATION.

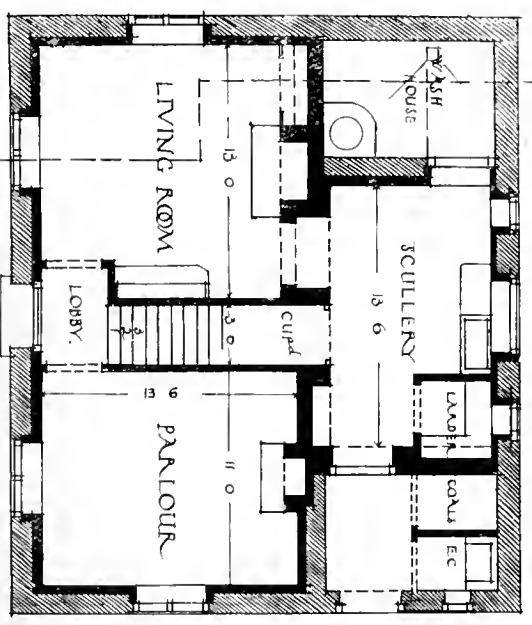

GROUND PLAN

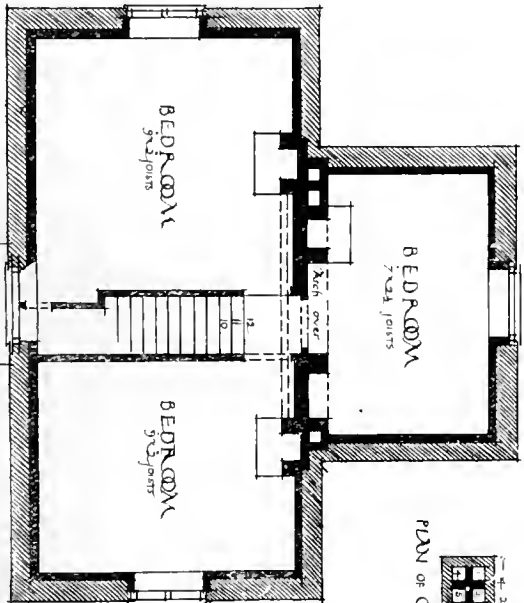

FIRST FLOOR PLAN

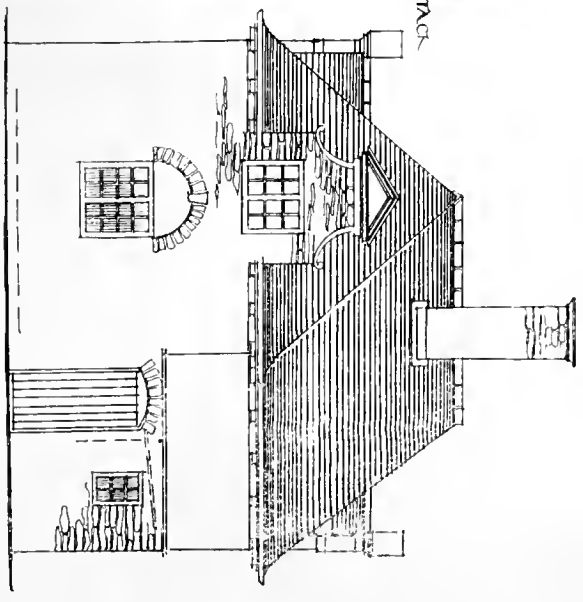

EAST ELEVATION



ENTRANCE LODGE, "BURDOCKS," FAIRFORD, GLOUCESTER.—Mr. E. GUY DAWBER, F.R.I.B.A., Architect.

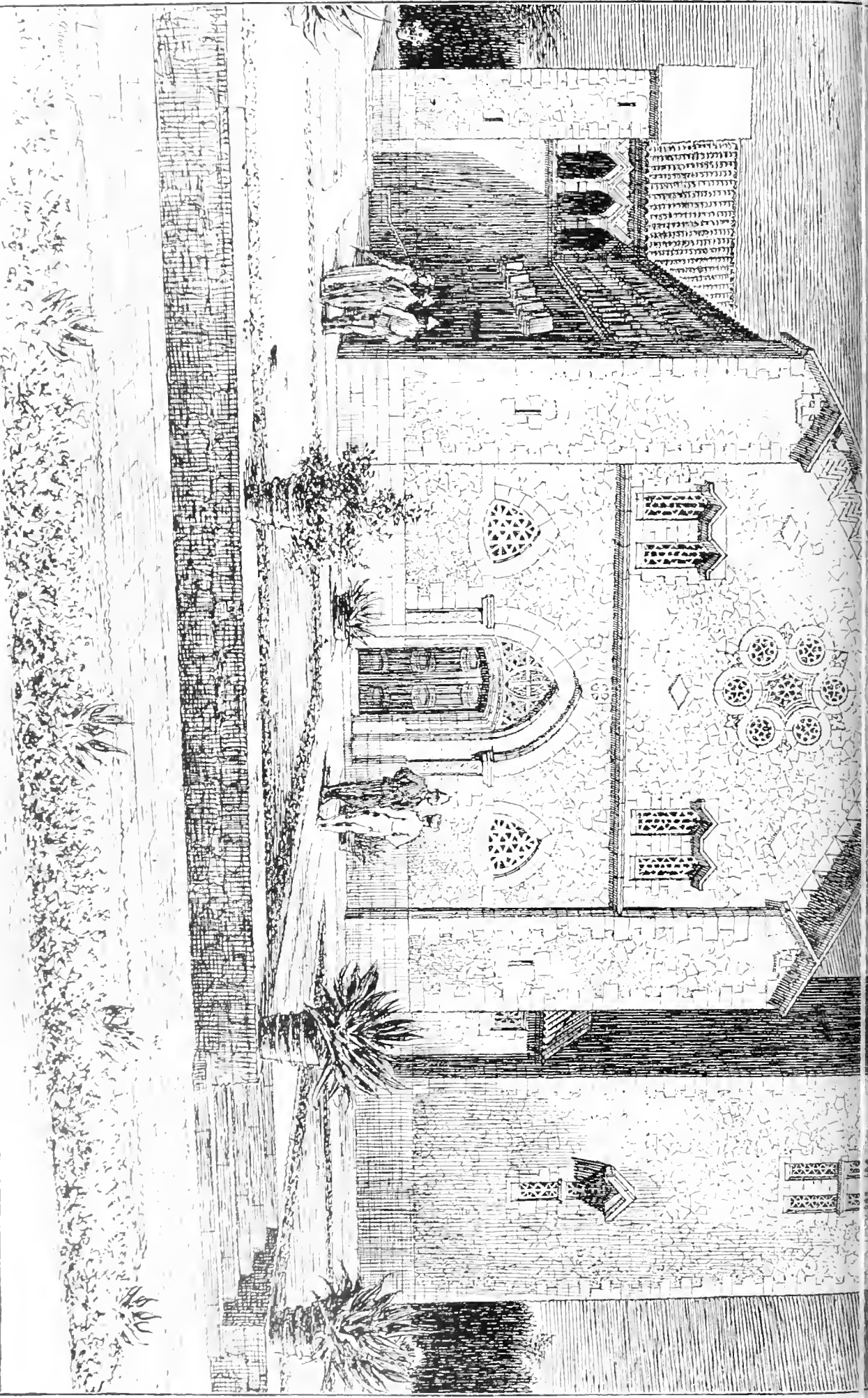

CATHEDRAL CHURCH OF ALL SAINTS KHARTOUM SUDAN

MR. ROBERT S. WHEAT, Architect.

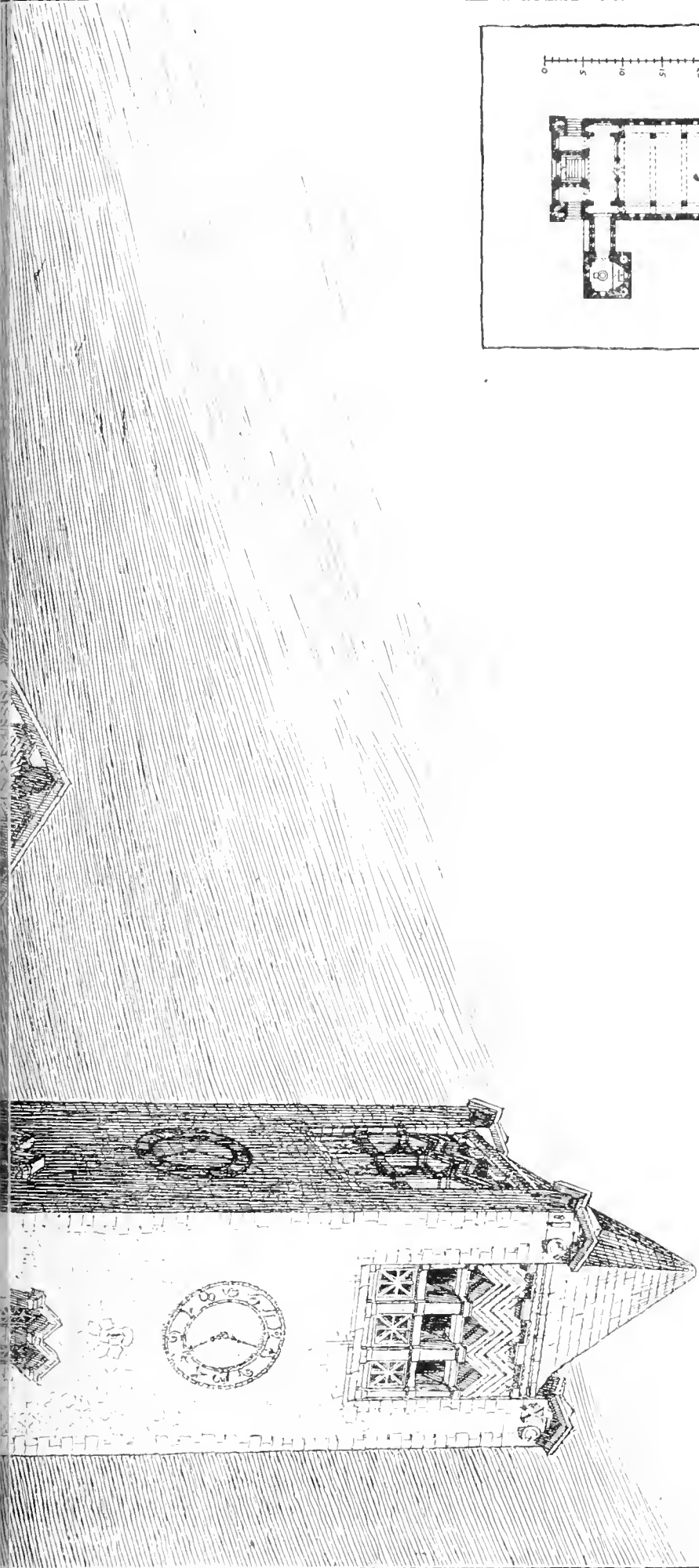
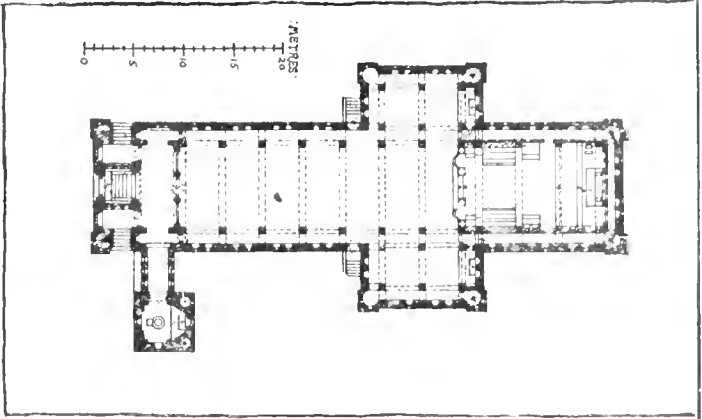

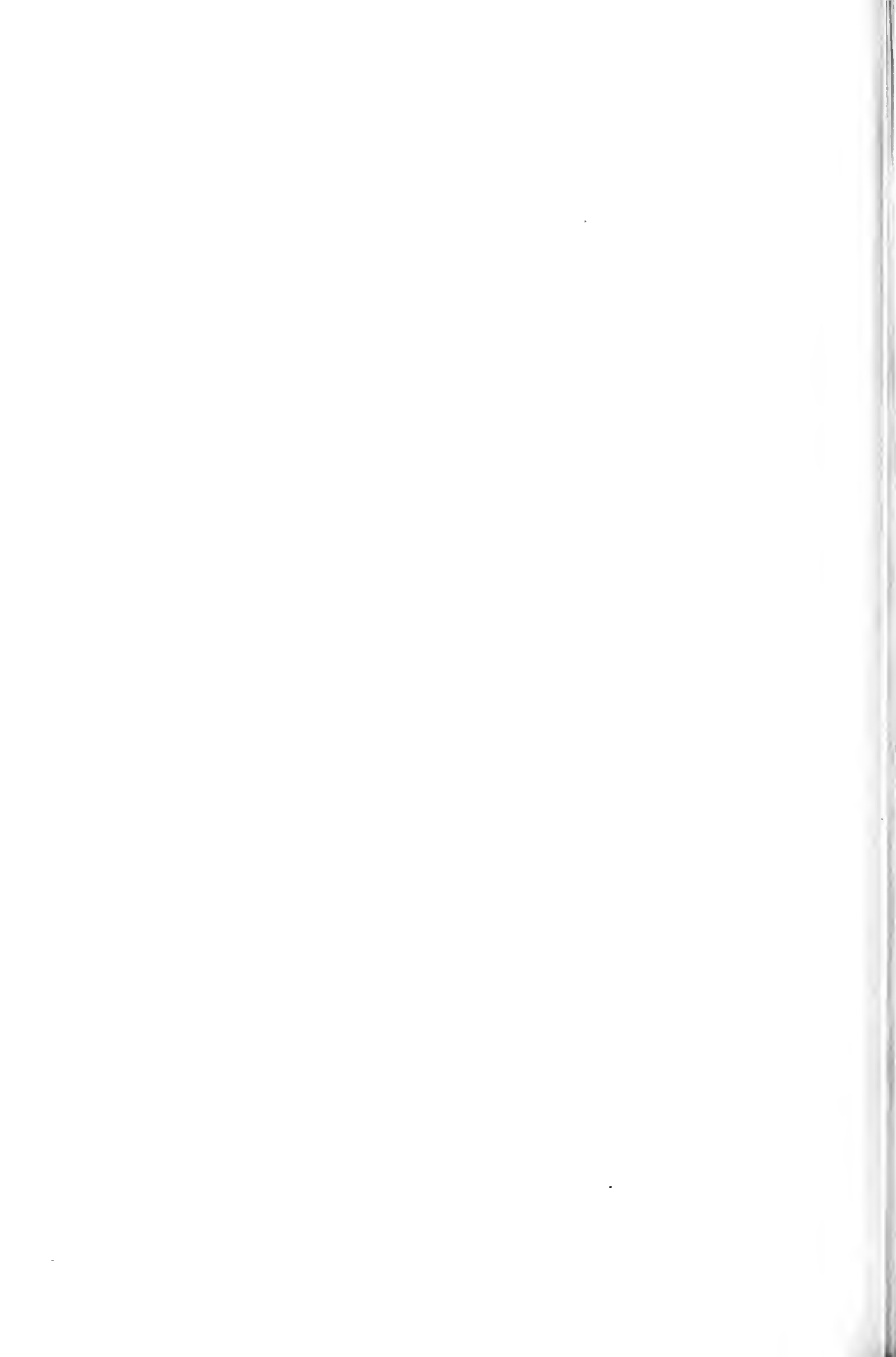

LIBRARY
1915
TORONTO



SOANL MEDALLION AND TRAVELLING STUDENTSHIP DRAWING



PALAZZO
FAVA
Alcorno
Alcorno

THE CORTILE, PALAZZO FAVA, BOLOGNA.

N. ITALY.—By Mr. ALICE G. HORSNELL, Medallist and Tite Prizeman.







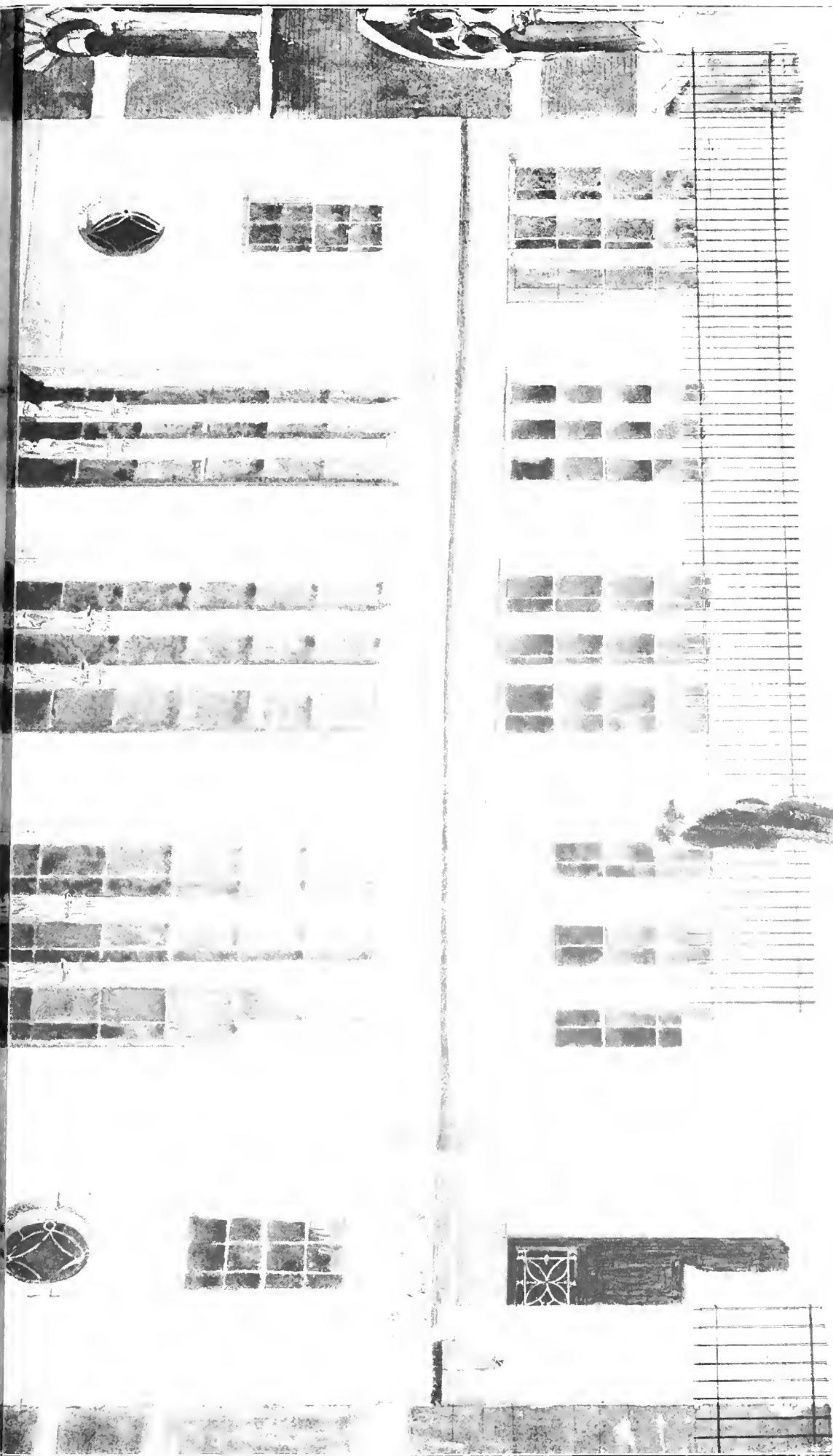

P. C. Spencer Architect
1908

PREMISES OF THE GENERAL MEDICAL COUNCIL, HALLAM STREET, W. MR. EUSTACE C. FREER, A.R.I.B.A., ARCHT.



HOUSING PROBLEMS IN BRISTOL.

A section of the annual report of the Medical Officer of Health for Bristol, just issued, deals with work done under the Housing Acts in 1914, and Dr. D. S. Davies explains what appears to him to be one of the causes of the large number of houses in Bristol letting at rentals not exceeding £26 a year which are unfit for habitation at the present time.

During the decades 1880 to 1900, he states, private enterprise more than supplied the demand for houses for the working classes. The price of houses during these years was somewhat inflated. From 1904 onwards a slump set in, and house property has depreciated far below its real value; consequently no inducement is offered to undertake the repairs which are required to be done from time to time to keep the houses in a tenable condition; hence the houses become so neglected that it requires a considerable expenditure to put them in a thorough state of repair. Under the circumstances, the landlord's only interest is to obtain as much rent as he can get for a house rapidly becoming uninhabitable, and when pressed to carry out adequate repairs, he allows the mortgagees to take possession. Mortgagees in possession are at present selling houses for sums varying from £5 to £30 per house. The new landlord objects to spending a sum far in excess of the purchase money in repairs, to comply with the requirements of the Housing and Town Planning Act, 1909.

The construction of the older type of house for the working classes without any—or with an inefficient—damp-proof course, with its front parapet walls, and zinc gutters between the "M" roofs, and the flat pitch roofs, has made it a very expensive building to keep in repair. In the poorer houses, the slightest defect in the zinc gutters or a heavy storm spoils the appearance of the ceilings and walls, as well as making unfit the room, or rooms, so affected. Owing to the absence of an efficient damp-proof course, the internal walls become insanitary, and also constant expense is involved by the frequent re-papering in order to keep the rooms decent and in a presentable condition. The fixed top sash of the windows is another characteristic of this type of houses, and apart from the insufficient ventilation, it prevents the housewife from cleaning the first-floor windows. An important defect also is the absence of ventilated larder accommodation, and the position of the larder under the stairs.

If landlords would reserve a portion of their rents for depreciation each year, and repair their property more frequently, fewer houses would be condemned as unfit for human habitation, says Dr. Davies. There are hundreds of houses in Bristol to-day that could be saved if the roofs were stripped, parapet walls and zinc gutters abolished, and the straight or stable roof, with ridge parallel to front and back walls, eaves and rain-water shutters and down-pipes provided; efficient damp-proof courses inserted; if back-to-back houses were converted into single houses with through ventilation; if houses without through ventilation had it provided; if external walls were properly cemented or rough-casted with brown lime mortar; if lighting areas were increased and sashes made to open; plastering of internal walls made good; floors and other woodwork renewed; sink, water tap, and ventilated pantry provided. With these requirements effected there would be no cause left to condemn or demolish a house so improved. A tenant cannot reasonably be expected to take an interest in a dilapidated house; there is an inclination to let everything slide, and thus the nucleus of a slum is formed.

There are many areas in Bristol which are very congested. The dwellings in these areas are small, and the majority of them are quite worn out; it is hopeless attempting to repair them. The only thing that can be done is to close and demolish them, or to prune liberally, thus providing more air-space and room for alterations and repairs to those allowed to remain. A very gratifying feature is the number of owners who visit Dr. Davies' office for advice as to repairs and the insertion of damp-proof courses, thus proving that the work done under the Housing Acts

is primarily of an educational character. No houses to let at 5s. 6d. or under per week have been built in Bristol during the years 1911, 1912, 1913, and 1914. The congestion is becoming very acute. During the year 3,875 houses were inspected, of which 2,903 were found defective, 1,455 were made habitable, and 508 were represented as unfit. A summary of the work done under the Housing Act, 1909, up to the end of 1914 shows that the total number of houses inspected was 6,832, of which 5,180 were found defective, and there were 1,652 as to which no action was necessary. Of the remaining 4,662, 271 were closed under order, 405 closed voluntarily, 3,046 were made habitable, and 940 were in hand.

MATHEW BOULTON'S HOUSE AT SOHO.

In the course of an address to the Birmingham Architectural Association the other evening on "Architecture in Birmingham and the Neighbourhood in the Last Half of the Eighteenth Century," Mr. Arthur T. Bolton, F.R.I.B.A., of London, suggested that the house of Mathew Boulton at Soho should be preserved as a memorial to the man who was one of the makers of Birmingham. Whether the interesting house at Soho was built in 1764, simultaneously with the factory, and perhaps from a design by Robert Adam, was a point, said Mr. Bolton, which, up to the present, he had been unable to ascertain. Smiles, in his life of Boulton and Watt, referred to a letter of 1770 from Boulton to Adam, which he hoped yet to trace, in which Boulton gave an account of his factory and the number of men employed. Unfortunately, that letter could not be traced, and the source from which Smiles appeared to be quoting was not known. Looking at the early date alleged for the house, and its self-evident architectural character, it seemed at least highly probable that it might have been based upon an Adam design. James Adam visited Baskerville in Birmingham and Shenstone at Leasowes, and saw the new Hagley house in May, 1758. There was no doubt the Soho house was enlarged later, as there was a letter from Boulton to Watt dated August 20, 1789: "The foundations of the new drawing and with-drawing room are begun to be laid this day, the earth being dug out." That might be taken to refer to the wing on the one side of the house. There had been some controversy in connection with the idea that about the year 1791 photography was invented and first used at Soho. To establish that it had been sought to show that the house as seen now was recast at this period, and a new story added. It was traditional that Sheraton stayed with Boulton, and made the fine mahogany sideboards fitted in behind the columns. It became a great question, therefore, whether the 1764 house had not been recast. Looking at it all round, the apparent unity of the design, which at first sight appeared in favour of the first period of 1764, gave place to doubts arising from unexplained features of the planning and construction. He was inclined to think the balance of evidence was in favour of the design being by Wyatt rather than by Adam, and what was seen now must be regarded as a reconstruction subsequent to 1770, and possibly contemporaneous with the design of the facade of the Birmingham Theatre which was given by Wyatt in 1780. In concluding his sketch of Boulton's career the lecturer said his life deserved to be honoured and commemorated. No city could afford to live merely in the present, ignoring the salutary influence of its own past. It was to be hoped that the house of Mathew Boulton might yet escape destruction, and, reverently repaired, serve as a museum or library forming a centre of enlightenment and research, and an entirely suitable memorial of a great personality.

Mr. Bolton showed a number of views of Hagley and Croome Court, as well as of Boulton's house at Soho.

The urban district council of Portadown have appointed Mr. J. Blakley as town surveyor in place of the late Mr. W. Wilson.

THE BROCH DWELLINGS OF SCOTLAND.

A Munro lecture in anthropology and prehistoric archaeology was delivered on Thursday, in the History Class room of Edinburgh University, by Mr. George Macdonald, F.B.A., LL.D., upon "Scotland During the Roman Period." The lecturer dealt first with native earth houses. The character of these structures was explained and illustrated, the main facts as to their geographical situation indicated, and their possible purpose discussed. A certain number of them had apparently been inhabited, at all events occasionally, but there were circumstances, notably their frequent occurrence in connection with hut circles, which suggested that the majority had been storehouses. The objects found in them were few, but they included implements of iron, rotary querns, and fragments of Samian ware, which furnished clear evidence as to their date. They were not peculiarly Scottish, for analogies could be cited, not only from elsewhere in Britain, but also from various parts of Europe and Asia.

The broch, on the other hand, was the most characteristic, as it was the most remarkable, monument of prehistoric Scotland. The total number of authentic examples recorded within the Scottish area was now not far short of five hundred, while not one was known outside of it. Obviously this architectural type must have played a very important part in the civilisation which produced it. Its true home was the region north of the Great Glen, including the various groups of outlying islands, although examples occurred sporadically as far south as Berwickshire and Selkirkshire, and three had recently been recognised in Galloway. Its Celtic origin was indisputable, and every fresh excavation added to the cumulative testimony which assigned it to the Roman period. The contents of the broch of Torwoodlee, in Selkirkshire, for instance, included Roman pottery, Roman glass, and a Roman coin, all pointing to an occupation that could not be much later than 150 A.D. On the other hand, so southerly an example could hardly come very early in the series to which it belongs, seeing that the type would require time to spread downwards from the north. This seemed to throw the oldest of the brochs back to a date well before the first Roman advance into Caledonia.

Nor must it be assumed that the type sprang full-fledged from the brain of some prehistoric Scottish architect. Minor variations in design showed that, even after it had been definitely evolved, development continued to go on. They might be certain that the broch itself was the outcome of a long process of evolution. When the Royal Commission on Ancient Monuments had completed its survey, material for tracing that process would probably be available. Meanwhile, it seemed fairly certain that the galleried "duns" of Argyllshire and the islands represented the immediately preceding stage. The crannogs of Scotland, with the scientific investigation of which Dr. Munro had been so prominently identified, were another phase of the civilisation represented by the brochs. That is, they belonged to the early Iron Age, and were occupied during the Roman period, as well as possibly earlier and certainly later. The remarkable results of the recent excavations on Traprain Law were also referred to.

A large new consumptive sanatorium is to be built at Ryse Hill, Galway, from the design of Professor W. A. Scott, M.R.C.S., of Dublin, and tenders for its erection are invited.

Captain Bernard Henry Holloway, 9th Sussex Regiment, of Burnt Wood Grange, Upper Tooting, Surrey, who was killed in France on September 27, aged 27, left property of the value of £10,540, with net personalty £9,050. Probate of the will, dated August 29 last, is granted to Henry Holloway, builder and contractor, father, and Roland Evelyn Holloway and Herbert John Holloway, builders and contractors, brothers. The testator gives his shares in Holloway's Properties, Limited, to his father and investments he had made in the War Loan to Miss Louisa Douglas Chapple.

LEGAL INTELLIGENCE.

WINDING UP FROM ENNIS.

THE COURT has given judgment in the case of the winding up of the Ennis Municipal Council. The Council had been dissolved in 1911 and the liquidator had to deal with the Council's affairs. The Council had a contract for the purchase of land and the liquidator had to deal with the Council's affairs. The Court has given judgment in the case and the liquidator has to deal with the Council's affairs.

WORKMAN AND EX-BOROUGH SURVEYOR COMMITTED FOR TRIAL.

W. E. E. of the New Romney Municipal Council, late of the New Romney Municipal Council, was committed for trial for the supply of false prices to the Municipal Corporation Act. The Council had a contract for the supply of false prices to the Municipal Corporation Act. The Council had a contract for the supply of false prices to the Municipal Corporation Act.

SUSPENDED INJUNCTION: NINE ALDERSHOT URRAN DISTRICT COUNCIL.

The Aldershot Urran District Council was suspended from its functions. The Council had a contract for the supply of false prices to the Municipal Corporation Act. The Council had a contract for the supply of false prices to the Municipal Corporation Act.

COMPETITIONS.

DUBLIN. The Cleansing Committee of the Dublin Corporation recently advertised for competitive designs for the laying out of the reclaimed slobland at Fairview as a public park. With the approval of the Municipal Council, premiums were offered of £50, £10, and £5 respectively for the first, second, and third designs selected. The designs have been placed as follows: First, Messrs. William Power and Co., landscape gardeners, King Street, Waterford; second, Mr. Horace T. O'Rourke, Lytlehome, Cabra Road, Dublin; and third, Miss Henrietta C. Take, 3, Upper Fitzwilliam Street, Dublin. The assessors were Sir Frederick Moore, curator of the Botanic Gardens at Dublin, and Mr. C. J. McCarthy, the city architect. Nine competitors sent in designs.

PROFESSIONAL AND TRADE SOCIETIES.

NORTHERN ARCHITECTURAL ASSOCIATION.—This association held its opening meeting of the session on Wednesday night at 6, Higham Place, Newcastle-on-Tyne. The president, Mr. R. Burns Dick, F.R.I.B.A., presided over a very good attendance. In his address, the president said that and other societies throughout the Empire mourned the death in battle of some of their most promising and talented members, whilst thousands of architects and students of their art had taken up arms. After urging the need for national service, he indicated what might be the effect upon the construction of cities by the greater development of aircraft. Among the possible changes, he thought, would be a gradual increase in the proportion of open spaces; the general introduction of underground or double-decked roadways; tiled and sloping roofs entirely abandoned in favour of very strong flat roofs, specially adapted for anti-aircraft appliances; picture galleries with suspended wall linings, on which the pictures would be fixed, and which could be swiftly dropped to their safety vaults below; museums with their cases of treasure, statuary, etc., arranged on continuous lift platform capable of being lowered by the pressing of a button; and schools and similar buildings so modified as to make them immediately available for the accommodation of the citizen-arms at the signal of alarm. He could also imagine a network of subways linking up important centres, and permanently constructed and well-equipped trenches protecting the great industrial centres, and great electric generating stations entirely underground.

THE SHROPSHIRE CRADLE OF THE ROYAL STUARTS.—The Rev. Professor Cooper, D.D., delivered a lecture, under the auspices of the Scottish Ecclesiastical Society, in St. Cuthbert's Lower Hall, King's Stables Road, Edinburgh, on "The Shropshire Cradle of the Royal Stuarts." Bishop Campbell, Glasgow, occupied the chair for the first time as president of the society. Professor Cooper said that, whatever might have been the remoter origin of the Royal Stuarts, and, as a matter of fact, they came from Brittany, where they had held the position of stewards to the Bishops of Dorset—it was in Shropshire that they laid the foundation of their fortunes on the soil of Great Britain. They came over, not with the Conqueror, but with the ablest of his sons; they took root in Shropshire on the fall of the Norman Earls of Montgomery. In Shropshire were born to Henry's follower, Alan Fitz Flood, the two sons William and Walter, whose descendants were to rise to such high distinction. From William Fitz Alan sprang the Fitz Alan Howards, Dukes of Norfolk; from Walter the Royal Stuarts. Both William and Walter showed their gratitude to Henry I. by adhering to the cause of his daughter Matilda against the usurping Stephen; and it was this loyalty to the legitimate heir, that recommended Walter—the younger brother to the notice of David I. of Scotland and led him to accompany that monarch to the north, where he was speedily appointed to the office which gave his descendants their historic surname; and, receiving lands in Renfrewshire, became the founder of Paisley Abbey. Walter, the Steward, left England in early life before he had much to

give to the Church, but his father, Alan, was a conspicuous benefactor to the Abbey of Shrewsbury; his brother William was the founder of that of Haughmond; and to his sister-in-law, the rich wife of William, the great Priory of Wenlock was deeply indebted. For this priory Walter had a deep veneration, and when he was about to found Paisley he stipulated that its first inmates should come from Wenlock, and associated the patron saint of that house, St. Milburgh, with St. James, and the local St. Mirren, as patrons of the new monastery. Naturally, monks from Wenlock would try to build at Paisley on the lines of the home which they had left; and he had found among the carved and moulded stones collected in the old cloister-garth at Wenlock several bearing distinct witness to the former existence there of a cloister-arcade very similar to that which Mr. P. MacGregor Chalmers, acting on the evidence supplied by capitals and bases dug up at Paisley, had just reproduced in his beautiful restoration of that abbey. The lecture was illustrated with a series of views of the Shropshire churches and abbeys referred to by the lecturer.

THE THREATENED DEMOLITION OF GLASGOW TOLBOOTH STEEPLE.—The proposed removal of the Tolbooth Steeple of Glasgow to a new site was referred to at the annual meeting on Thursday night of the Glasgow Archaeological Society. Mr. J. T. T. Brown presided. The council, in their report, stated that they had renewed the protest the Society made two years ago, when it was then proposed by the Town Council to remove the steeple. The President remarked that, notwithstanding all the protests they had received, the Town Council had gone on as if nothing had happened, and had decided that the steeple should be removed. Mr. Edwards moved that the Society promote a memorial to the Ancient Monuments Board, asking that body to move for a preservation order under the Ancient Monuments Protection Acts for the retention of the steeple on its present site, and that other local bodies be invited to support the motion. Professor Cooper seconded the motion, which was adopted.

TOWN PLANNING AFTER THE WAR.—The first national conference of housing societies and societies of public utility was held on Friday in London, under the auspices of the Garden Cities and Town Planning Association, with the object of providing for housing on town planning lines after the war. Mr. Cecil Harmsworth, M.P., presided, and representatives of sixty-one societies from all parts of England, Scotland, and Wales were represented. The questions discussed included the relations of housing societies to public money combines in the building industry, the co-operation between municipalities and public utility societies in future, and the amendment of the law to allow local authorities to invest in such societies. Stress was laid on the high price of money and material, and eventually it was agreed that the best time for taking action would be "so soon as the end of the war could be seen approaching." A committee was formed representing the whole of the groups interested in the scheme.

TRADE NOTES.

Boyle's latest patent "Air-Pump" ventilators have been applied to the Baptist Schools, The Green, Twickenham. Messrs. F. McNeill and Co., Limited, of Spencer House, 4, South Place, E.C., point out that they were the original patentees and manufacturers of asphalted roofing in the year 1835, and not only supplied practically the whole of the roofing felt required for the huts and hospitals of the British Army during the Crimean War, but supplied and applied the asphalted roofing felt on the whole of the military camps in this country at the time of the Crimean War viz., Aldershot, Colchester, Shorncliffe, and Curragh, Co. Kildare. Some of these contracts were held for over fifty years, and during the present war McNeill's roofing felts have been supplied in very large quantities not only for the roofing of the huts in this country but for export to the various bases abroad.

Messrs. A. J. King, of the Municipal Council, were committed for trial for the supply of false prices to the Municipal Corporation Act. The Council had a contract for the supply of false prices to the Municipal Corporation Act.

Our Office Table.

An inquiry has been held in the Merchants' Hall, Glasgow, regarding an application by the District Committee of the Middle Ward of Lanarkshire for authority to prepare a town-planning scheme for the Newton, Carmyle, and Baillieston area of the county. Mr. David Ronald, the commissioner appointed by the Local Government Board for Scotland, presided, Mr. W. E. Whyte, clerk of the committee, appeared for the applicants, while representatives were present on behalf of the Glasgow Town Council and landowners, who lodged objections to the scheme. Mr. W. R. Young, the engineer, gave a detailed description of the area which it is proposed to deal with. He pointed out that a similar scheme was contemplated for the Cambuslang area, and that it was intended that the two schemes should be inter-related. Care would be taken to foster the proper development of the area and its mineral operations. It was in the interest of the local authority to see that the area was developed, and there was no disposition on their part to hamper the mineral industry. Dr. John E. Wilson, County Medical Officer, said that it was an area which had developed very considerably, and could be easily governed by a town-planning scheme. The inquiry was concluded.

Under the title of "Expert Juggling," the *Contract Record* of Toronto publishes the following remarkable statement as to tendering practices in Winnipeg:—"Investigation into the construction of the Law Courts and Central Power Station at Winnipeg reveals the fact that seven tenders for the Law Courts were received on June 12, 1912. The three lowest were the National Construction Company at \$763,974, Thomas Kelly and Sons at \$887,500, and C. H. Simpson and Company at \$299,107. The National Construction Company, of which C. H. Simpson was president, were offered the contract, but they refused to sign, stating there had been an error in their tender. The Kelly firm were then offered the contract, but they replied that they had just received a large cut-stone job and could not undertake another contract involving a large quantity of cut-stone. C. H. Simpson and Company then signed a contract with the Manitoba Government at \$890,107. On August 14 they sub-let the entire work by contract to the National Construction Company at \$854,107. The National Construction Company later gave Thomas Kelly and Sons a sub-contract for stone work in the building."

The annual report of the city engineer for Sheffield, Mr. Charles F. Wike, for the year ended March 25 last, has just been published, and states that on November 16, 1914, fifty years had been completed during which the by-laws relating to new buildings and streets had been in operation. During these fifty years, 57,904 houses were erected, being at the rate of 1,158 houses per twelve months; the greatest numbers were built in 1899 and 1900, 2,710 and 2,876 respectively, and the least number in 1913, when the total fell to 542. Last year the length of new streets formed, of sewers constructed, and of plans submitted showed in each case a marked falling-off as compared with the preceding year and previous ones. During the latter half of 1914 great activity took place in the construction of huge works buildings for war munitions purposes, and this was greatly increased during the early part of the present year. Extensive additions or alterations have taken place, the number of plans approved being eighty-five in the last six months of 1914, and 142 in the first six months of 1915. The new buildings approved during the year included the Town Hall extension, eight picture palaces, additions to Jessop Hospital, and a new children's hospital. The scheme approved by the Local Government Board in 1905 for the extension of the city sewage works, at a cost of £270,369, was completed during the year, and well within the estimate, the actual expenditure being £262,654. The works consist of catchpits, continuous-flow settling tanks, first-contact beds, and storm beds, which can also be operated as contact beds, the whole being capable of dealing with 65,000,000 gallons per day. The reconstruc-

tion of High Bridge at Owlerton, at an estimated cost of £7,000, loaned by the Sheffield Corporation and the West Riding County Council, has been allowed to proceed. The bridge, which is on the Penitence main road and crosses the River Don, will in future be 50 ft. wide, and built of brick and concrete-faced with stone. Several important works, estimated to cost in all £35,654, have been cancelled or suspended until after the war. Since January 1, 1915, the work in connection with the building department has been under the control of Mr. E. A. Green; the improvement, town-planning, parks and estates department under Mr. E. Partington; and the sewage disposal works under Mr. J. Haworth.

The ordinary general meeting of the British Uralite Company (1903), Ltd., was held at 85, Gresham Street, London, E.C., yesterday. During the year which ended June 30, 1915, a profit has been made of £5,800 15s. 11d., which, together with the balance brought forward from the previous year, amounting to £181 3s. 8d., gives a sum standing to the credit of profit and loss of £5,982 2s. 7d. The directors were unable to recommend the payment of a dividend for the following reasons:—The items of buildings, patents, plant, machinery, and goodwill were taken over from the old company at an arbitrary figure, and from a valuation which the directors have had made, it would appear that they stand in the company's balance-sheet at a price far in excess of their true value. The Board have, from time to time, approached some of the largest shareholders with a view to coming to an arrangement for a reduction of the capital in order to bring these assets down to their actual value, and pending a comprehensive scheme dealing with the matter, no depreciation has been written off the plant, buildings, etc., taken over from the old company. The directors feel that before any dividend can be paid either a reduction of capital must take place, or the items in question written down out of profits. They have accordingly set aside the sum of £2,000 out of the profits of the past year, in depreciating the item of plant and machinery, and have placed to reserve account the sum of £1,500, carrying forward the sum of £482 2s. 7d.

A second edition of "The Magnet of Commerce," first published in October last, is issued by the Great Central Railway Company. It graphically describes the enormous capacity of the great Midland coalfield with which the Great Central Railway Company is principally identified, with its estimated contents of forty-nine thousand million tons of coal, the cheaper and more efficient transport of which the Great Central has done so much to facilitate by its completion of the great docks at Lamingham. The volume is lavishly illustrated, and the statistics and general information given are of the highest importance to every industry. It is obtainable at the Great Central Railway Publicity Department, 215, Marylebone Road, N.W.

Lieut.-Col. Charles Rosenthal, A.R.I.B.A., of Pitt Street, Sydney, N.S.W., commanding the 3rd Field Artillery Brigade, Australian Imperial Force, has been mentioned in dispatches for distinguished services in the field during operations at the Dardanelles, and has been appointed a C.B. (Military Division). Temporary Captain Matthew Hogan, Service Battalion, South Lancashire Regiment, has been specially mentioned in Sir Ian Hamilton's dispatch of September 22 for services during the Dardanelles operations.

The council of the Institution of Municipal and County Engineers have appointed Messrs. E. J. Elford, T. W. A. Hayward, and C. F. Wike to confer with three representatives of the Society of Engineers to consider the question of drawing up rules and scale of fees for salaried engineers.

The death has occurred at Walsall of Mr. C. W. Stephens, who was seventy-seven years of age. He fought under Sir Bartle Frere with the old 44th Foot Regiment during the war in the Far East in 1860. On retiring from the Army he was appointed borough sanitary inspector at Walsall, a post which he held for over eighteen years.

Building Intelligence.

BIRTLEY, MID-DURHAM.—Plans for wooden houses for Belgian workers at Birtley have been presented to the Chester-le-Street Rural District Council, as follows:—There will be 1,262 houses for two workers each; sixty hostels for fifteen workers each; seventy-three houses for foremen, and a camp for 1,003 persons. Each class of house will be painted a different colour, and the total population to be accommodated will be 8,500, which is practically the population of Birtley at the present time, so that the population will be doubled at one stroke.

SWANSEA Parcym Red Cross Hospital, Swansea, has now been altered and additions made in order to meet the requirements of a Red Cross Hospital for 100 patients. The chief entrance is on the east side, entered by a porch with a small porter's office. On the ground floor are wards, with the large hall to be used as a dining-room, the serving-room adjoining which is fitted up with hot plate, stoves, and carving table, also sinks and racks for washing up all china. Connected with these rooms are the kitchen, scullery, etc., all fitted out with gas stoves, steamboilers, ovens, sinks, etc. There is also on this floor the nurses' dining room, operating room, and dispensary, etc. On the first floor are nine wards, the matron and nurses' bath rooms and bedrooms, etc., also large linen rooms. A large kit room with 100 compartments is provided, and the stables have been converted into a recreation and reading room. The general contractors were Messrs. J. and F. Weaver, Swansea. Mr. Davies has acted as clerk of works. The work has been carried out from the design and under the supervision of Mr. Glendinning Moxham, F.R.I.B.A., architect, 18, Castle Street, Swansea.

WESTMINSTER CATHEDRAL.—Work on the new chapel of St. Andrew and the Saints of Scotland in the Roman Catholic Cathedral at Westminster is now almost completed, and the chapel, which is the gift of the Marquis of Bute, will be dedicated on St. Andrew's Day, November 30. Italian craftsmen have been engaged on the work, which was designed by Mr. R. Schultz Weir, for nearly three years. The chapel is entered by a bronze gilt gate, and has a noble pavement representing the sea, with inlaid fishes. The piers are of marble, with sculptured bands, and a cross inlaid with Egyptian porphyry bears a bronze figure of Christ. On the other side of the piers are sculptured representations of St. Ninian, St. Andrew, St. Columba, and St. Margaret. The arch of the east wall contains a jewelled cross in a flowered ball, with a peacock and doves in flight.

PARLIAMENTARY NOTES.

DISMISSALS FROM LAND VALUATION DEPARTMENT.—Captain Amey asked the Minister of Munitions on Tuesday night whether, in view of dismissals from the Valuation Department, he would be willing to employ in his department such dismissed officials who, being ineligible for military service, have shown capacity for work of organisation.—Dr. Addison, Parliamentary Secretary for Munitions, replied that applications for employment made by ex-officials of the Land Valuation Department who are ineligible for military service will always receive careful consideration in the event of suitable vacancies occurring. It must, however, be remembered that a large number of posts in the Ministry, other than those of a purely subordinate character, require some technical experience.

The Belgium Town Planning Committee have arranged a new series of lectures for Belgian architects and engineers, taking place at University College, London, on Thursdays in each week. Among those who are giving their services are Colonel R. E. Crompton, Consulting Engineer to the Road Board, Mr. G. Midgley Taylor, Mr. George L. Popper, Mr. W. R. Davidge, Mr. Raymond Unwin, Chief Town Planning Adviser to the Local Government Board, Mr. Amourin Williams, M.P., Professor Patrick Abercrombie, and Professor S. D. Ad-head.

LATEST PRICES.

N.B.—All prices must be regarded as merely approximate for the present, as our usual sources of information are in many cases failing us.

TIMBER.

Owing to stoppage of supplies all prices have advanced considerably.

IRON.		Per ton.	Per ton.
Rolled Steel Joists, English.	£14 0 0	to	£15 0 0
Compound Girders, Ordinary Sections	16 10 0		17 10 0
Wrought-Iron Girder Plates	13 10 0		13 12 6
Steel Girder Plates	13 15 0		13 17 6
Steel Sheets (Single or Double)	11 10 0		—
Steel Strip	10 15 0		—
Basic Bars	11 15 0		—
Bar Iron, good Staffs	13 10 0		13 15 0
Do., Lowmoor, Flat, Round, or Square	24 0 0		—
Do., Staffordshire Crown	14 0 0		14 10 0
Boiler Plates, Iron—			
South Staffs	8 0 0		8 15 0
Best Sneadhill	9 0 0		9 10 0
Angles, 10s, Tees 20s, per ton extra.			
Builders' Hoop Iron, for bonding, £13 5s. to £13 15s.			
Do., galvanised, £20 to £20 10s. per ton.			
Galvanised Corrugated Sheet Iron—			
No. 18 to 20. No. 22 to 24.			
6ft. to 8ft. long, inclusive gauge	£20 0 0		£20 10 0
Best ditto	20 10 0		21 0 0
Cast-Iron Columns	£7 7 6		£9 0 0
Cast-Iron Stanchions	7 7 6		9 0 0
Rolled-Iron Fencing Wire	8 15 0		9 5 0
Rolled-Steel Fencing Wire	7 15 0		8 0 0
Galvanised Wire Strand, 7 ply, 14 B.W.G.	6 5 0		6 15 0
Cast-Iron Sash Weights	6 5 0		6 15 0
Cut Floor Brads	15 0 0		15 5 0
Corrugated Iron, 24 gauge	16 0 0		—
Galvanised Wire Strand, 7 ply, 14 B.W.G.	14 5 0		—
B.B. Drawn Telegraph Wire, Galvanised—			
0 to 8	9	10	11
10 to 15s.	10	11	12
15s. to 20s.	11	12	13
20s. to 25s.	12	13	14
25s. to 30s.	13	14	15
30s. to 35s.	14	15	16
35s. to 40s.	15	16	17
40s. to 45s.	16	17	18
45s. to 50s.	17	18	19
50s. to 55s.	18	19	20
55s. to 60s.	19	20	21
60s. to 65s.	20	21	22
65s. to 70s.	21	22	23
70s. to 75s.	22	23	24
75s. to 80s.	23	24	25
80s. to 85s.	24	25	26
85s. to 90s.	25	26	27
90s. to 95s.	26	27	28
95s. to 100s.	27	28	29
100s. to 105s.	28	29	30
105s. to 110s.	29	30	31
110s. to 115s.	30	31	32
115s. to 120s.	31	32	33
120s. to 125s.	32	33	34
125s. to 130s.	33	34	35
130s. to 135s.	34	35	36
135s. to 140s.	35	36	37
140s. to 145s.	36	37	38
145s. to 150s.	37	38	39
150s. to 155s.	38	39	40
155s. to 160s.	39	40	41
160s. to 165s.	40	41	42
165s. to 170s.	41	42	43
170s. to 175s.	42	43	44
175s. to 180s.	43	44	45
180s. to 185s.	44	45	46
185s. to 190s.	45	46	47
190s. to 195s.	46	47	48
195s. to 200s.	47	48	49
200s. to 205s.	48	49	50
205s. to 210s.	49	50	51
210s. to 215s.	50	51	52
215s. to 220s.	51	52	53
220s. to 225s.	52	53	54
225s. to 230s.	53	54	55
230s. to 235s.	54	55	56
235s. to 240s.	55	56	57
240s. to 245s.	56	57	58
245s. to 250s.	57	58	59
250s. to 255s.	58	59	60
255s. to 260s.	59	60	61
260s. to 265s.	60	61	62
265s. to 270s.	61	62	63
270s. to 275s.	62	63	64
275s. to 280s.	63	64	65
280s. to 285s.	64	65	66
285s. to 290s.	65	66	67
290s. to 295s.	66	67	68
295s. to 300s.	67	68	69
300s. to 305s.	68	69	70
305s. to 310s.	69	70	71
310s. to 315s.	70	71	72
315s. to 320s.	71	72	73
320s. to 325s.	72	73	74
325s. to 330s.	73	74	75
330s. to 335s.	74	75	76
335s. to 340s.	75	76	77
340s. to 345s.	76	77	78
345s. to 350s.	77	78	79
350s. to 355s.	78	79	80
355s. to 360s.	79	80	81
360s. to 365s.	80	81	82
365s. to 370s.	81	82	83
370s. to 375s.	82	83	84
375s. to 380s.	83	84	85
380s. to 385s.	84	85	86
385s. to 390s.	85	86	87
390s. to 395s.	86	87	88
395s. to 400s.	87	88	89
400s. to 405s.	88	89	90
405s. to 410s.	89	90	91
410s. to 415s.	90	91	92
415s. to 420s.	91	92	93
420s. to 425s.	92	93	94
425s. to 430s.	93	94	95
430s. to 435s.	94	95	96
435s. to 440s.	95	96	97
440s. to 445s.	96	97	98
445s. to 450s.	97	98	99
450s. to 455s.	98	99	100

IRON.

IRON.		Per ton.	Per ton.
Rolled Steel Joists, English.	£14 0 0	to	£15 0 0
Compound Girders, Ordinary Sections	16 10 0		17 10 0
Wrought-Iron Girder Plates	13 10 0		13 12 6
Steel Girder Plates	13 15 0		13 17 6
Steel Sheets (Single or Double)	11 10 0		—
Steel Strip	10 15 0		—
Basic Bars	11 15 0		—
Bar Iron, good Staffs	13 10 0		13 15 0
Do., Lowmoor, Flat, Round, or Square	24 0 0		—
Do., Staffordshire Crown	14 0 0		14 10 0
Boiler Plates, Iron—			
South Staffs	8 0 0		8 15 0
Best Sneadhill	9 0 0		9 10 0
Angles, 10s, Tees 20s, per ton extra.			
Builders' Hoop Iron, for bonding, £13 5s. to £13 15s.			
Do., galvanised, £20 to £20 10s. per ton.			
Galvanised Corrugated Sheet Iron—			
No. 18 to 20. No. 22 to 24.			
6ft. to 8ft. long, inclusive gauge	£20 0 0		£20 10 0
Best ditto	20 10 0		21 0 0
Cast-Iron Columns	£7 7 6		£9 0 0
Cast-Iron Stanchions	7 7 6		9 0 0
Rolled-Iron Fencing Wire	8 15 0		9 5 0
Rolled-Steel Fencing Wire	7 15 0		8 0 0
Galvanised Wire Strand, 7 ply, 14 B.W.G.	6 5 0		6 15 0
Cast-Iron Sash Weights	6 5 0		6 15 0
Cut Floor Brads	15 0 0		15 5 0
Corrugated Iron, 24 gauge	16 0 0		—
Galvanised Wire Strand, 7 ply, 14 B.W.G.	14 5 0		—
B.B. Drawn Telegraph Wire, Galvanised—			
0 to 8	9	10	11
10 to 15s.	10	11	12
15s. to 20s.	11	12	13
20s. to 25s.	12	13	14
25s. to 30s.	13	14	15
30s. to 35s.	14	15	16
35s. to 40s.	15	16	17
40s. to 45s.	16	17	18
45s. to 50s.	17	18	19
50s. to 55s.	18	19	20
55s. to 60s.	19	20	21
60s. to 65s.	20	21	22
65s. to 70s.	21	22	23
70s. to 75s.	22	23	24
75s. to 80s.	23	24	25
80s. to 85s.	24	25	26
85s. to 90s.	25	26	27
90s. to 95s.	26	27	28
95s. to 100s.	27	28	29
100s. to 105s.	28	29	30
105s. to 110s.	29	30	31
110s. to 115s.	30	31	32
115s. to 120s.	31	32	33
120s. to 125s.	32	33	34
125s. to 130s.	33	34	35
130s. to 135s.	34	35	36
135s. to 140s.	35	36	37
140s. to 145s.	36	37	38
145s. to 150s.	37	38	39
150s. to 155s.	38	39	40
155s. to 160s.	39	40	41
160s. to 165s.	40	41	42
165s. to 170s.	41	42	43
170s. to 175s.	42	43	44
175s. to 180s.	43	44	45
180s. to 185s.	44	45	46
185s. to 190s.	45	46	47
190s. to 195s.	46	47	48
195s. to 200s.	47	48	49
200s. to 205s.	48	49	50
205s. to 210s.	49	50	51
210s. to 215s.	50	51	52
215s. to 220s.	51	52	53
220s. to 225s.	52	53	54
225s. to 230s.	53	54	55
230s. to 235s.	54	55	56
235s. to 240s.	55	56	57
240s. to 245s.	56	57	58
245s. to 250s.	57	58	59
250s. to 255s.	58	59	60
255s. to 260s.	59	60	61
260s. to 265s.	60	61	62
265s. to 270s.	61	62	63
270s. to 275s.	62	63	64
275s. to 280s.	63	64	65
280s. to 285s.	64	65	66
285s. to 290s.	65	66	67
290s. to 295s.	66	67	68
295s. to 300s.	67	68	69
300s. to 305s.	68	69	70
305s. to 310s.	69	70	71
310s. to 315s.	70	71	72
315s. to 320s.	71	72	73
320s. to 325s.	72	73	74
325s. to 330s.	73	74	75
330s. to 335s.	74	75	76
335s. to 340s.	75	76	77
340s. to 345s.	76	77	78
345s. to 350s.	77	78	79
350s. to 355s.	78	79	80
355s. to 360s.	79	80	81
360s. to 365s.	80	81	82
365s. to 370s.	81	82	83
370s. to 375s.	82	83	84
375s. to 380s.	83	84	85
380s. to 385s.	84	85	86
385s. to 390s.	85	86	87
390s. to 395s.	86	87	88
395s. to 400s.	87	88	89
400s. to 405s.	88	89	90
405s. to 410s.	89	90	91
410s. to 415s.	90	91	92
415s. to 420s.	91	92	93
420s. to 425s.	92	93	94
425s. to 430s.	93	94	95
430s. to 435s.	94	95	96
435s. to 440s.	95	96	97
440s. to 445s.	96	97	98
445s. to 450s.	97	98	99
450s. to 455s.	98	99	100

OTHER METALS.

OTHER METALS.		Per ton.	Per ton.
Lead Water Pipe, Town	£33 10 0	to	—
Country	34 10 0		—
Lead Barrel Pipe, Town	34 10 0		—
Country	35 10 0		—
Lead Pipe, tinned inside, Town	35 10 0		—
Country	36 10 0		—
Lead Pipe, tinned inside and outside, Town	38 0 0		—
Country	39 0 0		—
Composition Gas-Pipe, Town</			

TO CORRESPONDENTS.

We are not held responsible for the opinions of our correspondents. All communications should be drawn up as briefly as possible, as there are many communications upon the space allotted to correspondents.

It is particularly requested that all drawings and all communications respecting illustrations or literary matter for review, etc., should be addressed to the Editor of THE BUILDING NEWS, Effingham House, 1, Abchurch Lane, Strand, W.C., and not to members of the staff by name. Delay is not infrequently otherwise caused. All drawings and other communications are sent at contributors' risks, and the Editor will not undertake to pay for, or be liable for, loss of or damage to contributions.

Drawings of selected competition designs, important public and private buildings, details of old and new work, and good sketches are always welcome and for such no charge is made for insertion. Objects for commonplace subjects, small churches, chapels, houses, etc., we have usually far more sent than we can insert, but are glad to do so when space permits, on mutually advantageous terms, which may be ascertained on application.

When forwarding us with drawings or photographs, architects are asked kindly to state how long the building has been erected. It does neither them nor us much to illustrate buildings which have been some time erected, except under special circumstances.

Telephone: Gerrard 1201.

Telegrams: "Timeserver, E-strand, London."

NOTICE.

Bands 1-26 of Vol. XVIII are now ready, and should be ordered early (price 12s. each, by post 12s. 10d.) as only a limited number are done up. A few bound volumes of Vols. XXXIX., XL., XLV., XLVI., XLVII., XLVIII., XLIX., L., LI., LII., LIII., LIV., LV., LVII., LVIII., LVIX., LX., LXI., LXII., LXIII., LXIV., LXV., LXVI., LXVII., LXVIII., LXIX., LXX., LXXI., LXXII., LXXIII., LXXIV., LXXV., LXXVI., LXXVII., LXXVIII., LXXIX., XC., XCI., XCII., XCIII., XCIV., XCV., XCVI., XCVII., XCVIII., XCIX., C., CI., CII., CIII., CIV., CV., CVI., and CVII. may still be obtained at the same price; all the other bound volumes are out of print. Most of the back numbers of former volumes are, however, to be had singly. Subscribers requiring any back numbers to complete volume just ended should order at once, as many of them sell in our out-of-print.

Handsome Cloth Cases for binding the BUILDING NEWS, prices as per list on 2d. can be obtained from any Newsagent, or from the Publisher, Effingham House, 1, Abchurch Lane, Strand, W.C.

TERMS OF SUBSCRIPTION.

One Pound per annum (post free) to any part of the United Kingdom; for the United States, £1 6s. 0d. or 60s. 20s. odd; To France or Belgium, £1 6s. 0d. or 60s. 20s. 0d.; To India, £1 6s. 0d.; To any of the Australian Colonies or New Zealand, to the Cape, the West Indies, or Natal, £1 6s. 0d.

Our Direct Subscription Agents for Australia are Messrs. E. T. Chubb and Co., Printers and Publishers, 10, York Chambers, 10, Liverpool Street, Sydney, New South Wales; for Japan, The Maruzen Co., Ltd., 11-16, Nishishinjuku, Tori Sanjome, Tokyo; who will receive Subscriptions at 41 6s. 0d. per annum on our account. Copies of the paper will be sent by air to the above-mentioned addresses.

The special rate to Canada is 41 3s. 10d. = 50s. 0d. for 12 months, and 11s. 11d. 2d. 6s. for six months. Our Direct Subscription Agents for Canada are Messrs. S. B. 14, 5-2, Shaughnessy Building, 60 St. James Street, Montreal, who will receive Subscriptions at 41 3s. 10d. per annum on our account. Cheques and Postal Orders to be made payable to THE STRAND NEWS-PAPER COMPANY, LIMITED, and crossed London County and Westminster Bank.

ADVERTISEMENT CHARGES.

The charge for competition and Contract Advertisement, Public Companies and all official advertisements is 1s. per line of eight words, the first line counting as two, the minimum charge being 5s. for 10 lines.

The charge for Auction, Land Sales, and Miscellaneous and Trade Advertisements, except Situations (Advertisements) is 6d. per line of eight words (the first line counting as two), the minimum charge being 4s. for 10 lines, special terms for series of advertisements may be ascertained on application to the Publisher.

ESTIMATES AND PARTNERSHIPS.

The charge for advertisements, for estimations, variations and Partnerships is One Shilling per line of eight words, and 8 pence for every eight words thereafter. All situations and Partnerships must be prepared in duplicate.

ESTIMATES AND PARTNERSHIPS.

Advertisements for contracts, tenders, Wednesdays, Thursdays and Saturdays inserted under the heading "Situations Wanted" are of special charge. Rates for Trade Advertisements of first page, and special conditions of insertion, can be obtained on application to the Publisher.

REPLY TO ADVERTISEMENTS.

Replies to advertisements can be received at the Office, Effingham House, 1, Abchurch Lane, Strand, W.C., free of charge. It is to be forwarded under cover to a particular advertiser, an extra charge of 2s. 6d. is made (see Notice at head of "Situations").

Advertisements for the current week must reach the office not later than 3 p.m. on Tuesday. Front-page advertisements and alterations or stop orders

for serial advertisements must reach the office by first post on Monday to secure attention.

THE NEW POSTAL RATES.—Do not forget that though we are penalised by the new postal rates because we still keep to our old size, and therefore a copy of THE BUILDING NEWS exceeds the six-ounce limit, we are making no extra charge to subscribers who receive their copies direct from the office, the subscription rate remaining as before 41 per annum, 10s. half-yearly, and 5s. quarterly. Now is the time to subscribe.

RECEIVER: W. H. S. and Son, R. and S. J. W. V., Ltd., R. M. R. M. D. C. B. and Son, J. C. S., C. H. P. J. G. K. and Son, L. and C. W., and S. R. A. and Co., L. D. and T. D.

D. H. G. Yes.

R. P. Thanks, too.

CAITAN D. R. It is not reached us.

FRANK. See our "Directory" pages under "Damp-proof Courses."

Telephone: DALSTON 1488.

OGILVIE & CO.

Many years connected with the late firm of W. H. LASCHELLES & CO., of Bunhill Row.

Mildmay Avenue, ISLINGTON, N. EXPERTS in HIGH-CLASS JOINERY.

ALTERATIONS & DECORATIONS. ESTIMATES FREE.

FOR Olivers' Seasoned Hardwoods.

APPLY TO— WM. OLIVER & SONS, Ltd., 120, Bunhill Row, London, E.C.

TENDERS.

* Correspondents would in all cases oblige by giving the addresses of the parties tendering—at any rate, of the accepted tender: it adds to the value of the information.

ALLENBY.—For the construction of about fifty yards of pipe sewer, with ventilating manhole, in Brighton Place, for the town council:— Gall and Walker, 34, Rose Street, Aberdeen (accepted) .. £68 19 10

ALYBURY.—For the supply of a cable for Biester Road, for the urban district council:— Johnson and Phillips, Ltd. (accepted) .. £84 0 0

BARNSEY.—For extensions at electric works, in the town council. Accepted tenders:— Builder work:— Taylor, F. .. 443 0 0

Constructional work:— Birchall, Brown, and Co. .. 25 0 0

Plumber work:— Snowden, J., and Son .. 180 0 0

Carpenter and joiner work:— Gatelyear, W., and Son .. 139 0 0

Water work:— Sibley, E. .. 59 0 0

BROADSTAIRS.—For electric lighting installation at the new Christ Church. H. B. V. Broadstairs (accepted).

CHICKWOOD, N.W.—For three new classrooms and additional lavatory accommodation at Lodge, Shoot-up Hill, Chickwood, N.W. Mr. F. R. Gould Wills, architect:—

M. M. J. .. 478 0 0

Burgman, Son, and Co. .. 752 10 0

Gibby, J. .. 600 0 0

Fincham, J. H., and Co., Dalston .. 591 0 0

Roberts, C. P., and Co., Dalston Lane (accepted) .. 486 0 0

Foldback partitions:— Bennett, G., and Co. (accepted) .. 111 0 0

Iron, J. L., and Son, Ltd. .. 110 0 0

CHOFF.—For paving at Cliff Bridge, for the Barnet Council:— Baxwell, R., and Son, Barnet, London £107 0 0 (Accepted).

CHREWELL.—For repairs to the chimneys and buildings of the district schools at Broadall, for the Council of the Farnham and Hartley Witney District Schools. Mr. A. H. Guyer, South Street, Farnham, architect:—

Southall Bros., Galle Street .. 417 0 0

Page and Son, Epsom, Hants .. 95 0 0

Godwin and Sons, East Street .. 89 0 0

Green, J. G., Ltd., South Street .. 79 0 0 (Accepted. Rest of Farnham.)

CHRY.—For the supply of a motor generator, for the supply of lighting committee. Newton Bros., Derby .. £84 0 0 (Recommended for acceptance.)

COLEBURY.—For alterations and alterations at the Green, Ainslie, Fochabers. Accepted tenders:— Builder work:— Le22, W., and Son, Fochabers, Carpenter work:— Strachan, J., Taynt, Portgordon, Saltreaves, Davidson, A., and Son, Elgin, Painter work:— Ross, J., Elgin, Painter work:— Ross, C., Elgin.

DEGANWY.—For foundations only of new convalescent home for men at Deganyw, near Llandudno, for the Manchester and Salford Hospital Saturday and Convalescent Homes Fund. Mr. H. H. Brown, F.R.I.B.A., 20, Brazemose Street, Manchester, architect:—

Hughes, L., and Sons, Llandudno .. £708 4 7

Dalton, J., and Sons, Birmingham .. 650 0 0

Rowlands, R., Colwyn Bay .. 670 0 0

Thorpe, A., Llandudno .. 620 0 0

Shepherd, W., and Sons, Rochdale .. 583 17 2

Lewis, T., and Sons, Birmingham .. 570 0 0

Smith Bros., Ltd., Burney .. 565 0 0

Cartley, R., Manchester .. 525 0 0

Warrington, F., Hyde .. 500 0 0

Owain and Hughes, Deganyw .. 449 15 4

Salt, S., Deganyw .. 485 0 0

Ridyard, J., and Sons, Ltd., Ashton under-Lyne .. 485 0 0

Byrom, J., Ltd., Bury .. 475 0 0

Roberts, R. L., Llandudno .. 430 3 0

Hill, A., Llandudno .. 435 10 0

Hughes, H., Llandudno (accepted) .. 449 2 0

Griffiths and Owen, Llandudno .. 24 15 0

DEAGWY.—For the supply of carbons, from December to May next, for the cleansing committee:— Woodward and Co. (recommended for acceptance).

HALTWHISTLE.—For reinforced concrete bridge at Lamb Burn. Mr. G. R. Shield, surveyor. Quantities by surveyor:—

Watson, J. W. F. .. 4 0 0 0

Loagstaff Bros. .. 50 0 0

Watson, W., Haltwhistle (accepted) .. 45 0 0

KILMARNOCK.—For printing the new phthisis pavilion at Kamshill Sanatorium, for the town council:—

Bone, Q. (accepted) .. 4106 8 3

KIRKCALDY.—For outside painter work at the fever hospital, Dumnick Road, for the town council:— Stenhouse, D. B., Kirkcaldy .. £116 0 0 (Accepted.)

MAYMORE.—For the sinking of a well and the providing and erection of a pump at Maymore, for the Downpatrick Rural District Council:—

Gilston, D., Drumahess, Ballynahinch (accepted) .. £497 0 0

PORTOBELLO.—For constructing shafts and a tunnel for obtaining sea water at the Portobello power station, for the Edinburgh Town Council. Sir Alexander B. W. Kennedy, consulting engineer:—

Brand, Chas., and Son, Glasgow (accepted) .. £24,515 0 0

QUEENSTOWN.—For repairs to roadway at Lynch's Quay, for the urban district council:— Dolan, F. (accepted) .. £75 0 0

QUEEN VICTORIA STREET, F.U.—For maintaining the carriage-way pavement of Queen Victoria Street, from Canon Street to Poaltry, for a period of two years, for the City Corporation:—

French Asphalt Co., Ltd. (accepted), 2s. 4d. per yard super, per annum.

REDGATE.—For the supply of alternating-current induction motor meters, for one year, for the Reigate Town Council:— British Westinghouse Electric and Manufacturing Co., Ltd., Trafford Park, Manchester (accepted).

SHEENESS.—For supply of road material for the urban district council. Tenders recommended for acceptance:—

Grantie:—Penke and St. Ives Stone Quarries, Ltd., 24in. 15s. per ton, 1 1/2in. 15s. per ton, 3/4in. 14s. 6d. per ton, chips 11s. 6d. per ton.

Bagstone:—Bunsted, W. H., and Sons, 9s. per ton. Hoggins:—Horsford, J., and Co., 3s. 6d. per yard.

SHERBORN.—For laying-out cemetery, for the Sherborn Urban District Council:— Neale and Co., Wandsworth Common (accepted) .. £70 0 0

WEYMOUTH.—For making-up Salisbury Road, for the town council:— Pattinson (accepted) .. £352 0 0

Sir Thomas G. Jackson, Bart., R.A., will present the prizes at Carpenters' Hall on Monday, December 13, to the students of the Trades Training Schools, Great Titchfield Street, W.

Mr. C. Harold Norton, F.S.A., will act as guide on Saturday next on the occasion of the visit to be paid by the Students' Association for North London to the pre-Reformation churches of the City of London.

Mr. John Henry Joyce, of the Burlington Hotel and the Radnor Club, Folkestone, baronet, who died on July 26, and whose estate is sworn at £51,038, bequeathed £12,000 for the marble decoration of Westminster Cathedral.

It has been decided by the parishioners of Swardston, near Norwich, Nurse Cavell's birthplace, to place a memorial tablet and a stained glass window in the parish church, in which her late father officiated as vicar for forty-six years.

To meet the urgent need for housing accommodation, Greenock Corporation have decided to proceed with a building scheme in the East End of the town. Ground has been obtained from the superior on favourable terms, and it is proposed in the meantime to erect at least seventy-five dwellings of the cottage type. A larger scheme is at present well advanced.

THE BUILDING NEWS

AND ENGINEERING JOURNAL.

Effingham House,

CONTENTS.

Strand, W.C.

Emergency Canteens 611
 Pictures and Decorative Furniture at the Burlington Fine Arts Club 612
 Royal Institute of British Architects 613
 New Apparatus for Determining Fitness of Cement 613
 Restricting House Rents 614
 The Architecture of Ancient Egypt 614
 Preliminary Training for Recruits 614
 The Growth of London 614
 Obituary 617
 Currente Calamo 632
 Legal Intelligence 633
 Professional and Trade Societies 633
 Correspondence 634

Building Intelligence 634
 Trade Notes 634
 Our Office Table 635
 Chips 636
 To Arms! 636
 Meetings for the Building Week 636
 Latest Prices 637
 To Correspondents 638
 List of Competitions Open XI
 List of Tenders Open XI

Lord Digby's School, Sherborne, Dorset. Birdseye view and plans, Mr. Edward C. H. Maddiman, L.R.I.B.A., Architect.
 Coburg Court Hotel, Kensington Gardens, W. View from the Park, and plans, Mr. Delissa Joseph, F.R.I.B.A., Architect.
 Universal House, Oxford Street, and 14, Hatover Street, W. Mr. Delissa Joseph, F.R.I.B.A., Architect.
 Bridlington Priory, Yorkshire. The North porch of the church. Elevation, sections, and plans. Measured and drawn by Mr. Gordon Hemm.
 Old English Living-room Furniture. Drawn by Mr. Walter Willis.

OUR ILLUSTRATIONS.

W. Stanmer Cathedral, St. Andrew's Chapel; the gift of the Marquess of Bute. East end, West end, and plan, Mr. Robert Schultz Weir, Architect.

EMERGENCY CANTEENS.

The provision for our soldiers of some means of refreshment subsidiary to regulation rations, and accommodation for reading, writing, and recreation, is one of the problems of the war. The practical points needing solution are rapid organisation and building equipment. Temporary structure, wherein refreshments can be obtained and accommodation for recreative purpose, satisfies all demands. The several buildings heretofore erected for this purpose by charitably minded institutions are of the same temporary nature. For emergency hospitals wooden framing and galvanised iron coverings have chiefly been employed. The structural details are often of the simplest kind. We give in this article some examples of buildings erected by those institutions which have thrown them-

thing in which to wash-up are the obvious ultimate elements in kitchen planning. The fundamental principle of canteen

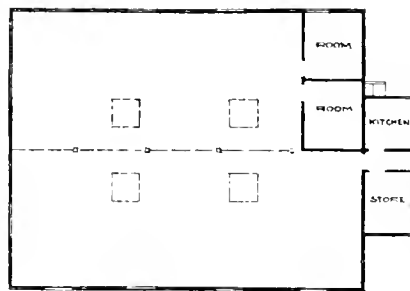

FIG. 2.

useful for ordinary Salvation Army purposes. A general foundation consists of 9 in. by 3 in. plates, sanded and tarred upon which as bed are constructed the temporary wooden posts and framing, quartering, etc. If necessary, short piers of brickwork are formed at suitable distances to hold up at a level the 9 in. by 3 in. bedplates, and also, if found necessary, concrete is put down under the brick piers. Quite the most elementary of the several emergency canteens are these huts. They are, we think, especially instructive on this account; for what we all, as architects, like to know under such circumstances is how far we can cut down and reduce recognised standard building practice.

Fig. 1 shows the general arrangements made for construction, the three rows of

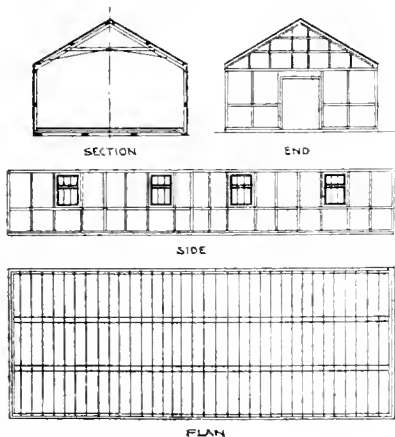

FIG. 1.

arrangement is convenient service. The Salvation Army canteens are put in charge of a married couple, and so the rooms appearing in our sketch plans are for their accommodation. Necessarily, the refreshment takers wait upon themselves, so that the compact placing of the kitchen with respect to the bar and the best arrangement of bar across refreshment-room are points to remember. And the plans, though so elementary, are useful just now when a wholesale provision of such buildings is wanted where munition and other war workers are engaged. Where we are requested to plan some novel idea in architecture it is invaluable, however simple the requirements may be, to have before us the results of other brains. Handing to us the plans from which the accompanying sketches were made, Brigadier Rowe remarked that he "saw nothing in them"; but then every modest expert feels that his knowledge is more or less commonplace, and we know well that our soldiers have nothing but praise for what the Salvation Army has done.

As regards foundations, anything that, with economy of structure and expedition in erection, will satisfy the demands of reasonable stability is considered satisfac-

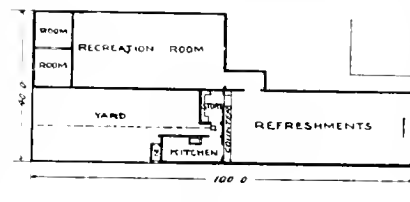

FIG. 3.

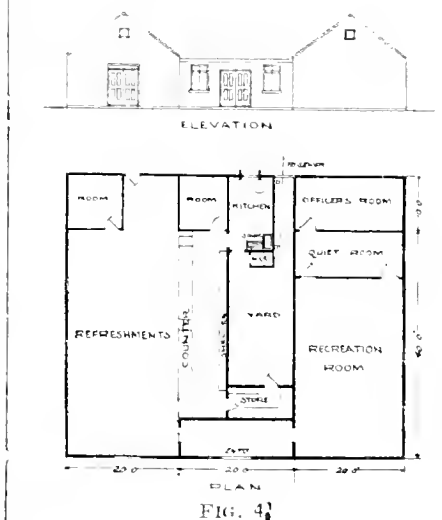

FIG. 4.

selves heartily into the work, and have erected many temporary hut-like buildings, with a large room as restaurant, and another for recreative purposes, cards, games, etc., and occasionally special rooms for reading and writing. Of necessity such buildings, in planning, centre around a kitchen, or its virtual representative, where the meals, coffee, tea, etc., are prepared, a refreshment bar and room. For this, where possible, gas is employed; but naturally many regiments are quartered in outlying districts, and often in country towns and villages gas supply is not available. In the canteens built by the Salvation Army, under the immediate direction of Brigadier Rowe, good use is made of oil stoves, either of the blow-lamp or ordinary type. On the plans given the kitchens certainly bulk modestly and unpretentiously, in spite of the fact that the dominant factor is the cooking apparatus. A stove and some-

tory. In general the huts are planned in sections, as 10 ft., and the idea is that if, by good fortune, our present requirements should cease, the huts would prove

9 in. by 3 in. plates, so arranged as to take the place of the sleeper walls of ordinary building construction. The plan, therefore, is such that very light joisting is required, 4 in. by 2 in. being unnecessarily heavy in this case. The quarters are bedded on cills, which bear upon the 9 in. by 3 in. sole-plates, and, as the drawings indicate, are sectionalised in design. The quarters, 4 in. by 2 in. generally, are spaced conveniently for the receipt of galvanised iron enclosures, a head, as usual, being provided to the framing. A favourite arrangement is 6 in. by 2 in. for the rafters and collars shown. Light-framed windows are inserted, and the roofs covered by galvanised iron.

There is a refreshing, elemental simplicity in the plans. A more or less standard arrangement is a pair of huts side by side, as in Fig. 2. They are here ad-

... site plan (Fig. 3) the site previously acquired has been drawn away from the main road, and in the angle formed by the main road and the new road two are arranged the kitchen and store, and in the scheme shown in Fig. 4 the rooms for refreshment and for rest respectively have been pushed aside, with kitchen and store-room next to the main road. Fig. 2 shows the two wings of the building within the main road. The kitchen and store form a lean-to. This part has two pitched roofs, with valley gutter. The entrances for the soldiers are the doors indicated on the left hand. Fig. 3 at Bullford has two side rooms and a kitchen and store as



FIG. 5

... conditions. A useful yard is here shown as part of the site acquired. Entrance is from the main road, at top of plan. There is a lobby connecting the two main rooms, and the counter at the junction of the two and close to kitchen and store must be deemed a good and convenient disposition. The plan in Fig. 4 is on a rather ambitious scale, including a "home room" and officers' room, and has a fine long counter, with good space and shelving at the back, the whole compactly grouped in one area of 60 ft. by 50 ft.

Drainage is an evident problem. These hut canteens are connected up when possible to existing drains, as in Fig. 4 where an ordinary waste is placed conveniently in the yard. Fig. 3 also includes waste and drainage as usual, but Fig. 2 is provided with earth closet, an arrangement that must often be necessary in outlying districts.

In planning emergency canteens, as in planning other works, knowledge of details gives a mastery in the conception of the whole. A study of life with a canteen is necessary to the architect engaged upon new proposals. We give a sketch, Fig. 5, showing roughly the arrangements inside a canteen. Among the workers in this field is the Church Army. The sketch shows a temporary refreshment-room for soldiers created in the Park, near the Marble Arch. It consists of a slight built wooden framing and is entered, as shown, at the end. On the left hand is the refreshment bar and counter, with gas cooking stove. There being no drainage available, the wash-up arrangements are of a purely supplementary nature, consisting of portable basins, etc. The warm the hall are two coke stoves and one gas stove. Tables 4 are disposed round the room, and ingeniously served with cork shelves and benches. At the end of the hall a partition and painted arrangement, the sides being curtained, and at one angle a little chapel has been painted. We are indebted to the manager of this Church Army canteen for facilities for making our study, which remarked in explanation of the arrangements to us, that "the only thing that accommodation encourages is the use of the room, which would not be possible without the refreshments." On a table in the room, the refreshments are neatly prepared. Our sketch is quite agreeable to the design and instructions as to the furnishing of these temporary canteens. They are diagonally arranged, respectively, to the positions of the main roads, King and Queen.

Among the energetic workers in this field is the Y.M.C.A., which has built, and is building, many temporary canteens on a considerably more pretentious scale. Our rough diagram, Fig. 6, shows a temporary canteen erected by the society near Waterloo Station. Beyond this building are sleeping accommodation, baths, and lavatories. Some sixty or seventy beds, in two tiers, on the cabin model, are arranged in cubicles, and so successful has this dormitory accommodation proved that another 100 beds are immediately contemplated as an addition. It must here be borne in mind that this particular building, at the London end of the South-Western Railway, is in a specially favourable position for making sleeping accommodation useful. The canteen arrangements comprise the large hall shown, entered by a porch. On the right is the refreshment bar, with counter and shelving. The Y.M.C.A. catering arrangements are on a considerably more extensive scale than in the case of other institutions whose buildings we have described. The kitchen in the Waterloo canteen comprises three powerful gas cooking stoves. Naturally, the nature of the cooking apparatus greatly tells in the success of these buildings, and the several appliances need to be suited to the special duty. The hot and cold water arrangements are very complete. There is a cistern on an R.S.J. in an angle of the kitchen, and a hot-water cylinder in another angle. The sink and draining board are well planned, and a very necessary convenience—a large food-preparation table—is included. The Y.M.C.A. provides substantial meals. Adjoining the kitchen is a small scullery, wherein vegetables may be prepared. Sanitary and lavatory accommodation is provided for those in attendance. In this case the working of the canteen is placed under the direction of a lady manager, who kindly explained to us the general arrangements. As the establishment is on a rather large scale, considerable

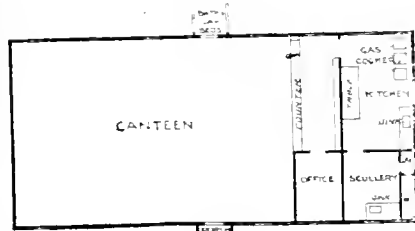

FIG. 6.

assistance is required, and this is a point met by voluntary lady helpers, who attend behind the bar.

We may mention, for the guidance of architects and others interested, that no makers of all constructional adjuncts are better able to co-operate in the building of canteens, huts, hospitals, and the like than Messrs. Haywards, Ltd., 187 to 201, Union Street, S.E., and certainly none have more generously offered to assist the authorities and others concerned to supply at practically cost rates. In one or two instances within our knowledge we are surprised these offers have not been taken advantage of. Messrs. Haywards, Ltd., have tendered for Admiralty and Army work, and they have carried out heating plants for Wellesley House, the Mobilisation Store, and the Soldiers' Institute at Albershot, with success and satisfaction.

Another firm who have carried out a large number of similar works are Messrs. F. A. Norris and Co., 11-12, St. Andrew's Hill, Queen Victoria Street, E.C., who have recently completed contracts at the

Internment Camp, Stratford Hutments, Cambridge, and many other important Government buildings.

Messrs. Benham and Sons, Limited, of 66, Wigmore Street, W., have also done much work of the first class for the Admiralty and other departments, and large factories. A particularly well-appointed gas and steam kitchen for a staff of 1,200 which they have erected in London can be seen by appointment. They also specialise in cabinet hot closets and cupboards and in every form of heating and cooking apparatus, either by steam, gas, or coal.

Several inquirers will find their requirements in the way of kitchen and cooking apparatus, urns, coffee extractors, etc., heated by gas, steam, and electricity, well met by Messrs. Sumerling and Co., Ltd., 63, Bunhill Row, E.C., whose advertisement appears in this issue, and who will supply estimates and drawings free.

PICTURES AND DECORATIVE FURNITURE AT THE BURLINGTON FINE ARTS CLUB.

A small but good and characteristically restful exhibition of pictures and decorative furniture at the Burlington Fine Arts Club is a welcome relief from present distractions. It will close about the end of February.

"The Virgin and Child" (1), a panel, lent by Sir Francis B. Palmer, is attributed to Roger van der Weyden, of the Brabant school, c. 1400-1464. It may possibly be his, but is more likely a reproduction of the well-known repetition of the prototype in the Boston Museum, a well-known replica of which exists in the Gallery at Munich. Lord Lytton sends two panels, one, "The Penitent Magdalen" (4), brought from a Peruvian convent, whither it had been conveyed by a party of Spanish Jesuits in the seventeenth century. It is stated to be a work by Fernando Gallegos, of the school of Castile, c. 1440-1507, but is evidently of later date, and more probably by the Flemish painter Jan Massys. The other, "A Love Feast" (5), also Flemish, is somewhat similar to Pieter Pourbus's picture in the Wallace collection. A good portrait of Colonel Francis James Scott (8), lent by Mrs. M. Trevelyan Martin, by Sir Henry Raeburn, was seen at the Burlington House Old Masters Exhibition in 1906. "The Concert" (13) is evidently a genuine canvas by Jan De Bray, c. 1627-1697. It is lent by Major-General Sir Coleridge Grove, K.C.B., and was formerly in the collection of Mr. Fiennes Dickinson at Syston Court. An "Heroic Landscape" (14), lent by Sir Frederick Cook, seems to have borne various titles. It is ascribed to Francois Millet, 1642-1679. It was exhibited at Leeds in 1868 as "Landscape, with Flight of Ahab," but no flight of Ahab is suggested, nor does there seem to be any flight of that monarch recorded. It is suggested in the catalogue that a more appropriate title might be "The Destruction of the Cities of the Plain." Sir Henry Howorth lends a "Virgin and Child" (15), probably by Galeazzo Campi, of the Cremona school, 1477-1536, and so signed, or rather "Galeacius Campo." There is a good deal about it after the style of Perugino, whose well-known altar piece of 1494 in the church of S. Agostino at Cremona was pretty well plagiarised by the painters of that city. "The Daughter of Herodias" (17), a panel lent by Mr. T. Humphry Ward, is said to be by Giulio Romano, c. 1485-1566. "The Virgin and Child, with St. Joseph Introducing the Donor" (19), by Francesco Bissolo, c. 1470-1554, is signed "Francesco Bissolo," and we

think genuine. It is lent by Mr. F. E. Sidney. "The Crucifixion" (20), lent by Mr. Herbert Cook, is by Cosimo Tura, c. 1430-1495. "Apollo Flaying Marsyas" (22) is one of the many copies made by Teniers of an Italian picture in the Archduke Leopold Wilham's collection at Brussels, of which Teniers was keeper; at any rate it is so included in the collection of engravings at Blenheim issued in 1660. It went with the rest in 1886 when the Duke of Marlborough sold his pictures, and is now owned by the Marquess of Clanricarde.

Among the furniture are a couple of very good long-case clocks, both of the seventeenth century. One is by Gaudron, of Paris, and is in a buhl case inlaid with a design of scrolls, amongst which are a morini and other figures, in white metal, the dial being supported by a figure of Time in ormolu. The other is English, by Jasper Taylor, of Gray's Inn. The case is of walnut with a domed hood, the whole front elaborately inlaid with a light-coloured wood in a geometrical design and floral scroll. A Northern French Credence cupboard of early sixteenth century date is of oak, the door carved with the Annunciation. A curious bureau lacquered in the Chinese style, acquired in Venice, shows strong Dutch influence. A couple of good mahogany barometers on either side of the alcove, one of Scotch and the other of London make, inspire the wish that present makers of these useful instruments could see their way to render them decorative. A good English carved oak settle of the first half of the seventeenth century is inlaid with holly and bog oak. The back is divided into six upright panels, with three oblong panels above, having carved borders and inlaid centres. On the front are four inlaid panels. There is also a desirable oak sideboard, the lower part five-sided with a splayed front and straight sides. The front is composed of six panels, three above and three below; two of the upper form cupboards and the two under them are drawers. The three chief panels are carved in relief with Renaissance ornament, consisting of figures, vases, dolphins, and arabesque foliage, the smaller panels having masks and foliage with interlaced cords. The sides are decorated with interlaced ornament. The upper part has a raised tier enclosed by two sliding panels carved with interlaced strapwork. The back is an openwork screen of four panels, the uprights terminating with carved finials; the two lower panels are of Gothic tracery, and the two upper form a cresting carved with dolphins and fleur-de-lis surmounted by a band of twisted ribbons with beading. A few good chairs are also exhibited.

A few other works of art are to be seen. There is a good pair of majolica jars, with panels of St. Francis and St. John the Evangelist in landscapes on a yellow background, probably of Italian seventeenth century work. A French thirteenth century of the Virgin and Child in carved oak was formerly painted and gilded. The Virgin, who is seated on a throne supported by four beasts—two lions and two griffins—holds the Christ with her left hand. His right hand raised in benediction. Her head is covered with a veil, which falls in stiff but not ungraceful folds on her shoulders, and is surmounted by a tall Gothic crown. Her robe reaches to just above her feet, and is partially covered by an ample mantle, the bordure of which, as well as the crown, has sunk spaces formerly filled with jewels. A pair of statuettes of Adam and Eve is carved in pearwood. In his left hand Adam holds a branch of the Tree of

Knowledge, his right arm held free from the side; his hair, which is thick and curly, falling over his shoulders. Eve holds a branch in her right hand, and with her left clasps an apple; her hair, which is wavy, falls over her shoulders as far as the waist. Both figures stand on rocky bases and have pedestals carved with grape vines. A quaint tambourin de Provence in straight-grained wood, probably walnut, is delicately carved in low relief with alternate waved and twisted lines divided by straight ones. These instruments were used by the criers in France to call the attention of the people in the same manner as the criers in England used bells. A flute and striker and a framed engraving of a crier with tambourin are shown with the instrument.

ROYAL INSTITUTE OF BRITISH ARCHITECTS.

A business meeting of members of the Royal Institute of British Architects was held on Monday afternoon at 9, Conduit Street, W., the President, Mr. Ernest Newton, A.R.A., occupying the chair.

The following Fellows and Associates were duly elected:—

As Fellows (12).—John Gordon Allen (Associate 1910), 4, Tavistock Square, W.C.; 13, Holmdale Road, West Hampstead, N.W.; James Westbrook Farmer (Associate 1908), Cangallo 564, Buenos Aires, Argentina; Edgar Quiggin (Associate 1905), 67, Lord Street, Liverpool; Philip Appleby Robson (Associate 1897), St. Stephen's House, Victoria Embankment, Westminster, S.W.; Rede Place, East Grinstead; together with the following Licentiates, who have passed the Examination qualifying for candidature as Fellows:—Alfred Barham Black, Gilbert Place, Adelaide; Stanley Street, North Adelaide; James Edwin Forbes, 16, Old Square, Lincoln's Inn, W.C.; The Shelling, Chalfont St. Giles; Willford Arthur Gagnon, 1,002 New Birks Building, Montreal, Canada; George Donaldson MacNiven, Local Government Board for Scotland, 125, George Street, Edinburgh; 15, Cluny Drive, Edinburgh; Charles Bulman Pearson, 18, Dalton Square, Lancaster; John Duncan Tate, 16, Old Square, Lincoln's Inn, W.C.; Lexden, Oval Way, Gerrard's Cross; Charles Clayton Thompson, The Market Place, Derby; 32, St. John Street, Lichfield; George Wittet, J.P., Public Works Secretariat, Bombay; Byculla Club, Bombay.

As Associates (25).—Percy Joyce Adams, Fairmead, Woodside Road, Woodford, Essex; Harry Andrew, 56, Whitefriargate, Hull; c/o Messrs. Lowther and Rigby, 77, Lowgate, Hull; Pherozshah Faribonji Balsara, Solakoti Building, Grant Road, Bombay; James Bennett, c/o Messrs. John Burnet and Son, 259, St. Vincent Street, Glasgow; Hillview, Saline, Fife; Reginald Bruce, P.A.S.I., 21, Holdenhurst Avenue, North Finchley, N.; Edgar Gooding Catchpole, 46, Christchurch Street, Ipswich; Town Hall, Ipswich; Alexander MacLachlan Duncan, Rahoy, Lenzie, Dumbartonshire; c/o R. J. Walker, 108, Douglas Street, Glasgow; Eric Carwardine Francis, 14, St. Andrew's Mansions, Dorset Street, W.; St. Tewdric, near Chepstow; John Henry Horniman, c/o Messrs. Stevens and Gregson, 32, Victoria Street, S.W.; 68, Bodingbroke Grove, Wandsworth Common, S.W.; Sidney Harold Loweth, 67, Downs Park Road, Hackney Downs, N.; Trafalgar House, Trafalgar Square, S.W.; Cyril Hawthorn Mitchell, Wellington, N.Z.; 8, Mecklenburgh Street, W.C.; Ernest Paul Brauder Musman, B.A.Lond., 27, Upper Phillimore Place, Kensington, W.; H.M. Office of Works, Storey's Gate, Westminster, S.W.; Charles Edwin Nichols, Rectory Farm, Eckington, Sheffield; Chesterfield; Charles Lancashire Pace, 28, St. George's Street, Primrose Hill, N.W.; H.M. Office of Works, Storey's Gate, Westminster, S.W.; Thomas Reive, Glencairn, Errowood Road, Levenshulme, Manchester; c/o Messrs. Bradshaw, Gass and Hope, 19, Silverwell Street, Bolton; Manning Durdin Robertson, 50, Norfolk Square, W.; Alfred Douglas Robinson, 45, Bishopsgate, E.C.; The Abbey, Thorpe-le-Soken, Essex; Harvey Robert Sayer, 3, Have-

lock Road, West Marlands, Southampton; 45, Choumert Road, Peckham, S.E.; Albert Isaac Turner, 65, Wilmington Gardens, New Barking, Essex; Harold Frederick Walker, 13, New Street, Dorset Square, N.W.; 19, Queen Anne's Gate, Westminster, S.W.; Enoch Williams, "Norton," 50, Canada Road, Cardiff; Glamorgan County Council, Cardiff; Reginald Sharman Wilshere, 10, Trinity Road, Chelmsford; Architects' Department, Essex County Council, Chelmsford; William Cecil Young, 19, King's Drive, Heaton Moor, near Stockport; c/o Mr. Isaac Taylor, 17, St. Ann's Square, Manchester.

The following motion in the agenda for the alteration of the Regulations for Architectural Competitions, as printed in the Kalendrar, was not proceeded with, owing to the absence of the quorum of members required under By-Law 67:—

1. The second paragraph to read: "Members of the Royal Institute of British Architects and of its allied societies are only permitted to take part in competitions in accordance with these regulations, which are intended to apply to all competitions other than private competitions instituted by private individuals or firms."

2. The footnote at the bottom of the first page to be omitted.

NEW APPARATUS FOR DETERMINING FINENESS OF CEMENT.

Three years' experiments, intended to produce a means of determining the exact fineness of cement, have resulted, at the United States Bureau of Standards, in the developing of an apparatus which is effective for this purpose. In the manufacture of Portland cement, clay or shale and limestone are ground together and "burned" in rotary kilns. The cement comes from the kilns in the form of hard, black, semivitreous lumps, or "clinker." When pulverised, this clinker becomes a greyish powder, which is the familiar article of commerce employed for a great variety of purposes in practically every type of building construction.

It has long been known that the fineness to which the cement is ground is one of its most important characteristics, and consequently specifications require that 75 per cent. or more of commercial cement shall pass through a No. 200 sieve, which has 40,000 openings per square inch. This is the practical limit of mechanical sieves in respect to fineness.

It is very important to have some means of measuring directly the entire state of subdivision of cement; in other words, to discover just what percentage of the material is made up of particles of certain definite sizes. If such a division can be made, it should be possible not only to compare the efficiency of different grinders, but also to determine what degree of fineness must be attained before the cement becomes "hydraulically active"—that is, capable of combining with water to form the binding material in mortar and concrete.

The apparatus devised by the Bureau of Standards consists of a vertical brass pipe about 3 in. in diameter and 5 ft. long, at the lower end of which is attached a glass bulb, in which the cement to be tested is placed. Air at constant pressure is blown into the cement through a glass tube or nozzle in the side of the bulb, and as the air can escape only through the vertical stack, it carries with it the cement dust, which is caught in a flannel hood surmounting the stack. The air-flow in the stack is very uniform, and in a short time all the dust will be removed from the cement, leaving a granular residue in the glass bulb. This residue is weighed, and the amount of dust is determined by subtracting the weight of the residue from that of the original sample of cement. Different grades are obtained by using different-sized nozzles, and thus a number of separations can be made in the very fine portion of the cement. With the aid of the microscope the size of the largest particles in any given separation can be readily determined, and in this manner the apparatus is standardised without reference to the size of the nozzles and other parts of the apparatus or the air-pressure used.

Our Illustrations.

WESTMINSTER R.C. CATHEDRAL: CHAPEL OF ST ANDREW AND THE SAINTS OF SCOTLAND.

The decoration of this chapel has now been completed, the curtains which have shut it off from the church for the last two years were yesterday removed, and solemn High Mass was celebrated in it yesterday—St. Andrew's Day. The Marquis of Bute, who had generously offered to bear the whole expense of the work, nominated as architect, with the consent of the cathedral authorities, Mr. Robert Schultz Weir, who, as is well known, has made a special study of Byzantine art. He has not only designed the whole

towards the aisle. The altar, which is constructed of Scottish granite, is raised on three steps, and is placed under a baldachino supported on pillars and pilasters of Verde Antico with bronze capitals and bases. The wall behind the altar has an inlaid cross of ancient Egyptian porphyry on which is placed a beaten copper figure of Our Lord. On either side are panels in low relief representing four of the principal Scottish saints: Ninian, Margaret, Bride and Columba. On the south side are two pairs of windows glazed with "crystal white" glass in leaded patterns, with the white cross of St. Andrew on a blue ground (azure, a saltire argent) introduced. Between the windows are two detached pillars of Cippolino with carved capitals, supporting the arches over. In the tympana under these arches are low-relief figures of the archangels Gabriel and Michael.

faces of the east and west arches. The plain gold mosaic is executed in fan-shaped forms, which may be taken to signify golden clouds screening Paradise from earthly view. A row of seven inlaid ebony stalls fill in the recess of the west end of the chapel. The altar candlesticks and the reliquary, set into a niche at the base of the cross over the altar, are in bronze and enamel. Altar-cards have been specially engrossed and illuminated on vellum for the chapel. The marble work has been executed by the firm of Messrs. Farmer and Brindley, the metal screen by Mr. W. B. Reynolds, and the glazing by Messrs. Lowndes and Drury. Mr. Stirling Lee is responsible for the sculpture, Mr. Ernest Gimson for the stalls, Mr. Harold Stabler for the reliquary and candlesticks, and Mr. Graily Hewitt for the altar-cards. The full-size cartoons for the mosaic were prepared

FIRST-FLOOR-PLAN

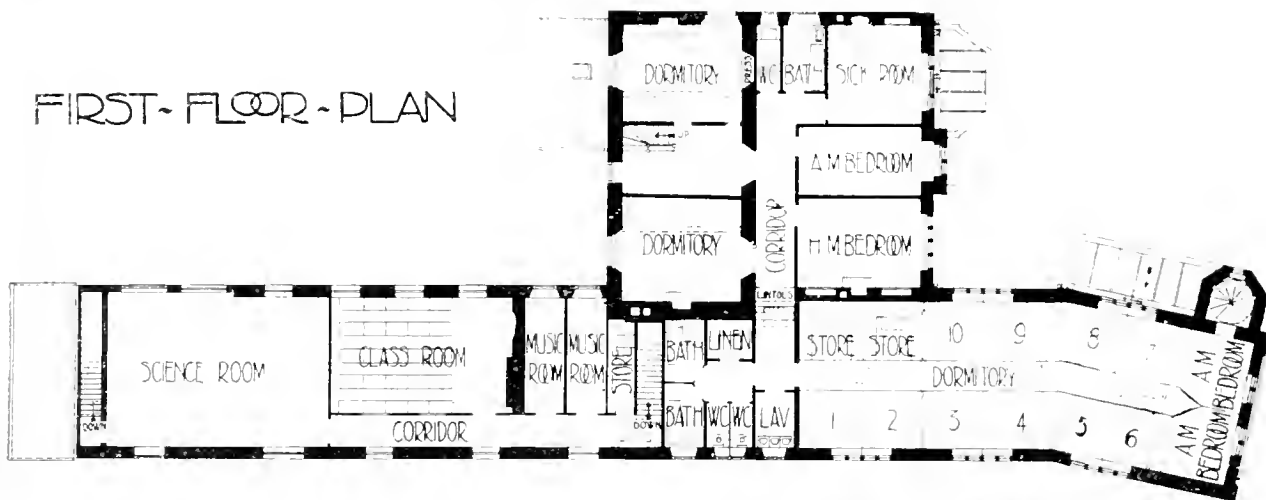

GROUND-FLOOR-PLAN

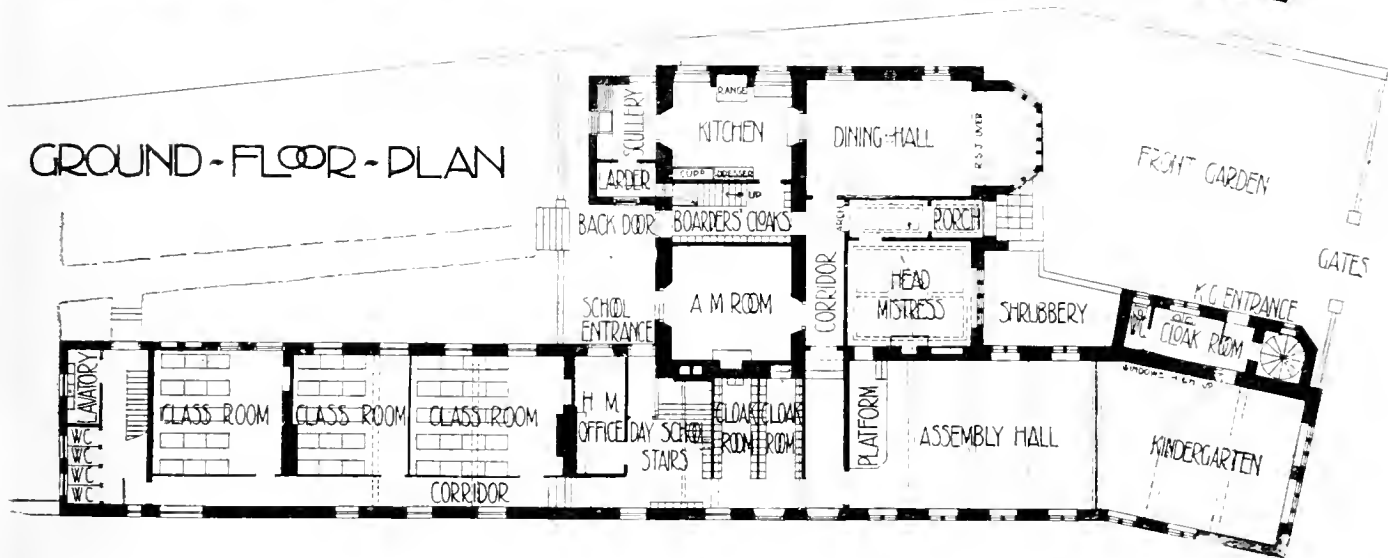

LORD DIGBY'S SCHOOL, SHERBORNE, DORSET: FIRST AND GROUND FLOOR PLANS

Mr. EDWARD C. H. MAIDMAN, Lic.R.I.B.A., Architect.

of the work, but has given his constant personal attention to the carrying out of his scheme, and in this he has been ably aided by the craftsmen whom he gathered round him to execute the various portions. The drawings which we illustrate show generally the designs for the east and west walls, but it is impossible to judge of the harmony of composition and colouring from a monotone reproduction. As the chapel is now accessible this can be best seen by a personal visit to the cathedral. Tall open-work screens of white metal separate the chapel from the south aisle. The pavement is of various coloured marbles and carries on the old tradition of a "pavement like the sea." The lower part of the walls is lined with marble; tall slabs of blue Hymettian below and panels of old Cippolino and Skyros above. Long, thin pilasters of porphyry-coloured Rosso Antico terminate the work

The upper part of the end walls and the vaults of the roof are covered with mosaics, the designs of which deal with the subject of St. Andrew. On the west wall is a large-sized figure of the Saint in the attitude of prayer, apostrophising the cross on which he suffered martyrdom, and which is represented on the opposite wall. On either side of the Saint are animals and trees, and on either side of the cross, representations of banners bearing in Latin and in English the text of the Saint's prayer or salutation to the cross. This comes in the "Office" for St. Andrew's Day in the Roman Breviary. The English translation is the one made by the late Marquis of Bute. On the lower parts of the vaults are views of cities connected with the story of the Saint, and this story is briefly told on the upper part of the west wall. Appropriate borders of a Celtic type frame the pictures and appear at the

by Mr. George Jack, and the mosaic work carried out by Mr. Debenham's group of mosaic workers, under the personal direction of Mr. Gaetano Meo, the friend and assistant of Rossetti, Burne-Jones, Richmond, and other artists. To his intimate knowledge of the selection and disposition of the material is due the most excellent effects of colour and texture which have been obtained in the work. With the exception of one Italian, who helped with the mosaics for a short time, all the workmen employed were British. Round the upper part of the blue slabs forming the high dado have been incised the names of Scottish saints arranged in chronological order according to centuries, thus emphasising the full dedication of the chapel, which is to "St. Andrew and the Saints of Scotland." The drawings now reproduced were shown at the Royal Academy this year.

OLD PIGBY'S SCHOOL, SUFRBORNE, DORSET.

...paving illustrations and plans... demonstrate the proposed... selected by the Board of... provides for grouping the... with one building in... in different parts of... under present conditions. The... practically the whole of the

COBURG COURT HOTEL, KENSINGTON GARDENS.

The extension of this hotel has recently been completed; the old portion, built some ten years ago, forming the superstructure of the Queen's Road Tube Station at the corner of Bayswater Road and Queen's Road. The extension, though not originally contemplated, has been incorporated with the old building to form a complete design externally.

bed and sitting rooms, besides servants' quarters, the greater part of each floor above the ground floor being arranged in suites of rooms, each suite having its entrance hall, bathrom, etc. The ground floor is occupied by shops on the frontage to Bayswater Road, the remainder of the space being used by the entrance hall, lounge, dining room, servery, etc., as will be seen from the plans given herewith. The basement contains the kitchen and

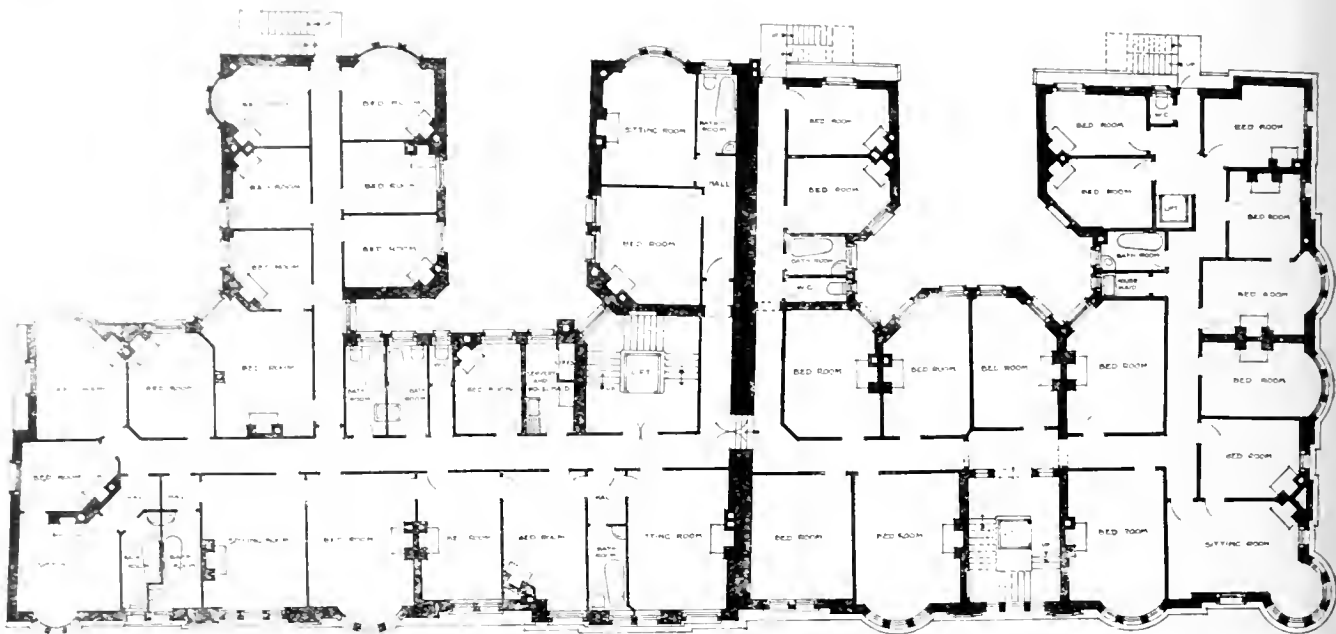

COBURG COURT HOTEL BAYSWATER ROAD, W. PLAN OF UPPER FLOORS

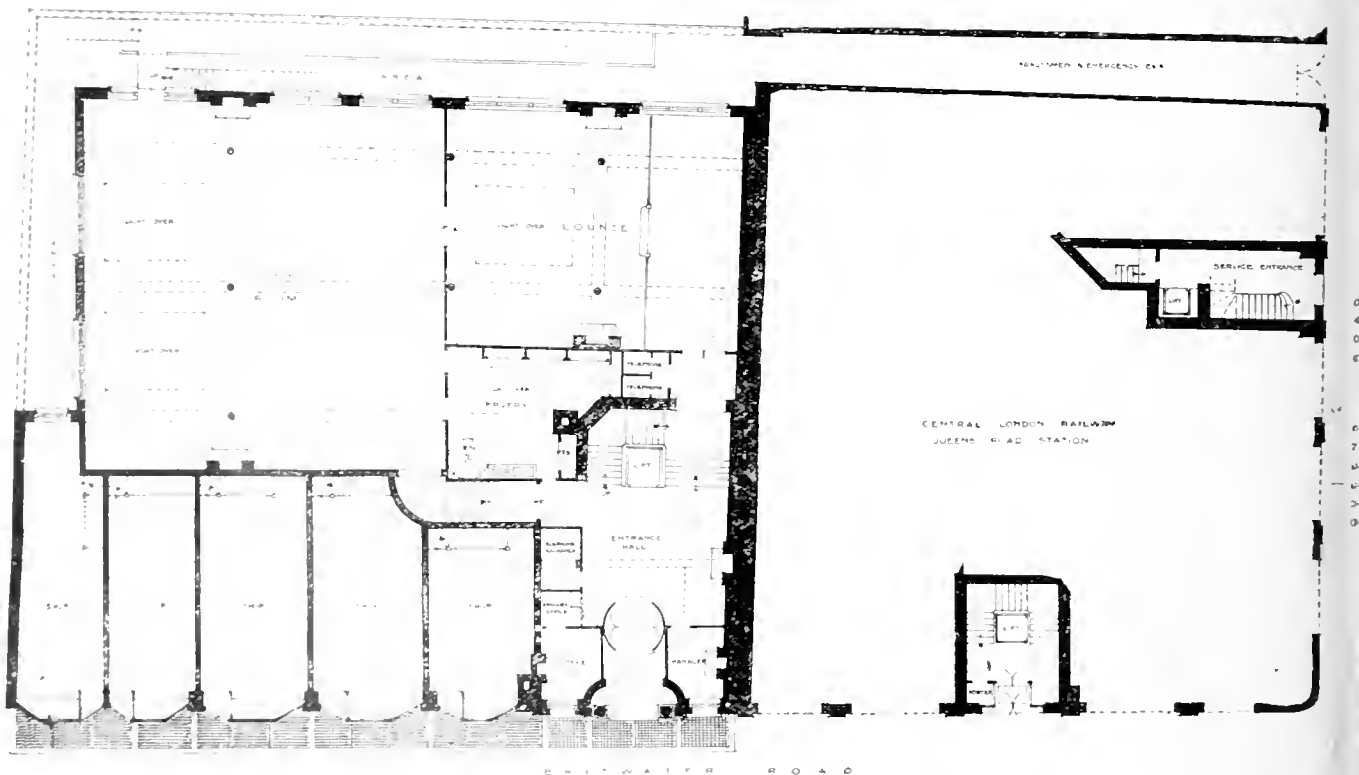

PLAN AT STREET LEVEL

COBURG COURT HOTEL, KENSINGTON GARDENS.—Mr. DELISSA JOSEPH, F.R.I.B.A., Architect.

...of the scheme, whereas the existing part... at the rear are indicated by the... and... modelling they are to undergo. The building provides accommodation for... in kindergarten and... Its architect is Mr. Edward... of Sher... The perspective was exhibited in this... and was drawn by Mr. T...

the character of the original elevation being repeated, and a large tower with a dome is introduced as a central feature of the complete front to Bayswater Road. The front is faced with buff terracotta and red pressed bricks. The main entrance and staircase are located in the centre, and the several floors are united with the old building by iron and fire-resisting doors of oak glazed with Luxfer glazing. The accommodation consists of 128

administrative offices, cloak-rooms, etc. The walls of the dining-room are panelled with Austrian oak, fumed and dull polished, the same material being used to case the steel columns as fluted Ionic columns. The decoration of the "Adam" Lounge is in fibrous plaster, with silk filling to the wall panels. The hall and staircase are paved with Sicilian marble, and the walls panelled in fibrous plaster, with coupled Ionic pilasters, dado,

etc. The building is heated by adopting an accelerated low pressure hot water scheme. A system of vacuum cleaning by hydraulic power is installed. Each room is provided with its own telephone. The general contractors for the work were Messrs. Perry and Co. (Bow), Ltd., and the building, steelwork, and decorations were carried out from the designs of Mr. Delissa Joseph, of 75, Basinghall Street, E.C., who was also the architect for the old portion. The heating and ventilation was carried out by Messrs. Burroughes and Sons, the constructional steelwork by Messrs. Redpath Brown and Co., the ornamental ironwork by Messrs. W. T. Allen and Co., the electric lifts and vacuum cleaning installation by Messrs. Waygood-Otis, Ltd., the marble and mosaic and tile work by Messrs. Fenning, and the fibrous plaster by Mr. W. F. Robinson. The terracotta was supplied by Mr. J. C. Edwards, of Rutabon.

UNIVERSAL HOUSE, OXFORD ST., W.

In the design of the front of this building, the two main objects aimed at were the admission of the maximum amount of light, and generally a massive and dignified effect, which has been obtained by the employment of simple Ionic columns on the second and third floors, with a heavy cornice and entablature, and the Doric order on the fourth and fifth floors, and the deeply-recessed windows. The two-storied iron window frames, with rather rich detail, form an important feature of the design. The basement and ground floors are occupied as shop premises, the first and upper floors being occupied by the Transatlantic Film Co., who have set the first floor apart as a private cinema for the exhibition of their films. The building was carried out from the designs of Mr. Delissa Joseph; the general contractors were Messrs. Ford and Walton, Ltd., the electric lift by Messrs. Waygood-Otis, Ltd., the constructional steelwork by Messrs. Redpath Brown and Co., the iron window frames and casements by Messrs. W. T. Allen and Co., the marble and mosaic by Messrs. Fenning, the carving by Mr. W. F. Robinson, and the heating by Messrs. Burroughes and Sons. The drawing here given was shown at the Royal Academy this year.

BRIDLINGTON PRIORY CHURCH: THE NORTH PORCH.

The nave is the only portion of this church still standing, and this portion alone represents now the once-magnificent monastic church, which is a most imposing and beautiful example of English architecture. In its entirety the church consisted of nave, chancel, transepts, large square central tower and two western towers, though these were originally not completed. The western front is profusely decorated, and is an exquisite specimen of the florid Perpendicular English style of architecture. The lower part of the north-western tower, with the north and south sides of the church, belong to the semi-Norman and Early English periods. The north porch is a splendid specimen of the latter. The foliage of the ornamental mouldings of the great western door is marvellously elegant, and rich with oak leaves and acorns. All the clerestory windows on the north and south sides are early specimens of Geometrical tracery, except the three most westerly on the south side, which are insertions of the Perpendicular style. Though only a fragment of the larger edifice, it is still remarkable for its great size, and is one of the finest of our parish churches. Mr. Gordon Hemm has kindly placed his excellent measured drawings at our disposal, and we give to-day the smaller sheet of the beautiful north porch. Double pages of the nave elevations and sections will follow at an early date.

OLD ENGLISH LIVING-ROOM FURNITURE.

Some of these pieces would look in place in almost any homely room, though they differ in many ways. Most historic furniture has essentially this adaptable quality, because it was for the greater part designed for use rather than mere display, and so possesses a human standard fit to be lived with and used anywhere for everyday purposes. The individual choice decided on for preparing

this sheet of sketches was arrived at primarily, however, to justify the title employed. The table, dresser, cabinet and chair, etc., are particularly suitable for a living-room where daily meals are taken. The word dining-room, or *salle-à-manger*, implies at least an occasional formal entertainment, and specially so abroad, in contradistinction to the ordinary routine *en famille*. In the more or less pretentious houses of the fairly well-to-do daily meals are relegated not uncommonly to the so-called breakfast-room, answering, consequently, to the living room, heretofore termed in some parts of the country the "keeping place." Though fashions change, and the fancy for old furniture is one just now in vogue, at least the *vogue*, when moderated by knowledge and governed by good taste, is in most respects admirably contributing to the amenities of life and the encouragement of an artistic sense of the fitness of things. Hence these examples are useful and timely. The Seventeenth Century oak table, lent by Miss E. P. McGee to the Victoria and Albert Museum, is an exceptionally interesting and pretty example on the gate-leg principle, with splat-shaped supports fitted with drawers. It cannot claim to be very convenient for meal use, and would be reserved more for occasional purposes. The oak dresser came from Eritwell Manor, Banbury. It is fitted with side cupboards, with panelled doors on either hand of the fixed shelves. There are two drawers below, and brass drop handles on turned front supports, and low stretcher rails 4 ft. 6 in. wide. The old walnut cabinet is beautifully veneered. It is 6 ft. high and 3 ft. 3 in. wide, and fitted with drawers, the piece being Queen Anne in character. It was sketched at Crovdon, like the Jacobean chest shown next to it. This is of about the same width. The Early Eighteenth Century mirror is in walnut.

XIV, HANOVER STREET, W.

These premises were built for Messrs. Weeks and Co., music publishers, from the designs of Mr. Delissa Joseph, and have been united to No. 6, Pollen Street, the premises in the rear, also designed by the same architect. The basement and ground floors are occupied by the shop and showrooms, some of the upper floors being used as practice rooms, with specially constructed sound-proof partitions. In designing the front, advantage was taken of an existing area, giving the right to construct the large bay. The front is carried out in Portland stone. The general contractor was Mr. C. F. Kearley, the electric lift by Messrs. Waygood-Otis, Ltd.

A block of buildings added to the Aberystwith County School, at a cost of over £3,000, has been formally opened. The contract was carried out by Mr. E. Jenkins, of Aberystwith, from plans prepared by Mr. G. E. Dickens-Lewis, M.S.A., Pride Hill, Shrewsbury.

A church hall and institute at Willington, Co. Durham, built at a cost of £3,000, has been formally opened. The architect was Mr. W. A. Kellett, of the firm of Messrs. Kellett and Clayton, Bishop Auckland, and the contractors were Messrs. W. Hope and Son, Condon.

The American Institute of Architects held its annual convention on the Pacific Coast in October, sessions being scheduled both at San Francisco and Los Angeles. The members were present in San Francisco during American Builders' week, when an address was delivered by Mr. R. Clinton Sturgis, president of the institute, on the subject of "The American Builder."

In the competition for the design of Carson College for Orphan Girls, to be built near Chestnut Hill, Pennsylvania, the design submitted by Mr. Albert Kelsey, of Philadelphia, has been selected. Under the terms of the will of Robert N. Carson, \$1,000,000 is now available for buildings. Should further buildings be required they are to be paid for from the income of \$3,000,000 left as an endowment.

With an injunction hanging over their heads, the Chester District Council have spent £3,694 on their sewage works out of the revenue, and now propose to further improve the works by loan, adding 50 per cent. to the efficiency of both the coarse and fine filter beds. The estimated cost is £8,030. The details were recently laid before Mr. P. M. Crosthwaite, M.Inst.C.E., of the Local Government Board, at a local inquiry.

OBITUARY.

Mr. Wilm Knox, architect, of Cleveland, Ohio, who has died in that city, aged fifty-five years, after two years' illness, was born at Springburn, Scotland, January 20, 1858. He was educated at the University of Edinburgh and at various art schools in that city. He had a successful architectural practice in Edinburgh, when in 1886 he suddenly made up his mind to see the world. He straightway took a ticket to Australia, via America, but on his way through Chicago he observed the opportunities for work in that city, and immediately entered the office of Messrs. Burnham and Root. It was there he met Mr. John H. Elliot. Later Messrs. Knox and Elliot formed a partnership and started business in Toronto, Canada, where they did some notable work, among which was the Confederation Life Building. In 1893 they opened an office in Cleveland, Ohio. The Rockefeller building, the Hippodrome building, the Brotherhood of Locomotive Engineers building, in Cleveland, the Hippodrome and Arcade at Youngstown, O., the Mooseheart Industrial School and Administration buildings, in Illinois, are among their principal works. Mr. Knox was a many-sided man. He made a study of mushrooms and fungi of Ohio, and was one of the most important contributors to that science. He made a number of beautiful water-colour drawings illustrating his mycological studies, and started to issue an illustrated work on mushrooms, but had only completed three parts. During the last two years of his life, when his health was failing, he took up etching, and did some very fine work, largely in etching former water-colours or sketches of his own. He was well known as a lover of art and a collector of rare books and etchings.

The death occurred at Seraing, Belgium, on November 29, of Adolphe Greiner, director-general of the John Cockerill Company and president of the Iron and Steel Institute. He was born in Brussels in 1843, the eldest son of M. Gustave Greiner, private secretary to King Leopold, and educated at the University of Liège. In 1864 he joined, as engineer-chemist, the Société Anonyme John Cockerill, which had been the first company on the Continent to adopt the Bessemer process in 1862. In 1859 Mr. Greiner was appointed manager of the steel works, and in 1887 he became director-general, and was responsible for the introduction into the Cockerill works of the basic process for steel making, the utilisation of blast furnace and coke-oven gas, and the general employment of electric energy for the transmission of power to all parts of the works. He was elected President of the Iron and Steel Institute in May, 1914, having been, for many years, a member of the council and Vice-President. In 1915 he was awarded the Bessemer Gold Medal. At the Leeds meeting of the Institute in 1912 the University of Leeds conferred upon him the honorary degree of Doctor of Science.

Mr. Ogilvie Dawson, builder Buckie, has been appointed burgh surveyor and sanitary inspector at Findochty.

Mr. W. A. James, J.P., builder, of Cowbridge, an alderman and three times Mayor of that borough, has died at his residence, Stafford House, Cowbridge, aged seventy-eight years.

The Dartford Rural District Council have decided to purchase 4½ acres of land in order to house munition workers in the Erith district, and the surveyor has been instructed to prepare plans and to obtain tenders for building seventy-two houses.

Frank Koester, consulting engineer, of New York, has been chosen by the City Planning Commission of Allentown, Pennsylvania, a city of 62,000 inhabitants, to develop an entire plan for the future development of the city along engineering, architectural, and land-scaping lines.

The district committee of Upper Renfrewshire have agreed to apply to the Local Government Board for authority to prepare a town-planning scheme for the districts of Quarrelton, Elderslie, Inkerman, Porterfield, Potterhill, Crookston, Cardonald, Halfway House, Crokerhill, Nisbhill, Hurler, Arthurlie, and Garside. All the areas mentioned are in course of development, or appear likely to be used for building purposes.

THE BUILDING NEWS, DECEMBER 1, 1915.

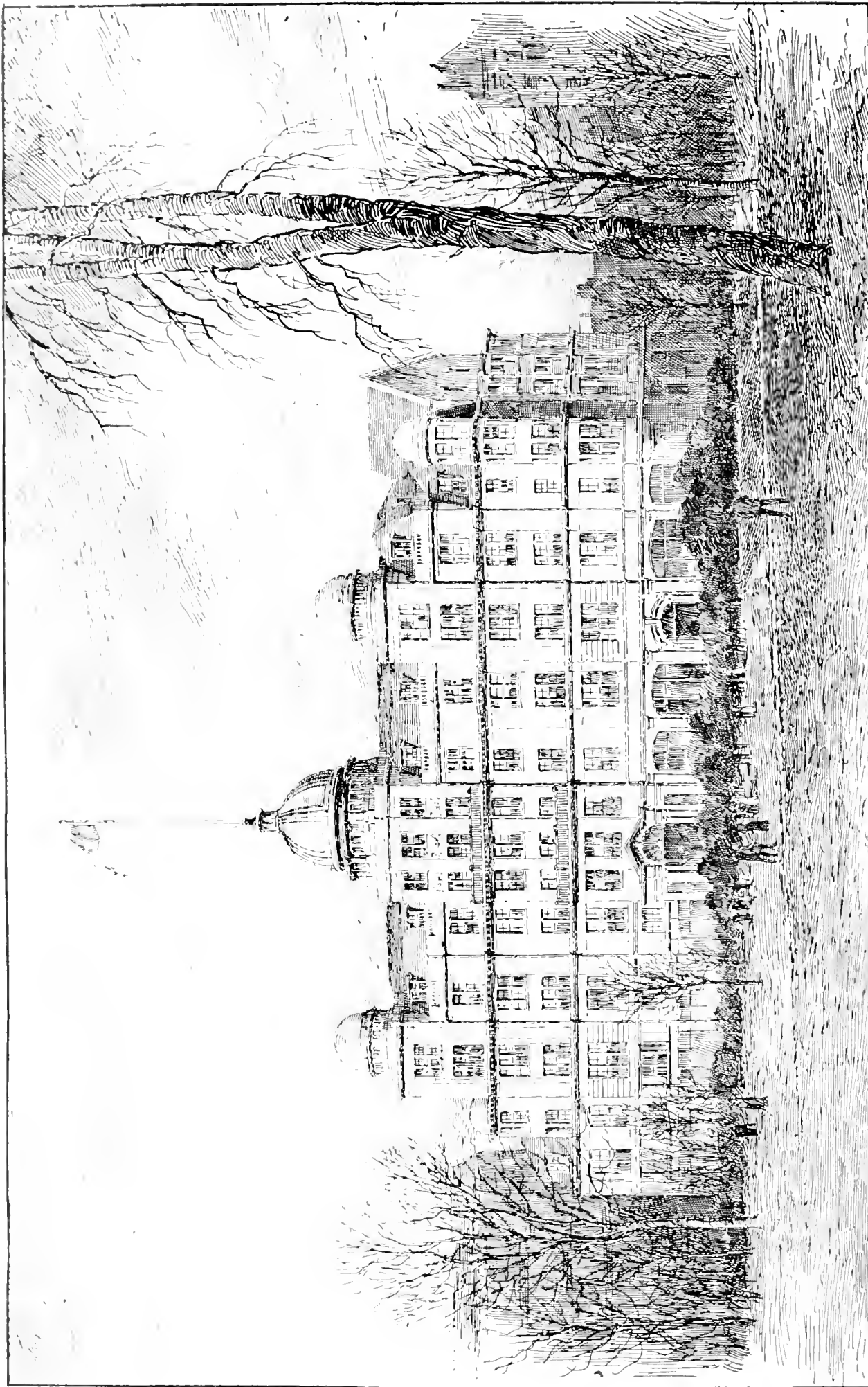

COBURG COURT HOTEL. KENSINGTON GARDENS.

DELISSA JOSEPH, ARCHITECT.

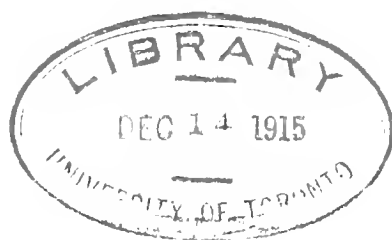

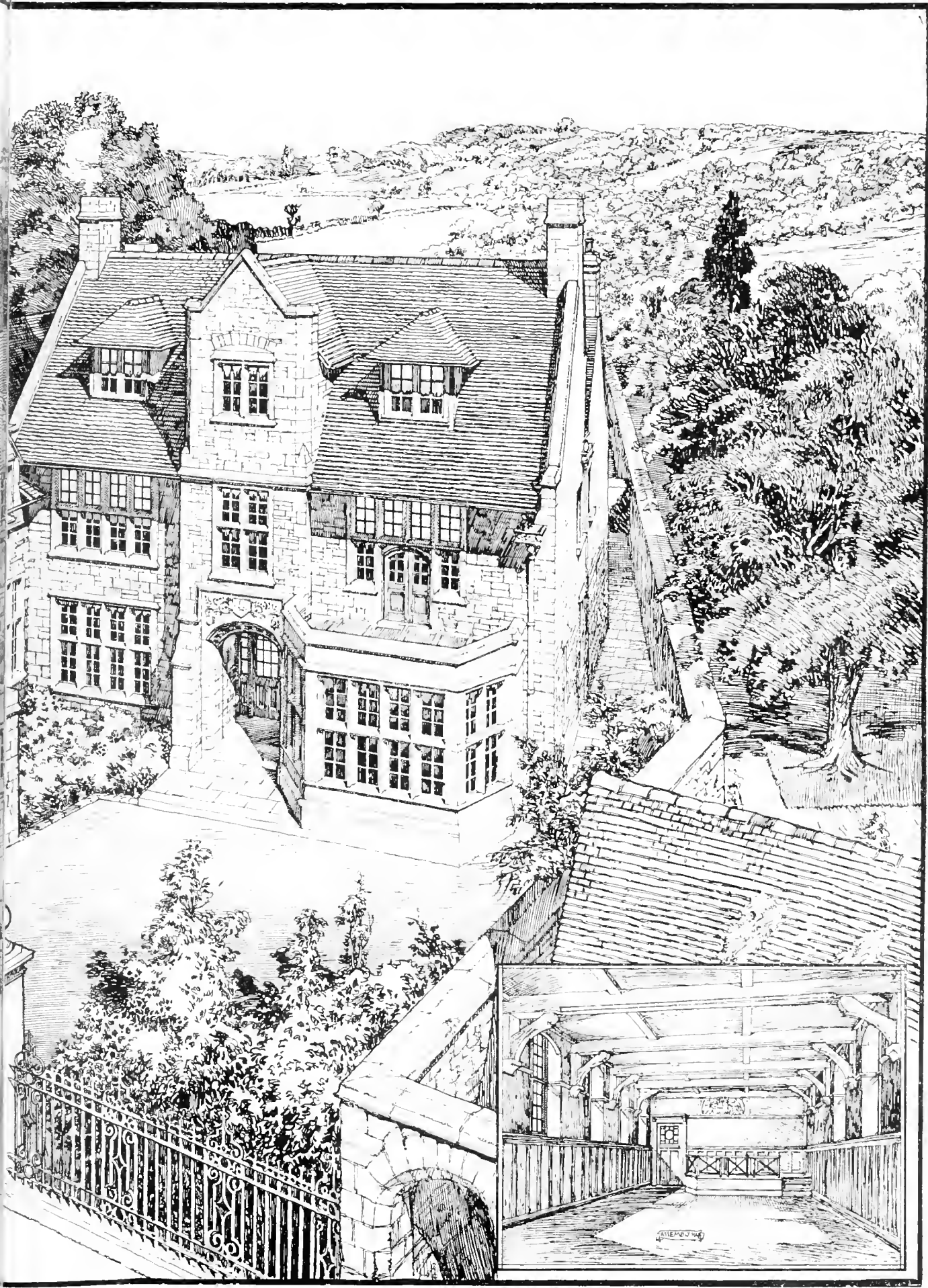

DESIGN.—Mr. EDWARD C. H. MAIDMAN, Architect.



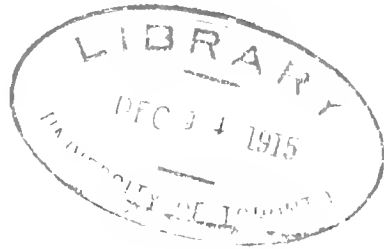

• WESTMINSTER •
• CATHEDRAL •

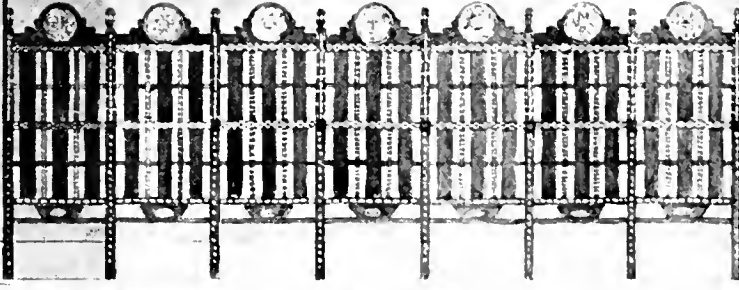

• WEST • END •

ROBERT SCHULTZ WEIR
• ARCHITECT •

THE MARQUESS OF BUTE.—Mr. ROBERT SCHULTZ WEIR, Architect.

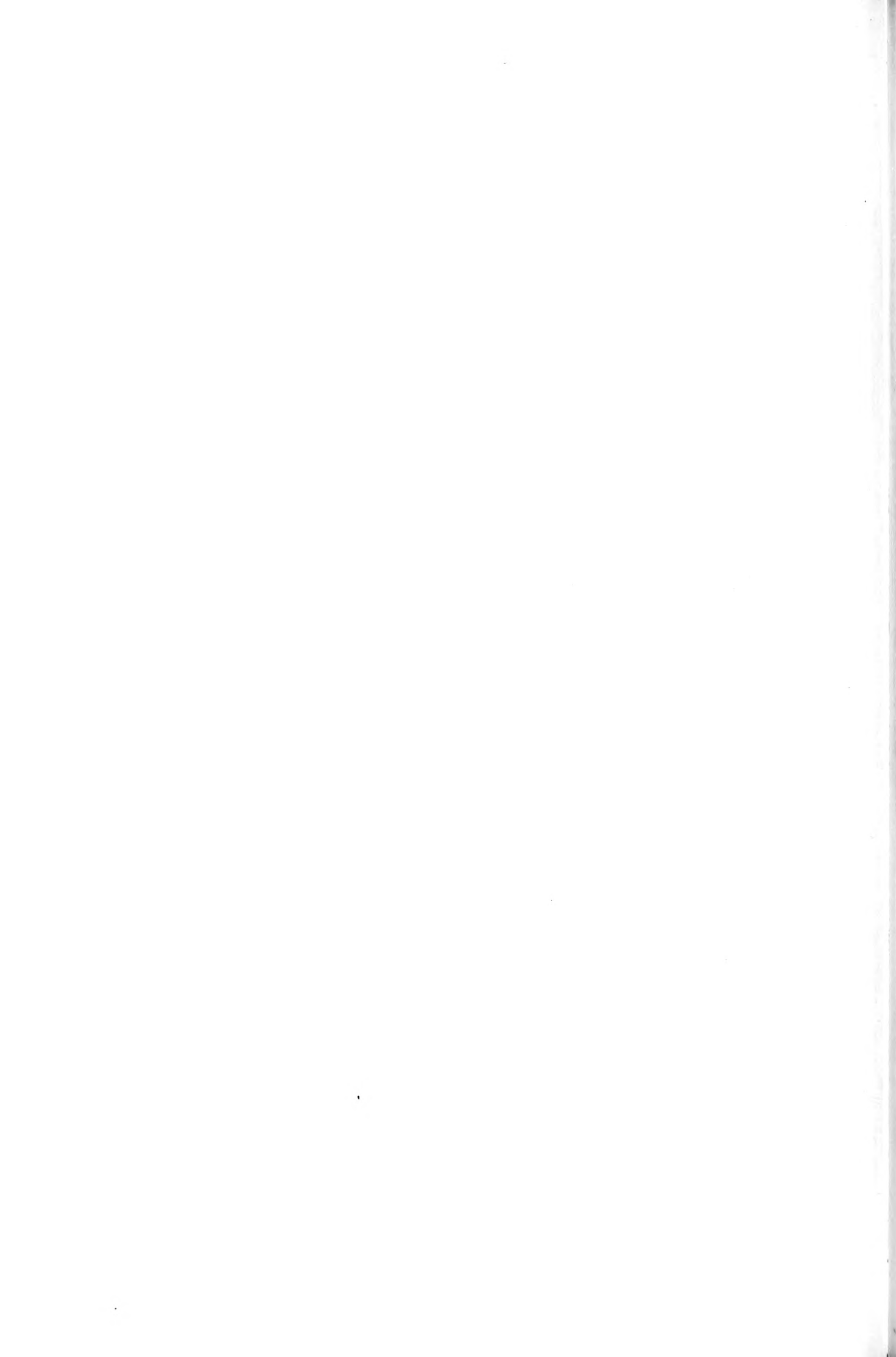

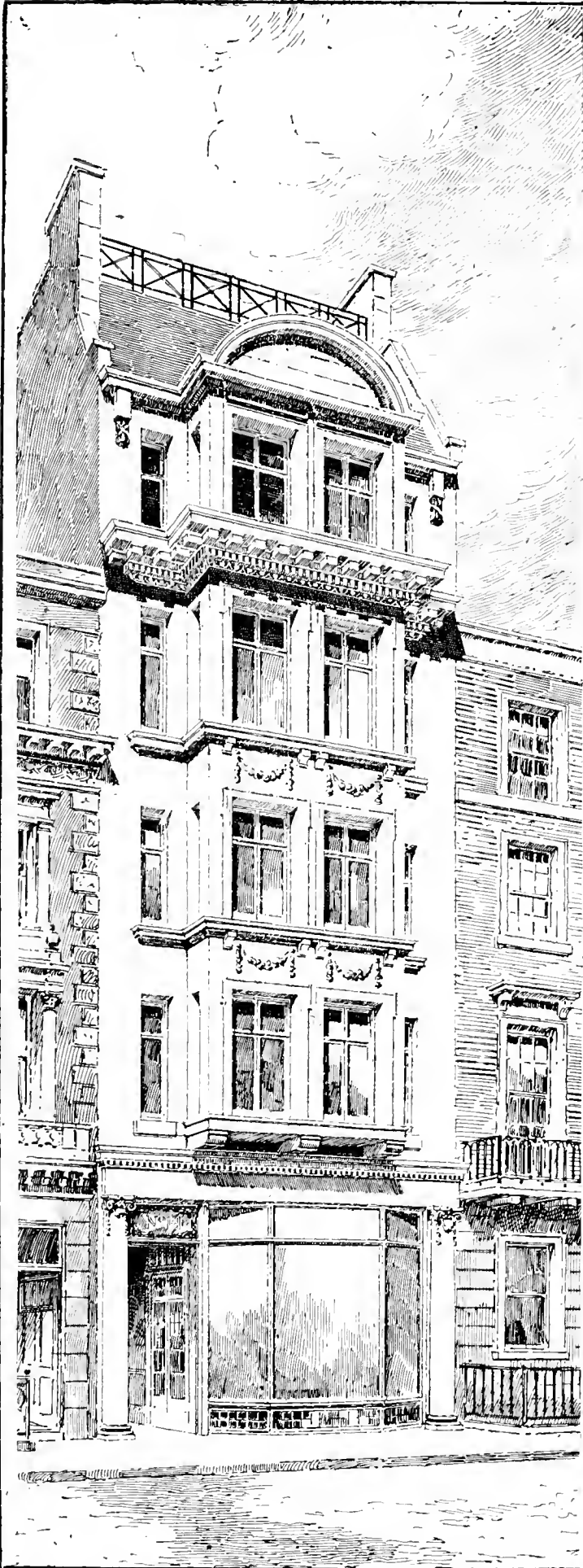

14 HANOVER ST. W. DELISSA JOSEPH ARCHITECT.

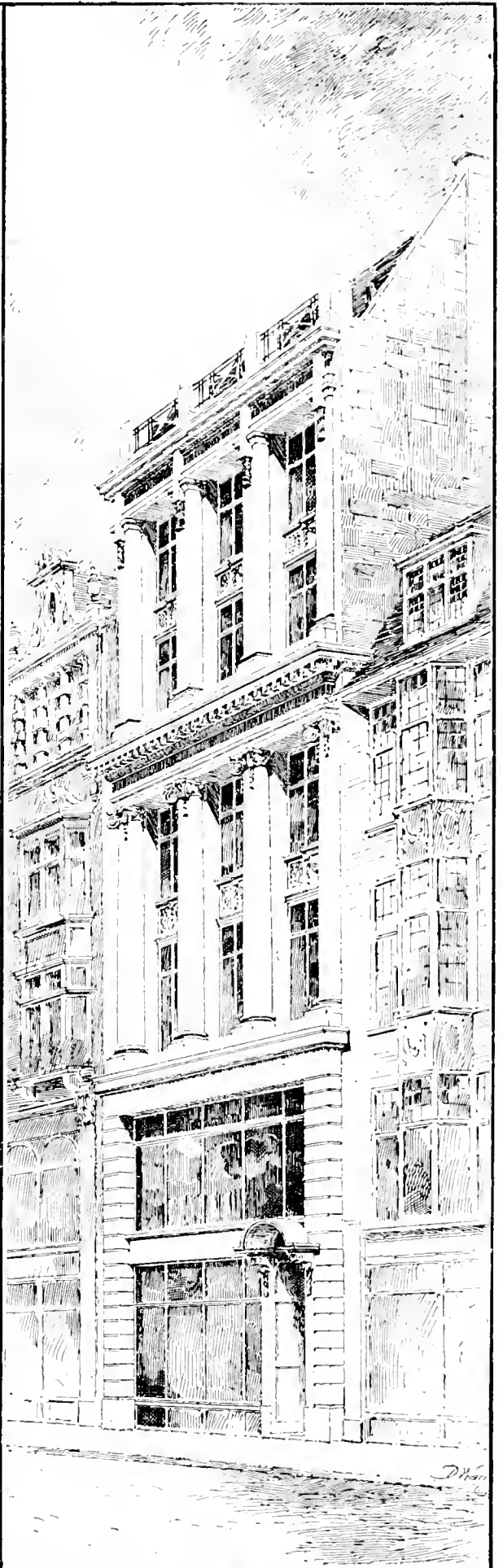

UNIVERSAL HOUSE, OXFORD STREET, W DELISSA JOSEPH ARCHITECT.

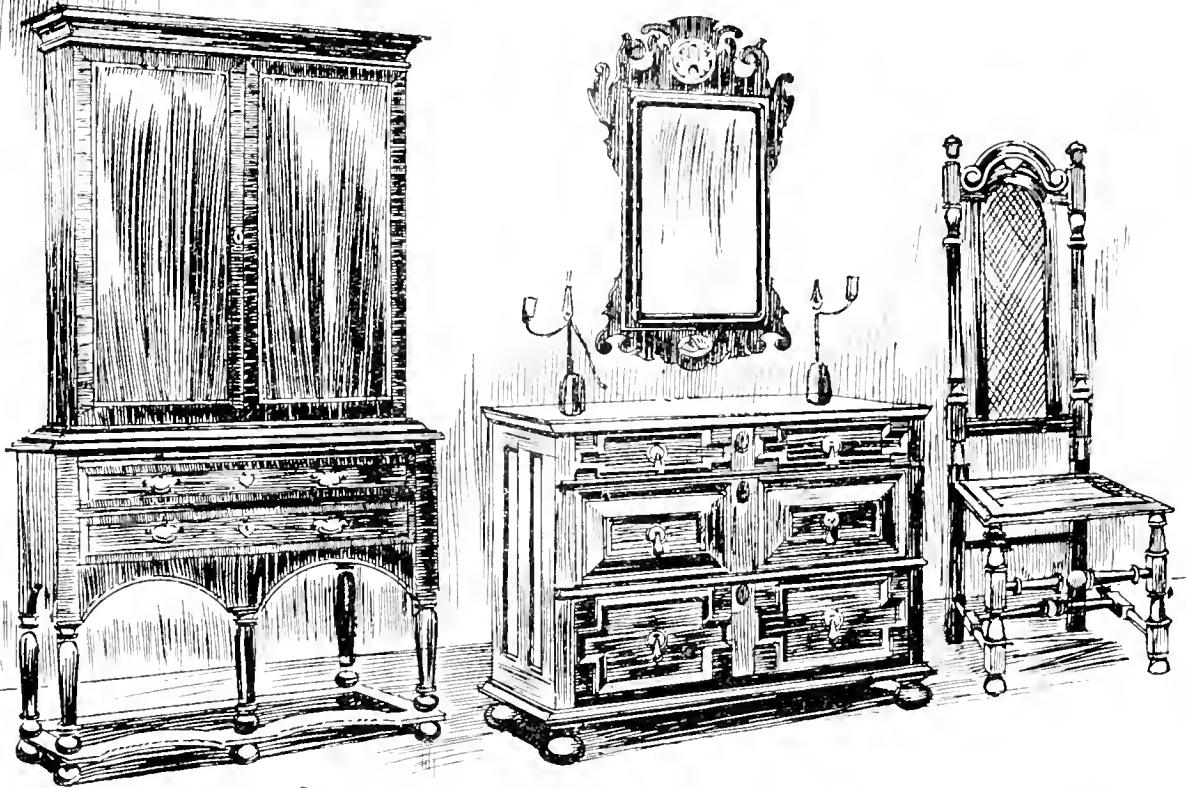

WALNUT VENEERED CABINET - JACOBEAN CHEST & CHAIR.

· OLD ENGLISH ·
· LIVING ROOM ·
· FURNITURE ·

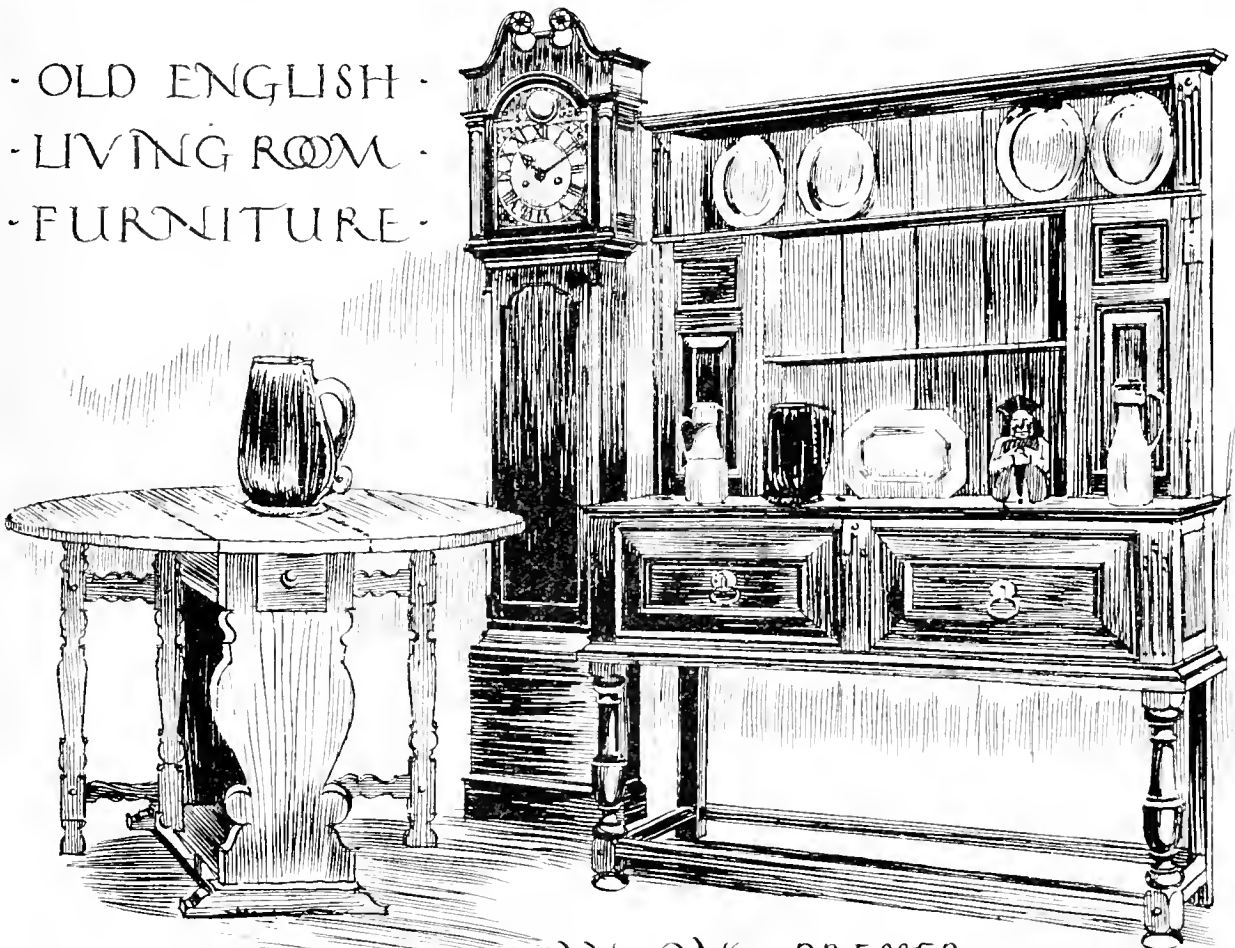

AN OAK DRESSER
TABLE & MAHOGANY LONG CASE CLOCK

W. W.

PROFESSIONAL AND TRADE SOCIETIES.

EDINBURGH ARCHITECTURAL ASSOCIATION.—The opening meeting of the session of the Edinburgh Architectural Association was held at 5, Queen Street, on Friday evening, the president, Mr. T. Forbes MacLennan, A.R.I.B.A., in the chair. Referring to the distress in the profession caused by the cessation of building work, Mr. MacLennan pointed out that if private enterprise in building was entirely stopped, as seemed to be the desire of the Government, the National Exchequer was bound to suffer. They all realised, however, that the one all-important thing for the nation was that the war must be fought out to a victorious conclusion. If we did not win, if German kultur were to be imposed on us, we were better dead; but if we did go on to complete victory there was every reason to hope for a great advance in the development of their art in a more peaceful atmosphere than they had ever known. Professor Charles Gourlay, B.Sc., A.R.I.B.A., of the Royal Technical College, Glasgow, delivered a lecture, illustrated by lantern slides, on "Santa Sophia, Constantinople." He referred to the interesting fact that this church, the greatest monument of the Byzantine style of architecture, was erected within the area comprised in the site of the ancient town of Byzantium, whence the style derived its name. He then showed illustrations of plans and interiors of Greek, Roman, Early Christian, and previously-erected Byzantine buildings to allow of a true appreciation of the great advance made by the magnificently-conceived plan of Santa Sophia, with its beautiful interior, upon those of any other building then in existence. Because of its size, the church was known as "The Great Church," and it was erected for the Emperor Justinian by the architects Anthemius of Tralles and Isidorus of Miletus, between the years 532 and 537, when the Byzantine style was at its culmination; hence its composition and details were of the choicest design and execution. The plan of the church was fully studied, including its nave, aisles, narthexes, and gallery; then followed views of the exterior and interior, and also of details, which were all described.

EGYPT EXPLORATION FUND.—The annual meeting of the Egypt Exploration Fund was held on Friday in the Hall of the Royal Society, Burlington House. Mr. J. S. Cotton occupied the chair. The report of the Committee pointed out that the reorganisation of the Society, carried out in 1913, had had to be modified owing to the exigencies of the war. The number of members had decreased from 321 to 260, and the Society had lost a large number of foreign subscriptions. Expenses too, had naturally gone up. No work had been done in Egypt during the past winter by the Fund as a whole. The American Committee, however, being under no obligation to save, had gone on with its special work at Balabish, under Professor Whittemore and Mr. Wainwright. Their most important discovery was that of a pan-grave cemetery, which yielded interesting Egyptian objects of Middle Kingdom types, besides those of the pan-grave people themselves, among which was a pot of pure predynastic type. An Eighteenth Dynasty cemetery was also explored, which yielded Mycenaean "Bügel-Kannen," and among many other objects, including a head of clear glass, which showed that transparent glass was undoubtedly already manufactured at that early period. The hon. treasurer reported that the income of the Fund, apart from special donations for the Osireion work or other purposes, showed a decrease as compared with the previous year, of £575, and that the adverse balance on the year was £653. Measures had been taken by the Committee which should effect a saving of at least £450 in salaries this year. No work in Egypt was proposed this season, either for the Fund proper or the Graeco-Roman branch, but the American Committee proposed to take up the exploration of a site in the Delta, Tell Tibelleh, near Mansûra. The public lectures of the Society would go on as usual, and the memoirs would continue to appear when ready for publication.

THE SANITARY INSPECTION OF DWELLINGS.—The annual meeting of the West of Scotland Sanitary Association was held on Friday in the Religious Institution Rooms, Glasgow. Mr. R. Easton Aitken presided, and moved the adoption of the report, which referred to the importance of a regular and systematic inspection of house drainage and piping. The Association had had before them numerous cases in which defects were only discovered after illness had drawn the attention of the occupants to the need of inquiry. It was a false economy to dispense with precautions simply because a defect might not be glaringly apparent. Mr. Paul Rottenburg, LL.D., seconded, and the report was adopted.

LEGAL INTELLIGENCE.

CLAIM AGAINST A CORPORATION.—At the Manchester Assizes last week, before Mr. Justice Ridley, the greater part of Tuesday was occupied with the hearing of an action in which Mr. Benjamin Place, the owner of the premises 95, Bury Road, Rawtenstall, was the plaintiff, and the defendants were the Mayor and Corporation of Rawtenstall, the local sanitary authority. By agreement between counsel on both sides the case was heard by the judge without a jury. Mr. Eastham represented the plaintiff and Mr. Sutton the defendants. The claim was brought to enforce an award under the Land Clauses Act for compensation in respect of damage alleged to have been done to the plaintiff's property during certain sanitary works which the defendants had carried out. There was an alternative claim for the disturbance of the plaintiff's rights. The questions at issue related to certain drainage, and the Court heard legal argument at some length. In the end the judge found for the plaintiff in the sum of £108. Mr. Sutton asked for a stay of execution in order to consider whether or not the judgment should be appealed against. He agreed to bring into court the amount of damages awarded, and the costs, and asked for three weeks in which to consider the question of appeal. The judge acceded to the application.

COLLAPSE OF BUSINESS PREMISES AT DEWSBURY.—**BLAKEY v. BOOTH.**—His Honour Judge McCarthy gave judgment at the Dewsbury County Court on Thursday, November 13, in the action brought by George Blakey and Son, Limited, shop fitters, of the National Works, Wakefield, against Herman Booth, contractor and builder, of 16, Cedar Grove, Bradford Road, Batley, for £35 15s. 3d., damages for alleged negligence in carrying out excavations in the passage formerly running between the London City and Midland Bank and the Oxford Market Place, Dewsbury, and now embraced in the premises occupied by the Public Benefit Boot Company. Mr. T. P. Perks, barrister, appeared for the plaintiffs, and Mr. J. A. Greene, barrister, represented the defendant. The case was heard on October 23, when evidence was given by many witnesses on both sides as to the circumstances which led to the sudden collapse of, and into, the trench which was being excavated, and his Honour reserved judgment. His Honour now said that by arrangement between the learned counsel the only question for his decision at the moment was that of liability. The figures were agreed, except as to one amount on which the defendant reserved his rights, and the negligence was admitted. In June last the plaintiffs were fitting up a shop for the Public Benefit Boot Company, and they arranged that the defendant's men should do all the necessary bricklayers' and masons' work. Defendant received from the plaintiffs 25 to 35 per cent. gross profit on the wages actually paid by him to his men, and a profit also on such materials as he supplied. Mr. Greene contended that the defendant's men were merely lent to the plaintiffs, and that defendant was not liable for their negligence. The question arose as to whether the contract was that the defendant was to do the work and have control of his men, or was it one merely to supply workmen who were to be under the control of the plaintiffs? Plaintiffs contended that they exercised no control whatever over the defendant's men. Defendant could send or take them away; he could change them for others; he paid them, and supplied the materials, and made a profit on both. Defendant was also frequently on the job, although the supervision required was necessarily slight. He (the judge) saw no reason why profit should be paid to the defendant if he did nothing but lend the workmen. The contract between the parties, in his

opinion, was that the defendant should do the builder's work which might be found necessary as the job progressed, as and when required by the plaintiffs, and that his remuneration was to be the profit which he made on the wages and materials by charging the scale of prices of the Federation of Builders of the district, and, therefore, he found that the defendant always had, and the plaintiffs had not, control of defendant's workmen. Accordingly he found the defendant liable. The question of how the judgment had to be entered relative to the figures on both sides was discussed at some length, and ultimately it was agreed that judgment should be deferred until counsel had had the opportunity of going thoroughly into the figures. It was agreed, however, that plaintiffs should have all costs on the issue of negligence in any event. Mr. Greene asked for a stay of execution, which was granted for twenty-one days.

THE LEGALITY OF STONE ALTARS.—At a sitting of the Consistory Court of Lincoln, before the Chancellor (Mr. G. J. Talbot, K.C.), the petition of the vicar and churchwardens of Swinstead, praying for a faculty to place a stone altar with brass cross and candlesticks thereon in the south aisle of the church has been heard in Lincoln Cathedral. The petition was opposed by Mr. Houlder, a parishioner, on the grounds that the proposed erection was illegal, and would be likely to promote superstition; that a cross resting directly upon the holy table was illegal; and that the application for a faculty had not been submitted for approval to the parishioners at a vestry meeting. Mr. Harold Hardy, for the petitioners, stated that the proposal was to place an ancient stone slab, which bore the Consecration crosses upon it, and had been in the church for many years, upon stone piers, or, in the alternative, upon a wooden frame as a side altar in the south side. Mr. Bond, the architect, stated that the stone slab had obviously formed part of an ancient stone altar belonging to the church. Mr. Houlder also gave evidence, and said that he objected to stone altars because they were associated with the Mass and tended to superstition and were illegal. After legal argument the Chancellor allowed a faculty to issue for the placing of an altar in the south aisle with the cross and candlesticks thereon, the altar to consist of the ancient stone slab upon a wooden frame. The Chancellor, in his judgment, said that the objection to the proposal was really merely a technical one. Its covering generally prevented one from knowing the material of which the altar was made. The question was whether a stone altar was allowed by law. Referring to the cases of "Faulkner v. Litchfield," in 1849, and "Western v. Liddell," in 1855, he said there were two decisions of the Arches Court and one of the Judicial Committee of the Privy Council, where fixed altars were held to be illegal, and he did not think he could refuse to follow those decisions. But the petitioners had suggested as an alternative to place an ancient slab, which originally formed part of an altar, upon a wooden frame which was movable, and the question was whether that fell within those decisions. In the present case there was no evidence of any probability of superstition, and the faculty would be allowed for the stone slab on a wooden frame.

RIGHT TO LATERAL SUPPORT.—**HORSHAM AND SHEARLEY v. T. C. SMITH.**—In this action, heard before Mr. Justice Bailhache, two freeholders at Blackheath, Kent, claimed damages from T. C. Smith, builder, of the same district, for removal of lateral support of the rear fences of seven houses in Eastcombe Avenue, Blackheath, by the excavation of gravel from the bank between plaintiffs' back gardens and Moretta Road. The defendant attributed the settlement of the fences to rainwater falling from plaintiffs' workshops, summer houses, and greenhouses upon the fences. After hearing evidence, Mr. Justice Bailhache gave judgment for plaintiffs, with costs, for £110, to be reduced to a shilling if within four months a bank was erected and the fences repaired to the satisfaction of an independent surveyor to be chosen by the experts on either side, or, failing that, his lordship.

It has been decided to enlarge the church at Cyfarthfa, Mon., from plans by Messrs. Johnson and Richards, of Merthyr Tydfil.

In the King's Bench Division last Friday Mrs. Helena Wakley, the wife of Mr. Horne Magennis Wakley, of Avenue Road, Regent's Park, claimed damages from Mrs. Elizabeth Davies, who formerly carried on the business of a Court dressmaker, as "Elise Kreuzler," at 11, Hanover Square, W., for alleged slander. The jury returned a verdict for the defendant.

Correspondence.

BUILDING LINES AND ROAD BOUNDARIES.

Mr. W. R. Chadwick... in another part... directed... laying out... Road, Woolwich... streets of a width of 30 ft... sufficient width to... traffic reasonably... every point of view... importance, the d.s... building lines. Areas... wide roads are costly... maintain, and the excess... better utilised as garden... or thought fre... to this question, it... assumed that the building... with the road board... quite permissible in... constructed road. It... that the opinion of... as implied in their building... wide in which the... on the boundary (for this... superior to a road of less... building line is well set back... necessary to comment on the... of this position, and one of the most... reforms in building by-laws... building lines and... The former might well be... liability than is usually... latter should carry in ac... the particular traffic require...

It is always to be desired what a great... road is when it has to be laid out... with houses of the cottage type... to be constructed, and subse... reconstructed as... when taken over by the... for much less than £5 a foot... It will be seen at once that this... added to the area value of the land, is... and it has undoubtedly had a... influence in imposing the narrow... of the average small... with which we are...

A width of 30 ft is ample for the vast... residential roads where... is the only visitor, and a... by the construction, ... by the maintenance of...

H. W. LAVARAK, Planning Officer, Goddard Green.

MILITARY EMERGENCY HOSPITALS.

Some of the original memorandums of... I said, in refer... East Eastern Hospital at Cam... It represents an act of faith and... of the part of the second initiated it... in my former report, Professor (now... Woodhead and Colonel... Commanding...

It is a pleasure to find that you have committed... Griffiths.

As the... as the... is... in the... of the... A.S.A. S... M... S...

ST. PAUL'S CATHEDRAL.

The Building News... under the... St. Andrew's... the... but, a... new, we... Mr. T... Mr. B...

bridge Reynolds, Limited, the glass mosaic by Signor Meo, and the whole of the marble work by ourselves; only on the glass mosaic were any Italians employed, and even on this mosaic work the greater part of the craftsmen, we believe, were English.—Yours faithfully,

FARMER AND BRINDLEY, LIMITED (H. W. Barnes, Director), 65, Westminster Bridge Road, London, S.E., November 24.

Mr. C. Blaney, surveyor to the Newry Urban District Council, has had his salary increased from £200 to £300 a year.

The city council of Cardiff have resolved to complete the electric installation at the new technical college at an estimated cost of £2,000.

The Local Government Board have given their sanction to the borrowing by the rural district council of Anusbury of £3,629 for works of road repair.

The Lincoln board of guardians have received the sanction of the Local Government Board for effecting alterations at the workhouse at an estimated cost of £1,200.

Mr. A. W. Ward, the borough surveyor of Shrewsbury, gave a lecture on "Town Planning," illustrated by lantern slides, at Technical Schools, Shrewsbury, on Thursday evening in last week.

The housing committee of the Corporation of Greenock have been authorised to prepare specifications and obtain plans for a minimum of seventy-five artisans' cottages at Craigieknows Farm.

Mr. Thomas Gelethorpe, who for many years carried on a builder's business at Bourne, Lancashire, until his retirement three years ago, died last week at his son's residence at Darwen, Lancs, aged 80 years.

Mr. H. T. Wakelam, M.Inst.C.E., M.S.A., the county surveyor of Middlesex, has consented to act as hon. secretary and treasurer to the County Surveyors' Society, in succession to the late Mr. T. H. B. Heslop, county surveyor of Norfolk.

Professor Geddes and Mr. H. Vaughan Lanchester, town-planning experts, have met the members of the Nagpur Municipal Committee at a special meeting, and had a discussion about the details of the exhibition to be held in Nagpur early in 1916.

The Corporation of Lancaster have decided to apply to the Local Government Board for leave to borrow £80,000 for an extension of the waterworks necessitated by the prospective huge increase of population due to Government works. The scheme includes the utilisation of the existing Aldwinstead compensation reservoir. The Government is to be asked to make a grant in aid.

The Down County Council have decided to reduce the number of assistant surveyors from twelve to six, with a salary commencing at £200 a year, with annual increments of £5, rising to £250, with 2d. per mile travelling expenses. It is proposed to offer the positions to the assistants in the order of seniority. Those whose offices are to be abolished are to be compensated. The assistant surveyors are appealing to the Local Government Board of Ireland against these drastic proposals.

At the last meeting of the rural district council of Chapel-en-le-Frith the clerk reported that the Local Government Board inquiry into the council's application for a loan for the erection of houses at Chapel-en-le-Frith has been well, and that the inspector had asked for an alternative scheme for sanitary accommodation, also for the building of eight of the houses in a smaller lot to effect a reduction in cost, also for the architect should prepare a revised estimate of the cost, in view of the increase in prices since the scheme was prepared. It was resolved that Mr. Flint, the architect, prepare the necessary plans and estimate.

Mr. A. W. Brightmore, an inspector under the Local Government Board, has held an inquiry at Walton-le-Dale into an appeal by the urban district council for sanction to borrow £17,970 for the Chorley main road. The clerk explained that the thoroughfare in question ran through Bamber Bridge, and was the main link road through Lancashire, leading from Warrington and Manchester in the south to Lancaster and Carlisle in the north. The heavy motor traffic that passed over the road had left it in a bad state. The council proposed to reconstruct the road, after the war, with 4 inches of tarmacum on a 9-inch curb foundation.

Building Intelligence.

BIRMINGHAM.—A 10,000 kilowatt temporary electric generating station has been constructed on a portion of a site at Nechells, for the Corporation of Birmingham, to meet pressing demands. The site is bounded by the Birmingham and Warwick Junction Canal and a branch line of the London and North-Western Railway, which is on a high embankment, and by the dust destructor. Between the entrance gates and canal is a roadway 32 ft. wide, and at right angles to this road is the inclined cartway carried on arches, which serves for the delivery of refuse to the destructor. The foundations for the temporary station rest upon a sub-soil consisting of ash from 5 ft. to 7 ft. deep. Over this sub-soil concrete rafts, composed of steel grillages and reinforced concrete varying in depth from 1 ft. to 2 ft. 6 in., were floated. The weight of the steel structure is distributed evenly over the steel grillages. The buildings are constructed of a steel framework covered with an asbestos corrugated sheeting, which forms the roof and the walls. The dimensions of the engine and boiler-house together are 92 ft. by 124 ft. wide. The boiler-house contains six marine type boilers. In the engine-room two 5,000-kilowatt 5,500-volt 25-cycle Westinghouse turbo-alternator sets have been erected. As there is no basement to the engine-room, the condensers and air filters have been erected on the same level as the turbines and alternators. The works have been carried out under the direction of Mr. R. A. Chattock, chief electrical engineer to the Corporation. The contractors for the foundation work were Messrs. J. J. Shardlow and Co., of Leicester, and for the walls and roofing Messrs. Thompson and Hughes-Jones, of Budge Row, Cannon Street, E.C.

HIGHFIELD, SOUTHAMPTON.—During the past sixteen months there has been in progress at Christ Church, Highfield, an enlargement of the fabric. The whole of the west end of the nave has been extended, thereby increasing the accommodation from 620 to 950, whilst a vestry has been added also. The extension of the east end, and the provision of a porch beneath the west window are improvements which will be taken in hand after the war. The present work has cost about £5,500. The walls have Bath stone dressings, and the west end is filled with a four-light window. The building has been carried out by Messrs. A. White-Bowman, of Bournemouth, to plans prepared by Messrs. J. Oldrid Scott and Sons, Dean's Yard, Westminster, the work being under the direction of Mr. H. C. Kite, the foreman and manager. During the progress of the work the builder, Mr. A. White-Bowman, and Mr. J. Oldrid Scott, F.S.A., the father of the present architect, both passed away.

TRADE NOTES.

Boyle's latest patent "Air-Pump" ventilators have been applied to the New Prison (Block B), Saughton, Edinburgh.

Messrs. Palgrave and Co., architects, announce that they have removed from 25, Bloomsbury Square, W.C., to Bloomsbury Mansions, 26, Hart Street, Bloomsbury Square, W.C. Their telephone will be as hitherto—Regent 5175.

Mr. S. F. Menier-Williams, A.R.I.B.A., Interior District Surveyor for St. Pancras (South), announces that after December 1 the district offices will be 45, Grafton Street, Tottenham Court Road, W. He has just been appointed Interior District Surveyor by the L.C.C.

In most towns swimming-baths are closed for the winter months. This gives an opportunity to repair any leaky places. The bottom of the swimming-bath at Fettes College, Edinburgh, which leaked very badly, has been re-cemented and lined with glazed bricks. We have received a report that for making the cement waterproof the powder Pullo was employed with excellent results.

As St. Augustine's Mission Church at Chesfield has become dilapidated, a new church is to be built at a cost of £2,500.

A nurses' home is to be added to the Herefordshire General Hospital in Hereford city after the war. Messrs. Nicholson and Clarke are the architects, and the proposed expenditure is about £4,000.

Our Office Table.

The memorial which the Committee on War Damage is to present to the Prime Minister says: "Although the Government scheme only came into force on July 19 last, immense losses and great hardships have been suffered in many districts, and it seems to your memorialists exceedingly unfair that these should not be borne by the nation; and notwithstanding the fact that the withdrawal of the scheme would now involve a considerable expense in the first instance, it is yet, for the reasons stated above, highly desirable that the Government should retrace their steps in the matter, repay the premiums already received, and, as trustees for the nation, proclaim their intention of giving fair compensation to the owners of property and goods that have already been, or may in future be, damaged or destroyed either by aircraft or bombardment. This, in the opinion of your memorialists, is the manifest duty of the Government, and one which they are bound by every consideration of justice, expediency and public policy, to recognise and carry into effect." The following bodies (in addition to those already reported) have decided to join in the presentation of this memorial:—*Municipal Corporations*: Bromley (Kent), Chatham, Croydon, Faversham, Hertford, Newcastle-under-Lyme, New Romney, Scarborough, Wednesbury; and *Urban District Councils*: Bracebridge, Lincolnshire, Clacton-on-Sea, Haverhill (Essex), Heston and Isleworth, Long Sutton, Normanston, Seaham Harbour (Durham), Sheringham (Norfolk), Stanley (Yorks), Tottenham.

The Kalendrar of the Royal Institute of British Architects for the eighty-second session, just published, contains 482 pages, against 492 last year. The list of membership contains the names of 864 Fellows, 32 retired Fellows, 1,707 Associates, 1,904 Licentiates, 12 Hon. Fellows, 54 Hon. Associates, 249 Hon. Corresponding Members, as against 858 Fellows, 32 retired Fellows, 1,694 Associates, 2,045 Licentiates, 12 Hon. Fellows, 55 Hon. Associates, and 65 Hon. Corresponding Members at the same period last year. There is thus shown a slight increase in the classes of Fellows and Associates, a natural decrease in the stationary class of Licentiates, part due to transference to the rank of Fellows, and more largely to the inevitable mortality, while the comparatively large decline in the number of Hon. Corresponding Members is the result of the excision of the names of those of nationalities at war with us. The sessional meetings will be restricted to business purposes and will be held at 3 p.m. on December 13, January 3 and 31, February 28, May 1 and 13, June 5 and 19. The competitions for prizes and studentships have been suspended for the duration of the war.

Four districts have been chosen for the work of the Civic Surveys now in progress—Greater London, South Wales, South Lancashire, and South Staffordshire. A number of professional men who have been hard hit by the war are doing the work. In each of the areas they are preparing a series of graphic diagrams showing the physical characteristics of the area; vital statistics as to death and disease for, say, fifty years; density and growth of population; provision of playing fields, recreation grounds and parks; character and growth of industries; extent to which present traffic needs are met, and forecast of probable future requirements; conditions under which housing areas have developed in the past, and a comparison with newer views in the laying out of building estates. These diagrams will be of the utmost value.

Shortly after the death of Sir Laurence Alma-Tadema, R.A., a committee was formed for the purpose of honouring his memory by a public memorial over and above the inscribed slab on his grave in St. Paul's Cathedral which the Royal Academy had undertaken to provide. While funds were being raised for the purpose, the Misses Alma-Tadema presented to the committee the original marble bust of their father executed

by the late Onslow Ford, together with the pedestal designed by Sir Laurence himself; and all the subscriptions were then devoted to the purchase of Sir Laurence's library, with a view to presenting it to some public institution in London, where it would be readily accessible to artists and students of art and archaeology. An offer of the collection, together with the bust, was made to the Victoria and Albert Museum, and was gratefully accepted. The "Alma-Tadema Memorial Library," which was formally presented to the Museum by Princess Louise, Duchess of Argyll, on Wednesday, and was accepted by Sir Cecil H. Smith, the director and secretary of the museum, contains over 4,000 volumes and pamphlets, dealing principally with the monumental and artistic side of the archaeology of antiquity. Numerous books treat upon the painting of the Historical School, and an important feature of the collection is a series of 163 portfolios containing photographs and sketches by Sir Laurence of details of Classical and Oriental architecture, art, costume, and life which interested him so deeply. The collection was purchased by subscribers for £1,000, but had been returned for probate at three times that figure, and is now housed in two wings of the West Room, No. 74, of the Art Library at the museum. Sir Cecil Smith has had a synopsis drawn up of the contents of the portfolios, and any subject can be referred to without delay. The collection of printed and illustrated books consists of several thousand volumes. A complete catalogue has been prepared, and when funds are forthcoming it will probably be printed.

The taxation of sewers was considered on Friday by the Treasurer's Committee of Edinburgh Town Council. The question came up through a letter that was received, intimating that the Treasury would not agree to relieve the corporation of the tax on sewers unless a Bill were introduced by agreement to have the sewers taken out of the Lands Valuation Act. It was resolved to communicate with the other four large cities, and with the Convention of Burghs, who had been associated with the corporation before in the representation made to the Treasury on the subject, with a view to adopting a uniform course. It is understood that the Treasury would not be unwilling to consider the matter sympathetically were it not for the present circumstances of the country and the difficulty of getting through Parliament a Bill that would be agreed to on all sides.

Presiding at the twenty-fifth annual meeting of the Glasgow Workmen's Dwellings Company on Thursday, Sir D. M. Stevenson recalled that the company was formed to provide decent, sanitary houses at rents no higher than those of the ticketed houses in the same neighbourhood. They had been able to do so for some years, the rents being sufficient to pay the normal value of money from time to time, which the company set down at 4 per cent. For the last nine years, however, the company had not been able to pay more than $3\frac{1}{2}$ per cent. But matters had now come to a crisis. An amount equal to 12½ per cent. of the rental had been laid aside from year to year for depreciation and repairs. That amount reduced the book value of their properties by something over £4,000, but still left the book value a great deal higher than the properties would bring in the market. On the other hand, if they were called upon to replace the buildings, it would cost them a very great deal more than their book values. To meet the present position the rents would require to be increased by about one-third, but meantime the directors did not propose to make any change, but to await the promised legislation. With regard to the higher rate of interest which bondholders were demanding, he thought it was a shocking thing that the Government should give 4½ per cent. to people for their money and say to bondholders that they should not ask more than $3\frac{1}{2}$ per cent. Mr. D. M. Scott seconded the adoption of the report, and other speakers urged the necessity for increasing the depreciation fund, but did not see how it could be done with

the present rents, and also pay the normal rate of interest. The report was adopted.

"Lime and Cement," by J. G. Alms and C. A. Elliott (London, Blackie and Sons, Limited, 50, Old Bailey, E.C.), is one of the interesting "Rambling Industry Books" issued by the publishers, and very readable. Most of the photographs and diagrams and much of the information has been supplied by the Associated Portland Cement Manufacturers (1900), Limited, and therefore it need hardly be said is valuable and reliable.

Two interesting old documents have been presented to Princeton University, near Trenton, New Jersey, by the Hon. Bayard Stockton, of the class of 1872. These are the original architect's drawing of Ivy Hall on Mercer Street and the Old Chapel, which stood near the eastern end of Nassau Hall until it was taken down in 1896 to make room for the new University Library. The drawing of the Old Chapel bears the signature of John Notman, the architect, and is dated April 15, 1847. It shows the front and side elevations, the interior and the ground plan, with its cruciform outlines, which at the time caused much concern in Presbyterian circles. The other drawing shows the front and side elevations and the ground plan of Ivy Hall, which was originally erected as the home of the Princeton Law School.

The new City Hall, in Cleveland, Ohio, which is rapidly nearing completion, is the third building of an important group plan to be erected. It is Free Classic in style and stands at the foot of East Sixth Street, on a high bluff, overlooking Lake Erie to the north, and balances the Cuyahoga County Court house in the group plan, being on the opposite side of the Mall. The Mayor of the city has been finally successful in coming to an agreement with Pennsylvania and New York Central Railroad interests, and the Graham-Burnham Company, Chicago, is now engaged in preparing plans for a new \$17,000,000 passenger terminal to be the keynote of the group. Mr. Walter R. McCorkack, architect to the Board of Education, has prepared plans for a central commercial high school and office building for the Board of Education, to be erected at East Sixth Street and St. Clair Avenue, on the Mall, at a cost of \$1,000,000. This building will be five stories in height, with an auditorium on the ground floor, a gymnasium on the top floor, and a running track on the roof. The Post Office has been built as part of the plan from designs by Mr. Arnold W. Brunner, of Boston, Mass. The sixth building in the group is the proposed public library, to occupy the site of the present City Hall, and for which an architect has not yet been selected. The group plan commission consists of Messrs. Fredrick Law Olmsted and Arnold W. Brunner, of Boston, and Frank B. Meade, of Cleveland, who receive \$1,500 a year each and travelling expenses for their advisory services.

Messrs. Robert Jenkins and Co., Rotherham, have issued a new catalogue and list of discounts of their well-known wrought-iron and steel-welded and riveted boilers of every description for heating by low-pressure, hot water or steam, and for domestic hot water supply, also of their brazed pure copper boilers and cylinders, and their vertical boilers for steam engines or cooking purposes. In either line the reputation and experience of this well-known firm is second to none in the Empire, and the preliminary notes in the introduction will be found most valuable by all architects, builders and others. It will be noted that the gross prices of boilers from pages 12 to 19 inclusive have been increased, but instead of their being under Class E as formerly, they are now subject to a greater discount under Class D.

Mr. Taylor having resigned his appointment as borough engineer to the Middleborough Corporation, Mr. Scotson was on Wednesday night appointed his successor at £350 a year.

New fire brigade premises in Dock Street, Newport, Mon., were opened last week. They cost £4,000, and have been built by Mr. A. Lovelock from plans by Mr. C. F. Ward, F.R.I.B.A., the borough architect.

CHIPS

M. C. ... Cat. ... H. Street, Wir. ... Messrs. ... Messrs. ...

... and I. ... plans for a ... to be built ...

... and R. ... District ... Mr. ...

... have con- ... carrying out ...

... Visitors to the ... Local Government Board ...

... considered at the ... Rural District ...

... Council have authorised ... to acquire an ...

... Church at ... plans by ...

... of West- ... for an ...

... of ... at ...

... of ... all ...

... of ... and ...

... of ... and ...

... of ... and ...

... of ... and ...

MEETINGS FOR THE ENSUING WEEK.

WEDNESDAY TO-DAY: Royal Society of Arts. "Insects and War," by Dr. A. L. Shipley, F.R.S., Master of Christ's College, Cambridge, 4.30 p.m. St. Paul's Ecclesiological Society. Some Churches in North-West Kent," by E. Reginald Taylor, St. Paul's Chapter House, E.C. 4, 8 p.m. Institute of Sanitary Engineers. "The Disposal of Sewage by Dilution," by Dr. W. E. Abney, 8 p.m. Shuffled Society of Architects. "The Struggle for Efficiency during Five Periods of English Architecture," by J. B. Mitchell-Walters, F.R.I.B.A.

FRIDAY: Glasgow Architectural Craftsmen's Society. "English Medieval Architecture," by Charles Gourlay, B.S., A.R.I.B.A., 7.45 p.m.

SATURDAY: Institution of Municipal and County Engineers. "Eastern Sub-District Meeting at Bury St. Edmunds. "War Time Economy by Local Authorities," by William H. Lloy, 2 p.m.

MONDAY: Royal Society of Arts. "Optical Glass," Canon Lecture No. 11, by Dr. W. Rosenham, F.R.S., 4.30 p.m. Farmers' Club. "Land Settlement in England as Affected by the War," by Christopher Turner, 6 p.m. Society of Engineers. "Modern Development of Water Power," by Alphonse Steiger, M.I.C.E., Canton Hall, Westminster, 7.30 p.m.

TUESDAY: Faraday Society. Discussion on "The Corrosion of Metals, Ferrous and Non-Ferrous," Institution of Electrical Engineers, Victoria Embankment, 8 p.m.

WEDNESDAY: Dec. 8. Royal Society of Arts. "The Art of Finding Your Way at Night without a Compass," by Lieut.-Col. A. Tinsley, 17th Lancers, 4.30 p.m. Association of Engineers-in-Charge. "Annuniation Manufacture," by Alfred E. Paine, St. Broth's Institute, E.C. 4, 7.30 p.m. Manchester Society of Architects. "The Necessity for Proportion," by C. E. Bloor, F.R.I.B.A., 6.30 p.m.

THURSDAY: Dec. 9. Association of Managers of Sewage Disposal Works. Annual Meeting. "Papers: "The Work Done at Salford by the Activated Sludge Process," by W. H. Duckworth; "Recent Improvements in the Construction of Cultivative Tanks," by W. D. Scott-Moncrieff, Caldeanham Saloon, Holborn Restaurant, W.C. 1, 5 p.m.

FRIDAY: Dec. 10. Institution of Water Engineers. Discussion on "The Necessity for Defining the Term 'Domestic Purpose' in General and Private Water Acts," Election of President and Council for 1916-17, and of Auditors for 1915. Geological Society's Apartments, Burlington House, W., 2.30 p.m. Town-Planning Institute. "Arterial Roads in Greater London," by W. R. Bridgman, A.R.I.B.A., F.S.I., 92, Victoria Street, S.W., 8 p.m.

The Spanish Government are about to construct a strategic railway from Estada and Tamarite to Balaguer, Spain.

Important additions to Messrs. Kynoch's ammunition factory at Arklow have lately been completed by Messrs. G. and Y. Crampton, contractors, Dublin.

The Corporation of Dublin are about to take up a loan of £22,400 in connection with the housing scheme on the Ormond Market site. It is proposed to erect 150 houses.

A Local Government Board inquiry has been held at Marlock into the application of the urban district council for sanction to continue the construction of a sewerage scheme at an estimated cost of £75,359.

A site has been purchased at the corner of Wexgrave Road and Fenlath Hall Drive, Newcastle-on-Tyne, for the erection thereon of a new church of St. Monica. The estimated cost of the church is £10,000.

In view of Lord Derby's recruiting campaign, the Council of the Royal Institute of British Architects have decided that the R.I.B.A. Unemployment Register shall be closed to all unmarried men of military age, unless they can produce evidence of physical fitness for service, or unless they have enlisted and been passed into the reserve.

A meeting of the Dundee Institute of Architects has been held for the purpose of considering regarding the proposition in Dundee and Lord Derby's scheme, and it was agreed to form a committee of all members eligible under the scheme to undertake with recommendation, the conduct of the business of those members who enlist when called out for service.

TO ARMS!

4TH BATTALION CENTRAL LONDON VOLUNTEER REGIMENT.

Recruits are urgently needed for the Regulars, Territorials, and Volunteers. Intending recruits should apply to Battalion Headquarters, where they will be advised as to the branch of the service for which they are best suited.

ORDERS FOR THE WEEK, BY SUB-COMMANDANT C. S. PEACH.

GENERAL PARADES.

Opening meeting of new Drill Headquarters this evening. Parade in uniform, 6.45 p.m. sharp. The Regimental Commandant, Brig.-Gen. the Hon. F. C. Bridgeman, and others have promised to be present. A large attendance is specially requested. Members acting as orderlies should report themselves to Platoon Commander C. H. C. Bond at 6.15 at headquarters.

Saturday, December 4.—Parade at East Putney Station at 2.45 p.m. Sharp for route march. As this is the first combined parade with the L.C.C. Staff Corps it is hoped that there will be a large muster. There will be no parade on Saturday, December 11.

ENTRENCHING PARADE.

Sunday next, December 5, at Victoria Station, L.B. and S.C. Railway indicator board, 5.55 a.m. Uniform, haversacks, and water bottles. Midday rations to be carried. Return to town about 6.40. Railway vouchers will be provided, and a special train run by the railway company.

LECTURE.

Tue-day next, December 7, 7 to 8 p.m., on "Field Engineering."

RESIGNATIONS.

Commandant Lieut.-Col. W. W. Warden resigns his appointment on receiving an active command. Acting-Company Commander Gervase Bailey resigns his appointment on receiving a Second Lieut. Commission, Kent (Fortress) R.E. (T.F.).

APPOINTMENTS AND PROMOTIONS.

Platoon Commander E. J. Castell to be Company Commander. Section Commander N. E. Brown to be Platoon Commander No. 1 Platoon. Section Commander C. H. C. Bond to be Platoon Commander No. 2 Platoon. Platoon Sergeant E. P. Hudson to be Platoon Commander No. 3 Platoon. E. L. Sanderson to be Platoon Commander No. 4 Platoon.

By Order, L. R. GUTHRIE, Adjutant, Drill Headquarters, Chester House, Eccleston Place, S.W. Battalion Headquarters, 18, Tufton Street, Westminster, S.W.

Dr. James M. Baldwin, honorary professor of the University of Mexico, will deliver the Herbert Spencer Lecture in the Lecture Room of the Oxford University Museum on Wednesday, March 15, 1916, at half-past two in the afternoon.

The West Sussex County Council have agreed to obtain further expert opinion upon the condition of Norfolk Suspension Bridge, which carries the main road over the Adur between Shoreham and Lancing. The scheme for reconstruction is estimated to cost £20,000.

At a representative meeting held at Newcastle on November 24 the Lord Mayor (Mr. George Lunn) presiding, it was resolved to invite the British Association to meet in Newcastle next year on lines similar to those adopted at the Manchester meeting.

A new building is to be erected for the Home of the Daughters of Jacob on the block bounded by 167th Street, Finlay and Teller Avenues, in New York City. Mr. Louis Allen Abramson, 220, Fifth Avenue, New York, the architect, estimates the cost at \$400,000.

Quartermaster and Hon. Major Llewellyn Thomas, 6th Battalion Welsh Regiment, died at Swansea on Monday while home from the front on sick leave. He was the second son of the late Mr. William Thomas, a well-known Swansea builder, and was staying with his brother, Captain Thomas, Chief Constable of Swansea.

A pavement of 2x4-in. timbers is the unique feature of an automobile speedway recently completed near the city of Chicago. The track, which is at Maywood, Ill., is two miles long, and consists of two parallel straight sections connected by curves at the ends. The track is about 65 ft. wide on the tangents and 75 ft. on the turns, which are banked to a maximum of 25 ft. The track is supported on timber trestling, the track proper resting on 2x12-in. joists. The flooring or pavement consists of 2x4 in tamarack timbers, placed on edge longitudinally of the course. The timbers are about 16 ft. in length, and lap about 2 ft. at the ends, and are spiked together at intervals.

TO CORRESPONDENTS.

We are not to be held responsible for the opinions of our correspondents. All communications should be drawn up as briefly as possible, as there are many demands upon the space allotted to correspondents.

It is particularly requested that all drawings and all communications respecting illustrations or literary matter, before being sent, should be addressed to the Editor of the BUILDING NEWS, Edinbrough House, 1, Abchurch-lane, Strand, W.C., and not to any other office of the staff by name. Delay is not infrequently otherwise caused. All drawings and other communications are sent at contributors' risks, and the Editor will not undertake to pay for, or be liable for, loss of or damage to contributions.

Drawings of selected competition designs, important public and private buildings, details of old and new work, and good sketches are always welcome, and for such no charge is made for insertion, of more commonplace subjects, small churches, chapels, houses, etc. We have usually far more sent than we can insert, but are glad to do so when space permits, on mutually advantageous terms, which may be ascertained on application.

When laying out us with drawings or photographs, architects are asked kindly to state how long the building has been erected. It does neither them nor us much to send illustrations of buildings which have been some time executed, except under special circumstances.

Telephone: Gerrard 1291.

Telegrams: "Times-Ver, E-Strand, London."

NOTICE

Bound copies of Vol. CXXIII are now ready, and should be ordered early, price 12s. each, by post. A few bound volumes of Vols. XXXIX, XL, XLV, XLVI, XLVII, XLVIII, XLIX, L, LI, LII, LIII, LIV, LV, LVI, LVII, LVIII, LIX, LX, LXI, LXII, LXIII, LXIV, LXV, LXVI, LXVII, LXVIII, LXIX, LXX, LXXI, LXXII, LXXIII, LXXIV, LXXV, LXXVI, LXXVII, LXXVIII, LXXIX, LXXX, LXXXI, LXXXII, LXXXIII, LXXXIV, LXXXV, LXXXVI, LXXXVII, LXXXVIII, LXXXIX, XC, XCI, XCII, XCIII, XCIV, XCV, XCVI, XCVII, XCVIII, XCIX, C, CI, CII, CIII, CIV, CV, CVI, and CVII may still be obtained at the same price, and the other bound volumes are out of print. Most of the back numbers of former volumes are, however, to be had singly. Subscribers requiring any back numbers to complete volumes just ended should order at once, as many of them soon run out of print.

Handsome Cloth Cases for binding the BUILDING NEWS, price 2s. post free, 5d., can be obtained from any Newsagent, or from the Publisher, Edinbrough House, 1, Abchurch-lane, Strand, W.C.

TERMS OF SUBSCRIPTION.

One Pound per annum post free to any part of the United Kingdom, for the United States, £1 6s. 6d. for 40s. 20s. 10s. 5s. To France or Belgium, £1 6s. 6d. for 40s. 20s. 10s. 5s. To India, £1 6s. 6d. To any of the Australian Colonies or New Zealand, to the Cape, the West Indies, or Natal, £1 6s. 6d.

Our Direct Subscription Agents for Australia are Messrs. B. T. Kibblywhite and Co., Printers and Publishers, 19, Park Chambers, 195, Liverpool Street, Sydney, New South Wales; for Japan, The Maruzen Co., Ltd., 11-16, Nombashi, Tori Sanchoke, Tokyo; who will receive Subscriptions at 41 6s. 6d. per annum on our account. Copies of the paper will be sent by us direct to the subscribers' address.

The special rate to Canada is 41 3s. 10d. = 54s. 8d. for 12 months, and 11s. 11d. = 26s. 9d. for 6 months. Our Direct Subscription Agents for Canada are Messrs. Selous, 174, 202, Shaftesbury Buildings, 206, 210, 212, Montreal, who will receive Subscriptions at 41 3s. 10d. per annum, on our account. Cheques and Postoffice Orders to be made payable to THE STRAND NEWS-LEAF COMPANY, LIMITED, and crossed London City and Westminster Bank.

ADVERTISEMENT CHARGES.

The charge for Competitive and Contract Advertisements, Public Companies, and all official advertisements is 1s. per line of Eight Words, the first line counting as two, the minimum charge being 5s. for four lines.

The charge for Auction, Land Sales, and Miscellaneous and Trade Advertisements (except Situations Vacant) is 6d. per line of Eight Words. The first line counting as two, the minimum charge being 4s. 6d. for 10 words. Special terms for series of insertions or notices can be ascertained on application to the Publisher.

SITUATIONS VACANT AND PARTNERSHIPS.

The charge for advertisements for "Situations Vacant" and "Partnerships" is One Shilling for Twelve Lines of Eight Words, and 5pence for every Eight Words after. All Situation Advertisements must be prepaid.

SITUATIONS WANTED.

Advertisements not exceeding Thirty Words, 1s. per line of name and address, are inserted under the heading "Situations Wanted," free of charge.

Rates for Trade Advertisements on front page, and special conditions for notices, can be obtained on application to the Publisher.

NOTICES TO ADVERTISEMENTS.

Responses to advertisements can be received at the office, Edinbrough House, 1, Abchurch-lane, Strand, W.C., or by post, if so far forwarded under cover to a particular notice, at an extra charge of 8 pence is made for each notice at head of "Situations."

Advertisements for the current week must reach the office not later than 3 p.m. on Tuesday. Front-

page advertisements and alterations or stop orders for serial advertisements must reach the office by first post on Monday to secure attention.

THE NEW POSTAL RATES. Do not forget that though we are penalised by the new postal rates because we still keep to our old size, and therefore a copy of the BUILDING NEWS exceeds the maximum limit, we are making no extra charge to subscribers who receive their copies direct from the office, the subscription rate remaining as before, £1 per annum, 10s. half-yearly, and 5s. quarterly. Now is the time to subscribe.

EDINBURGH, N. J. O. J. H. H. and Co. R. S. Co., Ltd. J. W. and Sons W. W. S. I. J. P., Ltd. J. C. S. M. and Co. G. Ltd. J. W. and Co. W. S. Co.

SIXTH No.

P. J. F. Please send

CASHES. See our first article this week.

E. I. It is one of a number of similar firms, all German controlled, in various countries, and a Government receiver is appointed here. You can see the list of shareholders, etc., at Somerset House, on payment of one shilling.

FOR **Olivers' Seasoned Hardwoods,** APPLY TO— **WM. OLIVER & SONS, Ltd., 120, Bunhill Row, London, E.C.**

TENDERS.

* * * Correspondents would in all cases oblige by giving the addresses of the parties tendering—at any rate, of the accepted tender: it adds to the value of the information.

BIRMINGHAM. For electric light installation at the steam and electric pumping stations, for the corporation. Wilson, W. S., and Co. (accepted).

BRIDGINGTON. For the supply of whinstone, for the town council. Ord and Madson, Ltd., 21st, whinstone, 11s. 6d. per ton (accepted).

BROWNHILLS, STAFFS. For carrying out works of sewage, Watling Street East, Chapel Street, and White Horse Road, for the urban district council.—Gidds and Withers, Bilston, £1,929 13 6 (Accepted).

DUBLIN. For works of drainage at University College, Dublin. Groompton, G. and T., Dublin (accepted).

LIVERPOOL, HANTS. For the supply and delivery of 400 tons of granite, for the urban district council.—Cooper and Co. (accepted), 15s. 10d. per ton.

LILAND. For the erection of milling and bushing works, with engine and boiler houses, chimney, and reservoir, South Lane. Messrs. Charles T. L. Horsfall and Son, Lord Street Chambers, Halifax, architects. Accepted tenders:—

Mason work: Marshall and Rushworth, Plains Lane, former work. Hawkyard, J., and Sons, Timber Street. Plumber-glazier work: Lamb, R. B., Brook Street. Plasterer, slater, and painter work:—Collins, S., and Sons, Stamford. Ironfounder work:—Mackell, J., and Co., Ltd., Union Foundry, All of Liland.

GLASGOW. For supply of rubber-insulated cables, for the town council. Parrell, Ltd. (recommended for acceptance).

HALFHAM, ESSEX. For an addition to the isolation hospital, Mount Hill, Halstead, for the Halstead Joint Hospital Board. Messrs. Goodley and Cressall, St. Peter's Chambers, High Street, Colchester, architects.

Bennett and Shute, Ltd., Ipswich, £2,160 0 0. Draves, G., Bures, £2,017 0 0. Sharp, G., Halstead, £1,999 10 0. Pudney and Son, Colne Engine, 1,391 0 0. Beaumont, R., and Son, Colchester, £1,375 0 0. Johnson, G., and Son, Colchester, 1,396 0 0. Wenden, C. B., Witham, £1,859 0 0. Chambers, W., Colchester, £1,778 0 0. Accepted.

LEEK, STAFFS. For roosting a bed of retorts at the gasworks, for the urban district council.—Gibbons Brothers, Ltd., Dudley, £227 15 0 (Accepted).

LEWISHAM, S.E. For the repair of footways, for the borough council. Per superficial yard: Manders, W., 78, 11d.; Manders, W., and Co., 7s. 4d.; Willis and Powis, 1s. 5d.; Foote and Miles, Ltd., 6s. 1d.; Davy and Armitage, 7s. 6d.; Alexandra Paving Stone Co., Ltd., 4s. 7d.; Brooks, Ltd., 5s. 5d.; Atlas Stone Co., Ltd., 7s. 6d. Recommended for acceptance.

LEWISHAM, S.E. For reconstruction of drains at 45, 47, 49, 51, and 53, Hurstbourne Road, for the borough council.

Norman and Co., £271 3 0. Blaxill Bros., £175 10 6. Jones, C. G. (accepted), 98 10 0.

LEWISHAM, S.E. For kelping, making-up, etc., Manwood Road (part only), for the borough council.—Davy and Armitage, £2,350 0 0. Foote and Miles, Ltd., £2,016 0 0. Willis and Powis, £2,000 0 0. Manders, W., and Co., £1,963 16 7. Fry Bros., Ltd., £1,915 0 0. Pearce, W., £1,905 0 0. Mowlem, J., and Co., Ltd., £1,869 0 0. Woodham, W., and Sons, £1,859 0 0. Recommended for acceptance.

LONDON. For lighting work at certain premises, for the London Insurance Committee.—Finch and Wheeler (accepted), £459 0 0.

PARK PREWELL. For the supply of water-softening plant at the New County Lunatic Asylum at Park Prewell, near Basingstoke, for the Hants County Council.—United Water Softeners, Ltd. (accepted).

QUEENFERRY. For providing and laying water main at Queenferry, for the Gloucester City Council.—Holbrough and Co., £2,648 0 0. (Recommended for acceptance.)

THORP TILNEY. For erecting fencing at Thorp Tilney for road improvements, for the Sleaford Rural District Council.—Blaze, J. W., Sleaford (accepted).

WATERLOO. For erection of 19 working-class houses at Walsh's Lane, for the corporation.—Nolan, G., £3,152 5 4. Hearne, J., and Son, £3,100 0 0. Recommended for acceptance.

WATERLOO. For the erection of thirteen working class houses, for the corporation.—Hearne, John, and Son (accepted), £3,100 0 0.

WESTMINSTER. For executing during four months items Nos. 5, 6, 7, 8, 10, and 11 of the contract for wood-paving carriage-way repairs, for the Westminster City Council.—Hayes, Frank, Century Buildings, North John Street Liverpool (accepted).

YORKSHIRE. For building retaining walls at the light house (10) and garden, for the urban district council.—

Callaghan, J., £119 19 9. Murray, M., and Son (concrete), 84 0 0. Ditto (masonry), 75 0 0. Kennolly, P. (accepted), 31 0 0.

Sir William Lever has presented to the Parks Committee of Bolton, for use as a park and pleasure grounds, sixty-eight acres of land on the east side of the borough, which the committee had previously arranged to purchase.

The Road Board have decided to grant the Hants County Council £7,000 towards the cost (£27,972) of surfacing roads with tarmac and tar dressing.

At Childrey Church, near Wantage, a memorial stained glass window to the members of the Old Berks Hunt who have fallen in the war has been unveiled by the Archdeacon of Oxford. The window represents the Unicornation.

The Victoria Rooms, Clifton, Bristol, have been reopened this week after renovation and internal decoration, carried out by Messrs. William Edkins and Sons, 5f Queen Charlotte Street, Bristol.

A memorial to the late Earl Nelson in Salisbury Cathedral was dedicated last week by the Bishop of Salisbury. It consists of a tablet composed of statuary marble surrounded by a green marble border. The tablet contains the Nelson arms and an inscription.

The Bridgewater Rural District Council at their meeting on Thursday gave permission to Mr. Charles Herbert (assistant surveyor) to join the Wessex Royal Engineers, and intimated that the question of Mr. Herbert's remuneration would be very fairly dealt with.

The Board of Trade has recently confirmed the order made by the Light Railway Commissioners, authorising the construction of light railways in Sussex from Hunston to West Itchenor, West Wittering and East Wittering, including the reconstruction and working as a light railway of the Hundred of Manhood and Selsey Tramway.

Now that the official tests have been successfully carried out, the floating dock at Prince Rupert, B.C., the Pacific terminus of the Grand Trunk's transcontinental railway, is ready for business. It has a length of 604 feet, and is capable of lifting the largest vessels at present engaged in the trade of the Pacific. The question of making an excavated dry dock, 1,150 feet long, at Esquimaux, is now being considered by the Dominion Government engineers.

THE BUILDING NEWS

AND ENGINEERING JOURNAL.

Effingham House,

CONTENTS.

Strand, W.C.

The Ventilation of Picture Halls	639	Building Intelligence	664
The Manufacture of Portland Cement	640	Parliamentary Notes	664
The New Housing Scheme for Walker-on-Tyne ..	642	Our Office Table	664
Legal Intelligence	642	Chips	665
Correspondence	641	To Correspondents	666
Obituary	644	To Arms!	666
Currente Calamo	645	Latest Prices	667
Our Illustrations	646	Meetings for the Enning Week	668
Professional and Trade Societies	663	Tenders	668
Trade Notes	663	List of Competitions Open	668
		List of Tenders Open	668

OUR ILLUSTRATIONS.

Young Men's Christian Association Premises, Edinburgh. Elevation and plans, Mr. G. Washington Browne, R.S.A., Architect.

The Alliance Assurance Company's New Premises, Sheffield. View of exterior, the main office, board room, and secretary's room, with two plans, Messrs. Goddard and Catlow, F.F.R.P.A., Architects.

Details of the Tower, Khartoum Cathedral, Sudan. Mr. Robert Schultz Weir, Architect.

THE VENTILATION OF PICTURE HALLS.

By ROBERT BOYLE.

The cinematograph may, at no very distant date, be generally adopted by the teaching communities as a valuable educational aid, and it undoubtedly forms one of the most instructive of object lessons, making an instantaneous and lasting impression upon the mind, especially of the young.

The picture hall may, therefore, justly rank as an educational institution where

doubtedly destined to completely revolutionise the present methods of teaching. The time will come when the cinematograph will be an essential in every school—as indispensable as the blackboard and the globes, and which it may supersede as a more efficient teacher.

There will be fewer truants then, and less disinclination to learn, and school hours will be looked forward to with joyful anticipation instead of aversion. Teachers will also be relieved of a great deal of very worrying drudgery, which will be beneficial for both their health and

commendable example of Leith. It is satisfactory to note that Brighton has already done so, making it compulsory for all picture halls and other places of amusement in that town to be efficiently and satisfactorily ventilated.

Government inspectors should certainly be armed with greater powers in respect to the ventilation of not only places of amusement, but of all public buildings, including churches, schools, hospitals, etc. It is, indeed, well known that many people abstain from going to church or to the theatre, much as they would like to do

THE "BOYLE" SYSTEM OF VENTILATION

Applied to Picture Hall, Glasgow.

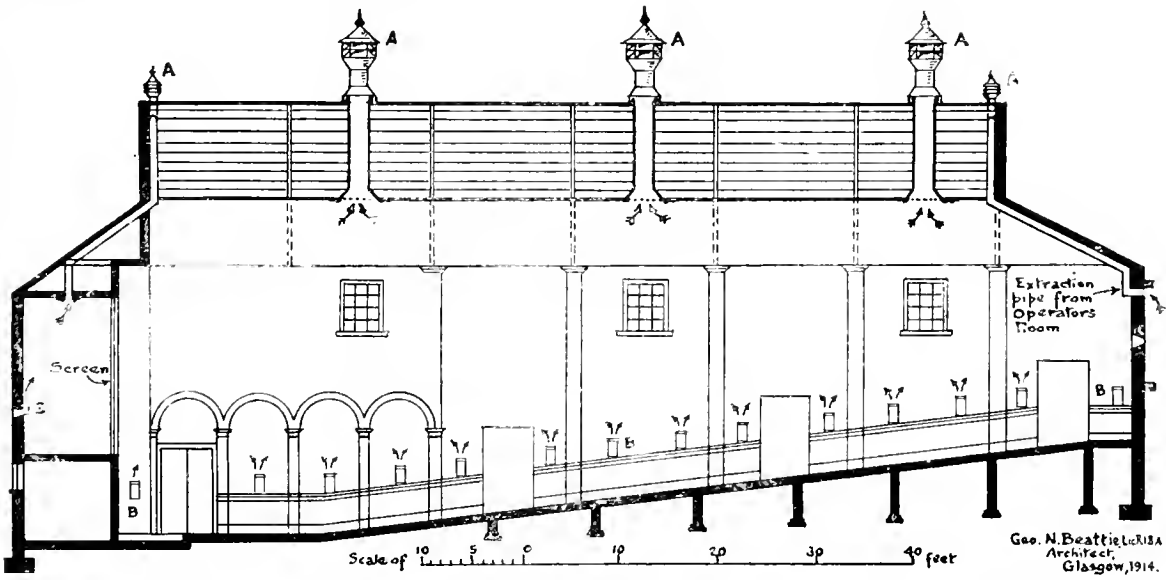

A, BOYLE'S LATEST PATENT "AIR-PUMP" VENTILATORS, DESIGNS Nos. 230 & 231. B, AIR INLET BRACKETS, FITTED WITH REGULATING VALVES.

those in quest of knowledge combined with a little judicious recreation may agreeably and profitably obtain both by making a visual acquaintance with almost everything and anything that is worth seeing or knowing about in this wonderful old world of ours; besides bringing within their immediate purview a faithful representation of important and interesting current events throughout the world.

There is really nothing that can compare with the cinematograph as a universal instructor, making the acquirement of knowledge a source of the keenest enjoyment, instead of, as is but too often the case, an irksome task to be shirked whenever possible. Its educational possibilities are, indeed, illimitable, and it is un-

temper, as well as that of the scholars, and more happiness will exist all round.

That the ventilation of picture halls, of which there are many thousands in this country, demands, in the interests of the public health, the most careful attention goes without saying, and also the closest supervision, as is evidenced by the published report of the investigations recently made at Leith into the sanitary condition of the air in a number of local picture halls, and which was found from the tests made to be so foul and poisonous that in at least one case the hall had to be closed. Franklin says: "A people's health's a nation's wealth," and it would be well for the community if the sanitary authorities of other towns followed the highly

so, simply because of the foul air or the intolerable draughts so often found in these buildings.

Parkes says: "Statistical inquiries prove beyond a doubt that, of the causes of death which are usually in action, impurity of the air is the most important. Air is the prime supporter of life; health, even life itself, is dependent upon its purity."

Many different forms of ventilation have been tried, but in most cases with but very indifferent results, artificial methods proving, apparently, as unsatisfactory as natural where these have been incorrectly and unscientifically applied.

De Chaumont says: "It is essential to the success of a natural system of ven-

cool down and another day to unload. It must be at once evident that the disadvantages of this kiln are:—

(a) The heavy cost of labour.

(b) The incomplete burning of the clinker; and it may here be said that, in order to obtain "uniform cement," every particle must be equally burnt.

There is another design of kiln which may be placed between the vertical intermittent and the vertical continuous, known as the "Hoffman ring kiln," which is simply a series of intermittent kilns with a common shaft. In the case of small works where the output does not exceed about 400 tons per week, and the conditions are suitable, the vertical continuous or shaft kiln may be used. It has the above disadvantages, but on a much smaller scale. In this case slurry and coke are fed into kilns in layers about every half-hour; this entails more labour than the intermittent type, and requires more skill, but obviates the large waste of time and heat inseparable from the intermittent type. The burnt clinker is taken from the bottom. The difficulty experienced is that the clinker fluxes and adheres to the lining. Methods have been used to overcome this: one is to have a lining of raw material, such as briquettes, built up round the lining when the kiln is loaded. It may be said, generally, that the vertical continuous type of kiln is used with the dry process, when only about 20 per cent. of moisture is added to the raw materials, so that it is particularly economical in fuel consumption.

ROTARY KILN.

The third type of kiln, which is a later invention, and was first introduced by Ransome, consists of a long boiler shell, the length of which varies according to the particular design and output required; but in some cases they have been built as long as 250 ft., those in more general use being about 180 ft. to 200 ft., having a capacity of about 1,000 tons per week.

The cement industry has been entirely revolutionised by the use of the rotary kiln, for, after a description of same, it will at once be seen that the labour employed is reduced to a minimum, that a much more uniform and even burning of the cement is possible, with the result that for ferro-concrete work rotary-kiln cement is nearly always specified, and will command a higher price than the other kind burned in brick kilns.

The kiln is made up of boiler plates, and consists of a tube, varying in diameter. For an output of 1,000 tons per week it is usually about 9 ft. 6 in. in diameter in the burning zone, and often weighs more than 300 tons. It is rotated on rollers, and is driven through gearing at a very low speed. The fuel is blown in, in the form of powdered coal, and ignited on reaching the burning zone, which attains a temperature of 2,500° Fahr. to 3,000° Fahr. The hot gases travel through the kiln, which is placed at a slight angle above the horizontal, with the cool end at the highest, and on thus to the chimney.

COOLER.

In the cool or chimney end the slurry, which is taken from the slurry mixers or storage tanks, is pumped in, and finally reaches the burning zone, and the clinker produced drops into the cooler, which is like a small kiln, and also revolving. Cold air is drawn in through this cooler to cool the clinker, which clinker takes the shape of round, hard pebbles. An immense amount of time, labour, and thought has been spent on the designing of these kilns, for it is no easy engineering matter when one remembers the enormous weight to be revolved, the expansion and contraction that take place on a length of 200 ft. or more. There are now several firms in this country who can build most excellent kilns, and there is no need to place orders for these kilns abroad. The hard burnt clinker, on leaving the cooler, is then taken to a clinker storage or to bins, and then to the dry grinding mill. With the rotary kiln it is possible to run a cement works having an output of 2,000 to 3,000 tons per week with a staff of only thirty men per shift; whereas for the same output with the "Chamber brick kilns" this number of men

would have been necessary for working the kilns only.

FUEL.

The fuel used for these kilns is generally coal, but sometimes oil is used, and there is reason to hope that in the future waste gases from blast furnaces might be used. For the brick kilns coke is used.

The cost of production of cement has been largely reduced since the introduction of rotary kilns, and many members will remember the visit the Institution paid to the Newhaven Works, and also to Messrs. Martin Earle's, at Rochester, where the rotary kilns were in use, as well as some of the brick kilns.

In the works completed there will be installed three rotary kilns, each having an output of 1,000 tons.

COAL-GROUNDING PLANT.

In connection with rotary kilns, the coal is ground to powder, and for this purpose some form of tube mill is generally used. There are, however, quite a number of other types of mills for grinding coal. The coal has to be dried and ground, then it is fed into a hopper, and from the hopper is blown by a fan into the burning zone of the kiln.

After leaving the cooler, the clinker is taken along a conveyer that is specially designed for conveying hot materials either to a storage silo or dumping yard, and is then elevated to the top of the bins over the dry grinding mill. The dry grinding mill requires considerable care in planning and designing, for the machinery required is very heavy.

Rotary kiln clinker takes more power to grind than chamber kiln clinker, and the horse-power absorbed in grinding is very large. There are several methods of grinding the clinker, but the usual one is the combination of a ball-and-tube mill, but sometimes only a combination tube mill is used.

Unless special means are arranged for the removal of dust, difficulty is experienced in keeping the grinding mill clean, for naturally the clinker is ground to such a fineness that it penetrates everything, and it is difficult to keep the mill sufficiently closed in to prevent this.

In their mills my firm have arranged for each mill to have a capacity for grinding five tons of clinker per hour continuously.

The cost of grinding depends upon the fineness to which the material is ground; the finer it is ground the more expensive. Purchasers should expect to pay more for rotary kiln cement on account of the extra cost of grinding, and because it is more thoroughly and uniformly burnt, making it much stronger and superior to chamber kiln cement.

SILOS.

After leaving the grinding mill, the clinker which is now ground is conveyed and elevated into silos for storage. The silo buildings will have several bins with a total capacity of three to four weeks' output of finished cement, which will enable any purchaser when carrying out an important contract to have his own bin, and draw from it as he desires, so that he can be assured of the uniform quality of the cement. For ferro-concrete work this is important, as you are all aware.

The why and wherefore of the greater use of reinforced concrete construction is not difficult to find. Those engineers who have had the designing of large structures to carry heavy machinery, such as is met with in industrial mills or for the building of large storage silos or bins, will fully appreciate these remarks, because with a reinforced-concrete construction it is a simple matter to demonstrate in figures the strength of such buildings and allow a proper margin or factor of safety; whereas with brickwork such a calculation is very difficult and certainly unreliable, for nobody can accurately say what is the adhesion of brickwork, and what factor of safety has been allowed.

Recently my firm has had to design some large silos, capable of holding 10,000 tons of cement, and it is surprising with brickwork how uncertain one is when finished as to the final strength. But if such silos are built with reinforced concrete, one can be certain of the factor of safety.

There are several methods of building the silos, but the best one, I think, is to design it of ferro-concrete. The emptying of cement silos when packed closely is not such a simple problem as it appears. An ingenious method to use is the vacuum process, in which a cement bag is put into a small chamber and the bag fixed on to a pipe connecting it with the silo. A vacuum is then produced in this chamber, causing the cement immediately to rush from the silo through the pipe into the bag, and fill the bag. As soon as the bag (which is automatically weighed) is filled to the correct weight, the vacuum is cut off and the door of the chamber opens to allow the man to remove the sack. The cement in the bag is then ready for rail or shipment. A large loading platform, with ample floor space, is required, with railway lines running alongside it, so that the bags of cement can be loaded into trucks.

To describe cement machinery in detail would require several papers, and probably many of you are familiar with the ordinary cement mills.

POWER PLANT.

One of the important questions to decide in relation to cement mills is the form of power to use, for in mills of this description the horse-power required is large, and the coal used for power purposes—i.e., for working the wash mills, the wet grinding mills, the pumps, the conveyers and elevators, the rotary kilns, the dry grinding mills, the coal dryer, and several other purposes—is quite an appreciable item of the total cost of cement, so that if this coal item for power can be reduced the price of cement can be appreciably lowered.

In older days—in fact in many cement mills to-day—the power question has been sadly neglected, and thousands of pounds are wasted annually in fuel in not bringing the power plant up to date. Cement mills, perhaps more than any other industry, form an excellent proposal for running electrically on account of the scattered area occupied by the works and the fact that the wet mills, the rotary kiln, the coal-grinding plant, and the dry grinding mills are usually some distance apart, and each require a considerable amount of power. If, therefore, steam was decided upon as the motive power, it would be necessary to install a large steam engine in each of the above buildings.

For the mills that are being erected under my firm's advice, the directors have decided to use electric power throughout, so that there will be an electric motor-house for the wet grinding plant, another for the kilns, another for the dry grinding plant, where the principal power will be absorbed. The total horse power taken to run mills of this description with the output mentioned would be approximately 2,000 to 2,500 horse-power. This entails a complete electric power-station and boiler-house, and my firm have designed it to contain water-tube boilers, with the usual auxiliary machinery, and in the power-house three turbines of 1,000 to 1,500 kw. capacity each. Great care has to be taken in designing the drives for the mills, as they are exceedingly heavy.

Mr. J. E. Hattersley, surveyor to the Sazmundham Urban District Council, has been appointed borough surveyor of Buckingham, at a salary of £150 a year.

At Foleshill Rural District Council meeting on Thursday it was stated that a committee had had before them plans of 600 houses which it is proposed to erect at Wyken, the dwellings to be for the use of munition makers in Coventry. As the by-laws were not complied with in regard to drainage and the width of some of the thoroughfares the plans were referred back. The plans provide for several classes of houses.

A chapel has been built, at a cost of £500, in connection with the 4th Northern General Hospital on the Wragby road at Lincoln. The chapel is timber built, with galvanised iron frame, lined with matchboard. There is a small chancel, and a nave 63 ft. long by 23 ft. wide, seating 326 people. The chancel has simple oak fittings, and there is in the nave an organ which formerly did service in Bardney church. The new chapel was dedicated on Tuesday last by the Bishop of Lincoln.

to his (the judge's) mind, was the use of Mr. Gafford's name and now subsequently the discharge of the man. He really failed to understand how they could have the audacity to treat it as a wrongful act on the part of Mr. Gafford—his protest against what was done—and to allow him to lose his employment. He thought that indicated a perversion of their sense of justice which was distinctly painful. He did not desire to punish defendants' conduct unduly, but the law must not be violated with impunity, and, therefore, Mr. Ellis must be fined £25 and Mr. Hayward the sum of £5, and the costs of the prosecution must be paid in equal parts by them.—Time for payment was granted.

A TEWKESBURY BUILDER'S ESTATE.—In the Probate Division, on November 30, the action of Godfrey v. Godfrey and Others, which concerned the estate, valued at about £160,000, together with a business, of the late Mr. Francis William Godfrey, builder and contractor, of Tewkesbury, came before Mr. Justice Horridge. The testator died in April, 1912, and the action related to a codicil dated April 4, 1912. In announcing that the parties had settled the action, Mr. J. H. Campbell, K.C., said the plaintiff was Mr. Harold Godfrey, the eldest son of the deceased. The defendants included the widow of the testator, and another surviving son, and trustees and executors under the will. There was also an intervener interested in a legacy of £200 which, under the codicil in question, was charged to an annuity of £100. Counsel added that he (on behalf of two of the defendants) had discussed the matter with Sir Edward Carson, K.C. (who represented the plaintiff), and Mr. Hume Williams, K.C. (who appeared for the widow), and a settlement had been reached. The deceased, by his will of 1903, subject to a provision for the wife, divided his property between his two sons, Harold and Francis, who assisted him in his business. In March, 1907, another will was made which was not contested in the present proceedings. By this later will he revoked the bequests to his eldest son, Harold, and made the second son, Francis, residuary legatee, leaving him practically the entire estate, subject to provision for the widow, the step-mother of the plaintiff. Trouble, however, arose out of a clause which gave the trustees power to make such provision as they thought fit for the eldest son. After a codicil of April 1, 1912, testator made another on April 4, 1912, the effect of which was to appoint a third trustee, Mr. Shanahan, the assistant secretary to the Dublin Board of Works, and a lifelong friend of the testator and his family. Under the codicil there was power for the majority of the trustees to determine any question that might arise, and it was in respect of the provision for the eldest son that differences developed. The widow took one view and the other trustees the other. By the arrangement now made substantial provision was made for the eldest son, who now discharged all the claims against the estate. In the circumstances the Court was asked to pronounce in favour of the will and the two codicils, the terms arranged to be made a rule of Court. Sir Edward Carson concurred in the statement as to the settlement between the parties. The codicil which had caused the differences was made by deceased the day before he died, April 5. Proper provision would now be made for the son, Harold, and funds invested for his benefit and that of his child. Mr. Hume Williams said the desire of the widow all along had been to carry out what she thought were her husband's wishes. After evidence, his Lordship pronounced for the second will and codicil.

APPEAL AS TO DEFECTIVE STREET GULLY.—PAPWORTH v. BATTERSEA BOROUGH COUNCIL.—In the Court of Appeal on Monday Lords Justices Pickford and Bankes and Mr. Justice Neville gave judgment in the appeal by the plaintiff, Miss Amy Papworth, asking for judgment or a new trial in an action which was twice tried, in which she claimed damages for personal injuries alleged to have been sustained on June 26, 1912, owing to her riding her machine over a defective surface gully in the Lombard Road, Battersea, which caused her to be thrown off into the road, where she was run over by a passing carriage. The original trial was before Mr. Justice Horridge and a common jury, as reported in our issue of November 13, 1914, p. 637, Vol. CVII. The jury answered a series of questions and awarded the plaintiff £1,961. On further consideration the Judge held the plaintiff was entitled to succeed, and entered judgment in her favour. The Court of Appeal set that judgment aside, and ordered a new trial on various grounds. The second trial (reported in our number for February 26, 1915,

p. 256, last volume), was before Mr. Justice Scrutton and a special jury. The jury found that the surface gully, which had been put in by the predecessors of the defendants, the Wandsworth Board of Works, had all along been defective and dangerous, but that the defendants, at the time of the accident, did not know, and could not by the exercise of reasonable care have known, of the defect in the gully. In the event of the plaintiff being entitled to damages they awarded her £755. Mr. Justice Scrutton, after hearing arguments, held that the action failed because the plaintiff had not established any misfeasance on the part of the defendants.—The plaintiff now applied for judgment or a new trial, and contended that judgment should have been entered for her in accordance with the verdict.—Mr. Greer, K.C., and Mr. Sidney H. Lamb, instructed by Messrs. W. W. Young, Son, and Ward, appeared for the plaintiff, Mr. Lewis Thomas, K.C., and Mr. W. R. Warren, instructed by Mr. P. Cudwell, for the Borough Council.—The case having been argued, the Court gave judgment dismissing the appeal, holding that as there was no negligence by the defendants or their predecessors in title in the construction of the gully in 1832, or in not observing that the gully had become dangerous, they were not liable to the plaintiff.

LANDLORD'S LIABILITY TO KEEP ROOFS IN REPAIR.—HART'S EXECUTORS v. ROGERS.—In this action, heard by Mr. Justice Scrutton without a jury, considered judgment was given on Thursday. The plaintiffs claimed £115 9s. 6d., two quarters' rent of a suite of furnished rooms at Moscow Mansions, Kensington, and for £20 agreed to be paid for dilapidations at the end of the tenancy. The defendant alleged that, owing to the landlord's neglect to repair the roof, water came through into the flat and rendered it unfit for human habitation, and that because of this the defendant's wife became ill and he had to find another house. He also counter-claimed for damages in respect of his wife's illness. Mr. Distarnel, K.C., and Mr. Morle appeared for the plaintiffs; and Mr. Rose-Innes, K.C., and Mr. E. Dodd for the defendant.—Mr. Justice Scrutton, in his judgment, said it was clear that the defect which caused the damage in this case was not in a part of the roof included in the demise. What was the legal obligation imposed on the landlord in respect of the roof? Ordinarily the lessor of an unfurnished house did not imply warrant that it is fit for occupation, and the lessor of a furnished house or apartments did imply warrant that it was fit for human occupation at the beginning of the tenancy. The Divisional Court in "Hargreaves v. Hartopp" (1905) held that such a landlord was at least under a duty to use reasonable care to keep the roof in repair, following Baron Martin in "Carstairs v. Taylor." Lord Alverstone suggested that in "Miller v. Hancock" (1895) the Court went further, and treated of a landlord who reserved the control of a staircase as an absolute duty to keep the premises in a safe condition at all events. In this case of "Miller v. Hancock" the real question was the liability of the landlord to a visitor of the tenant; but, said Mr. Justice Scrutton as he pointed out in "Huggitt v. Miers" (1908) and in "Hargreaves v. Hartopp," the Court approached the matter through the legal relation of landlord and tenant. Lord Alverstone, in the last-named case of "Hargreaves v. Hartopp," took the same view. Mr. Justice Atkin in "Lucy v. Bawden" (1904) came to the conclusion that the decision in "Miller v. Hancock" must be limited to the liability for trips as explained in "Indermann v. Daines." The defect, which the jury found in "Lucy v. Bawden," was the absence of a fence or rail, which was a defect that anyone could see. In "Miller v. Hancock," as reported, all the judges imposed an absolute duty to repair on the landlord. Having dealt in detail with the facts of the present case, his Lordship said he came to the conclusion that the illness of defendant's wife did not result from any negligence on the part of plaintiff. The legal result was that he was unable to see any principle on which these facts gave the tenant an answer to the whole claim for rent. In "Surplice v. Farnworth" it was held that the breach of an express covenant to repair, by which the premises were not fit for the purpose for which they were let, was no defence to a claim for rent, but a matter of cross action. This seemed clearer if the breach only affected the premises for part of the remainder of the demise, as in this case. The plaintiff's claim therefore, succeeded as to the rent and dilapidations. He saw no ground for making the defendant liable for the second quarter's telephone and electric light. There would be judgment for the plaintiff on the claim for

£114 15s. 6d. As to the defendant's counter-claim, he was not satisfied that the wife's illness was caused by the leakage, but allowing defendant the cost of substituted rooms, he awarded him in all £25 damages on the counter-claim, with costs. If the true view of the relation of this landlord and tenant was that the landlord only contracted to use reasonable care to keep the roof in repair, he found no negligence in this case, and, on that construction, the plaintiff would have judgment on the counter-claim, with costs.

SPIITALFIELDS MARKET ARBITRATION.—Mr. C. A. Russell, K.C., has given his decision, as arbitrator, in the case in which Mr. Robert Horner claimed £650,000 from the City Corporation for the acquisition of his leasehold interest in Spitalfields Market, and certain private property surrounding it. At the hearings held at the Surveyors' Institution in October last evidence on behalf of Mr. Horner was given by Mr. Daniel Watney, Mr. J. Seagram Richardson, Mr. W. P. Ryan, Mr. P. A. Meice, Mr. Howard Martin, and Mr. W. H. Payne, and other surveyors, and by Sir Alexander R. Steining, Mr. F. W. Pexley, Mr. Leslie R. Vigers, Mr. Howard Chatfield Clarke, Mr. Sydney Perks, F.S.A. (City surveyor), Mr. W. S. Walker, and others for the Corporation. The latter witnesses valued Mr. Horner's interests at not more than from £173,000 to £200,000. Mr. Horner claimed £600,000. Mr. Russell has decided that Mr. Horner is entitled to receive £316,500. At the meeting of the City Corporation on November 4 it was announced by Sir Home-wood Crawford, the City solicitor, that Mr. Horner had been awarded £284,500. Sir Home-wood Crawford explains that this announcement was quite correct. The total of £316,500 which Mr. Horner will ultimately receive includes an agreed sum of £32,000 in respect of certain outside properties for which Mr. Horner originally claimed £50,000. This claim was not investigated by the arbitrator, although, by mutual consent, the £32,000 appears in the award as a separate item.

TEST CASE AS TO INCREASED RAILWAY RATES.—THE ASSOCIATED PORTLAND CEMENT MANUFACTURERS (1900), IJMITED, v. GREAT NORTHERN RAILWAY COMPANY.—Mr. Justice Lush, the Hon. A. E. Gathorne-Hardy, and Sir James Woodhouse heard on four days of last week, and reserved judgment at the close of the legal arguments on Thursday, in the application of the Associated Portland Cement Manufacturers (1900), Limited, for a revision of the increased goods rates charged by the Great Northern Railway Company to meet the cost of the concessions granted to their employees in accordance with the terms of the settlement of the railway strike of 1911. The applicants complained that the increased charge of 4 per cent. for the carriage of goods from their works to different parts of the railway company's system, under the special Act obtained by the various railway companies in 1913, was unreasonable and excessive. They said that the £153,393, which the railway company put forward as their additional expenditure in respect of wages, had not been properly apportioned between the passenger and the different classes of goods traffic, and that, having regard to the volume of traffic in 1913 as compared with that of 1911, there had been no rise in the cost of working the railway within the meaning of the Act of 1913. The respondents contended that the additional expenditure in respect of wages imposed by the terms of the settlement of the strike had been properly apportioned between the different classes of traffic, and that the amount justified an extra charge of 4 per cent. on goods of the character forwarded by the applicants.—Mr. Rowland Whitehead, K.C., Mr. Holman Gregory, K.C., and Mr. Edwin Clements appeared for the applicants, and Mr. G. J. Talbot, K.C., Mr. Macasey, K.C., and Mr. W. Bruce Thomas for the respondents.—At the conclusion of the evidence and the addresses of the counsel, the Court reserved judgment.

The Borough Council of Foston has received the sanction of the Local Government Board to a loan of £3,693 for electric cable extensions.

At the Edinburgh Dean of Guild Court, on Thursday, Lord Dean of Guild Macintyre Henry presiding, a warrant was granted to Bettrams, Limited, for the erection of a pattern-making shop and pattern store at Sciennes. This is to be a four-story building, 100 ft. by 49 ft., with a frontage of stone. The façade will be treated in such a manner as to maintain the amenity of the district. Bailie David McArthur, Lic.R.I.B.A., Frederick Street, Edinburgh, is the architect.

Corrente Calama.

On the 30th ult. an urgently important question was put by Mr. G. A. Touche, M.P., in the House of Commons, which, with the reply thereto by the Prime Minister, will be found in our Parliamentary Notes on another page. It deals, as will be seen, with a matter of the most vital importance to builders and property owners, which is more fully explained in a communication elsewhere from Mr. Howell J. Williams, J.P., L.C.C., which, although posted on November 30, only reached us in the forenoon of Friday last, and, therefore, too late to deal with in our last issue. It will be seen, we regret to say, that, as usual, Mr. Asquith was unable to express an opinion whether it would be deemed desirable to apply the remedy suggested for the gross injustice detailed by Mr. Touche. He has, however, consented to receive a deputation from the London Master Builders' Association, and that body will meet this afternoon to consider the matter. We trust the deputation will be a strong one and that the grievance will be adequately presented; but, remembering the broken promises of the Premier and Mr. Lloyd George in the past, we are not sanguine as to the result.

If no redress is obtainable the position is that, as the law now stands, while everybody else is being relieved under the Defence of the Realm Act, or by subsidiary legislation, ground landlords can enforce on a builder a contract taken before the war began, under peace conditions, and sue the unfortunate lessee for ground rent, although he is totally unable to build, because the State has taken his men, money, and materials. Surely in such cases as that Mr. Howell Williams outlines, the least that can be asked for is a short Act creating a Court competent to deal promptly with such cases, and to grant postponement of contracts, or such other relief as seems just? If this is denied, ruin stares not a few of us in the face. Moreover, when a builder, at great sacrifice, manages to sustain the burden thrust upon his shoulders, he will for the time fly in the face of and frustrate all the appeals that are being made to us all to economise, and to facilitate the transfer of the services of every able-bodied man to the State that can be spared.

An important case affecting the position of auctioneers came last Thursday before Justices Ridley and Coleridge in the Divisional Court, on appeal from a decision by Judge Tindal Atkinson in the Southend-on-Sea County Court. It appeared that on February 26, 1914, a lady named Miss E. H. Hurley, of Westcliff, apprenticed her brother for three years to Mr. G. W. Creaser, auctioneer and estate agent, Leigh-on-Sea. On the outbreak of war the boy asked Mr. Creaser to cancel the deed, but he refused. The boy left, and Mr. Creaser sued Miss Hurley in the county court for £10 due on the deed of apprenticeship. It then came out on the evidence that Mr. Creaser had not taken out his excise licence entitling him to act as an auctioneer until six months after the date of the deed of apprenticeship, and this, it was contended, invalidated the deed. The county court judge upheld that contention, gave judgment for Miss Hurley, and cancelled the deed. Mr. Creaser appealed, submitting that, though he had not taken out his licence, he was entitled, as a member of the Auctioneers' Institute, to practise, and to take an apprentice. The Court, without calling on respondent's coun-

sel, dismissed the appeal, with costs, holding that the county court judge's decision was right.

The building of flats is a thorny subject. Many builders have burnt their fingers over the business. Some, indeed, have been burnt up altogether. For flats go in and out of fashion rapidly, rather like big hats. And an empty high-rented flat, with ground rent and mortgage interest running on and up, is a very sieve for losing money. But flats have also proved a dark problem for the lawyers. The recent case of "Hart and Another v. Rogers" raised some pretty points which are likely to be heard of a good deal in the Courts probably on appeal. The plaintiffs sued for two quarters' rent of a flat in the Cromwell Road, let furnished to the defendant for one year, from March 25, 1914, at a yearly rent of £180, with £20 to pay at the end for dilapidations. The defence was that owing to the roof being in a bad state of repair the place became quite uninhabitable, and so no rent was recoverable, and the defendant further counterclaimed damages for expenses and illness caused to his wife. Mr. Justice Scrutton, after saying that, in law, apart from agreement, there was no warranty that a house was habitable if let unfurnished, but that there was if it were let furnished, found the cases confusing as to flats, which were legally neither. In the end he inclined to hold that there was an absolute duty on the landlord to keep the roof of the flats in repair. He ruled that the roof was not let with this flat, so here we have the metaphysical mind of the lawyer regarding the roof as a separate entity, and dealing with the flats beneath it as dwellings without any roof. On the view of the absolute duty of the landlord to repair the roof, he found that a breach of this was no answer to his sacred claim for rent, so judgment was for the plaintiff, while, on the counter-claim, allowing nothing for the wife's illness, he gave £25 for expense incurred, with costs. But the Judge also held that if there was no absolute duty on the landlord to repair and only a contract to do so reasonably, then, as there was no proof of his negligence, the plaintiffs would have judgment also on the counter-claim, with costs. It is now the turn of the Court of Appeal to make what it can of this legal muddle.

Bulletin 47 of the University of Illinois is a valuable contribution to the none-too-plentiful literature concerning the influence of temperature on the attainment of strength of concrete, by Assistant-Professor A. B. McDaniel. It is issued in the United States at fifteen cents, and can be obtained here of Messrs. Chapman and Hall, Ltd., Henrietta Street, W.C. Full tables and diagrams are given of the results of the tests. The general conclusions arrived at are as follows: Under uniform temperature conditions, there was an increase of strength with age within the limits of the tests. For any temperature the rate of increase decreases with the age of the specimen; and this rate of increase is less correspondingly at the lower temperature conditions. For the specimens tested under normal hardening temperature conditions of from 60 to 70° F., the compressive strength of the concrete subjected to a uniform temperature at the ages of seven, fourteen, and twenty-one days may be taken as approximately 50 per cent., 75 per cent., and 90 per cent. of the strength at twenty-eight days, respectively. For lower temperatures, the percentage values are less; and for higher temperatures the percentages are higher. The relation between

the percentage values at the ages of seven, fourteen, twenty-one, and twenty-eight days is nearly the same for temperature conditions from 30° to 70° F. However, the values for the lower temperatures should be used with caution. Concrete which is maintained at a temperature of 60° to 70° F. will at the age of one week have practically double the strength of the same material which is kept at a temperature of 32° to 40° F. It should be noted that generally in this investigation the specimens were stored under temperatures which were nearly uniform during the whole storage period. In one set the variations in temperature include a number of alternations above and below the freezing point, and the specimens were seriously injured.

The first quarterly issue of the "Journal of the Institute of Arbitrators," published by this newly formed association, the headquarters of which are at 32, Old Jewry, E.C., sets out its aims and objects, and contains many short articles on arbitrations which will interest our readers. Lord Headley is the president of the Institute, and Mr. Henry Adams vice-president. The council embraces, among others, Messrs. E. C. P. Monson, the president of the society of architects; Mr. E. J. Sadgrove and Mr. A. Alban H. Scott, vice-presidents of that body; Mr. H. D. Searles-Wood, Mr. Max Clarke, and Mr. F. Malcolm Burr. The aim of the Institute, to which we wish all success, is to raise the status of arbitrator to the dignity of a distinct and recognised position as one of the learned professions. The successful achievement of that aim can only be realised by concerted action, by the association of members in the interchange of views, the dissemination of valuable information, and a closer study of those principles and conditions which have to be taken into consideration when dealing with difficult questions arising in the solution of differences and disputes, both in commercial and other relations. The settlement of matters by means of arbitration has received a considerable support from the public, but it has been found that the cost of arbitration has frequently been unnecessarily high, and the economy, looked for by parties in their avoidance of proceedings in the Courts in favour of a less fettered procedure in arbitration, and which the public has been led to expect, has not been realised. Hitherto there has been no special training in the discharge of those quasi-judicial functions which an arbitrator is called upon to exercise; and, although an expert of the highest integrity and experience has been called in to decide a matter in that sphere in which he had, through his profession, acquired a considerable knowledge and experience, difficulties in the construction of written contracts and other documents, the application of the rules of law and equity to the consideration of the matters in reference and other problems of a more or less technical character have arisen, and even in comparatively simple cases these difficulties have to be met by the invocation throughout of legal and other professional assistance, resulting ultimately in the statement of a case for the opinion of the Court. This special training it is one of the Institute's foremost aims to facilitate.

The Local Government Board have intimated to the Torquay Town Council that no further objection will be raised to the work of laying the second section of the new water main from the reservoirs on Dartmoor to the town, a distance of eighteen miles, being proceeded with. The main as a whole will cost about £50,000.

Our Illustrations.

THE ALLIANCE ASSURANCE COMPANY'S NEW PREMISES, EDINBURGH.

The new building presently in construction is sited in a limited space with the recommendation of a professional assessor. It is 100 feet long, a depth of 75 feet, and contains 100,000 sq. ft., including the basement. The main part of the four-story building is devoted to the office and the upper floors to a dining and dining accommodation, a restaurant, and a caretaker's quarters. The main part is built from granite and the floors and staircases are of concrete. The building is complete, but the fittings cost £12,000. The

result of a limited competition. We give a general exterior view of the building and interior of the public office, with plans of the four principal floors as well as views of the board-room and secretary's office.

THE SHEFFIELD FIRE OFFICE AND ITS AMALGAMATION WITH THE ALLIANCE ASSURANCE COMPANY.

At a meeting of the inhabitants of the town and neighbourhood of Sheffield, held on December 31, 1807, at the Cutlers' Hall, the Master Cutler in the chair, it was decided to establish a fire office with a capital of £50,000 in £100 shares with 10 per share paid. Of the sum asked for, £200,000 was readily subscribed, and the "Sheffield Fire Office" started business on June 24, 1808, in the Market Place, Sheffield, with Mr. T. Willey as "principal agent." Within a year larger premises were taken in the Hay Market and a salvage brigade was organised. The Sheffield Fire Office continued an honourable and prosperous career for over

have been in hands of Mr. John D. Hill. Mr. Arthur Wightman, J.P., of the old-established firm of Messrs. Broomhead, Wightman and Moore, is chairman of the local board, and other old and influential families in Yorkshire and Derbyshire are represented. The Alliance Assurance Company, of which the Hon. N. Charles Rothschild is chairman, has now an authorised capital of £5,450,000, of which £1,000,000 is paid up, whilst the accumulated funds of the Company amount to £24,000,000. The operations of the Company embrace all branches of insurance business, including life assurance of various descriptions, the granting of annuities, fire insurance, consequential loss following fire, marine insurance, workmen's compensation insurance, insurance against personal accident and disease, third party and drivers' risks policies, motor-car and lift insurance, plate glass, hailstorm, burglary and larceny insurances, together with fidelity guarantees, and the granting of capital redemption policies. The Company has branch offices in various

NUMBERBERRY STREET

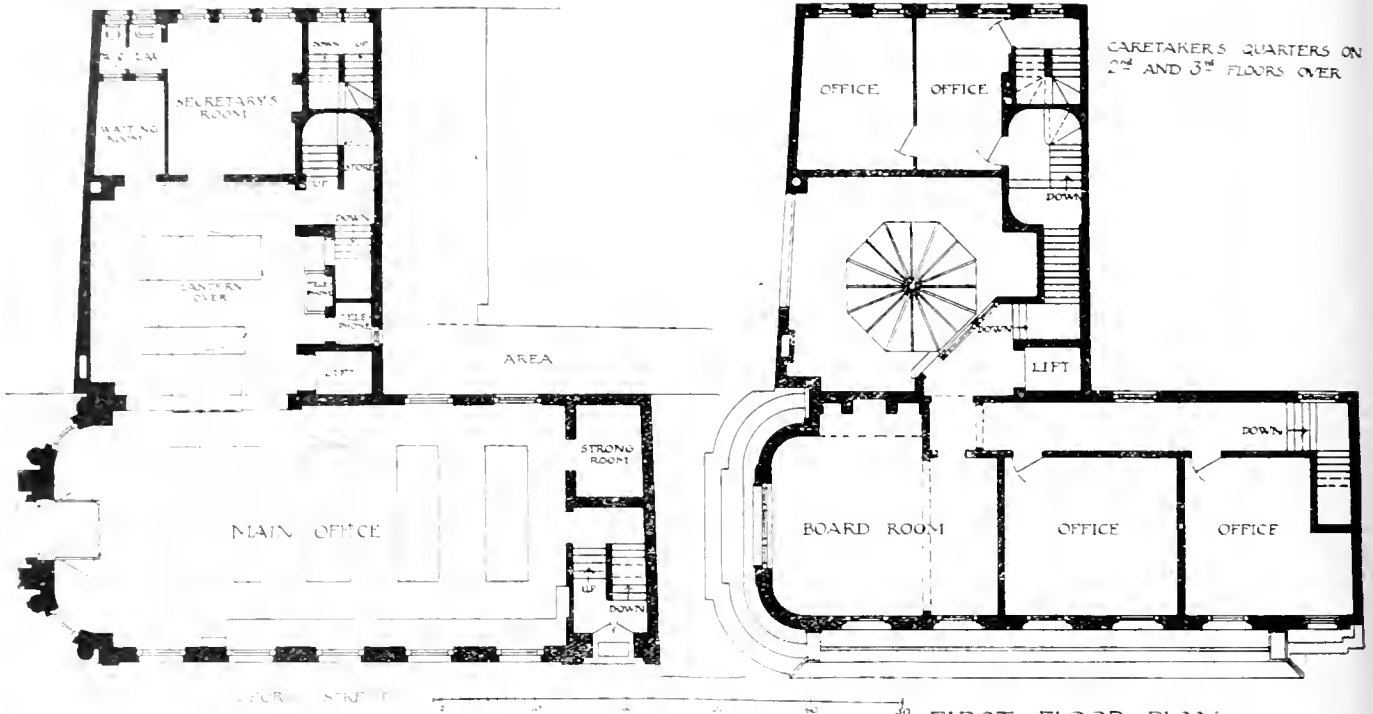

GROUND FLOOR PLAN

FIRST FLOOR PLAN

ALLIANCE ASSURANCE COMPANY'S OFFICE, GEORGE STREET, SHEFFIELD.

Messrs. GODDARD & CATLOW, F.F.R.I.B.A., Architects.

... of the ... B.S.A. of ...

ALLIANCE ASSURANCE COMPANY'S OFFICE, GEORGE STREET, SHEFFIELD.

The building, which has recently been completed, is wholly utilitarian for the Company's business. All the partitions, etc., throughout are faced with Portland stone, with a granite base, the main roof is covered with slate, and the floors and flats are of reinforced concrete. Internally, the principal rooms are finished in oak from floor to ceiling. There are also a wash-room, lavatory, and staircase vaults. There is an engineered plaster ceiling throughout the office. The general contractors were Messrs. Elliott and Son, of Sheffield, and the principal contractors were: For the ground floor, Messrs. Kirkpatrick Bros.; for the first floor, Messrs. Ewart and Son, Limited; for the roof, the Portland Tile Co.; for the staircase, Messrs. Wyle and Son; for the iron gates, Messrs. Hoole and Son; for the cast-iron casters and bronze door knockers, Messrs. Bramsgrove & Guild; for the cast-iron casters, the Foundry Co., Sheffield; for the cast-iron casters, T. A. Ashton, Sheffield; and for the architects, Messrs. Goddard and Catlow, F.F.R.I.B.A., Sheffield, their designs being accepted as

with a century. With the year 1854, however, its individuality became merged in the famous Alliance British and Foreign Life and Fire Assurance Company, now known as the Alliance Assurance Company, Limited. The "Alliance" was established in the year 1824 by deed of settlement, and was incorporated in 1902 under the Companies Acts 1862 to 1900 as a limited liability company. The *Sheffield Telegraph* of February 29, 1864, announced the amalgamation in the following words: "The terms upon which the two establishments are to be united appear to be very satisfactory, and it is stated that the business of the Sheffield Fire Office will be continued as heretofore (but with the addition of life-assurance business) under the management of a local board, constituted from the leading inhabitants of the town, an arrangement which will perpetuate the advantage which the insured have so many years enjoyed in having to deal with townsmen in effecting insurances and adjusting claims. At the same time it will afford the security of one of the most wealthy and influential offices in the kingdom, possessing a capital of five millions, and a paid-up capital of £500,000." The business has increased enormously and the Sheffield branch of the Alliance has now two sub-branches, one at Leeds and one at Derby. Since 1887 the affairs of the branch

parts of the country with officials of experience at each office, thus enabling their insured to transact business with the minimum amount of trouble.

THE TOWER, KHARTOUM CATHEDRAL, SUDAN.

A double-page illustration from this year's Royal Academy drawing of the west front of this cathedral, showing the tower, and giving a plan of the church, appeared in the *Building News* for November 24, with a description of the building. To-day we give a sheet of working drawings of the tower, lent us by the architect, Mr. Robert Schultz Weir, of Gray's Inn, London, W.C.

It was intimated at the last meeting of the Westminster City Council that, in view of the present national emergency, the Mall improvement scheme will not be completed for a considerable period.

In our description last week of the Coburg Court Hotel, Bayswater, no mention was made of the asphalt work, although this is one of the most important items of any contract of the sort. It should have been added that all the asphalt on this contract was supplied and laid by Claridge's Patent Asphalt Co., Limited, 3, Central Buildings, Westminster, S.W.

LIBRARY
JUN 27 1915
UNIVERSITY OF TORONTO.





THE ALLIANCE ASSURANCE COMPANY'S NEW PREMISES, SHEFFIELD: THE BOARD ROOM AND SECRETARY'S ROOM.
Messrs. G. G. G. and Co. Architects.

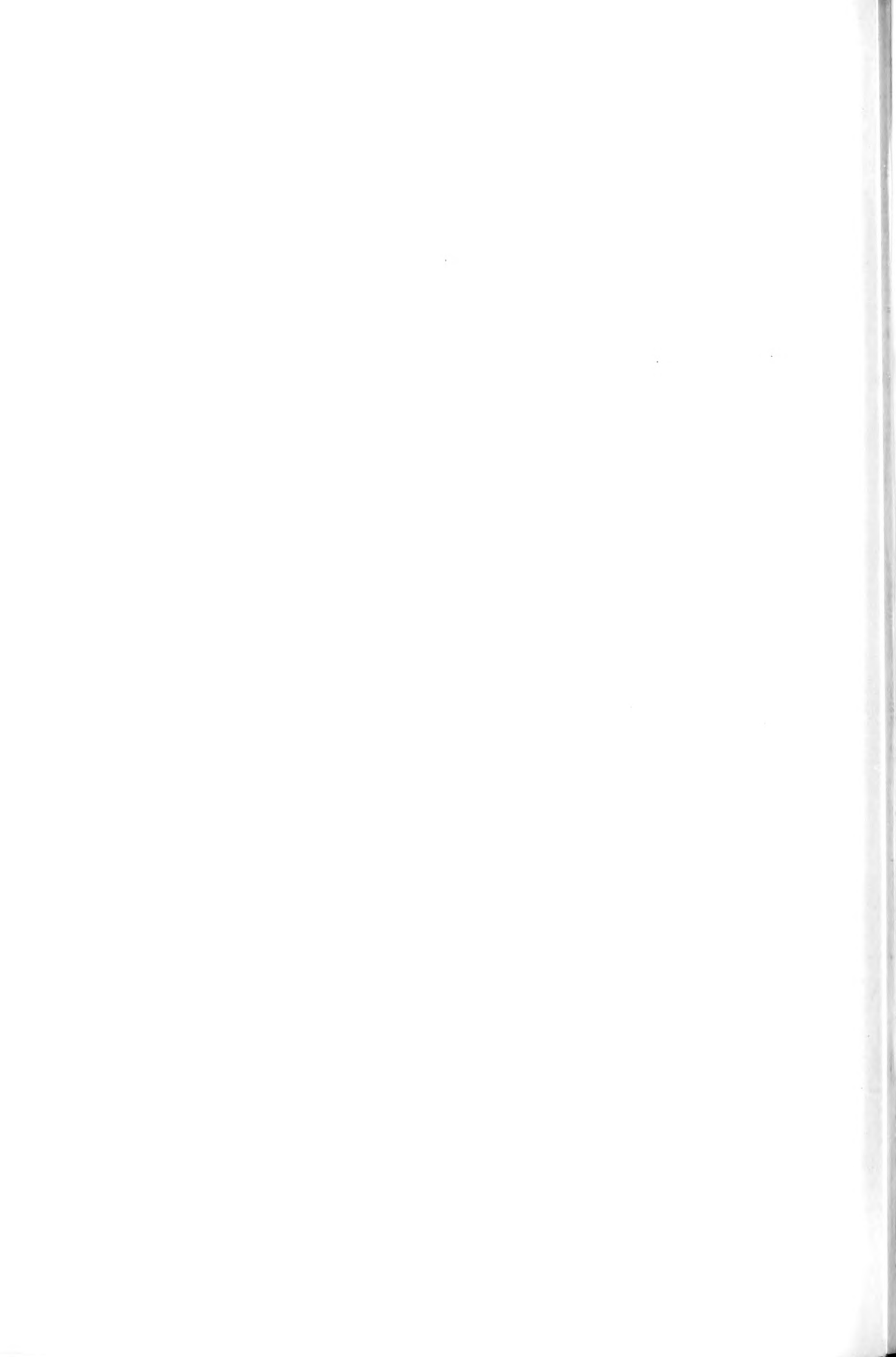

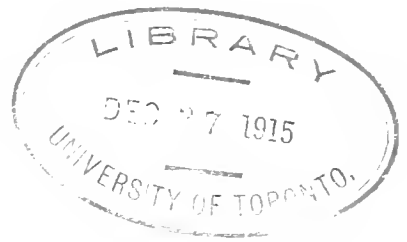

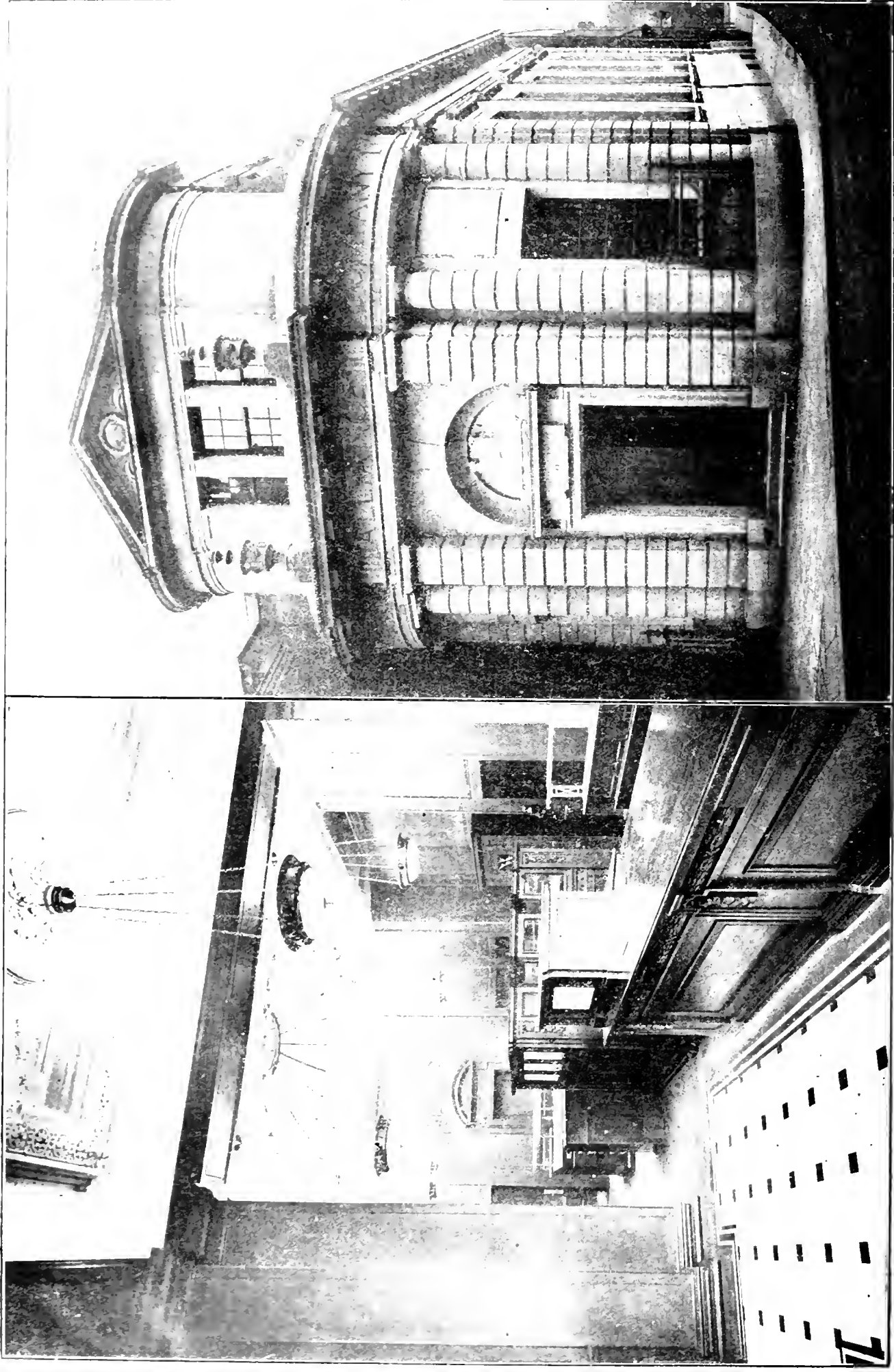

THE ALLIANCE ASSURANCE COMPANY'S OFFICE, GEORGE STREET, SHEFFIELD.—Messrs. GODDARD and CATLOW, F.F.R.I.B.A., Architects.

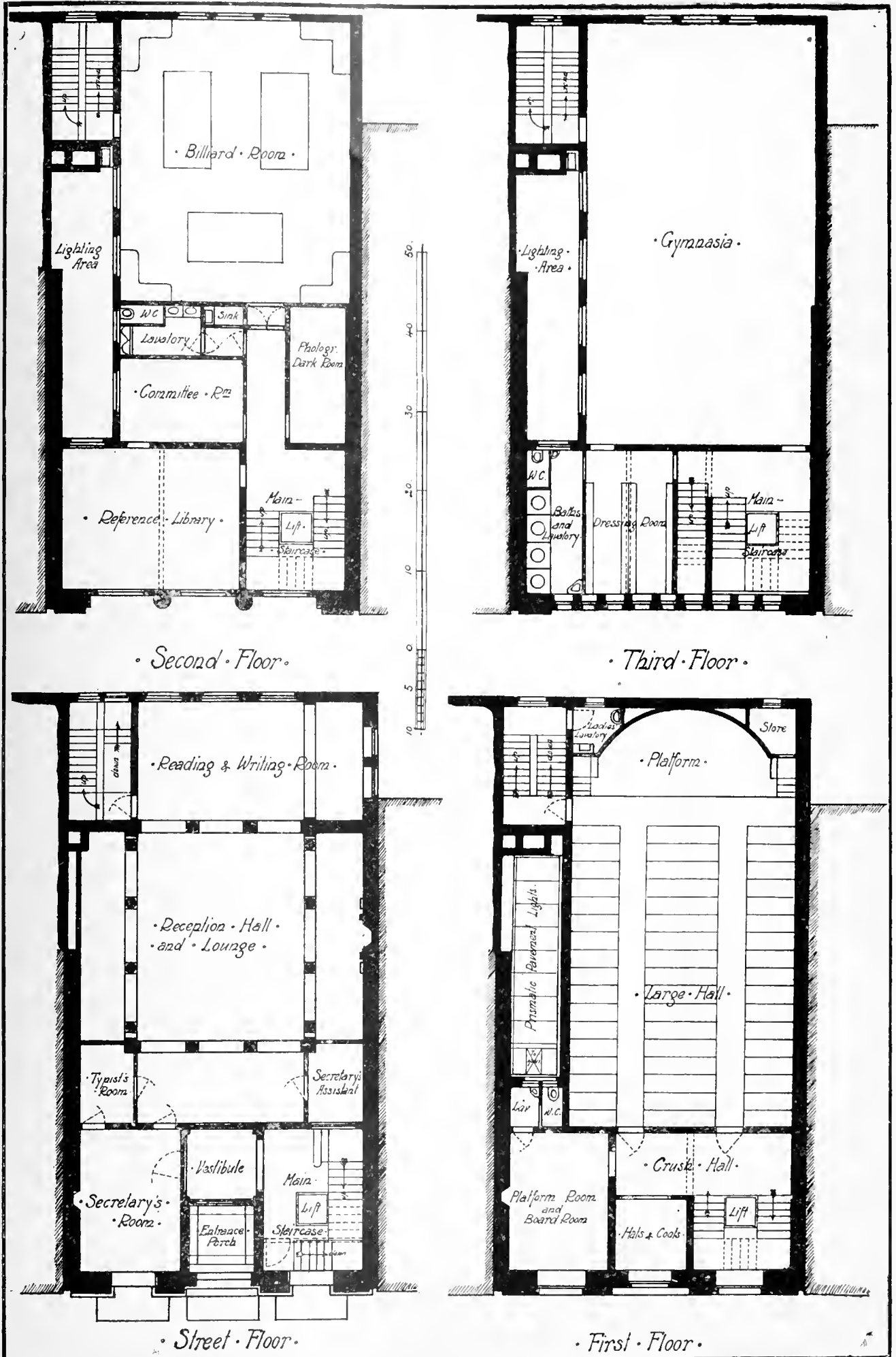

YOUNG MEN'S CHRISTIAN ASSOCIATION PREMISES, EDINBURGH.
 Mr. G. WASHINGTON BROWNE, R.S.A., Architect.

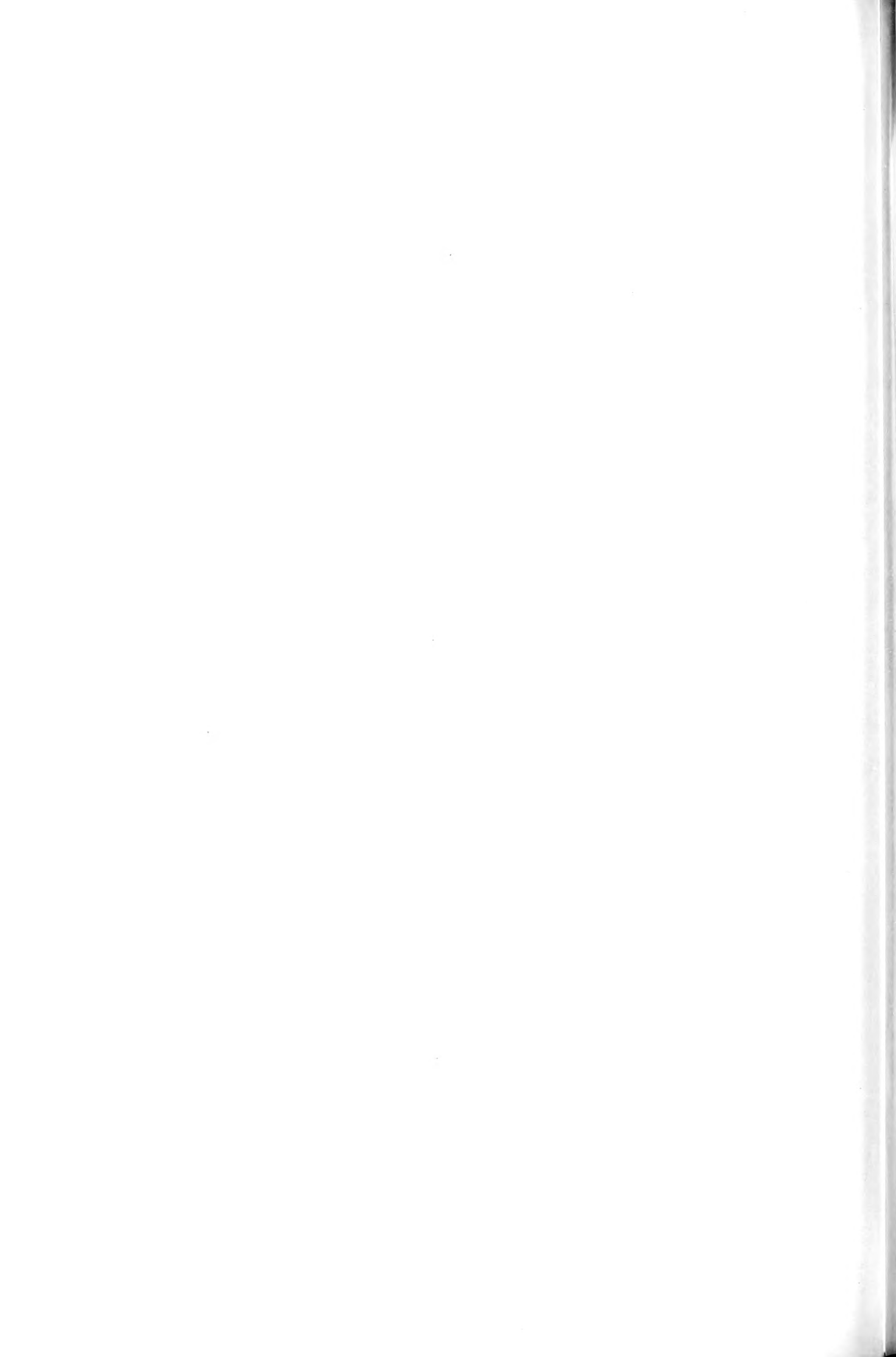

LIBRARY
—
DEC 17 1915
—
UNIVERSITY OF TORONTO

THE BUILDING NEWS, DECEMBER 8, 1915.

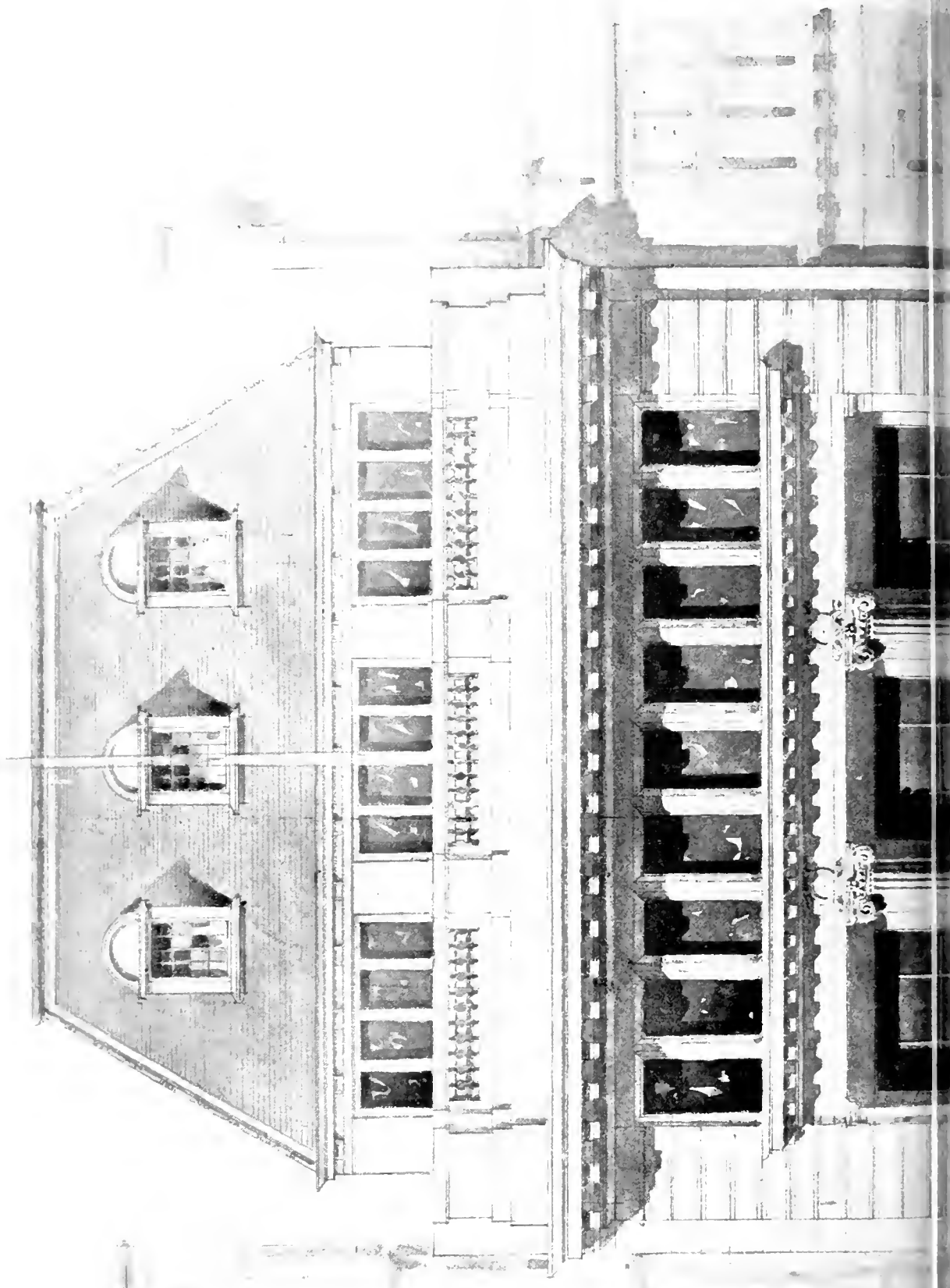

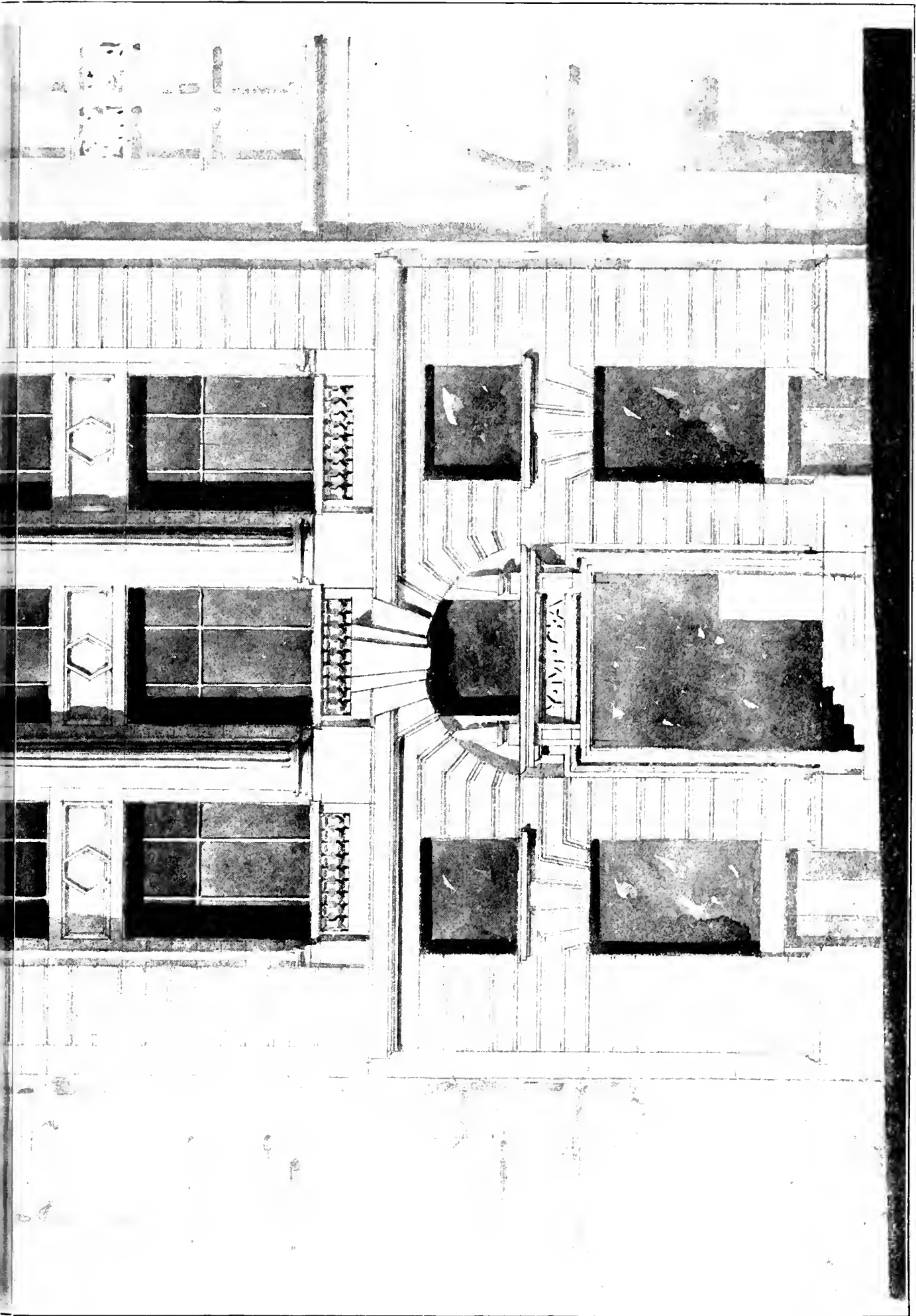

YOUNG MEN'S CHRISTIAN ASSOCIATION PREMISES, EDINBURGH. MR. G. WASHINGTON BROWN, R.S.A., ARCHT.



KHARTOUM CATHEDRAL: THE TOWER

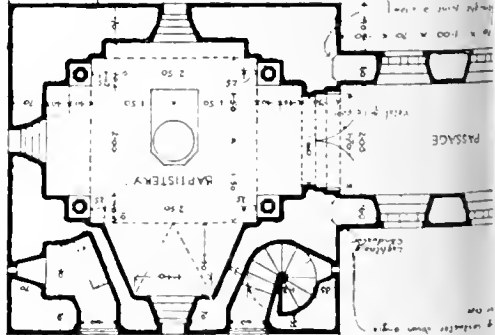
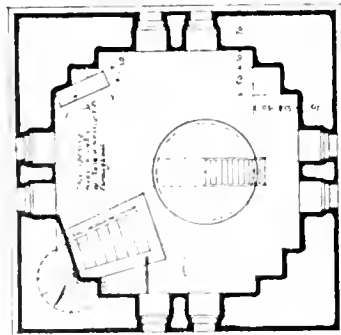
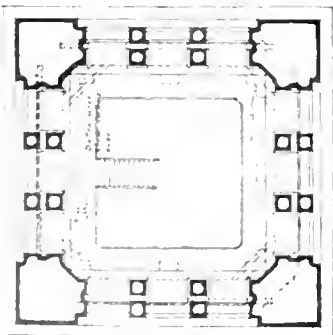
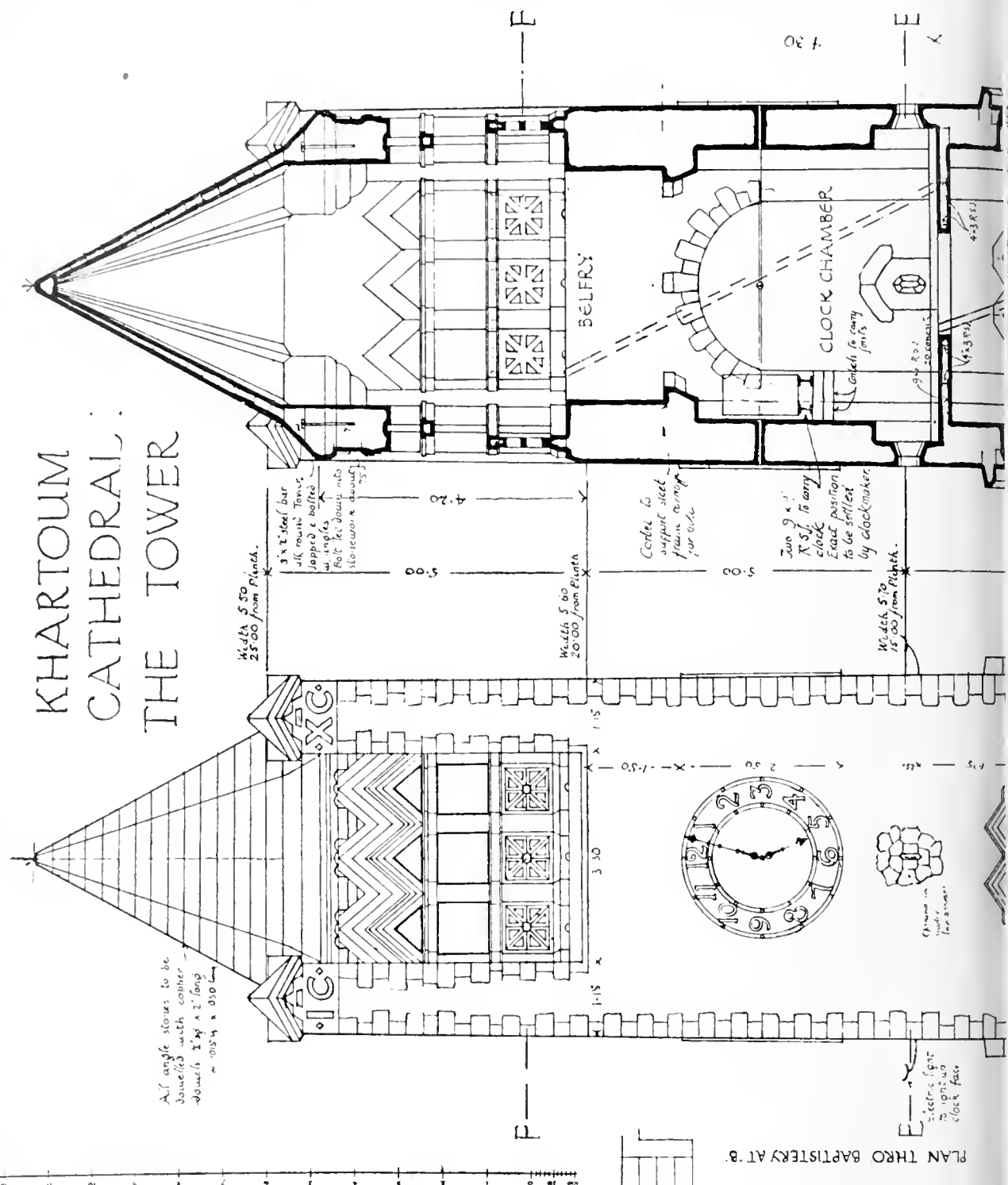

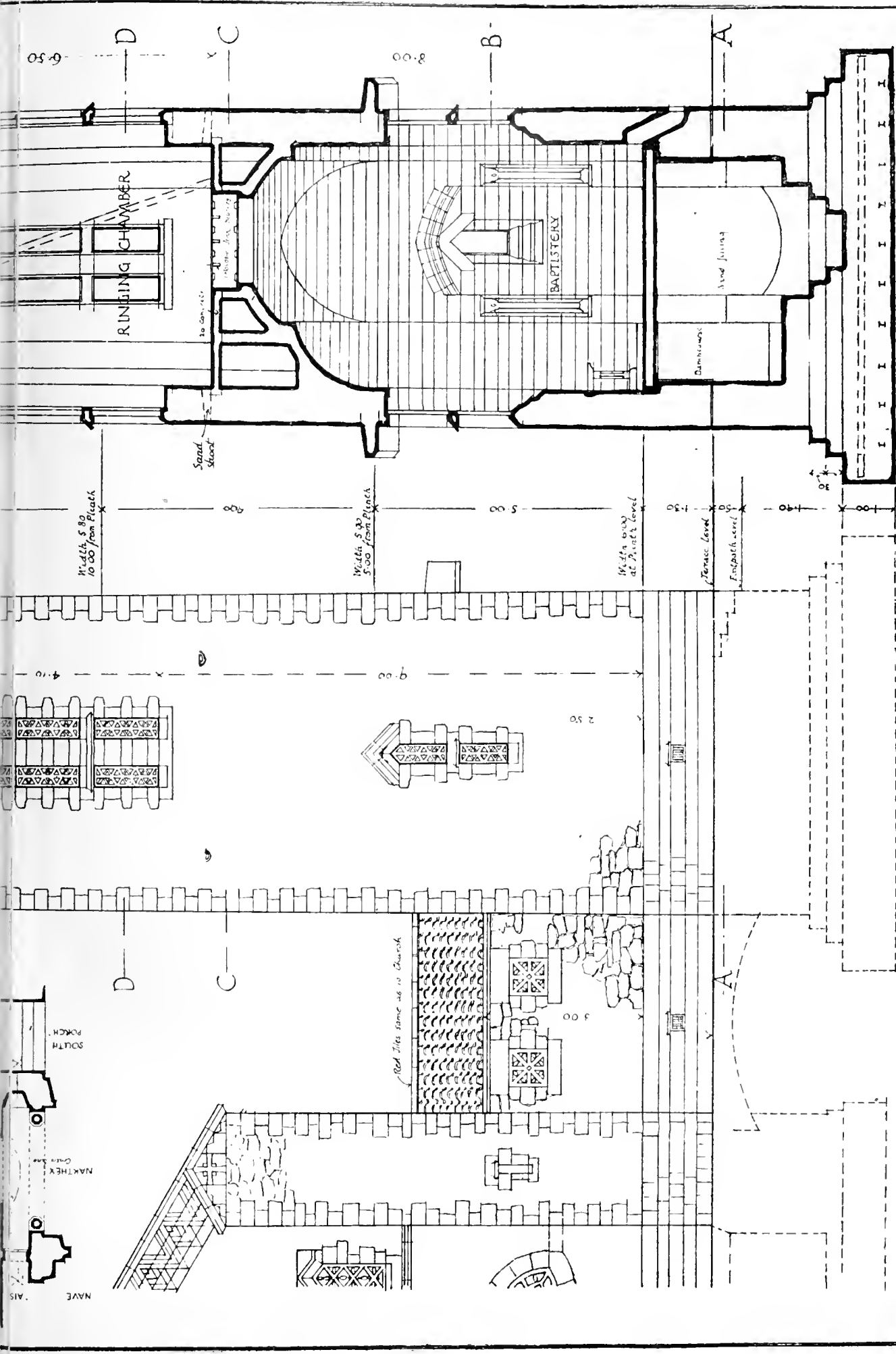

SECTION THRU TOWER LOOKING SOUTH
WEST ELEVATION :

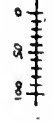



PROFESSIONAL AND TRADE SOCIETIES.

ARCHITECTURAL ASSOCIATION OF IRELAND.—At a meeting of the Architectural Association of Ireland on November 25, at the rooms, 15, South Frederick Lane, Dublin, Mr. H. G. Leask, President, in the chair, a lecture was given by Professor Steele, M.A., M.R.I.A., his subject being "Some Towns of Northern France Affected by the War." He spoke of the towns first occupied temporarily by the Germans when they invaded France. These were Rouen, Amiens, Beauvais, and some others. No harm was done to these towns, at least no serious harm, and the inhabitants rejoiced at their good luck. Pictures of many of the principal buildings in these towns were shown on the screen. The lecturer then showed scenes from Soissons, Compiègne, Rheims, and other towns which suffered grievously from the bombardment. The lecture was mainly a description of the Gothic cathedrals, the architecture of which was the admiration of all beholders. The lantern slides showed these buildings as they were before the Germans committed havoc upon them, and also as they are to-day, many of them in ruins. A cordial vote of thanks was passed to the lecturer.

RELICS OF ROMAN LONDON.—Mr. Frank Lambert, curator of the Guildhall Museum, in a lecture before the London and Middlesex Archaeological Society, given at the Bishopsgate Institute on the 30th ult., stated that on the old Post Office site, St. Martin's-le-Grand, he had found 120 old Roman rubbish pits, from which he had recovered 10,000 fragments of pottery. Many of these fragments he had been able to piece together, and they were now in the Guildhall Museum. One of the most interesting discoveries was a fine gold ring, now in the possession of the Goldsmiths' Company. Other discoveries of Roman pottery had been made in King William Street, E.C., where considerable clearances had lately been made. Part of the site belonged to the Corporation of London, and the relics found in that particular area had been housed at the Guildhall. On the other part of the site a large building had been erected for the Phoenix Assurance Office, and the company had taken possession of the old Roman remains found underneath, and had placed them in a private collection in the offices. Mr. John Todd, M.S.A., district surveyor for the Eastern Division of the City, the chairman, said that although those valuable relics of Roman civilisation might in law, and to a certain extent in ethics, belong to the company, in a very true sense they belonged to the public. Every private owner who had a site in the City where relics were found should consider earnestly whether it was not his duty, instead of preserving them in private ownership, to send them to the Guildhall Museum. A vote of thanks was passed to the lecturer on the motion of Dr. William Martin, F.S.A., seconded by Mr. A. C. Knight.

ROMAN MARCHING CAMPS IN SCOTLAND.—At Edinburgh University, on Tuesday in last week, Mr. George Macdonald, F.B.A., LL.D., delivered a Munro Lecture on "Scotland During the Roman Period." Dr. Macdonald enumerated the various temporary or marching camps, whose existence has been fairly established. These were described in geographical order, attention being drawn to the points that differentiated them from native strongholds and justified the conclusion that they were the work, not of the Caledonians, but of the invaders. The Romans had evidently crossed the Cheviots near the neadwaters of the Coquet, and marched north-west towards the great landmark of the Eildon. A mile or two to the north of what is now the border one can still distinguish the outline of what seems to have been one of their halting-places at Pennymuir or Towford, on the banks of the Kale Water. Eighteen miles further north, hard by the permanent settlement at Newstead, which must be Ptolemy's Trimontium or Town of the Three Peaks, Mr. James Curle discovered another temporary camp, between 40 and 50 acres in extent, ad-

mirably situated so as to command the crossing of the Tweed and the entrance to Lauderdale. Fifteen miles beyond this again, on the southern fringe of the Lammermoors, is Channelkirk, in the neighbourhood of which the remains of yet a third were observed by McVill and subsequently planned by Roy. Traces of the Roman invasion are less definite on the west. But remains at Cleghorn, near Lanark, and at Torwood Moor, near Lockerbie, suggest an advance through Annandale and Clydesdale, while yet a third line of attack is indicated by the comparatively well-preserved temporary camp at Glhockie, near Canonbie. This last must have been constructed by a force that was detailed to deal with Eskdale. Between the Forth and Clyde isthmus and the southern end of Strathmore there were also temporary camps at Ardoch, and at Grassy Walls on the east bank of the Tay.

THE ART OF THE ITALIAN RENAISSANCE.—In St. Andrew's Hall, Drumshugh Gardens, Edinburgh, Mrs. Webster began on Tuesday in last week a series of three lectures on the art of the Italian Renaissance. The Rev. Dr. Kelman, who presided, in introducing the lecturer, said that to the Italy of the past also, with its glorious literature and art, they were immensely indebted, more than many of them could realise, and infinitely more than they could ever pay. To hear that Venice was threatened with destruction by bombs from Zeppelins made them feel in the same way as if they saw a child in a den of ferocious beasts. Mrs. Webster defined art as the language of the emotions—the emotional utterance of life—and craftsmanship as its grammar or tool, and dealt with some of the early Florentine artists. Beginning with Cimabue, she showed how Italian art in the Gothic age advanced from the Byzantine pattern, and how this early Florentine, while not able to shake himself free of tradition, infused the figure with more appearance of life. This was illustrated by lantern pictures on the screen of one of three Madonnas, which were known to be from his hand. His pupil Giotto, whom Cimabue took from tending his sheep, advanced further along the same lines, and surpassed his master as an artist. Among his chief works were the frescoes in the Church of Assisi, illustrating the legend of St. Francis. The devout character of the art of Fra Angelico was next commented on, and in concluding Mrs. Webster gave a short sketch of the life and work of the sculptor Luca Della Robbia—speaking of his versatility as an artist in many materials, as the discoverer of the famous blue enamel Tuscan pottery, the secret of which had been lost; and showing on the screen fragments of the celebrated Cantoria frieze, with the singing angels which he made for the Cathedral, and which are now in the Museum at Florence. In her second lecture delivered on Friday, under the chairmanship of Professor G. Baldwin Brown, Mrs. Webster dealt with some of the great Florentines and Umbrians of the end of the fifteenth and the beginning of the sixteenth century. After referring to the Renaissance spirit as reconciling Christian sentiment, which at that time dominated the civilised world, with the imagery, legends, and theories of pagan poetry and philosophy, Mrs. Webster spoke of Botticelli, who made a religion of the study of beauty, and placed on the screen some of his principal work, and demonstrated in detail how his willowy figures were attractive in their tenderness and grace. Botticelli was the greatest artist in linear design that Europe ever had. Leonardo da Vinci was described as one of the most wonderful organisations that ever existed. The complexity of his nature included the gifts of the painter, sculptor, mystic, engineer, and savant. He had been called "the most universal genius of all time." Several of the most famous of Leonardo's pictures were shown on the screen and were individually discussed, especially the "Mona Lisa" of the Louvre, with its charming personal presence and alluring, wonderful smile. Bernardino Luini, the most distinguished pupil of Leonardo, cultivated the master's style. His pictures were always interesting, reflecting as they did his serene and beautiful outlook on life. Mrs. Webster expounded the art of

Perugino, the teacher of Raphael, with its tenderness and religious feeling materialised in beautiful types. One of his faults was that he frequently repeated himself. Dealing with Raphael, Mrs. Webster spoke of him as an "eclectic" who borrowed from all the masters that had gone before, and assimilated it by his genius in so marvellous a manner. By a union of all the elements he was above all others successful in his works in producing a perfect harmony. With a few words on Sodoma, of the Siena school, also a pupil of Leonardo, the lecturer passed to Michael Angelo with a consideration of whose genius as painter, architect, and especially as a sculptor, the discourse of the afternoon was brought to a close.

TRADE NOTES.

Boyle's latest patent "Air-Pump" Ventilator has been employed at Messrs. Pears' factory, Bradford.

The business of the London Cabinet and Joinery Co., Lyne Grove, N.E., has been acquired by H. H. Elliott, 63, Queen Victoria Street, London, E.C. He is manufacturing all kinds of cabinet and joinery work.

Messrs. C. Jennings and Co., timber importers, 952, Pennywell Road, Bristol, have received a parcel of birch plywood at London and Liverpool—large sheets 48 in. by 48 in. and 50 in. by 50 in., and would be pleased to quote against any inquiries. Their stock also includes ash, oak, and all other kinds of plywood, also Archangel red and white goods.

A cement finish to a concrete flat roof is likely to become much more prevalent now that the question of making them absolutely watertight has been solved by waterproofing the cement. In this respect we learn that some roofs have been successfully constructed at Newcastle-on-Tyne during the last three years. The cement waterproofing powder "Pudlo" was employed, and the architect has expressed his great appreciation of the result.

The church at Cyfarthfa, Mon., is about to be enlarged from plans by Messrs. Johnson and Richards, of Merthyr Tydfil.

In last week's issue, on page 655, we mentioned that Mr. Taylor had resigned his appointment as "borough engineer." This should have read "borough electrical engineer" of Middlesbrough.

The partnership hitherto subsisting between A. Skinner and S. Taylor, builders, at High Street, Acton, Middlesex, and at Linden Avenue, Wembley, Middlesex, under the style of Skinner and Taylor, has been dissolved.

A sub-committee has been appointed by the corporation of Preston to confer with the Estate Sub-committee with respect to the improvement of Fishergate Hill, consequent upon the erection of the new Penwortham Bridge.

In succession to Mr. J. Fazaackerley, who has resigned the position of gas and water manager to the Goolle Urban District Council, Mr. L. W. Nuttall, gas engineer, Gosport, has been appointed out of fifty applicants. Mr. Nuttall was formerly assistant gas engineer and manager with the Keighley Corporation.

The Bishop of London has dedicated the new military section which has been added to the Royal Free Hospital, Gray's Inn Road, together with a new chapel and mortuary chapel. The chapel stands apart from the main hospital buildings; its furnishing and decoration are of the simplest character.

The new wing of the Dental Hospital in Lincoln Place, Dublin, will be open for use by the New Year. On the ground floor is a new board and lecture-room; on the first floor is the anaesthetic department, with waiting and reception and lecture-room; on the first floor is the dispensary and general waiting-room; while on the third floor are an extension of the Weir Hall, students' room, and offices. There is also some remodelling of the older part of the building. The cost will amount to £3,600.

The new offices in Kingsway and Lincoln's Inn Fields, erected for the Public Trustee by H.M. Office of Works, are now so nearly completed that the furniture and deeds will be transferred thither from the present headquarters, Clements Inn, Strand, between the 17th and 20th inst. The new buildings, which are nine stories in height, in addition to a basement, are faced with Portland stone, the area of the premises being 20,400 square feet. They have been erected from plans passed by H.M. Office of Works, and were illustrated in our issue of August 2, 1912.

roduced them, said that at the close of the War there would be a great demand for national, regimental, local, and domestic memorials of those who had fallen, and there would be a national reaction in the architectural world after its enforced time of small output. It was of the greatest importance that such memorials should be excellent in both design and workmanship. They might often take the form of public buildings, such as recreation halls, or of small collections of beautiful objects for schools. There was thus a great chance and opportunity of bringing into prominence the advantages of order and beauty and town-planning. Other speakers addressed the Lord Mayor, who, expressing his warm sympathy with the objects of the Association, consented to allow it to hold a public meeting at the Mansion House, under his presidency, on Friday, January 23.

A scheme has been prepared for solving the housing difficulty in the Langley district, near Birmingham, which has become acute through the influx of so many workmen engaged upon Government work. It is proposed to develop a freehold estate of about 44 acres, having frontages to Darly Road and Bason's Lane, Langley, and extending to Victoria Road, West Smethwick. The owner of the land has expressed his interest in the scheme, and the promoters have obtained from him an option to purchase the estate upon advantageous terms. The co-operation of the district surveyor has been obtained. There is room on the estate for the erection of over 500 houses of modern design and convenience after allowing spaces for a playing field and allotments. Applications have been received already by the promoters for close upon 100 plots.

The Gwydyr Forest, which extends from Dolgarrog, in the Conway Valley, to Pont-a-Pant, in the Lledi Valley, and almost up to Capel Cerrig in another direction, is estimated to cover an area of about 45,000 acres of mountain slopes, and contains some of the finest timber in the United Kingdom. It is at present the scene of considerable activity. Messrs. Green, timber merchants, who have secured Government contracts for railway sleepers, employ a large number of men, who are engaged in felling the huge trees on the plateau adjoining the Park Lake, at an altitude of about 1,500 feet. The Gwydyr mountain here slopes steeply towards the main road to Bettws-y-Coed, and the trunks, denuded of branches, are released on the summit to slide down to the roadside, where a screen of timber has been erected to stem the rush. They are subsequently loaded up in traction and horse waggons and conveyed to the sawmills in the station yard, where they are converted into railway sleepers and despatched by rail en route to their destination. Large areas have already been denuded of timber, which includes a large percentage of oak. Trees gracing the mountain slopes facing the Conway Valley are as yet untouched.

A new mill is to be built at Brizhouse from the plans of Mr. E. C. Brooke, architect, Central Chambers, Brizhouse.

At a general meeting of the Royal Society of Painters in Water Colours, Mr. H. Hughes-Stanton, A.R.A., was elected a member.

It has been decided by the Board of Agriculture to appoint a committee, armed with somewhat extensive powers, to deal with the whole question of the timber supplies of Great Britain.

At Failsworth on Wednesday Mr. W. O. E. Meade-King held a Local Government Board inquiry into an application by the urban district council for sanction to borrow £1,150 for providing public offices.

At a meeting of the Public Health Committee of the Barking Urban District Council, Mr. C. J. Dawson, F.R.I.B.A., architect to the council, attended and reported upon the application of Messrs. Clement and Co. for a further allowance over and above their contract price for the erection of the second block of fifteen houses in Gascoigne Road, owing to the increased price of materials in consequence of the war. It was resolved that a further and final increase of £10 per house over and above the contract price be allowed the contractors, subject to the architect being satisfied with the contractors' accounts of the increased cost incurred.

CHIPS.

The urban district council of Bideford has received the sanction of the Local Government Board to a loan of £4,633 for works in connection with the water supply.

Mr. Charles R. Ashbee, F.R.I.B.A., lectured before the Society of the Fine Arts at Washington, D.C., on November 27, his subject being "The Province of the Arts and Crafts."

The Queen, Princess Mary, and Prince Albert have visited Sir George Frampton's studio to see a statue of her Majesty, which has been finished for Delhi. At the same time the Queen saw the model sketch for the Cavell memorial.

Mr. A. W. Brightmore, an inspector under the Local Government Board, held an inquiry at Whitefield yesterday (Tuesday) into an application by the urban district council for sanction to borrow £2,595 for sewerage and sewage disposal works.

Plans for the new Hall of Justice which will be erected in the Court House block at Sacramento, California, have been formally adopted by the City Commission. Tenders will be received in a short time for the construction of the building, which will cost about \$203,000.

The Mersey Docks and Harbour Board have under consideration a recommendation from the works committee to reconstruct the southernmost section of the shed on the east side of the Harrington Dock (recently destroyed by fire) at an estimated cost of £16,855.

After a long and heated discussion, the Austrian Society of Engineers and Architects has expunged the name of Sir William Ramsay from the list of its corresponding members. A fourth of those present voted against the motion, and urged that action in the matter should be postponed. We heartily congratulate Sir William Ramsay.

Mr. R. D. Summerfield recently read a paper on "The Inspection of Engineering Material" before the Birmingham Association of Engineers. He divided his subject into, The necessity for inspection, the advantage to the buyer, the benefit to the contractor, the abuse of inspection, the inspector and specifications and inspection.

The Rochdale Corporation were informed at their meeting on Thursday last that an experiment with a new invention for the treatment of "sewage sludge" (not sewage) at the borough sewage disposal works is embarrassed by the liquidation of the firm which initiated the work, and the matter is at a standstill.

At the Stral Cottage Homes, belonging to the Manchester Board of Guardians, the Bishop of Chester has formally dedicated a new chapel. It accommodates 613 children, and has cost £4,000. The work is carried out in a characteristic Cheshire style in brick and half-timber work, with red-tiled roof. Mr. F. H. Overmann, of King Street, Manchester, was the architect.

At an inquest held in St. Pancras on Saturday on the body of Elizabeth Bridle, forty-eight, wife of a builder and decorator, of Aybrook Street, Marylebone, it was stated that on Wednesday evening she and her husband while crossing High Street, Marylebone, were knocked down by a motor-cab. The wheel of the cab passed over the right leg of Mr. Bridle, but his wife sustained a fracture of the skull and internal injuries, from which she died. A verdict of accidental death was returned.

An interesting ceremony took place at Halifax, Nova Scotia, when the foundation stone of the quay wall of the new ocean terminals was laid by Sir Robert Borden, the Premier of Canada. Eight passenger steamers of 600 ft. each can be accommodated alongside the quay wall when the present unit is completed. The whole undertaking, however, provides that a fleet of twenty-ton ships, each 600 ft. long, can be loaded simultaneously at the piers. The depth of water at low tide alongside the piers will be 45 ft.

At a general assembly of academicians and associates held on Monday, Mr. Charles Sims, A.R.A., painter, was elected a Royal Academician. Mr. Sims, who is in his forty-third year, began to study art at South Kensington at the age of seventeen, and afterwards at a student of the Academie Julian in Paris and at the Royal Academy Schools. His "Childhood" was bought for the Luxembourg in 1900. He first exhibited at Burlington House in 1894. In the Tate Gallery he is represented by "The Fountain" and "The Wood Beyond the World," which were bought by the Chantry Trustees. He married a daughter of the late Mr. John MacWhirter, R.A.

The death is announced of Mr. John Dolan, late deputy surveyor for Roscommon. Less than three weeks ago he resigned his position after fifty years' service.

Mr. Bensford Graham Wallis, M.Inst.C.E., late superintendent engineer in the Punjab, Indian Public Works Department, died on the 23rd ult. at his residence in Queens-town, Co. Cork.

The corporation of Doncaster have appointed Mr. R. E. Ford as acting borough surveyor and water engineer during the absence of the borough surveyor, Mr. F. O. Kirby, on active service.

We regret to hear that Second Lieut. Cecil B. Tubbs (6th Somerset Light Infantry), the third son of Mr. Percy B. Tubbs, F.R.I.B.A., president of the Society of Architects, Aldersgate Street, E.C., has been wounded in action in Flanders.

The twentieth list of members, licentiates, and students of the Royal Institute of British Architects, published yesterday, who have joined the Army or Navy, gives the total to date of 47 fellows, 363 associates, 192 licentiates, and 234 students.

A petardrome and concert hall have been built in Chapel Street, Worthing, from plans by Mr. Peter D. Stomham, M.S.A., of Eastbourne and Bexhill. Accommodation is provided in the petardrome for 1,000 persons and for 150 in the concert hall.

In the course of excavations in connection with the extension of the Steney Borough Council's electricity generating station at Limehouse specimens of ancient pottery have been discovered. They are to be placed on exhibition in the Steney Borough Museum.

The new racecourse stand at Cheltenham is constructed in reinforced concrete, and is 90 ft. in length by a width of 44 ft. On the first floor behind the balcony is a restaurant. The architects were Messrs. Chatters and Smithson, Regent Street, Cheltenham.

At the last sitting of the Carlisle Consistory Court a faculty was granted to the vicar and gardens of St. Cuthbert's Church, Holme Cultram, to erect a tower at the west end of the nave and to carry out several other improvements, including re-hanging the bells.

Extensive additions to the county club premises in Phoenix Street, Cork, have been completed at a cost of about £3,000. The work has been executed by Messrs. J. D. Laney and Co., builders, Cork, from plans and specifications prepared by Mr. J. E. McMullen, architect, Cork.

The county surveyor of Monaghan, Mr. J. J. Hannigan, reported to his county council at their last meeting that over £4,900 worth of road works would this year be thrown on his hands in consequence of the failure of the rural council and county council to obtain contractors.

At the last meeting of the Stoke-on-Trent education committee the chairman reported that the architect, Mr. Ashworth had joined the forces, and had received a commission as second lieutenant in the Royal Garrison Artillery. The assistant architect was appointed in his stead during the continuance of the war.

Under the General Powers Bill to be promoted by the corporation of Tynemouth next session further authority is sought with respect to streets, buildings, sewers and drains, infections and other diseases, cleansing of verminous persons and houses, overcrowding, and removal of persons suffering from pulmonary tuberculosis. It is proposed to add the urban district of Ashington to the corporation's area of water supply, and to acquire the waterworks at Ashington.

The death has taken place at Carnarvon of Mr. John Williams, master builder. A native of Milford Haven, Mr. Williams took up his home at Carnarvon thirty-eight years ago, and carried on business with his sons and his brother. He was a skilled woodworker. Though in his eighty-fourth year, he worked regularly at the bench till his health began to fail him some two years ago. Mr. Williams leaves a daughter and four sons.

Lord Justice Bankes opened on Thursday the new buildings of the Francis Holland School for Girls in Clarence Gate, Regent's Park. Owing to the extension of Baker Street Railway Station the school has been removed from the site it had occupied since 1873. The new premises are faced with small red bricks, Portland stone being employed for dressings. The floors and stairways are of fire-proof construction, and the internal joinery is of white-wood. Mr. Henry T. Haro, F.R.I.B.A., was the architect, and Mr. James Carnichael the builder. The new schools were illustrated in our number for October 15, 1914.

TO CORRESPONDENTS.

We do not hold ourselves responsible for the opinions of our correspondents. All communications should be drawn up as briefly as possible, as there are many claimants upon the space allotted to correspondents.

It is particularly requested that all drawings and all communications respecting illustrations or literary matter, books for review, etc., should be addressed to the Editor of the BUILDING NEWS, Elingham House, 1, Arundel street, Strand, W.C., and not to members of the staff by name. Delay is not infrequently otherwise caused. All drawings and other communications are sent at contributors' risks, and the Editor will not undertake to pay for, or be liable for, unsought contributions.

*Drawings of selected competition designs, important public and private buildings, details of old and new work, and good sketches are always welcome, and for such no charge is made for insertion of more commonplace subjects, small churches, chapels, houses, etc. We have usually far more sent than we can insert, but are glad to do so when space permits, on mutually advantageous terms, which may be ascertained on application.

When favouring us with drawings or photographs, architects are asked kindly to state how long the building has been erected. It does neither them nor is much good to illustrate buildings which have been some time executed, except under special circumstances.

Telephone: Gerrard 1291.

Telegram: "Timeserver, Estrand, London."

NOTICE.

Bound copies of Vol. CVIII. are now ready, and should be ordered early (price 12s. each, by post 12s. 6d.), as only a limited number are done up. A few bound volumes of Vols. XXXIX., XLI., XLVI., XLIX., LIII., LXI., LXII., LXIV., LXV., LXVI., LXVII., LXVIII., LXIX., LXXI., LXXII., LXXIII., LXXIV., LXXV., LXXVI., LXXVII., LXXIX., LXXX., LXXXI., LXXXII., LXXXIII., LXXXIV., LXXXV., LXXXVI., LXXXVII., LXXXVIII., LXXXIX., XC., XCI., XCII., XCIII., XCIV., XCV., XCVI., XCVII., XCVIII., XCIX., C., CI., CII., CIII., CIV., CV., CVI., and CVII may still be obtained at the same price; all the other bound volumes are out of print.

BACK ISSUES.

Most of the back issues are to be had singly. All back issues over one month old will be charged 6d. each, postage 1d. Subscribers requiring back numbers should order at once, as they soon run out of print.

Handsome Cloth Cases for binding the BUILDING NEWS, price 2s., post free 2s. 6d., can be obtained from any Newsagent, or from the Publisher, Elingham House, 1, Arundel-street, Strand, W.C.

ADVERTISEMENT CHARGES.

The charge for Competition and Contract Advertisements, Public Companies, and all official advertisements is 1s. per line of Eight Words, the first line counting as two, the minimum charge being 5s. for four lines.

The charge for Auctions, Land Sales, and Miscellaneous and Trade Advertisements (except Situation Advertisements) is 6d. per line of Eight Words (the first line counting as two), the minimum charge being 4s. 6d. for 50 words. Special terms for series of six insertions or more can be ascertained on application to the Publisher.

SITUATIONS VACANT AND PARTNERSHIPS. The charge for advertisements for "Situations Vacant" and "Partnerships" is One Shilling for twenty-four Words, and Sixpence for every Eight Words after. All Situation Advertisements must be prepaid.

SITUATIONS WANTED.

Advertisements not exceeding Thirty Words, inclusive of name and address, are inserted under the heading "Situations Wanted," free of charge.

Rates for Trade Advertisements on front page and special and other positions can be obtained on application to the Publisher.

REPLIES TO ADVERTISEMENTS.

Replies to advertisements can be received at the office, Elingham House, 1, Arundel Street, Strand, W.C., free of charge. If to be forwarded under cover to advertiser, an extra charge of Sixpence is made. (See Notice at head of "Situations.")

Advertisements for the current week must reach the office not later than 3 p.m. on Tuesday. Front page advertisements and alterations or stop orders for serial advertisements must reach the office by first post on Monday to secure attention.

THE NEW POSTAL RATES. Do not forget that though we are penalised by the new postal rates, because we still keep to our old size, and therefore a copy of the BUILDING NEWS exceeds the six-ounce limit, we are making no extra charge to subscribers who receive their copies direct from the office. The subscription rate, remaining as before 41 per annum for half yearly and 15s. quarterly. Now is the time to subscribe.

RECEIVED: W. and D. Ltd. W. P. T. and Co. G. S. and Co. Ltd. G. and Co. W. H. S. and Son. T. M. T. Co. Ltd. B. M. S. S. S. C. and Co. D. Y. and Co. S. M. and S. T. F. C. and S. T. V. A. and Co. H. Ltd. O. and Co.

NATHAN: Yes. A. and G. P. has no bid. DEBS: W. have no record. CONE: It is not a system we should use.

TO ARMS!

400 BATTALION CENTRAL LONDON VOLUNTEER REGIMENT.

TELE. WEEK.

OFFICER for the week.—Platoon Commander C. H. C. Bond.

NEXT for duty.—Platoon Commander E. P. Hudson. GENERAL PARADES.

There will be no general parade on Saturday next, 11th inst.

Saturday, 11th inst., parade at Chester House, 2.45 p.m. Uniform, haversacks, and water-bottles. The next general parade will be on Saturday, 1st prox.

LECTURES.

This evening (Wednesday), 8th inst., Colonel Sir E. Rahau at the Institution of Civil Engineers, Great George Street, S.W., at 5.45 p.m.

Thursday, 9th inst., at Chester House, 5.45 p.m., the Adjutant's lecture to officers and N.C.O.'s on "Bridging."

Add at 7.15 Mr. Gunton's lecture to officers and N.C.O.'s on "Field Communications."

Tuesday, 14th inst., 7.15 to 8.15, at Chester House, the Adjutant's lecture on "Military Engineering."

DRILLS AND PARADES.

A detailed order of all drills and parades up to January 31, 1916, is posted on the notice board at headquarters. Members must make themselves familiar with same.

Wednesday, 8th inst., No. 2 Platoon drill at headquarters, 6.15 to 8.15.

Wednesday, 15th inst., No. 3 Platoon drill at headquarters, 6.15 to 8.15.

ENTRENCHING PARADE.

Sunday next, 12th inst., Victoria Station, L.B. and S.C. Railway indicator board. It is hoped that the special train, 9.15, will be run again on this Sunday. Notice will be posted on board at headquarters and also in later orders. Uniform, haversacks, and water-bottles. Midday and tea rations to be carried. Return to town about 6.40. Railway vouchers will be provided.

FIELD COMMUNICATION.

Parade, Saturday next, 11th inst., 3 p.m., Victoria Gate, Hyde Park, officers and N.C.O.'s only, for instruction in use of field communication and the sending and receiving of messages in the field. By kind permission of the Commandant of the Post Office V.T.C.

By order, L. R. GUTHRIE, Adjutant.

CORRESPONDENCE.

All correspondence should be addressed to the Orderly Room, Drill Headquarters and Orderly Room, Chester House, Eccleston Place, S.W., Battalion Headquarters, 18, Tufton Street, Westminster, S.W.

December 6, 1915.

A notable addition has been made to the decoration of the Royal Exchange by the unveiling of a fresco painted by Mr. A. E. Cox, R.B.A., and presented by Sir Frederick Green, the subject being "Philip the Good presenting the Charter to the Merchant Adventurers."

The borough surveyor of King's Lynn has reported to the corporation that a very serious settlement has occurred in the main outside wall on the east side of the Red Mount; he submitted that the restoration of an historic building of this description is the work of an expert. The corporation agreed to at once obtain a report on the building.

Mr. W. W. Gladwell, district surveyor for the East Harling division of Norfolk, has been appointed, temporarily, county surveyor of Norfolk, to fill the vacancy caused by the death of Mr. T. H. B. Heslop, at a salary of £700 a year. Mr. Gladwell has occupied his present post since 1894, and was previously assistant surveyor to the Prestbury Highway Board, and afterwards to the corporation of Sutton Coldfield.

At the meeting on Thursday of the Licensing Justices for Birmingham, Mr. Hurst applied on behalf of the London and North-Western Railway Company for alterations to certain plans which were approved by the justices when the provisional grant for the rebuilding of the Queen's Hotel and its extension was made in April, 1912. The scheme originally proposed to be carried through had been rendered impossible for the present. That was a scheme by which a new bridge was to be provided for thorough traffic through the station, but the necessary capital expenditure for the work had not received the sanction of the authorities. Consequently that part of the scheme would be abandoned until the necessary capital could be secured. The alterations which it was desired the justices should approve were three in number. The chairman asked whether, if they sanctioned this arrangement, it would shut out permanently any chance of making the station a closed one. Mr. H. A. Briggs, the architect, said the alteration would not preclude the station being made a closed one in the future. Having received this assurance the justices granted the application.

LATEST PRICES.

N.B.—All prices must be regarded as merely approximate for the present, as our usual sources of information are in many cases failing us.

TIMBER.

Owing to stoppage of supplies all prices have advanced considerably.

Table with columns for IRON, Per ton, and Per ton. Items include Rolled Steel Joists, Compound Girders, Wrought-Iron Girder Plates, etc.

Table with columns for Cast-Iron Columns, Cast-Iron Stanchions, Rolled-Iron Fencing Wire, etc.

Table with columns for Cast-Iron Sash Weights, Cut Floor Brads, Corrugated Iron, Galvanised Wire Strand, etc.

OTHER METALS.

Table with columns for Lead Water Pipe, Lead Barrel Pipe, Lead Pipe, Composition Gas-Pipe, Lead Soil-pipe, etc.

I BUY SCRAP METALS

ARTHUR P. COLLINS, Snow Hill, BIRMINGHAM. Phone: Central 1020. Telegrams: 'Metbase, Birmingham.'

SLATES.

Table with columns for Blue Portmadoc, First quality, Blue Bangor, etc.

Table with columns for Eureka unfading, Permanent Green, etc.

BRICKS.

Table with columns for First Hard Stocks, Second Hard Stocks, Picked Stocks, etc.

Table with columns for 3 1/2" Accrington Best Red Plastic Facing Bricks, 3 1/2" ditto Second Best Plastic ditto, etc.

GLAZED BRICKS.

Table with columns for White, Ivory, and Best Salt Glazed, Buff, Cream, Other Second Best, Seconds, & Bronze, Colours, etc.

MOLDED BRICKS.

Table with columns for Stretchers and Headers, 8d. each, 8d. each, 8d. each, etc.

Table with columns for Best Portland Cement, Ground Blue Lias Lime, Grey Stone Lime, etc.

STONE.

Table with columns for Red Mansfield, Darley Dale, Red Corsehill, etc.

Table with columns for Bath Stone—Delivered in railway trucks at Westbourne Park, Paddington (G.W.R.), or South Lambeth (G.W.R.), etc.

TILES.

Table with columns for Plain red roofing tiles, Hip and Valley tiles, Broasley tiles, Ornamental tiles, etc.

OILS.

Table with columns for Rapeseed, English pale, per ton, Ditto, brown, Cottonseed, refined, Olive, Spanish, etc.

GLASS (IN CRATES).

Table with columns for English Sheet Glass: 15 oz., 21 oz., 26 oz., 32 oz., etc.

VARNISHES, Etc.

Table with columns for Fine Pale Oak Varnish, Pale Copal Oak, Omniscop Copal Oak, etc.

The parishioners of Oaklands Park, Surrey, propose to erect an oak chancel screen in memory of the late Rev. J. H. Townsend, rural dean, who for twenty-eight years was vicar of the parish.

Burnley Corporation is promoting a Bill next session to extend the time limited by its Act of 1903 for the completion of the Hurstwood reservoir and the catchwater drains or conduits and other works authorised by the Act.

MEETINGS FOR THE ENSUING WEEK.

MONDAY, DECEMBER 7. 7.30 a.m. The Year Way at Night... 10.15 a.m. The Year Way at Night... 1.30 p.m. The Year Way at Night... 7.30 p.m. The Year Way at Night...

DUNNINGTON. For the supply and erection of a 250 k.v. turboalternator... GLOUCESTER. For providing and laying C.C. and F.P. water mains... GRIMSBY. For the cleansing and siding of the dyks and ditches... HAMMERSMITH, W. For installing electric light in the Thornfield Road School... LITON. For the supply of a water-cooler... MELBOURNE. For the supply of electric lighting material... NORTHWOOD. For erection of a small house... DARTMOUTH. For the supply of electrical plant to the mental diseases hospital...

Dec. 14.—Chapel Hall for English Presbyterian Church, Tonypetrol... Dec. 17. School, Linates, Spain.—The Municipal Authorities, Linates, Spain... Dec. 8.—Accumulators (294 of 15 ampere-hour capacity), Perth, Western Australia... Dec. 14.—Trunk Line Switchboard, Melbourne... Dec. 15. Low-tension Cable, Walthamstow... Dec. 20.—Telephones, Sydney, N.S.W... Dec. 31.—Telephone Apparatus, Durban... Jan. 4.—Measuring Instruments and Telephone Parts, Melbourne... Jan. 5.—Hard-drawn Copper-clad Steel Wire and Jointing Sleeves... Jan. 19.—Multiple switchboard at Telephone Exchange, Adelaide... Jan. 26.—Telephone Instruments and Galvanised Iron Wire, Brisbane... Jan. 31.—Three Freight Car Transferers, Sydney...

OGILVIE & CO. Mildmay Avenue, ISLINGTON, N. EXPERTS in HIGH-CLASS JOINERY. ALTERATIONS & DECORATIONS. ESTIMATES FREE. FOR 'Olivers' Seasoned Hardwoods, WM. OLIVER & SONS, Ltd., 120 Bunhill Row, London, E.C.

TENDERS. *Correspondents will in all cases oblige by giving the address of the parties tendering at a rate of the accepted tender, it adds to the value of the information.

NEW NORFOLK, TASMANIA. For the supply of electrical plant to the mental diseases hospital... SOUTHAMPTON. For the supply of high-tension, lead-covered, joint-insulated cables... WEXMOUTH. For repairs to No. 4 Devonshire Buildings... WINNIPEG. For the supply of 250 tons of stone for road repairs...

LIST OF COMPETITIONS OPEN.

March 1, 1916.—Dutch East Indian Rubber Factory—Premiums, 1,500 florins and 500 florins.—International Association for the Culture of Rubber in the Netherlands East Indies, 13, Kneuterdyk, The Hague.

LIST OF TENDERS OPEN.

BUILDINGS. Dec. 8. Public Market, Artigas, Uruguay... Dec. 9. Secondary Tower at Dewey Factory, Barnstaple... Dec. 9. Alterations and Repairs at Workhouse, Carleton... Dec. 14. Pavilion, County Sligo Sanatorium, Clontarf...

ENGINEERING.

Dec. 13.—Ventilating Shaft, Tewkesbury... Dec. 14.—Weighbridge, Johannesburg... Dec. 16.—Fifteen Cast-iron Wall Sluices... Dec. 17 30.—Water Supply to Athens and Piræus... Dec. 18.—Mechanical Tipping Apparatus for Coal Wagons... Dec. 20.—Centrifugal Pumps and Electric Motors... Dec. 30.—Ice-making Plant at Municipal Abattoirs... Jan. 12, 1916.—Two Water-tube Boilers... Feb. 9.—Filtering Plant at Public Baths, Dunedin... Feb. 19.—Strategic Railway from Estada and Lunart to Bolaguer, Spain... May 31. Secondary Railway from Palencia to Aranda de Duero, Spain... No date.—Steam-jacketed Cooking Boiler at Workhouse, Newbury... FENCES AND WALLS. Dec. 18.—Wrought-iron and Steel Fencing, Sowerby Bridge... No date.—Dwarf Wall and Oak Fence at corner of Five Arch Bridge, Aldershot...

THE BUILDING NEWS

AND ENGINEERING JOURNAL.

Effingham House,

CONTENTS.

Strand, W.C.

Royal Academy Annual Prize Distribution	659
The Society of Architects	670
The Trades Training Classes	672
The Architects' and Surveyors' Approval Society	673
Obituary	675
English Timber: Before, During, and After the War	674
Currente Calamie	686
Our Illustrations	691
Parliamentary Notes	697
Competitions	69
Professional and Trade Societies	69
Legal Intelligence	69
Water Supply and Sanitary Matters	69

Our Office Table	696
Trade Notes	696
Intercommunication	696
Clippings	696
Meetings for the Future	696
Latest Prices	697
To Correspondents	698
To Artists	698
Tenders	698
List of Competitions Open	698
List of Tenders Open	698

OUR ILLUSTRATIONS.

The New Zealand Government Office, Strand, London, W.C. Elevation and plans. Messrs. Cook, May and Sons, Architects.

The School Chapel, Cl. St. Hospital, Bournemouth. Section showing position of temporary decorations. Sir Aston Webb, R.A., and the late F. Inghes Bell, Architects. St. Wilfred, First Bishop of Selby, Teaching the South Saxons, A.D. 657. One of the panels of the series by Mr. Frank Brangwyn, R.A.
The White House, Beaton, near Bolton, for Mr. Oliver H. Hart. View of exterior, and interior of the sitting-room, with plan. Messrs. R. Heywood Haslam and Herbert Crook, Joint Architects.
Factory, Old Foundry Road, and St. Margaret's Street, Ipswich, for Messrs. Phillips and Payer, Ltd. Plan, sections, and elevation. Mr. R. C. Wrench, A.R.C.B.A., Architect.

ROYAL ACADEMY ANNUAL PRIZE DISTRIBUTION.

In the ordinary course of events this year's competitions among the Royal Academy students would have included the Council's gold medals for architecture, painting, and sculpture, but owing to the war and the consequent depletion of the Academy schools it was decided at the outset of the session to withhold these scholarships. This is the first time since the foundation of the Royal Academy 147 years ago that it has been found advisable to suspend these premier contests, but owing to the absence of so considerable a number of the best students with the colours abroad and to other contingent causes, competitions in subjects so advanced as those for the gold medals would not have insured results likely to justify their award. No fewer than 134 of the past and present students on the roll have given up their studies and joined His Majesty's Forces. Among those who have thus gone forth for the defence of hearth and home no fewer than seventy-nine men were architects, while fifty-five were painters and sculptors. So considerable is the number of architects and sculptors who have left that the Council had no choice but to close the Architectural Schools altogether during the duration of this devastating war, and also to discontinue the day classes in the Modelling School for sculptors. Besides this, ten lady students have sacrificed the profession of their choice and taken up work in hospitals for the Red Cross or at munition making. That this is most creditable to the patriotism of the students of the Royal Academy goes without saying, and as the President, Sir Edward Poynter, pointed out at the annual meeting last Friday afternoon at Burlington House, it is impossible to over-estimate the seriousness of such a step on the part of those who had their calling at heart in the pursuit and practice of the Arts. The realities of such self-sacrifice have, indeed, been brought home to the ranks of the architectural profession in almost every part of the Empire, and especially among the members of the Institute and the Royal Academy, where the members lately learned that one of their most promising painter students, who won the gold medal in that class, had been killed in action.

The exhibition of competition works this year naturally is comparatively small in extent and less attractive, but the collection of works displayed certainly, considering the conditions, must be described as highly creditable to those who remained at their posts. The lady students, as was reasonably to be anticipated, are found very much in evidence, though this, as the competitions for several years have

demonstrated, is no new experience, seeing that the women have many times out-distanced the men in work from the life, in figure cartoons, and in painting. The landscape competition for the Creswick Prize (£25 and a silver medal) this year is in evidence, the result being that two ladies come out at the top, though the entries were more than usually numerous, and, on the whole, the works submitted are highly creditable and above the average. The subject is an attractive one, being a homestead, or "rickyard," to use the official term. We entirely endorse Sir Edward Poynter's remarks upon the merit of Miss Sylvia Ellen Gantlett's winning picture. As he said, it was "not only first in the competition, but the best I have seen during the nineteen years that I have occupied the high position of President. In observation of the true effect of Nature, in the rendering of pure light and transparent shadow, and in study of detail, all of which was carefully given while unobtrusive, and in the quality of the painting simple, but free from pretentiousness of skill which looked clever but meant nothing. This work is worthy of all praise, setting a good example and giving promise of high success in the future." Miss Vera Hook is placed *proximo accessit*, and in such a connection her work deserves a degree of praise which a mere hon. mention would scarcely imply.

The Turner Gold Medal and £50 Scholarship is well won by Mr. Harold Williamson, the subject being "Dawn," and his picture, understood to represent sunrise from Hampstead Heath, is a remarkably fine piece of imaginative painting, with the dark foliage seen, as it were, in silhouette against the glamour of the rosy dawn, treated, as it must be, more from study of lighting effect than by going direct to Nature. The odd-shaped tree rising towards the front of the scene near the middle of the picture is quaintly handled and almost conventionalised in effect, recalling the ideal of an old master. The author has cleverly set out his work by inserting a black slip round the scene and using a broad, flat, gold frame in an adroit and admirable way which is very different from the expedient of painting in a low key to fit the scale of a dirty old gilt frame, often adopted by the so-called "New School." The President said that in this contest there was a tie between two of the works submitted, but he had no hesitation in giving his casting vote which resulted in the award.

"The Triumph of Peace" was the subject set for the design for the Decoration of a Public Building this year, and the result has certainly not been commen-

surate with the occasion, so that the Silver Medal and £30 have not been given. The schemes sent in as a whole tell short of what the President rightly called "Architectonic qualities," which are, of course, indispensable for great decorative designs. Most of the competitors seem to have simply sought to secure a pretty pictorial effect. The winner of the Second Silver Medal and £10, Mr. James Pollard, has pursued a truer decorative method, but his vertical composition falls far short of real success, and the ungainly upraised arm of the warrior, of whom a big cartoon is shown, goes far to spoil the whole scene, which is rather too theatrical and not sufficiently simple for mural treatment on a big scale such as the size of the cartoon determines. Miss Florence May Asher's scheme, placed *proximo accessit*, is in some respects preferable, and her full-size nude female figure has uncommon merit, but the riverside scene hardly realises, perhaps, "The Triumph of Peace," and it is not quite conformable to true decorative design as a panel for a public building in a technical sense. As a picture, however, we prefer her work, and are not surprised that the judges had to appeal to the President to give his casting vote to settle their divergent opinions concerning these twain.

Both the Silver and Bronze Medals for paintings of the Nude from Life were won by ladies, and both are quite excellent in drawing and charm. The first prize was taken by Miss Florence May Asher, and the second by Miss Marjory Florence Mostyn.

The three competitions for which Silver Medals were offered for an Architectural Design with coloured decoration for one bay of the nave of a big church, an original composition in ornament open to architects only, and an interior perspective drawing of St. Stephen's Church, Walbrook, fell through, no one responding. The first Silver Medal also and £15 for an Architectural Design was not awarded, though we rather fancy this decision was not arrived at till the last moment. The second Silver Medal and £10 for Architectural Design was given to Mr. Daniel Roye Lyle (108) for a design of a big set betwixt a pair of piazzas, each leading to an atrium, with a summer and winter withdrawing room at the ends of the building right and left of the block, these apartments being handsomely treated with palatial porches architecturally conceived. The scheme as a whole evinces more than common promise, besides showing good taste and refinement as well as study, for the detail is good and not mediocre. Another competitor

will never be less than one-fourth, and it may be as much as one-half of the first cost of the original structure. The necessity for partial or complete reconstruction of the sanitation is a matter which can only be judged by the individual property. In any case this important detail must be rendered above suspicion. Hot water supply will most likely have to be new throughout, while a system of central heating in some cases will be required as well. Electric light even if already installed will have to be separated into two systems, and the same will apply to the gas supply, which is a most important detail, both for cooking and heating. A certain number of chimney pieces and stoves with tiled hearths will usually have to be provided, certainly for the reception rooms. The decorations will have to be new throughout, and stinting the coats of paint will be found to be false economy, while good wall-papers always attract by giving the finishing touch. One detail which it is almost impossible to be too generous upon is the provision of cupboards, because flats, with which maisonnettes have to compete, seldom have more than one, or say two if the space in which the servants sleep is counted as one.

EXISTING MATERIALS.

In these days of scarcity of timber, every scrap of sound joinery should be preserved and refixed in fresh positions, doors and frames, architraves, windows, panels, skirting-boards, etc., used in again will not only keep down expense, but provide a more seasoned article than stuff newly put together.

SOME STRUCTURAL DIFFICULTIES.

The first most important, and certainly the most difficult, is that of the stairs, for the hardest task an architect is ever called upon to perform is to alter an old or provide a new staircase to an existing building. Like everything else in life, the simplest plan is the best, but inspiration does not always respond immediately to invocation. As soon as the architect has solved the staircase difficulty, the next most important problem is to plan the sanitation, so that, while the Public Health Acts are followed convenience of arrangement is studied and the whole system so designed that pipes of all descriptions are the fewest as regards numbers and the shortest as regards length. In most cases some strengthening will be necessary to the floors, especially of the original bedrooms, which are now to be changed into sitting-rooms, as what is strong enough for a bedroom with its comparatively light and scanty furniture and certainly few occupants is not necessarily strong enough for a sitting-room with, say, a metal frame piano, book-cases, heavy books, weighty tables and chairs, and, at times, possibly a dozen visitors, the latter a moving weight. Another matter which may require attention is the conversion of a room into a habitable apartment which before could only be legally used as a store or box-room. Any reasonable outlay in this direction should be a profitable investment where increased accommodation is effected.

ARRANGEMENT OF THE ACCOMMODATION.

Where the basement is not too extensive and possesses the advantage of being light and airy, it can be often included in the lower suite, which would then comprise the first, ground, and basement floors. This, however, has the disadvantage of possessing three flights of stairs, but as the suite is entered on the central floor and, by including the first floor, the basement can be given up to the domestics, it does not so much matter. The planning on three floors generally means more domestic service, and therefore, two servants, so one of the advantages of compact planning is at once lost. The best plan of all is no doubt to ignore the basement, or at least the greater part of it for letting purposes; and retain it for a residential caretaker, with provision for central heating and continuous hot water. This arrangement allows the lower suite to be entirely planned on two floors, while the upper suite can be arranged similarly on the same number. The accommodation appealing to the larger number of people comprises four bedrooms, bath-room, two w.c.'s, two reception rooms, kitchen, scullery, etc., and in many large houses of five floors, it is possible to get this accommodation contained both in the two lower and two

upper floors. Every inch of space must be utilised, and there must be no dark corners.

CONVENIENCES AND FITTINGS.

Economy of working must be the watch-word, and every detail arranged with this end in view. With central heating and radiators in the principal rooms, and auxiliary gas stoves, the labour and dirt of fires can be reduced to a minimum. With continuous hot water supply the cumbersome range with its extravagant fire is not required, as a gas cooker is all that is necessary in summer, while the smallest and most economical of grates can be used as an auxiliary in cold weather. Lavatory basins with hot and cold water supplies save much unnecessary work in bedrooms, and provide greater convenience. Electric light is so well known as to need no recommendation. Tradesmen's lifts to the upper suite obviate many difficulties, and they should, if possible, be made accessible from a special back-door entrance. One of the most important features is that the entrance should be impressive, and, therefore, sufficient space must be given up for the outer hall, entered through the street door, and from which the two doors lead to the respective suites. The arrangement of the staircase usually has to depend largely upon the original planning of the house, but the smaller the interference with existing stairs (providing they are well arranged), the better the effect and the smaller the expenditure. In some cases, however, nothing but a clean sweep will give satisfactory results. So many alterations of a residence into so-called maisonnettes merely amount to the enclosure of the ground floor stairs, generally by a match-lined partition, with a door at the foot. This is merely dividing the premises into a couple of tenements, the upper one with three complete sets of stairs, and therefore, having all the disadvantages of a house with none of the conveniences of a maisonnette, while the lower tenement comprises the ground floor and the basement with inconvenience of arrangement so palpably in evidence, that this suite, which should produce the larger return, is often empty and never commands a remunerative rent.

ADVANTAGES OF THE MAISONNETTE OVER THE HOUSE OR FLAT.

For a very much lower rent the resident can live in a much better neighbourhood than he otherwise would be able to afford, his payments are inclusive, while his liability for repairs is strictly limited and easily calculated. In comparison with flats, the rents are from 50 to 80 per cent. less, the accommodation is not only much better in every way, as nearly, if not all, the rooms have a bright and open outlook, instead of facing a blank wall in a central area, as is the case in so many flats. There is more privacy, as the stairs are in each case used only by the particular tenant, while, if there is central heating, continuous hot water and a resident caretaker, all the advantages are on the side of the maisonnette.

RENTAL RETURN.

In taking this into account, the price that the existing building would fetch in the open market (not what it originally cost), should be added to the cost of the alterations, and the total treated as capital outlay upon which to reckon the rate of interest returned. The outgoings on a freehold property comprise:—

- (1) Borough rates
- (2) Water rate.
- (3) Inhabited house duty
- (4) Caretaker's remuneration.
- (5) Fuel and sundries.
- (6) External and structural repairs.
- (7) Insurance.

The first two depend on the rateable value, and the rates current in the district, the third upon the amount of gross value. The outlay under 4 and 5 should be calculated and charged to the tenants, while to provide for the sixth item, a certain amount should be put away every year to form a fund available for periodical external repairs. As regards internal repairs, the suites should either be redecorated by the tenants on leaving, or an agreed sum paid by them in lieu thereof.

CLASS OF TENANT TO BE OVERED FOR.

In the properties dealt with, it must be assumed that while the neighbourhood is

eminently good and respectable, a fashionable part of town like Mayfair, or even Belgrave, is not alluded to, but rather Kensington, Bayswater or Chelsea, so that the possible tenants, although of fair position, would be of limited means, of incomes from, say, £2500 to £700 per annum, a rather numerous class who find each year greater difficulty in getting comfortably housed than the much subsidised working man with the buildings where rooms are to be rented upon uncommercial terms. The £2500 to £700 class have had their houses pulled down and replaced by mansions, if not palaces, so that small houses in really good positions fetch rents out of all proportion to their real value, and are therefore prohibitive as regards terms and tenure to this class of tenant. In regard to premises already altered and results so far obtained, these carried out as designed by incomplete buildings in various localities, and practically for all sorts and conditions of men, ranging from semi-shum neighbourhoods to a fashionable watering place, and in most cases the two-floor principle has been adhered to, although the working class maisonnettes were confined to one floor each, while those over shops had to be arranged on three. In all cases the works were carried out in the best possible manner, and where the owners have been sufficiently farsighted to keep them up to the original standard, the rents have been sustained, but where repairs have been neglected the rents have correspondingly fallen. That applies to all property of a residential class, and is often the reason for the deterioration of a neighbourhood.

MAISONNETTES AS AN INVESTMENT.

For purposes of comparison in judging the property from this standpoint, certain points must not be overlooked, viz.:

- (1) The present market value of the property unaltered.
- (2) The outlay required to put it into complete structural, sanitary and decorative repair, in order to secure a tenant in one occupation.
- (3) The sort of tenant likely to be obtained, the amount of rent and conditions as to repairs.

As an illustration, say, a five-floor residence with some eighteen rooms in a neglected condition, and requiring immediate expenditure of some hundreds to put it into order as a single dwelling, will only realise for the fee simple in its present condition, say, £300 but requires an immediate expenditure on structural repairs, new sanitation, hot water, electric light, new decorations, etc., costing, at present rates, say, £450

when complete will let at, say, £100 per annum on a three years' agreement, which, on paper, appears a very good return, but when, as each tenant vacates, a loss of six months' rent is entailed ere the property is let again, and partial, if not entire, redecoration has to be faced, the nominal 3 per cent. is reduced to 4 per cent., and that with much trouble entailed.

Now take the property remodelled. Original value of fee simple of the property in bad order, say, £300
Less costs of sale, £70

£230

COST OF WORKS.

New staircase, new partitions, additional windows (with prismatic glass), new ceiling, roof, etc., turning a room into a habitable apartment, provision of escape from fire, steel work necessary for strengthening upper floors, also 3 in. of concrete over basement with wood block floors	£180
New sanitation, complete with fittings	20
System of heating with radiators, hot water supply, and certain new stoves and chimney pieces	50
Installation of electric light with fittings complete, and electric bells	30
New gas services, heating and cooking for two flats, and lighting and heating for caretaker	20
Internal decorations	100
Cupboards and fittings	20
External repairs and painting	70
General and sundry work	40
	£420

became an artist in his way and took a real pleasure in his task. Every step in training a man to the higher qualities of his craft brought with it new interest and pleasure. There was one great danger inherent in all technical schools, against which the director and masters needed to continually be on their guard—the risk of stifling the originality of the student. There was a great tendency to persuade the student to follow the master's ways unthinkingly. This manifested itself at South Kensington and at the Royal Academy Schools. The highly trained master was tempted to induce the students to do their work in his way, and not to leave them free to exercise their own individuality. This was quite wrong, and if allowed to exist would destroy the originality of the young men. The master ought to welcome every spark of freshness in a student, and not seek to impress his own individuality upon him. He noted that the schools had suffered, like all other institutions of the kind, very seriously from the effects of the war. Many brave young fellows had felt the call to action, and they would never see some of them again in the schools. They looked forward to welcoming the great majority of the students back, and, when victory was gained, to a long period of peaceful and happy fellowship in their educational work.

Sir Thomas Jackson then presented the awards in accordance with the following prize list:—

EXAMINATION IN CARPENTRY AND JOINERY (held in London on June 30, July 1, 2, and 3, 1915).—J. W. Large—silver medal and first-class certificate (H.M. Forces); G. W. Gathercole—bronze medal and first-class certificate; A. E. Walker—bronze medal and first-class certificate. First-class Certificates: J. E. Fell (Grantham); T. S. Henley; D. F. Hilliar (Parkstone, Dorset); L. E. Trovers. Second-class Certificates: W. T. Wells (H.M. Forces); I. T. Wiggitt (Newport, Mon.).

TRADES TRAINING SCHOOLS.

Carpenters: Thomas James Woodard—certificate and £2 in books or tools; J. Harold West—certificate and £1 10s. in books or tools; Cecil Davies—certificate and 15s. in books or tools.

Joiners: G. Austin—Alexander Howard medal and £2 in books or tools; W. S. Hales—certificate and 15s. in books or tools; J. Dipple—certificate and 10s. in books or tools.

Handrailing: H. G. Howe—silver medal (presented by the Joiners' Company) and £2 in books or tools; E. C. Owen—certificate and £1 in books or tools; W. Chance—certificate and 15s. in books or tools.

Masons: Herbert George Bush—Banister Fletcher medal and £2 in books or tools (H.M. Forces); Henry Joseph Maibach—certificate and £1 10s. in books or tools (H.M. Forces); Richard Sherman—certificate and £1 in books or tools (H.M. Forces); Frederick James Moore—certificate and 15s. in books or tools; Horace James—certificate and £1 in books or tools.

Painters: Edward Leander—silver medal and £1 in books or tools; William Bedford—bronze medal and £1 in books or tools; E. Fowler—certificate and 15s. in books or tools; L. Nailor—certificate and 10s. in books or tools (H.M. Forces); W. Giddins—certificate and 10s. in books or tools.

Plasterers: Thomas McDonnell—silver medal and 15s. in books or tools (H.M. Forces); Alfred Austin—bronze medal and 15s. in books or tools; James Donovan—certificate and 15s. in books or tools; John Lowe—certificate and 15s. in books or tools; Stanley Thresher—certificate and 10s. in books or tools; Walter Pettitt—certificate and 10s. in books or tools.

Plumbers: Albert Henry Briffett—silver medal and £1 in books or tools; Alfred Griffey—silver medal and 10s. in books or tools; William Parson—silver medal and 10s. in books or tools; Charles Lambure—bronze medal and 15s. in books or tools; Charles Porter—certificate and 15s. in books or tools; Henry James Briffett—certificate and 15s. in books or tools; Percy Harris—certificate and 15s. in books or tools.

Smiths: Harry Collins—special prize of £2 in books or tools; Harold Pound—special silver medal and £1 in books or tools (former recipient of silver medal); S. Jones—bronze medal and £1 in books or tools (presented by the Blacksmiths' Company); S. Blake—certificate and 15s. in books or tools.

Stone Carvers: Alfred Phillips—bronze medal and £1 in books or tools; Reginald

Phillips—certificate and £1 in books or tools; William Cooke—certificate and £1 in books or tools; F. C. Large—certificate and £1 in books or tools; John Stock—certificate and £1 in books or tools.

Life Class: Alfred Hardiman—special prize of £2 in books or tools (former recipient of first prize); F. R. Hodges—special prize of £2 in books or tools (former recipient of first prize); Herbert Hart—certificate and £1 in books or tools; William Wheeler—certificate and £1 in books or tools.

Tylers and Bricklayers: Albert Henry Smith—silver medal and £1 in books or tools; George Henry Wilmet—silver medal and 15s. in books or tools; George John Reynolds—special prize of £2 in books or tools (former recipient of silver medal); Alfred Hurst—certificate and £1 in books or tools; George Wm. Billingham—certificate and £1 in books or tools; James Walsh—certificate and £1 in books or tools; Joseph Henry Grove—certificate and £1 in books or tools (H.M. Forces); Francis George Bond—certificate and 10s. in books or tools; George Wilks—certificate and 10s. in books or tools; Harry Wiles—certificate and 10s. in books or tools.

Whitewashers: W. H. Dawson—certificate and £1 10s. in books or tools; F. Mitchell—certificate and £1 in books or tools; G. Packham—the master's prize, £1 in books or tools; M. Ellis—certificate and 10s. in books or tools.

Wood Carvers: James Shirley—certificate and £2 in books or tools (H.M. Forces); Frederick Devise—certificate and £1 in books or tools (given by the Joiners' Company); Harold Crow—certificate and £1 in books or tools; Thomas Waltham—certificate and £1 in books or tools; Hugh Chitham—certificate and £1 in books or tools; Ernest Brock—certificate and £1 in books or tools; Sidney Lett—certificate and 10s. in books or tools (given by the Joiners' Company).

Wiremen: A. E. Darlow—certificate and £1 in books or tools; A. Jordan—special prize of £1 (former recipient of first prize); A. V. Morgan—certificate and 7s. 6d. in books or tools (H.M. Forces); G. Hastings—certificate and 5s. in books or tools; H. Rickard—certificate and 5s. in books or tools; P. Doady—certificate and 15s. in books or tools; H. A. Murphy—certificate and 10s. in books or tools.

A vote of thanks to Sir T. G. Jackson was proposed by Mr. W. Hayward Pitman, past-Master of the Painter-Stainers' Company, and seconded by Mr. F. L. Wighton, Master of the Joiners' Company, and a similar compliment to the Chairman on the motion of Mr. John Marsland, Master of the Tylers and Bricklayers' Company, and Mr. F. Costello, Master of the Plasterers' Company, concluded the proceedings.

THE ARCHITECTS' AND SURVEYORS' APPROVED SOCIETY.

The annual general meeting of the Architects' and Surveyors' Approved Society was held on Tuesday, December 7, 1915, at No. 18, Tufton Street, Westminster, S.W., when Mr. Ernest Newton, P.R.I.B.A. (retiring president of the society) occupied the chair.

Mr. F. R. Yerbury (secretary) gave a statement of the progress and work of the society. Approximately there were, on July 3, 1915, 1,800 members of the society, of whom thirty-six were women. These figures show an increase of 160 during the year.

It will not be possible to ascertain definitely the exact financial position of the society until the official Government valuation has taken place. This valuation, which became due when the Insurance Act had been in force for three years, will no doubt take place shortly, and the committee confidently anticipates that an extremely satisfactory state of affairs will be revealed. In the meantime, the society has investments to its credit amounting to £2,140, £700 of which consists of new Government 4½ per cent. War Loan Stock.

The claims paid by the society during the year have been as follows:—Men: Sickness claims, 96; maternity claims, 48; disablement claims, 4. Women: Sickness claims, 6.

The amount actually expended on sickness and maternity benefit during the year has been considerably below that allowed for by the Government actuaries. At the present time there are over 600 members known to be serving with the forces, and a very large percentage of these hold commissioned rank. From the committee of management, Messrs.

Maurice E. Webb, C. T. Steward, W. G. Newton, and H. A. James, are serving. It is with the deepest regret that the committee records the deaths of five members on active service. An expression of sympathy on behalf of the society has been communicated to the relatives in every case. The benevolent fund, which is supported by contributions and annual subscriptions from honorary members, has fortunately had no great calls upon its resources, but it has been able to render some really valuable assistance to certain members in urgent need of it.

Mr. Philip E. Webb (who is retiring from the office of treasurer on account of his enlistment) spoke on the financial position of the society.

Mr. Ernest Newton moved the election of the committee of management as follows:—Chairman, George Corderoy, F.S.I. Members: E. H. Blake, F.S.I.; C. MacArthur Butler, F.C.I.S.; A. G. Cross, F.S.I.; Ralph Ellis, F.S.I.; H. M. Fletcher, F.R.I.B.A.; A. Goddard; George Hubbard, F.R.I.B.A., F.S.A.; H. A. James; B. Marr Johnson, F.S.I.; R. G. Lovell, A.R.I.B.A.; Ian MacAllister, B.A.; E. C. P. Mounson, F.R.I.B.A.; W. G. Newton, M.A., F.R.I.B.A.; Herbert Passmore, F.R.I.B.A.; E. R. Priest; G. Reeves; Clifford T. Steward, F.S.I.; H. W. Virgo, Maurice E. Webb, M.A.; Philip E. Webb, A.R.I.B.A.; H. D. Whitham, Treasurer, H. D. Searles-Wood.

The motion was seconded by Mr. George Reeves, and carried unanimously.

Mr. George Corderoy, replying on behalf of the committee, endorsed Mr. Webb's remarks. Mr. George Reeves proposed a vote of thanks to the Architectural Association for granting the society free office accommodation. Mr. E. C. P. Mounson (president of the Society of Architects) seconded the motion, and it was carried unanimously.

Mr. Ralph Ellis proposed a vote of thanks to the retiring president, Mr. Ernest Newton, who was kindly presiding in the unavoidable absence of Mr. J. H. Hanson (president of the Surveyors' Institution). He regretted to say that Mr. Hanson was at present seriously ill. The motion was seconded by Mr. H. D. Searles Wood, and carried unanimously. Mr. Newton, in expressing his thanks, proposed that the secretary should write to Mr. Hanson, conveying the society's sympathy and hopes for a speedy recovery.

ARCHITECTS' AND SURVEYORS' APPROVED SOCIETY BENEVOLENT FUND

By Grants to Members of the Architects' and Surveyors' Approved Society	£9 14 6
Balance at Capital and Counties Bank, Victoria Street, on November 1, 1915	54 15 6
	<hr/> 494 10 0
November, 1912, to November, 1915	
To amount received for Hon. Members' subscriptions and donations	£91 10 0
To interest received on amount placed on deposit (1915-1916)	3 0 0
	<hr/> 494 10 0

We have examined the account of the Benevolent Fund as set out in the books, together with the vouchers for payments, and are of the opinion that the above balance-sheet correctly shows the position of the Fund at this date.

(Signed) FRANK R. PRIEST,
G. TURVILLE BROWN,
(Hon. Auditors).

November 1, 1915.

OBITUARY.

Mr. Frederick Simon, M.I.C.E., has died at the advanced age of eighty-one years. A pupil of the late Charles Vignoles, F.R.S., Mr. Simon, who was born in Jamaica, was one of that engineer's assistants in the making of the Bilboa and Tudela Railway, Spain. In 1864 Mr. Simon proceeded to Mexico, where he was engaged on the Imperial Mexican Railway. Twice during the Mexican revolt he was captured by bands of outlaws, and once he was ordered to be shot. Finally, he marched to the coast with the French Army under Marshal Bazaine, and returned to England in 1867. After several years in India on irrigation work in the service of the Public Works Department, Mr. Simon returned for a time to Mexico to assist in the making of the National Mexican Railway.

NATIVE TIMBER BEFORE, DURING, AND AFTER THE WAR

By RICHARD CLARKE, DISTRICT FORESTER, F.S.I.

As the war has proceeded, and present prices have risen, the M. P. has proceeded to discuss the subject.

STATUS OF NATIVE TIMBER

It is a well-known fact that detailed suggestions, especially those of a technical character, are more likely to be accepted if they are made by a person of known standing.

The scattered and distributed nature of the sources, and the varied character of the products, are the chief factors.

High railway rates and cost of haulage, and the wide distribution of supplies.

Want of enterprise and lack of initiative on the English timber trade, especially by the best and largest merchants, who are now interested solely in the foreign trade.

A lack of organised effort on our part to overcome difficulties.

A failure to see that the position is capable of improvement.

It is not my object to exaggerate these handicaps, but it is important to take them into consideration, and I refer to them later. I will now discuss the detailed suggestions, and will explain what I mean by "organised effort."

It is difficult to narrate details of the marketing of oak, variety, and, since the subject is so important, as the satisfactory disposal of oak, I will treat this timber fully in the others more generally. Please note, especially, that I am dealing with the matter locally, and it will depend upon the quantity and character of timber in any locality that any remarks will apply to any particular district. I deal with the war under a separate paragraph, and my arguments and conclusions apply to pre-war conditions.

MARKETS FOR ENGLISH OAK

We may divide the markets for oak into three classes, according to the size and quality of the trees.

1. The first class covers the largest and best trees, suitable for quartering, for which purpose character is important, but each of them is not necessarily required. Omitting ordinary spokes and other special war requirements, the best market for these trees is for panelling and for the various requirements of the building trade. The oak most generally used for these purposes is Austrian oak; but it is admitted to be strong and that, although a straight timber and easier to work than English, and therefore preferred by joiners, yet, as regards strength and other important features, is inferior. English oak is preferred for the manufacture of Austrian wood for the furniture. I have seasoned wood before the war, as at the rate of 10s. per cubic foot. Panelling made of English oak is now sold at a higher price than Austrian.

In the second class, the mass of the timber in the country, the marketing is looked upon as a secondary matter, and its fact alone is the determining factor. A large contract for the manufacture of English oak for the manufacture of furniture, and the cost of the material is the only consideration. Spanish oak is the most popular for quartering; but, as regards the timber, most the product is of a low quality. White-felled oak is preferred for the manufacture of furniture, and is now becoming a more important item. The price of the material is the only consideration.

The third class covers the small trees of under 20 cubic feet, which, on account of small size, large proportion of sapwood and to the high railway rates, should be converted principally locally. There should be ample room for increasing the demand for this converted oak in the great wood-consuming centres, where enormous quantities of oak are used. Many local markets also could be cultivated to a far greater extent than they are, such as gates, fencing, building fittings, repairs, and local requirements generally. Native timber could be used to a far greater extent in the district in which it is grown.

board a minimum of two years from the felling. Some might think a little longer seasoning advisable if artificial methods are not resorted to, but a very short time is necessary with the best modern artificial drying plants. The results are quite satisfactory, and I would point out that nearly all the much-advertised foreign timber is seasoned by these modern methods. The ancient prejudices against artificial seasoning of oak were due to the inferior results given by experimental stages. Again, objections that might be raised against seasoning oak artificially for shipbuilding or similar special purposes need not apply to timber required for panelling or interior work, or used under conditions which entail neither strain nor exposure to the weather.

Turning to the price, I think you will agree that, after allowing liberally for waste, cost of felling, hauling, transport, conversion and seasoning, the price which the producer receives for the standing oak tree differs ridiculously from that paid by the contractor for the same timber in 4 inch boards.

Much Austrian oak has been used for panelling and similar purposes, and there should be in the future a sufficient demand for all the English oak we can offer, provided the demand is cultivated and the market properly organised. Unfortunately this class of oak is now converted for interior purposes.

2. The second class of oak is the coppice-grown oak averaging 25 to 50 cubic feet per tree, for which the present largest outlet is the wagon and carriage departments of our railways. This is cultivated by English timber merchants, who have to compete principally with the white American oak, or, in some cases, with Russian oak or even Australian woods. The oak is converted into wagon scantling, and the price varies according to size, quality and specification; but we may assume an average figure for the converted timber of, say, 5s. 6d. per cubic foot. Thanks to the great superiority of English oak for this purpose a far wider demand should be possible at considerably enhanced prices, if united action were taken to encourage it and improved methods of marketing were organised. Owing to the ease with which the foreign oak can be obtained, and the greater trouble caused to the railway officials by the native timber, there is a prejudice against the latter, but it is absurd that native oak, much more valuable for this purpose, should invariably be priced at the same figure as the foreign.

3. The third class of oak comprises the small trees of under 20 cubic feet, which, on account of small size, large proportion of sapwood and to the high railway rates, should be converted principally locally. There should be ample room for increasing the demand for this converted oak in the great wood-consuming centres, where enormous quantities of oak are used. Many local markets also could be cultivated to a far greater extent than they are, such as gates, fencing, building fittings, repairs, and local requirements generally. Native timber could be used to a far greater extent in the district in which it is grown.

There are other outlets and uses for oak of various sizes and quality in London and other centres at correspondingly diverse prices, ranging from the high-priced Austrian of best quality to the various classes of American oak at prices ranging from 3s. 6d. to 6s. per cubic foot for converted sizes. The lowest is probably American windowsill oak at about 3s. per cubic foot, in which a proportion of sap is allowable. There has been an increase in price of nearly 5 per cent, since 1895 on lower classes of imported oak and also a decrease in quality. Much of our English oak might be suitable to replace these foreign grades, but the cost of marketing must determine what can be done in each instance, and competition might not be practicable in all cases. As I have shown, the present consumption of oak of all sorts is enormous. The imports of oak exclusive of staves and parts in 1915 exceeded 12 million cubic feet. As the demand improved and the market became better organised, we might expect to find plenty of scope for all the oak we could offer.

One of the staple objections taken to English oak is that it is harder than foreign. This should make English oak the timber par excellence for wood-block flooring—to name but one use in which such a characteristic is a recommendation. Yet, in spite of the large and increasing demand for wood-block flooring at good prices, there never has been any serious attempt to capture this and similar markets for English oak, and the softer foreign oak holds the field.

Again, take the question of oak spokes, for which the native timber is absolutely unequalled. Although the English market was flooded with cheap American spokes several years ago, and although the importation is still large, the price of these spokes has increased very considerably during the past ten years, and especially during the two years previous to the outbreak of war. Not only was there this considerable increase in price, but, as in the case of foreign timber generally, there was a considerable falling off in quality. We have an exceptional market for spokes; we have the finest timber of its kind in English oak for this purpose; we have large supplies of this timber obtainable at low prices; and yet there has been no serious attempt to retain or capture the spoke trade for this country.

I am quite aware that the introduction of motor vehicles has recently partially revolutionised the spoke trade, and that the introduction of iron or wire wheels would possibly appear to have restricted the market for wooden spokes. But here, as in other instances, restriction in some directions is accompanied by wider opportunities in others, and modern increased facilities for transport and travel greatly increase the number of vehicles required. The spokes used for high-class carriages for a long time past have been made principally from imported wood of special varieties. There has been, of course, a falling off in the quantity of spokes wanted, but the number of horse-drawn carts and other vehicles for agricultural purposes, local trades, and commercial industries generally, is still very large, and will not be greatly reduced by motor traffic in the near future. There are also great possibilities for English oak in the motor spoke trade.

These are only a few out of many directions where the conditions, possibly unfavourable twenty years ago, are now propitious to successful competition by the native produce. We must, however, instil enterprise into the native trade and surmount the difficulty of capital. We must also assist by organised marketing and regular supplies of the necessary timber, and to everything possible to cultivate the demand for the native produce. There are many other existing and suggested outlets for oak, but the above must suffice as an illustration.

METHODS OF MARKETING.

Having pointed out improved and proper outlets for our timber, it is now important to consider what is the most practical method of catering for these markets which lie open before us, and how we can take due advantage of these wider opportunities.

I will again take oak as an illustration, although similar arguments will apply to other timbers. The exact methods will depend on locality and character of timber.

We must appreciate fully all the existing conditions relating to the marketing of timber, and must shape our policy accordingly. In some cases it will be practicable for large merchants to purchase the timber standing, and arrange all details as to marketing. Facilities are necessary for estates to get in touch with such firms, and also to enable a firm to purchase timber from several estates in a district. In other cases large merchants and firms in London and other centres might require selected parcels limited perhaps to one variety. It might be difficult also for them in some cases to send teams and tackle for hauling, or gangs for felling, or to inspect small and detached parcels.

We all wish to assist any honest and old-established local firms who have dealt with estates for a number of years, and whose principal business fault, perhaps, is an old-fashioned conservatism, or want of capital. The local firm has knowledge of local condi-

tions and of felling and hauling, and can convert the smaller classes of trees, but it is want of capital that limits its trade.

I think it will oft n be best for the large firm at a distance to act in conjunction with the local firm, the latter felling, hauling and dealing with mixed parcels, and the former storing, marketing and cultivating the demand for the timber. For instance, the London or other large firm would purchase the first class of oak to which I referred, delivered on rail. The same principle might apply to ash, beech, and other classes of our timber. The local firm also, to a far greater extent than at present, could convert to the requirements and specification of the large firm in the consuming centre. Markets should be organised between producing and consuming centres so as to reduce expenses, railway charges especially.

I am not wishing to prejudice the trade and output of the local firm. There are many directions in which this might be encouraged or developed. And I appeal to landowners and land agents to specify native timber wherever possible. My object is to take advantage of those more lucrative markets to which I have made reference, but which at present are not developed for want of organised marketing; especially to encourage large firms who now deal so exclusively with imported timber to take up the marketing of the native timber and introduce capital, enterprise, and knowledge into the native timber trade. My object is also to organise marketing so as to eliminate unnecessary profits caused by the timber passing through so many hands.

A small amount of English oak is sold in spasmodic quantities somewhat on the above lines at present to a few large firms who have occasional inquiries for the timber. These inquiries are due to a few architects and other consumers who absolutely insist on English oak being supplied. No attempt, however, is made to deal with the problem on an organised and large scale, or to cultivate the demand for the native timber.

I have already detailed the handicaps with which the native timber has had to contend, and it is not necessary to explain the reasons why these better markets have not been cultivated. It is due principally to a succession of unfortunate conditions and influences. The architect and consumer complain of the difficulty or impossibility of getting the timber, and of there being no firm generally known to stock it. The contractor and builder inform them that supplies of English oak are not available, and persuade them to accept the readily obtained foreign timber. The large merchant says he is not asked for it, and the local merchant complains that there is no demand for it. And so one works round and round in a vicious circle.

The only method of dealing successfully with this problem is that an influential independent body should take up the matter and to organise supplies, and demand on proper lines and on an extensive scale. This is to be done by the English Forestry Association, who have formed a special committee to deal with the question, and on which committee this Institution and other bodies are represented. It is to the interest of all sections that this work should succeed, and to the prejudice of nobody, and, in view of the importance of diminishing imports and encouraging native supplies, I trust that everyone will render all possible co-operation and help.

I have taken English oak as an illustration, but I do not think there is any country whose native timbers and native industries experience so deplorable a lack of encouragement as our own. It is typical of the present position that our finest brown oak has to be exported to America to be appreciated, and that the high prices paid are due entirely to the foreign demand, to which the present consumption is almost wholly limited.

I believe that with organised marketing and proper encouragement there are outlets for English oak and other native timbers abroad, particularly in America and some of our colonies, and I hope, in the future, with our present allies. Let us hope that in the rebuilding of public buildings, churches, and

large residences in Belgium and France, the world-famed English oak shall find a place, if only as a memento of the war in which the nations have jointly shed their blood. What reminder could there be more typical of England and of the far-reaching influence of the British Navy, whose glorious history was founded on English oak?

As regards timber other than oak, I should hope to publish information and suggestions elsewhere, since I cannot explain this here. After years of careful investigation it is my opinion that given organised marketing, increased demand and improved prices are possible for nearly all kinds of native timber, and hardwoods particularly.

REPLACING EXPORTS.

We all welcome suggestions for extending the use of native supplies and displacing some of the imported timber, but I think that undue importance is often given to coniferous timber (excepted, to the exclusion of our relatively more important hardwoods. By providing native Scots pine for the Forestry Building at the Shrewsbury Royal, Snow and otherwise advertising it, I have tried to encourage its extended use and have organised supplies of it for cross-slab boards and other estate purposes. I think, however, that as a general policy we shall have a far better hope of success if we concentrate most of our energy on extended uses of native hardwoods. There is ample room for these woods in place of imported varieties of similar timber, and as a substitute for such timbers as Hickory and some of the finer foreign timbers. I would go even further and advocate that, given enterprise and proper encouragement we could with native goods displace some of the wood imports that arrive in a finished or partially-manufactured state. I hope that far greater attention and encouragement, especially by consumers and the public, will henceforth be given in this direction.

Taking all the facts into consideration, I think it will be agreed that it should be easier for English oak to compete with Austrian or American oak for building or other trades than for much of our native Scots pine, as at present grown in English woods, to compete with first, second, or even third Archangel. I would point out that our hardwoods are more plentiful and important; they are generally of comparatively better quality and possess superior characteristics; being higher priced, they can bear more cost in transport, and for many purposes length or freedom from knots is not so vital. Moreover, imported hardwoods usually have higher freights to pay than the nominal return freights which the large Baltic supplies enjoy.

I think, therefore, that, speaking generally, most of our present supplies of native Scots pine timber would be better used for sleepers, wagon battens, fencing, and many colliery requirements than if converted into scantling or building timber.

By encouraging our hardwoods we shall also encourage wood industries that can be carried on in the provinces and rural districts.

CONSUMERS OF NATIVE TIMBER.

The responsibilities and duties of the producer of timber in this country are constantly emphasised in the press, but never the obligations of consumers and manufacturers to use native supplies. Consumers and manufacturers have drawn their best labour from rural districts, and surely they have obligations in return to these districts. They have benefited far more than the much-abused land interests from the resources of the country, to which they owe a correspondingly greater debt. I think that many consumers would have felt far more comfortable at various periods of this war had there been larger native supplies available, or had planting in the past not been so much discouraged by consumers. This is not the time for vain regrets or accusations; we have all made mistakes, and the best course is for all sections to unite in preventing their repetition.

THE TIMBER TRADE.

All members of the native timber trade complain of the present poor demand for English timber, and the generally unsatisfactory state of affairs. Wheat at 20s. per quarter was

bad for the home merchant, for the producer, and for all interests. Good English oak at 1s. 6d. per cubic foot is equally bad for all. The native timber trade has been particularly short-sighted in thinking only of cheap buying instead of paying most attention to cultivating the consumer, encouraging the demand, and selling in the best market. I have no hesitation in saying that timber rings have been the cause of the native timber trade, and have largely contributed to the present position. They have inflicted great damage on the timber trade itself. They have brought discredit on what is an honest and honourable calling; they have prejudiced producers against improving their woods, and consumers against using native timber; they have diverted necessary capital from the industry, and have throttled enterprise so needful for competing with imported timber.

I have no wish to dwell upon the unfortunate practice of timber rings. I appreciate fully the depressing and anxious period through which the native timber trade has passed during the last thirty years.

I now appeal to members of the timber trade to decline to support, and, in fact, to deal severely with, those who try to form rings and prevent legitimate competition.

Merchants often criticise not always in the most complimentary terms our ignorance of the requirements of their trade, and of the variety, size and character of the timber that should be grown, and of its marketing. They are often mildly suspicious, however, when we discuss trade requirements, imagining that we wish to enter the timber trade.

It is important that people interested in woods should be better informed as to the markets for timber and the requirements of merchants and consumers. The various timbers can then be placed on the market more in the form required by purchasers and particular trades, and so secure the best results. It is part of the English Forestry Association's work to give information on these points.

Since our main object is to encourage the demand for the timber, and to see that this demand shall be properly met, the Association should receive the hearty support of the timber trade.

I would appeal strongly to the timber trade to cease from so constantly decriing native timber. It is perfectly natural that a merchant should wish to buy as cheaply as possible, and with that view to enquire on the inferiority of the timber he is good enough to purchase. I fear we take many of these bargaining criticisms far too seriously, and that they are advertised far too generously to consumers and others. For many of the best markets in oak, diameter is much more important than length of butt; but, because want of length is a fault that can be raised, we are apt to think that length is all important.

The native timber trade is carried on under many difficulties; we can do much to help place it on a more satisfactory footing, to the advantage of all concerned. I would appeal for a better spirit of co-operation, and would ask the trade to institute enterprise in developing new markets. Merchants must see that we cannot allow the welfare of our woods to be prejudiced.

ENGLISH TIMBER DURING THE WAR.

A detailed report of the demand, sales, and prices of English timber since the outbreak of war would be interesting but very long, and I can here deal with the matter in general terms only. I have also a rooted objection against quoting prices, excepting to illustrate a point, if separated from details of locality, quantity, size, and character of the trees, cost of transport, etc. It is common knowledge that good prices have ruled for ash and other timbers in special demand, although I fear that in many cases the landowner did not receive his proper share of the increased price. Without wishing to labour a point unduly, I think all must admit that the war has illustrated strikingly the great importance of organisation in marketing timber, and the very great need of a central body to keep owners and agents informed as to what is or is not in demand, and guide them as to prices ruling.

The great demand has been for ash for all kinds of military requirements, for general service and limbered wagons, for felloes, for

plank, boards and ribs, for tool handles, for packing pegs, and, in fact, for any purpose, waste elasticity and strength combined are required. The demand shows no present signs of subsiding, and landowners should do what is possible, so as to help with the supply of timber, and obtain record prices, for the purposes of the importance of place in the market of what is in special request, and the possibility of reserving oak or other timber for when the demand is not pressing. The demand for wood is wanted as to the prices in the various markets and prices and the demand for the different timbers. Many people are surprised, because they have not commanded a ready sale for their wood at a high price during the war. The demand for oak has been greatly handicapped by the various works (such as railways), post-roads, and the building of the various parts of a firming their activities to the various parts of the nation and war supplies. The demand for ash and other timbers for building purposes, combined with the various difficulties due to the various parts of the commanding of the various parts of the merchants concentrating their efforts on these timbers to the detriment of oak, etc.

The great dearth of sawyers and difficult attending conversion have affected demand on various timbers. It has had also the same result that, although small larch, Scotch, etc., found a ready sale at good prices for pit wood, etc., the larger sizes were often difficult to dispose of, even at lower prices. Sawyers have commanded a record price, and it is regrettable that our Scotch could not be converted much more extensively for the various other purposes connected with camps.

Being owing to its freedom from splitting and its general toughness, has been in demand for our use as war purposes, and also in some districts for chair seats, boat building, etc.

It has been in demand for tent pegs, chairs, trunks, furniture, toys, and all descriptions of turned parts.

Very prime oak has been in demand for military purposes and general service and limber wagons, and for various purposes.

There has been a large demand in some districts for coppice poles and inferior timber and thinnings for defence work, barbed wire entanglements, fuel for the camps, and other uses.

The actual demand for any particular class of native timber depends on sizes and other parts, but partly on the actual locality in the various parts of the country, and whether a particular district or other special demands within each of the district.

Dealing with the native supplies is now almost entirely dependent on labour and other factors, and also transport by rail. These factors are known to all and apply in every direction. It is needless for me to enter into the very serious nature of the position, particularly when all the native supplies are so urgently required for military purposes for our own industries. I am not sure that a way out of the difficulty ahead will be found, especially in view of the difficulty and cost of shipping, the increase of the foreign exchange and stoppage of the ports, and the necessity of being more dependent on the Baltic or other supplies.

NOTE ON THE SALE OF TIMBER.

It is a sad fact that, in connection with the various works, large sums have been lost in the various years, simply through lack of the necessary preparation about the sale of timber. The various estates command the services of the various parts of the country, and can afford to employ the various parts of the country. There is a great deal of timber in the country, however, and it is a great pity that the various parts of the country do not have a permanent and efficient system of timber sale. The various parts of the country are so interested in the various parts of the country, and it is a great pity that the various parts of the country do not have a permanent and efficient system of timber sale. The various parts of the country are so interested in the various parts of the country, and it is a great pity that the various parts of the country do not have a permanent and efficient system of timber sale.

producers has depressed prices, encouraged timber rings, and is particularly unfair to adjoining estates. It is, therefore, important that there should be facilities for obtaining experienced men to advise when advice is needed.

FORESTRY MUSEUM.

You will notice that the planks exhibited in this room are from the Institution's Forestry Museum. This museum was founded by Mr. Daniel Watney during his presidential year. I have been for some time reorganising this collection. Although it is slow and often discouraging work collecting good specimens of timber or other exhibits, I hope soon to make the collection a really interesting one. The upper floor has now been extended, so that we have more room for specimens.

I should like to state briefly the basis on which the exhibits will be arranged and the objects in view. We desire to interest three sections of members particularly: (1) Students who wish to study the exhibits with reference to forestry or architecture; (2) land agents or others interested in the production and commercial utilisation of timber; (3) architects, building surveyors and others interested in specifications for building construction.

In the botanical cases each tree is described botanically and illustrated by photographs of the tree in summer and in winter, with examples of the foliage, bud, twig, bark, timber, seed, and other features. There are many examples of the timbers of various trees, illustrated by cross and tangential sections. There are also photographs of fine specimens of trees growing in this country, taken principally from Messrs. Elwes and Henry's well-known book.

Planks are included of different timber as a basis for comparison of structure, rate of growth, proportion of sapwood, and other points. Both knife and saw-cut veneers of English timber are shown; also exhibits illustrating important points in forestry, injurious insects, effects of bad pruning, examples of oak paneling, the conversion of oak, etc. I hope to include an exhibit illustrating the conversion of coppice for rural wood industries. The specimens are now being re-labelled, and as much information as possible included on each label.

An exhibit which I hope will be of special interest is that of building timbers, which is now being arranged. This covers the timbers used in the building trade, showing (1) the popular and botanical names of the tree from which the timber is sawn; (2) the various names by which the timber is known in the trade and the country from which it is imported. Our familiar "Scotch," for instance appears as follows: "Scots pine (*Pinus sylvestris*), timber imported under the name of 'Baltic fir,' 'red deal,' 'red fir,' 'yellow deal,' 'Archangel,' etc." I hope also to illustrate trees whose planting in this country is advocated, such as Douglas fir. I shall include instances of the timber imported under the names of "Oregon pine," "Columbian pine," etc., and examples of the timber of the same species grown in this country. This will enable architects and land agents to appreciate the possibilities of our home-grown Douglas fir.

Other countries and colonies have exhibits in London and elsewhere, of their native timbers, and I should like to make this a fine permanent collection of English timber. The museum might then become the recognised exhibition of English timber and forestry, and I hope would do justice to and be a worthy memorial of its founder, our senior past president.

I appeal to members to take an interest in this museum. We shall welcome exhibits of general interest, and, especially, good specimens of native forest produce. Our space being somewhat limited, I do not wish to include too many "monstrosities."

I hope to arrange an exhibit illustrating the timbers required for the war, so members will appreciate the timber in demand and its uses.

ENGLISH FORESTRY ASSOCIATION.

I referred to the above in a previous paper, and I have further illustrated its work in this. The Association was formed, after

thorough investigation of all aspects of the forestry problem, to find a solution which, I am convinced, is bound up with the extent of the support it shall receive.

We now have a golden opportunity to try to remedy matters by joint action, since the public is sympathetic in discouraging imports, and consumers wish to avail themselves of native supplies.

An independent and influential body can succeed where individual and unorganised efforts would fail. A central body in close touch with estates, merchants, and consumers, must possess special information and be in a far stronger position to ensure good results in the sale of timber than are individuals working separately.

Let me summarise some of the details of our work:—

1. We keep a register of firms who supply goods made from English timber, and we give their names to Government departments and to all other people open to contracts or sales.
2. We keep a register of consumers who require English timber for their business, and we help them in every way possible to obtain, with the least trouble, the necessary supplies of the most suitable timber.
3. We keep a register of timber merchants, with details of the timber they consume or special trades for which they cater; we give their names where converted timber or such goods as they supply are required; and assist them in competing with imported timber. We also put them in touch with estates which have timber for disposal, and help them to secure the supplies of timber which they require.

4. We place estates who write to us offering timber for sale in touch with merchants requiring timber, selecting the best buyers in each case.

5. We collect and classify valuable information on practical points concerning timber and its markets, and we issue this information in leaflet form. We have experienced representatives in different districts, and give to members information relating to local and special demands. Only by means of a fuller knowledge of every section can we make proper use of our native supplies and their markets, and ensure each section receiving its due part of the price paid by the consumer.

We are not yet through this war, and it is impossible to foresee what the future has in store or what demands there will be on our native timber. We are dependent on other nations and on our shipping for the imported timber, and it would be serious for the country if the Baltic or other supplies were diverted or restricted from any cause.

When a struggle extends to the full resources of a nation it is a case of exhaustion in the final stage, and organisation must be a large determining factor at the time, and also as to the extent of the resulting injuries.

Again, no one can foretell the after-war conditions. Germany, like the United States of America, is more powerful as, and more adapted to be, a commercial than a military nation. We cannot foresee the industrial war which may follow the declaration of peace. We were unprepared for this present war, and are we all doing our best to prepare for an industrial war?

It is a time of great national emergency and there are great issues at stake in every direction, and particularly in the case of the native supplies of timber. Instead of being forced into action let us show what we can do by voluntary effort and give a lead to the country. By joint action we shall then be prepared for any emergency, and in any case we shall be able then to place English oak and our native timber in the position which they ought to occupy.

The Senate of the Queen's University, Belfast, have resolved that a tablet to the memory of the late Mr. W. H. Lynn, R.H.A., architect, be placed in the Examination Hall. Mr. Lynn was long and intimately connected with the University as consulting architect, and, by his will, a generous benefactor. The Senate of the University have also appointed Mr. R. M. Close, of Douggall Square North, as consulting architect in succession to Mr. Lynn.

LIBRARY
UNIVERSITY OF
MICHIGAN
ANN ARBOR MI 48106

THE BUILDING NEWS, DECEMBER 15, 1915.



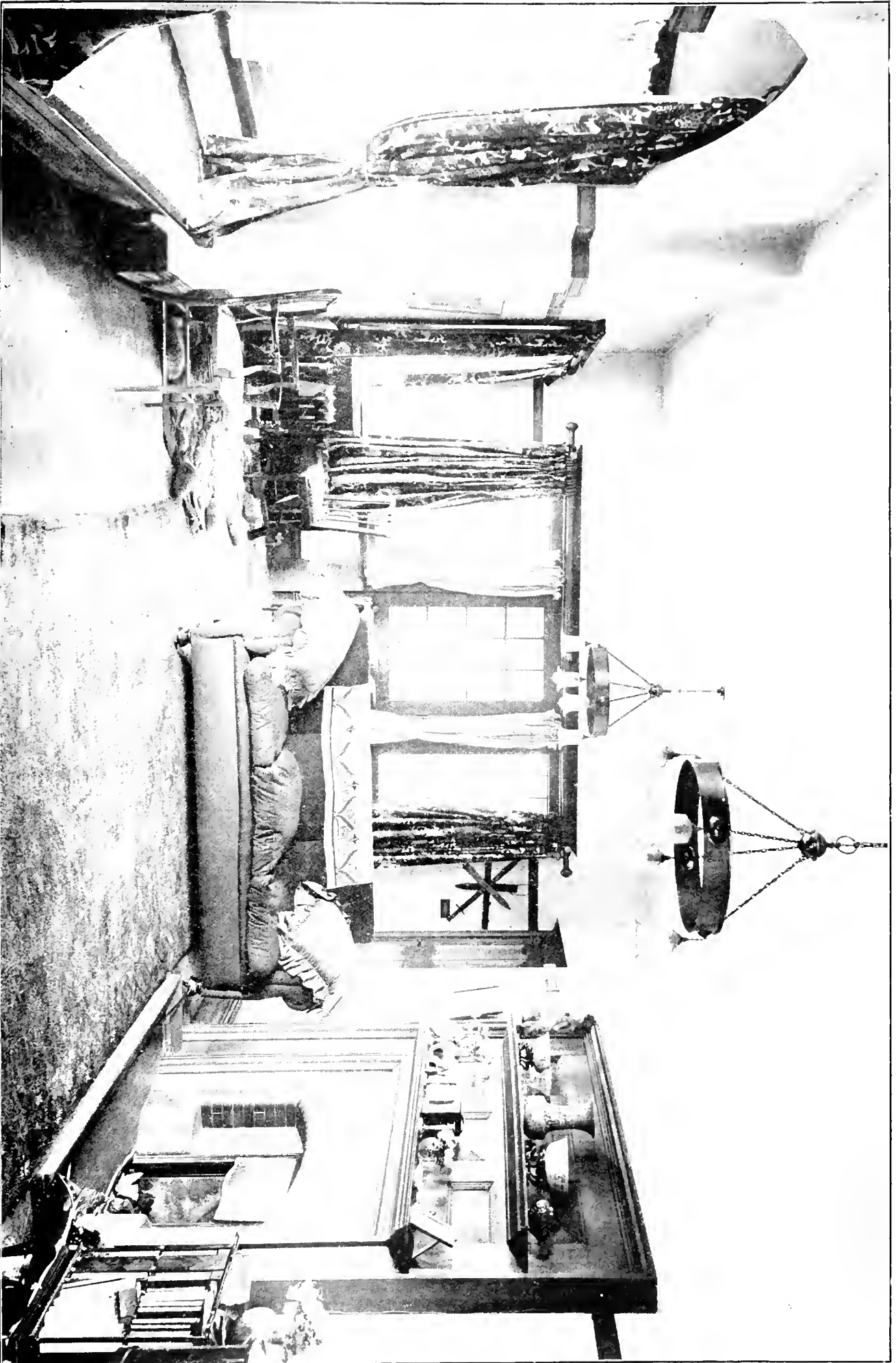

Thos. Lewis, Ltd., Photo.

THE SITTING-ROOM, "THE WHITE HOUSE," HEATON, NEAR BOLTON, FOR MR. OLIVER H. HASLAM.

DESIGNED BY MESSRS. R. HEYWOOD HASLAM AND HERMAN CROOK, Joint Architects.





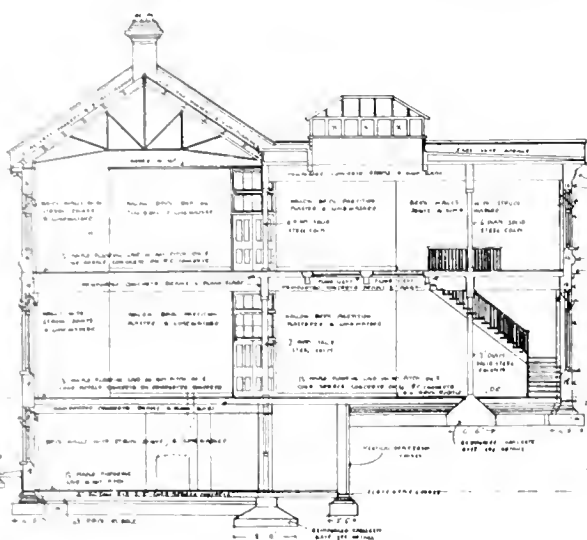

SECTION C-D

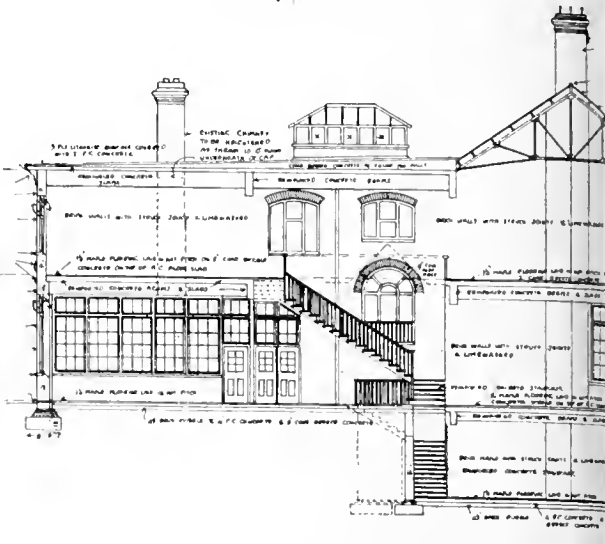

SECTION A-B

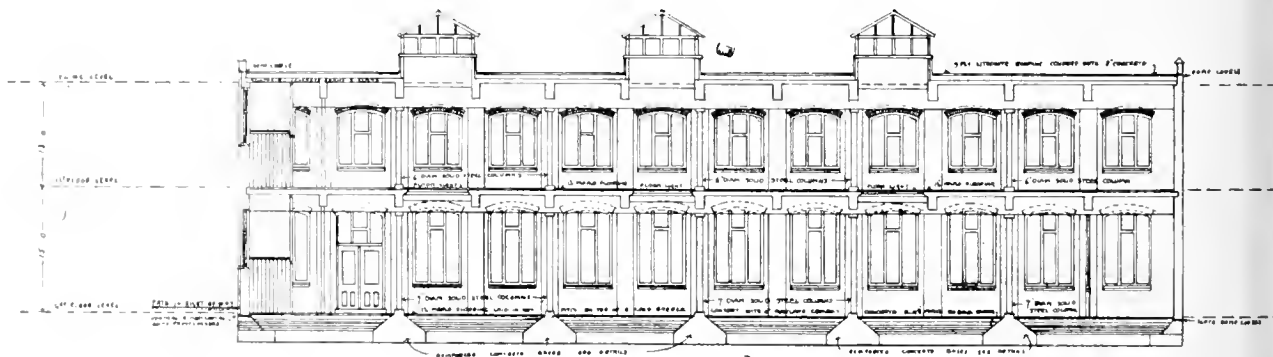

SECTION E-F



ELEVATION TO OLD FOUNDRY ROAD.

MESSRS PHILLIPS & PIPER LTD. IPSWICH

ADDITIONS TO FACTORY OLD FOUNDRY ROAD & ST MARGARETS STREET

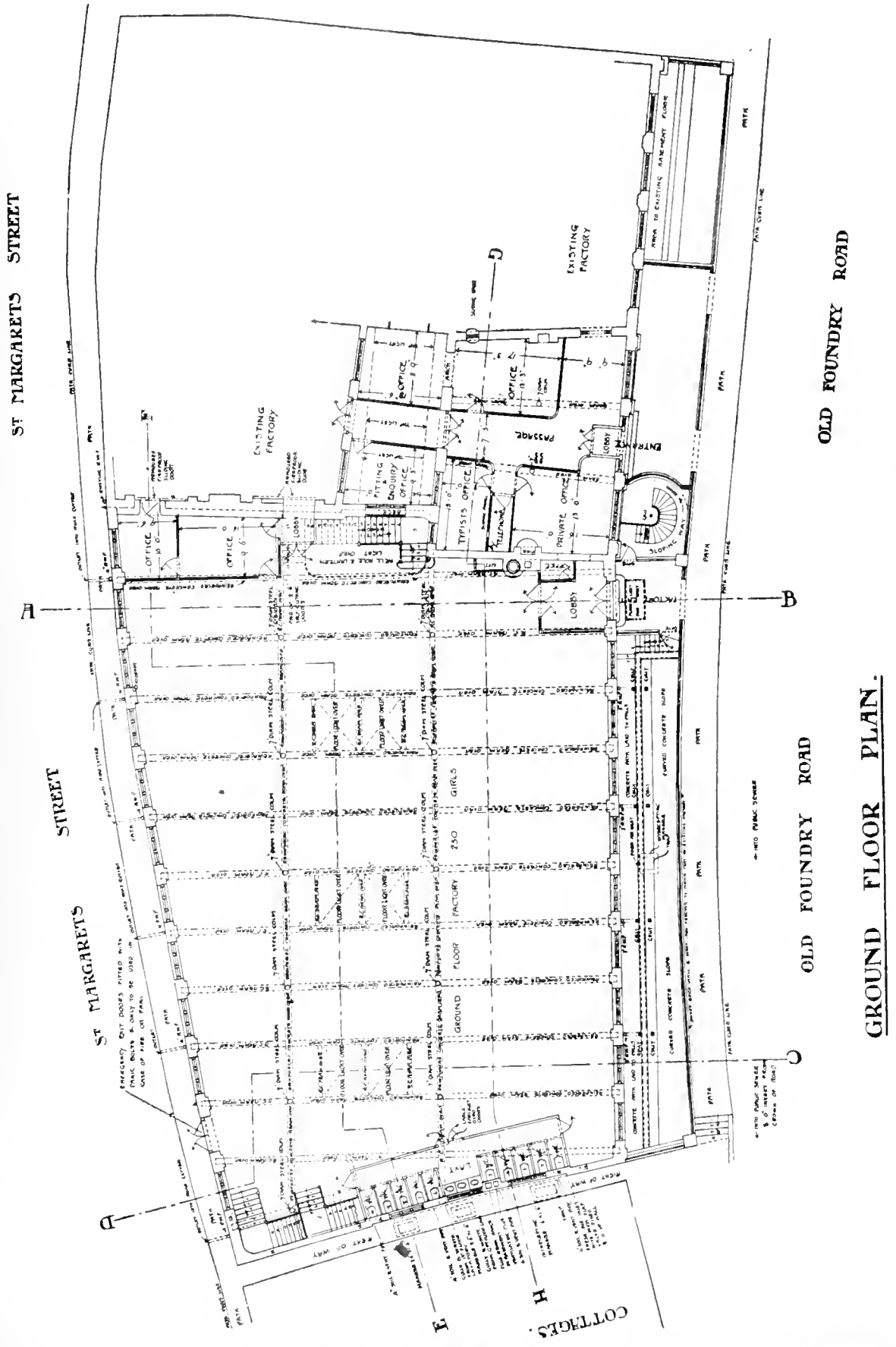

GROUND FLOOR PLAN

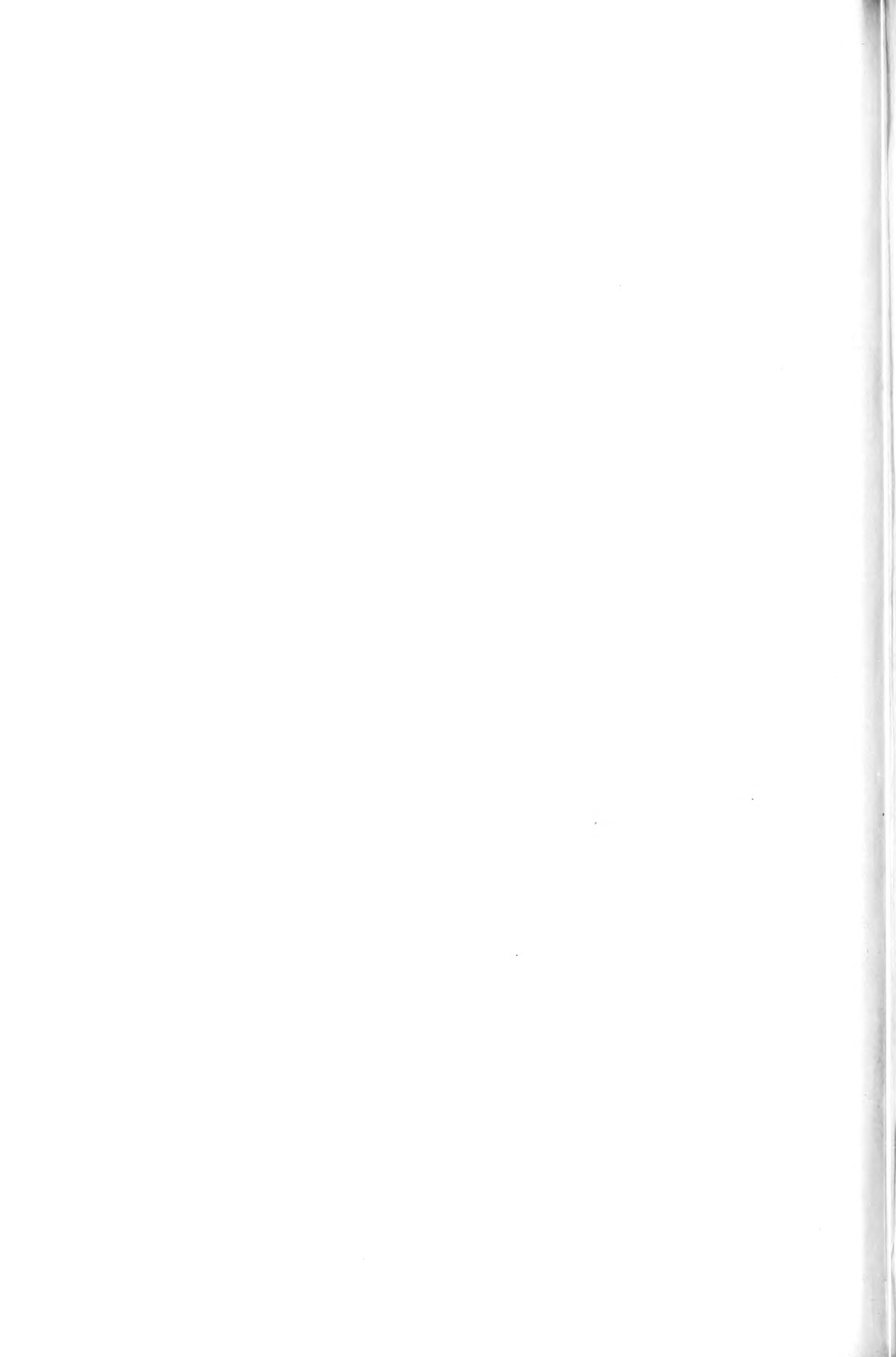

THE DOMINION OF NEW ZEALAND

NEW GOVERNMENT OFFICES, STRAND, W.C.

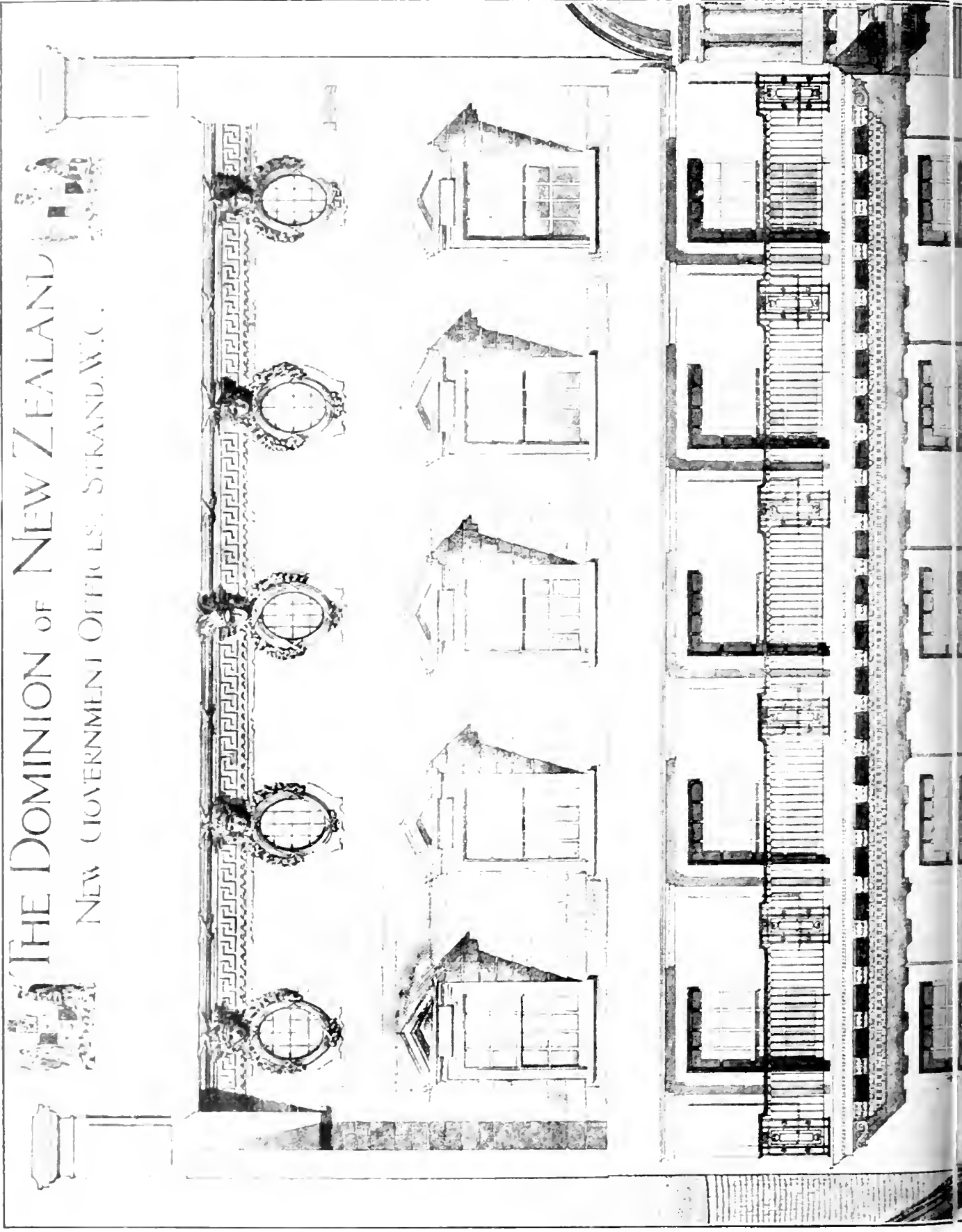

ARCHITECTS: MR. J. H. WOODS, MR. J. H. WOODS & COMPANY, LTD., 10, RIVER STREET, LONDON, W.C.

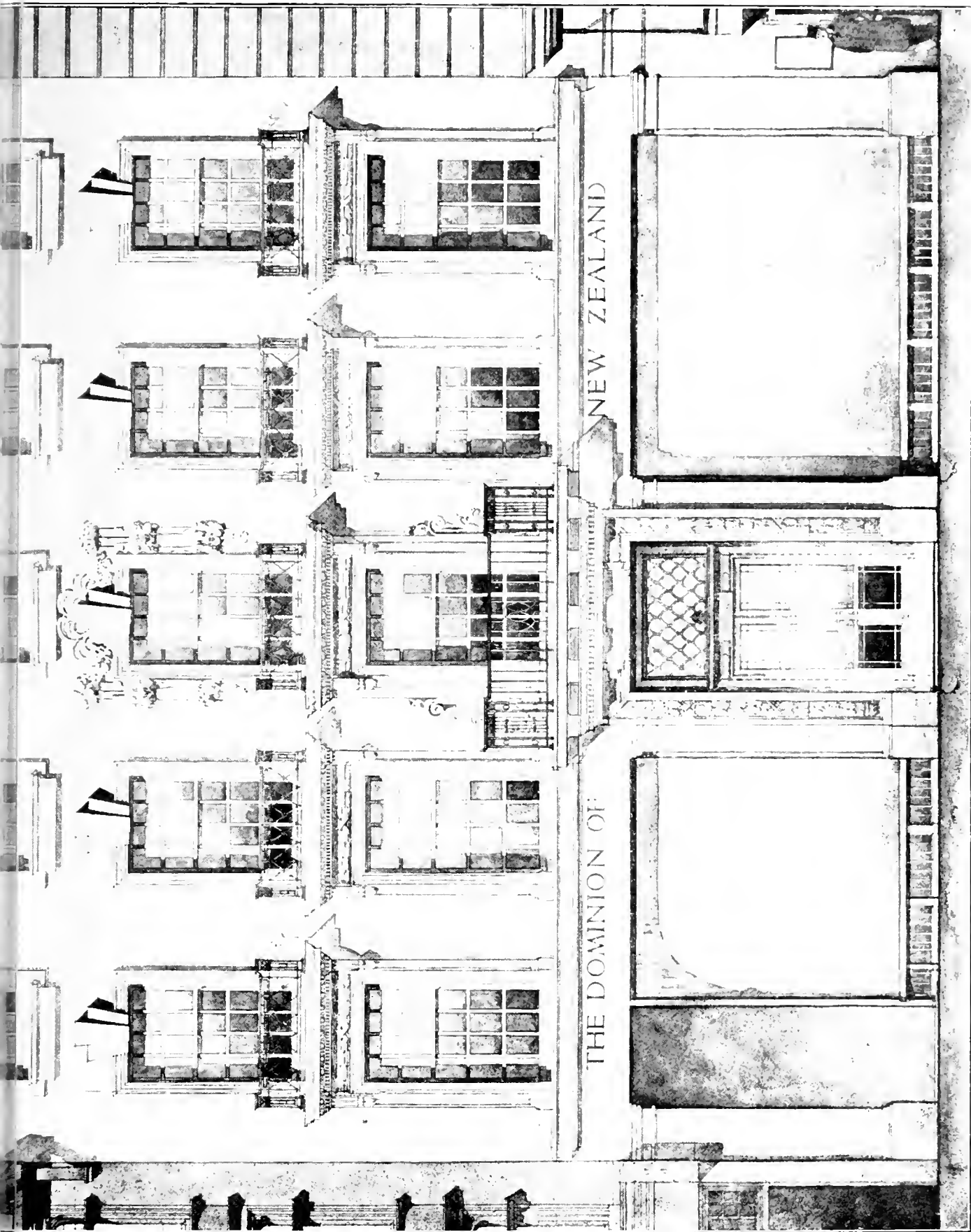

THE NEW ZEALAND GOVERNMENT OFFICES, STRAND, LONDON, W.C.—Messrs. CRICKMAY and SONS, Architects.





DECORATIONS OF THE CHANTRY TOMB BY SIR ASTON WARRER AND THE LATE LEONARD REYNOLDS

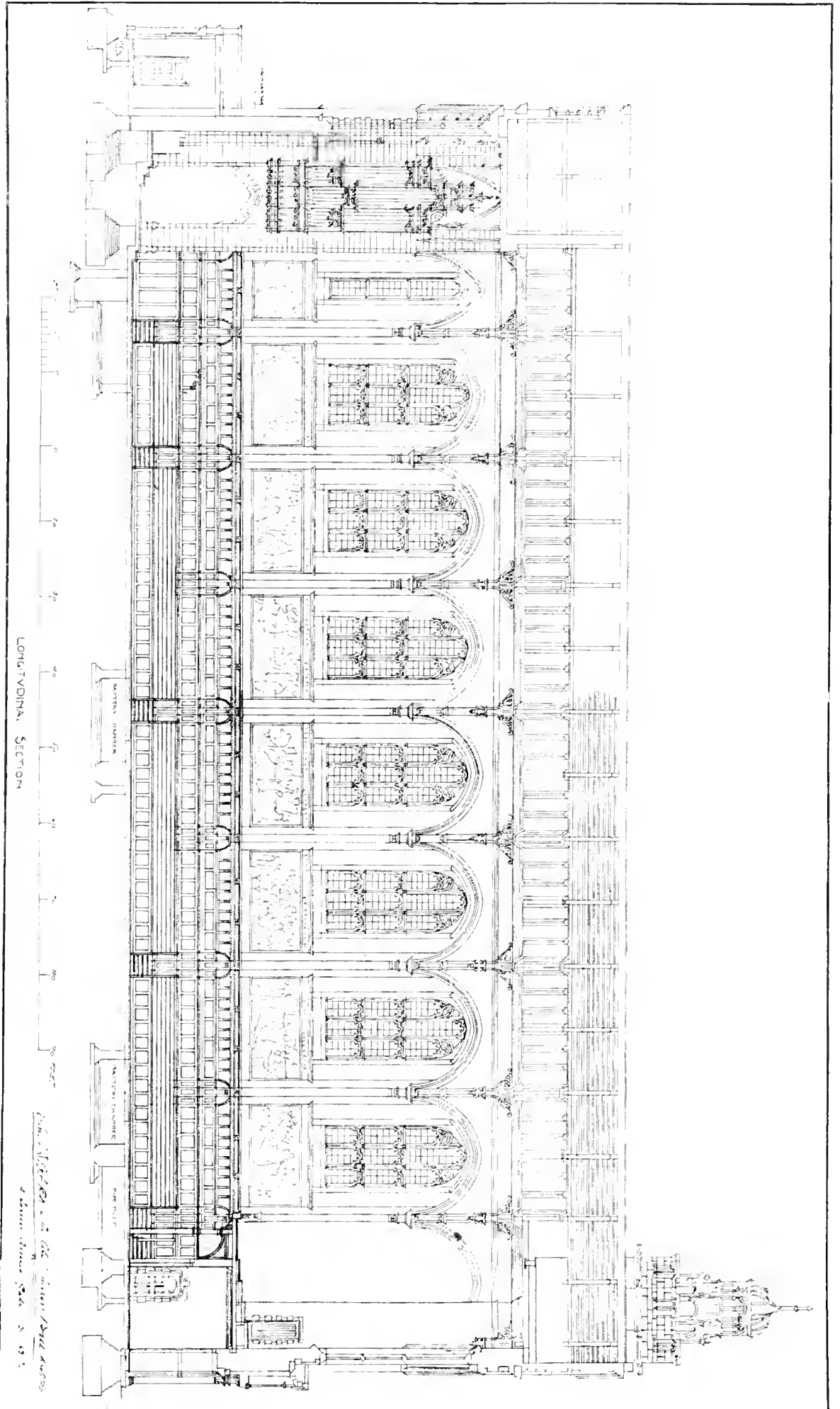

THE SCHOOL CHAPEL, CHRIST'S HOSPITAL, HORSHAM.
SECTION SHOWING POSITION OF TEMPERA DECORATIONS BY MR. FRANK BRANGWYN, A.R.A.
Messrs. Sir Aston Webb, R.A., and the late E. Ingress Bell, Architects.



Corrente Calama.

At the annual meeting of the London Master Builders' Association held at Koh-i-Nor House, Kingsway, W.C., on Wednesday afternoon, Mr. W. F. Wallis, of Maidstone, the president, in the chair, the urgent need for the extension of the scope of the War Emergency Act so as to relieve builders and lessees who had entered into pre-War contracts for the erection of buildings or for leasing building sites which altered circumstances render it impossible to fulfil, was brought forward. On the motion of Mr. Renshaw, seconded by Mr. Hill, of Messrs. Higgs and Hill, a resolution was unanimously adopted calling upon the council to collect evidence from their members, and from master builders' associations throughout the country, with a view to preparing a memorial to the Government urging the necessity for an amendment of the Act. When the terms of the memorial have been settled, a deputation will be appointed to wait upon the Prime Minister and put before him the gross injustice of the existing state of things and the need for further legislation.

The Officer commanding the Second Battalion of the Artists' Rifles, Officers' Training Corps, has decided to form a special company to consist mainly of professional men whose technical experience renders them qualified for appointment as officers to those units or branches of the Army in which knowledge of construction and civil engineering is especially useful in the conditions obtaining in modern war. A large number of men have already been enrolled, but there are still vacancies for civil, mechanical, and mining engineers, architects, public works surveyors, and borough engineers, to receive the military training which is essential if the military authorities are to make full use of their professional skill and experience. The training will be directed to the development of that portion of the candidates' peace training which is applicable to military work and such further instruction as will enable them to apply their technical knowledge effectively to military requirements. The scope of the training will extend beyond ordinary field engineering, and will be both of an individual and collective character. It will include engineers' reconnaissance, building and repair of bridges and roads, work in connection with embarkation and disembarkation of troops, military sanitation and water supply, the construction of defensive positions, animal management, and such other instruction as is necessary to render the candidate for a commission a thoroughly efficient officer. Professional men having Colonial experience will be particularly welcome, and during their training will be associated with men of like social position and education. Application for nomination to the Corps should be made to the Headquarters, Artists' Rifles, O.T.C., 7, Duke's Road, Erston Road, W.C.

No one conversant with the rapidly increasing badness of the roads in most districts can ignore the strong criticism offered last week of the action of some of the county councils, and more especially of the Road Board, at the meeting of the National Traction Engine Owners and Users Association. It was insisted that the proposals of the County Councils' Association were of such a drastic nature that if they became operative they would effectually ruin all those who were engaged in the business of heavy locomotive haulage. The Traction Owners also view with

considerable apprehension the proposal to suspend the activities of the Road Board during the war. If one fact has been demonstrated more clearly than another during the present crisis, it is that self-propelled traffic of every kind is of almost vital importance in the country. The railways are congested, and likely to become more so. The committee on Public Retrenchment appear to look upon the maintenance and strengthening of the highways as a species of luxury. If their recommendations as to the suspension of the Road Board, etc., are carried into effect, not only will present road transport be immediately impeded, but the country will pay dearly for such false and mistaken economy, for the roads will be living on their capital account, and unfortunately, in most cases, the margin is a narrow one.

In a sensible letter in the "Manchester Guardian," the secretary of the Manchester and District House Builders' Association, writing from 27, Brazenose Street, Manchester, deals trenchantly with some of the statements of well-meaning people who, while quite rightly deploring the present shortage of houses in Manchester and elsewhere, talk nonsense about the "enormous profits of the speculative builder," a statement which has no foundation in fact, and which is proved baseless by the records of the wealth left by men in the trade. As is further pointed out, two causes have combined to put an end to building in Manchester. First and foremost the Finance Act, 1909, rightly or wrongly, had the effect of frightening investors who had hitherto been the customers of the house builder and whose capital had enabled the house builder to provide homes for the working classes. This is not confined to Manchester alone; it has had the same effect throughout the land, and the housing problem is consequently a national affair. Next, the building by-laws which came into force in Manchester in 1908 imposed unreasonable and arbitrary regulations in certain respects, which have made the houses more expensive and thereby deterred the house builder from carrying on his trade.

As regards the alleged superiority of Manchester municipal-built houses, the secretary asks what was the total cost per house of the corporation houses on the Blackley estate, what interest on the outlay is received by the city, and whether those houses were passed by the building inspector as being built in accordance with the by-laws? If these questions are satisfactorily answered, it will be time, possibly, to consider the further building of cottages to the extent of £1,000,000. In opposing the municipality spending such a sum of money no one contends that the housing question must be left as it is. It is a difficult and intricate problem, but it is quite capable of solution on ordinary business lines. The house builder has built, according to the best authorities, 98 per cent. of the cottage houses in the country, and by his enterprise and foresight he has provided the comfortable and convenient homes which the people now enjoy. He can continue to supply the need, if only the many unnecessary exactions and restrictions which harass him on all sides are removed. At present, as far as the Government is concerned, there is little chance of that; but in any great centre of population it is surely the duty of all to see that those charged with the direction of local affairs should try to realise what are the real causes of the evils for which so many are seeking futile remedies.

The response to the appeal of the Empire has been so glorious that an impulse higher than the sense of duty calls upon those at home to give of our best in the interests of the gallant men who return sick and wounded from the conflict with a dishonourable foe. For some time Miss Margaret Lindsay Williams has been most desirous of helping this great cause, which must be near to the hearts of all. She is giving an exhibition of her pictures as a means of benefiting the funds of the Welsh Hospital, and feels sure that, in addition to the small entrance fee charged, many will avail themselves of this opportunity to contribute towards such an object. As a means of obtaining a substantial amount, it is her intention to offer to paint a life-size three-quarter-length portrait of the lady or gentleman on whose behalf the highest bid is made for an empty frame shown at the exhibition, no bid to be less than £100. The entire sum for this portrait, together with all subscriptions and receipts, are to be handed over to Sir William James Thomas, the hon. treasurer of the Welsh Hospital. In addition to her own work, some sculpture by Sir William Goscombe John, R.A., and Mr. Leonard S. Merrifield, and architectural designs by Colonel E. M. Bruce Vaughan, have been kindly lent for the exhibition, which opened on Monday at the New Galleries, 131, Queen Street, Cardiff, and closes on Saturday next.

One of the many ill-effects of the war is the hindrance to the work of building the Liverpool Cathedral. The staff of artisans and workmen has become so depleted that the committee have now reluctantly given up all hopes of completing the choir, and the magnificent double transept adjoining, within the period formerly thought possible. They propose now to concentrate their efforts upon the completion of the bare roof and the walls. Meanwhile, in the face of all difficulties the task of raising this great national monument goes unceasingly, if tardily, forward.

The late Mr. James Longley, of The Beeches, Crawley, Sussex, builder and contractor, left estate valued at £55,887.

Lieutenant Stanley Vanstone, of the Rifle Brigade, late assistant surveyor to the Teignmouth Urban District Council, has died from wounds in France.

Mr. A. W. Sinclair, of Scarborough, the president of the National Federation of Building Trade Employers of Great Britain and Ireland, has been appointed a justice of the peace for that borough.

A Primitive Methodist church is about to be built at East Cramlington. The architects are Messrs. Harrison and Ash, of Newcastle-upon-Tyne, and the contractor is Mr. W. Robertson, Whinney Hill, Choppington.

The urban district council of Sittingbourne received at their last meeting tenders for the erection of a public convenience, estimated to cost £500. As the lowest tender amounted to £217, the scheme was referred back for revision.

The church of St. John, Choppwell, in the parish of Winton, was consecrated on the 7th inst. by the Bishop of Jarrow. The district which it serves is shortly to be formed into a new parish, and has a population of quite 7,000.

A new Wesleyan church at Carcroft, near Doncaster, built at a cost of about £5,000, has been formally opened. Mr. O. M. Thorpe, of Long Eaton, was the architect, and Messrs. Sprakes and Sons, of Doncaster, were the builders.

At the meeting of the London County Council on Tuesday afternoon of last week, Mr. Debenham, replying to Mr. J. D. Gilbert, said that the new County Hall, now stood at about the average level of the fourth floor. There were 636 men employed on the work, but in view of the conditions obtaining it was not possible to say when the hall would be ready for use.

reinforced columns, being, in this instance, 15 in. in diameter. A goods lift has been provided between the ground floor and first floor. The whole of the floors, staircases, flat roofs, and columns have been constructed in reinforced concrete on the Kahn system of reinforcement, the bars having been supplied by the Trussed Steel Concrete Co., Limited, Caxton House, Westminster, and the floors have been calculated to sustain an evenly distributed load of 1½ cwt. per foot super, the spanning of the primary beams being 13 ft. 6 in. and the secondary beams 28 ft. The walls have been constructed with bricks on the inside, and best quality local facing bricks on the outside. The windows have wood mullions and transoms to match the existing windows to the old factory, and have been fitted with iron casements. Excellent lighting has been obtained by these large windows facing Old Foundry Road on the one side and St. Margaret's Street on the other, and in addition to these, four large lantern lights, each 15 ft. by 9 ft., have been constructed over the flat roof above the first floor, with prismatic lights in the first floor immediately underneath same to give additional lighting on the ground floor. These lights have been manufactured by the Luxfer Prism Company, 16, Hill Street, Finsbury, E.C. The ventilators are of copper, and have been manufactured by Messrs. Ewart and Sons, Limited, Euston Road, N.W. The heating is by low-pressure hot water from a Robin Hood boiler, connected with hot-water radiators throughout the building. The electric lighting throughout has been installed by the Ipswich Corporation Electric Supply Company. The whole of the work has been carried out from the designs and under the superintendence of Mr. Raymond C. Wrinch, A.R.I.B.A., architect, 16, Museum Street, Ipswich; the contractors are Messrs. Cubitt and Gotts, Station Works, Westerfield, the contract for building being £8,058. The sub-contractor for the heating engineering work is Mr. E. Scott, St. Margaret's Green, Ipswich, and for the reinforced concrete Mr. B. T. Yelf, of Norwich. The building is now nearing completion, and it is hoped to be able to hand it over to Messrs. Phillips and Piper, Limited, early in the new year.

"THE WHITE HOUSE," HEATON, NEAR BOLTON.

We give two photographs, and in this column a plan, of Mr. Oliver H. Haslam's house, near Bolton. There are very few particulars to give respecting the building. The house is of brick, rough-casted, and the roof is of heavy

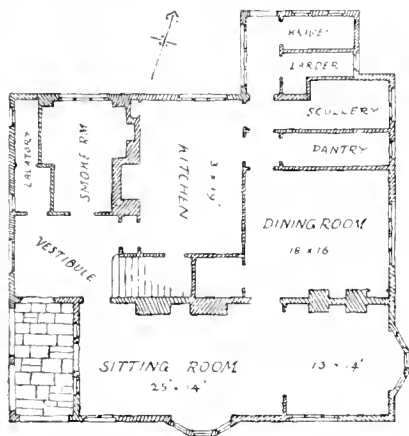

local stone flags. The contractors were Messrs. J. C. and F. Woods, of Bolton, and Mr. R. Herman Crook, also of Bolton, was acting architect on the spot, the design of the house being by Mr. R. Heywood Haslam, of 32, Essex Street, Strand, W.C.

THE CHAPEL, CHRIST'S HOSPITAL SCHOOL, HORSHAM: LONGITUDINAL SECTION AND DECORATIONS.

Having already illustrated six of the mural panels in tempera painting, giving incidents in the History of the Fathers of the Church,

by Mr. Frank Brangwyn, A.R.A., there is little to be said to-day in respect to the further subject now illustrated. The incident chosen is "St. Wilfred, First Bishop of Selsey, teaching the South Saxons, A.D. 684." Our previous reproductions of the photographs, lent us for the purpose by Mr. Brangwyn, appeared on October 6, 15, and 27 last, a general description appearing with the commencement of the series. To-day we are enabled, by the courtesy of Sir Aston Webb, R.A., to give a longitudinal section of the chapel, showing how these decorations range as a frieze over the stalls. This drawing greatly enhances the value of our representations of the paintings themselves, as it enables the reader to understand their positions and sequence in the general scheme. The late Mr. Ingress Bell was, of course, joint architect with Sir Aston Webb for all the buildings carried out for Christ's Hospital at Horsham. Our previous illustrations of the school will be found in the *Building News* for June 22, 1894, after the competition was decided, and on October 22, 1897, the day before the foundation-stone was laid by King Edward VII., when he was Prince of Wales. We hope shortly to give further illustrations of Mr. Brangwyn's tempera paintings, and complete the whole set with a general view of the chapel.

PARLIAMENTARY NOTES.

INCREASE OF RENT BILL.—Alterations of a far-reaching character in the first two clauses of the Increase of Rent Bill were made during its consideration in Committee on Wednesday evening. By the omission, on the proposition of Mr. Walter Long, of the first clause, which provided that the scheme should operate only in special areas, defined by Order in Council, the Bill was made applicable to any part of the United Kingdom where an unfair burden has been imposed on small tenants by the raising of their rents since the commencement of the war. A Government amendment was also inserted prohibiting the raising of rents on account of decorations or repairs. By a further change it was laid down that where the landlord pays the rates the Bill shall not apply to an increase of rent not exceeding any increase in the rates. Several other amendments were passed, and further alterations were foreshadowed by Mr. Long.—The Bill passed through Committee on Thursday last after some discussion as to its scope. As the outcome, Mr. Long said he understood that the Committee were willing to accept the suggestions to which the Government were prepared to agree. These came to this, that the rental or rateable value as mentioned in the Bill would now stand at £35 for London, £30 for Scotland, and £26 for the rest of the country. The compromise would be these differences in the rent, and the extension of the area from the administrative county of London to the London police area. A Government amendment was also agreed to providing that the Act should not apply to a house let at a rent which was less than two-thirds of its rateable value. A further Government amendment to the concluding provision of Clause 3 extending its protection to sub-tenants, was adopted.

WATER SUPPLY AND SANITARY MATTERS.

A DEFERRED SEWERAGE CONTRACT AT ADEL.—The war has created a singular problem with regard to the Adel sewerage scheme. Adel is a village on the Wharfedale boundary of the Leeds Corporation, and some time ago a scheme, to cost £6,764 was approved by the Local Government Board for the sewerage of the village, it being arranged that the Leeds Corporation should continue their main sewer in order that the sewage could be treated by them. On the outbreak of war only about half the scheme had been completed. A sum of £3,000 had been spent. The Leeds Corporation then wrote, stating that, owing to the altered conditions, they could not carry out the part of the contract, and, whilst the contractor for the rural district council would not agree to a suspension, he was willing that his contract should be broken. The difficulty of the Wharfedale authority is that their £3,000 has been spent to no purpose if a union cannot be made with Leeds, and they have therefore petitioned the Local Government Board to make an inquiry. The Board have promised to send an inspector down to hold a local investigation into the problem to-day (Wednesday).

COMPETITIONS.

ALEXANDER THOMSON TRAVELLING STUDENTSHIP.—As will be seen in our advertisement pages, owing to the war the Glasgow Institute of Architects announces that the Trustees have again decided to postpone this studentship for one year. All students who were originally eligible and have gone on military service will be allowed to compete when the competition is held.

PROFESSIONAL AND TRADE SOCIETIES.

THE SOCIETY OF ENGINEERS.—At the annual meeting of the Society of Engineers held on Monday night under the presidency of Mr. Norman Scoggo, borough engineer of Hackney, it was reported that the President's Gold Medal had been awarded to Mr. Arthur H. Barker, the Bessmer Premium to Mr. Alphonse Steiger, and Lacy Premiums to Mr. Sydney G. Turner and Mr. Frank Groves. Mr. Percy Griffith was elected president, and Messrs. H. O. Adams, W. B. Esson, and W. N. Twelvrees vice-presidents. The Secretary reported a membership of 593, with 85 affiliated members. About 50 were on active service, and many more engaged on miscellaneous war work is befitting engineers, when the result of the war depended so largely on engineering science. With regard to the effort of the society to improve the status of professional engineers, of all classes considerable progress had been made in the preparation of a comprehensive scheme dealing with the professional qualifications, fees, and etiquette of consulting engineers. Consideration was also being given to the position of salaried engineering officials, particularly those employed by municipal and similar bodies. The council welcomed information which would assist them in accomplishing their object.

LEGAL INTELLIGENCE.

COSTLY LITIGATION AS TO FLOODING.—The Halifax action at Leeds Assizes—Messrs. J. and J. Baldwin, Ltd. v. the Corporation—promises to rank in history as the longest case of litigation, and probably the most costly, the borough has provided. Already it has occupied Mr. Justice Atkin, sitting with a jury, five days, and the plaintiff's side of the case is still unfinished.—His Lordship, on the conclusion of Saturday's sitting, elicited that it would take until Wednesday to complete the plaintiff's case, and then he announced that the further hearing of the action would have to be adjourned to London. The action arises out of the flooding of plaintiff's mill premises in the great storm of January 1, 1914. Plaintiffs contend that the flooding was due to negligence on the part of the corporation in not providing, as they assert, adequate drainage provision for the district, and in failing to maintain it, provided in good condition. The corporation, on their part, plead that the flooding was "an act of God," caused by the abnormal rainfall.

The death is announced, at the age of eighty-three, of Mr. John Brown, one of the principals of Messrs. R. B. Huggar and Co., timber measurers, Port Glasgow.

At a meeting of the Preston Saw Mill Proprietors' Association, it has been unanimously agreed to advance all prices in their printed list a further 10 per cent.

Alongside the Alexandra Dock at Newport, Mon., the building of a warehouse 42 ft. by 60 ft. for goods for outward shipment has just been begun by a firm of shipowners. Large cold-storage depots will also be constructed near by.

A disastrous fire broke out at the timber works of Mr. W. J. Johnson, Oswestry, on Wednesday night, the whole of the extensive saw mills being gutted and all the valuable machinery which they contained being completely destroyed.

Mr. John Gordon has been appointed borough surveyor of Aberdeen, in succession to the late Mr. William Dyack, at a salary of £450 a year. Mr. Henry Stewart has been promoted to the office of assistant borough surveyor at a salary of £300 a year.

The remains of Mr. William Kidgell, a well-known Liverpool builder and contractor, who passed away at his residence, 353, West Derby Road, Turbopark, on Tuesday last, at the age of seventy-three years, were laid to rest in West Derby Cemetery on Saturday afternoon.

Our Office Table.

Friday afternoon of the Board the General Board reported that arising out of the Metropolitan Water Board's proposal the Treasury raised the question of the erection of the new building to be proceeded with. The Board was pressed at that time, but the matter having since been transferred to the Board of Sanitary and the Treasury now have no objection to any further definition of circumstances arising, under which it might be possible to proceed with any part of the building, the Board may be furnished with particulars of the Board's preliminary steps to continue the work. As there can be no objection to the Board's recommendation "that in the event of any further steps or new circumstances arising in connection with the erection of the new building in Rosebery Avenue, the Board may be furnished with particulars of any part of the building, the Board may be furnished with particulars before the Board's preliminary steps to continue the work." The Board's recommendation was adopted.

The annual exhibition of the Scottish Artists, which was opened at the Glasgow Art Galleries, the Mound, Edinburgh, Saturday afternoon, is chiefly occupied with the works of the older members of the younger members of the Glasgow Society for King and Country, which was executed by Mr. Walter B. MacCallum, Mr. J. In. Minch, are crowned with the names of the artists as a memento that they are the work of young painters, both students and graduates of the Edinburgh College of Arts, laid down in a list. Some naval pictures were shown in the last Royal Academy exhibition, in positions of honour, notably "The Life of Death" by Mr. Arthur J. Burgess's "The King's Landing" and Charles Dixon's "The Landing of the King" (July 25, 1914). The landings of the King, Mr. Robert MacCallum's "The Craft" Dyke" and "The King's Landing" are depicted in a fine and interesting manner. The works of interest and value are "The Evening on the River" by Mr. R. B. Nesbitt, "Evening on the River" by Mr. R. B. Nesbitt, "The Italian Land" by Mr. H. M. MacCallum, "Dundee from Tay" by Mr. A. J. Burgess, "The Neuk, East Dundee" by Mr. R. B. Nesbitt. Among the best of the works shown by the president of the Glasgow Society for King and Country are "The King's Landing" by Mr. J. A. F. H. and David

Intercommunication.

QUESTIONS.

(Our offer of guidelines for answers is suspended during the war, but we appeal to readers able to respond to the few queries that reach us to do so for the common good.)

WATER TANK.—I have to provide a water tank on the roof of a factory, the size being 40 ft. by 36 ft. and 2 ft. deep. The bottom of the tank will be 5 in. reinforced concrete, covered with 2 in. asphalt, and I propose to form the sides with brickwork in cement, battered from 14 in. to 9 in. as sketch. The tank will be in a very exposed position and liable to get frozen over, and I wish to be quite certain that the expansion of the ice in frosty weather will not push over the parapet walls. Would any of your readers give me an opinion as to whether

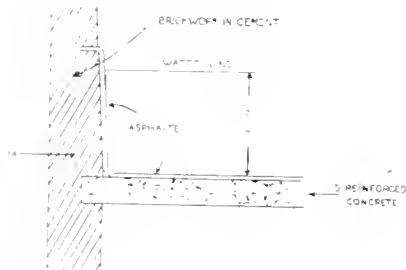

the walls as suggested would be strong enough, and if not, what would they recommend, or to what extent should the walls be battered.—Frost.

TRADE NOTES.

Messrs. C. Jennings and Co., 952, Pennywell Road, Bristol, inform us that the details in their page advertisement last week were not quite in order, but they will be pleased to send a revised sheet upon receipt of a postcard.

The "Boyle" system of ventilation (natural) embracing Boyle's latest patent "Air-Pump" ventilators and air inlets, has been applied to Wallingbrook School, Chulmleigh.

The last consideration of repairation is the most and many wet structures are neglected because the owners are unaware of an inexpensive remedy. The makers of Pudlo state that they will be glad to advise property owners of the least costly way of successfully combating dampness and water in any building. We learn that the wall of a lift at Hasleghden, which has recently been flooded, has been made bone dry with Pudlo cement.

Trade News.

WAGES MOVEMENTS.

THE PROSPERITY OF OPERATIVE ENGINEERS.—The December report of the Amalgamated Society of Engineers shows that the membership has advanced from 173,629 to 204,162 in eleven months, and the funds have increased by £237,070 in ten months. It is estimated that, taking into account increases in weekly wages, increase in piece-work prices, and amount of overtime, the earnings of members must have increased by about two million pounds per annum.

The death of Alderman William Braithwaite has occurred at his residence at Horsforth, Leeds. He was head of the firm of Messrs. H. Braithwaite and Co., Ltd., sanitary engineers and contractors, Leeds.

At the last meeting of the Western District Committee of East Lothian County Council, held in Haddington, it was reported that the Subalpine water supply reservoir had been raised to the water level being raised to 36 ft. and kept at that level for a week. This was done for the purpose mainly of ascertaining why the troublesome leakage in the embankment of the reservoir was possibly silting up. The results of the test had been generally successful.

The death of Mr. Thomas Parker at his residence, 15, St. George's House, Ironbridge, Salop, is the loss of one of the most notable of Midland engineers, to whose inventive genius is due a large part of the progress made in the development of electrical science in the latter part of the last century. Mr. Parker was also one of the pioneers of electric railways in England. He was the designer of the Liverpool Overhead Railway, which was constructed and is now in operation here.

MEETINGS FOR THE ENSUING WEEK

- WEDNESDAY (To-day).**—Royal Society of Arts. "Carillons and Carillon Playing," by J. J. Demyn, of Malines, and William W. Starmer. 4.30 p.m.
St. Paul's Ecclesiological Society. "Carols," by Rev. J. R. Woodward, M.A. Church of St. Mary Aldermary, Queen Victoria Street, E.C. 8 p.m.
THURSDAY (To-morrow).—Royal Society of Arts. "The Indian Jute Industry," by C. C. McLeod. 4.30 p.m.
Institution of Electrical Engineers. "The Design of High-pressure Distribution Systems," by J. R. Beard. 8 p.m.
Architectural Association of Ireland. "Rural Housing," by T. J. Byrne, A.R.I.B.A. 15, South Frederick Lane, Dublin. 8 p.m.
FRIDAY.—Institution of Mechanical Engineers. "Engineering Colleges and the War," by Dr. R. Mullineux Walmsley and C. E. Larard. Institution of Civil Engineers, Great George Street, Westminster. 6 p.m.

Mr. James Newman, for many years surveyor to the Sandown Urban District Council, died recently at Shanklin.

Sewage outfall works are about to be constructed at Newthorpe, near Nottingham, for the Basford Rural District Council. The engineers are Messrs. Elliott and Brown, of Parliament Street, Nottingham.

The Duchess of Marlborough opened on Friday the new nursery training school of the Women's Industrial Council, which has been erected on the Hampstead Garden Suburb at a cost of between £7,000 and £8,000. The school will provide accommodation for forty nurses and twenty-eight children.

There has opened at the Outlook Tower, Edinburgh, on Saturday, by Mr. James Cadenhead, A.R.S.A., the second exhibition and sale of the craftsmanship of the younger artists in Edinburgh, the general demand for whose work has greatly diminished since the war began. There are fifty-five exhibitors, and on the walls of the two rooms, which their exhibits occupy, are many artistic productions of merit. The works include framed specimens of wood block printing, etchings, lithographs, and water and oil paintings, and also hand-made and hand-painted pottery, leather and linen articles, and gesso jewellery.

At the meeting on Friday night of the Royal Birmingham Society of Artists a lecture was delivered by Sir Whitworth Wallis, who chose as his subject "The King's Pictures at Windsor Castle and Buckingham Palace." There was a large attendance, presided over by Mr. J. A. Cousins. Sir Whitworth described the painting, and gave the history of the Royal collection of pictures from its origin in the time of Henry VIII, down to the works acquired by Queen Victoria, the Prince Consort, and Edward VII. The lecture was illustrated by permission of his Majesty the King by a series of slides which had been specially prepared for the purpose.

Some Roman relics recently unearthed in King William Street, E.C., between Abchurch Lane and Nicholas Lane, have been added to the City Guildhall Museum. They include a fragment of tessellated pavement, some pottery, and a small whetstone. In some excavations at Finsbury Circus even more interesting discoveries were made, including a deer-horn hoe, an urn filled with burnt human remains, a Samian bowl, and some bronze bracelets. The museum has also received, as a gift from the City of London Real Property Company, three pilasters, with capitals, from the facade of the old Saracen's Head Inn, Aldgate. These date from the middle of the seventeenth century. The pilasters are of pitch pine, with repairs in deal, and the capitals in oak. The foliated ornaments of the pilasters are nailed upon the background, and many of the original nails remain.

The Bent Colliery Company, Ltd., who own the Bothwellhaugh Colliery adjoining the Hamilton Palace Estate, have been granted authority to work one of the four main coal seams. This is the ell coal, which here has a depth of 6 ft. 9 ins., but liberty to work it is confined exclusively to the area under the Palace. No authority to remove coal has been granted so far as the Mausoleum is concerned. Before operations are begun the driving of the connecting mines from the Bothwellhaugh Colliery will occupy about eighteen months. Any possibility of the Palace being affected by subsidence cannot occur within three or four years from the time operations were commenced. The Palace has long ceased to be a residence of the Hamilton family.

TO CORRESPONDENTS.

We do not hold ourselves responsible for the opinions of our correspondents. All communications should be drawn up as briefly as possible, as there are many comments upon the space allotted to correspondents.

It is particularly requested that all drawings and communications respecting illustrations of literary matter, books for review, etc., should be addressed to the Editor of the BUILDING NEWS, Effingham House, 1, Arundel Street, Strand, W.C., and not to members of the staff by name. Delay is not infrequently otherwise caused. All drawings and other communications are sent at contributors' risks, and the Editor will not undertake to pay for, or be liable for, unsought contributions.

*Drawings of selected competition designs, important public and private buildings, details of old and new work, and good sketches are always welcome, and for such no charge is made for insertion of more commonplace subjects, small churches, chapels, houses, etc. We have usually far more sent than we can insert, but are glad to do so when space permits, on mutually advantageous terms, which may be ascertained on application.

When favouring us with drawings or photographs, architects are asked kindly to state how long the building has been erected. It does neither them nor us much good to illustrate buildings which have been some time executed, except under special circumstances.

Telephone: Gerrard 1291.

Telegram: "Limesciver, Strand, London."

NOTICE.

Bound copies of Vol. CVIII. are now ready, and should be ordered early (price 12s. each, by post 12s. 10d.) as only a limited number are done up. A few bound volumes of Vols. XXXIX., XL., XLVI., XLIX., LIII., LVI., LXII., LXIV., LXV., LXVI., LXVIII., LXIX., LXX., LXXI., LXXII., LXXIII., LXXIV., LXXV., LXXVI., LXXVII., LXXVIII., LXXIX., LXXX., LXXXI., LXXXII., LXXXIII., LXXXIV., LXXXV., LXXXVI., LXXXVII., LXXXVIII., LXXXIX., XC., XCI., XCII., XCIII., XCIV., XCV., XCVI., XCVII., XCVIII., C., CI., CII., CIII., CIV., CV., CVI., and CVII. may still be obtained at the same price, and the other bound volumes are out of print.

BACK ISSUES.

Most of the back issues are to be had singly. All back issues over one month old will be charged 1s. each, postage 4d. Subscribers requiring back numbers should order at once, as they soon run out of print.

Handsome Cloth Cases for binding the BUILDING NEWS, price 8s., post free 2s. 6d., can be obtained from any Newsagent, or from the Publisher, Effingham House, 1, Arundel Street, Strand, W.C.

TERMS OF SUBSCRIPTION.

One Pound per annum (post free) to any part of the United Kingdom; for the United States, £1 6s. 9d. (or 60s. 9d. gold); to France or Belgium, £1 6s. 6d. (or 60s. 6d.); to India, £1 6s. 6d.; to any of the Australian Colonies or New Zealand, to the Cape, the West Indies, or Natal, £1 6s. 6d.

*Our Direct Subscription Agents for Australia are Messrs. E. T. Kibbleshaw and Co., Printers and Publishers, 19, York Chambers, 105, Liverpool Street, Sydney, New South Wales; for Japan, The Maruzen Co., Ltd., 11-16, Nishi-Shinjyuku, Bunkyo-Ku, Tokyo, who will receive subscriptions at 41 6s. 6d. per annum on our account. Copies of the paper will be sent by us direct to the subscribers' address.

*The special rate to Canada is £1 3s. 10d. = 540s., for 12 months, and 11s. 11d. = 2dols. 50c. for 6 months. Our Direct Subscription Agents for Canada are Messrs. Selby, Ltd., 202, Shaftesbury Buildings, 400 St. Paul Street, Montreal, who will receive subscriptions at 41 6s. 6d. per annum, on our account.

Cheques and Post-office Orders to be made payable to THE STRAND NEWS-LETTER COMPANY, LIMITED, and crossed London County and Westminster Bank.

ADVERTISEMENT CHARGES.

The charge for Competition and Contract Advertisements, Public Companies, and all official advertisements is 1s. per line of Eight Words, the first line counting as two, the minimum charge being 4s. for 10 lines. Special terms for series of advertisements may be ascertained on application to the Publisher.

The charge for Auctions, Land Sales, and Miscellaneous and Trade Advertisements (except Situations Vacant and Partnerships) is 1s. per line of Eight Words, the first line counting as two, the minimum charge being 4s. for 10 lines. Special terms for series of advertisements may be ascertained on application to the Publisher.

SITUATIONS VACANT AND PARTNERSHIPS.

The charge for advertisements for "Situations Vacant" and "Partnerships" is One Shilling for Twelve for Word, and Sixpence for every Eight Words after. All Situation advertisements must be prepaid.

SITUATIONS WANTED.

Advertisements not exceeding Thirty Words, including of name and address, are inserted under the heading "Situations Wanted," free of charge.

Rates for Trade Advertisements on front page and special and other positions can be obtained on application to the Publisher.

REFRIGERATOR ADVERTISEMENTS.

Replies to advertisements can be received at the Office, Effingham House, 1, Arundel Street, Strand, W.C., free of charge. It to be forwarded under cover to advertiser, an extra charge of 8 pence is made. (See Notice at head of "Situations.") Advertisements for the current week must reach the office not later than 3 p.m. on Tuesday. Front

page advertisements and alterations or stop orders for serial advertisements must reach the office by first post on Monday to secure attention.

Receives: J. C. J. and Co., W. A. W., L. S. C. Co., Ltd., C. A. Co., Ltd., S. T. S., W. F. S., and Co., Ltd., J. H. and Co., J. F. Mc N. and Co., Ltd., J. W. G. and Son, J. F. and Son, A. Ltd., L. and Co., H. M. W. H. S. and Son.

R. No.

P. T. Please send.

P. S. A. Thanks, hardly in our line.

DETAILS. With pleasure. Good details are always welcome.

NOTHINGS. 1. The system is not one we should adopt. 2. Yes. 3. Cannot advise.

OPTIMIST. Local by-laws commonly do not allow of an upper story being carried up on 9-in. walls, though for a restricted height as you propose the actual stability of the small house in question would suffice if extended as your sketch shows, always provided that the old walls are actually substantially built and in a thoroughly sound and stable condition. This is, of course, a prime question, and only the opinion of a qualified expert, who has personally examined the work, will be reliable enough to act upon. It is impossible for us to say or any reader who has not seen the premises. Why not construct the additions entirely of timber, including studding for the partitions, in lieu of the 9-in. walls proposed? The external parts could be covered with tiles. Sloping ceiling joists 5 in. by 1 1/2 in., as shown, do not furnish a very efficient tie to prevent the new 9-in. story from spreading. If in timber the ceiling joists 5 in. by 2 in. at the level of heads of the dormers would hold the framing of the roof together better and the weight of the brickwork would be avoided.

THE NEW POSTAL RATES. Do not forget that though we are penalised by the new postal rates because we still keep to our old size, and therefore a copy of the BUILDING NEWS exceeds the six-ounce limit, we are making no extra charge to subscribers who receive their copies direct from the office, the subscription rate remaining as before—41 per annum, 10s. half-yearly, and 5s. quarterly. Now is the time to subscribe.

TO ARMS!

THE BATTALION CENTRAL LONDON VOLUNTEER REGIMENT.

ORDERS FOR THE WEEK.

Officers for the week, Platoon Commander I. P. Hudson. Next for Duty, Platoon Commander R. W. J. Corbett.

GENERAL PARADES.

Saturdays, 15th inst., parade at Chester House, 245 pm. Uniform, haversacks and water-bottles. The next General Parade will be on Saturday, 1st prox.

SCHOOL OF ARMS.

Two-days, 6 to 7 pm. Members should give their names to Sergeant-Instructor Stubbs for new course now commencing.

LECTURES.

This evening (Wednesday), 15th inst., Colonel Sir E. Baban, at the Institution of Civil Engineers, Great George Street, S.W., at 7.45 pm. Thursday, 16th inst., Chester House, 5.45 pm. Admirals' Lecture to officers and N.C.O.s on "Brigading."

DRILLS AND PARADES.

A detailed order of all drills and parades up to January 31, 1916, is posted on the Notice Board at Headquarters. Members must make themselves familiar with same.

Wednesday, 15th, No. 3 Platoon Drill at H.Q., 6.15 to 8.15 pm. Wednesday, 22nd, No. 4 Platoon Drill at H.Q., 6.15 to 8.15 pm.

ENTRENCHING PARADE.

Sunday 13th, 19th inst., Victoria Station (L.R. and S.C. Railway), machine bond, at 9.55 sharp, for special train at 9.10. Uniform, haversacks and water-bottles. Mid-day rations to be carried. Return to town about 5.30. Railway vouchers will be provided.

By Order, E. R. GUTHRIE, Adjutant.

Note. The Drill Headquarters will be closed from Thursday, 23rd, to Sunday, 30th inst., inclusive. Correspondence. All correspondence should be addressed to the Drill Room.

Drill Headquarters and Drill Room, Chester House, Leadenhall Place, S.W.

Battalion Headquarters, 18, Tottenham Street, Westminster, S.W.

December 15, 1915.

Consequent on the additional space provided at the British Museum by the completion of Sir J. J. Burnet's galleries in the northern extension, Sir Hercules Read and his staff have rearranged the British and Medieval Departments. A fresh feature is the display of Early British and Anglo-Saxon antiquities in the new Loan Age Gallery, where a length of about 50 ft. is filled with illustrations of the history of Britain from the end of the Bronze Age to the Norman Conquest, as distinct from the four centuries of Roman occupation to be represented in another room.

FOR

Oliver's Seasoned Hardwoods,

APPLY TO—

WM. OLIVER & SONS, Ltd., 120, Bunhill Row, London, E.C.

TENDERS.

*Correspondents would in all cases oblige by giving the addresses of the parties tendering—at any rate, of the accepted tender: it adds to the value of the information.

ACCLINGROVE.—For widening of bridge over Seacroft Street, for the Lancashire and Yorkshire Railway Co.:

Fate and Gordon, 2, Park Lane, Higher Broughton, Manchester (accepted).

ASTONER.—For sinking a 14-in. borehole at Astoner, for the Alfreton Urban District Council:—

Rollinson, Basford (accepted) .. £395 0 0

BARLEY.—For carrying out a sewer extension, for the Recall Rural District Council:—

Parker and Sharp, of York (accepted).

BATTERSEA.—For the supply of 4-in. screw-down stopcocks and ferrules for wiped joints, at the Battersea Station of the Metropolitan Water Board:—

Woodhouse and Co., Ltd. (accepted) .. £47 10 0

For 1 1/2-in. screw-down ferrules:—

Woodhouse and Co., Ltd. (accepted) .. 108 6 0

BROMLEY, KENT.—For the supply of granite for the Bromley Rural District Council:—

Mountsorrel Granite Co., Ltd., Loughborough, Leicestershire (accepted), £204 10s.

CHESHAM.—For erection of a temporary engine-house at Admiral's Park waterworks, for the town council. Mr. P. T. Harrison, A.M.I.C.E., borough engineer:—

Rosser and Mace £98 10 0

Wendon, C. B. 97 0 0

DAVIS, H. 96 0 0

Barley, T. J., Chelmsford 93 10 0

*Accepted.

CHURWELL.—For erection of five through houses, Granby Avenue, for Sir Charles Scarth, J.P., Mr. P. A. Buttery, Fac.R.I.B.A., Morley and Leeds, architect. Accepted tenders:—

Mason work, including street forming:—

Pearson and Ainsworth, Britannia Road, Morley £746 7 8

Joiner work:—

Newton, L., Arkroyd Street, Morley 369 3 4

Plumber work:—

Hargreaves, F., Elland Road, Chelwell 128 6 8

Plasterer work:—

Brookdale, J., and Son, Bradford Road, Birstall 70 0 0

Slater work:—

Rogerson, G., Bank Top, Morley 68 13 4

Painter work:—

Habergham, C., Commercial Street, Morley 24 3 4

Fixtures:—

Verity, E., and Son, The Calls, Leeds 42 7 1

CHURWELL.—For the various works (in one contract) required in erection of three-stall stable and harness-room at Churwell, for Mrs. Stanhope, Mr. T. A. Buttery, Fac.R.I.B.A., Morley and Leeds, architect:—

Barley, H., Fountain Street, Morley (accepted) £299 5 0

CROFTON.—For erection of offices and stores at Crofton Hall Sidings, near Crofton, for the Lancashire and Yorkshire Railway Co.:

Leake, R., and Sons, Normanton, Yorks. (Accepted.)

FARHAM.—For the construction of a new road along the top of the cliff at Hill Head, Crofton, for the rural district council. Mr. J. F. Whitear, 16, Southampton Road, Fareham, surveyor:—

Croft, J., 98, High Street, Gosport £1,280 0 0

Franks Harris Bros., Ltd., Station Approach, Guildford 1,200 0 0

Grounds and Newton, Richmond Chambers, The Square, Bourne-mouth 950 0 0

Pedretti, T. W., 5, Queen Anne's Gardens, Bush Hill Park, Enfield (accepted) 685 0 0

FOCKESTONE.—For supplying a boatload (from 300 to 400 tons) of Chesham quartzite, delivered into carts, for the town council:—

Road Maintenance and Stone Supply, Ltd. (accepted), 17s. 6d. per ton.

GROESBEE.—For providing and laying 6-in. and 4-in. water mains, for the city council. Mr. R. Read, city surveyor:—

Hodgroun and Co., £2,648 0 0

(Recommended for acceptance.)

GRIMSBY.—For the supply of service and fuse-boxes, for the public lighting committee. Accepted tenders:—

House service boxes:—

Lucy, W., and Co., Ltd., £260 0 0

House fuse boxes:—

Lucy, W., and Co., Ltd., 261 0 0

MIPPLETON, LYONS.—For extensions at the electricity station boiler house, for the town council:—

Taylor, R. (accepted).

THE BUILDING NEWS

AND ENGINEERING JOURNAL.

Effingham House,

CONTENTS.

Strand, W.C.

Harmonious Accord in Architectural Form ..	699
Competition and Contracts ..	700
Rural Dwellings in Ireland ..	702
The London County Council ..	703
The R.I.B.A. Examinations ..	705
Norman Castles in Scotland ..	705
Corrente Calamo ..	704
Professional and Trade Societies ..	717
Legal Intelligence ..	718
Trade Notes ..	718

Building Intelligence ..	719
Obituary ..	719
Correspondence ..	719
Our Office Table ..	720
Parliamentary Notes ..	721
Clubs ..	721
To Correspondents ..	722
To Arms ..	722
Tenders ..	722
Latest Prices ..	ix
List of Tenders Open ..	x

OUR ILLUSTRATIONS

Restoration of a Fourteenth Century East Chamber in France, by Mr. Leshe B. Cook ..	699
Proposed Memorial to a Great War, from the Royal Academy Exhibition, 1915. Mr. William Warman, Architect ..	721
Bradington Priory Church. Detail of one bay of the Nave and South Aisle. Interior and Exterior Elevations with Plans of Parts. Measured and drawn by Mr. Gordon Hann ..	722

HARMONIOUS ACCORD IN ARCHITECTURAL FORM.

Since the forms seen in architecture are all reducible to the rectangular and the curvilinear, any principles that govern the harmonious co-ordination of such form must be founded, basically, on a general law relative to the juxtaposition of curves and angles. In a recent article on synthetic architecture we endeavoured to show that the laws regulating contrast

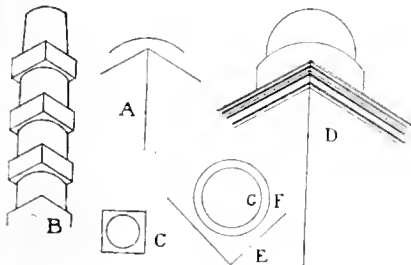

FIG. 1.

and harmony in two-dimension design bear relation, necessarily, to the rules regulating composition in three dimensions. In such, the circle, the circular, and the curvilinear are set off, and their aesthetic attributes enhanced by opposition to the sharp, spiny, and angular. The fundamental principle respecting the smooth and sharp in architecture may be reduced to a simple diagram, A, Fig. 1, wherein an arrow-like object—the rectangular, as seen in perspective—is brought into opposition with the rotund. We may note this effect everywhere in architectural detail and mass. It is displayed in crude boldness in the rusticated column, as in our rough isometrical sketch, B, Fig. 1. In any consideration of the principles governing harmony in architectural form we consider this effect paramount, because, wherever we may look, curve and angle, in their solid presentation, are offered to the eye.

The effect represented in B, Fig. 1, may, therefore, be considered to be the most crude and potent means of gaining effect by the opposition of curvilinear to rectangular mass. We cannot, justly, term it vulgar. It is crude and elementary; but vulgarity does not attend the vigorous handling of simple form, but the showy ostentation of high involution, as in a parade of unreasoning detail in great complication. We should undoubtedly revolt at the idea of rusticated columns of a refined Classic temple; but objections to rustication, as such, are futile, and the more so because, beyond any special aesthetic effect that may per-

tain, is highly expressive of constructionalism—the basic attribute in architectural effect, that we miss in wholesale homogeneous casting, as in ferro-concrete. We may take it, then, that the value of the square blocks in rusticated columns is to give emphasis by opposition, or a species of contrast, to the rotund drums of the columns. We should not get the same effect by employing circular rustication—that is, by the alternate insertion of drums of diameter beyond that of the column proper. In the same way, square pedestals to column bases must enhance the rotundity of the drums and of the circular-planned base-moulds. In Fig. 2 we give three bases, with round, multangular, and square pedestals, roughly sketched in isometrical perspective. The effect upon the column of base A—its smoothness and rotundity—is neutral; base B, by its angularity, sets off the rotund, but since this effect is an approach towards the circular, the opposition of character—the mutual enhancement of form—cannot be so powerful as in base C, where the cubical mass gives the fullest foil to the column and circular base-mould. These several points we do not note in elevational drawings; nothing of the angular effect is, in such representation, presented; we do not see the

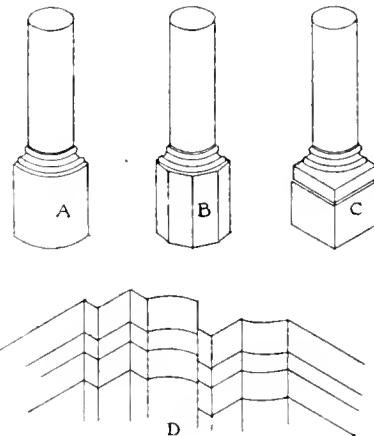

FIG. 2.

rotund swing of the mouldings or the elliptical drum-joints. Yet, strangely enough, some writers set out to criticise and expound the ultimate effect of architecture by direct and sole reference to elevational representation. In Fig. 1, D, we have a further representation of contrasting rectangular (perspective) mass, and the rotund of drum and dome. Elevation gives nothing of this, but a plan generally indicates, as by circles of drum

and dome, G and F, the contrast to be anticipated where viewed in perspective, opposed to the rectangular mass as E.

The considerations we have offered should afford some kind of base of reasoning respecting the pure aesthetics of such a building mass as the aggregated rectangular and curvilinear forms of Fig. 2, D. Assuming fitness for constructional duty, and discounting the effect of colour and texture, and allowing, also, that the joint-lines of the masonry sketched are

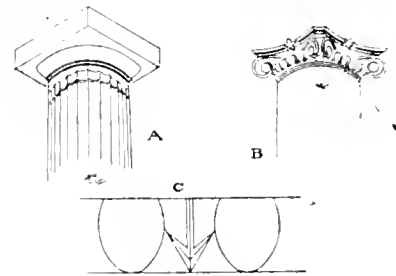

FIG. 3.

potent in architectural expression, we must conclude that the pure aesthetic resultant of design refers in direct manner to the bald composition as determined by the plan or contour of the masses, and that the correlation of square to round are basic in ultimate eye-effect. Admitting so much, the remaining effects are produced by that operation in design which we call "proportioning." The relative ratio of sets-off and the size of the rectangular and curvilinear masses must largely determine the ultimate effects, and we cannot, in analysing these effects, draw conclusions so simply as in the plan, square and round of "rustication." In some way the curved and incurved parts relate and react. The curved—"bellied"—and the incurved must be mutually enhancing—by opposition—and both are foil to aris of rectangle. Our bald representation, shorn of any colour or texture, must be an object of interest only so far as the proportion of areas is concerned.

As presented to the eye, in the sketch, these masses, whether or not specially elegant, appear suitable as means, say, of upholding arches, and in the effect of the sketch we must allow for the unsightly absence of caps or impost of any kind. But how far fitness, or association, or a combination of such, affects general aesthetic considerations may be easily comprehended by turning round the sketch and viewing it from either side and thinking of horizontal members of architecture. We cannot ignore fitness, but it does not assist us greatly in rendering the bare demands of construction-

ently—unless his work is very poorly done—for when he begins to spend, in dribbles perhaps, but yet to spend, for repairs and things he did not "expect to spend money on so soon, Heaven knows," but then "everybody's doing it"—even then Mr. Owner does not have an opportunity to learn that perhaps his neighbour's outlay for upkeep is one quarter of his own, nor possess sufficient impartiality to see that his neighbour's property continues to look fresh and in good condition, while his own does not.

It would be foolish to allege that an owner, in accepting a low figure, expects, usually, to get what he does not pay for. He believes that variations in estimates are due to inaccuracies or to larger profits taken by higher-priced men. Neither is true. Estimating is an exact science. A careful contractor, working on good plans and specifications by an architect with whose work he is familiar, gets his cost within two per cent. on new work, and will average but little higher on alteration work. A low-priced man can easily make as much money on a contract as a high-priced one—unless the low price is due to inability. Many an owner, on small work, has been impressed with the argument put out by small contractors that they can work cheaper because they have not so much expense to carry. And yet the man assenting to this argument may himself be in an organisation which knows by experience that up to a certain limit (?) the larger a business is the less it costs to do a thousand dollars' worth. The low-priced man is low, usually, because of a difference in quality of result. An owner who relies upon his architect to produce a proper result under all conditions is very often expecting the proverbial silk purse from a sow's ear. Good architects do not claim to do it—and the most successful among them aim for good contractors and shun those not doing the grade of work they want to get. A leading Boston architect voiced this opinion in saying, "Architect and contractor must both be good or the result is poor."

What is competition?

Competition is the life of trade.

Competition is the death of trade.

Your choice of phrases will vary as you are a buyer or a seller; as you have downed a competitor or are being stifled; or, you may say, competition is the other fellow after my job, the other man after my customers, the fierce struggle for life and means.

Competition! Unions will have none of it, neither will socialists nor capitalists!

What is competition?

Is it the success of the strong, well-managed, and efficient over the shrewd, the tricky, and the deceitful? Obviously not—when price is a large factor in the result—although the reverse may be true. One writer calls it a legalised form of struggle for annihilation in modern life. Any proposition that contractors, or any other producers, may be encouraged to ruin each other in order that the community may get something at cost or less is unworthy.

Trade has always had one meaning synonymous with trickery, and any business man need only recall personal experience and observation to know that business with its competition has been at best only a war of wits in a games the rules of which are business ethics. Business ethics—what are they? Certainly a very peculiar brand.

And what of competition at its worst? And who suffers from the results? In the business of building he is called the owner. Does he know this? No, not at the time; usually not at any time.

What is competition?

On a bank alteration job an alleged ambiguity in specifications led to one contractor's success. He found, after he had expended about one hundred dollars on the job, that the architect was expecting him to do things he had not estimated to do. Inquiries easily established the fact that four other bidders had all included the items in question—the successful one had not. Owner, architect, and builder each paid one-third of the cost of the error, about three hundred dollars each. But what of the unsuccessful bidders?

On a house some distance from Boston, about ten years ago, three bidders figuring

about alike were above the price set by the owner for his expenditure. The architects, a leading firm, told him he could cut his requirements, or could get another series of bids from men doing a lower grade of work. He chose the latter alternative, and his house was built within his price.

On a job of interior finish, some distance from Boston, three or four years ago, three Boston bidders doing a similar high grade of work were within one thousand dollars of 137,000 dollars. The work was let for 92,000 dollars in another city, and, even after adding on an acknowledged error of 25,000 dollars, the successful bidder would still have been 16 per cent. under the Boston men. None of the Boston men would have made over 15,000 dollars on the job.

On a small job in a small town, five figures were 9,500 dollars, 9,300 dollars, 9,000 dollars, 8,900 dollars, and 6,600 dollars. What is obviously within a few hundred dollars of the right price? The owner was delighted at the low price. Why should he have been?

On a recent bank alteration job with six bidders four were eliminated after the bids were in because they were not local men. Refiguring of cuts was done by the other two, and one dropped one thousand dollars more than the value of the cuts (finding he had to do so), and although still high was awarded the job because he was a depositor in that bank, while the other was not.

On a job in 1912, where cuts were figured, one competitor dropped five hundred dollars where twelve hundred dollars' worth of stone mason's foundation work was changed from stone to concrete in location where materials for either were easy to get. Cuts offer a splendid opportunity for one man to drop by another, and win by—in fact, submitting a second figure when he surmises his first one was a little too high.

Recently sub-contractors for painting figured so cleverly that the lowest on a job was 650 dollars and the highest 2,130 dollars, with enough good men together around 1,500 dollars to show that probably there was the right price. Some contractors figuring would use the low figure; others not wanting to must do so, or risk their chances of winning. This element is a common feature of competitive bidding.

In September, 1915, a reputable Boston architect of a fairly large job stated that the owner had a fixed price set for his work, and that he had purposely selected a list of bidders commonly varying widely in price and in quality of result. From them he had chosen as good a man as he could, and come within the price established; and he said that he regretted not being able to choose a better man.

Two or three years ago an owner, who formerly let a contract to a bidder about 20 per cent. under a group of competitors, and who was not satisfied with the results obtained, strove to mend matters upon some further work by a most stringent three-years' guarantee—the strongest document of the sort ever seen by Boston contractors who estimated the work. This document was the work of the owner, not of his architect. Here was a direct intent to make a silk purse out of a sow's ear by legal verbiage—followed, if needed, by legal procedure.

A few years ago a very hard-fought large job near Boston was awarded to the contractor fourth from the bottom in a list of six bidders. Later he was told that the owner always intended him to do the work.

Recently on a job a few miles from Boston the owner told one bidder that he wanted him to do his work, and that he would pay a preference, but not a large one. The job went to another man, who by the use of two sub-contractors, whose bids the preferred man had, but did not care to use, saved more than the difference between the two figures.

In 1915 a job near Boston had four bidders within a fifteen hundred dollar variation figuring around 62,000 dollars, while a fifth was about 50,000 dollars, and won the award. What will happen to the winner and to the work he does? What was the owner's reasoning?

"Time is of the essence of this contract. How often this is written! A year ago a large job was let to be completed August 15, 1915. On October 1, 1915, it was nearly done. A contractor's promises for time are commonly taken in preference to an examination of his performances.

Not long ago the wife of an owner told a friend about to build to put a forfeit clause into his contract, for the reason that it could always be collected, for some reason or other, and was a good way to save on a contract.

Recently an architect asked for two bids from general contractors. With one of these the architect was in league to the extent of giving him competitors' prices in order that he might bid under them—and the other contractor knew it—and knew the owner. After the bids were in he approached the owner, thus: "Now, Mr. Blank, I have a grudge against Smith, my competitor, and I can work it out and show you how to make a thousand dollars if you will give me fifty dollars." Mr. Blank agreed. "I will go to your architect, claim I made a mistake, withdraw my bid, put in another one, one thousand dollars lower; your architect will tell his friend, who will do the same thing. You will make a thousand, and can then send me fifty." It was all done as planned.

On a job of plumbing worth 750 dollars a low bidder was awarded the work at 475 dollars. Recently, two years later, alterations were made, and the hot and cold water piping, specified "iron-sized brass"—a good brass pipe—was found to be gilded iron. This meant that the architect was either ignorant, careless, or dishonest.

What is competition?

The above cases, excepting one or two, are typical instances of occurrences which are very common—so common that they would not be worth reciting were our readers only those familiar with building operations. The cases quoted are not garbled or exaggerated, but are normal, and are all actual happenings.

What is competition?

The statement that a careful contractor gets his estimate costs within 2 per cent. was carefully qualified to apply to well-made plans and specifications, and to an architect with whose methods the bidder is familiar. Architects vary widely in their methods—not affecting the quality of the result—and in their requirements in developing scale drawings from which estimates are usually made. Contractors knowing the architects of Boston (for example) can vary their figures according to the personality or office practice involved. This variation may, on the average, amount to 2 per cent., and is something for which, of course, a contractor figuring for a strange architect cannot allow.

Beyond the personality of the architect lie the plans and specifications—varying widely in definiteness and accuracy from a very low limit, amounting at times to guesswork upon many points, to a degree of perfection, leaving no element indeterminate which affects the estimate—and this latter accomplishment means some knowledge of how an estimate is made up and of what features affect cost, for no plans and specifications issued for estimating can ordinarily tell everything needful for the execution of the work. Here, again, a contractor's general familiarity with the architect's personality and usual customs are a great help.

What is competition?

The story is told of a contractor in Greece who stood before a statue of a famous oracle, which—following a custom set by Galatea, Hermione, and others—"came off his perch" and walked up to the contractor. "Why this variation from proper statuesque practice?" said the contractor. "Are you not," replied the oracle, "the man considered dishonest until proven honest; the man who has to know what is in an architect's mind when he draws a line; what 'suitable,' 'approved,' 'satisfactory,' and 'practicable' mean as he uses them; and how 'reasonable' he is going to be; and do you not have to forecast prices on materials, and particularly on labour with variations beyond your control?" "Certainly," said the contractor; "but that is my job, and I am used to it." "I am something of a prophet myself," said the oracle;

...the contractor walked away... that kind of a trust... estimates, as commonly... an average case the low... 1st cent. under the high... of understanding of an... and his plans and specifications... estimators are involved. The... in such cases would prob... except 1 or 2 per cent. and this... in a rather direction. With... a good contractor would be... a good architect a poor... to be too low. The balance of... variation in bids is from other... the use of sub-contractors... quality of the result. These two... related, but a good general con... doing good work for his own portion... squeeze, capole, or drive sub... so low that only poor work from... obtained. Of course, in dull times... will be cut, but in the best of times... half so large as the differ... figures. Probably any con... in Boston would be glad to be assured... 12 per cent. gross or 7 per cent. net, and... take all the work he could get at... figures.

The element of error in estimating, due to carelessness or other mistakes not arising from inability, is, of course, a recurring one. Among careful men this is far less frequent than is commonly supposed. Error due to bad judgment or downright incompetence in estimating always plays a part, and to avoid based upon price alone such an estimate is obviously dangerous. The use of a bid to secure an owner puts a certain amount of investigating the contractor upon the bidding company. It has no particular effect otherwise—contractors can get bonds.

An estimate far below a group of figures, a frequent happening, can only mean one of two things:

1. An error on the part of a man doing the work, and who will do the job properly and suffer by his error.
2. An honest price from an honest man who gets the best value of which he is capable, and whose work is low in quality.
3. A cut-throat price from a cheap man who does not skimp where he can, trust more to his neck than to come out square, and who does little for results if he can "get by."

The two latter are the usual low bidders. The first is the man more commonly found among everyone by his low figures, until he is pushed to the wall and another of the same kind takes his place.

What is competition? An estimator who, through carelessness or neglect, allows work to be done in any other manner, except as to quality which he can control, from what is planned for the best, helps the low bidders and hurts contractors, for the others may have figured on a more right, while the low man may have to have "modifications made for him."

Here have been cited some of the things that make modern competition in the building business usually a race. Here are laid out strange architects are telling their clients of things which are stated contrary to the general experience of all bidders and contractors.

The craze of the 19th century, the lawyer, any professional man, and the talent, the press, the influence, what do any of those things have to do with competition? The first of them, the press, but success depends on opportunity and capability. The last, the lawyer, have any of them ever got out of the business or prices are lowered? Why is it so? Why do not architects compete in a more honest way? Because a large group of them are getting most of the leading money and doing it. Why did they agree to do so? Because, but probably our readers would say, the R.I.B.A. and would read the Journal and R.I.B.A. method carried further in the future.

The Century Dictionary defines the word "endeavouring" as follows: "The act of endeavouring to gain what another

is endeavouring to gain at the same time." This definition in itself seems sufficiently clear to be easily comprehended by all of us. But what has become the meaning of the word as applied to the building business; what is it as we really understand it?

To such extremes has the meaning of the word been distorted as to almost blot out its primary definition. Competition in feats of prowess or skill or art always has meant, and always will mean, only strength, agility, perfection, excellence, and quality. Why should it not mean the same when applied to work?

Unfortunately, we have grown to associate this word with one consideration only—that of price; and the word to-day often means the endeavouring to gain what another wants by the exercise of cupidity, without regard to perfection, excellence, or quality. Such competition is unfair and is based on the policy of "each one for himself and the devil take the hindmost." Those conducting their business along these lines show an utter disregard for the rights of others. Competition in the form of mere price comparison is the most degrading form of competition to those who indulge in it. As has been said recently: "The only phase of competition which can benefit humanity is quality competition, and that is the exact antithesis of price competition. The two cannot ride in the same boat. When price competition begins, quality competition ceases." We all know that to be a fact. Why should it not be adopted as the fundamental principle of the building business?

Where did the practice of awarding the contract to the lowest bidder begin? What excuse has such a practice for existing? It is impossible to secure the best or even good work by such a method.

Why should not the Master Builders' Association take the initiative in an attempt to correct this method? Why should it not lead in an earnest endeavour to persuade architects and owners to abandon this practice and adopt a new one? Suppose, as another suggestion, they were to award the contract to the "average" bidder; would not this retain all the essentials of competitive bidding, eliminate all temptation on the part of the bidders to "skin the job," and secure for the owners better results in accordance with the true intent and meaning of the plans and specifications?

Mr. Owner, does all this mean nothing to you? Are you in the position of an interested listener to a Sunday morning sermon—which is a dandy and just fits the other fellow? If so, awake! The welfare of each of us helps us all, and in this case you, as well as ourselves, will benefit from these truths exacted from a burdensome experience.

The Roscommon County Council have appointed Mr. M. J. Leech to the position of assistant county surveyor, to succeed Mr. Dolan, deceased.

The partnership of T. Collinson and W. Collinson, in the business of builders and contractors, at Natby and Garstang, Lancaster, under the style of Jonathan Collinson and Sons, has been dissolved.

Mr. Clarke-Thornhill recently enriched the Department of Textiles in the Victoria and Albert Museum with a gift of Algerian embroideries. Most of the pieces of this collection date from the nineteenth century, and bear the influence of the Turkish domination which lasted from the time of Barbarossa in the sixteenth century until the French occupation in 1830. A descriptive catalogue has now been issued by the Museum authorities furnishing a summary of the history and artistic qualities of these embroideries, illustrated with reproductions of some specimens.

A new temporary chapel has been erected in connection with the Kensington Red Cross War Memorial Hospital at Balham on land adjoining the institution. A dado of dark oak runs round the sides and west end of the chapel, in which are inserted at regular intervals eight carved panels, presented by Princess Louise, Duchess of Argyll. Above the panels are old sacred paintings, and the reredos is a triumph of the Crucifixion; these also are gifts of her Royal Highness, who is President of the hospital. Other special gifts are the golden altar rails, becom Bible, priest's chair and desk, and four damask curtains for the altar.

RURAL DWELLINGS IN IRELAND.

Last Wednesday evening a general meeting of the Architectural Association of Ireland, was held in the Hall, South Frederick Lane, Dublin, when the principal feature of the evening was a lecture by Mr. T. J. Byrne, A.R.I.B.A., clerk and surveyor to the South Dublin Rural District Council, upon "Rural Dwellings in Ireland."

Mr. Leask, president of the association, occupied the chair, and the minutes were read by Mr. N. Giron, hon. secretary.

Mr. John O'Donoghue was elected a member of the association.

Mr. T. J. Byrne, in dealing with the subject of his lecture, said that at the present time every district council in Ireland had built some cottages for labourers living within their borders, and the cost of erecting such cottages had been very small on the rates, varying from the tenth of a penny in the £ in Cluden, County Galway, to twelve and a quarter in Gortnahoe, Tipperary; £8,950,000 odd had been spent by the Government in this direction; 53,868 houses had been built, with the result that over 325,000 persons had been decently provided for. Nearly 150 years ago the conditions of labourers' dwellings were as rotten as they could be, although in the year 1767 people were walking through large streets in the cities and building imposing dwellings. The conditions under which the labourer lived at that period were very bad; anything was considered good enough for him. The lecturer went on to contrast what was thought good enough for the labourer even so recently as the year 1873 with the great strides made up to the present day. Rural authorities had been better financed and given a much larger scope. In 1906 a great advance was made when money was available at a much lower rate of interest. Four and a-half millions was sanctioned then, and at the same time every effort was made to make all the houses much more decent and commodious.

Mr. Byrne, who exhibited several score of interesting drawings, which showed the various stages in the development of labourers' cottages, then explained in detail his minimum ideal of what such a dwelling should be. He considered, for one thing, that no cottage should have less than four rooms, and, in the metropolitan county at least, should have a water service if sewers were convenient. He would also be in favour of what were known as "parlour houses" in Belfast, where a little room could be provided that would not be immediately entered from the front door. Mr. Byrne then went on to deal with the extensive work which had been accomplished by his own council, the Dublin Rural District Council, and he was glad he was working for a council which recognised this great public necessity—(hear, hear)—and of the fact that they had given him Mr. Geoghegan as assistant architect. His council gave the most careful consideration to planning, and he was gratified to them for the latitude they had always given him in the details of construction. (Applause.)

A hearty vote of thanks was accorded to Mr. Byrne, on the motion of Mr. Eilwin Bradley, seconded by Mr. R. M. Butler.

A commission in the Royal Engineers (Tunnelling Section) has been granted to Mr. E. Potts, assistant to the Rotherham Borough surveyor.

Difficulties attending the construction of the headquarters of the Theosophical Society in Beconsbury have now been overcome. When the building is completed, it will have cost £200,000 instead of £40,000, as originally contemplated. Three years and a half have elapsed since the scheme was initiated. The builders' lock-out accounted for a delay of twelve months after a portion of the place had been erected, and then the war and other matters stopped the resumption of work. Now building operations have recommenced, and St. Pancras Borough Council has been informed that the financial difficulty has been removed, as a wealthy person has come forward and agreed to complete the building, which will have frontages to Tavistock Square and Burton Street. The architect is Mr. E. L. Lutyens, A.R.A., and we published the plan and perspective of his design in our issue of September 6, 1912.

THE LONDON COUNTY COUNCIL.

At the meeting of the London County Council held yesterday (Tuesday) afternoon the Finance Committee recommended that sanction be given to the borrowing by the Hackney Borough Council of £9,362 towards the cost of street improvements in Mare Street, Upper Clayton Road, and Ball's Pond Road; by the Hammersmith Borough Council of £16,000 in respect of the acquisition of property for an improvement at Hammersmith Broadway; by the Islington Borough Council of £985 for the purchase of electrical pressure-recording instruments; by the St. Pancras Borough Council of £15,099 for turbo-generator and building work in connection with their electricity undertaking; by the St. Marylebone Borough Council of £3,800 for mains and house services in connection with their electricity undertaking; and by the Wandsworth Borough Council of £1,400 in respect of the High Street and Felsham Road improvement.

The General Purposes Committee reported with regret that Mr. Arthur Maxwell Phillips, senior assistant in the Architect's Department and captain 11th Service Battalion the King's Own Yorkshire Light Infantry, has been killed in action. (Captain Phillips, who resided in Wolverton Gardens, Hammersmith, has been a Licentiate R.I.B.A. since 1911.)

The Building Acts Committee stated that on November 23 last they reported to the Council that under the Council's General Powers Act of 1909 they were advised that the regulations made in July last under Section 23 of that Act with regard to the construction of buildings wholly or partly of reinforced concrete, and with respect to the use and composition of reinforced concrete in such construction, must be published in full in the *London Gazette* at a purposeless expenditure of £180. The committee had been before the meeting of November 23 and were in communication with the Local Government Board, whose officers had endeavoured to arrive at an arrangement whereby, with the consent of the Treasury and the Stationery Office, a substantial saving of the Council's money might be effected. These efforts had not, however, met with any success, and the regulations must, therefore, be published in the ordinary way.

The Finance Committee stated that they are "strongly of opinion that the proposed expenditure, which both the Local Government Board and the Building Acts Committee admit will serve no useful purpose, is most difficult, in present circumstances, to justify, but in view of the legal necessity for advertising the regulations, and the failure of the efforts made to reduce the expenditure thereon, there appears to be no alternative but to submit the estimate."

The Establishment Committee recommended that the operation of standing order No. 342 be suspended, in order that the services of two assistants on the unestablished staff of the architect's department, who have attained the age of 65 years, be retained up to and including January 31, 1916.

THE R.I.B.A. EXAMINATIONS.

THE FINAL: ALTERNATIVE PROBLEMS IN DESIGN.

1. The drawings, which should preferably be on uniform sheets of paper of not less than imperial size, must be sent to the Secretary of the Board of Architectural Education, Royal Institute of British Architects, 9, Conduit Street, W., on or before the dates specified below.

2. Each set of drawings must be signed by the author, and his full name and address, and the name of the school, if any, in which the drawings have been prepared, must be attached thereto.

3. All designs, whether done in a school or not, must be accompanied by a declaration from the student that the design is his own work and that the drawings have been wholly executed by him. In the preparation of the design the student may profit by advice.

4. Drawing for subjects (a) are to have the shadows projected at an angle of 45° in line, monochrome, or colour. Drawings in subjects

(b) are to be finished as working drawings. Lettering on all drawings must be of a clear, scholarly, and unaffected character.

SUBJECT XXV.

(a) *A Small Public Library.* The building is to be on an open "island" site, and is to cover an area of 70 ft. by 40 ft., exclusive of projections. It is to be faced with stone, and should contain a lending library, magazine room, reference library, committee room, heating chamber, rooms for a resident caretaker, and usual offices.

Drawings: Two plans, three elevations, one section to $\frac{1}{8}$ -in. scale. Detail of small portion to $\frac{1}{2}$ -in. scale.

(b) *A Municipal Gymnasium.* To be a detached building on an open site. The interior dimensions of gymnasium are to be 60 ft. by 35 ft., and the building is to contain in addition an entrance hall, office and pay box, changing room with lockers, lavatory and shower-baths adjoining.

Drawings: Two plans, one elevation, one section to $\frac{1}{8}$ -in. scale. Detail of roof over gymnasium to $\frac{1}{2}$ -in. scale.

SUBJECT XXVI.

(a) *A Roll of Honour.*—A monumental tablet in a church, bearing the names of parishioners (male and female) who have served in the Forces, or as doctors and nurses in the hospitals, and have given their lives for their country in the war. The tablet to be either of stone, marble, or bronze, used separately or in combination. It is to be fixed on a blank wall inside a parish church, and the space it should cover is to be approximately 15 ft. by 8 ft.

Drawings: The tablet and details to one-eighth full size. Details of mouldings and lettering to full size.

(b) *A Cottage Hospital for both Sexes, to Accommodate Twenty Patients* (not infectious cases).—All suitable rooms to be provided upon an open site of four acres, approached from a main road.

Drawings: A block plan showing drainage, to a small scale; plan, elevations, and section, to $\frac{1}{8}$ -inch scale.

SUBJECT XXVII.

(a) *A Town House in a Terrace.*—Centre to centre of party walls, 25 ft. Cost not to exceed £4,000. Roadway in front is 50 ft. wide.

Drawings: Plan of each floor, cross section, back elevation to $\frac{1}{8}$ -inch scale, front elevation to $\frac{1}{2}$ -inch scale.

(b) *Small Warehouse in the City of London* for woven goods. Centre to centre of party walls 25 ft., depth 60 ft. Main building 40 ft. deep above the ground story. Workpeople's entrance to be at the back from a back street. The building is to contain a basement, ground floor, and four stories above; office and counting-house are to be provided.

Drawings: Plans of basement, ground, and first floors. Front elevation, and cross and longitudinal sections, to $\frac{1}{8}$ -inch scale, with constructional details to 1-inch scale.

DATES FOR SUBMISSION OF DESIGNS IN 1916.

	Subject XXV.	Subject XXVI.	Subject XXVII.
United Kingdom	Feb. 27	April 30	June 30
Johannesburg	April 30	June 30	Aug. 31
Melbourne	May 30	July 31	Sept. 30
Sydney	May 30	July 31	Sept. 30
Toronto	March 31	May 30	July 31

With a view to restoration, the interesting double piscina, near the high altar in All Saints' Church, Maidstone, has been cleared of the accumulated rubbish which, the vicar says, has been allowed to choke its deep drains ever since the days of the Puritan iconoclasts who first damaged it and the canopies of the adjoining sedilia. Amongst this rubbish Mr. Malyon, the vergier, has discovered some interesting remains of fifteenth-century stained glass, presumably from the great east window. These fragments comprise the lower half of a figure of a saint in flowing white robes, bespangled with yellow rosettes, which had become broken into about thirty separate pieces. These have been joined together. There are also some pieces of ruby and blue glass.

NORMAN CASTLES IN SCOTLAND.

Mr. Wm. M. Mackenzie, secretary of the Royal Commission on Ancient Monuments (Scotland), delivered a lecture to the members of the Edinburgh and South-East branch of the Historical Association of Scotland in the geography classroom of Edinburgh University last Friday night.

The lecturer said the private castle, that was the castle in the ordinary sense of the term, was introduced into this island by the Normans. The word first appeared in the Anglo-Saxon Chronicle in 1043 in circumstances which showed that the thing as well as the name was new. An historian of the Conquest expressly said there were very few in England at that time. What sort of structure the ordinary Norman castle was appeared on the Bayeux tapestry, from which several illustrations were shown. These, with accounts from various French and English chronicles, proved that its essential feature was a mound of earth, known as a dungeon, more familiarly as a mote, on which the defences of tower and wall were constructed of wood. These terms in time changed their meaning. A large enclosure on the level was also palisaded with timber, and was known as a bailey. Each division normally had an independent ditch.

Reference was made to the herisson or prickly hedge in advance of the ditch—the mediaeval equivalent of barbed wire—as it figured in the description of Scottish attacks upon English border castles in a French poem of the twelfth century. In Scotland there had been confusion as to Norman castles owing to a belief that these must have been great stone keeps. Now that it was known what to look for, the mote or mote-and-bailey earthworks were found to be numerous and present over the greater part of Scotland, indicating the thoroughness of Norman penetration, and probably, too, a following of Norman example. No precise figures, however, could be given till the archaeological survey was completed. So far a dozen were allotted to Wigton, twenty-six to Kirkeudbright, and nearly as many to Dumfries, but one only to Berwickshire. Many must have disappeared either by levelling or under subsequent building. The type seemed to cease at Dunskaith, on the north side of the Cromarty Firth, where the traces of the castle of 1179 were still distinct, but there were two cases in eastern Sutherlandshire where a mote foundation for a later stone building was strongly suggested. Examples were shown on the screen of various types of mote castles in Scotland. Mr. Mackenzie said there were certain puzzling features still awaiting explanation. The wooden "peel" of the War of Independence was substantially a revival of the same sort of fortress as had been used to subjugate England at the Conquest.

The town clerk of Edinburgh has been instructed to draft a town-planning scheme for Craighentny.

Mr. James Wyld, urban surveyor to the Clayton Urban District Council in the West Riding, has just completed a housing census and finds there is not a single house to let. A housing scheme has been prepared, and an inspector from the Local Government Board has viewed the proposed site.

A serious landslide in the Clarence Gardens, Scarborough, has been in progress for some time. The slide has reached such dimensions that, following upon a report from the borough engineer, the corporation have decided to approach the Local Government Board for permission to proceed with the work of repair.

Mr. D. Y. Cameron's picture of the castle of Craigevar, after being for some time on loan in the Aberdeen Art Gallery, has been presented thereto by the Hon. Gertrude Forbes-Semphill. The landscape, with "castle set in its own valley twixt the two main ways of the Dee and Don," was exhibited at the Royal Scottish Academy in 1909.

Alderman William Urquhart, of Mapesbury Court, Shootup Hill, and Church Street, Paddington, and High Street, Notting Hill, colour and varnish manufacturer, for nearly fifty years a member of the Paddington Vestry and Borough Council, and formerly a member of the London County Council, who died on September 7, left £7,442 personally.

LIBRARY
—
JUN 21 1903
—
UNIVERSITY OF TORONTO

BRIDLINGTON PRIORY. Number 1

2 Church, District of, Bay in, Nave.

Measurement & Dimensions by
Plans on the 1/1000 Scale

Vertical & Horizontal

Scale of 1/1000

Scale of 1/1000

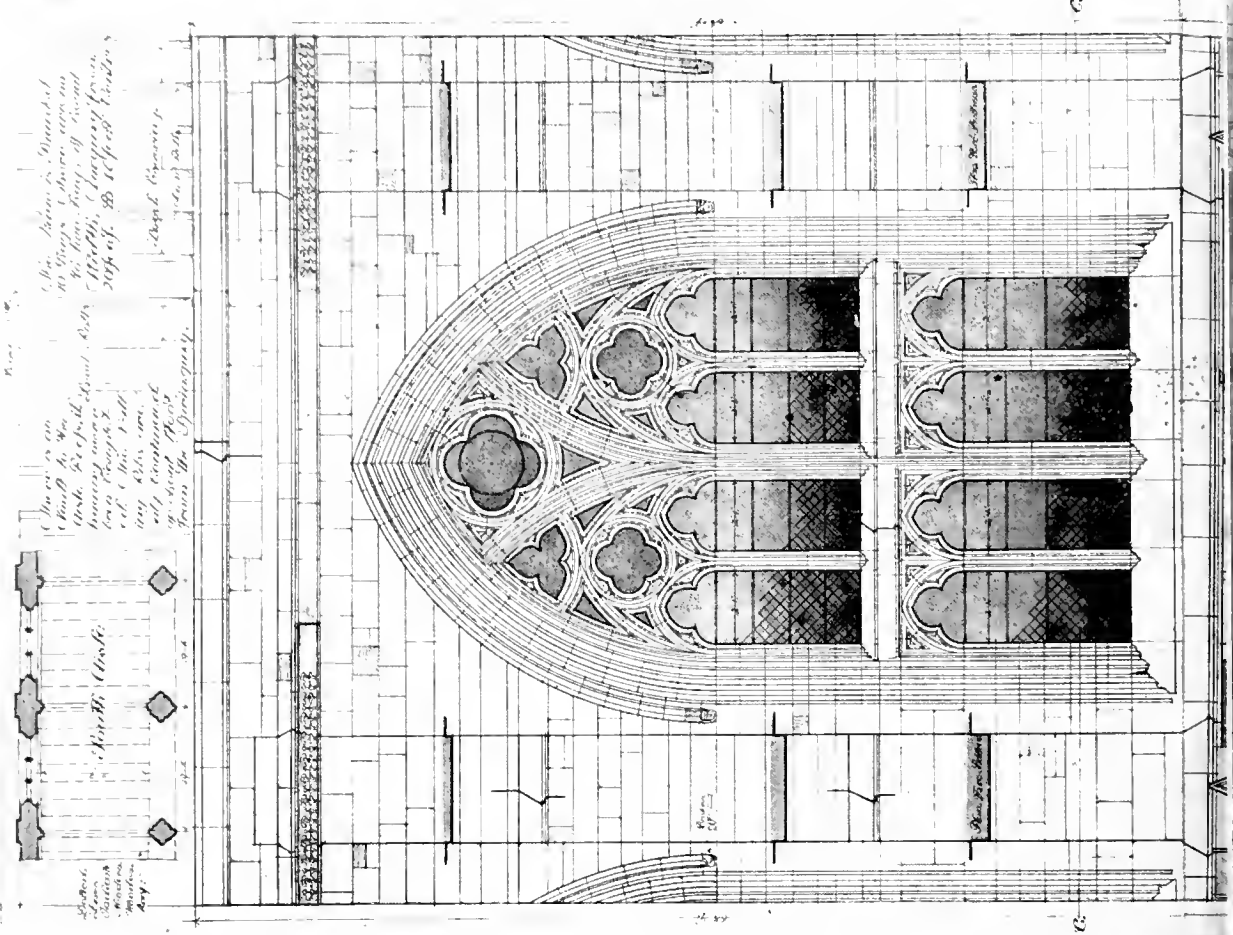
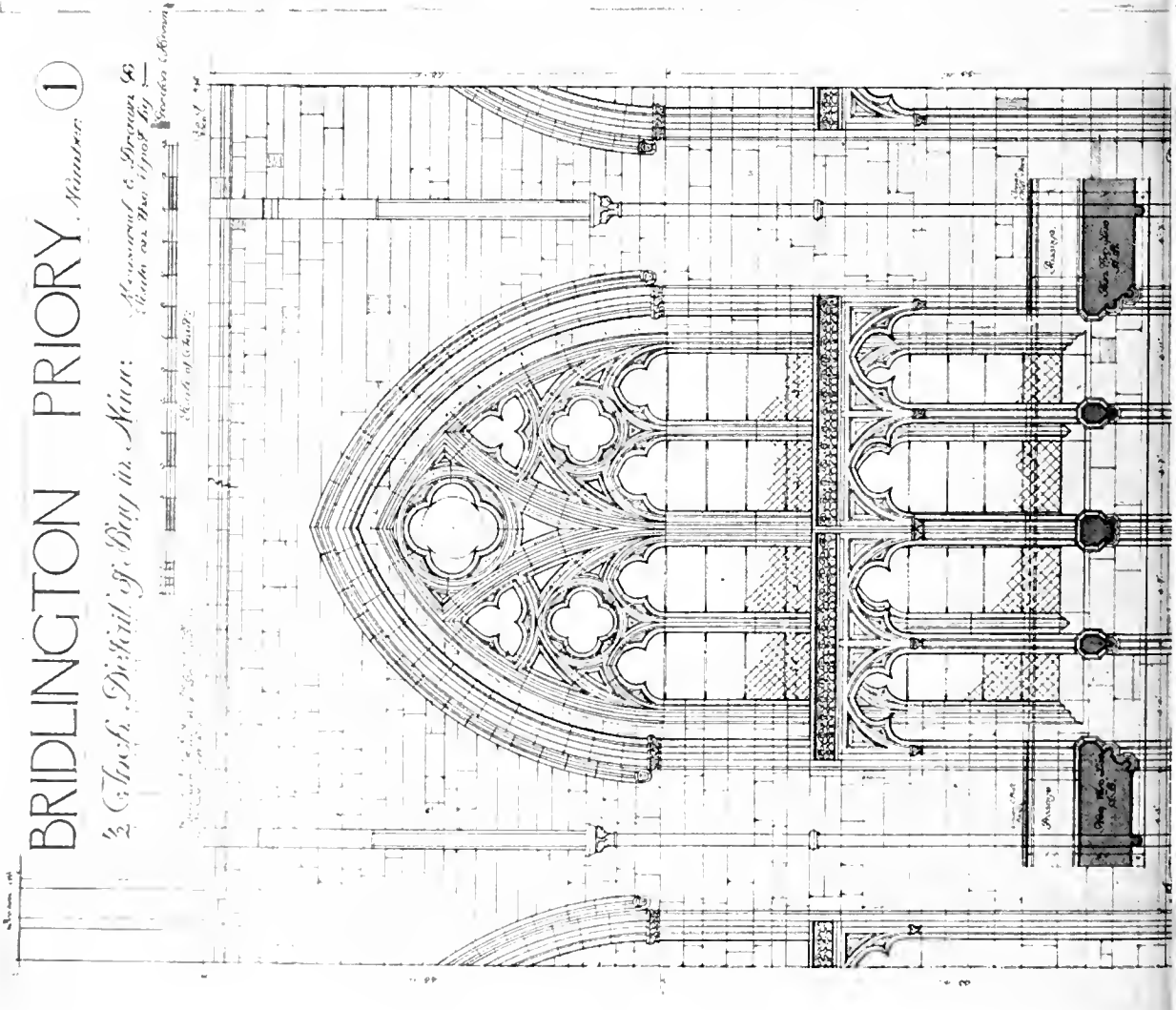

The nave is an
 aisleless church
 built by the
 monks of the
 priory of Bridlington
 in the 12th century
 and is a fine
 example of the
 early English style
 of architecture
 which is seen
 in the nave of
 the priory of
 Bridlington.

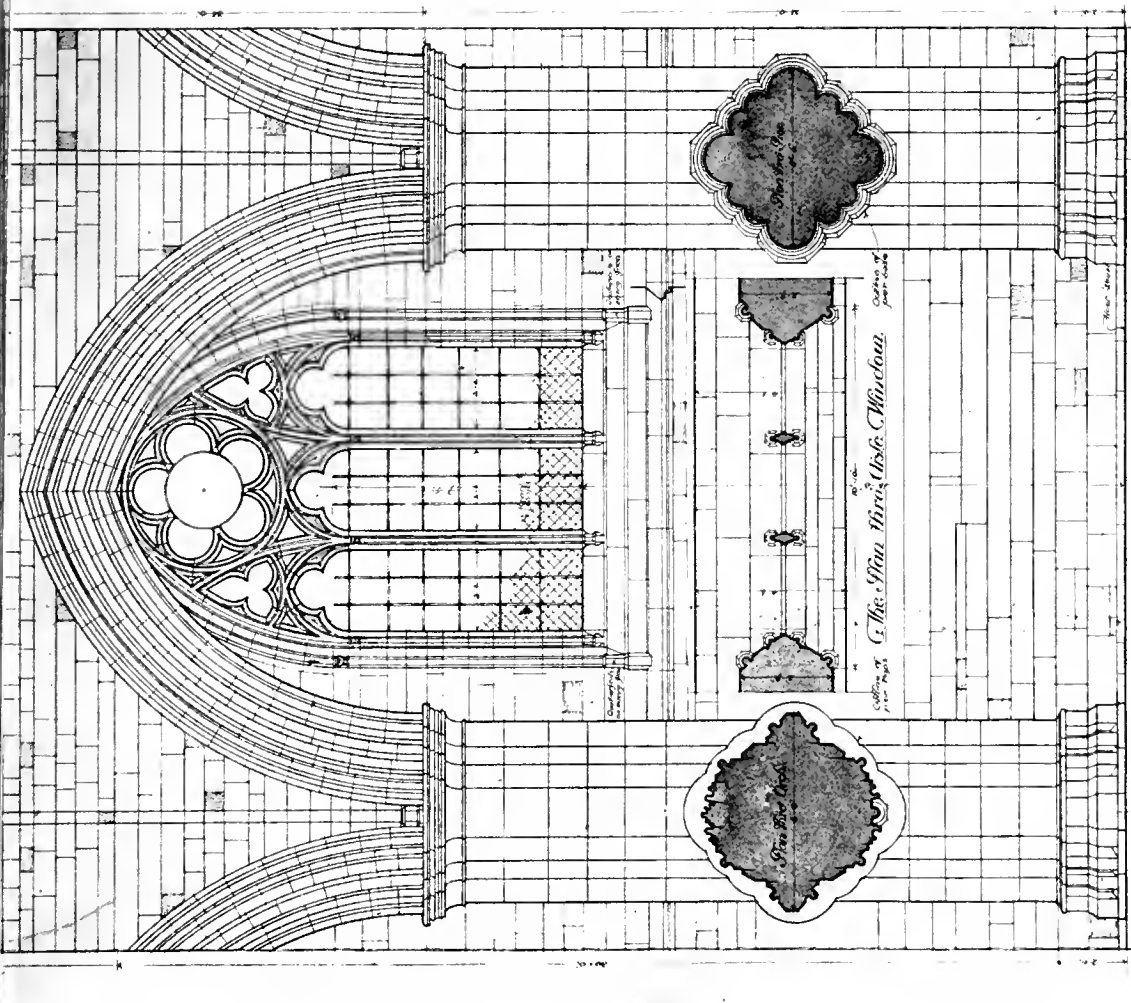

Elevation of Bay to the South Side of Nave
 Height of Window from Floor about 24 1/2 - 31 0
 C. M. S. Nave through Aisle of Church

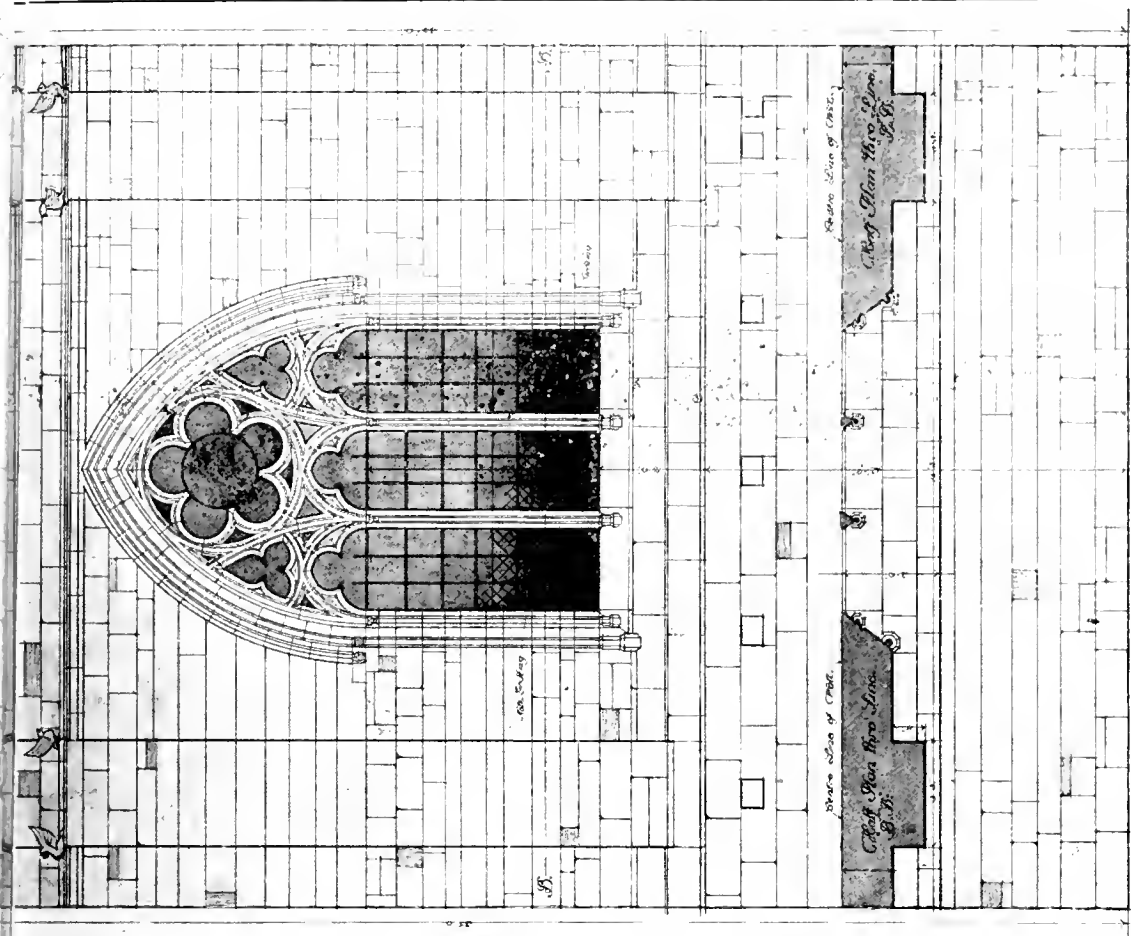

Exterior Elevation of Bay to the South Side of Nave
 Height of Window from Floor about 24 1/2 - 31 0
 C. M. S. Nave through Aisle of Church

DETAILS OF THE NAVE, BRIDLINGTON PRIORY CHURCH, YORKSHIRE.—Measured and Drawn by MR. GORDON HEWITT.





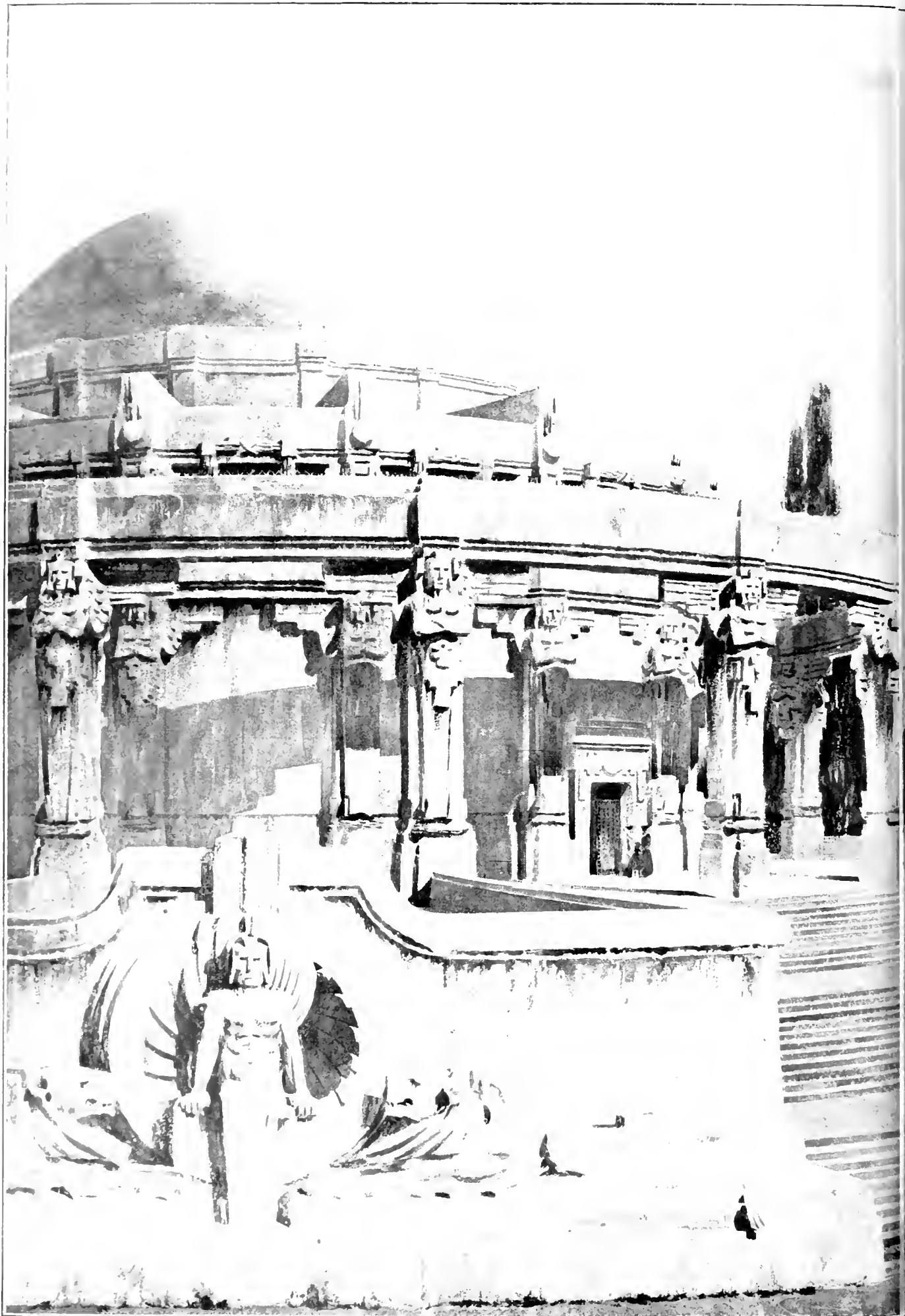

PROPOSED MEMORIAL TO A GREAT WAR, FROM THE RO

MEMORIAL

ACADEMY

EXHIBITION

1915

MEMORIAL

ACADEMY

EXHIBITION

1915

MEMORIAL

ACADEMY

EXHIBITION

1915

MEMORIAL

ACADEMY

EXHIBITION

1915

MEMORIAL

ACADEMY

EXHIBITION

1915

MEMORIAL

ACADEMY

EXHIBITION

1915

MEMORIAL

ACADEMY

EXHIBITION

1915

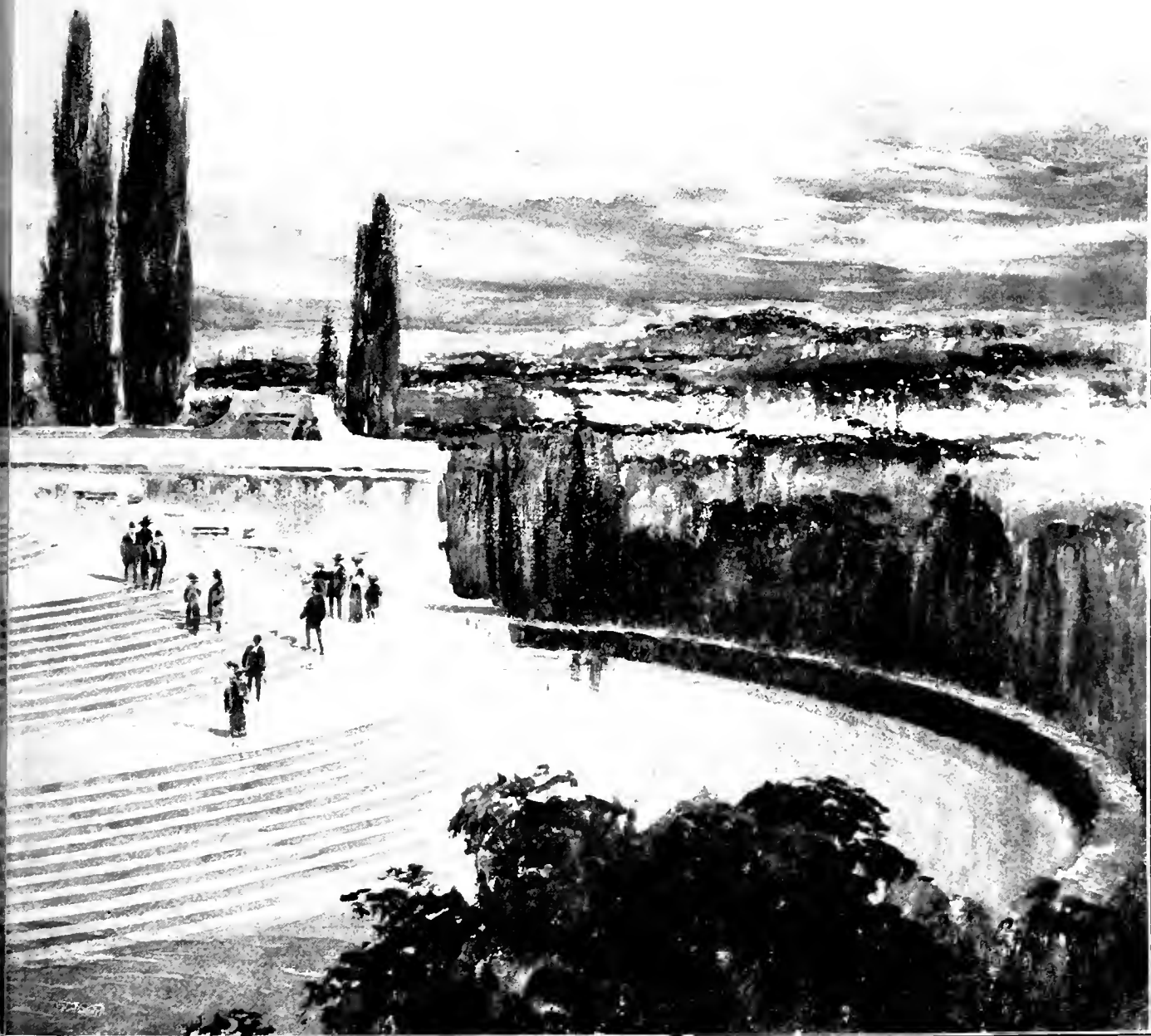

MEMORIAL ACADEMY EXHIBITION, 1915.—Mr. WILLIAM WARMAN, Architect.

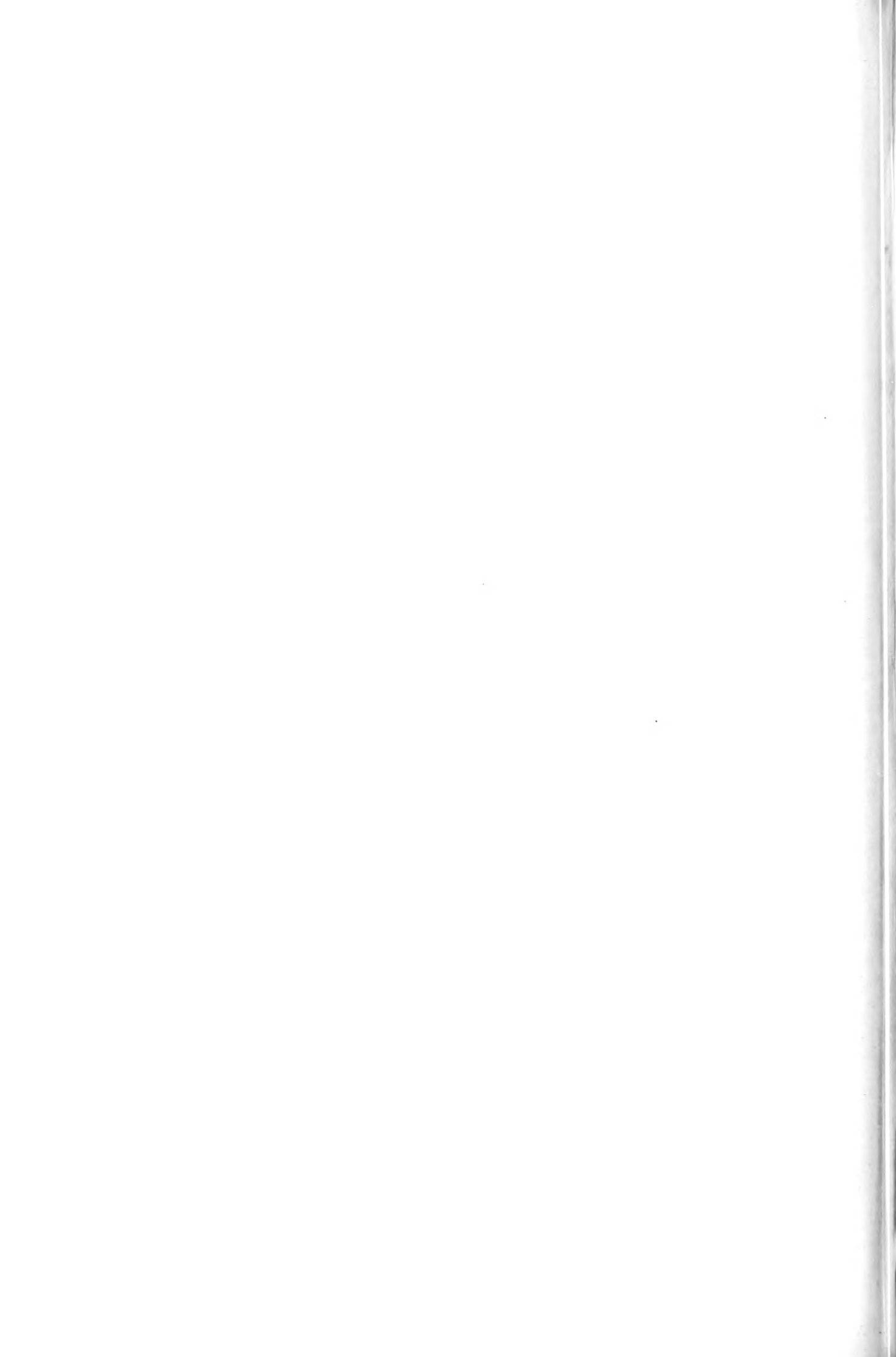





RESTORATION OF A XIV. CENTURY BED

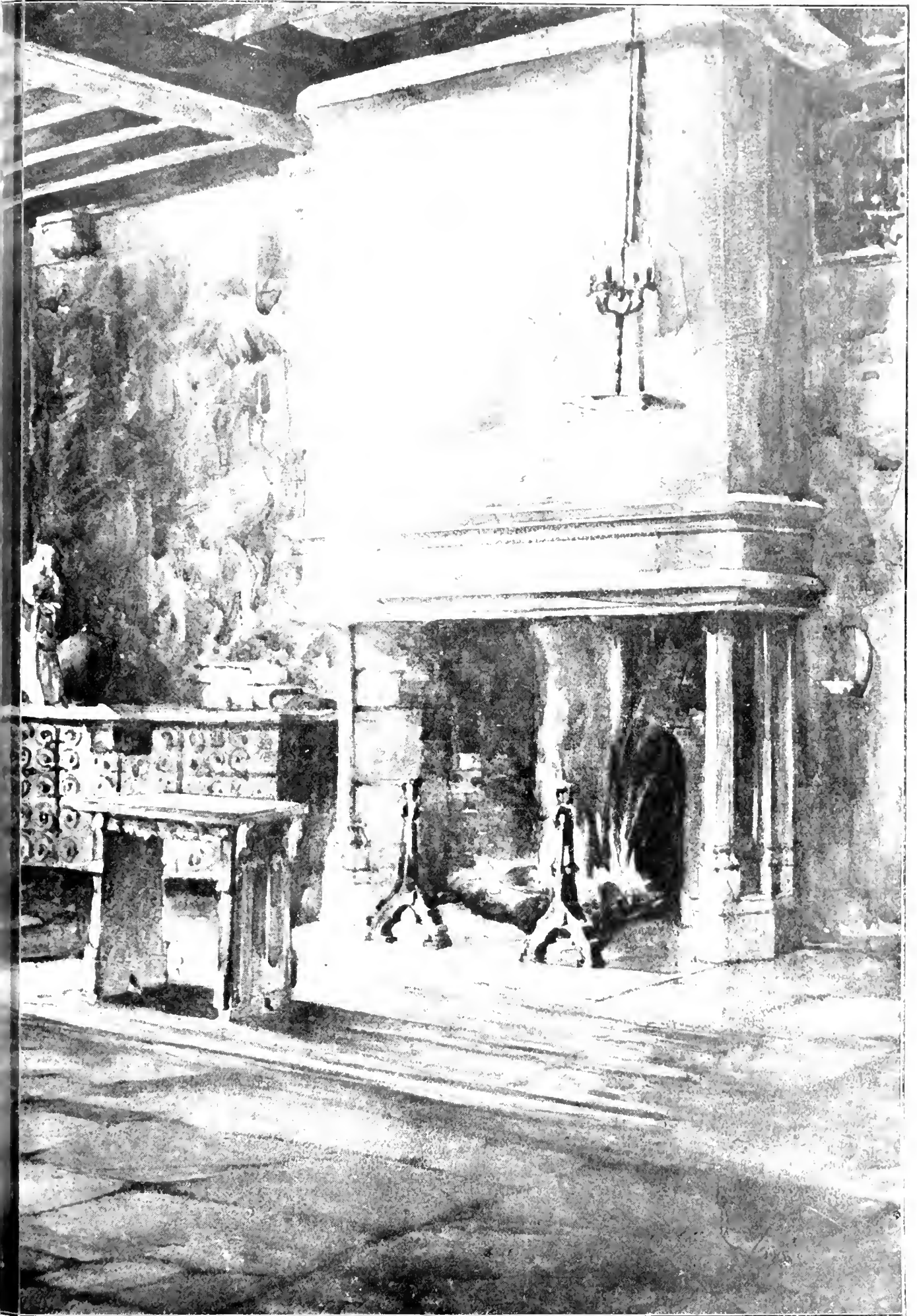

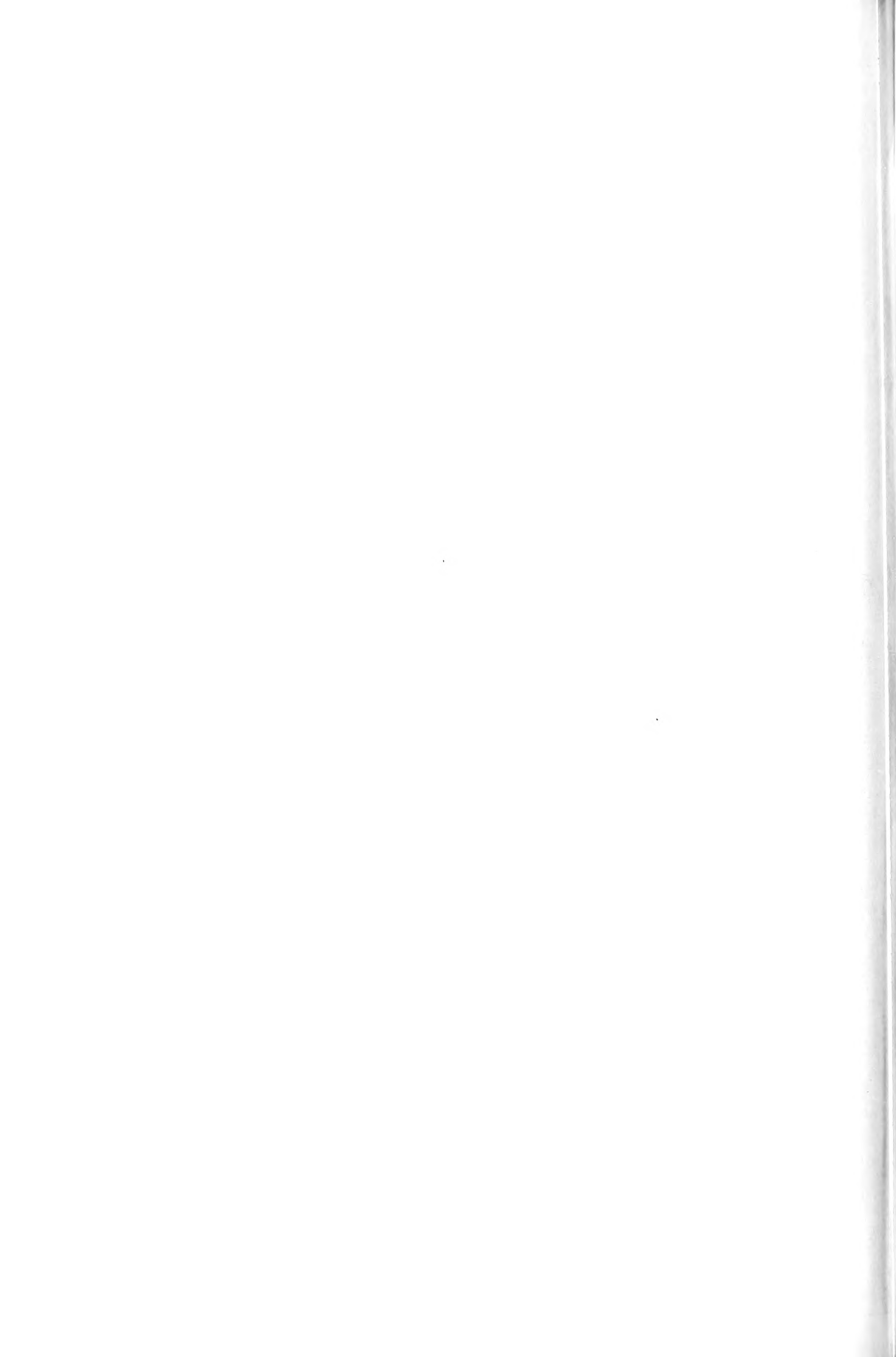

PROFESSIONAL AND TRADE SOCIETIES.

BRISTOL SOCIETY OF ARCHITECTS.—The third sessional meeting was held on Monday in last week, at Fort's, 6, Royal Promenade, Clifton, at 5.30 p.m. The President, Mr. Graham C. Awdry, F.R.I.B.A., having taken the chair, a lecture (illustrated by lantern slides) on "Modern Cement Manufactures" was delivered by Mr. W. S. Skinner, F.R.I.B.A., who described the various types of machinery used in the manufacture of cement, and traced the materials through the various processes from their raw state to the finished product. On the conclusion of the lecture a short discussion ensued, in which various members took part. A vote of thanks to Mr. Skinner, proposed by Mr. G. C. Lawrence, A.R.I.B.A., and seconded by Mr. C. E. Thompson, Lic.R.I.B.A., was carried with acclamation.

LONDON AND MIDDLESEX ARCHAEOLOGICAL SOCIETY.—The Lord Mayor presided at the Diamond Jubilee meeting of the London and Middlesex Archaeological Society, held in the Mansion House, on Tuesday afternoon in last week. The president, Sir Edward W. Brabrook, F.S.A., in the course of an address on "The Growth of Archaeology in London during the Past Sixty Years," remarked that the inaugural meeting of the Society was held on December 14, 1855, in Crosby Hall, and it was not the fault of the members that the hall had disappeared from the City of London. The very greatness and prosperity of London militated against the preservation of the relics of its history. Not one person was living of those who attended the inaugural meeting of the society; the oldest member was the vice-president, Mr. E. J. Barron, now in his ninetyth year, he joined in 1859, while he (the speaker) became a member in 1865. The society had been recognised by the Corporation and the City Companies, and it had been the means of making many archaeological discoveries, notably that concerning the trade guilds of the glovers, the blacksmiths, the water-bearers, and the clothworkers, as revealed in the documents of the Commissary Court of the Bishops of London. It had also provided the memorial window, representing the minor companies of the City in the Guildhall Library. During the last sixty years there had been a marked change of public opinion in regard to the preservation of old churches and other historic buildings, but improvement was still needed. The method of issuing faculties, he said, was a weak point in the present system, and he thought that no faculty should be granted until the Chancellor of the diocese was satisfied by independent expert advice that it was not open to objection on archaeological grounds. The love of antiquity, he continued, was a mental and moral quality as well as an aesthetic one, and we might contrast with this the depth of infamy our enemies had incurred by the destruction of the Library of Louvain, the Cloth Hall of Ypres, and the Cathedral of Rheims, all sacrificed to a brutal savagery which prided itself on rivaling that of the Huns.

OPEN-AIR SCHOOLS.—An address on "Open-Air Schools" was delivered on Saturday by Mrs. Leslie Mackenzie, Edinburgh, at a meeting of the Glasgow Branch of the Educational Institute of Scotland. The meeting was held in Percy Street Special School, Glasgow, which is of the open-air type. Mr. James Knight occupied the chair. Mrs. Mackenzie said an open-air school did not mean a playground. It did not mean a shed and a playground. It was an ordinary school built on open-air principles, and these principles ought to apply to all schools. The people to be first educated were the managers and the architects. The pupils in open-air schools must have extra clothing, and both teachers and pupils in such schools required and could take extra food. In Edinburgh a beautiful school for 1,400 children had been built, and the whole of the three floors were open. Mr. D. M. Wilson, convenor of the Committee on Special Schools under Glasgow School Board, who opened the discussion, referred to a visit which, as a member of a deputation, he made to open-air schools, and remarked that the deputation

were more struck by what they saw in the Duncan Street School in Edinburgh than by anything they saw in England.

SCOTTISH SOCIETY OF ANTIQUARIES. The first evening meeting of the Society of Antiquaries of Scotland for the session was held in the rooms of the Royal Society at 24, George Street, Edinburgh, on the 15th inst. the Hon. John Abernethy, LL.D., president, in the chair. Mr. Harry R. G. Hughes, F.S.A. Scot., read a paper on "The Roads that Led to Edinburgh." The paper was illustrated by copies of manuscript maps in the Advocates' Library and the British Museum. Mr. Hughes remarked that in endeavouring to ascertain which are the earliest roads leading to Edinburgh our knowledge is very much circumscribed by the absence of early road maps, the first of any real service being those of Adair, of 1680. The earliest known source of geographical information about Britain is a Ptolemy's Geography, but it is so confused as to be of little service as far as Scotland is concerned, while the Antonine Itinerary of 200 A.D., giving the Roman roads in Britain, mentions no roads in Scotland. In medieval times the most interesting document dealing with the routes in Scotland is an English manuscript in the British Museum known as Hardyng's Chronicle, written about 1425 by a supposed spy, describing the towns and castles, with the distances apart, and the order in which they should be taken, as well as the route the armies should follow in subjugating the country. The first survey of Scotland upon a large scale was by Timothy Pont, whose work of 1609 was added to by Gordon of Straloch, and the whole published in Blaeu's Atlas of 1649. Among these maps the Lothians is the only sheet showing the roads, but whoever filled these into the map had no sure knowledge of their course. Adair followed in 1680 with some beautifully drawn maps, which are preserved in the Advocates' Library, and these show the roads very accurately. These and Blaeu's maps were made use of and reproduced in small scale, with some roads roughly drawn in, in Moll's Atlas of 1722. It was not till 1745 that a real survey of the country was begun, and this was completed and revised to 1755. These road maps now lie in manuscript in the British Museum, and have never been published, though some maps reduced from them were issued from 1770 to 1820. A fine survey, mostly from estate plans, was issued about 1822 in Thomson's Atlas, but it was not till the publication of the Ordnance Survey between 1856 and 1886 that we have a true record of all the roads and paths in Scotland. Of the roads leading to Edinburgh, perhaps the most interesting is the road over the Cheviots from England. It is described in the Antonine Itinerary as a Roman road as far back as the third century, A.D., but the Romans lay no claim to it as extending beyond the Northumbrian border, and it is equally remarkable that the same thing applies to the Roman road on the west coast, which terminated a little beyond Carlisle. We are, therefore, faced with the question whether the Romans made any roads into Scotland, or whether they simply used the native highways as sufficiently direct for their purpose. In early times we do not know whether the roads in the South of Scotland all trended towards Edinburgh or not, because this city seems only to have grown in importance as the seat of government moved southwards, first from Perth to Dunfermline, then from Dunfermline to Edinburgh. We may take it as likely that the oldest roads leading to Edinburgh would be those from Dunbar, Lauder, Dumfries (via Biggar, Linlithgow, and Queensferry), all the others being only of local value. As to dates of construction, we have almost no records of any being actually made before 1600. Of the modern roads leading to Edinburgh, broadly speaking, the present roads were formed about 1830; if an older line is seen it would date from about 1780; and if a third and steeper line is observed, it is almost equally safe to say that it was laid down about 1755. A paper by Mr. P. M. C. Kernode, F.S.A. Scot., recounted further discoveries of early cross-slabs in the Isle of Man. The most interesting of these found

at the N. in Ker at Meig, on the 1st inst., is a Scandinavian monument, showing on each face the remains of a long shafted Celtic cross with a cabbed border, the shaft ornamented with a carelessly drawn and artistically designed vertical step pattern. Below one limb of the cross is carved a Viking ship, which is the first example of this device found in the island, and which affords a link with the later monuments of the western isles of Scotland. A runic inscription runs up the shaft, which is interpreted "Hodin set this cross to the memory of his daughter (Hliti. Anni cut these runes." The ship is realistically treated; it is high at the prow and poop, the bulwarks low amidship; the sail is furled, and instead of the fixed rudder at the stern, there is a steering oar on the starboard side. Mr. Kernode believed that the purpose of the ship was to indicate the descent of Hliti from Godred Crovan, from whom both the kings of Man and the Lords of the Isles had derived the ship as an armorial bearing.

THE ART OF THE ITALIAN RENAISSANCE.—The last of three lectures on this subject was given by Mrs. Webster, London, in St. Andrew's Hall, Drumshengh Place, Edinburgh, on Tuesday in last week. Mr. R. Morley Fletcher, director of the Art College, presided. The subject dealt with in this lecture was Venetian art. Venice, she said, was a name to conjure with. "See Venice and die" was an old saying, which she took to mean "see Venice before you die, which was good advice. In speaking of the distinction between Florentine and Venetian art, she indicated that while the former school concerned itself with form and line, the latter had more to do with colour and character. The influences which brought about the Renaissance were late in involving Venice owing to its insularity; the art of Venice was the last to come and the last to go of the Italian schools. The artists specially selected by Mrs. Webster for notice were the Bellini family, who laid the foundation of the Venetian school; Titian, Carpaccio, Giorgione, and Tintoretto, and of their admired works several notable examples were shown on the lantern screen. Speaking of Titian, Mrs. Webster said that in his time Venice was in the height of her power and the fulness of her beauty and intellectual vitality. The great endowment of Titian was in painting; unlike Leonardo da Vinci, he was not a man of all round accomplishments, but in the history of art none had used colour with such a majestic conception of its power. Carpaccio, who was one of the Bellini group, was an excellent artist, as his pictures of St. Ursula and St. George, still in Venice, showed. Tintoretto, another of the great Venetians, was a born painter, a great draughtsman who endeavoured to combine the Florentine line with the Titian colour. A picture of his masterpiece, "The Miracle of the Slave," now in the Academy at Venice, was shown and explained.

THE HISTORY OF ART IN SCOTLAND. Mr. J. Campbell Mitchell, F.R.S.A., of the Edinburgh College of Art, addressed the members of the Eastern Branch of the Scottish Art Teachers' Association, at Dundee, on Tuesday in last week. Miss Wrigley, president of the branch, presided. Mr. Campbell Mitchell, in tracing the early history of art in Scotland, said there was a popular belief that Scotland had always been an artistic nation, an error based on ignorance of Scottish history. Unfortunately, much of the art of earlier generations had been destroyed during the troublous times which followed the death of Alexander III. in 1286, the Reformation.

THE SOCIETY OF ENGINEERS (INCORPORATED). The sixth annual general meeting of the Society of Engineers (Incorporated) was held at the offices of the Society, 17, Victoria Street, Westminster, on Monday, December 15, 1915. The award of premiums made in respect of papers published in the Journal of the Society during 1915 were announced as follows:—The President's Gold Medal to Mr. Arthur H. Barker, B.Sc., for his paper entitled "Some Future Developments in Heating and Ventilation." The Bessemer Premium, value £5 5s., to Mr. Alphonse

... E. for his paper on "The Department of Water Power." A ... value £5 5s. to Mr. ... Barrister-at-Law, ... his paper entitled "Law ... Some Points of Contact." ... value £2 2s. to Mr. ... paper on "Main Roads, ... The report of the council ... adopted. The scrutineers of ... reported that the following ... as members of the council ... for 1916. President, Percy Griffiths; Vice-Presidents, Henry C. Adams, W. ... W. N. D. Twelvetrees; members, ... Henry Adams, C. F. Waller, F. L. B. B. Bernard Green, the Rt. Hon. ... H. H. Hummel, T. J. ... B. H. M. Hewett, G. A. Becks and ... Associate Member of Council, ... Hon. Secretary and Hon. Treasurer, D. B. Butler, Messrs. Begbie, ... and Cox, chartered accountants, were re-appointed as auditors for the year 1916. Votes of thanks to the council and officers for 1915 and to the scrutineers of the last year for the election of the new council were passed unanimously.

LEGAL INTELLIGENCE.

Biggs v. Biggs, Appeal.—In the King's Bench Division on Tuesday and Wednesday of last week the appeal was heard of Elliott v. Executrix of Thomas Woodbridge Biggs from the decision by his Honour Judge Woodfall in the Westminster County Court on October 25 last, and reported in our issue of the 3rd inst. (pp. 52-17). Mr. G. A. Scott and Mr. Stannard appeared for the appellant, and Mr. Elliott and Dr. C. Herbert Smith for the respondent, the executrix of a deceased architect, Mr. T. Woodbridge Biggs. Mr. Scott said that an action was brought some time since by Mr. Biggs, since deceased, for the payment of certain fees as architect for works of repair and decoration in a house near Maidenhead executed in 1914 by Mr. Elliott and was decided in plaintiff's favour. In June last an action was brought by the appellant as building owner against the executrix in two parts, first, a claim for £48 7s. 6d. on the ground that Mr. Biggs had negligently issued his certificate to the builder, and secondly, it was alleged that he had received from another contractor a sum of three and a-half guineas for the supply of additional copies of drawings and specifications for the reconstruction in 1912 of a greenhouse, and that this was not disclosed to the plaintiff, who, when such receipt of moneys being made by the building owner to be in the nature of a set-off commission. To the second part of the claim the defendant in the County Court action replied that it was of the nature of a set-off and gave notice of a special defence under the Statute 3 and 4 William IV., which in an action for tort against a person deceased must refer to acts alleged to have been committed within six months of death, and be brought within six months of his death. This was upheld by the learned County Court judge, and counsel contended, on behalf of the appellant, that Mr. Biggs, who died on February 1 of this year, was entitled to have received the moneys from the defendant on April 17, 1912, not the limitation period of the Statute, which did not apply where, as in this case, the receipt was concealed from plaintiff until some time afterwards, viz., until December 1, 1912. As to the first part of the claim, the plaintiff was allowed to give further particulars of the defence, and on January 19, 1915, which admittedly showed that plaintiff had "negligently and carelessly issued his certificate as architect," and that the defendant and better particulars issued on February 22 of this year, a month later, the learned County Court judge held that "negligence due to lack of care" was proved. The learned County Court judge also held that the original particulars in the County Court case were "Chambers v. Goldthorpe," and that the Master of the Rolls, and the Lord Justices, Lord Lindley and Romer in the Court of Appeal, and the judgment of Mr. Justice Backwell in the County Court, were fully reported in the Building News of March 1, 1911, p. 296, Vol. XXXV, and that in issuing his certificate the architect acted negligently, and that he could not be said to have been misled. The County Court judge also held that the plaintiff, holding the certificate, was entitled to sue on the ground that the defendant had not given notice of a special defence under the Statute 3 and 4 William IV., and that the County Court judge was right in awarding the costs in favour of the plaintiff.

plaintiff was entitled to submit such amended particulars as were sent in in this action, and that the County Court judge was bound to hear evidence as to the alleged negligence in supervision and give judgment upon the facts as to the alleged "lack of supervision" in which the architect acted not as an arbitrator, but merely as a supervisor. Dr. Herbert Smith, for the respondent, argued that if the learned County Court judge gave his decision on the actual facts there could be no grounds of appeal. Any grounds of appeal could only be based on points of law, and Judge Woodfall's decision, given in his discretion under Rule 12, related to two questions of a legal nature. First, as to the alleged tort—as to which they would have proved, if evidence had been called, that no fraud was committed—the secret commission was alleged to have been received in 1912 by Mr. Biggs, who died on February 1, 1915, and the action was tried on Oct. 25, 1915, so that in neither respect was the six months' limitation, before the death of the person alleged to have received the secret commission or the bringing of the action, observed. Then the further particulars, furnished a month after the original statement of claim was submitted, disclosed an entirely fresh cause of action, namely, negligence in supervision and not negligence in improperly granting a certificate. He cited "Chambers v. Goldthorpe," *supra*, which disposed, as the learned County Court judge had held, of any claims pleaded in the original particulars against Mr. Biggs. Dr. Herbert Smith further contended that the particulars of the case should have been dealt with as a set-off to Mr. Biggs's action during his lifetime and not as the appellant had done, when the appellant had lost the case brought by Mr. Biggs against him and present action was started against the executrix. In "Rogers v. James" it was held that an architect was liable for negligence in supervision, even although he had given a final certificate. In giving judgment, Mr. Justice Coleridge said he would dispose first of the point about which he thought there could be no dispute—a small claim for three and a-half guineas for extra copies of specification, regarded by appellant as a fraudulent or illegal commission. This was not a tort, the proceeds or nature of which had been appropriated by the deceased Mr. Biggs and added to his estate, and, therefore, it did not seem to him to be money or property within the purview of the Act 3 and 4 William IV., whichever was in the hands of the plaintiff. Therefore, it seemed to him not to be within the provisions of the Act nor to be in the nature of a tort to which the general maxim *personalis moritur cum persona* applied. A more difficult problem was raised by the question as to the amended statement of claim, the second portion of the appeal. It was admitted by counsel on both sides that the original particulars, showing a claim for negligence in improperly granting a certificate to the holder did not disclose a cause of action, and would not be upheld in view of the decision in "Chambers v. Goldthorpe," for the architect, in granting such a certificate, was acting as a quasi arbitrator. But further particulars were called for and were submitted, and it was open to consideration whether these did not give a good cause for action. His lordship was not persuaded that the learned County Court judge had his attention clearly drawn to this point, that the second set of particulars, in so far as they were merely a reiteration of the first particulars, added nothing, and that his attention was not drawn to the question as to whether or not it disclosed a good cause of action. So far as he could see, the County Court judge did not appear to have quite appreciated that point. Under those circumstances he considered the best course to pursue would be that the action should be sent down to the County Court judge for him to consider that point—if the second particulars did not show a cause of action. If they did not, there was nothing for the judge to decide. If, however, they did disclose a fresh cause of action he (the learned judge) ought to consider, whether or not it was not competent to him to try that cause of action and determine it. It would, he thought, be better that the judge should consider that point carefully and come to a judicial conclusion about it. Mr. Justice Low concurred, observing that it seemed to him that the question of whether or not these very confusing particulars disclosed a fresh cause of action was essentially one for the learned County Court judge to decide. His lordship would not express any opinion on this point because that was really for the County Court judge to decide. In answer to Dr. Herbert Smith, Mr. Justice Coleridge stated that there would be no order as to costs in this appeal.

HEAVY PENALTIES FOR RESUMING WORK.—At Newcastle-on-Tyne County Court on

Thursday, John Riddell, plumber, of 265, Shields Road, Newcastle, made an unusual claim against the United Operative Plumbers' and Domestic Engineers' Association of Great Britain and Ireland, of 82, Osborne Road, Newcastle. The plaintiff was a member of this trade union. About four years ago, owing to incapacitation through physical injury, he became entitled to and was granted superannuation benefit. In March, 1915, he applied for leave to resume work, and the request was granted, but the association demanded that he should repay the superannuation money he had received, amounting to about £64. Plaintiff resumed work at his trade, and offered to resume his contributions as a full member of the association. This was declined, and it was decided that the plaintiff, having started work, had severed his membership entirely. In consequence, his fellow-workmen refused to work alongside him. Threatened with the loss of his employment, he was compelled to rejoin the association as a trade member of the third degree, to whom benefit was restricted to strike pay. The plaintiff claimed a declaration from the Court that so long as he conformed to the rules of the association he was entitled to participate in the rights, privileges and benefits of a full member, that his exclusion from the association was invalid, and that the association should be restrained by injunction from excluding the plaintiff. His Honour Judge Greenwell said the society had made a fair offer for bringing Riddell back into the society when they suggested the repayment of the £64. If the plaintiff wished to argue further with regard to the Court imposing rules upon the society, then he was entitled to invite the Divisional Court or the High Court to do it. Judgment was given for the defendant association with costs.

TRADE NOTES.

Boyle's latest patent "Air-Pump" ventilators have been applied to Lanark District Asylum, Hartwood.

On and after the 20th inst., Mr. Percy B. Tubbs, F.R.I.B.A., will continue his practice of architect and surveyor at his new offices, No. 10, Gray's Inn Square, W.C. The telephone number will remain the same, but the Exchange altered to Holborn, viz., Holborn 2141.

Rough-cast walls are often porous owing to their uneven surfaces, which hold the water from driving rains. We are interested to hear that ten houses in an exceptionally exposed situation at Ebbw Vale were rough-cast with Pudloed cement over two years ago, and are still perfectly watertight.

The business meeting of the Royal Institute of British Architects, arranged for January 3, has been cancelled.

Mr. Henry E. A. Woods, recently Inland Revenue valuer at Chippenhams, has been appointed assistant valuer to the War Department (Eastern Command).

The death is announced of Mr. Thomas Bonner, who had been borough librarian at Ealing since 1883. He was the inventor of the Bonner indicator, which is in use in a number of libraries.

Mr. Charles Finch Dowsett, of Lincoln's Inn Fields, died on Friday last at the age of seventy-nine years. He was an authority upon ground rents, in which he transacted a large business. For many years he published "The Land Roll."

The Nantwich Rural District Council are faced with a demand for payment of £6,268 16s. for pipes cast for the Audlem and district water supply scheme, which the Government has now refused to sanction. There is, however, a probability of the Local Government Board taking over the pipes for a Government department.

Consequent on the retirement at the end of the year of Mr. A. C. Mountain, city surveyor, the City Council of Melbourne, Victoria, has decided to combine the offices of city surveyor and city architect, and to appoint Mr. H. E. Morton, the city architect, to the dual office under the designation of city engineer.

Mr. James Everett Bownass, A.R.I.B.A., of Princess Patricia's Canadian Light Infantry, has hitherto been reported "missing," and is officially stated to have been killed in the trenches at Bellegarde Wood, near Hooge, Belgium, so long since as May 8. He was an assistant in the office of Messrs. Darling and Pearson, Leader Lane, Toronto, and had been an Associate of the Royal Institute since 1909.

Building Intelligence.

BELFAST.—The new hall at Duncairn Presbyterian Church in memory of the late Right Hon. Thomas Sinclair, D.L., was opened on the afternoon of the 10th inst. The building, designed by Messrs. Young and Mackenzie, architects, Scottish Provident Buildings, has cost £5,500. The central feature is a large hall facing the Antrim Road. At the rear of this hall is a wide corridor lighted from above, and more than 100 feet in length. On one side of the corridor are entrances to the hall, kitchen, session room, and offices, and on the other to the ladies' room, minor hall, and two large class rooms. The contract was carried out by Messrs. McLaughlin and Harvey, Ltd., York Road, Belfast.

EDMONTON, ALBERTA.—Commenced in May, 1914, the central unit of the University of Alberta building scheme has just been completed at Edmonton by the contractors, the Geo. A. Fuller Company, Limited, Montreal, from plans by Messrs. Nobbs and Hyde, architects, Montreal. It is known as the Arts Building, and consists of a main building, with an assembly hall at the west end, together with separate structures for laboratories and power house. The style of architecture is Free Classic. The main building has four stories, and is 300 ft. long and 70 ft. wide, while the assembly hall is 100 ft. long and 60 ft. wide, and is seated for an audience of 1,000. The exterior of the main building has a base of granite, with walls of Tregillus brick and dressings of Indiana limestone. Between the third and fourth floors on the oriel windows four carved panels represent Philosophy, Music, History, and Mathematics. The basement, in red and grey brick, contains a stock-room, a book-receiving room, book store, a printing department, elementary physics laboratory, and a spare laboratory. There are also men's and women's dressing rooms, band room, storage room, and ventilation system. The first floor provides accommodation for the public activities of the students. The entrance hall has walls in semi-glazed terracotta, the doors being of marble. From this hall there is a wide passage, with a barrel vault, which leads directly to the assembly-hall. On this floor are the students' common-room, lecture room, and laboratory of the advanced physics department, offices of the University extension department, women's common-room, four class-rooms, and a lecture room, with offices. Other class-rooms are on the floor above. All the class and lecture rooms are constructed on the one, two, and three-unit system, which will permit of the hollow-tile curtain partitions being removed and any of the rooms enlarged to meet future requirements. The lecture-rooms throughout are provided with the stadium style of seating.

HERNHILL.—The Archbishop of Canterbury consecrated last week important additions to the parish church of Hernehill, East Kent, which have been carried out at the entire cost of Mr. William C. Dawes, of Mount Ephraim, as a monument to his father, the late Sir Edwyn Sandys Dawes, K.C.M.G. The additions comprise a chapel on the north side of the chancel, and an organ chamber on the south side. The original walls enclosed by the additions have been opened up by arches and an oak screen spans the new arch between the chapel and the choir. A new stained-glass window to the memory of Sir Edwyn is placed in the chapel, and there is also a memorial tablet of brass on marble. The work was executed under the direction of the diocesan architect, Mr. W. J. Jennings, J.P., M.S.A., of St. Margaret's Street, Canterbury.

Mr. J. C. Wilson has resigned his position as estates manager to the Bournemouth Corporation.

The Bristol Docks Committee have adopted recommendations for the reconstruction of the craft delivery plant on the east side of the Royal Edward Dock necessitated by the extensions to the Co-operative Wholesale Society's premises at the Royal Edward Dock; also the provision of barge discharging plant between Sheds O and P at the Royal Edward Dock.

OBITUARY.

Mr. Baldwin Brown, A.R.I.B.A., who had been for several years on the staff of the city architect for Bradford, Mr. W. Williamson, has died, after a surgical operation, in his fortieth year. He served his articles with Mr. Rhodes Calvert, of Bradford, and was afterwards in the offices of Mr. James Ledingham and of Mr. Edgar A. Parkinson. He was keenly interested in the housing problem and in town-planning, and had prepared several schemes for the replanning of the central area in Bradford preparatory to the competition recently instituted. A resolution of the City Architect's Committee has been passed, expressing sympathy with his sorrowing parents and their family, and high appreciation of his "devoted services." He became a student of the Royal Institute of British Architects in 1903, and was elected an Associate five years later.

We regret to announce the death of Mr. Samuel Elliott, of Caversham, the founder of the firm of Samuel Elliott and Sons (Reading), Ltd., which took place on December 13 last. The deceased was seventy-seven years of age, and was one of the early pioneers of the high-class joinery and moulding trade, with which his name was intimately connected for many years, both at Newbury and at Reading, and gained many gold medals and awards at home and on the Continent. Mr. Elliott was born at Newbury, Berks, in 1838, and commenced business in his native town in 1859, succeeding to the building business of his grandfather. Mr. Elliott was a builder and contractor of considerable ability and eminence, and carried out several church contracts under the late Sir G. Gilbert Scott, the late Mr. G. E. Street, and for the late Mr. John F. Bentley at Westminster Cathedral. He also carried out considerable building work under the late Mr. Alfred Waterhouse, R.A., and the late Mr. Norman Shaw, R.A., notably under the latter architect, "Greenham Lodge," Newbury, and "Greenlands," Henley-on-Thames. While Mr. Samuel Elliott was a contractor at Newbury, he erected in Reading the Old Newbury Court Offices, since pulled down, and the Congregational Church, Friar Street, Reading, which is now occupied by the Reading Theatre, besides several houses in the Katesgrove district. He undertook the re-erection of Temple Bar in Theobalds Park, Herts, but of recent years he turned his attention to high-class joinery and mouldings, first at Newbury, and latterly at Caversham, Reading. The business at Caversham is being carried on at the present time under the name of Samuel Elliott and Sons (Reading), Limited. Mr. S. Elliott was a Freemason, belonging to the Deptford Lodge. The deceased had been suffering lately from almost total blindness, but his mental faculties were unimpaired to the last. He leaves a widow, two daughters, and three sons, two of whom are directors of the company. The interment was at Caversham, on Thursday, December 16. Mr. Elliott was of a most genial disposition and great energy, and invented many useful and valuable patents.

The death took place at Portland Villas, Plymouth, on Sunday in last week, in his eighty-third year, of Mr. Robert Thomas Relf, a well-known contractor for considerable railway and Government works in Devon and Cornwall. With his son, Mr. George Robert Relf, deceased carried out several contracts for the Great Western Railway in Cornwall, including the doubling and diversion works on most of the line between Saltash and Penzance, including many new masonry viaducts to take the place of the old wooden structures designed by Brunel before 1859, when the Royal Albert Bridge across the River Tamar was opened, the principal being those between Saltash and St. Germans, and at Daubuz's Moors and Carvedras, at Truro. Messrs. Relf also carried out the improvement of the Trembley branch of the Cornwall Minerals Railway, the Newquay station improvement, the Retew branch from Retew to Mollangoose, Bodmin Station yard, and the Bodmin and Boscarne Junction Railway for the London and South-Western Co. In his last years Mr. Relf was also associated with his son in a railway on the Trenance Valley, St. Austell, now being built.

Correspondence.

THE ARCHITECTURAL ASSOCIATION VOLUNTARY AID DETACHMENT.

To the Editor of THE BUILDING NEWS.

SIR, The necessity and importance of Red Cross work hardly need emphasis at the present time. The interest to be found in it can be attested by anyone who has undertaken it. What does require emphasis is the need of a constant supply of workers, and I venture to draw the attention of your readers to the detachment now registered by the War Office as "London 43, V.A.D., Westminster Division," with headquarters at the Architectural Association, 13, Tufton Street, Westminster, S.W.

There is plenty of work to be done, and any man who joins may be sure that his services will be used as soon as he is qualified. Classes for instruction are held as recruits come in. The first course of first-aid lectures was given by Dr. Spicer in September. Dr. Brydone, the medical officer of the detachment, continued with a course on home nursing, and has given a course on first aid for the examination at the end of this month. He is now holding a third course, and another is to begin soon after Christmas. There are between sixty and seventy names on the roll, of whom between thirty and forty are already qualified.

As this is the only men's detachment in the Westminster Division, they have been called upon to assist in many ways. Thus, we provide orderlies for the Officers' Hospital at 24, Park Street, and for Lady Violet Brassey's Officers' Hospital, and propose to do the same for the large soldiers' hospital soon to be established at 184, Queen's Gate. We have volunteered professional services in advising the Westminster Division on the various houses which may be turned into hospitals. Our stretcher-bearers hope to assist the London Ambulance Column in meeting the trains of wounded at the railway stations and conveying them to hospitals, and we are almost hoping for another successful air-raid, because the police have asked us to be ready to render first aid and do what we can to succour the victims. Our commandant, Mr. Ambrose W. Coffin, is constantly asked for volunteers to undertake all kinds of jobs, from conveying stray convalescents across London to lending a hand to meet a rush of clerical work at headquarters. Parades for company and stretcher drill are held under the instruction of Sergeant Daniels, of the R.A.M.C., who in quieter times is an engineer in Canada.

We make a special appeal to architects and men of kindred occupations, because through them the detachment came into being, and most of our members are drawn from these callings. But we welcome all men of goodwill from any station in life. The only conditions are that they should be either not eligible for military service or already attested under Lord Derby's scheme, and the only financial contributions required are a nominal entrance fee and the provision of their own uniforms. The work will increase as the war goes on, and the more workers we can have to draw upon the better. It is certain that no man who undertakes the work will regret it, and the knowledge he will gain is such as every man ought to possess and as will make him more useful in every branch of life.

For further information and application forms, inquiry should be made to the Quartermaster, Mr. V. Wilkins, at 13, Tufton Street, or the Commandant can be seen there on Wednesdays at 6 p.m.—Yours faithfully,

HENRY M. FLETCHER,

Hon. Sec. Architectural Association,
13 Tufton Street, S.W.

A course of three Fothergill lectures on "Flemish Architecture" will be given at the Royal Society of Arts on February 7, 14, and 21 by the Rev. Herbert West, D.D., A.R.I.B.A.

In connection with the housing scheme at Bromford for the Dunlop Rubber Company, to be considered at the next meeting of the Birmingham City Council, the company have agreed to contribute £2,000 towards the cost of constructing an arterial road on the southern boundary of the estate.

of the twenty-eight boroughs give a total value of £9,298,000, which represents a decrease of £40,600.

A scheme for preventing disputes in the building trade has been decided upon at a meeting of the National Conciliation Board for Building Trades held in London. The meeting was attended by representatives of master builders and workmen of all trades from every part of the country. The scheme provides for the establishment of machinery for dealing with demarcation questions which may arise from time to time, and which in the past have led to some bitter and prolonged disputes in the building trades. Local districts and national Boards of joint representatives will be created to decide the demarcation problem. Of twenty-two unions affected by the proposal, eighteen have assented.

The great delay in the return of empties by rail is causing considerable expense and inconvenience to the paint, colour, and varnish manufacturers and their buyers. The National Federation of Associated Paint, Colour, and Varnish Manufacturers of the United Kingdom have been in communication with the Railway Executive Committee, and has suggested that the railway companies should consent to receive empties at all their stations in the ordinary way, say, once a week or at least four times a month, and undertake to return them to the paint producing centres as soon as possible thereafter, or not later than, say, three days after the time they receive them. On August 28, 1915, the Railway Executive Committee replied that every effort was being made by the Railway Companies under the prevailing conditions to facilitate the working of the traffic. Little or no improvement having taken place, the Federation have again drawn the attention of the Railway Executive Committee to this important question, emphasising the fact that in some districts, particularly London and the South of England, it is nearly an impossibility to get back these returned empties, also pointing out that some of the station masters were declining to accept these empties, even on the terms mentioned above. The Railway Executive Committee has been asked to cause instructions to be issued by the Railway Companies to their station masters to receive empties when presented and to despatch them with the least possible delay to the paint producing centres. It is obviously in the interests of buyers that they should cooperate in the movement for these returned empties, and we would appeal to them to make every endeavour to assist the railway companies in dealing with this traffic, by making delivery of their empties at the stations and not wait for them to be collected. We also urge that cases of refusal by station masters to accept these empties should at once be brought to the attention of either the Secretary of the National Paint Federation, Exchange Buildings, Bowdley Lane, Hull; or the Railway Executive Committee, 55, Parliament Street, Westminster, London, S.W.

The Val de Travers Asphalt Paving Company issues from Hamilton House, Bishopsgate, E.C., one of the neatest and most artistic desk or wall date plaques for 1916 that has reached us. It is a bronzed tablet about 8 by 6 ins., bearing a well-designed and executed representation of the company's men laying down asphalt in the street. In the lower right-hand corner an unobtrusive but convenient niche takes the date-cards, which are easily shifted, and which readily catch the eye without spoiling the effect of the plaque, which most of us will keep for many years.

Mr. Edward Palk Bax, of Bramfield, Torquay, builder and contractor who died on May 10, has left £22,159.

A carved oak clergy stall has been placed in the Ikley Parish Church. It is made out of an oak tree that grew in the playground of the Ikley Church school.

H.M. Chargé d'Affaires at Santo Domingo reports, under date November 5, that the construction of a concrete pier, 1,120 ft. in length, and Customs buildings, is projected at Puerto Plata. Tenders will be called for after the scheme has been approved by Congress.

PARLIAMENTARY NOTES.

The Finance Bill. The House of Commons on December 17th, by night into consideration of the Rent and Mortgage Interest Restriction Bill. On the motion of Mr. Long, President of the Local Government Board, a new clause was added to the Bill, empowering the Lord Chancellor to make rules as to procedure in order the measure. It was agreed that the raising of rates which would justify a mortgage interest should include water rates. It was also proposed that an increase of mortgage interest should be allowed if notice of it had been given before the war. Mr. Long moved an amendment of sub-section 5 that a tenant should not be evicted as long as he paid his rent and performed the other condition of his tenancy, except on the ground that he had committed waste or been guilty of conduct which was a nuisance or annoyance to neighboring occupiers or that the premises were reasonably required by the landlord for the occupation of himself or some other person in his employ. In answer to Mr. Wardle and Mr. Prothero he explained that it had been impossible to provide in the Bill against tenant evictions already obtained against tenants who had taken part in agitation against the raising of rents. But the Government were so much impressed with the injustice of such cases that the Solicitor-General had undertaken that the matter would be very carefully considered when the Bill came before the House of Lords which would prevent the recurrence of such grave acts of injustice. The amendment was agreed to. On the motion of Mr. Long it was agreed to add at the end of the clause the following sub-section: "Provided also that if, in the case of a mortgage of a household interest, the mortgage satisfies the County Court that its security is seriously diminishing in value or is otherwise in jeopardy, and that for that reason it is reasonable that the mortgage should be called in and enforced, the Court may by order authorise him to call in and enforce the same." Mr. Long, discussing a proposal that building societies should not be prevented from raising the rate of interest on mortgages, stated that he had received a letter from the Building Societies Association saying that as he could not exclude such societies from the operation of the Bill nor permit them to raise their rates of interest on mortgages, they thanked him for the concessions he had already made, and offered no more suggestions. The Government would carefully watch the effect of the Bill, and if it rendered the position of building societies unstable he would see whether relief could not be given. The amendment was negatived. On the motion of Mr. Long, an amendment was introduced to exclude from the Bill lodgers who made payments in respect of board, attendance, or use of furniture. A sub-section (5) was inserted in clause 2 in the following terms, on the suggestion of the Solicitor-General: "Where the standard rent payable in respect of any tenancy of a dwelling house is less than the amount of the rateable value thereof, this Act shall not apply to that rent or tenancy, nor to any mortgage by the landlord from whom the tenancy is held of his interest in the dwelling house." This concluded the Report stage, and the Bill was read a third time.

Mr. H. Howard has resigned his position as surveyor to the Littlehampton Urban District Council.

The Vice-Chancellor of Cambridge University announces that Sir Enstace Gurney, of Spowston Hall, Norwich, has offered to present to the University certain farms, producing a rental of about a hundred pounds a year, for the improvement of the theory and practice of forestry.

Mr. Alice G. Hosnoll, A.R.E., member of the council of the Architectural Association, and Some Medallist of the Royal Institute in 1910, second lieutenant in the 7th Suffolk Regiment, who was wounded in the left thigh on the 24th ult., as we are glad to hear, progressing favourably at the Eastern Military Hospital at Cambridge, and hopes to be about soon.

At a Consistory Court held in the Manchester Cathedral porch, on the occasion of the dedication of a stained glass window in the north transept of St. Martin's Church, Castleton, in the memory of the late Lieutenant O'Neill, of Marlton Grange, who was killed at the Dardanelles on June 10. It will be a four-light window, containing as many figures. St. Martin will be shown dividing his cloak with the beggar, and the other scenes depicted will be St. George's conquest of the dragon, the death of St. Oswald, and the martyrdom of St. Alban. Messrs. Shrigley and Hunt, of Leicester, were the artists.

CHIPS.

The London Architectural Association, serving with the Corps.

The Abingdon Rural District Council are considering a scheme for constructing a reservoir for the Witnold and Siphham water supply at an estimated cost of from £3,000 to £5,000.

To the buildings of Delaware College, at Newark, Del., a library and science buildings are about to be added from plans by Mr. Frank Miles Day, 925 Chestnut Street, Philadelphia.

The borough surveyor of Elm, Mr. A. A. Luffell, has been instructed to ascertain the cost of carrying out arrangements proposed by him to prevent a recurrence of the flooding at the foot of Lasse Wynd.

A Local Government Board inquiry will be held at Bentley, near Doncaster, on Friday in next week the 31st inst., into an application of the Bentley with Arksey Urban District Council for authority to prepare a town planning scheme with reference to an area within the urban district.

The city architect of Toronto, Mr. W. W. Pearce, has had tests made of all the brick supplied by the large brick manufacturing concerns in Toronto and the vicinity. The data and bricks are kept in a cupboard, and are available for the general public's use. The architect's department also has a cement testing machine.

With reference to the question of a water supply for the growing parish of Mellor, the Haslehead and Mellor Rural District Council have resolved that Mr. E. C. Arkwright be offered £250 for his private water undertaking in Mellor, and that in case of dispute the Local Government Board be asked to arbitrate between the parties.

The list of distinctions obtained by officers trained in the Army's Rules Officers' Training Corps includes two Victoria Crosses, 11 Military Crosses, one C.B., one Military Medal, two M.V.O.'s, and four Victorian medals, while nine members have been mentioned in despatches. It is believed that this record is unique for any single unit in the Army.

At the meeting of the Birmingham Education Committee, to be held on Friday (Wednesday) the School of Art Sub-Committee will report that a survey has been made of pupils at the School of Architecture, owing to enlargements, has made the continuance of this school inadvisable, and the sub-committee have decided to close it temporarily on January 31 next.

To the British Red Cross Hospital at Netley the Vasey memorial operating room, was added this week. It is 60 ft. by 30 ft., and is provided with a stage and scenic effects, with dressing-rooms. The hall was built by Mr. Jukes, of Southampton, to the design of Mr. Dyke, of H.M. Office of Works, London, under the supervision of Mr. H. Bridgman, the local representative of the Office of Works.

The Home-Grown Timber Committee, recently appointed by the Board of Agriculture, announce that they are prepared to purchase standing timber and to make arrangements where necessary for felling, hauling, and conversion. They will be glad to receive particulars of timber which landowners and others would be willing to sell for Government purposes. All communications should be addressed to the Secretary, Home-Grown Timber Committee, Chaven House, Northwick, and Avenue, W.C.

At the last meeting of the Linnæusville County Council a report was submitted with regard to a joint meeting of the Finance Committee and the Middle Ward District Committee in regard to the erection of houses at Mossend. In a letter received from the Local Government Board it was explained that under the scheme the local authority would lease 15 cottages at an estimated cost of £39,500, towards which the Ministry of Munitions would contribute £1,100. It was agreed to proceed with the scheme.

The Montreal Board of Control have appointed Mr. P. E. Mossion, late of the firm of Budge and Morton, as chief engineer of the city at a salary of \$2,000 per annum, and Mr. A. Martin as assistant engineer. Mr. Mercier, who has been acting chief engineer, succeeds Major Georges James, who enjoyed a salary of \$2,000 a year, till he joined the army as an engineer, and who lost his life by the sinking of the *Paula* while crossing from France to England. The city of Montreal has been allowing Major James one-third of his salary while on active service.

TO CORRESPONDENTS.

We are not responsible for the opinions... All communications should be addressed as follows: THE BUILDING NEWS, Effingham House, Strand, W.C., and not to individuals by name. Delay is not infrequently caused by contributors' risks, and we cannot be held liable to pay for, or be liable to receive, correspondence.

For special competition designs, including architectural drawings, details of old buildings, and other sketches are always welcome. No charge is made for insertion of competition designs, but more than we can deal with are not to be sent when space is limited. Designs are accepted on advantageous terms, which may be obtained on application.

When forwarding drawings or photographs of buildings, please state how long the building has been erected. It does neither them nor does it affect the value of buildings which have been erected in accordance with special circumstances.

Telephone: Gerard 1291.

Teleg. address: "Times-Inst. L Strand, London."

NOTICE.

Final copies of Vols. CVIII are now ready, and should be ordered early, price 12s. each, by post. A few final volumes of Vols. XXXIX, XL, XLII, XLIII, XLIV, XLV, XLVI, XLVII, XLVIII, XLIX, L, LI, LII, LIII, LIV, LV, LVI, LVII, LVIII, LVIX, LX, LXI, LXII, LXIII, LXIV, LXV, LXVI, LXVII, LXVIII, LXIX, LXX, LXXI, LXXII, LXXIII, LXXIV, LXXV, LXXVI, LXXVII, LXXVIII, LXXIX, XC, XCI, XCII, XCIII, XCIV, XCV, XCVI, XCVII, XCVIII, XCIX, C, CI, CII, CIII, CIV, CV, CVI, and CVII may still be obtained at the same price, and the other bound volumes are out of stock.

BACK ISSUES.

Most of the back issues are to be had singly. The price of back issues is 10s. per volume, and will be charged by post. Subscribers requiring back issues should order at once, as they soon run out.

Handsome Cloth Cases for binding the BUILDING NEWS, price 2s. post free. 2s. 6d. can be obtained from any Newsagent, or from the Publisher, Effingham House, 7, Abchurch-lane, Strand, W.C.

TERMS OF SUBSCRIPTION.

One pound per annum, post free to any part of the United Kingdom, for the United States, £1.6s. 6d. per annum, and £1.10s. 6d. for France or Belgium, £1.6s. 6d. for India, £1.10s. 6d. To any of the Australasian Colonies, New Zealand, to the Cape, the West Indies or Natal, £1.6s. 6d.

Agents for Australia are Messrs. J. T. Kingsford and Co., Printers and Publishers, 10, A. St. George's, Liverpool Street, Sydney, New South Wales; for Japan, The Maruzen Co., Ltd., 11, Nishinagaya, 10-1, Sanjohome, Tokyo, who will receive subscriptions at 41.6s. 6d. per annum, and a 10% excess of the paper will be sent by air to the subscribers' address.

The special rate to Canada is 41.2s. 10d. = 50s. 6d. for 12 months, and 11s. 11d. 2d. 6d. for 6 months. Our District Subscription Agents for Canada are Messrs. S. G. & J. B. Shaughnessy Buildings, 110, St. James Street, Montreal, who will receive subscriptions at 41.2s. 10d. per annum, on our account.

Checks and Postal Orders to be made payable to THE STRAND NEWS-PAPER COMPANY, LIMITED, and crossed London, County and Westminster Bank.

ADVERTISEMENT CHARGES.

The charge for a position in the United Advertiser is 1s. per line per day. For a position in the United Advertiser, the first insertion is 1s. per line, and the charge being 5s. for the first line.

The charge for a position in the United Advertiser is 1s. per line per day. For a position in the United Advertiser, the first insertion is 1s. per line, and the charge being 5s. for the first line.

SITUATIONS VACANT AND WANTED.

The charge for a position in the United Advertiser is 1s. per line per day. For a position in the United Advertiser, the first insertion is 1s. per line, and the charge being 5s. for the first line.

ADVERTISEMENTS.

Reports to advertisements can be received at the Office Effingham House, 7, Abchurch-lane, Strand, W.C., free of charge. If to be forwarded under cover to advertiser, an extra charge of 5s. per line is made. (See Notice at head of "Situations.")

Advertisements for the current week must reach the office not later than 3 p.m. on Tuesday. Front

page advertisements and alterations or stop orders for serial advertisements must reach the office by first post on Monday to secure attention.

RECEIVED: A. C. BULLOCK, W. L. H. B. and Co., W. L. F. B. and Co., F. S. G. W. H. W. and Co., S. O. P. W. H. S. and Co., C. I. S. W. C. and Co., J. F. N. M. C., J. F. W. and Co., S. F. S. Dept.

J. G. H. A. V. D. F. S. T. E. K. S. 10. W. L. F. B. and Co. of this.

MAHY: He-by we think, A. G. and Co. is a goodly time to spit straws, 2 Yes.

TO ARMS!

THE BATTALION GENERAL LONDON VOLUNTEER REGIMENT

ORDERS FOR THE WEEK, BY SUBCOMMANDANT C. STANLEY PEACH (Acting Commandant)

OFFICER FOR THE WEEK: Platoon Commander R. W. J. Corbett. NEXT FOR DUTY: Platoon Commander L. C. Hugson, B.A. (C).

REGIMENTAL APPOINTMENTS.

Sub-Commandant C. Stanley Peach to be Acting Commandant.

Sub-Commandant Major F. O. P. Mouson to be Commandant No. 1 Field Company.

Sub-Commandant Major J. F. Hobson to be Commandant No. 2 Field Company.

Company Commander W. D. Bentley to be Assistant Adjutant.

Company Commander W. Hyman to take charge of the training of all recruits, Section B, Army Reserve.

Company Commander McLeod, Yeasley, to be Second in Command, No. 2 Field Company.

Platoon Commander J. R. G. Williamson to be No. 5 Platoon.

Platoon Commander P. A. Beck to be No. 6 Platoon.

Platoon Commander W. J. A. Watkins to be No. 7 Platoon.

GENERAL PARADE.

Saturday, January 1, at Chester House, 245 p.m.

COMMITTEE MEETING.

A joint meeting of the Committees of the Architects' Corps, No. 1 Field Company and the I.C.C. Staff A.T.C. (No. 2 Field Company) will be held this Wednesday evening at Chester House, Ledeston Place, S.W., at 7.30 p.m.

LECTURES.

Lecture Sir L. Babian, Lectures at the Institution of Civil Engineers, Grosvenor Street, S.W., will be continued after Christmas. Dates to be announced later.

ENTRENCHING.

There will be no entrenching parade on Sunday, 20th inst. Work will be recommenced after the Christmas Vacation, see Orders 31st inst.

CHRISTMAS VACATION.

The Drill Headquarters will be closed from Thursday, 2nd to Friday, 11th inst., inclusive.

SOCIAL EVENING.

There will be a Social Evening at Headquarters, Chester House, on the 21st inst. Tickets may be obtained at Headquarters.

ORDERS.

The next Battalion Orders will be published on Friday, 10th inst.

By Order, L. R. GUTHRIE, Adjutant.

CORRESPONDENCE.

All correspondence should be addressed to the Orderly Room.

DRILL HEADQUARTERS AND ORDERLY ROOM, Chester House, Ledeston Place, S.W.

BATTALION HEADQUARTERS, 18, Tulton Street, Westminster, S.W.

December 22, 1915.

It was agreed by the City Corporation on Thursday to buy Spitalfields Market under the terms of the arbitration award, when £100,000 payment to Mr. Horner, the lessee, at £25,000.

Large buildings are about to be added to the Colorado Insane Asylum at Pueblo, according to plans and specifications on file at the offices of Messrs. George H. Williamson, Denver; Thomas P. Barber, Colorado Springs; and Warren W. Stickney, Pueblo, joint architects.

The new church of St. Modan's Falkirk, was opened for public worship on Wednesday by the Right Rev. Dr. Paul, Moderator of the Church of England. The church occupies a prominent site at the corner of the Glasgow and Glasgow Avenues. It is built of cream-colored stone in the Norman style of architecture. Accommodation is provided for 750 persons. Mr. P. Macgregor Chalmers, Glasgow, is the architect.

Telephone DAL-TON 1342. Many years connected with the late firm of W. H. LASSALLE & CO., of Bunhill Row.

OGILVIE & CO.

Mildmay Avenue, ISLINGTON, N. EXPERTS in HIGH-CLASS JOINERY. ALTERATIONS & DECORATIONS. ESTIMATES FREE.

FOR Oliver's Seasoned Hardwoods,

WM. OLIVER & SONS, Ltd., 120, Bunhill Row, London, E.C.

TENDERS.

* Correspondents would in all cases oblige by giving the addresses of the parties tendering—at any rate, of the accepted tender; it adds to the value of the information.

BRANDON, DURHAM.—For constructing a culvert at Sandbury Road tip, for the urban district council:— Wood, J. E., Brandon (accepted) £130 0 0 Walton, L., Crook ... 129 10 0 Innes, W., Langley Moor ... 127 15 0

BRISTOL.—For stores, supplies, and materials, for the Bristol Docks Committee. Accepted tenders:— Triple concrete paper-insulated cable at the North side of Royal Albert Dock:— Siemens Brothers and Co. ... £100 0 0 Fish bolts:— Phoenix Bolt and Nut Co. ... 290 straight and curved galvanised iron sheets:— Lyasghy, John, Ltd. Archangel redwood:— Denty, Heber, Ltd.

CASTLEBAR.—For erection of four bridges to cottages on Newport Road, for the urban district council:— McCormack, J. P., Thomas Street, Castlebar (accepted) ... £29 19 6

EASTBOURNE.—For building an aviation shed and messroom at the Crumblies, for the Eastbourne Aviation Co.:— Peerless, Dennis, and Co., Eastbourne (accepted).

EASTBOURNE.—For back-up motor-houses at St. Vincent's Lodge, Silverdale Road, for the Grand Hotel Co., Ltd.:— Birch, C. (accepted).

FOLKESTONE.—For a temporary recreation-room at York House nursing home, Cheriton Gardens, for Miss Edden, Mr. C. D. Jenner, architect:— Jenner, C., Folkestone (accepted).

FOREST HILL, S.E.—For installing heating apparatus at the county secondary school, Forest Hill, for the London County Council. Fresh tenders:— Prayen and Sons, Ltd., 27, Victoria Street ... £2,127 5 6

GARMACK, J., and Sons, Ltd., 30, Cayton House, Westminster ... 2,122 17 0 Cannon and Bedford, Sandbury Road, Peckham ... 1,958 0 0

MAY, J., and F., 58, Whitson Park, Lincoln's Inn Fields ... 1,897 0 0 Cannon, W. G., and Sons, Ltd., 107, London Road ... 1,820 0 0

YETON and Brackett, Ltd., Mutton Road, Southark ... 1,628 0 0 Brightside Foundry and Engineering Co., Ltd., 28, Victoria Street (accepted) ... 1,680 0 0 In lieu of tender, previously accepted and now withdrawn, from J. W. Vaughan and Co., Ltd. Architect's estimate, £1,440.

LONDON.—For the execution of temporary work at the London County Council's educational institutions throughout the county:— Hobman, A. C. W., and Co., South Bermondsey. (Accepted, lowest tender received). Estimates were also obtained from Chittenden and Ginnings, Ltd., Mad-stone, G. Neal, Blackshaw Road, Tooting; F. G. Shepard, Hope Wharf, Peckham; Josiah Smart and Son, 53, Victoria Street; and John Wainwright and Co., Ltd., 178, Maida Vale.

LONDON, E.C.—For the execution of mason and paving works during six months, for the City Corporation:— Mowlem, J., and Co., Ltd. (accepted, subject to 10 per cent. increase on schedule prices).

LONDON, E.C.—For maintaining the carriage-way of South Place, Finsbury Circus, during fifteen years, for the City Corporation:— Val de Travers Asphalt Co., Ltd. (accepted), 6d. per yard super per annum.

ST. HELENS, LANCs.—For erection of engine-house and other works at the Cropper Hill power station, for the electricity committee. Mr. E. M. Hollingsworth, borough electrical engineer:— Bywater and Sons ... £1,935 0 0 Abbott, D. A., and Son ... 1,852 0 0 Elliott and Forbes ... 1,678 0 0 Pilkington, J. ... 1,663 0 0 Warburton, F. ... 1,650 0 0 Middlehurst, C. J. ... 1,641 0 0 Yearley, J., St. Helen's (accepted) ... 1,568 0 0

THE BUILDING NEWS

AND ENGINEERING JOURNAL.

Effingham House,

Venice from the Steps of St. Giorgio Maggiore and the Church of St. Fosca, adjoining the Cathedral at Torcello, near Venice	723
Hammersmith	724
Some Rochdale Municipal Works	724
Benefits Derived by an Urban District Adopting a Town-planning Scheme	725
Corrente Calamo	727
Obituary	728
Our Illustrations	741
Correspondence	741
Professional and Trade Societies	742
Competitions	742
Legal Intelligence	742
Engineering Notes	742

CONTENTS.

Building Intelligence	743
Trade News	743
Trade Notes	743
Water Supply and Sanitary Matters	743
Stained Glass	743
Our Office Table	743
Parliamentary Notes	745
Meetings for the Ensign Week	745
Latest Prices	746
List of Tenders Open	IV.

Strand, W.C.

South Bank. Architect of the Land, Mr. Henry Lamer, F.R.I.B.A. Architect supervising the work for Messrs. Dickson and Jones, Messrs. Stephens and Mount. Architects to the Bank, Messrs. Dunn, Watson and Curtis Green	743
Venice from the Steps of St. Giorgio Maggiore and the Church of St. Fosca, adjoining the Cathedral at Torcello, near Venice. Drawn by Mr. Fred Richards (from "Venice," Artists' Sketch Book Series, by permission of Messrs. A and C. Black, Limited)	743
"Birdlocks," near Fairford, Gloucester. Working drawings, plans, elevations, and sections. Mr. E. Guy Dawber, F.R.I.B.A., Architect	743

OUR ILLUSTRATIONS

New Premises, Regent Street, W., in continuation of the rebuilding of Oxford Circus, and including the new branch of the Union of London and

VENICE FROM THE STEPS OF ST. GIORGIO MAGGIORE AND THE CHURCH OF ST. FOSCA, ADJOINING THE CATHEDRAL AT TORCELLO, NEAR VENICE.

[WITH ILLUSTRATIONS.]

Venice, no longer the mistress of the Adriatic, is once more in jeopardy, and has ranged herself as a great naval base in the front rank of this vast European war. Whether her magnificent architecture will be spared or not time alone can determine. Already the Zeppelins of the enemy have eight or nine times bombarded the town, and amongst other damage the Austrians have ruined the beautiful ceiling by Tiepolo in the church of the Scalzi, or bare-footed friars (1649-1689). This building is famous for its gorgeous display of marble work and inlaid decorations, but the gem of the church is the Madonna by Giovanni Bellini behind the High Altar. The municipality has been busy safeguarding the Venetian palaces, churches, and galleries of paintings. Sand-bags are piled up 30 ft. high to protect the Sansovino bronzes; the mosaics of St. Mark's are covered in, and big piers of solid brickwork in cement 5 ft. thick have been erected to shore up the marble arches of the grand portals of the great Basilica in case the fabric should be hit, and so risk a collapse. Everywhere inside the cathedral sand-bags are employed to screen the structure and its decorations, as well as save the fittings. On one pillar alone the bags form an embrasure 20 ft. in diameter to shield it from harm. The Pala d'Oro has been removed, and the façade of the Doges' Palace looks more like a fortress, being faced up with solid walling having towers built at the corners of the façade 20 ft. tall and constructed all in brickwork 5 ft. thick. The loggia is strutted up with centring supported by shores of massive timbering. The Scala dei Giganti and Celloni on his charger, now covered by a roof, are well entrenched and substantially shrouded in sand-bags, which are likewise employed to cover the well-known pair of well-heads in the famous courtyard. The Piazza San Marco is grim and grey and black looking, while the Loggetta of the Campanile has been compared to a well-devised "dug-out." The palaces along the Grand Canal are vacant, the Signori having sought safer quarters.

Our illustrations to-day from Venice and its suburbs as seen in times of peace have consequently special interest.

The cathedral at Torcello, with its massive campanile, is a five-aisled church with double aisles on either side of the nave. It was built A.D. 641, restored A.D. 864 and again about A.D. 1008, when it was practically rebuilt in the form of the earlier building. There are several curious mosaics of that date still in existence,

and these were probably by the same artist as those at Murano. Each of the aisles and the nave terminate with apses. The columns dividing the body of the church from its aisles are of veined marble with Composite caps designed partly on Corinthian lines mixed with Byzantine details. The crypt is probably a remnant of the seventh century church. A marble screen fences off the choir from the nave, and it is adorned with sculptures of lions and peacocks thought to have been brought from Aquileja. The scheme is spoken of as "the prototype of that at St. Mark's, Venice." George Edmund Street's description of it is worth quoting:—"North-west of the roof screen stands the marble ambon—a pulpit in two divisions, one (circular) facing south, and the other (square) facing west. This and the staircase leading to it are full of delicate and good carved work. The arrangement has an absurd likeness to many a modern English pulpit and reading pew, and there is certainly force in the observation that such an arrangement would never have been thought of unless the Gospel was to be understood by the people. Now that they do not understand it, it is no longer said from the ambon, and ambons seem to be much less useful to the Romans than roof screens are to us."

This cathedral was greatly injured and its exterior completely modernised during injudicious and hasty repairs under the regime of the Austrian authorities, when the new roof was put on. The setting out of the sanctuary and high altar in the chancel is most remarkable, the seats for the choir and clergy rising in six tiers within the semi-circular form of an auditorium or theatre, and the episcopal throne stands in the centre, raised above these seats, and is approached by its own steep staircase of eleven treads. Ruskin, in his "Stones of Venice," remarks upon this apsidal contrivance thus:—"There is one circumstance which we ought to remember as giving peculiar significance to the position which the episcopal throne occupies in this island church, namely, that in the minds of all Early Christians the Church itself was most frequently symbolised under the image of a ship, of which the bishop was the pilot. Consider the force which this symbol would assume in the imagination of men to whom the spiritual Church had become an ark of refuge in the midst of a destruction hardly less terrible than that from which the eight souls were saved of old, a destruction in which the wrath of man had become as broad as the earth and as merciless as the sea, and who saw the actual and literal edifice of the Church raised up, itself like an ark in the midst of the waters." The surf of the Adriatic recalled to them the storm-tossed craft on the lake of Tiberins. Let the student of the past "ascend the highest

tier of the stern ledges that sweep round the altar of Torcello, and then looking, as the pilot did of old, along the marble ribs of the goodly templeship, let him re-people its ruined deck with the shad-ys of its dead mariners, and strive to feel in himself the strength of heart that was killed within them when first, after the pillars of it had settled in the sand, and the roof of it had been closed against the angry sky that was still reddened by the fires of their homesteads, just within the shelter of its knitted walls, amidst the murmur of the waste of waves and the beating of the wings of the sea birds, and the rock that was strange to them, rose that ancient hymn, in the power of their gathered voices: "The sea is His, and He made it; and His hands prepared the dry land."

A picturesque cloister connects the baptistery or church of St. Fosca with the cathedral. It is square on plan, with small projections on either side and a deeper one at the east, where the high altar is raised above the relics of the virgin martyr Fosca, who suffered under Decius. The square centre dome rises above simple pendentives, and the caps correspond with those in the cathedral colonnade, and at the east end outside there is some good arcading. The mixture of red and buff brickwork is very effective. The big and impressive red brick campanile, standing south-east of the choir of the cathedral, is very simple, with its arcaded top stage, from whence a singular view of vast interest can be obtained, making the trying ascent well worth the while. This tower was erected in the eleventh century, and is of the usual Lombardic type. It stands seven miles away from Venice on the north, midst a waste of wild sea moor, so often looking deathlike in leaden ashen grey as far as the eye can reach. The weird solemnity of this disengaged and water-bound campanile at Torcello, standing forth in its plain Lombardic simplicity, is not so evident when the point of view is screened by the cathedral or, as it appears, partly hidden by the adjacent smaller church or baptistery to which we have already referred in our present notes. Mr. Fred Richards, of Chelsea, has lent us the accompanying pencil drawing, in which the cathedral tower necessarily takes a sub ordinate place in the grouping. The subject was drawn for Messrs. Adam and Charles Black's hand-book on "Venice," which is one of the charming little volumes lately issued in their "Sketch Book Series," and to which publications we called attention in our pages for October 20 and 27 last. This pair of originals, illustrated to a larger size than they appear in the book itself, have been placed at our disposal by the artist and publishers. The only note to make further about this first drawing is to

BENEFITS DERIVED BY AN URBAN DISTRICT ADOPTING A TOWN PLANNING SCHEME.*

By LOUIS CARR,

Surveyor of Ruislip-Northwood Urban District Council.

The town-planning scheme promoted by the Ruislip-Northwood Urban District Council received the approval of Parliament on September 7, 1914, and as the period of twelve months, during which all claims for compensation and betterment have to be lodged, has now elapsed, the author is able to state generally the benefits which have been secured to the public and the landowners, and to give some information as to the claims for compensation and betterment, which latter subjects have seriously engaged the attention of councillors and officials throughout the country.

The modifications of the "General Provisions" are not dealt with in this paper, but it will be of interest to describe the alterations in the draft scheme as shown on the 25-in. Ordnance map, which may be summed up as follows:—

STREETS AND FOOTWAYS.

The north end of a 60-ft. street, practically running north and south through the centre of the district, has been amended to obtain a better outlet across some golf links. In the original scheme a road was proposed across these golf links, but, owing to heavy opposition, the council decided to drop it; the Local Government Board have, however, reverted to the original scheme. Another alteration was with regard to a new road branching from an existing road which was shown to run over existing buildings. This was amended so as to avoid pulling down the buildings. A further alteration was a very interesting one. An alternative line of route was shown for a new 60-ft. road, but the Local Government Board decided that alternatives could not be shown, and a definite line had to be fixed. In another case two streets were indicated on the map by dotted lines, together with a single alternative road. The Board decided that the single alternative road must be omitted. In the case of a new road, which was shown as 40 ft., but had to be increased to 50 ft., the centre line had to remain as shown on the map. A number of new footways were amended as regards their width and position, and two footways which had been shown to be diverted were omitted.

APPROPRIATION OF LANDS.

One cemetery, allotments, land for store yards, and a refuse destructor, together with certain open spaces, were acquired under the Public Health Acts during the progress of the scheme, and could not therefore be included in the approved scheme. With regard to the suggested second cemetery in the south of the district, the board considered that the time was not ripe for another cemetery to be provided in this quarter, but my own opinion is that a mistake was made in not allowing us to acquire this land, as later on, in all probability, we shall have much difficulty in securing such a suitable site as the one scheduled.

The owner of the land originally selected for the purpose of a new sewage works objected strongly to the position, but willingly gave us the option of another site about three-quarters of a mile away. Unquestionably this will be a great advantage to the district, and it will enable a greater area of land to be satisfactorily developed without any nuisance being caused when the new sewage works are made.

Differential treatment was proposed for railway land, but after negotiations with the companies we were able to come to agreement with regard to all their various parcels of land in the district, which are now to be treated in the same way as the property of any other landowner.

BUILDING LINES.

The building lines shown on existing streets have been approved, except in one case, where it was reduced from 25 ft. to 15 ft. The reason for this alteration was

that the ground receded very quickly from the roadway, and serious difficulties would have arisen with regard to connection with sewers, aspect, etc. It would be advisable here to observe that in future schemes, if building lines are reduced under similar circumstances on one side of the street, arrangements should be made to set them back on the other side.

LIMITATION OF THE NUMBER OF BUILDINGS TO BE ERECTED.

The first alteration was the inclusion of a further area of land to carry from eight to twelve build ings to the acre, the reason being that this area lent itself to more equitable development than the land map which had been fixed. A further alteration enables us to secure in the future a more gradual form of development. Another small part of was scheduled under the draft scheme as six buildings to the acre, but after the inquiry, at which the owner put a number of facts before the inspector, this limitation was altered by agreement between the council and the owner, with the result that approximately ten buildings to the acre can be erected. As the result of opposition, the Local Government Board agreed to a certain area being scheduled at eight houses to the acre instead of six as provided in the draft scheme.

CHARACTER OF BUILDINGS, ETC.

As a result of the inquiry, certain alterations were made in the compulsory and optional shopping and factory areas.

With regard to the colouring of the final map, it should be pointed out that after the inquiry it was found necessary to amend the whole of the colouring to fit in with the new "reference" which was required. The Ruislip-Northwood Urban District Council and the Watford Rural District Council have to administer this scheme in their respective areas, and a copy of the map of the final scheme, so far as it relates to the part of the area in the Watford rural district, has to be provided by the council.

NEW STREETS.

There are some eighty-three new streets and footways to be constructed under the scheme, and in the lines, and of the width indicated on the maps. The words italicised require special notice, as the Local Government Board are insistent upon this being carefully considered when the scheme is prepared, and strictly adhered to afterwards. The district will benefit greatly in future by the linking up of existing streets and main traffic routes, and also by the improved access to railway stations, and the bringing of certain outlying areas into communication with others by streets with good gradients, instead of by streets which would have a gradient of 1 in 7. For instance, when one of the streets is made a distance of about three miles will be saved in communication between certain parts of the district.

Another great benefit, combined with economy, will be derived by the laying out of the streets on the line of the outfall sewers to the existing and new sewage works. Arrangements have also been made to take the house drainage from these new streets. A certain amount of the cost of these sewers will be defrayed by the frontagers, but such sum is not payable until the land is used for purpose other than agriculture, except by special agreement. In my opinion, many thousands of pounds will be saved to the district by thus laying out the streets to serve all purposes for which streets are generally required.

Streets shown on the map of a greater width than 40 ft. will be constructed and paid for by the council, but it is possible that as the council now have the power to make up streets with grass margins, etc., that no extra expenditure will be incurred beyond that of scavenging and maintenance. Thirty widenings of existing streets are shown on the map; these are in sixteen streets, and affect forty-four different owners.

When any plan is submitted for a new building to be erected in any of the existing streets the council can require the street to be widened to the width shown on the map, and will bear the cost. If the council require

a street to be widened before any plan for a new building is submitted, they have power to do the work after giving two months' notice. The cost of carrying out widenings in such case will include compensation for any buildings required to be altered, demolished, or removed, while the construction of the necessary carriage and footway and fencing off the land has also to be paid by the council.

As has already been stated, the council have power to lay out with grass margins, or plant with trees, or lay out as gardens, any part of a street repairable by the inhabitants at large, and the council may in any town in good order such grass margins, trees, or gardens, and alter or renew the same from time to time as circumstances require. They may add to the carriage-way or footway any part of such grass margins, whether planted with trees or laid out as gardens, and may from time to time alter or rearrange the parts of any street laid out as a carriage-way or footway respectively, provided that the council shall not obstruct access to premises abutting on any street from the metalled or paved portion of the road.

The owners of lands abutting upon any street shall, until such streets shall become a highway repairable by the inhabitants at large, maintain such street, fences, grass margins and trees, and embankments and other works thereon in good order and condition. The council may include in any private street works any works which they may consider necessary for forming off and laying out any street, or any part thereof, with grass margins and planting the same with trees, and apportion the expenses thereof as would be done under the Private Street Works Act. The permission given to the council under this Act to lay out existing streets or any new streets with grass margins, etc., is very important, and, besides leading to much amenity in the district, will also involve less expense in construction and upkeep; while in the case of streets about to be taken over by the local authority, a reduced expenditure has to be borne by the frontagers.

In shopping areas where a carriage road is intended to form the principal approach or means of access to buildings, we demand that the kerb or outer edge of the footway of the street in front of such buildings shall be set back a width of 6 ft. from the side of the carriage-way, and the width of the footway shall be reduced accordingly. The intervening space between the new line of the kerb and the original side of the carriage-way shall be so constructed as to fall towards the carriage-way. This requirement is believed to be quite new, and should prove of great value, as by means of it tradesmen's goods can be delivered by vehicles standing on this set-back, where they will not impede the fast traffic.

Particulars of the relaxation of by-laws with respect of (1) new streets (short streets), (2) as to width and construction of such streets, where land for open spaces is set apart, or wide streets are provided, or where the streets are formed around quadrangles, are all set out in the "General Provisions"; but it may be said that with the experience already gained in the district from the construction of streets of this character, the council and the owners are satisfied that they are not only unlikely to be a burden on the ratepayers, but are more economical to construct, sewer, light, and scavenge.

If at any time the council desire to construct any of the new streets on the map, they can do so upon giving six months' notice of their intention. Without this provision it is probable that the whole scheme of the streets shown would be wrecked. Where the map shows a new street exceeding 40 ft. in width, communicating at each end with a highway repairable by the inhabitants at large, the owner of the land over which it passes may, if he wishes it to be constructed, give notice to the council, who must construct the road within six months. Before the development of any estate can now be proceeded with the council can require the owner to furnish plans and particulars showing generally a scheme for the development or laying out of the whole

* A paper read at the recent Annual General Meeting of the Institution of Municipal Engineers.

... as the...
 ... otherwise than by...
 ... with such...
 ... by the council...
 ... development can...
 ... owner has first...
 ... of the council to his

... Board may, on the...
 ... owners, sanction...
 ... with reference to...
 ... of any of the...
 ... streets or proposed widenings...
 ... in the author's opinion...
 ... to modify the...
 ... streets marked on the map...
 ... would have accrued...
 ... between certain...
 ... of course of...
 ... as in the case of pro...

... highways...
 ... and stopped up, but not...
 ... streets or footways...
 ... to the satisfaction of the...
 ... for public traffic.

... such proposed new streets...
 ... portions, such portions of the...
 ... correspond to the portions...
 ... streets which have been...
 ... or stopped up, pro...
 ... are reasonably satisfied that...
 ... right of way has been...
 ... public use; and, where...
 ... right of way must be...
 ... from the portion of the proposed...
 ... which shall have been constructed...
 ... of the said public highway...
 ... at that time, to be diverted...
 ... up. For the purpose of any...
 ... or stopping up, such tem...
 ... shall be deemed to be...
 ... of the remaining portion of the said...
 ... highway. It is estimated that by...
 ... of some hundreds...
 ... has been effected by avoiding the...
 ... and technical process of obtaining...
 ... of Quarter Sessions, apart from the...
 ... of some cases of strictly complying...
 ... requirements of the Highway Act.

OPEN SPACES

... about 155 acres of open spaces...
 ... of which 106 acres have...
 ... for agreements, and 49 acres...
 ... as public open spaces. The...
 ... value of the land given to the...
 ... from £1,000 to £10,000. Private...
 ... shall be maintained in good...
 ... when required by the council...
 ... and at the expense of the...
 ... the open space...
 ... neglected, or a...
 ... may, after giving not...
 ... notice of them in...
 ... for the purpose...
 ... in good order and...
 ... Any expenses incurred by...
 ... from the owner...
 ... open spaces.

... private premises, and may...
 ... they may...
 ... which the...
 ... regulations...
 ... affecting its...
 ... other charges...
 ... of private...
 ... under its pro...
 ... and...
 ... houses...
 ... (1)...
 ... private...
 ... and...
 ... as the...
 ... owners of...
 ... as private...
 ... for the...
 ... well...
 ... secured...
 ... of...
 ...

ABOUT BUILDINGS, BUILDING LINES, AND BUILDING TINES.

... building lines shown on the map...
 ... streets averaged a 25 ft. set...
 ... excepting in one or two instances...
 ... been allowed. It is provided that

... any building has been erected, or is in...
 ... of erection, since the date of the re...
 ... resolution of the council applying to the Board...
 ... for authority to prepare the scheme, nearer...
 ... to a street than the building line shown on...
 ... the map, the council may require the owner...
 ... to pull down so much of the building as is...
 ... nearer to the street than the said building...
 ... line. In one case a building line of 7 ft. was...
 ... shown, but an owner built in front of this...
 ... very reasonable line, with the result that...
 ... he will now have to pull down where he has...
 ... infringed.

... In streets where no building lines are shown...
 ... on the map no buildings can be erected nearer...
 ... to the centre of the street than 30 ft., or...
 ... nearer to the boundary of such street than...
 ... 15 ft. Provisions are inserted with regard...
 ... to dwellings round quadrangles, but in any...
 ... case there has to be a width of 60 ft. between...
 ... every house. There are also saving clauses...
 ... with regard to lodges appurtenant to a dwell...
 ... ing house which may be built in advance of...
 ... the building line, and also in the case of long...
 ... frontages, say, a continual frontage of not...
 ... less than 500 ft., where parts of such building...
 ... may project 7 ft. in advance of the general...
 ... building line, provided the projection does...
 ... not exceed one-fourth of the total length of...
 ... the frontage. The above building lines do...
 ... not prevail in the case of shopping and busi...
 ... ness premises, the lines for which are prac...
 ... tically set out in the "General Provisions,"...
 ... and vary according to the different widths of...
 ... the streets. This is another means by which...
 ... to secure the extra width of the carriageway...
 ... to business premises.

... Another important provision is that no...
 ... post, rail, or other obstruction shall be...
 ... erected in front of the forecourt of any shop...
 ... ping premises; but cellarflaps are allowed...
 ... provided they do not project more than 3 ft...
 ... in advance of such premises. The building...
 ... lines for buildings and projections on corner...
 ... sites are specially provided for. Bay...
 ... windows, chimneys and porches are allowed...
 ... to project 4 ft. in advance of the building...
 ... line, except in the case of a street exceeding...
 ... 40 ft., when they may project 5 ft., provided...
 ... that these projections do not exceed three...
 ... fifths of the total width of the buildings, and...
 ... are not in any case nearer to the boundary...
 ... of lands belonging to another owner than the...
 ... extreme amount of such projections.

... The proportion of the area of a site which...
 ... may be covered by shops and other buildings...
 ... is one-half of the whole area of the curtilage...
 ... with the proviso that in the case of a shop...
 ... the extent of the buildings shall be measured...
 ... at a level of 14 ft. above the mean level...
 ... of the footway in front thereof. This appears...
 ... to be a reasonable provision. With regard to...
 ... dwelling-houses, one-third of the whole area...
 ... may be covered with buildings not exceeding...
 ... one story in height and one story in the...
 ... roof; but in cases of larger buildings the area...
 ... covered shall not exceed one-fourth.

... Certain provisions are made with regard to...
 ... air space to habitable rooms. This is a most...
 ... important provision, as, to a certain extent...
 ... it stops the erection of houses with kitchens...
 ... facing each other at a distance of, say, 2 ft...
 ... or 3 ft. away, which are practically always...
 ... dark and have had ventilation. The clause...
 ... with regard to the projection of wing build...
 ... ings is another important one, the idea being...
 ... to stop the addition at the rear of premises...
 ... of long wing buildings, which retard the free...
 ... action of the air and sunlight to the back...
 ... of the premises.

LIMITATION OF NUMBER OF BUILDINGS TO THE ACRE.

... In the clauses which have been framed to...
 ... carry out the limitation of the number of...
 ... buildings, regard has been had to the various...
 ... areas in the district, the development of...
 ... which have been commenced in a certain way...
 ... A limitation of four buildings to the acre...
 ... is made in the highly residential part; six...
 ... to the acre is the rate for the areas at...
 ... present developing; eight and twelve to the...
 ... acre is also adopted in other areas for the...
 ... same reasons while twelve is also adopted...
 ... for the shopping and factory areas, where it...
 ... is desirable that more buildings to the acre...
 ... should be allowed both to secure artisan and...
 ... working class buildings near the places of...
 ... employment, and also because by reason of

... the shops and business premises it would not...
 ... pay to erect better-class houses.

... The unit of five acres has been considerably...
 ... discussed, but the author cannot suggest any...
 ... other scheme to carry out the limitation in a...
 ... more satisfactory manner. The working of...
 ... this land unit is not easy, and possibly about...
 ... nine acres would be a good unit to adopt...
 ... In all areas, with the exception of land...
 ... specially set apart for factories, shops, and...
 ... business premises, private or professional...
 ... dwelling houses, with necessary stabling, etc.,...
 ... can alone be erected.

... No domestic building (other than flats or...
 ... sets of chambers) erected in the area of twelve...
 ... buildings to the acre may contain more than...
 ... two stories, exclusive of any story in the...
 ... roof.

CHARACTER OF BUILDINGS.

... In selecting the areas to be restricted to...
 ... buildings of the warehouse class, shops, or...
 ... business premises, consideration was given...
 ... to the lay of the land, the position of the rail...
 ... way stations, the convenience of access, and...
 ... the amenity of the district. The area for...
 ... factory purposes has been extended in the...
 ... vicinity of the existing sewage works.

... The clause relating to the height of win...
 ... dows in habitable rooms received consider...
 ... able attention, not only by the council, but...
 ... also by landowners, builders, etc., and the...
 ... final form represents the utmost advance that...
 ... could be made; but we believe it will be of...
 ... considerable value generally to the health of...
 ... the district. This provided that no bedroom...
 ... or other habitable room shall contain less...
 ... than 500 cub. ft., and in any dwelling one...
 ... living-room at least shall be provided, which...
 ... must have a floor area of not less than 144...
 ... sq. ft., and contain not less than 1,132 cub...
 ... ft., and one bedroom which must have a floor...
 ... area of not less than 132 sq. ft., and a cubical...
 ... capacity of 1,000 cub. ft. It is hoped that...
 ... considerable good will emanate from the pro...
 ... vision which enables the council to require...
 ... reasonable alterations in any building, the...
 ... character of which is objectionable on...
 ... account of the design, or the undue repetition...
 ... of the design, or the materials to be used.

SANITARY CONDITIONS AND AMENITY.

... With regard to the vexed question of com...
 ... bined drains, a clause has been secured which...
 ... it is hoped will solve the problem. Every...
 ... house has under this scheme to be provide...
 ... with a pantry or larder which shall have a...
 ... window opening into the external air, and in...
 ... the case of a dwelling-house adapted to the...
 ... occupation of more than one family, a...
 ... separate pantry or larder shall be required...
 ... for each. It is also provided that every...
 ... domestic building constructed for use of more...
 ... than one family shall be provided with...
 ... separate closet accommodation for each...
 ... family. To some extent these clauses will...
 ... prevent houses being let for two families...
 ... without proper accommodation being pro...
 ... vided. Further provisions are desirable, but...
 ... their inclusion could not be obtained.

... Frequently private gardens are in such a...
 ... state as to be a nuisance to neighbours, but...
 ... under the Order, on the report of the sur...
 ... veyor that the nuisance can be abated, the...
 ... council may do what is necessary, in default...
 ... of the owner doing it, and can recover the...
 ... cost. In the Ruislip-Northwood urban...
 ... district, in common with many others, a great...
 ... deal of untidiness and irregularity occurs in...
 ... planting and fencing of forecourts of pre...
 ... mises, which detracts from the general...
 ... appearance of the district. To remedy this...
 ... the council have power to agree with the owners...
 ... or occupiers to lay out, plant and fence...
 ... such forecourts, and maintain them at the...
 ... expense of the council.

... Advertisements are prohibited, except in...
 ... the factory and shopping areas; but this pro...
 ... hibition does not apply to the exhibition of...
 ... traders' names or notices on public buildings...
 ... Goods for sale or exhibition may be placed...
 ... in front of premises, but not more than 3 ft...
 ... beyond the building line. This is a most...
 ... useful provision, and will be of much assis...
 ... tance to the council in keeping the streets...
 ... from looking untidy and irregular. Con...
 ... siderable criticism has been made of the...
 ... clause dealing with the height of fences, but...
 ... it can still be said that the council are glad...
 ... to have got this clause, and they have not the

slightest difficulty in carrying it out. It is beneficial to the district to obtain solid walls or fences set back as far as possible from the backline of any street.

A careful consideration of all the clauses, which are set out in more detail in the "General Provisions," should prove a great stimulus to local authorities to promote a town-planning scheme for the benefit of their community, for it is unquestionably a fact that the health, welfare, and general tone of a district would be greatly enhanced by similar provisions to those included in the Ruislip-Northwood Town Planning Order.

COMPENSATION AND BETTERMENT.

Only four claims for compensation have been received, and two of these have practically been disposed of. As to betterment, thirteen claims have been made, totalling some £11,000. The cost of preparing the scheme, from start to finish, was about £700. A statement of expenditure was given at the inquiry on the draft scheme, regarding the purchase of land for open spaces, cemetery, allotments, recreation ground, and destructor; but these items were struck out as they had been acquired under the various Public Health Acts during the progress of the scheme. The proposed expenditure on another cemetery site at Ruislip was dropped after the inquiry. The estimated expenditure for the demolition or alteration of buildings, for compensation in regard to property injuriously affected by the scheme, for roads abutting on open spaces, for making up or alteration to roads or footways, and widenings, and for other purposes, such as fencing of open spaces, etc., remains about the same now the scheme has been approved. The greater part of this expenditure, however, is not likely to be incurred for many years. The receipts estimated to be obtained from betterment claims are largely increased from what was originally anticipated.

A church school, built at a cost of about £7,000, has been formally opened at Great Harwood. The architects were Messrs. Woodhouse and Dean, of King Street, Manchester, and the contractors Messrs. John Ferrit and Sons, Ltd., of Blackburn.

The twenty-first list of members, licentiates and students of the Royal Institute of British Architects who have joined H.M. Forces for the period of the war shows a total to date of 51 Fellows, 375 Associates, 196 Licentiates, and 239 Students.

On the recommendation of the public works committee, the city council of Truro have agreed to pay an honorarium of twenty-five guineas to Mr. F. A. Barnes, the city surveyor, for the care, attention, and ability shown by him in renovating the council chamber, mayor's parlour, and committee room after the recent disastrous fire.

At Southampton the bankruptcy adjudication has been annulled of Arthur Hugh Roberts (formerly trading as Roberts and Co.), 14, Cranbury Place, Southampton, lately residing at Bevois Hill, Southampton, estate agent and valuer, formerly auctioneer, it appearing to the Court that the debts in the bankruptcy have been paid in full with statutory interest.

A special sub-committee of the corporation of Glasgow, acting on the suggestion of H.M. Office of Works, recommend that consideration of the proposal to remove the Tolbooth Steeple should not be proceeded with, and that, under reservation of the rights of all parties, they should withdraw the notice of November 17, in which they adhered to their previous determination to remove the steeple. Unless the notice be withdrawn, the Commissioners of Public Works will issue a preservation order as to the steeple, which will remain in force for a period of six months.

At the last meeting of the Society of Antiquaries, the president, Sir Arthur Evans, occupying the chair, Mr. W. R. Lethaby, F.R.I.B.A., exhibited the head and foot of a carved and painted rood of the twelfth century from South Cerney Church, near Cirencester. These fragments were, he thought, probably the earliest important pieces of wood-carving remaining in the country. The figure must have been about half life-size, and the type was closely allied to the Christ of the Deposition painting at Winchester, c. 1180, and to the earliest painted crucifix at St. Albans, c. 1200. The object was discovered accidentally in 1913, walled up in the church.

THE REPLANNING OF ATHENS.

The students of the Liverpool University School of Civic Design, accompanied by post-graduates and friends, met the other day, at the invitation of Mr. Thomas H. Mawson, Hon.A.R.I.B.A., at the head office of his firm in Lancaster, to hear a lecture on Athens and to view the plans which have been prepared for the important commission with which the firm have been entrusted in the replanning of that world-renowned city. The lecture was illustrated by a large number of lantern slides, showing both the famous remains and the modern city which has grown up around them. The working plans for the scheme occupied the entire wall space of one of the largest draughting offices.

The first plan shown dealt with the topographical position of Athens in relation to the Port of Piræus and the railway system which is shortly to be connected with the trans-continental system at Salonika. The second dealt with the traffic problems of the city and environs and showed the roads for tram routes and motor traffic in relation to the railway facilities, both passenger and goods. It also showed the arrangement of factories, warehouses, and bonded stores in connection with the railway sidings and the placing of the electric generating station from which each factory and warehouse will obtain its power.

Another plan showed the areas covered with ancient remains, from which everything modern is to be cleared, and on the same sheet are indicated the new residential areas in zones for the varying classes of residents. Still another shows the park, playground, and forest areas connected by boulevards and parkways, in which the pepper tree and the ilex predominate.

These led up to the general plan, which, though it is of a most unusual size, being about 10 ft. long and half as broad, is crammed with fine detail in every part, and represents the labours of as many draughtsmen as could be employed upon it at the same time through many months. It shows the relationship of all the various factors dealt with in the sectional and diagrammatic plans in their relation to the governmental and civic centres.

These were the sections of the scheme which attracted special attention, as did also the plans for the rehousing of the working classes, which were illustrated by beautiful perspective drawings. In addition, there are diagrammatic drawings showing the schools and a splendid new University Campus, which occupies an area of over one hundred acres. Fire stations, hotels, and other public and semi-public buildings are all illustrated in a manner which shows that town-planning in Athens is being studied in a most exhaustive manner, and this fact impressed the students considerably.

At the close of the examination of the plans two questions were asked. Firstly, why is Athens being replanned, and secondly, how is the work to be paid for?

Mr. Mawson, in his reply, explained that Athens is at the present time growing enormously not only on account of the added importance which has come with the additional territory obtained after the second Balkan war, but also by the expansion of its maritime trade and the increased tourist traffic, which is alone enough to justify a town-planning scheme of considerable magnitude.

With regard to cost, Mr. Mawson explained that Greece, being at present a poor nation, could not afford to squander public money in unco-ordinated effort and temporary makeshifts, which could only be indulged in by nations like our own with money to waste. He reminded his hearers that a town plan was not a scheme for spending public money, but for saving it. It resulted from the recognition of the fact that the city would grow whether we liked it or no, and arranged in advance that it should grow in the public interest according to a co-ordinated plan, which should develop on economic principles both in regard to capital outlay and maintenance charges. If we proceed with this practical aim kept steadily in view we shall find that we have succeeded in producing a city which is, at least, potentially beautiful as well as practical.

Currente Calamo.

We have heard nothing more of Mr. Howell J. Williams' indictment of the City Bridge House Estates Committee and its strict insistence of the letter of the law with regard to the large site his company took before the commencement of the war, since we announced on this page in our issue of December 15 that a deputation from the Master Builders' Association is to wait on Mr. Asquith. In strong contrast with the action taken by the City authority, the *City Press* points out that the London County Council does not appear to be acting on like lines. In March of last year the Council granted as from the following September a ninety-nine years' lease of a plot in Aldwych. The restrictions imposed by the Treasury preventing the prosecution of the scheme, the Council has agreed to postpone until March next the date at which the lease shall commence to run. That is fair and reasonable, and builders have a right to expect that the City will do the same.

We are glad to note that Mr. Hugh Watkins, quantity surveyor, of London, has arrived in Winnipeg, and that he and his two assistants have commenced their duties in connection with the New Parliament Buildings, which are being erected from the designs of Mr. F. W. Simon, F.R.I.B.A. Quantity Surveyors hitherto have been unknown in Canada, but a strong movement is on foot to insist on their employment, as in this country, for all buildings of any importance. Under the existing system in Canada an architect is engaged to prepare the necessary drawings and specifications, which are forwarded to each contractor who has signified his intention of tendering for the work. Each contractor then sets to work to prepare the necessary measurements of materials and labour to enable him to arrive at the amount of his tender. This does not apply to build-ings alone. At the present moment a Canadian city is calling for tenders for a gravity filtration plant—plans and specifications to be furnished by the contractor. Thus, assuming twenty contractors tender for a job, nineteen sets of quantities are useless and waste labour. One result, of course, is that careful and accurate estimates are rare, and another that no reliable basis exists on which any extras or deductions can be arrived at.

The following, by the first living English novelist, of whom, as a member of our own calling, in earlier years, many readers have warm remembrances, appeared in the *Times* on Christmas Eve, and its reproduction is permitted:—

THE OXEN.

Christmas Eve, and twelve of the clock,
"Now they are all on their knees,"
An elder said as we sat in a flock,
By the embers in heartside ease.

We pictured the mock mild creatures where
They dwell in their strawy pen,
Nor did it occur to one of us there
To doubt they were kneeling then.

So fair a fancy few believe
In these years! Yet, I feel,
If someone nod on Christmas Eve
"Come; see the oxen kneel!"

"In the lonely barton by yonder coomb
Our childhood used to know,"
I should go with him in the gloom,
Hoping it might be so."

THOMAS HARDY.

The use of the zodiac in architectural decoration is discussed by F. Boquet, of the Observatory of Paris, in a recent memoir on "Art and Astronomy." The signs of the zodiac are a common sculptural motive in

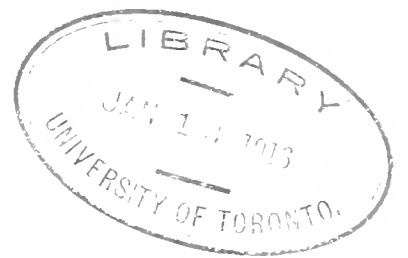

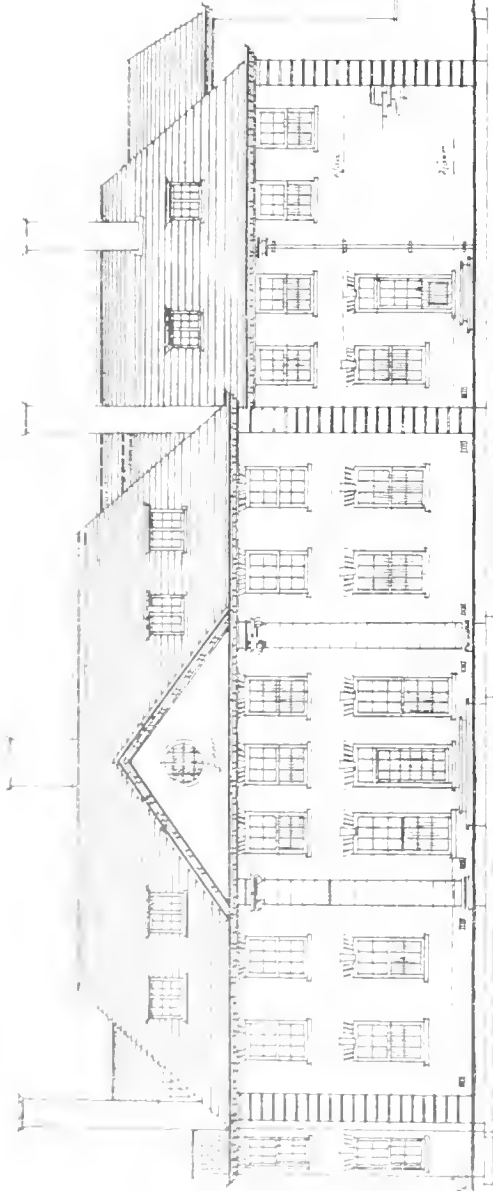

SOUTH ELEVATION

BURDOCKS, FAIRFORD,
GLOUCESTER

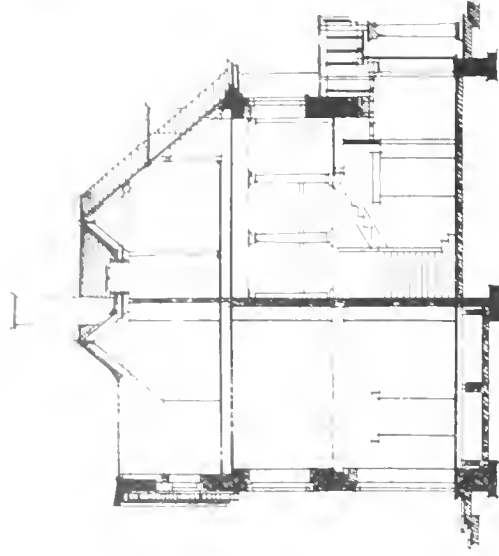

SECTION EF

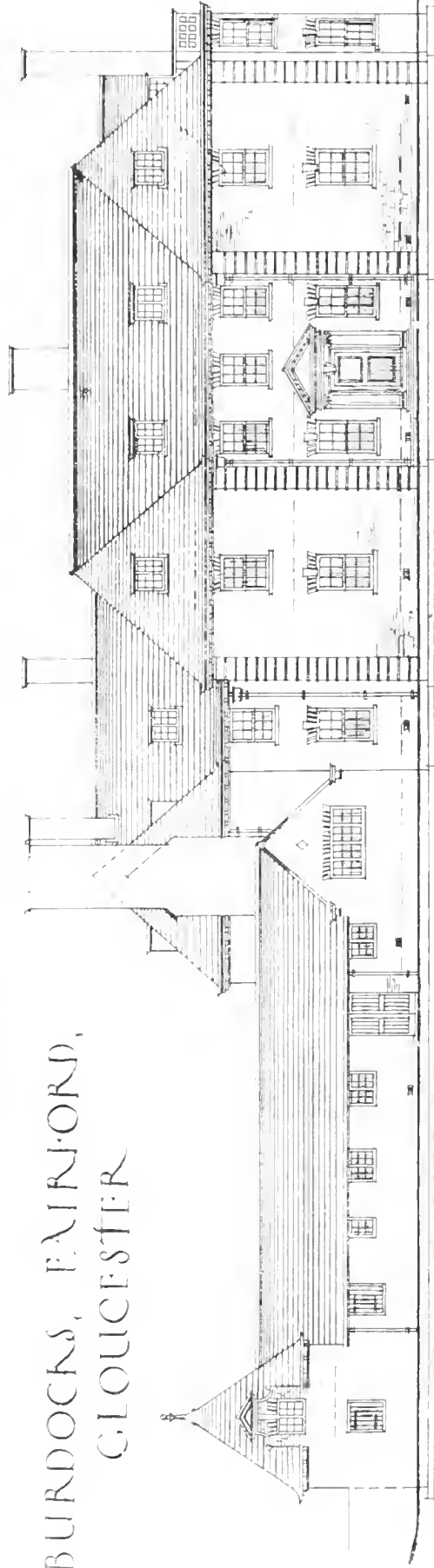

NORTH ELEVATION

E. GUY DAWBER FRIBA
ARCHITECT

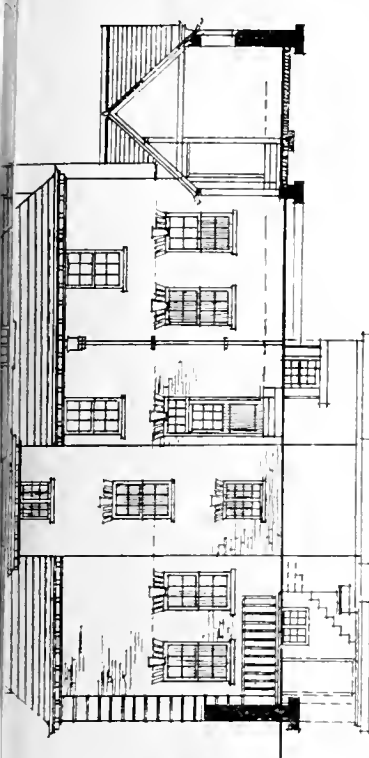

EAST ELEVATION

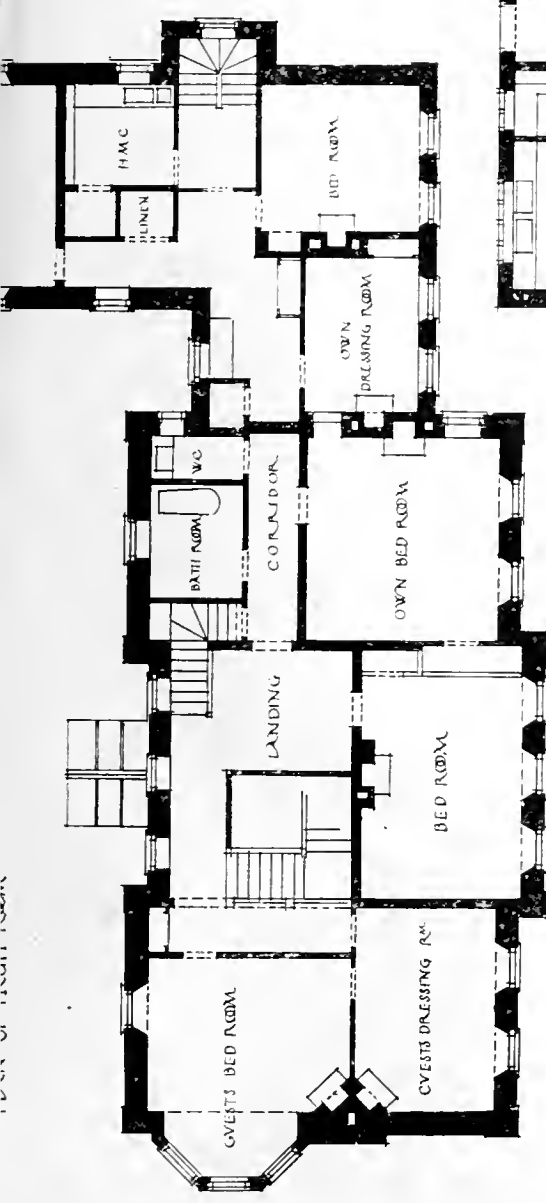

FIRST FLOOR PLAN

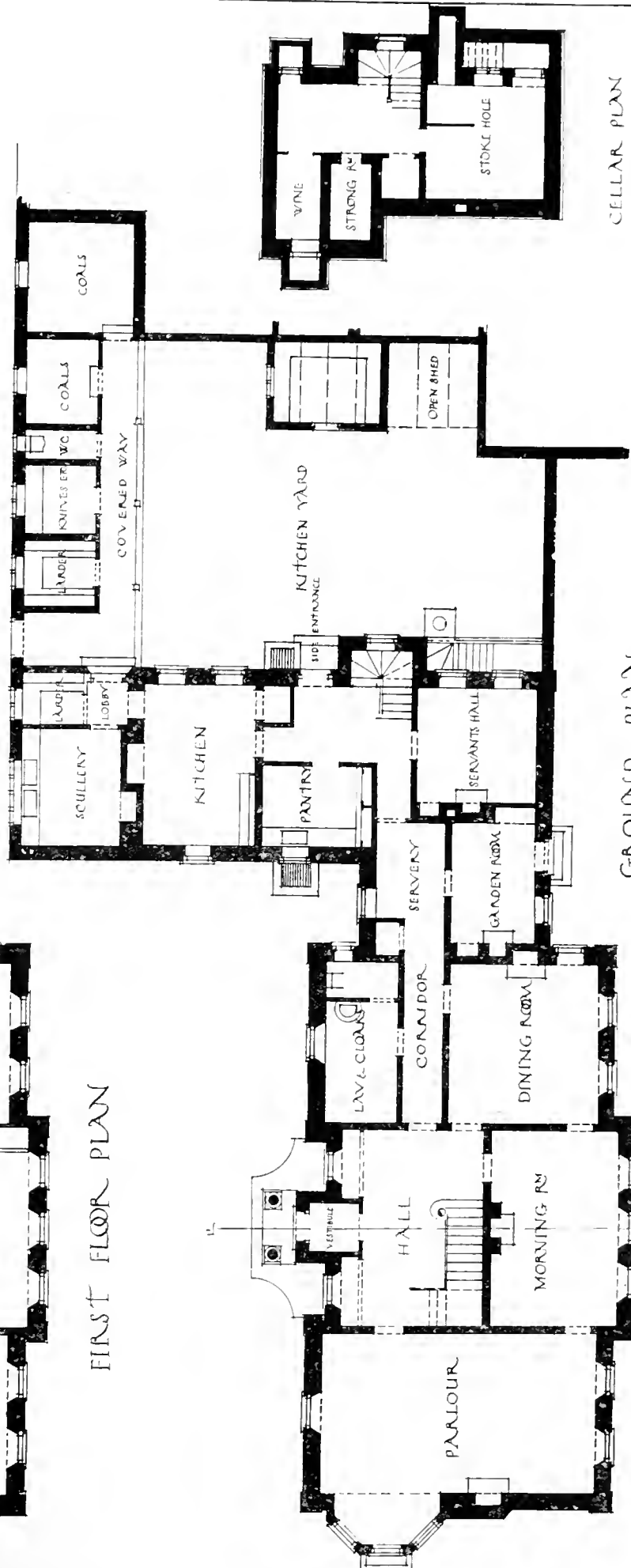

GROUND PLAN

CELLAR PLAN









AL PIAZZETTA AND PALACE OF THE DOGE. VIEW OF ST. GIORGIO MAGGIORE.

VENICE FROM THE STEPS OF ST. GIORGIO MAGGIORE AND THE CHURCH OF ST. GIORGIO. Drawn by Mr. FRED. RICHARDS (from the original drawing by Frederick Richards).

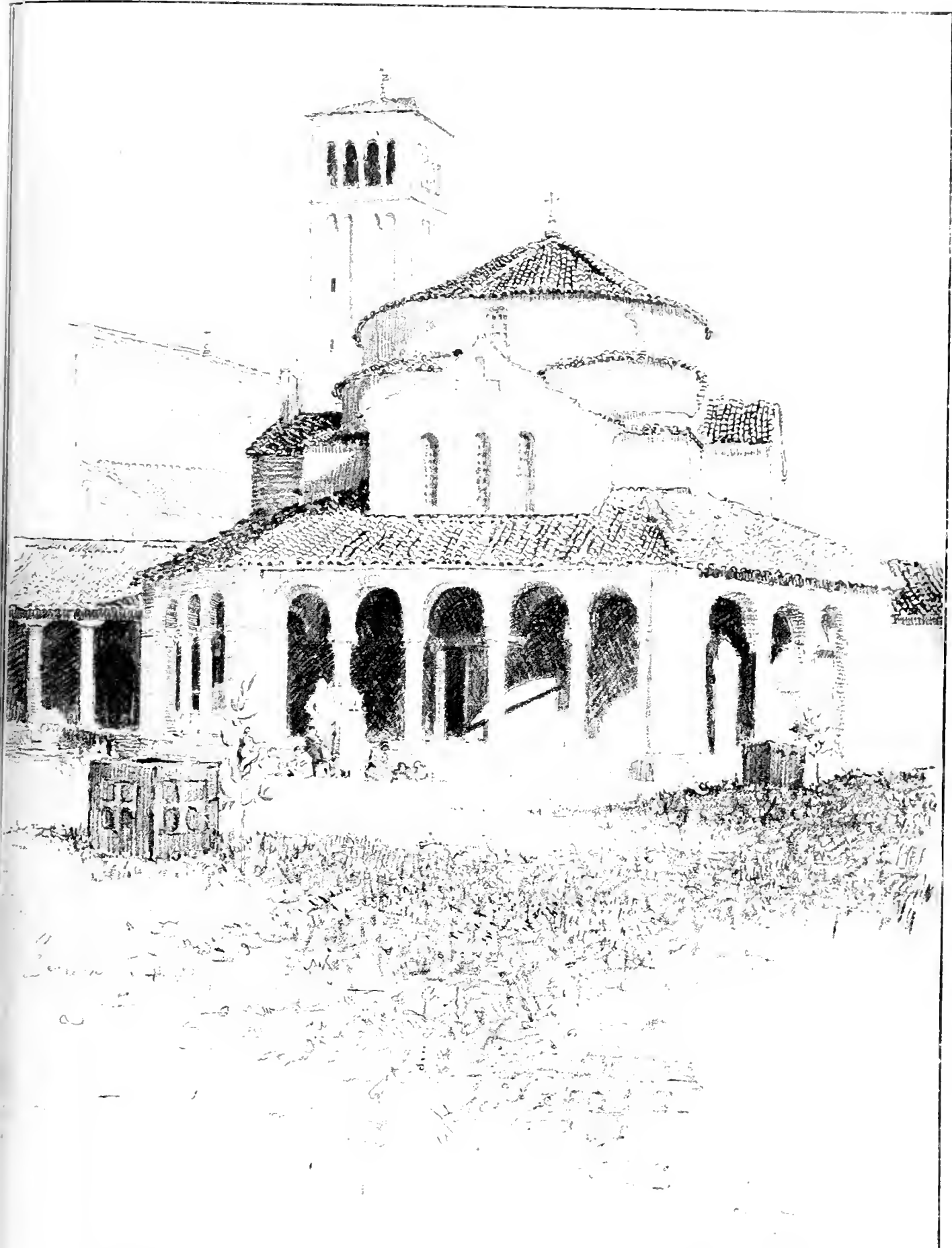

AT TORCELLO.

OF ST. FOSCA, ADJOINING THE CATHEDRAL AT TORCELLO, NEAR VENICE.

“Venice”—Artists’ Sketch Book Series).

By permission of Messrs. A. and C. Black.







ELEVATION TO REGENT STREET

ANGLE ELEVATION



SCALE OF FEET

NEW PREMISES, REGENT STREET, W., IN CONTINUATION OF THE REBUILDING OF
 AND SMITH'S BANK. Architect of the Facades, Mr. HENRY TANNER, F.R.I.B.A.
 Architects to the Bank, Messrs. D

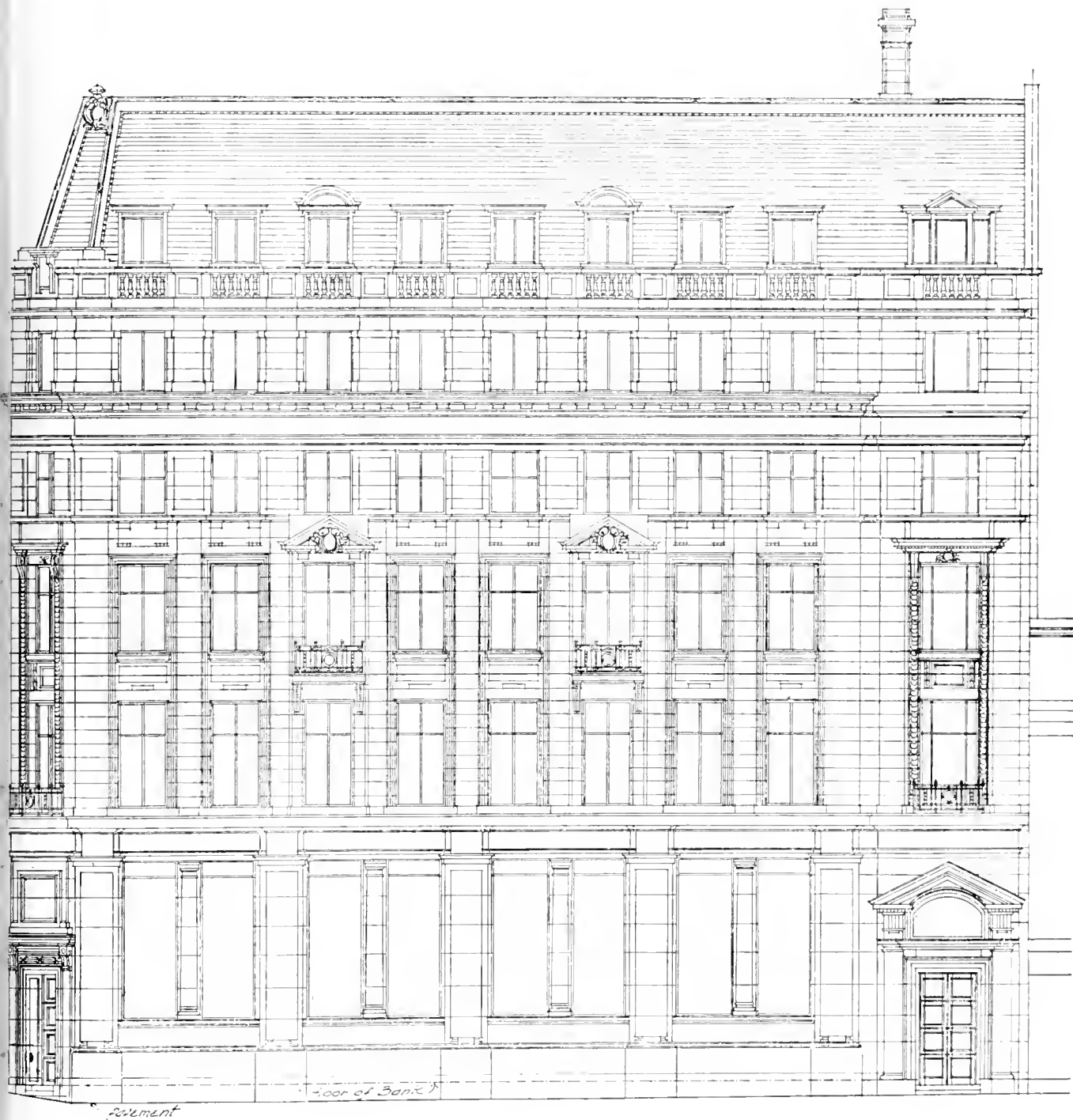

ELEVATION TO LITTLE ARGYLL STREET

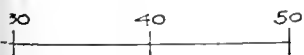

OXFORD CIRCUS, AND INCLUDING THE NEW BRANCH OF THE UNION OF LONDON
ects supervising the work for Messrs. Dickens and Jones, Messrs. STEPHENS and MUNT.
N, WATSON, and CURTIS GREEN.



Our Illustrations.

VENICE, AND THE CHURCH OF ST. FOSCA, TORCELLO.

A description of this plate will be found in our first article this week.

NEW PREMISES, REGENT STREET, IN CONTINUATION OF REBUILDING OXFORD CIRCUS, AND INCLUDING NEW BRANCH OF THE UNION OF LONDON AND SMITH'S BANK.

We published a double-page view, from the Royal Academy, in our issue for September 13, 1912, showing the comprehensive scheme prepared for the approval of the Office of Woods and Forests by Mr. Henry Tanner, F.R.I.B.A., the architect subsequently appointed for the rebuilding of Oxford Circus and upper part of Regent Street adjoining. This work is still in progress, and the several properties are gradually developing as their leases fall in. To insure uniformity in the contiguous frontages near to this great crossing, caused by the junction of Oxford Street and Regent Street, the Crown decided that all re-erectments incidental to this architectural recasting of these two great Metropolitan thoroughfares at this point should comply with the adopted improvement scheme designed by Mr. Tanner. The illustration published herewith shows the prominent section of the undertaking situate on the eastern side of Regent Street, extending northwards from the return frontage in Little Argyll Street. At this corner a branch is being built for the Union of London and Smith's Bank, which will, therefore, be located in a very splendid position and have a considerable frontage facing a south-westerly aspect. The next portion of the same block of buildings will be occupied by Messrs. Dickens and Jones' drapery and costume emporium, which business is now, we understand, a branch of Messrs. Harrods, Limited. The architects charged with the supervision of the work generally are Messrs. Stephens and Munt, of Chelsea, and in so far as the bank is concerned the execution, thus superintended, has to be done to the approval of Messrs. Dunn, Watson, and Curtis Green, of Lincoln's Inn Fields, the architects acting for the Union of London and Smith's Banking Company. This branch bank building is from their plans, and will have a handsome and spacious banking hall, directors' room, and manager's office. This work is to be in accordance with the bank architect's specifications. The entire frontages, however, are being built in strict compliance with the designs of Mr. Henry Tanner, of Carlton Chambers, Regent Street. We hope shortly to publish some large-scale drawings of his details, and we are likewise indebted to Mr. Tanner for the loan of the elevations printed among our plates to-day. Messrs. Stephens and Munt have designed the grilles, and have fitted up their shopfronts in "Kopperoid" steel in an effective and unobtrusive way, but we found it hardly practicable to show these properly to so small a scale in our illustration of the elevations. The builder who is carrying out the contract for the structure is Mr. James Carmichael. The steelwork is being made by Messrs. Moreland and Sons, who are doing the hollow-brick floorings. Messrs. Chubb will supply the strong-room iron doors, etc. The heating and hot-water service is entrusted to Messrs. Richard Crittall and Co. The steel windows are being made by the Crittall Manufacturing Co. The façades are all in Portland stone with green Westmoreland slates for the roofs, capped by ornamental lead ridges. The treatment adopted for the fenestration is primarily governed by ample lighting provision with as little obstruction as possible, and the intervening pavilions are flatly managed to avoid shadows. These pavilions lend emphasis to the lay-out of the design, and give architectural distinction to its composition.

"BURDOCKS," NEAR FAIRFORD, GLOUCESTER.

These copies of the general working drawings of this stone-built house erected in the beautiful neighbourhood of Fairfield, from

the designs of Mr. E. Guy Ducker, F.R.I.B.A., cannot fail to be appreciated. The building as most unpretentious and very well arranged, but is handled with dignity and breadth of design, so well in keeping with the old types of historic building in this district. The walls are of local stone, with dressings, and the roofs are covered with stone slates from the Eyford Quarries, Stow-on-the-Wald. Messrs. Sells, Bros., of Fairfield, erected the hull of the house. We gave a sheet of the details of the Lodge on November 24 last, and a prospective perspective appeared in our issue for June 23, 1911 from the Royal Academy of that season.

The corporation of South Shields have approved plans for additions to the Tynewinch Jubilee Lido.

The Stourbridge Board of Guardians have approved the erection of a receiving home for children at North cottage homes at a cost of £2,600.

Mr. L. Adams has resigned his position as surveyor to the Mayfield Rural District Council on his appointment to a similar position at Droyth.

The offices of the Road Board have been moved from Queen Anne's Chambers, to 51 Cranwell Road two minutes from South Kensington Station.

A new Baptist church is to be built in Denton Street, Blackhill, County Durham, from plans by Messrs. Davison and Parr, of New-castle-on-Tyne.

The urban district council of Saxmundham, East Suffolk, have appointed Mr. E. F. Wilson, of Kingsbridge, South Devon, to the post of surveyor and inspector of nuisances.

Acting upon a report from medical specialists, the Kensington Borough Council have granted Mr. A. R. Finch, the borough engineer and surveyor, complete freedom from duty for a period of three months.

The lighting restrictions at Dover have had a very serious effect on the corporation electricity undertaking, the loss upon which for the year ending March 31 next is now estimated by the borough electrical engineer at £2,000.

The plans of Messrs. Withers and Meredith, of London, have been adopted for the rebuilding of the Queen Street Wesleyan Chapel at Scarborough, which was destroyed by fire in February last. The estimated cost is £3,000.

A return issued by the Assessor of the city of Glasgow shows a total of 3,967 unoccupied dwellings in Glasgow, of which 2,633 are houses of one apartment, 4,791 of two apartments, 766 of three apartments, 239 of four apartments, and 536 of five apartments and over. Shops and other unoccupied premises number 5,692, making a combined total of 14,559.

A new home for men in connection with the Royal Institution for the Blind at Bradford has been formally opened. It is proposed to build a workshop on the grounds of what was once Highfield House, where they can carry on their brushmaking, basket weaving, and other industrial enterprises, and establish a centralised colony for the blind. Plans have been prepared, and the estimated cost of the building is £5,000, but the work will not proceed until after the war.

At the last meeting of the urban district council of Chudderton, the chairman stated that the clerk had received from the architects, Messrs. Taylor and Smister, a statement of the cost of the new town hall. The total contracts made amounted to £14,653 15s., architects' commissions £1,141, loan for site £1,700, making a total of £17,474. Sanction was obtained for loans for building, etc., £15,839, site, £1,700, total £17,539. One of the things very rare in public life was that the bill came out below the estimate.

In Liverpool and district the demand for convenient houses and for cottages cannot be readily met. The shortage of houses is causing real anxiety, and this scarcity is not due to any difficulty in obtaining suitable land, nor to its price. Speculative building, checked by legislation a few years ago, is now practically impossible owing to financial and labour difficulties and to the prohibitive cost of materials. The Head Constable's last return of empty houses showed a reduction of 5,000 in a period of four years. Unoccupied cottages let at 5s. weekly and under dropped from 1,643 to 558, of which, according to the acting-chairman of the Housing Committee, a considerable number were of an insanitary type.

Correspondence.

MILITARY EMERGENCY HOSPITALS.

For the Editor of THE BUILDING NEWS.

SIR: My friend Mr. Skipper has just called my attention to a report in your columns of November 17, 1915, of a very interesting lecture given by Mr. J. Savon Sack. As I know that you would not wish me to occupy any land to be perpetuated in your pages, I feel sure that you will allow me to state that instead of my name that of Colonel Griffiths, Commanding Officer of the First Eastern General Hospital, should appear.

For many years, Col. Griffiths has, to my knowledge, been making a close study of hospital construction. When the war broke out he had planned out in his mind the open-air hospital, and with the sanction of Mr. Skipper, these "hospitals" in the air became a fact. I had the privilege of watching their development as they grew, partly by direct observation and partly by Col. Griffiths' most generous and able co-operation. Col. Griffiths must be given the whole credit of the conception of this type of hospital, and to Mr. Skipper the credit of carrying out a most admirable fashion Col. Griffiths' ideas and plans.

I wish to set this matter straight at once, as in matters of this kind it is sometimes possible to determine who are the real initiators of a new departure, and in this instance it gives me very great pleasure to be able to make this correction without being called upon to depreciate the work of anyone else. I am satisfied that only in future years will we realise to the full how much we owe to this new method of hospital construction, and to Col. Griffiths for his persistent advocacy and brilliant carrying out of the open-air method of treatment of disease and injury other than those induced by the tubercle bacillus. He has, I am convinced, solved the great problem of hospital treatment for insured patients, and although it may be some little time before the method comes into full vogue, there can be little doubt that, in the long run, a mass of patients will be brought together into these hospitals, there to be treated by their Panel doctors and by those called to consult with them.

Apologising for occupying so much of your valuable space with what at first sight appears to be, but really is not, a personal matter, I am, yours faithfully,

G. SIMS WOODHEAD.

Pathological Laboratory.

New Medical Schools, Cambridge.

[We regret the lapse. Mr. J. Savon Sack himself promptly called attention to it in his letter which we inserted on p. 654 of our issue of December 1.—ED. "B.N."]

THE RENT AND MORTGAGE BILL.

SIR: Allow me to call the attention of your readers to the memorial which the British Constitution Association has presented to the Government against the proposed Rent and Mortgage Interest Bill. The memorial truly says:

"For the State to interfere to control the rent of houses or land, the rate of wages, or the rate of interest on capital, is to tax unfairly the owners of the particular property interfered with, and, so far from being justified by a state of war, is made less justifiable at a time when the sufferers are least able to bear the imposing especially must this be the case where one class of property is alone dealt with, for instance, where landlords and mortgagees are called upon to raise rents and interest while the manual labourer is obtaining a large increase of wages."

"Now that the needs of the State have called for a largely increased tax on houses as well as other property, to exclude this one kind of property in all cases from the general rise in prices is obviously arbitrary legislation in the interest of one class, and your memorialists trust that the measure will not be passed into law."

Unfortunately, the opposition to the measure is not likely to be successful, but surely even as a measure only intended to be in force during the continuance of the war it should be

PROFESSIONAL AND TRADE SOCIETIES.

CRYSTAL PALACE SCHOOL OF ENGINEERING.

Mr. P. Griffith, President of the Society of Engineers, in distributing certificates to the students at the Crystal Palace School of Practical Engineering on Wednesday, said the future of this and of every country lay in the hands of the engineer. In many respects in commerce, trade, and science we had been taking things too easily and letting our rivals get ahead. Now, under the stimulus of the war, the nation was waking up, and it was our duty to keep awake, make a fresh start in the world's race, and maintain the lead which our ancestors won. Mr. H. J. Buckland, on behalf of the Crystal Palace Trustees, said the members of that body had both collectively and individually, worked extremely hard to obtain outside assistance in order to carry on the school, but had failed to obtain financial help. Unfortunately, the loss in connection with the school for 1915 ran into four figures, and the Trustees having no money to meet the deficiency, felt they could not carry on the school, and their responsibility for it ended with the close of the present term. However, the Principal and his brother had decided to carry on the school, and during the next term would find more suitable and up-to-date premises for the purpose. During its forty-two years of existence the school had turned out something like 1,200 engineers, who now occupied important posts in all parts of the world. Mr. J. W. Wilson, the Principal, announced that the school's roll of honour included nearly 200 past and present students engaged in the country's service. The school, he said, had always paid its way until the war, although it had never had any private assistance, and it was not going to close. On January 5 they intended to start again, and go on as before.

ROMAN TILES IN LANCASHIRE.—At the December meeting of the Antiquarian Society, held at Chetham's Hospital, Manchester, Major Lees, J.P., of Egerton Villa, Heywood, read a short communication on some Roman tiles found at Castleshaw in 1907. One bore an inscription, two had graffiti markings upon them, and another, evidently a roofing tile, had been pierced with a hole which still retained the iron nail once used for fixing it to woodwork. The inscribed tile was of unusual interest, for it bore the name of a cohort of Roman troops. Tiles having a similar impress had been frequently found at the neighbouring Roman fort at Slack, near Huddersfield, distinctly bearing the mark COH IIII BRE, indicating, in all probability, the fourth cohort of the Breucres from Pannonia, and known to have been in Britain. The Castleshaw tile stamp closely resembled those found at Slack, but unfortunate abrasions or decay had rendered the lettering somewhat uncertain; all that remains clearly visible being COH IIII BR with an indication of a final E. A tile fragment bearing the first portion of a very similar type of impress was found in Manchester early in the nineteenth century.

THE ORIGIN OF THE NEOLITHIC CELT.—A paper on this subject was read by Mr. Reginald Smith before the Society of Antiquaries at their last meeting, held at Burlington House, St. Arthur Evans, the President, occupying the chair. The lecturer, who exhibited many specimens and lantern slides, traced one important class of flint weapon from the side-scraper or "point" of Le Moustier. The gap was in his opinion bridged by several intermediate forms recently found at Grime's Graves, Norfolk. The date of that industry was not an essential factor in the argument, and he claimed that there existed a curious connection in form between Grime's Graves specimens and palaeoliths of late type, from brick earth and possibly other deposits in the Thames Valley. The small platform often seen at one angle of the base of the triangular hand-axe seemed to represent the hilt of percussion or thickening on a side-scraper or "point" from Le Moustier; and its disappearance marked a change of function, the apex becoming the butt of the celt, and the butt of the hand-axe turning into the cutting edge of the celt. Granted that form alone was no criterion of date,

form-associations were the basis of pre-historic research, just as plant-associations were the mainspring of ecology. He argued that there was no great difference in time or civilisation between the flint-workers of Grime's Graves and the early cave-dwellers of France.

COMPETITIONS.

GOVAN SECONDARY SCHOOL.—Govan School Board, at their monthly meeting on Wednesday night, adopted plans for a new secondary school which is to be erected in the Hillhead district of Glasgow. The successful architect was Mr. Matthew Adam, Lic.R.I.B.A., 150, Hope Street, Glasgow.

LEGAL INTELLIGENCE.

WHAT IS PUBLIC USER OF A ROAD?—WILDING v. BILLINGTON.—In this action, tried in the Lancashire Chancery Court, the Vice-Chancellor, Mr. Stewart Smith, K.C., has given judgment. The plaintiffs, Messrs. S. B. Wilding and Sons, contractors and decorators, Preston, are the owners and occupiers of land through which runs a narrow road with outlets in Lune Street and Hill Street. The plaintiffs claimed that the road was a private way, and they sought an injunction against the defendants, who are owners of adjoining property and whose case was that the road was a public thoroughfare between the two streets. It appeared that at one period there were gates set up which had decayed, and in 1913 the plaintiffs put up other gates. These were removed by the defendants in March, 1914, in the assertion of what they deemed a public right, as little damage being caused as possible.—The Vice-Chancellor said counsel for the defendants, exercising a wise discretion, had abandoned a claim to a private right, and the only question that remained was whether there was any and what public right of way over this land. The disputed road, which formed a continuous passage between the two streets, was tortuous and narrow, and in some places two carts could not pass. The claim of the plaintiffs was founded entirely on user. For the defendants it was said that as far, at any rate, as foot passengers were concerned, the user had extended for many years. There was also evidence that vehicles and sheep and cattle had used the road. At one time in its history a suggestion was made to the corporation of Preston that they should take over the road and keep it in repair, the owners being willing to give up their rights, but the corporation did not assent. On the evidence as presented he found no intention to make a dedication, and, in his opinion, the user, where it had not been by persons who had business there or passed through under some private right, had been by members of the public who were either tolerated or unobserved by the owners. He came to the conclusion, therefore, that the plaintiffs were entitled to the injunction they asked, and he fixed the damages at 10s., the defendants to bear the costs of the litigation. In his opinion, the defendants had acted with the single purpose of establishing a public right which, in good faith, they believed existed. The rights of the parties being once determined, it would seem that the convenience of those who desired to attend St. Wilfred's Church, Preston, or to pass over the land for legitimate purposes might be the subject of arrangement to which the plaintiffs might see their way to agree, while still preserving their own rights.—Mr. Glover, plaintiffs' counsel, said he would convey his honour's suggestion to his clients.

ENGINEERING NOTES.

ROGERS PASS TUNNEL.—Mr. W. J. Roche, Minister of the Interior at Ottawa, has cabled to the High Commissioner for Canada, 19, Victoria Street, London, S.W., stating that a very great engineering feat was accomplished on December 19 with the opening of the Rogers Pass tunnel on the main line of the Canadian Pacific Railway. A passage has been made east and west through the heart of Mount Macdonald, the ceremony of firing the connecting shot was performed in the presence of a number of prominent railway and business men and engineers, two and a half miles from either exit of the tunnel and at a distance of 5,000 feet below the surface. The tunnel, when complete, will be 25,400 feet long, with approaches an additional nine miles in length.

MURK H. JUDGE.

S. A. MURK H. JUDGE.

1915.

S. A. MURK H. JUDGE.

... of the War Service... The forms already submitted have so far been chiefly of these applicants...

... of these applicants by the... of these applicants have not...

... of these applicants for work... of these applicants at the openings as...

... of these applicants to appointments... of these applicants have been...

... of these applicants now provided at... of these applicants the country, and...

... of these applicants recommending of... of these applicants at once such...

... of these applicants may have obtained the... of these applicants by the time it is possible...

... of these applicants for such work, with a... of these applicants the Munition Authorities...

... of these applicants faithfully.

ALAN E. MUMBY.

H. S. S. Selects on Committee.

... of these applicants, Humber Street.

... of these applicants, W. D. 25, 1915.

... of these applicants, W. D. 25, 1915.

... of these applicants, W. D. 25, 1915.

... of these applicants, W. D. 25, 1915.

... of these applicants, W. D. 25, 1915.

... of these applicants, W. D. 25, 1915.

... of these applicants, W. D. 25, 1915.

... of these applicants, W. D. 25, 1915.

... of these applicants, W. D. 25, 1915.

... of these applicants, W. D. 25, 1915.

... of these applicants, W. D. 25, 1915.

... of these applicants, W. D. 25, 1915.

... of these applicants, W. D. 25, 1915.

... of these applicants, W. D. 25, 1915.

... of these applicants, W. D. 25, 1915.

Building Intelligence.

EDINBURGH.—The "Sandeman Memorial Halls," as the new building erected in Ashley Court, High Street, Edinburgh, behind Moray-Knox Church, in connection with the work of the Moray-Knox and St. Andrew's United Free Churches' Mission Board, has been named, were opened last week. The old tenements in the court have been removed, and a completely equipped mission centre erected, comprising a large hall, seating about 400 persons, two large clubrooms, committee-rooms, service kitchen, office, and caretaker's house. In the external design an effort has been made by the architects, Messrs. J. N. Scott and Lorne Campbell, to render the new building in keeping with the characteristics of the Old Town architecture, and the change in the old court is in the nature of a city improvement. The cost has been £2,000, exclusive of the purchase of the site and the laying out of the court.

QUEBEC.—The new Union Station, which is being built from the designs of Mr. H. E. Prindle, is a comparatively low building in the style of the chateaux on the Loire. The building is located on the property bounded by St. Paul, Henderson, and St. Roche Streets, which has been entirely re-arranged, with new tracks, coach storage yard, express yard, freight sheds, and freight office. The roof of the central block rises 90 ft., the roofs of the wings being 50 ft. high. The exterior walls are faced with a dark brick, laid in Flemish bond in white mortar, with deep-raised joints with stone facings and granite base. The roofs are of copper. The entire building rests upon a system of concrete piles; the floor and part of roof construction are of reinforced concrete, the sloping surfaces of roofs are of gypsum block, the frame throughout is of steel encased in concrete, and the walls are of masonry. There are 450 concrete pedestal piles, containing 400 tons of structural steel. The building will be electrically illuminated. The train-sheds will be of low umbrella type. The station proper will cost approximately \$500,000 when completed. The operations are being carried out entirely under the direction of Mr. D. H. Mapes, engineer of buildings, Canadian Pacific Railway, Windsor Station, Montreal. The general contractors are the Downing-Cook Company, of Montreal.

GLASGOW.—Operations are practically completed by which the building of the Glasgow Royal Exchange in Queen Street has been reconstructed. Externally it has always been one of the most striking structures in the city, with its dignified walls and massive columns. It was the residence of Mr. William Cunningham, of Lainslaw, one of the most successful of Glasgow's "tobacco lords," who built it in 1778. It came into the possession of a committee formed to institute a new Exchange in the city in 1827, and two years later was opened as the Royal Exchange. The entire building has been remodelled internally, under the advice and guidance of Mr. Colin Menzies, architect, Glasgow. There are three floors. On the ground floor is the main room of the Exchange—a lofty apartment, decorated in red, white, and gold—the massive columns dividing the floor space along the north and south sides. A considerable quantity of the gold used in the previous decoration was again utilised in the present scheme, in which are two large electroliers bearing fifty lamps on each. New entrances have been made, and a fresh staircase, all of which afford increased floor space amounting to nearly 300 square feet. Two additional fluted monoliths have been introduced, thereby retaining the proper proportion of the columns to the general design. On the first floor are the underwriters' rooms and the secretary's office, together with a suite of other offices. The corridors are finished in white and green tiles, with a dado. The second floor is occupied with offices of firms, nearly all of whom are associated with the Exchange. A feature of this portion of the building is the dome, which was part of the original mansion. The plaster decoration

remains practically the same as in the old days. Several new staircases have been introduced, as has also been a lift to all the floors. This upper portion was formerly occupied by the National Telephone Company, but it has been transformed into a series of apartments. The basement was formerly also in the occupancy of the Telephone Company, who vacated the premises when the Government took over control of the telephone service. This basement has been reconstructed to provide premises for a restaurant.

Trade News.

WAGES MOVEMENTS.

SHEFFIELD.—The operative painters of this city have received an advance in wages of a halfpenny per hour (from 2½d. to 3d.) under the award of Mr. E. A. Greer, K.C., who was appointed by the Board of Trade to act as arbitrator between masters and men. The application on behalf of the Sheffield branch Society of Operative Painters was for an increase of 1d. per hour.

TRADE NOTES.

Boyle's latest patent "air-pump" ventilator has been applied to Toxill School, Midsone. Mr. George Reavell, A.R.I.B.A., of Alwick, is taking into partnership Mr. W. Arthur Tolls, who has been for thirteen years his chief assistant. The firm will continue the practice at the old address, Lloyds-Bank Chambers, Alwick, and at the branch office at 51, Bridge Street, Morpeth.

WATER SUPPLY AND SANITARY MATTERS.

THE SEWERING OF BENTLEY, NEAR DONCASTER.—Mr. A. G. Down, D.Sc., M.Inst.C.E., held a Local Government Board inquiry at the Bentley Council Schools, on Thursday, into the application of the Bentley-with-Arksley Urban Council for power to borrow an additional £2,050 for sewerage and sewage disposal works. The Clerk to the Council (Mr. P. J. mentioned that in 1831 the population of the parish was 1,484, in 1901 it was 2,405, and in 1911 it was 6,497, while the estimated population now was 7,500. The rateable value of the parish is £65,642 2s. 6d., and the assessable value £54,521 11s. 5d. The balance on outstanding loans is £34,023, exclusive of loans under the Housing of the Working Classes Act. The present application arose chiefly out of a contract for sewerage works entered into in 1913, and the excess of expenditure over estimates was accounted for by the nature of the ground—the running sand and water—and the bad ground generally in the Bentley Toll Bar district, which necessitated the timber being left in the trenches. A bad state of ground was also met with at the new pumping station in Bentley village, and necessitated an expenditure far exceeding the estimate. The original estimate for the work was £11,956, but the contract was let for £12,458. A representative of the engineers (Messrs. Balfour and Sons) gave details of the cost of various portions of the work, and in reply to the Inspector, said the whole system now worked effectually. Dr. Wilson (representing the West Riding County Council) said he did not object to the application, but colliery villages had a way of increasing very rapidly, and in all probability the time would soon come when the scheme would have to be enlarged, and it was necessary to look ahead. The inquiry was concluded.

STAINED GLASS.

NEWCASTLE-ON-TYNE.—A three-light stained-glass window, erected to the memory of the late Mrs. W. B. Reid, of Cross House, was unveiled on Monday in St. Luke's Church, Newcastle. The subject is "Faith, Hope, and Charity." The figure of Faith is represented holding in one hand a cross and in the other a Bible. Hope is portrayed holding in her hand an anchor, and is looking up to Heaven. Charity is represented by a female figure mothering and succouring two orphan children. In the centre light there is an angel introduced into the canopy holding in his hand a scroll on which is the text 1 Corinthians xiii. 13. The work has been executed by Messrs. Bagdley and Son, Newcastle-on-Tyne.

Our Office Table.

THE MARSHAL Sir John French on his departure from France paid a striking tribute to the Artists Rifles (O.T.C.), which furnished his guard of honour. He said: "Officers and men.—It is singularly appropriate and nothing could give me greater pleasure than that your regiment, the Artists Rifles, should be the last British troops that I shall see in France. You have done wonderful work since you came out; you have furnished some of the finest leaders of the Army from your ranks, and in doing so you have suffered perhaps greater losses than any other regiment out here. You have done great work, and I have no doubt that you will continue to do so till the end of the campaign. I am very pleased that the guard of honour on my leaving France should be supplied by the Artists Rifles. I wish you goodbye and good luck."

Some antiquities of Burton Abbey have been presented to the Burton Club by its vice chairman, Mr. S. Briggs, J.P., the executor of the late Colonel J. A. Bindley, to whom the relics belonged. Colonel Bindley lived at the residence known as Burton Abbey, which occupied the site and formed a portion of the old Benedictine monastery on the north bank of the Trent at Burton, and this a few years ago was taken over by the Burton Club as their new quarters. The gifts include a plaster cast of the conventual seal of the abbey of the twelfth or thirteenth century, and a cast of the seal of the first abbot, William de Melburne (1197-1210), used in conjunction with that of the monastery. These are framed in wood, 300 years old, taken from St. Werburgh's Church, Derby. On one side of each seal there is engraved on vellum a brief history of the abbey and a complete list of the abbots (thirty five in number) from 1026 to 1534. The history states that the abbey was dissolved at the dissolution of the monasteries, and its possessions handed over by King Henry VIII. to his secretary, Sir (afterwards Lord) William Paget, ancestor of the present Marquis of Anglesey.

Writing with reference to the recent discovery of the foundations of Wulfrie's round church at St. Augustine's Abbey, Canterbury, mentioned last week, Mr. G. McN. Rushforth, F.S.A., points out that the main interest of the important discovery is that it adds another to a list of English round or polygonal churches which covers the whole of the Anglo-Saxon period and extends up to the beginning of the Crusades. They are all of Continental and ultimately Roman origin and inspiration. It was about 630 that Wilfrid built a round church of St. Mary at Hexham. Some time between 959 and 975 the abbey church of Abingdon was rebuilt in the same form. About 1080 Robert of Louvain, Bishop of Hereford, re-erected his cathedral, as William of Malmesbury tells us, after the pattern of the most famous building of his native land—Charlemagne's round church at Aix-la-Chapelle. And now we find, says Mr. Rushforth, that, some twenty years earlier, Abbot Wulfrie had built a round church at Canterbury; and the plan suggests that it too may have been derived from that of Charlemagne's Chapel Royal, or possibly from that of the not much later rotunda at Fulda. In discussing these buildings in his "Lombardic Architecture," Comm. Rivoira has well pointed out that all these circular plans are derived directly or indirectly from Roman models; and that, in choosing this form for the Church of the Holy Sepulchre itself, Constantine was only following the pattern of a typical Roman mausoleum on the grand scale.

At a meeting of the Midland Association of Local Government Officers in Birmingham last Monday week, Mr. Henry E. Stilgoe, city engineer and surveyor, gave an address on "Destruction of Macadam Streets," from notes supplied by Mr. Thomas Arnall, of the Birmingham Public Works Department, who was prevented from being present to speak on the subject. Mr. Stilgoe dealt generally with the chief causes of destruction,

Secretary. He explained that the Board of the Association of Experts with regard to the time required for its most effective work was a most important matter, and that it would give a lead to other matters. Mr. Fraser said when the Commission is ready to go, who of the experts is to go. The Town Clerk said he would be a member of the Commission, and suggested that the Commission should be appointed immediately. The Commission was appointed.

Mr. Hoff has issued a circular in connection with the proposed Commission. Mr. Hoff said that the Commission should be appointed immediately. Mr. Hoff said that the Commission should be appointed immediately. Mr. Hoff said that the Commission should be appointed immediately.

Mr. Hoff said that the Commission should be appointed immediately. Mr. Hoff said that the Commission should be appointed immediately. Mr. Hoff said that the Commission should be appointed immediately.

Mr. Hoff said that the Commission should be appointed immediately. Mr. Hoff said that the Commission should be appointed immediately. Mr. Hoff said that the Commission should be appointed immediately. Mr. Hoff said that the Commission should be appointed immediately. Mr. Hoff said that the Commission should be appointed immediately.

The British Standard Specification for Wrought Steel Bars, in connection with the proposed Commission. Report No. 175, issued by the British Standard Institution, is a valuable reference. The proposed Commission should be appointed immediately. Mr. Hoff said that the Commission should be appointed immediately.

The proposed Commission should be appointed immediately. Mr. Hoff said that the Commission should be appointed immediately. Mr. Hoff said that the Commission should be appointed immediately. Mr. Hoff said that the Commission should be appointed immediately. Mr. Hoff said that the Commission should be appointed immediately.

The proposed Commission should be appointed immediately. Mr. Hoff said that the Commission should be appointed immediately. Mr. Hoff said that the Commission should be appointed immediately. Mr. Hoff said that the Commission should be appointed immediately. Mr. Hoff said that the Commission should be appointed immediately.

Bahamas manifested a keen interest in their operations, and himself descended the deep sea tube from the bottom of the compartment. This tube, which hangs beneath a supporting vessel on the surface, is large enough to let a man pass up or down inside it, and strong enough to resist the pressure of the sea to a considerable depth, and it is flexible. When the tube is down, it usually stays on the Bahamas, the pictures are taken in a natural way, but there is an artificial light which can be switched on or off at any time. The films exhibited are interesting and instructive. The diver is taken on a rubber buoy, and the natives and the boats of the fleet follow, so that they can see the various varieties of marine flora and fauna. The film is a marine garden of the Bahamas, and a fine variety of fish, sponges, and shells. Mr. George Williams, a long sea diving suit, is seen exploring a fifty-year-old wreck, and special attention is given to the harpenna and capture of sharks, the final film depicting the exciting episode of an under-sea fight with one of the largest of the man-eating snakes which infest the inshore waters of the Atlantic around the Bahamas. The night cinematograph of the Williams pictures presented by the Trans-Atlantic Film Company, and the first public exhibition took place at the Plaza on Boxing Day.

The Dominion Conservation Commission, Ottawa, is an effort to reduce the great amount of waste in Canada, and taking up the matter of establishing a general building by-law to control the practices and secure some uniformity of construction. The Commission has asked a number of city architects of the chief cities of Canada to give their opinions as to what such a national building by-law should contain. Mr. Pearce, city architect of Toronto, has suggested that it would be a great help if a central bureau were maintained where municipalities could get information in reference to the fire-resisting qualities and the strength of various materials used in buildings; at present city departments are forced to obtain such information from fire and engineers of their United States cities. Mr. Pearce is of the opinion that, on account of differences in climate, physical condition, water supplies, and so on, it would be unworkable to have a uniform building by-law for the whole Dominion.

The Architects and Surveyors' Directory for 1916 reaches its thirty-fifth annual issue, and is the volume to hand, which is published as usual at 5s. red and 6s., according to day space and binding, by Messrs. Watkinson, Bell, and Lytton, Limited, Waterloo House, Bouverie Lane, E.C. In every respect the usefulness of this indispensable office help is fully maintained. The information on every matter of interest to our own profession is as comprehensive as it is possible to desire, including a well-selected list of prices; and the general contents and admirable compactness and quality of the paper are certain to recommend the purchase of the diary to all.

The annual report of the directors of the Leeds Free Press Company states that the war has seriously affected the sales during the past year, whereas the production rose to an abnormal figure. Public works and regular contracts, in which their specialties are used, were suspended, and a serious decline in the building trade was a further consequence. Notwithstanding these adverse conditions the directors have been able, by the development of new business and the purchase of fixed incomes, to limit the loss on the trading for the year ended Jun. 30 to £5,793, after charging £12,000 for debenture interest. Dealing for the £1,007,112 of fore- and after-war was a debit of £2,360, which has been charged to reserve fund. Early next year a somewhat more reduction of the capital will be paid out to the shareholders.

The Leeds Free Press Company, Mr. J. H. Taylor, 100, York Buildings, 100, Strand, London, W.C.2.

PARLIAMENTARY NOTES.

RESTRICTION ON INCREASE OF RENT.—In the House of Lords on Tuesday in last week, the Marquess of Lansdowne moved the second reading and explained the purposes of the Increase of Rent and Mortgage Interest (War Restrictions) Bill, a measure which had already passed through the House of Commons. The noble Marquess said that while the Bill restricted increase of rents of working-class houses, it was quite impracticable to legislate for the purpose of restricting rates of wages. A general demand for an all-round increase in wages would be disastrous, but the Government had by other legislation done something to discourage such a demand. Earl St. Aldwyn said the Bill could only be justified by the fact that the country was at war, and hoped it would not be taken as a precedent for legislation in the future. He could not understand why, if the Bill were intended only to apply to the working classes, the limit of rent should have been fixed as high as £26 a year in rural areas, which brought in persons of a much higher social status. In Committee he proposed to move an amendment to reduce the rental in rural areas. The Bill was read a second time. On Wednesday the measure passed through Committee and all the remaining stages. In Committee several Government amendments were agreed to on Clause 1. Viscount Middleton moved an amendment which Earl St. Aldwyn had put down to Clause 2 providing that in rural sanitary districts the Bill should apply to houses up to the value of £12 instead of £26 a year. He argued that in rural districts the figure at present in the Bill would not be consistent with the intentions of and promoters of the measure. The Marquess of Lansdowne justified the rental limit in the Bill on the ground that there were many areas to which the Bill must apply which, while technically rural, were really urban in character. It seemed better on the whole to include a certain number of persons not strictly entitled to protection than to exclude some who had claim upon the relief given by the Bill. During the discussion Earl St. Aldwyn came into the House and said that he recognised the difficulties of the position, and therefore withdrew the amendment. The measure received the Royal Assent on Thursday.

DETERIORATION IN GAS.—Dr. Addison, Secretary to the Ministry of Munitions, replying in the Parliamentary Papers to Mr. W. Thorne's inquiry whether the Minister of Munitions was aware that the loss in the illuminating and heating power of gas caused by benzol, toluol, and xylool being extracted could be made good to the use of oil and cannot coal, says that the cost and difficulty of obtaining the materials required restrict the possibility of adopting the processes required, and the deterioration in the quality of the gas supplied to customers is hardly appreciable.

Mr. Frank Bailey Passmore, aged 70, of Alexandra House, West Cliff, Herne Bay, and of Suffolk House, Laurence Pountney Hill, E.C., civil engineer, left net personalty £14,850 and gross £16,399.

At the last meeting of the Wolverhampton Town Council Mr. Charles Owen Silvers, Wolverhampton was appointed general manager and engineer of the Wolverhampton Corporation Tramways, in succession to the late Mr. W. A. Luntley, at a commencing salary of £350 per annum.

Fires in Dundee during the past year caused damage to the extent of almost £50,000. The fire brigade received 207 calls during the year, and the damage at which the outbreaks reached £10 and over amounted to £48,715 while they attended at outbreaks in the county at which the damages were estimated at £5,150. The most serious outbreaks occurred at the harbour; indeed, the total damage done by fires at the riverside amounted to £37,635.

A cross has been presented to Beccles Parish Church, East Suffolk, and dedicated by the Bishop of St. Asaph. It is inscribed: "Given by the officers and non-commissioned officers and men of the Shropshire R.H.A. Donagh Hussars Yeomanry, Headquarter Staff, Signal Troop, R.A.M.C., and A.S.C., of the 1st Welsh Border Mounted Brigade, who were quartered at Beccles during the European War, 1914-1915." The cross is three feet high, in the English style of 1490-1520, and consists of an enriched Latin cross, supported on a plain hexagonal base and stem. At the end of each of the four arms is an embossed silver plaque worked into the symbols of the four evangelists, and in the centre of the cross is a fifth silver plaque of the Lamb with the banner of the Resurrection.

TO CORRESPONDENTS.

We do not hold ourselves responsible for the opinions of our correspondents. All communications should be drawn up as briefly as possible, as there are many claimants upon the space allotted to correspondents.

It is particularly requested that all drawings and all communications respecting illustrations or literary matter, books for review, etc., should be addressed to the Editor of the BUILDING NEWS, Effingham House, 1, Arundel Street, Strand, W.C., and not to members of the staff by name. Delay is not infrequently otherwise caused. All drawings and other communications are sent at contributors' risks, and the Editor will not undertake to pay for, or be liable for, unsought contributions.

*Drawings of selected competition designs, important public and private buildings, details of old and new work, and good sketches are always welcome, and for such no charge is made for insertion. Of more commonplace subjects, small churches, chapels, houses, etc.—we have usually far more sent than we can insert, but are glad to do so when space permits, on mutually advantageous terms, which may be ascertained on application.

When favouring us with drawings or photographs, architects are asked kindly to state how long the building has been erected. It does neither them nor us much good to illustrate buildings which have been some time executed, except under special circumstances.

Telephone: Gerrard 1291.

Telegrams: "Timeserver, L-strand, London."

NOTICE.

Bound copies of Vol. CVIII are now ready, and should be ordered early (price 12s. each, by post 12s. 10d.), as only a limited number are done up. A few bound volumes of Vols. XXXIX., XLI., XLVI., XLIX., LIII., LXI., LXII., LXIII., LXIV., LXV., LXVI., LXVII., LXVIII., LXXI., LXXV., LXXVI., LXXVII., LXXIX., LXXX., LXXXI., LXXXII., LXXXIII., LXXXIV., LXXXV., LXXXVI., LXXXVII., LXXXVIII., LXXXIX., XC., XCI., XCII., XCIII., XCIV., XCV., XCVI., XCVII., XCVIII., XCIX., C., CI., CII., CIII., CIV., CV., CVI., and CVII. may still be obtained at the same price; all the other bound volumes are out of print.

BACK ISSUES.

Most of the back issues are to be had singly. All back issues over one month old will be charged 6d. each, postage 1d. Subscribers requiring back numbers should order at once, as they soon run out of print.

Handsome Cloth Cases for binding the BUILDING NEWS, price 2s. 6d. post free 2s. 9d., can be obtained from any Newsagent, or from the Publisher, Effingham House, 1, Arundel-street, Strand, W.C.

TERMS OF SUBSCRIPTION.

One Pound per annum (post free) to any part of the United Kingdom; for the United States, £1 6s. 0d. (or 60sols 20c. gold), To France or Belgium, £1 6s. 0d. (or 33s. 30c.). To India, £1 6s. 0d. To any of the Australian Colonies or New Zealand, to the Cape, the West Indies, or Natal, £1 6s. 0d.

*Our Direct Subscription Agents for Australia are Messrs. E. T. Kibblewhite and Co., Printers and Publishers, 19, York Chambers, 105, Liverpool Street, Sydney, New South Wales; for Japan, The Maruzen Co., Ltd., 11-16, Nishibashi Tori Sanchoine, Tokyo; who will receive Subscriptions at £1 6s. 0d. per annum on our account. Copies of the paper will be sent by us direct to the subscribers' address.

*The special rate to Canada is £1 3s. 10d. =50sols 80c. for 12 months, and 11s. 11d. =20sols 90c. six months. Our Direct Subscription Agents for Canada are Messrs. Sells, Ltd., 392, Shaftness Buildings, McGill Street, Montreal, who will receive Subscriptions, £1 3s. 10d. per annum, on our account.

Cheques and Post-office Orders to be made payable to THE STRAND NEWSPAPER COMPANY, LIMITED, and crossed London County and Westminster Bank.

ADVERTISEMENT CHARGES.

The charge for Competition and Contract Advertisements, Public Companies, and all official advertisements is 1s. per line of Eight Words, the first line counting as two, the minimum charge being 5s. for four lines.

The charge for Auctions, Land Sales, and Miscellaneous and Trade Advertisements (except Situation Advertisements) is 6d. per line of Eight Words (the first line counting as two), the minimum charge being 4s. 6d. for 50 words. Special terms for series of six insertions or more can be ascertained on application to the Publisher.

SITUATIONS VACANT AND PARTNERSHIPS.

The charge for advertisements for "Situations Vacant" and "Partnerships" is One Shilling for Twenty-four Words, and Sixpence for every Eight Words after. All Situation Advertisements must be prepaid.

SITUATIONS WANTED.

Advertisements not exceeding Thirty Words, inclusive of name and address, are inserted under the heading "Situations Wanted," free of charge.

Rates for Trade Advertisements on front page and special and other positions can be obtained on application to the Publisher.

REPLIES TO ADVERTISEMENTS.

Replies to advertisements can be received at the Office, Effingham House, 1, Arundel Street, Strand, W.C., free of charge. If to be forwarded under cover to advertiser, an extra charge of sixpence is made. (See Notice at head of "Situations.")

Advertisements for the current week must reach the office not later than 3 p.m. on Tuesday. Front-page advertisements and alterations or stop orders for serial advertisements must reach the office by first post on Monday to secure attention.

RECEIVED BY J. B. L. P. A. and Son B. S. Co., Ltd. W. P. L. and Co. S. P., Ltd. A. A. Co. G. G. S. I. S. C. W. H. I. G. M. H. and Co.

MEETINGS FOR THE ENSUING WEEK.

Wednesday, Dec. 30.—Institute of Military Engineers, 11, Bedford Square, London, W.1. Presidential Address, Cannon Hall, Westminster, 7.35 p.m.

Mr. W. G. H. H. City Engineer of Cardiff, was elected president by the Institute of Municipal Surveyors and Architects as their president for the coming year.

St. Ann's Calvinistic Methodist Chapel at Pwllheli, which was burned down some months since by an incendiary, has been rebuilt at a cost of £20,000, and was reopened last week. Mr. R. Lloyd Jones, of Carnarvon, was the architect, and Mr. Evan Jones, of Dolydd, the builder.

The Sanleuan Memorial Halls, built in Ayley Court, High Street, Edinburgh, behind the Mercat Knox Church, have been formally opened. The architects were Messrs. J. N. Scott and Louis Campbell, F.R.I.B.A., of Castle Street, Edinburgh, and the cost was £42,000.

At a meeting on Monday of St. Helen's District Council, Isle of Wight, a letter was read from the scavenging contractor, terminating his contract at the end of the year on the ground that he was put to such great expense in buying poison to keep down the rats that it was not worth doing.

The foundation stone of a new church at New Rossington, near Doncaster, has been formally laid. Land has been reserved for a parsonage house and church institute. The plans of the church are by Lieutenant F. N. D. Masters, M.A., F.R.I.B.A., of Bank Chambers, Doncaster, and the cost will be £5,250.

The city council of Wakefield are seeking powers to modify their waterworks scheme. Under the new proposal, two comparatively small dams and gauge basins will be substituted for the Booth Dean Reservoir originally contemplated, at an estimated cost of £20,000, as against £20,000 for the original project.

At the last meeting of the urban district council for Heanor, the proposal to build a school for the teaching of technical engineering was again under consideration, and it was resolved that the Heanor Education Committee be requested to submit plans for the erection of an engineering workshop, and that the Derbyshire Education Committee be asked to consent to Mr. G. H. Widdows, F.R.I.B.A., making the plans.

The death has occurred at Jarrow of Mr. Thomas Brown, aged 42 years, manager and surveyor for Mr. Thomas Lumsden, contractor, Jarrow. Mr. Brown had been in the service of the firm for twenty-four years, and until a few days ago was following his employment. The cause of death was pneumonia. The deceased was the second son of Mr. George Brown, traffic manager for Messrs. Bowes and Partners, Mr. Brown was actively associated with many important building contracts in the North of England, including the Pelaw Co-operative Stores and the extension of the Armstrong College. He was an athlete, and in later years was secretary and afterwards captain of the Jarrow Golf Club.

Mr. William Henry Lynn, R.H.A., of Innyard, near Fethard, Co. Wexford, and of Belfast, late of the Queen's University, Dublin, and of "Royal Cathedral," and President of the Royal Institute of Architects of Ireland, 1876 to 1878, who died on September 12, aged 80, son of Lieutenant Henry Lynn, R.N., left personal estate in the United Kingdom valued at £5,250. He left £5,000 London and North Western Railway ordinary stock for the completion of St. Ann's Cathedral Church, Belfast; £5,000 Belfast Harbour Consolidated stock to the Royal Victoria Hospital for the endowment of beds there; and £500 Belfast Harbour Consolidated stock for the Sustenance Fund of the Parish of Fethard. If the residue of his estate shall exceed £50,000, any balance above that sum is left to be distributed among Belfast local charities.

LATEST PRICES.

N.B.—All prices must be regarded as merely approximate for the present, as our usual sources of information are in many cases failing us.

TIMBER.

owing to stoppage of supplies all prices have advanced considerably.

IRON.

Table listing various iron products such as Mild Steel Joists, Wrought Iron Girder Plates, and Boiler Plates, with prices per ton.

Table listing Cast Iron Columns, Cast Iron Stanchions, Rolled Iron Fencing Wire, and other iron products.

Table listing Cast Iron Socket Pipes, Wrought Iron Tubes, and other iron products.

OTHER METALS.

Table listing Lead Water Pipe, Lead Barrel Pipe, Lead Pipe, Composition Gas Pipe, and other metal products.

Table listing Eureka unslating green, Permanent Green, and other roofing materials.

BRICKS.

Table listing various brick types including First Hard Stocks, Second Hard Stocks, and Accrington Best Red Plastic Facing Bricks.

Table listing Bath Stone, Portland Stone, and White Basebed, with prices per foot cube.

TILES.

Table listing Plain red roofing tiles, Hip and Valley tiles, and other types of tiles.

OILS.

Table listing Rapeseed, Cottonseed, Olive, and other oils, with prices per ton.

GLAZED BRICKS.

Table listing various glazed brick colors and types such as White, Ivory, and Salt Glazed.

MOULDING BRICKS.

Table listing Stretchers and Headers, Double Bullnose, and other moulding bricks.

GLASS (IN CRATES).

Table listing English Sheet Glass, Fourths, Thirds, and other types of glass.

VARNISHES, Etc.

Table listing Fine Pale Oak Varnish, Pale Copal Oak, and other types of varnishes.

STONE.

Table listing Red Mansfield, Darley Dale, and other types of stone.

I BUY SCRAP METALS

ARTHUR P. COLLINS, Snow Hill, BIRMINGHAM.

SLATES.

Table listing Blue Portland, Blue Banor, and other types of slates.

Sir George Buchanan, M.Inst.C.E., chairman of the Rangoon Port Trust, who had charge of the great works recently completed on the Rangoon river, has been placed on special duty for dredging operations in Mesopotamia.

