

HARVARD UNIVERSITY



Library of the
Museum of
Comparative Zoology

BULLETIN

4296
2

OF THE

MUSEUM OF COMPARATIVE ZOOLOGY

HARVARD UNIVERSITY

VOL. 132

CAMBRIDGE, MASS., U.S.A.

1964 - 1965

THE COSMOS PRESS, INC.
CAMBRIDGE, MASS., U. S. A.

CONTENTS

	PAGE
No. 1.—A SYNOPSIS OF THE AMERICAN BETHYLIDAE (HYMENOPTERA, ACULEATA). By Howard E. Evans. November, 1964	1
No. 2.—A PHOTOGRAPHIC SURVEY OF BENTHIC FISHES IN THE RED SEA AND GULF OF ADEN, WITH OBSERVATIONS ON THEIR POPULATION DENSITY, DIVERSITY, AND HABITS. By N. B. Marshall and D. W. Bourne. (4 Plates.) December, 1964	223
No. 3.—THE LESSER ANTILLEAN REPRESENTATIVES OF <i>Bothrops</i> AND <i>Constrictor</i> . By James D. Lazell, Jr. December, 1964	245
No. 4.—TRILOBITES OF THE ORDOVICIAN TABLE HEAD FORMATION, WESTERN NEWFOUNDLAND. By H. B. Whittington. (68 Plates.) March, 1965	275
No. 5.—A FURTHER ACCOUNT OF BATOID FISHES FROM THE WESTERN ATLANTIC. By Henry B. Bigelow and William C. Schroeder. (2 Plates.) April, 1965	443
No. 6.—VARIATION AND NATURAL HISTORY OF <i>Eleutherodactylus ruthae</i> ON HISPANIOLA. By Albert Schwartz. April, 1965	479

Bulletin of the Museum of Comparative Zoology

HARVARD UNIVERSITY

VOL. 132, No. 1

A SYNOPSIS OF THE AMERICAN BETHYLIDAE
(HYMENOPTERA, ACULEATA)

BY HOWARD E. EVANS

Museum of Comparative Zoology, Cambridge, Mass.

CAMBRIDGE, MASS., U.S.A.

PRINTED FOR THE MUSEUM

NOVEMBER 30, 1964

PUBLICATIONS ISSUED BY OR IN CONNECTION
WITH THE
MUSEUM OF COMPARATIVE ZOOLOGY
HARVARD UNIVERSITY

BULLETIN (octavo) 1863 — The current volume is Vol. 131.

BREVIORA (octavo) 1952 — No. 210 is current.

MEMOIRS (quarto) 1864-1938 — Publication terminated with Vol. 55.

JOHNSONIA (quarto) 1941 — A publication of the Department of Mollusks. Vol. 4, no. 43 is current.

OCCASIONAL PAPERS OF THE DEPARTMENT OF MOLLUSKS (octavo) 1945 — Vol. 2, no. 31 is current.

PROCEEDINGS OF THE NEW ENGLAND ZOOLOGICAL CLUB (octavo) 1899-1948 — Published in connection with the Museum. Publication terminated with Vol. 24.

The continuing publications are issued at irregular intervals in numbers which may be purchased separately. Prices and lists may be obtained from the Publications Office of the Museum of Comparative Zoology, Cambridge 38, Massachusetts.

Peters' Check-List of Birds of the World. Volumes 1, 4 and 6 are out of print; volumes 2, 3, 5, 7, 9, 10 and 15 are currently available.

Phylogeny and Evolution of Crustacea. Proceedings of a conference held at Cambridge, Mass., March 6-8, 1962. H. B. Whittington and W. D. I. Rolfe, editors. Cambridge, Mass., 192 pp., 80 figs., 1963. Cloth bound, \$6.75.

Fishes of the Gulf of Maine, by Henry B. Bigelow and William C. Schroeder. Washington, viii + 577 pp., 1953. Photo-offset reprint, \$6.50.

PUBLICATIONS OF THE
BOSTON SOCIETY OF NATURAL HISTORY

The remaining stock of the scientific periodicals of the Boston Society of Natural History has been transferred to the Museum of Comparative Zoology for distribution. Prices for individual numbers may be had upon request.

Bulletin of the Museum of Comparative Zoology

HARVARD UNIVERSITY

VOL. 132, No. 1

A SYNOPSIS OF THE AMERICAN BETHYLIDAE
(HYMENOPTERA, ACULEATA)

BY HOWARD E. EVANS

Museum of Comparative Zoology, Cambridge, Mass.

CAMBRIDGE, MASS., U.S.A.

PRINTED FOR THE MUSEUM

NOVEMBER, 1964

No. 1 — *A Synopsis of the American Bethyridae*
(Hymenoptera, Aculeata)

By Howard E. Evans

TABLE OF CONTENTS

Introduction	4
Acknowledgments	5
Biology	6
Phylogeny	8
Structure and Terminology	9
Taxonomy	15
List of genera and species not belonging to the Bethyridae or un- recognizable	16
Key to subfamilies of American Bethyridae	18
I. Subfamily Pristoerinae	19
Key to genera of Pristoerinae	20
1. Genus <i>Pristocera</i> Klug	22
2. Genus <i>Apenesia</i> Westwood	29
3. Genus <i>Parascleroderma</i> Kieffer	38
4. Genus <i>Dissomphalus</i> Ashmead	41
5. Genus <i>Pseudisobrachium</i> Kieffer	62
II. Subfamily Epyrinae	89
Key to tribes of Epyrinae	89
A. Tribe Epyrini	90
Key to genera of Epyrini	91
1. Genus <i>Rhabdepyris</i> Kieffer	92
2. Genus <i>Anisepyrus</i> Kieffer	96
3. Genus <i>Procalyza</i> Kieffer	102
4. Genus <i>Epyris</i> Westwood	104
a. Subgenus <i>Epyris</i> Westwood	104
b. Subgenus <i>Artiepyris</i> Kieffer	111
5. Genus <i>Aspidepyris</i> new genus	114
6. Genus <i>Bakeriella</i> Kieffer	116
7. Genus <i>Calyozina</i> Enderlein	136
8. Genus <i>Holepyris</i> Kieffer	139
9. Genus <i>Laelius</i> Ashmead	144
B. Tribe Cephalonomiini	148
Key to genera of Cephalonomiini	148
1. Genus <i>Plastanoxus</i> Kieffer	149
2. Genus <i>Prorops</i> Waterston	152
3. Genus <i>Cephalonomia</i> Westwood	155

¹ Supported by a research grant from the National Science Foundation, no. GB-15441.

C. Tribe Sclerodermini	160
Key to genera of Sclerodermini	161
1. Genus <i>Nesepyris</i> Bridwell	161
2. Genus <i>Chilepyris</i> new genus	166
3. Genus <i>Glenosema</i> Kieffer	168
4. Genus <i>Lepidosternopsis</i> Ogloblin	170
5. Genus <i>Scleroderma</i> Latreille	173
III. Subfamily Bethylinae	180
Key to genera of Bethylinae	180
1. Genus <i>Lytopenella</i> Kieffer	181
2. Genus <i>Prosierola</i> Kieffer	183
3. Genus <i>Parasierola</i> Cameron	195
4. Genus <i>Goniozus</i> Foerster	199
5. Genus <i>Bethylus</i> Latreille	202
Literature cited	205
Alphabetical list of abbreviations (of structures) used in text	215
Index of generic and specific names	216

INTRODUCTION

There are few major groups of Hymenoptera so poorly known, yet potentially so important from the standpoint of comparative structure and behavior, as the family Bethyridae (Aculeata, Bethyloidea). There has been no comprehensive review of the family since Kieffer treated the group in *Das Tierreich* in 1914 (as the Bethylinae). Kieffer's paper is, in fact, partially responsible for the neglect of the group since that time, for his keys and generic diagnoses have proved to be largely inadequate and sometimes based on erroneous descriptive bases. Furthermore, his types are widely scattered and mostly unavailable to all but the most persistent of workers. Kieffer recognized about 650 species in the world, placing these in about 100 genera. Some of his genera belong to other families, and many are synonyms, but there are enough genera with which he was unfamiliar to nearly make up the difference. Kieffer had studied a relatively small amount of material, especially from the New World, and it is probable that the actual number of species in the family is from five to ten times the number treated by Kieffer.

I do not mean to imply that no research has been done since Kieffer's time. Berland (1928) reviewed the species occurring in France, and Richards (1939) those occurring in England. Kurian has published several important papers on the Oriental

species (1954, 1955), and Benoit has recently been studying the very rich African fauna (1957, 1963, and papers in preparation). There have been numerous, mostly short papers treating the American species, the more active workers being Brues, Gahan, Muesebeck, Fouts, Ogloblin, and Evans. The lack of sound generic diagnoses and workable keys has provided a serious handicap. The present paper is primarily an attempt to clarify the genera and higher taxa occurring in the Americas and to list the species currently assigned to each. Species descriptions are included primarily in cases where they add to knowledge of the morphological scope of the genus or of its distribution; keys to species are included only in a few genera. I have described two new genera and placed several of Kieffer's generic names in synonymy. There will undoubtedly be many other changes made in the future in the generic classification of these wasps. When the Neotropical fauna has been better collected and more fully studied, and when the studies of Benoit on the African fauna have been completed, it may be possible to prepare a generic revision of the world fauna. In the meantime, I am hopeful that the present paper may provide a foundation for research on the bethylid fauna of the Western Hemisphere.

ACKNOWLEDGMENTS

Study of type specimens in the British Museum was made possible by a grant from the Permanent Science Fund of the American Academy of Arts and Sciences. I am indebted to the curators of several European museums for lending me the types of certain of Kieffer's species, and to Dr. R. L. Doutt, of the University of California at Albany, for making available many Kieffer types belonging to Pomona College, Claremont, Calif. The following is a list of institutions and individuals that have provided material for these studies, including the abbreviation by which each is referred to in the text.

- Academy of Natural Sciences of Philadelphia (ANSP)
- American Museum of Natural History, New York (AMNH)
- British Museum (Natural History), London (BMNH)
- Brasil: Secretaria da Agricultura, São Paulo (BSA)
- California Academy of Sciences, San Francisco (CAS)
- California Department of Agriculture, Sacramento (CDAS)
- California Insect Survey, Berkeley (CIS)
- Carnegie Museum, Pittsburgh, Pa. (CM)

Cornell University, Ithaca, New York (CU)
Escuela Nacional de Agricultura, Chapingo, Mexico (ENAC)
Hope Collections, Oxford University, England (HCOU)
H. K. Townes Collection, Ann Arbor, Mich. (HKT)
Illinois Natural History Survey, Urbana (INHS)
Kansas State University, Manhattan (KSU)
Kansas University, Lawrence (KU)
K. V. Krombein Collection, Arlington, Va. (KVK)
Museum of Comparative Zoology, Cambridge, Mass. (MCZ)
University of Arizona, Tucson (UA)
University of California, Davis (UCD)
United States National Museum, Washington (USNM)

BIOLOGY

Several brief surveys of the biology of the Bethyridae have been published (Wheeler, 1928; Nielsen, 1932; Clausen, 1940; Yamada, 1955), and the time does not seem ripe for a full-scale reconsideration of this subject. Under each of the genera treated in the present paper, I have presented a few notes on the life histories as well as references to the more significant sources of information. I am hopeful that this synopsis will stimulate workers to fill in some of the very many gaps in our knowledge of the life histories and behavior of these wasps. A few of the more significant general features are outlined in the following paragraphs.

The family Bethyridae apparently arose from some very primitive, long since extinct stock of Aculeata possessing 13-segmented antennae in both sexes. The bulk of the aculeate wasps evolved to exploit free-living hosts, originally of moderate to large size, later of small size (employing several to many per nest-cell). On the other hand, the Bethyridae evolved to exploit small larvae occurring in cryptic situations (such as the soil, stems, wood, or seeds). The Bethyridae have remained a family of small wasps (with minor exceptions, 1 to 10 mm long) exhibiting various adaptations for entering the habitats of their hosts (fossorial legs, depressed bodies, reduced wings, etc.). Some Bethyridae evolved to attack larger hosts, but the wasps remained small, subduing their hosts by repeated stinging and eventually laying several eggs on each host. The resulting multiple parasitism resembles that of some of the parasitoid Hymenoptera, but is quite unlike that of other Aculeata. Some of these gregarious

Bethylidae developed complex types of polymorphism, and some developed unique types of subsocial behavior. Many Bethylidae drag or carry their prey to a crevice, exhibiting types of prey carriage and nest closure paralleling those of some of the more typical Aculeata, but sometimes unique (for example, the dorsal prey carriage of some *Epyris* and *Cephalonomia*).

All in all, the Bethylidae display a fascinating diversity in their behavior and development. However, as Clausen has pointed out, they show an exceptional uniformity in their host preferences. The larvae (and occasionally pupae) of Coleoptera, particularly soil, wood, and seed-inhabiting types, provide the major hosts. Members of the subfamily Bethylinae, as well as a few Epyrinae, attack the larvae of Lepidoptera, again chiefly borers and seed-feeders, also case bearers and leaf rollers. There are a few instances of probable attack on hymenopterous larvae, but none of these have been definitely confirmed. Considering the rather limited host repertory of the family, it is surprising to learn that under experimental conditions some species of Bethylidae will attack and develop normally on insects of several different orders (see discussion under *Scleroderma*). Permanent paralysis of the host is usual, and development of the larva is external. Adult female Bethylidae usually feed on the body fluids of the host, and some are known to paralyze hosts specifically for feeding purposes and to take no other form of nourishment. However, adults of some genera (e.g., *Epyris*, *Anisepyrus*, *Goniozus*) also feed on carbohydrates, which they typically find in honeydew (rarely in flowers).

The family Bethylidae occupies a central position in the superfamily Bethyloidea. The family Chrysididae, with its several distinctive subfamilies, probably evolved directly from the Bethylidae, perhaps from an early stock of Mesitiinae. The Chrysididae (*sensu lato*) show considerable diversity in biology and attack such diverse insects as walking sticks, sawflies, and aculeate Hymenoptera. The Embolemidae and Dryinidae, which are predators on Homoptera, are more distantly related to the Bethylidae but may have shared a remote common ancestry with them. The Sclerogibbidae, which attack Embioptera, may also have shared a remote common ancestry with the Bethylidae. This entire superfamily provides a vast field for research in comparative structure and behavior.

PHYLOGENY

A detailed consideration of the phylogeny of the Bethyliidae is premature at this time, and the accompanying tree (Fig. 1) is no more than a very preliminary attempt to generalize regarding the probable relationships of the American genera. In this arrangement, it is assumed that the ancestral bethylid was tiphid-like, without strong sexual dimorphism, fully alate in both sexes and with at least six closed cells in the fore wing, with 13-segmented antennae, 6-segmented maxillary palpi, 3-segmented labial palpi, and a fully developed metanotum. This ancestor was moderately large (for a bethylid) and a single larva developed on each host. Ascent from this generalized form involved the reduction in body size and in development of various

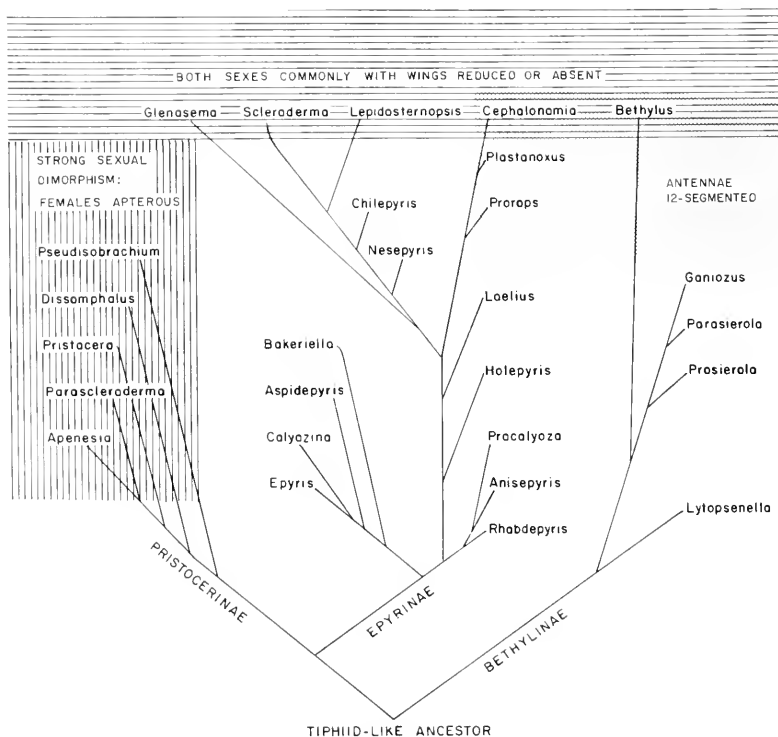

FIG. 1. Dendrogram showing possible relationships of the subfamilies and genera of Bethyliidae occurring in the Americas.

body structures, including antennal and palpal segmentation, eyes, ocelli, occipital carina, notauli, metanotum, and, of course, reduction in wing venation as well as in wing size, the wings and tegulae being wholly lost in all female *Pristocerinae* and in both sexes of a few specialized *Epyrinae*. Also involved was the acquisition of certain specializations such as the tergal pits of *Dissomphalus*, the pectinate antennae of *Calyozina* and *Procalyoza*, modifications of the pronotum in *Aspidopyris*, *Bakeriella*, and *Aniscopyris*, the bilobed condition of the parameres of the male genitalia in several genera, etc. The more advanced Bethylidae developed more elaborate behavior patterns, including the subduing of large hosts by repeated stinging, laying of several eggs on a single host, maternal care of eggs and larvae, etc. For further documentation of this phylogenetic arrangement, the reader is referred to the discussions of structure and biology under each of the genera.

STRUCTURE AND TERMINOLOGY

Bethylid wasps have a characteristic facies and with a little experience can be separated at a glance from other Hymenoptera. They can be defined as small, elongate, often depressed Aculeata, with the head usually elongate and somewhat prognathous, possessing antennae with either twelve or thirteen segments in both sexes, a pronotum which reaches the tegulae, relatively short legs which are generally non-spinose (except often the middle tibiae), wings sometimes reduced or absent, when present with reduced venation, fore wings without closed submarginal cells (rarely with one) and not more than one closed discoidal cell, hind wings without closed cells but with an anal lobe, abdomen with seven or eight visible segments.

Head.—The maxillary palpi have a maximum of six segments, the labial palpi a maximum of three; the segmentation of the palpi is of some importance, but often difficult to determine with certainty without dissection and study under high magnification. The mandibles have several apical teeth which are numbered from 1 to 5 (rarely to 7) starting with the outermost tooth. The clypeus is of much importance in classification although sometimes partially covered by the base of the antennae and hence difficult to study. Head shape and the size and position of the eyes and ocelli are of much importance and the following standard measurements and abbreviations are used for expressing these factors (see Fig. 2):

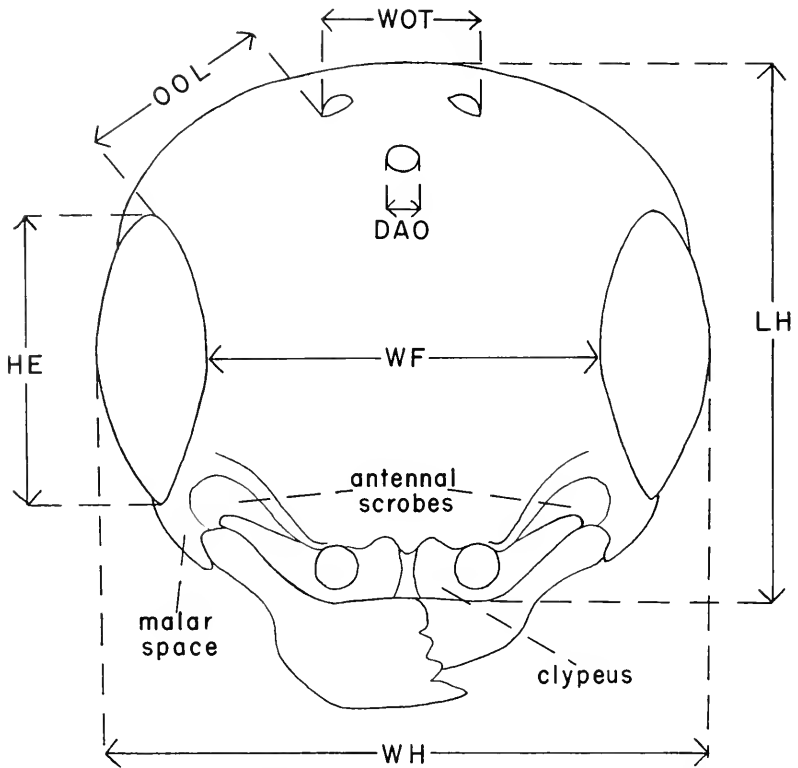

FIG. 2. Head of *Rhabdopyris megacephalus* (Ashmead), female, showing major structures and standard measurements. DAO: diameter of anterior ocellus; HE: height of eye; LH: length of head; OOL: ocello-ocular line; WF: (minimum) width of front; WH (maximum) width of head (including eyes); WOT: width of ocellar triangle.

Length of head (LH): measured from median apical margin of clypeus to median point of vertex, expressed in millimeters and/or as a ratio with width of head.

Width of head (WH): maximum width, including eyes, usually expressed as a ratio with length of head and/or maximum width of thorax.

Width of front (WF): minimum width, i.e., at the point of closest approximation of the eyes.

Height of eye (HE): maximum height (or length) of eye as measured in lateral view.

Diameter of anterior ocellus (DAO): measured as an indication of ocellar size, expressed as a fraction of WF.

Width of ocellar triangle (WOT): distance across and including lateral (posterior) ocelli.

Ocello-ocular line (OOL): shortest distance from a lateral ocellus to nearest eye margin.

Distance from eye tops to vertex crest: measured in lateral view (difficult to measure accurately and hence should be considered an approximation).

Angle of ocellar triangle: measured by superimposing a right angle of a grid micrometer over the outer sides of the anterior and one lateral ocellus and determining whether the angle of the line extending to the other lateral ocellus is greater or less than a right angle.

Antennal measurements: the length/maximum width for antennal segments three (sometimes four) and eleven are measured, as an indication of flagellar length.

Thorax. — The term thorax is used to mean the alitrunk or mesosoma (morphological thorax + propodeum). The pronotum consists of an anterior collar, projecting into the foramen of the head and usually on a lower plane than the disc, which is the dorsal portion of the main part of the pronotum. The mesoscutum may have two sets of furrows, the more lateral parasidal furrows and the more median notauli; the scutellum has a central, elevated disc which may have a transverse groove or a pair of pits at its base. The shape and sculpturing of the propodeum are of much use in classification, and several special terms are employed to designate the measurements and carinae involved (see below and Fig. 3). The mesopleura may be simple or strongly sculptured; in certain genera there is a sharply defined, depressed area near the top, called the upper fovea, and a larger one below, called the lower fovea. The following are the standard measurements and special terms employed for the thorax:

Length of thorax (LT): measured in lateral view from the pronotum (excluding the collar) to the apex of the propodeum.

Length of fore wing (LFW): measured as a more accurate indication of size (in fully winged forms) than body length, since the latter is much influenced by the position of the head and the amount of extension of the abdomen.

Length of propodeum: measured in full dorsal view including declivity and including the projections which embrace the sides of the mesonotum (in females in which these are present).

Length of propodeal disc: along midline but exclusive of declivity.

Width of propodeal disc: maximum in full dorsal view.

Discal carinae: the major longitudinal carinae of the propodeal disc, including median but excluding sublateral and lateral carinae.

Transverse carina: the transverse carina margining the propodeal disc behind (i.e., separating it from the declivity).

Lateral carinae: the longitudinal carinae along the sides of the propodeal disc.

Sublateral carinae: the longitudinal carinae closely paralleling the lateral carinae and located just mesad of them.

Propodeal formula: in wingless females, the width of the propodeum anterior to the constriction as compared to the width at the constriction and as compared to the greatest width posterior to the constriction.

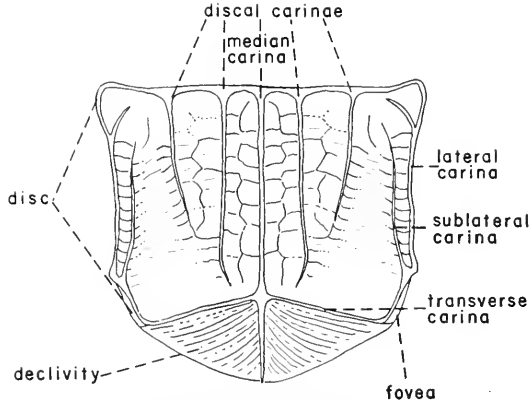

FIG. 3. Propodeum of *Anisepyrus bridwelli* (Evans), female, with major features labeled.

Wing venation.—The terminology employed for the wing veins and cells is the one employed by Kieffer and others who have worked on this group. The veins and cells present in *Pristocera* are labeled on Figure 4, where this system is compared with

the modified Comstock-Needham terminology with respect to the major veins. On the outer part of the fore wing in most bethylids there are several hyaline streaks which presumably mark the course of former veins; these are indicated on the figures as stippled lines. These hyaline streaks are not presently used in classification, but they appear to be quite constant in various complexes of genera and species, and it is probable that they will some day be utilized.

Although *Pristocera* possesses a reasonably complete venation for a bethylid, there are certain features not present in that genus which require explanation. In some genera the subcosta is so greatly thickened apically, just before the stigma, as to simulate a second stigma; this is called a prostigma (see Figs. 99, 101, 135, and 139). In *Pristocera* the cubitus (i.e., M in the modified Comstock-Needham system) is incomplete basally, but the base of this vein is typically preserved in the subfamily Bethylinae, where it appears as a short vein arising from the basal vein (Fig. 139). In some genera of Bethylinae this vein actually encloses a small cell or areola which is equivalent to the first discoidal cell of most Aculeata (Fig. 129). The so-called discoidal cell of *Pristocera* and other Bethylidae is actually the second discoidal cell. Closed marginal and submarginal cells are present only in certain Bethylinae (Fig. 125); in the Pristocerinae and Epyrinae these cells are open or indistinctly closed.

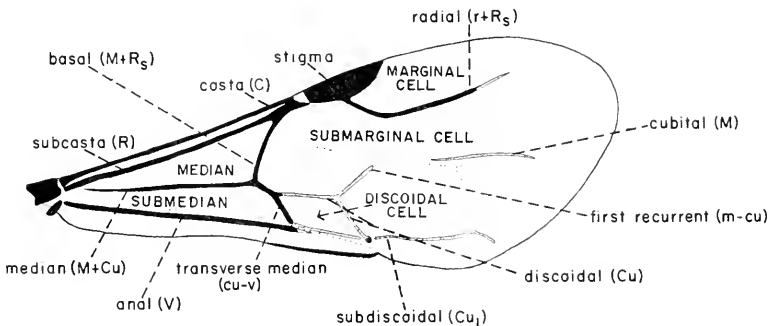

FIG. 4. Fore wing of *Pristocera armifera* (Say), male, with major veins and cells labeled. Following the name of each vein is indicated, in parenthesis, the standard abbreviation for the name of that vein according to the Comstock-Needham system as modified by H. H. Ross. The stippled lines signify hyaline streaks in the wing membrane.

Abdomen.—The term abdomen is used to mean the gaster or metasoma (morphological abdomen minus the propodeum); thus “tergite 2” should be taken to mean the true third abdominal tergite. The abdomen is said to be petiolate if the first tergite does not attain the extreme base of the first segment; it is said to be sessile if the first tergite does reach the base, even if it is rather slender. The apical sternite of the male is called the subgenital plate. The genitalia (Fig. 5) are described according to the terminology employed by Snodgrass (1941) except with respect to one feature. According to Snodgrass the position of the two apical lobes of the volsella is reversed in *Pristocera* (and presumably in other Bethyloidea). However, Ogloblin (1960) found that in *Perisierola* (i.e., *Parasierola*) the digitus and cuspis are in their normal position. I have examined the genitalia of all genera occurring in the Americas, and I am convinced that all Bethyloidea are alike with respect to the position of the volsellar structures. I have not studied the musculature, but I find it difficult to agree with Snodgrass that the immovable lobe (by definition the cuspis) is mesal in position; in all Bethyloidea (including *Pristocera*) the mesal lobes appear to articulate with the volsellar bases while the lateral lobes seem rigidly attached to them. Although I have followed Snodgrass in all my papers up to this date (including my revisions of *Pristocera*, *Apenesia*, *Pseudisobrachium*, *Dissomphalus*, and *Anisepyris*), I regrettably find it necessary to reverse my terminology in favor of that employed by Ogloblin.

In some genera of Bethyloidea the genitalia are very complex and special terms have had to be coined to describe certain structures. Both the parameres and the cuspides may be deeply divided into paired structures, which in each case are termed the dorsal and ventral lobes or arms. The volsellae, in one genus, possess a median basal portion bearing radiating lines, termed a vannus (see Fig. 59). The aedoeagus may be simple or complex; when it is complex it is convenient to distinguish between ventral, middle, and dorsal lobes, valves, or rami (in order of decreasing width, the last named being very slender). In some genera (most particularly *Dissomphalus*) the aedoeagus is so complex as to defy accurate description or illustration. Unless otherwise stated, all figures of the genitalia show the ventral aspect.

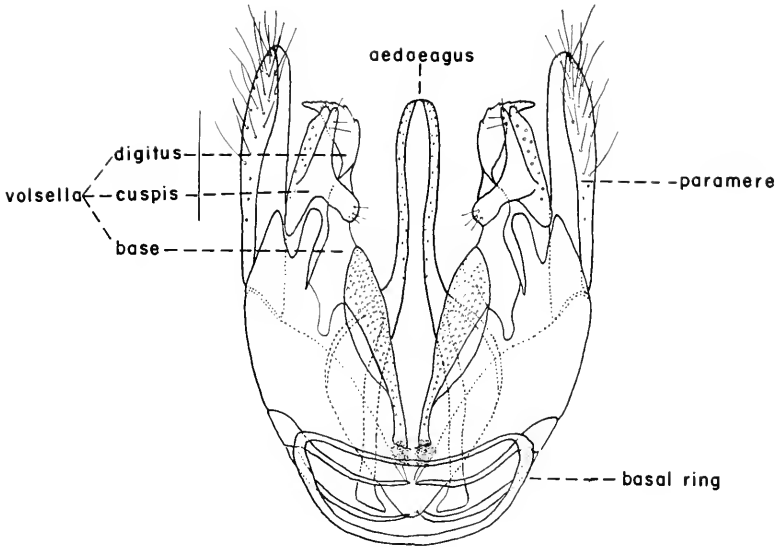

FIG. 5. Male genitalia of *Rhabdepyris megacephalus* (Ashmead), ventral aspect, with major structures labeled.

TAXONOMY

Although I have found much revision necessary on the generic level, on the whole Kieffer's (1914) suprageneric taxa appear valid, at least when one moves certain genera into more appropriate positions and eliminates others altogether. Kieffer recognized five tribes of Bethylinae (= Bethylidae in the modern sense): Sclerodermini, Mesitiini, Epyrini, Pristocerini, and Bethylini. With one exception, these groups (with somewhat altered content) deserve to be considered subfamilies. The one exception is the Sclerodermini, which appears to me to be connected with the Epyrini by a series of intermediate genera (e.g., *Laelius*, *Plastanoxus*, *Nesepyris*). I have therefore placed the Sclerodermini in the subfamily Epyrinae as one of three tribes, the other two being the Cephalonomiini and the Epyrini. One subfamily, the Mesitiinae, does not occur in the Americas and is therefore excluded from further consideration here. As indicated further below, Brues' *Mesitius neotropicus* is not a true *Mesitius*, and all the other genera included by Kieffer in the Mesitiinae belong elsewhere than in the Bethylidae.

Before proceeding further, it seems desirable to eliminate those genera which either are not Bethyridae or which are unrecognizable and likely to remain so. Although the following listing of these genera pertains chiefly to the American fauna, I have included a number of Old World genera which clearly are not bethyrids. I have also appended a list of American species which have been treated as bethyrids but which do not belong to this family or which are unrecognizable.

List of genera and species not belonging
to the Bethyridae or unrecognizable

Genera transferred to the Tiphiiidae

Bruesiclla Mann, 1914. The type specimen of the only known species, *formicaria* Mann, from Mexico, is in the MCZ. It is clearly a tiphiid of the subfamily Brachycistidinae, and Dr. Karl V. Krombein, who has examined the type, informs me that *Bruesiclla* is to be considered a senior synonym of *Euryeros* Mickel and Krombein.

Dryinopsis Brues, 1910. The type specimen of the only known species of this genus (*simplicipes* Brues, from Borneo) is also in the MCZ. As Reid (1941) has indicated, from a study of Brues' description and figure (Brues, 1910a), this insect is clearly not a dryinid or a bethyrid, although Kieffer placed it in the Sclerodermini. *Dryinopsis* is best considered a subgenus of the tiphiid genus *Methocha* (K. V. Krombein, *in litt.*).

Genera transferred to the Rhopalosomatidae

Saphobethylus Kieffer, 1911. Turner and Waterston (1917) placed this genus in the synonymy of *Olixon*, in the Rhopalosomatidae. I have examined the type of the only known species, *pallidus* Kieffer, from Mexico, in the BMNH, and can confirm this synonymy.

Algoella Kieffer, 1914 (= *Algoa* Brues, 1910a, *nec* Castelnau, 1861). This genus appears to be allied to *Olixon*, as indicated by Brues (1922); it was described from South Africa, and included by Kieffer in the Sclerodermini.

Harpagoeryptus Perkins, 1908. This Australian genus, although included by Kieffer in the Mesitini, is clearly a relative of *Olixon* (Brues, 1922; Reid, 1941).

Genera transferred to the Chrysididae

Godfrinia Kieffer, 1911. This genus, described from Mexico, has been transferred by Reid (1941) to the Chrysididae. I

have studied Kieffer's material in the BMNH and can confirm this placement. The genus falls in the Cleptinae and I presume is to be considered a junior synonym of *Cleptidca* Mocsáry, as suggested by Krombein (1957).

Promesitius Kieffer, 1905a. Reid (1941) transferred this Australian genus to the Chrysididae, and Krombein (1957) has placed it in the synonymy of the amisegine genus *Myrmecomimesis* Dalla Torre. Krombein also treats the Philippine genera *Cladobcthyllus* Kieffer, 1922 and *Rohweria* Fouts, 1925 as Amiseginae.

Genera transferred to the Loboscelidiidae

Laccomerista Cameron, 1910. This genus was described by Cameron from a specimen from Borneo. I have examined this specimen in the BMNH, and find it to be a species of *Loboscelidia*, a genus recently made the basis of a new family by Maa and Yoshimoto (1961). I consider *Laccomerista* a synonym of *Loboscelidia* (new synonymy).

Genera transferred to the Scolebythidae

Clystopsenella Kieffer, 1911. I have recently transferred this genus, described from Brazil, to the new family Scolebythidae (Scolioidea) (Evans, 1963a). The genus *Neoclystopsenella* of Kurian, 1955, described from India, is not at all related to *Clystopsenella*; I am unable to place it but question whether it is a bethylid.

Genera which cannot be recognized

Omaloderus Walker, 1843 (= *Homaloderus* Dalla Torre, 1898).

This genus was described from a specimen collected by Charles Darwin at Coquimbo, Chile. Kieffer listed the genus as unrecognizable, as it still remains. The antennae are said to have 14 segments, which if true would eliminate the genus from the Bethylidae. Walker's type is apparently no longer extant.

Xestobethylus Cameron, 1909. This genus was based on *X. pallidipes* Cameron, from Argentina. Cameron's type does not appear to be present in the BMNH, and I am unable to recognize the genus from the description. Kieffer (1914) treated it as a subgenus of *Rhabdepyris*, but this seems a very arbitrary and probably erroneous disposition of the name.

*American species assigned to the Bethylidae
but belonging elsewhere*

- formicaria* Mann, 1914, p. 182; ♀, Mexico (*Bruesiella*, here transferred to the Tiphiiidae as a synonym of *Euryceros*).
- longiventris* Kieffer, 1911, p. 204; ♀, Brazil (*Clystospencella*, transferred to the Scolebythidae by Evans, 1963a).
- neotropicus* Brues, 1914, p. 119; ♂, British Guiana (*Mesitius*, but properly belonging in the chrysidid genus *Cleptidea*, based on examination of type in MCZ).
- negrocineta* Kieffer, 1911, p. 207; ♂, Mexico (*Godfrinia*, here transferred to the Chrysididae, Cleptinae).
- pallidus* Kieffer, 1911, p. 216; ♂, Mexico (*Saphobethylus*, now regarded as a synonym of *Olixon* in the Rhopalosomatidae).
- scutellaris* Cameron, 1897, p. 275; ♂, Mexico (*Eypris*, omitted by Kieffer, 1914, here reassigned to *Cleptidea* in the Chrysididae on basis of type examination in BMNH).
- viridiceps* Kieffer, 1911, p. 206; ♀, Mexico (*Godfrinia*, here transferred to the Chrysididae, Cleptinae).

American species which cannot be recognized

- intrepidus* Walker, 1843, p. 188; (sex?), Chile (*Omaloderus*).
- musculus* Say, 1836, p. 280; (sex?), Indiana (*Bethylus*, placed in *Plastanoxus* by Kieffer but best treated as unrecognizable, following Muesebeck and Walkley, 1951).
- pallidipes* Cameron, 1909, p. 450; ♀, Argentina (*Xestobethylus*).

KEY TO SUBFAMILIES OF AMERICAN BETHYLIDAE

1. Wings (when fully developed) with a vein, or at least the stub of a vein, arising from the basal vein (Figs. 125, 139, 142); clypeus medially with a carina or at least a polished area which continues up the front well above the antennal bases as a median polished streak or carina (Figs. 130, 136, 140); claws very strongly curved, deeply bifid (Figs. 127, 128, 133, 134) III. BETHYLINAE, p. 180
- Wings (when fully developed) with the basal vein simple (or absent), not giving rise to a vein or stub (Figs. 6, 63, 99); clypeus variable, only occasionally (and chiefly in fully winged forms) with its median area continuous with a polished streak or carina on the lower front; claws variable, rarely exactly as above (Figs. 66, 87, 119) 2

2. Males with the metanotum well developed, fairly broad, medio-anteriorly with an emargination or fovea opposite apex of scutellum, scutellum and propodeum not nearly in contact medially (Figs. 8, 14, 20, 40); females always completely apterous, with the eyes small to absent (eye height at most .25 X head width), ocelli absent, antennal scapes flattened to a thin flange at base (Figs. 9, 15, 16, 21, 41)

I. PRISTOCERINAE, p. 19

- Males (also females) with the metanotum much reduced, the scutellum in contact with the propodeum medially or nearly so, or if slightly separated the metanotum not emarginate or foveolate medially (Figs. 64, 70, 75, 106); females alate, brachypterous, or apterous, if apterous not entirely as above (eye height more than .25 X head width, e.g., Figs. 109, 115, 121)II. EYPRINAE, p. 89

I. SUBFAMILY PRISTOCERINAE

Subfamilial characters. — *Males.* Antennae with thirteen segments, the flagellar pubescence semi-erect to erect, or if subappressed then with erect setae present; maxillary palpi with five or six segments, labial with three; median elevation of clypeus not extending up the lower front as a polished ridge. Mesoseutum moderately long, not greatly reduced by an elongated pronotum; metanotum well developed, fairly wide, more or less emarginate or with a strong fovea medio-anteriorly, against the posterior end of the scutellum, the scutellum and propodeum thus well separated; propodeum with or without a transverse carina margining the disc behind, never with the posterolateral corners foveolate. Fore wing with costal, subcostal, and submedian cells present, stigma strong, radial vein present and long, discoidal vein almost always indicated at least by a weak line, discoidal cell frequently outlined; cubitus absent or sometimes faintly indicated on outer part of wing, but basal vein not giving rise to another vein. *Females.* Completely without wings or tegulae, often pale in color and with swollen femora and somewhat fossorial legs. Palpi with the usual number of segments or both pairs much reduced; antennae 13-segmented, scape rather large, flattened to a thin flange at base and arising from distinct tubercles, eyes small, often very small or even absent, at the maximum eye height about .25 X head width. Mesopleura often (but not always) strongly developed, with a dorsal surface; propodeum usually at least weakly constricted near the spiracles, often strongly constricted either at the spiracles or at the extreme anterior margin; middle tibiae with or without spines above.

Included genera. — Kieffer (1914) included 14 genera in this group, which he gave the status of a tribe. Several of his genera are synonyms, but certain genera which properly belong here were placed in other tribes (*Kathepyris*, *Usakosia*, *Prosapenesia*, *Apenesia*, *Lyssepyris*, *Xanthepyrus*, *Acrepyris*, *Parisobrachium*, the last four names being synonyms of various genera of Pristocerinae). Benoit (1957) has recently described several new genera and subgenera from Africa. Altogether over 25 generic names are available for members of this complex. However, I find only five of these necessary to encompass the Nearctic and Neotropical species. Even with the use of only five names, one finds species which come close to bridging the gaps between the genera.

The material I have seen from other parts of the world can for the most part be placed in these same five genera. The Ethiopian region provides the major exceptions; this region is especially rich in Pristocerinae and presents a bewildering array of forms, many known from only one sex. Some of the names which have been proposed for African forms will doubtless hold for valid genera or at least subgenera (e.g., *Prosapenesia* Kieffer, *Dicrogenium* Stadelmann, *Neodicrogenium* Benoit), but most of the others seem to me of questionable status, tying in closely with one or another of the genera here recognized for the Americas (e.g., *Diepyris* Benoit, *Afrisobrachium* Benoit). Some of the African forms seem unusually primitive in body form and in wing venation, and a careful study of the Ethiopian fauna might do much to clarify not only the world fauna of Pristocerinae, but also the relationships of the Bethyridae to other families of Hymenoptera.

KEY TO GENERA OF PRISTOCERINAE

1. Completely apterous; ocelli absent (females) 2
 Fully winged; ocelli present (males) 6
2. Propodeum strongly constricted at its extreme anterior end, where it forms a pair of small processes which embrace the tip of the elongate mesonotum (Fig. 41); each eye consisting of a single facet, or eyes absent 5. PSEUDISOBRACHIUM Kieffer, p. 62
- Propodeum not reduced to a pair of small processes anteriorly, broadly in contact with the mesonotum, constricted at or near spiracles if at all (Figs. 9, 15, 21); each eye consisting of more than one facet (some exceptions) 3
3. Mesopleura, seen in dorsal view, very small, thorax barely wider across mesothorax than across prothorax (Fig. 21); propodeum more or less parallel-sided, at most weakly constricted; palpi very short, maxillary

- palpi with at most two segments (Fig. 22); abdomen petiolate 4
4. DISSOMPHALUS Ashmead, p. 41
Mesopleura, seen in dorsal view, quite large, thorax distinctly wider across mesothorax than elsewhere (Figs. 9, 15); propodeum with a more or less evident constriction at or near the spiracles (rarely nearly parallel-sided); maxillary palpi longer, with at least three segments; abdomen sessile or petiolate 4
4. Propodeal constriction strong, maximum width of propodeum at least twice the width at the constriction (Fig. 9); maxillary palpi with six segments (Fig. 11) 1. PRISTOCERA Klug, p. 22
- Propodeal constriction weak to moderate, maximum width of propodeum rarely up to 1.9 X width at constriction (Fig. 15); maxillary palpi with three or four segments (Figs. 13, 17) 5
5. Middle tibiae spinose above; thorax, seen from above, without a strong constriction between the prothorax and mesothorax, the propodeal constriction weak to moderate (Fig. 15); maxillary palpi with four segments (Fig. 13) 2. APENESIA Westwood, p. 29
- Middle tibiae smooth above; thorax, seen from above, with a distinct constriction between the prothorax and mesothorax; propodeal constriction weak (Fig. 16); maxillary palpi with three segments (Fig. 17); body strongly flattened; antennae relatively long, filiform 3. PARASCLERODERMA Kieffer, p. 38
6. Second abdominal tergite with one or two pairs of pale spots, depressions, pits, tubercles, or other modifications (Fig. 20); clypeus large, well developed in front of antennal sockets, medially with from one to three teeth (Figs. 24-28); maxillary palpi with five segments (Fig. 23) 4. DISSOMPHALUS Ashmead, p. 41
- Second abdominal tergite simple, without modifications; clypeus with a variously developed median lobe on each side of which (directly in front of the antennal sockets) it is much shortened (except in a very few species); maxillary palpi with six segments (rarely only five) (Fig. 10) 7
7. Clypeus with a strongly projecting, somewhat trapezoidal median lobe which is usually truncate, occasionally bidentate or with a median tooth (median lobe angulate in two known species) (Figs. 40, 44-54); eyes rather densely and uniformly covered with short hairs (rarely glabrous); subgenital plate with three short basal stalks (Figs. 56, 57, 60, 61); genitalia with the parameres deeply divided into two lobes (Figs. 55, 58, 59, 62) 5. PSEUDISOBRACHIUM Kieffer, p. 62
- Median lobe of clypeus truncate, angulate, or rounded, never trapezoidal; eyes glabrous, or with a band of short or rather long hairs above (uniformly sparsely short-haired in a very few species of *Apenesia*); subgenital plate with a long median basal stalk (Figs. 7, 19); genitalia with parameres not deeply divided 8

8. Propodeum with basal triangle marked off by a shallow depression and/or a carina, disc behind triangle with prominent sculpturing; median lobe of clypeus short, truncate or emarginate; fore wing with costa barely developed beyond stigma, at least not longer than stigma (Fig. 6); claws with a basal swelling as well as two outer rays, thus somewhat tridentate or trifid; cuspides of genitalia in the form of simple curved rods 1. PRISTOCERA Klug, p. 22
- Propodeum with basal triangle not set off as above, often poorly defined, remainder of disc weakly or not at all sculptured; median lobe of clypeus truncate or angularly or roundly projecting; fore wing costa extending as a distinct vein far beyond stigma (Fig. 12) (except in a few species having the clypeus angularly produced medially); claws dentate, usually without a well-formed basal tooth as above; cuspides divided into dorsal and ventral arms, the latter strongly setose (a few exceptions) 2. APENESIA Westwood, p. 29

1. Genus PRISTOCERA Klug

- Pristocera* Klug, 1808, p. 49 (type species *Bethylus depressus* Fabricius, monobasic). —Klug, 1810, pp. 202-206. —Ashmead, 1893, p. 32. —Ashmead, 1902, p. 270. —Kieffer, 1905b, pp. 287-288. —Kieffer, 1906a, pp. 289-294. —Kieffer, 1908a, pp. 21-22. —Kieffer, 1914, pp. 453-470 (spp. of world). —Yasumatsu, 1955, pp. 233-249 (Japanese spp.). —Benoit, 1957, pp. 46-55 (Central African spp.). —Benoit, 1963, pp. 32-95.
- Mangesia* Kieffer, 1911, pp. 209-211 (type species *M. fuscipennis* Kieffer [= *subviolacea* Enderlein], original designation; synonymy by Benoit, 1963). —Kieffer, 1914, pp. 452-453.
- Trichelobrachium* Kieffer, 1914, p. 425 (type species *Pristocera obliterated* Kieffer, monobasic; synonymy by Benoit, 1963).

Subgenus ACREPYRIS Kieffer

- Acrepyris* Kieffer, 1905b, p. 249 (type species *Epyris reticulatus* Kieffer [= *Pristocera armifera* (Say)], monobasic). —Kieffer, 1908a, pp. 33-34. —Kieffer, 1914, p. 418. —Evans, 1963b, pp. 241-290 (revision of American spp.).
- Neopristocera* Yasumatsu, 1955, p. 248 (type species *Pristocera japonica* Yasumatsu, original designation; synonymy by Evans, 1963b).

Generic and subgeneric characters. — *Males.* Maxillary palpi with six segments, labial palpi with three. Mandibles broad apically, with four or five large teeth; clypeus with the median lobe broad and short, truncate or emarginate apically; eyes glabrous or with short or fairly long hairs in a band on the upper part; antennae elongate, 13-segmented, filiform, submoniliform, or weakly serrate, flagellum densely clothed with erect or

suberect setae which may be short or long, one species with erect setae which stand out above the pubescence; ocelli not enlarged; occipital carina complete. Pronotum with a transverse impression at or paralleling the posterior margin; mesoscutum with the notauli complete or nearly so; scutellum with a strong basal groove; propodeum short, disc with or without a transverse carina behind, always with a basal triangular area which is set off by a carina or a shallow depression, disc behind the triangle more or less covered with sculpturing; claws with a broad, blunt basal

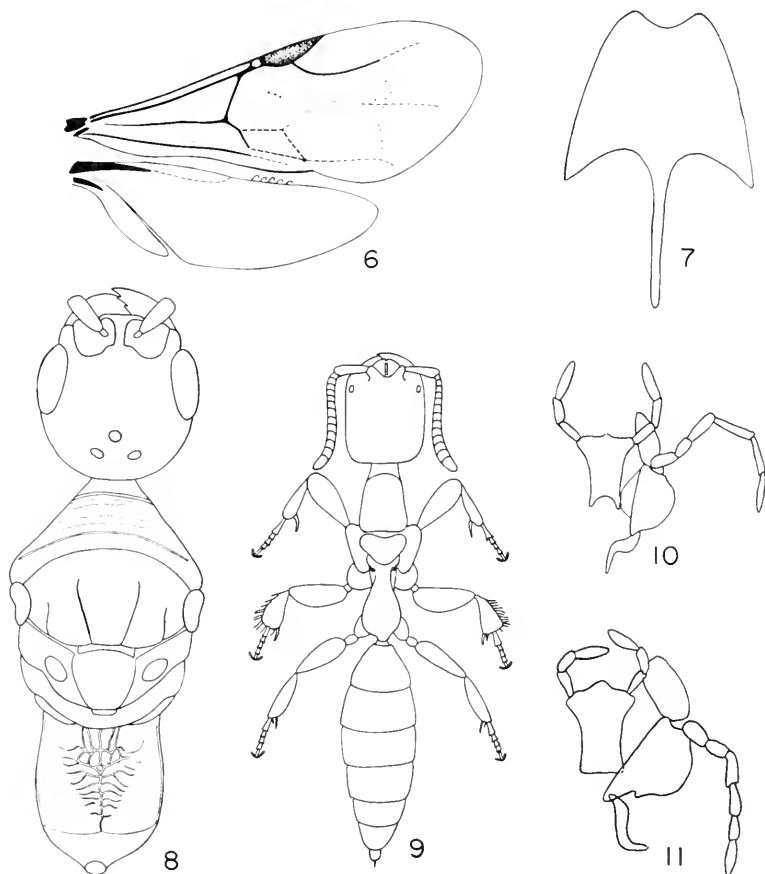

Pristocera armifera (Say). Fig. 6. Wings of male. Fig. 7. Subgenital plate of male. Fig. 8. Head and thorax of male. Fig. 9. Female. Fig. 10. Labium and maxilla of male. Fig. 11. Labium and maxilla of female.

tooth and two additional teeth, middle tooth short or long, erect or sloping. Fore wing with costa not extending beyond stigma to any appreciable extent; basal vein reaching subcosta a short distance basad of stigma; transverse median vein oblique; discoidal vein at least weakly indicated, often quite strong, most species with the discoidal cell fully outlined and the subdiscoidal vein extending nearly to outer wing margin. Abdomen sessile, relatively broad and short. Subgenital plate simple, with a long median basal stalk. Genitalia broad; parameres short, variously lobed but never deeply divided; cuspides in the form of simple curved rods, not divided or setose; vannus absent; aedeagus complex, consisting of a pair of simple, short ventral valves, a pair of usually somewhat longer middle valves, and a pair of large dorsal valves which are variously lobed apically.

Females. Maxillary palpi with six segments, labial with three. Mandibles with four teeth in all known species; clypeus carinate medially, apical margin truncate or somewhat rounded or subangulate; eyes small or of moderate size, with from about 15 to more than 50 facets each; head longer than wide; antennae of moderate length, slender or somewhat incrassate. Mesonotum subtriangular, narrowly rounded behind, its posterior third embraced by the projecting anterior angles of the propodeum; propodeum strongly constricted just behind the spiracles, then expanded again posteriorly, its maximum width at least twice its minimum width; mesopleura prominent dorsally; middle tibiae strongly spinose. Abdomen sessile. (Figs. 6-11.)

Remarks. — As I pointed out in my recent revision of this group, all of the American species are assignable to the subgenus *Acrepyris*. The nominate subgenus contains numerous species in the Ethiopian region and several in the Palaearctic and Oriental regions. The females of the two subgenera cannot presently be separated.

Biology. — These insects attack wireworms (Elateridae), a single parasite larva developing at the expense of one or two host larvae. The Nearctic species *armifera* has been reared from wireworms of the genera *Limonius* and *Acolus* (Hyslop, 1916; Hayes, 1927). Two Japanese species have also been reared from elaterid larvae. Presumably the females enter the ground to seek their hosts. Males of the genus are most commonly taken in sweepings from grass or low vegetation, especially in sandy areas. The males apparently carry the females in flight during copulation. Further details are provided by Evans (1963b).

Distribution. — The subgenus *Acrepyris* is known to occur in the Old World only in eastern Asia, including the Philippines and Java. In this hemisphere, species of this group occur throughout temperate and tropical North and Central America, but no species are known from the West Indies or from South America. Twenty-one American species are currently recognized; eight of these occur in the United States and extreme northern Mexico, thirteen in central and southern Mexico and in Central America.

Included American species:

United States and northern Mexico

armifera (Say), 1828, p. 80; ♂, Indiana (widely distributed in eastern North America) (synonyms: *thoracica* Westwood 1839, *contracta* Westwood 1839, *laeviventris* Cresson 1872, *reticulatus* Kieffer 1904a) (♀ also known).

atra Klug, 1810, p. 206; ♂, Georgia (Florida to Carolinas, west to New Mexico) (♀ described by Evans, 1963b).

bridwelli Evans, 1963b, p. 267; ♂, Arkansas (♀ also described).

californica Evans, 1963b, p. 263; ♂, California (also Utah, Wyoming).

chihuahua Evans, 1963b, p. 284; ♂, Chihuahua, Mexico (also Arizona).

cockerelli Evans, 1963b, p. 264; ♂, New Mexico (also Texas, Arizona, Mexico) (♀ also described).

fraterna Evans, 1963b, p. 261; ♂, North Carolina (also South Carolina, Florida, Kansas) (♀ also described).

hyalina Brues, 1906, p. 143; ♂, Texas (Louisiana to New Mexico, south to central Mexico).

Central Mexico to Panama

erythropoda (Cameron), 1888a, p. 450; ♂, Panama (also Costa Rica).

intermedia Evans, 1963b, p. 278; ♂, San Luis Potosí, Mexico.

nebulosa Evans, 1963b, p. 281; ♂, Guatemala.

oriplana Kieffer, 1911, p. 215; ♂, Guerrero, Mexico.

orizabae (Cameron), 1897, p. 273; ♂, Veraacruz, Mexico.

- otomi* Evans, 1963b, p. 268; ♂, state of Mexico, Mexico.
palliditarsis (Cameron), 1897, p. 274; ♂, Tabasco, Mexico
 (also Panama).
porteri Evans, n. sp. described below from ♂, British
 Honduras (sp. 2).
quiroga Evans, n. sp. described below from ♂, Michoa-
 can, Mexico (sp. 1).
rugifrons (Cameron), 1888a, p. 449; ♂, Guatemala.
sinaloa Evans, 1963b, 288; ♂, Sinaloa, Mexico.
tenochca Evans, 1963b, p. 279; ♂, Morelos and state of
 Mexico.
varidens (Cameron), 1904, p. 262; ♂, Mexico (widely
 distributed in central Mexico) (synonym: *alticola* Kief-
 fer, 1911)

(1) PRISTOCERA (ACREPYRIS) QUIROGA new species

Holotype. — ♂, MEXICO: MICHOACAN: Tzintzuntzan, 8 km S. Quiroga, about 7000 feet elevation, 6 Aug. 1962 (H. E. Evans) [MCZ, No. 30,795].

Description of type. — Length 8.5 mm; LFW 5.8 mm. Body and appendages black; wings subhyaline, veins and stigma dark brown. Body clothed rather densely with silvery hairs of moderate length. Mandibles with five sharp teeth in an oblique series, the fourth tooth slightly smaller than the others. Clypeus broadly truncate, its median carina weakly arched in profile. Antennae elongate, not at all serrate; first four segments in a ratio of about 24:5:17:15, segment three 2.3 X as long as thick, segment eleven about 3 X as long as thick; flagellar pubescence pale, suberect, setulae of segment eleven .3 X as long as width of segment. Eyes with a few weak, short hairs. Head slightly wider than high; front broad, WF .66 X WH, 1.55 X HE; front angle of ocellar triangle slightly less than a right angle, OOL 1.5 X WOT. Punctures of front large, subcontiguous, the spaces between them mostly reduced to a network of round-topped ridges; median line of front less densely punctate but not impressed.

Pronotum distinctly longer than in *armifera*, with somewhat closer setigerous punctures and with finer, more numerous transverse rugulae, as in that species depressed and smooth along posterior margin; sides of pronotum in large part smooth and polished. Mesoscutum polished, the punctures small and well separated, especially between the notauli, the latter strong and

complete; scutellum wholly covered with punctures. Propodeal disc about 1.3 X as wide as long, depressed along margins of basal triangle; disc wholly covered by large reticulations, margined behind by an irregular transverse carina. Mesopleurum with large, subcontiguous punctures except the elongate callus smooth, impunctate. Claws trifold, the innermost ray blunt, the middle ray shorter than the outer ray but sloping outward so as to be nearly parallel to it. Fore wing with the discoidal cell fully outlined by pigmented streaks. Subgenital plate truncate apically. Genitalia with the parameres simple, broadly rounded apically, very much as in *cockerelli* Evans; aedoeagus with the ventral valves elongate, acute apically, slightly exceeded by the blunt middle valves; distance from apex of middle valves to apex of dorsal valves about the same as that between apices of ventral and middle valves; dorsal valves slender, widely separated, each twisted mesad and ventrad apically.

Remarks. — This striking species is known only from the type. It is of special interest because of its close resemblance to *armifera* and its allies, although having the body more densely hairy, in this respect resembling *hyalina* and its allies. In my key (Evans, 1963b) *quiroga* runs well to couplet 9, separating *armifera* and *fraterna*, except that the antennae are relatively less slender, segment eleven measuring only 3 X as long as thick. This species differs from both *armifera* and *fraterna* in the genitalia and in having the middle tooth of the claws longer and more sloping, as well as in the more hairy body. However, there is little question that the species is closely related to *armifera*.

(2) PRISTOCERA (ACREPYRIS) PORTERI new species

Holotype. — ♂, BRITISH HONDURAS: Near Hummingbird Gap, Hummingbird Highway, Stann Creek Dist., 8 July 1963 (C. C. Porter) [MCZ, No. 30,866].

Description of type. — Length 12.0 mm; LFW 10.0 mm. Body black; appendages black, except basal segment of middle and hind tarsi white; wings subhyaline except clouded with brown along major veins and apical .4 of fore wing quite conspicuously clouded with brown (especially strong around and below stigma), apical .3 of hind wing weakly clouded. Mandibles with five teeth, the fourth tooth slightly smaller than the others. Clypeus with a very broad V-shaped emargination, its median carina very weakly arched in profile. Antennae elongate, not at all serrate;

first four segments in a ratio of about 37:7:22:22, segment three 2.2 X as long as thick, segment eleven 5 X as long as thick; pubescent light brown, suberect, setulae of segment eleven .2-.3X as long as width of segment; flagellum also with scattered fully erect setae (especially below) which are 2-2.5 X as long as the setulae. Eyes with sparse, short setae on the upper half. Head 1.1 X as wide as high; WF .55 X WH, 1.17 X HE; ocelli in a compact triangle on a level with the eye tops, OOL 1.38 X WOT. Front with a median linear groove and with a small median tooth just above the level of the bottoms of the eyes; punctures of front large, subcontiguous in longitudinal series, but the vertex more sparsely punctate, in fact just above the hind ocelli impunctate for a considerable space.

Pronotum very short, rounded in front, the surface of the disc with dense, transverse, setigerous punctures, obscurely transversely rugulose toward the midline. Mesoscutum polished, with strong punctures except along a median streak; notauli strong and complete; scutellum wholly covered with punctures. Propodeal disc about 1.4 X as wide as long; basal triangle well defined, slightly depressed, posterior part of disc wholly covered with irregular transverse rugae. Mesopleurum wholly covered with close-set punctures, the callus ill-defined. Claws trifold, the middle ray close to the outer ray, obliquely truncate, thicker than the outer ray and about as long; inner ray short and blunt. Fore wing with the discoidal cell fully outlined, the first recurrent vein strong, the subdiscoidal vein continuous to the outer wing margin. Subgenital plate truncate apically. Genitalia almost exactly as in *sinaloa* Evans (see Evans, 1963b, Fig. 28) except in details of the aedoeagus; the latter is very similar basally, but the median apical lobes are broader and are broadly truncate apically, while the lateral apical lobes are simple and finger-like, considerably exceeding the median lobes.

Remarks. — This species, known only from the type, is by far the largest species of Bethyilidae known from the Western Hemisphere (it is exceeded slightly by a few African species). In my key (1963b, p. 252) it runs to couplet 18; the antennae and most details of the genitalia agree with *sinaloa* Evans, but the color of the tarsi is the same as in *palliditarsis* (Cameron). *P. porteri* is considerably larger than both those species and also has more slender antennae, a mid-frontal tooth, and quite different apical aedoeagal lobes.

2. Genus APENESIA Westwood

- Apenesia* Westwood, 1874, p. 170 (type species *A. amazonica* Westwood, designated by Westwood, 1881). —Westwood, 1881, p. 130. —Ashmead, 1902, p. 271. —Kieffer, 1905b, p. 255. —Kieffer, 1908a, p. 25. —Kieffer, 1914, pp. 391-396 (key to spp. of world, ♀♀ [♂ misidentified]). —Evans, 1963d, pp. 249-359 (revision of American spp.).
- Aeluroides* Tullgren, 1904, pp. 428-430 (type species *A. sjöstedti* Tullgren, monobasic; synonymy by Kieffer, 1914).
- Propriostocera* Kieffer, 1905b, p. 247 (type species *P. interrupta* Kieffer, designated by Kieffer, 1914; synonymy by Evans, 1963d). —Kieffer, 1908a, p. 23. —Kieffer, 1914, pp. 484-488. —Evans, 1958, pp. 289-296.
- Cleistopyris* Kieffer, 1910b, p. 48 (type species *C. punctatus* Kieffer, 1910 [preoccupied in *Apenesia*, renamed *A. peruana* Evans, 1963d], designated by Kieffer, 1914; synonymy by Evans, 1963d). —Kieffer, 1914, pp. 490-494.
- Dipristocera* Kieffer, 1914, pp. 471-472 (type species *Pristocera microchela* Kieffer, monobasic; synonymy by Evans, 1963d).
- Neopristocera* Benoit, 1957, pp. 44-46 (type species *N. triloba* Benoit, original designation; synonymy by Evans, 1963d) (generic name preoccupied by Yasumatsu, 1955).

Generic characters.—*Males.* Maxillary palpi with six segments, essentially as in *Pristocera*, except a very few species with 5-segmented palpi; labial palpi with three segments. Mandibles with from three to five teeth, or occasionally all but the apical tooth confluent to form a single cutting edge; clypeus with a median lobe which may be truncate, rounded, angulate, bidentate, or tridentate, but never trapezoidally produced as in *Pseudisobrachium*; eyes glabrous, except with sparse, short hair in a very few species; antennae 13-segmented, filiform, the flagellar pubescence usually erect and bristling, in a few species subappressed and exceeded by some longer, erect setulae; occipital carina complete. Pronotum of variable shape, with or without a transverse carina anteriorly, with or without a transverse groove posteriorly; notauli complete or nearly so in most species; scutellum with a transverse groove at base; propodeum with basal triangle not marked off by a groove or carina, though usually more heavily sculptured than rest of disc, which is generally smooth or weakly striate or alutaceous; propodeal disc with or without a transverse carina behind; claws dentate. Fore wing with costa extending well past stigma as a strong vein (a few exceptions); discoidal vein usually distinct, discoidal cell often

outlined by weak veins. Abdomen sessile or petiolate. Subgenital plate simple, with a long basal stalk. Genitalia with the parameres simple or somewhat bilobed, never deeply divided; cuspis divided into a simple dorsal and a setose ventral arm (except in a few species); vannus absent; aedeagus complex, with from two to several apical lobes, but never consisting of three distinct sets of valves as in *Pristocera* (*Acrepyris*).

Females. Maxillary palpi with four segments, labial palpi with two or three segments. Mandibles with from two to four teeth; clypeus emarginate, truncate, or somewhat produced medially; eyes small, usually longer than wide, with from 1 to about 15 facets each; head usually longer than broad, but in a few species nearly square or very slightly broader than long; antennae short, 13-segmented, filiform or somewhat incrassate. Thorax not constricted behind pronotum; mesonotum short, rounded behind, anterior margin of propodeum broad, in broad contact with the mesonotum; propodeum weakly to fairly strongly constricted at or near the spiracles, often somewhat hour-glass shaped, its maximum width from 1.2 to 1.8 X its width at the constriction, sides of propodeum behind the constriction either straight or arched; mesopleura with a small dorsal and a large lateral surface, the thorax distinctly wider across the mesothorax than elsewhere; middle tibiae spinose above. Abdomen sessile or with a short or fairly long petiole. (Figs. 12-15.)

Remarks.—The synonymy of Kieffer's names *Propristocera*, *Cleistopyris*, and *Dipristocera* has been discussed elsewhere (Evans, 1963d). As pointed out in that paper, *Apenesia* occupies a central position in this subfamily, and certain species approach those of each of the other genera fairly closely. While males of *Dissomphalus* can invariably be separated by the characteristic modifications of the second tergite, and males of *Pseudisobrachium* by the divided parameres, there is no really hard and fast way of separating males of *Pristocera* and *Apenesia*. The females of these two genera can be separated by somewhat arbitrarily defining the permissible degree of constriction of the propodeum, also by the number of segments in the maxillary palpi. It may someday be found undesirable to maintain these two groups as separate genera.

Biology.—The females of this genus are generally taken in Berlese samples or found under bark or in rotten wood. There are two records of species from the Eastern Hemisphere having been reared from larvae of Curculionidae occurring in roots or

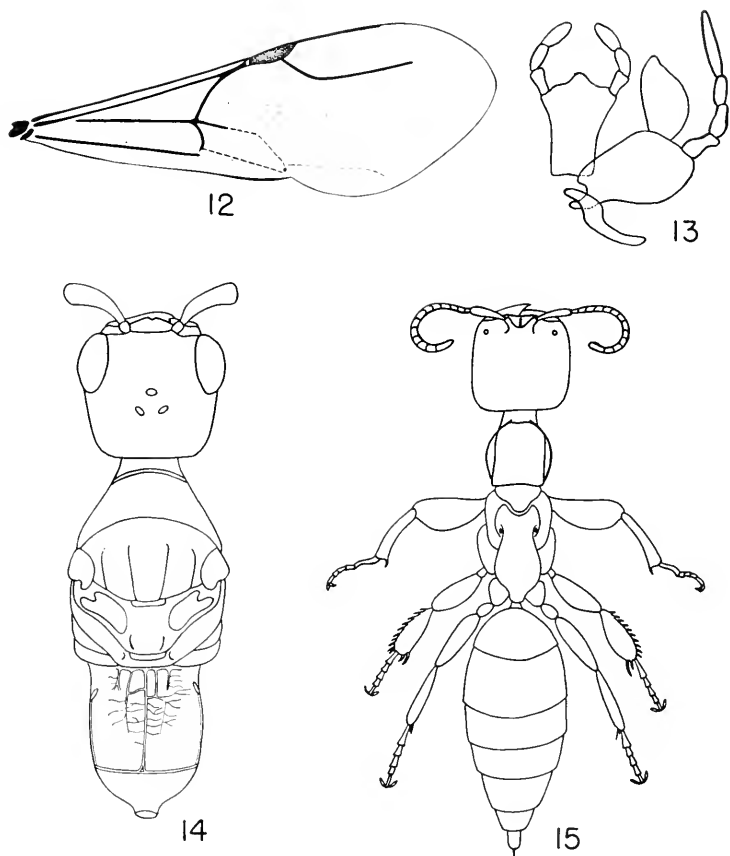

Apenesia spp. Fig. 12. Fore wing of *A. truncaticeps* (Kieffer), male. Fig. 13. Labium and maxilla of *A. chontalica* Westwood, female. Fig. 14. Head and thorax of *A. truncaticeps* (Kieffer), male. Fig. 15. *A. chontalica* Westwood, female.

stems (for details see Evans, 1963d). The males are most often taken in sweepings or on honeydew; a few species come to light at night in arid regions.

Distribution.— This genus occurs throughout the tropics and subtropics of the world. There are numerous species of *Apenesia* in the Ethiopian and Oriental regions, and the genus is abundantly represented in the Philippines. I have seen species from

Java, New Guinea, and Australia, and from the Bismareks, Solomons, Samoa, and the Society Islands. In the New World the genus occurs from Argentina and Bolivia north to southern United States, with one species ranging north to Illinois and New York. Three species have been described from the Greater Antilles, but none is currently known from the Lesser Antilles. In my recent revision of this group I recognized 63 species. Three additional species are described in the present paper, one other (*coarctatus* Kieffer) is reassigned to this genus, and another (*insolita* Evans) is here removed to *Parascleroderma*.

Included American species:

United States

chiricahua Evans, 1963d, p. 306; ♂, Arizona (also Mexico).

cochise Evans, 1963d, p. 296; ♂, Arizona.

dissomphaloides Evans, 1963d, p. 297; ♂, Arizona.

exilis Evans, 1963d, p. 293; ♂, Arizona (also California).

martini Evans, 1963d, p. 294; ♂, Florida.

mohave Evans, 1963d, p. 308; ♂, California (also Baja California).

pallidula Evans, 1963d, p. 300; ♂, Arizona.

parapolita Evans, 1963d, p. 322; ♂, South Carolina (widely distributed in eastern U.S.) (new name for *polita* Evans, 1958, preoccupied) (♀ described by Evans, 1963d, p. 347).

pima Evans, 1963d, p. 292; ♂, Arizona.

Mexico and Central America

amocna Evans, 1963d, p. 353; ♀, Costa Rica.

angustata Evans, 1958, p. 295; ♂, Costa Rica.

bugabensis (Cameron), 1888a, p. 453; ♂, Panama (also Costa Rica).

chontalica Westwood, 1881, p. 131; ♀, Nicaragua (Mexico to Costa Rica).

denticulata Evans, 1963d, p. 298; ♂, Veracruz, Mexico (new name for *tridentata* Evans, 1958, preoccupied).

flavipes Cameron, 1888a, p. 449; ♀, Panama.

guatemalensis Evans, 1963d, p. 278; ♂, Guatemala.

laevigata Evans, 1958, p. 293; ♂, Veracruz, Mexico.

malinche Evans, 1963d, p. 309; ♂, Puebla, Mexico.

maya Evans, 1963d, p. 316; ♂, Guatemala.

mexicana (Cameron), 1904, p. 263; ♂, Mexico (Morelos).

microchela (Kieffer), 1911, p. 214; ♂, Tabasco, Mexico (also Veracruz).

olmeca Evans, 1963d, p. 329; ♂, Veracruz, Mexico.

paradoxa Evans, 1963d, p. 349; ♀, Panama.

peculiaris Evans, 1963d, p. 310; ♂, Panama.

pilicornis Evans, 1963d, p. 270; ♂, Panama (also Costa Rica, Venezuela).

punctata (Cameron), 1888b, p. 173; ♂, Veracruz, Mexico.

sulcata Evans, 1963d, p. 283; ♂, Panama.

tarascana Evans, 1963d, p. 326; ♂, Michoacan, Mexico.

testaceipes (Cameron), 1888a, p. 452; ♂, Panama.

tlahuicana Evans, 1963d, p. 327; ♂, Morelos, Mexico.

West Indies

cubensis Evans, 1963d, p. 313; ♂, Cuba.

delicata Evans, 1963d, p. 352; ♀, Jamaica.

dominica Evans, 1963d, p. 352; ♀, Dominica.

South America

alutacea Evans, 1963d, p. 331; ♂, Venezuela.

amazonica Westwood, 1874, p. 171; ♀, Brazil.

angusticeps Evans, 1963d, p. 275; ♂, Bolivia.

brasilensis (Kieffer), 1910a, p. 298; ♂, Brazil.

browni Evans, n. sp. described below from ♀, Brazil (sp. 1).

coarctatus (Kieffer), 1910a, p. 292; ♂, Brazil (new combination).

columbana (Westwood), 1874, p. 164; ♂, Colombia (also Panama).

crenulata (Kieffer), 1910a, p. 289; ♂, Brazil.

elongata Evans, 1963d, p. 276; ♂, Brazil.

flammicornis Evans, 1963d, p. 287; ♂, Bolivia.

fulvicollis (Westwood), 1874, p. 165; ♂, Brazil.

funcbris Evans, 1963d, p. 286; ♂, Brazil.

inca Evans, 1963d, p. 319; ♂, Peru (also Ecuador).

laticeps Evans, 1963d, p. 345; ♂, Brazil.

leucophthalma Evans, n. sp. described below from ♀, Brazil (sp. 2).

ncotropica Evans, 1963d, p. 318; ♂, Brazil (new name for *paracnsis* Kieffer, 1910a, p. 298, preoccupied).

nitida (Kieffer), 1910b, p. 49; ♂, Peru.

ornata Evans, 1963d, p. 272; ♂, Brazil.

pallidicornis Evans, 1963d, p. 289; ♂, Brazil.

- pando* Evans, 1963d, p. 311; ♂, Bolivia (new name for *percurrrens* Kieffer, 1910b, p. 52, preoccupied).
paraensis Kieffer, 1910a, p. 290; ♂, Brazil.
peruana Evans, 1963d, p. 337; ♂, Peru (new name for *punctatus* Kieffer, 1910b, p. 48, preoccupied).
photophila (Ogloblin), 1930, p. 20; ♂, Argentina.
quadrata Evans, 1963d, p. 344; ♂, Brazil.
reducta Evans, 1963d, p. 277; ♂, Brazil.
santacatarinae Evans, n. sp., described below from ♂, Brazil (sp. 3).
striatula Evans, 1963d, p. 285; ♂, Brazil.
substriata Kieffer, 1904b, p. 365; ♀, Bolivia.
tenebrosa Evans, 1963d, p. 273; ♂, Brazil.
transversa Evans, 1963d, p. 333; ♂, Brazil.
truncaticeps (Kieffer), 1910b, p. 50; ♂, Bolivia (also Peru) (synonyms: *punctaticeps* Kieffer, 1914; *bolivensis* Ogloblin, 1938).
venezuelana Evans, 1963d, p. 335; ♂, Venezuela.
zamora Evans, 1963d, p. 332; ♂, Ecuador.

(1) *APENESIA BROWNI* new species

Holotype. — ♀, BRAZIL: Amazonas, High Falls, Rio Taruma, 28 Aug. 1962 (W. L. Brown) [MCZ, No. 30,796].

Description of type. — Length 3 mm; LH 0.54 mm; LT 0.88 mm. Entire body pale castaneous, head and thorax slightly darker than abdomen; extreme base of first abdominal tergite black; legs testaceous; antennae pale castaneous, fading to testaceous apically. Body clothed with short, golden setae, rather dense on the head, slightly less so on the thorax and legs; abdomen sparsely setose on all segments. Maxillary palpi short, but with four segments. Mandibles slender, terminating in two strong teeth. Clypeus broadly, angularly emarginate, revealing the semicircular labrum beneath; median ridge strong although very short. Head 1.22 X as long as wide, its sides subparallel on the anterior two-thirds, weakly converging behind, the vertex forming a straight line. Eyes minute and difficult to detect, apparently consisting of a single facet each and only very slightly paler than the color of the integument. Front shining, obscurely alutaceous and not at all so above; punctures small but clearly defined, on the center of the lower front separated by no more than their own diameters, but much more sparse above and on

the sides of the head. Scape curved, about 3 X as long as its maximum width; flagellum only about twice as long as scape, strongly incrassate, antennal segment eleven nearly twice as wide as long, 1.6 X as wide as segment three.

Pronotal disc 1.22 X as long as its posterior width, rather flat, without an anterior notch, but with a delicate arching carina margining the disc anteriorly. Surface of pronotum shining, obscurely alutaceous, the punctures largely absent from a broad median strip. Mesonotum about half as long as wide. Mesopleurum with only a small dorsal part, the thorax measured across the mesopleural shoulders only .32 mm, which is 1.15 X the width across the posterior part of the pronotal disc, .7 X the head width. Propodeum 1.85 X as long as its maximum width, maximum width only 1.3 X minimum width; constriction far forward, just behind spiracles, sides of propodeum behind constriction straight, weakly diverging to crest of declivity, which is quite abrupt; propodeal formula 17:14:19; propodeal disc shining, with a few weak punctures on the sides; declivity alutaceous. Middle tibiae with strong spines. Abdomen sessile.

Remarks.— This is a striking species which on first glance would appear to belong to *Dissomphalus*, for the propodeum is weakly constricted and the mesopleurum not nearly as strong as it typically is in *Apensia*. However, the four-segmented maxillary palpi and sessile abdomen at once place it in *Apensia*. The eyes are even more reduced than they are in *paradoxa* Evans, a not dissimilar species described from Panama.

(2) APENESIA LEUCOPHTHALMA new species

Holotype.— ♀, BRAZIL: Rio Grande do Sul, Caxias do Sul, Nov. 1959, 700 meters (F. Plaumann) [MCZ, No. 30,797].

Description of type.— Length 6.5 mm; LH 1.23 mm; LT 2.20 mm. Head and thorax dark castaneous, suffused with fuscous on the center of the head, both above and below, also on the pronotum and mesopleura; abdomen shining, bright rufo-castaneous except basal segment black at extreme base, dark castaneous in the center of the tergite, apical two segments fading to testaceous; scape rufo-testaceous, flagellum light brown except basal several segments annulated with darker brown; legs wholly testaceous, the front coxae and femora slightly darker than the remainder of the legs. Body with golden setae which are rather short, except longer on the abdominal venter and apical tergites. Mandibles

slender, the apex strongly oblique, bearing four teeth, of which the basal two are small and blunt. Clypeus broadly truncate, with a sharp median ridge which is angularly declivous apically. Head 1.28 X as long as wide, widest near the eyes, the sides arcuately convergent behind to a narrow, nearly straight vertex. Eyes remarkably large although consisting of a single subcircular lens, the eyes white in color, in strong contrast to the dark castaneous head; eye height about .2 X the distance between the eyes, approximately equal to the maximum width of the flagellum. Front moderately shining, very densely punctate, the punctures tending to be subcontiguous in longitudinal series on both the front and back of the head, less so on the sides; middle of front with a linear impression which turns into a narrow impunctate strip toward the vertex. Scape curved, about 3 X as long as its maximum width; flagellum not incrassate, nearly 3 X as long as the scape.

Pronotal disc about 1.5 X as long as its posterior width, without an anterior notch, surface shining, non-alutaceous, with large, well spaced punctures, but the side pieces more closely punctate and with fine longitudinal ridges. Groove between the pronotum and mesonotum deep, the latter subtriangular, slightly emarginate in front. Thorax as a whole quite slender, at its widest part, across the mesopleura, measuring about 1.2 X the posterior width of the pronotal disc; dorsal parts of mesopleura strongly rounded; surface of mesopleura punctate and with fine, irregular longitudinal ridges, especially below. Propodeum slender and with a weak constriction which is far forward; maximum length 2.5 X maximum width; distance from constriction to median anterior point of propodeum only about half the width at the constriction; sides, behind the spiracles, straight and weakly divergent; formula 15:12:18; disc shining, covered with large punctures except along a narrow median strip. Middle tibiae with strong spines on the apical third only. Abdomen sessile.

Remarks. — This large and striking species has no known close relatives. The large, white, single-faceted eyes are unique, and the shape of the propodeum unusual.

(3) APENESIA SANTACATARINAE new species

Holotype. — ♂, BRAZIL: Santa Catarina, Nova Teutonia, 7 May 1937 (Fritz Plaumann) [BMNH].

Description of type.—Length 5.2 mm; LFW 3.3 mm. Head black except clypeus rufo-testaceous; thorax dark brownish-fuscous except collar testaceous, posterior margin of pronotum light brown, propleura largely castaneous; abdomen dark brown, shining, the tergites indistinctly annulated with paler brown; mandibles testaceous, the teeth rufous; scape testaceous, flagellum pale castaneous except somewhat infuscated at extreme apex; tegulae testaceous; legs wholly light yellowish-brown; wings subhyaline, veins and stigma brown. Mandibles with three strong teeth in an oblique series. Clypeus with the median lobe broad and short, obtusely angulate except the tip bidentate; median carina low, weakly arched in profile. First four antennal segments in a ratio of about 20:6:12:11, segments three and eleven each about 2.5 X as long as thick; pubescence pale, suberect, longest setulae of segment eleven about half as long as width of segment. Front strongly alutaceous, moderately shining, punctures fairly strong, separated by from 0.5-1.5 X their own diameters. Eyes wholly covered with short hairs, the hairs as long as in many species of *Pseudisobrachium*, but more sparse. Head higher than wide, WH .93 X LH; WF .58 X WH, 1.15 X HE; inner orbits convergent below. Front angle of ocellar triangle much less than a right angle; OOL 1.3 X WOT. Vertex evenly rounded off a distance above eye tops equal to about two-thirds X HE.

Pronotum moderately long, its sides concave as seen from above, transverse carina at front margin of disc strong; surface strongly alutaceous, strongly punctate except along median line, which is weakly elevated, notauli complete, nearly parallel; mesoscutum and scutellum alutaceous and with strong punctures. Propodeal disc elongate, .96 X as wide as long; median carina elongate but not quite reaching the transverse carina; disc with only weak sculpturing, the basal triangle not strongly set off or with strong sculpturing. Mesopleurum alutaceous, callus not strongly differentiated. Middle tibiae weakly spinose above. Fore wing with the discoidal vein arising far down on the transverse median vein, discoidal cell wholly weakly outlined. Abdomen sessile. Subgenital plate broadly truncate. Genitalia with the parameres moderately large, with an angulation on the outer margin and a large mesal lobe (shaped about as in *venezuelana* Evans); ventral arms of digiti very broad and short, truncate apically; aedoeagus with a pair of slender ventral rami and a pair of simple, rounded apical lobes (much as in *inca* Evans).

Paratype.—BRAZIL: 1 ♂, same data as type except 24 April 1938 [BMNH].

Variation.—The paratype is considerably smaller than the type (LFW 2.6 mm). WH is .91 X LH; WF is 1.10 X HE; OOL is 1.5 X WOT. The vertex is somewhat more narrowly rounded and more strongly produced above the eye tops than in the type. Otherwise the resemblance is very close.

Remarks.—This species keys readily to *inca* in my key to species of this genus. There can be no question of its close relationship to that species; the mandibles and clypeus are virtually the same, the pronotum and propodeum very similar, the aedoeagus strikingly similar. However, the head is much longer than in that species, the eyes are hairier, the propodeum is longer and with weaker basal sculpturing, and the parameres are different.

3. Genus PARASCLERODERMA Kieffer

Parascleroderma Kieffer, 1904b, p. 376 (type species *P. fulviceps* Kieffer, original designation). —Kieffer, 1905a, p. 103. —Kieffer, 1905b, p. 257. —Kieffer, 1906a, p. 425 (European spp.). —Kieffer, 1908a, pp. 42-43. —Kieffer, 1914, pp. 250-252 (spp. of world). —Berland, 1928, pp. 129-130. —Maneval, 1930, pp. 53-61.

Generic characters (of female; male unknown). — Small wasps (1.5-4 mm) of testaceous, brown, or black coloration, completely apterous, strongly depressed. Head considerably wider than maximum width of thorax; maxillary palpi with three segments, the apical segment much longer than the basal two, terminating in a bristle which is longer than the entire palpus; labial palpus with two segments, the apical segment much longer than the basal and also terminating in a bristle which is longer than the palpus; mandibles with two or three apical teeth; clypeus broadly rounded, truncate, or somewhat emarginate; eyes small but with numerous (14-40) distinct, convex facets, glabrous; malar space strong, about half as long as eye height, eyes removed from posterior margin of head by three or more times their own height; eye height about .25 X head width; antennae simple, with 13 segments, flagellum slender, not incrassate; occipital carina complete; ocelli absent. Thorax constricted between pro- and mesothorax, pronotum very long, transversely convex, without a flattened disc; mesonotum small, subtriangular, convex; mesopleura very strong dorsally, forming much the widest part of the thorax; propodeum very long, weakly constricted at the spiracles, its maximum width 1.2-1.35 X its minimum width;

femora incrassate; middle tibiae smooth, completely without spines. Abdomen with a short petiole, rather broad, considerably broader than head or thorax. (Figs. 16, 17.)

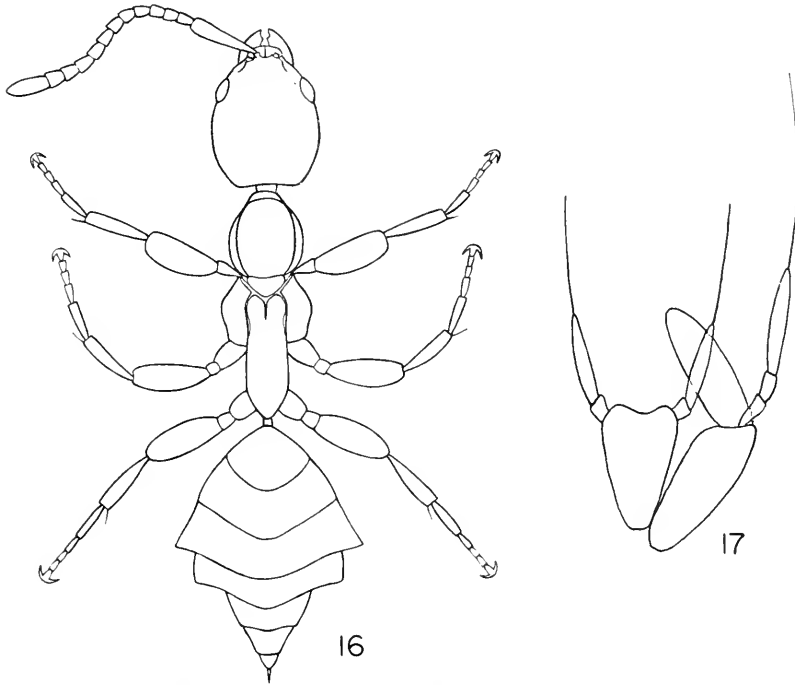

Parascleroderma spp. Fig. 16. *P. carinata* n. sp., female holotype (this specimen was mounted from alcohol, and the distortion of the abdomen is an artifact of drying). Fig. 17, *P.* sp. (African), labium and maxilla, female.

Remarks. — In describing *Apenesia insolita*, I pointed out that this species differs from typical *Apenesia* females in several respects and appears to be related to European and African species which have been placed in the genus *Parascleroderma*. Since that time I have seen additional material of this genus, including another American species, described below. I now feel that *Parascleroderma* should be maintained as a separate genus, at least until such time as the males are discovered and a better insight into the relationships of these species can be attained.

Since *Parascleroderma* shares certain of the characters of *Apenesia* and *Dissomphalus*, it seems possible that the males will be found to fall into what I have called the *dissomphaloides* species-group of *Apenesia*.

Biology.—These are among the most strongly flattened of Bethyliidae, suggesting that they may occur under bark or in crevices in wood. The available records indicate that this is, in fact, the normal habitat. *P. scobiciae* Kieffer is said to attack the bostrychid beetle *Scobicia chevrieri* (Berland, 1928), while *P. berlandi* Maneval attacks the larvae of the predaceous clerid beetle *Thanasimus formicarius* (Maneval, 1930). Maneval has described the manner in which the wasp paralyzes the prey and drags it backward into a crevice. The single egg is laid longitudinally on the side of the thorax of the beetle larva. Maneval described and figured the larva and cocoon of *P. berlandi*.

Distribution.—Southern Europe and Africa; in the Western Hemisphere known only from southern Texas and from Tamaulipas, Mexico.

Included species.—This genus includes several species in Europe and Africa, including *scobiciae* Kieffer (France), *berlandi* Maneval (France), *rugosulum* Kieffer (Gibraltar), *fulviceps* Kieffer (Sicily), *nigriceps* Kieffer (Italy), *unicolor* (Westwood) (Morocco), *seychellensis* (Kieffer) (Seychelle Islands), and *nigrum* Brues (South Africa). In the New World only two species are presently known, each from a single specimen:

carinata Evans, n. sp. described below from ♀, Tamaulipas, Mexico.

insolita (Evans), 1963d, p. 350; ♀, Texas (new combination).

PARASCLERODERMA CARINATA new species

Holotype.—♀, MEXICO: Tamaulipas: Crest first ridge west of Antiguo Morelos, 18 Nov. 1948 (E. S. Ross) [CAS].

Description of type.—Length about 1.7 mm; LH .43 mm; LT .70 mm. Body dark castaneous, shining, the propodeum and mesopleura very dark, almost piceous; mandibles and clypeus very light brown; antennae medium castaneous; legs dark brown except trochanters and tarsi very light brown. Body setae very short, very sparse except on legs. Mandibles with two sharp apical teeth and with a broad, indistinct third, basal tooth. Apical margin of clypeus prominent, broadly rounded; median carina

very strong, arched in profile. Head 1.37 X as long as wide, its sides strongly arched, the head much wider near the middle than in front or behind; vertex straight across in anterior view, the occipital carina strong, visible at crest of vertex in anterior view. Eyes relatively large, broadly elliptical, each with about 25 facets; HE .33 X distance between eyes across front, .25 X WH. Front strongly polished, non-alutaceous, punctures minute and widely spaced. Flagellum slender, not at all incrassate, more than three times as long as scape; antennal segment eleven slightly longer than wide.

Pronotum rather long and transversely convex, polished and obscurely punctate. Mesonotum slightly wider than long, polished, strongly elevated so that in side view the mesonotum protrudes distinctly above the general surface of the thorax. Propodeum elongate, measuring 2.4 X as long as its maximum width (which is well behind the spiracles); maximum width 1.2 X minimum width (at the spiracles); base of propodeum with a strong Y-shaped carina, the stem of the Y extending backward about one-third the distance to the constriction, the surface somewhat depressed on each side of the stem; surface of disc strongly polished except finely shagreened on posterior third. Mesopleura very prominent, the dorsum of the thorax about twice as wide across the mesopleura as across the propodeal constriction or the constriction between the pronotum and mesonotum. Legs smooth and completely without spines, even the middle tibiae. Abdomen with a short petiole (Fig. 16).

4. Genus DISSOMPHALUS Ashmead

Disсомphalus Ashmead, 1893, pp. 41-43 (type species *D. xanthopus* Ashmead, original designation). —Kieffer, 1905b, pp. 249-250. —Kieffer, 1908a, pp. 35-36. —Kieffer, 1914, pp. 495-503 (key to spp. of world). —Evans, 1955, pp. 288-309 (spp. occurring in U.S.). —Benoit, 1957, pp. 20-26 (African spp.). —Evans, 1962b, pp. 65-78 (U.S., Mexican, and Antillean spp.).

Ecitopria Wasmann, 1899, p. 55 (type species *E. crassicornis* Wasmann, monobasic; synonymy by Evans, 1955). —Ashmead, 1902, p. 270. —Kieffer, 1905b, pp. 256-257. —Kieffer, 1908a, p. 43. —Kieffer, 1914, pp. 285-286.

Dissemphalus Ashmead, 1902, p. 271 (error for *Disсомphalus*).

Thaumatepyris Kieffer, 1910b, p. 47 (type species *T. punctatus* Kieffer, monobasic; new synonymy). —Kieffer, 1914, p. 504.

Glenobethylus Kieffer, 1910b, p. 50 (type species *G. montanus* Kieffer, monobasic; new synonymy). —Kieffer, 1914, pp. 494-495.

Parecitopria Ogloblin, 1930, pp. 15-17 (type species *P. azarai* Ogloblin, monobasie; new synonymy).

Generic characters.—*Males.* Maxillary palpi with five segments, labial with three; mandibles with from two to four teeth, in some species only the apical tooth distinct, the other teeth fused to form a simple cutting edge; clypeus without a well-defined median lobe, the entire margin prominent, midline somewhat produced and angulate, or the apex tridentate; median line of clypeus carinate; eyes glabrous or covered with short, rather inconspicuous hairs; antennae 13-segmented, in many species the outer flagellar segments somewhat barrel-shaped, so that the antennae are submoniliform; flagellar pubescence coarse and suberect, flagellum also with a few erect setae which stand above the pubescence; occipital carina complete although usually rather weak dorsally. Pronotum short, surface usually smooth, occasionally weakly rugulose or carinate along the anterior margin of the disc; notauli linear, sometimes incomplete; groove at base of scutellum very thin; propodeum short, disc with transverse carina behind (sometimes weak and irregular), disc more or less reticulately sculptured, sometimes more heavily sculptured in basal triangle, which may be slightly depressed; claws dentate, sometimes very weakly dentate or apparently simple. Fore wing with costa extending well past stigma as a distinct vein; basal vein reaching subcosta far basad of stigma; transverse median vein erect or nearly so; discoidal vein often distinct, discoidal cell closed in a few species. Abdomen sessile or subsessile, relatively broad and short. Second tergite bearing one or two pairs of pale or roughened spots, depressions, pits, tufts of setae, or tubercles; these may be lateral or submedian in position and may have setae associated with them. Subgenital plate simple, with a long median basal stalk. Genitalia very broad; parameres simple or weakly bilobed; cuspides in the form of simple, straight or curved rods; aedoeagus exceedingly complex, consisting of several rather loosely consolidated valves and lobes, some of them often with serrated margins.

Females. Maxillary and labial palpi both very short, each with only one or two segments. Mandibles slender, terminating in three or four teeth; clypeus with a median lobe which is truncate or somewhat rounded; eyes small, each with from 2 to about 25 facets (in one known species eyes reduced to a single facet each); head longer than wide, its sides somewhat convex; antennae 13-segmented, short, incrassate apically. Mesonotum short,

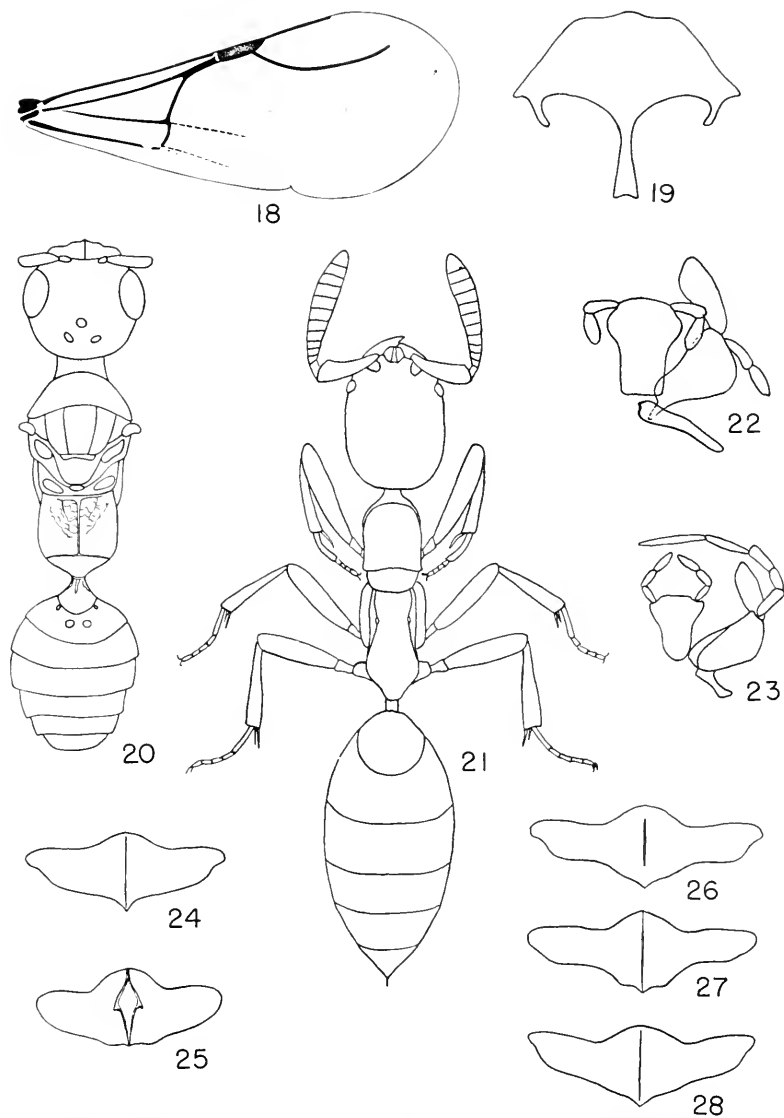

Dissomphalus spp. Fig. 18. *D. apertus* Kieffer, male, fore wing. Fig. 19. *D. plaumanni* n. sp., male, subgenital plate. Fig. 20. *D. apertus* Kieffer, male, dorsal view. Fig. 21. *D. scrupus* n. sp., female, dorsal view. Fig. 22. *D. claviger* n. sp., female, labium and maxilla. Fig. 23. *D. plaumanni* n. sp., male, labium and maxilla. Fig. 24. *D. brasiliensis* Kieffer, male, clypeus. Fig. 25. *D. cornutus* n. sp., male, clypeus. Fig. 26. *D. incomptus* n. sp., male, clypeus. Fig. 27. *D. plaumanni* n. sp., male, clypeus. Fig. 28. *D. rettenmeyeri* n. sp., male, clypeus.

transverse, its posterior margin gently convex at its broad junction with the propodeum; anterior margin of propodeum not embracing sides of mesonotum to any appreciable extent; propodeal disc elongate, more or less parallel-sided, in some species slightly constricted at the spiracles, maximum width at most 1.4 X minimum width; mesopleura almost wholly lateral in position, much less prominent than in other genera of this subfamily, the thorax only slightly wider across the mesothorax than elsewhere; middle tibiae with or without spines above; middle and hind tibiae not strongly expanded and flattened. Abdomen with a distinct short or fairly long petiole. (Figs. 18-36.)

Remarks.— These wasps are often exceedingly minute, some females measuring less than a millimeter in length. Kieffer's statement that the mandibles of *Ecitopria* are simple is probably an error of observation, for the mandibles have at least three teeth in all the species I have seen. The middle tibiae are without spines in many species, but in some species there are a few weak spines (for example, the Nearctic *nigrescens*), and in several Neotropical species the tibiae are strongly spinose. Ogloblin's *Parcecitopria*, described as having spinose middle tibiae, 4-toothed mandibles, and simple claws, I believe should be regarded as a synonym of *Dissomphalus*. In the males, the modifications of the second tergite assume many different forms, and there is no basis for splitting off *Thaumatopyris* for those species having a pair of spines (actually compacted setae) on this tergite. The type species of Kieffer's *Glenobethylus* has the second tergite modified as in *Dissomphalus*, although this was apparently overlooked by Kieffer. Incidentally, Kieffer is not correct in stating that the third tergite may also be modified; the pits on the third tergite of *brasiliensis* which Kieffer described are actually artifacts.

Biology.— Little is known regarding the host relationships of members of this genus. *D. crassicornis* (Wasmann) was described as a guest of the army ant *Eciton praedator* Smith, and *D. rettenmeyeri* is described below from refuse inside a log containing a colony of *Eciton burchelli* Westwood. The females are sometimes abundant in Berlese samples from soil, rotten wood, or debris in stumps and tree holes. Males have been taken in numbers at garage windows, suggesting that they may have emerged from the wooden walls. I suspect these insects attack small beetles, possibly including certain myrmecophiles. There is one record of a male being reared from a bruchid (Evans,

1955). Males are most often taken sweeping, and males of some species come to light. The males apparently carry the females about during copulation (Evans, 1962b).

Distribution. — This genus occurs throughout the warmer parts of the world. In this hemisphere, the species collectively range from Maine, Michigan, and California to Peru and northern Argentina. The genus is not definitely recorded from Europe, but it is possible that *Ecitopria proxima* Kieffer (Spain and Sardinia), *Psilobethylus luteus* Kieffer (Italy), and *P. atriceps* Kieffer (France) belong here. There are many African species, several Oriental species (including species from Sumatra and the Philippines), and at least two (undescribed) Australian species.

Included American species:

North and Central America

altivolans Evans, 1955, p. 307; ♂, Louisiana (known also from Alabama, Illinois, Texas, Arizona, and California, and from the ♀ sex).

apertus Kieffer, 1914, p. 60; ♂, Arkansas (eastern Mexico to Illinois and New York).

arizonicus Evans, 1962b, p. 70; ♂, Arizona.

barberi Evans, 1955, p. 298; ♂, Maryland (also Maine, North Carolina).

biforcatus Kieffer, 1906b, p. 250; ♂, Nicaragua.

californicus Ashmead, 1893, p. 42; ♂, California.

chiapanus Evans, 1962b, p. 70; ♂, Chiapas, Mexico.

clausus Kieffer, 1908b, p. 18; ♂, British Honduras.

clypeatus Evans, 1955, p. 303; ♂, Veracruz, Mexico (♀ also described).

falcatus Evans, 1962b, p. 72; ♂, State of Mexico, Mexico.

foveolatus (Brown and Cheng), 1952, p. 143; ♀, Virginia (Georgia and Arkansas to Illinois and Maryland).

kansanus Evans, 1955, p. 302; ♂, Kansas (also Pennsylvania, Illinois, and Florida).

mexicana (Westwood), 1839, p. 169; ♀, Mexico (type lost; may or may not belong to this genus).

nigrescens Evans, 1955, p. 308; ♂, Texas (also Louisiana and Alabama) (probable ♀ described by Evans, 1962b, from Arkansas).

ocellatus Kieffer, 1911, p. 211; ♂, Tabasco, Mexico.

rettenmeyeri Evans, n. sp. described below from Panama, both sexes (type ♀) (sp. 5).

- rufipalpis* Kieffer, 1910b, p. 44; ♂, British Honduras.
xanthopoides Kieffer, 1914, p. 500 (new name for *xanthopus* Kieffer, 1908b, p. 13, *ncc* Ashmead, 1893); ♂, British Honduras.
xanthopus Ashmead, 1893, p. 42; ♂, Maryland (Georgia, eastern Mexico, and Arizona to Illinois and Maryland) (synonym: *lucidus* Brown and Cheng, 1952, p. 146; synonymy by Evans, 1955).

West Indies

- bisulcus* Ashmead, 1894, p. 194; ♂, St. Vincent (also Grenada).
collaris Evans, 1962b, p. 73; ♂, Cuba.
confusus Ashmead, 1894, p. 194; ♂, St. Vincent (also Grenada).
politus Ashmead, 1894, p. 195; ♂, St. Vincent.
singularis Evans, 1962b, p. 77; ♀, Haiti.
tuberculatus Ashmead, 1894, p. 193; ♂, St. Vincent (also Grenada).

South America — Relatively few of the many South American species have been described. I have described below several species which are of unusual interest structurally. The following is a list of the fourteen described species.

- attaphila* (Bruch), 1916, p. 20; ♀, Argentina (new combination).
azarai (Ogloblin), 1930, p. 15; ♀, Argentina (new combination).
brasiliensis Kieffer, 1910a, p. 295; ♂, Brazil (redescribed below, sp. 3).
claviger Evans, n. sp. described below from ♀, Brazil (sp. 9).
cornutus Evans, n. sp. described below from ♂, Brazil (sp. 7).
crassicornis (Wasmann), 1899, p. 55; ♀, Brazil.
flavipes Kieffer, 1910b, p. 45; ♂, Brazil.
incomptus Evans, n. sp. described below from ♂, Brazil (sp. 4).
luscus Evans, n. sp. described below from ♀, Brazil (sp. 6).
montanus (Kieffer), 1910b, p. 50; ♂, Peru (redescribed below, sp. 2) (new combination).
platensis (Bruch), 1916, p. 22; ♀, Argentina (new combination).

plaumanni Evans, n. sp. described below from ♂, Brazil (sp. 8).

punctatus (Kieffer), 1910b, p. 47; Peru (also Ecuador) (re-described below, sp. 1) (new combination).

scrubeus Evans, n. sp. described below from ♀, Brazil (sp. 10).

(1) *DISSOMPHALUS PUNCTATUS* (Kieffer) new combination

Thaumatopyris punctatus Kieffer, 1910b, p. 47 [Type: ♂, PERU: Cajon, Bergland, Dept. Cuzco, 1500 meters elevation, 11-1-01 (Garlepp) (Berlin Museum, No. 195)]. —Kieffer, 1914, p. 504.

Description of type.—Length 6.7 mm; LFW 5 mm. Head and thorax black, abdomen dark reddish brown, shining; mandibles, scape, and sides of clypeus dull reddish brown, flagellum very dark reddish brown, nearly black; tegulae and posterior margin of pronotum brown; legs dark brown except the front tibiae and tarsi bright castaneous, middle and hind tarsi medium brown; wings faintly tinged with yellowish brown, especially in and around the radial cell, veins and stigma dark brown. Mandibles with two teeth, the inner margin convexly rounded but without additional teeth basad of the second tooth (Fig. 33). Clypeus broad and with a high median carina which is weakly arched in profile; apical margin obtusely angulate, but the median point acute (about as in *incomptus*, Fig. 26). Eyes not hairy. Antennae with first four segments in a ratio of about 16:4:5:5, segment three 1.3 X as long as thick, flagellum becoming more slender apically, segment eleven 1.9 X as long as thick; flagellar pubescence erect, bristly, some of the setulae on the apical segments nearly half as long as the thickness of the flagellum. Front alutaceous, moderately shining, with large, shallow punctures which on the lower front are separated from one another by less than their own diameters, on the vertex by slightly more than their own diameters. Eyes slightly closer together near the bottom than at the middle, WF .63 X WH, 1.33 X HE; front angle of ocellar triangle less than a right angle, OOL 1.24 X WOT; WOT 1.1 X the distance from the posterior ocelli to the vertex crest.

Pronotum short, its disc alutaceous, with close, small punctures. Mesoscutum also alutaceous, somewhat shining, with small, moderately close-set punctures; notauli strong and complete, reaching transverse groove at base of scutellum, which is long and narrow; disc of scutellum alutaceous, punctate. Propodeum

very short, the disc .62 X as long as broad; median carina strong, reaching the strong transverse carina; disc with strong, irregular, reticulate rugae, strongest toward the base; spiracles subcircular, directed dorsad. Mesopleurum wholly alutaceous, punctate except for the callus, which is convex and has only a few punctures. Claws simple although subdentate basally. Fore wing with discoidal vein rather strong, the discoidal cell completely outlined by weakly pigmented veins; subdiscoidal vein extending to wing margin as a very weakly pigmented line; first recurrent vein very weakly pigmented. Abdomen rather short and stout. Second tergite large, with a pair of shallow depressions, each giving rise to a tuft of strong setae, the tergite otherwise without setae; these depressions and tufts are well separated on the median portion of the tergite. Subgenital plate broadly truncate. Genitalia not examined.

Other males examined.—ECUADOR: 1, Abitagua, 1110 meters, 2 April 1940 (Clarke, MacIntyre) [MCZ]; 1, Puyo, Nago-Pastaxa Pr., 16 April 1958 (R. W. Hodges) [CU].

Variation.—The Ecuador specimens are slightly smaller than the type (LFW \pm 0.4, 4.8 mm). The Abitagua specimen has the wings rather strongly suffused with yellowish, the veins amber. In both Ecuador specimens the clypeus is wholly rufous, the first three antennal segments yellowish brown. Otherwise the resemblance to the type is very close indeed.

(2) DISSOMPHALUS MONTANUS (Kieffer) new combination

Glenobethylus montanus Kieffer, 1910b, p. 50 [Type: ♂, PERU: Cosnipata-Ebene, Dept. Cuzco, 1000 meters elevation, 5-1-01 (Garlepp) (Berlin Museum, No. 200)]. —Kieffer, 1914, p. 494.

Description of type.—Length 4.5 mm; LFW 3.9 mm. Body piceous, the abdomen slightly paler than head and thorax, especially sides of basal segments; mandibles and sides of clypeus yellowish brown; antennae light brown, gradually infuscated toward the apex; tegulae testaceous; legs bright castaneous, coxae and femora slightly darker than other parts of legs; wings subhyaline, veins and stigma amber. Mandibles slender and bidentate. Clypeus with median carina weakly arched in profile; apical margin tridentate, median tooth acute, the other two rounded (as figured for *plaumanni*, Fig. 27). Antennae with first four segments in a ratio of about 3:1:1:1, segment three 1.5 X as long as thick, outer antennal segments more slender, segment eleven twice as long as thick; flagellar pubescence erect,

bristling, setulae about half as long as width of flagellum. Eyes not hairy. Front alutaceous, weakly shining, with large but very shallow punctures which are separated from one another by about their own diameters (above) or less than their own diameters (below). Eyes somewhat convergent below, WF .61 X WH, 1.28 X HE; front angle of ocellar triangle acute, OOL 1.3 X WOT, posterior ocelli removed from vertex crest by a distance slightly less than width of ocellar triangle. Vertex broadly, weakly rounded off only a short distance above eye tops, distance from eye tops to vertex crest equal to about half HE.

Pronotum short, with close but shallow punctures. Mesoscutum alutaceous and weakly shining, its punctures smaller than those of the head or pronotum; notauli complete; scutellum alutaceous, also with small punctures. Propodeum short, the disc only .6 X as long as wide; median carina strong, reaching the transverse carina; disc shining, with irregular reticulate rugae; spiracles large, subcircular, directed dorsolaterad. Mesoscutum alutaceous and punctate, callus convex and only weakly punctate. Claws simple. Fore wing with discoidal vein strong; discoidal cell closed; first recurrent vein pigmented; subdiscoidal vein as well as radial vein reaching wing margin, although very weak apically. Abdomen relatively broad and short. Second tergite large, somewhat flat, with scattered minute, subapressed setae; disc with a pair of submedian opaque spots (not notably depressed) each of which gives rise to several slender but fairly long setae. Subgenital plate broadly truncate apically. Genitalia not studied.

Remarks.—I have seen no specimens of this species other than the type. Kieffer apparently overlooked the modifications of the second tergite. Simple claws occur also in *punctatus* and several other species.

(3) DISSOMPHALUS BRASILIENSIS Kieffer

Dissomphalus brasiliensis Kieffer, 1910a, p. 295. [Type: ♂, BRAZIL: Pará (C. F. Baker) (Pomona College, Claremont, Calif.)]. —Kieffer, 1914, pp. 502-503.

Description of type.—Length 2.7 mm; LFW 2.2 mm. Body rather uniformly dark brown; mandibles light brown; scape and base of flagellum light brown, greater part of flagellum dull, medium brown; legs wholly light yellowish brown except hind femora weakly suffused with darker brown; wings hyaline, veins

and stigma brown. Mandibles slender, bidentate (as in *punctatus*, Fig. 33). Clypeus broadly expanded apically, with a single strong median, acute process; median carina strong, in profile nearly straight (Fig. 24). First four antennal segments in a ratio of about 18:7:6:6, segment three 1.5 X as long as thick, segment eleven 1.7 X as long as thick; pubescence coarse and semi-erect, setulae more than half as long as width of segments, also with some erect setae which are nearly or quite as long as width of segments bearing them. Front shining, uniformly but rather weakly alutaceous, punctures shallow and inconspicuous; eyes glabrous. Head about as wide as high; inner orbits subparallel on lower two-thirds, WF .59 X WH, 1.13 X HE; vertex extended only slightly above tops of eyes, distance from eye tops to vertex crest only about one-third X HE. Ocelli slightly enlarged, DAO .18 X WF, forming a triangle the front angle of which is less than a right angle; OOL .93 X WOT.

Pronotum sloping evenly forward to the collar, without an anterior face except as indicated by a weak transverse groove; pronotal disc, like that of the mesoscutum and scutellum, shining, weakly alutaceous, obscurely punctate. Propodeum short, barely longer than wide, the dorsal surface wider than long; median carina strong but not nearly reaching the weak and irregular transverse carina margining the disc behind; disc with reticulate sculpturing basally, otherwise smooth and strongly polished; lateral carinae strong, interrupted by the spiracles, which are large, subcircular, directed laterad. Mesopleurum somewhat shining, weakly and uniformly alutaceous, obscurely punctate. Claws simple. Fore wing with basal vein erect, forming nearly a straight line with transverse median vein, which is curved only slightly; discoidal vein interstitial with media, pigmented to a distance greater than length of basal vein, subdiscoidal vein weakly pigmented and extending well out toward wing margin, vein closing off discoidal cell also very weakly pigmented. First abdominal tergite with a rather wide, subfoveolate groove which extends more than half the length of the tergite. Second tergite with weak, anterior, sublateral opaque spots, otherwise shining, without setae except for a small group arising from each pit; pits small, separated by about 3 X their own diameter, each located toward the inner side of a shallow, dish-like concavity. [Third tergite also biconcave, but with no indication of the pits mentioned by Kieffer; this tergite is somewhat distorted on both sides and these concavities are

probably artifacts. The tip of the abdomen (beyond segment four) is wholly missing.]

Remarks. — This species is known to me only from the type.

(4) *DISSOMPHALUS INCOMPTUS* new species

Holotype. — ♂, BRAZIL: Nova Teutonia, Santa Catarina, 2 May 1938 (Fritz Plaumann) [BMNH].

Description of type. — Length 2.6 mm; LFW 1.9 mm. Entire body dark castaneous; antennae light brown basally, gradually infuscated to nearly black apically; legs medium brown, tarsi and trochanters slightly paler; wings hyaline, with dark setulae, veins and stigma brown. Mandibles very slender, terminating in three teeth, the apical tooth large, the other two teeth minute and close together (Fig. 34). Clypeus large, median portion obtusely angulate, the mid-point acute; median carina not reaching apex (Fig. 26). First four antennal segments in a ratio of about 3:1:1:1, segment three 1.4 X as long as thick, segment eleven 1.8 X as long as thick; pubescence coarse, semi-erect, setulae of segment eleven over half the width of the segment. Eyes with scattered short hairs. Front alutaceous, moderately shining, punctures shallow, on lower front separated by about their own diameters, on upper front by 2-3 X their own diameters. WF .58 X WH, 1.12 X HE; OOL 1.15 X WOT, distance from posterior ocelli to vertex crest equal to about half WOT. Vertex broadly rounded off a distance above eye tops equal to about half HE.

Anterior margin of pronotal disc with a rather irregular transverse carina, behind which the disc is subfoveolate; posterior part of disc alutaceous, moderately shining. Mesoscutum alutaceous, obscurely punctate; basal groove of scutellum much constricted in the middle. Propodeal disc .7 X as long as wide, strongly margined laterally and behind, covered with coarse reticulations except for a small smooth area just before the transverse carina. Mesopleurum alutaceous, callus subtended by a pair of foveolate grooves which meet at a right angle. Claws weakly dentate. Fore wing with discoidal vein strong, interstitial with median vein; subdiscoidal vein weakly pigmented, discoidal cell barely closed on outer side. First abdominal tergite with a strong median groove which extends over half its length. Second tergite with a pair of pale, roughened spots at the extreme anterior margin toward the sides of the dorsum, otherwise completely smooth and without modifications. Subgenital plate

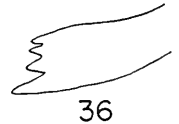
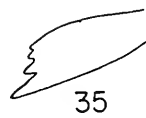
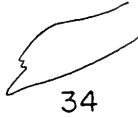
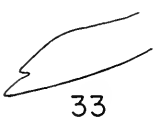
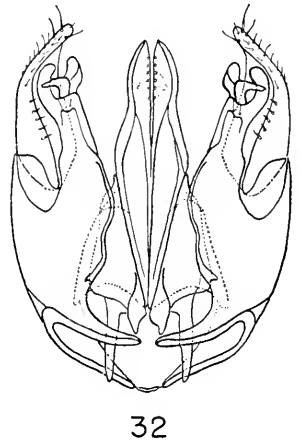
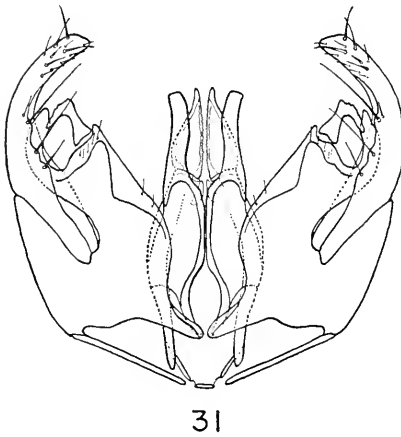
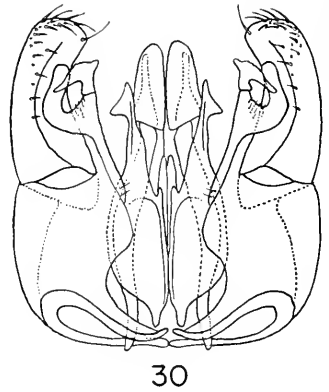
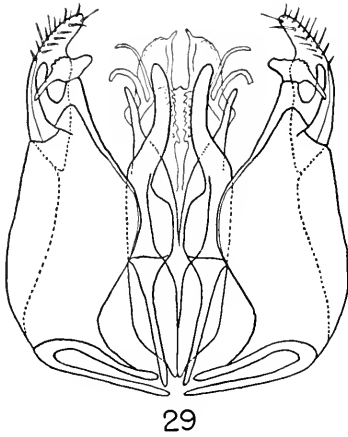

Dissomphalus spp. Fig. 29. *D. incomptus* n. sp., male genitalia. Fig. 30. *D. rettenmeyeri* n. sp., male genitalia. Fig. 31. *D. cornutus* n. sp., male genitalia. Fig. 32. *D. plaumanni* n. sp., male genitalia. Fig. 33. *D. punctatus* (Kieffer), male, mandible. Fig. 34. *D. incomptus* n. sp., male, mandible. Fig. 35. *D. plaumanni* n. sp., male, mandible. Fig. 36. *D. cornutus* n. sp., male, mandible.

emarginate. Genitalia with the parameres short, tapering apically; aedoeagus very complex, ventral rami large, convergent, their apices divergent; dorsal body of aedoeagus with two pairs of ventral flagella which are perpendicular to the main part of the aedoeagus (Fig. 29).

Paratypes. — BRAZIL: 7 ♂♂, same data as type except various dates (19 May 1937, 2 May 1938, 29 Dec. 1938, Dec. 1962) [BMNH, MCZ].

Variation. — LFW varies from 1.5 to 2.0 mm; WF/HE varies from 1.12 to 1.20; OOL/WOT varies from 1.15 to 1.30. In some specimens the antennae are uniformly medium brown.

Remarks. — This species is of unusual interest because of the fact that the second tergite bears no real pits, hair tufts, or spines, but merely a pair of pale, dull spots anterolaterally. Similar spots occur in other species (such as *apertus* Kieffer) which also possess an additional pair of large pits mesad of these. Species such as *incomptus* stand very close to members of the *dissomphaloides* species-group of the genus *Apenesia*, in which modifications of the second tergite are altogether lacking.

(5) DISSOMPHALUS RETTENMEYERI new species

Holotype. — ♂, PANAMA: Barro Colorado Island, Canal Zone, 26 February 1955 (Berlese refuse, colony no. 55B-IV, *Eciton burchelli*; Carl W. Rettenmeyer) [USNM, No. 64,996].

Description of type. — Length 3 mm; LFW 2.2 mm. Head and thorax black, abdomen dark, shining brown; mandibles light brown; antennae light brown basally, gradually infuscated to dark brown beyond segment six; legs testaceous except front coxae and front and middle femora weakly suffused with brown, hind femora strongly suffused with dark brown; wings subhyaline, setulae dark, veins and stigma brown. Mandibles with two apical teeth, the inner tooth at the end of an oblique cutting edge (about as in *punctatus*, Fig. 33). Clypeus large, its apical margin slightly sinuate, sharply angulate medially; median carina nearly straight in profile, reaching nearly to tip of median angulation (Fig. 28). First four antennal segments in a ratio of about 15:5:4:5, segment three only 1.2 X as long as thick, segment eleven 1.6 X as long as thick; flagellum with coarse, semi-erect pubescence and with many erect setae standing somewhat above the pubescence. Eyes covered sparsely with short hairs. Front strongly alutaceous, almost beaded, weakly

shining, punctures shallow and not at all conspicuous. Eyes rather strongly convergent below, WF .55 X WH, 1.05 X HE; OOL 1.15 X WOT; posterior ocelli removed from vertex crest by approximately their own diameters. Central part of vertex nearly straight across.

Pronotal disc rather flat, oblique, ecarinate, surface strongly alutaceous and obscurely punctate like that of mesonotum; notauli complete; groove at base of scutellum long and slender. Propodeal disc about .7 X as long as wide; transverse carina strong, somewhat sinuate; median carina not attaining transverse carina; surface of disc wholly covered with strong reticulations. Mesopleurum alutaceous, with a strong, oblique, foveolate groove. Claws weakly dentate at base. Fore wing with discoidal vein long, discoidal cell weakly outlined below and apically; basal vein reaching subcosta far basad of stigma. First abdominal tergite with a deep median basal groove. Second tergite polished and without setae, with a pair of depressed pale spots laterally, close to anterior margin; each of these pale spots is set on the inner side of a broad, very shallow, slightly roughened depression. Subgenital plate shallowly emarginate apically. Genitalia with the parameres unusually broad and truncate apically; aedeagus with the ventral rami weak but with an apical wing-like expansion, dorsal body rather slender (Fig. 30).

Allotype. — ♀, PANAMA: same data as type except 5 March 1955 (refuse deposit from inside log, colony no. 55B-IV, *Eciton burchelli*; Carl W. Rettenmeyer) [USNM].

Description of allotype. — Length 2.5 mm; LH .60 mm; LT .80 mm. Body pale castaneous, abdomen slightly paler basally and apically; legs and antennae testaceous. Mandibles with four teeth, basal tooth rather broad, arching into inner mandibular margin. Clypeus with its median area short, subtruncate, median carina abruptly cut off, the margin of the clypeus as seen from below narrowly subtriangular, the apex of the triangle being formed by the end of the median carina. Upper margins of antennal scrobes carinate for a short distance on each side of the midline. First four antennal segments in a ratio of about 15:4:2:2, segment three about 1.5 X as wide as long, segment eleven about twice as wide as long; antennae moderately incrassate, apical segments with numerous elongate sensoria. Head longer than wide, LH 1.20 X WH; vertex distinctly concave when head is viewed from in front. Eyes small, dark gray, elliptical, each with six facets. Front strongly alutaceous although moderately

shining, punctures large but shallow, separated for the most part by more than their own diameters; median line of front weakly impressed.

Dorsum of thorax and propodeum strongly alutaceous, weakly shining, obscurely punctate; pronotal disc about as long as wide; mesonotum a very short transverse band; propodeum 1.9 X as long as its maximum width, maximum width 1.15 X minimum width; lateral margins of propodeal disc carinate, the two carinae weakly convergent at the spiracles. Middle tibiae with five strong spines above, not counting those at apex. Abdominal petiole rather long, measuring (in dorsal view) about .4 X the length of the hind tibia. Abdomen shining although weakly alutaceous.

Remarks. — This species is known only from the type and allotype. The male resembles *incomptus* in many ways, including the shape of the clypeus and the nature of the tergal pits. The pits are, however, somewhat larger and more sunken than in *incomptus*, and furthermore the area around them is somewhat depressed and roughened. Perhaps this species represents an intermediate stage between species with barely visible tergal pits and the many species with strongly developed pits. The female is a typical "*Parccitopria*" in the sense of Ogloblin, the petiole being long and the middle tibiae strongly spinose.

(6) DISSOMPHALUS LUSCUS new species

Holotype. — ♀, BRAZIL: Rio Grande do Sul, Sinimbu, 200 meters elevation, Sept. 1960 (Fritz Plaumann) [MCZ, No. 30,798].

Description of type. — Length 3.1 mm; LH .67 mm; LT 1.05 mm. Head and thorax bright castaneous; abdomen pale castaneous, shining, the petiole blackish; antennae and legs testaceous. Mandibles with four teeth. Clypeus with a rather long and narrow median lobe, the apex of which is subtruncate; median carina strong, complete. Antennal scrobes not margined by carinae. First four antennal segments in a ratio of about 5:1:1:1, segment three slightly wider than long, segment eleven about 1.5 X as wide as long; antennae rather weakly incrassate, apical segments with numerous elongate sensoria. Head elongate, somewhat barrel-shaped, the sides convergent both in front of and behind the middle; LH 1.5 X WH; vertex, in anterior view, nearly straight across, the occipital carina strong. Eyes very

small, straw-colored (paler than head), each consisting of a single facet. Front shining, barely alutaceous but strongly punctate, the punctures separated by less than their own diameters.

Pronotal disc 1.2 X as long as its posterior width, shining, strongly punctate. Mesonotum .6 as long as wide, its posterior margin arenately embraced by the propodeum. Propodeum unusually elongate, measuring 2.8 X as long as its maximum width, 3.3 X as long as its minimum width; maximum width 1.15 X minimum width; spiracles and constriction far forward, the sides of the propodeum behind the constriction nearly straight, parallel; surface of propodeum shining on anterior half, distinctly duller and more alutaceous behind. Mesopleura without a distinct dorsal surface, as usual in the genus. Middle tibiae with several rather weak spines above. Abdominal petiole short, measuring (in dorsal view) about .3 X the length of the hind tibia. Abdomen slender, fusiform.

Paratypes. — BRAZIL: 1 ♀, same data as type [MCZ]; 1 ♀, Seara, Santa Catarina, July 1960 (Fritz Plaumann) [MCZ]; 4 ♀♀, Nova Teutonia, Santa Catarina (Fritz Plaumann) [MCZ, USNM, BSA, BMNH].

Variation. — The six paratypes vary in size from 2.4 to 3.3 mm. LII varies from 1.38 to 1.55 X WH; length of the propodeum varies from 2.6 to 2.8 X maximum width. Very little variation can be noted in this series.

Remarks. — This is the only *Dissomphalus* known to me which has the eyes reduced to a single facet each (as occurs in *Pseudisobrachium* and three known species of *Apenesia*). The species is also unusual because of the very elongate head and propodeum. The shape of the propodeum is not very different from that of some species of *Apenesia*, but the mesopleura is not nearly as well developed dorsally as it is in that genus.

(7) *DISSOMPHALUS CORNUTUS* new species

Holotype. — ♂, BRAZIL: Santa Catarina, Nova Teutonia, 15 June 1937 (Fritz Plaumann) [BMNH].

Description of type. — Length 2.3 mm; LFW 1.7 mm. Head and thorax dark castaneous; abdomen dark, shining brown except sides of basal tergite paler; basal two antennal segments light brown, remainder of antenna medium brown; legs medium brown except trochanters and tarsi very light brown; wings nearly clear hyaline, veins and stigma brown. Mandibles with four strong apical teeth, the basal two teeth very close together

(Fig. 36). Clypeus large, its apical margin weakly tridentate medially; median area of clypeus strongly elevated, each side of the elevation produced into a large, acute tooth (Fig. 25). First four antennal segments in a ratio of about 18:6:5:5, segments three and eleven each about 1.3 X as long as thick; flagellum with strong, semi-erect pubescence above which rise some fully erect setae. Eyes covered with short hairs. Front shining although uniformly alutaceous, punctures small and rather widely spaced. WF .59 X WH, 1.25 X HE; vertex broadly rounded off a distance above eye tops equal to about two-thirds X HE. OOL 1.45 X WOT; posterior ocelli removed from vertex crest by two-thirds X WOT.

Surface of pro- and mesonota alutaceous but rather strongly shining; pronotum obscurely rugulose anteriorly, but not actually carinate; notauli present only on anterior third of mesoscutum; scutellar groove strong, slender. Propodeal disc .9 X as long as wide, strongly margined laterally and behind, median carina extending only two-thirds the length of the disc; apical part of disc rather smooth, base reticulate. Claws simple except weakly dentate at base. Fore wing with the transverse median vein erect, the basal vein sloping only slightly and meeting subcosta far basad of stigma; discoidal vein weakly pigmented for a short distance. Basal groove of first abdominal tergite extending about .6 X the length of the tergite. Second tergite with a few weak setae on the sides, on each side of the median line with a small pencil of rather long setae, the pencils about as long as half the distance between them; these pencils appear to rise directly from the surface, not from pits. Subgenital plate broad, subtruncate. Genitalia with the parameres strongly curved mesad, rather slender apically, bearing several extremely large setae on their inner margin; aedeagus with the ventral rami unusually large, relatively broad and blunt apically, as long as the two acute lobes of the dorsal body (Fig. 31).

Paratypes. — BRAZIL: 29 ♂♂, same data as type except various dates Dec.-Mar. 1945-46 [BMNH, MCZ].

Variation. — LFW varies from 1.2 to 1.8 mm. The front and thoracic dorsum vary from weakly alutaceous and strongly shining to rather strongly alutaceous and weakly shining. In some specimens the clypeal processes are strong, acute, and horn-like; in others they are low and obtuse. In some specimens antennal segments three and eleven are only slightly longer than thick. Variation in other features is very slight.

Remarks.—The development of the clypeus of this species is unique and immediately separates it from other known species. The modifications of the second tergite are also unusual, as are the reduced notauli.

(8) DISSOMPHALUS PLAUMANNI new species

Holotype.—♂, BRAZIL: Santa Catarina, Nova Teutonia, 26 February 1945 (Fritz Plaumann) [BMNH].

Description of type.—Length 3.8 mm; LFW 3.2 mm. Head and thorax black; abdomen very dark brown, shining, somewhat paler basally and apically; mandibles light brown; margin and sides of clypeus suffused with castaneous; antennae light castaneous, slightly infuscated apically; coxae and trochanters brown, remainder of legs light yellowish brown; wings subhyaline, veins and stigma brown. Mandibles with four teeth (Fig. 35). Clypeus large, tridentate, median tooth acute, lateral teeth rounded (Fig. 27); median carina complete, highest about mid-way, simple. First four antennal segments in a ratio of about 18:5:5:7, segment three 1.2 X as long as thick, segment eleven twice as long as thick; pubescence coarse, semi-erect, flagellum also with scattered, fully erect setae which stand slightly above the pubescence. Eyes covered with very short hairs. Front alutaceous, moderately shining, wholly covered with shallow though sharply-defined punctures which are separated by about or slightly less than their own diameters. WF .62 X WH, 1.2 X HE; ocelli in a compact triangle far removed from eyes and well removed from vertex crest; OOL 1.35 X WOT.

Pronotum very short, sloping steeply in front, transversely rugoso-punctate except toward posterior margin. Mesoscutum shining, alutaceous, wholly covered with small punctures; notauli complete, strong; groove at base of scutellum strong. Propodeal disc short, .7 X as long as wide, wholly covered with strong reticulations; median carina complete, reaching the sinuous transverse carina. Mesopleurum coarsely sculptured in front, alutaceous behind, with a broad, oblique groove. Claws with a tooth at base. Fore wing with the discoidal cell very weakly outlined, the subdiscoidal vein weakly continuous to the outer wing margin. First abdominal tergite with a strong basal groove which extends for about half the length of the tergite. Second tergite with a pair of widely separated bowl-shaped depressions, each bearing on its outer side an umbiliform elevation bearing a tuft of pale

hairs, these directed mesad and slightly caudad; each depression bearing a few additional short setae, but the tergite otherwise devoid of setae. Subgenital plate broad, somewhat sinuate apically (Fig. 19). Genitalia with the parameres very broad, subacute and curved mesad apically; aedoeagus with the ventral rami short, dorsal body bilobed, strongly compressed (Fig. 32).

Paratypes. — BRAZIL: 7 ♂♂, same data as type except dates Jan., Mar., Aug., 1945, 1961, 1963 [BMNH, MCZ].

Variation. — In the paratypes LFW varies from 2.8 to 3.3, WF from 1.07 to 1.25 X HE, OOL from 1.26 to 1.35 X WOT. Some slight variation in the strength of the punctures of the front can be noted, but otherwise this series is remarkably uniform in structure.

Remarks. — This relatively large species has much in common with *punctatus* Kieffer, from Peru.

(9) DISSOMPHALUS CLAVIGER new species

Holotype. — ♀, BRAZIL: Rio Grande do Sul, Erechim, 750 meters elevation, July 1960 (Fritz Plaumann) [MCZ, No. 30,799].

Description of type. — Length 1.2 mm; LH .30 mm; LT .43 mm. Body wholly pale castaneous; antennae and legs straw-colored. Body setae abundant, pale, fairly long on the thoracic dorsum. Mandibles with four teeth. Clypeus with the median lobe narrowly trapezoidal, its median carina declivous between the antennal sockets, then turning upward at nearly a right angle and abruptly, angularly cut off at the apex; apical margin of median lobe of clypeus, seen from below, forming a small triangle, the truncate median carina forming its apex. Antennal scrobes not margined. Scape much thickened apically, flagellum slender at the base and much swollen apically, the flagellum only slightly more than twice as long as the scape; antennal segments 3-8 very short, hardly more than annuli; flagellar sensoria large, arranged in four widely spaced rows, so that each segment (except the most basal segments and the apical segment) has four sensoria, only two of which can be seen from any one view of the antenna. Head with its sides strongly arcuate, so that it is much wider near the middle than in front or behind; LH 1.3 X WH; vertex slightly concave in anterior view. Eyes minute, black-rimmed, each with only two visible facets. Head wholly but very weakly alutaceous, strongly shining, punctures shallow and inconspicuous although quite numerous, especially below.

Pronotal disc very slightly longer than wide, its surface, like that of the mesonotum and propodeum, alutaceous although moderately shining. Propodeum relatively short, measuring 1.7 X as long as its maximum width, twice as long as its minimum width; maximum width about 1.2 X minimum width; sides of disc carinate, the carina parallel in front of the spiracles, behind them weakly, arcuately divergent. Mesopleura conically produced above, so that in dorsal view the mesothorax is wider than is usual in this genus. Middle tibiae with some small spines near the apex. Abdominal petiole short, measuring (in dorsal view) about .15 X the length of the hind tibia. Abdomen relatively short and stout.

Paratypes. — BRAZIL: 14 ♀♀, same data as type [MCZ, CU, USNM, BSA, BMNH]; 4 ♀♀, Sinimbu, Rio Grande do Sul, 200 meters elev., Sept. 1960 (Fritz Plaumann) [MCZ]; 14 ♀♀, N. Petropolis, 800 meters elev., Nov. 1959 (Fritz Plaumann) [MCZ, BMNH]; 15 ♀♀, Seara, Santa Catarina, Jan. 1960 (Fritz Plaumann) [MCZ, USNM, BMNH]; 20 ♀♀, Nova Teutonia, Santa Catarina, various dates (Fritz Plaumann) [MCZ, BSA]; 9 ♀♀, Chapeco, Santa Catarina, May, Aug. (Fritz Plaumann) [MCZ, BSA]; 3 ♀♀ Rio Azul, Parana, 1000 meters, Oct. 1959 (Fritz Plaumann) [MCZ].

Variations. — The 79 paratypes vary in size from about 1.0 to 1.5 mm, in color from wholly straw-colored to medium castaneous, in the latter case with paler appendages and often a slightly paler abdomen. The eyes are minute in all specimens, but in some of the larger specimens one can make out up to four rather ill-defined facets. In many specimens the front is strongly polished, barely if at all alutaceous, and in some the punctures are slightly more sharply defined than in the type, though they are never very large. Variation in head shape is negligible, but there is considerable variation in the length of the propodeum (length 1.65-1.95 X maximum width). The antennal sensoria show only slight variation throughout this long series.

Remarks. — This is apparently a common species in southern Brazil; in fact, it is known from a longer series than any other species of the genus. Unusual features include the sparse antennal sensoria and the conical processes on the mesopleura. It is possible that this is the female of *cornutus*, but the rich *Dissomphalus* fauna of Brazil is so poorly known that this would be no more than a guess at this point.

(10) DISSOMPHALUS SCRUPEUS new species

Holotype.—♀, BRAZIL: Santa Catarina, Chapeco, 600 meters elevation, Aug. 1960 (Fritz Plaumann) [MCZ, No. 30,800].

Description of type.—Length 1.7 mm; LH .45 mm; LT .54 mm. Head and thorax light castaneous; abdomen shining, slightly paler than head and thorax; legs and antennae testaceous. Body setae pale, short, relatively abundant. Mandibles with four teeth. Clypeus with the median lobe slightly wider than in *claviger*, carinate as in that species. Scape much widened apically, flagellum much swollen toward the apex, almost as much so as in *claviger*, but the sensoria much more abundant than in that species; on the outer side of each of the more apical segments (except the last) 5-6 large sensoria can be seen; the inner sides of these segments are largely devoid of sensoria, but have a pair of longitudinal streaks (each consisting of microscopic pores); apical antennal segment with many sensoria. Head with its sides strongly arcuate, so that it is much wider at the middle than in front or behind; LH 1.3 X WH; vertex straight across in anterior view. Eyes blackish, slightly larger than in *claviger*, each with four ill-defined facets. Head rather weakly shining, front alutaceous and closely covered with shallow punctures, the two together giving the front a very much roughened surface, especially above.

Thoracic dorsum alutaceous, rather weakly shining, setigerous punctures numerous but shallow and inconspicuous. Propodeum 1.8 X as long as its maximum width, 2.6 X as long as its minimum width; propodeum with a relatively strong constriction (for the genus) at the spiracles, maximum width 1.4 X minimum width. Mesopleura not produced above; middle tibiae simple, without spines. Abdominal petiole measuring, in dorsal view, about .25 X as long as the hind tibia (Fig. 21).

Paratypes.—BRAZIL: 4 ♀♀, same data as type [MCZ]; 5 ♀♀, Seara, Santa Catarina, Jan. 1960 (Fritz Plaumann) [MCZ]; 11 ♀♀, Nova Teutonia, Santa Catarina (Fritz Plaumann) [MCZ, USNM, BMNH, BSA]; 6 ♀♀, Ibicare, Santa Catarina, 600 meters elev., Sept. 1960 (Fritz Plaumann) [MCZ, ANSP]; 7 ♀♀, Erechim, Rio Grande do Sul, 750 meters elev., July, Aug. (Fritz Plaumann) [MCZ, BSA].

Variation—The 31 paratypes vary in size from 1.6 to 2.0 mm. In several of the larger specimens, the head, thorax, and petiole are dark castaneous, considerably darker than the appendages

and the abdomen. The number of eye facets varies from four to six. Some variation can be noted in the degree to which the sides of the head are convergent above and below, but in all specimens head length approximates 1.3-1.35 X head width. Maximum width of the propodeum varies from 1.3-1.5 X minimum width.

Remarks.—This species has the strongest propodeal constriction of any species of this genus known to me, fully as strong as it is in some species of *Apenesia*.

5. Genus PSEUDISOBRACHIUM Kieffer²

Isobrachium Ashmead, 1893, pp. 35-40 (U.S. spp.; not Foerster, 1856, misidentification). —Ashmead, 1902, p. 270.

Pseudisobrachium Kieffer, 1904b, p. 368 (type species *P. laticeps* Kieffer, designated by Kieffer, 1906a). —Kieffer, 1905a, pp. 101, 125. —Kieffer, 1906a, pp. 295-305 (key to spp. of Europe). —Kieffer, 1908a, pp. 23-24. —Kieffer, 1914, pp. 472-484 (key to spp. of world). —Benoit, 1957, pp. 26-28 (African spp.). —Evans, 1961, pp. 211-318 (spp. of North and Central America).

Monopyris Kieffer, 1905a, pp. 101, 124 (type species *Epyris holidayi* Westwood, monobasic; synonymy by Kieffer, 1906a).

Plutobethylus Kieffer, 1910b, p. 51 (type species *P. distans* Kieffer, original designation; synonymy by Evans, 1961).

Lyssepyris Kieffer, 1913, p. 108 (type species *Holepyris flavicornis* Kieffer, monobasic; synonymy by Evans, 1961).

Xantepyrus Kieffer, 1913, p. 108 (type species *Epyris flaviventris* Kieffer, monobasic; synonymy by Evans, 1961).

Lissepyris Kieffer, 1914, p. 236 (error for *Lyssepyris* Kieffer, 1913).

Xantepyrus Kieffer, 1914, p. 417 (correction of typographical error in name *Xantepyrus* Kieffer, 1913).

Parisobrachium Kieffer, 1914, p. 424 (type species *Rhabdepyris* (?) *albipes* Kieffer, monobasic; synonymy by Evans, 1961).

Generic characters.—*Males.* Maxillary palpi with six segments, labial with three. Maudibles with from three to five teeth, clypeus with a trapezoidal median lobe the apex of which is usually truncate, but may be emarginate or dentate (in several South American species the median lobe is rounded or subangulate, not trapezoidal); eyes densely covered with short hair (except glabrous in *coralis* Cameron, from Panama); antennae 13-segmented, filiform, the flagellar pubescence appressed

² In a paper received too late for incorporation into this synopsis, Ogloblin has described three new species of *Pseudisobrachium*, one of them forming the basis of a new subgenus (Ogloblin, 1963, Rev. Soc. Ent. Argentina, 26: 133-138). The three species were described from females from the provinces of Buenos Aires and Misiones, Argentina. They are: *P. (P.) rapoporti*, *P. (P.) solenopsiphilum*, and *P. (Edapholigon) hypogaeum*. The subgenus *Edapholigon* agrees well with *Pseudisobrachium* in most characters, but the maxillary and labial palpi have a single segment each and the midventral carina on the head is distinct only on its anterior third.

or partially erect, never fully erect and bristling, but flagellum with sparse erect setulae which stand above the pubescence; occipital carina usually obsolete dorsally. Pronotum at most weakly rugulose and very weakly impressed along posterior margin, without a transverse carina anteriorly; notauli complete, incomplete, or even absent; scutellum with a transverse groove at base; propodeum with a median carina (rarely absent), without a well-defined basal triangle, commonly (but not always) without sublateral carinae and transverse carina; claws with a small, erect tooth (sometimes very small or even absent, sometimes large), base of claw subdentate (as in *Pristocera*) in a very few species. Fore wing with costal vein extending beyond stigma only slightly if at all; basal vein reaching subcosta well basad of stigma; discoidal vein partially or fully outlined or completely absent. Abdomen sessile (petiolate in one known species). Subgenital plate simple, with a relatively short basal stalk (highly specialized and deeply divided in two known species). Genitalia with the parameres deeply divided into two separate arms; inner margin of base of volsella with a vannus (rarely absent); aedeagus of relatively simple structure, generally flat and somewhat bottle-shaped, but in a few species compressed and with membranous areas on the ventral side.

Females. Maxillary palpi with five segments, labial with three. Mandibles with three or four teeth; clypeus truncate or emarginate apically; eyes each consisting of a single facet, sometimes indistinct; head longer than broad; antennae short, 13-segmented, slightly incrassate. Mesonotum subtriangular, elongate, somewhat pointed behind; propodeum gradually narrowed anteriorly to a pair of small points which embrace the posterior point of the mesonotum, the thorax much constricted at the junction of the propodeum and mesonotum; mesopleura large, bulging laterally; middle tibiae stout and with strong spines above. Abdomen sessile in all known species. (Figs. 37-62.)

Remarks.—The synonymy of several of Kieffer's genera with *Pseudisobrachium* was discussed by Evans (1961). It will be noted that exceptions can be found to most of the characters cited for the males. In spite of this, members of this genus have a characteristic habitus and can generally be placed with little difficulty. In cases of doubt, the parameres of the genitalia can be depended upon for reliable identification, for they are deeply divided in all *Pseudisobrachium*, but not at all so in other genera of this subfamily.

Pseudisobrachium spp. Fig. 37. *P. prolongatum* (Provancher), male, fore wing. Fig. 38. Labium and maxilla, same sp., male. Fig. 39. Labium and maxilla, same sp., female. Fig. 40. Head and thorax, same sp., male. Fig. 41. Female, same sp. Fig. 42. *P. haemorrhoidalis* (Westwood), mandible. Fig. 43. *P. argentanicum* n. name, mandible. Fig. 44. *P. boliviense* Kieffer, median lobe of clypeus. Fig. 45. *P. paraguayense* n. name, same. Fig. 46. *P. brasiliense* Kieffer, same. Fig. 47. *P. rufopictum* n. name, same. Fig. 48. *P. argentanicum* n. name, clypeus. Fig. 49. *P. coxalis* (Cameron), same. Fig. 50. *P. angulatum* n. sp., same. Fig. 51. *P. plau-manni* n. sp., same. Fig. 52. *P. distans* (Kieffer), same. Fig. 53. *P. pulcherrimum* n. sp., same. Fig. 54. *P. montivagum* n. sp., same.

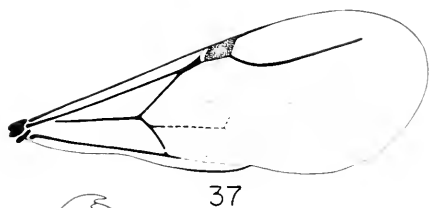

37

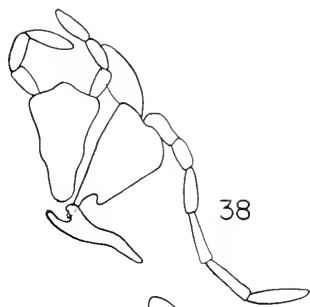

38

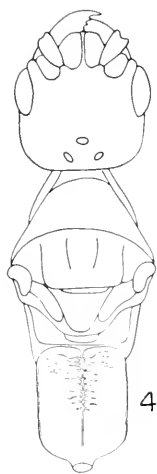

40

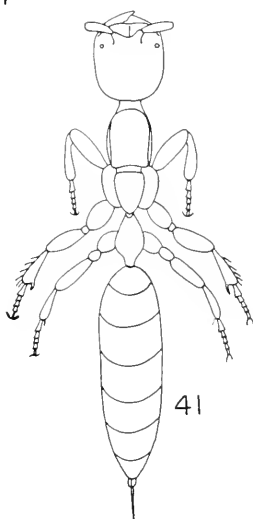

41

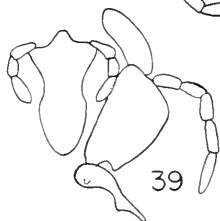

39



50



51



52

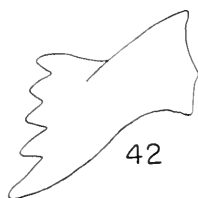

42

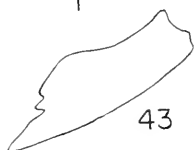

43

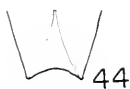

44

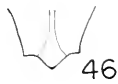

46



48



53



45



47



49



54

Biology. — The males of this genus are often taken in sweepings from low vegetation in fields and open woods; many species are nocturnal, especially in arid and semiarid regions. In my revision of this genus (1961) I summarized data from many parts of the world which indicate that the females inhabit ant nests. I pointed out that the evidence suggested that they are parasites of ant larvae, even though most if not all other *Pristocerini* attack beetle larvae.

Since this time I have come to feel that these wasps more probably attack soil-dwelling (perhaps myrmecophilous) beetle larvae, as suggested long ago by Ashmead (1893). In May 1963 I took a female *P. prolongatum* (Provancher) at Lexington, Mass., under a rock with worker *Camponotus* and *Acanthomyops* (no brood of either ant could be found). I placed the *Pseudisobrachium* in a rearing tin with some soil and from time to time presented her with ant larvae of various sizes, including species of *Lasius* as well as the above genera. She not only failed to attack them but appeared to avoid them; when introduced into other tins containing worker ants, eggs, and larvae, she appeared to avoid the ants and was in turn avoided by them. Unfortunately, I was unable to locate any beetle larvae before she died one week later. Of course it is possible that this female had already laid her full complement of eggs (the abdomen was slightly transparent and appeared to show no evidence of eggs) or that some other factor was unfavorable.

Distribution. — Members of this genus occur in all zoogeographic regions except the Australian. In the Americas, the genus occurs transecontinentally in southern Canada, south through the United States, Central America, and the Greater and Lesser Antilles, to Peru, Bolivia, and central Argentina; no species occur in Chile so far as presently known. In the Old World, the genus is represented in the Palaearctic, Ethiopian, and Oriental regions, but in none of these regions does one find the rich multiplicity of species characteristic of the Americas. Two species have been described from the Philippines and several undescribed species occur there, but I have seen no specimens from any other of the Pacific Islands, including the East Indies and the entire Australian region.

Included American species:

United States

anomalum Evans, 1961, p. 311; ♂, Virginia (also New Jersey, Florida, Illinois).

- apache* Evans, 1961, p. 299; ♂, Arizona.
- ashmeadi* Evans, 1961, p. 275; ♂, District of Columbia (widely distributed in eastern U.S.) (♀ also described).
- carbonarium* (Ashmead), 1893, p. 59; ♂, District of Columbia (widely distributed in eastern U.S.) (♀ described by Evans, 1961).
- carolinianum* Evans, 1961, p. 254; ♂, South Carolina (also Florida).
- castaneum* Evans, 1961, p. 248; ♂, California.
- comanche* Evans, 1961, p. 298; ♂, Arizona (also Texas).
- crassum* Evans, 1961, p. 239; ♂, Texas.
- emarginatum* Evans, 1961, p. 303; ♂, Texas.
- flavinervis* Fouts, 1928, p. 123; ♂, California (Texas to California; northern Mexico) (♀ described by Evans, 1961).
- flaviventre* (Kieffer), 1904a, p. 526; ♂, Texas (widely distributed in eastern U.S.) (♀ described by Evans, 1961).
- foutsii* Evans, 1961, p. 300; ♂, Texas (Texas to California; northern Mexico).
- gibbosum* Evans, 1961, p. 255; ♂, New Mexico.
- krombeini* Evans, 1961, p. 287; ♂, New Mexico.
- macrops* Evans, 1961, p. 309; ♂, Texas.
- matthewsi* Evans, 1961, p. 249; ♂, Texas (♀ also described).
- minimum* Evans, 1961, p. 280; ♂, New Mexico (also Arizona).
- minutissimum* Evans, 1961, p. 281; ♂, Baja California (also Arizona, New Mexico, Morelos, Guatemala).
- navajo* Evans, 1961, p. 283; ♂, Arizona.
- obscurum* Evans, 1961, p. 258; ♂, Texas (also Arizona, northwest Mexico) (♀ also described).
- occidentale* Evans, 1961, p. 244; ♂, California (also Arizona) (♀ also described).
- otiosum* Evans, 1961, p. 256; ♂, Arizona.
- pallidum* Evans, 1961, p. 258; ♂, Arizona.
- paucipunctatum* Fouts, 1928, p. 122; ♀, Utah (also California).
- persimile* Evans, 1961, p. 284; ♂, California.
- prolongatum* (Provancher), 1881, p. 265; ♂, Quebec (widely distributed in southern Canada and northern

- U.S.) (♀ described by Evans, 1961) (synonyms: *magnum* Ashmead, 1893, *myrmecophilum* Ashmead, 1893, *mandibulare* Ashmead, 1893, *montanum* Ashmead, 1893, *rugosulum* Fouts, 1928, *agilis* Whittaker, 1929).
- pusillum* Evans, 1961, p. 297; ♂, Louisiana (also Arkansas) (♀ also described).
- rectangulatum* Evans, 1961, p. 304; ♂, Texas (Nebraska to Nuevo Leon, Mexico).
- rufiventre* (Ashmead), 1893, p. 38; ♂, Virginia (widely distributed in eastern U.S.) (synonyms: *flavicoxis* Fouts, 1928, *puncticeps* Fouts, 1928).
- texanum* Evans, 1961, p. 240; ♂, Texas.
- Mexico and Central America*
- aztecum* Evans, 1961, p. 263; ♂, Morelos, Mexico.
- blomi* Evans, 1961, p. 235; ♂, Chiapas, Mexico (also Morelos).
- brunneum* Evans, 1961, p. 252; ♂, Hidalgo, Mexico.
- clypeatum* Evans, 1961, p. 242; ♂, Panama.
- cooperi* Evans, 1961, p. 241; ♂, Costa Rica.
- costaricanum* Evans, 1961, p. 317; ♀, Costa Rica.
- coxalis* (Cameron), 1888a, p. 450; ♂, Panama (re-described below, sp. 3) (new combination).
- dalmati* Evans, 1961, p. 237; ♂, Guatemala (also Mexico).
- flavicornis* (Kieffer), 1906b, p. 246; ♂, Nicaragua (also Honduras).
- gigas* Evans, 1961, p. 314; ♀, Panama.
- hurdi* Evans, 1961, p. 286; ♂, Durango, Mexico.
- manni* Evans, 1961, p. 315; ♀, Guatemala.
- micheneri* Evans, 1961, p. 234; ♂, Puebla, Mexico.
- michoacanum* Evans, 1961, p. 254; ♂, Michoacan, Mexico.
- montivagum* Evans, n. sp. described below from ♂, Guerrero, Mexico (sp. 1).
- nigriculum* Evans, 1961, p. 251; ♂, Hidalgo, Mexico (also Zacatecas).
- perpunctatum* Evans, 1961, p. 237; ♂, Oaxaca, Mexico.
- petiolatum* Evans, 1961, p. 310; ♂, Panama.
- pulcherrimum* Evans, n. sp. described below from ♂, Costa Rica (sp. 2).
- rettenmeyeri* Evans, 1961, p. 240; ♂, Panama (also Costa Rica).
- superbum* Evans, 1961, p. 313; ♂, Panama.

testaceipes Kieffer, 1906b, p. 240; ♂, Nicaragua.

zeteki Evans, 1961, p. 315; ♀, Panama.

West Indies.—I have seen representatives of this genus from all of the islands of the Great Antilles, and several species occur on St. Vincent, at least, in the Lesser Antilles. Up to the present time only the following three species have been described:

albipes (Ashmead), 1894, p. 191; ♂, St. Vincent.

collinum (Ashmead), 1894, p. 190; ♂, St. Vincent.

terresi Mann, 1915, p. 164; ♀, Haiti.

South America.—Relatively few (23) of the many South American species of this genus have been described. I have described below several species which are of note because they present certain exceptional structural features. I have also presented notes on several of the described species.

angulatum Evans, n. sp. described below from ♂, Peru (sp. 14).

argentinicum Evans, new name for *flaviventris* (Kieffer), 1910b, p. 53 (*nec* Kieffer, 1904a); ♂, Argentina (re-described below, sp. 9).

bolivianse Kieffer, 1910b, p. 45; ♂, Bolivia (re-described below, sp. 11).

brasiliense Kieffer, 1910a, p. 294; ♂, Brazil (re-described below, sp. 8).

burchellianum (Westwood), 1874, p. 165; ♂, Brazil (new combination).

crassicornis (Westwood), 1874, p. 164; ♂, Brazil (re-described below, sp. 6) (new combination).

distans (Kieffer), 1910b, p. 51; ♂, Peru (re-described below, sp. 10) (new combination).

distingucndum Kieffer, 1904b, p. 369; ♀, Paraguay.

elegantulum Ogloblin, 1925b, p. 24; ♂, Brazil.

graciliventre Ogloblin, 1925b, p. 27, new name for *distingucndum* Ogloblin, 1925a, *nec* Kieffer 1904b; ♀, Brazil.

haemorrhoidalis (Westwood), 1874, p. 166; ♂, Brazil (re-described below, sp. 5) (new combination).

haywardi Ogloblin, 1950, p. 490; ♀, Argentina.

inchoatum Kieffer, 1910a, p. 293; ♂, Brazil.

latiecps Kieffer, 1904b, p. 368; ♀, Bolivia.

merklei Bruch, 1917b, p. 464; ♀, Argentina.

mrazi Ogloblin, 1925a, p. 79; ♀, Brazil.

ogloblini Evans, new name for *flaviventre* Ogloblin, 1925a, *nec* Kieffer, 1904a; ♀, Brazil.

optimum Evans, n. sp. described below from ♂, Brazil (sp. 4).

paraguayense Evans, new name for *albipes* (Kieffer), 1904b, p. 411, *nec* Ashmead, 1894; ♂, Paraguay (re-described below, sp. 12).

plaumanni Evans, n. sp. described below from ♂, Brazil (sp. 13).

rufopictum Evans, new name for *rufiventris* (Kieffer), 1910a, p. 291 *nec* Ashmead 1893; ♂, Brazil (re-described below, sp. 7).

solenopsidicola Bruch, 1917a, p. 143; ♂, Argentina.

uruguayense Ogloblin, 1938, p. 41; ♂, Uruguay.

(1) PSEUDISOBRACHIUM MONTIVAGUM new species

Holotype.— ♂, MEXICO: GUERRERO: Omilteme, 8000 feet, Aug. (H. H. Smith) [BMNH].

Description of type.— Length 4.4 mm; LFW 4.0 mm. Head and thorax black; abdomen dark castaneous except first tergite blackish, all tergites indistinctly banded with light brown apically; apical half of mandibles yellowish brown, teeth rufous; antennae wholly medium castaneous except scape weakly infuscated; front trochanters and middle and hind coxae and trochanters bright testaceous, legs otherwise light brown; wings subhyaline, veins and stigma brown. Mandibles with five teeth in an oblique series. Median lobe of clypeus unusually broad and long, sides straight and parallel, apical margin weakly convex (Fig. 54); median line strongly carinate. Antennae very long, first four segments in a ratio of about 30:6:27:22, segment three 2.7 X as long as thick, segment eleven 3.2 X as long as thick, flagellum with subappressed, fairly coarse pubescence and with numerous erect setae standing well above it. Front polished, non-alutaceous, punctures separated, on the average, by about their own diameters. Eyes strongly hairy; occipital carina complete. WF .65 X WH, 1.5 X HE; distance from eye tops to vertex crest subequal to HE. Ocelli small, in a compact, right triangle; OOL 1.9 X WOT.

Pronotum crossed by some indistinct transverse ridges, its surface, like that of the mesoscutum, shining and closely punctate; notauli strong but not quite reaching anterior or posterior

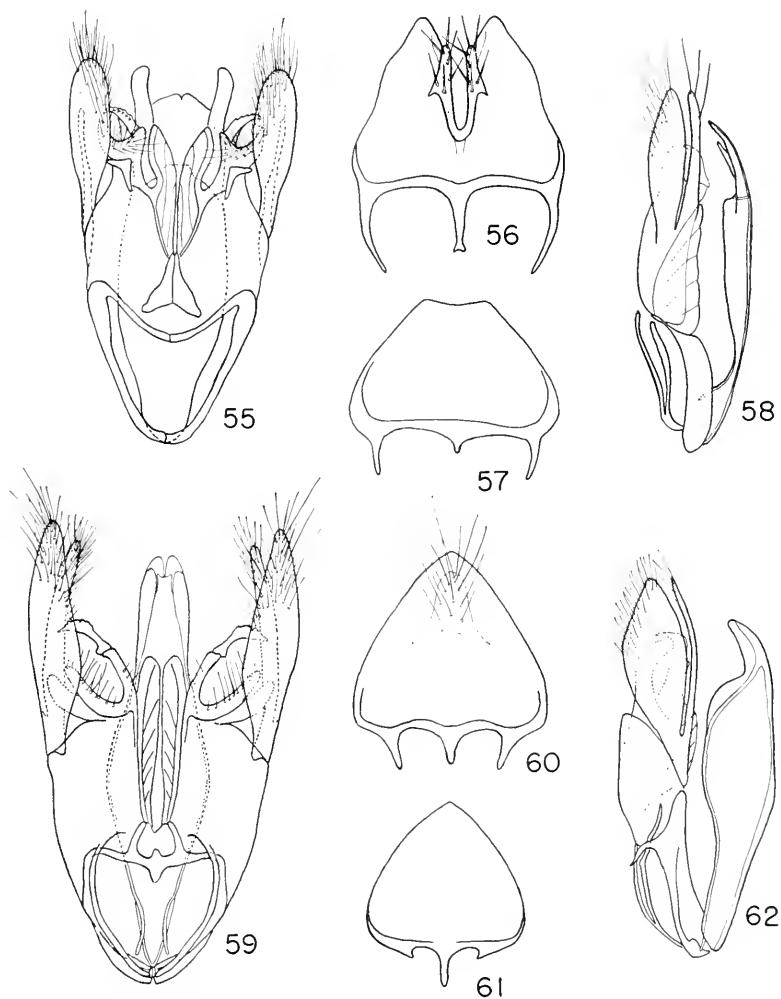

Pseudisobrachium spp., male terminalia. Fig. 55. *P. optimum* n. sp., genitalia. Fig. 56. Same sp., subgenital plate. Fig. 57. *P. plaumanni* n. sp., subgenital plate. Fig. 58. Same sp., genitalia, lateral view. Fig. 59. *P. montivagum* n. sp., genitalia. Fig. 60. Same sp., subgenital plate. Fig. 61. *P. pulcherrimum* n. sp., subgenital plate. Fig. 62. *P. coxalis* (Camerou), genitalia, lateral view.

margins of mesoscutum. Propodeum elongate, measuring 1.8 X as long as wide, in lateral view 2.4 X as long as high; disc with a number of weak, irregular carinae paralleling the strong median carina, not at all margined behind. Mesopleurum polished, non-alutaceous, punctate except on the callus. Fore wing with the discoidal vein pigmented for a distance greater than length of basal vein, nearly interstitial with median vein. Abdomen slender and elongate. Subgenital plate subtriangular, with three basal stalks rather close together, apex rounded (Fig. 60). Genitalia as shown in Fig. 59.

Paratype.—♂, MEXICO: GUERRERO: Chilpancingo, 4000 feet, Sept. (H. H. Smith) [MCZ].

Variation.—The paratype is slightly smaller than the type (LFW 3.6 mm) and differs in color only in that the coxae and trochanters are light brown like the rest of the legs. The eyes are smaller than in the type (WF 1.6 X HE), the vertex distinctly more narrowly rounded than in that specimen. Otherwise the resemblance to the type is very close.

Remarks.—This species is unusual because of the complete occipital carina and the large, subrectangular median lobe of the clypeus. It will run to the *occidentale* group in my revision of this genus, and agrees fairly well in general features with members of that group. However, all the members of that group have the occipital carina obsolete dorsally and the clypeus much smaller and with more oblique sides.

(2) *PSEUDISOBRACHIUM PULCHERRIMUM* new species

Holotype.—♂, COSTA RICA: Turrialba, 17 June 1949 (K. W. Cooper) [USNM, No. 64,995].

Description of type.—Length 8 mm; LFW 5.2 mm. Head black except mandibles and clypeus largely ferruginous; pronotum black except collar, lower sides, and broad posterior margin ferruginous; mesoscutum ferruginous except black on extreme sides, along notauli, and between the notauli on posterior third; scutellum piceous; metanotum dull ferruginous; propodeum black; mesopleurum piceous except ferruginous on the callus and in a band anterior to middle coxae; basal three abdominal tergites blackish except for orange-brown apical bands, remainder of abdomen bright orange-brown; palpi and tegulae testaceous; antennae uniformly light rufo-castaneous; front coxae piceous, other coxae and all the femora suffused with brown; hind tibiae brown except yellowish brown on apical fifth;

remaining tibiae light brown, tarsi yellowish brown. Fore wing subhyaline, with a rather strong brownish cloud in and just below the marginal cell; hind wing hyaline; veins and stigma dark brown. Body setae dense, short, golden. Mandibles with five teeth, basal three teeth rounded, fifth tooth slightly larger than third and fourth. Clypeus with a broad median lobe, the sides of which are rounded, the apex subtruncate (Fig. 53); median carina arched in profile. First four antennal segments in a ratio of about 26:5:16:16, segment three 2.2 X as long as thick, segment eleven 2.8 X as long as thick; flagellar pubescence rather fine, subappressed, much exceeded by sparse, erect setae. Front polished, non-alutaceous, covered with small but sharply defined punctures which are separated for the most part by less than their own diameters. Eyes strongly hairy; occipital carina obsolete dorsally. WF .68 X WII, 1.50 X HE; vertex broadly rounded off, distance from eye tops to vertex crest nearly equal to IIE. Ocelli in a compact triangle far removed from eyes; OOL 1.8 X WOT; posterior ocelli removed from vertex crest by a distance slightly less than WOT.

Pronotum shining, transversely striato-punctate. Mesoscutum polished, densely covered with small punctures except for a smooth area anteromedially; notauli strong on anterior .7 of scutum, absent behind; scutellar disc with a median impunctate streak. Propodeum 1.3 X as long as wide, the dorsal surface about as long as wide, indistinctly margined behind; median carina distinct, disc otherwise covered with rather strong reticulations; declivity and side-pieces striate. Mesopleurum closely punctate except for the callus, which is prominent and strongly polished. Claws with a sharp erect tooth. Fore wing with the discoidal vein interstitial with the median vein, discoidal cell fully outlined, subdiscoidal vein weakly pigmented almost to wing margin, first recurrent vein also weakly pigmented. Subgenital plate subtriangular, its apex rounded, median basal stalk longer than lateral stalks (Fig. 61). Genitalia of typical form for the genus, the dorsal arms of the parameres fairly wide and nearly as long as the ventral arms; aedoeagus simple.

Remarks.— This striking species is a member of the *crassum* species-group and will run to *dalmati* in my key (Evans, 1961). It differs from *dalmati* in the much longer antennae, the broader and more rounded median lobe of the clypeus, the rufous coloration on the clypeus, parts of the thorax, and the apical half of the abdomen, and in the diffuse brown spot on the outer part of the fore wing.

(3) PSEUDISOBRACHIUM COXALIS (Cameron) new combination

Epyris coxalis Cameron, 1888a, p. 450 [Type: ♂, PANAMA: Bugaba (G. C. Champion) (BMNH)].

Pristocera coxalis Kieffer, 1908a, p. 22. — Kieffer, 1914, p. 468.

Plesiotype. — ♂, PANAMA: Barro Colorado Island, Canal Zone, 18 July 1956 (C. W. & M. E. Rettenmeyer) [KU].³

Description of plesiotype. — Length 8 mm; LFW 5.4 mm. Body shining black except abdomen weakly suffused with brownish basally and apically; palpi light brown, mandibles wholly straw-colored except teeth rufous; scape black, flagellum dark brown, all coxae and trochanters, and basal fourth of all femora, light straw-colored, legs otherwise dark brown; wings lightly tinged with brownish, veins and stigma dark brown. Body setae grayish. Mandibles broad apically, with four very strong teeth and no evidence of a fifth tooth. Clypeus with a strong, somewhat trapezoidal median lobe, its sides weakly notched subapically, the apex with two strong teeth between which it is arcuately concave (Fig. 49). First four antennal segments in a ratio of about 24:5:16:15, third segment twice as long as thick, segment eleven 2.6 X as long as thick; pubescence dark, subappressed, flagellum also with numerous prominent erect setae on under side. Front polished, non-alutaceous, punctures small but sharply defined, separated by 1-2 X their own diameters. Eyes with only minute, barely noticeable setae; occipital carina complete. Head about as wide as high; inner orbits slightly closer together near bottom than at middle; WF .61 X WH, 1.30 X HE; vertex very broadly rounded, distance from eye tops to vertex crest equal to about .7 X HE. Ocelli small, in a compact triangle, front angle less than a right angle; OOL 1.35 X WOT; distance from hind ocelli to vertex crest slightly greater than WOT.

Pronotal disc rather flat, with a vague indication of a transverse impression; surface polished and with well spaced small punctures. Mesoscutum polished, sparsely punctate; notauli strong on anterior .8 of scutum; scutellar disc impunctate in the center. Propodeum 1.15 X as long as wide, the disc 1.2 X as wide as long; median carina strong except obsolescent behind, barely reaching the strong transverse carina; basal triangle with weak, irregular longitudinal carinae, remainder of disc shining

³I have studied the type of this species, but it is badly broken and various parts glued to a card. I therefore prefer to base my description on a specimen compared with the type and found to resemble it very closely.

and with only very weak sculpturing; declivity with fine transverse striations, side-pieces nearly smooth. Mesopleural callus large, convex, polished, subtended by a curving, punctate groove; remainder of mesopleurum sparsely punctate. Claws strongly curved, the inner ray slightly larger than the outer ray and subparallel to it. Fore wing with costa continued beyond stigma for a distance about equal to length of stigma; discoidal vein strong, interstitial with median vein; discoidal cell fully outlined, subdiscoidal vein weakly pigmented almost to wing margin; first recurrent vein and outer part of cubital vein weakly pigmented. Subgenital plate triangularly produced medially with three short, widely separated stalks. Genitalia rather typical of the genus; dorsal arms of parameres narrower than ventral arms but just as long; aedoeagus compressed, its apex somewhat hooked; vannus well developed (Fig. 62).

Other males examined.— PANAMA: 1, same data as plesio-type [MCZ]; 1, Porto Bello, 23 Feb. 1911 (A. Busck) [USNM].

Variation.— The Porto Bello specimen shows some striking color differences from the type and the two Barro Colorado specimens; the first two antennal segments are straw-colored, and the femora are straw-colored except at their extreme tips. In this specimen the sides of the median lobe of the clypeus are more strongly sinuate, almost angulate, and the apical teeth are longer. The available specimens show no important differences in size or in standard measurements.

Remarks.— This species was omitted from my 1961 treatment of the genus because I was unaware that it belonged in *Pseudisobrachium*. Indeed, until I studied the genitalia I was inclined to regard the species as an aberrant *Apenesia*, even though the clypeus was more *Pseudisobrachium*-like. The nearly glabrous eyes, the strongly margined and weakly sculptured propodeal disc, and the complete occipital carina all suggest *Apenesia*, and the costa is continuous beyond the stigma as in that genus. Nevertheless, the genitalia and subgenital plate indicate conclusively that this is an aberrant *Pseudisobrachium*.

(4) PSEUDISOBRACHIUM OPTIMUM new species

Holotype.— ♂, BRAZIL: Nova Teutonia, Santa Catarina, 7 Nov. 1944 (Fritz Plaumann) [AMNH].

Description of type.— Length 8.0 mm; LFW 6.0 mm. Head black; thorax black except pronotum tinged with dull ferruginous on all margins; basal four abdominal segments, and basal

third of fifth, piceous, remainder of abdomen bright ferruginous; apical half of mandibles dull ferruginous; antennae wholly castaneous except apical four segments somewhat infuscated; tegulae testaceous; legs bright yellowish brown except all coxae moderately infuscated. Fore wings strongly tinged with yellowish on basal half, the setulae golden; then with a broad fuscous band extending from stigma and marginal cell to posterior wing margin, the setulae here dark; apex of wing subhyaline, with golden setulae; hind wing weakly tinged with yellowish on basal half, apical half weakly infuscated. Body covered with rather dense, short, golden setae. Mandibles broad apically, with five strong teeth in almost a straight line. Clypeus with a strong median lobe the sides of which are somewhat rounded, the apex subtruncate, slightly reflexed upward; median line carinate basally. Eyes moderately hairy, occipital carina present but obsolescent dorsally. First four antennal segments in a ratio of about 11:3:5:5, segment three 2.2 X as long as thick, segment eleven 2.4 X as long as thick; pubescence coarse, semi-erect, flagellum also with some fully erect setae which stand well above the pubescence and are nearly as long as the width of the flagellum. Front shining, non-alutaceous, punctures small but sharply defined, separated for the most part by 1-2 X their own diameters. Head very slightly higher than wide, WH .98 X LH; front broad, WF .65 X WH, 1.4 X HE; vertex very broadly rounded off, distance from eye tops to vertex crest equal to about two-thirds HE. Ocelli in a compact triangle, the front angle slightly less than a right angle; OOL 1.25 X WOT; posterior ocelli removed from vertex crest by a distance slightly greater than WOT.

Pronotal disc short, finely transversely striate, depressed just before posterior margin. Mesoscutum polished, punctures small but strong, irregularly, fairly closely spaced; notauli strong except absent on posterior fifth; scutellar disc wholly punctate. Propodeum about 1.1 X as long as wide, the disc about 1.2 X as wide as long; lateral and transverse carinae distinct, median carina moderately distinct but not quite reaching transverse carina; disc and declivity wholly roughened by reticulate sculpturing; side-pieces in large part smooth and polished. Mesopleura with the callus large, strongly polished, impunctate, subtended by a broad, striate groove; remainder of mesopleurum covered with evenly spaced punctures. Claws with a strong erect tooth and also subdentate basally. Fore wing with discoidal cell

weakly outlined by pigmented lines, first recurrent vein weakly pigmented and subdiscoidal vein weakly continuous to outer wing margin; costa extended as a weak vein far beyond stigma. Abdomen sessile. Subgenital plate with a deep median cleft and with a pair of setose, fingerlike processes beside the cleft (Fig. 56). Genitalia with the ventral arms of the parameres very much broader and longer than the dorsal arms; volsellae with the vannus produced into an apical, knob-like expansion; aedoeagus with a pair of lateral lobes which extend well beyond the main body of the aedoeagus (Fig. 55).

Paratypes. — BRAZIL: 5 ♂ ♂, all same data as type except various dates in January and February, 1945-46 [BMNH, MCZ, HKT].

Variation. — LFW varies from 6.0 to 7.0 mm. In the larger specimens the vertex is somewhat more strongly produced behind the eyes, the posterior ocelli being removed from the vertex crest by as much as 1.3 X WOT. OOL varies from 1.1 to 1.3 X WOT, but other head measurements show little variation. In all of the paratypes the median carina of the propodeum reaches the transverse carina.

Remarks. — The subgenital plate of this species is uniquely modified. It is not unlike that of *Pristocera sensu stricto* (which is confined to the Old World), but the finger-like processes flanking the emargination are absent in *Pristocera*. The apical prolongation of the vannus of the genitalia is also unusual. Nevertheless, in most other respects the species is a typical *Pseudisobrachium*, and I see nothing to be gained by erecting a new generic or subgeneric name for it because of specializations of the terminalia.

(5) PSEUDISOBRACHIUM HAEMORRHOIDALIS (Westwood) new combination

Pristocera haemorrhoidalis Westwood, 1874, p. 166, pl. XXX, fig. 7 [Type: ♂, BRAZIL (Guérin-Méneville) (no further data) (HCOU)]. — Kieffer, 1914, p. 469.

Description of type. — Length 9.5 mm; LFW 6.9 mm. Head and thorax black; basal three segments of abdomen dark brown, remainder of abdomen bright rufo-castaneous; mandibles blackish except apical third rufo-castaneous; clypeus pale castaneous; scape medium brown, flagellum pale castaneous except apical few segments weakly infuscated; legs dark brown except front tarsi and apical half of front tibiae pale castaneous; wings

lightly tinged with brownish, fore wing with a very strong, broad brown band beginning at stigma and basal half of radial cell and extending to posterior margin of wing. Mandibles broad apically, with five strong teeth in an oblique series (Fig. 42). Clypeus with a prominent, trapezoidal medial lobe with a broadly V-shaped apical emargination, such that the sides are angularly produced. First four antennal segments in a ratio of about 27:6:15:12, segment three and segment eleven each about 3 X as long as thick; pubescence coarse, semi-erect. Front polished, non-alutaceous, punctures of moderate size, rather crowded medially but more widely spaced laterally and above. Eyes moderately hairy; occipital carina obsolete dorsally. Head about as wide as high; WF .64 X WH, 1.37 X HE; vertex broadly rounded off far above eye tops, distance from eye tops to vertex crest nearly equal to HE. Ocelli small, in a compact triangle far removed from eyes; OOL 1.65 X WOT.

Pronotum short, disc weakly transversely rugulose, just before the posterior margin depressed, smooth, and polished. Propodeal disc very short, 1.4 X as wide as long, margined behind by a carina which is curved forward and obsolescent medially; median carina strong, disc otherwise with irregular reticulations, dull. Mesopleural callus strong, polished, with a few punctures, sharply margined below, subtended by a broad, foveolate groove; rest of mesopleurum strongly punctate. Claws strongly dentate. Fore wing with discoidal cell outlined by pigmented lines, discoidal vein strong at base, interstitial with median vein; costa extended beyond stigma by a distance slightly greater than length of stigma. Abdomen slender, sessile [dirty and somewhat damaged apically; possibly the subgenital plate is deeply cleft as in the preceding species].

Remarks.— I have seen no specimens of this species other than the type. The clypeus differs in shape and color from the otherwise rather similar *optimum*, and the antennae are longer and the legs darker than in that species.

(6) PSEUDISOBRACHIUM CRASSICORNIS (Westwood) new combination

Pristocera crassicornis Westwood, 1874, p. 164, pl. XXIX, fig. 6 [Type: ♂, BRAZIL: Amazonas (H. W. Bates) (HCOU)]. —Kieffer, 1914, p. 470.

Description of type.— Length 8 mm; LFW 5 mm. Body entirely black; mandibles black, rufous apically, scape black, flagellum dark brown; legs dark brown except tarsi medium brown,

middle and hind trochanters yellowish brown; wings subhyaline, fore wing suffused with brownish anteriorly, especially in and below marginal cell. Mandibles large, their lower margin unusually straight, apex with five teeth. Clypeus with a narrow median lobe which terminates in two sharp teeth, between which the margin is arcuately concave (as figured for *coxalis* except sides of median lobe straighter). First four antennal segments in a ratio of about 25:5:13:11, segment three 1.6 X as long as thick, segment eleven 1.9 X as long as thick; pubescence brownish, subappressed, rather coarse, erect setae numerous, especially on under sides of basal segments. Front shining, non-alutaceous, extremely closely punctate, punctures strong and separated for the most part by much less than their own diameters. Eyes hairy; occipital carina complete. WH .90 X LH; WF .63 X WH, 1.27 X HE. Ocelli small, front angle of ocellar triangle less than a right angle; OOL 1.5 X WOT. Vertex broadly rounded off far above eye tops, distance from eye tops to vertex crest equal to about two-thirds X HE.

Pronotum rather long, with smooth contours; disc shining, non-alutaceous, punctures large, separated by about their own diameters. Mesoscutum polished, punctures strong, crowded along notauli but elsewhere rather sparse; notauli strong, not quite reaching posterior margin of scutum; scutellar disc weakly punctate. Propodeal disc 1.15 X as wide as long, declivity abrupt and steep, but not margined by a carina; disc with about 10 rather weak longitudinal carinae arising from base, behind and beside the longitudinal carinae wholly covered with arching striations. Mesopleural callus very large, convex, impunctate; remainder of mesopleurum with large punctures. Claws dentate. Fore wing with discoidal vein interstitial with median vein, weakly pigmented, discoidal cell faintly outlined; costa not extended beyond stigma. Abdomen slender, sessile. Terminalia not studied.

Remarks. — The two-pronged clypeus of this species is similar to that of the otherwise unrelated species *coxalis* (Cameron). Several other undescribed South American species also have a clypeus of this type and appear closely related to *crassicornis*.

(7) PSEUDISOBRACHIUM RUFOPICTUM new name

Pristocera rufiventris Kieffer, 1910a, p. 291 [Type: ♂, BRAZIL: Pará (C. F. Baker) (Pomona Coll., Claremont, Calif.)]. Preoccupied in *Pseudisobrachium* by Ashmead, 1893, p. 38. —Kieffer, 1914, p. 468.

Description of type.—Length 7 mm; LFW 4.5 mm. Head black; thorax piceous except pronotum ferruginous, somewhat infuscated medially; abdomen bright, pale rufo-castaneous except first tergite infuscated medially; mandibles yellowish brown, teeth rufous; clypeus deep amber, bordered with black; scape clear yellowish brown, flagellum dull castaneous, somewhat darker apically than basally; legs, including coxae, wholly bright yellowish brown; membrane of fore wing distinctly tinged with brownish below the stigma and marginal cell, veins and stigma brown. Mandibles broad apically, with five strong, subequal teeth in almost a straight line (much as in *haemorrhoidalis*, Fig. 42). Clypeus with a narrowly truncate apical margin, sides strongly oblique (Fig. 47); median carina very strong, in profile elevated in a strong arch. Antennae elongate, first four segments in a ratio of about 21:14:17:12, segment three unusually long, about 3.5 X as long as thick, segment eleven 2.5 X as long as thick; flagellar pubescence very coarse, semi-erect, erect setae also numerous, some of them nearly as long as thickness of segments bearing them. Front strongly polished, non-alutaceous, punctures small but deep and well-defined, separated by approximately their own diameters; punctures of vertex somewhat weaker; occipital carina strong below but obsolete dorsally. Eyes strongly hairy, strongly bulging from sides of head, WH 1.07 X LH. Front very narrow, WF .6 X WH, 1.0 X HE; ocelli slightly enlarged, DAO .20 X WF; ocellar triangle very compact, the ocelli separated by much less than their own diameters, front angle less than a right angle; OOL .9 X WOT. Vertex elevated above eye tops a distance equal to slightly more than half HE; top of vertex straight.

Pronotal disc short, with smooth contours but with some small but distinct transverse rugae. Mesoscutum polished, non-alutaceous, punctate about like the front; notauli strong on anterior .9 of mesoscutum; scutellum with basal groove rather wide, disc barely punctate. Propodeum 1.4 X as long as wide, disc with rather strong sculpturing, with lateral, sublateral and median carinae strong, some strong reticulations between the median and sublateral carinae, on the posterior part with strong but somewhat irregular transverse rugae, the one on the edge of the declivity stronger than the others and thus indistinctly margining the disc behind. Mesopleurum with the callus strongly convex, its central area shining, impunctate and non-alutaceous; remainder of mesopleurum non-alutaceous, punctures large, shallow, separated by about or less than their own diameters. Fore

wing with the discoidal vein pigmented to about the length of the basal vein, lower and outer sides of discoidal cell also weakly outlined. Claws strongly dentate. Terminalia not studied.

Remarks.—The mandibles of this species are much like those of *micheneri* Evans, described from Mexico, and the sculpturing, particularly the strong and nearly complete notauli, also suggests that species. In color, this species is similar to *Apenesia fulvicollis* (Westwood), also described from northern Brazil.

(8) PSEUDISOBRACHIUM BRASILIENSE Kieffer

Pseudisobrachium brasiliense Kieffer, 1910a, pp. 294-295 [Type: ♂, BRAZIL: Pará (C. F. Baker) (Pomona Coll., Claremont, Calif.)]. —Kieffer, 1914, pp. 481-482.

Description of type.—Length 3.8 mm; LFW 2.8 mm. Head and thorax black, abdomen dark brown, paler on sides of basal segments; mandibles wholly yellowish brown except teeth dark rufous; scape and base of flagellum straw-colored, flagellum infuscated beyond basal two segments, in greater part dull brownish; front coxae black but legs otherwise wholly bright straw-colored; wings subhyaline, with dark setulae, veins and stigma brown. Mandibles with five teeth, basal three teeth subequal, somewhat rounded. Apical margin of clypeus with a median, polished swelling which projects as a large, rounded tooth (Fig. 46); in profile the median ridge is straight and even, then elevated at the apical swelling. First four antennal segments in a ratio of about 34:7:20:18, segment three 2.2 X as long as thick, segment eleven twice as long as thick; flagellar pubescence coarse, suberect, erect setae also numerous and prominent. Front uniformly alutaceous, moderately shining, punctures small and shallow but very numerous, separated for the most part by about their own diameters; occipital carina obsolete dorsally; eyes strongly hairy. Head slightly higher than wide, WH .92 X LH; WF .67 X WH, 1.36 X HE; vertex extended far above eye tops, distance from eye tops to vertex crest subequal to HE, top of vertex nearly straight. Ocelli small, DAO .12 X WF, anterior ocellus far above line drawn between tops of eyes, ocellar triangle very compact, front angle less than a right angle; OOL 1.8 X WOT.

Pronotal disc rather flat, strongly alutaceous, punctures numerous but weak. Mesoscutum alutaceous, moderately shining, punctured about like front; notauli impressed narrowly but reasonably strongly on anterior .3 of scutum; center of scutellar disc shining, impunctate and non-alutaceous. Propodeal disc

1.4 X as long as wide, with well developed lateral, sublateral, and median carinae, disc otherwise with uniform but rather weak sculpturing which shows some tendency to form irregular transverse striae. Mesopleurum with callus large, convex, shining and wholly impunctate and non-alutaceous; remainder of mesopleurum alutaceous and with moderately strong, close punctures. Fore wing with the discoidal vein strong, perfectly interstitial with media, as long as basal vein and in fact discoidal cell wholly weakly outlined. Terminalia not studied.

Remarks. — This species is known to me only from the type. The clypeus is similar to that of *cooperi*, described from Costa Rica.

(9) PSEUDISOBRACHIUM ARGENTINICUM new name

Plutobethylus flaviventris Kieffer, 1910b, p. 53 [Type: ♂, ARGENTINA: Mendoza, 1906 (J. Haarup) (Berlin Museum, No. 206)]. Preoccupied in *Pseudisobrachium* by Kieffer, 1904a, p. 526. — Kieffer, 1914, p. 489.

Description of type. — Length 4.5 mm, LFW 4.1 mm. Head and thorax piceous, abdomen pale rufo-castaneous except center of first tergite infuscated; mandibles and scape light yellowish brown, flagellum dull, pale castaneous; tegulae testaceous; front coxae dark brown, but legs otherwise straw-colored; wings hyaline, stigma brown, veins amber, setulae on wing membrane very light brown. Mandibles with three teeth, the innermost tooth ill-defined, arching into inner mandibular margin (Fig. 43). Median lobe of clypeus narrowly subtruncate (actually very weakly convex), tectiform, median ridge straight in profile (Fig. 48). First four antennal segments in a ratio of about 33:8:15:13, segment three 1.8 X as long as thick, segment eleven 1.4 X as long as thick; flagellar pubescence pale, subappressed, erect setae fairly numerous. Eyes hairy. Front and vertex uniformly rather strongly alutaceous, weakly shining, punctures numerous but so shallow as to be scarcely noticeable. Head about as broad as high, vertex broadly rounded off a distance above the eye tops equal to about .7 X HE. Front rather narrow, WF .61 X WH, 1.17 X HE; ocelli large, DAO .24 X WF; OOL .62 X WOT. Occipital carina obsolete dorsally.

Pronotal disc alutaceous, closely but weakly punctate. Mesoscutum alutaceous, moderately shining, obscurely punctate; notauli distinct on anterior half; scutellum smooth and shining medially, basal groove narrow but deep, lateral foveae distinct. Propodeum rather long, 1.65 X as long as wide, in lateral view

2.25 X as long as high; median carina strong, reaching nearly to edge of declivity, disc otherwise alutaceous, less strongly so behind. Mesopleurum with callus large, biconvex, shining and only rather obscurely alutaceous; posterior portion of mesopleurum, below and behind callus, also shining, but anterior portion dull, alutaceous, and with distinct punctures. Legs with abundant short, whitish, subappressed hairs; claws weakly dentate. Fore wing with discoidal vein arising at junction of basal and transverse median veins, very weakly pigmented to about the length of the basal vein. Abdomen setose, more strongly so apically. Subgenital plate rounded apically. Genitalia not studied.

Remarks. — This species is known to me only from the type. I would judge it to be nocturnal.

(10) PSEUDISOBRACHIUM DISTANS (Kieffer) new combination

Plutobethylus distans Kieffer, 1910b, p. 51 [Type: ♂, PERU: Cosnipata-Ebene, Dept. Cuzco, 1000 meters elev., 3-12-1900 (Garlepp) (Berlin Museum, No. 201)]. —Kieffer, 1914, p. 488.

Description of type. — Length 4.1 mm; LFW 3.3 mm. Head black, thorax piceous, abdomen reddish brown, slightly paler basally and apically; mandibles yellowish, the teeth rufous; first two antennal segments yellow, remainder dull reddish brown; tegulae castaneous; legs, including coxae, bright yellowish brown; fore wing faintly infuscated, veins and stigma brown. Mandibles with five teeth, the basal three rounded, basal tooth slightly thicker than third and fourth teeth. Median apical margin of clypeus subtruncate, with a weak median tooth (Fig. 52). Antennae with the first four segments in a ratio of about 25:5:13:11, segment three 2.5 X as long as thick, segment eleven 1.9 X as long as thick; flagellum roughly pubescent, setulae suberect, some of them half as long as thickness of flagellum, erect setae fairly numerous. Front strongly alutaceous, only weakly shining, punctures shallow and inconspicuous. WF .69 X WH, 1.42 X HE; ocelli small, in a small triangle, the front angle acute; OOL 1.56 X WOT; posterior ocelli removed from vertex crest by a distance slightly less than WOT. Vertex broadly rounded off well above the eye-tops, distance from tops of eyes to vertex crest equal to about .8 X HE.

Pronotum short, weakly impressed medially, surface strongly alutaceous, weakly punctate. Mesoscutum also strongly alutaceous, punctures numerous but very shallow; notauli impressed

only on anterior .3; scutellar disc entirely alutaceous. Propodeum about 1.5 X as long as wide; median carina long, disc otherwise weakly shining and with numerous weak, irregular transverse rugae. Mesopleurum with callus moderately shining, weakly alutaceous, remainder of mesopleurum strongly alutaceous and with large, shallow punctures. Claws simple. Fore wing with discoidal vein arising slightly below top of transverse median vein, pigmented for a distance about equal to length of basal vein. Subgenital plate truncate apically. Genitalia not studied.

(11) PSEUDISOBRACHIUM BOLIVIENSE Kieffer

Pseudisobrachium boliviense Kieffer, 1910b, p. 45 [Type: ♂ BOLIVIA: Mapi (Staudinger) (Berlin Museum, No. 186)]. —Kieffer, 1914, pp. 482-483.

Description of type. — Length 5.8 mm; LFW 3.7 mm. Head and thorax black, abdomen piceous, sides of first tergite light brown; apical half of mandibles yellowish, the teeth rufous; scape black except its apical .2 light brown like the pedicel, flagellum reddish brown; tegulae light brown; coxae and femora dark brown, trochanters, tibiae, and tarsi light yellowish brown; wings subhyaline, veins and stigma dark brown. Mandibles with five teeth, the apical two sharp, the basal three rounded, the fourth tooth unusually small, fifth tooth broadly rounded into the inner mandibular margin. Median lobe of clypeus black and polished, without a sharp median carina but with a weakly defined, round-topped Y-shaped elevation, the arms of the Y terminating in lateral tooth-like projections of the apical margin, the latter evenly concavely arcuate between these projections (Fig. 44). Antennae with first four segments in a ratio of about 27:6:14:13, segment three 1.5 X as long as thick, segment eleven also about 1.5 X as long as thick; flagellar pubescence light brown, rather coarse, suberect, erect setae numerous but rather short. Front strongly polished, non-alutaceous, with large punctures which are separated from one another by 1.5-2 X their own diameters. WF .66 X WH, 1.27 X HE; ocelli in a small triangle, the front angle acute, ocelli not at all enlarged; OOL 1.6 X WOT; posterior ocelli removed from vertex crest by a distance about equal to WOT. Vertex rounded off far above eye-tops, distance from eye tops to vertex crest equal to about .8 X HE; occipital carina complete.

Pronotum rather long, disc rather flat, almost rectangular in front, shining and with widely spaced punctures. Mesoscutum shining, non-alutaceous, the few punctures mostly confined to posterior half; notauli present on anterior .7 of mesoscutum, slender and delicate; scutellum shining and with weak punctures. Propodeum 1.35 X as long as broad, disc with median and lateral carinae well developed, also with several irregular longitudinal rugae which start out from the base and soon terminate in some irregular reticulations; sculpturing of posterior half of propodeum in form of fine transverse rugae; spiracles subcircular, opening dorsally. Mesopleurum wholly polished and non-alutaceous, callus large, convex, impunctate, remainder of mesopleurum more or less punctate. Claws dentate. Fore wing with discoidal vein weakly pigmented, not quite as long as basal vein, interstitial with median vein. Genitalia not studied.

(12) PSEUDISOBRACHIUM PARAGUAYENSE new name

Rhabdepyris (?) *albipes* Kieffer, 1904b, p. 411 [Type: ♂, PARAGUAY: Puerto 14 de Mayo, Oct. 1896 (G. Boggiani) (Mus. Civ. Stor. Nat., Genova)]. (Studied one of two cotypes.) Preoccupied in *Pseudisobrachium* by Ashmead, 1894, p. 191.

Parisobrachium albipes Kieffer, 1914, pp. 424-425.

Description of cotype. — Length 2.7 mm; LFW about 2 mm (wings much crumbled). Body dark reddish brown, head nearly black; mandibles straw-colored except darker at extreme base and apex; scape yellowish brown, flagellum dull castaneous except paler at base and apex; legs straw-colored, tarsi almost white, front coxae somewhat infuscated; wings pale, veins and stigma straw-colored. Mandibles moderately wide, probably with five teeth (mandibles partially covered with glue). Median lobe of clypeus narrowly truncate (Fig. 45); median ridge strong, arched in profile. Antennae rather short, first four segments in a ratio of about 19:7:8:8, segments three and eleven each about 1.2 X as long as thick; flagellar pubescence very coarse, semi-erect, pale, longest setulae about half as long as segments bearing them. Front strongly alutaceous, weakly shining, punctures numerous, about their own diameters apart, but shallow and inconspicuous; occipital carina obsolete dorsally. Eyes strongly hairy, bulging and rather coarse-faceted; WH 1.04 X LH. Front slightly wider than height of eye, WF .60 X WH, 1.10 X HE; ocelli slightly enlarged, DAO .21 X WF, in a

rather large triangle, the front angle about a right angle; OOL .72 X WOT. Vertex broadly rounded off a distance above eye-tops equal to only about half HE.

Pronotum with smooth contours, alutaceous, obscurely punctate. Mesonotum wholly alutaceous, moderately shining, including scutellar disc; notauli very faintly indicated, almost absent. Propodeum 1.2 X as long as wide, disc shining and with rather weak sculpturing except for the median carina and some short carinae laterad of it; two of these carinae (very weak) extend about half the length of the propodeum, which can thus be described as obscurely tricarinate. Mesopleurum with callus large and convex, shining, weakly alutaceous, subtended by a strong groove; remainder of mesopleurum moderately alutaceous and obscurely punctate. Claws simple. Wings of cotype in poor condition. Terminalia not studied.

Remarks.—The propodeum of this species does not differ notably from that of several other South American species, and simple claws are not uncommon in the genus. This is a fairly typical *Pseudisobrachium*, and Kieffer's generic name *Parisobrachium* is unnecessary.

(13) *PSEUDISOBRACHIUM PLAUMANNI* new species

Holotype.—♂, BRAZIL; Nova Teutonia, Santa Catarina, 17 Dec. 1937 (Fritz Plaumann) [BMNH].

Description of type.—Length 5.5 mm; LFW 3.7 mm. Head black except mandibles and clypeus largely castaneous; thorax black except entire pronotum suffused with dull ferruginous; abdomen dark castaneous, shining, each segment with an indistinct apical band of lighter brown; antennae uniformly light castaneous; tegulae testaceous; legs medium brown except tarsi and apices of tibiae light yellowish brown; fore wings lightly tinged with brownish, more strongly so in an indistinct band below the marginal cell. Mandibles with five teeth, basal three teeth somewhat rounded, basal two teeth partially connate. Median lobe of clypeus obtusely subangulate, the sides actually weakly rounded (Fig. 51); median carina strong, arched in profile. Eyes hairy; occipital carina obsolete dorsally. First four antennal segments in a ratio of about 35:8:18:15, segments three and eleven each about twice as long as thick; flagellar pubescence pale, rather coarse, flagellum also with many short erect setae. Front shining, weakly alutaceous just above antennal bases and in ocellar triangle, elsewhere non-alutaceous; punctures small,

sharply defined, separated by about or slightly less than their own diameters. Head about as wide as high; front broad, WF .69 X WH, 1.55 X HE; vertex very broadly rounded off a distance above eye tops about equal to HE. Ocelli not enlarged; front angle of ocellar triangle slightly less than a right angle; OOL 1.6 X WOT; distance from hind ocelli to vertex crest nearly equal to WOT.

Pronotal disc finely transversely rugulose, broadly depressed along posterior margin. Mesoscutum short, weakly alutaceous on the sides, strongly punctate; notauli weakly impressed on anterior half. Propodeum 1.35 X as long as wide, disc 1.05 X as long as wide, margined behind by a delicate carina; median carina extending about .7 the length of the disc, surface of disc reticulate, somewhat striate behind; declivity steep, finely striate. Mesopleurum strongly punctate, weakly alutaceous; callus alutaceous but impunctate. Claws with a short, weak erect tooth. Fore wing with discoidal cell strongly outlined, discoidal vein interstitial with median vein; first recurrent vein pigmented. Abdomen slender, subsessile. Subgenital plate narrowly truncate, its median basal stalk shorter than the lateral stalks (Fig. 57). Genitalia with ventral arms of parameres slightly exceeding and much thicker than dorsal arms; aedocagus relatively short and broad (Fig. 58).

Paratypes. — BRAZIL: 5 ♂♂, same data as type except various dates (Jan. 1963, Mar. 1936, May 1938, Nov. 1937) [BMNH, MCZ].

Variation. — There is considerable size variation in this series (LFW 2.9-4.1 mm). The color of the clypeus and of the pronotum varies from bright castaneous to dusky ferruginous. WF varies from 1.43 to 1.58 X HE. Otherwise there is little noteworthy variation in this series.

Remarks. — This species is of interest because of the fact that the median lobe of the clypeus is not trapezoidal as is usual in this genus; in fact it resembles closely that of several species of *Apnesia*. Yet in most other respects this is a typical *Pseudisobrachium*. The color pattern is suggestive of *P. rufopictum* and *Apnesia fulvicollis*.

(14) PSEUDISOBRACHIUM ANGULATUM new species

Holotype. — ♂, PERU: Iquitos, March, April 1931 (R. C. Shannon) [USNM, No. 64,994].

Description of type.—Length 3.5 mm; LFW 2.7 mm. Head black except sides of clypeus suffused with dull ferruginous; thorax black except pronotal collar dull ferruginous; abdomen dark castaneous, shining, each segment with an apical band of light brown; mandibles pale castaneous, the teeth rufous; antennae pale castaneous, slightly dusky beyond third segment; tegulae testaceous; legs straw colored except front coxae fuscous; wings subhyaline, veins and stigma light brown. Mandibles broad apically, terminating in five sharp teeth. Median lobe of clypeus obtusely angulate (Fig. 50), median carina very high, in profile strongly arched. Eyes strongly hairy; occipital carina absent dorsally. First four antennal segments in a ratio of about 26:5:20:17, segment three 3 X as long as thick, segment eleven 2.5 X as long as thick; flagellar pubescence long, semierect, exceeded by scattered fully erect setae. Front polished, weakly alutaceous just above antennal bases but not elsewhere; punctures strongly defined, separated by less than their own diameters except slightly more widely spaced above. Head slightly higher than wide, WH .93 X LH; WF .63 X WH, 1.23 X HE; vertex extended above eye tops a distance about equal to IIE. Ocelli in a compact triangle, front angle much less than a right angle; OOL 1.5 X WOT.

Pronotum weakly and irregularly transversely rugoso-punctate, with a weak transverse depression just before the posterior margin. Mesoscutum polished, strongly punctate, notauli strong, not quite reaching posterior margin; scutellum with basal groove short and deep, center of disc impunctate. Propodeum 1.4 X as long as wide, disc 1.15 X as long as wide; lateral, sublateral, and transverse carina well developed, median carina strong on basal .7 of disc; surface of disc somewhat reticulate basally, weakly striate posteriorly. Mesopleurum with strong punctures except callus convex and impunctate. Claws dentate. Fore wing with costa extending far beyond stigma as a thin vein; discoidal vein pigmented for a distance greater than length of basal vein, but discoidal cell otherwise weakly outlined. Abdomen slender, sessile. Subgenital plate and genitalia resembling those of the preceding species very closely.

Remarks.—This species is known from the type only. The angulate and very strongly carinate clypeus is suggestive of the genus *Aponesia*, and the propodeum is not unlike that of some species of that genus. However, in most other respects this is a typical *Pseudisobrachium*.

II. SUBFAMILY EPYRINAE

Subfamilial characters. — Maxillary palpi with from three to six segments, labial palpi with from one to three; clypeus with its median elevation usually not extending up the lower front as a polished streak; antennae with twelve or thirteen segments, the flagellar pubescence usually short and appressed (some exceptions). Pronotum usually longer than mesoscutum, at least in female; scutellum in contact with the propodeum or very nearly so, the metanotum much reduced, if present as a narrow strip medially then not emarginate or foveolate anteriorly as in male *Pristocerinae*; propodeum with or without a transverse carina margining the disc behind; claws variable, rarely as strongly curved as in the *Bethylinae*. Wings fully developed, shortened, or absent (in either sex), when absent or much reduced the eyes often small, but eye height not less than .25 X head width, propodeum without a strong constriction; alate forms with the basal vein simple (or absent), not giving rise to a vein or stub of a vein, discoidal vein occasionally weakly indicated, second discoidal cell never fully outlined.

Remarks. — This large subfamily is difficult to characterize, since it contains several specialized genera as well as a nucleus of more generalized genera centering around *Rhabdepyris* and *Epyris*. Some workers have placed some of the more highly evolved genera, such as *Cephalonomia* and *Scleroderma*, in a separate subfamily, the *Scleroderminae*. I do not consider these two genera to be closely related, and each is linked to the *Epyrinae* through a series of intermediate genera, *Cephalonomia* through *Plastanoxus* and *Laclius*, *Scleroderma* through *Chilepyris* and *Ncsepyris*. It seems to me best to use the *Epyrinae* in a broad sense, dividing it into three tribes to include the generalized elements (*Epyrini*) and the two more specialized stocks (*Cephalonomiini* and *Sclerodermini*). So far as I know, this arrangement will work for the world fauna, but it is probable that some modifications of the following key will be necessary to accommodate all the Old World genera.

KEY TO TRIBES OF EPYRINAE

1. Antennae with twelve segments; maxillary palpi with 3-5 segments, labial palpi with 1-2 segments; alate forms with a prostigma, the submedian cell (and often the median cell) absent or closed off below and on the outer side by a very weak vein (Figs. 99, 101, 105); fore wing indented on the anterior margin opposite the prostigma; maximum size about 2.5 mm B. CEPHALONOMIINI, p. 148

- Antennae with thirteen segments (but in the males of *Aniscypris* and *Articpyris*, which are fully alate, the third segment may be so small as to escape ready detection); maxillary palpi with 5-6 segments, labial palpi with 2-3 segments; alate forms without a prostigma, the median cell (and often the submedian) fully formed and closed (figs. 63, 113, 118) 2
2. Clypeus short, median lobe, when distinct, broad and truncate or somewhat emarginate (Figs. 114, 117, 120); apterous and subapterous forms common; alate forms with radial vein present or (more often) absent; eyes situated well forward on head, in female not protruding much if any above surface of head and located well toward anterior side, temples thus very large (Figs. 111, 114, 115, 120, 121) C. SCLERODERMINI, p. 160
- Clypeus with a projecting angular or narrowly rounded median lobe (Figs. 64, 75, 95); apterous and brachypterous forms uncommon; alate forms with radial vein strong (although short in *Laelius*) A. EPYRINI, p. 90

A. TRIBE EPYRINI

Tribal characters.— Small to medium-sized bethylids, 1.5-10 mm in length. Maxillary palpi with six segments, labial palpi with three segments; antennae with thirteen segments, but in males of certain groups the third segment is reduced to a mere ring at the base of the fourth, evident only upon close study; clypeus with a median lobe which projects rather strongly and is angulate, subangulate, or narrowly rounded apically; occipital carina present, sometimes weak dorsally. Pronotum often longer than mesoseutum, sometimes very much longer; mesoseutum with notauli usually well developed, reduced or absent in *Holepyris* and *Laelius*; propodeum with a transverse carina margining the disc behind, nearly always with a complete median carina which often continues on down the declivity, disc often with other longitudinal carinae, posterolateral angles often foveolate; claws variable. Wings usually fully developed, shortened or absent in a few females, but these females show little or no reduction of the thorax or the ocelli; wings not especially slender basally, anterior margin of fore wing nearly straight, anal lobe of hind wing well developed; fore wing with three closed basal cells, including the narrow costal cell, prostigma absent, radial vein present (short in *Laelius*). Male genitalia with the parameres moderately long, strongly hirsute; euspides slender, often divided into ventral and dorsal arms; aedocagus of simple structure, slender or fairly broad.

Distribution. — Cosmopolitan.

Included genera. — The limits of the tribe Epyrini as here defined are roughly the same as in Kieffer (1914). Several genera are cosmopolitan or nearly so, and some of these genera are very large (*Epyris*, *Rhabdepyris*, *Holepyris*). Nine genera are here recognized for the Americas, four of them restricted to this hemisphere (*Anisepyris*, *Procalyzoa*, *Aspidepyris*, *Bakeriella*). Distinctive genera of the Old World which do not occur in the Americas include *Isobrachium* Foerster, *Pristobethylus* Kieffer, *Acanthepyrus* Kieffer, and *Allepyris* Kieffer. Berland (1928) included *Allepyris* and *Laelius* in the Scleroderminae, but these genera appear to me to fit much better in the Epyrini.

KEY TO GENERA OF EPYRINI

1. Scutellum with a transverse, undivided groove basally, straight or deflected backward at each end, sometimes much broadened on each side to form pits much as below, but in this case still connected by a groove that is fairly deep (Figs. 64, 70, 95) 2
- Scutellum with a pair of basal pits which are usually completely separate, but occasionally they are connected by a very thin and shallow line, or occasionally they are contiguous and separated only by a thin septum (then resembling a divided transverse groove) (Figs. 75, 80, 83) 6
2. Radial vein very short, at most slightly longer than the basal vein (Fig. 94); always fully winged; body and major veins of wings with large, black setae 9. LAELIUS Ashmead, p. 144
- Radial vein long, much longer than basal vein (except in the few subapterous forms) (Figs. 63, 68); body and wing-veins with setae smaller in proportion to size of body 3
3. Clypeus with three prominent lobes, the lateral lobes rounded, exceeded in most species by the more narrow median lobe (Fig. 93); notauli weak and incomplete, sometimes barely discernible; basal vein reaching subcosta well basad of base of stigma (Fig. 90) 8. HOLEPYRIS Kieffer, p. 139
- Clypeus with only the median lobe well developed, lateral lobes absent or very much shorter than median lobe (Figs. 64, 75); notauli well developed in most species, usually complete or nearly so; basal vein reaching subcosta close to base of stigma (Figs. 63, 68) 4
4. Pronotal disc rounded off anteriorly and laterally, its sides not sharp or carinate (Fig. 64); males with third antennal segment distinctly set off from fourth segment, usually slightly shorter than second segment (Fig. 67) 1. RHABDEPYRIS Kieffer, p. 92
- Pronotal disc with a transverse carina in front, the sides sharp and often also carinate (Fig. 70); males with third antennal segment very short, at most .8 X as long as second and usually much shorter than

- this, often so closely consolidated with fourth as to escape ready detection (Figs. 69, 72) 5
5. Eyes strongly hairy; groove at base of scutellum fairly wide, often widened into pits on each side; antennae simple 2. ANISEPYRIS Kieffer, p. 96
Eyes glabrous; groove at base of scutellum rather thin medially, although deep, much expanded on each side; antennae strongly pectinate (Fig. 72) (known from male only) 3. PROCALYOZA Kieffer, p. 102
6. Pronotum with its posterior part elevated and prolonged arcuately backward so as to overlie the base of the mesoscutum (Fig. 80); mesopleurum with an extremely deep fovea below the tegula (known from male only) 5. ASPIDEPYRIS new genus, p. 114
Pronotum with its posterior margin simple, not prolonged backward so as to overlie the base of the mesoscutum (Figs. 75, 83); mesopleurum not nearly so deeply foveolate 7
7. Antennae pectinate (Fig. 89); scutellar disc rather flat and sharp-edged; pronotum not margined anteriorly or laterally, but the anterolateral corners often prominent (known from male only) 7. CALYOZINA Enderlein, p. 136
Antennae simple; scutellar disc not sharp-edged; pronotum with or without a margining carina in front. 8
8. Pronotal disc transversely carinate in front, sometimes also with longitudinal carinae margining the sides and/or with a median carina (Fig. 83); scutellar pits large, in most species separated only by a thin septum; claws dentate 6. BAKERIELLA Kieffer, p. 116
Pronotum simple, without carinae of any kind (Fig. 75); scutellar pits variable, rarely as above; claws variable 9
9. Antennae with 13 distinct segments; male genitalia with the parameres relatively broad, the digiti not as elongate as below (Fig. 76) 4a. EPYRIS (Subgenus EPYRIS Westwood), p. 104
Antennae with only 12 distinct segments, segment three being reduced to a small, barely discernible ring at the base of four, less than half as long as segment two (Fig. 78); male genitalia with the parameres and digiti extremely long and slender (known from male only) (Fig. 77) 4b. EPYRIS (Subgenus ARTIEPYRIS Kieffer), p. 111

1. Genus RHABDEPYRIS Kieffer

Rhabdepyris Kieffer, 1904c, p. 32 (type species *R. myrmecophilus* Kieffer, designated by Kieffer, 1906a). —Kieffer, 1906a, pp. 375-384 (European spp.). —Kieffer, 1908a, pp. 30-32. —Kieffer, 1914, pp. 346-366 (spp. of world). —Berland, 1928, pp. 116-117 (European spp.). —Richards, 1939, pp. 326-327 (British spp.). —Kurian, 1954, pp. 270-271 (Oriental spp.). —Kurian, 1955, pp. 98-100 (Oriental spp.).

Trichotepyris Kieffer, 1906a, p. 376 (type species *Rhabdepyris pallidipennis* Kieffer, designated by Muesebeck and Walkley, 1951, p. 729; proposed

as subgenus of *Rhabdepyris* and placed in synonymy of that genus by Kieffer, 1914, p. 346).

Chlorepyris Kieffer, 1913, p. 108 (type species *Epyris semiviridis* Kieffer, designated by Kieffer, 1914; new synonymy). —Kieffer, 1914, pp. 412-416 (spp. of world). —Kurian, 1955, pp. 101-105 (Oriental spp.).

Generic characters.— Small wasps (2-9 mm); black or with dark metallic colors, abdomen sometimes tipped with rufous. Maxillary palpi with six segments, labial with three; mandibles with from two to five teeth; clypeus with an angular median lobe which is carinate medially, but without lateral lobes; base of clypeus overhung by the antennal sockets, which are at or below the level of the bottoms of the eyes and which arise from the lower side of the prominent lower front; antennae with 13 segments in both sexes, scape somewhat curved, slightly to strongly flattened, flagellum simple; male with third antennal segment distinct but often short; eyes glabrous or covered with hairs; occipital carina complete. Pronotum moderately long, the disc sloping slightly to strongly to the lower plane of the collar, the sides of the disc rounded; mesoscutum shorter than pronotum (except in some males), notauli typically complete although more or less reduced in a few species; scutellum with a basal groove which may be very slender or fairly wide, nearly always turned backward on each side and often widened there; propodeum with a median carina which extends the length of the disc and also down the declivity; propodeal disc margined laterally and posteriorly, with longitudinal carinae in addition to the median carina; posterior lateral corners of propodeal disc foveolate; middle tibiae spinose in some species; claws dentate, bifid, or trifid. Wings very short in females of a few species; fore wing without large setae on the veins; fully winged forms with the stigma rather small, radial vein elongate; basal vein reaching subcosta close to base of stigma, leaving median vein at same point as transverse median vein, the latter somewhat curved; discoidal and subdiscoidal veins at most very faintly indicated. Abdomen fusiform, shining, without modifications in most species. Male subgenital plate with a short median basal stalk, tapering to a truncate or concave apex. Male genitalia with the parameres large, usually rather broad and flat; volsellae complex, the cuspides large, divided into dorsal and ventral arms; aedoeagus simple, elongate. (Figs. 2, 5, 63-67.)

Remarks.— This large, protean, cosmopolitan genus presents fewer specializations than any other genus of Epyrinae, and is

probably rightly considered the most primitive genus of the subfamily. There are several well-defined species-groups, some of which may deserve subgeneric status. It is possible that Kieffer's names *Trichotepyris* and *Chlorepyris* may eventually be revived as subgenera, but pending further study of this genus they are best considered synonyms. A number of other genera of Epyrinae tie in closely to *Rhabdepyris* and may have evolved from it. For example, there is no wide gap between *R. megacephalus* and some of the species of *Anisepyris*; "*Chlorepyris*" appears to represent a stock evolving in the direction of *Epyris*; and several small, smooth-eyed but strongly setose species suggest *Laelius*.

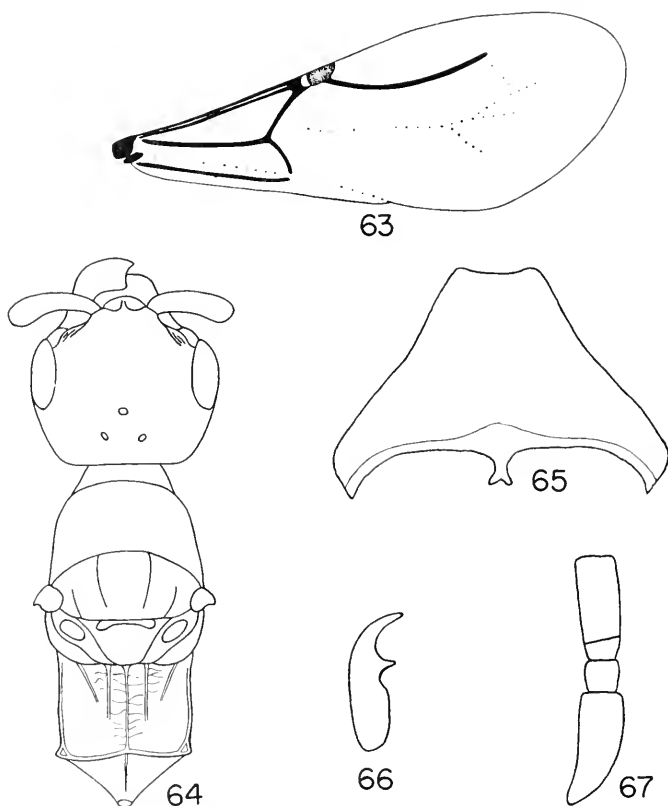

Rhabdepyris megacephalus (Ashmead). Fig. 63. Fore wing. Fig. 64. Head and thorax of female. Fig. 65. Subgenital plate of male. Fig. 66. Hind tarsal claw of female. Fig. 67. Basal four antennal segments of male (scape at bottom).

Biology. — The type species of this genus was taken from an ant nest (*Tetramorium*), and Kieffer (1914) records a second European species from ant nests. I am not aware that any of the American species have been taken from ant nests, and I suspect the occurrence of these two species with ants was accidental. To the best of my knowledge, there are no host records for any of the species of this genus. I have taken these wasps on vegetation covered with honeydew on several occasions, and several specimens before me are marked as having been taken in sweepings from trees, herbs, and crop plants (cotton, alfalfa, sorghum).

Distribution. — This genus appears to be well represented in all zoogeographic regions, although only a few African species have so far been described. In the Americas, the species collectively range from Argentina (but not Chile, so far as known) north to California, Texas, and Massachusetts. I am not aware that the genus occurs in the West Indies (except Trinidad). Only a small percentage of the species have been described.

Included species:

United States

amabilis Fouts, 1927, p. 165; ♀, Maryland.

fulgens (Brues), 1907a, p. 99; ♀, Texas (new combination).

megacephalus (Ashmead), 1893, p. 61; ♀, California (also Arizona, Texas).

Mexico and Central America

metallicus Kieffer, 1908b, p. 16; ♀, Nicaragua.

origenus Kieffer, 1911, p. 222; ♀, Guerrero, Mexico.

quinquelineatus Kieffer, 1906b, p. 249; ♀, Nicaragua.

semiviridis (Kieffer), 1913, p. 108; ♀, Tabasco, Mexico (new name for *viridis* Kieffer, 1911, *nec* Cameron, 1888a) (new combination).

septemlineatus Kieffer, 1906b, p. 250; ♂, Nicaragua.

subaeneus Kieffer, 1906b, p. 248; ♀, Nicaragua.

subviridis (Kieffer), 1911, p. 225; ♂, Tabasco, Mexico (new combination).

viridis Cameron, 1888a, p. 451; ♀, Guatemala.

viridissimus (Kieffer), 1911, p. 225; ♂, Tabasco, Mexico (new combination).

South America

lobatifrons Kieffer, 1910a; p. 297; ♀, Brazil.

microstoma Kieffer, 1910a, p. 296; ♀, Brazil.
muscarius (Westwood), 1874, p. 159; ♂, Brazil.
obscuripennis Kieffer, 1910, p. 40; ♂, Brazil.

2. Genus ANISEPYRIS Kieffer

Anisepyris Kieffer, 1905b, p. 248 (type species *Epyris amazonicus* Westwood, monobasic. —Kieffer, 1906e, p. 137. —Kieffer, 1908a, pp. 32-33. —Kieffer, 1914, pp. 434-444 (spp. of world). —Evans, 1959a, pp. 69-75 (spp. of Greater Antilles). —Evans, 1959b, pp. 97-120 (spp. of United States).

Lophepyris Evans, 1959c, pp. 201-204 (type species *Rhabdepyris* (*Lophepyris*) *bridwelli* Evans, original designation; proposed as subgenus of *Rhabdepyris*; new synonymy).

Generic characters. — Small wasps (2.5-9 mm); black or dark metallic in coloration, abdomen sometimes tipped with rufous. Palpi and mandibles as described for *Rhabdepyris*; median lobe of clypeus angular, rounded, or truncate, with a strong median carina, lateral lobes not developed; eyes strongly hairy; antennae arising from the lower side of a transverse prominence formed by the lower front; laterally this prominence extends obliquely upward to the lower inner eye margins, this portion often carinate; antennae simple, 13-segmented in both sexes, but in the males the antennae appear superficially 12-segmented, the third segment being reduced to a mere ring-segment closely consolidated with the fourth segment (not more than .8 as long as second segment and often much less than this, sometimes barely discernible); occipital carina complete. Pronotum with an anterior collar, an oblique or nearly vertical anterior face, and a large flat or weakly convex disc, the disc with a transverse carina in front, its sides rather sharp and often also carinate; notauli complete or nearly so; scutellum with a transverse basal groove which is fairly wide and commonly turned backward and slightly enlarged on each side; propodeal disc subquadrate, with strong lateral and posterior carinae, the posterior lateral corners often foveolate, also with at least three discal carinae, the median carina complete and extending down the declivity; mesopleura as in *Rhabdepyris*; claws variable, also as in *Rhabdepyris*, and wing venation differing in no way from that genus. Features of abdomen, including male terminalia, essentially as described for *Rhabdepyris*. (Figs. 3, 68-71; see also figures in Evans, 1959b.)

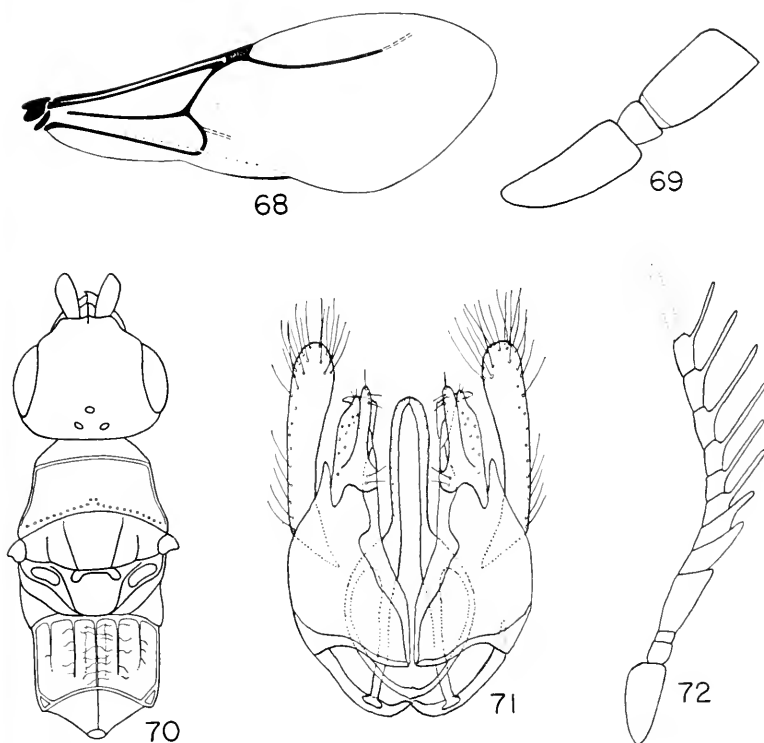

Anisepyrus and *Procalyzoa* spp. Fig. 68. Fore wing of *Anisepyrus venustus* n. sp., male. Fig. 69. Basal four segments of antenna of male *A. columbianus* (Ashmead). Fig. 70. Head and thorax of male *A. venustus* n. sp., holotype. Fig. 71. Male genitalia of *A. aeneus* Kieffer. Fig. 72. Antenna of male *Procalyzoa westwoodi* (Cameron), holotype. The shape of the apical segment is hypothetical, since this segment is missing in this, the only known specimen.

Remarks.—This large genus is confined to the New World, where it undoubtedly arose as an offshoot of that element of the genus *Rhabdepyris* which includes *megacephalus* Ashmead. Perhaps *Anisepyrus* should be treated as a subgenus of *Rhabdepyris*, especially since certain species, such as *bridwelli* Evans, are somewhat intermediate in structure between the two groups. These intermediate species lack carinae on the sides of the pronotal disc (although the edge of the disc is sharp) and also have the third segment of the male antennae slightly less reduced than

is usual in *Anisepyris*. Formerly I assigned these species to *Lophepyris*, which I placed as a subgenus of *Rhabdepyris*. I have since discovered that *amazonicus*, the type species of *Anisepyris*, is in fact a "*Lophepyris*" (as is also *acneus*, designated as type of the genus by Kieffer in 1905 although actually a *nomen nudum* at that time). Also, I have discovered that certain species have the sides of the pronotal disc carinate in front, the carinae fading out posteriorly. It appears that the sharpest break is between those species having the pronotal disc rounded in front and on the sides (*Rhabdepyris*) and those having it sharp, carinate at least in front (*Anisepyris*). Both of these genera can be divided into a number of species-groups, but it seems to me unwise to employ subgeneric names at this time.

Biology. — Nothing is known of the host relationships of members of this genus, even though some of the species are not uncommon. Adults have occasionally been taken at flowers, rather commonly on foliage covered with honeydew, also in sweepings from trees and herbaceous vegetation.

Distribution. — Members of this strictly American genus collectively range from Argentina, Bolivia, and Peru to Massachusetts, Michigan, and British Columbia, including the Greater and Lesser Antilles.

Included species. — About forty species of this genus have been described, but the total number probably exceeds 100, as there are many undescribed Central and South American species.

United States

acneiceps (Ashmead), 1893, p. 58; ♀, Florida.

analis (Cresson), 1872, p. 193; ♀, Texas (to Florida & North Carolina).

arizonicus Evans, 1959b, p. 112; ♀, Arizona.

bradleyi (Evans), 1959c, p. 203; ♀, Texas (new combination).

bridwelli (Evans), 1959c, p. 202; ♀, Texas (also eastern Mexico; ♂ also described) (new combination).

columbianus (Ashmead), 1893, p. 60; ♀, District of Columbia (Florida and Texas to Kansas, Illinois, Massachusetts; ♂ described by Evans, 1959b) (synonym: *pulehcllus* Fouts, 1928).

dictrichorum Evans, 1959b, p. 118; ♀, Arizona.

gibbosifrons Evans, 1959b, p. 116; ♀, New Jersey (also Florida; ♂ also described).

grandis (Ashmead), 1887, p. 76; ♀, Florida (♂ described by Evans, 1959b).

laticeps Evans, 1959b, p. 113; ♀, Arizona (♂ also described).

occidentalis (Ashmead), 1893, p. 58; ♀, California (Arizona & California to Idaho & Washington) (synonym: *punctaticeps* Kieffer, 1906c, ♂).

rugosicollis Brues, 1908, p. 48; ♀, Texas.

subviolaceus Kieffer, 1910b, p. 39; ♀, Colorado (Florida, Texas & New Mexico to Pennsylvania, Michigan, & British Columbia) (♂ described by Evans, 1959b).

williamsi Evans, 1959b, p. 106; ♀, California (Arizona & California to Oregon & Idaho; ♂ also described).

Central America

aeneus Kieffer, 1906c, p. 138; ♀, Nicaragua.

coriaceus Kieffer, 1908b, p. 15; ♂, British Honduras.

fasciipennis Kieffer, 1906c, p. 139; ♀, Nicaragua.

fuscicornis Kieffer, 1908b, p. 15; ♂, British Honduras.

rufosignatus Kieffer, 1908b, p. 14; ♀, British Honduras.

sublevis Kieffer, 1906c, p. 140; ♂, Nicaragua.

venustus Evans, n. sp. described below from ♂, ♀, Morelos, Mexico.

West Indies

aurcus Kieffer, 1910b, p. 38; ♀, Cuba (incorrectly placed in synonymy with *aurichalceus* by Evans, 1959a).

aurichalceus (Westwood), 1874, p. 160; ♀, Cuba (also Puerto Rico and Virgin Islands) (synonyms: *viridis* Kieffer, 1908b, *nec* Cameron, 1888a; *viridellus* Kieffer, 1914; *cubensis* Fouts, 1928).

darlingtoni Evans, 1959a, p. 73; ♀, Haiti.

excisus Evans, 1959a, p. 72; ♀, Haiti.

insularis (Ashmead), 1894, p. 189; ♂, St. Vincent.

planiceps (Fabricius), 1804, p. 201; ♀, "Americae insulis" (Cuba).

rufitarsis Kieffer, 1908b, p. 13; ♂, Cuba.

wolcottii Evans, 1959a, p. 72; ♀, Haiti.

South America

amazonicus (Westwood), 1874, p. 161; ♀, Brazil.

bogotensis Kieffer, 1910b, p. 41; ♀, Colombia (new combination).

eganellus (Westwood), 1874, p. 160; ♀, Brazil.

- eganus* (Westwood), 1874, p. 160; ♂, Brazil.
fabricii (Westwood), 1874, p. 161; ♂, British Guiana.
luteipes Kieffer, 1905d, p. 97; ♂, Trinidad.
metallicus Kieffer, 1905d, p. 95; ♂, Trinidad.
peruvianus Kieffer, 1910b, p. 40; ♀, Peru (new combination).
smithianus (Westwood), 1874, p. 160; ♀, Brazil (new combination).

ANISEPYRIS VENUSTUS new species

Holotype. — ♂, MEXICO: MORELOS: 3 mi. NW Cuernavaca, 6500 feet elevation, 3 June 1959 (H. E. Evans) [MCZ, No. 30,801].

Description of type. — Length 5.4 mm; LFW 3.2 mm. Dorsum of head and thorax dull olive-green; underside of head, sides and venter of thorax, coxae, and entire propodeum black; abdomen black, strongly shining; palpi testaceous; mandibles suffused with rufous above and apically; antennae dark brown, basal two segments nearly black; legs beyond coxae bright, pale castaneous except hind femora strongly suffused with brown, other femora as well as hind tibiae and tarsi very weakly suffused with brown. Wings nearly hyaline, fore wing very faintly tinged with brownish anteriorly; stigma brown, veins light brown. Mandibles terminating in five sharp teeth in almost a straight line. Apical margin of clypeus forming a right angle medially; median carina very strong, arched in profile. Antennae arising far below bottoms of eyes, the scrobes not carinate. First four antennal segments in a ratio of about 27:7:3:18; segment four about twice as long as thick, segment eleven about 2.5 X as long as thick. Eyes densely covered with short setae. Head rather broad, WH 1.12 X LH; WF .63 X WH, 1.26 X HE; OOL 1.20 X WOT; posterior ocelli separated from occipital carina by slightly more than their own diameters. Front strongly alutaceous although moderately shining, wholly covered with small, deep punctures which are separated by from 0.7-2.0 X their own diameters.

Pronotal disc with strong anterior and lateral carinae, its posterior margin paralleled by a line of foveae which projects forward at the midline (Fig. 70); pronotum, like the mesonotum, moderately alutaceous and with small, well-separated punctures. Notauli complete although very thin anteriorly; groove at base of scutellum deflected backward and somewhat expanded on

each side. Propodeal disc 1.9 X as wide as long, with five strong discal carinae and two additional weaker carinae close beside the median carina; surface shining, with fine transverse striae laterad of the discal carinae; lateral carinae and foveae of posterior corners strong, sublateral carinae absent; declivity with transverse striae and a strong median carina. Mesopleurum with the upper fovea small but fully outlined, lower fovea not well defined above. Middle tibiae not spinose; claws with a strong tooth which slopes outward somewhat. Fore wing as shown in Figure 68. Subgenital plate with a small, arcuate apical emargination. Genitalia almost exactly as figured for *aeneus* Kieffer (Fig. 71) except as follows: parameres with setae confined to apical third, stronger than in *aeneus*; ventral (mesal) arms of euspides slightly shorter than dorsal (lateral) arms.

Male paratypes. — MEXICO: MORELOS: 14, same data as type except dates varying from 20 May to 3 June, 1959 [MCZ, CU, USNM, ENAC]; 1, Cuernavaca, 5500 feet, 16 May 1959 (M. A. Evans) [MCZ]; 1, Huajintlan, 2800 feet, 1 June 1959 (H. E. Evans) [MCZ].

Variation in males. — LFW varies from 2.9 to 3.3 mm. Coloration of the dorsum of the head and thorax varies from dull olive-green through blue-green to a more shining dark steel-blue; in a few specimens the legs are less strongly suffused with brown than described for the type, in fact almost uniformly rufo-testaceous. The series is very uniform in sculpturing and in standard measurements, the Huajintlan specimen, although from a considerably lower elevation, differing in no noticeable way from the series from Cuernavaca and vicinity.

Allotype. — ♀, MEXICO: MORELOS: same data as type except dated 20 May 1959 [MCZ].

Description of allotype female. — Length about 6.5 mm: LFW 3.9 mm. Dorsum of head and thorax dull olive-green, also the mesopleura, remainder of head and thorax, including the propodeum, black; abdomen shining black; palpi testaceous; mandibles ferruginous; antennae wholly rufo-castaneous, the flagellum slightly paler below than above; tegulae testaceous; legs wholly bright rufo-castaneous except coxae blackish. Fore wing slightly more strongly suffused with brownish than in the male. Mandibles with an apical tooth, above this tooth the apical margin forming a single blade-like cutting edge. Antennae arising well below bottoms of eyes; scrobes not carinate; eyes densely hairy. WH 1.13 X LH; WF .61 X WH, 1.10 X HE; OOL 1.22 X

WOT. Front somewhat more closely punctate than in male. Thoracic dorsum as described for male, but somewhat duller and more strongly alutaceous; features of propodeum and mesopleura also differing in no important details from male. Middle tibiae not spinose; claws dentate.

Remarks.— Only one female is known. The entire type series was taken at honeydew on various trees; most of the specimens (all of those from 3 mi. NW of Cuernavaca) were taken on the tips of the branches of several spreading acacias growing in an open field just below the lower limit of the pine forest. This species, like most of those from the Neotropics, will not fit into any of the species-groups recognized by Evans (1959b) for the species occurring in the United States.

3. Genus *PROCALYOZA* Kieffer

Procalyza Kieffer, 1905b, p. 248 (type species *Calyza westwoodi* Cameron, monobasic). —Kieffer, 1908a, p. 34. —Kieffer, 1914, p. 433.

Generic characters (of male; female unknown).— Minute wasps (about 3 mm long), black, somewhat metallic in color. Mandibles with five sharp teeth in an even row; clypeus with an angular median lobe which is strongly carinate medially, without lateral lobes, eyes glabrous; front with a linear impression on lower half, at extreme base with a carina which is continuous with median carina of clypeus; antennae arising from ventral side of a prominence of the lower front, as in the preceding two genera; antennae of male 13-segmented, segment three much wider than long, only about one-third as long as second segment, not strongly set off from fourth segment, segment four very long, slightly produced apically, segments 5-12 each with a strong process, the processes on segments 7-10 much longer than the length of the segments; occipital carina complete, although rather weak dorsally. Pronotal disc very short, margined by a strong carina in front and on the sides; notauli strong, complete; groove at base of scutellum strongly expanded on each side, narrow medially although distinct and deep; propodeum and mesopleura as in *Anisopyris*; claws dentate; wings as in *Anisopyris*. (Fig. 72.)

Remarks.— This genus is known from a single male specimen in the British Museum. It is possible that the antennae of the female are simple, in which case this sex will resemble *Anisopyris* in all respects other than (presumably) the glabrous eyes. Probably the genus is a derivative of *Anisopyris*, and perhaps it deserves no more than subgeneric status. Kieffer is not correct in

stating that the scutellum has two pits at base rather than a transverse groove; there is a distinct, deep transverse groove which is expanded on each side to form a pair of pits, as in some species of *Anisepyris* (about as in Fig. 70).

Biology. — Unknown.

Distribution. — Panama.

Included species. — Only the type species, which is redescribed below.

PROCALYOZA WESTWOODI (Cameron)

Calyzoa (?) *westwoodi* Cameron, 1888a, p. 456, pl. 19, fig. 25 [Type: ♂, PANAMA: Bugaba (G. C. Champion) (BMNH)].

Procalyzoa westwoodi Kieffer, 1905b, p. 248. — Kieffer, 1914, p. 433.

Description of type male. — Length 3 mm; LFW about 2 mm. Head and thorax dark, dull olive-green; propodeum black; abdomen shining black, apical two segments suffused with brownish; mandibles castaneous, the teeth rufous; antennae wholly medium brown; legs dark brown except trochanters, front tibiae, and all tarsi light yellowish brown; wings hyaline, veins and stigma brown. Median lobe of clypeus forming about a right angle; median carina high, arched in profile. First four antennal segments in a ratio of about 16:7:2:15, segment three a mere ring at base of four, fourth segment slightly produced apically; segments five and six with somewhat longer apical processes, segments 7-10 with processes longer than length of segments, the processes of segments 11 and 12 about as long as length of segments (segment 13 missing on both antennae of type) (Fig. 72). Front strongly alutaceous, rather weakly shining; punctures small, shallow, inconspicuous. WH 1.07 X LH; inner orbits subparallel below, WF .66 X WH, 1.3 X HE. Ocelli in about a right triangle, OOL 1.1 X WOT. Vertex evenly rounded off a short distance above eye tops.

Pronotal disc only .35 X as long as its maximum width, only .8 X as long as mesoscutum; disc strongly alutaceous, moderately shining, obscurely punctate; posterior margin not paralleled by a groove. Mesoscutum and scutellum alutaceous, punctures obscure. Propodeal disc 1.4 X as wide as long, with five discal carinae, the median one complete, the submedians nearly complete, the lateral discals rather short; disc with a few transverse ridges between the three central carinae, on the sides with very fine transverse striae. Mesopleura with the pit strong, the surface otherwise without completely enclosed foveae. Fore wing with

transverse median vein strongly arched. Terminalia not examined.

Distribution. — Panama; known only from the type.

4. Genus EPYRIS Westwood

4a. Subgenus EPYRIS Westwood

Epyris Westwood, 1832, p. 129 (type species *Epyris niger* Westwood, monobasic). —Kieffer, 1905b, p. 250 (first use in more restricted sense). —Kieffer, 1906a, pp. 309-337 (European spp.). —Brues, 1907a, pp. 96-100 (key to U.S. spp.). —Kieffer, 1908a, pp. 26-28. —Kieffer, 1914, pp. 308-346 (spp. of world). —Berland, 1928, pp. 111-116 (French spp.). —Richards, 1939, pp. 321-326 (British spp.). —Kurian, 1955, pp. 88-98 (Oriental spp.).

Muellerella Saussure, 1892, pl. 25, fig. 20 (type species *Muellerella amabilis* Saussure, monobasic; new synonymy).

Mesitius Ashmead, 1893, pp. 62-67 (U. S. spp.; not *Mesitius* Spinola, misidentification). —Ashmead, 1902, p. 272.

Parepyris Kieffer, 1913, p. 108 (type species *Epyris interruptus* Kieffer, designated by Kieffer, 1914; new synonymy) (not *Parepyris* Brèthes, 1913, p. 87). —Kieffer, 1914, pp. 410-412.

Psilepyris Kieffer, 1913, p. 108 (type species *Epyris indivisus* Kieffer, designated by Kieffer, 1914; new synonymy). —Kieffer, 1914, pp. 400-401.

Subgeneric characters. — Small wasps (2-10 mm); body black, rarely metallic bluish or greenish, a few species marked with rufous or yellowish brown. Mandibles slender and curved, with from two to five teeth, rarely blunt and edentate; clypeus with a strong median lobe which is typically angular, occasionally rounded or subtruncate, generally with a strong median ridge; lateral lobes of clypeus not distinct or at least much less prominent than median lobe; antennae located on the ventral side of paired prominences of the lower front; antennal scrobes not margined; antennae arising at or below level of bottoms of eyes, simple, with 13 distinct segments in both sexes, female with scape strongly flattened; eyes glabrous or hairy, in most species short and not nearly reaching top of head. Pronotum very much longer than mesoscutum except in males of a few species, the disc rounded off laterally, anteriorly sloping down to the lower level of the collar; mesoscutum with parapsidal furrows and notauli distinct; base of scutellum with a pair of pits which are completely separate except sometimes connected by a very thin, shallow line, rarely separated only by a thin septum; propodeal disc margined laterally and posteriorly, median carina at least

weakly developed, usually with several well developed discal carinae; females with the femora strongly expanded and flattened, middle tibiae often spinose; claws variable, dentate, bifid, or trifid. Wings abbreviated or absent in females of a few species, fully winged forms with venation similar to that of *Rhabdepyris* and *Anisepyrus*. Abdomen sessile, fusiform, without unusual modifications; abdomen of male slightly compressed apically, the genitalia also slightly compressed; subgenital plate more

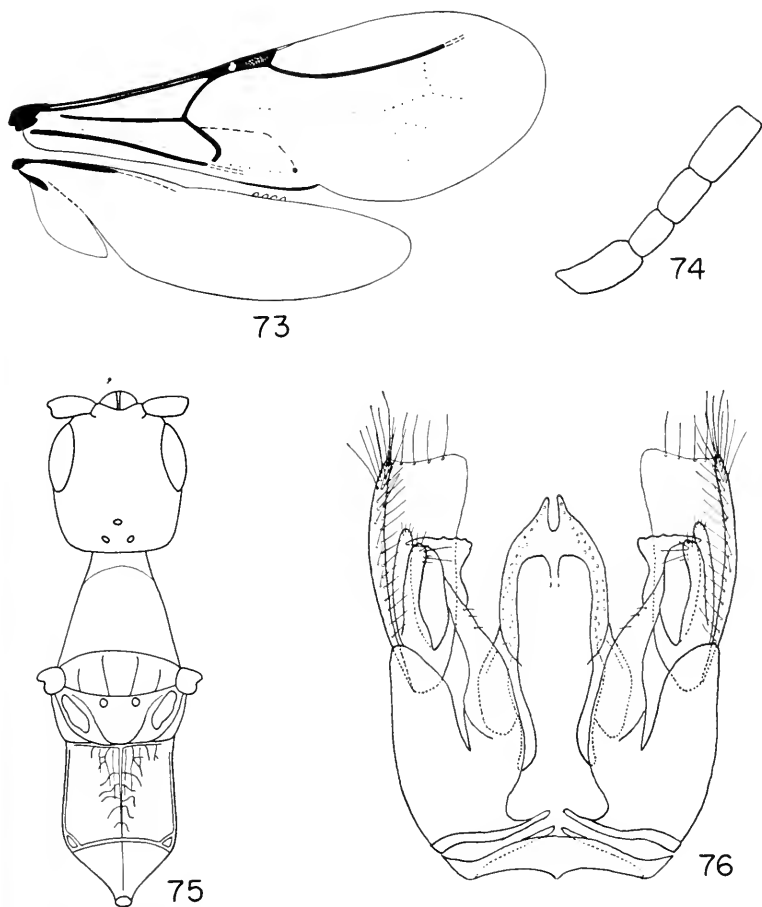

Epyris (Epyris) bifoveolatus (Ashmead). Fig. 73. Wings of female. Fig. 74. Basal four antennal segments of male (scape at lower left). Fig. 75. Head and thorax of female. Fig. 76. Male genitalia.

or less triangular, with a median stalk; genitalia with the parameres broad and hirsute, the cuspides biramous, as in *Rhabdepyris* (simple in a few species), the aedeagus simple but typically broader than in *Rhabdepyris* and *Anisepyris*. (Figs. 73-76.)

Remarks. — This is one of the largest genera of Bethyliidae. There is little question that it is a derivative of *Rhabdepyris*. In fact, some Neotropical species resemble that genus closely, having a similar transverse impression on the mesoscutum and having the scutellar pits slender and oblique, connected by a very thin line, representing only a slight change from those species of *Rhabdepyris* in which the scutellar groove is thin and deflected backward on each side. In all probability the present distinction made between *Epyris* and *Rhabdepyris* will be found to be superficial, and some of the species-groups of each genus will be found to be based on more fundamental characters. However, it seems unwise to make any major changes in the classification at this stage of our knowledge.

I have examined specimens of the type species of *Muellerella* and *Parepyris*, and I do not feel that these species are sufficiently sharply separated from *Epyris* to deserve generic status. I have also studied the type specimen of *Psilepyris indivisus* Kieffer. It is not true that the propodeum of this species is without longitudinal carinae, as Kieffer indicated. The median carina is weak, and there are no other discal carinae, but this condition is approximated by several other species and is of no generic value.

Biology. — The biology of *Epyris extraneus* Bridwell has been studied in Hawaii by Williams (1919). This species is a predator on the larvae of *Gonocephalum seriatum* (Boisduval) (Tenebrionidae), selecting partially grown larvae, 13 to 16 mm long, although the wasp is only about 6 mm long. After the larva has been immobilized by stinging, it is carried over the ground in a most unusual manner, the wasp seizing it by a palpus and "slinging it over her back"; the beetle larva hides the wasp from above, making it appear as if the larva were "making headway under its own steam." The prey is concealed between lumps of soil while the wasp selects a nesting place. The *Epyris* is an excellent digger, and prepares a simple nest in the soil in which the beetle larva is placed and a single egg laid upon it. Williams figured the egg, larva, pupa and cocoon of the wasp, and supplied many details on its biology which cannot be reviewed here. Williams also mentioned that Bridwell found

an *Epyris* in South Africa dragging a small tenebrionid larva. In the collection of the California Academy of Sciences there is a pinned tenebrionid larva taken by F. X. Williams at Danville, California, and labeled "parasitized by bethylid"; Williams also took several *Epyris* (sp. undetermined) at about the same time and place, although none seem to be definitely labeled as having been associated with this larva. It is probable that most if not all species of *Epyris* attack beetle larvae which live in the ground.

Wasps of this genus have been recorded as stinging humans on several occasions. Although the sting itself is not severe, it may produce systemic effects including numbness, itching, asthma, and even diarrhoea (Geldern, 1927; Essig, 1932; Essig and Michelbacher, 1932).

The species of *Epyris* are most commonly taken on vegetation covered with honeydew, and there are a few records of them visiting flowers. They are also commonly taken while sweeping, and occasionally in Berlese samples from soil. The type of Brues' species *myrmecophilus* was taken from a nest of the army ant *Eciton coecum*, but I suspect its occurrence in the nest was accidental.

Distribution. — This genus is represented by numerous species in all zoogeographic regions. In the Americas the genus occurs from Argentina to southern Canada. No species have previously been reported from the West Indies, but I have described below two species from the Greater Antilles. Only a small percentage of the Neotropical species have been described.

Included species:

United States

bifoveolatus (Ashmead), 1893, p. 66; ♂, Florida (widely distributed in eastern U.S.).

brachypterus (Ashmead), 1893, p. 66; ♀, "Carolina."

californicus (Ashmead), 1893, p. 65; ♀, California (also Utah).

clarimontis Kieffer, 1906b, p. 243; ♀, California.

deficiens Krombein, 1956, p. 156; ♀, West Virginia.

eriogoni Kieffer, 1906b, p. 245; ♂, California.

formicoides (Provancher), 1887, p. 179; ♀, Quebec (placed in *Epyris* by Krombein, 1958).

gracilicollis Kieffer, 1908a, p. 28; ♀, California (new name for *longicollis* Kieffer, 1906b, p. 244, *nec* Cameron, 1888a).

- indivisus* Kieffer, 1906b, p. 243; ♂, California.
minutus (Ashmead), 1893, p. 65; ♂, Virginia.
monticola Ashmead, 1890, p. 8; ♂, Colorado.
myrmecophilus (Brues), 1903, p. 124; ♀, Texas.
nevadensis (Ashmead), 1893, p. 64; ♀, Nevada.
nudicornis Kieffer, 1906b, p. 245; ♂, Nevada.
rufipes (Say), 1824, p. 329; "North-West Territory"
 (sex not stated).
texanus (Ashmead), 1893, p. 67; ♀, Texas.
vancouverensis (Ashmead), 1893, p. 64; ♀, British Columbia.
vierecki Krombein, 1962, p. 1; ♂, Maryland (♀ also described).

Mexico and Central America

- albipalpis* Kieffer, 1906b, p. 244; ♀, Nicaragua.
guatemalensis Cameron, 1888a, p. 453; ♀, Guatemala.
montezuma Cameron, 1888b, p. VII (Errata); ♀, Mexico
 (new name for *rufipes* Cameron, 1888b, p. 173; *nec* Say, 1824).
multicarinatus Cameron, 1888a, p. 452; ♀, Panama.
nigripilosus (Ashmead), 1895a, p. 539; ♀, Mexico.
nitidiceps Cameron, 1888a, p. 451; ♀, Panama.
oriplanus Kieffer, 1911, p. 228; ♀, Mexico.

West Indies

- hispaniolae* Evans, n. sp. described below from ♀, Haiti.
manni Evans, n. sp. described below from ♀, Haiti (also Puerto Rico).

South America

- bipunctatus* Kieffer, 1910b, p. 35; ♂, Bolivia.
flavicus Kieffer, 1910b, p. 36; ♂ Peru.
montivagus Kieffer, 1910b, p. 31; ♂, Peru (synonyms:
lindigi Kieffer, 1910b, p. 32; *bogotensis* Kieffer, 1910b,
 p. 34; new synonymy).
paraensis Kieffer, 1910a, p. 296; ♀, Brazil.
quinquepartitus Kieffer, 1910b, p. 33; ♀, Peru.
subspinus Kieffer, 1910b, p. 36; ♂, Bolivia.

EPYRIS (EPYRIS) HISPANIOLAE new species

Holotype. — ♀, HAITI: Etang Lachaux, SW Peninsula, under 1000 feet, 26-27 Oct. 1934 (P. J. Darlington, Jr.) [MCZ, No. 30,802].

Description of type.—Length about 3 mm. LFW 2.0 mm. Head entirely testaceous except for the blackish eyes; prothorax entirely testaceous except pronotum narrowly bordered with black behind, thorax and propodeum otherwise black; abdomen dark reddish brown, slightly paler basally and apically; antennae testaceous basally, brownish beyond segment two; front coxae and tibiae and all trochanters and tarsi testaceous, front femora and middle and hind coxae and tibiae weakly suffused with brown, middle and hind femora brown. Wings hyaline, fore wing with two conspicuous brown spots, one over the transverse median vein, the other over and below the radial vein. Mandibles bidentate. Clypeus with a narrowly rounded median lobe and a pair of broadly rounded lateral lobes which are very much shorter than the median lobe. Antennal sockets on level of bottoms of eyes; first four antennal segments in a ratio of about 5:2:1:2, segments three and eleven each slightly wider than long. Eyes with sparse, short setae. WH and LH subequal; WF .56 X WH, .95 X HE; vertex almost straight across, distance from eye tops to vertex crest equal to about one-third HE. Ocelli in a compact triangle slightly above eye tops, close to vertex crest, front angle less than a right angle; OOL 1.25 X WOT. Front strongly alutaceous although moderately shining, punctures shallow and widely spaced.

Pronotum with smooth contours, the disc nearly twice as long as mesoscutum; surface of pronotum, mesoscutum, and scutellum alutaceous, somewhat shining, obscurely punctate. Notauli complete although much thinner anteriorly. Scutellar pits elongate, oblique, separated by about twice their own length. Propodeal disc about 1.5 X as wide as long, polished and weakly sculptured except for seven strong, closely parallel discal carinae, the median three complete and the other four nearly complete; median extending down posterior slope, which is otherwise shining, with only some very weak sculpturing. Front femora 2.1 X as long as wide; middle tibiae very weakly spinose; claws with a strong, erect tooth and also subdentate basally. Fore wing with transverse median vein moderately curved. Abdomen polished, fusiform.

Remarks.—The coloration of this species is (so far as I know) unique in the genus. The weakly hairy eyes are also unusual. This species is known from a single specimen.

Epyris (Epyris) Manni new species

Holotype.—♀, HAITI: Grande Rivière (W. M. Mann) [MCZ, No. 30,803].

Description of type.—Length 4.4 mm; LFW 3.0 mm. Head and thorax black; abdomen piceous, apical two segments dark reddish brown; palpi testaceous; mandibles, antennae, and legs wholly bright rufo-testaceous, tegulae testaceous. Fore wing subhyaline, very weakly clouded at the radial vein; hind wings hyaline. Mandibles slender, bearing a longitudinal ridge, their apices blunt and not distinctly dentate. Median lobe of clypeus short, obtusely angulate, its tip somewhat rounded. Antennae arising well below level of bottoms of eyes; first four antennal segments in a ratio of about 28:6:5:8, segment three wider than long, segment eleven slightly longer than wide. Eyes bare. Head 1.05 X as wide as high; WF .64 X WH, 1.3 X HE; vertex passing straight across, distance from eye tops to vertex crest equal to about .4 X HE. Ocellar triangle well above eye tops, close to vertex crest, front angle greater than a right angle; OOL 1.15 X WOT. Front weakly alutaceous, shining, punctures small but sharply defined, separated by 1-2 X their own diameters except more widely spaced toward vertex.

Pronotal disc with smooth contours, about 1.5 X as long as mesoscutum; surface of pronotum punctate much like the front, but the mesonotum with somewhat weaker punctures. Notauli complete although very thin anteriorly; scutellar pits oblique, longer than wide, separated by slightly more than 3 X their own length, connected by a very thin, shallow line. Propodeal disc 1.6 X as wide as long, with five discal carinae, all weak and incomplete except the median carina, space between the carinae with transverse ridges, remainder of disc polished, with very delicate transverse lines; posterior face slightly concave, with weak sculpturing except for a strong median carina. Front femora 1.8 X as long as wide; middle tibiae strongly spinose; claws bidentate. Fore wing with transverse median vein strongly oblique, forming almost a right angle below. Abdomen polished, fusiform.

Paratype.—♀, PUERTO RICO: Maricao, July 1960 (J. Maldonado C.) [USNM].

Variation.—The paratype is slightly smaller (LFW 2.5 mm) and is slightly darker, the abdomen being wholly black, the front coxae strongly infuscated, and the antennae suffused with brownish on the apical half. WF measures .61 X WH, 1.25 X HE;

OOL measures 1.16 X WOT. There are no noteworthy differences in the scutellar pits or the sculpturing of the head, thorax, or propodeum.

4b. Subgenus ARTIEPYRIS Kieffer

Artiepyris Kieffer, 1913, p. 108 (type species *Epyris doddeatomus* Kieffer, monobasic). —Kieffer, 1914, p. 428.

Subgeneric characters (of male; female unknown). — Small wasps (3-6 mm); body black, without metallic reflections. Mandibles slender, with from one to three apical teeth; clypeus with a prominent, angular median lobe, lateral lobes absent; antennae arising slightly below bottoms of eyes, long and slender but with only 12 readily apparent segments, segment three being reduced to a small ring at the base of four, less than half the length of segment two; eyes glabrous. Characters of thoracic dorsum as in *Epyris sensu stricto*, known species all with the scutellar pits more or less round, fairly large but well separated; propodeum with several discal carinae, the median carina extending down the declivity; claws bifid, rather strongly curved. Wings fully developed, venation as in *Epyris sensu stricto*. Subgenital plate rounded apically, bearing strong setae. Genitalia differing greatly from those of *Epyris sensu stricto*, parameres very long and slender, cuspides also very long and slender, biramous; aedeagus relatively short and broad. (Figs. 77, 78.)

Remarks. — The above diagnosis was based on several Oriental species as well as our single Neotropical species. Presumably the females cannot be distinguished from *Epyris sensu stricto*, but the males differ so strikingly that it seems desirable to maintain *Artiepyris* as a subgenus. The genitalia of the Oriental species are closely similar to those of *doddeatomus*. With respect to the antennae, *Artiepyris* bears the same relationship to *Epyris* as *Anisepyris* bears to *Rhabdepyris*; however, *Artiepyris* is completely without the pronotal modifications of *Anisepyris*.

Biology. — Unknown.

Distribution. — There are several species in the MCZ from southeast Asia, including the Philippines. In the New World only one species is known, ranging from Costa Rica to southern Mexico.

Included species. — In our fauna, only *doddeatomus* Kieffer, which is redescribed below.

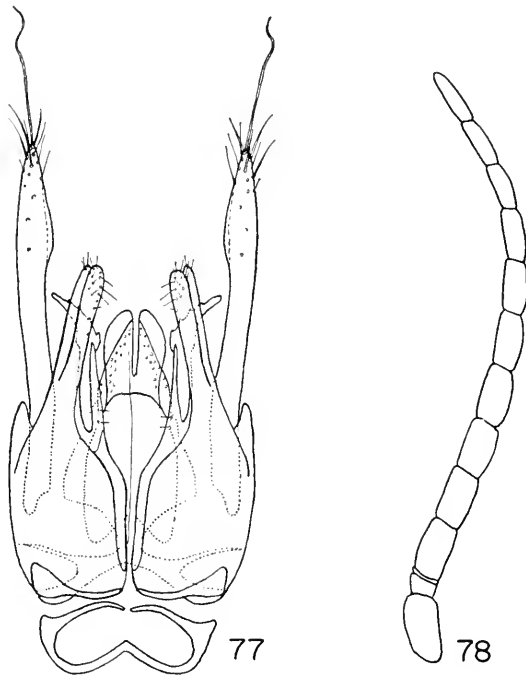

Epyris (Artiepyris) dodecatomus (Kieffer). Fig. 77. Male genitalia. Fig. 78. Antenna of male.

EPYRIS (ARTIEPYRIS) DODECATOMUS (Kieffer)

Epyris dodecatomus Kieffer, 1906b, p. 242 [Type: ♂, NICARAGUA: San Marcos (C. F. Baker) (Pomona College, Claremont, Calif.)].

Artiepyris dodecatomus Kieffer, 1913, p. 108. —Kieffer, 1914, p. 428.

Description of type.—Length 3.7 mm; LFW 3.0 mm. Body wholly shining black; palpi straw-colored; mandibles pale castaneous; antennae wholly rufo-castaneous, apical segments very weakly infuscated; tegulae testaceous; legs wholly bright yellowish brown except front coxae black, other coxae moderately infuscated; apical two abdominal segments weakly suffused with dark red; wings hyaline. Mandibles slender, tridentate apically. Clypeus with the median lobe obtusely angulate, with a strong median carina which is straight in profile and which forms a weak median tooth apically. First four antennal segments in a ratio of about 40:8:3:36, segment four twice as long as thick,

segment eleven 2.6 X as long as thick (Fig. 78). Front strongly shining, barely alutaceous, wholly covered with small punctures which are separated by 1-2 X their own diameters. Head about as wide as high; inner orbits strongly convergent below, WF .57 X WH, 1.10 X HE; ocelli situated far above eye-tops, front angle of ocellar triangle about a right angle; OOL 1.25 X WOT; posterior ocelli removed from crest of vertex by about their own diameters.

Pronotum considerably longer than mesoscutum, without a well-defined anterior face, merely sloping to the collar; disc shining, weakly alutaceous, punctures weak, separated by 2-3 X their own diameters medially, more crowded laterally. Mesonotum shining, obscurely alutaceous, punctures numerous but very weak; notauli attenuate and weakly divergent anteriorly; scutellar pits of moderate size, rounded although slightly longer than wide, separated by nearly twice their own diameters, apparently connected by a thin, shallow impression anteriorly. Propodeal disc 1.4 X as broad as long; lateral and posterior carinae strong, disc with five carinae, of which only the median is complete; extreme sides of disc somewhat foveolate, rest of disc shining and with weak transverse striae, obsolescent laterally and posteriorly. Mesopleurum weakly alutaceous, obscurely punctate, with a complex arrangement of ridges and grooves. Genitalia as shown in Figure 77.⁴

Other specimens examined. — MEXICO: MORELOS: 2 ♂♂, 4 mi. E. of Cuernavaca, about 6000 feet, 23-29 June 1959 (H. E. Evans) [MCZ]. COSTA RICA: 1 ♂, Suretka, Prov. Limon, 31 May 1924 (J. C. Bradley) [CU].

Variation. — The two Mexican specimens resemble the type very closely, including head measurements, but they are somewhat larger (LFW 3.4 mm in both). The Costa Rica specimen is also slightly larger (LFW 3.2 mm) and differs in color slightly, the apical half of the abdomen being suffused with dark rufous and the scape somewhat infuscated; in this specimen the head is longer, the front slightly wider, and the front angle of the ocellar triangle slightly less than a right angle (WH .92 X WH; WF .60 X WH, 1.15 X HE; OOL 1.35 X POL). The genitalia of the Mexican and Costa Rican specimens differ only in minor details of the volsellar structures.

⁴This figure was drawn from one of the Mexican specimens, those of the type not having been dissected.

5. Genus *ASPIDEPYRIS* new genus

Type species.—*Aspidepyris foveolatus*, new species.

Generic characters (of male; female unknown).—Small wasps (about 3.5 mm); body predominantly black, without metallic reflections. Palpi as in *Epyris*; mandibles moderately slender, terminating in three teeth; clypeus with a prominent, angular median lobe which is carinate medially; antennal sockets located very slightly below level of bottoms of eyes, opening obliquely downward; antennae with 13 clearly defined simple segments, segments two and three subequal in length, slightly shorter than four; eyes glabrous; vertex extending well above tops of eyes, crest of vertex very sharp, subcarinate; occipital carina distinct. Pronotum very much longer than mesoscutum, disc sloping upward very gradually from a short anterior collar, disc nowhere carinate but with very sharp margins which approach gradually behind; posterior median part of pronotum elevated above level of lateral parts and above level of mesoscutum, prolonged arcuately so as to overlie the base of the mesoscutum; notauli in the form of rather broad grooves, which are very close together; scutellar disc triangular, flat, and sharp-edged, scutellar pits large, deep, and circular; propodeum with several longitudinal carinae, median carina continuing on down the declivity; posterior lateral angles of propodeal disc foveolate; mesopleurum with very coarse sculpturing, with a lunate fovea just below the tegulae which is extremely deep in the center, elsewhere with a complex series of ridges and foveae; claws dentate; middle tibiae weakly spined. Wings as in *Epyris*, and as shown in Figure 79. Abdomen sessile, shining, somewhat tapering apically; subgenital plate simple, subtriangular; genitalia with the parameres broad and bearing strong setae, cuspides long and slender, not divided into dorsal and ventral arms, aedoeagus relatively short and broad. (Figs. 79-81.)

Remarks.—This genus, presently known from a single specimen, is undoubtedly a derivative of *Epyris*. It is possible that it should be included in *Epyris* as a subgenus, but I think not. The form of the pronotum is unique in the Bethyridae, and the very deep pits of the mesopleurum are also unusual. Presumably these characters will also be found to be present in the female sex.

Biology.—Unknown.

Distribution.—Honduras.

Included species.—Only the type species, described below.

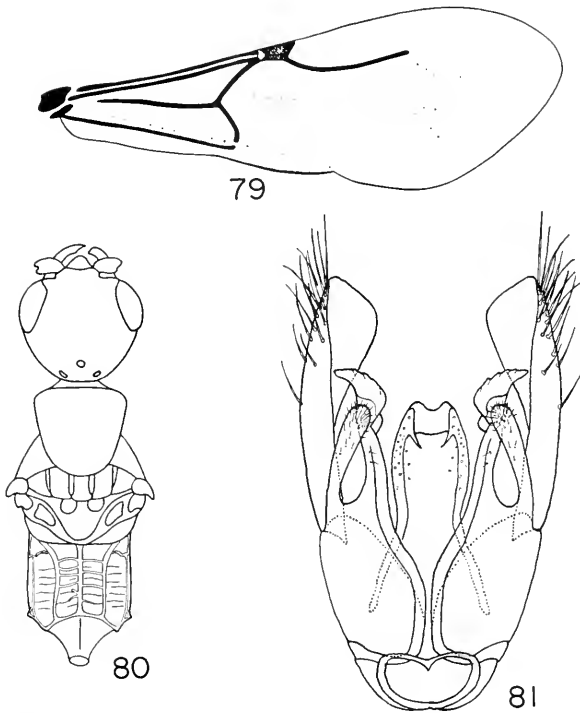

Aspidepyris foveolatus n. sp., male holotype. Fig. 79. Fore wing. Fig. 80. Head and thorax. Fig. 81. Genitalia.

ASPIDEPYRIS FOVEOLATUS new species

Holotype. — ♂, HONDURAS: La Ceiba, 18 Oct. 1916 (F. J. Dyer) [AMNH].

Description of type male. — Length about 3.5 mm; LFW 2.4 mm. Body shining, head and thorax black, abdomen dark reddish brown, slightly paler apically; palpi straw-colored; mandibles testaceous; antennae bright rufo-castaneous, except scape somewhat infuscated and apical few segments suffused with brownish; tegulae testaceous; legs bright testaceous, except all coxae strongly infuscated; fore wing weakly infuscated, somewhat more distinctly infuscated in and below marginal cell; hind wings subhyaline. Apical teeth of mandibles sharp, basal tooth broadly rounded. Median lobe of clypeus angular, but the tip rounded. First four antennal segments in a ratio of about

14:9:9:13, segment three very slightly wider than long, segment eleven 1.8 X as long as thick. Front strongly shining, weakly alutaceous, punctures small but well defined, separated by two to four X their own diameters. WH 1.03 X LH; WF .55 X WH, 1.06 X HE; vertex broadly rounded off a considerable distance above eye tops. OOL 1.10 X WOT; posterior ocelli removed from the sharp vertex crest by less than their own diameters.

Pronotum 3.5 X as long as mesoscutum; disc somewhat shining, alutaceous, with coarse but shallow punctures. Distance between notauli only slightly greater than width of notauli. Pits at base of scutellum separated by slightly less than their own diameters, large and bowl-shaped. Propodeum with three very strong discal carinae, all of them complete, the lateral discs flat-topped; lateral, sublateral, and transverse carinae all strong; disc shining, the space between the carinae filled with rather weak and irregular transverse striae; side-pieces obliquely striate. Wings as shown in Figure 79; genitalia as shown in Figure 81.

6. Genus BAKERIELLA Kieffer

Bakeriella Kieffer, 1910a, p. 288 (type species *Bakeriella flavicornis* Kieffer, monobasic). —Kieffer, 1914, pp. 444-445.

Generic characters.—Small wasps (2.5-5 mm) of predominantly black, non-metallic coloration. Mandibles moderately broadened apically, terminating in from two to five teeth; clypeus with the median lobe angulate or subangulate, sometimes very broadly so, lateral lobes not developed; antennae arising at or slightly below level of bottoms of eyes, scrobes sometimes margined; antennae simple, with 13 clearly defined segments, third segment no longer than second or fourth in either sex, usually slightly shorter; eyes glabrous or hairy; occipital carina complete. Pronotum with a distinct but short, oblique anterior face, the disc often rather flat, transversely carinate in front, sometimes also with longitudinal carinae margining the sides and/or with a median carina; notauli rather wide, much attenuate anteriorly, sometimes incomplete; scutellar disc not as flat and sharply margined as in *Aspidepyris*, the basal pits large, rounded or somewhat transverse, separated by a thin septum or by a broad, flat-topped ridge; propodeum with the median carina complete and continuing down declivity, disc with or without other carinae, lateral and posterior carinae well developed, posterior lateral angles more or less foveolate; mesopleurum of the same form as in *Rhabdepyris* and *Epyris*; claws

dentate; femora of female not greatly widened or strongly flattened. Wings fully developed, venation as in *Epyris*. Abdomen sessile, fusiform, slightly depressed apically, especially in female; male genitalia differing in no notable manner from those of *Epyris sensu stricto*. (Figs. 82-84.)

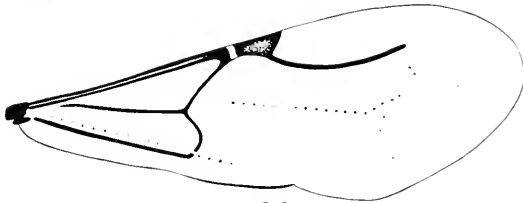

82



83

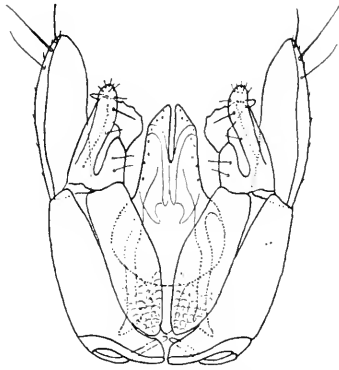

84

Bakeriella spp. Fig. 82. *B. azteca* n. sp., male holotype, fore wing. Fig. 83. Head and thorax of same specimen. Fig. 84. *B. floridana* n. sp., paratype, male genitalia.

Remarks.—Kieffer used the name *Bakeriella* for two species having the pronotum carinate laterally and medially as well as anteriorly. There are, however, some species in which the pronotum has only a weak indication of median or lateral carinae, and other apparently related species in which only the transverse, anterior carina is present. Thus I use the name *Bakeriella* somewhat more broadly than did Kieffer. The genus bears much

the same relationship to *Epyris* as *Anisepyris* does to *Rhabdepyris*, so far as the pronotum goes, but the antennae are not modified as in *Anisepyris*. Undoubtedly, *Bakeriella* is a derivative of a stock of *Epyris sensu stricto*.

Biology.—Unknown.

Distribution.—This genus is confined to the Americas, the known species ranging from Brazil and Bolivia to central Mexico and to southern Florida. I have seen no specimens from the West Indies, but the occurrence of a species in southern Florida suggests that the genus may occur in the Antilles. Ten new species are described below, bringing the total number of known species to twelve.

Included species:

North and Central America

azteca Evans, n. sp. described below from ♂, Morelos, Mexico (sp. 4).

floridana Evans, n. sp. described below from ♂, ♀, Florida (sp. 12).

inconspicua Evans, n. sp. described below from ♂, Panama (also southern Mexico, Costa Rica, Venezuela) (sp. 11).

olmeca Evans, n. sp. described below from ♂, ♀, Veracruz, Mexico (sp. 3).

South America

brasiliانا Evans, n. sp. described below from ♀, Brazil (sp. 7).

eristata Evans, n. sp. described below from ♂, Bolivia (also Brazil) (sp. 6).

depressa Kieffer, 1910b, p. 56; ♂, Peru (also Panama, Costa Rica; redescribed below, sp. 1).

flavicornis Kieffer, 1910a, p. 289; ♂, Brazil (redescribed below, sp. 2).

inea Evans, n. sp. described below from ♀, Peru (sp. 5).

polita Evans, n. sp. described below from ♂, Bolivia (also Peru), (sp. 9).

rossi Evans, n. sp. described below from ♂, Colombia (sp. 8).

rufocaudata Evans, n. sp. described below from ♂, Colombia (also Costa Rica) (sp. 10).

KEY TO SPECIES OF *BAKERIELLA*

1. Scutellar pits subcircular, slightly longer than wide, separated by a flat-topped ridge over half as wide as diameter of one of pits; pronotal disc with a strong transverse carina in front and a weak median carina, but the sides of the disc smoothly rounded (Bolivia, Brazil; known from ♂ only) (6) *cristata* n. sp.
 Scutellar pits wider than long, separated by only a thin septum; pronotal disc variable, but always with the sides abrupt, sometimes carinate or subcarinate 2
2. Temples with a strong, vertical carina, well separated from the occipital carina, curving forward below to approach or touch the lower outer eye margins (males only) 3
 Temples not carinate (males and females) 5
3. Pronotum with a rather delicate median carina, sometimes obsolescent in part, without distinct lateral carinae; apical half of flagellum rather strongly infuscated (Mexico) (3) *olmeca* n. sp.
 Pronotum with a very strong median ridge and also more or less carinate laterally; flagellum pale castaneous, weakly infuscated apically 4
4. Transverse carina of pronotum, as seen obliquely from behind, strongly sinuate, subdentate on the sides (Peru, Panama, Costa Rica) (1) *depressa* Kieffer
 Transverse carina of pronotum, as seen from behind, rather even, not produced or subdentate (Brazil) (2) *flavicornis* Kieffer
5. Pronotum with a well-developed, complete median carina 6
 Pronotum without a median carina 7
6. Median carina of pronotum occupying a shallow depression and continuous behind with a transverse polished band along the posterior margin; mesoscutum strongly transversely depressed; eyes hairy (Peru; known from ♀ only) (5) *inca* n. sp.
 Median carina of pronotum not in a depression, continuous with a dull, alutaceous elevation along posterior margin; mesoscutum barely depressed; eyes with only very weak hairs (Mexico; known from ♂ only) (4) *azteca* n. sp.
7. Antennal scrobes not carinate (females) 8
 Antennal scrobes margined by delicate carinae (males) 10
8. Legs wholly testaceous; scape testaceous, flagellum light reddish brown; transverse carina of pronotum gently arched (Florida) (12) *floridana* n. sp.
 Legs blackish, at least basally; antennae darker than above; transverse carina of pronotum broadly angulate 9
9. Mandibles with five teeth, the basal three teeth small; front with small punctures which are separated by 1.5-3.0 X their own diameters (Mexico) (3) *olmeca* n. sp.
 Mandibles with only the two large apical teeth; front with somewhat stronger and more widely spaced punctures (Brazil) (7) *brasiliانا* n. sp.

10. Antennae unusually elongate, segment eleven at least twice as long as thick; apical .4 of abdomen rufous; pronotal disc polished, weakly alutaceous (Colombia, Costa Rica) (10) *rufocaudata* n. sp.
 Antennae relatively short, segment eleven not more than 1.7 X as long as thick; tip of abdomen at most weakly suffused with reddish brown 11
11. Front and pronotal disc polished, weakly or hardly at all alutaceous; larger species, LFW 2.8-3.6 mm 12
 Front and pronotal disc weakly shining, strongly alutaceous; smaller species, LFW up to 2.4 mm 13
12. Vertex rather narrowly rounded off far above eye tops; median lobe of clypeus roundly subangular; antennae castaneous, somewhat infuscated on apical third (Bolivia, Peru) (9) *polita* n. sp.
 Vertex more broadly rounded off, not so strongly elevated above eye tops; median lobe of clypeus rather strongly angular; antennae dark brown on apical half to three-fourths (Colombia) (8) *rossi* n. sp.
13. Sides of pronotal disc subparallel, subcarinate; coxae and femora dark brown (Mexico, Panama, Costa Rica, Venezuela) (11) *inconspicua* n. sp.
 Sides of pronotal disc diverging behind, not at all carinate; legs bright testaceous except front coxae infuscated (Florida) (12) *floridana* n. sp.

(1) *BAKERIELLA DEPRESSA* Kieffer

Bakeriella depressa Kieffer, 1910b, p. 56 [Type: ♂, PERU: Marcapata (Staudinger) (Berlin Museum, No. 169)]. —Kieffer, 1914, p. 445.

Description of type male. — Length 4.1 mm; LFW 2.7 mm. Black; palpi light brown; mandibles yellowish brown except base infuscated; antennae light reddish brown except basal half of scape infuscated; tegulae castaneous; coxae and femora piceous, tibiae brown, somewhat infuscated, trochanters and tarsi castaneous; wings hyaline, veins and stigma amber. Mandibles with five teeth, the basal four subequal. Clypeus obtusely triangularly produced, tectiform medially. First four antennal segments in a ratio of about 2:1:1:1, segment three as well as segment eleven about 1.4 X as long as thick. Front strongly alutaceous, rather weakly shining, with weak punctures which are separated from one another by from 2-3 X their own diameters. Antennal scrobes margined by short, transverse carinae which run to the eye margins; upper, inner orbits weakly carinate; temples with a very strong carina and somewhat foveolate immediately in front of this carina. Eyes strongly converging below; WF .51 X WH, 1.1 X HE; ocelli small, in

about a right triangle, OOL 1.27 X WOT, posterior ocelli removed from vertex crest by about their own diameters. Vertex nearly straight across; distance from eye tops to vertex crest equal to slightly more than half HE.

Pronotum somewhat wider than long, subrectangular, bordered anteriorly by a high ridge, the two halves of which meet medially and continue backward as a strong median carina; this ridge is subdentate laterally, and forms a pair of submedian crests of irregular profile; lateral carinae running just inside the lateral margins and not quite reaching posterior margin; posterior margin paralleled by a row of fairly large foveae; disc of pronotum strongly alutaceous, punctures weak. Mesoscutum short, with notauli of unusual breadth which do not quite reach the anterior or posterior margin; scutellum alutaceous, the pits transverse, separated by a median ridge. Propodeum with disc .9 X as long as wide, median carina complete, also with two additional carinae which curve mesad posteriorly and extend .7 X the distance to the transverse carina. Mesopleurum shining, somewhat alutaceous. Femora flattened and rather short, posterior femur only 2.2 X as long as wide.

Other specimens examined.—PANAMA: 1 ♂, Barro Colorado Island, Canal Zone, 18 June 1924 (N. Banks) [MCZ]. COSTA RICA: 3 ♂♂, vic. of Santa Clara de San Carlos, Alajuela Prov., 17-19 Feb. 1964 (H. E. Evans) [MCZ]; 1 ♂, 5 mi. N of Quesada, Alajuela Prov., 20 Feb. 1964 (H. E. Evans) [MCZ]; 1 ♂, 12 mi. SW of Cañas, Guanacaste Prov., 27 Feb. 1964 (H. E. Evans) [MCZ].

Variation.—All of the Panama and Costa Rica specimens are smaller than the type (LFW 2.2-2.6 mm) and all have the antennae weakly infuscated apically and the fore wings weakly clouded, especially on the apical third. In these specimens WF varies from 1.0 to 1.15 X HE, OOL from 1.20 to 1.45 X WOT. Minor variations can be observed in the details of sculpturing on the pronotum and propodeum, and in the five Costa Rica specimens the upper, inner orbits are not really carinate, but merely weakly grooved.

(2) BAKERIELLA FLAVICORNIS Kieffer

Bakeriella flavicornis Kieffer, 1910a, p. 289 [Type: ♂, BRAZIL: Pará (C. F. Baker) (Pomona College, Claremont, Calif.)]. —Kieffer, 1914, pp. 444-445.

Description of type male.—Length 3.8 mm; LFW 2.5 mm. Black; palpi straw-colored; mandibles and antennae wholly pale castaneous; tegulae testaceous; coxae nearly black, femora dark brown, legs otherwise light yellowish brown; wings clear hyaline. Mandibles slender, with five apical teeth, all but the apical tooth very small. Clypeus obtusely produced medially, subdentate medially, its median carina very strong, strongly arched in profile. First four antennal segments in a ratio of about 20:8:8:9, segment three and segment eleven each about 1.3 X as long as thick. Front strongly alutaceous, moderately shining, with weak punctures which are separated from one another by 2-3 X their own diameters. Antennal scrobes margined by a transverse carina which extends all the way from the midline to both eye margins; upper inner orbits weakly carinate; temples with a strong carina which runs from the vertex close along the outer orbits to the base of the mandibles. Head very slightly longer than wide; inner orbits convergent below, WF .53 X WH, subequal to HE; distance between eyes at top 1.6 X distance between eyes at bottom; ocelli of moderate size, front angle of ocellar triangle less than a right angle, distance between hind ocelli and vertex crest about equal to diameter of one of ocelli; OOL 1.3 X WOT. Vertex straight across; distance from eye tops to vertex crest equal to slightly over half HE.

Pronotal disc somewhat wider than long, bordered anteriorly by a high ridge, the two halves of which meet medially and continue backward as a strong median carina; this ridge, seen from behind, has a rather even profile; disc also with weak lateral carinae which reach the posterior margin and with strong sublateral elevations, just above the lateral carinae, which do not reach the posterior margin; posterior margin of disc paralleled by a series of fairly large foveae; surface of disc alutaceous, shining, obscurely punctate. Mesoscutum short, notauli rather broad, tapering anteriorly and barely reaching anterior margin; scutellum with its basal pits separated by a median ridge which continues on behind as a weak median elevation on the disc; surface of mesoscutum and scutellum shining, rather weakly alutaceous. Disc of propodeum very slightly wider than long; lateral, sublateral, and posterior margining carinae all strong, median carina also strong; disc also with two additional carinae which curve mesad posteriorly and extend about .8 X the length of the disc; disc obscurely transversely striate between these carinae, otherwise shining and very weakly sculptured. Mesopleurum strongly alutaceous, weakly shining.

(3) *BAKERIELLA OLMECA* new species

Holotype. — ♂, MEXICO: VERACRUZ: 30 mi. S. Acayucan, 21 April 1962 (F. D. Parker) [CAS].

Description of type male. — Length 3.2 mm; LFW 2.2 mm. Body entirely black; mandibles testaceous except black at base, rufous at apex; palpi testaceous; antennae light brown except basal two-thirds of scape dark brown, flagellum gradually infuscated toward tip; legs dark brownish-fuscous except tibiae lighter brown, tarsi testaceous; tegulae brownish; fore wings lightly tinged with brownish, more distinctly so around the radial vein. Mandibles with five teeth, the basal three teeth small and more rounded than the two outermost teeth. Clypeus short, broadly, obtusely angulate, not distinctly carinate medially. Antennal scrobes weakly carinate; eyes with sparse, short setae. First four antennal segments in a ratio of about 18:7:8:9, segment three about 1.6 X as long as thick, segment eleven about 1.5 X as long as thick. Head 1.05 X as wide as high; inner orbits strongly converging below, WF .58 X WH, 1.20 X HE. Front angle of ocellar triangle less than a right angle; OOL 1.40 X WOT. Vertex very broadly rounded; occipital carina visible at top of vertex in full frontal view. Front strongly alutaceous, somewhat shining, obscurely punctate, with a linear median streak. Temples with a strong carina which starts at the vertex and extends to the base of the mandibles, approaching but not quite touching the lower outer eye margins.

Pronotal collar longitudinally ridged, the disc rather convex, margined in front with a transverse carina which is obtusely angulate behind medially, the angulation giving rise to a very weak median carina which extends to the elevated rim of the posterior margin, this rim preceded by a line of small foveae; sides of disc rather sharp, subcarinate in front; top and sides of pronotum alutaceous, moderately shining, obscurely punctate. Mesoscutum with the notauli very strong on the posterior part, surface of scutum and scutellum alutaceous, without noticeable punctures; pits at base of scutellum large, transverse, separated medially by a thin septum. Propodeum with three discal carinae, the median carina complete, the disc shining and with rather weak sculpturing. Mesopleurum with a very strong, arching ridge, about and behind which it is somewhat foveolate. Transverse median vein of fore wing moderately arched. Abdomen strongly shining; apical sternite with some strong bristles.

Allotype. — ♀, same data as type [CAS].

Description of allotype female.—Length about 4 mm; LFW 2.8 mm. Body black; palpi testaceous; mandibles castaneous except black at base, the teeth rufous; mandibles dull ferruginous except strongly infuscated on the apical segments; legs black except trochanters and tibiae ferruginous, tarsi light brown; wings lightly tinged with brownish, more especially so around the radial vein. Mandibles with five teeth, the basal three teeth small and rounded, in a more oblique series than in the male. Clypeus as in male. Antennal scrobes not carinate; eyes with somewhat stronger hairs than in male. Third antennal segment 1.3 X as long as thick; eleventh segment very slightly wider than long. WH .92 X LH; WF .60 X WH, 1.28 X HE; OOL 1.7 X WOT. Front shining, rather weakly alutaceous, the punctures small, separated by 1.5-3 X their own diameters. Vertex broadly rounded off far above eye tops; temples well developed, but completely without carinae.

Pronotal collar with longitudinal ridges; disc rather convex, margined in front by a carina which is weakly angled forward medially; median carina completely absent; posterior margin paralleled by a row of small foveae; sides of disc rather abruptly rounded onto side-pieces; surface somewhat shining and with small punctures like the front. Features of remainder of thorax differing in no important ways from those of the male. Front femora 2.5 X as long as their maximum width; middle tibiae with some strong spines. Abdomen strongly shining, with some strong setae toward the apex ventrally.

Paratypes.—One δ , same data as type and allotype [UCD].

Variation.—The single male paratype is very similar to the type in size, color, and nearly all details of structure. However, the median carina of the pronotum is quite distinctly stronger.

Remarks.—This species is of interest as indicating that carinae on the temples and a carina on the median line of the pronotum may be present in the male sex when absent in the female. Thus the females of the two previous species may be found to lack these carinae. There seems little question that the two sexes of *olmcea* are correctly associated, as the specimens were taken at the same time and place and have many striking similarities.

(4) BAKERIELLA AZTECA new species

Holotype.— δ , MEXICO: MORELOS: Huajintlan, 2500 ft., 14 May 1959 (H. E. Evans) [MCZ, No. 30,804].

Description of type male.—Length 4 mm; LFW 2.4 mm. Body entirely shining black; palpi testaceous; mandibles castaneous, the teeth rufous; antennae castaneous, slightly infuscated on apical half; tegulae testaceous; coxae nearly black, legs otherwise bright, pale castaneous, except femora weakly suffused with brownish; wings hyaline, veins and stigma brown. Mandibles with five teeth, basal four teeth small, sharp, and subequal. Clypeus broadly subangular, median carina arched in profile. Antennal sockets connected by a carina, this carina continuing laterad almost to eye margins; first four antennal segments in a ratio of about 20:8:7:8, segment three 1.2 X as long as thick, segment eleven 1.3 X as long as thick; flagellar pubescence rather coarse. Head about as wide as high; eyes strongly diverging above, WF .56 X WH, 1.15 X HE. Ocelli in a right triangle, OOL 1.3 X WOT; vertex very broadly rounded, distance from eye tops to vertex crest equal to about two-thirds HE. Eyes with some very short, scarcely noticeable hairs. Front strongly alutaceous, although moderately shining, punctures numerous but very shallow. Temples not carinate.

Pronotal disc about half as long as its maximum width, with a strong transverse anterior ridge which gives rise to a strong median carina; sides of disc subcarinate; posterior margin of disc paralleled by a weakly impressed, weakly foveolate groove; disc alutaceous and moderately shining, like the front. Mesoscutum with the notauli broad, not reaching anterior margin; surface of mesoscutum alutaceous, obscurely punctate. Basal pits of scutellum transverse, separated by only a very weak septum. Propodeal disc 1.25 X as broad as long, with three longitudinal carinae, the median carina complete, the other two carinae extending for about .8 X the length of the disc, converging behind; disc polished and very weakly sculptured, except between the carinae, where it is irregularly transversely striate. Wings shown in Figure 82.

Remarks.—This species is known only from the type, which was collected at honeydew on a broadleaved tree growing beside a draw. It is very similar to the preceding three species, but the temples are completely without carinae.

(5) *BAKERIELLA INCA* new species

Holotype.—♀, PERU: Puerto Bermudez, Rio Pichis, 12-19 July 1920 (Cornell Univ. Exped.) [CU].

Description of type female. — Length 4.2 mm; LFW 3.0 mm. Head and thorax black, abdomen dark reddish brown, slightly paler basally and apically; palpi brown; mandibles black at base, apical half testaceous, teeth rufous; antennae wholly dark brown; tegulae brownish; legs wholly dark brown, except tarsi and tips of tibiae light yellowish brown; wings lightly tinged with brownish, veins and stigma dark brown. Mandibles of unusual form, extending strongly downward, their lower margins nearly straight, apex with three teeth in a strongly oblique series, the most basal tooth very small. Median lobe of clypeus relatively very broad and short. Antennal scrobes not margined; eyes hairy. First four antennal segments in a ratio of about 3:1:1:1, segment three about 1.2 X as long as thick, segment eleven approximately as long as thick. Head very slightly longer than wide, WH .97 X LH; WF .59 X WH, 1.25 X HE. Ocelli in a compact triangle far removed from eyes, OOL nearly twice WOT; vertex passing straight across far above eye tops, distance from eye tops to vertex crest about .7 X HE. Front shining, weakly alutaceous, with small but sharply defined punctures which are separated by 2-4 X their own diameters. Temples not carinate.

Pronotal disc rather flat, about two-thirds as long as its posterior width, transverse anterior carina rather low, median carina also low but very distinct, occupying a shallow longitudinal depression, continuous behind with a polished streak along posterior margin of pronotum; sides of disc rather sharp, but not carinate; surface alutaceous, with fairly large punctures. Mesoscutum transversely depressed behind, notauli and parapsidal furrows rather short, not as wide as in preceding species; posterior part of mesoscutum alutaceous, somewhat punctate. Scutellum with basal pits transverse, separated medially by a thin septum. Propodeal disc slightly longer than wide, lateral and transverse carinae strong, disc with three carinae, median carina complete, other two carinae extending about .7 X the length of the disc; surface of disc smooth and shining except weakly sculptured between the carinae. Front femora 2.4 X as long as thick; middle tibiae strongly spinose. Abdomen fusiform, tapering and slightly depressed apically.

(6) *BAKERIELLA CRISTATA* new species

Holotype. — ♂, BOLIVIA: Cuatro Ojos, Prov. Santa Cruz, Nov. 1931 (Steinbach) [CM].

Description of type male.—Length 4 mm; LFW 2.9 mm. Black; palpi testaceous; mandibles castaneous, the teeth rufous; antennae dull castaneous, apical few segments dusky, scape strongly infuscated; tegulae brownish; legs dark brown except front tibiae and all tarsi testaceous; fore wing strongly tinged with brownish, hind wing subhyaline. Mandibles terminating in two large teeth. Median lobe of clypeus tectiform, subangular, but extreme tip subtruncate. Antennal scrobes not carinate; eyes very weakly hairy. First four antennal segments in a ratio of about 19:10:10:13, segment three barely longer than thick, segment eleven 1.4 X as long as thick. Head about as wide as high; WF .55 X WH, 1.0 X HE. Ocelli in a broad triangle, front angle slightly greater than a right angle; WOT slightly exceeding OOL; vertex rather sharp, broadly rounded off a distance above eye tops equal to much less than half HE. Front moderately shining, on lower half alutaceous and obscurely punctate, upper half more weakly alutaceous and with stronger punctures; temples not carinate.

Pronotum with a strong anterior ridge which extends down the sides, that portion of pronotum in front of ridge flat, nearly vertical; disc of pronotum with a very weak longitudinal carina which terminates behind in a pair of small pits just before the posterior margin, also with some additional very weak longitudinal irregularities; posterior margin of pronotum not paralleled by a punctate or foveolate groove; sides of disc broadly rounded onto side pieces, the latter rather flat but with a shallow longitudinal groove. Mesoscutum with the notauli rather broad and close together posteriorly, toward the front diverging and much attenuate. Scutellum rather flat, the basal pits large, bowl-shaped, slightly longer than wide, separated by a flat-topped ridge which is slightly more than half as wide as maximum diameter of pits. Propodeal disc 1.25 X as wide as long, with five widely spaced longitudinal carinae in addition to the lateral carinae, all these carinae complete or nearly so, space between carinae filled with rather small transverse striae; mesopleurum weakly alutaceous, with strong sculpturing. Fore wing as in Figure 82, except transverse median vein more strongly oblique and more distinctly subangulate.

Paratypes.—BRAZIL: 1 ♂, Chapada, Jan. [CM]; 1 ♂, Nova Teutonia, Santa Catarina, 5 April 1938 (F. Plaumann) [BMNH].

Variation.—The two paratypes are smaller than the type (LFW about 2.2 mm in both). The fore wing is subhyaline in both, but otherwise the coloration is very similar. All of the unusual features of the thorax and propodeum are shared in close detail by these two specimens. The Nova Tentonia specimen is without a head. In the Chapada specimen, WF measures .54 X WH, 1.0 X HE; OOL is .90 X WOT; the eleventh antennal segment is 1.25 X as long as wide.

(7) *BAKERIELLA BRASILIANA* new species

Holotype.—♀, BRAZIL: Minas Gerais, Ouro Preto, April 1954 (N. L. H. Krauss) [USNM, No. 64,997].

Description of type female.—Length about 4 mm; LFW 2.8 mm. Head and thorax black; abdomen piceous, tergites indistinctly annulated with dark ferruginous apically, apical tergite mostly ferruginous; palpi testaceous; apical half of mandibles testaceous; antennae dark brown, except outer side of basal flagellar segments light brown; tegulae brownish; legs wholly dark brown, except front tibiae and all tarsi light yellowish brown; wings very lightly tinged with brownish, veins and stigma dark brown. Mandibles much broadened apically, directed downward, their lower margin nearly straight, apex with two large teeth, their margins strongly oblique but without additional teeth. Median lobe of clypeus broadly subangulate. Antennal scrobes not margined; eyes strongly hairy. First four antennal segments in a ratio of about 28:9:7:9, segment 3 about as long as wide, segment 11 slightly broader than long. Head distinctly longer than wide. WH .93 X LH; WF .56 X WH, 1.15 X HE. Ocelli in a compact triangle far removed from eyes, front angle of ocellar triangle less than a right angle; OOL 1.8 X WOT; vertex extended far above eye tops, distance from eye tops to vertex crest about .7 X HE. Front polished, obscurely alutaceous, punctures small but sharply defined, separated by 2-3 X their own diameters. Temples polished, weakly punctate, not carinate.

Anterior face of pronotum, in front of transverse carina, strongly oblique; transverse carina fairly strong, subangulate medially, weak and extending obliquely backward on the side pieces; sides of disc weakly longitudinally humped, but not carinate; posterior margin of pronotal disc paralleled by a strongly punctate groove, behind which the surface is smooth and polished; main part of disc moderately alutaceous, with

strong punctures. Mesoscutum transversely depressed behind, the posterior part strongly alutaceous; notauli short, diverging anteriorly. Scutellum with basal pits transverse, separated medially by a thin septum. Propodeal disc about as long as wide, lateral, sublateral, and transverse carinae strong; disc with three carinae, median carina complete, other two carinae extending about .7 X the length of the disc; surface of disc smooth and shining except weakly sculptured between the carinae. Front femora 2.6 X as long as thick; middle tibiae strongly spinose. Abdomen polished, somewhat depressed apically.

Remarks. — This species is strikingly similar to *inca* in almost every respect, but the pronotum is completely without a median carina. The close resemblance of these two species demonstrates the fallacy of using the generic name *Bakeriella* for only those species possessing a median carina on the pronotum.

(8) BAKERIELLA ROSSI new species

Holotype. — ♂, COLOMBIA: 5 miles north of Anserma, Caldas, 1750 meters, 17 March 1955 (E. I. Schlinger and E. S. Ross) [CAS].

Description of type male. — Length about 3.5 mm; LFW 2.9 mm. Color black, except tip of abdomen suffused with light brown; palpi testaceous; apices of mandibles ferruginous; basal three segments of antennae bright castaneous, except scape infuscated above, third segment infuscated apically, remainder of antenna very dark brown; tegulae dark brown; legs dark brown except tarsi and tips of all tibiae light brown; fore wing lightly tinged with brownish, especially in and below marginal cell; hind wings hyaline. Mandibles with a strong apical tooth and with three very small additional teeth in a straight line. Median lobe of clypeus sharply, obtusely angulate; median carina straight in profile. Antennal scrobes margined by very delicate carinae which do not meet the eye margins; eyes very weakly hairy. First four antennal segments in a ratio of about 18:8:9:10, segment three 1.2 X as long as thick, segment eleven 1.8 X as long as thick. Head slightly longer than wide. WH .93 X LH; WF .58 X WH, 1.17 X HE. Ocelli in a compact triangle, front angle approximately a right angle; OOL about 1.4 X WOT; vertex forming an even arc considerably above eye tops, distance from eye tops to center of vertex crest equal to about .75 X HE. Front shining, weakly alutaceous, very weakly punctate; temples not strongly developed, not carinate.

Pronotum with a strong, nearly straight transverse carina; sides of disc carinate in front, but the carinae fading out on the posterior half; disc shining, weakly alutaceous, posterior margin paralleled by a strongly punctate groove. Mesoscutum somewhat depressed on sides, notauli diverging anteriorly, reaching the anterior margins only as very thin lines. Scutellar pits bowl-shaped, slightly wider than long, separated medially by a thin septum. Propodeal disc 1.1 X as wide as long, with three discal carinae, median carina complete, the others extending about .7 X the length of the disc; surface of disc entirely covered with weak sculpturing; posterior lateral angles strongly foveolate. Fore wing with transverse median vein strongly rounded.

Paratypes. — COLOMBIA: 2 ♂♂, 3 miles west of Villaviecio, Meta, 920 meters, 11 March 1955 (E. I. Schlinger and E. S. Ross) [CAS, MCZ].

Variation. — Both paratypes are slightly larger than the type (LFW 3.1, 3.2). In both specimens the antennae are more strongly suffused with castaneous basally, one specimen having the entire basal half of the antennae bright castaneous; this same specimen has all the tibiae castaneous, and the apical third of the abdomen rather strongly suffused with dark ferruginous. Only very minor differences in body measurements or in the details of the thoracic dorsum and propodeum can be noted.

(9) *BAKERIELLA POLITA* new species

Holotype. — ♂, BOLIVIA: Coroico [Prov. La Paz] (no further data) [MCZ, No. 30,805].

Description of type male. — Length about 5 mm; LFW 3.7 mm. Black; palpi and mandibles largely testaceous; antennae wholly bright, pale castaneous, except apical five segments somewhat infuscated; tegulae testaceous; legs dark brown, except front tibiae and all tarsi pale castaneous; wings faintly tinged with yellowish brown, veins amber. Mandibles with five teeth, the apical tooth strong, the other four teeth very small, subequal. Median lobe of clypeus obtusely subangular, actually slightly rounded, its median carina weakly arched in profile. Antennal scrobes carinate; eyes glabrous. First four antennal segments in a ratio of about 13:5:6:8, segment three 1.2 X as long as thick, segment eleven 1.4 X as long as thick. Head unusually elongate, WH .88 X LH; WF .60 X WH, 1.22 X HE. Ocelli in a compact triangle far above eye tops, front angle of ocellar triangle less than a right angle; OOL 1.35 X WOT. Vertex rather

narrowly rounded off far above eye tops, distance from tops of eyes to vertex crest nearly equal to HE; temples not well developed, not carinate. Front strongly polished, non-alutaceous, punctures small, separated by 3-5 X their own diameters.

Pronotal disc with a strong, weakly arching, transverse anterior carina, sides of disc sharp but not actually carinate; posterior margin of pronotum paralleled by a weak impression which is not distinctly punctate or foveolate; major part of disc alutaceous, moderately shining, the punctures rather weak. Mesoscutum weakly alutaceous, weakly punctate; notauli strong on posterior half, reaching anterior margin as very thin lines. Scutellar pits transverse, separated by a thin septum. Propodeal disc very slightly wider than long, with three discal carinae, median carina complete, the other two carinae incomplete, converging behind; surface strongly transversely striate between the carinae, elsewhere smooth and shining, except foveolate along inner side of lateral carinae.

Paratypes.—PERU: 2 ♂♂, Cosnipata-Ebene, Dept. Cuzco, 1000 meters elevation, 12 Mar. 1900 and 1 May 1901 (Garlepp) [Berlin Museum]; 1 ♂, Marcapata (Standinger) [Berlin Museum].

Variation.—The two paratypes from Cosnipata-Ebene are slightly larger than the type (LFW 4.3 mm in both), the paratype from Marcapata smaller (LFW 3.5 mm). All three paratypes have the head somewhat less strongly produced above the eye tops (WH .92-.94 X LH), but they are otherwise strikingly similar in almost every detail. WF varies from 1.05 to 1.20 X HE, OOL from 1.30 to 1.45 X WOT. These three paratypes are part of the type series of Kieffer's *Epyris montivagus*, but they are generically distinct from the type and most of the paratypes of that species, which is a true *Epyris*.

(10) BAKERIELLA RUFOCAUDATA new species

Holotype.—♂, COLOMBIA: NW Sierra Nevada de Santa Marta, 4000-8000 feet elevation, 20 July 1928 (P. J. Darlington, Jr.) [MCZ, No. 30,806].

Description of type male.—Length about 5 mm; LFW 3.9 mm. Head and thorax shining black; first three segments of abdomen and base of fourth dark reddish brown, remainder of abdomen bright rufo-testaceous; palpi straw-colored; apical third of mandibles testaceous; antennae dark brown, except second segment pale castaneous, scape suffused with blackish; tegulae dark brown; legs dark brown except tarsi and

tips of tibiae light yellowish brown, wings subhyaline, veins and stigma brownish. Mandibles with five teeth, the basal four teeth small. Clypeus rather sharply angular; median carina somewhat arched in profile. Antennal scrobes carinate; eyes with only a few weak hairs. Antennae elongate, first four segments in a ratio of about 13:5:7:8, segment three 1.6 X as long as wide, segment eleven 2.3 X as long as wide. WH .95 X LH; WF .58 X WH, 1.18 X HE. Front angle of ocellar triangle about a right angle; OOL 1.2 X WOT. Vertex broadly rounded; distance from eye tops to vertex crest equal to not much more than .6 X HE; temples not carinate. Front strongly polished, very obscurely alutaceous, punctures small, separated by 2-3 X their own diameters.

Pronotal disc also shining, slightly more evidently alutaceous than front; disc with a strong transverse carina in front, sides subcarinate near the front, elsewhere merely somewhat prominent; posterior margin paralleled by a shallow groove which is not distinctly punctate or carinate. Notauli diverging anteriorly, reaching anterior margin of mesoscutum only as thin lines. Scutellar pits transverse, almost quadrangular, separated by a thin septum. Propodeal disc very slightly wider than long, with three discal carinae, only the median carina complete, surface between the carinae with some very irregular transverse striae; remainder of disc shining and with only some very weak sculpturing. Subgenital plate rounded apically; parameres broad, obliquely subtruncate, strongly setose.

Paratype. — COSTA RICA: ♂, Santa Clara de San Carlos, Alajuela Prov., 17 Feb. 1964 (H. E. Evans) [MCZ].

Variation. — The paratype differs from the type in several details. The mandibles are testaceous except at the extreme base and apex; the first three antennal segments are testaceous, the remainder of the antennae rufo-testaceous, rather strongly infuscated on the apical half; the tibiae are mostly testaceous like the tarsi; and the fore wings are lightly infuscated, especially on the apical half. WH is .97 X LH, WF 1.07 X HE, OOL 1.35 X WOT. The antennae are somewhat shorter than in the type, segment three being only 1.2 X as long as wide, segment eleven 2.1 X as long as wide. There are no important differences in sculpturing, and it seems to me very probable that the two specimens are conspecific despite the several minor differences.

(11) *BAKERIELLA INCONSPICUA* new species

Holotype. — ♂, PANAMA: Corozal, Canal Zone, March 1912 (A. Busck) [USNM, No. 64,998].

Description of type male.—Length 3.6 mm; LFW 2.6 mm. Head and thorax black; abdomen dark brownish-fuscous except first sternite black; palpi and greater part of mandibles light castaneous; antennae light castaneous except rather strongly infuscated on apical half; tegulae light brown; coxae and femora dark brown, trochanters, tibiae, and tarsi light yellowish brown; fore wing lightly tinged with brownish around and below radial vein, veins and stigma brownish. Mandibles with five teeth, basal three teeth rather small. Median lobe of clypeus broadly, obtusely angulate, its sides somewhat rounded; median carina not arched in profile. Antennal scrobes margined by carinae; eyes with scattered short hairs. First four antennal segments in a ratio of about 19:7:7:10, segment three about 1.2 X as long as thick, segment eleven about 1.8 X as long as thick; flagellar pubescence semi-erect, longest setulae about one-fourth as long as width of flagellum. Head about as wide as high; inner orbits strongly converging below, WF .53 X WH, equal to HE. Front angle of ocellar triangle less than a right angle; OOL 1.4 X WOT; vertex very broadly rounded, distance from eye tops to vertex crest equal to not much more than half HE. Front moderately shining, rather strongly alutaceous, punctures small and rather indistinct; temples not strongly developed, not carinate.

Pronotal disc rather flat, subquadrangular, with a strong transverse carina anteriorly, sides margined with low, rounded ridges which become indistinct as they approach the posterior margin; the two side-ridges are subparallel, the disc between them 1.4 X as wide as long; posterior margin paralleled by a shallow, punctate groove, behind which the margin is smooth and polished; major part of disc strongly alutaceous, the punctures rather weak. Mesoscutum somewhat depressed on posterior half, this half also more strongly alutaceous and with a few small punctures; notauli strong on posterior half, reaching anterior margin only as very thin lines. Scutellar pits transverse, separated by a thin septum. Propodeal disc 1.1 X as wide as long; median carina complete, paralleled by two additional carinae which extend only .7 X the length of the disc, surface obscurely transversely striate between these carinae, elsewhere polished, with only very weak sculpturing; lateral carinae strong, sublaterals rather weak, posterolateral angles strongly foveolate. Mesopleurum alutaceous, the pits and ridges more prominent than usual in this genus.

Paratypes. — VENEZUELA: 1 ♂, Caipe, E. Barinas, Jan. 1943 (P. Anduze) [USNM]. PANAMA: 1 ♂, Barro Colorado Island, Canal Zone, 17 Aug. 1956 (C. W. Rettenmeyer; from over swarm raid of *Eciton burchelli*) [USNM]. COSTA RICA: 3 ♂♂, 5 mi. N. Quesada, Alajuela Prov., 20 Feb. 1964 (H. E. Evans) [MCZ]. MEXICO: TABASCO: 2 ♂♂, Teapa, Feb., Mar. (H. H. Smith) [BMNH].

Variation. — The seven paratypes vary slightly in size (LFW 2.2-2.7 mm) but show little variation in color except that the scape is weakly infuscated in the Mexican specimens. In the Venezuela specimen and that from Barro Colorado Island the antennae are slightly more compact than in the type, the third segment being no longer than thick, the eleventh segment about 1.2 X as long as thick. The Mexican and Costa Rican specimens have the front rather strongly shining and weakly alutaceous, the thoracic dorsum somewhat less strongly alutaceous than in the remainder of the series. WF varies from 1.0 to 1.15 X HE, OOL from 1.35 to 1.50 X WOT.

(12) *BAKERIELLA FLORIDANA* new species

Holotype. — ♂, FLORIDA: Paradise Key, Dade Co., Feb. (year not stated) (Brooks) [MCZ, No. 30,807].

Description of type male. — Length 3.1 mm; LFW 2.1 mm. Head and thorax black, abdomen dark brown, shining; palpi straw-colored; mandibles testaceous; first two antennal segments testaceous, next three segments brownish above, rest of antenna dark brown; tegulae testaceous; legs testaceous except front coxae strongly infuscated; wings hyaline, veins and stigma brownish. Mandibles with five teeth, basal three teeth small. Median lobe of clypeus rather sharply, obtusely angular; median carina somewhat arched in profile. Antennal scrobes carinate; eyes with sparse, short hairs. First four antennal segments in a ratio of about 17:7:6:8, segment three about as long as thick, segment eleven about 1.3 X as long as thick. Head about as wide as high; inner orbits strongly converging below, WF .54 X WH, 1.08 X HE. Ocelli in about a right triangle; OOL 1.12 X WOT; vertex broadly rounded, distance from eye tops to vertex crest equal to not much over half HE; temples not carinate. Front strongly alutaceous, rather weakly shining, obscurely punctate.

Pronotal disc with a strong transverse carina in front, sides subcarinate in front, less so behind, these indistinct ridges divergent behind; disc alutaceous, weakly punctate, posterior margin

narrowly raised, preceded by a shallow groove which is only rather indistinctly punctate. Mesoscutum wholly alutaceous, notauli strong on posterior half, reaching anterior margin only as thin lines. Scutellar pits transverse, separated by a thin septum. Propodeal disc as long as wide, with three discal carinae, the median carina complete; disc alutaceous, with weak transverse striae between the carinae; posterolateral angles less strongly foveolate than in the preceding species. Mesopleurum alutaceous, not strongly sculptured. Transverse median vein of fore wing rather weakly arched. Genitalia as shown in Figure 84.

Allotype. — ♀, same data as type [MCZ].

Description of allotype female. — Length 3.4 mm; LFW 2.4 mm. Head and thorax black, abdomen dark reddish brown, shining, somewhat paler toward the apex; palpi straw-colored; mandibles testaceous, the teeth rufous; scape testaceous, rest of antenna pale castaneous; tegulae testaceous; legs testaceous except front coxae infuscated at base; wings hyaline, veins and stigma brownish. Mandibles with five teeth, basal three teeth very small. Clypeus as in male. Eyes more strongly hairy than in male; antennal scrobes not carinate. Third antennal segment much shorter than second or fourth, wider than long; eleventh segment barely longer than wide. Head considerably longer than wide, WH .86 X LH; WF 7.62 X WH, 1.33 X HE. Front angle of ocellar triangle slightly less than a right angle; OOL 1.6 X WOT. Vertex broadly rounded off a distance above eye tops nearly equal to HE; temples not carinate. Front shining, moderately alutaceous, with small, widely spaced punctures.

Features of pronotum about as in male except transverse carina not quite as strong, sides more rounded, not subcarinate. Mesoscutum and scutellum as in male. Propodeal disc only .9 X as wide as long, with three discal carinae of which only the median is complete, disc wholly covered with rather weak transverse striations; lateral carinae strong, posterolateral angles foveolate. Front femora 2.3 X as long as their maximum width; middle tibiae strongly spinose.

Paratypes. — FLORIDA: 2 ♂♂, same data as type [MCZ]; 1 ♂, same locality but collected 21 Feb. 1919 (Schwarz and Barber) [USNM].

Variation. — The three male paratypes are all slightly smaller than the type (LFW 1.9-2.0 mm). They show few differences in color except that the specimen collected by Schwarz and Barber

has the entire basal half of the antennae testaceous (this specimen is lacking the abdomen). In the paratype series WF varies from .98 to 1.08 X HE, OOL from 1.10 to 1.15 X WOT.

7. Genus CALYOZINA Enderlein

Calyozina Enderlein, 1912, p. 263 (type species *Calyozina ramicornis* Enderlein, monobasic). —Kieffer, 1914, pp. 429-430.

Generic characters (of male; female unknown). — Small wasps (about 5-6 mm), of predominantly black coloration. Mandibles slender, with two large apical teeth; clypeus with an angular median lobe which is weakly elevated medially, without lateral lobes; antennae arising very slightly below level of bottoms of eyes, sockets as in *Epyris*; antennae with 13 distinct segments, segment three longer than two, simple or slightly produced apically on the under side; segments four through ten somewhat more strongly produced beneath, processes on segments five through eight 0.2-1.0 X as long as the length of the segment proper, last three antennal segments simple; eyes glabrous; vertex not sharply margined. Pronotal disc not margined anteriorly or laterally, but the anterolateral corners sometimes armed with a conical process; notauli broad, diverging anteriorly; scutellum as in *Aspidepyris*; propodeum with several discal carinae, the median carina extending down the declivity, posterolateral angles foveolate; claws bifid, also with an additional tooth at the base. Wings fully developed, venation of fore wing as figured for the preceding genus (Fig. 82). Abdomen stout, shining; subgenital plate subtriangular, its apex rounded; genitalia as described for *Aspidepyris*, the cuspides elongate, simple, and unbranched, bearing a few apical setae. (Figs. 85-89.)

Remarks.—The above generic description is based entirely on the two Neotropical species here assigned to this genus. I have not seen specimens of the type species, *ramicornis*, which is from Formosa. I am not certain that I am placing our two species correctly, as they disagree with Enderlein's description in several respects. According to Enderlein the third to the twelfth antennal segments bear processes which are longer than the length of the segment. The prothorax is said to be sharp-edged, but Enderlein does not indicate that the anterior angles are prominent. Clearly our species cannot be placed in the genus *Calyoza*, since in this genus the third antennal segment is a mere ring-joint no longer than the second segment. There is no question that *Calyoza*, *Calyozina*, *Calyozella*, and *Paracalyoza*

are closely related. It seems unwise to describe a new genus for our two Neotropical species, for it is possible that all these genera may ultimately be reduced to one, or for that matter to mere species-groups or subgenera of *Epyris*.

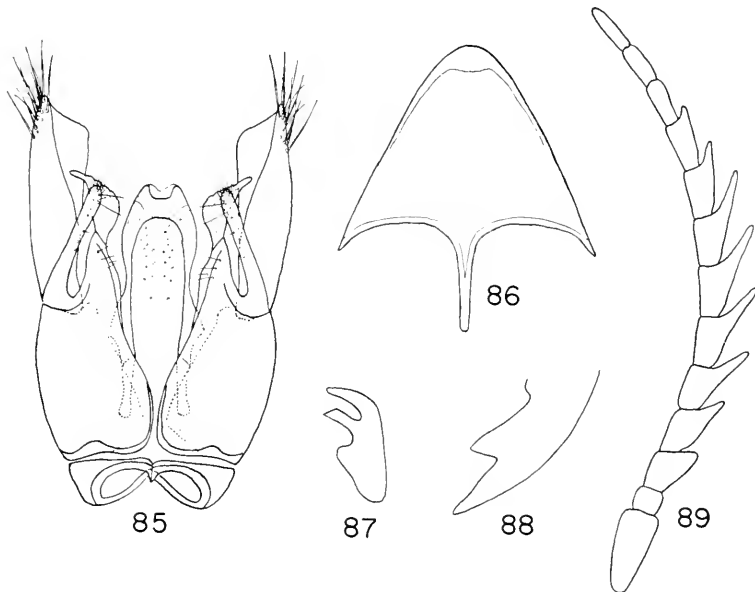

Calyozina neotroptica n. sp., holotype male. Fig. 85. Genitalia. Fig. 86. Subgenital plate. Fig. 87. Hind tarsal claw. Fig. 88. Mandible. Fig. 89. Antenna.

Biology. — *Unknown.*

Distribution. — Formosa, Panama, and Brazil.

Included species. — Only the type species, *ramicornis*, and the two Neotropical species described below. These two species may be separated by the following couplet (only males are known):

- Antennae rather stout and with the middle flagellar segments only weakly produced apically; scutellar pits oblique, elongate, connected by a thin, shallow groove; pronotum merely somewhat prominent anterolaterally (Brazil) (1) *amazonica* n. sp.
- Antennae more slender and with the processes of the middle flagellar segments nearly as long as the segments proper; scutellar pits subcircular, not distinctly connected; pronotum anterolaterally with conical processes (Panama) (2) *neotropica* n. sp.

(1) CALYOZINA AMAZONICA new species

Holotype. — ♂, BRAZIL: Santarem (no further data) [USNM, No. 67,127].

Description of type male. — Length 6 mm; LFW about 4 mm. Head and thorax black, with very faint olive-green reflections, especially on the front, the propodeum jet black; abdomen very dark reddish brown, slightly paler basally and apically; mandibles testaceous, teeth rufous; clypeus piceous, but the front suffused with testaceous around the antennal sockets; antennae light rufo-castaneous except the apical third infuscated; legs bright, pale castaneous except the coxae nearly black, the hind femora weakly infuscated; wings in poor condition but apparently somewhat luteous. Features of head as described under generic heading; first four antennal segments in a ratio of about 13:7:9:12, the third and fourth segments gradually expanded apically and weakly produced beneath; segments 5-10 each with a somewhat more prominent apical process, but the process not more than .2-.3 X as long as the segment proper. Front shining, weakly alutaceous, with small, sharply-defined punctures which are separated by 1-3 X their own diameters. Head as wide as high; WF .57 X WH, 1.0 X HE; OOL 1.2 X WOT.

Median length of pronotum 1.2 X that of mesoscutum; pronotal disc rather prominent anterolaterally, but not actually produced; disc alutaceous, moderately shining, wholly covered with small punctures. Mesoscutum more strongly shining, its punctures somewhat stronger and more widely spaced; scutellar pits elliptical, oblique, connected by a thin, shallow groove. Propodeal disc 1.6 X as wide as its median length; with five strong discal carinae, the sublateral carinae barely developed, the disc weakly transversely striate between the carinae; side-pieces of propodeum longitudinally striate. Abdomen robust, shining.

Remarks. — The extreme tip of the abdomen of the type has been destroyed, apparently by dermestids. There are no other known specimens.

(2) CALYOZINA NEOTROPICA new species

Holotype. — ♂, PANAMA: Close's, Cano Saddle, Canal Zone, June 1923 (M. F. Close) [USNM, No. 67,128].

Description of type male. — Length 5 mm; LFW 3.6 mm. Head and thorax black; abdomen with basal two segments black,

also median basal portion of third tergite, rest of abdomen ferruginous; mandibles light brown, teeth rufous; antennae castaneous, except scape and apical few segments somewhat infuscated; coxae nearly black, femora and middle and hind tibiae dark brown, front tibiae and all the tarsi light yellowish brown; wings lightly tinged with brownish, anterior portion of fore wing faintly luteous, veins and stigma dark brown. Features of head as described under the generic heading; first four antennal segments in a ratio of about 15:6:8:12, the third and fourth segments measured from their base to the apex of the apical process; segments 5-8 with their apical processes nearly as long as the segments proper; segment eleven 2.7 X as long as wide; flagellar pubescence brownish, semi-erect, of moderate length (Fig. 89). Front shining, weakly alutaceous, punctures small but sharply defined, separated by 1-3 X their own diameters. Head 1.01 X as wide as high; WF .61 X WH, 1.10 X HE. Ocellar triangle compact, front angle less than a right angle; OOL 1.07 X WOT.

Pronotal disc about half as long as its maximum, posterior width, 1.6 X length of mesoscutum; anterolateral angles of disc subdentate; surface of pronotum weakly alutaceous, with sparse small punctures. Mesoscutum strongly polished, barely alutaceous; notauli complete, wide, tapering and diverging anteriorly; parapsidal furrows also quite wide, tapering anteriorly. Scutellum with a pair of large, bowl-shaped pits, slightly longer than wide, separated from each other by slightly more than their own diameters. Propodeal disc 1.7 X as wide as its median length; lateral and posterior carinae very strong, sublaterals not developed, but extreme sides of disc depressed and foveolate; disc with three strong carinae which reach the posterior carina, also with a pair of weaker incomplete carinae close beside the median carina; disc with irregular sculpturing which tends to form weak transverse striae; side-pieces of propodeum longitudinally striate. Other features as described under generic heading; genitalia as in Figure 85.

8. Genus *HOLEPYRIS* Kieffer

Holepyris Kieffer, 1904b, p. 390 (type species *H. africanus* Kieffer, designated by Kieffer, 1906a). —Kieffer, 1905a, p. 121. —Kieffer, 1906a, pp. 340-369 (European spp.). —Kieffer, 1908a, pp. 29-30. —Kieffer, 1914, pp. 371-391 (spp. of world). —Berland, 1928, pp. 118-121 (French spp.).

Rysepyris Kieffer, 1906a, p. 341 (type species *Holepyris* (*Rysepyris*) *numidicus* Kieffer, designated by Kieffer, 1914; proposed as subgenus of *Holepyris*; new synonymy). —Kieffer, 1914, pp. 397-398 (generic status).

Miscepyris Kieffer, 1913, p. 108 (type species *Holepyris remotus* Kieffer, designated by Kieffer, 1914; new synonymy). —Kieffer, 1914, pp. 398-400.

Parepyris Brèthes, 1913, p. 87 (type species *P. sylvanidis* Brèthes, monobasic; new synonymy) (not *Parepyris* Kieffer, 1913, p. 108).

Generic characters. — Small wasps (2-8 mm); body black, brownish, or rarely partly rufous, without metallic colors. Maxillary palpi with six segments, the basal three rather short; labial palpi with three segments, the basal two short; mandibles slender, with from one to five apical teeth, in retracted position largely covered by the very large, trilobed clypeus; lateral lobes of clypeus large, rounded, exceeded in most species by the generally narrower and more acute, carinate median lobe; clypeal carina extending up lower front as a polished streak; antennae arising well below level of bottoms of eyes, arising from beneath paired prominences of the lower front; antennal scrobes not margined; antennae of male elongate, second segment more than half as long as the rather short scape, third and following segments more than twice as long as thick, covered with prominent pubescence which is sometimes erect or semi-erect; eyes hairy in most species, always rather short, not nearly reaching posterior margin of head; occipital carina present.

Pronotum much longer than mesoscutum, nearly always with a transverse carina margining the disc anteriorly; mesoscutum usually transversely impressed at least on the sides, notauli very thin, subparallel, usually incomplete, sometimes barely discernible; scutellum with a transverse groove at base, the groove often curved backward but not usually expanded on the sides; propodeal disc subquadrate, longer than wide in most species, carinate medially and laterally, disc usually also with additional longitudinal carina, posterior transverse carina sometimes weak or even absent, posterolateral corners of disc foveolate or not; mesopleurum with a pit below base of hind wings, a carina running forward from the pit, then downward and backward; claws variable, as in *Epyris*; females with the femora broadened and somewhat flattened, middle tibiae not or very weakly spinose. Wings abbreviated in females of a few species, when fully developed with the stigma rather small, radial vein very long, basal vein reaching subcosta basad of stigma by approximately

the length of the stigma (sometimes slightly more or less); discoidal vein not present; transverse median vein strongly oblique, strongly curved below. Abdomen somewhat depressed apically; male subgenital plate simple, apex more or less rounded; genitalia with parameres broad, setose, much as in *Epyris*; cuspis with a long ventral arm which bears some strong setae, with or without a short dorsal arm; aedoeagus broad and fairly long. (Figs. 90-93.)

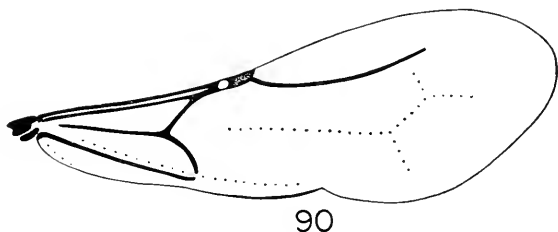

90

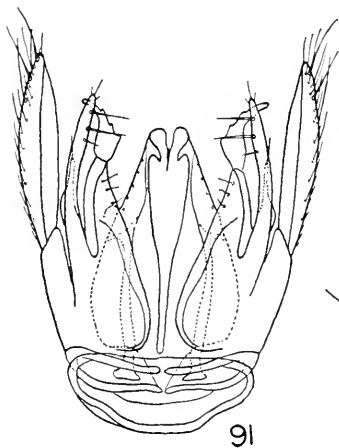

91

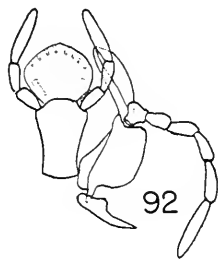

92

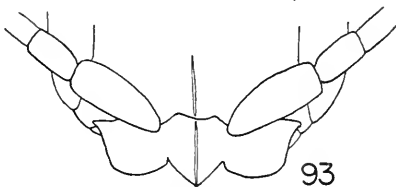

93

Holeyris spp. Fig. 90. *H. marylandicus* Fouts, fore wing, male. Fig. 91. Same species, male genitalia. Fig. 92. *H. subapterus* (Melander and Brues), labium and maxilla, female. Fig. 93. *H. marylandicus* Fouts, anterior portion of head, male.

Remarks.—This large genus is probably related to *Rhabdepyris* and is possibly a derivative of that genus. It is a very distinctive genus by virtue of the trilobed clypeus, the reduced notauli, and the fact that the basal vein reaches the subcosta well

basad of the stigma. These characteristic features also occur in Kieffer's genera *Rysepyris* and *Miscepyris*, which in my opinion cannot be retained even as subgenera; I have seen the type of the type species of *Miscepyris*, but I have not seen specimens of the type species of *Rysepyris*.

Biology.—These wasps are usually found on or close to the ground or under the bark of trees. Muesebeck and Walkley (1951, p. 730) record *Catogenus rufus* (Fabr.), a cucujid beetle occurring under bark, as host of *Holepyris coronatus* (Ashmead). These authors also record as host of *H. subapterus* (Melander and Brues) the bee *Halictus pruinosus* Robertson. However, Melander and Brues merely indicated that the wasps were found running about among the burrows of this bee, so there is no certainty that they were attacking the bee larvae. The fact that these wasps remain close to the substrate in which they live probably accounts for the fact that they are less common in collections than some other Epyrinae. I have taken occasional specimens on honeydew, but they seem to visit honeydew less frequently than, for example, the species of *Epyris* and *Anisepyris*.

Certain species of this genus occur mainly in buildings, where they attack the larvae of Coleoptera infesting grain. Brèthes reported *sylvanidis* from *Silvanus surinamensis* (Cucujidae) in Argentina. *H. sylvanidis* has been distributed throughout the world in commerce, although it has generally been called *zeae* Turner and Waterston, which is a later name. Gahan (1930) and Muesebeck and Walkley (1951) list as probable hosts *Laemophloeus ferrugineus* (Cucujidae), *Sitophilus oryzae* (Curculionidae), and *Tribolium* spp. (Tenebrionidae). This wasp has usually been placed in the genus *Rhabdepyris*, but it is a *Holepyris* as the genus is here defined.

A second species of *Holepyris* occurring in buildings and also widely distributed in commerce is *H. hawaiiensis* (Ashmead). This species occurs in England and Hawaii, and it is reported by Richards (1939) from cacao from W. Africa, St. Lucia, Venezuela, and Ceylon. Probably this species should be regarded as a member of the American fauna, but I have seen no specimens definitely established as representing *hawaiiensis*. This species is reputed to attack lepidopterous larvae (*Plodia* and *Ephestia*), but I do not consider it certain that these are the normal hosts. Bridwell (1920) was able to rear the species on three species of Microlepidoptera in the laboratory. The

wasp stings the caterpillar in the mouth region, feeds on it, then drags it around before laying a single egg on the abdomen. Bridwell found that the females require carbohydrates in addition to the fluids of the host. Considering the fact that Bridwell, in the same paper, reports that under artificial conditions he was able to rear *Scleroderma immigrans* on insects of several orders (even termites!), I do not consider that the true hosts of *Holepyris hawaiiensis* are necessarily Lepidoptera, although Bridwell does intimate that he and F. X. Williams have reason to believe that this is so. Bridwell also mentions that Silvestri found that an Italian species lays a single egg upon a caterpillar, but I have been unable to locate this reference. *H. hawaiiensis* is reported to sting man readily and to cause a lasting irritation to the skin (Pemberton, 1932).

Distribution. — This genus is well represented in the Palaearctic, Ethiopian, Oriental, and Australian regions. There are numerous species in North and Central America and several in the West Indies. I have seen only a few specimens from South America, and my impression is that the genus is not well represented on that continent.

Included species:

United States

coronatus (Ashmead), 1893, p. 47; ♂, Maryland.

floridanus (Ashmead), 1887, p. 76; ♂, Florida.

haemorrhoidalis (Kieffer), 1904a, p. 528; ♀, Texas (new combination).

marylandicus Fouts, 1928, p. 125; ♀, Maryland.

punctifrons Fouts, 1927, p. 166; ♀, Florida.

subapterus (Melander and Brues), 1903, p. 23; ♀, Massachusetts.

sylvanidis (Brèthes), 1913, p. 87; ♀. ♂. Argentina (reported from many parts of the U.S., Europe; probably cosmopolitan) (synonym: *zcae* Turner and Waterston, 1921, p. 29; new synonymy) (new combination).

Mexico and Central America

bakeri Kieffer, 1906b, p. 247; ♀, Nicaragua.

cameroni Evans, new name for *Epyris montezuma* Cameron, 1897, p. 276 (*nec* Cameron, 1888b, p. VII); ♀, Mexico (Orizaba).

longicollis (Cameron), 1888a, p. 455; ♀, Mexico (Cordoba).

remotus Kieffer, 1911, p. 218; ♀, Mexico (Atoyac, Veracruz).

West Indies

gracilis Kieffer, 1908b, p. 17; ♀, Cuba.

incertus (Ashmead), 1894, p. 189; ♂, St. Vincent.

pygmaeus (Ashmead), 1895b, p. 787; ♂, Grenada.

South America.—One species, *sylvanidis* Brèthes, was described from Argentina (see above, under U.S.), and Richards (1939) mentions *hawaiiensis* (Ashmead) as being found in cacao from Venezuela. There is at least one other apparently undescribed South American species.

9. Genus *LAELIUS* Ashmead

Laelius Ashmead, 1893, p. 50 (type species *Laelius trogodermatis* Ashmead, original designation). —Ashmead, 1902, pp. 271, 272. —Kieffer, 1906a, pp. 418-422 (European spp.). —Kieffer, 1908a, p. 38. —Brues, 1910b, p. 46 (key to U.S. spp.). —Kieffer, 1914, pp. 278-282. —Berland, 1928, pp. 122-124 (French spp.). —Muesebeck, 1939, pp. 171-176 U.S. spp.). —Muesebeck and Walkley, 1951, p. 728.

Bethylus Ashmead, 1893, pp. 52-54 (not *Bethylus* Latreille; misidentification). —Ashmead, 1902, pp. 271-272.

Paralaelius Kieffer, 1905a, p. 129 (type species *Bethylus pedatus* Say, designated by Kieffer, 1914; synonymy by Muesebeck and Walkley, 1951). —Kieffer, 1908a, p. 39. —Kieffer, 1914, pp. 282-289.

Generic characters.—Very small wasps (1.7-3.5 mm) of black coloration; head, thorax, and often the femora clothed sparsely with strong, black setae, major veins of wing also clothed with prominent black setae. Maxillary palpi with six segments, but the basal three segments very short; labial palpi with three segments; mandibles with four or five apical teeth; clypeus with the median lobe somewhat rounded, but usually with a small median tooth formed by the end of the median carina; clypeus without lateral lobes; eyes glabrous, small, well removed from base of mandibles and from posterior margin of head; antennae arising well below bottoms of eyes, simple, 13-segmented; occipital carina rather weak.

Pronotum with smooth contours, the disc rounded off anteriorly and laterally, not carinate, much broadened behind; notauli not or weakly indicated in female, tending to be stronger in male, but very thin, rarely complete; scutellum with a transverse groove at base; propodeal disc carinate laterally and posteriorly, median carina complete and extending down declivity in females, sometimes much reduced in males, disc usually with additional longitudinal carinae in females, posterolateral angles

sometimes foveolate; mesopleurum with a small pit opposite bases of hind wings, otherwise weakly sculptured; femora somewhat swollen and flattened, especially in female; claws dentate. Fore wing with stigma very small, giving rise to a short, oblique radius, at most slightly longer than the short basal vein, the latter reaching the subcosta close to the base of the stigma. Male subgenital plate with a median basal stalk, apex more or less truncate. Genitalia bearing considerable resemblance to those of *Epyris* and related genera; parameres short and broad, strongly setose; cuspides divided into dorsal and ventral arms, also with strong setae; aedoeagus rather broad. (Fig. 94-98.)

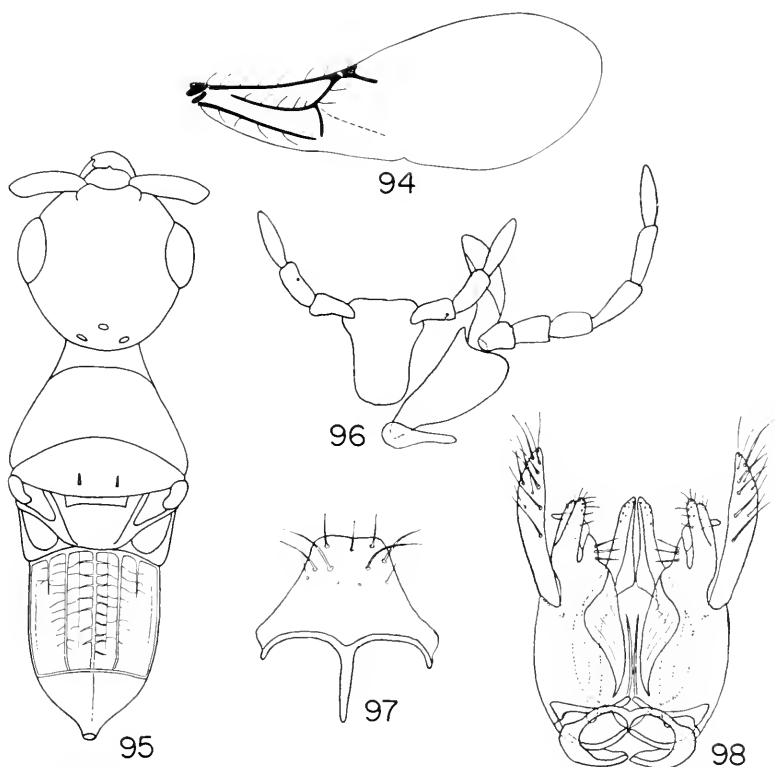

Laelius spp. Fig. 94. *L. pedatus* (Say), fore wing, female. Fig. 95. Same species, head and thorax, female. Fig. 96. *L. utilis* Cockerell, labium and maxilla, male. Fig. 97. Same species, male subgenital plate. Fig. 98. Same species, male genitalia.

Remarks.—Although several authors have considered the stigma to be lacking in *Laelius*, I can see no qualitative difference in this regard from *Holepyris* and several other genera. This genus appears to me to represent a somewhat specialized offshoot of typical Epyrinac, perhaps of *Rhabdopyris*.

Biology.—These wasps are usually found in or around buildings, and their biology is fairly well known as compared to most Bethyliidae. The usual hosts are the larvae of Dermestidae, although Kieffer (1914) presented several records for larvae of other kinds of beetles. One of the earliest accounts was published by L. O. Howard in "The Insect Book" (1901, pp. 34-36), relating to *Laelius trogodermitis*, described by Ashmead as a parasite of *Trogoderma tarsale*. According to Howard, the female *Laelius* jumps upon the back of the much larger dermestid larva and eventually stings it on the venter of the thorax. Before oviposition, she pulls out the hairs of the host at the oviposition site and also "thrusts her sting into the spot several times, apparently making an orifice through which the larva . . . can thrust its head . . ." From one to six eggs may be laid on a single larva; the eggs are laid longitudinally on the venter of the abdomen, often in a double row. The larvae feed with their heads inserted through the venter, their sae-like bodies extending free of the host. According to Howard, when only one parasite larva occurs on a host, it may enter the hollowed-out skin of the host and spin its cocoon within it. Spencer (1942) found four cocoons of *Laelius* sp. inside the last larval skin of an *Anthrenus*. Krombein (1955) found a *Laelius trogodermitis* female dragging a *Trogoderma* grub over a board; he considered it probable that the *Laelius* usually encounters her host in a concealed situation and leaves it *in situ*, but in this case the grub was in the open and was being dragged by the wasp into some type of crevice. Krombein (1958) records *Trogoderma parabile* and *T. simplex* as hosts of this species.

Another North American species, *L. utilis*, was described by Cockerell from museum beetles, and is recorded by Muesebeck and Walkley (1951) from *Trogoderma versicolor*. These authors also record *Anthrenus verbasci* as host of *L. pedatus* (Say), and *Anthrenus vorax* as host of *L. voracis* Muesebeck. Back (1940) presented a brief discussion and some excellent photographs of the biology of *L. voracis*.

The European species *L. anthrenivorus* Trani was found by its describer to be attacking the larvae of *Anthrenus musaeorum*,

and Vance and Parker (1932) studied this species further as a parasite of *A. verbascei*. According to Vance and Parker, females live for several weeks when given neither food nor water. This species also pulls off the hairs of the host prior to oviposition and may drag the paralyzed grub around "as if obeying an instinct to drag the prey to her lair." Vance and Parker described and figured the larva in some detail.

Further details, as well as additional references, may be found in the papers cited. Judd (1960) reports *Laelius utilis* stinging a child in Ontario, and I know of two instances of wasps of this genus stinging adults in buildings. The sting is not severe nor its effects serious.

Yamada (1955) has reported at length on the life history and development of the related wasp *Allepyris microneurus* Kieffer, which also attacks dermestid larvae.

Distribution. — Members of this genus occur in North America, Europe, North Africa, and India. In North America, the species collectively range from the southern tier of provinces of Canada south to Florida and to central Mexico.

Included species. — Six species are currently recognized in North America. Five of these were reviewed by Muesebeck (1939), whose paper remains the standard reference on the genus even though he intended it as no more than a preliminary treatment of the genus. Some of the eastern species appear to range to the Pacific, and there are some undescribed species in the Southwest. The following listing of species follows Muesebeck and Walkley (1951):

centratus (Say), 1836, p. 281; Indiana (sex ?) (also Florida, Colorado, according to Muesebeck and Walkley).

occidentalis Whittaker, 1929, p. 387; ♀, British Columbia.

pedatus (Say), 1836, p. 280; Indiana (sex ?) (widely distributed in eastern U.S., west to Colorado, south to Morelos, Mexico) (synonyms: *nubilipennis* Ashmead, 1887, *tricarinatus*, Ashmead 1893, *rufipes*, Ashmead 1893, *nigripilosus* Ashmead, 1893, *constrictus* Ashmead, 1893, *ashmeadi* Kieffer, 1908a, *fumipennis* Brues, 1910b).

trogodermatis Ashmead, 1893, p. 51; ♀, District of Columbia (also Quebec, Florida) (♂ also described).

utilis Cockerell, 1920, p. 34; ♀, Virginia (North Carolina to Ontario and Massachusetts).

voracis Muesebeck, 1939, p. 172; ♀, District of Columbia (♂ also described).

B. TRIBE CEPHALONOMIINI

Tribal characters.—Minute wasps, rarely exceeding 2.5 mm in length. Maxillary palpi with from three to five segments, labial palpi with one or two segments; antennae simple, with twelve segments; clypeus with median lobe short, bluntly rounded or truncate, sometimes indistinct; occipital carina absent. Mesoscutum without notauli; propodeum with or without a transverse carina margining the disc behind, with or without a median carina, never with discal carinae other than the median carina, posterolateral angles never foveolate; claws simple or dentate. Wings present, reduced, or absent, tegulae usually preserved at least as minute flaps in wingless forms (both sexes may be wingless); alate forms with the wings slender basally, hind wing with a very small anal lobe, apex of fore wing and apex and hind margin of hind wing fringed with fairly long, delicate setae; fore wing with subcosta strong, leading to a subtriangular or somewhat rounded prostigma which is followed by a smaller true stigma, the latter giving rise to a radial vein in some genera, but radial vein completely absent in *Cephalonomia*; median and anal veins present, very faintly indicated, or absent, when present curving up to join the prostigma; anal vein absent or very faintly indicated, costa absent; anterior margin of fore wing broadly indented at the prostigma. Abdomen relatively short and stout, slightly depressed; male genitalia with the parameres short and broad, cuspides undivided, rather broad and plate-like, bearing numerous setae, aedeagus large, bilobed apically.

Distribution.—Worldwide except in polar and subpolar regions and on some oceanic islands.

Included genera.—This tribe includes *Israclius* Richards, from southwestern Asia; *Prorops* Waterston, from Africa but introduced into South America and Java; and two closely related and widely distributed genera, *Plastanoxus* and *Cephalonomia*.

KEY TO GENERA OF CEPHALONOMIINI

1. Radial vein completely absent (Fig. 105); wings frequently absent or much reduced 3. CEPHALONOMIA Westwood, p. 155

- Radial vein present at least in part (Figs. 99, 101); wings always fully developed2
2. Front simple, not produced as below; maxillary palpi with four segments, labial with two (as in Fig. 108); propodeal disc margined behind 1. PLASTANOXUS Kieffer, p. 149
- Front strongly produced below into a bifid process which overlies the antennal sockets (Fig. 102); maxillary palpi with three segments, labial with one (Fig. 104); propodeal disc not margined behind ..
.....2. PROROPS Waterston, p. 152

1. Genus PLASTANOXUS Kieffer

Anoxus Ashmead, 1893, pp. 67-69 (U.S. spp.; not *Anoxus* Thomson, misidentification). —Ashmead, 1902, p. 272.

Plastanoxus Kieffer, 1905b, p. 244 (type species *Anoxus chittendenii* Ashmead, designated by Gahan, 1931). —Kieffer, 1908a, p. 18. —Kieffer, 1914, pp. 449-450. —Gahan, 1931, pp. 213-218 (key to spp.). —Richards, 1939, pp. 319-321 (British spp.).

Generic characters. — Very small wasps (1.0-2.5 mm) of predominantly brown or black coloration; wings fully developed although slender basally; body setae very small. Maxillary palpi with four segments, labial palpi with two, almost exactly as figured for *Cephalonomia* (Fig. 108); mandibles with four apical teeth, the basal three teeth small; clypeus short, with a broad median lobe which is rounded apically, rather gibbous medially; eyes bare, rather small, well separated from base of mandibles and from posterior margin of head; antennae arising far below bottoms of eyes, simple, 12-segmented; front somewhat convex, but not at all produced over bases of antennae; ocelli present; occipital carina absent.

Pronotum simple, considerably longer than mesoscutum; parapsidal lines distinct but notauli absent; base of scutellum with a pair of widely separated pits or a partially divided transverse groove; propodeal disc margined laterally and posteriorly, median carina present or absent; mesopleurum simple, with a small pit below base of hind wings; femora not much swollen, tibiae without spines; claws dentate. Fore wing slender basally, considerably broadened beginning just basad of stigma; costa absent, subcosta distinct, leading to a strong prostigma narrowly separated from the small stigma; radial vein present, fairly long; median and basal veins present or obsolete, anal and transverse median veins hyaline or only very faintly indicated; hind wing slender basally, the anal lobe small, this wing with two short veins at base at least in *tarsalis* and *chittendenii* (only

one according to Richards, 1939). Abdomen of female fairly broad, slightly depressed. Male subgenital plate simple, more or less rounded apically, with a strong median basal stalk. Male genitalia (of *P. chittendenii*, the only species studied) remarkably similar to those of *Cephalonomia tarsalis* (shown in Fig. 107), the basal ring, aedoeagus, and major portion of the volsella being virtually identical. The cuspis is, however, devoid of apical setulae, although with the usual strong setae at its base. The parameres are unlike those of *Cephalonomia* in that they are deeply divided into a broad ventral and a more slender dorsal arm; in this respect they are much like those of *Scleroderma*, except that the separation into two lobes is less complete than in that genus. (Figs. 99, 100.)

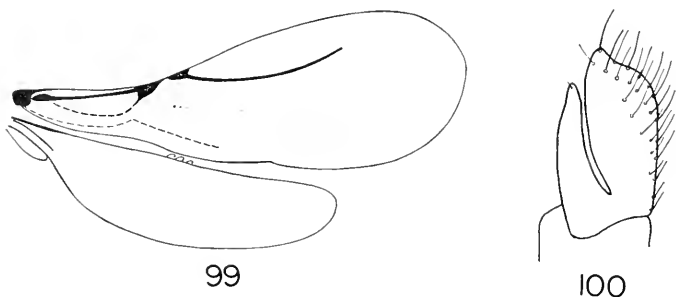

Plastanozus spp. Fig. 99. *P. laevis* (Ashmead), fore wing. Fig. 100. *P. chittendenii* (Ashmead), lateral view of paramere of male genitalia, dorsal surface toward left, ventral toward right.

Remarks. — These minute wasps may be related, on the one hand, to the Epyrini and, on the other hand, to the more specialized genus *Cephalonomia*. Only a few species are known, and these are not commonly encountered.

Biology. — *P. westwoodi* is believed to be a parasite of *Laemophloeus pusillus* Schönherr, a cucujid beetle occurring in stored grain (Gahan, 1931); it has been taken in England in shipments of grain from Australia, and was originally described from Indian corn from Africa. *P. monroi* Richards was taken in a warehouse and probably also attacks beetles occurring in stored products. Gahan remarks that *P. laevis* is not known to attack insects in stored products, and Richards characterizes *laevis* and *chittendenii* as “out-of-doors species.” However, *laevis* is poorly known and one notes that the type was taken on a window. A

series of what appears to be *laevis* from Santa Catarina, Brazil [BMNH], suggests that this species, like *westwoodi*, may occur widely throughout the globe, probably distributed by man in stored grain. The final species, *chittendenii*, was described from a series reared from *Cis* sp., according to Richards "found in fungi with *Cis fuscipes* Mell."

Distribution. — Although Kieffer (1914) records the range as North America, it is unlikely that all the species are native to that area, as some appear to occur widely throughout the globe in stored products. *P. monroi* Richards was described from London from a warehouse sample of cacao from the Gold Coast, Africa.

Included species. — Only five species are known, one of which, *monroi* Richards, is not known to occur in the Americas. Our four species are listed below, and a key is presented for them; one species is described as new.

chittendenii (Ashmead), 1893, p. 68; ♂, New York (transcontinental in U.S. and southern Canada; ♀ also known).

incompletus Evans, n. sp. described below from ♀, Arizona.

laevis (Ashmead), 1893, p. 68; ♀, District of Columbia (8 ♀ ♀ from Santa Catarina, Brazil [BMNH], appear to belong to this sp.).

westwoodi (Kieffer), 1914, p. 248; ♀, Africa (♂ also known; probably cosmopolitan; occurs widely in U.S.) (synonym: *kiefferi* Gahan, 1931, p. 217 [apparently an error for *westwoodi*]).

KEY TO SPECIES OF *PLASTANOXUS*

1. Fore wing with a closed median cell, the submedian cell also enclosed at least by faintly indicated veins; propodeum with median carina developed at least partially, often complete 2
Fore wing with no closed cells whatever; median carina of propodeum absent or weakly indicated 3
2. Radial vein long, continuous; head of female subcircular, only slightly longer than wide *laevis* (Ashmead)
Radial vein incomplete basally, i.e., not connected to stigma although present on outer part of wing; head of female rectangular, much longer than wide *incompletus* n. sp.
3. Radial vein extending a little more than half the distance from stigma to apex of wing, slightly curved; head of female rectangular, more than 1.5 X as long as wide *westwoodi* (Kieffer)

Radial vein extending distinctly less than half the distance from stigma to apex of wing, practically straight on the outer part; head of female less parallel-sided, much less than 1.5 X as long as wide
 *chittendenii* (Ashmead)

PLASTANOXUS INCOMPLETUS new species

Holotype. — ♀, ARIZONA: Mesa, Maricopa Co., 7 Oct. 1960 (G. Butler; sucked from cotton) [MCZ, No. 30,808].

Description of female type. — Length 1.9 mm; LFW 1.4 mm. Black; antennae dark brown; mandibles light brown, the teeth somewhat rufous; legs dark brown except front tibiae and all the tarsi testaceous; wings hyaline, the veins, stigma, and prostigma brownish. Head elongate, parallel-sided except sides arcuately convergent at top to a straight vertex, head 1.45 X as long as wide. Eyes not at all protruding from sides of head; WF 1.25 X HE; distance from eye to base of mandible about one-fourth HE, distance from eye to vertex crest about 1.5 X HE. Ocelli small, in a right triangle, the posterior ocelli removed from the vertex crest by slightly more than WOT; OOL more than twice WOT. First four antennal segments in a ratio of about 25:9:4:5, segment three barely longer than wide, but fourth segment and those beyond distinctly longer than wide.

Head and thoracic dorsum somewhat shining, wholly alutaceous, obscurely punctate. Pronotal disc, mesoscutum, scutellum, and propodeal disc in a ratio of 18:9:10:20 (measured along midline). Scutellum with a pair of round basal pits connected by a groove. Median carina of propodeum complete to the transverse carina, although rather indistinct at its base, where there are some additional, weak, longitudinal rugae. Wings with the median and submedian cells both strongly outlined by well-formed veins; radial vein absent basally, but its outer part present as a distinct vein, the preserved portion about as long as the distance from the stigma to its base (i.e., the obsolete portion). Abdomen stout, shining.

Remarks. — This species is of interest in demonstrating the close relationship between *Plastanoxus* and *Cephalonomia*. The radial vein is half obliterated; if it were all gone, this species would be placed in *Cephalonomia* as a close relative of *tarsalis*.

2. Genus PROROPS Waterston

Prorops Waterston, 1923, pp. 112-114 (type species *P. nasuta* Waterston, monobasic).

Generic characters.— Very small wasps, about 2 mm long, of dark brown coloration; fully winged, wings shaped as in the preceding genus. Maxillary palpi with three segments, the second segment much longer than the first or third; labial palpi with one segment; mandibles relatively very wide and short, with three teeth and a very weak indication of a fourth tooth basad of these; eyes covered with short hairs; malar space short, but eyes well removed from posterior margin of head, which is somewhat concave; lower part of front produced into a very strong, bifid process which overlies the base of the antennae and extends well beyond the clypeus, which is broadly truncate, short; in lateral view, the frontal process is flat-topped except reflexed at the tip, and the mandibles are directed obliquely downward, leaving a wide space between the mouth-parts and the frontal process, partially filled by the somewhat vertical clypeus; antennae simple, 12-segmented, bearing large sensoria; occipital carina absent.

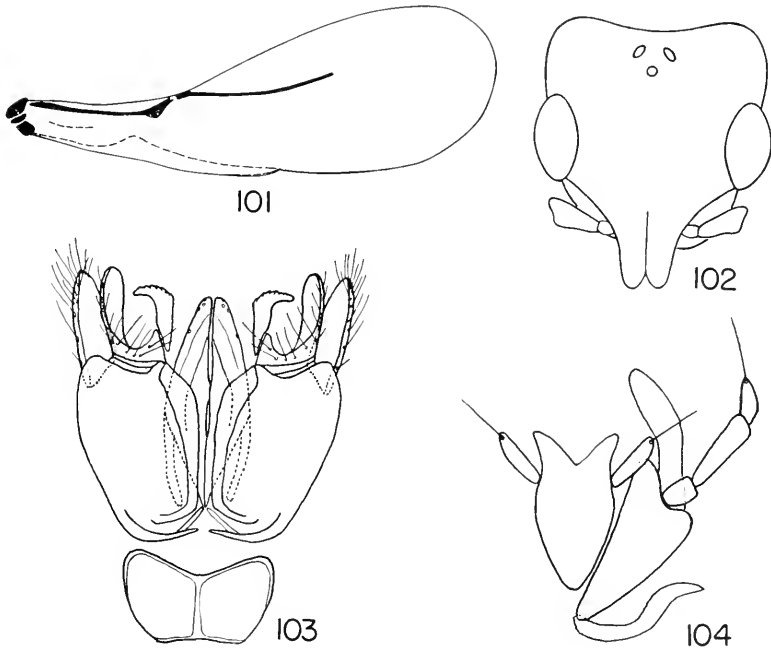

Prorops nasuta Waterston. Fig. 101. Fore wing, female. Fig. 102. Anterior aspect of head, female. Fig. 103. Male genitalia. Fig. 104. Labium and maxilla, female.

Pronotum and mesoscutum much as in *Plastanoxus*, except the latter with neither the notauli nor the parapsidal furrows distinct; scutellum separated from scutum by a thin line, without basal pits or a transverse furrow; propodeum completely without carinae, the dorsal surface rounded smoothly onto the steep, almost vertical declivity; mesopleurum simple, with a small pit on upper part; femora slightly swollen, tibiae without spines, although middle tibiae with dense, short, stiff setae on upper surface; claws simple. Wings slender basally, fore wing expanded beyond stigma, as in *Plastanoxus*, also fringed as in that genus; fore wing with only the subcosta present, leading to a prostigma which is larger than the stigma, stigma emitting a long, slightly curved radius, median and anal veins indicated only by very faint streaks; hind wing with anal lobe very small. Abdomen sessile, fusiform, rather strongly depressed. Male genitalia with the parameres relatively short and broad; cuspides undivided, forming broad plates; aedoeagus rather broad, not differing notably from that of *Holepyris* and other Epyrini; basal ring unusually large. (Figs. 101-104.)

Remarks.—Waterston's description of this genus and its single known species is detailed and well-illustrated. Waterston was undoubtedly correct in suggesting that the genus is related to *Cephalonomia*.

Biology.—*Prorops nasuta* Waterston is an important natural enemy of the coffee berry-borer, *Stephanoderes hampei* Ferr. (Scolytidae). It is one of the very few bethylids to have been employed in biological control work, having been introduced from Africa into Brazil and into Java for the control of this insect. Hargreaves (1926) discussed the biology of *Prorops nasuta* and its host in Uganda, Hempel (1934) presented an account of its successful introduction into Brazil, including a list of localities where it was released, and de Toledo (1942) presented further details on its life history and development.

According to Hargreaves, the female *Prorops* enters an infested coffee berry and spends most of her life there, feeding on immature beetle larvae and laying her eggs on the full-grown larvae. The egg is laid singly on the ventral surface of the thorax. The wasp larva feeds externally for only three or four days, then spins its cocoon in the berry; the adult wasp emerges from the cocoon about three weeks later. Adult females live in captivity about 50 days, laying a maximum of 37 eggs, at a rate of about one a day after the first two weeks. Parthenogenesis is

common, but the offspring of unfertilized eggs are all males. De Toledo reported nine generations a year in Brazil.

Males of this wasp seem to be very uncommon in collections.

Distribution. — The native home of *Prorops nasuta* is Africa (Uganda, Tanganyika, and the Congo), but as noted above it has been introduced into Brazil and Java. Releases in Brazil were primarily in the São Paulo area; a series in the USNM is from Campinas, near São Paulo, taken in 1938.

Included species. — Only the type species:

nasuta Waterston, 1923, pp. 113-114; ♀, Uganda (♂ figured by Hempel, 1934, figs. 4, 5) (introduced into Brazil).

3. Genus CEPHALONOMIA Westwood

Cephalonomia Westwood, 1833, p. 420 (type species *C. formiciformis* Westwood, monobasic). — Ashmead, 1893, pp. 47-50 (U.S. spp., in part). — Ashmead, 1902, pp. 271, 272. — Kieffer, 1906a, pp. 449-461 (European spp.). — Kieffer, 1908a, pp. 39-40. — Kieffer, 1914, pp. 242-249 (spp. of world). — Berland, 1928, pp. 131-137 (French spp.). — Gahan, 1931, pp. 218-221. — Richards, 1939, pp. 299-305 (British spp.). — Kurian, 1955, pp. 76-77 (key to Oriental spp.).

Holopedina Foerster, 1850, p. 502 (type species *H. polypori* Foerster [= *formiciformis* Westwood], monobasic; synonymy by Ashmead, 1893).

Cephaloderma Hoffer, 1936, pp. 459-461 (proposed as subgenus, type species *Cephalonomia (Cephaloderma) strandi* Hoffer [= *gallicola* Ashmead], monobasic; new synonymy).

Generic characters. — Very small wasps (0.7-2.5 mm), of black to brown or pale, yellowish coloration; wings fully developed, very short, or absent (in either sex). Head longer than wide, its width usually exceeding maximum width of thorax; maxillary palpi with four or five segments; labial palpi with one or two segments; mandibles with a strong apical tooth and two or three additional, smaller teeth; clypeus very short, median lobe absent or poorly developed, weakly rounded, truncate, or slightly emarginate; basal margin of clypeus produced upward medially, reaching a point well above antennal sockets; eyes small, HE sometimes measuring no more than about .3 X WH, eyes with sparse, very short hairs or somewhat more conspicuously hairy; ocelli generally present, but tending to be weak or even absent in wingless forms; antennae simple, with twelve segments; occipital carina absent.

Pronotum simple, with smooth contours; mesoscutum without notauli, parapsidal furrows present as thin lines in winged forms; scutellum often not separated from scutum in wingless forms, otherwise scutellum with a transverse groove or paired pits at base; propodeal disc at least weakly margined on sides, often more or less margined posteriorly, occasionally with a median carina; mesopleura with a pit above in winged forms;

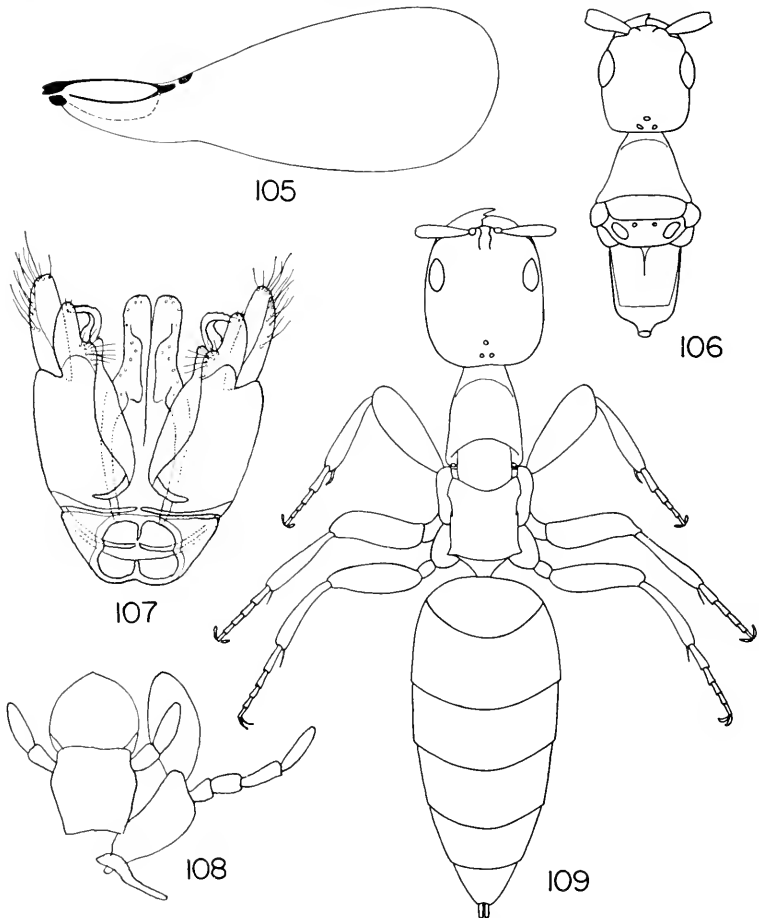

Cephalonomia spp. Fig. 105. *C. tarsalis* (Ashmead), fore wing, female. Fig. 106. Same species, head and thorax, female. Fig. 107. Same species, male genitalia. Fig. 108. Same species, labium and maxilla, female. Fig. 109. *C. gallicola* (Ashmead), female.

legs smooth and without spines or strong setae; claws simple or weakly dentate. Tegulae absent in some completely wingless forms, present when wings are short or of normal development; fully winged forms with subcosta leading to a strong prostigma, the latter separated slightly from the stigma; radial vein absent; median vein often absent, when present arching up to join prostigma; basal vein absent; hind wing with anal lobe very small; outer margin of fore wing and outer and hind margin of hind wing strongly fringed. Abdomen sessile, rather robust. Male subgenital plate simple, weakly rounded or truncate apically. Male genitalia with the parameres short and broad; cuspides in the form of broad, undivided plates; aedeagus elongate, bilobed apically; basal ring strong. Van Emden (1931, figs. 28-30) has figured the genitalia of *gallicola*, which do not differ notably from those of *tarsalis*, figured here. (Figs 105-109.)

Remarks.—Detailed studies of the morphology of *Cephalonomia* have been made by Grandi (1929) and by Van Emden (1931). There is considerable structural diversity in the genus, and future workers may find it desirable to recognize two or more subgenera. Richards (1939) recognized three types of species:

- (1) Both sexes macropterous (*tarsalis*, *waterstoni*, *utahensis*, *hyalinipennis*)
- (2) Males macropterous, females macropterous or brachypterous (*formiciformis*)
- (3) Males macropterous or apterous, females apterous; coloration pale (*gallicola*, *urichi*)

To this a fourth type can now be added:

- (4) Males macropterous or apterous, females macropterous, micropterous, or apterous (*perpusilla*)

Certain possibly important structural features appear to concord with this grouping of species; for example, the propodeum of *gallicola* is angularly produced on the sides behind, and the maxillary palpi of this species have five segments as compared to four in *tarsalis*. Kearns (1934b) has published on wing inheritance in *gallicola*. Although more has been published on the structure and behavior of *Cephalonomia* than of any other genus of bethylids, further studies will surely be rewarding. The subgeneric name *Cephaloderma* is available for *gallicola*, but I question the desirability of recognizing subgenera at this stage of our knowledge. Betrem (1961) has discussed the variation in palpal segmentation in this genus.

Biology.—So far as known, all species of *Cephalonomia* attack the larvae or pupae of small beetles occurring in cryptic situations. Much has been published on the biology of these wasps, and not all of it can be reviewed here. For convenience, the species can be grouped into three ethological types, but these three types are not completely in accord with the four types based on wing development:

- (1) Attack beetles infesting stored products (*tarsalis*, *waterstoni*, *gallicola*, *meridionalis*)
- (2) Attack ciid beetles occurring in fungus (*formiciformis*, *perpusilla*, *mycetophila*, *hammi*)
- (3) Attack bark beetles (*hyalinipennis*, *utahensis*, *hypobori*)

C. gallicola has been studied in some detail by Van Emden (1931) and by Kearns (1934a, b). The known hosts include the drugstore beetle, *Stegobium paniceum* (L.), the cigarette beetle, *Lasioderma serricornis* (Fabr.) (both Anobiidae), and spider beetles of the genus *Ptinus* (Ptinidae). The female wasps chew a hole into the wall of the cocoon of the host, sting it, and deposit from one to nine eggs on the full-grown larva, prepupa, or pupa in the cocoon; the wasp may remain within the cocoon for from a few hours to two days, and may feed on the host herself. Although one *Cephalonomia* larva is sufficient to kill the host, several of them commonly develop successfully on the same larva or pupa. Males and females may develop on the same host and spin their cocoons adjoining one another; the males emerge first and chew their way into the cocoons containing females and mate with them before they emerge. Females may reproduce parthenogenetically, producing male progeny. The life cycle from egg to adult requires only two to three weeks, and individual females may parasitize up to 76 hosts in a period of 36 days.

C. tarsalis is a parasite of the saw-toothed grain beetle, *Oryzaephilus surinamensis* (L.) (Cucujidae), the rice weevil, *Sitophilus oryzae* (L.) (Curculionidae), and probably other beetles occurring in stored grain. Either larvae or pupae are attacked, and after stinging they may be dragged about to a place of concealment. According to Powell (1938), the eggs are laid in pairs on the host, one to produce a male, the other a female; the male reaches the adult stage first and enters the cocoon of the female and copulates with her. Unfertilized females produce only male offspring. *C. waterstoni* also attacks beetle larvae occurring in stored grain, including *Laemophloeus ferrugineus* (Steph.) (Cucujidae); Finlayson (1950, 1952) has studied host preference

in this species. *C. meridionalis* is reported to attack *Oryzaephilus surinamensis* in Argentina.

Schaefer (1962) has recently published an account of the biology of *C. utahensis* as a parasite of the cone beetle *Conophthorus radiatae* Hopkins in California. The female wasps enter the galleries of these beetles and paralyze the second instar larvae or pupae. From one to six eggs are laid per host, but the mature larvae are smaller when four to six develop on a host than when fewer are present. Ruckes (1956) had previously reported *utahensis* from two other species of *Conophthorus* in California. *C. hyalinipennis* is recorded from bark beetles of the genera *Pityphthorus*, *Scolytus*, and *Hypothenemus*.

Little information is available on the species attacking Ciidae. Richards (1939) presented many records for *C. formiciformis* and one for *C. hammi* Richards being associated with fungus infested with Ciidae, and *C. perpusilla* attacks Ciidae occurring in fungi in western North America. Several species, including *hyalinipennis*, *gallicola*, and *cynipsiphila*, have been reared from galls, where they presumably developed on inquilinous beetles. *C. urichi* Brues is said to have been reared from a psocid, but I am inclined to question this record. Members of this genus are recorded as stinging man, especially in houses having heavy infestations of their hosts.

Distribution. — Cosmopolitan.

Included species. — This is apparently a relatively small genus, but those species which attack insects occurring in stored products are widely distributed as a result of commerce.

North America

cynipsiphila (Ashmead), 1887, p. 75; ♀, Florida.

gallicola (Ashmead), 1887, p. 75; ♀, Florida (widely distributed in North America, Europe, and Asia, probably cosmopolitan; ♂ also known) (synonyms: *nubilipennis* Ashmead, 1893, *xambeui* Giard, 1898, *quadridentata* Duchaussoy, 1917, *caesarorum* Van Emden, 1931, *strandii* Hoffer, 1936).

hyalinipennis Ashmead, 1893, p. 49; ♀, Florida.

perpusilla Evans, 1963c, p. 152; ♂, California (also Arizona, Nayarit Baja California; ♀ also described).

tarsalis (Ashmead), 1893, p. 45; ♀, Indiana (throughout U.S., also Europe, Australia, probably cosmopolitan; ♂ also known) (synonyms: *carinata* Kieffer, 1907, *kiefferi* Fouts, 1920).

utahensis Brues, 1909, p. 154; ♀, Utah (also California).
waterstoni Gahan, 1931, p. 219; ♀, Australia (widely distributed in North America, probably cosmopolitan).

South America

meridionalis Brèthes, 1913, p. 87; ♀, Argentina.

skottsbergi Brues, 1924, p. 315; ♂, Juan Fernandez Island.

urichi Brues, 1920, p. 151; ♂, Trinidad (♀ also described).

C. TRIBE SCLERODERMINI

Tribal characters.—Small wasps, rarely exceeding 5 mm, of slender build, wings fully developed or (fairly commonly) minute or absent. Maxillary palpi with five or six segments, labial palpi with two or three segments; mandibles relatively straight, slender or robust, with from two to seven apical teeth; antennae simple, with thirteen segments; clypeus with a short, broad median lobe which is truncate or emarginate apically; eyes of female rather small, not strongly convex, situated well forward and well toward front surface of head; occipital carina absent (except present in *Glenosema*). Pronotum elongate; mesoscutum with notauli absent or vaguely indicated; propodeum with or without a transverse carina margining the disc behind; tibiae with or without dense, short spines above; claws simple or dentate. Wings, when fully developed, somewhat variable; in *Nesepyris* the wings resemble the Epyrini, having three closed basal cells and a radial vein; in *Chilepyris* the radial vein has been lost (except for a very faint streak); and in *Scleroderma* the stigma is small and the costa (sometimes also the anal vein) absent; a prostigma is not present, although in *Nesepyris* the subcosta is somewhat thickened beyond the junction of the basal vein. Abdomen relatively elongate. Males are known only in the genus *Scleroderma*; in this genus the genitalia are of unusual form, the parameres being completely divided into dorsal and ventral lobes; the digiti are broad, setose; the basal ring is small.

Distribution.—Cosmopolitan.

Included genera.—Five genera occur in this hemisphere. I presume that *Atelcopterus* Foerster (Europe) and *Discleroderma* Kieffer (Burma) belong to this tribe, but I have seen no representatives of these genera.

KEY TO GENERA OF SCLERODERMINI

1. Wings fully developed, fore wing with costa and subcosta present and enclosing a slender costal cell, radial vein present or at least indicated by a very faint line (Figs. 110, 113); propodeum with a median carina (not always complete) 2
- Wings often reduced or absent, when fully developed without a costa or costal cell and without a radial vein or any indication thereof (Fig. 118); propodeum without a median carina 3
2. Radial vein strong, stigma small (Fig. 110); head elongate, much longer than wide, only slightly if at all wider than maximum width of thorax (Fig. 111) 1. NESEPYRIS Bridwell, p. 161
- Radial vein absent except indicated by a very faint line, stigma very large, almost circular (Fig. 113); head very large, wider than long, much wider than maximum width of thorax (Fig. 114) 2. CHILEPYRIS new genus, p. 166
3. Propodeal disc margined behind by a transverse carina (Fig. 115); occipital carina present; mandibles with seven apical teeth and the entire upper margin minutely denticulate; scutellum with a strong transverse groove at base 3. GLENOSEMA Kieffer, p. 168
- Propodeal disc not margined behind (Figs. 117, 120); occipital carina absent; mandibles with fewer teeth and not denticulate on upper margin 4
4. Abdominal sternites 4-6 deeply biemarginate, with broad median apical plates and more narrow lateral plates (Fig. 117b); abdominal venter with scales; tegulae and wings present but minute (Fig. 117a) (males unknown) 4. LEPIDOSTERNOPSIS Ogloblin, p. 170
- Abdominal sternites simple or their margins shallowly sinuate, without scales; either without tegulae and wings, or tegulae and wings fully developed (Figs. 118-121) 5. SCLERODERMA Latreille, p. 173

1. Genus NESEPYRIS Bridwell

Nesepyris Bridwell, 1920, pp. 309-311 (type species *N. ewa* Bridwell, monobasic).

Generic characters (of female; male unknown). — Very small wasps (about 2-3 mm), of dark coloration, known species fully winged. Head much longer than wide, its sides nearly parallel, the eyes situated toward the front, far removed from posterior margin; maxillary palpi with six segments, labial palpi very short, with only two segments; mandibles unusually long and slender, crossed in repose, terminating in two or three teeth; clypeus with a short median lobe which is truncate or emarginate apically; antennae inserted close to and overhanging base of clypeus, simple, with 13 segments; eyes covered sparsely with short hairs, eyes separated from posterior margin of head by

much more than their own height; ocelli in an acute triangle far above eye tops; occipital carina absent.

Pronotum elongate, disc on a somewhat higher plane than collar; mesoscutum short, transverse, parapsidal furrows present, notauli strong or vaguely impressed and incomplete; scutellum with a pair of basal pits which are connected by a groove or a very shallow impression; propodeal disc margined laterally and behind, median carina present, not or barely reaching transverse carina, not extending down the declivity, posterolateral angles of disc not areolate; mesopleura with an oblique depression in the center; femora moderately swollen and flattened; middle tibiae covered with minute spines on upper surface; claws simple or weakly dentate. Fore wing with three closed basal cells and a well-developed, long radius, as in the Epyrini; basal vein reaching subcosta basad of stigma by about two-thirds its own length, subcosta thickened beyond junction with basal vein, almost to the extent of forming a prostigma; stigma very short,

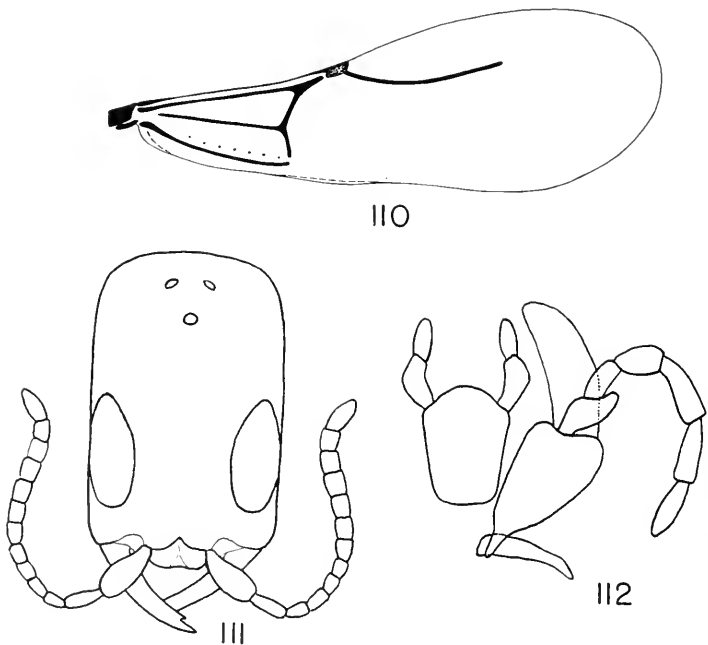

Nescopyris spp. Fig. 110. *N. virginianus* n. sp., fore wing, female. Fig. 111. *N. floridanus* n. sp., anterior aspect of head, female. Fig. 112. *N. floridanus* n. sp., labium and maxilla, female.

hardly longer than wide; margins of wings fringed with setae much as in *Cephalonomia* and *Scleroderma*. Abdomen relatively short and broad, slightly depressed. (Figs. 110-112.)

Remarks.—This genus is of unusual interest because of its resemblances, on the one hand, to *Holcypyrus* (mesoscutum, propodeum, wing venation) and, on the other, to *Scleroderma* (clypeus, head shape, eyes). The fact that this genus shares some of the characters of the Epyrini and Sclerodermini leads me to feel that it is unwise to place *Scleroderma* and its allies in a separate subfamily, as is commonly done.

Biology.—Bridwell states that “experiments made with the paratype female [of *ewa*] indicate that the species is predaceous upon small lepidopterous larvae, probably those feeding about dead wood.” Two specimens of the North American species *virginianus*, described below, are labeled as having been bred from redbud (*Cercis canadensis*), while another was taken “under hickory bark.” It is probable that these wasps, like those of the genus *Scleroderma*, occur chiefly around wood and stems and attack borers.

Distribution.—North and South America and Hawaii. It is probable that the type species, *ewa*, was introduced into Hawaii from tropical America. Bridwell remarks that the types were taken on Oahu near sea level, and I have studied a specimen from Santa Catarina, Brazil, closely resembling the type.

Included species:

ewa Bridwell, 1920, p. 310; ♀, Oahu, Hawaii (also Santa Catarina, Brazil).

floridanus Evans, n. sp. described below from ♀, Florida (also Mexico).

virginianus Evans, n. sp. described below from ♀, Virginia (also Maryland).

KEY TO SPECIES OF *NESEPYRIS* (FEMALES)

1. Mandibles with three teeth; scutellar pits connected by a transverse arching groove; notauli strong; antennae testaceous (Hawaii, Brazil) *ewa* Bridwell
- Mandibles with two teeth; scutellar pits separated, connected only by a very shallow impression; notauli very weak and incomplete; antennae brown (North America) 2
2. Head about 1.33 X as long as wide; WF slightly exceeding HE; transverse median vein of fore wing slightly oblique; clypeus truncate apically (Virginia, Maryland) *virginianus* n. sp.

Head distinctly more slender, about 1.5 X as long as wide; WF slightly less than HE; transverse median vein straight, erect; clypeus emarginate apically (Florida, Mexico) *floridanus* n. sp.

NESEPYRIS VIRGINIANUS new species

Holotype. — ♀, VIRGINIA: Rosslyn (no further data) [USNM, No. 65,000].

Description of female type. — Length 2.2 mm; LII .52 mm; LFW 1.4 mm. Entire body dark castaneous; first two antennal segments light brown, remainder medium brown; legs medium brown except tarsi light brown; wings hyaline, stigma brown, veins very light brown. Mandibles with two strong apical teeth. Clypeus truncate apically. Head .75 X as wide as high (1.33 X as high as wide), almost rectangular, the vertex nearly straight; eyes fairly large, rather close together, WF .52 X WH, 1.03 X HE; eyes removed from posterior margin of head by about 1.3 X HE. OOL subequal to HE, 2.2 X WOT. First four antennal segments in a ratio of about 4:2:1:1, segment three barely longer than wide, segment eleven wider than long. Head, in lateral view, somewhat convex on upper side but flat below; temples wider than eyes. Front somewhat shining but quite noticeably alutaceous; punctures minute but rather close together, giving rise to short, pale setae.

Pronotal disc with a weak transverse carina on the anterior end, sides gradually expanded from front to rear, surface alutaceous, obscurely punctate. Mesoscutum with notauli faintly indicated anteriorly; scutellum with basal pits small, widely separated, connected by only a very shallow impression. Propodeal disc 1.05 X as wide as long, median carina obsolete on apical .4, basal third with numerous weak carinae, remainder of disc polished, with very weak sculpturing. Fore wing as shown in Figure 110. Claws weakly dentate.

Paratypes. — MARYLAND: 1 ♀, Bethesda, 18 Aug. 1940, under hickory bark (J. C. Crawford) [USNM]. Also 2 ♀♀ without locality data but probably taken near Washington, D.C., labeled as bred from redbud, *Cercis canadensis* (Chittenden) [USNM].

Variation. — The Bethesda specimen has the body nearly black and is slightly larger than the type (about 2.5 mm; LH .67 mm; LFW about 1.7 mm); in this specimen WH is .77 X LII, WF .51 X WH, 1.08 X HE. The specimens from redbud resemble the type in color; one is lacking the head and is otherwise in poor condition, while the other measures slightly larger

than the type (LH .61 mm; LFW 1.6 mm). In this second specimen WH is .76 X LH, WF .51 X WH, 1.03 X HE. In all other respects the paratypes closely resemble the type.

NESEPYRIS FLORIDANUS new species

Holotype. — ♀, FLORIDA: Pasco Co., 27 Feb. 1930 (O. C. Tigner, Fla. fruit fly trap survey) [USNM, No. 64,999].

Description of type female. — Length about 1.9 mm; LH .55 mm; LFW 1.3 mm. Body dark brownish-fuscous; mandibles and basal segments of antennae medium brown, apical half of antennae dark brown; legs brown except tarsi and apical parts of tibiae light yellowish brown; wings hyaline, veins and stigma very light brown. Mandibles with two apical teeth, as in the preceding species. Clypeus with a shallow, V-shaped median emargination. Head .65 X as wide as high (1.54 X as high as wide), parallel-sided, vertex straight; eyes close together, WF only .47 X WH, .82 X HE; eyes removed from posterior margin of head by about 1.2 X HE. OOL subequal to HE, 2.5 X WOT. Antennae as described for *virginianus*. Front rather strongly alutaceous, moderately shining, punctures very small, closely spaced.

Characters of thoracic dorsum as in *virginianus*, but the scutellar pits slightly closer together. Propodeal disc approximately as wide as long, median carina complete although very weak on posterior third, disc strongly alutaceous and weakly longitudinally striate on anterior half. Fore wing as figured for *virginianus*, but the transverse median vein straight up and down, forming nearly a straight line with the basal vein.

Paratypes. — FLORIDA: 1 ♀, Orange Co., 3 July 1929 (M. M. Smith, Jr., Fla. fruit fly trap survey) [USNM]. MEXICO: 1 ♀, "On pineapple" 14 June 1938 (presumably intercepted at quarantine) [USNM].

Variation. — The Orange Co. specimen is the same size as the type and agrees with it in every detail, including measurements, except that the median carina of the propodeum is distinct on the anterior .8 of the disc, obsolete behind. The Mexican specimen is slightly larger than the type (LH .62 mm, LFW 1.4 mm); in this specimen the head is .66 X as wide as high, WF .47 X WH, .92 X HE, OOL 2.3 X WOT. The Mexican specimen also differs in having the scutellar pits somewhat more elongate, the propodeal disc only .95 X as wide as long, and the median carina of the propodeum obsolete on the posterior .3 of the disc. In all other respects it is very similar to the type.

2. Genus CHILEPYRIS new genus

Type species.—*Chilepyris herbsti*, new species.

Generic characters (of female; male unknown).—Known species about 4 mm long, of wholly dark coloration, fully winged. Head extremely large, much wider than thorax at its maximum, slightly wider than abdomen at its maximum; palpi slender, maxillary palpi with six segments, labial with three; mandibles robust, terminating in three large teeth; clypeus very short and broad, its apical margin slightly concave, with a transverse, U-shaped elevation which extends upward between the antennal sockets; antennae 13-segmented, arising slightly below level of bottoms of eyes; scape elongate, compressed, slightly curved; flagellum slender, filiform, only about 2.5 X as long as scape; eyes with sparse, short setae, relatively small, separated from top of vertex by nearly their own length; malar space absent; temples wide; occipital carina absent.

Pronotum much longer than mesoscutum, with smooth contours except for a transverse groove separating collar from anterior slope; notauli completely absent, but parapsidal grooves strong; scutellum with a long, slender transverse groove at base; propodeum very short, disc margined laterally and posteriorly and with a complete median carina which continues weakly down the steep declivity; posterolateral angles of disc not foveolate; mesopleura with a small pit, without other strong sculpturing; femora somewhat flattened and expanded, tibiae without spines although middle tibiae with rather dense, short setae; claws simple except with a sub-basal expansion. Fore wing with three closed basal cells (including the costal cell), stigma very large, rounded below and above, upper margin actually protruding slightly from outline of wing; radial vein absent, although a very faint streak can be made out in the position of this vein; basal vein short, reaching subcosta basal of stigma by nearly its own length. Abdomen stout, sessile, slightly depressed. (Figs. 113, 114.)

Remarks.—This genus is known from a single specimen. It is difficult to be certain of its proper position, but the features of the head suggest *Scicroderma*.

Biology.—Unknown.

Distribution.—Chile.

Included species.—Only the type species, described below.

CHILEPYRIS HERBSTI new species

Holotype. — ♀, CHILE: Baños de Cauquenes, Prov. Maule, Oct. 1907 (P. Herbst) [MCZ, No. 30,809].

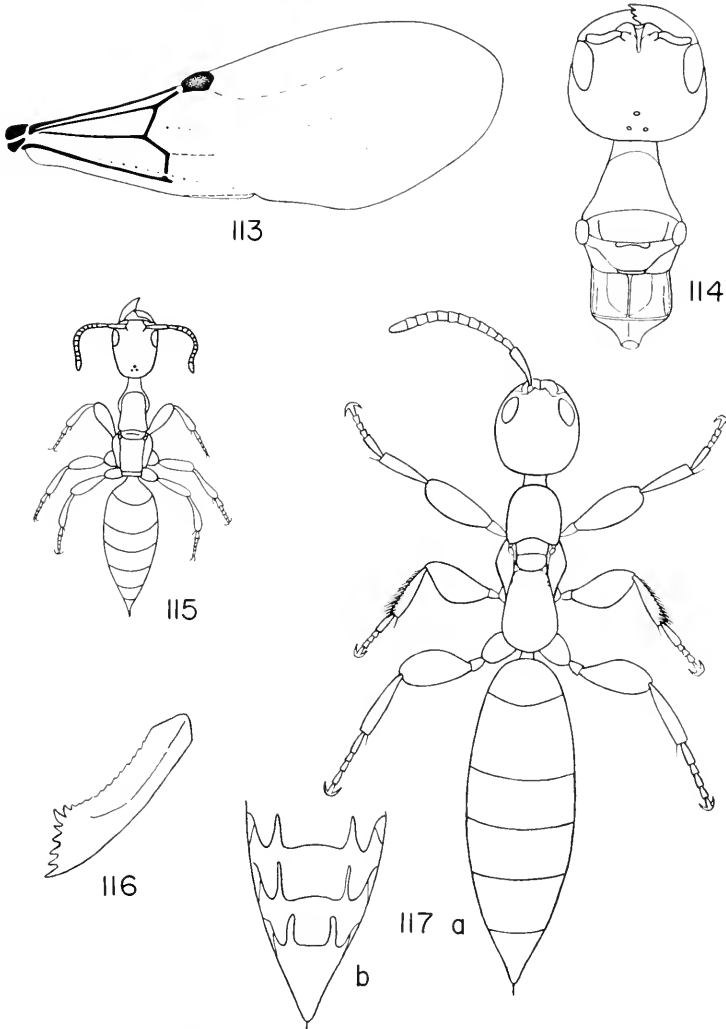

Fig. 113. *Chilepyris herbsti* n. sp., holotype female, fore wing. Fig. 114. Same specimen, head and thorax. Fig. 115. *Glenosema crandalli* n. sp., holotype female. Fig. 116. Same specimen, mandible. Fig. 117a. *Lepidosternopsis niveifemur* n. sp., holotype female. Fig. 117b. Same specimen, apical half of abdomen in ventral view.

Description of type female. — Length 4 mm; LFW 2.4 mm. Body piecous; mandibles, antennae, tegulae, and legs wholly dark brown; fore wing very lightly tinged with brownish, veins and stigma brown. Head 1.06 X as wide as high, the head actually slightly wider behind the eyes than through them. First four antennal segments in a ratio of about 13:4:3:3, segment three about twice as long as thick, segment eleven about 1.3 X as long as thick. WF .67 X WH, 1.70 X HE; ocelli in a compact triangle, front angle less than a right angle, OOL 2.4 X WOT. Front moderately shining, uniformly alutaceous, with small, widely spaced punctures.

Thoracic dorsum shining, weakly alutaceous, obscurely punctate; mesoscutum, between the parapsidal furrows, twice as wide as long; scutellar disc broad, not very convex. Propodeal disc 1.9 X as wide as long, median and basal parts of disc with irregular sculpturing, sublateral carina developed, disc otherwise somewhat shining, with only weak surface sculpturing. Front femora nearly 3 X as long as wide, hind femora about 2.1 X as long as wide. Wings as shown in Figure 113.

3. Genus GLENOSEMA Kieffer

Glenosema Kieffer, 1905a, p. 100 (no species). —Kieffer, 1905b, p. 253 (no species). —Kieffer, 1906a, pp. 431-432 (type species *G. nigra* Kieffer [= *merceti* Kieffer], monobasic). —Kieffer, 1908a, p. 43. —Kieffer, 1914, p. 250. —Berland, 1928, pp. 130-131.

Arysepyris Kieffer, 1905a, p. 102 (type species *A. merceti* Kieffer, monobasic; synonymy with *Glenosema* by Berland, 1928). —Kieffer, 1905b, p. 256. —Kieffer, 1906a, pp. 337-340. —Kieffer, 1908a, p. 30. —Kieffer, 1914, pp. 406-408.

Generic characters (of female; male unknown). — Length 2-5 mm; color predominantly black; wings minute, barely if at all longer than the tegulae. Head considerably wider than maximum width of thorax, gradually narrowed behind, the vertex rounded; palpi not noticeably reduced; mandibles relatively straight, their apices with seven minute but sharp denticles, the innermost ones directed upward; entire upper margin of mandibles with very small, sharp denticles; clypeus very short, extending beyond antennal sockets by little if any more than the diameter of the latter, medially broadly truncate or shallowly emarginate; upper margin of clypeus rather ill-defined, forming a median angulation which extends well above antennal sockets; antennal sockets widely separated, directed downward and laterad; antenna 13-segmented, scape elongate, slightly curved, second segment about

as long as third and fourth together; flagellum slender, apical segments with rather large sensoria; eyes fairly large, but not protruding from sides of head and separated from vertex by more than their own height, covered sparsely with short setae; ocelli present although small; occipital carina complete.

Pronotum more than twice as long as mesonotum, disc on a much higher plane than collar, anterior face and sides rounded; mesoscutum shorter than scutellum, without notauli or parapsidal furrows; scutellum short, with a strong transverse groove at base, posterior margin convex, in broad contact with the propodeum; propodeal disc quadrangular, longer than wide, margined laterally and posteriorly but otherwise smooth, without carinae, striae, or reticulations; declivity of propodeum nearly vertical; mesopleura without strong sculpturing, rather strong, protruding from sides of thorax in dorsal view; femora not much swollen, tibiae not spinose; claws dentate. Tegulae of nearly normal size, but fore wings extremely short, slightly if at all longer than tegulae, with one or two simple veins evident; hind wings absent. Abdomen sessile, tapering and weakly depressed apically. (Figs. 115, 116.)

Remarks. — The above diagnosis is based on the Palaearctic species *pedestris* Kieffer and *levis* Kieffer, as well as on the single known Nearctic species. Kieffer is incorrect in stating that the ocelli are lacking in the type species, *merceti* (see Berland, 1928). It is unlikely that *bifoveatus* Kieffer, from Spain, is correctly assigned to this genus.

Muesebeck and Walkley (1951, p. 727) reported *Glenosema* from North America, but their record was based on *Aryscopyris californicus* Bridwell, a species which I have transferred to the genus *Bethylus* as a synonym of *B. decipiens* (Provancher) (Evans, 1962a). The genus does occur in North America, however, the single known species being rather similar to the North African species *pedestris* Kieffer.

Biology. — Unknown.

Distribution. — Southern parts of the Palaearctic and Nearctic regions.

Included species. — The type species, *merceti*, occurs in France and Spain, the other two Palaearctic species, *pedestris* and *levis*, in North Africa. Our single species occurs in southern Arizona and is known from a single specimen.

GLENOSEMA CRANDALLI new species

Holotype. — ♀, ARIZONA: Santa Catalina Mts., "5-3" 1938 (R. H. Crandall) [MCZ, No. 30,810].

Description of type female — Length about 3 mm. Head and thorax black except pronotal collar light ferruginous; center of first abdominal tergite black, abdomen otherwise dark reddish brown except fading to yellowish brown apically; palpi straw-colored; mandibles testaceous; basal half of antennae testaceous except segments suffused with brown on upper side, remainder of antennae medium brown; legs testaceous except front coxae and all femora suffused with medium brown; tegulae testaceous, wings straw-colored. Mandibles as described under generic heading and as shown in Figure 116. Clypeus arcuately concave apically, with a small median elevation which is dentate in profile. Head widest across eyes, only a short distance back from base of mandibles, greatest width of head .92 X LH. WF .65 X WH, 1.57 X HE; eyes about 1.3 X as high as wide, removed from vertex crest by more than HE. Ocelli small, front angle of ocellar triangle only about 45°; OOL about 5 X WOT; ocellar triangle far above eye tops. Front polished, very weakly alutaceous, with small but sharply defined punctures which are separated by 3-5 X their own diameters; temples and under side of head also polished and very weakly alutaceous, but vertex, behind ocellar triangle, rather strongly alutaceous. First four antennal segments in a ratio of about 23:12:6:7, segment two nearly 3 X as long as wide, segments three and eleven each about 1.4 X as long as wide.

Dorsum of thorax and propodeum wholly alutaceous, more so on the mesonotum than elsewhere, pronotum and propodeal disc rather shining. Scutellum 2.6 X as wide as long, its base with an arching groove. Propodeal disc .83 X as wide as long, almost parallel-sided. Wings not quite as long as tegulae, broad and subtruncate apically.

4. Genus LEPIDOSTERNOPSIS Ogloblin

Lepidosternopsis Ogloblin, 1953, pp. 101-106, figs. 1-6 (type species *L. kuscheliana* Ogloblin, monobasic).

Generic characters (of female; male unknown). — Length 3-5 mm; color predominantly brownish or fuscous; wings present but extremely small. Head longer than wide, about 1.3 X as

wide as maximum width of thorax; head widest about or somewhat behind the middle, sides converging anteriorly and posteriorly, vertex evenly rounded; maxillary palpi with five segments, labial palpi with three segments, although very short; mandibles robust, terminating in three sharp teeth; clypeus with a very broad, truncate median lobe which is strongly carinate medially; antennae arising well below level of bottoms of eyes, their sockets close together, one on each side of base of median carina of clypeus; antennae simple, of thirteen segments, scape long and slightly curved, flagellum 2-3 X as long as scape; eyes with a few very short hairs, not very convex, located well toward front surface of head, malar space fairly long, temples very strong; distance from tops of eyes to vertex crest much greater than HE; ocelli absent; occipital carina absent.

Pronotum sloping upward gently from collar, with smooth contours, much longer than mesonotum; mesoscutum very short, without notauli or parapsidal furrows; scutellum separated from mesoscutum by a transverse pigmented streak (in the type species, according to Ogloblin, the mesonotum is undivided); scutellum without a transverse groove or pits; posterior margin of scutellum rounded, in broad contact with the propodeum; propodeum gradually expanded from front to rear, the disc without a transverse margining carina behind; mesopleurum rather convex, with a small dorsal surface; femora considerably swollen, somewhat flattened; middle tibiae densely covered with small spines on upper surface; claws dentate. Tegulae very small; fore wings very small, barely if at all longer than tegulae; hind wings absent. Abdomen sessile, slightly depressed apically; sternites 4-6 strongly biemarginate, the emarginations deep, cutting off a broad truncate median lobe, and a pair of much narrower lobes which are rounded apically; several of the sternites bear transverse rows of large scales (see figs. 5 and 6 in Ogloblin, 1953). (Fig. 117.)

Remarks.— This remarkable genus was described from the islands of Juan Fernandez. Ogloblin has provided a detailed, well illustrated description of the type species. The genus is perhaps less sharply separated from *Scleroderma* than Ogloblin thought. Some species of *Scleroderma* (e.g. *carolinense*) have dense, short spines on the middle tibiae as well as the “tres pequeñas celdillas marginales” on tergites 3-5 described by Ogloblin for the type species. These same species of *Scleroderma* also have the posterior margins of sternites 4-6 strongly sinuate,

although by no means as strongly modified as in *Lepidosternopsis*.

Biology. — According to Ogloblin (1953), the type species of this genus is an external parasite of the larvae of *Strongylopterus ovatus* Boh. (Curculionidae).

Distribution. — Islands of Juan Fernandez and continent of Australia; not known to occur on continental North or South America. The genus has not previously been recorded from Australia, but its occurrence on that continent seems of sufficient interest to justify describing two specimens in the MCZ collection which clearly belong here, each representing a distinct species. The three known species of the genus may be separated by the following key.

KEY TO SPECIES OF *LEPIDOSTERNOPSIS* (FEMALES)

1. Length about 4.8 mm; mesonotum undivided; body dark castaneous, legs, base of antennae, and median parts of pronotum and propodeum testaceous (Juan Fernandez) *Kuscheliana* Ogloblin
 Length about 3 mm; mesoseutum separated from scutellum by a linear streak; color not exactly as above 2
2. Head and thorax dark castaneous, legs brownish except hind femora contrastingly white; head considerably longer than wide, WH .85 X LH (New South Wales) *niveifemur* n. sp.
 Head light rufo-castaneous, thorax testaceous, legs testaceous except middle and hind coxae and hind femora straw-colored; head slightly longer than wide, WH .91 X LH (Western Australia)
 *darlingtoni* n. sp.

LEPIDOSTERNOPSIS NIVEIFEMUR new species

Holotype. — ♀, AUSTRALIA: NEW SOUTH WALES: The Dorrigo, 3,000 ft. (G. Heron) [MCZ, No. 30,811].

Description of type female. — Length about 3 mm. Head, prothorax, and mesopleura medium castaneous, mesonotum light castaneous, propodeum dark castaneous; abdomen piceous, except somewhat paler apically; mandibles testaceous, the teeth rufous; antennae testaceous except scape weakly suffused with brownish; clypeus and extreme lower front light brown; tegulae testaceous; front and middle legs medium brown, except tarsi light yellowish brown; hind legs of the same color, except femora contrastingly pure white. Median elevation of clypeus strong, angulate in profile, triangularly flattened as seen from below. First four antennal segments in a ratio of about 19:6:3:2, segments 3-12 all wider than long. WH .85 X LH; WF .51 X WH,

1.4 X HE; eye about 1.3 X as long as wide; malar space about one-third as long as eye. Head shining, weakly alutaceous, with weak, widely spaced punctures.

Pronotal disc nearly 1.5 X as long as mesonotum, shining, weakly alutaceous, with scattered punctures. Mesonotum 1.5 X as wide as long, mesoscutum and scutellum separated by a transverse line. Propodeum shining, very weakly alutaceous. Front and hind femora each about twice as long as their maximum width; middle tibiae with very numerous spines above. Margins of sternites 4-6 as described under generic heading, and almost exactly as figured by Ogloblin for *kuscheliana*; arrangement of scales on sternites difficult to work out in detail in the one available specimen.

LEPIDOSTERNOPSIS DARLINGTONI new species

Holotype. — ♀, AUSTRALIA: WESTERN AUST.: Geraldton, Oct. 1931 (Harvard Univ. Exped., P. J. Darlington, Jr.) [MCZ, No. 30,812].

Description of type female. — Length about 3 mm. Head light rufo-castaneous, suffused with brownish beneath; thorax and propodeum testaceous; abdomen dark castaneous dorsally, much paler, almost testaceous ventrally; antennae testaceous; legs testaceous except middle and hind coxae and hind femora straw-colored. Clypeus as in *niveifemur*. First four antennal segments in a ratio of about 8:2:1:1, segments 3-12 all wider than long. WH .91 X LH; WF .53 X WH, 1.65 X HE; eyes very small, removed from posterior margin of head by about 1.8 X HE; malar space about .4 X HE. Head shining, weakly alutaceous, punctures small, separated by 2-3 X their own diameters.

Pronotal disc about 1.5 X as long as mesonotum, weakly alutaceous, punctures widely separated. Mesonotum about 1.4 X as wide as long, scutum and scutellum separated by a linear groove which is darkly pigmented. Propodeum rather strongly alutaceous, moderately shining. Wings about as long as tegulae, abruptly truncate behind. Structures of legs as in *niveifemur*. Sternites 4-6 modified as in *kuscheliana* and *niveifemur*; sternites 2-4 with numerous large scales in transverse series.

5. Genus SCLERODERMA Latreille

Sclerodermus Latreille, 1809, p. 118 (type species *S. domesticus* Latreille, monobasic). —Kieffer, 1914, pp. 253-269 (spp. of world). —Bridwell, 1919, pp. 25-33 (biology, Hawaiian spp.). —Bridwell, 1920, pp. 291-314 (biology, Hawaiian spp.).

Scleroderma Oken, 1817, p. 1178 (emendation). —Westwood, 1839, pp. 164-172 (revision). —Saunders, 1881, pp. 109-116. —Westwood, 1881, pp. 117-125. —Ashmead, 1893, pp. 40-41. —Ashmead, 1902, p. 270. —Kieffer, 1905b, p. 256. —Kieffer, 1906a, pp. 432-449 (European spp.). —Kieffer, 1908a, pp. 41-42. —Berland, 1928, pp. 124-129 (French spp.). —Wheeler, 1928, pp. 62-64 (biology). —Bernard and Jacquemin, 1948, pp. 160-167 (North African spp.). —Kurian, 1955, pp. 77-78 (key to Oriental spp.).

Sclerochroa Foerster, 1850, p. 501 (proposed as new name for *Scleroderma*, preoccupied in the plant kingdom; type species *S. domesticus*, automatically).

Neoscleroderma Kieffer, 1905a, p. 106 (type species *Atleopterus virginicensis* Ashmead [= *carolinense* Ashmead], designated by Kieffer, 1914; new synonymy). —Kieffer, 1908a, p. 40. —Kieffer, 1914, pp. 269-271.

Generic characters. —Small wasps (1.5-6 mm) of light or dark coloration; wings present or absent (in either sex). Head longer than wide, its width slightly to considerably exceeding maximum width of thorax; maxillary palpi with five segments, labial palpi with three; mandibles with two sharp apical teeth, usually with from one to three small additional teeth basad of these; clypeus with a short median lobe which is truncate or emarginate apically; antennae inserted at base of clypeus, below level of bottoms of eyes; antennae simple, 13-segmented, the scape quite long; eyes glabrous or with sparse, short setae, rather small in apterous forms although their height measuring at least .25 X width of head; ocelli absent in apterous forms, normally developed in alate forms; occipital carina absent.

Pronotum with smooth contours, sloping but weakly from disc to collar; parapsidal furrows sometimes weakly indicated in alate forms, and these forms with the scutellum separated from the mesoscutum and with a narrow transverse groove basally, sometimes widened on each side; apterous forms with the mesoscutum and scutellum forming a single, smooth plate, the posterior margin of which is areuate, in broad contact with the propodeum; propodeum parallel-sided or somewhat broadened posteriorly, disc without longitudinal or transverse carinae; mesopleura prominent, forming the widest part of the thorax although without a distinct dorsal surface; femora somewhat swollen; middle tibiae bare or densely covered on upper side with short spines; claws dentate. Apterous forms with wings and tegulae normally completely absent; alate forms with the wings rather slender, anterior and outer margins of fore wing and outer and posterior margins of hind wings strongly fringed, fore wing slightly indented near base of stigma; fore wing with costa



118

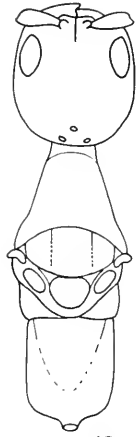

120



119

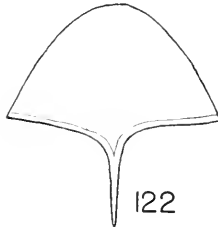

122

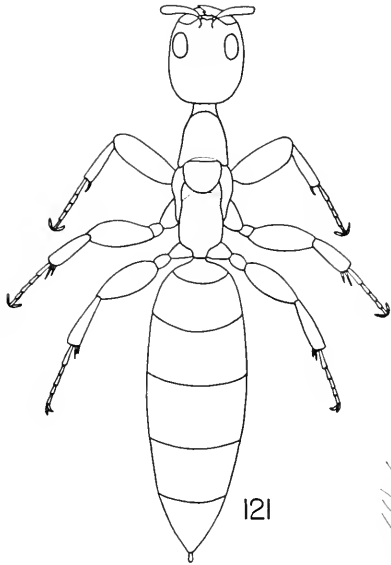

121

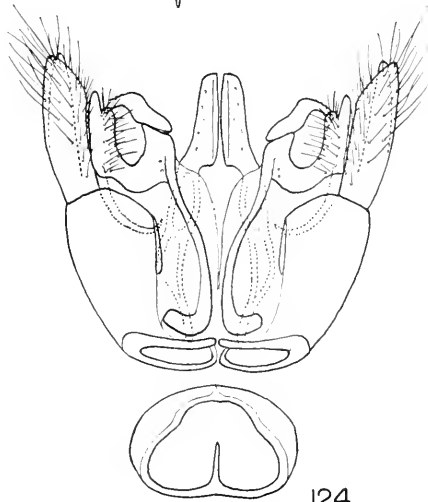

123

124

Scleroderma macrogaster (Ashmead). Fig. 118. Fore wing of alate female. Fig. 119. Hind tarsal claw of alate female. Fig. 120. Head and thorax of alate female. Fig. 121. Apterous female. Fig. 122. Male subgenital plate. Fig. 123. Male genitalia, lateral aspect, dorsal surface (aedeagus) at left. Fig. 124. Male genitalia, ventral aspect with basal ring detached from genital capsule.

absent, subcoستا, median, and basal veins present, anal and transverse median veins present or absent; basal vein meeting subcoستا basad of stigma by about its own length, subcoستا thickened between basal vein and stigma, but not forming a distinct prostigma; stigma minute, not giving rise to a radial vein; hind wing with anal lobe slender. Abdomen sessile, rather broad at base, relatively very long, especially in females; venter of female without scales, apical margins of some of sternites sinuate, but not deeply biemarginate as in *Lepidosternopsis*. Subgenital plate of male simple, with a long median basal stalk. Genitalia with the basal ring small; parameres divided into two completely separate lobes, much as in *Pseudisobrachium*; digiti broad, partially divided into ventral and dorsal arms, the ventral portion setose; aedoeagus simple, elongate. (Figs. 118-124.)

Remarks.—Some authors have objected to the emendation of the name of this genus to *Scleuroderma*. However, this spelling is etymologically more correct, and emendations of this type are within the spirit of the International Code. Furthermore, this spelling has been used much more commonly than *Scleurodermus*. The name *Scleurochroa* is properly considered a synonym of *Scleuroderma*, as indicated above. Kieffer included only Foerster's *rufa* in *Scleurochroa*, and this species is now regarded as a synonym of *Pristocera depressa*, type of the genus *Pristocera*. However, Foerster's *Scleurochroa* was proposed as a new (although unnecessary) name, so it has the same type species as *Scleuroderma*.

The majority (perhaps all) of the species of this genus are dimorphic in both sexes, being either fully winged, with ocelli well developed and mesonotum divided into scutum and scutellum, or completely apterous, without ocelli and with the mesonotum a single sclerite. Alate females are generally much less common than apterous females, but in the male sex the alate form is the more common. Males are generally much less common than females, and apterous males are very rare indeed. Bridwell (1920) found that in *S. immigrans* about one-third of the females are alate, while less than one per cent of the males are wingless. Bridwell states that in this species the ratio of females to males is about 5 to 1 but Keeler (1929a, b) found it to be generally about 12 to 1. The males are short-lived and hence are almost never collected except by rearing them from their hosts.

Biology. — Wheeler, in his book "The Social Insects" (1928), discussed the biology of these insects at some length, basing his discussion on his own studies of the North American species *macrogaster* as well as Bridwell's (1920) very similar observations on the Hawaiian species *immigrans*. Both of these species attack wood-boring beetle larvae, chiefly Cerambycidae, but they can be reared on a wide variety of beetle larvae; Bridwell also reared *immigrans* on various hymenopterous larvae and even on termites. The *Scleroderma* females, either singly or several together, subdue the much larger host by stinging it repeatedly, sometimes over a period of several days. The female then feeds on the blood of the host and eventually lays numerous eggs, chiefly at the intersegmental constrictions. The mother remains with the eggs and larvae, sometimes licking them, and may even remain on the host until her offspring emerge as adults. According to Wheeler, the mother "may mate with one of her sons and will readily paralyze another beetle larva, rear another brood and mate again with one of her grandsons." The female obtains all her nourishment from the host, and will not take water or carbohydrates. The males are said to die shortly after mating.

Keeler (1929a, b) found that virgin females of *S. immigrans* generally produced females. Bridwell (1929) questioned Keeler's techniques and felt that Keeler's females probably had mated. Thelytoky is apparently rare in the Bethylidae, but it has been reported in the genus *Parasicerola* in the Bethylinae.

The host of the North American *macrogaster* is recorded as *Megacyllene antennatus* (Cerambycidae) by Muesebeck and Walkley (1951), and I have seen specimens of *carolinense* reared from *Dicerea lepida* (Buprestidae) and *Urographis fasciata* (Cerambycidae). The European species *domestica* is said to attack cerambycid larvae, while *fonscolombeii* attacks Scolytidae (Yamada, 1955). The Japanese species *nipponica*, the Hawaiian *muiri*, and the Indian species *mori* are reported to attack Anobiidae, while other Indian species attack Bostrichidae and Lyctidae (Yamada, 1955; Kurian, 1955). Various unidentified species in the British Museum bear labels indicating an association with beetles of the families Anobiidae, Bostrichidae, and Cerambycidae. Thus it appears that the larvae of wood-boring Coleoptera provide the major hosts of these wasps. However, several Hawaiian species are reported by Bridwell (1920) to attack the larvae of wood-boring Lepidoptera such as *Hyposmocomma* and *Semnoprepia* (Tineoidea).

The types of all of the known South American species of *Scleroderma* were taken in association with ants, *iridomyrmicicola* Bruch with *Iridomyrmex humilis*, *formicarius* Kieffer with *Solenopsis saevissima*, and *galapagense* Brues with *Prenolepis fulva*. Although Bridwell reared *immigrans* successfully on ant larvae, it remains to be proved that ants are the normal hosts of species of *Scleroderma*.

Since these wasps are commonly associated with wood-boring insects, they not uncommonly are found in wooden buildings. There are many records of the females stinging humans. Some of the fairly extensive literature on *Scleroderma* attacking man has recently been reviewed by Guiglia (1958).

Distribution. — Cosmopolitan.

Included species. — Kieffer (1914) recognized over 40 species from various parts of the Old World, and several have been described since that time. Only six species have been described from the Americas, and a seventh is added here.

North America

carolinense (Ashmead), 1893, p. 43; ♀, North Carolina (New York to Georgia) (synonym: *virginiensis* Ashmead, 1893).

macrogaster (Ashmead), 1887, p. 75; ♀, Florida (north to Virginia, west to Texas).

soror Westwood, 1881, p. 123; ♀, Mexico (redescribed below).

West Indies

wilsoni Evans, n. sp. described below from ♀, Cuba.

South America

formicarius Kieffer, 1921, p. 41; ♀, Argentina.

galapagense Brues, 1919, p. 309; ♀, James Island, Galapagos.

iridomyrmicicola Bruch 1917a, p. 141; ♀, Argentina.

SCLERODERMA SOROR Westwood

Scleroderma soror Westwood, 1881, p. 123 [Type: ♀, MEXICO (no further data) (HCOU)].

Description of type female. — Length 2.0 mm; LH .40 mm; LT .65 mm. Entire body and appendages light yellowish brown; eyes dark gray. Head 1.25 X as long as wide, its sides rather evenly convex from front to rear, width at base of mandibles .8 X maximum width; vertex evenly convex; ocelli absent.

Eyes .5 X as long as WF, .3 X as long as WH. Front polished, obscurely alutaceous, without noticeable punctures. Scape 3.5 X as long as wide; flagellum about twice as long as scape, very slightly incrassate, segment eleven much wider than long, in fact all segments wider than long except first two and last.

Pronotal disc 1.4 X as long as wide; mesonotum .67 X as long as wide; median length of propodeum 1.4 X maximum width, maximum width 1.15 X minimum width, propodeum only slightly broadened posteriorly, its posterolateral angles not produced or angulate. Entire dorsum of thorax and propodeum shining, obscurely alutaceous, without noticeable punctures. Front femur 2.1 X as long as wide; middle tibiae apparently smooth. Wings and tegulae completely absent.

Remarks.—I have seen no specimens of this species other than the type.

SCLERODERMA WILSONI new species

Holotype.—♀, CUBA: Las Acostas, Pinar del Rio, 16 June 1953 (E. O. Wilson) [MCZ, No. 30,813].

Description of type female.—Length about 2.2 mm; LH .43 mm; LT .65 mm. Head and thorax wholly bright testaceous except posterior half of propodeum paler, straw-colored; eyes dark gray; antennae and legs wholly testaceous; abdomen piceous. Clypeus weakly emarginate, with a strong median carina. Head 1.20 X as long as wide, its sides subparallel except arcuately convergent behind; vertex evenly rounded; ocelli absent. Eyes .62 X as long as WF, .30 X as long as WH; distance from tops of eyes to top of vertex about twice HE. Entire head and thorax polished, very weakly alutaceous, punctures minute and scarcely noticeable. Scape about 2.5 X as long as wide; flagellum slightly more than twice as long as scape, very slightly thickened toward the apex, antennal segments four through twelve each wider than long.

Pronotal disc slightly longer than its maximum width; mesonotum .70 X as long as wide; median length of propodeum 1.35 X maximum width, maximum width 1.15 X minimum width; propodeum only weakly broadened posteriorly, its posterior dorsal angles blunt. Upper surface of middle tibia densely covered with very short spines. Wings and tegulae entirely absent.

Remarks.—This species is known to me only from the type. It is distinctively colored, and also differs from *soror* and *macro-gaster* in details of the shape of the head and of the propodeum.

III. SUBFAMILY BETHYLINAE

Subfamilial characters.— Small wasps without strong sexual dimorphism; both sexes occasionally short-winged or subapterous, but wings never completely absent. Maxillary palpi with five or six segments, labial palpi with two or three segments; clypeus with a prominent angular, subangular, or somewhat rounded median lobe, with a median polished streak or carina which extends on up the lower front usually well above level of bottoms of eyes; antennae with 12 or 13 segments, flagellum somewhat moniliform; eyes glabrous or with very short hairs; occipital carina absent. Pronotum smooth, without carinae or rugae; tegulae always present and scutellum separated from scutum; scutellum usually not in contact with base of propodeum, the metanotum present as a narrow, simple transverse band; propodeum with or without a transverse carina margining the disc behind, without a well-defined median carina (at least in the American forms) though often somewhat elevated medially; front femora somewhat broadened and flattened, especially in female; legs completely without spines; claws very strongly curved, hook-like, deeply bifid or trifid. Fore wings (except in brachypterous and subapterous forms) with three closed basal cells (costal cell sometimes partially obliterated) and a closed or open marginal cell; basal vein always giving rise to a vein (base of cubitus) which may be very short or fairly long and which may join the discoidal vein to form an areola (first discoidal cell); a closed submarginal cell present in some genera; hind wing with a strong notch on the anterior margin near the base.

Included genera.— This group is readily separated from other Bethylidae provided one removes certain discordant genera included here by Kieffer (1914), most particularly *Kathepyris* and *Clystospennella*. Of the five genera occurring in the Americas, two are restricted to this hemisphere (*Lytopsenella* and *Prosierola*), one is Holarctic (*Bethylus*), and two are cosmopolitan (*Parasierola* and *Goniozus*). Old World genera not occurring in the Americas include *Eupsenella*, *Sicrola*, *Odontepyris* and *Trissomalus*.

KEY TO GENERA OF BETHYLINAE

1. Antennae with twelve segments; frequently brachypterous or microp-
terous, when fully winged with the basal vein forming almost a
right angle, its basal portion appearing as a continuation of the
median vein, transverse median vein thus far basad of the apparent
basal vein (Fig. 142) 5. BETHYLUS Latreille, p. 202

- Antennae with thirteen segments; almost always fully winged, the basal vein oblique, only slightly angled, leaving median vein at about the same point as the transverse median vein (Figs. 125, 139) 2
2. Fore wing with six closed cells, including closed marginal and submarginal cells (Fig. 125); subcosta only slightly thickened beyond junction of basal vein (always fully winged) 1. LYTOPSENELLA Kieffer, p. 181
- Fore wing with at most four closed cells, marginal cell always open apically and on wing margin, submarginal cell absent (Figs. 129, 139); subcosta strongly thickened beyond junction of basal vein (except in the one known brachypterous form) 3
3. Vein arising from basal vein not enclosing a cell, merely extending blindly downward (Fig. 139) 4. GONIOZUS Foerster, p. 199
- Vein arising from basal vein joining the discoidal vein to form a small closed cell (Figs. 129, 135) 4
4. Propodeum with a pair of median basal pits, also with a pair of more lateral ridges which converge behind, depressed just mesad of the ridges (Fig. 130); scutellar pits large; prostigma nearly parallel-sided (barely justifying the term prostigma) (Fig. 129) 2. PROSIEROLA Kieffer, p. 183
- Propodeum simple, without basal pits or converging ridges (the latter sometimes weakly developed) (Fig. 136); scutellar pits very small; prostigma strong, subtriangular (Fig. 135) 3. PARASIEROLA Cameron, p. 195

1. Genus LYTOPSENELLA Kieffer

Lytopsenella Kieffer, 1911, p. 203 (type species *Eupsenella herbsti* Kieffer, original designation). —Kieffer, 1914, pp. 554-555.

Generic characters.—Small wasps (2-4 mm), of predominantly black coloration, fully winged. Maxillary palpi with six segments, the basal segment very short; labial palpi with three segments; mandibles with four apical teeth; clypeus angularly produced medially, with a very strong, sharp median ridge which is arched in profile and which extends up the front well beyond the level of the bottoms of the eyes; eyes glabrous or with short hairs; antennae 13-segmented. Pronotum simple, of moderate length; notauli present on posterior half of mesoscutum; scutellum with a very slender transverse groove at base which connects a pair of small, widely separated pits; propodeal disc not margined behind and only indistinctly so laterally, without discal carinae; claws deeply bifid, inner ray in the form of a lobe which on the front tarsal claws is stronger and less widely separated from the apical ray. Fore wings with six closed cells (costal, median, submedian, first discoidal, first

submarginal, and marginal); costal vein weak but present to end of marginal cell, radial vein curving up to close off marginal cell apically, the marginal cell longer than the first submarginal cell; basal vein meeting subcosta basad of stigma by about length of stigma, subcosta somewhat thickened beyond junction of basal vein, but not expanded to form a prostigma. Abdomen sessile, shining, somewhat depressed. (Males unknown.) (Figs. 125-128.)

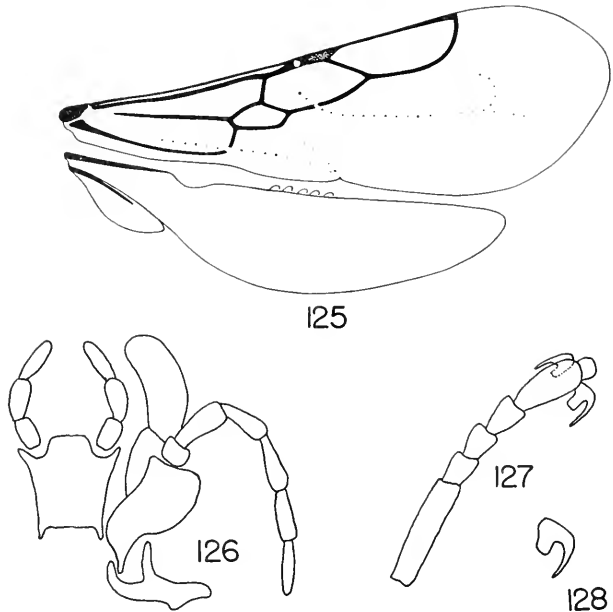

Lytopsenella herbsti (Kieffer). Fig. 125. Fore wing, female. Fig. 126. Labium and maxilla, female. Fig. 127. Front tarsus, female. Fig. 128. Hind tarsal claw, female.

Remarks.—This genus is very similar to *Eupsenella*, from Australia, differing chiefly in having the marginal cell longer and with its apex on the wing margin; it is also very similar to *Sicrola*, another Australian genus having a very similar marginal cell but lacking a closed submarginal cell. Kieffer's description and figure of the fore wing of *Lytopsenella* are highly misleading, as he indicates that the costa is absent and the costal and marginal cells open on the wing margin, which is by no means true. This genus and *Eupsenella* have the largest number

of fully closed cells on the fore wing of any bethylid. Since the marginal cell of *Eupsenella* is slightly reduced and modified, one may safely say that *Lytopsenella* is the most primitive genus of living Bethylidae with respect to the wing venation.⁵

Biology.— Nothing has been recorded regarding the biology of these wasps. In the MCZ collection there is a specimen of *L. herbsti* (Kieffer) taken by Luis E. Peña at Valle Ramón, Chile, labeled as having been taken while attacking an adult cantharid beetle. This is a most unusual record, as I know of no other bethylids which attack adult insects, and nearly all other records indicate that members of this subfamily attack Lepidoptera.

Distribution.— Chile.

Included species.— Only the two following:

herbsti (Kieffer), 1904c, p. 142; ♀, Chile (Concepcion).

testaceicornis (Kieffer), 1910b, p. 54; ♀, Chile (Rengotai).

2. Genus PROSIEROLA Kieffer

Parasierola Kieffer, 1905a, p. 104 (in part; not Cameron, 1883, misidentification). —Kieffer, 1914, pp. 542-544 (in part). —Muesebeck and Walkley, 1951, p. 734.

Prosierola Kieffer, 1905b, p. 243 (type species *Epyris ? nasalis* Westwood, monobasic). —Kieffer, 1908a, p. 13. —Kieffer, 1914, p. 544-545.

Generic characters.— Length 2.5-5.5 mm; body color black or partially rufo-testaceous; wings fully developed. Maxillary palpi with five segments, labial with three; mandibles with four apical teeth; clypeus large, angular or subangular apically, weakly tectiform and with a median carina which continues on well up the front, often to about the level of the middle of the eyes, sometimes indistinctly to the anterior ocellus; eyes glabrous; antennae 13-segmented. Pronotum short, its posterior margin sinuate, slightly produced backward medially; notauli absent; scutellum with a pair of fairly strong basal pits connected by a shallow impression; propodeal disc very short, nearly twice as wide as long, margined laterally and also with a complete transverse carina behind; disc with a pair of small, round pits at the extreme base medially, behind the pits roundly elevated, on each side of the elevation depressed, these depressions margined laterally by ridges which converge behind; mesopleura prominent, with a large pit above; claws of female

⁵ The three species of *Sierola* described by Brues (1923) from Baltic Amber, some specimens of which are beautifully preserved, all belong to the genus *Lytopsenella*.

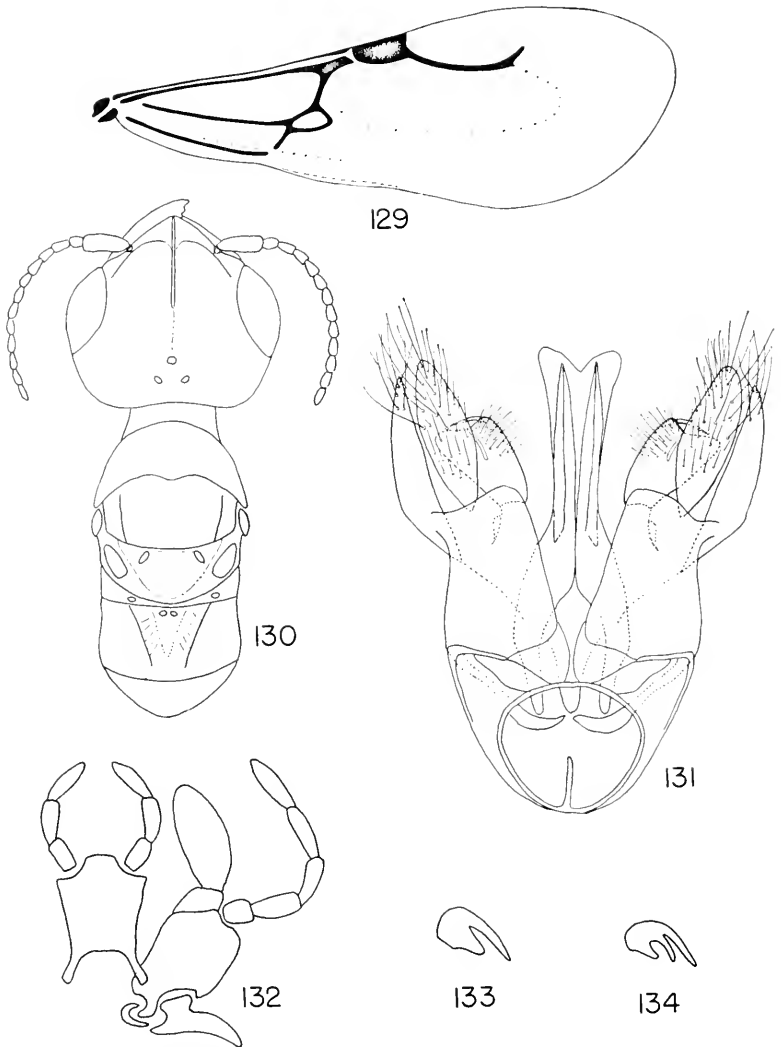

Prosierola bicarinata (Brues). Fig. 129. Fore wing, female. Fig. 130. Head and thorax, female. Fig. 131. Male genitalia, ventral aspect. Fig. 132. Labium and maxilla, female. Fig. 133. Hind tarsal claws of female. Fig. 134. Hind tarsal claws of male.

strongly hooked, deeply bifid, the inner ray lobe-like; claws of male trifid. Fore wing with four closed cells, the cubital and discoidal veins forming an areole, but the marginal cell open apically and on the wing margin, submarginal cell absent; subcosta thick and heavily pigmented beyond junction with basal vein, but usually nearly parallel-sided, the prostigma not as distinctly subtriangular as in *Parasierola*. Abdomen sessile, fusiform, shining. Abdomen of male with the apical sternites fringed with setae, the fifth sternite with a pair of tufts of more or less compacted setae; subgenital plate with its apical margin somewhat sinuate, but without a median notch; genitalia with the parameres divided into dorsal and ventral lobes, aedeagus slender, simple. (Figs. 129-134.)

Remarks.—This genus resembles *Parasierola* (*Perisierola* of many authors) in most particulars, but differs in the sculpturing of the propodeum and also in having the prostigma less strongly developed. Both of these characters show some variation in both *Prosierola* and *Parasierola*. In several species described below, the prostigma is nearly the same as in *Parasierola*, and in some species of *Parasierola*, such as *opaca* Cameron, there are weak, converging carinae on the propodeal disc. Hence there is some question in my mind as to whether the two groups should be maintained as separate genera. However, pending further study it is convenient to do so.

Biology. — *P. bicarinata* Brues is reported by Muesebeck and Walkley (1951) to attack *Laspeyresia caryana*, the hickory shuckworm (Lepidoptera, Olethreutidae). *P. cubana* n. sp. has been reared from a lepidopterous host, doubtfully determined as of the genus *Jocara* (Pyraloidea). Specimens of *P. lata* (Cameron) in the USNM are pinned with the cocoons of a lepidopterous leaf-roller or leaf-tier.

Distribution. — Neotropical region, north to Florida and Texas. I question whether the Australian and Indian species placed by Kieffer (1914) and by Muesebeck (1934) in *Parasierola* belong to either that genus or to *Prosierola*.

Included species. — The following eight species are known:

bicarinata (Brues), 1907a, p. 100; ♀, Texas (also Georgia, Florida) (new combination).

cubana Evans, n. sp. described below from ♀, ♂, Cuba (sp. 1).

insularis Evans, n. sp. described below from ♀, Dominican Republic (sp. 2)).

- lata* (Cameron), 1888a, p. 454; ♀, Panama (also Brazil, Paraguay, Tobago; redescribed below, sp. 4) (new combination).
- nasalis* (Westwood), 1874, p. 162; ♀, Brazil (redescribed below, sp. 3).
- obliqua* Evans, n. sp. described below from ♀, Bolivia (also ♀, ♂, Paraguay) (sp. 6).
- rufescens* Evans, n. sp. described below from ♀, Paraguay (sp. 5)
- variegata* Evans, n. sp. described below from ♀, Panama (sp. 7).

KEY TO SPECIES OF *PROSIEROLA*

1. Scutellar pits small, subcircular, widely spaced, separated by at least twice their own maximum diameters; propodeal pits small, subcircular, contiguous; sides of median elevation of propodeum at most very weakly ridged (Greater Antilles and southern United States) 2
 Scutellar pits larger, separated by less than twice their own maximum diameters; propodeal pits not usually as above; sides of median elevation of propodeum with distinct ridges (South America, southern Lesser Antilles, Panama) 4
2. Prostigma not well developed, the subcosta nearly parallel-sided beyond junction with basal vein; head of female barely if at all longer than wide; mesoscutum weakly shining (United States)
 *bicarinata* (Brues)
 Prostigma short, thick, subtriangular; head of female distinctly longer than wide (WH about .95 X LH); mesoscutum more strongly shining than pronotum (Greater Antilles) 3
3. Head and thorax wholly pale testaceous, abdomen castaneous; vertex of female gently concave as seen from in front; punctures of front rather small (Cuba) (1) *cubana* n. sp.
 Body blackish except anterior third of head testaceous; middle and hind legs dark brown except tibiae and tarsi lighter brown; punctures of front larger, flat-bottomed (Hispaniola) (2) *insularis* n. sp.
4. Head about as long as, or longer than, wide; scutellar pits subcircular, separated by 1.5-1.8 X their own diameters; mesopleura, as seen from above, less strongly produced than below; smaller species (LFW generally under 3.2 mm) of dark coloration 5
 Head distinctly wider than long (WH at least 1.03 X LH); scutellar pits elliptical, longer than wide, or if nearly circular then separated by barely more than their own diameters; mesopleura, as seen from above, strongly, angularly produced; larger species (LFW generally more than 3.2 mm) of variable coloration 6
5. Head much longer than wide, its anterior portion strongly produced (WH .93 X LH); legs dark brown, tibiae and tarsi paler (Brazil).
 (3) *nasalis* (Westwood)

- Head not or barely longer than wide, less strongly produced anteriorly (LH .96-1.02 X WH); legs of variable coloration, rarely as dark as above (Panama and Tobago to Brazil and Paraguay) (4) *luta* (Cameron)
6. Scutellar pits subcircular, separated by barely more than their own diameters; vertex distinctly concave in anterior view (males unknown) (Paraguay) (5) *rufescens* n. sp.
- Scutellar pits elliptical, oblique, separated by 1.2-1.7 X their own maximum diameters (in known males, by no more than their own diameters); vertex broad, somewhat sinuate 7
7. Body piceous to black, except the clypeus dull rufous, the legs and antennae mainly testaceous; head and thoracic dorsum, especially the mesoseutum and scutellum, somewhat more shining than below; median elevation of propodeum gently rounded (Bolivia, Paraguay) (6) *obliqua* n. sp.
- Body castaneous, the head and thorax somewhat darker than the propodeum and abdomen, legs and antennae testaceous; head and thoracic dorsum rather evenly alutaceous, weakly shining; median elevation of propodeum strong, rather narrowly rounded (Panama) (7) *variegata* n. sp.

(1) *PROSIEROLA CUBANA* new species

Holotype. — ♀, CUBA: Santiago de las Vegas, 4 April 1935 (S. C. Bruner; “*ex Jocara ferrififusalis*,” also labeled “reared from *Jocara?*”) [USNM, No. 67,129].

Description of type female. — Length 3.7 mm; LFW 2.7 mm. Head and thorax entirely bright, pale testaceous, including legs and antennae, except the eyes dark gray, the tips of the mandibles and apical margin of the clypeus rufous; abdomen shining, castaneous, irregularly suffused with testaceous, more especially toward the base; wings subhyaline, veins and stigma brown. Clypeus obtusely angulate, with a median ridge which is arched in profile and which continues on up the front to a point slightly below the middle of the eyes. Antennae short, the apical two-thirds moniliform. Front dull, rather strongly alutaceous, with rather small punctures which are separated by 1.2 X their own diameters; under surface of head more shining. WH .95 X LH; WF .63 X WH, 1.40 X HE; OOL 1.8 X WOT; vertex located above eye tops by a distance equal to about three-fourths X HE, the vertex gently concave as seen from in front.

Thoracic dorsum weakly punctate, the mesonotum more shining than the pronotum; scutellar pits well separated, subcircular, separated by 2.2 X their own diameter, connected by a shallow groove. Propodeal disc 1.9 X as wide as long, its basal pits

oblique, contiguous; sides of the median elevation very weakly striate toward the base. Mesopleura moderately prominent as seen from above. Fore wing with the areola rather slender, subtriangular; prostigma short, subtriangular.

Allotype. — ♂, same data as type [USNM].

Description of male allotype. — Length 2.5 mm; LFW 1.9 mm. Coloration as in female. Head with eyes somewhat more bulging than in female, the vertex straight across rather than concave; WH 1.0 X LH; WF .61 X WH, 1.28 X HE; OOL 1.5 X WOT. Other features of head and thorax essentially as in female. Abdomen relatively broad and short, with a rather large apical genital orifice; apical sternites with apical fringes of setae; fifth sternite with the usual pair of small hair-tufts. Terminalia not studied.

Paratypes. — CUBA: 4 ♀♀, same data as type [USNM, MCZ].

Variation. — The four female paratypes resemble the type closely. LFW varies from 2.4 to 2.8 mm; WF varies from 1.35 to 1.40 X HE; OOL varies from 1.65 to 1.85 X WOT.

Remarks. — The type alone bears the specific host data indicated above; all the specimens bear the label "Reared *Jocara?*". Two of the females are pinned with cocoons, presumably those of the host.

(2) PROSIEROLA INSULARIS new species

Holotype. — ♀, DOMINICAN REPUBLIC: San José de las Matas, 1000-2000 feet, June 1938 (P. J. Darlington, Jr.) [MCZ, No. 30,814].

Description of type female. — Length 4.3 mm; LFW 2.9 mm. Head and thorax black, abdomen dark reddish brown, almost black; mouthparts, clypeus, front anterior to level of bottoms of eyes, and entire antennae bright testaceous; front legs entirely testaceous, but middle and hind legs dark brown except light brown beyond femora; wings very lightly tinged with brownish, more especially along the veins and on the apical half, veins brown, stigma and prostigma dark brown. Mandibles with four small, sharp teeth. Median lobe of clypeus very prominent, subangular, median ridge strong, arched in profile, continuing up front to about middle of eyes and then as a faint streak to the median ocellus. Antennal scrobes earinate. First four antennal segments in a ratio of about 17:6:7:7, segments three and eleven each about 1.5 X as long as wide. Front strongly alutaceous,

especially below, with large, shallow, flat-bottomed punctures which are separated by 1-3 X their own diameters. Head slightly wider than maximum width of thorax; WH .95 X LH; WF .63 X WH, 1.44 X HE. Front angle of ocellar triangle slightly less than a right angle; OOL 1.45 X WOT.

Pronotum rather strongly alutaceous, its posterior margin arcuately produced medially. Mesoscutum with large, shallow punctures, less strongly alutaceous than pronotum; pits at base of scutellum subcircular, rather small, separated by slightly more than twice their own diameters, connected by a shallow groove. Propodeal disc about twice as wide as long, much as described for *rufescens* except the posterior carina only rather weakly curved. Mesopleura moderately produced on the upper part, just behind the rather large pit, but less prominently so than in *rufescens*. Fore wing with prostigma subtriangular, actually as well developed as in some species of *Parasierola*; areola small, subtriangular.

Remarks.— This species is known only from the type.

(3) PROSIEROLA NASALIS (Westwood)

Epyris ? *nasalis* Westwood, 1874, p. 162, pl. 31, fig. 2 [Type: ♀, BRAZIL (no further data) (HCOU)].

Parasierola nasalis Kieffer, 1905a, p. 104.

Prosierola nasalis Kieffer, 1905b, p. 243. —Kieffer, 1914, p. 545.

Description of type female.— Length 4.7 mm; LFW 3.0 mm. Black; mandibles light brown; clypeus dull ferruginous; antennae light brown, almost straw-colored, except scape and apical few segments weakly suffused with darker brown; legs dark brown except tibiae and tarsi amber; wings hyaline, veins and stigma dark brown. Mandibles with four small apical teeth. Median lobe of clypeus very prominent, narrowly rounded, the apex obtusely angulate; median line elevated as a sharp ridge which is arcuate in profile, continued on up front to a point opposite middle of eyes. First four antennal segments in a ratio of about 16:7:7:7, segment three about 1.4 X as long as thick, segment eleven about 1.3 X as long as thick; outer part of flagellum distinctly moniliform. Front alutaceous, moderately shining, with large, shallow punctures which are separated by 1-2 X their own diameters. Head relatively narrow, WH .93 X LH; WF .60 X WH, 1.25 X HE. Front angle of ocellar triangle less than a right angle; OOL 1.60 X WOT.

Pronotum of moderate length, its posterior margin weakly produced backward medially; surface alutaceous, somewhat punctate. Mesoscutum polished, barely alutaceous, punctures obsolete; scutellum with the basal pits round, separated by 1.7 X their own diameters, connected by a very shallow depression. Propodeal disc 1.8 X as wide as long, with a strong, complete transverse carina behind; base with a pair of circular median pits; median area roundly elevated and strongly polished, flanked by broad depressions which are margined laterally by strong, complete, oblique ridges. Fore wing with the prostigma small, parallel-sided, although heavily pigmented like the stigma; areola subtriangular.

Remarks.—I have seen no specimens of this species other than the type. This species differs from *lata* in the coloration of the legs and wings, also in head shape.

(4) *PROSIEROLA LATA* (Cameron) new combination

Parasierola lata Cameron, 1888a, p. 454, pl. 19, fig. 21 [Type: ♀, PANAMA: Bugaba (G. C. Champion) (BMNH)].

Perasierola lata Kieffer, 1914, p. 539.

Description of type female.—Length 5.0 mm; LFW 3.0 mm. Black; mandibles and clypeus pale castaneous; antennae pale castaneous except apical third weakly infuscated; legs bright rufo-testaceous except coxae somewhat infuscated; wings with a faint luteous tinge, fore wings somewhat clouded on apical half, most noticeably so just below radial vein. Mandibles with four apical teeth; clypeus produced as a right angle, the tip of which is somewhat rounded; median ridge strongly arched in profile, continued up the front as a carina to about the level of the middle of the eyes. First four antennal segments in a ratio of about 21:7:8:7, segment three 1.7 X as long as thick, segment eleven 1.5 X as long as thick; outer part of flagellum distinctly moniliform. Front alutaceous, moderately shining, punctures large although shallow, separated by 1.2 X their own diameters. Head slightly wider than thorax; WH .98 X LH; WF .60 X WH, 1.23 X HE; vertex straight across. Front angle of ocellar triangle less than a right angle; OOL 1.55 X WOT.

Pronotum short, disc along midline subequal in length to mesoscutum; posterior margin distinctly produced backward medially; surface alutaceous, with widely spaced punctures. Mesoscutum less alutaceous and more shining than pronotum or front, punctures obsolete; base of scutellum with two round,

bowl-shaped pits which are separated by 1.5 X their own diameters, connected by a very shallow depression. Propodeal disc 1.9 X as wide as long, with a strong, complete transverse carina behind; base with a pair of prominent, circular median pits; median area elevated, polished, flanked by broad depressions which terminate at a pair of oblique ridges. Mesopleura gibbous on upper part, and with a large pit. Fore wing with the prostigma small, parallel-sided; areola subtriangular.

Plesiallotype. — ♂, PARAGUAY: San Bernardino (K. Fiebrig) [USNM].

Description of plesiallotype male. — Length 3.0 mm; LFW 2.5 mm. Body wholly deep castaneous; mouthparts straw-colored except tips of mandibles rufous; clypeus testaceous, with a narrow dark border; antennae and legs wholly testaceous; fore wing very faintly clouded on apical half, wings otherwise hyaline. Features of head in general similar to female, but eyes somewhat more bulging, vertex narrower; WH 1.0 X LH; WF .59 X WH, 1.25 X HE; OOL 1.45 X WOT. Mesonotum more strongly shining than pronotum or front, as in female; scutellar pits slightly longer than wide, separated by 1.8 X their own maximum diameters. Abdominal venter obscured by glue, apparently with fringes and tufts of setae much as in *cubana* and *bicarinata*. Terminalia not studied.

Other specimens examined. — PARAGUAY: 7 ♀♀, same data as plesiallotype, one female pinned with cocoons of a lepidopterous leaf-roller or leaf-tier [USNM, MCZ]. BRAZIL: 1 ♀, Chapada, April [CM]; 1 ♀, Nova Teutonia, Santa Catarina, Mar. 1963 (F. Plaumann) [MCZ]. TOBAGO: 1 ♀, 23 Feb. 1912 (A. Busck) [USNM].

Variation. — Size variation among the females is slight (LFW 2.7-3.2 mm). There is little color variation except that the legs, although usually wholly testaceous, sometimes have the coxae and femora light to medium brown (in four of the Paraguay specimens) or even dark brown (in the Santa Catarina specimen). In some specimens the median carina of the front continues as a faint line to the anterior ocellus; the front varies from moderately to strongly alutaceous except in one Paraguay specimen, where it is polished and very weakly alutaceous. WH varies from .96 to 1.02 X LH; WF varies from 1.17 to 1.27 X HE; OOL varies from 1.4 to 1.7 X WOT. The scutellar pits are often slightly longer than wide and are separated by from 1.4 to 1.8 X their own maximum diameters.

(5) *PROSIEROLA RUFESCENS* new species

Holotype. — ♀, PARAGUAY: Carlos Pffanel, March (F. Schade) [MCZ, No. 30,815].

Description of type female. — Length 5.5 mm; LFW 3.8 mm. Front of head piceous, except suffused below and on the sides with rufo-castaneous, under side of head wholly rufo-castaneous; thorax and abdomen piceous; palpi and mandibles testaceous; clypeus and adjacent parts of front pale castaneous; antennae testaceous, weakly darkened apically; legs wholly testaceous; wings strongly tinged with yellowish, weakly clouded below stigma and radial vein, stigma and prostigma brown but veins otherwise amber and translucent. Mandibles with four teeth. Median lobe of clypeus rather narrow, forming nearly a right angle, median carina weakly arched in profile, extending up front not quite to level of middle of eyes; antennal scrobes carinate above. First four antennal segments in a ratio of about 21:7:9:9, segment three about 1.7 X as long as thick, segment eleven about 1.9 X as long as thick. Front alutaceous, moderately shining, punctures small but strong, less shallow than in *lata* and *nasalis*, separated by 1-2 X their own diameters; head subcarinate between anterior ocellus and vertex crest. Head subequal in width to maximum width of thorax (at mesopleura), much wider than pronotum; WH 1.06 X its median length, the vertex being slightly concave in anterior view; WF .61 X WH, 1.35 X HE. Front angle of ocellar triangle about a right angle; OOL 1.45 X WOT.

Posterior margin of pronotum arcuately produced backward medially; surface alutaceous, obscurely punctate. Mesoseutum less alutaceous and with more distinct punctures than pronotum; pits at base of scutellum large, subcircular, separated by scarcely more than their own diameter. Propodeal disc 1.7 X as wide as its median length, the posterior carina strongly arched backward medially; median area strongly elevated, the basal pits rather shallow, sides of median area strongly striate. Mesopleura strongly produced on upper part, the processes as seen from above almost dentiform, as seen from in front or behind strongly rounded, each process with a strong pit in front of it. Fore wing with prostigma strongly pigmented although essentially parallel-sided; areola subtriangular.

Paratypes. — PARAGUAY: 2 ♀ ♀, same data as type [MCZ, USNM].

Variation.—The two paratypes are of the same size as the type, but both are somewhat paler, one of them having the entire body bright rufo-castaneous except for some infuscation of the pronotum, propodeum, and abdomen. In the paratypes the antennae are slightly shorter, segment eleven measuring 1.5-1.7 X as long as wide, but there are no other important differences in structure or body measurements.

(6) *PROSIEROLA OBLIQUA* new species

Holotype.—♀, BOLIVIA: Santa Cruz, Roboré, Oct. 1959 [KU].

Description of type female.—Length 4.0 mm; LFW 3.2 mm. Head black except clypeus ferruginous, with a black apical border; mandibles testaceous; antennae testaceous except weakly darkened apically; thorax piceous, grading into dark reddish brown on parts of the prothorax and propodeum; tegulae light brown; legs entirely bright, pale castaneous; abdomen shining, piceous, obscurely banded with yellowish brown; wings wholly tinged with yellowish brown. Mandibles with four teeth; clypeus rounded at tip, its median carina weakly arched, continued up the front well above level of middle of eyes. First four antennal segments in a ratio of about 19:7:7:8, segments three and eleven each about 1.4 X as long as thick. Front alutaceous, moderately shining, punctures strong but not as large as in *lata*, separated by from 1.5-3 X their own diameters. WH 1.05 X LH; WF .60 X WH, 1.32 X HE; vertex broad, slightly sinuate; OOL 1.7 X WOT.

Thoracic dorsum shining, moderately alutaceous, with small, widely spaced punctures; pits at base of scutellum deep, elliptical, oblique, separated by 1.4 X their own maximum length. Propodeal disc 1.8 X as wide as long, its basal pits small, transverse; median area elevated, polished, with a few irregular carinae on the sides; transverse carina strong and complete. Upper part of mesopleura strongly produced, so that in dorsal view the pleura protrude greatly from the sides of the thorax. Fore wing with the areola small, subtriangular, the prostigma darkly pigmented but slender and nearly parallel-sided.

Allotype. ♂, PARAGUAY: San Bernardino (K. Fiebrig) [USNM].

Description of allotype male.—Length 4.0 mm; LFW 3.0 mm. Body piceous except clypeus testaceous, with a dark border, tip of abdomen dark yellowish brown; mouthparts testaceous except

tips of mandibles rufous; antennae and legs wholly testaceous; wings faintly tinged with yellowish brown. Head similar to that of female, but still broader, WH 1.08 X LH; WF .60 X WH, 1.33 X HE; OOL 1.4 X WOT; front moderately shining, alutaceous. Mesoseutum and scutellum alutaceous but rather strongly shining, with sparse, rather strong punctures; scutellar pits large, elliptical, oblique, separated by approximately their own maximum diameters. Abdominal sternites with apical fringes of setae, sternite five with the setae clumped on each side of the midline to form a pair of brushes; subgenital plate with a median longitudinal impression. Genitalia not studied.

Other specimens examined. — BOLIVIA: 2 ♀♀, Roboré, Santa Cruz (same data as type) [KU, MCZ]; 1 ♀, Rurrenabeque, Beni, 175 meters, 17 Oct. 1956 (L. Peña) [KU]. PARAGUAY: 3 ♀♀, San Bernardino (same data as allotype) [USNM].

Variation. — The two topotypic paratypes show no noteworthy differences from the type, but all the others are larger (LFW 3.8-4.0 mm). WH varies from 1.03 to 1.06 X LH, WF from .60 to .63 X WH, 1.20 to 1.40 X HE; the distance between the scutellar pits varies from 1.2 to 1.4 X their own maximum diameters.

(7) *PROSIEROLA VARIEGATA* new species

Holotype. — ♀, PANAMA: Ancon, Canal Zone, 1 Oct. 1923 (J. Zetek, no. Z-2306) [USNM, No. 67,130].

Description of type female. — Length 5.0 mm; LFW 3.5 mm. Head dark castaneous, center of front nearly piceous, except clypeus testaceous, with a darker border; thorax dark castaneous except lower pleura and entire propodeum paler castaneous; abdomen light castaneous, with indistinct transverse banding with dark castaneous; mouthparts straw-colored except tips of mandibles rufous; antennae straw-colored except apical third suffused with brownish; legs wholly testaceous except tarsal claws dark; wings lightly suffused with yellowish brown, especially around the radial vein. Clypeus narrowly rounded, its median carina weakly arched in profile, extending up front nearly to level of top of eyes, then as a weak line to anterior ocellus. Antennae of moderate length, fourth segment slightly longer than second or third, apical half strongly moniliform. Front moderately shining, rather uniformly alutaceous, punctures rather small, separated by 2-3 X their own diameters,

under surface of head strongly shining except alutaceous just behind mouthparts. WH $1.04 \times$ LH; WF $.62 \times$ WH, $1.42 \times$ HE; OOL $1.55 \times$ WOT; vertex broad, distance from eye tops to vertex crest equal to about two-thirds \times HE; vertex slightly concave, as seen from in front, but with a weak median convexity.

Thoracic dorsum rather evenly alutaceous, including the rather flat scutellar disc, moderately shining; scutellar pits oblique, elliptical, separated by $1.7 \times$ their own maximum diameters. Propodeal disc about $1.7 \times$ as wide as high, the transverse carina somewhat arching; median basal elevation strong, rather narrowly convex, the basal pits transverse, separated by less than their own maximum diameters; sides of median elevation with some strong ridges. Mesopleura, as seen from above, strongly, subangularly produced. Fore wing with the areola and the prostigma both rather small, but the latter darkly pigmented like the stigma.

Paratypes. — PANAMA: 10 ♀♀, same data as type [USNM, MCZ].

Variation. — The type series was apparently reared, and there is little variation worthy of note. LFW varies from 3.3 to 3.6 mm; WH varies from 1.03 to 1.05 \times LH, WF from 1.40 to 1.50 \times HE; the scutellar pits vary from 1.5 to 1.8 \times as far apart as their own diameters. The infuscation of the wings varies slightly in intensity, and in one specimen the head and thorax are medium castaneous, hardly any darker than the abdomen.

Remark. — This form differs only slightly from *obliqua*, and it is possible that the two are only subspecifically distinct.

3. Genus PARASIEROLA Cameron

Parasierola Cameron, 1883, p. 197 (type species *P. testaccicornis* Cameron, monobasie). —Cameron, 1888a, pp. 454-455. —Kieffer, 1904b, p. 381. —Kieffer, 1905b, p. 243. —Kieffer, 1908a, pp. 13-14.

Perasierola Kieffer, 1914, pp. 533-542 (type species *Parasierola gallicola* Kieffer, designated by Muesebeck and Walkley, 1951; new synonymy). —Berland, 1928, pp. 102-103 (French spp.). —Muesebeck, 1934, p. 227 (Indian spp.). —Kurian, 1954, p. 286 (Indian spp.). —Muesebeck and Walkley, 1951, pp. 733-734 (U.S. spp. listed). —Benoit, 1957, pp. 4-6 (central African spp.).

Generic characters. — Small wasps (1.5-5.0 mm) of predominantly black coloration; fully winged except for one species described from Juan Fernandez. Maxillary palpi with five segments, labial with three (as figured for *Prosierola*, Fig. 132);

mandibles with several (usually four) small apical teeth; clypeus with a strongly produced angular or subangular median lobe, with a median, polished carina which extends up the front a short distance, usually not as far as middle of eyes; malar space rather long; eyes glabrous or with some very short, inconspicuous hairs; antennae 13-segmented. Posterior margin of pronotum arcuate or slightly sinuate; notauli absent; scutellum with a transverse basal groove or a pair of very small pits which are connected by a weak groove; propodeum margined laterally, the transverse carina margining the disc behind complete, incomplete, or occasionally nearly absent; disc roundly elevated medio-basally and usually more polished here than elsewhere, without other irregularities except sometimes for a pair of very weak carinae which converge posteriorly; mesopleura with a strong pit above; claws of female bifid, those of male trifid, as in *Prosierola*. Venation of fore wing as in the preceding genus, but the prostigma strong, subtriangular, darkly pigmented like the stigma. Abdomen shining, sessile, slightly depressed, that of male hirsute on apical sternites, but without slender processes as in *Prosierola*; male subgenital plate typically truncate and with a small median notch; male genitalia with the parameres undivided, though often with a weak dorsal lobe, cuspides and digiti slender, aedoeagus of variable shape. (Figs. 135-138.) (Ogloblin, 1953 and 1960, has provided excellent drawings of members of this genus, including the genitalia of three species.)

Remarks.—I have studied the type specimen of the type species of *Parasierola*, and I find it to be a typical *Perasierola* in the sense of Kieffer (1914) and subsequent authors, the median carina of the propodeum being no more than a rounded, polished elevation similar to that of many species of this genus. Thus *Parasierola* is a senior synonym of *Perasierola*, the name *Prosierola* properly applying to those species having paired pits and carinae on the propodeum.

Biology.—The species of this genus are commonly taken in sweepings from herbaceous vegetation, and are also often taken at honeydew, rarely on flowers. There are many records which indicate that the usual hosts are microlepidopterous larvae, including such pest species as the pink bollworm and the Oriental fruit moth. Busck (1917) studied *P. emigrata* Rohwer, which occurs in cotton fields in Hawaii and attacks the pink bollworm, *Pectinophora gossypiella* (Saunders) (Gelechiidae). The wasp enters the boll and paralyzes the full-grown bollworm larva by

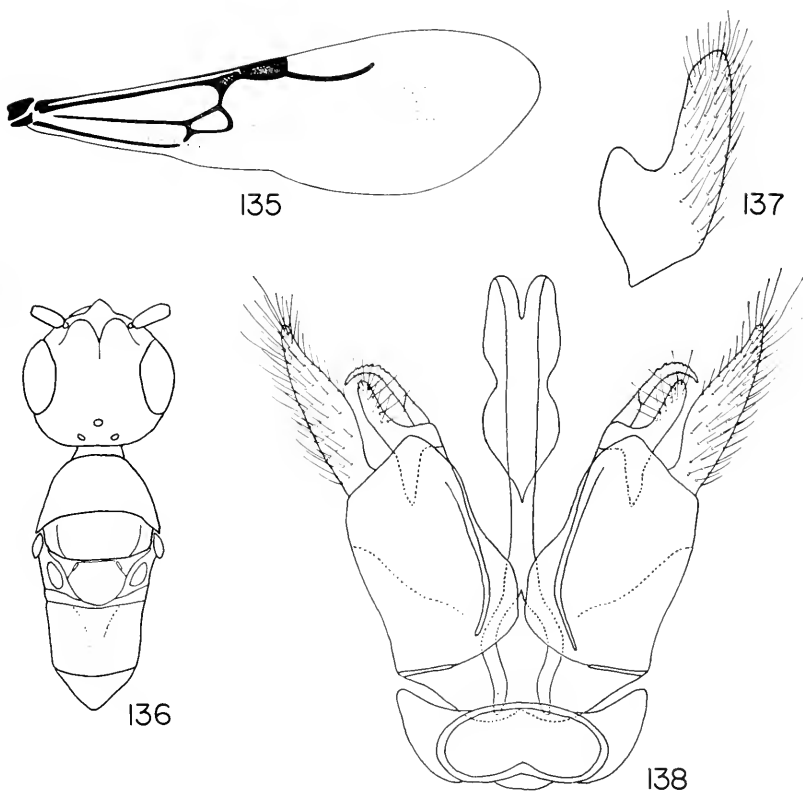

Parasierola spp. Fig. 135. *P. cellularis* (Say), fore wing, female. Fig. 136. Same species, head and thorax, female. Fig. 137. *P. gracilicornis* Kieffer, lateral view of paramere of male genitalia (ventral surface toward right). Fig. 138. Same species, male genitalia, ventral aspect.

stinging it several times, then lays 4-10 eggs (in the laboratory, up to 17 eggs) in two longitudinal rows on the caterpillar. The eggs hatch within 24 hours and the larvae reach maturity in two or three days, spinning their cocoons near the host larva. Bridwell (1919) found *emigrata* to be associated with a variety of lepidopterous larvae in the field and to attack almost any small lepidopterous larvae presented to them in the laboratory (also some beetle larvae). He observed females feeding upon the blood exuding from the wounds of their hosts on many occasions.

The Neotropical species *nigrifemur* (Ashmead) is also reported to attack the pink bollworm as well as the tortricoid moth *Evetria buoliana* (Ogloblin, 1960), while *bogotensis* Kieffer has been reared from the sugar-cane borer (*Diatraea saccharalis*, Crambidae) (Myers, 1932). The Nearctic species *cellularis* (Say) and *puncticeps* Kieffer are recorded from several microlepidopterous hosts (Muesebeck and Walkley, 1951). Several Old World species have been found to attack the larvae of Microlepidoptera (for summaries of records, see Berland, 1928, Kurian, 1954, and Yamada, 1955). There are a few records of Coleoptera as hosts, but all are fragmentary. Rohwer (1917) mentions *emigrata* as a parasite of *Bruchus* in Texas, and Bridwell (1919), as mentioned above, found that this species would attack beetle larvae in the laboratory. A specimen of an undetermined species from California [CIS] is labeled as a parasite of *Ernobius punctulatus* LeC. (Anobiidae).

Males of this genus are uncommonly collected, and it is possible that thelytokous parthenogenesis is common in the genus. Busck (1917) was able to produce four generations of females from a single unfertilized female.

Distribution.—This genus is well represented in all zoogeographic regions. In this hemisphere the species collectively range from the northern United States to Argentina (but not Chile), including the West Indies. There are many undescribed species.

Included species:

United States

alutacea Kieffer, 1906b, p. 254; ♂, Nevada.

breviceps (Krombein), 1954, p. 259; ♀, California (new combination).

cellularis (Say), 1836, p. 279; ♀, Indiana (Virginia and Kansas to Pennsylvania and Michigan; Muesebeck and Walkley, 1951).

distinguenda Kieffer, 1908a, p. 14; ♀, California and Nicaragua (new name for *cellularis* Kieffer, 1906b, p. 254, *nec* Say).

emigrata (Rohwer), 1917, p. 1; ♀, Hawaii (♂ also described; said to be introduced into Hawaii from Texas).

gracilicornis Kieffer, 1906b, p. 254; ♀, California (Texas and California to Oregon and Idaho; Muesebeck and Walkley, 1951).

punctaticeps Kieffer, 1906b, p. 254; ♀, California (also Texas, Muesebeck and Walkley, 1951).

Mexico and Central America.—Eight species have been described, and *distinguenda* and *nigrifemur* are also reported from Nicaragua and Mexico, respectively.

arcuata Kieffer, 1911, p. 208; ♀, Mexico.

flavicoxis Kieffer, 1904b, p. 381; ♀, Nicaragua (♂ also described).

fuscicornis Kieffer, 1908b, p. 21; ♀, British Honduras.

leviceps Kieffer, 1905c, p. 11; ♀, Nicaragua.

mexicana (Ashmead), 1895a, p. 540; ♀, Mexico.

nigricoxis Kieffer, 1904b, p. 382; ♀, Nicaragua.

opaca Cameron, 1888a, p. 454; ♀, Guatemala.

palliditarsis Cameron, 1888a, p. 455; ♀, Guatemala.

West Indies

luteipes Kieffer, 1908b, p. 20; ♀, Cuba.

nigrifemur (Ashmead), 1894, p. 195; ♀, St. Vincent (occurs widely in neotropics, Ogloblin, 1960) (synonym: *bonariensis* Brèthes, 1916; Ogloblin, 1960).

sancti-vincenti (Ashmead), 1894, p. 196; ♀, St. Vincent.

South America.—In addition to the eight species listed below, see also *nigrifemur*, described from the West Indies.

bogotensis Kieffer, 1909, p. 140; ♀, Colombia (also British Guiana; Myers, 1932).

boliviensis Kieffer, 1910b, p. 55; ♂, Bolivia.

excisa Kieffer, 1910a, p. 292; ♀, Brazil.

integra Kieffer, 1910a, p. 292; ♂, Brazil.

maculicornis (Ogloblin), 1953, p. 106; ♂, Juan Fernandez (new combination).

peruviana Kieffer, 1910b, p. 55; ♀, Peru.

sanctae-clarae (Ogloblin), 1953, p. 108; ♂, Juan Fernandez (new combination).

testaceicornis Cameron, 1883, p. 197; ♀, Brazil.

4. Genus GONIOZUS Foerster

Goniozus Foerster, 1856, p. 96 (type species *Bethylus claripennis* Foerster, designated by Ashmead, 1893). —Ashmead, 1893, pp. 72-77. —Ashmead, 1902, pp. 272, 273. —Kieffer, 1905b, pp. 244, 262-267 (European spp.). —Brues, 1907b, pp. 151-152 (key to U.S. spp.). —Kieffer, 1908a, pp. 14-15. —Kieffer, 1914, pp. 522-533 (spp. of world). —Berland, 1928, pp. 101-102 (French sp.). —Fouts, 1928, pp. 127-132 (key to U.S. spp.). —Kurian, 1955, pp. 113-130 (Oriental spp.).

Progoniozus Kieffer, 1905a, p. 105 (type species *Perisemus floridanus* Ashmead, original designation; synonymy by Muesebeck and Walkley, 1951). —Kieffer, 1914, pp. 519-522.

Generic characters. — Exactly as described for *Parasierola* except as follows: pits at base of scutellum and the groove connecting them very small, often obsolescent; wings fully developed in all known species, vein arising from basal vein very short to moderately long, directed obliquely downward, but not enclosing a cell inasmuch as the discoidal vein is absent; male subgenital plate sinuate apically, with a strong median notch; genitalia with the parameres completely divided into dorsal and ventral lobes (*cf.* Figs. 137 and 141). (Figs. 139-141.)

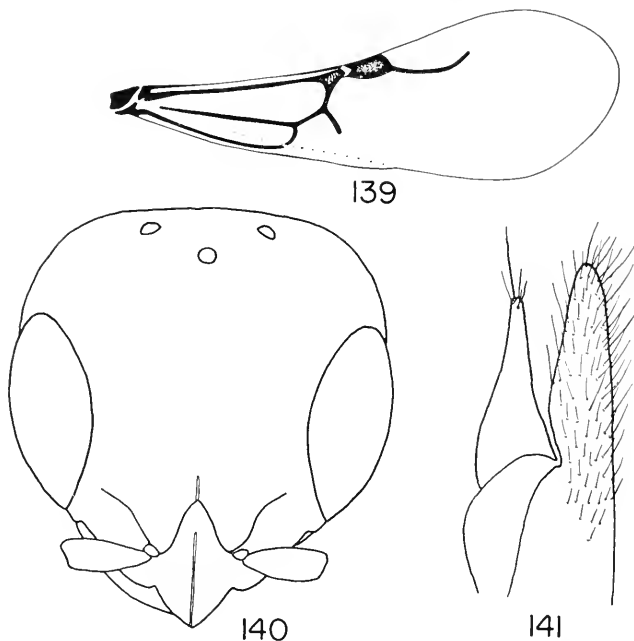

Goniozus platynotae Ashmead. Fig. 139. Fore wing, female. Fig. 140. Head of female. Fig. 141. Lateral view of paramere of male genitalia (ventral surface toward right).

Remarks. — There is some question in my mind as to whether this genus and *Parasierola* should be maintained as full genera, as they are nearly identical in structure and exhibit no known differences in biology. It is convenient to consider them full

genera for the present, as both groups are very large, and only a thorough revision of the species of this section of the Bethylinae can determine how these species should properly be grouped.

Biology.—The species of *Goniozus* occur in much the same situations as do those of *Parasierola*, and as in that genus most if not all of them attack Microlepidoptera. The most detailed study is that of Voukassovitch (1924) on the European species *claripennis* (Foerster). This species attacks tortricoid caterpillars, feeding at the oviposition punctures and laying from one to eight eggs on the host. Unfertilized eggs are said to produce males, which is the opposite of what Busck found to be true in a species of *Parasierola*. Iwata (1949) has published on the life history of *G. japonicus* Ashmead, a parasite of the persimmon leaf-roller in Japan. The papers of Kurian (1954, 1955) contain many host records for Oriental species, and Muesebeck and Walkley (1951) have presented many host records for the North American species. With a few minor and doubtful exceptions, all these host records are for Microlepidoptera, and the list includes many species of economic importance (in North America, the Oriental fruit moth, pistol casebearer, red-banded leaf roller, fruit-tree leaf roller, strawberry leaf roller, etc.). As in the other genera of Bethylinae, males are very much less common in collections than are females.

Distribution.—Cosmopolitan. Apparently no species have been described from South America, but the genus does occur on that continent at least as far south as Bolivia. Like *Parasierola*, this genus is a large one and much in need of revision.

Included species:

United States.—The following list of the 17 known U.S. species for the most part follows Muesebeck and Walkley (1951). A key to eleven of these species was presented by Fouts (1928).

brevinervis Fouts, 1928, p. 128; ♀, Ohio (also New Jersey).

castaneicolor Evans, new name for *castaneus* Kieffer, 1907, *nee* Kieffer, 1905c; ♀, "United States" (transferred to *Goniozus* by Evans, 1962a).

clarimontis Kieffer, 1906b, p. 253; ♀, California.

columbianus Ashmead, 1893, p. 76; ♂, District of Columbia (also New Jersey, Virginia, Utah) (synonym: *minimus* Ashmead, 1893, ♂).

- electus* Fouts, 1928, p. 132; ♀, Louisiana (♂ also described).
- flavipes* Fouts, 1928, p. 130; ♀, Kansas (♂ also described).
- floridanus* (Ashmead), 1887, p. 76; ♂, Florida (♀ also described).
- foveolatus* Ashmead, 1887, p. 76; ♀, Florida (Florida, Texas, and Arizona north to Saskatchewan and Ontario; Muesebeck and Walkley, 1951) (synonym: *hortorum* Brues, 1907b).
- gallicola* Fouts, 1942, p. 168; ♀, Oregon (also California).
- hubbardi* Howard, 1885, p. 217; ♀, Florida.
- longiceps* Kieffer, 1904a, p. 529; ♀, Texas.
- longinervis* Fouts, 1928, p. 131; ♀, Nebraska (♂ also described) (also South Dakota, California).
- megacephalus* Ashmead, 1893, p. 74; ♀, Florida.
- mellipes* (Ashmead), 1887, p. 76; ♀, Florida.
- occipitalis* Kieffer, 1906b, p. 252; ♀, Nevada (also California).
- platynotae* Ashmead, 1893, p. 75; ♂, Virginia (♀ also described) (widespread in U.S.) (synonym: *euliae* Fouts, 1926).
- politus* Ashmead, 1893, p. 75; ♀, Virginia.
- Mexico and Central America*
- brevicornis* Kieffer, 1904b, p. 382; ♀, Nicaragua.
- carinatus* Kieffer, 1905c, p. 10; ♀, Nicaragua.
- castaneus* Kieffer, 1905c, p. 11; ♀, Nicaragua.
- macrophthalmia* Kieffer, 1906b, p. 252; ♀, Mexico.
- tepicensis* Ashmead, 1895a, p. 540; ♂, Mexico.
- West Indies*
- grandiceps* (Kieffer), 1908b, p. 19; ♀, Cuba.
- incompletus* Ashmead, 1894, p. 196; ♀, St. Vincent (also Grenada).

5. Genus BETHYLUS Latreille

- Bethylus* Latreille, 1802, p. 315 (type species *Omalus fuscicornis* Jurine, designated by Internat. Comm. Zool. Nomen., Opinion 153, 1944). —Kieffer, 1905b, pp. 253, 267-282 (European spp.; review of nomenclature to 1905). —Kieffer, 1908a, pp. 15-16. —Kieffer, 1914, pp. 507-515 (spp. of world). —Berland, 1928, pp. 99-101 (spp. of France).

—Richards, 1939, pp. 305-319 (British spp.). —Evans, 1962a, pp. 1-12 (North American spp.).

Perisemus Foerster, 1856, p. 95 (type species *P. triareolatus* [= *fuscicornis* Jurine], monobasic). —Ashmead, 1893, pp. 69-72 (in part). —Ashmead, 1902, pp. 272-273. Synonymy by Kieffer, 1905b.

Episemus Thomson, 1862, p. 452 (type species *E. variabilis* Thomson [= *fuscicornis* Jurine], designated by Richards, 1939). Synonymy with *Perisemus* by Ashmead, 1893.

Digoniozus Kieffer, 1905b, p. 245 (type species *Perisemus oregonensis* Ashmead [= *decepiens* Provancher], monobasic). —Kieffer, 1914, p. 522. Synonymy by Evans, 1962a.

Generic characters. — Small wasps (under 5 mm in length), of dark coloration, wings often very short (in either sex) but tegulae present and thorax without reductions associated with flightlessness. Maxillary palpi with five segments, the basal segment very short; labial palpi with two segments; mandibles with four or five apical teeth, the most basal tooth broad and blunt; clypeus short, rounded or obtusely angulate apically, not strongly tectiform but with a median carina which is arched in profile and which continues up the lower front well above level of lower margins of eyes; antennae with twelve segments; eyes glabrous, situated close to base of mandibles but far removed from posterior margin of head. Mesoscutum short, notauli absent but parapsidal furrows present; scutellum with a transverse, slender basal groove which connects two very small, widely separated basal pits; propodeum margined laterally but without other carinae; front femora incrassate; tibiae without spines; claws strongly bent, deeply bifid. Fully winged forms with only three closed cells in the fore wing (costal, median, and submedian), marginal cell open apically and on the wing margin, radial vein turned up sharply at apex in most species; prostigma absent, but subcosta often slightly thickened beyond junction with basal vein; basal vein angular in such a way that the lower section appears as a continuation of median vein, giving rise to a short stub (base of cubitus) at the angulation; transverse median vein appearing to arise far basad of basal vein. Abdomen sessile, fusiform, slightly depressed. Male subgenital plate with a strong, U-shaped apical emargination (see fig. 3 in Evans, 1962a; fig. 102 in Richards, 1939). Male genitalia with the parameres completely divided into dorsal and ventral lobes; cuspis undivided, hirsute; aedoeagus simple (see fig. 103 in Richards, 1939). (Figs. 142-144.)

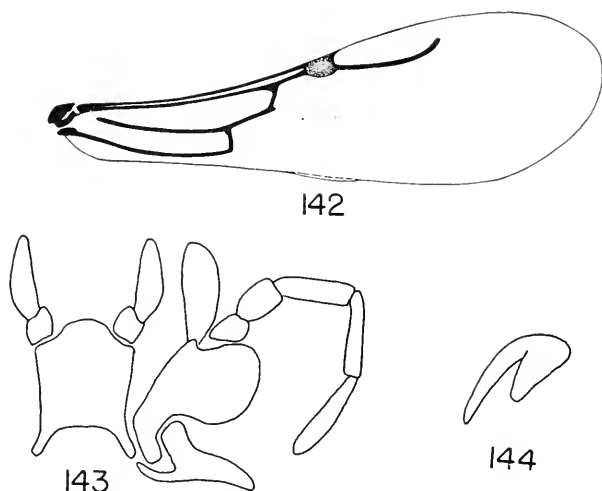

Bethylus decipiens (Provancher). Fig. 142. Fore wing, female. Fig. 143. Labium and maxilla, female. Fig. 144. Tarsal claw, female.

Remarks.—This genus has been treated in some detail by Richards (1939) and by myself (1962a), and further discussion seems unnecessary. Most of the species are polymorphic for wing length in both sexes; in the two North American species fully winged females are rare, and no fully winged males have yet been discovered.

Biology.—Richards (1939) has discussed the biology of the British species. The prey consists of caterpillars, chiefly of Microlepidoptera, which are stung and malaxated, then dragged to a place of concealment. Several eggs are laid on the prey and several larvae develop on a single host. The North American *B. amoenus* is reported to attack the olethreutid moth *Rhopobata naccana* and also the nitidulid beetle *Brachypterolus pulicarius*, although I am inclined to question the second record. Recently I have discovered a micropterous female *B. decipiens* from San Francisco, California [CIS], taken by J. Powell “grasping head of dead *Cncphasia* larva [Tortricidae] with mandibles.”

Distribution.—Holarctic; in North America occurring throughout much of Canada and Alaska, south to central California, Colorado, and New York.

Included species.—Only two species occur in North America: *amoenus* Fouts, 1928, p. 127; ♀, New York (Maine and

New York to Alberta and Northwest Territories; ♂ also described).

decipiens (Provancher), 1887, p. 179; ♀, Quebec (Nova Scotia to New York, west to California and to Alaska; ♂ also known) (synonyms: *oregonensis* (Ashmead), 1893, *californicus* (Bridwell), 1919, *brachypterus* Whittaker, 1929, *flavicornis* Whittaker, 1929).

LITERATURE CITED

ASHMEAD, W. H.

1887. Studies on the North American Proctotrypidae with descriptions of new species from Florida. Ent. Amer., **3**: 73-76, 97-100.
 1890. On the Hymenoptera of Colorado. Bull. Colorado Biol. Assoc., no. 1, 47 pp.
 1893. A monograph of the North American Proctotrypidae. Bethylinae. Bull. U.S. Nat. Mus., **45**: 27-77.
 1894. Report upon the parasitic Hymenoptera of the Island of St. Vincent. Bethylinae. Jour. Linnean Soc. London, **25**: 188-196.
 1895a. Some parasitic Hymenoptera from Baja California and Tepic, Mexico. Proc. California Acad. Sci., (2)**5**: 539-555.
 1895b. Report on the parasitic Hymenoptera of the island of Grenada. Bethylinae. Proc. Zool. Soc. London, 1895: 786-787.
 1901. Hymenoptera parasitica. Fauna Hawaiiensis, 1(3): 277-364.
 1902. Classification of the fossorial, predaceous, and parasitic wasps, or the superfamily Vespoidea. No. 9. Bethylidae. Canad. Ent., **34**: 268-273.

BACK, E. A.

1940. A new parasite of *Anthrenus vorax* Waterhouse. Proc. Ent. Soc. Washington, **42**: 110-113.

BENOIT, P. L. G.

1957. Hymenoptera-Bethylidae. Explor. Parc. Nat. Albert, Miss. deWitte, 1933-1935, **88**: 1-57.
 1963. Monographie des Bethylidae d'Afrique noire (Hymenoptera). I. Sous-famille Pristocerinae; tribu Dicrogeniini; tribu Pristocerini, gen. *Pristocera* Klug. Ann. Mus. Royal d'Afrique Centr., ser. 8 (Zool.), no. 119, 95 pp.

BERLAND, L.

1928. Bethylidae. Faune de France, v. 19. Hyménoptères vespiformes II. Paris, Lechevalier, pp. 96-137.

BERNARD, F. and P. JACQUEMIN

1948. Effets des piqûres de *Scleroderma* (Hyménoptères Bethylidae) et révision des espèces nord-africaines. Bull. Soc. Hist. Nat. Afr. Nord, **39**: 160-167.

BETREM, J. G.

1961. *Cephalonomia stephanoderis* n. spec. (Hym., Bethylidae). Ent. Bericht., **21**: 183-184.

BRÈTHES, J.

1913. Himenópteros de la América meridional. An. Mus. Nac. Hist. Nat., Buenos Aires, **24**: 35-165.
1916. Hymenoptères parasites de l'Amérique meridionale. An. Mus. Nac. Hist. Nat., Buenos Aires, **27**: 401-430.

BRIDWELL, J. C.

1919. Some notes on Hawaiian and other Bethylidae (Hymenoptera) with descriptions of new species. Proc. Hawaiian Ent. Soc., **4**: 21-38.
1920. Some notes on Hawaiian and other Bethylidae (Hymenoptera) with descriptions of a new genus and species. 2nd paper. Proc. Hawaiian Ent. Soc., **4**: 291-314.
1929. Thelytoky or arrhenotoky in *Scleroderma immigrans*. Psyche, **36**: 119-120.

BROWN, W. L. AND F. Y. CHENG

1952. *Psilobethylus* in the New World (Hymenoptera: Bethylidae). Psyche, **58**: 141-148.

BRUCH, C.

1916. Descripción de dos himenópteros mirmecófilos pertenecientes á los Bethylidae. Physis, **2**: 19-23.
- 1917a. Insectos mirmecófilos. Physis, **3**: 141-149.
- 1917b. Nuevas capturas de insectos mirmecófilos. Physis, **3**: 458-465.

BRUES, C. T.

1903. Descriptions of new ant-like and myrmecophilous Hymenoptera. Trans. Amer. Ent. Soc., **29**: 119-128.
1906. Notes and descriptions of North American parasitic Hymenoptera. II. Bull. Wisconsin Nat. Hist. Soc., (n.s.) **4**: 143-152.
- 1907a. Notes and descriptions of North American parasitic Hymenoptera. IV. Bull. Wisconsin Nat. Hist. Soc., (n.s.) **5**: 96-111.
- 1907b. Notes and descriptions of North American parasitic Hymenoptera. V. Bull. Wisconsin Nat. Hist. Soc., (n.s.) **5**: 150-161.
1908. Notes and descriptions of North American parasitic Hymenoptera. VI. Bull. Wisconsin Nat. Hist. Soc., (n.s.) **6**: 48-56.
1909. Notes and descriptions of North American parasitic Hymenoptera. VII. Bull. Wisconsin Nat. Hist. Soc., (n.s.) **6**: 154-163.
- 1910a. Some notes on the geological history of the parasitic Hymenoptera. Jour. New York Ent. Soc., **18**: 1-22.
- 1910b. Notes and descriptions of North American parasitic Hymenoptera. VIII. Bull. Wisconsin Nat. Hist. Soc., (n.s.) **8**: 45-52.
1914. The bethylid genus *Mesitius* in South America. Ent. News, **25**: 119-120.
1916. Bethylidae. Hymenoptera of Connecticut. Connecticut Geol. Nat. Hist. Survey, Bull. no. 22: 608-613.
1919. A new species of the hymenopterous genus *Scleroderma* from the Galapagos Islands. Proc. California Acad. Sci., (4)**2**: 309-310.

1920. A dimorphic species of *Cephalonomia* from Trinidad. *Psyche*, **27**: 151-153.
1922. On the hymenopterous genus *Harpagocryptus* and its allies. *Psyche*, **29**: 101-109.
1923. Some new fossil parasitic Hymenoptera from Baltic amber. *Proc. Amer. Acad. Arts Sci.*, **58**: 327-346.
1924. A new species of parasitic Hymenoptera from Juan Fernandez. *Nat. Hist. Juan Fernandez and Easter Island, Uppsala*, **3**: 315-316.
- BUSCK, A.
1917. Notes on *Perisierola emigrata* Rohwer, a parasite of the pink bollworm. *Insecutor Inscit. Menst.*, **5**: 3-5.
- CAMERON, P.
1883. Descriptions of new genera and species of Hymenoptera. *Trans. Ent. Soc. London*, 1883: 187-197.
- 1888a. Subfamily Bethylinae. *Biologia Centrali-Americana. Insecta. Hymenoptera*, Vol. I: 448-457.
- 1888b. Descriptions of twenty-three new species of Hymenoptera. *Mem. Proc. Manchester Lit. Phil. Soc.*, (4)**1**: 159-183.
1897. New species of Hymenoptera from Central America. *Ann. Mag. Nat. Hist.*, (6)**19**: 261-276.
1899. Genus *Epyris*. *Biologia Centrali-Americana. Insecta. Hymenoptera*, Vol. I, Supplement, p. 473.
1904. Descriptions of new genera and species of Hymenoptera from Mexico. *Trans. Amer. Ent. Soc.*, **30**: 251-267.
1909. A contribution to the knowledge of the parasitic Hymenoptera of Argentina. *Trans. Amer. Ent. Soc.*, **35**: 419-450.
1910. Description of a new genus and species of *Oxyura* (Hymenoptera) from Kuching, Borneo. *The Entomologist*, **43**: 22-23.
- CLAUSEN, C. P.
1940. *Entomophagous Insects*. New York, McGraw-Hill. 688 pp.
- COCKERELL, T. D. A.
1920. A parasite of dermestid beetles in entomological collections. *Canad. Ent.*, **52**: 34.
- CRESSON, E. T.
1872. *Hymenoptera texana*. *Trans. Amer. Ent. Soc.*, **4**: 153-292.
- DALLA TORRE, C. G. DE
1898. Bethylinae, Pristocerinae. *Cat. Hymen.*, **5**: 547-562.
- DUCHAUSSOY, A.
1917. Nouveau béthylide de l'Afrique du Nord. *Bull. Soc. Hist. Nat. Afr. Nord*, **8**: 111-112.
- EMDEN, F. VAN
1931. Zur Kenntnis der Morphologie und Oekologie der Brotkäfer — Parasiten *Cephalonomia quadridentata* Duchaussoy. *Z. Morph. Oekol. Tiere*, Berlin, **23**: 425-574.

ENDERLEIN, G.

1912. H. Sauter's Formosa-Ausbeute. Braconidae, Proctotrypidae, und Evaniidae (Hym.). Ent. Mitt., **1**: 257-267.

ESSIG, E. O.

1932. A small insect which stings severely. Science, **75**: 242-243.

ESSIG, E. O. AND A. E. MICHELbacher

1932. The stinging *Epyris*. Science, **76**: 407-408.

EVANS, H. E.

1955. The North American species of *Dissomphalus* (Hymenoptera, Bethylidae). Proc. Ent. Soc. Washington, **56**: 288-309.

1958. The North and Central American species of *Propriocera* (Hymenoptera: Bethylidae). Proc. Ent. Soc. Washington, **59**: 289-296.

- 1959a. The genus *Anisepyris* in the Greater Antilles (Hymenoptera, Bethylidae). Bull. Brooklyn Ent. Soc., **54**: 69-75.

- 1959b. The genus *Anisepyris* in America north of Mexico (Hymenoptera, Bethylidae). Proc. Ent. Soc. Washington, **61**: 97-120.

- 1959c. The Nearctic species of *Lophepyris*, a new subgenus of *Rhabdopyris* (Hymenoptera, Bethylidae). Proc. Ent. Soc. Washington, **61**: 201-204.

1961. A revision of the genus *Pseudisobrachium* in North and Central America (Hymenoptera, Bethylidae). Bull. Mus. Comp. Zool., **126**: 211-318, 5 pls.

- 1962a. The genus *Bethylus* in North America (Hymenoptera: Bethylidae). Breviora, Mus. Comp. Zool., no. 150, 12 pp.

- 1962b. Further studies on the genus *Dissomphalus* in the United States, Mexico, and the Greater Antilles. Proc. Ent. Soc. Washington, **64**: 65-78.

- 1963a. A new family of wasps. Psyche, **70**: 7-16.

- 1963b. A revision of the genus *Pristocera* in the Americas (Hymenoptera, Bethylidae). Bull. Mus. Comp. Zool., **129**: 241-290.

- 1963c. A new species of *Cephalonomia* polymorphic for wing length. Psyche, **70**: 151-163.

- 1963d. A revision of the genus *Apenesia* in the Americas (Hymenoptera, Bethylidae). Bull. Mus. Comp. Zool., **130**: 249-359.

FABRICIUS, J. C.

1804. Systema piezatorum. Brunswick, C. Reichard, 439 pp.

FINLAYSON, L. H.

1950. Host preference of *Cephalonomia waterstoni* Gahan, a bethylid parasitoid of *Laemophloeus* species. Behaviour, **2**: 275-316.

1952. Host selection by *Cephalonomia waterstoni* Gahan (Hym. Bethylidae). Trans. 9th Internat. Congr. Ent., Amsterdam, 1951, **1**: 370-374.

FOERSTER, A.

1850. Eine Centurie neuer Hymenopteren. Dritte Dekade. Verh. Naturhist. Ver. Rheinlande, **7**: 501-518.

1856. Hymenopterologische Studien. II: Chalcidiae und Proctotrupii. Aachen, Ernst ter Meer, 152 pp.

FOUTS, R. M.

1920. Some new parasites, with remarks on the genus *Platygaster* (Hymenoptera). Proc. Ent. Soc. Washington, **22**: 61-72.
1925. Descriptions of three new Hymenoptera from the Philippine Islands. Philippine Jour. Sci., **26**: 515-518.
1926. Notes on Serphoidea with descriptions of new species (Hymenoptera). Proc. Ent. Soc. Washington, **28**: 167-179.
1927. Descriptions of new nearctic Serphoidea (Hymenoptera). Proc. Ent. Soc. Washington, **29**: 165-179.
1928. Notes on the Bethylinae with descriptions of one new Cuban and twelve new North American species. Proc. Ent. Soc. Washington, **30**: 121-132.
1942. Description of a new species of *Goniozus* from Oregon. Proc. Ent. Soc. Washington, **44**: 168-169.

GAHAN, A. B.

1930. Synonymical and descriptive notes on parasitic Hymenoptera. Proc. U.S. Nat. Mus., **77**, art. 8, 12 pp.
1931. On certain hymenopterous parasites of stored-grain insects. Jour. Washington Acad. Sci., **21**: 213-221.

GELDERN, C. E. VON

1927. Systemic effects following the sting of a species of *Epyris*. Science, **65**: 302.

GIARD, A.

1898. Sur les *Cephalonomia* [Hymén. Proctotryp.] parasites des larves de ptinides. Bull. Soc. Ent. France, 1893 (3): 50-52.

GRANDI, G.

1929. Nota su un betilide del gen. *Cephalonomia* Westw. e contributo alla conoscenza della morfologia della famiglia. Boll. Lab. Ent. Bologna, **2**: 301-314.
1932. Sugli uniti degli adulti del gen. *Cephalonomia* Westw. e di altri Imenotteri e sulla loro interpretazione morfologica. Boll. Lab. Ent. Bologna, **5**: 13-21.

GUIGLIA, D.

1958. Les sclerodermines par rapport à l'homme. Proc. Xth Internat. Congress Ent., Montreal, **3**: 883-887.

HARGREAVES, H.

1926. Notes on the coffee berry-borer (*Stephanoderes hampei* Ferr.) in Uganda. Bull. Ent. Res., **16**: 347-354.

HAYES, W. P.

1927. Another host of *Pristocera armifera* (Say) (Hymenoptera, Bethylidae). Proc. Ent. Soc. Washington, **29**: 20-22.

HEMPEL, A.

1934. A *Prorops nasuta* Waterston no Brasil. Arch. Inst. Biol., São Paulo, **5**: 197-212.

HOFFER, A.

1936. Nouvelle Bethylidae (Hym.-Vespoidea) de France. Festschr. Embrik Strand. Vol. I. Riga, Spiestuve Latvija, 644 pp.

HOWARD, L. O.

1885. [In: Hubbard, Insects Affecting the Orange. Special Rept., Div. Ent., U.S. Dept. Agri., p. 217]

1901. The Insect Book. New York, Doubleday, Page & Co., 429 pp.

HYSLOP, J. A.

1916. *Pristocera armifera* (Say) parasitic on *Limonijs agonus* (Say). Proc. Ent. Soc. Washington, **18**: 169-170.

IWATA, K.

1949. Biology of *Goniozus japonicus* Ashmead, a parasite of the per-simmon leaf-roller, *Dichocrocis chlorophanta* Butler. Tech. Bull. Kagawa Agri. Coll., **1**: 58-60.

JUDD, W. W.

1960. *Laelius utilis* Cockerell (Hymenoptera: Bethylinidae) stinging a child at London, Ontario. Ent. News, **71**: 104.

KEARNS, C. W.

1934a. A hymenopterous parasite (*Cephalonomia gallicola* Ashm.) new to the cigarette beetle (*Lasioderma serricorne* Fabr.). J. Econ. Ent., **27**: 801-806.

1934b. Method of wing inheritance in *Cephalonomia gallicola* Ashmead (Bethylinidae). Ann. Ent. Soc. Amer., **27**: 533-541.

KEELER, C. E.

1929a. Thelytoky in *Scleroderma immigrans*. Psyche, **36**: 41-44.

1929b. Critical data upon thelytoky in *Scleroderma immigrans*. Psyche, **36**: 121-122.

KIEFFER, J. J.

1904a. Beschreibung neuer Proctotrypiden und Evaniiden. Ark. Zool., **1**: 525-562.

1904b. Description de nouveaux Dryininae et Bethylinae. Ann. Mus. Civ. Stor. Nat. Genova, **41**: 351-412.

1904c. Nouveaux proctotrypidés myrmécophiles. Bull. Soc. Hist. Nat. Metz, **23**: 31-34.

1905a. Description de nouveaux proctotrypidés exotiques. Ann. Soc. Sci. Bruxelles, **29**: 95-143.

1905b. Subfamily Bethylinae. [In: André, Spec. Hymen. Eur. Alger., v. 9, fasc. 91 & 92, pp. 227-288.]

1905c. Nouveaux proctotrypidés exotiques. Ann. Mus. Civ. Stor. Nat. Genova, **42**: 9-39.

1905d. Description de nouveaux Hyménoptères exotiques. Bull. Soc. Hist. Nat. Metz, **24**: 85-114.

1906a. Subfamily Bethylinae (cont.) [In: André, Spec. Hymen. Eur. Alger., v. 9, fasc. 93-96, pp. 289-483.]

1906b. Beschreibung neuer Proctotrypiden aus Nord- und Zentralamerika. Berlin Ent. Zeitschr., **50**: 237-290.

1906c. Description de nouveaux hyménoptères. Ann. Soc. Sci. Bruxelles, **30**: 113-178.

1907. Beschreibung neuer im British Museum zu London aufbewahrter Proctotrypiden. Berlin Ent. Zeitschr., **51**: 279-302.

- 1908a. Hymenoptera. Fam. Bethylidae. Genera Iusectorum, fasc. 76, 50 pp., 3 pls.
- 1908b. Nouveaux proctotrypides et cynipides d'Amérique. Ann. Soc. Sci. Bruxelles, **32**: 7-64.
1909. Description de quelques galles et d'insectes gallicoles de Colombie. Marcellia, **7**: 140-142.
- 1910a. Description de nouveaux microhyménoptères du Brésil. Ann. Soc. Ent. France, **78**: 287-348.
- 1910b. Description de nouveaux béthylides [Hymén.]. Ann. Soc. Ent. France, **79**: 31-56.
1911. Nouveaux bethylides et dryinides exotiques du British Museum de Londres. Ann. Soc. Sci. Bruxelles, **35**: 200-233.
1913. Nouveaux microhyménoptères de l'Afrique équatoriale. Boll. Lab. Zool. Portici, **7**: 105-112.
1914. Bethylinae. Das Tierreich, **41**: 228-595.
1921. Proctotrypides hôtes des fourmis en Argentine. An. Soc. Cient. Argent., **91**: 36-41.
1922. Philippine Serphidae (Proctotrypidae). Philippine Jour. Sci., **20**: 65-103.
- KLUG, F.
1808. Ueber die Geschlechtsverschiedenheit der Piezaten. Mag. Gesell. Naturf. Freunde, Berlin, **2**: 48-63.
1810. Fortsetzung des im vorigen Bande abgebrochenen Versuchs über die Gattungen *Scolia* und *Tiphia*. Beitr. Naturk., Kiel, **2**: 167-216.
- KROMBEIN, K. V.
1954. A new *Perisierola* from California (Hymenoptera: Bethylidae). Pan-Pac. Ent., **30**: 259-260.
1955. Miscellaneous prey records of solitary wasps. I. (Hymenoptera: Aculeata). Bull. Brooklyn Ent. Soc., **50**: 13-17.
1956. Biological and taxonomic notes on the wasps of Lost River State Park, West Virginia, with additions to the faunal list (Hymenoptera, Aculeata). Proc. Ent. Soc. Washington, **58**: 153-161.
1957. A generic review of the Amiseginae, a group of phasmatid egg parasites, and notes on the Adelphinae (Hymenoptera, Bethyloidea, Chrysididae). Trans. Amer. Ent. Soc., **82**: 147-215.
1958. Hymenoptera of America North of Mexico: Synoptic Catalog. Agri. Monogr. no. 2. First Supplement, pp. 97-98.
1962. Natural history of Plummers Island, Maryland. XIII. Descriptions of new wasps from Plummers Island, Maryland (Hymenoptera: Aculeata). Proc. Biol. Soc. Washington, **75**: 1-18.
- KURIAN, C.
1954. Catalogue of Oriental Bethyloidea. Agra Univ. J. Res. (Sci.), **3**: 253-288.
1955. Bethyloidea (Hymenoptera) from India. Agra Univ. J. Res. (Sci.), **4**: 67-155.

- LATREILLE, P. A.
 1802. Histoire naturelle des crustacés et insectes. Vol. 3. Paris, Dufort.
 1809. Genera crustaceorum et insectorum. Vol. 4. Paris, Koenig.
- MAA, T. C. and C. M. YOSHIMOTO
 1961. Loboscelidiidae, a new family of Hymenoptera. Pacific Insects, **3**: 523-548.
- MANEVAL, H.
 1930. Description et moeurs de l'adult et de la larve d'une espèce nouvelle du genre *Parascleroderma*. Bull. Soc. Ent. France, 1930, pp. 53-61.
- MANN, W. M.
 1914. Some myrmecophilous insects from Mexico. Psyche, **21**: 171-184.
 1915. Some myrmecophilous insects from Hayti. Psyche, **22**: 161-166.
- MELANDER, A. L. AND C. T. BRUES
 1903. Guests and parasites of the burrowing bee *Halictus*. Biol. Bull., **5**: 1-27.
- MUESEBECK, C. F. W.
 1934. Seven new species of Indian Bethylidae. Rec. Ind. Mus., **36**: 223-232.
 1939. The North American species of the genus *Laelius* Ashmead (Hymen.: Bethylidae). Proc. Biol. Soc. Washington, **52**: 171-176.
- MUESEBECK, C. F. W. AND L. M. WALKLEY
 1951. Family Bethylidae. [*In*: Muesebeck, Krombein, and Townes, Hymenoptera of America North of Mexico: Synoptic Catalog. U.S. Dept. Agri., Monogr. 2, pp. 726-734.]
- MYERS, J. G.
 1932. Biological observations on some neotropical parasitic Hymenoptera. Trans. Ent. Soc. London, **80**: 121-136.
- NIELSEN, E. T.
 1932. Sur les habitudes des hyménoptères aculéates solitaires I. (Bethylidae, Scoliidae, Cleptidae, Psammocharidae). Ent. Meddel., **18**: 1-57.
- OGLOBLIN, A. A.
 1925a. Descriptions of three new species of *Pseudisobrachium* Kieff. (Hym. Bethylidae) from Brazil. Časopis, Acta. Soc. Ent. Čechosloveniae, **21**: 77-81.
 1925b. Description of a new species of *Pseudisobrachium* Kieff. (Hym. Bethylidae) from Brazil. Časopis, Acta Soc. Ent. Čechosloveniae, **22**: 24-27.
 1930. Notes on Bethylidae with the description of two new species from Misiones. Rev. Soc. Ent. Argentina, **3**: 15-24.
 1938. Descripciónes de Bethylidae y Dryinidae de las colecciones del Museo Argentina de Ciencias Naturales. An. Mus. Argent. Cien. Nat., **40**: 35-50.

1950. Dos Bethyloidea nuevos de la colección de la Fundación Miguel Lillo (Hymenopt.). Acta Zool. Lilloana, Tucuman, **9**: 487-493.
1953. Los insectos de las Islas Juan Fernandez. 14. Bethylidae y Dryinidae. Rev. Chilena Ent., **3**: 101-115.
1960. Un betilido parasito de la *Evetria buoliana* (Schiff.) (Hymenoptera, Bethylidae). Rev. Invest. Agri., Buenos Aires, **14**: 35-40.
- OKEN, L.
1817. Cuviers und Okens Zoologien neben einander gestellt. Isis von Oken, **1**: 1146-1185.
- PEMBERTON, C. E.
1932. Irritation caused by the sting of the bethylid wasp, *Holepyris hawaiiensis* Ashm. Proc. Hawaiian Ent. Soc., **8**: 125-126.
- PERKINS, R. C. L.
1908. Some remarkable Australian Hymenoptera. Proc. Hawaiian Ent. Soc., **2**: 27-35.
- POWELL, D.
1938. The biology of *Cephalonomia tarsalis* (Ash.), a vespoid wasp (Bethylidae: Hymenoptera) parasitic on the sawtoothed grain beetle. Ann. Ent. Soc. Amer., **31**: 44-48.
- PROVANCHER, L.
1881. Faune Canadienne. Les insectes — hyménoptères. Fam. VII. Proctotrypoides. Nat. Canad., **12**: 258-265.
1887. Additions et corrections au Vol. II de la faune entomologique due Canada traitant des hyménoptères. Quebec, Darveau, 475 pp.
- REID, J. A.
1941. The thorax of the wingless and short-winged Hymenoptera. Trans. R. Ent. Soc. London, **91**: 367-446.
- RICHARDS, O. W.
1939. The British Bethylidae (*s.l.*) (Hymenoptera). Trans. R. Ent. Soc. London, **89**: 185-344.
- ROHWER, S. A.
1917. Two bethylid parasites of the pink bollworm (Hymenoptera, Bethylidae). Insector Inscit. Menst., **5**: 1-2.
- RUCKES, H., JR.
1956. A bethylid parasite of cone beetles (Hymenoptera: Bethylidae). Pan-Pac. Ent., **32**: 184-185.
- SAUNDERS, S. S.
1881. On the habits and affinities of the hymenopterous genus *Scleroderma*, with descriptions of new species. Trans. Ent. Soc. London, 1881, pp. 109-116.
- SAUSSURE, H. DE
1892. [*In*: Grandidier, Histoire de Madagascar, Vol. 20. Hyménoptères, Atlas.]
- SAY, T.
1824. Narrative of an expedition to the source of St. Peter's River . . . under the command of Stephen H. Long. Vol. 2. Philadelphia, pp. 268-378.

1828. A description of some new species of Hymenoptera of the United States. *Contr. Maclurian Lyceum Philadelphia*, **1**: 67-83.
1836. Descriptions of new North American Hymenoptera, and observations on some already described. *Boston Jour. Nat. Hist.*, **1**: 210-305.
- SCHAEFER, C. H.
1962. Life history of *Conophthorus radiatae* (Coleoptera: Scolytidae) and its principal parasite, *Cephalonomia utahensis* (Hymenoptera: Bethyridae). *Ann. Ent. Soc. Amer.*, **55**: 569-577.
- SNODGRASS, R. E.
1941. The male genitalia of Hymenoptera. *Smithsonian Misc. Coll.*, **99**(14): 1-86.
- SPENCER, G. J.
1942. A note on *Laelius* sp., a parasite of the carpet beetle *Anthrenus scrophulariae* (L.) (Hymenoptera, Bethyridae). *Proc. Ent. Soc. British Columbia*, **39**: 21-22.
- THOMSON, C. G.
1862. Skandinavians Proctotruper. *Förh. Ofvers. k. Vetensk. Akad.*, **18**: 452.
- TOLEDO, A. A. DE
1942. Notas sobre a biologia da vespa de Uganda *Prorops nasuta* Waterst., (Hym. Bethyl.) no estado de S. Paulo, Brasil *Arq. Inst. Biol. São Paulo*, **13**: 233-260.
- TULLGREN, A.
1904. On some Hymenoptera Aculeata from the Cameroons. *Ark. Zool.*, **1**: 425-462.
- TURNER, R. E. AND J. WATERSTON
1917. Notes on the hymenopterous families Bethyridae and Rhopalosomatidae. *Ann. Mag. Nat. Hist.*, (8)**20**: 101-108.
1921. Report on parasitic Hymenoptera bred from pests of stored grain. *Royal Society Reports on Grain Pests (War) Committee*, London, **9**: 8-32.
- VANCE, A. M. AND H. L. PARKER
1932. *Laelius anthrenivorus* Trani, an interesting bethylid parasite of *Antrenus verbasci* L. in France. *Proc. Ent. Soc. Washington*, **34**: 1-7.
- VOUKASSOVITCH, P.
1924. Sur la biologie de *Goniozus claripennis* Först., parasite d'*Oenophthira pilleriana* Schiff. *Bull. Soc. Hist. Nat. Toulouse*, **52**: 225-246.
- WALKER, F.
1843. Descriptions of Chalcidites discovered in Coquimbo by C. Darwin, Esq. *Ann. Mag. Nat. Hist.*, (1)**11**: 185-188.
- WASMANN, E.
1899. Die psychischen Fähigkeiten der Ameisen. *Zoologica*, **11**(36): 1-133.
- WATERSTON, J.
1923. Notes on parasitic Hymenoptera. *Bull. Ent. Res.*, **14**: 103-118.

WESTWOOD, J. O.

1832. Descriptions of several new British forms amongst the parasitic hymenopterous insects. London Edinburgh Phil. Mag. Jour. Sci., (3)1: 127-129.
1833. Further notices of the British parasitic hymenopterous insects. Mag. Nat. Hist., 6: 414-421.
1839. Monograph upon the hymenopterous genus *Scleroderma*. Trans. Ent. Soc. London, (1)2: 164-172.
1874. Thesaurus Entomologicus Oxoniensis. Oxford, Clarendon Press. 205 pp., 40 pls.
1881. Observations on the hymenopterous genus *Scleroderma* Klug, and some allied groups. Trans. Ent. Soc. London, 1881, pp. 117-138.

WHEELER, W. M.

1928. The social insects: their origin and evolution. New York, Harcourt Brace, 378 pp.

WHITTAKER, O.

1929. New Bethylidae (Hymenoptera) from British Columbia. Trans. Ent. Soc. London, 76: 385-390.

WILLIAMS, F. X.

1919. *Epyris extraneus* Bridwell (Bethylidae), a fossorial wasp that preys on the larva of the tenebrionid beetle, *Gonocephalum seriatum* (Boisduval). Proc. Hawaiian Ent. Soc., 4: 55-63.

YAMADA, Y.

1955. Studies on the natural enemy of the woollen pest, *Anthrenus verbasci* L. (*Allepyris microneurus* Kieffer) (Hymenoptera, Bethylidae). Mushi, 28: 13-30.

YASUMATSU, K.

1955. Taxonomic notes on three wireworm parasites of the genus *Pristocera* from the Far East (Hymenoptera: Bethyloidea). Jour. Fac. Agri., Kyushu Univ., 10: 233-249.

(Received November 18, 1963.)

ALPHABETICAL LIST OF ABBREVIATIONS (OF STRUCTURES)
USED IN TEXT

- DAO: diameter of anterior ocellus
 HE: height of eye (maximum, lateral view)
 LFW: length of fore wing
 LH: length of head (apical margin of clypeus to median vertex crest)
 LT: length of thorax (lateral view, excluding prothoracic collar but including propodeum)
 OOL: ocello-ocular line (minimum distance from eye to lateral ocellus)
 WF: width of front (measured at its minimum point)
 WH: width of head (maximum, including eyes)
 WOT: width of ocellar triangle (including lateral ocelli)

INDEX

Valid names are printed in italics. Page numbers refer to main references.

Generic Names

- | | |
|-----------------------------|-------------------------------|
| <i>Acanthepyris</i> , 91 | <i>Goniozus</i> , 199 |
| <i>Acrepyris</i> , 22 | <i>Harpagocryptus</i> , 16 |
| Aeluroides, 29 | <i>Holepyris</i> , 139 |
| <i>Afrisobranchium</i> , 20 | Holopedina, 155 |
| <i>Algoella</i> , 16 | Homaloderus, 17 |
| <i>Allepyris</i> , 91 | Isobranchium, 62 |
| <i>Anisepyris</i> , 96 | <i>Isobranchium</i> , 91 |
| Anoxus, 149 | <i>Israelius</i> , 148 |
| <i>Apnesia</i> , 29 | <i>Kathepyris</i> , 20 |
| <i>Articpyris</i> , 111 | Laccomerista, 17 |
| Arysepyris, 168 | <i>Laelius</i> , 144 |
| <i>Aspidepyris</i> , 114 | <i>Lepidosternopsis</i> , 170 |
| <i>Ateleopterus</i> , 160 | Lissepyris, 62 |
| <i>Bakcriella</i> , 116 | Lophepyris, 96 |
| <i>Bethylus</i> , 202 | Lyssepyris, 62 |
| <i>Bruesiella</i> , 16 | <i>Lytopsenella</i> , 181 |
| <i>Calyoza</i> , 136 | Mangesia, 22 |
| <i>Calyozella</i> , 136 | Mesitius, 104 |
| <i>Calyozina</i> , 136 | Misepyris, 140 |
| Cephaloderma, 155 | Monepyris, 62 |
| <i>Cephalonomia</i> , 155 | Muellerella, 104 |
| <i>Chilepyris</i> , 166 | <i>Neodicrogenium</i> , 20 |
| Chlorepyris, 93 | Neopristocera, 22 |
| <i>Cladobethylus</i> , 17 | Neopristocera, 29 |
| Cleistepyris, 29 | Neoscleroderma, 174 |
| <i>Clystopsenella</i> , 17 | <i>Nesepyris</i> , 161 |
| <i>Dierogenium</i> , 20 | <i>Odontepyris</i> , 180 |
| <i>Dicpyris</i> , 20 | Omaloderus, 17 |
| Digoniozus, 203 | <i>Paracalyoza</i> , 136 |
| Dipristocera, 29 | Paralaelius, 144 |
| <i>Disclroderma</i> , 160 | <i>Parascleroderma</i> , 38 |
| <i>Dissomphalus</i> , 41 | Parasierola, 183 |
| Dryinopsis, 16 | <i>Parasierola</i> , 195 |
| Ecitopria, 41 | Parcecitopria, 42 |
| <i>Edapholigon</i> , 62 | Parepyris, 104 |
| Episemus, 203 | Parepyris, 140 |
| <i>Epyris</i> , 104 | Parisobranchium, 62 |
| <i>Eupsenella</i> , 180 | Perisemus, 203 |
| Glenobethylus, 41 | Perasierola, 195 |
| <i>Glenosema</i> , 168 | <i>Plastanozus</i> , 149 |
| Godfrinia, 16 | Plutobethylus, 62 |

- Pristobethylus*, 91
Pristocera, 22
Procalyza, 102
Progoniozus, 200
Promesitius, 17
Propristocera, 29
Prorops, 152
Prosapenesia, 20
Prosierola, 183
Pseudisobrachium, 62
Psilepyris, 104
Rhabdepyris, 92
Rohweria, 17
Rysepyris, 140
Saphobethylus, 16
Sclerochroa, 174
Scleroderma, 173
Sclerodermus, 173
Sierola, 180
Thaumatopyris, 41
Trichelobrachium, 22
Trichotepyrus, 92
Trissomalus, 180
Usakosia, 20
Xanthepyris, 62
Xestobethylus, 17

Specific names

- aeneiceps*, *Anisepyris*, 98
aeneus, *Anisepyris*, 99
agilis, *Pseudisobrachium*, 68
albipalpis, *Epyris*, 108
albipes, *Pseudisobrachium*, 69
albipes, *Pseudisobrachium*, 85
altivolans, *Dissomphalus*, 45
alutacea, *Apenesia*, 33
alutacea, *Parasierola*, 198
amabilis, *Rhabdepyris*, 95
amazonica, *Apenesia*, 33
amazonica, *Calyozina*, 138
amazonicus, *Anisepyris*, 99
amoena, *Apenesia*, 32
amoenus, *Bethylus*, 204
analis, *Anisepyris*, 98
angulatum, *Pseudisobrachium*, 87
angustata, *Apenesia*, 32
angusticeps, *Apenesia*, 33
anomalum, *Pseudisobrachium*, 66
apache, *Pseudisobrachium*, 67
apertus, *Dissomphalus*, 45
arcuata, *Parasierola*, 199
argentinicum, *Pseudisobrachium*, 82
arizonicus, *Anisepyris*, 98
arizonicus, *Dissomphalus*, 45
armifera, *Pristocera*, 25
ashmeadi, *Laelius*, 147
ashmeadi, *Pseudisobrachium*, 67
atra, *Pristocera*, 25
attaphila, *Dissomphalus*, 46
aureus, *Anisepyris*, 99
aurichalceus, *Anisepyris*, 99
azarai, *Dissomphalus*, 46
azteca, *Bakeriella*, 124
aztecum, *Pseudisobrachium*, 68
bakeri, *Holepyris*, 143
barberi, *Dissomphalus*, 45
bicarinata, *Prosierola*, 185
bifoveatus, *Dissomphalus*, 45
bifoveolatus, *Epyris*, 107
bipunctatus, *Epyris*, 108
bisulcus, *Dissomphalus*, 46
blomi, *Pseudisobrachium*, 68
bogotensis, *Anisepyris*, 99
bogotensis, *Epyris*, 108
bogotensis, *Parasierola*, 199
boliviense, *Pseudisobrachium*, 84
boliviensis, *Apenesia*, 34
boliviensis, *Parasierola*, 199
bonariensis, *Parasierola*, 199
brachypterus, *Bethylus*, 205
brachypterus, *Epyris*, 107
bradleyi, *Anisepyris*, 98
brasiliiana, *Bakeriella*, 128
brasiliense, *Pseudisobrachium*, 81
brasiliensis, *Apenesia*, 33
brasiliensis, *Dissomphalus*, 49
breviceps, *Parasierola*, 198
brevicornis, *Goniozus*, 202
brevinervis, *Goniozus*, 201
bridwelli, *Anisepyris*, 98

- bridwelli*, *Pristocera*, 25
browni, *Apenesia*, 34
brunneum, *Pseudisobrachium*, 68
bugabensis, *Apenesia*, 32
burchellianum, *Pseudisobrachium*, 69
caesarorum, *Cephalonomia*, 159
californica, *Pristocera*, 25
californicus, *Bethylus*, 205
californicus, *Dissomphalus*, 45
californicus, *Epyris*, 107
cameroni, *Holcypyris*, 143
carbonarium, *Pseudisobrachium*, 67
carinata, *Cephalonomia*, 159
carinata, *Parascleroderma*, 40
carinatus, *Goniozus*, 202
carolinense, *Scleroderma*, 178
carolinianum, *Pseudisobrachium*, 67
castaneicolor, *Goniozus*, 201
castaneum, *Pseudisobrachium*, 67
castaneus, *Goniozus*, 201
castaneus, *Goniozus*, 202
cellularis, *Parasierola*, 198
centratus, *Laelius*, 147
chiapanus, *Dissomphalus*, 45
chihuahua, *Pristocera*, 25
chiricahua, *Apenesia*, 32
chittendenii, *Platanoxus*, 151
chontalica, *Apenesia*, 32
clarimontis, *Epyris*, 107
clarimontis, *Goniozus*, 201
clausus, *Dissomphalus*, 45
clariger, *Dissomphalus*, 59
clypeatum, *Pseudisobrachium*, 68
clypeatus, *Dissomphalus*, 45
coarctatus, *Apenesia*, 33
cochise, *Apenesia*, 32
cockerelli, *Pristocera*, 25
collaris, *Dissomphalus*, 46
collinum, *Pseudisobrachium*, 69
columbana, *Apenesia*, 33
columbianus, *Anisepyrus*, 98
columbianus, *Goniozus*, 201
comanche, *Pseudisobrachium*, 67
confusus, *Dissomphalus*, 46
constrictus, *Laelius*, 147
contracta, *Pristocera*, 25
cooperi, *Pseudisobrachium*, 68
coriaceus, *Anisepyrus*, 99
cornutus, *Dissomphalus*, 56
coronatus, *Holcypyris*, 143
costaricanum, *Pseudisobrachium*, 68
cozalis, *Pseudisobrachium*, 74
crandalli, *Glenosema*, 170
crassicornis, *Dissomphalus*, 46
crassicornis, *Pseudisobrachium*, 78
crassum, *Pseudisobrachium*, 67
crenulata, *Apenesia*, 33
cristata, *Bakeriella*, 126
cubana, *Prosierola*, 187
cubensis, *Anisepyrus*, 99
cubensis, *Apenesia*, 33
cynipsiphila, *Cephalonomia*, 159
dalmati, *Pseudisobrachium*, 68
darlingtoni, *Anisepyrus*, 99
darlingtoni, *Lepidosternopsis*, 173
decipiens, *Bethylus*, 205
deficiens, *Epyris*, 107
delicata, *Apenesia*, 33
denticulata, *Apenesia*, 32
depressa, *Bakeriella*, 120
diétrichorum, *Anisepyrus*, 98
dissomphaloides, *Apenesia*, 32
distans, *Pseudisobrachium*, 83
distinguenda, *Parasierola*, 198
distinguendum, *Pseudisobrachium*, 69
dodecatomus, *Epyris*, 112
dominica, *Apenesia*, 33
eganellus, *Anisepyrus*, 99
eganus, *Anisepyrus*, 100
electus, *Goniozus*, 202
elcgantulum, *Pseudisobrachium*, 69
elongata, *Apenesia*, 33
emarginatum, *Pseudisobrachium*, 67
emigrata, *Parasierola*, 198
eriogoni, *Epyris*, 107
erythropoda, *Pristocera*, 25
euliae, *Goniozus*, 202
ewa, *Nesepyrus*, 163
excisa, *Parasierola*, 199
excisus, *Anisepyrus*, 99
exilis, *Apenesia*, 32
fabricii, *Anisepyrus*, 100

- falcatus*, *Dissomphalus*, 45
fasciipennis, *Anisepyris*, 99
flammicornis, *Apenesia*, 33
flavicornis, *Bakeriella*, 121
flavicornis, *Bethylus*, 205
flavicornis, *Pseudisobrachium*, 68
flavicoxis, *Parasierola*, 199
flavicoxis, *Pseudisobrachium*, 68
flavicus, *Epyris*, 108
flavinervis, *Pseudisobrachium*, 67
flavipes, *Apenesia*, 32
flavipes, *Dissomphalus*, 46
flavipes, *Goniozus*, 202
flaviventre, *Pseudisobrachium*, 67
flaviventre, *Pseudisobrachium*, 70
flaviventris, *Pseudisobrachium*, 82
floridana, *Bakeriella*, 134
floridanus, *Goniozus*, 202
floridanus, *Holepyris*, 143
floridanus, *Nesepyrus*, 165
formicaria, *Bruesiella*, 18
formicarius, *Scleroderma*, 178
formicoides, *Epyris*, 107
foutsi, *Pseudisobrachium*, 67
foveolatus, *Aspidopyris*, 115
foveolatus, *Dissomphalus*, 45
foveolatus, *Goniozus*, 202
fraterna, *Pristocera*, 25
fulgens, *Rhabdepyris*, 95
fulvicollis, *Apenesia*, 33
fumipennis, *Laelius*, 147
funnebris, *Apenesia*, 33
fuscicornis, *Anisepyris*, 99
fuscicornis, *Parasierola*, 199
galapagense, *Scleroderma*, 178
gallicola, *Cephalonomia*, 159
gallicola, *Goniozus*, 202
gibbosifrons, *Anisepyris*, 98
gibbosum, *Pseudisobrachium*, 67
gigas, *Pseudisobrachium*, 68
gracilicollis, *Epyris*, 107
gracilicornis, *Parasierola*, 198
gracilis, *Holepyris*, 144
graciliventre, *Pseudisobrachium*, 69
grandiceps, *Goniozus*, 202
grandis, *Anisepyris*, 99
guatemalensis, *Apenesia*, 32
guatemalensis, *Epyris*, 108
haemorrhoidalis, *Holepyris*, 143
haemorrhoidalis, *Pseudisobrachium*, 77
hawaiiensis, *Holepyris*, 144
haywardi, *Pseudisobrachium*, 69
herbsti, *Chilepyris*, 167
herbsti, *Lytopsenella*, 183
hispaniolae, *Epyris*, 108
hortorum, *Goniozus*, 202
hubbardi, *Goniozus*, 202
hurdi, *Pseudisobrachium*, 68
hyalina, *Pristocera*, 25
hyalinipennis, *Cephalonomia*, 159
hypogeum, *Pseudisobrachium*, 62
inca, *Apenesia*, 33
inca, *Bakeriella*, 125
incertus, *Holepyris*, 144
inchoatum, *Pseudisobrachium*, 69
incompletus, *Goniozus*, 202
incompletus, *Plastanozus*, 152
incomptus, *Dissomphalus*, 51
inconspicua, *Bakeriella*, 132
indivisus, *Epyris*, 108
insolita, *Parascleroderma*, 40
insularis, *Anisepyris*, 99
insularis, *Prosierola*, 188
integra, *Parasierola*, 199
intermedia, *Pristocera*, 25
intrepidus, *Omaloderus*, 18
iridomyrmecicola, *Scleroderma*, 178
kansanus, *Dissomphalus*, 45
kiefferi, *Cephalonomia*, 159
kiefferi, *Plastanozus*, 151
krombeini, *Pseudisobrachium*, 67
kuscheliana, *Lepidosternopsis*, 172
laevigata, *Apenesia*, 32
laevis, *Plastanozus*, 151
laeiventris, *Pristocera*, 25
lata, *Prosierola*, 190
laticeps, *Anisepyris*, 99
laticeps, *Apenesia*, 33
laticeps, *Pseudisobrachium*, 69
leucophthalma, *Apenesia*, 35
leviceps, *Parasierola*, 199
lindigi, *Epyris*, 108

- lobatifrons*, *Rhabdopyris*, 95
longiceps, *Goniozus*, 202
longicollis, *Epyris*, 107
longicollis, *Holepyris*, 143
longinervis, *Goniozus*, 202
longiventris, *Clystopsenella*, 18
lucidus, *Dissomphalus*, 46
luscus, *Dissomphalus*, 55
luteipes, *Anisepyrus*, 100
luteipes, *Parasierola*, 199
macrogaster, *Scleroderma*, 178
macrophthalmia, *Goniozus*, 202
macrops, *Pseudisobrachium*, 67
maelicornis, *Parasierola*, 199
magnum, *Pseudisobrachium*, 68
malinche, *Apenesia*, 32
mandibulare, *Pseudisobrachium*, 68
manni, *Epyris*, 110
manni, *Pseudisobrachium*, 68
martini, *Apenesia*, 32
marylandicus, *Holepyris*, 143
matthewsi, *Pseudisobrachium*, 67
maya, *Apenesia*, 32
megacephalus, *Goniozus*, 202
megacephalus, *Rhabdopyris*, 95
mellipes, *Goniozus*, 202
merklei, *Pseudisobrachium*, 69
meridionalis, *Cephalonomia*, 160
metallicus, *Anisepyrus*, 100
metallicus, *Rhabdopyris*, 95
mexicana, *Apenesia*, 32
mexicana, *Dissomphalus*, 45
mexicana, *Parasierola*, 199
micheneri, *Pseudisobrachium*, 68
michoacanum, *Pseudisobrachium*, 68
microchela, *Apenesia*, 33
microstoma, *Rhabdopyris*, 96
minimum, *Pseudisobrachium*, 67
minus, *Goniozus*, 201
minutissimum, *Pseudisobrachium*, 67
minutus, *Epyris*, 108
mohave, *Apenesia*, 32
montanum, *Pseudisobrachium*, 68
montanus, *Dissomphalus*, 48
montezuma, *Epyris*, 108
montezuma, *Holepyris*, 143
monticola, *Epyris*, 108
montivagus, *Epyris*, 108
montivagum, *Pseudisobrachium*, 70
mrazi, *Pseudisobrachium*, 70
multicarinatus, *Epyris*, 108
muscarius, *Rhabdopyris*, 96
musculus, *Bethylus*, 18
myrmecophilum, *Pseudisobrachium*, 68
myrmecophilus, *Epyris*, 108
nasalis, *Prosierola*, 189
nasuta, *Prorops*, 155
navajo, *Pseudisobrachium*, 67
nebulosa, *Pristocera*, 25
neotropica, *Apenesia*, 33
neotropica, *Calyozina*, 138
neotropicus, *Cleptidea*, 18
nevadensis, *Epyris*, 108
nigrescens, *Dissomphalus*, 45
nigricoxis, *Parasierola*, 199
nigricolum, *Pseudisobrachium*, 68
nigrifemur, *Parasierola*, 199
nigripilosus, *Epyris*, 108
nigripilosus, *Laelius*, 147
nigrocineta, *Cleptidea*, 18
nitida, *Apenesia*, 33
nitidiceps, *Epyris*, 108
niveifemur, *Lepidosternopsis*, 172
nubilipennis, *Cephalonomia*, 159
nubilipennis, *Laelius*, 147
nudicornis, *Epyris*, 108
obliqua, *Prosierola*, 193
obscuripennis, *Rhabdopyris*, 96
obscurum, *Pseudisobrachium*, 67
occidentale, *Pseudisobrachium*, 67
occidentalis, *Anisepyrus*, 99
occidentalis, *Laelius*, 147
occipitalis, *Goniozus*, 202
ocellatus, *Dissomphalus*, 45
ogloblini, *Pseudisobrachium*, 70
olmeca, *Apenesia*, 33
olmeca, *Bakeriella*, 123
opaca, *Parasierola*, 199
optimum, *Pseudisobrachium*, 75
oregonensis, *Bethylus*, 205
origenus, *Rhabdopyris*, 95
oriplana, *Pristocera*, 25

- oriplanus*, *Epyris*, 108
orizabae, *Pristocera*, 25
ornata, *Apenesia*, 33
otiosum, *Pseudisobrachium*, 67
otomi, *Pristocera*, 26
pallidicornis, *Apenesia*, 33
pallidipes, *Nestobethylus*, 18
palliditarsis, *Parasierola*, 199
palliditarsis, *Pristocera*, 26
pallidula, *Apenesia*, 32
pallidum, *Pseudisobrachium*, 67
pallidus, *Olixon*, 18
pando, *Apenesia*, 34
paradoxa, *Apenesia*, 22
paraensis, *Apenesia*, 33
paracsis, *Apenesia*, 34
paracsis, *Epyris*, 108
paraguayense, *Pseudisobrachium*, 85
parapolita, *Apenesia*, 32
paucipunctatum, *Pseudisobrachium*, 67
peculiaris, *Apenesia*, 33
pedatus, *Laelius*, 147
percurrrens, *Apenesia*, 34
perpunctatum, *Pseudisobrachium*, 68
perpusilla, *Cephalonomia*, 159
persimile, *Pseudisobrachium*, 67
peruana, *Apenesia*, 34
peruviana, *Parasierola*, 199
peruvianus, *Anisepyrus*, 100
petiolatum, *Pseudisobrachium*, 68
photophila, *Apenesia*, 34
pilicornis, *Apenesia*, 33
pima, *Apenesia*, 32
planiceps, *Anisepyrus*, 99
platensis, *Dissomphalus*, 46
platynotae, *Goniozus*, 202
plaumanni, *Dissomphalus*, 58
plaumanni, *Pseudisobrachium*, 86
polita, *Apenesia*, 32
polita, *Bakeriella*, 130
politus, *Dissomphalus*, 46
politus, *Goniozus*, 202
porteri, *Pristocera*, 27
prolongatum, *Pseudisobrachium*, 67
pulchellus, *Anisepyrus*, 98
pulehrrimum, *Pseudisobrachium*, 72
punctata, *Apenesia*, 33
punctaticeps, *Anisepyrus*, 99
punctaticeps, *Apenesia*, 34
punctaticeps, *Parasierola*, 199
punctatus, *Apenesia*, 34
punctatus, *Dissomphalus*, 47
puncticeps, *Pseudisobrachium*, 68
punctifrons, *Holepyris*, 143
pusillum, *Pseudisobrachium*, 68
pygmaeus, *Holepyris*, 144
quadrata, *Apenesia*, 34
quadridentata, *Cephalonomia*, 159
quinquelineatus, *Rhabdepyris*, 95
quinquepartitus, *Epyris*, 108
quiroya, *Pristocera*, 26
rapoportii, *Pseudisobrachium*, 62
rectangulatum, *Pseudisobrachium*, 68
reducta, *Apenesia*, 34
remotus, *Holepyris*, 144
reticulatus, *Pristocera*, 25
rettenmeyeri, *Dissomphalus*, 53
rettenmeyeri, *Pseudisobrachium*, 68
rossi, *Bakeriella*, 129
rufescens, *Parasierola*, 192
rufipalpis, *Dissomphalus*, 46
rufipes, *Epyris*, 108
rufipes, *Laelius*, 147
rufitarsis, *Anisepyrus*, 99
rufiventre, *Pseudisobrachium*, 68
rufiventris, *Pseudisobrachium*, 79
rufocaudata, *Bakeriella*, 131
rufopictum, *Pseudisobrachium*, 79
rufosignatus, *Anisepyrus*, 99
rugifrons, *Pristocera*, 26
rugosicollis, *Anisepyrus*, 99
rugosulum, *Pseudisobrachium*, 68
sanctae-clarac, *Parasierola*, 199
sancti-vincenti, *Parasierola*, 199
santacatarinae, *Apenesia*, 36
scrupus, *Dissomphalus*, 61
scutellaris, *Cleptidea*, 18
semiviridis, *Rhabdepyris*, 95
septemlineatus, *Rhabdepyris*, 95
sinaloa, *Pristocera*, 26
singularis, *Dissomphalus*, 46
skottsbergi, *Cephalonomia*, 160

- smithianus*, *Anisepyrus*, 100
solenopsidicola, *Pseudisobrachium*, 70
solenopsiphilum, *Pseudisobrachium*, 62
soror, *Scleroderma*, 178
strandii, *Cephalonomia*, 159
striatula, *Apenesia*, 34
subaeneus, *Rhabdepyris*, 95
subapterus, *Holepyris*, 143
sublevis, *Anisepyrus*, 99
subspinosus, *Epyris*, 108
substriata, *Apenesia*, 34
subviolaceus, *Anisepyrus*, 99
subviridis, *Rhabdepyris*, 95
sulcata, *Apenesia*, 33
superbum, *Pseudisobrachium*, 68
sylvanidis, *Holepyris*, 143
tarascana, *Apenesia*, 33
tarsalis, *Cephalonomia*, 159
tenebrosa, *Apenesia*, 34
tenochca, *Pristocera*, 26
tepicensis, *Goniozus*, 202
terrcsi, *Pseudisobrachium*, 69
testaceicornis, *Lytopsenella*, 183
testaceicornis, *Parasicrola*, 199
testaccipes, *Apenesia*, 33
testaccipes, *Pseudisobrachium*, 69
texanum, *Pseudisobrachium*, 68
texanus, *Epyris*, 108
thoracica, *Pristocera*, 25
tlahuicana, *Apenesia*, 33
transversa, *Apenesia*, 34
tricarinatus, *Laelius*, 147
tridentata, *Apenesia*, 32
trogodermatis, *Laelius*, 147
truncaticeps, *Apenesia*, 34
tuberculatus, *Dissomphalus*, 46
urichi, *Cephalonomia*, 160
uruguayense, *Pseudisobrachium*, 70
utahensis, *Cephalonomia*, 160
utilis, *Laelius*, 148
vancouverensis, *Epyris*, 108
varidens, *Pristocera*, 26
variegata, *Prosicrola*, 194
venezuelana, *Apenesia*, 34
venustus, *Anisepyrus*, 100
vierecki, *Epyris*, 108
virginianus, *Nesepyrus*, 164
virginiensis, *Scleroderma*, 178
viridellus, *Anisepyrus*, 99
viridiceps, *Cleptidea*, 18
viridis, *Anisepyrus*, 99
viridis, *Rhabdepyris*, 95
viridissimus, *Rhabdepyris*, 95
voracis, *Laelius*, 148
waterstoni, *Cephalonomia*, 160
westwoodi, *Plastanoxus*, 151
westwoodi, *Procalyzoa*, 103
williamsi, *Anisepyrus*, 99
wilsoni, *Scleroderma*, 179
wolcottii, *Anisepyrus*, 99
xambeui, *Cephalonomia*, 159
xanthopoides, *Dissomphalus*, 46
xanthopus, *Dissomphalus*, 46
zamora, *Apenesia*, 34
zeae, *Holepyris*, 143
zeteki, *Pseudisobrachium*, 69



Bulletin of the Museum of Comparative Zoology

H A R V A R D U N I V E R S I T Y

VOL. 132, No. 2

A PHOTOGRAPHIC SURVEY OF BENTHIC FISHES
IN THE RED SEA AND GULF OF ADEN, WITH
OBSERVATIONS ON THEIR POPULATION DENSITY,
DIVERSITY, AND HABITS

By

N. B. MARSHALL and D. W. BOURNE

Woods Hole Oceanographic Institution

WITH FOUR PLATES

CAMBRIDGE, MASS., U.S.A.

PRINTED FOR THE MUSEUM

DECEMBER 21, 1964

PUBLICATIONS ISSUED BY OR IN CONNECTION
WITH THE
MUSEUM OF COMPARATIVE ZOOLOGY
HARVARD UNIVERSITY

BULLETIN (octavo) 1863 — The current volume is Vol. 132.

BREVIORA (octavo) 1952 — No. 210 is current.

MEMOIRS (quarto) 1864-1938 — Publication terminated with Vol. 55.

JOHNSONIA (quarto) 1941 — A publication of the Department of Mollusks. Vol. 4, no. 43 is current.

OCCASIONAL PAPERS OF THE DEPARTMENT OF MOLLUSKS (octavo) 1945 — Vol. 2, no. 31 is current.

PROCEEDINGS OF THE NEW ENGLAND ZOOLOGICAL CLUB (octavo) 1899-1948 — Published in connection with the Museum. Publication terminated with Vol. 24.

The continuing publications are issued at irregular intervals in numbers which may be purchased separately. Prices and lists may be obtained from the Publications Office of the Museum of Comparative Zoology, Cambridge 38, Massachusetts.

Peters' Check-List of Birds of the World. Volumes 1, 4 and 6 are out of print; volumes 2, 3, 5, 7, 9, 10 and 15 are currently available.

Phylogeny and Evolution of Crustacea. Proceedings of a conference held at Cambridge, Mass., March 6-8, 1962. H. B. Whittington and W. D. I. Rolfe, editors. Cambridge, Mass., 192 pp., 80 figs., 1963. Cloth bound, \$6.75.

Fishes of the Gulf of Maine, by Henry B. Bigelow and William C. Schroeder. Washington, viii + 577 pp., 1953. Photo-offset reprint, \$6.50.

PUBLICATIONS OF THE
BOSTON SOCIETY OF NATURAL HISTORY

The remaining stock of the scientific periodicals of the Boston Society of Natural History has been transferred to the Museum of Comparative Zoology for distribution. Prices for individual numbers may be had upon request.

Bulletin of the Museum of Comparative Zoology

H A R V A R D U N I V E R S I T Y

VOL. 132, No. 2

A PHOTOGRAPHIC SURVEY OF BENTHIC FISHES
IN THE RED SEA AND GULF OF ADEN, WITH
OBSERVATIONS ON THEIR POPULATION DENSITY,
DIVERSITY, AND HABITS

By

N. B. MARSHALL and D. W. BOURNE

Woods Hole Oceanographic Institution

WITH FOUR PLATES

CAMBRIDGE, MASS., U.S.A.

PRINTED FOR THE MUSEUM

DECEMBER, 1964

No. 2 — *A Photographic Survey of Benthic Fishes in the Red Sea and Gulf of Aden, with Observations on their Population Density, Diversity and Habits*¹

By

N. B. MARSHALL and D. W. BOURNE

Woods Hole Oceanographic Institution

INTRODUCTION

Automatic photography of the deep-sea floor began in 1940 (Ewing, Vine and Worzel, 1946). Since that successful beginning, many thousands of bottom photographs have been taken, but relatively few have been used by marine biologists. Concerning deep-sea fishes, interesting observations and photographs have been made from bathyscaphes (see, for instance, Fages et al., 1958). But more can be learned by analyzing a good series of pictures taken with an automatic camera (see Laughton, 1963). By taking a census of the fishes revealed, and knowing the area surveyed by the camera, an estimate can be obtained of their population density. At the same time, the sizes of these fishes should be known, so that due regard can be given to their weight. In this way, a measure can be got of the fish biomass supported per unit area of the deep-sea floor at different places and depths. One aim of this paper is to introduce such research. Further such analysis of photographs taken in parts of the North Atlantic is in progress.

The present study is based on some 2260 photographs, which were taken under the direction of Dr. J. W. Graham during ATLANTIS Cruise 242, June 1958. Six photographic stations were made, four in the Red Sea and two in the Gulf of Aden (see Table 1, and Figure 1). Though the fishes photographed often are not identifiable to family or smaller groups, it is possible to get a fair idea of the number of species involved. In the present instance, the photographs corroborate and extend earlier evidence that the Gulf of Aden contains more kinds of

¹ Woods Hole Oceanographic Institution Contribution No. 1402.

deep-sea fishes than exist in the Red Sea.¹ After considering this aspect, we give a brief, comparative review of the diversity of deep-sea fishes in certain basins.

Scrutiny of the clearest photographs can also reveal much of the habits and habitats of deep-sea fishes. Some, for instance, rest on the bottom; others swim over the bottom. Our concern here is with benthopelagic forms that have a well developed swimbladder, notably with species of halosaurs, morids and macrourids. In particular, we consider the hovering and swimming postures of halosaurs and macrourids with relation to the expected dynamics of their fin pattern. Again, further work on such aspects is in progress.

We are grateful to Dr. J. B. Hersey both for making the photographs available to us, and for his comments on the manuscript.

Dr. R. H. Backus gave us many valuable criticisms and suggestions.

Details of the cameras used on ATLANTIS Cruise 242 were supplied by Dr. H. E. Edgerton.

Gloria Gallagher, the present curator of the photograph collection, has been most helpful; her predecessor in that office, Jane F. Broughton, prepared the data from which areas were computed.

Grants NSF G-20702 and GB-543 from the National Science Foundation to the Woods Hole Oceanographic Institution supported the preparation of this paper. ATLANTIS Cruise 242 was supported by the Office of Naval Research under Contract Nonr 1367(00).

TECHNICAL ASPECTS

A pair of Edgerton cameras was used, rigged to provide stereo pictures at 15-second intervals. The cameras are shutterless, and were fitted with 50 mm focal length (in water) lenses; 100 watt/second electronic flash made the exposures and the ship's rate of drift determined the spacing between shots.

The rough bottom topography at these stations, together with the ship's motion, made it impossible to keep the cameras a uniform distance off the bottom, but the cameras' position, monitored with the aid of 12 ke sonar (the transducer mounted on

¹A list of the deep-sea fishes recorded from the Gulf of Aden appears at the end of this paper.

the camera frame), was kept between 1.5 and 3.5 meters off bottom for about two-thirds of the frames; the focus was set for 2 meters. Bottom areas covered in most of the pictures, then, are from 0.8 to 4.2 square meters, but the areas used in computing densities are totals of separate determinations for each picture, using camera-to-bottom distances from the ship's depth recorder.

Identifications from top views are not easy: for one thing, the dorsal aspect of a fish is not often figured in the literature, and for another, diagnostic features are likely to be obscured. Stereo photographs are a great help and, fortunately, most of the stereo pairs from these stations were successful (about one-quarter of the pictures are single-frame only). Features, such as filamentous rays, quite invisible in one of a stereo pair may be obvious when both are viewed together. Shadows, too, show structures otherwise concealed, pelvic fins for example.

The possible effect of the apparatus on the animals, particularly the flash and motor noises, is often questioned, but these pictures and many others give little evidence that bottom fishes are much disturbed by it. The small puffs of sediment raised by a fish darting off the bottom are seen rarely; furthermore, where the drift is slow, the same individual often appears in a series of pictures. For instance, one eel kept its position, a foot or so off the bottom, in 9 successive frames.

POPULATION DENSITY

With increasing depth, larger animals of the deep benthos become less numerous and less diverse. If values of these two faunal features are plotted against the depth, the graph described for the larger benthic invertebrates is exponential in form (Zenkevitch, 1963). The same relationship holds for benthic fishes. Their density and diversity are greatest over the upper reaches of the continental slope. At levels from 1000 to 2000 meters, there is a steady fall in the numbers of individuals and species, but beyond 2000 meters the gradient of fall is more pronounced. Somewhere between depths of 2000 and 3000 meters comes a transition to a restricted fauna of abyssal fishes.

Preliminary analysis of the number of fishes seen in bottom photographs taken at depths from 360 to 1960 fathoms (658 to 3584 meters) in parts of the North Atlantic shows very well the exponential nature of the decline. Some such decline in density and diversity must also occur in the Red Sea and Gulf of Aden.

For the latter area, these may be seen from Norman's (1939) report on the fishes of the John Murray Expedition. While the catches show that the density and diversity of benthic fishes are greatest from 200 to 500 meters, there is no abrupt change in these quantities from 500 to 1500 meters. In the present context, the camera lowerings at Station 1 (680 fathoms, 1240 meters) are thus above a depth where marked changes in density and diversity lead, so to speak, to the poor abyssal fauna. It is also fortunate that two stations in the Red Sea (3 and 6) are at much the same depth. Relevant comparisons can be made

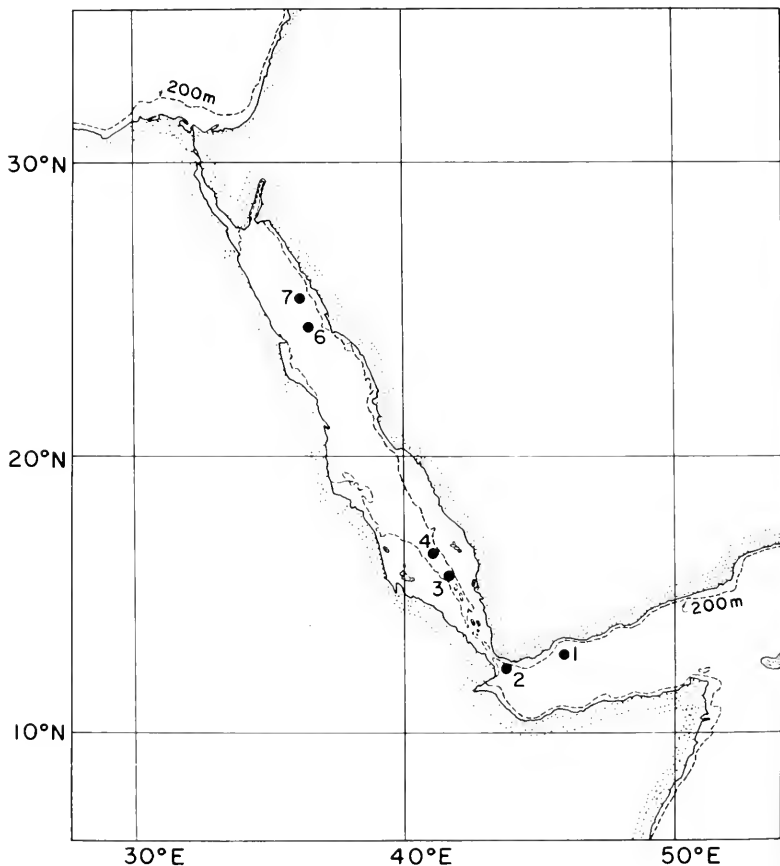

FIG. 1. Photographic stations in the Red Sea and Gulf of Aden.

TABLE 1

	Station	Position	Depth Fathoms (Meters)	Area Surveyed (Square Meters)	Number Specimens	Density (Fish/M ²)	Number Species
Gulf of Aden	2	12° 19.5'N, 43° 42.4'E	165 (300)	1750	19	1/90	15-16
"	1	12° 51.0'N, 45° 57.5'E	680 (1240)	1045	42	1/25	19
Red Sea	3	15° 42.5'N, 41° 43.0'E	660 (1210)	ca. 400	0	0	0
"	6	24° 29'N, 36° 27.5'E	610 (1115)	1660	19-231	1/87-1/70	4
"	4	16° 34'N, 41° 04'E	1000 (1830)	ca. 300	3	1/100	1
"	7	25° 21.7'N, 36° 06.5'E	1200 (2195)	850	7-101	1/120-1/85	1

¹ The same specimen may appear in more than 1 frame; thus, the range in numbers.

between these two stations and the one in the Gulf of Aden. The two deeper Red Sea stations (4 and 7) must be taken on their own, as should the shallow station (2) at the entrance to the Gulf of Aden (see map and Table 1).

The area surveyed by the camera at each station may be seen in Table 1. Even disregarding station 3, where no fishes were photographed, the area sampled at the 600-700 fathom depth was greater in the Red Sea than in the Gulf of Aden.

Data in Table 1 show that the population density at the 680 fathom (1240 meters) Gulf of Aden station (1 fish/25 m²) is about three times the estimate for the 610 fathom (1115 meters) station in the Red Sea (1 fish/87 m²). But, except for three photographs, all of the pictures at the latter station represented one small species of shark (length about 2 feet or 0.6 meter). The mean length of fishes in the Gulf of Aden was about 1 foot (0.3 meter). The mean weight of individual fish in the Red Sea, then, may well have been about six times that in the Gulf of Aden.¹ Perhaps the difference in density between the two areas is more than counterbalanced by the size factor, but it would seem fair to conclude that both areas support a roughly equivalent fish biomass.

In this respect it is worth recording that measurements made from ATLANTIS (Cruise 242) over the period May 16 to June 28, 1958, show that levels of primary production in the Red Sea and Gulf of Aden were low and of much the same quantity in the two places (Yentsch and Wood, 1961). The authors compare these values to those in poorly productive areas such as the Sargasso Sea. On an annual basis, though, parts of the Gulf of Aden, where upwelling occurs, may be more productive than the Red Sea. But whether this is true of that part of the Gulf in the neighborhood of station 1 (see Fig. 1) can hardly be predicted.

Densities are somewhat lower (*ca.* 1 fish/100 m²) at the deep stations 4 and 7 (1000 and 1200 fathoms, or 1830 and 2195 meters) in the Red Sea. In terms of biomass, comparison is most readily made between stations 7 and 6; for at the former all the fish taken represented the small species of shark that appeared in most of the pictures from station 6. There is no more than a slight fall in biomass in descending from 610 to 1200 fathoms (1115 to 2195 meters). Between these levels in the

¹In fishes of comparable form, the weight increases about six-fold for a two-fold increase in length.

North Atlantic there is a gradual (and rather gentle) decline in the population densities of fishes.

At the shallow Gulf of Aden station 2 (165 fathoms, or 302 meters), the density (1 fish/90 m²) is surprisingly low. Is this a biological reflection of the hydrographical conditions in this region? Station 2 is on the slope of the Red Sea sill. During part of the summer, at least, warm and highly saline water (20° C and 38 ‰) spills out of the Red Sea and flows down the sill (Neumann and McGill, 1962). In winter, according to Thompson (1939), this outflow is much greater. The hydrographic regime would thus seem to be both unusual and variable.

DIVERSITY

Though the photographs rarely capture enough detail of a fish for specific identification, prolonged scrutiny has convinced us that the camera photographed 4 different species in the Red Sea and 19 at station 1 in the Gulf of Aden. Since the total area surveyed at 600-700 fathoms in the first region (3100 m²) is three times that covered in the second (1045 m²), it looks as though fish diversity in the Gulf of Aden is at least 5 times that in the Red Sea (Table 1).

Before considering this faunal difference, we give here an account of the forms involved. As already mentioned, at station 7 in the Red Sea the records were confined to one species of shark. All but three of the individuals photographed at station 6 were of this same species. This shark has two (spineless)

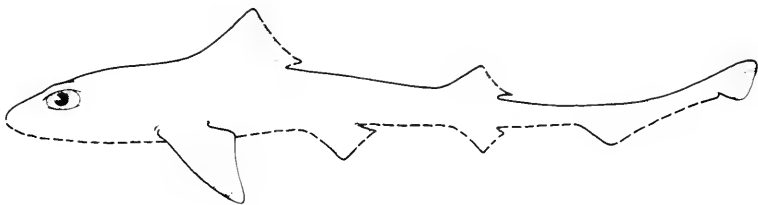

FIG. 2. Reconstruction of a Red Sea shark (from several pictures showing dorsal views).

dorsal fins and an anal fin. It is thus a galeoid (Fig. 2, and Pl. 1). But despite an extensive search of the literature, we are unable to assign this shark to any known family of galeoids. Dr. J. A. F. Garrick, who kindly looked at the photographs,

thought the fish might either belong to the Triakidae (=Mus-telidae) or Carcharhinidae. Yet the shape and fin pattern of this shark, particularly the forward position of the first dorsal, are unlike those of any triakid or carcharhinid genus. Perhaps we have a new genus of sharks.

The three other species from station 6 are teleosts; one of these is some kind of eel.

At station 1 in the Gulf of Aden, the commonest fish, shown in nine frames, is a morid with a pair of long rays in each pelvic fin. These rays (Fig. 3) are proportionately longer than those in *Physiculus roseus* Alcock, the only known morid from the Gulf (see check list). Though *P. longifilis* Weber has two long pelvic rays, perhaps *Laemonomodes* Gilchrist is closest to our fish. Halosaurs, probably belonging to one species, were taken in four frames (Pl. 2), and macrourids, representing at least three

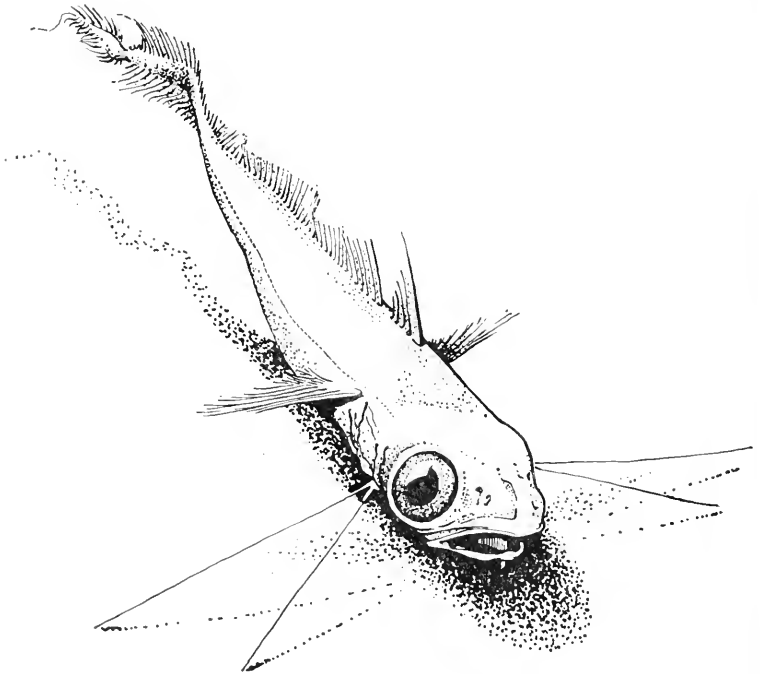

FIG. 3. Reconstruction of a morid fish having two long, moveable rays in each pelvic fin. This was the commonest fish photographed in the Gulf of Aden.

species, in another five frames. One of the best pictures (Pl. 2) is of a bathygadine macrourid with a long filamentous ray in the first dorsal and each paired fin. A second species is a *Coelorhynchus*. A fish very like a *Bathysaurus* and a rhinochimaerid, probably *Harriotta* (Pl. 3), are each seen in one frame. Of the remaining species, two are eels and one may be a lizard-fish (Synodontidae). The others are not identifiable to groups.

At station 2 in the Gulf of Aden photographs of 15 or 16 species were taken. There is a dogfish (*Halaelurus*, close to *quagga* Alcock, Pl. 4), a *Rhinobatus*, a rajid, a synodontid (Pl. 4), a peristediid and a cynoglossid. The remaining fishes, while recognizable as distinct species, cannot be assigned to families. The community is clearly unlike that revealed by the camera at the deeper Gulf of Aden station.

Returning to the contrast in diversity between the benthic fishes of the Red Sea and Gulf of Aden at depths of 600 fathoms and beyond, our findings corroborate and extend those of deep-sea expeditions. In the check list of deep-sea fishes from the Gulf of Aden (Table 2), there are 55 benthic species. Knowledge of the corresponding fauna in the Red Sea comes entirely from the 'Pola' Expedition (1895), which dredged at about 60 stations between depths of 200 and 2000 meters. While a dredge is not the best gear for catching fishes, five species were taken (Fuchs, 1901): *Hoplostethus mediterraneus* Cuvier and Valenciennes, a pleuronectid, a leptocephalus, *Chauliodus sloani* Schneider, and *Bregmaceros maclellandi* Thompson. The first two are to be regarded as benthic in habit. These two, together with the four seen in the photographs, are the only benthic deep-sea fishes known from the Red Sea.

The fauna of bathypelagic fishes is also poorer in the Red Sea than in the Gulf of Aden. In the Gulf, 32 species are given in the check list. There are nine Red Sea species: *Maurolicus mucronatus* Klunzinger, *Vinciguerria* sp., *Stomias affinis* Günther, *Astroncthes martensii* Klunzinger, *Chauliodus sloani* Schneider, *Diaphus coeruleus* (Klunzinger), *Benthosoma pterota* (Alcock), *Bregmaceros maclellandi* Thompson, and a paralepidid (see also Marshall, 1963).

The evolution of a diverse fauna requires time and a favorable environment. The latter, which must obviously be accessible, needs to be stable, though a relatively high and constant temperature, both through the year and geological time, is not everywhere an essential condition for great diversity. Prolonged

exploration at fixed points in the tropical and subtropical ocean has revealed that the deep-sea fish fauna is remarkably diverse there (Marshall, 1963). Such species live in waters that are cool or cold, and that have evidently been so for a great time. Indeed oxygen-isotope measurements on calcareous benthic foraminiferans from deep-sea cores indicate that the temperature of the bottom water in the eastern equatorial Pacific has decreased from about 10° C in mid-Oligocene times to about 2° C in the late Pliocene (Emiliani and Flint, 1963). But constant water temperatures alone are not enough to permit a high diversity, otherwise we might expect such to have evolved in polar waters. As is well known, the number of species of deep-sea fishes in polar (and temperate) waters is relatively low. But in these waters phytoplankton production is restricted to a few months in the year. In subtropical and tropical waters the growing season is more or less continuous, which indicates that a fairly steady supply of food through the year is linked somehow to faunal diversity. The reasons for this are not immediately obvious, and, so far as deep-sea fishes are concerned, will remain obscure until detailed studies are made of their food.

Considering these factors, why are there so few kinds of deep-sea fishes in the Red Sea? Regarding the invertebrates (mainly shallow water species) and their high degree of endemism, Ekman (1953) wrote that “. . . we know with considerable accuracy the amount of time which has been available for the formation of new species in the Red Sea. This sea came into existence at the end of the Pliocene or the beginning of the Quaternary period (Pleistocene) when the large inland sea which formerly covered the “erythraic” depression first joined up with the Mediterranean and later on with the Indian Ocean. The transition from Pliocene to the Quaternary period occurred roughly one million years ago, and this time was accordingly sufficient for a fairly large number of animal species to undergo changes of a magnitude which differentiated them as new species.”

Time has also been sufficient for the evolution of a fairly high degree of endemism (*ca.* 10 per cent) in a diverse fauna of reef fishes in the Red Sea. These came from the Indian Ocean, either as adults or young stages. They were not barred by the sill, nor by the hydrographical conditions that depend on the sill. The same is true for a few species of deep-sea fishes. If certain species have managed to enter, why not more?

Concerning the bathypelagic species, Marshall (1963) concluded that physical conditions in the Red Sea, particularly the

warm isothermal structure, are so unlike those in the open ocean that invaders would have to be very adaptable to gain a footing. Such genetic plasticity is likely to be rare. For the benthic deep-sea fishes, the sill, which rises to within 150 meters of the surface, would be a barrier except to markedly eurybathic species. Moreover, few benthic species appear to pass their early life history in the surface waters, so reducing their chances of being carried into the Red Sea. In any event, the high temperatures of the bottom water (*ca.* 21.5° C) must be a barrier to all but the species that live in the relatively warm waters over the upper part of the continental slope. As Balss (1931) found, certain benthic decapods that live in the deeps of the Red Sea are found at shallower levels in the outer oceans. But cosmopolitan deep-sea decapods, which live below a depth of 1500 meters, seem to be absent from the Red Sea.

The Red Sea holds a poor fauna of deep-sea fishes. Is the same true of other deep basins having shallow sills, but where there is little or no stagnation in the water column? What of the Sea of Japan, the Mediterranean, the Gulf of Mexico and the Sulu Sea?

Diversity is least in the first, moderate in the Mediterranean, but quite high in the last two basins. Some 20 species, mostly benthic, are known from the Sea of Japan (Zenkevitch, 1963). There are about 550 species of fish in the Mediterranean, of which 120 live at depths of 200 meters or more (Tortonese, 1959). At least three-quarters of the deep-sea species are bathypelagic. Four of the benthic species are known to live at depths beyond 2000 meters.

Though a check list has yet to be made, it is clear that the Gulf of Mexico contains a rich fauna of deep-sea fishes. Grey (1958 and 1959) has recorded some 50 species of which about a third are bathypelagic. Bigelow and Schroeder's work (e.g. 1962 a, b) shows that the Gulf contains a diverse fauna of batoid fishes at moderate depths. There are also at least 30 species of macrourid fishes (Marshall, 1964). The number of macrourids is also a good guide to diversity in the Sulu Sea. Gilbert and Hubbs (1920) list 40 species, of which 16 are endemic.

The Red Sea and the Sea of Japan thus contain few species of deep-sea fishes. In contrast, the Gulf of Mexico and the Sulu Sea have rich faunas. Some of the factors favoring or restricting diversity have been mentioned earlier (p. 233), but can one assume that the number of species, whether in rich or poor basins, is related to a common set of factors?

Comparison of the Red Sea and the Sea of Japan soon shows that one must be more circumspect. The geological history of the latter is somewhat obscure, though it may, like the Red Sea, have assumed its present form at the end of the Pliocene (Zenkevitch, 1963). It is like the Red Sea in being isolated from the open ocean by a sill that rises close to the surface. But it differs sharply from the Red Sea in being isothermally cold below the level of the sill. In winter, cooled waters sink along the slopes causing temperatures between 1° and 0° C below a depth of 150 meters. Regarding plankton production, the annual growing season is probably more or less continuous in the Red Sea. In the Sea of Japan there are spring and autumn blooms (Zenkevitch, 1963).

The sill forming the Sea of Japan, like that at the mouth of the Red Sea, will bar most kinds of benthic deep-sea fishes. Once over the sill, an invading animal faces either abnormally cold or hot waters below a level of 150 meters. It is not surprising, then, that the bathypelagic fauna of the Red Sea consists of forms that live at upper, and therefore warm, mid-water levels in the outer ocean. Perhaps this fauna is more diverse than the benthic one. In the Sea of Japan, on the other hand, nearly all species belong to benthic or deep bathypelagic groups; this is understandable considering the cold waters at depths below sill level. One exception, *Maurolicus japonicus*, occurs in the upper reaches of the bathypelagic zone in the outer ocean. In the Sea of Japan it presumably lives near the lower limit of the warm surface layer.

The two basins with a rich fauna of deep-sea fishes may be of much the same geological age as the Red Sea and the Sea of Japan. The Gulf of Mexico seems not to have become a deep-sea basin until late Tertiary times (Lynch, 1954). According to Kuenen (1950) the deep-sea morphology of the Moluccas, which includes the Sulu Sea, is entirely of Upper and post-Tertiary development. But both basins have deeper sills than the Red Sea and the Sea of Japan. The Gulf of Mexico leads to the Atlantic over an 800-meter sill and to the Caribbean over a sill about 1600 meters in depth. The sill dividing the Sulu Sea from the South China Sea is nowhere more than 400 meters below the surface.

While the Gulf of Mexico is isothermal (at about 4° C) below a level of 1200 meters, temperatures in the Sulu Sea are close to 10° C at depths from 1000 meters to the bottom. The regimes of temperature are thus less stringent than those in the Red Sea

and the Sea of Japan. But the higher bottom temperatures in the Sulu Sea, and, perhaps, the relatively shallow sill, have precluded the invasion of abyssal species, judging by the macrourid fauna. In the Gulf of Mexico there is a fairly diverse fauna of abyssal benthic fishes (Grey, 1958).

Besides having more suitable conditions of temperature than those obtaining in the 'poor' basins, the Sulu Sea and the Gulf of Mexico are close to oceanic areas containing rich faunas of deep-sea fishes. There are thus more potential invaders than exist outside the Sea of Japan. The annual plankton cycle in both the Sulu Sea and the Gulf of Mexico is presumably of the stable tropical type.

Though geologically young, the Gulf of Mexico and the Sulu Sea contain relatively rich deep-sea faunas. Some of this diversity is borrowed, some created *in situ*. Concerning the Sulu Sea, one must conclude that the endemic species have evolved during the last million years or so. The situation in the Gulf is more complicated. Some species have come from the Atlantic, some from the Caribbean, while a third group is presumably the result of local speciation. Thorough exploration of the Gulf and Caribbean will be needed before we can be sure of the endemic species. Regarding the species that are common to both but absent from the Atlantic, there seems no way of deciding where they evolved. Perhaps speciation has been greater in the Caribbean. It is also a basin, and is older than the Gulf of Mexico.

HABIT AND HABITAT

Underwater photographs are valuable in resolving doubts regarding the living spaces of deep-sea fishes. Trawls catch fish as they are hauled to the surface, and may thus contain pelagic as well as benthic species. For the most part, near-bottom photographs have confirmed suspicions, based largely on the form, fin pattern and position of the mouth, as to which groups are benthic in habit. Certain sharks (e.g. *Etmopterus*), chimaeras, bathypteroids, *Bathysaurus*, halosaurs, macrourids, morids and brotulids have been photographed on, or close to, the bottom.

Fishes of the last four groups, which have a capacious swim-bladder, should be able to hover and swim with ease over the deep-sea floor (Marshall, 1960). Again, near-bottom photographs provide valuable evidence that these groups are benthopelagic

in habit.¹ Furthermore, close study of the pictures reveals the attitudes adopted in hovering or swimming.

The macrourids are of particular interest. Most of the present photographs, and many more taken in parts of the Atlantic Ocean, show that macrourids wander nose-down over the sediments, the long body axis being inclined at a slight angle to the bottom (Fig. 4). Considering the dynamics of their fin

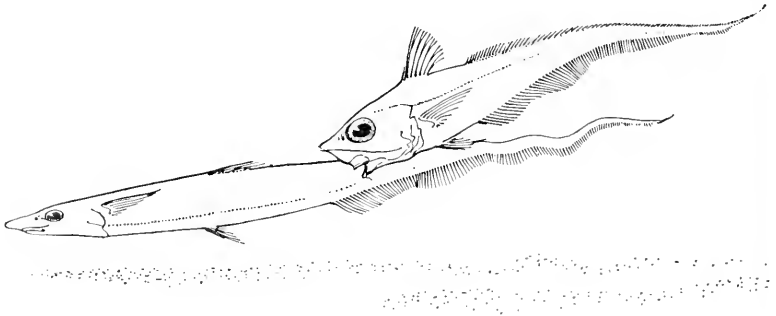

Fig. 4. A halosaur (left) and a macrourid (right), showing the snout-down posture adopted when hovering or swimming. Note the convergence of fin pattern.

pattern, this attitude is to be expected. In most macrourids the rays of the anal fin are considerably longer than those of the second dorsal. As the tail is undulated—and pictures of macrourids often catch the posterior half in sinusoidal motion—the side to side swing of the anal fin will generate a lift, and thus depress the head. The action is rather like that of a heterocercal tail fin. A lift can also be got from undulations of the anal fin itself. When analyzing the motions of the pectoral and dorsal fins of a seahorse, Breder and Edgerton (1942) show that two vectors are involved “. . . in connection with the resultant of the simple wigwagging of fin rays and in the consequent passage of a wave along such a series of identical members.” One component of the resultant thrust is along the axis of the fin; the other is in the same plane but perpendicularly away from the axis. When the long anal fin of a macrourid is set in wavy motion it will thus generate a lift as well as drive the animal forward.

¹ A few species of macrourids are bathypelagic (Marshall, 1964).

The present photographs and others show that halosaurs adopt a slightly inclined posture like that of a macrourid. Again, this is to be expected. Halosaurs also have a long tail and an anal fin with long rays, but the single dorsal member has a short base. Undulations of the tail and anal fin will again drive the animal forward and incline it head-down to the sediments. The photographs often show halosaurs with short wave undulations passing down the posterior half to a third of the tail. But longer wave, eel-like undulations have also been seen.

A head-down attitude is apt in a fish with jaws suspended underneath the snout. All halosaurs and most macrourids have such jaws, which are more easily able to pick food organisms off the bottom. Moreover, the head, which ends in a triangular snout, can be used to root in the oozes, so turning up food organisms. The reinforced snout of a macrourid or a halosaur is thus a decidedly useful structure.

The bathygadine macrourids are unlike the macrourine species not only in having a terminal mouth and long gill rakers but their fins show certain differences as well. The salient feature is that the second dorsal fin has rays that are equal or greater in length than those of the anal fin. If the latter differential holds, one might expect the fish to swim with a slight head-upward inclination to the horizontal. In this respect, it is interesting that the photograph of a bathygadine rat-tail (Pl. 3) which is particularly clear, shows it swimming more or less parallel to the bottom. The posture is plainly different from that shown in a number of other photographs of rat-tails.

Lastly, certain photographs of the morid that is common in the Gulf of Aden show that it swings the long rays of the pelvic fin through an arc of about 60° . By this means the animal (Fig. 3) scans the oozes, presumably with tactile and gustatory endings on the fin rays.

SUMMARY

During ATLANTIS Cruise 242, May to June, 1958, six photographic stations were made, four in the Red Sea and two in the Gulf of Aden. Over 2000 bottom photographs were taken, many of which show deep-sea fishes.

Analysis of these photographs shows that at depths around 600 meters the density of fishes in the Gulf is about three times that in the Red Sea. But in terms of biomass (the Red Sea pictures being mainly of a two-foot shark) there is not much difference between the two regions.

Though the Red Sea has not been well explored, the photographs support earlier indications that the Gulf of Aden contains a more diverse fauna of benthic, deep-sea fishes. This is also true of the bathypelagic fauna. After considering the factors that seem to favor or restrict diversity in the deep sea, we conclude that the very shallow sill and the unusually warm, isothermal structure of the water below sill level make the Red Sea unsuitable to all but a few very adaptable species of deep-sea fishes.

A faunal comparison of deep-sea basins shows that the Sea of Japan, like the Red Sea, contains relatively few kinds of deep-sea fishes. But the factors restricting diversity are certainly not the same for the two regions. By contrast, the Gulf of Mexico and the Sulu Sea have rich faunas. Some of this diversity is borrowed from the open ocean, some created *in situ*, seemingly during the last million years or so.

Study of the clearest photographs can show much of the habits and habitats of deep-sea fishes. Attention is drawn to benthopelagic species with a well developed swimbladder, notably the halosaurs, macrourids and morids. With the means to achieve neutral buoyancy, these fishes are easily able to hover or swim over the sediments. The snout-down inclination of halosaurs and macrourine rat-tails is seen to be related to the hydrodynamics of their (convergent) fin patterns.

REFERENCES CITED

BALSS, H.

1931. Dekapoden des Roten Meeres, 4; Exp. S. M. Schiff "Pola" in das Rote Meer. Zool. Ergebn. Denkschr. Akad. Wiss. Wien, Math.-nat. Kl., **102**:1-30.

BIGELOW, H. B. and W. C. SCHROEDER

- 1962a. Fishes of the western North Atlantic. Part two: Sawfishes, guitarfishes, skates, rays, and chimaeroids. Mem. Sears Found. Mar. Res., No. 1, 588 pp.
- 1962b. New and little known batoid fishes from the western Atlantic. Bull. Mus. Comp. Zool., Harvard Univ., **128**(4):159-244.

BRAUER, A.

1906. Die Tiefsee-Fische. I. Systematischer Teil. Wiss. Ergebn. "Valdivia," vol. 15, 432 pp.

BREDER, C. M. and H. E. EDGERTON

1942. An analysis of the locomotion of the seahorse *Hippocampus*, by means of high speed cinematography. Ann. New York Acad. Sci., **43**:145-172.

- EKMAN, S.
1953. Zoogeography of the sea. Sidgwick and Jackson. London, 417 pp.
- EMILIANI, C. and R. F. FLINT
1963. The Pleistocene record. *In* The sea. Vol. III, pp. 888-927. Ed. M. N. Hill, John Wiley & Sons, New York. 3 vols.
- EWING, M., A. VINE and J. L. WORZEL
1946. Photography of the ocean bottom. *J. Opt. Soc. Amer.*, **36**:307-321.
- FAGES, L., *et al.*
1958. Résultats scientifiques des campagnes du Bathyscaphe F.N.R.S. III: 1954-1957. *Ann. Inst. Oceanogr. Monaco*, **35**(4):237-341.
- FUCHS, T.
1901. Über den Charakter der Tiefseefauna des Roten Meeres auf Grund der von österreichischen Tiefsee-Expeditionen gewonnenen Ausbeute. *Sitz.-Ber. Akad. Wiss. Wien, Math.-nat. Kl.*, **110**(1): 249-258.
- GILBERT, C. H. and C. L. HUBBS
1920. The macrouroid fishes of the Philippine Islands and the East Indies. *Bull. U. S. Nat. Mus.*, **100**(1):369-588.
- GREY, M.
1958. Description of abyssal benthic fishes from the Gulf of Mexico. *Fieldiana. Zool.*, **39**(16):149-183.
1959. Deep sea fishes from the Gulf of Mexico, with a description of a new species *Squalogadus intermedius* (Macrouroididae). *Fieldiana. Zool.*, **39**(29):323-346.
- KUENEN, P. H.
1950. Marine geology. John Wiley & Son, New York, pp. 568.
- LAUGHTON, A. S.
1963. Microtopography. *In* The Sea. Vol. III, pp. 437-472. Ed. M. N. Hill, John Wiley & Son, New York. 3 vols.
- LYNCH, S. A.
1954. Geology of the Gulf of Mexico. *In* The Gulf of Mexico its origin, waters, and marine life. *Fishery Bull., U.S. Fish and Wildlife Service*, **55**:67-86.
- MARSHALL, N. B.
1960. Swimbladder structure of deep-sea fishes in relation to their systematics and biology. *Discovery Rep.*, **31**:1-122.
1963. Diversity, distribution, and speciation of deep sea fishes. *Systematics Assoc. Publ. No. 5*:181-195.
1964. Bathypelagic macrouroid fishes. *Copeia*, No. 1:86-93.
- NEUMANN, A. C. and D. A. MCGILL
1962. Circulation of the Red Sea in early summer. *Deep-Sea Res.*, **8**:223-235.
- NORMAN, J. R.
1939. Fishes. John Murray Exp. 1933-34. *Sci. Rep.*, **7**:1-116.

THOMPSON, E. F.

1939. The exchange of water between the Red Sea and the Gulf of Aden over the "sill." John Murray Exp. 1933-34. Sci. Rep., 2:105-119.

TORTONESE, E.

1959. General remarks on the Mediterranean deep-sea fishes. International Oceanographic Congress. Preprints. Pp. 386-387.

YENTSCH, C. S. and L. WOOD

1961. Measurements of primary production in the Red Sea, Gulf of Aden, and Indian Ocean. Woods Hole Oceanogr. Inst. Ref. No. 61-6, Appendix B, 6 pp. (Unpublished manuscript.)

ZENKEVITCH, L.

1963. Biology of the seas of the U.S.S.R. Allen and Unwin, London. 955 pp.

(Received February 21, 1964)

TABLE 2
FISHES REPORTED FROM DEPTHS GREATER
THAN 150 METERS IN THE GULF OF ADEN

BENTHIC FISHES

Scyliorhinidae	<i>Halaclurus indicus</i> (Brauer) ¹ <i>Cephaloseyllum sufflans</i> (Regan)
Triakidae	<i>Eridacnis radcliffei</i> Smith
Torpedinidae	<i>Heteronarce mollis</i> (Lloyd)
Rajidae	<i>Raja powelli</i> Alcock <i>R. johannis-davisi</i> Alcock <i>Raja</i> sp. egg capsule
Chimaeridae	<i>Harriotta</i> (?) <i>indica</i> (Garman) egg capsule
Alepocephalidae	<i>Alepocephalus bicolor</i> Alcock
Chlorophthalmidae	<i>Chlorophthalmus bicornis</i> Norman
Bathypteroidae	<i>Bathypterois atricolor</i> Alcock
Congridae	<i>Ariosoma guttulata</i> (Gunther) <i>A. nigrimanus</i> Norman
Ophichthyidae	<i>Ophichthus multiserialis</i> Norman
Halosauridae	<i>Halosaurus parvipennis</i> Alcock
Macrouridae	<i>Macrurus firmisquamis</i> Gill & Towns ¹ <i>Nezumia sclerorhynchus</i> (Valenciennes) ¹ <i>Coryphaenoides wood-masoni</i> (Alcock) ¹ <i>C. lophotes</i> (Alcock)? <i>Hymenocephalus heterolepis</i> (Alcock) <i>Bathygadus furrescens</i> Alcock <i>Gadomus multifilis</i> (Gunther)
Moridae	<i>Physiculus roseus</i> Alcock
Trachichthyidae	<i>Hoplostethus</i> (<i>Hoplostethus</i>) <i>mediterraneus</i> Cuvier & Valenciennes
Bathylupeiidae	<i>Bathylupea hoskynii</i> Alcock
Nemipteridae	<i>Parasclopsis townsendi</i> Boulenger
Bembropsidae	<i>Bembrops platyrhynchus</i> (Alcock) <i>B. adenensis</i> Norman
Uranoscopidae	<i>Uranoscopus crassiceps</i> Alcock
Gobiidae	<i>Gobius comites</i> Alcock
Callionymidae	<i>Callionymus carebares</i> Alcock
Brotulidae	<i>Neobythites steaticus</i> Alcock <i>Dicrolene longimana</i> Smith & Radcliffe <i>D. nigricaudis</i> (Alcock) <i>Bassozetus glutinosus</i> (Alcock) <i>Porogadus trichiurus</i> (Alcock) <i>Glyptophtidium macropus</i> Alcock <i>Luciobrotula bartschi</i> Smith & Radcliffe

¹ Records so marked are reported by Brauer (1906); the others are taken from Norman (1939). Where the authors are aware of changes, names conform to recent usage.

	<i>Catactyr squamiceps</i> (Lloyd)
	<i>Grammonus robustus</i> Smith & Radcliffe
	<i>Diplacanthopoma raniceps</i> Aleoek
	<i>Mironus caudalis</i> Garman ¹
Scorpaenidae	<i>Phenacoscorpius adenensis</i> Norman
Triglidae	<i>Lepidotrigla omanensis</i> Regan
Synanciidae	<i>Miurus inermis</i> Aleoek
Bothidae	<i>Arnoglossus arabicus</i> Norman
	<i>Lacops nigriscens</i> Lloyd
Cynoglossidae	<i>Cynoglossus (Areliscus) acutirostris</i> Norman
	<i>Symphurus gilcisi</i> (Aleoek)
	<i>S. macrophthalmus</i> Norman
Lophiidae	<i>Chirolophius mutilis</i> (Aleoek)
Ogeocephalidae	<i>Halictona fumosa</i> Aleoek
	<i>Dibranchius nasutus</i> Aleoek
	<i>D. obscurus</i> Brauer ¹
	<i>Coclophrys micropus</i> (Aleoek)
BATHYPELAGIC FISHES	
Alepocephalidae	<i>Bathyroctes longifilis</i> Brauer ¹
	<i>Roulina guntheri</i> (Aleoek)
	<i>Xenodermichthys copei</i> Gill
	<i>Bajacalifornia burragei</i> Townsend & Nichols
Gonostomatidae	<i>Cyclothone signata</i> Garman var. <i>alba</i> , Brauer ¹
	<i>C. pallida</i> Brauer
	<i>C. acclinidus</i> Garman ¹
	<i>Yarella corythacola</i> (Aleoek)
Sternoptychidae	<i>Argyroplecus affinis</i> Garman ¹
Chauliodontidae	<i>Chauliodus sloani</i> Bloch & Schneider ¹
	<i>C. pammelas</i> Aleoek ¹
Stomiidae	<i>Stomias affinis</i> Gunther ¹
Malacosteidae	<i>Malacosteus niger</i> Ayres
Myctophidae	<i>Hygophum</i> sp. close to <i>reinhardti</i> (Lutken)
	<i>Diogenichthys laternatus</i> (Garman) ¹
	<i>Diaphus rafinesquii</i> (Cocco)
	<i>D. coeruleus</i> (Klunzinger)
	<i>Diaphus</i> sp.
	<i>Lampantus macropterus</i> (Brauer) ¹
	<i>L. nigrum</i> (Gunther) ¹
Nettastomidae	<i>Garialiceps taniola</i> Aleoek
Nemichthyidae	<i>Aroettina infans</i> (Gunther) ¹
Melanphaidae	<i>Melanphaes megalops</i> Lutken ¹
Chilodipteridae	<i>Syngrops philippinensis</i> (Gunther)
Champsodontidae	<i>Champsodon omanensis</i> Regan
Trichiuridae	<i>Aphanopus carbo</i> Lowe
Oncirodidae	<i>Dolopichthys</i> sp.
Ceratiidae	<i>Cryptosaras carunculatus</i> (Gunther)
	<i>Ceratias concsi</i> (Gill) ¹
	<i>Melanoeetus</i> sp. ? ¹

PLATES

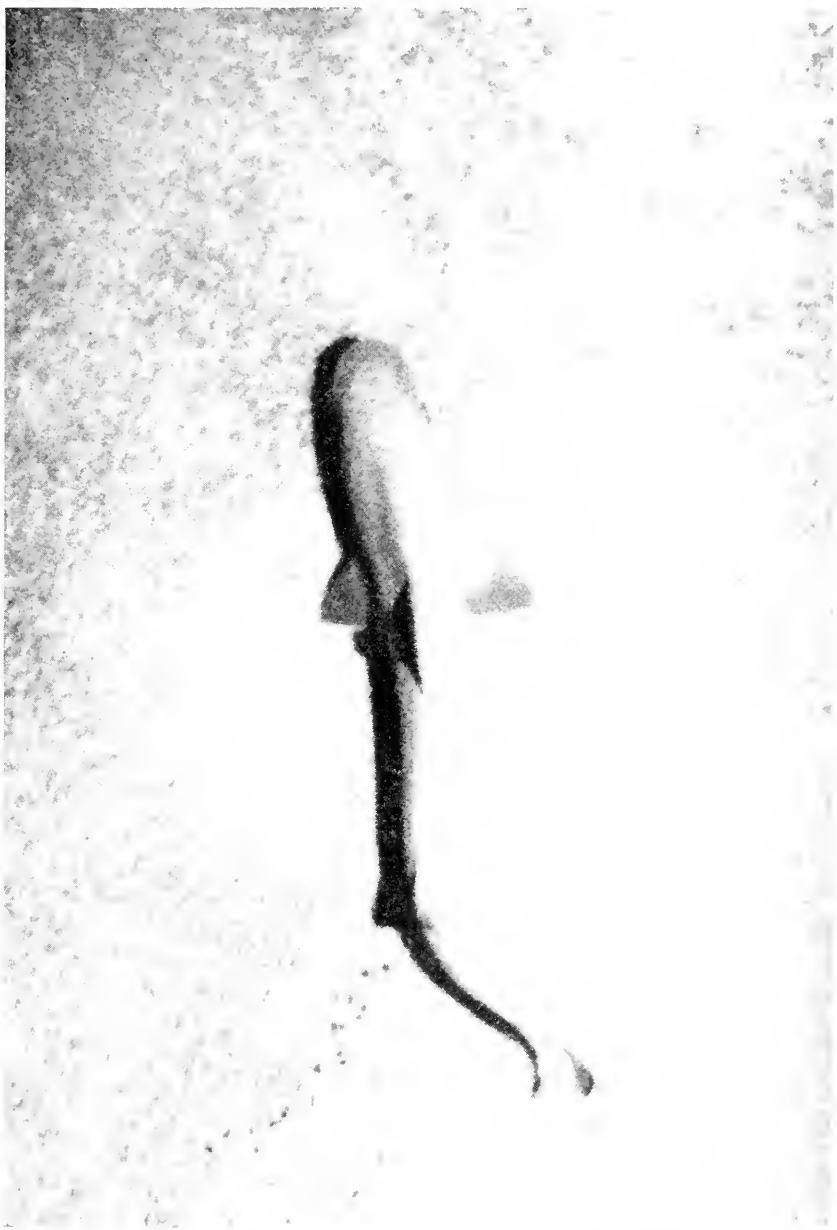

Plate I. Shark from the Red Sea. Most of the photographs show the fish swimming just above the bottom.



Plate 2. A halosaur (left) and a bathygadine macrourid (right), from the Gulf of Aden. Note the shadows of the elongated rays in the paired fins of the latter.



Plate 3. A rhinochimaerid, probably *Harriotta*, from the Gulf of Aden.

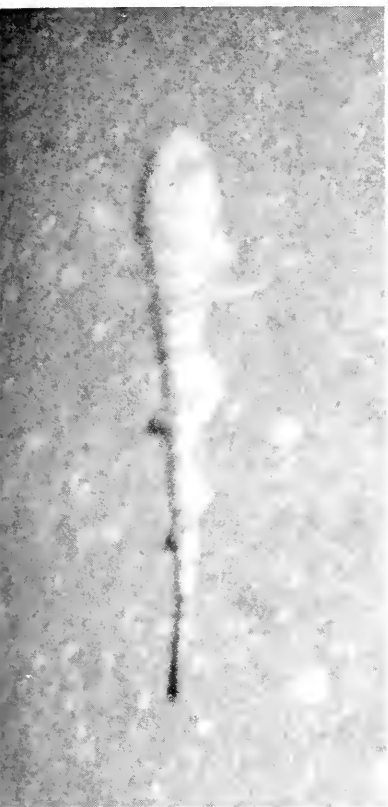

Plate 4. A dogfish (*Halaclurus*) (left) and a lizard-fish (*Synodontidae*) (right), from the Gulf of Aden.





Bulletin of the Museum of Comparative Zoology

HARVARD UNIVERSITY

VOL. 132, No. 3

THE LESSER ANTILLEAN REPRESENTATIVES
OF *BOTHIOPS* AND *CONSTRUCTOR*

BY JAMES D. LAZELL, JR.

CAMBRIDGE, MASS., U.S.A.
PRINTED FOR THE MUSEUM
DECEMBER 21, 1964

PUBLICATIONS ISSUED BY OR IN CONNECTION
WITH THE
MUSEUM OF COMPARATIVE ZOOLOGY
HARVARD UNIVERSITY

BULLETIN (octavo) 1863 — The current volume is Vol. 132.

BREVIORA (octavo) 1952 — No. 210 is current.

MEMOIRS (quarto) 1864-1938 — Publication terminated with Vol. 55.

JOHNSONIA (quarto) 1941 — A publication of the Department of Mollusks. Vol. 4, no. 43 is current.

OCCASIONAL PAPERS OF THE DEPARTMENT OF MOLLUSKS (octavo) 1945 — Vol. 2, no. 31 is current.

PROCEEDINGS OF THE NEW ENGLAND ZOOLOGICAL CLUB (octavo) 1899-1948 — Published in connection with the Museum. Publication terminated with Vol. 24.

The continuing publications are issued at irregular intervals in numbers which may be purchased separately. Prices and lists may be obtained from the Publications Office of the Museum of Comparative Zoology, Cambridge 38, Massachusetts.

Peters' Check-List of Birds of the World. Volumes 1, 4 and 6 are out of print; volumes 2, 3, 5, 7, 9, 10 and 15 are currently available.

Phylogeny and Evolution of Crustacea. Proceedings of a conference held at Cambridge, Mass., March 6-8, 1962. H. B. Whittington and W. D. I. Rolfe, editors. Cambridge, Mass., 192 pp., 80 figs., 1963. Cloth bound, \$6.75.

Fishes of the Gulf of Maine, by Henry B. Bigelow and William C. Schroeder. Washington, viii - 577 pp., 1953. Photo-offset reprint, \$6.50.

PUBLICATIONS OF THE
BOSTON SOCIETY OF NATURAL HISTORY

The remaining stock of the scientific periodicals of the Boston Society of Natural History has been transferred to the Museum of Comparative Zoology for distribution. Prices for individual numbers may be had upon request.

Bulletin of the Museum of Comparative Zoology

HARVARD UNIVERSITY

VOL. 132, No. 3

THE LESSER ANTILLEAN REPRESENTATIVES
OF *BOTHROPS* AND *CONSTRUCTOR*

BY JAMES D. LAZELL, JR.

CAMBRIDGE, MASS., U.S.A.

PRINTED FOR THE MUSEUM

DECEMBER, 1964

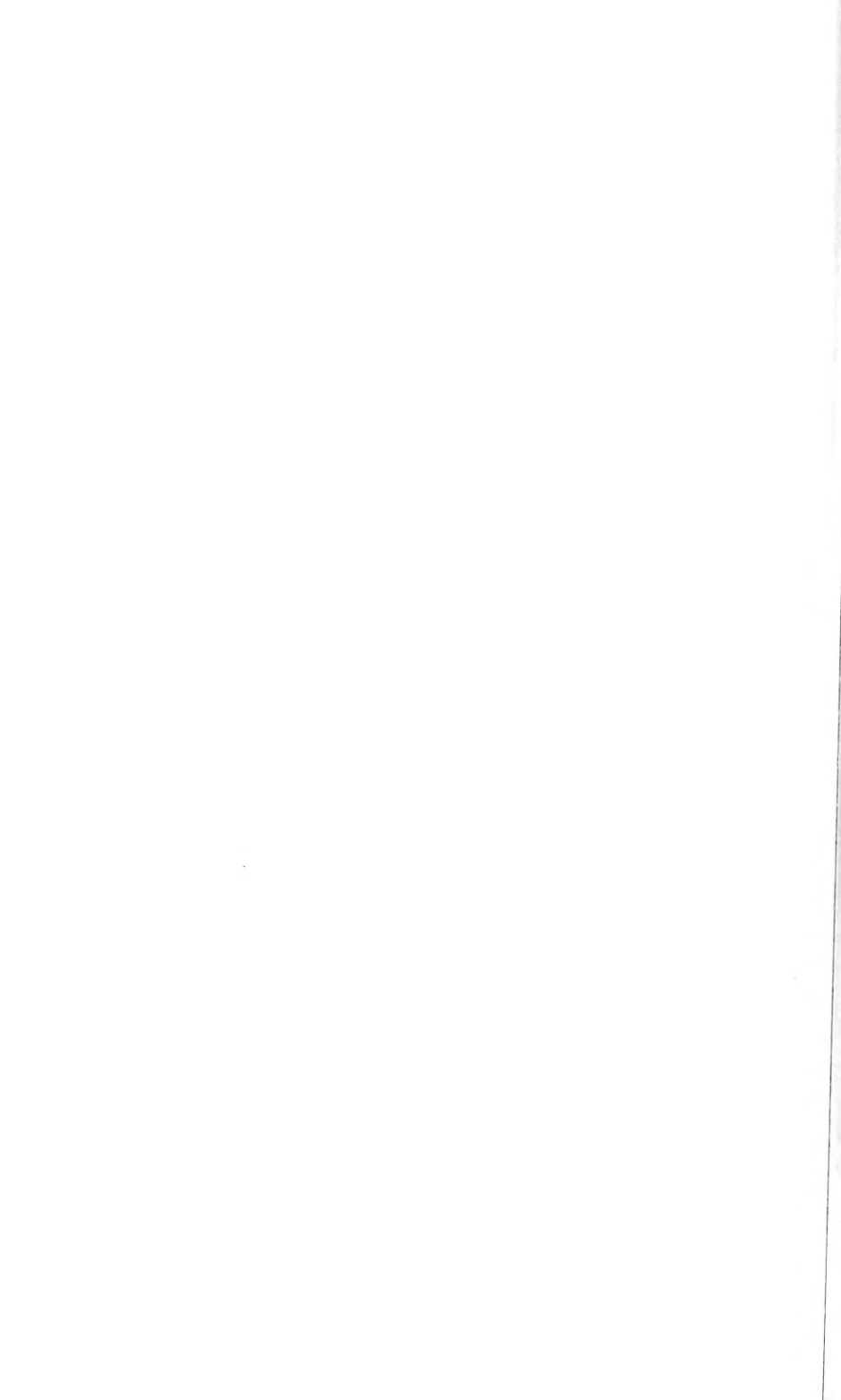

No. 3—*The Lesser Antillean Representatives of Bothrops
and Constrictor*

By JAMES D. LAZELL, JR.

The taxonomy of four Lesser Antillean populations of snakes, two of *Bothrops* and two of *Constrictor*, has long been in a state of confusion. This situation is perhaps explicable, as so many similar situations in West Indian herpetology are, because there were until now very few examples of these populations in collections, and there was virtually no record of the animals in life. I have combined in this paper a revision of the Lesser Antillean populations of the two genera because their zoogeography is quite comparable, while their taxonomy presents two very different patterns of differentiation in island forms.

BOTHRUPS

Bothrops has been erroneously recorded from numerous islands in the Lesser Antilles. Barbour (1914) pointed out that, in the Lesser Antilles proper, members of this genus occur only on Martinique and Saint Lucia. Lacépède (1789) described the Martinique serpent and concocted the name "Fer-de-lance" himself, stately (pp. 121-122) because he did not particularly like the vernacular name "Vipère jaune." It is interesting to note that many authors (e.g. Ditmars, 1954) have attributed the use of the term "Fer-de-lance" to the natives of Martinique, Saint Lucia, or both; the term "Fer-de-lance" is not the vernacular name of any reptile occurring in any French or Creole-speaking country in the New World, and *Bothrops*, on both Martinique and Saint Lucia, is known merely as "Serpent."

Lacépède cited a specimen of his *Coluber lanceolatus* (Tables, p. 80) from Martinique with 228 ventrals, and mentions a second (p. 126) that had 225 ventrals. These figures unequivocally assign the name to the Martinique form: no other member of the genus *Bothrops* that has divided subcaudals can equal such high ventral counts.

Amaral (1925) differentiated three sympatric species of *Bothrops* from Brazil: *atrox*, *jararaca*, and *jararacussu*. At the same time he placed *lanceolatus* in the synonymy of *atrox*. The three sympatric species he differentiated (pp. 41-43) do not differ

absolutely on any character of squamation — except that *jararacussu* is implied to have a divided anal constantly. Amaral said also (p. 22), “color characteristics, . . . of course, are among the main points on which . . . specific differentiation can be based.” Unfortunately, Amaral apparently failed to note that the dorsal pattern of the Saint Lucian specimens he examined was absolutely distinct from any of the other forms.

Hoge (1952) attempted to revalidate the name *lancoletatus* for the Martinique form. He believed that the number of scale rows around the middle of the body, the number of ventrals, the structure of the hemipenes, the carination, and the coloration of the Martinique form justified its recognition as a distinct species.

Amaral (1954) stated that none of Hoge’s arguments “resists . . . scientific analysis.” To be sure, the color characters cited by Hoge are not those which are distinctive: Hoge did not mention the unblotched venter. Also, to date, no one has been able to make taxonomic sense out of the remarkable variants in carination that appear in the South American snakes referred by Amaral to *atrox*; some of these do match the condition of carination found in Martinique specimens. I have not seen sufficient material of properly prepared hemipenes to be able to refute Amaral’s rejection of this character, though there certainly appear to be differences between Martinique and mainland specimens that I have examined.

With respect to squamation, Amaral’s method of “scientific analysis” consisted of lumping together *all* of the “island populations” (Martinique, Saint Lucia, Trinidad, and “Tobago”), and pointing out that this composite was not distinctive from his concept of *Bothrops atrox*. An “analysis” such as this admirably succeeds in obscuring real differences, and *Bothrops lanceolatus* was once again returned to synonymy of *atrox*.

The specimens Amaral examined from “Tobago” agreed with Martinique material in dorsal and ventral counts, and Amaral felt that this fact alone was enough to deprive the Martinique Serpent of taxonomic rank, since those from the geographically intermediate island of Saint Lucia agreed with Trinidad material. This presented a situation that Amaral could not make agree with his concepts of taxonomy and zoogeography: recognition of the Martinique form would be “impossible, in the light of our present knowledge of the phenomena of speciation among ophidians.”

As Dunn (1934a) pointed out, the Lesser Antilles give every appearance of random population by "waifs." In such cases one can hardly expect distribution patterns to be orderly. Furthermore, unless "ophidian" is to be taken here as excluding the possibility of comparable phenomena in, for example, saurians, the situation with respect to the distribution of the two species of *Iguana* in the Lesser Antilles (Dunn, 1934b) may be taken as an excellent precedent for the sort of pattern Amaral thought he was seeing. There is, therefore, no possible recourse in either speciation or zoogeography — as these fields are known now, or as they were known in 1934 — that can support Amaral's contention.

As a matter of fact, however, I have personally collected in Tobago, and I am quite sure there are no *Bothrops* there; nevertheless, for confirmation, I wrote to Arthur Greenhall, Royal Victoria Institute, Port of Spain, Trinidad. Greenhall replied (pers. comm.): "I have done some checking for you on *Bothrops* and can find nothing here to indicate that *Bothrops* or Fer-de-lance or for that matter any highly venomous snake occurs on Tobago or has ever been recorded from Tobago. Tobagonians make no reference to any poisonous snakes on the island."

I have examined two specimens of *Bothrops* in the United States National Museum (USNM) collected by F. A. Ober in 1878 and labelled "Tobago": USNM 10116, a male, has 31 dorsal scale rows at midbody, 218 ventrals, and three rows of suboculars; USNM 10122, a female, has 33 dorsal scale rows at midbody, 231 ventrals, and also three rows of suboculars. These specimens appear, therefore, to be those on which Amaral's remarks were based. Also collected by Ober in 1878 and labelled as coming from "Tobago," is a series of typical *Anolis roquet roquet*, *sensu stricto*, USNM 10102-12. These anoles occur only in Martinique. It is therefore not surprising that the two supposed "Tobago" *Bothrops* agree in every respect of coloration and pattern, as well as squamation, with the Serpent of Martinique, *Bothrops lanceolatus*. If these specimens are, in fact, those Amaral referred to, then we need not give further consideration to a Tobagonian population: the locality is simply in error.

Garman's (1887) *Trigonoccephalus caribbaeus* has been almost universally ignored. The name is available for the St. Lucian *Bothrops*, but the tendency has been that when *lanccolatus* was lumped with *atrox*, *caribbaeus* went with it, though with con-

siderably less ceremony. On the basis of Garman's description, the beast is indeed not separable from *B. atrox* of South America, and it was Boulenger (1896) who first synonymized it in his composite concept of *B. lanceolatus*.

My own re-evaluation of the taxonomy of these forms is based on fresh material of precisely known provenance from both islands (see Tables 1 and 2). Although I do not have the number of specimens that Amaral claimed to have had from Martinique, I do at least know that the specimens I report on here actually came from Martinique, for I collected them myself. With respect to Saint Lucia, however, I collected twenty specimens myself (nearly three times the number examined by Amaral) and have since removed twenty-six young from one of the larger females of this series — making in all forty-six specimens.

The two *Bothrops* populations — Martinique and Saint Lucia — are absolutely distinct from each other on the basis of color, pattern, squamation, habits, and habitat. However, differentiating either of them from *B. atrox* of South and Central America seemed at first an almost impossible task: *B. atrox* as currently conceived is so remarkably variable, often with respect to those characters that are most constant in the island forms, that many of the differences I at first thought valid crumbled before the sheer number of preserved *atrox* I examined. It was not until I began using a combination of characters that I was able to define the Lesser Antillean forms unequivocally.

I regard both island species as distinct not only from each other but also from their relatives on the continent. A full discussion of why I regard them as distinct species rather than as geographic races of one of the South American forms will be presented below. The closest population of *Bothrops*, geographically, to a Lesser Antillean form is *B. atrox* of Trinidad; thus, discussing the populations in order of geographic proximity to their closest neighbor, the first is:

BOTHIROPS CARIBBAEUS (Garman)

Trigonocephalus caribbaeus Garman, 1887, Proc. Am. Phil. Soc., 24: 285.

Lachesis lanceolatus (part), Boulenger, 1896, Cat. Snakes Brit. Mus., 3: 535-537.

Bothrops atrox (part), Amaral, 1925, Contr. Harvard Inst. Trop. Biol. Med., 2: 22-43.

Lectotype: Here designated as MCZ 4814, "St. Lucia," S. Garman, collector.

Type locality: Here restricted to Grande Anse, Saint Lucia.

Diagnosis. A *Bothrops* with divided subcaudals, 25 to 29 dorsal scale rows at midbody, 7 or 8 supralabials, 9 to 11 infralabials, 2 rows of scales between the eye and the supralabials, and 198 to 212 ventrals; venter yellow to cream-colored, sometimes finely peppered with grey laterally but never blotched or mottled; an irregular, dull, dark stripe from the eye passes well dorsal to the commissure of the mouth and never crosses the infralabials; dorsal pattern best developed middorsally, vague or nonexistent laterally; dark dorsal markings with borders that are parallel or diverging at middorsum.

Color. The ground color is usually grey (concrete-colored) to grey-brown; the markings vary from slate grey, on the paler, concrete-colored specimens, to chocolate on the darker ones. A common variant is yellowish ground color with rust-reddish markings. Males are much darker generally than females and

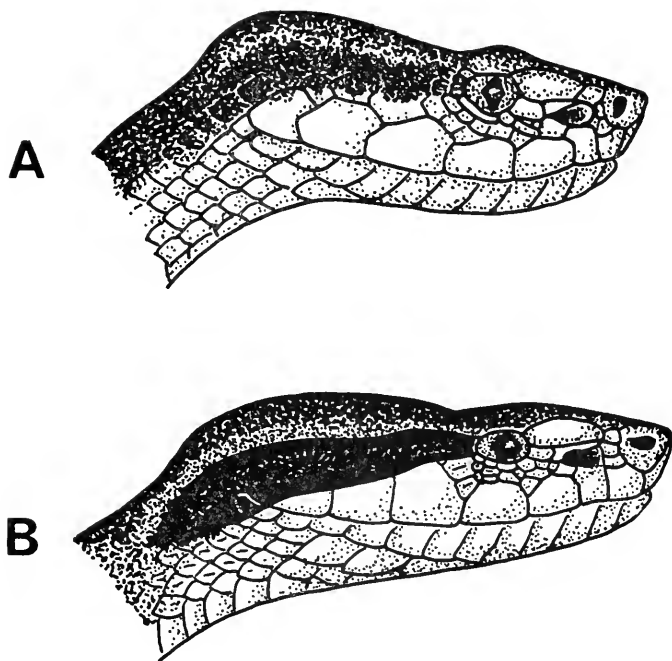

FIG. 1. Heads of two species of *Bothrops*. A, *B. caribbaeus* (Garman), Lectotype, MCZ 4814, Saint Lucia; B, *B. lanceolatus* (Lacépède), MCZ 75839, Morne Capot above Lorrain, Martinique.

sometimes have a slightly olive tint. The belly is always yellowish, though the chin is white, or, on those with the yellowest bellies, cream-colored. Some specimens, e.g. MCZ 70211, are very reddish — brick red to russet. Most specimens, of either sex and at any age, have "rust marks" on the face; these marks have remarkably the same appearance as the stain left on concrete by a rusting nail and are not arranged in any particular pattern — even varying on the two sides of the same snake.

Perhaps the most striking field mark is the dark temporal stripe. This stripe is usually present in *Bothrops* and passes from the eye across the temporal region onto the neck. In *Bothrops caribbaeus* this stripe is dull and irregular, rather than glossy and sharply defined; in addition, it passes well dorsal to the commissure of the mouth and does not involve any infralabials. This condition is shown in Figure 1A.

The dorsal pattern is immediately distinctive. The dark markings may alternate or coincide but are always well defined at the middle of the dorsum and generally extend across the middorsum, even when alternate. The markings are broad (at least 40% of the distance between them), and the borders are always either parallel or diverging at middorsum.

Amaral (1925, pl. IV, fig. 1) shows a figure supposedly of MCZ 4815 — a juvenile collected by Semper. In this figure the dorsal markings, as in *B. atrox* and its mainland relatives, converge towards the middorsum. Fortunately, I have MCZ 4815 before me and can state emphatically that the drawing is incorrect on this point: the specimen is a typical *caribbaeus* with respect to its dorsal pattern, and the borders of the markings are sometimes parallel, sometimes diverging, at the middorsum.

Habits and habitat. Compared to the Serpent of Martinique, or presumably to *Bothrops insularis*, this form is only semi-arboreal at best. Most of the specimens I collected were in rock piles or coconut husk piles. They do, however, climb frequently and are very often encountered in trees. The greatest height at which I collected one was six meters from the ground (MCZ 70210). *Bothrops caribbaeus* feeds to some extent on birds, but the introduced rats and mongooses seem to have earned a good deal of their present attention. In areas where *Bothrops* are plentiful there is said to be virtually no rat damage to such crops as cocoa; in parts of the island where there are no *Bothrops*, crop damage to cocoa is said to run as high as 70 per cent.

When cornered, *Bothrops caribbaeus* often shows a feeble tendency towards tail vibration and generally inflates the throat; if the throat and chin were yellow, this would produce the "yellow beard" that has presumably resulted in the vernacular name — "barba amarillo" — given to *B. atrox* in some parts of its range.

Range. *Bothrops caribbaeus* is confined to the coast and elevations under 200 meters. It occurs along both the windward and the leeward coasts and across the island in the north from the area of Grande Anse and Marquis to slightly north of Castries. The range (see Figure 2) is thus sharply U-shaped and covers

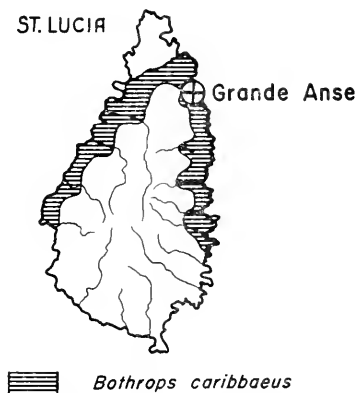

FIG. 2. Saint Lucia, showing the range of *Bothrops caribbaeus*.

the moderately dry lowlands of the island. Serpents are absent from the extremely dry north tip (Cap Estate), from the southern and central highlands and, rather inexplicably, from the entire south coast. The only place where man seems to have had any real effect on their abundance is in the vicinity of Castries; nevertheless, I got some reports of Serpents recently seen quite close to town. Elsewhere in its range the Serpent of Saint Lucia is plentiful compared to most North American snakes with which I am familiar (e.g. *Thamnophis sirtalis*). In some areas (e.g. Grande Anse) the Serpent is abundant almost beyond belief.

Size. The largest specimen I collected measured 1,545 mm (MCZ 70204). A larger specimen represented only by the

mangled carcass, from Marquis, was two meters without the head. There are a number of reasonable reports of individuals that were roughly "seven feet" (over two meters). They certainly average much smaller than do Serpents from Martinique; the average size of the twenty specimens I collected (the twenty-six young are not included) was about one meter.

Relationships. With respect to dorsal and ventral scale counts *Bothrops caribbaeus* does not differ from either *B. atrox* or *B. jararaca*. The incidence of 8 supralabials is 15 per cent; this is intermediate between the two latter species. The dorsal pattern, with transverse markings whose borders are parallel or diverging at middorsum, can be matched by some *Bothrops insularis*. A character which Amaral (1921, p. 80) mentions as being "not found either in *L. jararaca* or *L. atrox*" is the presence of three plate-like scales on the top of the snout; this condition is common in both *B. insularis* and *B. caribbaeus*, though not constant in either.¹

Bothrops caribbaeus and *B. lanceolatus*, of Martinique, have in common their characteristic ventral pigmentation (never blotched or mottled). Both share their arboreal, bird-eating habit with *B. insularis*.

I would suspect that *B. caribbaeus* was derived from the same stock as *atrox* and *jararaca*, and that its differentiation has paralleled that of *insularis*. There is no population both geographically and morphologically intermediate between *B. caribbaeus* and the South American forms, and *caribbaeus* is not at all intermediate morphologically between the South American forms and *B. lanceolatus* of Martinique. *Bothrops caribbaeus* seems certainly to possess an evolutionary role uniquely its own and cannot be interpreted to represent a geographic race of any other species on the basis of either geographical or morphological grounds.

The second population in geographic sequence is, of course, the Serpent of Martinique:

BOTHRUPS LANCEOLATUS (Lacépède)

Coluber lanceolatus Lacépède, 1789, Hist. Nat. Serpens, 2: 80.

Lachesis lanceolatus (part), Boulenger, 1896, Cat. Snakes Brit. Mus., 3: 535-537.

¹The following paratypes, for example, of *insularis* could not be distinguished from *atrox* with respect to this character alone: MCZ 17620-2 and MCZ 17625.

Bothrops atrox (part), Amaral, 1925, Contr. Harvard Inst. Trop. Biol.

Med., 2: 22-43; Amaral, 1954, Mem. Inst. Butantan, 26: 207-214.

Bothrops lanceolatus Hoge, 1952, Mem. Inst. Butantan, 24(2): 231-236.

Type: Jean Guibé, Muséum National d'Histoire Naturelle, reports (pers. comm.) that the Lacépède specimens apparently no longer exist. Because the characters cited by Lacépède render the allocation of the name unequivocal, I do not feel it necessary to designate a neotype.

Type locality: Here restricted to Morne Capot, between Ajoupa-Bouillon and Lorrain, Martinique.

Diagnosis. A *Bothrops* with divided subcaudals, 9 to 33 dorsal scale rows at midbody, 7 or 8 supralabials, 10 or 11 infralabials, 3 (70%) or 2 (30%) rows of scales between the eye and the supralabials, and 218 to 237 ventrals; venter white, sometimes finely peppered with grey laterally but never blotched or mottled; a sharply delineated, dark, black-bordered, glossy stripe from the eye to the commissure of the mouth, continuing to include at least part of the last infralabial; dorsal pattern of broadly U-shaped dark markings, well accentuated laterally, with borders that converge towards, but are often obscure or obliterated at, the middorsum.

Color. Young specimens are a rather warm grey-brown marked with dark grey; males retain this hue basically but become darker with age and, as adults, may be quite chocolate-brown with a reddish tinge laterally. Young specimens and males are referred to as either "Serpent jaune" or "Serpent rouge," regardless of what color they may appear to the exoteric. The females become gradually greyer, eventually losing all of the brown in the ground color and even the pinkish lateral tinge. They do, however, retain their patterns more boldly than do the males and, because of the crescentic markings, are called "Serpent croissant." The venter is always a virtual dead-white and quite without the mottlings and blotches characteristic of *B. atrox*.

There is a very bold, dark, temporal stripe, passing from the eye to the commissure of the mouth and onto the side of the neck. This stripe is sharply defined, in strong contrast to the surrounding coloration, and *shiny* or glossy in appearance in life. A large portion of the last infralabial is always included within this stripe. This condition is shown in Figure 1B.

Habits and habitat. *Bothrops lanceolatus* is markedly arboreal; it seems especially to prefer the masses of vine that form

interrupted canopies along the edge of the forest and may ascend to twenty meters above the ground. Very large and gravid females are often encountered on the ground and in rock piles, and other specimens may be collected in very steep, rocky hillsides on occasion. This species, because it lives in the better forested regions and in the highlands, is of much less economic value as a rat destroyer than is *B. caribbaeus*. They definitely do eat mongooses, and the larger ones are quite large enough to eat *Didelphis*, which they reportedly do. I suspect, from the type of habitat in which they are usually encountered, that they feed largely on birds, at least until they are too large to move around effectively in the tree tops.

I never saw a specimen either attempt tail vibration or inflate the throat at all, no matter how irritated. Large females are rather lethargic — to the point of docility; males, on the other hand, are fast and aggressive; for this reason the "Serpent jaune" is regarded by most Martinicans as being far more deadly than the other "varieties" they recognize.

Range. In direct contrast to the Serpent of Saint Lucia, this species is confined to wetter regions: highlands, and the well forested coast in the extreme north of the island of Martinique. The range, therefore, appears to be discontinuous. One population occurs in the highlands above Fort-de-France and northward in the mountains to the Montagne Pelée massif and also along the coast in wet regions: i.e. the north tip and the northern windward coast. The other population is confined to the southern highlands: from the region of Morne Serpent and Morne Vauclin southward and westward to the hills between Trois Ilets and Les-Anses-D'Arlets. The people in the central lowlands of Martinique maintain that there are no Serpents there at all. (See Figure 3.)

Size. The largest specimen I collected (MCZ 75836) was two meters long. This form seems to average much larger than *B. caribbaeus*: the average of eight specimens collected was over 1.5 meters. An estate manager from the area of Morne Rouge told of measuring a dead one killed by his workers some years ago that was "two centimeters less than three meters long;" I am inclined to believe this. Specimens in the two-meter range are very easily come by.

Relationships. This form is a bit harder to place than *B. caribbaeus*. The unblotched venter and the frequency of eight supralabials (ca. 33%) are the most evident links between

caribbaeus and *lanceolatus*. In other respects, however, they seem far more different from each other than either is from *atrox* or *jararaca*. Only *B. atrox* from Central America and Mexico can approach *lanceolatus* in squamation; I can, however, find no specimen of either form that is really equivocal with respect to squamation and, in any event, the ventral pigmentation is absolutely different. In short, I think the approach to *lanceolatus*-type squamation in Mexican *atrox* is not an indication of any relationship between the two species: if this situation obtained in Trinidad and Saint Lucia I would be very much more impressed with its value as an indication of relationship, but it does not.

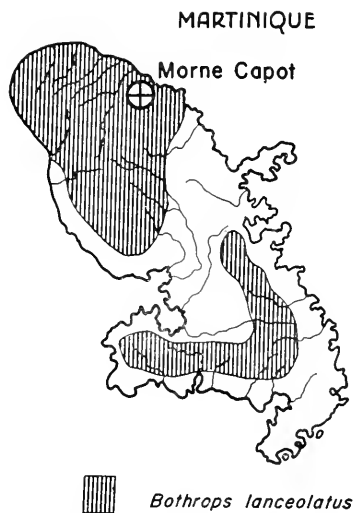

FIG. 3. Martinique, showing the range of *Bothrops lanceolatus*.

Bothrops lanceolatus may be a very much older form than *Bothrops caribbaeus*; in any case, there is no species or group of species (short of all *Bothrops* with divided subcaudals) to which it seems especially allied.

Discussion. The wealth of misinformation that has been perpetuated concerning the Lesser Antillean *Bothrops* populations requires some comment.

Amaral's (1925) lumping of *atrox* and *lanceolatus* is very difficult to explain. *Bothrops lanceolatus* is more different from

atrox with respect to more characters than are either of the two species (*jararaca* and *jararacussu*) which Amaral simultaneously (1925) differentiated from *atrox*. I do not have any means of commenting on Amaral's Martinique specimens, except to say that the scale counts given by Amaral are altogether in keeping with *Bothrops lanceolatus*. Garman (1887, p. 285) gives the minimum ventral count for this form as 217; Amaral lists 218. Garman's figure presumably came from an MCZ specimen, and there is one, MCZ 4817 — a male *lanccolatus* from Martinique — which has 218, as correctly counted by Amaral. This is at best a minor point.

Why *Bothrops caribbaeus* has so long gone unmentioned, and, worse, unsuccessfully differentiated from *B. lanccolatus*, may perhaps be explained by the previous paucity of material. However, all the variant patterns figured, described, and available to me for examination, that appear in *Bothrops atrox* and *B. jararaca*, fail to match the pattern of the Saint Lucian Serpent. It would seem to me that even one specimen would stand out in strong contrast, yet Amaral saw seven and failed to note the differences.

Most remarkable, to anyone who ever actually collected on either Martinique or Saint Lucia, are the statements that one encounters concerning the rarity or even extinction of these Lesser Antillean populations. The earliest one I can find is Amaral (1923, p. 97): "In Martinique Island they introduced mongooses to kill snakes, and they succeeded in extinguishing them, but the country is very small." Compared to Brazil, Martinique is small indeed, but the mongooses have apparently lost ground in the forty years which have elapsed since Amaral made this statement.

In Martinique and Saint Lucia, *Bothrops*, being essentially backward and illiterate, seem unable to distinguish mongooses from other small animals (e.g. rats), and therefore eat them with relish; perhaps, rather than trying to exterminate Serpents directly, it would be easier to merely educate them to the level of those who have pointed out their proper role with respect to mongooses: then the situation would presumably reverse itself.

As my collections of a few weeks suggest, the Lesser Antillean representatives of *Bothrops* have been there much longer than either men or mongooses; it seems to me that they will remain.

Barbour (1914, pp. 230 and 343) discusses the occurrence of *Bothrops* in the Grenadines, pointing out that the island of

Petite Martinique "received its name . . . on account of the abundance of Fer-de-lance there." Actually, this is a nomenclatural problem: the snake responsible for the name of the island is the "Serpent," and the "Fer-de-lance" was never mentioned by anyone except Lacépède, who is alone responsible for this term. In Martinique and Saint Lucia, as I have mentioned, the name "Serpent" refers to *Bothrops*, and only to *Bothrops* (never, for example, to *Constrictor*—which is referred to as the "Tet'chien"—or *Dromicus*, which is called "Couleuvre"). Throughout the Grenadines and in Grenada, however, the arboreal representative of the genus *Boa* is invariably called "Serpent" too; thus, while from the native point of view the woods are full of "Serpents," the term means entirely different things in each area. It is a confusion easily understood by anyone familiar with the habitus and temperaments of Lesser Antillean *Bothrops* and *Boa*.

CONSTRICTOR

The genus *Constrictor* is also known at present from only two islands in the Lesser Antilles. It occurs on Saint Lucia, with *Bothrops*, and on Dominica. Three specimens in the MCZ were received from the New York Zoological Society; two of these, MCZ 6710-11, have no data; the third (MCZ 6659) was supposedly taken on "St. Kitts." All three are typical specimens of the Saint Lucian population. A single specimen collected by Garman (MCZ 6106) represented the Dominican form. During 1958 and 1959 I collected extensively in Dominica and sent a number of *Constrictor* to the Philadelphia Zoological Gardens, as well as to the MCZ; subsequently, some of those sent to Philadelphia died and have been placed in the MCZ. During 1962 I collected in Saint Lucia and placed seven specimens of the *Constrictor* from that island in the MCZ. All MCZ specimens are tabulated (Tables 3 and 4).

The nomenclatural problem in this genus is not, perhaps, less muddled than it was in *Bothrops*, but it is certainly easier to untangle. There is only one South American species, and its nominate subspecies, *Constrictor constrictor constrictor*, is the one closest geographically to the Lesser Antillean forms, occurring both in Trinidad and Tobago. As opposed to *Bothrops atrox*, which I cannot effectively define in relation to the other species in the genus (except to define the others, and then merely say that anything not fitting those definitions is a "*Bothrops atrox*"),

C. c. constrictor may be defined for comparative purposes as follows:

Constrictor constrictor constrictor has a slightly prominent snout and a straight or nearly straight canthus; there are 81 to 95 dorsal scale rows at midbody, 234 to 243 ventrals, and 15 to 22 rather neat, geometric, dark dorsal saddles to the level of the anus; the dorsal ground color is fawn-brown to tan; the venter white to yellow with little dark marking; a dark stripe proceeds from the eye directly to the supralabials (subocular stripe), and a second proceeds from the eye anteriorly in the loreal region, then curves down onto the supralabials (loreal stripe); both stripes correspond to two dark blotches on the infralabials and chin. (See Figures 4 and 5.)

The oldest available name for a Lesser Antillean form is *Boa orophias* Linnaeus (1758); the ventral count given unequivocally assigns the name to the Saint Lucian form since no other member of the genus has 281 ventrals. Duméril and Bibron (1844) applied the name *diviniloqua* to a Saint Lucian specimen; this name was originally proposed by Laurenti (1768). Therefore, *diviniloqua*, *sensu* Duméril and Bibron, is a junior synonym of *orophias*; *diviniloquus*, *sensu* Laurenti, does not seem to apply to any Lesser Antillean form, though, of the two (the Saint Lucian or the Dominican), it could only have applied to *orophias*. No name has ever been proposed for the Dominican form, and the few available specimens have always been considered under *orophias*. Stull (1935) combined both Saint Lucian and Dominican forms under *orophias* and separated this composite from *constrictor* at the species level.

The analogous zoogeographical situation is clear: in *Bothrops* and *Constrictor* there are continental forms which occur also on Trinidad (and, in *Constrictor*, on Tobago too); there is a population far to the north on Saint Lucia in each case, and a third population even farther north, in the case of *Constrictor* on Dominica. The taxonomic situation is sharply different, however: the geographically intermediate *Constrictor* is, with respect to most characters of diagnostic value, morphologically intermediate as well. There is feasible evidence, then, in *Constrictor*, for continuity of evolutionary role which simply does not exist in *Bothrops*. I therefore regard the populations of *Constrictor* as members of a stepped-cline series demonstrating geographic variation in a single species and rank these forms as subspecifically related to each other. The first population in geographic sequence is the Tet'chien of Saint Lucia:

CONSTRICTOR CONSTRICTOR OROPHIAS (Linnaeus)

Boa orophias Linnaeus, 1758, Syst. Nat., 11: 215.

Boa diviniroqua, Duméril et Bibron, 1844, Erp. Gén., 6: 515.

Boa diviniroquax, Jan, 1864, Icon. Gén., p. 81, pl. iii.

Boa diviniroqua (part), Boulenger, 1893, Cat. Snakes, Brit. Mus., 1: 118.

Constrictor orophias (part), Stull, 1935, Proc. Boston Soc. Nat. Hist., 40(8): 405. Barbour, 1914, Mem. Mus. Comp. Zool., 44(2): 329.

Type: A specimen currently in the Museum de Geer with 280 ventrals is taken to be Linnaeus' type, *vide* Andersson (1899).

Type locality: None designated; here restricted to Praslin, Saint Lucia.

Diagnosis. A *Constrictor* with a prominent snout and a convex canthus; 65 to 75 dorsal scale rows at midbody, 270 to 288 ventrals, and 27 to 31 distinct, subrectangular, dark dorsal saddles to the level of the anus; dorsal ground color rich brown; venter white with black or grey spotting pronounced; subocular stripe distinct and complete; loreal stripe largely obsolete; dark pigment on chin and infralabials not closely corresponding to the facial stripes.

Description. In general habitus this form closely corresponds to *C. c. constrictor* of Trinidad, Tobago, and part of South America. The principal differences, aside from squamation, are in the darker dorsal coloration, increase of grey patches on the venter, and the general decomposition of the bold, regular pattern so characteristic of *C. c. constrictor*. Figures 4 and 5 show the facial markings, more prominent snout, and dorsal pattern of this form compared with those of *C. c. constrictor*.

As compared with *C. c. constrictor*, *orophias* shows an increase in the number of dark dorsal saddles, and their greater irregularity contributes to the anastomosis of some of the posterior ones. There is a decrease in number of dorsal scale rows at midbody; however, there is also an increase in number of ventrals and, with respect to this character, *orophias* is not intermediate between *constrictor* and *nebulosus* subsp. nov. of Dominica. The character, however, is far from being absolute; merely a higher average number of ventrals is not, I think, sufficient to claim that this form represents a distinct species. Nevertheless, *orophias* of Saint Lucia, not *nebulosus* subsp. nov. of Dominica, has the highest ventral counts in the genus.

Habits and habitat. Large adults are readily collected simply because of their stationary habits; a specimen seen a week, two weeks, or even a month previously is usually in the same vicinity

and easily relocated when one goes to collect it. Some, e.g. MCZ 75848, from Praslin, were said to have been using the same den sites for many years. Young specimens are very much more "as you find them"; I collected several while hunting for other things, and most often found young ones in trees — one as high as twelve meters from the ground (MCZ 75845). The Tet'chien

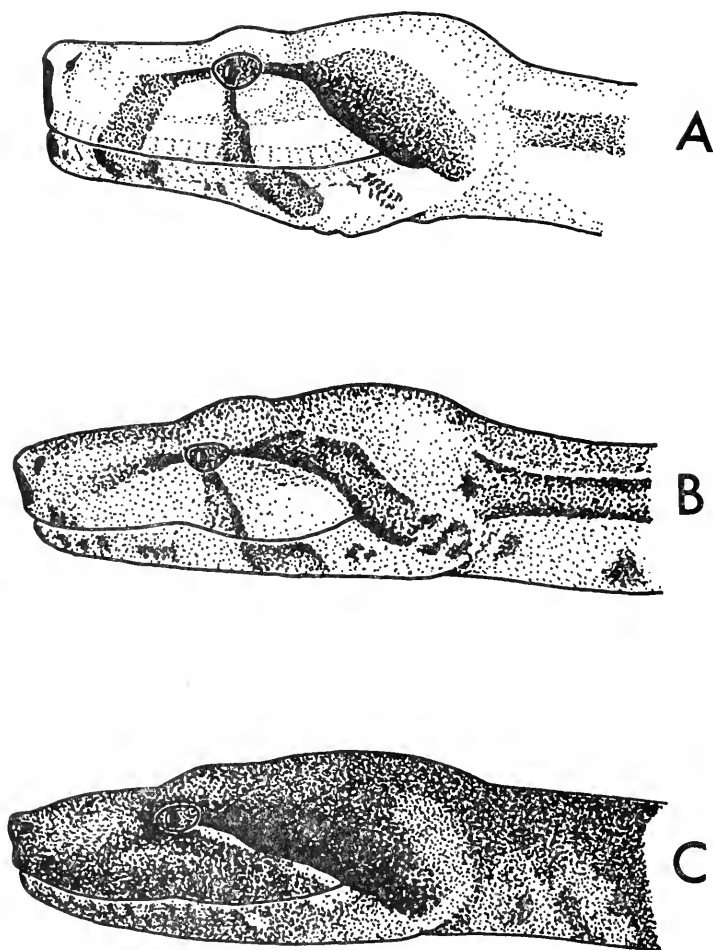

FIG. 4. Heads of three subspecies of *Constrictor constrictor*. A, *C. c. constrictor* (Linnaeus), MCZ 6105, Trinidad; B, *C. c. orophias* (Linnaeus), MCZ 74313, Praslin, Saint Lucia; C, *C. c. nebulosus* subsp. nov., Type, MCZ 65493, Woodford Hill, Dominica.

is, at any age, rather lethargic; they hiss a great deal when aroused and will strike savagely, though their accuracy leaves a good deal to be desired. They never seem to be found in the same places as *Bothrops*: for example, though I got both at Fond Citron of Grande Anse, the *Constrictor* was in uncultivated woods, the *Bothrops* in a coconut grove. Most estate owners and managers protect the Tet'chien, sometimes even fining workers for killing one; this practice is based on the belief that the Tet'chien destroys rats — which it certainly does — though probably not with anything like the efficiency of the Serpent.

Barbour (1937) claimed that the Tet'chien is "rare" on Saint Lucia; I could find no evidence of this. I never made any special attempt to find one, but rather collected them only when it was easy and convenient. The people of Saint Lucia certainly do not regard *Constrictor* as the least bit rare, though admit that they are not found in the fantastic concentrations that *Bothrops* often are. To anyone who has ever seen both a mongoose and a *Constrictor* — even a young one — the idea that mongooses could exterminate the latter must seem a shade ludicrous.

Range. The Tet'chien of Saint Lucia occupies the same region as does *Bothrops caribbaeus*, almost exactly. It does occur to higher elevations, however: *ca.* 350 meters.

Size. The largest specimen I collected, a male from Anse-La-Raye, was 2.365 meters (MCZ 75847); a female from Praslin (MCZ 75848) was 2.305 meters. Both of these are sizable snakes, but not by any means of maximum size: a considerably larger individual remains contentedly at Anse-La-Raye simply because I had no intention of either attempting to carry it out of the bush or to preserve it even if I got it out.

Relationships. The differences between this form and *C. c. constrictor* are absolute with respect to a number of characters (e.g., ventrals, dorsal saddles and loreal stripe). Were it not for the fact that the Dominican form is likewise absolutely distinct, and even more extreme *in the same direction* with respect to all characters except ventral count — so rendering *orophias* intermediate between two extremes of coloration, morphology, and geography — I would regard full species status as necessitated for this form. As it happens, however, we have a remarkable "stepped-cline" series of which *orophias* is the middle member of three steps.

Actually, in terms of color and shape of dorsal markings, *orophias* and *constrictor* are quite similar; with respect to squamation and number of dorsal markings, *orophias* is more similar

to the Dominican Tet'chien. In allusion to the extremely dark, clouded appearance of the latter form I describe it as:

CONSTRUCTOR CONSTRUCTOR NEBULOSUS subsp. nov.

Boa divinioloqua (part), Duméril and Bibron, 1844, Erp. Gén., 6: 515.

Boa divinioloqua (part), Boulenger, 1893, Cat. Snakes, Brit. Mus., 1: 118.

Constrictor orophias (part), Barbour, 1914, Mem. Mus. Comp. Zool., 44(2): 329; Stull, 1935, Proc. Boston Soc. Nat. Hist., 40(8): 405.

Type: MCZ 65493, J. D. Lazell, Jr. coll., 30 July, 1959.

Type locality: Woodford Hill, Dominica.

Diagnosis. A *Constrictor* with a prominent snout and a strikingly convex canthus; 59 to 69 dorsal scale rows at midbody, 258 to 273 ventrals, and 32 to 35 very obscure, irregular transverse markings to the level of the anus; dorsal ground color very dark, clouded, grey-brown; venter ash to slate grey, blotched and mottled with black; both loreal and subocular stripes absent, or, at most, partially indicated and largely obsolete; infralabials and chin merely grey.

Description of the type. MCZ 65493 is an adult female with 64 dorsal scale rows at midbody, and 264 ventrals. The anal is single. There are 19 supralabials on each side; there are 21 infralabials on the right, 20 on the left. Preserved, the type measures 1,438 mm, of which 172 mm are tail.

There are 33 dark transverse markings to the level of the anus; these markings are irregular in shape, not much darker than the dorsal ground color and appear almost more as mottling than actual transverse saddles. The dorsal ground color, in life, was greyish chocolate-brown. Posteriorly, the transverse markings become more distinct, black bordered and dark brown; the ground color, contrastingly, becomes yellower brown. On the tail, therefore, the pattern consists of very dark brown, black-bordered saddles set off by intervals of ochre.

The venter is ash grey anteriorly and becomes very dark—slate grey to black—posteriorly; there are irregular dark blotches along the lateral edges of the ventrals anteriorly, and these become obliterated posteriorly. The chin is entirely grey, though paler medially.

The head has a dark temporal stripe, extending from the eye to beyond the commissure of the mouth, distinctly darker-bordered along its ventral edge. In life, there was a discernible dark streak down the middle of the head. The face is paler grey, and there was, in life, a pink suffusion below the eye and on the loreal region. There are no indications of subocular or loreal stripes.

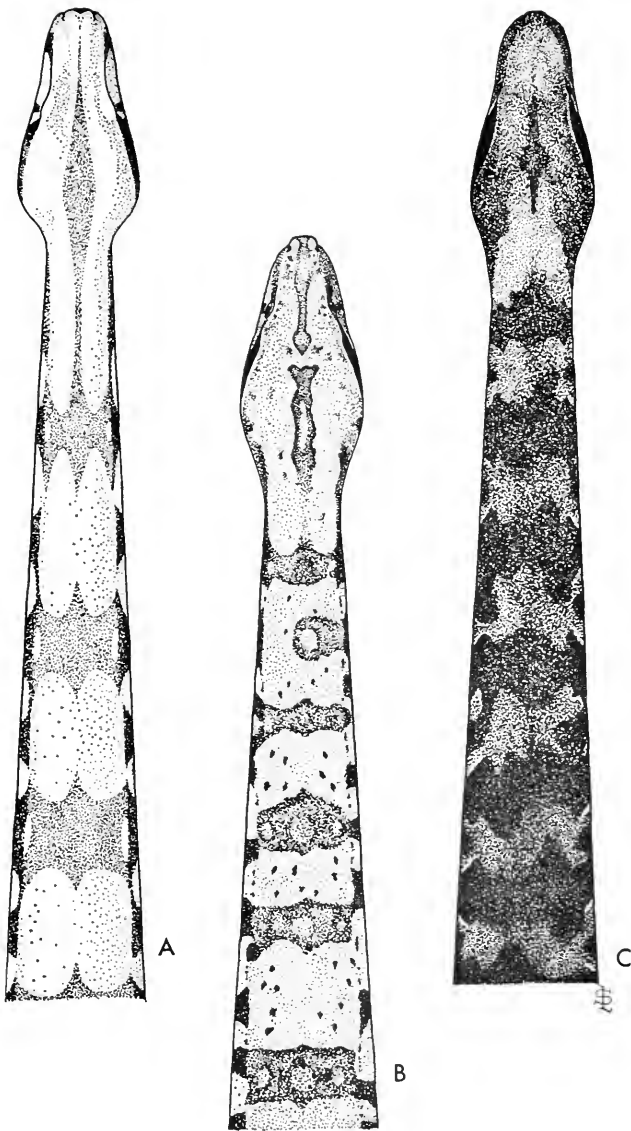

FIG. 5. Dorsal pattern in three subspecies of *Constrictor constrictor*. A, *C. c. constrictor* (Linnaeus), MCZ 6105, Trinidad; B, *C. c. orophias* (Linnaeus), MCZ 74313, Praslin, Saint Lucia; C, *C. c. nebulosus* subsp. nov., Type, MCZ 65493, Woodford Hill, Dominica.

Figure 4C shows the facial markings and Figure 5C the dorsal pattern.

Paratypes: MCZ 65494, same data as the type; MCZ 65492, Moore Park, Dominica, J. D. Lazell, Jr. coll., 21 June, 1958; MCZ 65495, Layou Park, Dominica, J. D. Lazell, Jr. coll., 14 August 1959; MCZ 58772, Trafalgar, Dominica, J. D. Lazell, Jr. coll., 18 June, 1958; MCZ 74371, Trafalgar, Dominica, J. D. Lazell, Jr. coll., 18 June, 1959; MCZ 6106, Portsmouth, Dominica, S. Garman coll., 1879.

Variation. Variation in dorsal scale rows at midbody, number of ventrals, and number of transverse markings to the level of the anus is tabulated (Table 4). Supralabials vary from 19 to 21; infralabials vary from 20 to 22.

The dorsal ground color varies somewhat, MCZ 65493 representing the light extreme (still cloudy grey-brown and with very indistinct markings), and MCZ 65492 representing the darkest individual collected (were MCZ 65492 any darker, I would be forced to call it black). MCZ 6106, collected in 1879, is pale, but this is due to fading; it is, despite this, typical in markings and shows them rather well. (A portion of a head also collected by Garman on the same trip bears the number MCZ 6107; it is deliberately not designated as a paratype.)

Habits and habitat. Barbour's (1937) comment that this form is "less uncommon" than the Tet'chien of Saint Lucia is misleading: I would describe them as being amazingly abundant. The Dominican Tet'chien, like its relative in Saint Lucia, hisses loudly when aroused and strikes rather blindly. Too, it is basically lethargic and prone to remaining in the same place for long periods of time. While staying at Woodford Hill I capitalized on their habitual laziness to save snake sacks, and merely left the snakes where I found them: they were almost always still there when I returned, even after several weeks. Congregations of three to twelve specimens denning in the same hollow log or tree stump are not at all uncommon, especially along the edges of machine-cleared banana fields where suitable den sites are often in profusion.

The people of Dominica, unlike most in Saint Lucia, have no *Bothrops* to fear and thus enjoy being deathly afraid of the Tet'chien; sometimes they even kill them, though usually only when the snakes take to raiding hen houses, which seems to be rare. Children, once initiated, are not at all afraid of even the biggest ones, however, and their parents are often shamed

into changing their minds about the danger of the Tet'chien simply because the children come to regard them as play-toys. Accidents are rare even so: even when a Tet'chien strikes with potentially dangerous accuracy, it will seldom remember to close its mouth in time to actually bite.

The Dominican *Constrictor*, like its relatives, is often encountered in trees (though large adults rarely are). Apparently they eat rats almost exclusively now, though agoutis (*Dasyproctis*) are abundant in many parts of the island and are no doubt taken as well.

Range. *Constrictor constrictor nebulosus* seems to occur throughout the island, at least to elevations of ca. 350 meters. It is, however, confined to wet ravines in dry country, e.g. at the south tip around Scott's Head, and may be largely replaced along the very dry northern leeward coast by the "Tet'chien Blanc," *Clelia*.

Size. The largest specimen collected, MCZ 65495, is a female of 1,847 mm total length; the tail is truncated, being only 87 mm long. Another female, MCZ 65492, is of more normal proportions, being 1,786 mm total length, of which 203 mm is tail. As with the Saint Lucian form, however, these specimens are far short of maximum for their taxon. A specimen owned by René Honegger of the Zurich Zoo (one of a litter produced in 1958 at the Philadelphia Zoo), is now "three meters" long (pers. comm.). For the sake of practicality, the biggest ones are best left in the bush.

Relationships. *Constrictor constrictor nebulosus* is the terminal form of a stepped-cline series, as discussed under *C. c. orophias*. Breeding experiments with other subspecies of *Constrictor constrictor* would be most interesting in assessing whether or not the subspecific rank I have accorded this form, due to its membership in a stepped-cline series, has merit from the standpoint of reproductive potential, as well as geographical and morphological characteristics. Such experiments are being contemplated by Honegger (pers. comm.), though the male he intends to use is a specimen of the very different *C. c. occidentalis*. It must be noted, however, that these two completely allopatric forms have never been subjected to any selection pressure whatever relative to interbreeding, and therefore the presence or absence of reproductive isolation between them may be entirely happenstance, if they are artificially placed in "sympatry."

DISCUSSION

In re-evaluating the taxonomy of Lesser Antillean *Bothrops* and *Constrictor* I have, in one case, separated at the species level two forms which had been previously lumped, not only with each other, but with their South American relatives; in the other case, I have split one "species" into two forms, both of which I have placed as subspecies of their South American relative. As these are island forms, I have had no possible recourse to evidence of reproductive isolation or the lack of it. It would appear also that morphological degree of difference has not been consistently used in my classification. Thus, *Bothrops caribbaeus* is absolutely different from all other members of its genus only in the characters of ventral pigmentation and dorsal pattern—color characteristics that many consider trivial, no matter how constant and definitive. *Bothrops lanceolatus*, though "more different" morphologically, is absolutely distinct ultimately only on the basis of its squamation characters combined with ventral pigmentation, thus falling back once again on a color character.

Constrictor constrictor orophias, however, is more different from any other subspecies of *Constrictor constrictor* than any of them are from each other (*nebulosus* excepted) with respect to such a conventionally respectable character as ventral count; this I have nevertheless made a subspecies. My reasons for ranking these forms as I have center around the concept of the species set forth by Simpson (1961), in which the principal criterion of conspecificity is continuity of evolutionary role.

A subspecies, as I would define it, is a rather peculiar sort of geographical variant within a species that has a wider range; it must be sharply defined (as opposed to gradually clinal) and diagnostically homogeneous (as opposed to the sort of situation which arises from discordant variation). Nevertheless, subspecies are, from the standpoint of evolutionary role, perfectly continuous with each other within their species. Continuity of evolutionary role, even between forms that are morphologically very dissimilar in many respects, can be maintained by direct intergradation and continuous gene flow. As Simpson (p. 153) points out, however, geographic isolation tends to break the continuity of evolutionary role by actually breaking the continuity of gene flow.

Therefore, I am willing to admit as geographic races of a single species only those geographically isolated forms in which there is apparent continuity of evolutionary role expressed in

the characteristics of the animals. (In the cases presented, the critical characteristics have been morphological but this is certainly not obligatory.) In *Constrictor* there is a sequential increase proceeding northward through the three populations in the following characters: scale size (= decrease in dorsal scale rows at midbody), number of transverse saddles, darkness of coloration, irregularity of pattern, obliteration of facial markings, and convexity of the canthus. On the other side of the slate is ventral count; in this case the sequence is broken and the geographically intermediate form has the highest average. Nevertheless, the balance of characters examined would seem to indicate that there is a continuity of evolutionary role, expressed in the morphology of the populations, proceeding from *Constrictor constrictor constrictor* through *Constrictor constrictor orophias* to *Constrictor constrictor nebulosus*.

In the case of the *Bothrops* populations, the geographic conditions are admirably suited for this sort of pattern, but the animals fail completely to conform in all discernible characters. Their morphological and behavioral characteristics are such that by any standard there can be no doubt that the Antillean forms are distinct species relative to each other. Assigning one or the other to subspecific rank under one of the South American forms would require an initial arbitrary choice as to which of the Antillean populations should be assigned to a South American form; a subsequent arbitrary choice would then be necessary to determine under which South American form to place the Antillean population chosen. In the end, we would be faced with the overwhelming reality that we had merged forms *merely because they were allopatric*.

Two primary objections to my criteria of continuity may be cited: first, the islands may have been populated in a way which obscures the true relationships of the animals. That is, had a distant island been the first place a new form differentiated, then a second, intermediate one colonized from that stock, and subsequently differentiated again, in each case the differentiation might have produced what would have been a stepped-cline series, had the geographic sequence been intelligible. Secondly, it is readily seen that no less than three populations are necessary before we can discern the stepped cline. That is, if Dominica and its *Constrictor* did not exist, I would have classified *orophias* as a full species, since there would have been no evidence for continuity of evolutionary role.

Both of these arguments are quite valid. It must be pointed out, however, that whenever a geographically and reproductively isolated, absolutely distinct population is classed as a subspecies (= a special sort of geographical variant within a more widespread species), this is an act of presumption. Conservatively speaking, the form qualifies as a species completely. It is only by means of strong evidence to the contrary that we may really refuse to rank it as such. As any taxonomist ultimately must admit, the relationships of an animal are not affected by our inability to discern them, but what we are able to say about them is.

ACKNOWLEDGMENTS

Roger Conant, of the Philadelphia Zoological Gardens, has unfailingly passed on to the Museum of Comparative Zoology any and all specimens collected by me that died while in his care. Arthur Greenhall was kind enough to supply authoritative information on Tobago. Ernest Williams, Museum of Comparative Zoology, provided the comparative material needed. G. G. Simpson, also of this Museum, was so good as to listen to and comment on my descriptions of the characters and distributions of the populations involved.

This work was supported by the Philadelphia Zoological Society and by National Science Foundation Grant G-16066, the latter held by Dr. Williams.

TABLE 1
Variation in some characters of *Bothrops caribbaeus*.
ST. LUCIA

MCZ No.	Locality	Sex	Dorsal Rows at Midbody	Ventrals	Supralabials		Subocular Rows
					Right	Left	
4812	"St. Lucia"	♀	27	210	7	7	2
4814	"St. Lucia"	♀	27	205	7	7	2
4815	"St. Lucia"	♂	25	199	7	7	2
70166 ¹	Grande Anse	♀	27	212	7	8	2
70193	Grande Anse	♀	27	211	7	8	2
70194	Grande Anse	♀	27	203	8	7	2
70195	Grande Anse	♀	27	206	7	7	2
70196	Grande Anse	♂	25	198	7	7	2
70197	Grande Anse	♀	27	209	8	7	2
70198	Grande Anse	♀	29	205	7	7	2
70199	Grande Anse	♀	27	206	7	7	2
70200	Grande Anse	♂	25	203	7	7	2
70201	Grande Anse	♀	27	211	7	7	2
70202	Grande Anse	♀	27	203	7	7	2
70203	Grande Anse	♂	25	200	8	7	2
70204	Marquis	♀	29	205	7	7	2
70205	Praslin	♀	27	209	7	7	2
70206	Praslin	♂	25	201	7	7	2
70207	Praslin	♀	27	210	8	7	2
70208	Praslin	♂	25	198	7	7	2
70209	Praslin	♂	25	203	7	7	2
70210	Anse-La-Raye	♀	27	207	7	7	2
70211	Anse Galet	♀	27	207	8	7	2

¹MCZ 70167-92, young *ex* MCZ 70166, are not tabulated. Their counts are within the ranges indicated above.

TABLE 2
Variation in some characters of *Bothrops lanceolatus*.
MARTINIQUE

MCZ No.	Locality	Sex	Dorsal Rows at Midbody	Ventrals	Supralabials		Subocular Rows
					Right	Left	
4813	St. Pierre	♀	31	218	7	7	3
4816	St. Pierre	♀	33	225	8	7	3
4817	Morne Rouge	♂	31	221	8	8	3
75834	Gallochat	♂	29	225	7	7	2
75835	Rivière Noire	♀	31	229	7	8	3
75836	Morne Capot	♀	31	227	7	7	3
75837	Morne Capot	♀	31	230	7	7	3
75838	Morne Capot	♀	33	237	7	7	2
75839	Morne Capot	♀	33	221	7	7	2
75840	Grande Savane	♂	31	224	8	7	3
75841	Grande Savane	♀	33	230	8	8	3
60145	Grande Savane	♀	33	229	8	7	3

TABLE 3
Variation in some characters of *Constrictor constrictor orophias*.
ST. LUCIA

MCZ No.	Locality	Sex	Dorsal Rows at Midbody	Ventrals	Transverse Markings to Anus
74313	Praslin	♂	71	277	30
75842	Anse-La-Raye	♀	74	275	31
75843	Anse-La-Raye	♀	75	270	31
75844	Grande Anse	♂	71	277	29
75846	Marquis	♂	70	273	31
75847	Anse-La-Raye	♂	74	278	29
75848	Praslin	♀	74	278	31
6659	—	♂	65	288	30
6710	—	♂	68	275	27
6711	—	♂	68	275	30

TABLE 4
Variation in some characters of *Constrictor constrictor nebulosus*.
DOMINICA

MCZ No.	Locality	Sex	Dorsal Rows at Midbody	Ventrals	Transverse Markings to Anus
6106	Portsmouth	♂	66	273	32
58772	Trafalgar	♀	66	263	34
65492	Moore Park	♀	58	264	35
65493	Woodford Hill	♀	64	264	33
65494	Woodford Hill	♀	69	266	34
65495	Layou Park	♀	66	270	33
74371	Trafalgar	♂	60	266	32

LITERATURE CITED

AMARAL, A.

1921. Contribuição para o conhecimento dos ofídios do Brasil. 1. Quatro novas espécies de serpentes brasileiras. *Anex. Inst. Butantan* 1(1): 1-90, 17 plates.
1923. The Brazilian contribution towards the improvement of the specific snake bite treatment. *Proc. New York Path. Soc., (N.S.)* 23: 89-98.
1925. On the differentiation of the species *Bothrops atrox* (Linné, 1758), *B. jararaca* (Wied, 1824), and *B. jararacussu* Lacerda, 1884. *Contrib. Harvard Inst. Trop. Biol. and Med.*, 2: 22-43.
1954. Contribuição ao conhecimento dos ofídios neotropicos XXXV. A propósito de revalidação de *Coluber lanceolatus* Lacépède, 1789. *Mem. Inst. Butantan*, 26: 207-214.

ANDERSSON, L. G.

1899. Catalogue of Linnean type-specimens of snakes in the Royal Museum in Stockholm. Bihang K. Svenska Vet.-Akad. Handl., **24** (6): 1-35.

BARBOUR, T.

1914. Contributions to the zoogeography of the West Indies, with especial reference to amphibians and reptiles. Mem. Mus. Comp. Zool., **44**(2): 1-359.
1937. Third list of Antillean amphibians and reptiles. Bull. Mus. Comp. Zool., **82**(2): 1-166.

BOULENGER, G. A.

1893. Catalogue of the snakes in the British Museum (Natural History). London, vol. I, xiii + 448 pp.
1896. Catalogue of the snakes in the British Museum (Natural History). London, vol. III, xiv + 727 pp.

DITMARS, R.

1954. Snakes of the world. New York, Macmillan Co., xi + 207 pp.

DUMÉRIL, A. AND G. BIBRON

1844. Erpétologie générale. Paris, vol. 6, xii + 610 pp.

DUNN, E. R.

- 1934a. Physiography and herpetology in the Lesser Antilles. Copeia, 1934 (3): 105-111.
- 1934b. Notes on *Iguana*. Copeia, 1934 (1): 1-4.

GARMAN, S.

1887. On the reptiles and batrachians of Grand Cayman. Proc. Amer. Phil. Soc., **24**: 273-286.

HOGE, A. R.

1952. Notas erpetológicas. Revalidação de *Bothrops lanceolata* (Lacépède). Mem. Inst. Butantan, **24**(2): 231-236.

JAN, G.

1864. Iconographie générale des ophidiens. Paris, Livr. 5.

LACÉPÈDE, B.

1789. Histoire naturelle des serpens. Paris, vol. II, 527 pp.

LAURENTI, J. N.

1768. Specimen medicum exhibens synopsis reptilium. Vienna, 214 pp.

LINNAEUS, C.

1758. Systema naturae. (London), ed. 10, vol. 1, 824 pp.

SIMPSON, G. G.

1961. Principles of animal taxonomy. New York, Columbia Univ. Press, xii + 247 pp.

STULL, O. G.

1935. A check list of the family Boidae. Proc. Boston Soc. Nat. Hist., **40**(8): 387-408.

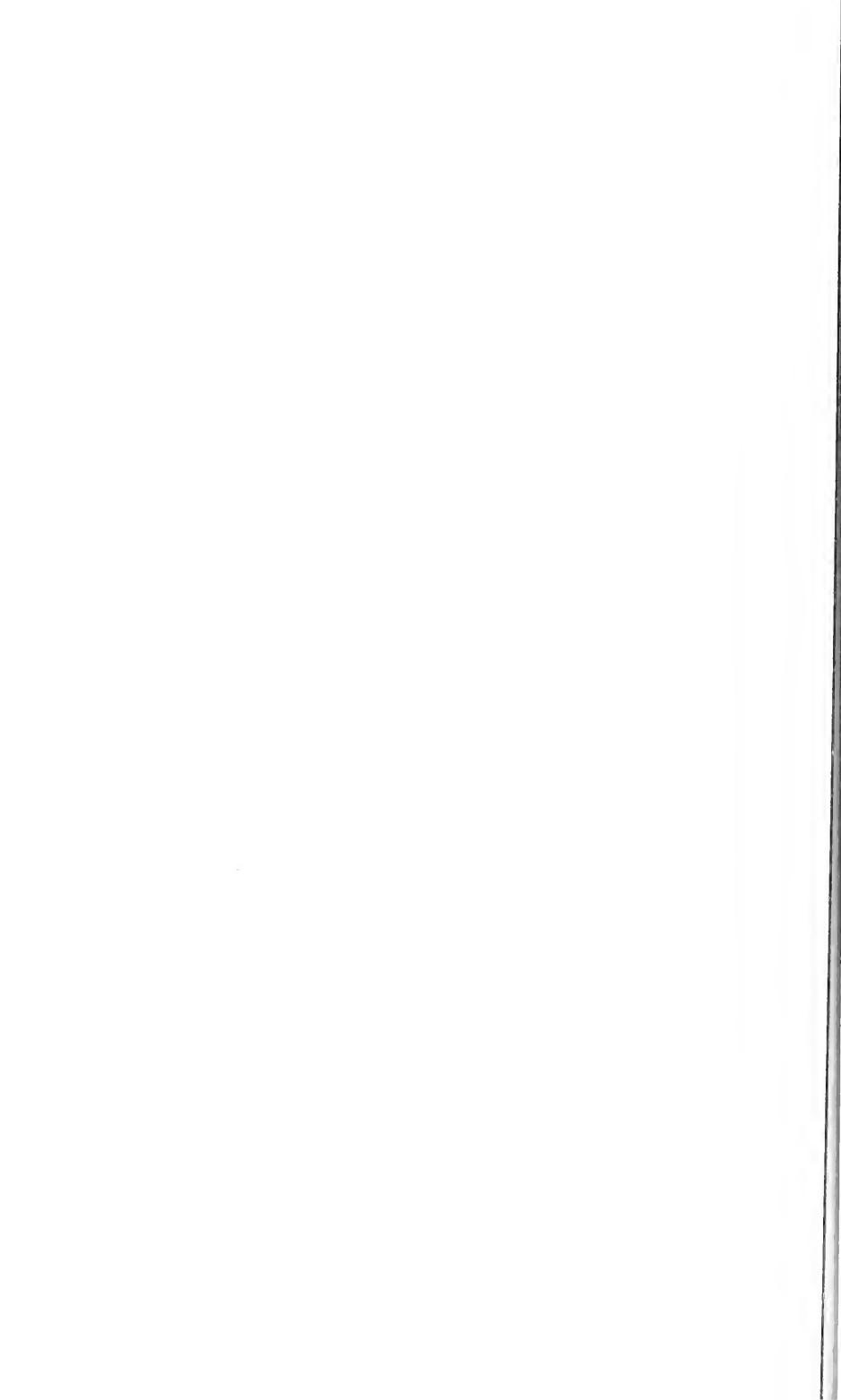

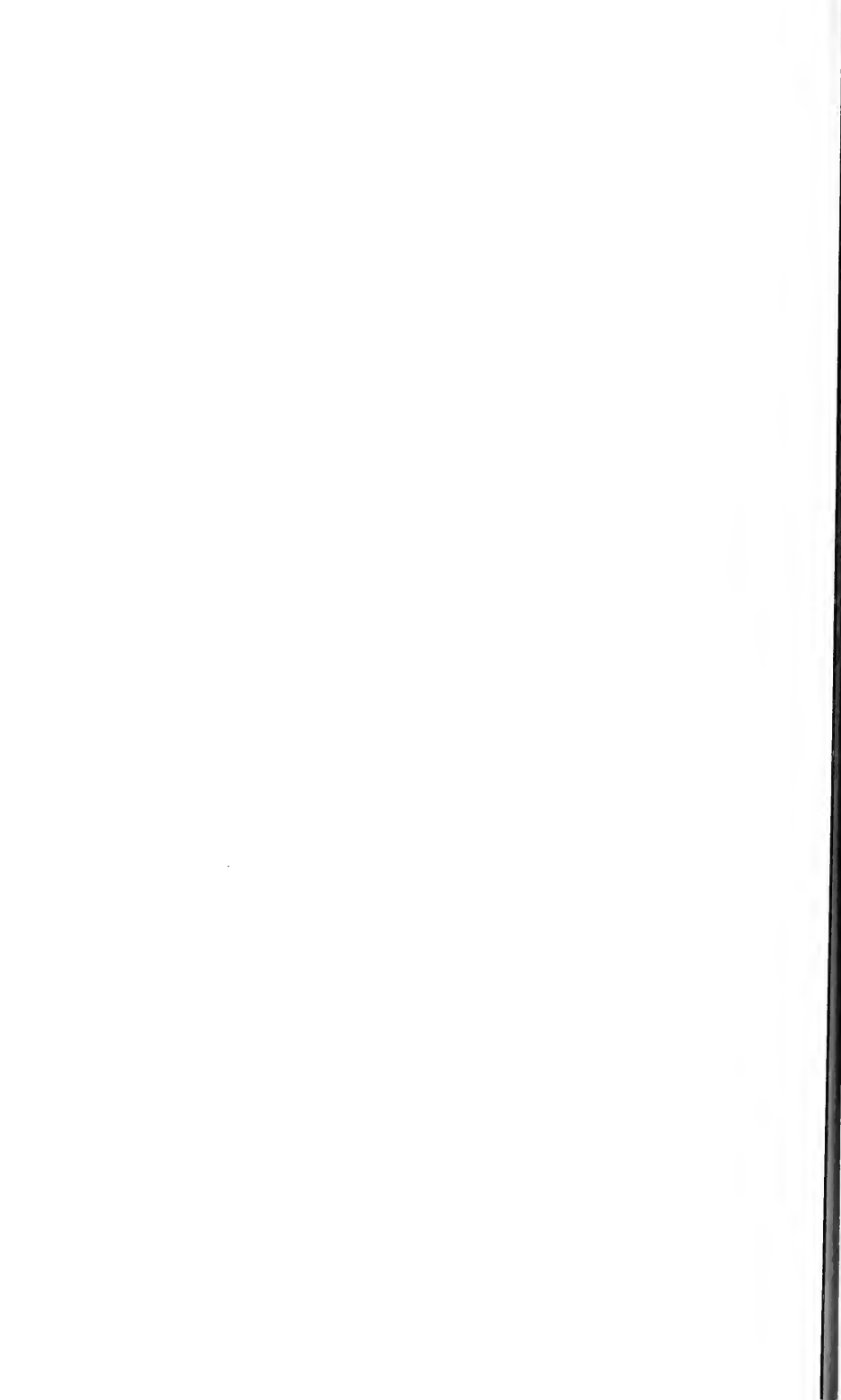

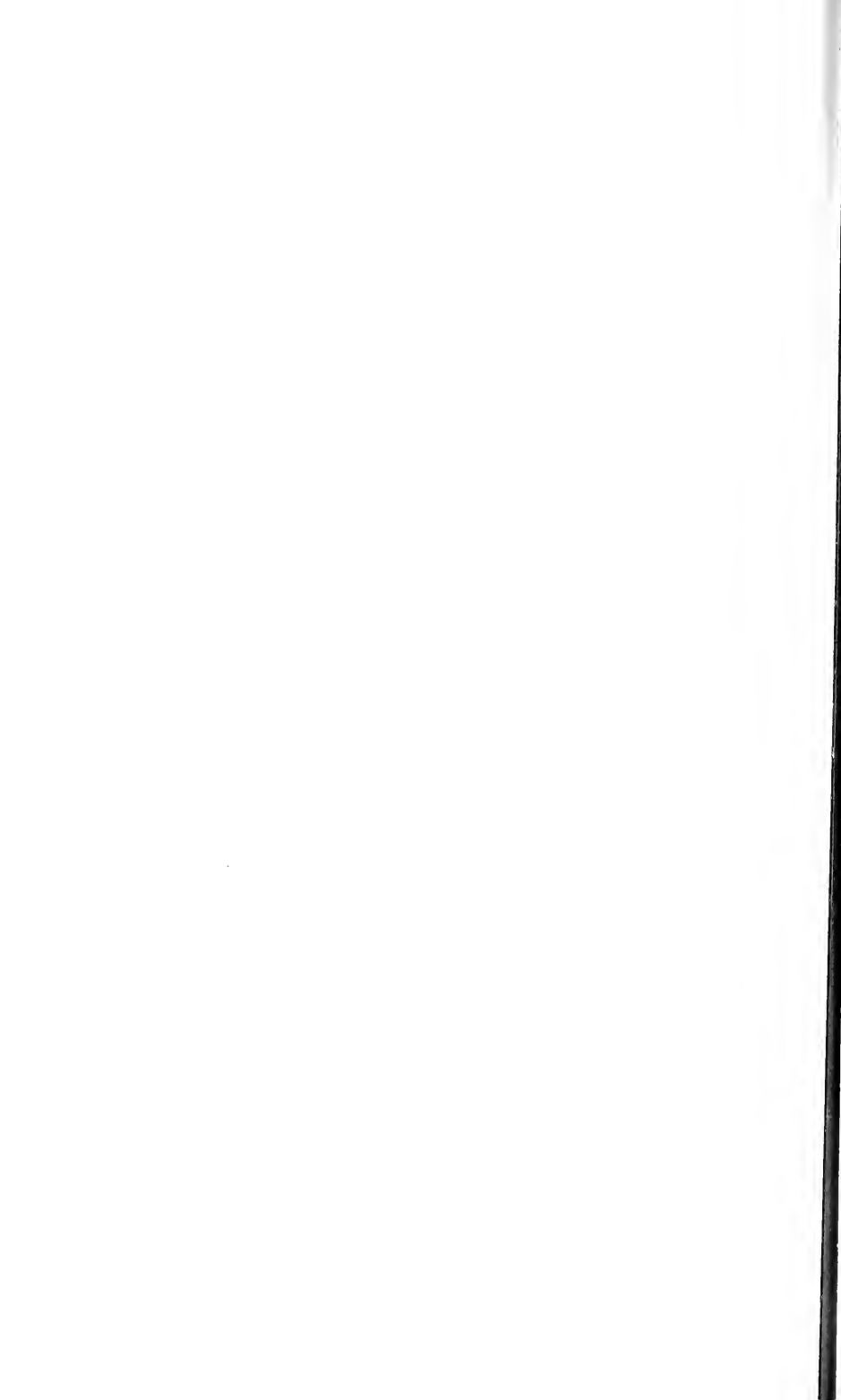

Bulletin of the Museum of Comparative Zoology

HARVARD UNIVERSITY

VOL. 132, No. 4

TRILOBITES OF THE ORDOVICIAN TABLE HEAD
FORMATION, WESTERN NEWFOUNDLAND

BY H. B. WHITTINGTON

WITH SIXTY-EIGHT PLATES

CAMBRIDGE, MASS., U.S.A.

PRINTED FOR THE MUSEUM

MARCH 30, 1965

PUBLICATIONS ISSUED BY OR IN CONNECTION
WITH THE
MUSEUM OF COMPARATIVE ZOOLOGY
HARVARD UNIVERSITY

BULLETIN (octavo) 1863 — The current volume is Vol. 132.

BREVIORA (octavo) 1952 — No. 217 is current.

MEMOIRS (quarto) 1864-1938 — Publication terminated with Vol. 55.

JOHNSONIA (quarto) 1941 — A publication of the Department of Mollusks. Vol. 4, no. 43 is current.

OCCASIONAL PAPERS OF THE DEPARTMENT OF MOLLUSKS (octavo) 1945 — Vol. 2, no. 31 is current.

PROCEEDINGS OF THE NEW ENGLAND ZOOLOGICAL CLUB (octavo) 1899-1948 — Published in connection with the Museum. Publication terminated with Vol. 24.

The continuing publications are issued at irregular intervals in numbers which may be purchased separately. Prices and lists may be obtained from the Publications Office of the Museum of Comparative Zoology, Cambridge 38, Massachusetts.

Peters' Check-List of Birds of the World. Volume 1 is out of print; volumes 2 to 7, 9, 10 and 15 are currently available.

Phylogeny and Evolution of Crustacea. Proceedings of a conference held at Cambridge, Mass., March 6-8, 1962. H. B. Whittington and W. D. I. Rolfe, editors. Cambridge, Mass., 192 pp., 80 figs., 1963. Cloth bound, \$6.75.

Fishes of the Gulf of Maine, by Henry B. Bigelow and William C. Schroeder. Washington, viii - 577 pp., 1953. Photo-offset reprint, \$6.50.

PUBLICATIONS OF THE
BOSTON SOCIETY OF NATURAL HISTORY

The remaining stock of the scientific periodicals of the Boston Society of Natural History has been transferred to the Museum of Comparative Zoology for distribution. Prices for individual numbers may be had upon request.

Bulletin of the Museum of Comparative Zoology

HARVARD UNIVERSITY

VOL. 132, No. 4

TRILOBITES OF THE ORDOVICIAN TABLE HEAD
FORMATION, WESTERN NEWFOUNDLAND

BY H. B. WHITTINGTON

WITH SIXTY-EIGHT PLATES

CAMBRIDGE, MASS., U.S.A.

PRINTED FOR THE MUSEUM

MARCH 30, 1965



No. 4—*Trilobites of the Ordovician Table Head Formation,
western Newfoundland*

By H. B. WHITTINGTON

CONTENTS

	Page
Introduction and acknowledgements	281
Localities and lists of species	282
Lower Table Head Formation	283
Type section	283
Pointe Riche	283
Middle Table Head Formation	284
Type section	284
Table Cove	285
Isolated limestone	286
Black Cove	286
Table Head boulders	286
Portland Creek	286
Daniel's Harbour	287
Table Head Trilobite Fauna	287
Numbers and relative abundance	287
Composition	289
Correlation	289
Age	294
Evolutionary and Geographical Relationships	294
Summary of Morphology and Classification	296
Systematic Palaeontology	299
Introduction	299
Terminology	300
Family Agnostidae	301
<i>Geragnostus</i> Howell, 1935	301
<i>G. longicollis</i> (Raymond, 1925)	301
<i>G. fabius</i> (Billings, 1865)	302
<i>Galbagnostus</i> n. gen.	304
<i>G. galba</i> (Billings, 1865)	305
Family Harpididae	309
<i>Harpides</i> Beyrich, 1846	309
<i>H. atlanticus</i> Billings, 1865	309
Family Harpidae	312
<i>Selenoharpes</i> Whittington, 1950	312
<i>S. singularis</i> n. sp.	312

	Page
Family Raphiophoridae	313
<i>Lonchodomas</i> Angelin, 1854	313
<i>L. normalis</i> (Billings, 1865)	313
<i>L. clavulus</i> n. sp.	316
<i>Ampyx</i> Dalman, 1827	318
<i>A. laeviusculus</i> Billings, 1865	318
<i>Ampyroides</i> n. gen.	319
<i>A. semicostatus</i> (Billings, 1865)	319
<i>Anisonotella</i> Whittington, 1952	321
<i>A. glacialis</i> (Billings, 1865)	321
Family Endymioniidae	324
<i>Endymionia</i> Billings, 1865	324
<i>E. schucherti</i> Raymond, 1920	324
<i>E. meeki</i> (Billings, 1862)	326
<i>E. raymondi</i> n. sp.	326
<i>E. sp. ind.</i>	327
Family Shumardiidae	327
<i>Shumardia</i> Billings, 1862	327
<i>S. granulosa</i> Billings, 1862	327
<i>S. sagittula</i> n. sp.	330
<i>Leioshumardia</i> n. gen.	330
<i>L. minima</i> n. sp.	331
Family Olenidae	331
<i>Triarthrus</i> Green, 1832	331
<i>T. fischeri</i> Billings, 1865	331
<i>Hypermeccaspis</i> Harrington and Leanza, 1957	335
<i>H. cf. bulmani</i> Harrington and Leanza, 1957	335
Family Proetidae	337
<i>Phaseolops</i> Whittington, 1963	337
<i>Phaseolops?</i> sp. ind.	337
Family Dimeropygidae	338
<i>Ischyrotoma</i> Raymond, 1925	338
<i>Ischyrotoma</i> sp. ind.	338
<i>Ischyrophyma</i> Whittington, 1963	339
<i>I. tumida</i> n. sp.	339
<i>Ischyrophyma?</i> sp. ind.	340
Family Asaphidae	340
<i>Stegnopsis</i> n. gen.	340
<i>S. solitarius</i> n. sp.	344
<i>S. huttoni</i> (Billings, 1865)	346
<i>Niobe</i> Angelin, 1851	348
<i>N. quadraticaudata</i> (Billings, 1865)	349
<i>N. morrisi</i> (Billings, 1865)	352
Protaspis	356
Asaphid? hypostome	357
Family Nileidae	358
<i>Nileus</i> Dalman, 1827	358

	Page
<i>N. affinis</i> Billings, 1865	358
<i>N. scrutator</i> Billings, 1865	360
<i>N. macrops</i> Billings, 1865	361
<i>N.?</i> <i>lacunosa</i> n. sp.	362
<i>Peraspis</i> n. gen.	363
<i>P. lineolata</i> (Raymond, 1925)	364
Nileid gen. ind.	366
Family Telephnidae	367
<i>Telephina</i> Marek, 1952	367
<i>T. americana</i> (Billings, 1865)	367
<i>T. sp.</i> ind.	371
Family Komaspidae	371
<i>Goniophrys</i> Ross, 1951	371
<i>G. breviceps?</i> (Billings, 1865)	371
<i>Carolinites</i> Kobayashi, 1940	373
<i>C. sp.</i> ind. 1	373
<i>C. sp.</i> ind. 2	373
Family Remopleuridae	374
<i>Remopleurides</i> Portlock, 1843	374
<i>R. pilulus</i> n. sp.	374
<i>R. sp.</i> ind.	375
<i>Robergia</i> Wiman, 1905	375
<i>R. schlothheimi</i> (Billings, 1865)	375
<i>Blosyropsis</i> n. gen.	377
<i>B. billingsi</i> n. sp.	378
<i>Eorobergia</i> Cooper, 1953	380
<i>E. grandis</i> n. sp.	380
Family Bathyuridae	383
<i>Acidiphorus</i> Raymond, 1925	383
<i>A. spinifer</i> Raymond, 1925	383
Family Illaenidae	385
<i>Illaenus</i> Dalman, 1827	385
<i>I. fraternus</i> Billings, 1865	387
<i>I. marginalis</i> Raymond, 1925	389
<i>I. alveatus</i> Raymond, 1925	391
<i>I. sp.</i> ind. 1	391
<i>I. consimilis</i> Billings, 1865	393
<i>I. gelasinus</i> n. sp.	397
<i>I. sp.</i> ind. 2	398
<i>I. sp.</i> ind. 3	399
Illaenid? pygidium	399
Family Scutelluidae	400
<i>Bronteopsis</i> Nicholson and Etheridge, 1879	400
<i>B. sp.</i> ind.	400
<i>Raymondaspis</i> Přibyl, 1949	401
<i>R. reticulatus</i> n. sp.	402

	Page
<i>R. angelini</i> (Billings, 1862)	405
<i>R. turgidus</i> n. sp.	406
Family Cheiruridae	408
<i>Ceraurinella</i> Cooper, 1953	408
<i>C. polydorus</i> (Billings, 1865)	408
Subfamily Sphaerexochinae	411
<i>Xystocrania</i> n. gen.	412
<i>X. perforator</i> (Billings, 1865)	413
<i>X. glaucus</i> (Billings, 1865)	414
<i>X. cf. glaucus</i>	415
<i>Cydonocephalus</i> Whittington, 1963	415
<i>C. sp. ind.</i>	415
<i>Kawina</i> Barton, 1916	416
<i>K. sp. ind.</i>	416
<i>Heliomera</i> Raymond, 1905	416
<i>H. sol</i> (Billings, 1865)	417
<i>H. (Heliomeroidea) sp. ind.</i>	419
Family Calymenidae	419
<i>Calymenidius</i> Rasetti, 1944	419
aff. <i>C. sp. ind.</i>	419
Family Enerinuridae	420
<i>Miracybele</i> n. gen.	422
<i>M. mira</i> (Billings, 1865)	424
Enerinurid gen. et sp. ind.	427
Family Dalmanitidae	428
<i>Calyptaulax</i> Cooper, 1930	428
<i>C. incepta</i> n. sp.	428
Family uncertain	432
Cranidium gen. ind. 1	432
Cranidium gen. ind. 2	433
References	434
Explanation of Plates 1-68	442

Figures

Figure	Page
1. Map showing localities in western Newfoundland	281
2. Muscle areas, tubercles, etc. in <i>Galbagnostus galba</i> (Billings)	306
3. <i>Stegnopsis solitarius</i> n. gen., n. sp.	342
4. <i>Stegnopsis huttoni</i> (Billings)	343
5. <i>Niobe quadrataudata</i> (Billings)	354
6. <i>Niobe morrissi</i> (Billings)	355
7. <i>Miracybele mira</i> (Billings)	423

INTRODUCTION AND ACKNOWLEDGEMENTS

A brief history of work on the Table Head Formation, and an account of the stratigraphy, have recently been given (Whittington and Kindle, 1963). These pages describe the trilobites and discuss the composition of the fauna, its age and relations to other faunas in time and space. The formation is 1100 feet thick at its type section at Table Point (Text-fig. 1). The lower 800 feet is of light gray limestone with some dolomite in the lower part. The middle part of the formation, 270 feet

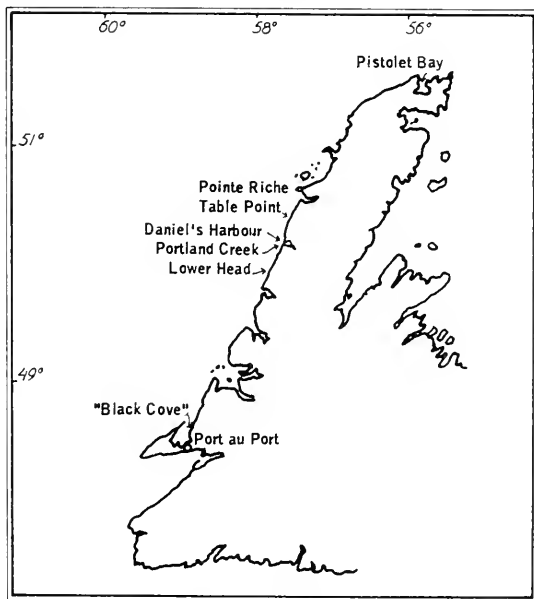

FIG. 1. Map showing localities in western Newfoundland referred to in the text.

thick, is darker in colour and interbedded with dark shale. The upper 30 feet is black shale containing graptolites. E. Billings, the first investigator, described 27 species of trilobites now considered valid, coming mostly from the middle part. P. E. Raymond described seven additional species here considered valid. Almost twice this total, 66 species, are recognized here, the vast majority from the middle part. The importance of this fauna lies not only in its richness, but in its excellence of preservation

and in its age. Varied, well-preserved Lower Ordovician faunas have been described in recent years (Ross, 1951; Hintze, 1953), as have middle to late Middle Ordovician faunas (Whittington, 1959). The Table Head fauna is early Middle Ordovician in age, and quite different from the slightly younger Chazy trilobites. The recently-described fauna of 45 species from a boulder at Lower Head, 30 miles south of Table Point (Text-fig. 1), is of about the same age but has only one species in common. Together, these faunas afford an extraordinary glimpse of the trilobites occupying a variety of ecological niches in Whiterock time. The approximately contemporaneous European faunas, in Llanvirn rocks of Bohemia and Britain, are of comparable richness and contain genera belonging to some of the same families, and to several different families. No species and very few genera are in common, a difference here ascribed to a difference in province. The photographs attest to the remarkable preservation, though complete exoskeletons are rare. The great amount of new morphological information has helped to clarify the systematic position of certain old species.

I am deeply indebted to Cecil H. Kindle for urging me to join him in work in western Newfoundland, and for placing at my disposal his earlier collections. The collections we made together in 1958 and 1961, with the enthusiastic assistance of Mrs. Whittington and Miss Mary Anne Kindle, form the basis of this work. Essential was the opportunity to study earlier material, including types. Drs. T. E. Bolton and D. J. McLaren kindly made this possible at the Geological Survey of Canada, and Prof. Karl M. Waagé at the Peabody Museum, Yale University. Field work in western Newfoundland in 1958 and 1961 was carried out by Kindle and me under National Science Foundation grant G-4189. The cost of publication of the plates, part of the costs of binding, and of technical assistance to me, have been borne by National Science Foundation grant G-19082. The skillful help of Eleanor A. Ormiston in preparing enlargements from my negatives and in mounting the plates is gratefully acknowledged. Mr. N. Strekalovsky prepared Text-figures 1-7.

LOCALITIES AND LISTS OF SPECIES

An account of the stratigraphy of the Table Head Formation (Whittington and Kindle, 1963) reviews previous work, describes in more detail the localities mentioned below, and includes lists of trilobites, graptolites and other fossils. The localities

given in the present systematic section and plate explanations are referred to by the paragraph headings used below and are shown on Text-figure 1. The lists of trilobite species given previously are emended and amplified. As an indication of relative abundance, counts are given of cephalata or cranidia (c) and pygidia (p), obtained from the type section and at Table Cove. These figures are not unbiased, since only better-preserved specimens were brought back to the laboratory. The species are listed in the same systematic order as given in the Table of Contents.

LOWER TABLE HEAD FORMATION

Type section. Exposed on the north side of Table Point (Text-fig. 1), 810 feet of limestone with some dolomites (Whittington and Kindle, 1963, pp. 747-9, fig. 1). Stratigraphical ranges of species are corrected where they differ from those given in Whittington and Kindle, 1963, figure 2:

	C	P
<i>Stegnopsis solitarius</i> n. gen., n. sp. (recorded as "aff. <i>Isoteloides</i> sp.")	0	8
<i>Nileus affinis</i> (now identified in the middle Table Head formation)	5	2
<i>Eorobergia grandis</i> n. sp.	0	6
<i>Uromystrum validum</i>	23	23
<i>Acidiphorus spinifer</i>	23	5
<i>Illaenus fraternus</i>	24	12
<i>Illaenus marginalis</i>	37	29
<i>Illaenus alveatus</i>	17	0
<i>Illaenus</i> sp. ind. 1 — from bed 8 at 280 feet above base	1	0
<i>Pseudomera barrandei</i>	8	18
<i>Ectenonotus westoni</i>	0	9
<i>Xystocrania perforator</i> (now recorded from middle Table Head Formation)	1	0
<i>Xystocrania</i> cf. <i>glaucus</i> — from bed 8 at 350 feet above base	1	0
<i>Calyptaulax incepta</i> n. sp. — from bed 8 at 350 and 379 feet above base	1	1

Pointe Riche. On the shore about one-half mile north of Pointe Riche lighthouse (Whittington and Kindle, 1963, p. 752) the following trilobites were found:

<i>Stegnopsis solitarius</i> n. gen., n. sp.	<i>Acidiphorus spinifer</i>
<i>Nileus affinis</i>	<i>Illaenus marginalis</i>
<i>Eorobergia grandis</i>	<i>Pseudomera barrandei</i>
<i>Uromystrum validum</i>	<i>Ectenonotus westoni</i>
	<i>Kawina</i> sp. ind.

MIDDLE TABLE HEAD FORMATION

Type section. Exposed on the south side of Table Point, 270 feet of limestone (Whittington and Kindle, 1963, pp. 749-750, fig. 1). The list of species (and their stratigraphical range) given in Whittington and Kindle, 1963, figure 3, is emended and amplified as follows :

	C	P
<i>Geragnostus longicollis</i>	4	3
<i>Geragnostus fabius</i> — 185 to 215 feet above base	14	8
<i>Galbagnostus galba</i>	5	2
<i>Harpides atlanticus</i> — 17 to 265 feet above base	3	0
<i>Lonchodomas normalis</i>	35	32
<i>Lonchodomas clavulus</i> n. sp. — 17 to 50 feet above base	12	7
*° <i>Ampyx laeviusculus</i>	14	11
<i>Ampyxoides semicostatus</i>	21	27
° <i>Endymionia schucherti</i>	19	10
<i>Shumardia sagittula</i> n. sp. — 130 to 265 feet above base	2	0
<i>Leioshumardia minima</i> n. gen., n. sp. — 17 to 190 feet above base	3	0
<i>Triarthrus fisheri</i>	23	1
* <i>Hypermeceaspis bulmani</i> — exact horizon unknown	2	1
* <i>Phascolops?</i> sp. ind. — 185 feet above base	1	0
<i>Ischyrophyma tumida</i> n. sp. — 50 feet above base	2	0
*° <i>Cranidium</i> gen. ind. 1 — 90 feet above base	1	0
<i>Stegnopsis huttoni</i>	9	14
<i>Niobe quadraticaudata</i>	14	13
<i>Niobe morrisoni</i> — 90 to 265 feet above base	6	19
<i>Nileus affinis</i> — 17 to 265 feet above base (recorded previously in part as <i>N. scrutator</i>)	20	16
° <i>Nileus scrutator</i> — 90 and 215 feet above base	5	5
<i>Nileus macrops</i>	12	11
<i>Peraspis lincolata</i> — 130 to 190 feet above base	6	19
° <i>Nileus?</i> <i>lacunosa</i> — 190 feet above base	2	1
<i>Tclephina americana</i>	33	3
<i>Goniophrys breviceps?</i> — 17 feet above base	3	0
*° <i>Remopleurides</i> sp. ind. — 190 feet above base	4	0
<i>Robergia schlotheimi</i>	7	5
<i>Blosyropsis billingsi</i> n. gen., n. sp.	6	1
<i>Iliaenus consimilis</i>	34	17
<i>Iliaenus gelasinus</i> n. sp. — 90 feet above base	6	6
<i>Raymondaspis reticulatus</i> n. sp.	28	17
*° <i>Raymondaspis turgidus</i> n. sp. — 190 feet above base	3	8
<i>Pseudomera barrandei</i>	8	12
<i>Ceraurinclla polydorus</i>	2	0
*° <i>Xystocrania perforator</i> — exact horizon unknown	1	0
* <i>Heliomera sol</i> — exact horizon unknown	1	0

*° <i>Heliomera (Heliomeroides)</i> sp. ind.. — recorded previously		
17 feet above base as “ <i>H. sol</i> ”	1	0
<i>Miracybele mira</i>	6	4
*° Cybelinid cranidium — 90 feet above base	1	0
Cybelinid pygidium — 265 feet above base	0	1

* Not found at Table Cove.

° Not found in isolated limestone.

Table Cove. The fossils came almost entirely from 30 to 40 feet of limestones exposed on the foreshore on the south side of Table Cove, which is 4000 feet south of Table Point (Whittington and Kindle, 1963, p. 752, fig. 1). A few specimens are from the highest beds exposed. The complete list of trilobites obtained is as follows:

	C	P
<i>Geragnostus longicollis</i>	9	12
<i>Geragnostus fabius</i>	6	6
<i>Galbagnostus galba</i>	13	23
<i>Harpides atlanticus</i>	52	0
* <i>Selenoharpes singularis</i> n. sp.	13	0
<i>Lonchodomas normalis</i>	18	4
<i>Lonchodomas clavulus</i> n. sp.	8	1
<i>Ampyroides semicostatus</i>	15	7
<i>Endymionia schucherti</i>	8	1
<i>Shumardia sagittula</i> n. sp.	12	0
<i>Leioshumardia minima</i> n. gen., n. sp.	2	0
<i>Triarthrus fischeri</i>	38	1
<i>Ischyrophyma tumida</i> n. sp.	28	0
* <i>Ischyrophyma?</i> sp. ind.	2	0
* <i>Ischyrotoma</i> sp. ind.	1	0
<i>Stegnopsis huttoni</i>	13	7
<i>Niobe quadraticaudata</i>	12	22
<i>Niobe morrissi</i>	2	2
<i>Nileus affinis</i>	15	4
<i>Nileus scrutator</i>	0	1
<i>Nileus macrops</i>	7	0
<i>Peraspis lincolata</i>	3	2
<i>Nileus?</i> <i>lacunosa</i> n. sp.	2	0
<i>Telephina americana</i>	36	1
<i>Goniophrys breviceps?</i>	6	0
* <i>Carolinites</i> sp. ind. 2	1	0
* <i>Remopleurides pilulus</i> n. sp.	12	0
<i>Robergia schlothcimi</i>	3	3
<i>Blosyropsis billingsi</i> n. gen., n. sp.	9	3
<i>Illaeus consimilis</i>	41	4
<i>Illaeus gelasinus</i> n. sp.	3	0
* <i>Illaeus</i> sp. ind. 3	0	2

<i>Raymondaspis reticulatus</i>	48	31
<i>Pseudomera barrandei</i>	14	22
<i>Ceraurinnella polydorus</i>	19	6
* <i>Cydonocephalus</i> sp. ind.	1	0
aff. <i>Calymenidius</i> sp. ind.	2	0
<i>Miracybele mira</i>	23	9
Cybelinid pygidium	0	2

* Not in middle Table Head Formation at type section, but may be present in isolated limestone.

Isolated Limestone. A small, isolated hill of limestone at the landward side of the beach at Table Cove (Whittington and Kindle, 1963, p. 752, fig. 1) yielded the following trilobites:

<i>Geragnostus longicollis</i>	<i>Nileus affinis</i>
<i>Geragnostus fabius</i>	<i>Nileus macrops</i>
<i>Galbagnostus galba</i>	<i>Peraspis lineolata</i>
<i>Harpides atlanticus</i>	<i>Telephina americana</i>
<i>Lonchodomas normalis</i>	<i>Goniophrys breviceps</i> ?
<i>Lonchodomas clavulus</i> n. sp.	<i>Robergia schlottheimi</i>
<i>Ampyroïdes semicostatus</i>	<i>Blosyropsis billingsi</i> n. gen., n. sp.
<i>Shumardia sagittula</i> n. sp.	<i>Illaenus consimilis</i>
<i>Leioshumardia minima</i> n. gen., n. sp.	<i>Illaenus gelasinus</i> n. sp.
<i>Triarthrus fischeri</i>	* <i>Illaenus</i> sp. ind. 2
<i>Phaseolops</i> ? sp. ind.	<i>Raymondaspis reticulatus</i>
<i>Ischyrophyma tumida</i> n. sp.	<i>Ceraurinnella polydorus</i>
<i>Ischyrophyma</i> ? sp. ind.	<i>Heliomera sol</i>
<i>Stegnopsis huttoni</i>	<i>Miracybele mira</i>
<i>Niobe quadraticaudata</i>	Cybelinid pygidium
<i>Niobe morrissi</i>	* <i>Cranidium</i> gen. ind. 2

* Not found in middle Table Head Formation at type section.

Black Cove. This locality, on the shore about one-half mile northeast of The Gravels at Port au Port peninsula (Whittington and Kindle, 1963, pp. 752-753), yielded trilobites from the thin limestones of bed 4, and the emended list is:

<i>Geragnostus fabius</i>	<i>Niobe quadraticaudata</i>
<i>Ampyroïdes semicostatus</i>	<i>Niobe morrissi</i>
<i>Anisonotella glacialis</i>	Nileid gen. ind.
<i>Endymionia</i> sp.	<i>Peraspis lineolata</i>
<i>Triarthrus fischeri</i>	<i>Telephina americana</i>
<i>Stegnopsis huttoni</i>	<i>Carolinites</i> sp. ind. 1

Robergia schlottheimi

TABLE HEAD BOULDERS IN COW HEAD GROUP CONGLOMERATES

Portland Creek. Boulders in conglomerates of the Cow Head Group exposed on the shore at the mouth of the creek and for some distance to the north (Whittington and Kindle, 1963, p. 753) yielded the trilobites listed below. James Richardson's

notebook of July, 1861, shows that he collected from these boulders, approximately 300 yards north of the mouth of Portland Creek.

<i>Geragnostus fabius</i>	<i>Triarthrus fischeri</i>
<i>Lonchodomas normalis</i>	<i>Iliaenus alveatus</i>
<i>Peraspis lineolata</i>	<i>Robergia schlothheimi</i>
<i>Nileus</i> ? <i>lacunosa</i> n. sp.	<i>Calypptaularx incepta</i> n. sp.
<i>Nileus</i> cf. <i>scrutator</i>	<i>Pseudomera barrandei</i>

Miraeybcle mira

Billings (1861-5) recorded some of these species and in addition *Anisonotella glacialis* and *Ceraurina polydorus*. *Iliaenus alveatus* is the only lower Table Head Formation trilobite from these boulders, all others being of middle Table Head age.

Daniel's Harbour. Boulders in conglomerates of the Cow Head Group at this locality yielded trilobites (Whittington and Kindle, 1963, pp. 753-754). At the time that the earlier paper was written it was thought that this locality was probably that described by Billings (1865, pp. 272-273, etc.) as being "four miles northeast from Portland Creek." Subsequent examination of James Richardson's notebook shows that he did indeed collect in July, 1861, from "Daniel's Cove." The emended list from these boulders is as follows:

<i>Geragnostus fabius</i>	<i>Nileus affinis</i> ?
<i>Ampyxoides semicostatus</i>	<i>Nileus macrops</i>
<i>Anisonotella glacialis</i>	<i>Nileus</i> ? <i>lacunosa</i> n. sp.
<i>Endymionia schucherti</i>	<i>Peraspis lineolata</i>
<i>Shumardia sagittula</i> n. sp.	<i>Telephina americana</i>
<i>Triarthrus fischeri</i>	<i>Robergia schlothheimi</i>
? <i>Stegnopsis huttoni</i>	<i>Blosyropsis billingsi</i> n. gen., n. sp.
<i>Niobe quadrataeudata</i>	<i>Iliaenus gclasinus</i> n. sp.
<i>Niobe morrisi</i>	<i>Raymondaspis reticulatus</i>

In addition, Billings (1861-5) recorded from this locality *Galbagnostus galba*, *Harpides atlanticus*, *Lonchodomas normalis*, *Iliaenus fraternus*, and *Heliomera sol*.

TABLE HEAD TRILOBITE FAUNA

NUMBERS AND RELATIVE ABUNDANCE OF SPECIES

The trilobites of the lower part of the Table Head Formation are moderately abundant and varied, those of the middle part exceptionally rich, as shown by the following table:

	Families	Genera	Species
Lower Table Head	8	11	14
Middle Table Head	21	38	55
In common to above	6	5	3
Faunal resemblance	75%	45%	21%

The index of faunal resemblance is the percentage in the smaller sample of the taxa in common (Simpson, 1960). These indices suggest that no important break in time occurs between the lower and middle parts of the formation. The different types of limestones that characterise the two parts reflect differences in conditions of deposition and preservation, and these differences may account for the disparity in numbers and kinds of trilobites in them. The lower Table Head Formation (Schuchert and Dunbar, 1934, p. 64; Whittington and Kindle, 1963, pp. 747-749, figure 2) is composed of gray limestone and dolomites in the lower one-fifth, the remainder of gray, rubbly limestones, the trilobites coming mainly from thin layers of lime-sand in this upper portion. In contrast, the middle Table Head limestones (Schuchert and Dunbar, 1934, pp. 63-64; Whittington and Kindle, 1963, pp. 749-750, fig. 3) are dominantly dark-gray in colour, muddy, and interbedded with black shale in increasing amounts upward. This distinction is a generalised one, and lime-sands from the upper part of the lower Table Head, the middle Table Head 90 feet above the base of the type section, at Table Cove and the isolated limestone, are similar in colour and grain size.

Stratigraphical ranges of species within the type section of the formation given previously (Whittington and Kindle, 1963, figs. 2, 3) are here emended and others added. These ranges are least reliable in the lower 90 feet of the middle part of the formation, in which collecting was least intensive. As a measure of relative abundance of species, total numbers are given of specimens collected from the type section and at Table Cove. In the limited and sporadically distributed fauna of the lower Table Head no one species dominates the assemblage. The same is true of the far more diverse fauna of the middle Table Head at the type section — no one species forms more than 10 per cent of the total numbers, and of nineteen species each constitutes between 2 and 10 per cent of the total. The collection at Table Cove is from a limited thickness of middle Table Head strata. Six rare species and two more abundant species at Table Cove have not yet been found in the type section, while eight rare and two more abundant species of the type section have not been recovered at Table Cove. At this latter locality no one species is more than 12 per cent of the total, and each of 21 species constitutes between 2 and 12 per cent of the total. Only eleven of the commonest species at Table Cove are abundant at the type section, and the order of relative abundance is different.

These differences are between exposures less than one mile apart. Those of relative abundance may reflect the limited thickness from which the Table Cove sample came, the type section sample being an average for the entire thickness. The middle Table Head Formation shows evidence of contemporaneous disturbance, so that particular beds may be present in one section and absent in a nearby one. This may help to account for the presence or absence of particular species at these two localities.

COMPOSITION. RELATION TO OLDER AND YOUNGER FAUNAS

All the trilobite species of the Table Head Formation are unique to it, except *Nileus affinis*, known from the boulder at Lower Head and the Island of Orleans, near Quebec City. Fourteen new species are named here, and an additional 20 are indeterminate. Of the eight new genera proposed, six are based on species unique to the formation. The remaining two, *Xystocrania* and *Miracybele*, include species from Nevada, and *Miracybele* is probably also represented in Norway. The fauna of the formation (especially that of the middle part) includes early Ordovician elements, some making their last appearance, and new genera belonging to families which characterise younger rocks. The genera *Geragnostus*, *Harpides*, *Shumardia*, *Triarthrus*, *Hypermeccaspis*, *Niobe*, *Nileus*, and *Pharostomina* (a close relative of *Calymenidius*) are known from the early Ordovician Tremadoc rocks of western Europe (Sdzuy, 1955; Henningsmoen, 1959), and many occur in these rocks in Argentina (Harrington and Leanza, 1957, pp. 24-29). In Canadian or Arenig rocks *Selenoharpes*, *Ampyr*, *Ischyrotoma*, *Carolinites*, *Gonio-phrys*, *Raymondaspis* and *Illaenus* are known. Genera making their first appearance in North America or elsewhere, and characteristic of younger Ordovician strata, are: *Lonchodomas*, *Phasclops?* (a proetid), *Telephina*, *Remopleurides*, *Robergia*, *Bronteopsis*, *Ceraurinella*, *Heliomera* and *Calyptaulax*. The latter elements give the fauna a post-Canadian aspect but do not include many typical Chazyan and younger genera (cf. Whittington and Kindle, 1963, p. 756).

CORRELATION WITH OTHER AREAS

The most suitable index of faunal resemblance for the present purpose appears to be method two of Simpson (1960), the percentage of taxa in common between two localities. In the following table a standard is provided by indices for the middle

Table Head Formation at two localities less than one mile apart, and by those for the lower and middle parts indicative of close relation but with some difference in age.

Faunal resemblance between:	Based on	
	genera	species
middle Table Head, type section/Table Cove	80	79
lower Table Head/middle Table Head	45	21
lower Table Head/Lower Head	64	7
middle Table Head/Lower Head	50	2
Table Head/Mystic Conglomerate, Quebec	76	
Lower Head/Mystic Conglomerate, Quebec	59	
Table Head/Antelope Valley Lst., Nevada	63	
Table Head/Chazy Group, New York	20	
Table Head/Tumbez Formation, Tennessee	20	
Table Head/Effna Formation, Virginia	25	
Table Head/Athens Shale, Tennessee	31	
Table Head/Kundan Stage, Sweden	23	
Table Head/Kundan Stage, East Baltic	21	
Table Head/Llanvirn Stage, Britain and Bohemia — less than	10	

Notes in explanation of this table follow, together with comments on other faunas.

Lower Head. The fauna of the boulder at this locality (Whittington, 1963), thirty miles south of Table Point, is like that of the Table Head, and most like that of the lower part. The strong similarity between, but not identity of, species of *Geragnostus*, *Selenoharpes*, *Phaseolops*, *Ischyrotoma*, *Ischyrophyma*, *Remopleurides*, *Acidiphorus*, *Illaenus*, *Cydonoccephalus*, *Kawina*, *Heliomera*, *Pseudomera* and *Ectenonotus* in the two deposits is a further expression of the close relationship.

The greater variety of the Lower Head fauna, compared to that of the lower Table Head, may be attributed to differences in environment of deposition. The Lower Head fauna includes *Isocolus*, *Glaphurus*, *Ceratocephala* and *Apatolichas*. Species of these genera, or of genera belonging to the same families, are absent from both lower and middle Table Head rocks. The middle Table Head fauna is more varied than the Lower Head, and contains raphiophorids, endymioniids, shumardids, olenids, asaphids, telephinids, komaspidids, calymenids, enerinurids and dalmanitids, none of which families is present in the Lower Head boulder. These and other differences between the faunas (e.g. different scutelluid genera in each, some cheirurid genera only

in Table Head) seem more likely to reflect differences in environment of deposition than to imply any great difference in age.

Lévis Shale, Québec. The highest part of these shales, zone D, includes the *Shumardia* Limestone and overlying shales which are of the same age as the high middle and upper parts of the Table Head Formation (Whittington and Kindle, 1963, pp. 755-756, fig. 4). As shown below, the species of *Shumardia*, *Endymionia* and *Triarthrus?* from Quebec are different from the Table Head species. *Endymionia meeki* and *Raymondaspis angelini*, from boulders in limestone conglomerate in the Lévis Shale, are like but not the same as Table Head species of the same genera.

Mystic Conglomerate, Québec. Brachiopods from boulders in this conglomerate have been described by Cooper (1956, p. 31, for list) and certain trilobites by Billings (1865), Raymond (1925), Ulrich (1930) and Whittington (1948, 1961). I have not studied the trilobite fauna in detail, but examination of collections in the U. S. National Museum, Geological Survey of Canada and Museum of Comparative Zoology suggests that the following are present (cf. Raymond, 1925, p. 170, who lists many of these species from a single boulder, together with *Goniophrys breviceps* [Billings, 1865]):

Geragnostus sp.

Ischyrophyma sp.

Ptyocephalus curiosus (Billings, 1865)

Nileus sp.

Telephina mysticensis (Ulrich, 1930)

Remopleurides affinis Billings, 1865

Acidiphorus scorpionis Raymond, 1925

Bathyporellus expansus Billings, 1865

Iliaenus sp. (of *tumidifrons* Billings, 1865, type)

Iliaenus simulator Billings, 1865

Illacnus incertus Billings, 1865

Raymondaspis marginata (Raymond, 1925)

Ectenonotus westoni (Billings, 1865)

Pliomerids — *bilirata* Raymond, 1925

— *convexus* Billings, 1865

Kawina billingsi Raymond, 1905

Kawina sp.

Cydonocephalus spp.

Nystocrania glaucus (Billings, 1865)

Apatolichas sp.

The strong similarity between this fauna and that from Table Head is evident. The species I have studied are like those from Newfoundland, but they do not seem to be identical.

Nevada. Collections from the Antelope Valley Limestone (Merriam, 1963, pp. 23-25) in the U.S. National Museum, my own collections, and those made by Kay (1962, table 2, pp. 1424-1425) suggest that at least 16 genera of trilobites are present in this formation. No species appears to be in common with the Table Head, but ten genera are, giving a high index of faunal resemblance. It is probable that these formations are of approximately the same age (cf. Whittington and Kindle, 1963, pp. 754-755).

Chazy Group, New York and Québec. Trilobites from these rocks (Raymond, 1905; 1910) are being studied by Frederick C. Shaw, Harvard University. His work shows that species of about 40 genera are present, which do not include any of the Lower Ordovician (Tremadoc and Canadian) genera mentioned above. In common with the Table Head are the genera *Lonchodomas*, *Remopleurides*, *Uromystrum*, *Ceraurinella*, *Kawina*, *Heliomera*, *Calyptaulax*, and possibly the asaphid *Stegnopsis* n. gen. No species is common to Chazy and Table Head strata, and the index of faunal resemblance based on genera is 20 per cent. The Chazy trilobites have a geologically younger aspect than those of the Table Head, and include a number of genera found only in Chazyan and younger rocks, such as *Dolichoharpes*, *Dimeropyge*, *Otarion*, *Sphaerocoryphe*, *Encrinuroides* and *Cybeloides*. This evidence supports the view (Cooper, 1956) that the Chazy rocks are younger than the Table Head (cf. Whittington and Kindle, 1963, p. 756, fig. 4).

Southern Appalachians. Of the same age as part of the Chazy Group is the Tumbez Formation of southern Virginia and adjacent Tennessee (Cooper, 1956, chart). Where it is exposed near Bluff City, Tennessee, this granular limestone yields a considerable trilobite fauna (Raymond, 1925, p. 171) including the type species of *Eorobergia*. The fauna shows little resemblance to that of the Table Head. Considerably younger are the shales and silty limestones of the Athens of Tennessee and the granular Effna limestone of Virginia (see lists in Raymond, 1925, pp. 173, 174; Cooper, 1953, table 1), for they belong to the early part of the Porterfield Stage (Cooper, 1956, chart 1). Such resemblance as they show to the Table Head is due to the presence of the long-ranging genera *Lonchodomas*, *Ampyx*, *Robergia*, *Raymondaspis* and *Calyptaulax*, as well as *Telephina* in the Athens and a species of *Nileus* in the Effna.

Scandinavia and the East Baltic. Strata of the Kundan Stage (Jaanusson, 1960, tables 3, 9) in Sweden, Norway, Estonia and the Leningrad district are latest Arenig and early Llanvirn in age, approximately the age of the Table Head Formation (Whittington and Kindle, 1963, p. 757, fig. 4). Species of *Ampyx*, *Niobe*, *Nilcus*, *Illacnus*, *Raymondaspis*, *Brontcopsis*, *Ceraurina*? and *Miracybele* n. gen. that have been obtained from them are like those in the Table Head, but other genera of asaphids, cheirurids, pliomerids and encrinurids in these strata are not represented in Newfoundland. The index for the beds in Sweden is based on Bohlin's list (1949, pp. 566-567), that for the East Baltic on Schmidt's (1907, pp. 90-98). These indices are similar to that of 20 per cent for Table Head and early Arenig trilobites of Sweden (Tjernvik, 1956).

Central Europe. Beds of Llanvirn age in Britain and Bohemia contain a large trilobite fauna, considered to belong in a quite different province to the Table Head (see below). The low index expresses the lack of resemblance.

South America. Bulman (1931) described graptolites and a few trilobites from beds of Llanvirn age of Korpa, Bolivia, a locality north of Lake Titicaca and near the border with Peru. The trilobites included *Triarthrus* aff. *fischeri* and *Saukia*? sp., the latter now *Hypermeaspis bulmani* Harrington and Leanza, 1957 (pp. 121-123). Fragments from the Table Head very like *H. bulmani* are described below, and *T. fischeri* is a common species. In addition, boulders at Daniel's Harbour (Whittington and Kindle, 1963, pp. 753-754) have yielded a species of *Glossograptus* like *G. holmi* Bulman, 1931, also present at the Korpa locality. A connection thus seems to have existed between Newfoundland and the South American geosyncline (Harrington, 1962, pp. 1781-1783, figs. 3-5). That such a connection existed in early Ordovician (Tremadoc) time has been claimed on the basis of similar or identical olenid species (Richardson, 1948; Newell, 1949; Shaw, 1950, pp. 110-111; 1951, pp. 102-103; 1956, pp. 1210-1211) in Argentina and Newfoundland. Harrington and Leanza (1957, pp. 23-37) have shown in much more detail the strong affinities in early Ordovician time between trilobite faunas of Argentina, Newfoundland, Britain and Scandinavia, and that these similarities are less evident by early Middle Ordovician time.

AGE OF THE TABLE HEAD FORMATION

The previous discussion (Whittington and Kindle, 1963, pp. 754-757) considered also evidence provided by brachiopods and graptolites. The more detailed examination of the trilobites does not seem to necessitate any change in the conclusions then drawn. Fifteen genera (one-third of the total) are relicts of older faunas, and few of them persist into younger strata. Nine genera are heralds of new faunas, widespread and at times abundant in Chazyan and younger faunas. The residue of fifteen genera may be regarded as typical of the Table Head Formation and the Whiterock Stage:

Galbagnostus n. gen., *Ampyroides* n. gen., *Ischyrophyma*, *Stegnopsis* n. gen., *Peraspis* n. gen., *Blosyropsis* n. gen., *Eorobergia*, *Uromystrum*, *Acidiphorus*, *Ectenonotus*, *Pseudomera*, *Xystocrania* n. gen., *Cydonoccephalus*, *Kawina*, *Miracybele* n. gen.

Of the new genera, only *Xystocrania* and *Miracybele* are not unique to the Table Head, other species being known from rocks of the same age. Only *Eorobergia*, *Uromystrum* and probably *Kawina* are known from Marmor Stage, Chazyan, rocks. None of these Table Head genera is known in rocks of Canadian age. Thus the trilobite fauna has a post-Canadian and pre-Chazyan aspect, and appears to fall within the Whiterock Stage of G. A. Cooper and B. N. Cooper (*in* G. A. Cooper, 1956, pp. 7-8), believed to be, in European terms, approximately lower Llanvirn in age.

EVOLUTIONARY AND GEOGRAPHICAL RELATIONSHIPS

These relationships were examined in connection with the Lower Head trilobites (Whittington, 1963, pp. 16-23, fig. 2), and only additional references are given here. The Lower Head boulder is approximately the same age as the Table Head Formation but exhibits a different facies. Both faunas show a high percentage of genera new to North America, but about one-half may be descended from North American stocks. Many of the remainder belong to new families which are rapidly evolving and become important in younger faunas. No modification of the faunal provinces previously outlined is proposed. The Table Head trilobites show additional links with Baltic faunas, and a link with contemporaneous Bolivian (but not Argentinian) faunas.

Relationships. Ten genera of Table Head trilobites are present in late Cambrian and Lower Ordovician rocks of North America: *Geragnostus*, *Harpides*, *Sclenoharpes*, *Ampyx*, *Shumardia* (Kobayashi, 1955, pp. 471-472), *Triarthrus* (Kobayashi, 1955, pp. 465-466, pl. 7, figs. 14-17; Henningsmoen, 1957, pp. 147, 273), *Ischyrotoma*, *Goniophrys*, *Carolinites*, *Calymenidius*. The remaining genera, 77 per cent of the total, are new to North America. Of these, thirteen — *Galbagnostus*, *Leioshumardia*, *Ischyrophyma*, *Stegnopsis*, *Telephina*, the four remopleuridid, two bathyurid, and two pliomerid genera — may be descended from stocks present in older North American rocks. Thus at least half the Table Head fauna may be of North American origin. Not found in North America before Table Head time are: *Hypermeccaspis*, *Niobe*, *Nileus*, *Raymondaspis* and *Illacnus*. However, *Hypermeccaspis* is present in the Tremadoc of Argentina, Britain and Norway (Harrington and Leanza, 1957, pp. 120-121) and its possible ancestor *Parabolinella* is widespread in North America (Henningsmoen, 1957, p. 133). The other four genera are well known in the Baltic Lower Ordovician, fragments of illaenids only being known in North America. The area in which many of the other genera arose is obscure, particularly in the case of raphiophorids, *Endymionia*, *Percaspis* and *Brontcopsis*, and whether to call them exotic or indigenous is quite uncertain. Cheirurid genera such as *Cyrtometopus* and *Ceraurinclla*?, the encrinurid *Cybice*, and *Pterygomctopus* are known from the Lower Ordovician of Scandinavia. In North America, fragments of cheirurids and cheirurid-like forms (e.g. Ross, 1951, pl. 35, figs. 3-17 19-21; Hintze, 1953, pl. 21, figs. 15-18) are rare in the Canadian. Thus while some of the cheirurids, encrinurids and dalmanitids of the Table Head may be exotic, others may be derived from indigenous stocks.

Faunal provinces. As has been shown, the Table Head fauna is like that of boulders in the Lévis Shale, the Shumardia Limestone, the Mystic Conglomerate, and the Antelope Valley Limestone of Nevada and formations of the same age in Utah. It clearly belongs within the bathyurid province (Whittington, 1963, p. 16, fig. 2), as the presence of komaspidids emphasises. The differences between the Table Head and contemporaneous Lower Head faunas seem to reflect differences in environments of deposition — dark limestone and shales versus pure white limestone of the Lower Head boulder. The genera listed above as

typical of the Table Head may also be taken as typical of the bathyurid province at that time and in that environment. Genera common to provinces at the same and different times were discussed previously. New is the faunal link, shown by the presence of two olenid genera, between dark limestones and shales of the Table Head and shaly rocks in Bolivia. No such link is apparent to contemporaneous shales, sandstones and limestones in Argentina. Links with the asaphid province in Scandinavia were discussed before, and are reinforced by the record of *Bronteopsis* in the Table Head. Yet though *Niobe* is common to the two provinces, other asaphids are quite different — *Stegnopsis* n. gen. in the Table Head and *Megistaspis*, *Ogygiocaris*, *Asaphus*, *Pseudasaphus*, *Ogmasaphus*, *Homalopyge* and *Pseudomegalaspis* in Norway and Sweden.

The fauna of the calymenid-trinucleid province in Llanvirn time is approximately contemporaneous with the Table Head and of comparable richness, for species of some 40 genera are known in Britain and Bohemia. The resemblance between the faunas is slight (see table above), for only *Geragnostus*, *Ampyx*, *Triarthrus* and *Raymondaspis* appear to be in common. The trinucleid, dionidid, cyclopygid and homalonotid family groups are known only in the calymenid-trinucleid province at this time, while the endymioniids, dimeropygids, komaspidids and bathyurids are peculiar to the bathyurid province. Other families — harpidids, asaphids, nileids, illaenids, calymenids, enerinurids, dalmanitids and pliomerids — are represented by quite different genera in the two provinces, suggesting that evolution was proceeding independently.

SUMMARY OF MORPHOLOGY AND CLASSIFICATION

Attention is drawn here to morphological features of special interest, and to certain taxonomic conclusions drawn from this study.

External and internal exoskeletal surfaces. These surfaces are exceptionally well preserved, the internal directly or as moulds. The patterns of fine lines, tubercles, pits and facets of eye surfaces are shown in many figures. The internal surface of the illaenids is finely granulate, the granules of two sizes (e.g. Pl. 45, fig. 19; Pl. 46, fig. 10; Pl. 51, figs. 9, 11).

Areas of muscle attachment. On the axial region of the cephalon and pygidium these areas are smooth and may be slightly impressed, as in *Galbagnostus galba* (Pl. 3, fig. 7; Pl. 4, fig. 8),

Niobe quadraticaudata (Pl. 25, fig. 1; Pl. 26, fig. 4), *Iliaenus gelasinus* n. sp. (Pl. 53, figs. 1, 7; Pl. 54, fig. 1) and *Raymondaspis turgidus* n. sp. (Pl. 59, fig. 7). These impressed areas may be visible on the internal mould. In other cases the areas may show as dark patches when photographed under alcohol (Pl. 12, figs. 5, 18, 20; Pl. 22, fig. 12).

A pattern of radiating, anastomosing ridges on the lateral regions of the exoskeleton is described in *Galbagnostus galba* (Pl. 3, fig. 14; Pl. 4, fig. 10), *Harpides* (Pls. 5-7), *Selenoharpes* (Pl. 8), and *Raymondaspis reticulatus* n. sp. (Pl. 57, fig. 13; Pl. 58, figs. 1, 7). Of exceptional interest is the pygidium of the latter species, showing that the ridges are arranged in relation to segmentation. These ridges are assumed (Öpik, 1961a) to be impressions of the caeca, ramified lateral extensions of the alimentary canal.

Median occipital organ. In the median occipital area of *Bron-teopsis* (Pl. 55, fig. 4) and *Raymondaspis* (Pl. 55, fig. 9) are four tiny pits arranged in a square. A similar arrangement of pits is visible in the median occipital tubercle of certain odontopleurids (Whittington, 1956, pp. 177-178), and structures of this type are known in other trilobites.

Lateral genal area. In species of *Galbagnostus* n. gen. (Pl. 2, fig. 24; Pl. 3, figs. 13, 15; Text-fig. 2A), *Geragnostus* (Pl. 1, fig. 14) and *Trinodus* there is a smooth area situated in the outer, posterior part of the cheek, beside the border furrow. It is raised externally and on the internal mould. The smooth, outer surface is like that of the muscle areas, but these are impressed, not raised. The function of this area is problematical.

Lower lamella of fringe of Harpides. Billings' species *Harpides concentricus* (Pl. 6, figs. 2-4) is shown to be based on a portion of the lower lamella of the fringe of *H. atlanticus*. The structure of this lower lamella is like that recently described of a Norwegian species.

Hypostome. This plate in *Nileus affinis* (Pl. 31, figs. 1-6) is known almost in place. The long anterior wing is extended vertically and must lie close beneath the dorsal exoskeleton. No anterior pit (apodeme on inner surface) is present. The hypostome has the maculae situated close to the anterior margin — an unusual condition which suggests that the anterior lobe of the middle body is either much reduced or absent. Such a condition is like that believed to obtain in *Remopleurides* (Whittington, 1959, pp. 393-396, fig. 3). Other reasons for suggesting a relationship between Nileids and remopleuridids are given.

The hypostome attributed to *Illaeus consimilis* (Pl. 52, figs. 6-13) has the macula smooth on the external surface, but showing hexagonal pits on the internal mould. This structure is like that described by Lindström (1901) and compared by him to that of the eye surface.

Homcomorphy. Raymond (1925, pp. 79-80) placed his new species *lincolata* in the asaphid genus *Niobe* without question, and Billings had pygidia of this species included under *N. morrissi*. The cephalon with genal spines, the thoracic segments, and particularly the furrowed pygidium with a smooth border are asaphid-like. However, the species *lincolata* is here regarded as the type of a new nileid genus *Peraspis*, the decisively nileid character being the lack of the median suture. In addition, the eyes abut against the axial furrow, the external surface bears fine raised lines, and there are only seven thoracic segments. The hypostome attributed to this species is also more nileid than asaphid in form.

Sexual dimorphism. Two trilobites occurring at the same horizon and differing in one or more characters have been thought to represent sexual dimorphs of one species (Whittington, 1963, pp. 23-24 and references). It may be that the two "species" of *Niobe* (Text-figs. 5, 6) described here, and *Illaeus marginalis* and *I. alvcatius* from the lower Table Head, are such dimorphs.

Ontogeny. Small eranidia and transitory pygidia of a number of species are described together with size series of eranidia of *Endymionia schucherti*, *Triarthrus fischeri*, *Niobe quadraticaudata* and *Illaeus consimilis*. The "lateral glabellar lobes" in *Endymionia* appear abruptly at an early stage in the axial furrows, and become larger, an unusual mode of development for such lobes. Protaspides of an asaphid were found (Pl. 29, figs. 4-11) and are like those of younger species described by Evitt (1961).

Classification. Groups of characters considered to be of generic or specific rank are like those employed previously (Whittington, 1963, pp. 24-25). In dealing with the agnostids the problem presented by a partially effaced form, *Geragnostus fabius*, arose. Particularly on the internal mould characters are preserved which seem to justify this generic assignment. The new genus *Galbagnostus* could not have been discriminated if the exoskeleton had not been so well preserved, showing muscle areas of the glabella, the glabellar tubercle, the muscle pits behind the "axis" of the pygidium, and the caeca. The discovery

and study of other well-preserved agnostid material will show how valid may be the bases on which this genus is erected.

Understanding of the genus *Shumardia* has been based on the European *S. pusilla*. The type species from Quebec is here re-described (Pl. 16), including an entire specimen with the free cheeks in position.

The use of many new characters in asaphid taxonomy by Jaanusson make it difficult to evaluate species and genera that have not been critically revised. These difficulties are acute in dealing with the present asaphid material, and in the case of *solitarius* n. sp. and *huttoni* I have chosen to erect the new genus *Stegnopsis*, with *S. solitarius* as type. Restudy of stratigraphically older and younger species is needed to evaluate this choice. The weight to be placed on particular characters newly employed by Jaanusson is also questionable. The much greater width of the pygidial doublure is an important character in distinguishing species of *Pseudasaphus* from those of *Stegnopsis*. I have regarded this same character as of specific or subspecific value in considering species of *Niobe*.

The cephalon of the bathyurid *Acidiphorus spinifer* is described and proves to be like those of the type and other species of *Goniotelus*, and the latter genus is here regarded as a subjective synonym of *Acidiphorus*.

The lectotype of *Heliomera sol* (Pl. 63, figs. 1, 3, 4, 5) has been prepared to reveal the fixed cheek. As a result of this and other discoveries it is thought that *Heliomeroidea* should be considered a subgenus of *Heliomera*, and the subfamily Heliomerinae merged into an enlarged concept of the Sphaerexochinae.

The new encrinurid genus *Miracybele* is based on *M. mira*, and almost the entire exoskeleton described. It shows, as other early encrinurids do, pliomerid-like characters.

Various species known only from cranidia are figured and briefly described. One (Pl. 59, figs. 10, 12-15) is like *Calymenidius* of the late Cambrian, and a calymenid. Two others (Pl. 19, figs. 13, 14, 18; Pl. 68, figs. 1-3) are indeterminate as to genus or even family.

SYSTEMATIC PALAEOLOGY

INTRODUCTION

A few of the trilobites described below are from the Lévis Shale, Quebec, and localities are given as fully as possible. The remainder are from the Table Head Formation. Localities are

shown in Text-figure 1 and explained in a preceding section. An account of the stratigraphy (Whittington and Kindle, 1963) gives further details, and also explains how the earlier lettered divisions of Logan and Billings are related to the present formation. The horizon of all specimens is given in modern terms.

Dr. Thomas E. Bolton, Geological Survey of Canada, is preparing a catalogue of type specimens of trilobites in the Survey collections. I have followed him in regarding as syntypes the specimens, collected by James Richardson, which E. Billings studied. If there was originally a single specimen, or if the original of a figure is unequivocal, it is called a holotype. In other cases a lectotype is selected and the remainder termed paralectotypes.

Type and figured specimens are in the collections of the Geological Survey of Canada (GSC), the Peabody Museum, Yale University (YPM), and the Museum of Comparative Zoology (MCZ). Catalogue numbers are preceded by the appropriate letters as given in parentheses. GSC numbers 18248-18581 are from Kindle and Whittington's collection, the remainder of this collection being in MCZ.

Synonymies in this section are given in a shortened form, the generic and specific name being omitted if the specific name is the same as that of the species under consideration. References to figures 2 and 3 of Whittington and Kindle, 1963, are omitted unless the name has been changed. New systematic names are arbitrary combinations of letters, except that *Percaspis* n. gen. incorporates the initials of Percy E. Raymond.

TERMINOLOGY

Terms are used in the same sense as previously (Whittington, 1963), and most are defined in Harrington, Moore and Stubblefield (*in* Moore, 1959, pp. 0117-0126). Terms requiring comment are:

Glabellar tubercle, a median glabellar tubercle, situated in the posterior half, and best developed on the inner surface of the exoskeleton. Jaanusson (1953a, pp. 381-382) recognized the tubercle in asaphids and nileids, and it is here used in illaenids.

Paradoublural line is "a line on the dorsal test and lies directly above the inner margin of the doublure" (Henningsmoen, 1960, p. 210).

Family AGNOSTIDAE M'Coy, 1849

Discussion. Recent work by Öpik (1961b, pp. 52-55) and Palmer (1962, pp. F-11 to F-12) shows that the suprageneric classification of these trilobites is in a state of flux. The species described below may be considered to belong within this family as recently defined by Palmer, but the lines of descent from Cambrian to Ordovician agnostids are not yet understood. Pending clarification of some of the problems, subfamilial groupings are not used.

Genus GERAGNOSTUS Howell, 1935

GERAGNOSTUS LONGICOLLIS (Raymond, 1925)

Plate 1, figures 1-12, 14, 16, 17

Raymond, 1925, pp. 12-13, pl. 1, fig. 5 (not fig. 6).

Holotype. YPM 13054, internal mould of pygidium, from the isolated limestone.

Other material. Middle Table Head Formation: at type section, fairly common at 90 and 185 ft. above base; common in isolated limestone and on foreshore south of Table Cove.

Description. Raymond associated an incomplete cephalon of *Galbagnostus galba* with the holotype pygidium, but the entire specimen (Pl. 1, figs. 4-7, 9, 10) shows that the cephalon is of a different type. Raymond (1925, p. 11) also reversed the then generally accepted orientation of agnostids, and so considered the holotype to be a "cephalon." Raymond's view is not accepted today, particularly because of the evidence from ontogeny (Stubblefield, 1926, p. 366).

Comparison of the present illustrations with those of the recently described *G. clusus* (Whittington, 1963, pp. 28-32, pl. 1, figs. 1-17; text-fig. 3) shows that these two species are exceedingly alike, but can be distinguished by certain minor characters. In *G. longicollis* the outline of the cephalon and pygidium is subcircular, the maximum width at about half the length, and the anterolateral and posterolateral borders of uniform width. In *G. clusus* the maximum width of the cephalon is at the anterolateral corners, which are obliquely angulate, and the border is widest at this point. The pygidium of *G. clusus* likewise attains the maximum width at the posterolateral angle, at which point the margin is obliquely angulate and the border widest. The outline of the lateral lobe of the axial rings of the thoracic segments is slightly different in the two species, and the posterior portion of

the pygidial axis in *G. longicollis* is relatively longer and marked off by a shallower ring furrow. No specimens of *G. longicollis* have the posterior portion of the axis expanded as in one specimen of *G. clusus* (Whittington, 1963, pl. 1, figs. 10, 11). These and other minor differences in convexities of parts combine to distinguish the species though they are obviously closely related. External surface is apparently smooth, while in some specimens of *G. clusus* a faint reticulation was observed on the external surface. Along the posterolateral margin of the cheek, immediately inside the border furrow, is a gently convex strip marked off by a faint furrow (Pl. 1, fig. 14). A similar strip in *G. clusus* is poorly preserved (Whittington, 1963, pl. 1, fig. 3).

G. longicollis is referred to *Geragnostus* for the reasons given when discussing *G. clusus*. One example of a pygidium (Pl. 1, figs. 13, 15, 18) in which the exoskeleton is preserved, differs from all other specimens in that the axis of the pygidium is relatively much shorter, and there is a faintly outlined protuberance on the posterior tip of the axis, behind which the axial furrow is deepened. Though no such protuberance has been observed on the outer surface of the exoskeleton of other specimens, internal moulds may show a faint tubercle at the tip of the axis (Pl. 1, figs. 1, 3, 16, 17). Whether or not this unique pygidium represents a variant of *G. longicollis* or a distinct but rare species, is not known. In the shortness of the pygidial axis, it approaches species of *Trinodus* (Whittington, 1950, pl. 68, figs. 4, 6).

GERAGNOSTUS FABIUS (Billings, 1865)

Plate 2, figures 1-23, 25, 26

Billings, 1865, pp. 298-299, fig. 289.

Lectotype (here selected). GSC 704c, internal mould of cephalon from Daniel's Harbour. Paralectotypes: GSC 704a, b, d, g, pygidia; GSC 704, 704f, cephalata; same locality as lectotype.

Other material. From the middle Table Head Formation, this species appears first 185 ft. (not at 155 ft., Whittington and Kindle, 1963, fig. 3) above the base. It is less common than *G. galba* and *G. longicollis* at exposures south of Table Cove and in the isolated limestone, but is the only agnostid present in the higher beds at the type section, in bed 4 at Black Cove, and the boulders at Daniel's Harbour.

Description. Anterior half of glabella extremely faintly outlined on external surface (Pl. 2, fig. 4); on internal mould (Pl.

2, fig. 20) it is distinctly outlined by shallow axial and preglabellar furrows. Occipital ring composed of short (sag.) median band and large triangular lateral lobes, shallow furrow defining proximal side of this lobe not straight but sinuous. Low median tubercle situated at about one-third length of glabella. Low median ridge on most posterior part of median glabellar lobe where it projects between the lateral occipital lobes. Faint transverse glabellar furrow runs in a curve that is concave forward, and is situated immediately in front of the median tubercle; on internal mould the furrow is continued forward and outward almost to the axial furrow. Convex cheeks descend steeply laterally, slope of preglabellar area less steep. Cephalic border relatively narrow and uniform in width anteriorly and anterolaterally, posterolaterally becoming narrower. At genal angle border curves around to meet the narrow posterior border, no genal spine at junction (Pl. 2, figs. 8, 9, 16, 20, 21).

Second thoracic segment (Pl. 2, fig. 10; first segment is pushed beneath cephalon) with semicircular lateral axial lobe, pleura curved forward and outward, deep pleural furrow situated nearer anterior than posterior margin and curving out to tip.

Pygidium with axis faintly outlined and not subdivided on external surface (Pl. 2, fig. 7); on internal moulds (Pl. 2, figs. 3, 26) furrows are deeper. First ring furrow absent medially, lateral part of ring slightly inflated. Second ring furrow continues across axis, medial tubercle situated immediately in front of this furrow. Second ring furrow is situated at about half length of axis, posterior portion of axis tapering and gently convex, at tip a low median tubercle projects over the furrow. Pleural regions gently convex, sloping most steeply laterally, gently posteriorly, border similar in width and outline to that of cephalon, no border spine.

External surface of exoskeleton apparently smooth, no evidence of convex region at posterolateral margin of cheek.

Discussion. From the relatively few specimens available, little evidence of individual variation has been observed. The original of Plate 2, figure 23, appears wider and shorter than typical pygidia. This appearance may be an expression of variation or of distortion during preservation. Small holaspid individuals appear little different from the largest. One enrolled specimen (Pl. 2, figs. 14, 15, 18, 19) is a meraspid degree one, the transitory pygidium including the portion that is to become the second thoracic segment. This portion is clearly outlined, the axial ring

displaying the lateral lobes. The remainder of the axis of the transitory pygidium is undivided. The posterolateral and posterior pygidial borders appear to be relatively wider than in holaspides. The cephalon is much like that of larger individuals, but the convexity of this meraspid is greater than in holaspides.

In the characters of the glabella and pygidial axis as revealed by internal moulds, this species is a typical *Geragnostus*. The partial effacement of axial furrows on the external surface, the narrow borders and lack of genal and pygidial spines, distinguish this species, and may have led Raymond (*in* Schuchert and Dunbar, 1934, p. 69) to regard it as representing a distinct genus, for he lists it as "*Diplaspis*" (a *nomen nudum*) *fabi*us. Effacement of furrows occurs in many lines of agnostids (Öpik, 1961b, pp. 53-54), but the characters in common between *G. fabius*, *G. longicollis* and *G. clusus* seem to place generic relationship beyond doubt. *G. fabius* also shares with *G. longicollis* and other species the character of the slight projection at the tip of the axis.

G. fabius appears rather rarely at the upper limit of the known stratigraphic range of *G. galba* and *G. longicollis*, and ranges upward for some 30 feet in the type section. This species thus replaces the other two in time, and is particularly characteristic of the fine grained, muddy, black, thin-bedded limestones of the highest part of the middle Table Head Formation.

Genus GALBAGNOSTUS n. gen.

Type species. *Aagnostus galba* Billings, 1865.

Diagnosis. Differs from *Geragnostus* in that median glabellar tubercle is situated far forward, no transverse glabellar furrow but six pairs of muscle areas, 1p on the occipital lobes, 4p beside the axial furrows at the mid-length, 6p flanking the median tubercle. Shallow median depression in preglabellar field. Posterior lobe of pygidial axis with median ridge, deep excavation in furrow behind this ridge. Low, subtriangular raised area on pleural region immediately behind the deep part of the furrow, outlined by muscle spots; pleural region behind axis inflated. Faint pattern of radiating caeca visible in axial and border furrows.

Discussion. These characters distinguish the type species *Galbagnostus galba* from such species of *Geragnostus* as *G. longicollis*, *G. clusus* and *G. fabius*, well-preserved specimens of all of which are available. They presumably also distinguish it from

other species of *Geragnostus*, but it is difficult to judge from published descriptions. As discussed below, there are similarities between *G. galba* and *Trinodus elspethi* which may indicate a relationship, but the nature of this is as yet uncertain.

GALBAGNOSTUS GALBA (Billings, 1865)

Plate 2, figure 24; Plates 3, 4; Text-figure 2

Billings, 1865, pp. 297-298, fig. 288.

Raymond, 1925, pp. 11-12, pl. 1, fig. 6.

Lectotype (here selected). GSC 689b, from middle Table Head Formation at type section. Paralectotypes include 689, incomplete cephalon, 689a, c-e, pygidia, from same locality and horizon.

Other material. From middle Table Head Formation, at type section, specimens are rare 17 feet above base, relatively common at 90 and 185 feet above base, abundant in the isolated limestone and exposures on foreshore at Table Cove. Also included here is YPM 13051, the original of Raymond, 1925, pl. 1, fig. 6, an incomplete cephalon which he regarded as the pygidium of his species *longicollis*.

Description. No entire specimen has been found, but the cephalon and pygidium here associated bear the reticulate pattern of raised ridges on the external surface inside the borders.

Glabella slightly longer (sag.) than maximum width across occipital lobes, tapering forward, and rounded at blunt tip. The median band of the occipital ring is short (sag.) and deeply indented by the backwardly projecting, carinate median glabellar ridge. Occipital lobe large, triangular, deeply indented at inner anterior margin by muscle area 1p (Text-fig. 2a). Median glabellar tubercle situated far forward, at about one-sixth the length from the anterior margin. At about the midlength of the glabella the axial furrows are widest, and there is an extremely faint depression, smooth on the outer surface, in the side of the glabella close to the axial furrow. This is muscle area 4p. There is a total of six pairs of muscle areas on the glabella (Pl. 3, figs. 7, 15; Text-fig. 2a), all smooth on the external surface, but only the 1p pair is slightly impressed. Areas 6p flank the median glabellar tubercle. Cheeks and preglabellar field form a continuous pleural region, convex and sloping vertically laterally. A faint shallow median depression crosses the preglabellar field. The posterior border (Pl. 3, fig. 3) commences as a narrow ridge beneath the midpart of the occipital lobe, and

extends out horizontally to the fulcrum, where it widens and is flexed down vertically. There is no genal spine at this point (Pl. 3, fig. 15). Below the fulcrum the narrow border curves forward to become the horizontal lateral border, which widens forward to the anterolateral and anterior borders which are the

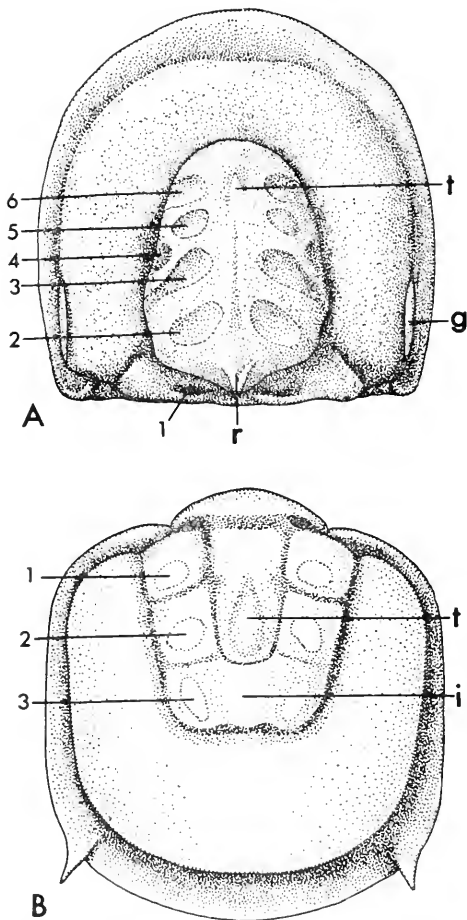

FIG. 2. *Galbagnostus galba* (Billings), middle Table Head Formation. A, dorsal view of cephalon; B, dorsal view of pygidium, c. X 15. Abbreviations: 1-6, muscle areas; g, lateral genal area; i, median ridge of third axial ring of pygidium; r, median posterior ridge of glabella; t, median tubercle.

widest. These borders are separated from the cheeks and preglabellar area by a broad, deep border furrow. At the outer, posterior margin of the cheek, beside this border furrow, is an ovate, smooth, gently inflated area (Pl. 2, fig. 24; Pl. 3, fig. 15). This area appears as a flat platform on the internal mould (Pl. 3, figs. 2, 13); on the external surface it distinctly projects beyond the adjacent part of the cheek. On internal moulds of the cephalon (Pl. 3, fig. 14) an extremely faint pattern of fine, radiating ridges separated by grooves in which there may be shallow pits, is seen on the cheeks, preglabellar area and borders. This pattern is best seen in the preglabellar furrow and the anterior and anterolateral border furrows. On the external surface (Pl. 3, figs. 7, 15) is a reticulate pattern of raised ridges which does not extend on to the borders, nor the deepest parts of the furrows. Along the midline of the glabella these raised lines are arranged roughly longitudinally between the median tubercle and the median ridge immediately in front of the occipital ring. Median glabellar tubercle, muscle areas, and lateral genal areas are smooth.

Pygidium with well-defined axis tapering back and bluntly terminated, reaching just beyond half the length (sag.). Axis divided into three rings which are of equal length. First ring not defined by ring furrow medially, and divided into three equal parts by longitudinal furrows. These furrows continue on to midpart of second ring, which is raised as a large, oval tubercle. Second ring furrow runs behind this tubercle. Third and posterior ring of axis with faintly raised median longitudinal ridge of similar width to the tubercle on the preceding ring; tip of axis behind this ridge excavated where axial furrow is considerably deepened. Pleural regions convex, and distinctly inflated behind axis, and especially so behind median posterior part of axis where there is a low, raised tubercle. This raised region immediately behind the axis is best seen on the internal moulds (Pl. 4, figs. 3, 7, 10) where it is roughly triangular in outline, gently convex, and outlined by an extremely shallow furrow in which there are a few tiny pits, the deepest pit being at the pointed posterior tip. Anterior border of pleural region a strongly raised ridge, which is faceted anterolaterally, and separated from pleural region by a deep border furrow. Doublure is flat and extends beneath border; posterolateral border spine is fold in dorsal exoskeleton only, not in doublure, and extends beyond border for a short distance. External surface inside borders bearing reticulate pattern of raised lines, this

pattern being absent in furrows and on the muscle areas (Pl. 4, figs. 8, 9; Text-fig. 2b) and median tubercle of second axial ring. On internal moulds an extremely faint pattern of fine, radiating caeca, separated by faint grooves or lines of pits, is visible. As on the cephalon, the pattern of caeca is best seen where it crosses the border furrows (Pl. 4, figs. 7, 10).

Discussion. Muscle areas in agnostids have frequently been illustrated and commented on (Westergaard, 1946, p. 96, pl. 16, figs. 1, 2; Palmer, 1955, pl. 20, figs. 13-15; Öpik, 1961a, figs. 2, 15, 16). They may take the form of paired depressions in the axial regions, or apparently sometimes paired convex regions, and on the internal mould may appear as depressed or raised regions, sometimes roughened. The smooth areas present on the glabella of the present species are like those seen in silicified specimens of *Trinodus elspethi* from Virginia (Cooper 1953, pl. 1, fig. 7). In this latter species the number of areas on the glabella in front of the occipital ring is the same, but the arrangement is different—the median glabellar tubercle is situated at about half the length, and the five pairs of areas are subradially arranged with respect to this tubercle. Muscle areas on the three rings of the axis, visible as smooth patches, are present in *T. elspethi* (Cooper, 1953, pl. 1, fig. 9) much as they are in *G. galba*. Unique to the present species are the tiny pits, referred to here as muscle pits, that surround the low triangular convexity immediately behind the axis of the pygidium. Similar lines of tiny pits, converging backward, have recently been described on the axis of the pygidium of *Glyptagnostus* (Öpik, 1961a, text-figs. 15, 16), and presumably those in *G. galba* are similar structures. If so, they must be on the axis of the pygidium, and thus the true axis must include these areas and so extend a short distance behind the area outlined by deep furrows and referred to in this description as the "axis." The pattern of caeca in agnostids has been described and discussed by Öpik (1961a), and the faint traces of radiating ridges shown by the internal moulds of the present material seem to represent the same structure.

The smooth, convex, area on the outer, posterior corner of the cheek, well developed in this species, and less conspicuously visible in species of *Geragnostus* (Pl. 1, fig. 14; Whittington, 1963, pl. 1, fig. 3) does not appear to have been described before in agnostids, and its function is not clear. It is like the muscle areas of the axis in being smooth externally, but unlike them in

being convex on the external surface, and visible on the internal mould as a slightly raised, flattened platform.

The distinctions between *Geragnostus* and the new genus have been emphasized in the diagnosis, but the many characters in common may be indicative of relationship. There is also the possibility that there may be a relationship between *G. galba* and certain species presently referred to *Trinodus*, particularly *T. elspethi* (Cooper, 1953, pl. 1, figs. 1-12). The latter species has the glabellar tubercle situated at about the midlength; the pygidial axis is even shorter, and does not appear to display the convexity behind the axis, though there may be a faint median ridge on the terminal portion of the axis. The external surface bears the reticulate pattern of raised lines, and the number (but not the arrangement) of the muscle areas is similar. It is also notable that the lateral genal area appears to be present in *T. elspethi* (Cooper, 1953, pl. 1, fig. 6).

Family HARPIDIDAE Hupé, 1953

Genus HARPIDES Beyrich, 1846

HARPIDES ATLANTICUS Billings, 1865

Plates 5-7

Billings 1865, pp. 281-282, fig. 267.

Harpides concentricus Billings, 1865, p. 282, fig. 268.

Holotype. GSC 674, 674c, counterparts of fragment of cranidium, original of Billings, 1865, fig. 267, from Daniel's Harbour.

Other material. GSC 674a, b, counterparts of glabella and surrounding part of cranidium; GSC 672, 672b, counterparts of part of lower lamella of fringe, holotype of *H. concentricus* Billings, 1865, fig. 268; GSC 672a, similar fragment; all from same locality as holotype of *H. atlanticus*. In the type section at Table Point this species is rare at 17, 185 and 265 feet above the base of the middle Table Head Formation; it is fairly common in the isolated limestone and at Table Cove.

Description. Glabella subtrapezoidal in outline, maximum width across basal glabellar lobes slightly greater than length (sag.). Occipital furrow curves gently forward medially where it is shallow; distally it is deep; occipital ring convex, bow-shaped outline to posterior margin. Lateral glabellar furrow 1p deep, straight, diagonally directed and outlining a subtriangular basal lobe; proximal portions of these basal lobes joined across

midpart of glabella by a low ridge, at the summit of which is a median tubercle. Lateral glabellar furrows 2p and 3p short, shallow, directed inward and only slightly backward; lateral lobe 2p suboval in outline and gently inflated, lateral lobe 3p much shorter (exs.) and less convex. Anterior margin of frontal lobe gently curved so that glabella is bluntly terminated. Axial furrow shallow beside occipital ring, beside lateral lobe 1p expanding to the deep, flat-based, crescentic ala; in front of outer end of lateral furrow 1p axial furrow is deep and narrow, but at eye ridge it becomes shallow and continuous with the faint preglabellar furrow. Cheek lobe convex, quarter-circle in outline, width at posterior margin slightly less than maximum width of glabella, cheeks united anteriorly by depressed concave preglabellar field. Prominent, crescentic eye lobe situated well out on cheek lobe, opposite outer ends of lateral glabellar furrows 1-3, palpebral lobe sloping inward and with gently convex rim, outward-facing slope of eye lobe steep. Prominent eye ridge gently curved, running inward and slightly forward to reach axial furrow opposite posterior part of frontal glabellar lobe. Brim broad and concave upward, the width (sag. and tr.) constant and at the posterior margin, greater than the width (tr.) of cheek lobe or glabella. External rim of upper lamella not raised above adjacent parts, continuous at genal angle with gently convex posterior border of cheek lobe. Lower lamella of fringe convex downward, external and posterior rims like those of upper lamella, external surface bearing 7 or more concentrically arranged narrow ridges, these ridges (or girders) placed progressively closer together as the inner margin of the lamella is approached; the inner 3 or 4 ridges thus placed quite close together anteriorly and merging laterally. External surface of cheek lobe and lamellae traversed by radiating, anastomosing genal caeca which extend from the axial and preglabellar furrows to the external rim, becoming reduced in convexity as they approach the rim so that they merge into the flattened external rim. The caeca radiate from the axial furrow opposite the anterior one-third of the glabella and they appear to run under and beside the eye ridge and eye lobe, and posteriorly to the latter they give the appearance of sweeping around the cheek behind it (Pl. 5, fig. 3; Pl. 7, figs. 1, 4). Only at one point, midway along the anterior side of the eye ridge, does a caecum appear to branch from this ridge. In front of the glabella the caeca curve toward each other and there are several junctions, but distally all the caeca tend to diverge, branch, and to be more widely

separated from each other. Of variable intensity is a ridge running along the outer side of the preglabellar furrow, between the proximal ends of the eye ridges. On the upper lamella of the fringe the inner margin is marked by the appearance of a single line of pits between the caeca; beyond the inner one-third of the fringe the rows of pits become double and irregularly placed between the divergent caeca. On the lower lamella (Pl. 6, figs. 2-4) the caeca are less convex, but are clearly outlined by the similarly arranged pits. On the upper lamella concentric smooth bands are outlined by gaps in the radial lines of pits (Pl. 5, fig. 3); these bands are placed more closely together towards the inner margin of the fringe. Their number and positions suggest that they correspond to the girders of the lower lamella. A genal ridge originates at the posterolateral margin of the eye lobe (Pl. 5, fig. 3), and runs outward and slightly backward toward the genal angle, becoming narrower and fainter distally, but traceable most of the way to this angle.

Except in alae and axial furrows, a fine granulation is present on the external surface including the rims and caeca of the fringe. On the glabella, posterior border, caeca, and eye ridge larger tubercles are irregularly scattered. These tubercles vary in size, and appear to be faint or absent on all but the outermost part of the gently convex, oval second lateral lobe (Pl. 6, fig. 1). On the palpebral lobe there is a conspicuous group of these tubercles, largest at the outer margin but the outer slope of the eye lobe appears to be smooth, and does not show any sign of eye facets (Pl. 7, figs. 3, 4).

Discussion. Henningsmoen (1959, pp. 166-169, pl. 2, figs. 5-11) has redescribed *Harpides rugosus* from Tremadoc of Norway, illustrating for the first time the nature of the lower lamella. As in *H. atlanticus* it bears several girders, and is crossed by radiating caeca and lines of pits. It is quite clear from the arrangement of these caeca and pits, the granulation of the external surface, and the form, that such specimens as the originals of Plate 6, figures 2-4, represent the lower lamella of the fringe, and not a different species of the genus as originally thought by Billings (1865, p. 282). Species of *Harpides* are characteristic of Tremadoc rocks of the world (Harrington and Leanza, 1957, p. 196, fig. 103, 1; Rasetti, 1952, p. 801; Troedsson, 1937, pp. 69-70, pl. 8, fig. 2; additional references in Henningsmoen, 1959), but specimens are found only rarely and in a fragmentary state in rocks of Lower Ordovician age (e.g. Tjernvik, 1956, p. 268), and the present species appears to be the youngest

known. It is distinguished from earlier species by the relatively wide and short glabella, the position and prominence of the eye lobe, the outward and backward direction of the eye ridge, and the convergence of the caeca in the preglabellar area.

The genal caeca of *Harpides atlanticus* have been described above as radiating out from the axial furrow beside the anterior part of the glabella, and as showing no obvious connection with the eye ridge. None appears to originate from the occipital ring, and there is no sign of separate groups arising opposite each glabellar furrow, as in the Cambrian *Papyriaspis* (Öpik, 1961a, p. 424, fig. 12). Öpik follows Hupé (1953, pp. 83-84) in believing that certain of the caeca are closely connected with palpebral lobe and eye ridge, and suggests also a connection with the parafrontal band (Öpik, 1961a, pp. 424-425). A parafrontal band is present in *H. atlanticus* (Pl. 5, fig. 1; Pl. 7, fig. 2), but it appears to me at least arguable that the anterior caeca run from this band and the eye ridge and palpebral lobe. One caecum (Pl. 7, fig. 4) does appear to branch from the eye ridge, but others may be interpreted as running uninterrupted beneath the eye ridge and lobe, and connection between caeca and parafrontal ridge is not beyond dispute, especially where this ridge is faint (Pl. 7, fig. 1).

The pattern of genal caeca in *Harpides* is thus like that in such harpids as *Selenoharpes* (Pl. 8, figs. 1, 4) in its seeming independence of eye ridge and lobe, in its point of origin, and in running out to the margin. In both genera the genal ridge runs independently of the caeca.

Family HARPIDAE Hawle and Corda, 1847

Genus SELENOHARPES Whittington, 1950

SELENOHARPES SINGULARIS n. sp.

Plates 8, 9

Holotype. GSC 18402, almost complete cephalon, middle Table Head Formation, Table Cove.

Other material. Parts of 10 additional cephala from same locality and horizon.

Discussion. This rare species, known from only one locality, is closely related to, but not exactly like either *Selenoharpes fragilis* (Raymond) or *S. vitilis* Whittington (1963, pp. 32-35, pl. 1, figs. 18-20, pls. 2, 3). In various minor characters the cephalon differs from either of the species named — the outline

is subcircular, the brim relatively narrower, sloping gently downward outside the girder and becoming flat peripherally; the cheek lobes project relatively farther anterolaterally, so that the anterior margin of these lobes and the depressed preglabellar field is transverse, not curved convexly forward; the anterior part of the cheek lobe is more convex, projecting upward so that there is a steep slope into the axial furrow; the band on the upper lamella of the fringe corresponding to the girder is relatively more pronounced, and curved back behind the genal margin to meet the internal rim of the fringe at about half the length of the prolongation. The few specimens are insufficient to show much of individual variation. One incomplete cephalon (Pl. 9, figs. 4, 6) is similar to the holotype except that the brim outside the girder slopes much more steeply outward and downward. In this particular character it approaches *S. fragilis*, but is different from it in the cephalic outline and the relative narrowness of the brim (compare Pl. 9, figs. 4, 6, with Whittington, 1963, pl. 2, figs. 1-3). In specimens referred to *S. vitilis?* (Whittington, 1963, p. 34, pl. 3, figs. 1, 5) the prolongation in dorsal view is much less strongly incurved than in typical specimens, and the girder reaches the internal rim at about half the length. These characters of the prolongation resemble those typical of *S. singularis*, but in other characters mentioned above the new species is not like *S. vitilis?*

In one small, incomplete cephalon (Pl. 9, figs. 2, 3, 5) the glabella is parallel-sided, the eye lobe prominent and situated far outward and forward on the cheek lobe, and the prolongation of the fringe relatively much shorter than in large cephalia. Thus during growth the glabella widens posteriorly and the prolongations increase in length, trends which characterize the development of *Dolichoharpes reticulata* (Evitt, 1951, p. 612).

Family RAPHIOPHORIDAE Angelin, 1854

Genus LONCHODOMAS Angelin, 1854

LONCHODOMAS NORMALIS (Billings, 1865)

Plate 10

Billings, 1865, pp. 295-296, fig. 286.

Raymond, 1925, pp. 38-39.

Lectotype (here selected). GSC 692, incomplete cranidium, from Daniel's Harbour. Paralectotypes: GSC 692b, c, e, cranidia; GSC 692a, d, f, g, j, k, l, pygidia: same locality.

Other material. GSC 693b, cranium, 693e, f, pygidia, from middle Table Head Formation, included by Billings in *Ampyx lacviusculus*. This species is most abundant in the type section of the middle Table Head Formation, less so in the isolated limestone and at Table Cove.

Description. Outline of glabella diamond-shaped, maximum width at about one-third the length from the anterior end, occipital ring wide, flat and sloping gently down to occipital furrow. Immediately in front of broad, shallow occipital furrow is short (sag. and exs.) basal ring of glabella, best outlined on internal moulds (Pl. 10, figs. 1, 14) by shallow depression of first lateral furrow, and extremely faint furrow connecting these areas across the median part of the glabella. A short distance in front of furrow 1p is lateral furrow 2p, a larger, less deeply impressed (in internal moulds) area situated higher up the side of the glabella. Median line of glabella may be faintly carinate. Anterior pit a deep and narrow slit situated at anterolateral margin of glabella, frontal lobe of glabella extended in long, tapering prismatic spine. Fixed cheek subtriangular in outline, posterior border flat and sloping inward to the posterior border furrow, which bears a deep pit distally. Along anterior margin of cheek is a broad, flattened border which runs inward to the base of the glabellar spine and is defined by a sharp change in slope (Pl. 10, fig. 10). Laterally fixed cheek bounded by gently sigmoidal line of facial suture, which runs forward along the margin of the anterior border. Two examples of a hypostome which may belong to this species are subdiamond-shaped in outline, with narrow, gently convex borders. The middle body is evenly convex, and only the most posterior part is less strongly convex and apparently represents the posterior lobe.

Thorax of five segments, first segment relatively longer (sag. and exs.) than those following it. Axis is of constant width, thorax widest at second segment, from here tapering both anteriorly and posteriorly. Shallow pleural furrow runs out to fulcrum, at which pleurae are bent vertically down. Pygidium triangular in outline, length about two-thirds of width (tr.), posterolateral margin almost straight. Axis gently convex, standing above horizontal pleural regions, tapering back and running to obliquely angulate posterior tip of pygidium. Narrow ridge along posterolateral margin of pleural region, border bent vertically down, broad. First pleural furrow narrow and deep,

running out to the facet in a curve that is concave forwards. On external surface (Pl. 10, fig. 7) axis of pygidium shows only articulating furrow, but muscle areas may appear as darker spots (Pl. 10, fig. 5). There are two pairs of such spots, the outer the larger and close to the margin of the axis, the inner pair smaller and joined by a faint line across the median region. On internal moulds (Pl. 10, fig. 4) these muscle areas may be represented by faint depressions. About 8 ring furrows are indicated by these paired muscle areas. External surface of exoskeleton smooth, except for fine, subparallel lines that traverse the angles of the glabellar spine, the border of the pygidium, and the borders of the hypostome. On internal moulds (Pl. 10, figs. 10, 14) a faint pattern of genal caeca may be seen on the cheek, running out from the axial furrow at the midlength of the glabella toward the genal angle.

Discussion. The cranium, thorax and pygidium exhibit the typical characters of *Lonchodomas* (Whittington, 1959, pp. 460-463, 473-479, pls. 32, 33, text-fig. 8, and references therein), including the size and arrangement of the muscle areas. Some specimens show faintly (Pl. 10, fig. 10) the muscle area at the margin of the glabella where it is widest. Distinctive of this species appears to be the well marked anterior border of the fixed cheek, and the relatively long, triangular pygidium with the narrow raised rim. The only other hypostome of *Lonchodomas* that has been described is that of *L. carinatus* (Whittington, 1959, pl. 32, figs. 6, 8, 9, 12, 17) and it is also sub-octagonal in outline, but relatively broader and with a larger posterior lobe of the middle body. *L. normalis* is considerably older than most species of the genus, and is not like the younger species from the Chazy described by Raymond (1905, pp. 332-334, pl. 10, figs. 3-7; 1910, pp. 216-217, pl. 32, figs. 3-7). In the Chazy species the glabella is elongated in front of the remainder of the cranium, and the pygidium is relatively shorter and less triangular in outline. Raymond referred his species to *L. halli* (Billings, 1861), the type of which came from Highgate Springs, Vermont. Material from this locality which I recently examined (Whittington, 1959, p. 479) shows that this species has the hooked genal spine similar to that of *L. carinatus*, and is probably of the same age. Thus it is uncertain that the Chazy species should be referred to *L. halli*, but in any event it appears to be quite different from the Table Head species. Still younger species such as *L. carinatus* and *L. megeheeii* (see Sutherland

and Amsden, 1959) lack the anterolateral cranial border and have a much shorter pygidium displaying several pleural furrows. *L. politus* Raymond, 1925 (pp. 39-40, pl. 2, figs. 8-10; Cooper, 1953, pp. 18-19, pl. 6, figs. 1, 2, 7, 8, 9, ?not 5, 6) displays the anterolateral border but has an otherwise different cranidium in which the suture curves inward across the lateral part of the cheek. The pygidium of *L. politus* is relatively short and shows 3 pleural furrows.

LONCHODOMAS CLAVULUS n. sp.

Plate 11

Holotype. GSC 18413, incomplete and largely exfoliated cranidium from 17 feet above base of middle Table Head Formation at type section.

Other material. Quite abundant 17 feet above base of middle Table Head Formation at type section, one pygidium from 50 feet above base; at Table Cove this species is about one-third as abundant as *L. normalis*; one pygidium comes from the isolated limestone.

Description. Outline of glabella in dorsal aspect like that of *Lonchodomas normalis*, but occipital ring slopes more steeply forward to occipital furrow, and laterally is joined by a wider, steeply sloping band to the posterior border. The basal glabellar ring is more prominent in internal moulds, the muscle areas appear similar except that 2p appears to be relatively large. In lateral view (Pl. 11, fig. 2) the frontal glabellar spine is seen to arise some distance above the anterior border, and to be directed forward and slightly upward, whereas in *L. normalis* (Pl. 10, figs. 6, 11) the glabellar spine arises immediately above the anterior margin and is horizontally directed. Anterior part of cheek curves down to sutural margin, and merges with narrow preglabellar field, and there is no broad flat border (compare Pl. 11, fig. 5 with Pl. 10, fig. 10). On the internal mould, (Pl. 11, figs. 5, 13) cheek is crossed by two or three faint genal caeca, which arise at the axial furrow a short distance in front of muscle area 2p and diverge slightly as they run out toward the genal angle. Doublure (Pl. 11, fig. 9) a plate which joins the fixed cheeks and is widest anteriorly, and there is a median furrow. The anterior margin is obliquely angulate, the rounded tip lacking the notch seen in *L. carinatus* (Whittington, 1959, pl. 32, figs. 2, 3). The doublure is seen to extend on the left side (Pl. 11, fig. 9) in a gently curving course and then is

broken, so that if it includes part of the under side of the genal spine, it only includes the slightly curved proximal portion. Hypostome shield-shaped, convex middle body divided by faint median ridge, which becomes more prominent and broader posteriorly; small macula at posterolateral corner, posterior lobe small. Anterior border broad, projecting steeply downward in front of anterior furrow, laterally and posteriorly border narrow, widening posterolaterally where it is extended on the dorsal side as a small, pointed posterior wing. External surface of exoskeleton apparently smooth, except along angles of glabellar spine, inner margin of doublure, and borders of hypostome, which are traversed by fine terrace lines. On internal mould surface appears finely pitted (Pl. 11, fig. 13).

Pygidium differs from that of *L. normalis* in that pleural region is considerably inflated so that adjacent to the axial furrow it slopes steeply forward to the pleural furrow, and slightly less steeply posteriorly; vertical border much broader and bearing a deep, broad posterior notch. On axis ring furrows are most conspicuous on internal mould, up to ten visible. These furrows are outlined by two pairs of muscle areas, the inner pair joined by a narrow band; in front of the most anterior pair is a conspicuous, elongate, median depressed area, this area lying immediately behind the deep articulating furrow. External surface apparently smooth, except for fine terrace lines on border. On internal mould, surface of axis and pleural regions appears finely pitted.

Discussion. In the type section of the Table Head Formation this species is the only one in the lower 20 feet; above here it becomes rare and is not known more than 50 feet above the base, being replaced by the more abundant *L. normalis*. In the exposures at Table Cove this species is moderately abundant. Since this is the only raphiophorid present in the lowest part of the middle Table Head, there can be little doubt that the hypostome belongs in this species. In general form it is more like that attributed to a species of *Ampyx*, *A. virginiensis*, than that attributed to a species of *Lonchodomas*, *L. carinatus* (Whittington, 1959, pl. 29, figs. 9, 10, 12-16; pl. 32, figs. 6, 8, 9, 12, 17). The anterior border is broader than that of *A. virginiensis* and projects more prominently and the faint subdivision of the median lobe into two lateral lobes is not seen in the Virginia species.

The position and direction of the frontal glabellar spine, course of the suture across the outermost part of the cheek, and

relatively long, convex pygidium, combine to distinguish this species from Chazyan and younger species referred to in the discussion of *L. normalis*.

Genus AMPYX Dalman, 1827

AMPYX LAEVIUSCULUS Billings, 1865

Plate 12, figures 1-12

Billings, 1865, p. 295, fig. 285.

Lectotype (here selected). GSC 693, pygidium with exoskeleton from type section, middle Table Head Formation. Paralectotypes: GSC 693a, c, internal moulds of pygidia (693b, e, f are here referred to *Lonchodomas normalis*, and 693d to *Ampyxoides semicostatus*).

Other material. Only from thin layer of lime sand about 90 feet above base of type section, middle Table Head Formation. Raymond (1925, pp. 36-37) based his description on material collected by Schuchert and Twenhofel from "zone 13, N₃, at Table Head." These specimens (YPM 3100/20) are in a black calcareous shale, and are mostly *Lonchodomas normalis*, a few being *Ampyxoides semicostatus*.

Description. Cranidium, free cheek and pygidium are typical of the genus (Whittington, 1950, pp. 554-556, pl. 74, figs. 3-9, text-fig. 6). The cranidium shows the musele areas as depressions in the internal mould of the glabella, the latter relatively convex anteriorly, with a long downward slope below the base of the glabellar spine. Particularly in lateral profile (Pl. 12, fig. 8), as well as in dorsal view, this cranidium is extremely like that of *A. camurus* (Whittington, 1959, pl. 30, figs. 15, 19) from the Liberty Hall facies of the Edinburg Formation, Virginia. In the characters in which it resembles *A. camurus*, the cranidium differs from that of *A. virginiensis* (Whittington, 1959, pp. 465-469, pl. 29; pl. 30, figs. 1-14, 16, 17, 20-30; pl. 31) — a second species from the Edinburg Formation. Width of pygidium is about 2½ times length (sag.), the axis is relatively narrow and gently tapering, the tip not well defined. The broad border slopes vertically downward. This pygidium is also like that of *A. camurus* in dorsal aspect, differing chiefly in that the border is less steeply sloping in the Virginia species. Two examples of a hypostome which may belong to this species are subdiamond shaped in outline, with narrow, gently convex borders. The middle body is evenly convex, and only the most

posterior part is less strongly convex and apparently represents the posterior lobe.

Genus *AMPYXOIDES* n. gen.

Type species. *Ampyx semicostatus* Billings, 1865.

Diagnosis. Differs from *Ampyxina* (Whittington, in Moore, 1959, p. 0426, fig. 329, 1; 1959, pp. 481-487, pl. 28, figs. 10, 11, 13; pls. 34, 35) in that alae are lacking, and there is a frontal glabellar spine which is sub-square in cross-section and curves gently upward. Pygidium with axis that tapers to narrow (tr.) tip, pleural furrows almost straight, distally curving slightly forward (not backward), pleural ribs flattened, after first furrow defined only distally, extremely faint interpleural furrows.

Discussion. The type species is a typical raphiophorid (Whittington, 1959, pp. 460-463) having a rather *Ampyx*-like glabella except that the frontal spine is square in cross section, not rounded, five thoracic segments, the first longer (sag. and exs.) than those following, the pleural regions of the pygidium not like those of *Ampyxina*. The muscle areas on the glabella are like those of *Ampyx* and *Lonchodomas*, only the outer parts of 2p and 3p being represented by depressions in the external surface, the areas extending far inward on the glabella. Muscle area 3p is present close to the axial furrow, as in *Ampyx*, and situated a short distance behind the anterior pit. On the axis of the pygidium only one pair of muscle areas, the larger outer pair, is present in the ring furrows. The type species appears to be closest to species of *Ampyxina*, but if the presence of alae in the holaspid is regarded as characteristic of *Ampyxina*, then it cannot be placed here, and seems to represent a different group.

AMPYXOIDES SEMICOSTATUS (Billings, 1865)

Plate 12, figures 13-20; Plate 13, figures 1-10, 12

Billings, 1865, p. 297, fig. 287.

Raymond, 1925, pp. 31-32, pl. 1, figs. 14, 15.

Lectotype (here selected). GSC 690, internal mould of pygidium from Daniel's Harbour. Paralectotypes include two similar pygidia, GSC 690a, 690b, from same locality.

Other material. GSC 693d, cranidium, placed by Billings in *Ampyx laeviusculus*. In the type section of the Table Head Formation this species is the third most abundant, occurring from 90 feet above the base to the top of the middle portion. Topotype material was collected from boulders at Daniel's

Harbour, at Table Cove, in the isolated limestone, and from bed 4 at Black Cove. YPM 13029, Dominion Iron and Steel Co. quarry, Aguathuna, Port au Port peninsula.

Description. Glabella expanding forward to maximum width close to anterior margin, moderately convex (sag. and tr.), frontal spine arising at upper edge of frontal slope, square in cross-section, extending forward horizontally, becoming rounded distally and turning gently upward. Occipital ring narrow, convex, shallow occipital furrow, elongate muscle area at outer end. A short distance in front of occipital furrow and a short distance in from the axial furrow is a small, circular depression, the outer part of glabellar furrow 1p, the remainder visible in some specimens (Pl. 12, fig. 20) as a dark area of the exoskeleton extending in a subcircular muscle area half way up the side of the glabella. Lateral furrow 2p situated a short distance in front of 1p, represented by a shallower subcircular depression situated a short distance in from the axial furrow. In occasional specimens (Pl. 12, fig. 20; Pl. 13, fig. 3) the entire muscle area is revealed as pear-shaped, extending far upward on the side of the glabella. Lateral furrow 3p represented by the dark, circular patch seen in the same specimens, situated close to the axial furrow and just behind the maximum width. Lateral furrow 4p, rarely visible (Pl. 12, fig. 20), is similar and situated at the maximum width, close to the anterior pit. Gently convex cheek sloping outward to narrow, rolled anterior and lateral border. These borders extended beneath the exoskeleton as the narrow doublure which is gently convex ventrally (Pl. 13, fig. 8). Posterior border well defined, narrow proximally and broadening outward, posterior border furrow ending distally in elongate pit. Cheek continued in front of glabella by narrow preglabellar field which diminishes and disappears before reaching the midline. Facial suture runs along border anteriorly, anterolaterally and laterally running just inside the border of the cheek in a course which is slightly sigmoidal, there being a concavity in the course just in front of the genal angle. Free cheek extremely narrow, poorly preserved, but apparently having the narrow border, which is extended posterolaterally as a long genal spine reaching back far beyond the pygidium (Pl. 13, fig. 1).

Thorax of five segments, axis tapering slightly back, first segment markedly longer (sag. and exs.) than those following, the succeeding four segments progressively shorter backward. Axial ring gently convex, articulating furrow with deep pit distally. Pleural furrow of first segment runs from axial furrow in a

curve that is at first convex forward, then runs out diagonally in a gentle curve that is concave forward. Pleural furrow of remaining segments straight, slightly diagonally directed. At fulcrum tips of pleurae bent down vertically. Pygidium with prominent axis that tapers back to narrow tip, articulating furrow and first four ring furrows defined on external surface, additional rings on internal mould. Pleural regions extend out horizontally to narrow rim and then are bent down vertically in broad (sag. and exs.) border. First pleural furrow deep and continuous, running slightly diagonally, and with a faint curvature that is concave forward, out to rim. Four additional pleural furrows are faintly indicated on the inner part of the pleural regions, but become deep and distinct distally. Thus the inner part of the pleural region behind the first segment is hardly at all divided. On the external surface of some specimens there are extremely faint interpleural furrows.

External surface of exoskeleton smooth, fine terrace lines on angles of frontal glabellar spine, borders and doublure. On pygidium paired dark spots (muscle areas) are prominent in some specimens (Pl. 12, fig. 18) in the articulating furrow and succeeding four ring furrows. Additional pairs visible as much fainter, smaller spots, closer together and extending back along the tip of the axis on to the upper edge of the border. On the cheek lobe in some specimens the internal mould shows extremely faint genal ridges which run out from the midlength of the glabella toward the posterolateral part of the cheek. Most prominent is the ridge which runs directly toward the genal angle. These lines are extremely faint or absent in some specimens, and do not appear to be visible on the external surface.

Discussion. This species is particularly characteristic of the fine-grained, dark, muddy limestones, but does occur in more coarsely grained, less muddy lime sands. Raymond described the frontal glabellar spine as circular in section, but it appears that he was in error. The present specimens do not show the free cheek well, but reveal the length and curvature of the genal spine.

Genus *ANISONOTELLA* Whittington, 1952

ANISONOTELLA GLACIALIS (Billings, 1865)

Plate 13, figures 9, 11, 13; Plate 14, figures 1-6, 8

Billings, 1865, p. 283, fig. 270; p. 296.

Raymond, 1920, pp. 279-280.

Raymond, 1925, pp. 44-46, pl. 2, fig. 17.

Whittington, 1952, pp. 4-5.

Whittington in Moore 1959, pp. O426-7, fig. 327, 5.

Lectotype (here selected). GSC 670c, cranidium. Paralectotypes include GSC 670, 670a, b, all cranidia, in dark limestone with *Triarthrus fischeri* and *Geragnostus fabius*. The accompanying label reads "Portland Creek and Pistolet Bay" but only 670a has Pistolet Bay written on the back of the specimen. Possibly the lectotype, 670, and 670b are from boulders in Cow Head Group conglomerates near Portland Creek.

Other material. GSC 691, holotype of "*Ampyx*" *rutilius* Billings, 1865, p. 296, from "four miles northeast of Portland Creek," that is, Daniel's Harbour. MCZ 1594, original of Raymond, 1925, pl. 2, fig. 17, from collection of Jules Marcou, from "east side of Port-au-Port," that is, probably bed 4 at Black Cove. The present investigation shows that the species is fairly common in bed 4 at Black Cove and in boulders at Daniel's Harbour.

Description. This species was fully described by Raymond, and the following notes amplify his description. Lateral glabular furrows 1p and 2p are circular in outline and deep, 3p shallower, and there is a faint longitudinal furrow joining these furrows and extending back to the extremity of the occipital ring. The lateral part of the glabella outside this longitudinal furrow is slightly inflated. On the outer edge it is bounded by the narrow alar furrow, outside which is the low, broad ala which extends forward as far as the genal ridge. Outside the ala is the broad shallow axial furrow. Posteriorly the ala is separated from the occipital ring by a shallow extension of the posterior border furrow. A cranidium (Pl. 14, figs. 3, 5, 6, 8) shows the course of the facial sutures, and one almost complete exoskeleton preserves parts of the free cheeks (Pl. 14, figs. 1, 2, 4). Laterally and anterolaterally there is a narrow convex border, separated from the cheek by a shallow border furrow. Anteriorly, the same border furrow and the upper part of the border are visible on the cranidium, so evidently the cephalon possessed a narrow border, though it is broken away anteriorly in the complete specimen. The semicircular backward prolongation of the posterior border (lapet of Raymond) is bounded by the facial suture which then runs forward and inward along the outermost part of the cheek to reach the border furrow in line with the axial furrow, and then crosses the upper surface of the anterior border. The connective suture joins these branches

along the anterior edge of the border. The cheek is thus narrow (tr.), but includes the outermost part of the prolongation of the cheek and bears a long genal spine which curves gently outward and reaches back far beyond the pygidium. The genal ridge (eye line of Raymond) commences in the axial furrow opposite lateral glabellar furrow 3p, and is most pronounced proximally; distally it curves outward and backward to run on to the outer edge of the prolongation of the fixed cheek. The cheek behind the genal ridge is inflated, and at and immediately in front of the proximal part of the genal ridge the cheek is depressed.

Pleural furrows of thorax and pygidium broad and well defined, those of thorax, particularly the anterior four, running in a curve that is convex forward. On the axis of the pygidium, up to 11 rings are demarcated, on the pleural region 9 pleural furrows; these furrows flexed back distally. On the anterior four flat pleural ribs faint interpleural furrows may be visible.

On the external surface of the median and frontal glabellar lobes is a pattern of fine, raised anastomosing lines. These lines are roughly concentrically arranged with reference to the area they cover, and center around the low median tubercle which is situated in line with lateral furrows 3p. Similar lines are absent from the lateral parts of the glabella, the furrows and the alae, but are present on the cheeks and preglabellar field inside the border. On the inner part of the cheek, behind the genal ridge, the lines run subparallel in curves convex forward, outside this ridge and on the preglabellar field the lines run subparallel to the border furrow.

Discussion. The reconstruction (Whittington, *in* Moore, 1959, fig. 327, 5) is based on the original of Plate 14, figures 1, 2, 4. It shows the branch of the facial suture cutting across the anterior border at a point much farther out than is correct — this crossing occurs at a point roughly in line with the anterior part of the axial furrow. The lines on the external surface of the cephalon were omitted. Raymond (1925, pp. 46-47) suggested that "*Ampyx*" *hornei* (Reed, 1903, pp. 19-21, pl. 3, figs. 8-10) and *Ampyx obtusus* Moberg and Segerberg, 1906 (pp. 100-101, pl. 7, figs. 8-10; Tjernvik, 1956, pp. 271-272, pl. 11, figs. 16-18) were species of *Anisonotella*. Neither of these species appears to belong to this genus; the former may well be a species of *Edmundsonia* Cooper, 1953; the latter is retained in *Ampyx* by Tjernvik. Thus the genus *Anisonotella* is so far known only from the middle Table Head Formation, from few

localities and apparently a limited stratigraphical horizon. Billings (1865, p. 296) did not figure his species "*Ampyx*" *rutilius*, but there is no doubt that the holotype (Pl. 13, fig. 9) belongs to *A. glacialis*, and additional pygidia and cranidia have been recovered from the locality.

Raymond (1925) regarded *Anisonotella* as belonging within the family Endymioniidae, but because of the presence of alae and of 3 pairs of glabellar furrows, and the large number of segments in the pygidium, it seems more likely that it belongs within the Raphiophoridae. This is particularly true if the genus *Salteria* is removed from the Endymioniidae (Whittington, 1959, p. 492) leaving this family centered around the peculiar genus *Endymionia*.

Family ENDYMIONIIDAE Raymond, 1920

Genus ENDYMIONIA Billings, 1865

ENDYMIONIA SCHUCHERTI Raymond, 1920

Plate 15, figures 1-18, 20

Raymond, 1920, pp. 277-278.

Raymond, 1925, pp. 43-44, pl. 2, fig. 13.

Lectotype (here selected). YPM 13040, cranidium, original of Raymond, 1925, pl. 2, fig. 13, type section, middle Table Head Formation.

Other material. YPM 23856, poorly preserved entire specimen, mentioned by Raymond. Moderately abundant in the type section, from 190 to 215 feet above the base. It also occurs in the highest beds exposed on the foreshore immediately south of Table Cove, and at Daniel's Harbour.

Description. Raymond's description may be amplified and emended as follows. There is a tuberele on the midline of the glabella immediately in front of the occipital furrow (Pl. 15, fig. 6). One or two specimens show a faint tuberele at about the midlength of the glabella. The triangular fixed cheek slopes steeply laterally, bounded by the slightly sinuous, diagonally-directed suture. The posterior border is broad, the posterior border furrow shallow adjacent to the axial furrow, but deepening as it curves outward, and deepest where it curves back distally. Cheek in front of outermost part of border furrow slightly inflated. Suture curves around extremity of border furrow and inward and backward across posterior border.

Cheeks united in front of glabella by gently convex, steeply sloping preglabellar field. Anterior border horizontally directed, narrow (sag. and exs.), bounded laterally by the suture so that the width (tr.) is less than the maximum width of the glabella. Free cheeks unknown.

Thorax of 7 segments, the segments successively shorter (sag. and exs.) backward, the axis tapering only at the last two segments. Pleura crossed by diagonally directed, deep pleural furrow which curves concavely forward. Posterior pleural band gently inflated, most strongly so adjacent to the axial furrow. Pygidium short (sag.), with rapidly tapering axis on which four rings and a small terminal portion are marked out. Horizontal pleural regions crossed by four pleural furrows which are straight and directed successively more strongly backward. Border of pygidium steeply sloping, with narrow rim at upper and lower edges. External surface of exoskeleton smooth except for fine terrace lines on border of pygidium. On preglabellar field a faint pair of tubercles (Pl. 15, fig. 2).

A size series of cranidia ranges from length (sag.) 0.65 mm to 6.5 mm. In the smallest specimen (Pl. 15, figs. 14, 15, 20) the narrow occipital ring is depressed, the glabella in front of it inflated and subparallel-sided, expanding slightly forward to a maximum width across the frontal lobe. Immediately in front of the occipital ring is a low tubercle. The axial furrow beside the glabella is broad, and there is a faint swelling extending forward from the outer end of the occipital ring part way along this furrow. Posterior border furrow of cheek is present on outer slope only, on steeply sloping preglabellar field a conspicuous pair of tubercles. In the next largest cranidium (Pl. 15, figs. 11, 12, 16) the glabella is longer than wide, but the "lateral lobes" are conspicuously developed and extend from immediately in front of the outer end of the occipital ring to a point just behind the frontal lobe, and are relatively narrower (tr.) than in larger specimens. The posterior border furrow extends farther inward but is faint proximally. In successively larger cranidia the glabella is of about the same length as width, and the "lateral lobes" become relatively wider, especially posteriorly, and increase slightly in convexity. The "lateral glabellar lobes" thus appear to originate in the axial furrow beside the glabella, like the alae of raphiophorids and trinucleids (Whittington, 1959, pp. 464-465). However, the alae in these latter families do not become larger and more inflated as size increases, as lateral glabellar lobes do in many non-trinucleid

trilobites. The "lateral glabellar lobes" in *Endymionia* develop in an unusual way and whether or not they correspond with these lobes in other trilobites is uncertain. The pair of tubercles on the preglabellar field is most conspicuous in the early stages, but is still present in the largest holaspides.

Discussion. The holotype and only known specimen of the type species of *Endymionia*, *E. meeki* (Billings, 1862, pp. 94-95, fig. 84; 1865, p. 281; this paper, Pl. 15, figs. 19, 23, 24; Pl. 68, figs. 4, 5) came from "the upper part of limestone No. 2," Point Lévis, Quebec, that is, from a limestone boulder in one of the conglomerates in the Lévis Shale. It is clear that *E. meeki* is closely related to *E. schucherti*, but differs from the latter species in minor details of the shape and lobation of the glabella, in that the posterior border furrow runs in a curve concave forward, and in that the course of the suture on the outer part of the cheek is more strongly incurved. The median tubercle situated at the midlength of the glabella is conspicuous, and there is no sign of a median tubercle immediately in front of the occipital furrow. Also distinctive of *E. meeki* is the very deep border of the pygidium posteriorly, on to the upper part of which the axis extends (Pl. 68, fig. 5).

Raymond (1914, p. 526; 1925, pp. 42-4) identified certain specimens from the Shumardia Limestone as *E. meeki*. His remarks on this species, and comments on the differences between *meeki* and *schucherti* are based on these specimens, and his original is here refigured (Pl. 15, figs. 21, 22, 25). Additional material obtained by Clark (1924, p. 60) includes MCZ 1961, 1962, 1964. The glabella of this species appears relatively narrower (tr.) than that of *E. meeki*, the posterior border and border furrow are similar in the two species, but they are distinguished readily by the preglabellar field, which in Raymond's specimen slopes steeply downward, is traversed by anastomosing terrace lines, and there is an extremely narrow (tr.), median, horizontally-sloping border. The suture limits this preglabellar area laterally, and the two branches approach quite closely before running on to the narrow horizontal border. In *E. meeki* the two branches are much farther apart (compare figs. 19 and 22, Pl. 15) where they run on to the horizontal border, which is consequently wider (tr.). Because of these differences I propose that Raymond's specimen, and those obtained by Clark, be considered to represent a new species, *Endymionia raymondi* n. sp., holotype MCZ 1963.

From bed 4 at "Black Cove" comes a single specimen (Pl. 14, fig. 7) that is similar to *E. schucherti*. It is flattened and of about twice the size of specimens from other localities. The glabella appears relatively longer than in *schucherti*, and the anterior border of the cranidium also wider (sag. and exs.). The pygidium has the same number of segments in it as large specimens of *E. schucherti*, but is relatively much longer (sag.). Whether these differences are the result of the flattening that the exoskelton has undergone is uncertain.

Family SHUMARDIIDAE Lake, 1907

Genus SHUMARDIA Billings, 1862

SHUMARDIA GRANULOSA Billings, 1862

Plate 16

Billings, 1862, pp. 92-93, fig. 83.

Clark, 1924, pp. 88-89, pl. 9, figs. 1-6.

Lectotype (here selected). GSC 880, incomplete cranidium, on same slab as syntype incomplete pygidium; also on slab are external moulds of two cranidia and one pygidium; Point Lévis, Quebec.

Other material. Museum of Comparative Zoology collections obtained by P. E. Raymond and T. H. Clark are from Lévis, Quebec, presumably largely from Clark's (1924, p. 101) locality D where the Shumardia Limestone is exposed. This limestone is in Raymond's (1914, p. 528) zone D1, which is of early Llanvirn age (Bulman, 1958, p. 166).

Description. Convex cephalon subsemicircular in outline, glabella occupying about one-third the width. Posterior part of glabella semicylindrical in form, anterior part expanded and transversely ovate. A straight occipital furrow isolates the convex occipital ring. Midway between the occipital furrow and anterolateral lobe the glabella adjacent to the axial furrow is deeply indented, and lateral furrow 1p runs inward and backward a short distance from this indentation, and isolates a tiny, circular basal lateral lobe (Pl. 16, figs. 12, 15). Lateral furrow 2p runs forward and inward from the same indentation, becoming progressively shallower but outlining the oval anterolateral lobe, which is of about the same width (tr.) as the intervening frontomedian lobe. Axial furrow is deep beside posterior half of glabella; as it curves forwards around the anterolateral lobe it becomes shallower, and is confluent with

the preglabellar furrow, this furrow being V-shaped in outline in anterior view. Cheek convex, sloping vertically distally, and merging anteriorly with the narrow preglabellar area. Latter divided by deep, longitudinal median depression. The cheek slopes inwards to the deep posterior part of the axial furrow, and vertically down to the posterior border furrow. Latter runs straight outward from midpoint of occipital ring, dying out on the steep distal slope of the cheek, and defining a narrow posterior border which lies well below the inner part of the cheek and widens outward. At margin of cheeks and preglabellar area is a narrow ridge; the exoskeleton then curves under to form the doublure, and is apparently traversed by additional ridges. Facial suture runs from genal angle across outer part of cheek and on to marginal ridge of preglabellar area, isolating the free cheeks which are widest (tr.) anterolaterally (Pl. 16, figs. 7, 9, 17). It is uncertain whether or not there is a median ventral suture, and the nature of the genal angle is also unknown. Posterolaterally, the suture curves around inward to the posterior margin, so that the posterolateral angle of the cranium is rounded. The lectotype is exfoliated, and along the margin of the left cheek runs a broad, shallow furrow, outside which the slope of the cheek is continued for a short distance (Pl. 16, fig. 3). This outermost part of the specimen may be the mould of the doublure, but the form of the doublure is uncertain. External surface granulate except in furrows.

Thorax apparently of six segments. The complete specimen (Pl. 16, figs. 5-7) shows five segments clearly, and what appears to be the first segment lies at a sharp angle to the others and was evidently pushed beneath the most posterior part of the cephalon, and only a small portion of the left pleurae is now visible. Axis broad, convex, pleurae curved downward to slope vertically distally, broadly faceted. There is no evidence on the right side of the complete specimen, where the pleurae are best preserved, that the pleura of the fourth segment was prolonged by the pleural spine as in *Shumardia pusilla* (Stubblefield, 1926, pl. 14, fig. 9). The course of the narrow pleural furrow is unusual, for it leaves the axial furrow close to the posterior margin and runs directly outward, dying out close to the inner edge of the facet. Thus the anterior pleural band is broad (exs.) and convex, the posterior band narrow, widening distally where the pleura curves slightly back. Pygidium triangular in outline, axis tapering rapidly to blunt point, pleural regions prolonged behind axis in a rounded, flattened tip. Axis

in largest individual (Pl. 16, fig. 16) divided by furrows into seven rings, which are successively shorter posteriorly, the seventh merely the small posterior tip of the axis. Pleural regions exhibiting four pairs of furrows, the first extending out to the inner edge of the facet, the next three successively shorter so that the fourth is merely a short indentation beside the axial furrow. Narrow posterior pleural band defined on first segment only. External surface granulate except in furrows, the granules becoming smaller, fainter, and dying out on the distal parts of the pleural regions.

Small cranidia (Pl. 16, figs. 1-4, 12, 15) have the two pairs of lateral glabellar lobes better defined, the axial furrows are deep, as also is the median depression in the preglabellar area. The latter bears a pair of tubercles, each in line (exs.) with the midpoint of the anterolateral glabellar lobe. Granulation is coarser and prominent on glabella and inner part of cheek. Small pygidia (Pl. 16, figs. 10, 11, 13) show five segments, the posterior pleural band defined in each, those of the fifth segment running back from the tip of the axis and converging. The tip of the pleural regions is drawn out into a blunt, horizontally-directed point. Granulation is relatively coarser.

Discussion. The single complete specimen is the original of Clark (1924, pl. 9, fig. 3) and I found upon excavation that it was indeed a complete exoskeleton, the cephalon being flexed down at right angles to the thorax and pygidium. As explained above, apparently the first thoracic segment is similarly flexed down, and almost entirely hidden beneath the posterior part of the cephalon. The latter is incomplete, especially at the genal angle, so it is uncertain whether or not there was a genal spine. This specimen is unusual in showing clearly the presence of the suture line running around the distal part of the cheeks and preglabellar area, isolating the narrow free cheeks. Unfortunately it is damaged medially, and one cannot be sure whether or not there was a median suture. This specimen shows that previously described "cephala" are in reality cranidia. Raw (*in* Lake, 1907, p. 41) describes the cephalon of *S. pusilla* as "without free cheeks" but Lake's plate 4, figure 1, shows the doublure of an enrolled specimen surrounding the pygidium and there is a median feature which may be a crack but may also be a median suture. Further study of European material is needed to determine whether or not, for example, *S. pusilla* (Lake, 1907, pl. 3, figs. 18-20; pl. 4, figs. 1-4; Stubblefield, 1926; Störmer, 1940, pl. 1, fig. 13) should properly be referred to *Shumardia*. The cranidium appears to have the same general form,

and the pleurae to be crossed by a pleural furrow which runs close to the posterior margin. However, *S. granulosa* does not have the long pleural spine on the fourth thoracic segment, and the pygidium is very different in shape. Cranidia described as *S. minutula* by Harrington and Leanza (1957, pp. 79-80, figs. 24, 1a, 1c, 1e) look similar to those of *S. granulosa*, though the pygidium attributed to this species by them (fig. 24, 1b) appears to be much shorter and broader than that of the Canadian species.

SHUMARDIA SAGITTULA n. sp.

Plate 17, figures 1-8, 11, 12

Holotype. GSC 18448, cranidium from highest beds of middle Table Head Formation exposed immediately south of Table Cove.

Other material. Cranidia have been obtained from the upper half of the middle Table Head Formation at the type section, from the isolated limestone, and from the boulders at Daniel's Harbour.

Description. These cranidia, when compared with cranidia of a similar size of *S. granulosa* (Pl. 16, figs. 12, 15), may be seen to represent a distinct species. The prominent occipital ring of the glabella is trapezoidal in outline, and bears a faint median tubercle. In front of the straight occipital furrow is a short sub-cylindrical part of the glabella, then the glabella expands abruptly into the large lateral lobes which are situated at about the midlength. In front of these lobes the axial furrows converge, becoming subparallel as they approach the anterior margin of the cranidium, but not joined by any preglabellar furrow. The slope of the anterior part of the cranidium is less steep than that in *S. granulosa*, and outside the anterior part of the axial furrow on the cheek is the small tubercle. The basal glabellar lobe is apparently not present, and the furrow outlining the anterior lateral lobe runs directly forward and dies out opposite about half the length of this lobe. The cheek is similar in form to that of *S. granulosa*, but there is no posterior border furrow.

Genus LEIOSHUMARDIA n. gen.

Type species. *Leioshumardia minima* n. gen. n. sp.

Diagnosis. Glabella widest posteriorly, occipital ring outlined by narrow occipital furrow which curves gently convexly forward. Midpart of glabella parallel-sided, of same width (tr.)

as occipital ring, anterior part tapering, defined by axial furrows that converge at an oblique angle and die out before meeting in the median line. No lateral furrows or lobes. Cheeks slope vertically distally, anteriorly continuous with narrow (sag.), steep preglabellar area. Posterior border furrow outlining extremely narrow border on inner part of fixed cheek.

LEIOSHUMARDIA MINIMA n. gen., n. sp.

Plate 17, figures 9, 10, 13, 15-17

Holotype. GSC 18450, cranidium from middle Table Head Formation, exposures on foreshore south of Table Cove.

Other material. A few additional cranidia have been obtained from the same locality as the holotype, and also from 17 and 190 feet above the base of the middle Table Head Formation at the type section.

Description. The diagnosis indicates the chief characters of this cranidium, and in the small example, as in the large, there is no sign of lateral glabellar furrows or lobes. The axial furrow is deep beside the posterior half of the glabella, and widest immediately in front of the occipital furrow; the anterior part becomes progressively shallower forwards, and the furrows appear to die out before intersecting. No pair of tubercles on the preglabellar area. External surface smooth. Remainder of exoskeleton unknown.

Family OLENIDAE Burmeister, 1843

Subfamily OLENINAE Burmeister, 1843

Genus TRIARTHURUS Green, 1832

TRIARTHURUS FISCHERI Billings, 1865

Plate 17, figures 14, 18-21; Plate 18, figures 1-9, 12-16

Billings, 1865, p. 291, fig. 280.

Raymond, 1925, pp. 51-52.

Lectotype (here selected). GSC 678c, the smaller and more complete of two cranidia in the same piece of limestone, from middle Table Head Formation, Pistolet Bay. Paralectotypes: GSC 678d, cranidium and seven thoracic segments; 678h, incomplete cephalon; 678a, b, e, f, g, i, cranidia. All from same horizon and locality as lectotype.

Other material. Type section, middle Table Head Formation, from 90 feet above the base to the top, from Table Cove, the

isolated limestone, bed 4 at Black Cove, and from boulders at Daniel's Harbour.

Description. Cephalon wider than long, moderately convex. Maximum width of glabella two-thirds that of cephalon at posterior border. Glabella of width about equal to length (sag.), maximum width across basal glabellar lobes. Occipital ring widest (sag.) medially, becoming narrower and curving forward distally; occipital furrow deep behind glabellar lobes, shallower medially. Two pairs of lateral glabellar furrows gently curved, directed inward and slightly backward. Frontal glabellar lobe longer than first and second, lateral lobes 1p and 2p of similar width (tr.), median lobe narrower than lateral lobes. Lateral lobe 1p gently inflated, frontal glabellar lobe rounded anteriorly, minimum width of glabella at anterior edge of this lobe. Lateral glabellar furrow 3p visible on some of larger cranidia (Pl. 18, figs. 1, 3) as a small, shallow pit situated in line within the inner ends of lateral furrows 1p and 2p, these three furrows situated at approximately equal distances from each other and the occipital furrow. Anterior pit situated in axial furrow a short distance back from anterior end, preglabellar furrow broader than axial, narrow, anterior border which in dorsal aspect is moderately curved. About 12 shallow pits are equally spaced along preglabellar furrow. Narrow cheek curved downward quite steeply distally, narrow, convex posterior and lateral borders similar to anterior border, defined by shallow border furrows. Midpoint of eye lobe situated opposite outer end of lateral glabellar furrow 2p, and about half way out across cheek. Low eye ridge runs inward and forward to axial furrow opposite anterior pit. Anterior branch of suture runs forward and slightly inward to border, curves over it and runs along outer edge. Posterior branch runs backward in the same line as the anterior branch, near posterior border curving slightly inward and across border. Free cheek (Pl. 18, fig. 7) thus narrow (tr.), and suture crosses broadly rounded genal angle which does not bear a spine. Similar pits to those in preglabellar furrow situated in border furrow of fixed cheek. Doublure of cephalon of similar width to borders, curled under to make a cylindrical border (Pl. 17, fig. 18). Hypostome unknown.

Thorax (Pl. 17, figs. 20, 21) of at least 14 segments, axis about one-third of total width, tapering gently backward, moderately convex. Articulating half ring about half length (sag.) of axial ring, articulating furrow deepened distally. Each pleura directed outward and slightly back, fulcrum at about one-third

width of axial furrow, outer part bent quite steeply downward. Deep pleural furrow extends from inner anterior corner to tip. Anterolateral margin of pleura faceted, posterolateral corner bluntly pointed. Small pygidium with four distinct axial rings, the first the most prominent, tip of axis showing a faintly defined 5th ring, bluntly rounded. Pleural regions exhibiting the articulating facet and three ribs, separated by pleural furrows which become shallow posteriorly, distal parts becoming smooth.

External surface apparently smooth, small median tubercle situated close to anterior margin of occipital ring. In available specimens midpart of axial rings of thorax are broken, but there is no evidence of a median axial spine.

Discussion. Few specimens are available that show the free cheek in position (Pl. 17, fig. 18; Pl. 18, fig. 7), and in all there has been some displacement, so that details of the eye lobe cannot be made out. The free cheek has a shallow border furrow and convex border, while on the fixed cheek there is a sutural ridge (Pl. 17, fig. 21), that is, a shallow furrow curves forward from the posterior border furrow to run beside the posterior branch of the suture to the palpebral lobe. The faintly convex strip between this furrow and the suture is referred to as the sutural ridge, and is visible in the smallest cranidia (Pl. 18, fig. 16). The material from most localities is not flattened, except a few specimens from Black Cove. The difference in appearance between a flattened cranidium (Pl. 17, fig. 19) and one retaining full convexity (Pl. 17, fig. 20) is notable — in the former the glabella does not appear to be widest across the basal lobes, but to be subsquare in outline, the anterior branches of the facial suture run almost directly forward, and the outline of the anterior margin of the cranidium is almost straight. It is evident that comparisons between specimens which are preserved in these different ways have to be made with caution.

The size series of cranidia, ranging from 0.55 mm (Pl. 18, figs. 15, 16) to approximately 5 mm (Pl. 18, figs. 1-3) in length (sag.), shows clearly changes that take place in the outline and proportions of the glabella. In the smallest cranidium the glabella is longer (sag.) than wide (tr.), and the maximum width is across the frontal lobe. Lateral furrows are straight, directed inward and slightly backward. In a cranidium 1.8 mm in length (Pl. 18, figs. 8, 9) the glabella is parallel-sided, the occipital ring like that of the largest specimens, and the lateral furrows have assumed a slight curvature. With increasing size the glabella continues to become relatively wider (and

the cheek to become relatively narrower) and in the larger examples the maximum width is across the basal glabellar lobes, which have become slightly inflated. There is little change in the position of the palpebral lobe, and the eye ridge and sutural ridge are visible in the smallest specimens. These changes during ontogeny are like those that take place in a size series of *Triarthrus eatoni* (Whittington, 1957, pp. 941-943, pl. 116, figs. 1-13).

Species of *Triarthrus* of Tremadoc age (Henningsmoen, 1957, pp. 147-151; Harrington and Leanza, 1957, pp. 113-117, figs. 42; 43, 2) differ from *T. fischeri* generally in possessing the short (sag. and exs.) preglabellar field, though some species exhibit an outline of the glabella similar to that of the Table Head species. Clark (1924, pp. 91-92, pl. 9, fig. 12) described a species *Boeckia? descensus* from the Shumardia Limestone of Lévis, Quebec. Henningsmoen (1957, p. 22) suggested that this species was not an olenid, but restudy of the holotype (Pl. 18, figs. 10, 11) shows that the incomplete cranidium is similar to cranidia of the same size of *T. fischeri* (Pl. 18, figs. 12-14). Thus Clark's species probably does belong within *Triarthrus*, and may represent a form closely related to *T. fischeri*. Bulman (1931, pp. 88-89, pl. 10, figs. 5-8) described *T. aff. fischeri* from beds of Llanvirn age in Bolivia, and this species is evidently closely related to that from Newfoundland. A species from the Llanvirn of Britain, *T. (sensu lato) convergens* Whittard (1961, pp. 190-191, pl. 24, figs. 16-18), appears to differ from *T. fischeri* in the much smaller free cheek and in that the thoracic axis is relatively broad and does not taper for the first six segments, after which it tapers rather rapidly.

Whittard (1961, p. 189, text-fig. 7) also gives new illustrations of *T. caecigenus* from the *N. gracilis* Athens Shale of Virginia. The large palpebral lobe and broad eye ridge of this species distinguishes it at once, as does the extreme shortness of the preglabellar area and the subrectangular outline of the glabella. At least four species of *Triarthrus* — *T. beckii* Green, 1832, *T. catoni* (Hall, 1838), *T. spinosus* Billings, 1859, *T. glaber* Billings, 1859 — are recognized from dark shales of the Trenton Group of New York and Canada (Ruedemann, 1926; Wilson, 1956; Whittington, 1957). Type and topotype material of these species suggest that in the combination of characters of glabellar outline, relative size of lobes, development of occipital spine, position of eye lobe and size of cheek, no one of the species is the same as *T. fischeri*.

Subfamily HYPERMECASPIDINAE

Harrington and Leanza, 1957

Genus **HYPERMECASPIS** Harrington and Leanza, 1957HYPERMECASPIS cf. **BULMANI** Harrington and Leanza, 1957

Plate 18, figures 17-22

Material. Incomplete cranium, fragment of glabella, incomplete pygidium, all from middle Table Head Formation at type section. The exact level from which these specimens came is not known, but the fine-grained black limestone is typical of the upper half of this part of the formation, and GSC 18460 also contains *Geragnostus fabius*, which has only been found between 185 and 215 feet above the base of the middle Table Head. GSC 458, a small pygidium, is from the west side of Pistolet Bay.

Description. Glabella subsquare in outline, lateral margin gently bowed outward, anterior margin similarly bowed forward, moderately convex longitudinally and transversely. Occipital ring defined by shallow furrow which curves forward in the outer one-third of its course, subparallel to the posterior margin of the ring. Ring (Pl. 18, fig. 19) subdivided by a transverse furrow running a short distance in front of the posterior margin, medially faint and passing directly behind the small median occipital tubercle. Laterally, a gently convex occipital lobe is defined by a shallow furrow which curves back from the occipital furrow, runs outward subparallel to the furrow in the occipital ring, and dies out without reaching the axial furrow. Four pairs of lateral glabellar furrows (Pl. 18, fig. 17), 1p situated a short distance in front of the occipital furrow, transverse, short and deep. Furrow 2p commences in the axial furrow at the point where the glabella is widest (just behind the midlength), is deep and curves inward and backward. Lateral furrow 3p similar in depth, direction and curvature to 2p. Lateral furrow 4p commences in the axial furrow just behind the anterolateral corner of the glabella, runs at first straight inward, then turns at an oblique angle and runs inward and backward subparallel to the inner part of furrow 3p. The inner ends of furrows 2p to 4p lie in the same exsagittal line, and the median glabellar lobe is much narrower (tr.) than the lateral lobes; inner parts of these three furrows are deeper and broader than the outer parts. Frontal glabellar lobe divided by shallow median furrow which runs inward from preglabellar furrow

and dies out just before reaching the posterior margin of the frontal lobe. Preglabellar field narrow (sag. and exs.), gently convex, becoming slightly wider distally. Anterior border narrow, convex, likewise becoming slightly wider (exs.) distally. Anterior part of fixed cheek extremely narrow (tr.), gently convex; beside lateral glabellar lobes 2p and 3p it separates the axial furrow from the palpebral furrow; the midpoint of the poorly preserved palpebral lobe appears to be opposite the outer end of lateral glabellar furrow 2p. Posterior part of fixed cheek of about the same width (tr.) as glabella, curving gently outward and downward, subdivided by broad, shallow, posterior border furrow which runs from beside lateral occipital lobe outward and slightly forward to die out distally. Remainder of cephalon not known.

Pygidium subdiamond-shaped in outline, moderately convex, axis tapering rapidly to about the midlength, beyond this point specimen poorly preserved and outline of axis uncertain. On anterior half of axis five rings defined by shallow ring furrows. Pleural regions crossed by five pleural furrows, the low rib between them crossed by faint interpleural furrow on the first four segments. Distally, pleural furrows die out and outer margin of pleural region appears smooth.

Discussion. These specimens appear most like the cranidium and pygidium described from the Llanvirn of Bolivia by Bulman (1931, pp. 90-91, pl. 11, figs. 4, 5), which were placed in the genus *Hypermeccaspis* by Harrington and Leanza (1957, pp. 121-123) and given the new specific name *bulmani*. Allowing for the compression of the Bolivian material, the glabellar shape and lobation appears extremely similar, likewise the pygidium, except that the latter shows a sixth pleural furrow. Of the species described by Harrington and Leanza from Argentina, the Newfoundland material is most like the type species of the genus *H. inermis* Harrington and Leanza (1957, pp. 121-125, figs. 45; 46, 1-7; 48, 6). There is some difference in the glabellar lobation, in that in the Argentine species, lateral furrow 2p branches and does not extend to the axial furrow, and the most anterior furrow is divided into two parts, referred to as the fourth and fifth furrows by Harrington and Leanza. Possibly the two parts of lateral furrow 4p in the Newfoundland specimen, which are placed at an oblique angle to each other, represent these two furrows in *H. inermis*. This latter species has a large pygidium, which is quite like that from Newfoundland.

The other species from the Argentine are distinguished by possessing a longer preglabellar field and a small pygidium.

Harrington and Leanza (1957, pp. 120-121) erected the family Hypermecaspididae, but Henningsmoen (1959, pp. 160-161) considered it more likely that this group should be a subfamily of the Olenidae. This suggestion is followed here.

Family PROETIDAE Salter, 1864

Subfamily PROETIDELLINAE Hupé, 1953

Genus PHASEOLOPS Whittington, 1963

PHASEOLOPS? sp. ind.

Plate 19, figures 1-5

Material. Three incomplete cranidia, two from the isolated limestone, and one from 185 feet above the base of the type section, middle Table Head Formation.

Discussion. This cranidium appears to be that of a proetid, and resembles that of the type and only known species of *Phaseolops* (Whittington, 1963, pp. 36-40, pl. 4, figs. 11-13; pl. 5, figs. 1-6). It differs from *P. sepositus* in a number of characters. The glabella tapers forward much more rapidly to the bluntly rounded frontal lobe, the occipital ring is much narrower (exs.) distally, the median occipital tubercle is situated close to the anterior margin. Lateral glabellar furrow 1p is continued backward by a faint furrow that reaches the occipital furrow and isolates the subtriangular basal glabellar lobe. Lateral furrow 2p is diagonally directed, subparallel to the outer part of 1p, lateral furrow 3p is exceedingly faint. There is a broad preglabellar field which slopes downward and forward, but the anterior border is flat and horizontally extended, not convex. Palpebral lobe is situated opposite lateral glabellar lobe 2p, and separated by a narrow convex band of the fixed cheek from the axial furrow; the lobe is gently convex and outlined by a faint furrow. The course of the anterior branches of the facial suture is not well preserved, but they appear to be almost straight and divergent, not strongly curved as in *P. sepositus* and less strongly divergent. Hardly any of the fixed cheek behind the palpebral lobe is preserved, but it appears to be gently convex, and the posterior branch of the suture appears to run outward and backward from the lobe. The appearance is not the same as in *P. sepositus*, for in that species the posterior branch of

the suture appears to run at first directly back from the palpebral lobe, before curving outward, and there is only a very small area of cheek between this suture and the axial and border furrows, not the much larger area seen in one specimen of the present species (Pl. 19, fig. 1). External surface is minutely granular.

This rare cranidium may belong to *Phaseolops*, and does not particularly resemble other Ordovician proetids.

A transitory pygidium from the middle Table Head Formation (Pl. 67, fig. 14) has the axis tapering rapidly to a blunt point, is divided by ring furrows into six rings, the tip situated at about two-thirds the length. On the pleural regions six segments are present, the pleural furrows deep, interpleural furrows shallower, and the convex posterior pleural bands of the fifth and sixth segments running outward and backward from the tip of the axis. This transitory pygidium is proetid-like in appearance, and not like that of *Raymondaspis reticulatus* n. sp. (compare Pl. 67, fig. 14 with Pl. 57, figs. 10, 11) in that the pleural furrows are more strongly marked. It is tentatively assigned to *Phaseolops*? sp. ind.

Family DIMEROPYGIDAE Hupé, 1953

Genus ISCHYROTOMA Raymond, 1925

ISCHYROTOMA sp. ind.

Plate 19, figures 17, 21, 22

Material. One incomplete and partly exfoliated cranidium from exposures on foreshore south of Table Cove.

Description. In shape and convexity of the cephalon, form of the glabella with the faint lateral depressions representing furrows 1p and 2p, convex cephalic border which arches upward medially, this cephalon is like that of the type species *I. twenhofeli* Raymond (Whittington, 1963, pp. 45-48, pl. 7). However, it does not appear identical with that species in that the glabella is less tumid, the frontal lobe is blunter and more square-ended, and the posterior branch of the suture runs much more strongly outward across the cheek. This latter character seems to indicate that the eye lobe is placed much further back, though it is not preserved. The lateral border furrow is wider and more prominent in the Table Head cranidium. Tuberculation on the external surface appears to be similar, and there is a notably large tubercle at the inner corner of the fixed cheek and on the posterior border in line (exs.) with it. Thus the Table

Head species seems not to be identical with that from Lower Head, but the single cranidium is inadequate as a basis for a new species.

Genus *ISCHYROPHYMA* Whittington, 1963

ISCHYROPHYMA TUMIDA n. sp.

Plate 19, figures 6-12, 15

Holotype. GSC 18465, incomplete internal mould of cranidium, from middle Table Head Formation, Table Cove.

Other material. Cranidia and free cheeks from same locality as holotype, the isolated limestone, and 50 feet above base, type section.

Description. The present material when compared with the type and only known species (Whittington, 1963, pp. 48-50, pl. 8, figs. 1-10) exhibits all the diagnostic features of the genus. The glabella is relatively longer and more inflated, and in lateral profile (compare Pl. 19, figs. 9, 10, with Whittington, 1963, pl. 8, figs. 7, 9) it projects much farther forward in front of the anterior border. There is no preglabellar field, and the anterior border projects outward at the margin of the cranidium, suggesting that the characteristic projection is present. Lateral glabellar furrow 2p is short and appears as a shallow, smooth depression in the internal mould. There is a faint suggestion of lateral furrow 3p as a much shorter and shallower depression adjacent to the axial furrow a short distance in front of 2p. The free cheek exhibits the thorn-like genal spine at the rounded angle, and the external surface is, except in the furrows, covered with medium sized tubercles, between which are scattered much smaller tubercles. On the lateral border there is no row of tubercles, but several terrace lines run subparallel to the margin. While most of the present material is much larger than any known of the type species, the relatively longer and forwardly projecting glabella distinguishes it, as does the much finer tuberculation on the external surface.

Discussion. Raymond (1925, pp. 151-152) described two cranidia (one from the type section and the other from the isolated limestone) which he referred to *Sphaerexochus desertus* (Billings, 1865). I have examined these cranidia and they are identical with the present material. Billings' (1865, pp. 333-334, fig. 321) species *desertus*, which he referred to *Harpides?*, is based on a glabella from a locality in Quebec (GSC 873) and is different from the present material.

ISCHYROPHYMA? sp. ind.

Plate 19, figures 16, 19, 20

Material. Two incomplete and exfoliated cranidia, one from the isolated limestone, the other from Table Cove.

Description. The glabella tapers slightly forward, is bluntly rounded anteriorly, and a small basal lobe is formed by the diagonally-directed lateral furrow 1p. Cheek is convex, the outer part sloping steeply, the well-defined posterior border widening outward. Palpebral lobe is situated far back, opposite lateral furrow 1p, and on the highest part of the cheek. The anterior branch of the suture runs forward and slightly inward, the posterior branch at first directly outward, then curving to cross the posterior border furrow and the border. Anterior border is not preserved.

This cranidium is like a cephalon recently described under the same designation (Whittington, 1963, p. 50, pl. 6, figs. 13-15) and seemingly represents the same or a closely related species. The affinities with *Ischyrophyma* are uncertain. The glabella is less tumid, and the cheek slopes less steeply laterally. The main similarity is in the position of the small basal glabellar lobes. The present cranidium also has a superficial resemblance to that here placed in aff. *Calymenidius* (Pl. 59, figs. 14, 15), though the glabella projects relatively farther forward, the eye lobe is situated much farther back and closer to the glabella, and the transverse curvature of the anterior border is not so pronounced.

Family ASAPHIDAE Burmeister, 1843

Subfamily ISOTELINAE Angelin, 1854

Genus STEGNOPSIS n. gen.

Type species. *Stegnopsis solitarius* n. gen., n. sp.

Diagnosis. Cephalon with preglabellar area of width (sag.) about one-fifth length of cephalon, forming a broad, gently sloping border which narrows progressively as it extends around the cheek to the base of the librigenal spine. Cephalon inside border moderately convex, glabella faintly outlined, constricted between the eye lobes, occipital and lateral furrows barely visible on external surface, faintly visible on internal mould, glabellar tubercle situated a short distance in front of occipital furrow. Eye lobe relatively large, situated close to glabella and length

(exs.) equal to, or slightly less than, distance from posterior margin of cephalon to posterior margin of eye lobe. Facial suture isoteliform, anterior branches widely divergent in front of eye lobe. Broad doublure is deeply notched anteriorly and crossed by median suture; doublure extends beneath border and half way up slope toward eye lobe; panderian opening situated at inner posterolateral corner of doublure. Hypostome with sub-circular middle body, lateral margin convex outward, posterior border deeply and widely notched. Anterior wing subtriangular with broadly rounded, upwardly-projecting tip.

Thorax unknown. Pygidium with broad, gently sloping border surrounding moderately convex inner portion, axis gently convex and extending to inner margin of border; axial rings faintly visible on internal mould, inner part of pleural region faintly furrowed. Doublure extends in beyond border to an almost straight line linking the midpart of the facet to the tip of the axis, where the margin of the doublure is notched.

Discussion. The work of Jaanusson (1953a, 1953b, 1956, 1959, in Moore) and Hintze and Jaanusson (1956) has brought many new characters into play in the discrimination of asaphid genera. Some discussion of these characters is contained in Jaanusson, 1953a (pp. 386-389), and it is clear that poorly known old species, such as many from Canadian and Chazyan rocks of the Appalachians, cannot be fitted into these genera. Species of *Isoteloides* (Hintze and Jaanusson, 1956, pp. 55-56; Jaanusson in Moore, 1959, p. O341, fig. 251, 1) may prove to be most closely related to the two species described below. However, the Newfoundland species are distinguished at once from the type species *I. whitfieldi* by the position of the eye lobe, which is much farther back and closer to the glabella. Associated with this difference is the different course of the anterior branch of the suture. Lack of knowledge of the doublure of *I. whitfieldi* precludes discussion of these portions of the exoskeleton. In other features, such as the cephalic and pygidial borders, the strength of furrows in both cephalon and pygidium, *I. whitfieldi* is like the Newfoundland species. Of other Lower Ordovician asaphid genera described by Ross and Hintze from Utah, only *Lachnostoma* Ross, 1951 (pp. 94-97, pl. 21, figs. 13-25; pl. 22, figs. 3, 6-8; pl. 25, figs. 5, 6; Hintze, 1953, p. 187, pl. 18, figs. 14-16) shows a likeness to *S. solitarius* and *S. huttoni*, in the position of the eye lobe and course of the anterior branches of the suture. In other features the Utah species is unlike those from Newfoundland.

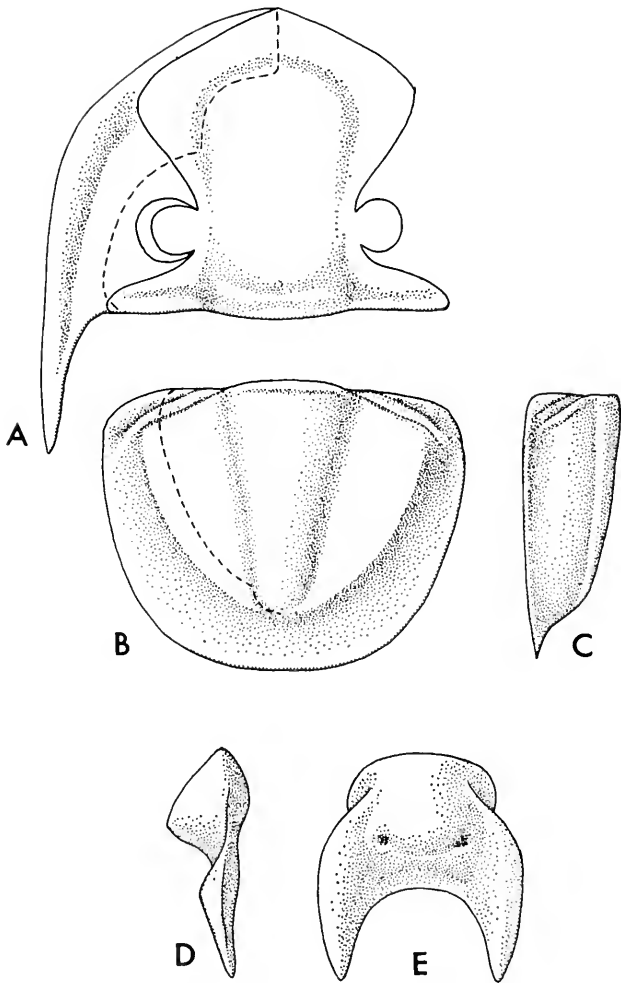

FIG. 3. *Stegnosis solitarius* n. gen., n. sp., lower Table Head Formation. A, cephalon with right free cheek absent, dorsal view; B, C, pygidium, dorsal, left lateral views; D, E, hypostome, right lateral, exterior views; c. X 1.5. Dotted line shows position of inner margin of doublure. Compare Plate 20; Plate 21, figures 1-4, 6.

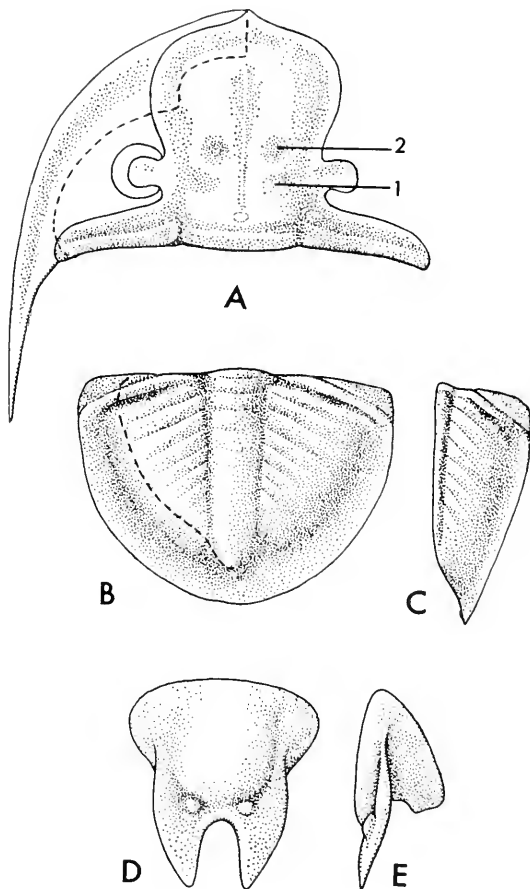

FIG. 4. *Stegnopsis huttoni* (Billings), middle Table Head Formation. A, cephalon lacking right free cheek, dorsal view; B, C, pygidium, dorsal, right lateral views; D, E, hypostome, exterior, left lateral views; X 1.5. 1, 2, muscle areas. Dotted line shows position of inner edge of doublure. Compare Plate 21, figures 5, 7-12; Plate 22, figures 1-7; Plate 23, figures 2-5, 8.

Raymond (1925, p. 81) placed *S. huttoni* in *Megalaspis* and compared it with the species "*M. pagiata*" (presumably an error for *patagiata*), a species which Jaanusson (1953a, pp. 456-459, pl. 9, figs. 4-7; pl. 10, fig. 1, text-fig. 5, 9) placed in *Pseudomegalaspis*. Though there are a number of characters in common between species of *Pseudomegalaspis* and *S. huttoni*, the shorter preglabellar field, lack of concave border of cephalon and pygidium, and form of the pygidial doublure distinguish the former. In a considerable number of characters *S. solitarius* and *S. huttoni* resemble species of *Pseudasaphus* (Jaanusson, 1953a, pp. 417-426; Schmidt, 1904, pp. 4-20). These common characters include shape of glabella, position of eye lobe, presence of cephalic border, width of cephalic doublure, form of hypostome (compare Pl. 20, figs. 4, 8 with Schmidt, pl. 1, figs. 6-8), form of pygidium including presence of border. Distinctive of *Pseudasaphus* are the lateral glabellar furrows 1p, the extremely wide pygidial doublure, and the strong terrace lines of the external surface. Following Jaanusson, I have regarded such differences as of generic rank, though species of *Pseudasaphus* are present in the Baltic Ordovician in rocks older, and contemporaneous with, the Table Head Limestone.

STEGNOPSIS SOLITARIUS n. gen., n. sp.

Plate 20; Plate 21, figures 1-4, 6; Text-figure 3

Asaphus canalis?, Billings, 1865, pp. 270-271, figs. 225a, b.
aff. *Isotcloides* sp., Whittington and Kindle, 1963, fig. 2.

Holotype. GSC 18472, incomplete cranidium with exoskeleton, from lower Table Head Formation, Pointe Riche.

Material. This species is the only asaphid in the lower Table Head, appearing in the type section in bed 2 and ranging up to above the middle of bed 8. Fragments of the exoskeleton appear occasionally, and on weathered surfaces large isolated hypostomes, six or more centimeters in length (exs.) have been found and are like that figured by Billings. The best material came from bed 8 in the type section, and from Pointe Riche.

Description. Cephalon slightly wider than long (sag.), gently convex, border flattened, sloping gently outwardly, widest (sag.) anteriorly, narrowing progressively laterally to a minimum at the base of the short, slim librigenal spine. Glabella of width (tr.) about one-third that of cephalon, extremely faintly outlined by change in slope but not by furrows, not displaying occipital or glabellar furrows, but with median glabellar tubercle

situated about one-sixth the length from the posterior margin. Highest point of eye lobe standing level with median part of glabella. Outside eye lobe cheek slopes steeply, in gently convex curve, anterolaterally and laterally, the slope changing to concave as it merges into the outward sloping border. At point of widest divergence anterior branches of suture are as far apart as outer margins of eye lobes. On posterior part of fixed cheek a faint posterior border furrow outlines a posterior border which widens outward. Because of the deep, broad anterior notch, the anterior part of the doublure, which is crossed by the median suture, extends only beneath the border. Posteriorly, close to the inner edge of the doublure where it curves beneath the posterior border, is the panderian opening, situated on a tubercle which appears as a depression in the inner surface of the doublure (Pl. 20, figs. 7, 10). Doublure lies close to dorsal exoskeleton, especially beneath the cheek inside the border.

Hypostome includes a subcircular, gently convex middle body which is indented posterolaterally by the macula. Lateral and posterior borders are broad and long (exs.), with a deep posterior notch the sides of which are strongly divergent. The length (exs.) of the posterolateral prong of the hypostome is such that the length (sag.) of the middle body is only about one-half that of the hypostome. On the ventral surface the prong is approximately flat, the inner edge raised along the margin of the notch. On the dorsal side the doublure is convex, so that the prong is thick at the base and tapers to the tip (Pl. 20, fig. 8). A sharp fold runs from the shoulder around the curving, anterolateral margin of the subcircular middle body, there is no anterior border, and on the dorsal side this fold is extended anterolaterally as the anterior wing, which is subtriangular in shape.

Thorax unknown. Pygidium wider than long, subsemicircular in outline and moderately convex, the lateral and posterior parts of the pleural regions forming a flattened, gently outwardly sloping border which is widest posterolaterally. The middle part of the pygidium is subtriangular in outline and stands high above this border and slopes steeply down to it posterolaterally. The axis tapers gradually and extends to the posterior margin of this central triangular region, and is defined by its slight additional convexity, but not by axial furrows, posterior tip bluntly rounded. In addition to the articulating furrow five or six ring furrows can be observed, most clearly on the internal

mould (Pl. 21, fig. 4). Pleural region with a large facet, against which the border ends. The shallow first pleural furrow runs outward and backward to end against the inner edge of this facet. Eight or nine additional pleural furrows are extremely faintly marked on the external surface (and more strongly on the internal mould) of the inner convex part. Doublure extends inward beneath the border and under the concave slope of the outermost part of the convex region. The inner margin is approximately straight, running from about the midpoint of the facet to the tip of the axis.

External surface apparently smooth, except for lateral part of pygidial border and outer part of facet, across which run irregular terrace lines, rather widely spaced. Doublure of both cephalon and pygidium traversed by closely-spaced terrace lines which run parallel to the external margin.

STEGNOPSIS HUTTONI (Billings, 1865)

Plate 21, figures 5, 7-12; Plates 22, 23; Text-figure 4

Billings, 1865, p. 271, fig. 256.

Raymond, 1925, pp. 80-81, pl. 6, fig. 11.

aff. *Lachnostoma huttoni*, Whittington and Kindle, 1963, fig. 3.

Holotype. GSC 657, internal mould of incomplete pygidium, original of Billings, figure 256, from the middle Table Head Formation at the type section.

Other material. GSC 658, small pygidium, from Portland Creek (GSC 658a, b, here referred to *Niobe morrisoni*; GSC 658c, d, e, to *Raymondaspis reticulatus* n. sp.). This species appears about 50 feet above the base of the middle Table Head Formation at the type section, and ranges to the top of this part of the formation. It is also present in the exposures south of Table Cove, in the isolated limestone, and pygidia have been found at Black Cove.

Description. At posterior margin, width (tr.) of glabella one-quarter that of cephalon, in front of here glabella narrows slightly to a minimum between the eye lobes, in front of here expanding to the rounded frontal lobe. Glabella gently convex, separated from cheek and preglabellar area by gentle change in slope. On external surface glabellar furrows are not visible, but glabellar tubercle is prominent. Internal moulds and some specimens of the exoskeleton (Pl. 22, figs. 3, 12) show areas of

muscle attachment — one at the distal part of the occipital furrow, a second running inward and backward from a point opposite the midlength of the eye lobe. The latter forms lateral furrow 1p; in front of it are two areas which are close to each other, one adjacent to the axial furrow and in line with the most anterior part of the eye lobe, the other between it and the midline. A low ridge runs forward from the glabellar tubercle to the frontal lobe. The visual surface of the eye lobe appears smooth, the minute facets being difficult to discern (Pl. 23, fig. 11). There is no external marginal rim to the eye lobe. The palpebral lobe stands high, level in a transverse line with the midpart of the glabella. The flattened, gently outward-sloping cephalic border is widest anteriorly, narrowing progressively around the cheek and extending on to the outer part of the short, slim librigenal spine. The doublure is pressed closely beneath the dorsal exoskeleton, the inner edge revealed by the paradoublural line (Pl. 22, figs. 1, 2, 7). The position of the panderian opening is shown by the pit situated close to the inner margin of the posterolateral part of the doublure (Pl. 22, fig. 6). The middle body of the hypostome is gently convex, length (sag.) greater than that of forked posterior border. Prominent macula situated in posterolateral part of middle body. Narrow lateral border widens to posterolateral shoulder, posterior border is deeply notched, lateral margin of border convexly curved, inner part of notch narrow. Anterior wing is large, proximally merging with middle body, distally extended upward and backward in a tongue-shaped projection (Pl. 23, figs. 4, 5).

Thorax unknown. Pygidium sub-semicircular in outline, gently sloping posterolateral border, relatively narrow axis tapering to rounded point and reaching inner edge of border. Eight to ten rings are faintly outlined on the axis in internal moulds, on pleural region first furrow is distinct, ending against large facet. Faintly visible on the external surface, and more strongly on internal moulds, are the succeeding eight pleural furrows, the anterior two or three ribs showing extremely faintly the interpleural furrows (Pl. 23, fig. 2). In ventral aspect the doublure is gently convex.

External surface of dorsal exoskeleton appears smooth, but on well-preserved specimens (Pl. 23, fig. 1) the surface is indented by closely spaced, extremely small pits, between which are irregular, short, fine terrace lines. The doublure and hypostome are traversed by terrace lines which run subparallel to the outer margin.

Discussion. In small cranidia (Pl. 22, figs. 9, 11, 13), the glabella is better outlined and relatively more convex, and two depressions are visible, one at the extremity of the occipital furrow, the second forming lateral glabellar furrow 1p. A gently convex basal glabellar lobe is also present, and appears to extend outward on to the cheek beside the posterior part of the large palpebral lobe. The glabellar tubercle is prominent. In small true pygidia (Pl. 21, figs. 9-11) axial and pleural furrows are more prominent, those of the anterior few segments extending to the lateral margin. In transitory pygidia (Pl. 23, figs. 6, 7, 9, 10, 12, 13) all furrows are stronger, and interpleural furrows are present. The notch in the posterior margin behind the axis is peculiar to this developmental stage, and in the smallest example (Pl. 23, figs. 12, 13) pleural ribs run back from the tip of the axis to the sides of the notch. The similarity between these small developmental stages and those attributed to *Isotelus* (Whittington, 1941, pl. 75, figs. 27, 28, 34, 35) and similar asaphids (Evitt, 1961, pl. 117, figs. 20-23) is remarkable.

The cephalon of *S. huttoni* differs from that of *S. solitarius* in the relatively shorter (sag.) preglabellar area, more expanded frontal glabellar lobe, the slightly stronger development of the posterior border furrow, and the quite different form of the hypostome. In *S. solitarius* the hypostome has the middle body much shorter (sag.) than the forked borders, and the outline of the lateral margins of the notch are quite different. The pygidium of *S. solitarius* is distinguished by its relatively greater width, less obvious development of pleural furrows, and relatively wider border.

Subfamily NIOBINAE Jaanusson, 1959

Genus NIOBE Angelin, 1851

Type species. *Niobe frontalis* (Dalman, 1827).

Discussion. The type species has recently been described by Bohlin (1955, pp. 143-148, pl. 6, figs. 5-9, text-figs. 9a, b) and comes from the *Gigas* Limestone of Sweden, which is of early Llanvirn age (Jaanusson, 1960, Table 9). The cranidium is extremely like that of *N. quadraticaudata*, not only in outline of the glabella and position of the palpebral lobes, but in the size and position of the musele areas, the alae, and the distribution of terrace lines on the external surface. The hypostome of *N. frontalis* (Jaanusson *in* Moore, 1959, fig. 259, 2c) is

much like that of *N. quadraticaudata*, but the pygidium has the inner part of the pleural regions subdivided into ribs, which are rounded and convex at their distal ends, in contrast to the pleural regions of the Newfoundland species, which are grooved only by the first pleural furrow. This relatively slight difference suggests that the Newfoundland species should be placed in *Niobe*.

The genus *Niobella* Reed, 1931 (see Lake, 1942, pp. 329-332, pl. 46, figs. 4-7; 1946, p. 333) is based upon a species from the British Tremadoc in which the hypostome tapers backward and is smoothly rounded. The dorsal exoskeleton is like that of species of *Niobe*, the pleural regions of the pygidium being ribbed. Lake preferred to regard *Niobella* as a subgenus of *Niobe*, but Tjernvik (1956, pp. 223-224) employed two generic groups, distinguishing them primarily on the characters of the pygidium — *Niobe* being used for those species in which the pleural ribs are convex distally and end abruptly, *Niobella* for those forms in which the pleural regions are faintly furrowed or smooth. Species of the former group occur in the Lower and early Middle Ordovician, of the latter in the upper Cambrian and Lower Ordovician, and in both evolution is towards species with a "frontally expanded glabella, a hypostome with a pair of large, rounded posterior limbs, and a broad pygidial doublure" (Tjernvik, 1956, p. 228). Jaanusson (1959, in Moore, p. O350) followed Tjernvik, but I do not find this single-character grouping satisfactory. It means that *quadraticaudata* must be excluded from *Niobe*, and both it and *morrisi* placed in *Niobella*, despite the different hypostome of *Niobella* and the great resemblance between the cephalae of *quadraticaudata* and the type species of *Niobe*. The use of additional characters may make different groupings possible. One such character is the ala, conspicuously developed in *N. frontalis* and *N. quadraticaudata*, but not particularly evident in the type and other species referred to *Niobella*. In this work I am following the practice of Lake and Bohlin rather than that of Tjernvik and Jaanusson.

NIOBE QUADRATICAUDATA (Billings, 1865)

Plates 24-26; Plate 27, figures 1-9; Text-figure 5

Billings, 1865, pp. 272-273, fig. 258.

Raymond, 1925, pp. 76-78, pl. 3, fig. 20; pl. 6, fig. 13.

Lectotype (here selected). GSC 654, incomplete and exfoliated pygidium, from the middle Table Head Formation at the type section.

Other material. All parts of the exoskeleton are fairly abundant in the middle Table Head Formation at the type section between 90 and 190 feet above the base, but rare either below or above these levels. All parts of the exoskeleton have been found in the exposures south of Table Cove and in the isolated limestone, pygidia at Black Cove, and a cranidium from the boulders at Daniel's Harbour.

Description. Cephalon wider than long, moderately convex; at the posterior margin width of cheek less than that of glabella. Latter narrowest at the midlength between the eye lobes, frontal lobe expanding to a width about equal to the width across the basal part of the glabella including the alae. Occipital furrow shallow, straight. External surface (Pl. 25, figs. 7, 10; Pl. 26, fig. 4) not impressed by glabellar furrows, but muscle areas visible on internal moulds (Pl. 25, figs. 1, 6) are shown on Text-figure 5a. The lateral part of the glabella between area 1p and 3p is slightly inflated. The ala is elongate-oval in outline, defined by the alar and axial furrows which are of similar depth, and extends from beside the occipital ring to a point opposite the most posterior part of the eye lobe. Glabellar tubercle (Pl. 25, fig. 7), low, situated in line with posterior part of palpebral lobe. Latter large, horizontal, semicircular in outline, without rim. Convex eye surface with minute facets (Pl. 26, fig. 3), separated from outer part of cheek by prominent external rim (Pl. 24, fig. 4), which is noticeably broader on the outer, anterior side of the eye lobe. Cheek outside eye lobe slopes gently outward and downward to the faintly concave, gently outward-sloping border. Latter confluent with preglabellar area, which is gently convex and forward-sloping, separated from glabella by shallow preglabellar furrow. Anterior branch of suture runs at first outward and forward, curves around over border so that branches meet in midline near outer edge of border in an oblique point. Posterior branch of suture curves outward and backward through approximately 90 degrees, so that the posterior part of the fixed cheek is quarter circle in outline, subdivided by the shallow posterior border furrow. Just before the posterior branch of the suture reaches the posterior margin, it curves outward and runs over the margin. Since the genal angle is rounded the posterior part of the free cheek is tongue-shaped. Doublure is broad, the position of the inner edge revealed on the dorsal exoskeleton by a paradoublural furrow (Pl. 24, figs. 3, 4) —this edge curves forward and runs beneath the anterolateral margin of the eye lobe before it curves forward in the hypostomal notch.

Deep vincular furrow in posterolateral part of doublure (Pl. 26, fig. 9), at the posterior end of which is the small panderian opening. Hypostome subquadrangular in outline, widest across the posterolateral borders which are deeply notched. Sutural margin with oblique median point, no anterior border. Long middle body divided by deep, triangular middle furrows into a large anterior and a much smaller posterior lobe. The posterior lobe is subdivided by a median depression into a pair of inflated oval areas. Lateral border commences as a sharp fold at about half the length of the anterior lobe of the middle body, widens progressively backward, and merges with the lobate, flattened posterior border. Posterior border furrow deep behind median notch. Anterior wing triangular in form, widest posteriorly and directed vertically upward.

The one entire specimen known (Pl. 24, figs. 1, 2, 6) shows the thorax to consist of eight segments. The inner part of the pleura is horizontal and crossed by a shallow, diagonally directed pleural furrow, the outer part curved down beyond the fulcrum and broadly faceted. The pleural furrow ends against the inner edge of the facet. The mould of the external surface of the doublure (Pl. 24, fig. 6) shows the narrow band that runs beneath the posterior edge of the inner part of the pleura, and the longitudinally-directed margin of the doublure of the outer part. A flexure runs diagonally outward and forward across this part of the doublure, and the panderian opening is situated on the anterior edge of the flexure at about half its length. The pleural doublure, with its flexure and panderian opening, is extremely like that of *N. frontalis* described by Siegfried (1936, p. 14, pl. 4, fig. 3). Pygidium subquadrangular in outline, moderately convex, the broad axis tapering back and narrowing to the ill-defined tip. On the external surface of the axis only the articulating furrow is visible, but on internal moulds (Pl. 24, fig. 5) muscle areas in six or seven ring furrows are evident. The pleural regions slope gently down to the broad border, which is outward-sloping and broadest laterally. Only the first pleural furrow is visible, shallow and curving outward and backward. Doublure (Pl. 26, fig. 5) is broad, the inner margin following around the tip of the axis and the axial furrow to about half the length of the axis, then running diagonally outward and forward to the inner edge of the facet. The doublure lies close below the dorsal exoskeleton.

External surface is crossed by raised terrace lines, the arrangement of which is shown by the photographs. Notable is the difference in direction between the concentric lines on the borders of the cephalon and the longitudinal lines of the glabella (compare Pl. 26, fig. 4 with Bohlin, 1955, fig. 9). On the hypostome the terrace lines run transversely, and on the anterior slope of the posterior lobe is the smooth area which Lindström (1901, p. 63, pl. 5, figs. 19-26) interpreted as the macula. Between the terrace lines on the exoskeleton are minute pits (Pl. 24, fig. 7; Pl. 26, fig. 4), similar to those noted by Bohlin.

In the size series of cranidia (Pl. 25), little change appears to take place. In the smallest, the glabella is relatively more convex, clearly outlined, and has prominent alae like those in the largest specimens. The transitory pygidia (Pl. 27, figs. 4-9) show an extremely shallow notch in the posterior margin, and a faint post-axial ridge. Three or four segments are outlined in the anterior region, the part that is to become the true pygidium being apparently smooth.

NIOBE MORRISI (Billings, 1865)

Plate 27, figures 10-13; Plate 28; Plate 29, figures 1-3;

Text-figure 6

Billings, 1865, p. 272, fig. 257.

Raymond, 1925, pp. 78-79, pl. 6, fig. 10.

Lectotype (here selected). GSC 656, external mould of almost complete pygidium, from middle Table Head Formation at type section. Paralectotypes: GSC 656e, external mould of large pygidium (GSC 656a probably pygidium of *S. huttoni*, 656d is *N. quadraticaudata* hypostome, 656f, g are pygidia of *Peraspis lineolata*); GSC 655, a, b, three small pygidia, probably this species.

Other material. Occurs at the same stratigraphical levels and localities as *N. quadraticaudata*, but much less abundantly. At the type section it is known from 90 to 265 feet above the base of the middle Table Head, and is present in the isolated limestone at Table Cove, in Black Cove, and in the boulders at Daniel's Harbour.

Description. Billings knew only the pygidium of this species, and while Raymond figured only another pygidium, his description and the YPM collection show that he recognized all the

parts of the exoskeleton here illustrated. *N. morrisoni* is extremely like *N. quadraticauctata*, and the differences between the species are shown in the Plates and summarized in Text-figures 5, 6. *N. morrisoni* is distinguished by the following characters:

1. The wider cheek and different course of the facial sutures. The posterior part of the fixed cheek is two-thirds the width (tr.) of the glabella, not less than half. Posterior branch of suture thus runs much farther outward before turning back, and anterior branch is more divergent in front of eye lobe—at the outermost point it is in line (exs.) with the outer extremity of the eye lobe, not the midpoint of the palpebral lobe.

2. The free cheek is thus not only of a different shape, but it is distinguished by the much stronger anterolateral projection from the external marginal rim of the eye lobe (compare Pl. 28, figs. 5, 8, with Pl. 24, figs. 1, 3, 4). The course of the paraclypeal furrow is different in that it runs just outside of the eye lobe. A vincular furrow is present (Pl. 28, fig. 7), and the panderian opening is in the fold at the posterior end of this furrow.

3. The hypostome is relatively shorter and wider, the anterior sutural margin more gently curved, and the terrace lines finer and more numerous.

4. The pygidium is relatively wider, less quadrangular in outline, more gently convex, with four or five shallow ring furrows and pleural furrows. Course of inner margin of doublure is subparallel to margin of pleural region, and doublure does not extend as far inward beneath posterolateral part of pleural region. Axis is relatively narrower, and more gently tapering, but the tip in both species is ill defined.

Discussion. Specimens of small-sized parts of the exoskeleton of *Niobe* are not abundant and those that have been found do not display two types that might be assigned to these two species, and all have been placed in *N. quadraticauctata*. The great similarity between the cephalae of these two species seems to require that they be placed in the same genus. The differences between the pygidia are quite considerable, yet their similar stratigraphical and geographical distribution suggests the possibility that the two "species" may be sexual dimorphs of one species.

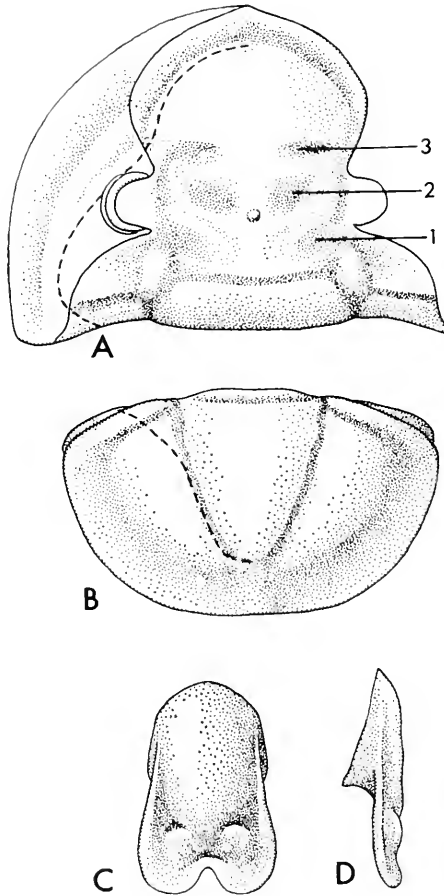

FIG. 5. *Niobe quadrataudata* (Billings), middle Table Head Formation. A, cephalon lacking right free cheek, dorsal view; B, pygidium, dorsal view; C, D, hypostome, exterior, right lateral views; X 1. 1-3, muscle areas. Dotted line shows position of inner edge of doublure. Compare Plate 24, figures 1-5; Plate 25, figure 1; Plate 26, figures 1, 2, 5-8; Plate 27, figures 1-3.

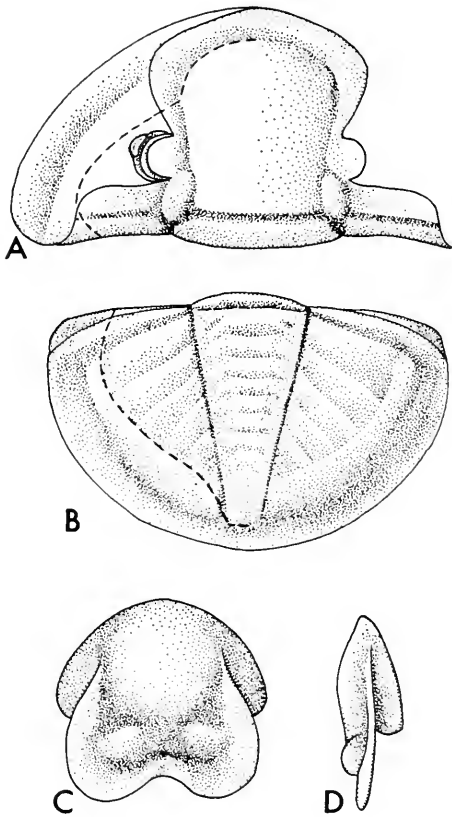

FIG. 6. *Niobe morrisi* (Billings), middle Table Head Formation. A, cephalon lacking right free cheek, dorsal view; B, pygidium, dorsal view; C, D, hypostome, exterior, left lateral views; X 1. Dotted line shows position of inner edge of doublure. Compare Plate 27, figures 10-13; Plate 28; Plate 29, figures 1-3.

Asaphid protaspis
Plate 29, figures 4-11

Material. Two incomplete examples, one from the isolated limestone, the other from Table Cove.

Description. The shield is strongly convex, the anteromedian area flattened but the pleural regions steeply sloping, the posterior portion narrower (tr.) and curled under so that the longitudinal convexity is greater than the transverse convexity. In the anterior half subparallel axial furrows outline the gently convex axis which is slightly narrower (tr.) than the adjacent pleural regions. In both specimens the anterior edge of the shield is broken so that the most anterior portion is not preserved. Only in one (Pl. 29, fig. 5), on the right side, is the axial furrow seen to expand into the anterior pit. Posteriorly the axis widens slightly before it is crossed by a shallower furrow which runs in a curve convex backward. In one specimen (Pl. 29, figs. 4-6) the narrower, posterior part of the shield behind the transverse axial furrow is not subdivided. In the second specimen the exoskeleton is adhering to part of this posterior area and there is evidence of subdivision. On the internal mould exposed on the left side (Pl. 29, figs. 7, 10, 11), an extremely faint axial furrow runs back and apparently dies out, and the axial region is faintly convex. The pleural regions are clearly divided by subparallel furrows which run almost straight out to the margin. On the external surface (Pl. 29, fig. 9) these divisions are outlined by smooth bands in the finely granulate external surface. About five segmental divisions may be seen, which become successively shorter (exs.) posteriorly. What appears to be the broken base of a spine, situated on the steep outer part of the pleural region and in a transverse line which lies in front of the trans-axial furrow, is visible on both specimens (Pl. 29, figs. 6, 9-11).

Discussion. In general form, width and length of that part of the axis outlined by furrows, and presence of the anterior pit, this protaspis resembles those of asaphids described by Evitt (1961). The resemblance is greatest to the late protaspis of Evitt (1961, pp. 988-991, text-fig. 3, pl. 117, figs. 9-12, 17, 18), which has the axis outlined on the anterior part of the shield, and shows segmentation in the posterior region. The maximum width (tr.) of the specimens described by Evitt is approximately 1 mm, whereas that of the present examples is 1.5

mm. Because of the size they may be presumed to represent a later developmental stage than Evitt's examples, and other features suggest this. One such is the furrow across the axis at the midlength, which may be either at the posterior margin of the glabella, or, because of its curvature, the occipital furrow. The preservation of the Table Head specimens is such that neither the anterior nor the posterior pair of spines, if present, can be seen. But the pair at the midlength on the pleural region is unlike any in Evitt's specimens, and is in the position of the fixigenal spines of the remopleuridid protaspis (Whittington, 1959, pp. 397-398). Evitt (1961, pp. 994-995) compared and contrasted the remopleuridid and asaphid protaspis, and, on the hypothesis he favours, this pair of spines would be the posterior pair of earlier developmental stages that have migrated forward and outward. Whether or not this hypothesis is accepted, these Table Head protaspides are asaphid rather than remopleuridid in form, and display a fixigenal spine in the midlateral region.

There is no sign in the protaspis of the lobe at the posterolateral margin of the glabella, so characteristic of meraspid asaphid cranidia (Pl. 22, fig. 11; Pl. 25, fig. 12; Evitt, 1961, pl. 117, figs. 20, 23; Whittington, 1941, pl. 75, fig. 27). This lobe is lost during development in some genera (*Stegnopsis* n. gen., *Isotelus*) but is retained in *Niobe* (Pl. 25, figs. 1, 6, 7, 8, 10, 12). In this latter genus it has been termed an alar lobe, implying that it lies outside the axial furrow. More knowledge of asaphid developmental stages is needed to establish the nature of this lobe, and to show whether or not it is homologous in all genera.

Asaphid? hypostome

Plate 67, figures 5, 7, 8

Material. GSC 18370, an incomplete specimen from Table Cove.

Description. Middle body gently convex, oval depression situated close to lateral margin and at three-fifths the length, the posterior lobe marked off as a crescentic, gently convex region, the tip of which abuts against the depression. No anterior furrow or anterior border, anterior margin straight, transverse, the large, triangular wing inclined to slope upward and backward. The anterolateral corner of the hypostome is acutely

angulate, the margins of the wing are straight and the tip rounded. Lateral and posterior borders broken off, but the appearance on the right side (left in Pl. 67, figs. 5, 7) suggests that the lateral border projected in a shoulder. The form of the posterior border is uncertain. External surface bearing faint lines running transversely in curves which are gently convex back; the lines run continuously from the proximal part of the wing across the middle body; on the distal part of the wing the lines run across and are curved progressively more strongly toward the tip.

Discussion. The general form of this hypostome and, particularly, the large, upwardly-projecting wing, suggest it belongs to either an asaphid or an illaenid. Hypostomes of the latter family (Pl. 45, figs. 14, 15; Pl. 52, figs. 6-13; Jaanusson, 1954, pl. 2, figs. 1, 6; pl. 3, figs. 1, 5, 7), however, have the lateral borders narrow and not projecting as a shoulder. Thus it seems more likely that this example belongs to an asaphid species, but it is unlike those (Pl. 23, figs. 3-5, 8; Pl. 26, figs. 1, 2, 6-8; Pl. 29, figs. 1-3) here assigned to the asaphid species in the middle Table Head Formation.

Family NILEIDAE Angelin, 1854

Genus NILEUS Dalman, 1827

NILEUS AFFINIS Billings, 1865

Plate 30, figures 1, 3, 5, 7; Plate 31, figures 1-6, 8, 10
Billings, 1865, p. 275, figs. 261a, b.

Whittington, 1963, pp. 53-55, pl. 9, figs. 7, 9-12; pl. 10, figs. 1-7, 10, 13.

Nileus scrutator (part), Whittington and Kindle, 1963, fig. 3.

Material. This species is moderately abundant in unit 8 of the lower Table Head Formation at the type section, and at exposures of a similar age near Pointe Riche. It is also the most abundant species of *Nileus* in the middle Table Head, found throughout this part of the formation. It is present in the isolated limestone, at Table Cove, and probably in boulders at Daniel's Harbour. The two exoskeletons mentioned by Billings (1865, p. 275) and referred to *N. scrutator*, belong in *N. affinis* (GSC 720, 720a, from the type section).

Discussion. The present material appears indistinguishable from the type specimens and those from the boulder at Lower Head. The abundant material has revealed various additional features of the exoskeleton, particularly the doublure and hypostome.

The exoskeleton is thick, and internal moulds of the cephalon show the glabellar tubercle prominently, a deep groove in the cranidium beside the anterior edge of the eye lobe (Pl. 30, fig. 3), a broader and shallower furrow on the free cheek outside the eye surface. The cephalic doublure is well shown in a specimen which has the hypostome preserved though slightly displaced (Pl. 31, figs. 1, 5). Anteriorly the doublure is broadest, with a wide furrow running beside the hypostomal suture, and a notch in the inner margin against which the hypostome fits along the suture. Anterolaterally, the inner part of the doublure is curled upward and outward, most strongly so laterally, where the ventrally-facing part is impressed by a vincular furrow. Immediately behind this furrow the doublure is flexed abruptly, and posterolaterally it is flat and lies close beneath the dorsal exoskeleton. Hypostome (Pl. 31, figs. 2-4, 6) twice as wide as long, anterior sutural edge straight, margins of lateral borders curved, posterior margin indented by shallow median notch. A narrow raised rim runs around the edge of the lateral and posterolateral borders, dying out as it approaches the median notch. Inside this rim the surface of the hypostome is almost flat, except for the deep, suboval depression of the macula, which is situated anterolaterally, a short distance inside the rim and in line with the anterior edge of the shoulder. The anterior wing is extremely long, directed vertically. The anterior edge is only slightly curved, the proximal part of it fitting against the doublure. In lateral aspect (Pl. 31, fig. 3) the wing is triangular in outline, but 'L'-shaped in transverse section, for the posterior edge is bent so that there is an inwardly extending part of the wing (Pl. 31, fig. 2). When the hypostome was in position, it appears that the tip of the wing would lie close to the dorsal exoskeleton of the anterior part of the glabella, approximately in line with the anterior end of the eye lobe, and a short distance in from this point.

Five complete specimens show that there are seven thoracic segments, and one (Pl. 31, fig. 8) shows the segments in ventral aspect (cf. Schmidt, 1904, p. 66, fig. 6). On the inner surface of the exoskeleton the lateral part of the ring is deeply excavated, the articulating furrow standing up as a thick ridge. On the external surface of the exoskeleton the ring is quite smooth, so that these features are produced by thickenings of the exoskeleton, particularly along the articulating furrow. At the posterior margin of the ring, at the axial furrow, there is a

prominent articulating boss, which is seen to fit into a deep socket in the anterior margin of the succeeding segment. Again, these structures are in the thick exoskeleton, and only slightly reflected in the dorsal surface. The doublure of the pleurae extends in close to the axial furrow, the inner margin gently concave inward. This doublure is crossed by a diagonally directed fold, which acts as a stopping device for the leading edge of the succeeding segment during enrollment. The pygidial doublure (Pl. 31, fig. 10) is wide, extending in around the posterior half of the axis and beneath all but the inner, anterior part of the pleural region. It lies close against the dorsal exoskeleton. The distribution of the prominent terrace lines on the hypostome, and on doublure of the thorax and pygidium, is shown by the photographs.

The hypostome differs from that of *Nileus armadillo* (Lindström, 1901, pl. 5, fig. 13) in that the middle body is not defined by shallow furrows, and the maculae are situated much farther forward and are in the form of deep, flat-based pits. Whether or not the anterior hypostomal wing is similarly shaped in the two species is uncertain. The general appearance of the hypostome of *N. affinis*, and particularly the extreme shortness (sag. and exs.) of the anterior lobe of the middle body, suggests a comparison with the hypostome of *Remopleurides* (Whittington, 1959, pp. 393-396, text-fig. 3). It may well be that the anterior wing in these two genera is homologous, and if so, the possibility of a relationship between remopleuridids and nileids is suggested. In common between the two families are the wideness of the doublure, particularly of the thoracic pleurae and pygidium, and the articulating processes and sockets situated in the axial furrow.

NILEUS SCRUTATOR Billings, 1865

Plate 30, figures 2, 4, 6, 8-14; Plate 31, figures 7, 9;

Plate 32, figures 1, 3, 5, 7, 9

Billings, 1865, pp. 274-5, fig. 260.

Raymond, 1925, pp. 84-85, not pl. 3, fig. 17.

Lectotype (here selected). GSC 667a, incomplete cephalon with exoskeleton partly exfoliated. Paralectotypes include 667, 677b, c, three pygidia, and 667d, a cranidium. All are labelled as from Portland Creek; 667d, however, bears the label "4 miles NE of Portland Creek" and is from Daniel's Harbour.

Other material. In the present investigation this species has been found to be rare, a few specimens coming from 90 feet above the base of the middle Table Head Formation, one cranium from 215 feet above the base, and one pygidium from the exposures on the foreshore south of Table Cove.

Description. The complete enrolled specimen (Pl. 30, figs. 2, 6, 9, 12; Pl. 31, figs. 7, 9) shows the characters of the dorsal exoskeleton, and how it may be distinguished from *N. affinis*. The eye lobe is relatively shorter, the free cheek relatively wider and more prolonged posterolaterally. But the most obvious distinguishing feature of the cephalon is the sharp flexure at the anterior and anterolateral margins between the dorsal exoskeleton and the horizontal doublure. Running along the sharply flexed margin is a narrow rim. In *N. affinis* there is no such rim and the margin is broadly rounded (compare Pl. 30, figs. 7, 9). On the internal mould the glabellar tubercle is much less conspicuous, and the shallow groove along the posterior margin of the glabella is less pronounced (compare Pl. 32, fig. 1, with Whittington, 1963, pl. 10, fig. 1). There are seven thoracic segments in both species, and in dorsal aspect the pygidia are similar, except that in *N. scrutator* there is a flattened border to the pygidium, which is widest laterally; though faintly defined this is more distinct than that of *N. affinis*. The eye surface is covered with closely spaced facets which are arranged in diagonal lines (Pl. 31, fig. 7). The small cranium (Pl. 30, figs. 10, 11, 13) differs from larger crania in being more convex both transversely and longitudinally.

Raymond identified this species both from boulders in the conglomerate at Mystic, Québec, and from beds of Porterfield age in Virginia and Tennessee. The material he studied suggests that a species of *Nileus*, of *affinis-scrutator* type, is present in the boulders in Québec, and that a Nileid of this general type is present in the southern Appalachians.

NILEUS MACROPS Billings, 1865

Plate 32, figures 2, 4, 6, 10, 12-14; Plate 33, figures 1-6

Billings, 1865, p. 273, fig. 259.

Raymond, 1925, pp. 83-84.

Lectotype (here selected). GSC 649a, incomplete and partly exfoliated exoskeleton, from middle Table Head Formation at

type section. Paralectotypes: GSC 649, a less complete and almost entirely exfoliated exoskeleton, 649b, cephalon with one segment, 649c, cranidium, same locality and horizon.

Other material. This species has been found to occur less commonly than *N. affinis*, but more commonly than *N. scrutator*, in the middle Table Head Formation at the type section from 90 feet above the base to the top, in the isolated limestone, the exposures at Table Cove, and in the boulders at Daniel's Harbour.

Description. The cephalon is distinguished from that of *N. affinis* and *N. scrutator* by the much longer (exs.) eye lobe, the narrower (tr.) free cheek, the steep slope of the cephalon in front of the eye lobes, the parallel course of the anterior branches of the facial suture immediately in front of the eye lobes, and the more strongly convex transverse profile. The cranidium is not, as Raymond believed, "much longer and narrower than in *N. scrutator*" (compare Pl. 32, fig. 2 with fig. 1), and the glabellar tubercle appears to be in much the same position in the two species, and moderately prominent on the internal mould. The entire specimens show that there are seven thoracic segments. The pygidium has the outer parts of the pleural regions slightly flattened, though there is no distinct border, and displays a broad, shallow first pleural furrow running immediately inside the inner part of the facet. The doublure extends in to the tip of the axis and about half way across the pleural regions, not quite as far in as in *N. affinis*.

NILEUS? LACUNOSA n. sp.

Plate 36, figures 1-10; ?Plate 32, figures 8, 11

Holotype. GSC 18549, incomplete cephalon from middle Table Head Formation at Table Cove.

Other material. One cranidium from boulder at Daniel's Harbour, one incomplete cranidium (and a pygidium that may belong here) from middle Table Head Formation, type section, 190 feet above base.

Description. Cephalon subsemicircular in outline, moderately convex, facial sutures nileid, slim genal spine. Eye lobe large, bearing many small facets on eye surface, length (exs.) greater than half that of cephalon. No axial furrow separates palpebral lobe from glabella, the two being united in a smooth, convex curve. Frontal lobe of glabella and preglabellar area, as well as

outer part of cheek, slope evenly and gently to sharply flexed margin of cephalon; there is no cephalic border as such but a flattened anterolateral region. As the cranidium (Pl. 36, figs. 5, 8, 9) shows, the glabella is most sharply convex close to the posterior margin. The small cephalon (Pl. 36, figs. 3, 6, 7) is more convex, has much broader-based genal spines and the flattened anterolateral border region is pronounced.

Discussion. The cephalon is like that of *P. lineolata*, but the lack of the border and axial furrows distinguishes it at once. Also distinctive are the tiny pits of the external surface of the glabella and palpebral lobes (Pl. 36, fig. 10), which become faint or die out on the cheek outside the eye lobe. The cephalon, and particularly the cranidium, is like that of *Nileus*, but the gentle slope outside and in front of the eye lobes, and the genal spines, distinguish it. An exoskeleton in which the cephalon is damaged, from a boulder north of the mouth of Portland Creek, suggests that the original of Plate 32, figures 8, 11, may represent the pygidium of this species. If so, this pygidium, distinguished by its subtriangular shape and flattened borders, is far more like that of *Nileus* than *Peraspis*, and this species is put with question in the former genus.

Genus *PERASPIS* n. gen.

Type species. *Niobe lineolata* Raymond, 1925.

Diagnosis. Broad anterior cephalic doublure not crossed by median suture, anterior branches of suture meeting on dorsal surface close to anterior margin in a smooth curve. Glabella subparallel-sided, slightly expanded anteriorly, without furrows, but glabellar tubercle close to posterior margin. Large eye lobe situated at midlength of cephalon adjacent to axial furrow, cheeks with flattened border, anterolaterally, which is continuous with flattened preglabellar area. Posterior part of fixed cheek extremely small, posterior border furrow on free cheek, short genal spine. Hypostome (that probably belongs here) transversely ovate in outline, no median notch, median furrow situated at midlength. Seven thoracic segments; pleural furrow runs close to anterior margin then curves distally beside facet and deepens. Pygidium with narrow tapering axis, pleural regions with narrow flattened border, four or five axial rings and pleural furrows present. Doublure wider than border, inner margin concentric with pygidial margin, except at notch behind axis. External surface covered with closely-spaced, extremely fine lines,

which run in curves convex forward on the axis, and diagonally on the pleural regions.

Discussion. Raymond placed this species in the Asaphidae, but the discovery that the anterior cephalic doublure is broad (sag. and exs.) and lacks the median notch and median suture, suggests that this species is a nileid. The shape of the glabella and lack of furrows, large eye lobes placed close to glabella, seven thoracic segments, type of pleural furrow, and fine lines of the external surface are characters typical of nileids rather than asaphids. The cephalon is like that of *Kodymaspis* Prantl and Příbyl, 1949, in possessing genal spines, but the furrowed pygidium is asaphid-like and not like that of other known nileids.

PERASPIS LINEOLATA (Raymond, 1925)

Plates 34, 35; Plate 36, figures 11, 12

Raymond, 1925, pp. 79-80, pl. 3, figs. 15, 16.

Holotype. YPM 13042, exoskeleton lacking free cheeks, middle Table Head Formation, Dominion Iron and Steel Company quarry, Aguathuna, Port au Port peninsula.

Other material. Middle Table Head Formation, from 130 to 190 feet above the base in the type section, the isolated limestone, exposures on foreshore south of Table Cove, at Black Cove, and in boulders at Daniel's Harbour. GSC 656f, g, two small pygidia from the type section, placed by Billings in *Niobe morrisoni*.

Description. Cephalon subsemicircular in outline, gently convex, border widest anteriorly and anterolaterally, narrowing toward genal angle which is prolonged by short spine. Glabella subquadrangular in outline, about twice as long (sag.) as wide, bounded by shallow, sinuous, axial furrow and shallow preglabellar furrow. No occipital or lateral furrows, faint glabellar tubercle situated close to posterior margin; glabella slightly expanded across frontal lobe. Large eye lobe of length (exs.) almost half that of cephalon, situated beside axial furrow, posterior margin adjacent to posterior border furrow. Palpebral lobe flat, without rim; eye surface (Pl. 35, fig. 7) bearing many small convex facets and bounded by narrow, convex external rim. Anterior branches of suture diverge forward from eye lobes, curve around and meet in a smooth curve, the anterior part of their course running close to the margin of the cephalon (Pl. 35, figs. 3, 5, 7). Posterior branch of suture runs directly outward and slightly backward, so that the posterior part of the fixed cheek is a wide

(tr.), short triangle. Cheek inside border gently convex, boundary of this convex region curves around to abut against anterior margin of eye lobe. Broad, shallow depression, the border furrow, separates this convex region from the outward sloping border — this depressed region widest (exs.) in front of eye lobe and beside frontal lobe of glabella. Preglabellar area horizontally extended, gently convex. Posterior border furrow runs directly outward and is situated on free cheek; at genal angle it becomes shallower and curves forward to join lateral border furrow. Genal spine is broad at base, tapering rapidly to sharp tip. Doublure of cephalon extends inward so that inner margin is beneath margin of convex part of cheek (Pl. 35, figs. 3-5), this line curving around and then running transversely immediately in front of eye lobes, so that anterior part of doublure is broad (sag. and exs.). Adjacent to midline inner edge of doublure is flexed. A small projection on the inner surface of doublure at genal angle (Pl. 35, figs. 1, 2) acts as a stop during enrollment, and does not appear to show a pandertian opening. Hypostome poorly preserved in place in one specimen (Pl. 35, fig. 1). Isolated specimens from Daniel's Harbour (Pl. 35, figs. 6, 8) and the isolated limestone may represent the same species. Outline oval, maximum width slightly greater than length, gently convex, the wing curving upward. The median furrow is a slight, broad depression running inward at about the midlength. A low, narrow posterior border projects in a blunt, median point.

Thorax of seven segments, axis of constant width; posterior segment the widest (tr.), where the axis is about one-quarter the total width, contrasting with the first segment, in which the axis is about one-third the width. Pleurae faceted so that tip is a sharp point, pleural furrow shallow and close to anterior margin on inner part, at fulcrum curving and deepening as it runs along the inner margin of the facet, shallowing and dying out without reaching the tip. Pygidium with narrow axis that tapers gradually to faintly defined tip at the posterior margin. Articulating furrow narrow. First six ring furrows are best defined distally, faint or absent medially. Pleural regions gently convex, sloping down distally to narrow, more gently sloping but ill-defined border. Five pleural furrows curve slightly distally and die out without reaching the border. The doublure (Pl. 34, fig. 10) is wider than the border, situated close against the dorsal exoskeleton, extending inward about one-third the width of the pleural regions, the inner margin parallel to the margin of the pygidium, notched where it extends beneath the tip of the axis.

External surface (Pl. 34, fig. 9; Pl. 35, fig. 7; Pl. 36, figs. 11, 12) covered by closely-spaced, extremely fine lines. These lines run in curves that are gently convex forward on the axis, and run diagonally inward and backward on the pleural regions, changing distally to run subparallel to the margins. On the doublure (Pl. 34, fig. 10; Pl. 35, figs. 1, 2, 4) the terrace lines are much coarser, and run subparallel to the margin. On the hypostome (Pl. 35, figs. 6, 8) the lines are coarse and run transversely.

Discussion. The small cranidium (Pl. 34, figs. 8, 11, 12) is relatively tumid, the glabella being slightly more convex, both transversely and longitudinally, than in larger examples. A transitory pygidium (Pl. 34, figs. 6, 7) has the pleural regions relatively more inflated so that the narrow border is much more distinct. A second example of a transitory pygidium (Pl. 67, figs. 10, 13) is similar in size, convexity, and in the presence of the border, to the original of Plate 34, figures 6, 7. The anterior segment is faintly marked off by an interpleural furrow, the pleural furrow is broad and shallow, running for a short distance immediately behind the inner part of the facet. This specimen lacks axial furrows outlining the axis on the part that is to become the true pygidium, and does not show shallow pleural furrows in this region. It is tentatively referred to this species.

Raymond referred this species without discussion to *Niobe*, but the additional material does not support this view. Whitard's (1961, pp. 221-228, pl. 31, figs. 6-11, pls. 32, 33) recent description of species of the Nileid *Barrandia* show the wide anterior cephalic doublure and the extremely fine lines on the external surface of the dorsal exoskeleton, much as in *N. lineolata*. The hypostomes in the two genera are similar in shape, but the middle furrow in *Barrandia* is deep and continuous across the middle body. In other respects the cephalon and pygidium in the two genera differ considerably, but the family likenesses are evident.

NILEID gen. ind.

Plate 33, figures 7-13

Material. A single cranidium retaining full convexity from bed 4 of the middle Table Head Formation, Black Cove. MCZ 3652, a fragment of a similar cranidium and the free cheeks joined by the doublure, both specimens flattened, labelled "east side, Port

au Port," and probably from the same locality and horizon, collected by A. Hyatt. Two pygidia from Black Cove may belong here.

Description. Gently convex glabella outlined by shallow, parallel, axial furrows that run forward to the inner, anterior corner of the palpebral lobe. In front of this point glabella expands and slopes steeply down to sutural margin of cranidium. The eye lobe is of length (exs.) about one-third that of the cephalon, and situated at about the midlength. Palpebral lobe is horizontal, cheek slopes gently outward. The anterior branches of the suture are widely divergent immediately in front of the palpebral lobe, then run in a smooth curve around the margins of the frontal glabellar lobe. Small glabellar tubercle situated in line with the posterior part of the palpebral lobe. The free cheek is wide (tr.), subtriangular in shape, genal angle rounded, the anterior cephalic doublure of width (sag.) about one-third the length of the cephalon, a shallow median notch in the inner margin, adjacent to which is a shallow groove in the external surface. A few terrace lines curve across the genal angle.

The pygidium included here is the only unassigned pygidium known from bed 4 at Black Cove, and may belong with the cephalon. Axis tapers to rounded tip, first ring furrow and first pleural furrow shallow but distinct. Narrow, flattened border, doublure of about twice the width of the border.

Discussion. The cephalon lacks median or connective sutures, and is clearly a nileid. However, the axial furrow, the difference in slope between glabella and palpebral lobe, and the size and position of the eye lobe, distinguish it from species of *Nileus* described here. The pygidium is quite unlike that of *Nileus*, being relatively longer, and in having a longer, narrower axis and the distinct border. From *Peraspis* n. gen. the cephalon is distinguished by the more forward position of the glabellar tubercle and lack of genal spines, the pygidium being differently furrowed, and the external surface being smooth.

Family TELEPHINIDAE Marek, 1952

Genus TELEPHINA Marek, 1952

TELEPHINA AMERICANA (Billings, 1865)

Plate 37 ; Plate 38, figures 7-9, 11

Billings, 1865, pp. 291-292, fig. 281.

Hadding, 1913, pp. 41-42, pl. 1, fig. 11, text-fig. 1.

Raymond, 1925, pp. 65-66.

Ulrich, 1930, pp. 21-22, pl. 2, figs. 22-27.

Lectotype (selected by Ulrich). GSC 700b, incomplete and exfoliated cranidium, from middle Table Head Formation, type section. Paralectotypes: GSC 700, 700a, two cranidia from the same locality as the lectotype; GSC 699, a-e, six cranidia from Daniel's Harbour.

Other material. Relatively abundant in the type section of the middle Table Head Formation, from 90 feet above the base to the top; also abundant in the isolated limestone, at Table Cove, and the boulders at Daniel's Harbour.

Description. Glabella of maximum width across occipital furrow, tapering forward and rounded anteriorly, moderately convex longitudinally and transversely. The occipital furrow is deep and straight, with a slight extra deepening distally, outside which it curves forward and dies out without reaching the axial furrow. Low, longitudinally-elongate median occipital tubercle on external surface (Pl. 37, fig. 5), barely visible on internal mould (Pl. 37, figs. 1, 3). On the internal mould (Pl. 37, figs. 1, 3) a faint, shallow depression at about half the length may indicate the presence of the first lateral glabellar furrow. Axial furrows deep and forming a continuous curve with preglabellar furrow, anterior pit at the junction of these furrows. Fixed cheek consisting of crescentic area adjacent to axial furrow, flexed down where it joins the palpebral rim; the latter a gently convex, outward-sloping band which is slightly wider anteriorly than posteriorly. Anteriorly (Pl. 37, fig. 18) the palpebral rim abuts against the axial furrow at the anterior pit; in front of this is the anterior border, which is narrow, convex, runs straight across in front of the middle part of the glabella, and is distally turned downward to form a spine, the outer edge of which is bounded by the anterior branch of the suture. Posterior border also spine-like in form, curving outward and downward, and bounded on the anterior side by the posterior branch of the suture. Free cheek (Pl. 37, figs. 14-17) includes the large, convex eye surface, covered with many convex facets. This surface is bounded on the outer side by a deep furrow, outside which is the narrow border. This border expands to a maximum width posterolaterally, has the upper and lower edges sharply flexed, and there is a small, short librigenal spine at the widest part. External surface covered by raised lines, which on the glabella (Pl. 37, fig. 18) are arranged in a multiple web-like pattern because individual lines radiate from low tubercles. Immediately in

front of the outer part of the occipital furrow is a transversely elongate, smooth area, an area of muscle attachment which lies in front of the deep outer part of the occipital furrow. Beside this area the axial furrow is deepened. A second area (lateral glabellar furrow 1p) is represented by a large oval, smooth area, which is diagonally directed and situated at about half the length of the glabella, and a short distance in from the axial furrow. A much smaller area just in front of it may represent furrow 2p. The inner, posterior part of the palpebral lobe is smooth, and this area may also be a muscle area.

The small cranidium (Pl. 37, figs. 8, 12, 13) is like larger specimens except that the palpebral lobe is wider and consequently has an angulate outline.

Pygidium triangular in outline, axis of width (tr.) at the anterior margin half that of the pygidium, consisting of two rings and a small terminal piece, and rapidly tapering to the bluntly rounded tip. Behind the axis is a low, postaxial ridge. Pleural regions narrow, outward sloping, with a narrow, wire-like rim which merges with the postaxial ridge at the tip. Anterior margin of pleural region a raised ridge, the furrow behind this presumably being the first pleural furrow, and the faint ridge following being the posterior band of the first pleura. First and second axial ring displaying a prominent pair of tubercles close together at the midline. Behind these tubercles is a faint flexure, which runs out laterally, and curves around distally to reach the posterior margin. Thus the posterior half of the first axial ring is slightly lower than the anterior half, and the latter bears a few scattered tubercles. On the posterior part of the axis is a pair of oval, slightly depressed regions, situated close behind the median pair of tubercles, and bearing some scattered tubercles. Raised terrace lines run along the rim and diagonally on the axial ring.

Discussion. Specimens that are not exfoliated (Pl. 37, fig. 18) reveal the unusual arrangement of tubercles and raised lines on the external surface, which are visible only as faint tubercles on internal moulds (Pl. 37, fig. 3). A somewhat similar arrangement of lines and smooth muscle areas appears to be present in *Telephina bipunctata* (Ulrich, 1930, pl. 5, figs. 1-6). Ulrich compared the present species to his *T. mysticensis* (1930, pp. 22-23, pl. 6, figs. 1-7). The cranidia of the two species appear similar, but the eye lobe in *T. americana* is much less convex; in both species there is only a small, short, genal spine. The pygidium

appears to be of normal telephinid type, but it is difficult to compare it in detail with such specimens as those illustrated by Ulrich (1930).

A single example of a hypostome (Pl. 37, figs. 10, 11) comes from the exposures on the foreshore south of Table Cove, in which beds *T. americana* is abundant. The middle body is elongate-oval, divided by a shallow but complete middle furrow, the anterior lobe the larger and the more convex. The tip of the posterior lobe is slightly inflated. The wide anterior border extends forward horizontally, and has a shallow median depression in the anterior edge. Laterally it is continuous with the large, triangular wings which are curved upward. The lateral and posterior borders are narrow, wire-like, defined by deep border furrows. The specimen appears to be exfoliated, but there is exoskeleton adhering to the borders, and it is traversed by fine terrace lines. Whether or not this hypostome belongs in *T. americana* is uncertain, but it is similar to the hypostome of *T. mysticensis* figured by Ulrich (1930, pl. 6, fig. 5). This illustration shows no wide anterior border, but apparently it is broken and there is a large anterior wing. The general aspect of the middle body and borders is similar to the present specimen.

Nikolaisen (1963) has described Middle Ordovician telephinids of Norway, and discussed the phylogeny of the group. As he remarks, *T. americana* and its close relative *T. mysticensis* (with which he associates, with some doubt, *T. gelasinosa* Ulrich from beds of early Porterfield age in Alabama) differ from Norwegian species in that the fixed cheek is relatively narrow (tr.) and well rounded. He describes only fragmentary free cheeks and pygidia, which are like those from Newfoundland and Quebec except that the cheeks bear a long genal spine. The external surface of the Norwegian species is tuberculate, and Nikolaisen describes reticulate or anastomosing raised lines, but the preservation does not reveal a pattern like that in *T. americana* (Pl. 37, fig. 18). Other features of the cranidium are shown in Nikolaisen's figures — the smooth, oval area immediately in front of the deep outer part of the occipital furrow, the smooth area on the posterior part of the fixed cheek, and the deep, elongate anterior pit (Nikolaisen, 1963, pl. 1, figs. 6, 11; pl. 2, fig. 2; pl. 3, figs. 1, 12). The Norwegian and American species of *Telephina* thus appear to be related, *T. americana* and *T. mysticensis* occurring at about the same time as the early Norwegian species and apparently representing a separate species group.

Small cranidia of *Telephina bicuspis* (Nikolaisen, 1963, pl. 1, figs. 1-4) have the fixed cheek no wider (tr.) than in large individuals, and lateral furrow 1p impressed, unlike that of the small cranidium of *T. americana* (Pl. 37, figs. 8, 12, 13).

TELEPHINA sp. ind.

Plate 38, figures 1-6, 18

Material. Three cranidia, partly exfoliated, from middle Table Head Formation at Table Cove.

Description. These three cranidia differ from those of *Telephina americana* in that the glabella is relatively wider posteriorly and tapers slightly more rapidly, and the occipital furrow is not straight but distally turns back, becomes deeper, then curves forward to become shallower but reaches the axial furrow. Thus the outer part of the occipital furrow is curved concavely forwards. The median occipital tubercle is more distinct, particularly on the internal mould. The palpebral rim is also different in that the anterior part is considerably wider, so that the anterior margin of the cranidium in dorsal aspect appears almost straight, distally curving sharply so that the anterolateral margin of the palpebral lobe is more angulate than in *T. americana*. The exterior surface bears a similar pattern of scattered tubercles from which fine lines radiate, giving a characteristic stellate appearance. The muscle area in front of the outer part of the occipital ring is represented by an oval smooth area, and lateral glabellar furrow 1p by a similar-appearing area that is diagonally directed and situated at about the midlength of the glabella. The differences appear to exist between both large and small cranidia.

Family KOMASPIDIDAE Kobayashi, 1935

Genus GONIOPHRYS Ross, 1951

GONIOPHRYS BREVICEPS? (Billings, 1865)

Plate 38, figures 10, 12-17; Plate 39, figures 1, 2, 5, 6, 10

Billings, 1865, p. 262, fig. 246.

Types. The specimen or specimens on which Billings based his description have not been traced. They came from the type section of the middle Table Head Formation. GSC 2254 is a cranidium from Portland Creek, collected by J. Richardson, but not the original of Billings' figure.

Other material. Ten cranidia from the isolated limestone and Table Cove, and one from 17 feet above the base of the type section.

Description. No cranidia of a length (sag.) greater than 2.5 mm have been found. Glabella widest across base, tapering forward and bluntly rounded, length slightly less than maximum width. Occipital furrow deep and narrow, course slightly bow-shaped, deepest distally, posterior margin of ring curved convexly backward. Glabella defined by deep and continuous axial and preglabellar furrows, in front of glabella a short (sag. and exs.), convex preglabellar field and a somewhat longer, convex anterior border. Fixed cheek is gently convex, outward sloping, anteriorly merging with the preglabellar field and bounded by the anterior border. Posterior border furrow narrow and deep, posterior border widening outward. Lateral margins of fixed cheeks almost straight, converging forward, narrow palpebral rim defined by deep palpebral furrow, having a gentle outward curvature, and running from just in front of posterior border furrow almost to anterior border furrow. The anterior border is curled under, and the anterior branch of the suture runs inward and forward on to the upper surface of this border, then turns to run inward and downward across the ventrally-facing surface of the border (Pl. 39, figs. 5, 6). The two branches do not appear to meet in the middle line, but appear to be joined by what may be the rostral suture, running in a curve that is convex forward.

External surface (except borders and in furrows) bearing scattered shallow pits. On the glabella, muscle areas are represented by smooth, unpitted patches (Pl. 38, fig. 17; Pl. 39, figs. 1, 10) — a large oval one extending from the axial furrow inward and backward at about the midlength of the glabella, and a smaller area situated on the anterolateral slope of the glabella and widening as it extends inward from the axial furrow. Traversing the anterior border are fine terrace lines.

The smallest cranidium (Pl. 38, figs. 10, 13, 14) is like the larger, except that the external surface is tuberculate rather than pitted. This cranidium displays the same smooth areas on the glabella.

Discussion. The forwardly tapering glabella, with well-defined occipital ring and two pairs of muscle areas, the short preglabellar field and long, prominent palpebral rim suggests that this cranidium is that of a komaspidid. It resembles most closely *Goniophrys* Ross (1951, pp. 81-82, pl. 18, figs. 9, 15, 17-20, 22,

27; Hintze, 1953, pl. 20, fig. 1), but differs from the type and only known species principally in that the palpebral rim in dorsal aspect is not so sharply flexed. There is no shallowing of the axial furrow adjacent to the glabella in front of the occipital ring, as described by Hintze (1953, pp. 156-157). The type species is not pitted on the external surface and does not display the smooth muscle areas, but the glabella is unfurrowed.

Genus CAROLINITES Kobayashi, 1940

CAROLINITES sp. ind. 1

Plate 39, figures 3, 4, 11

Material. A single cranidium (GSC 18567), partly exfoliated, from bed 4 of middle Table Head Limestone, Black Cove.

Description. In outline and convexity of the glabella, shape of fixed cheek, and presence of the convex lobe adjacent to the glabella in front of the occipital ring, this cranidium is like that of other species of this genus (Stubblefield, 1950; Ross, 1951, pp. 82-84, pl. 18, figs. 25, 26, 28-36; Hintze, 1953, pp. 144-147, pl. 20, figs. 2-13). It resembles the Irish species described by Stubblefield in the relatively great width of the fixed cheek at the posterior margin, but differs from all other known species in the subdivision of the occipital ring into three narrow, transverse, convex bands, the presence of the long, upwardly and backwardly directed occipital spine, and the tuberculation on the glabella in front of the occipital ring, the "basal lobe" and fixed cheek. The palpebral rim is not preserved, but the broad palpebral furrow is present, and shows the characteristic gentle flexure at about the midlength. At the distal extremity the posterior border widens abruptly, immediately inside the point at which it is crossed by the posterior branch of the suture. A similar structure is present on some of the species described by Hintze — the posterior border curves back distally to join the border of the free cheek.

CAROLINITES sp. ind. 2

Plate 39, figures 7, 12, 13

Material. A single incomplete and exfoliated cranidium (GSC 18568) from the middle Table Head Formation at Table Cove.

Description. This cranidium does not appear to represent the same species as that from Black Cove. The convexity of

both glabella and fixed cheek is greater, as seen in both longitudinal and transverse profiles, and the fixed cheek is much wider. Distally the cheek slopes down steeply to the broad, deep palpebral furrow, which is gently curved and runs almost directly backward posteriorly. External surface of glabella in front of occipital ring and fixed cheek bears tubercles which are larger and more widely scattered than in *Carolinites* sp. ind. 1.

A pygidium (Pl. 39, figs. 8, 9) from the same locality and horizon is like that of some species of *Carolinites* (Ross, 1951, pl. 18, figs. 28, 32, 35; Hintze, 1953, pl. 20, figs. 5a, 5b, 9) in outline, prominence of the axis, presence of deep first pleural furrow, but does not exhibit the distally-projecting posterior pleural bands.

Family REMOPLEURIDIDAE Hawle and Corda, 1847

Genus REMOPLEURIDES Portlock, 1843

REMOPLEURIDES PILULUS n. sp.

Plate 39, figures 14-16; Plate 40, figures 5-8

Holotype. GSC 18570, cranidium with exoskeleton from middle Table Head Formation at Table Cove.

Other material. Cranidia from the same locality and horizon as the holotype.

Description. This species is distinguished from *Remopleurides ligulus* Whittington, 1963 (p. 36, pl. 4, figs. 1-10) from the boulder at Lower Head by the much greater convexity which gives it a hemispherical form. In dorsal aspect the cranidium is wider (tr.) across the midpoint of the palpebral lobes, and tapers more rapidly forward to the rounded outline of the tongue. In lateral or transverse profile the greater convexity is readily evident, and in *R. pilulus* the convexity of the glabella between the eye lobes is greater than in *R. ligulus*, while that of the tongue is less. The palpebral rim is extremely narrow, separated from the glabella by the deep palpebral furrow. The external surface is finely granulate, this granulation most evident on the occipital ring and the distal areas of the glabella and tongue, dying out and disappearing in the median part of the glabella. Lateral furrow 1p is not visible, but 2p is a distinct, narrow furrow which curves inward. Lateral furrow 3p is represented by a faint, transversely-ovate smooth depression,

situated opposite the anterior end of the palpebral rim and in line (exs.) with the inner part of furrow 2p.

I have examined the type cranidia (GSC 881, a-c) of *Remopleurides affinis* Billings, 1865 (pp. 325-6, fig. 313), from a boulder in the Mystic Conglomerate, Quebec. They are like that of *R. ligulus*, not that of the Table Head species.

REMOPLEURIDES sp. ind.

Plate 40, figures 1-4

Material. Two cranidia (GSC 18572, 18573) from the middle Table Head Formation, 190 feet above the base in the type section.

Description. In dorsal aspect this cranidium appears relatively narrower and longer than that of *R. pilulus*, and both the longitudinal and transverse convexity is much less, so that the tongue curves down in front of the palpebral lobes to become vertical at the anterior margin. This convexity is less than that of *R. ligulus* (compare Plate 40, figure 2, with Whittington, 1963, pl. 4, figs. 7, 8). Thus this cranidium appears to represent a third species, in which the palpebral rim is wider than in *R. pilulus*, and the granulation on the glabella relatively coarser and confined to the distal edges. Muscle areas 1p and 2p appear as narrow, curved, faintly depressed smooth bands.

Genus ROBERGIA Wiman, 1905

ROBERGIA SCHLOTHEIMI (Billings, 1865)

Plate 40, figures 9-12; Plate 41

Billings, 1865, p. 294, figs. 284a, b.

Raymond, 1925, pp. 58-60.

Lectotype (here selected). GSC 694, internal mould of cranidium, from middle Table Head Formation at Pistolet Bay. Paralectotypes: GSC 694a, b, c, d, cranidia from same locality as lectotype; GSC 695, cranidium from middle Table Head Formation at Bonne Bay.

Other material. Raymond had before him specimens collected by A. Hyatt from the middle Table Head Formation at Black Cove and the south side of St. John Island. This species is common only in the highest part of the middle Table Head Formation, from 185 feet above the base to the top, in bed 4 at Black Cove, and the highest beds exposed immediately south

of Table Cove. Rare specimens have been obtained from the isolated limestone and exposures on the foreshore south of Table Cove, and in the boulders at Daniel's Harbour.

Description. The cranidium is typical of *Robergia* (Whittington, 1950, pp. 543-544, pl. 71, figs. 1-8; 1959, pp. 428-431, pl. 18, figs. 1-22, 25), displaying the characteristic inflated median outer part of the occipital ring, the subcircular gently inflated lateral glabellar lobe 1p, the three pairs of lateral glabellar furrows, the wide palpebral rim, and the narrow strip surrounding the tongue. On the external surface (Pl. 40, fig. 12) are fine raised lines in a Bertillon pattern. There is a small median occipital tubercle close to the anterior margin, best seen in the small cranidium (Pl. 41, fig. 5). The hypostome of the type species is not known, but I have described that of *R. major* (1959, p. 429, pl. 18, figs. 8-14), which is subsquare in outline, the middle body occupied almost entirely by the large oval areas, the borders narrow, and the anterior wing small. The hypostome (Pl. 41, figs. 3, 4, 7) here attributed to *R. schlothceimi* (it has been found at the type section and at Black Cove, where cranidia and pygidia are relatively abundant) is different in appearance. The outline is elongate-oval, the oval areas raised but occupying less than one-half of the gently convex middle body. There is no border on the curving anterior margin, but laterally there is a shallow furrow separating the middle body from the large, triangular anterior wing. The margin of the latter curves gently to the right-angled tip, which lies above the anterior part of the oval area. The lateral border commences opposite the anterior end of the oval area and is a narrow, convex ridge separated from the oval area by a deep furrow. The posterior border is wider (exs. and sag.), less convex medially and separated from the middle body by shallow furrows. External surface covered by fine, raised lines in a Bertillon pattern, on the anterior part of the middle body running in curves that are convex backward, on the oval area in curves that are convex laterally.

Pygidium subrectangular in outline, convex axis tapering to blunt point and reaching to about half the length (sag.). Pleural region broad and flat, crossed by two low, diagonally-directed ridges (the posterior pleural bands of the first two segments) which run out along the posterior margin of the first two border spines, and are separated from each other and the anterolateral corner by broad, shallow pleural furrows. The

first pleural spine is short, situated on the lateral border at about four-fifths the length from the anterior corner. The second pleural spine is much the longest and broadest, and along the posterior margin between the second spines may be seen the blunt points of the third spines, and a median notch. An extremely faint third posterior pleural band runs out to the third pleural spine. Doublure extends under the entire pleural regions to the axial furrow and is flexed up at the tip of the axis. On the external surface fine, closely-spaced lines run diagonally in a wavy course across the pleural regions; on the doublure similar lines run concentrically around the axis, there being a heavier line at intervals.

Discussion. Distinctive of this species are the large, prolonged, second pleural spines of the pygidium, giving it a forked outline. In the type species the outline is subrectangular, the three pairs of pleural spines are approximately equal in length, and the tips lie in a curve that is convex backward. *R. major* has the second pleural spines elongated, but not to the extent that is seen in *R. schlothcimi*. Billings (1865, p. 294) referred to a pygidium but did not figure it, and the type specimen is not preserved. It is described as ovate in outline with five or six well-defined ribs on each side, and appears not to belong to this species. Raymond (1925, p. 59) had only an incomplete specimen of the pygidium, and thought that the elongated pleural spine was the outer one.

Species of *Robergia* are relatively abundant in both North America and Europe, in rocks of approximately Llandeilo and somewhat younger age. The present species appears to be one of the oldest known.

Genus BLOSYROPSIS n. gen.

Type species. *Blosyropsis billingsi* n. gen., n. sp.

Diagnosis. Cranidium distinguished from *Remopleurides* by the deep pit at the inner end of lateral glabellar furrow 1p, which is connected by a shallow furrow running backward and slightly outward to the distal end of the occipital furrow, and the horizontal border in front of the tongue. Free cheek with narrow, convex border separated from eye lobe by narrow strip, base of genal spine situated opposite midlength of eye lobe, genal spine long, curving, blade-like. Hypostome longer than wide, rectangular in outline, oval areas covering about half the middle body, large anterior wing. Pygidium transversely

rectangular in outline, axis extending about half the length, strong postaxial ridge; pleural regions horizontal, composed of three fused pleurae divided by ribs and furrows, the tips extended by short spines. External surface with prominent pattern of closely-spaced fine lines.

Discussion. While the cranidium is most like that of *Remopleurides*, the free cheek and pygidium are more like those of *Robergia* and *Robergiella* (Whittington, 1959, pp. 431-434, pl. 6, figs. 16-33). This latter genus, from the lower Edinburg Formation of Virginia, has a remopleuridid-like cranidium in which the three pairs of glabellar furrows appear as shallow grooves, and a *Robergia*-like free cheek and pygidium. It may be a younger relative of the new genus, exemplifying an evolutionary line intermediate between *Remopleurides* and *Robergia*.

BLOSYROPSIS BILLINGSI n. sp.

Plate 42

Holotype. GSC 18250, incomplete cranidium from 17 feet above base of type section, middle Table Head Formation.

Other material. This species is not uncommon in the lower half of the middle Table Head Formation, from 17 to 155 feet above the base at the type section, where all parts of the exoskeleton except the thoracic pleurae have been found; it is also found in the isolated limestone, at Table Cove, and in the boulders at Daniel's Harbour.

Description. Convex occipital ring transversely oval in outline, sloping forward to deep, straight occipital furrow. In front of here median area of glabella is considerably wider (tr.) than occipital ring, gently inflated, and passes anteriorly into the steeply sloping tongue. Glabella circumscribed by deep palpebral, axial, and preglabellar furrows; in front of the latter is the narrow (sag. and exs.), horizontally-extended, gently convex preglabellar area forming the anterior border. Palpebral rim widest laterally and posteriorly, where it curves down abruptly immediately in front of the occipital ring; anteriorly the rim narrows and dies out at the base of tongue. Lateral glabellar furrow 1p (Pl. 42, fig. 2) is a smooth, diagonally-directed area situated just behind midlength of eye lobe, at inner end descending into a deep, diagonally-directed pit. This pit is connected by a shallower furrow to the outer end of the occipital furrow; between the furrows the basal part of the median area

of the glabella is convex, and outside the furrow the median area rises steeply. Lateral glabellar furrow 2p a smooth area, not depressed on the external surface, commencing opposite the anterior part of the eye lobe and curving inward and backward to end approximately in line with the pit of furrow 1p. Lateral glabellar furrow 3p a small, oval smooth area not depressed into the external surface, in line with the inner ends of furrows 1p and 2p. Eye surface (Pl. 42, fig. 10) gently convex, numerous convex facets arranged in vertical lines, prominent external rim of eye lobe separates it from horizontal inner part of cheek. Outer part of free cheek consists of raised gently convex border, continuous with anterior border of cranium, widest laterally at the base of the blade-like, long genal spine. The posterolateral border is slightly more convex, and ends against the outwardly and slightly backwardly directed posterior branch of the suture. Posterior part of fixed cheek not known. External surface of cephalon, except in deep furrows, traversed by strong, closely-spaced, fine raised lines. These lines run in curves directed concavely forward on the glabella, and continue this direction on the inner part of the free cheek; on the borders they run concentrically, on the upper surface of the genal spine, diagonally. In the midline of the glabella, between the inner end of lateral furrow 2p and the base of the tongue, the lines merge into a low, median ridge (Pl. 42, fig. 2).

Hypostome slightly longer than wide. Middle body gently convex, displaying prominent oval areas which extend from the midlength back to the posterior margin and are closer together posteriorly than anteriorly. Anterior edge of hypostome straight medially, distally curving back where the edge is extended as the triangular, upwardly-directed anterior wing. At the base of this wing is a shallow furrow, inside it a prominent smooth band on the anterolateral and anterior part of the median body. Behind the small shoulder is the narrow lateral border; there is a short posterolateral projection and a wider (sag. and exs.) posterior border. External surface bearing lines similar to those on the dorsal exoskeleton, running in curves deeply concave forward on the middle body, longitudinally on the oval area and borders.

Pygidium with short, prominent convex axis almost semi-circular in outline, prolonged backward by postaxial ridge which becomes narrower and lower and disappears just before

reaching the posterior margin. Articulating furrow is deep distally, shallower and broader medially, first ring furrow similar though distal parts less deep, second ring furrow extremely faintly indicated. Pleural regions extend out horizontally, transversely directed anterior margin, lateral margin curved convexly outward. These pleural regions divided by gently convex ribs and broad shallow pleural furrows, three of each, the third pair of pleural furrows flanking the postaxial ridge. The ribs appear to represent the anterior pleural bands, and in line with the furrows between are the pleural spines; the first is short, the second much longer, the third as short as the first and close to the midline. External surface (Pl. 42, fig. 15) covered by closely-spaced lines, which run transversely in a wavy course over the pleural regions, and in curves directed convexly forward on the axis.

Discussion. The combination of characters seen in this species is unlike those of any other remopleuridid known to me. It is the typical species of the lower half of the middle Table Head Formation, being replaced in the upper part by *Robergia schlotheimi*. So far these two species have not been found together, the latter being more characteristic of the platy, black limestones of the upper part of the middle Table Head Formation.

Billings (1865, p. 293, fig. 283) described the cranium of *Remopleurides panderi* from the type section of the middle Table Head, but the syntypes have not been traced in the collections of the Geological Survey of Canada. Raymond identifies this cranium from both the lower part of the type section and the isolated limestone. These descriptions, and Billings' figure, suggest that this cranium is the same as that here called *Blosyropsis billingsi*. However, without the syntypes one cannot be sure, and in the interests of nomenclatural stability I prefer to use a new name for this species, which is also the type of a new genus.

Genus *EOROBERGIA* Cooper, 1953

EOROBERGIA GRANDIS n. sp.

Plate 43; Plate 44, figures 1, 2

Eorobergia sp., Whittington and Kindle, 1963, fig. 2.

Holotype. GSC 18256, incomplete cranium with exoskeleton adhering, lower Table Head Formation, Pointe Riche.

Other material. Figured material and a few additional scraps from the same locality and horizon as holotype; fragments of pygidium from lower Table Head Formation, type section, 95 feet above the base of bed 3, 10 feet above the base of bed 8.

Description. The cranidium, free cheek and pygidium are extremely like those of the type species *Eorobergia marginalis* (Raymond, 1925, pp. 61-62, pl. 3, fig. 11; Cooper, 1953, pp. 21-22, pl. 8, figs. 1-6) from the Tumbez Formation, equivalent to the basal beds of the Lenoir Limestone (in the restricted sense of Cooper and Cooper *in* Cooper, 1956, p. 72), two miles south of Bluff City, Tennessee. The glabella of the Newfoundland species shows the same sharp flexure (Pl. 43, fig. 6) running inward and forward from the outer, posterior margin of the occipital ring to define a lateral occipital lobe, and the three pairs of lateral glabellar furrows are similar in position and depth. Lateral furrows 2p and 3p are smooth on the external surface, faintly impressed, and a similar smooth, faintly impressed area is seen adjacent to the inner, anterior margin of the lateral occipital lobe — presumably part of the muscle attachment area situated on the outer part of the deep occipital furrow. In both species the eye lobe is of length (exs.) about half that of the cranidium, but the curvature of the palpebral rim of the Newfoundland species is more even than that of the Tennessee species, which is strongly curved in the posterior part. In both species the palpebral furrow is widened posteriorly, and in the Newfoundland species there is a wide, depressed region between the posterior part of the palpebral rim and the gently inflated palpebral lobe. Anterior branch of the suture in *E. grandis* (Pl. 43, figs. 1, 5) runs strongly outward and downward at the edge of the visual surface, then changes course abruptly to run forward and less strongly outward, and as it reaches the horizontal, gently convex border it curves outward and forward to the margin of the border. The two branches meet in the midline at an oblique angle. The posterior branch of the suture (Pl. 43, fig. 6) runs downward and slightly outward beside the visual surface, then at the lower posterior corner turns abruptly outward and runs far out on the cheek before crossing the border. Thus the posterior part of the fixed cheek is a thin, outwardly-projecting strip. Three or four conspicuous pits are present in the anterior border a short distance in front of the preglabellar furrow. Only a fragment of the free cheek is available (Pl. 43, fig. 2), but it shows the broad lateral

border defined by a shallow furrow, the narrow posterior border and deeper posterior border furrow, and the long, curving, slim genal spine. Strongly raised anastomosing lines are present on the exterior surface of the exoskeleton except in the furrows, their distribution being shown in Plate 43, figures 1-3. The anastomosing character is best developed on the glabella—on the anterior border the lines run concentrically, on the lateral border and genal spine they zig-zag to give a herringbone pattern. The external surface of the glabella is not granulate as it is in *E. marginalis*.

Pygidium in the two species similar, the tapering, prominent axis defined by deep lateral furrows, the tip sloping steeply but not defined by well marked furrows; first two rings outlined by ring furrows. Pleural regions bearing four pairs of marginal spines which are flat and blade-like, and in *E. grandis* these spines are graduated in size, the second and fourth not markedly smaller than the first and third, as in *E. marginalis*. The anterior band of the first pleura is strongly convex; there is a deep, broad pleural furrow, and a narrow, gently convex posterior band which runs out into the posterior edge of the border spine. Similar bands and an intervening pleural furrow are present on the second pleura, the anterior band of the third pleura marked by a triangular raised area adjacent to the posterior end of the axis. External surface bearing raised lines that run roughly concentrically, with a marked curvature across the spines, giving a herringbone pattern, the flexure in the lines being nearer the outer margin of the spine than the inner, as on the genal spine.

Discussion. *E. grandis* differs in only minor characters from *E. marginalis*, and is the only other species of this genus known. Material described by Cooper, the originals of Raymond, and additional material collected by F. C. Shaw and me in 1962, show no specimens from Tennessee as large as those from Newfoundland. Accepting the correlations of Cooper (1956), the Tennessee species is slightly younger than that from Newfoundland.

In my arrangement of the remopleuridids (*in* Moore, 1959, pp. 0326-0331) I placed *Eorobergia* in the group including *Richardsonella* because of the divergent anterior branches of the suture, the pits in the anterior border, and the type of the pygidium. If this arrangement represents an evolutionary line, this line leads from *Richardsonella* of the Upper Cambrian through

early Ordovician and Canadian forms to *Eorobergia*, the youngest known representative.

Family BATHYURIDAE Walcott, 1886

Genus ACIDIPHORUS Raymond, 1925

Type species. *Acidiphorus spinifer* Raymond, 1925.

Subjective synonyms. *Goniotelus* Ulrich, 1927; *Gonotelus* Ulrich, 1932.

Discussion. The type species of *Goniotelus* is *G. perspicator* (Whittington, 1953, pp. 662-663, pl. 68, figs. 1-10) from a boulder of probable Whiterock age in Quebec. I have recently described additional material of the type species from the boulder at Lower Head, together with three additional species from the same horizon (Whittington, 1963, pp. 62-65, pl. 14, figs. 3-12; pl. 15, figs. 1-8; pl. 35, figs. 2, 5, 7, 9). If these species are accepted as belonging within one generic group, then Raymond's species *A. spinifer* belongs within the same group. The generic name for it should be the oldest one available, which is *Acidiphorus*.

ACIDIPHORUS SPINIFER Raymond, 1925

Plate 44, figures 3-16

Raymond, 1925, p. 131, pl. 8, figs. 15, 17.

Whittington, 1953, p. 669, pl. 68, fig. 12.

Holotype. YPM 13028, incomplete pygidium from "Leperditia bed at Table Head," that is, from bed 8 of the lower Table Head Formation.

Other material. YPM 13052, incomplete pygidium from "zone 11, Pointe Riche," that is, the higher beds of the lower Table Head Formation at Pointe Riche. YPM 13062, fragments of cranidium and a free cheek, from same locality and horizon. The present investigation has shown fragments of the exoskeleton to be fairly common in bed 8 (from 175 to 400 feet above the base) of the lower Table Head Formation at the type section, and at Pointe Riche.

Description. Cephalon differs from that of *A. rostratus* (Whittington, 1963, pp. 64-65, pl. 14, figs. 10-12; pl. 15, figs. 1-4, 6) in that the glabella is relatively narrower but more convex anteriorly, the frontal lobe being slightly but distinctly expanded. The palpebral lobe is slightly farther out from the axial furrow, and higher, standing above the middle part of the glabella (Pl. 44, fig. 3), and with a less wire-like rim. The free cheek does

not exhibit the deep border furrow seen in *A. rostratus*. The sculpture of the external surface is also different — in *A. spinifer* tuberculation is present on the median lobe of the glabella and the cheek adjacent to the eye lobe, elsewhere are anastomosing lines with pits between them. On the lateral part of the glabella inside the eye lobe, both tubercles and lines die out, and there are smooth areas which indicate the presence of lateral glabellar furrows 1p and 2p, but these are less clearly defined than in *A. rostratus*. The lines are conspicuous on the median and steeply sloping part of the frontal glabellar lobe, and are also present on the lateral borders.

Anterior branch of facial suture runs forward in a curve that is convex outward and subparallel to the axial and preglabellar furrows. Anteriorly, the branch runs on to the upper surface of the anterior border, the two branches converging and apparently meeting a short (tr.) rostral suture (Pl. 44, fig. 13). Posterior branch of suture curves downward and outward from the high eye lobe, and crosses the posterior border distally where it is widest. Doublure of free cheek wider than border, posterolaterally with a flexure which lies beneath the flexure of the dorsal surface at the base of the genal spine.

Pygidium triangular in outline, the axis and inner part of the pleural regions prolonged backwards in a stout spine which is directed slightly upward and has a gentle curvature. The spine is of length (sag.) twice that of the remainder of the pygidium. Convex, semicylindrical axis tapering slightly to base of posterior spine, deep articulating furrow and four ring furrows becoming successively fainter backward. Pleural regions slope steeply to flattened, ill-defined, smooth border. Narrow, deep first pleural furrow curves outward and backward immediately behind the facet, and dies out without reaching the margin. Second pleural furrow more backwardly directed, but shorter, faint third furrow. Flattened, outwardly sloping lateral border becomes narrower posteriorly and disappears beneath the base of the posterior spine. External surface of axis bearing irregular, anastomosing lines running in curves convex forward; at the base of the spine the curvature increases and on the spine the lines run longitudinally. Similar lines are present on the outer part of the border, and there are minute pits between them both on the axis and on the borders.

Discussion. Both *A. rostratus* and *A. spinifer* are like *Goniotelina williamsi*, the type species of *Goniotelina* (Whittington,

1953, pp. 663-667), in the outline of the glabella, position and curvature of the eye lobe, form of the genal spine, and of the pygidium. The chief difference between species placed in the two genera is in the much greater convexity of the glabella of *Acidiphorus*, and the expansion of the frontal lobe.

Family ILLAENIDAE Hawle and Corda, 1847

Subfamily ILLAENINAE Hawle and Corda, 1847

Genus ILLAENUS Dalman, 1827

Discussion. In dealing with illaenids from the boulder at Lower Head (Whittington, 1963, pp. 66-69) I referred to recent work and discussed characters used in the taxonomy of this group. In *Illaenus marginalis* the rostral plate (Pl. 47, figs. 8, 10) possesses an axe-shaped flange. This feature, and other characters of the exoskeleton shared by *I. marginalis* and the other four determined species described below, suggest that they should be placed in *Illaenus*. In these five species the doublure of the pygidium has a median projection, which is excavated in a notch where it surrounds the tip of the axis. This type of inner margin of the doublure is present in Scandinavian illaenids, particularly of the *I. sarsi* type (Jaanusson, 1957, p. 110, fig. 14a). The lower and middle Table Head species of *Illaenus* are related to (but in no case identical with) species of the same genus from Lower Head. A relationship between all these species and those from the Lower and early Middle Ordovician of Scandinavia and the East Baltic is evident from the discussions below.

One undetermined hypostome was obtained in the material from the boulder at Lower Head (Whittington, 1963, pl. 18, figs. 4, 7). Hypostomes of both *I. fraternus* (Pl. 45, figs. 14-16) and *I. consimilis* (Pl. 52, figs. 6-13) have been obtained in the present investigation, that of the latter species particularly well preserved and showing the large anterior wing and the notched anterior margin. This notch suggests that, since the hypostome fitted against the inner margin of the cephalic doublure, there was a median projection of this doublure. This projection was probably formed by the axe-shaped rostral flange, as in *I. marginalis* (Pl. 47, fig. 10). Thus the outline of the anterior margin of the hypostome can be used to argue for the presence of a rostral flange, when the rostral plate is unknown. In the subcircular outline of the anterior lobe of the

middle body and its convexity, the shape of the posterior lobe, narrow lateral and posterior borders and deep lateral border furrow beside the median lobe, these hypostomes are alike and like that from Lower Head. This similarity in hypostome is suggestive of relationship, and the Newfoundland hypostomes are like those of *I. sarsi* (Jaanusson, 1954, pl. 2, figs. 1, 2) from the Lower Ordovician of Norway and Sweden. Lindström (1901, pp. 57-59, pl. 4, figs. 22-43) described the maculae of illaenid hypostomes. As least in some cases it appears that the external surface of the macula was smooth, the internal surface (as revealed by the internal mould, Lindström, 1901, pl. 4, fig. 37) showing facets which are convex inwards and therefore the mould is pitted. The same structure appears to be revealed by the macula of the hypostome of *I. consimilis* (Pl. 52, figs. 6, 8) as described below. Whether or not the macula should be interpreted as a visual surface is uncertain, but the structure of the exoskeleton over that region does not appear to be the same as that in areas of muscle attachment.

In the taxonomy of the Asaphidae, Jaanusson (*in* Moore, 1959, pp. 0334-0355) used the position of the median glabellar tubercle as a significant character. A glabellar tubercle situated close to the posterior margin is present in the five species of illaenids here determined. Neither Šnajdr (1957) nor Jaanusson (1959, *in* Moore) use the presence or absence of this tubercle, and its position, as a taxonomic character in illaenids, though Jaanusson shows that it is present in *Bumastus* and *Bumastoides* (*in* Moore, 1959, fig. 283, 3a, 6). Further investigation is needed to determine the possible value of this character.

Characteristic of the external surface of the exoskeleton of illaenids are lines which vary in regularity and commonly run subparallel to the margins. These lines are described as "terrace" lines by Jaanusson (*in* Moore, 1959, p. 0372) though in the same volume these lines are defined (Harrington, Moore, and Stubblefield, *in* Moore, 1959, p. 0126) as being present on the doublure and border of trilobites. Raymond (1925, p. 105) referred to these lines as "cracks" or "striae," but in the species studied here they are raised lines and not grooves or cracks. However, in cross section, they are not symmetrical ridges, but the anterior slope is gentle, the posterior steep. It is the presence of this short, steep posterior slope that demarcates the line. The lines of the doublure are of the same

type, but in general are more regular in their course, and more evenly spaced. In this account I have followed Jaanusson, and call the lines on both dorsal exoskeleton and the doublure terrace lines. In addition to bearing terrace lines, the external surface of the exoskeleton may be pitted (Pl. 48, fig. 1). It is also characteristic of these species that the internal mould shows an extremely fine pitting, which may be of two sizes—small pits closely spaced, and larger scattered pits (Pl. 46, fig. 10; Pl. 51, fig. 11; Pl. 54, fig. 5). This pitting is the reflection of granulation on the inner surface of the exoskeleton (Pl. 45, fig. 19; Pl. 68, fig. 9). This granulation may be on the inner surface not only of the dorsal exoskeleton, but also of the doublure. When present on the inner surface the granulation may not be reflected on the outer surface, in the same way that terrace lines may be present on the outer surface, but are either faint or absent on the inner surface (Pl. 45, fig. 19; Pl. 46, fig. 10; Pl. 54, fig. 5). The sculpture of the external surface must therefore be described from both surfaces of the exoskeleton or the counterpart moulds. Reference to the internal mould alone may be misleading, e.g. pitting is present in the internal moulds of many species illustrated by Šnajdr (1957), but the nature of the external surface of the exoskeleton is not clearly shown.

ILLAENUS FRATERNUS Billings, 1865

Plate 45; Plate 46, figures 1-5, 6, 8, 10

Billings, 1865, pp. 276-277, fig. 262a, b.

Raymond, 1925, p. 105.

Lectotype (here selected). GSC 665e, cranidium, almost entirely exfoliated, original of Billings, 1865, figure 262a, from the lower Table Head Formation, exposed on the shore north of the lighthouse at Pointe Riche. Paralectotypes: GSC 665a, free cheek; GSC 665b, pygidium; GSC 665c, d, internal moulds of two cranidia; GSC 665, poorly preserved complete specimen apparently showing 9 thoracic segments; all from same locality and horizon as the lectotype.

Other material. Raymond described material only from Pointe Riche, whereas this species was found in the present investigation only in the type section, in bed 8 of the lower Table Head Formation, from 140 to 500 feet above the base. Specimens were most abundant in the middle part of this range.

Description. The strongly curved profile of the cephalon, in both dorsal and lateral aspects, and the lack of the projecting anterior border, distinguish this species from the other two in the lower Table Head Formation. The glabella is gently convex, defined by deep, subparallel axial furrows which extend forward a short distance in front of the eye lobe, and die out abruptly; on the internal mould the anterior part of the furrow forms a crescent-shaped depression, the lunette. There is no median glabellar depression, and the glabellar tubercle (Pl. 45, fig. 4) is situated close to the posterior border, the transverse line passing through it lying behind the eye lobe. Palpebral lobe without rim and not separated from fixed cheek by change in slope. Posterior branch of facial suture runs straight backward and slightly outward. Anterior branch runs at first straight forward, then curves gradually in to reach the anterior margin outside the projected line of the axial furrow. Anterior margin of cranidium flexed sharply to form doublure, rostral plate not known. Genal angle of free cheek broadly rounded, shallow, oblique notch in lateral margin approximately in line with anterior edge of eye lobe (Pl. 45, figs. 17, 18, 20). External surface traversed by raised lines which run subparallel to the posterior and anterolateral margins; on the free cheek outside the eye lobe, these two sets of terrace lines meet at acute angles. On the internal surface are widely scattered granules (Pl. 45, fig. 19) which are reflected as pits in the external surface of larger specimens.

Axis of pygidium extends about half the length, tapering rapidly and gently convex. Pleural regions bent down distally, so that posteriorly they slope vertically. Broad doublure (Pl. 46, figs. 6, 8) extends forward medially as a tongue, which is deeply excavated where it surrounds the posterior part of the axis, the lateral part extending beneath the axial furrow as a sharp projection. Terrace lines run transversely on axis and inner part of pleural regions, ending against terrace lines which run on outer part of pleural regions subparallel to margin. Doublure traversed by terrace lines running subparallel to the margin, and exhibiting a low median ridge. On internal surface scattered granules amid extremely fine granulation (Pl. 46, fig. 10), terrace lines of doublure not visible. External surface of large specimens may show pits corresponding to larger granules.

From a lens of lime-sand approximately 350 feet above the base of unit 8 of the lower Table Head Formation (Whittington and Kindle, 1963, fig. 2) seven species of trilobites were

obtained, the only illaenid present being *I. fraternus*. The single specimen of the hypostome (Pl. 45, figs. 14-16) obtained at this locality may thus be assigned with confidence to this species. The wings and anterior border are not complete, but the middle body, lateral borders, and position of the maculae are much like those in hypostomes of *Illaenus* portrayed by Lindström (1901, pl. 4, figs. 24, 30, 36, 38). It is also like the hypostome here assigned to *I. consimilis* (Pl. 52, figs. 6-13). Anterior lobe of middle body is subcircular in outline, moderately convex, separated by deep furrow from narrow lateral border. Middle furrow runs inward and backward from the deep part of this lateral border furrow, and the two furrows unite medially. Posterior lobe of middle body is gently convex, crescent-shaped, and the small, oval raised macula is situated adjacent to the inner part of the middle furrow. Posterolateral border narrow, posterior border not preserved. Anterior wing is evidently large and curves upward and outward.

Discussion. In outline and convexity of cephalon and pygidium, position and length of axial furrows, shape of pygidial doublure, and arrangement of lines on the external surface, this species resembles *I. tumidifrons* from the boulder at Lower Head (Whittington, 1963, pp. 69-71, pl. 15, figs. 9-13; pl. 16). The glabella of *I. fraternus* is less convex than that of *I. tumidifrons*, the cephalon less strongly curved in lateral profile, and there is no notch in the lateral margin of the free cheek of *I. tumidifrons*.

The smallest cranidium (Pl. 45, figs. 11-13) has the axial furrows extending farther forward than in larger specimens, and in this region they are widely divergent, suggesting that the glabella is widest anteriorly. Small cranidia appear more convex in both dorsal and longitudinal profiles, and the glabellar tubercle is prominent on the external surface. The raised, smooth region of the posterior part of the right fixed cheek of this specimen is unusual, perhaps the result of injury.

ILLAENUS MARGINALIS Raymond, 1925

Plate 46, figures 7, 9, 11, 12;

Plate 47; Plate 48, figures 1-6, 8, 10

Raymond, 1925, p. 109, pl. 7, figs. 8, 9.

Lectotype. YPM 13045, incomplete and exfoliated cranidium, original of Raymond's figure 8, from Pointe Riche.

Other material. YPM 13038, exfoliated pygidium from same horizon and locality as the lectotype. This species is common in bed 8, from 0 to 500 feet above the base, of the lower Table Head Formation at the type section, and a few fragmentary specimens which may represent this species occur in bed 3 of the same section. It is also common at Pointe Riche.

Description. Characteristic of this species is the relatively wide (tr.) and short (sag.) cephalon and pygidium (the former with a narrow, gently convex border around the margin), the relatively wide axis and steeply bent down outer parts of the pleurae. It appears to belong in the *Illaeenus sarsi* group of Jaanusson (1957, p. 110), and *I. incisus* Jaanusson, 1957, has a similar border around the cephalon. *I. marginalis* is like *I. tumidifrons* (Whittington, 1963, pp. 69-71, pl. 15, figs. 9-13; pl. 16; text-fig. 4a-c) from the boulder at Lower Head in the form of the rostral plate with its axe-shaped flange (Pl. 47, figs. 8, 10), and the pygidial doublure with its tongue that embraces the tip of the axis (Pl. 48, fig. 10). The axis in *I. marginalis* is much broader and lower than in *I. tumidifrons*, and on the cephalon the axial furrows converge forward to die out about in line with the most anterior part of the eye lobe. The latter is large, situated close to the posterior margin, the palpebral lobe at almost the same height as the median part of the glabella (Pl. 47, figs. 4, 6), so that the cheek slopes gently inward from the palpebral lobe to the axial furrow. The cephalic doublure is moderately wide (sag. and exs.) anteriorly, laterally (Pl. 47, fig. 9) it is bent upward to lie close beneath the dorsal exoskeleton of the free cheek, and at the genal angle is the vincular furrow. The latter is crossed transversely by ridges and grooves.

Ten thoracic segments and a pygidium are articulated in one specimen (Pl. 46, figs. 11, 12). The outer parts of the pleurae are bent to slope steeply down, and correspondingly the margin of the inner part of the pleural region of the pygidium runs transversely, then curves abruptly through an angle of about 80° so that the facet runs backward and outward. During enrollment the tips of the pleurae and the posterior end of the facet lay in the vincular furrow, the end of the facet at the anterior end of the furrow. The posterolateral margins of the pygidium are curved to fit approximately the curve of the inner margin of the cephalic doublure, and presumably the doublures of cephalon and pygidium were in contact during

enrollment. External surface of the cephalon with a slight depressed median region extending from between the eye lobes to slightly in front of them, this region impressed by irregular, large pits (Pl. 48, fig. 1). Pygidium bears prominent impressed lines running in inverted "V" on the axis and inner part of the pleural regions. On the doublure of cephalon and pygidium prominent terrace lines run subparallel to the margins. On internal surface of exoskeleton are granules of two sizes, small ones closely spaced and scattered larger ones. The tiny pits visible in the external surface correspond to these larger granules.

Discussion. Raymond identified this species from beds of middle Table Head age but I have found no trace of it in these younger beds. Two types of cephalon (*Illaeus* sp. ind. 1 and *I.* sp. ind. 2), each having a rim around the margin of the cephalon, were described from Lower Head (Whittington, 1963, pp. 73-74, pl. 19, figs. 1-9). Neither of these cephalon is at all like *I. marginalis*.

A pygidium with three thoracic segments (Pl. 46, fig. 9) shows an unusual feature in that the outer part of the pleura of the third segment from the posterior is much longer than that of the two succeeding segments. Apart from this, the segments and pygidium are like those of *I. marginalis*.

ILLAENUS ALVEATUS Raymond, 1925

Plate 48, figures 7, 9, 11-15; Plate 49, figures 1-10, 12, 13;
Plate 68, figure 9

Raymond, 1925, pp. 109-110, pl. 7, fig. 5.

Holotype. YPM 13058, incomplete and largely exfoliated cranidium, from Pointe Riche.

Other material. YPM 13034, small piece of limestone containing cranidium and adjacent to it six thoracic segments and a disarticulated, incomplete pygidium, from "zone 10," Gargamelle Cove on the east side of the Pointe Riche peninsula. These beds are in the upper part of the lower Table Head Formation (Schuchert and Dunbar, 1934, p. 65, fig. 4). In the recent investigation this species was found in bed 8, type section of the lower Table Head Formation, being most abundant in the middle part of bed 8, and in higher beds the fragments obtained are doubtfully referred to this species.

Description. This species is distinguished by the longitudinal profile of the cephalon, which is steeply curved down and has a prominent forwardly projecting anterior border. In the margin of the free cheek there is an obliquely angulate notch (Pl. 49, figs. 10, 13) and the glabellar tubercle is situated close to the posterior margin and most evident in internal moulds (Pl. 49, fig. 7; Pl. 68, fig. 9). These characters distinguish this species from *I. marginalis*, from which it also differs in the outline of the cranidium in dorsal view (less strongly curved transversely, compare Pl. 48, figs. 1 and 9), the downward slope of the fixed cheek to the palpebral lobe, which stands well above the level of the median part of the glabella, and the less strongly convergent axial furrows (compare Pl. 49, figs. 3, 6, 7, 9, with Pl. 47, figs. 1, 4-6). In internal moulds the most anterior part of the axial furrow shows a wide depressed portion anteriorly, the lunette. In both species there is a median depressed region in the glabella, in *I. alveatus* it is oval in outline, extending from a short distance in front of the median glabellar tubercle to a point in front of the lunettes. In the holotype the anterior border of the cranidium projects farther forward than in other specimens (compare Pl. 48, fig. 7 with Pl. 48, fig. 14, and Pl. 49, figs. 8, 12), and the longitudinal profile appears more strongly curved because the exoskeleton is bent downward behind the transverse fracture which runs across the posterior part of the cranidium. The posterior branch of the suture runs straight backward and outward from the palpebral lobe, which is situated close to the posterior margin. The anterior branch runs at first almost straight forward, then curves gently inward and runs on to the anterior border. The rostral suture runs along the doublure a short distance in from the margin of the border (Pl. 48, fig. 15). The rostral plate is unknown. Genal angle rounded, posterolateral part of free cheek projects slightly behind remainder of cephalon, anterior cephalic border apparently dies out as it passes on to the free cheek.

Raymond (1925, p. 110) described but did not illustrate the segments and pygidium shown in Plate 49, figures 1, 4. The pygidium is relatively wider (tr.) and shorter (sag.) than that of *I. marginalis*; the tongue of the doublure is wider and less deeply indented medially. The thoracic segments are like those of *I. marginalis* in that the outer parts of the pleurae are bent steeply down, and the anterior margin of the pygidium is angulate to conform with the shape of these pleurae.

External surface not well preserved since most specimens are partly or wholly exfoliated. The depressed median region of the glabella is crossed by 3 or 4 narrow grooves and similar grooves run in an inverted "V" on the axis of the pygidium. Elsewhere the dorsal exoskeleton is pitted, with terrace lines on the borders and margins, and on the doublure. The inner surface is granulated (Pl. 68, fig. 9), large granules being scattered amid minute, closely-spaced granules.

Discussion. Trilobites are abundant only in lenses of lime sand in bed 8 of the lower Table Head Formation at the type section. In some cases these layers have yielded both *I. marginalis* and *I. alveatus*, in other cases they have yielded one or the other species, and *I. alveatus* was not found in the exposures north of the lighthouse at Pointe Riche. Thus these illaenids occur sporadically, and the stratigraphic range represents the accidents of collection and preservation rather than true distribution. *I. fraternus* occurs in the same layers with these two species, but is a quite distinct type. Some layers have yielded all three species, some one, others two. It is possible that *I. marginalis* and *I. alveatus* represent sexual dimorphs of one species.

At 280 ft. above the base of bed 8 of the lower Table Head Formation, all three species mentioned above are present, and in addition a fourth type of cranidium (Pl. 49, figs. 11, 14, 15). In dorsal and anterior aspect this cranidium is most like that of *I. alveatus*, but is distinguished from the latter by the convex outward curvature of the anterior branches of the facial suture, and the narrow anterior border which does not project. In addition, the curvature of the longitudinal profile is greater. Whether or not this cranidium represents a distinct fourth species is uncertain.

ILLAENUS CONSIMILIS Billings, 1865

Plates 50, 51, 52

Billings, 1865, pp. 277-278, fig. 263a, b, c; pp. 331-332, fig. 317.

Raymond, 1925, p. 105.

Lectotype (here selected). GSC 663, exfoliated and incomplete cranidium, original of Billings' figure 263a, 263c, from the middle Table Head Formation at the type section. Paralectotypes: GSC 663h, partly exfoliated pygidium, original of Billings' figure 263b; GSC 663 i, free cheek, possibly original of Billings' figure 317; GSC 663a, c, cranidia; GSC 663j,

internal mould of pygidium; GSC 663b, crushed and disarticulated entire specimen, showing the cephalon and pygidium, and parts of only seven thoracic segments; all from same locality and horizon as the lectotype.

Other material. Second most abundant species from 50 to 190 feet above the base of the middle Table Head Formation in the type section; also common at Table Cove and in the isolated limestone.

Description. Cephalon of length (sag.) about one-third maximum width, curvature of profile in dorsal and lateral aspect moderate. Axial furrows broad and shallow, extending forward to a point about opposite the anterior end of the eye lobe and dying out. On the external surface this anterior part of the axial furrow forms a smooth, oval impression, which in the internal mould is the crescentic depression of the lunette. Glabella gently convex, median tubercle close to posterior margin, no median depressed area. Large eye lobe situated far out on cheek and close to posterior margin, palpebral lobe without rim, forming continuous slope with inner part of fixed cheek, this slope curving gently inward toward axial furrow. Posterior branch of suture runs outward and slightly backward. Anterior branch of suture runs forward and curves gently inward, reaching anterior margin at a point in a line (exs.) lying about midway between axial furrow and palpebral lobe. Free cheek is prolonged back at genal angle in a rounded flap-like form, there is an obliquely angulate notch in the lateral margin, and in front of this notch the marginal rim runs inward and forward around the cranidium. Doublure (Pl. 51, fig. 10) curled under lateral border and extending beneath flap-like part of free cheek. Rostral plate unknown. Vincular furrow situated close to inner margin of doublure of free cheek, in form of a sharp flexure and without transverse ridges and grooves.

Several examples of the isolated hypostome (Pl. 52, figs. 6-13) occur 90 feet above the base of the type section, at Table Cove and in the isolated limestone, at all of which places this species is relatively abundant. Middle body divided by shallow middle furrows into a subcircular, convex anterior lobe and a gently convex, crescentic posterior lobe. At maximum width of middle body, and at outer end of middle furrow, lateral border furrow is extremely deep, becoming shallower posterolaterally, but defining a narrow, raised, lateral and posterolateral border. At the posterolateral margin the steep outer

edge of this border is extended in a triangular, vertically-directed posterior wing (Pl. 52, fig. 7). Anteriorly and anterolaterally the margin of the middle body is ill defined, for it merges with a gentle change of slope into the large upward and outwardly extending anterior wing. This wing is quadrangular in shape, the two wings meeting anteriorly so that the anterior margin of the hypostome is broadly notched. This notched anterior margin is the sutural margin, and would presumably fit against the projecting rostral flange and adjacent parts of the doublure of the free cheeks. Macula conspicuous, situated adjacent to inner part of middle furrow, a gently convex, transversely ovate area, sloping most steeply on the anterior side. On the external surface the macula appears smooth (Pl. 52, fig. 8), but on the internal mould the sloping anterior face is impressed by closely spaced pits. This structure is like that described by Lindström (1901, pp. 57-59, pl. 4, figs. 33, 37).

External surface of cephalon traversed by raised lines, sub-parallel and occasionally branching, running in curves parallel to the anterolateral and anterior margins. These lines do not extend on to the flap-like part of the free cheek or across the lunette, and are not present on the anterior part of the glabella on the steeply sloping part of the cranidium (Pl. 51, fig. 2). This smooth area is circular, and behind it, situated a short distance in front of, and proximally to, the lunette, is a second smooth, oval area (Pl. 50, fig. 13), which may represent one of the glabellar muscle areas. On the marginal rim and doublure the lines are closer together and branch less frequently. In cross section the lines inside the borders are seen to be wave-like in form, the anterior slope gentle, the posterior slope extremely steep (Pl. 51, fig. 9). These lines are not "cracks" as Raymond called them, and are reflected less strongly on the inner surface of the exoskeleton. In addition, the internal mould shows scattered large pits, and closely spaced small pits (Pl. 51, fig. 11). This pitting reflects granulation on the inner surface of the exoskeleton (Pl. 51, fig. 9).

Pygidium of width more than twice length (sag.), axis gently convex, pleural regions curve down to slope steeply distally. Axis of width at anterior margin about one-third maximum width of pygidium, ill-defined, tapering rapidly and extending to about half the length. Anterior margin of pleural region runs straight out before being flexed sharply back at slightly

more than half the width. Posterolateral margin evenly curved. Broad doublure extended by short tongue (which is notched medially) around tip of axis, faint median ridge. On external surface lines similar to those of cephalon, the steep slope facing posteriorly, widely spaced and irregularly branching, running in curves convex forward across the axis, on the pleural regions subparallel to the posterolateral margin. The lines are best developed on the axis and lateral parts of the pleural region, absent in the median area. On the doublure the lines are closely spaced and more regular. Internal moulds display pitting similar to that of the cephalon.

Discussion. The size series of cranidia (Pl. 50; Pl. 51, figs. 1-8) shows the greater convexity of the small sizes — not only the longitudinal profile, but also the posterior part of the glabella and fixed cheek. The glabella appears narrower, the eye lobe large and far out. As size increases, the convexity is reduced, and axial furrows become more obviously forwardly converging.

In a great many characters this species resembles *Illacnus fraternus* from the lower Table Head Formation — nature of the axial furrows, position of the glabellar tubercle, lack of a median depressed area in the glabella, course of sutures, shape of free cheek and particularly in the presence of the notch in the lateral margin, form of pygidium and doublure. These species, though they may be related, are readily distinguished. *I. consimilis* is a less convex species, with a relatively wider cephalon and pygidium, the arrangement of the lines on the external surface is different, and there are not two sets of lines on the free cheek meeting at an acute angle. Resemblances between *I. consimilis* and *I. marginalis* or *I. alveatus* are less; the strongly raised eyes and rapidly converging axial furrows distinguish *I. marginalis*, for example, as does the prominent anterior border of the cephalon of *I. alveatus*.

This species resembles the Swedish *Illacnus crassicauda* (see Jaanusson, 1954, pp. 573-574, text-figs. 4, 17, pl. 1, figs. 1-7), particularly in the size of the eye lobe, the profile in anterior view, and the type of pygidial doublure. The hypostome is like that of the related species *I. sarsi* (Jaanusson, 1954, text-figs. 7a, 9a, pl. 2, figs. 1, 2) except that the anterior margin is not transverse, but deeply notched, presumably in order to fit against the flange of the rostral plate. The Swedish species mentioned do not have the notch in the lateral margin of the

free cheek, but it is present in the related *I. incisus* (Jaanusson, 1957, pl. 7, fig. 2). The Swedish species mentioned are from the upper part of the Lower and the Middle Ordovician.

ILLAENUS GELASINUS n. sp.

Plate 53; Plate 54, figures 1, 5

Holotype. GSC 18307, partly exfoliated cranidium from 90 feet above the base of the middle Table Head Formation, type section.

Other material. This species is much less common than *I. consimilis*, and has been found at one level in the type section of the middle Table Head Formation, in the exposures south of Table Cove, the isolated limestone, and the boulders at Daniel's Harbour.

Description. Axis of cephalon gently convex, defined by "S"-shaped axial furrows which are far apart at the posterior margin, but curve inward to the crescentic impressions of the lunettes. These latter are situated relatively far back, in the same transverse line as the posterior part of the eye lobe, and in front of them the glabella is not defined. Cephalon curves steeply down anteriorly, so that the anterior part overhangs the low, narrow rim that runs along the cephalic margin. Posterior margin of cheek runs almost directly outward to the rounded genal angle, which is about 90° . Eye lobe relatively small, situated far out and at two-thirds the length of the cephalon; posterior branch of suture runs outward and backward so that a long projection forms the most posterior part of fixed cheek. Anterior branch of suture runs forward and curves slightly inward to the margin. The course of the sutures and the genal angle give the free cheek a distinctive subquadrangular outline. Rostral plate and hypostome unknown. External surface of cephalon (Pl. 54, fig. 1) traversed by irregular wavy lines running subparallel to the anterior and lateral margins, shallow pitting between the lines. Internal moulds show the granulation on the inner surface of the exoskeleton — small granules closely spaced, and much more widely spaced larger granules. On the doublure the terrace lines are not wavy and are placed close together. Three pairs of smooth areas on the glabella (Pl. 54, fig. 1) probably represent areas of muscle attachment. On the internal mould only the first pair of muscle areas may appear as faintly depressed regions (Pl. 53, figs. 1, 7).

The pygidium that occurs at the same localities as the cephalon has a similar external sculpture of the exoskeleton. Axis relatively narrow, tapering rapidly, low convexity. Anterior margin of pleural region is transverse for over half the width, the outer part curving backward. Thus the pleural regions are divided into an inner horizontal part and an outer, gently curved-down portion, and the convexity of the entire pygidium is low. Doublure broad, extending in to the margin of the horizontal inner part of the pleural regions, behind the axis a very slightly projecting portion is excavated medially, and there is a low median ridge in the external surface. Doublure traversed by terrace lines, and internal surface of exoskeleton (Pl. 54, fig. 5) bearing granulation similar to that on the cephalon.

Discussion. The smallest cranidium (Pl. 53, figs. 9-11) shows the "S"-shaped, convergent axial furrows, and is like larger cranidia except that the convexity is slightly greater, notably that of the axis.

The profiles of the cephalon in dorsal and lateral aspect, the short (exs.), "S"-shaped axial furrows, the relatively small eye lobe, and the shape of the free cheek distinguish this species from *I. consimilis*. The outline and low convexity of the pygidium also distinguish it. These features also combine to distinguish *I. gelasinus* from the species in the lower Table Head Formation, and the projection of the doublure behind the axis is less prominent, and with shorter lateral points, than in any of the other species described.

ILLAENUS sp. ind. 2

Plate 54, figures 4, 6, 7

Discussion. One cranidium from the isolated limestone is quite different from *I. consimilis* and *I. gelasinus* in the outline in dorsal and lateral aspect, in the deep, straight axial furrows, which converge slightly forward, ending in well-marked, oval lunettes, the small palpebral lobe, placed far back, and the markedly inward convergence of the anterior branches of the suture. The cranidium is exfoliated, only a small fragment of the exoskeleton being present adjacent to the anterior branch of the suture on the left side. Here the external surface is seen to be impressed by close-spaced pits, a sculpture not seen in any other species from the Table Head Formation.

This cranidium is like that of *I. fraternus* from the lower Table Head Formation, but both the dorsal and lateral profiles

are different, and the external surface apparently lacks the terrace lines but is deeply pitted.

ILLAENUS sp. ind. 3

Plate 54, figures 2, 3, 8-11

Description. Two examples of an illaenid pygidium have been obtained from the exposures of the middle Table Head Formation on the foreshore south of Table Cove. The first (Pl. 54, figs. 2, 3, 10) differs considerably in outline and convexity from that of *I. consimilis* (Pl. 52, figs. 1-5) and is relatively larger and more convex than that of *I. gelasinus* (Pl. 53, figs. 13-18). The specimen is almost entirely exfoliated, and the external surface was apparently traversed by raised lines, but the sculpture cannot be seen in detail. The second example (Pl. 54, figs. 8, 9, 11) appears from the general form to represent this species, though the convexity in longitudinal aspect appears different, presumably because the dorsal exoskeleton is broken away to reveal the doublure. The latter is wide, with a low projection reaching forward medially behind the axis and a low median ridge. The projection is broken from the remainder of the doublure, but the tip appears to be clearly preserved, and shows a double scalloping—so that there are two small lateral projections as well as a median one. In this respect this doublure differs from any of the other species described from the Middle Table Head Formation, and is like that of *Illaenus sinuatus* Holm, 1886 (p. 105, fig.; cf. Jaanusson, 1957, fig. 14D), from early Llanvirn limestones of the east Baltic.

Illaenid? pygidium

Plate 67, figure 11

Discussion. This single example, from beds probably in the upper half of the middle Table Head Formation at the type section, is gently convex with a flattened peripheral region. The articulating furrow shows that the axis is wide at the anterior margin, occupying one-third the total width, but behind this point the axis is barely indicated. The width of the axis suggests that this is an illaenid pygidium, though the axis is wider than that of *Illaenus gelasinus* n. sp. (compare Pl. 67, fig. 11 with Pl. 53, figure 17). The identification of this specimen is thus uncertain.

Family SCUTELLUIDAE Richter and Richter, 1955

Genus BRONTEOPSIS Nicholson and Etheridge, 1879

BRONTEOPSIS sp. ind.

Plate 55, figures 1, 4

Bronteopsis scotica, Raymond, 1925, p. 69.

Material. A single incomplete cranidium from middle Table Head Formation, Dominion Iron and Steel Company Quarry at Aguathuna, Port au Port Peninsula. Gray, thin-bedded limestones at this locality yielded to Schuchert and Dunbar specimens of *Ampyxoides semicostatus*, *Stegnopsis huttoni* and the holotype of *Peraspis lincolata*, and there seems no doubt of their age.

Description. Posterior one-third of glabella parallel-sided, axial furrow deep and narrow in front of occipital ring, latter short (sag. and exs.) and defined by broad shallow furrow. Anterior part of glabella widens gradually, axial furrow shallower and sinuous, swinging out beside lateral lobes 2p and 3p, curving in opposite lateral furrow 3p, and running forward and outward to bound frontal lobe which is widest part of glabella. Outer part of occipital furrow slightly broader and deeper than median part, smooth on external surface. Lateral glabellar furrow 1p a depression in margin of glabella at point where axial furrow starts to swing outward, a shallow branch directed inward and forward, a second shallow branch directed inward and backward; smooth on external surface. Lateral furrows 2p and 3p are subcircular, shallow depressions, situated about one-third of the way across the glabella, and at an approximately equal distance from each other and lateral furrow 1p. Furrow 3p is connected by a faint, transversely directed depression to the axial furrow. In anterior part of frontal lobe, a shallow median depression runs from the anterior margin to about the midlength of the frontal lobe and dies out. Pre-glabellar furrow extremely narrow as is the anterior border. Only the inner part of the fixed cheek preserved, gently convex, most strongly so adjacent to the posterior part of the glabella. Prominent eye ridge runs inward and forward to reach the axial furrow in line with lateral glabellar furrow 2p. Eye lobe evidently situated centrally on the cheek, far from the glabella. Lateral muscle impression (of Šnajdr, 1960, text-fig. 2) a small crescentic smooth area adjacent to the axial

furrow immediately in front of the occipital furrow, and extremely faintly impressed. External surface bearing irregular, anastomosing fine raised lines, which on the glabella run subparallel to the margins, on the cheek is concentric circles around the eye lobe. Small median occipital tubercle beside occipital furrow, impressed by four tiny pits arranged in a square (Pl. 55, fig. 4), like those seen in *Raymondaspis reticulatus* n. sp.

Discussion. Raymond considered this cranidium identical with that of *B. concentrica* (see Skjeseth, 1955, pp. 16-17, pl. 5, figs. 1-3, 5, text-fig. 1), a species considered by Skjeseth to be identical with *B. scotica* (see Whittington, 1950, pp. 544-547, pl. 71, figs. 9-12, text-fig. 4). The cranidia are similar, but that from Newfoundland has the frontal glabellar lobe relatively narrower (tr.), and the eye lobe is apparently situated more centrally on the cheek. There is a considerable resemblance between the Newfoundland specimen and the holotype of *B. holtedahli* Skjeseth, 1955 (pp. 17-18, pl. 5, fig. 4) from a horizon of approximately the same age in Norway.

Skjeseth (1955, pp. 16, 18) regarded the V-shaped lateral glabellar furrow 1p as two separate furrows which run together as they reach the margin of the glabella. In 1950, I interpreted this impression as that of a single furrow, 1p, and this is accepted by Šnajdr, 1960.

Sinclair (1949) described species of the younger genus *Eobronteus*, and the cranidium differs from that of *Brontopsis* in that the glabella expands much more rapidly forward, the eye ridge is much less conspicuous, but the lateral muscle impression is larger and more distinct.

Genus **RAYMONDASPIS** Přibyl, 1949

Discussion. Since my discussion (Whittington, 1950, pp. 549-550) of the type species, Skjeseth (1955, pp. 20-21, pl. 4, figs. 2, 4-9; pl. 5, figs. 6, 8) has described additional material and I here accept his view that American species such as those described below are congeneric with the Swedish species. I recently advocated (Whittington 1963, p. 83) that the Styginiidae should be merged with the Scutelluidae. *Raymondaspis*, like *Brontopsis*, shows many scutelluid family characters: the three pairs of glabellar furrows, the first having two divergent branches; the lateral muscle impression; the position of the eye lobe; the course of the sutures and shape of the rostral plate and

hypostome; the radial arrangement of pleural ribs (in the transitory pygidium of *Raymondaspis*) and the presence of the postaxial ridge.

RAYMONDASPIS RETICULATUS n. sp.

Plate 55, figures 2, 3, 5-9; Plate 56, figures 1-10;

Plate 57; Plate 58, figures 1, 7

Holotype. GSC 18318, incomplete cephalon from middle Table Head Formation, exposures on foreshore south of Table Cove.

Other material. One of the four most abundant species in the lower 200 feet of the middle Table Head Formation at the type section; present in the isolated limestone, at Table Cove, and in boulders at Daniel's Harbour.

Description. No complete specimen is known, but the cephalon and pygidium are exceedingly like those of *R. gregarius* (Raymond, 1920, pp. 283-284; 1925, pp. 69-70, p. 3, figs. 12-14; Cooper, 1953, pp. 24-25, pl. 9, figs. 1-7, 12-16), and Raymond included the Newfoundland material in his species, which is founded upon specimens from the lower Edinburg Formation of Virginia. Raymond (1925, p. 70) considered that the Newfoundland specimens had "the cranidium a little shorter and broader, the posterior part of the glabella a little wider, and a slightly shorter axial lobe on the pygidium." These distinctions are not readily apparent, but the Newfoundland specimens appear to have the glabella expanded slightly less across the frontal lobe, which is less inflated and has a shallow pit in the anterior margin in the midline. The pygidium has the axis on the external surface (Pl. 57, fig. 3) clearly terminated, and the postaxial ridge is barely, if at all, visible, as in the Virginia specimens, though it is present on internal moulds (Plate 57, fig. 13). Comparisons are difficult because of the incompleteness of the material so far described from Virginia. The exoskeleton of the Newfoundland species is well preserved, and reveals many morphological details not previously observed in species of this genus:

Glabellar muscle areas (Pl. 55, fig. 9; Pl. 56, figs. 6, 7) include the broad, flat-based area of the outer part of the occipital furrow, outlined on the posterior side by a steep slope down from the ring. Lateral glabellar furrow 1p is V-shaped, smooth on the external surface, and lightly impressed. The posterior, inwardly and backwardly directed branch of the "V" is the larger and more impressed part of this area. In front of here

and adjacent to the axial furrow, the external surface is smooth, and on some specimens small, circular, lightly impressed areas represent lateral furrows 2p and 3p, the latter situated behind the greatest width of the glabella. The faint anterior pit is in the axial furrow opposite the widest part of the frontal lobe. The lateral muscle area is smooth, crescentic, lightly impressed, situated on the steep slope of the fixed cheek adjacent to the axial furrow and between the levels of the occipital and lateral 1p furrows. In this region the axial furrow is narrowest and deepest.

The eye lobe (Pl. 56, fig. 6; Pl. 57, fig. 12) shows the palpebral lobe to be circular in outline, almost completely circumscribed by a suture line so that it is connected to the fixed cheek only by a narrow, steeply sloping band on the inner side. The gently convex visual surface extends around the eye lobe from one margin to the other of this narrow band; thus there are facets directed not only forward, outward and backward, but also inward and forward, and inward and backward. Both anterior and posterior branches of the suture are widely divergent, the anterior branches joining in a smooth curve along the anterior margin of the cephalon, the posterior branches reaching the margin at about two-thirds the width of the cheek from the axial furrow. The cheek is divided into a convex inner and a concave, gently sloping outer part, the line between them being the paradoublural line. The doublure (Pl. 57, fig. 9) is horizontal in the outer part, the inner part curled up vertically. Anteriorly, it is crossed by inward and backwardly directed connective sutures that lie on the projected line of the axial furrows and isolate the rostral plate. The hypostome is shield-shaped, with lateral and posterior borders of similar width, the shoulders projecting. Gently convex middle body subdivided by diagonal, shallow middle furrows; crescentic posterior part of middle body of length (sag.) about one-third of remainder of middle body. Adjacent to the tip of this crescentic portion of the middle body (Pl. 55, figs. 2, 7, 8), at the inner end of the middle furrow, is a smooth area, the macula, on which is a prominent tubercle. The external surface of this tubercle appears to be smooth. Anterior wing large, triangular, directed upward and slightly outward, the distal corner a right angle, the posterolateral margin curved. There is a sharp flexure in the distal part of the wing which may form a wing process on the inner side.

On the external surface of the exoskeleton (Pl. 55, figs. 7, 9; Pl. 57, fig. 9) are fine, raised, anastomosing lines that on the glabella in front of the occipital ring run roughly concentrically with the margins, on the cheeks run concentrically around the eye lobe, towards the margins becoming subparallel to these margins. On the doublure the lines are stronger; on the hypostome they run roughly parallel to the margins on the borders. The occipital ring does not bear a median tubercle, but medially four pits, arranged at the corners of a small square, are impressed in it. This arrangement of pits recalls those seen in odontopleurids (Whittington, 1956, pp. 177-178). In this species, as in odontopleurids, the doublure of the occipital ring extends close beneath this area.

The smallest well-preserved cranidia (Pl. 56, figs. 3, 4) are not greatly different from larger examples, except that the axial furrow is markedly deeper where it passes between the glabella and the lateral muscle area.

Pygidium (Pl. 57, figs. 1-8) has the axis extending about half the length (sag.), bluntly terminated, and on the external surface the characteristic postaxial ridge is faintly or not at all visible. Pleural regions gently curving down to margin, no border, broad facet and shallow first pleural furrow immediately behind the facet. On the external surface the terrace lines run subparallel to margins. Doublure is broad, convex ventrally, the outer part flattened, the inner part curving up to the margin, which runs immediately behind the tip of the axis and curves around to the inner end of the facet. Transitory pygidia (Pl. 57, figs. 10, 11) have the axis relatively longer, and display radially-arranged pleural ribs. Those of the smallest example bear a few low tubercles, and at the tip are extended as short spines. The first four segments show that these pleural ribs are the posterior bands.

On internal moulds of both cephalon (Pl. 58, figs. 1, 7) and pygidium (Pl. 57, fig. 13), between axial furrow and inner margin of doublure, there is a reticulate pattern of low ridges. Such a pattern, common in older trilobites (Öpik, 1961a) has not previously been observed in species of scutelluids, and most remarkable is the arrangement seen on the pleural regions of the pygidium. Immediately behind the first pleural furrow is a main ridge that runs directly out from axial furrow to the inner margin of the doublure. Opposite the second and third

ring furrows of the axis similar ridges may be observed, running outward and backward. Between and behind these main ridges is a network of similar ridges. The main ridges appear to be related to segmentation, as Öpik (1961a, pp. 422, 426, pl. 69; text-figs. 10, 14) observed to be the case in certain Cambrian trilobites. The internal mould of the fixed cheek shows the relatively broad, flat-topped eye ridge, running inward to the axial furrow. This ridge is faintly, if at all, visible on the external surface of the exoskeleton, and is best seen in the small cranidium (Pl. 56, fig. 3). There is no sign on the external surface of the network of ridges, though the exoskeleton is thin.

Some variation is exhibited between specimens of the cephalon or cranidium of *R. reticulatus*. These are in outline and relative width of the glabella, and in convexity and relative height of the inner part of the cheek lobe (compare Pl. 56, figs. 8 and 10). Thus the eye lobe may be as high as the median part of the glabella or stand above it. Two examples of a cranidium (Pl. 58, figs. 2-4, 10; and one from Table Cove) are unusually convex. The anterior half of the glabella slopes steeply, as does the adjacent part of the fixed cheeks, these slopes being far more steep than in "typical" specimens, and the gently sloping border is much narrower. Other features of these cranidia appear to be the same—the muscle areas, arrangement of lines, and the four pits on the occipital ring. These cranidia may represent extreme variants, a rare, separate species, or least likely, the effect of distortion.

Discussion. The lectotype of *Raymondaspis angelini* (Billings, 1862, pp. 95-96, fig. 85a, b; this paper, Pl. 56, figs. 11-13) is from the "upper part of limestone No. 2," that is from a boulder in a band of limestone conglomerate in the Lévis Shale. Billings (1862, p. 67) states that limestone No. 2 is included in No. 4 of Logan, but Logan (1863, p. 864) records this species from band No. 8. The age may be Lower or Middle Ordovician. The cephalon of *R. angelini* appears similar in outline, position of eye lobe, course of sutures and paradoublural line, to that of *R. reticulatus* n. sp., differing in the lower convexity of cheek and glabella, the relatively narrower and shorter glabella, in front of which is a much longer (sag. and exs.) preglabellar area. Raymond (1925, pp. 70-71) described, but did not figure, the species *R. marginata* from a boulder in the Mystic Conglomerate, Quebec. The holotype (MCZ 1759) is that part of the cranidium in front of the palpebral lobes. The glabella is broad

(tr.) anteriorly, curving without interruption by a change in slope into the broad (sag. and exs.) preglabellar area. In these characters it appears to differ from both *R. angelini* and *R. reticulatus* n. sp.

As discussed above, *R. reticulatus* is like the younger *R. gregarius*, and the type material of the latter species shows the four pits on the occipital ring and the pattern of ridges on the internal mould of the pygidium. *R. brunleyi* (Cooper, 1953, p. 25, pl. 9, figs. 8-10) differs from both species in the rapid anterior expansion and convexity of the glabella, and the narrow preglabellar field. Comparison with *R. tennesseensis* (Cooper, 1953, p. 25, pl. 9, fig. 11) is less possible because of the indifferent preservation of the holotype.

RAYMONDASPIS TURGIDUS n. sp.

Plate 58, figures 5, 6, 8, 9; Plate 59, figures 1-9, 11

Holotype. GSC 18339, incomplete cranidium from middle Table Head Formation, type section, 190 feet above base.

Other material. Two cranidia, two free cheeks, and five pygidia from the same horizon and locality as the holotype.

Description. This rare species is quite different from *R. reticulatus* n. sp., and such similar species as *R. gregarius*, in that the glabella is much more convex both longitudinally and transversely, with more deeply impressed furrows and a basal lobe, a deep anterior pit and lateral muscle area; there is no anterolateral border to the cephalon, the genal angle is not prolonged into a blade-like spine, and the pygidium is relatively wider, with a bluntly terminated axis and the inner part of the pleural lobes inflated.

The outer part of the occipital furrow is broadened and deepened, and in front of it is the gently inflated, triangular, lateral glabellar lobe 1p. Lateral glabellar furrow 1p is markedly impressed, oval in outline, extending inward and backward along the inner side of the lateral lobe. Lateral glabellar furrows 2p and 3p (Pl. 59, fig. 7) are small circular areas, smooth but not impressed, situated a short distance in from the axial furrow, the terrace lines curving around them. Small, deep anterior pit near anterior end of axial furrow. Axial furrow beside lateral glabellar lobe 1p deeply and widely excavated, the excavation extending into the steeply sloping wall of the fixed cheek — this depressed region appears to be the lateral muscle area. Cheek triangular in outline, convex, eye lobe at highest

point (as high as median part of glabella), this point situated about halfway out across the cheek and far back, in line with the lateral muscle area. Anterior branch of suture runs almost directly forward to border, and continues along outer edge of narrow anterior border. Posterior branch curves slightly, running outward and backward to cross the posterior margin close to the genal angle.

Visual surface (Pl. 59, figs. 2, 3) extends around anterior, lateral and posterior side of eye lobe, but not as in *R. reticulatus* around the inner side. Outside the eye lobe the cheek descends steeply to the narrow, rim-like border, which continues around in front of the glabella (Pl. 59, fig. 8), separated from it and the cheek by a shallow furrow. Only the posterolateral part of the cheek is slightly flattened, separated by a change in slope from the inner portion. External surface of cephalon bearing anastomosing raised lines, which run in curves convex forward on the occipital ring, concentrically on the remainder of the glabella, and concentrically around the eye lobe.

Pygidium more than twice as wide as long (sag.), relatively broad axis extending slightly more than half the length and bluntly terminated, no postaxial ridge. First four axial rings outlined by ring furrows which are deepest distally, and become successively shallower posteriorly. Pleural regions divided into an inner, gently inflated portion and an outer sloping portion which lies over the broad doublure (Pl. 59, fig. 11). Anterolaterally there is a broad diagonal facet. First pleural furrow shallow, curving out along inner side of facet, faint second pleural furrow. External surface bearing raised lines which run in curves convex forward on the axial rings, concentrically on the inner part of the pleural regions, and on the outer part sub-parallel to the margins. Doublure lies close to the dorsal exoskeleton, and is traversed by heavier terrace lines.

Small pygidium (Pl. 58, figs. 5, 6) has four axial rings clearly defined, and a faint fifth, and the axis is prolonged across the outer part of the pleural regions to the margin. On the inner part of the pleural region the first pleural furrow is broad and relatively deep, and a shallow second and third furrow is visible.

Discussion. No pattern of radiating ridges has been observed on internal moulds, but few specimens are available. The lack of this pattern, and the many other differences between *R. turgidus* and *R. reticulatus*, suggest that they might be accorded

generic rather than specific rank. In view of the small amount of material of *R. turgidus* available, this is not done here.

Family CHEIRURIDAE Hawle and Corda, 1847

Subfamily CHEIRURINAE Hawle and Corda, 1847

Genus CERAURINELLA Cooper, 1953

CERAURINELLA POLYDORUS (Billings, 1865)

Plate 60

Billings, 1865, p. 286, fig. 274.

Barton, 1913, pp. 548-549.

Barton, 1916, p. 134.

Raymond, 1925, p. 143.

Whittington, 1963, pp. 85-86, pl. 25, fig. 10.

Lectotype. GSC 685, an incomplete cranidium (Whittington, 1963, pl. 25, fig. 10), previously designated holotype, but one of the syntypes studied by Billings. These latter also include GSC 685b, 685c, fragments of the glabella (GSC 685a is the posterior part of the glabella and cheek of *Pseudomera* sp.). All are from Portland Creek.

Other material. Both Billings and Raymond studied material from the upper half of the middle Table Head Formation. In the present investigation it was found rarely at 90 feet above the base of the middle part, and somewhat more abundantly in the isolated limestone and the exposures on the foreshore south of Table Cove.

Description. Glabella narrowest across occipital ring, which is broadest sagittally and projects behind the remainder of the cranidium. In front of this ring glabella expands gradually to the maximum width across lateral lobes 3p. Glabella moderately convex transversely, more strongly so longitudinally, and frontal lobe overhangs preglabellar furrow. Glabella subdivided by furrows which are deepest distally; occipital furrow curves forward slightly at midline; three pairs of lateral glabellar furrows subequally spaced from each other and from the occipital furrow and anterior margin. These furrows run transversely adjacent to the axial furrow, curving inward and backward proximally; lateral furrow 1p dying out without reaching the occipital furrow, but connected to the latter by the depression which separates the median glabellar lobe from the gently inflated basal lobe. Lateral lobes 2p and 3p progressively less strongly inflated, and not separated by a furrow or change in

slope from the convex median lobe. Anterior glabellar lobe relatively short, the length (as measured between the anterior margin and the outer ends of lateral furrows 3p) only slightly greater than the length (exs.) of lateral lobes 2p and 3p, but less than that of 1p. Axial and preglabellar furrows of similar depth, at their junction a deep anterior pit. Narrow, gently convex anterior border outside preglabellar furrow, margin defined by sutures, and the oblique angle in this margin (Pl. 60, fig. 1) probably marks the junction between rostral suture and anterior branch. Fixed cheek (Pl. 60, figs. 1, 4, 6) curves gently downward and outward from axial furrow. Posterior border convex, widening outward to a maximum width at the genal angle, where it merges with the equally broad anterolateral border. At the genal angle the specimen is broken, but the genal spine is evidently broad-based, directed backward and outward. Palpebral lobe situated at about one-third the width (tr.) out across the cheek and opposite lateral glabellar lobe 2p. The steeply inclined lobe is continuous with a broad eye ridge which runs inward and forward to reach the axial furrow opposite lateral glabellar lobe 3p. This eye ridge is well defined on the inner side by a furrow which continues along the inner margin of the palpebral lobe. In front of the eye ridge is a narrow part of the fixed cheek, which is separated by the deep outward and slightly forwardly directed border furrow from the anterior border. Anterior branch of facial suture bounds this portion distally, and curves inward and forward across the outer slope of the anterior border. Posterior branch of suture evidently runs outward and slightly forward to lateral border furrow, then curves outward and backward across the lateral border (Pl. 60, fig. 6). External surface of glabella and borders finely granulate, except in furrows. In no specimen is the external surface of the exoskeleton well preserved, and in that figured (Pl. 60, fig. 11) the exoskeleton is partly exfoliated. Fixed cheek inside border furrows impressed by deep, closely spaced pits.

Pygidium triangular in outline, the short axis composed of three convex rings separated from each other by deep ring furrows. At anterior margin pleural region of similar width (tr.) to axial ring, first pleura separated from ring by shallow axial furrow and adjacent to this furrow the short, shallow pleural furrow. Second and third pleural bands gently convex, separated from each other and the first pleural band by deep interpleural furrows. The first pleura extended by a large, thick,

upward, outward and backwardly directed pleural spine, the spine of the second and third pleurae much smaller, triangular in shape, those of the third pleurae separated by a narrow posterior part of the pleural region. Beneath the bases of these spines the pleural region descends vertically to the margin, where it is curled under to form the doublure. In posterior aspect (Pl. 60, fig. 10) this vertical border region is seen to be excavated by a broad, median notch. External surface finely granulate except in furrows.

Discussion. This species is quite like the type species of *Ceraurinella*, *C. typa* Cooper, 1953 (pp. 29-30, pl. 12, figs. 1-5, 7, 8, 15, 16; Whittington and Evitt, 1954, pp. 62-66, pls. 10-12, pl. 13, figs. 1, 3; text-figs. 2, 3, 4, 17), the cranidium differing in that the glabella is markedly tapered at the occipital ring, the frontal glabellar lobe is much shorter (sag.) and narrower (tr.), and the external surface is finely granulated and not coarsely tuberculate. The pygidium, like that of *C. typa*, possesses three pairs of pleural spines, the first much thicker and longer than the second and third; however in *C. polydorus* these three pairs of spines are more widely divergent, and the inner pair is separated by a narrow posterior portion of the pleural region. Tripp (1962, pp. 16-19, pl. 2, figs. 22-32) emphasizes that the distinguishing feature of his genus *Bartoninus* is the graduated size of the pleural spines of the pygidium, so that *C. polydorus* is probably better placed in *Ceraurinella* than in *Bartoninus*. The Table Head species differs from *Lchua argus* Whittington, 1963 (pp. 84-86, pl. 23, figs. 1-4, 6, 8, 9, 11; ? 5, 7) in that the frontal glabellar lobe of *L. argus* is relatively shorter and narrower, so that furrow 3p runs inward from the anterolateral corner, and the eye lobe is situated at the anterolateral margin of the cheek. If the pygidium described is correctly assigned to this species, it is quite different from that of *C. polydorus*. Prantl and Příbyl (1948, pp. 21-23, pl. 1, figs. 8, 9; pl. 5, fig. 8) erected the genus *Osekaspis* with the type species *Cheirurus comes* Barrande, 1872, from the Šárka Beds of Llanvirn (early Middle Ordovician) age, Bohemia. Only the cephalon of the type species is known, and while it is of general ceraurid type, it differs from that of *C. polydorus* in displaying a much broader, flattened, horizontally directed anterior border, in the course of the posterior branch of the suture, and the apparently smaller fixigenal spine. Most like the Table Head species is that described by Schmidt (1881, pp. 135-136, pl. 6,

figs. 1, 2) from the Lower Ordovician of the East Baltic, and also recorded from Sweden (Bohlin, 1949, p. 566) in rocks of similar age. The outline and lobation of the glabella is similar, as is the position of the eye lobe, course of the sutures, and particularly the broad-based, outwardly and backwardly directed fixigenal spine.

C. polydorus is the earliest representative of this genus in North America.

Subfamily SPHAEREXOCHINAE Öpik, 1937

Diagnosis. Axis of exoskeleton relatively wide, so that glabella dominates cephalon; three pairs of glabellar furrows, 1p deeper and longer than furrows 2p and 3p. Eye lobe situated close to axial furrow, free cheek triangular in outline. Rostral plate relatively wide (tr.) and short (sags. and exs.). Hypostome with small anterior wing, middle body gently inflated and subequally divided by short middle furrows, lateral borders of similar width to posterior borders, a shallow median notch in the posterior border. Doublure of thorax and pygidium extends in to axial furrow, pleurae may be tubular spines in thorax and similar free spines in pygidium, or may be flattened and faceted in the thorax and completely or partially fused in the pleural regions of the pygidium. External surface granulate and bearing scattered tubercles, cheek may be pitted inside border furrow.

Discussion. In a previous discussion (Whittington, 1963, pp. 89-90) of this subfamily it was enlarged to include the genera *Kawina* and *Cydonoccephalus*. It is here suggested that *Xystocrania* n. gen., which appears to be related to *Kawina*, be placed here, and in addition *Heliomera*. The latter genus was thought by Evitt (1951, p. 588) to occupy an isolated position among cheirurids in a separate subfamily, but his list of characteristics is like many of those given above, except for the radial arrangement of the glabellar furrows which is characteristic of the *Heliomera* group of species.

Sphaerexochinids as understood here include a group of trilobites particularly characteristic of Middle Ordovician rocks in North America, only *Sphaerexochus* being more widely known at this time and ranging into Silurian rocks. A possible older, Lower Ordovician, representative of this group may be "*Kawina*" *scapuglia* Ross, 1951 (pp. 126-129, pl. 35, figs. 6, 7, 11-17, 19-21), and another member may be Ross' undetermined

genus and species E (1951, pl. 35, figs. 3-5), the eranidium of which has an appearance reminiscent of *Heliomera*, though the glabellar furrows do not show the characteristic radial arrangement, nor is the glabella so markedly transversely oval in outline.

Genus *XYSTOCRANIA* n. gen.

Type species. *Cheirurus perforator* Billings, 1865.

Diagnosis. Differs from *Kawina* (see Whittington, 1963, pp. 90-91) in that lateral glabellar furrow 1p is less markedly S-shaped, furrows 2p and 3p may be faintly impressed, there is no hump on the glabella in front of the occipital furrow, but a long spine, directed upward and forward, situated on the anterior part of the median glabellar lobe. Fixigonal spine present, posterior branch of suture crosses border a short distance outside this spine. The pygidium attributed to *Xystocrania* (Hintze, 1953, pl. 28, figs. 4a, 4b, 5) differs from that attributed to *Kawina* in that the terminal portion of the axis, behind the third ring, is absent, and the three pairs of pleural spines diverge and are not fused, but separated from each other near the base. Differs from *Nieszkowskia* Schmidt, 1881, in the position of the glabellar spine, which is situated on the posterior part of the median glabellar lobe in *Nieszkowskia*, in the S-shape of lateral furrow 1p, in that lateral furrows 1p to 3p commence at the axial furrow in *Nieszkowskia*, and the pleural regions of the pygidium are composed of two pairs of spines, the first of which is long, the second much reduced.

Discussion. Included in this genus is the species from Quebec described below, and *X. unicornica* (Hintze, 1953, pp. 179-181, pl. 28, figs. 1-5) from zone N, upper Pogonip Group, Crystal Peak, Utah. A slightly different and undescribed species occurs in beds of the same age in Ike's Canyon, Toquima Range, Nevada. Only in the last-mentioned two species is the pygidium known.

From lower Ordovician rocks of Utah comes "*Kawina*" *sexapugia* (Ross, 1951, pp. 127-129, pl. 35, figs. 6, 7, 11-17, 19-21). The cephalon of this species is unlike that of *Kawina* in the form of the glabella, which lacks the posterior hump, and in the position of the eye lobe and course of the posterior branch of the suture; in these respects it is more like that of *Cydonocephalus*. The pygidium is like that of *Xystocrania*, consisting of three segments, the pleural spines being separate from each other and divergent. This species may represent a separate genus which is older than species of the genera mentioned above.

XYSTOCRANIA PERFORATOR (Billings, 1865)

Plate 61

Billings, 1865, p. 287, fig. 275.

Raymond, 1925, pp. 146-147.

Nieszkowskia excelsus Raymond, 1925, pp. 145-146, pl. 10, fig. 8.

Holotype. GSC 684, incomplete cranidium, original of Billings, 1865, figure 275, from "Division N, Table Head." This label implies that the specimen came from the upper part of the middle Table Head Formation at the type section and the matrix is a black, fine-grained limestone typical of this part of the formation.

Other material. YPM 23332, glabella lacking occipital ring, showing furrows 1p and base of spine, from Pointe Riche, original of Raymond, 1925, pages 146-147; YPM 13046, external mould of left half of cephalon, holotype of Raymond's *N. excelsus*, from lower Table Head Formation, Port au Choix. In the present investigation an incomplete cranidium was obtained from 379 feet above the base of bed 8, type section of lower Table Head Formation, and a hypostome from 350 feet above the base of the same bed.

Description. Maximum width of strongly convex glabella immediately behind outer end of lateral furrows 1p, at slightly more than half the length from the anterior margin. Occipital furrow straight medially, narrow and deep, occipital ring not markedly wider medially. Glabella bulges forward anteriorly and overhangs narrow anterior cephalic border, thick, forwardly and upwardly directed spine arises from anterior part of median lobe. Lateral furrow 1p commences a short distance inside axial furrow, is weakly sigmoidal, the inner ends of the two furrows close together but not extending to the occipital furrow. Lateral furrows 2p and 3p (Pl. 61, figs. 5, 8) are faint, curved, commence a short distance inside the axial furrow, 2p curving up toward the base of the median spine, 3p lying in front of the base of this spine. Narrow, deep, axial furrow forms a continuous curve with preglabellar furrow which is of similar depth. Check triangular in outline, curving outward and downward, borders defined by deep furrows and widest posterolaterally. The posterior border widens progressively outward to the base of the backwardly and outwardly directed fixigenal spine, outside the base of this spine (Pl. 61, fig. 8) the border curves gently forward to merge with the lateral border. Eye lobe

medially situated, opposite outer end of lateral furrow 1p, prominent, defined on inner side by deep, curved palpebral furrow. Anterior branch of suture runs inward and forward to cross anterior border in line with axial furrow, further course not clearly visible. Posterior branch curves outward and backward through about 90°, crossing the border a short distance outside the base of the fixigenal spine. The hypostome assigned to this species is subquadrangular in outline, the lateral and posterior borders of similar and constant width, separated from the middle body by broad deep furrows. Middle body gently convex, at about midway along lateral margin the middle furrow curves for a short distance inward and backward.

External surface except in furrows finely granulate. On glabella scattered tubercles, which are larger on the posterior portion behind the median spine, smaller in front of it. Cheek inside border furrows impressed by irregular, closely-spaced pits.

Discussion. This species is extremely rare, and only the cephalon is known, yet it is one of the few that ranges from the lower into the middle Table Head Formation. Raymond distinguished his species *excelsus* because of the supposed direction of the median glabellar spine. This is a matter of orientation, however, and Raymond's specimen is closely similar to the type both in size and appearance. *X. unicornica* (Hintze, 1953, pl. 28, figs. 1-5) is extremely like the present species, but distinguished by the less convex and forwardly projecting glabella, as evidenced by comparisons of the dorsal and lateral profiles. The hypostomes of the two species are similar in type, but that of *X. unicornica* is semicircular rather than subquadrangular in outline.

XYSTOCRANIA GLAUCUS (Billings, 1865)

Plate 62, figures 4, 8, 9

Billings, 1865, p. 323, fig. 308, a, b.

Lectotype. GSC 850, internal mould of incomplete cranium, from boulder in Mystic Conglomerate, Range 6, Lot 20, Stanbridge Township, Missisquoi County, Quebec.

Paralectotype. GSC 850a, distorted incomplete internal mould of part of glabella and left fixed cheek. Same locality as lectotype.

Description. Glabella widest at about midlength of lateral lobes 1p, in front of here tapering quite rapidly, highest point at

base of median spine, which is approximately in line with lateral glabellar furrows 2p; in front of spine, glabella slopes steeply forward and only slightly overhangs preglabellar furrow. Lateral glabellar furrows commence a short distance inside axial furrow, deepest and widest distally, narrowing and shallowing inward; furrow 1p the deepest and longest, the inner ends not reaching the occipital furrow and relatively far apart. Lateral furrows 2p and 3p successively shallower and shorter. Occipital furrow transverse, occipital ring of maximum width medially. Posterior border of fixed cheek narrow and convex adjacent to axial furrow, widening (exs.) rapidly outward. Fixed cheek curves steeply downward, palpebral lobe situated in line with lateral furrow 2p. External surface of exoskeleton not preserved, but pitting of cheek shows in internal mould.

Discussion. This cranidium differs from that of *X. perforator* in the outline and convexity of the glabella (compare Pl. 61, figs. 1-8 with Pl. 62, figs. 4, 8, 9), particularly as revealed in comparisons of the profiles. Lateral furrows 2p and 3p are deeper, the palpebral lobe is situated farther forward, being opposite lateral furrow 2p rather than 1p, and the median glabellar spine is differently placed in association with the different longitudinal convexity of the glabella.

From the lower Table Head Formation a single incomplete cranidium was collected (Pl. 62, figs. 1-3, 6) which is like that of *X. glaucus*. This specimen is not exfoliated, the occipital ring is complete, and close to the posterior edge is the base of a thick median spine. It appears probable that such a spine is not present in *X. glaucus*, but since the occipital ring is incomplete in the only two specimens known, one cannot be sure. On the external surface of the glabella and posterior border of the Table Head specimen is a fine granulation, amid which are scattered low tubercles apparently not arranged in pairs. The fixed cheek inside the border is pitted, and a few low granules are scattered on the ridges between the pits. The posterior border is preserved, showing the distal widening which is extended outward and backward by the long, stout fixigenal spine.

Genus CYDONOCEPHALUS Whittington, 1963

CYDONOCEPHALUS sp. ind.

Plate 63, figures 9, 10, 13, 16

Material. GSC 18356, incomplete cranidium, middle Table Head Formation, foreshore south of Table Cove.

Description. Cranidium is typical of the genus (compare Plate 63, figures 9, 10, 13, 16 with Whittington, 1963, pl. 28, figs. 1-15) in the outline of the glabella in dorsal and lateral profile, the deep lateral glabellar furrow 1p and faint furrows 2p and 3p, position of the palpebral lobe, and form of the posterior border with the thorn-like fixigenal spine. Of the species previously described, it resembles *C. scrobiculus* in the shape of the posterior part of the fixed cheek and particularly the broad, deep border furrow. However, the glabella of the present species has less deep and more backwardly directed lateral glabellar furrows 1p, so that the basal glabellar lobe is more triangular than quadrangular in outline, and furrows 2p and 3p are much fainter.

Genus **KAWINA** Barton, 1916

KAWINA sp. ind.

Plate 62, figures 5, 7

Material. GSC 18274, an incomplete pygidium in the same piece of rock as the original of Plate 47, figures 3, 5, 6, and partly concealed by this cranidium, lower Table Head Formation, Pointe Riche.

Description. This pygidium is typical of the kind assigned to this genus, and of the species recently described is most like that of *K. arnoldi* Whittington, 1963 (p. 94, pl. 26, figs. 12, 14; Pl. 27, figs. 2, 5, 6, 8 9). As in this species the terminal portion of the axis is relatively large and triangular in outline, but the axis is of width (tr.) across the first ring greater than the length (sag.), and the third ring furrow has a bow-shaped course rather than being curved convexly back as in *K. arnoldi*. The external surface of the present example is finely granulate (except in the furrows), and there are scattered low tubercles, which are smooth and may display a tiny opening on the posterior-facing slope.

Genus **HELIOMERA** Raymond, 1905

Type species. *Cheirurus sol* Billings, 1865.

Discussion. In 1951, Eviit redescribed the type species and distinguished from it three other species grouped in a new genus *Heliomeroides*. From the boulder at Lower Head came two species (Whittington, 1963, pp. 86-89, pl. 24; pl. 25, figs.

1-6), one being placed in each of these genera. All but the type species of *Heliomeroïdes*, *H. teres*, are known only from the glabella, cranidium, or at most, cephalon. Assignment to *Heliomera* or *Heliomeroïdes* depends entirely therefore on characters of the cephalon, particularly the glabella, and in practice on the development and depth of the longitudinal furrow that joins the inner ends of the lateral glabellar furrows to each other and to the occipital furrow. When the material available is in the form of internal moulds, as for example in *H. raymondi* (Evitt, 1951, pl. 85, figs. 6-14) the longitudinal furrow appears deep and broad, and the assignment to *Heliomeroïdes* may be made on the basis of this single character, although the appearance of the furrow on the external surface is unknown. In *Heliomera* there is a change in slope along the line of this furrow, but a furrow is not developed, while in *Heliomeroïdes alacer* Whittington, 1963 (pl. 25, figs. 1, 2, 4-6), the longitudinal furrow is broad and shallow, lying between the gently convex median glabellar lobe and the inflated lateral lobes. The variability in development of the furrow emphasizes the difficulty of using this one character in classification, and it is here suggested that the name *Heliomeroïdes* be used for a subgeneric group of species of *Heliomera*, pending a more complete knowledge of exoskeletons which may enable the use of more than one character to distinguish them.

HELIOMERA SOL (Billings, 1865)

Plate 63, figures 1-6, 8, 12

Billings, 1865, p. 288, fig. 276.

Evitt, 1951, pp. 603-605, pl. 85, figs. 24-29.

Whittington, 1963, p. 88.

Lectotype (selected by Evitt, 1951). GSC 683, incomplete cranidium from middle Table Head Formation, probably type section. Since Evitt described this specimen (from a cast), I have been permitted to prepare it, and the left side of the glabella and left fixed cheek are now visible. It is in a fragment of light gray, medium-grained lime sand with specimens of *Niobe quadraticaudatus*, and there is little doubt that age and locality are as given.

Other material. GSC 18354, a less complete cranidium from the isolated limestone.

Description. Glabella transversely oval in outline, gently convex, distal parts of lobes inflated so that close to axial and preglabellar furrows the slope is steep. Occipital and three lateral furrows divide the glabella so that the median lobe is approximately two-thirds the width (tr.) of the lateral lobes, and in the lateral region the furrows are subradially arranged. Occipital furrow deep and transverse behind median lobe, curving outward and backward and deepening behind lateral lobe. Posterior margin of occipital ring curves convexly back so that width (sag.) is greatest behind median lobe. Lateral glabellar furrows 1p and 2p of similar depth and length, slightly curved, furrow 3p straight and running inward from the preglabellar furrow. Median lobe expands abruptly into short (sag. and exs.) frontal lobe, which latter is indented by a shallow notch in the anterior margin at the midline. Axial and preglabellar furrows narrow and moderately deep, narrow anterior border. Fixed cheek slopes steeply outward, anterior portion extremely narrow (tr.), posterior portion of width at posterior border similar to width (tr.) of basal lateral glabellar lobe. Posterior border furrow narrow and deep, curving outward and forward, more strongly forward distally as it approaches sutural margin. Posterior border thus widens (exs.) outward; at genal angle it is extended by a slim, backwardly and outward directed spine; in front of base of spine a narrow border extends to the sutural margin. Palpebral lobe situated opposite anterior part of second lateral glabellar lobe, shallow palpebral furrow, posterior branch of suture curves outward and backward.

External surface except in furrows covered by scattered tubercles of varying size, irregularly arranged. Cheek inside border furrows impressed by pits.

Discussion. Distinctions between *H. sol* and the Lower Head species *H. albata* have been given (Whittington, 1963, p. 88), and now that *H. sol* is better known it is clear that the convexity of the glabella of *H. albata* distinguishes it, combined with the unusual "L" shape of lateral glabellar lobe 3p. It is also notable how like *H. sol* is *H. (Heliomeroides) alacer* Whittington, 1963 (compare Plate 63, figure 5, with pl. 25, fig. 6), the latter species being distinguished by the more inflated lateral glabellar lobes, the anterior median line of pits in the frontal lobe, the more anterior position of the eye lobe, and the stouter and differently directed fixigenal spine.

HELIOMERA (HELIOMEROIDES) sp. ind.

Plate 63, figures 7, 11, 14, 15

Heliomera sol, Whittington and Kindle, 1963, fig. 3.

Material. GSC 18355, internal mould of glabella, middle Table Head Formation, 17 feet above base of type section.

Description. The glabella is distinguished from that of *H. sol* by the depth of the furrows and the inflation of the lateral lobes, which gives a much more marked subdivision of the glabella, accentuated by its being preserved as an internal mould. Laterally the slope to the axial furrow is vertical, the longitudinal furrow is marked, and there is a short, shallow median furrow running inward from the anterior margin of the frontal lobe. This fragment is of the *Heliomeroides* type, and like *H. (H.) alacer* Whittington, 1963.

Family CALYMENIDAE Edwards, 1840

Genus CALYMENIDIUS Rasetti, 1944

aff. CALYMENIDIUS sp. ind.

Plate 59, figures 10, 12-15

Material. Two cranidia from middle Table Head Formation, Table Cove.

Description. Cranidium is incomplete but shows the subtrapezoidal outline of tapering glabella, which does not reach as far forward as the inflated fixed cheeks. Occipital ring narrow distally, curving forward; occipital furrow deep in front of this narrow outer part of the ring. Lateral glabellar furrow 1p runs diagonally inward from a point behind the midlength of the glabella, isolating a small, triangular basal lobe. Lateral furrow 2p a small depression in the side of the glabella close to the axial furrow at about one-third the length. Fixed cheek strongly convex, standing almost as high as the glabella, separated from it by the deep axial furrow. Opposite lateral glabellar lobe 1p is a shallow crescentic excavation in the steep wall of the cheek, the ala; opposite the anterolateral corner of the glabella is the shallow anterior pit. Palpebral lobe situated far out on the cheek and opposite the midlength of the glabella. Anterior branches of suture appear to converge forward, posterior branches not preserved. In anterior view (Pl. 59, fig. 14) the strongly convex anterior border is seen to be arched transversely through almost 180°, separated from the glabella by a deep preglabellar furrow,

and a similarly deep furrow from the cheek. The exoskeleton is preserved only in the anterior part of the right fixed cheek, and exhibits tubercles of varying size, closely spaced, on the external surface. On the internal mould a low eye ridge is seen to run inward and forward across the cheek to reach the axial furrow immediately behind the anterior pit.

The smaller cranium (Pl. 59, figs. 10, 12, 13) appears to belong to the same species, though the subparallel-sided glabella is relatively longer, extending as far forward as the fixed cheeks. The glabella shows the same two pairs of lateral furrows, the anterior border of the cranium is similarly arched transversely, and the position of the eye lobe is similar. External surface of exoskeleton is tuberculate.

Discussion. This cranium is like that of *Calymenidius tuberculatus* Rasetti, 1944 (pp. 240-241, pl. 36, fig. 54), from a presumed late Cambrian boulder in the Lévis Conglomerate. Only the holotype of the type species is known, the glabella trapezoidal in outline, the fixed cheeks convex, and the anterior border arched. The Table Head specimen has a shorter and shallower lateral glabellar furrow 2p, and a less prominent eye ridge. Rasetti does not mention the presence of the ala. Possibly congeneric with *Calymenidius* is *Pharostomina* Szalay, 1955 (pp. 30-34, pl. 2, figs. 80, 99, pl. 6, figs. 62-88, text-figs. 31-33), in which the ala is a characteristic structure. *Pharostomina* is known not only from the Tremadoc of Germany, but also from beds of similar age in Argentina (Harrington and Leanza, 1957, pp. 222-224, figs. 123, 1-6; these authors erected the genus *Colpocoryphoides*, which appears to be a synonym of *Pharostomina*). The Table Head crania are less like that of *Pharostoma* (Whittington, in Moore, 1959, p. O454, fig. 357) which has a relatively wider glabella, less convex fixed cheeks, and a wider, less arched preglabellar area.

Family ENCRINURIDAE Angelin, 1854

Diagnosis. Moderately or strongly convex glabella may expand forward, be parallel-sided or widest at the midlength. Occipital ring well-defined, widest (sag.) medially; up to three pairs of lateral glabellar furrows may be present; these furrows may deepen inwards to form apodemes, or may be absent distally so that the lateral lobes are fused. Lateral furrow 3p may be forked, lateral lobe 3p may be the longest (exs.). Deep anterior

pit at, or in front of, junction of preglabellar and axial furrows. May be median pit in preglabellar furrow, median furrow or pit at anterior end of frontal lobe. No preglabellar field, anterior border present but preglabellar furrow may be effaced medially. Eye lobe frequently elevated on stalk, strong eye ridge. Rostral plate steno-ptychopariid in type. Posterior branch of suture cuts lateral margin in front of genal angle, fixigenal spine may or may not be present. Hypostome with convex middle body ovate in outline, median bulge at anterior margin typical, no anterior border, narrow lateral borders, wide (sag. and exs.) posterior border; anterior wing with well-developed wing process.

Thorax of ten to twelve segments, posterior pleural bands wider and higher than anterior bands; former may be extended as spines; long spines on last six segments of thorax present in some genera. Pleural regions of pygidium composed of at least four segments, axis showing more rings than there are segments in the pleural regions; behind first few rings there may be a smooth median band on axis. External surface granulate, scattered tubercles or spines, frequently paired arrangement. Cheek inside border pitted.

Discussion. This diagnosis is similar to that recently given of the Pliomeridae (Whittington, 1961, pp. 912-914). The close relationship between Encrinuridae and Pliomeridae has frequently been commented on (e.g. Temple, 1956; Kielan, 1957, p. 157), and distinctive of the Encrinuridae is the nature of the pygidium, the axis showing many more segments than are present in the pleural regions, and the frequent presence of the smooth median band on the posterior part of the axis. In most Pliomeridae the number of rings on the axis does not greatly exceed the number of pleurae in the pleural regions, except in *Ectenonotus* (Whittington, 1961, pl. 99, figs. 2, 3, 6). This genus has a typically pliomerid cephalon, and reveals the closeness of the relationship between the two families. *Pseudocybele* Ross, 1951, has a cephalon more typical of encrinurids but a pliomerid pygidium. In addition to the distinctive pygidium, Encrinuridae have 10 to 12 segments in the thorax, not 12 to 18 as in Pliomeridae. The encrinurid hypostome, exemplified by those of *Encrinurus* (Lindström, 1901, pl. 4, fig. 5; Whittard, 1938, pp. 119-120, pl. 4, fig. 7) and *Cybeloides* (Cooper, 1953, pl. 13, fig. 12), appears different from those of typical pliomerids (Whittington, 1961, text-figs. 1-3, 5) particularly in showing the median anterior bulge on the middle body.

Enerinurids appear in the early Ordovician — *Cybele* in the Lower Ordovician of Scandinavia and the Baltic — and range through the Ordovician to the end of the Silurian. They originate at about the same time as pliomerids, and are well diversified by early Middle Ordovician times (Llanvirn or Whiterock Stages) being represented by *Cybellula* (Whittington, 1965), *Miracybele* n. gen., *Cornovica* Whittard, 1960 (a blind form from Britain), and *Plasiaspis* Prantl and Přibyl, 1948 (Whittard, 1960, p. 122), a related blind form from Bohemia. Additional genera appear in immediately succeeding stages (Llandeilo or Marmor-Ashby), such as another blind form *Dindymene*, *Cybeloides*, *Encrinuroides*, *Atractopyge*, and forms doubtfully referred to this latter genus.

Henningsmoen (*in* Moore, 1959, pp. 0445-449) used four subfamilial divisions of Enerinuridae, and now that Staurocephalidae have been shown to represent a separate family (Kielan, 1957), three divisions remain. In the present uncertainty as to the nature of particular genera, and details of parts of the exoskeleton and particularly the hypostome, these subgroupings are not used here.

Genus *MIRACYBELE* n. gen.

Type species. *Encrinurus mirus* Billings, 1865.

Diagnosis. Glabella expands evenly forward to maximum width across frontal lobe, three pairs of lateral furrows transversely directed, deepest at inner ends, extending inward more than one-third the width so that median lobe is narrow (tr.); from outer end of furrow 3p a short, inwardly and forwardly directed branch runs on to frontal lobe. Shallow preglabellar furrow separates frontal lobe from steeply sloping anterior border, deep, transversely elongate median pit in furrow, from which a deep, median longitudinal furrow runs back to bisect frontal glabellar lobe. Eye lobe situated more than half way out across cheek, opposite lateral glabellar furrow 1p, prominent eye ridge runs in to axial furrow opposite outer end of lateral furrow 3p. Rostral plate of maximum width at anterior margin, this width about equal to that of median glabellar lobe, narrowing backward. Thorax of at least twelve segments, posterior pleural band strongly convex, that of sixth segment from rear prolonged by long spine. Pygidium having about 14 rings on axis, median smooth band present from fifth ring back; pleural

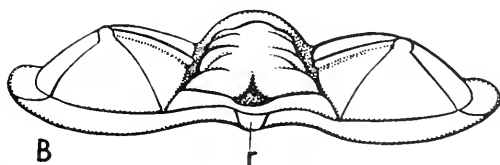
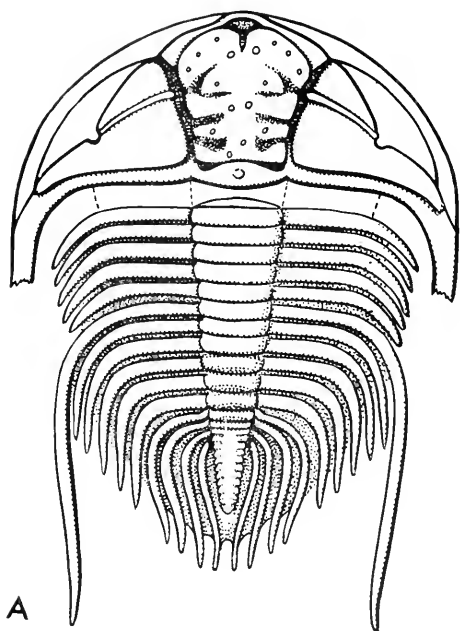

FIG. 7. *Miracybele mira* (Billings), middle Table Head Formation. A, reconstruction, dorsal view, showing eleven thoracic segments; complete thorax may have included twelve; B, anterior view of cephalon; r is rostral plate; X 3. Compare Plate 64, figures 1-7; Plate 65, figures 1-4; Plate 66, figure 4.

regions composed of four segments, posterior pleural bands prolonged as short spines.

Discussion. The deep pit in the preglabellar furrow, and the strong furrow running back from this pit on to the frontal

glabellar lobe, combined with the relatively narrow median glabellar lobe, distinguish this genus from *Cybele* (type species *C. bellatula*, Schmidt, 1881, pp. 203-206, pl. 13, figs. 9-13; pl. 15, figs. 1-5), species of *Cybellula* and "*Atractopyge*" (for discussion of these genera and allied forms see Whittington, 1965). It is known from the type species in the middle Table Head Formation, and a second species appears to be present in the *Ogygiocaris* Shale of Norway (Nikolaisen, 1961, p. 295, pl. 2, fig. 4).

MIRACYBELE MIRA (Billings, 1865)

Plates 64, 65, 66, figures 1-4;

? 5-8; Text-figure 7

Billings, 1865, pp. 292-293, fig. 282.

Raymond, 1925, p. 135 (in part).

Howell, 1947, pp. 12-13, pl. 1, figs. 1-4.

Lectotype (here selected). GSC 697, incomplete exfoliated cranidium from middle Table Head Formation, Pistolet Bay.

Other material. Paralectotypes: from same locality and horizon as lectotype, GSC 697b, c, exfoliated and incomplete cranidia, GSC 697a, exfoliated pygidium, from middle Table Head Formation at type section, GSC 698, a-c, all pygidia. YPM 23327, 23328, poorly preserved cranidia from type section of middle Table Head Formation, the former the original of Howell, 1947, plate 1, figure 3, and showing fixigenal spines. In the present investigation this species has been obtained at 90 and 185 feet above the base of the middle Table Head Formation at the type section, and is relatively abundant at Table Cove and in the isolated limestone.

Description. Glabella moderately convex (sag. and tr.), expanding evenly forward from occipital ring so that width across frontal lobe is half again that across occipital ring. Latter widest (sag.) medially, because of convexly backward curvature of posterior margin and forward swing of midpart of occipital furrow; this furrow shallow behind median lobe, deepened to form an appendifer distally. Lateral glabellar furrows 1p and 2p are placed at a similar distance from each other, and the occipital furrow 3p at a somewhat greater distance from 2p. Lateral furrows extend inward to more than one-third the width, so that the median glabellar lobe is relatively narrow; 1p at the inner end deepened and widened to form an apodeme; 2p also

deepened at inner end but not markedly widened; 3p runs slightly backward and inward and is deepest at the inner end, with a conspicuous branch commencing close to the outer end and running up the slope of the frontal lobe and dying out. Lateral glabellar lobes only slightly inflated, 3p the most strongly so. Deep anterior pit in axial furrow immediately in front of outer end of lateral glabellar furrow 3p. Anterior margin of frontal lobe rounded and outlined by preglabellar furrow which is shallow except for the short, straight, greatly deepened median portion. From this deep portion an equally deep median longitudinal furrow runs back on to the frontal lobe, rapidly shallowing and dying out at about half the length of this lobe. In front of anterior pit axial furrow runs outward beside that part of the anterior border which is on the cranium; border is gently convex, widest (exs.) adjacent to the axial furrow and narrow medially. Cheek strongly convex, highest point situated inside eye lobe and at same level as mid-line of glabella, outer part of cheek slopes very steeply. Deep border furrows define the borders, the posterior border narrow and convex, running transversely outward from the occipital ring and curving back outside the eye lobe; lateral and anterolateral borders moderately wide, gently convex, borders broad at genal angle and extended back by fixigenal spine. This spine is rarely preserved, but some specimens (Pl. 64, figs. 6, 8, 9) suggest that it was short and blunt. Eye lobe apparently stalked but not well preserved, eye ridge prominent. Anterior branch of facial suture (Pl. 64, figs. 2, 6, 9) runs straight inward and forward to cross border furrow at junction with axial furrow, then curves to run inward and forward along the outer margin of the anterior cephalic border; in front of the deep, median part of the preglabellar furrow the sutural margin of the border is straight, this straight portion being the rostral suture. Doublure of border (Pl. 64, figs. 4, 5) wide anteriorly, connective suture runs inward and backward over this doublure, outlining a rostral plate which is narrowest (tr.) posteriorly (Text-fig. 7). External surface covered by dense, fine granulation except in furrows (Pl. 64, fig. 11; Pl. 66, fig. 1). Cheek inside border furrows impressed by pits; granulation extends on ridges between pits. Scattered amid the granules are tubercles of various sizes, including a prominent median occipital tubercle and roughly paired tubercles on the median glabellar lobe opposite lateral lobes 3p, and on the frontal lobe.

One poorly preserved specimen (Pl. 66, fig. 4) shows twelve thoracic segments and the pygidium articulated together. The convex axis tapers gradually, the inner part of the pleural regions tapers rapidly in width. Posterior pleural bands are strongly convex, and that of the sixth segment from the posterior is extended as a long, backwardly directed spine. Outer parts of pleural regions of other segments appear to end in short spines, and to be faceted.

Pygidium (Pl. 65) triangular in outline, moderately convex axis, inner part of pleural region horizontal, outer part bent down vertically. Axis tapers and extends close to posterior margin, divided by ring furrows, which are deep distally, into fourteen rings. On the external surface shallow ring furrows define the median part of the first four or five rings; behind this point the median part of the ring is faintly or not at all defined, giving rise to the smooth median band. This smooth median band is less conspicuous on the internal mould, but made evident by shallow median part of the ring furrows. Pleural regions composed of four segments, each divided by deep pleural furrows into a narrow, gently convex anterior band and a broader and more strongly convex posterior band; these posterior bands extended beyond the margins (Pl. 65, fig. 4) as short, inwardly and backwardly directed spines, the fourth pair close together at the posterior margin. External surface (Pl. 65, fig. 6) covered except in furrows by fine granulation, some low tubercles scattered on posterior pleural bands. Pleural and interpleural furrows of second, third, and fourth segments are impressed by irregular pits, these pits being especially large in the region between the tip of the axis and the fourth pair of posterior pleural bands. These pits have only been observed in this specimen which has the exoskeleton preserved; other specimens are all internal moulds and the exoskeleton is thick so that the pits are faintly or not at all impressed on the internal mould.

In the middle Table Head Formation, 130 feet above the base at the type section, at Table Cove and the isolated limestone, occurs a type of hypostome (Pl. 66, figs. 5-8) which may belong to this species. The middle body is oval in outline, moderately convex, with prominent maculae and the posterior part of the middle body small and crescentic. The narrow lateral borders are separated from the middle body by a deep furrow, the posterior border is wide and bears a short, blunt median spine.

Striking is the large, quadrangular anterior wing, directed upward and outward, impressed by a fold along the outer margin. External surface is finely granulate, in a similiar manner to the external surface of *M. mira*. The size and occurrence of this hypostome is consistent with it belonging to this species, but the middle body does not display the median anterior bulge so characteristic of some encrinurid hypostomes (Lindström, 1901, pl. 4, fig. 5; Cooper, 1953, pl. 13, fig. 12). On the other hand, the hypostome attributed to *Cybele bellatula* (Lindström, 1901, pl. 4, fig. 2) apparently also lacked this bulge and possessed large anterior wings.

Discussion. Billings recorded this species from boulders from the shore north of the mouth of Portland Creek. In the present investigation a single pygidium was obtained from boulders at the same locality (Whittington and Kindle, 1963, p. 753). Raymond refers to "a rather poorly preserved thorax" obtained from the lower Table Head Formation on the west side of Gargamelle Cove (Schuchert and Dunbar, 1934, p. 25, fig. 4), but this specimen (MCZ 7568) appears to be that of the thorax of *Ectenonotus westoni* (Billings, 1865). This species is characteristic of the lower Table Head Formation, whereas *M. mira* has only been found in the middle Table Head Formation. A second species of *Miracybele* is present in basal calcarenites of the Antelope Valley Limestone, Nevada (Whittington in Kay, 1962, p. 1424, table 2). The fragment of a cranidium figured by Nikolaisen (1961, p. 295, pl. 2, fig. 4) as *Pliomerops* sp. has the glabellar shape and lobation, possible median furrow of the frontal glabellar lobe, and cheek with the eye ridge running far outward and backward, that make it appear quite probable that this specimen represents a third species of *Miracybele*. It is from the Ogygiocaris Shale (4ax) of the Oslo region, and is of approximately the same age as the Newfoundland species. Species of *Miracybele*, though rare, thus appear to be widespread.

Encrinurid gen. et sp. ind.

Plate 68, figures 6-8, 10, 11

Discussion. Two specimens indicate the presence of at least one additional encrinurid species in the middle Table Head Formation. The fragment of a glabella is quite strongly convex, the three lateral furrows directed inward and slightly backward, deepest at the inner end, the median glabellar lobe much

wider (tr.) than the lateral lobes. Scattered tubercles, including a prominent pair in line with lateral lobes 3p, are present on the external surface.

The internal mould of the pygidium is unlike that of *Miracybele* in both outline and convexity. The median smooth band of the axis extends back from the broken region of the first three or four rings, and there are up to sixteen rings indicated on this axis. On the pleural regions four narrow, raised bands represent the posterior pleural bands of four segments, the intervening region smooth and much broader than the bands. The fourth pair runs back and slightly inward behind the tip of the axis. Scattered tubercles are present on the raised bands, which are extended beyond the margin as short spines. This type of pygidium has not only been found 265 feet above the base of the type section, but in Table Cove and the isolated limestone.

Family DALMANITIDAE Vogdes, 1890

Genus CALYPTAULAX Cooper, 1930

CALYPTAULAX INCEPTA n. sp.

Plate 67, figures 1-4, 6

“*Calyptaulax*” sp., Whittington and Kindle, 1963, text-fig. 2.

Holotype. GSC 18368, incomplete and exfoliated cranidium, from 350 feet above base of unit 8, lower Table Head Formation.

Other material. Two fragments of external moulds of the pygidium, from 379 feet above base of unit 8, lower Table Head Formation; cranidia and pygidia from Portland Creek.

Description. Cephalon subsemicircular in outline, convex, the posterior part of the large eye lobe the highest point. Glabella expands forward from occipital ring to maximum width across frontal lobe (which is twice that of occipital ring), the length (sag.) slightly greater than the maximum width. Course of axial furrow sinuous; in front of outer end of lateral glabellar furrow 3p the axial furrow dies out, and anterior margin of glabella is outlined only by a slight change in slope, this change in slope being followed by the anterior branch of the facial suture. Occipital ring convex, the posterior margin the highest point of the glabella, widest behind the median lobe, narrowing and slightly inflated distally. Occipital furrow shallow medially, becoming deep distally between the outer part of

the ring and lateral lobe 1p. Lateral glabellar furrow 1p commences at axial furrow and runs a short distance straight inward, then bifurcates, one shallow branch running directly back and not quite reaching the occipital furrow, so that it outlines the slightly inflated, subtriangular basal glabellar lobe. The anterior branch of lateral furrow 1p runs inward and forward for a short distance and dies out, outlining the curved posterior margin of lateral lobe 2p. Lateral furrow 2p is directed inward and slightly forward, commencing at the axial furrow and deepening inward; lateral lobe 2p is quadrangular in outline. Lateral furrow 3p commences at the axial furrow and runs inward and backward, so that lateral lobe 3p is subtriangular in outline. The outer end of lateral furrow 1p is situated midway between the outer end of the occipital furrow and lateral furrow 2p; a much greater distance separates the outer ends of lateral furrows 2p and 3p. Inner ends of lateral furrows 2p and 3p, and of the anterior branch of furrow 1p, lie in the same exsagittal line, and width (tr.) of median lobe is approximately the same as that of lobe 3p. Median lobe is inflated adjacent to the occipital ring, so that it forms a low ring between lateral lobes 1p; anteriorly the median lobe merges with the diamond-shaped frontal lobe. The narrow (sag. exs.) preglabellar area in front of the fused branches of the facial suture has a similar slope to the slope of the frontal glabellar lobe, there is no preglabellar furrow, and at the margin the exoskeleton is flexed sharply to slope downward and backward as the gently convex doublure (Pl. 67, fig. 6). This anterior part of the doublure extends in beneath the frontal glabellar lobe, and at the inner margin is flexed ventrally. Convex, triangular cheek dominated by the prominent eye lobe, which extends from a point adjacent to the outer end of lateral glabellar furrow 3p to the posterior border furrow. The palpebral lobe is formed by a prominent, gently convex band curved in a semicircle, the palpebral furrow deep and broad. The eye surface slopes steeply to the furrow which marks the outer margin of the eye lobe, and the convex facets are arranged in diagonal lines. Inside the curved palpebral furrow the fixed cheek is gently inflated, and the narrow posterior portion separating the eye lobe and axial furrow slopes steeply to the border furrow. Behind the eye lobe the posterior border is narrow and convex; distally it becomes flattened. The genal angle is rounded, and the cheek outside the eye lobe slopes steeply. Lateral border furrow broad and shallow, curving

round in front of the eye lobe to merge with the axial furrow; posterolaterally the border furrow deepens and at the genal angle curves to merge with the posterior border furrow. The lateral border is relatively broad and gently convex, the exoskeleton at the margin sharply flexed so that posterolaterally the doublure lies immediately beneath the dorsal exoskeleton, as it does beneath the posterior border. The form of the anterolateral part of the doublure is not known, and hence it is uncertain whether or not a vincular furrow is present. Posterior branch of facial suture curves around behind eye lobe immediately outside the bounding furrow, then curves forward and outward across cheek to margin, reaching this margin approximately in line with lateral glabellar furrow 1p. Only a fragment of the exoskeleton is adhering to the left cheek, which shows a fine granulation on the lateral border. Elsewhere the internal mould shows the low, closely-spaced tubercles on the glabella and fixed cheek, and the shallow pits in the cheek outside the eye lobe.

The triangular pygidium is convex, the axis divided by seven ring furrows which become progressively fainter posteriorly. These furrows run transversely in the medial portion, the outer portion being a curve gently convex forward. Seven deep pleural furrows traverse the pleural regions, and on the outer part of these regions the shallower interpleural furrows are visible, running diagonally to the pleural furrows.

Discussion. In 1954 (p. 135) I attempted to distinguish between *Calyptaulax* and *Calliops* Delo, 1935, emphasizing particularly that in the latter genus the second glabellar furrow was distinct and deep throughout its length, and implying that it extended to the axial furrow. This is in contrast to the condition in the type species of *Calyptaulax*, *C. glabella* Cooper, 1930 (pp. 388-389, pl. 5, figs. 9-11), in which this furrow does not reach the axial furrow and lateral glabellar lobes 2p and 3p are partially fused. This single criterion is not easy to use, particularly as the definition of the lateral glabellar furrow (as Cooper recognized) is different on the external surface and internal mould. Both Delo (1940, pp. 94-95, pl. 11, fig. 1) and B. N. Cooper (1953, p.33, pl. 16, fig. 12) based their understanding of *Calliops callicephalus*, the type species, on material which came from the Trenton Group at Trenton Falls, New York State. However, Hall's (1847, p. 247, pl. 65, figs. 3a-i)

original material did not come from this locality, but from fourteen miles to the southeast, near Middleville, Herkimer County, New York State. The exact horizon from which the material came is uncertain, and the type specimens have not been traced. In these circumstances it seems best not to use the name *Calliops*. Thus the present species is referred to *Calyptaulax*, and I include in this genus many of the species referred by Delo (1940) and B. N. Cooper (1953) to *Calliops*. The suprageneric classification of trilobites of this type is uncertain but, as discussed previously (Whittington, 1962, p. 12), I incline to place *Calyptaulax* in the Dalmanitidae.

The new species from the lower Table Head Formation is the oldest known of the *Calyptaulax*—"Calliops" type. Slightly younger is a species from the Lenoir Formation (as restricted by Cooper and Cooper, in Cooper, 1956, p. 72, and referred to the Marmor Stage) — *gracilens* Raymond, 1925 (pp. 162-163, pl. 10, fig. 18; Cooper, 1953, p. 34, pl. 15, figs. 4-7, 15). Raymond described only the pygidium of *C. gracilens*, but Cooper figured the glabella in which lateral lobes 2p and 3p appear to be the same relative size and shape as those of the Table Head species. *C. annulatus* (Raymond, 1905), from the Chazyan of New York, is of approximately the same age as *C. gracilens*. Judging from the cranidia illustrated by Delo (1940, pl. 11, figs. 5, 6) the cephalon is different from that of *C. incepta* n. sp. in that lateral glabellar lobe 1p is considerably smaller, the frontal lobe relatively larger, and the curvature of the palpebral rim apparently different. From younger beds of the Porterfield Stage many species have been described, one of which is *C. angusta* (B. N. Cooper, 1953, pp. 35-36, pl. 14, figs. 1-6; B. N. Cooper gave the horizon as "Upper Lenoir" limestone, now the Arline Formation of Cooper and Cooper in G. A. Cooper, 1956, pp. 41-43). Particularly the holotype cephalon of *C. angusta* is like that of *C. incepta* n. sp., showing lateral glabellar lobes of similar relative size and shape, the eye lobe of the same size, a difference being that lateral lobe 1p appears to be less isolated. Quite different from *C. incepta* n. sp. are the species from the Edinburg Limestone of Virginia described by Cooper (1953, pls. 17, 18), notably in the direction of the glabellar furrows and consequent shape of the lobes, and particularly in possessing the small, subcircular basal lobes. Still more divergent is a contemporaneous species *C. holstonensis* (Raymond, 1925, pp. 161-162, pl. 10, figs. 9-11; Cooper,

1953, p. 41, pl. 15, figs. 16-18, not figs. 13, 14) in which lateral glabellar furrow 2p does not reach the axial furrow, lateral furrow 3p is sigmoidally curved, and the palpebral lobe is much less strongly curved.

The new species from the lower Table Head Formation thus appears to be the first known representative of an evolving plexus in middle and upper Ordovician rocks in North America. However, until better material of many species is more clearly described, it will not be possible to discern phylogeny and relationships.

Family uncertain

Cranidium gen. ind. 1

Plate 19, figures 13, 14, 18

Material. A single incomplete cranidium from 90 feet above the base of the middle Table Head Formation, type section.

Description. Glabella of maximum width at posterior edge of basal lateral lobes, this width only slightly less than the length (sag.), convex so that anterior part of the glabella overhangs preglabellar furrow. Posterior margin of occipital ring strongly curved, occipital furrow behind median glabellar lobe straight; transverse, distal part of furrow runs in curve which is convex backward behind the basal glabellar lobe, at the extremity curving forward and dying out without reaching the margin of the basal lobe. In lateral view (Pl. 19, fig. 18) the distal tip of the forwardly-curving occipital ring is seen to merge into the outermost posterior part of the basal glabellar lobe. This latter lobe defined by lateral furrow which commences at about half the length, runs inward and backward, curves and becomes shallower and runs directly back to the occipital furrow. The elongate-oval basal lobe is moderately inflated and set off from the remainder of the glabella. Lateral glabellar furrow 2p represented by a faint depression adjacent to the axial furrow, and situated a short distance in front of 1p. Median glabellar lobe rises steeply in front of occipital furrow to form a low hump; in front of this hump it slopes forward and merges with the frontal lobe. Glabella outlined by axial and preglabellar furrows which are distinct and continuous in front of lateral furrow 1p and around frontal lobe; beside basal glabellar lobe and occipital ring, axial furrow is shallow. Little of the fixed cheek is preserved, except the anterior part beside the axial furrow

which forms a continuous band with the gently convex preglabellar field. The outer margin of this band appears to be formed by the anterior branches of the suture as they run forward and curve around toward the midline. The posterior border is also preserved, narrow, gently convex, directed outward and slightly backward. External surface except in furrows covered with faint lines arranged in Bertillon pattern, on glabella running roughly concentrically. Low tubercles are scattered on the glabella and occipital ring, and are best seen on the preglabellar field.

Because so little of the cheek is preserved, the affinities of this form are problematical.

Cranidium gen. ind. 2

Plate 68, figures 1-3

Material. GSC 18377, incomplete glabella from middle Table Head Formation, isolated limestone.

Description. Glabella trapezoidal in outline, the straight sides diverging forward so that the maximum width is across the anterior lobe and slightly greater than that across the occipital ring; moderately convex transversely, more strongly convex longitudinally so that the frontal lobe overhangs preglabellar furrow. Occipital ring wide (sag. and exs.) behind median lobe, narrowing behind basal glabellar lobe, median part forming highest part of cephalon. Occipital furrow narrow and deep, median lobe rising as steeply from it as does the occipital ring. Three pairs of lateral glabellar furrows, lateral furrow 1p directed inward and backward, straight, reaching the occipital furrow and cutting off a small, triangular basal glabellar lobe which is gently convex. Lateral furrows 2p and 3p much fainter, directed straight inward for a short distance before dying out, situated at an equal distance from each other, furrow 1p, and the preglabellar furrow. Lateral furrow 2p appears slightly fainter and shorter than 3p. Frontal glabellar lobe with straight margin medially, anterolateral corner rounded; preglabellar furrow continuous with axial furrows and moderately deep. Fixed cheek and preglabellar area (if present) not preserved. The specimen appears to be an internal mould, and suggests that the external surface is either smooth or finely granulate.

Discussion. The affinities of this glabella are uncertain — the small basal glabellar lobes combined with the forward expansion

do not suggest, for example, a cheirurid. There is some resemblance to the catillicephalid glabella, for example, that of *Theodenisia* (Rasetti, 1954, pp. 607-609, fig. 3). In this genus the glabella is typically forwardly expanding, straight sided, with three pairs of lateral glabellar furrows. However, the basal glabellar lobe of the present example is much smaller than that in species of *Theodenisia*. A relationship of the Table Head cranidium to members of this late Cambrian genus is possible, but so far as I am aware intermediate forms in the Lower Ordovician are unknown.

REFERENCES

BARTON, D. C.

1913. A new genus of the Cheiruridae, with descriptions of some new species. Bull. Mus. Comp. Zool., vol. 54, no. 21, pp. 547-556, pl.
1916. A revision of the Cheirurinae with notes on their evolution. Washington Univ. Studies, ser. 4, vol. 3, pp. 101-152, 25 figs., chart.

BILLINGS, E.

- 1861- Palaeozoic fossils, vol. 1. Geol. Surv. Canada, pp. 1-426,
1865. figs. 1-401.

BOHLIN, B.

1949. The Asaphus Limestone in northernmost Öland. Bull. Geol. Institut. Uppsala, vol. 33, pp. 529-570, pls. 1, 2.
1955. The Lower Ordovician Limestones between the *Ceratopyge* shale and the Platyrus Limestone of Böda Hamm. Bull. Geol. Institut. Uppsala, vol. 35, pp. 111-173, pls. 1-10, figs. 1-14.

BULMAN, O. M. B.

1931. South American graptolites with special reference to the Norden-skiöld Collection. Ark. f. Zool., vol. 22 A, no. 3, pp. 1-111, pls. 1-12, figs. 1-41.
1958. The sequence of graptolite faunas. Palaeontology, vol. 1, pp. 159-173, figs. 1-3.

CLARK, T. H.

1924. The paleontology of the Beekmantown series at Levis, Quebec. Bull. Amer. Paleont., vol. 10, pp. 1-134, pls. 1-9.

COOPER, B. N.

1953. Trilobites from the Lower Champlainian formations of the Appalachian Valley. Mem. Geol. Soc. Amer., vol. 55, pp. 1-69, pls. 1-19, 2 figs., table.

COOPER, G. A.

1930. Upper Ordovician and Lower Devonian stratigraphy and paleontology of Percé, Quebec. Part II. New species from the Upper Ordovician of Percé. Amer. Jour. Sci., ser. 5, vol. 20, pp. 265-288, 365-392, pls. 1-5, figs. 1-7.

1956. Chazyan and related brachiopods. Smithsonian Misc. Coll., vol. 127 (in two parts), pp. 1-1245, pls. 1-269.
- DELO, D. M.
1940. Phacopid trilobites of North America. Spec. Pap. Geol. Soc. Amer., no. 29, pp. 1-135, pls. 1-13.
- EVITT, W. R.
1951. Some Middle Ordovician trilobites of the families Cheiruridae, Harpidae and Lichidae. Jour. Paleont., vol. 25, pp. 587-616, pls. 85-88, 1 fig.
1961. Early ontogeny in the trilobite family Asaphidae. Jour. Paleont., vol. 35, pp. 986-995, pls. 117-118, figs. 1-6.
- HADDING, A.
1913. Släktet *Telephus* Barr. Geol. Fören. Förhandl., vol. 35, pp. 25-50, pls. 1, 2.
- HALL, J.
1847. Descriptions of the organic remains of the lower division of the New-York system. Palaeont. New York, vol. 1, xxiii + 338 pp., 87 pls.
- HARRINGTON, H. J.
1962. Paleogeographic development of South America. Bull. Amer. Assoc. Petrol. Geol., vol. 46, pp. 1773-1814, figs. 1-34.
- HARRINGTON, H. J., AND A. F. LEANZA
1957. Ordovician trilobites of Argentina. Dept. Geol., Univ. Kansas, Spec. Pub. no. 1, pp. 1-276, figs. 1-140.
- HENNINGSMOEN, G.
1957. The trilobite family Olenidae. Skr. Norske Vid.-Akad. Oslo, 1 Mat.-Nat. Kl., no. 1, pp. 1-303, pls. 1-31, figs. 1-19.
1959. Rare Tremadocian trilobites from Norway. Norsk Geol. Tids., vol. 39, pp. 153-173, pls. 1-2.
1960. The Middle Ordovician of the Oslo region, Norway. 13. Trilobites of the family Asaphidae. Norsk Geol. Tids., vol. 40, pp. 203-257, pls. 1-14, figs. 1-5.
- HINTZE, L. F.
1953. Lower Ordovician trilobites from western Utah and eastern Nevada. Utah Geol. Mineral. Surv., Bull. 48, pp. 1-249, pls. 1-28.
- HINTZE, L. F., and V. JAANUSSON
1956. Three new genera of asaphid trilobites from the Lower Ordovician of Utah. Bull. Geol. Institut. Uppsala, vol. 36, pp. 51-57.
- HOLM, G.
1886. Die ostbaltischen Illaeniden. Revision der ostbaltischen silurischen Trilobiten, von F. Schmidt, Abt. III. Mém. Acad. Sci. St.-Pétersbourg, VII ser., vol. 33, pp. 1-173, pls. 1-12.
- HOWELL, B. F.
1947. Trilobite genus *Cybele*, in Ordovician of North America. Bull. Wagner Free Instit. Sci., vol. 22, pp. 11-16, pl. 1.

HUPÉ, P.

1953. Classe des Trilobites. *In* *Traité de Paléontologie*, vol. 3, pp. 44-246, Ed. J. Piveteau. Paris.

JAANUSSON, V.

- 1953a. Untersuchungen über baltoskandische Asaphiden. I. *Ark. f. Mineral. Geol.*, vol. 1, no. 14, pp. 377-464, pls. 1-10.
- 1953b. Untersuchungen über baltoskandische Asaphiden. II. *Ark. f. Mineral. Geol.*, vol. 1, no. 15, pp. 465-499, pls. 1-6.
1954. Zur Morphologie und Taxonomie der Illaeniden *Ark. f. Mineral. Geol.*, vol. 1, no. 20, pp. 545-583, pls. 1-3, 19 figs.
1956. Untersuchungen über baltoskandische Asaphiden. III. *Bull. Geol. Institut. Uppsala*, vol. 36, pp. 59-77, pl. 1, 3 figs.
1957. Unterordovizische Illaeniden aus Skandinavien. *Bull. Geol. Institut. Uppsala*, vol. 37, pp. 79-165, pls. 1-10, 26 figs.
1960. Graptoloids from the Ontikan and Viruan (Ordov.) limestones of Estonia and Sweden. *Bull. Geol. Institut. Uppsala*, vol. 38, pp. 289-366, pls. 1-5, 9 figs.

KAY, N.

1962. Classification of Ordovician Chazyan shelly and graptolite sequences from Central Nevada. *Bull. Geol. Soc. Amer.*, vol. 73, pp. 1421-1429, figs. 1, 2.

KIELAN, Z.

1957. On the trilobite family Staurocephalidae. *Acta Palaeont. Polonica*, vol. 2, pp. 155-180, pls. 1-6.

KOBAYASHI, T.

1955. The Ordovician fossils from the McKay Group in British Columbia, Western Canada. *Jour. Fac. Sci., Univ. Tokyo*, sec. 2, vol. 9, pt. 3, pp. 355-493, pls. 1-9.

LAKE, P.

1906. A monograph of the British Cambrian trilobites. *Paleontogr. Soc.*, London, pp. 1-350, pls. 1-47.

LINDSTRÖM, G.

1901. Researches on the visual organs of the trilobites. *Kongl. Svenska Vet.-Akad. Handl.*, vol. 34, no. 8, pp. 1-86, pls. 1-6.

LOGAN, W. E.

1863. Geology of Canada. *Geol. Surv. Canada, Rept. Prog. to 1863*, pp. xxvii + 983, 498 figs., atlas.

MERRIAM, C. W.

1963. Paleozoic rocks of Antelope Valley, Eureka and Nye counties, Nevada. *Prof. Pap., U.S. Geol. Surv.*, vol. 423, pp. 1-67, pls. 1, 2, figs. 1-8.

MOBERG, J. C., and C. O. SEGERBERG

1906. Bidrag till kändedomen om Ceratopygeregionen. *Lunds univ. Arsskr., N.F., Afd. 2*, vol. 2, pp. 1-113, pls. 1-7.

MOORE, R. C. (Editor)

1959. Treatise on Invertebrate Paleontology, Part O, Arthropoda 1, xix + 560 pp., 415 figs.

NEWELL, N. D.

1949. Comments on paleogeography and nomenclature. Jour. Paleont., vol. 23, pp. 220-223.

NIKOLAISEN, F.

1961. The Middle Ordovician of the Oslo region, Norway. 7. Trilobites of the suborder Cheirurina. Norsk Geol. Tids., vol. 41, pp. 279-310, pls. 1-4.
1963. The Middle Ordovician of the Oslo region, Norway. 14. The trilobite family Telephinidae. Norsk Geol. Tids., vol. 43, pp. 345-400, pls. 1-4, figs. 1-6.

ÖPIK, A.

- 1961a. Alimentary caeca of agnostids and other trilobites. Palaeontology, vol. 3, pp. 410-438, pls. 68-70, 16 figs.
- 1961b. The geology and palaeontology of the headwaters of the Burke River, Queensland. Dept. Nat. Devel., Bur. Miner. Res., Geol. Geophys., Bull. 53, pp. 1-249, pls. 1-24, figs. 1-59.

PALMER, A. R.

1955. Upper Cambrian Agnostidae of the Eureka district, Nevada. Jour. Paleont., vol. 29, pp. 86-101, pls. 19, 20, 2 figs.
1962. *Glyptagnostus* and associated trilobites in the United States. Prof. Pap., U.S. Geol. Surv., vol. 374-F, pp. 1-49, pls. 1-6, figs. 1-14.

PRANTL, F., and A. PŘIBYL

1948. Classification of some Bohemian Cheiruridae (Trilobitae). Sborn. Národní Mus. Praze, vol. 3B, no. 1, pp. 1-44, pls. 1-6.
1949. On the genus *Symphysurus* Goldfuss and allied forms from the Ordovician of Bohemia. Věstník Královské české spol. nauk, Tr. mat.-přírod., Ročník 1948, vol. 12, pp. 1-15, pls. 1, 2.

RASETTI, F.

1944. Upper Cambrian trilobites from the Lévis conglomerate. Jour. Paleont., vol. 18, pp. 229-258, pls. 36-39.
1952. Cephalic sutures in the Upper Cambrian trilobite *Entomaspis*. Jour. Paleont., vol. 26, pp. 797-802, pl. 117.
1954. Phylogeny of the Cambrian trilobite family Catilliecephalidae and the ontogeny of *Welleraspis*. Jour. Paleont., vol. 28, pp. 599-612, pl. 62, 4 figs.

RAYMOND, P. E.

1905. The trilobites of the Chazy limestone. Ann. Carnegie Mus., vol. 3, pp. 328-386, pls. 10-14.
1910. Trilobites of the Chazy of the Champlain Valley. Rep. Vermont Geol. Surv., No. 7, pp. 213-248, pls. 32-39.
1914. The succession of faunas at Lévis, P.Q. Amer. Jour. Sci., ser. 4, vol. 38, pp. 523-530.

1920. Some new Ordovician trilobites. *Bull. Mus. Comp. Zool.*, vol. 64, no. 2, pp. 273-296.
1925. Some trilobites of the lower Middle Ordovician of eastern North America. *Bull. Mus. Comp. Zool.*, vol. 67, no. 1, pp. 1-180, pls. 1-10.
- REED, F. R. C.
1903. The lower Palaeozoic trilobites of the Girvan District, Ayrshire. Pt. 1. *Palaeontogr. Soc.*, pp. 1-48, pls. 1-6.
- RICHARDSON, E. S.
1948. Paleogeography and nomenclature. *Jour. Paleont.*, vol. 22, pp. 369-370.
- ROSS, R. J.
1951. Stratigraphy of the Garden City formation in northeastern Utah, and its trilobite faunas. *Bull. Peabody Mus. Natur. Hist., Yale Univ.*, No. 6, pp. 1-161, pls. 1-36.
- RUEDEMANN, R.
1926. The Utica and Lorraine formations of New York. Pt. 2, Systematic paleontology, no. 2, mollusks, crustaceans and eurypterids. *Bull. N.Y. State Mus.*, No. 272, pp. 1-227, pls. 1-28
- SCHMIDT, F.
1881. Revision der ostbaltischen Silurischen Trilobiten. Pt. 1. Phacopiden, Cheiruriden, und Enerinuriden. *Mém. Acad. Sci. St.-Pétersbourg*, ser. 7, vol. 30, no. 1, pp. 1-237, pls. 1-16, figs. 1-16.
1904. Revision der ostbaltischen Silurischen Trilobiten. Pt. 5, Asaphiden, sec. 3. *Op. cit.*, ser. 8, vol. 14, no. 10, pp. 1-68, pls. 1-8, figs. 1-6.
1907. Revision der ostbaltischen Silurischen Trilobiten. Pt. 6. *Op. cit.*, ser. 8, vol. 20, no. 8, pp. 1-104, pls. 1-3, figs. 1-15.
- SCHUCHERT, C., and C. O. DUNBAR
1934. Stratigraphy of western Newfoundland. *Mem. Geol. Soc. Amer.*, vol. 1, vii + 123 pp., 11 pls., 8 figs.
- SDZUY, K.
1955. Die Fauna der Leimitz-Schiefer (Tremadoc). *Abh. senckenb. naturf. Gesell.*, vol. 492, pp. 1-74, pls. 1-8, figs. 1-48.
- SHAW, A. B.
1950. Paleogeography and nomenclature — another commentary. *Jour. Paleont.*, vol. 24, pp. 110-111.
1951. The paleontology of northwestern Vermont. 1. New late Cambrian trilobites. *Jour. Paleont.*, vol. 25, pp. 97-114, pls. 21-24.
1956. Quantitative trilobite studies. 1. The statistical description of trilobites. *Jour. Paleont.*, vol. 30, pp. 1209-1224.
- SIEGFRIED, P.
1936. Über das pandersche Organ bei den Asaphiden des ostbaltischen Ordoviciums. *Eessti Loodusteaduse Arhiiv*, ser. 1, vol. 11, pp. 1-42, pls. 1-10.

SIMPSON, G. G.

1960. Notes on the measurement of faunal resemblance. Amer. Jour. Sci., Bradley volume, vol. 258-A, pp. 300-311.

SINCLAIR, G. W.

1949. The Ordovician trilobite *Eobronteus*. Jour. Paleont., vol. 23, pp. 45-56, pls. 12-14.

SKJESETH, S.

1955. The Middle Ordovician of the Oslo region, Norway. 5. The trilobite family Styginidae. Norsk Geol. Tids., vol. 35, pp. 9-28, pls. 1-5, 2 figs.

ŠNAJDR, M.

1957. Classification of the family Illaenidae (Hawle et Corda) in the lower Palaeozoic of Bohemia. Sborník Ů. ú. geol., vol. 23, pp. 125-284, pls. 1-12, 37 figs. (Czech text, English and Russian summaries.)
1960. Studie o čeledi Scutelluidae (Trilobitae). Rozpravy, Ů. ú. geol., vol. 26, 264 pp., 37 pls., 61 figs. (Czech text, English summary.)

STØRMER, L.

1940. Early descriptions of Norwegian trilobites. The type specimens of C. Boeck, M. Sars and M. Esmark. Norsk Geol. Tids., vol. 20, pp. 113-151, pls. 1-3.
1953. The Middle Ordovician of the Oslo region, Norway. 1. Introduction to stratigraphy. Norsk Geol. Tids., vol. 31, pp. 37-141, pls. 1-6, 16 figs.

STUBBLEFIELD, C. J.

1926. Notes on the development of a trilobite, *Shumardia pusilla* (Sars). Jour. Linnean Soc. London, Zool., vol. 36, pp. 345-372, pls. 14-16.
1950. A new komaspid trilobite genus of wide distribution in early Ordovician times. Ann. Mag. Nat. Hist., ser. 12, vol. 3, pp. 341-352, 451-452, pl. 2.

SUTHERLAND, P. K., and T. W. AMSDEN

1959. A re-illustration of the trilobite *Lonchodomas megeheeii* Decker from the Bromide Formation (Ordovician) of southern Oklahoma. Oklahoma Geol. Notes, vol. 19, no. 10, pp. 212-219, pls. 1, 2, figs. 1-3.

TEMPLE, J. T.

1956. Notes on the Cheiruracea and Phacopacea. Geol. Mag., vol. 93, pp. 418-430, figs. 1, 2.

TJERNVIK, T. E.

1956. On the early Ordovician of Sweden. Stratigraphy and fauna. Bull. Geol. Institut. Uppsala, vol. 36, pp. 107-284, pls. 1-11, 45 figs.

TRIPP, R. P.

1962. Trilobites from the "Confinis" Flags (Ordovician) of the Girvan District, Ayrshire. Trans. Roy. Soc. Edinburgh, vol. 65, pp. 1-40, pls. 1-4.

TROEDSSON, G. T.

1937. On the Cambro-Ordovician faunas of western Quruq tagh, eastern T'ien-shan. Palaeontol. Sinica, new ser. B, no. 2, pp. 1-74, pls. 1-10.

ULRICH, E. O.

1930. Ordovician trilobites of the family Telephidae and concerned stratigraphic correlations. Proc. U.S. Nat. Mus., vol. 76, pp. 1-101, pls. 1-8.

WESTERGÅRD, A. H.

1946. Agnostidea of the Middle Cambrian of Sweden. Sveriges Geol. Unders, ser. C, no. 477, Arsb. 40, pp. 1-140, pls. 1-16.

WHITTARD, W. F.

1938. The Upper Valentian trilobite fauna of Shropshire. Ann. Mag. Nat. Hist., ser. 11, vol. 1, pp. 85-140, pls. 2-5.
1955. The Ordovician trilobites of the Shelve Inlier, West Shropshire, 1961. Parts 1-6. Palaeontogr. Soc., London, pp. 1-228, pls. 1-33.

WHITTINGTON, H. B.

1941. Silicified Trenton trilobites. Jour. Paleont., vol. 15, pp. 492-522, pls. 72-75, figs. 1-13.
1948. A new Lower Ordovician trilobite. Jour. Paleont., vol. 22, pp. 567-572, pls. 82-83.
1950. Sixteen Ordovician genotype trilobites. Jour. Paleont., vol. 24, pp. 531-565, pls. 68-75, figs. 1-9.
1952. The trilobite family Dionididae. Jour. Paleont., vol. 26, pp. 1-11, pls. 1, 2.
1953. North American Bathyruridae and Leiostegiidae (Trilobita). Jour. Paleont., vol. 27, pp. 647-678, pls. 65-69, 5 figs.
1954. Ordovician trilobites from Silliman's Fossil Mount, in Miller, A. K., Youngquist, W., and Collinson, C., Ordovician cephalopod fauna of Baffin Island. Mem. Geol. Soc. Amer., vol. 62, pp. 119-149, pls. 59-63.
1956. Silicified Middle Ordovician trilobites: The Odontopleuridae. Bull. Mus. Comp. Zool., vol. 114, pp. 155-288, pls. 1-24, figs. 1-25.
1957. Ontogeny of *Elliptocephala*, *Paradoxides*, *Sao*, *Blainia*, and *Triarthrus* (Trilobita). Jour. Paleont., vol. 31, pp. 934-946, pls. 115, 116.
1959. Silicified Middle Ordovician trilobites: Remopleuridae, Trinucleidae, Raphiophoridae, Endymioniidae. Bull. Mus. Comp. Zool., vol. 121, pp. 371-496, pls. 1-36, figs. 1-8.

1961. Middle Ordovician Pliomeridae (Trilobita) from Nevada, New York, Quebec, Newfoundland. *Jour. Paleont.*, vol. 35, pp. 911-922, pls. 99-102, 5 figs.
1962. The Ordovician trilobites of the Bala Area, Merioneth. Pt. 1. *Palaeontogr. Soc.*, London, pp. 1-32, pls. 1-8.
1963. Middle Ordovician trilobites from Lower Head, western Newfoundland. *Bull. Mus. Comp. Zool.*, vol. 129, pp. 1-118, pls. 1-36, figs. 1-6.
1965. The Ordovician trilobites of the Bala Area, Merioneth. Pt. 2. *Palaeontogr. Soc.*, London, pp. 33-63, pls. 9-18.
- WHITTINGTON, H. B., and W. R. EVITT
1954. Silicified Middle Ordovician trilobites. *Mem. Geol. Soc. Amer.*, vol. 59, pp. 1-137, pls. 1-33, 27 figs.
- WHITTINGTON, H. B. and C. H. KINDLE
1963. Middle Ordovician Table Head Formation, western Newfoundland. *Bull. Geol. Soc. Amer.*, vol. 74, pp. 745-758, pls. 1, 2, figs. 1-4.
- WILSON, A. E.
1956. A guide to the geology of the Ottawa district. *Canadian Field-Natur.*, vol. 70, pp. 1-68, pls. 1-5, map.

(Received January 7, 1964.)

EXPLANATION OF PLATES 1-68

To make the photographs each specimen and the immediately surrounding area was coated with a dilute "opaque" to give a dull surface, dark gray in colour. A light coating of ammonium chloride was then applied. Small specimens were mounted on pins, and these have been blacked out; otherwise the photographs have not been retouched. It is arbitrarily decided that the plane running through the posterior margin of the occipital or axial ring shall run in the dorsoventral direction, and views are described accordingly. Exterior views have been taken in a direction lying in the sagittal plane to give either the fullest possible view of the exoskeletal surface or to show particular features. Oblique views have been taken in a direction lying at an angle to the sagittal plane.

Abbreviations are explained in the introduction to the systematic section, and localities are given more fully in a separate chapter. In the type section the horizon, where known, is given in terms of feet above the base.

PLATES

PLATE 1

Geragnostus longicollis (Raymond, 1925)

Middle Table Head Formation

Figure

- 1-3 Holotype, internal mould of incomplete pygidium, YPM 13054, original of Raymond, 1925, pl. 1, fig. 5, dorsal, left lateral, posterior views, X 9. Isolated limestone.
- 4-7, 9, 10 Enrolled exoskeleton; oblique view to show thorax, X 15; dorsal views of cephalon, thorax, pygidium, anterior view, right lateral view, X 9. GSC 18378. Table Cove.
- 8, 11, 12, 14 Cephalon with genal spines, posterior, dorsal, anterior, right lateral views, X 9. GSC 18379. Table Cove.
- 16, 17 Internal mould of pygidium showing tubercle at tip of axis, dorsal, posterior views, X 9. GSC 18380. Isolated limestone.
- Geragnostus* sp. ind.
- 13, 15, 18 Pygidium, dorsal, posterior, left lateral views, X 9. GSC 18381. Table Cove.

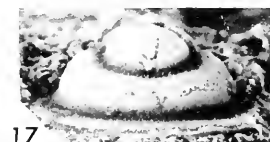
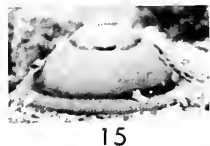
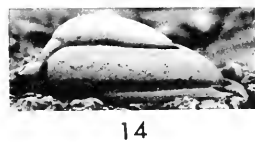
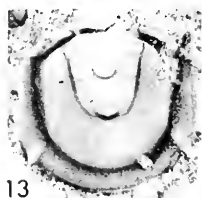
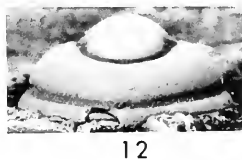
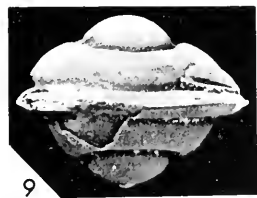
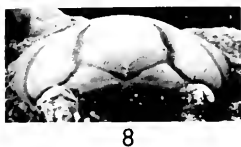
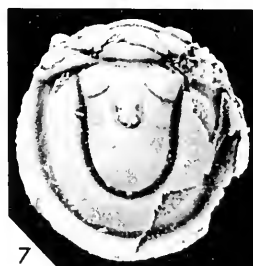
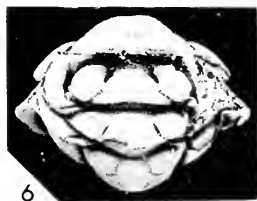
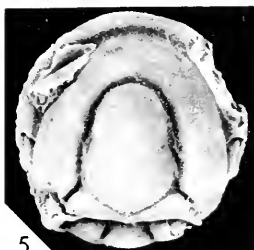
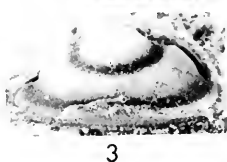
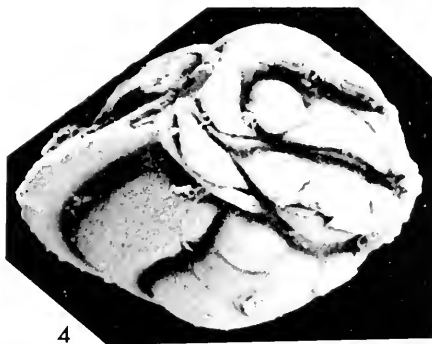
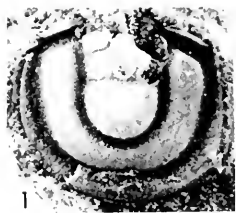

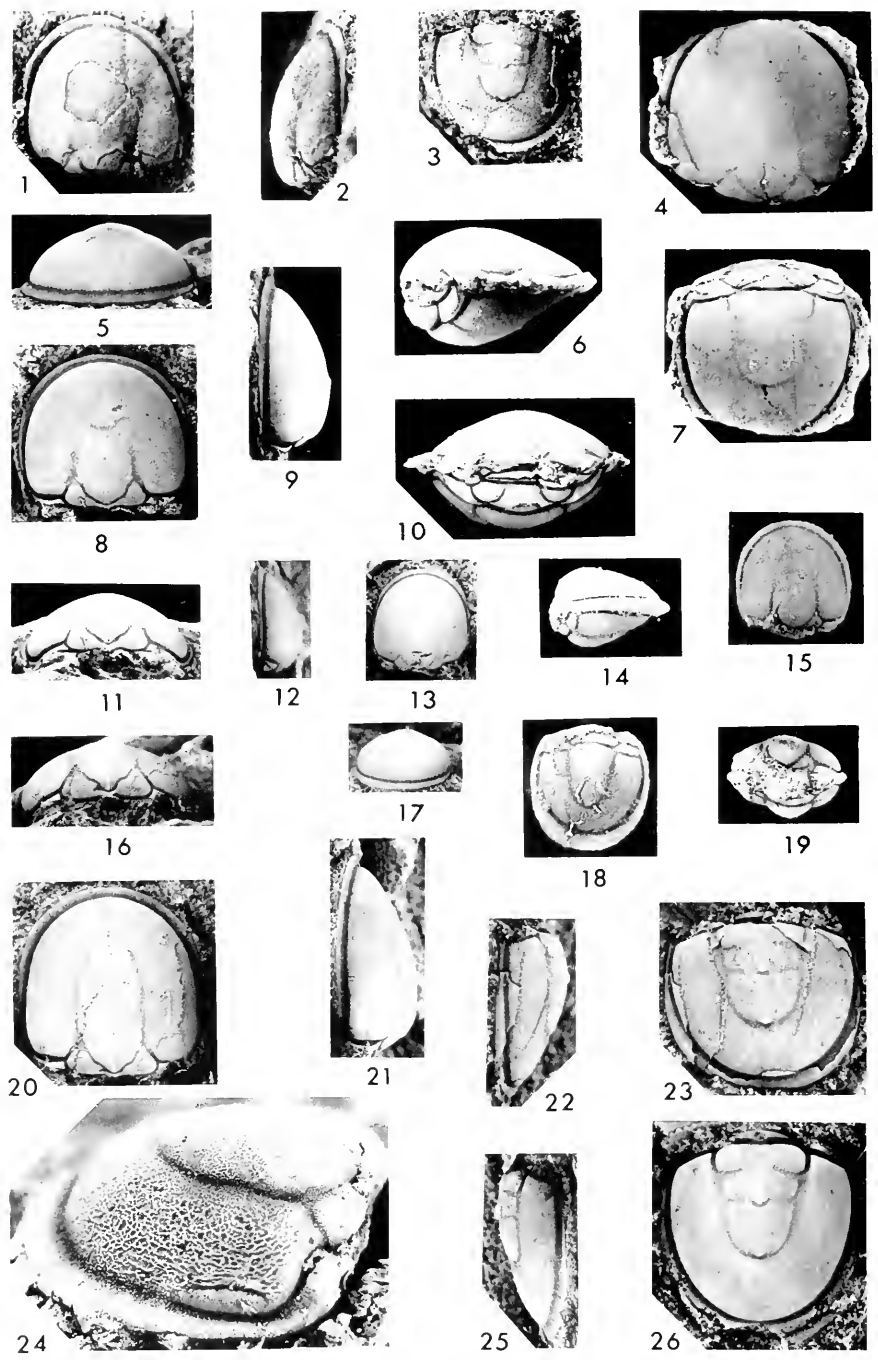

PLATE 2

PLATE 2

Geragnostus fabius (Billings, 1865)

Middle Table Head Formation

Figure

- 1, 2 Lectotype, cephalon, GSC 704c, dorsal, left lateral views, X 6. Daniel's Harbour.
- 3 Paralectotype, pygidium, GSC 704d, dorsal view, X 6. Locality same as lectotype.
- 4, 6, 7, 10 Large enrolled exoskeleton compressed so that margins are damaged and first thoracic segment hidden, dorsal view of cephalon, right lateral view, dorsal view of pygidium, dorsal view of second thoracic segment, X 9. GSC 18389. Daniel's Harbour.
- 5, 8, 9, 11 Internal mould of cephalon, anterior, dorsal, left lateral, posterior views, X 6. GSC 18382. Daniel's Harbour.
- 12, 13, 17 Small cephalon, left lateral, dorsal, anterior views, X 9. GSC 18383. Daniel's Harbour.
- 14, 15, 18, 19 Enrolled meraspid 1 exoskeleton, right lateral view, dorsal views of cephalon, pygidium, thorax, X 15. GSC 18388. Type section, 215 feet.
- 16, 20, 21 Internal mould of cephalon, posterior, dorsal, left lateral views, X 6. GSC 18386. Type section, 215 feet.
- 22, 23 Internal mould of short and broad pygidium, left lateral, dorsal views, X 9. GSC 18385. Type section, 215 feet.
- 25 Internal mould of pygidium, right lateral view, X 6. GSC 18387. Type section, 215 feet.
- 26 Internal mould of relatively long and narrow pygidium, dorsal view, X 9. GSC 18384. Daniel's Harbour.

Galbagnostus galba (Billings, 1865)

Middle Table Head Formation

- 24 Cephalon, oblique left view showing raised lines and smooth posterolateral area of cheek, X 15. GSC 18392. Table Cove.

PLATE 3

Galbagnostus galba (Billings, 1865)

Middle Table Head Formation

- Figure
1, 2, 4, Lectotype, incomplete cephalon, GSC 689b, dorsal, right
5, 12, 14 lateral, posterior, anterior views, X 6; dorsal view of glabella
 showing part of external surface with raised lines and
 smooth muscle areas, X 15; oblique view showing faint
 caeca crossing border furrow, X 15. Type section.
- 3, 7, 8, Cephalon with external surface preserved, showing reticulate
10, 15 raised lines, smooth muscle areas on glabella, and smooth
 posterolateral area on cheek; posterior view, X 15; anterior,
 right lateral views, X 9; left oblique view, X 15. GSC
 18391. Table Cove.
- 6, 9, 11 Small cephalon dorsal, right lateral, posterior views, X 9.
 GSC 18390. Isolated limestone.
- 13 Internal mould of cephalon, right lateral view showing raised,
 smooth posterolateral area of cheek, X 15. GSC 18393. Type
 section, 90 feet.

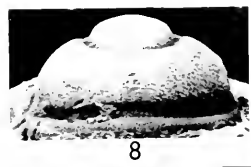
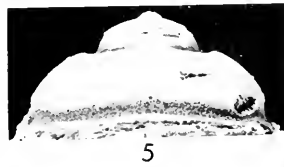
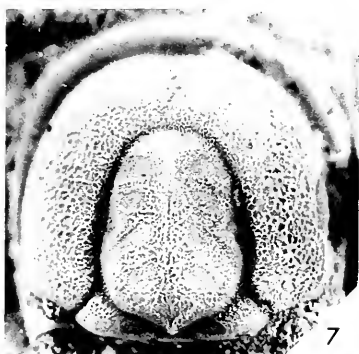
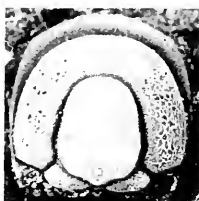
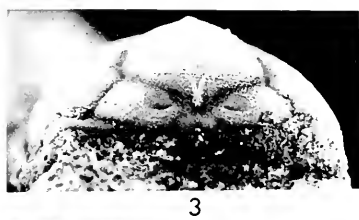
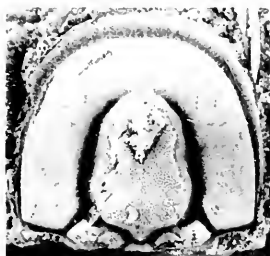

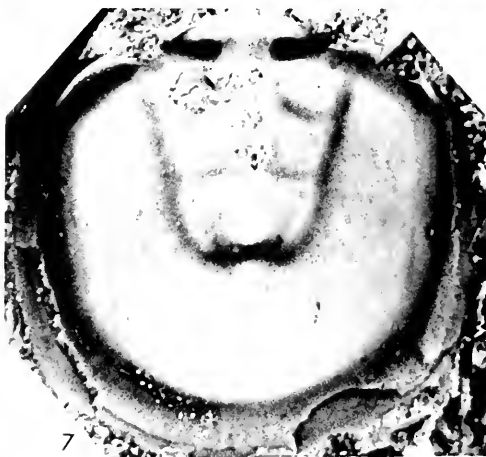
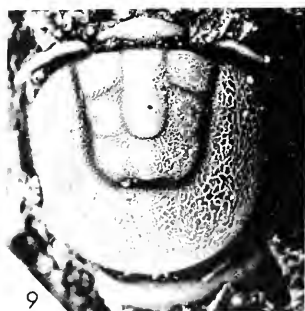
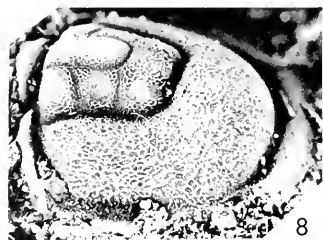
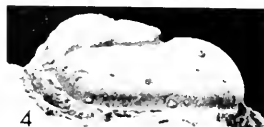
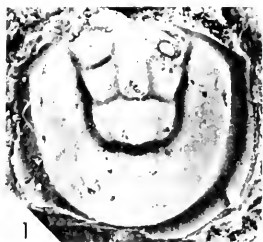

PLATE 4

Galbagnostus galba (Billings, 1865)
Middle Table Head Formation

- Figure
1, 2, 4 Paralectotype, exfoliated pygidium, GSC 689e, dorsal, posterior, left lateral views, X 9. Type section.
- 3 Internal mould of pygidium, dorsal view showing V-shaped row of pits behind tip of axis and caeca crossing border furrow, X 15. GSC 18394. Type section, 90 feet.
- 5, 6, 8, 9 Pygidium, left lateral, posterior views, X 9; left oblique, dorsal views, X 15, showing raised lines on external surface and smooth muscle areas on axis. GSC 18395. Table Cove.
- 7, 10 Exfoliated pygidium, dorsal and left oblique views, X 15, showing tubercle and furrow at tip of axis, pits behind axis, and caeca crossing border furrow. GSC 18396. Table Cove.

PLATE 5

Harpides atlanticus Billings, 1865
Middle Table Head Formation

Figure

- 1 Holotype, anterior portion of glabella and fringe, GSC 674 (counterpart 674c), original of Billings, 1865, fig. 267, dorsal view, X 3. Daniel's Harbour.
- 2, 3, 4 Incomplete cranidium, right lateral, dorsal, anterior views, X 4. GSC 18397. Table Cove.



1



2

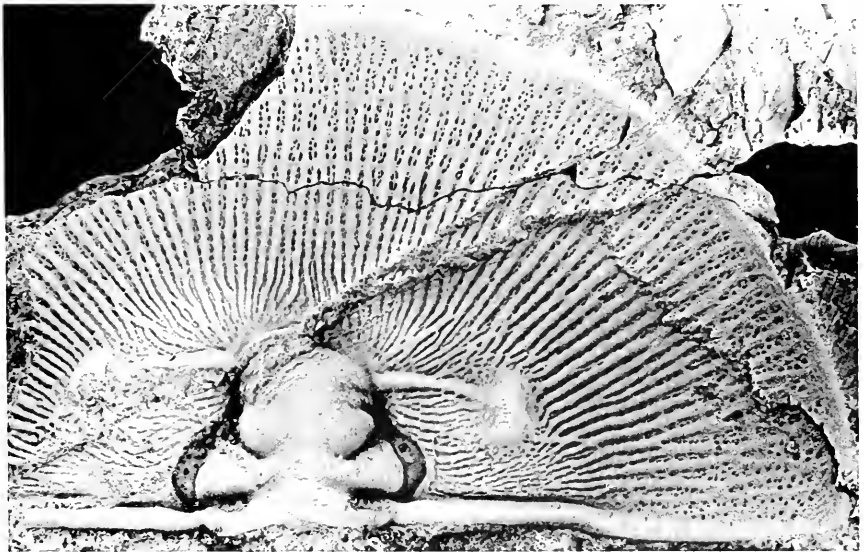

3



4

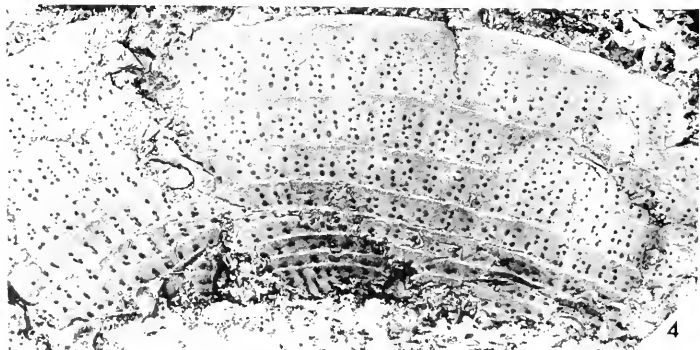
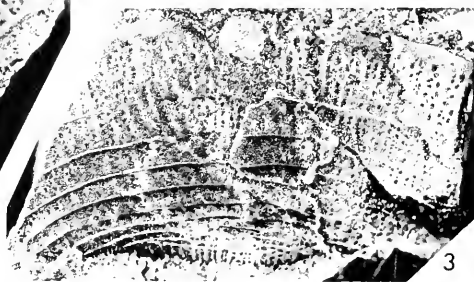

PLATE 6

Harpides atlanticus Billings, 1865
Middle Table Head Formation

Figure

- 1 Original of Plate 5, figs. 2-4, right oblique view, X 6.
- 2 Part of right side of lower lamella of fringe, exterior view, X 6, GSC 18400. Type section, 265 feet.
- 3 Anterior portion of lower lamella of fringe, GSC 672, original of Billings, 1865, fig. 268, exterior view, X 4. Daniel's Harbour.
- 4 Anterior portion of lower lamella of fringe, exterior view, X 4½. GSC 18401. Table Cove.

PLATE 7

Harpides atlanticus Billings, 1865
Middle Table Head Formation

Figure

- 1, 3 Incomplete cranidium showing marginal rim of upper lamella at right anterior; dorsal view, X $4\frac{1}{2}$; oblique view of left eye lobe, X 15. GSC 18398. Table Cove.
- 2, 4 Cast of external mould of part of cranidium, dorsal view, X $4\frac{1}{2}$, right oblique view showing eye lobe and ridge, X 10. GSC 18399. Table Cove.

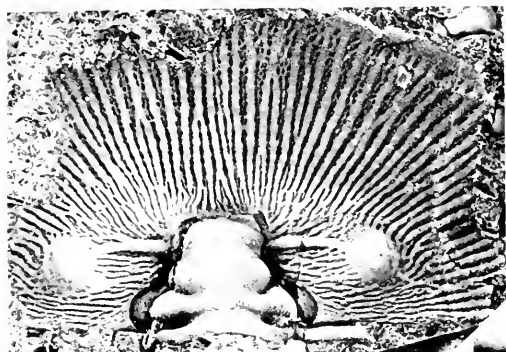

1

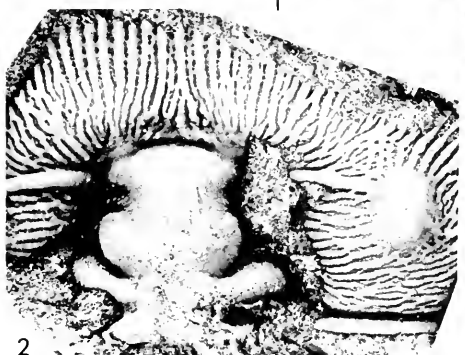

2

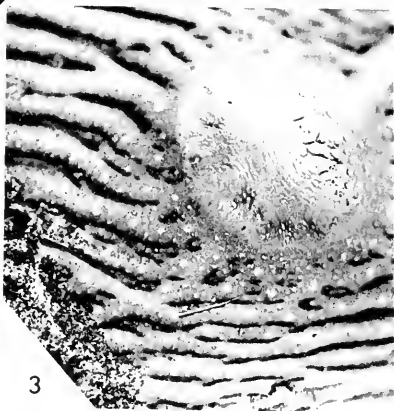

3

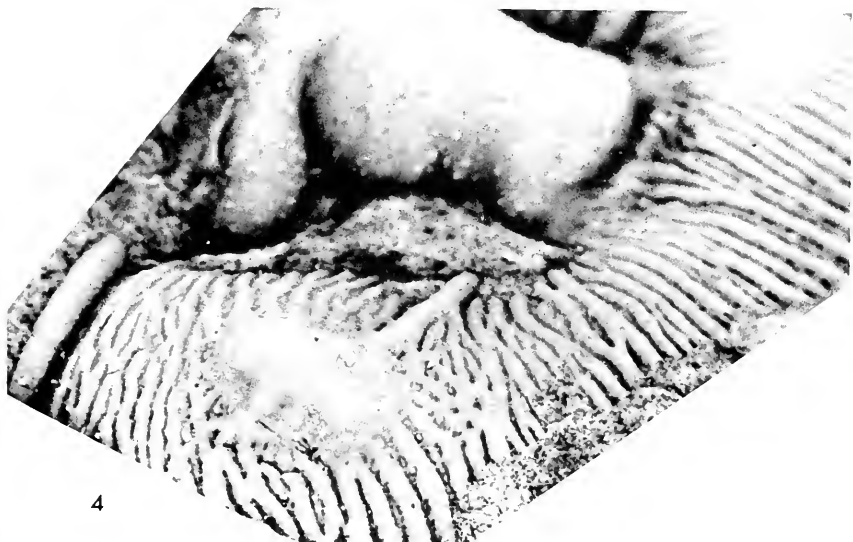

4

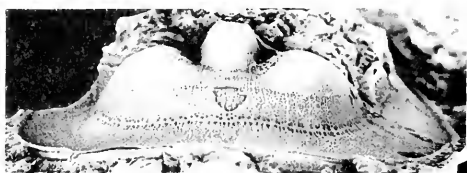
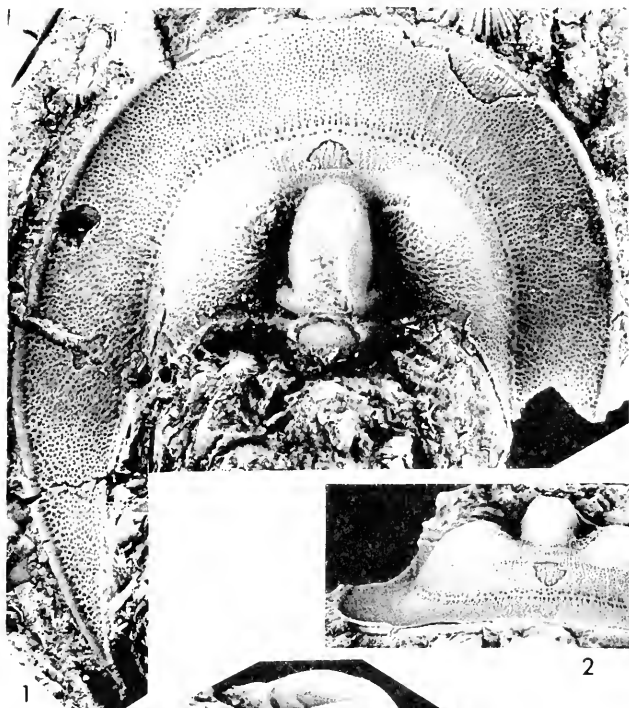

PLATE 8

Selenoharpes singularis n. sp.

Middle Table Head Formation, Table Cove

Figure

1-4

Holotype, incomplete cephalon, GSC 18402; dorsal view, X 6;
anterior view, X 4½; right lateral, left oblique views, X 6.

PLATE 9

Selenoharpes singularis n. sp.

Middle Table Head Formation, Table Cove

- Figure
1 Fringe of incomplete cephalon showing caeca, dorsal view, X 4½. GSC 18404.
2, 3, 5 Incomplete small cephalon, dorsal, left lateral, anterior views, X 12. GSC 18405.
4, 6 Fragment of cephalon, fringe without prominently developed caeca, and outer lamella steeply sloping anteriorly, right lateral, dorsal views, X 8. GSC 18403.

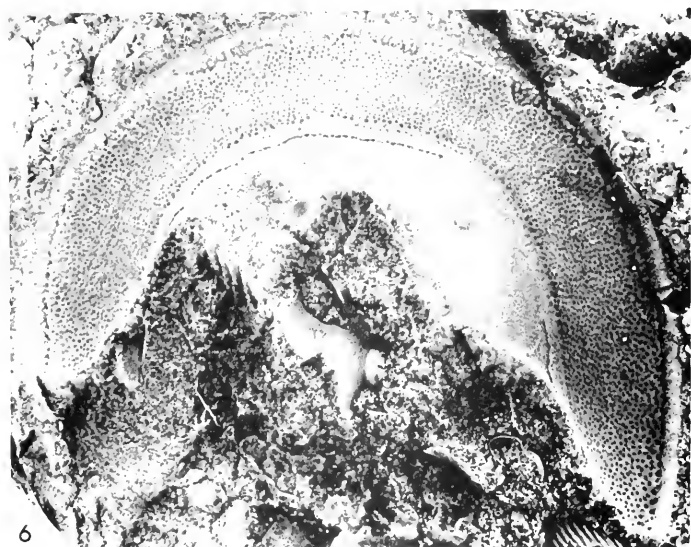
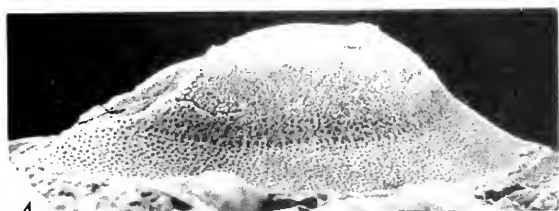
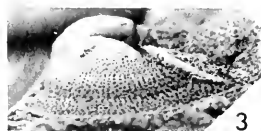

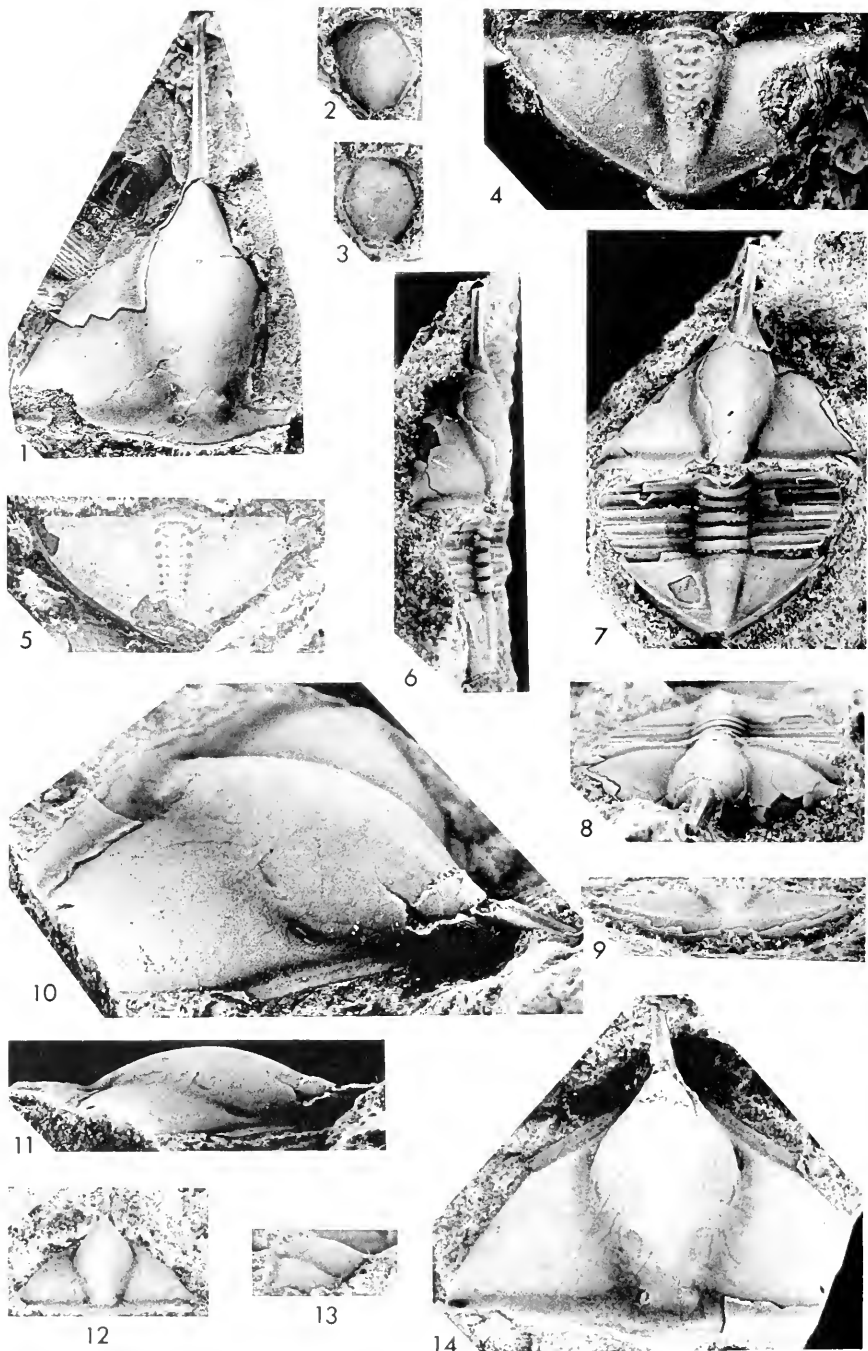

PLATE 10

PLATE 10

Lonchodomas normalis (Billings, 1865)
Middle Table Head Formation

Figure

- 1 Lectotype, incomplete and exfoliated cranium, GSC 692, dorsal view, X 4. Daniel's Harbour.
- 2 Incomplete hypostome, external view, X 6. GSC 18409. Type section, 258 feet.
- 3 Incomplete hypostome, external view, X 6. GSC 18410. Type section, 258 feet.
- 4 Paralectotype, internal mould of incomplete pygidium, GSC 692a, dorsal view, X 4. Locality as lectotype.
- 5 Pygidium, dorsal view photographed under alcohol to show muscle areas, X 4.5. GSC 18411. Type section, 90 feet.
- 6-8 Exoskeleton lacking free cheeks, left lateral, dorsal, anterior views, X 4.5. GSC 18406. Type section, 185 feet.
- 10, 11, 14 Internal mould of cranium; oblique view to show muscle areas and genal caeca, X 9; right lateral, dorsal views, X 6. GSC 18407. Type section, 185 feet.
- 9 Exfoliated pygidium, posterior view, X 4.5. GSC 18412. Type section, 185 feet.
- 12, 13 Small cranium, dorsal, right lateral views, X 6. GSC 18408. Isolated limestone.

PLATE 11

Lonchodomas clavulus n. sp

Middle Table Head Formation, type section, 17 feet above base,
except original of figure 10, from isolated limestone

Figure

- | | |
|---------|----------------------------------------------------------------------------------------------------|
| 1, 2, | Holotype, partly exfoliated cranidium, GSC 18413; dorsal, |
| 5, 13 | right lateral, oblique views, X 3; left oblique view to show
muscle areas and genal caeca, X 6. |
| 3 | Cranidium lacking frontal glabellar spine, anterior view,
X 3. GSC 18414. |
| 4, 6, 7 | Pygidium, dorsal, posterior, left lateral views, X 3. GSC
18418. |
| 8 | Small pygidium, dorsal view, X 4. GSC 18419. |
| 9 | Incomplete cephalic doublure, ventral view, X 4. GSC 18415. |
| 10 | Pygidium, dorsal view, X 4. GSC 18420. |
| 11, 12 | Hypostome, exterior, right lateral views, X 3. GSC 18416. |
| 14 | Hypostome, exterior view, X 6. GSC 18417. |

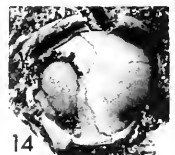
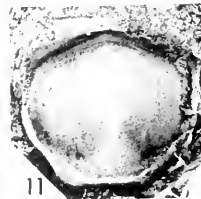
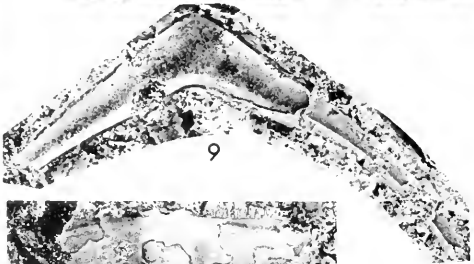
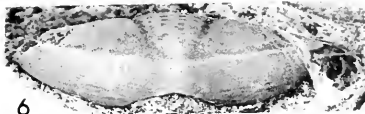
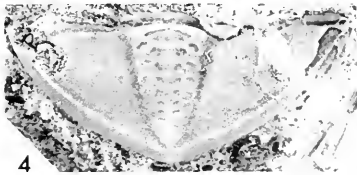
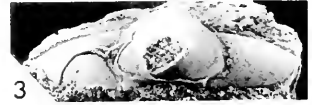
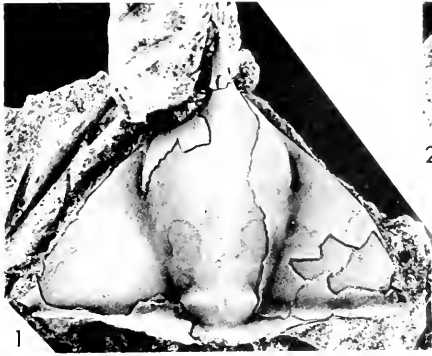

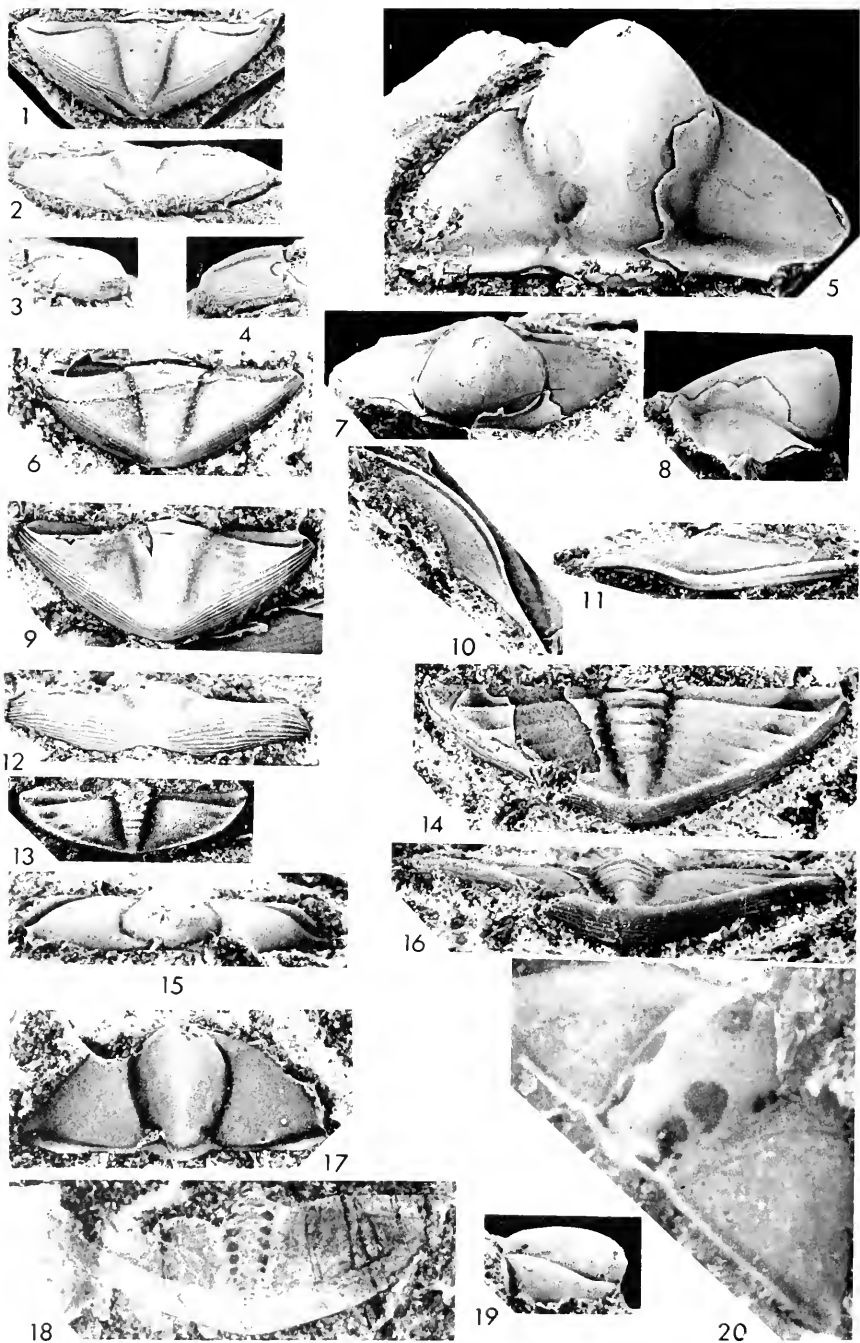

PLATE 12

PLATE 12

Ampyx laeviusculus Billings, 1865

Middle Table Head Formation, all except original of figures 1, 2, 4, from 90 feet above base at type section.

Figure

- 1, 2, 4 Lectotype, pygidium with exoskeleton, GSC 693, dorsal, posterior, right lateral views, X 3. Type section.
- 5, 7, 8 Partly exfoliated cranidium, dorsal view, X 6; anterior, right lateral views, X 4. GSC 18423.
- 3, 6 Internal mould of pygidium, left lateral, dorsal views, X 6. GSC 18421.
- 10, 11 Incomplete free cheek, exterior, lateral views, X 6. GSC 18424.
- 9, 12 Pygidium, dorsal, posterior views, X 6. GSC 18422.

Ampyxoides semicostatus (Billings, 1865)

Middle Table Head Formation

- 13 Lectotype, internal mould of pygidium, GSC 690, dorsal view, X 4. Daniel's Harbour.
- 14, 16 Pygidium with exoskeleton, dorsal, posterior views, X 9. GSC 18425. Daniel's Harbour.
- 15, 17, 19 Small cranidium, anterior, dorsal, right lateral views, X 9. GSC 18426. Daniel's Harbour.
- 18 Incomplete pygidium, photographed under alcohol, showing muscle areas of axis as dark patches, X 6. GSC 18428. Type section, 90 feet.
- 20 Oblique view of cranidium photographed under alcohol and showing muscle areas as dark patches, X 15. The dark area at the base of the frontal spine is where the exoskeleton is broken away, and not a muscle area. GSC 18427. Daniel's Harbour.

PLATE 13

Ampyxoides semicostatus (Billings, 1865)

Middle Table Head Formation

Figure

- 1 External mould of entire specimen, showing genal spine, exterior view, X 3. GSC 18429. Black Cove.
- 2 Exfoliated, incomplete exoskeleton, dorsal view, X 4.5. GSC 18430. Type section, 185 feet.
- 3 Oblique view of incomplete cranidium showing frontal glabellar spine, X 6. GSC 18433. Type section, 130 feet.
- 4-7 Cranidium with exoskeleton, glabellar spine broken off at base, anterior, dorsal, right lateral, oblique views, X 4.5. GSC 18434. Type section, 130 feet.
- 8 Incomplete, flattened exoskeleton, ventral view showing narrow cephalic doublure, X 6. GSC 18431. Black Cove.
- 10, 12 Pygidium, dorsal view, X 8; posterior view, X 6. GSC 18432. Type section, 130 feet.

Anisonotella glacialis (Billings, 1865)

Middle Table Head Formation

- 9 Incomplete pygidium, holotype of "*Ampyx*" *rutilius* Billings, 1865, p. 296, GSC 691, dorsal view, X 4. Daniel's Harbour.
- 11 Pygidium, dorsal view, X 4.5. GSC 18436. Daniel's Harbour.
- 13 Lectotype, cranidium, GSC 670e, dorsal view, X 4. Probably from Portland Creek, that is, probably boulders from the Cow Head conglomerate on the shore north of the mouth of the creek.

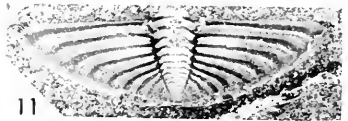
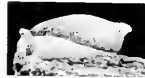
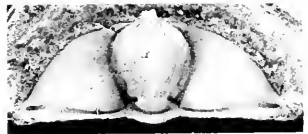
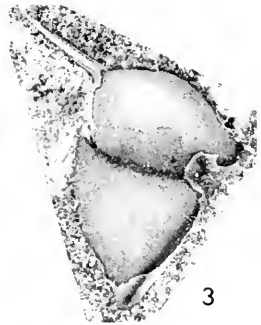
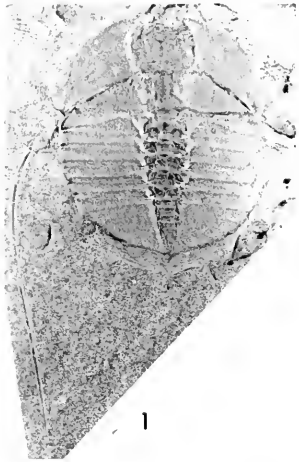

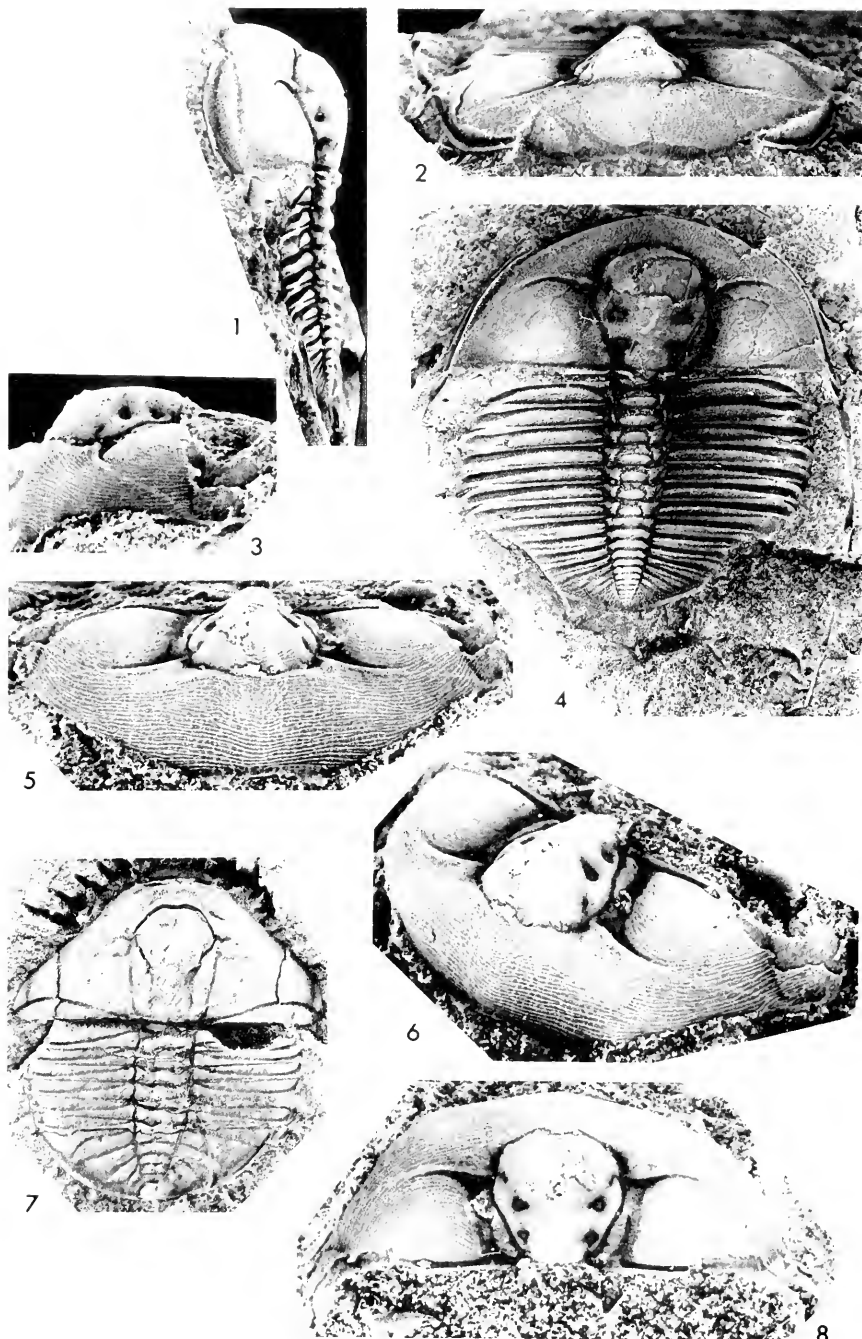

PLATE 14

Anisonotella glacialis (Billings, 1865)

Figure
1, 2, 4

Almost entire exoskeleton with free cheeks slightly displaced, but retaining genal spine on right side, left lateral, anterior, dorsal views, X 4.5. GSC 18435. Middle Table Head Formation, Black Cove.

3, 5
6, 8

Cranidium showing lines on external surface, left lateral, anterior, oblique, dorsal views, X 8. GSC 18437. Conglomerates of Cow Head Group, Daniel's Harbour.

Endymionia sp. ind.

Middle Table Head Formation, Black Cove

7

Flattened exoskeleton lacking free cheeks, dorsal view, X 3. GSC 18438.

PLATE 15

Endymionia schucherti Raymond, 1920
Middle Table Head Formation

- Figure
1, 5 Lectotype, cranidium, YPM 13040, original of Raymond, 1925, pl. 2, fig. 13, anterior, dorsal views, X 3. Type section.
2, 3, 6 Cranidium, anterior, right lateral, dorsal views, X 4.5. GSC 18440. Daniel's Harbour.
4, 7 Exoskeleton lacking free cheeks, anterior, dorsal views, X 4.5. GSC 18443. Type section, 215 feet.
8-10 Small cranidium, dorsal, anterior, left lateral views, X 6. GSC 18444. Type section, 215 feet.
11, 12, 16 Small cranidium, dorsal, anterior, right lateral views, X 12. GSC 18445. Table Cove.
13, 17 Exoskeleton lacking free cheeks, dorsal, left lateral views, X 4.5. GSC 18441. Type section, 215 feet.
14, 15, 20 Smallest cranidium with two thoracic segments, dorsal, right lateral, anterior views, X 15. GSC 18439. Type section, 215 feet.
18 Entire exoskeleton lacking free cheeks, dorsal view, X 4.5. GSC 18442. Type section, 215 feet.

Endymionia meeki (Billings, 1862)

Boulder in conglomerate in Lévis Shale, Point Lévis, Quebec

- 19, 23, 24 Holotype, incomplete exoskeleton, GSC 875, original of Billings, 1862, fig. 84, anterior, dorsal, left lateral views, X 4.5.

Endymionia raymondi n. sp.

Shumardia Limestone, Point Lévis, Quebec

- 21, 22, 25 Holotype, incomplete cranidium, left lateral, anterior, dorsal views, X 7.5. MCZ 1963.

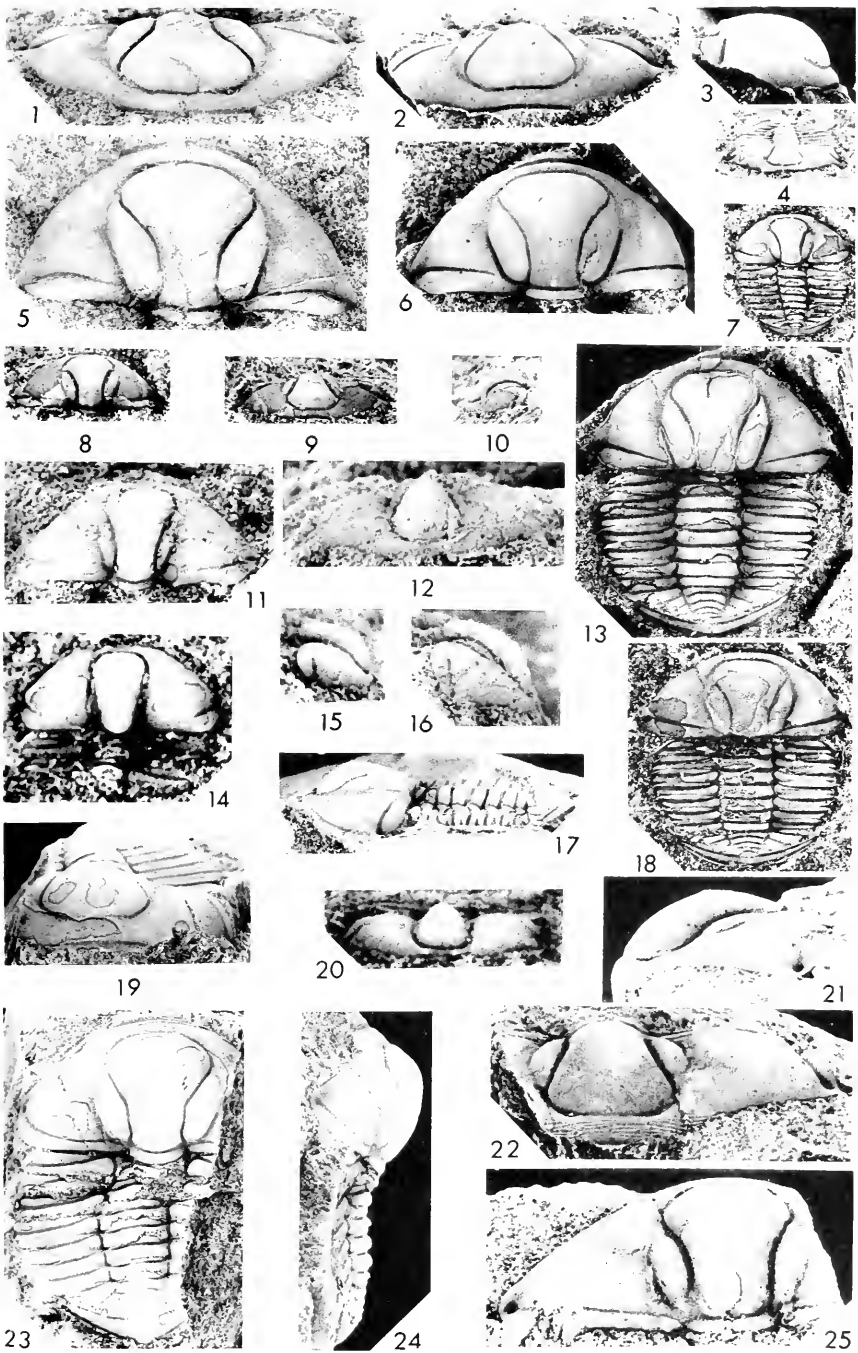



1

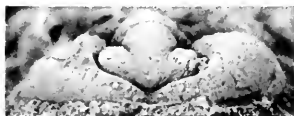

2



3

4

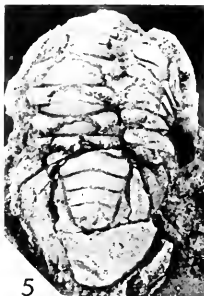

5



6



7



8

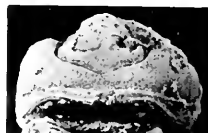

9

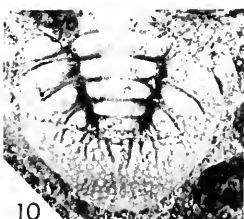

10

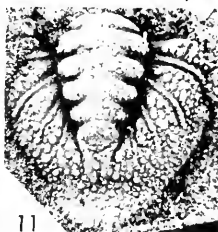

11



12

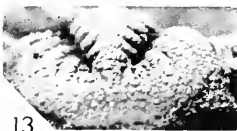

13



14



15

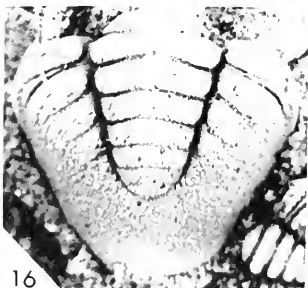

16

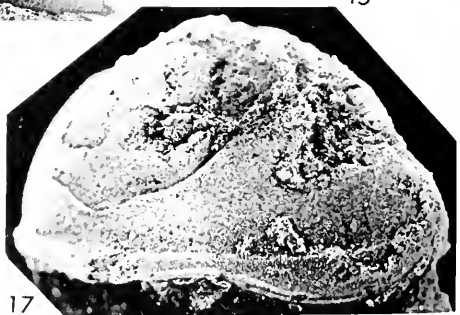

17

PLATE 16

Shumardia granulosa Billings, 1862
Shumardia Limestone, Lévis, Quebec

Figure

- 1-4 Lectotype, internal mould of cranidium, GSC 880, dorsal, anterior views, X 15; oblique view, X 30; right lateral view, X 15.
- 5-9, 17 Incomplete exoskeleton, MCZ 1738, original of Clark, 1924, pl. 9, fig. 3, two dorsal views of thorax and pygidium, right lateral view, dorsal and anterior views of cephalon, X 6; oblique view of cephalon showing cheeks and suture line, X 15.
- 10, 13 Paralectotype, pygidium, GSC 880, dorsal, posterior views, X 15.
- 11 Cast of external mould of pygidium, on same slab as lectotype, dorsal view, X 15. GSC 880.
- 12 Cranidium, dorsal view showing small basal glabellar lobes, X 15. MCZ 5504.
- 15 Cast of external mould of cranidium, oblique view to show basal glabellar lobe, same slab as lectotype, X 15. GSC 880.
- 14, 16 Pygidium, left lateral, dorsal views, X 15. MCZ 5513, original of Clark, 1924, pl. 9, fig. 6.

PLATE 17

Shumardia sagittula n. sp.
Middle Table Head Formation

- Figure
1, 2, Holotype, eranidium, GSC 18448. Anterior, left lateral, dorsal,
5, 6 oblique views, X 15. Table Cove.
3, 4, 8 Cranidium, dorsal, oblique, right lateral views, X 15. GSC
18447. Table Cove.
7, 11, 12 Cranidium, dorsal, anterior, right lateral views, X 15. GSC
18446. Type section, 258 feet.

Lcioshumardia minima n. gen., n. sp.
Middle Table Head Formation

- 9, 10, 13 Holotype, eranidium, GSC 18450, anterior, dorsal, left lateral
views, X 15. Table Cove.
15-17 Small eranidium, dorsal, anterior, left lateral views, X 15.
GSC 18449. Type section, 190 feet.

Triarthrus fischeri Billings, 1865
Middle Table Head Formation

- 14 Cranidium shown in lower part of figure is lectotype, GSC
678e, dorsal view, X 4. Pistolet Bay.
18 Cephalon, flattened and viewed from ventral side, showing
narrow cephalic doublure which shows no connective sutures,
X 4.5. GSC 18453. Black Cove.
19 Flattened eranidium, dorsal view (compare figure 20), X 4.5.
GSC 18452. Black Cove.
20, 21 Incomplete exoskeleton lacking free cheeks, dorsal, left lateral
views, X 6. GSC 18451. Type section, 185 feet.



1



2



3

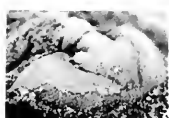

4

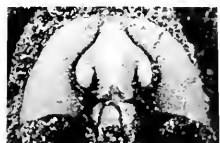

5

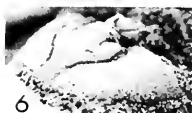

6



7

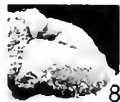

8

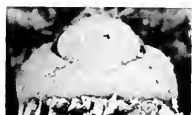

9



10



11



12



13



14



15

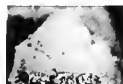

16

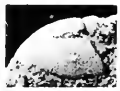

17



18

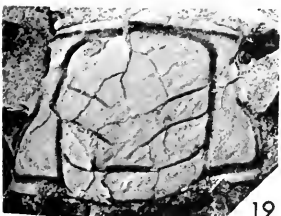

19

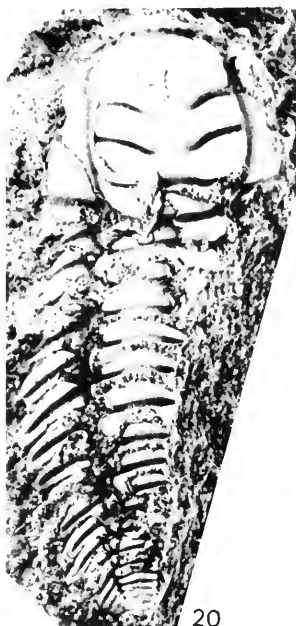

20



21



1



2



3



4



5



6



7



8



9



10

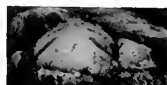

11



12



13



14



15



16

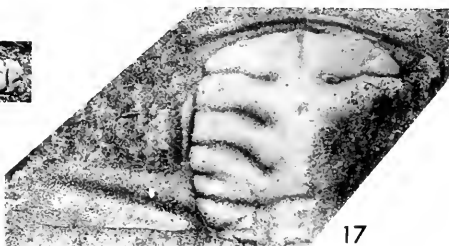

17

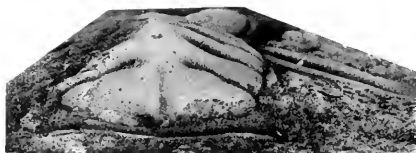

18



19

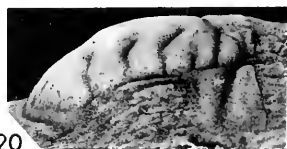

20

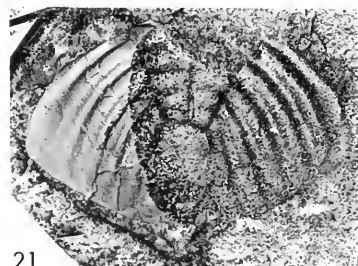

21

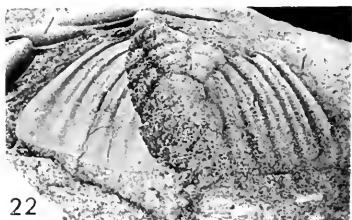

22

PLATE 18

Triarthrus fischeri Billings, 1865
Middle Table Head Formation

- Figure
1-3 Cranidium, dorsal, right lateral, anterior views, X 4.5. GSC 18454. Table Cove.
4-6 Cranidium, dorsal, right lateral, anterior views, X 4.5. GSC 18455. Type section, 185 feet.
7 Cephalon showing left free cheek, oblique view, X 9. GSC 18459. Table Cove.
8, 9 Cranidium, dorsal, left lateral views, X 6. GSC 18456. Daniel's Harbour.
12-14 Cranidium, dorsal, left lateral, anterior views, X 6. GSC 18457. Type section, 215 feet.
15, 16 Smallest cranidium, dorsal, left lateral views, X 25. GSC 18458. Daniel's Harbour.

Triarthrus? descensus (Clark, 1924) (p. 334)

Shumardia Limestone, cliff behind Fonderie de Lévis, Lévis, Quebec

- 10, 11 Holotype, incomplete cranidium, MCZ 1718, original of Clark, 1924, pl. 9, fig. 12, dorsal, anterior views, X 9.

Hypermeaspis cf. bulmani Harrington and Leanza, 1957

Middle Table Head Formation, probably upper half

- 17, 18, 20 Incomplete cranidium, dorsal, anterior, left lateral views, X 4.5. GSC 18460.
19 Fragment of glabella and inner part of fixed cheek, showing furrows, dorsal view, X 4.5. GSC 18461.
21, 22 Pygidium, dorsal, posterior views, X 2. GSC 18462.

PLATE 19

Phaseolops? sp. ind.

Middle Table Head Formation, isolated limestone

Figure

- 1-3 Incomplete cranidium, dorsal, anterior, left lateral views, X 9. GSC 18463.
4, 5 Incomplete cranidium, dorsal, right lateral views, X 9. GSC 18464.

Ischyrophyma tumida n. sp.

Middle Table Head Formation, Table Cove

- 6, 7, 9 Holotype, incomplete, exfoliated cranidium, GSC 18465, anterior, dorsal, left lateral views, X 6.
8, 10, 11 Cranidium with anterior border, anterior, left lateral, dorsal views, X 6. GSC 18466.
12 Right free cheek, exfoliated, exterior view, X 6. GSC 18467.
15 Left free cheek, partly exfoliated, exterior view, X 6. GSC 18468.

Cranidium gen. ind. 1

Middle Table Head Formation, type section, 90 feet

- 13, 14, 18 Incomplete cranidium, dorsal, anterior, right lateral views, X 8. GSC 18470.

Ischyrophyma? sp. ind.

Middle Table Head Formation, isolated limestone

- 16, 19, 20 Incomplete cranidium, left lateral, dorsal, anterior views, X 8. GSC 18469.

Ischyrotoma sp. ind.

Middle Table Head Formation, Table Cove

- 17, 21, 22 Incomplete cephalon, anterior, left lateral, dorsal views, X 6. GSC 18471.

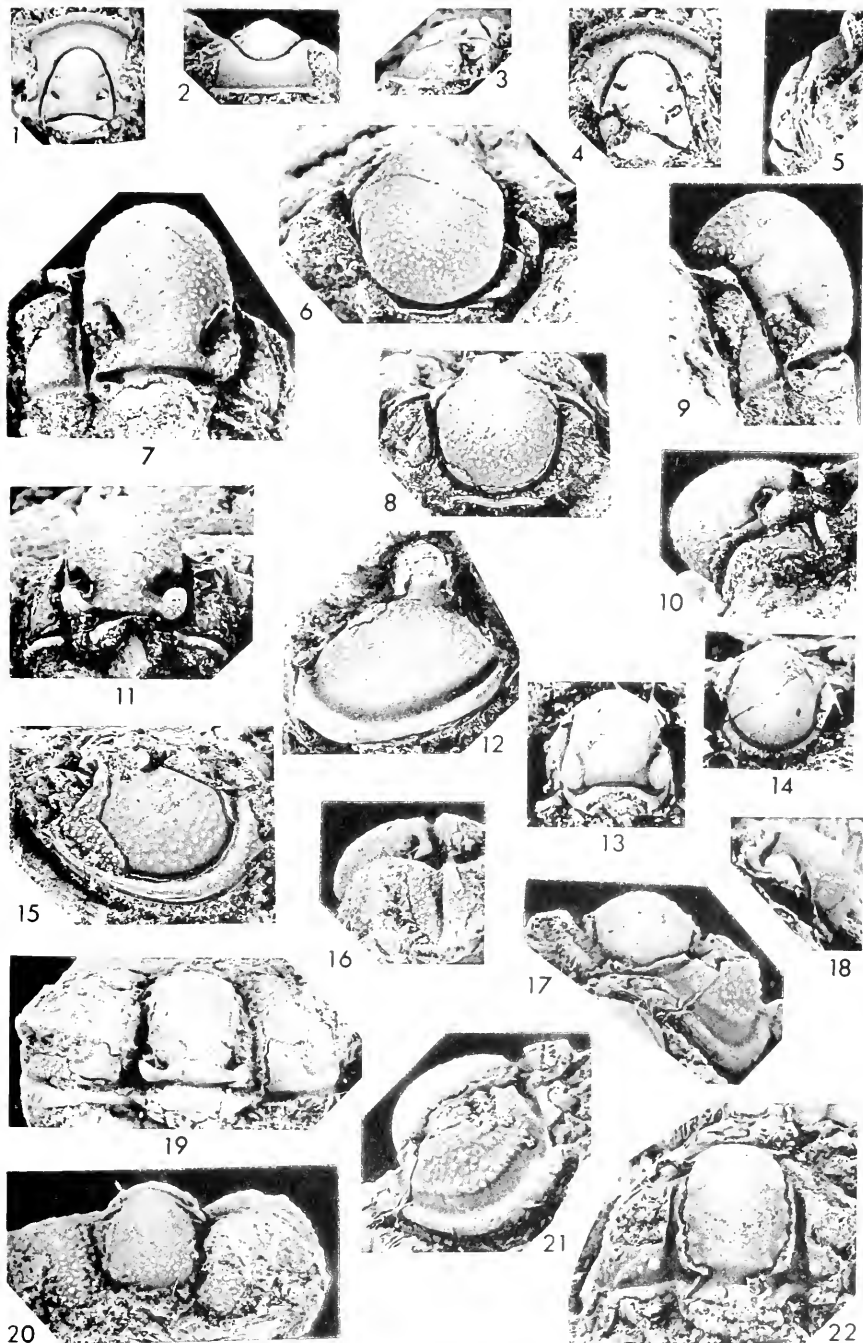

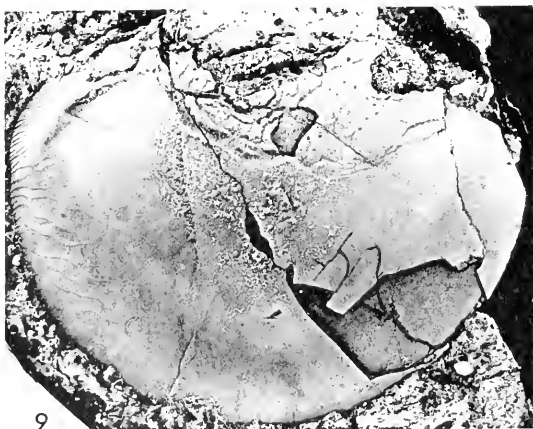
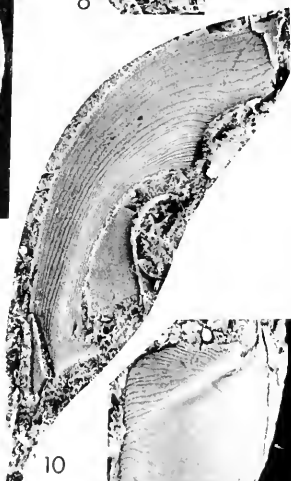
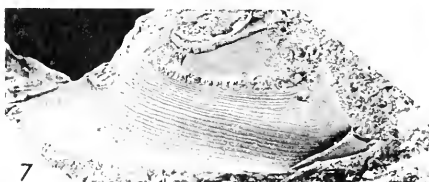
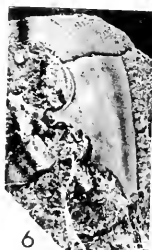
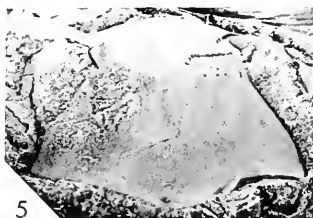
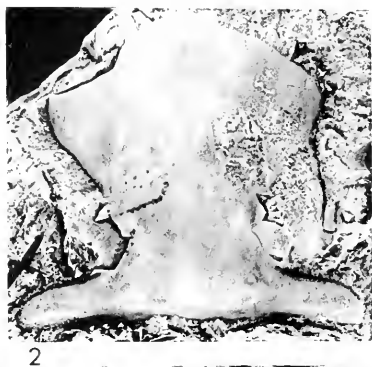

PLATE 20

Stegnopsis solitarius n. gen., n. sp.
Lower Table Head Formation

- Figure
1, 2, 5 Holotype, cranium, GSC 18472. Left lateral, dorsal, anterior views, X 2. Pointe Riche.
- 3 Free cheek showing course of anterior branch of suture and doublure, dorsal view, X 2. GSC 18474. Pointe Riche.
- 4, 8 Incomplete hypostome, exterior, right lateral views, X 2. GSC 18473. Type section, unit 8, 400 feet.
- 6 Posterior part of right free cheek, dorsal view, X 2. GSC 18475. Pointe Riche.
- 7, 10 Doublure of left free cheek, left lateral, dorsal views, X 2. GSC 18476. Pointe Riche.
- 9, 11 Pygidium, dorsal, left lateral views, X 2. GSC 18478. Type section, unit 8, 280 feet.

PLATE 21

Stegnopsis solitarius n. gen., n. sp.

Lower Table Head Formation

Figure

- 1 Pygidium showing doublure, dorsal view, X 2. GSC 18477. Type section, unit 8, 400 feet.
- 2, 3 Small pygidium, dorsal, right lateral views, X 3. GSC 18479. Pointe Riche.
- 4, 6 Pygidium, dorsal, posterior views, X 3. GSC 18480, Pointe Riche.

Stegnopsis huttoni (Billings, 1865)

Middle Table Head Formation

- 5, 7 Holotype, incomplete pygidium, GSC 657, original of Billings, 1865, fig. 256, dorsal, posterior views, X 3. Type section.
- 8, 12 Pygidium, right lateral, dorsal views, X 3. GSC 18492. Type section, 190 feet.
- 9-11 Pygidium, dorsal, posterior, left lateral views, X 6. GSC 18493. Table Cove.

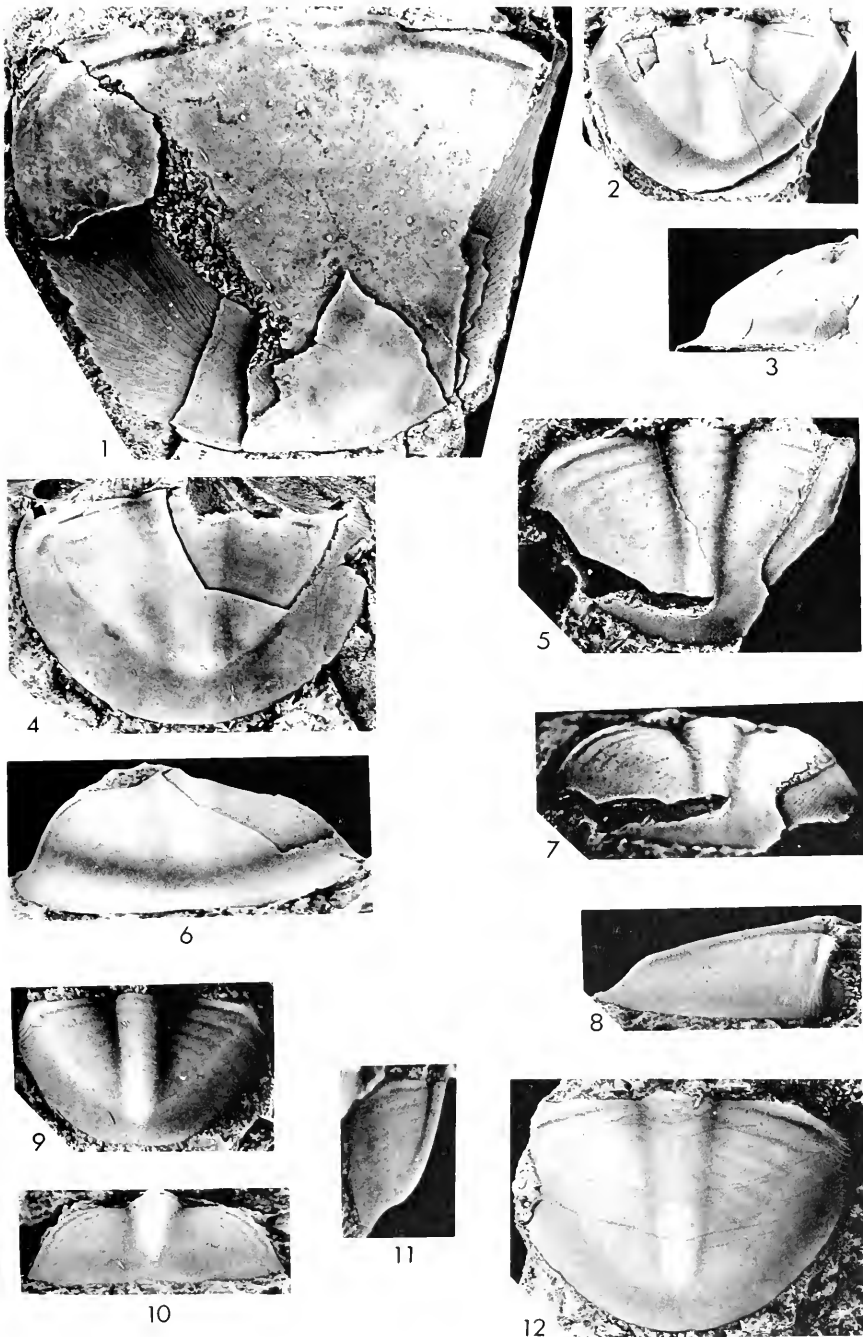

PLATE 21

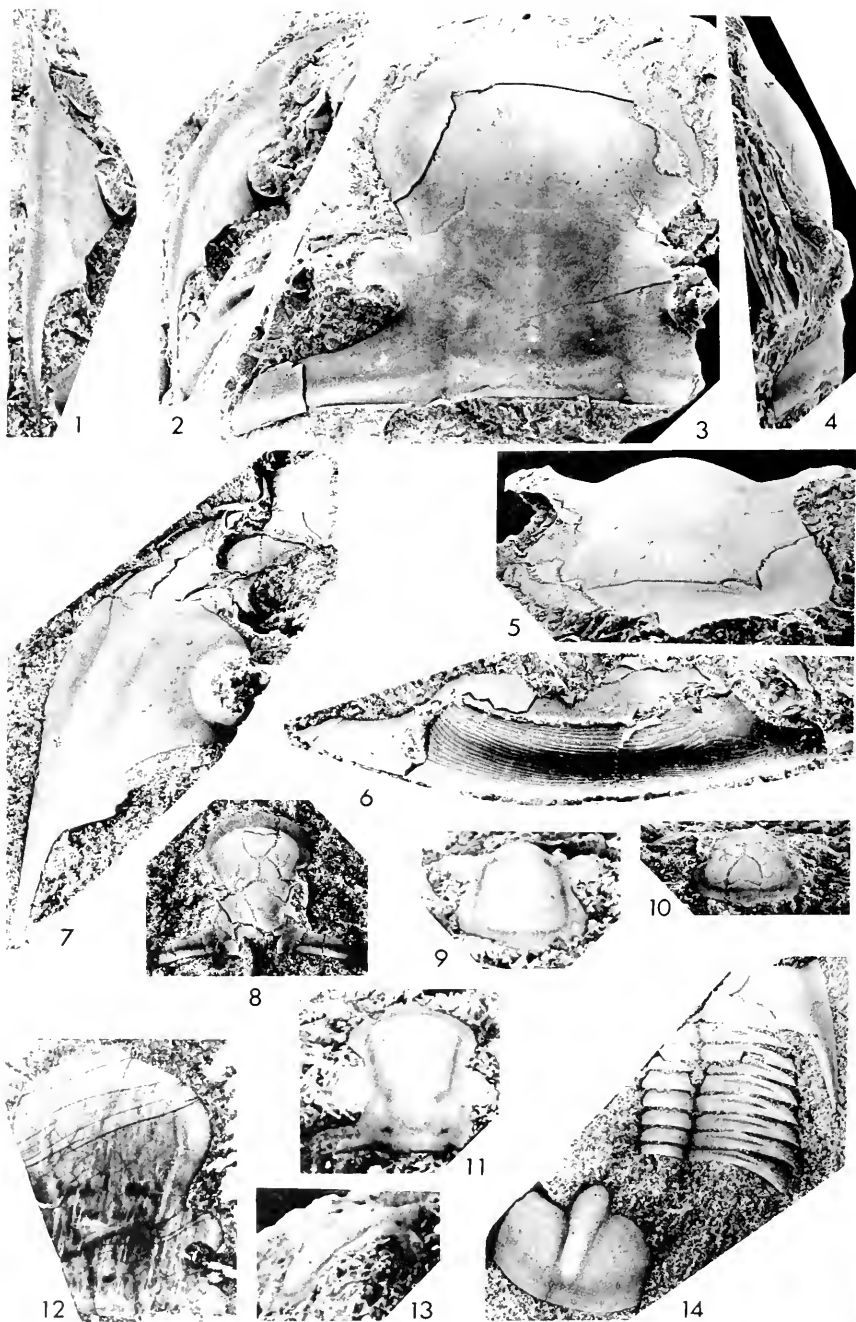

PLATE 22

Stegnopsis huttoni (Billings, 1865)

Middle Table Head Formation

- Figure
1, 2 Free cheek, left lateral, dorsal views, X 3. GSC 18487. Type section, 190 feet.
- 3, 4, 5 Cranidium, dorsal, left lateral, anterior views, X 2. GSC 18481. Table Cove.
- 6 Left free cheek, showing doublure, left lateral view, X 3. GSC 18490. Table Cove.
- 7 Cast of external mould of free cheek, showing doublure anteriorly, dorsal view, X 2. GSC 18488. Type section, 185 feet.
- 8, 10 Cranidium, dorsal, anterior views, X 3. GSC 18483. Type section, 190 feet.
- 9, 11, 13 Small cranidium, anterior, dorsal, left lateral views, X 8. GSC 18484. Table Cove.
- 12 Cranidium, photographed under alcohol and showing muscle areas as dark patches, dorsal view, X 3. GSC 18482. Type section, 185 feet.
- 14 Cast of external mould of disarticulated, incomplete exoskeleton, dorsal view, X 4.5 GSC 18491. Type section. 190 feet.

PLATE 23

Stegnopsis huttoni (Billings, 1865)
Middle Table Head Formation

- Figure
- 1 Mid area of exoskeleton of free cheek, original of Plate 22, figure 7, to show external lines and pits, X 15. GSC 18488. Type section, 185 feet.
- 2 Pygidium showing doublure, dorsal view, X 1.5. GSC 18495. Black Cove.
- 3, 5 Hypostome, exterior view, X 4.5; left oblique view showing left anterior wing, X 6. GSC 18486. Isolated limestone.
- 4, 8 Incomplete hypostome, left lateral, exterior views, X 3. GSC 18485. Type section, 190 feet.
- 6, 7 Transitory pygidium, dorsal, posterior views, X 9. GSC 18494. Isolated limestone.
- 9, 10 Transitory pygidium, dorsal, posterior views, X 15. GSC 18496. Type section, 185 feet.
- 11 Part of visual surface of eye lobe, showing extremely small facets, arranged in diagonal lines, X 15. GSC 18489. Isolated limestone.
- 12, 13 Transitory pygidium, dorsal, posterior views, X 15. GSC 18497. Table Cove.

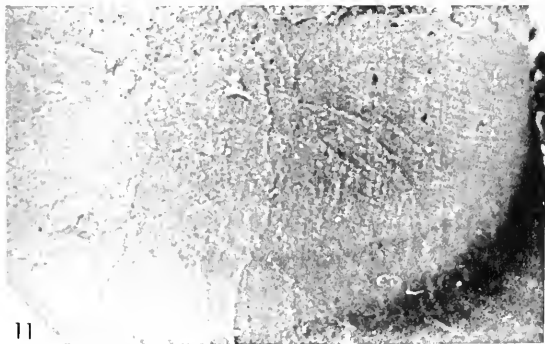
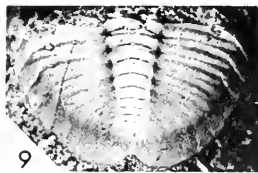
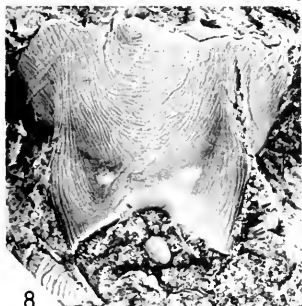
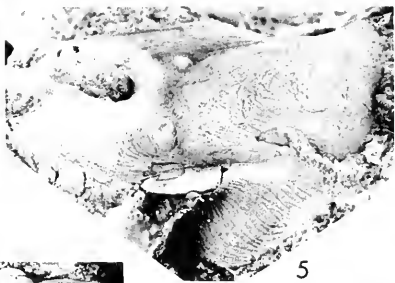
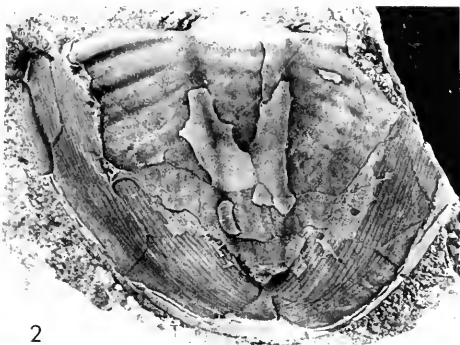

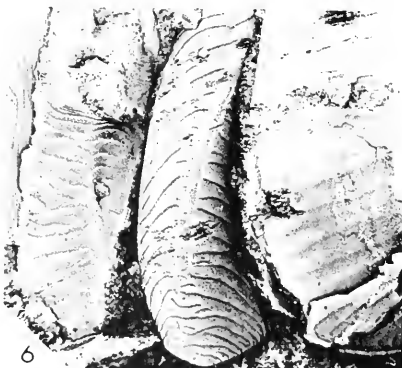
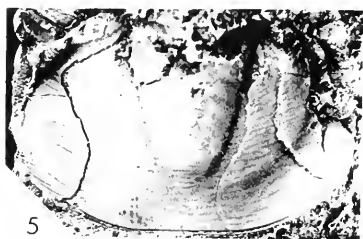
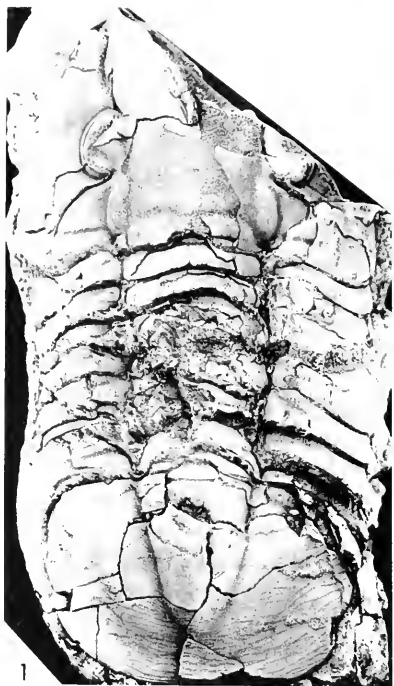

PLATE 24

Niobe quadraticaudata (Billings, 1865)
Middle Table Head Formation

Figure

- 1, 2, 6 Exoskeleton, YPM 13041, original of Raymond, 1925, pl. 6, fig. 13, dorsal, left lateral views, X 1.5; right lateral view of genal angle and outer parts of succeeding two pleurae, X 6. Type section.
- 3 Free cheek, dorsal view, X 2. GSC 18509. Isolated limestone.
- 4 Free cheek, lateral view, X 2. GSC 18508. Isolated limestone.
- 5 Lectotype, exfoliated and incomplete pygidium, GSC 654, dorsal view, X 1.5. Type section.
- 7 Part of original of Plate 25, figures 3, 5, 7, to show basal glabellar lobe, pits and lines in external surface, dorsal view, X 15.

PLATE 25

Niobe quadraticaudata (Billings, 1865)
Middle Table Head Formation

- Figure
1, 2, 4 Exfoliated cranidium, showing furrows on glabella, dorsal, left lateral, anterior views, X 2. GSC 18498. Type section, 90 feet.
- 3, 5, 7 Cranidium, left lateral, anterior views, X 3; dorsal view, X 4.5. GSC 18500. Table Cove.
- 6 Cranidium, dorsal view, X 2. GSC 18499. Type section, 50 feet.
- 8 Small cranidium, dorsal view, X 4.5. GSC 18502. Isolated limestone.
- 9, 11, 12 Smallest cranidium, left lateral, anterior, dorsal views, X 9. GSC 18503. Table Cove.
- 10 Cranidium with exoskeleton, dorsal view, X 4.5. GSC 18501. Daniel's Harbour.

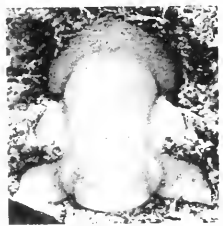
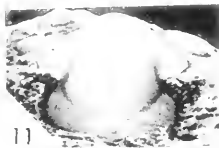
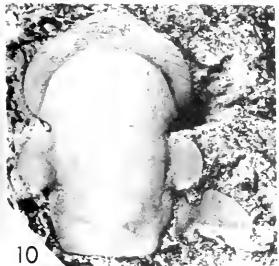
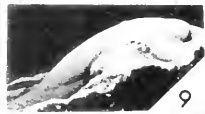
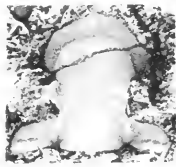
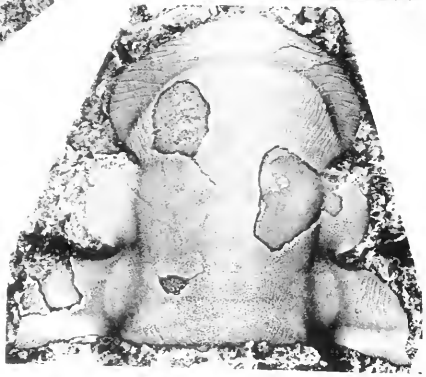
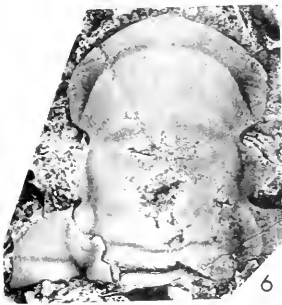
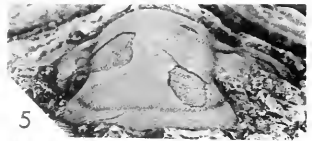
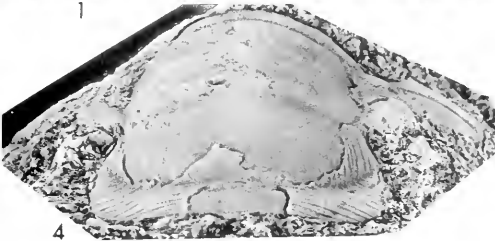
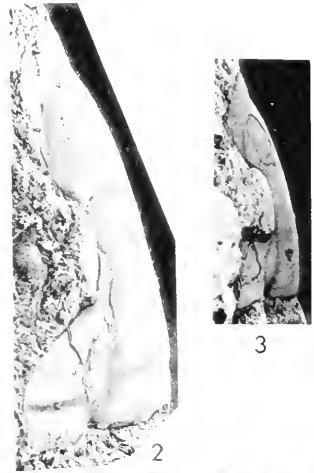
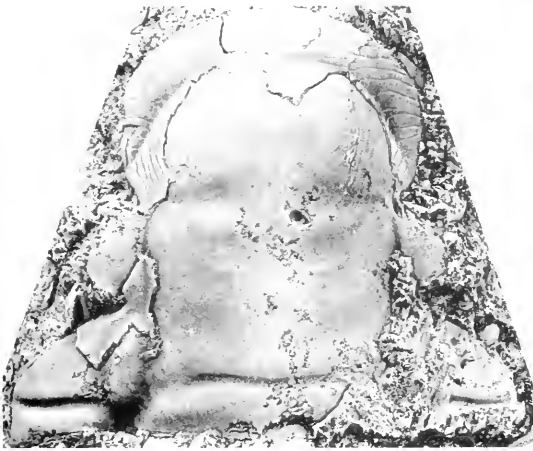

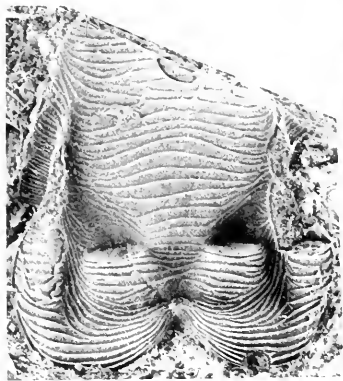

1



2



4



3

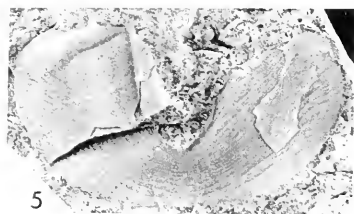

5

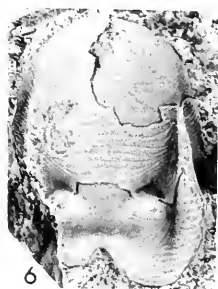

6



7

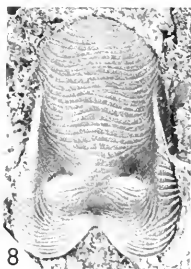

8

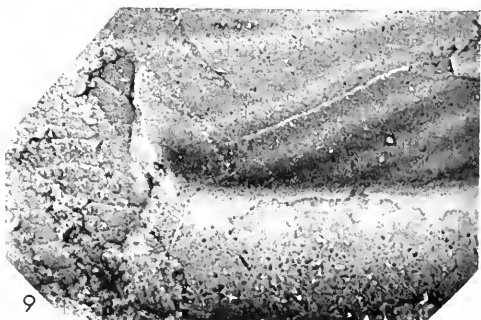

9

PLATE 26

Niobe quadraticaudata (Billings, 1865)
Middle Table Head Formation

Figure

- 1, 2 Incomplete hypostome, exterior, right lateral views, X 3. GSC 18505. Type section, 90 feet.
- 3 Part of eye surface of original of Plate 24, figure 4, exterior view, X 15.
- 4 Part of original of Plate 25, figure 10, to show pits and lines of external surface, and smooth areas of glabellar furrows, X 15.
- 5 Pygidium showing external mould of doublure, dorsal view, X 2. GSC 18511. Type section, 90 feet.
- 6, 7 Hypostome, exterior, left lateral views, X 4.5. GSC 18507. Type section, 90 feet.
- 8 Hypostome, exterior view, X 3. GSC 18506. Isolated limestone.
- 9 External mould of part of doublure of free cheek, showing vincular furrow (running horizontally) and panderian opening at end of furrow, X 9. GSC 18504. Isolated limestone.

PLATE 27

Niobe quadraticaudata (Billings, 1865)

Middle Table Head Formation

Figure

- 1 Pygidium, showing lines on external surface, dorsal view, X 2. GSC 18510. Table Cove.
- 2, 3 Pygidium, dorsal, posterior views, X 4.5. GSC 18512. Type section, 90 feet.
- 4, 7 Transitory pygidium, dorsal, posterior views, X 6. GSC 18513. Table Cove.
- 5, 8 Transitory pygidium, dorsal, posterior views, X 6. GSC 18516. Type section, 265 feet.
- 6 Transitory? pygidium, dorsal view, X 15. GSC 18515. Table Cove.
- 9 Transitory pygidium, dorsal view, X 6. GSC 18514. Type section, 50 feet.

Niobe morrisoni (Billings, 1865)

Middle Table Head Formation

- 10, 11 Lectotype, cast of external mould of pygidium, GSC 656, dorsal, right lateral views, X 2. Type section.
- 12, 13 Pygidium, dorsal, posterior views, X 3. GSC 18518. Type section, 90 feet.

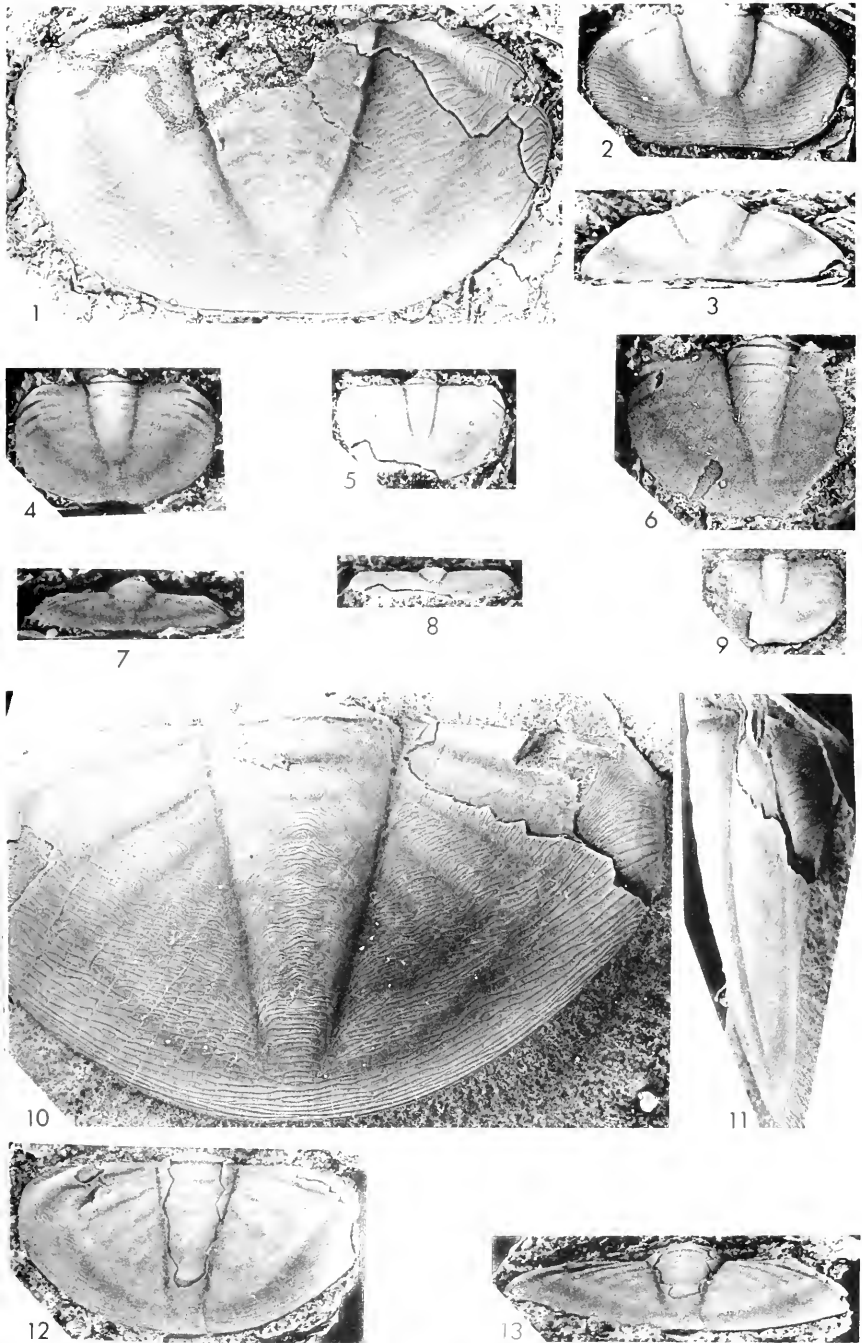

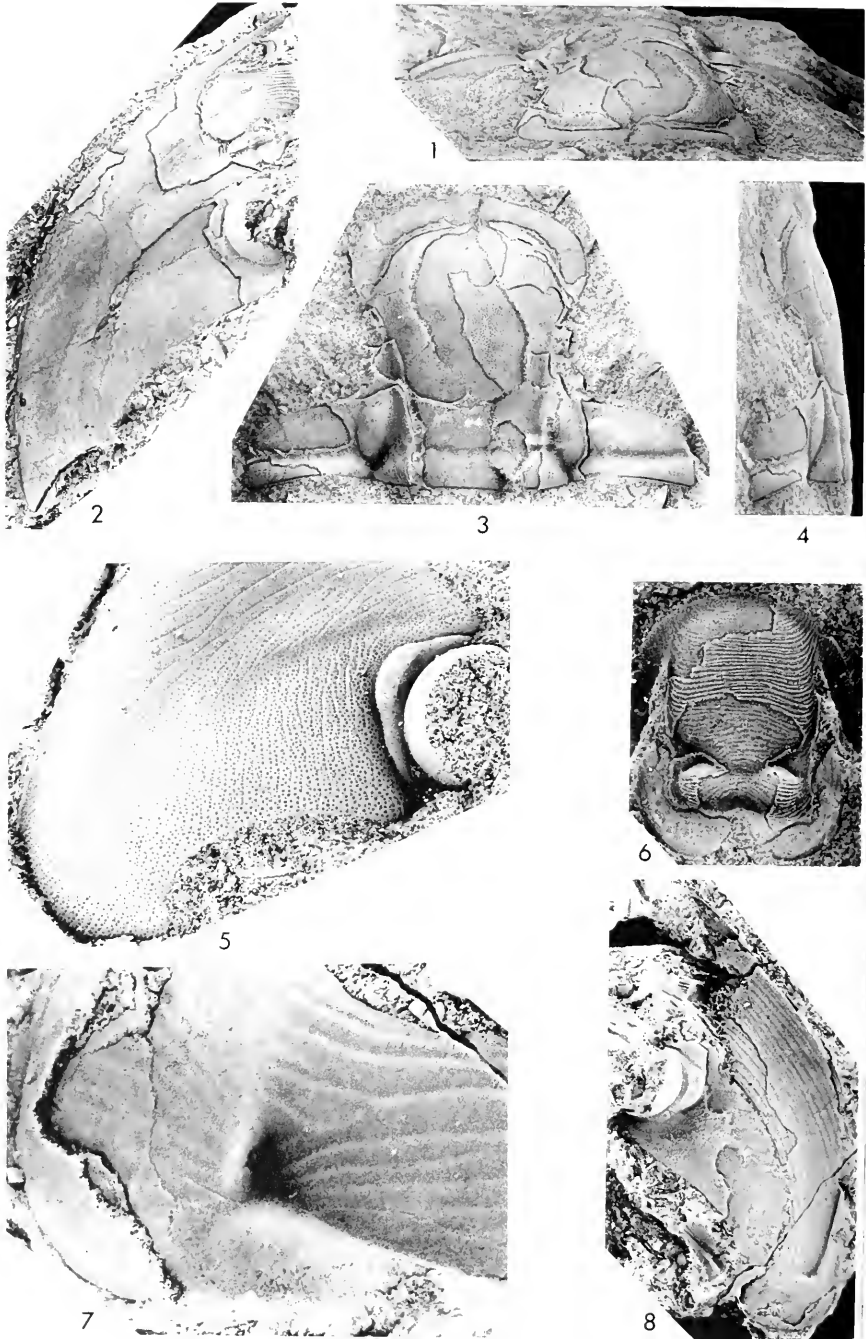

PLATE 28

Niobe morrisi (Billings, 1865)

Middle Table Head Formation

- Figure
1, 3, 4 Cranium, anterior, dorsal, left lateral views, X 2. GSC 18517. Black Cove.
- 2 Free cheek, dorsal view, X 2. GSC 18522. Table Cove.
- 5 Part of cast of external mould of free cheek, showing lines and pits in external surface, and external rim of eye lobe with anterolaterally inflated portion, exterior view, X 9. GSC 18523. Type section, 265 feet.
- 6 Small hypostome, exterior view, X 6, GSC 18520. Type section.
- 7, 8 Free cheek showing external mould of doublure; 7, genal angle showing vincular furrow and panderian opening at end of this furrow, X 9; exterior view, X 2. GSC 18524. Isolated limestone.

PLATE 29

Niobe morrisoni (Billings, 1865)
Middle Table Head Formation

Figure

- 1 Internal mould of hypostome, exterior view, X 3. GSC 18519. Type section, 90 feet.
- 2, 3 Hypostome, exterior, oblique views, X 4.5. GSC 18521. Type section.

Asaphid protaspis
Middle Table Head Formation

- 4-6 Exfoliated example, posterior, dorsal, left oblique views, X 22.4. GSC 18525. Isolated limestone.
- 7-11 Example with exoskeleton adhering posteriorly; posterior, dorsal views, X 20; right oblique view, X 30; left oblique, left lateral views, X 20. GSC 18526. Table Cove.

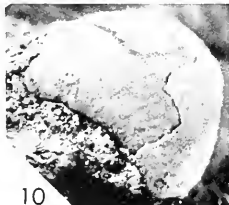
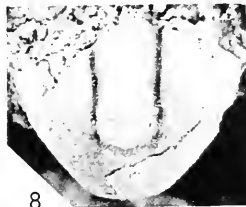
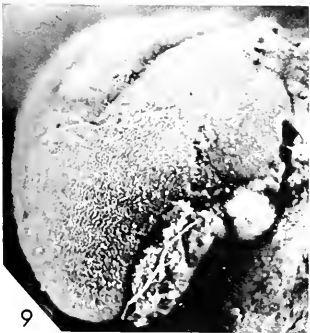
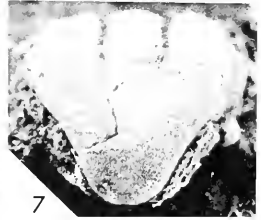
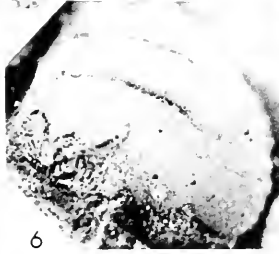
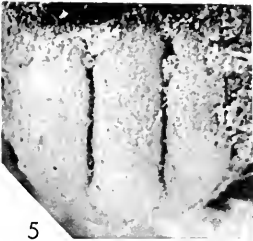
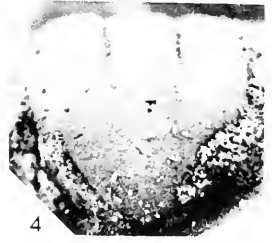
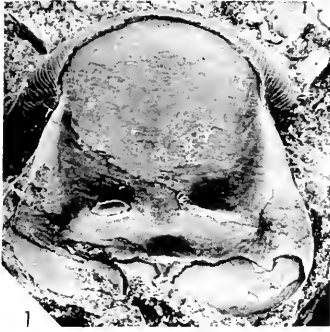

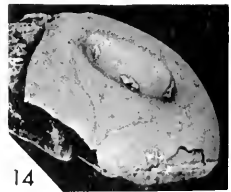
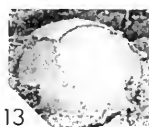
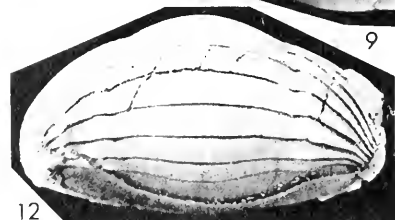
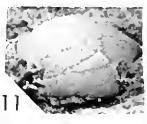
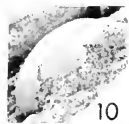
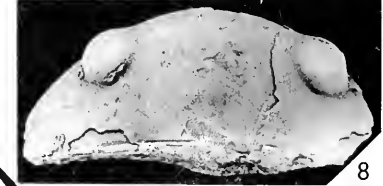
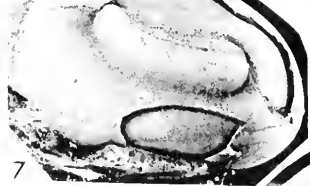
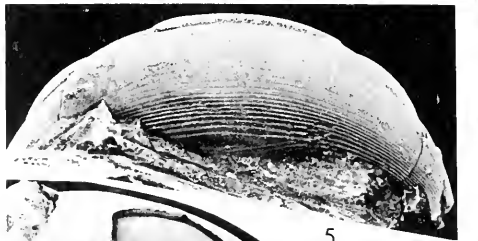
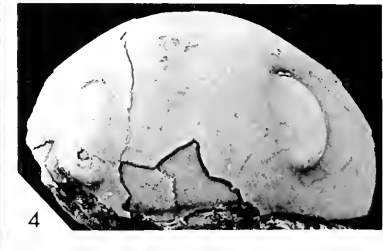
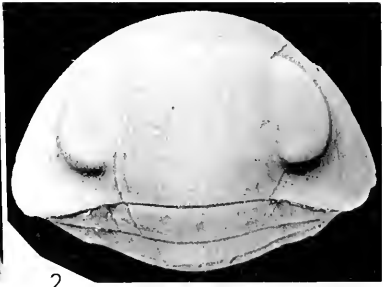

PLATE 30

Nileus affinis Billings, 1865

Lower Table Head Formation, Pointe Riche

Figure

1, 3, Cephalon, dorsal, anterior, ventral, right lateral views, X 3.
5, 7 GSC 18527.

Nileus scrutator Billings, 1865

Middle Table Head Formation

2, 6, Entire enrolled exoskeleton, dorsal view of cephalon, anterior
9, 12 view, left lateral view, dorsal view of thorax, X 6. GSC 18532.
Type section.

4, 8, 14 Lectotype, incomplete cephalon, GSC 667a, dorsal, anterior,
right lateral views, X 2. Portland Creek.

10, 11, 13 Small cranidium, left lateral, anterior, dorsal views, X 6. GSC
18534. Type section, 215 feet.

PLATE 31

Nileus affinis Billings, 1865

Table Head Formation

Figure

- 1, 5 Internal mould of exoskeleton, cephalon broken to reveal hypostome and doublure, anterior, left oblique views, X 3. GSC 18528. Middle part, type section.
- 2-4, 6 Hypostome, showing long, dorsally extended anterior wings, oblique dorsal view of left wing, lateral view, oblique ventral view, exterior view, X 3. GSC 18530. Middle part, type section, 185 feet.
- 8 Thoracic segments, revealed in ventral aspect, X 3. GSC 18531. Middle part, type section.
- 10 External mould of doublure of pygidium, exterior view, X 3. GSC 18529. Lower part, Pointe Riche.

Nileus scrutator Billings, 1865

Middle Table Head Formation

- 7, 9 Original of Plate 30, figures 2, 6, 9, 12, exterior view of right eye lobe showing facets, X 16.8, dorsal view of pygidium showing doublure of cephalon, X 9.

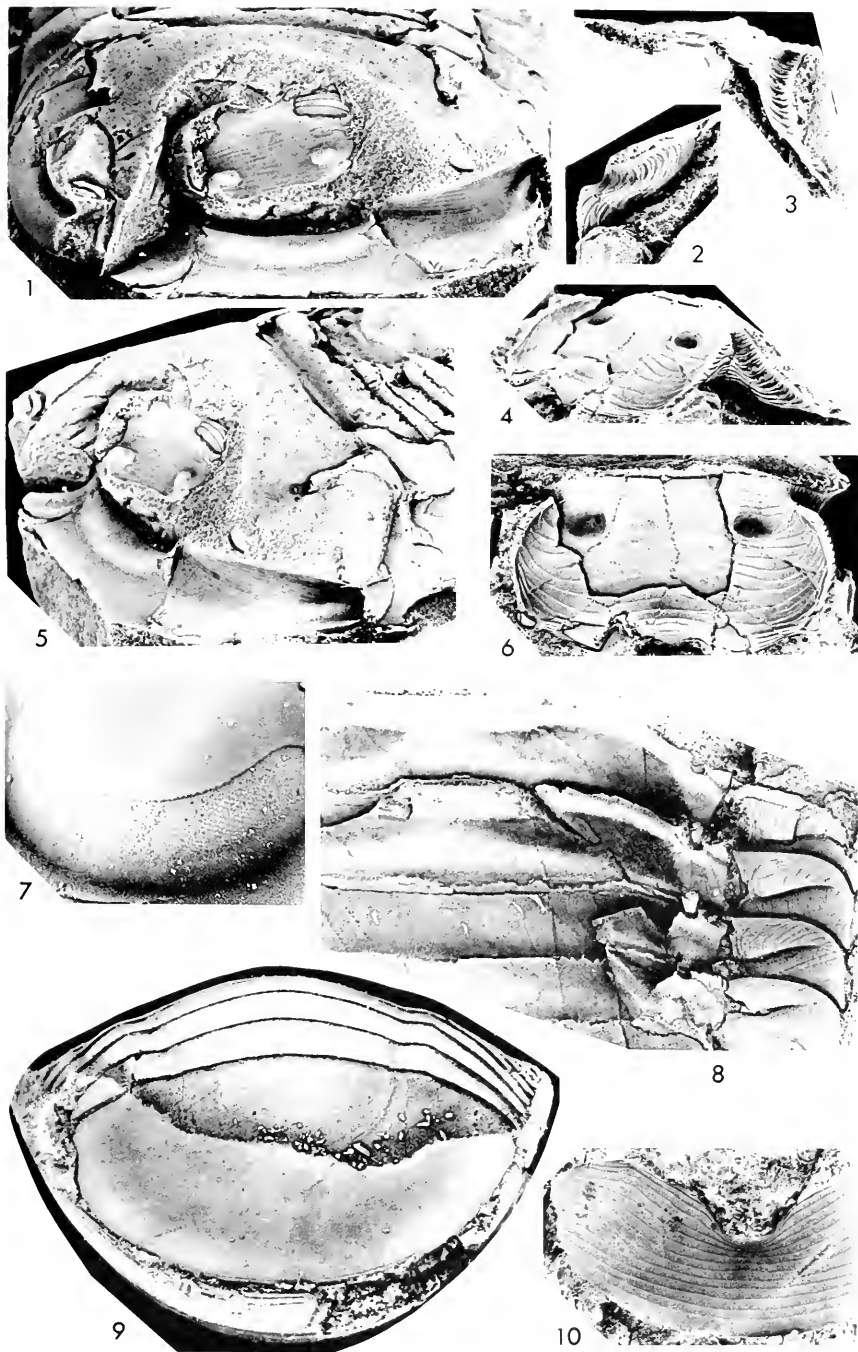

PLATE 31

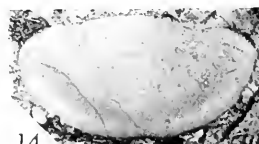
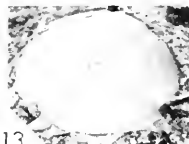
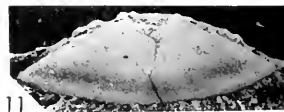
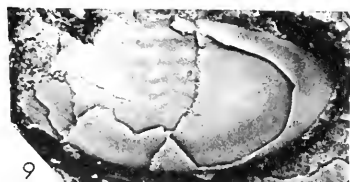
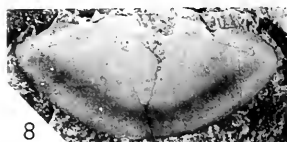
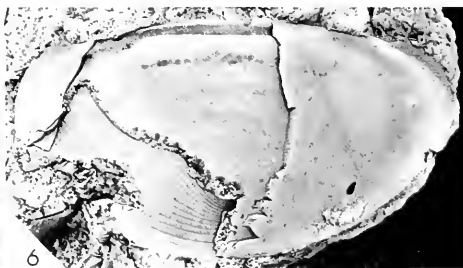
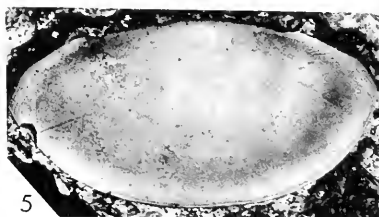
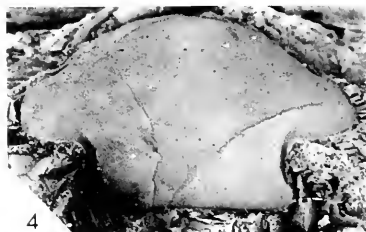
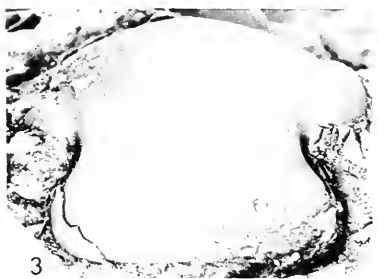
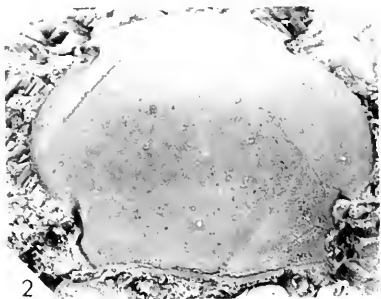
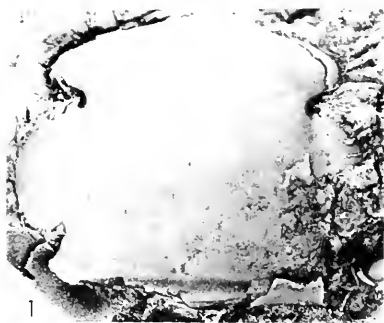

PLATE 32

Nilcus scrutator Billings, 1865

Middle Table Head Formation

Figure

- 1, 3 Internal mould of cranidium, dorsal, anterior views, X 4.5. GSC 18533. Type section, 90 feet.
- 5, 7 Pygidium, dorsal, posterior views, X 4.5. GSC 18535. Table Cove.
- 9 Partly exfoliated pygidium, dorsal view, X 4.5. GSC 18536. Type section, 90 feet.

Nilcus macrops Billings, 1865

Middle Table Head Formation

- 2,4 Internal mould of cranidium, dorsal, anterior views, X 4.5. GSC 18533. Type section, 90 feet.
- 6 Pygidium showing doublure, dorsal view, X 2. GSC 18535. Type section, 90 feet.
- 10, 12, 13 Small cranidium, left lateral, anterior, dorsal views, X 6. GSC 18534. Type section, 190 feet.
- 14 Small pygidium, dorsal view, X 6. GSC 18536. Type section.

Nilcus lacunosa n. sp.?

- 8, 11 Pygidium, dorsal, posterior views, X 4.5. GSC 18537. Type section, 190 feet.

PLATE 33

Nileus macrops Billings, 1865
Middle Table Head Formation

- Figure
1, 2 Lectotype, almost complete exoskeleton, GSC 649a, dorsal,
left lateral views, X 2. Type section.
3-6 Cephalon and four thoracic segments, dorsal, right lateral,
ventral, anterior views, X 4.5. GSC 18532. Type section,
215 feet.

Nileid gen. ind.

Middle Table Head Formation

- 7, 8, 11 Cranidium, anterior, dorsal, right lateral views X 4.5. GSC
18538. Black Cove.
9, 10 Exfoliated pygidium, right lateral, dorsal views, X 2. GSC
18540. Black Cove.
12 Free cheeks with external mould of connecting doublure, show-
ing absence of median or connective sutures, dorsal view, X 3.
MCZ 3652. Probably Black Cove.
13 Pygidium, dorsal view, X 2. GSC 18539. Black Cove.

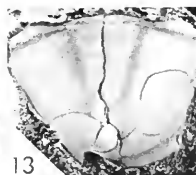
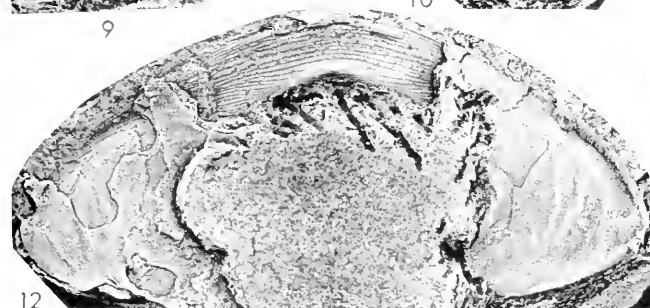
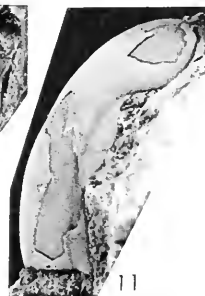
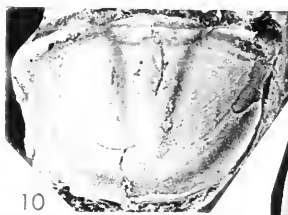
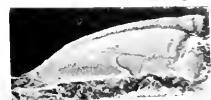
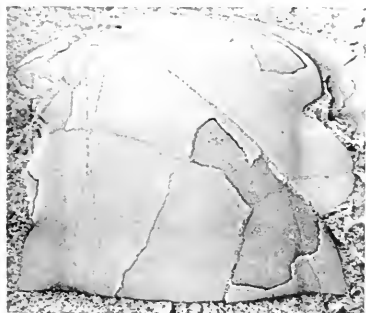
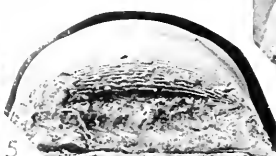

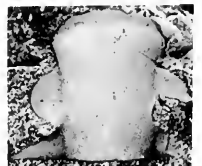
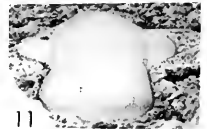
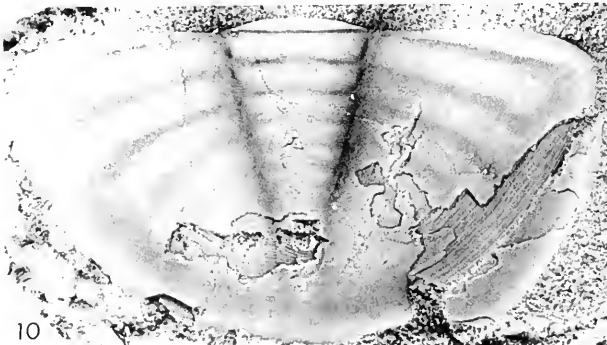
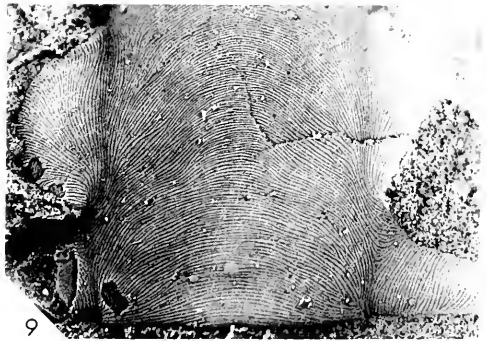
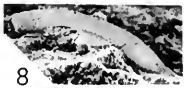
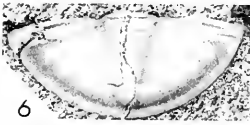
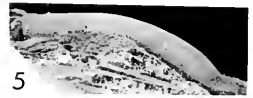
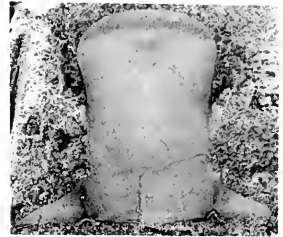
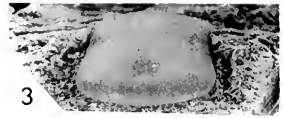
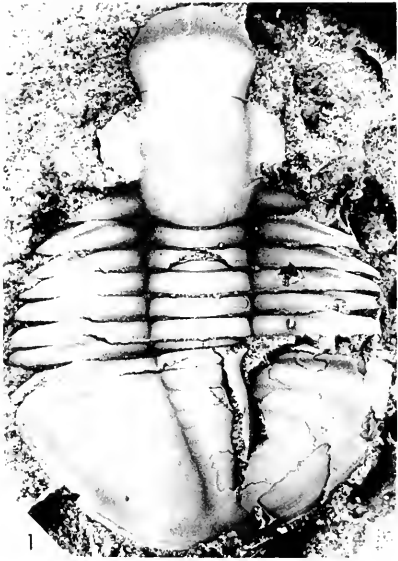

PLATE 34

Peraspis lineolata (Raymond, 1925)
Middle Table Head Formation

Figure

- 1, 2 Holotype, exoskeleton lacking free cheeks, YPM 13042, original of Raymond, 1925, pl. 3, fig. 15, dorsal, left lateral views, X 6. Dominion Iron and Steel Co. quarry, Aguathuna, Port au Port peninsula.
- 3-5 Cranidium, anterior, dorsal, right lateral views, X 3. GSC 18541. Daniel's Harbour.
- 6, 7 Pygidium, dorsal, posterior views, X 6. GSC 18546. Type section, 185 feet.
- 8, 11, 12 Small cranidium, right lateral, anterior, dorsal views, X 6. GSC 18543. Daniel's Harbour.
- 9 Part of cranidium, showing Bertillon pattern of raised lines, dorsal view, X 15. GSC 18542. Black Cove.
- 10 Pygidium, showing doublure, dorsal view, X 4.5. GSC 18545. Black Cove.

PLATE 35

Peraspis lineolata (Raymond, 1925)
Middle Table Head Formation

Figure

- 1 Cast of external mould of cephalon and 6 thoracic segments, showing doublure and poorly preserved hypostome, YPM 13047, original of Raymond, 1925, pl. 3, fig. 16, ventral view, X 6. Type section.
- 2 Part of free cheek showing mould of external surface of posterior part of doublure, exterior view, X 9, GSC 18544. Daniel's Harbour.
- 3, 5, 7 Incomplete free cheeks joined by anterior border of cephalon and doublure, dorsal, anterior views, X 4.5; oblique view showing facets of eye surface, lines on external surface, and anterior border, X 15. GSC 18370. Table Cove.
- 4 Incomplete free cheeks joined by mould of external surface of doublure, exterior view, X 4.5. MCZ 7569. Probably Black Cove.
- 6, 8 Hypostome, oblique, exterior views, X 4.5, GSC 18548. Daniel's Harbour.

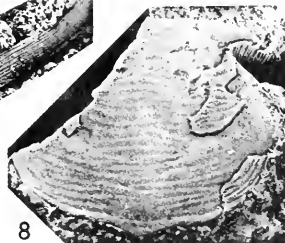
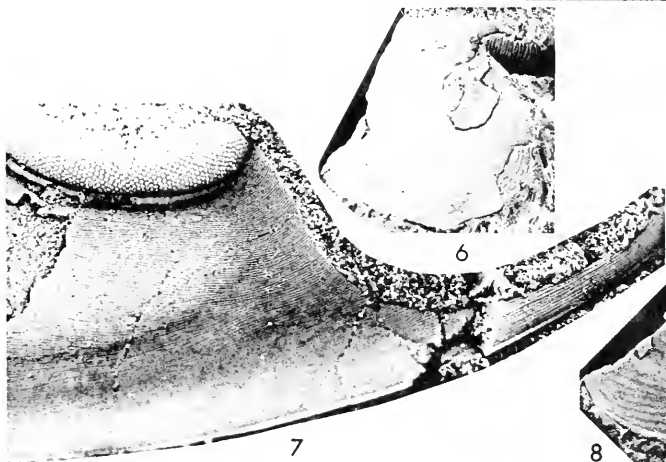
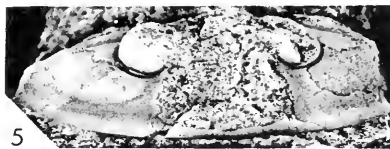
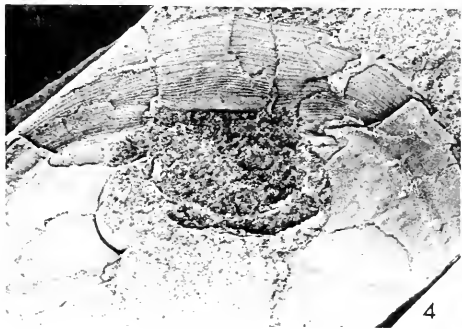

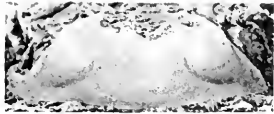

1



2



3

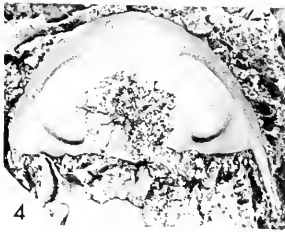

4

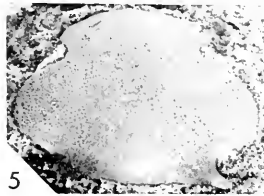

5

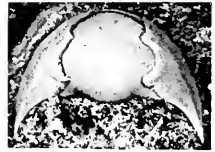

6



7

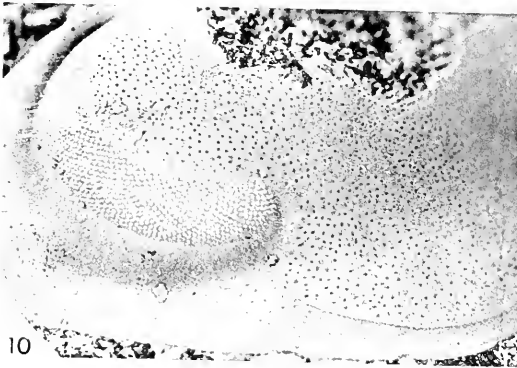

10

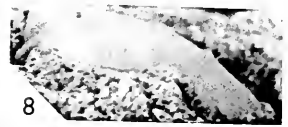

8

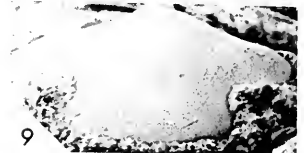

9



11

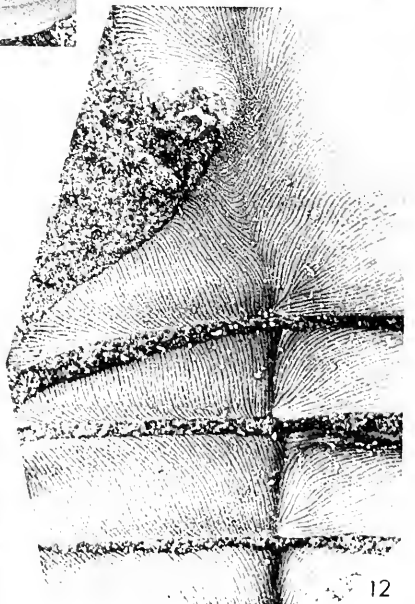

12

PLATE 36

Nileus? lacunosa n. gen., n. sp.

Middle Table Head Formation

Figure

- 1, 2, Holotype, incomplete cephalon, GSC 18549, anterior, right
4, 10 lateral, dorsal views, X 4.5; oblique view showing eye facets
and pits in external surface, X 15. Table Cove.
5, 8, 9 Cranidium, dorsal, right lateral, anterior views, X 8. GSC
18550. Daniel's Harbour.
3, 6, 7 Small cephalon, anterior, dorsal, right lateral views, X 9.
GSC 18551. Type section, 265 feet.

Pocraspis lineolata (Raymond, 1925)

- 11 Part of external surface of holotype (Plate 34, figures 1, 2),
showing lines on external surface, X 15.
12 Part of cast of external mould of disarticulated exoskeleton,
showing lines on external surface, X 15. GSC 18547. Portland
Creek.

PLATE 37

Telephina americana (Billings, 1865)
Middle Table Head Formation

- Figure
1, 2 Lectotype, incomplete exfoliated cranidium, GSC 700b, dorsal, left lateral views, X 4. Type section.
- 3, 4, 7 Internal mould of cranidium, dorsal, right lateral, anterior views, X 4.5. GSC 18552.
- 5, 6,
9, 18 Incomplete cranidium with exoskeleton, dorsal, anterior, right lateral views, X 9; oblique view showing lines on external surface and smooth muscle areas, X 25. GSC 18553. Type section, 90 feet.
- 8, 12, 13 Small cranidium, dorsal, anterior, left lateral views, X 20, GSC 18554. Isolated limestone.
- 10, 11 Hypostome, possibly belonging to this species, left lateral, exterior views, X 6. GSC 18559. Table Cove.
- 14 Free cheek, showing eye surface, border and base of genal spine, lateral view, X 12. GSC 18556. Table Cove.
- 15 Free cheek, border broken showing doublure medially, lateral view, X 8. GSC 18555. Type section, 90 feet.
- 16, 17 Free cheek showing eye surface, border and broken genal spine, oblique, dorsal views, X 12. GSC 18557. Table Cove.

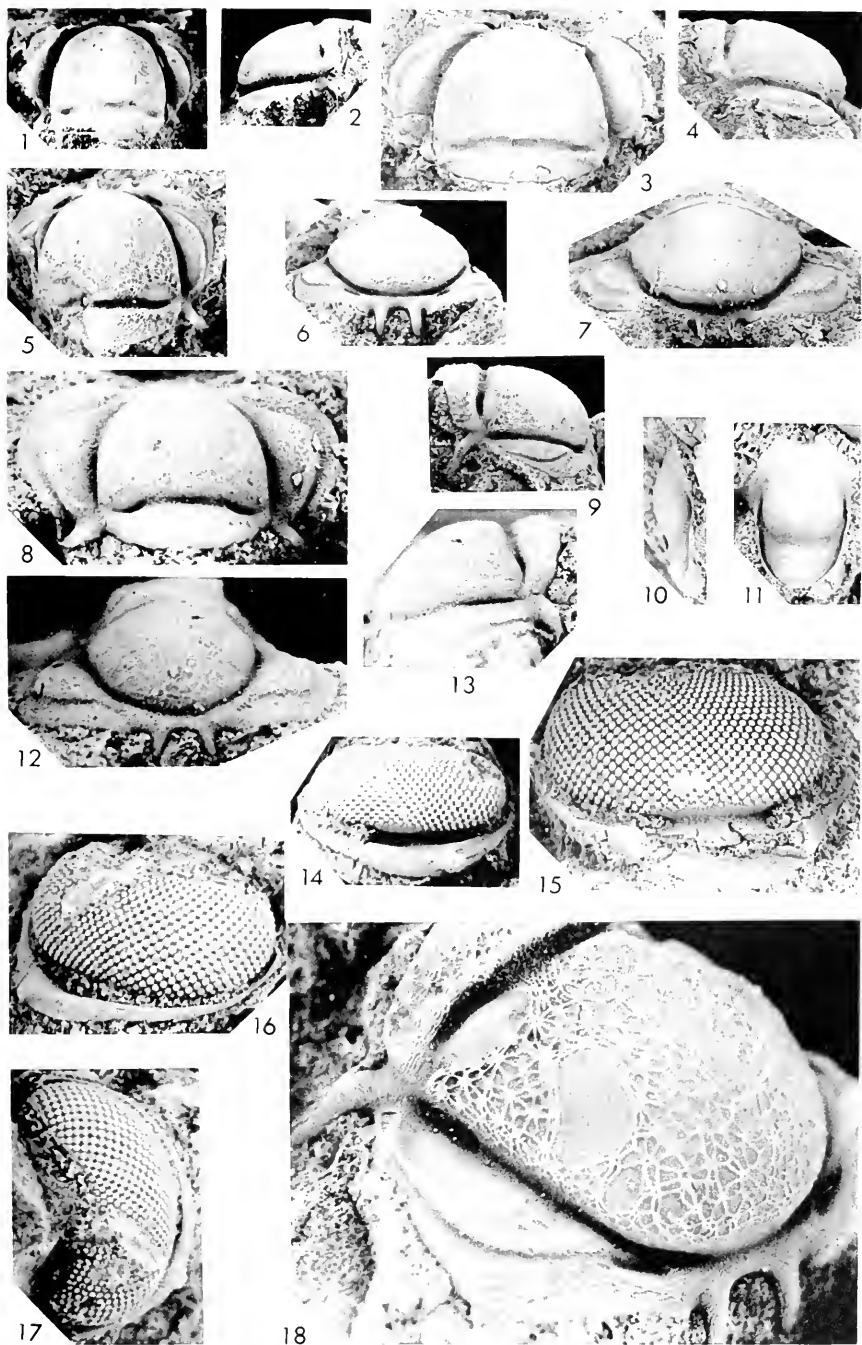

PLATE 37

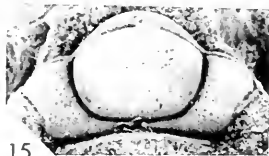
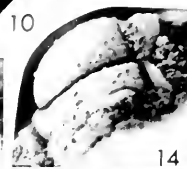
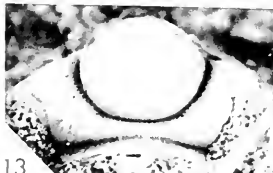
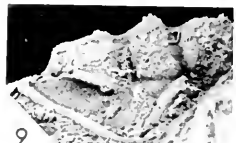
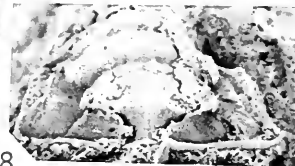
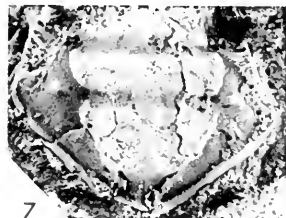
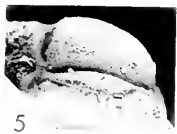
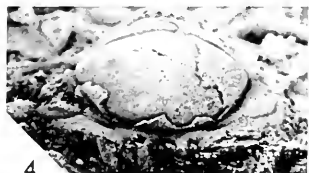
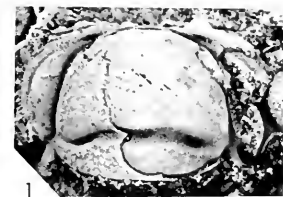

PLATE 38

Telephina sp. ind.

Middle Table Head Formation, Table Cove

Figure

- 1, 2, Incomplete cranidium, dorsal, left lateral, anterior views, X 6;
4, 18 oblique view showing external surface with raised lines and
smooth muscle areas, X 20. GSC 18560.
3, 5, 6 Small, incomplete cranidium, dorsal, right lateral, anterior
views, X 15. GSC 18561.

Telephina americana (Billings, 1865)

Middle Table Head Formation

- 7-9 Pygidium, dorsal, posterior, right lateral views, X 9. GSC
18558. Table Cove.
11 Pygidium, showing paired tubercles on axial rings, dorsal
view, X 9. GSC 18314. Type section, 90 feet.

Goniophrys breviceps? (Billings, 1865)

Middle Table Head Formation

- 10, 13, 14 Small cranidium, dorsal, anterior, left lateral views, X 20,
GSC 18565. Table Cove.
12, 15, 16 Large cranidium, dorsal, anterior, right lateral views, X 9.
GSC 18562. Table Cove.
17 Cranidium, left oblique view showing pits in external surface
and smooth areas on glabella, X 15. GSC 18563. Table Cove.

PLATE 39

Goniophrys breviceps ? (Billings, 1865)

Middle Table Head Formation

Figure

- 1, 2, Cranidium with anterior border, dorsal, right lateral, anterior,
5, 6 anteroventral views, X 15. GSC 18564. Isolated limestone.
10 Distorted cranidium, showing pits in external surface and
smooth muscle areas on glabella. Dorsal view, X 20. GSC
18566. Table Cove.

Carolinites sp. ind. 1

Middle Table Head Formation, Black Cove

- 3, 4, 11 Cranidium, dorsal, left lateral, anterior views, X 8. GSC
18567.

Komaspidid? pygidium (p. 374)

Middle Table Head Formation, Table Cove

- 8, 9 Internal mould, dorsal, posterior views, X 9. GSC 18569.

Carolinites sp. ind. 2

Middle Table Head Formation, Table Cove

- 7, 12, 13 Cranidium, left lateral, dorsal, anterior views, X 8. GSC
18568.

Remopleurides pibulus n. sp.

Middle Table Head Formation, Table Cove

- 14-16 Small cranidium, dorsal, right lateral, anterior views, X 6.
GSC 18571.

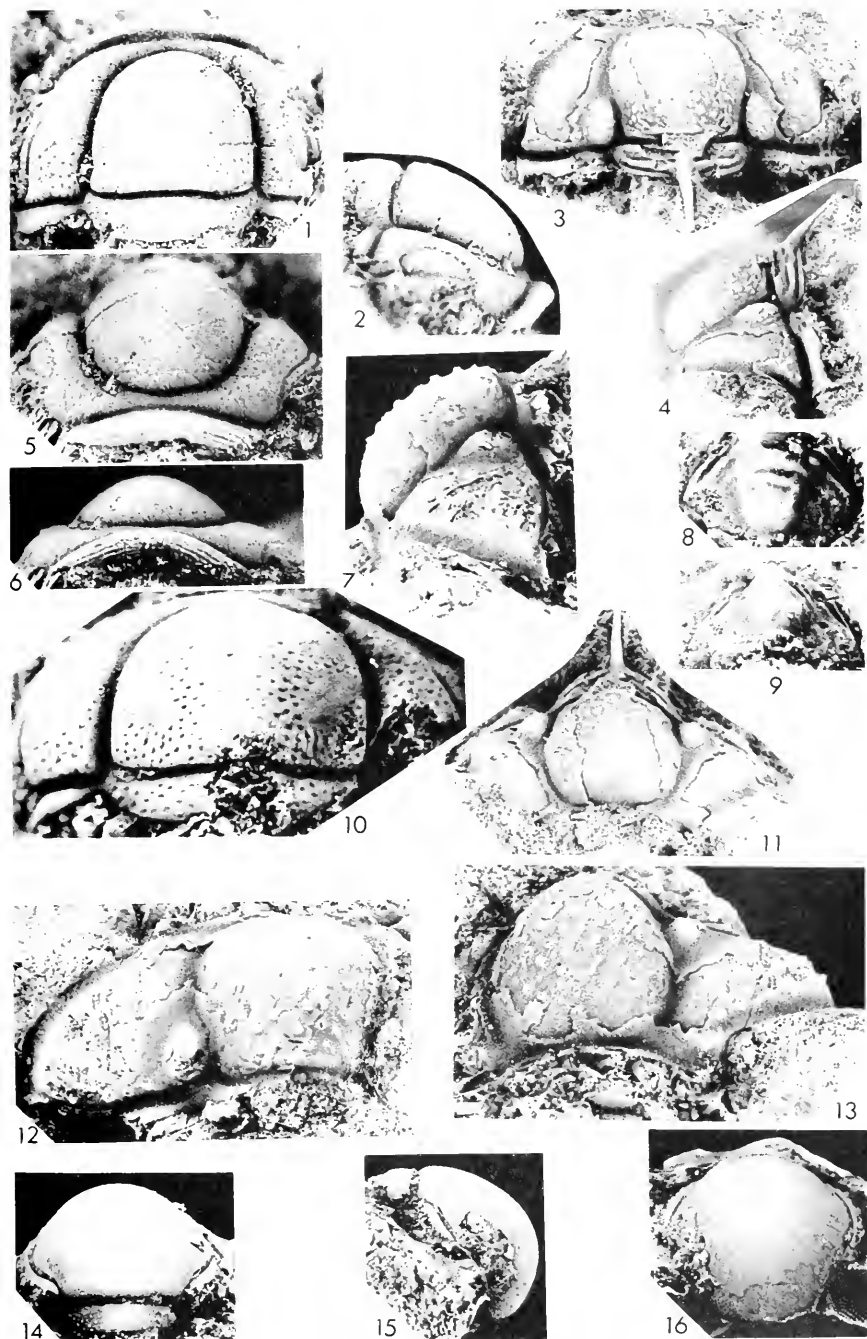

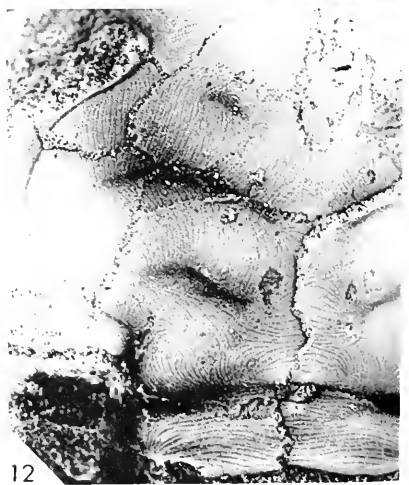
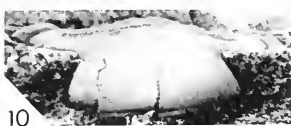
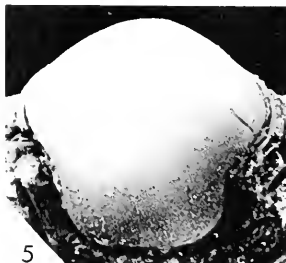
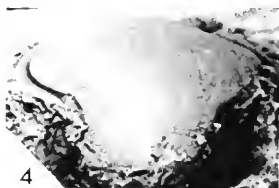
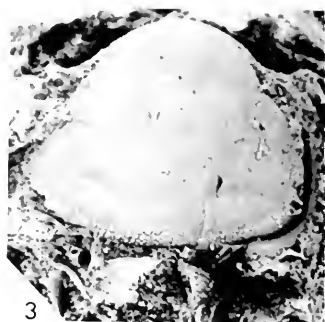
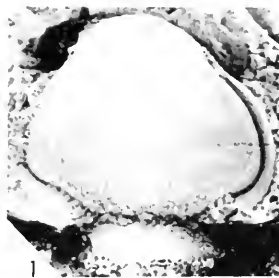

PLATE 40

Remopleurides sp. ind.

Middle Table Head Formation, type section, 190 feet

- Figure
1, 2, 4 Cranium, dorsal, right lateral, anterior views X 8. GSC
18572.
- 3 Incomplete cranium showing glabellar furrows and tubereu-
lation, dorsal view, X 8. GSC 18573.

Remopleurides pilulus n. sp.

Middle Table Head Formation, Table Cove

- 5-8 Holotype, cranium, GSC 18570. Anterior, right lateral,
dorsal, anteroventral views, X 6.

Robergia schlothceimi (Billings, 1865)

Middle Table Head Formation

- 9 Paralectotype, cranium, GSC 694a, dorsal view, X 4. Pisto-
let Bay.
- 10-12 Cranium, anterior, dorsal views, X 6: view of part of gla-
bella showing Bertillon lines on external surface and glabellar
furrows, X 15. GSC 18574. Black Cove.

PLATE 41

Robertia schlotheimi (Billings, 1865)
Middle Table Head Formation

Figure

- 1 Lectotype (here selected), distorted cranidium, GSC 694, dorsal view, X 4. Pistolet Bay.
- 2 Small pygidium, exterior view, X 9. GSC 18579. Black Cove.
- 3 Small hypostome, external view, X 15. GSC 18581. Type section, 215 feet.
- 4, 7 Large hypostome, right lateral, exterior views, X 9. GSC 18580. Type section.
- 5, 6 Small cranidium, dorsal, anterior views, X 6. GSC 18576. Black Cove.
- 8 Cranidium, dorsal view, X 6. GSC 18575. Type section, 215 feet.
- 9 Pygidium, dorsal view, X 9. GSC 18578. Type section, 215 feet.
- 10 Pygidium showing external mould of doublure, dorsal view, X 6. GSC 18577. Type section, 215 feet.

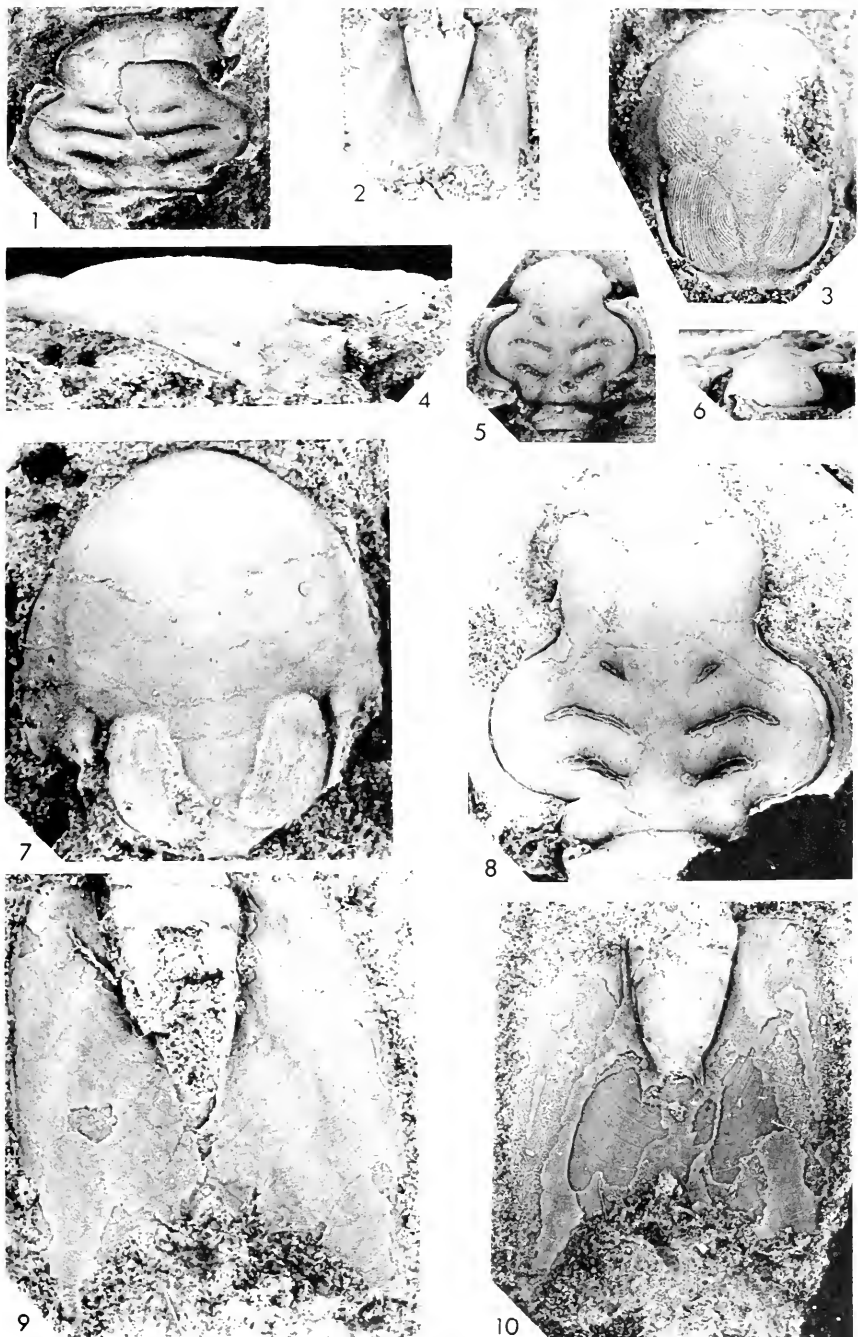

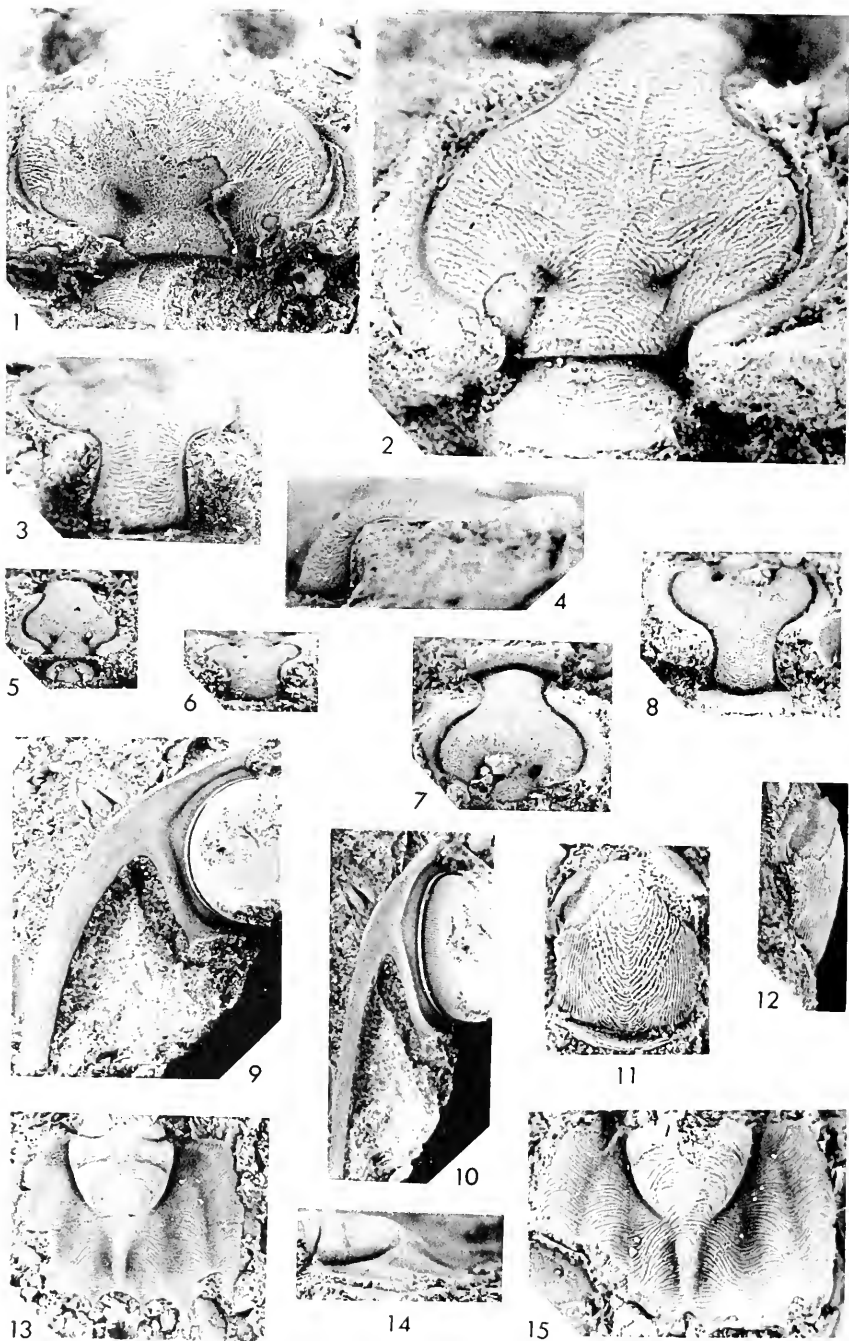

PLATE 42

Blosyropsis billingsi n. gen., n. sp.

Middle Table Head Formation

Figure

- 1 Cranidium, dorsal view, X 15. GSC 18249. Isolated limestone.
- 2-4 Cranidium, dorsal view, X 25; anterior, left lateral views, X 15. GSC 18252. Isolated limestone.
- 5, 6 Small cranidium, dorsal, anterior views, X 15. GSC 18253. Table Cove.
- 7, 8 Holotype, cranidium with anterior border, GSC 18250, dorsal, anterior views, X 15. Type section, 17 feet.
- 9, 10 Free cheek, dorsal, left lateral views, X 9. GSC 18248. Type section, 17 feet.
- 11, 12 Incomplete hypostome, exterior, right lateral views, X 15. GSC 18251. Type section, 90 feet.
- 13, 14 Incomplete pygidium, dorsal, left lateral views, X 15. GSC 18255. Table Cove.
- 15 Incomplete pygidium, dorsal view, X 15. GSC 18254. Table Cove.

PLATE 43

Eorobergia grandis n. sp.

Lower Table Head Formation, Pointe Riche

- Figure
1, 3, 4 Holotype, incomplete cranium, GSC 18256, anterior, dorsal,
right lateral views, X 3.
2 Cast of external mould of incomplete free cheek, dorsal
view, X 1.2. GSC 18258.
5, 6 Incomplete cranium, anterior, dorsal views, X 2. GSC
18257.
7 Cast of external mould of pygidium, dorsal view, X 2.
GSC 18259.

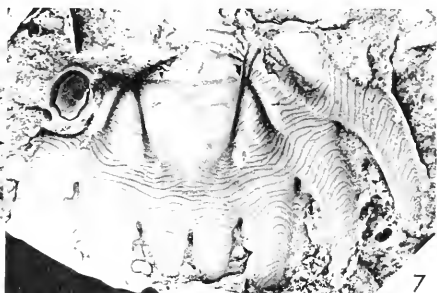
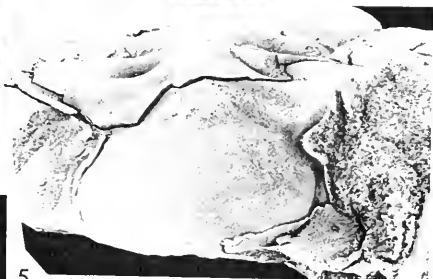
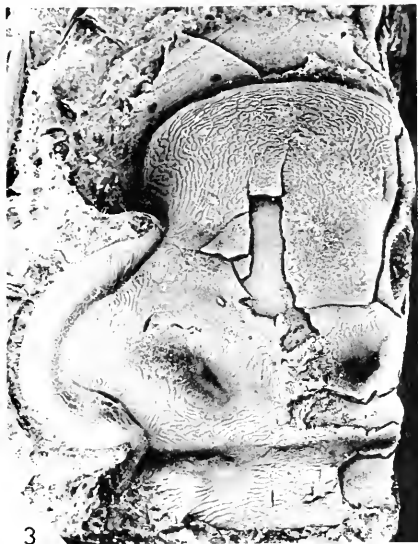
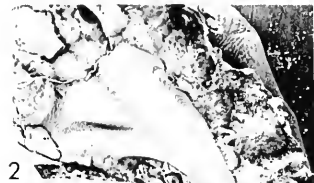

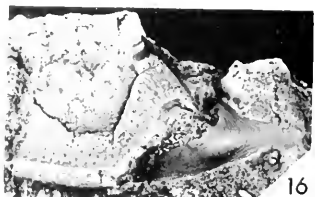
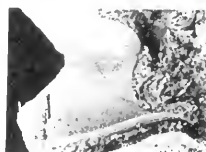
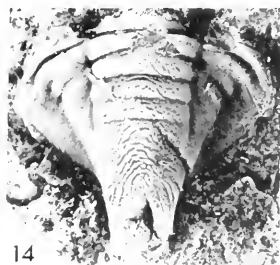
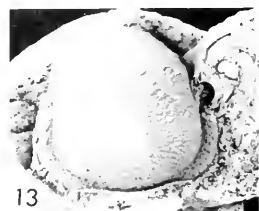
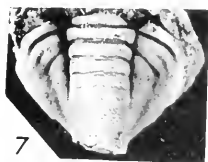
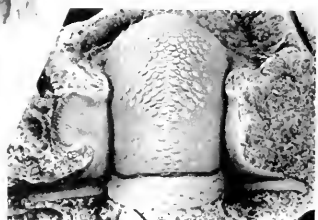
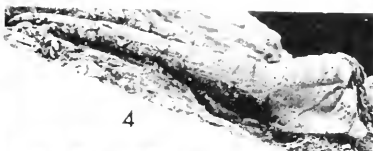
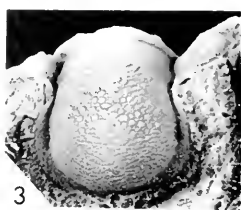
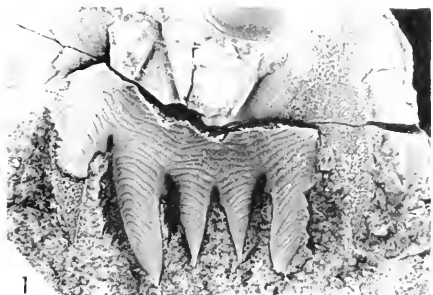

PLATE 44

Eorobergia grandis n. sp.

Lower Table Head Formation, Pointe Riche

Figure

1, 2 Incomplete pygidium, showing doublure of right pleural region, dorsal, right lateral views, X 3. GSC 18260.

Acidiphorus spinifer Raymond, 1925

Lower Table Head Formation

3, 5 Cranidium with left palpebral lobe, anterior, dorsal views, X 4.5. GSC 18261. Pointe Riche.

4, 6 Holotype, incomplete pygidium, YPM 13028, original of Raymond, 1925, pl. 8, fig. 17, and Whittington, 1953, pl. 68, fig. 12, right lateral, dorsal views, X 4.5. Bed 8, type section.

7, 8 Incomplete pygidium, original of Raymond, 1925, pl. 8, fig. 15, dorsal, right lateral views, X 4.5. YPM 13052. Pointe Riche.

9, 10, 13 Cranidium showing anterior border, right lateral, dorsal, anterior views, X 4.5. GSC 18262. Pointe Riche.

11, 15 Free cheek, dorsal, anterior views, X 6. GSC 18263. Type section, 400 feet above base of bed 8.

12, 14 Incomplete pygidium, posterior, dorsal views, X 4.5. GSC 18265. Pointe Riche.

16 Free cheek showing doublure posterolaterally, exterior view, X 4.5. GSC 18264. 479 feet above base of bed 8, type section.

PLATE 45

Iliaenus fraternus Billings, 1865
Lower Table Head Formation

- Figure
- 1-3 Lectotype, exfoliated cranidium, GSC 665e, dorsal, anterior, right lateral views, X 2. Pointe Riche.
- 4-6 Exfoliated cranidium, dorsal, anterior, right lateral views, X 3. GSC 18266. 245 feet above base of bed 8, type section.
- 7-9 Cranidium, dorsal, anterior, right lateral views, X 4.5. GSC 18267. 350 feet above base of bed 8, type section.
- 10, 17, 20 Free cheek, dorsal, lateral, exterior views, X 4.5. GSC 18270. 245 feet above base of bed 8, type section.
- 11-13 Cranidium, dorsal, anterior, right lateral views, X 6. GSC 18268. 245 feet above base of bed 8, type section.
- 14-16 Exfoliated hypostome, oblique view, X 15; exterior, left lateral views, X 9. GSC 18269. 350 feet above base of bed 8, type section.
- 18 Paralectotype, free cheek, GSC 665a, exterior view, X 3. Pointe Riche.
- 19 External mould of posterior part of cranidium, with exoskeleton adhering, showing faint lines and granulation on internal surface, mould of stronger lines on external surface, X 9. GSC 18273. 245 feet above base of bed 8, type section.

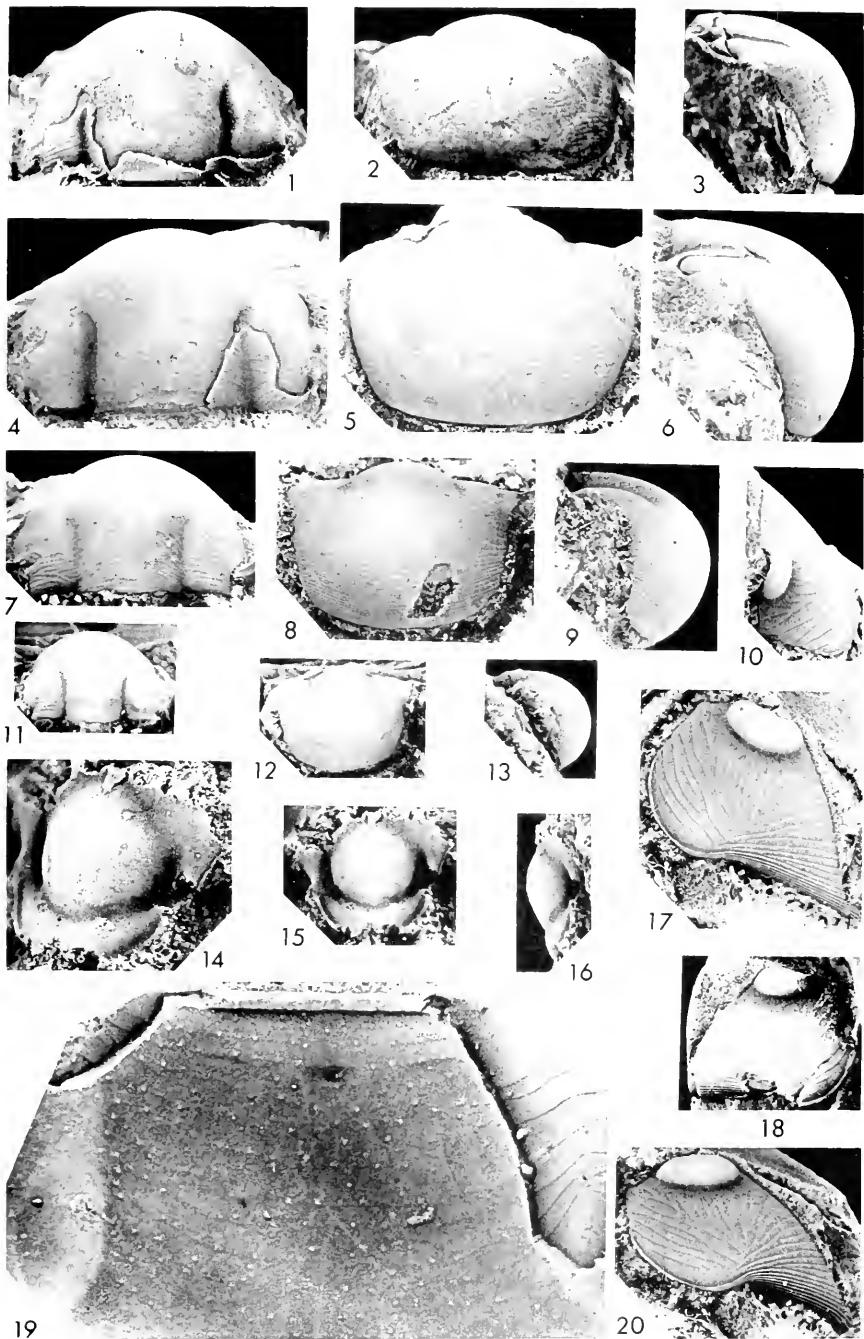

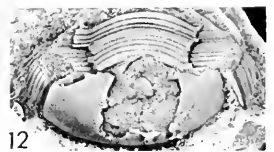
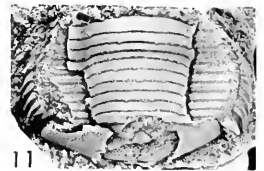
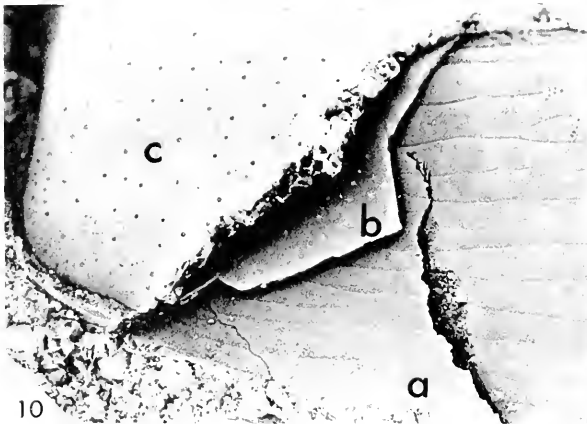
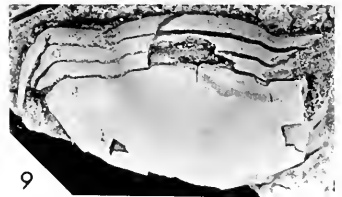
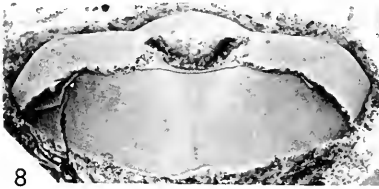
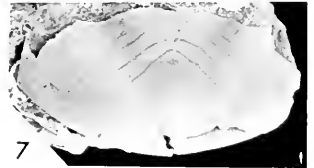
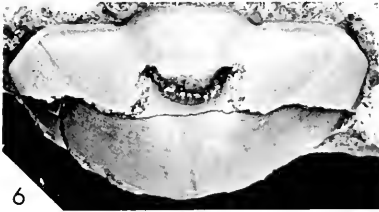
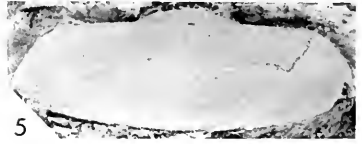
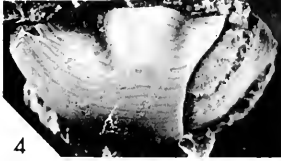
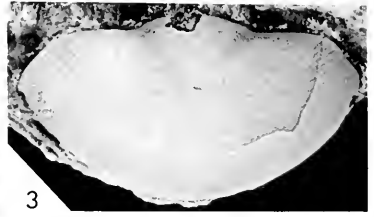

PLATE 46

Illiaenus fraternus Billings, 1865
Lower Table Head Formation

- Figure
1, 2, 4 Paralecotype, pygidium showing doublure on right side, GSC 665b, posterior, left lateral, dorsal views, X 2. Pointe Riche.
- 3, 5 Pygidium, dorsal, posterior views, X 4.5. GSC 18272. 350 feet above base of bed 8, type section.
- 6, 8, 10 Pygidium excavated to show mould of doublure, dorsal, posterior views, X 3; enlargement of left side to show (a) mould of external surface of doublure with terrace lines, (b) inner surface of doublure bearing granules, and (c) mould of inner surface of dorsal exoskeleton showing impressions of granules, X 15. GSC 18271. 350 feet above base of bed 8, type section.

Illiaenus marginalis Raymond, 1925
Lower Table Head Formation, type section

- 7 Incomplete pygidium with exoskeleton, dorsal view, X 1.7. GSC 18279. 400 feet above base of bed 8.
- 9 Posterior three segments of thorax and pygidium, showing elongated outer part of pleura of one segment, dorsal view, X 1.5. GSC 18282. 280 feet above base of bed 8.
- 11, 12 Thorax and pygidium, dorsal, posterior views, X 2. GSC 18281. 400 feet above base of bed 8.

PLATE 47

Ilacnus marginalis Raymond, 1925
Lower Table Head Formation, Pointe Riche

- Figure
1, 2, 4 Lectotype, exfoliated cranidium, YPM 13045, original of Raymond, 1925, pl. 7, fig. 8, dorsal, right lateral, anterior views, X 1.3.
- 3, 5, 6 Partly exfoliated cranidium, right lateral, dorsal, anterior views, X 1.5. GSC 18274.
- 7, 9 Incomplete cephalon, anterior view, X 1.5, right lateral view showing doublure of free cheek and vincular furrow, X 4. GSC 18276.
- 8 Rostral plate, exterior view, X 2. GSC 18277.
- 10 Incomplete cephalon excavated to reveal anterior part of doublure, and connective sutures which outline axe-shaped posterior part of rostral plate, X 2.5. GSC 18275.

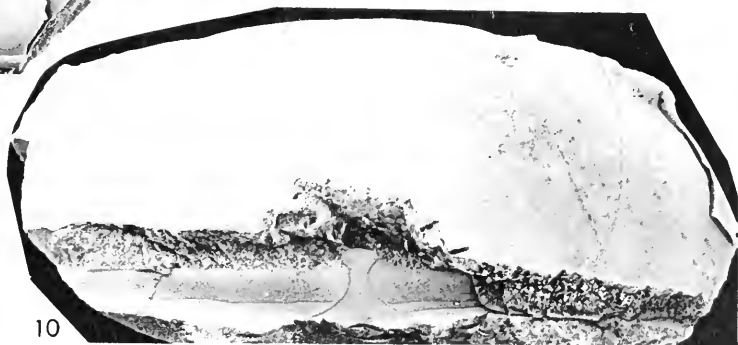
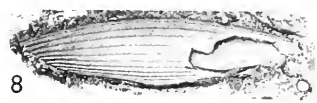
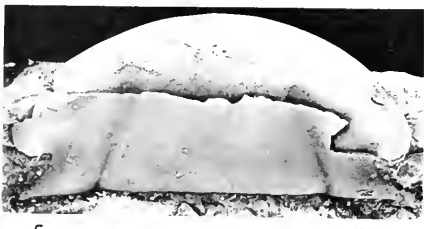
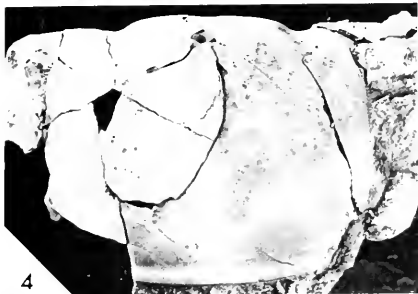
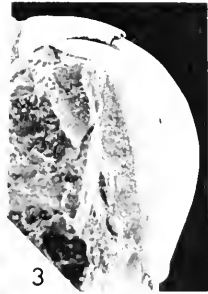
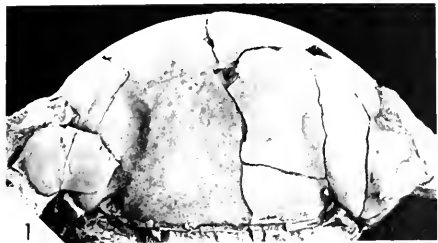

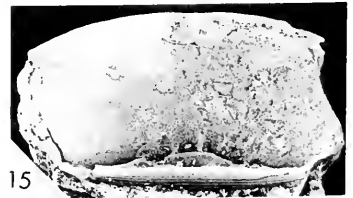
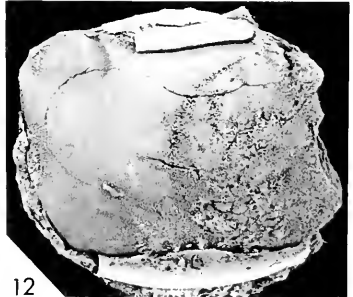
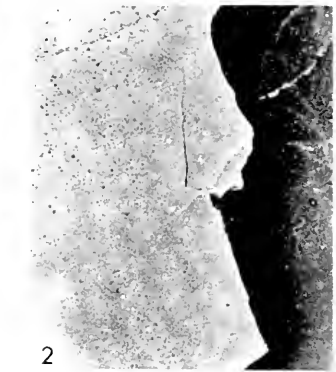
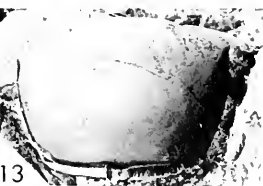
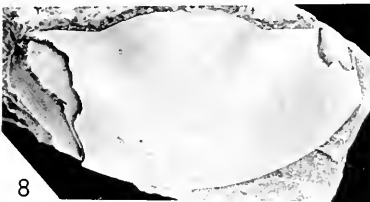
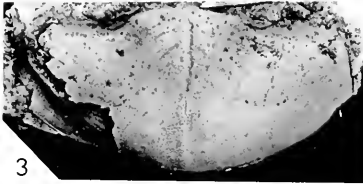

PLATE 48

Iliaenus marginalis Raymond, 1925
Lower Table Head Formation, Pointe Riche

Figure

- 1 Incomplete cephalon, dorsal view showing depressed, pitted, median area of glabella, X 3. GSC 18276.
- 2 Part of external mould (right side of figure) of cranidium, with exoskeleton adhering (left side of figure), showing granulation on inner surface of exoskeleton, X 9. GSC 18283.
- 3-5 Pygidium, YPM 13038, original of Raymond, 1925, pl. 7, fig. 9, dorsal, right lateral, posterior views, X 1.3.
- 6, 8 Pygidium, right lateral, dorsal views, X 1.5. GSC 18278.
- 10 Pygidium excavated to reveal mould of doublure, dorsal view, X 1.5. GSC 18280.

Iliaenus alveatus Raymond, 1925
Lower Table Head Formation, zone 11

- 7, 9, 12, 15 Holotype, exfoliated and incomplete cranidium, YPM 13058, original of Raymond, 1925, pl. 7, fig. 5, right lateral, dorsal, anterior, anteroventral views, X 2.
- 11, 13, 14 Exfoliated cranidium, dorsal, anterior, right lateral views, X 2. YPM 13034.

PLATE 49

Illacnus alvatus Raymond, 1925
Lower Table Head Formation,
originals of figures 1, 4, 5 from
Pointe Riche, remainder from type section

- Figure
1, 4, 5 Part of thorax and pygidium, two dorsal and a right lateral view, X 2. YPM 13034.
2, 10 Free cheek, dorsal, anterior views, X 3. GSC 18286. 245 feet above base of bed 8.
3, 6, 8 Partly exfoliated cranidium, dorsal, anterior, left lateral views, X 2. GSC 18284. 245 feet above base of bed 8.
7, 9, 12 Partly exfoliated cranidium, dorsal, anterior, right lateral views, X 4.5. GSC 18285. 479 feet above base of bed 8.
13 Free cheek showing mould of anterior part of doublure, exterior view, X 3. GSC 18287. 245 feet above base of bed 8.

Illacnus sp. ind. 1
Lower Table Head Formation,
280 feet above base of bed 8, type section

- 11, 14, 15 Cranidium, dorsal, anterior, right lateral views, X 4.5. GSC 18289.

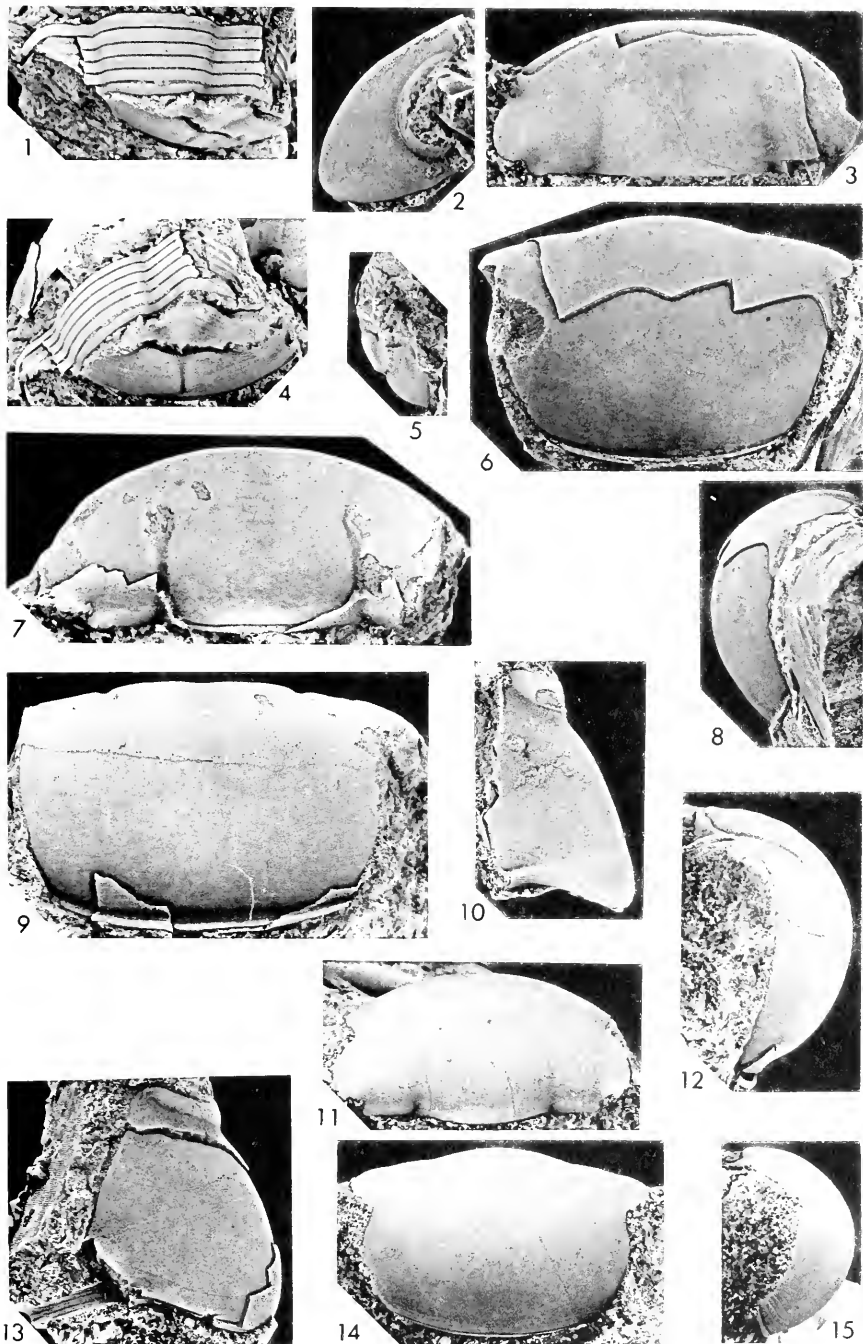

PLATE 49

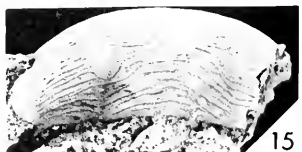
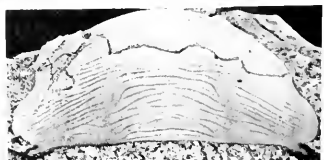
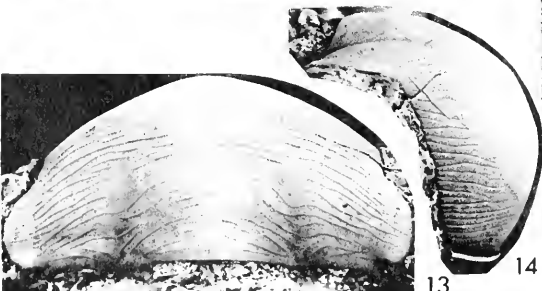
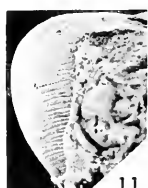
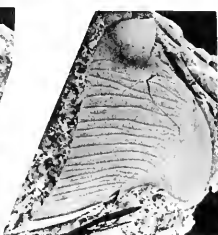
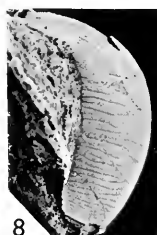
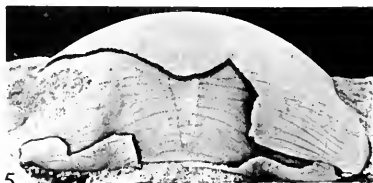
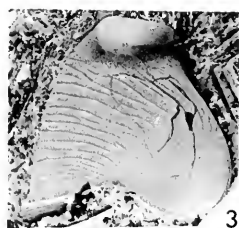

PLATE 50

Iliaenus consimilis Billings, 1865
Middle Table Head Formation

- Figure
1, 4 Lectotype, GSC 663, original of Billings, 1865, fig. 263a, c, anterior, dorsal views, X 1. Type section.
2, 7, 9 Cranidium, left lateral, dorsal, anterior views, X 1.5. GSC 18297. Type section, 90 feet.
3, 6, 10 Free cheek, lateral, dorsal, anterior views, X 2. GSC 18300. Type section, 90 feet.
5, 8 Partly exfoliated cranidium, dorsal, right lateral views, X 3. GSC 18296. Type section, 185 feet.
11, 15 Incomplete cranidium, left lateral, dorsal views, X 3. GSC 18294. Isolated limestone.
12 Large cranidium, dorsal view, X 1. GSC 18298. Type section, 90 feet.
13, 14 Cranidium, dorsal, right lateral views, X 4.5. GSC 18293. Table Cove.

PLATE 51

Iliaenus consimilis Billings, 1865
Middle Table Head Formation

- Figure
1, 2, 5 Cranidium, dorsal, anterior, right lateral views, X 6. GSC 18292. Table Cove.
- 3, 6 Cranidium, dorsal, anterior views, X 6. GSC 18291. Type section, 90 feet.
- 4, 7, 8 Smallest known cranidium, dorsal, anterior, right lateral views, X 15. GSC 18920. Type section, 90 feet.
- 9 Part of external mould of cranidium (right side of figure) with exoskeleton adhering (left side of figure, showing lines less strongly developed on internal surface and faint granulation). X 9. GSC 18306. Type section, 90 feet.
- 10 Exterior view of doublure of free cheek, X 3. GSC 18299. Table Cove.
- 11 Median anterior area of part of internal mould of cranidium, showing granulation of two sizes and lines, X 15. GSC 18295. Type section, 90 feet.
- 12 Paralectotype, free cheek, GSC 663i, exterior view, X 3. Type section.

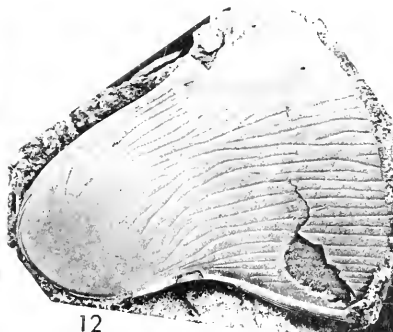
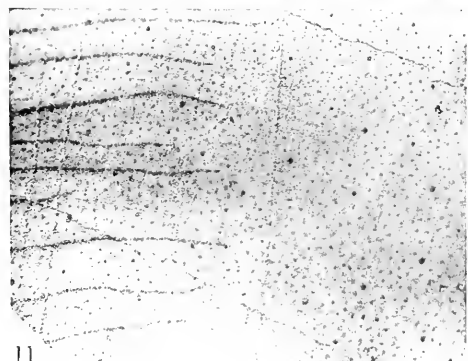
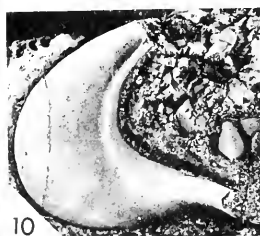
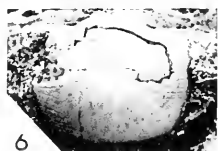
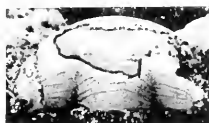
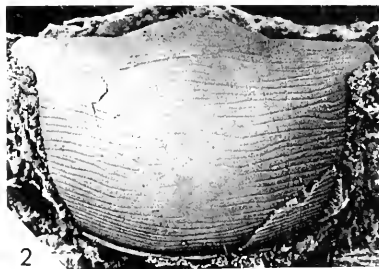
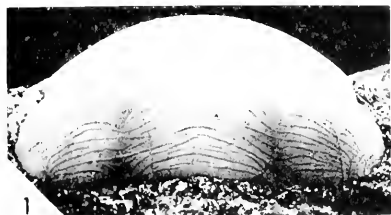

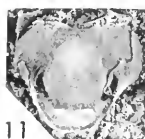
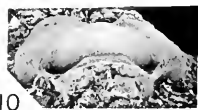
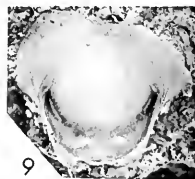
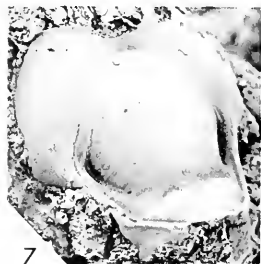
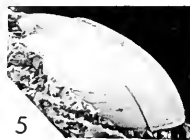
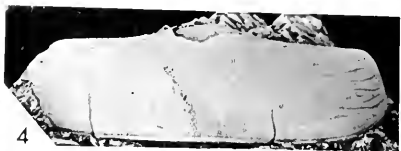
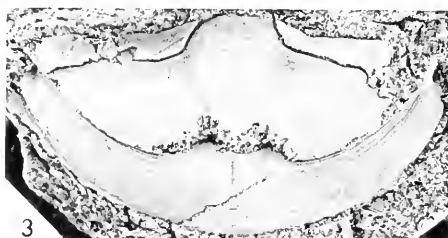
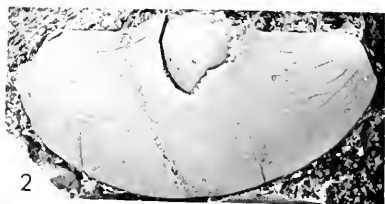
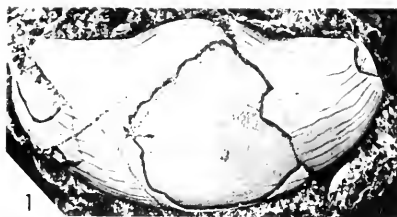

PLATE 52

Iliaenus consimilis Billings, 1865
Middle Table Head Formation

- Figure
1 Paralectotype, pygidium, GSC 663h. Original of Billings, 1865, fig. 263b, dorsal view, X 1. Type section.
- 2, 4, 5 Pygidium, dorsal, posterior, left lateral views, X 3. GSC 18301. Type section, 90 feet.
- 3 Pygidium, excavated to show internal mould of doublure, dorsal view, X 1.5. GSC 18302. Type section, 90 feet.
- 6, 11, 12 Hypostome, exterior view showing pits in maculae in internal mould, X 15; exterior, right lateral views, X 3. GSC 18305. Table Cove.
- 7, 9, 10, 13 Hypostome, oblique view, X 4.5; exterior, posterior, left lateral views, X 3. GSC 18303. Type section, 90 feet.
- 8 Exterior view of posterior part of hypostome with exoskeleton, showing smooth external surface of maculae, X 15. GSC 18304. Type section, 90 feet.

PLATE 53

Ulaenus gelasinus n. sp.
Middle Table Head Formation

- Figure
1, 5, 7 Holotype, partly exfoliated cranidium, GSC 18307, anterior, left lateral, dorsal views, X 3. Type section, 90 feet.
- 2, 4, 6 Free cheek, anterior, dorsal, lateral views, X 4.5. GSC 18311. Daniel's Harbour.
- 3, 8, 12 Cranidium, left lateral, anterior, dorsal views, X 3. GSC 18309. Isolated limestone.
- 9-11 Small cranidium, dorsal, anterior, left lateral views, X 4.5. GSC 18310. Isolated limestone.
- 13, 14, 16 Pygidium, dorsal, posterior, right lateral views, X 3. GSC 18312. Type section.
- 15 Pygidium showing doublure, dorsal view, X 4.5. GSC 18314. Type section, 90 feet.
- 17, 18 Small pygidium, dorsal, posterior views, X 4.5. GSC 18313. Type section, 90 feet.

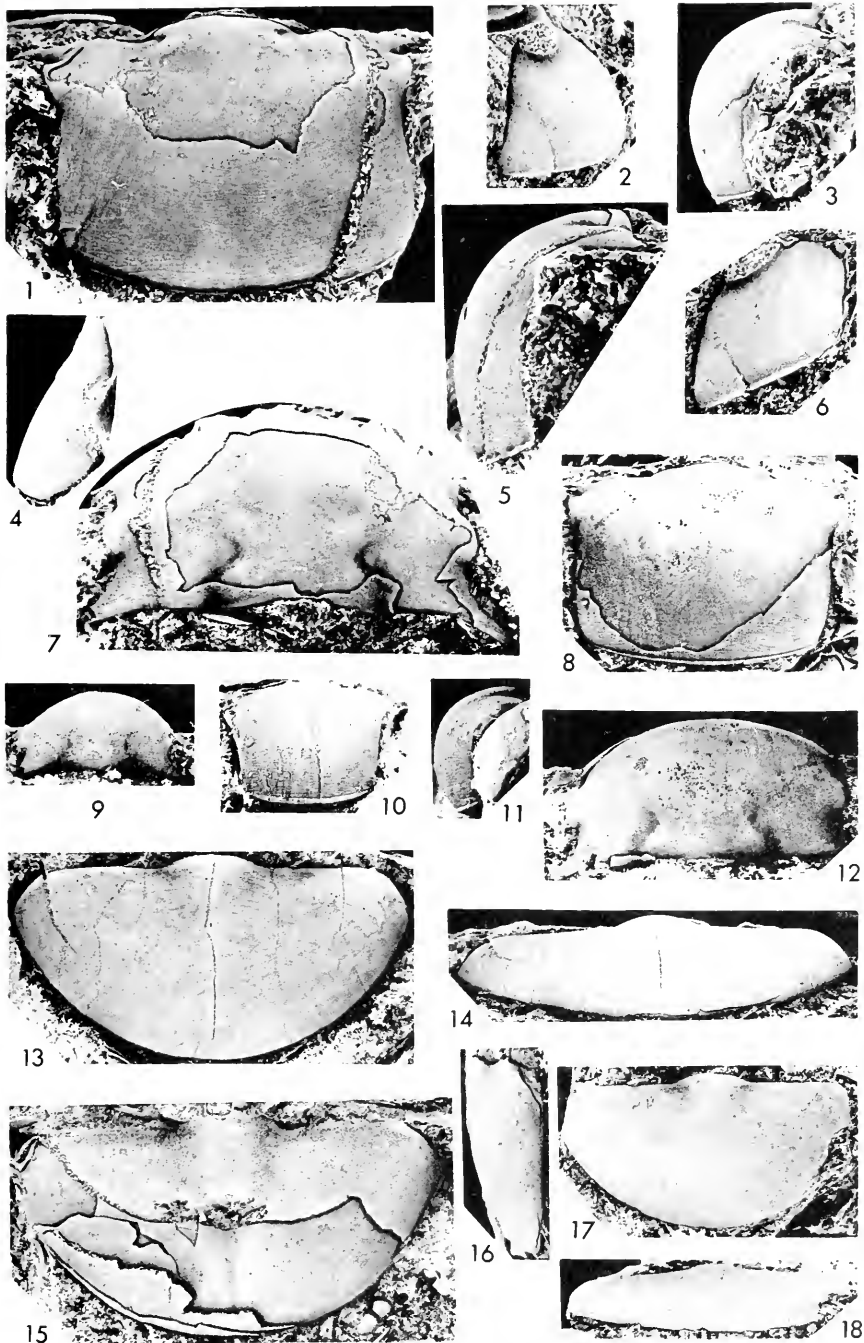

PLATE 53

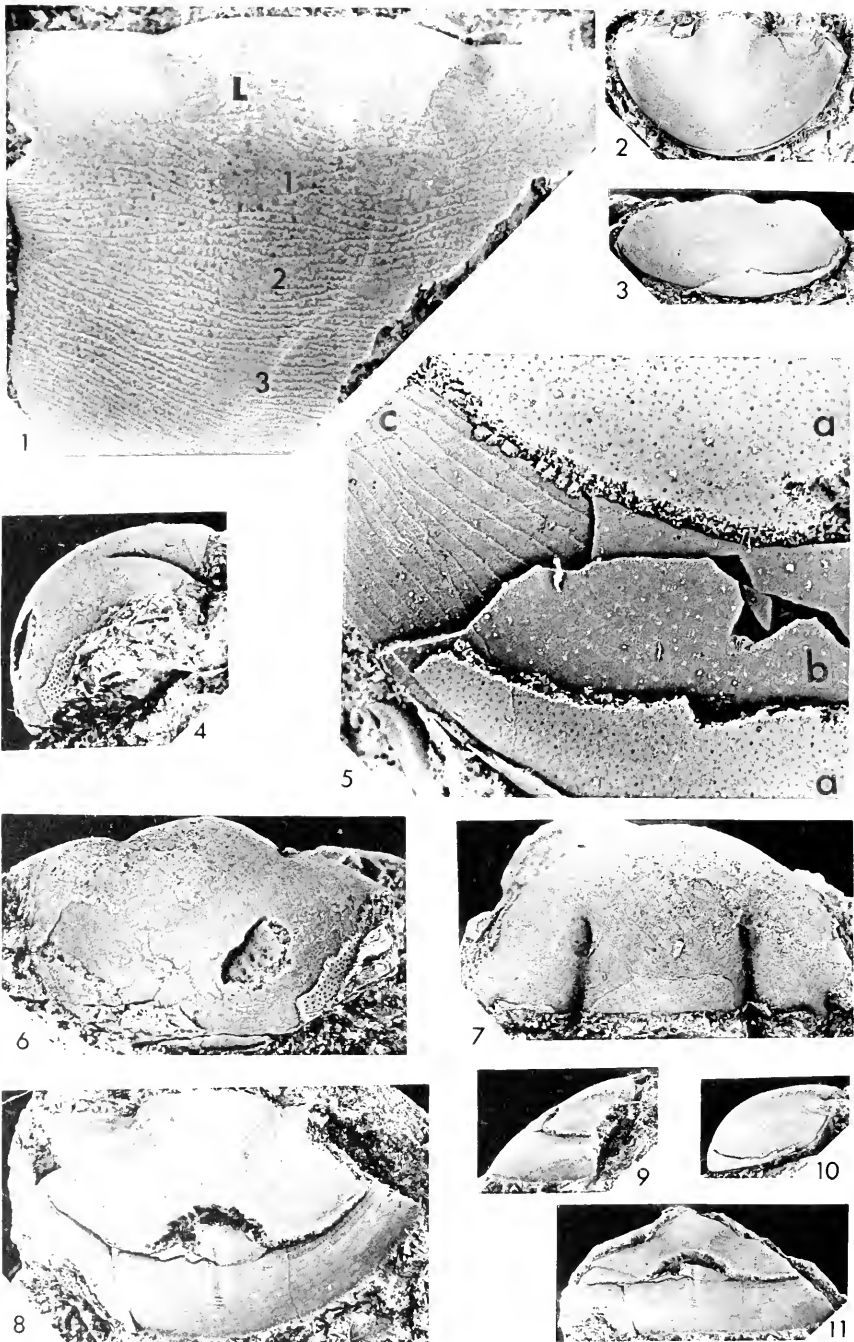

PLATE 54

Iliaenus gelasinus n. sp.
Middle Table Head Formation

- Figure
1 Exterior view of incomplete cranidium with exoskeleton, showing lines and smooth paired areas on external surface, X 9. L, lunette; 1-3 are muscle areas. GSC 18308. Daniel's Harbour.
- 5 Original of Plate 53, figure 15, showing (a) mould of inner surface of dorsal exoskeleton impressed by its granulation, (b) inner surface of doublure bearing granules, and (c) mould of outer surface of doublure showing terrace lines, X 15.

Iliaenus sp. ind. 3

Middle Table Head Formation, Table Cove

- 2, 3, 10 Pygidium, dorsal, posterior, right lateral views, X 2. GSC 18316.
- 8, 9, 11 Pygidium excavated to show doublure, dorsal view, X 3, right lateral, posterior views, X 2. GSC 18317.

Iliaenus sp. ind. 2

Middle Table Head Formation, isolated limestone

- 4, 6, 7 Internal mould of cranidium, left lateral, anterior, dorsal views, X 4.5. GSC 18315.

PLATE 55

Bronteopsis sp. ind.

Middle Table Head Formation, Dominion Iron and Steel Co. quarries,
Aguathuna, Port au Port peninsula

Figure

1, 4 Part of cranidium, dorsal views, X 4.5, X 9, latter showing
arrangement of lines on external surface. YPM 13061.

Raymondaspis reticulatus n. sp.

Middle Table Head Formation

2, 7 Incomplete hypostome, dorsal view, X 9, oblique view, X 15.
GSC 18332. Table Cove.

3 Small hypostome, exterior view, X 6. GSC 18331. Table
Cove.

5, 6 Hypostome, left lateral, exterior views, X 6. GSC 18330.

8 Cast of external mould of hypostome, exterior view, X 15.
GSC 18333

9 Cranidium with exoskeleton, showing lines of external surface
and muscle areas, X 15. GSC 18323. Isolated limestone.

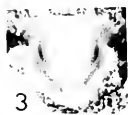
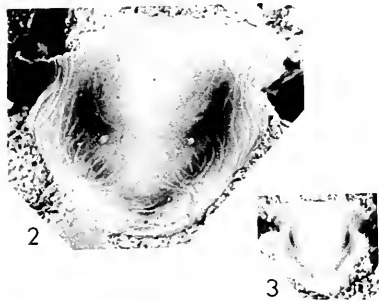
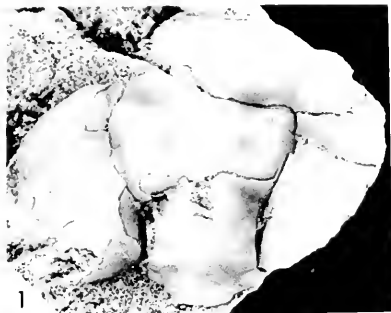

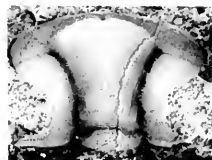

3

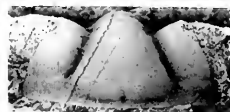

4

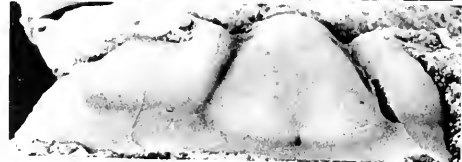

8

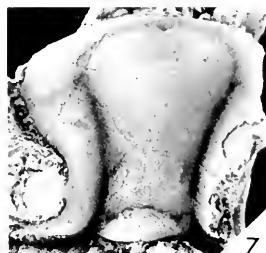

7

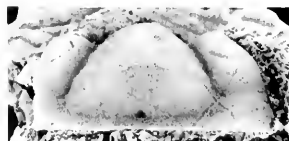

9

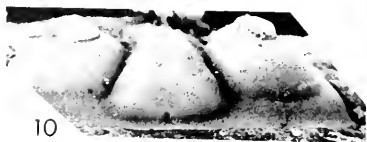

10



11

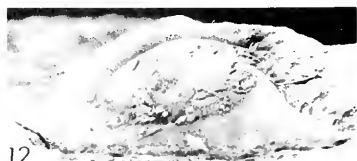

12



13

PLATE 56

Raymondaspis reticulatus n. sp.
Middle Table Head Formation

- Figure
1, 2, 5 Holotype, cephalon, GSC 18318, dorsal, left lateral, anterior views, X 6. Table Cove.
3, 4 Small cranidium, dorsal, anterior views, X 6. GSC 18324. Type section, 140 feet.
6, 8 Incomplete cephalon with right eye lobe, dorsal, anterior views, X 6. GSC 18321. Table Cove.
7, 9 Cranidium with left palpebral lobe, dorsal, anterior views, X 6. GSC 18319. Isolated limestone.
10 Cast of external mould of incomplete cephalon, anterior view, X 6. GSC 18322. Table Cove.

Raymondaspis angelini (Billings, 1862)

Boulder in limestone conglomerate in Lévis Shale, Point Lévis, Quebec

- 11-13 Lectotype (here selected), incomplete cephalon, GSC 872, anterior, left lateral, dorsal views. X 6.

PLATE 57

Raymondaspis reticulatus n. sp.
Middle Table Head Formation

- Figure
- 1, 4 Pygidium, dorsal, posterior views, X 6. GSC 18325. Table Cove.
- 2, 5 Pygidium, dorsal, posterior views, X 6. GSC 18326. Isolated limestone.
- 3, 6 Pygidium, dorsal, posterior views, X 6. GSC 18327. Table Cove.
- 7, 8 Pygidium excavated to reveal doublure, dorsal, posterior views, X 6. GSC 18328. Type section, 90 feet.
- 9 Incomplete cephalon excavated to show mould of doublure of right free cheek, oblique view, X 6. GSC 18320. Table Cove.
- 10 Transitory pygidium, dorsal view, X 30. GSC 18334. Type section.
- 11 Transitory pygidium, dorsal view, X 15. GSC 18335. Isolated limestone.
- 12 Original of Plate 56, figs. 6, 8, oblique view of eye lobe to show narrow inner part of palpebral lobe and facets of eye surface, X 15.
- 13 Internal mould of pygidium, showing muscle areas on axis and caeca on inner part of pleural region, dorsal view, X 12. GSC 18329. Isolated limestone.

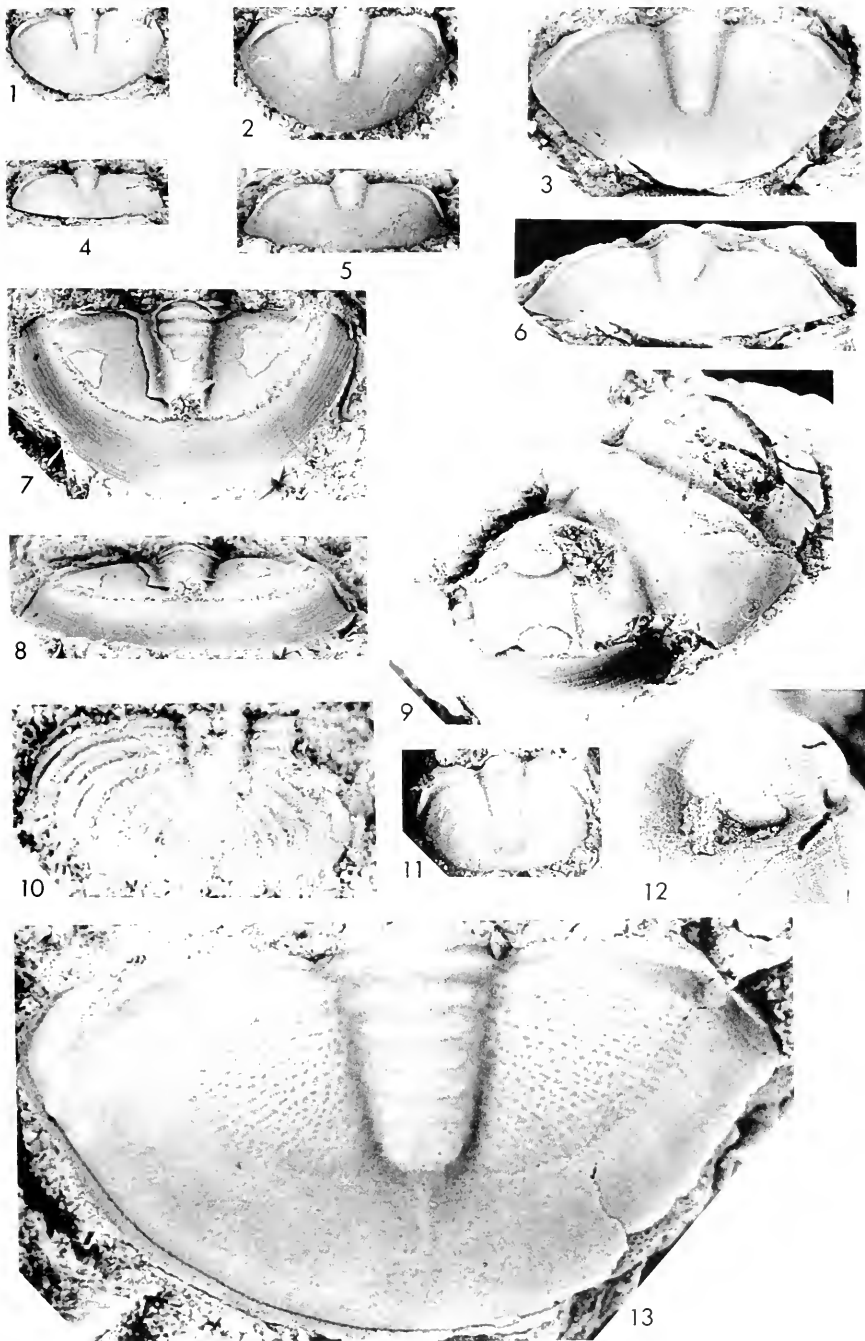

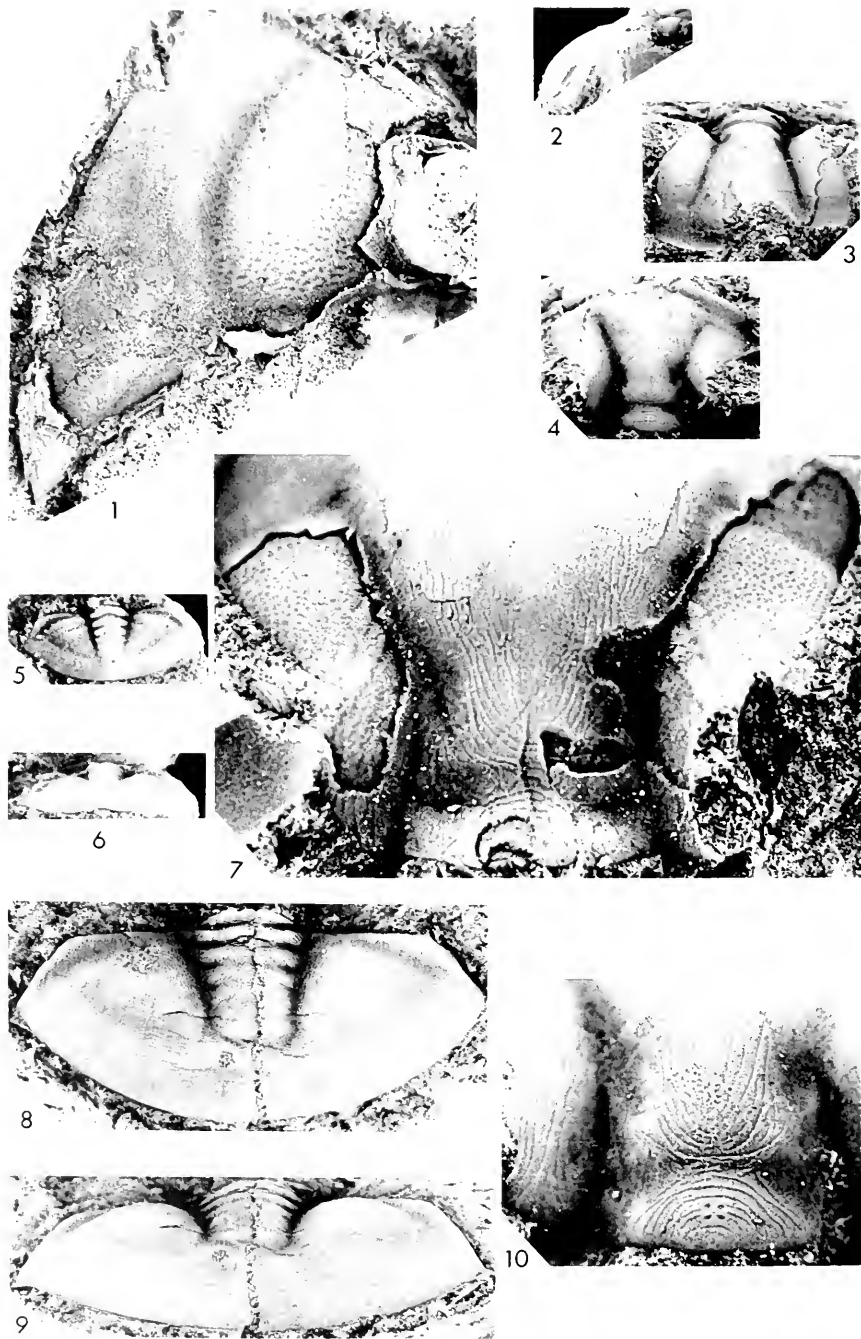

PLATE 58

Raymondaspis reticulatus n. sp.
Middle Table Head Formation

Figure

- 1 Internal mould of free cheek, showing caeca between eye lobe and paradoublural line, exterior view, X 15. GSC 18337. Isolated limestone.
- 7 Partly exfoliated cranidium, showing eye ridge and caeca on fixed cheek inside paradoublural line, dorsal view, X 15. GSC 18336. Table Cove.

Raymondaspis sp. ind. (p. 405)

Middle Table Head Formation, type section, 90 feet

- 2, 3, 4, Incomplete cranidium, left lateral, anterior, dorsal views, X 6; enlargement showing square, smooth medial area of occipital ring in which four pits are impressed, X 20. GSC 18338.
- 10

Raymondaspis turgidus n. sp.

Middle Table Head Formation, type section, 190 feet

- 5, 6 Small pygidium, dorsal, posterior views, X 9. GSC 18343.
- 8, 9 Large pygidium, dorsal, posterior views, X 6. GSC 18342.

PLATE 59

Raymondaspis turgidus n. sp.
Middle Table Head Formation,
190 feet above base, type section

- Figure
1, 5, 6, 7 Holotype, cranidium, GSC 18339, dorsal view, X 8; anterior, left lateral views, X 6; oblique view showing anterior pit and muscle areas, X 10.
- 2-4 Free cheek, dorsal, lateral, anterior views, X 6. GSC 18340.
- 8 Incomplete cranidium showing anterior border, anterior view, X 6. GSC 18341.
- 9, 11 Pygidium excavated to show mould of doublure on right side, right lateral, dorsal views, X 6. GSC 18344.

aff. *Calymenidium* sp. ind.

Middle Table Head Formation, Table Cove

- 10, 12, 13 Small cranidium, anterior, right lateral, dorsal views, X 12. GSC 18346.
- 14, 15 Incomplete cranidium, anterior, dorsal views, X 8. GSC 18345.

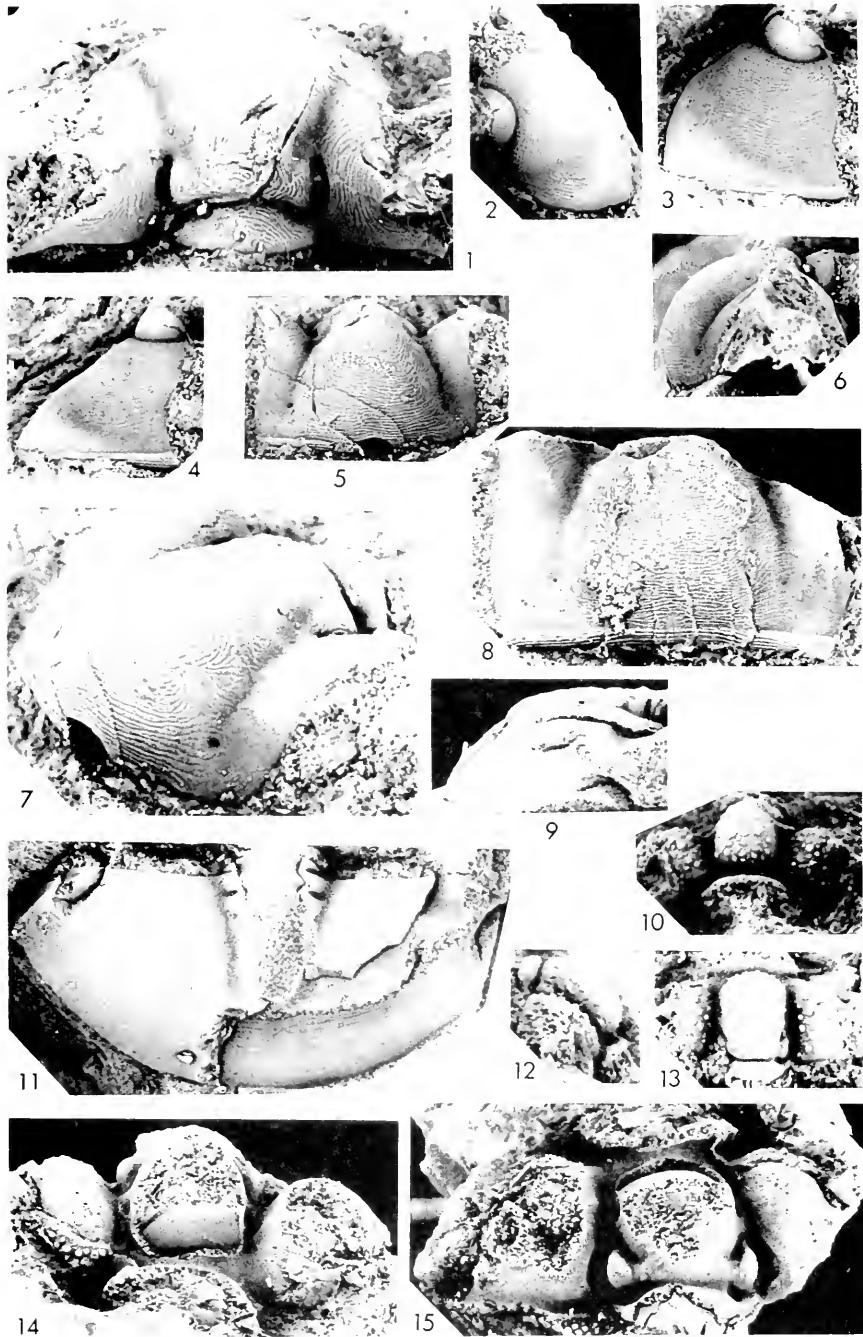

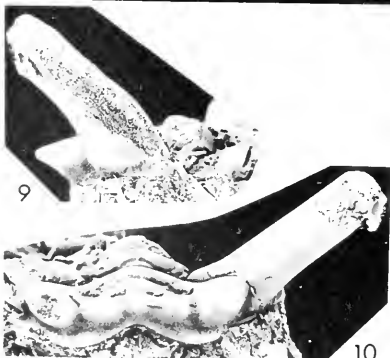
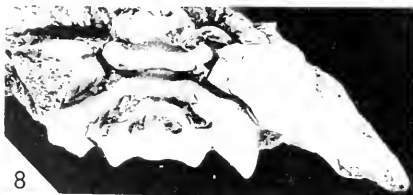
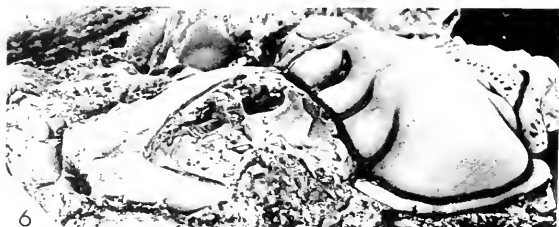

PLATE 60

Ceraurinella polydorus (Billings, 1865)
Middle Table Head Formation, Table Cove

- Figure
1, 2, 4, 6 Incomplete cranidium, anterior, right lateral, dorsal, oblique views, X 4.5. GSC 18347.
3, 5, 7 Incomplete cranidium, anterior, right lateral, dorsal views, X 4.5. GSC 18349.
8-10 Incomplete pygidium, dorsal, right lateral, posterior views, X 3. GSC 18350.
11 Left anterior part of glabella and fixed cheek of partly exfoliated cranidium, showing fine granulation, X 15. GSC 18348.

PLATE 61

Xystocrania perforator (Billings, 1865)

- Figure
1, 3, 6 Holotype, incomplete cranidium, GSC 684, original of Billings, 1865, fig. 275, dorsal, anterior, left lateral views, X 1.5. Type section, middle Table Head Formation.
- 2, 5, 8 Incomplete cranidium, dorsal, anterior, right lateral views, X 4.5. GSC 18351. 379 feet above base of bed 8, type section, lower Table Head Formation.
- 4, 7, 10 Cast of external mould of left half of cephalon, original of Raymond, 1925, pl. 10, fig. 8, dorsal, anterior, left lateral views, X 2. YPM 13046. 30-35 feet above zone 10, lower Table Head Formation, Port au Choix.
- 9, 11 Hypostome, probably belonging to this species, right lateral, exterior views, X 4.5. GSC 18352. 350 feet above base of bed 8, type section, lower Table Head Formation.

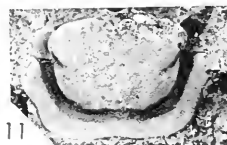
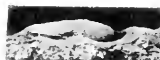
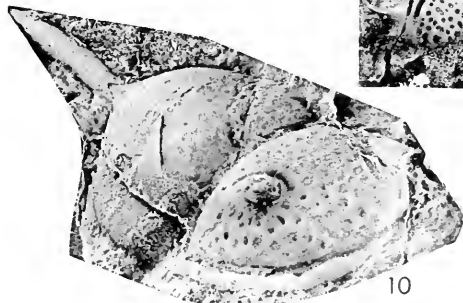
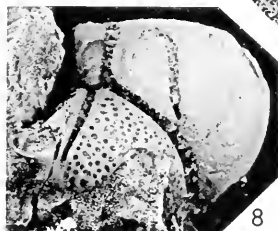
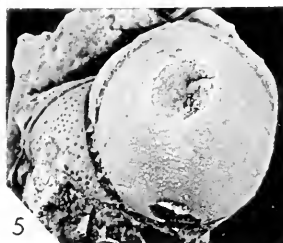
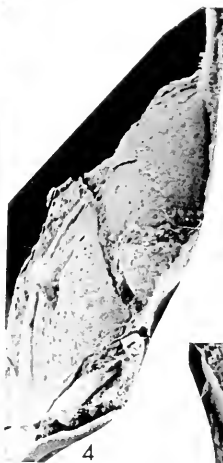
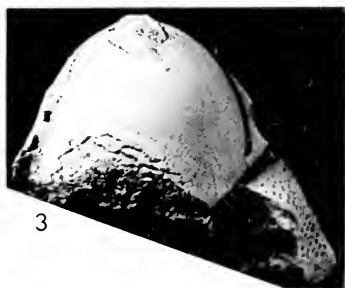

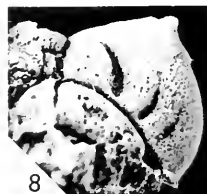
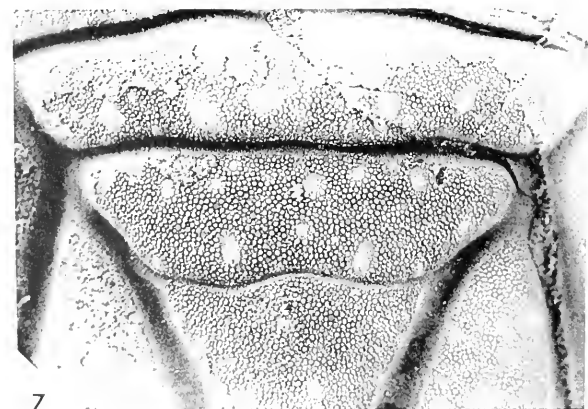
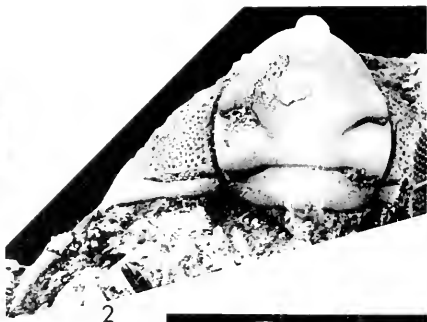

PLATE 62

Xystocrania cf. glaucus (Billings, 1865)
Lower Table Head Formation, type section,
350 feet above base of bed 8.

Figure

1-3, 6

Incomplete cranidium, anterior, dorsal, oblique, left lateral views, X 6. GSC 18353.

Xystocrania glaucus (Billings, 1865)
Boulder in Mystic Conglomerate, Range 6, Lot 20,
Stanbridge Township, Missisquoi County, Quebec.

4, 8, 9

Lectotype, incomplete and exfoliated cranidium, GSC 850,
probably original of Billings, 1865, fig. 308a, dorsal, right
lateral, anterior views, X 3.

Kawina sp. ind.

Lower Table Head Formation, Pointe Riche

5, 7

Incomplete pygidium, dorsal view, X 4.5; enlargement of part
of axis showing external surface, X 15. GSC 18274.

PLATE 63

Heliomera sol (Billings, 1865)

Middle Table Head Formation

Figure

- 1, 3, 4 Lectotype, incomplete cranidium, GSC 683, anterior, dorsal,
5 left lateral views, X 6; oblique view, X 9. Type section.
2, 6, 8, Incomplete cranidium, anterior, dorsal, left lateral, exterior
12 views, X 4.5. GSC 18354. Isolated limestone.

Heliomera (Heliomeroides) sp. ind.

Middle Table Head Formation,

type section, 17 feet

- 7, 11, 14, Exfoliated glabella, dorsal, anterior, right lateral, exterior
15 views, X 6. GSC 18355.

Cydonocephalus sp. ind.

Middle Table Head Formation,

Table Cove

- 9, 10, 13, Cranidium, right lateral, left lateral, anterior, dorsal views,
16 X 6. GSC 18356.

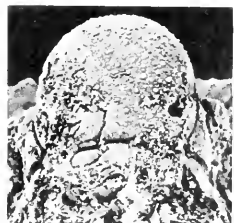
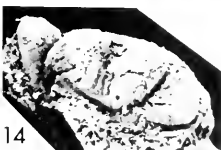
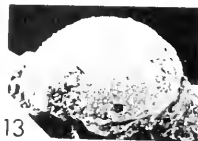
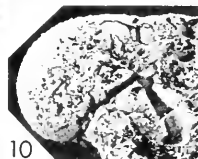
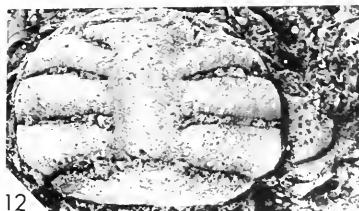
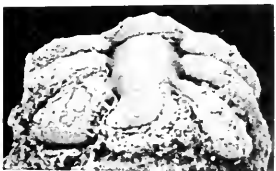
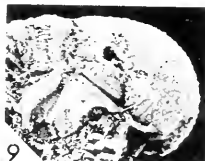
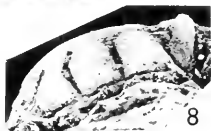
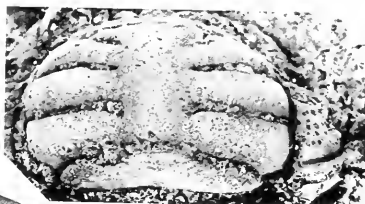
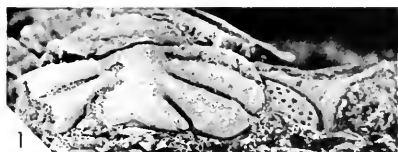

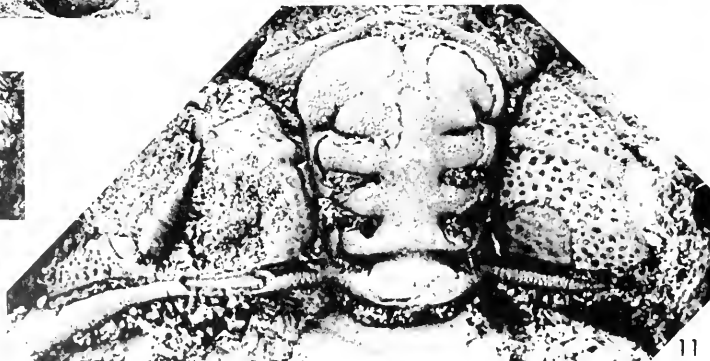
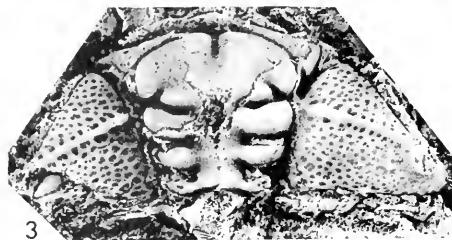

PLATE 64

Miracybele mira (Billings, 1865)
Middle Table Head Formation

Figure

- 1, 3 Lectotype, incomplete cranidium, GSC 697, anterior, dorsal views, X 4.5. Pistolet Bay.
- 2, 6, 8, 9 Cranidium with left fixigenal spine, anterior, dorsal, left lateral, oblique views, X 3. GSC 18357. Isolated limestone.
- 4, 5 Free cheek, showing most anterior part with doublure, anterior, ventral views, X 4.5. GSC 18366. Isolated limestone.
- 7 Free cheek, dorsal view, X 4.5. GSC 18364. Isolated limestone.
- 10 Fragment of small cranidium, dorsal view, X 6. GSC 18361. Table Cove.
- 11 Small cranidium, partly exfoliated, dorsal view, X 12. GSC 18360. Table Cove.

PLATE 65

Miracybele mira (Billings, 1865)
Middle Table Head Formation

Figure

1, 5, 6

Incomplete pygidium with exoskeleton, dorsal, left lateral views, X 4; oblique view showing granulation and pitting of external surface, X 10. GSC 18362. Isolated limestone.

2

Paralectotype, incomplete, exfoliated pygidium, GSC 698a, dorsal view, X 4. Type section.

3, 4

Exfoliated pygidium, left lateral, dorsal views, X 6. GSC 18363. Isolated limestone.

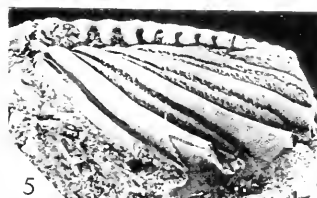
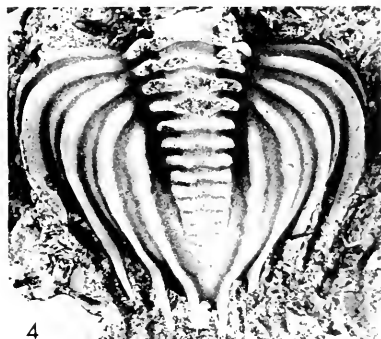
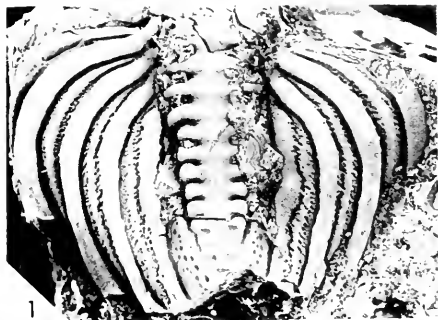

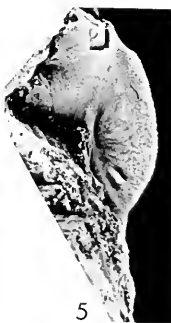
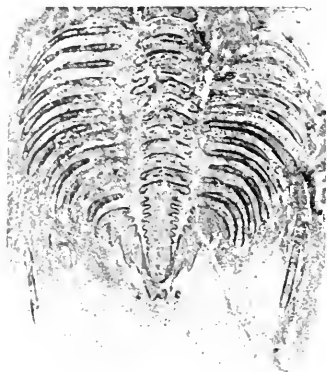
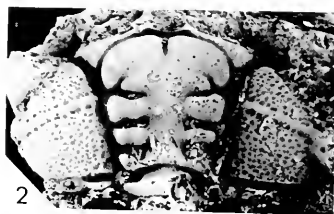

4

5

6



PLATE 66

Miracybele mira (Billings, 1865)
Middle Table Head Formation

- Figure
1 Lateral lobes 1-3p of glabella with exoskeleton, dorsal view showing granulation, X 15. GSC 18358. Table Cove.
2, 3 Exfoliated cranidium, dorsal, anterior views, X 6. Type section, 90 feet.
4 Twelve thoracic segments and pygidium, dorsal view, photographed under alcohol, X 2. GSC 18365.
5-8 Hypostome possibly belonging to this species, right lateral, exterior, posterior views, X 6; oblique view showing middle body with macula, X 15. GSC 18367. Isolated limestone.

PLATE 67

Calyptaulax incepta n. sp.
Lower Table Head Formation

- Figure
1-3, 6 Holotype, incomplete and exfoliated cephalon, GSC 18368,
anterior, right lateral, dorsal, oblique ventral views, X 4.5.
350 feet above base of bed 8, type section.
- 4 External mould of part of pygidium, exterior view, X 4.5. GSC
18369. 379 feet above base of bed 8, type section.

Asaphid ? hypostome
Middle Table Head Formation, Table Cove

- 5, 7, 8 Incomplete example, exterior, posterior, left lateral views, X 9.
GSC 18370.

Pygidium gen. ind. (p. 366)
Middle Table Head Formation,
bed 4 at Black Cove

- 10, 13 Dorsal, posterior views, X 4.5. GSC 18371.

Iliaenid ? pygidium
Middle Table Head Formation, type section

- 11 Dorsal view, X 15. GSC 18372.

Proetid pygidium (p. 338)
Middle Table Head Formation, type section

- 14 Transitory pygidium, dorsal view, X 30. GSC 18373.

Cheirurid hypostome
Middle Table Head Formation,
Table Cove

- 9, 12, 15 Exterior, right lateral, posterior views, X 3. GSC 18374.

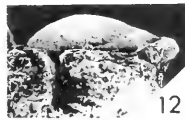
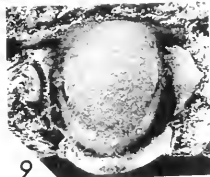
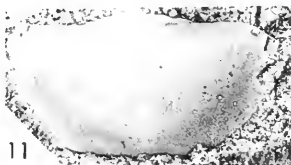
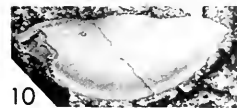
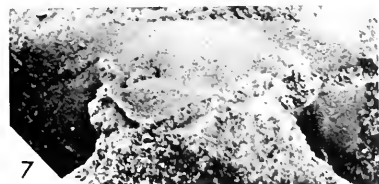
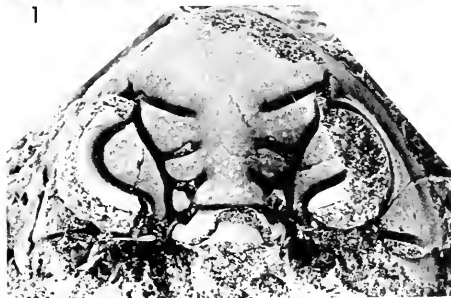
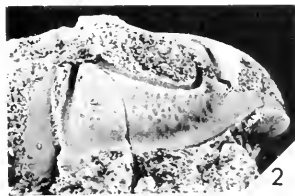
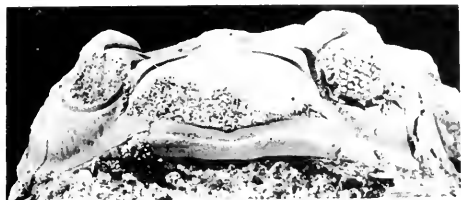



1

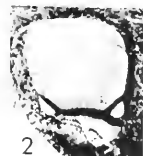

2



3

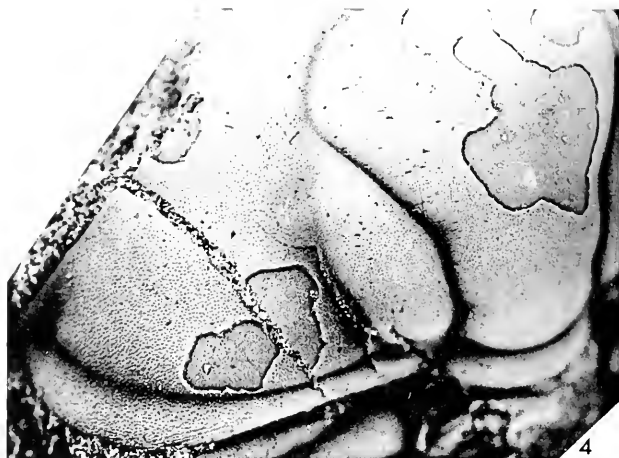

4

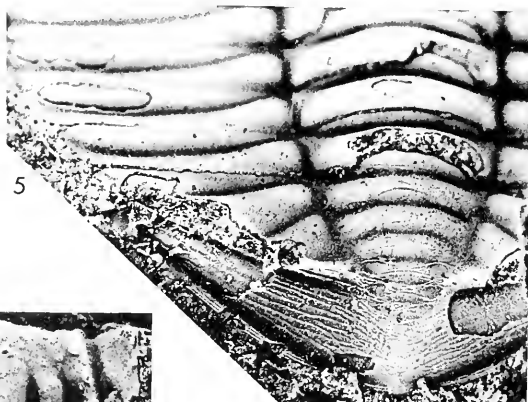

5



7



6

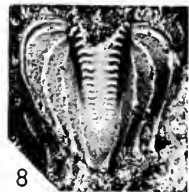

8



9

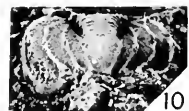

10

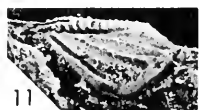

11

PLATE 68

Cranidium gen. ind. 2

Middle Table Head Formation, isolated limestone

Figure

1-3 Incomplete example, anterior, dorsal, right lateral views, X 6.
GSC 18377.

Endymionia mecki (Billings, 1862)

Boulder in limestone conglomerate
in Lévis Shale, Point Lévis, Quebec

4, 5 Holotype, exoskeleton lacking free cheeks, GSC 875, oblique
view of cranidium showing suture line and minute pits in
external surface, X 15; pygidium and steep posterior border
showing smooth muscle areas in axial region of border, oblique
view, X 15.

Enerinurid gen. et sp. ind.

Middle Table Head Formation

6, 7 Part of glabella, dorsal, oblique views, X 9. GSC 18375. Type
section, 90 feet above base.

8, 10, 11 Exfoliated pygidium, dorsal, posterior, left lateral views, X 6.
GSC 18376. Table Cove.

Iltaenus alvcatus Raymond, 1925

Lower Table Head Formation,
245 feet above base of bed 8, type section

9 External mould of cranidium with exoskeleton adhering, pos-
terior part of glabella (posterior margin at bottom of figure),
showing granulation on inner surface, median posterior de-
pression and glabellar tubercle, X 9. GSC 18288.

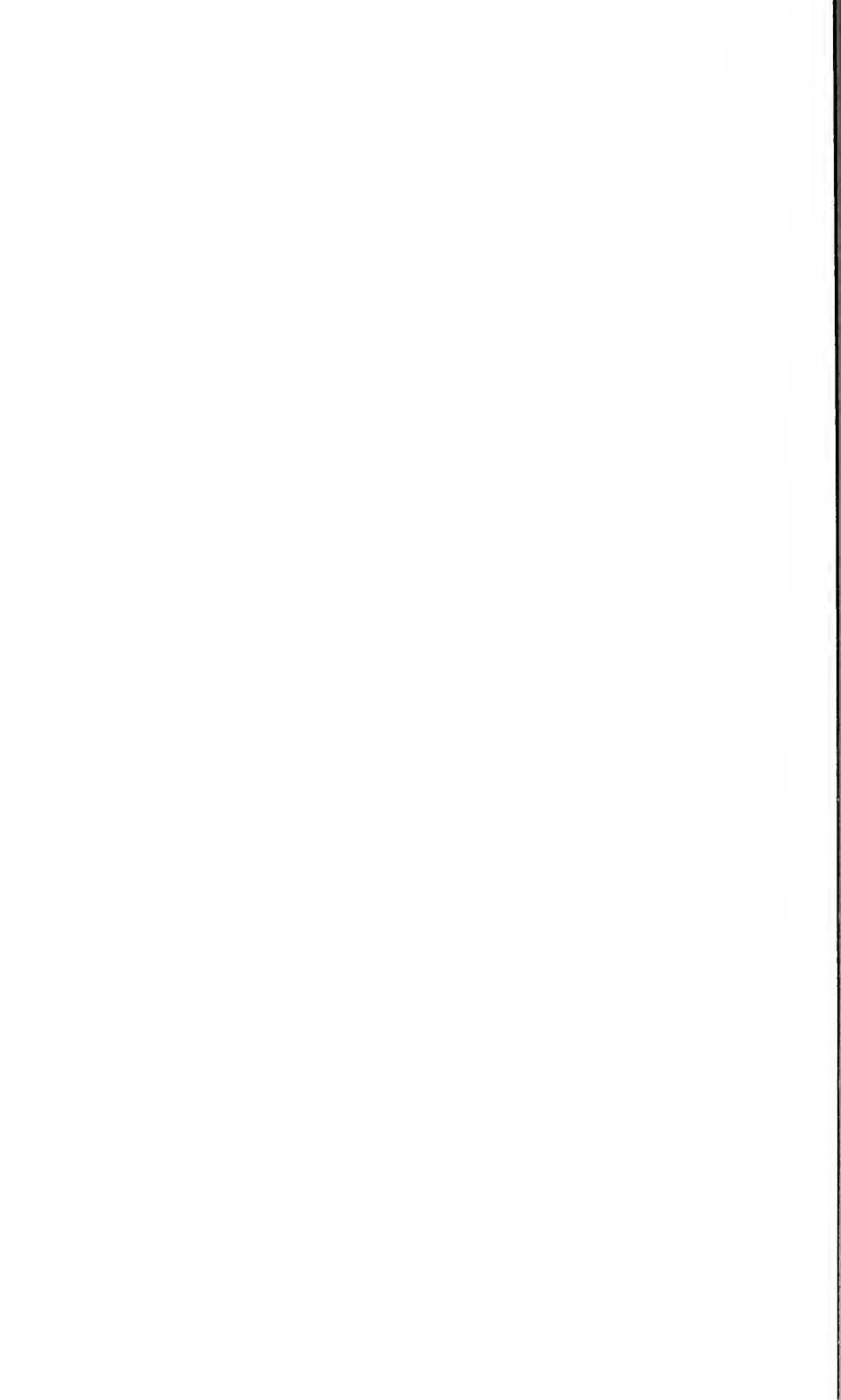



Bulletin of the Museum of Comparative Zoology
HARVARD UNIVERSITY
VOL. 132, No. 5

A FURTHER ACCOUNT OF BATOID FISHES FROM
THE WESTERN ATLANTIC

By Henry B. Bigelow and William C. Schroeder

WITH TWO PLATES

CAMBRIDGE, MASS., U.S.A.
PRINTED FOR THE MUSEUM
APRIL 8, 1965

PUBLICATIONS ISSUED BY OR IN CONNECTION
WITH THE
MUSEUM OF COMPARATIVE ZOOLOGY
HARVARD UNIVERSITY

BULLETIN (octavo) 1863 — The current volume is Vol. 132.

BREVIORA (octavo) 1952 — No. 217 is current.

MEMOIRS (quarto) 1864-1938 — Publication terminated with Vol. 55.

JOHNSONIA (quarto) 1941 — A publication of the Department of Mollusks. Vol. 4, no. 43 is current.

OCCASIONAL PAPERS OF THE DEPARTMENT OF MOLLUSKS (octavo) 1945 — Vol. 2, no. 31 is current.

PROCEEDINGS OF THE NEW ENGLAND ZOOLOGICAL CLUB (octavo) 1899-1948 — Published in connection with the Museum. Publication terminated with Vol. 24.

The continuing publications are issued at irregular intervals in numbers which may be purchased separately. Prices and lists may be obtained from the Publications Office of the Museum of Comparative Zoology, Cambridge 38, Massachusetts.

Peters' Check-List of Birds of the World. Volume 1 is out of print; volumes 2 to 7, 9, 10 and 15 are currently available.

Phylogeny and Evolution of Crustacea. Proceedings of a conference held at Cambridge, Mass., March 6-8, 1962. H. B. Whittington and W. D. I. Rolfe, editors. Cambridge, Mass., 192 pp., 80 figs., 1963. Cloth bound, \$6.75.

Fishes of the Gulf of Maine, by Henry B. Bigelow and William C. Schroeder. Washington, viii + 577 pp., 1953. Photo-offset reprint, \$6.50.

PUBLICATIONS OF THE
BOSTON SOCIETY OF NATURAL HISTORY

The remaining stock of the scientific periodicals of the Boston Society of Natural History has been transferred to the Museum of Comparative Zoology for distribution. Prices for individual numbers may be had upon request.

Bulletin of the Museum of Comparative Zoology
HARVARD UNIVERSITY
VOL. 132, No. 5

A FURTHER ACCOUNT OF BATOID FISHES FROM
THE WESTERN ATLANTIC

By Henry B. Bigelow and William C. Schroeder

WITH TWO PLATES

CAMBRIDGE, MASS., U.S.A.
PRINTED FOR THE MUSEUM
APRIL, 1965

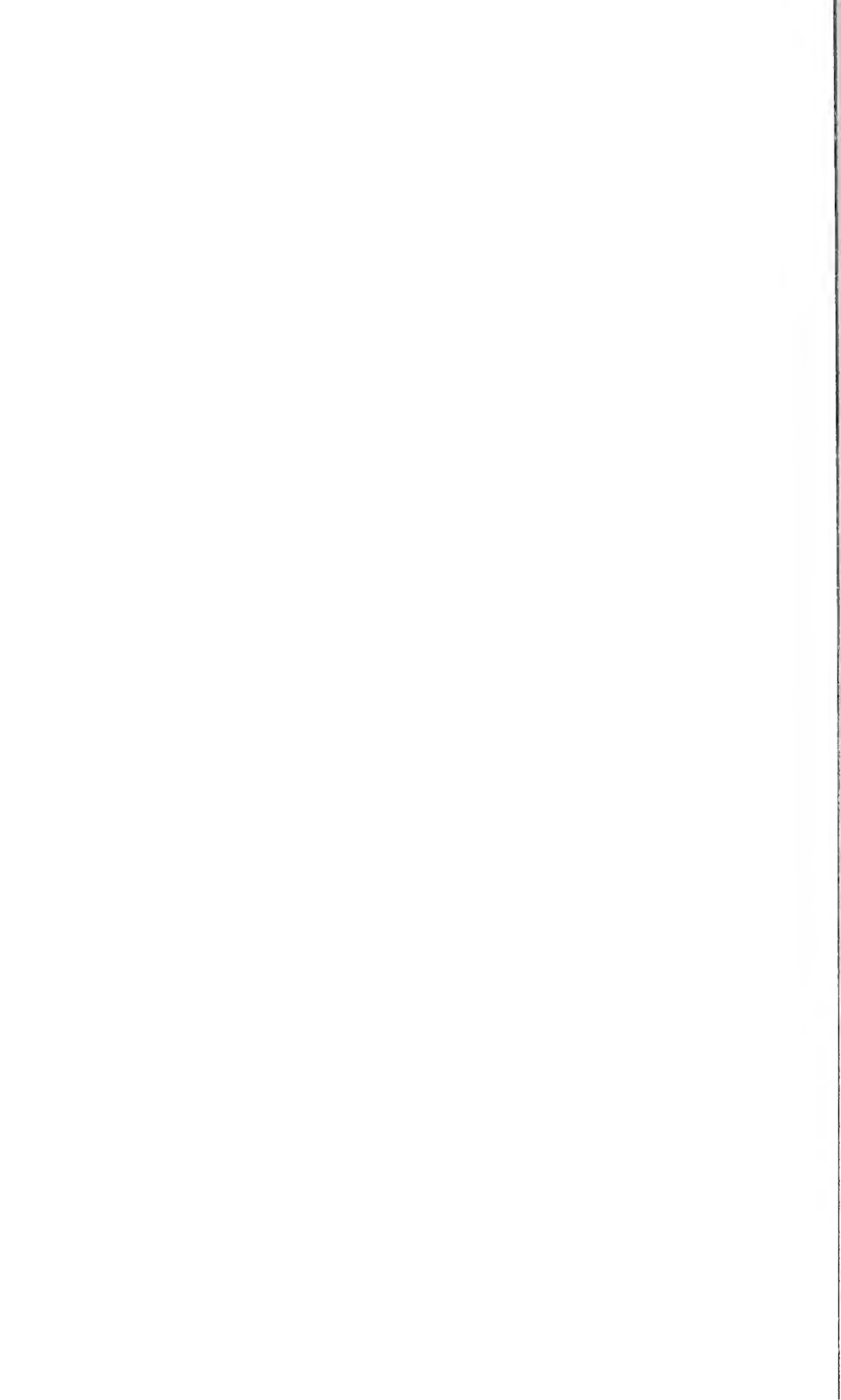

No. 5 — *A Further Account of Batoid Fishes from the Western Atlantic*¹

BY HENRY B. BIGELOW AND WILLIAM C. SCHROEDER

	Page
Introduction	446
Order Batoidei	446
Suborder Torpedinoidea	446
Family Torpedinidae	446
<i>Torpedo nobiliana</i>	446
Suborder Rajoidea	447
Family Rajidae	447
<i>Raja bahamensis</i> sp.nov.	447
<i>Raja bullisi</i>	450
<i>Raja clarkii</i>	451
<i>Raja fuliginosa</i>	453
<i>Raja garricki</i>	453
<i>Raja lentiginosa</i>	454
<i>Raja purpuriventralis</i>	454
<i>Raja tecrani</i>	457
<i>Raja terana</i>	459
<i>Breviraja atripinna</i>	460
<i>Breviraja ishiyamai</i>	460
<i>Breviraja sinuamericana</i>	462
<i>Cruriraja atlantis</i>	462
<i>Cruriraja pocyi</i>	463
<i>Cruriraja rugosa</i>	464
<i>Dactylobatus armatus</i>	465
Family Pseudorajidae	467
<i>Pseudoraja atlantica</i>	467
<i>Pseudoraja fischeri</i>	467
Family Anacanthobatidae	469
<i>Anacanthobatis americana</i>	469
<i>Anacanthobatis longirostris</i>	470
<i>Springeria folirostris</i>	472
Suborder Myliobatoidea	475
Family Dasyatidae	475
<i>Dasyatis violacea</i>	475
References cited	476

¹Contribution No. 1499 from the Woods Hole Oceanographic Institution.

INTRODUCTION

Recent exploratory fishing by the U. S. Fish and Wildlife Service vessels "Oregon" and "Silver Bay" has yielded further collections of batoids trawled, by the former, within the Gulf of Mexico and along the coasts of Central and South America to as far southward as $07^{\circ}15'N$ off the Guianas, and by the latter off the Bahamas and the east coast of Florida. These specimens were trawled within a depth range of 40-750 fathoms, chiefly between 100-500 fathoms.

We thank the various investigators who collected and preserved these specimens and Harvey R. Bullis, Jr., of the U. S. Fish and Wildlife Service for placing them at our disposal. We also thank Peter C. Wilson, Field Party Chief of the Fish and Wildlife Service "Delaware" and Frank J. Mather, III and Martin R. Bartlett of the Woods Hole Oceanographic Institution for furnishing us pertinent data and specimens of the pelagic ray *Dasyatis violacea*, the third and fourth known captures of this species in the western Atlantic.

Most of the material is deposited in the Museum of Comparative Zoology.

Order BATOIDEI

Suborder TORPEDINOIDEA

Family TORPEDINIDAE

TORPEDO NOBILIANA Bonaparte 1835

Our recent account (1962) of this species includes captures from off North Carolina, South Carolina, the Gulf of Mexico, and the offing of Trinidad at $11^{\circ}36'N$, $62^{\circ}52'W$ in depths ranging from 10 to 290 fathoms (18 to 530m). The present collection includes a male 470 mm long from the Caribbean coast of Panama, $9^{\circ}00'N$, $81^{\circ}23'W$, in 250 fathoms (457m), "Oregon" station 3599, its most southerly known range in the western Atlantic. Three more, of 530-700 mm, were taken off the Mississippi Delta in 40-260 fathoms (73-475m), "Oregon" stations 3174, 3688, 3763. As but few very large ones have been both measured and weighed we can report one, a female, caught in a fish trap June 6, 1963, near Woods Hole, Massachusetts, that was $58\frac{1}{2}$ inches (1486 mm) long, $38\frac{1}{2}$ inches (978 mm) wide and weighed 140 pounds (64 kg), for which information we thank Charles L. Wheeler of the U.S. Fish and Wildlife Service.

Suborder RAJOIDEA

Family RAJIDAE

RAJA BAHAMENSIS sp. nov.

Plates 1, 2

Holotype. Mature male, 540 mm in total length, USNM No. 198034, from about 5 miles (8km) off the northwest part of Little Bahama Bank, 27°23'N, 78°26'W, in 212-225 fathoms (382-411 m), "Silver Bay" station 3471.

Study Material. Also three paratypes, a female 490 mm long, MCZ No. 41957 from off the northwest tip of Great Bahama Bank, 26°07'N, 79°12'W, in 200 fathoms (366 m), station 2482, and two males 343 and 530 mm long, respectively, MCZ Nos. 41959 and 41958, from off the western part of Great Bahama Bank in the Straits of Florida, in 200 fathoms (366 m), station 2472.

Comparison with Previously Known Species. The presence of an ocellus on each pectoral fin distinguishes *bahamensis* from other known rajids in the western Atlantic except *texana* Chandler 1921, *ackleyi* Garman 1881, *ocellata* Mitchill 1815, and *cyclophora* Regan 1903. It may be distinguished from half grown and larger *texana* and *ackleyi* by the absence of thorns between the scapular region and a point slightly in advance of the axils of the pectorals, by having but one row of thorns on each side of the midrow along the tail and, on the lower surface, few if any prickles anterior to the nostrils except on end of snout and in a band along edge of disc (half grown and larger *texana* and *ackleyi* have a more or less continuous row of thorns from the nuchal region to the first dorsal, very small in size between the scapular region and about opposite the axils of the pectorals, two rows each side of the midrow along the tail, and below with the disc anterior to the nostrils more or less covered with prickles; young individuals, however, have but one side row of thorns on the tail and, below, prickles are limited to a narrow band along the edge of the disc from near tip of snout to about opposite nostrils). Its relatively smooth disc and a space between the dorsals separate it from *ocellata* all sizes of which have a thorny disc, confluent dorsals and, on half grown and larger individuals, the upper surface is marked with numerous blackish spots. While some lack ocelli others may have on each pectoral from 1 to 4 varying from round to oval. The relatively large number of thorns (34-47) along the midline of the

tail and the rather inconspicuous ocelli set apart *bahamensis* from *cyclophora* the types of which (410-480 mm long) are described as having 10-11 tail thorns.

Description of Holotype. Proportional dimensions in per cent of total length.

Disc. Extreme breadth 69.5; length¹ 54.1.

Snout length in front of. Orbits 14.8; mouth 16.7.

Orbits. Horizontal diameter 4.2; distance between 3.3.

Spiracles. Length 3.0; distance between 6.4.

Mouth. Breadth 8.0.

Exposed nostrils. Distance between inner ends 7.8.

Gill openings. Length 1st 1.6; 3rd 1.9; 5th 1.4; distance between inner ends 1st 14.6; 5th 8.0.

First dorsal fin. Height 2.4; length of base 4.0.

Second dorsal fin. Height 2.0; length of base 5.2.

Pelvic. Anterior margin 9.9.

Distance. From tip of snout to center of cloaca 51.0; from center of cloaca to 1st dorsal 34.4; to tip of tail 49.0; from rear end of 2nd dorsal to tip of tail 2.4. Interspace: 1st and 2nd dorsals 3.0.

Disc 1.3 times as broad as long, the maximum angle in front of spiracles about 90°; anterior rays of pectorals extending 57 per cent of distance from level of front of orbits toward tip of snout, the latter projecting; rostral process firm, narrow, extending nearly to tip of snout; anterior margins of disc slightly convex to about opposite mouth, thence concave to outer corners which are abruptly rounded, the width of disc across anterior edge of orbits 28.7 per cent of total length of specimen; posterior margins and corners and inner margins all rounded. Axis of greatest breadth 64 per cent of distance rearward from tip of snout to axils of pectorals. Tail with a narrow lateral fold low down on each side, originating opposite tips of pelvics, extending to tip of tail, scarcely widening rearward; length of tail from center of cloaca to origin of first dorsal 0.7 times, to origin of second dorsal about 0.9 times, and to tip almost as great as distance from center of cloaca to tip of snout.

There are no thorns on tip of snout but several very small ones over anterior part of rostral cartilage; malar thorns absent; a patch of very small thorns, in area about that of spiracular opening, outward and forward from and close to anterior margin of

¹For outlines of a typical skate illustrating terminology and methods of measurement, see Bigelow and Schroeder, 1953, figure 1.

orbit; 5-7 thorns along inner edge of orbits anteriorly, 4 posteriorly, with an additional one opposite spiracles; midline of back with 4 nuchal thorns followed by a row of 47 thorns, the first one a little in advance of axil of pectorals, extending along middle of tail to first dorsal, the thorns alternating large and small, sharp pointed, the tips directed rearward, in a straight line anteriorly but staggered posteriorly; one row of similar thorns, slightly smaller in size, low down each side of the mid-row, beginning opposite axil of pelvis reaching almost to tip of tail; 5 thorns in space between dorsals; no scapular thorns; a single row of 14-15 narrow backward pointing sharp thorns along edge of disc, about equally spaced and lying horizontally, beginning opposite spiracles and extending rearward a distance a little less than that from orbits to tip of snout; alar thorns in a single row with evidence that a second row will appear, the length of row about equal to distance between outside rim of orbits. Upper surface otherwise smooth. A short row of 8 or 9 inconspicuous mucous pores on each side and close to nuchal thorns. Lower surface with prickles on end of snout and with a band of closely arranged small thorns and prickles extending along edge of disc from tip of snout to opposite first gill openings. Remainder of lower surface of disc and the tail, smooth.

Snout in front of orbits 3.5 times as long as orbit, its length in front of mouth 2.1 times as great as distance between exposed nostrils. Distance between orbits 0.8 times as great as length of orbit; orbits 1.4 times as long as spiracles. Distance between first gill openings 1.9 times the distance between exposed nostrils, between fifth gill openings the distance is equal; first gill openings slightly wider than fifth and about 20 per cent as long as breadth of mouth. Nasal curtain and expanded (outer) margin of nostrils fringed. Jaws moderately arched.

Teeth $\frac{42}{40}$, arranged in quincunx, close-set, with circular bases, those in central section with sharp triangular cusps, those toward corners of jaws with low rounded cusps.

Dorsal fins similar in shape, the base of second slightly longer than first; interspace three-fourths as long as base of first dorsal. Caudal very small, its base about half that of second dorsal with which it is confluent. Pelvis deeply concave, weakly scalloped rearward; anterior lobe about half as long as distance from its own origin to rear tip of pelvic, with 3 radial cartilages in addition to the first stout one; posterior lobe gently convex outwardly, with 19 radial cartilages, the rear tips abruptly rounded.

Claspers reaching rearward nearly two-thirds the distance from axils of pelvics toward first dorsal.

Color. Disc and tail pale grayish brown above; a round ocellus, in diameter about length of orbit, brown in the center with a pale outer rim, on each pectoral, situated a little posterior to the greatest axis of disc. Distance of ocelli from outer angle of disc about the same as from each other, which distance from center to center is 1.06 times the distance to center of orbit. Lower surface probably white in life, with no dark pores.

Our other three specimens are in close agreement in nearly all the proportional dimensions given for the holotype but their disc is wider, 72.8-73.5 per cent of total length of the specimen compared with 69.5 per cent on the holotype, and somewhat broader across the anterior edge of the orbits, 32.5-34.9 per cent compared with 28.7 per cent. The distance between the center of the ocelli times that from the ocelli to center of orbits is virtually the same as that of the holotype on two specimens (1.02-1.03 times) but on the 490 mm female it is 1.25 times. The tooth count on the female is $\frac{36}{5}$ and on the 343 and 530 mm males $\frac{35}{4}$ and $\frac{40}{8}$, respectively. The larger male has an additional pair of ocelli, smaller in size, situated posteriorly slightly in advance of the axil of pectorals.

There are one or two fewer orbital thorns on each of the paratypes and the space along the central part of the inner rim of the orbit lacks thorns, as on the holotype. The smallest male has but one nuchal thorn, the other two paratypes three thorns. The mid row of tail thorns number 34, 41 and 41 and there are 3 or 4 thorns in the space between the dorsals on these three specimens.

So far known only off the Bahama Banks in depths of 200-225 fathoms (366-411 m).

RAJA BULLISI Bigelow and Schroeder 1962

All the previously known specimens of this recently described species, 8 males and 3 females 168-400 mm in total length, were taken in the vicinity of Dry Tortugas, Florida, between 24°18' and 24°36'N, in depths of 200-300 fathoms (366-549 m).

Ten more were trawled by the "Oregon" as follows: 1 at 18°37'N, 64°57'W, in 220 fathoms (400 m), station 2606 off the Virgin Islands; 1 each at 11°31'N, 62°24'W, in 185-200 fathoms (339-366 m), and 11°30'N, 62°29'W, in 180 fathoms (330 m), stations 2351 and 2772, respectively, off Venezuela; 3 at 09°04'N,

81°25'W, in 150-160 fathoms, (275-293 m), station 3597, off the north coast of Panama; 1 at 07°27'N, 54°32'W, in 110 fathoms (200 m), station 2290, 1 at 07°27'N, 54°27'W, in 120-135 fathoms (220-247m), station 2291, and 2 at 07°15'N, 53°21'W, in 135 fathoms (247 m), station 2023, off the coast of Surinam. These specimens, 5 males and 5 females, range in length from 166 to 478 mm.

The upper surface of the disc of those up to 400 mm long have 2 widely spaced thorns along the anterior margin of the orbit and 1 posterior thorn, 1 nuchal thorn, and 13 to 15 thorns along the midline of the tail beginning somewhere between the axils of the pectorals and the pelvics, ending a little before the origin of the first dorsal. Some are otherwise smooth above but others have minute prickles sparsely distributed on the disc and along the sides of the tail. The tail may have, low down, a more or less incomplete row of very small thorns that might easily be overlooked.

The lower surface is smooth on two males of 166 and 175 mm, respectively, but on all sizes upward of 195 mm, of both sexes, there are coarse prickles and small thorns along the anterior half of the rostrum and a narrow band of prickles along the margin of the disc from the tip of the snout to opposite the nostrils, in some cases as far as a point opposite the mouth. The disc below is otherwise smooth, and the tail also.

The largest specimen, a female of 478 mm, is more closely prickled over the upper surface of the disc and on the sides of the tail, with a few prickles on the pelvics, dorsals, and caudal fin, and there are 17 thorns along the midline of the tail. It has, in addition to the orbital thorn arrangement given above, a thorn at the center of the orbit's inner margin.

The known range now extends from Dry Tortugas, Florida, to the coast of Surinam, in 110-300 fathoms (200-549 m).

RAJA CLARKII Bigelow and Schroeder 1958

Figure 1

This species is characterized among western Atlantic rajids by the presence of a band of formidable and very sharp thorns extending along the margin of the lower surface from the tip of the snout almost to the outer corners of the disc. The three largest specimens we have seen, (including the type), 580-745 mm long, are marked above on the disc with one or more pairs

of prominent white roundish or barlike spots. Two of 255 and 364 mm, respectively, described in 1962 (Bigelow and Schroeder), lack the spots but otherwise agree closely with the larger specimens. The type was trawled in the northern part of the Gulf of Mexico in 260 fathoms (476 m), the other two off the coast of Nicaragua, in 275-300 fathoms (503-549 m).

The present collection includes a male of 228 mm from $14^{\circ}10'N$, $81^{\circ}55'W$, off the coast of Nicaragua, 240-250 fathoms

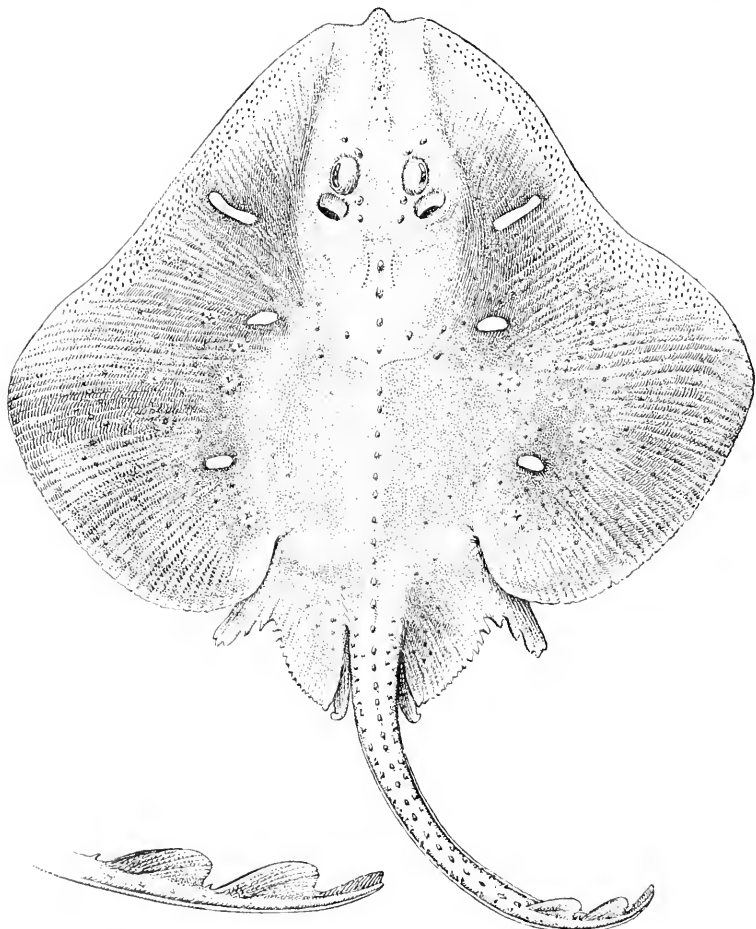

Figure 1. *Raja clarkii*, holotype, immature male 665 mm long; end of tail showing dorsal fins and caudal fin, about $\times 0.5$. (After Bigelow and Schroeder, 1958.)

(439-457 m), "Oregon" station 3565, and a female of 176 mm from 9°03'N, 81°22'W, extending the range to Panama, 200-220 fathoms (366-400 m), station 3598. These also lack the prominent white spots. But a male of 341 mm trawled in the northeastern part of the Gulf at 27°54'N, 85°09'W, in 200 fathoms (366 m), station 4086, already has three pairs of white spots, the front pair elongate, the middle pair very small and roundish, and the rear ones oval and slightly larger than the latter.

RAJA FULIGINEA Bigelow and Schroeder 1954

Known heretofore only from the type, a juvenile male 306 mm long, USNM No. 163367, from "Oregon" station 534, in the northwestern part of the Gulf of Mexico, 27°32'N, 93°02'W, in 400-450 fathoms (732-823 m).

The present collection includes the second known specimen of this skate, a female 330 mm long, from "Oregon" station 4147, about 45 miles southwest of Dry Tortugas, 24°12'N, 83°32'W, in 500 fathoms (915 m).

R. fuliginca closely resembles *R. bathyphila* Holt and Byrne 1908, the recorded captures of which include only the 5 specimens taken by the "Albatross" in 1884 and 1886 between the offings of Chesapeake Bay and southern Nova Scotia, in 835-1188 fathoms (1525-2175 m) (Bigelow and Schroeder, 1953, p. 159), and the type trawled on the Irish Atlantic slope between 893 and 673 fathoms (1635-1230 m). *Fuliginca* differs from *bathyphila* chiefly in its considerably more obtuse (125°-130°) anterior angle of the disc; prickles cover the entire upper surface of the disc, posterior lobes of pelvis, and the tail. Also, the tail below is prickly over most of its area. *Bathyphila* has an anterior disc angle of 90°-108°; the upper surface of the disc and the tail lack prickles in some areas, particularly the disc along its posterior margins; the pelvis have few prickles or may be naked, and the tail below is smooth except along its anterior part where the lateral bands of prickles encroach on the lower surface.

RAJA GARRICKI Bigelow and Schroeder 1958

This skate has been known from only two specimens, mature males, one of 975 mm in total length, holotype, USNM No. 156711 and one of 1019 mm, paratype, MCZ No. 39616, both from the northern part of the Gulf of Mexico, 28°32'N, 86°20'W, in 260 fathoms (476 m), "Oregon" station 1277.

We now have a female, 763 mm long, which differs from the males chiefly in the arrangement of certain of the thorns and prickles. Thus, the female has on the tail, in addition to the midrow of thorns which extends from the nuchal region to the first dorsal fin, a nearly complete side row from the axils of the pelvies to opposite the first dorsal fin and, in addition, a second side row low down originating a little posterior to the upper one. The band of prickles along the margin of the upper surface of the disc extends from the snout to the outer angle and continues to the posterior corners. On the types there is only one row (incomplete) of thorns each side of the midrow on the tail and the prickles which edge the disc above run out before reaching the outer angle.

The female was taken at 14°10'N, 81°58'W, off Nicaragua, in 150-160 fathoms (275-293 m), "Oregon" station 3566, MCZ No. 42079.

RAJA LENTIGINOSA Bigelow and Schroeder 1951

We have reported this skate as apparently widespread in the Gulf of Mexico within its known depth range of 29 to 305 fathoms (53-558 m), and as occurring off the coasts of Honduras and Nicaragua to as far south as 11°27'N (Bigelow and Schroeder, 1962). It appears to be well distributed along the coast of Central America for our present collection includes 7 more specimens from off Honduras, "Oregon" stations 3623, 3625, 3626, and 6 from British Honduras, stations 3634, 3635. They range in length from 108 to 329 mm and were trawled in depths of 105 to 250 fathoms (192-457 m).

The smallest mature male we have seen, with elasper hooks exposed, is 345 mm, and the largest specimen, a female, is 435 mm in total length.

RAJA PURPURIVENTRALIS Bigelow and Schroeder 1962

Figure 2

The holotype, a female 510 mm long, the only previously known specimen, was trawled in the northern part of the Gulf of Mexico, 27°48'N, 88°45'W, in 850-1100 fathoms (1555-2010 m), "Oregon" station 2577. Additional captures are as follows: a female of 320 mm from 28°56'N, 88°19'W, in 600-750 fathoms (1095-1375 m), station 3658; also 3 males and 4 females of 150-314 mm from 7°55'N, 53°55'W, in 500 fathoms

(915 m), station 4296, and a 300 mm male from 7°46'N, 54°00'W, in 400 fathoms (732 m) off the Guianas, station 4299.

Following are certain proportions in per cent of total length of all known specimens.

Total length mm	Disc width	Disc length	Snout to center of cloaca	Center of cloaca to 1st dorsal	Center of cloaca to tip of tail	Sex
150	60.6	48.7	43.3	43.3	56.7	♂
162	61.7	48.1	42.0	42.0	58.0	♀
173	56.7	46.3	41.0	42.2	59.0	♀
225	53.8	45.4	41.3	42.2	58.7	♀
252	52.1	46.8	42.8	42.2	57.2	♂
300	52.0	48.3	43.0	41.4	57.0	♂
312	56.2	48.7	45.0	39.1	55.0	♂
314	53.8	50.3	46.2	38.5	53.8	♀
320	56.0	46.7	43.2	44.6	56.8	♀
510	53.7	49.6	46.7	41.9	53.3	♀

The maximum angle of the disc in front of spiracles ranges from 105° to 115° on the three smallest, which still show the yolksac scar, from 88° to 101° on those 225-320 mm long and 85° on the holotype. The axis of greatest breadth of the disc, rearward from the tip of snout toward axils of pectorals, falls within the narrow range of 70-75 per cent.

In armature, the upper surface of the disc, tail, and posterior lobe of the pelvis, is closely covered with small sharp prickles. The dorsals, caudal fin and the skin over eyes also have prickles. There is a single thorn at the inner anterior margin of each orbit, and another at the posterior margin, save on one specimen which has 2 small posterior thorns at one orbit. There are 1 or 2 small thorns slightly inward from the rear margin of each spiracle. A row of 35-43 thorns extends along the midline to the first dorsal fin, the first 3 from the nape to the pectoral arch being the most prominent, followed by 5-10 smaller thorns, then by larger thorns to the dorsal fin, the last 3 or 4 being somewhat smaller on several specimens, all rather evenly spaced and not alternating in size from thorn to thorn. Apparently the row of thorns on each side of the midrow on the tail, present on the holotype, develops with age for it is lacking on all the present specimens. The tooth count is 36 in the upper jaw of a specimen 175 mm long, and 38 to 42 on 5 specimens ranging from 310 to 510 mm, there being 2 to 5 less in the lower jaw except on the type which shows no variation. Most of the teeth, of both sexes,

have a very small triangular cusp. The largest male of 312 mm is immature, the claspers failing to reach the tip of the pelvics by a distance about equal to $1\frac{1}{2}$ times the diameter of the orbit.

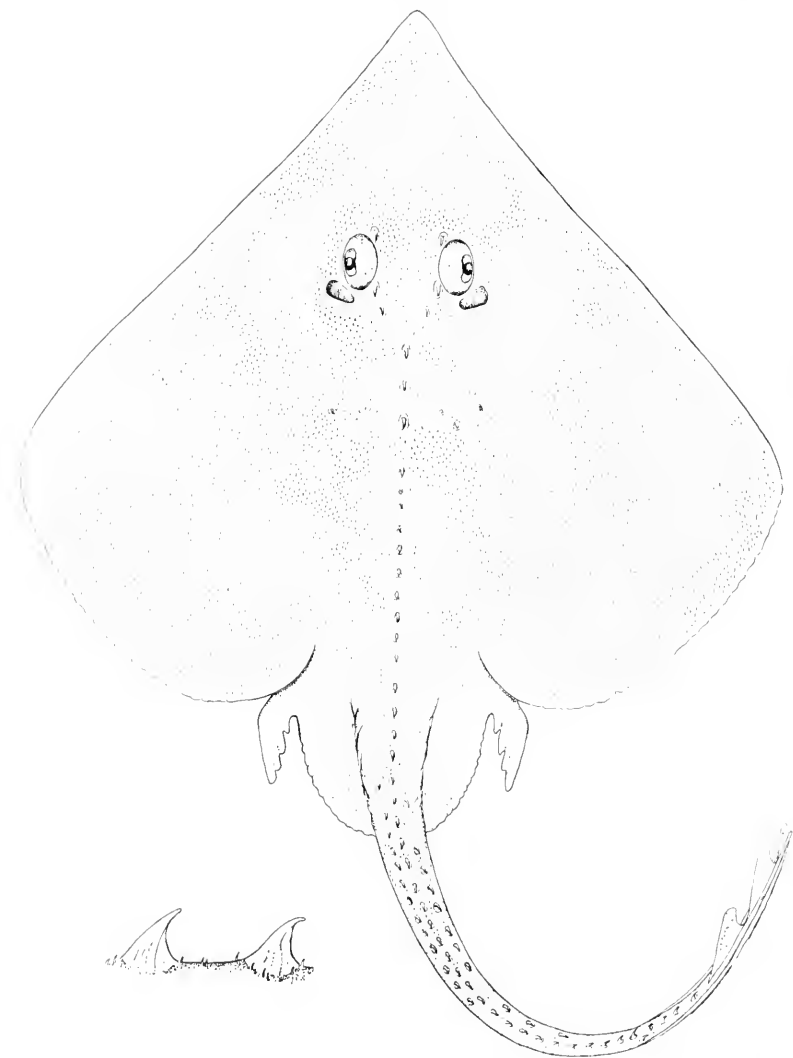

Figure 2. *Raja purpuriventralis*, holotype, female 510 mm long. Lower left, side view of thorns along the midline, about $\times 3$. (After Bigelow and Schroeder, 1962.)

The color of the upper surface in preservative is plain dark gray. The lower surface of the disc is black, dark brown or chocolate plum, the tail being of the same shade or somewhat lighter. White areas are present around the jaws, along the rostrum on some, and just below the pectoral arch on 6 specimens but lacking on 4. A 300 mm long skate has, in addition, white areas below the cloaca, on the pelvics, end of tail, and on the tip of snout which is also white above. When fresh from the water the holotype was purplish above and below.

RAJA TEEVANI Bigelow and Schroeder 1951

Figure 3

The original description of *teevani* is based on two specimens, both males, the holotype 558 mm in total length and the paratype of 302 mm, trawled at 29°11'N, 86°32'W, off Pensacola, Florida, in 305 fathoms (558 m), "Oregon" station 279. Subsequently, two females of 247 and 455 mm were taken in the same region, in 260-320 fathoms (476-585 m), stations 3688 and 3217, respectively, one of 264 mm off the northwest edge of Great Bahama Bank and another, of 340 mm in Santaren Channel, in 300-340 fathoms (549-622 m), "Silver Bay" stations 2475 and 3514. The known geographic range has now been extended still further south for the "Oregon" captured 4 males and 7 females, ranging in length from 175 to 635 mm, between 16°43 and 12°25'N, off the coasts of Honduras and Nicaragua, in 240-400 fathoms (439-732 m), stations 1888, 1919, 1921, 1924, 1944, 3561, 3565, 3571 and 3576.

The account of this species is amplified as follows. The upper surface may be sparsely prickled, chiefly anterior to the spiracles on some, over much of the disc, pelvics and sides of tail on others, but prickles usually are lacking on young individuals. The thorns on the tail, in a single row, range in number from 11 to 20 on our specimens up to 577 mm in length.

The largest, a nearly mature male of 635 mm, has about 30 tail thorns, alternating in size, and it is apparent that the smaller thorns developed between the larger as the row begins at about the axil of the pelvics and ends at the first dorsal as it does on all the smaller sizes. There are coarse prickles on the rostrum and along the margin of the disc from opposite the orbits to opposite the scapular arch. The exposed alar thorns are in 2 to 3 rows and the claspers extend nearly two-fifths the distance from the axil of the pelvics toward the tip of the tail.

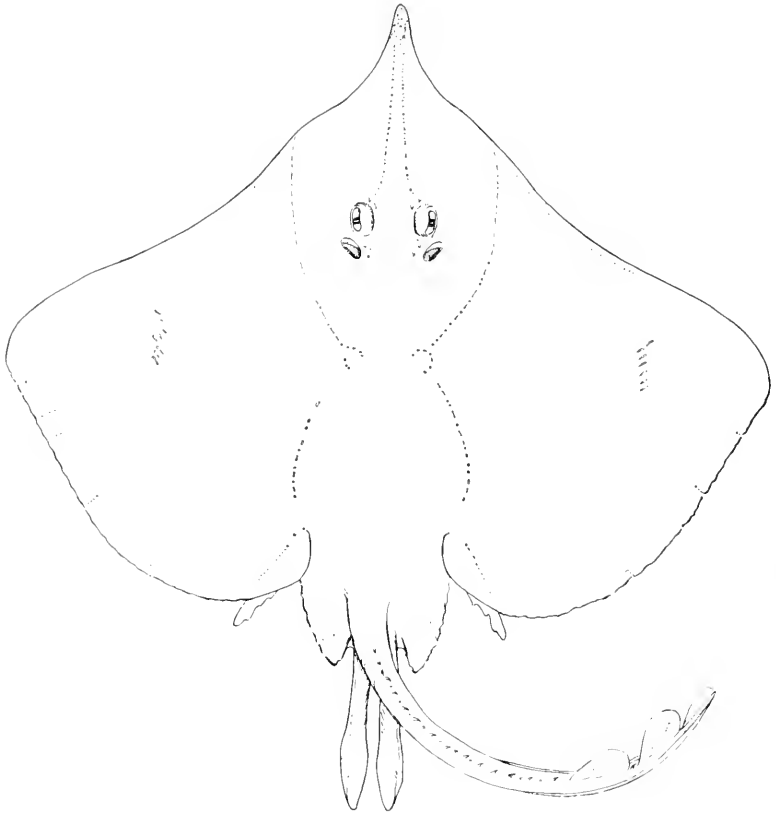

Figure 3. *Raja teevani*, nearly mature male, 635 mm long. Drawing by Jessie Sawyer.

The dorsals are virtually confluent on the types but all the other specimens have a short interdorsal space of from $\frac{1}{14}$ to $\frac{1}{4}$ the length of the first dorsal base. There are 26 to 36 series of teeth in the upper jaw and about the same in the lower. The marginal dusky band on the lower surface may extend from the outer angle of the disc rearward and on to the pelvics, or forward toward the tip of the snout, or be scarcely evident. Also, below, individuals may be pale brownish, mottled brown, or whitish, the pelvics and the tail sometimes darker. A few dark-edged pores are present, most noticeably anterior to the mouth within the translucent areas beside the rostrum.

RAJA TEXANA Chandler 1921

This skate, formerly known only from within the Gulf of Mexico, has recently been taken on the southeastern coast of Florida. We are obliged to Dr. C. Richard Robins and the University of Miami Marine Laboratory for the opportunity of examining a small collection of *texana* which includes several juvenile specimens collected in Biscayne Bay in 1958 and 1959. Also, the "Silver Bay" trawled two specimens of 150-225 mm on the eastern side of the Florida Keys in the Straits of Florida, 24°43'N, 80°43'W, in 48 fathoms (88 m), station 2383.

We have stated (Bigelow and Schroeder 1953, p. 281) that "*R. texana* is closely allied to *R. ackleyi*, but it appears to be distinguishable from the latter by its relatively wider disc with abruptly rounded corners (broadly rounded on *R. ackleyi*), by its color, the upper surface of its disc lacking the small light and dark spots that mark *R. ackleyi*, and by the shape of the ocellar spots, which are round in *R. texana* but oval in *R. ackleyi*." And in the same publication (p. 155, footnote 67), we report, "In *R. ackleyi* the distance from the center of the ocellus to the center of the orbit is about 1.0-1.3 times the distance between the centers of the ocelli; in four specimens of *R. texana* this distance was 0.83-1.0 times." These statements must now be modified, based on additional specimens of *texana* and of one more *ackleyi*.

The width of the disc proves to be of but limited value as a character in recognizing *texana* from *ackleyi*. Thus, *texana* has been found to have a disc width 58.4-70.0 per cent of the total length of the specimen, while on the holotype of *ackleyi*, a male of 410 mm, this proportion is only 53.7 per cent; on two females it is 61.4 and 63.0 per cent, respectively.

The shape of the outer corners of the disc and the color of the upper surface are as previously described for the two species but, while the ocellar spots are round on most of the *texana* seen, on a few the outline is ragged, and on one of our *ackleyi* they are roundish rather than oval. Perhaps the character that might prove most useful for distinguishing the two species, in combination with the other small differences, is that on *texana* (24 specimens) the distance, center to center, from ocellus to orbit is 0.77-1.00 times (average 0.87) the distance, center to center, between the ocelli, while on the 3 known *ackleyi* this distance is 1.00, 1.07 and 1.30 times, respectively. Also, *texana* has no thorn or thorns on each shoulder whereas one or more small ones are present on *ackleyi*.

Texana has now been recorded from depths of less than 8 fathoms (15 m) down to 60 fathoms (110 m). In the Gulf of Mexico the "Oregon" trawled it at 68 stations from May 1950 to September 1955 (Springer and Bullis, 1956).

BREVIRAJA ATRIPINNA Bigelow and Schroeder 1950

Four specimens of this species, 2 males 275-293 mm in total length and 2 females of 244-287 mm, were taken at "Silver Bay" station 2458, 23°40'N, 79°15'W, in Santaren Channel, Bahamas, at a depth of 290 fathoms (530 m).

The 293 mm male is the first mature specimen we have seen. The claspers are narrow, firm, and extend $\frac{1}{3}$ the distance from the axil of pelvics to the first dorsal fin. There are 3-5 rows of very small alar thorns on the outer part of the pectorals, the longest row about $1\frac{1}{2}$ times the diameter of orbit. The teeth have narrow sharp cusps in the central sector of the jaws and wide triangular cusps toward the outer corners. The 275 mm male is still immature, the claspers flexible and extending only $\frac{1}{5}$ the distance to the first dorsal: the alars have not yet appeared, and all the teeth have low triangular cusps.

The known range of *atripinna* extends from the north coast of Cuba to the offing of Cape Fear, North Carolina, 33°51'N, 76°18'W, within depths of 225 to 500 fathoms (410 to 915 m).

BREVIRAJA ISHIYAMAI Bigelow and Schroeder 1962

Figure 4

One specimen was trawled off Palm beach, Florida, 26°39'N, 79°30'W, in 400 fathoms (732 m), "Silver Bay" station 2484, 6 in the Straits of Florida, 24°24'N, 80°00'W, 400-470 fathoms (732-860 m), station 3516, and 2 to the southwestward of Dry Tortugas, Florida, 24°12'N, 83°32'W, in 500 fathoms (915 m), "Oregon" station 4147. These range in length from 120 to 358 mm, all females.

Previous records include a female from off Cape Canaveral, Florida, 1 from southwestward of Dry Tortugas, and 2 from the coast of Nicaragua (one of these the only male seen), in depths of 275-520 fathoms (503-950 m).

Its lack of a space between the dorsals or a very short one (the widest about $\frac{1}{3}$ the base of the first dorsal fin on the 13 known specimens) and absence of prickles on the lower surface of tail easily separate it from *atripinna* which it most closely

resembles but which has an interdorsal space at least as great as the first dorsal base and a tail covered with prickles on its lower surface. All our specimens have a short space between the second dorsal fin and the origin of caudal except one where these fins are confluent.

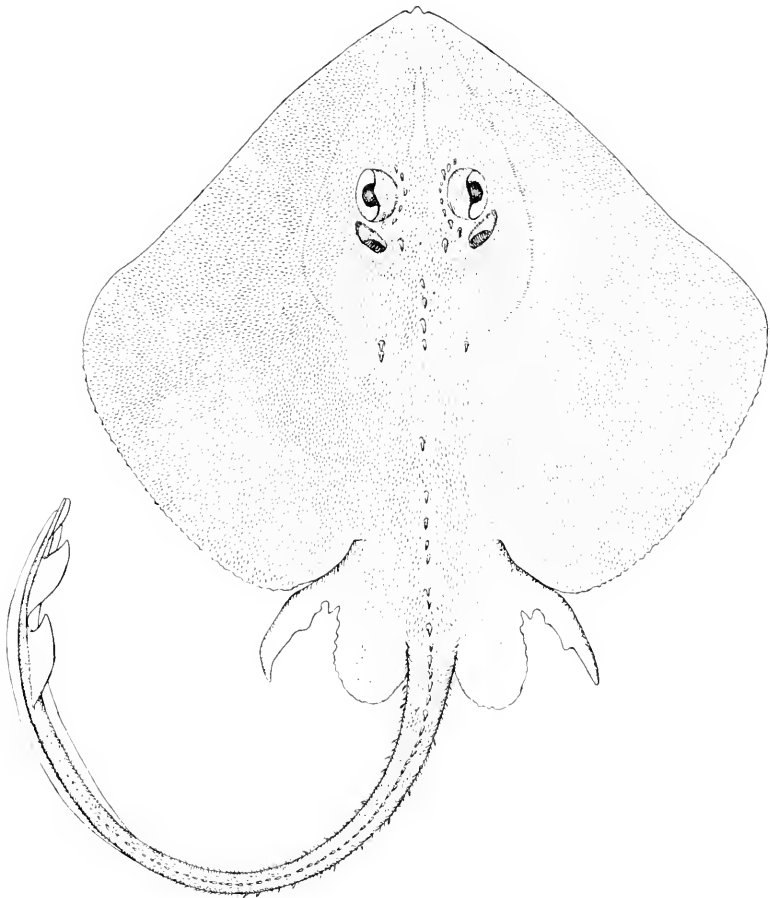

Figure 4. *Breviraja ishiyamai*, holotype, female 338 mm long. (After Bigelow and Schroeder, 1962.)

BREVIRAJA SINUSMEXICANUS Bigelow and Schroeder 1950

Our most recent collection of this species comprises 141 specimens, 77 males and 64 females, ranging in length from 97 to 360 mm, trawled at 16 "Oregon" stations, in 200-500 fathoms (366-915 m), most of them taken within an area some 40 to 70 miles to the eastward of the Mississippi Delta.

The thorniness of this species is conspicuous even on the smallest specimens for two, only 97 and 102 mm long, respectively, with a disc 45 mm wide, have the upper surface of the disc and tail covered with spines and prickles.

The ground color is pale brown, the disc peppered with minute spots of darker brown or brownish purple, some with blotches still darker, while the tail on those up to about 250 mm long has about 10-12 dark cross bars, most prominent on the young. An occasional specimen has a very small light spot on each side opposite the pectoral arch about halfway between the midline and outer edge of the disc.

Known from the northern part of the Gulf of Mexico and from 1 station in the southwest in the Gulf of Campeche, 19°37'N, 92°40'W, within a depth range of 170-500 fathoms (310-915 m).

CRURIRAJA ATLANTIS Bigelow and Schroeder 1948

This rajid, separable from its genus mates by a wider space between the dorsals, has been known only from the north central coast of Cuba where "Atlantis" trawled 13 specimens 100-332 mm long, in depths of 280-425 fathoms (512-777 m), during cruises made in 1938 and 1939. Our present collection includes 23 specimens, 13 males and 10 females, 100-340 mm long, taken off Cape Canaveral and in the Straits of Florida south of Miami, "Silver Bay" stations 442, 3516; in Santaren Channel east of Cay Sal Bank, stations 2458, 2469, 3514; and off the northwest edge of Great Bahama Bank, station 2475, ranging from 23°30' to 27°53'N, and 79°09' to 80°00'W, in 290 to 470 fathoms (530 to 860 m).

Six males 247-330 mm long have a disc width ranging from 52.8 to 57.3 per cent of total length of specimen, distance from tip of snout to center of cloaca 37.3-38.0, space between dorsals 8.1-10.5 and distance from rear end of second dorsal to tip of tail 3.3-4.9. On five females 261-336 mm long these proportions are 51.7-57.2, 35.3-39.1, 8.1-9.6 and 3.9-4.7, respectively. All these proportions are in close agreement with previous accounts

of this species as are the arrangements of spines and prickles. However, while the pelvics have been described as being smooth, and a re-examination of the types prove this to be the case, one of our females, 317 mm long, has a patch of prickles on the pelvics while another of 305 mm has a scattered few. The alar thorns have not yet appeared on an immature male of 247 mm, are in 2-3 short rows on one of 280 mm, 3-4 rows at 295 mm, and 6-7 rows at 300-330 mm, the latter specimens having the longest rows about equal in length to the distance from tip of snout to orbit. The claspers of the 247 mm male do not reach the tip of the pelvics while on 5 nearly mature and mature specimens of 280-330 mm they reach about two-fifths the distance from the axil of pelvics to the origin of the first dorsal.

All these specimens are plain pale brown above with dusky dorsals and caudal. The lower surface of the smallest male is whitish except the limb-like anterior segment of the pelvics which is brown. The other specimens are variously blotched with brown on the abdomen and posterior part of the pectorals: on some the pelvics (including the claspers) are more or less brownish, on others white, while the tail is dusky at the tip.

CRURIRAJA POEYI Bigelow and Schroeder 1948

This species has heretofore been recorded from a number of trawling stations made off the south central and north central coasts of Cuba, in the Bahamas, and at one station off St. Augustine, Florida, within a depth range of 210-475 fathoms (385-870 m).

Recent captures include 25 specimens 84-337 mm in total length from the Bahamas, in 200-300 fathoms (366-549 m) "Silver Bay" stations 2457, 2458, 2469, 2472, 3514, and 2 specimens of 175-260 mm from the offing of Palm Beach, Florida, in 400 fathoms (732 m), station 2484.

The smallest four specimens 84, 96, 100 and 103 mm in total length, respectively, have the following arrangement of thorns and prickles: there are 5 thorns on the rostrum, 1 at the tip followed by 2 pairs; 4 thorns around the inner margin of each orbit and 2, 1, or no thorn inward from each spiracle; malar thorns in the region between the orbits and outer margins of disc are present on the 84 mm specimen, 5 thorns on one side, 10 on the other, 2 or 3 on each side of the 96 mm, both females, while the 100 and 103 mm ones, a male and a female, have none. A midrow of 31-39 thorns begins in the nuchal-scapular region and

continues in a straight line to the first dorsal fin with 1 thorn in the space between dorsals; 1 or 2 scapular thorns on each side. A band of prickles extends along the midzone of disc, beginning about midway between the scapular and pelvic arches and running out between axil of pectorals and tip of pelvis. A side row of thorns, low down on the tail, extends from about the tip of pelvis to opposite the first or second dorsal. The disc above is otherwise smooth, including the dorsals and skin over eyes. Smooth below.

Two specimens, both males, 147-156 mm long, have 7-10 rostral thorns, 6-7 orbitals and 1-2 opposite each spiracle, 5 to 12 malars on each side, a midrow of 44-52 thorns from the nuchal region to the first dorsal, the last few staggered near dorsal on the 147 mm specimen and staggered rearward from the tips of pelvis on the 156 mm one, thus approaching the arrangement on grown individuals. There are 2 thorns between the dorsals, and a second side row of thorns is developing on the tail. By the time a length of about 200 mm is attained the thorns in the midrow, from the nuchal region to a point about half way between the scapular and pelvic arches, have been shed. (For the thorn arrangement on grown individuals see Bigelow and Schroeder, 1953, p. 321 and fig. 75.)

Young specimens up to a little more than 100 mm in length are pale brown, conspicuously marked with roundish dark brown spots about half as large to as large as the orbit, rather evenly spaced over disc, with one to several bars on tail and the dorsals faintly blotched. At about 150 mm the spots are less intense but the dorsals and caudal are intense black and the lower surface is faintly mottled with pale brown, or much the same as on adults.

CRURIRAJA RUGOSA Bigelow and Schroeder 1958

The most recent account of this species (Bigelow and Schroeder, 1962) includes 39 specimens, 90-165 mm in total length, taken at 19 "Oregon" stations off the Atlantic coasts of Nicaragua and Honduras between 12°50' and 16°46'N, in 200-350 fathoms (366-640 m). It was previously known only from the holotype, trawled in the northern part of the Gulf of Mexico, "Oregon" station number lacking.

Our present collection¹ of this species includes 63 specimens,

¹ "Oregon" stations 3552, 3560, 3565, 3571, 3573, 3575, 3576, 3586, 3600, 3616, 3628, 3635, 3653, and "Silver Bay" station 3516.

90-485 mm long, of which 3 are from the north coast of Panama, 38 from off Nicaragua and Honduras, 12 from off British Honduras, 1 from the south coast of Jamaica and 7 from the Straits of Florida, ranging in north latitudes from $9^{\circ}03'$ to $24^{\circ}24'$ and in depth from 240 to 500 fathoms (439-915 m). Also, 2 were trawled in the northern part of the Gulf of Mexico, $29^{\circ}12'N$, $87^{\circ}52'W$, in 280-300 fathoms (512-549 m). Of these, 5 males 314-485 mm long and 3 females of 305-442 mm, selected at random, have the following proportions in per cent of total length, there being no significant difference in proportions between the sexes.

Disc. Extreme width 53.2-66.0; length 39.0-44.4.

Orbits. Horizontal diameter 4.3-4.6; distance between 2.9-3.1.

First dorsal fin. Height 2.5-2.9; length of base 3.8-4.9.

Second dorsal fin. Height 2.5-3.6; length of base 3.8-4.6.

Interspace. 1st and 2nd dorsals 0.7-2.3.

Pelvic. Length of anterior limb 13.6-15.0.

Distance. From tip of snout to center of cloaca 39.0-44.7; axis of disc across anterior margin of orbits 19.3-25.5.

These percentages fall in line with those given previously. Also, the tooth counts (38-44 series in the upper jaw on the 4 specimens examined) and arrangement of prickles and spines are in agreement.

The specimen taken at greatest depth, in 470-500 fathoms (860-915 m), "Oregon" station 3586, is dark brown both above and below instead of the usual pale brown above and whitish, sometimes with a few brown mottlings, below. It has only 28 thorns in the midrow, although in addition there are scars in spaces where thorns are missing, and the row of thorns low down along each side of the tail is lacking, a condition that has been found on an occasional specimen but usually these side thorns (smaller in size than those in the midrow) are in a complete or an incomplete row.

DACTYLOBATUS ARMATUS Bean and Weed 1909

Figure 5

This bizarre species has been known from only two specimens 264-278 mm long, one of which Bean and Weed had reported from $32^{\circ}36'N$, $77^{\circ}29'W$, in 258 fathoms (472 m) and the other from $31^{\circ}N$, $80^{\circ}W$, in about 270 fathoms (495 m). However, this latter position, which appears to be an approximate one, places the depth close to the 50 fathom (92 m) curve and we are inclined to believe that the longitude actually was closer to $79^{\circ}30'$

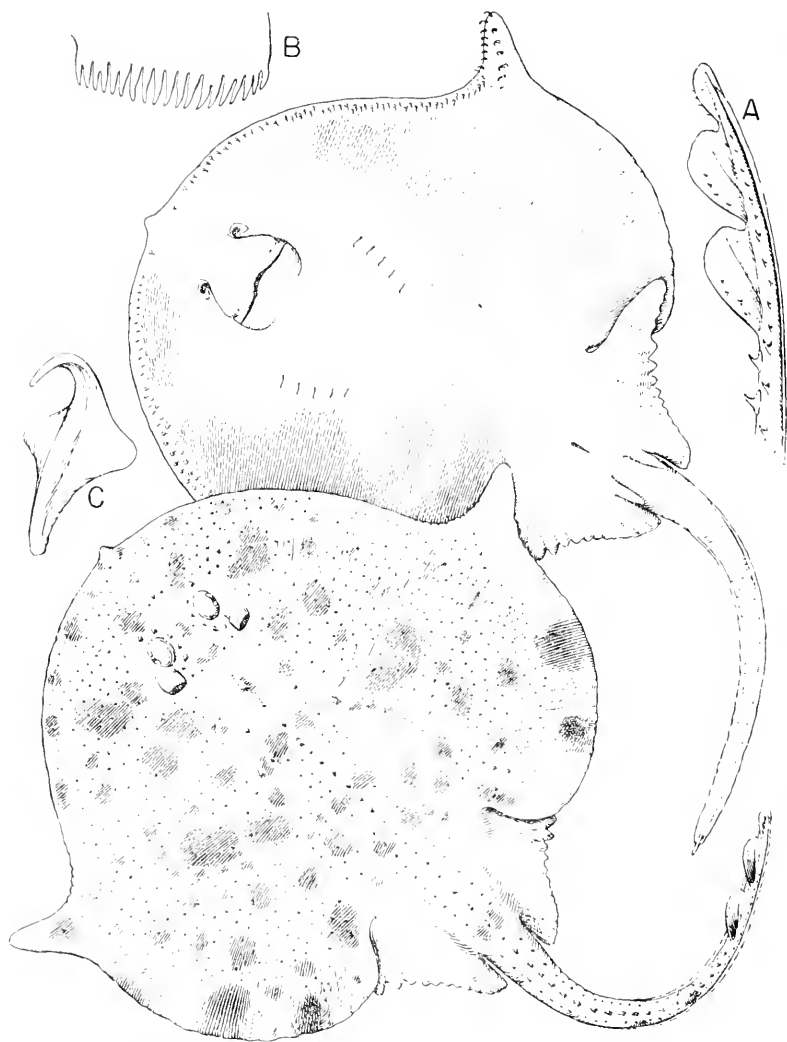

Figure 5. *Dactylobatus armatus*, male 278 mm long. *A*, Side view of posterior part of tail, about $\times 0.7$. *B*, Margin of left-hand nasal curtain, about $\times 4$. *C*, Hooked thorn from lower surface of outer corner of pectoral fin, about $\times 7$. (After Bigelow and Schroeder, 1953.)

than to 80° which would place the capture within close range of the 270 fathoms (495 m) stated by the authors. We had given these localities as from the offing of South Carolina (Bigelow and Schroeder, 1953, p. 323), and while this is so for the northern one the southern is directly off the coast of Georgia.

Our present collection adds two more specimens, a female of 316 mm from off Cape Canaveral, Florida, 28°23'N, 79°49'W, in 185-190 fathoms (338-348 m), "Silver Bay" station 3095, and a female of 250 mm from off St. Augustine, Florida, 29°42'N, 80°10'W, likewise in 185-190 fathoms (338-348 m), station 3726. Both specimens agree closely with previously published descriptions of the species.

Family PSEUDORAJIDAE

PSEUDORAJA ATLANTICA Bigelow and Schroeder 1962

Figure 6

The original account of this species is based on 105 specimens 170-481 mm long taken between the offing of the Amazon River and coast of Nicaragua, 1°45'-13°20'N, in 135-350 fathoms (247-640 m) at 22 "Oregon" stations. Apparently it is relatively abundant within its known range for our present collection includes 86 more, 86-460 mm long, from the north coast of Panama to Nicaragua, 9°00'-14°23'N, in 200-330 fathoms (366-604 m), trawled at 12 "Oregon" stations.

The yolk sac is but partly absorbed on the smallest specimen, 86 mm in total length. A female of 100 mm has left but a trace of the yolk, its disc is 53 mm wide, distance from snout to center of cloaca 32 mm, upper surface covered with prickles and below there are a few prickles in front of the mouth and on the tail. The peculiar knoblike malar thorns which have been described and illustrated for mature and nearly mature males of this species (Bigelow and Schroeder, 1962, p. 214 and fig. 13) prove to be a variable character, for on some of the large males in the present collection these thorns are sharp, as is usual among rajids.

PSEUDORAJA FISCHERI Bigelow and Schroeder 1954

This species, on which a new family and genus was based, has been known from only 5 specimens, three females and a male 262-479 mm long, taken in the southern part of the Gulf of

Mexico (type locality) in 225 fathoms (412 m), "Oregon" station 726, and a female of 270 mm from within or near the Straits of Florida, station number lacking (Bigelow and Schroeder, 1962, p. 216).

One specimen, a female 383 mm long, is in the present collection, MCZ No. 41851, trawled at 16°35'N, 80°10'W, in 315 fathoms (576 m), "Oregon" station 3560, east of Rosalind Bank off the coast of Honduras. It agrees closely with our original account.

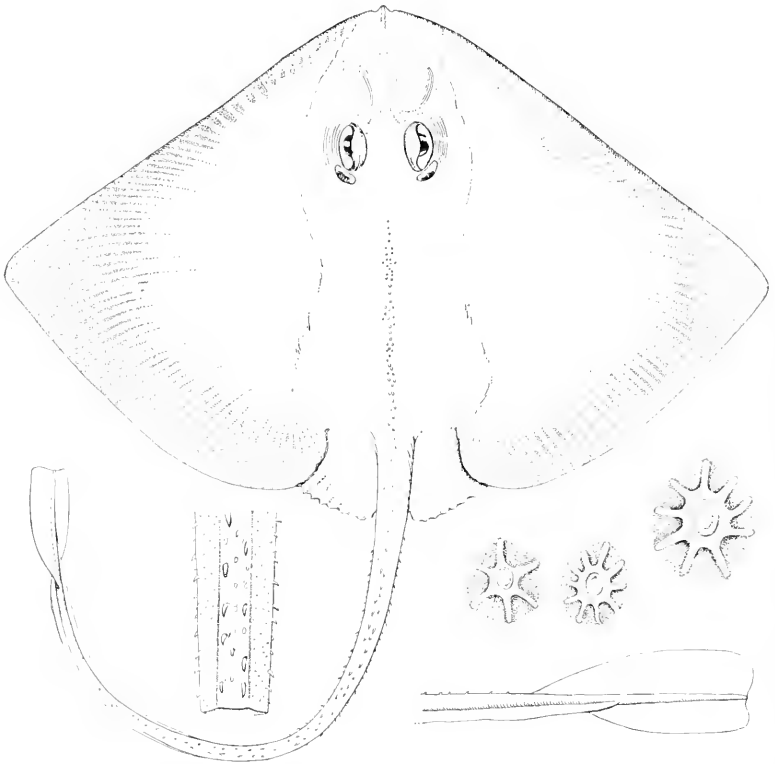

Figure 6. *Pseudoraja atlantica*, holotype, female 450 mm long; section of tail about $\times 1.8$; thorns from along middle of disc, about $\times 12$; caudal fin and ending of tail fold, about $\times 1$. (After Bigelow and Schroeder, 1962.)

Family ANACANTHOBATIDAE

ANACANTHOBATIS AMERICANUS Bigelow and Schroeder 1962

Figure 7

A total of 21 specimens 95-350 mm long had previously been trawled at 4 "Oregon" stations off British Guiana, 3 off Venezuela and 1 off Honduras, 7°34' to 16°35'N, in 100-400 fathoms

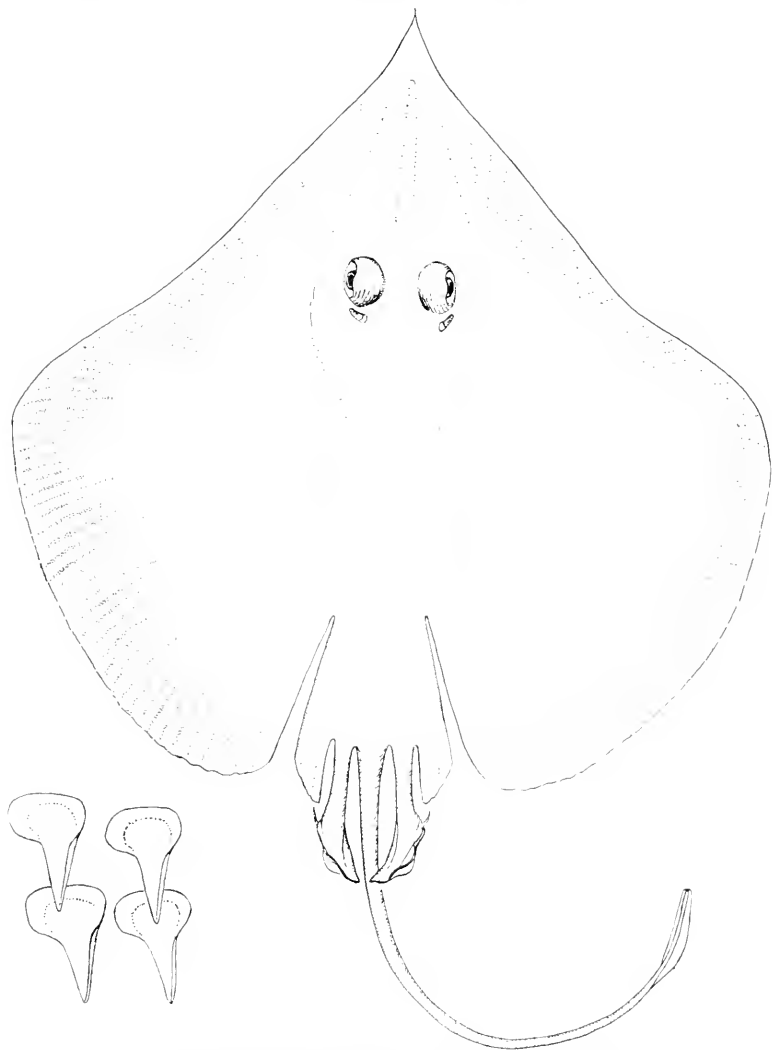

Figure 7. *Anacanthobatis americanus*, mature male 327 mm long; teeth from upper jaw, about $\times 10$. (After Bigelow and Schroeder, 1962.)

(183-732 m). Our present collection includes 31 specimens, 17 males and 14 females, 175-345 mm long, from "Oregon" stations 3582, 3599, 3600, 3601, all off the north coast of Panama $9^{\circ}00'$ to $9^{\circ}15'N$, in 250-400 fathoms (457-732 m).

The color of the upper surface of the disc varies from grayish to brown, the filament at tip of snout being a little darker than the ground color on specimens larger than about 225 mm but about the same color on smaller. Below, most specimens have some white anterior to the gill openings and a white patch just below the scapular arch, the rest of disc being mottled or solid brownish. The anterior lobe of the pelvies is mottled brown and white, and the claspers of mature males, brown. The tail is brownish above and below except at and near the tip which is conspicuously white with a few brownish mottlings.

In our original account the alar thorns of the mature male are described (1962, p. 222) but they were inadvertently omitted on the illustration (p. 220, fig. 15) which is included here as Figure 7.

ANACANTHOBATIS LONGIROSTRIS Bigelow and Schroeder 1962

Figure 8

An immature male 483 mm in total length to base of terminal filament, MCZ No. 41836, was trawled in Santaren Channel, west of Great Bahama Bank, $23^{\circ}40'N$, $79^{\circ}18'W$, in 290 fathoms (530 m), "Silver Bay" station 2458. This species has been known only from the holotype, a female 507 mm long, recorded as probably from the northern part of the Gulf of Mexico, and from a very young male 135 mm long from Santaren Channel, $23^{\circ}59'N$, $79^{\circ}43'W$, in 350 fathoms (640 m), "Combat" station 450. Following are proportional dimensions in per cent of total length of the 483 mm male.

Disc. Extreme breadth 63.2; length 66.3.

Snout length. In front of orbits 26.3; in front of mouth 28.5.

Orbits. Horizontal diameter 3.5; distance between 3.5.

Spiracles. Length 1.3; distance between 6.4.

Mouth. Breadth 4.9.

Exposed nostrils. Distance between inner ends 5.0.

Gill openings. Length, 1st 1.0; 3rd 1.0; 5th 0.8; distance between inner ends, 1st 10.7; 5th 7.4.

Caudal fin. Length of base, upper 3.5; lower 1.4.

Pelvies. Length of anterior limb 14.5; distance, origin of anterior limb to tip of posterior lobe 13.5.

Distance. From tip of snout (from base of filament) to center of cloaca 59.2; from center of cloaca to tip of tail 40.8.

Disc 0.95 times as broad as long; maximum angle in front of spiracles 72° ; axis of greatest breadth 63 per cent of distance

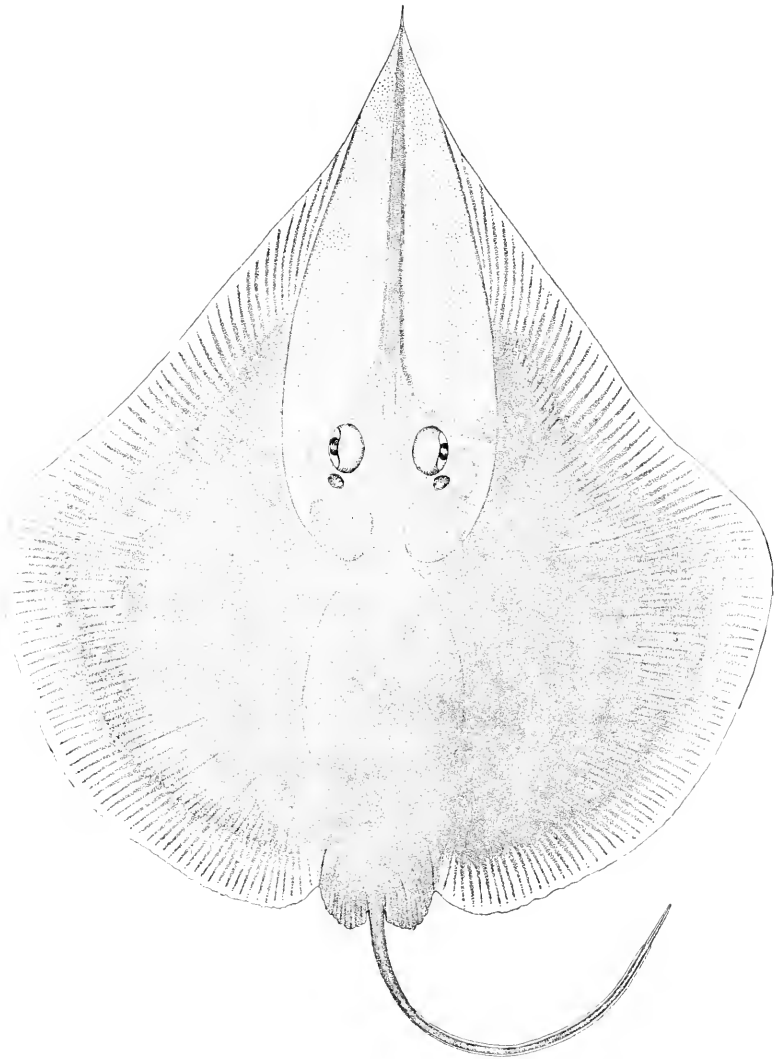

Figure 8. *Anacanthobatis longirostris*, holotype, female 507 mm long. (After Bigelow and Schroeder, 1962.)

rearward from tip of snout (exclusive of filament) to axils of pectorals; length of tail from center of cloaca 0.69 times distance from center of cloaca to tip of snout.

Snout in front of orbits 7.5 times as long, to base of rostral filament, as distance between orbits; its length in front of mouth 5.5 times as great as between exposed nostrils. Orbits as long as distance between orbits and 2.8 times as long as spiracles. Mouth very slightly arched. Teeth $\frac{28}{24}$ and, as on the holotype, they have an ovate base, are arranged in quincunx, with a nearly flat crown but with a small triangular cusp on posterior edge directed toward throat.

Pectoral rays extending forward to within 30 mm of the base of terminal filament. Pelvics with anterior leglike subdivision slightly longer (when pulled back) than the distance from its own origin to rear tip of pelvic, with two radial cartilages; posterior lobe of pelvic with abruptly rounded tip, reaching slightly beyond rear limit of disc; outer margin adnate to pectorals for about $\frac{2}{3}$ its length, inner margin joined about $\frac{3}{4}$ its length to side of tail. Claspers very small and flexible, not reaching tip of pelvics.

Color olivaceous above, probably caused by the preservative, the holotype being light purplish; terminal filament black. Lower surface a lighter shade of that above, end of snout black, and a narrow faint dusky band extends along edge of disc to about opposite mouth.

This specimen differs but little from the holotype, the widest divergence being in its broader disc and shorter snout which are 63.2 and 26.3 per cent of total length, respectively, compared with 56.8 and 29.8 per cent on the holotype.

SPRINGERIA FOLIROSTRIS Bigelow and Schroeder 1951

Figure 9

In an early account of this species (1951a, p. 110) we state that, "In 1924 von Bonde and Swart proposed a new genus *Anacanthobatis* for *Lciobatis marmoratus* von Bonde and Swart, a curious batoid from the Natal coast; skatelike in that its pelvic fins are so deeply concave outwardly that they are entirely subdivided with the anterior subdivision limblike, but differing from all typical skates in their perfectly naked skins and in lacking dorsal fins. A second new species, *dubia*, agreeing with *marmoratus* in naked skin and in filamentous prolongation of the

snout, but differing from it in that the outer margins of the posterior subdivision of its pelvic fins are fused along their anterior one-half with the inner margins of the pectorals, was also referred to *Anacanthobatis* by von Bonde and Swart. But the unique specimen seems to have lost most of its tail, so that the presence or absence of dorsal fins remains to be learned. . . .

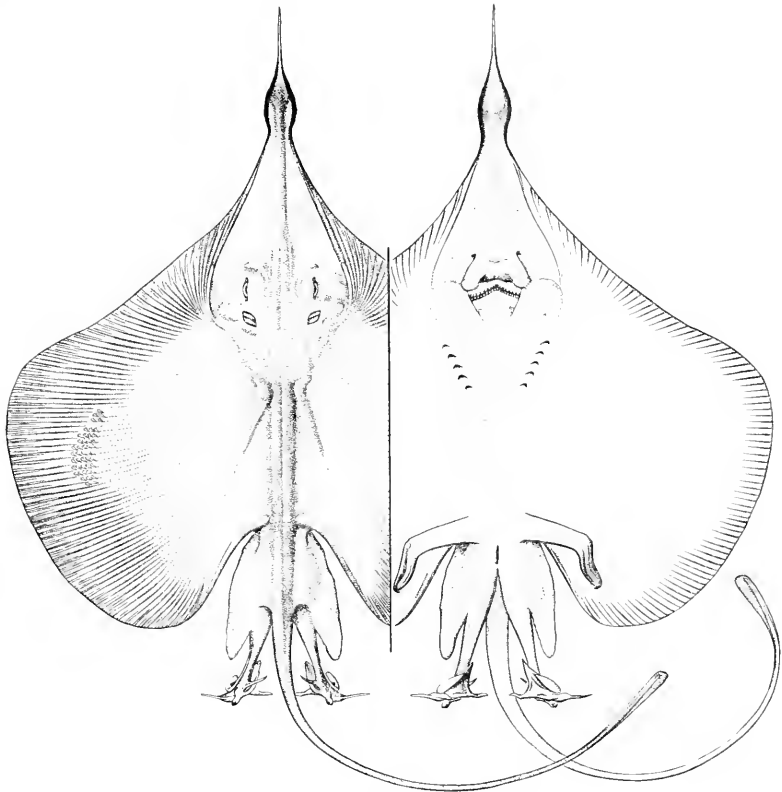

Figure 9. *Springeria folirostris*, mature male 576 mm long. Drawing by N. W. Strekalovsky.

“No batoid resembling *Anacanthobatis* was seen again until the autumn of 1950, when trawlings by the U.S. Fish and Wildlife Service vessel *Oregon* in the northern side of the Gulf of Mexico, off the Mississippi, yielded two specimens that agree with the South African *A. marmoratus* von Bonde and Swart

in structure of pelvies, wholly naked skin, and long slender tail without dorsal fins, but with *A. dubia* von Bonde and Swart in the fact that the outer margins of the posterior subdivision of the pelvic fin is fused along the anterior two-thirds with the inner margin of the pectorals, which is not the case with *marmoratus*. But the Gulf of Mexico form differs from both *marmoratus* and *dubia* in that the end of the snout is expanded in leaflike form."

The marginal fusion of the pelvic fins with the pectorals, an unusual character in the Rajoidea, seemed to us to justify a new genus, *Springeria*, set off from *Anacanthobatis* chiefly because, up to that time (1951) on the few known specimens of the latter, the outer margins of the posterior lobes of the pelvies were not united to the inner margins of the pectorals, and also by the peculiar leaflike expansion of the snout. Subsequently, however (1962), in describing *Anacanthobatis americanus* we had enough material to prove that, while the outer margin of the pelvies is fused along part of its length to the inner margin of the pectorals on females small to large and on immature males, it is entirely free from the pectorals on mature males.

We now have a mature male *Springeria folirostris* (Fig. 9), 576 mm in total length ("Oregon" station 3677), on which the pectorals and pelvies are free, as on mature males of *A. americanus*, hence it is probable that this condition obtains for all anacanthobatids when the males reach maturity. On this specimen the alar thorns are slender and sharp, pointing diagonally inward and rearward, arranged in nearly straight lines, in 5 rows, the greatest width and length of the patch being 14 mm and 40 mm, respectively, on the left side and 14 mm and 34 mm on the right. The jaws are rather strongly arched. Teeth $\frac{25}{24}$, the uppers with a narrow triangular cusp in the central series, most of them blunted, the cusps becoming low broadly triangular in the outer series; the lowers are similar except those near the corners of the mouth have an obscure cutting edge but no cusp. The claspers extend beyond the tips of the pelvies a distance about equal to that between the 4th pair of gill openings, the hooks very sharp, the distance between the tips of the longest pair, which are in a horizontal plane, being 38 mm.

Folirostris was recorded from 24 "Oregon" stations during the years 1950-1955 (Bigelow and Schroeder, 1953; Springer and Bullis, 1956) and our present collection adds a total of 11 specimens from "Oregon" stations 3677, 3682, 3683, 3686, 3688,

3714 and 3724. All the captures have been made in the northern half of the Gulf of Mexico, the range in latitude being from $26^{\circ}46'$ to $29^{\circ}30'N$, in longitude from $85^{\circ}09'$ to $96^{\circ}20'W$, and in depth from 164 to 280 fathoms (300-512 m). Of the 24 specimens we have seen, the largest male is 576 mm in total length to base of the terminal filament and the largest female 620 mm. The claspers on the next largest male, of 427 mm, do not reach the tips of the pelvics, these being still fused with the pectorals.

The tooth count appears to vary but slightly there being 25 to 28 series in the upper jaw and 1 or 2 less in the lower, on 8 males 182-427 mm long and 3 females of 340-440 mm. The teeth of the 182 mm male lack cusps while those of the 427 mm male and the 3 females have a very low triangular cusp except toward the corners of the mouth where they have an obscure cutting edge.

The color above is ash gray or light brown except for the unpigmented translucent spaces between the rostral ridge and the anterior rays of the pectorals; some have one or more sooty blotches, haphazardly located, while others are plain; the terminal expansion of the snout is narrowly and irregularly margined with black both above and below. The lower surface is whitish on the disc centrally, sometimes with a few small grayish patches, the outer belt of the pectorals usually with a grayish band extending from somewhere in advance of the outer angles to the rear margin of the disc; the tail is variously whitish and grayish, generally with a blotch opposite the tips of the pelvics.

Suborder MYLIOBATOIDEA

Family DASYATIDAE

DASYATIS VIOLACEA (Bonaparte) 1832

The first known captures in the western Atlantic of this pelagic ray were of a female with a disc width of 800 mm, taken on a tuna long-line by the U. S. Fish and Wildlife vessel "Delaware" south-southeast of Nantucket Island, $38^{\circ}35'N$, $68^{\circ}14'W$, and another (lost overboard) in the offing of Chesapeake Bay, $36^{\circ}46'N$, $70^{\circ}00'W$, about 300 miles from the coast (Bigelow and Schroeder, 1962, pp. 230-234).

A third one, a female with a disc width of 675 mm and a total length of 1465 mm, weighing 18 pounds (8.2 kg), was long-lined by the "Delaware" in the North Atlantic on April 29, 1963 at $39^{\circ}40'N$, $44^{\circ}50'W$, about midway between the United States

and Portugal, and a fourth, also a female, with a disc width of 767 mm and total length of 1513 mm, weighing $22\frac{1}{4}$ pounds (10.1 kg), was taken by the "Delaware" at $39^{\circ}07'N$, $66^{\circ}30'W$, about 90 miles (140 km) southeast of the southwestern slope of Georges Bank.

Most of the species of the suborder Myliobatoidea (except those in the family Mobulidae) have the free posterior edge of the nasal curtain fringed or with lobelets and with a median notch or gap. Some individuals of the same species may have fringes or lobelets while others lack them, and the notch or gap may be present or absent, as on *Gymnura* and as we have found on *Dasyatis violacea*.

Our 800 mm specimen has a smooth nasal curtain with no notch or gap; the 767 mm one has a curtain with a rough edge and no notch or gap, while on the 675 mm ray the curtain has a ragged edge and the notch is present.

REFERENCES CITED

BEAN, B. A. AND A. C. WEED

1909. Description of a new skate (*Dactylobatus armatus*) from deep water off the southern Atlantic coast of the United States. Proc. U.S. Nat. Mus., vol. 36, pp. 459-461, 1 fig., 1 pl.

BIGELOW, H. B. AND W. C. SCHROEDER

1948. New genera and species of batoid fishes. Jour. Mar. Res., vol. 7, no. 3, pp. 543-566, 9 figs.
1950. New and little known cartilaginous fishes from the Atlantic. Bull. Mus. Comp. Zool., vol. 103, no. 7, pp. 385-408, 7 pls.
- 1951a. A new genus and species of anacanthobatid skate from the Gulf of Mexico. Jour. Washington Acad. Sci., vol. 41, no. 3, pp. 110-113, 1 fig.
- 1951b. Three new skates and a new chimaerid fish from the Gulf of Mexico. Jour. Washington Acad. Sci., vol. 41, no. 12, pp. 383-392, 4 figs.
1953. Fishes of the western North Atlantic. Mem. Sears Found. Mar. Res., no. 1, part 2, x + 588 pp., 127 figs.
1954. A new family, a new genus, and two new species of batoid fishes from the Gulf of Mexico. Breviora, Mus. Comp. Zool., no. 24, 16 pp., 4 figs.
1958. Four new rajids from the Gulf of Mexico. Bull. Mus. Comp. Zool., vol. 119, no. 2, pp. 201-233, 11 figs.
1962. New and little known batoid fishes from the western Atlantic. Bull. Mus. Comp. Zool., vol. 128, no. 4, pp. 159-244, 23 figs., 1 pl.

BONAPARTE, C. L.

- 1832- Iconografia della fauna Italica - - -, vol. 3, Pesci, 78 pls. (not
1841. numbered) and accompanying text (pages not numbered).
For dates of publication see Salvadori, Boll. R. univ. Mus.
Zool. Anat. Comp., Turin, vol. 3, no 48, 1888.

BONDE, C. V. AND D. B. SWART

1924. The *Platosomia* (skates and rays collected by the S.S.
"Pickle." Rep. 3, Fish. Mar. Biol. Surv., S. Africa (1922),
Spec. Rept. 5, 22 pp. pls. 20-23.

CHANDLER, A. C.

1921. A new species of ray from the Texas coast, and report of
the occurrence of a top minnow new to the fauna of eastern
Texas. Proc. U.S. Nat. Mus., vol. 59, pp. 657-658.

GARMAN, S.

1881. Reports on the results of dredging under the supervision of
Alexander Agassiz, along the Atlantic Coast of the United
States. Report on the selachians. Bull. Mus. Comp. Zool.,
vol. 8, no. 11, pp. 231-237.

HOLT, E. W. L. AND L. W. BYRNE

1908. Second report on the fishes of the Irish Atlantic Slope. Fish-
eries, Ireland, Sci. Invest. (1906), no. 5, 63 pp., 5 pls.

MITCHILL, S. L.

1815. The fishes of New York, described and arranged. Trans. Lit.
Philos. Soc. New York, vol. 1, pp. 355-492, pls. 1-6.

REGAN, C. T.

1903. On a collection of fishes made by Dr. Goeldi at Rio Janeiro.
Proc. Zool. Soc. London, part 2, pp. 59-68, 2 pls.

SPRINGER, S. AND H. R. BULLIS, JR.

1956. Collections by the "Oregon" in the Gulf of Mexico. U.S. Fish
and Wildlife Service, Special Scientific Report — Fisheries,
no. 196, 134 pp.

(Received May 21, 1964.)

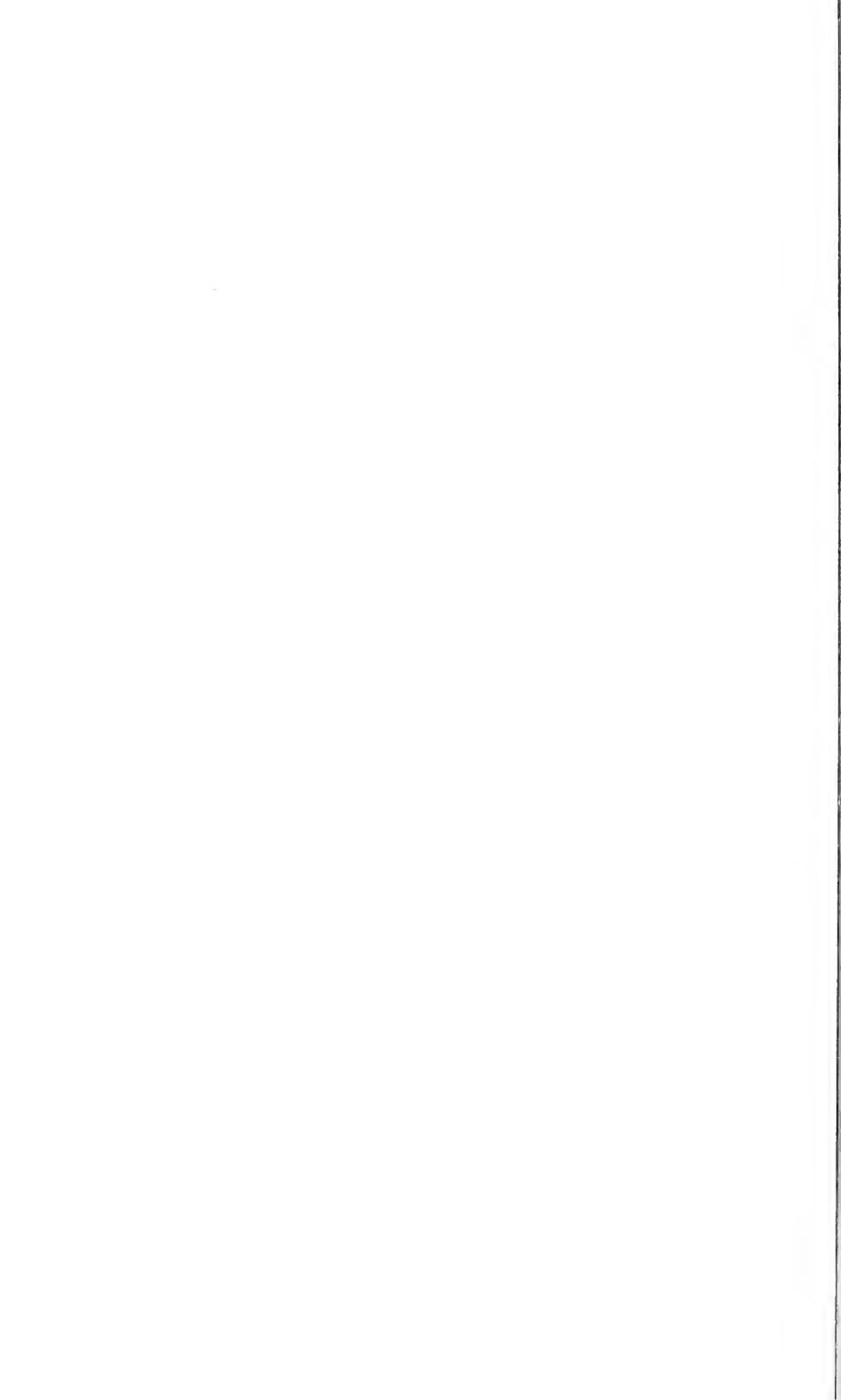

PLATES

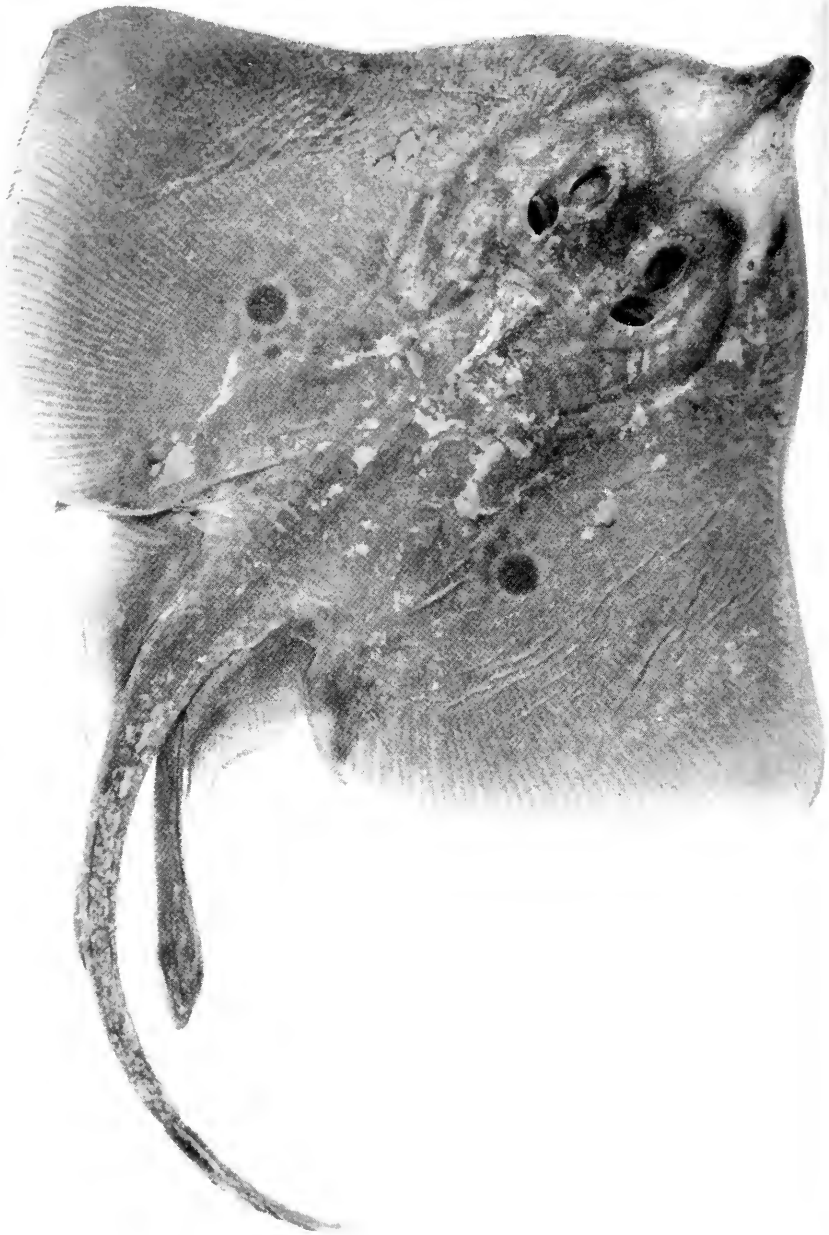
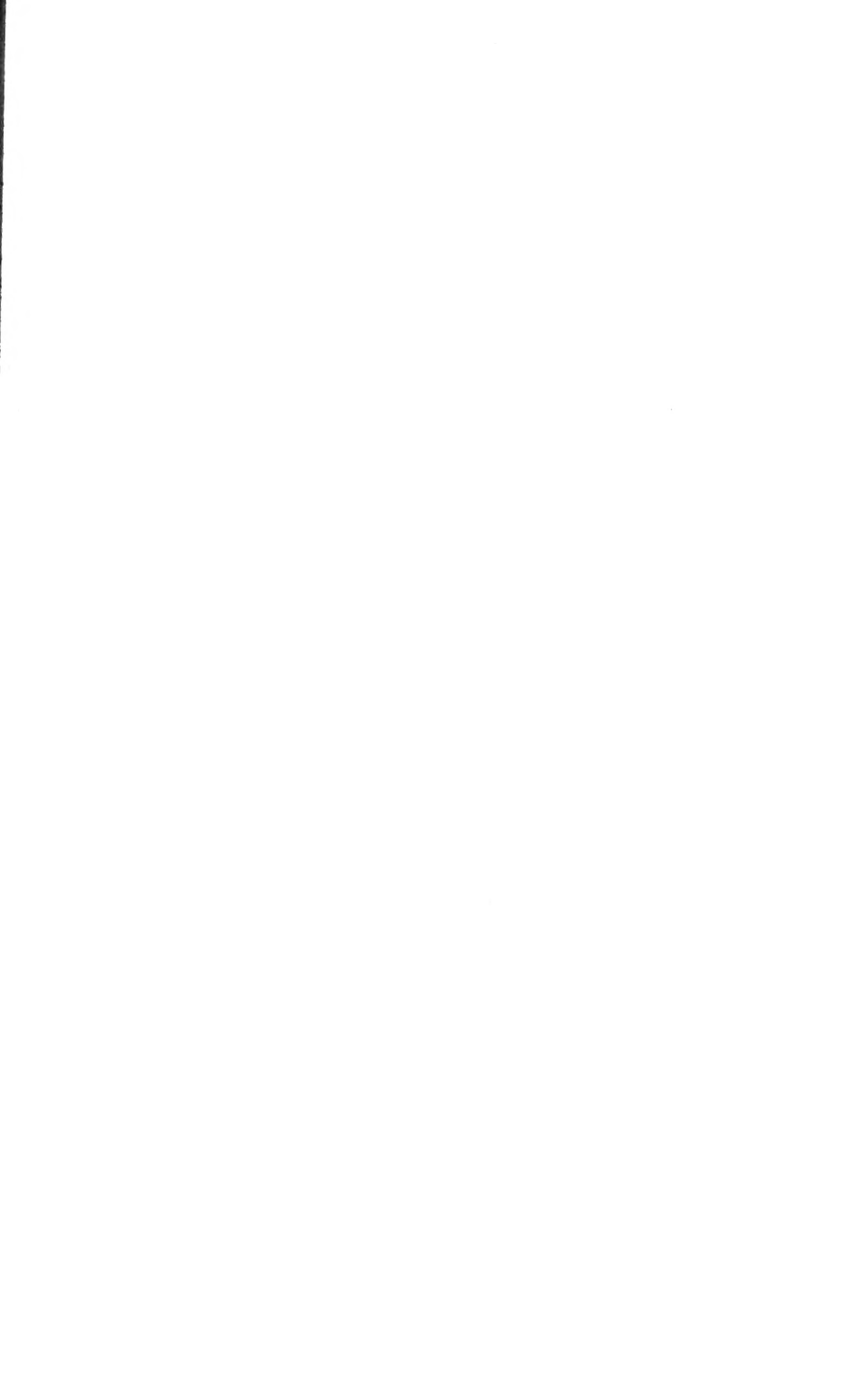
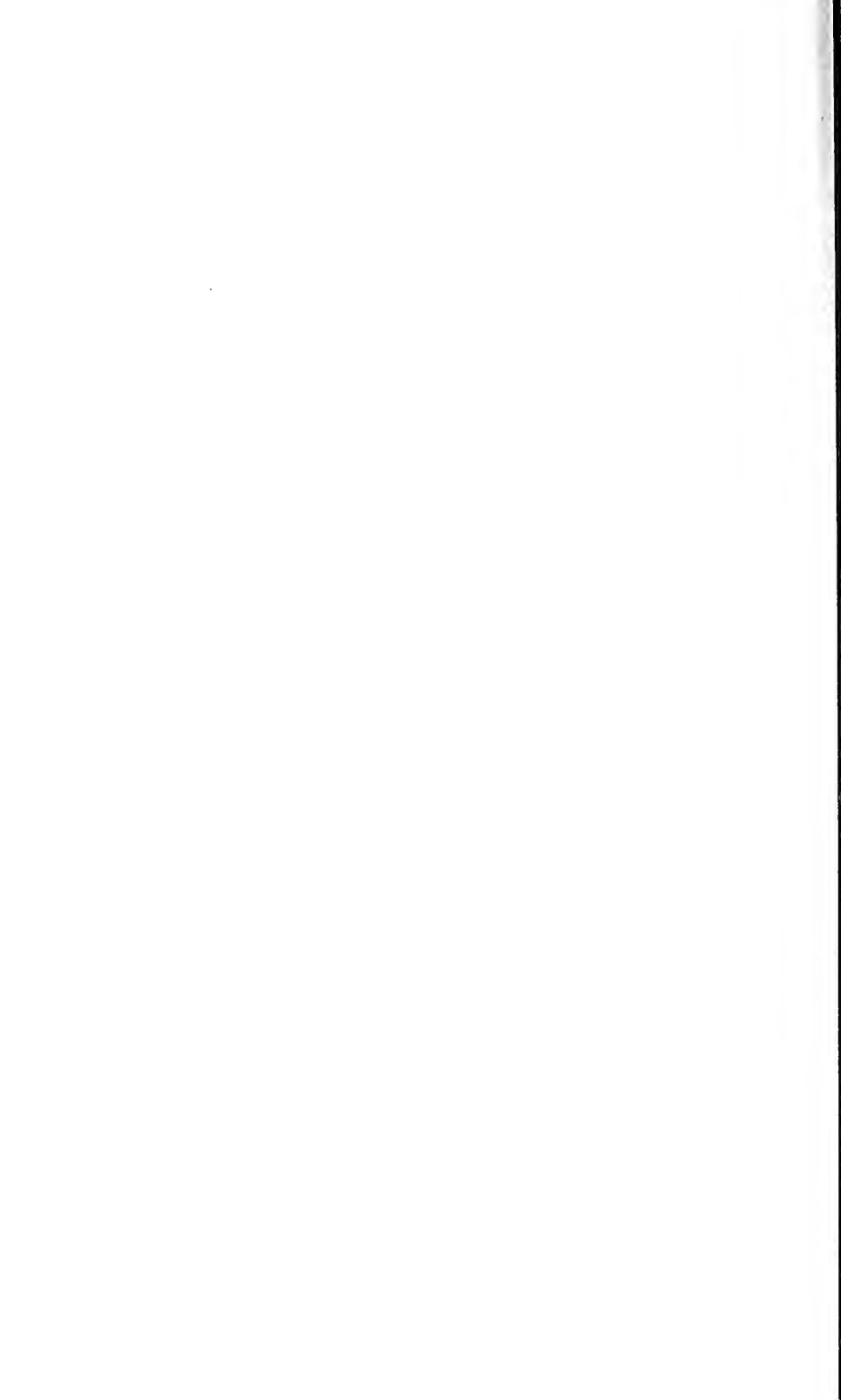

Plate 1. *Raja bahamensis*, dorsal view of holotype, mature male 540 mm long.



Plate 2. *Raja bahamensis*, ventral view of specimen shown in Plate 1.





Bulletin of the Museum of Comparative Zoology

HARVARD UNIVERSITY

VOL. 132, No. 6

VARIATION AND NATURAL HISTORY OF
ELECTHERODACTYLUS RUTHAE ON HISPANIOLA

BY ALBERT SCHWARTZ

CAMBRIDGE, MASS., U.S.A.

PRINTED FOR THE MUSEUM

APRIL 8, 1965

PUBLICATIONS ISSUED BY OR IN CONNECTION
WITH THE
MUSEUM OF COMPARATIVE ZOOLOGY
HARVARD UNIVERSITY

BULLETIN (octavo) 1863 — The current volume is Vol. 132.

BREVIORA (octavo) 1952 — No. 217 is current.

MEMOIRS (quarto) 1864-1938 — Publication terminated with Vol. 55.

JOHNSONIA (quarto) 1941 — A publication of the Department of Mollusks. Vol. 4, no. 43 is current.

OCCASIONAL PAPERS OF THE DEPARTMENT OF MOLLUSKS (octavo) 1945 — Vol. 2, no. 31 is current.

PROCEEDINGS OF THE NEW ENGLAND ZOOLOGICAL CLUB (octavo) 1899-1948 — Published in connection with the Museum. Publication terminated with Vol. 24.

The continuing publications are issued at irregular intervals in numbers which may be purchased separately. Prices and lists may be obtained from the Publications Office of the Museum of Comparative Zoology, Cambridge 38, Massachusetts.

Peters' Check-List of Birds of the World. Volume 1 is out of print; volumes 2 to 7, 9, 10 and 15 are currently available.

Phylogeny and Evolution of Crustacea. Proceedings of a conference held at Cambridge, Mass., March 6-8, 1962. H. B. Whittington and W. D. I. Rolfe, editors. Cambridge, Mass., 192 pp., 80 figs., 1963. Cloth bound, \$6.75.

Fishes of the Gulf of Maine, by Henry B. Bigelow and William C. Schroeder. Washington, viii - 577 pp., 1953. Photo-offset reprint, \$6.50.

PUBLICATIONS OF THE
BOSTON SOCIETY OF NATURAL HISTORY

The remaining stock of the scientific periodicals of the Boston Society of Natural History has been transferred to the Museum of Comparative Zoology for distribution. Prices for individual numbers may be had upon request.

Bulletin of the Museum of Comparative Zoology

HARVARD UNIVERSITY

VOL. 132, No. 6

VARIATION AND NATURAL HISTORY OF
ELEUTHERODACTYLUS RUTHAE ON HISPANIOLA

BY ALBERT SCHWARTZ

CAMBRIDGE, MASS., U.S.A.

PRINTED FOR THE MUSEUM

APRIL, 1965

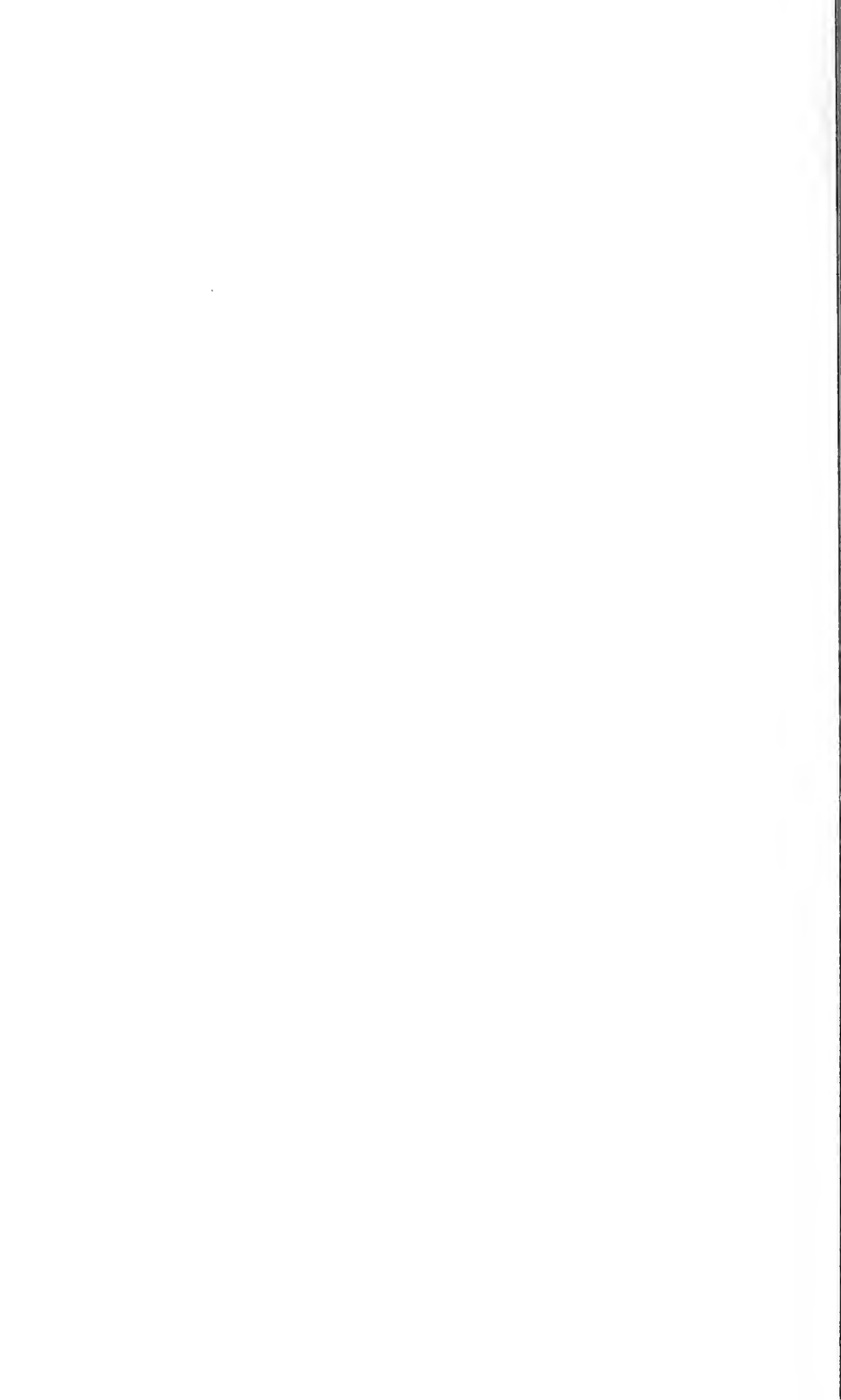

No. 6 — *Variation and Natural History of Eleutherodaetylus ruthae on Hispaniola*

BY ALBERT SCHWARTZ

Eleutherodaetylus ruthae Noble is one of the least known leptodaetylid frogs of Hispaniola. Described first from the Peninsula de Samaná by Noble (1923), this shovel-snouted frog was later recorded by Dr. Cochran (1941:33) from several localities on the Samaná and from Jovero south of the Bahía de Samaná; these localities are all in eastern Hispaniola, and thus the distribution of *E. ruthae* was presumed to be extremely circumscribed.

In July, 1962, in the company of Ronald F. Klinikowski and David C. Leber, a very strange frog call was heard near Camp Perrin, in extreme southwestern Haiti near the tip of the Tiburon Peninsula. After much patience and persistence, the maker of this call was found, and the frog was at once recognized as *E. ruthae*. It was thus evident that the species must occur throughout much of Hispaniola, since the two areas whence it was now known were at diagonally opposite corners of the island. During the summer and early autumn of 1963, Messrs. Klinikowski and Leber, Richard Thomas and myself succeeded in collecting *E. ruthae* from several localities in the República Dominicana. Although we heard no frogs calling in the same voice as those from Camp Perrin, the voice of *ruthae* in any of its variations is usually recognizable as such, if for no other reason than its purely "different" quality and tonality. Thus with some awareness of the vocal proclivities of *ruthae* and with much perseverance, we managed to delimit the distribution of *E. ruthae* somewhat more fully, and succeeded in securing specimens from several interesting localities. I wish to thank Messrs. Klinikowski, Leber and Thomas for their enthusiastic pursuit of what can be extremely elusive and frustrating prey. Mr. Leber, who first unlocked the secret to *ruthae* collecting at Camp Perrin, also made the illustrations for the present paper; I wish especially to render my thanks to him for his work.

Strangely, nothing has been published on the habitat and life history of *E. ruthae*, although the Nobles apparently collected a large series of specimens on the Samaná, and Dr. W. L. Abbott's collector, John King, must likewise have been familiar with the habits of the frog. It is possible that in this area *E.*

ruthae has different habits than elsewhere, although just south of the Bahía de Samaná the frog's activities are typical.

As might be induced from the shovel-shaped snout, *E. ruthae* is a burrowing leptodactylid. Males call from underground chambers, apparently of their own manufacture; these chambers are completely roofed and smoothed inside, and there is no surface evidence of the existence of the burrow. Judging from our experience at Camp Perrin, the eggs are deposited in the same sort of burrow and hatch therein. I presume that the froglets escape from their chamber when rains soften the ground sufficiently for their departure. Thus, when collecting *ruthae*, each individual calling male must be tracked down; the area whence the call seems to proceed is cleared of trash and herbaceous cover, and the collector waits patiently for a repetition of the call, which at times is uttered at 20-minute or longer intervals. The call itself, which varies from place to place and will be described in detail below, is brief, and in a single sequence may be repeated only two or three times. During this short period, the collector must try to locate the source on the bare ground before him (assuming that he has not frightened the frog into silence by careless walking to the spot or careless clearing of the surface debris), and then begin poking the fingers into the ground. If luck is with him, and if he is persistent, and if the frog continues to call, and if he does not encounter stinging nettles, scorpions or other noxious flora and fauna, a finger may ultimately break through the roof of the chamber in which the male is calling. Upon contact, the frog usually utters a wheezy "wheep," and either crouches in the burrow or quickly escapes. It should be clear from the above that there are many instances of spending an hour trying to track down a calling male without success. The sport can be most discouraging. It is indeed a rewarding occurrence when one of these creatures is found sitting out in the open; insofar as we know, males rarely call from above ground, although in several instances males were heard to vocalize above ground. It is possible that males habitually call from above ground in some areas, but this has certainly not been our experience.

E. ruthae is a denizen of broad-leaf mesic forest. We have taken specimens, however, in a hillside pasture (which may originally have been forest adjacent to a lowland stream), a corn field and in upland pine woods. Near the latter locality the frogs were heard calling also from pastures in what had primitively been pine woods. Altitudinally, *E. ruthae* and a related species

described herein occur from sea level to at least 3500 feet in the Sierra de Baoruco. It is remarkable that these burrowing frogs are as yet unknown from the Massif de la Selle and Massif de la Hotte in Haiti, although both species occur on the southern slopes of the latter to at least 1000 feet at Camp Perrin. One requirement for the habitat is moisture; another is a friable loamy soil which is not sandy. Forests where *E. ruthae* has been taken are usually fairly open; the frogs make their burrows in the open, and only once did I encounter a *ruthae* in a burrow adjacent to a log. However, they must on occasion live beneath rocks or logs, since twice natives brought us specimens of *ruthae* which they had taken while searching for snakes and geckos. In the Sierra de Baoruco, the call of the species related to *E. ruthae* was an important and conspicuous part of the anuran chorus after rains; individuals were collected here with relative ease in open coffee groves, and one was taken within two feet of the paved highway in the road shoulder. Although an afternoon rain enhances the chances of finding *E. ruthae*, males often call sporadically at night after dry days. Under these circumstances finding the frog which is calling hesitantly and intermittently is a real project, and success is extremely doubtful.

As in many burrowing animals, the likelihood of geographic variation in *E. ruthae* seemed very great. "Colonies" may be widely separated, and I imagine that the home range of these frogs is rather restricted. I have no idea how the female finds the male, or how she enters the burrow of the male, if she does. That the eggs are laid below ground is assumed from the fact that a nursery burrow was found by Mr. Leber at Camp Perrin. At the insertion of his finger, at least eighteen hatchlings jumped forth and were taken. Although we have a large and adequate series from only one locality (there are also available many specimens from the Samaná), study of all the material shows that there is indeed variation in size, proportions, coloration and pattern between various populations in Hispaniola. The total material is inadequate in many ways, but in certain regards the differences are quite obvious and distinct. I cannot outline the ranges of the forms except in the most tentative and general terms, based upon my knowledge of the geography of the island. Additional material may be slow in coming, but it will be interesting to ascertain what the entire distribution of *E. ruthae* eventually will prove to be.

Since females are encountered above ground, and merely by chance, they are rare in collections. In the present series of specimens, there are only six females, all from within the range of the nominate form. These specimens are discussed under *Eleutherodactylus ruthae ruthae*; descriptions of all other races are based exclusively on males. The differences between the sexes are very small although females reach slightly larger snout-vent length, have greater head length and width, greater tympanum diameter, greater naris to eye distance, longer femur, tibia and fourth toe. It is thus probable that the characters proposed for the new subspecies will occur in females as well as in the paratypic males. One wonders if the similarity in size between the sexes of *ruthae*, a condition which is unusual in West Indian *Eleutherodactylus*, is correlated with their habits.

In addition to specimens collected by myself and party (ASF'S), I have borrowed material from the following collections: Dennis R. Paulson (DRP), Richard Thomas (RT), Charles M. Bogert and Margaret Bullitt, American Museum of Natural History (AMNH), the late Norman E. Hartweg and Charles M. Walker, Museum of Zoology, University of Michigan (UMMZ), Doris M. Cochran, United States National Museum (USNM), and Ernest E. Williams, Museum of Comparative Zoology (MCZ). I wish to acknowledge the cooperation of all the above persons in allowing me to study material in their care. Paratypes have been deposited in the Museum of Natural History, University of Kansas (KU), as well as in some of the above collections.

The population of *Eleutherodactylus ruthae* from extreme eastern Hispaniola, including the Península de Samaná whence the frog was described, is distinctive and may be defined as follows:

ELEUTHERODACTYLUS RUTHAE RUTHAE Noble, 1923

Definition of Subspecies: A moderate sized, shovel-snouted *Eleutherodactylus* with a dorsal pattern of spots and usually with some inter-spot mottling or marbling, lores dark with a paler vertical preocular bar and a dark canthal stripe; concealed surfaces of thighs more or less uniformly speckled light on a dark background, a single band present across the antebrachium, small digital discs, and a tibia/snout-vent ratio of 51.3 to 57.9 per cent in males.

Specimens Examined: República Dominicana, Samaná Province: Samaná and Laguna, 7 (UMMZ 92208; USNM 65714-15, 65717-20); Samaná, 11 (AMNH 20917-18; AMNH 31362-70); Río San Juan, 3 (USNM 74597-99); Península de Samaná, 5 (USNM 66767-69, 66978-79); El Seibo Province: 1.4 mi. (2.2 km) SE Miches, 2 (ASFS X9335-36); Jovero, 3 (USNM 65710,

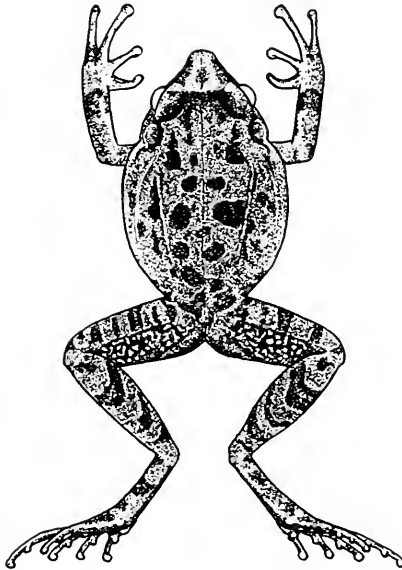

FIG. 1. *Eleutherodactylus ruthae ruthae*, ASFS V967, adult female from 0.5 mi. (0.8 km) NW Boca de Yuma, La Romana Prov., República Dominicana; snout-vent length 47.8 mm.

65713; MCZ 25719); La Romana Province: 2.4 km NW Boca de Yuma, 1 (ASFS V1039); 0.5 mi. (0.8 km) NW Boca de Yuma, 5 (ASFS V942; ASFS V967-70).

Measurements (means and extremes, in millimeters) of 30 males: Snout-vent length, 45.3 (39.6 - 50.0); head length to posterior border of tympanum, 17.8 (16.1 - 19.3); greatest width of head, 19.3 (18.0 - 21.1); longitudinal diameter of tympanum, 3.6 (3.2 - 4.0); longitudinal diameter of eye, 5.9 (5.3 - 6.8); naris to eye, 5.5 (4.8 - 6.7); femur, 22.4 (19.1 - 25.2); tibia, 24.5 (22.0 - 26.7); fourth toe, 20.1 (17.6 - 22.4); tibia/snout-vent length, 53.9 per cent (51.3 - 57.9 per cent). The same measurements for five females are: snout-vent length, 48.8 (46.8 - 52.3);

head length, 18.8 (17.6 - 19.9); head width, 21.0 (19.9 - 21.9); tympanum, 3.8 (3.4 - 4.1); eye, 6.2 (5.8 - 6.6); naris to eye, 5.8 (5.5 - 6.2); femur, 23.4 (21.7 - 25.5); tibia, 26.4 (24.8 - 27.4); fourth toe, 21.6 (20.6 - 23.9); tibia/snout-vent ratio, 54.0 (51.7 - 55.7).

Coloration and Pattern: The drawing of *E. ruthae* in Dr. Cochran's *Herpetology of Hispaniola* (1941:31) shows the pattern of the nominate form; another illustration is included in the present paper (Fig. 1). Both show the typical pattern for *E. r. ruthae*. The dorsum varies from pinkish buff to a rich dark brown, with all dorsal spots black, and often outlined by a faint pale pinkish to tan line. The interspaces between the dorsal spots are always marbled or mottled with a darker hue, and the dorsal spots and dorsal interspace mottling are continuous onto the sides. A fine glandular dorsolateral ridge is often set off by a fine pale line. The interocular bar is sharp-edged and straight anteriorly, scalloped and somewhat diffuse posteriorly. There is a single antibrachial band which in this subspecies is not set off from the remainder of the dorsal arm mottling by a pale line. The lores are dark, with a diffuse pale preocular bar or blotch, and the canthus rostralis is marked by an even darker brown line. A black semicircle proceeds from the posterior border of the eye, crosses the upper edge of the tympanum and progresses ventrad to a warty area at the angle of the jaw; this warty area in life is crossed horizontally by a bold and bright broad yellow line. The upper surfaces of the hindlimbs are crossed by dark brown transverse bars, from three to four bars on the crus, and from three to six on the thigh. The concealed surfaces are heavily dotted with pinkish buff to creamy tan to orange, on a ground color of rich brown. Some specimens show shadow-bars on the upper surfaces of the hind limbs and some do not; the modal condition is: shadow-bars present but inconspicuous. Ventrally, the ground color is creamy with the margin of the lower jaw always speckled with dark brown; there are specimens with the throat likewise stippled, and occasionally there are a few dark flecks on the pectoral region or even the lower sides and onto the venter. The digital discs are small, that of the second finger equalling a bit less than one-quarter of the tympanum.

Observations: I have not collected specimens of *E. r. ruthae* from the Península de Samaná; calling males were collected by us at the Miches and Boca de Yuma localities. At Miches,

the call was one of two variations on a two-note guttural call, almost a pair of loud grunts, with the second note either higher or lower than the first. This pair of notes was at times preceded by a warm-up grunt, sounding much like "whup." At Boca de Yuma, the call was a series of five to eight ascending "brrrp" 's, each about one note higher than the former, and uttered rather deliberately and not in a rapid *glissando* fashion. At Miches, one male was taken calling under a very small heap of trash in a cornfield, about five feet from its edge, and the other was on a bank in a gully adjacent to the corn field under dry leaves among herbs. At Boca de Yuma, one male was calling from a burrow adjacent to a small limestone sinkhole; two more were found calling in underground cavities in broad-leaf forest on a limestone ridge. At this same locality, a frog was taken crossing the paved road after a nocturnal deluge, another one foot above the ground in a *Bryophyllum* thicket, and a female was brought to us by natives, who presumably found it while turning logs or rocks looking for snakes.

Despite the apparent differences in call between Miches and Boca de Yuma males, I cannot differentiate them structurally or chromatically from one another nor from topotypical material. Since neither of the two calling males from Miches was taken in an underground burrow, and since, additionally, Thomas and myself heard a two-note call at Boca de Yuma from a frog which was perched in herbaceous cover one foot above the ground surface, I wonder if the two-note grunt heard at Miches is an above-ground call, which possibly differs from the more "typical" five to eight note subterranean call. Without information on the call of Samaná males, it is impossible to generalize about the call throughout the entire range of this subspecies. Variability in call structure is not unknown in *Eleutherodactylus*; the best known example is the call of *Eleutherodactylus pantoni* in Jamaica (Lynn and Dent, 1943).

Two specimens of *E. ruthae* from the western end of the Tiburon Peninsula in Haiti are distinct from the populations from extreme eastern Hispaniola, and may be named, in reference to the practical impossibility of collecting this subspecies:

ELEUTHERODACTYLUS RUTHAE APOROSTEGUS new subspecies

Holotype: MCZ 43186, an adult male, from Camp Perrin, Dépt. du Sud, Haiti, collected by David C. Leber, 23 July 1962. Original number X2796.

Paratype: ASFS X2713, Camp Perrin, Dépt. du Sud, Haiti, 23 July 1962, collected by a native.

Diagnosis: A subspecies of *E. ruthae* distinguished from the nominate form by a combination of larger size, low tibia/snout-vent ratio (49.2 to 50.3 per cent), very small digital discs, a distinct, vertical, pale preocular bar, throat marbled with black, dorsal spotting reduced with clear dorsal interspaces, posterior faces of thighs with large pale areas and a black reticulum, rather than a dark background with individual pale dots as in *ruthae*.

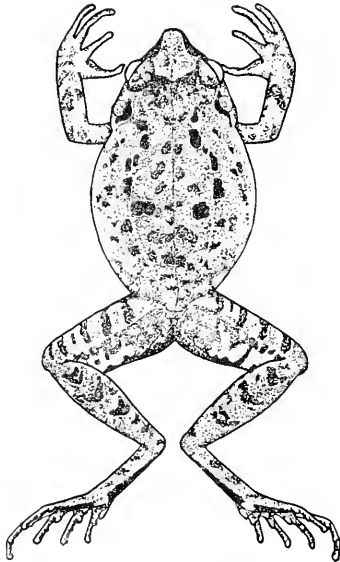

FIG. 2. *Eleutherodactylus ruthae aporostegus*, MCZ 43186, type, adult male from Camp Perrin, Dépt. du Sud, Haiti; snout-vent length 47.8 mm.

Description of Holotype: Snout-vent length, 47.8; head length, 18.6; head width, 20.0; tympanum, 3.8; eye, 6.5; naris to eye, 5.8; femur, 22.2; tibia, 23.5; fourth toe, 20.0; tibia/snout-vent length, 49.2 per cent.

Head broader than long; snout very acute and slightly declivous with nares inconspicuous at anterior end of canthus rostralis; lores concave; diameter of eye greater than distance from naris to anterior corner of eye; interorbital space 6.6 mm, about equal to diameter of eye; diameter of tympanum much less than

diameter of eye, distance from tympanum to eye equal to about one-quarter diameter of tympanum. Digital discs present, very small, that of digit two the largest and equal to about one-eighth the size of the tympanum. Fingers relatively long, unwebbed, 2-4-1-3 in order of decreasing length. Toes long, unwebbed except for a vestigial web between toes four and five, 4-3-5-2-1 in order of decreasing length on right foot; left foot deformed. Heels do not touch when hindlimbs held at right angles to body axis. Dorsum finely rugose with a raised median line and slightly raised very narrow dorsolateral folds; a group of warts at angle of jaw with a pale low ridge above. Throat and chest smooth; belly smooth to faintly granular; no vocal sac indicated or inflated; abdominal disc fairly prominent, delimited anteriorly and posteriorly by pectoral and posterior abdominal transverse folds. Posterior surface of thigh with many small flattened juxtaposed granules.

Vomerine teeth in two short, almost transverse rows, separated from each other by a distance equal to about one-quarter of the length of one row. Internal choanae irregularly placed, the right more anterior and more lateral than the left. Left choana normal, the left vomerine row reaching barely to the level of the inner margin of the choana and separated from it by a distance equal to the diameter of the choana. Tongue large, ovoid, entire, free behind, and equal to about one-half the floor of the mouth in area.

Dorsum in life pale reddish tan with a pattern of both blackish-brown and gray spots; by this difference in spot coloration some spots are more prominent than others (see Fig. 2), as follows. There is a pair of dark brown scapular crescents which are fragmented and have their apices pointing laterally; a pair of dark sacral spots, and a single irregular tripartite blotch on the midline between the sacral spots and the vent. All the remaining dorsal and lateral spots are dull gray, and thus not prominently in contrast to the ground color as are the darker spots mentioned above. The interblotch areas of the dorsum lack any pronounced marbling; the interocular bar is gray and like the pale dorsal spots in color. The lores are clouded with a darker hue, and there is a prominent vertical bar (bright orange in life) or blotch before the eye; the supratympanic line is black and short, not outlined in white. The thighs have four to five narrow dark transverse bars, which are paler centrally, and the crura have three or four bars which are

likewise narrow and washed out centrally. The concealed surfaces were pale yellow in life with a black to gray reticulum, darker along the posterior edge of the thigh. The soles of the feet are dark gray, the subarticular tubercles moderately prominent and gray, the outer metatarsal tubercle low and obscure, as is typical of all subspecies of *E. ruthae*. There is a single antebrachial bar and faint indications of a wrist bar as well, but all forelimb markings are rather obsolescent. Ventral color pale cream in life, with definite gray marbling (rather than stippling) on the chin. Underside of limbs dark brown, forming a sharp line along the lateral faces of the crus and antebrachium; underside of thigh and brachium more or less marbled with dark and light, most intense toward the knee in the former.

Variation: The single male paratype has the following measurements and ratio: snout-vent length, 47.1; head length, 18.2; head width, 20.6; tympanum, 3.5; eye, 6.7; naris to eye, 5.8; femur, 20.7; tibia, 23.7; fourth toe, 20.0; tibia/snout-vent length, 50.3 per cent. The paratype is even more strikingly marked than the type; the dorsal ground color in life was reddish brown. All blotches except the scapular crescents (which are entire), the sacral spots, the supratympanic line, and one spot on each side adjacent to the sacral spots, are much reduced and represented only by diffuse pale gray areas. The interorbital bar is obsolescent. The hindlimbs are marked as in the type, but the bars are even more hollowed centrally and the shadow-bars are much more reduced, as is the antebrachial bar. The ventral patterns are comparable, although the paratype has somewhat less marbling on the chin and throat. The pattern on the concealed surfaces is identical; the pale areas on the posterior face of the thighs, the axilla, and groin were all yellow-orange in life. The iris was dark brown. The paired vocal sacs are inflated and are supra-axillary in position.

Comparisons: *E. r. aporostegus* differs from *E. r. ruthae* in coloration and pattern. In effect, *aporostegus* is *ruthae* with part of the dorsal pattern blanched, thus placing in prominence the scapular crescents, the sacral spots, and some lateral spots — all of which are present in *r. ruthae* but are not outstanding on the spotted dorsum wherein all spots and markings are of the same intensity of pigmentation. The marbled (rather than dotted) concealed surfaces, and the marbled (rather than stippled) chin and throat also will distinguish *aporostegus* from *ruthae*.

In size, *aporostegus* is larger than *ruthae* in all measurements except the three hindlimb measurements, which are smaller than average for *r. ruthae*. The larger eye (mean 6.6 for *aporostegus*, 5.9 for *ruthae*) is especially noteworthy. Measurements of femur, tibia, and fourth toe all are less in *aporostegus*, with fourth toe being the least different. The difference in tibia length between the two forms is expressed in the tibia/snout-vent ratio, which averages 53.9 per cent for *ruthae* and 49.8 per cent for *aporostegus*. There is at present no overlap in the extremes of this ratio between the two subspecies.

Observations: The taking of the type of *E. r. aporostegus* was outlined in the introduction to the present paper. After tracking down the "whoop-whoop-whoop" call to a grassy hillside adjacent to a slowly flowing stream, the male was finally located in its small subterranean chamber. The paratype was brought us by natives, who doubtless had happened upon it by chance under an overturned log or rock. Eighteen juvenile *E. r. aporostegus* were also collected by Mr. Leber at Camp Perrin; these hopped from an underground cavity when the roof was broken in by chance at night after a moderate rain. This cavity was on the same grassy hillside as the cavity of the type. The juveniles are colored like the adults, but had the snouts and the dorsolateral lines bronzy and very distinct in life.

A single specimen from west central República Dominicana is so different in size and proportion from the two preceding races that I have no hesitancy in describing it as new, despite its uniqueness. The frog was taken from what is possibly one of the least known areas of the República Dominicana, and apparently *E. ruthae* is not common in this region. For this subspecies, since the type was finally collected by chance after much patient search, I propose the name:

ELEUTHERODACTYLUS RUTHAE TYCHATHROUS new subspecies

Holotype: MCZ 43188, an adult male from 7 km northwest Vallejuelo, 2600 feet (790 m), San Juan Province, República Dominicana, collected by Ronald F. Klinikowski, 17 August 1963. Original number V528.

Diagnosis: A subspecies of *Eleutherodactylus ruthae* characterized by a combination of very large size, relatively short tibia, low tibia/snout-vent length ratio (46.3 per cent), very large tympanum, and concealed surfaces extensively dark brown with scattered cream dots.

Description of Holotype: Snout-vent length, 57.8; head length, 20.9; head width, 20.2; tympanum, 4.5; eye, 6.5; naris to eye, 6.4; femur, 24.6; tibia, 26.8; fourth toe, 24.5; tibia/snout-vent length ratio 46.3 per cent.

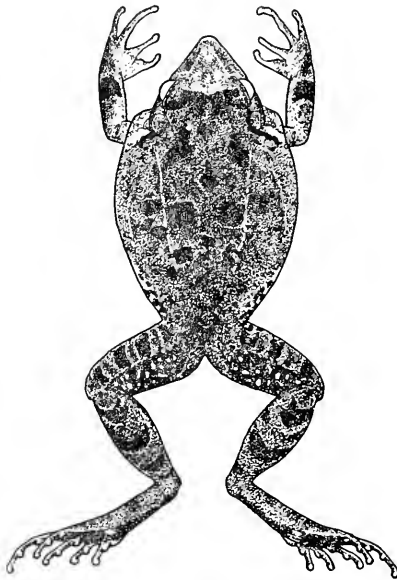

FIG. 3. *Eleutherodactylus ruthae tychathrous*, MCZ 43188, type, adult male from 7 km NW Vallejuelo, San Juan Prov., República Dominicana; snout-vent length 57.8 mm.

Head slightly longer than broad; snout very acute with nares inconspicuous at anterior end of canthus rostralis; lores concave; diameter of eye equal to distance from naris to anterior corner of eye; interorbital space 6.3, slightly less than diameter of eye; diameter of tympanum much less than diameter of eye, distance from tympanum to eye equal to about one-quarter diameter of tympanum. Digital discs present, small, that of digit two the largest and equal to about one-seventh the size of the tympanum. Fingers relatively long, unwebbed, 2-1-4-3 in order of decreasing length. Toes long, unwebbed except for a vestigial web between toes three and four, 4-3-5-2-1 in order of decreasing length. Heels touch when hindlimbs held at right angles to body axis. Dorsum very finely rugose, practically

smooth with fine raised dorsolateral and median lines, and short diagonal lines starting from behind the tympanum and proceeding ventrolaterally down the side for about one-half the length of the dorsolateral lines. Throat and chest smooth; belly smooth to faintly granular; vocal sacs inflated and large, supra-axillary in position; abdominal disc fairly prominent, its pectoral margin obscure, its abdominal fold fairly conspicuous. Posterior surface of thigh with many rounded granules.

Vomerine teeth in two short, straight transverse rows, separated from each other by a distance equal to about one-quarter of the length of one row, extending laterally at least midway across the opening of the internal choana, and separated from the choana by a distance equal to twice the diameter of a choana. Tongue small, oval, very slightly nicked, free behind, and equal to about one-half the floor of the mouth in area.

Dorsum in life dark brown with a pattern of darker brown spots, all of equal darkness and none suppressed or obsolescent; snout grayish tan, interocular bar dark brown and sharp-edged anteriorly and blending into the dorsal ground color posteriorly; dorsolateral thin ridges yellow in life; interblotch area of dorsum without marbling or mottling (Fig. 3). Lores dark brown with a pale preocular blotch or bar, which is not conspicuous; supratympanic line black and long, not outlined above with white and passing above the posttympanic yellow bar. Thighs with three dark transverse bars, and crura with three dark, rather angled bars; shadow-bars not especially prominent. Concealed surfaces uniform dark brown with widely separated and discrete cream dots. A single antibrachial bar which is prominent and no indication of a wrist bar. Ventral color pinkish in life with dark stippling on the lower jaw, chin and throat, as well as some isolated stippling on the belly and chest. Underside of forelimbs dark brown; underside of hindlimbs dark brown mottled with pinkish, the brown pigment on the thigh concentrated distally and the crus being almost uniformly mottled. Iris was very dark brown in life.

Comparisons: The single specimen of *tychathrous* differs from both *ruthae* and *aporostegus* in tibia/snout-vent length ratio (see Fig. 8); no other specimen even approaches this figure closely, although the two specimens of *aporostegus* have the lowest ratio of all other races. The greater snout-vent length is also apparent. The long body and short hindlimbs are quite obvious when the type of *tychathrous* is compared directly with specimens of the other forms. The greater size of the tympanum is

likewise apparent. In having small digital discs, *tychathrous* resembles both *ruthae* and *aporostegus*, but differs from the latter in having a uniform and unfaded dorsal pattern and from the former in pattern of the concealed surfaces.

Observations: The type of *tychathrous* was taken at night while it was calling from among rocks in the wooded flood-plain of a small river. Messrs. Klinikowski and Leber had spent some time in tracking down an individual but did not succeed in collecting it, although the burrow was discovered and the frog disturbed. After waiting for some time, a frog began to call from among a pile of rocks, and it is possible that this was the original frog which had been calling from the burrow. The call itself is made up of four ascending syllables, similar to the Haitian three-note series of "whoops," but the last two syllables are slowly trilled and more or less on the same pitch. It is probable that the call of *tychathrous* is a modified *aporostegus* call, with the final *aporostegus* note duplicated instead of single, and trilled rather than "whooped."

In the upland pine forests on the northeastern slope of the Cordillera Central, three specimens of *E. ruthae* were taken which represent a fourth subspecies; this race, in reference to its underground calling, may be called:

ELEUTHERODACTYLUS RUTHAE BOTHIROBOANS new subspecies

Holotype: MCZ 43189, an adult male, from 12 km northeast of Jarabacoa, 2100 feet (640 m), La Vega Province, República Dominicana, collected by Richard Thomas, 31 October 1963. Original number V1945.

Paratypes: ΔSFS V1946-47, same data as holotype.

Diagnosis: A subspecies of *Eleutherodactylus ruthae* characterized by a combination of moderate size, dark dorsal coloration with interblotch area irregularly marbled, heavy ventral stippling, distinctive concealed surface pattern, and moderately well developed digital discs.

Description of Holotype: Snout-vent length, 48.8; head length, 18.4; head width, 21.0; tympanum, 3.7; eye, 6.1; naris to eye, 5.3; femur, 23.6; tibia, 24.7; fourth toe, 24.7; tibia/snout-vent ratio, 50.6 per cent.

Head broader than long; snout very acute with nares inconspicuous at anterior end of canthus rostralis; lores concave; diameter of eye greater than distance from naris to anterior corner of eye; interorbital space 5.9, slightly less than diameter

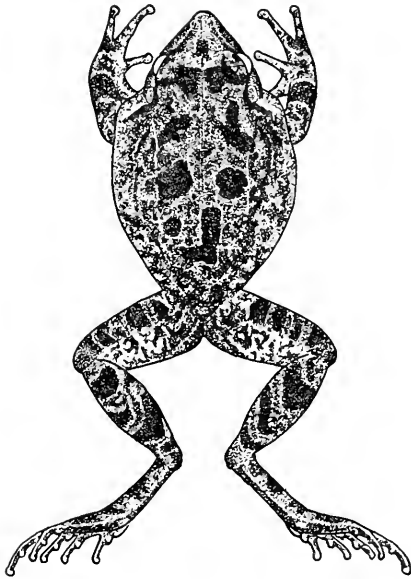

FIG. 4. *Eleutherodactylus ruthae bothroboans*, MCZ 43189, type, adult male from 12 km NE Jarabacoa, La Vega Prov., República Dominicana; snout-vent length 48.8 mm.

of eye; diameter of tympanum much less than diameter of eye, distance from tympanum to eye equal to about one-third diameter of tympanum. Digital discs present, moderate in size, that of digit two the largest and equal to about one-half the size of tympanum. Fingers relatively long, unwebbed, 2-1-4-3 in order of decreasing length. Toes long, unwebbed, 4-3-5-2-1 in order of decreasing length. Heels overlap strongly when hindlimbs held at right angles to body axis. Dorsum almost smooth, sides heavily rugose; slightly raised median, dorsolateral and oblique lateral folds; a group of warts at angle of jaw with a pale and low ridge above. Throat and chest smooth; belly smooth centrally, and granular laterally; vocal sacs slightly inflated and supra-axillary in position; abdominal disc clearly delimited anteriorly and posteriorly by fairly prominent pectoral and abdominal folds. Posterior surface of thighs with many rounded juxtaposed granules.

Vomerine teeth in two short, almost transverse rows, separated from each other by a distance equal to about one-third the

length of one row, their lateral ends overlapping the choanae and separated from them by a distance equal to the diameter of one choana. Tongue large, ovoid, entire, free behind, and equal to about one-half the floor of the mouth in area.

Dorsum in life rich reddish brown with darker brown spots. Typical suprascapular spots present but diffuse, the postsacral area with an asymmetrical reversed L-shaped blotch. Blotch interspaces much mottled and clouded with darker brown pigment. Snout slightly paler than the remainder of the dorsum, and set off from it by the anteriorly sharp-edged interocular bar, which is diffuse posteriorly. Lores dark, lacking a prominent preocular light bar or blotch, but with a small pale line just anterior to the eye; supratympanic line dark brown and not outlined above with white. Thighs with four bold dark transverse bars, crura with three or the remnants thereof; shadow-bars prominent, the limbs very contrastingly and vividly marked. Concealed surfaces dark brown centrally, laterally showing pink heavy blotching, with more light than dark area involved (Fig. 4). Soles of the feet very dark gray. A single antebrachial bar which is rather conspicuously set off from the ground color by pale outlining. Ventral color cream in life, with heavy dark brown stippling on the lower jaw, chin and throat, pectoral region and venter. Underside of the hindlimb dark brown, marbled with cream, the dark brown pigment continuing onto the distal portion of the underside of the thigh.

Variation: The two paratype males and the type have the following measurements: snout-vent length, 46.3 (43.5-48.8); head length, 17.9 (16.8-18.4); head width, 20.0 (18.9-21.0); tympanum, 3.6 (3.4-3.7); eye, 6.0 (5.7-6.1); naris to eye, 5.2 (5.1-5.3); femur, 23.0 (21.9-23.6); tibia, 24.3 (23.3-25.0); fourth toe, 21.1 (20.1-21.7); tibia/snout-vent ratio, 52.6 per cent (50.6-53.6 per cent). In life the series was reddish brown to dark brown dorsally, with the appearance of the dorsal spots dependent upon the intensity of the ground color. In all, the legs are heavily banded, with prominent shadow-bars, and the ventral ground color is creamy with heavy stippling on the lower jaw, throat, and belly. The two paratypes have the scapular crescents more well defined than the type, and also have a more orthodox postsacral round blotch, rather than the L-shaped blotch of the type in this region. The digital discs are all moderately large. The vocal sacs are slightly inflated in one paratype and more inflated in the other. The

concealed surfaces are as described for the type — dark medially and with much light vermiculation and confluence of pink blotches laterally.

Comparisons: From *E. r. aporostegus*, *bothroboans* differs in having a very dark rather than very light dorsum, a heavily stippled venter rather than only a marbled throat, large digital discs, and a higher tibia/snout-vent ratio: the latter will presently separate the two races. *E. r. tychatrous* is much larger than *bothroboans*, with a much shorter tibia and lower tibia/snout-vent ratio, has small digital discs and a dotted concealed surface pattern. From *E. r. ruthae*, *bothroboans* differs in having moderately enlarged digital discs, a much stronger dorsal pattern, and a different concealed surface pattern. Apparently these two subspecies are comparable in size, although *ruthae* averages slightly smaller than *bothroboans*; the tibia/snout-vent ratios of the two are comparable.

Observations: The three *bothroboans* were all collected while calling from underground cavities in open pinewoods; the call is a series of five to eight “wherp”’s, each “wherp” with a slight ascending inflection, but the whole series on about the same tone. The population at the type locality was not concentrated and the frogs seemed to be rather widely scattered throughout the area; elsewhere, several were heard close to the town of Jarabacoa and others between the type locality and La Vega, at an elevation of 1400 feet (440 m).

In the Sierra de Baoruco, between the crest of the ridge to the north of Polo and Las Anyamas, we encountered a burrowing frog which is related to *E. ruthae* and which we regarded at the time as another very distinct subspecies of the latter. However, there are specimens of this frog also from the mountains north of Les Cayes (Massif de la Hotte), in the general vicinity of Camp Perrin, where *E. r. aporostegus* occurs. It is probable that this new species occurs throughout much of the length of the La Hotte-La Salle-Baoruco massif, perhaps not at extremely high elevations, and that it has been overlooked in the region between the Sierra de Baoruco and the extreme western La Hotte. Because of the apparent proximity of specimens of this form and of *E. r. aporostegus* in the vicinity of Camp Perrin without any indication of intergradation, and because of certain structural and pattern features which differentiate the two, I propose that this new form be regarded as a full species and be called, in allusion to its underground calling:

ELEUTHERODACTYLUS HYPOSTENOR new species

Holotype: MCZ 43187, an adult male, from 10.5 mi. (16.8 km) S Cabral, 3500 feet (1060 m), Barahona Province, República Dominicana, one of a series collected by David C. Leber, Albert Schwartz, and Richard Thomas, 1 August 1963. Original number V39.

Paratypes: ASFS V40-49, AMNH 71936-37, MCZ 43190-91, KU 79768-69, USNM 150723-24, RT 758-59, DRP 2898, all with same data as type; ASFS X9797-800, 1.8 mi. (2.8 km) N Las Auyamas, 3400 feet (\pm 1035 m), Barahona Prov., República Dominicana, D. C. Leber, A. Schwartz, R. Thomas, 26 July 1963; ASFS X9790, 0.6 mi. (0.9 km) N Las Auyamas, 3000 feet (914 m), Barahona Prov., República Dominicana, D. C. Leber, 26 July 1963.

Associated specimens not designated as paratypes: MCZ 36511, Haiti, Dépt. du Sud, mountains north of Les Cayes; AMNH 44074, 44079, Haiti, Dépt. du Sud, 25 mi (40.2 km) N Les Cayes.

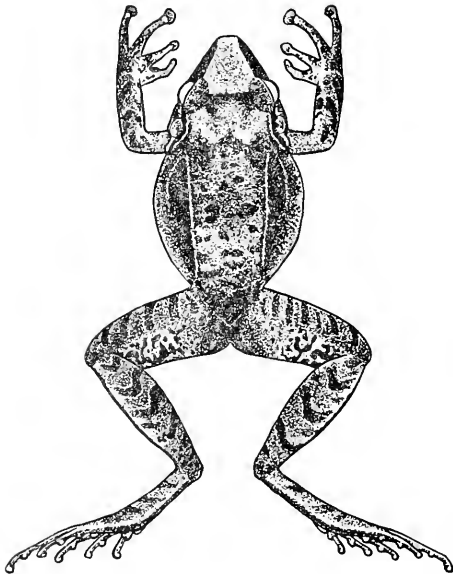

FIG. 5. *Eleutherodactylus hypostenor*, MCZ 43187, type, adult male from 10.5 mi (16.8 km) S Cabral, 3500 feet (1060 m), Barahona Prov., República Dominicana; snout-vent length 54.4 mm.

Diagnosis: A species of *Eleutheroactylus* related to *E. ruthae* and *E. inoptatus*, and distinguished by a combination of large size, high tibia/snout-vent ratio (55.7 to 61.3 per cent), very large digital discs, unicolor dark brown and flat (rather than concave) lores, stippled chin and throat, dorsal pattern a middorsal zone enclosed between two dorsolateral lines, set off strongly from much darker lateral coloration, and with dorsal spots much obscured or absent, posterior faces of thighs dark centrally and with pale vermiculations or vertical bars (never dots) laterally, a pair of chevron-like antibrachial bars, supratympanic black bars outlined above with white, a more truncate and less overhanging snout, and absence of external vocal sacs.

Description of Holotype: Snout-vent length, 54.4; head length, 20.1; head width, 22.2; tympanum, 4.0; eye, 7.0; naris to eye, 7.0; femur, 26.3; tibia, 31.0; fourth toe, 25.5; tibia/snout-vent ratio, 57.0 per cent.

Head broader than long; snout acute but truncate with nares inconspicuous at anterior end of canthus rostralis; lores flat; diameter of eye equal to distance from naris to anterior corner of eye; interorbital space 6.2 mm, less than diameter of eye; diameter of tympanum less than diameter of eye, distance from tympanum to eye equal to about one-quarter diameter of tympanum. Digital discs present, very large, that of digit two the largest and equal to about three-quarters the size of the tympanum. Fingers relatively long, unwebbed, 2-1-3-4 in order of decreasing length. Toes long, with vestigial webs between all digits, 4-3-5-2-1 in order of decreasing length. Heels overlap strongly when hindlimbs held at right angles to body axis. Dorsum very finely and uniformly rugose, with fine raised dorsolateral folds, a raised supratympanic bar, an accessory longitudinal fold which arises in the scapular region and progresses thence down the side to parallel the dorsolateral fold for about half its length, and a group of warts at the angle of the jaws. Throat and chest smooth; belly smooth to slightly granular; abdominal disc fairly prominent, delimited anteriorly by a transverse inconspicuous pectoral fold and posteriorly by a more prominent transverse abdominal fold. Posterior surface of thigh with many small low rounded granules.

Vomerine teeth in two short, straight, slightly diagonal series, separated from each other by a distance equal to one-third of one row, overlapping the median margin of the choanae very slightly, and separated from them by a distance equal to about

one and one-half times the diameter of a choana. Tongue large, ovoid, slightly nicked, free behind, and equal in area to about two-thirds the floor of the mouth.

Snout and intertympanic area in life tan with a brown interocular bar, sharp-edged anteriorly and diffuse posteriorly; a middorsal band, bounded on either side by the thin dorsolateral folds, tan overlaid with dark brown, with a dark brown pair of sacral spots just visible; other dorsal dots slightly paler brown and about the same color as the dark interocular bar; scapular crescents absent, but a few raised scapular warts forming a faint V (which is emphasized by being the line of transition between the tan intertympanic coloration and the darker middorsal zone coloration); sides very dark brown with no indication of lateral spotting (Fig. 5); lores dark brown without a preocular bar or pale area; supratympanic black line conspicuous and outlined above with a fine white line. Thighs and crura brown with about five transverse bars on the former and three complete bands on the latter; shadow-bars virtually absent. Concealed surfaces brown and unmarked proximally, black with cream vermiculations distally. Soles of feet very dark gray, all metatarsal tubercles except the inner one are gray; all are prominent, except the outer one, which is low and inconspicuous. A pair of chevron-like antebrachial bars which are quite conspicuous even against the dark ground color of the arm. Ventral ground color cream in life, with brown stippling on the chin and lower jaw. Underside of limbs creamy, sharply set off from the dorsal ground color, especially laterally, by a clear-cut dark brown zone along the outer face of the crus.

Variation: The measurements and ratios of twenty-seven specimens (type and paratypes) are: snout-vent length, 51.0 (47.3-54.4); head length, 19.7 (18.9-20.9); head width, 21.2 (20.2-22.7); tympanum, 3.8 (3.3-4.2); eye, 6.9 (6.2-7.5); naris to eye, 6.3 (5.7-7.0); femur, 26.0 (24.5-27.6); tibia, 29.8 (27.8-31.3); fourth toe, 24.4 (22.7-25.7); tibia/snout-vent length ratio, 58.4 per cent (55.7-61.3 per cent).

All specimens are like the type in general pattern, i.e., there is a median dorsal zone (pinkish-buff to dark brown), delimited laterally by the yellow dorsolateral folds, which is paler than the sides, but darker at least than the tan to reddish tan snout anterior to the interocular bar. In some individuals the interocular bar separates the two dorsal colors rather than having the intertympanic region the same color as the snout, as in the type.

The sides are uniformly darker than the dorsal zone, although in two cases the entire animal is presently a pale tan rather than a dark brown. Even in these two pale frogs the sides are darker than the dorsum. The dorsal spotting varies from present to absent (at least obscured); the scapular crescents, which are absent in the type, are present in a few specimens, and the sacral spots are usually discernible, although at times they too have disappeared. The supratympanic line is black and is always outlined above in white, thus rendering it doubly conspicuous. The concealed surfaces of the thighs are variable also; the type shows the usual condition, although in some specimens the pale pinkish-buff to creamy yellow areas form vertical bars on the distal portion of the thigh; in no case are there actual dots or pale marblings. Although the ventral surfaces are immaculate cream there is a variable amount of gray stippling on the lower jaw and throat, and the underside of the hindlimbs may have additional dark pigment at the area of the knee. The ventral limb pigmentation never reaches an extreme condition of darkening as in *E. r. aporostegus*. The iris is golden above, brassy below.

The enlarged digital discs are a conspicuous structural feature of all specimens. The abdominal disc is usually well defined.

Comparisons: The much greater bulk of *E. hypostenor*, as well as the enlarged discs and greater size, at once distinguish it from all the races of *ruthae* except *tychathrous*, which exceeds *hypostenor* in size but has very small digital discs. The dorsal pattern of *hypostenor*, and especially the pair of antebrachial chevrons, is like that of no race of *ruthae*. The tibia/snout-vent ratio in *hypostenor* averages greater than that of any subspecies of *ruthae*, and is overlapped only by that of the nominate form of *ruthae*; the higher ratios of *hypostenor* are statistically significant.

E. hypostenor in general appearance bridges very nicely the gap between *E. ruthae* and *E. inoptatus*. In fact, inspection of specimens of these three species confirms the suspicion that *hypostenor* may be closer to *inoptatus* than to *ruthae*. The dorsal pattern of *hypostenor* is much more like some dorsal patterns of *inoptatus*, but the "hidden" *ruthae* pattern elements — the scapular crescents and the sacral spots — are present but much subdued. It is almost as if *hypostenor* were combining, with some modification, the general pattern features of *ruthae*

and *inoptatus*. *E. hypostenor* does not reach the extremely large size of *inoptatus* (largest recorded size, 88 mm snout-vent; Shreve and Williams, 1963:304), lacks the spine-like upper eyelid tubercle, and has flat and dark brown (unicolor), rather than concave and variegated, lores. The two species resemble each other in having two antibrachial chevrons, although these are regularly less prominent and definite in *inoptatus*, and in crural crossbanding, although again in *inoptatus* this is not so diagrammatic as in *hypostenor*. The digital discs in *hypostenor* are relatively larger than in *inoptatus*, and the head appears longer and with a slightly more overhanging snout. The venter of *inoptatus* is distinctly granular, that of *hypostenor* smooth to slightly granular.

Observations: All but two of the large series from 10.5 miles south of Cabral were taken from earthen cavities in and about a mountain *cafetal* on the upper slopes of the Sierra de Baoruco at an elevation of 3500 feet. The two exceptions were found hopping on the ground in the same *cafetal*. As noted in the introduction, the burrows were at this locality in open situations among the coffee trees, although one was adjacent to a roadside log. The frogs from the other localities were from similar coffee stands, and the penetrating voice, a single noted "wherp," resounded through the wet groves at night. The single note was sometimes repeated as many as three times in succession, followed by a period of complete silence; in quality the "wherp" call is very reminiscent of the sound made by humans while regurgitating.

DISCUSSION

Eleutherodactylus ruthae is widespread in the República Dominicana and likely has a comparably wide distribution in Haiti. It seems to occur in rather isolated colonies. In many areas we listened for calling males under optimum weather conditions without success. An example of such a locality is the region to the south of Sabana de la Mar, where lowland forest and cacao groves offer excellent habitat for this species; this locality is only about 40 kilometers west of the Miches region, where *ruthae* was taken, and between Miches and the Península de Samaná, where the frog is probably abundant. Again, although the region about Higüey has suitable areas for *E. ruthae*, we encountered it only on the limestone ridge which parallels

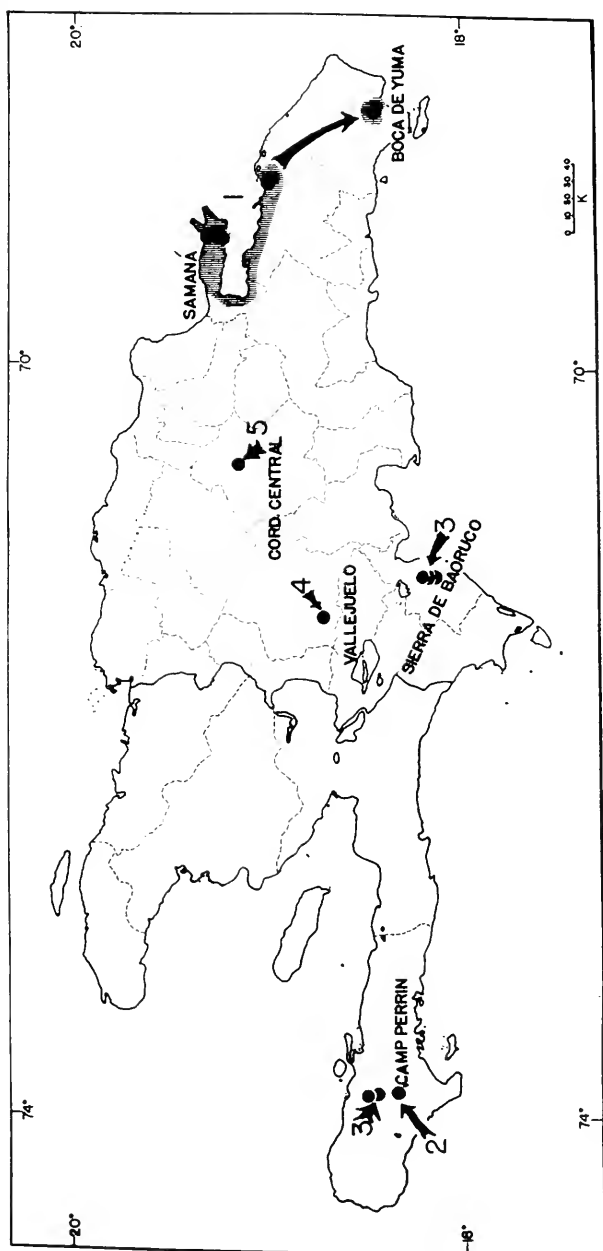

FIG. 6. Map of Hispaniola, showing distribution of *Eleutherodactylus hypostenor* and of the races of *E. ruthae* as follows: *r. ruthae*, 1, vertical lines (range discontinuous); *r. aporostegus*, 2; *hypostenor*, 3 (range discontinuous); *r. typhathrous*, 4; *r. bothroboans*, 5.

the coast at Boca de Yuma. In the uplands we did not encounter it in the Constanza area nor elsewhere in the high pine-woods, nor in the lowlands near La Vega and Bonao; however, it was fairly common but scattered in the pinewoods on the northeastern slopes of the Cordillera Central. I noted previously the absence of this species from the uplands of the Massif de la Selle and Massif de la Hotte, while *E. hypostenor* does occur in the Sierra de Baoruco, and *E. ruthae* occurs in the southern foothills of the La Hotte. In six weeks intensive collecting in the Port-au-Prince region, we never heard this frog nor had it brought to us by natives; at Camp Perrin we encountered it only in one locality. It is of course possible that there are small and localized colonies of *E. ruthae* throughout the whole Tiburon Peninsula area and even near Port-au-Prince; future collecting in these areas may well reveal some interesting material.

In the ranges to the north of the Valle de Neiba, we heard scattered calls in the Sierra de Neiba (northern range) south of Elías Piña in a coffee grove; the night was dry and the males were calling very infrequently. Probably these frogs were *E. r. tychothrous* since the type locality of this subspecies is farther to the east in the northern foothills of the Sierra de Neiba. Near Sosúa on the north coast of the República Dominicana, a single male was heard in the limestone hills southeast of the village, but was not collected. These are the only localities where we heard the species and did not succeed in securing at least one example.

The distribution of the species *ruthae*, then, appears to be disjunct (although this may be an artifact of collecting), and the frog is now known to occur in the following regions (see Fig. 6): 1) *r. ruthae*—Península de Samaná south and east along the south shore of the Bahía de Samaná and to Boca de Yuma (although even in this range the frog is not continuously distributed in suitable habitat and the map shows the range as disjunct); 2) *r. aporostegus*—the southern foothills of the Massif de la Hotte at Camp Perrin; 3) *r. tychothrous*—at least the northern range of the Sierra de Neiba; 4) *r. bothroboans*—the northeastern pine-clad slopes of the Cordillera Central.

The presumed occurrence of the related *E. hypostenor* throughout the Tiburon Peninsula and in the Sierra de Baoruco on the Península de Barahona makes it possible to postulate that in *E. ruthae* and *E. hypostenor* we have two burrowing

frogs which are geographic cognates of one another, the former a north island species which has secondarily invaded the south island and has extended as far as the tip of the Tiburon Peninsula, and the second a typically south island species. *E. hypostenor* has evolved less from the parent stock (assuming that it and *E. inoptatus* are closely related) than has the more specialized *E. ruthae*.

Noble (1923:6) suggested that *E. ruthae* is related to *E. inoptatus*; Cochran (1941:33) agreed with this relationship, and mentioned as characteristics common to the two species the "essential color pattern, . . . presence of a dorsolateral fold and a subsidiary diagonal row of glands on the sides, and in the relative proportions of the toes." The two frogs are quite different species; the shovel-shaped snout of *ruthae* and the supraorbital spine of *inoptatus* serve to differentiate the two forms with ease. Judging only from Samaná specimens of *ruthae*, this relationship seems far distant; no *inoptatus* which I have seen has a pattern of dorsal spots, for example, and

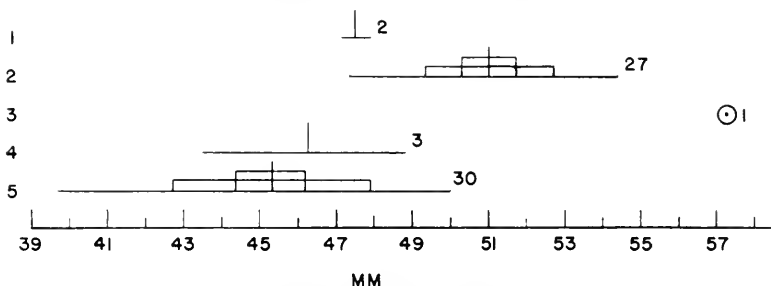

FIG. 7. Subspecies of *Eleutherodactylus ruthae* and *E. hypostenor*, showing variation in snout-vent lengths of males; low rectangles include one standard deviation, high rectangles include two standard errors of mean. Number of specimens follows horizontal line which represents range of sample; mean is shown by vertical line. Samples arranged as follows: 1) *apostegus*; 2) *hypostenor*; 3) *tychathrous*; 4) *bothroboans*; 5) *ruthae*.

inoptatus reaches a far larger size than *r. ruthae*. The habitus of the two animals is different; *inoptatus* is a large-headed, long-legged frog whereas *r. ruthae* is small, sharp-snouted, rather small-headed, and not so long-legged as *inoptatus*. As pointed out previously, *E. hypostenor* neatly bridges the gap between the two species. It is long-legged (like *inoptatus*), is patterned with

a typical *inoptatus* pattern, but has the hidden *ruthae* pattern and calls from underground in the manner of *ruthae*. Despite the obvious differences of *ruthae* and *inoptatus*, I feel that they, through *hypostenor*, are indeed closely allied.

Shreve and Williams (1963:318) assign *inoptatus* to their *varians* group; I see no special advantage for changing the name of this group (which Dunn originally called the *auriculatus* group, a name which I have maintained despite the fact that the name *auriculatus* is no longer used for the same frog as it was at the time of Dunn's usage) and continue to refer to this assemblage of frogs as the *auriculatus* group. The frogs which have been assigned to this group consist of arboreal, small to moderately sized frogs, which have granular venters, small vomerine tooth series (usually almost patch-like), and greatly enlarged digital discs. Incidentally, although this is not customarily given as a character of the group, all members have a single gular vocal sac which is unusually large for the size of the frog. All members call from trees, vines, grasses or shrubs, and thus are not associated with terrestrial calling sites. The calls are likewise characteristic, and will be discussed in a shortly forthcoming paper.

To associate *inoptatus* (and *ruthae* and *hypostenor*, if we regard them as related to *inoptatus*) with this compact group of small to moderate sized frogs with very specific habits, vocal sac structure, and voice, I feel is inappropriate. *Inoptatus*, *ruthae* and *hypostenor* together have granular bellies (although the bellies of *ruthae* and *hypostenor* may often be weakly granular or almost smooth), enlarged discs (although of the *ruthae* races only *bothroboans* has discs which are in any way comparable to those of *inoptatus* or *hypostenor*), and short vomerine series (although these series in both species are rather long, and hardly patch-like). These characteristics ally these three frogs more or less with the *auriculatus* group, although the parenthetical notes above indicate how they differ from more orthodox members. It might be necessary then to redefine the *auriculatus* group to include the variants of these three species.

However, in one major character neither *inoptatus*, *ruthae* nor *hypostenor* agree with other *auriculatus* members. *E. ruthae* has a very distinctive feature in the double vocal sacs, a condition which is found in West Indian *Elcutherodaetylus* only in the Puerto Rican *E. karlschmidti* (which is not related to this assemblage). As far as *inoptatus* and *hypostenor* are concerned,

there appears to be no vocal sac, a condition usual for more advanced members of the genus in the West Indies (i.e., the *ricordi*, *dimidiatus*, and *symingtoni* groups in Cuba). It is of course conceivable that *inoptatus* represents a gigantic member of the *auriculatus* group which has secondarily lost the vocal sac, and *ruthae* a large member of the group which has developed a double vocal sac. The voices of *inoptatus*, *ruthae* and *hypostenor* are likewise not comparable to those of the *auriculatus* members; the voices of *ruthae* and *hypostenor* have been discussed in the present paper. That of *inoptatus* is a single bark or snore, which is repeated regularly and continuously at well spaced intervals. The voices of *ruthae*, *hypostenor*, and *inoptatus* are quite different from the voices of *auriculatus* group members, where the voice ranges from a single metallic note to a telegraphic series of clicks, with intermediate conditions represented by various

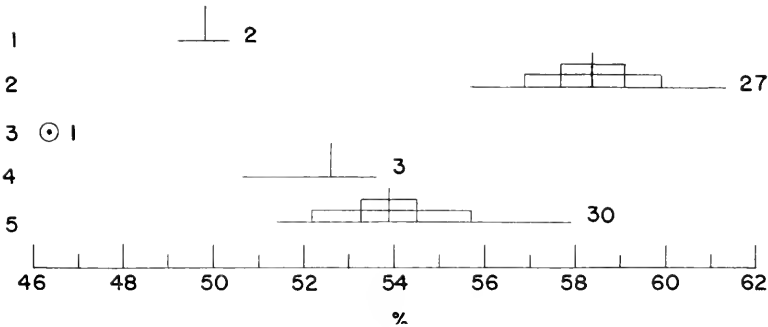

FIG. 8. Distribution of tibia/snout-vent length ratios by subspecies of male *Eleutherodactylus ruthae* and male *E. hypostenor*; horizontal line shows range of ratio, mean is vertical line, rectangles as in Figure 7. Samples coded and number of specimens as shown for Figure 7.

species. Additionally, *ruthae* and *hypostenor* call from subterranean burrows, and *inoptatus* calls from the ground or from low shrubs, vine tangles, or even from trees (coffee) at only moderate elevations above the ground (eight to ten feet). Although the latter situation is arboreal in a strict sense, one has the impression that this site for *inoptatus* is not the customary one. In any event, of the three species, only *inoptatus* approaches the truly arboreal calling sites of the remainder of the *auriculatus* group.

In the light of the foregoing, I feel it best to separate *E. inoptatus*, *E. ruthae*, and *E. hypostenor* from the *auriculatus* group, and assign them to a separate group, the *inoptatus* group, which will thus contain only these three species. I know presently of no other frogs in the West Indies which may with confidence be placed with them. When more information has been gathered on West Indian *Eleutherodactylus*, it is probable that relationships between the various groups will be clarified. At present, just as with the two members of the *symingtoni* group in Cuba (a pair of frogs which are large and quite different), I cannot form a conjecture about the origin of the *inoptatus* group. I may be maintaining too rigid an outlook towards membership in a particular group; this is especially true since Shreve and Williams have convincingly demonstrated annectant forms between several such assemblages. However, I think that with our present state of knowledge regarding Antillean amphibians, this is preferable to any sort of indiscriminate lumping without rather full knowledge not only of variation but also of life history data.

LITERATURE CITED

COCHRAN, DORIS M.

1941. The herpetology of Hispaniola. Bull. U.S. Nat. Mus., **177**:i-vii, 1-398, 12 pls., 120 figs.

LYNN, W. GARDNER, AND JAMES N. DENT

1943. Notes on Jamaican amphibians. Copeia, 1943 (4):234-242, 1 fig.

NOBLE, G. K.

1923. Six new batrachians from the Dominican Republic. Amer. Mus. Novitates, no. 61:1-6.

SHREVE, BENJAMIN, AND ERNEST E. WILLIAMS

1963. The herpetology of the Port-au-Prince region and Gonave Island, Haiti. Pt. II. The frogs. Bull. Mus. Comp. Zool., **129**(5): 302-342, 5 pls.









Harvard MCZ Library



3 2044 066 303 991

Date Due

OCT 31 1990

~~OCT 31 1992~~

~~JUN 3 1994~~

~~MAY 15 1995~~

JAN 31 1998

