





701
B8X
NH



Bulletins of American Paleontology

Begun in 1895

NUMBER 362

AUGUST 20, 2002

The Genus *Heliophyllum* (Anthozoa, Rugosa)
in the Upper Middle Devonian (Givetian) of New York

by

William A. Oliver, Jr.

and

James E. Sorauf



Paleontological Research Institution
125 Trumansburg Road
Ithaca, New York, 14850 U.S.A.

PALEONTOLOGICAL RESEARCH INSTITUTION

Officers

PRESIDENT	CHRISTOPHER G. MAPLES
FIRST VICE-PRESIDENT	JOHN POJETA, JR.
SECOND VICE-PRESIDENT	HOWARD P. HARTNETT
SECRETARY	SHIRLEY K. EGAN
TREASURER	PATRICIA A. JOHNSON
DIRECTOR	WARREN D. ALLMON

Trustees

JOHN D. ALLEN
CARLTON E. BRETT
WILLIAM L. CREPET
W. MICHAEL DRISCOLL
J. THOMAS DUTRO, JR.
PATRICIA HAUGEN
ROBERT M. HORN, JR.
HARRY G. LEE
AMY R. McCUNE

PHILIP PROUHANSKY
MEGAN D. SHAY
MARY M. SHUFORD
CONSTANCE M. SOJA
JOHN C. STEINMETZ
PETER B. STIFEL
DAVID H. TAUBE
SALLY T. TRUE
ARTHUR WATERMAN

Trustees Emeritus

HARRY A. LEFFINGWILL
ROBERT M. LINSLEY
SAMUEL T. PEES
EDWARD B. PICOU, JR.
JAMES E. SORAUF
RAYMOND VAN HOUTTE
WILLIAM P. S. VENTRESS
THOMAS E. WHITELEY

BULLETINS OF AMERICAN PALEONTOLOGY and PALAEOONTOGRAPHICA AMERICANA

WARREN D. ALLMON EDITOR
ROBERT J. ELLAS AND J. THOMAS DUTRO, JR. REVIEWERS FOR THIS ISSUE

A list of titles in both series, and available numbers and volumes is available online at www.priweb.org. Volumes 1–23 of *Bulletins of American Paleontology* are available from Periodicals Service Company, 11 Main St., Germantown, New York 12526 USA. Volume 1 of *Palaeoontographica Americana* has been reprinted by Johnson Reprint Corporation, 111 Fifth Ave., New York, NY 10003 USA.

Subscriptions to *Bulletins of American Paleontology* are available for US \$165 per year (individual or institution) plus postage. Issues are available and priced individually. Numbers of *Palaeoontographica Americana* are priced individually.

for additional information, write or call:

Paleontological Research Institution
1259 Trumansburg Road
Ithaca, NY 14850 USA
(607) 273-6623
FAX (607) 273-6620
www.priweb.org



Bulletins of American Paleontology

Begun in 1895

NUMBER 362

AUGUST 20, 2002

The Genus *Heliophyllum* (Anthozoa, Rugosa)
in the Upper Middle Devonian (Givetian) of New York

by

William A. Oliver, Jr.

and

James E. Sorauf

Paleontological Research Institution
1259 Trumansburg Road
Ithaca, New York, 14850 U.S.A.

ISSN 0007-5779

ISBN 0-87710-457-3

Library of Congress Control Number: 2002108977

Note: Beginning with issue number 356, *Bulletins of American Paleontology* is no longer designating volumes. The journal will continue to publish approximately 2–4 issues per year, each of which will continue to be individually numbered.

Printed in the United States of America
Allen Press, Inc.
Lawrence, KS 66044 U.S.A.

CONTENTS

	Page
Abstract	5
Introduction	5
Acknowledgments	6
Stratigraphy	6
Age of the Hamilton Group	9
Biogeography	10
Environments and Paleocology	10
Previous Systematic Work	12
Morphology and Individual Variation in <i>Heliophyllum halli</i>	12
Terminology	12
Carinae	13
Gross internal morphology	14
Growth form: solitary/colonial	14
Ontogenetic variation	14
Systematic Paleontology	16
Introduction	16
Repositories	16
Systematics Genus <i>Heliophyllum</i> Hall	16
<i>H. halli</i> species group	18
<i>H. halli</i> Milne-Edwards and Haime	18
<i>H. halli halli</i> Milne-Edwards and Haime	18
<i>H. halli confluens</i> (Hall)	24
<i>H. halli bellonense</i> n. subsp.	26
<i>H. halli joshuense</i> n. subsp.	27
<i>H. delicatum</i> Oliver and Sorauf	28
<i>H. stewarti</i> Oliver and Sorauf	29
<i>H. cribellum</i> n. sp.	29
References Cited	30
Appendix: Collection Localities	34
Plates	39

LIST OF ILLUSTRATIONS

Text-figures	Page
1. Stratigraphic section	7
2. Index map of Middle Devonian outcrop area in New York	8
3. Middle Devonian paleobiogeography of North America	10
Plates	
1–13. <i>Heliophyllum halli halli</i> Milne-Edwards and Haime	40
1. Exterior views.	40
2. Specimens from populations 1 and 2, Halihan Hill and Case Hill coral beds.	41
3. Populations 3 and 4, Centerfield Limestone and Staghorn Point coral bed.	42
4. Population 5, Joshua coral bed.	43
5. Population 6, Darien coral bed.	44
6. Population 7, Jaycox Member, Greens Landing coral bed.	45
7. Population 7 (continued).	46
8. Population 8, lower Deep Run Shale.	47
9. Population 8 (continued).	48
10. Population 9, Fall Brook coral bed.	49
11. Population 10, Bellona coral bed, Tully Limestone.	50
12. Exteriors of specimens with peripheral offsets, including " <i>praecoquus</i> ."	51
13. Thin sections of specimens illustrated on Plate 12.	52
14–19. <i>H. halli confluens</i> (Hall).	53–58
20, 21. <i>H. halli bellonense</i> new subsp.	59, 60
22–28. <i>H. halli joshuense</i> new subsp.	61–67

29. <i>H. delicatum</i> Oliver and Sorauf.	68
30, 31. <i>H. cribellum</i> new sp.	69, 70

LIST OF TABLES

Table	Page
1. Abbreviations used in descriptions and tables.	12
2. Summary morphologic data from thin sections of solitary <i>Heliophyllum halli halli</i> and closely related compound forms: organized by populations.	15
3. Maximum known size of <i>Heliophyllum halli halli</i> in collections of each population.	20

THE GENUS *HELIOPHYLLUM* (ANTHOZOA, RUGOSA) IN THE UPPER MIDDLE DEVONIAN (GIVETIAN) OF NEW YORK

WILLIAM A. OLIVER, JR. AND JAMES E. SORAUF

U. S. Geological Survey and Department of Paleobiology
E-305 National Museum of Natural History
Smithsonian Institution, Washington, DC 20560-0137

AND

Department of Geological Sciences, Binghamton University
Binghamton, New York 13902-6000

ABSTRACT

Specimens of the genus *Heliophyllum* are among the most common components of the upper Middle Devonian coral fauna (Givetian; Hamilton Group and Tully Limestone) in New York State. Although these corals are abundant and widespread, examination of large numbers of specimens indicates that most of them belong in a single, variable species, *H. halli* Milne-Edwards and Haime, including both solitary and colonial forms. This study has resulted in the recognition of four subspecies of *H. halli*, the solitary *H. halli halli*, and three colonial subspecies, *H. halli confluens* (Hall), *H. halli bellonense* n. subsp., and *H. halli joshuense* n. subsp. The three colonial subspecies occur in restricted stratigraphic positions, each in a coral bed in which it is associated and intergrades with solitary *H. halli halli*.

Two additional species of *Heliophyllum* are recognized in the Hamilton, the small, solitary *H. cribellum* n. sp. and the dendroid branching *H. delicatum* Oliver and Sorauf. The former has been found only in the Centerfield Limestone, lower Ludlowville Formation; the latter is limited to the lower Deep Run Shale, Moscow Formation.

Heliophyllum halli flourished in muddy but well-oxygenated parts of the Hamilton sea floor because basal, rootlike structures (talons) and shape adaptations helped keep the living polyp from being overwhelmed by the mud. Septal carinae are thought to have helped anchor the polyps in their calices, perhaps making it easier for them to remove any sediment that accumulated on the oral surface.

Heliophyllum cribellum is common in the Centerfield Limestone, which represents a more calcareous, relatively stable sea floor, while *H. delicatum* seems to have adapted to a more muddy, subsiding sea floor by fast upward growth. However, both species were associated with solitary *H. halli halli*, a further indication of the great adaptability of this species.

INTRODUCTION

Heliophyllum Hall is the most important and one of the most common rugose corals in the Middle Devonian of eastern North America. Hill (1957, p. 49) termed the eastern North American coral fauna "the *Heliophyllum* fauna" long before formal recognition of the currently accepted biogeographic realms and provinces (see Biogeography, p. 10). In New York, the genus ranges from the middle Emsian Bois Blanc Formation to the late Givetian Tully Limestone (see Text-fig. 1). The only known earlier, possible occurrence is in the Pragian or early Emsian Indian Cove Formation, Gaspé, Québec. One fragmental zaphrentid known from there may be a *Heliophyllum* (Oliver, 1997b, p. 318).

Heliophyllum is not restricted to eastern North America or to the Eastern Americas Realm (EAR) but this is its area of greatest abundance and longest stratigraphic record. It is present or common from Venezuela to the Hudson Bay Lowlands and from the Mississippi Valley (Kentucky, Missouri, Illinois) to the Appalachians (New York, southwest to the Virginias).

Outside of the EAR, *Heliophyllum* occurs in northwest Africa and southwestern Europe and possibly other areas (see Oliver and Sorauf, 1988, p. 4–5).

This is the latest of several papers that we have published on aspects of the genus *Heliophyllum* (Sorauf and Oliver, 1976; Oliver, 1974, 1976, 1993b, 1997a, b; Oliver and Sorauf, 1988, 1994; Sorauf, 2001). Our main purpose is to describe, classify, and interpret typical *Heliophyllum halli* and allied forms from the Hamilton Group in New York. An additional purpose is to demonstrate the need for population studies of a species as variable as *H. halli*; we hope that our descriptions and illustrations will demonstrate the variation and provide a better basis for comparison with other taxa than has been available previously.

Most or all of our "populations" are Givetian in age although the earliest ones (Halihan Hill and Case Hill coral beds; population levels 1 and 2 on Text-fig. 1) may be Eifelian. Pre-Hamilton, Emsian-Eifelian, colonial *Heliophyllum* were described by Oliver (1976) and solitary forms were included in the microstructure study of Sorauf and Oliver (1976).

ACKNOWLEDGMENTS

We are indebted to many people for help and cooperation during the course of this project. The late J. W. Wells, Ithaca, N.Y., contributed many Hamilton specimens from now-disappeared localities; P. H. Heckel, Iowa City, Iowa, gave many corals from his Tully Limestone study including most of our specimens of *H. halli bellonense*; and G. Kloc, Rochester, N.Y., gave us several beautifully prepared specimens for study and illustration of exteriors. M. Coen-Aubert, Brussels, Belgium, kindly sent new photographs of the neotype of *H. halli*; F. Debrenne and C. Perrin facilitated study of this specimen in Paris, France.

The cooperation and help of J. W. M. Thompson and M. Florence, Collections Management, Department of Paleobiology, U.S. National Museum of Natural History (USNM), Washington, has been particularly important. Type and other previously described or illustrated specimens were loaned by the following: M. Hinkley, American Museum of Natural History, New York; M. H. Nitecki, Field Museum of Natural History, Chicago; E. Landing and several of his predecessors, New York State Museum and Geological Survey, Albany; K. H. Meldahl, Oberlin College Geological Museum, Oberlin, Ohio; and W. L. Taylor, Paleontological Research Institution, Ithaca, New York.

Most of the more than one thousand thin sections used in this study were prepared by the late W. P. Pinckney, Jr., U.S. Geological Survey, Washington (USGS); some were made by K. Moore, USGS, and R. Jacyna, Binghamton University.

Most photomicrographs were processed and printed by D. Tuttle, Binghamton University, who also photographed many of the exteriors; additional photographs, especially of the colonial forms, were prepared by Pinckney and Moore. Text-figures were computer drafted by F. Marsh, Department of Paleobiology, USNM.

Field conferences with three individuals actively studying Hamilton biostratigraphy were useful and stimulating: G. C. Baird, State University College at Fredonia, New York; C. E. Brett, University of Cincinnati, Ohio, formerly at University of Rochester, N.Y.; and C. A. Ver Straeten, New York State Museum, Albany, New York.

W. T. Kirchgasser, State University of New York College at Potsdam, kindly sent an advance manuscript copy of his recent paper (2000) for our use in preparing Text-figure 1 and in making age assignments.

At various stages, the manuscript was critically reviewed by J. T. Dutro, Jr., USGS, Washington; R. J. Elias, University of Manitoba, Winnipeg, Manitoba, Canada; and ultimately by editor W. D. Allmon, Pa-

leontological Research Institution; we thank them for their helpful suggestions.

STRATIGRAPHY

The Hamilton Group in New York and adjacent areas is a complex of facies ranging from continental red beds in eastern New York to offshore marine black shales in the west. Between these extremes are a spectrum of shallow marine facies, including gray calcareous shales with varied marine faunas and several coral beds (sedimentary units with corals as a significant component and of measurable thickness and extent) (Text-fig. 1). *Heliophyllum* is an important constituent of most of the coral beds, and is associated with other invertebrates in non-coral bed situations, especially in the upper half of the section (Centerfield and younger in Text-fig. 1). See Brett et al. (1983) for an extended discussion of coral associations in the Hamilton Group.

Hamilton strata were deposited during early and middle stages of the Acadian Orogeny. Sediments came from the east and, as the source area continued to rise, facies shifted westward so that coral beds and other environments favorable for corals are found in the east in the lower Hamilton and in the west in the upper Hamilton. Our systematic analysis is partly based on collections or "populations" (defined in Systematic Paleontology) of *Heliophyllum* from 10 stratigraphic levels. Text-figure 1 is simplified to show the stratigraphic position of these populations without the facies complexities of the Hamilton as a whole. However, the relative east-west positions of the coral beds in the figure show the general westward shift of facies with time. See Brett et al. (1990), Brett and Baird (1996), and included references for detailed stratigraphy and discussions.

The named coral beds (Text-fig. 1) were described and discussed by B. Smith (1912, 1935), Cooper (1933, 1943), Oliver (1951), Lane (1955), Grasso (1968, 1986), Heckel (1973), Brett et al. (1983), Mayer et al. (1994), and Ver Straeten (1994). Most of the populations of *Heliophyllum* that we analyzed are from the coral beds and are informally named after their source. Two populations, Centerfield and Deep Run, are not from well-developed coral beds, and are named for the stratigraphic unit in which they occur. Additional *Heliophyllum* specimens occur scattered through the Hamilton gray calcareous shale facies and in additional thin coral beds. The stratigraphy of the 10 populations is briefly noted in the following paragraphs (ascending stratigraphic order). Numbers 1 to 10 identify the populations in Text-figure 1 and in the systematic descriptions. All map quadrangles (Quads.) are from the 7.5 minute series of the U.S. Geologic al

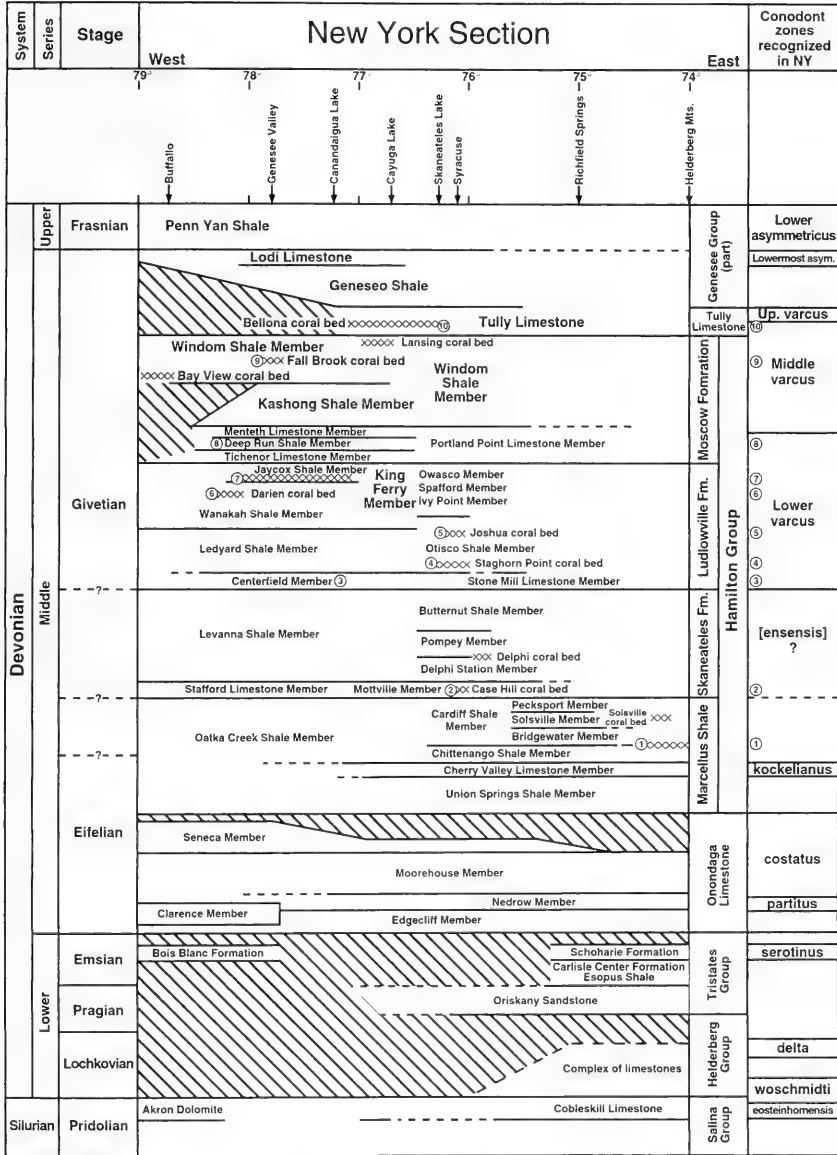

Text-figure 1.—Generalized diagram of Lower and Middle Devonian stratigraphic units in New York. Series and stages are indicated on the left. The position of the Eifelian-Givetian boundary in the Middle Devonian is uncertain. The right-hand column indicates the positions of the standard conodont zones recognized in New York (updated following Kirchgasser, 2000). The circled numerals on the left side of the conodont zone column mark the stratigraphic levels of *Heliophyllum halli halli* populations 1 to 10; the same symbols on the main part of the diagram show the level and approximate west-east position of the source units. Unit 1 is the Hallihan Hill coral bed; unit 7 is the Jaycox Member, Greens Landing coral bed; other source units are labeled on the diagram. Modified from Oliver (1993a, fig. 1).

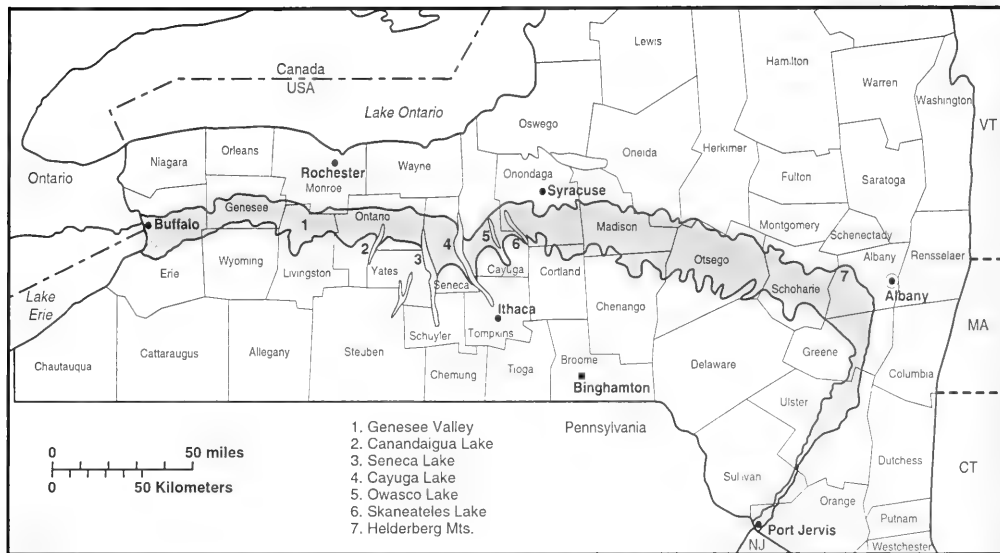

Text-figure 2.—Index map of New York showing the approximate outcrop area of Middle Devonian strata. It is impractical to show the 7.5 minute quadrangle boundaries at this scale but the counties, some of the principal cities, and seven regional reference points are labeled as an aid in finding the approximate positions of collection localities mentioned in the text and the Appendix. Modified from various small-scale outline maps of the New York State Geological Survey.

Survey. The quadrangles are too small to be shown on the map (Text-fig. 2) but citation of counties and other geographic features that are shown, gives a general location.

1. *Halihan Hill*.—Cooper (1933) first reported a coral bed in the lower Marcellus (now Mount Marion) Formation at two localities west of Albany, in the Schoharie Valley (Schoharie County) and northern Helderberg Mountains (Albany County) naming it the “*Meristella*-coral zone” after its principal components at these localities. Later, Cooper (1943) noted two additional exposures 55 km to the south in the Mount Marion-Kingston area, Ulster County. Lane (1955) described Cooper’s four exposures and additional ones in the Schoharie-Helderberg area, and showed that in this northern area, the coral bed was essentially continuous for an east-west distance of some 20 km but that the bed did not appear in any of the numerous outcrops in the 55 km between the Helderberg and Mount Marion localities. Lane noted that the corals in this bed are markedly smaller than those of other Hamilton coral beds and that the thickness of the coral bed varies from 0.3 to 0.6 m (Lane, 1955). Ver Straeten (1994) gave the coral bed its geographic name from Halihan Hill, northwest of Kingston (Kingston West

Quad.), near the two southern Cooper-Lane localities and just north of a new roadcut exposure. Ver Straeten’s detailed stratigraphy fully supported Lane’s earlier conclusion that the northern and southern outcrop clusters were in the same stratigraphic position. The Halihan Hill bed is late Eifelian or early Givetian in age, more likely the latter (see below and discussion in Kirchgasser, 2000).

2. *Case Hill*.—The Case Hill coral bed was described by Grasso (1968, 1986) as a limestone “abounding” with rugose and tabulate corals (dominated by *H. halli*), within the Mottville Member, Skaneateles Formation. The unit is approximately 2.5 m thick in the area from Lords Hill southeast to the south side of Bare Mountain (South Onondaga and Otisco Valley Quads., Onondaga County). The Mottville is either late Eifelian or, more likely, early Givetian in age (Kirchgasser, 2000).

3. *Centerfield*.—The Centerfield Member at the base of the Ludlowville Formation is the most widespread of the coral-bearing units in the Hamilton. It is one of the key units used by Cooper (1930, 1933–34) to divide the Hamilton into the four formations that are still widely recognized. The Centerfield is a mixture of thin limestones and calcareous shales, locally

almost a coral bed, but with a rich and varied assemblage of marine fossils. The unit extends from Erie County in the west to the Onondaga Valley in central New York (Onondaga Co.), some 200 km; corals are present to very common over much of this distance. The thickness of the coral-bearing beds is commonly 1 to 2 m. The small, commonly ceratoid-cylindrical *Heliophyllum cribellum* n. sp. is associated with solitary *H. halli* in the Centerfield. The member contains Lower *varcus* Zone conodonts, so this and all younger populations are Givetian or younger in age.

4. *Staghorn Point*.—The Staghorn Point coral bed is within the Otisco Shale Member of the Ludlowville Formation, approximately 15 m above the Centerfield Member. The bed consists of solitary rugose corals, a few tabulate corals, and little else other than shale matrix; it is as much as 3.5 m thick and extends for more than 29 km from the most spectacular exposure along the east side of Skaneateles Lake (Spafford Quad.) eastward to the Butternut Creek Valley (Jamesville and Tully Quads.) in Onondaga County. The most complete description of the unit is by Oliver (1951). It is Givetian in age.

5. *Joshua*.—The Joshua coral bed is approximately 30 m above the Centerfield Limestone Member and 12 m above the Staghorn Point coral bed in the Otisco Shale (Text-fig. 1). The Joshua occurs in the same general area as the Staghorn Point (Onondaga Co.) and is similar in being crowded with solitary rugose corals. However, it is thicker, up to 15 m, and extends only 14 km from Skaneateles Lake to Case Hill (Spafford and South Onondaga Quads.). Oliver (1951) described and named the unit. The semiceratoid to phaceloid *Heliophyllum halli joshuense* n. subsp. is associated with solitary *H. halli halli* in the Joshua. It is Givetian in age.

6. *Darien*.—The Darien coral bed is in the upper part of the Wanakah Shale Member of the Ludlowville Formation in western New York. The nature and extent of the bed is discussed by Brett *et al.* (1983, p. 84–85). The *Heliophyllum*-rich part of the bed is in a limited area of Genesee County, centering around Darien (Alexander Quad.), where it is approximately 0.3 m thick. It is Givetian in age.

7. *Jaycox (Greens Landing)*.—A prominent coral bed in the lower part of the Jaycox Member of the Ludlowville Formation was described and discussed as the Greens Landing coral bed by Mayer *et al.* (1994). Specimens of *Heliophyllum* are common at many localities from eastern Erie County (Buffalo Creek, East Aurora Quad.) to Canandaigua Lake (Greens Landing, Canandaigua Lake Quad., Ontario Co.), a distance of over 100 km. According to Mayer *et al.*, the bed has a maximum thickness of 1 m. The asteroïd *H. halli*

confluens Hall is apparently limited to this bed where it is associated with numerous *Heliophyllum halli halli*. It is Givetian in age.

8. *Deep Run*.—The Deep Run population occurs in the lower 0.5 to 2 m thick interval of the Deep Run Shale Member of the Moscow Formation at many localities from eastern Erie County to the east side of Seneca Lake (Seneca Co.), a distance of 140 km. This is not a coral bed, rather, occurrences are sporadic; solitary and weakly phaceloid *H. halli halli* (Wells', 1937, "form *praecoquus*") are associated with colonies of the phaceloid *H. delicatum* Oliver and Sorauf and diverse other shelly invertebrates. For description of the general stratigraphy see Baird (1979) and Brett and Baird (1994). The extent and occurrence of the *Heliophyllum* fauna are described in Oliver and Sorauf (1994). The Deep Run is Givetian in age.

9. *Fall Brook*.—The Fall Brook coral bed is in the Windom Shale Member of the Moscow Formation; it was described and named by Baird and Brett (1983) and discussed several times later (*e.g.*, Brett and Baird, 1994). The bed is 0.5 to 2 m thick; parts with large corals (including *Heliophyllum*) are mostly in the Genesee Valley, near Leicester and Genesee (Livingston Co.). Our population is from the Little Beards Creek locality, just north of Leicester; this is also a possible source for the species neotype (see Systematic Paleontology section). The coral bed is in the Middle *varcus* Zone, of Givetian age.

10. *Bellona*.—The Bellona coral bed is in the Tully Limestone which immediately overlies the Hamilton Group over much of the state. The Tully and the coral bed were described in great detail by Heckel (1973). The bed has a maximum thickness of 8 cm, but has a west to east extent of over 100 km. Large solitary corals, including *Heliophyllum halli halli* and the asteroïd *H. halli bellonense* n. subsp., span much of this distance. Our collections are from just west of Seneca Lake (Stanley Quad., Yates Co.) to Skaneateles Lake (Spafford Quad., Cayuga Co.), a distance of 60 km. The Bellona bed is in the Middle *varcus* conodont Zone, of Givetian age. The *Heliophyllum* specimens are the youngest known in New York, and possibly the youngest anywhere.

AGE OF THE HAMILTON GROUP

Kirchgasser (2000) reviewed available information on the positions of Devonian stage boundaries in eastern North America and the following notes are based on his discussion. Most of the stage assignments in the Hamilton Group are derived from the conodont work of G. Klapper, summarized in Klapper (1981) and in Text-figure 1.

The Hamilton Group and Tully Limestone are Mid-

dle Devonian in age. Centerfield and younger populations (populations 3–10) are well dated within the Lower and Middle *varcus* conodont Zones and by definition are Givetian. The next older well-dated stratigraphic unit is the Cherry Valley Limestone within the *kockelianus* Zone in the upper Eifelian (Text-fig. 1). The Cherry Valley is below populations 1 and 2 leaving both as either late Eifelian or early Givetian in age. Klapper (1981, p. 61) suggested that the Mottville and higher members of the Skaneateles Formation could logically be assigned to the *ensensis* Zone on the basis of available conodont data. This would make our Case Hill population (2) early Givetian. Some workers have placed the base of the Givetian as low as the top of the Cherry Valley Limestone or within the overlying Chittenango Shale (see summary discussion of Kirchgasser, 2000); either boundary would be below our Halihan Hill population (1).

We conclude that the Halihan Hill and Case Hill populations (1, 2) are more likely early Givetian in age than late Eifelian, although the older one is very close to the boundary. The Centerfield and higher populations (3–10) are Givetian.

BIOGEOGRAPHY

The Early and Middle Devonian world was remarkably provincial and corals were among the most provincial of marine animals (Oliver, 1977, 1980, 1990; Oliver and Pedder, 1989). Three marine biogeographic realms are recognized: 1) the Eastern Americas Realm (EAR) included the North American Plate east of the Transcontinental Arch and south of the central Canadian Shield, and northern South America (with principal coral faunas in Venezuela and Colombia); 2) the Old World Realm (OWR) was much larger, including most of the rest of the world's rich coral faunas; and 3) the Malvinokaffric Realm included areas that were at a high Devonian southern latitude; the realm was coral poor, presumably because of cold water.

Three Middle Devonian EAR provinces are recognized (Text-fig. 3): 1) the Appohimchi Province was the Appalachian-Ouachita belt (including New York and neighboring areas); 2) the Illinois-Iowa-Michigan Basins-Hudson Platform Province included areas north of the Ozark and Nashville Domes and west of the Cincinnati, Findlay and Algonquin Arches; and 3) the Venezuelan-Colombian Province (with the typical EAR *Heliophyllum* fauna; Wells, 1943; Scrutton, 1973; Oliver, 1989a, p. 3–4). All of the *Heliophyllum* described in this paper are from the Appohimchi Province, but previously described specimens from Venezuela are noted in the synonymies and the Illinois and Michigan Basin faunas are discussed.

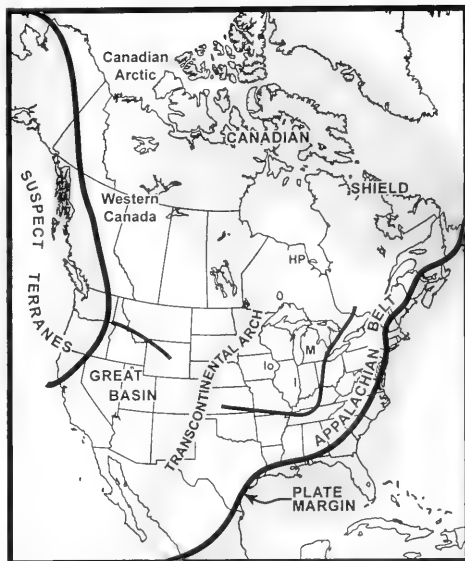

Text-figure 3.—Devonian paleogeography shown on a modern outline map of North America showing generalized plate boundaries and biogeographic divisions. North America east of the Transcontinental Arch was part of the Eastern Americas Realm (EAR), divided into the Appohimchi Province (Appalachian Belt or Basin) and the Illinois-Iowa-Michigan Basins-Hudson Platform Province (I, Io, M, and HP on map). Most of the *Heliophyllum* spp. described or cited in this paper are from New York (just below the B in Belt). Modified from Oliver and Pedder (1989, fig. 2).

ENVIRONMENTS AND PALEOECOLOGY

Among the generally large, dissepimented rugose corals in the Hamilton Group, specimens of the *Heliophyllum halli* species group are second in abundance only to co-occurring specimens of cystimorphs (*Cystiphyllodes* and *Zonophyllum* spp.) Their abundance and wide distribution indicate that members of the complex of species and subspecies were well adapted to life on and in fine clastic sediments. The nature of this adaptation is indicated partly by corallum form and partly by inference based on preservation details and character of the enclosing rocks. Most coralla are unbroken but many are abraded, commonly on the upper side as preserved in the rock. This, and the abundance of epibionts (*Aulopora* spp., bryozoans, and less common echinoderm holdfasts; Baird and Brett, 1983, fig. 5) on the coral exteriors in some situations, indicate long exposure on the sea floor.

Depositional environments.—In the Hamilton Group, *Heliophyllum* spp. lived in the well-oxygenated

shallow shelf environments where gray, somewhat calcareous muds were deposited (Brett *et al.*, 1983); the coral beds described in the stratigraphy section are found within this facies along with other shallow-marine fossil assemblages that include corals in association with other animals. Environmental interpretations are based on the type of sediment and sedimentary features as well as on taphonomic features and the morphology of the preserved skeletons. For *Heliophyllum* spp., as for corals generally, larval settlement was the most vulnerable stage of life. For most corals, a hard substrate was optimal; this could be a hard ground or an accumulation of shelly material to which larvae could attach. The Staghorn Point coral bed was built on and is coextensive with a siltstone platform that provided a surface on which initial growth was feasible (Oliver, 1951). In contrast, the Joshua coral bed was initiated by the development of a 30 cm thick layer of a branching colonial rugosan, *Eridophyllum*, which could successfully spread over the mud surface and form a hard platform of another sort (Oliver, 1951). Other apparently suitable substrates were areas of hardened mud or shell accumulation (Baird and Brett, 1983, p. 426). On these varied surfaces of quite different origins, larval settlement and attachment took place. *Heliophyllum* and other corals were adapted to grow by cementing to available materials with talons, or by being laterally supported by sediment or larger fragments of shells or other corals.

Away from areas of suitable substrate, the muds appear to have been extremely soft and easily disturbed by storms or currents, resulting in turbid water over water-saturated muds. Larvae would be easily smothered in such situations but, given a start, large corals could grow partly buried in and supported by the sediment. Such a substrate would be unstable and frequent toppling of corals could be expected; but, even without water movements, increased skeletal mass with growth would produce instability and toppling. Bioturbation may also have been a factor in causing instability. Baird and Brett (1983, p. 433) suggested that bioturbation was the principal cause of toppling; we think that physical factors were more important, but more detailed study in the field is needed to determine if any cause predominated and what other factors may have been involved.

Adaptations.—The Hamilton *Heliophyllum* and associated corals appear to have been adapted to living in turbid waters. In living corals, life in turbid waters is facilitated by having large numbers of tentacles and a ciliated, mucus-secreting ectoderm. According to Hubbard and Pocock (1972) silt-sized or finer particles can be removed by cilia and by entanglement in mucus that is then sloughed off; larger particles can be re-

moved by controlled distention (swelling) of the polyp and by tentacular action. *Heliophyllum* polyps probably had some of these abilities. The large numbers of septa in *H. halli* suggest equally numerous tentacles, possibly in two rings corresponding to the major and minor septa (Fedorowski, 1997). Polyp distention with arching of the oral surface may have been facilitated by the septal carinae that would have increased the polyp's "grip" on its base. Analogy with living corals described by Yonge (1940) suggests that the reflexed peripheral platform of many coralla would also have helped the sediment-shedding operation.

Corallum shape is, at least partly, an ecological adaptation. Shape variation is discussed in another section but some forms are clearly related to life in turbid conditions. Patellate, almost platelike form indicates rapid increase in diameter relative to height; it provides a relatively flat base that would resist overturning. Patellate *Heliophyllum* commonly have reflexed peripheral platforms and may have depended on distention and ciliary action to resist burial in the mud. Polyps of long, straight individuals, if supported in an erect position, would have been above much of the mud that would be in motion near the mud-water interface. Some elongate individuals are found in this growth position (*e.g.*, Brett and Baird, 1986, fig. 1). In elongate coralla, geniculations (right-angle bends) are common and indicate toppling; apparently recovery was rapid and recorded in the skeleton by widely spaced tabulae and the presence of large dissepiments on the convex side of the bend (Sorauf, 2001).

Talons are well developed in many solitary *Heliophyllum*. These are rootlike extensions of the lower dissepimentarium that provided attachment to a hard substrate. Talons near the apex of some specimens reflect the shape of the hard object such as a shell, pelmatozoan stalk, or another coral, that may have been alive or lying on the sea-bottom. Talon development in some specimens continued to a diameter of 3 or 4 cm, possibly permitting a rough estimate of the maximum size of coral that could be supported by such attachment (Sorauf, 2001).

Rejuvenation results from rapid diameter decrease during the growth of skeleton and polyp, followed by expansion. The decrease may indicate polyp trauma due to muds encroaching on the calice margin. The continued formation of outer wall and epitheca through the episode of diameter decrease protected the polyp from the mud and permitted the continued growth and rejuvenation.

Summary.—The abundance of *Heliophyllum* individuals in the gray shale facies of the Hamilton Group indicates that they were well adapted to life in a turbid water environment. Most, however, are found in coral

beds or in widespread calcareous units. The coral beds formed on relatively hard surfaces of greater or lesser extent; the Centerfield was a widespread shale and limestone unit with an abundant and varied shelly fauna. The Bellona (Tully Limestone) environment seems to have been a little of each kind; the coral bed rests on a relatively firm base in a widespread limestone (Heckel, 1973). Not all Hamilton *Heliophyllum* are preserved in such favorable situations. Some did live in the muds, either apparently isolated or in assemblages that were too scattered to be recognized as a coral bed or other named unit. The Deep Run population is of this type; specimens of *H. halli* and *H. delicatum* are widespread over a distance of 140 km, but no locality produced more than a few of either species. They were clearly opportunistic; larvae seem to have been there to occupy local hard attachment sites when they became available.

PREVIOUS SYSTEMATIC WORK

Previous work on *Heliophyllum* from areas within the Eastern Americas Realm, including Venezuela, is noted and discussed in Systematic Paleontology. However, "*Heliophyllum*" and "*H. halli*" have been listed and described from many additional parts of the world, warranting separate discussion. Most of these non-EAR reports are unconvincing or unacceptable, either because of inadequate information or because the specimen(s) on which the report is based lack characters that we consider diagnostic. In 1988 we reviewed reported occurrences and summarized what seemed acceptable at that time (Oliver and Sorauf, 1988, p. 4–5, table 1). We are more sceptical now. The genus and probably the species occur in northwest Africa (LeMaitre, 1947; Coen-Aubert, 1987; Pedder, 1999) and Spain (Oliver and Sorauf, 1988) but reported occurrences in other areas, especially Asia, now seem more questionable, most of them because they are based on inadequate samples. A major purpose of this paper is to demonstrate the need for population studies of species as variable as *H. halli*. We hope that our descriptions and illustrations will provide a better basis for comparison than has been available previously. Our synonymies are intended to be reasonably comprehensive for the Eastern Americas Realm only; Old World Realm materials are included only if particularly pertinent.

H. halli is one of the most common rugose corals in the Middle Devonian of eastern North America. Most specimens are solitary but, in New York, four stratigraphically limited populations of colonial *Heliophyllum* differ from each other, but are intimately associated with solitary forms and are clearly closely related. This close relationship, represented by the in-

Table 1.—Abbreviations used in descriptions and in Tables 2 and 3.

A. Characters measured or counted in thin sections (Table 2).	
d.	corallite diameter
d'	tabularium diameter
n.	number of major septa
w.	width of dissepimentarium (d-d'/2)
c.	number of carinae on major septa
r.	corallite radius ($\frac{1}{2}$ d)
l.	length of major septa
l ^m .	length of minor septa
tab.	number of tabulae per cm
N.	sample size (number of specimens or populations)
B. Ratios (dimensionless numbers used to reduce or eliminate the effect of size)	
d'/d	(relative width of tabularium)
n/d	(septal ratio; higher ratios indicate more closely spaced septa)
c/w	(approximates the number of carinae per mm)
l/r	(length of major septa relative to corallite radius)
l ^m /w	(length of minors relative to width of dissepimentarium).
C. Exterior measurements (Table 3); other features:	
D.	maximum diameter
L.	length (measured along the convex side of the bent or curved corallum).
C.	cardinal septum
K.	counter septum

clusion of solitary and colonial forms in the same species, has long been accepted by some paleontologists who have worked on New York *Heliophyllum*. Most important, because of included discussions, are Nicholson (1876, p. 245, 246), Wells (1937), Sorauf and Oliver (1976), and Oliver (1989b, 1997a). In contrast Hall (1877), Fenton and Fenton (1938), Ehlers and Stumm (1953), and Coen-Aubert (1987) interpreted solitary and colonial forms (except weakly fasciculate ones) as separate species. We recognize three of the colonial populations as subspecies and the fourth as a species in the *H. halli* species group.

MORPHOLOGY AND INDIVIDUAL VARIATION IN *HELIOPHYLLUM HALLI*

Terminology.—Most morphologic terms are used here as defined in the 1956 *Treatise* (Moore *et al.*, 1956). Additional terms or usages are explained here, in Table 1, or in the systematic descriptions. All descriptions, except of form and external features, are based on thin sections.

Existing terminology for description of trabeculae is inadequate, perhaps indicating that pattern variation is too great for easy classification. The revised *Treatise* (Hill, 1981, p. F14) illustrates simple monacanthine and two types of compound trabeculae, rhabdacanthine and rhipidacanthine, based on the studies of Hill (1936) and Jell (1969) of two different rugose coral families. The compound forms bear only a partial similarity to the *Heliophyllum* trabeculae described as Types II and III by Sorauf and Oliver (1976).

Carinae.—Carinae are flangelike elevations on the sides of septa. They are fundamental parts of the septa and have the same or comparable microstructure. Parts of septa between carinae are termed intercarinae. *Heliophyllum* septa are trabeculate and carinate. Each carina is formed by one or more simple or compound trabeculae; the intercarinae consist of several parallel, simple elements that may or may not be fine trabeculae. Within each septum, carinae and intercarinae grew as a unit, but at any growth position, the carinae projected above or inward from the intercarinae forming a denticulate septal margin. Growth lines on septa mark the positions of the distal edge of septa during growth; these and the carinae indicate growth direction and shape of the calice. Carinae are perpendicular to growth lines; in the outermost dissepimentarium they are approximately parallel to the wall but lean outward in specimens with a reflexed calcinal platform. In the inner dissepimentarium they bend toward the axis and may be nearly horizontal at the tabularium margin. Carinae are commonly limited to the dissepimentarium but are present in the tabularium of some individuals.

In transverse sections, carinae are described as yard-arm, zigzag, irregular, or complex. In *Heliophyllum*, yard-arm carinae are the most characteristic but combinations of yard-arm and one or more of the other kinds in a single section are common.

Sorauf and Oliver (1976) described three types of carinae in Hamilton *Heliophyllum*. Type I carinae were defined as formed by a single monacanthine trabecula. Type II were formed by compound trabeculae prolifically branching at high angles. Type III were composed of subparallel, bundled trabeculae with infrequent branching at a low angle. In working with much larger samples for this monograph, we have recognized and used the same classification but we note more variation and less clear boundaries between the types and more extensive descriptions are given in the following paragraphs.

Type I carinae are formed by single monacanth consisting of an axis and radiating fibers of calcite; the fibers are at a constant angle to the axis, diverging in the direction of growth, and giving a featherlike appearance to the trabeculae in longitudinal sections. Sorauf and Oliver (1976, p. 339–340) noted that this is the characteristic type of carina in early growth stages of *Heliophyllum halli* and we have found no exceptions to this generality in the additional material studied.

Type I carinae are also common in later, more mature stages of many individuals (e.g., Pl. 3). With growth, the monacanth may thicken and become bushy in appearance. With further growth, or with better preservation or resolution, some of these become

rhabdacanth-like with second-order trabeculae seeming to take the place of the fibers. They differ from rhabdacs in that the second-order trabeculae are longer in the septal plane than at right angles to it, giving an elliptical cross-section to the trabecula; "typical" rhabdacs are equidimensional in cross-section. Some carinae are rhipidacanth-like with the second-order trabeculae radiating from a point or a succession of points. In longitudinal sections through trabecular axes, the second-order trabeculae have diameters of 0.08 to 0.16 mm. Vepreculae seen (as stiples) in longitudinal sections tangential to the first-order trabeculae, are the axes of the second-order trabeculae cut transversely. These compound trabeculae are referred to Type IIb (e.g., Pl. 8), to differentiate them from Type IIa discussed in the next paragraph. Carinae showing the progression from Type I to IIb are designated Type I→IIb. With growth and increased corallite diameter, Type I and Type IIb trabeculae tend to fan out in the mid-plane of the septum, and new trabeculae are inserted midway between the older ones. Occasional low-angle branching of Type I or IIb trabeculae has been noted; this is one kind of Type III. In transverse sections, most Type I carinae are yard-arm; the bushy or more complex derivatives of Type I are irregular.

Type II (now Type IIa; e.g., Pl. 7) carinae, as originally defined, are rhipidacanth-like but with branching primarily in the plane of the septum. They consist of a succession of fans (bushes) of second-order trabeculae branching or radiating from points. They are similar to our Type IIb but larger. Second-order trabeculae of our original Type II examples (Sorauf and Oliver, 1976, pl. 3, figs. 2–4) have diameters of 0.20 to 0.40 mm, more than twice the size of those noted above for Type IIb. However, diameters of the first-order trabeculae of Types IIa and IIb both range from 1.0 to 1.5 mm (in the plane of the septa) and there are second-order trabeculae of intermediate sizes. Both are Type II but the size range is notable. In transverse sections of *Heliophyllum*, Type II carinae are zigzag to irregular.

Type III carinae (e.g., Pls. 4, 17) are the most complex type seen. Some appear to be braided with two or three strands (first-order trabeculae?) seeming to interweave; smaller branches (second-order trabeculae?) are irregularly spaced (some with intervening open spaces) and at irregular angles to the main strands. The carinae as a whole may branch at low angles. In transverse sections of carinae, these are the most complex in appearance. Type III trabeculae develop from Type I and are designated as Type I→III where this is evident in longitudinal sections.

Confirmation of carina type requires a longitudinal

thin section, but good guesses can be made from transverse sections in many instances. Well-developed yard-arm carinae, especially if attenuate, are almost always Type I. Zigzag carinae are commonly Type I or II. Irregular and complex carinae tend to be Types II and III, respectively, but they are difficult to separate in transverse sections.

Gross internal morphology.—Variation in morphologic features that can conveniently be measured or counted is summarized in Table 2. Some characters that are difficult to analyze quantitatively are discussed here; these include discontinuous septa, relative thickness of major and minor septa, and the complexities of dissepimental structures between septa. These could have been analyzed on a presence-absence basis but there is so much variation in each character, from slight to extreme, that this was deemed impractical.

In transverse sections of presumably mature parts of the *Heliophyllum* skeleton, major and minor septa can be: 1) equal in thickness (e.g., Pl. 2), or major septa can be up to twice as thick as the minors (e.g., Pl. 5); 2) complete (e.g., Pl. 10), or minors, and less frequently majors, can be discontinuous, commonly in the outer dissepimentarium (e.g., Pl. 3); and 3) separated (or connected) by simple, discrete, gently curved dissepiments (e.g., Pl. 2), or a network of lateral and irregular transverse dissepiments can dominate the interseptal spaces (e.g., Pl. 5).

In *Heliophyllum halli*, these characters vary within individuals (even in a single transverse section) and populations. There are some correlations; uniformly attenuate septa tend to be complete peripherally and to be separated by simple dissepiments, but thick major/thin minor septa are commonly associated with peripheral discontinuities and complex dissepimental networks. In addition, attenuate septa commonly have Type I carinae, but bushy Type I and Types II and III carinae tend to occur in thicker septa. Some individuals more or less conform to these combinations of characters but, in most populations and in the species as a whole, the three characters vary independently and all combinations are found. Attenuate septa can be discontinuous with or without a network and septa can be uniformly thickened and have any type of carinae.

Growth form; solitary/colonial.—Variation in the external form of Hamilton *Heliophyllum halli* is extreme (see, e.g., Pls. 1 and 16) ranging from low turbinate to elongate ceratoid or cylindrical, from smooth to very irregular, and from solitary to astreoid. Interpretation of this variation in Hamilton *H. halli* has a long and controversial history. Nicholson (1876) included various solitary and colonial forms in his concept of the species at the same time that Hall (1877)

was illustrating and naming five new species (two colonial) and two new varieties (subspecies) from Hamilton collections, largely on the basis of form.

Wells (1937) studied large new collections and recognized "intermediate stages" between Hall's species and varieties. He concluded that only one species was represented but divided *H. halli* into one "variety" (subspecies) and 11 "formae" that were the result of continuous individual variation. At the same time, Fenton and Fenton (1938) described and illustrated seven species (two new) and four subspecies (one new) from the New York Hamilton, mostly from the Hall collection.

In large collections, the boundaries between the nominal species and subspecies of Hall and of Fenton and Fenton disappear; there are too many intermediate forms. In addition, we have found no internal characters that correlate with form and would support separation. We agree with Wells' broad interpretation and consider that most of the Hall (1877) and Fenton and Fenton (1938) taxa are *H. halli*. We have recently discussed these questions in both colonial (Oliver, 1997a) and solitary (Sorauf, 2001) forms and consider that only the branching *H. delicatum* Oliver and Sorauf (1994) and the small *H. cribellum* n. sp. can reasonably be recognized as separate species.

Ontogenetic variation.—Most *Heliophyllum halli* individuals followed a pattern of continuing diameter increase throughout their lives whether solitary or within a colony. In solitary forms, the septa are commonly dilated in an early stage, even completely filling the lumen. These two characteristics make the recognition of the conventional ontogenetic stages impractical in most individuals. With growth, dilation may become restricted to the axial region, and eventually eliminated. Partial dilation may persist in the axial region or along the full length of the septa to a greater or lesser extent. Transverse sections of the early, completely dilated stage of large individuals, or of small individuals with fully dilated septa, are difficult to interpret. Septa can be recognized but carinae may be obscure. Most coralla with complete early stage dilation begin to open up at a diameter of approximately 20 mm. We have arbitrarily set this as a working boundary between immature and mature. Our statistical samples include data from sections with diameters 20 mm or more unless exceptions are noted. It is important to emphasize that using data from "mature" stages only does not eliminate ontogeny as a factor in our analyses of variation. The corals continued to grow and expand and only a few reached a steady state morphology. Environmentally controlled diameter decrease in mature corals and subsequent rejuvenation,

Table 2.—Character data for species, subspecies, and populations described in text. Within each box the upper figure is the mean value of the character indicated at the top of the column, and the lower figure is the observed range of values for that character. The data are arranged in stratigraphic order; numerals and names in the left column are those assigned to the 10 populations of *Heliophyllum hallii*. Data for the four colonial subspecies and species are entered immediately below the data for the associated population. The summary data near the bottom of the chart are based on the population means for populations 2 to 10; population 1 data are excluded as explained in the text. The *H. cribellum* data at the bottom are unrelated to the rest of the table but this placement facilitates comparison.

Population	d	d [†]	d/d	n	n/d	w	c	c/w	l	l/r	l ^m	l ^w /w	tab	Carniae type		
														N	Dominant	Secondary
10—Bellona	30/4	12.5	0.42	35/6	1.21	8.8	6.6	0.77	14.8	0.99	8.2	0.94	15.4	25	I bushy	III, IIb
	20/40	8/17	0.33/0.54	27/44	0.95/1.58	5.5/12.5	4/11	0.44/1.09	10/20	0.92/1.03	5/12	0.75/1.08	11/21	7	III	I
<i>bellonense</i>	26/1	7.4	0.29	26.3	1.02	9.4	20.0	2.03	12.9	0.98	9.4	1.01				
9—Fall Brook	20/30	6/10	0.23/0.35	22/31	0.85/1.21	6.5/11.5	15/26	1.58/2.40	10/15	0.88/1.08	7/11	0.96/1.08				
	38/8	16.8	0.44	38.0	1.02	11.0	9.1	0.87	18.9	0.98	10.3	0.95	15.1	20	I	III
8—Deep Run	24/57	10/26	0.32/0.58	31/45	0.61/1.54	5.0/18.5	5/13	0.49/1.22	12/28	0.83/1.03	5/16	0.62/1.08	11/30	18	I to IIb	I, III
	35/1	14.6	0.42	39.3	1.14	10.2	9.8	0.97	16.2	0.92	10.1	0.98	15.4	18	I to IIb	I, III
<i>delicatum</i>	27/46	10/20	0.24/0.54	30/50	0.78/1.48	7.0/17.0	6/20	0.64/1.55	12/22	0.81/1.00	6/17	0.73/1.05	9/25	31	IIa	III
	31/3	11.0	0.35	31.3	1.01	10.2	11.6	1.16	14.6	0.93	9.8	0.97	16.4	16	III	I
7—Jaycox	21/42	8/14	0.24/0.45	25/40	0.71/1.32	6.0/14.0	6/18	0.57/1.63	9/19	0.67/1.04	6/14	0.77/1.14	11/23	26	I	III (IIb rare)
	38/2	13.6	0.36	36.5	0.99	12.3	14.6	1.20	18.3	0.96	12.1	1.00	15.7	26	I	III (IIb rare)
<i>confuens</i>	19/54	8/19	0.26/0.52	25/48	0.69/1.32	5.5/18.0	4/25	0.44/2.10	10/27	0.78/1.05	6/18	0.86/1.08	11/28	13	II	I
	34/4	11.1	0.33	31.8	0.93	11.7	19.5	1.69	16.8	0.96	11.7	1.01	16.4	25	I bushy	III
6—Darien	25/47	8/16	0.21/0.41	26/37	0.66/1.15	7.5/18.5	12/29	1.15/2.42	13/22	0.85/1.06	8/16	0.81/1.16	11/26	18	III	IIb
	30/2	10.0	0.33	36.7	1.20	10.2	7.9	0.79	13.9	0.92	7.5	0.74	17.0	13	II	I
<i>justuense</i>	23/36	8/12	0.28/0.40	34/40	1.03/1.48	7.0/12.0	6/10	0.67/1.00	11/17	0.80/1.00	5/11	0.48/0.92	11/27	18	III	IIb?
	40/3	16.0	0.41	45.2	1.16	12.0	12.4	1.09	19.4	0.97	11.8	1.00	16.7	25	I bushy	III
4—Staghorn Pt.	25/52	12/21	0.23/0.57	36/54	0.81/1.60	5.5/20.0	4/22	0.60/2.22	13/26	0.87/1.04	5/19	0.75/1.56	10/26	18	III	IIb
	35/4	14.0	0.39	42.7	1.24	10.7	17.8	1.75	16.7	0.97	10.4	1.00		12	I	III, IIb?
<i>justuense</i>	20/55	9/24	0.17/0.54	33/54	0.84/1.70	5.0/17.5	10/25	1.20/3.00	10/27	0.85/1.00	5/17	0.88/1.26	16.4	24	I bushy	IIb
	31/3	12.8	0.44	39.1	1.27	9.2	8.4	0.92	13.3	0.85	7.7	0.84		20	I	IIb
3—Centerfield	22/40	8/17	0.32/0.57	32/48	1.06/1.58	6.0/13.5	5/18	0.57/1.33	9/18	0.72/1.00	5/12	0.65/1.08	12/22	24	I bushy	IIb
	31/3	13.8	0.45	35.8	1.19	8.7	6.4	0.77	14.9	0.94	8.0	0.92	13.6	20	I	IIb
<i>cribellum</i>	22/42(64)	9/20(23)	0.30/0.73	31/41(52)	0.81/1.79	3.5/20.5	4/11	0.54/1.23	9/21(32)	0.69/1.00	4/13(21)	0.71/1.20	5/22	44	I to bushy	IIb
	25/1	10.7	0.43	36.4	1.49	7.2	7.3	1.04	11.6	0.94	7.1	0.98	15.8	21	I	III rare
<i>cribellum</i>	18/37	8/14	0.35/0.52	30/44	1.03/1.85	5.0/12.0	5/11	0.71/1.60	8/19	0.82/1.03	4/11	0.88/1.06	12/20	15	I	bushy rare
	28/5	12.4	0.44	36.1	1.33	8.0	6.8	0.89	13.4	0.94	7.6	0.95	14.7	44	I to bushy	IIb
total	18/42(64)	8/20(23)	0.30/0.73	30/44(52)	0.81/1.85	3.5/20.5	4/11	0.54/1.60	8/21(32)	0.69/1.03	4/13(21)	0.71/1.20	5/22	21	I	III rare
2—Cave Hill	33/2	13.4	0.41	38.7	1.19	9.9	6.6	0.66	15.4	0.93	8.4	0.85	17.3	15	I	III rare
	25/41	10/16	0.32/0.50	34/43	0.89/1.72	6.5/14.0	4/15	0.47/1.25	10/20	0.73/1.00	5/12	0.59/1.08	12/22	15	I	bushy rare
1 ^s —Haitian Hill	20/3	10.2	0.51	34.1	1.71	5.0	4.6	0.93	9.9	0.98	4.9	1.01	19.2	9	I	III, II
	15/25	9/12	0.36/0.67	28/40	1.33/2.27	2.5/8.0	3/6	0.71/1.25	8/12	0.90/1.07	3/8	0.71/1.20	14/24	30	I	III, II
<i>H. hallii hallii</i>	34/0	13.6	0.41	38.4	1.17	10.2	9.1	0.91	16.0	0.94	9.3	0.92	16.0	9	I	III, II
by population	28.5/40.3	10.0/16.8	0.33/0.44	35.6/45.2	0.99/1.27	8.0/12.3	6.6/14.6	0.66/1.23	13.3/19.4	0.85/0.99	7.5/12.1	0.74/1.00	14.7/17.3	30	I	
<i>H. cribellum</i>	14/0	5.8	0.42	26.4	1.97	4.1	7.4	1.86	5.2	0.73	3.8	0.95	17.9	30	I	
	10/20	3/8	0.30/0.50	22/34	1.44/2.40	2.5/6.0	4/16	1.33/2.67	3/8	0.56/0.91	2.5/6.0	0.70/1.33	11/24			

already discussed, are additional complications (Sorauf, 2001).

Not all *H. halli* fit this generalized ontogenetic pattern. Many solitary *H. halli* have little early stage dilation, but we used the arbitrary cut-off, regardless. In addition, few individuals in colonies show early stage dilation; in most instances, we do not know whether or not their protocorallites did.

In addition to the characteristic early-stage septal dilation, all immature-stage carinae and trabeculae are yard-arm and Type I but, as noted in the discussion of carinae, this condition persisted in early "mature" stages and throughout the lives of many larger individuals.

SYSTEMATIC PALEONTOLOGY

INTRODUCTION

Our taxonomic unit terminology follows Oliver (1997a, p. 54–55). Descriptions are partly based on samples that we term *populations*. These are assemblages of *individuals* from a limited stratigraphic interval and geographic area that one would recognize as representing a species-level taxon if no other information were available. For this purpose a colony is an individual. Each population is assumed to include several coral generations and embraces much individual variation. Ten populations of solitary corals and four of colonies, from 10 different stratigraphic units or intervals (Text-fig. 1), were statistically analyzed to determine the amount and nature of any differences within and between populations.

If sufficiently distinct, populations may be recognized as *species* or *subspecies*, depending on degree of distinctness and other circumstances. Both are morphologically defined; *species* are separated from other species by recognizable morphologic gaps. Our goal is to recognize species that are analogous to those of living corals; these are commonly based on morphology also (see Veron, 1995, p. 229). *Subspecies* are morphologically separable populations or groups of populations within species (Mayr, 1970, p. 210). Presumably they are potential species although our subspecies are based on unique morphologies that represent one end of a continuum connecting them to another subspecies (of the same species). See Oliver (1997a, pp. 54–55) for more extensive discussion.

Our *species group* is a cluster of species more similar, and presumably more closely related, to each other than to other species of *Heliophyllum*.

Localities are in New York State unless otherwise indicated; map quadrangles (Quads.) belong to the USGS 7.5 minute series.

REPOSITORIES

This study of *Heliophyllum* is based primarily on collections made by one or both authors over a period of 50 years; a few specimens have been contributed by other individuals. The collection data for this material are recorded in the U.S. Geological Survey, Silurian-Devonian catalog (USGS-SD numbers); all specimens from these collections that are illustrated, or individually cited in any other way, are deposited in the U.S. National Museum of Natural History (USNM). Specimens from older USNM collections and from other museums have served taxonomic purposes or been used to illustrate certain points. The following abbreviations are used in the text:

AMNH—American Museum of Natural History, New York, N.Y.

FMNH—Field Museum of Natural History, Chicago, Illinois.

NYSM—New York State Museum, Albany, N.Y.

OCGM—Oberlin College Geological Museum, Oberlin, Ohio.

OSU—Orton Museum, Ohio State University, Columbus, Ohio.

MNHN—Muséum National d'Histoire Naturelle, Paris, France.

PRI—Paleontological Research Institution, Ithaca, N.Y.

USGS—U.S. Geological Survey, Washington, DC.

USNM—U.S. National Museum of Natural History, Smithsonian Institution, Washington, DC.

SYSTEMATICS

Phylum **CNIDARIA** Hatschek, 1888

Class **ANTHOZOA** Ehrenberg, 1834

Subclass **ZOANTHARIA** de Blainville, 1830

Order **RUGOSA** Milne-Edwards and Haime, 1850

Family **ZAPHRENTIDAE**
Milne-Edwards and Haime, 1850

Genus **HELIOPHYLLUM** Hall *in* Dana, 1846a

Cyathophyllum (*Heliophyllum*) Hall *in* Dana, 1846a, p. 356; 1846b, p. 183; Dana, 1849, pl. 26, fig. 3 (?), (not fig. 4).

Cyathophyllum Goldfuss, Rominger, 1876, p. 98–99 (in part); Lambe, 1901, p. 133–134 (in part). Not Goldfuss, 1826.

Heliophyllum Hall, Milne-Edwards and Haime, 1850, p. 1xix; 1851, p. 408; Billings, 1859, p. 124; Nicholson, 1874a, p. 24–25 (in part); 1874b, p. 58–59 (in part); 1875, p. 141–143 (in part); 1878, p. 44–51 (in part); Nicholson and Thompson, 1877, p. 149–150; Holmes, 1887, p. 15 (in part); Grabau, 1899b, p. 124; Fenton and Fenton, 1938, p. 209–210; Stewart, 1938, p. 35–36 (in part); Lang, Smith, and Thomas, 1940, p. 66; Smith, 1945, p. 25; LeMaire, 1947, p. 30 (in part); Stumm, 1949, p. 21; Wang, 1950, p. 217 (in part); Hill, 1956, p. F278; Cranswick and Fritz, 1958,

- p. 36; Stumm and Tyler, 1962, p. 267; Scrutton, 1973, p. 256–257; Oliver, 1974, p. 174; 1976, p. 123–124; Sorauf and Oliver, 1976, p. 331–343; Hill, 1981, p. F296; Coen-Aubert, 1987, p. 154; Oliver and Sorauf, 1988, p. 5; Pedder, 1990, p. 91–92; Oliver and Sorauf, 1994, p. 1185, 1188; Pedder, 1999, p. 405.
- Heliophyllum* Dana. Sloss, 1939, p. 58.
- Heliogonium* Chapman, 1893, p. 45; Stumm, 1949, p. 21; Hill, 1956, p. F278; 1981, p. F296; Pedder, 1990, p. 91.
- Heliophylloides* Stumm, 1949, p. 18; Hill, 1956, p. F278; 1981, p. F296; Pedder, 1990, p. 91.
- Hexagonaria* Gürich. Stumm, 1948b, p. 11–13 (in part). Not Gürich, 1896.
- Billingsastraea* Grabau. Stumm, 1949, p. 35 (in part); Ehlers and Stumm, 1951, p. 85 (in part); 1953, p. 9 (in part); Stumm, 1955, card 230 (in part). Not Grabau, 1917.

Type species.—*Heliophyllum halli* Milne-Edwards and Haime, 1850, as replacement name for *Strombodes helianthoides*? Hall, 1843, p. 209–210, text-fig. 87-3 (pl. 48, fig. 3 is same figure). Not *Strombodes helianthoides* of Phillips, 1841, or *Cyathophyllum helianthoides* Goldfuss, 1826, to both of which Hall, 1843 referred. Middle Devonian (Givetian), Hamilton Group, New York.

Date of publication.—Confusion regarding the date(s) of publication of Dana's "Zoophytes" was removed by Stumm (1948a) who presented evidence that the official text of volume 7, printed by C. Sherman, Philadelphia, was published in 1846 (as indicated on the title page), not 1848 as stated by Lang *et al.* (1940, p. 173). Parts of the text describing fossil corals were excerpted the same year in the *American Journal of Science*. The plate volume was published in 1849. We cite these as Dana 1846a, 1846b, and 1849, respectively.

Diagnosis.—Solitary and colonial rugose corals, widely varying in corallum form and size, characteristically having moderately deep calice with broad flat, inclined, or reflexed peripheral platform and shallow cardinal fossula. Major septa commonly long and bilaterally arranged about cardinal-counter plane; mature septa generally attenuate but commonly dilated in early ontogenetic stages, especially in solitary forms. Carinae abundant and very prominent, commonly long or short yard-arm, but zigzag carinae are also present and may predominate; carinae generally limited to dissepimentarium. Septal trabeculae simple or compound, commonly both. Dissepiments globose in numerous rows. Tabulae incomplete or complete. (Modified from Oliver and Sorauf, 1994, p. 1185.)

Discussion.—*Heliophyllum* is one of the most common rugose corals in the Middle Devonian of the Eastern Americas Realm. In New York, specimens, mostly *H. halli*, are present to abundant in upper Emsian (Bois Blanc Formation) to upper Givetian (Tully Limestone) strata (Text-fig. 1); this is our principal area and range of study. *H. halli* and other species have been de-

scribed or noted in rocks within the same age range from Venezuela to the Hudson Bay Lowlands and from many localities in the Illinois, Michigan, and Appalachian Basins (Text-fig. 3). Most of the many nominal species from the Illinois and Michigan Basins need further study before their status can be evaluated.

Rominger (1876), Hall (1882, 1883, 1884), Davis (1887), Greene (1898–1906), and others named hundreds of Emsian to Givetian "species" of rugose corals from the Falls of the Ohio River area in and around Louisville, Kentucky, in the southeastern part of the Illinois Basin. Stumm (1965) reviewed and outlined the history of Falls work and provided yeoman service in locating and putting on record type specimen data, reillustrating many of the types, and synonymizing some two-thirds of the "species." Still, with few exceptions, species descriptions are based only on the external morphology of silicified specimens and most *Heliophyllum* species from the Falls area are identifiable only at the generic level. Stumm (1965) referred most solitary *Heliophyllum*, and some branching ones, to this genus, but astreoid and cerioid forms were referred to *Billingsastraea* and *Hexagonaria*, respectively.

A second important source of nominal *Heliophyllum* spp. is the Traverse Group (Givetian) in Michigan. This group is of particular interest because it represents facies comparable to the age-equivalent Hamilton Group of New York. Solitary *Heliophyllum* are common; they were most recently revised by Stumm and Tyler (1962) who described nine species and subspecies including *H. halli*. All of the taxa need restudy to determine the extent of individual variation and whether or not some are synonyms. *Billingsastraea romingeri* (Ehlers and Stumm, 1951) is a probable Traverse colonial *Heliophyllum*. This and other Traverse "*Billingsastraea*" need restudy, but there is no indication that any are conspecific with any of the solitary forms.

Most *Heliophyllum* are solitary, but dendroid, phaceloid, cerioid, and astreoid colonies are known. Most of the colonial forms seem to be distinct species; Oliver (1976, pp. 123–133) described several from the Bois Blanc and Onondaga Formations (Emsian and Eifelian) in New York and Southwestern Ontario, and additional species are known from Emsian to Givetian-age rocks in many other parts of the EAR. As far as we know, *H. halli* is unique among *Heliophyllum* spp. in that it includes both solitary and colonial forms.

Our principal concern in this paper is to describe, classify, and interpret typical *Heliophyllum halli* and allied forms from the Hamilton Group in New York. Our taxonomic framework is as follows:

Heliophyllum halli species group

- H. halli* Milne-Edwards & Haime, 1850
H. halli halli Milne-Edwards and Haime, 1850
 Form "praecoquus" of Wells, 1937
H. halli confluens (Hall), 1877
H. halli bellonense new subsp.
H. halli joshuense new subsp.
H. delicatum Oliver & Sorauf, 1994
H. stewarti Oliver & Sorauf, 1994
H. cribellum new species

HELIOPHYLLUM HALLI species group

Diagnosis.—Species of *Heliophyllum* with characters in common that suggest that they are more closely related to *H. halli* and each other than to other species of the genus.

Heliophyllum halli Milne-Edwards and Haime, 1850

Type specimens.—Holotype by monotypy, the specimen illustrated by Hall (1843, fig. 10, p. 209) is now lost or mislaid. Neotype, MNHN IP S.11661, illustrated by Milne-Edwards and Haime (1851, pl. 7, figs. 6, 6a, 6b), designated by Coen-Aubert (1987, p. 155, pl. 1, figs. 1, 2), who prepared and illustrated thin sections; reillustrated herein, Plate 10, figures 1 and 2.

Occurrence of neotype.—Milne-Edwards and Haime (1851) did not indicate the source of their illustrated specimen but Coen-Aubert (1987) indicated that the following information accompanies the specimen: Hamilton Group, Moscow (now Leicester), Livingston County, New York. This would almost certainly be the Windom Shale Member, Moscow Formation, Givetian, and probably the Fall Brook coral bed (our population 9). The appearance of the specimen is compatible with this source.

Diagnosis.—Solitary, branching, cerioid and astreoid *Heliophyllum*; solitary forms and corallites in colonies range up to 6 cm or more in diameter. Calice with axial pit, small, well-marked cardinal fossula, and with or without a peripheral platform. Major septa commonly long and biradially arranged; minor septa limited to wide dissepimentarium within which septal carinae are abundant on both major and minor septa. Tabularium typically occupies approximately one-third the diameter; tabulae incomplete or complete. Septal and carinal trabeculae are simple or branching monacanth and/or compound with varying complexities.

Outline history.—Detailed synonymies accompany the descriptions of the subspecies and related species. The following annotated chronology outlines the nomenclatural and interpretational history of *Heliophyllum halli*:

1843. *Strombodes helianthoides*? Hall, p. 209–210, fig. 87-3 (pl. 48, fig. 3 is same); (not Goldfuss, 1826,

or Phillips, 1841). Hall's illustrated specimen became holotype by monotypy in 1850; specimen now lost or mislaid.

1850. *Heliophyllum halli* Milne-Edwards and Haime, p. 1xix. Based species on Hall (1843), making Hall's single illustrated specimen the holotype.

1851. *H. halli* Milne-Edwards and Haime. Milne-Edwards and Haime, p. 408–409, pl. 7, figs. 6, 6a, 6b. First illustrations after Hall's (1843) woodblock print; this single illustrated specimen was designated neotype by Coen-Aubert (1987).

1876. *H. halli* Milne-Edwards and Haime. Nicholson, p. 245. Early discussion of variation within the species.

1877. *H. halli* Milne-Edwards and Haime and new species. Hall, pls. 23–27. Illustrations of *H. halli* and seven new species and "varieties" gives relatively complete representation of form variation in *H. halli* as we understand it; see subspecies synonymies for details.

1937. *H. halli* Milne-Edwards and Haime. Wells, p. 5–20. First modern analysis of individual form variation in this species. Wells' formae have no standing in formal taxonomy but are included in synonymies for clarity and completeness.

1938. *Heliophyllum* spp. of Milne-Edwards and Haime, Hall, and new species. Fenton and Fenton, p. 211–227, figs. 1–19, pl. 17–22. Followed Hall (1877), in recognizing many species that we consider synonymies of *H. halli*.

1976. *H. halli* Milne-Edwards and Haime. Sorauf and Oliver, p. 331–343, pl. 1–5. Described, illustrated and discussed microstructural variation in this species.

1987. *H. halli* Milne-Edwards and Haime. Coen-Aubert, p. 151–162, pl. 1–5. Detailed description of "typical" form; essentially restricted species to solitary forms with simple trabeculae; selected original of Milne-Edwards and Haime (1851, pl. 7, fig. 6, 6a, 6b) as neotype.

1997a. *H. halli* Milne-Edwards and Haime. Oliver, p. 55–60, pl. 1–2. Discussed varied relationships of colonial and solitary forms.

2001. *H. halli* Milne-Edwards and Haime. Sorauf, p. 24–33, figs. 3–5. Detailed analysis and interpretation of shape variation in solitary forms.

Heliophyllum halli halli
 Milne-Edwards and Haime, 1850
 Plates 1–13

- Strombodes helianthodes*? Hall, 1843, p. 209–210, text-fig. 87-3 (pl. 48, fig. 3 is same fig.). Not Goldfuss, 1826 or Phillips, 1841.
Cyathophyllum (Strombodes?) turbinatum? Hall, 1843, pl. 49, fig. 1, (?). Not Goldfuss, 1826.
 Subgenus *Heliophyllum*, Dana, 1849, pl. 26, fig. 3, (?) (not fig. 4).

- Heliophyllum halli* Milne-Edwards and Haime, 1850, p. lxi: 1851, p. 408–409, pl. 7, figs. 6, 6a, 6b; 1853, p. 235–236, pl. 51, fig. 3 (part?); Hall, 1859, p. 89–90, (part?); Billings, 1859, p. 126; Nicholson, 1874a, p. 26–27, fig. 4, (part?).
- Cyathophyllum hallii* (*sic*) Milne-Edwards. Rominger, 1876, p. 99–101, pl. 35, upper tier, 4 specimens left and center. (?).
- H. halli* Milne-Edwards and Haime, Hall, 1877, pl. 23, figs. 1–5, 12, pl. 25, figs. 1–7.
- H. halli* var. *reflexum* Hall, 1877, pl. 23, figs. 6–11.
- H. irregulare* Hall, 1877, pl. 24, figs. 1–7, 13.
- H. arachne* Hall, 1877, pl. 24, figs. 8–12, 14.
- H. degener* Hall, 1877, pl. 25, figs. 8–11.
- H. halli?* var. *obconicum* Hall, 1877, pl. 25, figs. 12–13.
- H. proliferum?* Hall, 1877, pl. 26, fig. 5.
- H. halli* Milne-Edwards and Haime, Nicholson, 1878, figs. A, B (p. 46); Hall, 1883, p. 259, pl. 6, fig. 1, (?); 1884, pl. 16, figs. 4–5, (?).
- Cyathophyllum halli*, Davis, 1887, pls. 77, 92, figs. 2, 3, (not?).
- H. halli* Milne-Edwards and Haime, Holmes, 1887, p. 15, pl. 3, fig. 2, a–c; Grabau, 1899a, p. 124–125, fig. 7.
- Cyathophyllum halli* Milne-Edwards and Haime, Lambe, 1901, p. 148–150 (in part).
- H. halli* Milne-Edwards and Haime, Brown, 1909, p. 75–78, figs. 21a–f, Cleland, 1911, p. 28–29, pl. 1, fig. 5, (?).
- Cyathophyllum halli* Milne-Edwards and Haime, Branson, 1924, p. 49–50, text-fig. 2_{1–3}, pl. 1, fig. 1, (?).
- H. halli* Milne-Edwards and Haime, Stewart, 1927, p. 19, pl. 1, fig. 3, (?).
- H. halli* forma *typicum* Wells, 1937, p. 9–10, 18, pl. 1, figs. 1–4, text-figs. 1–7.
- H. halli* forma *praeoquus* Wells, 1937, p. 11, 18, pl. 1, figs. 5–6, 12, text-figs. 10–11.
- H. halli* forma *reflexum* Hall, Wells, 1937, p. 11, text-figs. 12–14.
- H. halli* forma *irregulare* Hall, Wells, 1937, p. 11, 15, 18.
- H. halli* forma *pravum* Wells, 1937, p. 11, 18, pl. 1, figs. 13–15, text-figs. 15–16.
- H. halli* forma *arachne* Hall, Wells, 1937, p. 14, 18, pl. 1, fig. 7, text-figs. 17–19.
- H. halli* forma *degener* Hall, Wells, 1937, p. 14, 18, text-fig. 20.
- H. halli* forma *obconicum* Hall, Wells, 1937, p. 14, 18, text-fig. 21.
- H. halli* forma *oplatum* Wells, 1937, p. 18, pl. 1, figs. 10–11, text-fig. 30.
- H. halli* forma *infundibulum* Wells, 1937, p. 18, pl. 1, figs. 8–9, text-fig. 29.
- H. halli* Milne-Edwards and Haime, Fenton and Fenton, 1938, p. 211–214, pl. 17, figs. 1–5, pl. 18, fig. 1, text-fig. 6.
- H. halli degener* Hall, Fenton and Fenton, 1938, p. 214–215, pl. 17, figs. 6–8, pl. 18, fig. 2.
- H. halli irregulare* Hall, Fenton and Fenton, 1938, p. 215–216, pl. 18, figs. 3–6, text-fig. 8.
- H. decorosum* Fenton and Fenton, 1938, p. 216–217, pl. 18, figs. 7–9, text-fig. 5.
- H. arachne* Hall, Fenton and Fenton, 1938, p. 217, 219, pl. 17, figs. 1–2, text figs. 1–2.
- H. obconicum* Hall, Fenton and Fenton, 1938, pl. 19, figs. 1–5, pl. 20, figs. 8–10, text-figs. 9–10.
- H. obconicum* form *confluens* Hall, Fenton and Fenton, 1938, text-figs. 14–19 (part?), not pl. 21, fig. 1.
- H. obconicum teres* Fenton and Fenton, 1938, p. 222–223, pl. 19, fig. 6, pl. 20, figs. 1–7, pl. 21, fig. 3, text-figs. 11–13.
- H. reflexum* (Hall), Fenton and Fenton, 1938, p. 224–225, pl. 22, figs. 4–5, pl. 23, fig. 1, text-figs. 3–4.
- H.?* *asperum* Fenton and Fenton, 1938, p. 225–226, pl. 21, figs. 4–6, text-fig. 7 (?).
- H. halli* Milne-Edwards and Haime, Stewart, 1938, p. 37–38, pl. 6, figs. 7–8, (?); Stumm, 1942, pl. 82, fig. 11, (?); Wells, 1943, p. 363–364 (95–96), pl. 36 (10), figs. 1–2; Smith, 1945, p. 26, pl. 33, figs. 3a–b; Le Maitre, 1947, p. 34–35, pls. 1, 2, 3, fig. 1, (?).
- H. halli* var. *nodulosa* Le Maitre, 1947, p. 34–35, pl. 3, figs. 4–6, (?).
- H. halli* Milne-Edwards and Haime, Stumm, 1949, p. 21, pl. 9, figs. 8–11, not? fig. 12; Wang, 1950, pl. 6, fig. 40; Lecompte, 1952, p. 475, fig. 118a–c; Hill, 1956, p. F278, fig. 190–4a, b; Ma, 1956, p. 48, pl. 41, figs. 1a–b, pl. 42, fig. 1, pl. 57, figs. 1–9, pl. 58, figs. 1–6 (in part); Cranswick and Fritz, 1958, p. 36–37.
- H. halli* var. *dilatiseptatum* Cranswick and Fritz, 1958, p. 37–38, pl. 1, fig. 5, (?).
- H. halli* Milne-Edwards and Haime, Stumm and Tyler, 1962, p. 268–269, pl. 1, figs. 15–16, pl. 2, figs. 7–8, (?).
- H. halli bellense* Stumm and Tyler, 1962, p. 269, pl. 1, figs. 6–7, pl. 2, figs. 3–4, (?).
- H. halli potterense* Stumm and Tyler, 1962, p. 269–270, pl. 1, figs. 4–5, pl. 3, figs. 10–13, (?).
- H. halli* Milne-Edwards and Haime, Kato, 1963, text-fig. 12(10–13), (?); Stumm, 1965, p. 36, pl. 32, figs. 5, 6, 20–23 (in part); Stumm, 1968, p. 38, pl. 1, figs. 1–2, pl. 3, fig. 13.
- H. halli* forma *praeoquus* Wells, Stumm, 1968, p. 38 (not). = *H. stewartii* Oliver and Sorauf, 1994, Not Wells, 1937.
- H. halli* Milne-Edwards and Haime, Stumm, 1968, p. 38, pl. 1, figs. 1–2, pl. 13, fig. 13; Oliver, 1971, p. 196, pl. 3, figs. 1, 7, 9; Scrutton, 1973, p. 257–260, pl. 5, figs. 6–8, pl. 6, figs. 1–6; Sorauf and Oliver, 1976, p. 331–343 (part, solitary forms only).
- H. halli halli* Milne-Edwards and Haime, Coen-Aubert, 1987, p. 155–162, pls. 1–5.
- H. sp. cf. H. halli* Milne-Edwards and Haime, Oliver and Sorauf, 1988, p. 9, figs. 4A–F (?).
- H. halli halli* Milne-Edwards and Haime, Pedder, 1990, pl. 4.1, figs. 1–11; Oliver, 1997a, p. 56 (including form “*praeoquus*” of Wells), pl. 1, figs. 1–4, 7.
- H. halli* Milne-Edwards and Haime, Sorauf, 2001, p. 24–33, 3 pls. (figs. 3–5).

Type specimens.—Same as for species.

Diagnosis.—*H. halli* that are solitary or with small, short (commonly <2 cm) offsets, rarely forming dendroid colonies of several corallites.

Discussion.—It is convenient to refer solitary *H. halli*, and small semicolonial forms that seem to be parts of solitary populations, to *H. halli* subspecies *halli*. Wells (1937) used the name *H. halli* forma *typicum* in such a restricted way that it is not suitable for this purpose; Wells clearly meant “*typicum*” to refer to the form’s generalized shape, central to the *H. halli* complex, without systematic implications. In any case, as noted by Oliver (1997a) and below, Wells’ formae have no standing in formal nomenclature. As far as we know, Coen-Aubert (1987) was the first to use the trinomial *H. halli halli* in formal recognition of the typical subspecies, although her concept was more restricted than ours. Specimens of *H. halli halli* are in coral beds and elsewhere in the gray, calcareous shale facies of the Hamilton Group. In the overlying Tully Limestone, they are limited to the Bellona coral bed.

Table 3.—Maximum known size of *Heliophyllum halli halli* specimens in each stratigraphic unit represented by an analyzed population. The column headings are explained at the bottom of the table; measurements are in mm and cm as indicated.

Population	d	ORd	D	H
1. Halihan Hill ¹	20.3 mm	15/25 mm	3 ½ cm	8 cm
2. Case Hill	33.2 mm	25/41 mm	4 cm	11 cm
3. Centerfield	28.5 mm	18/64 mm	6 cm	16 cm
4. Staghorn Point ²	31.3 mm	31/40 mm	5 ½ cm	7 ½ cm
5. Joshua ³	40.3 mm	25/52 mm	6 cm	12 cm
6. Darien	30.2 mm	23/36 mm	6 cm	11 cm
7. Jaycox	38.2 mm	19/54 mm	6 cm	18 cm
8. Deep Run	35.1 mm	27/46 mm	5 cm	15 cm
9. Fall Brook	38.8 mm	24/57 mm	6 cm	14 cm
10. Bellona	30.4 mm	20/40 mm	4 cm	14 cm

d, ORd—Mean and Observed Range of diameter in thin sections; in mm (from Table 2.) D, H—Maximum diameter and height (length measured on specimen's convex side) in largest and longest specimen; in cm.

¹ See text discussion of small size in this population.

² Hall (1877, pl. 25) illustrated a specimen with height of approximately 10 cm.

³ Wells (1937) reported maximum diameter and height of 6.5 and 14 cm respectively.

The offsetting forms are scattered through the section and nowhere form a recognizable population.

Terminology.—Table 1 gives abbreviations for skeletal characters measured or counted in thin sections (Table 2) and hand specimens (Table 3) and explains our use of ratios in analyses of thin section data.

Additional terms used to describe morphology as it appears in transverse sections are from our discussion of "Morphology and Individual Variation": *network* and *simple* refer to the most and least complex dissepimental structures between septa; *continuous* and *discontinuous* refer to peripheral parts of the septa, usually the minors; *equal* and *thick and thin* refer to the relative thickness of the major and minor septa, usually in the outer dissepimentarium.

External features.—Neglecting irregularities, form varies from turbinate to cylindrical with trochoid and ceratoid coralla being most common. Rare individuals expanded at an apparently steady rate but growth is irregular in most with erratic expansions and contractions of the outer wall; the corallum is smoothly or irregularly curved, or geniculate (Sorauf, 2001), rarely straight. Maximum size varies within and between populations (Table 3) but ranges up to diameters of 6 to 6.5 cm and heights of 16 to 18 cm in the Centerfield and Jaycox. Wells (1937) reported diameters up to 8 cm and lengths of 22.5 cm in Hamilton specimens from various (unspecified) New York localities. Small individuals are common but it is impractical to recognize a lower limit to observed ranges of size because diameter increase continued through the life of most individuals.

Calices are bowl shaped, moderately deep with a well marked cardinal fossula. Calice walls commonly slope gently upward to a broad, flat or reflexed peripheral platform or, less commonly, to the outer wall. Upper edges of septa serrated by projecting, rounded ends of carinae. Calice floor flat, slightly depressed, or gently arched.

External markings are fine growth lines and coarser growth increments as well as longitudinal septal grooves and interseptal ridges. The finer growth lines and septal grooves are present on unworn exteriors, but the epitheca is commonly worn without preservation of detail. However, in some individuals the fine growth lines are so well preserved as to provide evidence of individual age as demonstrated by Wells (1963). Wells' pioneering work on annual growth was based on New York Hamilton corals. He suggested an age of approximately 13 years for one specimen (10 cm in height) and a duration of approximately 400 days for the Devonian year.

Internal features.—Measurements and counts of various skeletal elements are given in Table 2. Means and observed ranges aid in comparing populations but are primarily of use in demonstrating overlap between populations and the overall range of variation in Hamilton specimens of *H. halli halli*. All of the characters tabulated are more or less size dependent and to some extent controlled by extrinsic factors (e.g., age at death and environment of growth). The ratios are dimensionless and more useful than means and observed ranges for comparing individual and population differences.

Major septa are long; commonly some extend to or nearly to the corallite axis while others are shorter. Minor septa are generally restricted to the dissepimentarium. Septa biradially arranged; in the calice the C is marked by a fossula; in transverse sections below the calice, the C-K plane is commonly marked by a short C and long K, but the K varies and may be short or the same as other major septa; if short, the C-K plane is evident but the two protosepta may not be separable unless the K is flanked by long minor septa. Carinae are present to abundant on both major and minor septa in the dissepimentarium.

Septal thickness and continuity in transverse sections varies both ontogenetically and within mature individuals and populations; this is described in the section on Morphology and Individual Variation.

Tabularia occupy one-third to nearly one-half of the corallum diameter leaving over half the space in longitudinal sections to numerous rows of dissepiments (Table 2). The dissepiments vary in size and shape, at least partly depending on position on the convex or concave side of a bent or geniculate corallum (Sorauf,

2001). In longitudinal sections, there is no apparent difference between the simple and network dissepimentaria noted in transverse sections. Tabulae are complete or incomplete; the former are flat or somewhat depressed near the axis with downturned margins; incomplete tabulae or tabellae tend to form an arched pattern. There are gradations between the two extremes and both can occur in the same specimen. Whether they are complete or incomplete is determined by the amount of open space in the axial region; numerous shorter or more attenuate septa tend to correlate with more numerous complete tabulae, whereas a preponderance of major septa extending to the axis leaves space only for incomplete tabulae or tabellae.

Microstructure.—The wall is two-layered; an inner, light-colored layer is thicker, and apparently composed of fibers radially arranged in transverse sections, inclined upward in longitudinal sections. The outer layer, epitheca, is thin, darker and of less certain fine structure.

The trabecular microstructure of the septa and the abundant carinae is described in the section on Morphology and Individual Variation.

Increase.—Wells (1937) based two of his formae on offsetting at different stages. One of these, "forma *praecoquus*," is interpreted as a variant of *H. halli halli*. Form "*praecoquus*" has one to four or more peripheral offsets. Protocorallites are commonly small, but diameters up to 4.5 cm are known; offsets tend to be short (1–2 cm). Specimens are not common but have been found in several of our populations and elsewhere in the Hamilton, associated with other solitary and colonial *Heliophyllum*. The three specimens illustrated by Wells (1937, pl. 1, figs. 5, 6, 12, text-figs. 10, 11) are from the Staghorn Point population; the specimen of Oliver (1997a, pl. 1, figs. 1, 2) is from the Jaycox population. Additional specimens in our collections are from the Centerfield, Staghorn Point, Darien, Jaycox, and Deep Run populations. Specimens from the Staghorn Point and Jaycox populations are illustrated on Plates 12 and 13. In the lower Deep Run Shale, "*praecoquus*" occurs with the branching *H. proliferum*, which differs in the long tapering form of its corallites and common increase by lateral offsetting (see description below).

Wells described *H. halli* forma *praecoquus* as having "precocious buds," that is, offsets developed at an early stage. This variant is interesting for its incipient coloniality. Wells' (1937) other offsetting form, "forma *proliferum*," has a distinct morphology, includes large colonies, and occurs as a stratigraphically limited population that we recognize as a species (*H. delicatum* Oliver and Sorauf, 1994; see below). Wells clearly differentiated between *formae* and *varieties* in describ-

ing individual variation in *H. halli* (Wells, 1937). Under the current code of zoological nomenclature, his variety is a subspecies but his formae have no standing. However, "*praecoquus*" has been cited in the literature and we include it in our synonymy, even though we do not accord it formal recognition.

Population analyses.—In each of the 10 populations analyzed statistically, most of the measured specimens are individuals for which at least two thin sections, transverse and longitudinal, have been prepared. Additional sections, especially transverse ones, are available for many of these, but tabulated data are from the highest section, most commonly one from just below the base of the calice. Insofar as was practical, data from immature individuals, or early stages of apparently mature ones, are not included in the tabulations but sections of these and of other excluded specimens (poorly or incompletely preserved, single section, etc.) provided additional information for descriptions. Photographs on Plates 2 to 11 are grouped by population. They illustrate variation in the subspecies but do not adequately show variation in the individual populations which, in some, is as great as in the subspecies as a whole.

1. **Halihan Hill population.**—The analyzed sample (Table 2) includes 15 specimens from the Halihan Hill coral bed in eastern New York. Only seven or eight of these would have been used in the analysis of any of the other populations because specimens are small, mostly immature individuals (in Table 2 note size characters and that these data are not used in the subspecies totals). Early stage septal dilation masks other characters, but comparable early stage individuals from other populations show some mature characters, so the Halihan Hill data is of value for some comparisons. In addition, these are the oldest Hamilton *Heliophyllum* and should be included for the sake of completeness. Morphologically, the population is the simplest of the 10 analyzed (see Pl. 2, figs. 8–13). Septa are peripherally attenuate with only rare discontinuities or lateral dissepiments. Long and short yard-arm carinae are most common, zigzag carinae are uncommon. Almost all carinae are Type I, some are moderately bushy; Type I→III were seen in only one or two individuals.

Thirteen of our specimens came from a locality just west of Mount Marion (Ulster County), two specimens are from the Helderberg area (Albany County). Lane (1955) noted that the Halihan Hill corals were smaller than those from other coral beds. A later collection from Ver Straeten's (1994) roadcut locality near Kingston (Ulster County) includes a few *H. halli halli* with diameters at the base of the calice up to 3.5 cm (Table

3) but these were collected too late to be included in the Table 2 analysis.

2. *Case Hill population*.—The total sample includes 37 thin sectioned individuals from the Case Hill coral bed, Mottville Member, Skaneateles Formation, at two localities on Bare Mountain, Onondaga County; 21 of these are included in the sample analyzed (Table 2). Specimen diameters are small to medium; numbers of carinae on major septa and in proportion to the width of the dissepimentarium are low; in these values the Case Hill population is comparable to the Centerfield, Staghorn Point, and Bellona populations.

Major septa are bilaterally arranged, extend somewhat over 0.9 the distance to the axis, and have relatively few carinae (Table 2). Most of the carinae are Type I (some bushy) and a few are Type I→III. In transverse sections, most interseptal space is filled by networks of lateral and small globose dissepiments intersecting at odd angles, but some are occupied by simple, discrete, gently curved dissepiments. Most septa are attenuate and complete but some thickening of major septa is seen and a few are irregularly discontinuous in the outer dissepimentarium; in earlier stages dissepiments are simple. In a few thin sections zigzag carinae are nearly as common as yard-arm; this seems to correlate with septal thickening and development of Type III trabeculae. See Plate 2, figures 1–7 for examples.

3. *Centerfield population*.—Our sample consists of over 200 sectioned individuals; 44 of these were measured and analyzed (Table 2). The Centerfield population is the most widespread of the *Heliophyllum* populations considered here; measured specimens are from localities spaced along the outcrop over an east-west distance of 120 km (75 mi). The principal localities (and counties) from west to east are: Murder Creek and East Alexander (Genesee), East of York (Livingston), Centerfield (Ontario), and Fayette (Seneca). Average specimen diameters are relatively small although they range up to 64 mm or more. Number of carinae on major septa and in proportion to the width of the tabularium are low; in these and other values, the Centerfield population is closest to the Bellona solitary population (Table 2). Major septa are bilaterally arranged and extend to or nearly to the axis.

In transverse sections, septa vary from attenuate and equal in thickness (e.g., Pl. 3, figs. 9, 10) to thick and thin (major up to twice as thick as minor septa although nearly attenuate in outer dissepimentarium; e.g., Pl. 3, fig. 11). In our analysis (Table 2) we separated the population into two roughly equal-sized subpopulations, A (attenuate) and B (thick and thin). These intergrade in the character used for the separation as well as in other characters (Table 2); further-

more, variation in other characters did not correlate with the A-B division. At either A-B extreme, minor septa can be peripherally complete (some or most in all specimens) or discontinuous; major septa rarely are discontinuous. Interseptal dissepiments appear simple or as a network; not uncommonly, both conditions are seen in the same individual, in either the same or successive sections. Axial dilation varies from slight to complete in immature stages and from none to significant in adults.

Type I carinae predominate, commonly bushy; Type I→IIb is present (but not common) in specimens with thicker septa, rare in attenuate forms; Type I→III was seen but is very rare.

This is our largest and most variable population. Both sample size and large source area with diverse environments are factors, but the latter is considered more important. Specimens are illustrated on Plate 3.

4. *Staghorn Point population*.—Our sectioned sample includes 29 individuals of which 12 were statistically analyzed. Collections are from three different points on Skaneateles Lake: Jenny Point, Staghorn Point, and Willow Point, representing the center and two extremities of the 2.2 km-long exposure of the coral bed; and also from the ravine at Lord's Hill (all Onondaga County). Average diameters are relatively small although large specimens are not uncommon. Major septa are bilaterally arranged (commonly with a short C), relatively short, attenuate, and commonly dilated in axial region, especially in early growth stages. Mean septal ratio is high. Minor septa are relatively short, some very short, but rarely discontinuous. Interseptal dissepiments are generally simple, but lateral dissepiments are not uncommon. A single specimen of Wells' "forma *praecoquus*" is in our sample and the three illustrated specimens of Wells (1937) are from this unit.

Type I carinae predominate, commonly bushy; Type III are uncommon; Type I→IIb are present (possibly a matter of preservation). Specimens from this population are illustrated on Plates 3 and 12.

5. *Joshua population*.—Our sectioned sample includes 31 specimens of which 25 were analyzed (data on Table 2); several specimens are illustrated on Plate 4. Collections are from two localities on Lord's Hill and four localities along Otisco Lake (all Onondaga County). Specimens are robust; major septa are long, reaching to or nearly to the axis, numerous, and bilaterally arranged. Septa are somewhat dilated, but majors are only locally thicker than minors; peripheral discontinuities are rare. Interseptal dissepiments are generally simple although lateral dissepiments are common.

Types I, I→III, and III carinae are common in ma-

ture stage; Type I carinae are thick and bushy and predominate in early stages; Type III dominates in several mature individuals; occasional bursts have Type II structure. Our "type example" of Type III carinae (Sorauf and Oliver, 1976, pl. 5, figs. 2-4; USNM 219922; herein Pl. 5, figs. 1, 2) is from this population.

The colonial, *H. halli joshuense*, occurs with this solitary population. The colonial form is similar to the solitary in many characters (Table 2 and see description). Colonial corallites are smaller and septa are proportionately more numerous. These differences are attributed to crowding in cerioid parts of the colonies and to necessarily different sampling methods. Microstructure is similar, although in the colonial subspecies Types I→III and advanced III carinae are more dominant, Type IIb is present, and there seem to be more carinae on major septa. There is considerable overlap in the observed ranges of all analyzed characters.

6. *Darien population*.—The total sample includes 18 thin sectioned individuals from the Darien coral bed, Wanakah Shale Member, Ludlowville Formation, at a single locality (Murder Creek, near Darien, Genesee County); 13 of these are included in the sample analyzed (Table 2). Specimens are medium-sized. Major septa do not reach the axis, are distinctly bilateral in arrangement, and rarely incomplete near the outer wall. Minor septa are relatively short and are commonly discontinuous peripherally; some are entirely missing in a thin section. Septa are commonly attenuate and equally thick, but majors are significantly thicker than minors in parts of some transverse sections. Interseptal dissepiments are a network in most of the sections (e.g., Pl. 5, fig. 9), but one individual and parts of others are almost simple. Type IIb and I→IIb carinae (e.g., Pl. 5, fig. 3) predominate and vepreculae are common; Type I occurs in immature stages of mature specimens and in small specimens that did not reach maturity (not included in analyzed lot); questionable Type III carinae were noted in three specimens. In transverse section, carinae are yard-arm, complex or zigzag, reflecting the prevalence of Types I and II.

A single individual of Wells' (1937) "forma *prae-coquus*" is in the population but not in the measured sample because of its small size; the offset is peripheral, midway between the floor and margin of the calice.

Individuals in the Darien population are remarkably uniform in character. This is most likely due to the small size and limited provenance of the sample. Examples are illustrated on Plate 5.

7. *Jaycox population*.—The sample includes 53 thin sectioned individuals from the Green's Landing coral bed in the Jaycox Member of the Ludlowville

Formation; 26 of the specimens are in the analyzed sample (Table 2). Approximately equal numbers of specimens are from each of three areas: 1) near the Erie-Genesee County boundary, 2) in the Genesee Valley west of York (Livingston County), and 3) both sides of Canandaigua Lake (Ontario County). Areas 1 and 3 are separated by an east-west distance of over 100 km; area 2 is approximately midway between 1 and 3. Several specimens are illustrated on Plates 6 and 7.

Specimens are robust; most have long major septa that extend to, or nearly to, the axis and are bilaterally arranged. Septa are attenuate or somewhat dilated; extra dilation in the axial area is minimal, even in early stages. Minor septa commonly nearly equal to majors in thickness; some minors short or peripherally discontinuous, but most are complete. Interseptal dissepiment structure varies from simple to network, commonly intermediate and varying within a single section.

Type I (most are bushy), I→III, and I→IIb carinae are common. Some I→IIb→III carinae suggest that Types IIb and III intergrade or are partly artifacts of preservation. Our example of Type IIa (Sorauf and Oliver, 1976, pl. 3, figs. 2-4, pl. 4, fig. 2; herein Pl. 7, figs. 1, 2) may be from this stratigraphic unit.

This population is associated with and grades into astreoid *H. halli confluentis* (see description). Types I and III carinae are common in both but Type III predominates in the colonial form. Corallite diameters are comparable but mean septal number and relative number of septa are smaller and there seem to be more carinae on major septa in the colonies (Table 2). There is a large overlap between associated solitary and colonial types in the observed ranges of all of these characters.

8. *Deep Run population*.—Our sample includes 32 individuals from the lower part of the Deep Run Shale Member of the Moscow Formation; 18 specimens were statistically analyzed. Collections are from several localities in the area between East Bethany (Genesee County) and the east shore of Seneca Lake (Seneca County), a west to east distance of 100 km. Examples are illustrated on Plates 8 and 9.

Specimens are moderately robust. Major septa are long but commonly fail to reach the axis; they tend to be bilaterally arranged. Septa vary from attenuate to markedly dilated and from equal to thick and thin; axial dilation varies. Septa are commonly complete but some sections show peripherally discontinuous minors and majors and, rarely, a partially lonsdaleoid sector. Interseptal dissepiments vary from simple to complex networks, commonly more or less intermediate.

Types I (often bushy), I→IIb, and I→III carinae are

common; Types IIb and III commonly are present in the same longitudinal section. The original of text-figure 2 in Sorauf and Oliver, 1976 (renumbered USNM 498542; herein Pl. 8, figs. 1–5) is from this population at a Canandaigua Lake (Ontario County) locality.

The Deep Run solitary *H. halli halli* are associated in the field with the dendroid *Heliophyllum delicatum* Oliver and Sorauf (1994); see description. Most specimens can be assigned to species on the basis of external form; *H. halli halli* has a large apical angle and is more robust; *H. delicatum* is relatively more elongate with a smaller apical angle and mean diameter. Internally, *H. delicatum* has thinner, more delicate structures, relatively smaller tabularia, and fewer septa. See Table 2 and the description of *H. delicatum* for further comparisons.

9. *Fall Brook population*.—The sample includes 32 individuals from a single exposure of the Fall Brook coral bed, Windom Shale Member, Moscow Formation, on Little Beards Creek, north of Leicester (Livingston County); 20 of the specimens are in our statistical sample (Table 2) and several are illustrated on Plate 10.

Specimens are robust with most major septa extending to, or nearly to, the axis. Septa bilaterally arranged, attenuate to moderately thickened, commonly with long, thin cross-bar carinae. Minor septa equal to majors in thickness; some minors and rare majors are peripherally discontinuous; one specimen has additional discontinuities at the margin of the tabularium. Interseptal dissepiments vary from simple to complex networks. Axial dilation varies, commonly marked in early stages.

Type I carinae are universal in sample; most are thin in longitudinal section but some are thickened and bushy, and approach Types II or III in structure.

The neotype of *Heliophyllum halli* (MNHN IP S.11661) is probably from the Fall Brook coral bed and possibly from this locality. The general appearance and internal morphology of the neotype are compatible with this source. Six sectioned specimens from the Lansing coral bed (Tompkins County), and one from the Bay View coral bed (Erie County), both in the Windom Shale (see Text-fig. 1), have morphologies that are well within the Fall Brook population's range of variation.

10. *Bellona population*.—The sample includes 67 sectioned individuals from the Bellona coral bed in the Tully Limestone at six localities along the outcrop from Bellona (Yates County), just west of Seneca Lake to Carpenter Falls (Cayuga County), just west of Skaneateles Lake, a west to east distance of 60 km; 25 of the specimens are in the measured sample (Table 2). Illustrated specimens are on Plate 11. Two-thirds of

the measured sample and three-fourths of the total sample are from Bellona.

Specimens are medium sized; major septa are long, reaching to or nearly to the axis, numerous, and are bilaterally arranged. In most transverse sections major and minor septa are equally thick, attenuate to moderately thickened, and rarely peripherally incomplete; these have relatively simple interseptal structure; a few specimens have more unequal septal thickening, more peripheral discontinuities in the minor septa, and/or a more complex dissepimental network between septa. Virtually all specimens show axial septal dilation in both immature (nearly complete) and mature stages.

In transverse sections, yard-arm carinae predominate; they are widely spaced, averaging 6–7 on major septa, a number and spacing more common in lower Hamilton populations than in upper ones (Table 2). Longitudinal sections show that most carinae are Type I (characteristically thick and bushy), but types I→IIb (e.g., Pl. 11, fig. 8), and I→III (e.g., Pl. 11, fig. 1) are present to common.

The Bellona solitary corals are associated with *H. halli bellonense*, an astraeoid subspecies described below. Internal structures in the two forms are quite different. The colonial form has more attenuate septa with abundant, closely spaced zigzag and yard-arm carinae (averaging 18 to 24 on major septa). The morphologic contrast between the solitary and colonial *H. halli* in the Bellona coral bed is much greater than that in the Joshua and Jaycox beds in which separation of the solitary and colonial subspecies is primarily based on growth form. See description of *H. halli bellonense* for further discussion.

Material.—Neotype and other illustrated specimens (Plates 1 to 13); specimen numbers and collection data (USGS catalog numbers or other information) are given in the Plate descriptions.

Other numbered specimens: Additional specimens in statistically analyzed samples, or otherwise mentioned in the text, are listed by population and collection in the Appendix.

Heliophyllum halli confluens (Hall), 1877

Plates 14–19

Cyathophyllum (*Strombodes*?) *turbinatum*? Goldfuss, Hall, 1843, pl. 49, fig. 1 (?). Not Goldfuss, 1826.

Heliophyllum halli, Hall, 1859, p. 89 (?).

Heliophyllum confluens Hall, 1877, pl. 26, figs. 3, 4, pl. 27.

Heliogonium Chapman, 1893, p. 45 (part).

Heliophyllum confluens Hall, Grabau, 1899a, p. 126, fig. 8; 1899b, p. 288.

H. halli var. *confluens* (Hall), Wells, 1937, pp. 10, 14–15, 18, 19, not text-fig. 8 (see *H. halli joshuense*).

H. obconicum form *confluens* (Hall), Fenton and Fenton, 1938, p. 221–222, pl. 21, fig. 1 (not text-figs. 14–19).

H. confluens Hall, Stumm, 1942, pl. 82, fig. 16 (?).

- Heliogonium confluens* (Hall). Stumm, 1949, p. 21.
Billingsastraea confluens (Hall). Ehlers and Stumm, 1953, p. 8, pl. 6, fig. 4.
B. ingens (Davis). Ehlers and Stumm, 1953, p. 9, pl. 6, figs. 1–3 (New York material), not? pl. 5, figs. 1–5.
B. confluens (Hall). Stumm, 1955, cards 234, 234.1.
B. ingens (Davis). Stumm, 1955, card 236.1, (? cards 235, 236, 236.2); Stumm, 1968, p. 41, pl. 2, figs. 1, 2, (?).
 Astroid *Heliophyllum*, Sorauf and Oliver, 1976, p. 340–343.
Heliogonium or *Heliophyllum confluens* Hall. Pedder, 1990, p. 91–92.
Heliophyllum halli var. *confluens* (Hall). Mayer, Baird, and Brett, 1994, text-figs. 8A, B.
H. halli confluens (Hall). Oliver, 1997a, p. 55–56, pl. 2, fig. 1; (? pl. 1, figs. 5, 6).

Type specimen.—Lectotype, FMNH UC 18974, the original of Hall, 1877, pl. 27, selected by Wells, 1937, p. 10. Hall gave the locality as York, Livingston County, N.Y.; this is almost certainly the Greens Landing coral bed, Jaycox Member, Ludlowville Formation, Hamilton Group. The coral bed outcrops along Browns Creek, a mile west of York, where numerous specimens of *H. halli confluens* have been collected from both outcrop and talus.

Comments.—Wells (1937, p. 10) selected the original of Hall (1877, pl. 27) as “holotype” (lectotype) of *Heliophyllum halli confluens*. Stumm (1949) selected *H. confluens* as the type species of *Heliogonium* Chapman making it a subjective junior synonym of *Heliophyllum*, but his selection of the original of Hall’s pl. 26, figs. 3–4 as lectotype of *H. confluens* is invalid because of Wells’ (1937) earlier selection.

Diagnosis.—*H. halli* forming astreoid colonies consisting of from two to 40 or more corallites; both yard-arm and zigzag carinae are abundant but the former predominate.

Occurrence.—*H. halli confluens* is known primarily from, and may be limited to, the Green’s Landing coral bed in the lower part of the Jaycox Member, Ludlowville Formation, Hamilton Group, in New York. In westernmost New York, near where the Jaycox Member wedges out due to removal of higher parts, we have seen specimens in the uppermost Jaycox, directly underlying the Tichenor Limestone Member (*e.g.*, at Bullis Bridge over Buffalo Creek). Still farther west, from Lake Erie shore sections, Grabau (1899b, p. 288) reported: “This coral occurs only in the Encrinal [*i.e.*, Tichenor] limestone. Several specimens were noted in blocks of this rock on the lake shore. On Morse creek it is not uncommon in the lower Encrinal associated with the preceding [solitary *H. halli*].”

We have not seen the Grabau material, but a large specimen in the USNM collection (USNM 133683) is labeled as from the Tichenor Limestone just southeast of Buffalo (Buffalo SE Quad., Erie County); crinoidal limestone matrix supports this provenance. Some early

workers (*e.g.*, Cooper, 1930) included shaly beds below the Tichenor Limestone (of later workers) in the member; this may account for some of the Tichenor reports. Occurrences west of the Jaycox pinch-out may include lag specimens incorporated into the basal Tichenor and/or survivors into the time of Tichenor deposition; but this deposition may have begun earlier in the western area than farther east. However, some “Tichenor” occurrences are more difficult to explain. Collection locality USGS 5693-SD (Stafford Quad., Genesee County) is discussed in the Appendix as primarily a Deep Run site; however, when first visited, a *H. halli confluens* was collected “from deeply weathered Tichenor” in the roadbed, not quite in place (WAO field notes, July 1960), so the source remains questionable. For a diagram of the stratigraphic relationships see figure 2 in Oliver and Sorauf (1994); Mayer *et al.* (1994) gave a very detailed description of the Jaycox Member and Greens Landing coral bed in western New York.

Two triplets from the Prout Limestone in Ohio (Pl. 16, figs. 5–7) are similar to *H. halli confluens* but are completely silicified and cannot be confidently identified at the species or subspecies level. One of these was illustrated by Stumm (1942) and is listed in the synonymy (although queried) because of its similarity in external morphology and age.

External features.—Astreoid coralla are composed of 2 to 40 or more large corallites. The largest available, reasonably complete specimen is the lectotype (FMNH UC 18974): diameter, 18 by 20 cm, height (incomplete), 7.5 cm; 27 corallites are seen on the convex growing surface (Pl. 14, figs. 4, 6). The underside was covered by a holotheca, now partly worn away. Most of the corallites radiate from two central corallites, the larger of which may be the protocorallite (Pl. 14, fig. 5); the relationship of the two corallites is not clear and the possibility of the colony being a composite from the growth of two or more larvae cannot be ruled out.

Larger colonies known to us are incomplete; we estimate that some have diameters of 30 cm or more and include 40 or more corallites. The heights of some coralla more nearly equal their diameters; one such specimen is 11.5 cm high with a diameter of 18 cm (USNM 519490, “West of York,” Leroy Quad., Livingston County). Smaller colonies, with fewer than 10 corallites, are more likely to be nearly complete; these most commonly have heights equal to less than half their diameters.

Corallite diameters on colony surfaces range up to more than 50 mm; commonly the larger corallites range from 30 to 40 mm. Broad, flat or gently arched peripheral platforms surround a relatively deep axial

pit that occupies the central third of the calice surface. Peripheral platforms of adjacent corallites merge, at or without a shallow depression; septa commonly are confluent, appearing to pass from one corallite to the other. Increase is lateral and/or peripheral, but offsets expand rapidly to apparently mature diameters.

Internal features.—A wide dissepimentarium, consisting of 10 to 20 rows of globose dissepiments, commonly occupies two-thirds or more of the corallite diameter (Table 2). The tabularium is composed of mostly incomplete tabulae that form an arched pattern with the axial ends of the long septa but, where septa are shorter, tabulae tend to be axially flat or gently concave. Many longitudinal sections show both arrangements more or less alternating.

In transverse thin sections, septa are attenuate and commonly bilaterally arranged; cardinal and/or counter septa tend to be shorter than other major septa. Major septa extend to or nearly to the axis and are more or less straight in the dissepimentarium, becoming quite irregular in the tabularium; minor septa are essentially limited to the dissepimentarium. At corallite margins, septa are confluent (thamnasterioid), or alternating in position with peripheral ends of septa that turn irregularly and form a discontinuous septal wall. Numbers of major septa range from 22 to 38 in corallite sections 20–50 mm in diameter. Carinae are abundant in the dissepimentarium, uncommon in the tabularium; most are yard-arm, but zigzag and irregular patterns are not uncommon; counts of 15 to 25 carinae per septum are typical.

Microstructure.—Type I→III carinae, composed of compound trabeculae branching at very low angles (see Plate 17) predominate in most corallites; type I carinae (formed by simple monacanth) are present and may predominate in parts of some individuals.

Discussion.—*H. halli confluens* is morphologically defined but its recognition is partly based on its distribution. It is most common in, and possibly restricted to, the Green's Landing coral bed in the lower part of the Jaycox Member. Stumm (1955 and earlier) assigned Hamilton solitary *Heliophyllum* to *H. halli*, small astreoid colonies to *Billingsstraea confluens*, and large colonies to *B. ingens* (Davis). However, in large samples there is a complete gradation in growth form from solitary to twins, triplets, etc. to colonies of 30 to 40 or more corallites. Among the associated solitary specimens, type I and III individuals also predominate; conceivably these should be considered part of the same subspecies, but other populations of solitary forms include both type I and III individuals, and many individual specimens include both type I and III carinae. Biologically, some or most of the associated solitary corals must be part of the same population and

subspecies as the colonies, but it is impractical to identify them as such and the name has been applied only to compound forms.

Astreoid *Heliophyllum* of Emsian and Eifelian age in New York were described by Oliver (1976); additional astreoid taxa of Emsian to Givetian age have been named from other parts of eastern North America but most are inadequately described. All of these are known from large colonies only; they lack the essential character of *H. halli confluens*, that of forming populations of small to large colonies associated with solitary corals that appear to be conspecific.

It seems clear to us that *H. halli confluens* is too closely allied to the associated solitary corals to be a separate species. Description as a subspecies is the most satisfactory way to recognize both its special morphology and its close relationship to solitary *H. halli*.

Material.—Lectotype, FMNH UC 18974 (Hall, 1877, pl. 27; herein, Pls. 14 and 15, fig. 7). The lectotype and the following are illustrated but not included in the measured sample: AMNH 517241 (Hall, 1877, pl. 26, figs. 3–4), USNM 487252, 518545–518546. Specimens illustrated and included in the measured sample: USNM 518542–518544, 518548–518551; unillustrated specimens in measured sample with collection numbers: USNM 518552–518554 (USGS 5708-SD); 518555 (USGS 5693-SD); 518556–518560 (USGS 5323-SD). Cited in text as "Tichenor, SE of Buffalo", USNM 133683; cited as 11.5 by 18 cm, USNM 519490. Cited and illustrated from Prout Limestone in Ohio: OGCM 6085; USNM 518547. Collection data for illustrated specimens are given in the plate explanations; collection locality descriptions are in the Appendix.

***Heliophyllum halli bellonense* n. subsp.**
Plates 20–21

Billingsstraea sp. C Ehlers and Stumm, 1953, p. 10–11.
Heliophyllum halli form 4 ("Bellona") Oliver, 1997a, p. 56.

Type specimens.—Holotype, USNM 518562; Bellona coral bed, Tully Limestone, Bellona, N.Y.; collected by P. H. Heckel. Illustrated paratypes, USNM 518561, 518563–518564; unillustrated paratypes, USNM 518565–518567, 518622.

Occurrence.—*H. halli bellonense* is known only from the Bellona coral bed in the Tully Limestone (Givetian), west-central New York.

Diagnosis.—Astreoid colonies of few to many corallites; both zigzag and yard-arm carinae are present but zigzag seem to predominate, or be equal to yard-arm in numbers.

External features.—Exteriors of coralla poorly

known; specimens occur in massive limestone that tends to break through, rather than around the coral; coralla are partly crushed and, in addition, seem to have been eroded prior to burial; none is complete. Astreoid coralla of 3 to 10 or more corallites are known; diameters range from 5 to 20 cm; heights from 5 to 10 cm. Traces of holotheca are preserved on some specimens; no colony upper surfaces have been seen.

Internal features.—The dissepimentarium commonly occupies two-thirds of the corallite diameter (Table 2), and is composed of 12 to 16 or more rows of small globose dissepiments. The tabularium is composed of incomplete tabulae forming a gently arched pattern.

In transverse sections, septa are attenuate, probably bilaterally arranged but this is obscure in most corallites owing to internal crushing. Major septa extend to the axis and are more or less straight; minor septa are essentially limited to the dissepimentarium. At corallite margins, septa are confluent or irregular. The number of major septa, in corallites 20–30 mm in diameter, ranges from 22 to 31 (Table 2). Carinae are abundant in the dissepimentarium, rare in the tabularium; zigzag and yard-arm are approximately equal in number; 15 to 25 per septum were counted.

Microstructure.—Types I and III carinae are approximately equal in number; either type may predominate in longitudinal sections.

Discussion.—Description of *H. halli bellonense* is based on nine coralla from three localities in the Bellona coral bed; recognition is based on both morphology and restricted distribution. Our sample includes colonies with 3 to 10 corallites; larger colonies with more corallites are known. Few associated solitary *H. halli halli* have the internal structure of the colonies (see Table 2); most have dilated septa, widely spaced yard-arm carinae, and a relatively wide tabularium. *H. halli bellonense* is more similar to *H. halli confluens* and some of the Hamilton *H. halli halli* than it is to the Bellona solitary forms. In this clear separation from associated solitary forms, *H. halli bellonense* is unlike both *H. halli confluens* and *H. halli joshuense*.

The delicate morphology of the colonies and a few of the solitary forms are more like that of Hamilton shale facies forms than that of the majority of associated solitary corals in the limestone. However, all of the Bellona *Heliophyllum* fit within the *H. halli* range of variation.

Colonies in the two astreoid populations are morphologically similar; *H. halli bellonense* seems to have greater proportions of zigzag and type I carinae than does *H. halli confluens*. Comparison is made difficult by differences in preservation and apparent abundance. *H. halli bellonense* is less well preserved and was only collected from bedding plane exposures of the lime-

stone where there is little color difference between the coral and the matrix. In contrast, most *H. halli confluens* specimens are undistorted and occur in relatively soft shales in various kinds of outcrops where color and texture contrasts are high and collecting is relatively easy. *H. halli bellonense* may be much more common than our sample indicates. See the discussion of *H. halli confluens* for comparisons with other astreoid *Heliophyllum*.

Material.—Holotype, USNM 518562; illustrated paratypes, USNM 518561, 518563–518564. The measured sample includes the holotype and USNM 518563–518564 (illustrated) and the following unillustrated paratypes (with collection numbers): USNM 518565–518567 (USGS 5341-SD; Heckel, 1973, loc. 9c), and USNM 113668 ("Bellona"; *Billingsastraea* sp. C of Ehlers and Stumm, 1953). Additional paratype: USNM 518622 (USGS 8766-SD). Collection data for illustrated specimens are in the plate explanations; collection locality descriptions are in the Appendix.

Heliophyllum halli joshuense n. subsp.

Plates 22–28

H. confluens Hall, Wells, 1937, p. 10 (Lords Hill specimens only), text-fig. 8 (Type A).

H. proliferum Hall (not Nicholson), Wells, 1937, text-fig. 9 (? Type B).

H. halli form 1 ("Joshua") Oliver, 1997a, p. 55–57, pl. 2, fig. 2.

Type specimens.—Holotype, PRI 24560 (original of Wells, 1937, text-fig. 8); illustrated paratypes, USNM 518568–518575, 487758; unillustrated paratypes, USNM 518576–518585. All are from the Joshua coral bed.

Occurrence.—Known only from the Joshua coral bed, Otisco Shale Member, Ludlowville Formation, Hamilton Group in central New York. Specimens are most common at Lords Hill, 10 km SW of Nedrow, in the upper part of the coral bed; additional specimens are from a ravine on the west side of Otisco Lake; both localities are in Onondaga County.

Diagnosis.—Massive to fasciculate *H. halli* with discontinuous cerioid (three-layer) wall between corallites where in lateral contact.

External features.—Incomplete coralla are composed of 2 to 14 or more corallites. Some specimens (Type B) consist of a protocorallite and a cluster of from 5 to 13 peripheral, parricidal offsets that grow together as a massive, semicerioid colony in which individuals are separated by a discontinuous wall; protocorallite diameters up to 60 mm are known; offset diameters range from 25 to 60 mm (30–40 mm is common).

Other specimens lack a distinct protocorallite and

consist of a massive stage only (Type A); most of these seem to offset laterally although, in many cases, specimens are too incomplete to determine their growth patterns. Corallite diameters in Type A coralla range from 30 to 60 mm, and are comparable to those of Type B. All specimens referred to the subspecies have the massive, semicerioid stage in common. In general, Type A specimens have fewer corallites (2–5 or 6?) than Type B specimens (5–13, plus the protocorallite).

All specimens in our sample are worn and incomplete but corallum heights and diameters of more than 15 cm are represented. Corallites have broad, flat or gently arched peripheral platforms and a moderately deep axial pit that occupies the central third of the calice. The colony surface tends to be depressed along corallite boundaries: the wall may or may not be visible.

Internal features.—A wide dissepimentarium occupies one-half to two-thirds of the corallite diameter and is composed of 15 to 25 rows of globose dissepiments (Table 2). Tabulae are incomplete and form a gently arched pattern that is difficult to discern because of interference with the axial ends of the long major septa.

In transverse thin sections, septa are attenuate in the dissepimentarium and attenuate or slightly to markedly dilated in the tabularium; minor septa are limited to the dissepimentarium, commonly thinner than major septa, and locally discontinuous. Bilateral arrangement in some corallites is suggested by shorter septa that are presumed to be cardinal or counter.

Corallites are separated by a discontinuous wall that may extend for several millimeters or be virtually absent, although nearly all transverse, and many longitudinal, sections show some wall segments. Where present, the wall is a typical cerioid, three-layered wall with a dark median line and light-colored stereome on either side in which the septa are based. Where wall is lacking, septa of the adjoining corallites meet irregularly. The number of major septa, in corallite sections 25 to 50 mm in diameter, ranges from 35 to 54. Carinae are abundant in the dissepimentarium; most are yard-arm, zigzag are present but much less common; counts range from 10 to 25 per septum.

Microstructure.—Type III carinae are present or predominant in most sections. Type I carinae are common on minor septa and are present and may predominate locally on major septa.

Discussion.—*H. halli joshuense* is characterized by its fasciculate to massive growth form and internal, discontinuous, cerioid wall. We know of no other *Heliophyllum* with this combination of characters. However, recognition as a subspecies is partly based on its restricted distribution. It occurs only in the upper part

of the Joshua coral bed in a very limited area. It is associated with morphologically similar solitary corals, many of which have Type III microstructure. Recognition of the subspecies boundaries pose the same problems as discussed for *H. halli confuens*; some of the co-occurring solitary corals probably belong to the same population as the colonial form, but recognition is not practical and the subspecies name is used only for the colonies.

Material.—Holotype, PRI 24560 (Type A, Lords Hill); illustrated paratypes, USNM 518568–518573 (Type A, Lords Hill); 518574 (Type B, Lords Hill); 518575, 487758 (Type B, Otisco Lake). Collection data for illustrated specimens are in the plate explanations. The measured sample includes the holotype and most illustrated paratypes (not 518571, 518573) and the following unillustrated paratypes, USNM 518576–518585 (all Type A, USGS 8762-SD, Lords Hill). Collection localities are described in the Appendix.

Heliophyllum delicatum Oliver and Sorauf, 1994 Plate 29

H. proliferum Hall, 1877, pl. 26, figs. 1, 2, not fig. 5. Not Nicholson, 1874b.

H. delicatum Oliver and Sorauf, 1994, p. 1188–1198, figs. 3–10; Oliver, 1997, p. 56.

Type specimens.—Holotype, USNM 474690; 37 paratypes, USNM 474691–474727. All from the lower part of the Deep Run Shale Member, Moscow Formation, Hamilton Group, western and west-central N.Y.

Diagnosis.—Dendroid *Heliophyllum*, commonly offsetting laterally, forming colonies of a few to 20 or more corallites and up to 46 cm or more in diameter. Corallites ceratoid, gently expanding to diameters of 4 cm or more and with lengths of 30 cm or more. Corallites weakly constructed with thin walls, septa, and carinae, and no lateral supports. (Oliver and Sorauf, 1994, p. 1190).

Discussion.—For a full description and comparison with other colonial *Heliophyllum*, see Oliver and Sorauf (1994) and Oliver (1997a). All of the Hamilton colonial forms are thought to be derivatives of solitary *H. halli halli* with which they commonly occur. *H. delicatum* differs from *H. halli halli* in its long, gently tapering corallites and its delicate internal structures. Associated branching colonies of *H. halli halli* (including “form *praecoquus*”) have a larger apical angle, reflecting a more rapid diameter increase relative to length, are more robust (thicker walls, septa, and carinae), and offset peripherally. Because of its distinct morphology and the lack of intermediate forms, we

interpret *H. delicatum* as a separate species, rather than a subspecies of *H. halli*.

***Heliophyllum stewarti* Oliver and Sorauf, 1994**

Heliophyllum proliferum Nicholson, Stewart, 1938, p. 38–39, pl. 7, fig. 6. Not Nicholson, 1874a, b, or Hall, 1877.

H. halli forma *praecoxus*? Wells, Stumm, 1968, p. 38. Not Wells, 1937.

H. stewarti Oliver and Sorauf, 1994, p. 1198–1199, fig. 13, 1–7.

Holotype.—OSU 17732; the only known specimen, Tennile Creek Dolomite, Middle Devonian (lower middle Givetian), south of Silica, Ohio.

Diagnosis.—Phaceloid *Heliophyllum*, commonly offsetting laterally, in which ceratoid corallites may remain in contact without developing a separating wall (astreoid) for several cm of linear growth.

Discussion.—For a full description with illustrations and comparisons, see Oliver and Sorauf (1994). *H. stewarti* differs from other known phaceloid *Heliophyllum* in having an astreoid stage. Corallites in astreoid *H. halli confluens* rarely branch but with prolonged colony growth, corallites may become laterally separated, either completely or in chains or small clusters; however, individuals remain short and none are known to develop the elongate ceratoid form of *H. stewarti*.

This brief description is included here because it adds to the overall picture of variation in EAR *Heliophyllum* and to emphasize its position in the *H. halli* species group.

***Heliophyllum cribellum* new species**

Plates 30, 31

Type specimens.—Holotype, USNM 518586 (Pl. 30, figs. 1–8); Centerfield Member (Givetian), Ludlowville Formation near East Alexander, New York (USGS 4678-SD). Most illustrated and measured paratypes are from the same collection. See *Material* for detailed listings of paratypes from this and other localities.

Diagnosis.—Small, mostly ceratoid to cylindrical *Heliophyllum* with short major septa and little or no dilation in any growth stage. Relatively long and thick yard-arm carinae commonly touch those of adjacent septa giving the dissepimentarium a reticulate appearance in transverse sections.

Comments.—The following description is based on specimens from several Centerfield localities in the area between East Alexander (Genesee County) and Centerfield (Ontario County). The measured sample of 30 individuals (Table 2) is from a large collection at the type locality 2.9 km east of East Alexander, Genesee County (USGS 4678-SD). With minor exceptions, specimens from other localities fall within the observed ranges of variation of the measured sample.

External features.—Growth form is most commonly ceratoid or ceratoid→cylindrical; trochoid forms are uncommon. The cylindrical stage indicates a steady-state polyp diameter and is assumed to represent maturity; by this criterion adult diameters range from 10 to 20 mm. Specimens are small; the maximum measured diameter (in a trochoid specimen) is 22 mm; maximum observed length, more than 75 mm.

Several specimens exhibit rejuvenation. In at least one specimen, diameter contractions and expansions proceeded along a straight coral axis; in several others a 90-degree bend accompanied a more marked contraction with expansion to the former diameter in a few millimeters. Some of the latter appear to be large peripheral (and parricidal) offsets in the parental calice, but one or two specimens preserve epitheca over the pre-contraction calice that indicates rejuvenation.

Offsets, other than the questionable ones of the previous paragraph, are rare, but two specimens in the measured population have very small peripheral offsets within the calice, near the outer wall. The most notable specimen has seven offsets, each 4 to 5 mm in diameter in a calice 20 mm in diameter (Pl. 30, figs. 14–16); the second example has one or two 5 mm offsets in a 12 mm calice; another specimen from a nearby locality is similar but with three offsets. None of these offsets grew to a length of more than a few millimeters.

Calices are broad and shallow; depth is one-half the diameter or less; the sides of the calice flatten near the margin but there is no distinct peripheral platform; the distal ends of the carinae and septa project prominently on the sides. Some thin sections from just below or within the lower calice indicate the presence of a shallow cardinal fossula that is only weakly apparent in the calice itself.

Exterior markings are fine and coarse growth lines and septal grooves and interseptal ridges as in other species of the genus. Talons are present on some individuals.

Internal features.—Analysis of measurements and counts of various skeletal elements made from thin sections (Table 2) follow the same methods used in analyzing the populations of *H. halli* and the same definitions and qualifications apply.

Major septa are relatively short; the length of minor septa approximates the width of the dissepimentarium but commonly is more or less than that. In any transverse section, length of both major and minor septa may be quite variable. Septa are biradially arranged; the axial plane is commonly marked by shorter or longer major septa, presumably C and K; examples of long minors next to the axial plane (presumably next to K) have been seen. Some long counter(?) septa ex-

tend discontinuously to the axis (amplexoid?) and form short vertical projections that cause tent-like up-bending of one or a few tabulae; additional major septa may also extend discontinuously into the otherwise empty axial area and appear in transverse sections as detached septal fragments.

Carinae are abundant; most are yard-arm, and relatively thick; many are long enough to touch or connect with carinae extending from the adjacent septa. In transverse sections dissepimentaria look like screens or grids. This character varies in most specimens; the "screen" is locally broken by shorter yard-arm carinae and less commonly by zigzag carinae or randomly discontinuous major or minor septa. The parts of major septa that extend into the tabularium are carinate in many specimens but zigzag carinae are more common than yard-arm in this area. All observed carinae are Type I, many are bushy.

Septal dilation is minimal or absent, even in the earliest growth stages.

The tabularium occupies three-tenths to half the total diameter. Tabulae are complete, incomplete, or irregular; they are closely spaced although all counts (Table 2) are approximate. Where complete, they are axially flat and down-bent at the contact with the dissepimentarium. Some 5 to 12 rows of globose dissepiments form the dissepimentarium.

Microstructure.—Only simple monacanthine tabeculae (many bushy) and Type I carinae have been observed. Wall structure is as described for the genus.

Discussion.—The relatively short major septa and the screen- or grid-like dissepimentarium in transverse sections are characteristic and are the principal bases for the separation of *H. cribellum* from the associated *H. halli*. Lack of early stage dilation is an additional

basis but this character is too inconsistent and variable in *H. halli* to be definitive.

Distribution.—*H. cribellum* is known only from the Centerfield Member, Ludlowville Formation, in west-central New York. Our principal sample is from near East Alexander (Genesee County) but additional specimens from the Centerfield in the outcrop belt between East Alexander and Canandaigua (Ontario County) have added to the description and known geographic range.

Material.—Holotype, USNM 518586, Centerfield Member, east of East Alexander (Batavia So. Quad., USGS 4678-SD). Illustrated paratypes, USNM 518587–518598; collection data is in the plate explanations. The measured sample (all USGS 4678-SD) includes the holotype and several illustrated paratypes, USNM 518587–518589, 518592, 518596, and 518598, and unillustrated paratypes, USNM 518599–518621. Illustrated paratypes, not in the measured sample (with collection numbers): USNM 518590 (USGS 4678-SD), 518591 (USGS 11210-SD), 518593 (USGS 11211-SD), 518594 (USGS 11468-SD), 518595 (USGS 5692-SD), and 518597 (11197-SD). Collection localities are described in the Appendix.

Additional studied specimens (unillustrated paratypes) are USNM 519491, 519492 (White Creek, USGS 5692-SD, Stafford Quad.); USNM 519493 (Jaycox Run, USGS 11211-SD, Genesee Quad.); USNM 519494 (Brown's Creek, USGS 11197-SD, Genesee Quad.); and USNM 519495 (Schaeffer Creek north of Centerfield, USGS 11468-SD, Canandaigua Quad.). All specimens are from the Centerfield Member (Givetian), Ludlowville Formation, Hamilton Group, in west-central New York. See Appendix for collection locality data.

REFERENCES CITED

- Baird, G.C.**
1979. Sedimentary relationships of Portland Point and associated Middle Devonian rocks in central and western New York. New York State Museum, Bulletin 433, 24 pp.
- Baird, G.C., and Brett, C.E.**
1983. Regional variation and paleontology of two coral beds in the Middle Devonian Hamilton Group of western New York. *Journal of Paleontology*, vol. 57, pp. 417–446.
- Billings, E.**
1859. On the fossil corals of the Devonian rocks of Canada West. *Canadian Journal of Industry, Science, and Art*, new ser., no. 20, pp. 97–140.
- Branson, E.B.**
1924. The Devonian of Missouri. Missouri Bureau of Geology and Mines, 2nd ser., vol. 17, 129 pp.
- Brett, C.E., and Baird, G.C.**
1986. Comparative taphonomy: a key to paleoenvironmental interpretation based on fossil preservation. *Palaios*, vol. 1, pp. 207–227.
1994. Depositional sequences, cycles, and foreland basin dynamics in the late Middle Devonian (Givetian) of the Genesee Valley and western Finger Lakes region. New York State Geological Association, Field Trip Guidebook, 66th Annual Meeting, pp. 505–585.
1996. Middle Devonian sedimentary cycles and sequences in the northern Appalachian Basin. *Geological Society of America, Special Paper 306*, pp. 213–241.
- Brett, C.E., Baird, G.C., Gray, L.M., and Savarese, M.L.**
1983. Middle Devonian (Givetian) coral associations of western and central New York State. In Sorauf, J.E. and Oliver, W.A., Jr., eds., *Silurian and Devonian corals and stromatoporoids of New York*. International Association for the Study of Fossil Cnidaria, 4th International Symposium, Washington, D.C., pp. 65–107.
- Brett, C.E., Miller, K.B., and Baird, G.C.**
1990. A temporal hierarchy of paleoecological processes within a Middle Devonian epicritic sea. *Paleontological Society, Special Publication 5*, pp. 178–209.

- Brown, T.C.**
1909. Studies on the morphology and development of certain rugose corals. New York Academy of Sciences, Annals, vol. 19, part 1, pp. 45-97.
- Chapman, E.J.**
1893. On the corals and coralliform types of Palaeozoic strata. Royal Society of Canada, Proceedings and Transactions, vol. 10, section 4, pp. 39-48.
- Cleland, H.F.**
1911. The fossils and stratigraphy of the middle Devonian of Wisconsin. Wisconsin Geological Survey, Bulletin 21 (science series 6), 222 pp.
- Coen-Aubert, M.**
1987. Révision d'*Heliophyllum halli* Milne-Edwards et Haime, espèce-type du genre *Heliophyllum* Hall in Dana (Tétracoralliaire dévonien). Muséum national d'Histoire naturelle, Paris, Bulletin, sér. 4, no. 9, section C, no. 2, pp. 151-180.
- Cooper, G.A.**
1930. Stratigraphy of the Hamilton Group of New York; Parts I and II. American Journal of Science, vol. 19, pp. 116-134, 214-236.
1933-34. Stratigraphy of the Hamilton Group of eastern New York; Parts I and II. American Journal of Science, vol. 26, pp. 539-551; vol. 27, pp. 1-12.
1943. Note on the Berne Member. In Goldring, W., Geology of the Cossackie Quadrangle. New York State Museum, Bulletin 332, p. 249.
- Cranswick, J.S., and Fritz, M.A.**
1958. Coral fauna of the Upper Abitibi River Limestone. Geological Association of Canada, Proceedings, vol. 10, pp. 31-81.
- Dana, J.D.**
1846a. Zoophytes, vol. 7, Text. In United States Exploring Expedition during the years 1838-1842, under the command of Charles Wilkes, U.S.N., 740 pp.
1846b. Genera of fossil corals of the family Cyathophylloidae. American Journal of Science, vol. 1, pp. 178-186.
1849. Zoophytes, vol. 7, Atlas. In United States Exploring Expedition during the years 1838-1842, under the command of Charles Wilkes, U.S.N., 61 pls.
- Davis, W.J.**
1887. Kentucky fossil corals—a monograph of the fossil corals of the Silurian and Devonian rocks of Kentucky. Kentucky Geological Survey, part 2, 139 pls. (1885 on title page, published, 1887.)
- Ehlers, G.M., and Stumm, E.C.**
1951. Corals of the Devonian Traverse Group of Michigan. Part IV, *Billingsstraea*. University of Michigan, Museum of Paleontology, Contributions, vol. 9, pp. 83-92, 3 pls.
1953. Species of the tetracoral genus *Billingsstraea* from the Middle Devonian of New York and other regions. Buffalo Society of Natural Sciences, Bulletin, vol. 21, pp. 1-11, 6 pls.
- Fedorowski, J.**
1997. Remarks on the palaeobiology of Rugosa. Geologos (Uniwersytet im. Adama Mickiewicza, Poznan), vol. 2, pp. 5-58.
- Fenton, C.L., and Fenton, M.A.**
1938. *Heliophyllum* and "*Cystiphyllum*," corals of Hall's "Illustrations of Devonian Corals." Carnegie Museum, Annals, vol. 27, pp. 207-250.
- Goldfuss, G.A.**
1826. Petrefacta Germaniae, Part I. Düsseldorf, 76 pp., 25 pls.
- Grabau, A.W.**
1899a. The palaeontology of Eighteen Mile Creek and the lake shore sections of Erie County, New York. Buffalo Society of Natural Sciences, Bulletin, vol. 6, nos. 2, 3, 4, pp. 93-403.
1899b. The faunas of the Hamilton Group of Eighteen-Mile Creek and vicinity in western New York. New York State Museum, Annual Report 50, vol. 2, pp. 227-339. (Also in State Geologist's Annual Report 16, pp. 227-339.)
1917. Stratigraphic relationships of the Tully Limestone and the Genesee Shale in eastern North America. Geological Society of America, Bulletin, vol. 28, pp. 945-958.
- Grasso, T.X.**
1968. A new coral bed in the Hamilton Group (Middle Devonian) of New York. Journal of Paleontology, vol. 42, pp. 84-87.
1986. Redefinition, stratigraphy and depositional environments of the Mottville Member (Hamilton Group) in central and eastern New York. New York State Museum, Bulletin 457, pp. 5-31.
- Greene, G.K.**
1898-1906. Contribution to Indiana paleontology. Vol. 1, parts 1-20, 204 pp., vol. 2, parts 1-3, 38 pp., New Albany, Indiana.
- Gürich, G.**
1896. Das Paläozoikum des Polnischen Mittelgebirge. Verhandlungen der Russisch-Kaiserlichen Mineralischen Gesellschaft, St. Petersburg, ser. 2, vol. 32, 539 pp.
- Hall, J.**
1843. Geology of New York, Part 4, comprizing the survey of the fourth geological district. Albany, 683 pp.
1859. Catalogue of the species of fossils, described in volumes I, II and III of The Palaeontology of New York; with Corrections in Nomenclature, as far as determined to the present time. New York State Museum, Annual Report 12, pp. 63-96.
1877. Illustrations of Devonian fossils: Corals of the upper Helderberg and Hamilton groups. New York Geological Survey, Paleontology, 39 pls. and explanations. (1876 on title page, published 1877; see Stumm, 1948a.)
1882. Fossil corals of the Niagara and upper Helderberg groups. Albany, 59 pp.
1883. Descriptions of fossil corals from the Niagara and upper Helderberg groups of Indiana. Indiana Department of Geology and Natural History, Annual Report 12, pp. 271-318, pls. 15-28.
1884. Descriptions of fossil corals from the Niagara and upper Helderberg groups. New York State Museum, Annual Report 35, pp. 407-464, pls. 23-30.
- Heckel, P.H.**
1973. Nature, origin, and significance of the Tully Limestone. Geological Society of America, Special Paper 138, 244 pp.
- Hill, D.**
1936. The British Silurian rugose corals with acanthine septa. Royal Society of London, Philosophical Transactions, ser. B, no. 534, vol. 226, pp. 189-217.
1956. Rugosa. In Moore, R.C., ed., Treatise on Invertebrate Paleontology, part F, Coelenterata. Geological Society of America and University of Kansas Press, pp. F233-F324.
1957. The sequence and distribution of upper Palaeozoic coral faunas. Australian Journal of Science, vol. 19, no. 3a, pp. P42-61.
1981. Rugosa and Tabulata, Supplement 1 to part F, Coelenter-

- ata. In Teichert, C., ed., Treatise on Invertebrate Paleontology. Geological Society of America and University of Kansas, 2 vols., 762 pp.
- Holmes, M.E.**
1887. Morphology of the carinae upon the septa of rugose corals. Bradlee Whidden, Boston, 31 pp., 16 pls.
- Hubbard, J.A.E.B., and Pocock, Y.P.**
1972. Sediment rejection by recent scleractinian corals: a key to palaeo-environmental reconstruction. Geologischen Rundschau, vol. 62, pp. 598-626.
- Jell, J.S.**
1969. Septal microstructure and classification of the Phillipsastraeidae. In Campbell, K.S.W., ed., Stratigraphy and Palaeontology, Essays in Honour of Dorothy Hill, Australian National University Press, Canberra, pp. 50-73.
- Kato, M.**
1963. Fine skeletal structures in Rugosa. Hokkaido University, Faculty of Science, Journal, Series 4, vol. 11, pp. 571-630.
- Kirchgasser, W.T.**
2000. Correlation of stage boundaries in the Appalachian Devonian, eastern United States. Courier Forschungsinstitut Senckenberg, 225, pp. 271-284.
- Klapper, G.**
1981. Review of New York conodont biostratigraphy. In Oliver, W.A., Jr. and Klapper, G., eds., Devonian Biostratigraphy of New York: Part 1, Text. Subcommittee on Devonian Stratigraphy, Washington, DC, pp. 57-67.
- Lambe, L.M.**
1901. A revision of the genera and species of Canadian Palaeozoic corals—the Madreporaria Aporosa and the Madreporaria Rugosa. Geological Survey of Canada, Contributions to Canadian Paleontology, vol. 4, pp. 97-197, pls. 6-18.
- Lane, B.O.**
1955. The paleontology and stratigraphy of the "Meristella"-coral Zone (Devonian) of eastern New York State. Unpublished M.Sc. thesis, Brown University, Providence, Rhode Island, 41 pp.
- Lang, W.D., Smith, S., and Thomas, H.D.**
1940. Index of Palaeozoic coral genera. British Museum (Natural History), London, 231 pp.
- Lecompte, M.**
1952. Madreporaires Paléozoïques. In Piveteau, J., ed., Traité de Paléontologie, vol. 1, pp. 419-539. (Paris).
- Le Maitre, D.**
1947. Le récif coralligène de Ouhilane, Maroc, Service Géologique, Notes et Mémoires, no. 67, 112 pp., 24 pls.
- Ma, T.Y.H.**
1956. A reinvestigation of climate and the relative positions of continents during the Devonian. Research on Past Climate and Continental Drift, vol. 9, 116 pp., 70 pls. (Taipei).
- Mayer, S.M., Baird, G.C., and Brett, C.E.**
1994. Correlation of facies divisions in the uppermost Ludlowville Formation (Givetian) across western and central New York State. New York State Museum, Bulletin 481, pp. 229-264.
- Mayr, E.**
1970. Populations, species and evolution. Harvard University Press, Cambridge, Massachusetts, 453 pp.
- Milne-Edwards, H., and Haime, J.**
1850. A monograph of the British fossil corals. Introduction. Palaeontographical Society, London, pp. i-lxxxv.
1851. Monographie des polypiers fossiles des terrains palaeozoïques. Paris, Muséum d'Histoire Naturelle, Archives, vol. 5, 502 pp., 20 pls.
1853. A monograph of the British fossil corals, part 4, Corals from the Devonian formation. Palaeontographical Society, London, pp. 211-244, pls. 47-56.
- Moore, R.C., Hill, D., and Wells, J.W.**
1956. Glossary of morphologic terms applied to corals. In Moore, R.C., ed. Treatise on Invertebrate Paleontology, part F, Coelenterata. Geological Society of America and University of Kansas Press, pp. F245-251.
- Nicholson, H.A.**
1874a. Report upon the palaeontology of the Province of Ontario. Toronto, 133 pp.
1874b. Descriptions of new fossils from the Devonian formations of Canada West. Geological Magazine, ser. 2, vol. 1, pp. 10-16, 54-60, 117-126, 159-165, 197-201.
1875. Descriptions of new fossils from the Devonian rocks of western Ontario. Canadian Naturalist, new ser., vol. 7, pp. 138-147.
1876. On the mode of growth and increase amongst the corals of the Palaeozoic Period. Royal Society of Edinburgh, Transactions, vol. 27, pp. 237-250, pl. 17.
1878. On the minute structure of the corals of the genera *Heliophyllum* and *Crepidophyllum*. Annals and Magazine of Natural History, ser. 5, vol. 1, pp. 44-54.
- Nicholson, H.A., and Thompson, J.**
1877. Descriptions of some new or imperfectly understood forms of Palaeozoic corals [abs.]. Royal Society of Edinburgh, Proceedings, vol. 9, pp. 149-150.
- Oliver, W.A., Jr.**
1951. Middle Devonian coral beds of central New York. American Journal of Science, vol. 249, pp. 705-728.
1971. The coral fauna and age of the Famine Limestone in Quebec. Smithsonian Contributions to Paleobiology, no. 3, pp. 193-201.
1974. Classification and new genera of noncystimorph colonial rugose corals from the Onesquethaw Stage in New York and adjacent areas. U. S. Geological Survey Journal of Research, vol. 2, pp. 165-174.
1976. Noncystimorph colonial rugose corals of the Onesquethaw and lower Cazenovia stages (Lower and Middle Devonian) in New York and adjacent areas. U. S. Geological Survey Professional Paper 869, 156 pp., 108 pls.
1977. Late Silurian and Devonian biogeography of rugose corals. Palaeogeography, Palaeoclimatology, Palaeoecology, vol. 22, pp. 84-135.
1980. Corals in the Malvinokaffric Realm. Münstersche Forschungen zur Geologie und Paläontologie, no. 52, pp. 13-27, 1 pl.
1989a. An early Middle Devonian coral faunule from the Needmore Shale in south-central Pennsylvania and adjacent areas of West Virginia and Virginia. U. S. Geological Survey Bulletin 1860-C, pp. 1-11, 7 pls.
1989b. Intraspecific variation in pre-Carboniferous rugose corals: a subjective review. Association of Australasian Paleontologists, Memoir 8, pp. 1-6.
1990. Extinctions and migrations of Devonian rugose corals in the Eastern Americas Realm. Lethaia, vol. 23, pp. 167-178.
1993a. The Siphonophrentidae (rugose corals, Devonian) of eastern North America. U. S. Geological Survey Bulletin 2024-B, 32 pp., 22 pls.
1993b. Origins and relationships of Devonian Rugosa endemic

to the Eastern Americas Realm. Courier Forschungsinstitut Senckenberg, 164, pp. 131–140.

- 1997a. Origins and relationships of colonial *Heliophyllum* in the upper Middle Devonian of New York. Real Sociedad Española de Historia Natural, Boletín (Sección Geológica), vol. 91, pp. 53–60.
- 1997b. Evolutionary relationships of the Zaphrentidae and Craspedophyllidae (rugose corals, Devonian) in eastern North America. Geological Society of America Special Paper 321, pp. 317–325.
- Oliver, W.A., Jr., and Pedder, A.E.H.**
1989. Origins, migrations, and extinctions of Devonian Rugosa on the North American Plate. Association of Australasian Paleontologists Memoir 8, pp. 231–237.
- Oliver, W.A., Jr., and Sorauf, J.E.**
1988. *Heliophyllum* Hall and *Charisiphyllum* n. gen. (Devonian rugose corals) of the Cantabrian Mountains (NW Spain). Trabajos de Geología, Oviedo, vol. 17, pp. 3–17.
1994. Branching *Heliophyllum* (Devonian rugose corals) from New York and Ohio. Journal of Paleontology, vol. 68, pp. 1183–1201.
- Pedder, A.E.H.**
1990. Variation and generic identity of *Heliophyllum boreale* McLaren, 1964, a Middle Devonian rugose coral from western Canada. Geological Survey of Canada Bulletin 396, pp. 89–115, pls. 4.1–4.9. (1989 on title p., published Feb. 1990).
1999. Paleogeographic implications of Devonian (Givetian, Lower *Varcis* Subzone) rugose coral fauna from the Ma'der Basin (Morocco). Abhandlungen der Geologisch-Bundesanstalt, A. Bd. 54, pp. 385–434, 11 pls.
- Phillips, J.**
1841. Figures and descriptions of the Palaeozoic fossils of Cornwall, Devon, and West Somerset. Geological Survey of Great Britain and Ireland, London, 231 pp., 60 pls.
- Rominger, C.L.**
1876. Palaeontology. Fossil corals. In Lower Peninsula, 1873–1876. Geological Survey of Michigan, vol. 3, part 2, 161 pp., 55 pls.
- Scrutton, C.T.**
1973. Palaeozoic coral faunas from Venezuela, II. Devonian and Carboniferous corals from the Sierra de Perijá. British Museum (Natural History), Bulletin, Geology, vol. 23, pp. 223–281, 10 pls.
- Sloss, L.L.**
1939. Devonian rugose corals from the Traverse beds of Michigan. Journal of Paleontology, vol. 13, pp. 52–73, pls. 9–12.
- Smith, B.**
1912. Observations on the structure of some coral beds in the Hamilton shale. Philadelphia Academy of Natural Sciences Proceedings, vol. 64, pp. 446–454.
1935. Geology and mineral resources of the Skaneateles quadrangle. New York State Museum Bulletin 300, 120 pp.
- Smith, S.**
1945. Upper Devonian corals of the Mackenzie River region, Canada. Geological Society of America Special Paper 59, 126 pp., 35 pls.
- Sorauf, J.E.**
2001. External morphology and paleobiology of *Heliophyllum halli* (Zooantharia, Rugosa), from the Middle Devonian Hamilton Group of New York State. Journal of Paleontology, vol. 75, pp. 24–33.
- Sorauf, J.E., and Oliver, W.A., Jr.**
1976. Septal carinae and microstructure in Middle Devonian *Heliophyllum* (Rugosa) from New York State. Journal of Paleontology, vol. 50, pp. 331–343.
- Stewart, G.A.**
1927. Fauna of the Silica Shale of Lucas County, Ohio Geological Survey, 4th ser., Bulletin 32, 76 pp., 5 pls.
1938. Middle Devonian corals of Ohio. Geological Society of America Special Paper 8, 120 pp., 20 pls.
- Stumm, E.C.**
1942. Fauna and stratigraphic relations of the Prout Limestone and Plum Brook Shale of northern Ohio. Journal of Paleontology, vol. 16, pp. 549–563, pls. 80–84.
- 1948a. The priority of Dana, 1846–48, versus Hall, 1847, and of Rominger, 1876, versus Hall, 1876 (?1877). University of Michigan, Museum of Paleontology Contributions, vol. 7, pp. 1–6.
- 1948b. Lower Middle Devonian species of the tetracoral genus *Hexagonaria* of east-central North America. University of Michigan, Museum of Paleontology Contributions, vol. 7, pp. 7–49, 14 pls.
1949. Revision of the families and genera of the Devonian Tetracorals. Geological Society of America Memoir 40, 92 pp., 25 pls.
1955. Tetracoralla, Division 1, Unit 1-F, Part C. In Type invertebrate fossils of North America (Devonian). Wagner Free Institute of Science, Philadelphia, cards 128–337.
1965. Silurian and Devonian corals of the Falls of the Ohio. Geological Society of America Memoir 93, 184 pp., 80 pls. (1964 on title p., but issued Jan. 27, 1965).
1968. The corals of the Middle Devonian Tenmile Creek Dolomite of northwestern Ohio. University of Michigan, Museum of Paleontology Contributions, vol. 22, pp. 37–44, 3 pls.
- Stumm, E.C., and Tyler, J.H.**
1962. Corals of the Devonian Traverse Group of Michigan, Part IX, *Heliophyllum*. University of Michigan, Museum of Paleontology Contributions, vol. 17, pp. 265–276, 3 pls.
- Veron, J.E.N.**
1995. Corals in space and time. Australian Institute of Marine Science, University of New South Wales Press, 321 pp.
- Ver Straeten, C.A.**
1994. Microstratigraphy and depositional environments of a Middle Devonian foreland basin: Berne and Otsego Members, Mount Marion Formation, eastern New York State. New York State Museum Bulletin 481, pp. 367–380.
- Wang, H.C.**
1950. A revision of the Zooantharia Rugosa in the light of their minute skeletal structures. Royal Society of London, Philosophical Transactions, Ser. B, Biological Sciences, no. 611, vol. 234, pp. 175–246, pls. 4–9.
- Wells, J.W.**
1937. Individual variation in the rugose coral species *Heliophyllum halli* E. & H. Palaeontographica Americana, vol. 2, no. 6, pp. 3–22, 1 pl.
1943. The Rio Cachirí section in the Sierra de Perijá, Venezuela, part 2B. Anthozoa. Bulletins of American Paleontology, vol. 27, no. 108, pp. 95–100, pl. 10.
1963. Coral growth and geochronometry. Nature, vol. 197, pp. 948–950.
- Yonge, C.M.**
1940. The biology of reef-building corals. Great Barrier Reef Expedition, 1928–29. Scientific Reports. British Museum (Natural History), vol. 1, pp. 354–391.

APPENDIX—COLLECTION LOCALITIES

Localities are listed by stratigraphic unit, from oldest to youngest, and from west to east (north to south locally) along the New York outcrop belt shown on the index map (Text-fig. 2). Counties (Co.) are cited for each locality and shown on the figure. Principal map references are to the USGS 7.5 minute quadrangles (Quad.). Numbers ending with -SD are listed in the USGS Silurian-Devonian catalog (copy at U. S. National Museum of Natural History, USNM, Washington, DC). These are collection numbers but also can serve as locality numbers.

The list is a comprehensive catalog of collections and localities for all New York Hamilton specimens on which this study is based (including data for unillustrated specimens of *H. halli halli* in the statistical samples). Specimen numbers (and number of specimens) for *H. halli halli* only, are listed with the appropriate collection; additional unillustrated specimens cited in text are noted. Field data for illustrated specimens are in plate explanations. Comparable data for other taxa are in the *Material* section of the systematic descriptions.

1. Halihan Hill Coral Bed

Westerlo Quad: USGS 11221-SD, drainage ditch on W side of Cole Hill Rd., 1.5 km S of Bensons Corners (elev. 1282 ft), Albany Co. USNM 518312, 518313 (2 specimens).

Plattekill (now Woodstock) Quad: USGS 5305-SD, bed of Plattekill Creek at bridge, 1.2 km W of Mount Marion (or 2.7 km E of High Woods (village) on Glasco Turnpike). Ulster Co. USNM 518314–518322 (9 specimens) plus 3 illustrated and measured.

USGS 11222-SD, same as 5305-SD. USNM 518323 (1 specimen).

Kingston West Quad: USGS 11497-SD, cut on S side of US 209 at Sawkill Rd. exit ramp, N of Kingston. Ulster Co. USNM 518324 is "large" specimen mentioned in text.

2. Case Hill Coral Bed

South Onondaga Quad: USGS 9747-SD, creek on N slope of Case Hill just W of Case Rd.; type locality of Grasso (1986). Onondaga Co. USNM 518329–518341 (13 specimens) plus 4 illustrated and measured.

Otisco Valley Quad: USGS 11458-SD, Rattlesnake Gulf on Bare Mountain, just N of Otisco Rd. (on W side of Tully Valley); locality 10 of Grasso (1986). Onondaga Co. USNM 518342–518345 (4 specimens).

3. Centerfield Limestone

Alexander Quad: USGS 5705-SD, Murder Creek, just W of Harper Rd., 2 km N of Darien. Genesee Co. USNM 518349–518352 (4 specimens).

Batavia South Quad: USGS 4678-SD, 3 km E of East Alexander just N of D.L. and W. RR tracks (0.6 km E of Francis Rd.). Genesee Co. USNM 518353–518361 (9 specimens). This exposure is "3 mi W of East Bethany" and is probably the locality of collections USNM 134874 and 134883 (see expl. Pl. 1).

USGS 6061-SD, same as 4678-SD. USNM 518362 (1 specimen).

USGS 11210-SD, RR cuts 5.2 km E of East Alexander, along D. L. and W. RR line, E of Center Rd. Genesee Co. USNM 518363 (1 specimen).

Stafford Quad: USGS 5692-SD, 1.6 km E of East Bethany along White Creek; S of D. L. and W. RR and W of Transit Rd. Genesee Co. USNM 518364–518365 (2 specimens).

Genesee Quad: USGS 5324-SD, NW corner of map; Browns Creek, 0.2 km W of Genesee and Wyoming RR bridge over creek. Locality is approximately 1.6 km E of York. Livingston Co. USNM 518366–518372 (7 specimens) plus 2 illustrated (1 of which is not measured).

USGS 5714-SD, same as 5324-SD. USNM 518373–518374 (2 specimens).

USGS 11197-SD, same as 5324-SD. USNM 518375–518378 (4 specimens) plus 1 illustrated.

USGS 11211-SD, Jaycox Creek, 0.15 km NE of Nations Rd. at a point approximately 1.6 km NW of NY 39 and 4+ km N of Genesee. Livingston Co. USNM 518379 (1 specimen).

Canandaigua Quad: USGS 11468-SD, Schaeffer Creek, E of McCann Rd. at a point 1.4 km N of Centerfield (SW corner of map). Ontario Co. USNM 518380–518382 (3 specimens).

Stanley Quad: USGS 5683-SD, Wilson Creek under Ross Rd. bridge over creek. (E edge of map, 4.5 km S of Geneva). Ontario Co. USNM 518383 (1 specimen).

Romulus Quad: USGS 5375-SD, small quarry, S of road, 0.5 km W of Fayette; Fayette Town quarry. Seneca Co. USNM 518384–518385 (2 specimens).

USGS 11465-SD, same as 5375-SD. USNM 518386–518390 (5 specimens).

4. Staghorn Point Coral Bed

Spafford Quad: USGS 9093-SD, E shore Skaneateles Lake from Jenny Point to Willow Point. Onondaga Co. USNM 518396–518398 (3 specimens).

USGS 9094-SD, same as 9093-SD. USNM 518399–518400 (2 specimens).

USGS 8763-SD, Staghorn Point, E shore of Skaneateles Lake. USNM 518401–518402 (2 specimens).

USGS 7542-SD, just N of Willow Point, E shore of Skaneateles Lake. USNM 518394–518395 (2 specimens) plus 2 illustrated and measured.

The “Skaneateles Lake” locality of Wells (1937) may have included all of the nearly continuous exposure from north of Jenny Point to Willow Point (2.2 km), but his collecting is thought to have been concentrated near Staghorn Point. PRI 24550 and 24561, “form *praecocuous*,” are from Wells’ collection.

South Onondaga Quad: USGS 9102-SD, Ravine on Lords Hill, E of Rt 80, approximately 0.3 km S of US 20. Onondaga Co. 1 specimen, illustrated and measured.

5. Joshua Coral Bed

Spafford Quad: The following collection localities are all ravines on the SW side of Otisco Lake. Onondaga Co.

USGS 9122-SD, ravine 2 km NW of old causeway; Joshua 25.7 m thick; collection from lower 5 m. USNM 518407 (1 specimen).

USGS 9123-SD, same ravine as 9122-SD; collection from upper 0.5 m. USNM 518408 (1 specimen).

USGS 9115-SD, ravine 0.2 km NW of old causeway; Joshua 9.6 m thick, collection from lower 5.5 m. USNM 518409 (1 specimen).

USGS 9110-SD, ravine 0.3 km SE of old causeway; Joshua 10 m thick, collection from lower 3.2 m. USNM 518410–518411 (2 specimens).

USGS 5667-SD, same ravine and beds as 9110-SD.

USGS 9114-SD, same ravine as 9110-SD; collection from top 0.6 m. USNM 518412 (1 specimen).

Otisco Valley Quad: USGS 9364-SD, ravine on NE side of Otisco Valley near SE end of Otisco Lake, 1.9 km NW of village of Otisco Valley. Onondaga Co. USNM 518413 (1 specimen).

South Onondaga Quad: The following collections are from two sections (road cut and ravine) on Lords Hill, S of Lords Corners (on US 20); the road cut thickness is distorted by local faulting (Oliver, 1951); thickness in both sections is probably close to 15 m. The Lords Hill collection(s) of Wells (1937) may be from either of the two sections. Onondaga Co.

USGS 9131-SD, road cuts on NY 80, approximately 0.4 km S of Lords Corners; Joshua 21 m thick (due to faulting). Onondaga Co. 1 specimen, illustrated and measured.

USGS 4669-SD, same as 9131-SD. USNM 518419–518427 (9 specimens) plus 3 illustrated and measured.

USGS 8783-SD, cornfield (currently apple orchard), estimated 0.3 km E of NY 80, just W of upper end of

ravine; repeated ploughing of field over a period of several years produced our largest collection of Joshua *Heliophyllum*, presumably from the uppermost part of the coral bed as the ravine exposure is 14 m thick and only slightly lower. Onondaga Co.

USGS 8762-SD, same as 8783-SD. USNM 518414–518418 (5 specimens).

6. Darien Coral Bed

Alexander Quad: USGS 5706-SD, Murder Creek, 1 km NNW of US 20 in Darien, and 0.1 km S of Sharrack Rd. Genesee Co. USNM 518432–518439 (8 specimens) plus 1 illustrated and measured.

USGS 11208-SD, same as 5706-SD. USNM 518440 (1 specimen) plus 3 illustrated and measured.

The specimens illustrated on Plate 1, figures 1–10 (exterior views) are probably from this coral bed and locality.

7. Jaycox Member, Greens Landing Coral Bed

Buffalo SE Quad: Erie Co. See Tichenor Member.

East Aurora Quad: USGS 5708-SD, Buffalo Creek, just N of Bullis Rd. bridge, 3.6 km W of Marilla (loc. 4 of Baird, 1979). Erie Co. USNM 518445–518449 (5 specimens) plus 1 illustrated and measured. PRI 40200, illustrated on Plates 12 and 13, is from this locality.

Corfu Quad: USGS 5703-SD, Peck Creek S of US 20 and just N of Erie or D, L & W RR tracks, 3.4 km E of Alden (1.1 km E of County Line Road). Genesee Co.

USGS 5704-SD, Elevenmile Creek on S side of US 20 (loc. 5 of Baird, 1979). Genesee Co. USNM 518450–518451 (2 specimens).

Stafford Quad: the USNM locality “Tichenor; 1.5 mi SE of East Bethany” (see Pl. 7 explanation) is from the west branch of White Creek between US 20 and NY 63 (loc. 9 of Baird, 1979); the specimen (illustrated but not measured) is probably from the Jaycox Member. Genesee Co.

USGS 5693-SD, small cut on Transit Road, discussed more fully as a Deep Run locality (*q.v.*). A loose specimen of *H. halli confluens* was thought to be from deeply weathered Tichenor when collected (July 1960) but might have come from Jaycox beds disturbed during road building. Genesee Co.

Leroy Quad: Hill’s Gulch, or Hill Farm, waterfall 0.3 km W of Asbury Rd. and 0.4 km S of US 20 (loc. 10 of Baird, 1979); see also former Deep Run collection list. Tichenor Limestone lower waterfall with lower Deep Run well exposed above and Jaycox below; the old USNM locality 134884 specimens on Plate 1 may be from either or both units. None of our illustrated

or measured specimens is from the Jaycox at this locality. Genesee Co.

USGS 5323-SD, at S edge of map; Browns Creek, 1.9 km W of York (NY 36, at edge of map). This is the "west of York" locality, source of many collections over many years. Livingston Co. USNM 518452 (1 specimen) plus 1 illustrated and measured.

USGS 5715-SD, same as 5323-SD. USNM 518453 (1 specimen).

USGS 11196-SD, same as 5323-SD. USNM 518454–518459 (6 specimens).

Specimen USNM 519490, cited in discussion of *External features of H. halli confluens*, is from this locality.

Genesee Quad: Jaycox Run, approximately 0.5 km W of NY 39 at a point 4.7 km NNE of US 20A in Genesee. USNM 487251, "form *praeoquus*," collected by G. Kloc (Pl. 12, figs. 9–10) is from this locality. Livingston Co.

Canandaigua Lake Quad: USGS 5687-SD, Tichenor Gully on W side of Canandaigua Lake. Ontario Co. USNM 518460 (1 specimen).

USGS 11470-SD, Greens Landing ravine on E side of Canandaigua Lake, near E edge of map. Ontario Co. USNM 518461–518466 (6 specimens) plus 2 illustrated and measured. One "form *praeoquus*" from this collection is illustrated on Plate 12, figs. 2–4 (USNM 518541).

Tichenor Limestone Member

Buffalo SE Quad: USNM loc. 1014, "N. branch of Smoke Creek, just E of Berg Road Bridge, SE of Buffalo," Erie Co. USNM 133683 is specimen cited in discussion of *H. halli confluens* as representing an occurrence in the Tichenor, west of the known limit of the Jaycox Member.

8. Lower Deep Run Member

Localities for the colonial *Heliophyllum delicatum* were described by Oliver and Sorauf (1994); these are repeated here only for the three specimens illustrated on Plate 29 and for the *H. halli halli* that are illustrated and/or part of the statistical sample.

Corfu Quad: USGS 5703-SD, Peck Creek, 3.4 km E of Alden, 0.5 km S of US 20, near Erie RR bridge over creek. (Loc. 2 of Oliver and Sorauf). Genesee Co.

Stafford Quad: USGS 5693-SD, Transit Road, 1.1 km N of NY 63 intersection. (Same as 11481-SD, loc. 4 of Oliver and Sorauf). Genesee Co. A small roadcut exposes a complete Deep Run section (measured in July 1990) as follows (compare with Text-fig. 1):

Menteth Limestone 17 cm.

Deep Run Shale 46 cm (corals common including *H. delicatum*, characteristic of member and *H. halli*

halli) Tichenor Limestone 29 cm (poorly exposed). A loose specimen of *H. halli confluens* is thought to have come from the Tichenor or Jaycox although the latter was not exposed. The following are almost certainly from the Deep Run: USNM 518475–518479 (5 specimens) plus 1 illustrated and measured. USNM 518480–518482 (3 specimens) are examples of "*praeoquus*" cited in discussion (not illustrated or in measured sample). See discussion of this locality in Jaycox collections section.

USGS 4676-SD, creek bed (tributary of Oatka Creek) 1 km SSE of Pavilion Center, and approximately 0.3 km SW of Rogers Rd. (Loc. 5 of Oliver and Sorauf). Genesee Co. USNM 518483–518484 (2 specimens).

Leroy Quad: USGS 5698-SD, Hill's Gulch, or Hill Farm, waterfall 0.3 km W of Asbury Rd. and 0.4 km S of US 20; see also notes in the Jaycox Member collection list. Collection is from lower Deep Run above the Tichenor Ls. (Loc. 6 of Oliver and Sorauf). Genesee Co. USNM 518485 (1 specimen) plus 2 illustrated and measured.

Honeoye Quad: USGS 11491-SD, West Bloomfield Twp. in branch of Beebe Creek that passes Taft Rd. just S of elevation 870 ft; 0.5 km W of Taft Rd. (Loc. 8 of Oliver and Sorauf). Collected by D. Griffing. Livingston Co.

Canandaigua Lake Quad: USGS 5691-SD, unnamed gully, 1.2 km N of Tichenor Point on W side of Canandaigua Lake; approximately 0.2 km W of West Lake Rd. (Loc. 9 of Oliver and Sorauf). Ontario Co.

USGS 11473-SD, Tichenor Gully on W side of Canandaigua Lake, approximately 0.25 km W of West Lake Rd. (Loc. 10 of Oliver and Sorauf). Ontario Co. 1 specimen, illustrated and measured.

USGS 11475-SD, lake shore, 0.9 km S of creek at Tichenor Point, W side of Canandaigua Lake. Ontario Co. USNM 518486 (1 specimen) plus 2 illustrated (1 not in measured sample).

Rushville Quad: USGS 5684-SD, W edge of map; Greens Landing Ravine on E side of Canandaigua Lake (enter from E side of Canandaigua Lake Quad.); Tichenor Ls. exposed near boundary of quads., Deep Run is approximately 0.1 km east of boundary. (Loc. 13 of Oliver and Sorauf). Ontario Co. 1 illustrated and measured specimen.

Geneva South Quad: USGS 11490-SD, Kashong Glen, W side of Seneca Lake, approximately 1.5 km W of NY 14. (Loc. 17 of Baird, 1979). Ontario Co. USNM 518487 (1 specimen) plus 1 illustrated but not measured.

Dresden Quad: USGS 11489-SD, E shore of Seneca Lake 1 km NNW of Indian Creek (N boundary of

cemetery on N side of Willard). (Loc. 15 of Oliver and Sorauf). Seneca Co. USNM 518488 (1 specimen) plus 1 illustrated and measured.

Bay View Coral Bed

Buffalo SE Quad: USGS 9140-SD, large, low abandoned quarry N of Big Tree Rd. and W of old Erie RR position; 1.5 km S of Blasdell. See discussion in section on the Fall Brook population, Erie Co.

9. Fall Brook Coral Bed

Leicester Quad: All of our collections are from one locality north of Leicester (formerly Moscow); Livingston Co. The different collections were made at different times. The neotype was stated to be from Moscow, Livingston County. This is probably the Fall Brook coral bed and possibly the Little Beards Creek locality.

USGS 5700-SD, east side of Little Beards Creek in farmyard 0.7 km E of NY 36 and 1.3 km N of Leicester (US 20A), Livingston Co. USNM 518492–518505 (14 specimens) plus 2 illustrated and measured.

USGS 8770-SD, same as 5700-SD. USNM 518506 (1 specimen) plus 1 illustrated and measured.

USGS 11476-SD, same as 5700-SD. Collected by P. E. Cloud. USNM 518507–518508 (2 specimens).

Lansing Coral Bed

Ludlowville Quad: USGS 5678-SD, large abandoned quarry above Portland Point, N of Gulf Creek. Tompkins Co. USNM 518509–518514 (6 specimens) make up the sample compared to the Fall Brook sample in discussion of the latter.

10. Bellona Coral Bed, Tully Limestone

Stanley Quad: USGS 5341-SD. Kashong Creek in Bellona, upstream from falls, SW of Pre-emption Road

bridge. (Loc. 9c of Heckel, 1973). Yates Co. (NE corner). USNM 518520–518528 (9 specimens) plus 1 illustrated and measured.

USGS 8766-SD, same as 5341-SD. 1 illustrated specimen, not in measured sample.

USNM 113668, illustrated by Ehlers and Stumm (1953), is “Kashong Creek, Bellona, N.Y., collected by G.A. Cooper.”

Locality USNM 11671, “Yates County, N.Y.” is most likely Kashong Creek in Bellona. USNM 518529–518531 (3 specimens) plus 1 illustrated and measured.

USGS 11204-SD, old quarry, 2.1 km N of Bellona. Probably loc. 9n of Heckel, 1973. Ontario Co. USNM 518532 (1 specimen) plus 1 illustrated and measured.

Ovid Quad: USGS 5344-SD, Old Chamberlain Quarry, 2.7 km NNE of Ovid. (Loc. 8ab of Heckel, 1973). Seneca Co. USNM 518533–518534 (2 specimens).

USGS 5718-SD, same as 5344-SD. USNM 518535 (1 specimen).

Scipio Center Quad: J.W. Wells colln., Scipio Town Quarry, 1.35 km N of Scipio Center. (Loc. 5c of Heckel, 1973). Cayuga Co. USNM 518536 (1 specimen).

Owasco Quad: Loc. 5t of Heckel (1973); glen, 1.1 mi (2 km) northwest of Twelve Corners (upstream from bridge). Collected by P. H. Heckel. Cayuga Co.

Spafford Quad: USGS 6094-SD, Carpenter Falls on Bear Swamp Creek, 1.7 km SW of mouth of creek (at Carpenter Point, SW side of Skaneateles Lake). (Loc. 5p of Heckel, 1973). Cayuga Co. USNM 518537–518540 (4 specimens) plus 1 illustrated and measured.

EXPLANATION OF PLATES

Transverse sections of solitary forms are oriented with cardinal septum (if known) toward the top of the page; where not known, an interpretation, based on examination of section and specimen is used. All "sections" are thin sections. Most are photographed as though looking down from the calice; those photographed as though from below are marked UD (upside down). Collection localities (USGS 0000-SD) are in New York State unless otherwise indicated.

EXPLANATION OF PLATE I

Figure	Page
1–19. <i>Heliophyllum halli halli</i> Milne-Edwards and Haime; exterior views (×1); specimens are from old USNM collections (USNM collection numbers in parentheses) and were selected to illustrate form variation.	18
1–10. "Wanakah Shale, <i>Pleurodictyum</i> bed, Murder Creek, Darien." Almost certainly our Darien coral bed (population 6; see USGS 5706-SD). 1. USNM 518302 (113933); 2. USNM 518303 (72718); 3, 4. USNM 518304 (113933); 5–7. USNM 918305 (133936); 8. USNM 518306 (113934); 9. USNM 509792 (72718); 10. USNM 518307 (113936).	
11–14. "Hill Farm near Pavilion." (134884). This is our Hill's Gulch locality in the town of Pavilion, but both Jaycox Shale and lower Deep Run crop out there (populations 7 and 8) and the specimens may be from either or both units; see discussion in Appendix—Jaycox, Leroy Quad. 11. USNM 509791; 12. USNM 509793; 13, 14. USNM 518308.	
15–19. "Centerfield Member, 3 mi west of East Bethany." This is our population 3 and probably our Francis Road locality (see USGS 4678-SD). 15. USNM 518299 (134874); 16, 17. USNM 509789 (134883); 18. USNM 518300 (134874); 19. USNM 518301 (134874).	
Figures 9, 11, 12, and 16–17 are from Sorauf (2001).	

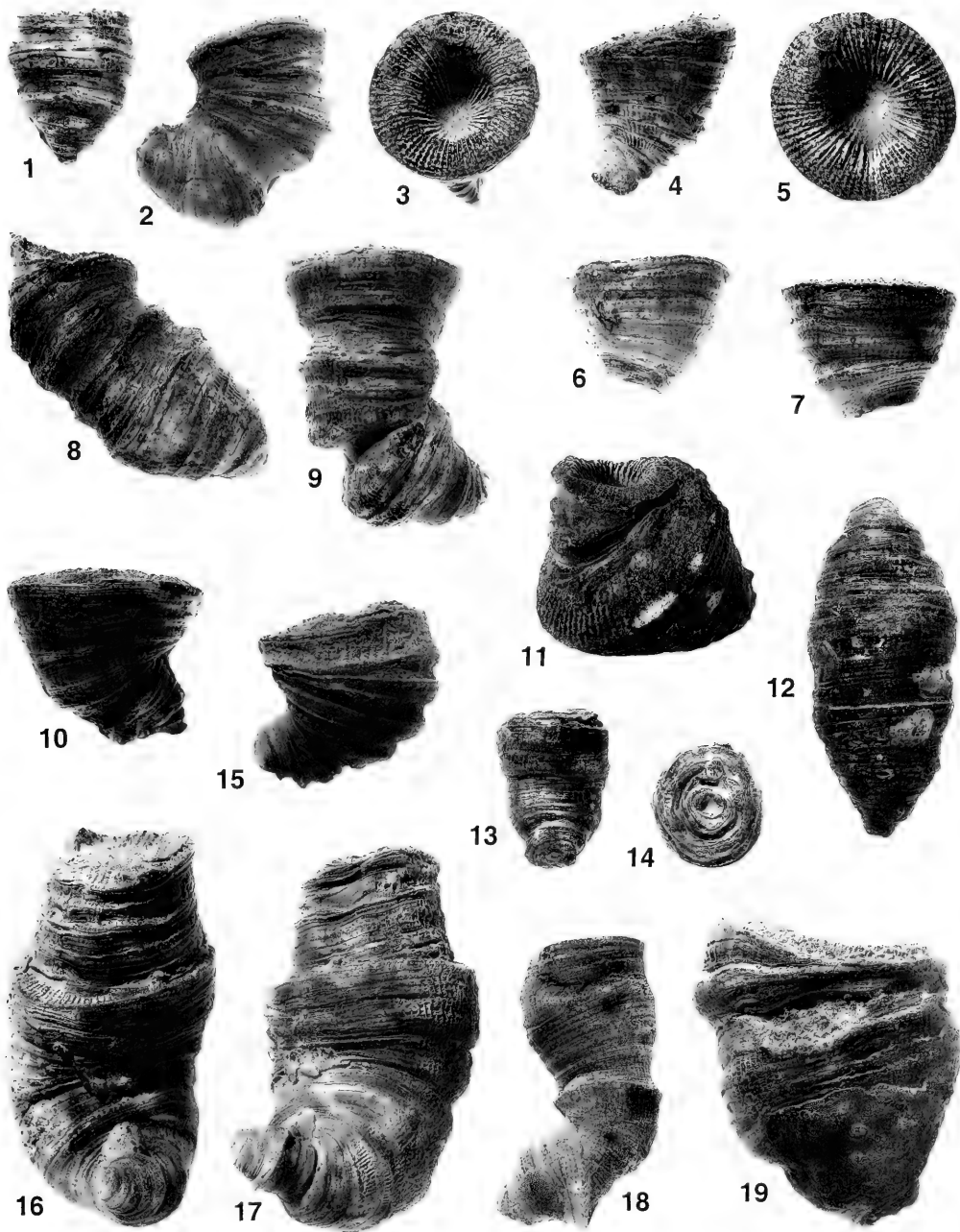

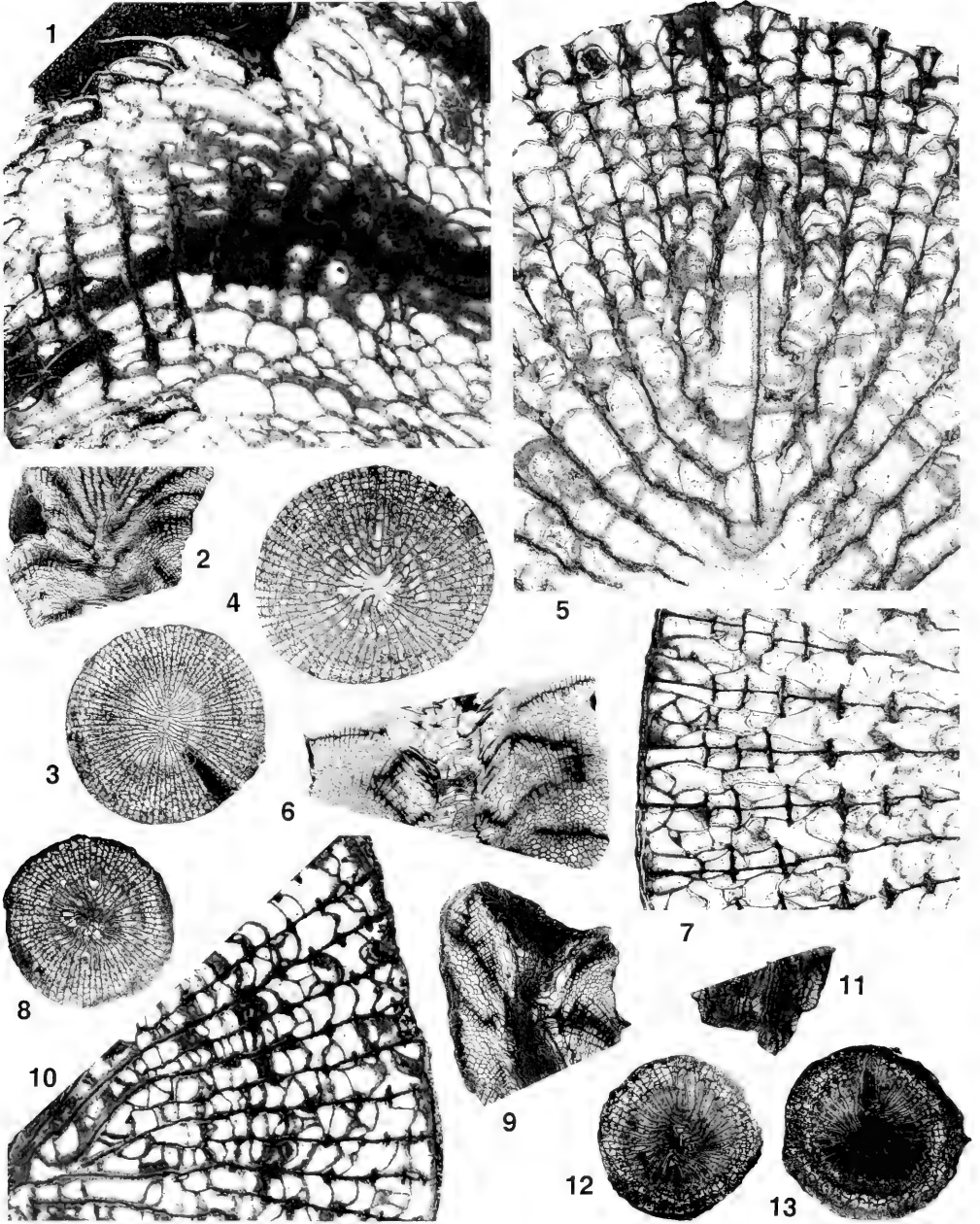

EXPLANATION OF PLATE 2

Figure	Page
1-7. <i>Heliophyllum halli halli</i> Milne-Edwards and Haime: Case Hill coral bed (population 2), USGS 9747-SD, Case Hill.	18
1-3. USNM 518325; 1, 2, longitudinal ($\times 10$, $\times 1.5$) and 3, transverse ($\times 1.5$) sections.	
4, 5. USNM 518326; transverse (UD) sections ($\times 1.5$, $\times 7.5$).	
6. USNM 518327; longitudinal section ($\times 1.5$).	
7. USNM 518328; transverse section ($\times 7.5$).	
8-13. <i>Heliophyllum halli halli</i> Milne-Edwards and Haime: Halihan Hill coral bed (population 1), USGS 5305-SD, Mount Marion.	18
8. USNM 518309, transverse (UD) section ($\times 1.5$).	
9, 10. USNM 518310, longitudinal ($\times 1.5$) and partial transverse (UD; $\times 7.5$) sections.	
11-13. USNM 518311, longitudinal and lower (UD) and upper transverse sections (approximately 3 mm apart) (all $\times 1.5$).	

EXPLANATION OF PLATE 3

Figure	Page
1-7. <i>Heliophyllum halli halli</i> Milne-Edwards and Haime; Staghorn Point coral bed (population 4).	18
1-6. USGS 7542-SD, Skaneateles Lake. 1-3. USNM 518391; transverse ($\times 1.5$, $\times 10$) showing short and discontinuous minor septa, and longitudinal ($\times 1.5$) sections. 4-6. USNM 518392; upper transverse, intermediate longitudinal, and lower transverse (UD) sections (all $\times 1.5$).	
7. USNM 518393, USGS 9102-SD, Lords Hill; longitudinal section through calice of specimen with reflexed margin ($\times 1.5$).	
8-11. <i>Heliophyllum halli halli</i> Milne-Edwards and Haime; Centerfield Member (population 3), east of York.	18
8. USNM 518346, USGS 5324-SD; longitudinal section ($\times 1.5$) of unusually large specimen.	
9, 10. USNM 518347, USGS 11197-SD; transverse sections (UD; $\times 1.5$, $\times 7.5$).	
11. USNM 518348, USGS 5324-SD; transverse section ($\times 1.5$).	

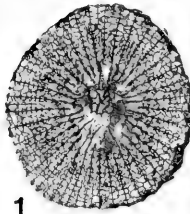

1

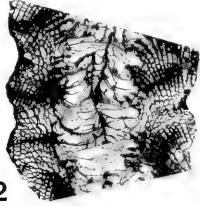

2

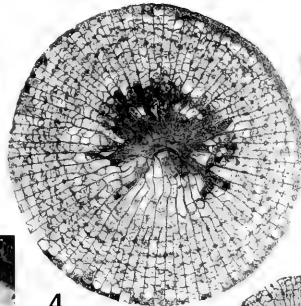

4

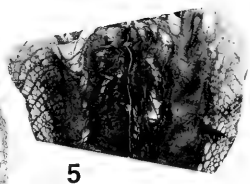

5

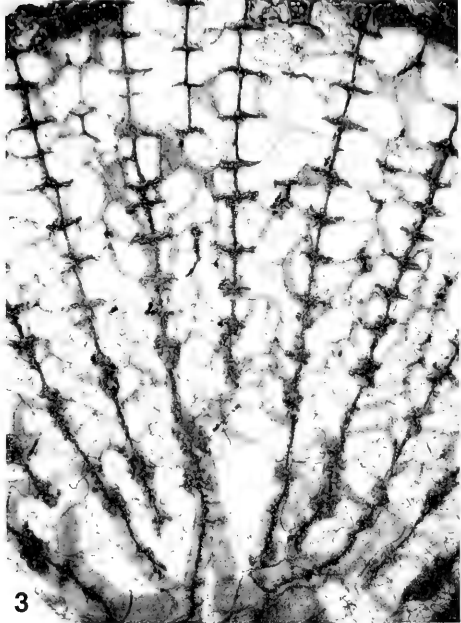

3

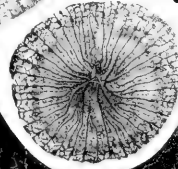

6



7

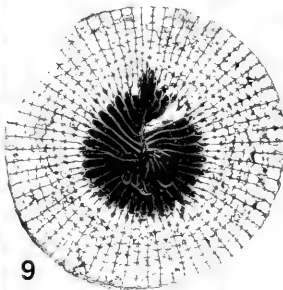

9

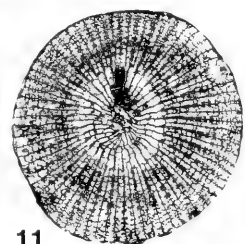

11

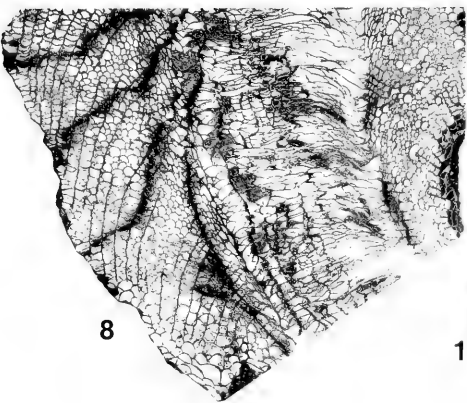

8

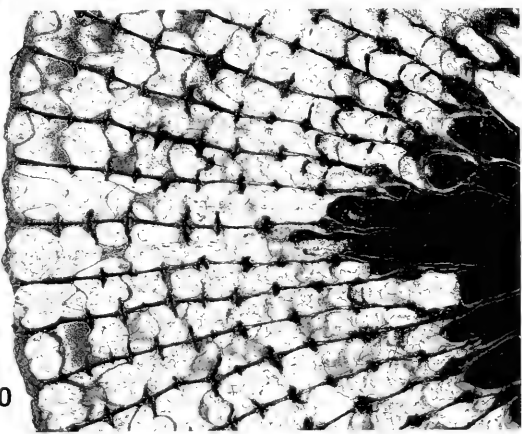

10



1

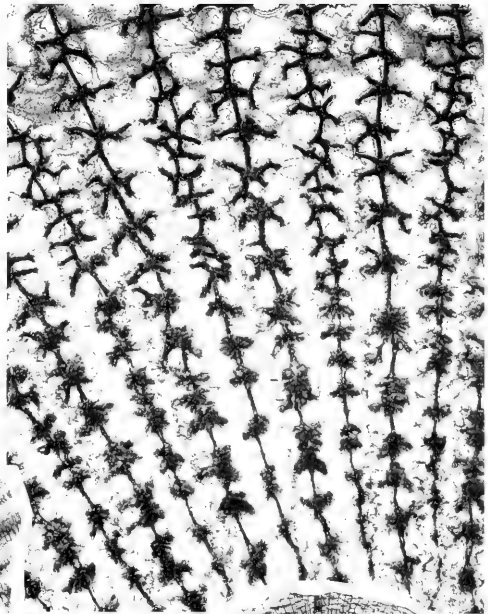

2

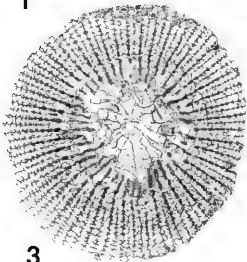

3

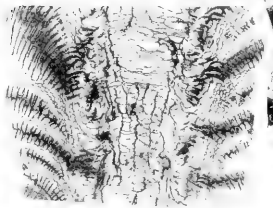

4

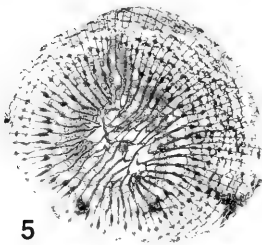

5

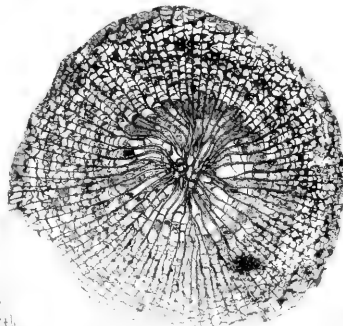

7

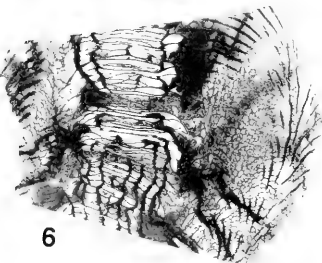

6

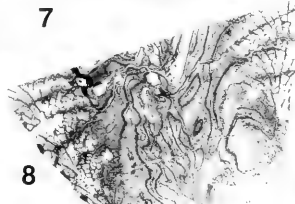

8

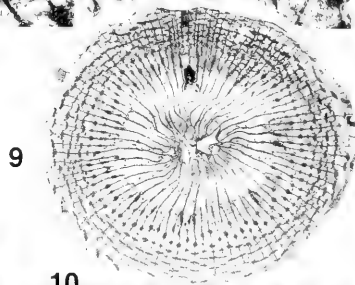

9

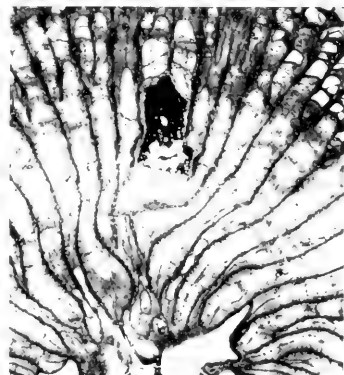

10

EXPLANATION OF PLATE 4

Figure	Page
1-10. <i>Heliophyllum halli halli</i> Milne-Edwards and Haime; Joshua coral bed (population 5); Lords Hill.	18
1, 2. USNM 219922, USGS 4286-SD; longitudinal and transverse sections ($\times 10$), illustrating Type III carinae (fig. 2 is after Sorauf and Oliver, 1976).	
3, 4. USNM 518403, USGS 4669-SD; transverse (UD) and longitudinal sections ($\times 1.5$).	
5, 6. USNM 518404, USGS 4669-SD; transverse (UD) and longitudinal sections ($\times 1.5$).	
7, 8. USNM 518405, USGS 9131-SD; transverse (UD) and longitudinal sections ($\times 1.5$).	
9, 10. USNM 518406, USGS 4669-SD; transverse sections ($\times 1.5$, $\times 5$).	

EXPLANATION OF PLATE 5

Figure	Page
1-9. <i>Heliophyllum halli halli</i> Milne-Edwards and Haime; Darien coral bed, Murder Creek, Darien (population 6).	18
1-3. USNM 518428, USGS 5706-SD; transverse (UD; $\times 1.5$, $\times 7.5$) and longitudinal ($\times 7.5$) sections illustrating short and discontinuous minor septa and Type IIb carinae.	
4, 5. USNM 518429, USGS 11208-SD; longitudinal and transverse sections ($\times 1.5$), the latter with short and discontinuous minor septa.	
6, 7. USNM 518430, USGS 11208-SD; transverse (UD) and longitudinal sections ($\times 1.5$); note long, peripherally discontinuous minor septa and Type IIb carinae.	
8, 9. USNM 518431, USGS 11208-SD; transverse sections (UD; $\times 1.5$, $\times 7.5$); minor septa relatively long; figure 9 illustrates "network" dissepimentarium discussed in text.	

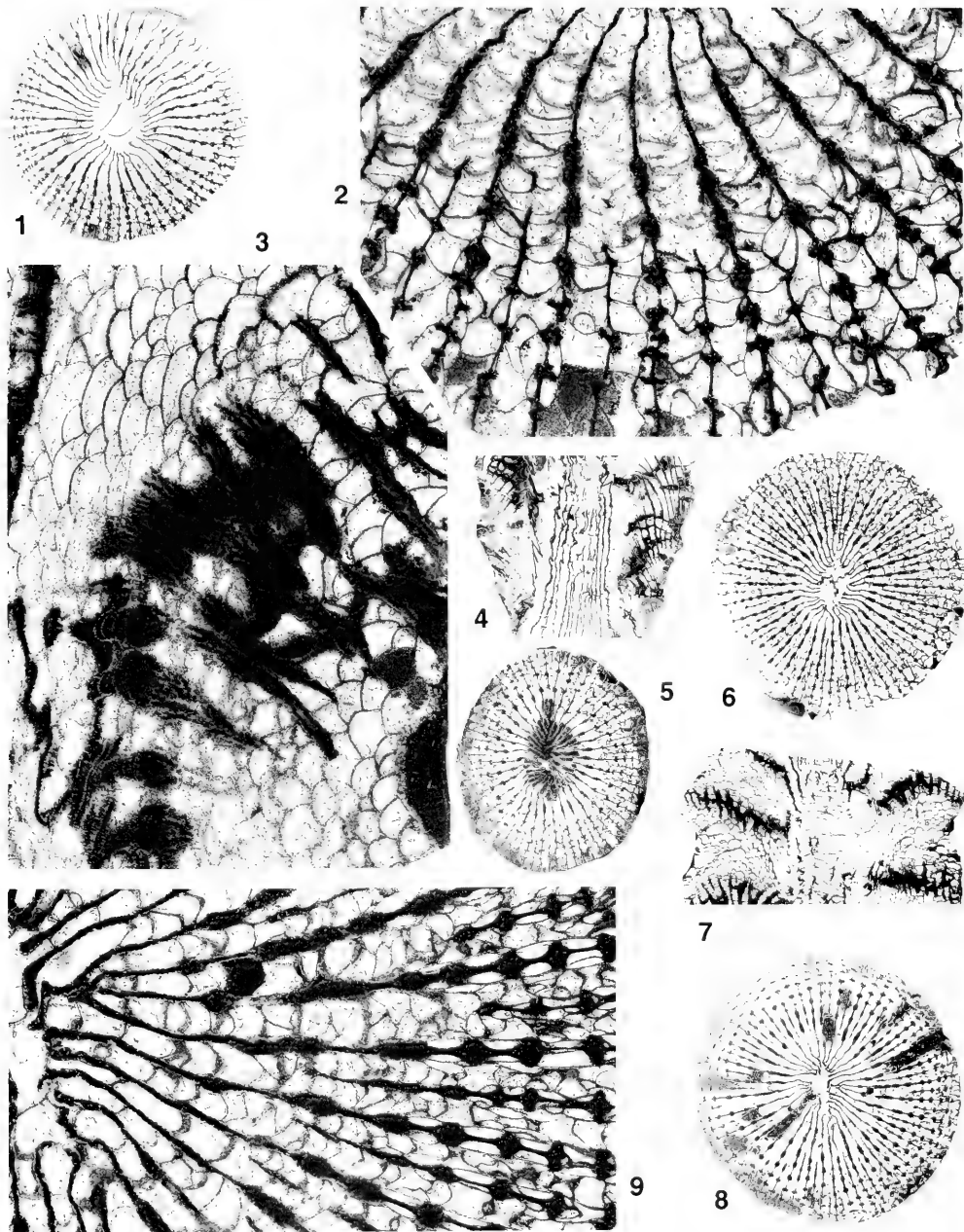

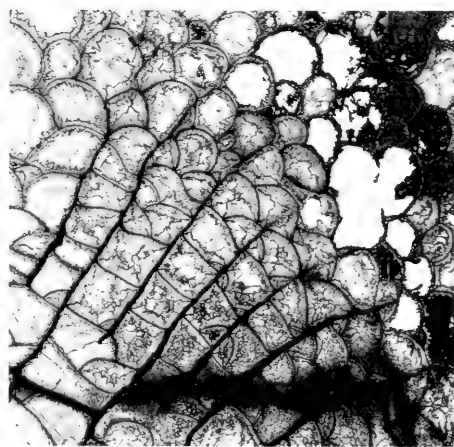
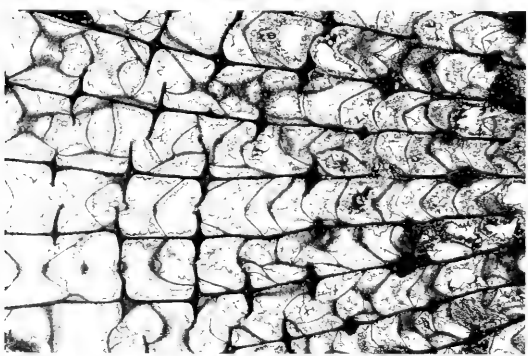
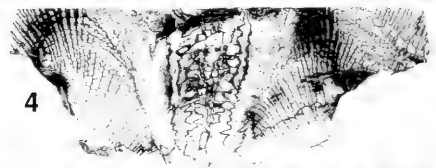
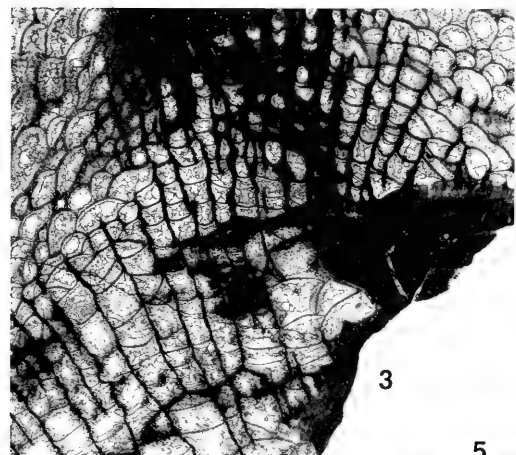
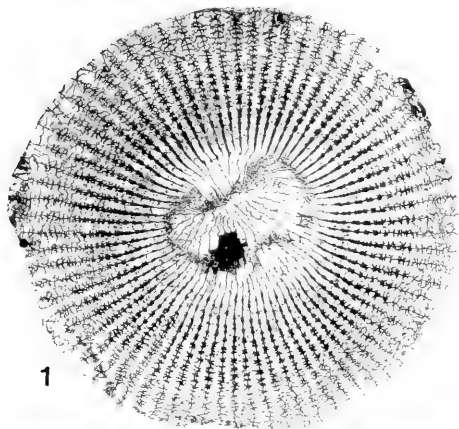

EXPLANATION OF PLATE 6

Figure	Page
1-6. <i>Heliophyllum halli halli</i> Milne-Edwards and Haime; Greens Landing coral bed, Jaycox Member (population 7); USGS 11470-SD, Greens Landing ravine on Canandaigua Lake, N.Y.; two specimens with contrasting carinae.	18
1-4. USNM 518441; transverse and longitudinal sections ($\times 1.5$) and details of each ($\times 7.5$); Type I-III carinae.	
5, 6. USNM 518442; parts of transverse (UD) and longitudinal sections ($\times 7.5$); simple, Type I carinae.	

EXPLANATION OF PLATE 7

Figure	Page
1, 2. <i>Heliophyllum halli halli</i> Milne-Edwards and Haime. USNM 219925; specimen is from an old USNM collection "Hamilton, Ludlowville, Tichenor; 1.5 miles SE of E. Bethany." The locality is the west branch of White Creek and the specimen is probably from the Greens Landing coral bed, Jaycox Member (population 7), because the richly fossiliferous beds beneath the Tichenor Limestone were long included in the Tichenor. However, the Deep Run Shale (with population 8) overlies the Tichenor at this locality and this is a possible source. Two details of longitudinal section ($\times 10$) to illustrate Type IIa carinae (compare these with Type IIb on Plate 8); for additional illustrations of same specimen, see Sorauf and Oliver (1976, pl. 3, figs. 2-4).	18
3-5. <i>Heliophyllum halli halli</i> Milne-Edwards and Haime; Greens Landing coral bed, Jaycox Member (population 7).	18
3. USNM 518443, USGS 5708-SD, Bullis Bridge; detail of longitudinal section ($\times 10$) with Type IIb carinae.	
4, 5. USNM 518444, USGS 6108-SD, west of York; transverse and longitudinal sections ($\times 1.5$) showing Type I and I-III carinae.	



1

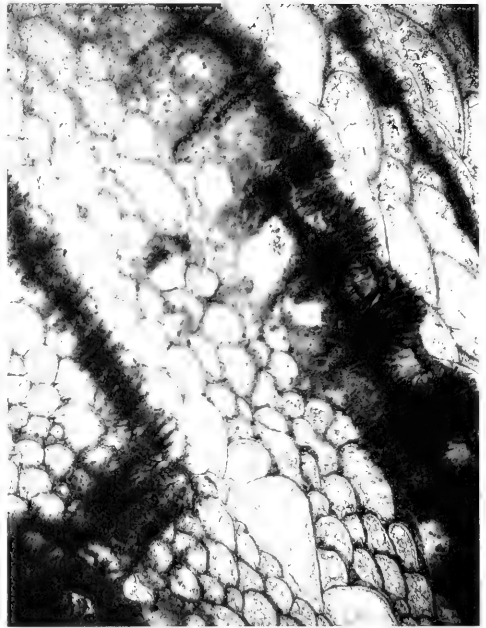

3

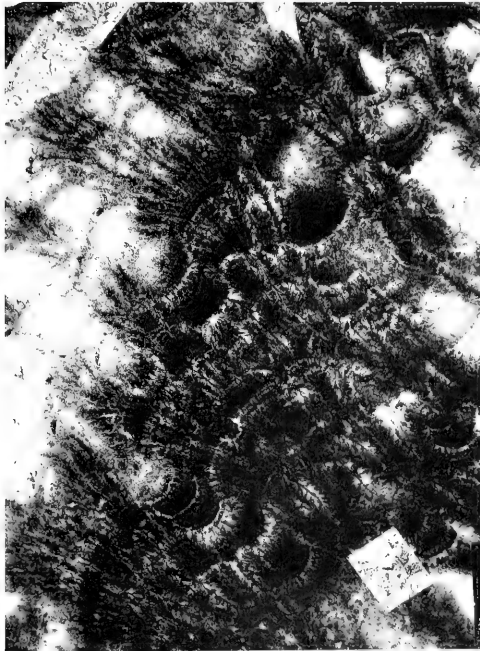

2

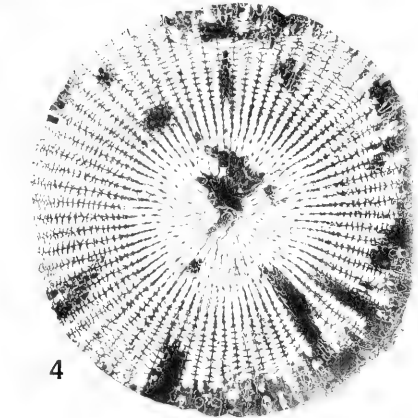

4



5

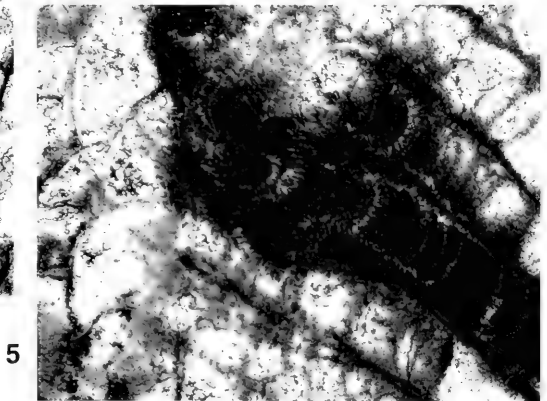
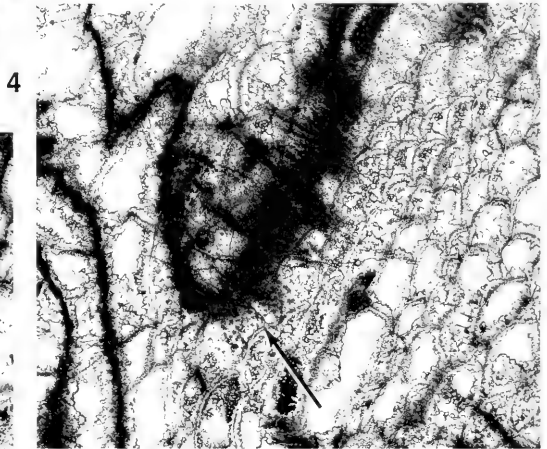
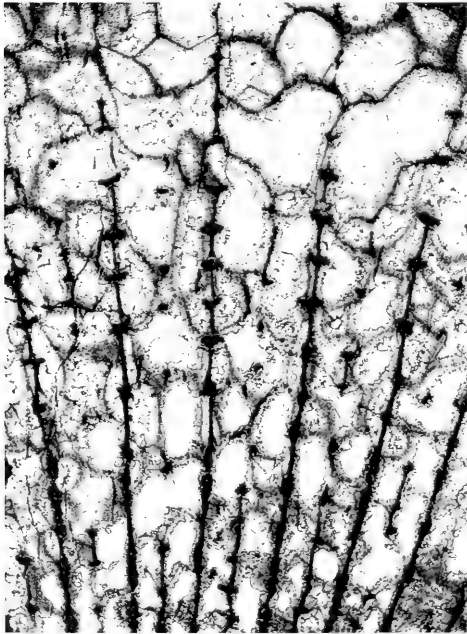
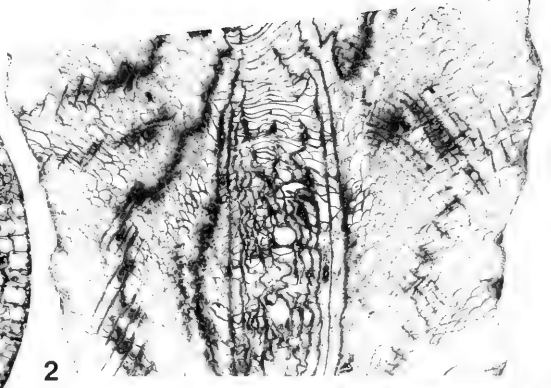
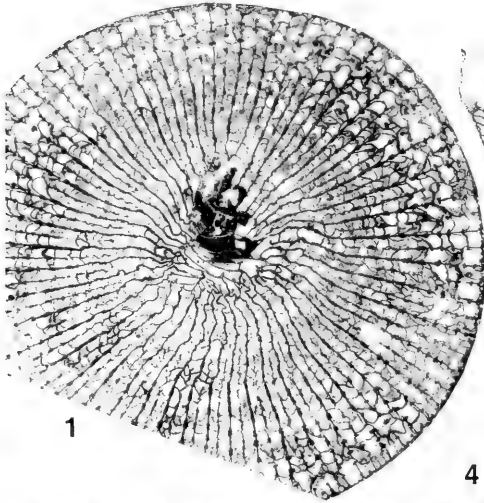

EXPLANATION OF PLATE 8

Figure	Page
1-5. <i>Heliophyllum halli halli</i> Milne-Edwards and Haime; lower Deep Run Shale (population 8). USNM 498542, USGS 5684-SD, Deep Run ravine on Canandaigua Lake.	
1-2. transverse and longitudinal sections ($\times 2$); photographs of these two sections were published by Sorauf and Oliver (1976, text-fig. 2) with erroneous stratigraphic and locality data, here corrected.	
3. detail of another transverse section with peripheral discontinuities in minor and some major septa ($\times 7.5$).	
4. detail of Type IIb carinae in upper right of figure 2; vepreculae (arrows) are the outer ends of secondary trabeculae approximately perpendicular to section ($\times 10$).	
5. detail of another longitudinal section with Type IIb carinae ($\times 15$). Compare Type IIb carinae illustrated here to Type IIa on Plate 7.	18

EXPLANATION OF PLATE 9

Figure	Page
1-14. <i>Heliophyllum halli halli</i> Milne-Edwards and Haime; lower Deep Run Shale (population 8); from various localities in western and west-central N.Y.; all <1.5.	18
1-3. USNM 518467, USGS 11475-SD, Canandaigua Lake; upper and lower (UD) transverse and intermediate longitudinal sections.	
4, 5. USNM 518468; USGS 11473-SD, Canandaigua Lake; upper and lower transverse sections.	
6, 7. USNM 518469, USGS 5693-SD, Transit Road; transverse and longitudinal sections.	
8, 9. USNM 518470, USGS 11475-SD, Canandaigua Lake; longitudinal and lower transverse sections of immature individual.	
10, 11. USNM 518471, USGS 5698-SD, Hill's Gulch; longitudinal and transverse sections with Type IIb carinae producing vepreculae.	
12. USNM 518472, USGS 11490-SD, Kashong Glen; transverse section through calice showing cardinal fossula.	
13. USNM 518473, USGS 11489-SD, Seneca Lake; transverse section with long, complete minor septa.	
14. USNM 518474, USGS 5698-SD, Hill's Gulch; transverse section (UD).	

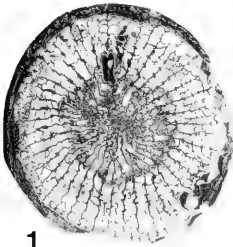

1



3

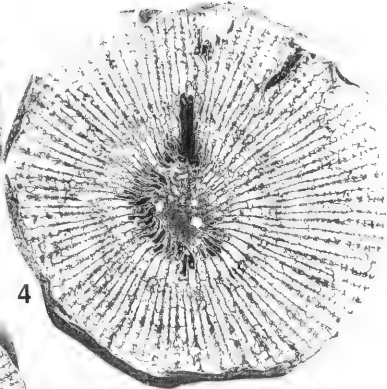

4



2

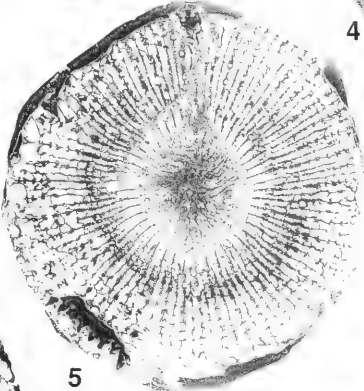

5

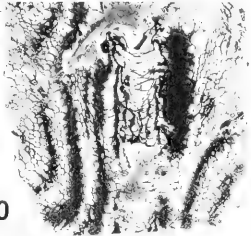

10

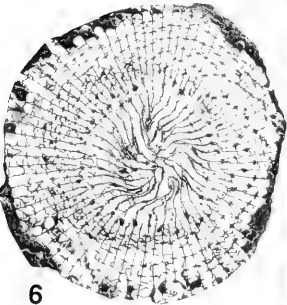

6

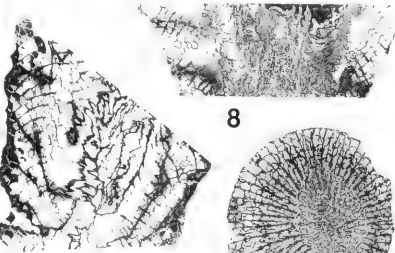

7

8

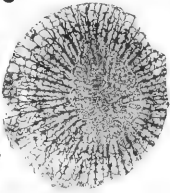

9

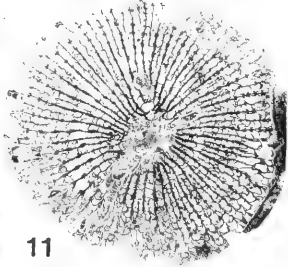

11

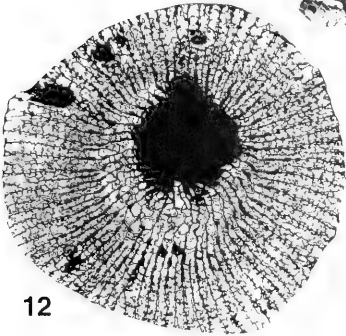

12

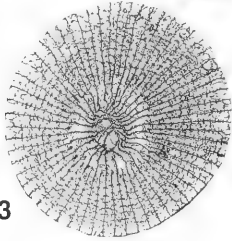

13

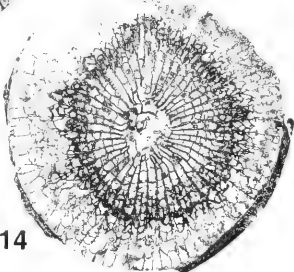

14

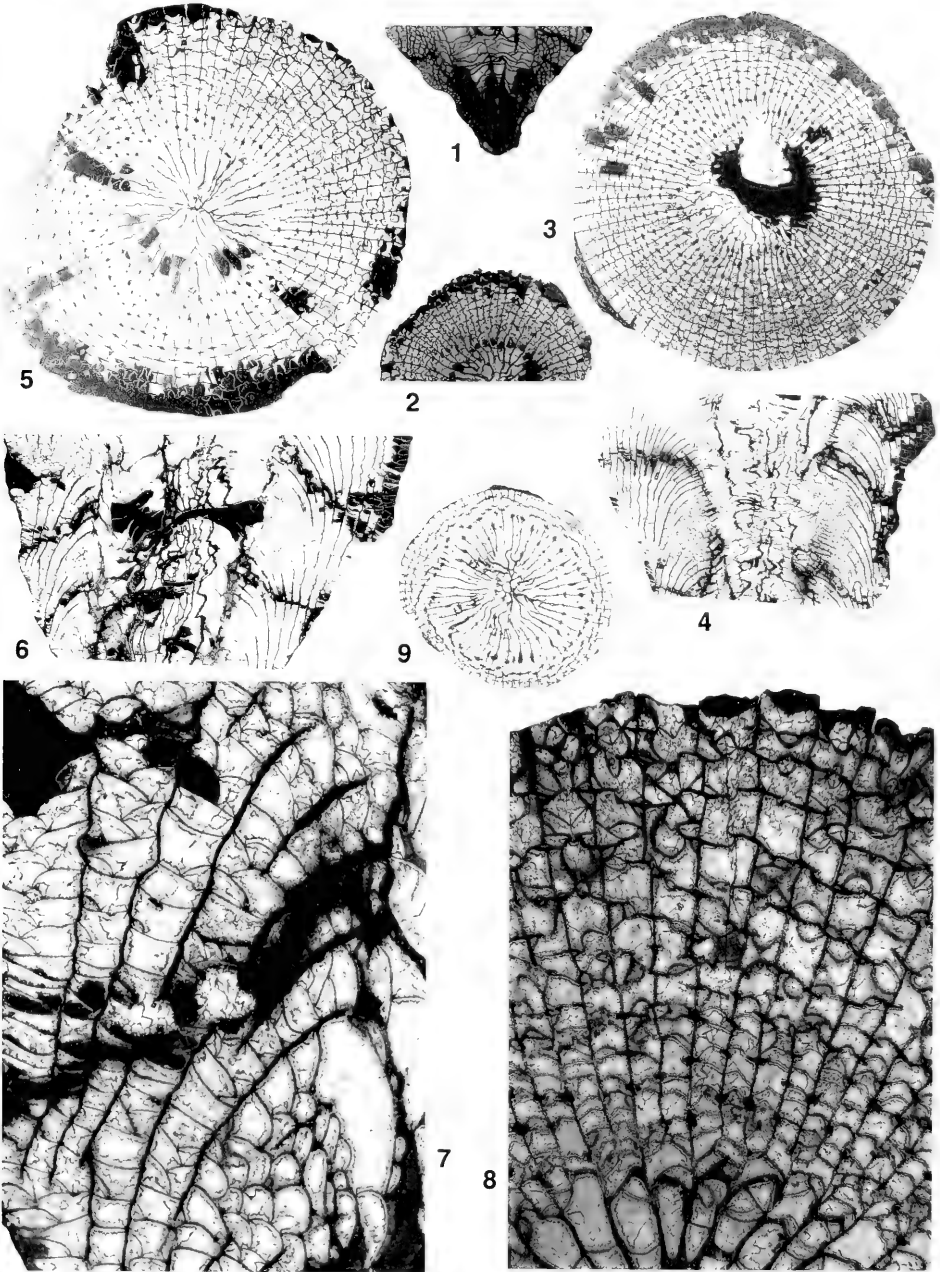

EXPLANATION OF PLATE 10

Figure	Page
1, 2. <i>Heliophyllum halli halli</i> Milne-Edwards and Haime; Neotype, MNHN IP S.11661 (Paris); longitudinal and transverse sections ($\times 1.5$); specimen illustrated by Milne-Edwards and Haime (1851, pl. 7, figs.6, 6a, 6b) and Coen-Aubert (1987, pl. 1, figs. 1, 2). Locality given as Hamilton Group, Moscow (now Leicester), Livingston County, New York; this is probably the Fall Brook coral bed (our population 9), and may be our Little Beards Creek locality.	18
3-9. <i>Heliophyllum halli halli</i> Milne-Edwards and Haime; Fall Brook coral bed (population 9); Little Beards Creek, north of Leicester.	18
3, 4. USNM 518489, USGS 5700-SD; transverse and longitudinal sections ($\times 1.5$).	
5-8. USNM 518490, USGS 8770-SD; transverse (UD) and longitudinal sections ($\times 1.5$), and parts of same ($\times 7.5$, $\times 5$).	
9. USNM 518491, USGS 5700-SD; transverse section (UD).	

Note that virtually all carinae are simple Type 1.

EXPLANATION OF PLATE 11

Figure	Page
1-8. <i>Heliophyllum halli halli</i> Milne-Edwards and Haime; Bellona coral bed, Tully Limestone (population 10); Bellona and other localities in central N.Y.	18
1, 2. USNM 518515, USGS 5341-SD, Bellona; longitudinal section ($\times 1.5$) and part of same ($\times 10$) with Type I-III carinae.	
3, 4. USNM 518516, USGS 11204-SD, Bellona; part of longitudinal ($\times 7.5$) and transverse (UD; $\times 1.5$) sections, with Type I carinae.	
5. USNM 518517; Yates County, probably Bellona; transverse section (UD; $\times 1.5$).	
6. USNM 518518; USGS 8766-SD, Bellona; transverse section through immature growth stage with partial dilation ($\times 1.5$).	
7, 8. USNM 518519; USGS 6094-SD, Carpenters Falls; longitudinal section ($\times 1.5$, and detail $\times 10$) showing Type IIb carinae.	

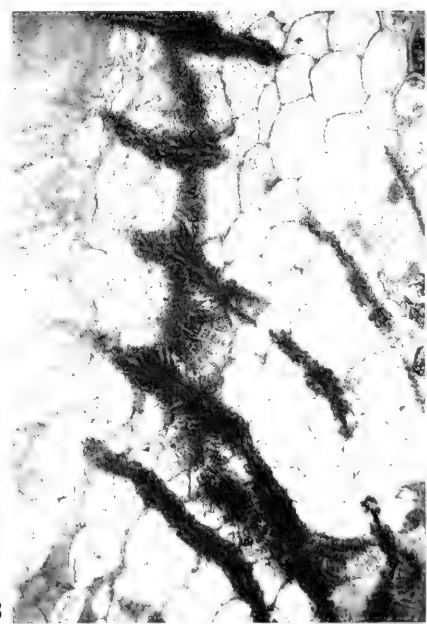
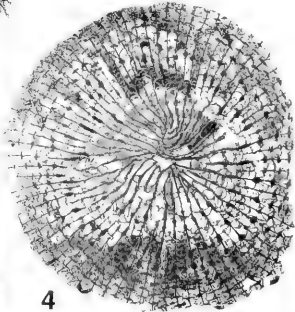
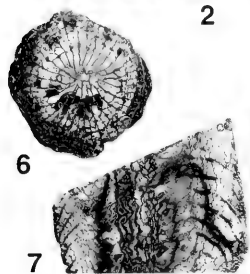
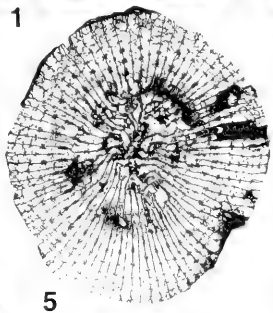
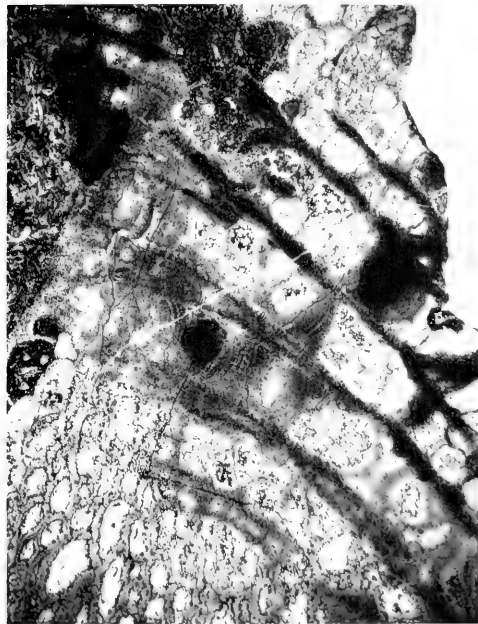

1

3

2

5

6

4

7

8

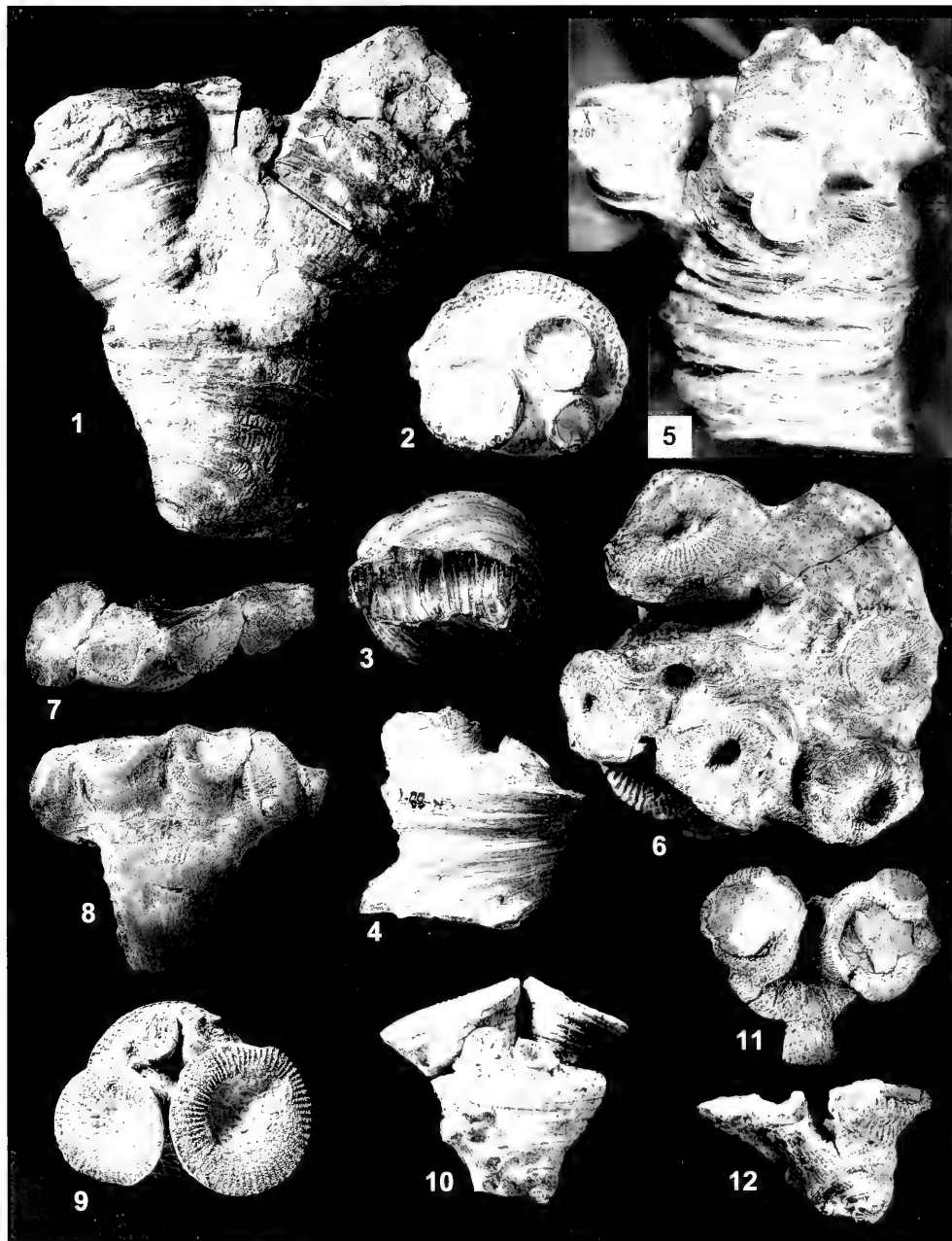

EXPLANATION OF PLATE 12

Figure	Page
1–12. <i>Heliophyllum halli halli</i> Milne-Edwards and Haime; Exterior views of specimens with offsets, including “forma <i>praecoquus</i> ” of Wells (1937). (×1, except fig. 1).	18
1. PRI 40200 (coll. E.J. Buehler); Jaycox Shale, Bullis Bridge, Green’s Landing coral bed (our population 7); (×0.9); protocorallite is nearly complete with apex to lower left, photograph shows large apical angle of protocorallite and offsets (see also Pl. 13).	
2–4. USNM 518541, USGS 11470-SD, Greens Landing ravine, Jaycox Member, Greens Landing coral bed (population 7); 2, top view of calice and three offsets; 3, basal view showing scar of attachment to another coral; 4, side view.	
5, 6. AMNH 517220; Hamilton Group, Livingston County (probably Jaycox or younger); side and top views of <i>Heliophyllum proliferum</i> of Hall (1877, pl. 26, fig. 5) (see also Pl. 13).	
7, 8. PRI 24550; Staghorn Point coral bed (our population 4), Skaneateles Lake; top and side views of <i>H. halli</i> “forma <i>praecoquus</i> ” (“holotype” of Wells, 1937, pl. 1, fig. 12, and text-fig. 10).	
9, 10. USNM 487251; Jaycox Member, Green’s Landing coral bed, Jaycox Run (collected, prepared, and given to USNM by G. Kloc); top and side views of near-perfect specimen of “forma <i>praecoquus</i> ”.	
11, 12. PRI 24561; Staghorn Point coral bed (our population 4), Skaneateles Lake; top and side views of “forma <i>praecoquus</i> ” of Wells (1937, text-fig. 11).	
In addition to cited illustrations, specimens in figures 1 and 7–10 were illustrated by Oliver (1997a, pl. 1).	

EXPLANATION OF PLATE 13

Figure	Page
1-7. <i>Heliophyllum halli halli</i> Milne-Edwards and Haime; thin sections of two specimens with offsets illustrated on Plate 12.	18
1-4. AMNH 517220 (see explanation of Pl. 12, figs. 5, 6); 1. transverse section ($\times 1.5$) just below the crowd of offsets in Plate 12, figures 5, 6; 4. longitudinal section (1.5) from lower end of specimen as shown in Plate 12, figure 1; 3. detail of figure 4 showing Type III carinae.	
5-7. PRI 40200 (see explanation of Pl. 12, fig. 1); 5. transverse section ($\times 2.5$) through calice of protocorallite and lower ends of offsets; 7. transverse section ($\times 1.5$) approximately 1 cm lower than the one in figure 5; 6. longitudinal section ($\times 1.5$) from below transverse sections.	

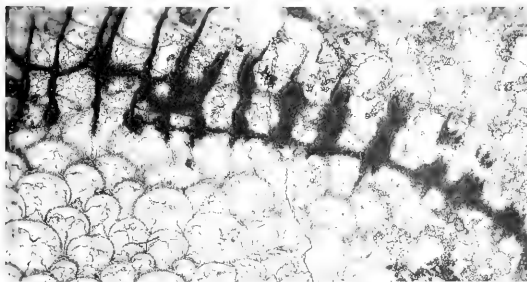
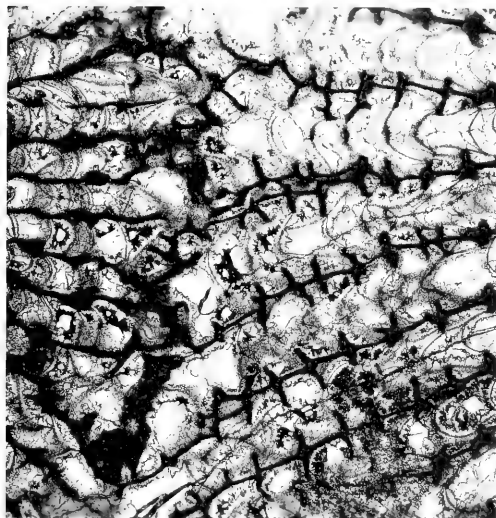
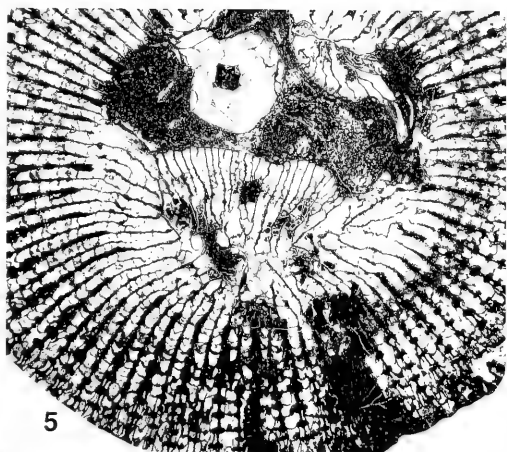
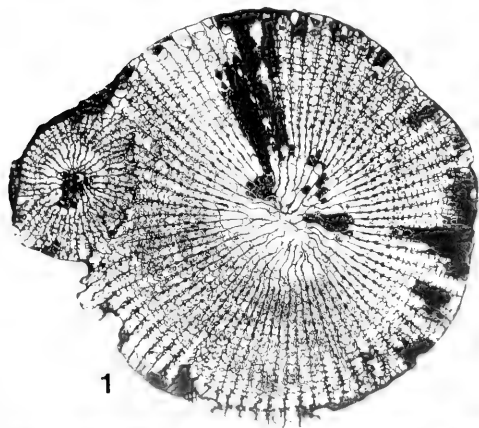

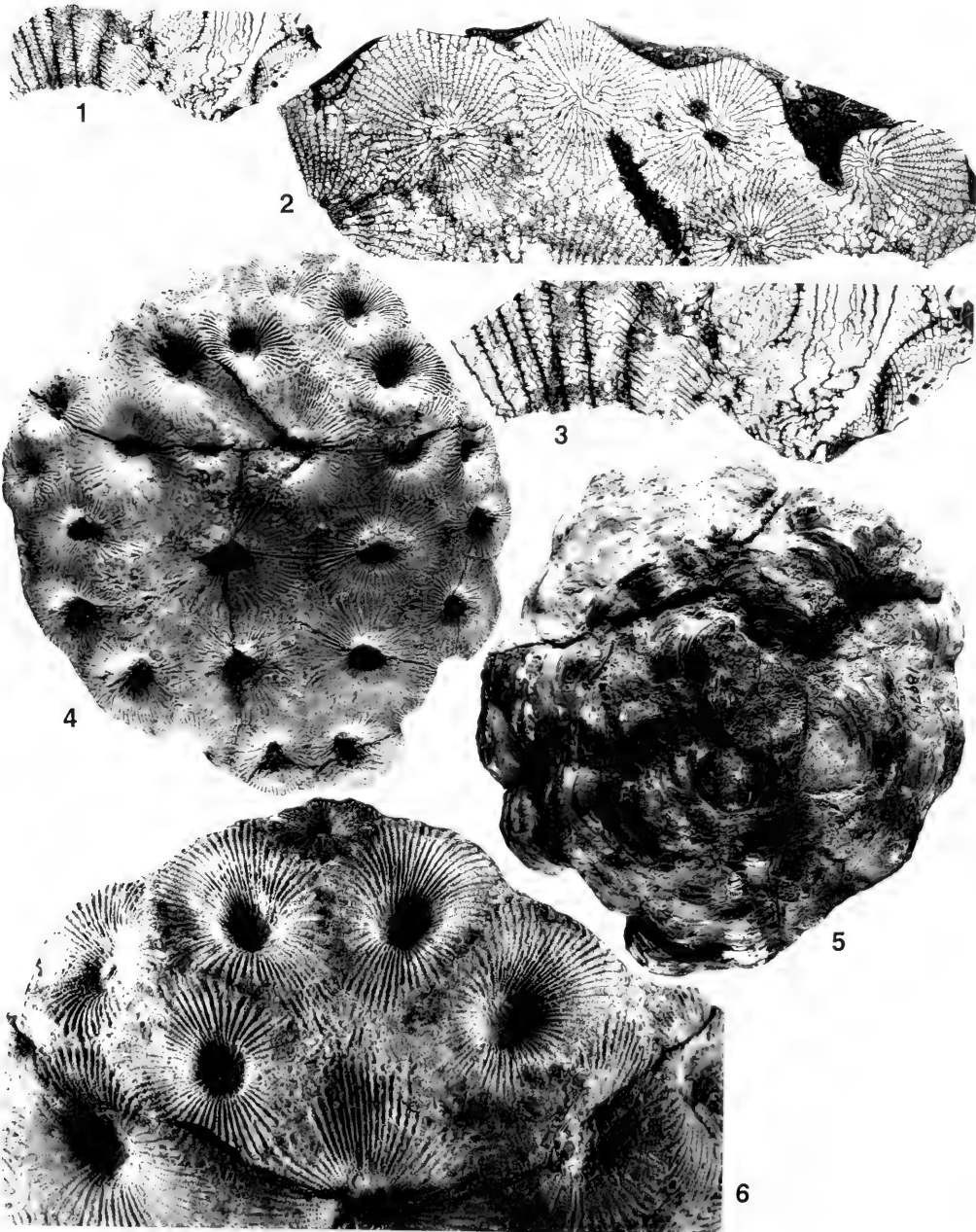

EXPLANATION OF PLATE 14

Figure	Page
1-6. <i>Heliophyllum halli confluens</i> (Hall); FMNH UC 18974, Lectotype, original of Hall (1877, pl. 17); York, Livingston County. Assumed to be from Greens Landing coral bed, Jaycox Member, along Browns Creek, west of York (associated with our population 7). 1-3, thin sections taken from the underside of the part of the colony toward the top of the plate in figures 4-6 (see also Pl. 15, fig. 7); 1, 2, longitudinal and transverse (UD) sections ($\times 1.5$); 3, same as figure 1 ($\times 2.5$); 4, 5, upper and lower surfaces of corallum ($\times 0.5$) with the same part of specimen toward the top of plate; 6, part of upper surface ($\times 1$) removed and cleaned by E.C. Stumm in preparation for his study (1955); this is uppermost in figure 4 but here is tilted slightly toward the camera for better detail. . . .	24

EXPLANATION OF PLATE 15

Figure	Page
1-9. <i>Heliophyllum hali confluens</i> (Hall); Greens Landing coral bed, Jaycox Member (associated with population 7);	24
1, 2. USNM 518542; Locality USGS 5323-SD, west of York; top surface of corallum ($\times 1$) and transverse section just below ($\times 1.5$).	
3, 4. USNM 487252, "East Bethany, N.Y." ($\times 1$); top and side views of twins(?), may have been product of fusion of two larvae.	
5, 6. AMNH 517241, Paralectotype, original of Hall (1877, pl. 26, figs. 3, 4); Genesee Valley, N.Y. (AMNH catalog); upper and lower surfaces of corallum ($\times 1$) composed of 7 or more corallites.	
7. FMNH UC 18974, Lectotype, see explanation of Plate 14; part of transverse section (UD) shown on Plate 14, figure 2 ($\times 5$).	
8. USNM 518543, USGS 5323-SD, west of York; part of transverse section ($\times 1.5$).	
9. USNM 518544, USGS 5703-SD, Alden; part of transverse section ($\times 1.5$).	
Specimens without USGS collection numbers are assumed to be from the Greens Landing coral bed because the subspecies is known only from this unit. Figures 7, 8, and 9 are to illustrate boundaries between corallites.	

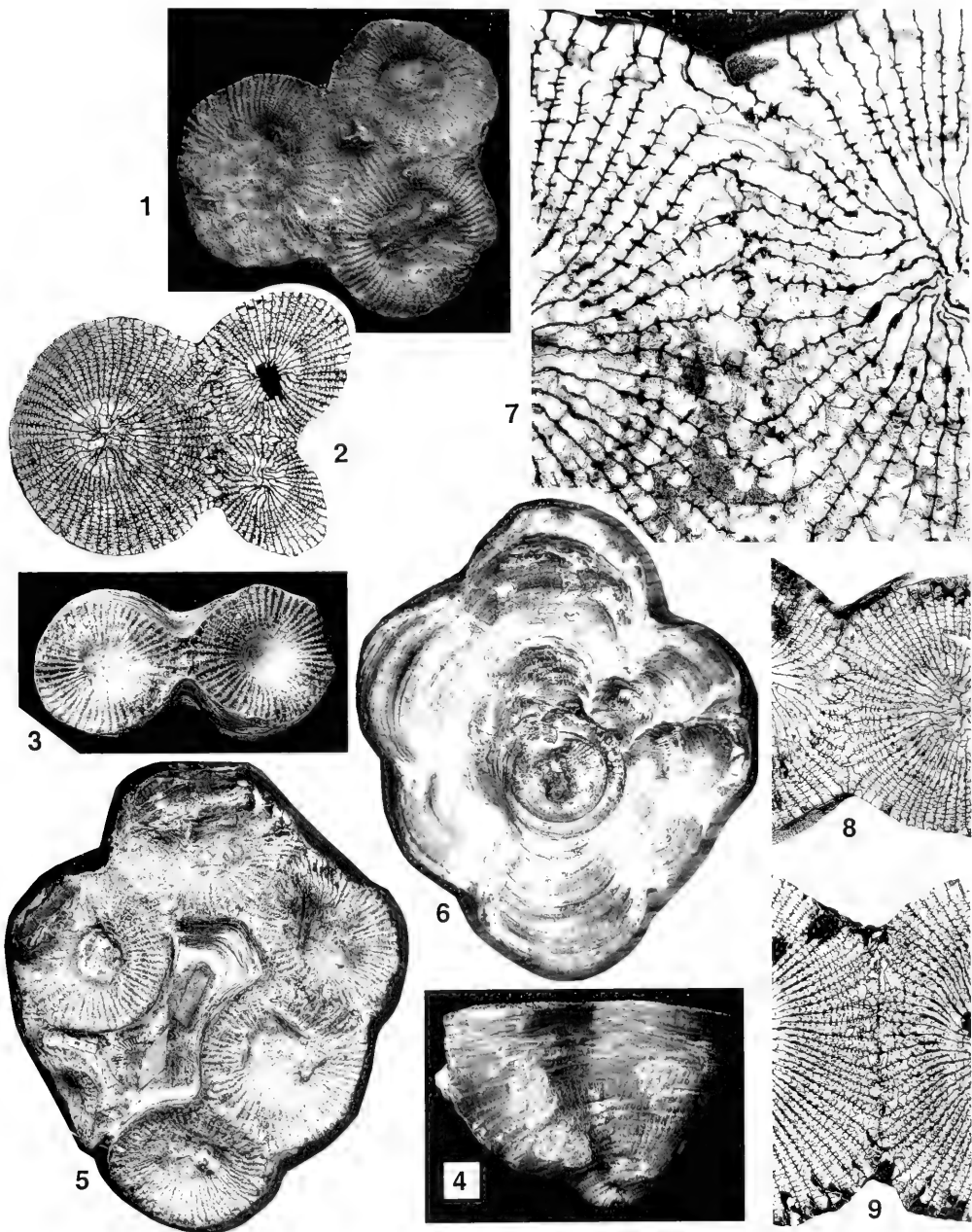

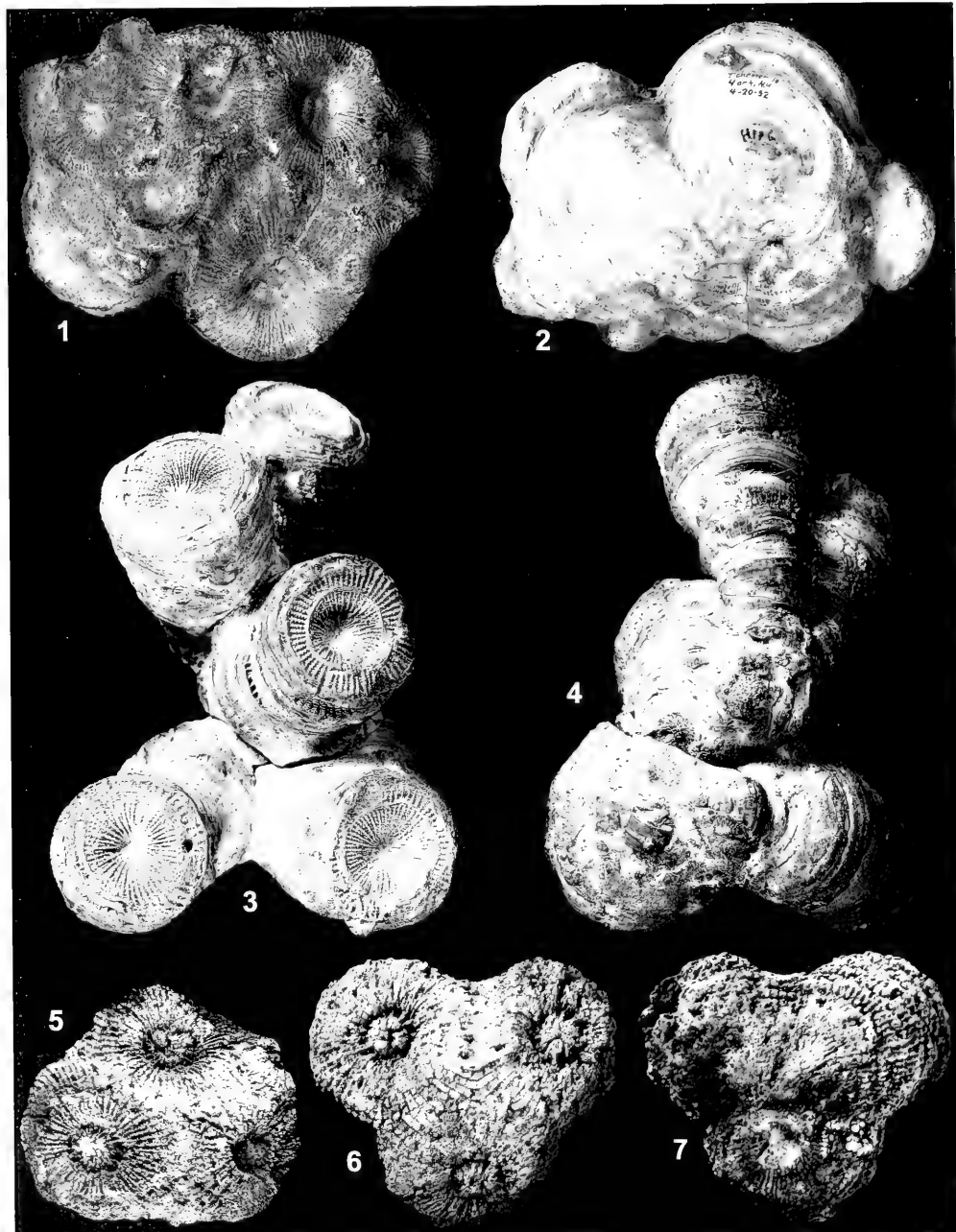

EXPLANATION OF PLATE 16

Figure	Page
1-4. <i>Heliophyllum halli confluens</i> (Hall): Greens Landing coral bed, Jaycox Member (associated with population 7):	24
1, 2. USNM 518545: collection USGS 11196-SD, west of York; upper and lower surfaces of corallum with 10 or more corallites ($\times 0.66$).	
3, 4. USNM 518546: East Avon, collected, prepared, and given to USNM by G. Klooc; corallum with astreoid stage succeeded by separate, continued growth of 5 corallites ($\times 1$).	
5-7. <i>Heliophyllum halli</i> cf. <i>H. halli confluens</i> (Hall); Prout Limestone, Bloomingville, Ohio; two coarsely silicified triplets ($\times 1$):	24
5. USNM 518547; upper surface.	
6, 7. OCGM 6085; upper and lower surfaces; illustrated by Stamm (1942, pl. 82, fig. 16).	

EXPLANATION OF PLATE 17

Figure	Page
1-3. <i>Heliophyllum halli confuens</i> (Hall): sections illustrating Type III carinae; USNM 518548 (see also Pl. 18); Greens Landing coral bed, Jaycox Member (associated with population 7), USGS 5323-SD, west of York: 1, 2, parts of transverse (UD) and longitudinal sections ($\times 10$); 3, part of same longitudinal section ($\times 50$).	24

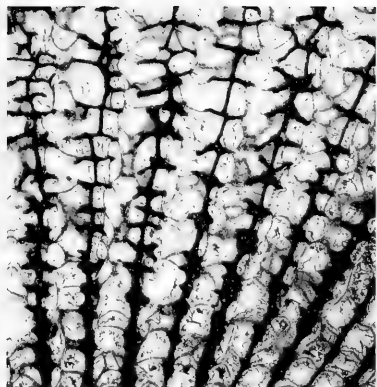

1

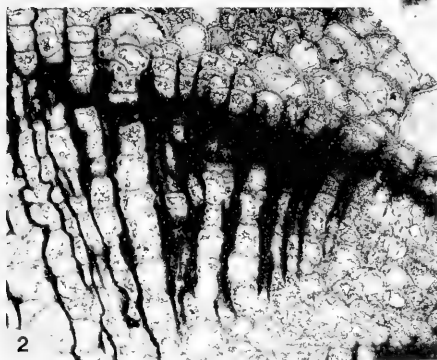

2



3

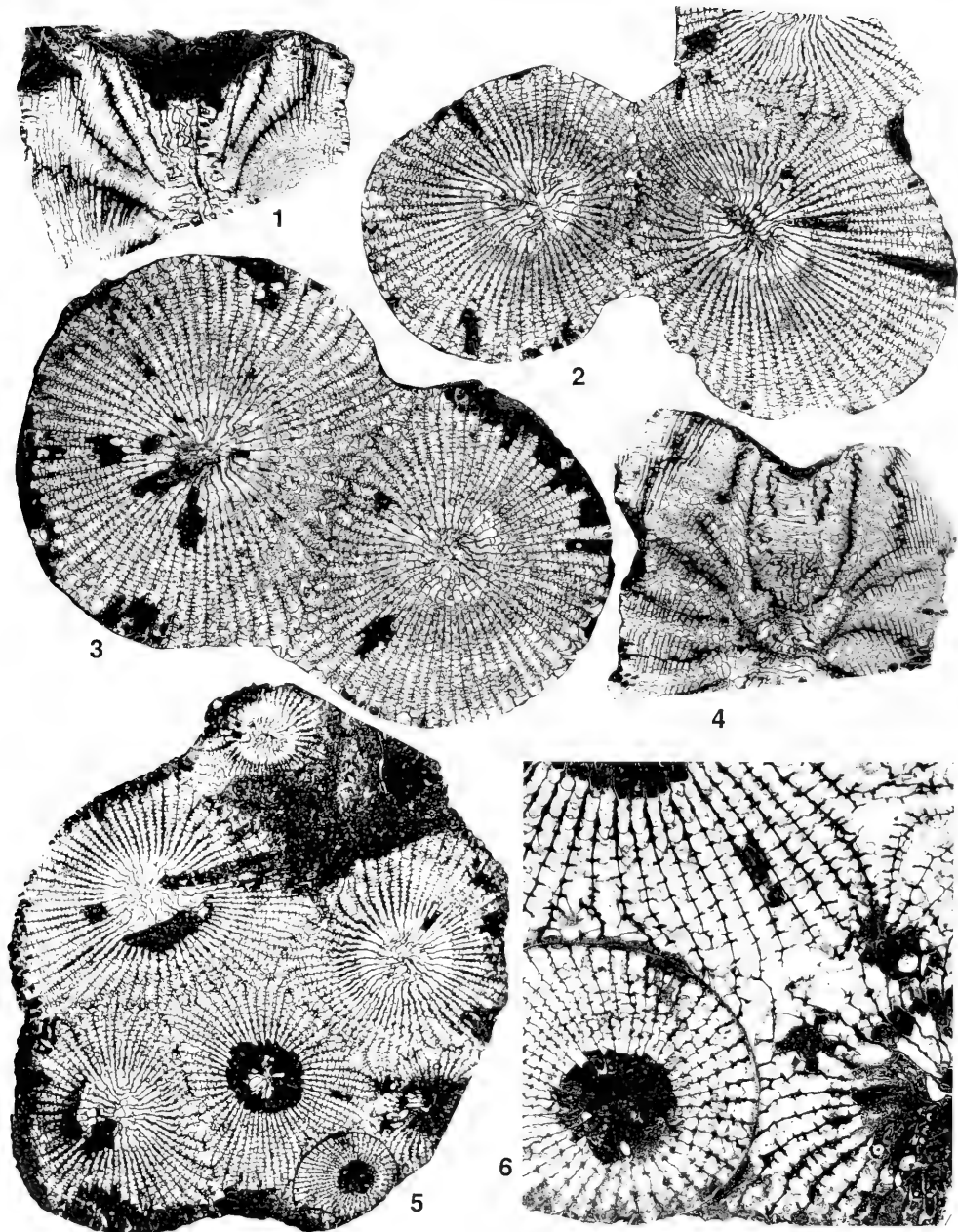

EXPLANATION OF PLATE 18

Figure	Page
1-6. <i>Heliophyllum halli confluens</i> (Hall); Greens Landing coral bed, Jaycox Member (associated with population 7);	24
1-4. USGS 5323-SD, west of York, 1, 2, USNM 518548 (see also Pl. 17); longitudinal and transverse sections of triplet ($\times 1.5$).	
3, 4, USNM 518549; transverse and longitudinal sections of twin ($\times 1.5$).	
5, 6. USGS 5708-SD, Bullis Bridge; USNM 518550 (see also Pl. 19); transverse section ($\times 1.5$) and detail of same ($\times 5$) in corallum of 7 or more corallites, showing cerioid-type wall bounding one small corallite, possibly a young offset at the margin of the colony.	

EXPLANATION OF PLATE 19

Figure	Page
1-5. <i>Heliophyllum halli confuens</i> (Hall); Greens Landing coral bed, Jaycox Member (associated with population 7);	24
1. USNM 518550, USGS 5708-SD, Bullis Bridge: detail of transverse section in Plate 18, figure 5 ($\times 10$).	
2-5. USNM 518551, USGS 5323-SD; 2, 5, longitudinal and transverse sections of corallum with three or more corallites ($\times 1.5$);	
3, 4, details of section in figure 2; 3 ($\times 5$), showing contact between two corallites in longitudinal section; 4 ($\times 10$), showing	
Type III carinae (right side of right-hand corallite).	

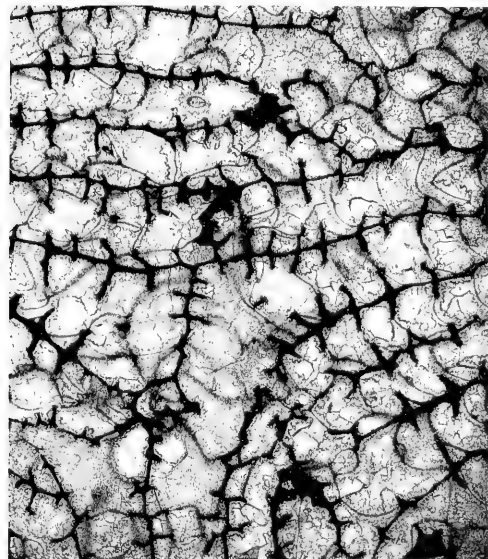

1



3



2

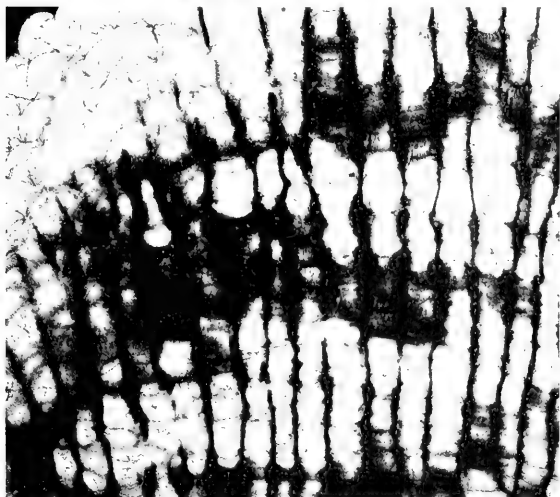

4

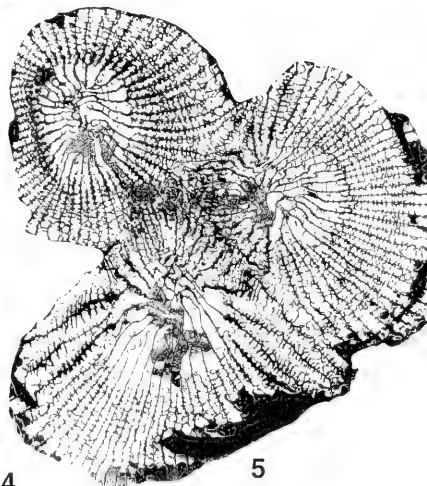

5

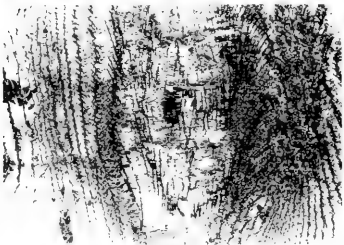
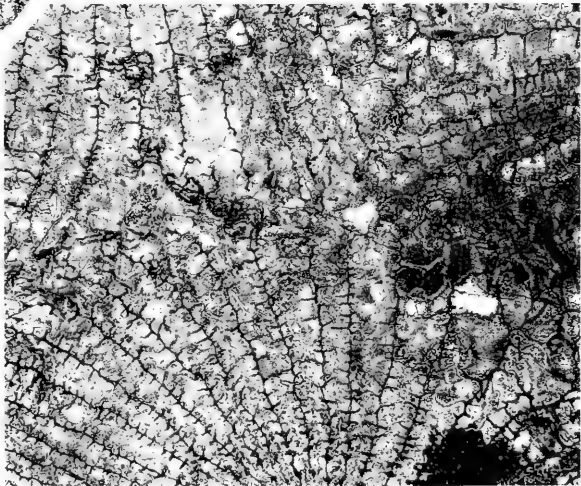
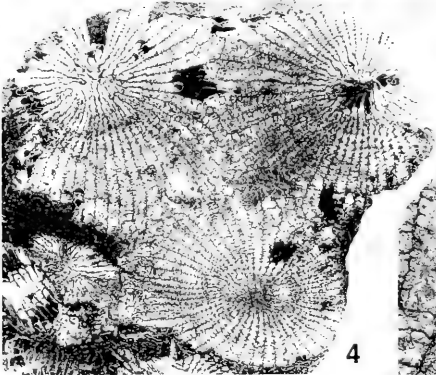
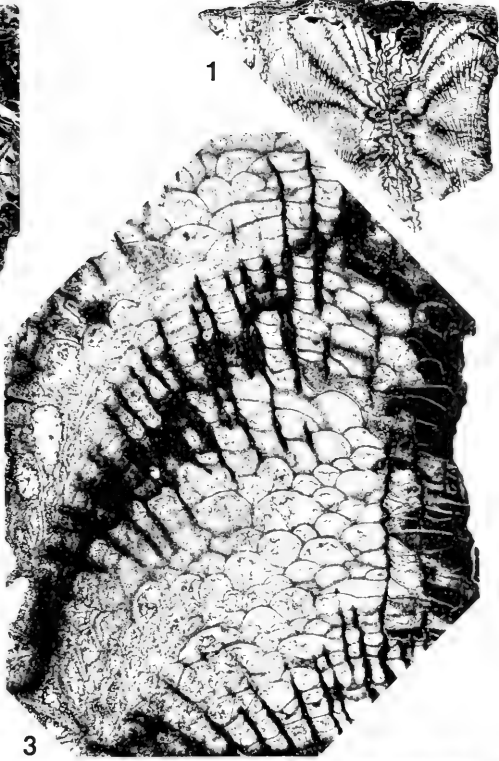

EXPLANATION OF PLATE 20

Figure	Page
1-6. <i>Heliophyllum halli bellonense</i> n. subsp.; Bellona coral bed, Tully Limestone (associated with population 10);	26
1-3. Paratype, USNM 518561; Scipio Town Quarry, collected by J.W. Wells; longitudinal section ($\times 1.5$) and details of same ($\times 5$, $\times 10$), showing Type III and I \rightarrow III carinae.	
4-6. Holotype (herein designated), USNM 518562, USGS 5341-SD, Bellona; collected and given to USNM by P. H. Heckel; transverse and longitudinal sections ($\times 1.5$) and detail of transverse ($\times 5$).	

EXPLANATION OF PLATE 21

Figure	Page
1-5. <i>Heliophyllum halli bellonense</i> n. subsp.; Bellona coral bed, Tully Limestone (associated with population 10); collected and given to USNM by P. H. Heckel.	26
1-3. Paratype, USNM 518563, Bellona; transverse and longitudinal sections ($\times 1.5$) and detail of transverse ($\times 5$); note crushing of marginal parts of corallites.	
4, 5. Paratype, USNM 518564, Twelve Corners, Owasco Quad.; transverse section ($\times 1.5$) and detail ($\times 5$).	

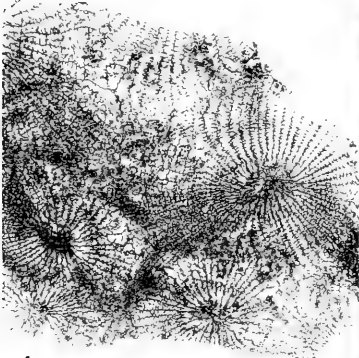

1

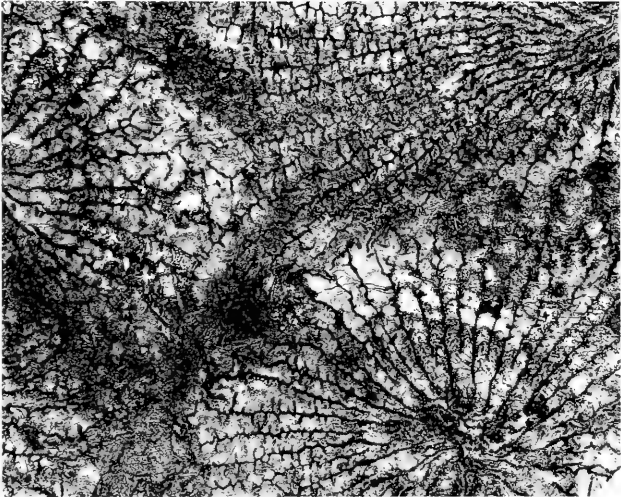

3

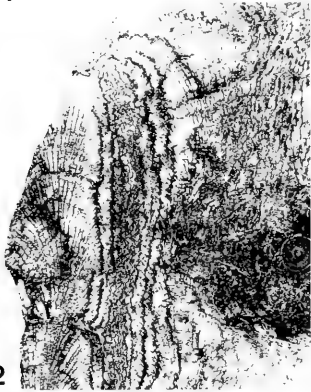

2

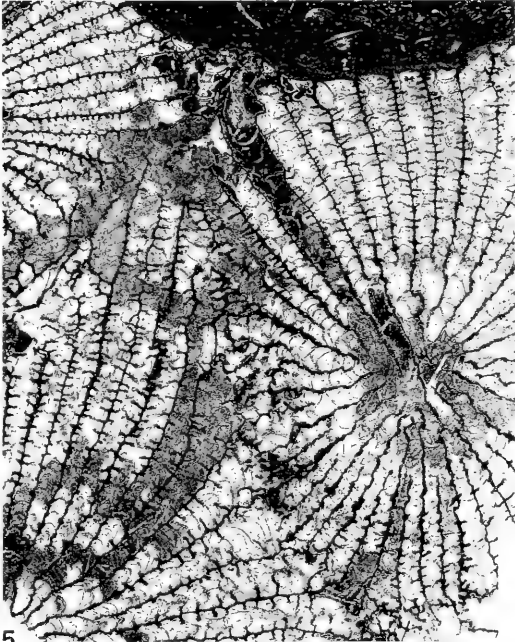

5

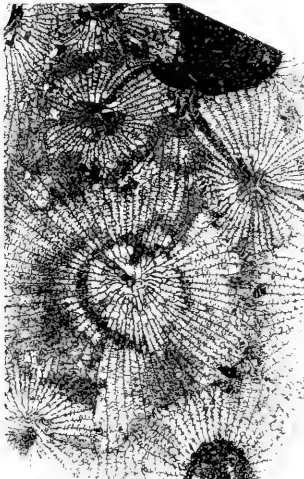

4



1



4

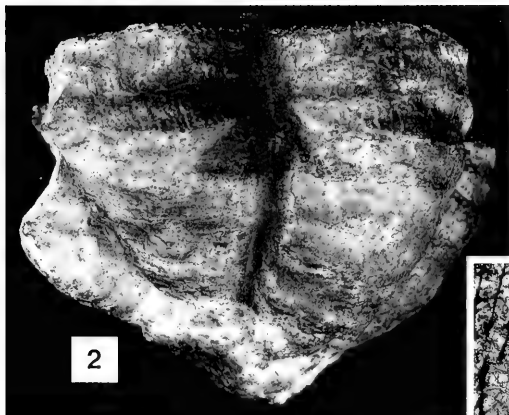

2

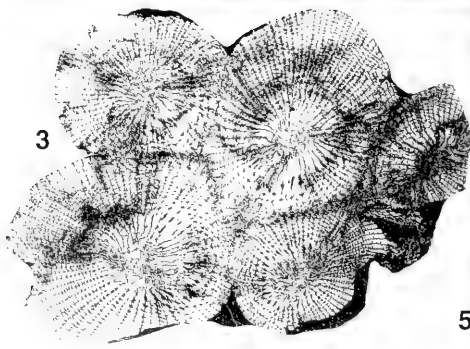

3

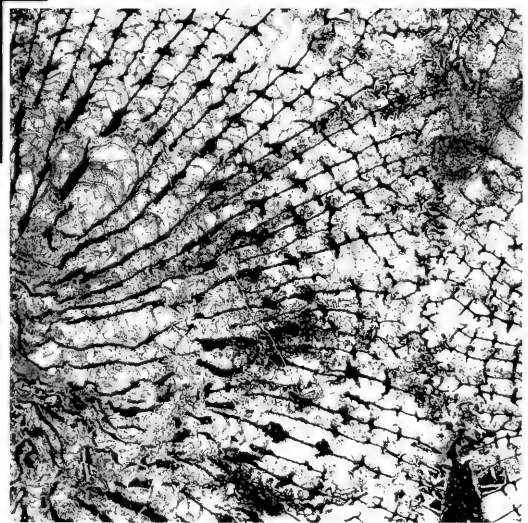

5

EXPLANATION OF PLATE 22

Figure	Page
1-5. <i>Heliophyllum halli joshuense</i> n. subsp. (form A); Joshua coral bed (associated with population 5). Holotype (here designated), PRI 24560, Lords Hill (<i>H. confluens</i> of Wells, 1937, text-fig. 8); 1, 2, exterior views of upper surface and side ($\times 1$); the latter is the aspect outlined by Wells in his figure 8; 3-5, transverse section ($\times 1$) and two details ($\times 5$) showing general nature of carinae and contact zones between corallites; short segments of the cerioid wall are seen in figure 4.	27

EXPLANATION OF PLATE 23

Figure	Page
1-5. <i>Heliophyllum halli joshuense</i> n. subsp. (form A); Joshua coral bed (associated with population 5). Paratype, USNM 518568, USGS 8783-SD, Lords Hill cornfield. 1, 2, transverse and longitudinal sections ($\times 1.5$). 3, detail of transverse section ($\times 5$) showing incomplete cerioid wall between corallites. 4, 5, details of longitudinal section ($\times 10$, $\times 5$) with Type III carinae.	27

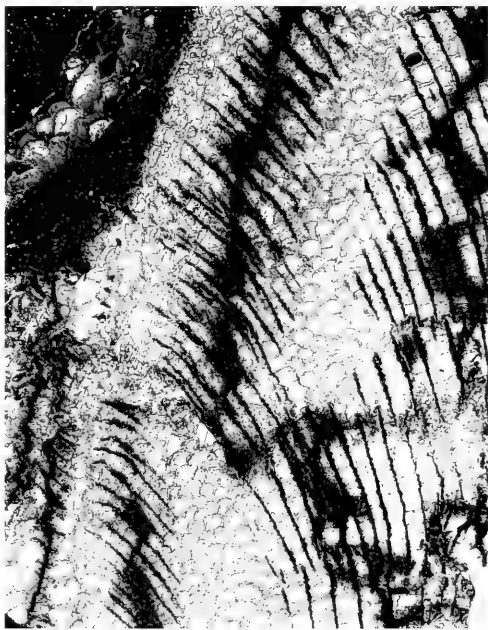
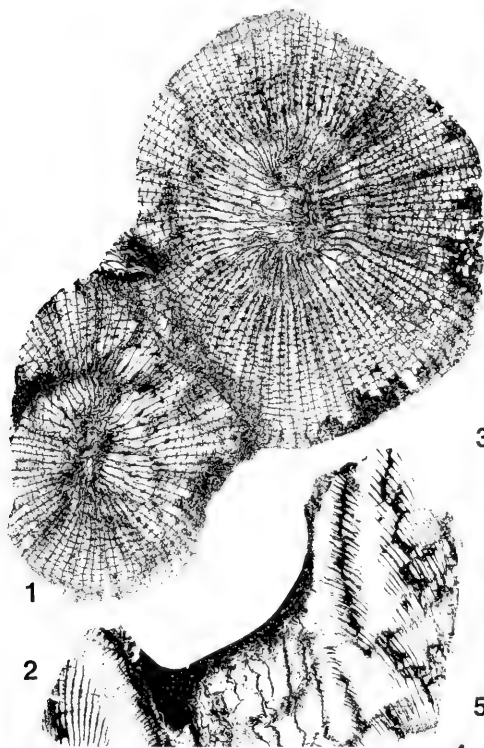

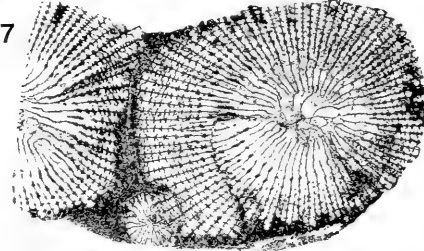
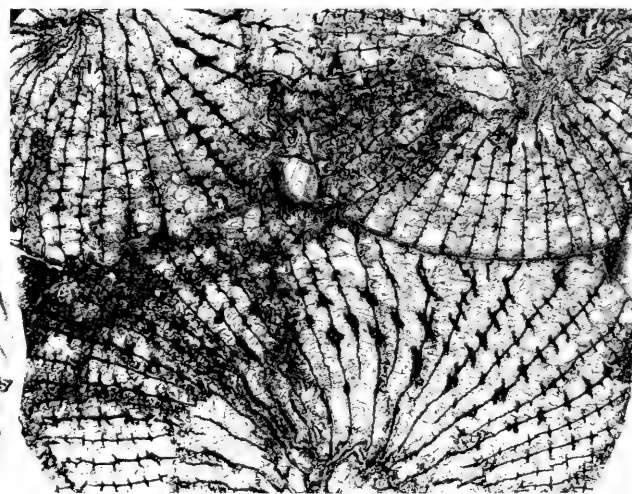
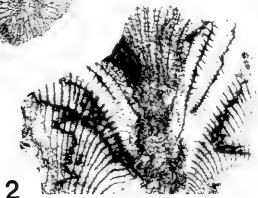
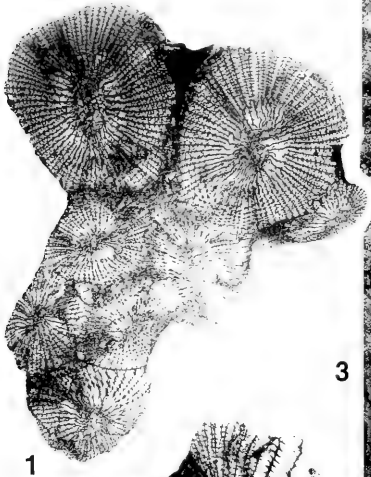

EXPLANATION OF PLATE 24

Figure	Page
1-7. <i>Heliophyllum halli joshuense</i> n. subsp. (form A); Joshua coral bed (associated with population 5). USGS 8783-SD, Lords Hill cornfield.	27
1-4. Paratype, USNM 518569; 1, 2. transverse and longitudinal sections of corallum with 8 or more corallites ($\times 1.5$); 3, 4. details ($\times 10$, $\times 5$) of transverse section showing nearly complete cerioid wall between corallites in upper right and lower parts of figure 1.	
5-7. Paratype, USNM 518570; 6, 7. longitudinal and transverse sections ($\times 1.5$); 5. detail ($\times 5$) of longitudinal section showing Type III carinae.	

EXPLANATION OF PLATE 25

Figure	Page
1-6. <i>Heliophyllum halli joshuense</i> n. subsp. (form A); Joshua coral bed (associated with population 5), USGS 8762-SD, Lords Hill cornfield.	27
1, 2. Paratype, USNM 518571; longitudinal section ($\times 1.5$) and detail ($\times 5$) of twin showing intercorallite cerioid-type wall and Type III carinae.	
3, 4. Paratype, USNM 518572; transverse section ($\times 1.5$) and detail ($\times 10$) of twin showing very incomplete intercorallite wall.	
5, 6. Paratype, USNM 518573; longitudinal section ($\times 1.5$) and detail ($\times 5$) of corallum with 4 corallites showing nearly complete wall between two of them.	

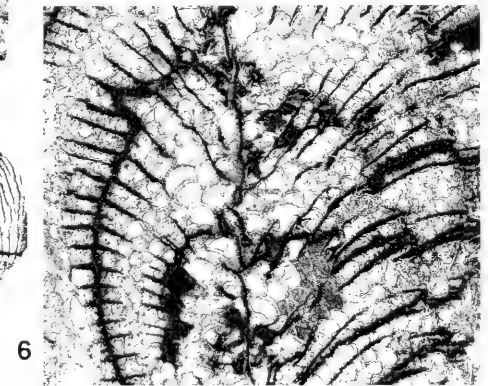
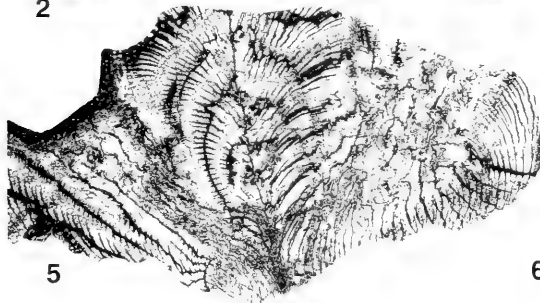
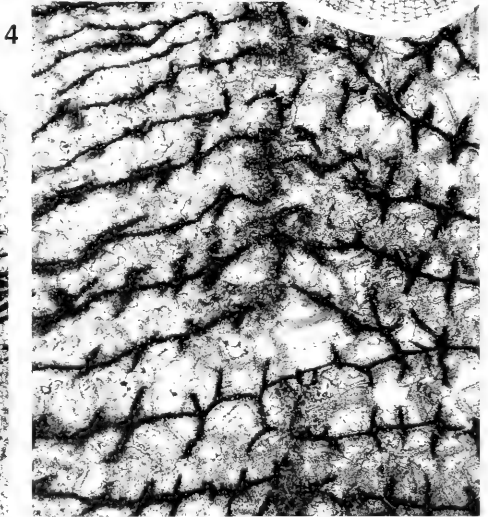
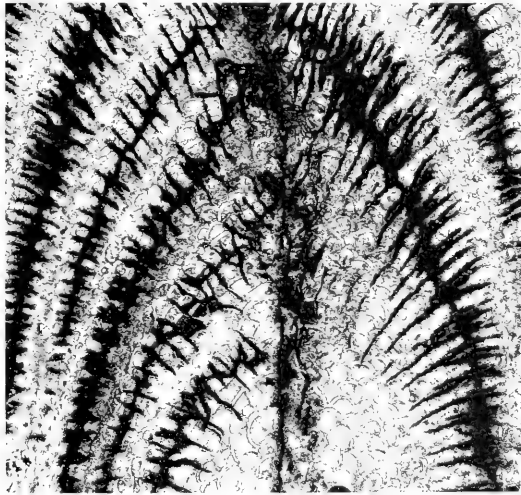
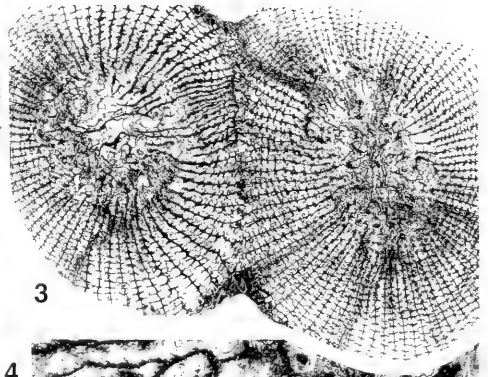
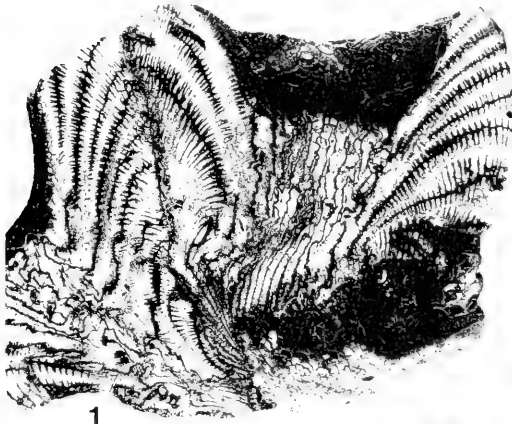

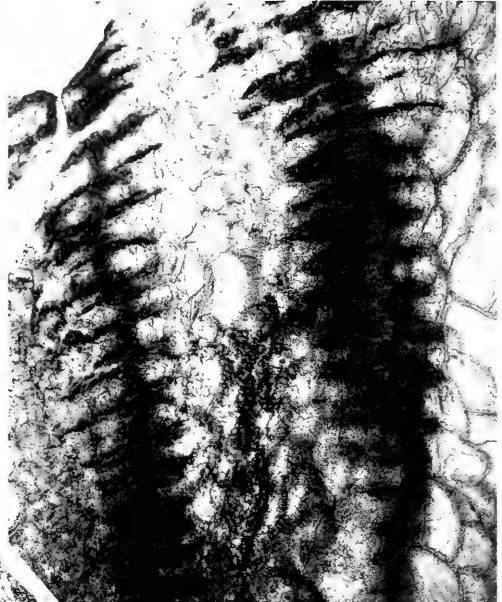
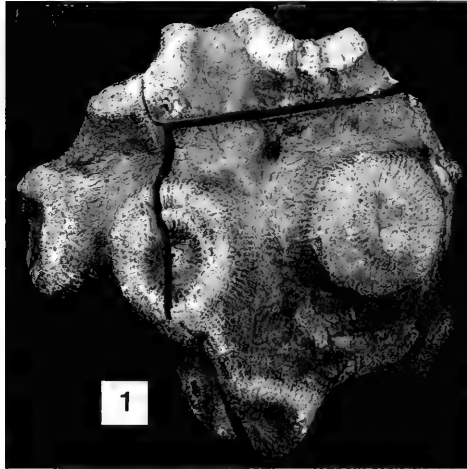

4

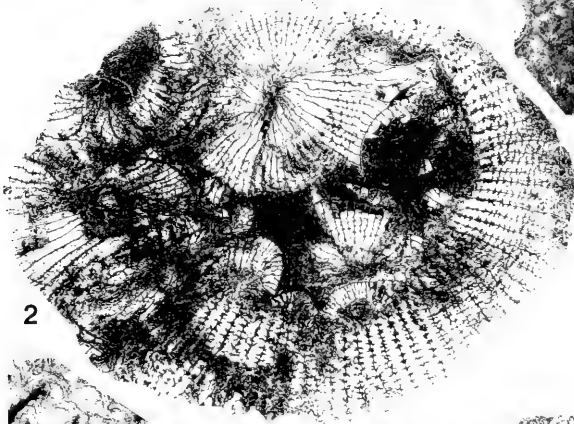

2



5

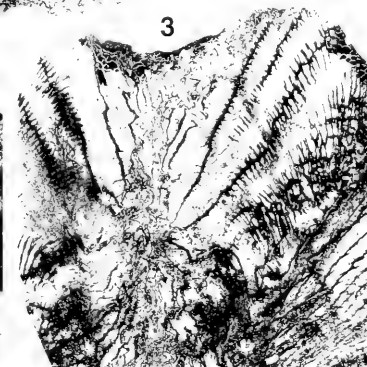

3

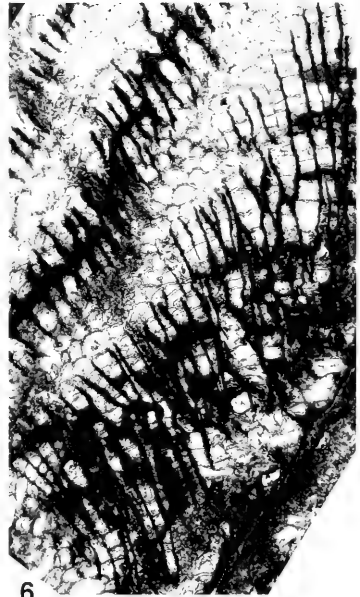

6

EXPLANATION OF PLATE 26

Figure	Page
1-6. <i>Heliophyllum halli joshuense</i> n. subsp. (form B); Joshua coral bed (associated with population 5); Paratype, USNM 518574, USGS 8762-SD, Lords Hill cornfield; 1. exterior (top) view of corallum ($\times 0.67$); corallites in this view are distal ends of the offsets seen in figure 2; 2. transverse section ($\times 1.5$) showing 8 or more peripheral offsets within calice of large turbinate protocorallite; section is from approximately 5 cm below the highest point on the top surface in figure 1; 3-6. longitudinal section ($\times 1.5$) of an offset (position of cut can be seen in fig. 1) and details ($\times 10$, $\times 10$, $\times 5$) to show Type III carinae.	27

EXPLANATION OF PLATE 27

Figure	Page
1-7. <i>Heliophyllum halli joshuense</i> n. subsp. (form B); Joshua coral bed (associated with population 5), USGS 5667-SD, SW side of Otisco Lake.	27
1-3. Paratype, USNM 487758; 1, 2, transverse section ($\times 1$) and detail ($\times 5$) of semiphaceloid corallum with 6 or more corallites; detail, showing intercorallite cerioid wall, is from upper right part of figure 1; 3, part of longitudinal section ($\times 5$) with Type I \rightarrow III carinae.	
4-7. Paratype, USNM 518575 (see also Pl. 28); 4, longitudinal section ($\times 1.5$) from above the transverse sections on this and Plate 28; 5, transverse section ($\times 1.5$) of apparent protocorallite with 12(?) peripheral offsets; 6, detail ($\times 25$) of protocorallite septa in figure 5 (at 6 o'clock position); 7, detail ($\times 5$) of some of the offsets in figure 5; note that some of the septa connect through the crush zone; the section in figures 5-7 is approximately 15 mm below the next higher section shown on Plate 28 (fig. 2).	

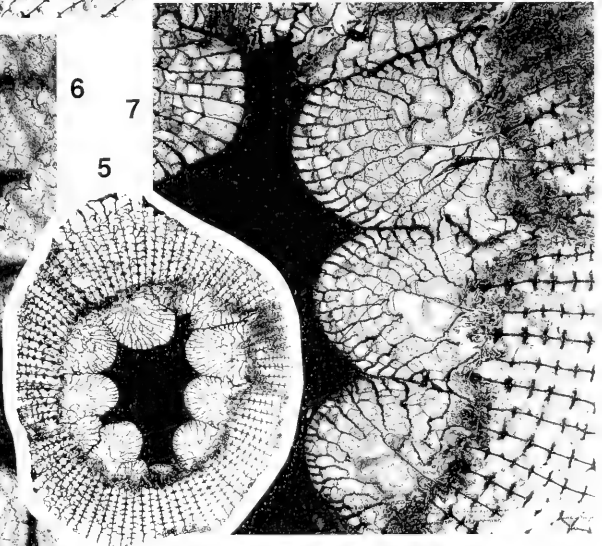
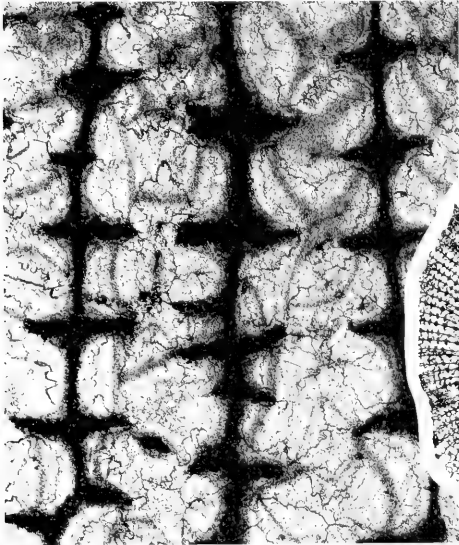
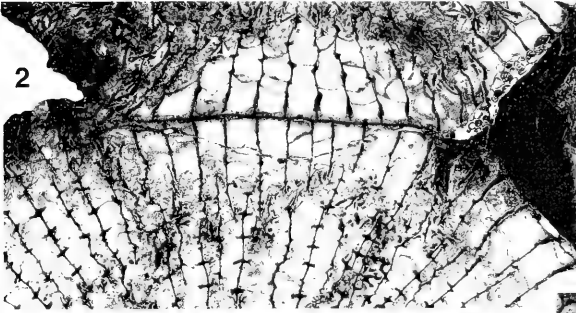
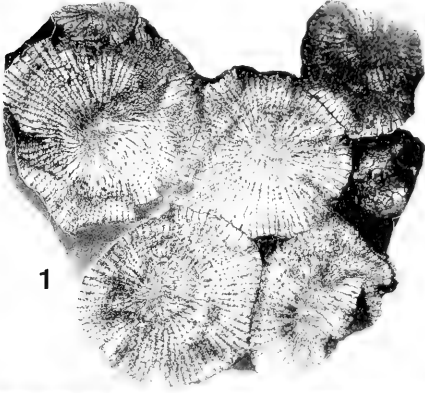

6

7

5

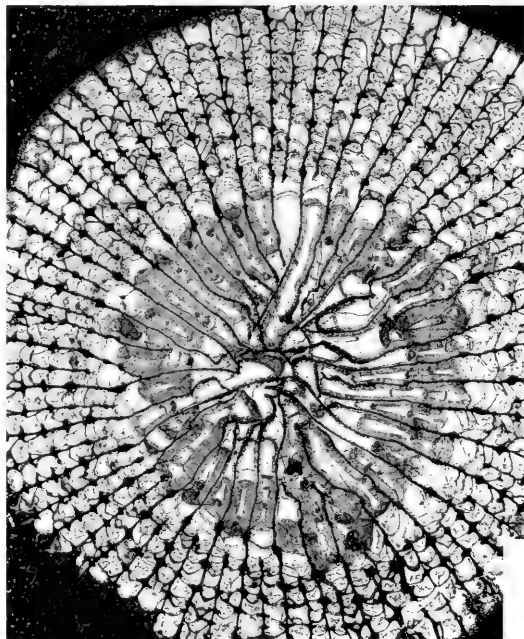
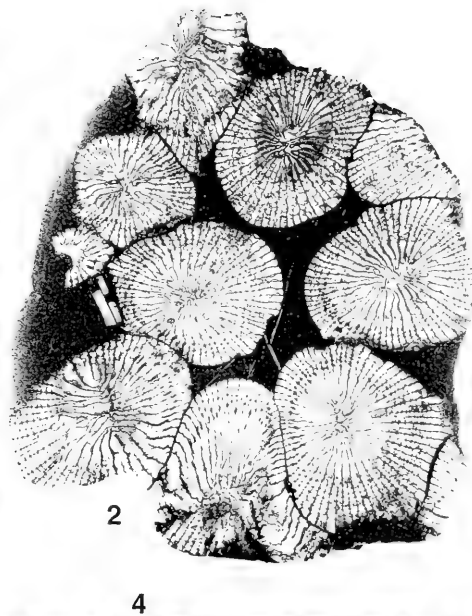
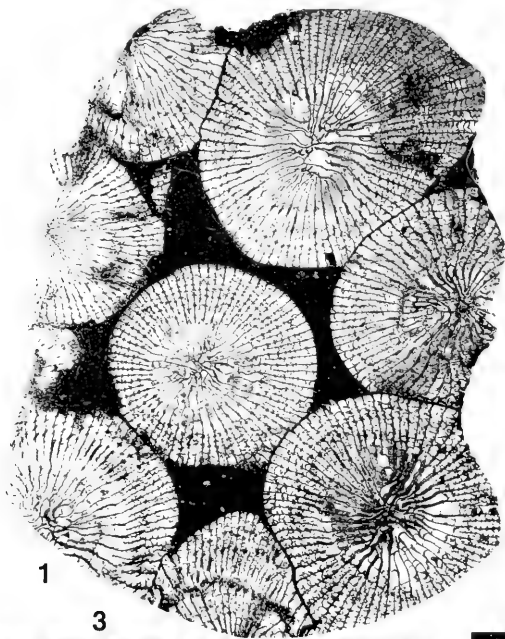

EXPLANATION OF PLATE 28

Figure	Page
1-4. <i>Heliophyllum halli joshuense</i> n. subsp. (form B): Paratype, USNM 518575 (see also Pl. 27), USGS 5667-SD, Joshua coral bed (associated with population 5), SW side of Otisco Lake. 1, 2. transverse sections ($\times 1.5$); the section in figure 2 is parallel to and approximately 15 mm above the section in Plate 27, figure 5; the section in figure 1 is some 10 mm higher than that in figure 2; 3, 4. details of section in figure 1 ($\times 5$); 3. ceroid intercorallite wall between corallites in upper right; 4. center corallite showing dilation of major septa in tabularium	27

EXPLANATION OF PLATE 29

Figure	Page
1-7. <i>Heliophyllum delicatum</i> Oliver and Sorauf, 1994.	28
1-5. Holotype (by original designation), USNM 474690, Canandaigua Lake, locality 9 of Oliver and Sorauf (1994, p. 1201). 1, exterior view of large colony from above ($\times 0.2$); 2, 3, transverse sections ($\times 1.5$) from immediately above and below longitudinal section in figure 5; 4, detail ($\times 10$) of upper part of transverse section in figure 3; 5, longitudinal section ($\times 4$) between the two transverse sections in figures 2 and 3; note predominance of Type 1 carinae.	
6. Paratype, USNM 474709, Alden, locality 2 of Oliver and Sorauf (1994, p. 1200). Longitudinal section ($\times 1.5$) showing Type I carinae.	
7. Paratype, USNM 473715, Honeoye quad., locality 8 of Oliver and Sorauf (1994, p. 1200). Exterior of corallum lying on bedding plane ($\times 0.5$).	
All figures except 6 after Oliver and Sorauf (1994).	

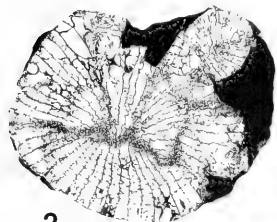

2

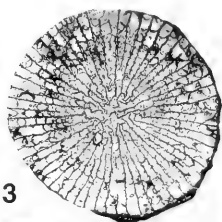

3

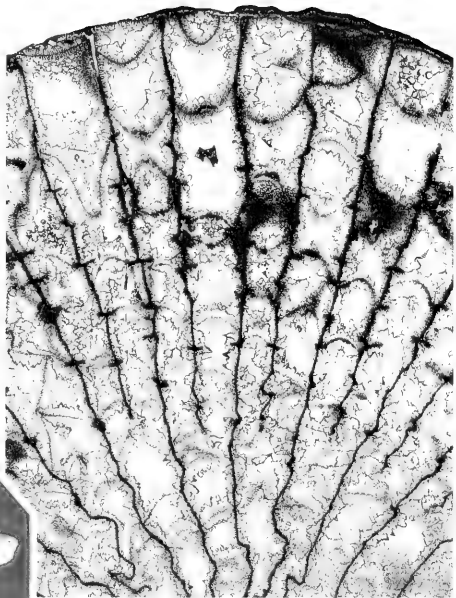

4



1

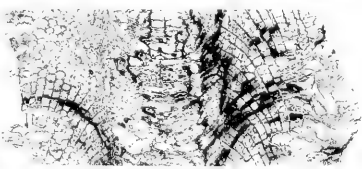

6



7

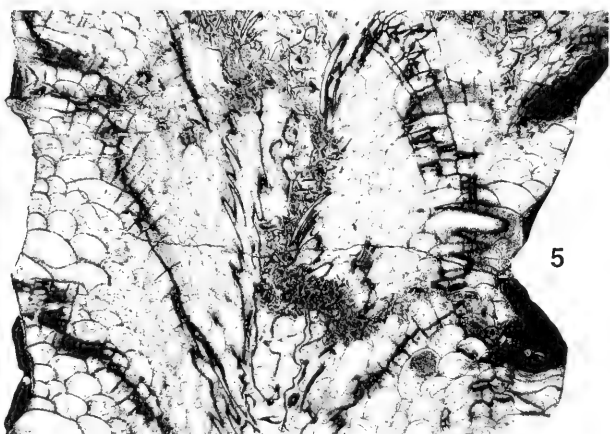

5

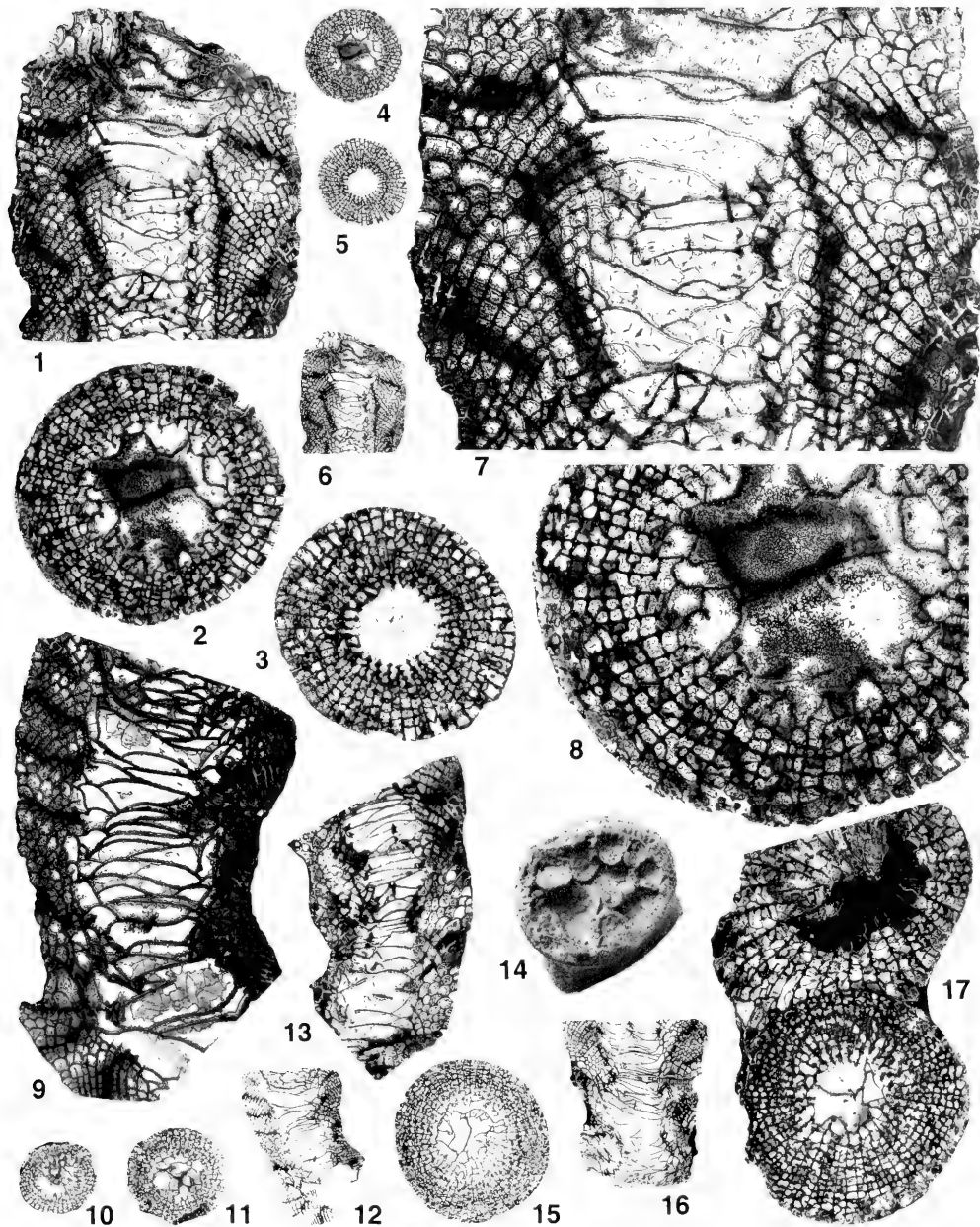

EXPLANATION OF PLATE 30

Figure	Page
1-17. <i>Heliophyllum cribellum</i> n. sp.: Centerfield Limestone, associated with <i>H. halli halli</i> population 4; USGS 4678-SD, East Alexander	29
1-8. Holotype, here designated, USNM 518586; medium sized, ceratoid-cylindrical form. 1-3, longitudinal and two transverse sections ($\times 4$); the transverse sections are from below the longitudinal and were separated by approximately 4 mm. 4-6, the three sections in figures 1-3 ($\times 1.5$) for comparison with our standard <i>H. halli</i> photos. 7, 8, parts of sections in figures 1 and 2 ($\times 8$); 7, showing simple Type 1 carinae; 8, long yard-arm carinae.	
9-12. Paratype, USNM 518587, medium sized, ceratoid-cylindrical form showing rejuvenation; 9, longitudinal section ($\times 4$); 10-12, lower and upper transverse sections and intervening longitudinal section ($\times 1.5$).	
13. Paratype, USNM 518588, medium sized, ceratoid-cylindrical form; longitudinal section ($\times 4$).	
14-16. Paratype, USNM 518589, large ceratoid form. 14, top view of calice with 7 peripheral offsets ($\times 1.5$). 15, 16, transverse section from below calice and lower longitudinal section ($\times 1.5$).	
17. Paratype, USNM 518590, small <i>H. cribellum</i> partly overgrown by an <i>H. halli halli</i> ($\times 4$).	

EXPLANATION OF PLATE 31

Figure	Page
1-16. <i>Heliophyllum cribellum</i> n. sp.; Centerfield Limestone, associated with population 4 of <i>H. halli halli</i>	29
1-3. Paratype, USNM 518591, USGS 11210-SD, Center Road; large ceratoid-cylindrical form. 1, part of transverse section with long yard-arm carinae ($\times 5$); 2, 3, longitudinal section ($\times 1.5$) and part of same showing bushy, Type 1 carinae ($\times 7$).	
4, 5. Paratype, USNM 518592, USGS 4678-SD, East Alexander; small, trochoid form; transverse and longitudinal sections ($\times 1.5$).	
6, 7. Paratype, USNM 518593, USGS 11211-SD, Jaycox Run; large ceratoid form; longitudinal section ($\times 1.5$) and transverse section with typical "screen" appearance ($\times 4$).	
8, 9. Paratype, USNM 518594, USGS 11468-SD, Schaeffer Creek; large ceratoid form; longitudinal and transverse sections ($\times 1.5$).	
10, 11. Paratype, USNM 518595, USGS 5692-SD, White Creek; trochoid form; upper and lower transverse sections, approximately 15 mm apart ($\times 1.5$).	
12, 13. Paratype, USNM 518596, USGS 4678-SD, East Alexander. 12, transverse section ($\times 1.5$); 13, longitudinal section showing sequence of trochoid growth, trauma, rejuvenation and further growth at right angle to initial growth direction ($\times 3.5$); transverse section in figure 12 is from below calice in final stage (upper left in fig. 13).	
14, 15. Paratype, USNM 518597, USGS 11197-SD, east of York; medium sized, ceratoid form; longitudinal and transverse sections ($\times 1.5$).	
16. Paratype, USNM 518598, USGS 4678-SD, East Alexander; ceratoid-cylindrical form; longitudinal section ($\times 4$).	

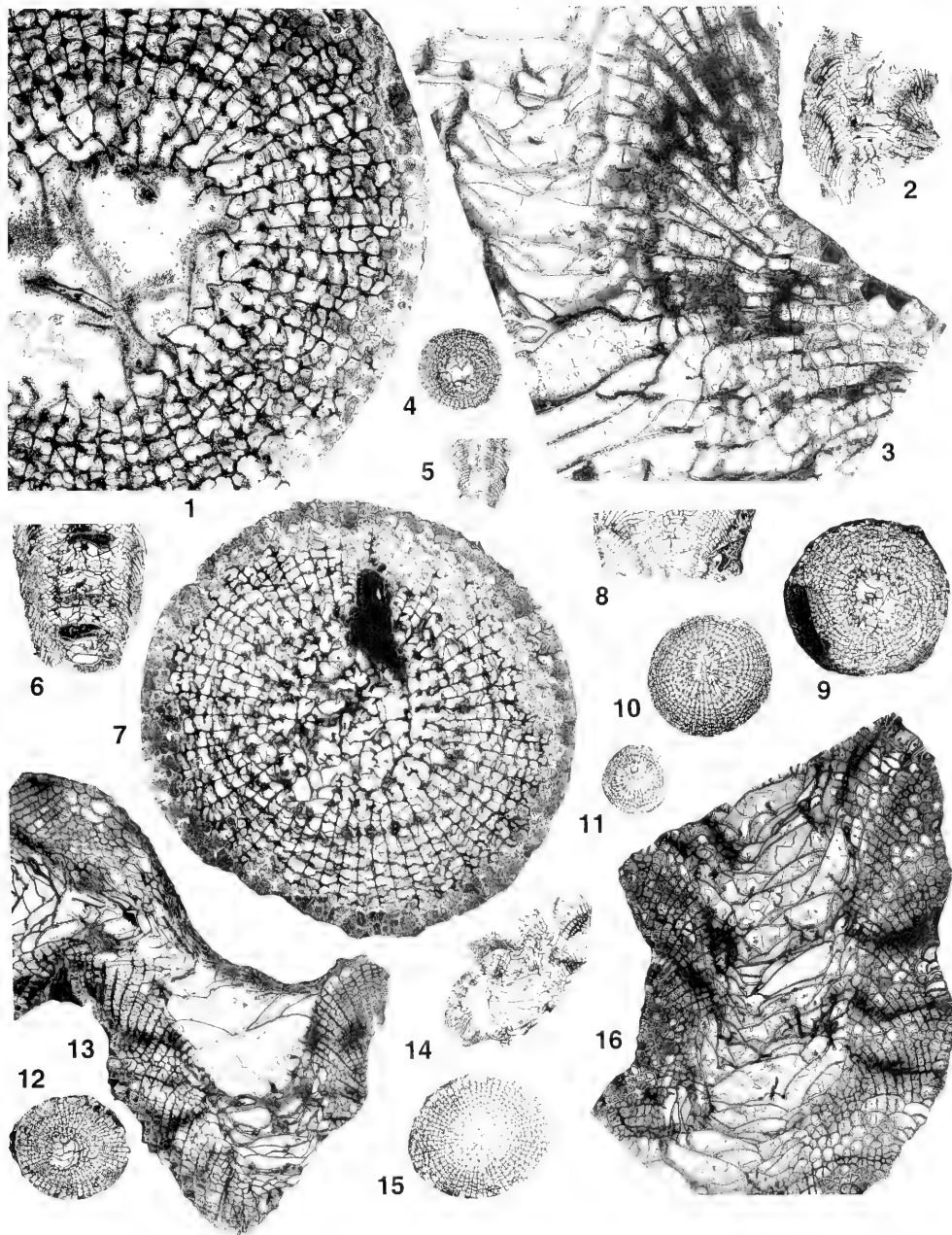

INDEX

Note: Page numbers for descriptions of genera and species are shown in **bold type**.

- Acadian Orogeny 6
 Africa, distribution in 5, 12
 Albany County 8, 21
 Appohinchi Province 10
 Astreoid 14, 24, 26, 27, 29
- Bay View coral bed 24, 37
 Bellona coral bed 9, 12, 19, 24, 26, 37, 50, 59–60
 Bellona population 24
Billingsstraea 17, 26, 27
 Biogeography 5, 10
 Bioturbation 11
 Bois Blanc Formation 5, 17
 Browns Creek 25, 53
 Buffalo Creek 25
- Calice 20
 Canandaigua Lake 45–48, 68
 Cardinal plane 17, 20, 28, 29, fossula, 19, 20
 Carinae 11, 13, 20–24, 26–30
 Carinae, types 2, 13, 22–24, 30
 Case Hill coral bed 5, 8, 34, 41
 Case Hill population 22
 Cayuga County 9, 24
 Centerfield Limestone 8, 12, 22, 30, 34, 40, 42, 69, 70
 Centerfield population 22
 Ceratoid 14, 28, 29
 Cerioid 27–28
 Cherry Valley Limestone 10
 Confluent septa 26–27
 Conodont zones 7
 Coral bed 6, 7, 11, 15
 Corallum shape 11
 Counter septum 20
 Cylindrical 14, 20, 29
 Cystimorphs 10
Cystiphyllodes 10
- Darien coral bed 9, 35, 40, 44
 Darien population 21, 23
 Deep Run Shale 9, 28, 36, 47, 48
 Deep Run population 12, 21, 23
 Dendroid 28
 Devonian year 20
 Dissepimentarium 18, 21, 26–28
- Eastern Americas Realm (EAR) 5, 10, 12, 29
 Eifelian 5, 7, 10
 Emsian 5, 7
 Epibionts 10
 Epitheca 11, 20, 29
Eridophyllum 11
 Erie County 23
 External form, variation in 14
- Facies 6
 Fall Brook coral bed 9, 18, 24, 37, 49
 Fall Brook population 24
 Falls of the Ohio River area 17
- “formae” 14, 19, 21
- Genesee County 9, 22, 23, 25, 29, 30
 Gemuculation 11, 20
 Givetian 5, 7, 9, 29
 Globose dissepiments 26, 28, 30
 Green’s Landing coral bed 23, 25, 29, 30, 35, 45, 46, 51, 53–58
 Growth increments 20, 29
- Halihan Hill coral bed 5, 8, 10, 21, 34, 41
 Halihan population 21
 Hamilton Group 6
Heliogonum 17, 25
Heliophylloides 17
Heliophyllum cribellum **29–30**, 69, 70
Heliophyllum delicatum 21, 24, **28**, 68
Heliophyllum halli halli 9, **18**, **19**, 24, 30, 40–52
 “forma *typicum*” 19
 “forma *praecoxus*” 21, 23, 28, 51, 52
 “forma *proliferum*” 21
Heliophyllum halli bellonense 24, **26**, **27**, 59–60
Heliophyllum halli confluens 23, **24**, **25**, 27, 29, 53–58
Heliophyllum halli joshuense 23, **27**, 61–67
Heliophyllum halli species group 18
Heliophyllum stewarti **29**
 Holotheca 25
 Hudson Bay Lowlands 17
- Illinois Basin 10, 17
 Indian Cove Formation 5
- Jaycox Member 9, 25, 35, 40, 45, 46, 51, 53–58
 Jaycox population 21, 23
 Joshua coral bed 9, 11, 35, 43, 61–67
 Joshua population 22
- kockelianus* Zone 10
- Lansing coral bed 24, 37
 Larval settlement 11
 Lectotype (*confluens*) 26
 Leicester 18, 24, 49
 Little Beard’s Creek 24, 49
 Livingston County 22, 23, 25
 Lord’s Hill 21, 27, 28, 42, 62–65
 Ludlowville Formation 8, 9, 23, 25, 30
- Major septa 20, 26, 27, 29
 Malvinokaffric Realm 10
Meristella-coral zone 8
 Michigan Basin 10, 17
 Microstructure 21
 Middle Devonian 5, 7
 Minor septa 20
 Monacanthine trabecula 12, 13
 Moscow Formation 18, 23, 25, 28
 Mottville Member 22
 Mount Marion 8, 21
 Mucus 11

Neotype (<i>halli</i>)	9, 18, 24	Substrate	11
Ohio	29, 55	Tabellae	21
Old World Realm	10, 12	Tabulae	21, 28, 30
Ontogeny	14, 16	Tabularium	18, 20, 27, 30
Onondaga County	8, 9, 22, 27	Talons	11, 30
Ontario County	22, 23, 24	Tennile Creek Dolomite	29
Otisco Lake	27, 28, 66-67	Tentacles	11
Otisco Shale	9, 27	Thamasterioid	26
Parricidal budding	27, 29	Tichenor Limestone	25, 36, 46
Patellate	11	Trabeculae	12, 13, 26
Peripheral offsets	29	Traverse Group, Michigan	17
Populations	5, 6, 15, 16	Triples	25
Protocorallite	25, 27	Trochoid	20, 29
Prout Limestone	25, 26, 55	Tully Limestone	9, 24, 37, 50, 59-60
Province	10	Turbid water	11
Rejuvenation	11, 14, 29	Turbinate	29
Rhabdacanthine trabeculae	12, 13	Twins	26
Rhipidacanthine trabeculae	12, 13	Ulster County	21
Schoharie County	8	Vercus Zone	9, 10
Screen, of dissepiments	30, 70	Venezuelan-Colombian Province	10, 12
Seneca County	22, 23	Vepreculae	13
Skaneateles Lake	22, 42	Wanakah Shale	40
Spain	12	Windom Shale	18, 24
Species, definition	16	Yard-arm carinae	13, 14, 17, 21, 24, 26, 28
Species group, definition	16	Yates County	9, 24
Staghorn Point coral bed	9, 11, 34, 42, 51	Zigzag carinae	13, 17, 21, 26, 27
Staghorn Point population	21, 22	<i>Zonophyllum</i>	10
Stratigraphic units	7, 15		
<i>Strombodes helianthoides</i>	18		
Subspecies, 26, definition	16		

PREPARATION OF MANUSCRIPTS

Bulletins of American Paleontology usually comprises two or more separate papers in two volumes each year. The series is a publication outlet for significant, longer paleontological monographs (*i.e.*, more than approximately 50 printed pages), for which high quality photographic illustrations and the large quarto format are required.

Submissions are welcome from any author, regardless of institutional or organizational affiliation. Authors must, however, be members of the Paleontological Research Institution at time of publication; annual membership is currently US\$25.00. Publication costs of the *Bulletins* are heavily subsidized by the Institution, but authors are currently required to pay illustration charges at a rate of \$120.00 per plate and \$35.00 per text-figure.

Important references for style and format are 1) *Bulletins of American Paleontology* "Instructions for Authors" (volume 108, number 347, pages 149-153); 2) *Chicago Manual of Style* (fourteenth edition) 1993. Recent issues of the *Bulletins* provide useful guides but note changes with the "Instructions for Authors" mentioned above.

Manuscripts must be typewritten, and double-spaced *throughout* (including direct quotations, tables and references). All manuscripts should contain a table of contents, lists of text-figures and/or tables, and a short, informative abstract that includes names of all new taxa. Format should follow that of recent numbers in the series. All measurements must be given in the metric system, alone or in addition to their English system equivalents. The maximum dimensions for photographic plates are 178 mm × 229 mm (7 inches × 9 inches; outlined on this page). Single-page text-figures should be drafted for reproduction as single column (82 mm; 3½ inches) or full page (178 mm; 7 inches) width, but arrangements can be made to publish text-figures that must be larger.

Authors must provide three (3) printed copies of the text and accompanying illustrative material. Authors are *strongly* encouraged to prepare their manuscripts on word processors, as this considerably expedites publication. On initial submission, however, only printed copies of the manuscript should be sent; the disk copy should be retained so that revisions can be made after the review process. The text and line-drawings may be reproduced xerographically, but glossy prints at publication size must be supplied for all half-tone illustrations and photographic plates. These prints should be identified clearly on the back.

Referenced publication titles *must be spelled out in their entirety*. Particular care should be given to reference format. Consult the "Instructions for Authors," referred to above, as several changes have been introduced with that issue. Citations of illustrations within the text bear initial capitals (*e.g.*, Plate, Text-figure), but citations of illustrations in other works appear in lower-case letters (*e.g.*, plate, text-figure).

Format of systematic descriptions should follow that in any recent number of the *Bulletins*.

Original plate photomounts should have oversize cardboard backing and strong tracing paper overlays. These photomounts should be retained by the author until the manuscript has been formally accepted for publication. The approximate position of each text-figure in the text should be indicated. Explanations of plates and text-figures should follow the References Cited.



Gilbert Dennison Harris
(1864 - 1952)

Founder of the *Bulletins of American Paleontology* (1895)

101
BSX
NH



Bulletins of American Paleontology

Begun in 1895

NUMBER 363

SEPTEMBER 16, 2002

A Compendium of Fossil Marine Animal Genera

by

J. John Sepkoski, Jr.

Edited by David Jablonski and Michael Foote

Paleontological Research Institution
1259 Trumansburg Road
Ithaca, New York, 14850 U.S.A.

PALEONTOLOGICAL RESEARCH INSTITUTION

Officers

PRESIDENT	CHRISTOPHER G. MAPLES
FIRST VICE-PRESIDENT	JOHN POPLA, JR.
SECOND VICE-PRESIDENT	HOWARD P. HARRIS
SECRETARY	SHIRLEY K. EGAN
TREASURER	PATRICIA A. JOHNSON
DIRECTOR	WARREN D. ALLMON

Trustees

JOHN D. ALLEN	PHILIP PROFFANSKY
CARLTON E. BRETT	MELAN D. SHAW
WILLIAM L. CREPPE	MARY M. SHUFORD
W. MICHAEL DRISCOLL	CONSTANCE M. SOFA
J. THOMAS DUTRO, JR.	JOHN C. STEINBLIZ
PATRICIA HAUGEN	PETER B. STEEL
ROBERT M. HORN, JR.	DAVID H. TAUBI
HARRY G. LIU	SALLY T. TRUB
AMY R. MCCUNE	ARTHUR WATERMAN

Trustees Emeritis

HARRY A. ETTINGWELL
ROBERT M. EINSLEY
SAMUEL E. PLES
EDWARD B. PICCOLI, JR.
JAMES E. SOPER
RAYMOND VAN HOUTTE
WILLIAM P. S. VENTRESS
THOMAS E. WHITTELY

BULLETINS OF AMERICAN PALEONTOLOGY and PALAEOONTOGRAPHICA AMERICANA

WARREN D. ALLMON EDITOR

A list of titles in both series, and available numbers and volumes are available online at www.priweb.org. Volumes 1-23 of *Bulletins of American Paleontology* are available from Periodicals Service Company, 11 Main St., Germantown, New York 12526 USA. Volume 1 of *Palacontographica Americana* has been reprinted by Johnson Reprint Corporation, 111 Fifth Ave., New York, NY 10003 USA.

Subscriptions to *Bulletins of American Paleontology* are available for US \$165 per year (individual or institution) plus postage. Issues are available and priced individually. Numbers of *Palacontographica Americana* are priced individually.

for additional information, contact:

Paleontological Research Institution
1259 Trumansburg Road
Ithaca, NY 14850 USA
(607) 273-6623
FAX (607) 273-6620
www.priweb.org



Bulletins of American Paleontology

Begun in 1895

NUMBER 363

SEPTEMBER 16, 2002

A Compendium of Fossil Marine Animal Genera

by

J. John Sepkoski, Jr.

Edited by David Jablonski and Michael Foote

Paleontological Research Institution
1259 Trumansburg Road
Ithaca, New York, 14850 U.S.A.

ISSN 0007-5779

ISBN 0-87710-450-6

Library of Congress Control Number: 2002108976

Note: Beginning with issue number 356, *Bulletins of American Paleontology* is no longer designating volumes. The journal will continue to publish approximately 2–4 issues per year, each of which will continue to be individually numbered.

Printed in the United States of America
Allen Press, Inc.
Lawrence, KS 66044 U.S.A.

CONTENTS

	Page
Introduction, by Michael Foote and David Jablonski	5
The Compendium	10
References Cited	324
Alphabetical Listing of Genera	364

A COMPENDIUM OF FOSSIL MARINE ANIMAL GENERA

J. JOHN SEPKOSKI, JR.¹

EDITED BY DAVID JABLONSKI AND MICHAEL FOOTE

Dept. of Geophysical Sciences, University of Chicago, 5734 S. Ellis Ave., Chicago, IL 60637

ABSTRACT

This is a listing of approximately 37,000 taxonomic genera of marine animals known from the fossil record, based on the late J. John Sepkoski, Jr.'s working database, which he last updated July 13 to November 13, 1998. These data are the basis of many analyses by Sepkoski and others, and are published here with minimal—and surely incomplete—clerical corrections to make this extraordinary compendium widely available. It covers invertebrates, vertebrates, and animal-like protists, gives time intervals of first and last known occurrence, and provides literature sources for these data. The time intervals are mostly the internationally recognized stratigraphic stages; many are resolved to substage divisions. Genera are presented in a classification by order, class, phylum, and kingdom, reflecting current classifications in the published literature.

INTRODUCTION

Michael Foote and David Jablonski

The taxonomic data compilations of the late J. John Sepkoski Jr. are broad in their scope and profound in their impact on biology, geology, and paleontology. By recording the first and last stratigraphic occurrence of fossil families and genera, Sepkoski was able to carry out many important studies of biodiversity, origination, and extinction over the Phanerozoic. He also shared his data generously with others in the profession. The family compendium has been most extensively analyzed and is already published (Sepkoski, 1982, 1992), and he had intended to publish the much larger genus database as well. Although he (*e.g.*, Sepkoski, 1986, 1996, 1997, 1998, 2001; Raup and Sepkoski, 1986; Miller and Sepkoski, 1988; Foote and Sepkoski, 1999) and numerous others had carried out analyses of the genus compendium, this compilation remained unpublished at the time of his death.

The compendium of genera, like that of families, was constantly evolving, with the addition of new genera, revision of taxonomy, and refinement of stratigraphic ranges. The data come largely from the primary literature on systematic paleontology, but Sepkoski had also consulted extensively with specialists in certain taxonomic groups. The compilation is not complete in its coverage. We presume that it is also not exactly in the form in which Sepkoski would have published it himself. Because much published research has already been based on the genus compendium, however, it is necessary to make the data available. Publishing these data will not only allow previous

studies to be assessed, but will also facilitate future research. With a few minor exceptions to be noted explicitly below, we have retained the data essentially in the form in which Sepkoski left them. The files for higher taxa were the most recent that we could find on Sepkoski's computer. The dates on these files range from July 13 to November 13, 1998.

The nature and arrangement of the genus compilation are similar to those for family data (Sepkoski, 1992). We repeat certain information here for the benefit of those readers who do not have access to the family compendium.

TAXONOMIC SCOPE AND CONVENTIONS

The genus compendium covers animals and animal-like protists (mainly Foraminiferida and Radiolaria) with a marine fossil record. Genera are arranged hierarchically by kingdom, phylum, class, and order. Note that genera are not assigned to families; thus, the genus and family compilations cannot be linked to form a single, comprehensive compendium. The list of genera, their classification, and their stratigraphic ranges were initially based on a few synoptic sources, principally the *Treatise on Invertebrate Paleontology*, Romer (1966) for vertebrates, and Loeblich and Tappan (1988) for Foraminiferida. Later modifications to the classification are explicitly noted at the section head for each higher taxonomic group. The classification used is not always the same as that for the family compendium. For example, many changes in trilobite systematics were reflected in the revised family data (Sepkoski, 1992), but properly assigning all of the thousands of genera would have been a daunting task, even for a specialist.

Each genus added after the initial compilation from

¹ Deceased May 1, 1999.

synoptic sources is indicated by a "+" to the left of its name, and bibliographic references, keyed to the list at the end of this compendium, are given on the right-hand side of each entry. These references serve both for taxonomic and stratigraphic information. Some new genera are not explicitly keyed to references, but we presume that they would have been if Sepkoski himself had prepared the compendium for publication. Some genera are followed by one or more genus names in parentheses. These names are junior synonyms. A question mark to the left of a genus name indicates uncertain assignment to higher taxonomic group.

We have corrected a few typographical errors in genus names, for example changing the bivalve name *Lunullicardia* to *Lunulicardia*. We must emphasize, however, that these errors were discovered casually while using the compendium for our own research. We have not systematically vetted the work.

Each genus name is followed by abbreviated stratigraphic names (Table 1) giving the first and last occurrence of the genus, separated by a hyphen. Where there is a single stratigraphic name, the genus is confined to that interval. A question mark denotes an uncertain stratigraphic placement. A handful of genera have a stratigraphic range with two questioned occurrences separated by a comma. An example of such an entry, from the Bivalvia, is the following:

+Byssonychia O (Cara)?, O (Ashg)? (1046)

This indicates that the genus is confined to one of the two stratigraphic intervals, in this case the Caradoc and the Ashgill, but it is not clear which one.

THE BIBLIOGRAPHY

Sepkoski's genus data are keyed to about 1300 sources from the literature on systematic paleontology. About 50 references in this list are not cited for any genus. In most cases, it is not possible to know with certainty why the work was not cited. After checking a sample of about 25% of the listed works, we gain the impression that most of the uncited papers reflect cases in which a genus entry was modified (for example, because of a range extension or correction), making the citation obsolete. For example, reference 253 (Kelly and Ausich, 1978), which describes the new crinoid genus *Pogonipocrinus* (as *Pogocrinus*; see Kelly and Ausich, 1979 for emendation) and assigns it to the Upper Tremadoc, is not cited in the version of the database that Sepkoski left. Instead, reference 1066 (Benton, 1993), assigning this genus to the Lower Arenig, is cited. We have been able to identify (and correct) a small number of unambiguous typographical errors. For example, reference 1263 (Blodgett and

Boucot, 1998), which describes the new brachiopod genus *Geniculigypa*, is not cited. For *Geniculigypa*, reference 1264 (Rong and Boucot, 1998) was inadvertently cited instead. We have also identified several cases of duplicate references. Numbers 198 and 350 refer to the same paper, as do numbers 589 and 594, 593 and 1095, 726 and 1079, and 1028 and 1042. Numbers 323, 730, and 739 are missing, and were evidently deleted by Sepkoski.

About 50 references were present in the bibliography only in an abbreviated form (e.g., "511. Ross, 1969"). By checking bibliographic sources such as GeoRef and Zoological Record, as well as our own libraries, against the list of genera keyed to the references, we have been able to narrow down the likely range of possible works, in some cases quite unambiguously. Because there is some interpretation involved here, however, we have followed these references with the original citation in brackets. Explanatory notes are included for some of these. Two references (e.g., "197. Bergstrom, 1981") were given in abbreviated form and were not keyed to any genus.

Although we have corrected such clerical errors as we have found, we must again stress that we have not checked the compendium for accuracy.

In addition to the systematic works listed in the bibliography, the Zoological Record has been cited extensively in the compendium. References for particular genera are cited in the format "ZR89", for example, indicating Zoological Record for 1989.

THE ALPHABETICAL LISTING

Sepkoski prepared the alphabetized list included here in late 1997, and intended it for separate publication as a resource for (as he described it) "systematists naming new organisms, both fossil and living, and attempting to avoid inadvertent introduction of homonyms into the formal literature of zoological classification".

STRATIGRAPHIC CODES

The stratigraphic subdivisions used here (Table 1) largely follow the family compendium (Sepkoski, 1992). In some cases, finer sub-intervals (indicated here with an asterisk) are used here than in the family compendium. We have been unable to find notes among Sepkoski's papers indicating the zones and stages that make up these sub-intervals. A small number of genera have stratigraphic occurrences in intervals that do not nest within those listed as part of the principal scheme below. These additional intervals are indicated in brackets, along with the number of genera having first and/or last occurrences in each.

Table 1.—List of stratigraphic intervals and codes used in the Compendium.

Stratigraphic interval	Code
QUATERNARY	Q
Recent (Holocene)	R
Pleistocene	Plei
TERTIARY	T
Neogene	Ng
Pliocene	Plio
*Upper	Plio-u
*Lower	Plio-l
Miocene	(Mi)
Upper	Mi-u
Messinian	Mi-u-u
Tortonian	Mi-u-l
Middle (Langhian + Serravallian)	Mi-m
Lower	Mi-l
Burdigalian	Mi-l-u
Aquitanian	Mi-l-l
Paleogene	Pg
Oligocene	(Ol)
Upper (Chattian)	Ol-u
Lower (Rupelian)	Ol-l
*Upper	Ol-l-u
*Lower	Ol-l-l
Eocene	(Eo)
Upper (Priabonian)	Eo-u
Middle	Eo-m
Bartonian	Eo-m-u
Lutetian	Eo-m-l
Lower (Ypresian)	Eo-l
Paleocene	Pale
Thanetian	Than
*Upper	Than-u
*Lower	Than-l
Danian	Dani
*Upper	Dani-u
*Lower	Dani-l
CRETACEOUS	K
Upper	(u)
Senonian	(Sn)
Maastrichtian	Maas
<i>neuberigicus</i> Zone	Maas-u
<i>tridens</i> Zone	Maas-l
Campanian	Camp
upper	Camp-u
lower	Camp-l
Santonian	Sant
lower	Sant-l
Coniacian	Coni
upper	Coni-u
lower	Coni-l
Gallic	
Turonian	Turo
<i>bizeti-deveriai</i> Zones	Turo-u
lower	Turo-l
Cenomanian	Ceno
upper	Ceno-u
middle	Ceno-m
lower	Ceno-l
[Middle	(m) 18 genera]

Table 1.—Continued.

Stratigraphic interval	Code
Lower	(l)
Albian	Albi
upper	Albi-u
middle	Albi-m
lower	Albi-l
Aptian	Apti
upper	Apti-u
lower	Apti-l
Barremian	Barr
upper	Barr-u
lower	Barr-l
Neocomian	(Nc)
Hauterivian	Haut
upper	Haut-u
lower	Haut-l
Valanginian	Vala
upper	Vala-u
lower	Vala-l
Berriasian	Berr
Ryazanian	Berr-u
lower	Berr-l
JURASSIC	J
Upper	(u)
Tithonian	Tith
Portlandian	Tith-u
<i>elegans-fittoni</i> Zones	Tith-l
Kimmeridgian	Kimm
<i>mutabilis autvisioderensis</i> Zones	Kimm-u
<i>baylei + cynodoce</i> Zones	Kimm-l
Oxfordian	Oxfo
upper	Oxfo-u
middle	Oxfo-m
lower	Oxfo-l
Middle	(m)
Callovian	Call
<i>athleta + lamberti</i> Zones	Call-u
<i>jason + coronatum</i> Zones	Call-m
<i>macrocephalus + calloviense</i> Zones	Call-l
Bathonian	
upper	Bath-u
middle	Bath-m
lower	Bath-l
Bajocian	Bajo
upper	Bajo-u
lower	Bajo-l
Aalenian	Aale
Lower	(l)
Toarcian	Toar
<i>variabilis-levesquei</i> Zones	Toar-u
<i>tenuicostatum-bifrons</i> Zones	Toar-l
Pliensbachian	Plie
<i>margaritatus + spinatum</i> Zones	Plie-u
<i>jamesoni davoei</i> Zones	Plie-l
Sinemurian	Sine
upper	Sine-u
lower	Sine-l
Hettangian	Hett
<i>hiasicus + angulata</i> Zones	Hett-u
<i>planorbis</i> Zone	Hett-l

Table 1.—Continued.

Stratigraphic interval	Code
TRIASSIC	Tr
Upper	(u)
Norian	Nori
[Rhaetian	Rhae 244 genera]
upper (Sevastian + Rhaetian)	Rhae-u
middle (Alaunan)	Rhae-m
lower (Lacian)	Rhae-l
Carnian	Carn
Tuvanian	Carn-u
Julian	Carn-l
Middle	(m)
Ladinian	Ladi
upper	Ladi-u
lower	Ladi-l
Anisian	Anis
Illyrian	Anis-u
Pelsonian	Anis-m
Aegean	Anis-l
Lower (Scythian)	(l)
Olenekian	Olen
Spathian	Olen-u
Smithian	Olen-l
[Nammalian	Nm 17 genera]
Induan	Indu
Dienerian	Indu-u
Griesbachian	Indu-l
PERMIAN	P
Upper	(u)
Tatarian	Tatr
Dorashamian (Changxingian)	Dora
Djulfian (Longtanian)	Djhu
Guadalupian	Guad
Capitanian (Kazanian)	Guad-u
Wordian (Ufimian)	Guad-l
[Middle	(m) 15 genera]
Lower	(l)
Leonardian	Leon
^u Upper	Leon-u
^m Middle	Leno-m
^l Lower	Leon-l
Sakmarian	Sakm
Sterlitamakian	Sakm-u
Tastubian	Sakm-l
Asselian	Asse
^u Upper	Asse-u
^l Lower	Asse-l
[Wolfcampian	We 75 genera]
CARBONIFEROUS	C
Pennsylvanian	(Pn)
Upper	(u)
Stephanian	Step
Gzelian	Step-u
Kasimovian	Step-l
Moscovian	Mosc
Podolskian + Myachkovskian	Mosc-u
Vereiskian + Kashirskian	Mosc-l
Bashkirian	Bash
Cheremshanskian + Melekesskian	Bash-u
Kinderscoutian - Yeadonian	Bash-l

Table 1. -Continued.

Stratigraphic interval	Code
Serpukhovian	Serp
Chokierian + Alportian	Serp-u
Pendleian + Arnsbergian	Serp-l
Mississippian	(Ms)
Lower	(l)
Visean	Vise
Holkerian - Brigantian	Vise-u
Chadian + Arundian	Vise-l
Tournaisian	Tour
Ivorian	Tour-u
Hastarian	Tour-l
DEVONIAN	D
Upper	(u)
Famennian	Fame
<i>Wocklumeria</i> Zone	Fame-u
<i>Platyclymenia</i> + <i>Clymenia</i> Zones	Fame-m
<i>Cheileceras</i> Zone	Fame-l
Frasnian	Fras
<i>P. gigas</i> + <i>P. triangularis</i> Zones	Fras-u
<i>A. triangularis</i> Zone	Fras-m
<i>A. asymmetricus</i> Zone	Fras-l
Middle	(m)
Givetian	Give
<i>varcus cristatus</i> Zones	Give-u
<i>ensensis</i> Zone	Give-l
<i>australis-kockelianus</i> Zones	Give-u
<i>costatus</i> Zone	Give-l
Eifelian	Eife
<i>australis-kockelianus</i> Zones	Eife-u
<i>costatus</i> Zone	Eife-l
Lower	(l)
Emsian	Emsi
<i>wenkenbachi</i> Zone	Emsi-u
<i>zorgensis</i> Zone	Emsi-l
Siegemian	Sieg
<i>dehiscens</i> Zone	Sieg-u
<i>subcatus</i> Zone	Sieg-l
Gedinnian	Gedi
<i>postvoschmidti-pecavis</i> Zones	Gedi-u
<i>woschmidti</i> Zone	Gedi-l
SILURIAN	S
Upper	(u)
Pridolian	Prid
Ludlovian	Ludl
Ludfordian	Ludl-u
Gorstian	Ludl-l
Middle	
Wenlockian	Wenl
Homerian	Wenl-u
Sheinwoodian	Wenl-l
Lower	
Llandoveryan	Ldov
Telychian	Ldov-u
Aeronian	Ldov-m
Rhuddanian	Ldov-l
ORDOVICIAN	O
Upper	(u)
Ashgillian	Ashg
Hirnantian	Ashg-u

Table 1.—Continued.

Stratigraphic interval	Code
Cautleyan + Rawtheyan	Ashg-m
Pushgillian	Ashg-l
Middle	(m)
Caradocian	Cara
Actonian + Onnian	Cara-u
Soudleyan–Marshbrookian	Cara-m
Costonian + Harnagian	Cara-l
Llandeilian	Llde
<i>gracilis</i> Zone	Llde-u
<i>teretinsculus</i> Zone	Llde-l
Llanvirnian	Llvi
<i>murchisoni</i> Zone	Llvi-u
<i>bifidus</i> Zone	Llvi-l
Arengian	Aren
<i>hirundo</i> Zone	Aren-u
<i>extensus</i> Zone	Aren-l
Tremadocian	Trem
<i>heres–serratus</i> Zones	Trem-u
<i>flabelliforme–incipiens</i> Zones	Trem-l
CAMBRIAN	Cm
Upper	(u)
Trempealeuan	Trep
upper	Trep-u
lower	Trep-l
Franconian	Fran
upper	Fran-u
lower	Fran-l
Dresbachian	Dres
upper	Dres-u
lower	Dres-l
Middle	(m)
upper Middle	uMid
upper	uMid-u
middle	uMid-m
lower	uMid-l
mid Middle	mMid
upper	mMid-u
lower	mMid-l
lower Middle	lMid
*upper	lMid-u
*lower	lMid-l
Lower	(l)
Tojonian	Tojo
upper	Tojo-u
lower	Tojo-l
Botomian	Boto
upper	Boto-u
lower	Boto-l
Atdabanian	Atda
upper	Atda-u
lower	Atda-l
Tommotian	Tomm
<i>regularis–lenicus</i> Zones	Tomm-u
<i>summaginicus</i> Zone	Tomm-l
VENDIAN	V
Upper	(u)
Nemakit–Daldyn (<i>Anabarites–</i> <i>Protohertzina</i> Zone)	N-Da
*upper	N-Da-u
*lower	N-Da-l

ACKNOWLEDGMENTS

Jack Sepkoski was a wonderful friend and valued colleague who is sadly missed. For help and encouragement in preparing Sepkoski's compendium for publication, we thank Warren Allmon, Christine Janis, Susan Kidwell, and David Sepkoski. We also thank Mary L. Droser and Seth Finnegan for assistance in tracking down missing or incomplete references. Many people provided Jack with data and expert opinions during the construction of this working database; we cannot thank them individually here, but Jack deeply appreciated their contributions. Jack Sepkoski's research efforts were supported over the years by the National Aeronautics and Space Administration.

REFERENCES CITED

- Kelly, S.M. and Ausich, W.I.
1979. A new name for the Lower Ordovician crinoid genus *Pogocrinus* Kelly and Ausich. *Journal of Paleontology*, vol. 53, p.1433.
- Foote, M. and Sepkoski, J.J., Jr.
1999. Absolute measures of the completeness of the fossil record. *Nature*, vol. 398, pp. 415–417.
- Loeblich, A. and Tappan, H.
1988. Foraminiferal genera and their classification. Van Nostrand Reinhold, New York.
- Miller, A.I. and Sepkoski, J.J., Jr.
1988. Modeling bivalve diversification: the effect of interaction on a macroevolutionary system. *Paleobiology*, vol. 14, pp. 364–369.
- Raup, D.M. and Sepkoski, J.J., Jr.
1986. Periodic extinction of families and genera. *Science*, vol. 231, pp. 833–836.
- Romer, A.S.
1966. *Vertebrate paleontology*, 3rd. edition. University of Chicago Press, Chicago.
- Sepkoski, J.J., Jr.
1982. A compendium of fossil marine animal families. Milwaukee Public Museum Contributions in Biology and Geology, no. 51, pp. 1–125.
1986. Phanerozoic overview of mass extinctions. In D.M. Raup and D. Jablonski, eds., *Patterns and processes in the history of life*. Springer, Berlin, pp. 277–295.
1992. A compendium of fossil marine animal families, 2nd edition. Milwaukee Public Museum Contributions in Biology and Geology, no. 83, pp. 1–156.
1996. Patterns of Phanerozoic extinctions: a perspective from global databases. In O.H. Walliser, ed., *Global events and event stratigraphy*. Springer, Berlin, pp. 35–53.
1997. Biodiversity: past, present, and future. *Journal of Paleontology*, vol. 71, pp. 533–539.
1998. Rates of speciation in the fossil record. *Philosophical Transactions of the Royal Society of London B*, vol. 353, pp. 315–326.
2000. Crustacean biodiversity through the marine fossil record. *Contributions to Zoology*, vol. 69, pp. 213–222.

Taxon	First Appearance	Last Appearance	Reference	Taxon	First Appearance	Last Appearance	Reference
Ph. ACTINOPODA				+Cenodiscaella	K (Vala-l)	-K (Ceno)	
Cl. RADIOLARIA				Cenodiscus	K (Vala-l)	-R	
Or. SPUMELLARIA				Cenolarcopyle	T (Plio)		
+Acaeniolyte	J (Call-m)	-K (Camp-l)	(753)	Cenosphaera	Tr(Ladi)	-R	
Acanthopyle	Tr(Carn)?	-J (u)		+Cerachocyrtrium	D (Fame-u)	-C (l)	(701)
Acanthosphaera	K (Albi-m)	-R		Ceratoikiscum	S (Wenl)	-C (Serp-u)?	(546,701)
+Acrosphaera	T (Mi-l)	-R		+Cessipylorum	O (Llde)		
Actinomma	T (Eo-m)	-R		Chitonastrum	K	-R	
+Albaillella	D (Fame-l)	-P (Djhu)	(2,535,701)	+Circularforma	C (Vise-u)	-C (Bash-u)?	(701)
+Allocyrtium	C (l)			Cococyclia	T (Eo)	-R	
Amphibrachium	J (u)	-K (l)	(755)	Coccodiscus	K (Maes)	-R	(2)
Amphicyclia	T (Eo)	-R		Coccolaricus	T (Eo)	-R	
Amphimnium	K (Sant)	-R		+Coccolarnacium	T (Eo-m)		(ZR90)
Amphisphaera	K (Camp-l)	-R	(86)	+Conocaryomma	K (Camp)	-T (Eo-u)	(685)
Amphistylus	J	-R		Conosphaera	Tr(Nori-l)?	-R	
+Anakrusa	O (Llde)	-O (Cara-l)		+Copicyntra	C (Step-u)	-P (Guad)	(535)
+Angulobracchia	J (Bajo-l)	-K (Apti)	(755)	+Copicyntroides	P (Guad-u)		(535)
+Archaeohagiastrium	J (Call-m)	-J (Tith)?		+Copiellintra	C (u)	-P (Leon)	(535)
+Archaeopyramisa	C (Serp-l)	-C (Bash-u)?	(701)	-Corythoecia	D (Fame)	-P (Sakm)	(525)
+Archaeotritrabs	J (Tith)	-K (Vala-l)	(1018)	Cromyodruppa	J (u)?	-R	
+Archaeosemantis	Tr(l)	-Tr(Nori-u)	(938)	Cromyodruppacarpus			
+Archaeospongoprimum				Cromyomma	T (Mi)		
+Archocyrtrium	J (Call-m)	-K (Maes)	(155)	Cromyostaurolonche	T (Mi)	-R	
+Archicrinella	S (Ldov)	-C (Serp)	(701)	-Crucella	J (Hett)	-K (Camp-u)	(753)
+Arrectoalatus	C (Step-u)		(525,546)	-Cryptolarancium	T (Than)	-T (Eo-m)	(ZR90)
Artiscus	K (u)?	-R		Cyclastrum	K (Haut)?	-R	(ZR76)
+Astroentactinia	D (Eife)	-P (Leon-l)	(536)	Cyrtentactinia	D (Fras)	-C (Tour)	(701)
Astractura	T (Eo-m)	-R		+Cyrtiphaeromnium	D (Fame-u)	-C (Vise-l)	(701)
Astrocoecus	T (Eo)			-Cyrtisphaeractenium	D (Fame)	-C (Vise-l)	
Astrocyclia	T (Eo-m)	-R		Dactylosphaera	K		
Astromma	T (Eo)	-R		+Deflandrella	P (Guad-u)		(1007)
Astrophacus	T (Eo-m)?	-R		-Deflandrellium	D (Fame-u)		(701)
Astroestrum	T (Eo-l)	-R		+Diactoma	K (Ne)		(1018)
+Auliella	O (Llde)	-O (Ashg-l)		+Diartus	T (Mi-m)	-T (Mi-u-l)	(686)
+Australisaturnalns	Tr(Nori)		(754)	Dicoccura	T (Eo)		
+Axoprimum	T (Dani)?	-R		Dicranastrum	K	-R	
+Belowea	C (Vise-l)			-Dicroa	K (Haut)	-K (Apti-u)	(685)
+Betraccium	Tr(Nori-m)	-Tr(Rhae)	(707,754)	Dictyastrum	J (u)	-R	
+Bissulentactinia	O (Cara)	-D (u)?	(546)	Dictyocoryne	Tr	-R	
+Bistarkum	J (Pliu-u)	-J (Toar-l)	(763)	-Didactylum	J (Tith)	-K (Haut)	(755)
+Bivallupus	J (Tith-u)			-Diparvapila	S (Ldov-u)		
+Brianellium	C (Bash-l)		(701)	Diplactura	Tr	-R	
-Callosphaera	T (Mi-l)	-Q (Plei)		Diploplegma	O	-R?	
-Campanulithus	P		(546)	Disofenia	T (Mi-l)?	-R	
-Camptolatus	C (Step-u)	-P (Leon)	(525,546)	Distriactis	T (Eo)	-R	
Cannartidium	T (Eo)	-R		-Ditrabs	J (Tith-u)	-K (Apti)	(755)
Cannartiscus	T (Mi)	-R		Doryconthidium	J	-T (Mi)	
+Cannartus	T (Ol-u)	-T (Mi-m)		Dorydictyum	O (u)	-K (u)	(ZR86)
+Cantalum	Tr(Nori-m)	-J (Bajo)?	(707,754)	Dorydiscus	T (Mi)		
-Capnodoce	Tr(Carn-u)	-Tr(Nori-u)	(707,757)	Dorydruppa	T (Mi)		
-Capnucho-sphaera	Tr(Carn-u)	-Tr(Nori-u)	(707,757)	Dorylonchidium	T (Pale)	-T (Mi)	
Caryosphaera	D	-R		Doryphacus	T (Mi)		
-Caspiaza	C (Serp)			Doryplegma	O (Cara)?		(2)
+Catoma	Tr(Nori-l)	-Tr(Nori-m)	(707,757)	Dorysphaera	O (Cara)?	-T (Mi)	(2)
+Caucasicus	T (Eo-u)		(ZR84)	Druppastylus	K	-T (Mi)	
+Cavaspongia	K (Turo-l)	-K (Camp-l)		Drupptractus	J	-R	
+Cecrops	K (Vala-u)	-K (Barr-u)		Druppocarpus	T (Eo)	-R	
Cenellipsis	J (u)?	-R		Druppula	T (Than)?	-R	
				Echinomma	J (u)	-R	
				Ellipsoidium	J (u)	-R	
				Ellipostylus	J (u)	-R	

Taxon	First Appearance	Last Appearance	Reference	Taxon	First Appearance	Last Appearance	Reference
Ellipsoxiphus	J (l)	-R		+Larcospira	T (Mi-l)?	-R	
+Emiluvia	J (Bath-u)	-K (Vala-u)	(753,1018)	Larnacalpis	T (Pale)	-R	
Entactinia	Cm(Atda-u)	-P (Guad-u)	(2,579)	Larnacantha	T (Mi)	-R	
Entactinosphaera	O (Cara-l)	-P (Guad-u)	(2,546)	+Latentidiota	C (Step-u)		(535)
+Entopium	T (Than-l)	-T (Eo-l)	(86)	+Latentistulca	C (Vise-l)	-P (Guad-u)	(535)
+Eostylodictya	C (Vise-l)			Liosphaera	R		
Euchitonia	K (Albi-m)	-R		Lithapium	J (Tith-l)	-R	
+Ferresium	Tr(Nori-u)	-Tr(Rhae)	(707)	Lithatractus	J (u)?	-R	
Flustrella	P (Dora)?	-R		Lithelius	K?	-R	
+Follicucullus	P (Guad-l)	-P (Djhu)?	(546,1007)	Lithocyelia	T (Eo-l)	-R	(686)
+Foremanella	J (Oxfo-m)	-K (Apti-u)	(685)	Lithomespilus	K (Camp-l)?	-R	
+Formanhelena	P (Guad)			+Loffa	Tr(Nori-l)	-Tr(Nori-u)	(707)
+Gorgansium	Tr(Carn-l)	-K (Berr)	(938,1018)	Melittosphaera	Tr	-R	(ZR80)
Hagiastrium	Tr(Nori)	-K (Camp-l)	(754)	+Meschedea	C (Vise-l)		
+Halesium	J (Call-m)	-K (Turo-l)		+Mesovallupus	J (Tith-u)		
Halidictyum	P (u)	-Tr(l)		+Mostlerium	D (Fame-u)		(701)
Haliomma	O (Cara)?	-R	(2)	Myelastrum	K	-R	
Haplentactinia	O (Aren)	-D (Fame)	(154,546)	+Natraglia	Tr(Nori-m)		(754)
+Haplodiacanthus	C (Step-u)?	-P (Leon-l)	(535)	+Nazarovella	P (Leon)	-P (Guad-u)	(1007)
+Hegleria	P (Guad-l)	-P (Guad-u)	(535)	+Neolbaillella	P (Guad)	-P (Dora)?	(1007)
+Helenifore	D (Fras)	-C (Vise)		+Neovallupus	J (Tith-u)		
Helicladus	T (Eo)	-R		+Nodotetraedra	J (Tith)	-K (Vala-l)	(1018)
Heliodiscus	C (Vise)?	-R	(2)	+Octoramentum	P (Leon)	-P (Guad-u)	(535)
+Helioentactinia	Cm(m)	-P (Leon)		+Oertlispongus	Tr(Ladi)?	-Tr(Carn)	(938)
+Heliosaturnalis	Tr(Nori)		(754)	+Ommatartus	T (Mi-l)	-R	
Heliosoma	T (Eo-m)	-R	(86)	Ommatocampe	T (Mi)	-R	
Heliosphaera	K (Vala-l)	-R		Ommatodiscus	T (Than)?	-R	
+Heliostylus	T (Than)?	-T (Ol-u)		Ommatospyrus	T (Eo)	-R	
Heterosestrum	T (Eo-m)	-T (Eo-u)		+Orbiculiforma	Tr(Nori)	-K (Maes)	(155)
Hexacladus	T (Mi)			+Oriundogutta	S (u)		
Hexacantium	T (Than-u)	-R		+Ormistonella	P (Guad)		
Hexacromyum	T (Eo-u)	-R		Orostaurs	T (Eo)	-R	
Hexadoras	K			+Ouaka	C (Serp-l)	-C (Bash-l)	(701)
Hexalonche	T (Than-u)?	-R		+Pacyoncus	J (Bajo-u)	-J (Bath)	
Hexaloncharium	T (Mi)	-R		+Palacantholithus	C (l)		(546)
+Hexasaturnalis	J (m)	-K (u)	(ZR88)	+Palaeodeccardiium	S (Ldov-u)	-S (Wen-l)	
Hexastylarium	J (u)	-R		+Palaeoephippium	O (Cara)	-S (Wen-l)	
Hexastylus	Tr(m)	-R	(ZR86)	+Palaeopyramidium	S (Ldov-u)	-S (Wen-l)	
+Higumastra	J (Sine)	-K (Albi)	(763)	+Palaeorubus	D (Fras)		
Histiastrium	K (Vala-l)	-R		Palaeoscenidium	O (Cara)	-C (Vise-l)	(546)
Holoeiciscus	D (Fame-l)	-C (Tour-l)	(546,701)	+Palaeotetraphyle	T (Dani)		(ZR89)
+Homoeoparonaella	Tr(Carn)	-K (Apti)	(755,763,938)	+Palaeothalonnus	D (Fame)		(546)
+Huasha	D (Fame-u)?	-C (Tour-l)	(701)	+Palaeotripus	O (Cara)	-S (Wen-l)	
Hymenactura	T (Eo)	-R		+Pantanelium	Tr(Carn-l)	-K (Apti-u)	(707)
Hymeniastrium	J (u)	-R		+Parafollicucullus	P (Sakm)	-P (Guad-l)	
+Ieriona	Tr(Carn-u)	-Tr(Nori-m)	(707)	+Parasaturnalis	J (Plie-u)	-J (Toar-l)	(754,763)
+Inanibigutta	O (Ashg)		(546)	+Parentactinia	P (u)	-Tr(Carn)?	(938,1007)
+Inanigutta	O (Llde)	-O (Cara-l)	(546)	+Parvalanapila	S (Ldov-u)		
+Inanihella	S (Ludl)		(546)	+Parvicuspis	K (Camp-l)		
+Ishigaconus	P (Guad-u)	-P (Djhu)	(1007)	+Patulibracchium	J (Call-m)	-K (Maes)	(755)
+Ishigaum	P (Guad-u)		(1007)	+Pentactinoecapus	Tr(Ladi)?	-Tr(Carn)	(938)
+Japonisaturnalis	Tr(Carn)	-Tr(Nori)	(754)	Pentactura	T (Eo)	-R	
+Justium	Tr(Nori-l)	-Tr(Nori-u)	(707)	Pentastrium	J (u)?	-R	
+Kalimnasmaera	O (Cara)	-O (u)		Pentastriaera	J (Oxfo)	-J (Tith)?	(1018)
+Kahlerosphaera	Tr(Carn)	-Tr(Nori)	(938)	Perichlamydium	T (Eo)	-R	
+Kantollum	D (Fame-u)	-C (Serp-l)	(701)	Periphaena	K (Ceno)	-R	
+Kashiwara	P (Guad)		(1007)	Phacodiscus	K (Vala-l)	-R	
+Kreyzstella	K (Camp)			Phacostylus	T (Eo)	-R	
+Lapidopiscum	C (Tour-l)		(546,701)	Phacotriactis	T (Eo)	-T (Eo-u)	
Larcidium	T (Eo)	-R		+Phaseliforma	K (Ceno)	-K (Camp-u)	
+Larcopyle	T (Mi-l)?	-R		Phorticum	T (Mi-l)?	-R	
				Phyletripes	J (l)		

Taxon	First Appearance	Last Appearance	Reference	Taxon	First Appearance	Last Appearance	Reference
Pipetta	T (Mi)	-R		Spironium	C (l)	-R	(2)
Pipettaria	T (Mi-l)	-R	(2)	Spongasteriscus	K (Vala-l)	-R	
+ Platkerium	Tr(Ladi)?	-Tr(Nori-u)	(754)	J	J	-R	
Plegmosphaera	T (Mi)	-R		+ Spongattractus	T (Eo-l)	-T (Eo-m-l)	(686)
+ Pleuristratocentactinia	D (Fame)			+ Spongenticactinella	D (Fras)		
Polytactinia	Cnt(Atda-u)	-P (Leon-m)	(535,546,579)	+ Spongenticactinia	O (Cara-u)	-P (Leon)	(546)
+ Polyfistula	P (l)	-P (Leon)	(546,ZR86)	Spongoacanthus	K (u)		(ZR81)
Polysolenia	K (Sn)	-R	(2)	Spongobrachium	K (u)?	-R	
+ Popofskyellum	D (Fame)	-C (Step)	(546,701)	Spongocoelia	D		
+ Porodiscus	Tr(u)	-R		Spongocore	T (Mi)	-R	
+ Praeconocaryomma	J (Hett)	-K (Camp-l)	(156,763)	Spongodiscus	D (Give)	-R	(2)
+ Praedeflandrella	P (Leon)		(1007)	Spongolena	J (u)	-R	
+ Praestyllosphaera	K (Camp)			Spongolomche	R		
+ Protoalbaillella	D (Fame-u)	-C (Tour-l)	(701)	Spongophacus	K	-R	
+ Protovallupus	J (Kimm-l)	-J (Tith-u)		Spongoplegma	T (Mi-m)?	-R	(ZR72)
+ Protoxiphotractus	J (Tith)?	-K (Camp-l)		Spongoprimum	K (Sant)	-R	
+ Proventocitum	O (Aren)		(546)	Spongopyle	T (Eo)	-R	
+ Provisocyntra	C (Tour-l)	-C (Mosc-u)		Spongostaurnalis	Tr(Carn)	-T (Than-l)	(86)
Prunocarpus	T (Eo)	-R		+ Spongostaurnalisoides	Tr(Nori)		(754)
Prunopyle	T (Eo)	-R		Spongostaurus	J (l)	-R	
+ Pseudoalbaillella	C (Bash-u)	-P (Guad-l)		Spongotropus	K (Apti-u)	-R	
Pseudoaulophacus	K (Ceno-u)	-K (Maes-u)		Spongotrochus	K (Apti-u)	-R	
+ Pseudocrucella	J (Plie-u)	-K (Camp)	(763)	Spongoxiphus	T (Eo)	-R	
+ Pseudohagiastrum	Tr(Nori-m)	-Tr(Nori-u)	(754)	Spongurus	T (Eo-l)	-R	
+ Pseudoheliodiscus	Tr(Nori-m)	-J (Plie-u)	(707,763)	Stauracontium	Tr(Ladi-u)	-Tr(Carn)?	(938)
+ Pseudopantanelium	J (Plie-u)	-J (Toar-l)	(763)	Stauralastrum	T (Eo)	-R	
+ Pseudosaturnalis	K (Maes-u)		(754)	Staurancistra	T (Mi)		
+ Pseudostyllosphaera	Tr(Ladi-u)	-Tr(Nori)	(938)	Staurococcura	T (Eo)		
+ Pseudotomentus	P (Guad)		(1007)	Staurocromyum	K (l)	-R	
+ Pylentonema	D (Fame-u)?	-C (Vise-l)	(546)	Staurocyelia	T (Eo)	-R	
+ Pyloctostylus	K (Barr)	-K (Ceno)		Staurodictya	J (u)	-R	
+ Pyramispongia	K (Ceno-l)	-K (Turo-l)		Staurodoras	Tr(Carn-u)	-R	
+ Quadrapesus	D (Fame-u)	-C (Tour-l)	(701)	Staurodruppa	D (Fame)		(154)
+ Quadrimis	C (Step-u)	-P (Guad)	(535)	Staurolonche	J (u)	-K (l)	(753)
+ Quinquecapsularia	K (Ceno-l)	-K (Ceno-u)		Stauroplegma	O	-P (Guad)	(ZR82)
+ Quinqueremis	C (Step-u)	-P (u)	(535)	Staurosphaera	J (Call-l)?	-R	
+ Rectotomentum	P (Leon-l)		(535)	Staurostylus	J (u)	-R	
+ Renzium	Tr(Carn-u)	-Tr(Nori-m)	(707)	Stephanastrum	K (Haut-l)	-R	
Rhizoplegma	T (Than)?	-R		Stigmospaera	D	-R	(ZR74)
Rhodospaera	J (u)?	-R		Stigmospaerostylus	C (l)		
Rhopalastrum	J (u)	-R		Stomatodiscus	T (Pale)	-R	
Rhopalodictyum (+ Paronaella)	C (Vise-l)	-R	(155,754)	Stylatractus	K (Camp)?	-R	(86)
+ Robotium	D (Fame-u)	-C (Tour-l)	(701)	Stylochlamydidium	T (Eo)	-R	
+ Rotasphaera	S (Ldov-u)			Stylocyelia	T (Eo-m)	-R	(86)
Rustia	J (u)			Stylodictya	J (l)	-R	
+ Ruzhencevispongius	P (Leon-l)	-P (Guad-u)	(535)	Stylosphaera	J (Call)	-R	
+ Sarla	Tr(Carn-l)	-Tr(Nori-u)	(707)	Stylosporgia	K	-R	
Saturnalis	J (l)	-R	(2)	Stylostaurus	K (Vala-u)	-R	
+ Saturniforma	K (Ceno-l)	-K (Camp-u)		Stytophaera	T (Mi-l)?	-R	
+ Secuicollacta	O (Cara-u)	-S (Ludl)	(546)	+ Supravallupus	J (Tith-u)		
Sethodiscinus	T (Eo-m)	-R		Syntagenticactinia	O	-S	(546)
Sethostaurus	C (Vise)	-R	(2)	Tessarastrum	J (u)	-R	
Sethostylus	T (Eo-l)	-R	(86)	+ Tetracircinata	P (Leon-m)		(546)
Siphonosphaera	T (Mi-l)	-R	(2)	+ Tetraditryma	J (Plie-u)	-J (Tith-u)	(&55)
+ Solenosphaera	T (Mi-u)	-T (Plio-l)	(686)	+ Tetragregnon	C (Tour-u)	-P (Djhu)	(535,1007)
+ Sompheactactinia	D (Fras)			Tetrypale	T (Mi-u)	-R	(2)
+ Sontonaella	Tr(Carn)	-J (Toar-l)	(763,938)	Tetryplyonium	J	-R	
Sphaeropyle	J (l)	R		+ Tetractangulum	J (Kimm)?	-K (Vala-u)	(1018)
Sphaerostylus	J (Tith)?	-R		+ Tetratormentum	C (Step-u)	-P (Asse-l)	(535)
Sphaerozoum	T (Plio)?	-R		+ Tetratrabas	J (Toar-l)	-K (Berr)	(755,763,1018)
				Tetrentactinia	D (Fame)		(154)

Taxon	First Appearance	Last Appearance	Reference	Taxon	First Appearance	Last Appearance	Reference
Thalassicola	R			Artoperina	T (Eo)	-R	
Thecosphaera	J (u)	-R		+ Artophormius	T (Eo-m-u)	-T (Mi-l-l)	(686)
Theodiscus	K (Albi-m)	-R?		Artostrobium	K (Camp)	-R	(2)
Tholonium	Q (Plei)	-R	(2)	Artostrobos	T (Eo)	-R	
+Tiborella	Tr(Ladi-l)	-Tr(Carn-l)	(938)	+Bagotum	J (Heit)	-J (Bajo)	
+Tormentum	C (Vise)	-P (Guad-u)	(535,546)	Bathrocalpis	T (Eo-u)		
Triactis	Tr	-R	(ZR80)	Bathropyramis	K (Camp)?	-R	
+Triactofenestrella	C (u)		(546)	+Bekoma	T (Than)	-T (Eo-l)	(686)
+Triactoma	Tr(Ladi)?	-K (Albi-u)		+?Bernoullius	J (Call-u)	-J (Tith-l)	
+Triactosphaera	D (Fame-u)?	-C (Vise-u)		+Birkenmajeria	J (Oxfo)	-K (l)	
Trigonactura	Tr	-T (Ol-l)	(2)	+Bisphaerocephalina	R		
Trigonocyclus	J?	-R		Botryocampe	T (Eo)	-R	
+Trilacertus	C (Serp-l)	-C (Bash-l)	(701)	Botryocella	T (Eo)	-R	
+Trillus	J (Plie-u)	-J (Bajo-u)		+Botryocyrtis	K (Camp)?	-R	
Trilonche	D	-Tr(u)	(ZR79)	Botryopyle	T (Eo)	-R	
+Triplanospongos	P (Guad-u)	-P (Djhu)	(1007)	+Botryostrobos	T (Mi-l-u)	-R	
Tripocyclus	Tr(Carn)	-K (l)	(753)	Brachiospyris	T (Than)?	-R	
+Trisolenia	T (Mi-l)	-Q (Plei)		+Broctus	J (Sine-u)	-J (Plie-u)	(756,763)
+Tritrabs	J (Sine-l)	-K (Haut)	(755)	+Buryella	T (Than)?	-T (Eo-m-l)	(686)
Trochodiscus	K (Vala-l)	-R		+Bustuanga	Tr(Ladi)		
+Tuscaritellum	C (l)		(546)	+Callimitra	T (Eo-u)	-R	
+Tympaneides	J (l)		(ZR89)	Calocyclus	T (Eo-l)?	-T (Eo-u)	
+Uberinterna	P (u)		(ZR89)	+Calocyclella	T (Mi-l-l)	-T (Mi-u)	(686)
+Vallupus	J (Tith-u)		(156)	+Calocyclus	T (Eo-l)	-T (Eo-m-l)	(686)
+Veghicyclus	Tr(Carn-u)	-Tr(Nori-m)	(754,938)	+Calyptocoryphe	K (Maes-u)		
+Xenorum	Tr(Nori-l)	-Tr(Nori-m)	(707)	+Canesium	Tr(Nori-l)	-Tr(Nori-u)	(707)
+Xiphachistrella	C (l)		(546)	Cannobotrys	K (Maes)	-R	
Xiphactraetus	T (Eo-m)?	-R		+Canoptum	Tr(Carn)	-J (Bajo-l)	(707)
+Xiphocabrrium	C (l)		(546)	+Canutus	J (Sine-u)	-J (Toar-l)	(756,763)
+Xiphoclaediella	C (l)		(546)	+Carpocanarium	T (Mi-l)	-R	
Xiphodietya	J	-R		+Carpocanistrum	T (Eo-u)	-R	
Xiphosphaera	K (Vala-l)	-R		Carpocanium	T (Eo-u)	-R	(2)
Xiphostaurus	J (u)			+Carpocanopsis	T (Ol-u)?	-T (Mi-m)	
Xiphostylus	J (Plie-u)	-J (Tith-u)	(763)	+Cassideus	K (Ceno-l)		
+Zartus	J (Plie-l)	-J (Bajo-u)	(763)	+Castrum	Tr(Carn-l)	-Tr(Nori-m)	(707)
Zonodiscus	K (Nc)	-R		+Centrobotrys	T (Ol-l)	-R	(686)
Or. NASSELLARIA				Cephalopyramis	T (Eo)	-R	
+Abnormisphaera	Tr(u)		(ZR90)	Cincolpyramis	T (Eo)	-R	
Acanthocircus	Tr(Carn)	-K (Maes)	(707,763,938)	+Cinguloturris	J (Oxfo-u)	-J (Tith)	
Acerahedrina	T (Mi)			Cladospyrus	T (Eo)	-R	
Acerocanium	T (Mi)			Clathrocyclus	J	-R	
+Acidnomelos	K (Maes-u)		(ZR70)	Clathrospyris	T (Eo)	-R	
Acotropis	J			+Collicyrtidium	J (Tith-l)		(1018)
+Acrobotrys	T (Mi-u)	-R?		+Combusta	J (Toar-l)		(763)
Acrospyris	T (Eo)	-R		Conarehnum	K (u)?	-R	
Adelocyrtis (+ Sethocapsa)				+Confironia	K (Camp-l)		
	J (Tith)?	-R		Corocalyptra	K	-R	
Aegospyrus	T (Eo)	-R		Cornutella	Tr	-R	
+Alievium	J (Call)	-K (Maes-l)	(685)	+Cornutovum	K (Maes-u)		
Amphipyndax	K (Apti)?	-K (Maes-u)	(2)	Cortina	T (Eo)	-R	
+Andromeda	J (l)	-J (Tith-u)	(156)	Cortiniscus	T (Eo)	-R	
+Antartissa	T (Mi-l)?	-R		+Conum	Tr(Carn-l)	-Tr(Nori-m)	(707)
Anthocyrtidium	T (Mi-l)	-R		+Crolanium	K (Barr-l)	-K (Apti-l)	(685)
Anthocyrtis	R			+Crubus	J (Plie-u)	-J (Toar-l)	(763)
Anthocyrtoma	T (Pale)	-R		+Cryptamphorella	Tr(Carn)	-K (Maes-u)	(685)
Anthospyris	T (Eo)	-R		Cryptocapsa	J	-R	
+Archaeodictyomitra	J (Toar)	-K (Maes-u)	(155,685)	+Cytrocapsella	T (Mi-l-u)	-T (Mi-m)	(686)
+Archeuecyrtis	Tr(Ladi)?	-Tr(Nori-u)		Cryptoccephalus	J	-R	
Archicorys	J (Tith)	-R	(1018)	Cryptopora	T (Eo-m-u)	-R	(686)
Artocapsa	J (Tith-l)	-R		+Cryptostephanidium	Tr(Amis)	-Tr(Carn)	(938)
				Cycladophora	T (Eo)	-R	
				+Cyclampterium	T (Ol)?	-R	

Taxon	First Appearance	Last Appearance	Reference	Taxon	First Appearance	Last Appearance	Reference
Cyrtocalpis	J (u)	-R		+Latium	Tr(Nori-l)	-Tr(Nori-m)	(707)
Cyrtocapsa	Tr	-R		+Lipmanium	K (Ceno-l)		
+Cyrtocapsella	T (Mi-l-l)	-T (Mi-u-l)		Liriospyris	T (Eo)	-R	
Dendroircus	T (Eo)	-R		Lithobotrys	T (Eo-u)	-R	(2)
Dendrospyris	T (Eo)	-R		Lithocampana	T (Eo)	-T (Eo-u)	
Desmospyris	T (Eo)	-R		Lithocampe	Tr(Ladi)?	-R	
Diacanthocapsa	J (Bajo-u)	-K (Camp)?		Lithocarpium	T (Eo)	-R	
+Dibolachras	J (Oxfo)	-K (Apti-l)	(685,1018)	Lithochytrix	J	-R	
Dicolocapsa	Tr(Carn)	-R		Lithomelissa	Tr(m)	-R	
Dictyocephalus	Tr	-R	(ZR80)	Lithomitra	Tr	-R	
Dictyomitra	Tr(Anis)	-R	(2)	+Lithopera	T (Mi-m)	-R	(686)
+Dictyomitrella	Tr(Carn)			Lithornithium	J	-R	
Dictyophimus	K (Apti-u)	-R		Lithostrobos	P	-R	
Dictyopodium	T (Eo)	-R		+Livarella	Tr(Rhae)	-J (Toar)	(938)
+Dictyoprora	T (Eo-l)	-T (Ol-l)	(686)	Lophoconus	T (Than)?	-R	
Dictyospyris	J	-R		Lophocorys	J	-R	
+Didymocyrtis	T (Ol-u)	-R	(686)	Lophocyrtis	J	-R	
Dipodospyris	T (Eo)	-R		Lophophaena	T (Eo)	-R	
Dorcadospyrus	T (Ol-l)	-R	(686)	+Lophospyris	T (Mi-l)?	-R	
+Drollus	J (Sine)	-J (Bajo-u)		+Lupherium	J (Plie-u)	-J (Bajo)	(756)
+Drulanta	J (Plie-u)	-J (Toar-l)	(763)	Lychnocanium	K (l)	-R	
+Ectonocorys	K (Maes-l)	-K (Maes-u)		+Lychnocanoma	T (Eo-u)	-T (Mi-m)	(686)
+Ectuchomitra	K (Camp)			Lychnodictyum	T (Ol-u)	-R	(686)
+Eostingium	Tr(Anis-u)	-Tr(Nori)	(754,938)	+Marinoum	T (Mi-u)		
+Eribotrys	K (Maes-l)	-K (Maes-u)		Microcubus	T (Eo)	-R	
Eucecyrphalus	T (Eo)	-R		+Microsciadiocapsa	K (Ceno-l)	-K (Coni-u)	
Eucoronis	T (Eo-u)	-R		+Milax	J (Call-m)		(155)
+Eucyrtidellum	J (Toar-l)	-J (Tith-u)		+Mirifusus	J (Bath)	-K (Haut-u)	(156)
Eucyrtidium	J (Tith-l)	-R	(685)	Mitracalpis	K (u)	-R	
Eucyrtis	J (Call-u)	-K (Apti-u)	(685)	+Monosera	J (m)	-J (Oxfo)?	(ZR86)
Eusyringium	K (Camp)	-R		+Morosyringium	J (Tith)	-K (Berr)	(1018)
+Ewingella	K (Ceno-l)			+Myliocercion	K (Camp-l)	-T (Pale)	(685)
+Fantus	J (Plie-u)	-J (Toar-l)	(763)	+Napora	J (Sine-u)	-K (Ceno-l)	(155,145)
+Farcus	J (Plie-u)	-J (Toar-l)	(763)	+Nebespecha	P (l)		(ZR86)
+Favosyringium	J (Tith)	-K (Berr)	(1018)	+Neosciadiocapsa	K (Camp-l)		
+Foremanina	K (Camp)			+Neosemantis	T (Mi-l-u)	-R	
Giraffospyris	T (Eo-m)?	-R		+Neowrangellium	J (Plie-u)	-J (Toar-l)	(763)
Glycobtrys	T (Eo)	-R		+Nephrosyris	T (Mi-u)	-R	
+Gomberellus	Tr(Ladi)			+Noritus	J (Plie-l)	-J (Toar-l)	(756,763)
+Gongylothorax	J (Bajo-u)	-K (Maes-u)		+Obesacapsula	J (Oxfo-u)	-K (Ceno-u)	(156,685)
Gorgospyris	T (Eo)	-R		Octodympanum	T (Eo)	-R	
Halicalyptra	R			+Orbula	T (Than)		
Haliphormis	T (Plio)	-R	(ZR84)	+Pachus	Tr(Nori-l)	-Tr(Nori-m)	(707)
+Heliocryptocapsa	K (Albi)	-K (Camp)	(ZR70)	+Paracanoptum	J (Sine-u)	-J (Toar-l)	(763)
+Heloringulum	J (Tith)	-R	(1018)	+Parahsuum	J (Hett)	-J (Plie)	
Helotholus	T (Eo)	-R		+Parapodocapsa	J (Tith)	-K (Berr)	(1018)
+Hemieryptocapsa	K (Ceno-m)	-K (Maes-u)	(ZR70)	+Parapoulpus	Tr(Carn)		(938)
Hexaspyris	T (Eo)	-R		+Parvicingula	J (Aale)	-K (Haut-l)	(156)
+Holocryptocanium	K (Berr)?	-K (Camp-l)	(685)	Patagospyris	T (Eo)	-R	
Holocryptocapsa	Tr	-T (Plio)		+Perispyridium	J (Toar-u)	-J (Tith-u)	(155,156,763)
+Homeoarchieorys	K (Camp)			Peromelissa	T (Plio)	-R	
+Hozmadia	Tr(Ladi)?	-Tr(Carn)	(938)	+Petasiforma	K (Ceno-l)	-K (Ceno-u)	
+Hsuum	J (Plie)	-K (Haut-l)	(156)	Phaenocalpis	T (Eo)	-R	
+Immersothorax	K (Camp-l)		(ZR70)	Phaenoscenium	J	-R	
Kassina	K			Phormocyrtis	T (Pale)?	-R	(686)
+Katroma	J (Sine)	-K (Berr)	(763,1018)	+Phormospyris	T (Eo-u)?	-R	
+Krempelinella	K (Camp)			+Phormostichoartus	T (Ol-l)	-R	(686)
+Lamprocyclas	T (Ol-l)?	-R		Plagionium	R		
+Lamprocyrtis	T (Plio)	-R	(686)	Platybursa	T (Eo)	-R	
+Lampterium	T (Eo-l)	-T (Eo-m)		Plectopyramis	T (Eo)	-R	
+Lamptonium	T (Than)	-T (Eo-m-l)	(686)	+Pleesus	J (Toar-l)		(763)
+Lantus	J (Plie-u)	-J (Toar)	(763)				

Taxon	First Appearance	Last Appearance	Reference	Taxon	First Appearance	Last Appearance	Reference
+Conicarcella	T (Eo-l)	-T (Ol-l)?	(729)	+Afrobolivina	K (Camp)	-K (Maes)	
Coviella	J (Toar)	-R		Agathammina	C (Serp)	-P (Dora)	
Covliellina	K (Berr)			+Agathamminoides	C (Ms)	-Tr(Nori-l)?	(684)
Favelloides	K (Nc)			+Agglutinella	T (Eo)	-R	
Heterotrichina	T (Dani)	-R		+Agglutisolena	Tr(Rhae)		
Hypotrichina	T (Eo)	-R		Akiyoshiella	C (Mosc-u)		(146)
Parafavella	J (u)	-R		Aktinorbitoides	K (Camp-u)?	K (Maes-l)?	
+Praetinnopsella	J (Tith-u)			Alabama	K (Sant)	-R	
+Pseudarcella	T (Than)	-T (Ol-l)?		+Alabaminoides	T (Ol-u)?	-R	
+Remaniella	K (Berr-l)	-T (Eo-u)	(729)	+Aleomorphella	K (Camp)		
Rhabdonelloides	K (Nc)			-Alfredina	T (Eo-m-l)		
Salpingellina	K (Nc)			Alliatina	T (Plio-l)	-R	
+Spinarcella	T (Eo-m-l)	-T (Eo-m-u)		Alliatinella	T (Plio)	-R	
Stenosemellopsis	J (Toar)	-K (Nc)		Allomorphina	K (Camp)	-R	
Tintinnopsella	J (Plie)	-K (Vala-u)		Allomorphinella	K (Maes)		(148)
+Titthocorys	T (Pg)			Almaena	T (Eo-u)	-T (Mi-l-l)	
+Tylthocorys	T (Eo-l)	-T (Eo-u)	(729)	+Alpillina	K (Barr)		
+Yvonniellina	T (Eo-l)	-T (Eo-u)	(729)	+Alpinophragmium	Tr(Rhae)		(674)
incertae sedis	O (Ashg)			+Altasterella	T (Eo-m)	-T (Eo-u)	
				+Altinerina	Tr(Nori-u)		
				Altistoma	T (Eo-m)	-T (Mi-l)	
				+Alveocyclammina	K (Albi-l)		
				Alveolina	T (Than)	-T (Eo-u)	
				Alveolinella	T (Mi-l-u)		(2)
				+Alveolophragmium	T (Eo-l)	-R	(1051)
				+Alveosepta	J (Oxfo-u)	-J (Kimm-u)	
				Alveoxalulina	T (Mi-l-u)	-T (Plio-l)	
				+Alzonella	J (Bath)		
				-Anbitropus	T (Mi)	-R	
				+Amijiella	J (Plie)	-J (Bath)	
				Ammoastuta	K (Turo)	-R	
				Ammobacularia	Tr(Rhae)		
				Ammobaculites	C (Tour-l)	-R	(2)
				Ammobaculoides	K (Vala)	-K (Maes)	
				Ammocycloculina	K (Vala-l)?		
				Ammodiscella	C (Step-u)		
				Ammodiscoides	C (Mosc)	-R	(537)
				Ammodiscus	Cm(uMid)?	-R	(579)
				+Ammoelphidiella	Q (Plei)		
				+Ammoglobigerina	K (Turo)	-R	
				Ammolagena	T (Than)	-R	(1051)
				Ammomarginulina	Tr(Nori-m)	-R	
				Ammonia	T (Mi-l)	-R	
				+Ammopalmula	J (Bajo-u)		(868)
				+Ammoscalaria	K (Sant-l)	-R	(1051)
				+Ammosiphonia	Tr(u)		
				Ammosphaeroidina	K (Sant)	-R	
				Ammospirata	T (Ol)		
				+Ammotium	K (Nc)	-R	
				-Ammotrochoides	Q (Plei)	-R	
				Ammovertella	C (Mosc-l)	-P (l)	
				Ammovertellina	C (Mosc)?	-T (Than-u)	
				+Ammovolummina	S (Lud-l)		
				Amphicervicis	S (Ldov-m)		
				Amphicoryna	T (Mi-l)	-R	
				Amphimorphina	T (Eo-m)	-R	
				Amphisorus	T (Mi)	-R	
				Amphistegina	T (Eo-m)	-R	
				+Amphitremoida	O (m)?		
				+Amphoratheca	C (Step-u)	-P (Asse-u)	(1249)
				-Amplectopductina	T (Plio)	-Q (Plei)	
				+Anaticinella	K (Ceno-m)	-K (Turo-l)	

CI. INCERTAE SEDIS

Or. CALPIONELLIDA

Calpionella	J (Tith-u)	-K (Barr-u)	
Calpionellites	K (Vala-l)		
Calpionellopsis	K (Berr-u)	-K (Vala-l)	
+Chitinoidea	J (Tith-l)		
Colomiella	K (Apti-u)	-K (Albi-l)	
+Crassicollaria	J (Toar)	-K (Berr-u)	
+Lorenziella	K (Berr-u)	-K (Vala-l)	
+Semichitinoidea	J (Tith-u)		(868)

Ph. RHIZOPODEA

CI. RHIZOPODEA

Or. FORAMINIFERIDA

(Classification and basic stratigraphic ranges from Loeblich and Tappan [1987])

+Abadehella	P (Guad-l)	-P (Dora)	(667)
Abathomphalus	K (Maes-u)		
+Abditodentrix	T (Plio)	-R	
+Abdullaevia	K (Turo-l)		
+Abrardia	K (Camp)	-K (Maes)	
+Abyssamina	T (Than)	-T (Mi-l-l)	
+Acarinina	T (Dani)	-T (Eo-m-u)	
Accordiella	K (Coni)	-K (Sant)	
Acervoschwagerina	P (Sakm-l)	-P (Leon-m)	(145)
Acervulina	T (Mi)	-R	
+Aciculella	K (Sn)		
Acostina	T (Ol-u)	-R	
Acruilammina	K (Haut)	-K (Camp)	
+Actinocyclina	T (Eo-m)	-T (Eo-u)	
Actinosiphon	T (Than)		
+Adelosina	T (Mi-u)?	-R	
+Adelungia	J (u)?	-K (Albi)	
+Adercotryma	K (Camp-l)	-R	(1051)
Adhaerentia	T (Dani)		
+Adraheutina	K (Maes)		
Aeolisaccus	P (Guad)	-K (Maes)	
+Aeolostreptis	K (Sant)	-K (Camp)	
+Aflinetrina	T (Mi)	-R	
Afghanella	P (Guad-u)		(146)

Taxon	First Appearance	Last Appearance	Reference	Taxon	First Appearance	Last Appearance	Reference
Anchispirocyclina	J (Kimm-l)	-K (Vala-l)		Asterocyclina	T (Than)	-T (Eo-u)	
+Andamookia	K (Apti-l)			+Asterohedbergella	K (Ceno-m)	-K (Ceno-u)	
+Andersenia	K (Barr)			+Asterolepidina	T (Ol-l)	-T (Ol-u)	
+Andersenolina	J (Call)	-K (Vala-l)		+Asterorbis	K (Camp)	-K (Maes)	
+Andrejella	C (Vise)			+Asterophragmina	T (Eo-u)		
+Androsina	Q (Plei)	-R		Asterorotalia	T (Mi-u-l)	-R	
+Angotia	T (Eo-m-l)	-T (Eo-u)		Astrononion	T (Eo-m)	-R	
+Angulodiscus	Tr(Ladi-l)	-Tr(Rhae)	(684)	Astrorhiza	O (m)	-R	
Angulogavelinella	K (Maes-u)	-T (Dani)		+Astrorotalia	T (Eo-l)		
+Angulogerina	T (Eo-u)	-R		Asymmetrina	Tr(Rhae)		
+Anictosphaera	S (Ludl)	-D (Gedi)?		+Atactolituola	K (Albi)		(76)
+Annectina	T (Than)	-R		+Ataxoobignyna	K (Coni)	-K (Maes)	
Annulocibicides	T (Mi-l)			Ataxophragmium	K (Ceno-l)	-T (Dani)	(959)
+Annulofrondicularia	T (Mi-u-l)?			+Atelikamara	S (Ludl-l)		
Annulopatellina	T (Mi-l)	-R		+Atwillina	T (Ol-l-u)	-T (Mi-l)	
Anomalinella	T (Eo-u)	-R		+Aubignyna	T (Mi-u)	-T (Plio)	
Anomalinoidea	K (Albi-u)	-R		+Audiensusina	J (Kimm-u)	-J (Tith-u)	
+Antalya	K (Maes-u)			Auloconus	Tr(Carn-u)	-Tr(Rhae)	(674)
+Antarcticella	T (Ol-u)	-T (Mi-m)		Aulotortus	Tr(Anis-l)	-J (m)	(674)
+Apertauroria	D (Give)	-D (Fame)		+Auroria	D (Give)	-D (Fame)	
+Apterinella	C (Serp)	-J (m)		Austrocolomia	Tr(Anis)	-Tr(Rhae)	
+Aragonella	T (Eo-m-l)			Austrotrillina	T (Ol-l)	-T (Mi-l-u)	
Aragonia	T (Dani)	-T (Eo-u)		+Avesnella	D (Fame-u)		
+Arakaevela	S (Ludl)			+Awhea	T (Mi-u)	-T (Plio)	
+Archaealveolina	K (Apti)			+Axiopolina	K (Berr-u)	-K (Vala)	
Archaeacyclus	K (Ceno)			+Ayalaia	K (Camp)	-K (Maes)	
Archaeochintinia	S (Ldov)			+Babelispirillina	J (mi)		
Archaeochoitosa	O (Cara-l)	-J		Baculogypsina	R		
Archaeodiscus	C (Vise-l)	-C (Mosc-l)		Baculogypsinoides	R		
+Archaeoglobigerina	K (Coni-l)	-K (Maes-u)		+Baefenia	D (Fame)		
+Archaeosepta	J (Bajo-u)	-J (Bath)		Baggatella	T (Eo-m-l)	-T (Ol-u)	
+Archaeosphaera	D (Give)?	-C (Vise-l)?		Baggina	K (u)	-R	
Archaias	T (Mi)	-R		+Baggerinoides	K (Albi)	-K (Maes-l)	
+Archiacina	T (Ol-l)			+Baisalina	P (Guad-l)	-P (Dora)	(667)
+Arenagula	T (Eo-m-l)	-T (Ol-l)		+Baituganella	C (Tour)	-C (Vise-l)?	(79)
+Areniconulus	S (Wenl)	-S (Ludl-l)		+Balkhanina	K (Barr)	-K (Apti-u)	
Arenolimmina	K (Albi-l)	-T (Than-u)	(79,148)	Bandyella	K (Coni)	-K (Maes-u)	
+Arenodosaria	T (Eo-m)	-T (Mi-m)		+Banffella	C (Vise-l)	-C (Vise-u)	
+Arenogaudryina	K (Sant-l)	-K (Camp-u)		+Bannerella	T (Eo)	-R	
Arenonionella	T (Mi-u-l)			Barbourinella	T (Ol-u)	-R	
Arenoparrella	R			Barkerina	K (Vala-l)	-K (Maes)?	
+Arenosiphon	O (Cara)	-S (Wenl)		+Barnardina	T (Than)		
Arenoturrispirillina	J (Call)	-R		Bartramella	C (Mosc-u)	-C (Step-l)	(145)
+Arenovidalina	Tr(Olen-l)	-Tr(Rhae)	(684)	Bathysiphon (+ Platysolenites)			
+Armenina	P (Leon-m)	-P (Guad-u)		Bdelloidina	T (Than)	-R	
Arnaudieella	K (Camp-u)			+Beedeina	C (Mosc-u)		(145)
+Articularia	T (Mi-u-l)			Beella	T (Mi-u-l)	-R	
Articulina	T (Eo-m-l)	-R		Belorussiella	K (Berr)	-K (Sant-u)	(959)
Asanoina	T (Plio)	-R		+Berggrenia	T (Plio)	-R	
+Asanonella	T (Plio)	-R		+Bermudezella	T (Ol-l-u)		
+Asanospira	K (Ceno)	-T (Ol-u)		+Bermudezinella	T (Mi-m)	-R	
+Aschemoecella	K (Camp)	-K (Maes)	(1051)	Bermudezina	T (Than)	-T (Mi)	(939)
+Asciella	K (Apti)	-K (Albi-u)	(857)	+Berthelina	K (Albi)		
+Asselodiscus	C (Mosc-u)	-P (Asse-l)	(1249)	Berthelinella	Tr(Rhae)	-J (Plio-u)	
Assilina	T (Than-l)	-R		+Berthelinopsis	K (Camp)		
Astaculus	J (Sine-u)	-R	(1051)	+Biapertorbis	T (Eo-u)	-T (Ol-l)	
Asterigerina	T (Eo-l)	-R		Biarrizina	T (Eo-m)	-R	
Asterigerinata	T (Ol-u)?	-R		+Biasterigerina	T (Than)?	-R	
Asterigerinella	T (Eo-u)			+Bibradya	C (Vise-u)		
Asterigerinoides	T (Ol-l-u)	-T (Mi-m)		+Biconcava	K (Albi-m)	-K (Turo)	(646)
+Asteroarchaediscus	C (Vise-u)	-C (Mosc-l)	(144,752)	+Bifarilaminella	T (Ol-u)	-R	
+Asteroammonia	T (Mi-m)	-T (Plio)					

Taxon	First Appearance	Last Appearance	Reference	Taxon	First Appearance	Last Appearance	Reference
Bifarina	K (Albi-u)	-T (Pale)		Bueningia	T (Mi-l)	-R	
+Bifarinnella	Q (Plei)	-R		+Bulbobauculites	J (Tith-l)	-T (Eo-u)	(1051)
Bifurcammina	S (Wenl)			+Bulbobaucierenata	K (Ceno)		
Bigenerina	T (Than)	-R	(1051)	Bulbophragmium	K (Camp)		
Biglobigerinella	K (Camp)			Bulimina	T (Dani)	-R	
+Bilingulogavelinella	K (Albi)	-K (Turo)		Bulminella	K (Maes-l)	-R	
Biloculinella	T (Ol-u)?	-R		Bulminellita	T (Eo-u)	-T (Plio-l)	
+Bimonilina	K (Albi)	-K (Ceno)		Bulminoides	T (Ol-l)	-R	
+Biokovina	J (Plie)			Bullalveolina	T (Ol-l)		
Biorbis	C (Vise-u)			Bullopura	J (l)	-K (Maes)	
+Biparietata	P (Leon-u)			Burseolina	T (Eo-u)	-R	
+Biplanata	K (Ceno-l)	-K (Turo)	(646)	+Buzasina	K (Sant)	-T (Eo-l)	(1051)
Biplanispira	T (Eo-m)	-T (Eo-u)		+Bykovaena	K (Sant)	-K (Camp)	
+Bireophax	K (Albi)	-K (Sn)		+Bykoviella	K (Turo)		
Biseriammina	C (Tour-l)			+Calcarina	T (Plio)	-R	
+Biseriella	C (Vise-l)	-C (Mosc-l)	(79)	Calcitornella	C (Step-u)	-P (Dora)	
Bisphaera	D (Give-u)	-C (Vise-l)	(752)	Calcivertella	C (Step-u)	-P (Dora)	
+Bispiranella	Tr(Carn)			Caligella	D (Fras)	-D (Fame)	
+Bitaxia	J (Tith-u)	-K (Berr)		+Calveziconus	K (Camp)		
+Biticinella	K (Albi-u)	-K (Ceno-l)		+Calvezina	P (Djhu)	-P (Dora)	
+Bituberitina	C (Vise)			Camagueyia	T (Eo-m-l)	-T (Eo-m-u)	
+Bitubulogenerina	T (Eo-m-l)	-T (Mi-u-l)		+Campanellula	K (Vala)	-K (Barr)	
Biwaella	P (Asse)			Cancellina	P (Leon-m)?	-P (Guad-u)	
Blastammina	O (Caru)?	-C (Tour)	(537)	Canceris	T (Eo-m)	-R	(79)
+Blefusciana	K (Barr-l)	-T (Dani)?	(857)	+Cancerisiella	J (Kimm-l)	-K (Albi)	
+Blowiella	K (Barr-u)	-K (Apti-u)	(857)	Candelea	T (Mi-u)	-R	
+Bogushella	C (Vise-l)	-C (Vise-u)	(79)	+Candorbulina	T (Mi-m)	-T (Mi-u-l)	
+Bojarkaeella	J (Call-u)	-K (Berr)		+Carbonella	C (Tour-u)	-C (Vise-l)	
Boldia	T (Than-l)	-T (Eo-m)		Caribeanelia	T (Plio)	-R	
Bolivina	K (Camp-u)	-R		+Carinoconus	K (Albi-u)	-K (Ceno-l)	
+Bolinella	T (Eo-u)	-R		Carixia	J (Plie-l)	-J (Plie-u)	(79,715)
+Bolinellina	T (Plio)	-R		Carpenteria	T (Eo-u)	-R	
Bolivinita	T (Mi-m)	-R		Carterina	T (Eo-u)	-R	
Bolvinoides	K (Sant-u)	-T (Than-u)		+Caspella	P (Leon-l)		
Bolvinopsis	K (Camp-u)	-K (Maes-l)	(1051)	Cassidella	K (Albi-m)	-T (Ol-l-u)	(959)
+Bolkarina	T (Than)			+Cassidelina	T (Plio)	-R	
+Bollia	Q (Plei)	-R		Cassidulina	T (Dani)	-R	
+Boltovskoyella	T (Eo-u)	-T (Ol-l)		+Cassidulinita	T (Plio)		
Borelis	T (Eo-u)	-R		Cassidulinella	T (Mi-l-u)	-T (Plio-u)	
Boreloides	T (Eo-m)	-T (Eo-u)		Cassidulinoides	T (Plio-l)	-R	
Borodinia	T (Mi-l-l)			Cassigerinella	T (Eo-m-u)	-T (Mi-m)	
+Bosniella	J (Plie)	-J (Bajo-l)		+Cassigerinelloita	T (Eo-l)	-T (Eo-m-l)	
Boultonia	P (Asse-u)	-P (Guad-l)	(145)	Cataspnydrax	T (Eo-l)	-T (Mi-m)	
+Bozorginiella	T (Mi-l-l)			Caucasina	T (Dani)	-T (Mi-u-u)	
Brachysiphon	R			+Caudriella	T (Eo-m)		
Bradyina	C (Vise-u)	-P (Dora)	(144)	+Cellonina	O (Ashg)?, S (Ldov)?		
+Bramkampella	J (u)	-K (l)		Ceratammia	D (Gedi)		
+Brasiliella	K (Maes)			Ceratobulimina	K (Albi)	-R	
+Brebina	T (Eo-u)			Ceratocanceris	T (Eo-m)	-T (Mi-l)	
+Brenckleina	C (Serp-l)			Ceratolamarckina	K (Albi)	-T (Dani)	
Brevaxina	P (Sakm)	-P (Guad-u)		Cerobertina	T (Eo-l)	-R	
Brizalina	K (Camp)	-R		+Cerobertinella	K (Apti)	-K (Albi)	
Broeckina	K (Ceno-l)	-K (Maes)	(148)	+Chablaisia	J (m)		
Broeckinella	K (Sant)	-T (Dani)		+Chalilovella	K (Haut)	-K (Apti-l)	
+Bronnimannia	T (Mi)	-R		+Chalaroschwagerina	P (Sakm-u)	-P (Leon-l)	(145)
+Brunsiella	C (Vise)	-P (l)		Chapmanina	T (Eo-m-l)	-T (Mi-u-l)	
Brunsia	D (Fame)	-C (Serp-u)		+Charentia	K (Barr-u)	-K (Ceno-m)	(646)
Buccella	T (Eo-m)	-R		Charltonia	K (Albi)	-T (Mi-l-u)	
Buccierenata	K (Barr)	-K (Ceno)		+Chenella	P (Leon-m)		(146)
+Bucherina	K (Maes-u)		(148)	+Chenia	P (Leon-u)	-P (Guad)	
+Buchnerina	Q (Plei)	-R		+Chernobaculites	C (Serp)		
Budashevella	T (Eo-u)	-T (Mi-l)		Chernyshinella	D (Fame-m)	-C (Tour-u)	(678)

Taxon	First Appearance	Last Appearance	Reference	Taxon	First Appearance	Last Appearance	Reference
+Chernyshinellina	C (Tour)			+Conorbitoides	K (Camp-u)?	K (Maes-l)?	
Chiloguembelina	T (Dani)	-T (Ol-u)		Conorbooides	K (Apti)	-K (Albi-u)	(959)
+Chiloguembelitria	T (Dani)	-T (Ol)		Conorotalites	K (Barr-l)	-K (Albi-l)	(2)
Chilostomella	K (u)	-R		Conotrochammina	K (Camp)	-T (Eo-l)	(728)
Chilostomelloides	T (Dani)	-T (Mi)		+Contusotruncana	K (Sant-u)	-K (Maes-u)	
+Chilostomina	T (Mi-l)	-T (Mi-u)		Coprolithina	K (Barr-u)	-K (Maes)	(148)
Chitinodendron	Cm(u)	-S		+Corrigatella	T (Eo-u)	-R	
Chitinolagena	O (Cara)			+Cordatella	D (Give)	-D (Fame)	
+Chitralina	P (Leon-u)	-P (Guad-u)		Cornuloculina	R		
Choffatella	J (Oxfo)	-K (Ceno)		+Cornuspira	C (Vise)	-R	
+Chomatemediocris	C (Vise-u)			+Coronipora	Tr(Nori)	-Tr(Rhae)	
Chrysalidina	K (Ceno-m)	-K (Ceno-u)	(646)	+Corrigotubella	C (Tour-u)	-C (Vise-l)	
Chrysalidinella	T (Eo)	-R		+Corrosina	T (Ol-u)		
Chrysalogonium	K (Camp)	-R		Coryphostoma	K (Ceno)	-R	
+Chrysothurammina	D (Give)	-C (Tour)		Coscinostracum	K (Albi-m)	-K (Turo-l)	
+Chubbina	K (Camp-u)	-K (Maes)		+Coscinspira	R		
+Chusenella	P (Sakm-l)	-P (Guad-u)	(146)	Coskinolina	T (Pale)	-T (Eo-m)	
Cibicides	T (Than)?	-R		Coskinolinoides	K (Apti-u)	-K (Albi-u)	(646)
Cibicidina	T (Than)	-R		+Coskinon	T (Than-l)	-T (Eo-m)	
+Cibicidoides	T (Dani)?	-R		+Costayella	C (Tour)	-C (Vise)	
Cibicorbis	T (Mi-m)			+Costellagerina	K (Ceno)	-K (Camp)	
Cimcoriola	T (Pale)	-T (Eo-l)		+Costifera	Tr(Nori)		
+Ciperozea	T (Ol-l-u)	-T (Mi-u-l)		Coxites	K (Ceno-u)	-K (Turo-l)	
+Circinaitella	K (Albi)	-K (Ceno)		+Crenatella	T (Mi-u-l)?		
Cisalveolina	K (Ceno-m)	-K (Turo-l)	(646)	+Crenavermetulina	K (Albi)	-K (Ceno-u)	
Citharina	J (Toar-l)	-T (Than-u)	(79,148)	+Crenulostomina	T (Mi-l)		
Citharinella	J (Bath)	-K (Camp)		Crespinella	T (Mi)		
+Civrieuxia	T (Eo-m)			Crespinina	T (Eo-u)	-T (Ol-u)	
+Claudostriatella	T (Eo-m)			+Cribellopsis	K (Haut-u)	-K (Apti-l)	
Clavatorella	T (Mi-l-u)	-R		+Cribranopsis	C (Vise-l)	-C (Vise-u)	(79)
Clavelloides	T (Eo-l)	-T (Eo-m)		Cribratina	K (Albi)	-K (Ceno-l)	
Clavigerinella	T (Eo-m-l)	-T (Eo-u)		+Cribroaperturata	C (Vise-l)		
Clavibergella	K (Apti)	-K (Coni-u)		Cribroelphidium	T (Mi)	-R	
+Claviticinella	K (Albi-u)			Cribrogenina	C (Mosc-l)	-P (Dora)	(667)
Clavulina	K (Sant-l)	-R	(1051)	Cribroglobrotalia	T (Eo)		
+Clavulinoides	T (Dani)	-T (Than)		Cribrogoesella	T (Mi)	-R	
+Clavulinopsis	K (Camp)	-K (Maes)		Cribrohanckenina	T (Eo-u)		
Climacaminna	C (Tour-u)	-P (Dora)	(150)	+Cribrohemisphaeroides	S (Prid)	-D (Eife)	
+Clnapertina	T (Eo-l)	-T (Eo-m-l)		+Cribrolenticulina	T (Plio)		
+Clypeorbis	K (Maes-u)			Cribrolinoides	T (Plio)	-R	
+Coccarota	T (Eo-u)			+Cribronodosaria	K (Maes)		
Codonofusiella	P (Guad-l)	-P (Dora)	(145)	Cribronomion	T (Eo)	-T (Mi-l-u)	
+Colania	P (Guad-l)		(145)	Cribroparella	T (Mi-l)	-T (Mi-u)	
Colamiella	P (Dju)	-P (Dora)	(2,150,667)	+Cribropleurostomella	K (Ceno-u)		
+Coleiconus	T (Eo-l)	-T (Eo-m)		Cribropullenia	T (Eo)	-T (Ol)	
Coleites	T (Dani)	-T (Eo-m-l)		Cribronobulina	T (Mi)	-R	
Colomia	K (Turo)	-K (Maes)		+Cribrorotalia	T (Eo-u)	-T (Mi-m)	
+Colomita	T (Mi-u-l)			+Cribrosphaeroides	D (Eife)	-D (Fame)	
Colonammina	S (Ldov)			Cribrospira	C (Vise-u)	-C (Serp-l)	(79)
+Comalianna	K (Albi)			Cribrostomoides	K (Sant)	-R	(1051)
Compressigerina	T (Ol-u)?	-R		Cribroturretoides	T (Mi-m)		
+Concavatoruncana	K (Ceno-u)	-K (Sant)		+Cristellariopsis	T (Pg)		
+Concavella	T (Mi-m)			+Croneisella	S (Ldov-m)	-S (Ldov-u)	
Condonofusiella	P (u)			Cruciloculina	T (Plio)	-R	
+Condru stella	C (Tour-u)	-C (Vise-u)	(79)	+Cryptoseptida	P (Guad-l)	-Tr(Carn)	
+Conicorbitolina	K (Ceno)			+Ctenorbitoides	K (Camp-u)?	K (Maes-l)?	
Conicospirillina	Tr(Ladi-u)	-J (Bajo-u)	(1051)	Cubanina	T (Ol-l)		
+Conilites	C (Tour-u)	-C (Vise-l)		+Cuburbita	Tr(Carn-l)	-Tr(Rhae)	(684)
+Conoglobigerina	J (Bajo-u)	-K (Vala-u)	(857)	Cuneolina	K (Barr-l)	-K (Maes-u)	
+Conolagena	T (Ol-l)	-R	(1033)	+Cuneolinella	T (Mi-m)		
Conorbina	K (Berr)	-K (Coni)		+Cuneus	K (Coni)	-T (Pale)	
+Conorbinella	K (Barr-l)	-K (Apti-l)					

Taxon	First Appearance	Last Appearance	Reference	Taxon	First Appearance	Last Appearance	Reference
+ Cuniculinella	P (Asse-u)	- P (Sakm-u)		Dicyclina	K (Albi-u)	- K (Maes-u)	
+ Cursina	Q (Plei)	- R		Dimorphina	T (Mi)	- R	
+ Cushmania	T (Eo-m)			+ Diplosphaerina	D (Eife)	- P (Dora)	
+ Cushmanina	T (Mi-u)	- R		Diplotremina	Tr (Anis-u)	- Tr (Rhae)	
Cuvillierina	T (Eo-l)			Discamminoides	T (Ol-u)	- T (Mi-l)	
Cyclammima	K (Sant-l)	- R	(1051)	Discanomalina	T (Mi)	- R	
+ Cycledomia	K (Ceno-u)	- K (Turo-l)		Discocyclina	T (Than)	- T (Eo-u)	
Cyclindroclavulina	T (Ol)	- R		+ Discogypsina	T (Eo-u)	- R	
Cycloclypeus	T (Ol-l)	- R		+ Discoramulina	T (Eo-m)	- R	
+ Cycloforina	J (u)?	- R		+ Discorbinella	T (Mi)	- R	
Cyefolina	K (Ceno-m)	- K (Maes)	(646)	Discorbis	T (Than-l)	- R	
Cyefoloculina	T (Eo-m)	- T (Mi-l)		+ Discorbitina	Q (Plei)	- R	
+ Cyclopsseudomia	K (Camp)	- K (Maes)		Discorbitura	T (Ol-l)		
Cyclopsinella	K (Ceno-m)	- K (Sant-u)	(646)	Discorinopsis	T (Eo-m)		
+ Cycloputeolina	T (Mi-m)	- R		+ Discorotalia	T (Ol-l)	- T (Mi-m)	
+ Cyclorbiculina	T (Ol-l)	- R		Discospirina	T (Mi-m)	- R	
+ Cyclorbiculinoïdes	T (Eo-m-l)	- T (Eo-u)		+ Dizerina	K (Maes-u)		
+ Cyclorbitopsella	J (l)			+ Dobrogelina	K (Berr-u)	- K (Barr-u)	
+ Cylihydroclavulina	T (Ol-u)?	- R		Dogielina	T (Mi-u)		
+ Cylihydroclaniella	P (Guad)	- P (Dora)	(667)	Dohaia	K (Ceno-u)	- K (Turo)	
+ Cylihydrotrocholina	J (m)			+ Dolosella	J (Bajo-u)	- J (Kimm-l)	
Cymbalopora	K (u)	- T (Than-l)		Dorothia	K (Vala-u)	- T (Eo-u)	(1051)
Cymbaloporella	R			+ Drepaniota	K (Maes)	- T (Eo-u)	
Cymbaloporetta	T (Plio-l)	- R		+ Drevennia	K (Barr-u)	- K (Apti-l)	
Cystamma	K (Camp)	- R	(1051)	+ Droegerinella	T (Eo-u)		
+ Dagmarella	C (Mosc-l)		(145)	+ Dryorhizopsis	C (Step-u)		
+ Dagmarita	P (Guad)?	- P (Dora)	(150)	K (l)		- K (m)	
+ Daimella	C (Tour-u)	- C (Vise-u)	(79,144)	Dunbarinella	C (Step-u)	- P (Sakm)	
Daimita	K (Haut)	- K (Maes)		Dunbarula	P (Guad-l)	- P (Djhu)	(145)
+ Daimitella	J (Oxfo)	- J (Tith-u)		Duostomiina	Tr (Anis)	- Tr (Rhae)	
+ Daixina	C (Step-u)	- P (Sakm-l)	(146)	+ Duotaxis	Tr (Rhae)		
+ Danubiella	K (Barr)			+ Duplella	Q (Plei)	- R	
+ Dariellina	K (Maes)	- T (Pale)		+ Dutkevichella	C (Mosc-u)		
+ Dariopsidae	C (Tour)	- C (Vise)		+ Dutkevichites	C (Step-u)	- P (Asse)	
+ Darjella	C (Tour-u)	- C (Vise-l)	(79,752)	+ Dutkevitchia	C (Step-u)	- P (Sakm-u)	
+ Darvasites	P (Sakm)	- P (Leon-u)	(145)	Dyfrondicularia	T (Plio)		
Daucina	T (Eo-l)	- T (Mi-l)		+ Dymia	T (Eo-u)		
Daucinoides	T (Mi-l)			Dyocibicides	T (Eo)	- R	
+ Daviesiconus	T (Eo-l)			Earlandia	S (Ludl)	- P (Dora)	
Daviesina	T (Than-l)	- T (Eo-m)		+ Earlandinella	C (Tour-l)	- C (Vise-u)	(1249)
Davia	K (Ceno-l)	- K (Ceno-u)	(646)	Earlandinita	C (Vise-u)?	- C (Serp)	(1249)
Debarina	K (Vala-u)?	- K (Apti)		Eblanaia	C (Tour-u)	- C (Vise-u)	(79)
+ Deckerella	C (Vise)	- C (Step)		+ Echigoina	T (Mi-u)?	- T (Plio)	
Deckerellina	C (Vise)	- C (Mosc)		+ Echinoporina	K (Albi-m)		
+ Demirina	K (Ceno-u)			+ Eclusia	K (Vala)		
Dendritina	T (Eo-m-l)	- R		+ Econgella	K (Barr)	- K (Apti-l)	
Dendrophyta	T (Eo-l)	- R	(1051)	+ Edhemia	K (Ceno-l)		
Dentalina	K (Berr)	- R	(959)	+ Edithaella	K (Albi-m)		
+ Dentalinella	J (Sine)?			Edomia	K (Ceno)	- K (Turo)	
Dentalinoides	K (Camp)?	- T (Mi)		Eggerella	T (Eo)	- R	
Dentalinopsis	K (Haut)			Eggerellina	K (Albi-m)	- K (Maes-u)	(79,148)
+ Dentoglobigerina	T (Eo-m-u)	- T (Plio-l)	(939)	Eggerina	T (Than-u)		
+ Derventina	K (Berr-u)	- K (Apti-l)	(649)	Ehrenbergina	T (Eo)	- R	
+ Deuterospira	K (Ceno)			+ Elenella	S (Ludl)	- C (l)	
+ Dhrumella	J (Biath)			+ Elergella	C (Tour)		
+ Dictyoconella	K (Turo)	- K (Maes)	(2)	+ Elhasaella	K (Camp-l)	- K (Maes-u)	
Dictyoconoides	T (Eo-m-l)	- T (Eo-m-u)		Ellipsobulimina	T (Mi-m)	- R	
Dictyoconus	K (Barr-u)	- T (Eo-u)	(2)	Ellipsocristellaria	K (Albi)		
Dictyokathina	T (Pale)			Ellipsodimorphina	T (Eo-m-l)		
Dictyopsella	K (Ceno)	- K (Maes)		Ellipsoglandulina	K (Turo)	- R	
+ Dictyopselloides	K (Sant-u)			Ellipsoidella	K (Ceno-l)	- K (Turo)	(959)
+ Dictyorbitolina	K (Barr)	- K (Apti)		Ellipsoidina	T (Eo)	- T (Plio)	

Taxon	First Appearance	Last Appearance	Reference	Taxon	First Appearance	Last Appearance	Reference
Ellipsolingulina	T (Eo-m-l)	-T (Ol-l)?		Epistominoides	J (Oxfo)	-T (Eo-l)	
Ellipsopolymorphina	T (Eo-m-l)	-Q (Plei)		+ Epithemella	K (Berr)	-T (Mi-u-l)	
+Elongobola	T (Ol-l)?			Eponidella	T (Mi)	-R	
Elphidiella	T (Dani)	-R		Eponides	T (Dani)	-R	
Elphidioides	T (Eo-u)			+Escornebovina	T (Ol-l-u)	-T (Mi-m)	
Elphidium	T (Eo-l)	-R		+Eubulminella	T (Eo-m-u)	-R	
+Enatiodontalina	K (Camp)	-R		+Eulepidina	T (Ol-l-u)	-T (Mi-l-l)	
Enantiomorphina	K (Sn)			+Eulinderina	T (Eo-m)		
+Endochernella	C (Tour-l)	-C (Vise)		+Euloxostomum	T (Plio)	-R	
+Endospiroplectamina				Eurycheilostoma	K (Albi)		
	C (Tour-u)	-C (Vise-l)		Euuvigerina	T (Eo-m)	-R	
+Endostaffella	C (Tour-u)	-C (Mosc-l)	(79)	+Euxinita	C (Vise)	-C (Serp)	
+Endoteba	P (u)	-Tr(Carn)	(1113)	+Evlania	D (Give-u)	-D (Fras)	
+Endotebanella	Tr(Olen)	-Tr(Rhae)	(1113)	+Everticyclammina	J (Oxfo-u)	-K (Ceno)	
Endothyra	D (Fame-u)	-C (Mosc)	(73,144)	+Evolutinella	J (Tith-u)?	-T (Mi-u)	(1051)
Endothyranella	C (Bash-u)	-C (Step-u)		+Evolutononion	Q (Plei)		
Endothyranopsis	C (Vise-l)	-C (Serp-u)	(79,144)	+Evolvocassidulina	T (Eo-u)	-R	
+Endotriada	Tr(Anis)	-Tr(Nori)	(1113)	+Exsculptina	Q (Plei)	-R	
+Endotriadella	Tr(Anis-u)	-Tr(Nori)	(1113)	+Eygalerina	K (Barr)		
+Eoammosphaeroides	S (Ludl-u)	-D (l)		Fabiania	T (Than)	-T (Eo-u)	
Eoannularia	T (Eo-m)	-T (Eo-u)		Fabularia	T (Eo-m-l)	-T (Eo-m-u)	
+Eoclavatorella	T (Eo-l)			+Fallotella	T (Than-l)		
Eoconuloides	T (Eo-m-l)	-T (Eo-u)		Fallotia	K (Sant)		
Eoecrstellaria	P (Guad)	-P (Djhu)	(667)	Falsocibicides	T (Ol-l-u)	-T (Mi-l-u)	
+Eoendothyra	D (Fame-m)	-C (Vise)		+Falsogaudryinella	K (Vala-u)	-K (Ceno)	
+Eoendothyranopsis	C (Vise-l)	-C (Vise-u)	(144)	Falsoguttulina	K (Vala)	-K (Maes)	
Eoeponidella	K (Camp-l)	-R		+Falsopalmula	J (Toar)	-J (Bath)	
Eofabiania	T (Eo-m)?			+Falsoplanulina	T (Pale)	-T (Mi)	
+Eoforschia	C (Tour-u)	-C (Vise-u)	(79,144)	+Falsotruncana	K (Turo-u)	-K (Coni-l)	
+Eofusulina	C (Mosc-l)			+Falsurgonina	K (Barr-u)	-K (Apti-l)	
+Eoglobigerina	T (Dani-l)			Faujasina	T (Plio-u)	-Q (Plei)	
Eoguttulina	Tr(Nori-l)	-K (Albi)	(73)	+Favocassidulina	T (Mi-m)	-R	
+Eohastigerinella	K (Coni)	-K (Sant)		+Favulina	T (Mi-u)	-R	(1033)
Eolagena	S (Ludl)			+Favusella	K (Barr-u)	-K (Ceno-m)	(857)
+Eoliasiodiscus	C (Serp-l)	-C (Mosc-l)	(144)	+Felsinella	T (Plio-l)		
+Eomarrsonella	J (Oxfo)			Ferayina	T (Eo-m-l)	-T (Eo-m-u)	
+Eonodosaria	D (Fras-u)		(678)	Feurtilla	J (Tith-u)	-K (Vala-u)	
+Eoophthalmidium	Tr(Anis)			+Fijnionia	T (Mi-l)	-R	
+Eopalorbitolina	K (Barr)			+Finlayina	T (Eo-u)	-T (Ol-l)	
Eoparafusulina	P (Asse-l)	-P (Leon-m)		Fischerina	T (Plio-u)	-R	
+Eopolydiexodina	P (Leon-u)			Fissoelphidium	K (Maes)		
+Eoquasiendothyra	D (Fame-m)	-C (Tour)		Fissurina	K (Apti-u)	-R	(959)
Eorupertia	T (Eo-m-l)	-T (Eo-u)		Flabellammina	K (Albi)	-K (Maes)	(148)
Eoschubertella	C (Bash-u)	-C (Mosc-u)	(145)	Flabellamminopsis	J (m)		
Eosigmoilina	C (Vise)	-C (Bash-l)	(2)	Flabellinella	K (u)	-T (Eo-m-u)	
Eostaffella	C (Vise-l)	-C (Mosc-u)	(145)	+Flabellocyclolina	J (Oxfo)	-K (Sant)	
+Eostaffeloides	P (Leon-l)	-P (Guad-u)	(146)	+Flagrospira	Tr(Carn)		
Eotextularia	C (Tour-u)	-C (Vise-l)	(79,144)	Flectospira	P (Leon)		
+Eotournayella	D (Fras)			Flintinella	T (Mi-u)		
+Eotuberitina	D (Give-u)?	-P (Dora)	(150)	Flosculinella	T (Mi-l)	-R	
Euovigerina	K (Albi-u)	-K (Maes-u)		Flourensina	K (Albi-u)	-K (Ceno-l)	(79)
Eoverbeekina	P (Leon-l)	-P (Dora)?		+Fontbotia	T (Mi)	-R	
Eovolulina	S (Prid)	-D (Fame)		Forschia	C (Vise-l)	-C (Vise-u)	(79)
+Eowaeringella	C (Mosc-u)	-C (Step-l)		Forschieella	C (Vise-l)	-C (Vise-u)	(79)
+Eowedekindellina	C (Bash)			+Francesita	T (Mi-m)	-R	(741)
+Eozellia	P (Asse)			+Freixialina	J (Kimm-u)	-J (Tith-u)	
+Epiannularia	T (Eo-m-l)	-T (Eo-m-u)		Frondicularia	J (Call-u)?	-R	(868)
Epistomaria	T (Than-l)	-T (Eo-m-u)		+Frondiculinata	J (Phe)		
Epistomina	J (Bajo-l)?	-K (Sant)	(959)	Frondilina	D (Fras-u)		
Epistominella	T (Mi-l-u)	-R		+Fronolina	P (Djhu)	-P (Dora)	(752)
Epistominita	J (Oxfo)	-K (l)		+Fron dovaginulina	K (Ceno)	-K (Sant)	
+Epistominitella	K (Barr)	-K (Apti-l)		+Frumentella	C (Mosc-u)		(146)

Taxon	First Appearance	Last Appearance	Reference	Taxon	First Appearance	Last Appearance	Reference
Fursenkoina	K (u)	-R		+Globorosalina	T (Eo-u)	-T (Mi)	
Fusarchaias	T (Mi-l)		(2)	Globorotalia	T (Mi-m)	-R	
Fusiella	C (Mosc-l)	-C (Step-u)	(145)	Globorotalites	K (Barr)	-K (Maes-u)	(959)
Fusulina	C (Mosc-l)	-C (Mosc-u)	(146)	Globorotaloides	T (Than)	-R	(939)
Fusulinella	C (Mosc-l)	-C (Step-u)	(146)	+Globospirillina	J (Tith)	-K (Apti)	
+Gabonita	K (Coni)	-K (Maes)		+Globotrtrataxis	C (Vise-u)		
Galeanella	Tr(Nori)	-Tr(Rhae)		Globotruncana	K (Sant-l)	-K (Maes-u)	
+Galliferina	T (Mi-m)	-T (Mi-u)		+Globotruncanella	K (Maes-l)	-K (Maes-u)	
+Gallitellia	Q (Plei)			+Globotruncanita	K (Camp)	-K (Maes-u)	
+Gallowaiina	P (Dora)			+Globotruncorotalita	T (Ol-u)	-R	
+Galwayella	T (Mi-m)	-R		+Globuligerina	J (Bath-m)	-J (Oxfo-u)	(857)
+Gandinella	Tr(Nori-u)	-Tr(Rhae)		Globulina	J (Call)	-R	
Ganella	T (Eo-l)	-T (Eo-m-l)		+Globulospinella	T (Mi-m)	-R	(1033)
+Gansserina	K (Maes-l)	-K (Maes-u)		+Glomalveolina	T (Than-l)	-T (Eo-m)	
Garantella	J (Aale)	-K (Haut)		Glomodiscus	C (Vise-l)	-C (Vise-u)	
+Gastroammina	S (Wen-l)?			Glomospira	C (Vise)	-R	
Gaudryina	Tr(Carn)	-R		+Glomospiranella	D (Fame-l)	-C (Vise-u)	(2,678)
Gaudryinella	K (Vala-u)	-K (Ceno)		Glomospirella	C (Bash)	-T (Mi)	
+Gaudryinoides	K (Ceno)			Glomospiroides	C (Bash-l)	-C (Step)	
+Gaudryinopsis	Tr(u)	-T (Eo-u)		+Glomotrocholina	P (u)		
Gavelinella	K (Barr)	-T (Than)		+Glubokoevella	S (Ludl)		
+Gavelinopsis	T (Eo)	-R		Glyphostomella	C (Mosc)	-C (Step-u)	(537)
+Geintzina	P (Assc)	-P (Dora)	(1249)	Goesella	K (Sant-u)	-R	(1051)
+Gemellides	K (Maes-l)	-R		Gonatosphaera	T (Ol-u)	-T (Mi)	
Geminospira	T (Plio)	-R		+Gorbachikella	J (Call-l)	-K (Apti-u)	(857)
+Gendrotella	K (Sant-u)			+Gorisella	T (Mi-m)		
+Gerkeina	P (Leon-u)			Goupillaudina	K (Coni)	-K (Maes)	
+Gheorghianina	Tr(Anis-u)	-Tr(Carn)		+Granuliferella	D (Fame)	-C (Vise)	
+Gigasbia	C (Vise-u)			+Granuliferelloides	C (Tour-u)		
Giraliarella	P			Gravellina	T (Than)	-T (Mi-l)?	(1051)
Glabrattella	T (Eo-u)	-R		+Grigelis	T (Eo-u)	-R	
+Glabrattellina	T (Mi)	-R		+Grillina	Tr(Carn)	-Tr(Rhae)	
Glandulina	T (Than-l)	-R		+Grillita	K (Albi-m)		
+Glandulinoides	Tr(Carn)			Grimsdaleinella	K (Turo)	-K (Coni)	
Glandulopleurostomella	Tr(u)			Gsolibergella	Tr(Carn-l)	-Tr(Carn-u)	(73)
Globanomalina	T (Eo)	-Q (Plei)		Gubkinella	K (Camp)	-K (Maes)	
+Globocuniculus	T (Dani)	-T (Eo-l)		Gubierina	K (Sant)	-K (Maes-u)	
Globigerapsis	T (Mi-l-u)	-T (Mi-m)		Guembelitria	K (Albi-m)	-T (Dani)	
Globigerina	T (Eo-m)			Guembelitriella	K (Ceno-l)		
Globigerina	T (Eo-m-u)	-R	(939)	+Guembelitrioides	T (Eo-l)	-T (Eo-m-l)	
Globigerinatella	T (Mi-l-u)	-T (Mi-m)		Gunteria	T (Eo-m)		
Globigerinatheka	T (Eo-l)	-T (Eo-u)	(939)	Guppyella	T (Mi-l-u)	-R	
+Globigerinella	T (Eo-m-u)	-R		+Gutnicella	J (m)		
Globigerinelloides	K (Apti-l)	-K (Maes-u)	(147)	Guttulina	J (Bath)	-R	
Globigerinita	T (Ol-u)	-R	(939)	Gypsina	T (Eo-u)	-R	
Globigerinoides	T (Ol-u)	-R		+Gyroconulina	K (Maes-u)		
+Globigerinoidesella	T (Mi-l)	-R		Gyroidina	T (Mi-u)	-R	(1051)
Globigerinoita	T (Mi-l-u)	-R		+Gyroidinella	T (Eo-m-l)	-T (Eo-m-u)	
Globigerinopsis	T (Mi-m)			Gyroidinoides	K (Ceno)	-R	
+Globigerinopsoides	T (Mi-m)	-T (Mi-u)		+Gyrovalvulina	T (Eo-m-l)	-T (Eo-m-u)	
+Globiophina	K (Turo)	-T (Eo-l)		Haddonia	T (Eo)	-R	
+Globispiroplectammina	C (Vise)			+Haerella	K (Sant)	-K (Camp)	
Globivalvulina	C (Serp-l)	-P (Dora)	(150)	Haeslerella	T (Ol-l)	-T (Plio-l)	(728)
Globobulimina	T (Dani)	-R		+Hagenowella	K (Ceno)	-K (Maes-u)	
Globocassidulina	T (Eo-u)	-R		Hagenowina	K (Camp)	-K (Maes)	
+Globochernella	C (Vise)			+Haimasiella	K (Albi)		
Globoconusa	T (Dani)			+Halenia	C (Vise)		
Globocentothyra	C (Vise-l)	-C (Mosc)	(144)	Halkyardia	T (Eo-m-l)	-T (Ol-l-u)	
+Globotissurella	T (Ol-u)	-R	(1033)	+Hanostaffella	C (Mosc-u)		
Globouadrina	T (Eo-u)	-T (Mi-u)	(939)	+Hansensisca	T (Ol-u)		
+Globoreticulina	T (Eo-m)			Hantkenina	T (Eo-m-l)	-T (Eo-u)	
				Hanzawaia	T (Ol-u)?	-R	

Taxon	First Appearance	Last Appearance	Reference	Taxon	First Appearance	Last Appearance	Reference
+Haoella	P (Djhu)		(146)	Hormosina	T (Than)	-R	(1051)
Haplophragmella	C (Tour-u)	-C (Vise-u)		+Hormosinella	T (Than)	-R	(1051)
+Haplophragmina	C (Serp-u)	-C (Mosc)		+Hospitella	R		
Haplophragmium	J (Bajo-u)	-K (Albi-u)	(959)	+Hottingerella	K (Berr)	-K (Barr)	
Haplophragmoides	K (Berr-u)	-R	(1051)	+Hottingerina	T (Than-l)		
Hastigerina	T (Mi-u-u)	-R		+Hottingerita	K (Barr)		
+Hastigerinella	T (Eo-l)	-T (Eo-m-l)		+Howchinella	P (Sakm)		
Hastigerinoides	K (Coni)	-K (Camp-l)		Howchinia	C (Vise-u)	-C (Mosc)	
+Hastigerinopsis	T (Mi-m)	-R		+Hoyenella	Tr(Rhae)		
Haurina	T (Eo-l)	-R		+Hubciella	P (Leon)		
+Haurania	J (Sine-u)	-J (Bath)		+Hyalinea	Q (Plei)	-R	
+Hayasakaina	P (Leon)			+Hyalinonetrion	T (Ol-l-u)	-R	
+Haynesina	T (Plio-l)	-R		+Hydrania	Tr(Carn)		
+Hechtina	K (Vala)	-K (Apti)		+Hyderia	T (Eo-l)		
Hedbergella	K (Apti-u)	-K (Maes-u)	(857)	Hyperammina	D (Gedi-u)	-R	(1070)
+Hedraites	P (l)			+Hyperamminita	P		
+Helentappanella	T (Eo-m-u)			+Hyperamminoides	C (Step-u)		
Helicolepidina	T (Eo-m)	-T (Eo-u)		+Hyperbathoides	S (Wenl)		
+Helicorbitoides	K (Camp-u)			+Ichthyolaria	P (Djhu)	-J (u)	
Helicostegina	T (Eo-m-l)	-T (Eo-u)		Idalina	K (Camp)?	-K (Maes)	(148)
+Helicosteginopsis	T (Eo-u)			+Igorina	T (Than)	-T (Eo-l)	
+Hellenocyclina	K (Maes-u)			+Ilerdorbis	K (Camp)		
+Helvetoglobatruncana				Illigata	S (Ldov)		
Hemicyclammina	K (Turo-l)	-K (Coni-l)		+Inaequalina	T (Mi)	-R	
Hemidiscus	K (Apti)	-K (Ceno-m)		+Inauris	D (l)	-D (m)	
Hemifusulina	C (u)	-P (Dora)	(150)	+Inflatobolivinella	T (Eo-u)	-T (Plio)	
Hemifusulinella	C (Mosc-l)	-C (Mosc-u)		+Inordinatosphaera	T (Eo-m-l)		
+Hemirobulina	K (u)	-R		+Insculptarentula	K (Albi)	-T (Than)	(1051)
Hemisphaerammina	Cm(m)	-R	(579)	+Insolentitheca	C (Vise-l)	-P (Asse)	
+Hemithurammina	C (Vise)			Involutaria	Tr(Carn)		
+Hemlebenia	K (Apti-u)			Involutina	Tr(Nori)	-K (Ceno)	
Hensonina	K (Camp)	-K (Maes)	(148)	Involvina	Tr(Rhae)		
+Hensonina	K (Albi)	-K (Ceno)		+Iowanella	C (Step-l)		
+Hergottella	K (Apti)			Iraqia	K (Apti)	-K (Maes)	(2)
Heronallenia	T (Eo-m-l)?	-R		+Irenita	Q (Plei)	-R	
+Heterantyx	K (Barr)	-K (Albi)		Irregularina	D (Give)	-C (Tour)	
Heterillina	T (Eo-m-l)	-T (Ol-l)?		Islandiella	T (Than)	-R	
+Heteroskoskinolina	K (Ceno-m)			+Ismailia	K (Ceno)		
Heterohelix	K (Ceno-m)	-K (Maes-u)		+Istriloculina	K (Berr-u)	-K (Apti-l)	
Heterolepa	K (Maes-l)	-R		+Iuliusina	K (Barr)		
+Heteromorphina	R			+Ivanovella	S (Ludl)		
Heterostegina	T (Eo-l)	-R		+Ivdelina	D (l)		
Heterostomella	K (Sant)	-K (Maes-u)		Jaculella	R		
Hidaella	C (Mosc-u)			+Jadammina	T (Eo-m)	-R	
+Hidina	T (Mi-l-u)	-T (Mi-m)		Janischewskina	C (Vise-u)		
+Hiltermannella	K (Maes)			Jarvisella	T (Mi-l-u)	-T (Mi-m)	
Hippocrepina	R			+Jascottella	K (Sant)	-K (Camp-l)	
+Hippocrepinella	C (Bash)?	-R		+Jurella	J (Call-m)	-J (Oxfo)	
+Hirsutospirella	Tr(Nori)			+Kaeveria	Tr(Nori)	-Tr(Rhae)	
Histopomphus	K (Albi)			+Kahlerina	P (Leon-m)	-P (Djhu)	
+Historbitoides	K (Maes)			+Kalamopsis	K (Sant)	-R	(1051)
Hoeglundina	T (Than)?	-R		+Kalosha	T (Plio-l)		
Hofkerina	T (Mi)			+Kamurana	P (Djhu)	-Tr(l)	
+Hofkeruva	T (Ol-l)	-T (Plio-l)		Kanakaia	T (Mi-l-l)		
+Holkeria	C (Vise-u)?			+Kangvarella	P (u)		
+Hollandina	T (Than)			Kansanella	C (Step-l)	-C (Step-u)	(145)
Holmanella	T (Mi-m)			+Karaburunia	Tr(Anis-u)		
+Homalohedra	Q (Plei)	-R		+Karaissella	J (Oxfo)		
Homotrema	T (Mi-m)	-R		Karrerria	K (Albi)	-R	
Hopkinsina	T (Eo)	-R		Karrerriella	T (Than-l)	-R	
+Hopkinsinella	T (Mi-u)	-R		+Karrerrotextularia	T (Eo-m-u)	-R	
				+Kasachstanodiscus	C (Vise-l)	-C (Serp-u)?	(1249)

Taxon	First Appearance	Last Appearance	Reference	Taxon	First Appearance	Last Appearance	Reference
+Kassabiana	K (Maes-u)			+Lepidosemicyclina	T (Mi-l-u)		
Kathina	K (u)	-T (Than-u)		+Leptotrititices	P (Asse-l)	-P (Asse-u)	
+Kechenotiske	C (Mosc)	-K (Nc)	(76)	+Lernella	T (Ol-u)?	-R	
+Keramosphaerina	K (Coni)	-K (Maes)		Leupoldina	K (Barr-u)	-K (Albi-l)?	(857)
Kerionammia	O (Cara-m)			Liebusella	T (Eo-u)	-R	
Kettnerammia	D (Give-u)	-D (Fras-m)		+Lilliputianella	K (Apti-l)	-K (Apti-u)	(857)
Kiliania	J (Bath-u)	-J (Tith-l)		+Linaresia	T (Eo-u)	-T (Ol-l)	
+Klamathina	P (Sakm-u)	-P (Leon-l)	(145)	Linderina	T (Eo-m-l)	-T (Eo-u)	
Klubonibelia	C (Vise-u)			Lingulina	K (Berr)	-R	(959)
Klubovella	D (Fame-u)			+Lingulogavelinella	K (Apti-u)	-K (Sant-l)	(79)
+Kolchidina	T (Dani)			Lingulonodaria	P (l)	-K (Albi)	
Kolesnikovella	T (Eo)			+Lipinella	C (Vise-l)		
+Korobkovella	T (Eo-m)	-T (Eo-u)		+Lipinella	D (Fame)	-C (Vise)	
Koskinobigenarina	C (Vise-u)	-C (Serp-l)	(79)	+Lippina	T (Mi-l-l)		
+Koskinotextularia	C (Vise-l)	-C (u)	(79)	Lituola	Tr(u)	-R	
+Krikoumbilica	Tr(Anis)	-Tr(Ladi)		+Lituolipora	J (Plie)		
+Kuglerina	K (Maes-l)	-K (Maes-u)		+Liuonelloides	K (Maes)		
+Kunklerina	C (Tour-l)	-P		Lituotuba	K (Haut-l)	-R	(1051)
Kurnubia	J (l)	-J (Tith-u)		Lituotubella	C (Vise-l)	-C (Vise-u)	(79)
+Kutsevella	J (Tith-u)?	-T (Eo)		+Lobatula	T (Than)?	-R	
Kwantoella	P (Sakm-u)	-P (Leon-l)	(146)	Lockhartia	T (Than)	-T (Eo-m-l)	
Kyphopyxa	K (Coni)	-K (Camp)		Loeblichia	C (Vise-l)	-C (Serp-l)	(79)
+Labiostoma	K (Sn)			Loftusia	K (Maes-l)	-K (Maes-u)	
Labyrinthina	J (Sine-u)?	-J (Tith-l)		+Loisthostomata	T (Eo-u)		
+Labyrinthidoma	K (Sant-l)			+Longiapertina	T (Eo-u)		
Labyrinthochitina	O (Cara)			+Louissetia	P (Djhu)		
Lacazina	K (Sant)	-K (Maes)	(148)	+Loxostomina	T (Eo)	-R	
Lacazinella	T (Than)	-T (Eo-u)		Loxostomoides	K (Camp-u)	-T (Eo-l)	
Lacosteina	K (Camp)			Loxostomum	K (Coni-u)	-T (Pale)	
+Laculatina	T (Mi-u)	-R	(1033)	Lugtonia	C (Tour-u)	-C (Serp-l)?	(79)
Ladoronia	T (Mi)			+Lunatriella	K (Turo)	-K (Camp)	
+Laevidentalina	K (u)?	-R		Lunucamiina	D (Fras)	-P (Dora)	
+Laevipeneroplis	T (Mi-l-l)	-R		+Lysella	C (Vise-l)		(752)
Laffiteina	K (Maes)			+Magnesoina	T (Ol-u)?	-R	
Lagena	J (Sine)?	-R		+Maichelina	P (u)		
Lagenammia	S (Ldov)	-R	(537)	Makarskiana	T (Eo-l)	-T (Eo-u)	(148)
Lagenoglandulina	T (Eo-m-l)	-T (Mi-l-l)		+Maklaya	P (Leon-m)	-P (Leon-u)	(146)
+Lagnea	T (Plio)	-R	(1033)	+Mandorovella	T (Mi-l)		
+Lamarckella	J (Aale)	-J (Bajo)		+Mandjina	T (Eo-u)		
Lamarckina	K (Barr)	-R	(959)	Manorella	K (Coni)	-K (Maes)?	(148)
+Lamarmorella	K (Coni)?	-K (Sant)		+Marginara	D (Give-l)		
+Lamelliconus	Tr(Anis-u)	-Tr(Carn-u)	(684)	Marginopora	T (Mi-m)	-R	(2)
+Lamina	K (Camp)	-K (Maes-u)		Marginotruncata	K (Turo-l)	-K (Camp-u)	(79)
+Laminononion	T (Eo-m)	-R		Marginiula	J (Plie-l)	-R	(868)
+Langenosolenia	R			+Marginulinita	Tr(u)	-K (l)	
Lankesterina	T (Eo-u)	-T (Ol-l)?		Marginulinopsis	J (Hett-u)	-R	(715)
+Lantschichites	P (Leon-u)	-P (Guad-u)	(146)	Marieta	K (Sant)		
+Laraxetia	K (Camp)	-K (Maes-l)		Marsipella	R		
Lasiiodiscus	C (Mosc)	-P (Dora)	(2.667)	Marssonella	K (Haut-l)	-T (Eo-l)	(1051)
Lasiotrochus	P (l)	-P (Dora)		Martiguesia	K (Sant)		
Laterostomella	T (Eo-u)	-R		Martiniottiella	K (Maes-l)	-R	(1051)
+Latibolivina	T (Eo-u)	-R		Maslinella	T (Eo-u)		
Laticarinina	T (Mi-l)	-R		Massilina	J (Bath-u)	-R	(79)
+Latiendothyra	C (Tour-u)	-C (Vise-l)		Matanzia	T (Ol-l)	-T (Plio)	(728)
-Latiendothyranopsis	C (Vise-l)	-C (Vise-u)	(79)	Maylisoria	O (Cara)		
+Lixoendothyra	C (Tour)	-C (Vise)		+Maycinea	K (Ceno-m)		
+Laxoseptabrunsiina	C (Vise-l)	-C (Vise-u)	(79)	+Mccloudia	P (Sakm-u)	-P (Leon-l)	(146)
Leella	P (Guad-u)		(146)	Meandroloculina	T (Mi-u)		
Lenticulina	Tr(Anis-u)	-R	(73)	Meandropsina	K (Ceno)?	-K (Maes)	(2)
-Lenticulinella	K (Ceno)			Meandrospira	P (Leon)	-R	
Lepidocyclina	T (Eo-m-l)	-T (Mi-m)		+Meandrospiranella	Tr(Anis-m)	-K (Ceno)	
Lepidorbitoides	K (Camp)	-K (Maes-u)	(2)	Mediocris	C (Vise-u)	-C (Mosc-l)	

Taxon	First Appearance	Last Appearance	Reference	Taxon	First Appearance	Last Appearance	Reference
+Mediopsis	C (Tour-u)	-C (Vise)		+Murgella	K (Sn)		
+Medipsia	D (Give)?	-C (Tour-u)		+Muricoglobigerina	T (Than)	-T (Eo-u)	
+Medocia	T (Eo-m-l)			+Murrayinella	T (Plio)	-R	
+Megastomella	T (Mi-l)	-T (Mi-u)		+Mychostomina	K (Barr)	-R	
+Meidamonella	T (Eo)	-R		Nagatoella	P (Leon-u)		
+Melathrocrion	K (Barr-u)	-K (Albi)		Nanicella	D (Give-u)	-D (Fras-u)	
+Melatolla	C (Vise-u)			Nankinella	C (Bash)	-P (Dora)	
Melonis	T (Eo-m-l)	-R		+Nanlingella	P (Guad-u)	-P (Dora)	
+Merlingina	K (Ceno-m)	-K (Turo)	(646)	+Narayania	T (Eo-m-l)		
+Mesammina	D (Emsi)	-D (Eife)		+Nauphiella	K (Albi-u)		
+Mesodontalina	J (Sine-u)			Nautiloculina	J (Bath-u)	-K (Apti)?	
Mesoendothyra	Tr(Ladi)	-J (Kimm-l)		Navarella	K (Camp)	-K (Maes)	
+Mesorbitalina	K (Apti)	-K (Ceno-l)		+Neaguites	T (Eo-m-l)	-T (Ol-l-u)	
Mesoschubertella	P (Sakm-u)	-P (Leon-l)	(146)	+Neocarinina	Q (Plei)		
+Metadolifolia	P (Guad-u)	-P (Djhu)		+Neoarchaediscus	C (Vise-u)	-C (Bash-u)	(144)
+Metapolymorphina	T (Ol-l)	-R		+Neoarchaephyra	D (Fras-u)	-D (Fame-l)	
Meyendorffina	J (Bath)			+Neobrunsiina	C (Tour-u)	-C (Vise-u)	(79)
Migros	K (Camp-l)	-R	(1051)	Neobulimina	K (Albi)	-K (Maes)	
+Mikhailovella	C (Vise-u)			+Neocarpenteria	T (Eo-u)		
+Miliammellus	T (Mi-u)	-R		+Neoclavulina	T (Eo-m)		
Miliammmina	K (Berr)?	-R		Neocribrella	T (Eo-m-l)		
Miliola	T (Eo-m-l)	-T (Ol-l)		+Neodiscoeyclina	T (Eo-m-l)	-T (Eo-u)	
+Miliolochina	Tr(Nori)			Neoponides	T (Mi-u-l)	-R	
Miliolinella	T (Mi-u-l)	-R		Neoflabellina	K (Turo-u)	-T (Dani)	
Miliolipora	Tr(Nori-u)	-Tr(Rhae)		+Neofusulina	C (Mosc-u)		
Miliospirella	J (Bajo)	-J (Kimm)		Neofusulinella	C (Mosc-l)		
Millerella	C (Vise-u)	-C (Mosc)		+Neogloboquadrina	T (Mi-l-l)	-R	
+Miniacina	T (Mi-l-l)	-R		+Neogyroidina	T (Eo-m)		
+Miniuva	T (Mi-m)			+Neoiraqia	K (Albi-u)	-K (Ceno-u)	(646)
Minojapanella	P (Sakm-u)	-P (Leon-u)	(146)	+Neolenticulina	T (Plio)	-R	
Minouxia	K (Sant)	-K (Maes)		+Neomisellina	P (Leon-u)		
+Minyaichme	K (Albi)	-K (Ceno)		+Neoparadainella	C (Vise)		
Miogypsina	T (Ol-u)	-T (Mi-m)		+Neoplanorbulinella	T (Mi-l)		
+Miogypsinita	T (Ol-u)	-T (Mi-l-u)		+Neorbitalinopsis	K (Albi-l)	-K (Albi-u)	(646)
Miogypsinoides	T (Ol-l-u)	-T (Mi-l-u)		+Neorotalia	T (Eo-m)	-R	
Miolepidocyclina	T (Mi-l-l)			+Neoschubertella	P (Sakm)	-P (u)	
+Miosorites	T (Mi-l-u)	-T (Mi-u)		Neoschwagerina	P (Leon-u)	-P (Guad-u)	(145)
+Mirifica	C (Vise-u)			Neostaffella	C (Bash-u)	-C (Mosc-u)	
+Mironovella	J (Kimm)	-K (Haut)		+Neothailandina	P (Leon-m)	-P (Guad-l)	(146)
Miscellanea	T (Than-u)		(2)	+Neouvigenna	T (Ol-u)	-R	
Misellina	P (Sakm)	-P (Leon-m)?		+Nephrolepidina	T (Eo-m-u)	-T (Mi-m)	(151)
Mississippina	T (Ol-l)	-R		+Nephrosphaera	O (Ashg)?	S (Ldov)?	
+Moeciloculina	K (Berr-u)	-K (Apti-l)	(649)	+Nevillella	C (Vise-u)		(79)
+Moncharmontia	K (Turo)	-K (Camp)		Nezzazata	K (Albi-m)	-K (Turo)	
+Monodiexodina	P (Sakm)	-P (Guad-l)	(145)	+Nezzazatinella	K (Barr)	-K (Turo-u)	
+Monspeliansina	T (Mi-l-l)			+Nikitinella	P (Guad)		
+Monotaxinoides	C (Vise-u)	-C (Bash-u)	(144)	+Ninella	C (Vise)		
+Montfortella	T (Plio-l)	-R		Nippoitella	P (Sakm-l)	-P (Leon-l)	
+Montiparus	C (Step-l)			+Nodasperodiscus	C (Vise-u)	-C (Bash)	(79)
+Montschiana	K (Sant-u)			Nodellum	R		
Mooreinella	C (Bash)	-P (Guad-u)		Nodobaculalaria	J (l)	-K (Albi)	
Moravammina	D (Give)	-D (Fras)		Nodobaculariella	T (Plio-l)	-R	
+Morozovella	T (Than-l)	-T (Eo-m-u)		+Nodobolvinella	T (Eo-m)	-T (Ol-u)	
+Mstinia	C (Vise-l)	-C (Vise-u)	(79,752)	+Nodochernyshinella	C (Tour)		
Mstiniella	C (Vise-u)		(79)	+Nodogenerina	K (Camp)	-R	
Mucronina	T (Mi-l-l)	-R	(728)	+Nodogordiospira	Tr(Ladi)		
+Mufushanella	P (m)			+Nodoinvolutaria	P (l)		
Multifidella	T (Mi)	-R		+Nodomorphina	T (Mi)		
Multiseptida	D (Fras-u)	-D (Fame-l)	(678)	Nodophthalmidium	T (Pg)	-R	
Multipirina	K (Ceno-u)	-K (Turo-l)		+Nodosarchaediscus	C (Vise-u)	-C (Scrp-l)	(79)
+Murciella	K (Camp-u)			Nodosarella	K (Albi-m)	-R	(959)
+Murgeina	K (Ceno-u)	-K (Sn)		Nodosaria	J (Toar-l)?	-R	

Taxon	First Appearance	Last Appearance	Reference	Taxon	First Appearance	Last Appearance	Reference
Nodosinella	P (l)	-P (Dora)	(150)	+Orthotrinacria	Tr(Nori)	-Tr(Rhae)	
+Nodosinelloides	C (Step-l)	-P (Tatr)?	(1249)	Orthovertella	C (Mosc-u)	-C (Step-l)	
Nonion	K (Camp)	-R		Oryctoderma	P (Leon)	-R	
Nonionella	K (Coni)	-R		Osgularia	K (Albi-m)?	-R	
+Nonionellata	T (Dani)	-T (Ol-l)?		Oxalveolina	K (Albi-u)	-K (Ceno-u)	(646)
Nonionellina	T (Mi)	-R		Oxinoxis	D (Fame-u)	-C (Tour-l)	
+Norcottia	T (Mi-m)	-T (Mi-u-l)		Ozawainella	C (Bash-l)	-P (Guad-l)	(146)
+Nothia	K (Sn)	-K (Maes)		+Ozourina	T (Pale)		
+Notoconorbina	K (l)			Paalozowella	J (Bajo-u)	-J (Oxfo-u)	(79,868)
+Notoplanulina	K (Coni-l)	-K (Maes)		Pachyphloia	P (Asse)	-P (Dora)	(2,150)
+Notorotalia	T (Eo-m-u)	-R	(728)	+Pachythurammina	D (Give)	-C (Vise)	
Nouria	T (Eo)?	-R		+Pacimonion	T (Eo-u)	-R	
+Novalesia	K (Apti-u)	-K (Albi-l)		Palachemonella	D (m)		
Novella	C (Serp-u)	-C (Mosc-l)	(145)	Palaeobigenerina	C (Vise)	-P (Guad)?	
Nubecularia	J (Kimm-u)?	-R	(868)	Palaeofusulina	P (Guad-u)	-P (Dora)	(146)
+Nudarchaediscus	C (Vise-l)	-C (Serp-l)?	(79)	+Palaeolittonella	Tr(Anis)	-Tr(Rhae)	
Nummodiscorbis	T (Eo-m-l)	-T (Mi-l-l)		Palaeomitiolina	J (Bajo-u)	-J (Tith-u)	(868)
Nummofallotia	K (Coni)	-K (Maes-u)		+Palaeoreichelina	C (Mosc)		
Nummocolulina	T (Mi-u-l)	-R		+Palaeospiroplectammina			
Nummulites	T (Than-l)	-R			D (Fame)	-C (Vise-l)	
Nuttallides	T (Than)	-R		+Palaeostaffella	C (Mosc)	-P (l)	
Nuttallinella	K (Sant-u)	-K (Maes-u)		Palaeotextularia	C (Tour-u)	-P (l)	
+Nuttallus	T (Mi-l-u)			+Paleodictyoconus	K (Vala)	-K (Apti-l)	
+Obliquina	T (Mi-l)?	-T (Mi-u)	(1033)	+Palaeogaudryina	J (Call)	-J (Tith-l)	(868)
+Obsoletes	C (Step-l)			+Paleopatellina	J (m)	-K (Apti)	
+Oberhauserella	Tr(Anis-m)	-J (Hett)	(674)	+Paleopoly morphina	K (Albi)	-K (Maes)	
+Occidentoschwagerina				+Pallaimorphina	K (Albi)	-T (Pale)	
	P (Asse-l)	-P (Sakm-l)	(146)	+Palliolatella	K (Camp-u)	-R	(717)
	C (Step-u)	-P (Sakm-l)	(146)	+Palmerinella	T (Mi-u)	-R	
Okeataella	T (Eo-m)			Palimula	T (Dani)	-T (Mi-m)	
Olssonina	T (Eo-m)			+Palorbitolina	K (Barr-u)	-K (Apti-l)	
Omphalocyclus	K (Maes-l)	-K (Maes-u)	(2)	+Palorbitolinoides	K (Apti-u)		
+Omphalotis	C (Vise-l)	-C (Serp-u)	(79,144)	+Pamirina	P (Sakm-u)	-P (Leon-m)	(146)
Oolina	J (Hett-l)	-R	(2)	Pandaglandulina	T (Mi)	-R	
Oolitella	Q (Plei)			+Pannellaia	T (Ol-l-u)	-R	
+Operculina	T (Eo-l)	-R		+Paracaligella	S (Ludl)	-C (Tour-u)	
Opertorbitolites	T (Than)	-T (Eo-l)		+Paracassidulina	T (Mi)	-R	
+Opertum	K (Camp-u)	-K (Maes)		+Paracoskinolina	K (Barr)	-K (Albi)	
Ophthalmidium	Tr(Anis-u)	-J (Kimm-l)		Paracyclammina	J (u)?	-K (Berr)?	
-Ophthalmipora	Tr(Carn)			+Paradagmarita	P (Djhu)	-P (Dora)	(667)
Orbignyina	K (Sant-u)	-K (Maes-u)		+Paradaiaella	C (Tour-u)		
Orbitammina	J (Bath)			Paradoxiella	P (Guad-u)		(145)
+Orbitoclypeus	T (Than)	-T (Eo-u)		Paradunbarula	P (Guad-l)		(146)
+Orbitocyclina	K (Camp)	-K (Maes)		+Paraeofusulina	C (Mosc)		
Orbitoides	K (Sant-u)	-K (Maes-u)		Paraeoethyria	C (Tour-u)	-C (Vise-u)	(79)
-Orbitokathina	K (Coni)			Paratissurina	T (Eo-m)	-R	
Orbitolina	K (Barr)	-K (Ceno-u)	(959)	+Parafondicularia	T (Eo-l)	-R	
Orbitofinella	K (Ceno-u)?	K (Turo)		Parafusulina	P (Sakm-u)	-P (Dora)	(145,936)
+Orbitolinopsis	K (Barr)	-K (Apti-l)		+Parafusulinella	C (Mosc-u)		
Orbitolites	T (Eo-l)	-T (Eo-u)		+Paragaudryina	K (Turo)		
Orbitopsella	J (Sine)	-J (Plie-l)	(2)	+Paraglobivaululina	P (Guad-u)	-P (Dora)	(667)
Orbulina	T (Mi-l-u)	-R		+Paraglobivalulinoides			
+Orbulinoides	T (Eo-m-l)				P (Dora)		
+Orcadia	Q (Plei)	-R		+Paragloborotalia	T (Eo-u)	-T (Mi-m)	(939)
Ordovicina	O (Aren)	-D (Sieg-l)	(1070)	+Paralabamina	K (Maes)	-T (Pale)	
Oridorisalis	T (Eo)	-R		+Paralingulina	J (Sine-u)	-K (Vala)	(1051)
+Orientina	D (u)			+Parananlingella	P (Dora)		
Orietalia	K (Ceno)			+Paraophthalmidium	Tr(Carn)		
+Orithostella	K (Ceno)	-K (Turo)		Paraplectogyra	C (Tour-u)	-C (Vise-l)	
+Ornatomalina	T (Than)?	-T (Eo-l)		+Parareichelina	P (Djhu)	-P (Dora)	(146)
Orthella	Tr(Rhae)	-J (Oxfo-u)		Pararotalia	K (Coni)	-R	
Orthokarstenia	K (Turo-l)	-K (Maes-u)		Paraschwagerina	P (Asse-u)	-P (Sakm-u)	(145)
Orthomorphina	T (Eo-m-l)?	-R					

Taxon	First Appearance	Last Appearance	Reference	Taxon	First Appearance	Last Appearance	Reference
+Parasorites	Q (Plei)	-R		Planispirinella	R		
+Parastegnammina	D (Eife)	-D (Fame)		+Planoarchaediscus	C (Vise-l)	-C (Bash)	(79,752)
Paratextularia	D (Give)	-D (Fras)		+Planoendothyra	C (Tour-u)	-C (Step-u)	
Parathurammina	S (Ludl)	-C (Tour-l)		+Planoglabratella	T (Mi-u-l)	-R	
+Parathuramminites	S (Wenl)	-C (Vise)	(678,1249)	Planoglobulina	K (Coni-l)	-K (Maes-u)	
Paratikhinella	D (Fras-u)			Planogypsina	T (Mi)	-R	
+Paratriasina	Tr(Ladi)			+Planoliderina	T (Ol-u)	-T (Mi-l-u)	
+Paratrochamminoides				Planomalina	K (Albi-u)	-K (Ceno-l)	
	K (Turo-u)	-T (Pale)		+Planomiliola	T (Mi-l-u)		
+Paravulvulina	T (Mi-u-l)			Planopulvinulina	T (Ng)	-R	
Parawelekindellina	C (Mosc-u)			Planorbulina	T (Eo)	-R	
+Parinvolutina	J (Kimm-u)			Planorbulinella	T (Eo)	-R	
+Parphia	D (u)			+Planorotalites	T (Eo-l)	-T (Eo-m-u)	
Parrellina	T (Ol-l)	-R	(2)	C (Vise-l)	-C (Bash-u)	(144)	
+Parrelloides	R			Planularia	T (Mi)	-R	
+Partisania	P (Guad)			Planulina	T (Eo-u)	-R	
+Parurgonina	J (Oxfo)	-J (Tith-u)		Planulinoides	T (Plio)	-R	
+Parvularugoglobigerina				+Plectanium	T (Mi)	-T (Plio)	
	T (Dani)			Plectina	K (Ceno-l)	-T (Eo)	(79,959)
+Patrikella	K (Ceno-m)	-K (Ceno-u)	(959)	+Plectinella	J (Call)	-T (Than)	(1051)
Patellina	K (Berr)	-R		Plectofrondicularia	T (Eo-m)	-R	(728)
+Patellinella	J (Bajo)	-R		Plectofusulina	C (Mosc-l)	-C (Step-l)	
+Patellovalvulina	K (Vala-u)	-K (Apti-l)		+Plectogyranopsis	C (Vise-l)	-C (Serp)	
+Paulbronnimannella	Tr(Anis)			+Plectomediocris	C (Vise)		
+Paulina	J (Bajo)	-J (Kimm)		+Plectomillerella	C (Serp)?		
+Pavlovecina	K (Berr)			Plectorecurvodes	K (Barr)	-K (Ceno-u)	
Pavonina	T (Mi)	-R		Plectotrochammina	T (Eo-u)	-R	
Pavoninoides	T (Eo-u)			+Pleuroskelidion	T (Plio)		
Pavonitina	T (Ol-l)	-T (Mi-u)		Pleurostomella	K (Apti)	-R	
+Pavopsammia	T (Ol-l)			-Pleurostomelloides	K (Turo)	-K (Maes)	
+Pealerina	J (Bath)			Plummerinella	C (Step-u)	-P (l)	
Pegidia	T (Mi)	-R		Plummerita	K (Maes-u)		
Pellatispira	T (Eo-m-u)	-T (Eo-u)	(2)	Podolia	T (Mi-u-l)		
Pellatispirella	T (Eo-m)			+Pohlia	C (Tour-u)	-C (Vise)	
Pelosina	R			Pojarkovella	C (Vise-u)		
Peneroplis	T (Mi)	-R		Polychasmina	K (Albi-u)		
Penoperculoides	T (Eo-m-l)			Polydiexodina	P (Leon-u)	-P (Guad-u)	
+Percultazonaria	K (Turo)	-R		+Polylepidina	T (Eo-m-u)		
Periloculina	K (Camp)?	-K (Maes)	(148)	Polymorphina	T (Dani)	-R	
Permodiscus	C (Vise-l)	-C (Bash)		+Polymorphinella	T (Than)	-Q (Plei)	
+Permerina	K (Turo)	-K (Coni)		+Polyperibola	T (Mi-u-l)		
+Perouvianella	K (Sant)			Polystomellina	T (Plio)		
Petchorina	D (Fras)			Polytaxis	C (Bash)	-C (Step)	(537)
+Pfenderella	J (Bath)?, J (Call)?			-Popovia	T (Than)	-T (Eo-u)	
+Pfendericonus	T (Than)	-T (Eo-u)		Poroarticulina	T (Mi)		
Pfenderina	J (Bath)	-K (Ceno)		Poroepoides	T (Plio)	-R	
Phenacophragma	K (Albi)			Porosorotalia	T (Mi-u)	-T (Plio-l)	
+Piallina	Tr(Carn-u)			Porticulusphaera	T (Eo-m-l)	-T (Eo-m-u)	
+Picounina	T (Ol-l-u)			+Postendothyra	P (Sakm)?		
Pijpersia	T (Eo-m)	-T (Eo-u)		+Postrugoglobigerina	T (Dani-l)		
+Pilammia	Tr(Anis-m)	-Tr(Anis-u)	(684)	Praevalveolina	K (Albi-u)	-K (Turo-l)	
+Pilaminella	Tr(Anis-u)	-Tr(Rhae)	(684)	-Praeammoastuta	T (Ol)	-T (Mi-m)	
Pinaria	T (Eo)			Praebulimina	J (Bath)	-K (Maes-u)	
Pisolina	P (Leon-m)		(146)	-Praebullalveolina	T (Eo-u)		
+Pityusina	K (Haut)	-K (Barr)		-Praechrysalidina	K (Apti-l)	-K (Albi-u)	(646)
+Placentammia	K (u)	-T (Mi-u)		-Praecystammia	K (Sant)	-K (Maes-u)	
Placopsilina	J (m)	-R		-Praedictyorbitolina	K (Barr-l)		
+Plagioparpe	Tr(Ladi-u)	-Tr(Nori-u)		Praeglobobulimina	T (Than)	-R	
Plagiotomella	Tr(Carn)			Praeglobotruncana	K (Albi-u)	-K (Turo-l)	
Planinvoluta	Tr(Carn-l)	-Tr(Rhae)	(684)	+Praehedbergella	K (Haut-l)	-K (Apti-u)	(857)
Planispirillina	R			+Praekaraisella	J (Call-l)	-J (Oxfo)	
+Planispirina	T (Plio)	-R		+Praekurnubia	J (Bath)?, J (Call)?		

Taxon	First Appearance	Last Appearance	Reference	Taxon	First Appearance	Last Appearance	Reference
+Praelacazina	K (Maes)			Pseudofusulina	P (Asse-l)	-P (Leon-u)	(146)
+Praemurica	T (Dani)	-T (Than)		Pseudofusulinella	C (Mosc)	-P (Sakm-u)	(145)
+Praeophthalmidium	J (Hett)	-J (Plie)		+Pseudogadryina	K (Sn)	-R	
+Praeorbitolina	K (Apti-l)			+Pseudogadryinella	K (Sant)	-K (Maes-u)	(1051)
+Praeorbulina	T (Mi-l-u)	-T (Mi-m)		+Pseudogavelinella	K (Camp)		
+Praeparafusulina	P (Sakm)	-P (Leon)		Pseudogloborotalia	T (Pale)		
Praepeneroplis	K (Maes)			Pseudoglossospira	D (u)?	-C (u)	
+Praepseudofusulina	P (Asse)			Pseudogumbelina	K (Maes-l)	-K (Maes-u)	
+Praeteticulinella	K (Barr)			+Pseudohastigerina	T (Dani)	-T (Ol-l)	
Praerhapydionina	T (Eo-m-l)	-T (Ol-l)		+Pseudohaureina	T (Ol)	-R	
+Praesiderolites	K (Sant)	-K (Camp-u)		+Pseudohelenina	Q (Plei)	-R	
+Praestorsella	K (Sant)	-K (Maes-u)		Pseudohyperammia	P		
+Pragsoculus	Tr(Ladi)	-Tr(Carn)		+Pseudokahlerina	P (Guad-u)		(146)
+Pravitschwagerina	P (Leon)			+Pseudolacazina	T (Eo-m)		
+Pravoslavlevia	J (Sine)	-T (Mi-m)?		Pseudolamarckina	J (Call-u)	-K (Vala)	(79)
Presumatrina	P (Leon-u)	-P (Guad-l)	(146)	Pseudolepidina	T (Eo-m-l)		
+Primorina	P (u)			Pseudolituonella	K (Ceno-m)	-K (Camp)	(646)
+Priscella	C (Tour-u)	-C (Serp)	(144)	+Pseudolituotuba	C (Vise-l)	-C (Mosc)	(79)
+Prismatomorpha	T (Plio-l)	-R		+Pseudolituotubella	C (Tour-u)	-C (Vise-l)	(79)
+Pristinosceptrella	Q (Plei)	-R		+Pseudomarssonella	J (Bajo-u)	-J (Call)	
+Procerolagena	T (Dani)	-R	(1033)	+Pseudomphalocyclus	K (Maes-u)		
+Prodentolina	J (Plie-l)	-J (Plie-u)	(868)	Pseudonodosaria	K (Berr)	-R	
Profusulinella	C (Bash-u)	-C (Mosc-u)	(146)	+Pseudononion	T (Dani)	-R	
+Proninella	D (Give-u)	-D (Fame)		+Pseudonovella	C (Bash-u)	-C (Mosc-u)	
+Pseudophaeroidinella	T (Mi-l-u)	-T (Mi-u-l)		+Pseudoolina	Q (Plei)	-R	
Protelphidium	T (Dani)	-T (Ol-l)?		Pseudopalmula	D (Eife)	-D (Fras)	(2)
+Protentella	T (Mi-l-u)	-T (Mi-m)		+Pseudoparrella	T (Ol-u)?	-R	
+Protoglobobulimina	T (Mi-u-l)	-R		Pseudopatellinella	K (Ceno)	-K (Maes)	
+Protonodosaria	C (Step-l)	-P (Dora)	(752,1249)	Pseudopatellinoides	T (Mi-u-l)		
Protopenneroplis	J (Call)?	-K (Berr-u)		+Pseudopenderina	J (Sine-u)	-J (Plie-l)	
+Protriticites	C (Step-l)			Pseudophragmina	T (Eo-l)	-T (Eo-u)	
+Proxifrons	T (Eo)	-R		+Pseudoplanoendothyra	C (Tour-u)	-C (Vise-l)	
+Psmmatodendron	K (Camp)	-R		+Pseudoplanoglobulina	K (Turo)	-K (Camp)	
Psmminopelta	K (Albi)?	-K (Maes)	(148)	+Pseudoplanulinella	T (Ol-l)	-T (Mi)	
Psmmolingulina	T (Mi-u-l)			Pseudopolymorphina	T (Ol-u)?	-R	
+Psmmophax	D (l)	-R		Pseudopolymorphinoides	T (Eo-m-l)		
Psmmosphaera	O (Cara-m)	-R	(2)	Pseudorbitoides	K (Camp)	-K (Maes)	(2)
Pseudastrothiza	O (Cara)	-T (Than-u)	(2,148)	Pseudorbitolina	K (Camp)		
Pseudedomia	K (Ceno-m)	-K (Maes)	(2)	+Pseudoreichelina	P (Sakm-u)	-P (Leon-u)	(146)
+Pseudomodiscus	C (Tour-l)	-C (Vise-u)		Pseudoreophax	J (Kimm)	-K (Barr-l)	
+Pseudobaisalina	P (Guad)			+Pseudorhapydionina	K (Ceno-u)		
Pseudobolivina	R			+Pseudorhipidionina	K (Ceno-m)	-K (Turo-l)	(646)
+Pseudobradyna	C (Mosc)	-P (Sakm)		Pseudorotalia	T (Mi-u-l)	-R	
+Pseudobroeckinella	K (Sant)			+Pseudoruttenia	T (Eo-l)		
Pseudobulimina	T (Eo-m-l)	-R		+Pseudosaracenaria	K (Vala)		
+Pseudobulminella	T (Eo-l)	-T (Eo-m)		Pseudoschwagerina	P (Asse-l)	-P (Guad-l)	(145)
+Pseudocassidulinoides				Pseudosiderolites	K (Camp-u)		
T (Mi-l)				+Pseudosigmoilina	K (Berr)		
+Pseudocherny-shinella	C (Tour)			+Pseudosiphonella	J (Tith)	-K (Vala)	
Pseudochoffatella	K (Apti-u)	-K (Albi-l)		+Pseudosolenina	Q (Plei)	-R	
Pseudochrysalidina	T (Eo-l)	-T (Eo-u)		+Pseudospirocyclus	J (Kimm)	-J (Tith-u)	
+Pseudocibicides	T (Eo-m-l)			Pseudostaffella	C (Bash-l)	-C (Mosc-u)	(145)
-Pseudoclavulina	K (Apti)	-T (Eo-l)	(728)	+Pseudotaxis	C (Tour-u)	-C (Bash)	
Pseudocylammina	J (Plie-u)	-K (Coni)		Pseudotextularia	K (Coni-l)	-K (Maes-u)	
Pseudodoliolina	P (Leon-l)	-P (Tatr)	(146)	Pseudotextulariella	K (Albi-u)	-K (Ceno-m)	
Pseudoendothyra	C (Vise-l)	-P (Dora)		+Pseudotribrachia	K (Albi)		
Pseudoepistominella	K (Barr)			+Pseudotriloculina	T (Eo-m-l)	-R	
Pseudoepionides	T (Plio)	-R		+Pseudotriplasia	T (Mi-u)		
+Pseudofabularia	T (Eo-m)			Pseudotritix	P (Guad-u)	-P (Dora)	(667)
+Pseudofissurina	T (Ol-u)?	-R					
-Pseudofrondicularia	J (Plie-u)						

Taxon	First Appearance	Last Appearance	Reference	Taxon	First Appearance	Last Appearance	Reference
Pseudotriticites	C (Mosc-u)	-C (Step-l)		+Rectocornuspira	C (Mosc)		
+Pseudouvirgerina	K (Camp-u)	-K (Maes-u)		+Rectocyclammina	J (Kimm)		
+Pseudovidalina	P (Leon-u)	-P (Guad)		+Rectodictyoconus	K (Barr)		
+Pseudowanganella	P (u)			+Rectoelphidiella	Q (Plei)	-R	
Pseudowedekindellina				+Rectoendothyra	C (Serp-u)		
	C (Mosc-u)		(146)	Rectoepistominoides	J (Oxfo-l)	-J (Oxfo-m)	
Pseudowoodella	T (Than)?	-T (Eo-l)		Rectoepionides	T (Than)?	-T (Eo-u)	
+Psilocitharella	J (Plic)	-K (Ceno-m)		+Rectoglossospira	Tr(Olen)	-Tr(Anis)	
+Pterammia	K (Ceno-u)			+Rectomillerella	C (Serp)?	-C (Mosc)	
Ptychocladia	C (Step)			Rectoseptaglossospirane			
Pullenia	K (Camp-u)	-R	(79)	D (Fame-u)	-C (Tour-u)	(144)	
Pulleniatina	T (Mi-u-l)	-R		+Rectoseptatournayella			
Pullenoides	K (Maes)				C (Tour)		
Pulsisiphonina	K (Maes)	-T (Eo-l)		+Rectostipulina	P (Dju)		
+Punctobolivinella	T (Mi-m)	-R		+Rectotournayellina	D (Fame)	-C (Vise)	
Putrella	C (Mosc-l)	-C (Mosc-u)		Rectuvigerina	T (Eo-u)	-R	
+Pygmaeoseistron	K (Maes)	-R		+Recurvoides	J (Aale)	-R	(868)
+Pyramidina	K (Sant)	-T (Eo-u)		+Redmondina	T (Eo-l)		
+Pyramidulina	J (Plic-l)	-R	(1051)	-Reedella	T (Eo-l)		
+Pyrenina	K (Albi-u)			Reichelina	P (Guad-u)	-P (Dora)	(145)
Pyrgo	T (Eo-u)	-R		-Reichelinella	T (Mi-l-l)		
Pyrgoella	T (Plio-u)	-R		Reinholdella	J (Plic-u)	-K (Apti)	
Pyrulina	J (m)	-R		+Reissella	K (Ceno)		
Pyrulinoides	Tr(Rhae)	-T (Ol-l)		+Reitlingerina	C (Vise)	-P (u)	
+Pytine	T (Plio)	-R	(1033)	Remesella	K (Camp)	-T (Than)	(1051)
Qataria	K (Ceno-u)	-K (Turo)		Renulina	T (Eo-m-l)		
Quadratobuliminella	T (Dani)	-T (Than-l)		Reophaella	K (Albi)	-T (Eo-u)	
Quadrimorphina	K (Ceno)	-R		Reophax	O (Cara-l)	-R	
+Quadrimorphinella	K (Coni)	-T (Eo-m)		+Repmanina	J	-R	
+Quasibolivinella	T (Eo-u)	-T (Mi-u-l)	(728)	+Resigia	T (Eo-m-l)	-T (Eo-u)	
+Quasiborelis	T (Dani)			+Reticulinella	K (Ceno)	-K (Maes)	
+Quasicyclammina	T (Than)			+Reticulogyra	T (Eo-m-l)	-T (Eo-m-u)	
Quasiendothyra	D (Fame-m)	-C (Vise-u)	(79,678)	+Reticulopalmula	T (Eo-l)	-T (Ol-l-u)	
Quasifusulina	C (Mosc-u)	-P (Sakm-u)	(145)	Reticulophragmium	T (Than)	-R	(1051)
Quasifusulinoides	C (Step-l)	-P (Sakm)		-Reticulophrgmoides	T (Than)	-T (Ol-l)	(1051)
+Quasiregularina	D (Fras)	-D (Fame-l)		Reusella	T (Eo-m-l)	-R	
+Quasilituotuba	C (Serp)			-Reusoolina	J (Plic)	-R	
+Quasirothalia	T (Plio)			Rhabdammina	K (Turo-l)	-R	(1051)
+Quasisiroplectammia				-Rhabdorbitoides	K (Camp)		(2)
	K (Albi)	-K (Ceno-l)		Rhapydiomina	K (Ceno-u)	-K (Maes)	
+Quasiverbeckina	P (Leon)			Rhenothyra	D (Give-u)		(2)
Queralina	T (Eo-m-l)	-T (Eo-m-u)		Rhizammina	R		
Quinqueloculina	K (Barr)	-R		+Rhodanopeza	T (Eo-m-u)		
+Quydatella	C (Bash)			+Rhodesinella	C (Vise-l)		
Raadshoovenia	K (Camp)			+Rhombobolivinella	T (Eo-u)	-T (Mi-u-u)	
Rabanitina	K (Ceno-l)			+Rimalina	K (Camp-u)		
Racemiguembelina	K (Maes-u)			+Ripacubana	K?		
+Radiocyclopeus	T (Mi-l-u)	-T (Mi-m)		+Riveroinella	T (Ol-l)	-T (Mi-l)	
+Radotruncana	K (Camp-u)			-Riyadhella	J (Bajo)	-J (Call)	
+Raibosammia	O (Cara-u)?			Robertina	T (Than)	-R	
+Ramosvia	P (Asse)	-P (Dju)		+Robertinoides	T (Eo-l)	-R	
Ramulina	J (u)?	-R		Robuloides	P (m)	-Tr(Ladi)	
Raminellina	J (Oxfo)			+Robustopachyphloia	P (Dora)		
+Ranikothalia	T (Than)			Robustoschwagerina	P (Asse)	-P (Sakm)	
+Raphconilia	C (Step-u)	-P (Tatr)?	(1249)	Roglicia	T (Eo)		
Rauserella	P (Leon-u)			+Rosalina	T (Eo-u)	-R	
Rauserina	D (Give)	-D (Fame)		Rotalia	K (Coni)	-T (Eo-m-l)?	
+Rectoavesmella	D (Fame)			+Rotaliatinopsis	T (Plio)	-Q (Plei)	
Rectobolivina	T (Eo-m)	-R		+Rotalidium	T (Mi-u)	-R	
Rectobulimina	K (Maes)			Rotalipora	K (Albi-m)	-K (Turo)	
+Rectochernyshinella	D (Fame-u)	-C (Tour-l)		Rotaliatina	T (Eo-u)	-T (Ol-l)	(728)
Rectocibicides	T (Mi)			+Rotalinoides	T (Mi-m)	-R	

Taxon	First Appearance	Last Appearance	Reference	Taxon	First Appearance	Last Appearance	Reference
+Rotamorphina	K (Camp)			+Senalveolina	K (Camp-l)		
+Rothina	K (Albi)			+Septabrunsiina	D (Fame-l)	-C (Vise-u)	(144,678)
+Ruakituria	T (Mi-l)	-R		+Septaforschia	C (Tour)		
+Ruatoria	T (Mi-l-l)	-T (Mi-m)		+Septagathamina	P (Leon)?		
+Rugobolivinella	T (Eo-u)	-R		+Septatourayella	D (Fame-m)	-C (Vise-l)	(79,144)
+Rugoglobigerina	K (Sant-l)	-K (Maes-u)		Septigerina	T (Eo-m)		
+Rugosochusenella	P (Sakm-u)	-P (Leon-l)	(145)	+Serovina	K (Barr)	-K (Maes-l)	
Rugososchwagerina	P (Sakm-u)	-P (Guad-l)	(145)	+Serpenulina	S (Ludl-u)	-D (l)	
+Rugotruncana	K (Camp-u)	-K (Maes-u)		Serpulopsis	D (Fras)	-C (Step-u)	
Rupertina	T (Mi-m)?	-R		Sestronophora	T (Plio)	-Q (Plei)	
+Russiella	P (Guad-l)		(146)	+Shanita	P (Guad)	-P (Dora)	
+Rutherfordoides	T (Ol-u)?	-R		+Shastrina	T (Eo-m-l)		
+Ryadhella	J (Bajo)	-J (Call)		+Shengella	P (Asse-l)		
Rzehakina	K (Turo-l)	-T (Than-u)		Sherbornina	T (Than)	-T (Mi-m)	
+Sabaudia	K (Haut-u)	-K (Ceno-l)	(646)	+Shouguania	C (Vise)		
+Sabellovoluta	T (Ol-l)	-T (Ol-u)	(1051)	+Shuguria	D (Fras)		
+Sabulina	K (Albi-u)			+Sichotenella	P (Leon-u)	-P (Dora)	(146)
Saccamina	S (Wenl)	-R		+Siculocosta	Tr(Nori)	-Tr(Rhae)	
Saccaminis	C (Step)			Siderolites	K (Maes-l)		
Saccaminoides	T (Eo-l)			+Sieberina	J (Hett)		
+Saccaminopsis	D (Fame)	-C (Serp-l)		+Sigalia	K (Coni)	-K (Sant-l)	
+Saccarena	S (Ludl)			+Sigalitruncana	K (Turo)	-K (Camp-l)	
+Sacchararena	C (Mosc)	-P		Sigmavirgulina	T (Mi)	-R	
+Saccorhina	D (Give)	-D (Fras)		+Sigmella	T (Ol-u)?	-R	
Saccorhiza	R			Sigmoideella	T (Eo-m)	-R	
Sagenina	T (Eo)	-R		+Sigmoidhaerina	T (Mi-l-u)	R	
Sagoplecta	Tr(Rhae)			Sigmoilina	T (Mi-l-u)	-R	
Sagrina	T (Plio-l)	-R		+Sigmoilinita	T (Mi-u-l)	-R	
+Sagrinopsis	T (Mi)	-R		Sigmoilopsis	T (Ol-l)	R	(728)
+Saidovina	T (Plio)	-R		Sigmomorphina	T (Than)	-R	
Sakesaria	T (Dani)	-T (Eo-l)		+Silicomassilina	T (Dani)		
+Sakhiella	T (Pale)			Silicosigmoilina	K (Turo-u)	-T (Than-u)	
+Salpingthurammia	D (Eite)	-D (Fame)		+Silicotuba	K (Sn)		
+Saltovskajina	D (Fame-l)	-D (Fame-u)		+Silvestriella	T (Eo-m-u)	-T (Eo-u)	
+Sanderella	J (Bath-l)	J (Call)?		+Simionescella	K (Apti-l)		
+Sansabaina	D (Fame)?	-P (Guad)?	(76)	+Simobaculites	C (Step)	-T (Mi-l)	(76)
Saracenaria	K (Berr)	-R	(959)	+Simplalveolina	K (Ceno)		
+Saracencella	J (Plie)	-K (Albi)		+Simplorbites	K (Maes)		
+Sarawati	T (Eo-m)			Simplorbitolina	K (Apti-u)	-K (Albi-m)	(646)
+Satorina	J (m)			Sinzowella	T (Mi-u)		
Saudia	T (Than-l)	-T (Eo-u)		+Siphogaudryina	K (Turo)	-K (Maes-u)	
+Scandonea	K (Camp)	-T (Than-l)		Siphogenerina	T (Eo)	-R	
+Scarificatina	T (Than-l)			Siphogenerinoides	K (Turo)	-T (Than)	(148)
Schackoia	K (Albi-u)?	-K (Maes-u)	(857)	Siphoglobulina	T (Than-l)	-R	
+Schackoinella	T (Eo-m-l)	-R		+Sipholagena	Q (Plei)	-R	
+Scheibnerova	K (Ceno-l)			Siphonaperta	T (Mi)	-R	
+Scherochorella	C (Vise)?	-R	(76)	Siphonides	T (Eo-m)		
Schlosserina	T (Eo-u)			Siphonina	T (Eo-u)	-R	
Schlumbergerella	Q (Plei)	-R		Siphoninella	T (Eo-m)	-R	
Schmidia	Tr(Ladi-u)	-Tr(Rhae)		Siphoninoides	T (Mi)	-R	
Schubertella	C (Bash-u)	-P (Guad-l)	(146)	Siphonodosaria	T (Eo)	-R	
Schwagerina	P (Asse-l)	-P (Guad-u)	(145)	+Siphonofera	Tr(Nori)		
+Sculptobaculites	K (Albi)	-K (Ceno-u)	(76)	+Siphonoscutula	T (Mi)		
+Scyphocodon	S (Ludl)			+Siphotextularia	T (Eo)	-R	
+Scythilocolina	K (Berr-u)	-K (Apti-l)	(649)	Siphovigerina	R		
Seabrookia	K (Maes)	-R		+Sirtina	K (Sant)	-K (Maes-l)	
+Semiendothyra	C (Serp)			+Sitella	K (Coni)	-K (Maes-u)	
Semiinvoluta	Tr(Nori-l)	-Tr(Rhae)	(684)	+Sivasella	K (Maes)		
Seminovella	C (Serp-u)	-C (Mosc-l)		+Skinnerina	P (Leon-u)	-P (Guad-l)	
-Semirosalina	T (Mi-l)			Smoutina	K (Maes)	-T (Eo-m-l)	
Semitextularia	D (Give)	-D (Fame)		+Sogdianina	C (Vise)		
Semivalvulina	T (Eo-m)	-T (Mi-l)		Somalina	T (Eo-m-l)		

Taxon	First Appearance	Last Appearance	Reference	Taxon	First Appearance	Last Appearance	Reference
+Soriella	T (Eo-m-l)			Storrsella	T (Than-l)	-T (Eo-l)	
Sorites	T (Mi-l-u)	-R		+Storthosphaera	C (Tour)	-R	
Sornayina	K (Coni)			+Streptalveolina	K (Ceno-l)		
Sorosphaera	S (u)	-R		Streptochilus	T (Eo-m-l)	-R	
+Sorosphaerella	D (Fame)?	-C (Tour-l)		+Streptocyclammina	J (Plei)	-J (Kimm)	
+Sorosomasphaera	S (Wen-l)	-S (Lud-l)		+Striatella	K (Coni)	-K (Maes)	
+Spandelinoides	P (l)			+Strictocostella	T (Eo)	-R	
Sphaerogypsina	T (Than)?	-R		+Strigialifusus	T (Ol-l-u)		
Sphaeroidina	T (Eo-u)	-R		Subalveolina	K (Sant-u)	-K (Camp)	
Sphaeroidinella	T (Plio-l)	-R		Subdelloidina	J (Toar)	-J (Kimm-u)	
Sphaeroidinellopsis	T (Mi-l-u)	-T (Plio-l)		Subbotina	T (Dani)	-T (Ol-u)	(939)
+Sphaeroschwagerina	P (Asse-l)	-P (Sakm-u)	(146)	+Sublamarckella	J (Aale)	-J (Bajo)	
Sphaerulina	P (Leon-l)	-P (Dora)	(146)	Suggrunda	T (Mi-m)		
+Spinobrunsiina	C (Tour-l)	-C (Vise-u)	(79)	Sulcoperculina	K (Camp)	-K (Maes-u)	
+Spinochernella	C (Tour)	-C (Vise-l)		Sulcorbitoides	K (Camp)	-K (Maes-u)	(2)
+Spinodiscorbis	T (Plio-u)	-Q (Plei)		Sumatrina	P (Guad-l)	-P (Guad-u)	(145)
+Spinoenodothyra	C (Tour-u)	-C (Vise-l)		+Svenia	K (u)	-R	
+Spinolaxina	C (Vise)			Svratkina	K (Maes)	-R	
+Spinothyra	C (Vise-u)	-C (Serp-l)?		+Syzranella	C (Mosc-u)	-P (Sakm-u)	(1249)
+Spinotourmayella	C (Tour-u)	-C (Vise-u)	(144)	+Syzrania	C (Mosc-l)	-P (Tatr)	(1249)
+Spiralococcus	J (m)			Taberina	T (Dani)		
+Spirapertolina	K (Sant)			Taitzehoella	C (Mosc-u)		(146)
+Spiriaphorella	Tr(Carn-l)	-Tr(Carn-u)	(684)	+Takayanagia	T (Plio-l)	-R	
Spirillina	Tr(Rhae)	-R	(537)	+Talmuella	K (u)		
Spirobovina	T (Than)?	-T (Eo-u)		+Talpinella	K (Camp-l)	-K (Maes-u)	
Spirocyclus	T (Eo-m-l)	-T (Mi-l-l)		+Tappanella	Q (Plei)	-R	
Spirocyclina	K (Sant)			Tappanina	K (Coni)	-T (Eo-l)	
Spirofrondicularia	J (Tith)	-K (Apti)		+Tasmanammina	D (Fame-m)		(154)
Spirolina	T (Eo-l)	-R		+Tayamaia	T (Mi-l-l)		
+Spirolingulina	T (Eo)	-R		Technitella	T (Eo-l)	-R	(1051)
Spiroloculina	K (Albi-u)	-R	(959)	+Tensonina	T (Mi-l)		
+Spiroloxostoma	T (Mi-l)	-T (Plio-u)		+Tenuitella	T (Eo-u)	-R	
+Spiroplecta	K (Apti)	-T (Pale)		Tentifrons	K (Camp)?	-K (Maes)	(148)
Spiroplectammina	C (Tour)	-R		+Tentilenticulina	J (Oxfo-m)		
+Spiroplectina	K (Ceno-m)	-K (Turo-u)		+Tergrigorjanzaella	T (Eo-u)	-T (Ol-l)	
Spiroplectinella	K (Apti)	-K (Ceno-u)		+Testacarinata	T (Eo-m-l)	-T (Eo-m-u)	
+Spiroplectinella	K (Turo-l)	-R	(1051)	+Tetragonulina	T (Mi-u)		
+Spirosammia	T (Ol-l)	-T (Plio-l)	(1051)	+Tetraminouxia	K (Sant)		
Spirosigmolima	T (Eo-u)	-T (Mi-u)	(1051)	Tetrataxis	C (Tour-u)	-C (Mosc)	
Spirosigmoliminella	K (Camp)	-T (Mi-m)	(1051)	+Tewoella	P (u)		
+Spirosolenites	Cmt(Boto)?		(579)	Textularia	T (Than-l)	-R	
Spirotecta	K (Camp)	-K (Maes)		Textulariella	T (Mi)	-R	
+Spirotricholina	J (Oxfo-l)	-J (Oxfo-m)		+Textulariopsis	J (Plei)	-K (Maes)	
Sporadotrema	T (Eo-l)?	-R		+Textulina	T (Mi)	-R	
Sporobulimina	K (Sn)	-T (Eo-m)		+Tezaquina	C (Step-u)	-P (Sakm-l)	(1249)
Sporobuliminella	K (u)			+Thailandina	P (Leon-m)	-P (Guad)	(146)
Staffella	P (Leon)	-P (Dora)	(936)	+Thalamophaga	T (Eo)	-R	
Stainforthia	T (Eo)	-R		Thalammammmina	K (Berr)	-R	
+Stedumia	K (Apti-u)	-K (Albi-l)		Thalammnita	T (Than-l)	-T (Ol-l)?	
Stegnammina	S (Ldov)	-S (Wenl)		+Thekammina	S (Ldov-m)		
+Steinetella	J (Oxfo)			Tholosina	O (Cara)	-R	
+Stellarticularia	T (Mi-u-l)			Thomasinella	K (Ceno)		
+Stenocyclina	T (Eo-m-l)	-T (Eo-m-u)		+Thompsonella	C (Step-u)		
Stensioina	K (Turo-u)	-K (Maes-u)		Thurammina	S (Ldov)	-R	(537)
+Stetsonia	T (Plio-l)	-R		Thuramininoides	Cm(m)?	-C (Mosc)	(579)
Stichocassidulina	T (Eo-u)			+Thuramininopsis	J (Oxfo)?		
Stichocibicides	T (Eo-l)	-T (Eo-u)		Ticinella	K (Apti-u)	-K (Ceno-l)	
Stilostomella	T (Eo-m-l)	-T (Plio)		+Tikhinella	D (Fras-u)	-C (Tour-l)	(678,1249)
Stomasphaera	S (Ldov-m)	-S (Ludl-l)	(537)	+Timaella	C (Mosc)		
Stomatorbina	T (Eo)	-R		+Timidonella	J (m)		
Stomatostoecha	K (Albi)			Tinophodella	T (Mi-l)	-R	
+Stomoloculina	Q (Plei)	-R		Tiphrotrocha	R		

Taxon	First Appearance	Last Appearance	Reference	Taxon	First Appearance	Last Appearance	Reference
Tobolia	K (Maes)			Turrispiroides	C (Serp-l)	-C (Mosc-l)	
+ Tollmannia	T (Mi-u-l)	-T (Plio-l)		Turritellella	S (Ldov)	-R	(537)
Tolypanmina	D (Sieg-l)	-P (Dora)	(1070)	Unitesiphonia	T (Than)	-T (Mi-l)	(148)
+ Topalodiscorbis	J (Oxfo-u)	-J (Kimm-l)		+ Unitendina	J (u)?	-T (Mi-l)?	
Torinosuella	J (Kimm)	-J (Tith-u)		Uralinella	D (Give)	-C (Tour-l)	
Toriyamaia	P (Leon-l)	-P (Leon-u)	(146)	Uralodiscus	C (Vise-l)	-C (Vise-u)	(79,144)
+ Torreina	K (Maes)			+ Uralofustulinella	P (Leon)		
+ Torremiroella	K (Barr)			+ Urbanella	C (Tour)	-C (Vise-u)	(79)
Torresina	T (Plio)	-R		+ Urgonina	K (Barr)		
+ Tortaguttus	Q (Plei)	-R	(1033)	+ Urnuliniella	Tr(Carn-u)	-Tr(Nori-l)	(684)
Tortonella	T (Mi-u-l)			Usbekistania	K (Barr)	-R	
+ Torulumbonina	Q (Plei)	-R		Uslonia	D (Fras-u)		
Tosaia	T (Mi-m)	-R		+ Uviella	C (Tour)	-C (Vise)	
+ Tournarchaediscus	C (Vise)			Uvigerina	T (Eo-l)	-R	(79)
Tournayella	C (Tour)	-C (Vise-u)	(678)	Uvigerinammina	K (Vala-u)	-K (Maes-u)	(148,959)
+ Tournayellina	D (Fame-m)	-C (Vise-u)	(79,678)	Uvigerinella	T (Mi-l-l)	-T (Mi-m)	
Trachelinella	K (Camp)	-K (Maes)		+ Vacuoalvulina	T (Than-l)		
+ Transversigerina	T (Ol-u)	-T (Mi-u)		Vaginulina	J (Sine-l)	-R	(79,715)
+ Trenmachora	T (Mi-m)			Vaginulinopsis	Tr(Rhae)	-R	
Trepeilopsis	C (Vise)	-P (Leon)		+ Valdanchella	K (Vala)	-K (Ceno-m)	(646)
+ Triadodiscus	Tr(Olen)?	-Tr(Carn-u)?		+ Valserina	K (Barr)		
Triasina	Tr(Nori-m)	-Tr(Rhae)	(2)	+ Valvalabamina	K (Turo)	-T (Pale)	
Tribrachia	J (Call)	-K (Maes)	(148)	+ Valvoreussella	K (Turo)	-K (Camp)	
+ Tricarinea	K (Albi)			Valvulammina	T (Eo-m-l)		
+ Trichohylas	Q (Plei)	-R		Valvulina	T (Eo-m)	-R	
Trifarina	T (Than)?	-R		Valvulinella	C (Vise-l)	-C (Bash)	(537)
Triloculina	T (Eo-m-l)	-R		Valvulineria	T (Dani)	-R	
+ Triloculinella	T (Ol)	-R		+ Valvulinoides	K (Maes-l)	-K (Maes-u)	
+ Triloculinoides	T (Mi-m)	-R		Vandenbroeckia	K (Coni)	-K (Maes)	(2)
+ Triloculinopsis	T (Mi-l-l)			+ Vanderbeckia	K (Maes-l)		
Trinitella	K (Maes-l)	-K (Maes-u)		+ Vania	T (Than)		
Triplasia	J (l)	-R		+ Varidentella	T (Mi-u-l)	-R	
+ Trispirina	J (Aale)	-J (Call)		Variostoma	Tr(Anis)	-Tr(Nori)	
Tristix	J (Phe-l)	-T (Eo)	(868)	Vasicckia	D (Give)		
Tritaxia	K (Apti)	-K (Maes-u)	(959)	+ Vasicostella	Q (Plei)	-R	(717)
Tritaxilina	T (Eo-l)	-R	(1051)	+ Vasioglobulina	T (Eo-u)	-T (Plio)	
Triticides	C (Step-l)	-P (Sakm-u)		Vaughanina	K (Camp-u)	-K (Maes-u)	(2)
+ Tritubulogenerina	T (Eo-m)	-T (Eo-u)		+ Velapertina	T (Mi-u-l)		
Trochammina	C (Vise)	-R	(537)	+ Vellaena	T (Eo-u)	-T (Ol-l)	
Trochaminoides	K (u)?	-R		Ventilabrella	K (Sant)	-K (Maes-u)	(153)
Trochaminula	R			+ Ventrostoma	T (Plio)	-R	(1033)
+ Trochospira	K (Albi-l)	-K (Turo)	(646)	Verbeekina	P (Leon-m)	-P (Djhu)	
+ Trochospirillina	J (Oxfo-l)			+ Vercorsella	K (Barr-u)	-K (Apti-l)	
Trochulina	Tr(Nori)	-K (Ceno)		Verella	C (Bash-u)		(145)
+ Trochylina	T (Eo-m)	-R		Verneuilina	J (Call-m)	-K (Maes-u)	
+ Truncorotalia	T (Mi-u-u)	-R		+ Verneuilinella	K (Apti)	-K (Turo)	
Truncorotaloides	T (Eo-m)			Verneulinoides	J (Sine-u)	-K (Maes-l)	(79,148)
+ Tschokrakella	T (Mi-m)			Vernonia	T (Eo-u)		
+ Tubeporella	D (l)	-D (m)		+ Verseyella	T (Eo-l)		
Tubeporina	D (Give)			+ Vialovia	K (Turo-l)	-K (Maes)	
+ Tuberendothyra	C (Tour-l)	-C (Vise-u)	(79,144)	+ Vialovella	K (Ceno)	-K (Camp)	
Tuberitina	C (Serp)	-P (Dora)		+ Vicinesphaera	D (Fame)		
+ Tubinella	Q (Plei)			Victoriella	T (Eo-u)	-T (Mi-l-u)	
Tubispirodiscus	C (Vise-l)	-C (Serp-u)		Vidalina	K (Ceno)	-K (Sant)	
Tubulogenerina	T (Eo-l)	-T (Ol-u)		+ Vindeloides	J (Oxfo)		
+ Tuborecta	S (Prid)	-D (Gedi)		Virgulinea	T (Mi-l-u)	-R	
Turborotalia	T (Than)	-T (Ol-l)	(939)	+ Virguloides	T (Ol-l)		
+ Turborotalita	T (Mi-u-u)	-R		Virgulopsis	T (Ol-u)	-R	
+ Turceniella	D (Give)	-D (Fame)		+ Viscidiscus	C (Vise-l)	-C (Serp-l)	(1249)
+ Turkmenella	T (Eo-m)	-R		+ Viseina	C (Vise)		
Turnilina	T (Eo-l)	-T (Mi-u)		Vissariotaxis	C (Vise-u)		(79)
Turrispirillina	J (Bajo-u)	-R	(1051)	Vitriwebbina	K (Albi)		

Taxon	First Appearance	Last Appearance	Reference	Taxon	First Appearance	Last Appearance	Reference
+Voloshinoides	K (Albi)	-K (Maes)		+Gotlandochitina	S (Ldov)?	-D (Fras-m)	
Voloshinovella	K (Camp)	-K (Maes-u)		+Halochitina	S (Ludl)		
+Vostokovella	C (Vise-l)			+Hercoclitina	O (Cara-m)	-O (Ashg-m)	
Vulvulina	K (Camp)?	-R		Hercoclitina	O (Ashg-m)		(2)
+Wadella	T (Eo-u)			Hoegisphaera	O (Llde-l)	-D (Fras-u)	(2)
Waeringella	C (Step-u)	-P (Wc)?		-Jenkinochitina			
+Walterparria	Q (Plei)	-R	(717)	-Kalochitina	O (Cara-l)	-S (Ldov-l)	
+Warnantella	C (Vise-u)	-C (Mosc)	(79)	Lagenochitina	O (Trem-l)	-D (Fame)	
Washiella	K (Albi)	-K (Ceno)		-Linochitina	O (Llde)	-D (Give)	(2)
Webbinella	K (Albi)	-R		Margachitina	S (Ldov-u)	-D (Give)	
Webbinelloidea	D (m)			+Muscochitina	D (Gedi-u)	-D (Fras-m)	
Wedekindellina	C (Mosc-u)		(146)	+Ollachitina	O (Trem-u)	-O (Aren)	
Wellmanella	T (Eo-u)			+Parisochitina	D (Fras)		
Wheelerella	K (Coni)			+Pistillachitina	O (Llde)	-S (Ldov)	
+Whiteinella	K (Ceno-m)	-K (Camp-u)		Plectochitina	S (Ldov)	-D (Sieg)	(2)
+Wiesnerina	Q (Plei)	-R	(717)	+Pogonochitina	O (Cara-m)?	-S (Ldov)	
+Wilfordia	T (Eo-u)			+Pseudoclaithrochitina	S (Ldov-u)	-D (Gedi)	
+Woodella	T (Than)			Pterochitina	O (Llvi-u)	-D (Gedi)	(2)
Woodringina	T (Dani-l)			+Ramochitina	D (Gedi)		
+Wutuella	P (Leon)?			Rhabdochitina	O (Aren-l)	-S (Wenl)	(2)
+Xenostaffella	C (Mosc-u)			+Sagenachitina	O (Llvi)	-O (u)	
+Xintania	P (Leon)			+Salopochitina	S (Wen-l)		
Yabeina	P (Guad-l)	-P (Guad-u)	(145)	-Siphonochitina	O (Aren)	-O (Cara-l)	
Yaberinella	T (Eo-m-l)	-T (Eo-u)		+Sphaerochitina	O (Cara-m)	-D (Fame)	
+Yangchienia	P (Leon-m)	-P (Guad-u)	(146)	+Spinachitina	O (Cara-l)	-O (Ashg-u)	
+Yaucorotalia	T (Ol-u)?	-T (Mi-l)		+Tanuchitina	O (Aren-l)	-S (Ludl)	
+Ynezziella	T (Than-l)			Urochitina	D (Gedi)	-D (Give)?	(2)
+Zarodella	P (Sakm)			-Velatachitina	O (Aren-u)	-S (Ldov-l)	
+Zeaflorilus	T (Mi-m)	-R		+incertae sedis	C (Serp-l)		
+Zeauvigerina	K (Sn)	-T (Eo-m-u)					
+Zelamarckina	T (Plio-u)						
+Zellerina	C (Vise-u)	-C (Serp-u)					
Zellia	P (Asse-u)	-P (Sakm-l)	(146)				
+Ziguiella	P (Dora)?						
Zotheculifida	T (Ol-u)	-T (Mi-l-l)					
+incertae sedis	CmtuMid		(579)				

Or. ?CHITINOZOA

Acanthochitina	O (Cara-u)	-O (Ashg-m)	(2)
Alpenachitina	D (Give-l)		(2)
+Amphorachitina	O (Trem-u)	-O (Aren)	
Ancyrochitina	O (Cara-l)	-D (Fame)	(2)
Angochitina	O (Cara-u)	-D (Fame)	(2)
+Anthochitina	S (Prid)?	-D (Sieg)	
Belonechitina	O (Llde-u)	-O (Ashg)	(2)
+Bursachitina	D (Gedi-u)	-D (Emsi-u)	
+Calpichtina	O (Llde-l)	-D (Sieg-l)	
+Cingulochitina	S (Ldov-u)	-D (l)	
+Cladochitina	D (Gedi)	-D (Eife)	
+Clathrochitina	O (Aren-u)	-S (Prid)?	
+Clavachitina	O (Llde)	-S (Ldov)	
Conochitina	O (Trem-l)	-D (Fame)	(2)
+Coronochitina	O (Ashg)		
Cyathochitina	O (Trem-u)	-D (Fras)?	(2)
+Cylindrochitina	O (Llvi)	-O (Llde)	
Desmochitina	O (Trem-u)	-S (Ludl-u)	(2)
Earlachitina	D (Gedi)	-D (Give)	(2)
Eisenackitina	S (Ldov-u)	-D (Give)	(2)
Eremochitina	O (Trem-l)	-D (Give)	(2)
+Euconchitina	O (Aren-u)	-S (Ldov-l)	
+Fungochitina	S (Wenl)	-D (Fras)	
+Fustichitina	O (Aren-l)	-O (Llvi)	

Ph. PORIFERA

[Classification and basic stratigraphic ranges based on the TREATISE, Part E (1955).]

CI. DEMOSPONGIA

Or. POECILOSCLERIDA

Acanthoraphis	K (Sn)		
Chondrocladia	Q (Plei)?	-R	
Cladorhiza	Q (Plei)?	-R	
Forcepia	Q (Plei)?	-R	
Hamacantha	Q (Plei)?	-R	
Hamptonia	Cm(mMid-u)	-Cm(uMid-m)	(766)
-Hymedesmia	Tr(Carn-l)		(1118)
Iophon	K (u)?	-R	(643)
+Lenica	Cm(Boto)		(1006)
+Leptomitella	Cm(Atda-u)	-Cm(uMid-u)	(766,858)
Leptomitus	Cm(Atda-u)	-Cm(uMid-m)	(766,858, 883)
Makiyama	T		
Melonanchora	Q (Plei)	-R	
Myxilla	Q (Plei)	-R	
Ophiodesia	J (u)		
Oppligera	J (l)		(1066)
+Paraleptomitella	Cm(Atda-u)		(858)

Or. HAPLOSCLERIDA

-Aka	Tr(Carn-l)	-R	
Climacospongia	S (Wenl)?		
+Coelocladiaella	C (Step-l)	-P (Djhu)	(203,204)
Corralio	Cm(mMid-u)		
+Crumillospongia	Cm(mMid-u)		(766)

Taxon	First Appearance	Last Appearance	Reference	Taxon	First Appearance	Last Appearance	Reference
Esperites	K (l)			Ortmannia	K (Camp-u)		(1066)
Eurydiscites	K (Albi)?			Pachastrella	C (Vise-u)?	-R	(1066)
+Euzkadrella	K (Apti-u)			Paropsites	K (u)		
+Falospongia	Cm(mMid-u)	(766)		Polytretia	K (Camp-l)		(1066)
Guitarra	Q (Plei)?	-R		Propachastrella	K (Ceno)	-K (Camp-l)	(642)
Halichondrites	Cm(mMid-u)	-O (Trem)?	(766,883,1066)	Rhabdospongia	K (Albi)		
Hazelia	Cm(Boto-u)	-Cm(uMid-m)	(766,883,1019)	Rhaxella	J (Bajo)	-J (Tith-u)	
+Heliospongia	C (Step-l)	-P (Leon-l)	(203,204)	+Rhaxelloides	J (Oxfo)	-J (Tith-u)	
+Hispidopetra	Tr(Carn-l)	-R	(1118)	Scolioraphis	K (Sant-u)		(1066)
+Nepheliospongia	D (u)			Stelletta	K (Sn)	-R	
+Newellia	C (Pn)			Stolleya	K (Albi-m)		
+Petrosstroma	Tr(Carn-l)		(1118)	-Stromatorhaxella	K (Sant)		(1118)
Petrosites	O (Trem)			Tetillopsis	K (u)		
Takakkawia	Cm(mMid-u)		(766)	Thenecopsis	K (Albi-m)	-K (Sn)	
+?Thalamohaliclona	Tr(Carn-l)		(1118)	Thrombus	K (Camp-u)?	-R	(1066)
Toriscodermia	J (u)?			Youngella	C		
Wapkia	Cm(mMid-u)		(766)				
Or. DICTYOCERATIDA				Or. LITHISTIDA			
Dysidea	T (Eo)	-R		+Achrochordiella	T (Eo-u)		(698)
Felixium	K			Achrochordonia	K (Apti)	-K (Camp-u)	(642)
Spongelites	J (u)?			+Actinocoelia	P (Leon-m)	-P (Dora)	(203,666)
Spongeoliomorpha	T (Mi)			Adrianeella	P		
Or. VERONGIIDA				Allomera	T (Mi)		
Vauxia	Cm(Atda-u)	-Cm(uMid-l)	(883,1006)	Allosaccus	O (Llde)?	-O (Cara-l)	
Or. VERTICILLITIDA				Amphilectella	K (u)	-K (Camp-u)	(1021)
+Boikothalamia	J (m)		(941)	Anomoclonella	O (Cara)?	-S (Wenl)	
+Marinduquia	T (Pg)		(941)	Anomorphites	J (u)		
+Murguithalamia	K (u)		(941)	Anthaspidella	O (Llde-u)		
Stylothalamia	P (Leon-u)	-K (Camp)	(941,1066)	Anthracoscycon	P (Leon-l)	-P (Guad-u)	(203)
+Vaceletia	T (Eo-u)	-R		+Antrospongia	S (Ludl-l)		(880)
+Vascothalamia	K (u)		(941)	+Arborohindia	O (Cara)		(1066)
Verticillites	P (Leon-u)	-K (Maes)	(2,218)	Arbuscula	P		
Or. ASTROPHORIDA (= Choristida)				+Archaeodermida	C (Vise)		(1066)
Acanthastrella	J (Oxfo)	-K (Camp-u)	(1021)	Archaeoscyphia	O (Aren-l)	-S (Ludl-l)	(2,880)
Acanthophora	K (Albi)			Asterocalyx	K (u)		
Arthaberia	J (Call-l)		(868)	Asterospongia	K (Sn)		
Calthropella	K (u)	-R		Astrobofia	K (u)?		
Cephaloraphidites	K (Camp-l)		(205,1066)	Astrocladia	K (Sant)?	-K (Maes)?	
Condyliacanthus	K (u)?			Astrolemnia	K (Sn)		
Corticium	Q (Plei)?	-R		Astylomanon	S		
Cranella	T (Eo)?	-R	(1066)	Astylospongia	O (Cara-m)	-D (Sieg-l)	(2,4,207)
Discispongia	J (u)			+Astylospongiella	S (Ludl-l)		(216,880)
+Dysactospongia	O (Cara-m)	-O (Ashg-m)	(206)	+Attugia	D (Sieg-l)?		(207)
Erylus	Q (Plei)?	-R		Aulacospongia	P (Dju)?		(2)
Euleraphe	J (u)	-K (Camp-l)	(641)	Aulaxinia	K (Apti)	-K (Maes-u)	(642)
Fusiferella	K (u)			Aulocopella	O (m)	-O (Ashg-m)	(209)
Geodia	K (Camp-l)	-R		Aulocopina	S (Wenl)		
Geodiopsis	K (u)			Aulocopium	O	-S (Ludl-l)	(880)
Geodites	C (Vise-u)	-Q (Plei)	(2,643)	Aulosoma	K (Sant-u)	-K (Camp-u)	(1021)
Halina	K (u)	-R		Azorica	J (Call)	-R	(1066)
Helminthophyllum	J (Kimm-l)		(1066)	Bathotheca	J (u)		
Heteroraphidites	K (u)			+Belubulaspongia	O (Cara)		(1066)
+Loganella	O (Llvi-l)		(206)	Bolidium	K (Ceno)	-K (Camp-l)	(641)
Megaloraphium	K (Camp-l)		(1066)	Bolojera	K (u)		
Ophraphidites	K (Sn)	-T (Eo-m)	(1066)	Bolospongia	J (Oxfo-m)	-K (Sn)	(868)
				+Boonderoioa	O (Cara)		(1066)
				Bothoteca	J (Call-u)		(868)
				Bothrochlaenia	J (Call-l)	-J (Call-u)	(868)
				Bothrolemnia	J (u)?		
				+Brianispongia	D (Sieg-l)		(207)
				Brochodora	K (Apti)	-K (Camp-u)	(642)
				Callopegma	K (Apti)	-K (Maes)	(642,1066)

Taxon	First Appearance	Last Appearance	Reference	Taxon	First Appearance	Last Appearance	Reference
Calycoecolia	O (Llvi-l)	-S (Ludl-l)	(210,880)	+Fenestrospongia	O (Cara)		(1066)
Calymmatina	K (Sn)			+?Fieldospongia	Cm(Mid-l)		
+Camellasporgia	O (Ashg-m)		(209)	+Finksella	S (Ludl)		(212)
+Capsospongia	Cm(mMid-u)		(766)	+Garrasporgia	D (Sieg-l)		(207)
+Carpospongia	S (Wenl)?	-S (Ludl-l)	(205,880)	Gignouxia	K (Camp)		(1066)
Carterella	K (Albi-u)	-K (Camp-l)	(642)	+Gillettia	K (Apti)		(1066)
Caryomanon	O (Cara)?	-S (Ludl)?		Hallirhoa	K (Albi-u)	-K (Ceno)	
Caryospongia	O (Cara-m)	-S (Wenl)?	(1066)	Haplition	O (Cara)	-P (Guad-l)	(1066)
+Cauliculospongia	S (Ludl-l)			+Haplitionella	S (Ludl)		(212)
Chalaropegma	K (u)			Helobrachium	K (Camp-l)		(1066)
+Chaunactis	C (Step-l)	-P (Guad-l)	(203)	Heloraphinia	J (Kimm-l)	-K (Camp-l)	(642,1066)
Chenendopora	K (Albi-u)	-K (Camp-u)	(1021)	Hesperocoelia	O (Livi)	-O (Ashg-m)	
Chiastoclonella	S (Wenl)		(203)	Heterospongia	O (Ashg-m)		
Chonellopsis	J (Call-u)		(868)	Heterostinia	K (Ceno)	-K (Camp-u)?	(642)
Cladodermia	K (Apti)	-K (Camp-u)	(1021,1066)	Hippalimus	K (u)		
Cladodia	K (u)			Holodietyon	K (Albi-u)		
Cladolithosia	K (u)			Homalodora	K (Ceno)	-K (Camp-u)	(642)
+Cnemaualx	K (Apti)	-T (Mi-u-l)	(698)	Hudsonospongia	O (Llde)	-O (u)	
Cnemidiastrum	J (Oxfo-l)	-T (Mi-u-l)	(698,1066)	Hyaloderma	J (u)		
Coelocorypha	K (Ceno-m)	-K (Camp-l)?		Hyalospongia	J (Oxfo-l)	-J (Kimm)	(775)
Coelosphaeroma	K (u)			Hyalotragos	J (Oxfo-l)	-J (Tith-l)	(775)
+Collatipora	P (Leon)	-P (Guad-u)	(203)	Hypothyra	K (u)?		
Colossolacis	K (u)			Ingentilolus	K (Apti)	-K (Turo)?	(1066)
+Columellaespongia	D (Sieg-l)	-D (Eife)	(207)	Inodia	K (Ceno)	-K (Maes-l)	(642)
Compsaspis	K (Albi)	-K (Maes)?	(1066)	+Insulipora	P (Leon-l)		(203)
Corallidium	J (Kimm-l)		(868)	Iouea	K (u)		
Corallistes	T (Than)?	-R	(643)	Ishadia	T		
Coscinodiscus	J (u)			+Isispongia	D (Sieg-l)?		(207)
Coscinospongia	K (Albi)	-R	(641)	Isoraphinia	K (Ceno)	-K (Camp)?	(1066)
+Cotylahindia	O (Ashg-m)		(209)	+Jerea	K (Apti)		(1066)
+Cucumaltina	T (Mi-u-l)		(698)	+Jereica	J (Oxfo)		(1066)
Cupulina	K (u)			+Jereina	D	-P (Leon-u)	(203)
Cyathospongia	S			Jereomorpha	K (u)		
Cyclocoema	K (Ceno)	-K (Camp-u)	(642)	Jereopsis	K (Albi-u)	-T (Mi-u-l)	(698)
Cylinderophyma	J (Oxfo-l)	-J (Kimm-u)	(775,1066)	+Jianghania	O (Trem-u)?	O (Aren-l)?	
Cymbochlaenia	K (u)?			Kalpinella	K (Albi-u)		
Cytoracea	J (Oxfo-l)	-K (Sn)	(1021,1066)	+Kazania	P		
Dactylites	P (Leon-m)?		(2)	+Kozlowskispongia	K (Camp-u)		(642)
Dactylocalyctes	K (l)	-T		Kyphoclonella	J (Kimm-u)		(1066)
+Defordia	P (Sakm)	-P (Leon-u)	(203)	Lasiocladia	D (l)	-C (l)	
Dendroclonella	S (u)			Laubenfelsia	P (Guad-u)		
+Devonospongia	D (Sieg-l)	-D (Emsi)	(207)	Lecanella	J (Kimm-l)	-K (Sn)?	(1066)
Diacyparia	K (u)?			Leiocarenus	K (u)?		
Dichojerera	K (u)?			Leiochonia	K (Camp-l)	-K (Maes-l)	(641)
Dieranoclonella	J (Oxfo-l)	-J (u)	(2)	+Leiodermatium	J (m)	-R	
Didymosphaera	J (u)			Leiodorella	J (Oxfo-l)	-J (Kimm)	(775,1066)
Dimorpha	K (u)			Leiophyllum	K (u)	-K (Camp-l)?	(1021)
Discodermia	K (Apti)	-R	(1066)	Lerouxia	K (Sn)		
Discodermites	K (u)?			+Lewinia	O (Cara)		(1066)
Discostroma	J (u)?			Linochone	J (u)		
Doryderma	K (Albi)	-K (Camp)	(1066)	Lissocoelia	O (Llvi)	-O (Ashg-m)	
+Dunhillia	O (u)	-S (Ludl-l)	(880)	+Lithostrobilis	K (Apti)		(1066)
Edriospongia	O			Lopadophorus	K (u)		
Elasmalimus	K (u)?			Lyidium	T (Eo-u)	-R	
+Ellesmerespongia	P (l)		(214)	Macandrewia	K (u)	-R	
+Eochaunactis	S (Ludl)		(212)	Macandrewites	K (u)?		
Eospongia	O (Llde)?			Macrobroctus	K (u)		
+Epiplastospongia	O (Cara-l)		(215)	+Malinowskiella	D (Fras)		(1066)
Epistomella	J (u)?			+Mamelohindia	O (Cara)		(1066)
Exochopora	O (Llde)?			Marginospongia	K (Ceno)		
Exodictydia	K (Sant)	-K (Sn)		Mastophorus	K (Camp-u)		(1021)
Eustrobilus	K (Apti)	-K (Camp-u)?	(642)	Mastophyma	P		

Taxon	First Appearance	Last Appearance	Reference	Taxon	First Appearance	Last Appearance	Reference
Mastostia	J (Kimm-u)	-K (Albi-u)	(2)	Placosecytus	K (Camp-u)		
Megalithistida	J (Kimm-u)	-J (Tith-l)	(1066)	Platyspongia	K (u)		
Megarhiza	K (Ceno)?	-K (Camp-l)	(1066)	Platychnonia	J (Plie)	-T (Mi)?	
Melonella	J (Ade)	-J (Kimm-u)	(2)	Pleroma	T (Eo-u)	-R	
Microdendron	K (u)	-K (Camp-u)	(1021)	Plethosiphonia	T		
Microrhizophora	J (u)			Pleuronera	T (Mi)		
Microspongia (+ Hindia)	O (Cara-l)	-P (Djhu)?	(2)	Pleurophymia	T (Mi-u-l)		(1066)
Moretia	K (u)?			+Pliogattella	T (Mi-u-l)		(698)
+Moretispongia	T (Mi-u-l)		(1066)	Plinthodermatium	K (Camp-u)		(1066)
Mortieria	C	-P		Plinthosella	K (Ceno)	-K (Maes)	(642)
Multipocula	K (u)			Pliobolia	K (Apti)	-T (Mi-u-l)	(698)
+Multistella	P (Guad-l)		(203)	+Pliobiolopsis	T (Mi-u-l)		(698)
Myrmeciophytum	K (Camp-l)		(642)	Plococonia	K (u)?		
Nelumbia	K (Ceno-m)	-K (Sn)		Pocilloispongia	K (u)		
Nematinion	K (Albi-u)			Podapsis	K (u)?		
Neohindia	K (u)			Polyrhypidium	K (Sn)		
Neopelta	K (u)?	-R		Polyrhizophora	J (u)		
Nevadocoelia	O (Llvi)	-O (Ashg-m)		Polysiponeudea	K (u)		
Nipterella	Cm?	-O (Aren)	(2)	Polystoma	K (u)		
Ocellaria	K (u)			Polythra	K (u)?		
Okulitchina	O (Cara)			Poterionella	K (u)?		
Olkenbachia	D			Procorallistes	K (u)	-T (Mi)	
Oncocladia	J (u)			Prokaliapsis	K (u)?	-T (Mi)	
Oncodona (+ Oncophora)	K (Sn)			Propleroma	K (Sn)		
Oreocyta	K (u)?			Proschicothon	J (Call-u)	-J (Oxfo-m)	(868)
Orosphreom	K (u)?			Protachilleum	S		
Ortmannispongia	K (u)			Protetracelis	J (Kimm-u)		(1066)
Ozarkocoelia	O (Aren)			Psarodictyon	O (Llde-u)	-S (Ludl-l)	(880)
Ozotrachelus	J (u)	-K (u)	(205)	Pseudoguettardia	K (u)?		
Pachyculymma	K (Sn)			Pseudojerea	K (Sn)		
Pachycorynea	K (u)			Pseudoplocosecyphia	K (u)		
Pachycothion	J (u)	-K (Camp-l)?		Pseudosecytalia	K (Camp-l)	-K (Camp-u)	(1021)
Pachynion	K (Apti)	-K (Camp-u)	(642,1066)	Pseudoselischthon	K (u)		
Pachypsechia	J (u)			Pseudoverruculina	K (Apti)	-K (Sant)	(1066)
Pachypoterion	K (Albi-u)	-K (Camp-l)	(642)	Pseudovirgula	P	-P (Guad-u)	
Pachysalax	K (Camp-u)		(1021)	Pterocalpia	K (u)?		
Palaeojerea	P			+Pycnoclonella	K (Apti)		(1066)
Palaeomanon	S (Wenl-l)			Pycnodesma	K (u)		
Palaeophyma	P			Pycnopegma	O	-S (Wenl)	(2)
+Palmatohindia	O (Cara)		(1066)	Pycnospongia	P		
Paraspelaeum	K (Camp-u)		(1021)	Pyrogochonia	J (Oxfo-l)	-J (Kimm-u)	(868,1066)
+Parodospongia	S (Ludl-l)		(880)	+Raanespongia	P (Leon)		(213)
Patanophyma	J (u)?			Racodiscula	K (u)?	-R	
Patellispongia	O (Llvi)	-S (Wenl-l)	(880)	Ragadinia	K (Ceno)	-K (Camp-u)	(642)
Perimera	K (u)?			+Rankenella	Cmd(Mid-l)		(205,766)
+Perissocoelia	O (u)		(880)	Regnardia	K (Ceno)		
Phacellopegma	C (Bash-u)	-P (Guad-u)	(203)	+Reiswigia	J (Oxfo-l)		(775)
Phalangium	K (Sant)	-K (Camp-u)	(642)	Rhabdotum	K (Camp-l)		(1021)
+Phialaspongia	O (Ashg-m)		(209)	Rhagosplecion	K (u)?		
Phlyctia	T (Mi-u-l)		(1066)	Rhizostele	K (u)?		
Pholidocladia	K (Sn)			Rhizotetracelis	J (Kimm-u)		(1066)
Phrissospongia	K (u)			Rhopalocoelia	O (Aren-l)?	-O (Llde)?	
Phylodermia	K (Apti)	-K (Camp-u)?	(1021,1066)	Rhopalospingia	K (Albi-u)		
Phymplecia	K (u)			Rhoptrum	K (u)		
Phymplectia	K (Sn)			Rhytidoderma	J (u)		
Phymaraphinia	K (Apti)	-K (u)	(1066)	-Rutkowskiella	D (Give-l)	-D (Fras)	(211)
Phymatella	K (Apti)	-K (Maes)	(642,1066)	Succospongia	O (Cara-m)	-S (Ludl)?	(2)
Physocalpia	K (u)?			+Sadleria	D (Guad)		(1066)
Placojerea	K (u)?			+Scheiella	P (Guad-u)		(217)
Placonella	J (Kimm)		(1066)	+Scheielloides	D (Fras)	-D (Fame)?	(1066)
				+Scheia	C (Visc)?	-P (Djhu)	(203,208,1066)

Taxon	First Appearance	Last Appearance	Reference	Taxon	First Appearance	Last Appearance	Reference
+Schrammeniella	K (Camp-u)		(1066)	Actinostroma (+ Lamellistroma)	O (Ashg)	-D (Fras-u)	(363)
Sclerioderma	K (u)	-R		+ Actinostromella	S (Wenl)	-D (Gedi-l)	
Scytalia	K (Apti)	-K (Camp-u)	(641)	+ Aculatostroma	D (Emsi-l)	-D (Fras)	(363,970)
Strophophyma	T (Mi-u-l)		(1066)	+ Allynodietyon	O (Cara-l)		
+Selischotho	K (Apti)	-K (Camp-l)?	(1066)	+ Amnestostroma	S (Ludl)	-D (Sieg)?	(363)
Siphonia	K (Apti)	-K (Maes)?	(642,1066)	Amphipora (+ Paramphipora, Stellopora, Vicinustachyodes)	S (Ludl)	-D (Fame)	(363)
Siphonoceolia	J (u)			+ Anostylostroma	D (Gedi)?	-D (Fame-u)	(363)
+Somersetella	S (Ludl-l)		(212)	+ Arctostroma	D (Give)	-D (Fras)	(363)
Sontheimia	J (Kinn-u)		(1066)	+ Atelodietyon	D (Emsi-u)	-D (Fame-u)	(363)
Sphaerpegma	K (u)?			+ Atopostroma	D (Gedi-l)	-D (Eife-l)	(969)
+Spinocladia	K (Apti)		(1066)	Aulacera	O (Lide)	-O (Ashg-u)	(1006)
Stachyspongia	K (Apti)	-T (Mi)	(641)	+ Auroria	D (Gedi)?		(363)
Steliella	O (Cara-m)			+ Belemnostroma	D (Sieg)		(969)
Stelletites	K (l)			+ Bicolunostratum	S (Ludl)	-S (Prid)	
Stichophyma	K (Ceno)	-T (Mi)	(641)	+ Bifariostroma	D (Eife)	-D (Give-u)	(363)
Streptosolen	O (Livi)	-O (Ashg-m)		+ Bullulodietyon	D (Fras)		(363)
Streptospongia	O	-O (Ashg-m)		+ Clathrocoelona	D (Emsi-l)	-D (Fame-u)	(363)
Sulcastrella	K (u)	-R		+ Clathrodictyella	S (Ludl)	-D (Gedi)?	(903)
+Syllispongia	O (Cara)?, O (Ashg)?		(1066)	Clathrodictyon	O (Cara-l)?	-D (Fame-u)	
+Taplowia	O (Cara)		(1066)	+ Clathrostroma	S (Wenl)	-D (Fame-u)	(363)
Thamospongia	K (Ceno-m)?	-T		Clavidietyon	S (Ldov)	-D (Eife)	(363,903)
Thecosiphonia	K (Sn)			+ Coenostroma	D (Gedi-l)	-D (Fras)	
Theonella	T	-R		Columna	O (u)		
Timidella (+ Timorella)				+ Columnostroma	D (Sieg)	-D (Eife)	(363)
	P (Djhu)?		(2)	+ Cryptophragmus	O (Lide)	-O (Cara-u)?	
+Timorella	P (Djhu)		(1066)	+ Cystistroma	O (Cara-l)	-O (Cara-u)?	
Trachydietya	J (u)	-T (Mi-u-l)	(698)	+ Cystocerium	S (Ldov)	-S (Wenl)	(903)
Trachynoton	K (Camp-l)	-K (Camp-u)	(641)	+ Cystostroma	O (Lide)	-O (Ashg-m)	(265)
Trachysycon	K (Albi-u)	-K (Sn)		Dendrostroma (+ Araneostroma)	D (Eife)	-D (Fame-u)	
Tragalimus	K (u)?			+ Densastroma	S (Wenl-l)	-D (Gedi-l)	
Tretoechus	J (Kinn)		(1066)	+ Dermatostroma	O (Cara-l)	-O (Ashg-m)	
Turonia	K (Camp-l)	-K (Maes-l)	(642)	+ Desmlostroma	S (Wenl)		
Urnacristata	K (u)			+ Diplostroma	S (Wenl)	-S (Ludl)	
Valhalla	K (u)			+ ?Drosodoria	Cm (Atda)		
+Varneycoelia	D (Sieg-l)		(207)	+ Ecclimadietyon	O (Cara-m)	-D (Give-l)	(205)
+Velellospongia	O (Trem-u)?, O (Aren-l)?			+ ?Edelsteinia	Cm (Atda)	-Cm (Boto)	(1006)
Vermiculissimum	K (u)			+ Euryamphipora	D (Fras)		(363)
Verrucospongia	K (u)			+ Faciledietyon	S (Wenl)	-D (l)	
Verruculina	J (Call)	-T (Mi-u-l)	(698)	+ Ferestromatopora	D (Emsi-l)	-D (Fame)	(363)
Vetulina	T (Eo-u)?	-R		+ Flexiostroma	D (Emsi-u)	-D (Give)	(363)
+Virgaspongia	C (Bash-u)			+ Forolina	S (Ldov-u)		
Virgula	P (Leon-m)	-P (Dora)	(203,936)	+ Gerronodietyon	S (Wenl)	-S (Ludl)	(903)
+Warrigalia	O (Cara)		(1066)	+ Gerronostroma	O (Cara)	-D (Fame-u)	(363)
Yrrhiza	J (Kinn-u)		(1066)	+ Glyptostromoides	D (Emsi-l)	-D (Fras)	(238)
Zittellella	O (Aren-u)	-O (Cara-m)		+ Habrostroma	D (Gedi-l)	-D (Eife)	
Zitteleus	K (u)			+ Hammatostroma	D (Sieg)	-D (Fras-m)	
Or. HADROMERIDA				+ Hermatoporella	D (Eife)	-D (Give)	
Alectona	Q (Plei)?	-R		+ Hermatostroma	D (Eife)	-D (Fame)	(363)
+Calciostella	J (Tith-l)		(1118)	+ Hermatostromella	S (Ludl)	-D (Gedi)	(363)
+?Cassianothalamia	Tr (Carn)	-Tr (Nori-l)	(941)	+ Hexastyllostroma	S (Ludl)		(903)
Cliona	D (Fras)?	-R		+ Idiostroma	D (Eife)	-D (Fras)	(363)
Ditraenella	Q (Plei)?			+ Imponodietyon	D (Eife)	-D (Fras)	(363)
Gomphites	K (l)			+ Intexodietyon	S (Ldov-u)	-D (Gedi-l)	
Latrunculia	Q (Plei)?	-R		+ ?Khasaktia	Cm (Atda-l)	-Cm (Boto-l)	(1006)
+Moleculospina	Cm(mMid-u)		(766)	Labechia	O (Livi-u)	-D (Fame-u)	(266,363)
Pirania	Cm(mMid-l)	-Cm(mMid-u)	(883)	Labechiella	O (Livi-u)	-D (Fras)	(363)
Rhopaloconus	K			Lamellopora	S (Wenl)		
Thoosa	Q (Plei)?	-R		+ Lecomptella	D (l)		(363)
Or. STROMATOPOROIDEA				+ Lineastroma	D (Give)	-D (Fras)	
+Acosmstroma	S (Prid)						
Actinodietyon	S (Wenl)	-D (Sieg)	(969)				

Taxon	First Appearance	Last Appearance	Reference	Taxon	First Appearance	Last Appearance	Reference
Lophiostroma	O (Llde)	-S (Prid)	(903)	Or. GUADALUPIIDA			
+Ludictyon	O (Llvi)?	-S (Ldov)	(903)	Guadalupe	P (Sakm-u)	-P (Guad-u)	(227)
+Mixtustodyctyon	S (Wenl-u)			+Lemonea	P (m)	-P (Guad)?	(941)
+Neosbeatricea	S (Wenl)		(903)	Or. AXINELLIDA			
+Neosyringostroma	D (Eife)	-D (Give-u)	(363)	(= post-Devonian "Stromatoporoidea")			
+Novitella	D (Fras)			Actinofungia	Tr(Carn-l)		(218)
+Nuratadictyon	S (Prid)?			Actinostromaria	J (Oxfo-u)	-K (Ceno)	(761)
+Osiodictyon	S (Ldov)	-S (Wenl)	(903)	Actinostromarianina	J (Oxfo-u)	-J (Kimm-u)	(761,1066)
+Pachystylostroma	O (Llvi-u)	-D (Gedi)	(266)	+Actostroma	J (Kimm-l)		(761)
Parallelopora	S (Ludl)	-D (Fras)	(903)	+Adriatella	J (u)		(920)
+Parallelostroma	S (Wenl-l)	-D (Eife)		+Aksopora	Tr(Nori)		
Pennastroma	D (Fame-u)		(363)	+Astroserlerida	Tr(Nori)	-R	(1066)
+Perplexostroma	S (Prid)		(903)	+Astrostylopsis	J (u)		(920)
+Petroidistroma	S (Wenl)	-D (Fame)	(970)	Balatoria	P (Leon-u)	-Tr(Carn-l)	(920,953)
+Pichiostruma	S (Ludl)			Carterina (+ Carta)	P (Guad)		
+Platiferostroma	D (Fame)			+Cassianochaetes	Tr(Carn-l)		
+Plectostroma	O (Ashg-l)	-D (Eife)	(363)	+?Cassianostroma	Tr(Carn)		
+Plexodictyon	S (Ldov-u)	-S (Prid)	(903)	Ceraostroma	J (Tith)		
+Plumatina	O (Cara)	-S (Ludl-l)		Circopora	P (u)	-Tr(u)	
+Praeidiostroma	S (Prid)		(903)	+Cladocoropsis	J (Kimm-l)	-J (Tith)	
+Pseudoactinodictyon	D (Emis-u)	-D (Fras)?	(363)	+Coenostella	J (u)		(920)
+Pseudoactinostroma	D (Eife)		(363)	+Cylicoopis	Tr(Nori)	-J (u)	(920)
Pseudolabechia	S (Wenl)	-S (Ludl-u)		Dehornella (+ Astroporina)	J (Oxfo-u)	-K (Apti-l)	(761)
+Pseudostromatoporella	D (Eife)	-D (Fame-u)	(363)	Desmopora	J (u)		(920)
Pseudostyloidiectyon	O (Cara-l)	-O (Ashg-m)		?Dissectopora	P (Guad-l)	-Tr(Carn-u)	(218,953)
+Pseudotrupetostroma	D (Emis)	-D (Give)		+Disparistromaria	J (u)		(920)
+Pulchritamina	O (Aren)	-O (Llvi)		+?Ellipsactinia	J (Oxfo)	-K (Ceno)	(2,920, 1066)
+?Rackovskia	Cm(Atda)	-Cm(Boto)	(106)	+?Heptastylis	Tr(u)	-J (Tith)	(953,1066)
+Radiostroma	O (Cara-u)			+?Heltastylis	J (Tith)		(1066)
Rosenella (+ Rosenellinella)				+Hudsonella	J (u)		(920)
O (Llvi)		-D (Fame-u)	(363)	Irregularopora	P (Guad)		
+Salairella	S (Prid)	-D (Fras)		+Konia	C (Pn)		(205)
+Schistodictyon	S (Ludl)	-D (Fras)	(970)	+Lamellata	Tr(u)		(953)
+Sergaelites	D (Sieg)			Leiospongia	Tr(Carn-l)		(218,978)
+Shirdagopora	D (Gedi)			+?Lichuanopora	P (Dora)		(953)
+Simplexodictyon	S (Wenl)	-S (Prid)	(903,970)	?Lithopora	Tr(Nori)	-K (Ceno)	(1066)
Sinodictyon	O (Cara)			+Megastroma	P (m)		
Stachyodes	D (Eife)	-D (Fras-u)	(363)	Milleporella	J (Oxfo)?	-K (Sn)	
+Stelodictyon	S (Wenl-u)	-S (Ludl)	(970)	Milleporidium	J (Oxfo)?	-K (Ceno)	
+Stictostroma	S (Prid)	-D (Fras-m)	(363)	+Murania	Tr(Nori)	-K (Apti-l)	(1066)
+Stratodictyon	O (Llde-l)	-O (Cara-l)?		Myrioporina	J (u)		
Stromatocerium	O (Llde-l)	-D (Fame-u)		+Palaeoaplysina	C (Step-l)	-P (Dora)	(175,666)
+Stromatodictyon	S (Wenl)			+Pamiropora	Tr(Nori)		
Stromatopora	S (Ldov-u)	-D (Fame-u)		+Pamirostroma	Tr(Nori)		
Stromatoporella	D (Emis-l)	-D (Fras-u)	(363)	+?Pantokratoria	Tr(Carn)		
+Styloporella	D (Fras)		(363)	+Parastromatopora	Tr(Nori)?	-J (Tith-u)	(761)
Stylostroma	D (Fras)	-D (Fame-u)	(363)	Parksia	J (u)		
+Synthetostroma	D (Sieg)	-D (Fras)	(363)	+Promilleporella	J (Oxfo-u)	-J (Kimm-l)	(761)
Synthetostroma	D (Give)	-D (Fras)		+?Pseudopalaeoaplysina	P (Dora)		(953)
+Syringodictyon	D (Eife)			+?Radiotrabcuculopora	P (Leon-u)	-P (Dora)	(953)
Syringostroma	D (Emis)	-D (Fras-u)		+Reticullina	J (u)		(920)
+Syringostromella (+ Yavorskiina)	S (Wenl-l)	-D (Give-l)	(363)	+Shuqraia	J (Oxfo-u)	-J (Kimm-l)	(761)
Taleastroma	D (Emis-u)	-D (Fras-l)	(363)	Siphostroma	K (Vala-l)	-K (l)	
Tienodictyon	D (Emis-u)	-D (Fras)	(363)	Sphaeractinia	J (Call-m)	-K (Ceno-l)	(2,920)
+Trigonostroma	S (Ludl)		(903)	+Spongiomorpha	P (Dora)?	-Tr(Rhac)	(666)
Trupetostroma	D (Emis-u)	-D (Fras-m)	(363)	+Sporadoporidium	J (u)	-K (Sn)	(920)
+Tubuliporella	D (Eife)	-D (Fame-u)	(363)	Steinerella	K (Vala-l)	-K (l)	
+Vikingia	S (Wenl)	-S (Prid)	(903)				
+?Vittia	Cm(Atda-l)		(1006)				
+Yabeodictyon	S (Wenl)	-S (Prid)	(903)				
+Zeravshanella	D (Sieg)						

Taxon	First Appearance	Last Appearance	Reference	Taxon	First Appearance	Last Appearance	Reference
+Steinera	J (Oxfo-u)	-J (Kimm-l)	(761)	Or. HOMOSCLEROMORPHA			
+Stromatoxinellia	K (Coni)	-K (Sant)	(1118)	Plakina	K (Albi-u)	-R	(1066)
+Stromatomorpha	Tr(Carn-l)	-J (Tith)	(2,920)	Or. UNCERTAIN			
Stromatoporellata	Tr(u)			+Allantospongia	Cm(Atda-u)		(1214)
Stromatoporellina	J (Oxfo)	-K (Sn)		+Alpinothalamia	Tr(Ladi)	-Tr(Carn)	(941)
+?Stromaporiidum	Tr(Nori)		(953)	Aplysinofibra	C (Mose)		(643)
Stromatorium	Tr(l)	-J (Tith-u)?		Belemnospongia	C (Vise-l)	-C (Pn)	
Stromatorhiza	J (Oxfo-l)			+Choiarella	Cm(Atda-u)		(1214)
Stromatostroma	Tr(u)			Choia	Cm(Atda-u)	-O (Trem)?	(883,1019, 1066)
+Syringostromina	J (Oxfo)?			+Coniculuspongia	D (Gedi-l)		(1123)
Tosastroma	J (u)			+Ginkgospongia	D (Gedi-l)		(1123)
+Tabuliella	J (u)		(920)	+Ichnospongia	C (Vise-u)		(201)
+Xizangstromatopora	J (Oxfo)?, J (Kimm)?			+Infexiostella	Cm(Atda-u)		(1006)
+Zlambachella	Tr(Rhae)			+Jablonskyia	Tr(Carn)		(941)
Or. TABULOSPONGIDA				+Karatubulus	Cm(Atda-u)		(58)
(= Chaetetida + Ceratoporellida)				Metschnikowia	Q (Plei)	-R	
+Acanthochaetetes	K (Apti)	-R	(1066)	+Offella	O (Llvi)		
?Amsassia	O (Cara-m)	-O (Ashg-m)	(160)	Opetionella	J (l)		
Atrochaetetes	Tr(Carn-l)	-Tr(Carn-u)	(920)	+Paraaplysinofibra	K (Barr)		(643)
Barrandeolites	S (Wenl-l)	-S (Ludl)		Protohyalostelia	Cm(Atda)?		(1006)
Baunea	J (Oxfo)	-J (Tith-u)		+Quadrolaminiella	Cm(Atda-u)		
Blastochaetetes	Tr(Carn-u)	-K (Maes)	(691)	Reniera	O (Trem)?	-R	
Burgundia	J (Oxfo)	-K (Haut)	(1066)	Rhizopsis	K (u)		
Carnegiea	C (u)			+Riasanospongia	K (Barr)		(643)
+Ceratoporella	P (Guad-l)?	-R	(1066)	Seninella	Cm(Atda-u)	-Cm(uMid-l)	(1019)
Chaetetella	O (Ashg-l)	-C (Pn)		Sphaeriella	C (l)		(200)
Chaetetes	O (Ashg-l)	-P		+Spitsbergenia	P		
Chaetetipora	O (Ashg-m)	-C		Stramentella	J (Tith-u)		(200,643)
+Chaetetopsis	J (Kimm)	-K (Apti)?		Trichospongia	O (Cara-m)		
Desmidopora	S (Wenl)	-D (Eife)	(1066)	+Wareiella	S (Ldov-u)	-S (Wenl)	(231)
Diplochaetetes	T (Eo)			Cl. CALCAREA			
Favoschaetetes	C (l)			Or. HETERACTINIDA			
Fistulimurina	C (Vise)			Asteractinella	C (Tour-u)	-C (Vise)	(221)
+Goreauiella	R			+Asteriospongia	O (Cara)?		
Guizhouchaetetes	C (l)			+Astraeoconus	O (m)		(766)
+Keriocoelia	Tr(Carn)?			Astraeospongium	O (Ashg)?	-D (Give-l)	(2,219,766)
+Leiochaetetes	J (Tith-u)		(267)	+Canistrumella	Cm(mMid-u)		(766)
Litophyllum	D (Eife)			+Constellatospongia	O (Ashg-m)		(205)
+Meandripetra	Tr(Carn)?			Eiffelia (+Actinolithes, Lenastella, Niphadus)			
+Merlia	R				Cm(Atda-u)	-Cm(mMid-u)	(219,1006)
Metamsassia	D (m)			+Enisferites	D (Eife)	-D (Fame-u)	(220)
Moskovia	C (u)			+Gondekia	D (Give-l)	-D (Give-u)	(952)
+?Neuropora	J (Hett)	-K (u)		+Gravestockia	Cm(Atda)		(1118)
Nodulipora	S (Wenl)			+Heterostella	Cm(Atda-u)		(923)
Pachytheca	D (Eife)			?Hyalostelia	O (Llvi)?	-C (Mose-u)?	
+Pamirochaetetes	Tr(Carn-u)		(920)	+Jawonya	Cm(Atda-u)	-Cm(Tojo)	(1006)
Porkunites	O (Ashg-m)			?Leptopterion	O (Ashg-l)		
+Precaratoporella	P	-Tr(u)		+?Malluviospongia	D (Eife-l)?		
+Pseudochaetetes	J (u)		(920)	+Regispongia	C (Serp-l)	-P (Asse-u)	(2,222)
Pseudoseptifer	Tr(Nori)	-J (Tith-u)	(920)	+Stellarispongia	D (Emsi)		(221)
+Ptychochaetetes	J (u)		(920)	Talpaspongia	P (Asse)	-P (Sakm)	(2)
Schizolites	O (Ashg-l)		(1066)	+Taraxaculum	Cm(Atda-u)		(923,1006)
+Scleroocoelia	Tr(Carn)?			Tholiasterella	C (Vise)?		(221)
Septochaetetes	T (Eo-m-l)			+Toquimicella	O (Aren)?		(221)
+Spherolichaeetes	P	-P (Dora)	(936)	?Uranosphaera	Cm(l)		
Spongiothecopora	C (Vise)			+Wagima	Cm(Tojo)		(952,1006)
Staphylopora	D (Eife)	-D (Give)		Wewokella	C (Serp-l)	-P (Leon-u)	(222)
+Stromatopongia	R			+Zangerlispongia	C (Mose-u)		(221)
Tiverina	D (Emsi)?		(1066)				

Taxon	First Appearance	Last Appearance	Reference	Taxon	First Appearance	Last Appearance	Reference
Or. CALCARONEA (= Lebetida, Syconosa)				Peronidella (+ Peronella)			
Leucomia	J (Ple)	-R	(2)	Petrostromia	P (Leon-u)	-K (Maes)	(886)
Protoleucon	C (Vise)?		(643)	Pharetrosporgia	K (Vala)	-R	
Protosycon	J (Kimm)		(1066)	Plectinia	K (u)?	-K (Camp)	(1066)
Or. PHARETRONIDA (= Inozoa)				Plectronia	K (l)	-R	
+ Acoelia	P			Polycnemiseudea	K (u)		
Alasonia	J (u)?			Polyendostoma	K (l)	-K (Ceno)	
Aphlebospongia	J (u)?			Porosphaera	K (Turo-l)	-K (Maes)	
Aplosphecion	T			Porosphaerella	K (Albi)?		
Bactronella	J (u)	-T (Eo)		+ Precorynella	P (Leon-u)	-Tr(Carn-u)	(2,218,223)
Blastinia	J (Bath-u)?	-K (Vala)		+ Radicanalosporgia	P (Leon-u)	-P (886)	
Blastinoidea	J (m)			+ Radicispongia	J (Oxfo)	-J (Kimm)	(224)
+ Brevisiphonella	Tr(Carn)		(202)	Raphidonema	Tr	-T (Eo-m)	
+ Calicia	Tr(Carn)		(978)	?Rauflia	J (u)		
+ Catenispongia	P (Sakm-u)	-P (Guad-u)	(204)	+ Reticulcoelia	Tr(Carn)	-Tr(Nori)	(978)
+ Cavusonella	P (Leon-u)		(886)	Sagittularia	K (Albi)?		
Cnemicoipanon	K			Stestrostomella	Tr(Ladi-u)	-K (Albi-u)	(978)
Coeloconia	T			+ Solenocoelia	Tr(Nori)	-P (978)	
Coniatopenia	K (u)?			+ Spinospongia	P (u)		
Conispongia	J (u)			Steinmanella	K (Albi)?		
Conocoelia	K (Vala)			Stellispongia	P (Leon-u)	-J (Oxfo-u)?	(2)
+ Cornuaspongia	Tr(Nori)	J (l)?	(1120)	+ Stratispongia	P (Sakm-u)	-P (Guad-u)	(204)
Corynella	P (Guad-u)	-K (Camp-l)	(204,223)	Synopella	K (Vala)	-K (Maes)	
Crispispongia	J (Kimm)?	-J (Tith-l)	(224)	+ Thallospongia	P (u)		
+ Daharella	P (u)			Thamnonema	J (m)		
Diaplectia	J (Aale)	-J (Oxfo-u)		Trachyphyctia	J (Bath-u)	-K	
Diasterofungia	J (m)			Trachysinia	J (m)		
Diostosphecion	K			Trachyspecion	K (u)?		
Diplostoma	K (Ceno)	-K (Sn)		Trachytia	K (l)		
Discocoelia	J (m)			+ Trammeria	Tr(Nori)		(1120)
Dyoconia	T			Tremospongia	K (Ceno)	-K (Sn)	
Dyocopan	K			Tretocalia	T (Eo)	-R	
Elasmocoelia	K (Vala)	-K (Albi-u)		+ Tubispongia	J (Oxfo)	-J (Kimm-u)	(224)
Elasmoierca	K (Nc)	-K (Apti)	(1066)	+ Virgola (+ Virgula)	P (Guad-u)		(1066)
Elasmostoma	J (Bath-u)?	-K (Maes)	(1066)	Virnula	P		
Enaulofungia	J (Bath-u)	-K (Sn)	(218)	Winwoodia	J (m)		
Endostoma	K (Ceno)			Or. ?PERMOSPINCTA			
Epithales	J (Oxfo)?	-J (u)	(643)	(including many "Sphinctozoa"			
Eudea	Tr(Carn)?	-J (Tith-u)	(202,224)	[= Thalamida])			
+ Euepirrhysia	Tr(Carn)		(978)	+ Alaska-spongia	O (Cara-m)?		(941)
Eusiphonella	Tr(Nori)	-J (Tith-l)	(224,1120)	Ambly-siphonella	Cm(Tojo)	-Tr(Rhae)	(652,941,978)
Euzittelia	J	-K		+ Ambly-siphonelloides	O (Llde)?		(652)
Fissispongia	C (Mosc-u)	-P (Guad-l)	(2,203)	+ Amphorithalamia	P (Guad-u)	-P (Tatr)	(941,1066)
+ Fissigatosporgia	P (Guad-u)			+ Angullongia	O (Cara-l)	-O (Ashg-u)	(652,1066)
+ Grossotubencilla	P (Leon-u)		(886)	+ Annaecoelia	Tr(Carn)	-Tr(Rhae)	(941,1066)
+ Hartmanina	Tr(Carn-l)		(205)	?Aphrosalpinx	S (Ludl-l)		(2)
Himatella	Tr(Carn)		(978)	+ Apocoelia	P (Leon-u)?		
+ Hodsia	Tr(Nori)	-Tr(Rhae)	(643,978)	+ ?Aulocyclus	P (Asse-l)	-P (Sakm-u)	(204)
+ Holcospongia	J (Bajo-u)	-K (Vala)		+ ?Autospongia	P (Asse-l)	-P (Asse-u)	(204)
+ Holocoelia	Tr(Ladi)	-Tr(Carn)	(978)	+ Battaglia	Tr(Nori)		(941)
Inobolia	J (Aale)			+ Belubulaia	O (Cara)?		(652)
+ Intrautospongia	P (Leon-u)	-P (Tatr)	(886)	+ Blastulospongia	Cm(Tomm-l)	-Cm(Dres-l)	(652,1030)
+ Lynnorella (+ Lynnorea)	J (Aale)	-K (Albi-l)	(225)	Celyphia	Tr(Anis-u)	-Tr(Carn)	(218,941)
+ Meandrostia	C (Mosc-u)	-P (Dora)	(203,936)	+ Cheilosporites	Tr(Nori)	-Tr(Rhae)	(941,1066)
Molengraafia	Tr(Carn)	-Tr(Rhae)	(643,978)	+ Cinnabaria	Tr(Carn-u)	-Tr(Nori)	(941)
Myrmedidium	J (Bajo-u)	-J (Tith-l)	(224)	+ Clifdenella	O (Cara-l)	-O (Ashg-u)	(652,941,1066)
Oculospongia	J (Bajo-u)	-K (Maes)					
Pachymura	K (Albi)?						
Pachytilodia	K (Albi-u)	-K (u)					

Taxon	First Appearance	Last Appearance	Reference	Taxon	First Appearance	Last Appearance	Reference
+?Coelocladia	C (Mosc-u)	-P (Dora)	(203,204,936)	+Pseudoporefieldia	O (Cara-l)?	-O (Ashg)	(941)
Colospongia (+ Waagenium)				+Radiothalamos	D (Sieg-l)		(207)
+Corymbospongia	P (Leon-u)	-Tr(Nori)	(666)	+Rhabdalthalmia	P (Guad)?		
+Cribrothalamia	O (Cara-l)	-O (Ashg)	(652)	+Rhabdactinia	P (Guad-l)?	-P (Dora)	(873)
Cryptocoelia	Tr(Nori)	-Tr(Rhae)	(941)	+Rigbyetia	O (u)		(941)
Cystothalamia	Tr(Ladi)	-Tr(Rhae)	(218,978)	+Rigbyspongia	S (Ludl-l)?		(941)
+Cystothalamiella	O (Cara-l)?	-S (Ludl-l)	(652)	+Russospongia	Tr(Nori)	-Tr(Rhae)	(941,1066)
Deningeria	Tr(Nori)		(218,978)	Sahraja	Tr(Nori)	-Tr(Rhae)	(643,978)
+Diecithalamia	Tr(Carn)		(941)	+Salzburgia	P (Asse)	-Tr(Rhae)	(873,1066)
Discosiphonella	C (Mosc-u)	-Tr(Nori)	(204,277,941)	Sebargasia	C (Bash-u)?		(2)
Enoplocoelia	P (Guad-u)	-Tr(Carn)	(218,941)	+Senowbaridaryana	Tr(Carn)		(941)
+Faniathalamia (= Fania)	Tr(Carn-l)	-Tr(Rhae)	(941,1066)	Seranella	Tr(u)		(941)
+Fistulispongia (= Spicia)	P (Guad)?		(941)	+Solenolmia (+ Dictyocoelia)	Tr(Anis)	-Tr(Rhae)	(218)
+Follicalena	P (m)	-Tr(Rhae)	(218,941,978)	Sollasia	C (Bash-u)	-P (Dora)	(2,936)
Girtycoelia	O (Cara-l)	-P (Guad-l)	(227,652,203)	+?Stylopegma	P (Asse-l)	-P (Guad-u)	(204)
+Glomocystospongia	P (Dora)		(873)	+Subascosylegma	P (Guad-l)?	-P (Tatr)	(873)
+Graminospongia	P (Leon-u)	-P (Dora)	(936)	+Tebagathalamia	P (Leon)	-P (Tatr)	(1066)
Henricellum	Tr(Nori)		(218,941)	Thaumastocoelia	Tr(Carn)		(941)
+Hormospongia	D (Eife-l)		(226)	+Tolminothalamia	Tr(Carn)		(941)
+Imbricatocoelia	P (Guad-l)?	-P (Dora)	(873)	+Tristratocoelia	P (u)		(941)
+Intrasporocoelia	P (Guad-l)	-P (Dora)	(936)	+Uvacocelia	C (u)		(941)
+Khallinaea	O (u)		(941)	+Uvothalamia	P (Leon-u)		(941)
+?Lichuanospongia	P (Tatr)?		(873)	+Vasothalmia	K (u)		(941)
+Madonia	Tr(Nori)		(941)	+Vesicocaulis	Tr(Ladi)	-Tr(Nori)	(218,920)
+Muellerithalamia	J (u)		(941)	+?Wanella	Tr(l)?		
+Nematosalpinx	S (Ludl-l)			Welteria	Tr(Carn-l)	-Tr(Rhae)	(920,941)
+Neogualupia	P (Guad)	-Tr(Nori-l)?	(873)	+Yukonella	Tr(Nori)		(941)
+Nevadathalamia	Tr(Nori-l)		(941)	+Zanklithalamia	Tr(Nori)		(941)
+Nibionia	O (u)		(941)				
+Nucha	Cm(Tojo)		(652)	Or. SPHAEROCOELIDA			
+?Olangocoelia	Tr(Anis)	-Tr(Ladi)	(941)	Barroisia	J (Tith)	-K (Ceno)	(941)
+Palaeoschada	S (Ludl-l)			Sphaerocoelia	P (u)	-K (Ceno)	(941)
+Palermocoelia	Tr(Nori)	-Tr(Rhae)	(941,1066)	+Sphinctonella	J (Oxfo-u)		(941)
+Panormida	Tr(Nori)		(941)	Thalamopora	J (u)	-K (Ceno)	(218,941)
+Paradeningeria	Tr(Nori)	-Tr(Rhae)	(941)				
+Paramblysisphonella	P (l)		(941)	Or. UNCERTAIN			
+Paravesicocaulis	Tr(Nori)		(941)	+?Ceotinella	Tr(Ladi)	-Tr(Carn)	(941)
+Paruvanella	P (Guad)	-Tr(Rhae)	(936,941)	Dodecaactinella (+ Polyactinella, Sardospongia)	Cm(Atda-u)	-O (u)	(923)
+Phragmocoelia	Tr(Carn-l)		(207,941)	Epeudea	J (m)		
+Pisothalamia	P (Guad-u)	-P (Tatr)	(941,1066)	Gaspespongia	S		
+Platythalamiella	P (Leon-u)	-Tr(Rhae)	(941)	Imperatoria	O (Llde)	-P (Guad-l)	(218,652)
+Polycystocoelia	P (Dora)	-Tr(Nori-l)	(666,873,941)	Leinia	Tr(Carn)		(941)
+Polyedra	P (u)	-Tr(Rhae)	(941,1066)	Oligoplagia	Tr		
+?Polysiphonella	P (Leon-m)	-Tr(Carn)	(204)	Polysiphon	P (Guad-u)		
+Polysiphospongia	Tr(Nori)	-Tr(Rhae)	(941)	+Phobetreactinia	Cm(Bofo)?	-C (l)	(1006)
Polytholosa	Tr(Carn)	-Tr(Nori)	(218,978)	+?Prosiphonella	Tr(Carn)		(941)
+Porefieldia	O (Ashg)		(652)	Scribroporella	D (m)		
+Praethalamopora	Tr(Carn)		(202,941)	+Uvanella	P (Guad-l)?	-Tr(Nori-u)	(218,873,920,941)
+Preverticillites	P (Guad)	-P (Dora)	(941)	+?Zardinia	Tr(Ladi)	-Tr(Carn)	(941)
+Pseudoamblysisphonella	P (u)		(941)	+Zigzagella	Cm(Tojo)		(1006)
+Pseudogualupia	P (Leon-u)	-P (u)	(941)				
+Pseudoimperatoria	O (u)		(941)	Cl. HEXACTINELLIDA			
				Or. HEXACTINOSA (= Dictyida)			
				Andreaea	K (Ceno)		(622)
				Aphrocallistes	K (Albi)	-R	(1066)
				Aulacosia	K (u)?		
				Aulodomus	J (Oxfo-l)		(775)
				Belonisia	K (u)?		

Taxon	First Appearance	Last Appearance	Reference	Taxon	First Appearance	Last Appearance	Reference
Botroclonium	K (Ceno)	-K (u)	(622)	-Protremadictyon	D (Fras-u)		(1066)
Botryoseella	K (u)			Psephosyllogus	J (u)		
Caesaria	Tr(Anis-m)	-J (Kimm)	(2,868)	Pseudopenmatites	D (Fras)		(218)
Caseispongia	J (u)			+Psilocalyx	J (Oxfo-l)		(1066)
Cincliderma	K (Turo-u)	-K (Sn)	(622)	Ptychodesia	K (u)		
Craticularia	J (Bajo-u)	-T (Mi)		Purisiphonia	K (l)?		
Criobrospongia	J (Bajo)		(1066)	Pycnocalyptra	J (u)		
Cyrtobolia	K (u)			+Ramalmerina	T (Mi-u-l)		
+Diphyllospira	T (Than)		(1024)	Ramispongia	J (Bajo-u)	-J (Bath-l)	(868)
Ecblastesia	K (u)?			Rhodanospongia	J (m)		(218)
Emploca	J (Bajo-u)	-J (Bath-l)	(868)	Rhogostomium	J (Oxfo-l)	-J (Kimm-u)	(775)
Erineum	K (u)			Rhombedonium	J (u)		
Etheridgia	K (Sant)	-K (Sn)	(622)	+Rhopalicia	J (Call-u)	-J (Oxfo-l)	(868)
Eubrochis	K (Albi-u)	-K (u)	(622)	Saynospongia	J (u)		
Eubrochus	K (Albi-u)	-K (u)		+Sclerothamnopsis	T (Mi-u-l)	-R	
Eurete	K (Albi-u)	-R	(622)	Sestrodiclyon	K (Albi-u)	-K (Ceno-m)	(622)
+Eutactostomium	T (Than)		(1024)	Sphenaulax	J (Call-l)	-J (Oxfo-l)	(868)
+Farrea	K (Albi-u)	-R		Stauroderma	J (Bajo-u)	-J (Kimm-l)	(775,1066)
Feifelia	J (u)			Stichmartyx	K (u)		
Gevreya	J (u)			Strephimia	K (Albi-u)	-K (Ceno-m)	
Guettardiscyphia	K (Ceno-l)	-T (Eo)	(622)	-Stromatidium	P (Guad-l)	-P (Guad-u)	(203)
Habrosium	K (u)			Synaulia	K (u)		
Hexactinella	K (Ceno)	-R	(622)	Thyroidium	J (Oxfo-l)	-J (Kimm-l)	(775)
-Hormathospongia	K (Sant-u)			Tremadictyon	Tr(Anis-m)	-J (Tiñh)	(2,775)
Intextum	K (u)			Tretodictyon	K (Ceno)	-R	
Koleostoma	K (Ceno)			Typhlopleura	K (u)	-K (Maes)	(622)
Laocaetis	J (u)	-T (Mi)		Ubiquiradius	K (u)		
Leptolacis	J (u)			Verrucocoeilia (+ Periphragella)	J (Bajo-u)	-R	
Leptophragma	J (Call-l)	-T (Than)	(622,868,1024)	Walcottella (+ Ordinatus)	J (Oxfo-l)	-K (u)	(775)
Linonema	J (u)			Wapkiosa	K (u)		
Lonsda	K (u)?			Wollemania	K (Sant)	-K (Maes)	(622)
Lopanella	K (u)			Xenoschrammentis (+ Tremaphorus)	J (Oxfo-l)	-K (Apti)	(622,775)
Mastodictyum	J (Bajo)		(1066)	Zittelospongia	K (Sant)		(643)
Mimeticosia	K (u)						
Multiloqua	J (u)						
Myliusia	K (u)	-R					
Mysterium	J (u)						
Nitidus	J (u)						
Octobrum	J (u)						
Oxyrhizium	K (u)						
Pachyasacus	J (u)						
+Palaeostauronema	D (Fras-u)		(1066)				
Paracraticularia	J (Oxfo-u)	-K (Maes-u)	(641,868)				
Peripleptum	K (u)?						
Petalope	K (u)						
+Pileolites	P (Leon-l)		(203)				
Placochlaenia	T (Mi)						
Placotrema	K (Turo-u)	-K (Sn)	(622)				
+Plecteurette	T (Than)		(1024)				
Plectospyris	J (Bajo)		(1066)				
Pleurochorium	K (u)	-R					
Pleurostoma	K (Sn)	-T (Eo)					
Polyosepia	K (Sant)	-K (Sn)	(622)				
Polyschema	J (u)?						
Polystigmatium	K (u)						
Polysyge	J (u)						
Polythyris	K (u)						
-Poriferella	D (Fras-u)		(1066)				
Porospongia	J (u)	-K (Albi-u)					
Proeurete	K (u)						
Prohexactinella	K (u)						

Or. LYCHNISCOSA (= Lychniskida)

+Alosculum	Tr(Carn)		
Astropegma	K (l)		
Aulophax	K (Sant)?	-R	(622)
Balantonella	K (Camp-l)		(1066)
Beaussetia	K (u)		
Becksia	K (Apti)	-K (Maes)	(622)
Bolitesia	K (u)		
Calathiscus	J (Bajo)		(1066)
Callicylix	K (u)		
Callodictyon	K (Albi)	-K (Camp-u)	(1066)
+Calycospongia	Tr(Carn)		
Calyptrella	K (Ceno)?	-K (Camp-u)	(622,1066)
Cameroptychium	K (Turo-u)	-K (Camp-l)	(622,1021)
Camerospongia	K (Vala)	-K (Camp-u)	(1066)
Cavispongia	J (u)?		
Cephalites	K (Turo-u)	-K (Maes)	(622,1066)
Ceriodictyon	J (Oxfo-u)		
Cinclidella	K (Turo-l)	-K (Sn)	(622,1066)
Coeloptychium	K (Albi)	-K (Camp-u)	(622,1066)
Coeloscaphia	K (Albi-u)	-K (Sn)	(622)
Coscinaulus	J (Kimm-l)		(1066)
Coscinapora	K (Turo-l)	-K (Maes)	(622,1066)
Cyclostigma	K (Sant)	-K (Camp-u)	(622,1066)
Cypellia	J (Aale)	-J (Kimm-l)	(775)

Taxon	First Appearance	Last Appearance	Reference	Taxon	First Appearance	Last Appearance	Reference
Cystispongia	K (Turo-u)	-K (Sn)	(622)	Tremabolites	K (Apti)	-K (Sn)	(622)
Dactylocalyx	T	-R		Triadocoelia	Tr(Carn-u)		(2,934)
Desmoderma	K			Trochobolus	J (Oxfo-l)	-J (Oxfo-u)	(775,868)
Diploctyton	K (Sn)			Ventriculites	K (Ceno)	-K (Maes-u)	(641)
+Dracolychnus	Tr(Carn)			Xylosporgia	K (u)		
Elasma	K (u)			Zittelispongia	K (u)		
Etalloniella	J (u)?			Sporadopyle	J (Oxfo-l)	-K (u)	(643,775)
Exanthesis	K (Apti)	-K (u)	(622)				
+Flabellispongia	K (Ceno-u)			Or. LYSSACINOSIDA (= Lyssakida)			
Gyrispongia	K (u)?			+Acanthocoryna	P (Leon-u)		(203)
Hapalopegma	K (Ceno)			Acanthospongia	S		
Jima	K (u)			+Arakespongia	C (Bash-u)		(205,262)
Kentrosia	K (u)			+Asthenospongia	O (Aren-u)		(233)
Lefroyella	K (u)	-R		Brachiospongia	O (Cara-m)	-O (Ashg-m)	(214)
Leiostracosia	K (Sant)	-K (Maes)	(622,1066)	Calathospongia	C (Tour-l)	-C (Vise-l)	(913)
Lepidospongia	K (Camp-l)	-K (Maes)	(622)	+Calcihexactinia	Cm(Boto)	-Cm(mMid)	(1006)
Licmosinon	K (l)			Caulophacus	T (Eo)	-R	
Lychniscalus	J (Call-u)		(868)	Colpospongia	O (Ashg)		(1066)
Marshallia	K (Camp-u)		(1066)	+Corticulospongia	S (Ludl-l)		(880)
Meandrospongia	K (u)?			Crateromorpha	T (Eo)	-R	
Microblastidium	K (u)			+Cypellospongia	Tr(Olen-u)		(228)
+Monilispongia	Tr(Carn)			+Divaricospongia	S (Ludl-u)		
Moretia	K (Apti)			+Endoplegma	P (Leon-u)		(203)
+Moretiella	K (Apti)		(622,1066)	Euplectella	T (Mi)	-R	
Myrmeciopychiium	K (Sn)			+Fistellaspongia	S (Ludl-u)		
Napaena	K (u)			Foerstella	O (Cara-m)		
+Nelumbifolium	Tr(Carn)			+Hydnogangulus	C (Vise-l)		(234)
Oncotoechus	K (Ceno)	-K (Turo)	(1066)	+?Kerogastrospongia	Tr(Carn)		(1066)
Ophrystoma	K (Albi-u)	-K (Ceno-m)	(622)	Lasiothrix	O		
Ornatus	K (u)			+Malumispongium	S (Ldov)		(1066)
+Orthodiscus	K (Turo)	-K (Maes)	(641)	+Mattaspongia	D (Fras)		(263)
Pachyrachis	J (u)			+Norfordia	S (Wenl-l)?		(231)
Pachyteichisma	J (Call-u)	-J (Oxfo-u)	(868)	Oncosella	S (Wenl-u)		(263)
+Phanerochiderma	J (Call-u)	-J (Oxfo-u)	(868)	Opeamorphus	O	-C	
Phylactaenium	J (Oxfo)?	-J (Kimm-l)?	(1066)	Palaeosaccus	O (Trem)		
Placotelia (+ Discophyma)	J (Oxfo-l)	-J (Oxfo-u)	(775)	+Pileospongia	C (Vise-u)	-C (Serp-l)	(220)
Plectascus	K (Maes)?		(1066)	Proeuplectella	K (Ceno)		
Plectodermatium	K (u)			Pyritonema	S		
Pleurope	K (Camp-u)		(1066)	+Pyruspongia	O (Ashg-l)		(1066)
Pleuropyge	K (u)			Regardrella	K (Ceno)	-R	(622)
Plocoscyphia	J (u)?	-K (Sn)		Rosella	T (Eo)	-R	(1066)
Polyblastidium	K (Albi-u)	-K (Camp)	(1066)	Stauractinella	J (Oxfo-l)	-J (Kimm-l)	(1066)
Polygonatium	J (Oxfo-l)		(1066)	+Testispongia	Cm(uMid-m)		(225,766)
Porochonia	K (Turo-u)	-K (Sn)	(622)	+Toomeyospongia	P (Guad-u)		(229)
Porocypellia	J (u)			+Valospongia	Cm(uMid-m)		(225,766)
Pyrospongia	K (u)?			+Vaurealispongia	O (Ashg-l)	-S (Wenl)	(230)
+Radioplicia	Tr(Carn)			+Wongaspongia	O (u)		
Rhizocheton	K (u)?						
Rhizopoteronopsis	K (u)?			Or. RETICULOSA			
Rhizopterion	K (Turo)	-T (Than)	(622,641,1024)	Acanthactinella	C (l)		
Sarophora	K (Apti)	-K (Camp-u)	(622,1066)	Acanthodictya	O (m)?		
Sclerokalia	K (Albi-u)			Acloeoedictya	C (l)		
Scleroplegma	K (u)	-R		Actinodictya	D (Fras-u)		(913)
Scolecusia	K (u)			Agolithodictya	D (Fras-u)		(913)
Sestrocladia	K (Ceno-m)	-K (Ceno-u)		Armstrongia	D (u)		
+Spirospongia	K (Maes-u)			Arystidictyon	D (Fras-u)		(913)
Sporadoscinia	K (Albi)	-K (Maes)	(622)	Astroconia	S		
+Stammia	K (Turo-u)		(622)	Botryodictya	D (Fras-u)	-C (Pn)	(643)
Stauronema	K (Albi-u)	-K (Ceno-m)		+Carphites	P (Leon-l)	-P (Guad-l)	(203)
Toulminia	J (Oxfo-l)	-K (Sn)	(1066)	Ceratodictya	D (Fras-u)		(913)

Taxon	First Appearance	Last Appearance	Reference	Taxon	First Appearance	Last Appearance	Reference
Clathrospongia	D (Give-l)	-C (Serp-l)	(913)	Thamnodictya	C (Tour-l)		(913)
Cleodictya	C (Tour-l)	-C (Vise-l)	(913)	Thysanodictya	D (Fame-l)	-D (Fame-m)	(235)
Clepsydraspongia	D (Fras-l)?		(913)	+Tiddalickia	O (Ashg-m)		
Corticispongia	D (Fame)			Titusvillia	D (Fame-u)		
Cryptodictya	D (Fras-u)		(913)	+Triticispongia	Cm(Atda-u)		(1214)
Cyathodictya	O (Cara-m)	-D (u)		Uphantena	D (Fras-u)		
Cyathophycus	O (Livi)	-S (Wen-l)		Or. AMPHIDISCOA			
Diagoniella	Cm(mMid-l)	-S (Ludl)?	(883)	Hyalonemia	T (Eo)?	-R	
Dietyophyton	S (Ludl-u)	-D (Fras)		+Itararella	C (Bash)?	-C (Step)	(205,264)
Dietyorhabdus	O (Cara-l)			+Kalimnospongia	O (Cara)		(1066)
Dietyospongia	S (Wen-l)	-C (Mose-l)	(4,262,880)	+Liscombispongia	O (Cara)		(1066)
+Dierespongia	O (Cara-l)		(237)	Pattersonia	O (Livi)	-O (Ashg-l)	(1066)
+Docoderma	C (Mose)	-P (Guad-u)	(203,1066)	+Pelicaspongia	S (Ludl)	-D (Fras)	(230)
Ectenodictya	C (l)?			Pheronema	T (Eo)?	-R	(1066)
+Gabelia	S (Wen-u)	-D (Fame)?	(232,1066)	Semperella	K (Camp)?	-R	
Gongylospongia	D (Fras)			+Stoderma	C (Vise)	-P (Guad-u)	(203,1066)
Griphodictya	C (Tour)?	-C (Vise-l)	(205,913)	+Twenhofeella	S (Wen-u)	-D (Gedi-l)	(220,1123)
Hallodictya	D (Fras-u)		(913)	+Wallispongia	O (Cara)		(1066)
Helicodictya	D (Fras-u)		(913)	+Warembra	O (Cara)		(1066)
+Hexactraetiella	S (Wen)			Or. HEMIDISCOA			
+Hintzespongia	Cm(uMid-l)	-Cm(uMid-m)	(237)	Hemidiscella	K (Camp-l)		(264,1066)
Holasterella	C (l)			Microhemidiscia	C (Bash)?		(264)
Hydnoceras	D (Fras-m)	-C (Tour-u)	(2,235)	Or. UNCERTAIN			
Hydnocerina	D (u)?			Acanothyra	K		
+Hydnodictya	O (Ashg-m)		(1066)	Antrispungia	K (l)		
Hydriodictya	D (Fras-u)	-C (Vise-l)?	(234)	+Australispongia	Cm(Dres-u)		(1216)
Iowaspongia	D (u)			+Azyrtalia	Cm(Atda-u)?		(1006)
Ithacadietia	D (Fras)			Baccispongia	J		
Kiwetinokia	Cm(lMid-l)	-O		Bothroconis	P		
Lebedictya	D (Fras)?	-C (Vise-l)	(913)	Chirospongia	O (m)		
+Lumectospongia	S (Ludl-l)		(880)	Crucispongia	J		
Lyrodia	C (Tour-u)	-C (Vise-l)	(913)	Diplopleura	K		
Mastodictya	C (Vise-l)		(913)	+Echidnina	Cm(Dres-l)		
Megastylia	O (Trem-l)			+Eudictyon	J (Hett)		(218)
+Microstaura	P (Leon-u)		(203)	Farreopsis	K (u)		
Multivasculatus	Cm(Fran)	-Cm(Trep)		+Flosculus	Cm(Dres-u)		(1216)
Ozospongia	D (u)?			+?Gonamispongia	Cm(Tomm)		(580)
+Palaeophragmodictya	V (u)		(1217)	+Hintzespongia	Cm(uMid-m)		(1019)
Phormosella	O?	-S		+Humanspongia	Cm(Tomm-u)?		(1006)
Phragmodictya	C (Vise-l)	-C (Serp-l)	(913)	Idiodictyon	J (l)		
Physospongia	C (Vise-l)			Konyrium	Cm(Dres-l)	-O (Lide-u)	(373)
Plectoderma	S (Ludl-u)			Lysactinella	D (l)		
+Polylophidium	P (Leon-u)		(203)	Nephelespongia	D (u)		
Polyplectella	O (Cara-u)			Pachylepisma	K (u)		
Prismodictya	D (Fras-u)	-C (Vise-l)	(235,913)	+Pinnatispongia	Cm(Dres-u)		(1216)
Protoarstrongia	D (Fras-m)		(1066)	+Rigbyella	Cm(u)		(218)
Protospongia	V (N-Da-l)	-S (Wen-l)?	(231,1030)	+Silicunculus	Cm(Dres-l)	-O (Cara-u)	
Pseudohydnoceras	D (Give)			+Stödermiella	D (Gedi-l)		(1123)
Ratcliffespongia	Cm(uMid-m)		(766)	Textispongia	J		
Rhabdosispongia	D (Fras-u)		(913)	Uralonema	C (l)		(264)
Rhakiella	C (Bash)			Cl. UNCERTAIN			
Rhombodictyon	D (u)?			Calicutospongia	O (u)		
Roemerispongia	D (Eife)			Clathrispongia	J		
+Saetaspongia	Cm(Atda-u)		(1214)	Cotylicus	C (Ms)		
Sphaerodictya	O (Cara-m)			Cyathophycus	O		
Spiractinella	C (l)			+?Drosodovia	Cm(Atda)	-Cm(Boto)	(1006)
Stephanella	Cm(mMid-u)?	-O		Eocoryne	Cm(Boto)	-Cm(m)	(1006)
+Stephenospongia	Cm(mMid-u)		(766)				
+Stereodictyum	C (Bash)	-P (Leon-l)	(203,236)				
Sycodictya	O (Cara-m)						
Teganium	O (Cara-l)	-O (Cara-u)					

Taxon	First Appearance	Last Appearance	Reference	Taxon	First Appearance	Last Appearance	Reference
Glenodictyum	K			Cyathocricus	Cm(Atda-u)	-Cm(Boto-u)	
Megalelasma	K			Cyclocyathella	Cm(Atda-u)	-Cm(Boto-u)	(1243)
+Microcyrne	Cm(Atda-u)		(923,1006)	Dailycyathus	Cm(Boto-l)	-Cm(Boto-u)	(1243)
+Nabaviella	Cm(Atda)	-O (l)	(923)	+Deceptionicyathus	Cm(Boto-l)	-Cm(Boto-u)	(1243)
Spirolophia	K			Degeletticyathus	Cm(Atda-u)	-Cm(Boto-l)	
"archaeocyathids"				Denaecyathus	Cm(Atda-u)	-Cm(Boto-u)	
Cl. REGULARES				Densocyathus	Cm(Boto-l)	-Cm(Boto-u)	
[Classification and stratigraphic ranges from Debrenne, Rozanov, and Zhuravlev, 1988.]				Dentatocoscinus	Cm(Boto-l)		
Or. MONOCYATHIDA				+Didymocyathus	Cm(Boto-l)	-Cm(Boto-u)	(1243)
Archaeolythius	Cm(Tomm-l)	-Cm(Boto-u)		+Diplocyathellus	Cm(Boto-l)	-Cm(Boto-u)	(1243)
+Butakovicyathus	Cm(Atda-u)	-Cm(Boto-l)		Dokidocyathella	Cm(Atda-l)	-Cm(Boto-l)	
+Favilythius	Cm(Atda-u)	-Cm(Boto-l)		Dokidocyathus	Cm(Tomm-u)		
+Kyarocyathus	Cm(Boto-l)	-Cm(Boto-u)		+Dupliporocyathus	Cm(Atda-u)		
Melkanicyathus	Cm(Atda-u)	-Cm(Boto-u)		Erboocyathus	Cm(Boto-l)	-Cm(Tojo-u)	
+Palaeoconularia	Cm(Boto-l)	-Cm(Boto-u)		Erismaecoscinus	Cm(Tomm-u)	-Cm(Boto-l)	
Propriolythius	Cm(Atda-u)	-Cm(Boto-l)		Erugatoeyathus	Cm(Atda-u)	-Cm(Boto-u)	
+Robertiolythius	Cm(Boto-l)			Ethmocoscinus	Cm(Boto-l)?	-Cm(Boto-u)	(1243)
+Sajaniolythius	Cm(Boto-l)	-Cm(Boto-u)		Ethmocyathus	Cm(Boto-l)	-Cm(Boto-u)	
+Tumuliolythius	Cm(Tomm-u)	-Cm(Boto-u)		Ethmophylum	Cm(Atda-u)	-Cm(Boto-u)	(1243)
Or. AJACICYATHIDA				Fallocyathus	Cm(Atda-l)	-Cm(Boto-l)	
Afiacyathus	Cm(Atda-u)	-Cm(Boto-u)		Fansycyathus	Cm(Atda-u)	-Cm(Boto-l)	
Agyrekocyathus	Cm(Boto-l)	-Cm(Boto-u)		+Flexanulus	Cm(Boto-l)	-Cm(Boto-u)	(1243)
Ajaciacyathellus	Cm(Atda-l)	-Cm(Boto-u)		Formosocyathus	Cm(Atda-l)	-Cm(Boto-u)	(1243)
Ajaciacyathus	Cm(Atda-l)	-Cm(Tojo-l)	(1243)	+Frinalicyathus	Cm(Atda-u)	-Cm(Boto-l)	
Alphacyathus	Cm(Boto-l)	-Cm(Boto-u)	(1243)	Gagarinicyathus	Cm(Boto-l)		
Anaptyctocyathus	Cm(Boto-l)	-Cm(Boto-u)		Geniculicyathus	Cm(Atda-l)	-Cm(Atda-u)	
Angariocyathus	Cm(Tojo-l)			Geocyathus	Cm(Atda-l)	-Cm(Boto-l)	
Annulocyathella	Cm(Boto-l)	-Cm(Boto-u)		Gloriosocyathus	Cm(Boto-l)		
Annulocyathus	Cm(Boto-l)	-Cm(Boto-u)		+Gnaltacyathus	Cm(Atda-u)	-Cm(Boto-l)	
Annulofungia	Cm(Boto-l)			Gordonicyathus	Cm(Atda-l)	-Cm(Boto-u)	(1243)
+Antoniosciscinus	Cm(Atda-u)	-Cm(Boto-l)		Gordonifungia	Cm(Atda-u)	-Cm(Boto-l)	
+Aporosocyathus	Cm(Boto-l)	-Cm(Boto-u)	(1243)	+Gumbicyathus	Cm(Boto-l)	-Cm(Boto-u)	(1243)
Aptocyathella	Cm(Boto-l)	-Cm(Boto-u)		Halysicyathus	Cm(Atda-u)	-Cm(Boto-l)	
Aptocyathus	Cm(Boto-l)	-Cm(Boto-u)		Heckericyathus	Cm(Atda-l)	-Cm(Atda-u)	
+Arturocyathus	Cm(Atda-l)	-Cm(Boto-l)		Hemithalamocyathus	Cm(Atda-u)	-Cm(Boto-l)	
Asterocyathus	Cm(Atda-l)	-Cm(Boto-l)	(1243)	Hupecyathellus	Cm(Boto-l)		
Asterotumulus	Cm(Atda-u)	-Cm(Boto-l)		+Hyptocyathus	Cm(Boto-l)	-Cm(Boto-u)	(1243)
+Atulocricus	Cm(Boto-l)			+Ichnusocyathus	Cm(Boto-l)	-Cm(Boto-u)	(1243)
+Baikalocyathus	Cm(Atda-l)	-Cm(Boto-u)		+Iljuncyathus	Cm(Atda-u)		
+Batschkykicyathus	Cm(Atda-u)			+Inacyathella	Cm(Boto-l)	-Cm(Boto-u)	(1243)
+Bipallicyathus	Cm(Boto-l)			Incurvocyathus	Cm(Boto-l)	-Cm(Boto-u)	
+Borocyathus	Cm(Boto-l)			+Inessocyathellus	Cm(Boto-u)	-Cm(Tojo-l)	(1243)
+Botocyathus	Cm(Atda-u)	-Cm(Boto-l)		Inessocyathus	Cm(Atda-l)	-Cm(Boto-u)	(1243)
+Bractocyathus	Cm(Boto-l)	-Cm(Boto-u)	(1243)	+Irinaeyathus	Cm(Boto-l)	-Cm(Tojo-l)	
Cadnacyathus	Cm(Boto-l)	-Cm(Boto-u)	(1243)	+Isiticyathus	Cm(Atda-u)	-Cm(Boto-l)	
Carinacyathus	Cm(Atda-l)	-Cm(Boto-u)		Jakutocarinus	Cm(Atda-l)	-Cm(Boto-l)	
Carpicyathus	Cm(Atda-u)	-Cm(Boto-l)		+Jangudacyathus	Cm(Boto-l)		
+Chakassicyathus	Cm(Atda-u)	-Cm(Boto-u)	(1243)	Japhanicyathus	Cm(Atda-u)	-Cm(Boto-l)	
+Churanocyathus	Cm(Atda-u)	-Cm(Boto-l)?		+Jebiletosciscinus	Cm(Boto-l)	-Cm(Boto-u)	(1243)
Clathricyathus	Cm(Boto-l)	-Cm(Boto-u)		+Joanaeyathus	Cm(Boto-l)		
+Clathrithalamus	Cm(Boto-l)	-Cm(Boto-u)	(1243)	Kaltatocyathus	Cm(Atda-l)	-Cm(Boto-u)	
Compositocyathus	Cm(Atda-l)	-Cm(Boto-l)?		Kasyricyathus	Cm(Boto-l)		
+Conannulofungia	Cm(Atda-u)	-Cm(Boto-l)		+Kellericyathus	Cm(Atda-u)	-Cm(Boto-u)	(1243)
+Cordobicyathus	Cm(Atda-u)			Kidjasocyathus	Cm(Boto-l)	-Cm(Boto-u)	(1243)
Cordilleracyathus	Cm(Atda-u)	-Cm(Boto-u)		Kijacyathus	Cm(Atda-u)	-Cm(Boto-u)	(1243)
Coscinopycta	Cm(Boto-l)	-Cm(Boto-u)		+Kisasacyathus	Cm(Atda-u)	-Cm(Boto-u)	
+Crassiosciscinus	Cm(Boto-l)			+Kiwicyathus	Cm(Tojo-l)		
				+Kolbicyathus	Cm(Atda-u)	-Cm(Boto-l)	
				Kordecyathus	Cm(Boto-l)	-Cm(Boto-u)	(1243)
				Kotuyicosciscinus	Cm(Atda-u)	-Cm(Boto-l)	
				+Krasnopeevacyathus	Cm(Boto-l)		
				+Kymbecyathus	Cm(Boto-l)		

Taxon	First Appearance	Last Appearance	Reference	Taxon	First Appearance	Last Appearance	Reference
Ladaecyathus	Cmt(Boto-l)	-Cmt(Boto-u)		+Stephancicyathus	Cmt(Boto-l)		
Lenocyathus	Cmt(Atda-l)	-Cmt(Boto-l)	(1243)	Stillicidocyathus	Cmt(Boto-l)	-Cmt(Boto-u)	
+Leptosocyathellus	Cmt(Atda-u)		(1243)	Subtilocyathus	Cmt(Boto-l)		
Leptosocyathus	Cmt(Atda-l)	-Cmt(Boto-l)?	(1243)	Svetlanocyathus	Cmt(Boto-l)	-Cmt(Boto-u)	
+Lunulacyathus	Cmt(Boto-l)			+Sylviacoscinus	Cmt(Boto-l)		
Mackenziecyathus	Cmt(Boto-l)	-Cmt(Boto-u)	(1243)	Syringocyathus	Cmt(Boto-l)	-Cmt(Boto-u)	
+Mattajacyathus	Cmt(Boto-l)			Tabulacyathus	Cmt(Boto-l)		
Membranacyathus	Cmt(Atda-u)			Taylorcyathus	Cmt(Atda-l)	-Cmt(Boto-l)	(1243)
+Mennericyathus	Cmt(Atda-u)	-Cmt(Boto-l)		Tegerocyathus	Cmt(Boto-l)	-Cmt(Tojo-u)	
+Mikhnoeyathus	Cmt(Atda-u)	-Cmt(Boto-l)	(1243)	Tennericyathus	Cmt(Atda-l)	-Cmt(Boto-l)	
+Mootwingecyathus	Cmt(Boto-l)			+Tercyathellus	Cmt(Boto-l)	-Cmt(Boto-u)	
+Morenicyathus	Cmt(Atda-u)			Tercyathus	Cmt(Boto-l)	-Cmt(Boto-u)	
Mrossocyathus	Cmt(Atda-u)			Thalamocyathus	Cmt(Atda-u)	-Cmt(Boto-u)	(1243)
+Muchtatocyathus	Cmt(Boto-l)			+Tolagoicyathus	Cmt(Atda-l)	-Cmt(Boto-l)	(1243)
+Nalvikinicyathus	Cmt(Atda-u)			+Torosocyathus	Cmt(Atda-u)	-Cmt(Boto-l)	
Nochoroicyathus	Cmt(Tomm-l)	-Cmt(Boto-u)		Trininaeyathus	Cmt(Atda-u)	-Cmt(Boto-l)	
+Olgaeyathus	Cmt(Boto-l)	-Cmt(Boto-u)?		Tubioscinus	Cmt(Boto-l)		
Orbasterocyathus	Cmt(Atda-u)			Tumulifungia	Cmt(Atda-u)	-Cmt(Boto-u)	
+Orbicoscinus	Cmt(Boto-l)			Tumulocoscinus	Cmt(Atda-u)	-Cmt(Boto-l)	
+Orbicyathellus	Cmt(Atda-l)	-Cmt(Atda-u)	(1243)	Tumulocyathus	Cmt(Tomm-u)	-Cmt(Boto-u)	
Orbicyathus	Cmt(Tomm-u)	-Cmt(Boto-u)		Urcyathella	Cmt(Atda-u)	-Cmt(Boto-l)	
Orienticyathus	Cmt(Boto-l)			Urcyathus	Cmt(Atda-l)	-Cmt(Boto-u)	
+Pachycoscinus	Cmt(Boto-l)	-Cmt(Boto-u)	(1243)	+Ussuriyathus	Cmt(Atda-u)	-Cmt(Boto-u)	(1243)
Palmericyathus	Cmt(Boto-l)			+Veronicacyathus	Cmt(Boto-l)		
Papilloeyathus	Cmt(Atda-u)	-Cmt(Boto-l)		+Vologdinocyathellus	Cmt(Boto-l)	-Cmt(Boto-u)	
+Parethmophyllum	Cmt(Atda-u)	-Cmt(Boto-l)		Vologdinocyathus	Cmt(Boto-u)	-Cmt(Tojo-u)	(1243)
Peregrinicyathus	Cmt(Boto-l)	-Cmt(Boto-u)	(1243)	+Wrighticyathus	Cmt(Boto-l)	-Cmt(Boto-u)	
Piamaeyathellus	Cmt(Boto-l)			+Xesteyathus	Cmt(Boto-l)	-Cmt(Boto-u)	(1243)
Phiocyathus	Cmt(Atda-l)	-Cmt(Boto-u)		+Yudjaicyathus	Cmt(Atda-u)		
Polyoscinus	Cmt(Boto-l)	-Cmt(Boto-u)	(1243)	Yukonocyathus	Cmt(Atda-u)	-Cmt(Boto-l)	(1243)
Porocoscinus	Cmt(Boto-l)			Zhuravlevacyathus	Cmt(Boto-l)		
+Pretimophyllum	Cmt(Atda-u)	-Cmt(Boto-u)		-Zonacoscinus	Cmt(Boto-l)	-Cmt(Boto-u)	(1243)
+Procyathellus	Cmt(Boto-l)			Zonacyathus	Cmt(Atda-u)	-Cmt(Boto-u)	
+Pretiosocyathus	Cmt(Atda-l)	-Cmt(Boto-l)					
Putapacyathus	Cmt(Boto-l)	-Cmt(Boto-u)	(1243)				
+Rasetticyathus	Cmt(Boto-l)	-Cmt(Boto-u)					
+Rectannulus	Cmt(Atda-u)	-Cmt(Boto-u)	(1243)				
Retecoscinus	Cmt(Tomm-u)	-Cmt(Boto-l)					
+Retetumulus	Cmt(Boto-l)	-Cmt(Boto-u)	(1243)				
Ringifungia	Cmt(Atda-u)	-Cmt(Boto-l)	(1243)				
Robertocyathus	Cmt(Atda-l)	-Cmt(Boto-l)	(1243)				
+Robustocyathellus	Cmt(Atda-u)	-Cmt(Boto-l)					
Robustocyathus	Cmt(Atda-u)?	-Cmt(Boto-l)?					
Rossocyathella	Cmt(Boto-l)	-Cmt(Boto-u)					
Rotundocyathus	Cmt(Tomm-u)	-Cmt(Boto-u)					
Rozanovicoscinus	Cmt(Boto-l)	-Cmt(Boto-u)	(1243)				
Rozanovicyathus	Cmt(Boto-l)		(1243)				
+Rudanulus	Cmt(Boto-l)						
Russocyathus	Cmt(Atda-u)	-Cmt(Boto-l)					
Sajaniocyathus	Cmt(Boto-l)	-Cmt(Boto-u)					
Salairocyathus	Cmt(Boto-l)	-Cmt(Boto-u)					
Sanarkoeyathus	Cmt(Atda-u)	-Cmt(Boto-l)					
+Sanarkophyllum	Cmt(Boto-l)	-Cmt(Boto-u)	(1243)				
Schumnyicyathus	Cmt(Boto-l)						
Sclerocyathus	Cmt(Atda-u)	-Cmt(Boto-l)	(1243)				
Sekwicyathus	Cmt(Boto-l)	-Cmt(Boto-u)					
Sibirecyathus	Cmt(Tomm-u)	-Cmt(Boto-u)	(1243)				
Sigmocoscinus	Cmt(Boto-l)						
Sigmocyathus	Cmt(Boto-l)						
Squamosocyathus	Cmt(Atda-u)	-Cmt(Boto-l)					
Stapicyathus	Cmt(Boto-l)	-Cmt(Boto-u)					
+Statanulocyathus	Cmt(Boto-l)	-Cmt(Boto-u)	(1243)				

Or. CAPSULOYATHIDA

Acanthopyrgus	Cmt(Boto-l)	-Cmt(Boto-u)	
Alatacyathus	Cmt(Atda-l)	-Cmt(Boto-l)	
Calyptocoscinus	Cmt(Boto-l)		
Capsulocyathus	Cmt(Atda-l)	-Cmt(Boto-u)	
Clathricoscinus	Cmt(Boto-l)	-Cmt(Boto-u)	
Coscinoeyathella	Cmt(Atda-u)	-Cmt(Boto-l)	
Coscinoeyathellus	Cmt(Boto-l)	-Cmt(Boto-u)	
Coscinoeyathus	Cmt(Atda-l)	-Cmt(Boto-l)	
Cryptoprococyathus	Cmt(Tomm-l)	-Cmt(Tomm-u)	
Fransuaacyathus	Cmt(Atda-l)	-Cmt(Boto-l)	
+Korshunoviccyathus	Cmt(Tomm-u)	-Cmt(Atda-l)	
+Laniccyathus	Cmt(Boto-l)		
+Mawsonicoscinus	Cmt(Boto-l)	-Cmt(Boto-u)	(1243)
+Rhabdolythus	Cmt(Boto-l)	-Cmt(Boto-u)	
+Tubericyathus	Cmt(Boto-l)		
+Tylocyathus	Cmt(Boto-l)	-Cmt(Boto-u)	(1243)

Or. TABULACYATHIDA

Hupecyathus	Cmt(Atda)		(1)
-------------	-----------	--	-----

Cl. IRREGULARES

[Classification and stratigraphic ranges from Debrenne and Zhuravlev (1992).]

Or. ARCHAEOCYATHIDA

Agastrocyathus	Cmt(Atda-l)	-Cmt(Atda-u)	
+Alaskacoscinus	Cmt(Boto-l)		

Taxon	First Appearance	Last Appearance	Reference	Taxon	First Appearance	Last Appearance	Reference
+Alconeracyathus	Cm(Atda-l)	-Cm(Boto-l)		+Usloncyathus	Cm(Atda-u)	-Cm(Boto-l)	
+Antarcticocyathus	Cm(Tojo-u)	-Cm(Dres-u)		+Warrriootacyathus	Cm(Atda-u)		
Anthomorpha	Cm(Boto-l)			+Williamicyathus	Cm(Boto-l)		
Archaeocyathus	Cm(Atda-u)	-Cm(Tojo-u)		+Zunyicyathus	Cm(Boto-l)?		
Archaeopharetra	Cm(Atda-u)	-Cm(Boto-u)					
Archaeosycon	Cm(Boto-l)	-Cm(Tojo-l)					
Ardrossacyathus	Cm(Boto-l)	-Cm(Boto-u)					
+Arrhythmocricus	Cm(Boto-l)	-Cm(Tojo-l)					
+Ataxiocyathus	Cm(Boto-u)						
+Auliscocyathus	Cm(Atda-u)	-Cm(Boto-u)					
Beltanacyathus	Cm(Atda-u)						
Bottonaeyathus	Cm(Atda-u)	-Cm(Boto-l)					
Cambrocyathells	Cm(Tomm-l)	-Cm(Boto-l)					
+Cellicyathus	Cm(Boto-u)	-Cm(Tojo-l)?					
+Changicyathus	Cm(Boto-l)?						
+Chankacyathus	Cm(Boto-l)	-Cm(Boto-u)					
Chouberticyathus	Cm(Atda-l)	-Cm(Boto-l)					
Claruscoscinus	Cm(Boto-u)	-Cm(Tojo-l)					
Copleicyathus	Cm(Atda)						
Dictyocyathus	Cm(Tomm-u)	-Cm(Boto-l)					
+Dictyofavus	Cm(Atda-l)	-Cm(Atda-u)					
+Dictyosyon	Cm(Atda-l)	-Cm(Atda-u)?					
+Eremitacyathus	Cm(Atda-l)	-Cm(Atda-u)					
Fenestrocryathus	Cm(Boto-l)	-Cm(Boto-u)					
Fragilicyathus	Cm(Boto-l)						
+Gabrielsocyathus	Cm(Boto-l)?						
+Gatagacyathus	Cm(Boto-l)?						
+Graphoscyphus	Cm(Atda-u)?	-Cm(Boto-u)					
+Jugaliccyathus	Cm(Boto-l)						
+Kechikacyathus	Cm(Boto-l)						
+Keriocyathus	Cm(Boto-l)						
+Kruiseinema	Cm(Boto-u)						
+Landercyathus	Cm(Boto-l)?						
+Loculicyathus	Cm(Boto-l)	-Cm(Boto-u)					
+Maiandrocyathus	Cm(Boto-u)						
+Markocyathus	Cm(Boto-l)						
Metaldetes	Cm(Atda-u)	-Cm(Tojo-l)					
+Metyacyathellus	Cm(Atda-u)	-Cm(Tojo-l)					
Mikhncyathus	Cm(Atda-u)	-Cm(Boto-l)					
+Molybdocyathus	Cm(Boto-l)						
+Neoloculicyathus	Cm(Atda-l)	-Cm(Boto-l)					
Okulitchicyathus	Cm(Tomm-l)	-Cm(Atda-u)?					
Parascocinus	Cm(Boto-u)	-Cm(Tojo-l)					
Paranacyathus	Cm(Boto-l)	-Cm(Boto-u)?					
Protopharetra	Cm(Atda-u)	-Cm(Boto-l)					
Pseudosyringocnema	Cm(Boto-l)	-Cm(Boto-u)					
Pycnoidocoscinus	Cm(Boto-u)						
Pycnoidocyathus	Cm(Boto-u)	-Cm(Tojo-u)					
+Retillamina	Cm(Boto-l)	-Cm(Tojo-l)					
+Sakhacyathus	Cm(Tomm-u)						
Shiveligocyathus	Cm(Boto-l)						
Sigmofungia	Cm(Boto-l)						
+Spinocyathus	Cm(Tomm-u)	-Cm(Boto-l)?					
Spirillicyathella	Cm(Boto-l)	-Cm(Boto-u)					
+Stevocyathus	Cm(Boto-l)?						
Syringocnema	Cm(Boto-u)						
+Syringothalamus	Cm(Boto-l)?						
Tabulacyathellus	Cm(Atda-l)	-Cm(Boto-l)?					
Taeniacyathellus	Cm(Boto-l)	-Cm(Boto-u)					
+Tchojacyathus	Cm(Atda-u)?						
Tollicyathus	Cm(Boto-l)						
+Tuvacnema	Cm(Boto-l)?						

Taxon	First Appearance	Last Appearance	Reference
Or. KAZAKHSTANICYATHIDA			
+Altaicyathus	Cm(Boto-l)?		
+Bicoscinus	Cm(Boto-l)?		
+Korovinella	Cm(Boto-l)?		
Cl. UNCERTAIN			
Or. UNCERTAIN			
+Cysticyathus	Cm(Tomm)		(1023)
Mathewcyathus	Cm(Tojo)		(1023)
?Nostrocryathus	Cm(Atda-u)?	-Cm(Boto)?	
Ph. TRILOBOZOA			
Or. UNNAMED			
Albumares	V (u)		(193,647)
Anafesta	V (u)		(647)
Skinnera	V (u)		(647)
Tribrachidium	V (u)		(647)
Or. ?**anabaritida**			
+Aculeochrea	V (N-Da)	-Cm(Tomm-l)?	(1006,1244)
+Anabarites (+ Anabaritellus, Tiksitheca)	V (N-Da-l)	-Cm(Boto-l)	(522,580, 1030)
-Cambrotubulus	V (N-Da-l)	-Cm(Boto-u)	(580,885, 1030)
-Gastrochrea	Cm(Tomm-l)		(580,1030)
+Kotuites	V (N-Da-u)		(1006,1030)
+Lobiochrea	V (N-Da)		(1006)
+Longiocrea	V (N-Da)?	-Cm(Tomm-l)	(580)
+?Paragloborilus	Cm(Tomm-l)	-Cm(Atda-u)	(580,885, 951,1030)
+?Salanytheca	V (N-Da)	-Cm(Tomm)	(702,1006)
+Tinsithecua	V (N-Da)	-Cm(Tomm-u)	(1244)
Ph. CNIDARIA			
	[Classification and basic stratigraphic ranges from from TREATISE, Part F (1956) and Part F (Suppl. 1) (1981); Cyclozoa, Inrdozoa, and Trilobozoa from Fedonkin (1985).]		
Cl. CYCLOZOA			
Cyclomedusa	V (u)	-V (N-Da)?	(193,647)
?Hallidaya	V (u)		(647)
?Medusimites	V (u)		(647)
Nimbia	V (u)	-Cm(u)	(196,647, 1234)
?Planomedusites	V (u)		(647)
?Sakwia	V (u)		(647)
Cl. UNCERTAIN			
(**melanosclerites**—Scyphozoa or Hydrozoa)			
+Melanofurcata (+ Menola)			(1025)
+Melanosteus (+ Semenola)			
	S (Wenl)?	-D (Eife)	(1025)

Taxon	First Appearance	Last Appearance	Reference	Taxon	First Appearance	Last Appearance	Reference
+Melanostylus (+ Eichbaumia)	O	-D (Emsi-l)	(1025)	+Holoconularia	D (Sieg-u)	-D (Fras)	
CI. SCYPHOZOA				+Mabianconullus	Cm(Tomm)?		(1006)
Or. CARYBDEIDA (= Cubomedusae)				Mesoconularia	D (l)	-C (Pn)	
Anthracomedusa	C (Mosc-u)			Metaconularia	O (Cara-l)	-S (Ludl)	(1016)
Quadrimedusa	J (Tith-l)			Neoconularia	P (l)		
Or. CORONATIDA				+Notoconularia	P (Sakm)	-P (Guad-u)	
Cannostomites	J (Tith-l)			Palaeonigma	O (l)		
Epiphyllina	J (Tith-l)			Paraconularia	D (Fame)	-Tr(Rhae)	
+?Lorenzinia	K	-T (Eo)		Pseudoconularia	O	-S (Ldov)	
+Octomedusa	C (Mosc-u)			+Quadrosiphonuchites	V (N-Da)	-Cm(Tomm-u)?	(1006)
+?Camptostroma' germanicum	O (Trem-u)			+Reticulaconularia	D (l)		(1016)
Or. SEMAEOSTOMATIDA				?Sphenothallus	O (Trem-u)	-C (Bash-l)	
Eulithota	J (Tith-l)			+Tasmanoconularia	O (u)		
Semacostomites	J (Tith-l)			Or. UNCERTAIN			
+?Lascoa	C (Mosc-u)			+?Corumbella	V (u)		
Or. LITHORHIZOSTOMATIDA				Ediacaria (- Kaisalia)	V (u)	-Cm(u)	(1234)
Rhizostomites	J (Tith-l)			?Tirasiana	V (u)		
Or. RHIZOSTOMATIDA				CI. HYDROZOA			
+Essexella	C (Mosc-u)			Or. TRACHYLINIDA			
Leptobrachiites	J (Tith-l)			Acalepha	J (Tith-l)		
+Prothysanostoma	C (Step-l)		(176)	?Acsaspedites	J (Tith-l)		
+Reticulomedusa	C (Mosc-u)			Hydrocsaspedita	J (Tith-l)		
+Simplicibrachia	T (Eo-m-l)			Or. HYDROIDA			
Or. ?CONULARIIDA				Archaeoantennularia	D (m)		
+Adesmoconularia	C			Archaeocryptolaria	Cm(mMid)?	-O (m)	(2)
Anaconularia	O (m)			Archaeolafoea	Cm(uMid-m)	-O (Cara-m)	(2)
Archaeoconularia	O (Aren)?	-S (Wenl)?	(1016)	+Archaeonectris	O (Ashg)?, S (Ldov)?		(187)
+Arthrochites (+ Barbigothireca, Lagenaconularia, Sacchiella)	V (N-Da)	-Cm(Tomm-l)	(885,951, 1006)	Calyhydra	O (Llde)?		(671)
+?Australoconularia	S (Ludl)			Crucimedusina	C (Step)		
Calloconularia	C (Step-l)	-P (Asse)		Discophyllum	O (Cara-m)		(2)
+?Carinachites (+ Aciconularia)	V (N-Da)	-Cm(Tomm-u)?	(1006)	+Drevoniella	C (Mosc-u)		
+Circonularia	S (Ldov-l)			+Eisenaekiella	K (Sant)		
Climacoconus	O (Cara-m)?	-O (Ashg-m)	(1016)	O			(671)
?Conchopeltis	O (Cara-m)			+?Gelenpton	Cm(mMid-u)		(1131)
?Conomedusites	V (u)			Hydractinia	T (Eo-l)	-R	
Conularia (+ Diconularia, Yangoconularia)				+Hydrallmania	K (Maes-u)	-R	
O (l)	-C (Ms)			Inocaulis	O (Aren)	-D (Gedi-l)	(671,1066)
?Conulariella	Cm(mMid)	-O (Llvi)	(1075)	Kristinella	K		
?Conularina	O (Llde)			+Kullingia	V (u)	-V (N-Da)	(944)
?Conulariopsis	Tr(Olen)		(2)	+Mazohydra	O (Mosc-u)		
Ctenoconularia	O (Cara-l)?	-D (Eife)?		Mesokylix	J (m)		
Eoconularia	Cm(Tomm-l)	-S (Wenl)	(885)	+?Palaeacmea	Cm(Trep)		
Exoconularia	O (l)	-O (u)		Palaeokylix	O		
+Flectoconularia	Tr			+Palaeolophacmea	O (l)	-K (Barr-u)	(182)
+?Garraconularia	S (Ldov-l)	-D (Gedi-u)?		Palaeonectris	D (Gedi)	-D (Emsi-l)	(2)
+Glyptoconularia	O (Cara-m)		(1016)	Palaeotuba	O (Llde-u)		(671)
+Hondoconularia	P (m)	-Tr(Carn-l)		+Parleria	K (Ceno)		(1111)
+?Hexangulaconularia	Cm(Tomm-l)	-Cm(Tomm-u)?	(725,885, 1006)	Philippinaetinia	T (Ol)		
				Plectodiscus	S (Ludl)	-Tr(Carn-u)	
				Protohalcium	Cm(mMid)?		(2)
				+Protulophila	J (Bajo)	-T (Plio)?	
				+Psammaetinia	K (Maes-l)		(1111)
				+Rhabdohydra	O (Llvi)	-O (Ashg)	(671)
				Sphenocium	Cm(mMid)?		(2)
				?Velubrella	Cm(Atda-u)	-Cm(mMid)	

Taxon	First Appearance	Last Appearance	Reference
Or. SIPHONOPHORIDA			
Paropsonema	Cm(u)	-D (Fras-m)	(2,1019)
?Protolyella	Cm(Aida-l)	-Cm(m)	(1006)
+Rotadiscus	Cm(Aida-u)	-Cm(mMid-l)	(779,1006)

Or. MILLEPORINA

Axopora	T (Eo-m-u)	-T (Ol)	
Axoporella	T (Eo)		
Diamantopora	T (Eo)		
Heterastridium	Tr(Nori-u)		
Milleaster	T (Mi)	-Q (Plei)	
Millepora	T (Dani)	-R	
+?Palaeomillepora	J (Plie-u)		
+Subaxopora	J (u)		

Or. STYLASTERINA

Allopora	T (Ol-u)?	-R	
Astyia	T (Dani)	-R	
Congregopora	T (Dani)		
Conopora	T (Dani)	-R	
Distichopora	T (Eo)	-R	
Errina	T (Dani)	-R	
Pliobothrus	T (Dani)	-R	
Sporadopora	T (Dani)	-R	
Stylaster	T (Eo)	-R	
+incertae sedis	K (Maes)		(934)

Or. LEMNISCATERINA

+Cassianastraea	Tr(Ladi-u)	-Tr(Nori-l)	
-----------------	------------	-------------	--

Or. SPHAERACTINIDA

Cycloporidium	K (Ceno)		(2)
+Globostroma	T (Ol-l)		
+Parkeria	K (Ceno-l)		
+Paronaria	K (Apti)		
Stromactinia	Tr(u)		

Or. UNCERTAIN

Delheidia	T (Ol)		
Eoporpita	V (u)		(188)
Graptogeitonina	O		
Jillua	Tr(u)		
+?Likinia	C (Mosc-u)	-P (Asse)	
Lovenipora	Tr(u)	-J	
Ovatoscutum	V (u)		
Plumalina	D (Give-l)	-D (Fras)	
Rhizostromella	K (Ceno)		
Roseoporella	D		
Spriggia (+ Madigania)	V (u)		
+Stoliczkaria	Tr(u)		
Stoliczkiella	K (Ceno)?		

Cl. MEDUSAE INCERTAE SEDIS

+?Arkarua	V (u)		(759)
+Bonata (+ Elasenja + Eviaksia)	V (u)		(196)
Bronicella	V (u)		
?Bunyerichnus	V (u)		
+Cambromedusa	Cm(uMid-m)		(178)

Taxon	First Appearance	Last Appearance	Reference
+?Cambrorhytium	Cm(mMid-l)	-Cm(uMid-m)	(809)
Chondroplon	V (u)		(188,189)
Duodecimedusina	S (Ldov-u)	-C (Step-l)	
+Hiemalora (+ Pinegia)	V (u)		(196)
+Inaria	V (u)		
+Irridinites	V (u)		
+?Jyxiella	V (u)		(179)
?Kimberella	V (u)		
+Kuibisia	V (u)		
Lorenzinites	V (u)		
+?Mashania	V (u)		(179)
"Medusytes"	J (Tith-l)		
+Nadalina	V (u)		
Orthogonium	V (u)		
+Parasolia	S (Ldov-u)		(177)
+Patanacta	O (Ashg)?, S (Ldov)?		
Persimedesites	V (u)		(647)
Pomorja	V (u)		(196,647)
Pseudorhizostomites	V (u)		(647)
Rugoconites	V (u)		
Staurinidia	V (u)		(647)
+Tateana	V (u)		

Cl. HYDROCONOZOA

+Alatoconus	Cm(Boto)?		
+Asteroconus	Cm(Boto)?		
+Dasyconus	Cm(Boto)		
+Gastroconus	Cm(Boto)		
+Hydroconus	Cm(Atda)	-Cm(Boto)	
+Radioconus	Cm(Boto)?		
?Tabulaconus	Cm(Boto)	-Cm(lMid)	(580)
+Tavaeconus	Cm(Boto)		

Cl. ?PETALONAMAE (may be a separate phylum)**Or. ERNIETTAMORPHA**

+Bomakellia	V (u)		
?Dickinsonia (+ Praecambridium)	V (u)		
Ernietta (+ Namalia)	V (u)		
+Mialsemia	V (u)		
Nasepia	V (u)		
Phyllozoon	V (u)		
Peridinium (+ Inkrylovia, Valdania)	V (u)		
?Spriggina	V (u)		
+Swartpuntia	V (u)		
?Vendia	V (u)		
?Vendomia	V (u)		
+?Windermeria	V (u)		
+?bush-like form (Newf)	V (u)		
+?pectinate form (Newf)	V (u)		
+?spindle form (Newf)	V (u)		

Or. RANGEOMORPHA

Charnia (+ Glaessnerina)	V (u)		
--------------------------	-------	--	--

Taxon	First Appearance	Last Appearance	Reference	Taxon	First Appearance	Last Appearance	Reference
Charniodiscus (+ Arborea)	V (u)			+ Pachyseptron	T		
+ ?Khatyspytia	V (u)		(1131)	Palaeoseptron	K (u)		
+ ?Paracharnia	V (u)			- Pavonaria	K (Sn)	-T (Dani)?	
Rangea	V (u)			Prographularia	Tr(Rhae)		
+ ?Thaumoptilon	Cm(mMid-u)		(1131)	Pterocides	T (Eo)	-R	
+ ?Vauzutsinia	V (u)		(1131)	Virgularia	K (Berr)?	-R	
Or. UNCERTAIN				Or. ACTINIARIA			
+ Archaeichnium	V (u)			?Beltanelliformis (+ Beltanelloidea, Nemiana)	V (u)	-V (N-Da)	
+ Ausia	V (u)		(647)	?Mackenzia	Cm(mMid-u)		(199,1131)
- ?Emmonsaspis	Cm(Boto)		(1131)	+ ?Xianguangia	Cm(Atda-u)		(1019)
Ramellina	V (u)		(196)	Or. KILBUCHOPHYLLIDA			
- Vauzutsubua	V (u)		(647)	+ Kilbuchophyllum	O (Cara-m)		(949)
+ Zolotytsia	V (u)		(647)	Or. TABULATA			
Cl. ANTHOZOA				Acaciapora	C (Vise)	-C (Bash)	
Or. ANTIPATHARIA				Acdalina	O (Ashg)		
Leiopathes	T (Mi)	-R		Acidolites	O (Cara-m)	-S (Wen-l)	(160)
Or. STOLONIFERA				Adaverina	O (Ashg-m)	-S (Ldov-u)	(160)
+ Scyphopodium	Q (Plei)	-R	(934)	Adetopora	C (u)		
Tubipora	T (Mi)	-R		Agelotilitta	O (Ashg-l)	-O (Ashg-m)	
Or. ALCYONACEA				Agelolites	O (Cara-u)	-O (Ashg-m)	
Atractosella	S (Ldov-u)	-S (Wen-l-u)	(180)	Aimia	S (Ludl)		
Nephtea	J (Hett)	-R		Alveolites	S (Ldov-m)	-D (Fras-u)	(711)
+ Nephtya	K (Turo-u)		(1066)	Amniopora	C (Mosc)		
Or. HELIOPORACEA (= Coenothecalia)				Antherolites	S (Wen-l)	-S (Wen-l)	
Epiphaxum	K (Berr)	-R		Antholites	D (Give)		
Heliopora	K (Sant)	-R	(86)	Aracopora	D?		
+ Kaluginella	T (Dani)	-T (Than-l)	(86)	Araiostron	S (Ludl-u)?		
Ocotremacis	T (Mi)			Archypora	S (Ldov)		
+ Parapolytremacis	K (Sant-u)	-T (Eo-u)		Armalites	D (Emsi)	-D (Fras-u)	
Polytremacis	K (Vala)	-T (Ol-l)?	(86)	Astrocerium	S (Ldov)	-S (Wen-l)	
+ Proheliopora	K (Albi)		(86,934)	Aulocaulis	D (Fras)		
+ Pseudopolytremacis	K (Barr)	-K (Apt-l)	(86,934)	Aulocystella	C (Vise)		
Or. GORGONIDA				Aulocystis	D (Eife)	-D (Fras-u)	(2)
Acabaria	T (Dani)	-R	(86,750)	Aulohelia	P (Leon-m)	-P (Guad-u)	(2)
Axogaster	K (Sn)			Aulopora	O (Aren)?	-P (Guad-u)	(2)
+ Coptocampylodon	K (l)			Auloporella	S (Ldov-u)	-S (Wen-l)	
Corallium	K (Berr)	-R		Aulostegites	D (Give)		
?Eogorgia	T (Eo-u)			Aulozoa	S (Wen)		
+ gorgonoid	T (Eo-m)		(181)	Avicenia	S (Ludl)		
+ Isis	K (Camp)	-R?		Axulolites	S (u)	-D (Eife)?	
+ Krimella	K (Maes-l)		(750)	Baikitolites	O (Cara-u)	-S (Ldov-m)	(651)
Melithaea	T (Dani)	-R	(750)	Bainbridgia	S (Ludl-l)		
Moltkia	K (Ceno-l)	-T (Than-l)	(86,750)	Baitalites	S (u)		
Mopsea	T (Eo)			Bajgolia	O (Cara-l)	-O (Ashg-l)	(160)
+ Nicella	K (Maes-l)	-R	(750)	Bayhantium	C (Step-u)	-P (Sakm)?	(161)
+ Paramoltkia	K (Turo-l)			Beaumontia	C (Tour-l)	-C (Vise-u)	
Parisis	K (Camp-l)	-R		Beiliupora	D (Eife)		
Primnoa	K (Camp)	-R		Bibucia	C (Tour)		
Verrucella	T (Dani)	-R		Billingsaria	O (Llde)	-O (Ashg-l)	
Or. PENNATULACEA				Bogimbailites	D (l)		
Glyptosceptron	K (Sn)			Bractea	D (Emsi)		
Graphularia	K (Camp)	-T (Eo-l)	(86)	Calapoecia	O (Cara-l)	-O (Ashg-u)	(160)
				Caliapora	D (Sieg-l)	-D (Give-u)	
				Campiolithus	S (Ldov-u)	-S (Wen-l)	
				Cannapora	S (Ldov)		
				Catenipora (+ Quepora)	O (Cara-l)	-S (Ludl)	(2)

Taxon	First Appearance	Last Appearance	Reference	Taxon	First Appearance	Last Appearance	Reference
Celechopora	D (Give-u)			Halysites (+ Acanthahalysites, Schedchalysites)			
Chia	S (u)	-C (l)			O (Cara-u)	-S (Ludl)	
Chonostegites	D (Emsi-u)	-D (Eife)		Hamarilopora	D (Sieg)	-D (Eife-l)	
Cladochonus	D (Emsi)	-P (Djhu)?	(2)	Hattonia	S (Ludl-u)	-D (Emsi)	
Cladopora	S (Ldov-u)	-D (Fras-u)		Hayasakaia	P (Sakm)	-P (Djhu)	(2)
Cleistopora	D (Sieg)	-D (Eife)	(2)	Helenolites	S (u)		
Coccoseris	O (Cara-m)	-O (Ashg-l)	(160)	Heliolites (+ Amphilites, Dnestrites)			
Coenites	S (Ldov-u)	-D (Fras)			O (Llde)	-D (Fras)	(2)
Columnoporella	O (u)			Helioplasma	S (u)	-D (Emsi)?	
Conopoterium	C (Tour-l)			Helioplasmolites	S (Wenl-l)	-S (Ludl-u)	
Corrugopora	S (Ldov-u)			Hemiplasmodora	S (Wenl-l)		
+Cornwallatia	C (Step-u)	-P (Sakm)?	(161)	Heterocoenites	P (Guad-u)		
Cosmiolithus	O (Ashg-l)	-S (Ludl-l)	(2)	Hexismia	S (Ldov)	-S (Wenl)	
Crassialveolites	D (Sieg-u)	-D (Fras-u)		Hillaepora	D (Gedi)	-D (Fras-m)	
Crenulipora	D (Emsi)	-D (Eife)		Holacanthopora	D (Eife-l)		
?Cryptolithenaria	O (Aren-u)	-O (Ashg-m)	(160)	Hyostragulum	D (l)	-D (m)	
Cylindrostylus	S (Wenl)		(2)	Innapora	S (Ludl)		
Cyrtophyllum	O (Cara-m)	-O (Ashg-m)	(2)	Isolites	S (Ludl)		
Cystihalysites	S (Ldov-m)?	-S (Ludl)?	(1066)	+Jiangshanolites	O (m)	-O (u)	
Cystitrypanopora	D (l)			Karagemia	O (Cara)	-O (Ashg-m)	
Cystodendropora	C (Vise)			Kerfordicidictyum	D (Sieg-u)	-D (Give)	
Daljanolites	S (Ludl)			Khangailites	O (Ashg-l)		
Dendrofavosites	D (Give)			Khmeria	P (Leon-l)		
Dendrozoum	D (Emsi)			Kiaerites	S (Ldov-u)	-S (Wenl-l)	
Derivatolites	S (Wenl)			Kiaerolites	O (Cara-u)	-O (Ashg-m)	
Dictyofavosites	D (Gedi)	-D (Fras-u)		+Kimilites	O (Ashg-l)	-O (Ashg-m)	
Dictyopora	P (u)			Kitakamilia	S (Ludl)	-D (Fras-u)	
Diorychopora	S (Wenl-l)?			Klaamannipora	S (Ludl)		
Diploepora	O (Ashg-l)	-S (Ludl-l)?		Kolymopora	O (Cara-u)	-O (Ashg-m)	(160)
Donetzites	C (Mosc-l)			Kozlowskicystia	D (Eife-u)		
Ducdonia	S (Wenl-l)			Kueichowpora	C (l)		
Duncanopora	C (Serp-l)			Labyrinthites	O (Cara-m)?	-D (Eife)	
Echyropora	D (Emsi-u)?, D (Eife-l)?			Laceripora	S (Ludl-l)		
Egosiella	S (Wenl)	-D (Fras)		Lamellaeporella	D (l)	-D (Eife)	
Emmonsia	D (Emsi-l)	-D (Give-u)		?Lamottia	O (Llvi-u)		
Emmonsiaella	S (Prid)?			Leefédites	D (Emsi)	-D (Eife-l)?	
Enigmolithes	C (u)	-P (Guad-u)	(1066)	Lessnikovaeia	O (Cara-m)		(160)
Eocatenipora	O (Ashg)	-O (Ashg-m)		?Lichenaria	O (Trem-u)	-O (Cara-u)	(160)
Eofletcheria	O (Llvi-u)	-O (Ashg-l)	(160)	Liscombea	S (Ldov-u)		
Eofletcheriella	O (Ashg)			Lyopora	O (Llde-l)	-O (Ashg-l)	(160)
Erlangbapora	S (Wenl)			Manipora	O (Cara-u)	-O (Ashg-m)	(160)
Estonia	O (Cara-m)	-O (Ashg-m)		Mariusilites	D (l)	-D (Give)	
+Fainella	D (Give)	-D (Fras)		Mastopora	S (Wenl)	-D (Fras)	
Falsicatenipora	S (Wenl)	-S (Ludl)?	(1066)	Maurenia	D (Eife-l)		
Favosites	O (Llde-u)	-D (Give-u)	(1066)	Meleodea	O (Ashg-l)		
Fletcheriella	O (Cara-u)	-S (Ldov)	(2)	Meitanopora	S (Ldov-m)		(651)
+Flindersipora	Cm(Boto-l)?		(1026)	Mesofavosites	O (Ashg)	-D (Gedi-l)	
Foerstephyllum	O (Llde-l)	-O (Ashg-m)		Mesolites	D (Emsi)	-D (Fras)	
Fomichevia	D (Eife)			Mesosolenia	S (Wenl-u)	-S (Ludl-l)	
Fossopora	S (u)	-D (Eife)		Michelinia (+ Paramichelinia)			
Fossoporella	D (Sieg)	-D (Eife)			D (Gedi-l)	-P (Djhu)	
Fuchungopora	D (Fame-u)	-C (Vise)	(798)	Microcyathus	C (Tour-u)	-C (Vise)	
Gertholites	P (Sakm)	-P (Djhu)	(2)	+Minatolites	P (Leon)		
Gorskyites	C (Tour)			Mongoliolites	O (Ashg-l)	-O (Ashg-m)	
Gracilopora	D (l)	-D (Fras-u)		+?Moorowipora	Cm(Boto-u)		
Grandalveolites	D (Emsi-u)	-D (Give)		Multisolenia	S (Ldov-l)	-S (Prid)	
Granulidictyum	D (Sieg)	-D (Eife)		Multithecopora	S (Ldov)	-P (Guad-u)	(2)
Granulina	O (u)			Natalophyllum	D (l)	-D (Fame-l)	(798)
Groessensia	C (Tour-l)			Navoites	O (Ashg)		
Guanziyaopora	D (m)			Neofletcheriella	S (Ldov-u)	-S (Wenl)	(651)
Guizhoustriatopora	S (Ldov)?, S (Wenl)?			Neomultithecopora	C (Vise-l)	-P (Sakm)?	
				Neoroemeria	D (Give)		

Taxon	First Appearance	Last Appearance	Reference	Taxon	First Appearance	Last Appearance	Reference
Neosyringopora	C (Step-l)	-P (Sakm-l)		Pseudoromingeria	P (Guad-u)		
Neowormsivopora	O (Ashg-l)			Pycnololithus	S (Ldov-u)?	S (Wen-l)?	(2)
Ningqiangolites	S (Wen-l)			Qianbeilites	S (Ldov-l)?		
Nitkovicepora	D (Give-u)			Remesia	D (Eife-l)	-D (Give-u)	
Nyctopora	O (Llde-u)	-O (Ashg-m)	(160)	Reuschia	O (Cara-m)	-S (Ldov-l)	(160)
Oculinella	P (Leon-m)			Rhabdotetradium	O (Cara-l)?	-O (Ashg-u)	
Oculipora	D (Sieg-u)?	-D (Eife-l)		Rhacopora	D (Give)		
Oharaia	C (Vise)	-C (Serp)?		Rhapidophyllum	O (Ashg-m)		
Ohnopora	D (l)			Riphaeolites	S (Ludl-u)?	-D (Emsi)	
Ortholites	C (Tour-l)	-C (Tour-u)?	(798)	Roemeria	D (Eife)	-D (Give-u)	
Ozopora	D (l)			Roemeripora	D (Sieg)	-P (We)	
Pachyfavosites	D (Gedi-l)	-D (Fras-m)		Roemerolites	D (Sieg)	-D (Fras-u)	
Pachyhelioplasma	S (Prid)	-D (Eife)		Romingeria	S (Ldov-u)	-D (Eife-l)	
Pachylites	S (Ludl-l)			Rosopora	C (Tour-l)	-C (Mose-u)	(798)
Pachyphragma	D (Give-u)			Rudakites	D (Sieg)	-D (Emsi-l)	
Pachypora	S (Wen-l)			Saeremolites	S (Wen-l)		
Pachystelliporella	S (Wen-l)	-D (Eife)?		Saffordophyllum	O (Llde-u)	-O (Ashg-m)	
Pachystriatopora	D (Emsi-u)	-D (Eife-l)		Salairia	D (Gedi)		
Paeckelmannopora	D (Gedi)?			Salpingium	C (Tour-u)		
Palaeacis	C (Tour-l)	-C (Step-l)		Sapporipora	S (Wen-l)		
Palaeocorolites	S (Wen-l)			Sarcinula	O (Cara-m)	-O (Ashg-m)	
Palaeofavosivopora	S (Wen-l)			Scharkovaelites	S (Ludl)		
Palaeoporites	O (Cara-m)	-O (Ashg-u)		Schizophorites	P (Guad-l)		
Paleoalvolites	O (Cara-l)		(160)	Schmidtilites	O (Ashg-l)	-O (Ashg)	
Paleofavosites	O (Cara-m)	-S (Ludl-l)	(160)	Scoliopora	D (Emsi)	-D (Fame-l)	
Parasarcinula	O (Ashg-l)?			Septentrionites	O (u)		
Parastelliporella	O (Ashg-l)			+ Shanxipora	S (Ldov-u)		(651)
Parastriatopora	S (Wen-l)	-D (Eife)		Sibiriolitella	O (Cara-u)	-O (Ashg-l)	
Parastriatoporella	C (Bash-l)			Sibiriolites	O (Ashg-l)	-O (Ashg-m)	
Paratetradium	O (Cara-m)	-O (Ashg)		Sinkiangopora	C (u)		
Periphacelopora	D (Give-l)			Sinopora	D (Fras)	-P (Leon-l)	
Petridictyum	D (Sieg)	-D (Eife)		Sinoporella	S (Ldov)		
Phytopsis	O (Llvi)?	-O (u)		Snythina	C (Vise-u)		
Planalveolitella	D (Give)			Solenihalysites	S (Wen-l)	-S (Ludl)	
Planalveolites	S (Wen-l)			Somphopora	S (Wen-l)		
Planocoenites	S (Ldov-u)	-D (Give-u)		Sparsisolonia	S (Ldov-u)		
Plasmadictyon	O (Ashg-m)			+ Spirapora	O (Ashg-m)		(162)
Plasmopora (+ Eolaminoplasma, Laminoplasma)	O (Cara-l)	-S (Ludl)		Spiroclados	D (l)	-D (Eife-l)	
Plasmoporella	O (Cara-m)	-O (Ashg-u)	(160)	Spongialveolites	D (Eife-u)		
Platyaxum	D (Emsi)	-D (Fras)		Spumaeolites	S (Ldov)		
Pleurodictyum	S (Ludl-u)	-D (Fras-l)		Squamealveolites	D (Eife-u)	-D (Give-l)	
Pleurosiphonella	C (Tour-l)	-C (Serp-l)		Squameofavosites	S (Ludl-u)	-D (Eife-u)	
Plectituba	D (Give-u)	-D (Fras-u)		Squameolites	S (Ludl-u)		
Plicatomurus	D (Gedi-u)	-D (Give)		Squameophyllum	C (Tour-u)		
Podolites	S (Ldov)	-D (Eife)		Squameopora	D (Emsi)	-D (Eife)	
Pragnellia	O (Cara-m)	-O (Ashg-m)		Stelliporella	O (Ashg-m)	-S (Ludl-u)	
Priscosolenia	O (Ashg-m)			Stratophyllum	C (Tour)		
Procteria	D (Eife)			Striatopora	S (Ldov-m)	-S (Ludl)	(711)
Proheliolites	O (Ashg-m)			Striatoporella	D (Gedi)		
Propora	O (Cara-l)	-S (Ludl-u)		Stylonites	P (Guad-u)		
Proporella	O (u)			Subalveolitella	S (Ldov-u)	-S (Wen-l)	
Protaraea	O (Cara-m)	-O (Ashg-m)		Subalveolites	S (Ldov-u)	-S (Ludl)	
Protoheliolites	O (Cara-u)	-O (Ashg-m)		Subcaliapora	S (Ludl)	-D (Emsi)	
Protomichelinia	C (l)	-P (l)		Sutherlandia	C (Tour-l)	-P (Leon-l)	(798)
Protopora	C (Vise-l)	-C (Vise-u)		Syringoaelycon	C (Vise)		
Prototrachypora	S (Ldov)			Syringocolumnna	S (Wen-l)		
Protochiscolithus	O (Cara-m)	-O (Ashg-m)		Syringoheliolites	S (Ludl)		
Pseudofavosites	P (Guad-u)	-P (Djhu)		Syringolites	S (Ldov-m)	-S (Ludl)	
Pseudoflecteria	D (Eife)			Syringopora	O (Ashg-m)	-C (Serp-l)	(160,163)
Pseudoroemeria	D (Gedi)			Syringoporella	D (l)	-D (Fras-m)	
Pseudoroemeripora	C (Vise-u)		(957)	Syringoporiella	S (u)		
				Syringoporinus	O (Cara-u)	-S (Wen-l)	(160)

Taxon	First Appearance	Last Appearance	Reference	Taxon	First Appearance	Last Appearance	Reference
+Sytovaelites	S (Wenl)	- S (Ludl-l)?		Amandophyllum	C (Vise-u)	-P (Sakm-u)	
Tabellaephyllum	C (Tour-l)	-C (Ms)		Amaraphyllum	D (Give-l)		
+Tectamichelina	C (Serp-l)	-C (Mosc-l)		Amplexiphyllum	D (Emsi-l)?	-D (Give)	
Taeniolites	O (Ashg-l)	-O (Ashg-m)		Amplexizaphrentis	D (Fame-u)	-C (Serp-l)	(174,680)
Tetradium	O (Ldde-u)?	-O (Ashg-u)	(160)	Amplexocarinia	D (Eife-u)	-P (Dora)	(893)
+?Tetraporella	O (Ashg-l)	-S (Ldov-m)	(651)	Amplexoides	S (Ldov-l)	-S (Ludl)	
Tetraporinus	S (u)	-P (Leon)		Amplexus	D (Fame-m)	-C (Step)	(174,680, 1240)
Thamnopora	D (Gedi)	-D (Fras-u)		Amsdenoides	S (Ludl)		
Thamnoporella	C (Mosc)			Amygdalophyllidium	C (Serp)		
Thamnoptychia	D (l)	-D (Give)		Amygdalophylloides	C (Serp)	-C (Step-u)	(1240)
Thamatolites	S (Wenl-l)	-S (Wenl-u)		Amygdalophyllum	C (Tour-u)	-C (Serp)	(2,1240)
Thecia	S (Ldov-u)	-S (Ludl)	(2)	+Anactolasma	D (Sieg)		(1261)
Thecipora	S (Wenl)			Angulophyllum	S (Ldov-u)		
Thecostegites	D (Gedi)	-C (Tour)		Angustiphyllum	D (Eife)		
Tollina	O (Cara-u)	-O (Ashg-m)	(160)	Anisophyllum	S (Wenl)	-S (Ludl)	(2)
Trabeculites	O (Cara-u)	-O (Ashg-m)	(160)	Ankhelasma	C (Vise-l)	-C (Vise-u)	
Trachypsammina	P (Guad-u)		(2)	Antheria	C (Step)		(1240)
Transitolites	O (Ashg-l)			Antikinkaidia	D (Fame-u)	-C (Tour-l)	(798)
Trochiscolithus	O (Cara-m)	-O (Ashg-m)	(1066)	+Antracophyllum	P (Asse)	-P (Sakm)	(1240)
Troedssonites	O (Ashg-l)	-S (Ldov-m)	(160,651)	Aphraxonia	D (Fras)		(1240)
+Turnacipora	C (Tour-u)	-C (Vise-l)		+Aphroelasma	D (Gedi)	-D (Emsi)	(1240)
Tyrganolithes	D (Give)	-D (Fras-u)		Aphroidophyllum	D (Gedi)	-D (Eife)	(422)
Uralopora	O (Cara-u)?			Aphrophylloides	C (Vise-u)		
Urceopora	O (Llvi-l)			Aphrophyllum	C (Vise-l)	-C (Vise-u)	(957)
Vacuopora	O (Cara-u)	-S (Ldov)		Aphyllum	O (Ashg-m)	-D (Give)	(1066)
Vaughania	C (Tour-u)			Arachnastraea	C (Mosc-l)	-C (Mosc-u)	
Verolites	C (Tour)			Arachniophyllum	C (Vise-l)		
+Victorilites	D (Emsi)	-D (Give)		Arachnolasma	D (Fame-u)	-C (Serp-u)	(163,680)
Visbylites	O (Cara-u)	-S (Ldov-u)		Arachnolasmaella	D (Fame-u)	-C (Serp)	(680)
Wormsipora	O (Cara-m)	-O (Ashg-m)		Arachnophyllum	S (Ldov-u)	-S (Ludl-u)	(711)
Xenoommonia	D (Emsi)?			Araeopoma	S (Ldov-u)	-S (Wenl)	
Yacutiopora	D (l)			Archaeozaphrentis	S (Ldov-m)		
?Yaoxianopora	O (Aren)			+Arcoocyathus	C (Vise)		(1240)
Yavorskia	D (Fame-u)	-C (Vise-u)		+Arcoplasma	D (Eife)	-D (Give)	(1240)
Or. RUGOSA				Arctophyllum	C (Step-u)	-P (Sakm)	(1240)
+Acanthophillia	D (Eife)		(1240)	Argutastrea	D (Emsi)	-D (Fras-u)	(422,680)
Acanthophyllum	D (Sieg-l)	-D (Fras-l)	(680)	Aristophyllum	D (Give-l)	-D (Fras-u)	(164)
+Accurganaxxon	D (Gedi)		(1240)	+Asarcophyllum	D (Emsi)		(1261)
Acervularia	S (Wenl-l)	-S (Ludl)		Aspasmophyllum	D (Eife)	-D (Give)	
Acinophyllum	D (Emsi)	-D (Eife)?		Asperophyllum	S (Ldov-u)	-D (Eife-u)	
Acemophyllum	D (Gedi)			Asserulinia	P (Guad-u)		
Acrococyathus	C (Vise-l)	-C (Vise-u)		Asterobillingsia	D (Emsi)	-D (Give-u)	(1066)
Acrophyllum	D (Gedi)	-D (Emsi)	(1240)	+Asterodisphyllum	D (Eife)		(1240)
Actinocyathus	C (Vise-u)	-C (Serp-l)		Asthenophyllum	S (Ldov-u)	-S (Wenl)	
Actinophrentis	C (Step-l)		(1240)	Astracophyllum	S (Wenl)		
Adamanophyllum	C (Serp)			Astrictophyllum	D (Eife)		(1240)
+Adinophyllum	D (Gedi)			+Asturiphyllum	C (Bash)		(1240)
Adradosia	D (Sieg)	-D (Give-u)?		Aulacophyllum	D (Eife)	-D (Give)	
Aemulophyllum	D (Emsi)			Aulina	C (Vise-u)?	-C (Serp-u)	(163)
+Agastophyllum	D (Eife)	-D (Give)	(1240)	Auloclisia	C (Vise-u)		
Akagophyllum	P (Leon-m)	-P (Guad-u)	(1240)	Aulokoninckophyllum	C (Vise-u)	-C (Serp-l)	
Akiyosiphyllum	C (Vise)			Aulophyllum	C (Vise-u)	-C (Serp-u)	(163)
Aknisophyllum	D (Gedi-l)	-D (Sieg)		Aulostrotion	C (Vise-u)		
Alaiophyllum	D (Give)	-D (Fras-u)	(798)	Aulostylus	C (Tour-l)	-C (Vise-u)	
+Alinkioduncanella	C (Vise-u)		(957)	Australophyllum	D (Gedi)	-D (Give)?	(422)
Alleynia	D (Eife-l)			Axinura	D		
Allophyllum	P (Sakm)		(1240)	Axiphoria	O (Ashg)		(1240)
Allotropiophyllum	C (Tour)	-P (Guad)		Axoclisia	C (Vise-l)		
Altaja	S (Ldov)	-S (Wenl)		+Axocricophyllum	D (Eife)		(1240)
Altaiophyllum	D (Give-u)						
Amandaraia	D (Gedi)						

Taxon	First Appearance	Last Appearance	Reference	Taxon	First Appearance	Last Appearance	Reference
Axolasma	S (Ldov-u)			Carinthiaphyllum	C (Mosc-u)	-P (Asse)	(1240)
Axolithophyllum	C (Bash-l)	-C (Step-u)		+Carlinastraea	D (Gedi)		(1240)
Axophyllum	D (Fame-u)	-C (Serp-l)	(163,680)	Carniaphyllum	C (u)		
Barbarella	P (u)			Carruthersella	C (Tour-u)	-C (Vise-u)	
Barrandeophyllum	D (Emsi)	-D (Fame-l)	(680,1240)	Catactotoechus	D (Fras-m)	-D (Fame-u)	(174,680)
Barylasma	C (Tour-u)			Cavilasma	S (Ldov)		
Baryphyllum	C (Tour)	-C (Serp)	(1240)	+Cecliahyllum	D (Fras-u)		(680)
Barytichisma	C (Serp-l)	-C (Mosc)	(163)	Centristella	D (Give)		
Basleophyllum	P (Guad-u)			Ceratophyllum	D (Eife)	-D (Fras-u)	(422)
-Bassius	P (Sakm)		(1240)	Ceriaster	S (Ldov-m)	-S (Ldov-u)	(651)
Batangophyllum	C (Vise)			Cericoecysta	D (Sieg)	-D (Emsi)	(1240)
+Bathybalva	C (Tour-l)		(798)	+Cerioclasma	S (Wenl)	-P (Leon-u)	(1240)
Belgradeophyllum	C (l)			+Ceriphyllum	D (Fame-u)		(680)
Bensonastraea	D (Eife)		(422)	+Ceristella	D (Give)		(1240)
-Benxiophyllum	C (Step-l)		(1240)	Chalcidophyllum	D (Sieg-u)	-D (Emsi)	
Beogradophyllum	C (l)			Changjianggouphyllum			
Berkhia	C (Ms)		(1240)	P (l)			
Bethanyphyllum	D (Eife)	-D (Give)	(1240)	Charactophyllum	D (Fras-m)	-D (Fras-u)	(680)
+Beugmiesastraea	D (Give)		(1240)	+Charisphyllum	D (Eife)		(1240)
Bitossularia	C (Tour-u)	-C (Vise-u)		Chavsakia	D (Gedi)		
Bighornia	O (Cara-u)	-O (Ashg-m)		Chielasma	C (Step-l)	-C (Step-u)	(1240)
Biphyllum	C (Vise-u)			Chiihiaphyllum	P (Leon-l)	-P (Leon-u)	
Bitraria	D (Eife-u)			Chlamydoephyllum	D (Sieg)	-D (Emsi)	
Biothrophyllum	D (Eife)			+Chonoplasma	D (Eife)		(1240)
Blysmatophyllum	D (Give)			Chonaxis	C (l)		
Bodophyllum	O (Ashg-l)	-O (Ashg-u)		Chonophyllum	S (Wenl)		(2)
Bojocyclus	D (Eife)			+Chostophyllum	D (Eife-u)	-D (Give-u)	(164)
Boolelasma	D (Sieg)	-D (Emsi-u)		+Chuanbeiphyllum	D (Fras-m)	-D (Fras-u)	
Bordenia	C (Ms)			Chusenophyllum	P (Leon-l)	-P (Leon-u)	
Borelasma	O (Ashg-u)			Cionodendron	C (Vise)		
Bothroclisia	C (Mosc-u)	-C (Step-l)		Circophyllum	S (Wenl-l)	-D (Gedi)	(1240)
Bothrophyllum	D (Fame-u)	-C (Mosc)	(680,1240)	Circumtextiphyllum	D (Give)		(1240)
+Bouvierphyllum	D (Fras-u)		(165,680)	+Cladonophyllum	D (Eife)		(1240)
Bowanophyllum	O (Ashg)		(1240)	Clavilasma	C (Vise-u)		
Bowenelasma	D (Eife)			Claviphyllum	C (Tour)	-C (Bash-u)	(2,163)
Bradyphyllum	C (Serp-l)	-C (Mosc)	(1240)	Clinophyllum	C (Tour-l)	-C (Ms)	
Breviphrentis	D (Emsi)	-D (Give-l)		Clisiophyllum	D (Fame-u)	-C (Serp-u)	(163,174,680)
Breviphyllum	D (Emsi-l)		(164)	+Codonophyllum	S (Ldov-m)		(651)
Breviseptophyllum	D (Eife)	-D (Fras-u)	(174)	Coelolasma	O (Cara-m)		
Briantelasma	S	-D (Eife)		Coelostylis	O (Llde)	-O (Cara-m)	(1240)
Briantia	D (Emsi)		(1240)	Coenaphrodia	C (Vise-u)		(957)
Bucanophyllum	D (Eife)			Colocephyllum	D (Eife)		
Bulvankeriphyllum	D (Gedi)	-D (Sieg)	(422,1240)	Columnaria	D (Give)	-D (Fras-u)	(2,174,1240)
Calceola	D (Emsi-u)	-D (Give-u)		Columnaxon	S (Ludl)		
Calinastrea	D (Gedi)			Columnolasma	S (Ludl)		
Calmiussiphyllum	C (Tour-u)	-C (Vise-l)		+Comanaphyllum	D (l)	-D (Give)	(1240)
Calophylloides	P (l)			Combophyllum	D (Emsi)	-D (Eife-l)	(2,1240)
Calophyllum	C (Vise-u)	-P (Dora)	(666,957)	Commutatophyllum	C (Tour-l)	-C (Tour-l)	(798)
Calostylis	O (Cara)	-D (Gedi)	(1066)	Communia	D (Fame-u)		
Campophyllum	D (Fame-u)	-C (Serp-l)?	(680)	+Complanophyllum	D (Fame-u)		(680)
Camurophyllum	D (Sieg)			-Complexophyllum	O (Ashg-l)		
Canadiphyllum	C (Vise-l)	-C (Vise-u)		Compressiphyllum	D (Emsi)		
Caninella	C (u)			Contortophyllum	S (Prid)		(1240)
Caninia	D (Fame-u)	-P (Leon-l)	(174,680)	Copia	C (Vise-u)	-C (Serp-l)	
Caninophyllum	D (Fame-u)	-C (Step-u)?	(680)	Corphalia	C (Vise-l)		
Caninostrotion	C (Serp-l)			Corwenia	C (Vise-u)	-C (Step-l)	(163)
Cantrillia	O (Ashg-l)	-S (Ldov-u)		+Cosjuria	D (Give)	-D (Fras-u)	(680,1240)
Capnophyllum	S (Ludl-l)			Crassicyclus	D (Give)		
+Cardiaphyllum	P (Leon)		(1240)	Crassilasma	O (Ashg-l)	-S (Ldov-m)	(651)
Carinotachylasma	P (l)			+Crassophrentis	D (Eife)		(1240)
+Carinowaagenophyllum	P (Guad-l)						

Taxon	First Appearance	Last Appearance	Reference	Taxon	First Appearance	Last Appearance	Reference
Crateniophyllum	C (Step-u)		(1240)	Dinophyllum	S (Ldov-m)	-S (Ludl-u)	(711)
Craterophyllum	S (Ludl-l)	-D (Eife-l)		+Dinostrophinx	C (Vise-u)		(957)
Cravenia	C (Tour-u)	-C (Vise-l)		Diphyphyllum	C (Vise-l)	-P (Asse)	(163)
Crenulites	O (Ashg)			Diplochone	D (Sieg)	-D (Give)	(422)
+Crepidophyllia	C (Vise)		(1240)	Diplophyllum	S (Wenl-u)		
Crista	D (Give)			Dipterophyllum	C (Tour-u)		
Cronyphyllum	S (Wenl)	-S (Ludl)		Disphyllia	D (Emsi)	-D (Fras-u)	(174,1240)
+Cruciphyllum	S (Prid)		(1240)	Disphyllum	D (Emsi)	-D (Fras-u)	(680)
+Cuctienophyllum	D (m)		(1240)	Ditoecholasma	S (Ludl)		
Cumminsia	C (Serp)	-C (Mosc-l)		+Diversiphyllum	P (Sakm)		(1240)
+Curtastrum	D (Eife)		(1240)	Dohmophyllum	D (Sieg-l)	-D (Give)	
+Cyanaphyllum	D (Eife)		(1240)	Dokophyllum	S (Wenl-l)	-S (Ludl)?	
Cyathactis	S (Ldov-m)	-S (Ldov-u)	(711)	Donacophyllum	O (Ashg)	-S (Ludl)	(1240)
Cyathaxonella	C (l)			Donophyllum	C (Bash-u)	-C (Mosc-l)	
Cyathaxonia	D (Fame-l)	-P (Guad-u)	(680)	Dortodotia	C (Vise-l)	-C (Serp)	(1240)
Cyathoclisia	D (Fame-u)	-C (Vise-l)	(174,680)	+Drewerelasma	C (Tour-l)		(798)
Cyathocylindrum	D (Emsi)	-D (Eife)		Dubrovja	S (Prid)	-D (Sieg)	(1240)
Cyathopaedium	D (Give-l)			Duncanella	S (Wenl)		
Cyathophylloides	O (Ashg-l)	-S (Ldov)		Duncania	C (l)		
Cyathophyllum	D (Emsi)	-D (Give-u)	(422)	+Duplocarina	P (Leon)		
Cylindrophyllum	D (Emsi)	-D (Give-u)		+Duplophyllum	P (Tair)		(1240)
Cymatlasma	S (Ldov-u)	-S (Ludl)		Durhamina	C (Pn)	-P (Leon-u)	(2)
Cymatella	S (Prid)			Dushanophrentis	D (Eife)		
Cystelasma	C (Vise-u)			Dybowskia	O (Cara-m)		
+Cysticonophyllum	S (Ldov)	-S (Wenl)	(1240)	+Eastonastraea	P (Wc)		(857)
†Cystihexagonaria	D (Fras-m)			Eastonoides	P (Asse)	-P (Sakm)	(1240)
Cystilophophyllum	C (Bash-u)			Echigophyllum	C (l)?, C (u)?		
Cystipaliphylum	S (Ldov-l)			Edaphophyllum	D (Eife)		
Cystiphorolites	S (Wenl)			Ekvasophyllum	C (Vise-u)		
Cystiphylloides	D (Gedi)	-D (Give)	(422)	Elasmophyllum	D (Eife-l)		
Cystiphyllum	S (Ldov)	-D (Give)	(1240)	+Ellesmerelasma	D (Eife)		(1240)
+Cystocantrilla	O (Ashg)		(1240)	Ellipsocyathus	D (Eife)		
Cystolonsdaleia	C (Bash-u)	-C (Mosc-u)	(163)	Embolophyllum	D (Gedi)	-D (Eife)	(422,1240)
+Cystolyriellasma	D (Give)		(1240)	Empodesma	C (Bash)		
Cystoprentis	D (Fame-u)	-C (Tour-u)?	(680)	+Enallophrentis	D (l)	-D (Eife)	
+Cytaroplasma	D (Emsi-l)			Endamplexus	P (Guad-u)		
Czarnockia	D (Fame-u)	-C (Tour-l)	(798)	Endophyllum	S (Prid)	-D (Fras-u)	(680)
Dagmaraephyllum	D (Fame-u)	-C (Tour-l)	(680)	Endothecium	P (Guad-u)		
Dalmanophyllum	O (Ashg-l)	-S (Wenl-u)	(711)	Entelophyllia	S (Wenl)	-S (Ludl)?	
Dalnia	D (Fame-u)			Entelophyllum	S (Ldov-u)	-S (Ludl-u)	
Darwasophyllum	C (Serp)	-C (Mosc-u)		Enterolasma	S (Ludl)	-D (Emsi)	(1240)
Debnikiella	D (Fras-u)		(174,680)	Enygmophyllum	D (Fame-u)	-C (Vise-u)	(680)
Decaphyllum	D (Fras)		(1240)	Eoglossophyllum	D (Sieg-l)		(422)
Deiracorallium	O (Ashg-l)	-O (Ashg-m)		Eostrotion	C (Tour)		
Denayphyllum	S (Prid)			Epiphanothyllum	P (Guad-u)		
Dendrofolmia	S (Wenl-u)	-S (Ludl)	(1240)	+Ericina	P (Leon)		(1240)
Dendrostella	D (Gedi)	-D (Fras)?	(422)	Eridophyllum	D (Eife-l)	-D (Give-u)	
Densigrewingkia	O (Ashg)			Estonielasma	O (Cara)	-O (Ashg-l)	(1240)
Densiphrentis	S (Ldov-u)			Euryphyllum	P (Asse)	-P (Dora)	(1240)
Densiphyllum	S (Ldov-l)			Evenkiella	S (Ldov-u)?	-D (Gedi)	(1240)
Dentilasma	S (Ldov-u)			Exilifrons	D (Gedi)	-D (Emsi-l)	(1240)
Depasophyllum	D (Sieg)?	-D (Give)	(422)	Exostega	D		
+Dialeptophyllum	D (Eife)		(1240)	Faberolasma	C (Bash)?, C (Mosc)?		
+Dialytophyllum	D (m)		(1240)	Faberophyllum	C (Vise-u)		
Diaschophyllum	C (Serp)			Famaxonina	D (Fame-u)		(680)
Dibunophyllum	D (Fame-u)	-C (Bash-u)	(163,680)	Famennelasma	D (Fras-l)	-D (Fame-u)	(174,680)
†?Diffingia	P (Asse-l)	-P (Sakm)		Farabophyllum	D (Emsi-l)		
+Diffusolasma	D (Fras-l)			Fasciculiamplexus	C (Bash)		
Digonoclisia	D (Gedi)	-D (Eife)	(422)	Fasciculophyllum	D (Fame-u)	-C (Vise-u)	(680)
Digonophyllum	D (Emsi)	-D (Give)	(422)	Fasciphyllum	D (Sieg)	-D (Give)	(422)
+Dillerium	P (Sakm)		(1240)	Favistina	O (Cara-l)	-O (Ashg-m)	
Dmelasma	O (Cara)		(1240)	Fedorowskicyathus	D (Fras-l)	-D (Fras-u)	

Taxon	First Appearance	Last Appearance	Reference	Taxon	First Appearance	Last Appearance	Reference
+Fedorowksiella	P (Wc)		(856)	Hexalasma	P (Leon-m)	-P (Dora)	(1240)
Flagellophyllum	C (Vise)			Hezhangophyllum	D (l)		
Fletcheria	S (Wenl)			+Hezhouphyllum	C (Vise-u)		
Fletcherina	D (Give)			Hillaxon	D (Fame-m)	-D (Fame-u)	(798)
Fomichivella	C (Bash-l)	-P (Leon-l)?	(163,856)	Hilophyllum	O (Cara-l)	-O (Ashg-l)	
Frechastrea	D (Emsi)	-D (Fras-u)	(174,680, 1240)	+Hinganastraea	D (Fras)		(1240)
Friedbergia	D (Fame-u)			Hiroshimaphyllum	C (Serp)		(1240)
+Fromeophyllum	D (Emsi-u)			Holmophyllum	S (Ldov)	-D (Gedi)	(1240)
+Fruehwirthia	D (Fras-l)			Holophragma	S (Ldov-u)	-S (Wenl-l)	
Gagamophyllum	C (Vise-u)	-C (Serp-u)	(163)	Homalophyllites	C (Tour-l)	-C (Vise-u)	
+Gaofengophyllum	D (Give-u)			Homalophyllum	D (Emsi)		
Gaynaphyllum	D (Eife-u)			+Honggulosma	D (Eife)		(1240)
Gazimuria	D (Eife)		(1240)	Hornsundia	P (Sakm)		
Gerthia	P (Asse)	-P (Dora)	(1240)	Houershanophyllum	D (m)		
+Geyeronaotia	C (Step-l)		(1240)	+Huananaxonia	D (Give)		(1240)
Geyerophyllum	C (Mosc)	-C (Step-u)	(1240)	Huangia	C (Step-l)	-C (Step-u)	(1240)
Gissarophyllum	S (Ldov-l)			Huanglongophyllum	C (Mosc)		
Glossophyllum	D (Emsi-u)	-D (Give-u)	(164)	Huangophyllum	P (Guad)		
Goniophyllum	S (Ldov-u)	-S (Wenl)		+Huayunophyllum	P (Dihu)	-P (Dora)	(936,1086)
Gorizdronia	D (Fras-u)	-D (Fame-u)	(680)	Hunanoprentis	D (Fras-u)		(174,680)
+Gorskyella	C (Bash-u)		(1066)	Ibukiphyllum	C (Mosc-u)		
Grabauphyllum	S (Wenl)			Idiophyllum	S (Wenl-l)	-S (Wenl)	
Grewgiphylum	D (Emsi)	-D (Eife)		Immenovia	S (Ludl-u)		
Grewingkia	O (Cara-u)	-O (Ashg-u)		Implicophyllum	D (Gedi)		(1240)
Greenlandophyllum	P (Guad)			+Indiophyllum	S (Wenl)	-D (Sieg)	(1240)
Grypophyllum	D (Give-l)	-D (Fras-l)	(680)	Insoliphyllum	D (Fras)		(1240)
Gshelia	C (Step-u)			Iowaphyllum	D (Sieg-u)	-D (Fras-u)	(174,680)
Gubbera	D (Emsi-l)	-D (Emsi-u)		Ipsiphyllum	P (Leon-m)	-P (Dora)	(1086)
Guerichiphyllum	D (Eife)	-D (Fame-u)	(798,1240)	Iranophyllum	P (Asse)	-P (Dora)	(1086)
+Gundarina	P (Guad-l)			Ivanovia	C (Mosc-l)	-C (Mosc-u)	
Gurieuksiella	D (Sieg-l)	-D (Give)	(422)	Ivdelephyllum	D (Emsi-u)		(1261)
+Gyalophyllum	S (Ludl)		(1240)	Jintingophyllum	C (u)		
+Gyaloplasma	D (Gedi)		(1240)	+Jipaolasma	D (Give)		(1240)
Gymnophyllum	C (Mosc-u)			Kabakovitchiella	P (Guad-u)		
Hadrophyllum	D (Emsi)	-D (Eife)	(1240)	+Kakisaphyllum	D (Fras-u)		(165,680)
Hallia	D (Give)			Kaljolasma	O (Ashg-m)		
Hankaxis	D (Eife)	-D (Fras-u)	(174,680, 1240)	Katranophyllum	C (Vise-u)		
Haplolasma	C (Vise-l)			Kazachiphyllum	C (Vise)	-C (Serp)	
Haplothecia	D (Give-u)	-D (Fras-u)	(174,680)	+Keimanelasma	O (Cara)		(1240)
Hapsiphyllum	C (Tour-u)	-C (Bash-u)	(163)	Kenelasma	O (Cara-u)		
+Hapsizaphrentis	D (Eife)		(1240)	Kenophyllum	O (Ashg-l)		
Haptophyllum	D (Emsi)			+Kepingophyllum	P (Asse)	-P (Leon)?	(1086)
+Hebukophyllum	D (Eife)		(1240)	Keriphyloides	D (Eife)		
+Hedstroemophyllum	S (Ldov)	-S (Prid)	(1240)	Ketophylloides	S (Ldov)	-S (Wenl-l)	
Heintzella	C (Step-u)	-P (Sakm)	(1240)	+Ketophyllum	S (Ludl-l)	-S (Ludl-u)	(651)
Helicelasma	O (Lvli)	-O (Ashg-u)	(1240)	Keyserlingophyllum	C (Tour-u)	-C (Vise-l)	
Heliophyllum	D (Emsi-u)	-D (Give-u)		Kielcephyllum	D (Fame-l)		(680)
Helminthidium	S (Wenl)	-S (Ludl)		Kinkaidia	C (Serp-l)		
Hemiaulacophyllum	D (Emsi)		(422)	Kionelasma	D (Emsi)	-D (Eife)?	(1240)
+Hemicosmophyllum	D (Give)		(1240)	Kionophyllum	C (Bash-l)	-C (Step-l)	(163)
Hercophyllum	S (Ludl)		(1240)	+Kitakamiphyllum	S (Ludl)		(1240)
Heritschiella	C (Bash-l)	-P (Sakm)		Kizilia	C (Vise-u)	-C (Serp-u)	(163)
Heritschioides	P (Asse)	-P (Guad-l)	(856)	Klamathastrea	S (Ludl)?		
Heterocœnina	C (Vise-u)			Kleopatrina	C (Bash-l)	-P (Guad-l)	
Heterolasma	S (Ldov-u)?, S (Wenl-l)?			Kobeha	D (Sieg)		
Heterophaulactis	D (Sieg)		(422)	Kodonophyllum	S (Ldov)	-D (Gedi)	(1240)
Heteroprentis	D (Emsi-u)	-D (Give)		Koninekocarina	C (Bash-l)	-C (Mosc-u)	
Heterospongophyllum				Koninekophylloides	C (Bash-u)		
	S (Ldov)			+Koninekophyllum	C (Tour-u)	-C (Mosc-u)	
Hexagonaria	D (Give-u)	-D (Fras-u)	(680)	Kowalaephyllum	D (Fras-u)		
				Kozlowskinia	D (Fame-l)		(680)
				+Kuangxiastraea	D (Give)	-D (Fras-u)	

Taxon	First Appearance	Last Appearance	Reference	Taxon	First Appearance	Last Appearance	Reference
Kueichophyllum	C (Vise-u)			Melanophyllum	D (Fame-u)	-C (Vise)?	(798)
+Kullmannophyllum	C (Vise-u)	-C (Serp-u)		Melrosia	D (Emsi)	-D (Give)	(422,1240)
Kumpaphyllum	C (Bash-u)			Meniscophyllum	C (Ms)		
Kungejophyllum	S (Ldov-u)			Menophyllum	C (Tour)		
Kunthia	D (Eife-l)		(164)	Merlewoodia	C (Vise-l)	-C (Vise-u)	(957)
Kusbassophyllum	C (Vise)			Mesophyllum	D (Emsi-l)	-D (Give-u)	(422)
Kwangsiphyllum	C (Vise-l)			Mesouralina	S (u)		
+Kypophyllum	S (Wen-l)	-D (Sieg)	(422)	Metrionaxon	D (Sieg)	-D (Give)	(422)
Kysylagathophyllum	D (Gedi)			Metriophyllum	D (Emsi)	-C (Tour-l)	(174,422,1240)
Laccophyllum	S (Wen-l)			Metrioplexus	D (Eife-u)	-D (Fame-u)?	(798)
Lambelasma	O (Cara-l)	-O (Cara-m)		Microcyclus	D (Emsi)	-D (Give)	(422)
Lambeophyllum	O (Cara-l)	-O (Ashg-u)		Microplasma	S (Ldov-u)	-D (Give-l)	(422)
+Langenhemia	P (Sakm)		(1240)	Mictocystis	S (Ldov-u)		
+Lekanophyllum	D (m)		(1240)	Mictophyllum	D (Give-u)	-D (Fras-u)	(680)
Leolasma	O (Cara-m)	-S (Ldov-l)		Micula	S (Wen-l)	-D (Gedi)	(1240)
Leonardophyllum	C (Serp-l)	-P (Djhu)	(893)	Miculiella	S (Wen-l)		
+Leptelasma	S (Wenl)		(1240)	Migmatophyllum	S (Prid)		
Leshiella	C (Serp-l)			+Mikkwaphyllum	D (Fras-l)	-D (Fras-m)	(165,680)
+Leurelasma	D (Eife)		(1240)	Minatoa	C (Bash-l)		
+Liangshanophyllum	P (Leon)?	-P (Dora)	(1086)	Minussiella	D (Eife-l)	-D (Give-u)	
Liardiphyllum	C (Vise-l)			+Miroelasma	D (Eife)		(1240)
+Liauria	P (Guad-l)			+Mixogonaria	D (Give-u)	-D (Fras-u)	
Lindstroemia	D (Give-l)			+Mochiophyllum	D (m)		(1240)
Lindstroemophyllum	S (Wenl)			Modesta	O (Ashg)		(1240)
Lithostrotion	C (Vise-l)	-C (Serp-u)	(2,163)	Molophyllum	D (Fame-u)	-C (Tour-l)	(680,798)
Lithostrotionella	C (Vise-l)	-C (Serp-l)?	(163)	+Monsterephyllum	P (Asse)		(1240)
+Litvolasma	P (Leon)		(1240)	Moravophyllum	D (Emsi)	-D (Give)	(422)
Lobocorallium	O (Ashg-l)	-O (Ashg-m)		Mucophyllum	S (Wenl)	-D (Gedi)	(2,422,1240)
Longiclavata	C (Serp)		(1240)	Multicarinophyllum	D (Eife)		
Lonsdaleia	C (Vise-u)	-C (Serp-u)	(163,1066)	+Murphyphyllum	D (Sieg-l)		(1261)
Lonsdaleiastraea	P (Asse)	-P (Guad-u)	(1086)	Nadotia	D (Give)		
Lonsdaleoides	C (Mosc-u)	-P (Leon)	(2)	Nagatophyllum	C (Mosc-l)	-C (Mosc-u)?	
Loomberaphyllum	D (Emsi)			Nalivkinella	D (Fras-m)	-D (Fame-u)	(680)
Lophamplexus	C (Serp-l)	-P (Leon-u)	(163,1240)	Nanshanophyllum	S (Ldov)	-S (Wen-l)	(1240)
Lophocarinophyllum	C (Mosc)	-P (Dora)	(1086)	Naoides	C (Tour-u)		
Lopholasma	D (Give-l)	-C (Mosc-l)		Naos	S (Wen-l)		
Lophophrentis	C (u)			Nataliella	S (Prid)?, D (Gedi)?		
Lophophyllidium	C (Serp-l)	-P (Dora)	(893,1086)	Neaxon	D (Emsi-u)	-C (Vise)	(798,1240)
Lophophyllum	D (Fame-u)	-C (Tour-u)	(680)	Neaxonella	D (Emsi)		
Lophotichium	C (Bash-u)	-P (Asse)	(163)	+Neepaliphyllum	S (Wenl)		(1240)
Loyolophyllum	D (Sieg)			Nemistium	C (Vise-u)	-C (Bash-l)	(163)
Lublinophyllum	C (Vise)			Neobrachyelasma	S (Prid)		
Lyliophyllum	D (Eife)		(1240)	+Neocantrilla	O (Ashg)		(1240)
Lyrielasma	D (Gedi)	-D (Give-u)	(422)	Neoclassiphyllum	C (Vise)	-C (Serp)	
+Lythophyllum	D (Eife)	-D (Give)	(1240)	Neocolummaria	D (Eife)	-D (Fras)	(422)
Lytvolasma	P (Asse-l)	-P (Djhu)	(893)	Neocystiphyllum	S (Wenl)		
Lytvophyllum	C (Bash-l)	-P (Leon-l)	(163)	Neokeyserlingophyllum	C (Tour)		
+Macgeea (= Pterorhiza)	D (Eife)	-D (Fras-u)		Neokoninckophyllum	C (Bash-l)	-C (Step-l)	(163)
Mackenziephyllum	D (Eife)	-D (Give)	(422)	Neokyphophyllum	D (Gedi)		
Maikottaphyllum	D (Gedi)		(1240)	Neomophyma	S (Prid)	-D (Eife)	(1240)
Maikottia	S (Ldov-u)	-S (Prid)	(1240)	Neopaliphyllum	S (Wenl)		
Majiaobaphyllum	C (Vise)			Neospongophylloides	D (Give-u)		
Mansuyphyllum	D (Eife)	-D (Fras)	(422)	+Neospongophyllum	D (Emsi)	-D (Give)	(1240)
Marisastrum	D (Fras-u)		(798)	+Neopetrozium	D (Emsi-l)		(1261)
Martinophyllum	D (Sieg)	-D (Emsi)?		+Neostringophylloides	D (Give)		(1240)
Mazaphyllum (+ Labechiellata)	S (Ludl)	-D (Gedi)	(1240)	Neotabularia	D (Sieg)	-D (Emsi)	(422)
+Mecloudius	P (Sakm)		(1240)				
Medinophyllum	S (Ludl)		(1240)				
+Medusaephyllum	D (Give)	-D (Fras-u)					
Melanophyllidium	C (Vise-u)						

Taxon	First Appearance	Last Appearance	Reference	Taxon	First Appearance	Last Appearance	Reference
+ Neotemnophyllum	D (Fras)		(1240)	+ Parapavona	C (Serp-l)		
Neotryplasma	O (Cara-m)	-O (Ashg-m)		+ Pararachnastraea	P (Wc)		(856)
Neovepresiphyllum	D (Give)			Parasiphonophyllia	C (Tour-l)		(798)
Neozaphrentis	D (Fame-u)	-C (Tour-u)	(680)	+ Parasmitiphyllum	D (Give)?	-D (Fras-u)	(165,680)
Nephelophyllum	C (Bash)?	-P (Sakm)?	(1086)	Parasociophyllum	D (Give-u)		
Nervophyllum	C (Vise)	-C (Serp-u)	(1240)	Parastauria	S (Ldov)		
Nevadaphyllum	D (Emsi)			+ Parasterophrentis	C (Bash-u)		(163)
Niajuphyllum	S (Ludl)			Parathysanophyllum	C (Vise)		
Nicholsoniella	D (Fras-u)	-D (Fame-l)	(680)	Parawentzelella	P (Leon-m)	-P (Djhu)	
+ Ninghuaphyllum	C (Bash)?			Parawentzellophyllum			
Ningnanophyllum	O (Cara)				C (Step-u)		
Ningquiangophyllum	S (Wenl-u)			+ Parazolophyllia	D (l)		(1240)
Nipponophyllum	S (Wenl)	-S (Prid)	(1240)	Parazonophyllum	D (m)		
Nodophyllum	D (Gedi)			Pareynia	C (Vise-u)		
+ Nordastrea	S (Ludl)		(1240)	- Parvaxon	C (Serp-l)		
Nothaphrophyllum	C (Vise)			Paterophyllum	D (Gedi)		
+ Nothophyllum	P (Asse)		(1240)	Pavastehphyllum	P (Asse)	-P (Guad-u)	(1240)
+ Novichuska	D (Eife)		(1240)	Pedderelasma	D (Eife)		
Numidiaphyllum	P (Djhu)		(1240)	Peneckiella	D (Emsi)	-D (Fras-u)?	(174,680, 1240)
Odontophyllum	D (Give)			Pentamplexus	P (Leon)	-P (Dora)	(893)
Ogilvilasma	D (Emsi-l)			- Pentaphyllia	C (Vise)		(1240)
Oligophyllum	D (Sieg)	-D (Fame)	(422,1240)	Pentaphyllum	D (Fame-m)?	-P (Dora)	(798,1086)
Oliveria	S (Ludl-l)?			Peripaedium	D (Eife)	-D (Give)	(1240)
Omiphylum	C (Serp)			- Peronophyllum	D (Sieg-l)		(1240)
Onychophyllum	S (Ldov)			Petalaxis	C (Vise-u)	-C (Mosc)	(856,1240)
Opiphyllum	C (Bash-l)	-C (Bash-u)	(163)	Petraia	S (Ludl)	-D (Fame-u)	(680)
Orionastraea	C (Vise-u)	-C (Serp-l)	(163)	Petraicella	D (Fame-l)	-D (Fame-u)	(680)
Ornatophyllum	D (Gedi)		(1240)	+ Petraphyllum	P (Leon)		
Orthocyathus	D (Eife)			Petronella	D (Eife)		
Orthophyllum	D (Gedi)		(1240)	Petrozium	S (Ldov-l)	-S (Wenl-l)	(711)
Orygmophyllum	C (Bash)	-C (Step-u)	(163)	Pexiphyllum	D (Give-u)		
Ozakiphyllum	C (Serp)			+ Phacellophyllum	D (Emsi)	-D (Fras)	(1240)
Palaearaea	S (Ldov-u)			+ Phacelloplasma	D (Eife)		(1240)
Palaeocyathus	S (Ludl)	-D (Eife)	(422)	Phaulactis	S (Ldov)	-D (Sieg)	(1240)
Palaeocyclus	S (Ldov-u)	-S (Wenl-l)		Phillipsastrea	D (Sieg)	-D (Fras-u)	(680)
Palaeoentelophyllum	O (Ashg)		(1240)	Phineus	C (u)		
Palaeolithostrotion	O (Ashg)		(1240)	Phymatophyllum	D (Emsi)	-D (Eife)	(1240)
Palaeophyllum	O (Cara-l)	-S (Wenl)		Piceaphyllum	D (Fras-l)	-D (Fras-u)	(174,680)
Palaeosmia	D (Fame-u)	-C (Bash-l)	(163,680)	Pilophyllia	S (Ldov-u)	-S (Wenl-u)	
Palastraea	C (Vise)		(1240)	Pilophylloides	S (Ludl)		
+ Paleogrypophyllum	D (Gedi)		(1240)	Pilophyllum	S (Ldov-u)?	-D (Gedi)	
Paliophyllum	O (Cara-u)	-S (Ldov-m)	(711)	Planetophyllum	D (Eife)		(422)
Pamirophyllum	P (l)			Plasmophyllum	S (Wenl-u)		
+ Pantophyllum	D (Give)	-D (Fras-u)		Pleophyllum	C (Vise)	-P (u)	
Papiliophyllum	D (Emsi)	-D (Fras-u)	(680)	Pleramplexus	P (Guad-u)	-P (Dora)	(893)
- Pararachnastraea	C (Step-u)		(1240)	?Plerodiffia	P (Sakm)		
Paraaulina	C (l)			Pleurophyllum	P (l)	-P (Dora)	(666)
Parabrachyellasma	O (Ashg)		(1240)	+ Polaroplasma	D (Gedi)		(1240)
Paracannia	P (l)	-P (Dora)		+ Poliphyllum	C (Vise)		(1240)
Paracarruthersella	P (Wc)			+ Polyadelphia	D (Give)		(1240)
- Paracolumnaria	D (Fras)		(1240)	Polydilasma	S (Wenl)		
Paracystiphyloides	D (Eife-u)			Polygonaria	C (Vise)		
Paradisphyllum	D (Sieg-l)	-D (Emsi)		Polyrophe	S (Ldov)?	-S (Prid)	(1240)
+ Paradoxaphyllia	C (Vise)		(1240)	Polythecalis	P (Asse)	-P (Djhu)	
+ Paraduplophyllum	P (Asse)	-P (Leon)	(1240)	+ Polythecalloides	P (Asse)		(1240)
Parafletcheria	S (Ldov)			Porfirivieilla	S (Ldov)		
+ Paraherischioides	C (Bash-l)	-C (Step-u)	(1240)	Praewentzelella	P (Sakm-u)	-P (Guad-u)	
Paraipciphyllum	P (Guad-l)	-P (Guad-u)		Primitophyllum	O (Cara-l)	-O (Ashg)	(2,1240)
Paralithostrotion	C (Vise-u)	-C (Serp-u)	(163)	Prismatophyllum	D (Emsi)	-D (Give)	
Paralleynia	P (Leon)			+ Prodarwinia	S (Ldov-m)	-S (Ludl-l)	
+ Paramixogonaria	D (Give)		(1240)	Prohexagonaria	S (Wenl-l)	-S (Prid)	
Paramplexoides	O (Ashg-m)						

Taxon	First Appearance	Last Appearance	Reference	Taxon	First Appearance	Last Appearance	Reference
Prosmilia	D (Fame-l)	-P (Guad-u)	(680)	Pycnostylus	S (Ldov)	-S (Prid)	(1240)
Proterophyllum	O (Cara)?	-O (Ashg)	(1240)	Qiannanophyllum	D (m)		
+Protoaulacophyllum	D (Eife)		(1240)	Qinghaiophyllum	C (Vise-u)		
Protocaninia	C (Tour-l)			+Qinlingophyllum	D (Eife)		(1240)
Protocarcinophyllum	C (Vise)			Rachaniophyllum	D (Fras-u)		(174,680)
Procyathactis	O (Cara-u)	-S (Ldov-m)	(711)	Radiastrea	S (Prid)	-D (Fras-u)	(680,1240)
Protocyathophyllum	C (Vise)			Radiophyllum	D (Sieg)	-D (Eife)	(1240)
Protodurhamina	C (Serp-u)	-C (Bash-l)	(163)	Ramiphyllum	C (Vise-u)		
Protolonsdaleiastraea	C (Step)	-P (Guad-l)		Ramulophyllum	D (Gedi)		(1240)
Protomacgeea	D (Eife)			Rectigrewingkia	O (Ashg-l)		
Protopilophyllum	S (Ldov-u)	-S (Wenl)		Redstonea	D (Eife)		(422)
Protoramulophyllum	S (Ldov)			Reimanelasma	O (Cara)		
Prototryplasma	S (Ldov-u)			Reimanophyllum	D (Gedi)		
Protowentzellia	P (Asse)	-P (l)		Retiophyllum	D (Gedi)	-D (Emsi)	(422,1240)
Protozaphrentis	O (Cara)			Rhabeleasma	O (Ashg)		(1240)
+Pseudallotropiophyllum				Rhabdocyclus	S (Ldov-m)	-D (Gedi)	
	C (Step-u)		(1240)	Rhegmaphyllum	S (Ldov-m)	-S (Ludl)	(711)
Pseudamplexophyllum				Rhipidophyllum	D (Sieg)		
	D (Gedi)			Rhizophylloides	S (Ludl)		(1240)
Pseudamplexus	S (Ldov)	-D (Emsi)	(422,1240)	Rhizophyllum	S (Ldov-m)	-D (Emsi)	
Pseudoamplexus	P (l)			+Rhytidolasma	D (Eife)		(1240)
+Pseudoamygdalophyllum				Rhytidophyllum	S (Ludl)		
	C (Bash)		(1240)	Ridderia	D (Eife)		
Pseudoblothrophyllum				Rotiphyllum	C (Vise-l)	-C (Mosc-u)	
	D (Gedi-l)			+Rozkowskaella (+ Trigonella)			(680)
Pseudobradiphyllum	C (Step-u)				D (Fras-u)		
Pseudocampophyllum				Rozkowskia	C (Vise-u)		(163,1240)
	D (Give)			Rukhinia	S (Ldov-u)		
Pseudochonophyllum				Ryderophyllum	S (Ludl-l)		
	D (Sieg)	-D (Emsi)	(422)	Rylstonia	C (Tour-u)	-C (Vise-u)	
Pseudoclaviphyllum	D (Fame-u)	-C (Vise)	(680)	Salairophyllum	D (Gedi)		
Pseudocryptophyllum				Saleelasma	C (Tour-l)	-C (Vise-l)	
	C (Tour)?	-P (u)?	(1240)	+Salvadorea	O (Ashg-l)	-O (Ashg-m)	
Pseudocystiphyllum	S (Wenl)			Sanidophyllum	D (Eife-u)	-D (Give)	
Pseudodigonophyllum				Sassendalia	P (Leon)		
	D (Eife)		(1240)	Saucrophyllum	D (Gedi)		
Pseudodorlodotia	C (Vise-u)			Scenophyllum	D (Emsi)		
Pseudogrypophyllum				Schindewolfia	S (Ludl)	-D (Gedi)	(1240)
	D (Gedi)			Schizophaulactis	S (Ldov-m)		
+Pseudohexagonaria	D (Eife)	-D (Give-u)		Schlothemiphyllum	S (Ldov-m)	-S (Ludl)	(711)
Pseudohuangia	P (Asse)	-P (Guad-u)		+Schlueteriphyllum	D (Give)		(1240)
+Pseudomicrocroplasma				Schoenophyllum	C (Tour-u)	-C (Vise-u)	(957)
	S (Prid)			Schreteria	C (u)		
Pseudomucophyllum	S (Ludl)		(1240)	Sciophyllum	C (Vise-u)		
Pseudopavona	C (Serp-u)	-C (Mosc-u)		Sclerophyllum	O (Ashg-m)	-S (Ldov)	
Pseudophaulactis	S (Ldov-u)			Scruttonia	D (Fras-l)	-D (Fras-u)	(174,422,680)
Pseudopilophyllum	S (Wenl-l)			Scyphophyllum	S (Prid)	-D (Gedi)	
Pseudopolythecalis	P (Guad)			+Segdianophyllum	O (Ashg)		(1240)
+Pseudorhabdophyllum				Sestrophyllum	C (Mosc-l)	-C (Step-u)	
	D (Eife)		(1240)	+Shansiphyllum	S (Wenl-l)		(651)
Pseudotimania	C (Mosc-u)	-C (Step-u)		Shastaphyllum	S (Ludl)		(1240)
Pseudotryplasma	D (l)			Shensiphyllum	S (Wenl)		
Pseudowannerophyllum				Siedleckia	C (Bash)	-C (Step-u)	(1240)
	C (Bash-l)			+Sigelophyllum	D (Eife)		(1240)
Pseudoyatsengia	P (Leon)			Sinochlamydeophyllum			
Pseudozaphrentoides	C (Vise-u)	-C (Mosc-u)	(163)		D (Eife)		
Psydracophyllum	D (Emsi-u)	-D (Give-l)		Sinodisphyllum	D (Eife)	-D (Fras-u)	(422,680)
Pterophrentis	S (Ldov-l)			Siphonodendron	C (Tour-u)	-C (Serp-l)	(163)
Ptychophyllum	S (Ldov)	-S (Ludl)	(1240)	Siphonolasma	O (Ashg-m)		
+Puanophyllum	D (Eife)			Siphonophrentis	D (Sieg)	-D (Give)	(2,1240)
Pycnactis	S (Ldov-m)	-S (Ludl)	(711)	Siphonophyllia	D (Fame-u)	-C (Serp-l)	(174,680)
Pycnactoides	O (Ashg-m)						

Taxon	First Appearance	Last Appearance	Reference	Taxon	First Appearance	Last Appearance	Reference
Skolekophyllum	C (Bash-u)	-C (Mosc-l)		+Synamplexoides	S (Ldov-u)	-S (Wenl)	
-Skolophyllum	D (Eife)		(1240)	Synamplexus	S (Wenl)		
Slimoniphyllum	C (Vise-u)			Synaptophyllum	D (Eife)		
Smithicyathus	D (Fras-u)		(174,680)	Syringaxon	S (Wenl-l)	-D (Fame-u)	(174,680)
Smithiphyllum	D (Eife-u)	-D (Fame-l)	(680)	+Szechuanophyllum	P (Asse)?	-P (Guad)	(1086)
Sochkineophyllum	C (Mosc)	-P (Leon-m)		Tabularia	S (Wenl)		
Sociophyllum	D (Emsi)	-D (Fras)	(422)	Tabulophyllum	D (Emsi)?	-D (Fame-u)	(174,680, 1240)
+Soetenia	D (Give)		(1240)	Tachylasma	P (Leon)	-P (Dora)	(893)
Sogdianophyllum	O (Ashg)			Tachyphyllum	C (Tour)		
+Sokoloviella	S (Ludl)		(1240)	Tainyrophyllum	D (Gedi)	-D (Give)	(422,1240)
Solenodendron	C (Tour-u)	-C (Serp-l)	(163)	Taisyakophyllum	C (Serp-u)	-C (Mosc-u)	
Solipetra	D (Eife)	-D (Give)	(422,1240)	+Taiziheophyllum	C (Step-l)		(1240)
Soshkinolites	S (Ludl)			Tambaella	P (Guad-l)		
Spasskyella	D (Give)			Taralasma	D (Emsi)		
Spineria	P (Guad-u)			+Tarphyphyllum	D (Fras-l)	-D (Fras-u)	(165,680)
Spinophyllum	D (Give-l)	-D (Fras)		+Tarophyllum	D (Eife)		(1240)
Spirophyllum	C (Vise-u)	-C (Serp)	(1240)	Tatjanophyllum	C (Vise)		
+Spissophyllum	D (Eife)		(1240)	Tawuphyllum	D (Eife-u)		
+Spongastraea	D (Eife)		(1240)	Temnophyllum	D (Emsi)	-D (Fras-u)	(422,680)
+Spongielasma	D (Eife)		(1240)	Tenuilasma	S (Ldov-u)		
Spongonaria	D (Emsi)	-D (Eife)	(422,1240)	Tenuiphyllum	S (Wenl-u)		
Spongophylloides	S (Wenl)	-S (Prid)		+Tetrafoossularia	S (Ldov)		(1240)
Spongophyllum	S (Ludl)	-D (Eife)	(1240)	Tetralasma	C (Vise-l)	-P (Djhu)	(893)
Stauria	S (Ldov)	-S (Wenl-l)		+Texturiphyllum	D (Siegl-l)		
+Stauromatidium	D (Gedi)		(1240)	Thamnophyllum	D (Siegl)	-D (Fras-u)	
Staurophyllum	C (Vise-u)	-C (Serp-l)		Thecaeristatus	S (Ludl)		
Stelechophyllum	C (Tour-u)	-C (Vise-u)		Thecaxon	D (Fras-m)	-D (Fame-l)	(174,680)
Stellatophyllum	D (Eife)	-D (Fras)	(1240)	+Thololasma	D (Emsi)		(1240)
Stereocorypha	C (Bash-u)			+Thoulelasma	D (Eife)		(1240)
+Stereodespasophyllum	C (Vise-u)		(957)	+Thulioicyclus	S (Prid)		
Stereolasma	D (Eife)	-D (Give)	(1240)	+Thuriantha	C (Tour-l)		(798)
+Stereophrentis	C (Bash-l)	-C (Bash-u)	(163)	+Thyryptophyllum	D (m)		(1240)
Stereophyllum	D (Eife)			Thysanophyllum (+ Phacellophyllum)			
Stereostylus	C (Vise-u)	-P (Djhu)	(2,893)	C (Vise-l)	-P (Asse)		
Sterictophyllum	D (Siegl)		(422)	Timania	C (Bash)	-C (Step-u)	(1240)
Stewartophyllum	D (Give-l)			Timorphyllum	P (Guad-u)?	-P (Djhu)	(893)
+Stikineastraea	P (Wc)		(856)	Tiphoeophyllum	D (Siegl-l)	-D (Emsi)	(422)
+Stilbophyllum	P (Sakm)		(1240)	+Tjanshanophyllum	O (Ashg)		(1240)
Stortophyllum	S (Ludl)	-D (l)		Tonkinaria	D (Gedi)		
Strephophyllum	S (Wenl-l)			Toquimaphyllum	S (Ludl)	-D (Gedi)	
Streptelasma	O (Cara-l)	-S (Ldov-m)	(2,711)	Tortophyllum	D (Eife)		(1240)
+Streptophyllum	P (Sakm)		(1240)	+Trachylasma	P (l)	-P (u)	(1240)
+Stringophylloides	D (Eife)		(1240)	Trachyphyllum	S (Wenl)	-S (Ludl)	
Stringophyllum	D (Emsi)	-D (Give-u)	(422)	Trapezophyllum	D (Siegl)	-D (Fras-m)	(422,680)
Strombodes	S (Ldov-m)	-S (Ludl-l)	(711)	+Traskina	P (Sakm)		(1240)
Stylastraea	C (Step)	-P (Sakm)	(1240)	+Trigonella	D (Fras-u)		(798)
Stylopleura	S (Ludl)	-D (Gedi)		+Triphyllia	C (Vise)		(1240)
+Submesofavosites	S (u)			Triplophyllum	D (Eife)		
+Subatarauia	D (Eife)		(1240)	Trochophyllum	C (Tour-l)	-C (Tour-u)	
Sudeia	D (Fras-l)	-D (Fras-u)	(174,680)	Tropidophyllum	D (Siegl)	-D (Emsi)	(422)
Sugiyamaella	C (Tour-u)	-C (Vise-l)		+Truncarinulum	D (Eife)	-D (Give-u)	
Sulcophyllum	D (Emsi)	-D (Fras)	(422)	+Trypaecystiphyllum	S (Ldov)		(1240)
Sumsarophyllum	O (Ashg)		(1240)	Tryplasma	O (Ashg-l)	-D (Eife)	(2,1240)
Sunophyllum	D (Eife-u)?	-D (Give-u)		Tschussovskenia	C (Step-u)	-P (Sakm)	(1240)
Sutherlandia	S (Ludl)	-D (Siegl)	(422)	+Tumanophyllum	S (Wenl)		(1240)
Svalbardphyllum	P (l)			+Tumucophyllum	O (Ashg)		(1240)
Sverigophyllum	S			Turbinatocanina	C (Serp-l)		(1240)
Svetlania	S (Prid)		(1240)	Turbophyllum	C (Vise-u)?		
Sychnoelasma	C (Tour-l)	-C (Vise-l)		+Turgidifria	P (Sakm)		
Symphiphyllum	D (Siegl)		(1240)	Ufimia	D (Emsi-u)	-P (Dora)	(680,893, 1066)
Symplectophyllum	C (Vise-u)						

Taxon	First Appearance	Last Appearance	Reference	Taxon	First Appearance	Last Appearance	Reference
+Ulanophyllum	S (Ludl)		(1240)	+Zonophyllum	D (l)	-D (Give)	(1240)
Ullernelasma	O (Ashg)		(1240)	Zhushanophyllum	S (Ldov-m)		
Uralinia	D (Fame-u)	-C (Tour-u)	(680)	Or. HETEROCORALLIA			
Utaratuia	D (Give)	-D (Fras)	(1240)	+Dichophyllia	C (Vise)		(1240)
+Vacoca	P (Asse)	-P (Leon)		+Fossaphyllia	C (Vise)		(1240)
Variseptophyllum	D (m)			+Haptaphyllina	C (Vise)		(1240)
+Vepresisociophyllum	D (Eife)		(1240)	Heterophyllia	D (Fame-u)	-C (Vise-u)	
Vepresiphyllum	D (Emsi)			+Heterophylloides	C (Vise)		(1240)
+Veraephyllum	S (Wenl)		(1240)	Hexaphyllia	C (Vise-u)		(1240)
Verbeekiella	C (Step-u)	-P (Djhu)	(893)	+Longlinophyllia	C (Vise)		(1240)
Vesiculophyllum	C (Tour-l)	-C (Serp)	(1240)	Oligophylloides	D (Fame-u)		
Vesiculotubus	C (Tour-u)			+Pristiophyllia	C (Vise)		(1240)
Vestigiphyllum	D (Emsi)	-D (Eife)	(422)	Pseudopetraia	D (Eife)		
Vischeria	O (Cara)?			+Quadratiphyllia	C (Vise)		(1240)
+Vojnovskija	S (Ldov)		(1240)	+Radiciphyllia	C (Vise)		(1240)
Waagenophyllum	P (Sakm)	-P (Dora)		Or. SCLERACTINA			
+Wapitiophyllum	D (Fras-u)		(680)	Acanthastrea	T (Mi)	-R	
Weiningophyllum	C (l)			Acanthocyathus	T (Mi)	-R	(796)
Weissermelia	S (Ludl-u)	-S (Prid)	(1240)	Acanthogyra	J (Oxfo-l)	-K (Apti-l)	(819,820)
Wenlockia	S (Wenl)			Acanthophyllia	T (Mi-m)?	-R	
Wentzelella	C (Step)	-P (Djhu)	(893)	+Acrohelia	T (Mi-u)	-R	(796)
Wentzelellites	P (Leon-u)	-P (Djhu)		Acropora	T (Eo-l)	-R	
Wentzelloides	P (Leon-u)	-P (Djhu)	(893)	Acrosmitia	J (Oxfo)	-K (Coni)	(2)
Wentzelophyllum	P (Asse)	-P (Guaid-u)	(1240)	Actinacis	K (Ceno-l)	-T (Mi-l-l)	(2)
+Wenxianophyllum	D (Sieg)		(1240)	Actinaraea	J (Sine)	-K (Apti)	(819,821, 825,919)
Werneckelasma	D (Sieg-u)			+Actinaraeopsis	J (Oxfo-m)	-J (Kimm-u)	(868)
+Wexolina	P (Sakm)		(1240)	Actinatraea	Tr(Ladi-u)	-K (Maes)	(817)
+Weyerelasma	C (Serp-l)			+Actinastaeopsis	K (l)		(658,ZR84)
+Wilsonastraea	P (Wc)		(856)	+Adekoheastrea	T (Pale)		(658)
Windelasma	D (Gedi-l)			+Adelocoenia	J (Bath)	-J (Call)	(847)
Wintunastraea	S (Ludl)?			Adkinsella	K (Albi)		(2)
Xenocyathellus	D (Giv e-l)			Agaricia	T (Mi-m)	-R	
Xiangzhouphyllum	D (Eife)		(1240)	Agathelia	K (Haut)	-K (Maes)	(837)
Xiphelasma	S (Wenl)	-S (Ludl)	(1240)	Agathiphyllia	K (u)?	-T (Mi-m)	(658)
Xystrigona	D (l)			+Aggomorphastraea	J (Bajo)		(658)
Xystriphylloides	D (Emsi-l)	-D (m)		Ahrdorffia	K (Ceno)	-K (u)	(2)
Xystriphyllum	S (Prid)	-D (Give)		+Alakiria	Tr(Nori-l)		(919)
Yabeiphyllum	C (u)	-P (Sakm-u)		+Allocoenia	J (Bath-l)	-J (Tith)	
Yakovliella	C (Mosc-u)			+Allocoeniopsis	J (Hett)	-J (Call)	(183,833, 919)
Yanbianophyllum	S (u)			+Alloiteaucoenia	J		(658)
Yassia	S (Ldov-u)	-S (Prid)		+Alloiteausmitia	J (Plie-u)		(682)
Yatsengia	P (Leon-l)	-P (Djhu)		+Alpinophyllia	Tr(Nori)	-Tr(Rhae)	(919)
+Yishanophyllum	D (Fame)		(1240)	+Alpinoseris	Tr(Rhae)		(919)
Yohophyllum	O (Cara)			+Alveocyathus	K (Maes)		(1125)
Yokoyamaella	P (Asse)	-P (Djhu)	(893)	Alveopora	T (Eo-l)	-R	
Yuanophylloides	C (Mosc)	-C (Step-u)	(1240)	+Ampakabastraea	Tr(Nori-l)	-J (Call)	(183,834)
Yuanophyllum	D (Fame-u)	-C (Vise)	(680)	+Amphelia	T (Eo)	-R	(796)
+Yurievstiella	D (Emsi)		(1240)	Amphiastrea	J (Toar)	-K (Ceno)	(2,828)
Zakowia	C (Vise-u)			+Amphiaulastrea	J (u)		(920)
Zaphrentis	D (Emsi)	-D (Eife)	(1240)	+Amphimeandra	J (u)		(851)
Zaphrentites	D (Fame-u)	-C (Mosc-u)	(680)	+Amphiphora	J		(658)
Zaphrentoides	D (Fame-u)	-C (Vise)	(680)	Andemantastraea	J (Toar)	-J (u)	(183)
Zaphrentula	C (Serp)		(1240)	+Andrazella	Tr(Ladi-u)	-Tr(Carn-u)	(185)
Zaphriphyllum	D (Fame-u)	-C (Vise-u)	(680)	+Angeliphyllia	T (Oh)		(658)
Zeliaphyllum	P (Asse)?			+Anisastrea	K		(658)
+Zelocystiphyllum	S (Ldov)		(1240)	Anisocoenia	T (Mi)		
Zelolasma	D (Sieg)	-D (Emsi)	(422)	+Annotocyathus	T (Eo)		(658)
Zelophyllia	D (Gedi)	-D (Eife)	(422)				
Zelophyllum	S (Wenl)	-S (Ludl)?					
Zenophyllia	S (Ludl)						
Zeravschania	S (Ldov-u)						
+Zonodigonophyllum	D (Eife)		(1240)				

Taxon	First Appearance	Last Appearance	Reference	Taxon	First Appearance	Last Appearance	Reference
Anomastrea	K (Apti)	-R	(2)	+ Brachycyathus	T (Dani)		(2,86)
+ Anomopora	T (Mi)		(658)	+ Brachymeandra	K		(658)
+ Anthostylis	Tr(Rhae)		(919)	Brachyphyllia	K (Apti)	-K (Turo)	(2)
Antiguastraea	K (Ceno)	-T (Mi-m)		Brachyseris	J (Plie)	-K (Maes)?	(2,682)
Antillia	T (Eo-l)	-T (Plio)		+ Bracystrochus	T (Ol)	-R	(796)
Antillocyathus	T (Mi-u)			+ Bracthelia	J (Call)		(658)
Antillophyllia	T (Ol-u)?	-T (Plio)		+ Brevimeandra	J (u)		(658)
Antilloseris	T (Eo-u)		(2)	Budaia	K (l)	-K (Ceno)	
+ Apelismilia	Tr(Nori)		(834)	+ Bussonastraea	J		(658)
Aplocyathus	T (Eo)	-R	(796)	+ Calameastolia	K		(658)
Aplophyllia	J (m)	-J (Kimm-l)	(823)	Calamophyllia	J (Bajo)	-K (Maes)?	(2,806)
+ Aplopsammia	K (Albi)	-K (Ceno)	(658)	+ Calamophylliopsis	J (Oxfo-m)	-K (u)	(796,823)
Aplosmilia	J (Oxfo-l)	-K (Sant-u)	(2)	+ Calamoseris	J (m)		
+ Apocladophyllia	J (Kimm)?	-K (Berr)		+ Calostylopsis	K		(658)
+ Aquitanastraea	T (Ol)		(658)	+ Carantophyllum	J		(658)
+ Aquitanophyllia	T (Mi)		(658)	Carciocoenia	K (m)		
+ Araiophyllum	Tr(Carn)	-J (Plie-u)	(682,919)	+ Cardiastraea	J (Toar-u)		(658,682)
+ Archaeolasmogyra	Tr(u)?		(658)	+ Carolastraea	J (Call-m)	-J (Tith)	(688)
+ Archaeophyllia	Tr(u)?		(658)	Caryophyllia	J (u)	-R	(796,ZR85)
+ Archaeosmilia	J (Hett)	-J (Plie-u)	(682,919)	Caryosmilia	K (Maes)		(1270)
+ Archaeosmiliopsis	J (Hett)	-J (Sine)	(919)	Cassianastraea	Tr(Ladi-u)	-Tr(Carn-u)	
Archohelia	K (Ceno)	-R		Caulastraea	T (Eo)	-R	
Arctangia	K (Berr)		(2)	Cenomamina	K (Ceno)		(2)
Areopsammia	K (Maes)		(86)	Ceratocoenia	J (Bath)		(2)
Aspidastraea	K (Sn)			Ceratophyllia	T (Eo)		
Aspidiscus	K (Ceno-m)			+ Ceratopsammia	K (u)	-K (Maes)	(658,796)
Asterosmilia	T (Eo)	-R	(796)	+ Ceratothecia	J (Oxfo-u)	-J (Kimm-l)	(658)
+ Astraefungia	K (Ceno)	-K (Maes)		Ceratotrochus	K (Ceno)?	-R	
Astraemorphia	Tr(Carn-u)	-Tr(Rhae)	(919,920)	+ Cerceiophyllia	T (Ol)		(658)
Astrangia	T (Mi)	-R	(796)	+ Cerioheterastraea	Tr(Carn)	-Tr(Nori-l)	(919)
Astraraea	K (Sant)?, K (Camp)?		(818)	+ Ceriostella	Tr(Ladi-u)		
Astreopora	K (Turo)	-R	(2)	Cheliosmilia	J (Oxfo-l)	-J (Kimm)	(919)
Astrhelia	T (Mi)			+ Chevalieria	Tr(Anis)	-Tr(Nori)	(919)
Astrocoenia	J (u)	-T (Mi-m)		T (Eo)			(658)
Astrogyra	K (Turo)	-K (Maes)	(691)	+ Chevalierismilia	J (Hett)?	-J (Call)	(2)
+ Astroides	Q (Plei)	-R	(796)	Chomatoseris	J (Hett)?	-J (Call)	(2)
+ Athecastraea	T (Mi)		(658)	+ Chondrocoenia	Tr(Nori-l)	-Tr(Rhae)	(919)
+ Atopocoenia	T (Ol)		(658)	Circophyllia	T (Eo-l)	-T (Eo-u)	(86)
+ Aulastraea	J (Tith)			Cladangia	T (Mi-m)	-R	(796)
Aulastraeopora	K (m)			Cladocora	K (u)	-R	
Aulosmilia	K (Ceno)	-T (Dani)	(86)	Cladophyllia	J (Bajo)	-K (Albi)	(806)
Axocyathus	K (u)			+ Cladophylliopsis	J (Bath-l)		(658)
Axosmilia (+ Plesiosmilia)				Clausastraea	J (Bajo)	-K (m)	(2,796)
	J (Bajo)	-K (Ceno)	(2,833)	+ Clausastraeopsis	J (u)		(658)
+ Axotrochus	J (Toar-l)		(682)	+ Clonosmilia	T (Ol)		(658)
+ Baksanophyllia	K (Berr-u)		(658)	Cocophyllum	Tr(Nori-m)	-J (Plie-l)	(825,919)
Balanophyllia	T (Dani)	-R		Codonosmilia	J (Bath)	-J (u)	(2)
Bantamia	T (Mi)			+ Coelocoenia	Tr(Anis-m)	-Tr(Carn)	(919)
+ Baryhelia	J (Kimm-u)	-K (u)	(796,829)	+ Coelomeandra	Tr(u)?		(658)
Baryphyllia	K (Ne)	-K (Maes)?	(806)	Coeloseris	T (Mi)?	-R	(796)
Barysmilia	K (u)	-T (Eo-u)	(86)	Coenangia	T (Mi)	-R	(796)
+ Bathmosmilia	J (Bath-u)	-J (u)	(658)	+ Coenastrea	J (l)	-K	(828)
+ Bathycoenia	J (Bath)		(833)	Coenocyathus	T (Ol)	-R	
Bathycyathus	T (Ol-u)?	-R	(796)	+ Collignonastraea	J (Bath-l)	-K (Maes)	(658,691)
+ Beneckastraea	Tr(Carn)		(919)	Colophyllia	T (Eo-l)	-R	(850)
+ Bilaterocoenia	J (Tith)		(868)	Columactinastrea	K (Barr)	-T (Eo)	(821)
+ Blastosmilia	J (Oxfo)		(830)	Columastraea	K (Sant)?	-K (Maes)	(86,796, 818)
Blothrocycathus	K (Ne)?	-K (Apti)?		+ Columellogyra	K (l)	-K (Sn)	(ZR85,920)
+ Bodeurina	J		(658)	Columnaphyllia	J (u)		
Bothrophoria	K (Turo)	-K (Maes)	(2,1125)	Columnocoenia	J (Call-u)	-K (Maes)	(2,691,823)
+ Brachiatusmilia	T (Than-l)		(86)	+ Columnogyra	J		(658)
+ Brachycoenia	K (Turo)	-K (Maes)	(691)	+ Comophyllastraea	K (u)		(658)

Taxon	First Appearance	Last Appearance	Reference	Taxon	First Appearance	Last Appearance	Reference
Comophyllia	J (Bath-l)	- J (Kimm)?		Dasmiopsis	K (l)	- K (Sn)	(796)
+Comophylliopsis	K (Sant-u)	- K (Maes)	(691)	Dasmosmilia	K (u)	- R	
Comoseris	J (Plie)?	- K (Turo)	(796,919,1270)	+Decaheliocoenia	J		(658)
Complexaestraea	J (Bath)	- K (m)		+Defrancia	T (Mi)		(658)
+Complexaestraeopsis	J (Oxfo-u)	- J (Tith-u)	(868)	Deltocyathus	T (Eo-l)	- R	
+Confusastraea	J (Bajo)	- J (Oxfo)	(847)	Dendracis	T (Eo-l)	- T (Mi)	
Confusastraraea	T (Eo-u)			Dendraraea	J (Bath-l)	- K (l)	(2)
+Conicosmiliotrochus	K (Turo)	- K (Maes)	(658)	Dendrocycathus	K (Ceno)		(2)
+Connectastrea	J (Call)	- J (Kimm)	(796,833)	Dendrogyra	K (Barr)	- R	
Conocycathus	K (Maes)	- R	(1125)	Dendrophyllia	K (Maes)	- R	
Conophyllia	Tr(Carn)		(919)	Dendrosmilia	T (Eo)	- T (Ol)	
Conosmilia	T (Eo-u)?	- T (Mi)		+Dermosastraea	J		(658)
Conotrochus	T (Eo)	- R	(796)	Dermoseris	J (m)	- K (Maes)	(183)
+Convexaestraea	J (Oxfo-u)	- J (Tith)	(823,824)	Dermosmilia	J (Oxfo-l)	- K (Apti)?	(822)
Corbariastraea	K (Turo)	- K (Maes)	(691)	+Dermosmiliopsis	K (Sant)		(818)
+Coronocyathus	T (Than-l)		(86)	Desmocladia	T (Ol)		
+Coryphyllia	Tr(Carn-l)	- J (Plie-u)	(682,919,920)	+Desmocoenia	Tr		(658)
Coscinaeraea	T (Eo-u)	- R		Desmophyllum	K (Ceno)	- R	
Craspedophyllia	Tr(Carn-l)	- Tr(Rhae)	(919,920)	+Dermosmiliopsis	K (Sant)		(818)
+Crassistella	Tr(Nori-l)	- Tr(Rhae)	(919)	Diblasus	K (u)	- K (Maes)	(86)
+Craterastraea	J (Bath)		(658)	+Dichocoeniopsis	K		(658)
Crateroseris	J (Oxfo)			Dichocoenia	K (Turo)	- R	(796)
Cricocycathus	T (Eo)	- T (Mi-m)		+Dichotomosmilia	J (m)		(658)
Cryptangia	T (Mi)	- T (Plio)		Dictyaraea	T (Ol-l)	- T (Plio)	(850)
+Cryptocoenia	J (Bath)	- J (Kimm-u)	(826,829)	+Diegosmilia	K		(658)
+Ctenactis	T (Mi)	- R	(796)	+Digitosmilia	J (Bath)		(658)
+Cuifastraea	Tr(Nori-m)	- Tr(Rhae)	(919)	Dimorpharaea	J (Bajo)	- K (m)	(796)
+Cuifia	Tr(Nori-m)		(919)	Dimorphastrea	J (Plie-u)	- T (Eo-l)	(682,796)
Culicia	T (Mi-l-u)	- R		+Dimorphastraepsis	J (m)	- K (l)	(183)
+Cunolites	K (Ceno)	- K (Maes)	(796)	+Dimorphocoeniopsis	J (u)	- K (Apti-l)	(821,826)
+Cyathelia	Q (Plei)	- R	(796)	+Dimorphocoeniopsis	K (Barr)	- K (m)	(658)
Cyathoceras	T (Dani)	- R	(841)	+Dimorphofungia	J		(658)
Cyathocoenia	Tr(Anis-u)	- Tr(Nori)	(869,919,920)	+Dimorphomeandra	J (Oxfo-u)	- K	(658)
Cyathophora	J (Bajo)	- K (Maes)?	(806,833)	+Dimorphophyllia	T (Pg)		(796)
+Cyathophyllia	J (Aale)	- K (Berr-u)	(846,848)	Dimorphoseris	J (m)	- K (u)	
+Cyathophylliopsis	J (Bajo-u)		(658)	Dimorphosmilia	J (m)		
Cyathoseris	K (Ceno)?	- T (Ol-u)	(1110)	Diplaraea	J (Oxfo-u)	- K (l)	(823)
Cyathosmilia	T (Eo-u)	- T (Mi)	(796)	Diploaetra	K (Nc)	- R	(806)
+Cyathotrochus	T (Mi)	- R	(796)	Diplocoenia	J (Bath)	- K (Turo)	(819,820,1270)
Cyclaestraea	K (Ceno)			+Diplocteniopsis	K (Apti)		(658,1270)
+Cyclobacia	K (Turo)		(845)	Diploctenium	K (Ceno)	- K (Maes)	
+Cycloflabellum	T (Plio)		(658)	Diplogyra	K (l)		
Cyclolites	K (Haut)	- T (Eo-u)	(2)	Diplohelia	T (Eo-l)	- T (Eo-u)	(86)
Cyclolitopsis	T (Eo-l)	- T (Eo-m-u)	(86)	Diploria	T (Eo)	- R	(796)
Cyclomussa	T (Ol)			+Diplothecangia	T (Ol)		(658)
+Cyclophyllia	K (Sant)	- K (Camp)	(1270)	Disaraea	J (u)		
Cyclophyllopsis	J (Plie-u)	- K (Apti)	(2,682)	Discocoenia	J (Hett-u)	- J (m)	(833)
Cycloseris	K (Apti)	- R		Discocoeniopsis	J (Hett)	- J (Sine)	(658,919)
Cyclindrocycathus	K (u)?	- K (Maes)		Discocycathus	J (l)	- K (Ceno)	(2)
Cylindrophyllia	T (Ol-l)	- R		+Discoidocycathus	T (Eo)		(658)
+Cylindrosmilia	J (Bajo)	- J (Kimm-u)	(658,688)	+Discosmilia	T (Dani)	- T (Than-l)	(86)
+Cylismilia	J (Kimm-l)			Discotrochus	T (Dani)	- T (Mi)	
Cyosmilia	J (Oxfo-l)	- J (Kimm)	(2)	+Distichomeandra	Tr(Nori-l)	- Tr(Rhae)	(919)
Cyphastraea	T (Mi)	- R	(796)	+Distichoflabellum	Tr(Rhae)		(919)
+Cyrtoycathus	K (Maes)		(86)	+Distichophyllia	Tr(Carn)	- Tr(Rhae)	(919)
Dactylaraea	J (u)			Dominicotrochus	T (Mi-l)	- T (Mi-m)?	
+Dactylocoenia	J (Bath)		(847)	Donacosmilia	J (Bajo)	- J (Tith)	(822,833)
Dactylosmilia	K (m)			+Dordonophyllia	K		(658)
Dasmia	T (Eo-l)	- T (Eo-m)	(86)	Duncanopsammia	T (Mi)	- R	
				+Duncanosmilia	J (Hett)	- J (Sine)	(919)
				Dungulia	J (Kimm)	- R?	(2)

Taxon	First Appearance	Last Appearance	Reference	Taxon	First Appearance	Last Appearance	Reference
+ Ebocotrochus	T (Pale)		(658)	+ Fromentelligyra	K (Sant-u)		
+ Ebrayia	J (Tith-u)		(832)	Fungia	T (Than)?	-R	
+ Eburneotrochus	T (Pale)		(658)	Fungiacyathus	K (Camp)	-R	(1125)
Echinophyllia	T (Mi)	-R		Fungiastraea	Tr(Nori)	-K (Camp)	(817)
Echinopora	T (Mi)	-R		+ Funginella	J (Plie)		(796)
- Eckastraea	Tr(Anis-l)	-Tr(Anis-u)	(869)	+ Funginellastrea	T (Eo-l)		(796)
- Edwardsastraea	J (Tith-u)		(832)	Fungophyllia	T (Ol-u)	-T (Mi)	(796)
+ Edwardsomeandra	J (Bath)		(658)	+ Gablonzeria	Tr(Nori-l)	-Tr(Rhae)	(919)
Edwardsoveris	J (m)	-K (l)?		Galaxea	T (Ol-u)	-R	(1110)
Edwardsosmia	K (Maes)		(86)	+ Gallitellia	Tr(u)?		(658)
+ Edwardsotrochus	T (Ol)	-R	(796)	+ Gardineroveris	T (Mi-m)	-R	(1110)
Elasmocoenia	K (Ceno)	-T (Eo)		Genabacia	J (Bajo)	-J (Bath)	(847)
+ Elasmofungia	K		(658)	- Ghireobocynthus	T (Than-l)	-T (Than-u)	(86)
+ Elasmogyra	K		(658)	Gigantostylis	Tr(Rhae)		(919)
+ Elasmophora	J		(658)	+ Gillastraea	Tr(Nori-m)	-Tr(Rhae)	(919)
Elasmophyllia	K (Nc)	-T (Eo-m)	(2,806)	Glenaraea	K (Toar)	-K (Apti)?	(822)
Elephantaria	K (u)			- Goldfussastraea	J (Barr-l)	-J (m)	(682)
- Ellipsasteria	J (Tith-u)		(658)	Gombertiphyllia	T (Ol)		(658)
+ Ellipsocoenia	J (u)	-K (Apti-u)	(821,826)	Goniastrea	T (Dani)	-R	(86)
+ Ellipsoidastraea	J (Toar)	-J (Bajo)	(828)	Goniocora	J (Aale)	-J (Tith)	(2,682)
Ellipsosmia	K (Sant)?, K (Camp)?		(818)	Goniopora	J (Kimm)?	-R	(920)
Elliptoseris	T (Eo)			Gonioseris	J (m)		
Elysastraea	Tr(Anis)	-Tr(Nori)	(2,920)	Gosaviaraea	K (u)	-K (Sant)	(2)
Enallhelia	J (m)	-K (Apti-l)?	(819)	+ Grandifavia	J (u)		(658)
+ Enallocaloemia	J (l)	-K (Maes)	(796)	Gravieropsamma	T (Eo-m)		
Enallopsammia	T (Mi)	-R		+ Gregorycoenia	J (Bath)		(658)
Endopachys	T (Eo-m-l)	-R		Grumphyllia	T (Ol)		
+ Eoehydorphora	K (Barr-l)	-K (Albi-l)		+ Guembelastraea	Tr(Carn-l)	-Tr(Nori-u)?	(834,919, 920)
+ Epiphyllum	J (l)		(796)	Guynia	T (Eo-u)	-R	
+ Epismilia	J (Toar)?	-K (l)	(828)	Gyrodendron	J (Kimm)?	-K (Apti-l)?	(819)
+ Epismiliopsis	J (l)		(846)	+ Haimeicyclus	J (l)		(658,ZR86)
Epistreptophyllum	J (Plie-u)	-K (Albi)	(2,682)	Haimesastraea	T (Dani)	-T (Eo-u)	(807)
Epirochus	T (Dani-u)		(86)	- Haimesiphyllia	K (Turo-u)	-K (Camp)	(691)
Etallonasteria (Etallonia)	J (Oxfo-m)	-J (Kimm-l)	(868)	Halomitra	T (Mi)	-R	(184)
+ Eugyra	K (Berr-l)	-K (Ceno-u)	(821)	+ Halystastraea	J (u)		(658)
+ Eugyriopsis	J (u)		(658)	Haplaraera	J (Oxfo-l)	-K (Maes)	(796,1270)
Euhelia	J (Bajo)	-J (u)	(2)	Haplohelia	K (Ceno)	-T (Ol-l)?	
Euphyllia	T (Ol-u)?	-R	(1110)	+ Hedeliastrea	K (Ceno)		(844)
Eupsammia	K (u)	-R		Heliocenia	J (Oxfo-u)	-K (Apti)?	(823)
Eusmia	T (Ol-u)?	-R		+ Heliofungia	T (Mi)	-R	(184)
Eusmiliopsis	K (m)			+ Heliostylina	J		(658)
Eusthenotrochus	T (Eo)	-R	(796)	+ Helioseris	T (Mi-u-l)	-R	(1102)
Ewaldocoenia	T (Eo-l)	-T (Eo-u)	(86)	+ Heliadophyllia	Tr(Rhae)		(919)
+ Faksephyllia	T (Dani)		(841)	Helloceras	T (Mi-u)	-R	
+ Fasciatiphyllia	T (Ol)		(658)	Hemiporites	K (Turo)		
+ Fasciseris	J		(658)	Herpolitha	T (Plio)	-R	(184)
Favia (+ Barbadiastrea)	T (Eo-m)	-R	(796)	Heterastraea	J (Hett)	-J (Bajo-l)	(2,919)
Favites	T (Eo)	-R		Heterocoenia	J (u)	-K (Maes)	(796,920, 1270)
+ Favitopsis	J		(658)	Heterocyathus	T (Mi-u)	-R	(796)
+ Faxsephyllia	T (Dani)		(86)	Heterogyra	T (Ol-l)		
+ Felixaraea	K		(658)	Heteropsammia	T (Plio)	-R	(796)
Felixastraea	K (Turo)			+ Hexaheliocenia	J		(658)
Felixigyra	J (u)	-K (Ceno)	(2,819)	+ Hexapetalum	J (Kimm-u)		(829)
Ferrya	J (Bath)		(2)	Hindeastraea	K (u)		
Ficariastraea	K (Coni)	-K (Sant)	(1270)	+ Hispaniastraea	J (Sine-u)	-J (Plie-l)	(658,825)
Flabelliosmia	K (u)			Holcotrochus	T (Mi-l)	-R	
Flabellum	T (Dani)	-R		Holocousioi	K (Barr)	-K (Apti-l)	(819)
+ Floria	K (l)		(658,ZR85)	Homophyllia	T (Ol-u)	-R	
+ Frescocyathus	T (Than-l)	-T (Than-u)	(86)	Hydnophora	K (Apti)	-R	
Fromentellia	J (m)	-J (u)		Hydnophorabacia	T (Eo)		

Taxon	First Appearance	Last Appearance	Reference	Taxon	First Appearance	Last Appearance	Reference
+Hydnophorareá	K (Apti-l)	-K (Sn)	(920)	Lobophyllia	T (Mi)	-R	(796)
+Hydnophoromeandraraea	K (Vala)	-K (Apti-l)	(658)	Lobopsammia	T (Eo-m-l)	-T (Ol-l)?	
+Hydnophorosaris	T (Mi)		(658)	+Loboseris	K (u)		(658)
+Hydnophyllon	T (Pale)		(658)	Lochnaemosmia	J (Bajo)	-K (u)	(847)
+Hydnoseris	K (u)		(658)	Lophelia	T (Dani)	-R	(86)
+Hykeliphylum	J (u)		(658)	+Lophophyllia	T (Mi)	-R	(796)
+Icaunhelia	J		(658)	Lophosmia	K (Ceno-l)	-R	
Idiotrochus	T (Mi-l)	-R	(796,1102)	+Lubowastraea	Tr(Carn-u)	-Tr(Nori-l)	(919)
+Ilariosmia	T (Eo)		(658)	+Lupitschia	Tr(u)?		(658)
Indophyllia	T (Ol)	-T (Mi)		+Maegeopsis	J (Toar-u)	-K?	(658,682)
Indosmia	T (Ol)	-T (Mi)		Madracis	K (Turo)?	-R	(2)
+Intersmia	J (Sine)	-J (Kimm-l)	(658,688)	Madrepora	T (Dani)	-R	(1125)
+Ironella	J (Oxfo-l)	-K (Vala)	(822)	+Maeandramorpha	J		(658)
Isastraea	Tr(Anis)	-K (Ceno)	(2,833,919)	Maendrosaris	Q (Plei)		
Isastrocoenia	J (l)	-J (Bath)	(828)	Maendrostylis	Tr(u)		
Isiphyllastrea	T (Mi-u-l)	-R	(1102)	Manicina	T (Mi-u-l)	-R	(1102)
Isophyllia	T (Mi-l-u)	-R	(1102)	Margarastraea	Tr(Nori-l)?	-Tr(Nori-u)	
+Ixogyra	T (Eo)		(258)	+Margarastreopsis	J (u)		(658)
+Kängilacüathus	T (Dani)	-T (Than-u)	(86)	Margarophyllia	Tr(Ladi-u)	-Tr(Carn-u)	(2,919,920)
+Káratasóraea	Tr(Nori-l)		(919)	Margarosmia	Tr(Carn-l)	-J (Toar)	(183,919,920)
+Keriphyllia	J (m)		(658)	+Matejka	T (Eo)		(658)
+Kionotrochus	T (Than-l)	-R	(86)	+Meandraraea	J (m)	-K (u)	(796)
+Kobyastraea	J (Call)	-J (Tith)	(820)	Meandrestrea	K (Berr-u)	-K (u)	(848)
+Kobycoenia	J		(658)	Meandrina	T (Ol-u)?	-R	(1110)
Koilocoenia	Tr(Anis)	-Tr(Rhae)	(2)	Meandrophyllia	J (m)	-K (Apti-l)	(847)
Koilotrochus	T (Eo-u)?	-T (Mi)		+Meandroria	K (Turo)?	-K (Maes)	
Kologyra	J (Oxfo-l)	-J (Tith)	(820)	Meandrosomia	K (Sant)	-K (u)	(2)
+Kompasteria	Tr(Rhae)		(919)	+Meandrostylis	Tr(Rhae)		(796,919)
+Ksiazkiewiczia	K		(658)	+Meandrovoltzia	Tr(Nori-l)		(919)
+Kuhnastraea	Tr(Nori)	-Tr(Rhae)	(919)	+Melikerona	J (Bath)	-J (Call)	(847)
+Kumbiopsammia	K (Maes)	-T (Than-u)	(86)	Merulina	T (Mi-u)	-R	(796)
Lamellastraea	T (Ol-l)	-T (Ol-u)	(1110)	Mesomorpha	Tr(Ladi-u)	-T (Than-l)	(796,837)
Lamellofungia	K (Sant)		(2)	+Michelinaraea	K (Apti-l)	-K (u)	(183)
+Lamellomeandra	J (u)		(658)	+Michelotiphyllia	T (Ol)		(658)
+Lamellophyllia	T (Mi)		(658)	Micrabacia	K (Barr)	-R	(2)
+Laminocyathus	K (Maes)		(1125)	Microphyllia	J (Toar)	-K (u)	(2,183,796)
Lasmosmia	K (Ceno)	-K (Turo)	(2)	+Microphylliopsis	J		(658)
Laterophyllia	T (Mi)			Microsmilia	J (Bajo)	-J (u)	(842)
+Latiastrea	J (Oxfo-u)	-K (Albi-l)	(658,821)	Microsolena	J (Bajo)	-K (Ceno-u)	(819,920,1270)
Latiphyllia	J (Bajo)	-K		+Microsolenastraea	K (Barr)	-K (Apti-l)	(819)
Latomeandra	J (Bajo)	-J (Tith-l)	(2,796,838)	+Miophora	T (Ol)		(658)
Latusastrea	J (Kimm)?	-K (Ceno-u)	(821)	+Mioscapophyllia	T (Mi)		(658)
+Lepiconus	Tr(Rhae)			+Mioseris	T (Ol)		(658)
Lepidophyllia	J (Sine)	-J (Bajo-l)	(2)	+Miscellosmia	J		(658)
+Lepidophylliopsis	J (Oxfo)?, J (Kimm)?		(826)	+Mistella	J (u)		(658)
Leptastrea	T (Ol-l-u)	-R		Mitrodendron	J (Oxfo-u)	-J (Tith-u)	
Leptocyathus	K (Ceno)?	-T (Eo-l)	(86)	+Mixastraea	J (Oxfo-u)	-J (Kimm-l)	(658)
Leptonussa	T (Eo-u)	-T (Ol-u)	(1110)	Miyakosimilia	K (l)		
Leptophyllaraea	K (m)			+Molukia	Tr(Rhae)		(919)
Leptophyllastraea	K (Ceno)		(2)	+Monocyclastraea	J (Kimm)	-K (Barr)	(658)
+Leptophyllia	J (Hett)	-K (Maes)	(796,919,1270)	Monomyces	K (u)?	-R	
+Leptophyllon	T (Pale)	-T (Eo-u)	(658)	Montastrea	T (Eo-m)?	-R	(796)
Leptoria	T (Eo)	-R	(796)	+Monticyathus	T (Than-l)		(86)
Leptosaris	T (Ol-u)?	-R		+Monticuliphyllia	T (Ol)		(658)
+Levicyathus	K (Maes)		(1125)	Montipora	T (Eo)	-R	
+Liptodendron	T (Eo-u)			Montivaltia	Tr(Anis-l)	-K (l)	(796,934)
+Litharaeopsis	K		(658)	+Morphastrea	K (Vala)	-K (Ceno)	(849)
Lithophyllon	T (Eo-u)	-R		Morchellastraea	K (u)		
+Lithostrozioides	K (Maes)		(86)	+Morycastraea	Tr(Anis-l)	-Tr(Nori)	(869)
Lithotrozioides	K (Maes)			Multicolumnnastraea	K (u)	-K (Maes)	(86)

Taxon	First Appearance	Last Appearance	Reference	Taxon	First Appearance	Last Appearance	Reference
Mussa	T (Mi-m)	-R	(1102)	Paradeltoocyathus	T (Eo-u)	-R	(796)
Mussisifilia	T (Mi-l)	-R		+Paradistichophyllum	Tr(Nori)	-Tr(Rhae)	(835)
Mycedium	T (Plio)	-R	(796)	Parahalomitra	T (Mi)?	-R	(796)
Mycetaraea	J (Kimm)			+Paraphylogyra	J (Plie)?	-J (Call)	(183,919)
Mycetophyllia	T (Ol-u)?	-R	(1110)	+Paraplacocoenia	K		(658)
Mycetophylliopsis	K (Turo)	-K (Sant-u)?	(2,818)	+Parapleurismelia	J (Plie-u)		(682)
+Mycetoseries	T (Pg)		(796)	Parasmilia	K (Nc)	-R	
Myriophyllia	J (Oxfo-l)	-K (Albi)	(806)	+Parastraeociorpha	Tr(Nori)	-Tr(Rhae)	(919,1120)
+Myriophyllum	Tr(Ladi-u)	-J (Plie)	(185,682)	+Parastroaeopora	T (Eo)		(658)
Nefocoenia	K (u)			+Parasystraea	K (u)		(658)
Nefophyllia	K (Turo)	-K (Maes)	(1270)	+Parathecosmilia	Tr(Rhae)	-J (Plie-u)	(658,674,682)
+Neocoeniopsis	K (Sant)	-K (Maes)	(691)	+Parepsilia	J (Kimm-l)		(658)
+Neocoenia	K (Sant)?	K (Camp)?	(818)	+Paretallonia	J (u)	-K (Haut)	(796,821)
+Neoconophyllia	Tr(Anis)	-Tr(Ladi)	(836,919)	+Parisstraea	J (m)		(658)
+Nerthastraea	T (Ol)		(658)	+Paronastrea	K (m)		(658)
+Nicaetrochus	T (Eo)		(658)	+Pattalophyllia	T (Dani)	-T (Ol-l)?	(2)
Notocyathus	T (Than-l)	-R	(86)	+Pattalophylliopsis	T (Eo)		(658)
Notophyllia	T (Mi)	-R		Pavona	T (Eo)	-R	(796)
+Ochoheliocoenia	J		(658)	Pectinia	R		
Oculina	K (Turo)	-R	(844)	+Pentacoenia	K (Haut-l)	-K (Apti-l)	(821)
Odontocyathus	T (Mi)	-R	(796)	Peplosmilia	J (Kimm)	-K (Ceno)	(2)
+Odontocyathoides	T (Eo)		(658)	Peponocyathus	T (Mi)	-R	(796)
+Oedalmia	Tr(Rhae)		(919)	Periseris	J (m)	-K (Maes)	(806)
Ogilviatraea	K (Turo)	-K (Sn)	(2)	Petrophyllella	T (Ol-l)	-T (Mi-l)	(839)
+Ogilvinella	J (Tith)		(820)	+Phacelepismilia	J (Hett)	-J (Sine)	(833,919)
+Omphalophyllia	Tr(Carn-l)		(919,920)	+Phacellastraea	J (m)	-J (u)	(658)
+Omphalophylliopsis	J (Plie-u)		(682)	+Phacellocoenia	J	-T (Than-l)	(86,658)
Onchotrochus	K (m)	-K (Maes)	(86)	+Phacelophyllia	J (l)		(919)
+Ondadiplocteniopsis	K		(658)	+Phacelostylophyllum	Tr(Carn)	-J (Plie-l)	(658,674,682)
Oppelisia	J (Hett)	-J (Sine)	(919)	Phyllangia	T (Mi)	-R	
+Orbignycoenia	J (Bajo-l)	-K (Ceno-l)	(847)	+Phyllocoenia	K (Vala)	-K (Maes)	
Orbignygyra	K (u)			Phyllogyra	J (m)		
Oulangia	T (Mi)	-R	(796)	+Phyllohelia	K (Maes)	-T (Than-u)	(86)
Oulastrea	K (Ceno)	-R		+Phylloseriopsis	J (m)		(183)
Oulophyllia	T (Mi)	-R	(796)	Phylloseris	J (Bajo)		
Ovalastrea	J (Bajo)	-K (Ceno)	(2)	Phyllosmilia	K (Turo)?	-T (Eo)	
+Ovalastraeopsis	J (m)		(183)	+Physogyra	T (Plio)	-R	(796)
Oyonnavastraera	J (u)			Physoseris	T (Eo-l)	-T (Eo-u)	(86)
+Pachycoenia	K (u)	-K (Maes)	(796)	Phytogyra	J (Oxfo-l)	-J (u)	
+Pachycyathus	K		(658)	Pinacophyllum	Tr(Carn)	-J (Plie)	(2,825,1120)
+Pachydendron	Tr(Carn-u)	-Tr(Nori-l)	(658,919)	+Pindosmilia	T (Ol)		(658)
Pachygyra	K (Turo)	-T (Eo-u)		Pinostrea	T (Eo)	-T (Mi-m)	
+Pachyphyllia	K (Sant)	-K (Maes)	(691)	Placocoenia	K (Turo)	-K (Maes)	(86,691)
Pachyseris	T (Mi-m)	-R	(2)	Placocoeniopsis	K (Maes)	-T (Than-u)	(86)
+Pachysolenia	Tr(Ladi)	-Tr(Nori-l)	(919)	Placocyathus	T (Mi-l)	-T (Plio)	(1110)
+Paähythecalis	Tr(Nori-l)		(658,919)	Placogyra	J (Oxfo)	-J (Tith-u)	(820)
Palaeastraea	Tr(Nori)	-Tr(Rhae)	(919)	+Placogyropsis	K		(658)
+Palastroepora	K (u)		(796)	Placophora	K (l)		
+Palacohelia	K (Albi-l)		(658)	Placophyllia	J (m)	-K (Apti-l)	(819)
Palacomussa	J (Oxfo-l)			Placosmilia	K (Apti-l)	-T (Eo-u)	
+Palaeophyllia	J		(658)	Placotrochus	T (Than-l)	-R	(86)
+Palaeoplesiastrea	T (Mi)		(658)	Platycoenia	T (Eo-m)	-T (Mi)	
Palaeopsammia	K (Barr)	-T (Than-l)	(86,819)	Platycyathus	K (Turo)?	-R	(796)
+Palaeosmilia	J (u)		(828)	Platygyra	T (Mi)	-R	(796)
+Paleastroides	T (Mi)		(658)	Platyhelia	T (Ol-u)	-T (Mi)	
Palaeastraea	Tr(Ladi)	-Tr(Nori)	(919)	+Platytrochopsis	K (l)		(658,ZR84)
+Palocyathus	K (Maes)		(1125)	Platytrochus	K (Turo)	-R	(2)
+Pamiroseris	Tr(Anis-l)	-Tr(Rhae)	(674,919)	+Plavicia	T (Eo)		(658)
+Paraclausastraea	K (Barr-l)		(821)	Plesiastrea	T (Mi-l)	-R	
+Paracunnolites	K (Turo)	-K (Maes)	(691)				
Paracyathus	T (Dani)	-R	(86)				
Paracycloseries	K (u)	-K (Maes)	(86)				

Taxon	First Appearance	Last Appearance	Reference	Taxon	First Appearance	Last Appearance	Reference
+Plesiocaryophyllia	K		(658)	+Quenstedtiphyllia	Tr(u)		(658,688)
+Plesiocoenia	J (m)		(658)	Rabdastraea	J (u)		
+Plesiocunolitopsis	K (Ceno)	-K (Maes)		+Recticostastraea	Tr(u)		
+Plesiodiplentienopsis	K		(658)	+Reimaniophyllia	Tr(u)?		(658)
+Plesiodiploria	K		(658)	+Reisocyathus	T (Ol)		(658)
+Plesiofavia	K		(658)	+Remismilia	Tr		(658)
+Plesiomontivaltia	J		(658)	+Renirsmilia	Tr(Carn)	-Tr(Nori)?	(827)
+Plesiophyllia	J (u)		(796)	Rennensismilia	K (Turo)	-K (Maes)	(691)
+Plesiophyllum	J (l)	-K (l)	(828)	+Retiophyllia	Tr(Carn-u)	-J (Aale)?	(674,682)
+Plesiosiderastraea	K (Maes)			Reussangia	T (Eo-m-l)	-T (Ol)	
+Plesiostylina	J (u)?	-K (Berr-u)	(658,848)	+Reussicoenia	K		(658)
+Plesiothamnastraea	K		(658)	+Reussiphyllia	T (Ol)		(658)
Pleurocora	K (Ceno)	-T (Than-l)	(837)	+Reussiphyllon	T (Eo)		(658)
+Pleurophyllia	J (Oxfo)	-K (Apti-l)	(840)	Reussopsammia	T (Ol)		
Pleuropodia	T (Eo)			Rhabdocora	K (Ceno)	-K (u)	
+Pleurostylina	J (u)		(826)	+Rhabdofavaria	J		(658)
+Plocoastraea	Q (Plei)		(658)	+Rhabdophyllia	J (Plie)	-K (m)	(796)
Pocillopora	T (Eo-l)	-R		+Rhabdophylliopsis	T (Than-l)	-T (Ol-l)?	(86,658)
Podabacia	T (Mi)	-R	(184)	+Rhaetiastrea	Tr(Nori)	-Tr(Rhae)	(919)
Podoseris	K (m)			Rhipidogyra	J (Oxfo-l)	-K (Maes)	(1270)
+Polyastropsis	J (m)	-K (l)		+Rhipidomilia	J		(658)
Polymorphastraea	J (Bath-l)		(2)	Rhizangia	K (Ceno)	-T (Eo)	(796,1270)
Polyphyloseris	J (Oxfo)	-K (Apti-l)		+Rhopalophyllia	Tr(Carn)		(919)
+Polyseris	K		(658)	+Rodinosmilia	J (Plie-u)		(682)
+Polystylium	J		(658)	+Saeptiphyllia	T (Ol)		(658)
Porites	T (Eo-l)	-R		+Sagittastraea	T (Dani)		(86)
+Pourtaocyathus	T (Mi-u)	-R		+Sakalavastraea	J (Call-l)	-J (Oxfo)?	(658,826)
+Proaplophyllia	J (Oxfo-u)	-J (Kimm-l)	(658)	+Sakalavastraeopsis	J (Bajo-l)	-J (Call-l)	(831)
+Procladocora	K (Barr)	-K (Sant)	(818,819)	+Sakalavicyathus	K (Maes)		(86)
Procyathopora	Tr(Anis)		(2)	+Saltastraea	K (u)		(658)
Procycolites	Tr(Rhae)	-J (Plie-l)?	(919)	+Sandalolitha	T (Mi)?	-R	(184)
+Prodonacosmilia	J (Sine)	-J (Tith)	(658,688)	Scalariogyra	T (Ol)	-T (Mi)	(839)
Progyrosmilia	T (Mi)			Schizosmilia	J (Oxfo)	-K (Vala)	(2,837)
+Proleptophyllia	J (Hett)	-J (l)	(796)	+Schizosmiliopsis	J		(658)
+Protethmos	J (Bath)		(796)	Sclerosmilia	J (Oxfo)	-J (Tith)	
Protobeterastrea	Tr(Ladi)	-Tr(Nori-l)	(919)	+?Sclydolithus	K (Maes)		(86)
Protoseris	J (u)			+Scolymia	T (Mi)	-R	(796)
+Protrochocyathus	K (Maes)	-T (Than-u)	(86)	Selenegyra	J (u)		
+Provinciastraea	T (Eo)		(658)	Sematetheos	J (m)	-J (u)	
+Pruvostastraea	J (Oxfo-l)	-J (Tith)	(820)	Semeloseris	J (m)		
Psammiphora	K (Ceno)	-K (u)		+Semidistichophyllum	Tr(Anis)		(836)
Psammocora	T (Mi-l-u)	-R	(1110)	Septastrea	T (Mi-u-u)	-T (Plio)	(1110)
+Psammocyathus	T (Ol)		(658)	+Seriastraea	Tr(Rhae)		(919)
Psammogyra	J (Oxfo)	-J (Tith-l)	(838)	Seriatopora	T (Mi-l-l)	-R	(1110)
+Psammohelia	J (u)	-K (Turo)	(826,845)	Siderastrea	K (Barr)?	-R	(822)
+Pseudisastraea	J (Bajo)	-J (Call-l)	(847)	+Siderocoenia	K		(658)
+Pseudocoenia	J (Oxfo-m)	-K (Apti)	(821,823)	Siderofungia	K (u)	-T (Ol)	(796)
+Pseudocoenopsis	J (Kimm-l)	-K (Turo)	(868,1270)	Sideroseris	J		(796)
+Pseudocycloseris	K		(658)	+Siderosmilia	J (Toar-u)		(682)
+Pseudodiplocoenia	J (Call)	-J (Tith-u)	(658)	+Silesiastraea	Tr(Anis-l)	-Tr(Anis-u)	(869)
Pseudofavaria	K (Turo)?	-K (Sn)	(920)	+Siliningastraea	K		(658)
+Pseudofavites	K		(658)	+Sinaimandra	K (Ceno)	-K (u)	(658)
Pseudogatheria	K (Apti)		(2)	+Sinasteria	Tr(Anis)		
+Pseudoheliastraea	K		(658)	Siniastrea	J (u)		
+Pseudoironealla	K		(658)	+Sinuosiphylia	T (Ol)		(658)
+Pseudomyriophyllia	K (Haut)	-K (Apti-l)	(658,821)	+Smilostylia	J (Oxfo-u)	-J (Kimm-l)	(868)
+Pseudopisthophyllum	J (Tith-u)	-K (l)?	(658,868)	Smiloochus	K (Barr)?	-R	(819)
Pseudoseris	K (u)			Solenastrea	T (Eo)	-R	(796)
Pseudosiderastraea	K	-R	(658)	+Silenocoenia	J (Oxfo-m)	-J (Kimm-u)	(868)
+Puchastraea	J (Bath-u)	-J (Oxfo-u)	(846)	+Sphenotrochopsis	T (Pale)		(658)
+Pyramisasteria	K		(658)	Sphenotrochus	T (Dani)	-R	(86)
				Stelloria	K (m)		

Taxon	First Appearance	Last Appearance	Reference	Taxon	First Appearance	Last Appearance	Reference
Stenocùathus	K (u)?	-R		Tiarasmilia	K (l)	-K (Apti-u)?	
+Stephanaria	Q (Plei)	-R	(796)	+Toechastreaea	Tr(Carn)	-Tr(Nori-l)	(919)
Stephanasòrea	J (Oxfo-m)	-K		+Tortoflabellum	T (Mi)		(658)
+Stephanavocoenia	J (m)	-J (u)	(658)	Trachyphyllia	T (Mi-l-l)	-R?	(1102)
+Stephanaxophyllia	K (Turo)	-K (Maes)	(691)	Trechmannaria	K (u)	-K (Maes)	(86)
Stephanocoenia	J (Bath)	-R	(2)	Trematotrochus	T (Ol-u)	-R	
Stephanocyathus	T (Dani-u)	-R	(86)	Triadophyllum	Tr(Anis)		
Stephanophyllia	K (u)	-R	(796)	+Tricassastreaea	K		(658)
Stephanosmilia	K (l)	-K (Sn)	(920)	Tricycloseris	J (Plie)?		(834,919)
Stereocoenia	J (Bajo)	-K (Nc)	(847)	Trigerastreaea	J (Plie-u)?	-K (Ceno)	(2,183)
Stereopsammia	T (Eo)			+Trigerastreaeopsis	J (u)		(183)
Stübastrea	J (Bath)?	-J (u)		Trocharea	J (m)	-K (Camp)?	(1270)
Süboria	J (u)			Trochocyathus	J (Bath)	-R	(2)
Stichopsammia	T (Eo)			+Trochoidomeandra	K (Barr)	-K (Apti-l)	(819)
†Streptocyathopsis	T (Eo)		(658)	-Trochoplegmopsis	J (Oxfo-u)	-J (Kimm-l)	(658)
†Streptocyathus	T (Eo)		(658)	Trochoseris	K (Apti-u)	-T (Ol-u)	(2,1110)
Strotogyra	K (u)	-T (Eo-m-l)		Trochosmilia	K (Apti)	-T (Mi-u)	(2)
+Stuoresia	Tr(u)		(658)	†Tropiastraea	Tr(Carn)		(919)
+Stuoresimorpha	Tr(Rhae)		(919)	+Tropidendron	Tr(Ladi-u)	-Tr(Nori)	(185,920)
Stylangia	K (Apti)	-T (Mi-l-l)	(1110)	Tropidocyathus	K (Maes)	-R	(1125)
Stylina	Tr(Nori)	-K (Maes)?	(821,834,1270)	+Tropiphyllum	Tr(u)?		(658)
				+Truncatocyathus	T (Mi)		
Stylocoenia	K (Nc)	-T (Mi-m)	(2)	-Truncatoflabellum	T (Ol-u)?	-R	
Stylocoeniella	T (Eo)	-R		+Truncoconus	K		(658)
Stylocora	T (Mi)			+Tskanorella	K		(658)
Stylocyathus	J (Oxfo)	-K (Maes)	(2,86,820)	Tubicora	T (Eo)		
Stylophora	T (Eo-l)	-R		Tubinacis	T (Ol)		
†Stylophyllopsis	Tr(Anis)	-J (Plie-u)	(183,919)	Turbinaria	T (Ol-l)	-R	(2)
Stylophyllum	Tr(Nori)?	-Tr(Rhae)		Turbinolia	T (Dani)?	-T (Eo-u)	(86,796,807)
Stylopsammia	K (Camp-l)			+Undaria	T (Mi-m)	-R	(1102)
Stylosmilia	J (Plie-u)	-K (Albi)	(682,806)	+Valliculastraea	K		(658)
Stylotrochus	K (u)			+Vallimeadra	J (m)	-K (u)?	(183)
+Substuoresis	Tr(Ladi)		(919)	+Vallimeandropsis	J (Toar-u)	-J (m)	(183)
Subtilicyathus	T (Mi)			+Valliseris	K		(658)
Summiktaraea	K (u)			Valloria	K (u)	-K (Camp)	(86)
+Symbiangua	T (Mi)		(658)	+Variabilifavia	T (Ol)		(658)
Symphyllia	T (Mi-l-u)	-R	(1110)	Vaughanoseris	K (u)		
Synastraea	J (Plie)	-K (Maes)	(691,825,1270)	+Verrilliofungia	T (Mi)	-R	(796)
				+Vielicyathus	T (Mi-m)		
Synhelia	K (l)	-K (Turo-u)		Viminohelia	J (u)		
Syzygophyllia	T (Ol-u)?	-T (Plio-u)	(1110)	+Vivesastreaea	T (Than-l)		(86)
Tarbellastraea	T (Ol-l)	-T (Mi-u-u)		+Volzeia	Tr(Anis-l)	-J (Toar)	(183,185,869)
†Tarraconogyra	K		(658)				
Taxogyra	K (u)			Wadecopsammia	K (Camp)		(2)
Teleiophyllia	T (Mi-m)	-T (Plio-l)		+Wellstotrochus	K		(658)
Tethocyathus	T (Eo-l)	-R		+Zardinophyllum	Tr(Ladi)	-Tr(Carn)	(919)
-Texastrea	K (Albi)			+Zittlofungia	T (Eo-l)		(86)
Thamnasteria	Tr(Anis)	-T (Dani)	(86,796,807,1066)				
-Thamnasteriamorpha	Tr(Carn)	-J (Plie-u)	(682)				
Thamnastraea	Tr(Nori-l)	-Tr(Rhae)					
+Thamnoseris	J (Bajo)	-K (Sant-u)?	(818,831)				
Thamnosmilia	J (m)						
+Thamnotropis	Tr(Carn-u)		(920)				
-Thecactinastraea	J (l)		(919)				
Theocyathus	J (Sine)	-J (Oxfo)	(2,830)				
+Thecomeandra	J (Bajo)	-J (u)	(658)				
Thecoseris	J (l)	-K (Apti)					
-Thecoseriopsis	K (u)		(796)				
Thecosmilia	J (m)	-K (Maes)	(796,806)				
Thysanus	T (Eo-u)	-T (Plio-u)					
Tiaradendron	J (Oxfo-u)	-J (Tith-l)	(838)				

Or. UNCERTAIN

Archaeotrypa	Cm(Dres)		
Bija	Cm(l)		
Bolboporites	O		
Cambrophyllum	Cm(Dres-l)		
Cambrotrypa	Cm(l)?	-Cm(lMid-u)	
Coelenteratella	Cm(mMid)		
Cothonion	Cm(lMid)		
Lipopora	Cm(lMid)		
Protoaulopora	Cm(u)		
Roselletona	Cm(Boto-l)		(186)
Spongarium	S (u)		

Taxon	First Appearance	Last Appearance	Reference	Taxon	First Appearance	Last Appearance	Reference
Cl. UNCERTAIN				+Dorvillea	K (Camp-l)	-R	(769,770)
+Escumasia	C (Mosc-u)		(376)	-Drilonereis	K (Camp-l)	-R	(769,770)
Spatangopsis	Cm(Atda-l)		(1006)	+Elleriprion	D (Fam-l)	-Tr(Anis-m)	(674,769)
Ph. CTENOPHORA				+Eunice	Tr(Anis-l)	-R	(1041)
+Archeocydippida	D (Emsi-l)			Eunicites (+ Kielanoprion, Lumbriconereites)			
+?Fasciulus	Cm(mMid-l)	-Cm(mMid-u)	(883)	P (Djhu)		-K (u)	(366,769, ZR88)
+Paleoctenophora	D (Emsi-l)			+Euryprion	O (Llde-u)		(365)
Ph. NEMATODA				+Falkosites	D (u)	-C	(769)
+Eophasma	J (Sine-l)		(623)	+Gotlandites	S (Wen-l)		(945)
Ph. NEMERTINA				+Hadoprion	O (Cara-m)	-S (Ldov)	
Archisymplectes	C (Serp-l)?	-C (Mosc-u)	(375)	+Halla	Tr(Anis-u)	-R	(769,770)
+incertae sedis	J (Tith-l)			+Hindenites	S (Wen-l)	-S (Ludl-u)	(945)
Ph. PRIAPULIDA				+Hindeoprion	D (Fras-u)		(366)
+Ancalagon	Cm(mMid-u)			+Kalloprion	O (Llde-u)?	-Tr(Anis-l)	(365,770)
+Cricocosmia	Cm(Atda-u)		(782)	Kettnerites (+ Paulinites)			
+Fieldia	Cm(mMid-u)			O (Llde-u)		-D (m)	(366,945)
+?Lecythioscopa	Cm(mMid-u)			+Lanceolatites	S (Ldov-u)	-S (Ludl-u)	(945)
+Louisella	Cm(mMid-u)			+Langeites	S (Ldov)	-P (l)	(365,945)
+Ottoia (+ Maotianshanis)				Lumbriconereis	T (Plio)	-R	
	Cm(Atda-u)	-Cm(uMid-m)	(782)	+Lysaretides	K (Camp-l)		(770)
Priapulites	C (Mosc-u)		(375)	?Marlenites	O (u)	-P (l)?	(366)
+?Scolecofura	Cm(mMid-u)			?Marphysaites	O (m)	-D (u)	(366)
Selkirkia	Cm(Tojo)	-Cm(uMid-m)	(883)	-Microdactylophora	S (Wenl)		(366)
Ph. ECHIURIDA				Mochtyella	O (Llde-u)	-K (Ceno-l)	(366,ZR91)
+?Coprinoscolex	C (Mosc-u)		(1066)	Multiprion	D (Fras-u)		(366)
Ph. POGONOPHORA				Nereidavus	O (Cara-m)	-K (u)	(366,ZR90)
+Adekunbiellida	T (Ol-u)		(1066)	Nothrites	O (Cara-m)	-D (u)	(366)
+Tasselia	T (Plio)		(1066)	+Notocirrus	Tr(Ladi-l)	-R	(770)
Ph. PENTASTOMIDA				+Oblongiprion	D (m)		
+Boecklericambria	Cm(Trep-l)		(1101)	Oeonites (+ Leptoprion)			
+Haffnericambria	Cm(Trep-l)		(1101)	O (Llde-u)		-Tr(m)?	(366,769)
+Heymonsicambria	Cm(Trep-l)	-O (Trem-l)	(1101)	+Onuphis	K (u)?	-R	(796)
Ph. ANNELIDA				Ophryotrocha	J (Call-m)	-R	
Cl. POLYCHAETA				Orthopelta	O (m)	-D (m)	(366)
Or. AMPHINOMORPHA				?Ottawella	O (Cara-m)		
Meringosoma	J (Tith-l)			Oxyprion	S (Ldov)	-P (Djhu)	(366)
Raphidiophorus (+ Palaeocampa)				+Palaeodactylophora	S (Ldov)		(366)
	C (Mosc-u)	-C (Step)	(1041)	+Palaeopolyx	S (Wenl)		(366)
Or. EUNICEMORPHA				?Paleononites	O (m)	-P (l)?	(366)
+Aglaurides	K (Camp-l)	-R	(769,770)	+Palurites	Tr(Anis-l)	-K (Camp-l)	(770)
+Albertaprion	D (Give-u)			+Paragnathites	T		(366)
+Anisocerasites	D (Give)?	-T (Mi-u)	(366)	Pernerites	O (m)	-O (u)	(366)
+Arabella	K (Camp-l)	-R	(769,770)	+Phiops	C (Serp-l)		(1041)
Arabellites (+ Atraktoprion)				+Pistoprion	O (Cara-m)	-O (u)?	(367)
	O (Cara-l)	-Tr(Ladi-l)	(366,367, 769)	Polychaetaspis	O (Llde-l)?	-D (Fras)	(366,1066)
+Archaeoprion	O (Llde-u)	-Tr(Ladi-l)	(365,367)	Praelumbrineris	Tr(Anis-l)	-Tr(Anis-u)	(366,674)
+Brochosogenys	C (l)	-P (l)		Processoprion	D (Fras-u)		(1066)
Delosites	P (Guad)	-Tr(Anis-u)	(366,674)	Protarabellites (+ Palaeosigma)			
Diopatrites	O (Ashg)?	-D (Give-u)	(366)	O (Cara-m)		-D (Eife)?	(366)
				Pteropelta (+ Polychaetus)			
				O (Llde-u)		-S	
				+Rampoprion	O (Llde-u)?	-O (Ashg-m)	(365)
				+Rhamphogenys	K (Camp)		(366)
				+Rhytiprion	O (Llde-u)	-O (Ashg)	(365,367)
				+Schistomerings	J (Plie-l)	-R	
				+Sciotoprion	D (Eife)		
				+Serratula	D (Fras-u)		(366)
				+Skalenoprion (+ Drilonereisites)			
				O (Ashg)?		-P?	
				Staurocephalites (+ Vistulella)			
				O (Llvi)?		-J (Kimm-u)	(366,770)

Taxon	First Appearance	Last Appearance	Reference	Taxon	First Appearance	Last Appearance	Reference
+Symmetron	S (Wenl)?	- S (Ludl-l)?	(365)	Or. TEREBELLOMORPHA			
+Tetraprion	O (Cara-l)	- D (Fras)	(365,367, 1066)	Amphictene	P	- R	
+Trentonia	O (Cara-m)		(1041)	+Crimnicaminus	C (Serp-l)		(1066)
+Trianguligenys	D (Give)?	- D (Fras)	(366)	Cryptosphon	O (Llvi)		
+Uncinogenys	D (Fras)		(366)	Lepidenteron	K		
+Xanioprion	O (Llde-u)	- D (Fras-u)	(365)	Paraterbella	C (Pn)		
Or. PHYLLODOCEMORPHA				Pectinaria	T (Mi)	- R	
+Arites	Tr(Anis-l)	- K (u)	(769,770)	Proterebella	P (Leon)		
+Astreptoscolex	C (Serp-l)	- C (Mosc-u)	(1041)	Psammosphon	S (Wenl)	- C	
‡ Canadia	Cm(mMid-l)	- Cm(uMid-u)	(370,1041)	Scoleoderma	Cm(mMid)		
‡Carbososistris	C (Serp-l)		(1041)	Streblosoma	T (Eo)		
Ctenoscolex	J (Tith-l)		(1041)	Terebella	J (u)	- R	
+Didontogaster	C (Mosc-u)		(1041)	Terebellites	Cm(m)		
Dinoscolites	O (Cara-m)			Terebellolites	D		
+Dryptoscolex	C (Mosc-u)		(1041)	Titahia	Tr?		
‡ Eotomopteris	C (Vise-u)		(1041)	Or. FLABELLIGERIMORPHA			
‡ Esconites	C (Serp-l)	- C (Mosc-u)	(1041)	flabelligerid	C (Mosc-u)	- R	
+Fastuoscolex	C (Mosc-u)		(1041)	Or. SERPULIMORPHA			
+Fossundecima	C (Mosc-u)		(1041)	Asterosalpinx	D		
Glyceria	Tr	- R	(366)	Bipygmaeus	K (Ceno-l)	- T (Dani)	(368,1052)
Glycerites	O (u)	- D (m)	(366)	Camptosalpinx	S (u)		
Goniada	Tr(Anis-m)	- R	(366)	Cementula	J (Sine-l)	- R	(1052)
+Homaphroditis	Tr(Anis-l)		(769)	Chaetosalpinx	S (u)		
+Hystriciola	C (Mosc-u)		(1041)	+Circeis	T (Pale)	- R	(1052)
Ildraites	O (Aren)?	- D (Fame-l)	(366)	Clavulites	C (Step-u)		(369)
+Levisettius	C (Mosc-u)		(1041)	Conora	K (Coni-u)	- K (Maes-u)	(368)
+Melanoraphia	J (Sine-l)		(623,1041)	+Cubiculovinea	T (Pale)	- R	(1052)
Ottawina	O (Cara-m)			Cycloserpula	J (Toar-u)	- T (Eo-m-l)	(1052)
+Palaeoaphroditis	Tr(Olen)?	- Tr(Rhae)		Diploconcha	K (u)		
Palaeochaeta	S	- D (Fras)		Discouvermetulus	T (Eo)		
Paleonereites	O (Cara-m)			Ditrupa	T (Dani)	- R	(1052)
+Paradrilonereigenys	K (Camp)			Ditrupula	K (Sn)		
Paraglycerites	Tr(Rhae)	- J (u)	(769)	Filograna	D (m)	- R	(368)
Paranereites	Tr(Anis-l)	- K (u)	(770)	Filogramula	J (Toar)	- R	(368)
+Pieckonia	C (Mosc-u)		(1041)	Flucticularia	K (Apti)	- K (u)	
‡Praeglycera	K (Camp-l)		(769)	Galeolaria	J	- R	
?Pronereites	O (Cara-l)			Genicularia	J	- K (Ceno)	
Protonympha	D (Fras-u)		(1066)	Gitonia	S	- D (Eife-l)	
+Rutehifrons	C (Mosc-u)		(1041)	Hamulus	J (Kimm)	- K (Maes-u)	(368)
Siphonostomites	T (Eo-m-l)		(1041)	Hicetes	D (Give-l)		
Stauronereites	D (u)		(366)	+Howellitubus	C (Mosc-u)		(1041)
Sthenelaites	T			Hydroides	T (Than)	- R	(1052)
Thalenessites	O (Cara-m)			Iquitosia	T (Ng)		
Triadonereis	Tr(m)			Janita	K (Ceno-u)	- R	(368)
Ungulites	O (Cara-m)	- P (l)?	(366)	Jereminella	K (Maes)	- R	(1052)
Or. SPIOMORPHA				Josephella	K (Maes)	- R	(1052)
Dodecaeceria	K (Sant)?	- R		Laqueoserpula	K (Haut)	- K (Maes)	(368)
+Macandropolydora	K (Maes)	- R	(ZR85)	Longitubus	K (Camp-l)	- K (Maes)	(1052)
Polydora	K (u)?	- R		Mercierella	T (Mi)	- R	
Sabellaria	C	- R		+Metalaeospira	T (Pale)	- R	(1052)
?Vetustovermis	Cm(Boto)		(566)	+Metavermilia	J (Toar-l)	- R	(1052)
Or. DRILMORPHA				Muroserpula	K (Ne)	- K (Maes)	(1052)
Archarenicola	Tr(Rhae)			+Neodexiospira	K (Maes-l)?	- R	(1052)
Arenicola	K	- R		Neomicrorbis (+ Spirorbula)	J (Tith-l)	- R	(1052)
† incertae sedis	J (Call)		(1041)	Neovermilia	K (Barr)	- R	(368)
				Ornatopora	K (u)	- K (Maes-u)?	
				Orthoconorca	J (u)	- T (Dani)	(368)
				Paliurus	T (Eo-u)		

Taxon	First Appearance	Last Appearance	Reference	Taxon	First Appearance	Last Appearance	Reference
+Paralaeospira	T (Pale)	-R	(1052)	Pontobdellopsis	O (Cara-m)		
Parsimonia	K (Vala)	-K (Maes-u)	(368)	Propolynoe	O (Cara-u)?		
+Pegmaticula	J (Oxfo)	-K (Maes)	(1052)	Ramesses	C (Serp-l)		(1041)
Pentaditrupa	J (Sine-l)	-T (Dani)	(368,1052)	Ruedemannella	S (Prid)		
Phragmosalpinx	D			Sarcionata	K		
+Pileolaria	K (Ceno-l)?	-R	(1052)	Schizoproboscina	C		
Placostegus (+ Eoplacostegus)	J (Oxfo)	-R	(1052)	Soris	C (Serp-l)		(1041)
Pomatoceros	K (Maes)	-R		+Stephanoscolex	Cm(mMid-u)		(1041)
Propomatoceros	K (Apti-l)	-K (Maes)		Stoma	O (Ashg)?		
Protectoconorca	K (Ceno-l)	-K (Maes-u)	(368)	Tosalorbis	T (Eo)	-T (Ol)	
Proterula	T (Pale)			Tubulelloides	O (Cara-m)		
Protula	K (u)	-R		Cl. MYZOSTOMARIA			
Protulites	T (Ol)			+Myzostomites	O		(1066)
+Protulophila	J (Plie)	-R	(1052)	Cl. PALAEOSCOLECIDAE			
Pyrgopolon	K (Ceno-l)	-R	(1052)	+Bohemoscolex	O (l)		(1105)
Rotularia	J (Toar)	-T (Eo-u)		+Cowiella	Cm(Atda-u)		(1006)
Salmacina	Tr(Anis-m)?	-R	(674)	+Gammascoclex	O (l)		(1105)
Sarcinella	K (l)			+Hadimopanella (+ Lenargyrion, Utahphospha)	Cm(Atda-u)	-S (Ldov-u)	(522,885)
Sclerostyla	K (Haut-u)	-R	(368)	+Houscolex	Cm(Atda-u)		(1219)
Semiserpula	T (Pg)			+Kaimenella	Cm(Tojo)	-Cm(Trep)?	(1057)
Serpentula	K (u)	-T (Pale)		+Milaculum	Cm(Boto-l)	-O (Llde-l)	
Serpula	Tr(Anis-m)?	-R	(368,674)	-Palaeoscolecida	Cm(Atda-u)		(1219)
Serpularia	O (Llvi)			Palaeoscolex	Cm(Atda-u)	-O (Trem)	(566,783, 1105)
Serpulites				+Plasmuscolex	O (Aren-u)		(1105)
Serpulopsis	C (Pn)			Protoscolex	O (Cara-u)?		
Sinuocornu	S (Wenl)			Ph. PROBLEMATICA			
Spiraserpula	K (Apti-l)?	-R?	(1052)	Cl. CAMBROCLAVIDA			
Spirographites	T (Dani)			+Cambroclavus (+ Isoclaves, Phyllochiton, Sinoclaves, Sugaites, Tanbaotites, Washichites)	Cm(Atda-l)	-Cm(Boto-u)	(885,923)
Spirorbis	O (Trem)	-R		+Deiradovclavus	Cm(Atda-u)		(962)
Streptindytes	S	-C		+Deltaclavus	Cm(Atda-u)		(962)
Tetraserpula	J (Bajo-u)	-K (Maes-u)	(368)	+?Nikolarites	Cm(Atda)		
Torlessia	Tr?			+Parazhijinites	Cm(Atda)		
Turbinia	T (Dani)	-T (Eo-m-l)	(1052)	-Pseudoclavus	Cm(Atda-u)		(1006)
Vepreculina	K (Sant)	-T (Mi-u-l)	(368)	+Samsonoffoclavus	Cm(Tomm)		
Vermilia	C	-R		-Zhijinites	Cm(Tomm-l)	-Cm(Atda-u)	(923,1030)
Vermiliopsis	K (Ceno)	-R	(368)	Cl. COELOSCLERITOPHORA			
Or. UNCERTAIN				Or. SACHITIDA (= Thambetolepida)			
+Biconulites	Cm(l)	-Cm(Tojo)		+Adversella	Cm(Atda-u)		(1006)
+Bundenbachochaeta	D (Emsi-l)			+Carubacgutes	Cm(Tomm)		
+Burgessochaeta	Cm(mMid-u)		(1041)	+?Dabashanites	Cm(Tomm-l)	-Cm(Atda-l)	(1006,1244)
Campylites	O (Llde-u)	-S (Prid)		+Drepanochites	Cm(Tomm-l)	-Cm(Tomm-u)	(951,1006)
+Ebetallites	S (u)	-D (l)	(366)	+Halkieria (+ Aerosquama, Dactyosachites, Microsachites, Tianzhushania)	V (N-Da-u)	-Cm(Boto-l)	(951,1006, 1030,1244)
Eopolychaetus	O (Cara-m)			+Hippopharangites	Cm(Atda-u)		(923)
Eotrophonia	O (Cara-u)			+Lomasulacchites	Cm(Tomm-u)?		(951,1006)
Epitrachys	J (Tith-l)			+Lopochites	V (N-Da-u)	-Cm(Boto-l)	(1030,1244)
Haileyia	O			+?Miriella	Cm(m)?		(1006)
Hammatopsis	O			+?Monospinites	Cm(Boto)		(923,1006)
Hesionites	C (Pn)			+?Oikozetetes	Cm(mMid-u)		
Hirudopsis	O (l)			+Quadrochites	Cm(Tomm)?		(1006)
+Insulicorypha	Cm(mMid-u)		(1041)	+Rosella	Cm(Tomm-l)		(1006)
Khemisina	O						
Klakesia	S (Ldov-u)?						
Lecathylus	S (Ludl)						
+Lercaritubus	P (l)		(ZR91)				
Lockportia	S (Wenl)						
Lumbricopsis	P						
+Microtubus	Tr(Rhae)						
Nawnites	D (Fras-m)?						
Oliveirania	S						
+Peronochaeta	Cm(mMid-u)		(1041)				

Taxon	First Appearance	Last Appearance	Reference	Taxon	First Appearance	Last Appearance	Reference
+Sachites	Cm(Tomm-l)	-Cm(Atda-u)	(522,1006,1030)	+Topolincocyathus	Cm(Atda)		(1006)
+Sinosophites	Cm(Atda-u)		(885,951)	+Tortococyathus	Cm(Atda)	-Cm(Boto)	(1006)
+Siphogonuchites (+ Palaeosulcochites, Trapezochites)	V (N-Da-u)	-Cm(mMid)	(1030,1244)	+Turricyathus	Cm(Boto)		(1006)
+Thambetolepis	Cm(Atda-u)		(923,1006)	+Vologdinophyllum	Cm(Atda)		
+Wiwaxia	Cm(Tojo)	-Cm(mMid-u)	(809)				
Or. CHANCELLORIIDA				Cl. DINOCARDIA ("anomolocarids")			
+Aldania	V (N-Da-u)	-Cm(Tomm-l)	(1006,1244)	+Anomolocaris	Cm(Atda-l)	-Cm(uMid-m)	(883)
+Aldanospina	Cm(Tomm-l)		(1006)	+Cassubia	Cm(Atda-l)		
+Allonia (+ Dimidia, Onychia)	Cm(Tomm-u)			+Cerabonusoides	Cm(Tomm)?		(1006)
+Archiaerella	Cm(Atda-l)	-Cm(Boto-u)	(1244)	+Hurdia	Cm(mMid-u)		(883)
	Cm(Atda-l)	-Cm(lMid)	(221,951,1006,1057)	+Kerygmachela	Cm(Boto)		
+Archicladium	Cm(Tomm)?			+Laggani	Cm(mMid-u)		
Chancelloria (+ Stellaria, Rolycladium Fangxianites)	V (N-Da-l)	-Cm(Dres-l)	(522,1030)	+?Myoscolex	Cm(Boto)	-Cm(mMid)	(566,1006)
	V (N-Da-l)	-Cm(u)?	(923,1244)	+?Opabinia	Cm(mMid-u)		
+Diplospinella	Cm(Tomm-u)		(1006)	+Proboscicaris	Cm(mMid-u)	-Cm(uMid-l)	(349,883)
+Elkanospina	Cm(Tomm-u)		(923)				
+Eremactis	Cm(Atda-u)		(1006)	Cl. MACHAERIDIA			
+Ginospina	Cm(Tomm-l)		(1006)	Or. TURRILEPADIDA			
+?Platyspinites	Cm(Tomm-u)		(1006)	+Ambonlepidos	C (Mosc-l)	-C (Step-u)	(1232)
+Stellispinella	Cm(Tomm-l)	-Cm(Boto-l)?	(1244)	+Aulakolepos	O (Llvi-u)	-D (Give)	(784)
				+Deltaoleus	O (Aren-u)	-O (Ashg-l)	(1116)
				+Mojczalepas	O (Aren-u)	-O (Ashg-l)	(784,1116)
				+Plicacoleus	O (Aren-u)	-O (Cara-l)	(1116)
Cl. CRIBRICYATHEA				Or. LEPIDOCOLEOMORPHA			
+Abicyathus	Cm(Tojo)		(1006)	+Carnicoleus	S (Ludl)		(784)
+Achorocyathus	Cm(Atda)		(1006)	+Clarkeolepis	O (Cara-l)	-C (Step-u)	(784,1232)
+Akademiohyllum	Cm(Atda)		(1006)	+Compacoleus	O (Llvi)	-C (Tour)	(784,1129)
+Apocyathus	Cm(Boto)		(1006)	+Lepidocoleus	O (Cara-u)	-S (Wenl-u)	(784,1129)
+Archaeophyllum	Cm(Atda-u)		(1006)	+Plumulites	O (Trem-u)	-C (Tour)?	(784)
+Azyricyathus	Cm(Tojo)		(1006)	+Sokolophocoleus	O (m)		
+Butovia	Cm(Atda-u)		(1006)	+Turrilepas	S (Ldov-u)	-P (Leon)	(1129,1232)
+Capillicyathus	Cm(Boto)		(1006)				
+Cardiophyllum	Cm(Atda)		(1006)	Or. HERCOLEPADIDA			
+?Cloudina	V (u)	-V (N-Da)?		+?Aenigmatectus	C (Serp-l)	-C (Mosc-u)	(1232)
+Conoidocyathus	Cm(Boto)		(1006)	+Hercolepas	S (Wenl-l)		(784)
+Cribricyathus	Cm(Boto)	-Cm(Tojo)	(1006)	+Protobalanus	D (Eife-u)		(784)
+Crispus	Cm(Atda)		(1006)				
+Dolichocyathus	Cm(Tojo)		(1006)	Cl. MULTIPLACOPHORA			
+Dubius	Cm(Atda)		(1006)	Or. STROBILEPIDA			
+Erphyllum	Cm(Atda)		(1006)	+Diadeloplax	C (Bash)		(1224)
+Gracilocyathus	Cm(Atda)		(1006)	+Strobilepis	D (Give-l)	-D (Fame-u)	(1224)
+Laceratus	Cm(Atda)		(1006)				
+Lagenicyathus	Cm(Boto)		(1006)	Cl. TOMMOTIIDA			
+Leibaella	Cm(Atda)		(1006)	Or. MITROSAGOPHORA			
+Lomatoccyathus	Cm(Tojo)		(1006)	+Bercutia	Cm(Tomm-u)		(1244)
+Longaeus	Cm(Atda)		(1006)	+Camenella (+ Camena, Tommotia)	Cm(Tomm-l)	-Cm(Boto-l)	(522,655,885,1244)
+Longicyathus	Cm(Boto)		(1006)	+Dailyatia	Cm(Atda-u)?		(1006)
+Manacyathus	Cm(Atda)		(1006)	+Geresia	Cm(Tomm-u)		(1006)
+Peripterocyathus	Cm(Tojo)		(1006)	+Kelanella (+ Bengtsonia)	Cm(Atda-u)		(1006)
+Pterocyathus	Cm(Atda)		(1006)	+Kennardia	Cm(Atda-u)		(923,1006)
+Pubericyathus	Cm(Boto)		(1006)	+Lugoviella	Cm(Atda)	-Cm(Boto-l)	(522,885,1244)
+Pyxidocyathus	Cm(Boto)		(1006)				
+Radicicyathus	Cm(Tojo)		(1006)	+Micrina	Cm(Atda-u)		(923,1006)
+Ramifer	Cm(Atda)		(1006)	+Ninella	Cm(Atda-u)		(1006)
+Rarocyathus	Cm(Atda)		(1006)				
+Sinossabellidites	V (u) ?		(1006)				
+Striatocyathus	Cm(Atda)	-Cm(Boto)	(1006)				
+Sunicyathus	Cm(Boto)		(1006)				
+Thecocyathus	Cm(Boto)		(1006)				

Taxon	First Appearance	Last Appearance	Reference	Taxon	First Appearance	Last Appearance	Reference
+Paterimitra	Cm(Atda-u)		(923,1006)	Or. PAIUTIIDA			
+Porcauricula (+ Yunnanotheca)	Cm(Tomm-u)		(885,951)	+?Huaiyuanelia	V (N-Da)		(1006)
+Sonella (+ Tesella)	Cm(lMid)		(1006)	+Paiutitubulites (+ Cambrotubulites)	Cm(Atda-u)?		(371)
+Tannuolina	Cm(Atda-u)	-Cm(Tojo-l)	(885,951, 1006,1244)	Or. SABELLIDITIDA			
Or. UNNAMED				+ Acanthocassis	Cm(Tomm-u)?		(1006)
+Eccentrotheca	Cm(Tomm-l)	-Cm(Boto-l)	(655,1006)	+ Acidocharacus	Cm(Tomm-u)?		(1006)
+?Jaycea	Cm(Atda-u)		(1127)	+?Anhuicella	V (N-Da)		(1006)
+Kulparina	Cm(Atda-u)		(923)	+Calyptrina	V (N-Da)		(1006)
+Lapworthella	Cm(Tomm-l)	-Cm(Tojo)	(522,885, 1006)	+Paleolina	V (N-Da)		(1006)
+Stenothecopsis	Cm(Atda)	-Cm(mMid)?	(1006)	+Parasabellidites	Cm(l)		(1006)
+Sunnaginina	Cm(Tomm-l)	-Cm(Boto-l)	(885,1006)	+Saarina	V (N-Da)		(1006)
				Sabellidites	V (N-Da-l)	-Cm(Atda-u)?	(1006,1030)
				+?Sokoloviina	Cm(Tomm-l)	-Cm(lMid)?	(1006)
Cl. UNCERTAIN				Or. VOLBORTHELLIDA (= Agmata)			
Or. COLEOLOIDA				+?Acuticloudina	Cm(Boto-l)?		(1006)
Coleolella	Cm(Tomm-l)	-Cm(mMid)	(522,885, 1244)	+Ellisella	Cm(m)		
Coleoloides (+ Glayderia)	Cm(Tomm-l)	-Cm(Boto-l)	(655,1006, 1030)	Salterella	Cm(Boto-l)	-Cm(Boto-u)	(885,1006)
Coleolus	Cm(Tomm-l)	-C (Tour-l)	(2,522, 1030)	Volborthella (+ Campitius)	Cm(Atda-l)	-Cm(Boto-l)	(885)
Cleoprion	S	-D (u)		?Vologdinella	Cm(uMid)		
Polshanelia	O (l)			Or. INCERTAE SEDIS			
Polylophia	O (m)			+Acanthoclava	Cm(l)		(1006)
				+Acanthosphaera	Cm(Atda-u)?		(1006)
				+Actinotheca (+ Arcitheca, Cupitheca)	Cm(Tomm-l)	-Cm(Tojo)	(923,1006, 1057)
Fm. CORNULITIDAE				+Acutitheca	Cm(Tomm)?		(1006)
Conchicolites	O (Llvi)	-D (l)	(1075)	+Ainiktozoon	S (Ldov-u)		(1066)
Cornulitella	O (m)	-C (Serp-l)		+Aksuglobulus	Cm(Atda-u)?		(1006)
Cornulites	O (Cara-m)	-D (Eife)?	(2)	+Amiskwia	Cm(mMid-u)		
Kolihaia	S (Wenl)			+Amoebinella	Cm(Tomm-u)?		(1006)
				+Ancienta	O (Cara-l)?	-O (Ashg-m)	
Or. HYOLITHELMINTHES				Anzalia	Cm(l)		
+?Aktugaia	Cm(Atda-u)		(1006)	+Apistoconcha	Cm(Atda-u)		(923)
?Barella	Cm(m)?, Cm(u)?			+Archaeopetanus	Cm(Atda-u)		(923)
?Beklemishevites	O (m)?		(671)	+Archaeotremaria	Cm(Tomm-u)?		(1006)
+Byronia (+ Scoleciellus)	Cm(Atda-u)	-O (Cara-m)	(173,671, 1006)	+Aroonia	Cm(Atda-u)		(923)
+?Discinella	Cm(Boto)?		(1006)	+Ascossyrinx	O (m)	-O (Ashg)	(671)
+?Hippoklosma	Cm(Boto-l)			+Aurisella	Cm(Atda-u)?		(1006)
Hyolithellus	V (N-Da-u)	-Cm(uMid-m)	(522,1019, 1030)	+Bacinella	Tr(Anis)	-K (Apti)?	
+?Ivanovites	O (Trem)		(1066)	+Banfia	Cm(mMid-u)		
+Koksuja	Cm(Boto-l)		(1244)	+Bicornifera	T (Ol)		
?Mobergella	Cm(Tomm-u)	-Cm(Boto-l)	(522,885, 1006)	+Bioistodina	Cm(Boto)		(1006)
Phosphannulus	Cm(Trep)	-P (Sakm)		Bovicornellum	Cm(uMid)	-Cm(u)	
Pseudorthotheca	V (N-Da-u)	-Cm(Atda-u)	(885,1006, 1030,1244)	+Brushenodus	Cm(Tomm-u)?		(1006)
Rushtonina	Cm(Tomm-u)	-Cm(Boto-l)	(522,1006, 1244)	+Cambrogeorgina	Cm(mMid-u)		(1028)
?Salopiella	Cm(Atda-u)?	-O (Llvi)?	(1006)	+Cambrocassis	Cm(Atda-u)	-Cm(Boto-l)	(1006,1244)
?Sokolovites	O (Trem-u)		(671)	+Caveacus	Cm(Atda-u)?		(1127)
+?Thorslundella	Cm(Atda-u)		(1006)	Cestites	O (m)?		
Torellella	V (N-Da-u)	-Cm(lMid)	(885,1030)	+Chalasioocranos	Cm(Tojo)		(1057)
+Torellelloides	Cm(Tomm-u)		(522,1006)	+Cristatodus	Cm(u)		
				+Cyclogeorgina	Cm(mMid-u)		(1028)
				+Cyrtochites (+ Planuspira)	Cm(Tomm-u)?		(951,1006)
				+Dentachites	Cm(Tomm)?		(1006)
				+Deuteronectanebos	C (Serp-l)		
				+Dimorphoconus	O (Trem)		(923)

Taxon	First Appearance	Last Appearance	Reference	Taxon	First Appearance	Last Appearance	Reference
-Dinomischus	Cm(Atda-u)	-Cm(mMid-u)	(883)	+Paracarinachites (+ Luyanhaochiton, Yangtzechiton)	Cm(Tomm-u)?-Cm(Atda-u)?		(951,1006)
-Eldonia (+ Stellostomites, Yunnanomedusa)	Cm(Atda-u)	-Cm(uMid-m)	(809)	+Pararenicola	V (u) ?		(1006)
+Emeithella	Cm(Tomm)?		(1006)	+Parvulonoda	Cm(Atda-u)		(1214)
Enchostoma	C (Tour)?			+Plinthokonion	Cm(Tomm-l)	-Cm(Atda-l)?	(1006)
Endosacculus	K (Camp)	-K (Maes-u)		+Pollingeria	Cm(mMid-u)		
+Eoescharopora	Cm(Tomm-u)?		(1006)	+Polysiphonidia	S (u)		
+Etacystis	C (Mosc-u)			+Poraites	Cm(Tomm-u)?		(1006)
+Fensiangia	O (l)			Porocystis	K (Albi-l)	-K (Albi-m)	
+Flabetheca	Cm(Tomm)?		(1006)	+Portalia	Cm(mMid-u)		
+Fomitichella	V (N-Da-u)	-Cm(Atda)	(1006,1030)	Pragmotheca	S		
+Fusuconcharium	Cm(l)		(1006)	+Primaconulariella	Cm(Tomm)?		(1006)
Gochtia	S (Ludl-l)			+Problematikum	Cm(m)		(1006)
+Gonamella	Cm(Tomm-l)		(1006)	+Protoarenicola	V (u) ?		(1006)
Hartites	Cm(m)			+Protomelission	Cm(Tojo)		(1057)
+Henaniodus	Cm(Boto)		(1006)	+Protopterygotheca	Cm(Tomm-u)?		(962)
Hensonella	K (l)			+Pterpmus	Cm(Tomm)?		
+Heterosculpotheca	Cm(Tomm)?		(1006)	+Ptilonocodus	O (Llde-l)?	-O (Ashg-m)	
+Huishea	O (Trem)			+Punctatus	V (N-Da)	-Cm(Tomm-u)?	(1006)
+Huiz/enodus	Cm(Tomm-u)?		(1006)	+Pyrgites	Cm(Atda-u)		(1006)
+Humboldtochaeta	Cm(l)		(1006)	-Quadratopora	Cm(l)		(1006)
+Indoceras	Cm(Tomm-l)		(725)	+Quadrorites	Cm(Tomm)?		(1006)
+Jiangshanodus	Cm(Atda-u)		(1006)	+Radiaxialia	Cm(uMid)	-Cm(Dres)	(1006)
+Kaiyangites	Cm(Atda-u)?		(1006)	+Redkinia	V (u)		
+Kazakhstanotubulus	Cm(Atda)			+Redoubtia	Cm(mMid-u)		
+Kiehnensius	O (Cara-m)		(377)	+Resegia	Cm(Boto-l)		(1244)
+Koksodus	Cm(Tomm-l)		(1006,1244)	+Rhabdochites	Cm(Tomm)?	-Cm(Atda-u)?	(1006)
+Korilacus	V (N-Da)		(1006)	+Rhagnura	Cm(Boto-l)		(1244)
+Labyrinthotuba	O (Aren-u)			+Rhombocorniculum	Cm(Tomm-u)	-Cm(Boto-l)	(522,885, 1006,1244)
+Labyrinthus	Cm(Boto)?		(186,1006)	+Rugatotheca	Cm(Tomm-l)		(885,1006)
+Lenaella	Cm(Atda)		(1006)	+Rushtonites	Cm(Tomm-u)	-Cm(Boto-l)	(1244)
+?Libodiscus	C (Tour-l)?			+Sagittitheca	Cm(Tomm)?		(1006)
+Lidaconus	Cm(Boto)		(1006)	-Salanactus	Cm(Tomm-l)		(1006)
Lombardia	J (Titl-u)			+Scissotheca	Cm(Tomm)?		(1006)
Lonchosaccus	O (Cara-u)			-Scoponodus	Cm(Tomm-u)?		(951,1006)
+Lukatiella	Cm(Atda)			+Selenoplax	S (Ludl-u)		
+Mabiania	Cm(Tomm)?		(1006)	+Seleniticus	Cm(Atda)		(1244)
-Mamillodus	Cm(u)			+Shinteinefla	Cm(Boto-l)		(1244)
+Marcusodictyon	O (Trem)		(374)	-Sinotubulites	V (N-Da)		(702,1006)
+Megasphaera	V (N-Da)?		(1006)	-Solenotia (+ Lunachites, Phyllochites)	Cm(Tomm-u)?		(1006)
Meghystrichosphaeridium	V (N-Da)?		(1006)	+Spinoceras	Cm(Tomm-l)		(1006)
+Melopetatus	O (u)			-Spiralella	Cm(Boto-l)		(1244)
-Microancientia	O (u)			+Stetania	Cm(Boto-l)		(1006,1244)
+Microplepora	Cm(Tomm-u)?		(1006)	+Stictoconus	Cm(Tomm-u)?		(951)
+Microschedia	Cm(Atda-l)			+Stoibostrombus	Cm(Atda-u)	-Cm(Tojo)	(923,1057)
+Miratheca	Cm(Tomm)?		(1006)	-Strictocorniculum	Cm(Atda-u)		(1127)
+Mongoliacus	Cm(Boto-l)		(1006)	-Taitia	S (Ludl)		
+Mongolitesa	Cm(Boto-l)		(1244)	+Tayshira	Cm(Boto-l)		(1244)
+Mongolitubulus	Cm(Atda-l)	-Cm(mMid)	(1244)	+Tchang sichiton	Cm(Tomm-u)?		(1006)
Nannoconus	J (u)	-K (u)		+Tianzhushanella	Cm(Tomm-u)?		(1006)
+Nectocaris	Cm(mMid-u)			+Tintinoidella	Cm(Atda-u)		
+Nevadatubulus	Cm(Boto-l)?		(702)	-Tommitotubulus	Cm(Tomm-l)	-Cm(Boto)	(1006,1030)
+Ningqiangsclerites	Cm(Tomm)?		(1006)	+Tripletella	Cm(Tomm-l)	-Cm(Atda-u)?	(923,1030)
+Odontogriphus	Cm(mMid-u)			+Tubigeorgina	Cm(mMid-u)		(1028)
+Oesia	Cm(mMid-u)			-Tubiphytes	C (Ms)	-K (Albi-l)	
+Onuphionella	Cm(Tomm-u)		(1006)	-Tubulella	Cm(Boto-u)	-Cm(uMid-l)	(883)
+Palaeobotryllus	Cm(Trep)			-Tullmonstrum	C (Mosc-u)		
+Paleocenosphaera	Cm(Atda-u)?	-Cm(u)?	(1006)	+Tumulduria	Cm(Tomm-l)		(1030)
-Paleoxiphosphaera (+ Lithapium)	Cm(Atda-u)?		(1006)	-Tuvinia	Cm(Boto)		(1006)
+Paracanthodus	Cm(Tomm)?		(1006)	+Westgardia	Cm(Boto-l)		(372)

Taxon	First Appearance	Last Appearance	Reference	Taxon	First Appearance	Last Appearance	Reference
+Worthenella	Cm(mMid-u)			Allatheca	Cm(Tomm-l)	-Cm(Atda-u)	(268,885, 1006)
+Wushicites	Cm(Atda-u)?		(1006)	+Ancheilotheca	Cm(Tomm)?		(1006)
+Yangtzesclerites	Cm(Tomm)?		(1006)	Antiquatheca	Cm(Tomm-u)		(522)
+Yuliunia	Cm(Tomm-u)?		(1006)	Bactrotheca	O (Aren-u)	-O (Ashg-m)	(288)
+Yunnanodus	Cm(Tomm-u)?		(951,1006)	+Boliitheca	D (Emsi)		(979)
Ph. HYOLITHA				+Brevitheca			
[Classification and stratigraphic ranges from various sources, as listed.]				?Bucanotheca	Cm(Tomm-u)		(89)
Cl. ORTHOTHECIMORPHA				Carinitheca	Cm(Atda)		(287)
Or. CIRCOTHECIDA				Ceratotheca	S (Ludl)	-D (Gedi)	(1)
+Arathecus	Cm(Tomm-l)		(1006)	+Chelsonella	Cm(m)?	-O (Trem)?	(731)
+Asijatheca	Cm(Atda-u)		(1006)	Contitheca	Cm(Boto)		-Cm(Dres-u) (1006)
Circotheca	V (N-Da-l)	-S (Ludl)	(288,885, 1030)	Curtitheca	Cm(Tomm)		(1006)
Conotheca	V (N-Da-u)	-Cm(Boto-u)	(268,885, 1030)	+Devoniotheca	D (l)		(731)
Costatheca	Cm(Atda-u)		(268)	+Ebianotheca	Cm(Tomm)?		(1006)
+Crossbitheca	V (N-Da)?	-Cm(Tomm-l)	(1006)	Egdetheca	Cm(Tomm-l)	-Cm(Boto)	(268,1006)
+Ensitheca	Cm(Tomm-l)		(1006)	Eonovitatus	Cm(Tomm-u)	-Cm(Atda-u)	(287,885)
Extentitheca	Cm(Tomm-u)		(287)	+Foersteintheca	S (Wenl)		(731)
+Khetatheca	V (N-Da)		(1006)	+Grandicornus	Cm(Atda)		(1066)
+Kotuyitheca	V (N-Da)?	-Cm(Tomm-l)	(1006)	Hexitheca			
Kugdatheca	Cm(Tomm-l)	-Cm(Tomm-u)	(268,1030)	+Inflaticornus	Cm(Boto)		(1066)
+Kunyangotheca	Cm(Tomm)?		(1006)	Isititheca	Cm(Tomm-u)		(287)
Ladatheca	V (N-Da-u)	-Cm(Tomm-u)	(287,885, 1030)	Kygmæoceras	Cm(Trep-u)		(290)
Laratheca	Cm(Tomm-l)	-Cm(Tomm-u)	(268,522)	Lentitheca	Cm(l)		(1006)
+Leibotheca	Cm(Tomm)?		(1006)	Lophotheca	V (N-Da-u)	-Cm(Tomm)	(271,1030)
Loculitheca	V (N-Da-u)	-Cm(Tomm-u)	(287,1030)	Majatheca	Cm(Tomm-u)	-Cm(Boto)?	(268,522)
+Mojezatheca	O (Cara-u)		(1116)	+Malykanotheca	Cm(Atda-l)		(1006)
+Petasotheca	Cm(Boto-u)?		(1235)	+Minitheca	Cm(Atda)		(1006)
Spinulitheca	V (N-Da-u)	-Cm(Atda-l)	(287,655, 885,1030)	Mooritheca	Cm(Tomm-u)	-Cm(Boto)	(289)
+Stimulitheca	Cm(Atda-u)?		(1006)	+Neobactrotheca	D (Emsi)		(979)
Turcutheca	V (N-Da-u)	-Cm(Boto)	(287,885, 1006)	Nephrotheca	O (Trem)	-O (Ashg-m)	(288)
Uniformitheca	Cm(Tomm-u)	-Cm(Atda-u)	(287,522, 885)	Nikatheca	Cm(Tomm-l)		(289,1030)
Or. EXILITHECIDA				Novitatus	Cm(Atda-l)	-Cm(Boto-l)	(287,522)
Exilitheca	Cm(Tomm-l)	-Cm(Tomm-u)	(287,885)	Orthotheca	Cm(Tomm-l)	-D (Eife)?	(1,268,885)
Gracilitheca	Cm(Tomm-u)	-Cm(mMid)	(287,289)	Panitheca	O (Ldle-l)	-O (Cara-m)	(288)
Holmitheca	Cm(Atda-u)	-Cm(Boto-u)	(287,522)	Plicitheca	Cm(Atda-u)	-Cm(Boto-u)	(287,522)
Lenatheca	Cm(Tomm-u)	-Cm(Boto-l)	(268,270, 885)	+Renitheca	Cm(Boto-l)		(1006)
Micatheca	Cm(Boto-l)	-Cm(Boto-u)	(287,522)	Senielliptotheca	Cm(Tomm-l)	-O (m)	(1,1006)
Obliquatheca	Cm(Atda)	-Cm(Boto)	(287,1006)	Tcharatheca	Cm(lMid)?	-Cm(u)	(287,1020)
Sokolovitheca	Cm(Tomm-u)	-Cm(lMid-l)	(287,522)	Tehuranitheca	Cm(Tomm-u)	-Cm(Atda-u)	(287)
Or. GLOBORILIDA				Tetratheca	Cm(Tomm-u)	-Cm(Atda-u)	(287,522, 885)
+Cobboldiella	Cm(Atda-u)		(1006)	Trapezotheca	Cm(Tomm-u)	-O (Llivi-l)	(1,1006)
Globorilus	Cm(Atda)	-Cm(Tojo)	(292,293)	Cl. HYOLITHOMORPHA			
+Globoritubulus	Cm(l)		(1006)	Or. HYOLITHIDA			
+?Neogloborilus	Cm(Atda-u)?		(1006)	Aimitus	Cm(Tomm-u)	-Cm(Atda-u)	(89,1006)
Suleagloborilus	Cm(Tomm-u)?		(89,1006)	+Altaicornus	Cm(Atda-u)?		(1006)
+Xiadongtubulus	Cm(l)		(1006)	Ambrolinevitus	Cm(Atda-u)	-O (u)?	(1,1006)
Or. ORTHOTHECIDA				Amydaicornus	Cm(mMid)		(289)
+Adyshevitheca	Cm(Atda-u)	-Cm(Boto-l)	(1006)	Anabarcornus	Cm(mMid)		(289)
+Aldanotheca	Cm(Tomm-l)	-Cm(Tomm-u)	(1006)	Angusticornus	Cm(Atda-u)	-Cm(Boto-l)	(522)
				+Aidabanithes	Cm(Tomm-u)	-Cm(Atda-u)	(1006)
				Borealicornus	Cm(Atda)	-Cm(Boto-l)	(522)
				Brevilabicus	Cm(Atda)		(1006)
				Burithes	Cm(Tomm-u)	-Cm(Boto-l)	(268,522, 885)
				Camerotheca	Cm(Boto)		(1,295)
				Carinolithes	Cm(l)	-O (Cara-u)	(1,1116)
				Cavernolithes	O (Aren)	-O (Cara)?	(288)
				Crestjähitus	Cm(Tomm-u)	-Cm(mMid)	(522)

Taxon	First Appearance	Last Appearance	Reference	Taxon	First Appearance	Last Appearance	Reference
Decipilites	O (Ashg-m)	-O (Ashg-u)	(288,1076)	Tuojdachithes	Cm(Tomm-u)	-Cm(Atda-u)	(289,1006)
Diplothecha	Cm(Boto)		(1,295)	+Virgatolthecha	Cm(Tomm-u)		(1006)
+Doescherina	Cm(m)?	-Cm(Fran)	(866)	Virgulaxonaria	O (l)		(1)
Doliutus	Cm(Tomm-u)	-Cm(Boto)	(289,655, 885)	+Yacutolithuus	Cm(Tomm-u)		(1006)
				+Yankongovitus	Cm(Tomm)?		(1006)
Dorsojugatus	Cm(Tomm-u)	-Cm(Atda-l)	(522)	Cl. UNCERTAIN			
Dorsolinevitus	Cm(Tomm-u)	-O (m)?	(1,1006)	Or. TOXEUMORPHORIDA			
Elegantilites	O (Aren)	-O (Ashg-u)	(288)	Macrothecha	P (Dju)		(296)
+Emarites	Cm(lMid)		(1250)	Pseudotoxeuma	P (Leon-l)	-P (Leon-m)	(296)
Erraticornus	Cm(Boto-l)		(522,1006)	Toxeumorphora	C (Serp)	-P (u)	(296)
Firmicornus	Cm(Atda-l)	-Cm(Boto-l)	(522)	Or. HYOLITH UNCERTAIN			
Galicornus	Cm(Atda-u)	-Cm(Boto-l)	(289,522)	+Calcithecha	Cm(l)		(1006)
Gompholites	O (Aren)	-O (Ashg-m)	(288)	Decorithecha	Cm(l)	-Cm(Fran)	(731)
+Goniocornus	Cm(Atda-u)?		(1006)	Dilites	O (Llvi)		(288)
+Grantithecha	Cm(l)		(866)	Eumorpholites	O (Llde-l)	-O (Cara)?	(288)
+Hallothecha	D (Give-l)		(751)	Nervalites	O (Llde-l)		(288)
+Haplophrentis	Cm(lMid-u)	-Cm(mMid-u)		Ovalithecha	Cm(Tomm-l)	-Cm(Atda-l)	(885,1030)
+Helenia	Cm(Atda-u)?	-Cm(Boto)?	(1006)	+?Parahyolithes	Cm(Boto)		(1006)
Hyolithes	Cm(Atda-l)	-P (Guad-u)	(2,87)	-Percitthecha	Cm(Atda-u)?		(1006)
+Hyptiothecha	Cm(Atda-u)?	-Cm(Tojo)	(923,1057)	Ph. MOLLUSCA			
+Ingolithecha	Cm(Boto-u)?		(1235)	"MONOPLACOPHORA"			
Insignicornus	Cm(Boto-l)		(522,1006)	[Classification from Runnegar & Jell (1976) and Peel (1991), with many additions.]			
Jacuticornus	Cm(Tomm-u)		(522)	Cl. TERGOMYA			
Jacutolithus	Cm(Tomm-u)		(522)	Or. TRYBLIDIIDA			
Joachimilites	O (Llvi-u)	-O (Ashg-u)	(288,1116)	Archaeophiala	O (Ashg-l)	-O (Ashg-u)	(1)
Ketemecornus	Cm(Atda-u)	-Cm(Tojo-l)	(522,1006)	Archaeopraga	S (Prid)?		(2)
Korilithes	Cm(Tomm-u)		(268)	Bipulvina	O (Trem)		(1)
Kuonamkicornus	Cm(Atda-u)	-Cm(Boto-l)?	(289)	Drahomira	S (Prid)		(1)
+Laticornus	Cm(Atda-u)		(1006)	-Ellsworthocornus	Cm(u)		(1020)
+Lenalitus	Cm(Atda-u)		(1006)	Helcionopsis	Cm(lMid)?	-O (Ashg-m)	(110,615)
Leolites	O (Llvi-u)	-O (Ashg-m)	(288)	Kalbylella	Cm(Atda-u)	-Cm(mMid-u)	(272,1006)
Linevitus	Cm(Tomm)	-S (Ldov)?	(1006)	Micropileus	O (m)		(1)
Lirothecha	C (Step-l)		(291)	+Micropilina	Q (Plei)		(ZR91)
+Meitanovitus	Cm(Tomm)?		(1006)	Pilina	O (Ashg-m)	-S (Wenl)	(1,273)
Microcornus	Cm(Tomm-u)	-Cm(Boto-u)?	(87,270, 923,1006)	Propilina	Cm(Dres-u)	-O (Aren)	(1)
				Romaniella	O (Trem)		
+Neopauxillites	Cm(Boto)		(866)	Tryblidium	O (Cara-l)	-S (Wenl)?	(1)
+Nevadothecha	Cm(Boto)?	-Cm(Fran)?	(866)	Vallatothecha	Cm(lMid)	-O (Ashg-m)	(110)
Nitoricornus	Cm(Boto-l)		(522,1006)	Or. CYRTONELLIDA			
Notabilites	Cm(Tomm-u)		(522)	+Cornuella	Cm(Trep)		(644)
+Novakotheca	Cm(mMid)?			-Cyclocyrttonella	S (u)		
Oblicicornus	Cm(Tomm-u)		(522)	Cyrtolites	O (Llde)	-S (Wenl)	(1,909)
+Obsoedalites	Cm(lMid)		(1250)	Cyrtoneilla	S	-D (Give)	(1,110)
Oxytus	Cm(Tomm-u)	-Cm(Atda-l)	(522)	Cyrtoneolopsis	O (Trem-l)	-O (Llvi)	(1,110, 1075)
+Parakorilithes	Cm(Boto)		(1006)	-?Gasconadeocornus	O (Trem)		(644)
+Parkula	Cm(Atda-u)		(923)	?Orionstoma	O (Cara-l)	-D (Give)	(362,797, 1066)
+Patholites	Cm(lMid)		(1250)	?Pollicina	O (Aren-u)		(110,615)
Pauxillites	O (Trem)	-O (Llde-l)	(288)	Procarinaria	S (u)		(1)
+Planothecha	Cm(Boto-l)		(1006)	-Protoconus	Cm(Tomm-u)?		(1006)
Pterigothecha	D (l)		(1)	+Sinuitella	O (Trem)		
Quadrothecha	Cm(Tomm-u)	-O (Cara-u)?	(1,268, 1116)	Sinuitopsis	O (Llvi)	-O (Ashg)	
+Quinquelithes	Cm(l)		(1006)				
+Rarissimetus	Cm(Tomm-u)	-Cm(Atda-l)	(1006)				
Recilites	O (Llde-l)	-O (Cara-u)?	(288,1116)				
+Rodentilites	Cm(lMid)		(1250)				
-Slapyrites	Cm(lMid)		(1250)				
Sulcavitus	Cm(Atda)?	-O (l)	(1,1006)				
+Tajinella	Cm(lMid)		(1250)				
+Tizilites	Cm(lMid)		(1250)				
Trapezovitus	Cm(Atda-l)	-Cm(Boto-u)	(268,522)				
Tulenicornus	Cm(Boto)	-Cm(mMid)	(1,1006)				

Taxon	First Appearance	Last Appearance	Reference
+Tetamocornu	Cm(Dres-u)	-Cm(Trep)	
Trigyra	O (Llde)?		(1,615)
+Yochelsonia	S (u)		

Or. HYPSELOCONIDA

+Archaeoconus	Cm(Trep)		(644)
+Cambrioconus	Cm(Trep)		(644)
Hypseloconus	Cm(Dres-l)	-O (Trem)	(1,2,644)
Kirengella	Cm(uMid)	-O (Trem)	(110)
Nknightoconus	Cm(Fran-l)		(269)
?Ozarkoconus	Cm(Dres-u)	-O (Trem)?	(1)
Shelbyoceras	Cm(uMid)	-O (Trem-u)?	(644)
+Yochelsonella	O (l)?		

Cl. HELCIONELLOIDA

Anabarella	V (N-Da-u)	-Cm(uMid-u)?	(268,270, 885,1030)
+Asperconella	Cm(Boto-u)?		(1235)
Bemella	V (N-Da-u)	-Cm(mMid-l)	(268,699, 885,1030)
Calloconus	D (Sieg)	-D (Emsi)	(110)
Coreospira	Cm(Tojo)		(110)
+Dianella	Cm(Tomm)?		
?Eotebenna	Cm(Boto-l)	-Cm(uMid-l)?	(110,1006)
+Eurekapegma	Cm(uMid-u)		(529)
Helcionella	V (N-Da-u)	-Cm(Dres-l)?	(14,110, 1030)
Latouchella	V (N-Da-u)	-Cm(uMid-u)	(270,529, 885,1030)
+Leptostega	Cm(Atda-u)	-Cm(mMid-l)	(699,1006)
Melhoppegma	Cm(Tomm-l)	-Cm(uMid-m)	(885,1030)
Nyuella	O (l)		(110)
Oelandia	Cm(m)		
+Perssuakiella	Cm(uMid-u)		(ZR88)
Protowenella	Cm(Atda-u)	-Cm(uMid-u)	(110,529, 580)
?Scenella	Cm(Tomm-u)	-Cm(Dres)	(14)
Securiconus	V (N-Da-u)?	-Cm(m)	(1034)
Stenothecca	Cm(Atda)	-Cm(uMid-l)	(11,110, 1006)
Tannuella	Cm(Tomm-l)	-Cm(uMid-l)	(110,885, 1030)
+Yochelcionella	Cm(Tomm-l)	-Cm(uMid-l)	(110,1034)

Cl. INCERTAE SEDIS

Or. PELAGIELLIDA

(some question if these are molluscs)

+Aldanella	Cm(Tomm-l)	-Cm(Atda-u)	(580)
Cambretina	Cm(lMid)		
Costipellagiella	Cm(lMid)	-Cm(uMid-u)	(529)
+Paraldanella	Cm(Tomm-l)		(1006,1030)
Pelagiella	Cm(Atda-u)	-Cm(Fran-u)	(270,580)
+Protospira	Cm(Fran-u)		

Or. TUARANGIIDA

(disputed by Berg-Madsen (1987))

+Pseudomyona (= Myona)	Cm(uMid-l)	-Cm(Dres)	(543)
+Tuaringia	Cm(uMid-u)	-Cm(Dres)	(90)

Taxon	First Appearance	Last Appearance	Reference
Or. HEMITHECELLITINA			
+Conodia	O (Trem)		(1114)
+Elongata	Cm(Trep)		(1114)
+Robustum	O (Trem)		(1114)

Or. INCERTAE SEDIS

(many may not be molluscs)

+?Absidaticonus	Cm(Tomm-u)?		(1006)
+Acevina	Cm(m)		
+?Actinoconus	Cm(Tomm-u)?		(580)
+?Aculopileus	Cm(Atda-u)		(1006)
+?Acutirostriconus	Cm(Tomm-u)?		(1006)
+?Aegides	Cm(Tomm-u)		(89,951, 1006)
+?Aldanolina	V (N-Da-u)	-Cm(Tomm-u)	(522,1030)
+?Algomella	V (N-Da-u)		(1006,1030)
+?Anhuiconus	Cm(Boto)?		(1006)
+Archaeospira	V (N-Da-u)	-Cm(Tomm-u)	(951,1006, 1030)
Archinacellina	O (Llvi)		
+?Asperoconus	Cm(Tomm-u)?		(1006)
+Aviculocephaloconus			
	Cm(Tomm-u)?		(1006)
+Bagenoviella	Cm(Tojo)		(1006)
+Barskovia	V (N-Da-u)	-Cm(Atda-l)?	(522,885, 1006,1030)
+Beshtashella	Cm(Atda-u)		(1006,923)
+?Cambroconus	Cm(Tomm-u)		(1006)
+?Cambroscutum	Cm(Atda-u)		(1006)
+?Cambrospira	Cm(Tomm-u)?		(1006)
+?Centriconus	Cm(Tomm-u)?		(1006)
+?Ceratoconus	Cm(Tomm-u)		(1006)
+?Codonoconus	Cm(Tomm-u)?		(1006)
+?Crestoconus	Cm(Tomm-u)?		(1006)
+?Cycloconchoides	Cm(Atda-u)?		(1006)
Cycloholcus	Cm(Dres-l)		(11)
Cyrtodiscus	O (Llde)	-O (u)	(1)
+?Dengyingoconus	Cm(Tomm)?		(1006)
+?Dysnoetopla	Cm(Tomm-u)?		(1006)
+?Ebianella	Cm(Tomm)?		(1006)
+?Emarginoconus	Cm(Tomm-l)	-Cm(Atda-u)?	(1006,1030)
+Enigmaconus	Cm(uMid-u)		(529)
+Eocyrtolites	Cm(Boto)		(1006)
+Eohalobia	Cm(Tomm-u)?		(951,1006)
+?Eosoconus	Cm(Tomm-u)?		(1006)
+?Gibbaspira	Cm(Tomm-u)?		(1006)
+?Granoconus	V (N-Da-u)	-Cm(Tomm-u)?	(1006,1030)
+?Gutticonus	Cm(Tomm-u)?		(1006)
+?Hamatoconus	Cm(Tomm)?		(1006)
?Hampilina	Cm(m)		
+Hamusella	Cm(Tomm)		(1006)
+?Huanglingella	Cm(Tomm-u)?		(1006)
+?Huangshandongoconus			
	Cm(Tomm-u)?		(1006)
+?Hubeinella	Cm(Atda-u)?		(1006)
+?Hubeispira	Cm(Tomm-u)?		(1006)
+?Hujiagouella	Cm(Tomm-u)?		(1006)
Igorella	V (N-Da-u)	-Cm(Atda-u)?	(1006,1030)
+?Igorellina	Cm(Tomm-u)		(1006)

Taxon	First Appearance	Last Appearance	Reference	Taxon	First Appearance	Last Appearance	Reference
+ Hsanelia (+ Ginella)	Cm(Tomm-l)	-Cm(Atda-u)?	(522,885, 1006)	+ Protoconus	Cm(Fran)?		
+ ?Isitiella	Cm(Tomm-l)	-Cm(Tomm-u)	(522,1006)	Protoconchioides	Cm(Boto)	-Cm(m)	
?Janospira	O (Aren)			Pseudomatthevia			(1006)
?Jinonicella	O (Ashg-l)	-S (Ludl)?	(ZR79, 1116)	Pseudopollicina	Cm(uMid)		(1006)
?Kepinospira				+ Pseudoyangtzespira	Cm(Tomm-l)		
+ Khairkhania	Cm(Tomm)	-Cm(Boto)	(1006)	+ Purrella	V (N-Da-u)	-Cm(Atda-u)	(885,1006, 1030)
+ ?Kistasella	Cm(Boto-l)		(1006)	Pygmaeoconus	O (l)?	-O (LJde-l)	(110)
Kotysium				Randomia	Cm(Atda-l)	-Cm(m)	(655,885)
+ Kraikhania	Cm(Tomm-l)		(1030)	+ Reticulatoconus	Cm(m)		(ZR83)
+ ?Kuanchuanella	Cm(Tomm-u)?		(1006)	Retipilina			
+ Latirostratus	Cm(Tomm-u)?		(1006)	+ ?Rozanoviella	Cm(Tomm)	-Cm(Atda)	(1006)
Lenaella	O (Trem)		(737)	+ ?Saccionus	Cm(Tomm-u)?		(1006)
+ ?Lepidites	Cm(l)		(1006)	+ ?Salanyella	V (N-Da-u)	-Cm(Tomm-l)	(1006,1030)
+ ?Liantuoconus	Cm(Tomm-u)?		(1006)	+ ?Scamboscamma	Cm(Tomm-u)?		(1006)
+ ?Ligyrokala	Cm(Tomm-u)?		(1006)	?Scenellopsis	Cm(l)	-Cm(m)	(1006)
Litavina				+ ?Scutatetostomaconus	Cm(Tomm-u)?		(1006)
+ ?Mackenziella	Cm(Atda)			+ ?Shabaktiella	Cm(Tomm-l)	-Cm(Tomm-u)	(885,1006)
+ Mackinnonia	Cm(Atda-u)	-Cm(Boto-u)?	(923,1235)	+ ?Sichuanospira	Cm(Tomm-u)?		(1006)
Macroscenella	Cm(Trep)	-O (Cara-l)	(2)	+ ?Sinuconus	Cm(Tomm-u)?		(1006)
+ ?Maidipingoconus	Cm(Tomm-u)		(1006)	+ ?Songlingella	Cm(Tomm-u)?		(1006)
+ ?Maikhanella	V (N-Da-u)	-Cm(Atda)	(885,1006, 1030)	+ ?Spatuloculus	Cm(Tomm-u)?		(1006)
+ ?Maishucunconus	Cm(Tomm-u)?		(1006)	+ ?Tannuspira	Cm(Boto)		(1006)
+ ?Makarakia	Cm(Tojo)		(1006)	+ ?Tianzhushanospira	Cm(Tomm-u)?		(1006)
+ Maroella	Cm(Boto)	-Cm(mMid-l)?	(699)	+ ?Tichkaella	Cm(Boto)	-Cm(mMid-l)?	(699)
+ ?Mastakhella	Cm(Tomm-u)		(1006)	+ ?Truncatoculus	Cm(Tomm-u)?		(1006)
+ ?Merismococcha	Cm(Tomm-u)?-Cm(Atda)		(1006)	+ ?Tuberoconus	Cm(Tomm-u)?		(1006)
+ ?Michniakia	Cm(Atda-u)		(1006)	+ ?Tuoraculus	Cm(Tomm-u)?		(1006)
+ ?Minynerisma	Cm(Tomm)?		(1006)	+ ?Uncinaspira	Cm(Tomm-u)?		(1006)
+ Mirabella	Cm(Atda)		(1006)	+ ?Xiadongoconus	Cm(Tomm-u)?		(951,1006)
Moyerokania	O (l)			+ ?Xianfengella	Cm(Tomm-l)	-Cm(Tomm-u)?	(951,1006, 1030)
Neocytrolites				+ ?Xianfengococcha	Cm(Atda-u)?		(1006)
+ Nongoliella	Cm(Tomm-l)	-Cm(Atda-l)	(1006,1030)	+ ?Xilingxiaconus	Cm(Tomm-u)?		(1006)
+ ?Nothamusium	Cm(l)		(1006)	Xinmanospira	Cm(m)?, Cm(u)?		
+ ?Obtusoculus	Cm(Tomm-l)	-Cm(uMid-u)	(89,529, 1030)	+ Yangtzeconus	V (N-Da-u)	-Cm(Tomm-u)?	(1006,1030)
+ ?Ocuranus	Cm(Tomm-l)	-Cm(Tomm-u)	(951,1006)	+ ?Yangtzeimerisma	Cm(Tomm)?		(1006)
+ ?Omalemia	Cm(Tomm-u)?		(1006)	+ Yunnanopleura	Cm(Tomm-u)?		(951,1006)
+ Orthoculus	Cm(Trep-u)		(644)				
+ Ozarkplina	Cm(Trep)		(644)				
Palaeoscurria	S (Ludl)?	-S (Prid)	(615)				
+ ?Paraceratoculus	Cm(Boto)?		(1006)				
+ ?Parafornicella	Cm(Atda-u)?		(1006)				
+ ?Paraisanella	Cm(Atda-u)		(1006)				
+ ?Pararaculus	Cm(Atda-u)		(923)				
+ ?Parascenella	Cm(Tomm)?		(1006)				
?Parnophorella	Cm(Boto)?		(1006)				
Patelliconus							
Pentalina							
+ Peotoculus	Cm(Trep)		(644)				
?Pichynella	O (l)		(1)				
+ ?Pileconus	Cm(Tomm-u)?		(1006)				
Pilinopsis							
+ Planutenia	Cm(Atda-u)						
Platypilina							
+ ?Poraculus	Cm(Tomm)?		(1006)				
+ ?Postacanthella	Cm(Tomm)?		(1006)				
+ ?Praelamellodonta	Cm(Atda-u)?		(1006)				
+ Proconus	Cm(u)		(1020)				

CL. POLYPLACOPHORA (= Amphineura)

[Classification and basic stratigraphic ranges from the TREATISE, Part I (1960).]

OR. PALEOLORICATA

+ Bursata	O (Cara-u)		(1116)
Caleocochiton	O (Trem)?		
Chelodes	O (Trem-l)	-D (Gedi-u)?	(274,1005)
+ ?Coberophora	O (Cara)	-S (Ludl)	(1066)
Eocheilodes	O (Cara)		(274)
Gotlandochiton	O (Aren)	-S (Wen-l)	(1029)
Haeggochiton	K (Camp-l)		(2)
+ ?Hawthorneachiton	S (Ludl)		
Hemithecella	Cm(Trep-l)	-O (Trem-l)	(274)
Ivoechiton	O (Aren)	-K (Camp-l)	(2,1066)
Matthevia	Cm(Fran-u)	-O (Trem-l)	(274)
Olingechiton	K (Camp-l)		(2)
+ Paleochiton	O (Aren)		
Pracanthochiton	Cm(Trep-l)	-O (Trem-l)	(274)
Priscochiton	O (Cara-l)	-O (Cara-u)	(1116)
Probolaecum	D (Eite)?		
+ Sarkachiton	O (Aren)?	-O (Cara-u)	(1116)
Scanochiton	K (Camp-l)		(2)

Taxon	First Appearance	Last Appearance	Reference
Septemchiton	O (Ashg-m)		(274)
+Solenocaris	O (Cara)		(1066)
+Spichelodes	S (Wenl-u)		
Or. NEOLORICATA			
Acanthochitona	T (Ol-u)	-R	(889)
Acanthopleura	Q (Plei)	-R	
+Acuichiton	C (Serp-l)	-P (Wc)	(277)
Afosschiton	T (Mi-l)	-T (Plio)	(1029)
Allochiton	J (Hett)?, J (Sine)?		
Amicula	Q (Plei)	-R	
+Arcochiton	C (Mosc-l)	-C (Mosc-u)	(277)
+Aulochiton	K (Maes-l)		(1066)
Austrochiton	T (Mi-m)		
Beloplax	D		
Callistochiton	T (Mi-l)	-R	
Callochiton	T (Ol-u)	-R	(899)
+Camptochiton	C (Mosc-u)		(277)
Chaetopleura	T (Ol-u)	-R	(1029)
+Chauliochiton	C (Vise)?	-P (Leon-u)	(278)
Chiton	K (Maes-l)	-R	
+Colapterochiton	C (Bash)	-C (Mosc-l)	
+Coryssochiton	C (Mosc-u)		(277)
Craspedochiton	T (Ol-l)	-R	
+Crenatorica	Tr(Ladi-u)		(276)
Cryptochiton	T (Plio)	-R	
Cryptoconchus	T (Plio)	-R	(1029)
Cryptoplax	T (Mi-l)	-R	
Cyanoplax	Q (Plei)	-R	
Cymatochiton	C (Vise)	-P (Guad)?	(1029)
+Elachyichiton	C (Serp-l)		
+Eudoxochiton	Q (Plei)	-R	(899)
+Eulachyichiton	C (Serp-l)		
+Euleptochiton	D (Emsi)		
+Glaphurochiton	C (Bash-u)	-C (Step-u)	
Glyptochiton	C (Tour)	-C (Serp)	(1029,1066)
+Gryphochiton	C (Vise-u)	-C (Mosc-u)	
Guildingia	T (Mi-l)	-R	(681)
Hanleya	T (Ol-u)	-R	(1029)
Helminthochiton	O (Aren)	-P (Leon-u)	(275,1029)
Heterochiton	J (Sine)?		
Ischnochiton	J (Plie-u)	-R	
Katharina	T (Plio)	-R	
+Kindbladochiton	O (Aren-l)		
+Laculina	T (Mi-m)	-R	
Lavenachiton	T (Mi-m)		
+Lekiskochiton	P (Leon-u)	-P (Guad-l)	(1029)
Lepidochitona	T (Dani)	-R	(1029)
Lepidopleurus	T (Eo-m)	-R	(1029)
Lepidozona	T (Ng)	-R	
+Leptochiton	T (Ol-l)	-R	(1029)
Lirachiton	T (Plio-l)	-R	
Llandeilochiton	O (Llde)		
+Loborochiton	C (Tour-l)		(1066)
Lorica	K (Maes)	-R	(1029)
Loricella	T (Mi-l)	-R	
+Mesochiton	J (l)		
+Notoplax	T (Mi-l)	-R	(1029)
Nuttallina	Q (Plei)	-R	
+Ochmazochiton	P (Sakm)	-P (Leon-u)	(278)
+Onithochiton	T (Plio-u)	-R	(899)
Oochiton	T (Mi-m)		

Taxon	First Appearance	Last Appearance	Reference
+Pedanochiton	C (Mosc-u)		(277)
+Permochiton	P		(1029)
+Pileochiton	C (l)	-C (Mosc-u)	(277)
Placiphorella	Q (Plei)	-R	
Plaxiphora	T (Eo)	-R	(1066)
+Proleptochiton	C		(ZR77)
Protalochiton	C (l)		
Protochiton	T (Eo)	-T (Mi-m)	(1029)
Pseudoischnochiton	T (Mi-l)		
Pterochiton	C (Tour)	-P (l)	(277)
Pterygochiton	J (Sine)?	-J (Plie)	
+Rhyssoplax	T (Ol-u)	-R	(899)
Schizochiton	T (Mi-l)	-R	
+Soleachiton	C (Serp)	-P (Leon-u)	(278)
+Stegochiton	P (Sakm)		(278)
Stenoplax	T (Eo-m)	-R	(1029)
Tonicella	T (Ol-l)	-R	(1029)
Tonicia	T (Eo-m)	-R	(1029)
+Trachypleura	Tr(Anis-l)		(1029)

Cl. ROSTROCONCHIA

[Classification and basic stratigraphic ranges from Pojeta and Rungger (1976).]

Or. RIBEIROIDA

Anisotechnophorus	O (Trem-l)		(542)
Aoptopegma	Cm(Dres-l)	-O (Trem-l)	
Cynatopegma	Cm(Trep-u)		(543)
Eoischyrina	Cm(Trep-u)		(1066)
?Euchasmella	O (Trem)		(543)
Heraulitopegma	Cm(Tomm-l)	-Cm(Atda-l)	(522,580, 885)
Ischyrinia	O (Cara-l)	-O (Ashg-m)	(542)
Kimopegma	Cm(Trep-u)		(543)
Myocaris	O (Llde)		(542)
Oepikila	Cm(Dres-u)		(542)
Pauropegma	O (Trem-u)	-O (Aren)	(543)
Pinnocaris	Cm(Trep-u)	-S (Ldov-u)	(542)
Pleuropegma	Cm(Dres-l)		(543)
?Pseudoeuchasma	O (Trem)		(543)
Pseudotechnophorus	Cm(Trep-u)		(542)
Ptychopegma	O (Trem-l)	-O (Trem-u)	(543)
Ribeiria	Cm(Dres-l)	-O (Ashg)	(542)
Riberina	O (Aren)		(542)
+?Rostroconus	Cm(Tomm-l)	-Cm(Tomm-u)?	(89,1006, 1030)
Technophorus	O (Trem-l)	-S (Ldov-u)	(542,543)
Tolmachovia	O (Trem-u)	-O (Llde)?	(542)
Wanwania	Cm(Dres-u)	-O (Trem)	(542)
Watsonella	V (N-Da)	-Cm(Atda)	(1006)

Or. CONOCARDIOIDA

+Aphelakardia	C (Tour-l)	-C (Tour-u)	
Arceodomus	C (Serp-l)	-P (Sakm)	(542)
Bigalea	S (Wenl)	-D (Give-l)	(542)
Bransonia	O (Trem-l)	-P (Guad-u)	(542,1066)
+Cassowarioides	S (Wenl)		
Conocardium	D (Sieg)	-C (Mosc)?	(542)
Eopteria	Cm(Trep-u)	-O (Cara-l)	(542)
Euchasma	Cm(Dres)	-O (Llvi-l)	(16,281)
Hippocardia	O (Llde)	-C (Mosc-u)	(542)
Mulecodens	S (Wenl)	-D (Give-l)	(542)

Taxon	First Appearance	Last Appearance	Reference
+Nehedia	S (Wenl)		
+Pojetaconcha	P (Sakm-u)		(ZR87)
+Pseudobigalea	C (Mosc-u)		(282)
Pseudoconocardium	C (Serp-l)	-P (Guad-u)?	(282)
-Pseudomulceodens	C (Tour-u)		
Wanwanella	Cm(Trep-u)	-O (Trem)	(542)
Wanwanoida	O (Trem)		(543)

CI. SCAPHOPODA

[Classification and basic stratigraphic ranges from the TREATISE, Part I (1960).]

Antalis	T (Dani)	-R	
Cadulus	K (l)	-R	(1066)
Calstevenus	P (Sakm)		(283)
Coccodentalium	T (Mi-u-l)	-R	
Compressidens	T (Ol-l)	-R	
Dentalium	K (Maes)	-R	(888)
Dischides	T (Eo-m)	-R	
Entalina	T (Than-l)	-R	(914)
Episiphon	J (l)	-R	
Fissidentalium	K (l)	-R	
Fustiaria	T (Eo-u)?	-R	
Gadila	K (l)	-R	
Gadilina	T (Mi-l)	-R	
Graptacme	T (Than)?	-R	
Laeidentalium	Tr(Ladi)?	-R	
Lobantale	T (Eo-m)	-R	
Paradentalium	T (Mi)	-R	
+Pipedentalium	C (Tour-u)		(896)
Plagioglypta	D (Fame)?	-K (Albi)	(914)
Polyschides	T (Pale)	-R	
Prodentalium	D (Sieg-l)	-J (Call-m)	(2)
Progadilina	J (l)		
Pseudantalis	T (Eo)	-R	
Pulsellum	T (Than-l)	-R	(914)
Rhabdus	T (Ol-l)	-R	(852)
+Rhytidentalium	O (Cara-m)		(284)
+Scissuradentalium	C (Tour-u)		(899)
Siphonodentalium	T (Eo-m)	-R	(914)
Spadentaline	Q (Plei)	-R	
+Striocadulus	T (Mi-l-u)	-T (Plio-u)	(899)
Tesseracme	T (Eo-m)	-R	
Throopella	D (u)		

CI. UNCERTAIN

+?Ardrossania	Cm(Atda-u)		(923)
---------------	------------	--	-------

CI. ?STENOTHECOIDEA

Bagenovia	Cm(Atda-u)?	-Cm(Boto)	(1006)
+Beroides	Cm(Boto)		(1006)
Cambridium	Cm(Atda-u)	-Cm(lMid-u)	(1,14,522)
+Dingus	Cm(Boto)		(1006)
-Kaschkadakia	Cm(Tojo)		(1006)
+Katuniooides	Cm(Boto)?		(1006)
+Sargaella	Cm(Atda)?		(1006)
+Stenothecella	Cm(Boto)?		(1006)
Stenothecooides	Cm(Tomm-l)	-Cm(uMid)	(10,14,885,1030)
+Sulcocarina	Cm(Boto)?		(1006)

Taxon	First Appearance	Last Appearance	Reference
-------	------------------	-----------------	-----------

CI. ?CRICOCONARIDA (= Tentaculitoidea)

[Classification and basic stratigraphic ranges from the TREATISE, Part (19 .).]

Or. TENTACULITIDA

+Aleksites			
Alternatus	D (Sieg)	-D (Fras-u)	
+Arcites			
+Bicingulites			
Contractenus	D (Sieg)	-D (Eife-u)	
Denticulites	D (Give-u)		
Dicricononus	S (Ldov-m)	-D (Fras-u)	
+Gotlandellites	S (Ldov-u)	-S (Wenl-l)	(758)
+Hemicricus (+ Semicycylus)			
	D (Emsi-u)		(285)
+?Ljaschenkovites	C (Serp-l)		
+Lonchidium	S (Ludl)?	-S (Prid)?	(758)
+Longulatus	D (Sieg)		
Multiconus	D (Fras-m)		
+Odessites	S (Ludl-u)	-D (l)	(758)
+Omulites			
+Parvulites			
+Podolites	S (Wenl-u)	-S (Ludl-u)	(758)
+Prolationus	D (Sieg)		
+Rossites			
+Samarites			
+Sektionites	D (Fras-l)		
+Seritites	D (Sieg)?	-D (Fras-l)	(758,1066)
+Sokolites			
Tentaculites	O (Trem)	-D (Fras-m)	(1066)
+Tractabilis			
+Tractabilopsis	S (Wenl-l)		(758)
+Tripartites	D (Fras-l)		(1066)
+Turmalites	S (Wenl-l)	-D (Fras-l)	(758)
+Ukrainites	D (Sieg)		
Uniconus	S	-D (Fras-u)	
+Uniformites			
+Vjalovites	D (Sieg)		
Volynites	S (Wenl-u)	-D (Fras-u)	
+Zandadjanites	D (Fras-l)		

Or. HOMOCTENIDA

Homoctenus	D (Eife-l)	-D (Fras-u)	
Polycylindrites	D (Fras-l)	-D (Fras-u)	

Or. DACRYOCONARIDA

+Corniculina	D (Gedi)		(286)
+Corniculinooides	D (Sieg-l)?		
+Costulatostyliolina	D (Emsi-u)		(364)
Crassilina	D (Eife)	-D (Fras-l)	
+Cyrtonowakia	D (Sieg-l)?		
+Distriatostylus	D (Give-u)		(364)
Guerichina	D (Sieg-u)	-D (Give-u)?	(364)
+Homoctenowakia	D (Gedi-u)	-D (Sieg-l)	
Metastyliolina	D (Sieg-l)?	-D (Emsi-l)	(364)
Nowakia	S (Ldov-m)	-D (Fras-m)	
+Paranowakia	D (Gedi-u)	-D (Sieg-l)	
+Peneutia	D (Sieg)		(364)
+Sogdiana	D (Sieg)		(364)
Striatostyliolina	D (Emsi-u)	-D (Fras-m)	(364)
+Styliola	D (Emsi-u)		(1066)

Taxon	First Appearance	Last Appearance	Reference
Styliolina	S (Wenl)	-D (Fame-l)	
+Undastriatostyliolina	D (Fras-l)		(1066)
Viriatella	S (Ludl)	-D (Fras-l)	
+Viratellina	D (Sieg-u)	-D (Fras)	(285,364)

Cl. PARAGASTROPODA

Or. HYPERSTROPHINA

+Angulospira	O (Ashg-l)	-S (Ludl-l)	
+Antispira	O (Cara-m)		
+Antizyga	O (Ashg)	-D (Sieg)	(362)
+Atracura	D (Sieg)		(362)
+Bodospira	O (Ashg)		
+Clisospira	O (Trem)	-O (Ashg)	(797)
+Conoclisia (+ Antigyra)	S (u)	-D (Eife)	(797)
+Ferrogyra	O (Llde)		(797)
Helicotis	O (Llvi-l)		(615)
+Hyperstrophema	D (Eife)		(362)
+Hypomphalocirrus	D (Emsi-u)	-D (Give)	(362)
+Invertospira	O (Llvi)		(797)
Kobayashiella	Cm(Fran)	-Cm(Trep-u)	
Laeogyra	O (Llvi)	-O (Ashg)	(797)
+Liomphalus	D (Sieg)		(362)
Matherella	Cm(Dres-u)	-Cm(Trep)	
Matherellina	Cm(Trep-u)	-O (Trem)?	
Mimospira	O (Trem-l)	-S (Ludl-u)	(1075)
Omphalocirrus	D (Eife)	-D (Give)	(362)
Onychochilus	S (Wenl-l)	-D (Gedi)	(797)
+Paleopupa	S (Ldov-l)		
Paragaleus	D (Sieg)		(362)
+Pervertina	O (Ashg)		
Procerucibulum	D (Sieg)		(362)
Progaleus	D (Eife)	-D (Give)	(362)
+?Protoscaevogyra	Cm(Dres-l)		
Scaevogyra	Cm(Dres-u)	-Cm(Trep-u)	(111,112)
Sinistracirsa	D (Sieg)	-D (Emsi)	(362)
+Tapinogyra	D (Sieg)		(797)
+Trochoclisia	D (Sieg)		(362)
+Undospira	O (Llvi)	-O (Llde)	
Versispira	O (Cara-m)		(615)
+Voskopella	D (Emsi-u)		
+Yuwenia	Cm(Atda-u)		(113,923)

Cl. GASTROPODA

Or. BELLEROPHONTIDA

(Classification and basic stratigraphy from the TREATISE.
Pt. I [1960].)

Aglaogypta	D (Eife)	-D (Fame)	(362)
+Aiptospira	P (Dora)		(1130)
+Anapetopsis	S (Prid)		
Aspidotheca	D (Sieg)		(362)
?Atlantobellerophon	Tr(Rhac)		(797)
Bellerophon	O (Ashg)	-Tr(Anis)	(2,110, 1130)
+Beyrichidiscus	S (Ludl-u)		(797)
Boiotremus	S (Ldov)	-D (Emsi)	(797)
+Boucotspira	O (Llde)	-S (u)?	(797)
+Bubovicus	S (Wenl)		(909)
Bucanella	O (Trem-u)?	-D (Give)	(362)
Bucania	O (Cara-l)	-C (Step)	(797)

Taxon	First Appearance	Last Appearance	Reference
Bucanopsis	O (Llde)	-C (Serp)	(797)
Carinaropsis	O (Cara-m)?	-O (Ashg-l)	(797)
Chalarostrepis	Cm(Trep)		(2,110)
+Chippewaella	Cm(Dres-l)		
Cloudina	Cm(Trep)		
Coelocyclus	S (Wenl)	-D (Give)	(362)
+Collina	D (Emsi)		(797)
Crenistriella	D (Eife)	-D (Give)	(362)
Cyclotheca	S (Wenl)		(797)
Cymatospira	C (Serp-l)	-C (Sieg-u)	(797,1258)
Cymbularia	O (Llvi-l)?	-S (Ludl-u)	(615)
+Dicellonema	P (Dju)	-P (Dora)	(1130)
Eobucania	O (Trem)		(797)
?Euphemitella	C (Step-u)		
Euphemites	D (Fras)	-Tr(Indu-l)	(362,797)
Euphemitopsis	P (Asse)	-P (Dju)	(109,797)
+Extendilabrum	P (Dora)		(1130)
Gammadiscus	O (Llvi)	-D (Sieg)	(362,797)
Grandostoma	O (Cara)	-O (Ashg-u)	(797)
+Groomodiscus	O (Llvi-l)?		(797)
Gyrosira	D (Gedi)	-D (Fame)	(362)
+Hispanosinuites	O (Llvi-l)		
Isospira	O (Cara-u)	-O (Ashg)	(615)
+Khumerspira	P (Guad)		(797)
Knightsites	C (Tour)	-P (Guad-l)	(109,797)
+Kodymites	S (u)	-D (Emsi)	(797)
Kokenospira	O (Llde)	-O (Cara-u)	(797,1116)
+Lenticularis	C (Tour-l)		(797)
Liljevallospira	S (Wenl)	-S (Ludl)	(909)
Megalomphala	O (Llvi-l)?	-D (Fame)	(362)
+Merriamites	D (Eife-l)		(1004)
+Mirochillicus	P (Dora)		(1130)
Modestospira	O (Aren)	-O (Cara-l)	(797,1116)
Multiarites	O (Aren)?		(110,737)
+Offleya	S (Ldov-u)		(1194)
Owenella	Cm(Trep-u)	-O (Trem-l)	(797)
+Palcuphemites	D (Sieg-u)	-D (Emsi)	(362)
Patellilabia	D (Give)	-P (Sakm)	(797)
Patellostium	D (Sieg)	-P (Guad)	(362)
Pedasiola	D (Give)		(362)
Peelerophon	O (Trem-l)	-O (Aren-l)	(797)
Pharetrolites	S (Wenl)	-D (Emsi)	(1,362,797)
Pharkidonotus	C (Serp-l)	-P (Dju)	(109,797, 1195)
Phragmolites	O (Llde)?	-S (Wenl)	(797)
Phragmosphaera	S (Ludl-u)	-C (Tour)?	(362,797)
+Plectonotoides	S (Ldov-u)	-D (Emsi-l)	(1196)
Plectonotus	S (Ldov-l)	-D (Eife)	(362,797, 1196)
+Praematuratropis	D (Emsi)		(362)
Prosoptychus	S (Ldov)	-D (Emsi)	(362,797)
+Pseudowartha	D (m)		(ZR83)
Pterotheca	O (Llvi)?	-O (Ashg-m)	(797)
Ptomatis	D (Sieg)	-D (Give)	(362)
Ptychobellerophon	P (l)	-P (Dora)	(1130)
Ptychosphaera	S (Ludl-u)	-S (Prid)	(615)
Retispira	D (Emsi-u)	-Tr(Indu-l)	(362)
+Rotadiscoides	O		(ZR80)
Salpingostoma	O (Llde)	-S (Wenl-l)	(615,797)
+?Siluracmaea	S (Dju)		
+Singulitubus	P	-P (Dora)	(1130)
Sinuella	Cm(Dres-u)	-Cm(Fran)	(797)

Taxon	First Appearance	Last Appearance	Reference	Taxon	First Appearance	Last Appearance	Reference
Simuites	O (Llvi)	-O (Ashg-m)	(1,797)	?Babylonites	P (Leon)	-P (Guad-l)	(109,797)
Sinuitina	S (Ldov)	-P (Djhu)	(797,1130)	Barnesella	O (Trem-u)	-O (Llvi)	(1084,1197)
Sphenospaera	O (Cara-l)	-O (Ashg-m)	(797)	+?Bassotrochus	D (Emsi)		(ZR78)
+ Squarrosus	D (m)		(ZR83)	+ Biformispira	D (Gedi)	-D (Sieg)	(797)
Stachella	P (Leon-u)	-Tr(Olen-l)	(110,1130)	+ Boucotispira	O (Llde)	-O (Ashg-m)	(1197)
Strangulites	O (Ashg-l)	-O (Ashg-m)	(797)	+ Bridegites	O (Trem-u)	-O (Aren-l)	(797)
+ Streptodiscus	Cm(uMid-u)	-O (Trem-l)		Centrifugus	S (Ludl-l)	-S (Ludl-u)	
+ Sylvestrospira	S (Ludl-l)		(ZR81)	Centropea (+ Proliospira)			
Temnodiscus	O (Cara-m)	-S (Prid)	(797)		O (Trem-u)	-O (Aren-u)	(797)
Tetranota	O (Llde)?	-O (Cara-u)?	(615)	+?Coronopsis	P (Sakm)		(797)
+ Tetratubispira	P (Dora)		(1130)	Cyclonema	O (Cara-l)	-D (Fras)	(362)
Tremanotus	S (Ldov)	-D (Fras)	(362,797)	Cylicioscapha	C (Vise)	-P (Guad-u)	(109,797)
+ Tritonophon	S (Ldov-l)	-D (Eife)	(362)	?Diploconula	P (Leon)		(797)
Tropidodiscus	O (Trem-l)	-P (Guad)	(797)	Tr(Ladi)	Tr(Ladi)	-K (Maes)?	(797,914)
+ Undulabucania	O (Cara-m)	-O (Ashg-l)		Discordichilus	S (Wenl-l)	-S (Wenl-u)	(797,1197)
Warthia	C (Step-l)	-P (Dora)	(1130,1258)	?Discotropis	C (Mosc)	-Tr(Nori)	(797)
Or. PATELLOGASTROPODA				Eccliomphalus	O (Aren-u)	-O (Cara-u)	
Acmaea	Tr(Nori)	-R	(909)	+ Eccliopterus	O (Aren-u)	-O (Cara-u)	(1197)
Actinolouca	T (Ol-u)?	-R	(909)	- Ellisella	O (Llvi)		(797)
Ancistromesus	T (Plio)	-R		?Euomphalopsis	O (Trem-l)		(797)
Ansates	T (Plio)	-R		Euomphalopterus	O (Ashg)	-D (Emsi)	(797)
Archinacella	Cm(Trep)?	-S (Ldov)	(1,2)	Euomphalus	S (Wenl-u)	-Tr(Nori)	(797,1197)
Asteracmea	T (Plio-u)	-R	(899)	+ Fletcheriopsis	D (Give)?		
Atalacmea	T (Mi)	-R		+?Fujiispira	D (Eife-u)		
Cellana	T (Eo-m-u)	-R	(530,909)	Hemitoma	T (Dani)	-R	(914)
Collisella	Q (Plei)	-R		+ Heteronodostus	P (Leon)?	-P (Guad)	(797)
Conoidacmaea	Q (Plei)	-R		Holope	O (Aren-u)	-C (Serp-l)	(797)
Conorhytis	J (Bajo-u)	-J (Bath-m)		Hystericoceras	S (Ludl)?		
Deslongchampsia	J (Bath-u)	-J (Oxlo)		+Hafarispira	S (Ldov-u)?	S (Wenl-l)?	
Dietrichiella	J (Kimm)			+ Kiaeromphalus	S (Ldov-u)	-S (Ludl)	(909)
+ Floripatella	O (Llvi)		(909)	Lecanospira	Cm(Trep-u)	-O (Trem)	(797)
+ Guelphinacella	S (Ludl)		(797)	Leptomphalus	P (Leon)	-P (Guad)	(797,1130)
Hamptoniella	J (Bath)			Lesueurilla	O (Aren-l)	-O (Cara-u)	(797)
Helcion	T (Plio)	-R		+ Linsleyella	O (Llvi)		(797)
Hennocquia	J (Sine)?			+ Lophonema (+ Polehemia, Walcottoma)			
Lepeta	T (Eo-m-l)	-R	(1066)	Lytopira	O (Aren-l)	-O (Llvi-l)	(1084)
Lepetopsis	C (Vise-l)	-Tr(Ladi-u)	(362,797, 1066)	Macluritella (+ Prohelicotoma)	O (Trem-l)	-D (Eife-u)	(797,1005)
+ Lottia	T (Plio-u)	-R			Cm(Trep)	-O (Aren)	(909)
Marbodeia	J (Bath-u)			-Malayaspira	O (Aren-l)	-O (Aren-u)?	(1084)
?Metoptoma	C (Vise)	-P (Dora)	(797,1130)	Mastigospira	D (Eife-u)	-D (Give)	(362)
Nacella	T (Eo-u)	-R		Micromphalus	S (u)	-C (Vise)	(362,797)
Notoacmea	T (Ol-u)	-R	(681)	+ Nevadaspira	D (Fras)		(362)
Palaescurria	O (Llde-l)	-D (Give)	(362,797)	+ Offhyetochus	S (Ldov)		(797)
Parvacmea	T (Ol)			?Omphalotrochus	C (Step)	-P (Tatr)	(797)
Patella	K (Albi)	-R		Ophileta	O (Trem-l)	-O (Aren-l)	
Patellastra	T (Mi)	-R		Ophiletina	O (Trem)	-O (Cara-u)?	(797)
Patelloida	K (Albi-m)	-R	(909)	?Oreopia	D (Emsi)	-D (Fras)	(362,797)
Pectinodonta	T (Mi-l)	-R		Orospira	O (Trem-u)	-O (Aren-l)	(797)
Phryx	Tr(Ladi-u)	-Tr(Carn)	(1066)	Ozarkina	O (Trem)		(797)
Scurriopsis	Tr(Olen-u)	-J (Tith-u)	(1130)	+ Pachystrophia	O (Ashg)		(797)
Scutellastra	T (Ol)	-R	(909)	Pararaphistoma (+ Climacrophistoma)			
Symmetrocapsulus	K (Apti)	-T (Eo-m-u)	(909,1066)		O (Aren-l)	-O (Cara-u)	(797)
Tectura	T (Plio-l)	-R		Phanerotinus	C (Vise)		(797)
Or. EUOMPHALINA				Philoxene	D (Give)?	-D (Fras)	
+ Actomphalus	D (Eife)		(797)	Planitrochus	S (Ludl)	-D (Emsi)	(797)
Amphiscapa	C (Bash-u)	-P (Sakm)	(797,1258)	Planotectus	P (Leon)	-P (Guad-l)	(109,797)
Anomphalus	D (Eife)	-Tr(Nori)	(362,797)	Pleuromphalus	S (Ludl)		
+ Austerum	D (Give)		(362)	Pleuonotus	S	-D (Eife)	(362,797)
				Poleumita	O (Ashg)	-D (Emsi)	(797)
				+Pseudomphalotrochus	D (Eife-u)	-D (Give)	(797)
				Pseudophorus	O (Ashg)	-P (Dora)	(797,1066)

Taxon	First Appearance	Last Appearance	Reference	Taxon	First Appearance	Last Appearance	Reference
Pycnomphalus	S (Ldov-m)	-S (Ludl)		Anematina	D (Eife-l)	-P (Guad-l)	(362,797, 1004)
Raphistoma	O (Llde)	-S	(797)	Angaria	J (Aale)	-R	(909)
Raphistomina	O (Aren-l)	-S		Angyomphalus	D (Emsi-u)	-C (Serp-l)	(797,1004)
Scalites	O (Llde)		(157)	Anisostoma	Tr(Ladi)?	-Tr(Nori)	(797)
Serpulospira	D (Eife-u)	-C (Step-l)	(797,1258)	+ Anodomaria	J (l)		(ZR80)
Siluriphorus	S (Wenl-l)	-D (Eife)	(362)	+ Anoriostoma	D (Gedi-u)		(1005)
+ Sinistrospira	D		(797)	Anticonulus	Tr(Ladi)	-J (Plie-u)	(615,661)
Sinutropis	O (Ashg)	-S (Prid)	(797)	Antillachelus	T (Mi)	-R	
+ Spinicharybdis	S (Ludl-u)			Antisolarium	T (Mi-l-l)	-R	(681)
Spirodentalium	Cm(Trep)		(797)	Antitrochus	D (Eife)	-D (Give)	(362)
Straparollus	O (Ashg)	-Tr(Anis)	(797,1130)	Apachella	C (Vise)	-P (Dora)	(797,1130)
Streptotrochus	S (Ludl)?			+ ?Aplocus	K (Ceno-u)		(747)
+ Triassocirrus	Tr(Anis)	-Tr(Carn)?	(115)	Araconema	C (Tour-u)	-C (Step)	(797,896)
Trochomphalus	O (Ashg-m)		(615)	Arastra	D (Fras)	-D (Fame)	(362)
Turbocheilus	S (Wenl)?	-S (Ludl)?	(797)	+ Arémella	Cm(u)		(1020)
+ ?Tyochobrachea	D (Sieg)			Aréne	T (Ol-l)	-R	(852)
				Argalista	T (Eo-m-u)	-R	(899)
Or. MACLURITINA				Arginula	T (Eo-m)		
Maclurites (+ Maclurina)				Aristostoma	Tr(Ladi)?	-Tr(Nori)	
	O (Aren)	-O (Ashg-m)	(797)	Aristerella	J (Plie)		
Palliseria (+ Zhuozishanospira)				Arizonella	D (Eife)	-D (Fras)	(797)
	O (Aren-u)	-O (Llde)	(797)	+ Arjamannia	O (Cura-u)	-S (Wenl-u)	(797)
+ Rousseauospira	O (Llde)	-O (Ashg)		+ Arribazona	C (Mosc)		(797)
+ Teichispira (+ Monitorella)	O (Aren-l)	-O (Aren-u)	(1084)	Asperilla	Tr(Nori)	-J (Kimm)	
				Astele	K (Albi-u)	-R	(615)
				+ Asterohelix	J (Sine-l)?		(661)
Or. ARCHAEOGASTROPODA				Astraea	T (Than-l)	-R	(914)
(Classification and basic stratigraphy modified from the TREATISE, Pt I [1960].)				Astralites	D (Give)		(362)
+ Aalenella	J (Aale)		(ZR82)	Astrarium	T (Eo)	-R	
+ Abylea	C (Mosc-l)	-C (Step-u)	(797,1258)	+ Ataphropsis	J (Bajo)		(909)
Acanthonema	D (Eife)		(1066)	Ataphrus	J (Bajo)	-K (Camp-u)	(615,1066)
Aclisina	C (Tour)	-P (Dora)	(797,1130)	Atira	K (Turo)	-K (Maes-u)	(790)
Acrosolarium	Tr(Nori)			Attractotrema	T (Eo-m)	-R	(914)
+ Aehmospira	C (u)		(ZR83)	+ Auricularia	Tr(Anis)		(ZR79)
Aequispirella	T (Mi)			Auseria	J (Sine)		(615)
+ Affiniptyxis	K (Berr-l)		(1198)	+ Australonema	S (Wenl-l)	-D (Sieg-l)	(1199,1201)
+ Affrollonia	T (Than)		(705)	+ Austriacopsis	J (Sine-u)?	-J (Tith-u)	(661)
Agathistoma	T (Plio)	-R		+ Austroscalata	P (Leon-m)	-P (Guad-u)	(745)
Agathodonta	K (Nc)	-R	(615)	+ Austrowthenia	C (Tour)	-C (Vise)	(797)
Agnesia	D (Emsi)	-P (Guad-l)	(109,362)	+ Bakonyia	J (Bajo-u)		(661)
Agniesella	D (Emsi)	-D (Eife)	(362,1066)	+ Bajanerita	K (Camp-u)?, K (Maes-l)?		
Aizyella	T (Eo)			Balinula	J (Aale)	-J (Bajo)	
+ Alaionema	D (Sieg)?	-D (Emsi)		+ Bandelium	Tr(Ladi-u)		(1120)
+ Alaskacirrus	D (Emsi)			Bankivia	T (Plio-l)	-R	
+ Alaskiella	D (Emsi)			Barbotella	T (Mi-m)		
Altomarginula	J (Bath)			+ ?Barocospira	D (Gedi)	-D (Sieg)	(362)
Altrix (+ Esmeria, Folia)				+ Barrandecirrus	S (Ludl-u)		
	K (Maes-u)	-R	(1008)	-Barrealispira	C (Serp)	-C (Bash-l)	(1202)
Amaurotoma	C (Tour)	-C (Step-l)	(797,1258)	-Barroisucaulus	D (Sieg)?	-D (Emsi)	
Amberleya	Tr(Anis)?	-J (Oxfo-l)	(909)	Basilissa	K (u)	-R	
+ Ambozone	C (Mosc)	-P (Guad)	(797)	Bathrotomaria	J (Sine-u)	-K (Maes)	(661)
Amonilea	T (Eo)			Bathybembix	T (Eo-u)	-R	
+ Ampezzotrochus	Tr(Ladi-u)		(1120)	Bathyclides	Tr(Carn)	-Tr(Nori)	(797)
Amphinerita	K (Sn)	-R		Baylea	D (Eife)	-P (Djhu)	(109,797, 1130)
Amphitrochus	Tr(Nori)	-K (Nc)					
Ananias	C (Vise)	-Tr(Carn)	(115,797)	Bellastraea	T (Plio)	-R	
+ ?Anarconcha	D (Sieg)		(362)	+ Bellazona	C (Vise-u)	-C (Serp)	(797)
Anastes	T (Plio)	-R		Bembexia	D (Gedi)	-C (Serp)	(362,797)
Anatoma	T (Than-l)	-R	(899)	?Beraunia	S (Ludl)	-D (Give)	(362)
Anceps	T (Mi-m)			Beraua	T (Mi)		
				Berleria	J (Oxfo-u)		

Taxon	First Appearance	Last Appearance	Reference	Taxon	First Appearance	Last Appearance	Reference
Biangularia	D (Emsi)	-D (Give)	(362)	Cirsostylus	Tr(Ladi)	-J (Hett)?	
+Bicarina	D (Sieg)	-D (Eife-u)	(797,1004)	Cittarium	Q (Plei)	-R	
+Boeckhia	J (Bajo-l)		(661)	Claibornia	T (Eo)		
Bolma	T (Dani)	-R	(899)	Clanculopsis	T (Mi)	-R	
Bonnetella	T (Eo)	-T (Ol)		Clanculus	K (Camp)?		
Borestus	C (Tour)	-Tr(Nori)	(109,797)	Clathrospira	O (Aren-l)	-O (Ashg-m)	(797)
Boutillieria	Tr(Olen-l)	-T (Ol-l)?	(797)	Clypeolum	T (Mi)	-R	
Bowdenagaza	T (Mi)			Clypidina	T (Plio)	-R	
Brachytomaria	O (Cara-m)	-O (Ashg-u)		Coanollonia	T (Ol-u)?		(615)
+Bradyospira	P (Leon)		(797)	+Coccapigya	T (Mi-l-u)	-R	(1066)
+Bridegeina	O (Trem-u)	-O (Aren-l)	(797,1203)	Cocculina	T (Mi-l-u)	-R	(530,1066)
Briionella	D (Give)		(362)	Cocculinella	T (Mi-m)?	-R	
Brookula	T (Than)	-R		Cochleochilus	J (Bath)	-J (Tith-u)	
Buechelia	D (Eife-u)		(797)	Codinella	Tr(Ladi-u)		(1120)
Buckmanina	J (Oxfo-l)	-K (Ceno-u)		Coelbolma	K (Ceno)	-K (Camp)?	
Burdikinia	D (Give)		(362)	Coelocaulus	O (Cara-u)	-D (Emsi)	(797)
+Byzantia	P (Leon-u)	-P (Guad-l)		+Coelocentrus	Tr(Ladi-u)		(1120)
Calaurops	O (Aren-l)		(615)	Coelozone	S (Ludl-l)	-D (Eife)	(797)
Caliendrum	C (Vise)	-C (Pn)		Coelotrochus	T (Plio)	-R	
+Calliobasis	T (Eo-u)		(1066)	+?Collabrina	C (Step-l)		(745)
Calliomphalus	K (Barr)	-T (Eo-u)		Colliculus	T (Than)	-R	
Calliostoma	K (Barr)	-R	(615)	Collonia	T (Dani)	-T (Plio)	
Calliotropis	T (Plio)	-R		Collonista	T (Eo-u)	-R	(530)
Calliovarica	T (Eo-l)		(914)	Colpites	C (Mosc-l)?	-P (Guad-l)	
Callistadia	D (Eife-u)	-P (Dora)	(109,1130)	Colpomphalus	J (l)	-J (Bath)	
+Callistete	T (Mi-m)	-R	(1231)	Colubrella	Tr(Ladi)	-Tr(Nori)	
Callitomaria	C (Mosc)	-P (Guad-u)	(109,797)	+Commonozonispira	S	-C (l)	(ZR83)
Callopoma	T (Mi)	-R		+Componema	C (Serp-l)		(114)
Callotrochus	Tr(Nori)			+Concinnispira	C (Serp-u)		(ZR87)
Calthalota	T (Plio)	-R		Condonella	K (u)		
+Campellospira	C (Tour-u)		(797)	Conjectura	T (Mi-l-l)	-R	(681)
+Cantharidella	Q (Plei)	-R	(899)	Conominolia	T (Dani)	-R	(899)
Cantharidus	T (Mi-l)	-R	(530)	Conotoma	S (Wenl)?	-S (Prid)	
Cantrainea	T (Mi)	-R		Conotomaria	J (Aale)	-T (Than)	(909)
Cardinalia	T (Plio)	-R		Cookia	T (Mi-l-l)	-R	(681)
Carinator	T (Plio-u)			+Cupidocatomus	D (Emsi)	-D (Eife)	(362,797)
+Cassianastraea	Tr(Ladi-u)	-Tr(Nori)?	(1120)	+?Cordispira	C (u)		(ZR83)
+Cassianocirrus	Tr(Ladi-u)		(1120)	Corsania	K (Apti)	-T (Than)	
+Cassipelia	K (l)		(ZR84)	+Cortinella	Tr(Ladi-u)		(1120)
Catantostoma	D (Eife)	-D (Give)	(362)	Cosmetalepas	T (Eo-u)	-R	(530)
Cataschisma	O (Cara-u)	-S (Wenl-u)	(797)	Cranopsis	T (Plio)	-R	
+Catazona	C (Serp-l)		(114)	+Crassimarginata	D (Emsi)		(362)
Catazone	S (Ludl-u)	-D (Gedi)	(797)	Cremides	T (Ol-u)?	-R	
Cerithioides	D (Emsi)	-C (Bash)	(362,797)	Crenilunula	S (Ldov-u)	-S (Ludl-l)	
Chartrioniella	Tr(Olen-l)	-J (Tith-u)	(785)	Creniturbo	J (Oxfo-l)		
Cheilotomona	Tr(Anis-m)	-Tr(Carn)		+Crenulazone	D (Emsi)		(362)
Chelotia	T (Eo-m-l)			Crossea	T (Eo-u)	-R	(530)
Chepultapacia	O (Trem-l)	-O (Aren)		Crosseola	T (Mi-l-l)	-R	(681)
Chilodonta	J (Oxfo)	-K (Maes-u)	(790)	+?Crossoceras	D (Sieg-u)		(362)
Chilodontoidaea	J (Bajo)			Crossostoma	J (Plie)?	-J (Bajo-u)	(661)
Chingua	T (Eo)			Cryptobranchia	T (Plio)	-R	
Chlorostoma	T (Mi)	-R		Cryptonerita	Tr(Olen-u)	-Tr(Carn)	(1130)
+Chlupacispira	D (Sieg)	-D (Emsi)	(797)	Cyclites	P (Guad-l)	-P (Djhu)	(109)
Chrysostoma	K	-R		Cyclobathmus	P (Guad-u)		(797)
Cibeuca	P (Leon)		(797)	Cycloscena	P (Asse)		(797)
Cidarina	Q (Plei)	-R		+?Cyclosporgia	D (Give)		(362)
Cinclidonema	C (Vise-l)	-C (Mosc)	(797)	+Cyclotomaria	J (Plie-l)	-J (m)	(661)
Circulopsis	T (Dani)	-T (Mi)		Cyclostrema	K (u)	-R	
Circulus	T (Than-l)	-R	(794)	+?Cyclostremela	T (Eo-u)	-R	(909)
Cirrus	Tr(Carn)	-J (Bath)	(797)	+Cycloturbo	J (Bajo)		(909)
Cirsochilus	J (Bajo)	-T (Plio)		+?Cynisca	T (Mi-m)	-R	(557)
Cirsonella	T (Mi-l-l)	-R	(681)	Cyniscella	T (Than)	-T (Ol-l)?	

Taxon	First Appearance	Last Appearance	Reference	Taxon	First Appearance	Last Appearance	Reference
+?Cyrtostropha	S (Ldov-m)	-S (Ludl-l)	(1197)	Ethalia	T (Mi-m)	-R	(1231)
Daidia	O (Cara-l)	-O (Ashg-m)	(797)	Euchelus	T (Mi-u)	-R	(557)
Damesia	K (Maes)			Eucochlis	C (Tour-u)	-P (Leon)	(797,896)
+Decorospira	D (Eife-l)		(1004)	Euconia	O (Aren-l)		(797)
Deianira	K (Albi)	-T (Dani)		Euconospira	C (Vise)	-P (Guad-l)	(109,797)
Delphinulopsis	Tr(Anis)	-Tr(Carn)	(797)	Eucyclomphalus	J (Sine-l)	-J (Plie-u)	(661)
+Denayella	D (Eife-l)	-D (Eife-u)?	(1004)	Eucycloscala	Tr(Anis)	-T (Dani)	(1130)
Dentallopoma	T (Ng)			Eucyclus	Tr(Carn)	-T (Ol-l)	(797,1066)
Dentistyla	T (Mi)	-R		-Eugabrielona	T (Phio)	-R	
+Desertospira	C (Vise-u)			Eunema	O (Cara-l)	-O (Ashg-m)	
+Dickinsiella	P (Guad)		(797)	Eunemopsis	Tr(Ladi)	-Tr(Nori)	(797)
Dicosmos	P (Djhu)	-Tr(Anis)	(1130)	+Euminella	T (Ol-u)	-R	(530)
+Dictyobembix	D (Give)		(362)	Euriclanculus	T (Phio)	-R	
Dictyotomaria	D (Eife)	-Tr(Ladi-u)	(362,797,1120)	Euryalox	Tr(Anis)	-Tr(Nori)	
				Euryzone	S (Ludl-l)	-D (Fras)	(362)
+Didianema	T (Mi)	-T (Mi-u)		+?Euthyrachis	D (Give)		(362)
Diloma	T (Mi)	-R		Eutinochilus	T (Eo)		
Dimorphotectus	Tr(Carn)	-J (Bajo-u)	(661)	Euzone	Tr(Anis)	-Tr(Carn)	(797)
Diodora	K (Camp)	-R		Eymarella	Tr(Ladi)	-Tr(Nori)	
Diplochilus	Tr(Ladi-u)	-Tr(Carn)?	(1066)	+Fascivelvata	Tr(u)		(ZR82)
Diplozone	S (Ludl-l)	-D (Sieg)	(362)	+Fautor	T (Mi-m)	-R	(1231)
Dirachis	D (Eife)	-D (Give)	(362)	Feneoniana	T (Mi-m)		
Dirhachopea	Cm(Trep-u)	-O (Trem-l)		+Fischeriella	J (Kimm)	-J (Tith)	(909)
Discocirrus	J (Sine)?			Fissurella	K (Maes-u)	-R	(1008)
+Discogenus	Tr(Anis)		(ZR83)	Fissurellidea	T (Eo-l)	-R	(914)
Discotectus	J (Bath)	-K (Camp)	(1204)	Fissurisepta	T (Mi)	-R	(681)
+Discotheca	D (m)		(ZR83)	D Floyd	D (Give-u)	-D (Fras-u)	(362)
Discotoma	J (Bath)	-J (Oxf-o-l)	(1066)	Forskaelena	T (Mi)	-R	
Discotomaria	C (Step-l)	-Tr(Carn)	(109,797)	+Fossariopsis	Tr(Anis)	-Tr(Ladi)	(797)
Dolicrassea	T (Mi-l-u)	-R	(899)	Frombachia	Tr(Carn)		
Donaldiella	O (Cara-m)	-S (Ldov-l)		Gabrielona	T (Mi-l)?	-R	(557)
+Dongiovannia	D (Emsi)		(797)	Ganesa	T (Phio)	-R	
Dostia	T (Eo)	-R		Gargania	K (Ceno)	-K (Turo)	
Drepanoconcho	J (l)			Garramites	K (Maes)		
+Dutrochus	D (Eife-l)			Gasconadia	Cm(Trep-u)	-O (Trem-l)	
Dyeria	O (Ashg)	-S (Ludl)?	(797)	Gelasinostoma	T (Phio)	-Q (Plei)	
Echinocirrus	C (Vise)		(615)	Gibbula	K (Ceno)	-R	(615)
Ectomaria	O (Aren-l)	-O (Ashg-u)	(797)	Ginebis	T (Ol-u)?	-R	
+Ehlersina	D (Eife)		(797)	Glabrocingulum	C (Tour-u)	-Tr(Nori)	(115,896)
Eirlysia	P (Asse)	-P (Djhu)	(109,797)	Globonema	O (Ashg)	-S (Ludl-l)	
Eiselia	P (Guad)	-P (Tatr)	(797)	Glyphodeta	C (Vise)	-P (u)	(797)
Elasmonema	S (Wenl-u)	-D (Fras)	(362,797)	Glyptomaria	C (Vise)	-Tr(Anis)	(115,797)
+Eleutherospira	D (Emsi)	-D (Eife-u)	(1004)	Glyptospira	P (Asse)	-P (Leon-u)	(797)
Emarginula	Tr(Ladi-u)	-R	(1066)	Goniasma	C (Tour)	-P (Dora)	(797,1130)
Emarginulina	T (Than)	-R		Gossetina	D (Eife)	-Tr(Nori)	(362,797)
Emersonia	J (Plie)			+Grantlandispira	S (Ldov)		(797)
Enantiotoma	Tr(Nori)			-Guidonia	Tr(Nori)	-J (Plie)	(797)
Encyclomphalus	J (l)	-J (Plie)?		Guilfordia	T (Ol-u)	-R	(728,899)
Endianaulax	J (l)	-J (Tith-u)		-Guizospira	P (Djhu)	-P (Dora)	(797,1130)
Enida	Q (Plei)	-R		+Guizhouia	Tr(Anis)	-Tr(Ladi-u)	(115,1130)
Entemnotrochus	T (Eo)	-R		Gyrodoma	D (Sieg)		(362)
Entomella	T (Eo)			?Gyroma	D (Emsi)	-D (Fras)	(362)
Eocallioptoma	Tr(Nori)			Gyronema	O (Cara-l)	-O (Cara-m)	(362)
+Eoliotina	K (Albi-u)			Haliotis	K (Maes)	-R	(1066)
Eosolariella	Tr(u)	-Tr(Rhae)		Haliotiomorpha	Tr(Ladi)	-Tr(Carn)	
Eotomaria	O (Cara-l)	-O (Ashg-m)	(797)	Haliostylus	T (Phio-u)	-R	
Eotrochus	C (Vise)	-C (Serp)	(797)	+Hammatospira	C (Serp-l)		(114)
Epifaxis	D (Sieg)		(362)	Hamusina	J (Toar)?	-J (Bajo)	
Epiptychia	D (Sieg)		(362)	+Hanaispira	K (Sn)		(1066)
Epulotrochus	J (Plie)		(615)	+Haplospira	S (Ldov)	-S (Prid)	(797)
+Erginus	T (Plio-u)	-R		+Hayamiella	K (l)		(ZR84)
+Erymarella	Tr(Ladi)	-Tr(Nori)	(797)	Helicacanthus	J (u)	-K (Camp)	(1204)

Taxon	First Appearance	Last Appearance	Reference	Taxon	First Appearance	Last Appearance	Reference
Helicocryptus	J (Bath)	-K (Ceno-u)	(615)	Leptomaria	J (Sine-l)	-T (Dani)	(661)
Helicospira	P (Guad)	-P (Djhu)	(109,797)	Leptorima	S (Ludl)?		
Helicotoma	O (Aren)	-O (Ashg-m)	(615)	+ Leptothyra	T (Mi-m)	-R	(1231)
Heniasstoma	T (Pale)	-T (Mi)		Leptothyropsis	T (Mi)	-R	
Herpetopoma	T (Eo-u)	-R	(530)	Leptozone	D (Sieg)	-D (Fras)	(362)
Hespericella	D (Emsi)	-P (Guad)	(362,797)	Lesperonia	T (Ol-l)		(615)
Hesperocirrus	Tr(Nori)		(797)	Leucorhynchia	T (Dani)	-R	(615)
Himantonia	D (Sieg)		(362)	Levella	T (Mi-l-u)	-T (Plio-l)	(899)
Hippocampoides	K (Maes-l)			Lewisella	J (Sine-u)	-J (Toar)	(661)
+ Hologyra	Tr(Anis)	-Tr(Carn)	(797)	- Linglingella	J (l)		(ZR82)
Homalopoma	Tr(Anis)	-R	(797)	Liospira	O (Lvi-l)	-O (Ashg-m)	(157,1197)
Horiostomella	O (Cara-l)	-S (Ludl)?	(797)	+ Liotella	T (Plio-u)	-R	(899)
Hormotoma	O (Trem-u)	-S (Ludl-l)	(797,1197)	Liotia	T (Mi)	-R	
Hormotomina	D (Emsi)	-D (Give)	(362)	Liotina	T (Eo-m-l)	-R	(615)
Horologium	S (Ludl)			Lirularia	T (Plio-u)	-R	
Houdasia	T (Eo-m-l)			Lischkeia	K (Ceno)	-R	
+ Humilivorthenia	Tr(Anis)		(909)	Lissochilus	J (Bath)	-K (Sn)	
Hungariella	Tr(Nori)			Lissospira	T (Plio)	-R	
Hybochelus	T (Plio)	-R	(557)	Lissotesta	T (Mi-l-l)	-R	(681)
Hyperacanthus	Tr(Nori)	-J (l)		Lissotestella	T (Eo-m-u)	-R	(899)
?Hypergonia	C (Tour)	-P (Guad-l)	(896,1205)	Lithopoma	T (Mi)	-R	
+ Hypodema	C (l)		(797)	Lithotrochus	J (l)	-J (Toar)	(615)
Hypselentoma	C (Mosc-u)	-P (Guad-l)	(109,797)	Littorinides	C (Vise)		(615,797)
+ Ilanga	T (Mi-m)	-R	(1231)	Lodanaria	D (Gedi)	-D (Emsi)	(362)
Inciifaster	T (Eo)	-T (Ol-l)	(681)	Lodderena	T (Mi-l-l)	-R	(681)
Inciisilabium	T (Eo)			Lodderia	T (Mi-l-l)	-R	(681)
Infundibulops	Q (Plei)	-R		Longstaffia	S (Ldov-l)	-D (Eife)	(797)
Iothia	T (Plio)	-R		Lophospira	O (Aren-l)	-O (Ashg-m)	
Isanda	T (Dani)	-R		+ Lovisionia	P (Leon)	-P (Guad)	(797)
Islipia	J (Bath)			Loxoplocus	O (Ashg-m)	-S (Ludl-u)	(1197)
Isonema	D (Emsi)	-D (Fame)	(362)	Lovotoma	J (Tith-u)	-T (Eo)	
Jedria	D (Eife-u)	-P (Guad-l)	(362,797)	Lucapina	T (Ol)	-R	
Jujubinus	K (Turo)	-R		Lucapinella	T (Ol-u)?	-R	
Kaawatina	T (Plio-l)		(899)	Luciella	D (Eife)	-Tr(Carn)	(362,797)
+ Kaiparapelta	T (Mi-l-u)			Luciellina	C (Vise)	-Tr(Carn)	(797)
+ Kangapaya	T (Pale)		(ZR80)	Lunatica	T (Plio)	-R	
+ Kaurnella	T (Plio)		(650)	Lumella	T (Mi)	-R	
+ Kawanamia	C (Vise)		(797)	+ Lunulazona	C (Vise-l)	-C (Serp-l)	(797)
Keeneia	C (Pn)	-P (Guad)	(1130)	- Lyxosoma	J (Bajo)	-K (Maes)	(558,747)
Keration	Tr(Carn)		(119,797)	- Magticapulus	P (Leon-u)?	-Tr(Anis)	(1130)
+ Kinkaidia	C (Serp)		(797)	- Manzanospira	P (Asse)	-P (Guad)	(797)
Kishinewia	T (Mi-u)			Marevalvata	T (Plio)	-R	
Kittlidiscus	Tr(Ladi-u)			Margarella	T (Eo)	-R	(681)
Kittlitrochus	Tr(Ladi)			Margarites	T (Eo-u)	-R	
+ Kiviasukkaan	S (Ldov)	-S (Wenl)	(797)	Marinauris	T (Mi-l)	-R	(530)
Kokenella	Tr(Anis)	-Tr(Nori)		+ Mariothia	J (Aale)		(ZR82)
Koniakaua	J (Tith)			Marmarostoma	T (Mi-m)	-R	(1231)
+ Kyndalya	C (Vise)		(797)	Marmolatella	C (Vise)?	-Tr(Nori)	(615)
+ ?Labroctospis	D (Give)		(362)	Maurea	T (Mi)	-R	
- Lacunospira	P (Sakm)	-P (Guad-l)	(109,797)	?Meandrella	D (Sieg)	-D (Emsi)	(362)
Tr(Ladi-trochus)	Tr(Ladi-u)		(1120)	- Megalonoda	K (u)		(ZR84)
Laetifautor	T (Mi-m)	-R	(530)	Megatebennus	T (Mi-u-l)	-R	
- Laevicomulus	J (m)	-J (u)	(909)	Megathura	T (Plio)	-R	
- Laevitomaria	J (Ple)	-J (Bajo)	(ZR87)	Melagraphia	T (Mi)	-R	
+ Lamellospira	P (Sakm)	-P (Guad-l)	(109,797)	- Mellarium	Tr(Ladi)		(157)
+ Lancecellia	Tr(Ladi-u)		(1120)	+ Mesocoelia	S (Ludl-u)	-D (Eife)	(797,1197)
Latitaenia	O (Cara)?	-O (Ashg-m)		Mesogena	Tr(Nori)		
Laubella	Tr(Ladi-u)		(797,1066)	Mesoneritina	K (Albi)		
Leicopyrga	T (Mi-u)	-R	(530)	Metaconulus	T (Eo-m-l)	-T (Ol-l)?	
Leiotrochus	T (Mi)			Metriomphalus	Tr(Nori)	-K (Maes)	(914,1066)
Lepetella	T (Plio-u)	-R	(899)	Michaelia	K (Barr)	-K (Maes)	
Lepidotrochus	Tr(Indu-u)	-Tr(Nori)	(797,1130)	Michelia	S (Ludl-u)	-D (Emsi)	(362,1206)

Taxon	First Appearance	Last Appearance	Reference	Taxon	First Appearance	Last Appearance	Reference
+?Micheliopsis	P		(ZR77)	Olivia	T (Dani)	-R	
Micrelenchus	T (Ol-u)	-R	(899)	-?Omanimaria	P (u)		(ZR76)
Micrentom	C (Vise-u)			Omospira	O (Cara-l)	-O (Cara-m)	
Microcheilus	Tr(Ladi)			Omphalium	T (Mi)	-R	
Microdoma	D (Emsi)	-P (Guad-l)	(109,362, 797)	Omphalonema	P (Asse)	-P (Dora)	(797,1130)
+Microgaza	T (Plio)	-R	(1231)	Oncochilus	Tr(Ladi)	-K (Turo)	(615)
Mikadotrochus	T (Mi-u)	-R		Onkospira	J (Oxf-l)	-K (Barr)	(615)
Minolia	K (u)	-R		Ooliticia	J (Hett)	-K (Maes)	(615)
Miofractarmilla	T (Plio-l)			+?Otomaria	P (Guad-l)		(109)
Mirachelus	T (Than)	-R	(705)	Opella	T (Ol-u)	-T (Mi-n)	(899)
Modelia	T (Mi)	-R		+?Opisthonema	O		(ZR79)
Moelleria	T (Mi-l)	-R	(557)	Ormastralium	T (Mi)	-T (Plio)	
Monilea	T (Plio)	-R		+Ornatospira	Tr(m)	-Tr(u)	(ZR82)
+Monodilepas	T (Mi-l-u)	-R	(681)	Orthonychia	S (Ldov)	-Tr(Ladi-u)?	(362,797)
Monodonta	K (Albi)	-R		Osilinus	T (Dani)	-R	
Monodentella	T (Mi)			+?Ostioma	D (Sie-g-u)		(1199)
Montfortia	T (Eo)	-R		Otollonia	T (Ol-u)?		(615)
Montfortula	T (Mi-l)	-R	(530)	Otomphalus	T (Eo-m-l)		
+Montospira	C (Mosc)	-P (Sakm)	(797)	Otostoma	J (u)	-T (Eo-m)	(615,909, 914)
?Morphotropis	S (u)	-D (Emsi)	(1005)	Otuaka	T (Plio)	-R	
Mourlonia	D (Emsi)	-P (Djhu)	(1130)	Ovinotis	T (Mi)	-R	
Munditia	T (Plio-l)	-R		Oxysteles	T (Ol-l)	-R	(96)
Murchisonia	S (Wen-l)	-P (Dora)	(1130,1197)	Ozarkispira	O (Trem-l)		
Muricotrochus	J (Bajo-u)	-J (Kimm)		Ozodochilus	J (Bajo)	-J (Kimm)	
Myagrostoma	K (Turo)			Pachydomella	T (Plio-u)		(899)
+Nannubasa	J (l)		(ZR82)	Pachyomphalus	Tr(Olen)	-Tr(Ladi)	(797)
Naticonema	S (Ldov)?	-D (Fras)	(362)	Pagodea	D (Sieg)	-D (Eife)	(362,797)
Naticopsis	S (Wen-l)	-Tr(Carn)	(797)	Pagodina	P (Guad-l)		(109,797)
+Neamphitomaria	Tr(Ladi-u)		(1207)	-?Pagodospira	O (Aren-u)	-O (Llde)	
Neilsonia	C (Vise-l)?	-P (Sakm)	(797)	Pakistania	T (Eo-l)		(914)
?Nematrochus	S (Ludl)?			Palaeocolonia	Tr(Ladi-u)	-J (Bajo)	(909,1066)
Nemrac	T (Eo-u)		(914)	Palaeoschisma	O (Cara-l)	-O (Ashg-m)	
+Neoplatytaichum	C (Serp)	-C (Pn)	(797)	Palaeotrochus	D (Sieg)	-D (Emsi)	(362,797)
Nereina	T (Mi)	-R		+Palangaria	K (Apti)	-K (Albi)	
Neridomus	J (l)	-K (Sn)		Paleunema	Tr(Ladi)		
Nerita	K (Turo)	-R	(615)	+Paracirculus	T (Plio)		(ZR82)
Neritaria	Tr(Olen-l)	-Tr(Nori)	(785,797)	Paragoniozona	C (Mosc-l)	-P (Guad)	(797,1258)
Neritina	J (Bajo)?	-R	(558)	+Paraliospira	O (Cara-l)	-O (Ashg-m)	
Neritoma	J (Plie-l)	-K (Sn)	(661)	+?Paraplatschisma	C (Step-l)	-P (Sakm-l)	(745)
Neritoplica	J (Bath)	-T (Ol-u)	(615,794, 899)	+?Pararaphispira	C (u)		(ZR83)
Neritopsis	Tr(Ladi)	-R	(797)	Parataphrus	J (u)		
Neritoptyx	K (u)			Paraturbo	J (Sine)	-K (Ceno)	(615,1066)
Ninella	T (Eo)	-R		Paraviviana	Tr(Nori)		
Nododelphinula	J (Bajo)	-K (Albi)		Pareuchelus	T (Than)	-T (Plio)	(914)
+Nodonema	D (Eife)		(797)	Pareuryalox	Tr(Nori)		(797)
+Nodospira	C (Vise)		(797)	Partubiola	T (Plio)	-R	
+Nordospira	P (Leon)		(797)	Parvirota	T (Than)?	-T (Plio)	
Norrisella	T (Than)	-T (Mi)	(705)	+Parviviana	Tr(Nori)		(797)
Norrisia	Q (Plei)	-R		Paua	T (Mi)	-R	
Notocrater	T (Mi-l-u)	-R	(899)	Pellax	T (Plio)	-R	
Notohaliotis	T (Mi-l)	-R	(530)	+Pentagonodiscus	J (Sine-u)	-J (Bajo-u)?	(661)
Notomella	T	-R		Perialav	K (u)	-T (Plio)	
Nudangarita	T (Ng)			+Pernerircirus	S (Ludl-u)		
Nummocalcar	J (Bajo)	-K (Maes)	(914)	Perneritrochus	S (Ludl)?	D (l)	(615,797)
+Nummotectus	J (Bajo)		(909)	Perotrochus	K (Camp)	R	(157)
Obornella	J (Toar)	-J (Oxf-l)		Perrinia	T (Plio)	R	
+Odoardia	J (Kimm)	-J (Tith)	(909)	+?Periniscus	O		(909)
Odontomaria	D (Gedi)	-D (Give)	(362)	Peruvispira	D (Eife-u)	-P (Djhu)	(109,797)
Odontoturbo	J (Kimm)			Petropoma	K (Albi-u)		(615)
Oehleria	S (Wen-l)	-D (Emsi)	(797)	Phanerolepida	T (Eo-u)	-R	
				Phanerotrema	S (Ludl-u)	-C (Bash)	(797,1197)

Taxon	First Appearance	Last Appearance	Reference	Taxon	First Appearance	Last Appearance	Reference
Phasianella	T (Mi-m)	-R	(557)	Pseudocryptaenia	O (Cara)?	-O (Ashg-m)	
Phasianochilus	T (Eo)	-T (Ol)		Pseudodiloma	T (Eo)		
Phasianotrochus	T (Plio)	-R		Pseudofissurella	J (Bath-u)	-J (Tith-u)	
Phorculus	T (Eo-l)	-T (Mi)	(914)	Pseudoliotina	K (Albi-u)	-K (Maes)	
Phorcus	T (Ol-u)?	-R		Pseudonina	T (Mi-u-l)	-T (Plio)	
Phymatopleura	C (Tour)	-P (Guad)	(797)	Pseudoninella	T (Dani)	-T (Mi-m)	
Pictiformes	T (Mi-m)			Pseudophasianus	T (Eo-u)		(615)
Pileolus	J (l)	-T (Eo-u)	(914)	+?Pseudoplatyceras	D (u)		(ZR83)
Pirper	J (Bajo)			Pseudorhytidopilus	J (Sine-l)	-J (Tith-u)	(661)
+Pisulina	T (Mi-u)	-R	(557)	+Pseudoscalites	S (Ldov-l)	-S (Ludl-u)	(1197)
Pithodea	C (Vise)	-P (Guad-u)	(109)	Pseudoschizogonium	Tr(Ladi-u)	-Tr(Carn)	(1120)
Plagiothyra	D (Emsi)	-D (Fras)	(362,797)	Pseudostomatella	T (Plio)	-R	(557)
+Planicollonia	J (m)	-J (u)	(909)	Pseudotectus	D (Gedi)	-D (Sieg)	(362)
+Planolateralus	K (Camp)	-T (Eo)	(909)	Pseudotubina	Tr(Carn)		
Planospirina	C (Mosc)	-Tr(Ladi)	(416)	Pterocheilos	J (l)		
Planozone	D (Sieg)		(362)	Ptychocaulus	D (Sieg)		(362)
Platyacra	Tr(Rhae)	-J (l)		Ptychomphalina	D (Eife-u)	-Tr(Nori)	(797,1004)
Platybassis	J (Bajo)			Ptychomphalus	Tr(Ladi-u)	-J (Plie)	(661,1120)
Platyceras	O (Cara-l)	-Tr(Anis)?	(797)	Ptychospirina	S (Ludl-u)	-D (Give)	(362,1197)
Platychilina	Tr(Ladi)	-Tr(Carn)		?Ptychozone	S (Ludl-u)?		(1197)
?Platyconus	S (Wenl)?	-S (Prid)?		Pulchrastele	T (Plio)	-R	
Platyloron	S (Wenl-l)	-D (Fame)	(362,1197)	Puncturella	T (Than)	-R	(794)
Platyschisma	D (Eife-u)	-P (Leon)	(36,797,1004)	Puncturellopsis	J (Bajo)	-J (Bath)	
				Puperita	T (Mi)	-R	
				Pupillaea	T (Plio)	-R	
Platyteichum	P (Sakm)	-P (Tatr)	(797)	Pupillaria	T (Eo-u)	-R	
+?Platyworthenia	P (Wc)		(909)	Purunnella	T (Eo-u)		
Platyzona	D (Sieg)	-P (Dora)	(109,362,1130)	Putilla	T (Mi-l)	-R	(557)
				Putzeysia	T (Mi)	-R	
Plesiothyreus	T (Eo-m-u)	-R	(615)	Pycnotrochus	S (Ludl-u)		(1197)
Plethospira (+ Seelya)				Pyrgotrochus	J (Plie-l)?	-K (Ceno)	(661)
	O (Trem-u)	-O (Aren-u)		Pythmenema	S (u)		
Pleuratella	J (Sine)			+Quadracarina	D (Eife-l)	-D (Give)	(1004)
Pleurorima	S (Wenl-l)	-D (Fras)	(362,1197)	‡Rangimata	T (Plio-u)		(899)
Pleurotomaria	Tr(Anis)	-K (Maes-u)	(661,888,1130)	?Raphischisma	C (Vise)		(615)
				Raphispira	S (Ludl)?		
+?Plicafoliosa	C (l)	-C (u)	(ZR83)	+?Retiopustula	C (l)		(ZR83)
Plocanema	D (Sieg)			Rhabdotocochlis	C (Tour)	-P (Djhu)	(797,1130)
Plocostoma	C (Vise)?	-P (Leon-u)	(109,909)	Rhaphischisma	C (Vise)		(615)
Plocostylus	J (Sine)?			Rhaphistomella	Tr(Ladi)	-Tr(Rhae)	(797)
Polytremaria	C (Vise)		(615,797)	Rhinoderma	C (Tour-l)	-C (Serp-l)?	(797)
Pomaulax	T (Mi)	-R		Rhombella	O (Trem-l)	-O (Aren-l)	(797)
Porcellia	D (Sieg)	-C (Mosc-u)	(797)	Rhytidopilus	J (Bath)	-K (Albi)	
Portlockiella	C (Vise)	-C (Serp)	(797)	Rimula	K (u)?	-R	
Praelittorina	Tr(Carn)			Rimulopsis	J (Toar)	-J (Tith-u)	
Praenatica	S (u)	-D (Eife-u)	(362,1004)	+Rinaldomphalus	Tr(Ladi-u)		(1120)
Praestomatia	Tr(Nori)	-J (u)		Risselloidea	Tr(Anis)	-K (Nc)	(1130)
Priotrochus	Q (Plei)	-R		Ritena	T (Eo)	-R	
+Prisogaster	T (Plio-u)	-R		Robus	T (Mi-m)		
Procancellaria	K (Maes)		(615)	Rochia	T (Plio)	-R	
Proconulus	J (Sine-u)	-K (Camp)	(661,914)	Rollandiana	T (Mi)		
Promartynia	Q (Plei)	-R		+Rolandomphalus	Tr(Ladi-u)		(1120)
+Promourlonia	S (Ldov-m)	-S (Ludl-u)	(1197)	Rossiteria	T (Plio)	-R	
Propilidium	T (Mi)	-R		Rothpletzella	Tr(Ladi)		
Proscutum	T (Eo-l)	-T (Eo-m)?		Roya	T (Ol-u)?	-R	
Prosolarium	S (Ludl-u)	-S (Prid)		Ruedemannia	O (Cara-u)	-C (Tour)	(797)
Protocalyptaea	D (Fras)	-D (Fame)	(362)	Rutilla	Tr(Carn)		(797)
Protoretella	T (Mi)			+Rugulina	J (m)		(ZR88)
Protospiralis	D (Fras)	-D (Fame)	(362)	+Rumerloella	Tr(Ladi-u)		(1120)
+Prototurbo	K (l)		(ZR84)	+Sablea	T (Eo-m)	-T (Ol-l)	(852,1066)
Proturritella	O (Aren-u)	-O (Llde-l)	(1197)	+Sabrinella	Tr(Ladi-u)		(1120)
+Pseudobaylea	C (Serp)	-P (l)	(797)	Sallya	P (Asse)	-P (Guad-l)	(109,797)
Pseudoclanculus	Tr(Ladi-u)	-Tr(Nori)	(797)				

Taxon	First Appearance	Last Appearance	Reference	Taxon	First Appearance	Last Appearance	Reference
+Salterospira	C (Vise)	-C (Step)	(797)	Stuorella	Tr(Ladi)	-Tr(Carn)	
Sanhaliotis	T (Mi)	-R		Subninnella	T (Plio-l)	-R	(530)
Sarmates	T (Mi-m)			Suchium	T (Plio-l)	-R	
Sarmaticus	K (Camp-l)	-R		Sulculus	T (Mi)	-R	
Sarmaturbo	T (Mi-l-l)	-T (Mi-m)	(899)	+Suprazonalis	P (Dju)		(1130)
Scaevola	J (Sine)			Synaptochochlea	T (Mi-m)	-R	(557)
Scalaetrochus	D (Sieg)	-D (Eife)	(362)	-?Taemasotrochus	D (l)		(ZR83)
Scaliina	D (Give)	-C (Vise)	(362)	Taeniaturbo	T (Mi)	-R	
Schizogonium	Tr(Ladi-u)		(797)	Taeniospira	Cm(Trep-u)	-O (Trem-l)	(797)
+?Schizolopha	O (Cara-u)	-O (Ashg-m)?		Talantodiscus	J (Plie)	-J (Bajo)	
Schizopea	Cm(Trep-u)	-O (Aren)		+Talopena	T (Mi-m)	-R	(1231)
Scissurella	K (Maes-l)	-R	(1008)	Tanaliopsis	K (Turo)		
Scissurona	Q (Plei)	-R	(681)	Taasia	C (Mosc-l)	-P (Guad-u)	(109,1258)
Scutus	T (Than-l)	-R	(914)	Tapinotomaria	C (Tour)	-P (Guad-l)	(109,797)
Seelya	O (Aren)	-S (Ludl-u)		Tauschia	J (Sine)?		
Seguenzia	T (Eo)	-R		Tectariopsis	T (Eo-m-l)	-T (Eo-u)	(914)
Seisa	Tr(Anis)	-Tr(Nori)	(797)	Tectospira	Tr(Anis)?		
Sellinema	S (Ludl)?			Tectus	K (u)	-R	
Semeritina	K (Turo)	-T (Eo)		Tegula	T (Ol-u)	-R	(554)
?Semitubina	S (Wenl)	-D (Give)	(797,1066)	Teinostomopsis	J (Oxfo-l)		(558,1066)
+Semperia	T (Than)	-R		Temnotropis	Tr(Ladi-u)	-Tr(Carn)	
+Serpentubina	S (u)	-D (Give)	(362,797)	+Testudinalia	Q (Plei)	-R	
+Serratotrochus	J (Bajo)		(909)	Thalotia	T (Mi-l)	-R	(530)
Shansiella	C (Tour)	-P (Dju)	(797)	Tharsiella	T (Plio)	-R	
+Shikamacirrus	K (Apti)		(1066)	Theliostyla	K (Sn)	-R	
+?Shikokuspira	P (Guad-u)		(157)	Thorista	Q (Plei)	-R	
Shwedagonia	P (Asse)	-P (Guad-l)	(109,797)	+Thorstella	T (Ol-u)	-R	(899)
Sinezona	T (Eo-u)	-R	(559)	Threavia	O (Ashg)		(797)
Sinuopea	Cm(Trep-u)	-O (Trem-l)	(2,797, 1197)	Tiburnus	K (Maes)	-T (Plio)	(914)
Sinuspira	S (Wenl-l)	-S (Ludl-u)	(1197)	Timisia	T (Mi)		
Sinzowia	T (Mi-u)			Tipua	T (Eo-m-u)		
Sisenna	Tr(Anis)	-J (Plie-u)	(615,661)	Tomostoma	T (Eo)		
+Siskyospira	S		(ZR80)	Tournouerella	K (l)	-T (Dani)	
Skena	T (Ol-u)	-R	(1066)	Trachybembix	P (Leon-u)?	-Tr(Indu-u)	(1130)
Smaragdia	T (Mi-l)	-R	(557)	Trachydomia	C (Mosc-l)	-P (Tatr)	(797,1258)
Solariella	K (Barr)	-R	(615)	Trachynerita	Tr(Olen-u)	-J (Bath)	(797,1130)
Solarioconulus	Tr(Olen-u)	-Tr(Nori)	(1130)	+Trachysma	T (Ol-u)		(1066)
+Sorapisella	Tr(Ladi-u)		(1120)	Trachyspira	P (Leon-u)	-P (Dora)	(109,1130)
Sororcula	Tr(Nori)		(797)	-?Trajana	T (Plio)		(909)
Sosiolytes	P (Leon)	-P (Guad-l)	(109,797)	Transylvanella	Tr(Carn)		
Spectamen	T (Ol-u)	-R	(899)	Trepospira	D (Eife)	-P (Guad-l)	(362,909)
+Spinulrichospira	D (Eife-l)		(797)	+Triadoskenea	Tr(Ladi-u)		(1120)
+?Spiraculinella	C (Step-l)	-P (Sakm-l)	(745)	Triangularia	D (Gedi)	-D (Emsi)	(362)
Spirocirrus	J (l)	-J (Bath)		Tricolia	T (Than)	-R	
+Spironemella	P (Sakm)	-P (Guad-u)?	(745)	+?Tripidotomaria	P (Guad-l)		(109)
Spiroscala	D (Emsi)	-P (Tatr)	(157,797)	Tristichotrochus	T (Ol)	-R	
Spirotomaria	O (Aren-u)	-O (Llvi)	(1197)	Trochacanthus	K (Apti)	-K (Maes-u)	(790,909)
Staffinia	J (Bath)			Trochodon	K (Albi-u)		(615)
Stegocoelia	D (Emsi)	-P (Dju)	(109,797, 1004)	Trochonema	O (Llvi)	-O (Ashg-u)	(1075)
Stenoloron	S (Ldov-u)	-D (Eife-u)	(797,1004)	Trochonemella	O (Llvi-l)	-O (Ashg-m)	(797)
+?Stenozone	P (Guad-u)		(109)	Trochonemopsis	D (Gedi)	-D (Emsi)	(362)
Steromphala	T (Mi)	-R		Trochonerita	K (Nc)	-K (Apti)	(615)
Stomatella	T (Plio)	-R	(909)	Trochopsidea	J (Sine)	-J (Bajo-u)	(661)
Stomatia	T (Plio)	-R	(557)	+Trochotectus	J (Bajo)		(909)
Straparella	C (Vise)	-P (Leon-u)	(109,797)	Trochotoma	Tr(Olen-u)	-J (Tith-u)	(1130)
Straparollina	O (Aren-l)	-O (Ashg)	(797)	+Trochotomaria	J (Aale)		(ZR82)
+?Strictohumerus	C (u)		(ZR83)	+Trochotrochus	T (Mi)		(ZR77)
Strigosella	T (Than)?	-R		Trochus	T (Mi)	-R	(909)
Strophostylus	O (Cara-m)	-C (Mosc)	(362,797)	Tropidostropha	C (Vise)	-C (Serp)	(797)
+Strotostoma	P (Leon-u)		(109,745)	Trypanochochlea	P (Leon-u)?	-Tr(Nori)	(797,1130)
				Trypanotrochus	J (Plie)	-K (Apti)	(157)
				+Tuberleviathana	K		(ZR86)

Taxon	First Appearance	Last Appearance	Reference	Taxon	First Appearance	Last Appearance	Reference
?Tubina	D (Sieg)	- D (Give)	(362)	Or. ARCHITAENOGLOSSA			
Tubiola	T (Eo-l)	- R		(Classification and basic stratigraphic range from Wenz [1938].)			
Tubomphalus	S (u)	- D (Sieg)	(362)	+ Brochidium	P (Guad)	- Tr(Nori)?	(109,797, 1066)
Tugali	T (Mi-l-l)	- R	(530,899)	+ Bucanospira	S (Wenl)		(1066)
Tumulus	T (Mi)	- R		+ Codonocheilus	S (Ludl)		(1066)
Turbiniopsis	D (Give)	- P (Guad)	(615,797)	+ Craspedostoma	S (Wenl-l)	- S (Ludl-u)	
Turbo	T (Ol-u)?	- R		+ Dichostasia	P (Asse)	- P (Guad)	(797)
Turboidea	K (Ceno)			+ Dihelice	D (Eife)	- D (Give)	(362)
Turbonellina	C (Vise)		(615,797)	+ Natiria	D (Fras)	- Tr(Carn)	(362,797)
Turbonitella	D (Sieg)	- P (Guad)	(362,797)	+ Scoliostoma	D (Emsi)	- D (Fame)	(362,797)
Turbonomaria	S (Ludl)?			+ Spirina	S (Wenl)	- D (Give)	(362)
Turbonopsis	D (Emsi)	- D (Fras-u)	(116,362)	+ Temnospira	S (Wenl)?		(797)
Turcica	T (Eo-u)	- R	(559)	+ Umbonellina	O (Ashg-m)		(615,1066)
Turritoma	O (Trem-u)	- O (Aren-l)		+ Ventricaria	Tr(Carn)	- J (Bajo-u)	(797,1066)
Tychonia	C (Vise)		(615)	Or. NEOTAENIOGLOSSA			
Tylotrachus	Tr(Ladi)	- Tr(Nori)	(615)	(Classification and basic stratigraphic range from Wenz [1938].)			
+ Tylozone	D (Eife)		(797)	+ Aciculiscala	K (Camp-u)	- T (Eo-m-u)	(700)
Ulrichospira	S (Ldov-m)	- D (Eife-u)	(797)	+ Acilia	Tr(Anis)	- Tr(Carn)	(119)
Umbonium	T (Plio-l)	- R	(909)	+ Acirsa	K (Apti)	- R	(157)
Umbospira	S (Ldov-u)	- S (Ludl)?		+ Acirsella	T (Eo-m-l)	- T (Mi)	
+ Umbotrochus	S (Wenl)			+ Achiceratia	T (Dani)	- R	(909)
Umbotropis	D (Sieg)		(362)	+ Aclis	T (Ol-l)	- R	(852)
+ Urkutitoma	J (Sine-l)?		(661)	+ Acme	T (Ol-u)?	- R	(614)
Uvanilla	T (Mi)	- R		+ Acrilla	K (Camp-l)	- R	
Valfinia	J (Oxfo-l)?	- J (Kimm)?		+ Acrilloscala	T (Eo-l)	- R	(852)
Vanitrochus	T (Ol)	- R		+ Acrocoelum	K (Maes)	- T (Eo-m-u)	(700)
Velainella	T (Eo-m-l)			+ Acrosomia	Tr(Carn)		(119)
Velatella	K (Maes)			+ Acrospira	P (Leon)	- P (Guad)	(797)
Velates	K (Camp-l)	- T (Eo-u)	(548)	+ Actaenomena	T (Eo-m-u)	- R	
Vergnesia	T (Eo-u)			+ Aderbis	T (Eo-l)		(1066)
Vernelia	C (Pn)	- Tr(Carn)	(797)	+ Actinopsis	T (Eo)	- R	
+ Vestulia	Tr(Nori)		(1066)	+ Adusta	T (Ol-l)	- R	
Vexinia	T (Eo-m-l)		(615)	+ Aepystoma	T (Mi-m)		
+?Vigescentis	C		(ZR8,3)	+ Africoterbellum	T (Eo-m)		(1074)
Visitor	S (Ludl)	- D (Gedi)	(362)	+ Afriscrobs	T (Mi)	- R	(909)
Vistulia	Tr(Anis-m)	- Tr(Nori)		+ Afrocornulina	T (Than)		(ZR77)
Vitta	T (Mi)	- R		+ Afrocypraea	K (Camp)		(914)
Vivanelia	Tr(Nori)	- J (Bajo)	(797)	+ Agathirses	T (Eo-l)	- R	(1066)
+?Vorticina	C (Vise-u)		(ZR90)	+ Ageria	K (Albi-u)		
Waisiolia	T (Ol-u)			+ Alaba	K (Camp)?	- R	(914)
?Walnichollisia	P (Leon-u)	- P (Guad-u)	(745)	+ Alabina	T (Eo)	- R	
Weeksia	K (Camp)	- K (Maes-u)	(2)	+ Alariopsis	J (Sine)?		
+ Wellergyi	C (Vise)	- C (Pn)	(797)	+ Alaskozygopleura	D (Eife-u)		(797)
Westerna	D (Fras-u)		(362)	+ Alciidiella	T (Mi)	- R	
Wilsoniconcha	J (Toar-l)?	- J (Oxfo-l)		+ Aletes	Q (Plei)	- R	
+ Wisonsinella	D (Eife-u)		(797)	+ Algaroda	T (Eo)	- R	
Woehrmannia	Tr(Ladi-u)	- Tr(Carn)	(797,1207)	+ Aliger	T (Mi)	- R	
Worthenia	D (Fras)	- J (Plio-u)?	(362,797)	+ Allosomia	P (Guad-l)?	- J (l)	(1,1066)
- Wortheniella	Tr(Ladi-u)		(1120)	+ Allostrophia	Tr(Ladi)	- Tr(Nori)	(1)
Wortheniopsis	Tr(Ladi)	- Tr(Nori)		+ Alocaxis	T (Than)		
+?Yingicus	C (l)		(ZR8,3)	+ Alvania	K (Maes-l)	- R	(650)
+ Yoehelssonopsis	C (Serp-l)		(797)	+ Alvinia	T (Eo)	- R	
Yunnania	D (Gedi)	- P (Guad-l)	(109,362)	+ Amaea	K (u)	- R	(1248)
Zalipais	T (Plio-l)	- R	(681)	+ Amaurellina	K (Albi)	- T (Ol)	(909)
- Zalozone	D (Eife)		(797)	+ Amauropisina	T (Eo-m-l)	- T (Ol-l)?	
+ Zardubinihelix	Tr		(ZR90)	+ Amauropisina	K (Maes)	- R	(1061)
Zeidora	T (Plio)	- R		+ Amauropsona	T (Dani)		
Zethalia	T (Plio-l)	- R	(899)				
+ Zircia	J (Bajo-l)?	- J (Bajo-u)	(661)				
Ziziphinus	T (Ol-u)?	- R					
+?Zosterospira	C (u)		(ZR8,3)				
Zygitis	Tr(Anis)	- Tr(Nori)	(115,1066)				

Taxon	First Appearance	Last Appearance	Reference	Taxon	First Appearance	Last Appearance	Reference
+Amekichilus	T (Eo-m)		(1074)	+Austrocypraea	T (Eo-m-u)	-T (Mi-m)	(614,909)
+Ampezzoella	Tr(Ladi-u)		(1120)	+Austrossasia	T (Eo)	-R	
+Ampezzopleura	Tr(Ladi-u)		(976)	+Austrotirton	T (Eo)	-T (Mi-l)	(909)
+Ampezzoscala	Tr(Ladi-u)		(1120)	+Bactrospira	T (Plio)		
+Amphiperas	T (Mi-m)		(530)	+Balcis	T (Dani)	-R	
+Amphithalamus	T (Mi-l)	-R	(557)	+Banis	K (Sant-u)		
+Amplicolpus	T (Eo-l)	-T (Mi-m)	(728)	+Barlecia	T (Eo-u)	-R	(909)
+Amplogladius	T (Than)?	-T (Eo-m-u)	(705)	+Baryocypraea	T (Ol-l)	-T (Plio-l)	
+Amplostoma	K (Maes)		(914)	+Basilirata	T (Pg)		(ZR78)
+Ampullella	K (Maes)	-T (Eo-m-u)	(909)	+Basilitrona	T (Mi-l)	-R	
+Ampullina	J (l)	-T (Mi-u-l)	(909)	+Bathraspira	K (Nc)	-K (Sn)	
+Ampullinopsis	T (Ol-l)	-T (Mi-l)	(547,909)	+Bathygalea	T (Mi)	-R	(550)
+Ampulonatica	T (Eo-m)	-T (Mi)		+Batillaria	T (Dani)	-R	(1066)
+Ampullospira	J (Bajo)?	-T (Mi)	(614)	+Batillona	T (Ol-u)		(899)
+Anchura	K (Barr)	-K (Maes-u)		+Bauxia	T (Dani)		
+Anculosa	K (u)?	-R		+Bayania	K (Maes)	-T (Mi-l-u)	(614,1066)
+Andangularia	Tr(Nori)		(797)	+Bellatara	T (Eo-m-l)	-T (Ol)?	(614)
+Aneurychilus	T (Eo-l)	-T (Eo-u)	(914)	+Bellerophina	K (Albi)		
+Angulostoma	T (Dani)	-T (Than)	(909)	+Belliscala	K (Camp-u)	-K (Maes)	
+Angularia	Tr(Ladi-u)	-Tr(Nori)	(797)	+Bembicium	T (Eo-m)	-R	(914)
+Anoptychia	Tr(Olen-l)	-J (Bajo-u)	(661,785)	+Bembridgia	T (Ol-l)		
+Annepona	K (Camp)?	-R		+Benoistea	T (Than)	-T (Ol)	
+Anozyga	C (Mosc-l)	-C (Mosc-u)	(117,1258)	+Beretra	K (Camp-l)	-K (Maes)	(909)
+Antarctodardwinella	T (Eo-m-u)	-T (Ol-l)	(909)	+Bernaya	J (Tith)	-T (Ol-l)	(121)
+Anteglossia	K (Ceno)	-K (Maes)		+Bezania	T (Eo-l)	-T (Eo-u)	(551)
+Anticlimax	T (Ol-l)	-R	(852)	+Bicarinella	K (Ceno-u)		(815)
+Antinodulus	T (Mi-l)	-R		+Bicatillus	T (Mi)	-R	(614)
+Apataxia	T (Mi)	-R	(650)	+Bifidoscala	K (Camp-l)	-T (Ol-l)?	
+Apicaria	Tr(Carn)			+Bigotella	J (Plie)		
+Apiocypraea	T (Ol-l)	-T (Plio-u)		+Billiemia	J (Tith)		(615)
+Apollon	T (Eo)	-R		+Biplex	T (Mi-l)	-R	(530)
+Aporrhais	K (Camp)?	-R		+Bittiolium	T (Mi)	-R	
+Arabia	T (Eo-u)	-R		+Bittiscala	K (Sn)	-T (Dani)	
+Arabica	T (Mi-u)	-R	(909)	+Bittium	T (Dani)	-R	(700)
+Aracodactylus	T (Than)			+Bivonia	T (Eo-m)	-R	(914)
+Araratella	K (Coni-l)	-K (Camp)	(815,914)	+Blasicrura	T (Plio-u)	-R	
+Archicypraea	K (Ceno)	-T (Eo-u)		+Boggisia	T (Than)		(914)
+Archierato	T (Eo-l)	-T (Mi-m)	(530,899)	+Bohaispira	T (Pg)		(ZR78)
+Archimediella	K (Turo)	-R	(614)	+Bohaispiropsis	T (Pg)		(ZR78)
+Arestorides	Q (Plei)	-R		+Boreoscala	T (Eo-u)	-R	(158)
+Argobuccinum	T (Than)	-R		+Bourgetia	Tr(Anis)	-J (Kimm)	
+Argyropeza	T (Mi-m)	-R	(550)	+Brachycerithium	Tr(u)		
+Ariadnaria	T (Plio)	-R		+Brachystoma	K (Apti)	-K (Albi)	(909)
+Aristerostrophia	Tr(Ladi)			+Brachytrema	J (Plie)	-J (Tith-u)	(1066)
+Armenostoma	K (Turo)	-K (Coni)	(1209)	+Bramertonia	T (Plio)		
+Arrhoges	K (Nc)	-R	(1074)	+Broecchia	T (Ol-l)	-T (Plio)	(852)
+Aspa	T (Mi)	-R		+Brochina	T (Mi)	-R	
+Asperiscala	T (Eo-u)	-R	(700)	+Brookesena	T (Mi-l-u)	-R	(899)
+Astandes	K (Camp)		(914)	+Brunonia	K (Barr)	-K (Sn)	
+Ataxocerithium	T (Eo-u)	-R	(530)	+Bufonariella	T (Mi)	-R	
+Ataxotrochus	Tr(Ladi)			+Bulbus (+ Bulbusoides)			
+Atlantia	T (Dani)	-R	(122)		T (Mi-u-l)	-R	
+Atresius	K (Apti)	-T (Than)	(914)	Bulimorpha	C (Vise)	-C (Mosc-l)	(1,797, 1258)
+Attenuata	T (Eo-u)	-R	(650)				
+Aulacodiscus	T (Eo)			+Bursa	T (Than)	-R	(705)
+Aulacostrepsis	D (Sieg)	-D (Emsi)	(362)	+Burtinella	K (Ceno)	-R	
+Aurelianelia	T (Than)	-T (Eo-u)		+Buvignieria	J (u)	-T (Than)	(794)
+Auriala	K (Camp)?	-K (Maes)	(914)	+Byramia	T (Eo-m)	-T (Ol-l)	(852)
+Auriptygma	S (Ludl)	-D (Gedi)	(362)	+Cabestanna	T (Ol-u)	-R	(909)
+Australolaxispira	T (Plio)		(ZR82)	+Caecum	T (Ol-u)?	-R	(909)
+Austroporphais	K (Maes)	-T (Pale)		+Callispira	C (Mosc-l)	-C (Step-l)	(797,1258)
+Austrocochlis	T (Mi-l)	-T (Mi-m)	(530)	+Callistocypraea	T (Eo-u)	-R	(121)

Taxon	First Appearance	Last Appearance	Reference	Taxon	First Appearance	Last Appearance	Reference
+Callusaria	T (Mi-l-l)	-Q (Plei)	(126,728)	+Chileutomia	T (Eo)	-R	
+Calpuria	T (Eo-l)	-R	(614)	-Chilocyclus	Tr(Ladi)	-K (Ceno)	
+Calvadosiella	J (Oxfo-u)			-Chlathrus	T (Eo)	-R	
+Calyptraea	K (u)	-R	(122)	+Chondrocerithium	T (Than)	-T (Mi)	
-Calyptroides	T (Eo-m)	-T (Eo-u)?	(914)	+Cimoliocentrum	K (Barr)		
+Calyptrophorus	K (Camp)	-T (Eo-u)	(700,1074)	+Cimolothium	K (Barr)	-K (Maes)	(914)
+Calyptropsis	T (Eo-u)	-R	(530)	+Cinctiscala	T (Eo)	-R	
+Cambodia	P (u)		(797)	+Cingula	T (Mi-u)	-R	(557)
+Campaniella	T (Than)	-R	(914)	-Circuloscala	T (Than)	-T (Plio)	
+Campanilopa	T (Dani)	-T (Eo-u)		+Circocerithium	K (Apti)	-K (Ceno)	(157)
+Camposcala	Tr(Ladi-u)		(1120)	+Cirsomphalus	T (Than)		
+Canaliscala	T (Eo-m)		(914)	+Cirsope	T (Than)	-T (Ol-l)?	
+Canarium	T (Mi-l)	-R	(1074)	+Cirsotrema	T (Eo-m-l)	-R	(123,899)
+Capulacmaea	T (Plio)	-R		-Clathrobaculus	J (Hett)	-T (Eo)	
+Capulus	K (Camp-l)	-R		-Clathronema	D (Eife-u)	-D (Give)	(1004)
+Carinacca	T (Eo-l)	-T (Eo-m-u)	(899,1248)	-Clathroscala	T (Mi-l-u)?	-R	(899)
-Carinaria	T (Eo)	-R	(122)	-Clathrus	T (Eo)	-R	
+Carinomphalus	J (l)		(ZR79)	+Clava	T (Than)	-R	
+Casimiria	T (Eo)			+Claviscala	K (Ne)	-R	
+Casmaria	Q (Plei)	-R	(909)	-Clavocerithium	T (Eo)		
+Cassianozyga	Tr(Ladi-u)		(976)	+Cleotrivia	T (Mi-m)	-R	
+Cassidaria	T (Eo-l)	-R	(914)	+Chimacina	J (Sine)		
-Cassiope	K (Apti-l)	-K (Camp)	(4,157, 1066)	+Cloughtonia	J (Plic)	-J (Tith-u)	
+Cassiopella	K (l)		(815)	+Clypeola	T (Eo-u)	-R	(530)
+Cassis	T (Than)	-R	(614)	+Clypeomorus	T (Mi-l)	-R	
+Catenoscala	T (Mi)			+Coalingodea	T (Eo-m-l)?	-T (Eo-m-u)	
+Caucasella	K (Camp)		(914)	+Cocholepis	T (Mi-u)	-R	(557)
+Cautotriphora	T (Plio)		(559)	-Coelochrysalis	Tr(Ladi)	-Tr(Nori)	
+Cavernisa	T (Mi-u)		(ZR78)	+Coelodiscus	J (Toar-l)	-J (Bajo)	(1,1066)
+Cavilabium	T (Than)	-T (Eo)		-Coelostylina	P (Guad)	-J (Kimm)?	(797)
-Caviumbonia	T (Pg)		(ZR78)	+Colina	T (Eo-l)	-R	(914)
+Cenomanella	K (Ceno)	-K (Maes)	(615,914, 1066)	+Colposigma	T (Dani)	-T (Eo-l)	(914)
+Cepatia	T (Eo-m)	-T (Ol-l)?	(914)	+Colpospira	T (Eo-l)	-R	
+Ceratia	T (Than)	-R	(794)	-Colubraria	T (Than)	-R	(700)
+Ceraunocochlis	C (Tour)	-P (Guad-l)	(777)	+Colubrellina	T (Eo)	-R	
+Cerithidea	Q (Plei)	-R	(909)	-Columbellaria	J (Bath)	-K (Maes)	(123,157, 790)
-Cerithideops	T (Mi)	-R		+Columbellina	K (Ne)	-K (Maes-l)	
+Cerithideopsilla	T (Mi)	-R		+Conchothyra	K (Turo)	-T (Dani)	(899)
+Cerithideopsis	T (Plio)	-R	(909)	+Confusiscala	K (Ne)	-K (Maes-u)	(790)
+Cerithidium	T (Mi)	-R		-Coninoda	K (Albi)	-K (Sant)	(773,815)
+Cerithiella	K (Barr)	-R		+Coniscala	K (Turo)	-T (Than)	
+Cerithina	K (Coni)			-Conocerithium	T (Mi)	-R	
+Cerithinella	Tr(Nori)		(119)	+Conomurex	T (Plio-u)	-R	(909)
-Cerithioclava	T (Plio)	-R	(909)	+Contemiscala	T (Eo-l)		
+Cerithiocyga	Tr(Ladi-u)		(1120)	+Contortella	J (Kimm-l)	-K (Vala)	
-Cerithioderma	K (Coni)	-T (Ol)		-Conuber	T (Ol-u)	-R	(530)
-Cerithiomorpha	K (Turo)	-K (Coni)	(1209)	+Coriandria	T (Mi)?	-R	
+Cerithiopsida	Q (Plei)	-R		+Coronatica	K (Apti)	-K (Ceno)	
-Cerithiopsidella	T (Plio)	-R		+Coroniscala	T (Than)	-R	
-Cerithopsina	T (Eo)	-T (Plio)	(1248)	+Cosmocerithium	J (Plic)	-K (Barr)	
-Cerithiopsis	K (Coni)	-R		-Cossmannia	T (Than)	-T (Ol)	(794,909)
-Cerithiscala	T (Dani)	-R		+Couthouyia	T (Mi)	-R	
+Cerithium	Q (Plei)	-R		+Cowlitzia	T (Eo-m)	-T (Eo-u)	(815)
+Charadream	T (Eo-u)		(551)	+Craginia	K (Ceno)		
+Charonia	K (Camp-u)	-R		+Crassiscala	T (Eo-m-l)	-T (Plio)	
+Chasmotheca	T (Mi)	-R		+Crebriscala	T (Mi-m)	-R	
+Chavanicerithium	T (Mi-l)	-T (Plio)	(530)	+Crenetocerithium	T (Ng)		(ZR81)
+Chedevilla	T (Than)	-T (Eo-l)	(1074)	+Crepidula	J (Oxfo-u)	-R	(122)
-Cheilea	T (Eo-m-u)	-R	(899)	+Crepidatella	T (Plio)	-R	
-Chevallieria	T (Than)	-R	(794)	+Cribraria	T (Mi-l-l)	-R	(121)
				+Crisposcala	T (Eo-m-l)	-T (Eo-u)	(614,700)

Taxon	First Appearance	Last Appearance	Reference	Taxon	First Appearance	Last Appearance	Reference
+Crommium	K (u)	-T (Mi)	(614)	+Digitolabrum	T (Eo-l)	-T (Eo-u)	(1074)
+Crossata	T (Plio)	-R		+Dilatilabrum	T (Eo-m)	-T (Mi-l)	(1074)
+Crossotrema	K (Camp-u)		(1211)	+Diminovola	Q (Plei)	-R	
+Crucibulum	T (Mi-l)	-R	(548)	+Dinaxis	T (Pale)		
+Cryptaulax	Tr(Ladi)	-K (Albi-u)	(793,797)	+Diplocyma	T (Eo-u)		(914)
+Cryptonica	T (Ol-l)	-R		+Diptychophilus	T (Eo)		
+Cryptoptyxis	J (Call)	-K (Apti-l)		+Dircella	K (Maes-l)		
+Ctenocolpus	T (Eo)	-R		+Dirocerithium	T (Eo-m-l)	-T (Eo-u)	(547)
+Cubestana	T (Plio)	-R		+Discopsis	T (Ol-l)	-R	(852)
+Cupaniella	J (Plei)			+Discoscala	T (Eo)	-R	
+Cuphotifer	J (Bath-u)	-J (Kimm)	(1074)	+Disoketa	K (Albi-u)		
+Cuphosolenus	J (Bath)	-K (Sant-l)	(1074)	+Dispotaea	T (Ol-l)	-R	(852)
+Cyclomolops	K (Maes)?	-T (Eo-m-l)	(1074)	+Dissochilus	T (Than-l)	-T (Mi)	
+Cycloscala	T (Mi)	-R		+Dissostoma	T (Than)	-T (Ol-l)	(614)
+Cyclostremiscus	T (Eo-l)	-R	(700)	+Distorsio	T (Eo-m-u)	-R	(909)
+Cyclothyca	T (Plio)	-R		+Ditretus	J (Oxfo-l)	-J (Tith-u)	
+Cyclozyga	C (Tour-u)	-C (Step-u)	(797,896,1258)	+Dizoniopsis	T (Eo)	-R	
				+Docomphala	Q (Plei)	-R	
+Cylindriscala	T (Mi-u-l)	-R		+Doellocosmia	Tr(m)	-Tr(u)	
+Cylindritopsis	C (Mosc-u)	-P (Dora)	(1,109,797,1130)	+Dolichupis	T (Ol-u)	-R	(909)
				+Doliocassis	T (Eo-m-u)		(700)
+Cymatiella	T (Eo)	-R		+Dolomena	T (Mi-u)	-R	(909)
+Cymatium	T (Eo-m-l)	-R	(125)	+Douvilletoma	T (Than)		(ZR77)
+Cymenorhytis	T (Eo-l)	-T (Mi)	(914)	+Doxander	T (Mi-u-u)	-R	(909)
+Cyphoma	T (Mi-l-u)	-R	(551)	+Drepanocheilus	K (Apti-l)	-T (Eo-u)	(157,614)
+Cypraea	T (Dani)	-R	(700)	+Druidwilsonia	T (Than)		(705)
+Cypraeacassis	T (Mi)	-R		+Dumasella	T (Eo-m-l)		
+Cypraedia	T (Dani-l)	-T (Ol-l)	(121)	+Eatonella	T (Mi)	-R	(681)
+Cypraerato	T (Mi-l)	-R		+Ecliseogyra	K (Camp-u)		(976)
+Cypraegemmula	T (Ol-l)			+Echinellopsis	T (Eo)	-R	
+Cypraepsis	T (Ol-l)	-T (Mi-m)		+Echinimathilda	K (Maes)		
+Cypraeorbis	T (Eo-l)	-T (Mi-m)	(121,1248)	+Echinobathra	K (Apti)	-K (Camp)	(914,1066)
+Cypraetrivia	T (Ol-l)	-T (Mi-u)		+Echinophoria	T (Eo-m)	-R	(96)
+Cyroglobina	K (Camp)	-T (Mi-m)	(121,909)	+Ectinochilus	T (Than)	-T (Eo-u)	(1074)
+Cypropterina	T (Eo-m-l)	-T (Eo-u)	(121)	+Eglisia	T (Mi)	-R	
+Cyrbasia	T (Eo-m-l)	-T (Mi-m)	(557)	+Eichwaldiella	T (Mi-m)?	-T (Plio)	
+Cyrtspira	O (Llde)	-S (Ludl)?	(1)	+Elachorbis	T (Ol-u)	-R	(681)
+Cyrulotibia	T (Eo-m)		(1074)	+Elegantiscala	T (Eo-m-l)	-R	
+Dallitella	T (Eo-l)	-T (Mi)	(914)	+Elephantanellum	T (Plio)?	-R	(559)
+Dallitesta	T (Mi-u)	-R		+Eligmoloxus	J (Bath)	-K (Apti)?	
+Dardanula	T (Mi-l-l)	-R	(899)	+Ellatrivia	T (Eo-u)	-R	(530)
+Daronia	T (Eo-u)	-R	(559)	+Eliptovermetus	T (Mi-l-l)		
+Dasyostoma	T (Eo-u)			+Endiataenia	J (Hett)		
+?Demibabaspira	C (l)		(ZR75)	+Endoptygma	K (Sn)		
+Dentiscala	T (Than)	-R		+Entomope	T (Than)	-T (Mi)	(794)
+Depressiscala	T (Mi-u-l)	-R		+Eoatlanta	T (Dani)	-T (Eo-m)	(914,1066)
+Derstolida	T (Mi-m)	-R		+Eocerithium	Tr(u)		
+Deshayesia	T (Eo)	-T (Ol)		+Eocernina	T (Than)	-T (Eo-m-l)?	
+Devonozyga	D (Eife)		(362)	+Eocymatium	T (Than)	-T (Eo-m-l)	(909)
+Diaerecallus	T (Mi-m)			+Eocypraea	K (Ceno)	-T (Plio-u)	(121)
+Diala	T (Mi-l)	-R	(559)	+Eomathilda	T (Dani)		(914)
+Dialopsis	T (Eo-m-l)	-T (Mi)		+Eoptychia	D (Eife)	-C (Mosc)	(362,797)
+Dialytostoma	T (Eo-m-l)	-T (Mi)		+Eoranela	K (Barr)?		(1066)
+Diameza	T (Eo-m-l)			+Eosolarium	K (Camp)		
+Diarthema	J (Bath-l)	-K (Ceno)?	(1074)	+Eotrivia	T (Eo-m)	-T (Eo-u)	(614)
+Diastoma	K (Camp)?	-R		+Eotympantonotus	T (Eo)		(614)
+Diastomella	T (Than-l)		(914)	+Eovolva	T (Eo-m-l)	-T (Eo-u)	(121)
+Diatinostoma	J (Bajo)		(1066)	+Epetrium	T (Dani)	-T (Plio)	
+Diatrypesis	J (Toar)	-K (Apti)		+Epheria	T (Than)	-R	
+Dicroloma	J (Bajo-l)	-K (Camp-l)	(1074)	+Episcynia	T (Eo-m-l)	-R	(700)
+Diempterus	J (Bath)	-J (Kimm)	(1074)	+Epitonium	T (Mi-u-l)	-R	
+Dientomochilus	K (Coni)?	-R	(1066)	+Erato	T (Eo-u)	-R	(121)

Taxon	First Appearance	Last Appearance	Reference	Taxon	First Appearance	Last Appearance	Reference
+Eratopsis	T (Ol-u)	-R		+Gamiyga	C (Mosc-u)	-P (Leon)	(797)
+Eratotrivia	T (Eo-l)	-T (Ol-l)	(121,909)	+Garnotia	T (Mi)	-R	
+Erosaria	T (Mi-l-l)	-R	(121)	+Gazameda	T (Ol-u)		(728)
+Erronea	T (Mi-l-l)	-R	(121)	+Gegania	K (Coni)	-R	
+Escoffieria	T (Plio)			+Geolcomia	C		(ZR76)
+Estea	T (Mi)	-R	(681)	+Gelagna	T (Eo)	-R	
+Euchrysalis	Tr (Anis)	-J (Bath)		+Georgia	T (Ol)	-R	
+Eucycloidea	J (Bajo-l)	-J (Call)	(661)	+Gibberulus	T (Plio)	-R	(1074)
+Eucypraedia	T (Eo-l)	-T (Ol-u)		+Gigantocapulus	K (Camp-l)		
+Eudolium	T (Ol-u)	-R	(909)	+Gigantocypraea	T (Ol-u)	-T (Mi-m)	(530)
+Eulimene	T (Plio-u)			+Gigantogonia	Tr (Ladi)		
+Eumetula	T (Eo-l)	-R	(852)	+Girvania	O (Cara-u)	-O (Ashg-l)	(1)
+Eunaticina	K (Turo)	-R		+Gisortia	T (Than-l)	-T (Eo-u)	(121)
+Euprotomus	T (Plio)	-R		+Glauconia	K (Nc)	-K (Maes)	
+Eurissolina	T (Mi-l)	-R		+Glauconiella	K (Coni)?	-K (Camp)	(815,914)
+Euseila	K (Camp-u)	-R		+Glabiomorpha	C (Tour-l)		(797)
+Euspira	K (Apti)	-R		+Globisinum	T (Dani)	-R	(899)
+Euspirocrommium	K (Turo)	-T (Ol-u)	(909)	+Globozygia	C (Serp-l)		(797)
+Eustoma	J (Bath)	-K (Turo)		+Globularia	J (l)	-R	(909)
-Eustrombus	T (Plio)	-R	(1074)	+Globulocerithium	T (Pale)		(ZR81)
+Euthymella	T (Ol-l)	-R	(852)	+Glosia	J (Bath)	-K (Camp)	(914)
+Euthystylus	Tr (Ladi)	-Tr (Rhae)	(119)	+Glossaulax	T (Eo-m)	-R	
+Ewekoroia	T (Than)		(705)	+Glyptochrysalis	Tr (Ladi)	-J (l)	(797)
+Ewekorolaxis	T (Than)		(ZR77)	+Glyptozaria	T (Eo-l)	-R	(614,1248)
+Exechestoma	K (Maes)	-T (Eo)		+Goniatogyra	T (Than-l)		
+Exechocirsus	K (Albi-u)	-K (Maes)	(1066)	+Goniocheila	K (Sn)	-R	
+Exlessia	J (Hett)	-K (Barr)		+Gonioconcha	Tr (u)		
+Faloriella	Tr (Ladi-u)		(1120)	+Goniogyra	Tr (Carn)		(119)
+Fartulum	T (Mi-l-u)	-R	(899)	+Goniospira	Tr (Ladi)		
+Fastigiella	T (Than)	-R		+Gonytycon	T (Ol-u)		(547)
+Faxxia	T (Dani)		(1066)	+Gothicispira	T (Mi-m)		(ZR90)
+Fibula	Tr (Rhae)		(119)	+Gouetina	T (Eo-m-l)		
+Ficopsis	T (Than-l)	-T (Eo-u)	(4)	+Gourmya	T (Eo)	-R	(614)
+Fictionoba	T (Plio-l)	-R	(681)	+Graciliala	K (Maes-l)		(1074)
+Ficus	T (Than)	-R	(122)	+Gradiella	Tr (Ladi)	-Tr (Carn)	
+Fimbriatella	T (Than)	-T (Plio)		+Granosolarium	K (Camp-l)?	-R	
+Flacilla	Tr (Carn)	-Tr (Nori)		+Granulitorina	T (Mi)	-R	(909)
+Flenningia	Tr (Ladi-u)		(1120)	+Granulolabium	T (Than)?	-R	
+Folina	Q (Plei)	-R	(650)	+Graphis	T (Dani)	-R	
+Foratiscala	T (Than)	-R		+Gregorioiscala	T (Plio)	-R	(909)
+Fossacypraea	T (Mi-l)	-T (Plio-l)		+Gutturium	T (Mi-l)	-R	
+Fossarius	T (Eo-m-l)	-R	(123,1066)	+Gymnarus	K (Turo-l)	-K (Maes-l)	(1074)
+Fossatrvia	T (Ol-l)	-R		+Gymnentome	K (Apti-l)	-K (Camp)	(815,914)
+Friginatica	T (Eo-m-l)	-R	(899)	+Gymnocerithium	J (Bath)	-K (Nc)	
-Fulguroficus	T (Dani)	-T (Mi-l-u)	(794,814,914)	+Gyrineum	T (Plio)	-R	
+Fumis	K (Apti)	-K (Sn)	(909)	+Gyroides	K (Apti-u)	-T (Than)	(4,157)
+Fumiscala	T (Ol-l)	-T (Plio-u)	(852,899)	+Gyroscala	T (Eo-m-u)	-R	(700)
+Fuscoscala	T (Mi-m)?	-R		+Gyrotropis	K (Camp)?	-K (Maes)	
+Fusispira	O (Trem)	-D (Eife-u)	(2,797,1004)	+Haha/rimania	T (Eo-m)		(158)
-Fusitriton	T (Mi-m)?	-R		+Haliphoebus	T (Eo)	-R	(614)
+Fusitron	T (Ol-l)	-T (Plio)	(96)	+Halloysia	T (Dani)	-T (Than-l)	
-Fusoficula	T (Eo-m)	-T (Ol-l)		+Hallstadiata	Tr (Carn)		
+Fusoidella	Tr (Ladi)			+Hanaibursa	K (Apti)		(1066)
+Futhystylus	P (Dora)		(1130)	+Hapatorbis	T (Mi-m)	-R	
+Galeodaria	T (Eo)	-T (Ol-u)?		+Haplocochlias	T (Mi-u)	-R	(557)
+Galeodea	T (Than)	-R	(700)	+Harmeria	T (Plio-u)		
+Galeodina	Q (Plei)	-R		+Harpago	Q (Plei)	-R	(909)
-Galeodinopis	T (Ol-u)?	-T (Plio)		+Harpagodes	J (Bath)	-K (Ceno-l)	(122,157,558)
+Galeocoryps	T (Mi-l-u)	-R	(899)	-Harrisianella	T (Dani)	-T (Eo-u)	(547,914)
-Galericulus	K (Albi-u)		(1066)	+Hartungia	T (Mi-u-u)	-T (Plio)	(728,899)
				+Haustator	K (Vala)	-R	

Taxon	First Appearance	Last Appearance	Reference	Taxon	First Appearance	Last Appearance	Reference
+Haurakia	T (Eo-m-u)	-R	(728)	+Keilostoma	K (Albi)	-T (Ol)	(793)
+Haydenia	K (Camp-u)			+Khetella	J (Kimm)	-K (Berr)	
+Hebeseria	T (Mi)	-R		+Kinishbia	P (Leon)		(1)
+Heliacus	K (Sn)	-R		+Kittlia	Tr(Ladi)	-Tr(Carn)	(119)
+Helicaulax	K (Apti-u)?	-K (Maes-u)	(790)	+Kitticoncha	Tr(Olen-l)?	-Tr(Nori)	(785,797)
+Heligmope	T (Mi)			+Kittlitylus	Tr(Ladi)	-Tr(Nori)	(797)
+Heligmostylus	Tr(Ladi)			+Kjerulfonema	S (Ldov-l)	-S (Ludl-u)	(797)
+Helminthozyga	C (Mosc-u)	-C (Step-l)	(797,1258)	+?Knightella	C (Vise-u)		(797)
+Hemiacirsa	K (Sant)	-R	(909)	+Korovina	T (Mi)	-R	
+Hemicerithium	K (Coni)	-R		+Kraebia	T (Mi-m)		(ZR75)
+Hemichenopus	T (Plio)			+Krebsia	T (Eo)	-R	
+Hemizyga	C (Tour-u)	-P (Guad)	(797,896)	+Labiostrombus	T (Mi-u)	-R	(909,1074)
+Hespererato	T (Eo-m-u)	-R		+Labiidrens	P (Leon)	-P (Guad-l)	(1,2,777)
+Heterocerithiopsis	T (Mi-u)			+Lachryma	T (Fo-l)	-T (Mi-m)	(899)
+Heterogyrella	Tr(Ladi)	-Tr(Carn)		+Lacuna	T (Mi-l)	-R	(876)
+Heterospira	Tr(Ladi)	-Tr(Nori)	(797)	+Lacunaria	T (Dani)	-T (Eo-m)	(700)
+Hexaglauconia	K (Ceno-l)	-K (Sant-u)	(815)	+Lacunella	T (Eo)		
+Hilda	T (Eo)	-T (Mi-m)		+Lacunina	Tr(Ladi-u)	-Tr(Carn)	
+Hippobrene	T (Pale)	-T (Ol-l)	(1074)	+Lacurmaria	T (Than)	-T (Eo-m)	
+Hipponix	K (Albi-u)	-R	(1066)	+Ladmla	Tr(Ladi-u)	-Tr(Nori)?	(1120)
+Hironella	J (Bath)		(650)	+Laevella	T (Eo-u)		(1074)
+Hirtoscala	T (Mi)	-R		+Laevibaculus	J (Hett)?		
+Hopkinsiana	T (Eo)	-T (Eo-u)		+Laevistrombus	T (Mi-u)	-R	(909)
+Hordeulina	T (Mi-u-l)			+Lagunitus	T (Eo-u)		(914)
+Horizostoma	K (Albi-m)	-K (Ceno)		+Laiocochlis	T (Fo-m)	-R	(914)
+Hudlestonella	J (Bajo)	-J (Call)		+Lambis	T (Mi-l)	-R	(1074)
+Hwaania	J (l)		(ZR82)	+Lamellaria	T (Than)	-R	(122)
+Hyalia	T (Ol-u)	-R	(909)	+Lamelliphorus	J (Aale)	-K (Ne)?	(1066)
+Hyalorisia	T (Mi)?	-R		+Lampanela	T (Ol-u)?	-R	
+Hyaloscala	T (Mi-l-u)	-R	(899)	+Lampasopsis	T (Mi)	-R	
+Hyphantozyga	D (Gedi)	-C (Mosc-u)	(1,362)	+Lampusia	T (Mi)	-R	
+Hypocassis	T (Ol)	-R	(909)	+Latiola	K (Apti)	-K (Maes-u)	(790)
+Hypsipleura	Tr(Ladi)	-J (Plic)	(1)	+Laxispira	K (Albi-u)	-K (Maes-u)	(790)
+Hypertita	K (Maes)	-R		+Leaella	K (Camp-u)	-T (Ol)	
+?Lanthinopsis	D (Eife)	-P (Djhu)	(109,362)	+Leiorhinus	T (Eo-m-u)		(700)
+Iddingsia	T (Eo-u)?	-T (Ol-l)?		+Leiostraca	K (Camp)?	-R	(914)
+Idiographie	T (Eo-u)	-T (Mi-m)	(852)	+Lemintina	K (Maes)	-R	(914)
+Ihungia	T (Ol-u)	-T (Plio-u)	(899)	+Lemnicolittorina	K (Maes-l)		(1066)
+Ilijinella	T (Mi-u)		(ZR78)	+Lentigo	T (Eo-u)	-R	(1074)
+Indocerithium	T (Mi)	-R	(909)	+Leporicypraea	T (Plio-u)	-R	
+Iradia	T (Eo)	-R	(557)	+Leptocolpus	T (Dani)		(728,899)
+Ischnoptygma	P (Leon-u)		(777)	+Leptopygma	C (Serp)	-C (Step)	(1,797)
+Ispharina	T (Than)	-T (Eo-u)		+Leptozyga	C (Tour)	-P (Dora)	(1,1130)
+Isselia	T (Mi)	-R		+Levenia	T (Plio)	-R	
+Itomelania	K (l)		(157)	+Leviathania	J (Oxfo-u)	-K (Vala)	
+Janacus	T (Mi)	-R		+Lewinskia	J (Kimm-l)		(ZR78)
+Janthina	T (Mi-u-u)	-R		+Ljabenia	T (Pg)		
+Jeffreysina	T (Mi-m)	-R		+Libycerithium	K (Maes)		
+Jenmeria	T (Eo-m-u)	-R	(909)	+Ligatella	T (Mi)	-R	
+Jetwoodsia	T (Eo-u)	-T (Mi-m)	(530)	+Lilax	T (Eo-u)	-R	(914)
+Jogiacartanus	T (Eo-u)			+Limmeria	T (Plio)	-R	
+Johnstrupia	T (Dani)		(914)	+Linatella	T (Plio)	-R	
+Joussemea	T (Than)	-T (Mi-u-l)	(121,794)	+Linemera	T (Eo-m-u)	-R	(899)
+Jurassiphorus	Tr(Nori)	-J (Call)	(797)	+Liocerithium	T (Mi-l)	-R	(559)
+Kaitangata	T (Dani)		(914)	+Liocium	K (Ceno)		(1066)
+Kahua	T (Mi-l)?	-T (Plio-u)	(728)	+Lippistes	T (Mi)?	-R	
+Kangilioptera	T (Dani)		(1074)	+Liracassis	T (Ol-l)	-T (Mi-m)	(96)
+Kangxianospira	K (l)		(ZR82)	+Lirobittium	T (Plio)	-R	
+Kapua	T (Ol-u)?	-T (Plio-u)	(899)	+Lirocingula	T (Eo)	-R	(650)
+Katoptychia	D (Sieg)	-D (Emis)	(362)	+Lironoba	T (Mi)	-R	
+Katsira	Tr(Ladi-l)	-J (Bajo)	(1,797)	+Lispodesthes	K (Ceno)	-K (Maes-l)	(1074)
+Kaunhowenia	K (Maes-u)		(790)	+Litiopa	T (Dani)	-R	

Taxon	First Appearance	Last Appearance	Reference	Taxon	First Appearance	Last Appearance	Reference
+Littorina	T (Than-l)	-R	(876)	+Micomphalina	T (Eo-m-l)	-T (Plio)	
+Littorniscala	T (Than)	-R		Microptychis	C (Tour)	-P (Guad-u)	(109,797)
+Littorinolacuna	T (Ol-l)	-R		+Microschiza	Tr(Ladi)	-K (Turo)	
+Littorinopsis	T (Eo)?	-R	(1066)	+Microstelma	T (Mi-l)	-R	(650)
+Longicerithium	T (Mi)	-R	(909)	+Microtaphrus	T (Than)	-R	(794)
+Lophocoelias	T (Mi-l)	-R	(557)	+Microthyca	T (Mi)	-R	(909)
Lovonema	O (Cara-l)	-Tr(Nori)	(2,797,896)	+Milletes	Q (Plei)	-R	(909)
+Lucidestea	T (Mi)	-R	(650)	+Minutiscala	T (Plio)	-R	
+Lunatia	K (Apti)	-R	(123,157)	+Miolyncina	T (Eo-l)	-T (Mi-m)	
+Luponovula	T (Eo-m)	-T (Ol-l)		+Mioipila	T (Ol)	-T (Mi)	
+Luria	T (Mi-l-l)	-R	(121)	+Mirlaminatus	K (u)	-T (Pg)?	(ZR77)
+Lydiiphnis	T (Eo-l)	-R	(700)	+Modulus	T (Ol-u)?	-R	(614)
+Lyncina	T (Mi-l)	-R		+Moerckea	Tr(Ladi-l)	-Tr(Rhae)	(119)
+Lysiogyrus	T (Pg)	-R	(ZR78)	+Monalaria	T (Than-l)	-T (Eo-m-l)	(126,909)
+Lysis	K (Sant-l)	-K (Maes)		+Monetaria	T (Mi-l-u)	-R	(121)
+Macilentos	T (Eo-l)	-T (Eo-m-l)		+Monocirsus	T (Eo-m-l)	-R	
+Macrocypraea	T (Mi-l)	-R		+Monocuphus	J (Bath-l)	-K (Albi)	(1074)
+Magnatica	T (Dani)	-T (Mi-u)	(899,914)	+Monoplex	T (Eo-m)	-R	(909)
+Malea	T (Eo)	-R	(614)	+Morania	S (Lud-l)?	-S (Prid)	(797)
+Malluvium	T (Mi)	-R		+Morchella	T (Plio)	-R	
+Mambriina	T (Eo-l)	-T (Ol-l)	(852)	+Morgania	T (Dani)	-T (Eo)	(614)
+Mammilla	T (Eo)	-R		+Morionella	T (Eo)	-R	
+Manawatawhia	T (Plio-l)	-R	(681)	+Morum	T (Eo-m)?	-R	(547)
+Mandolina	T (Ol-l)	-T (Mi-m)	(121)	+Mourlonopsis	P (Leon)	-P (Guad)	(745,797)
+Manzonia	T (Ol)	-R	(650)	+Motyris	T (Eo-m)	-T (Eo-u)	(914)
+Maoricolpus	T (Ol-u)	-R	(909)	+Muconalia	T (Eo-m)	-R	(914)
+Maoricrypta	T (Ol)	-R	(909)	+Mundicella	T (Eo-u)	-R	(559)
+?Margaritella	K (Camp-l)	-R		+Murchisonella	T (Eo)	-R	
+Margeuulima	T (Eo-m-l)	-R	(530)	+Muricassis	T (Ol)	-R	(909)
+Mariacolpus	T (Mi)	-R	(ZR90)	+Nacca	T (Than-l)	-R	(914)
+Marsupina	T (Mi)	R		+Nairiella	K (Camp)	-K (Maes)	(914)
+Marticia	T (Plio)	-R		+Nanggulania	T (Eo-u)	-R	
+Mathilda	J (Bajo-u)	-R	(661)	+Nannopyrgula	T (Pg)	-R	(ZR78)
+Mathurifusus	J (Bajo-u)	-R	(661)	+Napulus	K (Camp-l)	-K (Maes-u)	(123,909)
+Mauritia	T (Mi-u)	-R	(121)	+Naricava	T (Mi-l-u)	-R	(681)
+Mauryna	T (Than)	-T (Eo-u)	(1074)	+Naricopsina	J (Bath)	-K (Ceno)	
+Maussenetia	T (Than)	-T (Eo-m-l)?	(1074)	+Natella	T (Eo-m)	-R	
+Mediargo	T (Ol-u)?	-R		+Natica	T (Than-l)	-R	(914)
+Medoriopsis	T (Dani)	-T (Mi-u)	(914)	+Naticarius	T (Than-l)	-R	(700,914)
+Meekospira	D (Sieg)	-P (Dora)	(109,797, 1130)	+Natitaria	Tr(Indu-u)	-Tr(Ladi)	(115,1130)
+Megalocypraea	K (Maes-l)	-T (Eo-u)	(121,614)	+Neobernaya	T (Plio)	-R	
+Megalomphalus	T (Eo-l)	-R	(914)	+Neojanacus	T (Ol-u)	-R	(681)
+Meioceras	T (Eo)	-R		+Neosimnia	T (Eo-l)	-R	(121,700)
+Melanatria	K (Camp-u)	-R		+Neozeba	T (Plio)	-R	(909)
+Melanella	T (Eo-l)	-R	(123,1248)	+Nerinatica	T (Eo-u)	-R	(914)
+Melaraphe	T (Than)	-R	(876)	+Nerineopsis	J (Tith-u)	-T (Dani)?	
+Mellevillia	T (Eo-l)	-R		+?Nerinoides	J (l)	-K (Apti)	(157,909)
+Menthafonia	T (Ol-l)	-R	(852)	+Neritrema	T (Plio)	-R	
+Merelina	T (Mi-l-l)	-R	(557,899)	+Neverita	T (Than)	-R	(123)
+Mesalia	K (Albi-l)	-R		+Nigerithium	T (Than)	-R	(ZR77)
+Mesoglauconia	K (Haut)	-K (Albi-l)	(815)	+Nina	T (Eo)?	-R	
+Mesohalina	T (Mi)	-R	(ZR87)	+Nisacelis	T (Mi-m)	-R	(ZR76)
+Mesospira	J (Bajo)	-J (Bath)		+Niso	T (Dani)	-R	(614)
+Mesovalvata	K	-R	(ZR90)	+Nitidiscala	T (Mi-m)	-R	(854)
+Metacerithium	K (Nc)	-T (Than)	(794)	+Niveria	T (Mi-m)	-R	
+Metaxia	T (Mi)	-R		+Nodilittorina	T (Mi-m)	-R	(876)
+Mertorhonema	P (Asse)	-R	(787)	+Nodiscala	T (Eo)	-R	
+Micranellium	T (Mi-m)	-R	(559)	+Nodulus	T (Mi-u)	-R	
+Microschara	T (Eo)	-T (Mi)		+Notacirsa	T (Eo-m-u)	-T (Mi-m)	(899)
+Microlacuna	T (Eo)	-R		+Notadusta	T (Mi-l)	-R	
+Microliotia	T (Mi-m)	-R		+Notocypraea	T (Mi-l-l)	-R	(121)
				+Notolaponia	T (Eo-m-u)	-T (Plio-l)	(909)

Taxon	First Appearance	Last Appearance	Reference	Taxon	First Appearance	Last Appearance	Reference
+Notoscrobs	T (Mi-l-u)	-R	(681,899)	+Payradeautia	T (Eo-l)	-R	(914)
+Notoseila	T (Eo-m-l)	-R	(899)	+Peasiella	T (Eo-m-l)	-R	(876)
+Notosetia	T (Mi)	-R		+Pedicularia	T (Eo-u)	-R	(550)
+Notosinister	T (Mi)	-R		+Pelicularia	T (Mi-u)	-R	(126,681)
+Nototrivia	T (Mi-l)	-T (Mi-m)	(530)	+Pellasiimnia	T (Ol-u)	-R	(909)
+Nozeba	K (Camp)	-R	(1066)	+Pereiraca	T (Eo-m)	-T (Mi-u-l)	(914,1074)
+Nuclearia	Q (Plei)	-R	(121)	+Pericarinata	J (l)		(ZR82)
+Nudivagus	K (Camp-u)	-T (Dani)		+Peringiella	T (Mi)	-R	
+Obex	T (Mi-m)	-R	(530)	+Perissity	K (Turo-u)	-T (Than-l)	(727)
+Obortio	T (Mi-l)	-R	(559)	+Perissodonta	T (Dani)	-R	(126)
+Obtusella	T (Mi)?	-R	(650)	+Perissolax	T (Than)	-T (Eo-l)	(700)
+Ochetochilus	J (Bajo-l)	-J (Call)	(661)	+Perissoptera	K (Haut)	-T (Dani)	(909)
+Ochetoclava	T (Eo-l)	-R	(700)	+Personella	T (Eo-l)	-T (Ol-u)	(530,1248)
+Ogivia	T (Dani)	-R		+Perucerrithium	T (Eo-u)		
+Olequahia	T (Eo-l)	-T (Ol-l)		+Peruchilus	T (Ol-l)		
+Omphalotycha	P (Guad-l)	-Tr(Rhae)	(109,119,797)	+Perustrombus	K (Maes)		(1074)
+Omphalotropis	Q (Plei)	-R		+Petalocochus	T (Eo-m-u)	-R	(909)
+Oniscidia	T (Ol-l)	-R	(852)	+Petersia	J (Oxfo)	-J (Tith-u)	
+Onoba	T (Eo)	-R	(650)	+Peyrotia	T (Dani)	-R	(914)
+Oocorys	T (Eo-m)	-R		+Pezantia	T (Than)	-T (Eo)	
+Oonia	Tr(Ladi)	-K (l)		+Phalium	T (Eo-m-l)	-R	(614,700)
+Oostrombus	T (Eo-l)	-R	(1074)	+Phenacovolva	T (Phio)	-R	(550)
+Opalia	T (Than-l)	-R	(914)	+Phosinella	T (Mi-m)	-R	
+Opaliopsis	T (Mi-u-l)	-R		+Phyllocheilus	J (Bajo)	-K (Ceno)	(1074)
+Opimilda	T (Eo-u)	-R	(681)	+Pictavia	Tr(Nori)	-K (Albi-u)	(119,157)
+Orectospira	T (Eo)	-R	(158)	+Pictoscala	T (Eo)	-R	
+Ornamentaria	T (Mi-l)	-R		+Piettea (+ Trietieia)	J (Sine)	-K (Apti)?	(1074)
+Orthaulax	T (Eo-l)	-T (Mi-m)	(814,1074)	+Pirena	T (Than)	-R	(614)
+Orthochetus	K (Apti-l)	-T (Eo-u)	(122,530)	+Pirenella	K (Ceno)	-R	
+Orthochilus	T (Eo-m-l)	-T (Eo-u)	(914)	+Pisinna	T (Ol-u)	-R	(909)
+Orthonema	C (Tour)	-Tr(m)	(786,1066)	+Planaxis	T (Than)	-R	(705)
+Orthostomia	Tr(Ladi)			+Platyla	T (Eo)	-R	
+Otatara	Q (Plei)	-R	(1066)	+Platyoptera	T (Eo-l)	-T (Eo-u)	(1074)
+Ottoino	T (Eo-m-u)	-T (Eo-u)	(909)	+Plesioacirsa	K (Coni)	-R	
+Ovatipsa	Q (Plei)	-R		+Plesiotriton	T (Eo-m-l)	-T (Eo-u)	(914)
+Ovirissoa	T (Mi-l-l)	-R	(899)	+Plesiotrochus	T (Mi-l)	-R	(559)
+Oxycypraea	T (Eo-m-l)	-T (Eo-m-u)	(700)	+Pleuracme	T (Mi-u)	-R	
+Oxygyrus	T (Phio)	-R	(550)	+Pliciscala	K (Camp-u)	-R	
+Oxyspira	D (Emsi)	-D (Eife-u)	(1004)	+Pliconacca	T (Eo-l)	-T (Mi-m)	(550,914,1248)
+Pachyrommium	T (Eo-l)	-T (Mi)		+Plocezyga	C (Mosc)?	-P (Guad)	(1,797)
+Pachyrissoina	T (Mi)?	-R		+Polinella	T (Dani)	-T (Phio-u)	(899)
+Paladmete	K (Apti)	-K (Maes-u)	(909)	+Polinices	K (Camp-l)?	-R	(123)
+Palaeocypraea	J (Tith)	-T (Than)		+Polygyreulima	T (Eo)	-R	
+Palaeonarica	P?	-Tr(Carn)		+Polygyrina	Tr(Indu-l)	-Tr(Nori)	(1,1130)
+Palaeonisco	Tr(Carn)	-J (Plie)		+Pomatias	T (Ol)	-R	(614)
+Palaeostylus	P (Leon)	-P (Dora)	(109,797,1130)	+Ponocyclus	T (Mi-m)	-R	
+Palaeozygopleura	D (Sieg-u)	-C (Mosc-u)	(362,797,1258)	+Popenella	Tr(Ladi-u)		(1120)
+Pallioeypraea	T (Ol-u)	-T (Mi-m)	(530)	+Portoricia	T (Ol-u)		
+Palmadusta	T (Phio-l)	-R	(121)	+Postalia	T (Eo-l)	-T (Eo-u)	(1248)
+Paracerithium	Tr(Ladi)	-J (Tith)	(558,797)	+Potamides	K (Camp)	-Q (Plei)	(909)
+Paraglauconia	K (Berr-l)	-K (Albi-l)	(815)	+Potamidopsis	T (Than)	-T (Eo)	(794)
+Parangularia	Tr(Nori)		(909)	+Powellisetia	T (Mi-l-u)	-R	(650,681,899)
+Paraseraphs	T (Eo-l)	-T (Eo-u)		+Prestrombus	T (Dani)	-T (Eo)	(909)
+Parazebinella	T (Mi)	-R	(909)	+Priene	T (Phio)	-R	
+Pareora	T (Eo-l)	-T (Phio-l)	(899,1066)	+Primovula	T (Phio)	-R	(550)
+Parviscala	T (Eo)	-R		+Prionovolva	Q (Plei)	-R	
+Parvisetia	T (Mi)	-R		+Priscoficus	T (Dani)	-T (Eo-m-l)	(728,899)
+Pasiitheola	T (Eo-m-u)			+Pristinaacca	T (Dani)		
+Paulonaria	T (Mi-l)	-R		+Proacirsa	J (Bath)	-J (Call)	
				+Proadusta	T (Eo-l)	-T (Ol-l)	

Taxon	First Appearance	Last Appearance	Reference	Taxon	First Appearance	Last Appearance	Reference
+Procalpurnus	Q (Plei)	-R	(121)	+Pterodonticeras	K (Ceno)		
+Procampile	K (Ceno)	-K (Maes)	(914,1066)	+Pterolabrella	T (Ol-u)	-T (Plio-u)	(899)
+Procerithiopsis	P (l)		(1)	+Pterotrachea	J (Toar-l)		(1066)
+Procerithium	P (Guad-u)	-K (Albi-u)	(109,157,793)	+Ptychoerithium	T (Than)	-R	(614)
				+Ptychopotamidés	T (Than)	-T (Plio)	
+Proclava	T (Eo)	-R	(909)	+Ptychostoma	Tr(Ladi)	-Tr(Carn)	(119)
+Proficus	T (Dani)			+Pugnellus	K (Sant)	-K (Maes)	(909)
+Profundialvania	T		(ZR75)	+Punctiscala	T (Eo-u)	-R	(852)
+Propemurchisonia	J (Sine)			+Punctospira	K (Camp)?	-K (Maes)	(914)
+Propustularia	T (Eo-l)	-R	(121)	+Punjabia	T (Eo-l)		(914)
+Proscala	K (Haut)?	-T (Dani)	(157,914)	+Pupantonia	Q (Plei)	-R	(899)
+Prosimnia	T (Plio-u)	-R	(121)	+Purpuradusta	T (Plio-l)	-R	
+Prosthenodon	T (Eo-l)	-T (Eo-m-l)?	(1248)	+Purpurina	J (Bajo)	-K (Sn)	(909,1066)
+Proterato	T (Eo-u)	-R	(530)	+Purpuroidea	Tr(Ladi)	-K (Turo)	
+Protoatlanta	T (Mi)	-R	(547)	+Pusillina	T (Pale)	-R	(650)
+Protobarlecia	T (Mi-u)	-R	(909)	+Pustularia	T (Ol-l)	-R	
+Protocypraea	K (Barr)?	-R		+Pustulifer	Tr(Anis-u)	-Tr(Nori)	(674,797)
+Protocyprædia	T (Eo-u)			+Pusula	T (Ol-l-u)	-R	(121)
+Protodolium	K (Maes)			+Pyktes	K (Turo-u)	-K (Maes-u)	(118)
+Protofusus	Tr(m)	-Tr(Nori)	(797)	+Pyramidelloides	T (Mi)	-R	
+Protoma	T (Ol)	-R	(614)	+Pyrazella	K (Camp)?	-K (Maes)	(914)
+Protonema	T (Ol)			+Pyrazisinus	T (Ol-u)?	-T (Plio)	
+Protopirula	K (Camp-u)?			+Pyrazus	K (Apti)	-R	(157)
+Protercula	Tr(Anis-m)	-Tr(Nori)	(674,797)	+Pyxipoma	T (Eo-l)	-R	(1066)
+Protostylifera	Tr(Ladi-u)		(1120)	+Quadrinervus	J (Bath-l)	-K (Maes-u)	(1074)
Protostylus	P (Sakm)	-P (Dora)	(797,1130)	+Quimalea	Q (Plei)	-R	(550)
+Protuba	Tr(Ladi)			+Quoyia	T (Plio)	-R	
+Proturboella	K (Berr)		(909)	+Radimista	T (Mi-l-u)	-Q (Plei)	(899)
+Provermicularia	Tr(Ladi)	-Tr(Nori)	(119)	Raha	P (Guad-l)?	-Tr(Carn)	(1,1066)
+Proxicharonia	T (Mi-l-l)	-R	(681)	+Ramina	Tr(Ladi)	-Tr(Nori)	(797)
+Proxiuber	T (Mi-m)	-R	(530)	+Ranella	T (Dani)	-R	(125)
+Psammodulus	T (Mi-m)			+Ranelina	T (Eo-m-u)	-T (Eo-u)	(700)
+Pseudalaria	J (Pliè)	-J (Oxfo)		+Ranularia	T (Than)	-R	
+Pseudamaura	Tr(Carn)	-T (Mi)		+Ravitrona	T (Mi-m)	-R	
+Pseudoaluco	T (Eo-u)			+Redocla	Tr(u)		(ZR83)
+Pseudobrochidium	Tr(Ladi-u)?	-Tr(Nori-u)	(1066)	+Renea	Q (Plei)	-R	
+Pseudochrysalis	Tr(Ladi)	-Tr(Carn)	(909)	+Reymentella	T (Than)		(705)
+Pseudocirsope	T (Than)	-T (Plio)		+Rhabdocolpus	Tr(Nori)	-K (Apti)	(797)
+Pseudocymia	K (Turo-u)	-K (Maes-l)	(727)	+Rhabdoconcha	P (Guad)	-J (Kimm)	(109,119)
+Pseudodiartema	K (Barr)			+Rhinoelanus	T (Mi-l)	-R	(559)
+Pseudogaleodea	K (Coni)?, K (Sant)?		(909)	+Rhombostoma	T (Mi)	-Q (Plei)	(909)
+Pseudoglauconia	K (u)	-T (Eo)		+Rhychoerithium	Tr(Nori)	-K (Albi)	(1120)
+Pseudolacuna	T (Mi)	-R	(909)	+Rhynchocypræa	T (Ol-u)	-T (Mi-m)	(530)
+Pseudomelania	Tr(Anis)	-K (Ceno)	(119,157)	+Ricinella	Q (Plei)	-R	(909)
+Pseudomesalia	K (Apti)	-K (Sant)	(747,909)	+Rigauvia	J (Pliè-u)?	-J (Call)	(1,661)
+Pseudomurchisonia	Tr(l)	-Tr(u)		+Rimella	K (Maes)	-R	(914)
+?Pseudoplocezyga	C		(ZR76)	+Risella	T (Eo)	-R	(122)
+Pseudorotella	T (Mi-m)	-R		+Risellopsis	T (Mi-l-u)	-R	(681)
+Pseudoscalites	Tr(Ladi)	-Tr(Nori)	(119)	+Rissoa	T (Than)	-R	(794)
+Pseudosetia	T (Mi-m)?	-R		+Rissoerithium	J (Bajo)		(909)
+Pseudotaphrus	T (Than)	-T (Mi)		+Rissoina	J (u)	-R	(650)
+Pseudotritonium	Tr(Ladi)	-Tr(Nori)	(797)	+Rissolina	T (Mi)	-R	
+Pseudotrivia	T (Mi-l)	-R		+Rostellaria	K (u)	-R	(122)
+Pseudotruncatella	T (Ol-u)			+Rostreulima	T (Than)	-T (Plio)	
+Pseudotylostoma	T (Dani)			+Rostrocerothium	K (Turo)	-K (Sn)	
+Pseudovertagus	T (Than)	-R		+Rothpeltzia	T (Eo)	-T (Mi)	(909)
+Pseudozonaria	T (Mi-l-l)	-R	(121)	+Ruggatiscala	T (Eo-l)	-T (Mi-m)	(854)
+Pseudozygopleura	C (Vise-u)	-P (Dora)	(797,1130)	+Sabia	T (Mi-l)	-R	
+Pterculima	T (Eo-m-l)	-T (Eo-m-u)	(700)	+Sabinella	Q (Plei)	-R	
+Pterocera	Q (Plei)	-R		+Sandbergeria	K (Maes)	-T (Mi)	(914)
+Pterocerella	K (Albi-u)	-K (Maes-l)	(1074)	+Sassia	K (Camp-u)	-R	(790)
+Pterodonta	K (Ceno)	-K (Camp)?	(914)	+Scalaria	Tr(Ladi)	-Tr(Rhae)	(119)

Taxon	First Appearance	Last Appearance	Reference	Taxon	First Appearance	Last Appearance	Reference
+Sclaronoba	T (Mi-l-l)	-R	(681)	Spiromphalus	C (Mosc-l)	-P (Guad-u)	(117,157, 1258)
+Sclenostoma	T (Mi)	-R		+Spironema	K (Maes-l)		
+Scalina	T (Dani)	-R	(700)	+Spirostylus	Tr(Anis-m)	-Tr(Nori)	(674,797)
+Scaliola	T (Than)	-R		+Spirgaleia	K (Maes)?		(1066)
+Scalituba	K (Nc)	-K (Albi)		+Staphylaea	T (Mi-l)	-R	
+Schlideria	T (Mi-l-l)	-R	(121)	+Stellaria	T (Eo)	-R	(852)
+Schizobasis	K (Camp-u)	-K (Maes)		+Stelzneria	K (Ceno)		
+Schwartziella	T (Mi)	-R	(650)	+Stenorhytis	T (Ol-l)	-R	(852)
+Sconsia	T (Eo-l)	-R	(852)	+Stenotis	T (Plio)	-R	
+Scrobs	T (Ol-u)	-R	(681,899)	+Stephanocosmia	Tr(Ladi)	-Tr(Nori)	(119)
+Scrupus	T (Mi-l-u)	-R	(681,899)	+Stephanozyga	C (Vise)	-P (Guad-l)	(797)
+Sculpturea	J (Oxfo-u)	-J (Tith)	(868)	+Stereokion	Tr(Ladi)	-Tr(Carn)	(909)
+Seila	K (Albi-u)	-R		+Stigmaulax	T (Mi-l)	-R	(548)
+Semibittium	K (Maes)	-R	(790)	+Stilifer	T (Mi)	-R	
+Semicassis	K (Maes)	-R	(614)	+Stracolpus	T (Plio-l)	-R	(681,728, 899)
+Semicypraea	T (Eo-m)			+Stosicia	T (Mi-l)	-R	(650)
+Semistylifer	T (Eo-m-l)		(1066)	+Strebloceras	T (Eo-m)	-R	(914)
+Semiterrebellum	T (Than)	-T (Eo-u)	(614)	+Striatesta	T (Plio-l)	-R	(681)
+Semitriton	T (Eo-u)	-T (Mi)	(530)	+?Striaticostatum	K (Camp-l)	-K (Maes)	
+Semitritia	T (Mi-l)	-T (Mi-m)	(530)	+Striaticus	T (Plio)		
+Semivertagus	K (Maes)	-R		+Striocarinata	T (Mi)		(ZR75)
+Sentularia	P (u)		(797)	+Strobeus	D (Gedi)	-Tr(Olen)	(362,785)
+Septa	T (Ol-l)	-R	(852)	+Strombiformis	K (Maes)	-R	(909)
+Seraphs	T (Than)	-T (Ol-l)?		+Stromboconus	T (Eo-m)		(1074)
+Serpulorbis	T (Dani)	-R	(700)	+Strombolaria	T (Eo-l)	-T (Eo-m-l)	(914,1074)
+Serratocerithium	T (Than)	-T (Eo-m)	(914)	+Strombopugnellus	T (Ol-u)		(1074)
+Settsassia	Tr(Ladi-u)		(1120)	+Strombus	T (Eo-l)	-R	(1074)
+Sigapatella	K (u)	-R	(614)	+Struthiochenopus	K (Camp)	-T (Mi-l)	(1074)
+Sigaretopsis	K (u)	-T (Eo-u)		+Struthiolarella	T (Dani)	-T (Mi)	(126,614)
+Sigaretotrema	T (Dani)	-R	(914)	+Struthiolaria	T (Ol-l)	-R	(728)
+Sigatica	T (Than)	-R	(914)	+Struthioptera	K (Maes)	-T (Eo-u)	(127)
+Sigmesalia	K (u)	-T (Mi)	(614)	+Sturgeoconspira	C (Mosc-u)		(117)
+Siliquaria	Tr(Ladi-u)?	-R	(119,1066)	+Stylidium	T (Eo-l)	-R	(700)
+Simmia	T (Mi-m)	-R	(121)	+Stylonema	S (Ldov)	-D (Emsi)	(362)
+Sinorificium	K (l)		(ZR82)	+Stylopocus	T (Eo)		
+Sinospira	P (Asse)		(797)	+Subclimax	T (Mi-l)	-T (Mi-u)	
+Sinuozyga	P (Leon)	-P (Guad)	(797)	+Subditotectarius	T (Mi-l)		(909)
+Sinum	T (Than)	-R	(700)	+Subuliscala	T (Mi)	-R	
+Siphocypraea	T (Mi-l)	-R		+Subulites	O (Cara-l)	-D (Gedi)	(1,362)
+Siphonophyla	Tr(Ladi)	-Tr(Carn)		+Sulcoocypraea	T (Than-l)	-T (Ol-l)	(121)
+Siphopatella	T (Plio)	-R		+Sulecogladius	T (Eo-u)	-T (Mi-m)?	
+Sirius	T (Eo-u)	-R	(530)	+Sulconatica	Q (Plei)	-R	
+Socotora	T (Ol)	-R		+Sulcosubularia	T (Mi)		
+Sohlella	K (Ceno)	-K (Maes)		+Sulcotrivia	T (Ol-l)	-R	
+Sohlitella	K (Camp-l)	-K (Maes)		+Sundabittium	T (Eo)		(ZR78)
+Solariaxis	K (u)	-R		+Supplanaxis	T (Mi)	-R	
+Solariorbis	T (Dani)	-R	(700)	+Syncera	T (Mi)	-R	(614)
+Solarium	K (Albi)	-T (Eo-m-l)		+Tachyrhynchella	T (Ol-u)?	-T (Mi-l-l)?	
+Soleniscus	D (Gedi)	-P (Djhu)	(797,1130)	+Tachyrhynchus	T (Ol)	-R	
+Spanionema	D (m)		(1)	+Taieria	T (Dani)		
+Specula	T (Ol-u)?	-R		+Talosolida	T (Mi-l)	-R	
+Spelaenacca	T (Dani)	-T (Mi-l-u)	(728,899)	+Talparia	T (Plio)	-R	
+Sphaerocypraea	T (Eo-l)	-T (Mi-m)		+Tanea	T (Eo-m-l)	-R	(899)
+Spinigera	J (Aale)	-J (Call-u)	(1074)	+Taniella	T (Eo-l)	-Q (Plei)	(728,899, 914)
+Spiniscala	T (Mi)	-R		+Taramellia	T (Than)	-R	(794)
+Spirochrysalis	Tr(Anis)	-Tr(Nori)	(119,1130)	+Tatara	T (Eo-m-l)	-T (Mi-l-u)	(899)
+Spirocolpus	T (Eo-l)	-T (Mi-l-l)	(728,899)	+Tateiwaia	T (Mi)		
+Spirocrypta	T (Eo-u)			+Taxonia	T (Mi-u)	-T (Plio-u)	(899)
+Spiroceus	O (Ashg-m)			+Tectarius	T (Eo-m)	-R	(914)
+Spirogaleus	T (Mi)						
+Spiroglyphus	Q (Plei)	-R					

Taxon	First Appearance	Last Appearance	Reference	Taxon	First Appearance	Last Appearance	Reference
+ Tectonatica	T (Dani)	-R		+ Trobus	K (Maes)		(914)
+ Teinostoma	J (Kimm)?	-R	(909)	+ Trochita	T (Than)	-R	(614)
+ Tejonia	T (Eo-m-l)	-T (Eo-u)		+ Trochocerithium	T (Than)	-R	(914)
+ Telescopium	K (Turo)	-R		+ Trochotugurium	K (u)	-R	(614)
+ Teliochilus	J (Sine)			+ Trochoturibella	J (Aale)	-J (Oxfo-l)	(909)
+ Teilstoma	T (Than)	-T (Eo-m)	(914)	+ Trona	T (Ol-l)	-R	(121)
+ Telleria	Tr(Ladi)	-J (Bajo-l)		+ Trophosycon	T (Mi-l)	-T (Plio-l)	(4)
+ Temanella	T (Plio-u)	-R		+ Tropicolpus	T (Eo-m)	-T (Mi-u)	(728)
+ Tembrockia	T		(ZR80)	+ Tropidophora	Q (Plei)	-R	
+ Tenagodus	Tr(Ladi)	-R		+ Trypanaxis	K (Maes)	-T (Ol-l)?	
+ Teneposita	K (Maes-l)			+ Trypanostylus	P (Leon)	-J (u)	(797)
+ Tenuicerithium	T (Than)	-T (Ol)	(914)	+ Tubena	T (Eo-l)	-T (Mi-l-u)	(728,899)
+ Tenuiscala	T (Dani)	-R		+ Tudorella	T (Mi-u-l)	-R	
+ Tephlon	K (Maes)		(118)	+ Tugurium	T (Ol-l)	-R	(614)
+ Terebellopsis	T (Eo)		(614)	+ Tulochilus	T (Dani)		
+ Terebellum	T (Than)	-R	(614)	+ Tumidiacirsa	T (Eo)		
+ Terebralia	K (Albi)	-R	(122)	+ Tundora	K (Camp-l)	-K (Camp-u)	
+ Terebraliopsis	K (Ceno)	-T (Dani)	(914)	+ Turbinea	J (Oxfo-l)	-J (Kimm-l)	(868)
+ Teretrina	Tr(Ladi)	-J (Oxfo-u)		+ Turbinopsis	K (Camp-l)	-K (Maes-l)	
+ Tessarolax	K (Haut)	-K (Maes-l)	(909,1074)	+ Turboella	K (Ceno)	-R	
+ Tetraptyxis	J (Tith)		(868)	+ Turriculina	J (Sine)		
+ Thericium	T (Than)	-R	(914)	+ Turriola	T (Eo-u)	-T (Mi-l)	
+ Thersitea	T (Eo-l)		(614,1074)	+ Turriscala	T (Eo)	-R	
+ Thierachella	J (Bath)		(650)	+ Turritella	K (Apti)	-R	(157)
+ Thylacus	K (Camp-l)	-K (Maes-u)		+ Turritellopsis	Q (Plei)	-R	
+ Tianjinospira	T (Pg)		(ZR78)	+ Turritron	T (Plio)	-R	
+ Tiaracerithium	K (Maes)	-R		+ Tylocassis	T (Ol)	-R	
+ Tiarellacerithium	T (Eo-u)			+ Tylochilus	T (Than)	-T (Eo-l)	(914)
+ Tibia	K (Coni)	-R	(157)	+ Tylospira	T (Mi-l)	-R	
+ Tibiaporrhais	K (Camp)		(1074)	+ Tylostoma	J (Kimm)	-T (Dani)	(914)
+ Tintorium	K (Camp-u)	-K (Maes)		+ Tympanotonos	K (Turo)	-R	
+ Tioria	T (Eo-m-u)	-R	(681)	+ Tyrsosacus	Tr(Ladi)	-J (Oxfo-l)	(1,797)
+ Tmetonema	C (Serp)		(797)	+ Uberella	T (Mi-l-u)	-R	(681,899)
+ Tomyris	T (Ol)			+ Uchauxia	K (Vala)	-K (Maes)	(914,1066)
+ Tonna	T (Plio)	-R	(614)	+ Umbilia	T (Ol-l)	-R	(614)
+ Torcula	T (Eo-m)?	-R	(914)	+ Undiscala	T (Eo-u)	-T (Mi)	
+ Torculoidella	T (Mi)	-R	(614)	+ Undularia	Tr(Anis-u)	-Tr(Nori)	(797,1130)
+ Torgnellus	K (Maes)		(1074)	+ Unicarinata	J (l)		(ZR82)
+ Tornus	T (Than)	-R	(614)	+ Urceolabrum	K (Albi-u)	-K (Maes)	
+ Torquatiscala	T (Eo-l)			+ Urganella	K (Barr-l)	-K (Apti)	(909)
+ Torquesia	K (Vala)	-R	(614,1066)	+ Vaderos	T (Eo)	-T (Eo-u)	
+ Torquesiella	K (Camp-u)	-K (Maes-l)	(747)	+ Vanikoro	J (Tith)	-R	(909)
+ Touzinia	T (Mi)	-T (Plio)		+ Vanikoropsis	K (Apti)?	-T (Dani)	(914,1066)
+ Toxoconcha	Tr(Anis-u)	-Tr(Nori)	(115,797)	+ Varicospira	T (Mi-l)	-R	(1074)
+ Trachoeus	Tr(Carn)			+ Veatchia	T (Eo)		
+ Trachytriton	K (u)	-T (Eo)		+ Velutina	T (Plio)	-R	
+ Trajanella	K (Barr)	-K (Maes)		+ Vermetus	T (Than)	-R	(704)
+ Transovula	T (Than)	-T (Eo-u)	(121,614)	+ Vermicularia	T (Than)	-R	(122)
+ Tretospira	C?	-J (l)		+ Vernedia	K (Ceno)	-K (Sn)	(120)
+ Trianglospira	J (l)		(ZR82)	+ Veterator	T (Mi)	-R	(650)
+ Triaracerithium	K (u)	-R	(614)	+ Vicarya	T (Dani)	-T (Mi-l)	(559)
+ Trichosirus	T (Plio-u)	-R	(899)	+ Vicaryella	T (Mi-l)	-T (Mi-m)	(909)
+ Trichotropis	K (Maes)	-R	(909)	+ Vicetia	T (Eo-l)	-T (Eo-u)	(121,614)
+ Tricornis	T (Ol-u)	-R	(1074)	+ Vicinocerithium	K (Sant)	-T (Eo-u)	
+ Tridactylus	K (Albi-u)	-K (Maes)	(1074)	+ Virgella	C (Step)	-J (Sine)	(797)
+ Triforis	T (Eo-u)		(614)	+ Viriola	T (Mi-l)	-R	(559)
+ Triphora	K (Camp)?	-R	(914)	+ Vitrinella	T (Eo-l)	-R	(700)
+ Trituba	T (Eo-m)			+ Vitrinellops	T (Ol-l)	-R	(852)
+ Trivia (+ Gravesicerithium)	T (Eo-l)	-R	(121)	+ Volva	T (Plio-u)	-R	(121)
+ Triviella	T (Ol-u)	-R	(909)	+ Voorwindia	T (Ol)		(ZR85)
+ Trivirostra	T (Mi-m)	-R	(550)	+ Vouastia	T (Eo-u)		(914)
				+ Waluia	T (Mi)?		

Taxon	First Appearance	Last Appearance	Reference	Taxon	First Appearance	Last Appearance	Reference
+Wateletia	T (Eo-l)		(1074)	+Akburunella	T (Mi-u)	-R	
+Watsonia	T (Than)	-R		+Alcira	T (Plio)	-R	
+Wendella	T (Than)		(705)	+Alcithoe	T (Eo)	-R	(614)
+Wexfordia	T (Plio)			+Aldrichia	T (Eo-m-l)		
+Willungia	T (Eo-m-u)	-R	(899)	+Alectrion	T (Eo-l)	-R	(614,914)
+Woodsalia	K (u)	-T (Eo-u)	(909)	+Alia	T (Mi)	-R	
+Wyatella	T (Eo-m)	-T (Eo-u)	(914)	+Aliofusus	K (Camp)	-K (Maes-l)	(909)
+Xenogalea	T (Plio)	-R		+Alocospira	T (Eo-m-u)	-T (Plio-u)	(728,899)
+Xenophalium	T (Eo)	-R	(681)	+Altivasum	T (Mi-l)	-R	(530)
+Xenophora	K (Ceno)?	-R	(4)	+Amalda	K (u)	-R	(614)
+Xizangospira	Tr(u)		(ZR80)	+Amarophos	T (Mi-l)	-T (Plio)	(553)
+Xuwenospira	T (Plio)		(ZR82)	+Amblyacrum	T (Eo-l)	-R	(914)
+Xystrella	J (Toar)	-J (Oxfo-l)		+Amekicythara	T (Eo)		(914)
+Zaclys	T (Mi)	-R		+Amorena	T (Mi)	-R	
+Zardinistylus	Tr(Ladi-u)		(976)	+Amoria	T (Mi-m)	-R	(530)
+Zaria	K (Sn)	-R		+Amphissa	T (Ol)	-R	(122,123)
+Zeaolpus	T (Eo-m-u)	-R	(681)	+Ampliosipho	T (Eo)		
+Zeaerypta	T (Mi-l)	-R	(530)	+Ampulla	T (Mi)	-R	(553)
+Zecacumanthus	T (Mi-l)	-R		+Amuletum	K (Camp)	-K (Maes)	(914)
+Zebina	T (Than-l)	-R		+Amyclina	T (Mi)	-R	
+Zebittium	T (Mi-l-u)	-R	(899)	+Amyssodropa	T (Ol-l)		(852)
+Zefallacia	T (Eo)	-T (Plio-u)	(899)	+Anachis	T (Mi-l)	-R	(550,553)
+Zegalerus	T (Mi-u)	-R	(899)	+Anacithara	T (Ol-u)	-R	(899)
+Zenbinostoma	J (Bajo)		(1066)	+Anapepta	T (Eo-l)	-R	(899)
+Zeradina	T (Eo-m-u)?	-R	(681)	+Anazola	T (Mi-l-l)	-R	
+Zinolia	T (Plio-u)			+Anbullina	T (Eo-m-l)		(700)
+Zittelja	J (Kimm)	-J (Tith-u)		+Ancilla	K (Camp-u)	-R	
+Zoila	T (Mi-l)	-R		+Ancillarina	T (Than)	-T (Mi-u-l)	(794)
+Zonaria	T (Than)	-R	(794)	+Ancillina	T (Ol)	-T (Mi)	
+Zonarina	T (Eo-l)	-T (Mi-u)	(121)	+Ancillista	T (Eo-u)	-R	(530)
+Zygopleura	Tr(Olen-l)	-J (Call)	(785,1066)	+Ancilopsis	T (Eo-m-u)	-T (Eo-u)	(4,814)

Or. NEOGASTROPODA

(Classification and basic stratigraphic ranges from Wenz [1938].)

+Abretiella	T (Mi)	-R		+Aneurystoma	T (Than)	-T (Mi-u-l)	(794)
+Acampiochetus	T (Mi-u)	-T (Plio)	(614,681)	+Anomalisipho	T (Plio)	-R	
+Acampitogenotia	T (Dani)	-T (Plio)	(914)	+Anomalofusus	K (Camp-u)	-K (Maes-u)	
+Acanthina	T (Mi-l-u)	-R		+Antecepta	T (Dani)		
+Acanthinucella	T (Plio)	-R		+Antiguraleus	T (Eo-u)	-R	(696)
+Acmaturris	T (Mi-l)	-T (Mi)		+Antillophos	T (Eo-l)	-R	(1248)
+Acominia	T (Ol-u)?	-R		+Antimelatoma	T (Mi)	-R	(533)
+Acuminia	T (Ol)	-R		+Antimitra	T (Plio)	-R	
+Acupurpura	T (Plio)	-R		+Antiplanes	T (Eo)	-R	
+Adelocythara	T (Mi-l)			+Antizafra	T (Mi-u)	-R	(899)
+Adelomelon	T (Ol-u)?	R		+Aoteadrillia	T (Ol)	-R	(681)
+Ademtitula	T (Eo-l)	-R	(1248)	+Aphera	T (Mi-l)	-R	(549)
+Adinus	T (Eo)	-R		+Apiotoma	T (Eo-l)	-R	(530)
+Admete	T (Dani)	-R	(914)	+Appisania	T (Ol)	-R	(909)
+Admetopsis	K (Sn)			+Aptycholathyrus	T (Eo-m-l)		
+Aeneator	T (Mi-u-u)	R	(681,899)	+Aptyxis	T (Ol)	-R	
+Aesopus	T (Plio)	-R	(909)	+Aquifolusus	T (Than)	-T (Mi-u)	(614)
+Afer	K (u)	-R	(914)	+Arayana	T (Plio-l)	-R	(890)
+Afloria	T (Eo-u)	-R	(552)	+Arctomelon	T (Eo-m-u)	-R	
+Afrovolutilithes	T (Than)		(ZR77)	+Arcularia	T (Mi)	-R	(614)
+Agaronia	T (Dani)	-R		+Argyrobessa	T (Ol-u)		(1272)
+Agasoma	T (Ol)	-T (Mi)	(614)	+Ascensovoluta	K (Camp)?	-T (Than)	(914)
+Agathotoma	T (Mi-m)	-R		+Ascolatirus	T (Ol-u)	-T (Mi-u-l)	(909)
+Agatrix	T (Ol-l)	-R	(852)	+Aspella	T (Mi-u)	-R	
+Agladrillia	T (Mi-l)	-T (Plio)	(553)	+Asperdaphne	T (Eo-u)	-R	(696)
+Agnewia	T (Plio)	-R		+Asthenotoma	T (Eo-m-u)?	-R	(700)
				+Astryris	T (Eo-l)	-R	(614)

Taxon	First Appearance	Last Appearance	Reference	Taxon	First Appearance	Last Appearance	Reference
+Athleta	T (Eo-l)	-T (Mi-u-l)	(700)	+Brocchitas	T (Eo)	-T (Mi-m)	(530)
+Atilia	T (Mi)	-R	(614)	+Brucclarkia	T (Ol-l)	-T (Mi-m)	(552,854)
+Atkinsonella	T (Ol)			+Buccinanops	T (Ol-u)?	-R	(926)
+Atoma	T (Mi)	-T (Mi-u-l)		+Buccinaria	T (Mi-m)?		
+Atraktus	T (Pale)	-T (Ol-l)	(852)	+Buccinofusus	K (Ceno-u)	-R	
+Atrimitra	T (Mi-m)	-R	(854)	+Buccinopsis	K (Coni)	-K (Maes-u)	(1066)
+Attiliosa	T (Mi-l)	-R		+Buccinorbis	T (Eo-m)		
+Aulacofusus	T (Ol-u)?	-R		+Buccinulum	T (Ol)	-R	(614)
+Aulica	K (Maes)	-R		+Buccinum	K (Vala)	-R	(1066)
+Aulicina	K (Maes)	-R		+Buccitriton	T (Eo-l)	-T (Eo-u)	(700)
+Aurina	T (Mi)	-R	(4)	+Bucchozia	T (Than)	-T (Eo-m)	(914)
+Austroclavus	T (Mi-l-l)	-T (Mi-m)	(530,899)	+Bulbihastula	T (Eo-l)		(1248)
+Austrocominella	T (Eo)			+Bullata	T (Eo-m-l)	-R	(700)
+Austrodrillia	T (Ol)	-R		+Bullia	T (Plio)	-R	(926)
+Austrofusus	T (Dani)	-R	(914)	+Bulliopsis	T (Eo-l)	-T (Mi-u)	(926)
+Austroharpa	T (Mi-m)	-T (Plio)	(909)	+Bulovia	T (Eo-m-l)		
+Austrolithes	T (Eo-u)	-T (Mi-m)	(530)	+Busycon	T (Ol-l)	-R	(814)
+Austromitra	T (Mi-l-u)	-R	(899)	+Busycotypus	T (Mi-l)	-R	(985)
+Austrosphaera	T (Dani)?			+Cabanaria	T (Mi-l)		(ZR85)
+Austrotoma	T (Dani)	-Q (Plei)	(914)	+Caesia	T (Mi)	-R	
+Austrotrophon	T (Mi-l)	-R	(854)	+Calcarata	T (Mi)	-T (Plio)	
+Awateria	T (Mi-u)	-R	(533,899)	+Calcitrapessa	Q (Plei)	-R	(1267)
+Axelella	T (Ol-u)			+Calicantharus	T (Eo)	-Q (Plei)	(123)
+Axymene	T (Plio)	-R		+Callianax	T (Eo)	-R	
+Babylonella	K (Camp)?	-T (Plio)		+Calophos	T (Mi-l)	-T (Plio-u)	(553,926)
+Babylonia	T (Ol)	-R	(614)	+Calorebama	K (Maes-l)	-T (Eo-u)	
+Bactrocythara	T (Mi-l)	-R		+Calotrophon	T (Mi-u)	-R	
+Baileyia	T (Mi-m)	-R	(551)	+Callioectum	T (Plio)	-R	(614)
+Barbarofusus	T (Plio)	-R	(123)	+Calverturris	T (Mi-l-u)	-T (Mi-m)	(1039)
+Barkeria	T (Mi-m)			+Camarnia	T (Eo-u)		(914)
+Bartonia	T (Eo-l)	-T (Eo-m-u)		+Campylacrum	T (Dani)		(899)
+Baryspira	T (Ol-u)	-R	(899)	+Cancellaria	K (Sant)	-R	(790)
+Bastropia	T (Eo-m-l)		(700,728)	+Cancellariella	T (Mi-u-l)		
+Bathytoma	T (Eo-l)	-R	(122,700)	+Cancellana	T (Than)	-T (Eo-m-l)	(700,794)
+Bedeva	T (Mi-u)	-R	(530)	+Cancilla	T (Plio)	-R	(550)
+Beisselia	K (Camp)		(914)	+Cantharulus	K (Bar-u)	-T (Pale)	
+Bela	T (Eo-m-l)	-R	(614,700)	+Cantharus	T (Eo)	-R	
+Belatamina	T (Mi-l)	-T (Mi-m)	(530)	+Caribiella	T (Mi-u)	-R	
+Bellaspira	T (Mi-u-l)?	-R		+Caricella	K (Sn)	-T (Eo-u)	(4,700)
+Bellifusus	K (Ceno)	-K (Maes-u)	(790)	+Carinodrillia	T (Mi-l)	-R	(549)
+Belloliva	T (Mi-l)	-R	(550)	+Carinotropis	T (Plio)	-R	(ZR84)
+Belophos	T (Mi-l)		(530)	+Carota	K (Ceno-m)	-R	(614)
+Bendeia	T (Eo-u)		(614)	+Caseyella	T (Eo-u)	-T (Ol-l)	(852)
+Benthomangelia	T (Mi)?	-R		+Catenotoma	T (Eo-m-l)		
+Beringius	T (Ol-u)	-R	(158)	+Cation	T (Mi-m)		(854)
+Bifurcium	T (Mi-u-l)	-R	(890)	+Caveola	K (Ceno)	-K (Maes-u)	
+Bivetiella	T (Mi)	-R		+Celatoconus	T (Eo)	-T (Mi-m)	(614)
+Bivetopsia	T (Mi)	-R		+Centrifuga	T (Eo)	-R	
+Blackdownia	K (Albi-u)	-K (Ceno-m)	(792)	+Ceratostoma	T (Mi-l)	-R	
+Boettgeriola	T (Mi-l)	-T (Mi)		+Chauvetia	T (Plio)	-R	
+Bolinus	T (Plio)	-R		+Chelyconus	T (Eo)	-R	
+Bolis	T (Eo-m-u)		(4,700)	+Chesaclava	T (Mi)		(ZR90)
+Boltenella	K (Camp-u)	-K (Maes)		+Chesasyrinx	T (Mi-l-u)	-T (Mi-m)	(1039)
+Bonellitia	K (Camp)	-T (Plio)	(909,914)	+Chesathais	T (Mi-l-u)	-T (Mi-m)	(1039)
+Boreocomitas	T (Ol-l)		(ZR76)	+Chesatrophon	T (Mi)		(ZR90)
+Boreotrophon	T (Mi-m)	-R		+Chicoreus	T (Ol-u)	-R	(614)
+Borsonella	T (Mi)	-R		+Chiralithes	T (Eo-m-u)		
+Borsonia	T (Dani)	-R	(914)	+Chirafuta	T (Eo-u)	-T (Ol-l)	(914)
+Brachycythara	T (Mi-l)	-T (Plio)		+Chorus	T (Ol)	-R	(614)
+Brachysphingus	T (Dani)	-T (Eo-l)	(614)	+Christitys	K (Coni)	-K (Camp-l)	(727)
+Brachytoma	T (Eo)	-R	(614)	+Chrysame	T (Mi)	-R	
+Brocchinia	T (Mi)	-R		+Cigelirina	T (Mi-l)	-T (Plio)	

Taxon	First Appearance	Last Appearance	Reference	Taxon	First Appearance	Last Appearance	Reference
+Cilara	T (Ol-u)?	-R		+Cottonia	T (Mi)	-R	
+Cinguliturris	T (Mi-l)	-T (Mi-m)	(530)	+Crassilabrum	Q (Plei)	-R	(1272)
+Cirillia	T (Plio)	-R		+Crassimurex	T (Eo-l)	-T (Eo-m-l)	
+Clathrodrillia	T (Ol-l)	-R	(123)	+Crassispira	T (Eo-l)	-R	(914)
+Clathromangelia	T (Mi)	-R		+Crassispirella	T (Ol-l)	-R	(852)
+Clathurella	T (Ol-l)	-R	(852)	+Crassopleura	T (Ol)	-R	(909)
+Clavatula	T (Eo-m-u)	-R	(122,700)	+Crawfordina	T (Mi-m)	-R	(854)
+Clavellofusus	T (Than)	-T (Plio)	(614)	+Crenaturricula	T (Than)	-T (Eo-m-l)	(794)
+Clavidrupa	T (Ol-l)	-R	(852)	+Crenisutura	T (Mi)	-T (Plio)	
+Clavilithes	T (Than)	-R	(852)	+Cretacomurex	K (Albi-l)	-K (Albi-m)	
+Clavstoma	T (Plio)	-R	(728)	-Cronia	T (Eo)	-R	(909)
+Clavus	T (Ol-l)	-R	(96)	+Cruziturrucula	T (Eo-l)	-T (Plio)	(914)
+Clebula	T (Mi)	-R		+Cryoturris	T (Mi-l)	-R	
+Clifdenia	T (Eo-m-u)	-T (Mi-m)	(728,899)	+Cryptoborsonia	T (Ol-u)	-T (Mi-m)	(530)
+Clinopegma	T (Plio)	-R		+Cryptochorda	T (Dani)	-T (Eo-u)	(614,914)
+Clinura	T (Than)	-T (Plio)	(794)	+Cryptoconus	K (Camp-u)	-T (Eo-u)	
+Clinurella	T (Eo-l)	-T (Mi)	(1248)	+Cryptocordieria	T (Eo-u)	-R	(530,696)
+Clinuropsis	T (Than)	-R	(914)	+Cryptomella	T (Dani)	-R	
+Clivoluturris	T (Ol-l)	-R		+Crypthythis	K (Camp)	-K (Maes)	(909)
+Closia	T (Mi)	-R		+Crytopspira	T (Than)	-R	(705)
+Closteriscus	K (Camp)	-R		+Ctenilyria	T (Eo-m)	-T (Eo-u)	(553)
+Closteroides	K (Maes)	-R	(914)	+Culmia	K (Albi-u)	-R	
+Cochlespira	T (Dani)	-R	(914)	+Cupidoliva	T (Mi-u)	-R	(530)
+Cochlespirella	T (Eo-l)	-T (Eo-m-u)	(914)	+Cyclope	T (Plio)	-R	(614)
+Cochlespiropsis	T (Eo-m)	-R	(914)	+Cylinder	T (Mi)	-R	
+Cochliconus	T (Plio)	-R		+Cylindromitra	T (Plio)	-R	
+Columbarium	K (Maes)	-R	(1066)	+Cyllene	T (Mi)	-R	
+Columbella	K (Maes)	-R	(122)	+Cyllenina	T (Ol-u)	-T (Mi-u-l)	(926)
+Columbellisipho	T (Eo)	-R		+Cymakra	T (Mi-l)	-T (Plio)	
+Columbellopsis	T (Than-l)	-R	(794,909)	+Cymatophos	T (Mi-l)?	-R	(553)
+Colus	T (Eo-u)	-R		+Cymatosyrinx	T (Eo-u)	-R	(914)
+Coluzea	T (Eo-l)	-R	(899)	+Cymbiola	T (Ol-u)	-R	(530)
+Colwellia	T (Eo-l)	-T (Eo-u)	(914,926,1248)	+Cymbium	T (Eo-l)	-R	(914)
				+Cymia	T (Eo-u)	-R	(547)
+Comarmondia	T (Mi)	-R		+Cyphonocheilus	T (Ol-u)?	-R	
+Cominella	T (Than)	-R	(614)	+Cyrtochetus	T (Eo-m)	-T (Mi)	(614)
+Cominista	T (Mi)	-R		+Cythara	T (Mi)	-R	(614)
+Cominula	T (Plio)	-R		+Cytharella	T (Eo-m)	-R	(914)
+Comitas	T (Eo-u)	-R	(530)	+Dactylidella	T (Mi)	-R	
+Compsodrillia	T (Mi)	-R		+Dactylidia	T (Mi)	-R	
+Concholepas	T (Eo)	-R	(614)	+Daphnella	T (Eo-m-u)	-R	(700)
+Conolithes	T (Eo-m-u)	-R	(899)	+Daphnobela	T (Eo-l)	-T (Eo-u)?	(914)
+Conomitra	T (Dani)	-T (Plio)	(4,530,909,1066)	+Darbya	T (Mi-l)?	-R	(549)
				+Demoullia	T (Mi)	-R	(614)
+Conorbis	T (Eo-m-u)	-T (Ol-l)	(530,696)	+Dendroconus	T (Mi)	-R	
+Conus	T (Eo-u)	-R	(909)	+Dennantia	T (Eo-u)	-T (Plio-l)	(530)
+Cophocara	K (Maes)	-T (Dani)	(696)	+Dentimargo	T (Eo-m-l)	-T (Plio)	
+Coptochetus	T (Than)	-T (Ol-u)	(794)	+Dentiterebra	T (Eo-m-u)	-R	(700)
+Coptosipho	T (Ol)	-R	(ZR90)	+Dentrimitra	T (Than)	-T (Ol)	(909)
+Coptostoma	T (Than)	-T (Mi-m)	(794,854)	+Dermomurex	T (Ol-l)	-R	(852)
+Coptostomella	T (Dani)	-R		+Dertonia	T (Plio-l)	-R	
+Coraeophos	T (Mi-l)	-T (Mi)		+Desorinassa	T (Than)	-T (Eo-l)	(914,936)
+Coralliophila	T (Ol-u)?	-R		+Detussenia	K (Camp-u)	-K (Maes)	
+Cordieria	T (Than)	-R	(794)	+Dibaphimitra	T (Mi-m)	-R	(530)
+Cornulina	T (Than)	-T (Eo-u)	(700)	+Dibaphus	T (Mi-u)	-R	
+Coronia	T (Than-l)	-T (Eo-u)	(700,852)	+Diconomorpha	K (Maes)	-T (Dani)	(914)
+Coroniopsis	T (Ol-l)	-R	(852)	+Diplomeriza	T (Mi)	-R	
+Cosmasyrinx	T (Eo-u)	-T (Mi-u)	(899,909)	+Diplomitra	T (Eo)	-T (Ol-u)	
+Cosmolithes	T (Than)	-T (Eo)	(614,705)	+Dolicholathirus	K (Maes-l)	-T (Mi)	(909)
+Costellaria	T (Eo)	-R		+Dolostoma	T (Mi-m)	-R	(549)
+Costoanachis	T (Mi-m)	-R		+Dormeginella	T (Eo-l)	-T (Eo-m)	(914)
+Cotonopsis	T (Plio-l)	-R	(890)	+Dorsanum	R	-R	

Taxon	First Appearance	Last Appearance	Reference	Taxon	First Appearance	Last Appearance	Reference
+Dorsina	T (Mi-l-u)	-R	(890)	+Euryentome	T (Eo-m-u)		(700)
+Drillia	T (Than)	-R	(700)	+Euryochetus	T (Eo-l)	-T (Eo-m)	(914)
+Drilliola	T (Eo)	-R		+Eurypyrene	T (Mi-l)		
+Drilluta	K (Coni)	-K (Maes)	(4)	+Euscobinella	T (Eo-u)		(914)
+Drupa	T (Mi-u)	-R	(550)	+Euthria	T (Eo-l)	-R	(614,700)
+Duplicaria	T (Ol)	-R	(614)	+Euthrofusus	K (Camp-u)	-T (Plio)	(909)
+Eburna	T (Mi)	-R		+Evarnula	T (Ol)	-R	
+Eburnopsis	T (Eo)	-T (Plio)		+Exilia (+ Zexilia)	K (Maes)	-T (Mi-u-l)	(614,728,914)
+Echinofulgur	T (Eo-m-u)	-T (Eo-u)	(909)	+Exilifusus	T (Eo-m-u)		(614,700)
+Echinoturris	T (Mi-l)		(909)	+Exiloides	Q (Plei)	-R	
+Echphora	T (Ol-u)	-T (Plio-l)	(123,909)	+Exomilopsis	T (Mi)	-R	(681)
+Echporosycon	T (Mi-l-u)	-T (Mi-m)	(1039)	+Falsicolus	T (Eo-l)	-T (Plio)	(728,909)
+Edithais	T (Mi-l)	-T (Mi-u)	(1272)	+Falsifusus	T (Eo-l)	-R	(1248)
+Egereia	T (Ol-u)			+Fasciolaria	K (Turo)	-R	
+Egestas	T (Plio)	-R		+Fasciolex	T (Eo-l)	-T (Eo-m-l)	(899,914)
+Egotistica	T (Ol-u)			+Favartia	T (Eo-m)	-R	(914)
+Elaeocyma	T (Plio)	-R		+Favriella	T (Plio-l)		
+Ellicea	T (Mi-u)	-R	(728,899)	+Fax	T (Plio)	-R	
+Enaeta	T (Ol-l)	-R	(852)	+Fenestrosyrinx	T (Plio)	-R	
+Enatimene	T (Eo-u)	-R	(530)	+Fenolignum	T (Ol-u)		(1272)
+Endiatoma	T (Eo-l)			+Ficulomorpha	K (Camp)		(914)
+Endopachychilus	T (Than)	-T (Eo-m-l)	(700)	+Ficulopsis	K (Maes)		(914)
+Engina	T (Mi-m)	-R	(551)	+Filodrilla	T (Mi-m)	-R	(530)
+Engoniophos	T (Mi-l)	-T (Mi)		+Flexopteron	T (Eo-l)	-T (Plio-l)	
+Entacanthus	T (Ol)			+Forneria	T (Mi-l)	-R	(123,854)
+Eocithara	K (Maes)	-T (Mi-m)	(530,614,909)	+Forsia	K (Maes)		(1212)
+Eoclathurella	T (Eo-m-u)	-T (Eo-u)	(700)	+Fredenia	T (Ol-u)		(1119)
+Eocythara	T (Eo-l)		(1248)	+Fulgerea	K (Sant)	-K (Maes)	
+Eodrilla	T (Eo-l)	-T (Eo-m-u)	(1248)	+Fulguraria	T (Than)?	-R	
+Eoharpa	K (Maes)			+Fulgurofusis	T (Dani)	-R	(4)
+Eophrotoma	T (Than)	-T (Eo-u)	(614)	+Fuscibuccinum	T (Plio)	-R	
+Eosiphon	T (Plio)	-R	(909)	+Fusiaphera	T (Eo-m-u)	-T (Mi-l-u)	(899)
+Eosiphonalia	T (Eo-u)	-T (Mi-l)	(552)	+Fusigiraleus	T (Ol-u)	-Q (Plei)	(899)
+Eosurcula	T (Eo-l)	-T (Eo-m-u)	(700)	+Fusimilis	K (Turo)	-K (Camp)	(914)
+Eothesbia	T (Dani)			+Fusimitra	T (Dani)	-T (Ol-l)	(123,814)
+Eoturris	T (Dani)	-T (Mi-l-l)?	(728,899)	+Fusinus	K (Albi-u)	-R	(792)
+Eovasum	T (Dani)	-T (Eo-u)	(914)	+Fusitoma	T (Eo-l)		(700)
+Eovolutilithes	K (Ceno)	-K (Coni)	(ZR78)	+Fusiturricula	T (Than)	-R	(914)
+Eovancus	T (Eo-m-u)			+Fusiturris	T (Than-l)	-R	(914)
+Epalxis	T (Eo-l)	-T (Mi-l)	(533,914)	+Fusoterebra	T (Mi-m)	-R	(854)
+Epeideira	T (Ol-u)?	-R		+Fusus	T (Plio)	-R	
+Epidirella	T (Plio-l)	-R	(530)	+Fytea	T (Dani)		(899)
+Epidirona	T (Mi-m)	-R	(530)	+Galeropsis	T (Mi)		
+Eratoidea	T (Eo)	-R		+Gemaspira	T (Ol-u)	-T (Mi-u-l)	
+Ericusa	T (Eo)	-R		+Gemmaterebra	T (Mi-m)	-T (Plio-u)	(899)
+Eripachya	K (Camp-u)			+Gemmoliva	T (Eo-u)	-R	(530)
+Etrema	T (Ol-l)	-R	(696)	+Gemmula	T (Than)	-R	(549)
+Etrempopsis	T (Ol-u)	-T (Mi-m)	(899)	+Gemmuloiborsonia	T (Mi)		(ZR90)
+Eubela	T (Mi-l-u)	-R	(899)	+Genkaimurex	T (Plio-l)	-R	
+Eucheilodon	T (Eo-m-l)	-T (Eo-u)	(700)	+Genota	T (Than)	-R	(614)
+Euclathurella	T (Ol)	-T (Mi-m)	(533,549)	+Gergovia	T (Eo)		
+Euclia	T (Mi-l)	-R	(854)	+Gibberula	T (Dani)	-R	(1066)
+Eucominia	T (Ol-u)	-R	(909)	+Gibberulina	T (Mi)	-R	
+Eucymba	T (Eo-u)		(700)	+Gilbertturricula	T (Ol-l)		(ZR85)
+Eumetadrillia	T (Mi-l)	-T (Plio)		+Glabella	T (Eo)	-R	
+Eumitra	T (Mi-m)	-R	(530)	+Glaphyrina	T (Mi-l-u)	-R	(681,899)
+Euphyllon	T (Ol)	-R		+Globodrillia	T (Mi-l)		
+Eupleura	T (Than-l)	-R	(700,914)	+Glyphostoma	T (Mi-l)	-R	
+Euplica	T (Mi-l)	-R	(550)	+Glyphoturris	T (Mi)	-R	
+Eurydike	T (Mi-l)	-T (Mi-u)		+Glyptostyla	T (Eo-l)	-T (Mi)	(553,700)
+Euryentmeta	T (Mi-l)			+Glyptotoma	T (Eo-m-l)	-T (Ol)	(700)

Taxon	First Appearance	Last Appearance	Reference	Taxon	First Appearance	Last Appearance	Reference
+Gonioptyxis	T (Eo-m-l)			+Jaton	T (Ol-u)	-R	(1272)
+Gosavia	K (Turo)	-T (Eo-m)		+Johannaia	T (Eo-u)		(530,696)
+Gracilipurpura	T (Plio)	-R		+Josepha	T (Ol-u)	-R	(728,899)
+Gracilispira	T (Eo-l)	-R	(899)	+Jumala	T (Mi)	-R	
+Granula	T (Eo)	-R		+Jungbuhnia	T (Eo-u)		
+Graphidula	K (Coni-u)	-K (Maes-u)	(790)	+Kaweka	T (Mi-u)	-T (Plio)	(899)
+Graphiocomassa	T (Plio)	-R	(550)	+Kelletia	T (Eo)	-R	(554)
+Guraleus	T (Eo-u)	-R	(530)	+Keepingia	T (Ol-l)	-T (Mi-l)	(926)
+Hadriania	T (Mi-l)?	-R	(1272)	+Kestocembra	T (Mi-l-l)	-T (Mi-u-l)	(1272)
+Halia	T (Ol-u)?	-R		+Knefastia	T (Eo-l)	-R	(914)
+Haluginella	T (Plio-u)	-R	(899)	+Kuroshioturris	T (Mi-u)	-R	(909)
+Hanetia	T (Mi-m)	-R	(553)	+Kurtziella	T (Ol-l)	-R	(852)
+Haplovoluta	K (Camp-u)	-K (Maes-u)		+Laccinum	T (Eo-u)		(614)
+Harfordia	Q (Plei)	-R		+Lacinia	T (Eo-m-l)	-T (Eo-m-u)	(4,700)
+Harmatia	T (Ol-u)			+Laevibuccinum	T (Dani)	-T (Eo-m-u)	(700,914)
+Harpa	T (Than)	-R	(794)	+Laevihastula	T (Mi-m)		(1039)
+Harpella	T (Than)	-R		+Laeviterebrum	T (Ol-l)		(852)
+Harpula	T (Eo-m)	-R	(914)	+Laevityphis	T (Eo-l)	-T (Plio-u)	(899)
+Hastula	T (Eo-l)	-R	(914)	+Lamprodoma	T (Eo)	-R	
+Haustellum	T (Mi-l-u)	-R		+Lamprodomina	T (Mi-m)	-T (Plio-u)	(728,899)
+Hautura	T (Mi-m)		(530)	+Lapparia	T (Dani)	-T (Eo-u)	(4,123,914)
+Hebra	T (Plio)	-R		+Lathyriulus	T (Eo-l)	-R	
+Heilprinia	T (Mi)	-R	(4)	+Latiaxis	K (Camp-u)	-R	
+Heligmotenia	T (Dani)	-T (Eo)	(914)	+Latifusus	Q (Plei)	-R	
+Heligmotoma	T (Than)	-T (Eo-u)	(614)	+Latirolagena	T (Mi)	-R	
+Hemiconus	T (Than)	-R	(914)	+Latiurus	K (Ceno-u)	-R	(747)
+Hemifusus	T (Than)	-R	(614)	+Latisipho	T (Plio)	-R	
+Hemipleurotoma	T (Mi-l-u)	-T (Mi-m)	(1039)	+Lautoconus	T (Mi)	-R	
+Hemisurcula	T (Than)	-T (Eo-l)	(700,794)	+Lenitrophon	T (Ol)	-R	
+Hercorhynchus	K (Coni-u)	-K (Maes-u)		+Leptychthara	T (Mi-l)	-T (Plio)	(549)
+Hermineospina	T (Mi-l)	-T (Plio-l)		+Leporemax	T (Mi-l-l)	-R	(681,899)
+Hesperiturris	T (Eo-l)	-T (Eo-m-u)	(814,909)	+Lepsiella	T (Mi-l-u)	-R	(899)
+Heterocithara	T (Eo)	-R		+Lepsithais	Q (Plei)	-R	(681)
+Heterotrema	T (Dani)	-T (Than)	(899,914)	+Leptadrillia	T (Mi-l)	-R	(551)
+Hexachorda	T (Eo-u)	-T (Plio)	(909)	+Leptegaugana	T (Eo-m-u)	-R	(700)
+Hexaplex	T (Than-l)	-R	(914)	+Leptoconus	T (Eo-m)	-R	(814)
+Hillites	K (Albi-u)			+Leptomurex	T (Eo-u)		(551)
+Hima	T (Mi-l-u)	-T (Mi-u-l)	(899)	+Leptoscapha	T (Eo-m-l)	-T (Mi-m)	(530,614)
+Hinia	T (Than)	-R	(614)	+Leptosurcula	T (Eo-l)	-T (Eo-m-u)	(700,814,1248)
+Hironurex	T (Plio)	-R		+Leucosyrinx	T (Mi)	-R	(909)
+Hirotyphis	T (Ol-u)	-T (Mi-u-l)	(899,909)	+Leucozomia	T (Eo-m)	-R	(914)
+Hispidofusus	T (Mi-l)	-T (Mi-m)	(530)	+Leutrofia	T (Mi)	-R	
+Hiwia	T (Ol-u)	-T (Mi-u)	(899)	+Levivifusus	T (Dani)	-T (Ol-u)	(700,852)
+Holzapfelia	K (Camp)		(914)	+Lienardia	T (Mi)	-R	
+Houzeauia	T (Dani)	-T (Than-l)	(ZR75)	+Liniaxis	Q (Plei)	-R	(681)
+Hyalina	Q (Plei)	-R		+Lioclhamys	T (Plio)		
+Hydrotribulus	K (Coni-u)	-K (Maes-l)	(4)	+Lioglyphostoma	T (Mi)	-R	(533)
+Illyanassa	T (Mi-l)	-R		+Liomesus	T (Mi)	-R	(614)
+Imbricaria	Q (Plei)	-R		+Liopeplum	K (Coni)	-K (Maes-u)	(4)
+Indovoluta	T (Than)	-T (Eo-u)	(614)	+Liracraea	T (Mi-u)?	-R	
+Infracoronia	T (Eo-m-l)	-T (Eo-u)		+Liratilia	T (Eo-m-u)	-R	(899)
+Inglisella	T (Eo-l)	-R	(899)	+Lirastrombina	T (Mi-u-u)	-R	
+Inquisitor	T (Eo-u)	-R	(696)	+Lirasyrinx	T (Eo-m-u)	-T (Ol-u)	(899)
+Insolentia	T (Eo-m-l)	-T (Plio)	(696)	+Liratomina	T (Ol-u)	-T (Plio)	(530,909)
+Involuta	T (Eo-m)			+Lirofusus	T (Eo-l)	-T (Eo-m-u)	(700)
+Iredalina	T (Plio-l)	-R	(681)	+Lirosoma	K (u)	-T (Mi-m)	(123)
+Iredalula	T (Plio)	-R		+Lisbonia	T (Eo-m-l)	-T (Eo-m-u)	(700)
+Ishnula	T (Mi)	-R		+Lissapiopsis	K (Camp)		(914)
+Ithycthara	T (Mi-l)	-R	(549)	+Lissomuricopsis	T (Eo-l)		(ZR90)
+Itia	T (Mi-m)	-R	(681)	+Lithoconus	T (Eo-l)	-R	(1248)
+Janiopsis	T (Dani)	-T (Plio)	(705,914)	+Livonia	T (Ol-u)	-R	(530)
+Japelion	T (Plio)	-R					

Taxon	First Appearance	Last Appearance	Reference	Taxon	First Appearance	Last Appearance	Reference
+Lomirosa	K (Coni-u)	-K (Maes)		+Micantapex	T (Ol-u)	-R	(530)
+Longoconcha	K (Coni)	-K (Maes-u)		+Michela	T (Eo-l)	-T (Eo-m-u)	(814,1248)
+Lophiotarris	T (Mi)	-R	(909)	+Microclathurella	T (Mi-l)	-T (Mi)	
+Loxotaphrus	T (Eo)			+Microdrillia	T (Eo-l)	-R	(700)
+Lowenstamia	K (Camp)	-K (Maes-u)	(1066)	+Microfulgur	T (Dani)		(914)
+Lucerapex	T (Mi-m)	-R	(530)	+Microfusus	T (Plio)	-R	
+Lupira	K (Camp-u)	-K (Maes-u)		+Microgrytis	T (Mi-l)	-T (Plio-l)	(1272)
+Lutema	K (Camp)	-K (Maes-l)	(909)	+Microsurcula	T (Eo-l)	-T (Ol-l)	(700,852,1248)
+Lyria	K (Maes)	-R	(914)	+Microvoluta	T (Plio-l)	-R	(614)
+Lyrianea	T (Eo-l)			+Mioawateria	T (Mi-l-u)	-Q (Plei)	(899)
+Lyrischapa	T (Than)	-T (Eo-m-u)		+Mioecenebra	T (Ol-u)	-R	(1267)
+Lyromangelia	T (Mi)	-R		+Miomelon	T (Ol)	-R	(614)
+Lyropurpura	T (Eo-m-u)			+Miopleiona	T (Ol-u)	-T (Mi-m)	(854,909)
+Lytrosurcula	T (Eo-l)	-T (Eo-m-u)	(914)	+Miraculathurella	T (Mi)		(909)
+Lytrotyphis	T (Ol-l)			+Mirua	T (Eo)	-T (Mi)	
+Macron	T (Mi-l)	-R	(854)	+Misteia	T (Mi)		(ZR85)
+Macroniscus	Q (Plei)	-R		-Mitra	T (Eo)	-R	(909)
+Macrosinus	T (Mi-m)	-R	(899)	+Mitraria	T (Eo-l)	-R	(914)
+Macrozafra	T (Mi-l-u)	-R	(681)	+Mitratoma	T (Eo-u)		
+Macrurella	T (Mi)	-T (Plio)		+Mitrella	T (Mi-l)	-R	
+Madiella	T (Plio)	-R		+Mitrehoturris	T (Eo)		(914)
+Magilus	T (Eo)	-R	(614)	+Mitreola	T (Than)	-T (Mi)	(614)
+Makiyamaia	T (Mi)	-R	(909)	+Mitreolus	K (Camp-u)	-K (Maes)?	
+Mamiconus	T (Eo)			+Mitrithara	T (Ol-u)	-R	(681)
+Mancorus	T (Ol-l)	-T (Mi)		+Mitrodrillia	T (Ol-l)	-R	(852)
+Mangelia	T (Dani)	-R	(700)	+Mitrolumna	T (Eo-m-u)	-R	(614,700)
+Mangiliella	T (Eo-m)	-R	(914)	+Mitromorpha	T (Eo)	-R	
+Maoritomella	T (Ol-u)	-R	(530,899)	+Molopophorus	T (Eo-u)	-T (Mi-u)	(926)
+Maorivetia	T (Ol-u)	-T (Mi-l-u)	(899,909)	+Moniliopsis	T (Eo-l)	-R	(700)
+Marchia	T (Eo-l)	-R		+Monopophorus	T (Eo-l)	-T (Mi-u-u)	(552,555)
+Marginea	T (Eo-l)	-R	(914)	+Monotygmata	T (Eo-m)		(914,926)
+Mariatassia	T (Mi)		(ZR90)	+Montia	T (Dani)	-T (Than-l)	(914)
+Mariatrillia	T (Mi-m)		(1039)	+Morea	K (Coni-u)	-K (Maes)	
+Mariatufus	T (Mi-m)		(1039)	+Morula	T (Eo)	-R	
+Marianarona	T (Mi)		(ZR90)	+Morunella	T (Mi-m)	-R	(854)
+Mariasalpinx	T (Mi-m)		(1039)	+Muregina	T (Mi-l)?	-R	(1272)
+Mariasveltia	T (Mi)		(ZR90)	+Murex	T (Eo-l)	-R	(700)
+Mariaturricula	T (Mi-l-u)	-T (Mi-m)	(1039)	+Murexiella	T (Eo-m)	-R	
+Marshallaria	T (Dani)	-T (Mi-l-u)	(530,899)	+Murexul	T (Eo-m)	-R	
+Marshallena	T (Eo-m-l)	-R	(696,728)	+Muricanthus	T (Eo)	-R	
+Marwickara	T (Eo-m-u)	-T (Eo-u)	(909)	+Muricopsis	T (Than)	-R	(914)
+Masvyla	T (Mi)	-R		+Murotriton	T (Eo-m-u)	-T (Eo-u)	
+Mataxa	K (Camp-u)	-K (Maes)	(4)	+Murphytis	K (Coni)	-K (Maes-l)	(727)
+Maudrillia	T (Eo-u)	-T (Plio-l)	(899)	+Musashia	T (Ol-l)	-T (Mi-m)	(96,555)
+Mauria	T (Eo-m-l)	-T (Mi-u)	(728,899)	+Myobarbium	K (Camp-u)	-K (Maes)	
+Mauithoe	T (Plio)			+Myristica	T (Ol-l)	-R	(852)
+Maxwellia	T (Plio)	-R		+Myurella	T (Ol-u)	-R	(158)
+Mayeria	K (u)	-T (Plio)		+Myurellina	T (Mi)	-R	
+Mazzalina	K (Camp)	-T (Eo-u)	(123,700)	+Nannamoria	T (Ol-u)	-R	(530)
+Medionapus	K (Maes)		(914)	+Nannodiella	T (Mi-l)	-R	(549)
+Megalatractus	T (Plio)	-R		+Naquetia	T (Ol-u)	-R	
+Megasurcula	T (Ol-l)	-R	(96,555)	+Narona	T (Mi-m)?	-R	
+Melapium	T (Eo)	-R		+Nassa	T (Mi-l)	-R	(122,926)
+Melatoma	T (Mi)	-R		+Nassaria	T (Mi)	-R	
+Melongena	T (Than)	-R	(914)	+Nassarina	T (Mi)	-R	
+Merica	T (Than)	-R	(794)	+Nassarius	T (Ol-u)	-R	(158)
+Mericeella	T (Eo)	-R		+Nassicola	T (Dani)	-T (Plio-u)	(728,899)
+Mesochilotoma	K (Sn)?			+Nawenia	T (Plio)		(555)
+Mesorhytis	K (Albi-u)	-T (Than)		+Nebularia	T (Ol-u)	-R	(909)
+Metamelon	T (Ol-u)	-T (Mi-m)	(728,899)	+Nekewis	K (Maes)	-T (Ol-l)	(794)
+Metula	T (Eo-l)	-R	(1248)	+Neoathleta	T (Than)	-T (Mi)	(614)
+Metulella	T (Mi-l)	-T (Mi)					

Taxon	First Appearance	Last Appearance	Reference	Taxon	First Appearance	Last Appearance	Reference
+Neocola	T (Ol-u)	-T (Plio-l)	(728)	+Panormella	T (Plio)	-R	
+Neocylindrus	T (Mi)	-R		+Papillina	T (Eo-m-l)	-T (Ol-l)?	(700)
+Neoguraleus	T (Mi-l-l)	-R	(681,899)	+Paraborsonia	T (Ol-u)	-T (Mi-u)	(549)
+Neimibricaria	T (Ol)	-T (Mi)		+Paracanthurella	T (Plio)	-R	
+Neolairus	T (Mi-m)			+Paracomminia	T (Ol-u)	-T (Mi-l-u)	(728,899)
+Neopleurofusua	T (Mi-m)		(ZR84)	+Paracomitias	T (Plio)	-R	(899)
+Nepotilla	T (Mi-l-u)	-R	(681)	+Paradrilla	T (Eo)	-R	(909)
+Neptunea	T (Eo-u)	-R	(123)	+Parafusus	K (Camp-u)	-K (Maes)	
+Nicema	T (Mi-l)	-T (Mi-m)	(553,854)	+Paramarshallena	T (Eo-u)		(530,696)
+Nicolia	T (Eo-m)		(914)	+Parametaria	T (Mi)	-R	
+Nigerapana	T (Than)		(ZR77)	+Paramorea	K (Albi-u)	-K (Maes)	
+Nihonia	T (Mi-m)	-R	(533)	+Paranassa	T (Mi)	-R	
+Niotha	T (Mi)	-R		+Paraneistrolepis	Q (Plei)	-R	
+Nipponitys	K (Camp-u)	-K (Maes-l)		+Parangarenga	T (Mi-l-u)	-R	(728)
+Nitidella	T (Mi)	-R		+Parasyngonochilus	T (Eo-m-u)	-T (Ol-l)	(696)
+Nodisurculina	T (Mi-m)		(1039)	+Parasyrix	T (Dani)	-T (Mi-l-u)	(728)
+Noditerebra	T (Eo)	-R		+Paraterebra	T (Mi-l)	-R	
+Northia	T (Mi-l)?	-R	(553)	+Paratrophon	T (Plio-u)	-R	(681)
+Notocytharella	T (Mi-m)	-R	(854)	+Parinotus	T (Mi-l)	-R	
+Notogenota	T (Eo-m-l)	-T (Eo-m-u)	(899)	+Parvimitra	T (Ol-u)?	-T (Plio)	
+Notopeplum	T (Eo-u)	-R	(530)	+Parvisipho	T (Dani)	-T (Plio)	(914)
+Notopelejona	T (Eo-l)	-T (Eo-m)	(914)	+Parvivoluta	K (Camp)		(909)
+Notovoluta	T (Eo-u)	-R	(530)	+Patuxentrophon	T (Mi-l-u)	-T (Mi-m)	(1039)
+Nucella	T (Mi-l)	-R	(854)	+Pavora	T (Eo-m)	-T (Eo-u)?	(914)
+Oamarua	T (Eo-u)	-R	(530)	+Paxula	Q (Plei)	-R	(681)
+Ocenebra	T (Ol-u)	-R	(909)	+Paziella	T (Than)	-R	(704)
+Ocinebrellus	T (Mi-m)	-R	(1272)	+Peculator	T (Eo-m-u)	-R	(899)
+Ocinebrina	T (Ol-l)	-R	(1272)	+Pegocomptus	T (Pale)		
+Odontobasis	K (Maes)		(914)	+Penion	T (Dani)	-R	(530,728,899)
+Odontofusus	K (Turo)	-K (Maes-l)	(123)	+Peonza	T (Eo-u)?	-T (Mi-l)	
+Odontopolys	T (Than)	-T (Eo-m-u)	(700)	+Pepta	T (Eo)	-R	
+Odontopurpura	T (Ol-u)		(1272)	+Peridipsaccus	T (Ol)	-R	
+Oenopota	T (Mi)	-R		+Peristernia	K (u)	-R	
+Okinawavoluta	T (Plio)		(ZR80)	+Peritrophon	T (Ol-u)		
+Oliva	T (Than)	-R	(914)	+Perplicaria	T (Ol-u)?	-T (Plio-u)	
+Olivancillaria	T (Ol)	-R	(614)	+Perrona	T (Mi-u)	-R	(533)
+Olivella	K (Sn)	-R	(614)	+Perse	T (Eo-m-l)	-T (Mi-l)	(552)
+Olivula	T (Eo-l)	-T (Eo-m-u)	(4,814)	+Persicula	T (Eo-l)	-R	(914)
+Olssonella	T (Ol-l)	-R	(852)	+Peruticus	T (Eo-u)		
+Omogymna	T (Mi)	-R		+Perulithes	T (Eo-m)		
+Ootomella	T (Ol-u)?	-T (Plio)		+Peruluta	T (Than)	-T (Eo-u)?	(914)
+Ophiodermella	T (Mi-l)	-R	(555)	+Pervicacia	T (Mi-l-l)	-R	(899)
+Optoturris	T (Mi)	-T (Plio-l)	(909)	+Petraxia	T (Eo-l)	-T (Ol-l)	(1248)
+Ornatoptygmatis	J (Tith)		(ZR90)	+Phandella	T (Ol-l)		(852)
+Ornopsis	K (Camp-l)	-K (Maes-u)	(4,123)	+Phenatoma	T (Mi-l-l)	-R	(681)
+Orthosureula	T (Dani)	-T (Ol-l)	(700,909)	+Pholidotoma	K (Turo)		
+Ovilia	T (Mi-l)	-R		+Phoracanthus	T (Eo-u)		
+Oxyacrum	T (Eo-m-l)			+Phos	T (Eo)	-R	(614)
+Oxymeres	T (Ol-u)?	-R		+Phrontis	T (Mi-m)?	-R	(614)
+Pachycymbiola	T (Mi)	-R		+Phyllonotus	T (Eo-m-u)	-R	(700)
+Pachycythara	T (Mi-l)			+Piesticulus	K (Camp-u)	-K (Maes-u)	
+Pachymelon	T (Mi-l-u)	-R	(614,681)	+Pinquigemmula	T (Mi-u-u)	-R	(909)
+Pagodula	T (Mi-l-u)	-R	(899)	+Pirgos	T (Mi)	-R	
+Palaeatractus	K (Sn)			+Pisanella	T (Eo-u)	-T (Ol-l)	(914)
+Palaeocancellaria	K (Albi)		(792)	+Pisania	T (Eo-in)	-R	(914)
+Palaeosphaera	K (Ceno-l)	-K (Maes-u)	(888)	+Pisanianura	T (Eo)	-R	(614)
+Palaeorhaphis	T (Eo-l)		(700)	+Pittella	T (Plio)		
+Paleofusimitra	K (Maes-l)			+Platycythara	T (Mi-l)	-T (Plio)	
+Pallacera	T (Mi-l)	-R	(553)	+Plectocion	K (Coni)?		
+Palomelon	T (Mi)	-R		+Pleia	T (Mi-l)	-R	(681)
+Panamurex	T (Ol-l)	-R	(852)	+Pleioptygma	T (Mi)	-R	
+Pangoa	T (Mi-l)						

Taxon	First Appearance	Last Appearance	Reference	Taxon	First Appearance	Last Appearance	Reference
-Plentaria	T (Eo-m)		(914)	+Pterygia	T (Mi)	-R	(123)
+Plesiocerithium	T (Eo-l)		(914)	+Pterynotus	T (Than)	-R	(700)
-Pleurofusua	T (Eo-l)	-T (Mi-l)		+Ptychactractus	T (Than)	-R	(614)
+Pleuroliria	T (Eo-m-u)	-T (Ol-l)?	(700)	+Ptychoris	K (Turo)		
+Pleuroploca	T (Eo)	-R	(614)	+Ptychosalpinx	T (Mi-l-u)	-T (Mi-m)	(1039)
+Pleuropyramis	T (Mi)	-R	(533)	-Ptychosyrinx	T (Eo)	-R	(614)
-Pleurotomella	T (Than)	-R	(700)	-Ptychosyca	K (Camp-u)	-K (Maes)	(909)
-Pleurotomoides	T (Ol-l)	-R	(533)	+Pugilina	T (Than)	-R	(614)
-Plicarcularia	T (Plio)	-R		+Puha	T (Ol-l)		
+Plicifusus	T (Plio)	-R		+Pulchritima	T (Plio)	-R	
+Plochelaea	T (Mi-l)			+Purpura	T (Mi)	-R	
+Poliniciella	T (Mi)		(ZR90)	-Purpurellus	T (Mi-l)	-R	
+Poirieria	K (Ceno)	-R	(1066)	+Puruiana	T (Eo-u)		
+Pollia	K (Turo)	-R	(909)	+Pusia	T (Plio)	-R	
+Polystira	T (Ol-l)	-R		+Pusiolina	T (Plio)	-R	(909)
+Pomahakia	T (Ol-u)		(899)	+Pusionella	T (Eo)	-R	
+Ponderia	T (Eo-l)	-R		-Pyramimitra	T (Eo-m-l)	-T (Eo-u)	(700)
+Poponeoem	K (Maes)	-T (Eo-l)	(909)	-Pyramitoma	T (Eo-u)		
+Pornosis	K (Camp)	-K (Maes)	(909)	+Pyrene	T (Eo)	-R	(909)
+Poropteron	Q (Plei)	-R		+Pyrenomitra	T (Eo-m)		(914)
-Preangeria	T (Mi-l)			-Pyrenoturris	T (Eo-l)	-T (Eo-u)?	(914)
-Priscofusus	T (Than)	-T (Plio)		+Pyrgocothara	T (Mi-l)	-R	
+Pristimerica	T (Dani)			+Pyrifusus	K (Turo-l)	-K (Maes)	
+Procerapex	T (Ol-l)			+Pyropsis	K (Turo-u)?	-T (Than-l)	
+Procominula	T (Ol-u)	-T (Mi-l-u)	(728,899)	+Pyruclia	T (Mi-m)	-R	(854)
+Progabbia	T (Ol)	-R		+Pyrulofusus	T (Plio)	-R	
+Prosipho	T (Plio)	-R		-Quassisipho	T (Plio)	-Q (Plei)	(ZR82)
+Protobusycyon	K (Camp-u)	-T (Than)		+Rabicea	T (Eo)	-R	
+Protosurcula	T (Eo-l)?	-T (Eo-m-l)	(1248)	+Rapana	T (Mi)	-R	(614)
-Prototyphis	T (Eo-m-l)	-R	(899)	+Raphitoma	T (Than)	-R	(614)
-Proximitra	T (Eo-m-u)	-R	(728,899)	+Rapopsis	K (Maes-l)		
+Prunum	T (Mi)	-R		+Ratiffusus	T (Eo-u)	-R	(530)
+Psephaea	T (Than)	-R	(794)	+Rectiplanes	T (Mi-l)?	-R	(555)
+Pseudaulicina	T (Than)	-T (Eo-m-l)?	(614,705)	-Recurvina	T (Plio-l)	-R	(890)
+Pseudoaptyxis	T (Mi-m)		(1039)	+Remera	K (Ceno)	-K (Maes)	
+Pseudobuccinum	K (Maes)		(914)	-Remmita	K (Camp-u)	-K (Maes)	(909)
+Pseudocancilla	T (Than)	-T (Eo)		+Reticuloturris	T (Ng)?		(ZR84)
+Pseudocominella	T (Eo-m)	-T (Ol-l)	(914,926)	-Retipirula	T (Than)		
+Pseudofax	T (Dani)	-T (Eo)		+Retizafra	T (Mi-l)	-R	(530)
+Pseudofulgur	T (Ol-l)	-T (Mi-u-l)	(852)	-Rhomboidestoma	T (Eo-m)		(914)
-Pseudolatirus	T (Than)	-T (Plio)	(614)	+Rhombopsis	K (Coni-u)	-K (Maes)	(157)
+Pseudolimosus	Q (Plei)	-R		+Rhopalites	T (Than)	-T (Eo-m-l)?	(705)
+Pseudoliva	T (Dani)?	-R	(700)	-Rimosodaphnella	T (Mi)	-T (Plio)	
+Pseudolyria	T (Eo-u)			+Ripleyella	K (Camp-u)	-K (Maes-l)	(909)
+Pseudomelatomata	T (Ol-l)	-R	(96)	-Rissomangelia	T (Mi)	-R	
-Pseudometula	T (Eo-l)		(1248)	+Riugudhrillia	T (Ol-u)	-R	(158)
+Pseudomorea	K (Sn)	-K (Maes)		+Roperia	T (Plio)	-R	
+Pseudoneptunea	T (Eo-l)	-R	(700)	+Rostellaca	K (Sn)	-K (Maes)	
+Pseudoperissitys	K (Maes)		(157)	+Rostellana	K (Ceno-u)	-K (Maes-u)	(790)
-Pseudoperissolax	T (Than)	-T (Ol-u)	(158,614)	+Rostellinda	K (Turo)	-K (Maes)	
+Pseudopisania	T (Eo-l)			-Rugobela	T (Eo-m-l)	-T (Mi-m)	(899)
+Pseudorapa	K (Coni)	-K (Camp)	(914)	-Rugotyphis	T (Eo-m-u)	-R	(909)
+Pseudoraphitoma	T (Plio)	-R		+Saccaroturris	T (Mi-l)	-R	
+Pseudotoina	T (Than)	-T (Plio)	(794)	+Sagenella	T (Eo-m)		
+Pseudovaricia	T (Eo)	-T (Mi-m)	(530)	+Sargana	K (Camp-l)	-K (Maes-u)	(4,123)
+Psiliarius	T (Mi-m)		(553)	-Scabrella	T (Mi)	-T (Mi-u-l)	
+Psilocochlis	T (Eo-m)	-T (Eo-u)	(700)	+Scabricola	T (Mi-u)?	-R	(550)
+Pterochelus	T (Eo-m-u)	-R	(728)	+Scalaspira	T (Ol-l)	-T (Mi-m)	(123)
+Pteropurpura	T (Mi-u)	-R	(1267)	+Scalptia	T (Ol-u)	-R	(899)
+Pterorytis	T (Mi-u)	-R	(1267)	+Scaphella	K (Camp)?	-R	(122)
+Pterospira	T (Eo)	-R	(614)	+Scaphellopsis	T (Mi)		(ZR90)
+Pterotyphis	T (Mi)	-R	(909)	+Sceptrum	T (Than)	-T (Eo-l)	(700)

Taxon	First Appearance	Last Appearance	Reference	Taxon	First Appearance	Last Appearance	Reference
+Scobinella	T (Eo-m-l)	-T (Mi-u)	(123,549)	+Suavodrillia	T (Ol-l)	-R	(96)
+Scrinium	T (Ol-u)	-R	(530,681)	+Subcancilla	T (Mi-u)	-R	(550)
+Searlesia	T (Than)	-R	(794)	+Subpterynotus	T (Mi-l)	-R	
+Sedioliopsis	T (Mi-l-u)	-T (Mi-m)	(1039)	+Subula	T (Mi)	-R	(614)
+Semahana	T (Eo-u)			+Suessonia	T (Dani)	-T (Plio)	(914)
+Seminola	K (Camp)		(914)	+Sulcosipho	T (Mi)	-R	
+Semipirum	K (Albi-u)			+Surcula	K (Sn)	-R	(123)
+Semityphis	T (Eo-u)			+Surculina	T (Plio)	-R	
+Serrata	T (Eo)	-R		+Surculites	T (Than)	-T (Ol-l)	(700)
+Serratifusus	T (Mi-l)	-T (Mi-m)	(530)	+Surculoma	T (Eo-l)	-T (Eo-m-u)	(700,1248)
+Serrifusus	K (Camp)?	-K (Maes-l)		+Sveltella	T (Than)	-R	(794)
+Seymourisphaera	T (Dani)			+Sveltia	T (Eo-l)	-T (Plio)	(700)
+Sinaxila	T (Mi-l-u)	-R	(890)	+Swainsonia	Q (Plei)	-R	
+Sincola	T (Mi-m)	-R	(890)	+Sycodes	K (Camp-u)		
+Sinistrella	T (Eo-m)	-T (Eo-u)	(700,914)	+Syropsis	T (Mi-l-u)	-T (Mi-m)	(1039)
+Sinuina	T (Plio-l)	-R	(890)	+Sycostoma	K (u)	-T (Ol)	(614)
+Sipho	T (Ol-u)?	-R		+Sycotypus	T (Mi-l)	-R	(123,814)
+Siphonalia	K (u)	-R	(909)	+Sydaphera	T (Ol-u)	-R	(530)
+Siphonochelus	T (Eo-l)	-R	(914)	+Syngenchelus	T (Eo-u)	-T (Ol-u)	(530)
+Siphonorbis	T (Plio)	-R		+Syntomodrillia	T (Ol-l)	-R	(852)
+Siratus	T (Ol-l)	-R		+Tahudrilla	T (Eo-m-u)	-T (Eo-u)?	(914)
+Smithiella	T (Mi)	-R		+Tahusyrix	T (Eo-m-u)	-T (Eo-u)	
+Sohlia	K (Turo)?	-R	(1066)	+Taioma	K (Maes-u)	-T (Dani)	(899)
+Solatia	T (Mi)	-R		+Takia	T (Ol-l)	-R	(852)
+Solenosteira	T (Mi-l-u)	-T (Mi-m)	(1039)	+Talityphis	T (Mi-l)	-R	
+Solutofusus	T (Eo)	-T (Mi-m)	(530)	+Tanimasanoria	K (Maes-l)		(1066)
+Sparella	T (Than)	-R		+Tantunia	K (Albi-u)		(1066)
+Speightia	T (Eo-m-l)		(899)	+Taranis	T (Plio)	-R	
+Sphaeronassa	T (Mi)	-R		+Tarantinaea	Q (Plei)	R	
+Spinaspira	T (Mi-l-u)	-T (Mi-m)	(899)	+Taron	T (Plio-l)	-R	
+Spineoterebra	T (Mi)	-T (Mi-u-l)		+Taurasia	T (Mi-m)		
+Spinomelon	T (Ol-u)	-T (Plio-u)	(728,899)	+Tectaplica	K (Turo-l)	-K (Maes)	
+Spiradaphne	T (Ol-l)		(852)	+Tectifusus	T (Eo)	-T (Eo-u)	(530)
+Spiralta	T (Mi-u-l)	-R	(890)	+Telasco	T (Mi)	-R	
+Spirotropis	T (Eo-l)	-R	(1248)	+Teleochilus	T (Eo)	-T (Eo-u)	(530)
+Splendrilla	T (Ol-l)	-R	(696)	+Tenaturris	T (Mi)		
+Spoelia	T (Ol-u)		(ZR90)	+Terebra	T (Eo-l)	-R	(914)
+Stantonella	K (Coni-u)	-K (Maes)		+Terebrellina	T (Eo-m-u)	-T (Ol-l)?	(852)
+Stazzania	T (Eo-m)	-T (Mi-u-l)		+Terebrifusus	T (Eo-l)	-T (Eo-m-u)	(700)
+Sthenorytis	T (Ol)	-R	(547)	+Terebritoma	K (u)		
+Stephanocoonus	T (Eo)	-R		+Terefundus	T (Ol-u)	-R	(899)
+Stephanosalpinx	T (Mi-m)		(1039)	+Teremelon	T (Eo-l)	-R	(728,899)
+Stilla	T (Mi)	-R		+Teretia	T (Ol-u)?	-R	
+Stramonita	T (Mi)	-R		+Ternivoluta	T (Ol-l)	-R	(530)
+Strephona	T (Ol-u)	-R		+Tetraplica	K (Camp-u)		
+Strephonella	T (Ol-l)	-R	(852)	+Thais	T (Mi-l)	-R	(547)
+Strepsidura	T (Than)	-T (Eo-m-u)	(614,705,1066)	+Thaisella	T (Mi-m)	-R	(854)
+Streptocarina	T (Mi-u)		(1119)	+Thala	T (Eo)	-R	
+Streptochetus	T (Eo)		(1119)	+Thanetinassa	T (Than)		(914,926)
+Streptodictyon	T (Ol-l)	-T (Mi-m)	(1119)	+Thatcheria	T (Mi-m)	-T (Plio-l)	(899)
+Streptolathyrus	T (Than)	-T (Mi-u)	(794,1119)	+Thelecythara	T (Mi-l)	-T (Mi)	
+Streptopelma	T (Eo)			+Thesbia	T (Eo)	-R	
+Strigatella	T (Mi)	-R		+Thiarinella	T (Mi)	-R	
+Strigillibuccinum	T (Plio)	-R		+Tholitoma	T (Dani)	-T (Eo-u)	(696)
+Strioteretrum	T (Eo-m-l)	-R	(614,814)	+Tiara	T (Than)	-R	(794)
+Strombina	T (Mi-l-u)	-R	(890)	+Tomellana	T (Mi)	-R	
+Strombinella	T (Mi-l)	-T (Mi)		+Tomopleura	T (Dani)	-T (Mi-m)	(530,899)
+Strominella	T (Mi-l)	-T (Mi-m)	(553)	+Torquifer	T (Mi)		(ZR81)
+Strombinophos	T (Mi-m)	-T (Plio)	(553)	+Tortisipho	T (Eo-m-l)		
+Strongylocera	T (Than)	-T (Ol-l)	(852,909)	+Tortoliva	T (Eo)		
+Struthiolariopsis	K (Sant)		(1066)	+Trachelochetus	T (Eo-m)	-R	
				+Trachypollia	T (Mi-l)	-R	

Taxon	First Appearance	Last Appearance	Reference	Taxon	First Appearance	Last Appearance	Reference
+Tractolirina	T (Ol)	-R		+Vinceturris	T (Than)		(705)
+Trans-mariaturris	T (Mi-m)		(1039)	+Viridibuccinum	T (Plio)	-R	
+Tribia	T (Mi)	-R		+Vitularia	T (Mi)	-R	
+Trigonostoma	K (Maes-l)	-R		+Volema	T (Ol-l)	-R	(852)
+Tripia	T (Eo-m-u)	-T (Mi)		+Voluta	T (Than)	-R	(705)
+Tripterotyphis	T (Mi)	-R		-Volutulithes	K (Turo)	-T (Eo-u)	(614,909)
+Tritiaria	T (Dani)	-R	(814)	-Volutoconus	T (Eo)	-R	
+Tritonalia	T (Ol)	-R	(123)	+Volutocorbis	K (Camp)?	-R	
+Tritonactractus	T (Eo-u)			+Volutoderma	K (Ceno-u)	-K (Maes)	(4,157)
+Tritonomangilia	T (Eo-u)			+Volutolithes	K (Ceno-m)	-T (Eo-u)?	(914)
+Tritonopsis	T (Ol-l)	-T (Mi-l)	(852,985)	+Volutomitra	T (Eo-l)	-R	(899)
+Triumphis	T (Mi-m)	-R	(909)	+Volutomorpha	K (Coni)	-K (Maes)	(4)
+Trominina	T (Ol-u)		(158)	+Volutopsius	K (Albi-l)	-R	
+Trophon	T (Plio)	-R	(614)	+Volutospina	K (Turo)	-R	
+Trophonopsis	T (Eo-l)	-R	(914)	+Volvaria	T (Eo-l)	-T (Mi)	(914)
+Tropisurcula	T (Eo-l)	-T (Ol-l)	(852,1248)	+Volvariella	T (Eo-l)	-T (Eo-u)?	
+Trubosta	T (Eo-l)		(ZR90)	+Volvarina	T (Eo)	-R	
+Truncaria	T (Eo-m)	-R	(914)	+Volvarinella	T (Eo-m-l)	-R	(899)
+Trunculariopsis	T (Mi)	-R		+Waihaeia	T (Eo-m-u)	-T (Mi-u)	(728)
+Tryonella	K (Maes-l)			+Waimatea	T (Eo-m-u)	-R	(728)
+Trypanotoma	T (Eo-l)	-T (Eo-m-u)		+Waipaoa	T (Mi-l)	-R	(681)
+Trypanotopsis	T (Eo-m-u)		(814)	+Waiata	T (Ol-u)?	-T (Mi-u)	
+Tubicauda	T (Mi)	-R		+Whitecliffia	T (Eo-u)	-T (Ol-l)	(914,926)
+Tudicla	K (l)	-R	(909)	+Whitneya	T (Eo-m)		
+Tudiclana	T (Dani)		(899)	+Whineyella	T (Eo)	-T (Ol)	
+Tudicula	T (Plio)	-R	(909)	+Woodseella	K (Sant-u)	-K (Maes-l)	
+Turbinella	T (Ol-l)	-R	(614,852)	+Xancus	T (Ol-l)	-R	(814)
+Turehua	T (Eo-m-l)	-T (Plio-u)	(899)	+Xanthochorus	T (Ol-u)?	-R	
+Turriclavus	T (Plio)		(ZR84)	+Xenotrophon	T (Mi-m)	-R	(530)
+Turricolumbus	T (Eo)	-T (Mi-l)	(909)	+Xenuroturris	T (Mi-l)	-R	(533,555)
+Turricula	K (Camp-u)	-R	(790)	+Xestosurcula	T (Ol-l)	-R	(852)
+Turritulger	T (Mi-l-u)	-T (Mi-m)	(1039)	+Xymene	T (Eo-m-u)	-R	(728,899)
+Turrina	T (Plio-l)	-R	(890)	+Xymenella	T (Ol)	-R	
+Turrinosyrinx	T (Eo-u)	-T (Ol-l)	(696)	+Yasilia	T (Eo-u)		(547,914)
+Turris	T (Than)	-R	(794)	+Zafra	T (Plio)	-R	
+Typhina	T (Eo-u)	-R	(700)	+Zanassarina	T (Mi-m)	-R	(553)
+Typhinellus	T (Eo)	-R		+Zaphon	T (Mi)	-R	
+Typhis	T (Than)	-R	(914)	+Zeacuminia	T (Eo-l)	-T (Plio-u)	(728,899)
+Typhlomangelia	T (Plio)	-R		+Zealdmete	T (Ol-u)	-R	(899)
+Tyrannoberingius	T (Mi-l-u)	-T (Mi-m)	(128,909)	+Zecapollia	T (Eo)	-T (Mi)	
+Umpquaia	T (Eo-m)		(914)	+Zekilla	T (Dani)	-T (Eo-u)	(914)
+Unedogemmula	T (Mi-m)	-R	(533)	+Zelandiella	T (Dani)	-T (Plio-u)	
+Unitas	T (Eo-u)	-T (Mi-m)	(530,614,909)	+Zemacies	T (Dani)	-T (Plio-u)	(728,899)
				+Zemira	T (Ol-l)	-R	(530)
+Uromitra	T (Than)	-R		+Zemitrella	T (Eo-m-u)	-R	(681)
+Urosalpinx	T (Eo-l)	-R	(122,914)	+Zenepos	Q (Plei)	-R	(681)
+Uttleya	Q (Plei)	-R	(909)	+Zephos	T (Mi)	-R?	
+Uxia	K (Sn)	-T (Mi)		+Zeuxis	T (Plio)	-R	
+Uzita	T (Mi-l)	-R	(814)	+Zinsitys	K (u)		(ZR90)
+Vanpalmer	T (Than)		(ZR77)				
+Varicobela	T (Eo-l)	-T (Ol-l)	(852,1248)				
+Varicosiphon	T (Eo)						
+Varpalmeria	T (Than)		(705)				
+Vasum	T (Eo-u)	-R	(614,914)				
+Vaughanites	T (Mi-l)						
+Ventrilia	T (Eo-l)	-R	(1248)				
+Verruturris	T (Mi-l-u)	-T (Plio)					
+Vesantula	T (Mi-l)						
+Vetridrillia	T (Ol-l)		(852)				
+Vexillita	T (Ol-u)	-T (Mi)					
+Vexillum	K (Sn)	-R	(614)				
+Vexithara	T (Eo-u)	-T (Mi-l-u)	(530,728)				

Subcl. OPISTHOBRANCHIA

(Classification and basic stratigraphic ranges from Wenz [1938].)

Or. CEPHALASPIDA

+Abderospira	T (Eo-l)	-T (Eo-u)	(700)
+Acrocolpus	T (Eo)	-T (Ol)	
+Acrostemma	K (Camp)	-R	
+Actaeon	K (Turo)	-R	(123)
+Actaeonella	K (Apti-u)	-K (Camp)	(734)
+Actaeonellina	J (Bajo)?		
+Actaeonidea	T (Eo)	-T (Mi)	

Taxon	First Appearance	Last Appearance	Reference	Taxon	First Appearance	Last Appearance	Reference
+Actaeonina	C (Vise)	-K (Maes)	(1066)	+Mnestia	T (Eo-l)	-R	
+Acteocina	J (Oxfo-l)?	-R		+Mnestocylichnella	T (Eo)		
+Adamnestia	T (Eo)?	-T (Ol-l)	(158)	+Monilirretusa	K (Maes)		(909)
+Aliculastrum	T (Than)	-R	(614)	+Neocylichndrites	K (Barr)	-K (Maes)	
+Aplustrum	K (u)?	-R		+Neotrochaetaeon	K (Sant)	-K (Camp-l)	(733)
+Atys	T (Dani)	-R		+Noetca	T (Than)		(914)
+Avellana	K (Apti)	-K (Maes)		+Nonacteonina	K (Camp-l)	-T (Than)	(794)
+Biplica	K (Albi)	-K (Maes)		+Nucleopsis	T (Eo-m-u)	-T (Eo-u)	(700,814)
+Blancia	K (Turo)	-R		+Oligoptycha	K (Coni-u)	-K (Maes-u)	(4,888)
+Bucconia	T (Eo)	-R		+Ongleya	T (Dani)		(899)
+Bulinactaeon	T (Eo-u)		(914)	+Orthoptyxis	J	-K	(ZR85)
+Bulla	J (Plie)	-R		+Ossiania	T (Plio)	-R	
+Bullina	T (Mi-m)	-R	(909)	+Ovactaeonina	Tr(Olen-u)	-K (Sn)	(1130)
+Bullopsis	K (Camp-u)	-K (Maes)		+Ovulactaeon	K (u)	-R	
+Ceritella	J (Sine)	-K (Ceno)	(122)	+Ovulopsis	K (Sn)		
+Cinulia	K (Nc)	-K (Maes)	(914)	+Palaeohydatina	J (Sine)	-K (Sn)	
+Coeloscapha	T (Ol-l)		(852)	+Palaeotrochaetaeon	K (Albi)	-K (Ceno)	(733)
+Colostraeon	K (Apti)	-K (u)	(157)	+Parapuractaeon	K (Coni-u)	-K (Sant)	(733)
+Conactaeon	J (Plie)			+Parietiplicatum	K (Camp-u)	-K (Maes)?	
+Consobrinella	Tr(Nori)		(797)	+Pchelincevella	K (Albi)	-K (Sant)	(734)
+Cosmophilinae	T (Mi-u-l)			+Peruviella	K (Apti-u)	-K (Albi-l)	
+Crenilabium	K (Camp)?	-R		+Philine	T (Eo-l)	-R	(700)
+Cyllichna	K (Sant)?	-R	(1066)	+Pirsila	K (Ceno)		
+Cyllichnania	T (Dani)	-T (Mi-u)	(899)	+Plicobulla	T (Eo)		
+Cyllichnatys	Q (Plei)	-R		+Priscaphander	T (Dani)		(899)
+Cyllichnella	T (Dani)	-R		+Pseudaveta	T (Mi-m)		
+Cyllichnina	T (Than)	-R		+Pseudocassis	K (Apti)		
+Cyllichnopsis	K (Camp)	-T (Eo-m)	(909)	+Ptychocylichndrites	J (Kimm)	-J (Tith-u)	
+Cylindritella	K (Sn)			+Pseudonerinea	J (l)	-K (Apti-l)	
+Cylindrites	J (Plie)	-K (Barr)		+Pupa	T (Than-l)	-R	(914)
+Cylindrobullina	Tr(Olen-l)	-J (Bath)	(558,785)	+Pyrenculus	T (Ol-l)	-R	(852)
+Cylindrot truncatum	K (Coni-u)	-K (Maes)		+Raiucourtia	T (Plio)		
+Diaphana	J (Bajo)?	-R		+Retusa	J (Bath)	-R	
+Douvilleia	T (Pale)			+Rhizorus	T (Eo-l)	-R	
+Ellipsoscapha	K (Sant)	-T (Than)	(794)	+Rictaxis	K (Sant-l)	-R	
+Eoacteon	K (Ceno)	-K (Maes-u)		+Ringiculiella	T (Ol-l)	-R	(852)
+Eotrochaetaeon	K (Ceno)		(733)	+Ringicula	K (Albi-u)	-R	(792)
+Eriptycha	K (Nc)	-K (Maes)		+Ringiculina	K (Maes-l)	-R	
+Euactaeonina	J (l)	-K (Sn)?		+Ringiculocosta	T (Ol-u)?	-T (Plio)	
+Euconactaeon	J (Sine)	-J (Plie)		+Ringiculopsis	K (Sn)		
+Fictioacteon	K (Ceno)			+Ringiculoptycha	K (u)		(ZR86)
+Gilbertina	T (Dani)	-T (Mi)	(700)	+Ringiculospongia	T (Mi)	-T (Plio)	
+Girtyspira	C (Tour)	-P (Dora)	(797,1130)	+Ringinella	K (Nc)	-K (Ceno)	
+Globiconcha	K (Ceno)	-K (Camp-u)?		+Roxania	K (Sant)?	-R	(614,1066)
+Goniocylichna	K (Camp-u)	-K (Maes)		+Roxaniella	T (Ol-l)	-R	(852)
+Goniocylichndrites	J (Bath)	-J (Tith-u)		+Sabatia	T (Plio)	-R	
+Hacobjania	K (Sant)		(ZR86)	+Scaphander	K (Camp)	-R	(614,909)
+Haminoea	T (Eo)	-R	(614)	+Scobinodola	K (Maes-l)		
+Hamlinia	K (Ceno)	-K (Turo)		+Semiactaeon	T (Eo-l)	-T (Mi)	(914)
+Hermania	T (Mi)	-R		+Sevanella	K (Coni-u)		(733)
+Kaitoa	T (Ol)	-T (Mi)		+Sogdianella	K (Albi)	-K (Camp)	(734)
+Kleinacteon	T (Eo-m)	-R		+Spiractaeon	K (Coni)	-K (Camp-l)	(733)
+Lilota	T (Eo)?	-R	(158)	+Striaactaeonina	J (Hett)	-J (Bath)?	
+Limulatys	T (Mi-l)	-R	(681)	+Suleoactaeon	J (Bajo)	-K (Apti)	
+Liocarenus	K (Sant)	-T (Eo-u)	(614,914)	+Sulcoretusa	K (Maes)	-R	
+Lithophysema	T (Eo-m)	-T (Eo-u)	(700)	+Superstes	T (Dani)	-T (Eo-m-u)	(899)
+Maoriscaaphander	T			+Taita	T		
+Megistostoma	T (Eo-l)	-T (Plio)	(1066)	+Talahabia	T (Mi)		
+Mesotrochaetaeon	K (Turo-u)		(733)	+Tenuiactaeon	T (Eo-l)	-R	(700)
+Mexicotrochaetaeon	K (Coni-u)	-K (Camp-l)	(733)	+Toledonia	Q (Plei)	-R	
+Millosevichia	K (Maes)			+Tornatella	J (Sine)?	-T (Mi)	(123)
+Mirascapha	T (Than)	-T (Eo-m-l)		+Triploca	T (Eo-l)	-T (Mi)	(899)

Taxon	First Appearance	Last Appearance	Reference	Taxon	First Appearance	Last Appearance	Reference
+ Trochactaeon	K (Turo)	-K (Maes)		+ Disculus	T (Eo-m-l)		
- Trochactaeonina	J (Bath)	-T (Than)	(914)	+ Doliella	T (Eo-l)?	-R	(1248)
+ Troostella	K (Camp)		(914)	Tr(Ladi-u)			(1120)
+ Volvoey lindrites	J (Oxfo-l)	-K (Ne)		+ Dolomitella	Tr(Ladi-u)		(362,1130)
+ Volvulella	T (Eo-l)	-R	(1248)	Donaldina	D (Give)	-P (Dora)	
+ Wangacteon	T (Dani)			+ Dunkeria	T (Mi)	-R	
+ Zikkurata	K (Maes-l)			+ Ebala	Tr(Ladi-u)	-R	(1120)
				+ Egilina	Q (Plei)	-R	
				+ Elatiioriella	J (Oxfo-m)	-J (Kimm-l)	
				+ Eleganella	J (Oxfo-l)		
				+ Endiaplocus	J (Bath)	-K (Apti)	
				+ Endiatrachelus	J (Oxfo-u)	-K (Albi-m)	(792)
				+ Eulima	K (Maes-l)	-R	(1066)
				+ Eulimastoma	T (Mi-l)	-R	
				+ Eulimella	T (Eo-l)	-R	(614,852)
				+ Euparthenia	Q (Plei)	-R	
				+ Eustomia	Q (Plei)		
				+ Evalea	T (Eo)	-R	
				+ Evelynella	T (Ol-l)	-T (Plio-l)	(899)
				+ Falstostyliola	J (Toar)		(1208)
				+ Faluniella	T (Mi-m)		
				+ Favria	J (Tith-u)	-K (Barr)	
				+ Fibulella	J (Bajo)	-K (Apti-l)	
				+ Fibuloptygmatiss	J (Oxfo-u)	-J (Kimm-l)	(868)
				+ Fibulopyxis	J (Bath)		
				+ Finlayola	T (Ol)	-R	
				+ Fusipyxis	J (Oxfo-l)	-K (Barr)	(973)
				+ Gemmellaroia	K (Vala-l)		(973)
				+ Gispnyella	T (Mi-l)		
				+ Goniostomia	T (Mi-l)	-T (Mi)	
				+ Gonzagia	K (Turo)		
				+ Gumina	T (Plio)	-R	(681)
				+ Haplopyxis	K (Ceno)	-K (Coni)	(1209)
				+ Heida	T (Plio)	-R	
				+ Iolaea	Q (Plei)	-R	
				+ Iphiama	T (Eo-l)	-R	(700)
				+ Iselica	T (Eo)	-R	
				+ Italoptygmatiss	K (Turo)		(1209)
				+ Itheria	J (Oxfo-l)	-K (Maes)	(1066)
				+ Itruvia	K (Ceno)	-K (Maes)	(914)
				+ Ivara	Q (Plei)	-R	
				+ Ividella	Q (Plei)	-R	
				+ Jaccardiella	K (Ceno)		(1209)
				+ Kimina	C (Tour)		(797)
				+ Lacriiforma	K (Camp-u)	-K (Maes-l)	
				+ Laevinerinea	K (Ceno)	-K (Turo)	
				+ Laeviselica	K (u)		(ZR78)
				+ Linopyrga	T (Mi-l-u)	-R	(681,899)
				+ Longchaeus	T (Eo-m-u)	-R	(700)
				+ Loxopyxis	T (Eo)	-T (Eo-u)	
				+ Macrodostomia	T (Eo-l)	-T (Plio-u)	(914)
				+ Mecoliotia	Q (Plei)	-R	
				+ Megastomia	T (Than)	-R	
				+ Melaniopyxis	J (Bajo)	-J (Bath-u)	(120)
				+ Menestho	T (Mi)	-R	
				+ Milda	T (Eo)	-R	
				+ Miralda	T (Ol-l)	-R	(852)
				+ Mormula	T (Mi)	-R	
				+ Mrhilaia	K (Ceno-l)	-K (Ceno)	
				+ Multiptyxis	K (Sn)		(1066)
				+ Neonerinea	K (u)		(ZR78)
				+ Neopyxis	K (l)	-K (Ceno-m)	(1210)
				+ Nerinea	J (Bath-m)	-K (Maes)	(120,122)
Or. HETEROSTROPHIA (= Entomotaeniata)							
+ Acrostylus	J (Tith-u)						
+ Actaeopyramis	T (Eo)	-R					
+ Agatha	T (Ol-u)	-R	(681,899)				
+ Amaura	T (Plio)	-R					
+ Ampezzamilda	Tr(Ladi-u)		(1120)				
+ Ampezzogyra	Tr(Ladi-u)		(1120)				
+ Amphitomaria	Tr(Ladi-u)		(1066)				
+ Architeconica	T (Mi-l)	-R					
+ Aphanopyxis	J (Bath)	-K (Turo)					
+ Aphanotaenia	J (Kimm-l)	-J (Kimm-u)	(120)				
+ Aptyxiella	J (Oxfo-l)	-K (Albi-m)					
+ Auristomia	T (Eo)	-R					
+ Babella	Q (Plei)	-R					
+ Bactroptyxis	J (Bajo)	-J (Kimm)					
+ Bandellina	Tr(Ladi-u)		(1120)				
+ Bartschella	Q (Plei)	-R					
+ Belonidium	T (Eo-m-l)	-R					
+ Besla	T (Mi-m)	-R	(854)				
+ Boehmiola	J (Hett)						
+ Brachystomia	T (Eo)	-R					
+ Brouzetia	K (Barr)						
+ Callolongchaeus	T (Mi-l)	-R					
+ Calodisculus	T (Plio-u)						
+ Campanelle (+ Diozopyxis)	K (l)	-K (Maes)	(1066)				
	K (Barr)	-K (Apti)					
- Campichia	K (Barr)						
+ Camponaxis	Tr(Ladi-u)		(1120)				
+ Camponeila	Tr(Ladi-u)		(1120)				
+ Carbonia	Tr(Ladi-u)		(1120)				
- Careliopsis	T (Mi)	-R					
+ Cassianaxis	Tr(Ladi-u)		(1120)				
+ Cassianeala	Tr(Ladi-u)		(1120)				
+ Cassiamilda	Tr(Ladi-u)		(1120)				
+ Chemnitzia	T (Eo)	-R					
+ Chrysallida	T (Mi-l-u)	-R	(614,899)				
- Cingulina	T (Eo-l)	-R	(700)				
- Chimaopoma	K (Turo)	-T (Mi-l)	(559)				
+ Coemansia	T (Than)						
+ Colpostomia	T (Ol-l)						
+ Cossmannea	J (Bajo)	-R	(558)				
+ Cossmannica	T (Than)	-R					
- Costaela	K (Albi)?		(792)				
- Costosymnola	T (Ol-u)	-T (Mi-l-u)	(899)				
+ Creonella	K (Maes-l)	-T (Dani)	(914)				
+ Crimella	J (Tith)						
+ Crisalloella	Tr(Ladi-u)		(1120)				
+ Cryptoplocus	J (Oxfo-l)	-K (Apti)					
+ Curetia	K (Barr)						
+ Cyclodostomia	T (Eo)	-R					
+ Cyclostromella	T (Eo-u)?	-R					
+ Diptyxiella	K (Barr)		(ZR80)				
+ Discobasis	T (Eo)						
+ Discotectonica	T (Eo-u)	-R					

Taxon	First Appearance	Last Appearance	Reference
+Berthelinia	T (Eo-l)	-R	(934,1218)
+Candinia	T (Mi-m)	-T (Plio)	(1218)
+Elysiacea	T (Eo)	-R	
+Gougerotia	T (Eo-l)	-R?	(934,1066)
+Hemiplicatula	T (Eo-l)	-T (Eo-m-l)	(1218)
+Julia	T (Ol-l)	-R	(614,1218)
+Santia	T (Eo-l)		(1218)
+Squamalinia	T (Eo-m-l)		(1218)

Or. ANASPIDEA (= Aplysiomorpha, Aplysioidea)

+Akeria	J (Cali-u)	-R	(614)
+Dolabella	T (Mi-l-u)	-R	(614)
-Sabaziella	T (Plio-u)		

Or. UMBRACULOMORPHA (Notaspidea)

+Eosinica	T (Eo-l)		
+Tylothinella	T (Plio)	-R	
-Umbraculum	T (Eo-l)	-R	(614,852)

Or. BASOMMATOPHORA (marine only)

+Acroreia	T (Dani)	-T (Eo-l)	(914,1066)
-Anisomyon	K (Camp-l)	-K (Maes-u)	
+Patellopsis	T (Eo)	-R	
+Pleurolimnaea	K	-T (Eo-l)	(4)
-Pseudohercynella	K (Maes)		
+Ptychogyra	K (Barr)?	-K (m)	
+Siphonacmea	T (Plio)	-R	
+Siphonaria	K (Camp-u)	-R	
+Trimusculus	T (Ol-u)?	-R	
+Vasculum	K (Sn)		
+Williamia	T (Eo)	-R	

Or. UNCERTAIN

+Acanthotrophia	J (Bajo)		(909)
-Ameranella	T (Eo-m-u)	-T (Mi-m)	(909)
+Buscotypus	T (Mi)	-R	(909)
+Canepina	J (Bajo)		(909)
+Discogonius	Tr(Anis)	-Tr(u)	(909)
+Echininus	T (Plio)	-R	(909)
-Eurytorus	T (Mi)	-T (Plio)	(909)
+Fadaiaella	Tr(m)		(909)
+Gomphopages	T (Eo-m-u)	-T (Eo-u)	(909)
-Granulina	T (Plio)	-R	(909)
+Kotakaia	T (Tham)		(909)
+Littoraria	T (Mi)	-R	(909)
+Lutima	K (Maes)		(909)
+Macromphalus	T (Plio)	-R	(909)
+Mariottia	J (Bajo)		(909)
-Mennesieria	K (u)		(909)
+Mirula	T (Eo-u)		(909)
+Mistostigma	T (Plio)	-R	(909)
+Nicosiaella	J (Bajo)		(909)
+Paronaella	J (Bajo)		(909)
+Pedipes	Q (Plei)		(909)
+Personopsis	T (Tham)	-R	(909)
+Pseudofusua	T (Mi)	-T (Plio)	(909)
+Reticulacella	T (Eo-u)		(909)
+Scorbinidola	K (Maes)		(909)

Taxon	First Appearance	Last Appearance	Reference
-------	------------------	-----------------	-----------

Cl. CEPHALOPODA

[Classification and basic stratigraphic ranges from the TREATISE, Part K (1964) and Part L (1957).]

Or. PLECTONOCERIDA

+Balkoceras	Cm(Trep-u)		(297)
Palaeoceras	Cm(Trep-u)		(297)
Plectronoceras	Cm(Fran-u)	-Cm(Trep-l)	(297)
+Sinoeremoceras	Cm(Trep-l)	-Cm(Trep-u)	(297)
Wanwanoceras	Cm(Trep-l)	-Cm(Trep-u)	(297)

Or. ELLESMEROCERIDA

-Acaroceras	Cm(Trep-l)	-Cm(Trep-u)	(297)
Albertoceras	O (Trem-l)		(524)
Amsleroceras	O (Aren-l)?		(298,524)
Anguloceras	O (Trem)		(2)
-Anhuiceras	Cm(Trep-u)		(297)
-Annoceras	O (Trem)		(298)
-Antacaroceras	Cm(Trep)		
Apocrinoceras	O (Aren-l)		(524)
Avoceras	O (Aren)		
Bactroceras	O (Llvi-l)	-O (Llde-l)	(298,524)
-Bakeroceras	O (Aren-l)?		(298,524)
Baltoceras	O (Aren)	-O (Llvi)	(298)
-Bambusoceras	Cm(Trep)		
-Barnesoceras	O (Trem-l)		(524)
Bassleroceras	O (Trem-u)	-O (Llvi-l)?	(2,298)
Bathmoceras	O (Llvi-l)	-O (Llde-l)	(524)
Belloceras	O (Llvi)		(298)
Bridgeoceras	O (Trem)		(298)
Buehleroceras	O (Trem-u)		(524)
Burenoceras	O (Trem-l)		(524)
Cartersoceras	O (Llde)	-O (Cura)	(2,298)
Caseoceras	O (Trem-u)		(524)
Catoraphinoceras	O (Aren)	-O (Llvi)	(298)
-Centrocryocerina	O (Llde)		
+Chabactoceras	Cm(Trep-u)		(297)
Chepuloceas	O (Trem)		
Clarkoceras	Cm(Trep-u)	-O (Trem-l)	(297,524)
Clelandoceras	O (Aren-u)		(298,524)
Cochliceras	O (Aren-u)	-O (Llde)	(298,524)
Conocerina	O (Trem-l)		(524)
Copicers	O (Aren-u)		(524)
Cumberloceras	O (Aren-l)		(524)
Cyclostomiceras	O (Aren-u)		(524)
Cyrtobaltoceras	O (Aren)		(298)
Cyrtocerina	O (Cura-l)	-O (Ashg-m)	(524)
Dakeoceras	O (Trem-l)		(524)
Desioceras	O (Aren)		(298)
Diaphoroceras	O (Aren)		
Diastriloceras	O (Aren-u)		(524)
+Dongshanoceras	Cm(Trep-u)		(297)
Dwightoceras	O (Aren)		
Dyscritoceras	O (Aren)		(298)
+Ebuoceras	Cm(Trep-l)	-Cm(Trep-u)	(297)
+Ectenoceras	O (Trem)		(298)
+Ectenolites	Cm(Trep-u)	-O (Trem-l)	(297,524)
Ectocyloceras	O (Aren-l)		(524)
Ellesmeroceras	O (Trem-l)	-O (Trem-u)	(524)
Endocyloceras	O (Trem)	-O (Aren)	
Endorioceras	O (Aren)		(298)
+Eoelkoceras	Cm(Trep-u)		(297)

Taxon	First Appearance	Last Appearance	Reference	Taxon	First Appearance	Last Appearance	Reference
+Eocyckistomiceras	O (Aren)			Or. PROTACTINOCERIDA			
+Eodiaphragmiceras	Cm(Trep-u)		(297)	+Bexioceras	Cm(Trep-u)		(297)
+Eoectenolites	Cm(Trep-u)		(297)	+Mastoceras	Cm(Trep-u)		(297)
Eothinoceras	O (Aren-l)		(524)	+Physalactinoceras	Cm(Trep-u)		(297)
Eremoceras	O (Trem-l)		(524)	+Protactinoceras	Cm(Trep-u)		(297)
Hemichoanella	O (Aren-l)		(524)	Or. YANHECERIDA			
+Huaiheceras	Cm(Trep-l)	-Cm(Trep-u)	(297)	+Aetheloxoceras	Cm(Trep-u)		(297)
Huaihecerina	Cm(Trep-u)		(297)	+Archendoceras	Cm(Trep-u)		(297)
+Hunyuenoceras	Cm(Trep-l)		(297)	+Oomendoceras	Cm(Trep-u)		(297)
+Irianoceras	O (Aren)	-O (Llde)	(298)	+Yanheceras	Cm(Trep-u)		(297)
+Jiagouceras	Cm(Trep-u)		(297)	Or. ORTHOCERIDA			
+Keraiaceras	O (Trem)		(298)	+Acrosphaerorthoceras			
Kymioceras	O (Aren-u)		(524)		S (Ludl)?		(524)
Lawrenceoceras	O (Aren)			Adnatoceras	D (Give)	-D (Fras)	(299)
Levisoceras	O (Trem-l)		(524)	-Aethiosolen	O (Llvi-l)	-O (Llde)	(298,524)
+Llanoceras	O (Trem)		(298)	Allanoceras	S (Ludl)?		(524)
+Lunanoceras	Cm(Trep-l)	-Cm(Trep-u)	(297)	Allumetoceras	O (Llde-u)	-O (Cara-m)	(524)
+Meikeloceras	O (Aren-u)?		(298,524)	Anaspyroceras	O (Llde)	-D (Sieg-u)	(298,524)
Metabaltoceras	O (Llvi)		(298)	Anastomoceras	D (Gedi)		(299)
Microbaltoceras	O (Aren)		(298)	Ancistroceras	O (Llvi-l)	-O (Llde)	(524)
+MicrowSomiceras	O (Llvi-l)?			Angelinoceras	O (Llvi-u)?	-O (Llde-u)	(524)
Monogonoceras	O (Aren)			Antipteloceras	O (Cara-u)		(524)
Multicameroceras	O (Trem-l)		(298,524)	+Arionoceras	S (Wenl-u)	-S (Prid)	(524)
+Muriceras	O (Trem)		(298)	Arkonoceras	D (Gedi)	-D (Give)	(299)
Murrayoceras	O (Llvi)	-O (Cara-l)	(298)	Arpaoceras	D (Fras)		(299)
Oelandoceras	O (Cara-m)		(1066)	+Arterioceras	D (Gedi)		(1066)
Ogygoceras	O (Aren)		(298)	Artrophyllum	D (Emsi)	-D (Eife)	(299)
Oneotoceras	O (Trem-u)		(524)	-Badouceras	O (Cara)		(1066)
Pachendoceras	O (Trem-l)		(298,524)	Baltioceras	O (Ashg)		(298)
Paracyclostomiceras	O (Llvi-l)		(298,524)	+Baykonaroceras	O (Cara)	-O (Ashg)	(298)
+Paradakeoceras	O (Trem)		(297)	Bergoceras	C (Vise)		
+Parapalaeoceras	Cm(Trep)			Bifoveoceras	O (Llvi)	-O (Llde)	(298)
+Paraplectronoceras	Cm(Trep-l)	-Cm(Trep-u)	(297)	Bitauinoceras	P (Guad)		(524)
+Pictetoceras	O (Aren-u)	-O (Llvi-l)	(524,1066)	+Bogoslovskya	D (Eife)	-D (Fame-m)	(524)
Protoeycloceras	O (Aren-l)	-O (Llde)	(524,1066)	Bohemites	S		
+Pseudendoceras	Cm(Trep-u)		(297)	Brachycycloceras	C (Serp-l)	-C (Bash-u)	(524)
+Purmanaroceras	O (Trem)		(297)	Bradfordoceras	D (Fame)		(299)
+Qiushougouceras	Cm(Trep-u)		(297)	Buchanoceras	D (Sieg-u)	-D (Emsi)?	(299,524)
Quebecoceras	O (Aren)		(298)	Buttoceras	O (Aren-u)		(298)
Rangeroceras	O (Aren-l)?		(298,524)	Calocyrtoceras	S (Ludl-u)		(524)
+Rectseptoceras	Cm(Trep-u)		(297)	Campyloceras	C (Serp-l)?		(524)
Rhabdiferous	O (Aren-l)		(524)	Cayutoceras	D (Fras)		(299)
Rioceras	O (Aren-u)		(298,524)	+Cedarvilleoceras	S (Wenl-u)		(524)
Robsonoceras	O (Trem-u)	-O (Aren)	(298,524)	Centronoceras	O (Aren)	-O (Llde)	(298)
Rudolfoceras	O (Aren-u)		(524)	Chicagoceras	S (Wenl)		
Ruthenoceras	O (Trem)		(298)	Clinoceras	O (Llvi)	-O (Llde)	(298)
Shantungendoceras	O (Trem)		(298)	Columnoceras	S (Wenl-u)	-D (Eife-l)	(524)
Shideleroceras	O (Ashg-m)			+Coralloceras	D (Emsi)	-D (Eife)	(299)
+Sinolebetoceras	Cm(Trep-u)		(297)	+Cornuella	C (Vise-u)		(524)
Smithvilloceras	O (Aren)			Cryptocycloceras	S (Ldov-u)	-S (Ludl-u)	(524)
Stemtonoceras	O (Trem-l)		(298,524)	Cryptorthoceras	D (m)		
+Tanycameroceras	Cm(Trep-u)		(297)	Ctenoceras	O (Llvi-l)	-O (Llde)	(298,524)
+Theskeloceras	Cm(Trep-u)		(297)	Cycloceras	C (Vise)?	-P (Sakm)	(524)
Vassaroceras	O (Aren-l)?		(524)	Cycloluites	O (Llvi-l)?		(524)
Veneficoceras	O (Aren-l)?		(524)	Cyrtactinoceras	O (Llvi)	-S (Ludl-u)	(298,524)
Ventrioboceras	O (Aren)		(298)	Cyrtothoracoceras	C (Vise-l)	-C (Serp)	(524)
Walcottoceras	O (Trem-l)		(524)	Dawsonoceras	S (Ldov-m)	-S (Ludl-u)?	(524)
+Weishanhuaceras	Cm(Trep-u)		(297)	Dawsonocera	S (Ludl-l)	-S (Prid)?	(524)
Woosteroceras	O (Trem-l)		(524)	Diagoceras	D (Eife)		(299)
+Xiaoshaoceras	Cm(Trep-u)		(297)				
+Zhuibianoceras	Cm(Trep-u)		(297)				

Taxon	First Appearance	Last Appearance	Reference	Taxon	First Appearance	Last Appearance	Reference
Dietyoceras	S			+Neosichuanoceras	S (Wen-l)		(651)
Dnestroceras	S (Prid)		(524)	Neptunoceras	C (Mosc)	-C (Step-l)?	(524)
Dolorthoceras	D (Give)	-P (l)		Offleyoceras	S (Wen-l)	-D (Gedi)	
Eifeloceras	D (Eife)		(299)	Ohioceras	S (Wen-l)		
+Engorthoceras	D (Eife)			Orthoceras	O (Aren-u)	-O (Llvi-u)	(524)
+Eosomichelinoeras	O (Cara-m)	-O (Ashg)?	(524)	+Orthocycloeras	S (Wen-l-u)	-S (Ludl-l)	
Eotripteroceras	O (Llde)		(298)	+Ophidioceras	S (Ldov-u)		(524)
Ephippiorthoceras	O (Llde)	-S (Wen-l)	(298)	Ophioceras	S (Wen-l)	-S (Ludl-l)	(2,524)
Eridites	S (Ludl-u)	-S (Prid)	(524)	Oxfordoceras	O (Aren)		
+Esopoceras	D (Emsi)		(299)	+Palaeocycloeras	O (Llvi)		(2)
Euloxoceras	D (Fame)	-C (Bash)	(299,524)	Palmeroceras	D (Eife)		(299)
Eusthenoceras	C (l)			+Paradnatoceras	O (Llvi)		(1066)
+Folioceras	D (Emsi)	-D (Eife-l)	(299,524)	Parakionoceras	S (Ludl-u)	-D (Emsi-u)	(524)
Fusioceras	D (Give)			Paraloxoceras	C (Vise-u)?		(524)
+Gangshanoceras	O (Aren-u)?		(1066)	-Paramoeroeras	D (Fame-m)		
Garryoceras	O (Ashg)		(298)	Paraphragmites	S (Ludl)		(524)
Gaspocyrtoeras	S (Wen-l)			+Parasphaerorthoceras	S (Ludl-l)	-D (Gedi)?	(524)
Geisonoceras	O (Aren-u)	-D (Eife)	(298,524)	+Paratrematoceras	Tr(Olen)	-Tr(Ani)	(995)
+Geisonocerina	O (Cara)	-D (Give)	(298)	Petryoceras	D (Fras)		(299)
Geisonocerooides	D (Gedi)	-D (Give)		Plagiostomoceras	S (Wen-l-u)	-D (Fame-l)	(524)
Glenisteroceras	O (Aren-u)			Pleurorthoceras	O (Ashg-m)	-O (Ashg-u)	
Gorboceras	O (Llde)?	-O (Ashg-m)	(298,524)	+?Plicatoceras	D (Gedi-l)		
Gordonoceras	S (Ludl)?		(524)	+Podoliceras	S (Ludl)	-S (Prid)	(524)
Gorgonoceras	D (Eife)		(299)	Polygrammoceras	O (Llvi-l)	-D (Eife)	(298,524)
+Greenlandoceras	O (Cara-u)?		(524)	Proteoceras	O (Llde-u)	-O (Cara-l)	(524)
+Haruspex	C (Vise-l)		(524)	+Protobactrites	O (Llvi-l)	-S (Ludl-u)	(524)
Harrisoceras	S (Ludl)	-S (Prid)	(524)	Protoktionoceras	O (Cara-l)?	-D (Eife)	(298,524)
+Hedstroemoceras	O (Ashg)		(298)	Pseudactinoceras	C (Serp-l)?		(524)
+Helenites	S (Prid)		(524)	Pseudocycloeras	S (Wen-l)	-S (Prid)?	(524)
+Heloceras	O (m)	-S (Wen-l)		Pseudocyrtoceras	C (Tour)		
?Hemicosmorhoceras				+Pseudokionoceras	D (Eife-l)		(524)
	S (Ludl-l)		(524)	Pseudorthoceras	D (Fras)?	-P (Guad)	
Hesperoceras	C (Tour)			-Pseudotemperoceras	Tr(Olen)		(995)
Isorthoceras	O (Cara)	-O (Ashg-m)	(298)	+Pythonoceras	D (Eife)		(524)
+Jangziceras	S (Ldov-u)	-D (Gedi)	(524,1066)	+Rasmus-enoceras	O (Ashg-m)		
Joachimoceras	S			Reticycloeras	C (Vise-u)	-C (Serp-l)	(524)
+Joldagioceras	S (Ldov-m)?		(524)	-Rhabbites	D (Emsi-u)		(524)
Jonesoceras	S (Ludl-u)		(524)	+Rhipsites	D (Emsi-u)		(524)
Kionoceras	O (Llvi-l)	-P (Asse)?	(524)	Rhynchorthoceras	O (Aren-l)	-O (Cara-l)	(524,1066)
Lamellorthoceras	D (Emsi)	-D (Eife)	(299)	+Sactoceras	S (Wen-l)	-S (Prid)	(524)
Leurocyloeras	S (Ldov-u)	-D (Eife)	(524)	Sactorthoceras	O (Llvi-l)	-O (Cara-m)	(1066)
Lituites	O (Llvi-l)?	-O (Llde-u)	(524)	Sannionites			
Lopingoceras	P (Leon)?	-P (Tat)	(524)	Sceptrites	D (Eife)		
Loxoceras	C (Vise-u)	-C (Serp-l)	(524)	Shikhanoceras	P (Leon)		(524)
Lycoceras	S (Ludl)	-S (Prid)	(524)	+Siberioceras	S (Prid)		(524)
Macroloxoceras	D (Fame-m)?		(299,524)	+Sichuanaceras	S (Wen-l)		(1066)
+Mariceras	C (Serp-u)?	-C (Bash-l)?	(524)	Sigmoicycloeras	O (Llvi)		(298)
+Mericoeras	D (Fras-l)?		(524)	Simorthoceras	P (l)		
Mesnaquaceras	O (Llde)?			Sinoceras	O (Cara-l)	-O (Cara-m)	(298,524)
Metaspyroceras	O (Llde)	-D (Gedi)	(298)	Sphooceras	S (Wen-l-u)?	-S (Ludl)	(524)
Metastromatoceras	S (Wen-l-u)		(524)	Spyroceras	O (Llvi)?	-D (Fame-u)	(298,524)
Michelinoceras	O (Aren-u)	-Tr(Nori)	(2)	+Standardoceras	O (Llde)?		
Mitorthoceras	C (Tour)	-C (Serp-l)?		Stereoplasmoceras	O (Aren-u)	-O (Cara)	(298)
+Mongoceras	S (Ldov-u)		(524)	Stereospyroceras	O (Llde)		(298,524)
Monomuchites	O (Llde-u)?	-O (Cara-m)	(298,524)	Striacoceras	D (Give)		(1066)
Mooreoceras	D (Fras)	-P (Guad)		Stromatoceras	S (Wen-l-u)		(524)
+Murchisoniceras	S (Wen-l-u)	-S (Prid)	(524)	?Subspyroceras	O (m)		
Mysterioceras	O (Llde)	-O (Cara-m)	(298)	+Tajaroceras	O (Aren-u)		(298)
+Naivs	C (Vise-u)		(524)	+Tambegiroceras	S (Ldov-m)?		(524)
+Nebroceras	D (Eife-l)		(524)	+Tartaroceras	D (Fame-m)		
Neocyloeras	D (Fame-m)	-C (Serp-l)?	(524)	Temperoceras	S (Ludl-l)	-D (Give)	(1066)
Neorthoceras	P			Tetrapleuroceras	C (Mosc)	-C (Step-l)	(524)

Taxon	First Appearance	Last Appearance	Reference	Taxon	First Appearance	Last Appearance	Reference
Thoracoceras	C (Ms)	-P (l)		Georgina	O (Aren-u)	-O (Llvi)	(1066)
Tienoceras	P			Gonioceras	O (Llde)	-O (Cara-l)	(524)
Tofangoceras	O (Llvi)		(298,524)	+Hoeloceras	O (Llvi-l)	-O (Llde)	(524)
Trematoceras	Tr(Olen)	-Tr(u)		Huronia	S (Ldov-u)	-S (Wenl-u)	(524)
Tretoceras	O (Llvi)			Huronella	S (Wenl)		(524)
Trilacinocheras	O (Llvi-l)	-O (Cara)	(524)	+Kobyashiceras	D (Gedi)		
Tripteroceroides	C (Vise-u)		(524)	Kochoceras	O (Llde)?	-O (Ashg-m)	(298,524)
+Trispectes	D (Fame-m)			Lambeoceras	O (Cara-l)	-O (Ashg-m)	(298,524)
Troedssonella	O (Llvi-u)		(298,524)	Leurothoceras	O (Aren-u)	-O (Ashg)	(298)
+Tunguskoceras	O (Llde-u)		(524)	Megadisocerosus	O (Ashg)	-S (Wenl)	(298)
Uralorthoceras	P (Leon)		(524)	Meitanoceras	O (Llvi-u)	-O (Llde)	(298,524)
Vericeras	S (Ludl-l)		(524)	Mesactoceras	O (Llvi)		(298)
Virgoceras	S (Wenl)			+Metactinoceras	O (Aren)		(1066)
+Wardoceras	O (Aren-l)?		(298,524)	Metarmanoceras	S (Ludl)	-D (Sieg)	(524)
Whiteavesites	O (Ashg-l)		(298,524)	Monocyrtoceras	S (Wenl)		
Whitfieldoceras	O (Cara-u)	-O (Ashg-l)	(298,524)	Mstikhinoceras	C (Vise)		
Wolungoceras	O (Trem)	-O (Aren)		Nybyoceras	O (Aren-u)	-O (Ashg)	(298,524)
+Zeehanoceras	O (Cara-m)			Ordosoceras	O (Aren)	-O (Llvi-u)	(298,524, 1066)
+?Zhuralevia	K (Apti-u)			Ormoceras	O (Aren-u)	-D (Emsi-l)?	(524)
Or. ASCOCERIDA				Orthonybyoceras	O (Llde)	-O (Ashg)	(298)
Ascoceras	O (Ashg)	-S (Prid)	(298,524)	Paractinoceras	O (Cara-u)	-O (Ashg-m)	(298,524)
Aphragmites	S (Ludl-u)		(524)	Parormoceras	O (Llde)		(298)
Billingsites	O (Ashg-l)	-O (Ashg-m)	(298,524)	Polydesmia	O (Aren)	-O (Llvi-u)	(524,1066)
Choanoceras	S (Ludl-l)		(524)	Rayonoceras	D (Emsi-l)	-C (Serp-l)	(2,524)
Ecdyceras	O (Llde-u)	-O (Cara-u)?	(298,524)	Saffordoceras	O (Cara-u)		(298)
Glossoceras	S (Ludl-l)	-S (Ludl-u)	(524)	Selkirkoceras	O (Cara-m)	-O (Ashg)	(298)
Hebetoceras	O (Llde-u)			Stolbovoceras	O (Llvi)		(298)
Linstroemceras	S (Ldov)		(524)	Troedssonoceras	O (Cara)	-S (Ldov)?	(298)
Montyoceras	O (Llde-u)		(524)	Troostoceras	O (Llde)	-O (Cara-m)	
Parascoceras	S (Ludl-l)	-S (Ludl-u)	(524)	Wutinoceras	O (Aren-u)	-O (Cara)	(524)
Probillingsites	O (Cara-m)	-O (Cara-u)	(298,524)	+Zerashanoceras	D (Eife)		(524)
+Redpathoceras	O (Cara-l)		(2)	Or. ENDOCERIDA			
Schuchertoceras	O (Ashg-m)			Allocotoceras	O (Aren-u)		
Shamattawaceras	O (Ashg)			Allopioceras	O (Aren-l)		
Or. INTEJOCERIDA				Allotrioceras	O (Llvi-u)		
Bajkaloceras	O (Aren-u)	-O (Llvi-l)	(298,524)	Anthoceras	O (Aren-l)	-O (Llde)	(298)
Evencoceras	O (Aren-u)	-O (Llvi)	(298)	Bisonoceras	O (Trem-u)	-O (Llvi-l)	(524)
Intejoceras	O (Aren-u)	-O (Llvi-l)	(298,524)	Boreoceras	O (Trem-l)?		(524)
Majoceras	O (Trem)	-O (Aren)	(298)	Botryceras	O (Ashg-l)		(298,1066)
Padunoceras	O (Llvi-u)?		(298,524)	Cacheoceras	O (Aren-u)	-O (Llvi)	(298,1066)
Rossoceras	O (Aren)	-O (Llvi)	(298)	Camerooceras	O (Llvi-l)?	-O (Ashg)	(298,524)
Or. ACTINOCERIDA				Campendoceras	O (Aren)		
Actinoceras	O (Aren-u)	-O (Ashg-m)	(298,524)	Cassinoceras	O (Aren-u)		(524)
Adamsocheras	O (Aren-u)	-O (Llvi)	(298)	Changkiuoceras	O (Llvi)	-O (Llde)	(298)
+Aluveroceras	O (Cara-m)		(524)	+Chaohuoceras	O (Aren-l)	-O (Llvi-l)?	(1066)
Armenoceras	O (Llvi-l)	-S (Ludl-u)	(1066)	Chazyoceras	O (Llde)?		
Aploceras	C (Vise)?			Chihlioceras	O (Aren-u)		(524)
+Astoceras	D (Emsi-u)			Chisiloceras	O (Aren)	-O (Llde)	
Calhounoceras	O (Llvi)		(298)	-Choreanoceroides	O (Aren-l)		(1066)
Carbactinoceras	C (Vise)			Clitendoceras	O (Aren-l)	-O (Aren-u)	
Cyrtonybyoceras	O (Llvi-l)	-O (Llde)?	(298)	Coreanoceras	O (Aren-l)	-O (Aren-u)	(524)
Deiroceras	O (Cara-l)	-O (Ashg-m)	(298,524)	Cotteroceras	O (Aren-l)	-O (Aren-u)	(524)
Discoactinoceras	O (Llvi)	-O (Cara-l)	(524,1066)	Cyclocyrtendoceras	O (Aren-u)		(298,524)
Ellinoceras	O (Llvi-l)		(298,524)	Cyptendoceras	O (Aren-u)		(524)
Eldroceras	S (Ldov-u)	-S (Ludl-l)		Cyrtendoceras	O (Aren-l)	-O (Llde-l)	(298,524, 1066)
Eskimoceras	O (Ashg)		(298)	Cyrtovaginoceras	O (Aren)	-O (Llde)	(298)
+Eushantungoceras	S (Ludl-l)		(524)	Dartonoceras	O (Aren)		
Floweroceras	O (Cara-m)	-O (Ashg)?	(524)	Dideroceras	O (Aren-u)	-O (Llde)	(298,524)
				Disphenoceras	O (Trem-u)		(524)

Taxon	First Appearance	Last Appearance	Reference	Taxon	First Appearance	Last Appearance	Reference
+Atomoceras	D (Eife)		(299)	+Hiregiroceras	S (Ldov-m)	-S (Ldov-u)	(524)
+Atopoceras	D (Fame-m)		(299)	Inversoceras	S (Wen-l)	-S (Ludl)	(524)
Augustoceras	O (Cara-u)		(298,524)	-Iowoceras	S (Wenl)		(524)
Austinoceras	S (Wenl-u)?		(524)	-Irinites	D (Fame-m)		(299)
+Balashovia	D (Eife-l)		(299,524)	Jovellania	D (Gedi)	-D (Siegl)	(299,524)
Beloitoceras	O (Llde)?	-O (Ashg-m)	(298,524)	+Kallholoceras	O (Ashg-m)		
Blakeoceras	S (Ldov-l)	-D (Eife)	(524)	Karcoceras	S (Wenl)	-D (Gedi)	
Bolloceras	D (Eife)	-D (Fras)	(299)	Kentlandoceras	O (Cara)		(298)
Brachydomoceras	D (Emsi)		(299)	+Kijoceras	D (Fame-m)	-D (Fame-u)	(299,524, 1066)
Byronoceras	S (Wenl)			Kindleoceras	O (Ashg-m)		(298)
+Calchasiceras	C (Tour)		(524)	+Kophinoceras	D (Give)		(524)
Centrorizoceras	S (Wenl)			Laumontoceras	D (Siegl)		(524)
Chadwickoceras	S (Wenl-u)		(524)	Laureloceras	S (Wenl)		(524)
Clathroceras	S (Prid)		(524)	+Leonardoceras	O (Llvi-l)	-O (Llvi-u)	(524)
Clonyssiceras	S (Wenl)			Loganoceras	O (Cara-m)		(298,524)
Codoceras	S (Wenl)			Lorieroceras	D (Gedi)	-D (Siegl)	(299)
Coelocyrtoceras	D (Eife)		(299)	Lyckholmoceras	O (Ashg-l)	-O (Ashg-m)	(298,524)
Conostichoceras	D (Eife)		(299)	+Lychnoceras	D (Fame-m)?		(299,524)
+Corbuloceras	S (Ludl)?	-S (Prid)	(524)	Lysagoroceras	D (Fame-l)	-D (Fame-m)	(524)
+Corysoceras	D (Fame-m)?		(299,524)	Macrodomoceras	D (Emsi)		(299)
Crateroceras	S (Wenl)			Maelonoceras	O (Llde)	-O (Ashg)	(298)
Cycloplites	D (Fras)	-D (Fame)	(299)	Manitoulinoceras	O (Cara)	-O (Ashg-m)	(298)
Cyrthoceratites	D (Give-u)		(299,524)	+Megaloceras	D (Emsi)		(299)
Cyrtoeras	S (Ludl-u)	-S (Prid)?	(524)	+Meloceras	C (Vise)		(524)
Cyrtoeratites	D (Siegl)	-D (Fras)	(299)	Metaphragmoceras	D (Eife)		(299)
Cyrtocheilus	D (Eife)	-D (Give)	(299)	Metarizoceras	S (Wenl)		
Cyrtogomphus	D (Give)		(299)	+Metephippiorthoceras	O (Llde-u)		(524)
Cyrtorizoceras	O (Cara-m)?	-O (Ashg-m)	(298)	Miamoceras	O (Cara-m)	-O (Ashg-m)	(298,524)
Cyrtopyroceras	D (Fras-l)		(524)	+Mimolychnoceras	D (Fame-m)?		(299,524)
+Dalecarlioceras	O (Ashg-m)			Minganoceras	O (Cara-l)?		(524)
Danaoceras	S (Ludl-u)		(524)	Mitroceras	S (Wenl-u)		(524)
Danoceras	O (Ashg-l)		(298,524)	Mixosiphonoceras	O (Ashg-l)	-D (Emsi)	(524)
Diestoceras	O (Cara-l)	-O (Ashg-m)	(298,524)	+Mnemoceras	D (Fame-m)?		(299,524)
Digenuoceras	O (Ashg-m)		(298,524)	Neoceras	S (Ldov)		(524)
+Doleroceras	D (Eife-l)		(299,524)	Neumatoceras	O (Ashg-m)		(298,524)
Dowlingoceras	O (Ashg-m)		(298)	Nothoceras	D (Eife-l)		(299,524)
Dunleithoceras	O (Ashg)		(298)	+Oligoceras	D (Eife)		(299)
Ectocyrtoceras	S (Wenl)			Oncoceras	O (Llde)	-O (Ashg-m)	(298)
+Edenoceras	S (Ldov-m)	-S (Ldov-u)	(524)	Oocerina	S (Ludl-u)	-S (Prid)	(524,1066)
Ehlersoceras	O (Cara)		(298)	Oonoceras	O (Llvi-l)	-S (Prid)	(524)
Ekwanoceras	S (Wenl)			+Oratoceras	S (Ldov)		(524)
+Eocyrtoceras	S (Wenl)		(1066)	Osbornoceras	S (Ldov-m)	-S (Ldov-u)	(524)
Eorizoceras	O (Llde-u)?		(298,524)	Pachtoceras	D (Fame-m)		(524)
Eotrimoceras	S (Ludl-u)?		(524)	Paracleistoceras	D (Eife-l)		(299,524)
Eudoceras	D (m)			Paraconradoceras	D (Eife)		(299)
Euryrizoceras	S (Wenl)			Parioocerina	S (Wenl)	-S (Prid)	(1066)
Evlanoceras	D (Fras-m)		(299,524)	Pectinoceras	D (Emsi)		(299)
Fayetoceras	O (Cara)	-O (Ashg-m)	(298)	Pentameroceras	S (Wenl-l)	-S (Ludl)	(524,651)
Galtoeras	S (Wenl-l)		(524)	Perimecoceras	S (u)		
Gonatocyrtoceras	S (Wenl-u)	-D (Fame-m)	(524,1066)	Perioidanoceras	S (Wenl)		
Graciloceras	O (Llde)	-O (Ashg)	(298)	+Phthanonoceras	O (Aren-u)		(1066)
Grimisbyoceras	S (Wenl-u)		(524)	+Piersaloceras	O (Ashg-l)	-O (Ashg-m)	(298,524)
+Guangyuanceras	S (Ldov)		(1066)	Polyelasmoceras	D (Emsi)		(299)
+Guangyuancerooides	S (Ldov)		(1066)	Poterioceras	C (Tour-l)	-C (Vise-u)	(2,524)
+Gyroceras	D (Eife-u)	-D (Give)	(524)	Poteriocerina	D (Eife)	-D (Fame)	(299)
Hadoceras	O (Ashg-m)		(298)	Projovellania	S (Ludl)		(524)
+Hemibeloitoceras	O (Llde-u)		(524)	+Pseudobrevioceras	D (Fame)		(299)
Hemiphragmoceras	S (Wenl)			Psiaoceras	D (Fame)?	-C (Vise)	(1066)
Hercocyrtoceras	S (Wenl)		(524)	+Pyramidoceras	D (Eife)		(299)
Herkimeroeras	S (u)	-D (Gedi)	(299)	Ramussenoceras	O (Cara)	-O (Ashg)	(298)
Hexameroceras	S (Wenl)	-S (Ludl)	(524)				
Hipparionoceras	D (Eife)	-D (Fame)?	(299)				

Taxon	First Appearance	Last Appearance	Reference	Taxon	First Appearance	Last Appearance	Reference
Rhomboceras	S (Wenl)			Carilloceras	D (Fame-u)		(299,524)
Richardsonoceras	O (Llvi)	- S (Ludl-u)	(524,1066)	Casteroceras	D (Give-l)		(299,524)
Ringoceras	O (Cara-u)?	- O (Ashg-m)?	(524)	+ Catastrobocheras	C (Vise-u)	- C (Serp-l)	(524)
Rizoceras	S (Ludl-u)	- S (Prid)	(524)	+ Celox	C (Vise-u)		(524)
Rhomboceras	S (Wenl)			Cenoceras	Tr(Carn)	- J (Call)	(524)
Romingoceras	O (Llvi)	- O (Llde)	(298)	Centroceras	D (Eife)	- D (Give-u)	(524,1066)
Scofieldoceras	O (Cara)		(298)	Centrolitoceras	D (Give)		(299)
Shuranoceras	S (u)		(524)	Chouteauoceras	C (Tour-u)		(524)
Slocmoceras	S (Wenl)			Cimomia	J (Kimm)	- T (Ol-l)?	
+ Spanioceras	D (Eife)		(299)	Clydonautilus	Tr(Ladi)	- Tr(Nori-u)	(995)
Staufferoceras	O (Cara)	- O (Ashg-m)	(298)	Clymenonautilus	Tr(Carn)	- Tr(Nori)	(995,1066)
Stenogomphoceras	S (Wenl-u)		(524)	Coelogasteroceras	C (Bash)	- P (Leon)	(524)
Streptoceras	S (Wenl-u)	- S (Ludl-l)	(524)	- Coloceras	C (Vise-u)	- C (Step-l)?	(524)
Suttonoceras	O (Ashg)		(298)	Condraoceras	C (Mosc-u)	- P (Leon)?	(524)
Sycoceras	D (u)			Cooperoceras	C (Step-l)	- C (Step-u)	(524)
+ Talatoceras	S (Prid)		(524)	Cosmonautilus	Tr(Carn-l)	- Tr(Nori-m)	(995)
Tetrameroceras	S (Wenl)	- S (Ludl)	(524,1066)	+ Cranoceras	D (Give-u)	- D (Fras-l)	(524)
+ Torquatoceras	S (Wenl-l)			Cymatoceras	J (Bath)	- T (Ol-u)	(524,1066)
Trimeroceras	S (Ludl-u)		(524)	Cymatonautilus	J (Call)		(524)
Tripleuroceras	S (Wenl-u)	- D (Give-u)	(299,524,1066)	+ Danzikoceras	D (Eife)		
				+ Dasbergoceras	D (Fame-u)		
Tripterocheras	O (Llvi)	- O (Ashg-m)	(298)	Deltocymatoceras	K (Maes)?		(524)
Tripterocherina	O (Ashg)		(298)	Deltoidonautilus	K (Albi)	- T (Ol-l)?	(524)
+ Tshingizoceras	O (Ashg)		(298)	Dentoceras	P (Leon)		
Tumidoceras	D (Eife-u)		(524)	Diademoceras	D (Eife)	- D (Give)	(299)
Turnoceras	D (Emsi-u)		(299,524)	Diodoceras	C (Vise-u)?		(524)
Valcouroceras	O (Llde-u)		(298,524)	Diorugoceras	C (Vise-u)		(524)
+ Valhallocheras	O (Aren)		(1066)	Discitoceras	C (Eife)	- C (Serp-l)	(524)
Vaupelia	O (Cara)	- O (Ashg-l)	(298)	Domatoceras	C (Bash)	- P (Tatr)	(524)
Wadeoceras	D (Fras)	- D (Fame)	(299)	Duerleyoceras	C (l)		
Welleroceras	C (Vise)		(524)	- Dzhinsetoceras	D (Emsi)	- D (Eife)	
Worthenoceras	S (Wenl-l)	- S (Ludl)	(524)	Edaphoceras	C (Msi)		
+ Xainzanoceras	O (Llvi)?		(1066)	Encoiloceras	Tr(Carn-u)	- Tr(Nori)	(524,995)
Xenoceras	D (Gedi)	- D (Eife)	(299)	Endolobus	C (Serp-l)	- C (Mosc-u)	(524)
Zitteloceras	O (Llde-l)	- O (Ashg-m)	(298,524)	Enoploceras	Tr(Olen)	- Tr(Nori)	(2,524,995)
				Ephippioceras	C (Vise-u)	- P (l)	(524,1066)
				Epicymatoceras	K (Maes)		(524)
Or. NAUTILIDA				Epidomatoceras	C (Vise-u)		(524)
Acanthonautilus	C (Vise-u)		(524)	Epistrobocheras	C (Vise-u)		(524)
+ Adoloceras	D (Emsi-u)		(299,524)	+ Euciphoceras	T (Eo-l)		
Adelphoceras	D (Eife-l)		(299,524)	Eucymatoceras	K (Barr)		(524)
Aipoceras	C (Tour-l)	- C (Tour-u)?	(524)	Eutrephoceras	J (Call)?	- T (Mi-u)	(524)
+ Alethynoceras	D (Emsi)		(299)	Foordiceras	P (Sakm)?	- P (Guad-u)	(524)
Alexandronautilus	P (Guad-l)		(524)	+ Geitonoceras	D (Fame-l)?		(299,524)
+ Anepheloceras	D (Emsi)		(299)	Germanonautilus	Tr(Olen)	- Tr(Nori)	(2,524,995)
Anglonautilus	K (Haut)	- K (Ceno)		Goldringia	D (Emsi)	- D (Give)	(299)
Anomaloceras	D (m)			Gonionautilus	Tr(Nori-u)		(995)
Anoploceras	Tr(Olen)	- Tr(Carn-u)	(524,995)	Grypoceras	Tr(Olen)	- Tr(Nori)	(2,524,995)
+ Aphractus	C (Bash)		(1066)	Gryponautilus	Tr(Carn)	- Tr(Nori)	(524)
Aphelaeceras	C (Tour-u)	- C (Serp-l)	(524)	+ Grzegorzewskia	S (Wenl)?		
Apogonoceras	P (l)			Gzheloceras	C (Vise-u)?	- P (Leon)	(524)
+ Articheilus	P (Leon)		(524)	Halloceras	D (Emsi-u)		(524)
+ Askeatonoflucidum	C (Vise-u)		(524)	Hemiliroceras	P (Leon)		
Asymptoceras	C (Tour-u)?	- C (Vise-u)	(2,524)	Heminautilus	K (Apti)	- K (Albi)	(524)
Aturia	T (Than)	- T (Mi-u-u)	(899)	+ Hergoclossoceras	J (Sinc-u)		(524)
Aturoidea	K (Sn)	- T (Eo)	(524)	Hercoceras	D (Eife-l)		(299,524)
Aulaconautilus	J (Tith-u)	- K (Vala)	(524)	Hergoclossa	T (Dani)	- T (Eo-m-l)	(700)
Aulamatacoceras	P (Leon)	- Tr(Carn)	(524)	Hexagonites	P		
+ Bastindoceras	D (Eife)		(299)	Hindoceras	D (Give-u)	- D (Fras)?	(299,524)
Bistrialites	C (Vise)?			Holconautilus	Tr(Anis-u)	- Tr(Nori)	(524,995)
Callaionautilus	Tr(Nori-m)	- Tr(Nori-u)	(2,524,995)	Homaloceras	D (Give-l)		(524)
+ Capriocornites	D (Eife-l)		(524)	Homoadelphoceras	D (Eife-l)		(299,524)
Carinonautilus	K (Apti)	- K (Sant)	(524)				

Taxon	First Appearance	Last Appearance	Reference	Taxon	First Appearance	Last Appearance	Reference
Humanoceras	P (Leon)		(524)	† Pseudocatastrobocheras	C (Vise-u)		(524)
Indonauutilus	Tr(Anis-l)	-Tr(Nori-u)	(524,995,1120)	Pseudocenocheras	J (Tith-u)?	-K (Maes-l)	(524)
Juvavaionauutilus	Tr(Carn)	-Tr(Nori)	(995)	Pseudonauutilus	J (Tith-l)?	-K (Vala-l)	(524,1066)
Knightoceras	C (Serp-l)	-P (Leon)	(524,1066)	† Pseudophacoceras	C (Vise-u)		(524)
+ Krykyloceras	D (Eife-l)?			+ Pseudostenopoceras	C (Serp-l)	-C (Mosc-u)	(524)
- Kummeloceras	P (Wc)	-P (Leon)	(524)	- Pseudotemnocheilus	P (Leon)		(524)
- Leuroceras	C (Vise)		(1066)	+ Pseudotitanoceras	P (u)		(524)
Librovitschiceras	C (Step-l)		(524)	Ptenoceras	D (Sie-g-u)	-D (Eife)	(2,299)
Liroceras	C (Vise-u)	-P (l)?	(524)	Ptyssoceras	D (Emsi)		(299)
Lisporceras	C (Vise)		(524)	Rhiphaeceras	P (Leon)		(524)
Litogyroceras	D (Emsi)		(299)	Rhiphaeonauutilus	P (l)		
Lophoceras	C (Vise)?		(1066)	Rinceras	C (Vise-l)	-C (Vise-u)	(524)
Maccocyoceras	C (Vise)		(524)	Roussanoffoceras	D (l)?		
+ Mahoningoceras	C (Mosc-u)	-C (Step-l)	(524)	Rutocheras	D (Gedi)	-D (Give-u)	(299)
Megaglossoceras	C (Mosc-u)		(300)	Scyphoceras	P (Leon)		
Menuthionauutilus	Tr(Indu)		(995)	Sholakoceras	P (Sakm)?		(524)
Mesochasmoceras	C (Vise-u)		(524)	Siberionauutilus	Tr(Nori-m)		(995)
Metaoceras	C (Step-l)	-P (Guad-u)	(524)	Sibyllonauutilus	Tr(Anis-l)	-Tr(Nori-u)	(995,1120)
Millkoninckioceras	C (Vise)	-P (l)	(1066)	† Simplicioceras	T (Eo-l)		
Mojscarcoceras	Tr(Olen)	-Tr(Nori)	(995)	J (m)		-J (u)	
+ Mosquoceras	C (Mosc)	-C (Step-l)?	(524)	Solenochilus	C (Vise-u)?	-P (Leon)	(2,524)
Muiroceras	D (Give)		(299)	Somalinauutilus	J (Bajo)	-J (Kimm-u)	(524,1066)
Nassauoceras	D (Eife)		(299)	Sicarcoceras	C (Bash-u)	-C (Mosc-l)	(524)
+ Nauutiloceras	C (Tour-u)		(524)	Stenopoceras	C (Step-l)	-P (Dju)	(524)
Nauutilus	T (Eo-m)	-R		- Stenzeloceras	K (Camp-l)		(301)
+ Neobistrialites	C (Serp-l)	-C (Mosc-u)		Strionauutilus	K (l)		
+ Neocymatoceras	T (Ol-u)			Stroboceras	C (Vise-u)	-C (Serp-l)	(524)
+ Neodontoceras	P (Guad-l)?		(524)	Strophoceras	D (Give-u)		(299,524)
+ Nikenauutilus	C (Serp-l)		(524)	Styriionauutilus	Tr(Anis)	-Tr(Nori)	(524,995,1066)
+ Ophionauutilus	J (Bajo)		(524)	Subclymenia	C (Vise-l)?		(524)
Oxyntauutilus	Tr(Nori)		(524)	Subvestinauutilus	C (Vise-u)		(524)
+ Palaskensis	Tr(Carn)		(524)	Syringoceras	Tr(Olen)	-Tr(Nori)	(995)
+ Palaelia	K (Barr-u)?	-K (Albi)	(524)	Syringonauutilus	Tr(Olen)	-Tr(Nori)	(995)
+ Paracenoceras	J (Bath-u)?	-K (Albi)	(524)	Syrionauutilus	Tr(Olen)	-Tr(Nori)	(995)
Paracymatoceras	J (Bath)?	-J (Tith-u)?	(524)	Syrionauutilus	K (Maes)?		(524)
Paradomatoceras	C (u)			Syrreghmatoceras	D (Fras)		(299)
Parametacoceras	C (Step-l)	-C (Step-u)	(524)	Taimionauutilus	P (Guad)	-Tr(Olen)	(524,995)
Paranauutilus	Tr(Anis-m)	-Tr(Nori-u)	(524,995,1120)	Tainoceras	C (Step-l)	-Tr(Carn)	(524,995)
Pararhiphaeceras	P (l)			Tangchiashanites	P (Leon-u)	-P (Guad-l)	(524)
Pararineceras	C (Vise)		(524)	- Teichertia	T (Dani)?	-T (Eo)?	(524)
Parastenopoceras	P (Leon)			Temnocheilus	C (Vise-u)	-P (Tatr)	(524)
Peripetoceras	C (Vise)?	-P (Guad-l)		Tetragonoceras	D (Eife)	-D (Give)	(299,1066)
Perinoceras	P (Guad-l)		(524)	Tetranodoceras	D (Give-l)		(299,524)
† Permodomatoceras	P (Leon)		(524)	† Thymastoceras	D (Give-u)		(299,524)
Permonauutilus	P (u)			Threaceras	D (Eife)?		(524)
- Perunauutilus	Tr(Nori)		(1120)	Thrinoceras	C (Vise)	-P (Wc)	(524)
Phacoceras	C (Vise-u)	-P (Wc)?	(524)	Thuringionauutilus	Tr(Anis)	-Tr(Ladi)	(524,995)
Phaedrysmocheilus	Tr(Olen)	-Tr(Nori)	(995)	Tirolonauutilus	P (Guad)		(524)
Phloioceras	Tr(Ladi-u)	-Tr(Nori)	(524,995)	C (Titanoc)	C (Mosc)	-P (Guad-u)	(524)
+ Piratoceras	D (Eife)		(299)	Tithonoceras	J (Tith-u)		(524)
Planetoceras	C (Vise-u)		(524)	† Tomponauutilus	Tr(Indu)		(1120)
Pleuronauutilus	P (Leon)	-Tr(Nori)	(524,995)	Trachynauutilus	Tr(Anis)	-Tr(Carn)	(995)
Pleuronoceras	D (Eife-u)		(524)	† Trematodiscus	Tr(Carn)	-Tr(Nori)	(524)
Plummicoceras	P (Sakm)?		(524)	† Triboloceras	C (Tour-u)	-C (Vise-l)	(524)
Potoceras	C (Vise-u)		(524)	Trigonoceras	C (Vise-u)?	-C (Serp-l)	(524)
Proclydonauutilus	Tr(Anis-u)	-Tr(Rhae)	(524,995)	Trochoceras	D (Sie-g-u)	-D (Eife-l)	(299,524)
Procyomatoceras	J (Bath)		(1066)	† Tumidonauutilus	Tr(Ladi)		(524)
Pselioceras	P (l)			Tylosidoceras	C (Vise)		(524)
Pseudaganides	J (l)	-J (Tith)	(524,1066)	Tylonauutilus	C (Serp-l)	-P	(524)
† Pseudaturoidea	K (Barr-u)?	-K (Albi)	(524)	Tylorthoceras	D (Emsi)	-D (Eife)	(299)
				† Uloceras	D (Emsi)		(299)

Taxon	First Appearance	Last Appearance	Reference
Valhallites	C (Ms)	-P (l)	
Venatoroceras	P (Leon)		
+Vertorhizoceras	D (Fame)		
Vestinautilus	C (Tour-u)	-C (Vise-u)?	(524)
Virgaloceras	P (u)		
Wellsoceras	D (Eife-u)	-D (Give-l)	(299,524)
Xenocheilus	J (u)	-K (Barr)	(524)
+Yakutionautilus	Tr(Nori-m)		(995)

Or. TARPHYCERIDA

Aethoceras	O (Aren-u)		(524)
Alaskoceras	O (Aren-l)		(298,524)
Aphetoceras	O (Aren-l)?	-O (Llvi)?	(298,524)
Arkoceras	O (Aren-u)	-O (Llvi)	(298)
+Bateroboceras	S (Wenl-u)	-S (Ludl)	
+Beekmanoceras	O (Trem-u)	-O (Aren-u)	(524)
+Bentoceras	O (Aren-u)		(298,524)
+Bodieceras	O (Cara-m)		
+Bodoceras	O (Ashg-m)		
+Campbelloceras	O (Aren-l)	-O (Cara-l)?	(524)
Catyrephoceras	S (Ludl-l)		(1066)
Centrotarphyceras	O (Aren-u)		(524)
Charactoceras	O (Cara-u)	-O (Ashg-m)	(298,524)
Clytoceras	O (Aren-u)		(524)
+Craiftonoceras	S (Wenl)		(524)
Curtoeras	O (Aren-u)	-O (Llde-u)?	(298,524)
Cycloplectoceras	O (Aren-u)		(524)
Deltoeras	O (Aren)		(298)
Discoceras	O (Llvi)	-S (Ldov-l)	(298,524)
Eichwaldoceras	O (Aren-u)		(524)
Estonioceras	O (Aren-u)	-O (Llvi-l)	(524)
Eurysomites	O (Aren-u)		(524)
Graftonoceras	S (Ludl)?		
Hardmanoceras	O (Aren-u)		(524)
Holmiceras	O (Aren-u)?		(524)
+Inclytoceras	S (Ludl-u)		(524)
Jasperoceras	O (Llde)?		
Kinaschukoceras	O (Ashg-m)		(298,524)
+Kosovoceras	S (Wenl-u)?	-S (Ludl)	(524)
Leurotrochoceras	S (Wenl-u)		(1066)
Litoceras	O (Aren-u)	-O (Llde)?	(524)
+Magdoceras	S (Ludl)		(524)
Moreaucoceras	O (Aren-l)		(524)
+Pakrioceras	O (Llvi)		(1066)
+Paradisoceras	O (Cara-u)	-O (Ashg)	(298,524)
Peismoceras	S (Wenl-l)	-S (Prid)	(524)
Pilotoceras	O (Aren-l)		(524)
Pionoceras	O (Aren-u)		(524)
Plectolites	O (Llvi-u)		(298)
+Pseudancistroceras	O (Aren)		(1066)
Pycnoceras	O (Aren-l)	-O (Aren-u)	(524)
Rhadinoceras	D (Give-l)?	-D (Fras-l)	(299,524)
+Schroederoceras	O (Llde)	-O (Ashg-m)	(524)
Seelyoceras	O (Aren)		
Shumardoceras	O (Aren-l)		(524)
Systrophoceras	S (Ludl-u)		(524)
Tarphyceras	O (Aren-u)	-O (Ashg-l)?	(524)
Tragoceras	O (Aren-u)	-O (Llvi-l)	(524)
Trochodictyoceras	S (Wenl-u)		(1066)
Trocholithes	O (Llvi-u)	-O (Ashg-l)	(524)
Trocholithoceras	O (Aren-u)		(524)
Tyrioceras	O (Ashg-l)	-O (Ashg-m)?	(524)

Taxon	First Appearance	Last Appearance	Reference
+Vasalemmoceras	O (Cara-u)		(524)
Weberoceras	O (Cara-u)?	-O (Ashg-m)	(298,524)
Wichitoceras	O (Aren-u)		

Or. BARRANDEOCERIDA

Apsidoceras	O (Cara-u)		(524)
Avilionella	O (Llde-l)?	-O (Cara)	(2,298)
Baeopleuroceras	D (Emsi)	-D (Give-u)	(2,299)
Barrandoceras	O (Llde)		(2,524)
Bickmorites	S (Ldov-u)	-S (Wenl)	(524)
Centrocyrtoceras	O (Llvi)	-O (Ashg-l)?	(298)
Charactocerina	O (Ashg-m)		(298)
Chidleyoceras	O (Cara-l)	-O (Cara-m)?	(524)
Cliftonoceras	S (Wenl)		(524)
Cumingsoceras	S (Wenl)		(524)
Deckeroceras	O (Ashg-m)		(298)
Endoplanoceras	D (Give)		(299)
Fremontoceras	O (Cara-m)	-O (Ashg)	(298,524)
Gasconoceras	S (Wenl)		
Haydenoceras	D (Eife)		(299)
Heraeloceras	D (Give-u)		(524)
Jolietoceras	S (Wenl-l)		(524)
Lechritrochoceras	S (Wenl-u)		(524)
Lyrioceras	D (Give-l)		(299,524)
Nephriticeras	D (Eife)	-D (Give)	(299)
Nephriticerina	D (Eife-u)	-D (Give)	(299,524)
Paquettoeras	O (Cara)		(298)
Plectoceras	O (Aren-l)?	-O (Ashg)	(298,524)
Savageoceras	S (Wenl)		
Sphyradoceras	D (Emsi-u)		(299,524)
Triplooceras	D (Eife)	-D (Give-u)	(2,299)
Uranoceras	S (Wenl)	-S (Ludl)	(524,1066)
Wilsonoceras	O (Ashg-l)	-O (Ashg-m)	(298,524)

Or. UNCERTAIN

+Burronoceras	S (Ludl-u)		(651)
Dartoceras	S (Wenl)		
+Desmoceris	S (Ludl-l)		(651)
+Heyuncoceras	S (Ludl-l)		(651)
+Kaillceras	S (Wenl-l)		(651)
+Orthodochmioceras	S (Wenl-l)		(651)
+Sichunoceras	S (Wenl-l)		(651)
+Songkanoceras	S (Ldov-m)		(651)
+Werthenoceras	S (Ludl-u)		(651)
+Yunnanoceras	S (Ludl-u)		(651)
+Yichangoceras	S (Ldov-m)		(651)

Or. ANARCESTIDA

+Acanthoelymenia	D (Fras-l)	-D (Fras-m)	(1042)
Agoniatites	D (Eife-l)	-D (Give-u)	(457)
Aktastioceras	P (Asse)	-P (Leon)?	(2)
Anarcestes	D (Emsi-l)	-D (Emsi-u)	(302)
Anetoceras	D (Emsi-l)	-D (Emsi-u)	(302)
+Angustobacrites	C (Vise-u)		(1066)
Archoceras	D (Give-u)	-D (Fame-l)	(1042)
Atlantoceras	D (Fras-l)	-D (Fras-m)	(457)
Augurites	D (Emsi-u)		(302)
Bacrites	D (Emsi-l)	-P (Tatr)	(302,1066)
Belemnitomimus	P (Asse)	-P (Sakm)	
Beloceras	D (Fras-m)	-D (Fras-u)	(302,1042)
Cabrievoceras	D (Give)		(457)

Taxon	First Appearance	Last Appearance	Reference	Taxon	First Appearance	Last Appearance	Reference
Carinoceras	D (Fras-m)	-D (Fras-u)	(302,457)	+Pseudofoordites	D (Give)		(457)
Celaeceras	D (Emsi-u)		(302)	Pseudoproboceras	D (Give-u)		(1066)
+Ceratpbeloceras	D (Fras-u)		(1042)	Renites	D (Fame-m)		(302,457)
Clymenoceras	D (Fame-m)		(302,457)	Sandbergeroceras	D (Fras-l)	-D (Fras-m)	(392,1042)
Cochleiferoceras	D (m)			Schindewolfoceras	D (Fras-m)		(302,457)
Convoluticeras	D (Sieg-l)	-D (Emsi-u)	(457,1103)	Sellagoniatites	D (Give-l)		(457)
Crickites	D (Fras-u)		(302)	Sellanarcestes	D (Emsi-u)		(302,457)
Ctenobactrites	C (Serp-l)	-P (Leon-l)	(524)	+Serramanticoceras	D (Fras-m)	-D (Fras-u)	(1042)
Cyclobactrites	D (m)			Sicilioceras	P (Leon)		
Cyclolymenia	D (Fame-m)		(302,457)	+Sinuobactrites	C (Bash)		(1066)
Cyrtobactrites	D (Emsi-l)		(302)	Sobolewia	D (Eife-u)	-D (Give-u)	(457)
Devonobactrites	D (m)			Sphaeromanticoceras	D (Fras-m)	-D (Fras-u)	(302,457)
Devonopronorites	D (Fras-m)		(302)	-Stenophariceras	D (Give-u)	-D (Fras-l)	(1042)
+Dilatobactrites	C (Step-l)		(1066)	Subanarcestes	D (Eife-l)	-D (Give-l)	(457)
+Dillerites	Tr(Car-u)		(1066)	Synphariceras	D (Fras-l)		(302)
?Eobactrites	O (Aren)	-O (Llde)	(2)	Tabantoloceras	P (Asse)	-P (Sakm)	
Eobeloceras	D (Fras-u)		(302)	-Talenticeras	D (Emsi-l)		(457)
Erbenoceras	D (Sieg-l)	-D (Emsi-u)	(302,457, 1103)	Tamarites	D (Give-u)	-D (Fras-l)	(302,457, 1042)
Fasciculoceras	D (Eife-l)	-D (Eife-u)	(457)	Taskanites	D (Sieg-l)	-D (Emsi-u)	(302,457, 1103)
Foordites	D (Eife-u)	-D (Give)	(457)	Teicherticeras	D (Emsi-l)		(2,457)
+Gaurites	D (Emsi-l)			Timanites	D (Fras-l)		(302,457, 1042)
+Gogoceras	D (Fras-m)		(1042)	Timanoceras	D (Fras-m)		(302,457)
+Gracilites	D (Sieg-u)	-D (Emsi-u)	(457,1103)	Triainoceras	D (Fras-l)		(302)
Gyroceratites	D (Emsi-l)	-D (Emsi-u)	(1066)	Trimanticoceras	D (Fras-m)	-D (Fras-u)	(302,457, 1042)
Hoeninghausia	D (Fras-l)		(302,457)	Uchtites	D (Fras-m)		(302,457)
Holzapfeloceras	D (Give)		(457)	Wedekindella	D (Give-u)		(302)
+Kimoceras	D (Emsi)		(1066)	-Wellsites	D (Fras-m)		(1042)
Koenenites	D (Fras-l)		(302,457)	Werneroceras	D (Eife-l)	-D (Give-u)	(457)
Komioceras	D (Fras-l)		(302,457, 1042)				
Kokenia	D (Eife-u)		(1066)				
Latanarcestes	D (Emsi-l)	-D (Eife-u)	(457,1103)				
Lobobactrites	D (Sieg-u)	-D (Fame-m)	(524)				
Maenioceras	D (Give-l)	-D (Give-u)					
Manticoceras	D (Fras-l)	-D (Fras-u)	(302)				
Maternoceras	D (Fras-m)		(302,457)				
Melonites	D (Fame-m)		(302,457)				
Mesobeloceras	D (Fras-m)	-D (Fras-u)	(1042,1103)				
Microbactrites	P (Sakm)	-P (Leon)?	(2)				
Mimagoniatites	D (Emsi-l)	-D (Eife-l)	(302)				
Mimantarcestes	D (Eife)		(457)				
Mimosphinctes	D (Emsi-l)	-D (Emsi-u)	(302,457)				
+Mixomanticoceras	D (Fras-m)		(1042)				
Neomanticoceras	D (Fras-m)		(1042)				
Neophariceras	D (Give-u)	-D (Fras-l)	(302,1042)				
Nordiceras	D (Fras-m)		(1042)				
Palaeogoniatites	D (Emsi-l)	-D (Emsi-u)	(302,457)				
Parabactrites	P (Leon)		(1066)				
Paraphyllites	D (Emsi-u)		(457)				
Parentites	D (Emsi-l)	-D (Emsi-u)	(302,457, 1103)				
Petteroceras	D (Give-u)	-D (Fras-l)	(302,1042)				
Phariceras	D (Give-u)	-D (Fras-l)	(302,1066)				
Pinacites	D (Eife)		(457)				
-Playfordites	D (Fras-m)		(1042)				
Ponticeras	D (Fras-l)	-D (Fras-m)	(302)				
Proboloceras	D (Fras-m)		(302,1042)				
+Prochorites	D (Fras-m)		(1042)				
Prolobites	D (Fame-l)	-D (Fame-m)	(302,457)				
+Protimanites	D (Fras-l)		(1042)				
+Pseudobactrites	D (Emsi-u)	-D (Eife-l)	(1066)				

Or. CLYMENIIDA

Acriclymenia	D (Fame-m)		(302)
Aktuboclymenia	D (Fame-m)		(302)
Biloclymenia	D (Fame-m)		
-Borkinia	D (Fame-m)		(1066)
Carinoclymenia	D (Fame-m)		(302)
Clymenia	D (Fame-m)		
Costaclymenia	D (Fame-m)		
Cteroclymenia	D (Fame-m)		(302)
Cymaclymenia	D (Fame-m)	-D (Fame-u)	
Cyrtoclymenia	D (Fame-m)	-D (Fame-u)	
-Dimeroclymenia	D (Fame-m)		(1066)
Epiwocklumeria	D (Fame-u)		
Falciclymenia	D (Fame-m)		
+Finiclymenia	D (Fame-u)		(1042)
+Flexiclymenia	D (Fame-m)		(1042)
Genuclymenia	D (Fame-m)		
Glatzia	D (Fame-u)		
Goniclymenia	D (Fame-m)		
+Gyroclymenia	D (Fame-m)		(1042)
Hexaclymenia	D (Fame-m)		
Kalloclymenia	D (Fame-m)	-D (Fame-u)	(1042)
Kamptoclymenia	D (Fame-u)		
Karaclymenia	D (Fame-m)		(302)
Kazachoclymenia	D (Fame-m)		(302)
Kiaclymenia	D (Fame-m)		(302)
+Kielcensia	D (Fame-u)		(1042)
Kosmoclymenia	D (Fame-m)	-D (Fame-u)?	
Laganoclymenia	D (Fame-u)		(302)

Taxon	First Appearance	Last Appearance	Reference	Taxon	First Appearance	Last Appearance	Reference
+Linguaclymenia	D (Fame-u)		(1042)	Atsabites	P (Leon)		
+Lissoclymenia	D (Fame-u)		(1042)	Aulartoceras	D (Fras-m)	-D (Fame-l)	(457,1042)
+Mesoclymenia	D (Fame-m)		(1042)	Axinolobus	C (Bash-u)		(302)
Miroclymenia	D (Fame-m)			Balvia	D (Fame-u)		(302,1042)
+Nodosoclymenia	D (Fame-m)		(1042)	Baschkirites	C (Bash-l)		(302)
Ornatoclymenia	D (Fame-m)		(302)	Bashkorticeras	C (Bash-l)		(302,304)
Pachyclymenia	D (Fame-m)			Basleoeras	P (Guad-u)?		
Parawoeklumeria	D (Fame-u)			Beleutoceras	C (Serp-l)		(304)
Pinaclymenia	D (Fame-m)		(302)	Beyrichoceras	C (Vise-u)		(302)
Piricyclenia	D (Fame-m)			Beyrichoceratoides	C (Vise-l)	-C (Serp-l)	(304,954)
Platyclymenia	D (Fame-m)			Bilinguites	C (Bash-l)		(302,304)
Postglaziella	D (Fame-u)			Bisatoceras	C (Bash-l)	-C (Step-u)	(1066)
+Pricella	D (Fame-m)		(1042)	Bogdanoceras	C (Bash-l)		(302,304)
Progonioclymenia	D (Fame-m)			Bollandites	C (Vise-l)	-C (Vise-u)	(302)
+Protactoclymenia	D (Fame-m)		(1042)	Bollandoceras	C (Vise-l)	-C (Vise-u)	(304,954)
Protoxyclymenia	D (Fame-m)			Branneroceras	C (Bash-u)		(302)
Rectoclymenia	D (Fame-m)			Branneroceratoides	C (Vise)?		(302)
+Rhiphaeoclymenia	D (Fame-u)		(1042)	Brevikites	C (Bash-l)		(302,304)
Schizoclymenia	D (Fame-m)?		(302)	Caenocyclus	C (l)		(302)
Sellaclaymenia	D (Fame-m)	-D (Fame-u)		Caenolyroceras	C (Serp-l)		(304)
Soliclymenia	D (Fame-m)	-D (Fame-u)	(1042)	Cancelloceras	C (Bash-l)		(302)
Sphenoclymenia	D (Fame-m)	-D (Fame-u)	(1042)	+Cardiella	P (Asse)	-P (Leon-m)	(732)
Stenoclymenia	D (Fame-m)		(302,1042)	Cavientia	C (Serp-l)		(304)
Sulcoclymenia	D (Fame-m)		(302,1042)	+Changhsingoceras	P (Dora)		
Synwoeklumeria	D (Fame-u)		(302)	Cheiloceras	D (Fame-l)	-D (Fame-m)	(302,1042)
Triaclymenia	D (Fame-u)			Christioceras	C (Mosc-l)		(1066)
Trochoclymenia	D (Fame-u)			Chumazites	C (Bash-l)		(302,304)
Uraloclymenia	D (Fame-m)		(302)	Clinolobus	P (Guad-l)		(1066)
Woeklumeria	D (Fame-u)			Clistoceras	C (Mosc)?, C (Step)?		(302)
Or. GONIATITIDA				Cluthoceras	C (Serp-l)		(304)
+Acrimeroceras	D (Fame-l)		(1042)	Collectoceras	C (Serp-l)		(304)
+Acutimitoceras	C (Tour-l)		(1042)	Costimitoceras	C (l)		(302)
Adrianites	P (Guad-l)			+Crasotornoceras	D (Fras-m)	-D (Fame-l)	(304)
Aenigmatoceras	C (Bash-l)		(304)	Cravenites	C (Serp-l)		
Agastrioceras	C (Bash-l)		(302)	Cravenoceras	C (Serp-l)		
Agathiceras	C (Mosc-l)	-P (Guad-l)	(2)	Cravenoceratoides	C (Serp-l)		(302)
Aktubites	C (Mosc-l)	-C (Step-u)		Crimites	P (Sakm)	-P (Leon)	
Alaoeras	C (Vise-u)?	-C (Serp-l)	(302,304)	Cryptoclymenia	D (Fame)		(302)
Aldanites	C (Bash-u)		(302)	Cunitoceras	C (l)		(302)
+Almites	C (Step-u)	-P (Sakm-u)?		Cyclolobus	P (Djhu)	-P (Dora)	
Alpinites	D (Fame-m)	-D (Fame-u)	(302,457, 1042)	Cymoceras	C (Bash-u)		(1066)
Altudoceras	P (Leon)	-P (Guad-u)		Decorites	C (Serp-u)	-C (Bash-l)	(302,304)
Alurites	C (Bash-l)		(302,304)	Delepinoceras	C (Serp-l)		(302,304)
Ammonellipsites	C (Tour-u)	-C (Vise-l)	(304)	Demarezites	P (Leon-u)		(732)
Anatsabites	P (Guad)			Diaboloceras	C (Bash-u)	-C (Mosc-l)	(304)
+Angranoceras	P (Guad-u)?		(1066)	Dimeroceras	D (Fame-l)	-D (Fame-m)	(302,1042)
Anthracoceras	C (Serp-l)		(302)	Dimorphoceras	C (Vise-u)		(954)
Anthracoceratites	C (Bash-l)	-C (Mosc-l)	(302,304, 1066)	Dimorphoceratoides	C (Mosc)?, C (Step)?		(302)
Anthracoceratoides	C (Mosc)?		(302)	Discoclymenia	D (Fame-m)	-D (Fame-u)	(302,457)
Aphanites	C (Bash-l)		(304)	Dombartites	C (Serp-l)		(2,302)
Aquilonites	C (Vise-l)		(304,954)	Dombarigloria	C (Serp-l)		(304)
Aranites	D (Fame-m)		(302,457)	Donetzoceras	C (Bash-u)	-C (Mosc-u)	(302)
Arcanoceras	C (Vise-u)	-C (Serp-l)	(302,304)	Doryceras	P (Guad)		
Aricoceras	P (Leon)	-P (Guad)		+Doubichites	P (Guad-u)		
Aristoceras	C (Step-u)	-P (Asse)		Dunbarites	C (Mosc-u)	-C (Step-u)	(1066)
Aristoceratoides	P (Guad)			+Dyscheiloceras	D (Fame-l)		(1042)
Arkanites	C (Bash-l)		(302)	Dzhaprakoceras	C (Tour-u)?	-C (Vise-l)	(954)
+Armatites	D (Fame-l)	-D (Fame-m)	(1042)	+Elephantoceras	P (Leon-u)	-P (Guad-l)	(303)
Asturoceras	C (Vise)?		(302)	Emilites	C (Step-l)	-P (Asse-l)	
				Entogonites	C (Vise-u)		
				Eoasianites	C (Bash-u)	-P (Asse-u)	(302)

Taxon	First Appearance	Last Appearance	Reference	Taxon	First Appearance	Last Appearance	Reference
Eogonioloboceras	C (Vise-u)	-C (Serp-l)	(302,304,1066)	Kayutoceras	C (Bash-u)		(302)
+Eohyattoceras	P (Sakm)	-P (Leon-u)?	(732)	Kazakhoceras	C (Tour-u)	-C (Serp-l)	(302)
Eonomismoceras	C (Vise-l)		(304)	Kazakhstania	C (Tour-l)		(302,304)
Eoparalegoceras	C (Mosc-l)			Kenseyoceras	D (Fame)		(302)
Eoschistoceras	C (Mosc-u)	-C (Step-l)	(304)	Kirsochoceras	D (Fame-m)		(1042)
Eothalassoceras	C (Step-l)	-C (Step-u)	(1066)	Kozhimites	C (Vise-l)		(304)
Eothinites	P (Leon)			Kraftoceras	P (Djhu)		
Eowellerites	C (Mosc-l)		(302)	Kufengoceras	P (Leon)?	-P (Guad-l)	
Epadiamites	P (Djhu)		(1066)	Kushanites	C (Bash-l)		(302,304)
Epiglyphioceras	P (Leon)	-P (Guad)		Lagowites	D (Fame-l)	-D (Fame-m)	(302,1042)
+Epijuresanites	P (Leon)			Lanceoloboceras	P (Guad-l)		(303)
Epithalassoceras	P (Guad-l)			+Leeites	P (Sakm)?		(1066)
Epitornoceras	D (Give-u)	-D (Fras-l)	(302,1042)	+Linguatormoceras	D (Fras-m)	-D (Fame-l)	(457)
+Eptitauroceras	P (Djhu)		(1066)	Lobotornoceras	D (Fras-l)	-D (Fras-m)	(1042)
+Erinoceras	P (Leon-u)		(303)	Lustanites	C (Vise-u)	-C (Serp-l)	(302,304)
Eumorphoceras	C (Serp-l)		(304)	Lyrogoniatites	C (Vise-u)	-C (Serp-l)	(302,304,1066)
Eupleuroceras	C (Step-u)			Lytheoceras	C (Serp-l)		(302,304)
+Eurites	C (Tour-u)		(954)	Maenioceras	D (Fame-l)	-D (Fame-m)	(302,457)
Euroceras	C (Serp-l)		(302,304)	Mangeroceras	C (Mosc-u)		
+Exotornoceras	D (Fame-l)	-D (Fame-m)	(1042)	Marathonites	C (Step-u)	-P (Leon)	
+Falcitornoceras	D (Fame-l)	-D (Fame-u)	(1042)	Marianoceras	C (Bash-l)		(302,304)
Fallacites	C (Bash-l)		(302,304)	Maximites	C (Mosc-l)	-C (Step-l)	(302)
Fascipericyclus	C (Tour-u)	-C (Vise-l)	(302,304)	Melvilloceras	C (Bash-u)		(1066)
Fayettevillea	C (Serp-l)		(302)	Mescalites	C (Step-u)	-P (Sakm-u)	
Ferganoceras	C (Serp-l)		(302,304)	Metadimorphoceras	C (Vise-u)	-C (Bash-l)	(304)
Gaetanoceras	P (Leon)			Metalegoceras	P (Asse)	-P (Sakm-u)	
Gastrioceras	C (Bash-l)	-C (Bash-u)	(302,304)	Mexioceras	P (Guad-l)		
Gattendorfia	C (Tour-l)	-C (Tour-u)	(302)	+Miminitoceras	D (Fame-m)	-C (Tour-l)	(1042)
Gattenpleura	C (Tour-l)		(302,1042)	Mirilentia	C (Serp-l)		(302,304)
Girtyoceras	C (Vise-u)	-C (Serp-l)	(302,304)	Mongoloceras	P (Guad-l)		(302)
Glaphyrites	C (Serp-l)	-P (Asse-l)	(302)	Muensteroceras	C (Tour-l)	-C (Vise-l)	(304,954)
Glassoceras	P (Leon-u)	-P (Guad)	(302)	Nautellipsites	C (Vise-l)		(302)
Gleboeras	C (Step-u)			Neogoniatites	C (Step-l)	-P (Dora)	(303)
Glythiolobus	C (Serp-u)	-C (Bash-l)	(302,304)	Neocrimites	P (Leon-l)	-P (Guad)	
Goniatites	C (Vise-u)		(302)	Neodimorphoceras	C (Step-l)	-P (Asse-l)	
+Gonioeyclus	C (Tour-l)		(1042)	Neoglaphyrites	C (Step-u)	-P (Asse)	(302)
Gonioglyphioceras	C (Step-u)			Neoglyphioceras	C (Vise-u)	-C (Serp-l)	(302,304,1066)
Gonioloboceras	C (Bash-u)	-C (Step-u)		Neogoniatites	C (Vise)	-C (Serp-l)	(302,304)
Gonioloboceratoides	C (Mosc-l)		(1066)	Neoioceras	C (Bash-u)	-P (Asse)	(1066)
+Hammatocyclus	C (Tour-l)	-C (Vise-l)	(954,1042)	+Neopericyclus	C (Tour-u)		(954)
Helicyocyclus	C (Vise-l)		(954)	Neoshumardites	C (Step-l)	-P (Leon-l)	
Hibernioceras	C (Vise-u)		(302)	+Nevadoceras	P (Sakm-u)	-P (Leon-l)	
Hodsonites	C (Bash-l)		(302,304)	Nomismoceras	C (Vise-u)	-C (Serp-l)	(954)
Hoffmannia	P (Guad)			Nothosporadoceras	D (Fame-m)		(302,457)
Homoceras	C (Serp-u)		(302)	Nuculoceras	C (Serp-l)		(302)
Homoceratoides	C (Bash-l)		(302,304)	Nummoceras	C (Vise-u)?	-C (Serp-l)	(302,304)
Hudsonoceras	C (Serp-u)	-C (Bash-l)	(302,304)	Ophilyoceras	C (Vise-u)?	-C (Serp-l)	(302,304)
Hunanites	P			Orulganites	C (Bash-u)		(302)
Hyattoceras	P (Leon)	-P (Djhu)	(1066)	Owenoceras	C (Mosc-l)	-C (Step-l)	
Hypergoniatites	C (Vise)	-C (Serp-l)	(302,304)	Oxintoceras	C (Vise-l)		(954)
Imitoceras	D (Fame-m)?	-C (Tour-u)	(2,302,304,1042)	+Oxytornoceras	D (Fame-l)		(1042)
Intoceras	C (Tour-l)	-C (Vise-l)	(302,1042)	Pachylyroceras	C (Vise-u)?	-C (Serp-l)	(302,304)
Inzeroceras	C (Mosc)?	C (Step)?	(302)	Palermites	P (Guad)		
Iranoceras	D (Fame-m)		(302,457)	+Paprothites	C (Tour-l)		(1042)
Irinoceras	C (Tour-u)	-C (Serp-l)	(302,304,954)	Paracravenoceras	C (Serp-l)	-C (Bash)?	(302,304)
+Isohomoceras	C (Serp-u)	-C (Bash-l)	(304)	Paradimeroceras	D (Fame-l)	-D (Fame-m)	(302,457,1042)
Juresanites	P (Asse-l)	-P (Sakm-l)		Paradimorphoceras	C (Vise-u)		(2,302)
Karagandoceras	C (Tour-l)	-C (Tour-u)	(302)	Paragastrioceras	P (Asse)	-P (Leon-m)	
Kardalitites	C (Serp-l)	-P (Leon)	(304)	+Paragattendorfia	C (Tour-l)		(1042)

Taxon	First Appearance	Last Appearance	Reference	Taxon	First Appearance	Last Appearance	Reference
+Parahomoceras	C (Serp-u)		(304)	Rhymnoceras	C (Serp-l)		(302,304)
Paralegoceras	C (Mosc-l)			Richardsonites	C (Serp-l)		(302,304)
Paralyticoceras	C (Tour-l)		(302)	Rotopericyclus	C (Tour-l)	-C (Vise-l)	(304,954,1042)
Paraperinites	P (Leon-l)	-P (Leon-m)?	(305)	+ Sangzhitites	P (Guad-l)		(303)
Paraschartymites	C (Bash-l)		(304)	Schartymites	C (Bash-l)		(302,304)
Paraschistoceras	C (Step-u)			Schistoceras	C (Step-l)	-C (Step-u)	
Parashumardites	C (Step-l)		(304)	Schuihengoceras	C (Bash-u)		
+Paratorleyoceras	D (Fame-l)		(1042)	+ Shangraoceras	P (Guad-l)		(303)
Paratornoceras	D (Fame-l)		(302)	+ Shaoyangoceras	P (Guad-l)		(303)
Parayakutoceras	C (Bash-u)		(302)	Shengoceras	P (Leon)		
Parodoceras	D (Eife-u)	-D (Give-l)	(302,457,1066)	Shouchangoceras	P (Guad-l)	-P (Guad-u)	(303)
Pennoceras	C (Step-u)			Shumardites	C (Step-u)	-Tr (Indu-l)	(1066)
Pericleites	C (Serp-l)		(304)	+ Simichelloceras	D (Fame-l)		(1042)
Pericyclus	C (Tour-l)	-C (Tour-u)	(304,954)	Simmoceras	C (Vise)?		(302)
Peritochia	C (Mosc)	-P (Leon)		Sinotites	D (Fame-l)		(302)
+Pernoceras	D (Fame-m)		(1042)	Sizilites	P (Guad)		
Perrinites	P (Leon-m)	-P (Leon-u)	(305)	Somoholites	C (Step-l)	-P (Sakm)	(302,304)
Peytonoceras	C (Serp-l)		(302,304)	+ Sosioceras	P (Guad-l)		(303)
Phaneroceras	C (Bash-u)	-C (Mosc-l)	(302)	Spirolegoceras	P (Leon-u)		
Phillipoceras	C (Bash-l)		(304)	Sporadoceras	D (Fame-l)	-D (Fame-u)	(302,457)
+Phoenixites	D (Give-u)	-D (Fame-l)	(1042)	Stacheoceras	P (Leon)	-P (Dora)	(302,1066)
Physematites	C (Serp-u)		(304)	Stenocyclus	C (Tour-u)		(954)
Platygoniattites	C (Vise-u)	-C (Serp-l)	(302,304)	Stenoglyphyrites	C (Serp-l)	-C (Bash-l)	(302,304)
+Polariocyclus	C (Tour-u)		(954)	Strigogoniattites	P (Guad-u)		
Politoceras	C (Bash-u)	-C (Mosc-l)	(302)	Subitoceras	C (Serp-u)		(304)
+Polonites	D (Fame-l)		(1042)	Subperrinites	P (Sakm-l)	-P (Sakm-u)	(305)
Polonoceras	D (Fame-l)		(1042)	Subshumardites	C (Step)		
Popanoceras	P (Leon-l)	-P (Leon-u)		Sudeticeras	C (Vise-u)		(302,304)
Postornoceras	D (Fame-m)		(1042)	+ Sulcimitoceras	C (Tour-l)		(1042)
Praeglyphioceras	D (Fame-m)		(302)	Sulcoedimorphoceras	C (Serp-l)		(302)
+Praemeroceras	D (Fame-l)		(1042)	Sulcogirtyoceras	C (Vise)?		(302)
Preshumardites	C (Step-u)	-P (Sakm)		Sunites	D (Fame-l)		(302)
Prionoceras	D (Fame-m)		(302,1042)	Surenites	C (Bash-l)		(302,304)
Properrinites	P (Sakm-l)	-P (Sakm-u)	(305)	+ Sverdrupites	P (Leon-u)		
Propopanoceras	P (Sakm-l)	-P (Sakm-u)		Svetlanoceras	P (Asse-l)	-P (Sakm-u)	(1066)
Proshumardites	C (Serp-l)	-C (Step-u)	(2)	Syngastroiceras	C (Serp-l)	-C (u)	(302,304)
Prostacheoceras	P (Asse-l)	-P (Guad)		Synuraloceras	P (Sakm)		
Prothalassoceras	C (Step-u)	-P (Guad-u)		Tabantalites	P (Asse)	-P (Sakm-l)	
Protopopanoceras	P (Asse)			+ Tauroceras	P (Guad-l)		(305)
Protornoceras	D (Fame-m)		(1042)	Tectiretites	C (Bash-l)		(302,304)
Pseudagathiceras	P (Guad-u)			Terekites	C (Tour-u)		(302)
Pseudarietites	C (Tour-l)			Texoceras	P (Leon)		
Pseudoclymenia	D (Fame-m)			Thalassoceras	P (Sakm)	-P (Guad)	
Pseudogastroiceras	P (Guad-l)	-Tr (Indu-l)	(1066)	Timorites	P (Guad-u)	-P (Dju)	(302)
Pseudoglyphyrites	C (Serp-l)		(304)	+ Tongluceras	P (Leon-u)		(732)
Pseudohalorites	P (Sakm)	-P (Guad-u)	(303)	Torleyoceras	D (Fame-l)		(302)
Pseudonomismoceras				Tornia	D (Fame-m)		(1042)
	C (Vise-l)		(302,1066)	Tornoceras	D (Give-l)	-D (Fame-m)	(302,457)
Pseudoparalegoceras	C (Bash-u)	-C (Mosc-u)	(1066)	Trettinoceras	C (Mosc)?, C (Step)?		(302)
Pseudoschistoceras	P (Leon)			Trigonogastroiceras	C (Pn)		(302)
Pseudovidrioceras	P (Guad-l)		(1066)	Trizonoceras	C (Vise-u)	-C (Serp-l)	(302,304)
+Qiannanites	C (Tour-l)		(1042)	+ Tryuloceras	D (Fame-l)		(1042)
Quasicravenceras	C (Serp-l)		(302,304)	Tumarcoceras	P (Leon)		
Quasintoceras	C (Vise-l)		(954)	Tumilites	C (Serp-l)		(302)
Quinnites	C (Bash-l)		(304)	Tympanoceras	C (Serp-l)		(302,304)
Ramosites	C (Serp-u)	-C (Bash-l)	(304)	Umbetoceras	C (Bash-l)		(302,304)
Raymondiceras	D (Fame-l)	-D (Fame-m)	(1066,1103)	+ Unquatornoceras	D (Fras-m)	-D (Fame-l)	(1042)
Reticuloceras	C (Bash-l)		(302)	Uraloceras	P (Sakm-l)	-P (Leon-m)	
Retites	C (Bash-l)		(302)	Vallites	C (Bash-l)		(304)
Rhadinites	C (Serp-l)		(302,304)	Verancoceras	C (Serp-l)		(302,304)
Rhiphaeocyclus	C (Vise-l)		(954)	Verneuilites	C (Bash-l)		(302)

Taxon	First Appearance	Last Appearance	Reference	Taxon	First Appearance	Last Appearance	Reference
Vidrioceras	C (Step-u)			Stenopronorites	C (Serp-l)	-C (Mosc-l)	(304,1251)
Vöehringierites	C (Tour-l)		(302)	Sundaïtes	P (Djhu)		(1066)
Waagenina	P (Asse)	-P (Guad)		-Synartinskia	P (Sakm)	-P (Leon-u)	(1251)
Waagenoceras	P (Guad-l)	-P (Guad-u)	(302)	-Syndenites	P (Guad-u)	-P (Djhu)	(1251)
Wellerites	C (Mosc-u)	-C (Mosc-u)	(1066)	Tridentites	C (Vise-u)		(2)
Wewokites	C (Step-l)	-C (Step-u)	(302)	Uddenites	C (Step-u)		(304,1251)
Wiedeyoceras	C (Bash-l)	-C (Mosc-u)	(304,1066)	Uddenoceras	C (Step-l)	-C (Step-u)	(1251)
Winchelloceras	C (Tour-u)	-C (Vise-l)	(304)	-Uralopronorites	C (Serp-l)		(304)
Winslowoceras	C (Bash-u)		(304)				
Yakutoceras	C (Bash-u)		(302)	Or. CERATITIDA			
Yakutoglyphyrites	C (Bash-u)	-C (Step-u)	(302)	-Abichites	P (Dora)		(1066)
Yinoceras	P (Leon)	-P (Guad-l)	(302,304)	Acanthinites	Tr(Nori-l)	-Tr(Nori-m)	(302)
Zadelsdorfia	C (Tour-l)		(1042)	Acanthoceratites	Tr(Ladi-l)		(302)
Zephyroceras	C (Serp-l)		(302,304)	Acrochordiceras	Tr(Anis-m)		(302)
				Alanites	Tr(Anis-m)		(302)
Or. PROLECANITIDA				Albanites	Tr(Olen-u)		(302)
Acrocanites	C (Tour-u)		(1066)	Alloceratites	Tr(Carn-l)?		(302)
-Akmilleria	P (Asse)	-P (Leon)		Allochionites	Tr(Nori-m)		(302)
-Aktubinskia	P (Leon)			Alloptychites	Tr(Anis-l)		(302)
Artinksia	C (Step-u)	-P (Leon)		Amarassites	Tr(Nori-m)		(302)
+Artioceras	P (Leon)			Amphipoanoceras	Tr(Anis-u)		(302)
+Artioceratoïdes	P (Leon)		(1251)	Amphistephanites	Tr(Olen-l)		(302)
-Bamyaniceras	P (Leon)	-P (Guad-l)	(1251)	Anaflemingites	Tr(Nm)		(302)
Boesites	C (Bash-u)	-P (Sakm)	(304,1251)	Anagyminites	Tr(Anis-l)		(302)
-Cantabricanites	C (Vise-u)		(1251)	Anagyminotoceras	Tr(Anis-m)		(302)
Daisites	C (Step-u)	-P (Sakm)	(1251)	Ananorites	Tr(Anis)		(302)
Daraelites	P (Asse)	-P (Guad-l)	(1066,1251)	Anasibirites	Tr(Olen-l)		(302)
-Darvasiceras	P (Leon)		(1251)	Anasirenites	Tr(Carn-u)		(302)
-Difunites	P (Guad-u)	-P (Djhu)	(1251)	Anatibetites	Tr(Nori-m)		(302)
Dombarocanites	C (Vise-u)	-C (Serp-u)	(304,1251)	Anatomites	Tr(Nori-l)		(302)
Eocanites	C (Tour-l)		(302)	Anatropites	Tr(Carn-u)		(302)
-Eoprodromites	C (Tour-l)		(1042)	Anaxenaspis	Tr(Nm)		(302)
Epicanites	C (Vise-u)	-C (Bash-l)	(304,1251)	Anderssonoceras	P (Djhu)		(302)
Episageceras	P (Djhu)	-Tr(Indu-u)	(302,1251)	Anfaceras	P (Djhu)		(302)
-Eumedlicottia	P (Leon)	-P (Djhu)	(1251)	Anisarcestes	Tr(Ladi)	-Tr(Carn)	(302)
+Katacanites	C (Vise-u)			Anolcites	Tr(Ladi-u)		(302)
Latisageceras	Tr(Nm)		(302)	Anotoceras	Tr(Indu-l)		(302)
Medlicottia	P (Sakm)	-P (Guad-l)	(1251)	Apleuroceras	Tr(Ladi)		(302)
-Megapronorites	C (Vise-u)	-C (Serp-l)	(304,1251)	Aplococeras	Tr(Anis-u)		(302)
Merocanites	C (Tour-u)	-C (Vise-u)	(304)	Araxoceras	P (Guad-u)?	-P (Dora)	(302)
-Metacanites	C (Serp-l)		(1066)	Arcestes	Tr(Carn)	-Tr(Rhae)	(302)
-Metapronorites	C (Mosc-l)	-P (Leon)	(1251)	Arctoceras	Tr(Olen-l)		(302)
-Michiganites	C (Vise-l)	-C (Vise-u)	(954)	Arctogymnites	Tr(Anis-u)		(302)
-Miklukhoceras	P (Leon)		(1251)	Arctohungarites	Tr(Anis-m)		(302)
-Neogeoceras	P (Guad-l)	-P (Djhu)	(1251)	Arctomeekoceras	Tr(Olen-u)		(302)
-Neopronorites	C (Step-u)	-P (Leon)		Arctopronites	Tr(Olen-l)		(302)
-Neouddenites	P (Leon)			Arctoptychites	Tr(Ladi-l)		(302)
-Nodosageceras	P (Djhu)		(1251)	Arctosirenites	Tr(Carn-u)		(302)
Parapronorites	P (Leon)	-P (Guad-l)	(1251)	Arctotiroliotes	Tr(Olen-u)		(302)
-Praedaraelites	C (Vise-u)	-C (Serp)?		Argolites	Tr(Ladi)		(302)
-Prodromites	C (Tour-l)	-C (Tour-u)	(302)	Argosirenites	Tr(Nori-m)		(302)
Prolecanites	C (Vise-u)	-C (Serp-l)	(304)	Arianites	Tr(Olen-u)		(302)
Pronorites	C (Vise-u)		(2,304,1251)	Arietocellites	Tr(Carn-u)		(302)
				Aristoptychites	Tr(Ladi-u)		(302)
Propinacoceras	P (Leon)	-P (Guad-u)		Arniocellites	Tr(Carn-u)		(302)
Protocanites	C (Tour-l)	-C (Tour-u)		Arpadites	Tr(Ladi)		(302)
Protosageceras	Tr(Indu-l)		(302)	Arthaberites	Tr(Anis)		(302)
Proudtenites	C (Mosc-u)	-C (Step-u)	(304)	Asklepioceras	Tr(Ladi-u)		(302)
-Pseudopronorites	C (Bash-u)	-C (Step-u)	(1251)	Aspenites	Tr(Olen-l)		(302,1066)
-Sakmarites	P (Asse)	-P (Leon)		Austroceratites	Tr(Ladi)		(302)
Shikhanites	P (Asse)		(302)	Bacchites	Tr(Carn-u)		(302)
Sicanites	P (Asse)	-P (Guad-l)	(1251)	Badiotites	Tr(Carn-l)		(302)

Taxon	First Appearance	Last Appearance	Reference	Taxon	First Appearance	Last Appearance	Reference
Balatonites	Tr(Anis-m)		(302)	Eoacerochordiceras	Tr(Olen-u)	- Tr(Anis-l)	(302)
Balkanites	Tr(Olen-u)		(302)	Eoaxoceras	P (Guad-u)		(302)
Barrandeites	Tr(Carn-u)		(302)	Eodanubites	Tr(Olen-u)		(302)
Beatites	Tr(Olen-u)		(302)	Eogymnites	Tr(Olen-u)		(302)
Beneckeia	Tr(Olen-u)	- Tr(Anis-m)	(302)	Eoprottrachyceras	Tr(Ladi-l)		(302)
Beyrichites	Tr(Anis)		(302)	Eosagenites	Tr(Carn-u)		(302)
Biltnerites	Tr(Olen-u)		(302)	- Eosturia	Tr(Olen-u)		(1066)
Boreomeekoceras	Tr(Olen-u)		(302)	Epacerochordiceras	Tr(Anis-m)		(302)
Bosnites	Tr(Anis)		(302)	Epicellites	Tr(Olen-u)		(302)
Brouwerites	Tr(Nori-m)		(302)	Epicellitoides	Tr(Olen-u)		(302)
Buddhaites	Tr(Anis)		(302)	Epiceratites	Tr(Carn-u)		(302)
Bukowskiites	Tr(Anis)		(302)	Epigymnites	Tr(Anis-u)	- Tr(Ladi)	(302)
Bulogites	Tr(Anis-m)		(302)	Episculites	Tr(Nori-m)		(302)
Carnites	Tr(Carn-l)?	- Tr(Carn-u)	(302,1066)	Eremites	Tr(Carn-u)?		(302)
Caucasites	Tr(Anis)		(302)	Eudiscoceras	Tr(Anis-u)		(302)
Ceratites	Tr(Anis-u)	- Tr(Ladi-l)	(302)	Euflemingites	Tr(Olen-l)		(302)
Chioceras	Tr(Olen-u)		(302)	Euisculites	Tr(Carn-u)	- Tr(Nori-l)	(302)
Chioites	Tr(Olen-u)		(302)	Eupinacoceras	Tr(Nori)		(302)
Choristoceras	Tr(Nori-u)	- Tr(Rhae)	(302)	Eusagenites	Tr(Carn-u)		(302)
Cibolites	P (Leon-u)	- P (Guad-u)	(302)	Eutomoceras	Tr(Anis-u)		(302)
Cladiscites	Tr(Carn)	- Tr(Rhae)	(302)	Flemingites	Tr(Indu-u)		(302)
Clonimites	Tr(Ladi-u)	- Tr(Nori-l)	(302)	Flexoptychites	Tr(Anis-u)	- Tr(Ladi-l)	(302)
Clydonites	Tr(Nori-m)		(302)	Frankites	Tr(Ladi-u)		(302)
Clypeoceras	Tr(Indu-u)		(302,1066)	Frechites	Tr(Anis-u)	- Tr(Ladi-l)	(302)
Coelhoceras	Tr(Nori-u)		(302)	Gangadharites	Tr(Anis)		(302)
Coeloceltites	Tr(Carn-u)?		(302)	Gevanites	Tr(Anis-u)	- Tr(Ladi-u)	(302)
Collignonites	Tr(Nm)		(302)	Glamocites	Tr(Carn-u)		(302)
Columbites	Tr(Olen-u)		(302)	Glyphidites	Tr(Nori-u)		(302)
Coroceras	Tr(Carn-l)		(302)	Gnomohalorites	Tr(Nori-u)		(302)
Cuccoceras	Tr(Anis-m)		(302)	Gonionotites	Tr(Carn-u)	- Tr(Nori-l)	(302)
Cycloceltites	Tr(Rhae)		(302)	Grambergia	Tr(Anis-l)		(302)
Cyrtopleurites	Tr(Nori-m)		(302)	Griesbachites	Tr(Carn-u)	- Tr(Nori-l)	(302)
Czekanowskites	Tr(Anis-m)		(302)	Groenlandites	Tr(Anis-l)		(302)
Dagnoceras	Tr(Olen-u)		(302)	Guembelites	Tr(Nori-l)		(302)
Dalmatites	Tr(Olen-u)		(302)	Gymnites	Tr(Anis-l)		(302)
Danubites	Tr(Anis)		(302)	Gymnotoceras	Tr(Anis-u)		(302)
Daphnites	Tr(Nori-m)		(302)	Gymnotropites	Tr(Carn-u)		(302)
Daxatina	Tr(Ladi-u)		(302)	Gyromites	Tr(Indu-u)		(302,1066)
Diaplococeras	Tr(Olen-u)		(302)	Haidingerites	Tr(Carn-l)		(302)
Didymites	Tr(Nori-m)		(302)	Halilucites	Tr(Anis-u)		(302)
Dieneria	Tr(Carn-u)		(302)	Halorites	Tr(Nori-m)	- Tr(Nori-u)	(302)
Digitophyllites	Tr(Olen-u)		(302)	Hanielites	Tr(Olen-l)		(302)
Dimorphites	Tr(Nori-l)		(302)	Hannaoceras	Tr(Carn-l)		(302)
Dimorphotoceras	Tr(Nori-l)		(302)	Hauerites	Tr(Nori-m)		(302)
Dinarites	Tr(Olen-u)		(302)	Hedenstroemia	Tr(Olen-l)		(302)
Dionites	Tr(Nori-u)		(302)	Helicites	Tr(Nori-m)		(302)
Diplosirenites	Tr(Carn-l)		(302)	Hemiaspenites	Tr(Nm)		(302)
Discoceratites	Tr(Ladi)		(302)	Hemilecanites	Tr(Olen-u)		(302)
Discophiceras	Tr(Indu-l)	- Tr(Indu-u)	(302)	Heraclites	Tr(Nori-m)		(302)
Discoptychites	Tr(Anis-m)	- Tr(Anis-u)	(302)	Himavattites	Tr(Nori-m)		(302)
Discotropites	Tr(Carn-u)		(302)	Hollandites	Tr(Anis-m)		(302)
Distichites	Tr(Nori-m)		(302)	Homerites	Tr(Carn-u)		(302)
Dittmarites	Tr(Carn-l)		(302)	Hoplotropites	Tr(Carn-u)		(302)
Dobrogeites	Tr(m)		(302)	Huishuities	Tr(Anis-m)		(302)
Dorikranites	Tr(Olen-u)		(302)	Hungarites	Tr(Anis-u)	- Tr(Ladi-u)	(302)
Drepanites	Tr(Nori-m)		(302)	Hyattites	Tr(Nori-l)		(302)
Drumoceras	Tr(Ladi-u)		(302)	Hyparpadites	Tr(Ladi)		(302)
Dunedinites	Tr(Indu-u)		(302)	Hypisculites	Tr(Nori-m)		(302)
Durvilleoceras	Tr(Nm)		(302)	Hypocladiscites	Tr(Carn)		(302)
Dzhulfoceras	P (Djhu)		(302)	Hycranites	Tr(Olen-u)		(302)
Ectolcites	Tr(Nori-m)?		(302)	Iberites	Tr(Ladi-u)		(302)
Edmundites	Tr(Ladi)?	- Tr(Carn-l)	(302)	Inaigymnites	Tr(Anis-m)		(302)

Taxon	First Appearance	Last Appearance	Reference	Taxon	First Appearance	Last Appearance	Reference
Indigirites	Tr(Ladi-l)	-Tr(Ladi-u)	(302)	Metussuria	Tr(Olen-l)		(302)
Indocelites	Tr(Ladi-u)		(302)	Microtropites	Tr(Carn-u)		(302)
Indojuvavites	Tr(Nori-l)		(302)	Milites	Tr(Nori-l)		(302)
Indonesites	Tr(Carn-u)		(302)	Mirojuvavites	Tr(Nori-l)		(302)
Intornites	Tr(Anis-m)	-Tr(Anis-u)	(302)	Mojsisovicsites	Tr(Nori-l)		(302)
Inyoites	Tr(Olen-l)		(302)	Monacanthites	Tr(Olen-u)		(302)
Isculites	Tr(Anis-l)	-Tr(Anis-m)	(302)	Muensterites	Tr(Ladi-u)		(302)
Isculitoides	Tr(Olen-u)		(302)	Nairites	Tr(Nori-m)		(302)
Ismidites	Tr(Anis-m)		(302)	Nannites	Tr(Carn-l)		(302)
Istreites	Tr(Ladi-l)		(302)	Nassichukites	Tr(Nori-u)		(302)
Japonites	Tr(Anis-l)		(302)	Nathorstites	Tr(Ladi-u)	-Tr(Carn-l)?	(302)
Jellinekites	Tr(Nori-m)		(302)	Negebites	Tr(Ladi-u)		(302)
Joannites	Tr(Anis-u)	-Tr(Carn-l)	(302,1066)	Neocladiscites	Tr(Ladi)		(302)
Jovites	Tr(Carn-u)		(302)	Neoclypites	Tr(Carn-l)		(302)
Judicarites	Tr(Anis-u)		(302)	Neocolumbites	Tr(Olen-u)		(302)
Juvavites	Tr(Nori-l)		(302)	Neohimavavites	Tr(Nori-m)		(302)
Juvenites	Tr(Olen-l)		(302)	Neopopanoceras	Tr(Olen-u)		(302)
Karangatites	Tr(Olen-u)		(302)	Neoprotrachyceras	Tr(Carn-l)	-Tr(Carn-u)	(302)
Kashmirites	Tr(Nm)		(302)	Neosiremites	Tr(Carn)		(302)
Kazakhstanites	Tr(Olen-l)	-Tr(Olen-u)	(302,1066)	Neotibetites	Tr(Nori-m)	-Tr(Nori-u)	(302)
Kellnerites	Tr(Anis-u)		(302)	-Nevadisculites	Tr(Anis-m)	-Tr(Anis-u)	(302)
Keltroceras	Tr(Olen-l)		(302)	Nevadites	Tr(Anis-u)		(302)
Keyserlingites	Tr(Olen-u)?	-Tr(Anis-l)	(302,1066)	Nicomedites	Tr(Anis-m)		(302)
Khvalynites	Tr(Olen-u)		(302)	Nielsenoceras	P (Guad-u)		(302)
Kingites	Tr(Nm)		(302)	Nitanoceras	Tr(Ladi-u)		(302)
Kingoceras	P (Guad-u)	-P (Djhu)	(302)	Nodoitibetites	Tr(Nori-l)		(302)
Kiparisovia	Tr(Anis-m)		(302)	Noethingites	Tr(Anis)		(302)
Kiparisovites	Tr(Olen-u)		(302)	Nordophiceras	Tr(Olen-u)		(302)
Klamathites	Tr(Carn-u)		(302)	Nordiscites	Tr(Nori-m)		(302)
Klipsteinia	Tr(Carn-l)		(302)	Norites	Tr(Anis-u)	-Tr(Ladi-l)	(302,1066)
Koninckites	Tr(Indu-u)		(302)	Obrutchevites	Tr(Carn)		(302)
Laboceras	Tr(Anis)		(302)	Olenikites	Tr(Olen-u)		(302)
Lanceolites	Tr(Olen-l)	-Tr(Olen-u)	(302,1066)	+Olenokoceras	Tr(Olen-u)		(1066)
Lecanites	Tr(Ladi-u)	-Tr(Carn-l)	(302,1066)	Ophiceras	Tr(Indu-l)		(302)
Leconteiceras	Tr(Carn-u)		(302)	Orestites	Tr(Ladi-u)?	Tr(Carn-l)?	(302)
+Leislingites	Tr(Nori-m)	-Tr(Nori-u)	(1066)	Orthocelites	Tr(Ladi)?	-Tr(Carn-l)	(302)
Lenotropites	Tr(Anis-l)		(302)	Otocelites	Tr(Ladi-u)		(302)
Lenticocelites	P (Djhu)		(302)	Otoceras	Tr(Indu-l)		(302)
Liardites	Tr(Ladi-u)		(302)	Owenites	Tr(Olen-l)		(302)
Lingyunites	Tr(Nm)		(302)	Palaeokazakhstanites	Tr(Nm)		(302)
+Lipuites	Tr(Nori-l)		(1066)	Paliticites	Tr(Nori-l)		(302)
Lissonites	Tr(Nm)		(302)	Pamphagosirenites	Tr(Carn-u)		(302)
Lobites	Tr(Ladi-u)	-Tr(Carn-l)?	(302)	Paraacrochordiceras	Tr(Olen-u)	-Tr(Anis-l)?	(302,1066)
Longobardites	Tr(Anis-m)	-Tr(Ladi-l)	(302)	Paracelites	P (Leon-u)	-P (Guad-u)	(302)
Longobarditoides	Tr(Anis)		(302)	Paraceratites	Tr(Anis-m)	-Tr(Anis-u)	(302)
Malayites	Tr(Nori-l)		(302)	Paraceratitoides	Tr(Ladi-l)	-Tr(Ladi-u)	(302)
Malletophycites	Tr(Anis-m)		(302)	Paracladiscites	Tr(Carn)	-Tr(Rhae)	(302)
Margaritropites	Tr(Carn-u)		(302)	Paradanubites	Tr(Olen-u)	-Tr(Anis-l)?	(302,1066)
Martolites	Tr(Nori-m)		(302)	Paradinarites	Tr(Olen-u)		(302)
Meekoceras	Tr(Olen-l)		(302)	Paradistichites	Tr(Nori-m)		(302)
Megaphyllites	Tr(Olen-u)	-Tr(Rhae)	(302,1066)	Paraganides	Tr(Carn-u)		(302)
Meginoceras	Tr(Ladi-u)		(302)	Paragoceras	Tr(Olen-u)		(302)
Melagathiceras	Tr(Olen-l)		(302)	Paraguembelites	Tr(Nori-u)		(302)
Mesocladiscites	Tr(Anis)		(302)	Paragymnites	Tr(Nori)		(302)
Metacarnites	Tr(Nori-l)	-Tr(Nori-m)	(302)	Parahuerites	Tr(Carn-u)		(302)
Metadagnoceras	Tr(Olen-u)		(302)	Parajuavites	Tr(Nori-m)		(302)
Metadinarites	Tr(Anis-u)		(302)	Parakellnerites	Tr(Anis-u)		(302)
Metahedenstroemia	Tr(Olen-u)		(302)	Paralobites	Tr(Carn-l)		(302)
Metasibirites	Tr(Nori-u)		(302)	Paranannites	Tr(Olen-l)		(302)
Metassuria	Tr(Olen-l)		(1066)	Paranorites	Tr(Nm)		(302)
Metatibetites	Tr(Nori-l)		(302)	+Paranoritoides	Tr(Olen-u)		(1066)
Metinyoites	Tr(Olen-l)		(302)	Paranoritoides	Tr(Olen-u)		(302)

Taxon	First Appearance	Last Appearance	Reference	Taxon	First Appearance	Last Appearance	Reference
Parapinacoceras	Tr(Anis)		(302)	Pseudocarnites	Tr(Ladi-u)		(302)
Paraplocites	Tr(u)		(302)	Pseudocellites	Tr(Olen-l)		(302)
Parapopanoceras	Tr(Anis-m)	-Tr(Anis-u)	(302)	Pseudodanubites	Tr(Anis)		(302)
Pararcestes	Tr(Anis)	-Tr(Carn)	(302)	Pseudoflemingites	Tr(Nm)		(302)
Parasagceras	Tr(Anis)		(302)	Pseudokymmites	Tr(Olen-u)		(302)
Parasibirites	Tr(Olen-u)		(302)	Pseudosagceras	Tr(Olen-l)	-Tr(Olen-u)	(302,1066)
Paraspidites	Tr(Nm)		(302)	Pseudosirenites	Tr(Nori-m)	-Tr(Nori-u)	(302)
Parasturia	Tr(Ladi-l)		(302)	Pseudothetidites	Tr(Nori-m)		(302)
Parathetidites	Tr(Nori-m)		(302)	Pseudotibettes	Tr(Nori-l)		(302)
Parathisbites	Tr(Nori-m)		(302)	Pseudotirolites	P (Dora)		(302)
Paratibites	Tr(Nori-l)	-Tr(Nori-u)	(302,1066)	Pseudotoceras	P (Dora)?		(302)
Paratrolites (= Dzhulites)				Psilocladiscites	Tr(Anis)		(302)
	P (Dora)		(302)	Psilosturia	Tr(Olen-u)	-Tr(Anis-l)	(302,1066)
Paratrachyceras	Tr(Carn)		(302)	Pterosirenites	Tr(Nori-l)		(302)
Paratropites	Tr(Carn-u)		(302)	Ptychacestes	Tr(Nori)?		(302)
Parussuria	Tr(Olen-l)		(302)	Ptychites	Tr(Anis-m)	-Tr(Ladi-l)	(302)
Paulotropites	Tr(Carn-u)		(302)	Reiflingites	Tr(Anis-m)		(302)
Pearylantides	Tr(Anis-l)		(302)	Reposia	Tr(Anis-u)		(302)
Pentagonoceras	P (Dora)		(302)	Rhabdoceras	Tr(Nori-u)	-Tr(Rhae)	(302)
Pericarinoceras	P (Djhu)		(302)	Rimkinites	Tr(Ladi-u)		(302)
Peripleurites	Tr(Nori-u)		(302)	Romanites	Tr(Ladi)?		(302)
Perrinoceras	Tr(Carn-l)		(302)	Rotodiscoceras	P (Dora)		(302)
Phillipites	Tr(Anis-m)		(302)	Sagceras	Tr(Anis)	-Tr(Carn-l)	(302)
Phormedites	Tr(Nori-m)		(302)	Sagenites	Tr(Nori-m)	-Tr(Rhae)	(302)
Phyllocladiscites	Tr(Anis)		(302)	Sakhaites	Tr(Nm)		(302)
Phyllytoceras	Tr(Carn)?		(302)	Salterites	Tr(Anis)		(302)
Pinacoceras	Tr(Carn)	-Tr(Rhae)	(302)	Sandlingites	Tr(Carn-u)		(302)
Pinacoplocites	Tr(u)		(302)	+Sanyangites	P (Djhu)		(1066)
Placites	Tr(Carn)	-Tr(Rhae)	(302)	Semiornites	Tr(Anis-u)		(302)
Platrotropites	Tr(Carn-u)		(302)	Serpiantites	Tr(Anis-u)		(302)
+Platycuccoceras	Tr(Anis-m)?		(1066)	Sibirites	Tr(Olen-u)		(302)
Pleurodistichites	Tr(Nori-m)		(302)	Sibyrites	Tr(Ladi-u)?, Tr(Carn-l)?		(302)
Pleuronodoceras	P (Dora)		(302)	Siculites	Tr(u)		(302)
Pleuropinacoceras	Tr(Carn-u)		(302)	+Silberlingites	Tr(Anis-l)		(1066)
Pompeckjites	Tr(Carn-l)		(1066)	Silenticeras	Tr(Ladi-u)		(302)
Poporites	Tr(Olen-u)		(302)	Sirenites	Tr(Carn-l)		(302)
Preflorianites	Tr(Nm)	-Tr(Olen-u)	(302)	Sirenotrachyceras	Tr(Ladi-u)	-Tr(Carn-l)	(302)
Preflorianitoides	Tr(Olen-u)		(302)	Sphaerocladiscites	Tr(Ladi)		(302)
Prenkites	Tr(Olen-u)		(302)	Sphingites	Tr(Ladi-u)	-Tr(Carn-l)?	(302)
Prionites	Tr(Olen-l)		(302)	Spiromoceras	Tr(Carn-u)		(302)
Proarcestes	Tr(Anis-m)	-Tr(Carn)	(302)	Stacheites	Tr(Olen-u)		(302)
Proavites	Tr(Anis)		(302)	Steinmannites	Tr(Nori-m)	-Tr(Nori-u)	(302)
Procarinites	Tr(Olen-u)		(302)	Stenarcestes	Tr(Nori-m)	-Tr(Rhae)	(302)
Procladiscites	Tr(Olen-u)	-Tr(Rhae)	(302,1066)	Stenopopanoceras	Tr(Anis-l)	-Tr(Anis-m)	(302)
Procolumnites	Tr(Olen-u)		(302)	Stephanites	Tr(Olen-u)		(1066)
Progonoceratites	Tr(Ladi-l)		(302)	Stikmoceras	Tr(Nori-l)		(302)
Proharpoceras	Tr(Olen-l)		(302)	Stollites	Tr(Ladi-u)	-Tr(Carn-l)?	(302)
Prohungarites	Tr(Olen-u)		(302)	Stoppaniceras	Tr(Anis-u)		(302)
Projuvavites	Tr(Carn-u)		(302)	Striatosirenites	Tr(Carn-l)		(302)
Pronoeflingites	Tr(Anis-m)		(302)	Sturia	Tr(Ladi)		(302)
Proptychites	Tr(Indu-l)	-Tr(Indu-u)	(302)	Styrites	Tr(Nori-l)		(302)
Proptychitoides	Tr(Olen-u)		(302)	Subcolumnites	Tr(Olen-u)		(302)
Prosphingites	Tr(Olen-u)		(302)	Subinyoites	Tr(Olen-l)		(302)
Proteusites	Tr(Anis-u)		(302)	Submieekoceras	Tr(Olen-l)		(302)
+Protoceras	P (Djhu)		(1066)	+Subolenekites	Tr(Olen-u)		
+Protoplattes	Tr(Nori-u)		(302)	Subvishnuites	Tr(Olen-l)		(302)
Protoceras	P (Djhu)		(302)	Svalbardiceras	Tr(Olen-u)		(302)
Protrachyceras	Tr(Ladi-l)	-Tr(Ladi-u)	(302)	Symplocyclus	Tr(Ladi-u)	-Tr(Carn-l)	(302)
Protropites	Tr(Olen-u)		(302)	Tapashanites	P (Dora)		(302)
Pseudaspidites	Tr(Nm)	-Tr(Olen-u)	(302)	Tardeceras	Tr(Carn-u)		(302)
Pseudoharpoceras	Tr(Olen-u)		(302)	Thanamites	Tr(Ladi-u)		(302)
Pseudocardioceras	Tr(Nori-l)		(302)	Thetidites	Tr(Nori-m)		(302)

Taxon	First Appearance	Last Appearance	Reference	Taxon	First Appearance	Last Appearance	Reference
Thisbites	Tr(Carn-u)		(302)	Mojsvarites	Tr(Carn)		(302)
Tibetites	Tr(Nori-m)		(302)	Monophyllites	Tr(Anis)	-Tr(Ladi-u)	(302)
Ticinites	Tr(Anis-u)		(302)	-Neophylloceras	K (Maes-l)	-K (Maes-u)	
Tirolites	Tr(Olen-u)		(302)	-Nevadophyllites	J (Hett-l)		(1066)
Tjururpites	Tr(Olen-u)		(302)	Palaeophyllites	Tr(Olen-u)		(2,302)
Tornophyceras	Tr(Indu-l)		(302)	Paradasyceras	J (Hett)	-J (Sine-u)	
Tornquistites	Tr(Carn-u)		(302)	Partschiceras	J (Sine-u)	-K (Maes-u)	(971)
+Tozerites	Tr(Anis-u)		(1066)	Phylloceras	J (Hett)	-K (Maes-u)	(730)
Trachyceras	Tr(Carn-l)	-Tr(Carn-u)	(302)	Phyllophyceras	K (Haut-l)	-K (Maes-u)	(2)
Trachyleuraspides	Tr(Nori-m)		(302)	Procliviceras	J (Plie)		
+Trachysagenites	Tr(Carn-u)		(1066)	Ptychophylloceras	J (Toar-u)	-J (Tith)	
Trachystenoceras	Tr(Carn-u)		(302)	Rhacophyllites	Tr(Carn-l)	-Tr(Rhae)	(302)
Traskites	Tr(Carn-u)		(302)	Schistophylloceras	J (Hett-l)		(1066)
Tritropidoceras	Tr(Carn-u)		(302)	Simonyceras	Tr(Carn)		(302)
Tropicellites	Tr(Nori-l)		(302)	Sowerbyceras	J (Oxo-f-l)	-J (Kimm-u)	
Tropigastrites	Tr(Anis-u)		(302)	Spinolephyllites	Tr(Anis)		(302)
Tropigymnites	Tr(Anis)		(302)	Tragophylloceras	J (Plie-l)		
Tropites	Tr(Carn-u)		(302)	Ussurites	Tr(Anis)	-Tr(Ladi)	(302)
Tsvetkovites	Tr(Ladi-u)		(302)	Wopingtonites	Tr(Nori-u)?		(302)
Tunglanites	Tr(Olen-u)		(302)	Zetoceras	J (Sine)	-J (Bajo)	
Ussuria	Tr(Olen-l)		(302)				
Vandaites	Tr(Rhae)		(302)	Or. AMMONOIDEA			
Vavilovites	Tr(Indu-l)	-Tr(Indu-u)	(302)	Abbasites	J (Aale)		(1066)
Velebites	Tr(Ladi)		(302)	+Abrytasites	K (Haut-l)		
Vickohlerites	Tr(Olen-u)		(302)	Acanthaeccites	J (Call-u)		
Vishnuites	Tr(Indu-l)		(302)	Acanthoceras	K (Ceno-l)	-K (Ceno-u)	
Vredenburgites	Tr(Nori-m)		(302)	Acanthodiscus	K (Haut-l)		
Waldthausenites	Tr(Nori-l)		(302)	Acanthohoplites	K (Apti-u)		
Wangoceras	Tr(Nori-l)		(302)	Acantholytoceras	K (Barr)		
Wasatchites	Tr(Olen-l)	-Tr(Olen-u)	(302,1066)	Acanthopleuroceras	J (Plie-l)		(302)
Welterites	Tr(Nori-m)		(302)	+Acanthophlites	K (Apti-u)		
Wordieoceras	Tr(Indu-l)		(302)	K (Acanthocaphtes	K (Maes-u)		(971,1107)
Wyomingites	Tr(Nm)		(302)	Acompsoceras	K (Ceno-l)	-K (Ceno-m)	
Xenocellites	Tr(Olen-l)		(302)	Aconoceras	K (Barr-u)	-K (Albi-u)	
Xenodiscus	P (Guad-u)?	-Tr(Indu-l)	(302,1066)	Acrioceras	K (Haut-u)	-K (Apti-l)	
Xenodrepanites	Tr(Nori)		(302)	Acuariceras	J (Call-l)	-J (Call-m)	(302)
Xiphogymnites	Tr(Anis)		(302)	Acuticostites	J (Tith-u)		
Zenoites	Tr(Olen-u)		(302)	+Adkinsites	K (Albi-u)		
Ziyunites	Tr(Olen-u)		(302)	Adkinsia	K (Ceno-l)		
				Aegasteroceras	J (Sine-u)		(302)
Or. PHYLLOCERATIDA				Aegoceras	J (Plie-l)		(302)
Burijites	Tr(Olen-l)		(302)	Aegocrioceras	K (Haut-l)		
Calaiceras	J (Plie-u)			+Aegolytoceras	J (Plie-l)		
Calliphylloceras	J (Hett-l)	-K (Albi-m)		Agassiceras	J (Sine-l)		(302)
+Carinophylloceras	K (Albi-l)			+Ainoceras	K (Camp-l)		
Dasyceras	J (Sine)			Aioloceras	K (Albi-l)		
Discophyllites	Tr(Carn)	-Tr(Nori-l)	(302)	+Alcidellus	J (Bath-u)	-J (Call-l)	(868)
Eophyllites	Tr(Olen-l)	-Tr(Olen-u)	(302)	+Alfeldites	J (Bajo)		
Eopsiloceras	Tr(Nori-u)?		(302)	Algericeras	K (Ceno-l)		
+Euphylloceras	K (Apti-u)			Algerites	K (Ceno)		
Galaticeras	J (Plie)			Alligaticeras	J (Call-u)	-J (Oxo-f-l)	
Geyeroeras	J (Sine-l)	-J (Plie)		Allocrioceras	K (Ceno-u)	-K (Coni-l)	(716)
Hantkeniceras	J (Plie-u)			+Almohadites	K (Barr)		
Haplophylloceras		J?, K?		Alocolytoceras	J (Toar-l)	-J (Toar-u)	
Harpophylloceras	J (Plie-l)			Alsaites	J (Hett-u)		(302)
Holcolissoceras	J (Kimm)			Amaltheus	J (Plie-u)		(302)
Holcophylloceras	J (Toar-u)	-K (Apti)		Amauroceras	J (Plie-u)		(302)
K (Vala)		-K (Maes-u)	(2,730,971)	Ammonitoceras	K (Apti-l)	-K (Apti-u)	
Indigirophyllites	Tr(Ladi)	-Tr(Carn)	(302)	Ammonooceratites	K (Apti-u)	-K (Albi-u)	(1066)
Juraphyllites	J (Sine-l)	-J (Toar-l)	(1066)	Amoebites	J (Kimm-l)		
Leiophyllites	Tr(Olen-u)	-Tr(Anis)	(2,302)	Amoeboceras	J (Oxo-f-u)	-J (Kimm-l)	(2)
Meneghiniceras	J (Sine)	-J (Toar-l)	(1066)	Amphillia	J (Oxo-f-u)		

Taxon	First Appearance	Last Appearance	Reference	Taxon	First Appearance	Last Appearance	Reference
+Anacleoniceras	K (Albi-l)			Barroisiceras	K (Coni-l)		
Anadesmoceras	K (Albi-l)			+Baskaniceras	K (Ceno-l)		(730)
Anagaudryceras	K (Albi-m)	-K (Maes-u)	(730,971)	+Bauchioceras	K (Turo-l)		
Anahamulina	K (Haut-u)	-K (Barr-u)		Bayleites	K (Sant)	-K (Camp-l)	
Anahoplites	K (Albi-m)	-K (Albi-u)		+Beaniceras	J (Plie-l)		
+Anaklinoceras	K (Camp-l)	-K (Camp-u)		Benacoceras	J (Kimm-l)		
+Analytoceras	J (Hett-l)		(1066)	Benueites	K (Turo-l)		
Anapachydiscus	K (Coni-l)	-K (Maes-u)	(971)	Berbericeras	J (Bath)		
+Anasaphites	K (Coni-l)	-K (Coni-u)	(1107)	Berniceras	J (Oxfo-l)		
Anavigatites	J (Kimm-u)	-J (Tith-l)		Berriacella	J (Tith-u)	-K (Berr-u)	
+Ancolioceras	J (Aale)			+Berrosiceras	K (Turo-u)		
Anelyoceras	K (Barr-l)	-K (Apti-u)		+Betyokites	K (Turo)		
+Andersonites	K (Coni-u)			Beudanticeras	K (Apti-u)	-K (Albi-u)	
Andesites	K (Berr)			Beudantiella	K (Albi-u)		
Andiceras	J (Tith-u)			Bevalites	K (Sant-u)	-K (Camp-l)	
Androgynoceras	J (Plie-l)		(302)	Bhimaites	K (Albi-u)	-K (Ceno)	(730)
+Aneurotocras	K (Coni-u)			Bifericeras	J (Sine-u)		(302)
Angulaticeras	J (Sine-u)		(302)	Bigotites	J (Bajo-u)		
Anisoceras	K (Albi-l)	-K (Turo-u)	(943)	Bihenduloceras	J (Tith-u)		
+Ankinatsytes	K (Coni-l)			+Billcobbanoceras	K (Sant-l)	-K (Sant-u)	(1107)
+Annuloceras	K (Barr-u)			Binatisphinctes	J (Call-m)	-J (Call-u)	
Apoderoceras	J (Plie-l)		(302)	Binneyites	K (Turo)	-K (Sant-l)	(2,302)
+Apsoroceras	J (Bajo-l)			+Biplices	J (Oxfo-u)		
Archthoplites	K (Albi-l)?, K (Albi-m)?			Blanforidoceras	J (Tith-u)?	-K (Berr)	
Arcticoceras	J (Bath-l)	-J (Bath-u)		Bochianites	J (Tith-u)	-K (Apti-l)	
Arctoccephalites	J (Bath-l)			+Bodylevskites	K (Vala-l)		
Arctomercaticeras	J (Toar-l)		(302)	Boehmoceras	K (Sant-u)		
Arestoceras	K (Albi-u)			Borissiakoceras	K (Albi-u)	-K (Turo-l)	
Argentiniceras	K (Berr)			Bornhardtceras	K (Ne)		
Argonauticeras	K (Apti-u)			Bostrychoceras	K (Ceno)	-K (Maes-u)	
Arieticeras	J (Plie-u)		(302)	Bouleiceras	J (Toar-l)		(302)
+Arietites	J (Sine-l)			+Bostrychoceras	K (Camp-l)	-K (Camp-u)	
Arisphinctes	J (Oxfo-u)			+Boucaulliceras	J (Sine-u)		
Arnioceras	J (Sine-l)	-J (Sine-u)	(302)	Bradfordia	J (Aale)	-J (Bajo-l)	(302,1066)
+Arniotites	J (Sine-l)			Brahmaites	K (Maes-l)	-K (Maes-u)	(971)
Asaphoceras	J (Sine)?		(302)	Bramkampia	J (Bath-l)		
Asapholytoceras	J (Toar)			Brancoceras	K (Albi-l)	-K (Albi-m)	
+Asphinctites	J (Bajo-l)	-J (Bath-l)		+Brasilia	J (Aale)		
Aspidoceras	J (Oxfo-u)	-K (Berr-l)	(1066)	Bredyia	J (Aale)		(302)
Aspidostephanus	J (Tith-u)	-K (Berr)		Brewericeras	K (Albi-l)		
Aspinoceras	K (Haut-u)	-K (Barr-l)		Brightia	J (Call-u)	-J (Oxfo-l)	
Asteroceras	J (Sine-u)		(302)	Brodieia	J (Toar-u)		(302)
Asthenoceras	J (Aale)	-J (Bajo-l)	(302)	Buchiceras	K (Coni-l)		(1066)
Astiericeras	K (Albi-m)			Budaiceras	K (Ceno-l)		
Astieridiscus	K (Barr)			Bullatimorphites	J (Bath-l)	-J (Bath-m)	
+Astreptoceras	K (Camp)			+Bunburyiceras	K (Ceno)		
Ataxioceras	J (Kimm-l)	-J (Kimm-u)		Burckhardtites	K (Apti-u)		
Audaxlytoceras	J (Plie-l)	-J (Plie-u)	(1066)	+Busnardoites	K (Vala)		
Aulacosphinctes	J (Tith-u)			Cadoceras	J (Bath-l)	-J (Bath-m)	
Aulacosphinctoides	J (Kimm)	-J (Tith-u)		Cadomites	J (Bajo-u)	-J (Call-l)	
Aulacostephanus	J (Kimm-u)			Cadomoceras	J (Bajo-l)	-J (Bajo-u)	
Aulasimoceras	J (Tith-l)		(1066)	Caenisites	J (Sine-l)		(302)
+Austiniceras	K (Ceno-l)	-K (Camp-l)	(730)	Cainoceras	K (Albi-u)		
Australiceras	K (Apti-l)	-K (Apti-u)		Californiceras	K (Vala-u)		
Aveyroniceras	J (Plie-l)	-J (Plie-u)	(302)	Callihoplites	K (Albi-u)		
Axonoceras	K (Camp)	-K (Maes)?		Calliptychoceras	K (Vala)		
Baculina	K (Vala)			Callizoniceras	K (Barr-u)	-K (Albi-l)	
Baculites	K (Turo-u)	-K (Maes-u)	(2,971)	Caloceras	J (Hett-l)	-J (Hett-u)	(302)
Balearites	K (Haut-u)			Calycoceras	K (Ceno-l)	-K (Ceno-u)	
Balticeras	J (Oxfo-u)			Campylites	J (Oxfo-l)	-J (Oxfo-u)	
Barremites	K (Haut-l)	-K (Barr-u)		Canadoceras	K (Sant-u)	-K (Maes-l)?	(971)
+Baronities	K (Vala-u)			Canavarella	J (Aale)		(302)

Taxon	First Appearance	Last Appearance	Reference	Taxon	First Appearance	Last Appearance	Reference
Canavaria	J (Plie-u)		(302)	Creniceras	J (Oxfo-l)		
Canavarites	J (Hert-u)	-J (Sine-l)	(302)	-Crioceras	K (Haut-l)		
+ Cantabrigites	K (Albi-u)			-Crioceratites	K (Vala-u)	-K (Barr-u)	(1066)
Cardioceras	J (Oxfo-l)	-J (Oxfo-u)		-Crusiaceras	K (Haut-u)		
Carstena	K (Barr-u)			-Crucilobicerias	J (Sine-u)		(302)
Carthaginites	K (Ceno-u)			-Crussolicerias	J (Kimm-u)		
Catacoeloceras	J (Toar-l)	-J (Toar-u)	(302,1066)	+ Cryptotexanites	K (Camp-l)		
Catasigaloceras	J (Call-l)			-Cubaochetoceras	J (Oxfo-u)		
Catulloceras	J (Toar-u)		(302)	Cuneicardioceras	J (Oxfo-u)		
Caumontisphinctes	J (Bajo-u)			+ Cunningtoniceras	K (Ceno-m)		(901)
+ Cenisella	K (Albi-u)			-Cutchisphinctes	J (Call-l)		
Chamoussetta	J (Bath-l)	-J (Bath-u)?		Cuyanicerias	K (Berr)		
Chanasia	J (Call-l)	-J (Call-u)		Cylioeceras	J (Aale)		(302)
Chelonicerias	K (Apti-l)	-K (Apti-u)		Cymaceras	J (Kimm-l)		
Cheltonia	J (Sine-u)		(302)	Cymapholites	K (Albi-l)?, K (Albi-m)?		
+ Chesapeakeceras (= Chesapeakella)	J (Sine-l)			Cymbites	J (Sine-l)	-J (Plie-u)	(302)
	K (Camp-l)			-Cyrochilus	K (Albi-u)		
+ Chetaites	K (Berr-u)		(1066)	Cyrtosicerias	J (Tith)		
Choffatia	J (Bath-u)	-J (Call-u)		Daelythoceras	J (Plie-u)	-J (Toar-l)	(302)
Choffaticeras	K (Turo-l)			Dalmasiceras	J (Tith-u)		
Chondroceras	J (Bajo-l)			-Damesiceras	K (Coni)		
+ Christophoceras	K (Camp-l)			Damesites	K (Ceno)	-K (Camp-u)	
+ Cibolaites	K (Ceno-u)			-Danubisphinctes	J (Tith-l)		
Cicatriles	K (Apti-l)	-K (Apti-u)		Darellia	J (Bajo-l)		(302)
Cirroceras	K (Camp)	-K (Maes-u)	(2)	Dayiceras	J (Plie-l)		(302)
Clambites	J (Oxfo-u)			Decipia	J (Oxfo-m)	-J (Oxfo-u)	(1066)
Cleistosphinctes	J (Bajo-u)			+ Deiradoceras	K (Albi-u)		
Cleoniceras	K (Albi-l)	-K (Albi-m)		Deflecticeras	J (Bath-u)		
Clioscaphtes	K (Coni-u)	-K (Camp-l)	(1107)	Delfhinites	K (Vala)		
Cloioceras	K (Apti-u)			+ Derolytoceras	J (Sine)?	-J (Plie-u)	(1066)
Clydomphalites	J (Bath-m)			Deshayesites	K (Barr-u)	-K (Apti-u)	
Clydonicerias	J (Bath-m)	-J (Bath-u)		Desmoceras	K (Apti-u)	-K (Turo)	(730)
Coahuilites	K (Maes-l)		(971)	Desmophyllites	K (Sant)	-K (Maes-u)	(971)
+ Cobbanites	J (Bath-l)	-J (Call-l)		Desmoscaphtes	K (Sant-u)	-K (Camp)	
+ Cobbanoscaphites	K (Camp-l)			Dhosaites	J (Oxfo-u)		
Cochlocioceras	J (Tith-u)			Dhrumaites	J (Bath-u)		
Coeloceras	J (Plie-l)		(302)	Diadochoceras	K (Apti-u)		
Coeloderoceras	J (Plie-l)			Diaziceras	K (Sant-u)	-K (Camp-l)	
Coilopoceras	K (Turo-l)	-K (Turo-u)	(1066)	Dichotomites	K (Vala-u)		
Colchidites	K (Barr-u)			Dichotomoceras	J (Oxfo-u)		
Collignonicerias	K (Turo-l)	-K (Turo-u)		Dichotomosphinctes	J (Oxfo-l)	-J (Oxfo-u)	
Collina	J (Toar-l)	-J (Toar-u)	(302)	Dickersonia	J (Tith-u)		
+ Coloradoscaphtes	K (Turo-u)	-K (Coni-l)	(1107)	-Dicostella	K (Haut-l)		
Collotia	J (Call-l)	-J (Call-u)		-Didymoceras	K (Sant-u)	-K (Maes-l)?	(971)
Colombiceras	K (Apti-l)	-K (Apti-u)		Dimorphinites	J (Bajo-u)		
Concavites	J (Oxfo-l)			Dimorphoplites	K (Albi-m)	-K (Albi-u)	
+ Conlinoceras	K (Ceno-m)		(901)	-Diodochoceras	K (Apti-u)		
-Constileioceras	J (Aale)			Diplacmoceras	K (Camp-l)		
+ Cordubiceras	J (Tith-u)		(1066)	-Diplasioeceras	K (Albi-u)		
Corongoceras	J (Tith-u)			Diplesioceras	J (Bajo-u)		(302)
Coroniceras	J (Sine-l)		(302)	Diplomoceras	K (Camp-l)	-K (Maes-u)	(971)
Coronites	K (Barr-u)			Dipoloceras	K (Albi-m)	-K (Albi-u)	
Costidiscus	K (Barr)	-K (Apti-l)		+ Dipoloceroides	K (Albi-m)		(943)
Costileioceras	J (Aale)		(302)	Dirrymoceras	K (Barr-u)	-K (Apti-l)	
+ Cottreautes	K (Albi-u)	-K (Ceno-l)		Discophlites	K (Albi-u)		
-Couloniceras	K (Ceno)			Discoscaphites	K (Camp-u)?	-K (Maes-u)	(971,1107)
Cowtoniceras	J (Oxfo-u)			Discosphinctes	J (Oxfo-u)		
Cranoecephalites	J (Bajo-u)	-J (Bath-l)		+ Discosphinctoides	J (Tith-l)		
Craspedites	K (Berr-l)			Distichoceras	J (Call-u)		
Craspedodiscus	K (Haut-u)	-K (Barr-l)	(2,1066)	Distoloceras	K (Vala-u)	-K (Haut-l)	
-Crassiceras	J (Toar-u)			Divisosphinctes	J (Oxfo-u)		
-Crassiplanulites	J (Call-l)			Djurjuriceras	J (Tith-l)		

Taxon	First Appearance	Last Appearance	Reference	Taxon	First Appearance	Last Appearance	Reference
+Dobrodgeicerias	K (Vala-u)			Ermoceras	J (Bajo-u)		
Docidoceras	J (Bajo-l)			Erycites	J (Toar-u)	-J (Aale)	(302)
Dorsetensia	J (Bajo-l)		(302)	Erymnoceras	J (Call-m)		
Dorsoplantes	J (Tith-u)			Erymnocerites	J (Call-m)		
Douvillieceras	K (Albi-l)	-K (Albi-m)		Esericeras	J (Toar-u)		(302)
+Duashnoceras	J (Bajo-l)	-J (Bajo-u)		Euagassiceras	J (Sine-l)		(302)
Dumfrenoyia	K (Apti-l)	-K (Apti-u)?		Euapetoceras	J (Aale)	-J (Bajo-l)	(302)
Dumortieria	J (Toar-u)		(302)	Euaspidoceras	J (Call-u)	-J (Oxfo-u)	
Dunveganoceras	K (Ceno-u)			Eubaculites	K (Maes-l)	-K (Maes-u)	(971)
Durangites	J (Tith-l)?	-J (Tith-u)		+Eubrostrichoceras	K (Turo-u)	-K (Camp)	
Durotrigensia	J (Bajo-u)			Eubranoceras	K (Albi-l)	-K (Albi-m)	
Eboracicerias	J (Call-u)			Eucalyoceras	K (Ceno-m)	-K (Ceno-u)	
Eboroceras	K (Coni)			+Eucoronicerias	J (Sine)		
Ebrayicerias	J (Bath-l)			Eucycloceras	J (Call-m)		(302)
Echiocheras	J (Sine-u)		(302)	Eudmetoceras	J (Aale)	-J (Bajo-l)	(302)
+Echioceratoides	J (Sine-u)			Euhoplites	K (Albi-m)	-K (Albi-u)	
+Ectocentrites	J (Hett-u)	-J (Sine-u)		Euhoplaceras	J (Aale)	-J (Bajo-l)	(302)
+Egrabensicerias	J (Call)			Euhystrichoceras	K (Ceno-l)	-K (Ceno-u)	(1066)
Eleganticerias	J (Toar-l)		(302)	Eulophoceras	K (Coni-u)	-K (Camp-l)	
Ellipsoceras	K (Albi-u)			Eulyticeras	K (Haut)	-K (Barr-u)	
Elobiceras	K (Albi-u)			Euomphaloceras	K (Ceno-m)	-K (Ceno-u)	
Emaciacicerias	J (Plie-u)		(302)	Eupachydiscus	K (Coni)	-K (Camp-u)	
Emileia	J (Bajo-l)			Euprionoceras	J (Kimm-l)		
Emperoceras	K (Camp)			Euptychoceras	K (Haut-l)	-K (Barr-l)	
+Enayites	J (Oxfo-u)			Eurycephalites	J (Call-l)		
Engonoceras	K (Albi-m)	-K (Ceno)		Eurynoticeras	J (Kimm-l)	-J (Kimm-u)	
Enosphinctes	J (Kimm-l)	-J (Kimm-u)		+Euturillites	K (Ceno)		
+Eocephalites	J (Bajo-u)			Exiteloceras	K (Camp-u)	-K (Maes-l)?	(971)
Eocheaterias	J (Oxfo-l)			Ezilloella	K (Turo-l)		
Eocrioceratites	K (Vala-l)			Fagesia	K (Ceno-u)	-K (Turo-l)	(716)
Eoderoceras	J (Sine-u)		(302)	Falciferella	K (Albi-m)		
Eodesmoceras	K (Vala-u)	-K (Barr)	(2,302)	Fallotoceras	K (Albi-m)		
+Eodouvillieceras	K (Apti-u)			+Fanninoceras	J (Plie-l)	-J (Plie-u)	(1066)
Eogaudryceras	K (Apti)	-K (Albi-u)	(943)	Farbesiceras	K (Ceno-l)	-K (Ceno-u)	
Eogunnarites	K (Albi-u)	-K (Ceno)		Farnhamia	K (Albi-l)		
+Eohecticoceras	J (Bath-l)	-J (Bath-u)		Favrella	K (Haut)	-K (Apti)	
+Eoheteroceras	K (Barr-l)	-K (Barr-u)		Fehlmannites	J (Oxfo-l)		
Eomadrastites	K (Ceno)			Ficheuria	K (Albi-u)	-K (Ceno-l)	
Eopachydiscus	K (Albi-u)			+Fikaïtes	K (Ceno-u)		
Eoscapites	K (Albi-u)	-K (Ceno-m)		Fissilobicerias	J (Bajo-l)		(302)
Eotetragonites	K (Apti-l)	-K (Albi-l)		+Flabellisphinctes	J (Call-m)	-J (Call-u)	
+Eotissotia	K (Turo-l)			+Flexispinites	J (Call-u)	-J (Oxfo-l)	
Epancyloceras	K (Apti-u)			Flickia	K (Albi-u)	-K (Ceno-l)	
Eparietites	J (Sine-l)	-J (Sine-u)	(302)	Fontanelliceras	J (Plie-u)		(302)
Epaspidoceras	J (Kimm)			Fontannesia	J (Aale)	-J (Bajo-l)	(302)
Epicephalites	J (Kimm-l)			Fontannesicella	J (Kimm)	-J (Tith-l)	
+Epicheloniceras	K (Apti-u)			Forbesiceras	K (Ceno-l)	-K (Ceno-u)	(730)
Epicosmoceras	J (Call-m)?			Forresteria	K (Coni-l)		
Epideroceras	J (Sine-u)	-J (Plie-l)	(302)	+Fourmierella	K (Sant-u)		
+Epiglyptoxoceras	K (Camp-l)			Frechiella	J (Toar-l)		(302)
+Epigonites	K (Camp-l)			Frenguehliceras	K (Vala)		
Epiphoplites	K (Albi-m)	-K (Albi-u)		+Fresvillia	K (Maes-u)		(971)
Epileymeriella	K (Albi-l)			Frogdenites	J (Bajo-l)		
Epimayaites	J (Oxfo-u)			Fucinoceras	J (Plie-l)	-J (Plie-u)	(302)
Epimorphoceras	J (Call-l)			Gabbioceras	K (Apti-u)	-K (Ceno-l)	
Epipallasiceras	J (Tith-u)			+Gabillytes	J (Toar)		
Epipeltoceras	J (Oxfo-u)			Gagaticeras	J (Sine-u)		(302)
Epistrenoceras	J (Bajo-u)	-J (Bath-u)	(302)	+Galbanites	J (Tith-u)		
Epivirgatiates	J (Tith-u)			Garantiana	J (Bajo-u)	-J (Bath-m)	
Epophioceras	J (Sine-l)	-J (Sine-u)	(302,1066)	Gargasiceras	K (Apti-u)		
Erioliceras	K (Albi-u)			Garniericeras	K (Berr-l)		
+Eristavites	K (Vala)			+Garnierisphinctes	J (Kimm)		

Taxon	First Appearance	Last Appearance	Reference	Taxon	First Appearance	Last Appearance	Reference
Gastrolites	K (Albi-m)			Helicanelylus	K (Apti-l)		
Gaudryceras	K (Albi-u)	- K (Maes-u)	(2,730,971)	Hemibaculites	K (Barr-u)		
Gauthiericeras	K (Coni-u)			Hemigarantia	J (Bath-u)		
+Gazdagianites	K (Albi-u)			Hemihaploceras	J (Kimm-u)		
Gemellaroceras	J (Sine-u)	- J (Plie-l)	(302)	Hemihoplites	K (Haut-u)	- K (Barr-u)	
+Gentoniceras	K (Ceno)			Hemilytoceras	J (Call-u)	- J (Tith-u)	
Georgioceras	K (Apti)			Hemiptychoceras	K (Albi-u)	- K (Ceno-l)	
Germariceras	K (Turo-u)			Hemisimoceras	J (Kimm-u)		
Glabrophysodoceras	J (Oxfo-u)			Hemitetragonites	K (Haut)	- K (Albi-m)	
Glaucolithites	J (Tith-u)			Hemitissotia	K (Coni)		
Glebosoceras	K (Turo-l)			-Hengestites	K (Albi-u)		
Gleviceras	J (Sine-u)		(302)	Hertlemites	K (Haut-u)		(2)
Glochiceras	J (Oxfo-u)	- J (Kimm-l)		Herznachites	J (Oxfo-l)		
Glottopychinites	J (Tith-u)			Heteroceras	K (Barr-u)	- K (Apti-u)	(1066)
+Glyptarmites	J (Toar-l)			Heterotissotia	K (Turo-u)	- K (Coni)	
+Glyptoceras	K (Sant)			Hildaites	J (Toar-l)		(302)
Glyptoceras	K (Turo-l)	- K (Maes-u)	(971)	Hildoceras	J (Toar-l)	- J (Aale)	(302)
Goliathiceras	J (Oxfo-l)	- J (Oxfo-u)		+Hildoceratoides	J (Toar-l)		
Goliathites	J (Oxfo-l)	- J (Oxfo-u)		Hildoglochiceras	J (Kimm-u)	- J (Tith-u)	
Gonolites	J (Bath-l)			Himalayites	J (Tith-u)	- K (Vala-l)	(1066)
+Goodhallites	K (Albi-u)		(943)	+Himantoceras	K (Vala-u)		
Gracilisphinctes	J (Bath-m)			Himispiticeras	J (Tith-u)		
Grammoceras	J (Toar-u)		(302)	Hlawiceras	J (Bajo-u)		
+Grandidiericeras	K (Camp-u)			-Hoepinites	K (Sant-l)	- K (Camp-u)	
Graphoceras	J (Aale)	- J (Bajo-l)	(302)	Holcodiscoides	K (Turo)		
Gravesia	J (Kimm-u)	- J (Tith-l)	(302)	Holcodiscus	K (Haut-u)	- K (Barr-l)	(1066)
Grayiceras	J (Oxfo-u)			-Holcolytoceras	J (Plie-l)	- J (Toar-u)	(1066)
+Graysonites	K (Ceno-l)		(1066)	Holcoptychites	K (Haut-l)		
Gregoryceras	J (Oxfo-u)			+Holzbergia	J (Bath-m)		
Groebericeras	J (Tith-u)	- K (Berr)		Homoeoplantulites	J (Bath-u)	- J (Call-m)	
Grossouvrites	K (Camp)	- K (Maes-u)		Hoplikosmokas	J (Call-m)		
Grossouvria	J (Call)			Hoplites	K (Albi-l)	- K (Albi-u)	(943)
Guhnsania	J (Bajo-l)		(302)	Hoplitoides	K (Turo-l)		
Guleimiceras	J (Call-l)	- J (Call-m)		Hoplioplacenticeras	K (Camp-l)	- K (Maes-u)	(2,1066)
Guleimina	J (Call-l)			Hoplocardioceras	J (Kimm-l)		
Guleimites	J (Call-m)			Hoplocroceras	K (Haut-u)	- K (Barr-l)	
Gunnariites	K (Camp-u)	- K (Maes-u)?	(971)	Hoploscapites	K (Camp-u)	- K (Maes-u)	(2,971, 1107)
Gyaloceras	K (Apti-u)	- K (Albi-u)		Horioceras	J (Call-u)		
Gymnodiscoceras	J (Tith)?			-Hourquia	K (Turo-u)	- K (Coni-l)?	
Gymnoplites	K (Barr)			Hubertoceras	J (Call-m)	- J (Call-u)	
Hamites	K (Apti-u)	- K (Turo-l)		Hudlestonia	J (Toar-u)		(302)
Hamiticeras	K (Barr-u)	- K (Apti-u)		Hulenites	K (Apti-u)	- K (Albi-u)?	
Hamitoides	K (Albi-m)	- K (Albi-u)		Hyboniticeras	J (Kimm-u)	- J (Tith-l)	
Hammatoceras	J (Toar-u)	- J (Aale)	(302)	Hypacanthoplites	K (Apti-u)	- K (Albi-l)	
Hamulina	K (Barr-l)			Hypengonoceras	K (Albi-u)		
Hamulinites	K (Barr-l)	- K (Barr-u)		Hyperderoceras	J (Plie-l)		(302)
Haploceras	J (Kimm-u)	- J (Tith-u)		Hyperlioceras	J (Aale)?	- J (Bajo-l)	(302)
Haplopleuroceras	J (Aale)	- J (Bajo-l)	(302)	Hyphantoceras	K (Turo-u)	- K (Camp-l)	
+Haploscapites	K (Camp-u)			Hypopholites	K (Albi-u)	- K (Ceno-l)	(730)
Haresiceras	K (Camp-l)		(1107)	Hypoturrilites	K (Ceno-l)	- K (Ceno-m)	
Harpoeceras	J (Toar-l)	- J (Aale)	(302)	+Hypoxynoticeras	J (Plie-l)		
+Harpoeratoides	J (Toar-l)			Hysteroceeras	K (Albi-m)	- K (Albi-u)	
+Harphildoceras	J (Toar)			Idiocycloceras	J (Call-m)		
Hatchericeras	K (Haut-l)?			Idiohamites	K (Albi-u)	- K (Ceno)	
Hauericeras	K (Coni)	- K (Maes-u)	(971)	Idoceras	J (Oxfo-u)	- J (Kimm-l)	
Haugia	J (Toar-u)		(302)	Illoaiskyia	J (Tith-u)		(302)
Hebetoxyites	J (Bajo-l)			+Imlayiceras	K (Turo-l)		
+Hectioceras	J (Call-l)	- J (Call-u)		Indocephalites	J (Call-l)		
Hectioceras	J (Bath-l)	- J (Call-m)		Indoceras	K (Maes-l)		
Hectioceratoides	J (Call-l)			Indoscaphites	K (Maes-u)		(1107)
Hectoroceras	K (Berr-u)			Indosphinctes	J (Call-l)	- J (Call-m)	
+Heinzia	K (Barr-l)	- K (Barr-u)					

Taxon	First Appearance	Last Appearance	Reference	Taxon	First Appearance	Last Appearance	Reference
+Iniskinites	J (Bath-l)	-J (Bath-u)		Lemuroceras	K (Albi-l)	-K (Albi-m)	
Intranodites	J (Oxfo-l)			Lenticeras	K (Coni-l)	-K (Sant-l)	
Involucriceras	J (Kimm-l)			Leopoldia	K (Vala-u)	-K (Haut-l)	
+Isopholites	K (Albi-m)		(943)	Leptaleoceras	J (Plie-u)		(302)
+Isterites	J (Tith-u)			Leptechioceras	J (Sine-u)		(302)
Jacobites	K (Camp)	-K (Maes-l)	(971)	Leptholites	K (Albi-u)		
Janenschites	K (Barr)			Leptoceras	K (Berr-u)	-K (Vala-u)	
+Jauberticeras	K (Apti-u)		(1066)	+Leptonotoceras	J (Sine-u)		(1066)
+Jeanniticeras	J (Call-l)	-J (Call-u)		Leptosphinctes	J (Bajo-l)	-J (Bajo-u)	(2)
+Jeanvogericeras	K (Ceno-u)			Leptotetragnostes	K (Berr)	-K (Vala)	
+Jeletzkytes	K (Camp-l)	-K (Maes-l)	(1107)	Leukadiella	J (Toar-l)		(302)
Jimboiceras	K (Turo)	-K (Sant-l)		Lewesiceras	K (Ceno-l)	-K (Turo-u)	(730)
+Jimenites	K (Camp-l)			+Lewyites	K (Camp-u)		
Jouaniceras	K (Sant)			Leymeriella	K (Albi-l)	-K (Albi-m)	
Juddiceras	K (Vala-u)			Libycoceras	K (Camp-u)	-K (Maes-l)	
Kabylites	K (Barr)		(1066)	Lilloetia	J (Bath-u)	-J (Call-m)	(302)
Kachpurites	J (Tith-u)		(1066)	Limaite	K (Berr)?	K (Vala-l)?	
Kamerunoceras	K (Ceno-u)	-K (Turo-l)	(716)	Lioceratoides	J (Plie-u)		(302)
Kammerkaroceras	J (Hett-u)		(302)	Liosphinctes	J (Oxfo-m)	-J (Oxfo-u)	
Kamptokephalites	J (Call-l)			Liparoceras	J (Plie-l)	-J (Plie-u)	(302,1066)
+Karamaiceras	K (Albi-u)			Lissoceras	J (Bajo-l)	-J (Bath-u)	
+Karamaites	K (Albi-u)	-K (Ceno-u)		Lissoceratoides	J (Call-u)	-J (Oxfo-m)	
+Karapadites	K (Sant-u)	-K (Camp-u)		Lissonia	K (Berr)?		
+Karaschiceras	K (Vala-l)	-K (Vala-u)		Lithacoceras	J (Oxfo-m)	-J (Tith-u)	
+Karlwaaegites	K (Maes-l)		(1107)	+Lithancyclus	K (Apti)		
Karsteniceras	K (Barr-l)	-K (Barr-u)		Lobokosmokeras	J (Call-u)		
Katrolliceras	J (Kimm-l)	-J (Tith-u)	(302)	Lobolytoceras	J (Toar)		
+Katrolites	J (Kimm-l)			Lobosphinctes	J (Bath-l)		
Kazanskyella	K (Apti-u)			+Loezyceras	J (Call-m)	-J (Call-u)	
Kellawaysites	J (Call-u)			Lomonosovella	J (Tith-u)		
Kepplerites	J (Bath-u)	-J (Call-l)		Longaeviceras	J (Call-m)	-J (Oxfo-l)	(302)
Kerberites	J (Tith-u)			Lopholobites	K (Barr-u)		
Kheraiceras	J (Bath-u)	-J (Call-u)		Lorioloceras	J (Call)		
Kheraites	J (Bath-m)	-J (Call-u)		+Lotzeites	K (Ceno)		
Kilianella	K (Berr)	-K (Vala-u)		Ludwigia	J (Aale)		(302)
Kinkelinceras	J (Call-m)	-J (Call-u)		Lunuloceras	J (Call-l)		
Kitchinites	K (Sant)	-K (Maes-u)	(971)	+Lupherites	J (Bajo-u)		
Klematosphinctes	J (Oxfo-l)			+Luppovella	K (Vala)		
Knemericeras	K (Apti-u)	-K (Albi-u)	(1066)	Lycetticeras	J (Bath-m)		
Kohaticeras	J (Toar)		(302)	Lycelliceris	K (Albi-l)	-K (Albi-m)	
+Koloceras	K (Albi-u)			Lyticoceras	K (Vala)	-K (Haut-l)	
Korythoceras	J (Oxfo-l)			Lytoceras	J (Sine-u)	-K (Ceno-l)	(302)
Kosmermoceras	J (Bajo-u)			Lytocrioceras	K (Barr-l)		
Kosmoceras	J (Call-m)	-J (Call-u)		Lytodiscoides	K (Albi-u)		
Kossmatella	K (Albi-l)	-K (Ceno-l)		Lytogyroceras	J (Kimm)	-J (Tith)	
Kossmatia	J (Kimm)	-J (Tith-u)		Lytolophites	J (Tith-u)		
Kossmaticeras	K (Turo-u)	-K (Maes-u)		Macrocephalites	J (Bath-u)?	-J (Call-m)	
Kranaosphinctes	J (Oxfo-u)			Macroscaphites	K (Barr)	-K (Turo)	(1066)
Krumbeckia	J (Bath-m)			+Madagascarites	K (Turo-u)	-K (Sant-u)	
Kumatostephanus	J (Bajo-l)			Magharina	J (Bajo-u)		
+Kurnubiella	J (Call-m)	-J (Call-u)		+Malladaites	J (Aale)		
+Kutatissites	K (l)			Mallonitoceras	J (Oxfo-u)		
Labeceras	K (Albi-l)	-K (Albi-u)	(1066)	Mammites	K (Turo-l)		(716)
Labyrinthoceras	J (Bajo-l)			Manambolites	K (Camp-l)	-K (Maes-l)	
Lambericeras	J (Call-u)			+Mancosiceras	K (Sant-u)		(1107)
Laqueoceras	J (Hett-u)		(302)	+Manoloviceras	K (Barr-l)		
Laugaites	J (Tith-u)			Mantelliceras	K (Albi-u)	-K (Ceno-l)	
Lechites	K (Albi-u)	-K (Ceno-l)		+Manuaniceras	K (Albi-m)	-K (Albi-u)	
+Lecointriceras	K (Turo-l)			Maorites	K (Camp-l)	-K (Maes-u)	(971)
Leconteites	K (Albi-l)			Mariella	K (Albi-u)	-K (Ceno-l)	
+Lehmaniceras	K (Sant-u)			Marshallites	K (Ceno)	-K (Turo-l)	
Leioceras	J (Aale)		(302)	+Masiaposites	K (Turo)		

Taxon	First Appearance	Last Appearance	Reference	Taxon	First Appearance	Last Appearance	Reference
+Masonites	K (Camp)			+Nebraskites	K (Turo-u)		
-Mathoceras	K (Apti-u)			Nebrodites	J (Kimm-l)		
Mathoceratites	K (Apti-u)	-K (Albi-m)	(302)	Nejdia	J (Toar-u)		(302)
Mayaites	J (Oxfo-l)	-J (Oxfo-u)	(302)	+Neobibolites	K (Albi-l)		
Mazapilites	J (Kimm-u)	-J (Tith-l)?		Neocardioceras	K (Ceno-u)		
Megalytoceras	J (Toar-u)	-J (Bajo)		Neochetoceras	J (Tith-l)		
Megasphaeroceras	J (Bajo-u)			Neocomites	K (Berr)	-K (Haut-l)	
Megalytloceras	K (Apti-u)			Neocosmoceras	K (Berr-u)		
Melchiorites	K (Apti-l)	-K (Apti-u)		Neocraspedites	K (Vala-u)		
Menabites	K (Sant-u)	-K (Camp-u)		Neocrioceras	K (Turo-l)	-K (Camp-u)	
+Menabonites	K (Coni)			Neogastrolites	K (Albi-u)		
Menutites	K (Sant-u)	-K (Maes-u)	(971)	+Neogauthierceras	K (Camp-l)		
Menuthiocereras	K (Vala-u)	-K (Haut-u)		+Neoglytloceras	K (Camp-l)	-K (Camp-u)	
Mercaticeras	J (Toar-l)		(302)	Neogrammites	K (Maes-u)		(971)
Mesogaudryceras	K (Ceno-m)		(730)	Neoharporoceras	K (Albi-u)		
Mesopuzosia	K (Turo-l)	-K (Camp-l)		Neohoploceras	K (Vala-l)	-K (Vala-u)	
Mesosimoceras	J (Kimm-u)			Neokentoceras	K (Albi-u)		
+Mesoturrilites	K (Ceno-l)			+Neolioceratoides	J (Toar-l)		
†Metacymbites	J (Plie-l)			Neolisoceras	J (Tith-u)	-K (Haut-u)	(302,1066)
Metaderoceras	J (Plie-l)		(302)	Neolobites	K (Ceno-u)		
Metagravesia	J (Kimm-u)			-Neomantelliceras	K (Ceno)		
Metahamites	K (Apti-u)	-K (Albi-m)	(1066)	Neomicroceras	J (Sine-u)		(302)
Metahaploceras	J (Kimm)			Neomorphoceras	J (Oxfo-u)		
Metahoplites	K (Barr)			Neophylticeras	K (Albi-u)		
Metalytloceras	K (Vala)			Neoptychites	K (Turo-l)		(716)
+Metapatoceras	J (Call-m)			Neopulchellia	K (Ceno-l)?		
Metapeltocheras	J (Call-u)			Neosaynoceras	K (Ceno-l)		
Metaplacenticeras	K (Camp-u)			+Neoselwynoceras	K (Sant-u)		
Metapychoceras	K (Turo-u)			Neosilesites	K (Apti-u)	-K (Albi-m)	
Metarrioceras	J (Sine-l)		(302)	+Neostlingoceras	K (Ceno-l)	-K (Ceno-u)	
Metasigaloceras	K (Ceno-u)?			Neuquiceras	J (Bath-u)	-J (Call-l)	(302)
†Metatissotia	K (Coni-u)		(1066)	+Newboldiceras	K (Ceno-m)		
Metengonoceras	K (Albi-u)?	-K (Ceno-u)	(1066)	+Newmarracarroceras	J (Bajo-l)		
Metoicoceras	K (Ceno-m)	-K (Ceno-u)	(716,901)	Niceforoceras	K (Ceno-l)		
+Metoxyntoceras	J (Sine-u)	-J (Plie-l)		Nicklesia	K (Haut-u)	-K (Barr-u)	
Metrolytloceras	J (Bajo)			Nigericeras	K (Ceno-u)		
Micocephalites	J (Call-l)			Nipponites	K (Turo-u)	-K (Sant-l)	
Michalskia	J (Tith-u)			Nodiocoeloceras	J (Toar-l)		(302)
Micracanthoceras	J (Tith-u)			+Nodosohoplites	K (Apti-u)		
Microbiplices	J (Oxfo-u)			†Nolaniceras	K (Apti-u)		
+Microdactylites	J (Toar)			Normannites	J (Bajo-l)		
Micröderoceras	J (Sine-l)	-J (Sine-u)	(302)	Nostoceras	K (Camp-l)	-K (Maes-u)	(971)
Micromphalites	J (Bath-l)	-J (Bath-m)		Nothocephalites	J (Call-l)		
Miroshintces	J (Oxfo-l)			Nothostephanus	J (Tith)		
†Mitonia	K (Turo-l)			+Notoceras	K (Camp-u)		
+Miyakoceras	K (Apti-u)			Nowakites	K (Coni)	-K (Sant)	
†Mollitites	K (Albi)			Obtusicosites	J (Call-m)	-J (Call-u)	
Mojsisoviczia	K (Albi-m)			Ochetoceras	J (Oxfo-l)	-J (Kimm-l)	
-Moremanoceras	K (Ceno-m)		(901)	+Ochetoceras	J (Toar)		
Morphoceras	J (Bath-l)			Odontodiscoceras	K (Vala)		
Morrisiceras	J (Bath-m)			Oecoptychius	J (Bajo-u)	-J (Call-m)	
+Morrowites	K (Turo-l)			Oecotraustes	J (Bajo-l)	-J (Call-m)	
Mortoniceras	K (Albi-m)?	-K (Albi-u)		Oiophyllites	K (Camp)	-K (Maes)?	
†Moutoniceras	K (Haut-l)		(1066)	-Oistoceras	J (Plie-l)		
-Microdactylites	J (Toar)			Okribites	J (Bajo-u)	-J (Bath-l)	
Muniericeras	K (Coni)	-K (Sant-u)		Olcostephanus	K (Vala-u)	-K (Haut-l)	
Myloceras	K (Albi-u)			Onitoceras	K (Coni)		
Nannocardioceras	J (Kimm-l)	-J (Kimm-u)	(1066)	Onychoceras	J (Toar-u)		(302)
Nannolytloceras	J (Bajo)	-J (Bath-m)		Oosterella	K (Vala-u)	-K (Haut-l)	
Nannostephanus	J (Tith)			Oppelia	J (Bajo-l)	-J (Bajo-u)	
†Nannovaseoceras	K (Turo-l)			Oraniceras	J (Bath-l)		
Neaneyloceras	K (Camp-u)	-K (Maes-u)		+Organoceras	J (Oxfo-m)		

Taxon	First Appearance	Last Appearance	Reference	Taxon	First Appearance	Last Appearance	Reference
Orionoides	J (Bath-u)	-J (Call-u)		Parasaynoceras	K (Barr)		
Orthaspidoceras	J (Kimm-u)			+ Parasilesites	K (Albi-l)	-K (Albi-m)	(943)
+ Orthildaites	J (Toar-l)			+ Parasolenoceras	K (Camp-l)	-K (Camp-u)	
Orthograntiana	J (Bajo-u)			Paraspidoceras	J (Oxfo-u)		
Orthosphinctes	J (Kimm-l)	-J (Kimm-u)	(302)	Parasptitoceras	K (Haut-u)	-K (Barr-u)	(1066)
Ostlingoceras	K (Albi-m)	-K (Ceno-l)	(943)	Parastertia	K (Haut-l)		
Ottophilos	K (Albi-l)	-K (Albi-m)		+ Parastrenoceras	J (Bajo-u)		
Otoites	J (Bajo-l)			Paratexanites	K (Coni-l)	-K (Sant-l)	
Otoscapites	K (Ceno-l)	-K (Coni-l)	(1107)	Paratissotia	K (Coni)		
Ovaticeras	J (Toar-l)		(302)	+ Paraturillites	K (Albi-u)		
+ Oxybeloceras	K (Camp-u)			Paravirgatites	J (Tith-l)		
Oxycerites	J (Bajo-u)	-J (Call-m)		Parawedekindia	J (Oxfo-l)	-J (Oxfo-u)	
Oxydiscites	J (Kimm-l)			Parargonoceras	K (Albi-l)	-K (Albi-m)	
Oxytenticeras	J (Tith)			Parinodiceras	J (Phe-l)		(302)
Oxynoticeras	J (Sine-u)		(302)	Parkinsonia	J (Bajo-u)	-J (Bath-l)	
Oxyparomiceras	J (Toar-u)		(302)	Parodontoceras	J (Tith-u)		
Oxytropidoceras	K (Albi-l)	-K (Albi-u)		Paroecotraustes	J (Bath-l)	-J (Call-u)	
Pachycardioceras	J (Oxfo-l)	-J (Oxfo-u)		Paroniceras	J (Toar-l)	-J (Toar-u)	(302)
Pachyceras	J (Call-u)	-J (Oxfo-l)		Paroxynoticeras	J (Sine-u)		(302)
Pachydesmoceras	K (Albi-u)	-K (Coni)		Parpyhoceras	J (Oxfo-u)		
Pachydiscoides	K (Coni)	-K (Sant-u)		Pascocites	K (Barr)		
Pachydiscus	K (Sant-u)	-K (Maes-u)	(2,971)	+ Paskentites	K (Vala)		
Pachyerymnoceras	J (Call-m)	-J (Call-u)		Passendorferia	J (Oxfo-u)		(302)
Pachylytoceras	J (Toar)	-J (Bajo-l)		Patagiosites	K (Camp-u)	-K (Maes-l)	(971)
Pachypictonia	J (Oxfo-u)	-J (Kimm-l)		Pavlovia	J (Tith-u)		(302)
Pachysphinctes	J (Kimm-u)			Pavloviceras	J (Oxfo-l)		
Padragosiceras	J (Aale)	-J (Bajo-l)	(302)	Pectinatites	J (Tith-u)		(302)
Padagrosites	J (Toar-u)		(302)	Pedioceras	K (Barr)	-K (Apti)	
+ Paltaopites	J (Phe-u)			Peltoeras	J (Call-m)	-J (Call-u)	
Paltechioceras	J (Sine-u)		(302)	Peltoeratoides	J (Oxfo-l)	-J (Oxfo-m)	
Paquiericeras	K (Vala-l)			+ Peltolytoceras	J (Sine-l)		
+ Parabehavites	K (Sant-u)			Peltoamorphites	J (Oxfo-l)		
Paraberriasella	J (Tith-l)			Perisphinctes	J (Call-m)	-J (Tith)	
+ Parabevalites	K (Coni-u)			Peroniceras	K (Coni-l)	-K (Sant-u)	
Paraboliceras	J (Kimm)	-J (Tith-u)		Peronoceras	J (Toar-l)		(302)
Paraboliceratoides	J (Kimm)	-J (Tith-u)		+ Pervinquieria	K (Albi-u)		
Paracadoceras	J (Call-l)	-J (Call-m)		Peticlercia	J (Call)		
Paracalyoceras	K (Ceno-l)			+ Petrolytoceras	J (Tith-u)		
Paracanthoplites	K (Albi-l)			Phanerostephanus	J (Tith-l)		
+ Paraconlinoceras	K (Ceno-m)		(901)	+ Phaularmites	J (Toar)		
+ Paracorniceras	J (Sine-l)			Phaulostephanus	J (Bajo-l)		
Paracraspedites	K (Berr-u)?			Phaulozigzag	J (Bath-l)		
Paracrioceras	K (Haut-u)	-K (Barr)		Phlycteras	J (Call-l)	-J (Call-m)	
Paracuariceras	J (Call-l)	-J (Call-m)	(302)	Phlyctieroceras	K (Coni-l)	-K (Coni-u)	
Paracymbites	J (Sine-u)		(302)	Phlyseogrammoera	J (Toar-u)		(302)
+ Paradicidia	J (Call-u)			Phricodoceras	J (Phe-l)	-J (Phe-u)	(302,1066)
+ Paradolphia	K (Albi-u)		(1066)	Phylloptychoceras	K (Camp)	-K (Maes-u)	(971)
Parahildaites	J (Toar-l)		(302)	Phymatoceras	J (Toar-l)	-J (Aale)	(302)
Parahoplites	K (Apti-l)	-K (Apti-u)	(1066)	+ Physseogrammoceras	J (Toar-u)		
Parajaubertella	K (Ceno)			Physodoceras	J (Kimm-l)	-J (Tith-l)	
Paralcidia	J (Bath-m)	-J (Call-u)		+ Pictetia	K (Apti)	-K (Albi)	
Paralentoceras	K (Coni-l)	-K (Sant-l)		Pictionia	J (Kimm-l)		
Paramammites	K (Turo-l)			Pimelites	J (Phe-l)		(302)
+ Parammatoceras	J (Aale)			Placenticeras	K (Ceno-l)	-K (Maes)	
Paranclyoceras	K (Barr-u)			Planammattoceras	J (Aale)		(302)
Parandiceras	K (Vala)			+ Palnerostephanus	J (Tith)		
Parapallasiceras	J (Tith-l)	-K (Berr-l)	(1066)	Planisphinctes	J (Bath-l)		
Parapatoceras	J (Call-l)	-J (Call-m)	(302)	Plasmatoceras	J (Oxfo-l)	-J (Oxfo-u)	
Parapeltoceras	J (Call-m)			Platylenticeras	K (Vala-l)		(302)
Parapuzosia	K (Ceno-l)	-K (Camp-u)	(730)	+ Platynoticeras	J (Phe-l)		
Pararasenia	J (Kimm-l)			Platyleuroceras	J (Phe-l)		(302)
+ Pararnioceras	J (Sine)			+ Plesiacanthoceras	K (Ceno-m)	-K (Ceno-u)	(901)

Taxon	First Appearance	Last Appearance	Reference	Taxon	First Appearance	Last Appearance	Reference
-Plesiacanthoides	K (Ceno-m)	-K (Ceno-u)	(901)	Prorsiphinctes	J (Bajo-u)		
Plesiohamites	K (Albi-u)			Prosaphites	J (Oxfo-l)	-J (Oxfo-u)	
Plesiospidiscus	K (Haut-u)	-K (Barr-l)		Prosiceras	J (Call-l)		
Plesiossotia	K (Coni-l)			Prososiphinctes	J (Call-u)	-J (Oxfo-l)	
†Plesioturrilites	K (Albi-u)	-K (Ceno-l)		Prososiphinctoides	J (Call-u)		
†Pleuroacanthites	J (Hett)		(1066)	Protacanthioceras	K (Ceno-u)		
Pleurocephalites	J (Call-l)			Protacanthodiscus	J (Tith-u)		
Pleuroceras	J (Plie-u)		(302)	†Protacanthoplites	K (Apti-u)		
Pleurohoplites	K (Albi-u)	-K (Ceno-l)		Protaconeceras	K (Haut-u)		
Pleurolytoceras	J (Toar)			Protanlyoceras	J (Tith-l)	-K (Vala-l)	(2)
†Pleurotexanites	K (Sant-l)			Protanisoceras	K (Apti-u)	-K (Albi-m)	(943)
Pleydellia	J (Toar-u)	-J (Aale)	(302)	Protengonoceras	K (Albi-m)		
Plicetia	K (Albi-l)	-K (Albi-m)		Protetragonites	J (Tith-l)	-K (Apti-u)	
Poculisphinctes	J (Call-u)			Protexanites	K (Turo-l)	-K (Sant-u)	
†Poecilomorphus	J (Bajo-l)			Protoecotrausites	J (Bajo-l)		
Polymorphites	J (Plie-l)		(302)	Protogrammoceras	J (Plie-l)	-J (Toar-l)	
Polyplectites	J (Bath-l)			Prothoplites	K (Albi-l)	-K (Albi-m)	
Polyplectus	J (Toar-l)	-J (Toar-u)	(302)	Protophites	J (Oxfo-m)		(302)
Polyptychites	K (Vala-l)	-K (Vala-u)		Protothurmannia	J (Tith-u)		
Polyptychoceras	K (Coni-u)	-K (Maes-l)?	(971)	Proturrilitoides	K (Albi-m)	-K (Albi-u)	
Polysphinctes	J (Bath-l)			Pseudacompsoceras	K (Ceno-l)		
Pomerania	J (Oxfo-u)			Pseudaeotomoceras	J (Hett-u)		(302)
Pompekioceras	J (Sine-u)		(302)	†Pseudogonidites	J (Bath-u)		
†Ponteixites	K (Maes-l)		(1107)	†Pseudammaticeras	J (Aale)		
Popanites	J (Oxfo)			Pseudargentiniceras	J (Tith-u)	-K (Berr)	
Poroceras	J (Toar-l)		(302)	Pseudarisphinctes	J (Oxfo-u)		
Praebigotites	J (Bajo-l)	-J (Bajo-u)	(2)	Pseudaspidoceras	K (Ceno-u)	-K (Turo-l)	(716)
†Praemanambolites	K (Camp-l)			Pseudhelicoceras	K (Albi-m)	-K (Albi-u)	
†Praemuniericeras	K (Sant-l)	-K (Sant-u)		Pseudhimalayites	J (Kimm-l)?		
Praeparkinsonia	J (Bajo-u)			†Pseudinvoluticeras	J (Tith-l)		
Praesphaeroceras	J (Plie-l)		(302)	†Pseudospidoceras	K (Turo)		
Praestrigitites	J (Aale)	-J (Bajo-l)		Pseudobaculites	K (Coni-u)	-K (Camp-u)	
Praetollia	K (Berr-u)			Pseudobarroisiceras	K (Coni)		
Pravitoceras	K (Maes-l)			Pseudobrightia	J (Oxfo-l)		
†Presimoceras	J (Kimm-l)			Pseudocadoceras	J (Call-l)	-J (Call-m)	
Prionocycloceras	K (Turo-l)	-K (Coni-l)		†Pseudocalycoceras	K (Ceno-u)		
Prionocyclus	K (Turo-u)			Pseudoclambites	J (Tith)		
Prionodoceras	J (Oxfo-u)			Pseudocosmoceras	J (Bath-l)		
Procerites	J (Bajo-u)	-J (Bath-u)		†Pseudofavrella	K (Haut)		
Procerozigzag	J (Bath-l)			†Pseudogarantiana	J (Bajo-u)		
Procheloniceras	K (Apti-l)			Pseudogamieria	K (Berr-u)		
Procraspedites	J (Kimm-u)			Pseudogrammoceras	J (Toar-u)		(302)
Proctactyliceras	J (Plie-l)	-J (Plie-u)	(302)	Pseudogregoryceras	J (Oxfo-l)		
†Prodeshayesites	K (Apti-l)		(1066)	Pseudohaploceras	K (Barr)	-K (Apti-u)	
†Progalbanites	J (Tith-u)			Pseudoinvoluticeras	J (Tith-l)	-J (Tith)	
Progeronia	J (Kimm-l)			Pseudojacobites	K (Turo-u)		
Prograyiceras	J (Oxfo-u)			Pseudokatroliceras	J (Kimm-u)		
Prohauericeras	K (Turo-l)			Pseudokossmaticeras	K (Camp-u)	-K (Maes-u)	(971)
Prohcticoceras	J (Bath-m)	-J (Bath-u)		†Pseudoleymeriella	K (Albi-l)		
Prohelicoceras	K (Albi-l)	-K (Albi-m)		Pseudolillia	J (Toar-u)		(302)
Prohysteroceas	K (Albi-u)			Pseudolioceras	J (Toar-l)	-J (Bajo-l)	(302)
Proleopoldia	K (Berr)?			Pseudolissoceras	J (Tith-u)		
Proleymeriella	K (Albi-l)			Pseudomercaticeras	J (Toar-u)		(302)
Prolyelliceras	K (Albi-l)	-K (Albi-m)		†Pseudoneoptychites	K (Turo-l)		
†Promantelliceras	K (Ceno)			Pseudooosterella	K (Vala-u)		
Promicroceras	J (Sine-l)	-J (Sine-u)	(302)	Pseudopeltoceras	J (Call-u)		
Proniceras	J (Tith-u)			Pseudoperisphinctes	J (Bath-m)	-J (Bath-u)	
†Propectinaites	J (Kimm-u)		(1066)	Pseudophyllites	K (Sant-u)	-K (Maes-u)	(971)
Propersiphinctes	J (Call-u)	-J (Oxfo-l)		Pseudoplacenticeras	K (Coni)		
Proplacenticeras	K (Ceno)	-K (Coni)		Pseudopolyplectus	J (Toar-l)	-J (Toar-u)	(302)
Proplanulites	J (Call-l)			Pseudoppelia	J (Kimm-l)		
Prorasenia	J (Kimm-l)			Pseudopuzosia	K (Turo-u)		

Taxon	First Appearance	Last Appearance	Reference	Taxon	First Appearance	Last Appearance	Reference
Pseudosaynella	K (Apti-l)	- K (Albi-l)		Savoceras	J (Hett-u)		(302)
Pseudoschloenbachia	K (Sant-l)	- K (Camp-l)		Saynella	K (Haut-l)		
Pseudosimoceras	J (Kimm-l)			Saynoceras	K (Vala-u)		
Pseudosonneratia	K (Albi-l)	- K (Albi-m)		+ Scaphamites	K (Albi-m)	- K (Albi-u)	(943)
Pseudothurmannia	K (Haut-u)	- K (Barr)		Scalarites	K (Turo)	- K (Coni)	
Pseudotissotia	K (Ceno-u)	- K (Turo-l)		Scaphites	K (Albi-u)	- K (Camp-u)	
Pseudotites	J (Bajo-l)			Scaphitoides	J (Oxfo-l)		
Pseudotropites	J (Sine-l)		(302)	Scarburgiceras	J (Oxfo-l)		
Pseudovirgatites	J (Tith-u)		(302)	+ Schindewolfites	K (Turo)		
Pseudowaagenia	J (Kimm-l)			Schloenbachia	K (Albi-u)	- K (Ceno-u)	
Pseudoxybeloceras	K (Turo-l)	- K (Camp-u)		Schlotheimia	J (Hett-u)		(302)
Pseuduptonia	J (Sine-u)		(302)	Schwandorfia	J (Bath-m)		
Psiloceras	J (Hett-l)		(302)	Sciponoceras	K (Albi-u)	- K (Turo-u)	
+ Psilohamites	K (Albi-u)			Scoticardioceras	J (Oxfo-l)	- J (Oxfo-u)	
Psilophylites	J (Hett-u)		(302)	+ Selwynoceras	K (Turo)		
Psilotissotia	K (Haut-u)	- K (Barr)		+ Semenovites	K (Albi-u)		(1066)
Pterolytoceras	K (Vala)			Semiformiceras	J (Tith-l)		
Pteroscaphites	K (Ceno-u)	- K (Sant-l)	(1107)	Seymourites	J (Call-l)		
Ptychoceras	K (Barr-u)	- K (Albi-u)		Shakraceras	J (Toar)		(302)
Ptycholytoceras	J (Toar)			Sharpeiceras	K (Ceno-l)		
Puchenquia	J (Aale)			Shastierioceras	K (Barr)		
+ Puebloites	K (Turo-l)			Shastoceras	K (Apti-l)		
Pulchellia	K (Barr-l)	- K (Barr-u)		Shirbuirnia	J (Bajo-l)		(302)
Putealiceras	J (Call-u)			+ Siberiptychites	K (Vala-l)		
Puzosia	K (Albi-l)	- K (Sant-u)		Siemradzka	J (Bajo-u)	- J (Bath-u)	
Puzosigella	K (Albi-l)			Sigaloceras	J (Call-l)		
Quenstedtoceras	J (Call-u)	- J (Oxfo-l)		Silesites	K (Barr-l)	- K (Barr-u)	(1066)
Quitmannites	K (Turo-l)			Silesitoides	K (Albi-l)	- K (Albi-m)	
Radstockiceras	J (Sine-u)	- J (Plie-l)	(302)	Simaspidoceras	J (Kimm-l)		
Raimondiceras	J (Tith-u)			Simbirskites	K (Haut-l)	- K (Haut-u)	(2)
+ Rakusites	J (Toar)			Simoceras	J (Tith-l)	- J (Tith-u)	(302)
Rasenia	J (Kimm-l)			Simocosmoceras	J (Kimm-u)	- J (Tith)	
Rasenoides	J (Kimm-l)			+ Simosphinctes	J (Kimm-l)	- J (Kimm-u)	
Reesidites	K (Turo-u)	- K (Coni-l)		Simotoichites	J (Tith-u)		
+ Rehmanna	J (Call-l)	- J (Call-u)		Sindetites	J (Call-m)		
Reineckea	J (Bath-u)	- J (Call-u)	(302)	+ Sinzovia	K (Apti-u)	- K (Albi-l)	
Reineckeites	J (Call-u)			Sivajiceras	J (Call-m)		
Rezniceras	J (Toar-l)		(302)	Skirroceras	J (Bajo-l)		
Reynesella	J (Aale)?	- J (Bajo-l)	(302)	Skolekostephanus	J (Bajo-l)		
Reynoceras	J (Plie-l)	- J (Plie-u)	(302,1066)	Slatterites	J (Sine-u)		(302)
Reynosoeloceras	J (Plie-u)		(302)	+ Sohlites	J (Bajo-u)		
Rhaeboceras	K (Camp-u)	- K (Maes-l)	(1107)	+ Sokolovites	K (Albi-l)		
+ Rhampidoceras	K (Turo-l)			Solenoceras	K (Camp-u)	- K (Maes-l)?	(971)
Rhytidohoplites	K (Albi-l)			Solgerites	K (Coni-l)		
Riasanites	J (Tith-u)	- K (Berr-l)		Somaliceras	J (Tith-u)		
Ringstedtia	J (Oxfo-u)	- J (Kimm-l)		Somalites	K (Apti-u)		
Rollerites	J (Call-m)			Sonneratia	K (Albi-l)	- K (Albi-m)	
+ Rollieria	J (Call-u)			Sonnimia	J (Aale)?	- J (Bajo-l)	(302)
Roboceras	K (Apti-l)	- K (Albi-l)?	(302)	+ Sornayceras	K (Coni)		
Romaniceras	K (Ceno-u)?	- K (Turo-u)		Spathiceras	K (Albi-u)		
+ Rossalites	K (Albi-l)			Spathites	K (Turo-l)		
+ Rubroceras	K (Ceno-u)			Speetoniceras	K (Haut-l)		
Rugiferites	J (Bath-m)			Sphaeroceras	J (Bajo-l)	- J (Bajo-u)	
Rursiceras	J (Call-u)			Sphaerocoeloceras	J (Toar-u)		(302)
+ Rusoceras	K (Albi-u)			Sphaerodomites	J (Oxfo-l)		
Ryugasella	K (Camp)			Sphaeropychius	J (Bath-m)		
+ Saghalinites	K (Sant-u)	- K (Maes-u)	(971)	Sphenarpirites	J (Toar)		(302)
Salaziceras	K (Albi-u)			Sphenodiscus	K (Maes-l)	- K (Maes-u)	(2,971)
+ Salfeldiella	K (Apti)			Spinammatoeras	J (Aale)	- J (Bajo-l)	(302)
+ Saltericeras	K (Albi-u)		(1066)	Spinokosmoceras	J (Call-m)	- J (Call-u)	
Sanmartinoceras	K (Barr-u)	- K (Albi-l)		Spiroceras	J (Bajo-u)		(302)
Sarasinella	K (Vala-l)			Spiticeras	J (Tith-u)	- K (Vala)	

Taxon	First Appearance	Last Appearance	Reference	Taxon	First Appearance	Last Appearance	Reference
Spitidiscus	K (Haut-l)	-K (Barr-u)		Thamboceras	J (Bajo-u)		
Stantonoceras	K (Sant-u)	-K (Camp-l)		Theganoceras	K (Apti-u)		
Staufenia	J (Aale)		(302)	Thomasites	K (Ceno-u)	-K (Turo-l)	(716)
Stegoxyites	J (Bajo-l)			+ Thomelites	K (Ceno-u)		
+ Stelinocephalites	J (Bath-u)	-J (Call-l)		+ Thorsteinssonoceras	K (Vala-l)		
Stemmatoceras	J (Bajo-l)	-J (Bajo-u)		+ Thraxites	J (Call-l)		(868)
Stenocadoceras	J (Call-l)			+ Thurmannia	K (Haut-u)		
Stephanoceras	J (Aale)	-J (Bajo-u)	(302)	Thurmanneroceras	K (Berr)	-K (Vala-l)	
Stoliczkaia	K (Albi-u)	-K (Ceno-l)	(730)	Tiltonoceras	J (Toar-l)		(302)
Stomohamites	K (Albi-u)	-K (Turo-l)		Tissotia	K (Coni)	-K (Sant-l)	
Strebliticeras	J (Oxfo-u)	-J (Kimm-l)		Titanites	J (Tith-u)		
Streblites	J (Kimm-l)			Tithopeltoceras	J (Tith-u)		
Strenoceras	J (Bajo-u)			Tmaegoceras	J (Sine-l)		(302)
Strigoceras	J (Bajo-l)	-J (Bajo-u)		Tmaegophioceras	J (Sine-u)		
Strungia	J (Bath)	-J (Call-l)		Tmetoceras	J (Toar-u)	-J (Aale)	(302)
Styracoceras	J (Call-m)			Tollia	K (Berr-u)	-K (Vala)	
Subalpinites	K (Berr)			Tolypeceras	K (Vala-l)		
Subarthrophlites	K (Albi-m)			+ Tongoboroceras	K (Coni)		
Subastertia	K (Haut-l)			Tonoceras	K (Barr-u)		
Subbarroisicerias	K (Coni)			Torcapella	K (Barr-l)		(302)
Subbonarellaia	J (Call-u)			Toricellites	J (Call-l)		
Subcollina	J (Bajo-l)			Tornquistes	J (Oxfo-l)	-J (Oxfo-m)	
Subcraepedites	J (Tith-u)	-K (Berr-u)?		Torquatisphinctes	J (Kimm-l)	-J (Tith-l)	(302)
Subdichotomoceras	J (Kimm-l)	-J (Tith-l)		+ Tovebirkelundites	K (Maes-u)		(1107)
Subgrossouviria	J (Bath-l)	-J (Call-u)		Toxamblyites	J (Bajo-l)		
Subkossmatia	J (Call-m)			+ Toxolioceras	J (Bajo-l)		
Sublithacoceras	J (Tith-l)			+ Trachybaiculites	K (Maes-l)		
Sublunuloceras	J (Call-m)	-J (Oxfo-l)		Trachylytoceras	J (Toar)		
+ Submantelliceras	K (Ceno)			+ Trachyscaplites	K (Camp-u)	-K (Maes-l)	(1107)
Submortoniceras	K (Camp-l)	-K (Camp-u)		Tragodesmoceras	K (Turo-l)	-K (Coni)	
Subnebrodites	J (Oxfo-u)		(302)	Tragodesmocerooides	K (Turo)		
Subneumayria	J (Kimm-l)			+ Tragolytoceras	J (Sine-l)		
Suboosterella	K (Haut-l)?			+ Transicoeloceras	J (Toar-l)		
Subplanites	J (Kimm-u)	-J (Tith-u)		+ Treptoceras	J (Bath-u)		
Subprionocyclus	K (Turo-u)			+ Triagolytoceras	J (Sine-l)		
Subpulchellia	K (Barr-l)	-K (Apti-l)	(302)	Trilobiuceras	J (Aale)	-J (Bajo-l)	
Subsaynella	K (Haut-u)	-K (Barr-l)		Trimarginia	J (Bajo-u)		
Substeueroceras	J (Tith-u)			Trimarginites	J (Oxfo-u)		
Substreblites	J (Tith)	-K (Vala)		Triozites	J (Kimm-l)		
Subthurmannia	K (Berr)		(302)	Trochleiceras	K (Apti-u)	-K (Albi-l)	
+ Subtissotia	K (Coni-u)			+ Troilliceras	J (Bath-m)		
Subvertebriceras	J (Oxfo-l)	-J (Oxfo-u)		Tropaeum	K (Apti-u)		
Sulciferites	J (Sine-l)		(302)	Tropidoceras	J (Plie-l)		(302)
Sulcohamites	J (Bath-l)	-J (Bath-m)	(302)	Tropioides	K (Turo-l)	-K (Turo-u)	
+ Sulcohamitoides	J (Bath-l)	-J (Bath-m)		+ Tuberosidocoides	K (Sant-u)		
+ Sulcophlites	K (Albi-m)	-K (Albi-u)		+ Tugurites	J (Aale)	-J (Bajo-l)	
+ Suteria	J (Oxfo-u)	-J (Tith-l)	(302)	Tulites	J (Bath-l)	-J (Bath-m)	
Taffertia	J (Toar-l)		(302)	Tunesites	K (Ceno-l)		
Taramelliceras	J (Call-l)	-J (Kimm-u)		Turrilites	K (Ceno-l)	-K (Ceno-u)	
+ Tarrantoceras	K (Ceno-m)	-K (Ceno-u)	(901)	Turrilitoides	K (Albi-m)	-K (Albi-u)	(1066)
Tegoceras	K (Albi-l)	-K (Albi-m)		+ Tyrannites	J (Call-l)		
Telermoceras	J (Bajo-u)			Uhligella	K (Apti-u)	-K (Albi-u)	(943)
Teloceras	J (Bajo-l)	-J (Bajo-u)		Uhligia	K (Barr-l)		
+ Telodactylus	J (Toar-l)			Uhligites	J (Tith-l)	-K (Vala-u)	
Temnoptychites	K (Berr)?			Umiaies	J (Tith-l)	-J (Tith-u)	
Teshioites	K (Camp-u)			Unipeltoceras	J (Call-u)		
Tetragonites	K (Apti-u)	-K (Maes-u)	(730)	Uptonia	J (Plie-l)		(302)
Tetrahoplites	K (Albi-l)			Urakawites	K (Camp)		
Tetrahoplitooides	K (Albi-l)			Utaturiceras	K (Ceno-l)	-K (Ceno-u)	
Tetraspidoceras	J (Sine-u)	-J (Plie-l)	(302)	+ Vacekia	J (Toar-u)	-J (Bajo-l)	(1066)
Texanites	K (Coni-u)	-K (Camp-l)		Valanginites	K (Vala-u)		
Thambites	J (Bath-l)			Valdedorsella	K (Haut-l)	-K (Apti-u)	

Taxon	First Appearance	Last Appearance	Reference	Taxon	First Appearance	Last Appearance	Reference
Vascoceras	K (Ceno-u)	- K (Turo-l)	(716)	+ Belemnocamax	K (Ceno-m)		
Veleziceras	K (Barr-l)?			+ Belemnopsis	J (Aale)	- K (Haut-l)	(1066,1222)
Venezoliceras	K (Albi-m)	- K (Albi-u)		+ Belospirula	K (Albi)		(1066)
Vermiceras	J (Hett-u)	- J (Sine-l)	(302)	+ Brachybelus	J (Sine)	- J (Bath-u)	(308,868)
Vermisphinctes	J (Bajo-u)			+ Brexibelus	J (Toar-u)	- J (Bajo-u)	(1222)
Vertebriceras	J (Oxfo-l)	- J (Oxfo-u)		+ Chialalabelus	K (Barr-u)	- K (Apti)	(306)
Vertebrites	K (Sant)	- K (Maes-u)	(2,971)	+ Chondroteuthis	J (Toar-l)		(307)
+ Veveysiceras	K (Barr-l)			+ Coeloteuthis	J (Sine-u)	- J (Plie-l)	(2,308)
+ Viciniodiceras	J (Sine-u)		(1066)	+ Conobelus	J (Tith)	- K (Valaj)?	(308)
Villania	J (Plie-l)	- J (Call)		+ Conodicoelites	J (Plie)	- J (Kimm)	(308,1066)
Vinalesites	J (Tith-u)			+ Conoteuthis	K (Apti)	- K (Ceno-u)	(307)
Vinalesphinctes	J (Oxfo-u)			+ Curtohibolites	K (Barr)	- K (Apti)?	(309)
Virgatixioceras	J (Kimm-u)			+ Cyhndroteuthis	J (Plie-u)	- K (Haut-u)	(308,1222)
Virgatiites	J (Tith-u)			+ Dactyloteuthis	J (Sine)	- J (Toar)	(308)
+ Virgatopavlovia	J (Hett-l)			+ Dicoelites	J (Hett)?	- J (Kimm)	(308)
Virgatosimoceras	J (Tith-l)	- J (Tith-u)	(302)	+ Dimitobelus	K (Albi-l)	- K (Maes-u)	(2,309, 1222)
Virgatosphinctes	J (Tith-l)	- J (Tith-u)		+ Diplobelus	J (Tith)		(308)
+ Virgatospinctoides	J (Kimm)			+ Duvalia	J (Tith-l)	- K (Turo-u)	(308,1066, 1222)
Waehneroceras	J (Hett-u)		(302)	+ ?Eoblemnites	C (Scrp-l)?		(308)
Wagnericeras	J (Bath-m)	- J (Bath-u)?		+ Fusiteuthis	K (Maes-u)		(309)
Watinoceras	K (Turo-l)			+ Gastrobolus	J (Sine)	- J (Call-l)	(308,868)
Wheatleyites	J (Tith-l)			+ Goniotheuthis	K (Coni-l)	- K (Camp-l)	(309,993)
Whitbyiceras	J (Toar-l)		(302)	+ Hastites	J (Plie-l)	- J (Tith)	(308)
Wichmanniceras	K (Vala)			+ Hibolites	J (Bajo-l)	- K (Ceno-l)	(308,868)
Windhauseniceras	J (Tith-u)			+ Holcobelus	J (Aale)	- J (Bajo-l)	(308,1222)
Wintonia	K (Ceno-l)			+ Homaloteuthis	J (Aale)		(308)
Witchellia	J (Bajo-l)		(302)	+ Lagonibelus	J (Tith)	- K	(308)
Worthoceras	K (Albi-u)	- K (Turo-u)	(716)	+ Lenobelus	J (Toar-l)	- J (Bajo-u)	(308,1222)
+ Wrightoceras	K (Turo-l)		(716)	+ Megateuthis	J (Aale)	- J (Call-l)	(308)
Xenocephallites	J (Bath-m)	- J (Oxfo-l)		+ Mesohibolites	K (Haut-u)	- K (Apti-u)	(309,1222)
Xenostephanus	J (Kimm-l)		(302)	+ Mesoteuthis	J (Toar)	- J (Bajo-u)	(308,1222)
Xiphroceras	J (Sine-u)		(302)	+ Nannobelus	J (Hett-u)	- J (Toar)	(2,308)
Yabeiceras	K (Coni)			+ Neoblemnella	K (Maes-u)		
+ Yakounia	J (Toar-u)			+ Neohibolites	K (Barr)	- K (Ceno-u)	(309)
+ Yezoites	K (Ceno-l)	- K (Sant)		+ Oxyteuthis	K (Barr)	- K (Apti-u)	(309)
Yokoyamaceras	K (Turo)?, K (Coni)?			+ Pachyduvalia	J (Call-l)	- J (Kimm)	
Zaraiskites	J (Tith-u)			+ Pachyteuthis	J (Aale)	- K (Haut-l)	(1222)
Zealandites	K (Albi-l)	- K (Maes-u)	(2,730,971)	+ Parahastites	J (Toar-l)	- J (Aale)	(308)
Zemistephanus	J (Bajo-l)			+ Parahibolites	K (Apti-l)	- K (Ceno-u)	(309,1222)
+ Zigzagiceras	J (Bath-l)			+ Paramegateuthis	J (Aale)	- J (Call)	(1066,1222)
Zonovia	J (Kimm-l)		(302)	+ Parapassaloteuthis	J (Plie-u)	- J (Toar-l)	(1222)
+ Zuercherella	K (Apti)			+ Passaloteuthis	J (Plie-u)	- J (Toar-l)	(1222)
Zugodactylites	J (Toar-l)		(302)	+ Patagonibelus	K (Vala-u)	- K (Haut-l)	
Zugokosmoceras	J (Call-m)	- J (Call-u)		+ Pavloviteuthis	K (Haut)	- K (Albi)	(307)
+ Zuluceras	K (Coni)			+ Peratobelus	K (Apti-l)	- K (Apti-u)	(2)
Zuluscapites	K (Albi-m)	- K (Albi-u)	(2)	+ Pleurobelus	J (Plie-u)		(1222)
Zurcherella	K (Barr-u)	- K (Apti-u)		+ Praeoxyteuthis	K (Haut)		(1066)
Zurcheria	J (Bajo-l)		(302)	+ Produvalia	J (Bajo)	- J (Tith)	
Or. BELEMNITIDA				+ Pseudobelus	K (Vala)	- K (Haut)?	(309)
+ Acanthoteuthis	J (Tith-l)?		(308)	+ Pseudodicoelites	J (Toar)	- J (Bath)	(308,1066)
+ Acrocoelites	J (Toar-l)	- J (Aale)	(308,1222)	+ Pseudohastites	J (Plie-l)	- J (Toar-l)	(1222)
+ Acroteuthis	J (Oxfo-m)	- K (Barr-l)	(1066,1222)	+ Quircobelus	J (Tith)		(1066)
+ Actinocamax	K (Ceno-l)	- K (Camp-l)	(2,309,993)	+ Raphibelus	J (Tith-l)?		(308)
+ Arcobelus	J (Toar)		(1222)	+ Rhabdobelus	J (Aale)		(1066)
+ Aulacoteuthis	J (u)	- K (Barr)?	(309,1222)?	+ Rhopaloteuthis	J (Bath)	- J (Oxfo-m)	(868)
+ Bayanoteuthis	T (Eo-u)		(2)	+ Sachsibelus	J (Aale)	- J (Bajo-l)	(308)
+ Belemnella	K (Camp-u)	- K (Maes-u)	(309)	+ Salpingoteuthis	J (Toar)	- J (Aale)	(1066)
+ Belemnelloamax	K (Ceno-m)	- K (Camp-u)	(309,993)	+ Schwegleria	J (Hett)		(1066,1222)
+ Belemnitella	K (Coni-u)	- K (Maes-u)	(309,993)	+ Simpsonibelus	J (Toar-l)	- J (Toar-u)	(1222)
+ Belemnites	J (Hett)	- J (Toar)	(308)	+ Sinoblemnites	Tr(Carn)		(1066)
+ Belemnitiina	J (Bajo-u)		(1222)				

Taxon	First Appearance	Last Appearance	Reference	Taxon	First Appearance	Last Appearance	Reference
+ Somalibelus	J (Kimm-l)			+ Muensterella	J (Tith-l)		(307)
+ Tauriconites	K (Berr)	-K (Vala-l)	(306)	+ ?Necroteuthis	T (Ol-l)		(307)
+ Tetrabelus	K (Apti-l)	-K (Albi-u)		+ Neoligosepia	K (Barr-u)	-K (Turo)	(1066)
+ Vectubelus	K (Apti)		(306)	+ Niobrateuthis	K (Coni-u)?	-K (Camp-l)	(310)
+ Volgobelus	K (Vala)	-K (Haut-l)		+ Palaeologigo	J (Kimm-l)	-K (Sant-u)	(307)
+ Youngibelus	J (Toar-l)			+ Parabelopeltis	J (Toar-l)		(307)
Or. OCTOPIIDA				+ Paraplesioteuthis	J (Toar-l)		(307)
+ Argonauta	T (Mi)	-R	(307)	+ Parateudopsis	K (Sant-u)		
+ Kapal	T (Mi)			+ Plesioteuthis	J (Tith-l)		(307)
+ Obinautilus	T (Ol-u)		(524,1066)	+ Romanteuthis	J (Call-l)	-J (Call-m)?	
+ Palaeoctopus	K (Coni)		(2)	+ Stylioteuthis	K (u)		(307)
+ Proteroctopus	J (Call)		(307,1066)	+ Symplectoteuthis	T (Plio-u)	-R	(573)
Or. SEPIIDA				+ Teudopsis	J (Plie)	-J (Call-l)	(1066)
+ Adygeya	K (Apti-u)			+ Trachyteuthis	J (Oxfo-l)	-J (Tith-u)	(2,307)
+ Amerirostra	T (Mi-l)?		(1066)	+ Triadoteuthis	Tr(Ladi-l)		
+ Archaeosepia	T (Eo-m-u)		(1066)	+ Tusoteuthis	K (Camp-l)		(310)
+ Belemnossella	T (Eo-l)		(307)	Or. PHRAGMOTEUTHIDA			
+ Belemosis	T (Dani-u)?	-T (Eo-l)	(307)	+ Belemnoteuthis	J (Oxfo-u)	-J (Kimm-u)	
+ Belocurta	T (Than)?		(1066)	+ Permoteuthis	P (Tatr)		(307,1066)
+ Beloptera	T (Than)	-T (Ol-l)?	(307)	+ Phragmoteuthis	P (Guad)	-J (Toar-l)	(307,1066)
+ Belopteridium	T (Eo)		(307)	+ inc. sedis	J (Sine)		
+ Belopterina	T (Eo-l)		(307)	Or. BOLETZKIDA			
+ Belosepia	T (Eo-l)	-T (Eo-m-u)	(700)	+ Boletzkyidae	D (Emisi-l)		
+ Belosepiella	T (Eo-m)		(307)	+ Naefiuteuthididae	D (Emisi-l)		
+ Groenlandibelus	K (Maes-u)		(307)	Or. AULACOCERIDA			
+ Naefia	K (Apti-u)	-K (Maes-u)	(1066)	+ Atractites	Tr(Nori)	-J (Toar)	
+ Pseudosepia				+ Aulacoceras	D (Effe)?	-Tr(Nori-l)	(307,1066)
+ Sepia	T (Mi-m)	-R	(307)	+ Aussites	Tr(Carn-l)	-J (l)	
+ Spirula	T (Mi-l-u)	-R	(307,1066)	+ Austroteuthis	Tr(Rhae)		(1066)
+ Spirulirostra	T (Mi-m)?		(307)	+ Bactritimimus	C (Serp-l)		(2)
+ Spirulirostrella	T (Ol-l)		(307)	+ Breviatractites	Tr(Anis)	-Tr(Ladi-l)	
+ Spirulirostridium	T (Ol-l)		(1066)	+ Buelowiteuthis	Tr(Carn)?	-Tr(Nori-l)	(307)
+ Spirulirostrina	T (Mi)		(307,1066)	+ Calliconites	Tr(m)	-Tr(Nori)	(307)
+ Styrcoteuthis	T (Eo-m)		(307)	+ Chitinodeuthis	J (Plie-l)	-J (Plie-u)	(2,1066)
+ Vasseuria	T (Eo-m-l)		(307)	+ Crassiatractites	Tr(Anis)	-J (Plie-u)	
Or. TEUTHIDA				+ Dietyconites	Tr(Carn)	-Tr(Nori)	(307)
+ Actinosepia	K (Camp-u)		(310,1066)	+ Hematites	C (Serp-l)		(2)
+ Berryteuthis	T (Plio-u)	-R	(573)	+ Metabelemnites	Tr(Carn)	-Tr(Nori-l)	(307)
+ aelaeoteuthis	J (Tith-l)		(307)	+ Mojsisovicsteuthis	Tr(Anis-l)	-J (Hett)	(307)
+ Dorateuthis	K (Sant-u)		(307)	+ Palaeobelemnopsis	P (u)		(1066)
+ Dosidicus	T (Plio-u)	-R	(573)	+ Paleoconus	C (Serp-l)		(2)
+ Enchoteuthis	K (Camp-l)		(310)	+ Prographularia	Tr(Rhae)		(1066)
+ Geopeltis	J (Toar-l)	-K (Sant)	(307,1066)	+ Protoaulacoceras	D (Emisi-l)		(307)
+ Geoteuthinus	J (Tith-l)		(307)	+ Zugmontites	Tr(Carn)?		(307)
+ ?Glochynomorpha	P (Leon)?		(310)	Cl. BIVALVIA			
+ Glyphiteuthis	K (u)		(307)	(Classification and basic stratigraphic data from the Treatise, Pt. N [1969]).			
+ Jeletzkyteuthis	J (Toar-l)			Or. NUCULOIDA			
+ Kansasteuthis	K (Sant-l)?		(310)	+ Acila	T (Ol-u)?	-R	
+ Kelaeno	J (Tith-l)		(307)	+ Adrana	T (Eo-l)	-R	(914)
+ Leptoteuthis	J (Tith-l)		(307)	+ Afganodesma	O (Aren)		(98,1046)
+ Libanoteuthis	K (Ceno-l)	-K (Ceno-u)		+ Aloconcha	O (Llvi)?, O (Llde)?		(1046)
+ Liooteuthis	J (Toar-l)		(307)	+ Antactinodion	D (l)		(2R82)
+ Listroteuthis	J (Tith-l)		(307)	+ Arsaigia	S (Wen-l)		
+ Loligo	T (Eo-m-l)	-R	(573)	+ Australoneilo	K (Maes)	-T (Eo-u)	(890)
+ Loligosepia	Tr(Rhae)	-J (Toar-l)	(307,1066)	+ Australoportlandia	T (Eo-u)		
+ Maioteuthis	K (Barr-u)	-K (Maes)	(1066)				
+ Mastigophora	J (Call)	-K (Apti-l)	(307,1066)				
+ Moroteuthis	T (Plio-u)	-R	(573)				

Taxon	First Appearance	Last Appearance	Reference	Taxon	First Appearance	Last Appearance	Reference
+Bicrenucula	S (Ldov)		(ZR84)	Metapalaeoneilo	S (u)		(95)
Bicrenula	D (Fras)			Myoplusia	O (Llvi-u)	-O (Cara-m)	(91,948)
Borissia	T (Mi)?			Neilo (+ Saturnia)	K (Camp-l)	-R	
Brevinucula	T (Mi)	-R		+Neiloides	K (Maes)		(991)
Cadomia	O (Llvi-u)	-O (Llde-u)	(948)	+Neilonella	K (Maes)	-R	(991)
+Caesariella	S (Wenl-u)	-S (Ludl-l)	(1117)	+Notonucula	D (l)		
Calorhadia	T (Eo-l)	-T (Eo-u)	(700)	Nucula	K (Berr-l)	-R	(663)
Cardiolaria	O (Aren-u)	-S (Ludl)	(948,1046)	Nuculana (+ Leda)	Tr(Indu-l)	-R	
Chinopista	D (Gedi)	-P (Sakm)		+Nuculavus	O (Vise-u)	-P (Leon-u)	
+Cnestrifella	K (Maes)		(991)	Nuculites	C (Cara-m)	-P (Djhu)	(95,157)
Cnesterium	T (Dani)	-R		+Nuculodonta	S (Ldov-u)	-S (Wenl-u)	(ZR83, 1117)
Concavodonta	O (Cara-u)	-O (Ashg-m)		Nuculoidea	S (Wenl-u)	-D (Fame-u)	(1117)
+Costaledopsis	O (Ashg)		(1046)	Nuculoma	J (Bajo-u)	-K (Berr-u)	(93,663)
Costatoleda	T (Ol)	-R		Nuculopsis	C (Tour-u)	-Tr(Indu-l)	
Ctenodonta	O (Trem-l)	-O (Ashg-u)	(91,977, 1066)	Nucundata	P		
Ctenodontella	D (l)			Orthoyoldia	T (Eo-l)	-R	(1248)
+Dacryomya	Tr(l)	-J (Tith)	(159)	Palaeoconcha	O (Cara-u)	-S (Ldov-u)?	
Deceptrix	O (Llvi-l)	-D (Emsi-l)	(91,1066)	Palaeoneilo	O (Aren-u)	-J (Plie-u)?	(91)
+Deminucula	T (Mi)	-R		Palaeonucula	Tr(Ladi)	-J (Tith)	(93,159)
Ditichia	D (l)			+Paleostraba	S (Wenl-u)		(1117)
Dysondonta	D (Emsi)?			Paleyoldia	O (Vise-u)?	-P (Guad)	
+Economolopsis	C (Serp-l)		(879)	+Paulinea	C (Aren-l)		(1238)
+Ekaterodonta	O (Aren)	-O (Llvi-u)	(948,1046)	Pectinucula	K (l)	-K (Maes-u)	
Ekstadia	S (Wenl-u)	-S (Ludl-l)	(95,1117)	+Pensarnia	O (Aren-l)		(1238)
+Eleganuculana	Tr(u)		(ZR83)	Phaenodesmia	Tr(Anis)	-Tr(Nori)	(94)
+Ennucula	T (Dani)	-R	(899)	Phestia	D (Give)	-Tr(l)	(1066)
+Eritropsis	O (m)		(1046)	+Phestoides	D (l)	-D (m)	(ZR87)
Ezonuculana	K (Coni)?	-K (Maes)	(159)	+Pojetaia	Cm(Atda-l)	-Cm(lMid)	
+Fidera	O (Cara-m)		(1046)	Poroleda	K (Maes-u)	-R	(545)
+Freja	S (Wenl-u)		(ZR84)	Portlandia	K (Sant)	-R	(159)
Gibbonucula	T (Eo-l)		(914)	Praenucula	O (Aren-l)	-S (Wenl-u)	(948,1077, 1117)
Glyptoleda	P (Guad-l)		(745)	Praesacella	J (Plie)	-J (Tith)	(93)
+Habonucula	J		(ZR77)	Pronucula	T (Ol-u)	-R	
Hataiyoldia	T (Mi)			+Propeleda	T (Mi-m)	-R	(530)
Hilgardia	T (Eo-l)	-T (Eo-m-u)	(700,914)	+Pseudoleda	S (Prid)?	-D (Sieg)	
+Iheringimucula	T (Eo-u)	-T (Mi-l)?		Prosoleptus	Tr(m)?	-Tr(Carn)	(94)
+Inaequidens	O (m)	-O (Cara-m)	(1046)	+Pseudonucula	P (Guad)		
+Indoculana	J (Call-l)			+Pseudonuculana	D (l)	-D (m)	(ZR87)
+Johmartinia	O (Llvi)?, O (Llde)?		(1046)	+Pseudoportlandia	T (Eo-m-l)	-T (Mi-u)	(899)
Jupiteria	K (Albi)?	-R	(789)	+Pseudotindaria	T (Eo-m-l)	-R	(899)
Kalayoldia	T (Eo-u)	-R	(816)	Ptychostolis	J		
+Kasachia	D (m)		(ZR85)	+Qionghouinia	T (Plio)		(ZR83)
Koenenia	D (l)	-D (Fame-u)		Quadratonucula	C (Mosc-u)	-P (Sakm-u)	
+Kufralaria	D (m)	-D (u)	(ZR81)	Rollieria	J (Hett-u)	-J (Oxfo)	(93)
Lamellinucula	T (Than-l)	-R	(914)	Ryderia	J (Hett-l)	-J (Plie-u)	(93,715)
Ledella	T (Eo-m-u)	-R	(899)	Saccella	K (Maes)	-R	(991)
Ledina	T (Dani-l)	-T (Eo-u)	(700,899)	Sarepta	T (Eo-u)	-R	(530)
Ledopsis	S (Ludl-u)	-D (l)	(1117)	+Scaeoleda	T (Ol-u)	-R	(530)
+Leiodydodonta	D (l)	-D (m)	(ZR87)	+Scyphoconcha	D (l)		(ZR90)
Leionucula	K (Haut-l)	-R	(789)	+Sibiroctenia	O (Cara)		
Lembulus	T (Eo)	-R		+Similoconcha	D (m)		(ZR79)
+Lepteviella	Tr(m)		(ZR85)	Similodonta	O (Llde-l)	-S (Wenl-u)	(91,97, 1117)
Linucula	T (Ol-l)	-R	(899)	Sluha	O (Cara)	-O (Ashg-u)	
+Lissanucula	T (Mi)			+Spathelopsis	C (Serp-l)		(879)
Lithorhadia	T (Dani)	-T (Mi-m)	(816)	+Spineilo	T (Dani)		(899)
+Lophoconcha	O		(ZR81)	+Sthenodonta	O (m)		(1046)
Malletia	K (Vala-l)	-R		+Suria	O (Aren-l)		
Megayoldia	T (Ol)	-R	(816)	Tancrediopsis	O (Llvi-l)?	-D (Give)	(91,97)
+Menneroctenia	K (Maes)	-T (Mi-m)		Tellinopsis	D (Give-u)		
+Mesoneilo	Tr(Nori)	-Tr(Rhae)	(676)				
Mesosacella	J (Sine)?	-T (Than)	(791,914)				

Taxon	First Appearance	Last Appearance	Reference	Taxon	First Appearance	Last Appearance	Reference
Thestyleda	T (Plio)	-R		+ Snoopyia	S (Prid)		(673)
+ Thorafia	O (Aren-l)		(ZR80)	Vevoda	S (u)	-D (l)?	
Tindaria	T (Than)	-R	(914)	Vlasta	O (Ashg-m)	-S (Ludl)?	
+ Tironuctula	O (Livi-l)		(98)	Or. ARCOIDA			
Trigonucula	Tr(Carn)	-Tr(u)	(159)	Acar	K (Maes-l)	-R	(545)
Tropinuculites	S (u)?			Aegilops	O (Cara-m)		
Truncacila	K (Apti)?	-R		+ Alytodonta	S (Ldov-l)		
+ Varinuctla	T (Eo-m-l)	-R	(899)	Anadara	T (Eo-m-l)	-R	(1112)
Veteranella	Tr(Nori)		(94)	+ Antoneila	C (u)		(ZR86)
+ Xiaoshuisulena	T (Plio)		(ZR83)	Arca	K (u)	-R	
Yoldia	K (Maes)	-R	(1066)	Arcopsis	K (Maes-u)	-R	
Yoldiella	K (Maes)	-R	(991)	Arcullaea	K (l)		
Zaleda	T (Mi-l-u)	-R	(728)	Arginopsis	T (Eo-u)		
+ Zechania	O (Cara-m)		(1046)	Aupouria	T (Mi-l)	-R	(1112)
Or. SOLEMYOIDA				+ Austraculiacca	T (Palc)		(ZR88)
Acharax	P (Leon)	-R	(977)	+ Axinola	T (Ol-u)	-R	(1112)
Adulomya	T (Mi)			Barbatia	Tr(Nori)	-R	(94)
+ Dystactella	O (Llde)	-D (Give-l)	(977)	Bathyarca	K (Maes-l)	-R	(545,1112)
Huxleyia	T (Plio)	-R	(816)	+ Bellaxinaea	T (Eo-u)	-R	(1112)
?Janeya	S (Wenl-u)	-P (Djhu)		Bentharca	T (Mi-l-u)	-R	(1112)
Manzanella	P (Leon-u)	-P (Guad-l)		Calloarca	T (Than)	-R	(1112)
Nucinella	J (Hett)	-R		Carbonarca	C (Pn)		
+ Ovatoconcha	O (Aren-l)		(1238)	+ Cardiollita	S (Ludl-u)	-S (Prid)	(673)
+ Palaeosolemya	O (Cara-l)			+ Catamarenia	O (Aren-u)		
Petrasma	T (Plio)	-R		Catella	Tr(Nori)	-T (Than)	(159,545)
+ Posterodonta	K (l)		(ZR76)	Cosa	T (Eo-l)	-R	(914)
Psilococoncha	O (Llde-u)	-O (Ashg-m)	(91,977)	Cosmetodon	P (Leon-m)?	-J (Tith-u)	(663)
Solemya	C (Step-l)	-R	(977)	+ Costaglycymeris	T (Mi-l)	-T (Plio-u)	(985)
Solemyarina	T (Ol-u)?	-R		Cratis	T (Mi-l-l)	-R	(681)
+ Vorkutella	P		(ZR76)	+ Crenulimopsis	T (Mi-m)	-R	(1112)
Or. PRAECARDIOIDA				Cucullaea	J (Hett)	-R	
Antipleura	S (Wenl)?			Cucullaearca	K (Ceno)	-R	
Buchiola	D (Fras)	-D (Fame)		Cucullaria	T (Than-l)	-T (Eo-l)	(700,705)
Butovicella	S (Wenl-u)	-S (Ludl-l)		Cunearca	T (Eo-m)	-R	(1112)
+ Cardiacarnia	S (Wenl-l)		(673)	Curvirostrum	J (Bajo)		
+ Cardiobebeba	S (Wenl-l)	-S (Wenl-u)	(673)	Cypricardites	O (u)		
Cardiola	S (Wenl-u)	-C (Tour)?	(673)	Cyrtodonta	O (Aren-l)	-S (Ldov-u)	(2,157, 1046,1238)
Cardiolopsis	S (Wenl-l)		(673)	Cyrtodontula	O (Aren-l)	-O (Ashg-m)	(948,1046, 1238)
+ Carnalpia	S (Wenl-l)		(673)	+ Dallarca	T (Mi-l)	-T (Plio-u)	(985)
+ Cominucula	S (Wenl-l)		(673)	+ Dicranodonta	J (Tith-u)	-K (Apti)	(663)
Dexiobia	C (Tour-l)			+ Didimacae	T (Mi-m)	-R	(1112)
Dualina	S (Wenl)?	-S (Prid)		+ Ekaterdonta	O (Aren-u)		
Ethydesma	S (Ldov-m)	-D (Fras-l)		+ Empleconia	T (Mi-l)	-R	
Hercynella	S (Prid)	-D (Fras)		Eonavicula	J (Aale)	-R	(92,1066)
+ Isiola	S (Wenl-u)	-S (Ludl-u)	(673)	Eontia	T (Mi-l-l)	-R	
Lunulacardium	S (u)	-C (l)	(1066)	+ Falcatodonta	O (Aren-l)		(1238)
+ Manulica	S (Ludl)			Felicia	T (Plio)	-R	
Necklandia	S (u)?			Fugleria	T (Plio)	-R	
+ Nutricula	S (Wenl-u)		(673)	Glycymerella	T (Mi-l-u)	-R	(1112)
Opisthocoeilus	S (u)	-D (Fras)?		Glycymeris	K (Vala)	-R	
Panenka	D (Gedi)			+ Glycymerita	K (Maes)	-T (Plio-u)	(991)
+ Patrocardia	S (Wenl)	-S (Prid)	(1066)	+ Glycymerula	T (Plio-l)	-R	(1112)
Praecardium	S (Wenl)?	-D (Fame)		Grammatodon	J (Hett)	-K (Ceno-u)?	(93)
+ Pseudocostatoria	S (u)		(ZR88)	+ Grandaxinea	T (Eo-m-u)	-R	(1112)
+ Pygollia	S (Ludl-u)	-S (Prid)	(673)	+ Grandiarca	T (Mi-l-u)	-R	(816,1112)
Shanina	O (Llde)		(1066)	+ Hawaiiarca	T (Eo-m-l)	-R	(1112)
Silurina	S (u)	-D (l)?		Heikea	O (Cara)	-O (Ashg-m)	(1046)
Slava	S (Ldov-m)	-S (Ludl-l)		+ Hoernesarca	T (Plio)		(ZR75)
+ Slavinka	S (Ludl-l)			Hoferia	Tr(Ladi-u)	-Tr(Carn)	(94)

Taxon	First Appearance	Last Appearance	Reference	Taxon	First Appearance	Last Appearance	Reference
+Megacrenella	T (Eo-m)	-R	(1112)	Or. PTERIOIDA			
Modiolarca	T (Plio)	-R	(1112)	Abruptolopha	K (Camp)?	-K (Maes)	(914)
Modiolatus	Q (Plei)	-R	(1112)	Acanthopecten	C (Vise-l)	-P (Djuh)	(524)
+Modiolula	T (Eo-m-l)	-R	(1112)	Acesta	J (u)	-R	
Modiolus (+ Sanda)	D (Fame)	-R		+Acobaeacardium	T (Plio)		(ZR86)
Modiolusia	T (Plio)	-R	(1112)	Actinodesma	D (Emsi)?	-D (Fame-u)	
-Modiomylilus	T (Eo-u)?	-T (Mi)		Actinopteria	S (Wenl)	-P (l)	
+Musculista	Q (Plei)	-R	(1112)	Actinopterinia	O (Ashg-m)		
Musculus	J (Sine-u)	-R	(93)	Actinostreon	J	-K (Maes)	
Myapalmula	Q (Plei)	-R	(1112)	Acustrorea	K (Ceno)	-K (Maes)	(790,991)
Myoforceps	T (Mi-l)	-R		Aequipecten	T (Eo-m)	-R	(1112)
Mysidiella	Tr(Ladi)	-Tr(Rhae)		Aetostreon	K (Vala-l)	-K (Albi)	(789)
Mytella	T (Eo-u)	-R	(816,1112)	Africogryphaea	J (Bath-u)	-J (Call)?	(99)
+Mytilaster	T (Mi-l)	-R		Agerostrea	K (Camp-l)	-K (Maes)	(790)
Mytilisepta	T (Pg)	-R		Aguilerella	J (Pli-u)	-J (Oxfo-u)	(749,791)
+Mytilon	T (Dani)		(1061)	Ahtioconcha	O (Llde-u)		
Mytilops	D (Fras-u)			Allectryonella	T (Plio)	-R	
Mytilus	T (Ol-l)	-R	(1112)	+Allobuchia	J (Aale)	-J (Bajo)	(ZR84)
Notobotula	Q (Plei-l)	-R		Allonychia	O (Cara)?	-O (Ashg-l)	
Orthodesma	O (Ashg-m)		(1046)	Alnifia	O (Llde)		
Palaeosolen	D (l)	-D (Fras)		-Altaipecten	C (l)	-C (Step)	(ZR85, 1058)
Perna	T (Than)	-R	(1112)	+Ambigostrea	K (Maes)		(991)
Pernomytilus	J (u)			Ambonychia	O (Llde)	-O (Ashg-m)	(2)
Pholadomorpha	O (Ashg-l)	-O (Ashg-m)	(91)	Ambonychiopsis	O (Llde)	-S (Wenl)	
Phthonia	D (Emsi)	-D (Fras)		Amonotis	Tr(Carn)		
Pinna	C (Vise-l)	-R		Amphidonte	K (Apti)	-K (Maes)	(159)
Plesioinna	K (Ceno)	-K (Maes-u)	(790)	Amphijanira	Tr(Anis)	-Tr(Carn)	(94,524)
+Plicatomytilus	T (Mi-l)	-T (Mi)	(816)	Amphiococlia	S (Ldov)	-S (Ludl)?	
Praemytilus	J (Bath)			+Amuropecten	J (Pli-u)		(ZR86)
+Praeostrea	S (Ludl)	-D (Gedi)		Amussiopecten	T (Ol-u)	-T (Plio-l)	(101)
Promytilus	C (Ms)	-P (Guad-u)	(157)	Amusium	T (Ol-l)	-R	(1112)
Protopsis	Tr(l)	-Tr(Carn)		Anatipecten	T (Eo-u)	-T (Plio)	
+Pseudocolpomya	O (Cara)?	O (Ashg)?	(1046)	Anderkenia	O (Cara)?	O (Ashg)?	(1046)
Pteronites	C (Vise)	-P (Guad-u)		Anguipecten	T (Mi)	-R	
Quendreda	T (Plio)	-R	(1112)	Annachlamys	T (Mi-m)	-R	
Regoria	K (Sant)	-K (Maes)	(991)	Anningella	Tr(Rhae)	-J (Sine-u)	(93,94)
+Regulifer	J (u)		(ZR88)	Annuliconcha	C (Tour)	-P (Guad)	(524)
Rhomboidella	T (Eo-m-u)	-R	(1112)	+Annulinctes	Tr(Anis)	-Tr(Ladi)?	(524)
Rhynchomytilus	J (Oxfo-u)			Anomalococlia	O (Ashg-m)		
Ryenella	T (Eo-u)	-R	(530)	Anomalodonta	O (Ashg-m)		(91)
Semimodiola	T (Eo-u)			Anomia	K (Apti-l)	-R	
Septifer	Tr	-R		Anopaea	J (Tith-u)	-K (Albi-l)	(663)
+Servatrina	T (Mi-m)	-R	(1112)	+Anshunopecten	P (Dora)		(524)
Shaninopsis	O (Cara)	-O (Ashg-m)		Antijanira	Tr(Anis)	-Tr(Carn-l)	(94,524)
-Skarlatella	T (Eo-m-l)	-R	(1112)	Antipecten	T (Mi-l-u)	-T (Mi-m)	
Solamen	T (Ol-l)	-R	(1112)	Antiquilima	Tr(Carn)	-K (Apti)	(94,159)
+Sootryenella	T (Than)		(705)	Anulipecten	D (l)		
-Sphenosolen	O (m)		(1046)	Anulostrea	K (Coni)	-K (Sant)	
Stegoconcha	J (Oxfo-l)	-T (Than)	(663,914)	Aphanaia	P (Sakm)	-P (Guad-l)	(100,745, 1040)
-Streptopinna	T (Mi-l)	-R	(530)	Arcavicula	Tr(Ladi-u)	-Tr(Carn)	(94,1066)
+Striamodiolus	K		(ZR84)	Arcticeramus	J (Call)	-J (Tith-u)	
+Strimodiolus	J (Oxfo-u)	-J (Tith-u)	(791)	+Arctomyalina	C (Mosc)		(102)
+Synek	O (Aren)	-O (m)	(1046)	Arctostrea	K (Apti-l)	-K (Maes-l)	
Tommasina	Tr(Carn)			Arctotis	J (Sine)	-K (Haut)	(93,1233)
Trichites	Tr(Nori)	-K (l)	(94)	Argopecten	T (Mi-l-l)	-R	
Trichomusculus	T (Eo-m-u)	-R	(1112)	+Arzelella	Tr(Ladi)		(524)
Trichomya	T (Mi-l-l)	-R	(899)	Asoella	Tr(Anis)	-Tr(Nori)	(159,524)
Undatimusculus	T (Eo-l)			Athlopecten	T (Ol-u)	-T (Mi-l-l)	(728,899)
Volcellina	C (Mosc-u)	-P (Guad-u)	(745)	Atomodesma	P (Asse)?	-Tr(Indu-l)	
+Xenostrobus	T (Mi-u-l)	-R	(899)				
Zelithophaga	T (Plio)	-R	(1112)				

Taxon	First Appearance	Last Appearance	Reference	Taxon	First Appearance	Last Appearance	Reference
Atrata	Tr(Rhae)	-K (Maes-u)	(790,1066)	Claraia	P (Djhu)	-Tr(Olen-u)	(524)
Aucellina	K (Barr)	-K (Ceno)	(1233)	Clavicosta	C (Step-l)	-P (Guad-u)	(524)
Augea	C (u)	-P (l)		Cleidochondrella	K (Sant)	-K (Camp)	
Aulacomyella	J (Kimm)			Cleionychia	O (Aren-l)	-O (Ashg-m)	(1238)
+Australobuchia	J (u)	-K (Haut)	(ZR81)	Cliopectera	S (Ludl-u)		
+Avichlamys	Tr(Indu-u)	-Tr(Olen-u)	(524)	Cochlearites	J (Plie)		(1066)
Avicularca	Tr(Carn)	-Tr(Rhae)?	(1233)	+Colpentalium	J (Oxfo-u)		(ZR83)
Aviculolima	Tr(Anis)			+Conradostrea	T (Mi-u)	-Q (Plei)	(985)
+Aviculomonotis	P (Guad)		(524)	+Convexopecten	T (Mi-l)	-R	
Aviculomyalina	Tr(Anis-m)	-Tr(Anis-u)	(674)	Corallospendylus	T (Ol-u)?	-R	
Aviculopecten	D (Fame-u)	-P (Dora)	(157,524)	Cordiceramus	K (Sant-l)	-K (Maes)	(991)
Aviculoperna	T (Eo-m)	-T (Eo-u)	(914)	+?Cornellites	S (Ldov-l)	-D (Fras-u)	
Aviculovulsa	T (Eo-m)	-T (Eo-u)		+Cornutoentolium	J (u)		(ZR86)
+Azumapecten	T (Mi)	-R	(1112)	+Corrugopecten	P (Sakm-u)	-P (Dora)	(665)
Badiotella	Tr(Ladi)	-Tr(Carn)	(94)	Costagyra	K (Albi)	-K (Maes)	(991)
Bakevella	C (Mosc-u)	-K (Maes)	(914,1066)	Costeina	K (Camp-u)		
Bakevelloides	Tr(l)	-J (u)		Costiellacosta	K (Maes)		
Barbosaia	P (Guad-u)?			+Costellamussiopecten			
+Barehamia	T (Mi-l-u)	-T (Plio-u)	(899)		T (Ol-u)	-T (Mi-u-l)	
+Batequeus	T (Eo-m-l)			-Costentalium	K (u)		(ZR80)
Bilobissa	J (Aale)	-J (Kimm)?		+Costicamptonectes	J (u)		(ZR87)
Birostrina	K (Nc)	-K (Ceno-m)		Costigervillia	J (Bath)	-J (Kimm)	(93)
Bitneria	Tr(u)			+Crassadoma	T (Mi-l-u)	-R	(1112)
Boiomytilus	D (l)			Crassostrea	K (Nc)	-R	(159)
Borionectes	J (Oxfo-u)	-K (Vala)	(791)	Cremmoceramus	K (Turo)	-K (Maes)	(991)
Bositra	J (Toar-l)	-J (Kimm)	(92,93)	+Crenamussium	Tr(Nori-l)		
Bouleigmus	K (Camp)?	-K (Maes)	(914)	Crenatula	T (Dani)	-R	(914)
+Bractechlamys	Q (Plei)	-R		Crenipecten	D (Fras)	-P (Djhu)	(524,1066)
Buchia	J (Oxfo-u)	-K (Haut)	(93,1066)	Crenostrea	T (Eo-l)	-T (Mi-l-u)	(899)
Burckhardtia	Tr(Carn)			+Crittendenia	Tr(Indu)		(1227)
+Byssonychia	O (Cara)?, O (Ashg)?		(1046)	Cryptopecten	T (Mi-m)	-R	
Byssopteria	D (Fras-u)			Cteniopleurium	K (Sant)		
+Calicanicularia	P (Leon-u)	-P (Guad-u)	(745)	Ctenoides	J (Kimm)	-R	(93)
+Calvaentolium	Tr	-J	(ZR86)	Ctenostreon	J (Hett-l)	-K (Nc)	(93,715)
Cameloleopha	K (Ceno)	-K (Maes-l)		Cubitostrea	T (Eo-m-l)	-T (Mi-u)	(899)
Camptochlamys	J (Aale)	-T (Dani)	(1061)	Cultrospis	Tr(Carn)	-J (Toar)	(749)
Camptonectes	J (Hett-l)	-K (Maes-u)	(92,790)	Cuneigervillia	J (Hett-l)	-K (l)	(715)
+Canadotis	J (Tith-u)			Curvostrea	K (Ceno)	-K (Maes)	(991)
Caneyella	C (Vise-l)	-C (Serp-l)		+Cussetostrea	K (u)		(ZR79)
+Capedopecten	T (Mi)		(ZR88)	+Cyclochlamys	T (Mi-l-u)	-R	(899)
+Caribachlamys	T (Plio-u)	-R	(1112)	Cyclopecten	T (Mi-l-l)	-R	(681)
+Carinonychia	D (l)		(ZR88)	Cyrtrostra	P (Sakm)	-Tr(Indu-l)	(1066)
+Caritodens	O (Ashg-m)		(1046)	Daonella	Tr(Anis)	-Tr(Ladi-u)	
Carolia	T (Than)?	-T (Eo-u)?	(705,914)	Darteplicatula	T (Than)	-T (Mi-l)	(705)
+Carolinapecten	T (Mi-u)	-T (Plio-u)	(ZR87,985)	Datta	Tr(Rhae)		
Cassianella	P (Sakm)	-Tr(Rhae)	(94,745,1066)	Decatopecten	T (Ol-l)	-R	(96)
+Cassianoides	P (Leon)	-P (Guad-l)	(1227)	Delectopecten	T (Eo-m-l)	-R	(1112)
Cataceramus	K (Sant)?	-K (Maes)		Delloideum	J (Bajo-u)	-J (Tith-u)	(92)
Catinula	J (Oxfo)		(93)	Dellopecten	C (Step-l)	-P (Guad-u)	(524,745)
Ceratostreon	K (Vala)	-K (Maes-u)	(789)	Dendostrea	T (Mi-m)	-R	
Chaenocardia	C (Mosc-u)			-Denguiria	P (Leon)	-P (Guad-u)	(524,1227)
Chalmasia	K (Camp)?	-T (Eo-m-u)?		+Denticelax	O (Livi)		(1046,1066)
+Chiopteria	S (Prid)			+Dereconchia	P (Leon-m)		(524)
+Chesapecten	T (Mi-l-u)	-T (Plio)	(985)	Didymotis	K (Turo)	-K (Coni-l)	
Chlamys	Tr(Anis)	-R	(524)	+Dimarzipecten	T (Ol-u)	-T (Mi-l)	(985)
Chondrodonta	K (Albi)	-K (Turo)		Dimya	T (Dani)	-R	(914)
+Christinapecten	T (Mi-m)		(985)	Dimyodon	Tr(Anis)	-K (Maes-u)	(524,991)
Ciclopecten	T (Plio)			Diotis	J (Sine)?	-J (Plie)	
+Cigarella	P (Leon)	-P (Guad-l)	(1040)	Dipleurites	Tr(Anis)	-Tr(Ladi)	(524)
+Cingentolium	J (Oxfo-u)		(ZR83)	+Diploschiza	K (Camp)	-K (Maes)	
Cladoceramus	K (Sant-l)			Dolichopteron	D (l)		
				+Dolponella	P (Dora)		(524)

Taxon	First Appearance	Last Appearance	Reference	Taxon	First Appearance	Last Appearance	Reference
+ Dorcadungula	C (Bash-u)		(ZR79)	+ Gervillietia	J (Sine-u)	-J (Plie-u)	
Dunbarella	C (Tour)	-P (Djhu)	(524)	Gervillia	Tr(Olen-u)?	-K (Maes)	(914)
Duplipecten	T (Eo-l)	-T (Mi-m)	(728,899)	+ Gigantopecten	T (Mi-l-u)	-T (Plio)	
Eburnopecten	K (Apti)?	-T (Mi-m)	(700,985)	+ Giralliapecten	K (Maes-u)		(991)
Echinorbis	P (Leon-u)		(745)	Girtypecten	P (Sakm)	-P (Dora)	(524)
Echinopecten	J (Hett)	-J (Bajo)		+ Glabripecten	P (Guad-u)		(665)
Ectenodesma	D (l)	-D (u)		+ Glendella	P (Leon-u)		
Electroma	K (Sant)?	-R		+ Gloripallium	T (Mi-m)	-R	(1112)
Eligmus	J (Bajo)	-J (Call-u)	(93,99)	+ Glyptonychia	O (Livi)?	O (Llde)?	(1046)
Elimata	P (Leon-l)	-P (Tatr)		+ Gondwanella	P		(ZR90)
Enantiostreon	P (Djhu)	-Tr(Rhae)	(524)	+ Gosseletia	D (l)	-D (m)	
Endocostea	K (Sant-u)	-K (Maes-u)		+ Grabella	Tr(Ladi)		(524)
Enigmonia	T (Eo-l)	-R	(914)	+ Granulochlamys	Tr(Ladi)	-Tr(Carn-l)	(524)
Enkelbergia	D (Fame-l)			Gryphaea	Tr(Carn-l)	-J (Tith-u)	
+ Ensipteria	P (Guad-u)	-P (Dora)	(157,666)	- Gryphaeligmus	J (Bath-u)		(99)
Enteropleura	Tr(Anis)	-Tr(Nori)		Gryphaeostrea	K (Vala)	-T (Mi-u-l)	
+ Entolioides	Tr(l)	-Tr(Nori-l)	(1227)	Gryphellina	P (Guad-l)	-P (Guad-u)	
Entoliopsis	T (Eo-l)			+ Guichiella	Tr(Olen-l)		(524)
Entolium	Tr(Anis)	-K (Maes-u)	(524,790,1066)	+ Guizhoupecten	P (Leon)	-P (Dora)	(157,524)
				Gyrostrea	K (Albi-u)	-K (Maes)	(991)
Entomonotis	Tr(Nori-l)	-Tr(Nori-u)	(740)	Haenleinita	K (Sn)		
Eocampnitectes	C (Tour)	-P (Djhu)	(524,1058)	Halobia	Tr(Ladi)	-Tr(Nori-u)?	(94,524)
Eolimea	Tr(Ladi)			Haumea	T (Plio)	-R	(1112)
+ Eomonotis	Tr(Nori-l)	-Tr(Nori-u)	(740)	+ Hayasakapecten	C (u)	-P (Guad-u)	(157,1058)
+ Economia	J (Bath-u)	-J (Oxio-m)		Heligmina	K (Camp)?	-T (Mi-l)	
Eopecten	Tr(Olen-u)	-K (Albi)	(674)	Heligmopsis	K (Ceno)	-K (Coni)	
Eopinactada	K (Ceno)	-K (Turo)		Hemipecten	T (Plio)	-R	
Equichlamys	T (Plio-l)	-R		+ Heteropecten	C (Step-l)	-P (Guad-u)	(524)
+ Etalia	Tr(Anis)	-Tr(Nori)	(ZR88)	Heterostrea	J (Bajo-l)?		
Etheripecten	P (Sakm-l)	-Tr(Indu-l)	(524)	Hilberia	T (Eo)	-T (Mi-m)	
Euchondria	D (Fame-u)	-P (Dora)	(524)	Hinnites	T (Mi-m)	-R	(1112)
Eumorphotis	Tr(Indu-l)	-Tr(Carn)	(94)	Hippochaeta	T (Eo)	-T (Plio)	
Euphenax	T (Eo-m-l)		(1066)	Hoernesia	Tr(Olen-u)	-Tr(Rhae)	(94,674)
Euptera	K (Apti)	-K (Maes)?	(914)	Hoernesiaella	Tr(Carn)		
Eurydesma	C (Mosc)	-P (Guad-l)	(1066)	Hokounea	Tr(Carn)		
+ Euthymipecten	K (Vala-u)	-K (Ceno-u)	(789)	Honeyeya	D (Fras)	-D (u)	
Euvola	T (Mi-m)	-R	(1112)	+ Hunanopecten	P (Dora)		(524)
+ Evenia	P (Guad-l)	-P (Tatr)	(1040)	+ Huyella	T (Eo)		(ZR77)
Excellichlamys	T (Mi-u)	-R	(1112)	Hyalopecten	T (Mi-l)	-R	
Exogyra	J (Kimm)	-K (Maes-u)	(93)	Hytossia	K (Turo)	-R	
Exputens	T (Eo-l)	-T (Eo-u)	(700)	Hypotrema	J (Plie-u)	-J (Tith)	(93,749)
Fasciuliconcha	C (Tour)	-C (Step-u)	(1058)	Hypoxytoma	K (l)	-T (Dani)	(790,1061)
Fascinewellipecten	D (l)			+ Ignara	S (u)		(ZR88)
Fergania	T (Ol)			Ilymatogyra	K (Ceno)		
+ Fibrosopecten	J (u)		(ZR86)	+ Imoella	C (Serp-l)		(879)
+ Filopecten	Tr(Ladi)	-Tr(Carn-u)?	(524)	+ Indonectes	J (u)		(ZR79)
Flabellipecten	T (Ol-u)	-R		Indopecten	Tr(Nori-u)		
Flemingostrea	K (Ceno)	-T (Mi)		Indoplacuna	T (Mi-l)	-T (Mi-m)	
+ Fletcheripecten	P (Sakm-u)	-P (Guad-u)	(665)	+ Inflatomonotis	Tr(Nori)		(740)
Flexopecten	T (Eo-u)	-R	(700)	Inoceramus	J (l)	-K (Maes-u)	(545)
Follmannia	D (Emsi)			Inoceramya	K (u)		
Fortipecten	T (Plio-u)			+ Intodesma	P (Guad-l)	-P (Tatr)	(1040)
Fractoceramus	J (m)			Isognomon	Tr(Carn)	-R	(94)
+ Fransonia	P (Leon)	-P (Guad-l)	(1227)	+ Janopecten	Tr(u)		(ZR80)
Freneixita	K (Ceno)	-K (Turo)		+ Janupecten	T (Eo-u)	-T (Ol-u)	(728,899)
+ Freneixostrea	K (u)		(ZR85)	+ Jelezkiella	J (u)		(ZR77)
+ ?Fylgia	S (Wenl-u)			+ Jianchuania	Tr(u)		(ZR80)
Gerlus	Tr(u)			+ Juranomia	J (Kimm-u)		
Gervillaria	Tr(u)	-K (Maes)	(914)	+ Kabayiapecten	C (Serp-l)		
+ Gervilleiogoma	J (Aale)			Kaparachlamys	T (Plio-u)		(899)
Gervilleioperma	J (Plie-l)	-J (Plie-u)	(749)	Kinderkaella	C (u)		
Gervillella	Tr(u)?	-K (Maes)	(914)	Kobayshites	J (Bajo)		

Taxon	First Appearance	Last Appearance	Reference	Taxon	First Appearance	Last Appearance	Reference
Kochia	D (Sieg)	-D (Emsi)	(1066)	+ Mclearnia	J (Tith-u)	-K (Apti)	(663)
Kokanostrea	T (Eo-m)	-T (Eo-u)	(914)	Meleagrinnella	Tr(Rhac)	-J (Tith)	(1233)
+Kolymia	P (l)	-P (u)		Meotolima	T (Eo)		
+Kolymonectes	Tr(Nori)	-J (u)?	(ZR78)	Merismopteria	P (Leon-u)	-P (Guad-u)	(745)
+Konbostrea	K (u)		(ZR86)	-Merklinia	K (Turo)	-K (Maes-u)	(790)
Korobkovia	T (Mi-u)			Mesopcpplum	T (Eo-m-u)	-R	(899)
Krumbeckiella	Tr(Nori-l)			+ Microchlamys	K (l)	-K (Maes-u)	(ZR85,991)
Labrostea	K (Camp-u)?	-T (Eo-l)?	(914)	Micronectes	K (Camp)	-K (Maes-u)	
+Laevichlamys	T (Mi-u)	-R	(1112)	Mifa	S (Ludl)	-D (l)?	
Langsonella	Tr			+ Mimachlamys	T (Eo-m-l)	-R	(1112)
+Leconychia	O (Llvi)?, O (Llde)?		(1046)	+ Minervapecten	J (u)		(ZR86)
Leiopecten	S (u)	-D (l)		Minnivola	T (Mi-m)	-R	
Leiopteria	S (Ldov-l)	-P (Guad-l)		Mirapecten	T (Mi-u)	-R	
Lenella	J (Plie-u)			Mixipecten	K (Sn)	-K (Maes)	
+Lentilla	J (Toar)	-J (Aale)		Miyagipecten	T (Mi-m)	-T (Mi-u)	
Lentipecten	T (Eo-l)	-T (Plio-u)		-Mizuhopecten	T (Mi-l)?	-R	
Leochlamys	T (Ol-u)	-R	(1112)	+ Molinicola	S (Wenl)		(ZR84)
+Leopecten	T (Plio)	-R		Monia	T (Ol)	-R	
Leproconcha	Tr(m)			Monopteria	C (Mosc-u)	-C (Step-u)	(1066)
Leptochondria	P (Guad)	-Tr(Nori)	(94,524)	Monotis	Tr(Nori-m)	-Tr(Nori-u)	(94,740)
Leptodesma	O (Cara-m)	-P (Guad-u)		+ Morrisipecten	P		(ZR87)
+Leptolima	P (u)		(ZR79)	+ Moussonella	Tr(Ladi)		(524)
Leptopecten	T (Mi-u-l)	-R	(1112)	Mirassella	C (u)	-P (l)	
Liebea	P (Leon)	-P (Djhu)		Mulletia	K (Berr-l)	-K (l)	(663)
Lilangina	Tr(Carn)			Myalina	C (Tour)	-P (Djhu)	(1066)
Lima	Tr(Anis-l)?	-R	(674)	Myalinella	C (Vise)	-Tr(l)	(1058)
Limanomia	D (Fras-m)			Myalinopterella	D		
Limaria	K (Albi)	-R		+ Myodakryotus	O (Cara-m)		(1066)
Limatuella	T (Eo-l)	-R		-Myrakeena	T (Mi-l)?	-R	
Limatula	Tr(m)?	-R		Myridopectera	Tr(l)		(94)
+Limatulina	C (Vise)?			+ Mytilidesmatella	P (Sakm)	-P (Guad-l)	(1040)
Limea	K (Ceno)	-R		Mytilarca	S (Ldov-m)	-D (Fras-u)	
Limipecten	C (Vise)	-P (Djhu)	(157,1058)	Mytiloceramus	J (Aale)	-J (Bath-u)	
Limoptera	S (u)	-D (Give)		Mytiloides	J (Sine-u)	-K (Sn)	
Linsdallia	J (Aale)		(92)	Mytiloperna	J (l)	-J (u)	
Liostrea	Tr(Carn)	-J (Tith-u)	(93)	Nanaochlamys	T (Ol-u)	-O (Plei)	
Lissochlamis	T (Mi-u)	-T (Plio-l)		+ Nanlingella	Tr(u)		(ZR80)
Lissopecten	T (Plio)	-R	(1112)	Nanogyra	J (Bath)	-K (Berr-u)	(93,663)
+Lithioperna	J (Plie-u)			Nathorstella	D (Emsi)		
Lituyapecten	T (Ol-u)	-T (Plio)		Nayadina	K (Ceno)	-T (Eo-m)	(914)
+Loemmelella	Tr(Ladi)		(524)	Neithea	K (Vala)	-K (Maes-u)	(545,789)
+Longidaonella	Tr(Anis)	-Tr(Ladi)	(524)	Neithella	K (Vala)	-K (Maes)	(789,991)
Lopha	Tr(Nori-l)	-R		Neitheops	K (Vala)	-K (Maes)	
Lupherella	J (Plie)		(93)	Neoinoceramus	T (Ol-l)	-T (Ol-u)	
+Lyriochlamys	K (u)?	-K (Maes)	(ZR77,991)	+ Neomorphotis	Tr(Olen-l)	-Tr(Anis)	(524)
Lyriopecten	D (m)	-D (Fras-u)		+ Neontolium	Tr	-J (ZR86)	
Lyropecten	T (Ol-l)	-T (Plio)	(1112)	Neopycnodonte	T (Mi-l)	-R	
+Lywcea	J (Sine)		(1066)	Newaagia	Tr(Anis)	-Tr(Carn)	(524)
Maccoyella	K (Apti)	-K (Albi)	(1233)	Newellipecten	D (l)		
Macrochlamis	T (Ol)	-T (Plio)		Nicsomella	S (Wenl-u)	-S (Ludl)	
Magadiceramus	K (Coni-u)			Nicaisolopha	K (Turo)	-K (Maes)	
+Maiaia	P (Leon-m)	-P (Guad-l)	(1040)	Nodipecten	T (Mi-l-u)	-R	
Malayomaorica	J (Kimm-l)			+ Nodonychia	D (m)		(ZR87)
Malvufundus	T (Plio)	-R	(1112)	+ Notochlamy	T (Mi-m)	-R	
Maminka	O (Cara-m)?	-S (Ludl)		+ Notolimea	T (Ol-u)	-R	
Mantiellina	T (Mi-m)			Notostrea	T (Eo-u)	-T (Ol-l)	(530)
Manticula	Tr(Carn-u)		(1066)	Notovola	Q (Plei)	-R	(1112)
Manupecten	T (Mi-l-u)	-R		+ Novaculaperma	P (Leon)		
+Maorimonotis	Tr(Nori-l)	-Tr(Nori-u)	(740)	+ Obliquipecten	C (Tour)	-P (Guad-l)	(524)
Margostrea	K (Sant)	-K (Maes)	(914)	+ Ochotochlamys	Tr(u)		(ZR78)
+Marinopecten	P (l)		(ZR75)	Odontogryphaea	K (Maes)	-T (Eo-m-l)	
+Maryonychia	O (Cara)?, O (Ashg)?		(1046)	+ Opitoptera	O (u)		(1046)

Taxon	First Appearance	Last Appearance	Reference	Taxon	First Appearance	Last Appearance	Reference
Opisthoptera	O (Ashg-m)			Placunopsis	Tr(Olen-u)	- T (Dani)	(545,1061)
Oppenheimopecten	T (Mi-l-l)	- R		Plagiostoma	Tr(Indu-l)	- K (Maes-u)	(790)
+Orbiculopecten	C (Mosc)?		(104)	Planospirites	K (Maes)		
Oretia	Tr(Carn-l)		(1066)	Platyceramus	K (Coni-l)	- K (Maes-l)	
Ornithopecten	Tr(Anis)	- Tr(Nori)	(94)	Platygena	T (Eo-u)		
Orthomyalina	C (Mosc-u)	- P (Leon)		+Plethocardia	O (u)		(1046)
Ostrea	K (Berr)?	- R		Pleuromysidia	Tr(Carn)		
Ostreinella	T (Ol-l)	- T (Mi-u-l)		Pleuronectites	Tr(l)	- Tr(Carn)	(1227)
Ostreola	T (Plio)	- R		Plicacesta	T (Dani)	- R	
Ostreonella	K (Camp)		(914)	Plicatostylus (+ Lithisthis)			
Otapiria	Tr(Carn)	- J (Tith-l)	(1233)	Plicatula	J (Plie-l)	- J (Toar-u)	(1066)
Oxypteria	Tr(Carn)				Tr(Anis)	- R	(524)
Oxytoma	Tr(Carn)	- K (Maes-u)	(94)	Pododesmus	T (Eo-u)	- R	
Pachymytilus	J (Oxfo)			+Polynemamussium	Q (Plei)	- R	
Pachyperna	T (Eo-l)	- T (Eo-u)?	(914)	+Pomiropecten	J (u)		(ZR86)
+Pachypteria	C (Tour-l)	- C (Vise)		Pompeckjina	D (Fame-l)		
+Pacimonotis	Tr(Nori-m)	- Tr(Nori-u)		Posidonia	C (Tour)	- J (u)	(1058)
Pacipecten	T (Mi-l-l)	- R		Posidoniella	C (Tour)	- C (Bash)	(1058)
Palaeocardia	S (Wenl-u)			Posidonotis	J (Plie-u)	- J (Aale)?	(749)
+Palaeontolium	Tr		(ZR86)	+Praemonotis	P (Sakm-u)	- P (Guad-u)	(745,ZR87)
Palaeolima	C (Tour)	- Tr(u)	(1058)	Praeomalodonta	O (Ashg-m)		
Palaeopecten	S (Ludl-l)	- D (l)		+Praeaeullina	J (Tith-u)	- K (Berr)	(1233)
Palaeopinna	D (Sieg)?	- D (m)		+Praebuchia	J (Call-u)	- J (Oxfo-u)	
Palaeopteria	O (Aren-l)	- O (u)	(1233)	+Praechlamys	Tr(Ladi)	- Tr(Carn-l)	(524)
+Paleowaagia	P (Asse-u)	- P (Guad-l)	(103)	Praexogyra	J (Bajo-u)	- K (Berr-l)	(92)
Palliolium	T (Than)	- R	(1112)	+Praesondylopecten	J (l)		(ZR90)
Palmoxytoma	J (Hett)	- J (Plie-u)	(93)	Prismatro	T (Plio)		
Panis	K	- K (Maes)	(914)	Prociopievskia	P (l)		
+Paradoxipecten	P (Djhu)	- P (Dora)	(524)	Prohinnites	K (Vala)	- K (Apti)	
+Parahalobia	Tr(Lad)		(524)	Prolobella	O (Cara-m)		
Parainoceramus	Tr(Carn)	- J (Tith-u)	(663)	Promyalina	Tr(Indu-l)	- Tr(Olen)	
Paramytilarca	O (Cara)	- O (Ashg-m)	(1046)	+Proostrea	Tr(Anis)		(1066)
Paranomia	K (Camp-l)?	- K (Maes)		Propeamussium	Tr(Carn)	- R	(94)
Paraplacuna	K (Maes)	- T (Eo)	(991)	Prosochasma	D (l)		
Paraucellina	K (Ceno)			Prospondylus	P (Leon-l)	- P (Guad-l)	
Parinomya	T (Eo)			Pseudacesta	Tr(u)		
Parvamussium	K (Berr)	- R	(1112)	Pseudamussium	T (Eo-u)	- R	
Parvochlamys	T (Mi-m)			Pseudaucella	J (Plie)		(93)
Patinopecten	T (Ol-u)	- R		Pseudavicula	K (Apti)	- K (Albi)	(1233)
Patro	T (Mi-u-u)	- R	(899)	Pseudaviculopecten	D (Give-l)	- C (Tour-u)	
Pecten	T (Mi-l-l)	- R	(1112)	+Pseudentolium	T (Eo-l)	- T (Plio-u)	
Pectinula	J (Plie-u)			Pseudodidemotis	K (Nc)		(1066)
+Pegma	T (Eo-l)	- T (Eo-m-l)		+Pseudogyra	K (Barr)		
+Pegmavalvula	P (Leon-l)	- Tr(l)	(103)	Pseudoheligmus	K (Sant)	- T (Eo-m-l)	(1066)
+Pelilina	K (Albi-u)			Pseudolimea	Tr(m)?	- K (Maes-u)	
Pergamidia	Tr(Nori)			Pseudomonotis	C (Tour-l)	- P (Dora)	(524)
+Peribositra	Tr(l)		(ZR81)	Pseudomyalina	P (Leon-u)		
+Periclararia	Tr(Olen-u)		(524)	Pseudomytiloides	J (Toar-l)	- J (Aale)	(93,715)
+Permanomia	P (Leon-l)	- P (Guad-l)	(103)	Pseudopachymytilus	J (l)		
+Permoceramus	P (Sakm)		(1066)	Pseudopecten	J (Hett-l)	- J (Bajo-u)	(715)
Pernopecten	C (Tour-u)	- P (Dora)	(524,1066)	Pseudoperna	K (Coni)	- K (Sant-u)	
Pernostrea	J (Bath)	- J (Call)		Pseudoplacuna	T (Eo-m)		
Pethopecten	K (Ceno)	- K (Maes)?		Pseudoplacunopsis	Tr(u)		
Phleopteria	K (Albi-u)	- K (Maes-u)	(790)	Pseudoptera	K (Nc)	- K (Maes-u)	(159,790)
Phialopecten	T (Mi-u-u)	- T (Plio-u)	(728,899)	Pseudovola	J (Bath)		
Phygraea	K (Apti)	- T (Mi)		Psilonychia	O (u)		
+Pichlerella	Tr(Ladi)		(524)	Pteria	Tr(Indu-l)	- R	
Pinctada	T (Ol-l)	- R	(1112)	Pterinea	O (Cara-u)	- D (Eife-l)?	
Placopecten	T (Mi-l-l)	- R	(1112)	Pterinella	K (Nc)	- K (Albi)	(159)
+Placopterina	C (Mosc-l)		(105)	+Pterinoactinodesma	D (l)		(ZR79)
Placuna	T (Eo-l)	- R	(914)	Pterinopecten	S (Ludl)	- C (Tour)	(1058,1066)
Placunanomia	T (Mi)	- R		Pterinopectinella	C (Serp-l)?	- P (Guad-l)	(524)

Taxon	First Appearance	Last Appearance	Reference	Taxon	First Appearance	Last Appearance	Reference
Pterochaenia	D (Give-l)	-D (Fras-u)		Stappyersella	D (Emsi-u)		
Pteronitella	S (Wenl)	-S (Prid)		Stefaninia	Tr(Ladi)		
Pteronitina	O (Cara)			Stefaniiniella	K (Ceno-u)		
+Pteronychia	O (Llde)?		(1046)	Stolidotus	S		
Pteroperna	Tr(Nori)	-J (Tith)	(93,94)	Stralopecten	T (Mi)	-T (Plio)	
Ptychopteria	D (Fras-l)	-C (Serp-l)		Streblochondria	C (Tour)	-P (Dora)	(524,1058)
Pulvinites	K (Ceno)	-R		Streblopteria	D (Fame-u)	-P (Dora)	(524)
Pulvinostrea	T (Eo-m-u)			Streptomytilus	S (Wenl)	-S (Ludl)?	
Pycnodonte	K (Haut-l)	-R		Striatoceramus	J (m)		
+Qiyangia	J (l)	-J (m)	(ZR86, ZR90)	Striostrea	T (Eo-m)	-R	
Quadrostroma	K (Camp)		(914)	+Subulataclamys	J (u)		(ZR86)
Radiopecten	K (Camp)?	-K (Maes-u)		Swiftopecten	T (Eo-u)	-R	
Radulonectites	Tr(Anis)	-J (Plic)?	(159,524)	Syncyclonema	K (Albi-u)	-K (Maes-u)	(790)
Radulopecten	J (Aale)	-J (Tith-u)		+Tarturia	K (Maes)		
+Raricardium	T (Plio)		(ZR86)	Tenka	O (Cara-m)?	-S (u)	
Rastellum	J (Call)	-K (Maes-u)		Tenuipteria	K (Camp-u)?	-K (Maes-u)	(790)
-Rebeccapecten	T (Ol-u)	-T (Mi-l)	(985)	Terquemina	Tr(Ladi)	-J (Oxfo-u)	(92,94)
Regalilima	J (Bajo)			Tetinka	O	-S (u)	
Retroceramus	J (Aale)	-K (Berr-l)	(92,93)	Texigryphaea	K (Albi-m)	-K (Ceno-l)	
Reubenia	Tr(Carn)		(94)	Tirolidia	Tr(Ladi)	-Tr(Carn)	(94)
Rhaetavicula	Tr(Rhae)			+Titaonpecten	J (u)		(ZR86)
Rhombopteria	S (Ludl)		(1066)	Tosapecten	Tr(Carn)	-Tr(Nori)?	(666)
Rhynchostreon	K (Berr)?	-K (Maes)		+Towapteria	P (Sakm)	-Tr(Indu)	(157)
+Rhyssomytilodes	K (Turo-l)		(ZR88)	+Trabeculata	P (Guad-l)	-P (Djhu)	(1040)
Roncania	T (Eo-u)			+Trematiconcha	P (Guad)		(524)
Rostroperna	K			+Trichiplatula	K (u)		(ZR83)
-Saccostrea	T (Mi)	-R		Trochoceramus	K (Maes-l)		
+Saikraconcha	P (Guad-l)			Turkmenia	K (Barr-l)		
Saintia	T (Eo-l)			Turkostrea	T (Eo-l)	-T (Eo-m)	
Saintiopsis	T (Plio)			+Umburra	S (Wenl-u)		
Scaechlamys	Q (Plic)	-R	(1112)	+Undopecten	P (Sakm)?		(1227)
+Scythemtolium	Tr(Olen-l)	-Tr(Olen-u)	(524)	+Undulostrea	T (Mi-m)	-R	
Secuipecten	T (Mi-m)	-T (Plio-u)	(728,899)	+Unica	K (u)		(ZR86)
Selenimyalina	C (Mosc-u)	-P (Leon)?		+Uralopteria	S (u)		(ZR83)
Semipallium	T (Mi-m)	-R		+Varvaria	P (u)		(ZR86)
Semuridia	J (Sine-l)	-J (Sine-u)	(92,715)	Veldidenlla	Tr(u)		
Septihoernesia	Tr(Anis-l)	-Tr(Carn)	(94)	Ventalium	J (l)		
Septimyalina	C (Vise)	-P (Guad-l)		+Vertinoimia	K (l)		(ZR81)
Serania	Tr(Nori)		(94)	Vertipecten	T (Eo-u)	-T (Mi-m)	(101)
Sergipia	K			Vertumia	D (m)	-D (Fame-u)	
Serripecten	T (Than)	-T (Plio-l)	(728)	+Vnigripecten	P (Leon)	-P (Guad-l)	(1227)
+Seymourtula	T (Pale)		(ZR88)	Volachlamys	T (Mi-l)	-R	(1112)
+Shikamaia	P (Leon-m)	-P (Guad-l)		Voiviceramus	K (Coni-l)	-K (Sant)	
+Sichuania	Tr(Olen)?	-Tr(u)		+Vorkutopecten	P		(ZR87)
Similipecten	T (Ol-l)	-R	(1112)	Vulsella	T (Than)	-R	(1066)
Sinectenolium	T (Pale)			Vulsellina	T (Eo-m-l)		(914)
Sokolowia	K (Maes)?	-T (Eo-u)?	(914)	Vultogryphaea	K (Ceno)	-K (Maes)	
+Soleniscostrea	K (u)		(ZR79)	Waagenoperna	P (Guad-u)	-Tr(Nori)	(94,157, 1066)
Somapecten	J (Kimm)	-J (Tith)	(159)	Wakullina	T (Eo-m)	-T (Mi)	
Somapteria	J (Kimm)			Weylia	J (Hetl)	-J (Toar-u)	(93,94)
+Songdaella	Tr(Nori)	-Tr(Rhae)	(ZR77)	+Wuxuanites	D (m)		(ZR87)
+Soragyaceramus	K		(ZR85)	Yabepecten	T (Mi-u)	-T (Plio)	
Spanila	S (Wenl-u)	-S (Ludl)		+Xenium	T (Eo)		(ZR86)
+Spathochlamys	T (Mi-u)	-R	(1112)	Zygochlamys	T (Eo-u)?	-R	(1112)
Sphenoceramus	K (Coni-u)	-K (Camp-l)	(159)				
+Spia	Tr(u)		(ZR81)				
Spondylopecten	J (Aale)	-J (Tith-u)	(92)				
Spondylus	J (Bajo)	-R	(1066)				
Spyridoceramus	K (Camp)	-K (Maes-u)	(790)				
+Spyridopecten	C (Ms)	-C (Step-u)	(1227)				
+Squamuliferipecten	C (Step-l)	-P (Sakm-u)	(745)				

Or. MODIOMORPHOIDA

Actinodonta	O (Aren-l)	-S (Ludl-l)	(91,1066, 1077)
+Aleodonta	S (Wenl-u)		(1117)
Allodesma	O (Cara-m)		
+?Ananterodonta	O (Llvi-l)		(948)

Taxon	First Appearance	Last Appearance	Reference	Taxon	First Appearance	Last Appearance	Reference
Anodontopsis	S (Ludl-u)			?Xestocoencha	O (Aren-l)		(1046,1238)
Aristerella	O (Cara-l)	-C (Ms)		Whiteavesia	O (Cara-l)	-O (Cara-u)	
Babinka	O (Trem-u)	-O (Llvi)	(1066)	Or. UNIONOIDA			
+?Brahcylyrodesma	O (m)		(1046)	Cardinoides	Tr(Carn)	-J (Plie)?	(159)
+?Buluniella	Cm(l)		(ZR87)	Pachycardia	Tr(m)	-Tr(Carn)	(94)
Byssodesma	O (Ashg-m)			Trigonodus	Tr(m)	-Tr(Nori-u)	(94)
Caliodonta	O (Ashg-m)			Unionites	Tr(Indu-l)	-Tr(Nori-u)	(94)
+Carminodonta	O (Aren-l)		(1238)	+Zhiifangia	Tr		(ZR80)
Carydium	D (Sieg-u)	-D (Fras)		Or. TRIGONIOIDA			
+Celtocoencha	O (Aren-l)		(1238)	+Acanthotrigonia	K (Coni-l)	-K (Maes)	(891)
+?Colpantyx	O (Aren)		(1046)	Actinotrigonia	K (Ceno)		
Colponya	O (Cara-l)	-S (Ludl-u)	(1117)	Agonisca	Tr(Ladi)		(562)
+Copidens	O (Llvi)?		(1046,1066)	+Andritrigonia	J (Bath)	-K (Barr)	(1115,1124)
+Corallidomus	O (Ashg-m)			+Andivaugonia	J (Bath)	-J (Call)	(1115)
Cosmogoniophora	O (Trem-u)	-D		Anopisthodon	K		
Cosmogoniophorina	O (Aren-l)	-O (Ashg-m)	(1238)	+Antutitrigonia	J (Tith-u)	-K (Vala)	(1124)
+Coxiconcha	O (Aren)	-O (Llde-u)	(948,1046)	Apiotrigonia	K (Haut-u)	-K (Maes)	
Cycloconcha	O (Llde-u)	-O (Ashg-m)	(91)	+Arabitrigrionia	K (Apti)		(891)
Cymatonta	O (Cara-m)	-O (Ashg-m)	(91,762)	Asiatotrigonia	K (Ceno)		
Dceruska	O (Llde-l)	-O (Cara-u)	(1075)	+Atalantia	Tr(Cara-l)		(562)
Dipleurodonta	O (Ashg-m)			Aulacopleurum	K		
+Dulcineaia	O (Llvi-u)	-O (Llde-u)	(948)	Austrotigonia	K (Haut)	-K (Maes)	(991)
Ectenocardiomorpha	O (Ashg-m)			Buchotrigonia	J (Tith)	-K (Camp-l)	(1115,1124)
Eurymya	O (Aren-l)	-O (Cara-m)	(1238)	+Caledogonia	Tr(Cara-u)	-Tr(Nori-l)	(562)
Eurymyella	S (Ludl-u)			Callitrigonia	K (Apti)	-K (Albi-u)	(1124)
+Fordilla	Cm(Atda-l)	-Cm(Boto)	(87,88)	Climacotrigonia	K (Ceno)		
+Fortowensia	O (Aren-l)		(1238)	+Columbitrigonia	K (Barr)	-K (Ceno)	
+Glyptarca	O (Aren-l)	-O (Llde-u)?	(948,1238)	Costatoria	P (Guad)	-P (Djhu)	(1066)
Goniophora	O (Cara-l)	-P (Leon)		Cytherodon	D (m)		
Goniophorina	O (Cara-m)	-P (Leon)		+Dampitrigonia	K (Haut-u)	-K (Apti)	(1124)
Gueringeria	D (l)			Dolabra	C		
Hippomya	O (Aren-l)	-S?	(1046)	Eoastarte	P (Leon-u)		(1066)
Ischyrodonta	O (Cara-u)	-O (Ashg-m)	(91)	Eoschizodus	D (Give)	-Tr(Anis-l)?	(1066)
+Jellia	Cm(l)		(ZR86)	Eotrigonia	T (Than)	-T (Mi-u)	(530)
+Junjagiana	P (l)		(ZR79)	Eselaevitrigonia	J (Tith)	-K (Maes-u)	(888)
Liromytilus	D (m)			+Erugonia	Tr(Nori-l)		(ZR87)
Lyrodesma	O (Aren-u)?	-S (Ldov-u)	(91)	+Flattopia	P (Guad-u)		(745)
Megambonia	S	-D (m)		Frenguelliella	J (Hett)	-K (Maes)	(93,991)
+Mimerodonta	S (Ludl-l)	-S (Ludl-l)	(1117)	Geratrigonia	J (Hett)	-J (Toar)	(93)
+Modiodonta	S (Wen-l)	-S (Wen-l)	(1117)	+Gobiella	K (l)		(ZR81)
Modiolodon	O (Cara-m)	-O (Ashg-m)		Gruenewaldia	Tr(m)	-Tr(Nori-u)	(94)
Modiolopsis	O (Aren-l)	-S (Prid)?	(91,1238)	+Guineana	Tr		
Modiomorpha	S (Wen-l)	-P (l)		Hefleria	D (l)		
+Moridunia	O (Aren-l)		(1238)	Heminajas	Tr(l)	-Tr(Carn)	(94)
+Neofordilla	O (Cara-u)		(1046)	+Heslingtonia	Tr		(ZR87)
Paramodiola	O (Cara-m)			+Heteroschizodus	P		(ZR75)
Paraphtonia	O (Cara)		(1046)	Heterotrigonia	J (Kimm)	-K (Ceno)	
+Plicatomorpha	O (u)		(1046)	+Hijitrigonia	J (Bajo)	-J (Bath)	(1115)
Pseudarca	O (Llde)	-D		Ibotrigonia	J (Call)		(93)
Pyanomya	O (u)			Indotrigonia	J (Oxfo)	-K (Haut)	(1115)
Radiatodonta	S (Ludl-u)	-D (l)	(1117)	Iotrigonia	J (Kimm)	-K (Maes)	(914,1115)
Redonia	O (Aren-l)	-O (Llde-u)	(948,1046)	Jaworskiella	J (Plie)	-J (Toar)	(93,1115)
+Rimymjima	P (Leon)		(1066)	Korobkovitrigonia	K (Barr)	-K (Camp)	(914)
+Runnegaria	O (m)		(1046)	Kumatrigonia	Tr(Carn)		(159)
Saffordia	O (Cara)	-O (Ashg-m)	(91)	+Kupenga	K (Albi)	-K (Ceno)	(ZR86)
Semicorallidomus	O (Ashg-m)			Laevitrigonia	J (Kimm)	-K (Berr)	(93,663)
Spathella	D (Fras)	-C (Ms)		Leptotrigonia	K (Barr)	-K (Turo)	
Sphenotomorpha	S (Prid)	-D (Ged)?		Linotrigonia	K (Ceno-l)?	-K (Maes)	(991)
Tainyria	P (l)	-P (Guad-u)		Liotrigonia	J (Sine)	-J (Plie-u)	(93)
Tanaodon	D (n)						
+Tromelinodonta	O (Aren-u)		(1066)				
Tylophora	D (Sieg)						

Taxon	First Appearance	Last Appearance	Reference
Litotrigonia	J (m)	- J (u)	
Litschkovitrigonia	K (Vala)	- K (Apti)	
Lyriomyophoria	P (Tatr)	- Tr(Rhae)	
+Lyroschizodus	P (Leon-m)		(1066)
+Macrotrigonia	K (l)		(ZR87)
Malagastrigonia	J (Bajo)	- K (Barr)	(1115)
Maoritrigonia	Tr(Carn-l)	- Tr(Nori)	
+Mediterraneotrigonia	K (Barr)	- K (Apti)	(1124)
Megastrigonia	J (Tith-u)	- K (Maes)	(914)
Mesotrigonia	K (Camp)	- K (Maes)	(914)
Microtrigonia	K (Camp-u)	- K (Maes)	(159)
Minetrigonia	Tr(Carn)	- Tr(Nori-u)	(94)
Myophorella	J (Plic)	- K (Barr)	(1115)
Myophoria	Tr(Olen-u)	- Tr(Nori-u)	(94)
Myophorotrigonia	Tr(Carn)	- J (Bajo)	(94)
+Nakanotrigonia	K (Sant)	- K (Camp-l)	
Neoschizodus	P (m)	- Tr(Rhae)	(94)
Neotrigonia	T (Mi-m)	- R	(1112)
+Neuquenitrigonia	J (Bath-u)	- J (Call-l)	(1115)
Nipponitrigonia	J (Call)	- K (Camp)	(93,1124)
+Notoscabrotigonia	K (Nc)	- K (Camp)	(891)
Nototrigonia	K (Haut)	- K (Albi-u)	(1124)
Oistotrigonia	J (Call-u)	- K (Maes-u)	(888)
Opisthotrigonia	J (Kimm)	- K (Apti)	(1115)
Orthotrigonia	J (Sine)?	- K (Berr)	
Pacitrigonia	K (Albi-u)	- K (Maes)	(1124)
+Paranditrigonia	J (Tith-u)	- K (Berr)	(1115,1124)
+Paraschizodus	P (Leon-u)		(1066)
+Paulckella	K (Haut)	- K (Apti-l)	(1124)
+Pisotrigonia	J (Tith)	- K (Maes)	(891)
Pleurotrigonia	K (Albi-u)	- K (Ceno)	(1124)
Praegonia	Tr(Ladi)		
+Procostaria	P (Leon-u)		(1066)
+Promyophorella	K (Vala)		(1124)
Prorotrigonia	Tr(Carn)	- Tr(Nori)	(94)
Prosgyrotrigonia	Tr(Carn)	- J (Sine)	(93,94)
Pseudomyophorella	J (Bajo)?	- K (Vala)?	(663)
Psilotrigonia	J (Plic)	- K (u)	(93)
Pterotrigonia	J (Tith-u)	- K (Maes)	(789,891, 991,1115)
+Ptilotrigonia	K (Albi-u)	- K (Maes)	(891)
+Quadratowajorskiella	J (Sine)		(1115)
Quadratotrigonia	J (Tith)	- K (Ceno)	
Quoieccchia	K (Haut)	- K (Barr)	
Rhenania	D (Give)		
Rutitrigonia	J (Oxf)	- K (Maes)	(868,914, 1115)
Sainschandia	K (Barr)	- K (Sant)	
Scabrotigonia	K (Barr)	- K (Maes-u)	(891,1124)
Scaphellina	P (Leon-u)	- P (Guad-u)	
+Scaphogonia	J (Bajo)	- K (Vala)	(1115)
+Scaphorella	J (Bajo)	- J (Call)	(1115)
Scaphotrigonia	J (Toar-u)	- J (Call)	(93)
Schizodus	S (Lud-l)	- P (Djhu)	(1066)
Setotrigonia	K (Camp)		
+Silurozodus	S (Wen-l)	- S (Ludl)	
+Skwarkoella	K (Maes-l)		(1124)
Sphenotrigonia	K (Haut)	- K (Albi-m)	(1124)
Steinmanella	J (Kimm)	- K (Maes)?	(1115)
Syrotigonia	J (Tith)	- K (Apti)	(1115)
Toechomya	D (m)		

Taxon	First Appearance	Last Appearance	Reference
Trigonia	Tr(Anis)	- K (Maes)	(914)
+Turbitrigonia	J (Tith-u)	- K (Haut)	(663)
+Turkestanella	K (Ceno)		
Vaugonia	J (Hett)	- J (Tith-u)	(93)
+Virgotrigonia	J (Tith)	- K (Berr)	
Yaadia	K (Barr)	- K (Maes)	(991)
+Yangella	D (l)		(ZR90)
Yeharella	K (m)	- K (Maes)	
-Zaletrigonia	K (Haut)		(1124)
+Zulutrigonia	D (l)		(ZR90)

Or. VENEROIDA

Abra	T (Than-l)	-R	(914)
Acanthocardia	T (Ol-u)	-R	
Acorylus	T (Eo-m-u)	-R	(1112)
Acrosterigma	T (Mi-u-l)	-R	(1112)
Acyrena	J (m)		
-Adansonella	T (Dani)	-T (Than-l)	(864)
-Adelodonex	K (u)	- K (Maes)	(ZR90,991)
Adontorhina	T (Mi-u)?	-R	
Aenona	K (Camp-l)	- K (Maes-u)	
Aeora	K (Camp-l)	- K (Maes)	(914)
Aeretica	T (Mi-l-l)	-R	
Afrocardium	Q (Plei)	-R	
Agapella	K (Apti)		
Agelasia	K (Coni)	-K (Maes)	
Agnocardia	T (Eo-l)	-T (Plio-u)	
Agnomyx	K (u)	-K (Maes)	
Agriopoma	T (Eo-m)	-R	
Aligena	T (Mi-m)?	-R	
+Aliodonax	K (u)		(ZR90)
Aliomactra	K (Ceno)	- K (Maes)	(914)
-Alleinacin	K (u)		(ZR81)
Allomactra	T (Mi-l-u)		
Allopagus	T (Eo-m)		
Alveinus	T (Eo-l)	-T (Mi-m)	(700,1248)
Ambocardia	K (Sant)	-K (Maes)	
Ameghinomya	T (Dani)	-T (Mi-m)	(914)
Americardia	T (Mi)	-R	
Amerycina	T (Mi)	-R	
Amiantis	T (Eo-l)	-R	(914)
Amphiarus	K (Apti)		
Amphichaena	Q (Plei)	-R	
+Amphidesma	T (Plio)	-R	(1112)
Amphipsammus	T (Eo)	-T (Ol)	
Anatina	T (Plio-l)	-R	
Ancliffia	J (Bath)		
Andrusella	T (Plio)		
+Andrusovicardium	T (Mi-l-u)	-T (Plio)	(ZR86)
Angulus	T (Tham)	-R	(1112)
Angusticardo	T (Eo-l)	-T (Eo-u)?	(914)
Anisocardia	J (Aale)	-K (Apti)	(92)
Anisodonta	T (Dani)	-R	(914)
Anodontia	T (Tham)	-R	(705)
Anofia	K (u)	-K (Maes)	(914)
Anomalocardia	T (Ol-u)	-R	(985)
Anomalodiscus	T (Mi-u)	-R	
Anomalokellia	T (Dani)	-T (Than)	(914)
Anthonya	K (Apti)	-K (Maes)	(159)
Antigona	Q (Plei)	-R	(1112)
Antinoche	T (Mi-m)	-R	(1112)
Antiquieyprina	J (Bath)		

Taxon	First Appearance	Last Appearance	Reference	Taxon	First Appearance	Last Appearance	Reference
+ Aphaea	K (Camp-u)	-K (Maes-l)	(914)	Borniola	T (Mi-l-u)	-R	(899)
Aphrodina	K (Albi)?	-T (Eo-u)		Brachymeris	K (Camp)	-K (Maes-l)	
Apocardia	T (Mi-l-u)	-R	(1112)	Brevicardium	K (Camp)	-K (Maes)	
Apolymetis	T (Ol-u)	-R	(96)	Bruetia	T (Dani)	-T (Mi)	(914)
Aralocardia	T (Eo-u)	-T (Ol-l)		Bruniastarte	J (Bajo)		
Archivesica	T (Ng)	-R		Bucardium	T (Mi-l-l)	-R	(1112)
Arcinella	T (Mi-l)	-R		+ Bungoella	K (Albi-u)		(ZR88)
Arcopagella	K (Albi-l)	-K (Maes)	(914)	Byssocardium	T (Eo-m)	-T (Mi-l)	
Arcopagia	K (Maes-l)	-R	(991)	+ Byssomera	T (Plio)	-R	(1049)
Arcopaginula	T (Eo-m)	-R		Bythiamena	T (Mi)		
Arcopagiopsis	T (Eo-l)	-T (Eo-u)?	(914)	Cabralista	T (Mi-u)		(1066)
Arctica	J (Oxfo-u)	-R	(791)	+ Cadella	T (Ol-u)?	-R	(1112)
Arctoprattulum	T (Ol)	-T (Mi-m)		+ Califodesma	K (u)		(ZR90)
Arcturellina	T (Dani)	-R	(914)	Callanaitis	T (Ol-u)	-R	(530)
Ardeamya	T (Plio)	-R	(1112)	Callista	T (Than)	-R	(1112)
Arthritica	T (Mi-l-l)	-R	(681)	Callistalox	K (Turo)	-K (Maes-u)	(1067)
Asa	T (Ol-u)	-R	(1112)	Callistotapes	T (Eo-m-l)	-R	(899)
Asaphinoides	T (Mi-l)			Callithaca	T (Mi-u)	-R	(1112)
Asaphinella	T (Eo-l)	-T (Eo-u)?	(914)	Callocardia	R		
Asaphis	T (Mi-m)	-R	(1112)	Callucina	K (Apti)	-R	
Ascitellina	T (Eo)	-R	(681)	Callucinella	T (Eo-m-l)	-T (Plio)	
Ashtarotha	T (Ol-l)	-T (Mi)		Callucinopsis	K (Sn)	-R	
Astarte	J (Hett)	-R		Calptaria	T (Eo-l)	-T (Eo-u)	(700,1248)
Astartella	C (Vise)	-P (Tatr)	(159,879,1058)	Calva	K (l)	-K (Maes-u)	
Astartellopsis	P (u)?, Tr(l)?			Calyptogena	T (Eo-u)	-R	
Astartemya	K (Camp)	-K (Maes)	(914)	Capsella	T (Mi-m)	-R	(1112)
Astartopsis	Tr(u)			Cardilia	T (Than)	-R	(914)
Astartopsis	J			Cardilona	T (Ol)		
Atamarcia	T (Ol-l)	-T (Plio-u)	(728,899)	Cardinia	Tr(Carn)	-J (Toar-l)	(715)
Atopodonta	T (Eo)	-T (Mi)		Cardiniopsis	J (Bajo)	-K (l)	(93)
+ Austrocardium	K (Camp)	-K (Maes)		Cardiocardita	T (Eo-m)	-R	
Austrodozinia	T (Ol-u)	-R	(1112)	Cardiomantea	S (Prid)		(1066)
Austromacoma	T (Mi-l)	-R	(1112)	Cardita	T (Dani)	-R	(914)
Austroscintilla	T (Mi)			Carditamera	T (Eo-u)	-R	(914)
Austrovenus	T (Mi-l-l)	-R	(899)	Carditella	T (Than)	-R	(1112)
Avicularium	T (Eo-l)	-T (Ol-u)	(1066)	Carditellopsis	T (Than)	-R	(1112)
+ Aviculocardium	T (Mi-u)		(ZR79)	Cardites	T (Eo-l)	-R	
Avimactra	T (Plio)			Carditomantea	D (Gedi-l)		
Axinopsida	T (Mi-u)?	-R		Carditopsis	T (Ol-l)	-R	(1112)
Axinulus	T (Plio)	-R		Cardium	T (Plio)	-R	
Azor	K (Camp)	-T (Eo)	(864)	Carinastarte	T (Ol)	-T (Plio)	
Azorinus	T (Eo-l)	-R	(914)	+ Caspimactra	T (Mi)		(ZR86)
Balantioselena	Tr(Ladi)			Cavilinga	K (Maes-l)	-R	
Baluchicardia	K (Sn)	-T (Than)	(700)	Cavilucina	T (Eo-l)	-T (Eo-m-u)	(914)
Barbierella	T (Eo-l)	-R	(914)	Celtoides	P (l)?	-P (Guad-u)	
Bartrumia	T (Mi-l-u)	-T (Mi-u)	(899)	Centrocordata	T (Eo-u)	-R	
Barymactra	T (Eo)	-T (Mi-l-u)?		Cerastoderma	T (Ol-l)	-R	(1112)
Barytellina	T (Plio-l)	-Q (Plei)	(899)	Ceratomyopsis	J (Toar)	-J (Tith)	(93,1066)
Bassina	T (Ol-u)	-R	(681,899)	Ceroniola	K (Maes)		(991)
Bassinaria	T (Plio-l)			Cerullia	T (Than-l)	-T (Plio-u)	(914,1066)
Basterotella	T (Mi)	-R		Chama	K (Camp)	-R	
Basterotia	T (Eo-l)	-R	(700)	Chamelea	T (Ol-l)	-R	(814)
Bathytormus	K (Camp)?	-R	(914)	Chametracea	T (Mi-u)	-R	
Batissa	J (Oxfo)	-R	(93)	+ Chartocardium	T (Mi-u)		(ZR80)
Bellucina	T (Eo-m)	-R		Chattonia	T (Pale)	-R	
Bendemacoma	T (Eo)			Chavanella	T (Than-l)	-T (Eo-u)	
Benthocardidella	T (Plio-l)	-R	(899)	+ Chesacardium	T (Mi-l)	-T (Plio-u)	(985)
Blagraveia	T (Eo-l)	-T (Eo-u)?	(914)	Chimela	K (Albi)	-K (Maes)	(991)
Blairella	C (l)			Chion	T (Eo-l)	-R	
Boetuvia	T (Eo-l)	-T (Ol)		Chione	T (Ol-l)	-R	(814)
Bornia	T (Dani)	-R	(914)	Chionella	T (Eo-u)	-T (Ol-l)	(814)
				Chioneryx	T (Plio)	-R	(1112)

Taxon	First Appearance	Last Appearance	Reference	Taxon	First Appearance	Last Appearance	Reference
Chionista	Q (Plei)	-R		Clena	T (Eo-m)	-R	
Chionopsis	T (Ol-u)	-R	(1112)	Ctenocardia	T (Mi-u)	-R	(1112)
Choniocardia	T (Eo-l)	-T (Eo-u)		+ Cterocardia	K (Camp)?	-K (Maes)	(914)
Cicatellia	T (Mi)	-R		Cultellus	K (Maes-u)	-R	(914)
Cicatrea	K (Coni)?	-K (Maes)		Cumingia	T (Eo-l)	-R	(914)
+ Cliatocardium	T (Ol-l)	-R		Cuna	T (Eo-m-u)	-R	
Clipeicella	T (Dani)		(914)	Cunanax	T (Plio)	-R	
Circe	T (Eo-m)	-R	(1112)	Cuneus	T (Mi)	-R	
Circomphalus	T (Mi-l-u)	-R	(1112)	Curionia	Tr(Carn)	-Tr(Rhae)	
Claibornicardia	T (Than)	-T (Eo-u)	(700,1049)	Cyamiomactra	Q (Plei)	-R	
Claibornites	T (Dani)	-T (Eo-u)?	(914)	Cyanocyclas	T (Plio)	-R	
Claudiconcha	T (Plio)	-R	(1112)	Cycladicama	T (Eo-u)	-R	
Clausinella	T (Mi-l)	-R		Cyclina	T (Eo-m-u)	-R	(158,1112)
Clementia	T (Eo-l)	-R	(914)	Cyclinella	T (Eo-l)	-R	(914)
Clinocardium	T (Ol-l)	-R	(1112)	Cyclinorbis	T (Mi-l)	-R	
Clisocolus	K (Turo-u)	-K (Maes)	(159)	Cyclocardia	T (Eo-m)	-R	
+ Cockburnia	T (Eo-u)			Cyclomactra	T (Plio)	-R	
Codakia	K (Maes-l)	-R		Cyclopellatia	K (Barr)	-R	
Codalucina	T (Dani)	-T (Mi-l-l)		Cyclorisma	K (Ceno-l)	-K (Maes-u)	
Coelastarte	J (Toar-u)	-K (Turo)	(715)	Cyclorismina	K (Ceno)	-K (Maes)	(914)
Coelocyprina	J (Bath)			Cyclosuneta	Q (Plei)	-R	(1112)
Coelopsis	Tr(Ladi)	-K (l)		Cyclotellina	T (Eo-l)	-R	(1112)
Collignonicardia	K (l)?			Cymatoica	T (Mi)	-R	
Compsomyax	T (Eo-l)	-R	(914)	Cymbophora	K (Albi)	-K (Maes-u)	
Comus	Q (Plei)	-R		Cypricardella	D (Gedi)	-C (Step)	
Conchocele	T (Eo-u)	-R		Cypricardinia	O (Llde)	-P (Guad-u)?	
Condylocardia	T (Eo-m-l)	-R	(1066)	Cyprimeria	K (Apti)?	-T (Eo)	
Condylocuna	T (Eo-m-u)	-R	(1066)	Cyrenobattissa	T (Eo)	-R	
Congeriomorpha	D (Fras-u)?			Cyrenodonax	Q (Plei)	-R	
Cooperella	T (Mi-m)	-R		Cyrenopsis	K (Apti)	-R	
Cooperellopsis	T (Mi)			Cytheriopsis	T (Eo-m-u)	-T (Mi)	(700)
Coralliophaga	T (Eo-l)	-R	(914)	Cytherocardia	T (Than)	-T (Mi)	(705)
Corbicellopsis	J (Bajo)	-K (l)		+ Dacicardium	T (Plio)	-R	(ZR75)
Corbicula	K (Camp)	-R		Daharina	J (Pli-u)	-R	
Corbiculella	T (Plio)	-Q (Plei)		Dallocardia	T (Ol-u)	-R	
Corbiculopsis	K (Apti)			Darcinia	T (Eo-l)	-T (Eo-u)?	(914)
Corburella	J (m)	-J (u)		Decipula	T (Plio)	-R	
Cordiopsis	T (Eo)	-T (Plio-u)		Dentonia	K (Ceno)	-T (Eo)	
Cordiula	T (Ol)			Devonia	T (Eo-l)	-T (Eo-u)?	(914)
Coripia	T (Mi-m)	-R		Dierocardium	Tr(Nori)	-Tr(Rhae)	
Cornucardia	Tr(Nori)		(94)	Dicranodesma	T (Mi-m)	-R	(1066)
Cossmannella	T (Dani)	-T (Mi-l)	(914)	Dietrichia	J		
Costacallista	T (Than)	-R	(705)	Digitaria	T (Ol)	-R	
Costellipitar	T (Ol-u)	-R	(1112)	Digitariopsis	T (Mi-l)	-R	
Costocyrena	K (Nc)	-K (Albi)	(159)	Dinocardium	T (Eo-l)	-R	(914)
Costokidderia	Q (Plei-u)	-R		Diplodonta (+ Taras)	K (Sant)	-R	
Cowperesia	P (u)?, Tr(l)?			Discomiltha	J (Oxfo)	-J (Tith-u)	(791)
Crassatella	K (Nc)	-T (Mi-m)	(159)	Discors	T (Eo-l)	-T (Mi-m)	(914)
Crassatellina	K (u)	-K (Maes)		Disparilia	K (Nc)	-K (Maes-u)	(545)
+ Crassatellites	K (Camp)	-R	(96)	Ditypodon	T (Mi-u)	-T (Plio-l)	
Crassatellopsis	D (l)		(ZR79)	Divalinga	T (Ol)	-R	
Crassatina	T (Eo-u)	-R		Divalucina	T (Eo-m-l)	-R	(899)
Crassinella	T (Eo-m-l)	-R	(700)	Divaricardium	T (Ol)	-T (Plio)	
Crenotrapezium	J (Pli)	-J (Toar)	(93)	Divaricella	T (Than-l)	-R	(914)
Crepispisula	T (Than)	-T (Eo)	(705)	Divarikellia	T (Eo-m-l)	-R	
Cretoecardia	K (u)	-K (Maes)	(991)	+ Dobroginaectra	T (Mi)		(ZR86)
Criocardium	K (Ceno)	-K (Maes-u)	(790)	+ Dochmiocardia	K (Apti-u)	-K (Maes)	(ZR78)
Crustuloides	T (Eo-l)	-T (Eo-m-u)	(700)	Dollfusia	T (Eo-l)	-T (Eo-u)?	(914)
+ Cryptolucina	T (Eo-m)?, T (Eo-u)?			Donacopsis	T (Pale)	-T (Eo)	
+ Cryptocarida	J (Bajo-u)	-J (Call)		Donax	T (Eo-l)?	-R	(914)
Cryptocoelopsis	Tr(Ladi)			Dosinella	T (Mi-m)	-R	(1112)
Cryptomactra	T (Mi-u)			Dosina	T (Eo-u)	-R	(530)

Taxon	First Appearance	Last Appearance	Reference	Taxon	First Appearance	Last Appearance	Reference
Dosinia	T (Ol-l)	-R		Finlayella	T (Mi)	-T (Plio)	
Dosiniopsella	K (l)			+Fischericardium	T (Mi)		(ZR79)
Dosiniopsis	K (Maes)	-T (Eo-u)?	(914)	Fissilunula	K (Camp)?	-K (Maes)?	(914)
Dosinobia	T (Dani)		(899)	Flaventia	K (Vala)	-K (Maes)	(789)
+Dosinorbis	T (Plio)	-R	(1112)	Florimetus	T (Ol-u)	-R	(1112)
Dozyia	K (Camp)?	-K (Maes-u)	(888)	Fossacallista	T (Eo-u)	-R	(530)
Dreissenomya	T (Plio)			Fragum	T (Ol-l)?	-R	(158)
Eamesiella	T (Ol)	-R		Freiastarte	K (Camp)?	-K (Maes)	
Eastonia	T (Mi-l)	-R		Frigichione	T (Ng)		
Egerella	K (Maes)	-T (Eo-u)?	(914)	+Frigidocardium	T (Mi-m)	-R	(1112)
Egesta	T (Mi-m)	-R	(814)	Fulcrella	T (Eo-l)	-R	
Egracina	Q (Plei)	-R		Fulpia	K (Ceno)		
Egrona	K (Turo)		(1067)	Fulvia	T (Ol-l)	-R	
+Elegantula	Q (Plei)	-R	(1112)	+Fuscocardium	T (Mi-m)	-Q (Plei)	
Elliptotellina	T (Than)	-T (Eo-m)	(705)	Gaftrium	T (Than-l)	-R	(914)
Ensiculus	T (Plio)	-R	(1112)	Gaimardia	T (Eo-u)	-R	
Ensio	J			+Gansuella	J (u)		(ZR86)
Ensis	T (Than-l)	-R	(914)	+Ganxiella	D (l)		(ZR90)
+Ensisolen	T (Mi-m)	-R	(1112)	Gardnerella	T (Eo-l)	-T (Mi)	
Ensitellops	T (Mi-m)?	-R		Gari	T (Mi-m)	-R	
Eocallista	J (Bajo)	-J (Tith-u)	(93)	Garum	T (Dani)	-T (Eo-m-u)	(700)
Eocrassina	T (Eo-u)			Gastrana	T (Eo-l)	-R	(914)
Eodon	D (Sieg)	-C	(1066)	Gastranopsis	T (Eo)		
Eodonax	J (Tith)	-K (l)	(93)	Geloina	T (Eo)	-R	
Eomactra	T (Eo)	-T (Plio)		Getena	K (Barr)?	-K (Maes)	(914)
Eomeretrix	T (Eo-l)	-T (Eo-u)?	(914)	Gemma	T (Eo-l)	-R	(914)
Eomiltha	T (Pale)?	-R		+Genaxinus	T (Plio)	-R	(899)
Eomiodon	J (Hett)	-K (Ceno)	(93,914,1066)	+Geoffbondia	J (u)		(ZR88)
Eophysema	T (Eo-l)	-T (Eo-u)	(700)	Gibbolucina	T (Eo-l)	-R	
Eoprosodacna	T (Mi-l)	-T (Mi-m)		+Gigantocycclus	P		(ZR77)
Eosolen	T (Than)	-T (Ol-l)		Gilbertharrisella	K (Camp)?	-K (Maes)	(914)
Eotrapezium	Tit(Rhae)	-J (l)		Glans	T (Dani)	-R	(914)
Epicodakia	T (Mi-m)	-R	(530)	Glibertia	T (Plio)		
Epicyprina	K (Haut)?	-K (Albi)		Globivenus	T (Mi-m)	-R	(1112)
Epilucina	J (u)	-R		Globocardium	K (Apti-l)	-K (Albi-u)	
+Ergenica	T (Ol-l-u)			Glossus (+ Isocardia)	K (Ceno)	-R	
Eriphylla	J (Bajo)	-K (Maes)	(159)	Glycydonta	T (Mi-m)	-R	(1112)
Eriphylopsis	K (u)	-T (Mi-m)	(545)	Glyptoactis	T (Dani)	-T (Mi-m)	(899)
Ervilia	T (Than)	-R	(1112)	+Gnidiella	T (Ol)	-R	(1112)
Erycina	T (Pale)	-T (Mi)	(1066)	Gobraeus	T (Dani)	-R	(864)
Erycinella	T (Ol-u)	-R	(1112)	+Goethemia	T (Plio)	-R	
Erycinopsis	T (Than)	-T (Eo)		+Gomphina	T (Eo-u)?	-R	
Etea	K (Camp-l)?	-K (Maes-u)		Gomphinella	T (Mi-m)	-R	(1112)
Ethmocardium	K (Camp-l)	-K (Maes)		Gomphomarcia	T (Mi)		
Eucallista	T (Mi-m)	-R	(1112)	+Goniacardia	T (Mi)	-T (Plio-l)	
Eucersatella	T (Eo-l)	-R	(899)	Gonilia	R		
Euloxa	T (Mi-u-l)	-T (Mi-u-u)		Gonimyrtea	K (Maes-l)	-R	
Eumarcia	T (Eo-u)	-R	(1112)	Gonicardium	T (Eo-m)	-T (Ol-l)	
Eurhomalea	T (Eo-u)	-R		Goodallia	T (Ol-l)	-R	
+Europicardium	T (Eo-m)	-T (Plio)		Goodalliopsis	T (Eo-m-l)		
Eurytellina	T (Eo-l)?	-R	(1248)	Goossensia	T (Dani)	-T (Eo-u)?	(914)
Exotica	Q (Plei)	-R	(1112)	+Goshoraia	K (Ceno)		(ZR77)
Fabella	T (Mi)	-R?		Gouldia	T (Dani)	-R	(914)
Fabulina	T (Mi-l-u)	-R	(1112)	Grammatodonax	Q (Plei)	-R	(1112)
+Farisia	T (Eo-m-u)	-T (Eo-u)		Granocardium	K (Apti)	-K (Maes-u)	(106,545)
+Fasciculicardia	T (Dani)	-T (Mi-m)	(728)	Grateloupia	T (Eo-l)	-T (Mi-m)	(914)
Felaniella	T (Pale)	-R		Grottriana	T (Ol)		
Fenestricardita	K (Ne)	-K (Maes)	(914)	Grundensia	T (Mi-m)		
+Fengjiachonia	J		(ZR90)	+Gujocardia	P (Dora)		(157,666)
Filosina	K (Ne)	-K (Apti)	(159)	Gythemon	J (Bajo)		
Fimbria	J (Hett)	-R	(93)	Haastina	J (Bajo)	-J (Bath)	(93)

Taxon	First Appearance	Last Appearance	Reference	Taxon	First Appearance	Last Appearance	Reference
Hamacuna	T (Plio-l)	-R	(681)	Kellia	T (Eo-l)	-R	(914)
Hartwellia	J (Tith)	-K (Nc)	(92)	Kelliella	T (Dani)	-R	(700,914)
Hedecardium	T (Eo-m-l)	-T (Mi-m)	(530,728,899)	Kereia	T (Eo-m-l)	-R	(1112)
Hemicorbicula	J (Tith-u)			+Kermadysmea	Q (Plei)	-R	(1112)
Hemicyclonosta	T (Eo-l)	-T (Plio)	(914)	Kidderia	T (Mi-l-u)	-R	(899)
Hemidonax	T (Ol-u)	-R	(530)	Kitsonia	T (Than)	-T (Eo)	
Hemilepton	T (Eo)	-T (Plio)		+Korobkoviella	T (Ol-l)		
Hemimacra	T	-R		Kuia	T (Eo-m-l)	-T (Plio-l)	(728,899)
Hercodon	K (Camp)	-K (Maes)		+Laciolina	Q (Plei)	-R	(1112)
Here	T (Eo-u)?	-R		Laevicardium	T (Eo-l)	-R	(1112)
Herella	T (Pale)	-T (Ol)		Laevicirce	T (Plio)	-R	(1112)
Herouvalia	T (Eo)			Lahilleona	K (Camp)	-T (Dani)	
Herzogina	K (Nc)			Lahillia	K (Camp-u)	-K (Maes)	(991,1066)
Heterodonax	T (Plio)	-R		Lajonkairia	T (Mi-l-l)	-R	(1066)
+Heteromacoma	T (Ol-u)?	-R	(1112)	Lamelliconcha	T (Eo-l)	-R	
Heteropis	J (Bath)	-J (u)		Landinia	K (Sn)	-T (Eo-u)	
Hiatula (+ Soletellina)	T (Ol-u)	-R	(1112)	+Langvophorus	Tr(Nori)	-Tr(Rhae)	(676)
Hina	T (Eo-m-l)	-T (Mi-u-u)	(899)	Larma	K (Cno)		
Hindsiaella	K (Maes)	-T (Eo-u)	(914,991)	Lasaea	T (Eo-l)	-R	(914)
Hinemoana	T (Ol-u)		(899)	Lasaena	T (Mi-l-u)		
Hippopodium	J (Hett)	-J (Tith)	(93,94)	Lasaekoellia	T (Mi-l)	-T (Mi-m)	
Hippopus	T (Mi-l-l)?	-R	(1112)	Lasaoneaera	T (Eo-m-l)	-T (Eo-u)?	(914,1066)
Homalina	T (Eo-m-l)?	-R	(1112)	Latona	T (Mi-m)	-R	(1112)
Hubertschenckia	T (Ol-u)			Laubriercia	T (Eo-m-l)	-T (Eo-u)?	(914,1066)
Humilaria	T (Plio)	-R		Lazariella	T (Mi-l-l)	-R	
+Hunanella	J (l)		(ZR80)	Leckhamptonia	J (Bajo)	-J (Bath)	
Hyalophus	T (Mi)	-R		Legumen	K (l)	-K (Maes-u)	(790)
+Hypanis	T (Plio-u)	-R		Lepidocardia	T (Plio)	-R	(1112)
Hyphantosoma	T (Ol-l)	-T (Plio)	(1112)	Leporimetis	T (Ol-u)	-R	(1112)
Hysteroconcha	T (Ol-u)	-R		Leptaxinus	T (Plio)	-R	
Iacra	T (Mi-m)	-R	(1112)	Leptesthes	K (u)		
Icanotia	K (Apt-l)	-K (Maes)		Leptocardia	K (l)	-K (Maes)	
Iliochione	T (Plio)?	-R	(1112)	+Leptomacra	T (Mi-m)	-T (Plio-u)	(985)
Illesca	T (Eo-u)			Leptomya	T (Mi-l-u)	-R	(899)
Illionia	S (Ludl-l)	-D (Give-l)		Lepton	K (Albi)	-R	(1066)
Inacardium	K (Maes)			Leptosolen	K (Albi-u)	-K (Maes-u)	(159,790)
Integricardium	J (Hett)	-T (Dani)	(93,914,1061)	+Leukomoides	T (Mi)		(ZR76)
Iphigenia	T (Mi-l)	-R	(1112)	Leuroactis	T (Eo-l)		
Irus	T (Ol)	-R		Levimyrtaea	T (Mi)		
+Irusella	T (Mi-m)?	-R	(1112)	Linearia	K (Haut-l)	-K (Maes-u)	(864)
Isocrassina	T (Eo-u)	-R		Lineta	J (Aale)	-J (Call)	
Isocyprina	J (Hett-l)?	-J (Oxfo)	(715)	Linga	T (Eo-l)	-R	(914)
Isodonella	K (Nc)		(159)	Lioconcha	T (Plio)	-R	
Isopristes	Tr(Nori)			Liocyma	T (Eo-u)	-R	(1112)
Isotancredia	J (Bath)?	-K (l)		Liodonax	T (Eo-l)	-T (Eo-u)?	(914)
Izumia	K (Camp)	-K (Maes)?	(159)	Liothyris	K (Apt-l)	-K (Maes)	
Izumicardia	K (Camp)	-K (Maes)	(914)	Lirodiscus	T (Than)	-T (Eo-u)	(700)
Jagolucina	T (Dani)	-T (Eo-u)?	(914)	+Liromissus	T (Mi-l)	-T (Mi-u)	
Jagonoma	J (Oxfo-l)	-T (Plio)		Lirophora	T (Ol-l)	-R	(1112)
Jesonia	T (Eo-u)	-R	(1112)	Litigiella	T (Mi)	-R	
Jurassicardium	J			Longimacra	T (Eo-l)	-R	(681)
Kaibabella	P (Leon)			Loparia	T (Eo-l)	-T (Eo-u)?	(914)
Kakahaia	T (Eo-m)			Lophocardium	T (Eo-u)?	-R	(1112)
Kalentera	Tr(Carn-u)	-J (Bath)	(93)	Loripes	T (Ol)	-R	
Kaneharaia	T (Mi)			Loripinus	T (Eo)	-R	
Katelsyia	T (Eo-l)	-R	(914)	Loxo	K (Camp-u)	-K (Maes-u)	
Katherinella	T (Eo-m-l)	-R	(700)	Loxocardium	T (Dani)	-T (Mi)	(914)
Keenaea	T (Ol-l)	-R		Loxoglypta	T (Plio)	-R	(1112)
+Keenocardium	T (Ol-l)	-R	(1112)	Loxoptychodon	T (Pale)	-T (Eo-l)	
				Lucina	K (Turo-u)	-R	(790)
				Lucinaxinus	T (Mi)	-T (Plio)	
				Lucinella	T (Mi)	-R	

Taxon	First Appearance	Last Appearance	Reference	Taxon	First Appearance	Last Appearance	Reference
Luciniola	J (Hett-u)	-J (PliE)	(92)	Mesocallista	K (u)	-K (Maes)	
Lucinisea	T (Dani)	-R	(700)	-Mesochione	K (Maes)		
Lucinoma	T (Eo)	-R		Mesodesma	T (Eo-u)	-R	
Luciploma	T (Plio-l)			Mesolonga	J (Bath)?	-K (Maes)	(159,914)
Ludbrookia	K (Apti)	-K (Ceno-u)		Mesomiltha	J (PliE)	-J (Tith-u)	(93)
Lunulicardia	T (Plio)	-R	(1112)	Mesopleura	T (Mi-m)?	-R	(1112)
Lutetia	T (Eo-l)	-T (Eo-u)	(814)	Mexicardia	T (Eo-l)	-R	(914)
Lutraria	T (Mi-l-l)	-R	(728)	Microcallista	T (Eo)	-R	
†Luxuridacna	T (Mi-u)		(ZR80)	Microcardium	T (Eo-u)	-R	(1112)
Lyratellina	T (Plio-l)	-R	(1112)	Microcirce	Q (Plei)	-R	
Lyrocardium	T (Mi)	-R	(1112)	Microcyprina	T (Eo-l)	-T (Eo-u)?	(914)
Macalia	T (Plio)	-R	(1112)	-Microfragum	Q (Plei)	-R	(1112)
Macaliopsis	T (Pale)	-T (Mi)		Microloripes	T (Pale)	-R	
Machaerodonax	T (Mi)	-R		Micromeris	T (Eo-m-l)	-R	(914)
Macoma	T (Ol-u)	-R	(1112)	Microstagon	T (Eo-l)	-R	
Macomona	T (Plio-l)	-R	(681)	+Milneria	T (Plio)	-R	(1049)
Macoploma	T (Plio)	-R		Miltha	T (Dani)	-R	(899)
Macridiscus	T (Plio)	-R	(1112)	Milthona	T (Mi)		
Macrocallista	T (Than)	-R	(705)	Mineparus	Tr(Carn)		(94)
Macrodonax	K (Sn)	-K (Maes)		Miocardiella	T (Ng)		
Macrosolen	T (Eo-l)	-T (Mi)		Miocardiopsis	K (Maes)	-T (Eo)	
Mactra	K (Turo-u)?	-R		Miodomeris	T (Eo-m-l)	-T (Eo-u)	
Mactrellona	T (Mi)	-R		Miodontiscus	T (Mi-m)	-R	(1112)
Mactrinula	T (Mi-l)	-R		Mioerycina	T (Mi-m)		
-Mactrodesma	T (Mi-u-l)		(985)	Miorangia	T (Mi)		
Mactromeris	T (Ol-l)	-R		-Miricardium	T (Plio)		(ZR86)
Mactromya	J (Hett-l)	-J (Tith-u)	(93,715)	Modiella	D (Emsi)	-D (Give-u)?	
Mactromyella	J (PliE)	-J (Bajo)		Modiolina	K (Ceno)		
Mactromyopsis	J (Hett)	-J (Call)	(1066)	Moerella	T (Eo-l)	-R	
Mactrona	T (Plio)			Mokattamia	T (Eo-l)	-T (Eo-u)?	(914)
Mactropsis	T (Eo-l)	-T (Eo-u)		Monitilora	T (Dani)	-R	(914)
+Maghrebella	K (Albi-u)	-K (u)	(ZR80)	Montacuta	T (Eo-l)	-R	(700)
Mancikellia	T (Plio)	-R		Montanaria	D (Emsi)		(ZR76)
Maoricardium	T (Ol-u)	-R	(728,899)	Mulinia	T (Plio-l)	-R	
Maorimactra	T (Mi-l-u)	-R	(899)	Mulinoides	K (Camp)?	-K (Maes)	(914)
Maorithyas	Q (Plei)	-R	(899)	Musculiopsis	K (l)		
Marama	T (Eo-m-u)	-T (Plio-u)	(899)	Mutiella	K (Turo-l)	-K (Maes-u)	(790)
Marcia	T (Mi-l-l)	-R	(1112)	Myadesma	T (Eo-l)	-T (Mi)	(914)
+Marvacrassatella	T (Mi-l)	-Q (Plei)	(985)	Mygallia	K (Albi)	-K (Maes)	
Marwickia	T (Dani)		(899)	Myllita	T (Plio)	-R	
Matheria	O (Cara-m)			Myllitella	T (Ol)	-R	
Mecynodon	D (Eife)			Myoconcha	Tr(Olen-u)	-K (Maes-u)	(545,674)
Medirao	K (Apti)			Myophoricardium	Tr(Carn)		
Meekia	K (Albi)	-K (Maes-u)		Myophoriopsis	Tr(Ladi)	-Tr(Rhae)	
Megaacardita	T (Eo-m-l)	-R		Myrene	J (Kimm)	-K (Berr-l)	(93)
Megalocardia	K (Albi)			Myrsopsis	T (Mi)	-T (Plio)	
†Megangulus	T (Mi-l)?	-R	(1112)	Myrtea	K (Sant)?	-R	
Megapitaria	T (Mi-m)	-R	(1112)	Myrteopsis	T (Mi)		
Megapraeconia	J (Bajo)	-J (u)		Myrtucina	T (Eo-l)	-T (Eo-u)?	(914)
Megaxinus	T (Ol)	-R		Mysella	T (Eo-l)	-R	(700)
Meiocardia	K (Maes)	-R		Mysia	T (Plio)	-R	(1112)
Meisenia	T (Mi)			Nagaoella	K (Albi)		
Melliteryx	T (Mi-l-l)	-R	(681)	Namnetia	T (Eo-m-l)	-T (Eo-u)?	(914,1066)
Melosia	T (Mi-l-u)	-T (Mi-m)	(985)	Nanopitar	T (Plio)	-R	(1112)
Mercenaria	T (Ol-u)	-R	(1112)	Naulia	K (u)	-K (Maes)	(914)
Mercimonia	T (Eo)	-T (Mi)		Neaeromya	T (Mi)	-R	
Meretrisa	T (Ol)			Nelltia	K (Apti)	-K (Maes)	(914,1066)
Meretrix	T (Eo-u)	-R		Nemelia	K (Apti)		
Merignacia	T (Mi-l-u)			Nemocardium	K (Apti-l)	-R	(1112)
Merisca	T (Eo-u)	-R	(1112)	Neocrassina	J (Hett)	-K (l)	(93)
+Merklinicardium	T (Ol-l)			+Neocypricardina	C (Vise)	-C (Step)	(1058)
Meroena	T (Eo-l)	-T (Eo-u)?	(914)	Neogaimardia	Q (Plei-l)	-R	

Taxon	First Appearance	Last Appearance	Reference	Taxon	First Appearance	Last Appearance	Reference
Neolepton	T (Ol-u)	-R	(899)	Papillicardium	T (Ol-l)	-R	(1112)
Neomiodon	J (Bajo)	-K (Ne)		Papyridea	T (Eo-l)	-R	(914)
+Neomiodonoides	J (u)		(ZR86)	+Paraectica	T (Ol)		(ZR75)
+Neotapes	T (Plio)	-R	(1112)	Paracorbicula	K (Ne)		
Neotrapezium	T (Eo-l)	-R	(1112)	Paracyclas	S (Wenl)	-D (Fame-u)	
+Neovenerella	T (Mi-m)		(ZR87)	Paradonax	T (Ol)	-R	
+Neovenericor	T (Ol-u)		(ZR82)	Paraesa	K (Albi-u)	-K (Maes)	(914)
Neritra	K (Turo-l)	-K (Maes)	(914)	Paraglans	T (Dani)	-T (Ol)	(914)
Nesobornia	T (Eo-m)	-R		+Paragouldia	T (Plio)		(ZR85)
Netschajewia	P	-P (Tatr)?	(157)	Paralucinella	T (Ol)		
Nevenulora	T (Eo-l)	-R		Parastarte	T (Mi-u-l)	-R	(1112)
Nicania	T (Mi-l)	-R		Parataneredia	J (m)	-J (u)	
Nicanicella	J (Toar)	-T (Than)	(93,914)	Parathyasira	Q (Plei)	-R	
Nidarica	J (Plie-u)	-J (Toar-l)	(93,715)	Parisiella	T (Eo-m-l)		
+Nilobia	T (Eo-u)			Parmulophora	Q (Plei)	-R	(1112)
Nipponomarcia	T (Mi)			Parvicardium	T (Eo-l)	-R	(914)
Nitidavenus	T (Than)	-T (Eo-l)		Parvicorbis	T (Eo-l)	-T (Eo-u)?	(914)
+Nitidotellina	T (Ol-u)	-R	(1112)	Parvilucina	K (Sn)	-R	
Notirus	T (Plio-l)	-R	(899)	+Parvivensus	T (Mi-l)	-T (Plio)	
Notocallista	T (Plio)	-R	(1112)	Passya	T (Eo-u)		
Notochione	T (Ng)	-R		+Patagocardia	K (Maes)		(991)
Notodonax	K (u)	-K (Maes)	(914)	Pectunculus	T (Ol-u)	-R	(1112)
Notophagia	Q (Plei)	-R		Pegophysema	T (Eo-l)	-R	(914)
Novathaca	Q (Plei)	-R	(1112)	Pececyora	T (Than)	-R	(914)
Numella	T (Mi)	-R		Peramphiata	J (Oxfo-u)		(92)
+Nutricola	T (Mi)	-R	(1112)	Periglypta	T (Ol-l)	-R	(1112)
Nuttallia	T (Ol-l)	-R	(1112)	+Permattella	P (Leon-m)		
+Nymphalucina	K (Maes)		(914)	Peronaea	T (Eo-m-l)	-R	(899)
+Olcesia	T (Ol-u)	-T (Mi-u)		Peronidia	T (Eo-m)?	-R	
+Olssonella	T (Eo-m-l)			Perrierina	T (Plio-l)	-R	
Omnivensus	T (Eo)			+Persikima	T (Mi-u)	-R	(1112)
Onestia	K (Apti)	-K (Albi-u)		Perucardia	K (Maes)		(991)
Opimaria	T (Plio)			Petalocardia	T (Eo-l)	-T (Ol)	(914)
Opis	J (Bajo)	-K (Maes-u)	(93,159,790)	Petricola	T (Than)	-R	(1112)
Opisoma	J (Plie-u)	-J (Oxfo-u)	(94)	Petricolaria	T (Mi-l-l)	-R	
Orobitella	T (Mi)	-R		Petricolirus	Q (Plei)	-R	(1112)
Oriocrassatella	C (Serp-l)	-P (m)?		+Petromactra	K (Camp-l)	-K (Maes-u)	
Orthocardium	T (Than-l)	-T (Eo-u)	(914)	Phacosoma	T (Ol-u)	-R	(1112)
Oryctomya	T (Than)	-T (Mi)	(700)	Pharella	T (Plio)	-R	
+Osoinia	T (Mi)		(ZR79)	Pharionella	T (Eo-m-l)	-R	(1112)
Ospriasolen	K (Camp)?	-K (Maes)	(914)	Pharodina	K (Ceno)		
Oudardia	T (Ol)	-R		Pharus	K (Apti)	-R	(1112)
Ovicardium	T (Mi-u-u)	-T (Plio-u)	(899)	Phaxas	T (Eo-l)	-R	(914)
Oxyperas	T (Mi-m)	-R		Phenacocyclus	D (m)		
Pachycardium	K (l)	-K (Maes-u)		Phlogocardia	T (Mi-l-u)	-R	(1112)
Pachydesma	T (Eo-l)	-R		Phlyctiderma	T (Mi)	-R	
Pachykellya	T (Plio)	-R	(681)	Phraëgena	T (Plio)	-R	
Pachyopis	J (Bajo)	-J (u)		Phylodina	T (Ol-u)	-R	
Pachyristmella	J (Oxfo-u)			Physocardia	Tr (Anis-m)	-Tr (Carn)	
Pachytherus	K (Haut)	-T (Eo-m)		Pillucina	T (Plio)	-R	
Pacificor	K (Maes)?	-T (Eo-u)	(1049)	+Pinguitellina	Q (Plei)	-R	(1112)
Palaeocardita	P (Guad-u)?	-Tr (Rhae)		Pisostriigilla	T (Mi-m)?	-R	
Palaeolucina	C (u)?	-P (Asse)?		Pitar	T (Than)	-R	(1112)
Palaeomoera	K (Albi-u)	-K (Maes)	(914)	Pitarella	T (Eo)	-R	
Palaeomya	J (l)	-J (u)		Pitarina	T (Mi-m)	-R	(1112)
Paleomarcia	T (Ng)			Placamen	T (Mi-u)	-R	(1112)
Panacoma	T (Mi)	-T (Plio)		Plagiocardium	T (Dani)	-T (Mi)	(914)
Panchione	T (Mi)			Planikellia	T (Eo-m-l)		
Paphia	T (Mi-l-l)	-R	(1112)	Planitiveta	T (Plio)	-R	(1112)
Paphies	T (Mi-l-u)	-R	(899)	Plastomiltha	T (Dani)	-T (Plio)	(700)
Paphirus	T (Eo-l)	-R		Platycardia	J (Kimm)	-J (Tith)	(93)
				Plebidonax	T (Mi-u)	-R	(530)

Taxon	First Appearance	Last Appearance	Reference	Taxon	First Appearance	Last Appearance	Reference
Plectosolen	T (Eo-l)	-T (Eo-m)		Pseudoirus	T (Mi-m)	-R	(1112)
Pleioritys	T (Mi-m)	-T (Plio-l)		Pseudolepton	T (Mi)		
Plesiasparta	T (Eo-l)	-T (Eo-u)?	(914)	Pseudolucinisca	T (Ol)	-R	
Plesioocyprina	Tr(Rhae)	-J (Call)		Pseudometis	T (Mi)	-R	
Pleurocardia	K (Albi-l)	-K (Maes-u)	(106,790)	Pseudomiltha	T (Eo-l)	-T (Plio)	(914)
Pleuroconcha	K (u)			Pseudomyoconcha	Tr(m)	-Tr(Carn)	(94)
Pleurolocina	T (Ol)	-R		Pseudopermorphus	P (Leon-u)	-P (Tatr)?	(157)
Pleuromeris	T (Eo-l)	-R	(899)	Pseudopleurophorus	K (Camp)?	-K (Maes)	(914)
Pleurophopsis	T (Ol-u)		(1066)	Pseudopis	J (Pli-l)	-J (Toar-u)	(93,715)
Pliocardia	T (Mi)			Pseudopythina	T (Plio)	-R	
Plionema	K (Ceno)			Pseudosanguinolites	D		
Plurigenis	T (Mi-u)	-R		Pseudotraperium	J (Toar-u)	-J (Tith-u)	(92)
Pollex	K (Ceno)	-K (Maes)	(914)	Pseudoxyperas	T (Eo-m-l)	-R	(899)
Polymesoda	T (Than)	-R	(914)	Pterolucina	T (Dani)?	-T (Mi)	
Pompholigina	T (Eo-m)	-R		-Pteroluter	K (Turo-u)		
+Potamomya	T (Eo-u)		(1066)	Pteromeris	T (Than-l)	-R	(914)
-Potidoma	T (Eo-m)	-R		Pteromyrtea	T (Dani)	-Q (Plei)	
Praeconia	J (Hett)	-J (Tith)	(93)	Pteropsella	T (Eo-l)	-T (Eo-m-u)	(700,914)
Praerangia	T (Than-l)			Ptychomya	J (Kimm)	-K (Maes)	(93,914)
Pratulium	K (Vala)	-R	(1112)	Punipagia	T (Mi-m)	-R	(1112)
Priscomactra	K (Ceno)	-K (Maes)	(914)	+Purpurocardia	T (Dani)	-R	(728)
+Pristes	T (Plio)	-R	(1049)	Puyseguria	T (Ol-u)	-R	(681)
Procyprina	J (Oxfo-u)	-K (Vala)		Pygoecardia	T (Ol)	-T (Plio)	
Prodreisensia	T (Ol-l)			Pythina	T (Eo-u)	-R	
+Profragum	K (Albi)	-K (Maes)		Quadrans	T (Plio)	-R	(1112)
-Profulvia	T (Ol)	-Q (Plei)		Quenstedtia	J (Toar-u)	-J (Tith-u)	(92,791)
Pronoella	J (Pli-l)	-J (Tith-u)	(93,715)	-Quidnipagus	Q (Plei)	-R	(1112)
Properycina	T (Eo-u)	-T (Plio-u)		Radiocondyla	T (Mi)	-R	
Prophetilora	T (Pale)			Raeta	K (Maes)	-R	
Prorokia	J (Bajo-l)	-J (Tith)	(93)	+Ragozinia	P		(ZR87)
Prosocoelogeton	D (u)			Raina	T (Ol-u)	-T (Plio-u)	(899)
Prosocoelus	D (Sieg)		(1066)	Rakhia	T (Eo-l)		
+Protagelus	K (Camp-l)	-K (Maes)?	(864)	Rangia	T (Than-l)	-R	(914)
Protapes	T (Mi-u)	-R	(1112)	Recticardo	K (u)	-T (Pale)	
Prothyris	D (l)	-P (Guad)		Recurvella	T (Eo-m-u)	-T (Ol)	
Protocallithaca	T (Plio)	-R		Rediciree	Q (Plei)	-R	(1112)
Protocardia	Tr(Rhae)	-K (Maes-l)	(674)	Regozara	T (Mi-m)	-R	(728)
Protodonax	K (Apt-l)	-K (Camp-u)	(864)	Remondia	K (l)		
Protothaca	T (Mi-m)	-R	(1112)	-Resania	T (Mi-m)	-R	(728)
Proveniella	K (Vala)	-K (Maes)	(789,914)	Resatrix	K (l)	-K (Camp)	(914)
+Proxichione	T (Ol-u)	-T (Mi-l-l)	(728,899)	Rexithaerus	T (Mi-l)	-R	(1112)
Psammacomma	T (Mi-l)	-R	(1112)	Rhabdopitaria	T (Eo-m-l)	-T (Eo-m-u)	(700)
Psammodonax	T (Eo-l)	-T (Eo-u)		Rhaetidia	Tr(Anis-u)	-Tr(Nori-u)	(864)
Psammobella	T (Plio)	-R	(1112)	Rhaiphiale	K (Turo)		(1067)
+Psammobia	T (Mi-l-u)	-R	(1112)	Rhectomyax	K (Camp)	-K (Maes)	(914)
Psammoica	T (Eo-m)?			Rictocyoma	T (Plio)	-R	
Psammotaena	T (Eo-m)?			Rimmyjimina	P (Leon)		
Psammotellina	Q (Plei)	-R	(1112)	Rochefortia	T (Plio)	-R	
Psammotreta	T (Mi-u-u)	-R	(1112)	Rochefortula	T (Mi)	-R	
Psathura	T (Eo-l)	-T (Eo-u)?	(914)	+Rochella	K (u)		(ZR80)
Psephidia	T (Plio)	-R		Rohea	T (Mi-l-u)	-T (Mi-m)	(728,899)
Pseudamiantis	T (Plio)			Rohini	T (Ol)		
Pseudaphrodina	K (l)			Rollierella	J (Bath)		
-Pseudarcopagia	T (Plio)	-R	(1112)	+Rostrocardia	K (u)		(ZR80)
Pseudasaphis	K (Ceno)?	-K (Maes)	(914)	Roudairia	K (Ceno)	-K (Maes-u)	
Pseudastarte	J (Hett)			Rudicardium	T (Mi-u)	-R	(1112)
Pseudisocardia	J (Aale)	-J (Call)	(93)	Ruditapes	T (Mi-l-l)	-R	(1112)
Pseudocardia	T (Mi)			Ruellia	T (Eo)		
Pseudocardium	T (Ol)	-R		Rupellaria	T (Eo)	-R	
Pseudochama	T (Eo-m-u)	-R	(700)	Rzehakia	T (Ol-l)	-T (Mi-m)	(1066)
Pseudocorbula	Tr(Olen-u)	-Tr(Rhae)		Sakawanella	Tr(Carn-l)		(94,864)
Pseudocyrena	T (Plio-l)	-R		Salaputium	T (Eo-m-u)	-R	

Taxon	First Appearance	Last Appearance	Reference	Taxon	First Appearance	Last Appearance	Reference
Saltocuna	T (Plio)	-R		Spaniodontella	T (Mi-m)	-T (Mi-u)	
+ Sarmatidonax	T (Mi-u-l)			Spaniorinus	K (Maes)	-R	
Sanguinolaria	T (Than-l)	-R	(914)	Sphaera	K (Vala)	-K (Albi)	(789)
+ Sarmaticardium	T (Mi-u)		(ZR79)	Sphaeriola	J (Hett)	-J (Bath)	(93)
Sarmatimacra	T (Mi-u)?			Spissatella	T (Eo-m-u)	-R	(899)
+ Saulella	T (Than)		(107)	Spisula	T (Than-l)	-R	(914)
Sawkinsia	T (Eo-m)	-T (Mi-l-u)		Spisulona	T (Plio-u)		(728,899)
Saxidomus	T (Eo-l)	-R	(914)	Sportella	T (Dani)	-T (Mi)	(914)
Saxolucina	T (Dani)	-T (Ol-l)	(700)	Staffinella	J (Bath)		
Scacchia	T (Eo-l)	-R	(914)	Stahlia	J (Toar)		
Scalaricardita	T (Ol)	-T (Plio-u)		Stechepinskya	K (Maes)	-T (Eo-u)	(991)
Scalpomaetra	T (Eo-m-l)	-R	(899)	Stearnsia	K (l)		
Scambula	K (Camp)?	-K (Maes-u)		Stereomaetra	T (Mi-u)	-T (Plio)	
Schaffhaeutlia	Tr(Anis-m)	-Tr(Nori-u)	(94,674)	Stewartia	T (Ol-u)	-T (Plio)	(985)
Schedocardia	T (Dani)	-T (Eo-u)		Stiphromaetra	T (Eo)		
Schedotrapezium	K (Camp)?	-K (Maes)	(914)	Storthodon	Tr(Ladi)		(94)
Schizocardita	Tr(Nori)		(94)	Striacallista	T (Ol)	-R	
Scintilla	T (Eo-m-l)	-R	(1066)	Strigilla	T (Eo-u)?	-R	(1112)
Scintillona	T (Mi-l)	-R		Striolucina	T (Eo)	-T (Plio)	
Scissula	T (Mi-m)	-R		+ Strophocardia	T (Plio)	-R	(1049)
+ Scissulina	T (Mi-m)	-R	(1112)	Stutchburia	C (u)	-P (Djhu)	(745,1058)
Scitilla	K (Haut-u)	-K (Apti-l)	(864)	+ Sublandinia	K (u)		(ZR80)
Scrobicularbra	T (Than-u)	-T (Eo-u)?	(864,914)	+ Subvenericardia	K (Maes)		(ZR80,991)
Scrobicularia	T (Than-l)	-R	(914)	Sulchicoconcha	T (Plio)	R	(1112)
Scutarcopagia	T (Plio)	-R	(1112)	Sulcoocardia	T (Ol)		
Sechurina	K (u)?	-K (Maes)	(991)	Sunetta	T (Than)	-R	(914)
Securella	T (Ol)	-T (Plio)		Sunettina	T (Plio)	-R	(1112)
Seebachia	J (Tith)	-K (Nc)	(93)	Symmorphomaetra	T (Mi)	-R	
Seendia	K (Nc)	-K (Albi-u)		Syndosmya	T (Eo-l)	R	
Semelangulus	T (Eo-u)	-R	(530)	Tagelus	T (Ol-u)	R	(1112)
Semele	T (Than)	-R	(864)	+ Taiwanorbicula	T (Ol)	-R	(ZR75)
Semelina	T (Ol-l)	-R		+ Taiwanobarnea	T (Mi-l)		(ZR90)
Semeloidea	T (Ol)	-R		Talabrica	T (Plio-u)	-R	
Semierycina	T (Mi)	-R		Talocodakia	T (Ol)	-R	
Senis	J (Tith-u)	-K (Maes)	(663)	Tancredia	J (Hett)	-T (Dani)	(1061)
Septeuilia	T (Eo-l)	-T (Eo-u)	(914)	+ Tancretella	K (Haut)?	-K (Albi)	(864)
Septocardia	Tr(Nori-l)			Tapes	T (Ol)	-R	(1112)
Serratina	T (Mi-l-u)	-R	(899)	Tauraxinus	T (Mi)	-R	
Serripes	T (Ol-l)	-R	(96)	Taurotapes	T (Mi)		
Serrula	T (Mi-u-l)	-R	(1112)	Tawera	T (Eo-l)	-R	
Sexta	K (Ceno)			Tealbya	K (Nc)		
Siliqua	T (Dani)	-R	(1112)	Tellidora	T (Mi-u-u)	-R	(1112)
Similivenus	T (Eo)	-T (Ol)		Tellidorella	T (Mi)	-R	
Sinodiopsis	T (Eo)			Tellimya	T (Mi)	-R	
Sinonovacula	T (Ol-u)	-R	(1112)	Tellina	T (Plio-u)	-R	
Sinonia	K (Ceno)			Tellinella	K (Sant)?	-R	
+ Sinopsammobia	J (u)		(ZR82)	Tellinidella	T (Mi-u-l)	-R	(1112)
Sinucongeria	T (Plio)			Tellinides	T (Ol-l)	-R	
Sinuosipagia	T (Eo)			Tellinimaetra	Q (Plei)	-R	(1112)
Siratoria	T (Mi)			Tellinimera	K (Camp-l)	-T (Dani)	(1061)
Sita	K (Maes)	-T (Eo-m-u)	(914)	Tellinocyclus	T (Pale)	-T (Eo)	
+ Siugiudella	J (l)		(ZR90)	+ Tellhnota	T (Ol-u)	-R	(899)
Sogamosa	T (Eo-u)			Tellipiura	K (u)	-K (Maes)	(914)
Solectradia	T (Plio)	-R		Tellurimya	J (Bath)	-J (Call)	
Solecturtus	T (Than-l)	-R	(914)	Temblornia	T (Eo-l)	-T (Plio)	
Solen	T (Than)	-R	(1112)	Temnoconcha	T (Mi-u-l)	-R	(1112)
Solena	T (Eo-m-u)	-R	(1112)	Tendagurium	J	-K	
Solyma	K (Ceno)	-K (Maes)		Tenca	K (Turo-u)	-K (Maes-u)	(790)
Somarcetica	J (Kimm)			+ Tentidonox	T (Plio-l)	-R	(1112)
+ Sourimis	K (Maes)		(914)	+ Tenuimaetra	T (Eo-l)		(1248)
Sowerbya	J (Toar-u)	-K (Vala-l)	(92,663, 1066)	Terraia	P (Guad-u)?	Tr(l)	
				Tetoria	J (m)		

Taxon	First Appearance	Last Appearance	Reference	Taxon	First Appearance	Last Appearance	Reference
Textivenus	T (Eo-m-u)		(700)	+Verchojanogrammysia	P		(ZR87)
Theora	T (Plio)	-R	(1112)	Veremolpa	T (Mi-m)	-R	(1112)
Thetiopsis	K (u)	-K (Maes)	(914)	Vermitexta	T (Eo)	-R	
Thetis	K (Haut-l)	-K (Turo)	(159,789)	Verticipronus	T (Plio-l)	-R	(899)
Thyasira	K (Albi)	-R	(1066)	Vesicomya	T (Eo-u)	-R	
Tikia	K (Camp)	-K (Maes)		Vetericardiella	K (Sn)	-K (Maes-u)	(545)
Timoclea	T (Mi-l-l)	-R		Viaderella	T (Mi)	-R	
Timothyus	T (Eo-l)	-R		+Vietnamocardium	Tr(Nori)	-Tr(Rhae)	(676)
+Titanocardium	T (Ol-u)	-T (Mi-u-u)	(728,899)	Villorita	T (Ol-l)	-R	(158)
Tivela	T (Ol-l)	-R	(1112)	Vimentum	T (Mi-u)	-R	(530)
Tivellina	T (Than)	-T (Mi-l)	(705)	Vokesella	J		
+Tobarum	T (Plio)		(ZR88)	Volupia	T (Eo-m)	-T (Eo-u)	
Torastarte	Tr(Rhae)		(94)	Volupicuna	T (Mi-l-u)	-R	(899)
Tortartica	K (Albi)			Waisiuconcha	T (Mi)	-R	
Tortucardia	K (Maes)			Wallucina	T (Mi)	-R	
Trachycardium	T (Than)	-R	(705)	+Willimaetra	K (Turo-u)	-K (Camp-u)	
Transennella	T (Than)	-R	(705)	Xenocardita	K (Apti)		
Trapezicardita	K (l)			Xenoloupia	T (Eo)		
Trapezium	K (Ceno)	-R	(790)	Yabea	J (u)?	-K (Albi)	(159)
Trautscholdia	J (Toar-u)	-J (u)	(715)	+Yagudinella	T (Mi-u-u)	-R	(1112)
Tresus	T (Eo-l)	-R	(914)	Yokoyamaina	J (Hett)		
Triaphorus	Tr(Ladi)	-Tr(Carn-u)	(94,159)	Zemyllita	T (Plio-l)	-R	
Tridacna	T (Mi-l)	-R		Zemysia	K (Camp)	-R	(1066)
Tridonta	K (Nc)	-R		Zemysina	T (Eo-l)	-R	(681)
Trifaricardium	T (Mi)	-R	(1112)	Zenatia	K (u)	-R	(899)
Trigonastarte	J (m)			Zenatiopsis	T (Mi-l)	-R	(530)
Trigonicardia	T (Ol-u)	-R		Zenatraria	Q (Plei)		(728)
Trigonocallista	K (Camp)?	-K (Maes)		Zorrita	K (Maes)	-T (Mi)	(991)
†Trigonocrassatella	K (l)		(ZR80)	Zoziella	T (Eo-l)		
Trigonopsis	J (l)	-K (l)					
Trinitasia	T (Mi)						
Tripleura	D (Sieg)		(1066)				
+Tulongcardium	Tr(u)		(ZR80)				
Turia	T (Eo-l)	-T (Mi-u)	(899)	Amotapus	T (Eo-m)		
Turtonia	T (Mi)	-R		Anapteris	T (Eo-l)	-T (Eo-u)?	(914)
Tusayana	D (Fras-u)			Anehomasa	K (Ceno)	-R	
Tutcheria	Tr(Carn)	-J (Toar-u)	(93,715)	Anisocorbula	T (Mi-u)	-R	
Uddenia	K (Camp-l)	-K (Maes-u)		Antiguamya	T (Eo)	-T (Ol-l)	
Ungulina	T (Mi-l-l)	-R		Arenomya	T (Eo-u)	-R	
Unicardium	Tr(Olen-u)?	-K (Maes)	(791,991)	Aspidopholas	T (Eo-l)	-T (Eo-u)?	(914)
Unicardiopsis	J (Toar-u)	-J (Kimm-l)	(864)	Bankia	T (Dani)	-R	(914)
Urbnisia	T (Ol-l-u)			Barnea	T (Mi-m)	-R	
Varicardium	T (Eo-m-u)	-T (Mi-m)	(899)	Bicorbula	K (Maes)	-R	(991)
Vasticardium	T (Eo-u)	-R		Bothrocorbula	T (Mi)		
Vectianella	K (Nc)	-K (Apti)		Caestocorbula	J (Bath)	-T (Eo-u)	(700)
Vectorbis	K (l)			Capistocorbula	T (Dani)	-T (Mi-m)	(530,914)
Veloritina	J (m)	-K (Maes)	(914)	-Carterochaena	J (Tith-u)		(1085)
Venerella	T (Eo-l)	-T (Eo-u)?	(914)	Caryocorbula	K (Camp-u)?	-R	
Venericardia	K (Albi)	-R	(790)	Chacera	T (Mi-m)	-R	
-Venericardiella	K (Camp)?	-K (Maes)	(914)	Clavipholas	K (Camp-l)	-K (Maes-u)	(803)
Venericor (+ Neovenericor)	K (Maes)	-T (Eo-u)	(700,991)	Coquandia	K (Ceno)	-R	
Venericyprina	J (Kimm)	-K (Apti)		Corbula	R		
Veneritapes	T (Eo-l)	-T (Eo-u)?	(914)	Corbulamella	K (Camp)	-K (Maes-u)	(545)
Venerupis	T (Ol-u)	-R	(1112)	Corbulomima	J (Toar)	-K (Apti)	(93)
Venidia	T (Eo)			Cryptomya	T (Mi)	-R	
Veniella	K (Apti)	-T (Than)	(914)	Cuneocorbula	T (Eo-l)	-T (Eo-m-u)	
Venilicardia	K (Nc)	-K (Maes)	(914)	Cuspicorbula	T (Eo)		
Ventricolaria	T (Ol-l)	-R		Cyrtodaria	T (Dani)	-R	(1061)
Ventriculoidea	T (Ol-u)	-R	(1112)	Cyrtopleura	T (Mi)	-R	
Venus	T (Eo-l)	-R	(914)	Degrangia	T (Mi)		
Vepricardium	T (Mi-l)	-R	(1112)	Eoursiviva	K (Nc)		
				Erodona	T (Eo-u)	-R	
				Eufistulana	K (Camp-u)	-R	

Or. MYOIDA

Taxon	First Appearance	Last Appearance	Reference	Taxon	First Appearance	Last Appearance	Reference
Gorjanovicia	K (Coni)	-K (Camp-l)		Petkovicia	K (Sant)		
Gyropleura	K (Vala)	-K (Maes-u)	(545,972)	Pileochama	K (Ceno)	-K (Sn)	
+Hacobjanella	K (Coni)	-K (Sant)	(ZR76)	Pinzonella	P (Guad-u)?		
Hardaghia	K (Maes)			Pironaea	K (Camp)	-K (Maes-u)	
-Hatayin	K (u)		(ZR75)	Plagioptychus	K (Turo)	-K (Maes-u)	(1066)
Heterodiscus	J (Tith)	-K (Berr)		Planocaprina	K (Albi-l)	-K (Ceno)	(972)
Himeraelites	K (Albi-l)	-K (Ceno)	(972)	Plesiodiceras	J (Oxfo-u)	-J (Kimm)	
Hippuritella	K (Turo)	-K (Maes)		Polyconites	K (Apti-l)	-K (Ceno-u)	(968)
Hippurites	K (Turo-u)	-K (Maes-u)	(2)	Pomarangina	Tr(u)		
Horiopleura	K (Apti)	-K (Ceno-m)		Praebraetitia	K (Camp-l)	-K (Maes-u)	(972)
Hypelasma	J (Tith)			Praecaprina	K (Barr-u)	-K (Apti-l)	(972)
Ichthyosarcolithes	K (Apti-l)	-K (Turo-u)	(972)	Praecaprotina	K (Apti)		
Immanitas	K (Albi-m)	-K (Ceno-u)	(972)	Praelapeirousia	K (Sant)		
+Jerjesia	K (Albi-l)		(972)	Praeradiolites	K (Apti)	-K (Maes-u)	(2)
Joulia	K (Turo-l)	-K (Maes-u)		+Praetorreites	K (Camp-l)		
†Juramegalodus	J (Tith-u)		(ZR75)	Protodiceras	J (Sine)	-J (Plie)	(92)
Katzeria	K (Camp-l)	-K (Maes)		†Protomegalodon	O (m)?		(ZR85)
†Kimbleia	K (Albi-m)	-K (Ceno-l)	(972)	+Pseudopironaea	K (u)		(ZR82)
Kipia	K (Apti-l)		(972)	Pseudopolyconites	K (Maes)		
-Klinghardites	K (Maes)		(914)	Pseudotoucasia	K (Apti-u)	-K (Albi-u)	
Krumbeckia	Tr(u)			+Pseudovaccinites	K (Sant)?	-K (Camp-u)	(972)
Kuehnia	K (Sant-u)	-K (Maes)	(914)	Pterocardia	J (Bath)	-K (Apti)	
Kugleria	K (Ceno)			Radiolitea	K (Maes)		(914)
+Kurtinia	K (Maes)		(ZR82)	Radiolites	K (Albi-u)	-K (Maes-u)	
Lapeirousella	K (Camp)			Requienia	K (Vala)	-K (Camp)	(914)
Lapeirousia	K (Sant)	-K (Maes)		Retha	K (Barr)	-K (Apti-l)	
Lithocalamus	K (Sn)			-Rhaetomegalodon	Tr(Rhae)		(674)
Lovetchenia	K (Vala-u)	-K (Apti-l)		Rhedensia	K (Turo-u)		
+Macrodiceras	J (Oxfo-l)	-J (Oxfo-u)	(868)	Robertella	K (Sant)	-K (Maes)	(991)
Matheronia	J (Tith)	-K (Apti-l)		Rousselia	K (Maes)		
Medeela	K (Turo)	-K (Coni)		+Rutonia	K		(ZR90)
Megadiceras	J (Tith)	-K (Vala)		Sabinia	K (Camp)?	-K (Maes)	
Megalodon	S (Ldov)	-Tr(u)	(1066)	Sauvagesia	K (Albi-m)	-K (Maes-u)	(972)
Megalomoidea	S (Wenl-u)	-S (Ludl-l)	(2)	Schiosia	K (Ceno-m)	-K (Maes)	
Mesodiceras	J (Oxfo)	-J (Kimm)		Sellaea	K (Albi-m)	-K (Ceno)	
+Mexicaprina	K (Albi-u)	-K (Ceno-u)	(972)	Simacia	K (Ceno)		
Milovanovicia	K (Turo)			Sphaerucaprina	K (Albi-l)	-K (Ceno-u)	(968,972)
+Miseia	K (Maes)		(991)	Sphaerulites	K (Apti)	-K (Maes)	(991)
Mitrocaprina	K (Sant-u)	-K (Maes-u)	(972)	Synodontites	K (Sant)		
Monnieria	J (Tith)			Tampsia	K (Sant-l)	-K (Maes-u)	(972)
Monopleura	J (Tith-u)	-K (Maes-u)		Tepeyacia	K (Albi-l)	-K (Turo)	(972)
Neocaprina	K (Ceno-m)?	-K (Ceno-u)	(968)	Tetracionites	K (Coni)		
Neomegalodon	Tr(Carn)	-Tr(Rhae)		†Tetravaccinites	K (Sant-u)		(ZR81)
Neoradiolites	K (Maes)			-Texitcaprina	K (Albi-l)	-K (Turo-u)	(972)
Offneria	K (Apti-l)			Thyrastylon	K (Camp-l)	-K (Maes-u)	(972)
†Orbignya	K (Maes-l)	-K (Maes-u)	(972)	Titanosarcolithes	K (Maes-l)	-K (Maes-u)	(914,972)
+Orestia	K (Maes)		(914)	Torreites	K (Sant-u)	-K (Maes-u)	(972)
Orthoptychus	K (Ceno-m)?	-K (Ceno-u)	(968)	Toucasia	K (Haut)	-K (Coni-u)	(972)
Osculigera	K (Camp)?	-K (Maes)	(914)	Vaccinites	K (Turo)	-K (Maes-u)	
Pachymegalodon	J (Sine)?			Valletia	J (Kimm)	-K (Vala)	
Pachyrisma	J (Bath)		(1066)	Vautrinia	K (Maes)		
Pachytraga	K (Haut)	-K (Albi-u)	(972)	Yvaniella	K (Camp)	-K (Maes)	(914)
Palus	K (Ceno-l)	-K (Ceno-u)	(972)				
Parabournonia	K (Ceno-l)	-K (Maes)	(972)				
Paracaprinnula	K (Maes)						
Paradiceras	J (Tith)						
Paramegalodus	Tr(Rhae)						
Paramonopleura	T (Than-u)						
Parasauvagesia	K (Camp)						
Parastroma	K (Camp-l)	-K (Maes-u)	(972)				
Paronella	K (Sant-l)						
Petalodontia	K (Albi-l)	-K (Ceno)					

Or. PHOLADOMYOIDA

Aelga	T (Eo-m)	-T (Mi)	
Alula	P (Leon-u)	-P (Guad-u)	(157)
Anatimya	K (Ceno)	-K (Maes)	
+Andinodesma	D (Gedi)		
Anomalopleuroides	Tr(u)		
Arcomya	Tr(Anis-l)	-K (Maes)	(991)
+Arcticlum	T (Dani)		(1061)
+Arenigomya	O (Aren-l)		(1238)

Taxon	First Appearance	Last Appearance	Reference	Taxon	First Appearance	Last Appearance	Reference
Argyromya	T (Eo-m)			Lyonsia	T (Than)	-R	(914)
+Ascauloocardium	K (Sant-u)	-K (Maes-u)		Machomya	J (Kimm)	-J (Tith)	(93)
+Asketomorpha	C (Serp-l)		(879)	Margaritaria	T (Mi-m)	-T (Plio-l)	(108)
Astartila	P (l)	-P (Djhu)		Megadesmus	P (Asse)	-P (u)	
+Australomya	P (Asse)?	-P (Leon-m)	(108)	Mioporomya	T (Mi)		
Bontaea	T (Plio)	-R		Molukkana	Tr(Nori)		
Boriesia	T (Dani)	-T (Than)	(914)	Myadora	T (Eo-u)	-R	(530)
Bowdenia	T (Mi)			Myadoropsis	Q (Plei)	-R	
+Bowlandia	C (Vise)		(967)	Myochama	T (Ol-u)	-R	(530)
Bryopa	T (Mi-l-l)	-R		+Myofossa	D (Fame-u)	-P (Leon-u)?	(745,967)
Bucardiomya	J (Toar)	-T (Eo-m)?		+Myonia	C (Step)	-P (Djhu)	
Burmesia	Tr(Carn)	-Tr(Rhae)	(1066)	Myopholas	J (Toar)	-K (Albi-u)	
Capillimya	J (Kimm)			Nearoporomya	T (Eo-l)	-T (Eo-m-u)	(914)
Cardiomorpha	C (Vise)?	-Tr(Carn)	(2)	Neoburmesia	J (Kimm)	-J (Tith)	(93)
Cardiomya	K (u)	-R		+Oblicarina	P (Guad-u)		(745)
Casterella	P (Asse)	-P (Guad-u)?		+Obrimia	D (l)		
Ceratomya	J (Sine-u)	-J (Tith)	(93)	Offadesma	T (Eo-m-l)	-R	(899)
Ceromya	Tr(Carn)	-K (Maes-u)	(94,790)	Orthonota	O (Llde)	-D (Give-l)	
Ceromyella	T (Mi-m)?			Osteomya	J (Toar)	-J (Call)	
Chaenomya	C (Mosc)	-P (Guad)	(157)	Ostomya	T (Ol-u)	-R	
Cimitaria	D (m)	-D (u)		+Ouamouia	Tr(Carn-u)	-Tr(Rhae)	
Clavagella	K (Ceno)?	-R		Pachymya	Tr(m)	-K (Maes)	(991)
Cleidothaerus	T (Mi-l-l)	-R	(899)	Pachymyonia	P (Sakm)	-P (Guad-u)	
Clidiophora	T (Mi)	-R		Palaeocorbula	P (l)		
Cochlodesma	T (Eo-l)	-R	(1248)	Pandora	T (Eo-l)	-R	(1066)
Cortinia	Tr(u)			Pandorella	T (Mi-l)?	-R	
Cosmomya	C (Vise)	-P (u)?	(967)	+Parapachytraga	K (Barr-u)		
Crassiconcha	P (u)			Paraprothyris	D (l)		
+Cunavella	C (Bash)	-P (Leon-u)		Parvithracia	T (Mi)	-R	
Cuneamya	O (Lvi)?	-C (Vise)	(1046,1058)	Pecchiolia	T (Eo-l)	-T (Plio)	(914)
Cuspidaria	Tr(Ladi)	-R	(2)	Penicillus	T (Mi-l-l)	-R	
Cyathodonta	T (Eo-u)?	-R	(814)	Pentagrammysia	C (Vise)		
Cymella	K (Camp-l)?	-K (Maes)		Periploma	K (Apti)	-R	(159)
Deltamya	K (Maes)		(991)	Periplomya	K (Sant)	-K (Maes)	(159)
+Dulunomya	C (Vise-l)	-C (Bash-l)		Permophorus	C (Vise)?	-P (Djhu)	
+Dyasma	P (Guad-u)		(967)	Pholadella	D (Emsi)	-C (Step)	
+Ectogrammysia	C (Serp-l)		(879)	Pholadomya	Tr(Carn)	-R	(94)
Edmondia	D (Fras-u)	-P (Djhu)		Pholadomyocardia	J		
Endomargarus	T (Eo)			Phragmorisma	T (Ol-u)	-R	(530)
Exochorhynchus	C (Serp)	-P (Leon-m)	(967)	+Planariomya	J (l)		(ZR80)
Fabagella	T (Eo-l)	-T (Eo-u)?	(914)	Platynyoidea	J (Plie-u)	-K (Barr)	(93,715, 789)
Farrazia	P (Guad-u)?		(108)	Plectodon	T (Plio)	-R	
Foegia	T (Mi-l-l)	-R		Plectomya	J (Kimm-u)	-K (Maes)	(159,991)
+Gilbertsonia	C (l)	-C (Pn)	(967)	Plesiocyprinella	P (Guad-u)?		(108)
Girardotia	J (Oxfo)	-K (Berr-u)	(93,663)	Pleurikodonta	P (l)	-P (Guad-u)	(745)
Glossites	D (l)	-C (Tour)		Pleurodapis	D (Eife)		(1066)
+Glyptoconcha	C (Vise)			Pleuromya	Tr(Olen-u)	-K (Maes)	(674,991)
Goniomya	Tr(Nori)	-K (Maes-)	(94,991)	Pleurophorella	C (Vise)	-C (Step)	
Grammysia	S (Prid)	-C (Tour-u)	(1066)	Pleurophorina	P		
Grammysioidea	S (Wenl)	-C (Step)	(1058)	Poromya	K (Apti)	-R	(1066)
Gresslya	J (Hett-u)	-J (Tith-u)	(663,715)	+Praemyonia	C (l)		
Halonympha	K (Maes-u)	-R	(545)	Praeundulomya	C (Tour)	-P (u)	
Heteroclidus	T (Plio)	-R		Procardia	J (Call)	-K (Maes-u)	(790)
Homomya	Tr(Olen-u)	-K (Albi-u)		Prolaria	Tr(Rhae)		
Hunkydora	T (Plio-u)	-R		Promacrus	C (Tour-l)		
+Indomya	J (m)		(ZR86)	Protomya	D (Give-l)		
+Jacquesia	P (Guad-u)		(108)	Protopalliolium	P		
Laevicordia	T (Plio)	-R		Pseudobrechites	T (Mi-l-l)		
Laternula	K (u)	-R		Pseudocuspidaria	T (Eo-l)	-T (Eo-u)?	(914)
Leinzia	P (Guad-u)			Psilomya	K (Ceno)	-K (Maes)	
Liopistha	K (Turo)	-K (Maes-u)	(790)	Pteromya	Tr(Rhae)	-J (Hett-l)	(715)
+Lophoprothyris	C (Serp-l)		(879)				

Taxon	First Appearance	Last Appearance	Reference	Taxon	First Appearance	Last Appearance	Reference
Pyramus	C (Serp)	-P (Dora)	(157,1066)	Ph. LOBOPODA (= Onychophora)			
+ Rhytimya	O (Cara-m)	-O (Ashg-l)	(91)	Aysheaia	Cm(mMid-l)	-Cm(uMid-l)	(883)
Sanguinolites	D (Gedi)	-P (Guad-u)	(157)	-Cardiodictyon	Cm(Atda-u)		(1126)
Scaldia	C (Tour)	-C (Vise)	(2,1058)	-?Facivermis	Cm(Atda-u)		(1019)
Sedgwickia	C (l)	-P (Guad-u)		-Hallucigenia	Cm(Atda-u)	-Cm(mMid-u)	(1126)
+ Siliquimya	C (Vise)		(967)	-Luolishania	Cm(Atda-u)		(1019,1126)
+ Sinodora	D (Emsi)	-D (Eife)	(ZR84)	+ Microdictyon	Cm(Atda-l)	-Cm(lMid)	(552,885, 1006)
+ Siphogrammysia	P (Guad-u)		(967)	-Necrogammarus	S (Ludl)		
Solenomorpha	D (l)	-P (Guad-u)		-Onychodictyon	Cm(Atda-u)		(1126)
-?Somareoides	Tr(Carn)			+ Paucipodia	Cm(Atda-u)		
Stirpulina	K (Turo-u)	-R		Xenusion	Cm(Tomm-u)		(345)
Taimyria	P (l)	-P (Guad-u)	(2)	-incertae sedis	S (Ldov-u)		(617)
+ Tellinomorpha	C (Vise)		(967)				
Tergulina	T (Ol)			Ph. ARTHROPODA			
Tetorimya	J (Oxfo)		(93)	Ci. MEROSTOMATA			
Tosarca	T (Plio)			[Classification and basic stratigraphic ranges from the TREATISE, Part P (1955).]			
Thracia	J (Hett)	-R		Or. ?AGLASPIDA			
Trichomyella	J (Call)			Aglaspella	Cm(Fran)	-Cm(Trep-u)	(1031)
Trigonulina	T (Eo-l)	-R	(1248)	Aglaspis	Cm(Fran)	-Cm(Trep-u)	(1031)
Triplicosta	T (Eo)			Aglaspoides	Cm(Trep-u)		(1031)
Undulomya	P (Leon)?	-P (u)		+?Angarocaris	O (Llde)		
+ Unklesbyella	C (Serp-l)	-C (Step-l)	(105,1066)	Beckwithia	Cm(uMid)	-Cm(Dres-l)	
Vacuella	P (Leon-u)	-P (Guad-u)	(745)	?Borchgrevinkium	D (Emsi-l)		
Verticordia	K (Albi)	-R	(1066)	Craspedops	Cm(Trep-u)		(1031)
Warnea	T (Plio)	-R		Cycloptes	Cm(Trep-u)		(1031)
Wilkingia	C (Tour-u)?	-P (Djhu)		+ Flobertia	Cm(Trep-u)		(1031)
				-?Girardevia	O (Llde)		
Or. UNCERTAIN				Glypharthrus	Cm(Fran)	-Cm(Trep-u)	(1031)
Anomianella	C (Tour)			+ Kodymirus	Cm(l)		
Aviculomya	C (l)			Neostrabops	O (Ashg-l)		
Barcoona	K (l)			Setaspis	Cm(Trep-u)		(1031)
-Beichuania	D (l)		(ZR90)	+ Sinaglaspis	P (Asse)		(1066)
Bleta	Tr(u)			Strabops (+ Paleomerus)			
Burriera	P (l)				Cm(Atda-l)	-Cm(Fran)	(1006)
Carnidia	Tr(u)			-Triopus (+ Drabovaspis)	O (Cara-l)		
Cruciella	Tr(Carn)			+ Tuboculops	Cm(Trep-u)		(1031)
Delia	J (Oxfo)			Uarthrus	Cm(Trep-u)		(1031)
Elasmatium	D (Fras)			Or. CHASMATASPIDIDA			
Elliptoidea	P (Leon)			Chasmataspis	O (Llvi)?		
Ensia	Tr			Diploaspis	D (Emsi-l)		
Gibboconcha	J (l)			Heteroaspis	D (Emsi-l)		
Guebhardia	J (Bath)			Or. XIPHOSURIDA			
Hemisterias	C (Pn)			-Archeolimulus	O (m)		
Laubeia	Tr(Carn)			-Bellinuroopsis	D (Fame-u)		(1066)
Libyaconchus	K (u)?, T (Dami)			Bellinurus	D (Eife)?	-C (Mosc-l)	(1066)
Megagrypha	D (l)			?Bembicosoma	S (u)		
+ Noradonta	O (Aren-u)	-O (Llvi)?	(1046)	Bunaia	S (Prid)		
Onkogrypha	D (l)			?Bunodella	S (u)		
Ostreavicula	K (Turo)			Bunodes	S (Ludl-l)		(1066)
Paradoxia	J (Plie)			-Casterolimulus	K (Maes-l)		
Pleureterites	C (Pn)			Cyamocephalus	S (Ldov-u)	-S (Ludl)?	(1066)
Praecardiomya	K (Ceno)			Elleria	D (Fras)		(359)
Praevicula	D (l)			Heterolimulus	Tr(Ladi)		(359,1066)
Productea	P (Leon)			Legrandella	D (Emsi-l)		(359)
Psammoconcha	Tr(l)			Limulitella	Tr(Ladi)?	-J (Hett)	(359)
Pseudomya	J (Oxfo)						
Rebusum	J (l)						
Rhenanomya	D (l)						
Taeniodon	J (Hett)						
Tatella	K (l)						
Telistrophis	C (Pn)						
+ Tulongella	Tr(u)		(ZR80)				

Taxon	First Appearance	Last Appearance	Reference
Limuloides	S (Ludl-u)		(1066)
Limulus	Tr(m)	-R	(359)
Mesolimulus	J (Tith-l)	-K (Ceno)	
+Moravurus	C (Serp-l)		(1066)
Neobelinuropsis	D (Fras)?		
Neolimulus	S (Ludl)?		(2)
Paleolimulus	D (Fame)	-P (Sakm)?	(359)
+Pasternakevia	S (Ludl-u)		
Psammonilimus	Tr(Olen-u)		(1066)
Pseudoniscus	S (Prid)		(1066)
+Rolfieia	C (Tour-u)		(1066)
Tachypleus	T (Mi)	-R	
Victalimulus	K (Aibi)?		(359)
Weinbergina	D (Emsi-l)		(2)
+incertae sedis	S (Ldov-u)		(617)

Or. INCERTAE SEDIS

Eolimulus	Cm(Atda)		
?Gdowia	Cm(Tomm-u)		
+Sanctacarus	Cm(mMid-l)		(804)

Or. EURYPTERIDA

Acutiramus	S (Prid)	-D (Gedi)	(360)
Adelophthalmus	D (Fame)	-P (Leon)?	(360)
Alkenopterus	D (Emsi-l)		(360)
Baltoourypterus	S (Wenl)	-S (Prid)	(360)
Bassipterus	S (Prid)		(360)
Brachopterella	S (Prid)		(1066)
Brachyopterus	O (Cara-l)		(360,1066)
Buffalopterus	S (Prid)		(360)
Campylocephalus	C (Serp)?		(360)
Carcinosoma	S (Ludl)	-D (Emsi-l)	(360)
Clarkeipterus	S (Prid)		(360)
Ctenopterus	S (Wenl)?		(360)
Dolichopterus	S (Wenl)	-D (Siegl)	(360)
Dorfopterus	D (Siegl-u)	-D (Emsi-l)	(360)
Drepanopterus	S (Ldov)	-D (Emsi-l)	(360)
Dunsopterus	C (Vise)	-C (Serp)	(360)
Echinognathus	O (Cara-m)	-O (Ashg)	(360,1066)
Eocarcinosoma	O (Ashg)		(360)
Erettopterus	S (Ldov)	-D (Siegl)	(360)
Erieopterus	S (Wenl)	-D (Siegl-u)	(360,1066)
Eurypterus	S (Ldov)	-D (Emsi-l)	(360)
Grossopterus	D (Siegl-u)		(360)
Hallipterus	D (Fras)		(360)
Hardieopterus	S (Ldov-m)?	-S (Prid)	(360,1066)
Hastimima	P (Sakm)?		(360)
Hibbertopterus	C (Vise)	-C (Serp)	(360)
Holmipterus	S (Wenl)		(360)
Hughmilleria	S (Ludl)		(360)
Jaekleopterus	D (Siegl)	-D (Emsi-l)	(360)
Kiaeropterus	S (Ldov)	-S (Ludl)	(360)
Kokomopterus	S (Prid)		(360)
Lamontopterus	S (Ldov-u)		(360,1066)
Lanarkopterus	S (Wenl-u)?, S (Ludl-l)?		(360,1066)
Laurieopterus	S (Ldov-u)		(360,1066)
Megalograptus	O (Cara)	-O (Ashg-m)	(360)
Mixopterus	S (Wenl)	-S (Prid)	(360)
Mosleopterus	D (Emsi-l)	-D (Eide)?	(360)
Nanahughmilleria	S (Ludl)	-D (Gedi)	(360)
Onychopterella	S (Prid)		(360)

Taxon	First Appearance	Last Appearance	Reference
Pagea	D (Gedi-u)		(360)
Paracarcinosoma	S (Wenl)	-D (Gedi-u)	(360)
Parahughmilleria	S (Ldov-m)?	-D (Emsi)	(360,1066)
Parastylonurus	S (Prid)		(360)
Pittsfordipterus	S (Prid)		(360)
Pterygotus	S (Ludl)	-D (Fame-m)	(360,1066)
Rhenopterus	D (Siegl-u)	-D (Fras-u)	(360)
Rhinocarcinosoma	S (Ludl-u)		(360)
Ruedemannipterus	O (Cara)?, S (Wenl)?		(360)
Salteropterus	S (Prid)		(360)
Slimonia	S (Ldov-u)	-S (Prid)	(360,1066)
Strobilopterus	D (Siegl-u)		(360)
Stylonurella	S (Ldov)		(360)
Stylonuroides	S (Ludl)		(360)
Stylonurus	D (Gedi)		(360)
Syntomopterus	D (Siegl)		(360)
Tarsopterella	S (Prid)	-D (Gedi-u)	(360)
Truncatiramus	S (Wenl)	-S (Prid)	(360)
Tylopterella	S (Ludl)		(360)
Waeringopterus	S (Prid)	-D (Gedi)	(360)
Willwerathia	D (Emsi-l)		(360)

Cl. ARACHNIDA

Or. SCORPIONIDA

Dolichophonus	S (Ldov-u)		(656,1066)
Palaeophonus	S (Wenl-l)		(656)
Palaeoscorpium	D (Emsi-l)		(656)
Proscorpius	S (Prid)		(656,1066)
Waeringscorpii	D (Emsi-l)		(656)

Cl. PYCNOGONIDA

Or. PALAEOPANTOPODA

Palaeopantopus	D (Emsi-l)		
----------------	------------	--	--

Or. PALAEOISOPODA

Palaeo-isopus	D (Emsi-l)		
---------------	------------	--	--

Or. PANTOPODA

Palaeothea	D (Emsi-l)		
+?Pentapalaeopycon	J (Kimm)		(1063)

Cl. "PARATRILOBITA"

Onega	V (u)		
Parvancorina	V (u)		

Cl. MEROSTOMOIDEA

Or. EMERALDELLIDA

+Ecnomocaris	Cm(uMid-l)		(809)
Emeraldella	Cm(mMid-u)		
+Thelxiope	Cm(mMid-u)		(809)

Or. LIMULAVIDA

Amiella	Cm(mMid-u)		
Sidneyia	Cm(mMid-u)	-Cm(uMid-l)	(883)

Or. CHELONIELLIDA

Cheloniellon	D (Emsi-l)		
--------------	------------	--	--

Taxon	First Appearance	Last Appearance	Reference	Taxon	First Appearance	Last Appearance	Reference
Or. INCERTAE SEDIS				Or. TRILOBITA			
+ Fuxianhuia	Cm(Atda-u)		(780)	Pahvantia	Cm(uMid-l)		(349)
Helmetia	Cm(mMid-u)			+?Parapunctella	Cm(Tomm-u)?		(580,951)
+Kuamaia (+ Rhombicalvaria)	Cm(Atda-u)		(780)	Protocaris	Cm(Boto)	- Cm(uMid)	
+Nathorstia	Cm(mMid-u)		(1019)	+Pseudarthron	S (Ludl)		
+Retifacies	Cm(Atda-u)		(859)	Pseudoarctolepis	Cm(mMid-u)	- Cm(uMid-l)	(349)
Cl. MARRELOMORPHA				Quasicaris	O (Cara-l)		
Or. MIMETASTERIDA				Schizodiscus	D (Give-l)		
Marrella	Cm(mMid-u)			Serracaris	Cm(Tojo)		(350)
Mimetaster	D (Emsi-l)			Shafferia	Cm(mMid-u)		
Paramarria	O (Ashg-m)			Skania	Cm(mMid-u)		
Or. ACERCOSTRACA				+ Urokodia	Cm(Atda-u)		(859)
Vachonisia	D (Emsi-l)			+ Utahcaris	Cm(mMid-l)		(809)
Or. CYCLINA (= Cycloidea)				+ Vetulicola	Cm(Atda-u)		(781)
- Apionicon	C (Mosc-u)			Yohoia	Cm(mMid-u)		(2)
Carcinaspides	Tr(Nori)		(2)	[Classification and basic stratigraphic ranges based on the TREATISE, Part O (1959).]			
Cyclocarcinides	Tr(u)			Or. NARAOIIDA (= Nektaspida)			
Cyclus	C (Vise-l)	- P (l)	(2)	+ Liwia (+ Livia)	Cm(Atda-l)		(1006)
Halicynce	C (Mosc-u)	- Tr(Nori)	(2)	- Maritimella	Cm(m)?, Cm(u)?		
Hemithrochiscus	P (Guad)			+ Naraoia	Cm(Atda-u)	- Cm(uMid-m)	(580,809)
Mesoprotopon	Tr(Nori)		(2)	+ Sapention	Cm(Atda-u)		
Oonocarcinus	P (Leon-u)	- Tr(u)		+ Soomaspis	O (Ashg)		
Cl. MYRIAPODA				+ Tarricoia	O (m)	- O (u)	(ZR91)
+ Cambropodus	Cm(uMid-l)		(1019)	+?Tegopelte	Cm(mMid-u)		
+?incertae sedis	S (Ldov-)		(1066)	Or. OLENELLIDA			
Cl. UNCERTAIN				Andalusiana	Cm(Atda-u)		
Actaeus	Cm(mMid-u)			Angustolenellus	Cm(Boto-u)?		
Alalcomenaeus	Cm(Atda-u)?	- Cm(uMid-l)	(778,883)	Archaeaspis	Cm(Atda-u)		(468,522)
Anatifopsis	O (Aren)?	- O (Ashg-l)		Arcuolenellus	Cm(Tojo)		
Aristocaris	D (Give)			Biceratops	Cm(Tojo-u)		
Bostriehopus	C (Tour)			Bolbolenellus	Cm(Tojo-l)		
Bundenbachiellus	D (Emsi-l)			Bondonella	Cm(Atda-u)		(473)
+ Chuandianella	Cm(Atda-u)		(1019)	Bradyfallotaspis	Cm(Atda-u)		(475)
+ Corcorania	O (Trem-l)		(567)	Bristolia	Cm(Tojo)		
Dalmaniopsis	P (l)			Buenellus	Cm(Atda-u)		
+ Dicerocaris	Cm(uMid-l)			Callavia	Cm(Atda-u)		(80,81)
Douglasocaris	O (Llde)			Campropallus	Cm(Boto-u)		
+ Duslia	O (Cara-l)			Choubertella	Cm(Atda-l)		(473)
+ Emeiella	Cm(Atda-u)?		(580)	Cirquella	Cm(Atda-u)		
+ Gaoqiaoella	Cm(Atda-u)		(1006)	Daguinaspis	Cm(Atda-l)		(473,885)
Habelia	Cm(mMid-u)			Elliptiocephala	Cm(Boto-u)		
+ Huangshandongia	Cm(Atda-u)			Eofallotaspis	Cm(Atda-l)		(885)
Isoxys (+ Cymbia, Glauderia)	Cm(Atda-l)	- Cm(mMid-u)	(566,781)	Esmeraldina	Cm(Atda-u)		
+ Jiantengia	Cm(Atda-u)		(778)	Fallotaspisella	Cm(Atda-u)		
+ Jiucunella	Cm(Atda-u)		(1019)	Fallotaspis	Cm(Atda-l)		(472,476, 522,885)
Kublikia	O (Llde)			Fremontella	Cm(Boto-u)		
+ Liantuoia	Cm(Atda-u)			Gabriellus	Cm(Boto-l)		
+ Meristosomo	Cm(mMid-l)	- Cm(uMid-m)		Geraldinella	Cm(Atda-u)		
Molaria	Cm(mMid-u)			Holmia	Cm(Atda-u)		(476,885)
Mollisonia	Cm(mMid-u)	- Cm(uMid-l)	(883)	Holmiella	Cm(Atda-u)		(475,885)
+?Motina	Cm(l)		(1006)	Iyouella	Cm(Atda-u)		
Naptile	Cm(mMid-u)			Judomia	Cm(Atda-u)	- Cm(Boto-l)	(462,468, 522)
Oxyuropoda	D (Fame)			Judomiella	Cm(Boto-l)		(462,471)
				Kjerulfia	Cm(Atda-u)		(80,473, 885)
				Laudonia	D		(476,885)

Taxon	First Appearance	Last Appearance	Reference	Taxon	First Appearance	Last Appearance	Reference
Lenallina	Cm(Atda-u)			+ Ceragnostus	Cm(Trep-l)		(618)
Mesolenellus	Cm(Atda-u)	-Cm(Boto-u)		Chatkalgnostus (+ Oculagnostus)	O (Llvi-l)	-O (Llde-l)	
Mesonacis (+ Fremontia)	Cm(Boto-u)	-Cm(Tojo)		Chelodiscus	Cm(Boto-u)		(462)
Mummaspis	Cm(Boto-l)			Ciceragnostus	O (Trem-u)?		
Neltneria	Cm(Atda-u)		(473)	Clavagnostus (+ Tomorhachis, Culipagnostus, Acanthagnostus, Stigmagnostus, Leptagnostus)	Cm(uMid-u)	-Cm(Dres-l)	(2)
Nephtroenellus	Cm(Tojo-l)			Cobboldites	Cm(Boto)		
Nevadella	Cm(Atda-u)		(81)	Condylopyge (+ Fallagnostus)	Cm(Tojo)	-Cm(uMid-m)	(81)
Nevadia	Cm(Atda-u)		(885)	Connagnostus	Cm(Dres-l)		(16)
Olenelloides	Cm(Boto-u)?			Corrugatagnostus	O (Trem-l)	-O (Ashg-m)	(1079)
Olenellus	Cm(Boto-l)	-Cm(Tojo-u)	(81,885)	Cotagagnostus	Cm(uMid-l)	-Cm(uMid-u)	
Paedumias	Cm(Boto-l)	-Cm(Tojo-l)		Criopyrus	Cm(uMid-l)	-Cm(uMid-m)	
Palmettaspis	Cm(Atda-u)			Cristagnostus	Cm(Dres-l)		(378)
Parafallotaspis	Cm(Atda-l)		(475)	Dawsonia (+ Aculeodiscus, Metadiscus)	Cm(mMid-l)	-Cm(uMid-l)	(81,378)
Paranevadella	Cm(Atda-u)			Delagnostus	Cm(uMid-u)		(16)
Peachella	Cm(Tojo)			Delgadella (+ Pagetiellus)	Cm(Atda-u)	-Cm(Tojo-l)	(462,470,522)
Pelmanaspis	Cm(Atda-u)			Denagnostus	Cm(Dres-u)		(721)
Poletaevella	Cm(Boto)			Dicerodiscus	Cm(Boto-l)		(463)
Postfallotaspis	Cm(Atda-u)		(885)	Dignagnostus	Cm(m)		
Profallotaspis	Cm(Atda-u)			Dipharus	Cm(Atda-u)	-Cm(Boto-l)	(464,885)
Pseudojudomia	Cm(Atda-u)			Diplagnostus	Cm(uMid-l)	-Cm(uMid-u)	(16,464)
Schmidtellus	Cm(Atda-u)			Diplorhina	Cm(uMid-l)	-Cm(uMid-u)	
Selindella	Cm(Atda-u)			Dividuagnostus	O (Trem)	-O (Ashg-l)	
Sinskia	Cm(Atda-u)	-Cm(Boto-l)	(522)	Dolichoagnostus	Cm(uMid-u)		(16)
Wanneria	Cm(Boto-u)		(81)	Doryagnostus (+ Ceratagnostus)	Cm(uMid-m)	-Cm(uMid-u)	(16)
Wolynaspis	Cm(Atda-u)			Egyngolia (+ Mongolodiscus)	Cm(Atda-u)		(923)
Or. AGNOSTIDA (= Miomera)				Ekwapagettia	Cm(Atda-u)		
Abakolia (+ Costadiscus)	Cm(Boto)	-Cm(lMid)		Eoagnostus	Cm(Boto)		(465)
Acadagnostus (+ Aragnostus)	Cm(mMid-u)	-Cm(uMid-u)		Eodiscus (+ Microdicus, Spinodiscus)	Cm(Boto)	-Cm(uMid-m)	(466,467)
Acidiscus	Cm(Boto)		(458)	Eolotagnostus	Cm(Trep-u)		
Acidus	Cm(uMid-l)	-Cm(uMid-u)		Euagnostus	Cm(mMid-u)	-Cm(uMid-m)	(16,1066)
Acimetopus	Cm(Boto)		(458)	Formagnostus (+ Kunshanagnostus)	Cm(uMid-u)	-Cm(Dres-u)	
Acmarhachis (+ Cyclagnostus, Wanagnostus)	Cm(Dres-l)	-Cm(Fran-u)	(16)	Gaibagnostus	O (Aren-l)	-O (Llvi-l)?	
Acutatagnostus	Cm(Dres-u)		(459)	Gallagnostus	Cm(uMid)?		
Agnostaridis	Cm(uMid-u)	-Cm(Dres-l)	(16)	Geragnostella	O (Aren-l)	-O (Cara-m)	(1075)
Agnostogonus	Cm(Dres-l)		(16)	Geragnostus	O (Trem-u)	-O (Cara-u)	(1268)
Agnostotes	Cm(Fran-l)	-Cm(Fran-u)	(16,618)	Glaberagnostus	Cm(Dres-u)		
Agnostus	Cm(uMid-l)	-Cm(Dres-l)	(16,460,1066)	Glyptagnostus (+ Barradagnostus)	Cm(Dres-l)	-Cm(Dres-u)	(16)
Aistagnostus	Cm(Fran)?			Goniagnostus	Cm(uMid-l)	-Cm(uMid-u)	
Alaskadiscus	Cm(l)			Grandagnostus	Cm(uMid-u)	-Cm(Dres-u)?	(378)
Allobodochus	Cm(uMid-u)			Granulagnostus	O (Llvi)		
Ammagnostus	Cm(uMid-u)	-Cm(Dres-l)	(16)	Gratagnostus	Cm(uMid-l)		
Analox	Cm(Boto)		(458)	Gymnagnostus	Cm(Trep-u)		
Anglagnostus	O (Trem-l)		(927)	Hadragnostus	Cm(uMid-u)	-Cm(Dres-l)	(16)
Aotagnostus	Cm(uMid-m)	-Cm(uMid-u)		Hastagnostus	Cm(uMid)		
Archaeagnostus	Cm(Boto)			Hebediscina	Cm(Atda-u)	-Cm(Boto-u)	(463,464,923)
Armagnotus	Cm(uMid)			Hebediscus (+ Maryodiscula, Szechuanaspis)	Cm(Atda-l)	-Cm(Tojo-u)	(81,522)
Arthrorhachis (+ Girvanagnostus)	O (Trem-u)	-O (Ashg-u)	(795)	Helepagettia	Cm(uMid-m)	-Cm(uMid-u)	(16)
Aspidagnostus (+ Biragnostus)	Cm(Dres-l)	-Cm(Dres-u)	(16)	Homagnostoides	O (Trem-u)		
Baltagnostus	Cm(mMid-u)	-Cm(uMid-u)	(379)				
Bathydiscus	Cm(Boto)		(458)				
Blystagnostus	Cm(uMid-u)		(16)				
Bolboparia	Cm(Boto)		(458)				
Calodiscus	Cm(Atda-u)	-Cm(Boto-l)	(458,461)				
Cephalopyge	Cm(Atda-l)						

Taxon	First Appearance	Last Appearance	Reference	Taxon	First Appearance	Last Appearance	Reference
Homagnostus	Cm(Dres-l)	-Cm(Fran-l)		Peronopsis	Cm(mMid-u)	-Cm(uMid-u)	(81,464)
Hypagnostus (+ Cyclopagnostus, Spinagnostus)				Phalacroma (+ Platagnostus)			
	Cm(uMid-l)	-Cm(Dres-l)	(16,458)		Cm(mMid-u)	-Cm(uMid-m)	(1066)
Idolagnostus	Cm(uMid-u)	-Cm(Dres-u)	(16,1020)	Phalagnostus (+ Phalacromina)			
Inispheniscus	Cm(uMid-l)	-Cm(uMid-m)			Cm(uMid-m)	-Cm(Dres-l)?	
Innitagnostus	Cm(uMid-u)	-Cm(Fran-u)	(16)	Phaldagnostus	Cm(Dres-u)		
Itagnostus	Cm(mMid-u)			Phoidagnostus	Cm(uMid-u)		
Ivshinagnostus	Cm(Fran-l)		(459)	Pleurinodus	Cm(Dres-l)		(16)
Jinghediscus	Cm(mMid)			Pleuroctenium (+ Dichagnostus)			
Kiskinella	Cm(mMid)				Cm(mMid-u)	-Cm(uMid-m)	(80,378)
Kormagnostella (+ Litagnostoides)				Proagnostus	Cm(uMid-u)	-Cm(Dres-l)	(379)
	Cm(Dres-l)	-Cm(Dres-u)	(1020)	Pseudagnostina	Cm(Dres-l)		(16)
Kormagnostus	Cm(uMid-u)	-Cm(Dres-l)		Pseudagnostus	Cm(Dres-l)	-Cm(Fran-u)	(16,80)
Korobovia	Cm(Boto-u)		(923)	Pseudocobboldia	Cm(Tojo-l)	-Cm(lMid)	(473)
Kymagnostus	Cm(Fran-l)		(887)	Pseudoglyptagnostus	Cm(Fran-l)		
Lavsandiscus	Cm(Atda)			Pseudoperonopsis	Cm(uMid-l)		
Leiagnostus (+ Phoidagnostoides)				Ptychagnostus	Cm(uMid-m)		
	Cm(Trep-u)	-O (Llde-l)	(1075)	Quadragnostus	Cm(uMid)		
Lejopyge (+ Miagnostus, Pseudophalacroma)				Quadrahomagnostus	Cm(Dres-l)		
	Cm(uMid-m)	-Cm(uMid-u)	(16,458)	Raragnostus	Cm(mMid)	-Cm(uMid-u)	
Lenadiscus	Cm(Boto-l)		(468,522)	Rhaptagnostus	Cm(Fran-l)	-O (Trem-l)	(16)
Leptochilodiscus	Cm(Boto)		(458)	Rhodotyiscus	Cm(mMid-u)	-Cm(uMid-u)	
Linguagnostus	Cm(mMid-u)	-Cm(uMid-u)	(16)	Runcinodiscus	Cm(Boto-u)?		
Lisogoragnostus	Cm(uMid-l)			Semadiscus	Cm(Boto-l)		
Litagnostus	Cm(Fran-l)	-O (Trem-u)	(795)	Serrodiscus (+ Paradiscus)			
Litomatopus	Cm(Boto)				Cm(Atda-u)	-Cm(Tojo-u)	(458,462, 885)
Lotagnostus	Cm(Trep-l)	-Cm(Trep-u)					(463,464)
Macannaia	Cm(Tojo-u)	-Cm(mMid-l)		Sinodiscus	Cm(Atda-u)		
Machairagnostus	Cm(Trep-u)			Sinopagettia	Cm(mMid)?		
Mallagnostus (+ Ladadiscus)				Skyrjagnostus	Cm(mMid)?		
	Cm(Boto)	-Cm(Tojo)		Sphaeragnostus	O (Trem-u)	-O (Ashg-m)	(2,862)
Meniscuchus	Cm(Boto)			Stigmadiscus	Cm(Boto)?		
Micagnostus	Cm(mMid)			Strictagnostus	Cm(Trep-u)	-O (Trem-l)	
Micragnostus	Cm(Dres-u)	-O (Llvi-l)	(16,721, 1066)	Sulcatagnostus	Cm(Dres-u)	-Cm(Trep-l)?	(378)
?Miraculaspis	Cm(Boto)			Svenax	Cm(uMid-m)	-Cm(uMid-u)	
Monexagnostus	Cm(m)			Tannudiscus	Cm(Tojo)		
Myrmecomimus	Cm(uMid-m)			Tasagnostus	Cm(uMid-u)		
Nahannagnostus	Cm(uMid-u)	-Cm(Dres-l)	(1017)	Tchernyshvioides	Cm(mMid)		
Natalina (+ Limbadiscus)				Tentagnostus	Cm(Fran-u)?		
	Cm(Boto)			Tomagnostella	Cm(uMid-m)	-Cm(Dres-l)	
Neoagnostus (+ Hyperagnostus, Pseudorhaptagnostus)				Tomagnostus	Cm(mMid-m)	-Cm(uMid-m)	(80)
	Cm(Fran-l)	-O (Trem-l)	(16,887)	Toragnostus	Cm(uMid-u)		(ZR89)
Neocobboldia	Cm(Boto-l)	-Cm(Tojo-l)	(81,463, 522)	Triadaspis	Cm(uMid-u)		(16)
Neopagettina	Cm(Boto-l)	-Cm(Tojo-u)	(468,522)	?Triangulaspis (+ Acutaspis, Angusteva)			
Ninadiscus	Cm(Boto)				Cm(Atda-u)	-Cm(Boto-l)	(468,470, 885)
Oedorhachis	Cm(uMid-u)	-Cm(Dres-l)	(16,1017)	?Triangulina	Cm(Atda-l)		(522)
Ordalagnostus (+ Ovalagnostus)				Trilobagnostus (+ Rudagnostus)			
	Cm(uMid-u)	-Cm(Dres-l)	(16,460)		Cm(Trep-l)	-O (Trem-l)	
Oncagnostus (+ Eurudagnostus)				Trinodus	O (Llde)		
	Cm(Dres-u)	-Cm(Trep-u)		Triplagnostus (+ Solemagnostus)			
Onymagnostus	Cm(mMid-u)	-Cm(uMid-u)			Cm(mMid-u)	-Cm(uMid-m)	
Oodiscus	Cm(Boto)?			Trisulcagnostus	Cm(Trep-l)		
Opsidiscus	Cm(uMid-u)		(16,80)	Tsunyidiscus (+ Mianxiandiscus)			
Oxyagnostus	Cm(Dres-l)		(16)		Cm(Atda-u)		(463,885)
Pagettia	Cm(Boto-l)	-Cm(mMid-u)	(16,885)	Utagnostus	Cm(uMid-u)	-Cm(uMid-u)	
Pageides	Cm(Atda-u)	-Cm(Tojo-u)	(81,885)	Valenagnostus	Cm(uMid-m)	-Cm(uMid-u)	(1020)
Parapagettia	Cm(Boto)			Weymouthia	Cm(Atda-l)	-Cm(Atda-u)	(81)
Pentagnostus	Cm(lMid)	-Cm(mMid-u)		Xestagnostus	Cm(Dres-l)		(16)
Peratagnostus	Cm(Dres-u)	-Cm(Fran-l)	(16,1017)	+Xyoeax	D (Emsi)		
Peronopsella	Cm(mMid-u)	-Cm(uMid-l)		Yukonia	Cm(l)		
				Yukonides	Cm(Atda-u)		(475)
				Zeteagnostus	Cm(mMid-u)	-Cm(uMid-m)	

Taxon	First Appearance	Last Appearance	Reference	Taxon	First Appearance	Last Appearance	Reference
Or. REDLICHIIDA				Lunolenus	Cm(l)		
Abadiella	Cm(Atda-l)		(473)	Malongocephalus	Cm(Boto-l)		
Acadoparadoxides	Cm(lMid)	- Cm(uMid-l)?	(378)	Malungia	Cm(Boto-l)	- Cm(Boto-u)	
Akbashlichia	Cm(Atda-u)			Maopingaspis	Cm(Boto-u)		
Anabaraceps	Cm(Tojo)		(474)	Mayiella	Cm(Boto-u)		(463,885)
Anabaraspis	Cm(Tojo)	- Cm(mMid)		Meitanella	Cm(Boto-u)		
Anopolenus	Cm(uMid-m)			Menneraspis	Cm(Tojo-u)		
Astenaspis	Cm(Boto-u)		(471)	Metadoxides (+ Anadoxides)	Cm(Atda-u)	- Cm(Boto-l)	(462,473)
Australaspis	Cm(l)			Metaredlichia	Cm(Boto-l)		
Balcoracania	Cm(Tojo-l)		(472)	Miniinsella (+ Minusella)	Cm(Atda)		
Baltoparadoxides	Cm(mMid)			Nebidella	Cm(Atda-u)		(990)
Beishanella	Cm(uMid-u)			Neoredlichia	Cm(Tojo-u)		
Belliceps	Cm(Boto)?		(471)	Ningqiangaspis	Cm(Boto-l)		
Bornemannaspis	Cm(Atda-u)		(990)	Oligaspis	Cm(Boto-u)?		
Breviredlichia	Cm(Tojo-l)			Onaraspis	Cm(Tojo)		(16,923)
Bulaiaspis	Cm(Atda-u)	- Cm(Boto-u)?	(467)	Pachyredlichia	Cm(Boto-l)		
Centropleura	Cm(uMid-u)		(81,378)	Paokannia	Cm(Boto-u)		(463,885)
Chaaspis	Cm(Boto-l)			Parabadiella	Cm(Atda-u)		
Chenjiangaspis	Cm(Boto-l)			Paradoxides	Cm(lMid)?	- Cm(uMid-u)	(80)
Chengkouaspis	Cm(Tojo-l)			Paramalungia	Cm(Boto-u)		(463)
Churkinia	Cm(l)			Parapaokannia	Cm(Boto-u)		
Clarella	Cm(uMid-l)	- Cm(uMid-u)	(80)	Parasajanaspis	Cm(Atda)?		
Clariondia	Cm(Atda-u)?			Paratungusella	Cm(Boto)?		(471)
Comluella	Cm(Atda-u)	- Cm(Tojo-u)	(473,885)	Parayinities	Cm(Boto-u)		
Conoredlichia	Cm(Tojo-l)			Parazhenbaspis	Cm(Boto-u)		
Despujolsia	Cm(Atda-l)		(473)	Pareops	Cm(Atda-u)		(473)
Dolerolenus	Cm(Atda-u)	- Cm(Boto-l)	(473)	Perrector	Cm(l)		
Dolerolichia	Cm(l)			Plutonides	Cm(mMid-u)	- Cm(uMid-l)	
Drepanopyge	Cm(Boto-u)		(463,885)	Primoriella	Cm(Tojo)		
Drepanuroides	Cm(Boto-u)		(463)	Pseudopokannia	Cm(Tojo-l)		
Eccaparadoxides	Cm(mMid-l)	- Cm(mMid-u)		Pseudoredlichia	Cm(Boto-u)		(463)
Elegestina	Cm(Boto)			Pseudoreserops	Cm(Atda-u)		(468,522)
Elganellus	Cm(Atda-u)			Pseudosaukianda	Cm(Boto-l)		(473)
Emuella	Cm(Tojo-l)		(472)	Pteroredlichia	Cm(Tojo-u)		(463)
Enantiaspis	Cm(Atda-u)		(990)	Qiaodiella	Cm(Boto-u)		
Eops	Cm(l)			Qiaotingaspis	Cm(Boto-u)		(463)
Eoredlichia (+ Archaeops, Galloredlichia, Pararedlichia, Saukiandops)	Cm(Atda-l)	- Cm(Boto-l)	(472,885, 990)	Qingkouia	Cm(Boto-u)?		
Fuminaspis	Cm(Boto-l)			Realaspis	Cm(l)		
Gigantopygus	Cm(Boto-l)		(473)	Redlichia	Cm(Boto-u)	- Cm(Tojo-u)	(461,464)
Guangyuanaspis	Cm(Atda-u)		(463)	Redlichina	Cm(Boto-l)	- Cm(Tojo)	(462,474)
Hongshiyanaspis	Cm(Boto-l)			Redlichops	Cm(l)		
Huolenus	Cm(Tojo-u)		(928)	Resserops	Cm(Boto-l)		(462,473, 885)
Hydrocephalus (+ Rajkocephalus)	Cm(mMid)			Richterops	Cm(Atda-l)		
Iglesiaella	Cm(Atda-l)		(990)	Sajanaspis	Cm(Boto)		(471)
Inella	Cm(Boto)?		(471)	Sapushania	Cm(Boto-l)		
Iolgia	Cm(Boto)			Sarassina	Cm(Atda)		
Irgithemia	Cm(Tojo)	- Cm(mMid)		Sardaspis	Cm(Boto-l)	- Cm(Boto-u)	
Jingyangia	Cm(Boto-l)			Sardoredlichia	Cm(Atda-l)		(990)
Keptingaspis	Cm(Boto-u)?			Saukianda	Cm(Boto-l)		(473)
Kolbaspis	Cm(Boto-u)?			Schagonaria	Cm(mMid)?		
Kuanyangia	Cm(Boto-l)			Shaaxia	Cm(Boto-l)		
Kueichowia	Cm(Boto-u)		(463)	Shatania	Cm(Boto-u)		(463)
Latiredlichia	Cm(Tojo-u)			Sibiriaspis	Cm(Atda)		
Lemdadella	Cm(Atda-u)		(ZR88)	Syndianella	Cm(Boto-u)		(463)
Leptoredlichia	Cm(Tojo-u)			Terechtaspis	Cm(Atda-u)	- Cm(Boto-l)	
Lermontovia	Cm(Tojo-u)		(474,522)	Tungusella	Cm(Atda-u)	- Cm(Boto-l)	
Longianda	Cm(Boto-l)		(473)	Ushbaspis (+ Metaredlichioides)	Cm(Boto-l)		
Luhops	Cm(uMid-m)			Wutingaspis	Cm(Boto-l)		

Taxon	First Appearance	Last Appearance	Reference	Taxon	First Appearance	Last Appearance	Reference
Xela	Cm(Tojo-l)?			+Chienaspis	Cm(mMid)		(16)
Xenoredlichia	Cm(Tojo-u)			Chilometopus	Cm(lMid)	- Cm(mMid)	(464,522)
Yiliangella	Cm(Boto-u)			Chilonorria	Cm(mMid-l)		(481)
Yiliangellina	Cm(Boto-u)		(463,885)	Cholopilus	O (l)		
Yinites	Cm(Boto-u)		(463,464)	Chondagraulos	Cm(Tojo-u)		(468,522)
Yorkella	Cm(Boto-u)			- Chondrinouovina	Cm(Boto-l)		(1006)
Yunnanaspidella	Cm(Boto-u)		(463)	Chuangia	Cm(Dres-u)		(464,472)
Yunnanaspis	Cm(Boto-u)		(463,885)	Chuangiella	Cm(Trep)		
Zhangshania	Cm(Boto-u)			Chuangiopsis	Cm(Fran-u)		(618)
Zhenbaspis	Cm(Boto-l)		(885)	+ Chuchiaspis	Cm(Tojo-l)		(463)
Or. CORYNEXOCHIDA				Clavaspidella	Cm(lMid)	- Cm(uMid)	(479)
+ Abakania	Cm(Boto)			- Clavigellus	Cm(lMid)		
Acontheus	Cm(uMid)		(16)	Compsoccephalus	Cm(Atda-l)		(522)
Albertella	Cm(lMid)		(80)	- Cornuscuteillum	D (Sieg)		(421,1106)
- Albertellina	Cm(lMid)		(478)	Corynexochides	Cm(lMid)	- Cm(mMid-l)	(80)
+ Albertelloides	Cm(lMid)		(478)	Corynexochina	Cm(m)		
+ Altaepeltis	D (Sieg)	- D (Eife)	(421,1106)	Corynexochus	Cm(mMid)	- Cm(Dres-u)	(16)
Ambonolium	Cm(Trep)			+ Cybantyx	S (Wenl)		
+ Anginoerbia	Cm(lMid)	- Cm(mMid)	(522)	+ Decoroscuteillum	S (Prid)	- D (Gedi)	(421,1106)
Amphoton	Cm(mMid)?	- Cm(uMid)	(16,472)	+ Delamarella	Cm(lMid)		
Amphotonella	Cm(uMid)		(464)	+ Dictyella	Cm(Trep-u)		(472)
+ Ancropyge	D (Eife)	- D (Give-l)	(421,1106)	Dictyites	Cm(Trep)		(464)
+ Anhuaspis	Cm(u)		(ZR83)	Dinesus	Cm(mMid)		(16)
Anoria	Cm(mMid-l)	- Cm(uMid)	(479)	Dolichometopsis	Cm(Tojo)	- Cm(lMid)	(80)
Aojia	Cm(uMid)		(464)	Dorypyge	Cm(mMid-u)	- Cm(uMid-u)	(81,464)
+ Arctipeltis	D (Sieg)	- D (Eife)	(421,1106)	Dorypygina	Cm(m)		
+ Arthricocephalites	Cm(Boto-u)		(463)	+ Duotingia	Cm(Atda)		(463)
+ Arthricocephalus	Cm(Boto-u)		(463,1066)	Dysplanus	O (Aren)	- O (Ashg-m)	
Asperocare	Cm(m)			Ectillaenus	O (Aren-l)	- O (Ashg)	(378)
Ataktaspis	Cm(uMid-u)	- Cm(Dres-l)	(379)	Edelsteinaspis	Cm(Boto-u)	- Cm(Tojo-u)	(472,474,885)
+ Atadabanelia	Cm(Boto-l)		(468,522)	+ Elankaspis	Cm(lMid)	- Cm(mMid)	(522)
Athabaskia	Cm(lMid)	- Cm(mMid-u)	(80)	+ Emsurella	Cm(Fran-u)		(618)
Athabaskiella	Cm(mMid-l)		(458)	Eochuangia	Cm(uMid)		(472)
Babakovia	Cm(Boto)	- Cm(mMid)?		+ Eokaolishania	Cm(u)		(ZR84)
+ Balangia	Cm(Boto-u)	- Cm(Tojo)	(463)	+ Eoscutellum	D (Gedi)		(1106)
Basocephalus	Cm(m)			+ Erbiopsidella	Cm(Boto)		(474)
Bathuriscidella	Cm(mMid-u)	- Cm(uMid)	(80,458)	Erbioopsis	Cm(Boto)		(462)
+ Bathuriscopsis	Cm(Boto-u)			Evansaspis	O (l)		
Bathuriscus	Cm(mMid-u)	- Cm(uMid-m)	(81)	+ Exastipyx	D (Emsi)		
Bienella	Cm(Dres-l)		(379)	+ Extrania	Cm(m)		(ZR83)
+ Blandiaspis	Cm(u)		(ZR83)	+ Ezhuangia	Cm(m)		(ZR83)
+ Bojoscutellum	D (Sieg)	- D (Eife)	(421,1106)	Fieldaspis	Cm(Tojo-u)		(80)
Bonnaria	Cm(Atda-u)	- Cm(Boto-l)	(80)	Fordaspis	Cm(Atda-u)	- Cm(Tojo)	(80)
Bonnaspis	Cm(Boto-l)	- Cm(mMid-u)	(80)	Fuchouia	Cm(uMid)	- Cm(uMid-u)	(16,464)
Bonnia	Cm(Atda-u)	- Cm(Tojo-l)	(463,472,885)	Girandia	Cm(uMid)?		
Bonniella	Cm(Tojo)		(465)	Glossopleura	Cm(mMid-l)		(80)
Bonniopsis	Cm(Tojo)		(480)	Granularapis (= Granularia)	Cm(Boto-l)	- Cm(mMid)	(468,474)
+ Borcoscutellum	D (Gedi)	- D (Sieg)?	(421,1106)	?Hanburia			
+ Botomella	Cm(Atda-u)		(468)	+ Hapsidocare	Cm(Fran-u)		(16)
+ Breviscutellum	D (Sieg)	- D (Eife)	(421,1106)	Hardya	Cm(Trep-l)		(697)
Bronteopsis	O (Llde-u)	- O (Ashg-m)	(795)	+ Harpillaeus	O (Llvi-l)		(618,795)
+ Brylyella	Cm(mMid)			+ Hemikaoishania	Cm(u)		(ZR83)
+ Bubupeltina	D (Emsi-u)		(1106)	Hemirhodon	Cm(uMid-l)	- Cm(Dres-l)	(80)
Bumastoides	O (Llde-l)	- O (Ashg-l)	(382,795)	Hoffetella	Cm(Boto-u)	- Cm(Tojo-l)	(463,464)
Bumastus	O (Aren-l)	- S (Ludl)		Holteria	Cm(uMid-m)	- Cm(uMid-u)	(16,80)
Cekovia	O (Llde-u)	- O (Cara-u)	(1075,1268)	+ Hunnaocephalus	Cm(Boto-l)		(463)
+ Chengkouia	Cm(Boto)		(463)	Hyboaspis	O (Llde)		(795)
+ Changaspis	Cm(Tojo)		(463)	Idamea	Cm(u)		
Cheilocephalus	Cm(Dres-u)	- Cm(Fran-l)	(2,81,486)	Illaenoides	S (Ldov)		
Cheiruroides	Cm(Boto-u)	- Cm(lMid)?	(463,474)	Illaenurus	Cm(Trep-l)	- Cm(Trep-u)	(379,697)

Taxon	First Appearance	Last Appearance	Reference	Taxon	First Appearance	Last Appearance	Reference
Illaeus	O (Trem-u)	-O (Ashg-u)	(690,795)	+Palacorona	Cm(Fran-u)?	-Cm(Trep)	(496)
Inouyina	Cm(Boto-l)	-Cm(lMid)	(468,522)	+Paleofossus	Cm(Boto)		(923)
Iranaspis	Cm(Trep)?			Panderia	O (Aren)	-O (Ashg-m)	
Ithycephalus	Cm(uMid)	-Cm(Dres)		+Panxinella	Cm(Tojo-l)		(463)
Jakutus	Cm(Boto-l)	-Cm(Tojo-u)	(474,522)	+Paracybantyx	S (Ldov-u)	-S (Ludl)	
Kaolishania	Cm(Fran-u)		(16,464)	+Paralbertella	Cm(lMid)		(478)
Kaolishaniella	Cm(Dres-u)?	-Cm(Fran-u)	(464)	Paralejurus	D (Gedi)	-D (Eife-u)	(421,1106)
Kassinius	Cm(mMid)?	Cm(uMid)?		+Paralevisia	Cm(m)		(ZR89)
Kiowaia	Cm(Fran-l)		(379)	+Paralisaniella	Cm(u)		(ZR83)
Klotziella	Cm(mMid-u)		(80)	Paraolenoides	Cm(m)		
+Kobayashipeltis	D (Emsi-u)?	-D (Eife)?	(1106)	Parapoliella	Cm(Tojo)		(474)
Kolihapeltis	D (Sieg)	-D (Emsi-u)	(421,1106)	+Parillaenus	O (Llvi-u)	-O (Llde-l)	(795)
Komaspidella	Cm(Dres-l)		(379)	Parkaspis	Cm(mMid-u)		(81,1089)
Kootenia	Cm(Atda-u)	-Cm(uMid-l)	(463,479,885)	Perischodory	O (Trem-u)		
Kooteniella	Cm(Tojo-u)	-Cm(mMid)	(474,522)	Phillipsinella	O (Aren-u)	-O (Ashg-u)	(2,690)
Kooteniellina	Cm(mMid)?			Platillaenus	O (Llvi)	-O (Cara-l)	(382)
+Kotispeltis	D (Gedi)		(1106)	+Platyscutellum	D (Sieg)	-D (Eife)	(421,1106)
+Labradoria	Cm(Boto-l)		(468,522)	Plethopeliella	O (l)		
Lancastria	Cm(Boto-u)	-Cm(Tojo)	(80)	Poliella	Cm(Tojo)	-Cm(mMid-u)	(80)
+Leiostephium	O (Trem-l)	-O (Trem-u)	(16,795)	Poliellaspis	Cm(Boto)		(474)
+Lenaspis	Cm(Tojo)		(522)	Poliellina	Cm(Boto-l)		(462,474)
+Ligiscus	S (Ldov-u)			+Poliixias	Cm(Boto-u)		(472)
+Linguchuangia	Cm(l)		(ZR83)	Polypleuraspis	Cm(mMid-l)		(80)
+Liokootenia	Cm(m)		(ZR83)	+Popigia	Cm(mMid)		
Lisania	Cm(uMid)		(464,472)	Prochuangia	Cm(Dres-u)	-Cm(Fran-u)	(16,464)
+Lisaniella	Cm(uMid)	-Cm(Dres)	(459)	Prokootenia	Cm(Boto)?		
+Longduia	Cm(Atda-u)		(463,990)	Prosymphysurus	Cm(mMid-l)	-Cm(uMid)	(80)
+Majiangia	Cm		(ZR83)	Protoryctocephalus	Cm(Tojo-l)		(463)
+Malykania	Cm(Boto-l)			?Protypus	Cm(Tojo)		(469)
Mansuyia	Cm(Fran-u)	-Cm(Trep)	(16,464)	+Prouktaspis	Cm(Atda-u)		(923)
+?Mansuyites	Cm(Fran-u)		(16)	Prozacanthoides	Cm(Boto-u)	-Cm(lMid)	(80)
+Megalisania	Cm(m)		(ZR83)	+Pseudocalvinella	Cm(u)		(ZR84)
Mendospidella	Cm(mMid-l)		(481)	+Pseudocalymene (+ Eucalymene)	O (Aren)	-O (Llvi-l)	(1266)
+Metakootenia	Cm(m)		(ZR83)	+Pseudoerbia	Cm(Boto)?		(1221)
+Metalsania	Cm(m)		(ZR83)	+Pseudolancastria	Cm		
+Metascutellum	D (Sieg)	-D (Emsi-l)?	(421,1106)	+Pseudostygina	O (Cara)		
Mexicapsis	Cm(Tojo-u)	-Cm(lMid)	(478)	Ptarmigania	Cm(lMid)	-Cm(mMid-u)	(80,479)
Micmaccopsis	Cm(Atda-u)	-Cm(Tojo-u)	(468,522,923)	Ptarmiganoides	Cm(lMid)		(478)
+Microscutellum	D (Gedi)	-D (Eife)	(421,1106)	+Ptilillaenus	O (Ashg-m)	-S (Ldov-m)	(690)
Namanoia	Cm(Tojo-u)	-Cm(uMid)?	(474)	+Radioscutellum	D (Sieg)		(1106)
Nanillaenus	O (Llde-l)	-O (Cara-l)	(382,795)	+Rondocephalus	Cm(Boto)		(462,474)
Neochilonorria	Cm(Dres)?			+Sandoveria	Cm(lMid)		(16)
Nixonella	Cm(uMid-u)	-Cm(Dres-l)	(379)	+Scabriscutellum	D (Gedi)	-D (Give-u)	(421)
+Nodiceps	Cm(Boto-u)			Scutellum	S (Ldov)	-D (Fras)	(421)
Notasaphus	Cm(m)			+Shabaella	Cm(Boto)		(463)
Octillaenus	O (u)	-O (Ashg-m)		+Shanghaia	Cm(l)		(ZR87)
Ogygopsis	Cm(Tojo)	-Cm(mMid-u)	(81,883)	+Shanghataspis	O (Ashg-l)		(ZR87)
Olenoides	Cm(Tojo)	-Cm(Dres-l)	(80)	Shivchicus	Cm(Boto)		(462)
+Olenoidestransans	Cm(Dres-l)		(1066)	Sinjaniella	Cm(Boto-l)		(468,474)
+Opsiosoryctocephalus	Cm(mMid-u)		(1089)	+Spiniscutellum	S (u)?	-D (Sieg)	(1106)
Ordosia	Cm(Dres-l)		(464)	Stenoparcia	O (Llvi-u)	-S (Wenl-u)	(795)
Orria	Cm(m)			Stephenaspis	Cm(Tojo-u)		(80)
Oriella	Cm(lMid)	-Cm(uMid)	(80)	Strettonia	Cm(Boto-l)	-Cm(lMid)	(80,81,885)
Oryctocare	Cm(mMid)	-Cm(mMid-u)	(80)	Stygina	O (Llde-l)	-O (Ashg-m)	(2,795)
+Oryctocephalina	Cm(lMid)		(478)	Sunia	Cm(m)		
Oryctocephalites	Cm(Tojo-u)	-Cm(mMid)	(80)	Tabatopygellina	Cm(Boto)?		
Oryctocephalops	Cm(Tojo)	-Cm(mMid)	(474)	Taitzia	Cm(uMid)		(464)
Oryctocephalus	Cm(Boto-l)	-Cm(mMid-u)	(80,474)	+Tarynaspis	Cm(Boto-l)		(468)
Pagodia	Cm(Dres-u)	-Cm(Trep)	(16,464)	+Tenuipeltis	D (Give)?	-D (Fras)	(421,1106)
				Thaleops	O (Llde)	-O (Cara-l)	(795)
				Theamataspis	O (Aren-u)	-O (u)	(795)

Taxon	First Appearance	Last Appearance	Reference	Taxon	First Appearance	Last Appearance	Reference
Thomastus	S (Ldov)			+ Richterarges	S (Ldov-u)	-S (Prid)	(774)
-Thysanopeltella	D (Emsi-u)	-D (Give)	(421,1106)	+ Rontrippia	O (Ashg)	-S (Ludl-l)?	(774)
Thysanopeltis	D (Eife-l)	-D (Give-l)	(1106)	+ Terraspis	D (Eife-l)		(421)
Tingocephalus	Cm(Fran)?			+ Terranovia	D (Gedi-l)	-D (Eife-l)	(421,774)
Tolanaspis	Cm(m)			+ Trimerolichas	S (Wenl)		(774)
Tollaspis	Cm(mMid)?			+ Trochurus	O (Ashg-m)	-S (Wenl-u)	
Tonkinella	Cm(Mid)	-Cm(mMid-u)		+ ?Tsunlichas	O (Ashg-u)		(690)
Tsinania	Cm(Fran)	-Cm(Trep)	(16,464)	+ Uralichas	O (Livi-u)	-O (Llde)	(774)
+ Uktaspis	Cm(Atda-u)		(522)	+ Uripes	O (Ashg)	-S (Ludl)	(774)
+ Unicapeltis	D (Emsi-l)	-D (Emsi-u)	(1106)				
+ Uraloscutellum	D (Sieg)		(1106)				
+ Ursinella	Cm(Mid)						
+ Vanuxemella	Cm(Mid)		(80)				
Weberopeltis	D (l)	-D (Eife)?	(421,1106)				
Wenckhemnia	Cm(Tojo-u)	-Cm(mMid-u)	(80)				
- Xuigiella	Cm(Boto)		(463)				
Zacanthoides	Cm(Tojo-u)	-Cm(uMid-m)	(80,478)				
Zacanthopsis	Cm(Tojo)	-O (uMid-l)	(81)				
Zbirovia	O (Llde-l)	-O (Ashg-m)	(1075)				
Or. LICHIDA							
Acanthopyge	D (Eife)		(774)	+ Acantaloma	D (Gedi)	-D (Give)	(421)
Akantharges	D (Eife)		(774)	+ Acidaspidella	Cm(Dres-u)	-Cm(Trep)?	
Amphilichas	O (Livi-l)	-O (Ashg-u)	(382)	+ Acidaspidina	Cm(Fran-u)	-Cm(Fran-l)	(618)
+ Apatolichas	O (Aren-u)		(774)	+ Acidaspides	Cm(uMid)	-Cm(Fran)	(459)
Arctinurus	S (Ldov-m)	-S (Wenl-u)		+ Acidaspis	O (Cara-m)	-D (Eife)	(421)
+ Autoloxolichas	O (Aren)	-O (Ashg)	(774)	+ Anacaenaspis	S (Ldov-m)	-S (Ludl-l)	
+ Borealarges	S (Ldov-u)	-D (Eife)		+ Ancyropyge	D (Eife)	-D (Give-l)	(421,1106)
+ Brutonia	Cm(u)		(ZR89)	+ Apianurus	O (Llde-l)	-O (Cara-m)	(795)
Ceratarges	D (Emsi-u)	-D (Eife)	(774,1106)	+ Belovia	Cm(uMid-u)	-Cm(Dres-u)	(467,618)
Ceratolichas	D (Eife)		(774)	+ Blackwelderia	Cm(uMid-u)	-Cm(Dres-u)	(16,464)
Conolichas	O (Cara)		(774)	+ Borkopleura	S		(ZR84)
Craspedargus	D (Sieg)		(774)	+ Bounyongia	S		
Dicranomus	O (Ashg)	-S (Ludl)	(774)	+ Caliperurus	O (Cara-l)		(795)
Dicranopeltis	O (Ashg-l)	-S (Ludl-l)	(774)	+ Ceratocara	O (Llde)	-O (Cara-l)	
Echinolichas	D (Gedi-l)	-D (Eife)	(421,774)	+ Ceratocephala	O (Aren-l)	-D (Eife)	(421,1106)
Eifliarges	D (Eife)		(774)	+ Ceratocephalina	O (Cara-l)	-D (Sieg)	(421,735, 1106)
Eoacidaspis	Cm(Fran-l)	-O (Trem-l)	(618)	+ Ceratonurus	D (Gedi)	-D (Eife)?	(421,1106)
Gaspelichas	D (Sieg)		(774)	+ Clustinia	O (Cara-m)	-O (Ashg-m)	
Hemiarges	O (Livi-u)	-O (Ashg-m)	(774)	+ Colossaspis	Cm(m)		(ZR83)
Hoplofichas	O (Llde)	-O (Cara-l)	(774)	+ Cyrtopora	Cm(Dres-l)		(16,482)
+ Hoplochoides	O (Llde)	-O (Cara)	(774)	+ Damesella	Cm(mMid)	-Cm(mMid-u)	(16,464)
+ Jasperia	D (Emsi)	-D (Eife)	(774)	+ Dicranthaspis	O (Aren-u)	-S (Ludl-u)	(395)
Leioliichas	O (Cara)		(774)	+ Dicranurus	S (Wenl)	-D (Sieg)	(381,421, 1106)
Lichas	O (Ashg)	-S (Wenl)	(774)	+ Dipentaspis	Cm(uMid)		(16)
+ Lichakephalina	O (Aren)		(1066)	+ Dipyrogotes	Cm(Dres-l)		(482)
?Lichakephalus	O (Trem-l)			+ Drepanura	Cm(Dres-l)	-Cm(Dres-u)	(464,472)
+ Lobopyge	S (Ldov-u)	-D (Eife)	(774)	+ Dudleyaspis	S (Wenl-l)	-D (Emsi-u)	(1106)
Lyralichas	O (Llde)?			+ Edgecombeaspis	S (Wenl-l)	-S (Wenl-u)	(1245)
+ Mephiarges	D (Eife)	-D (Give)?	(774)	+ Eodontopleura	Cm(Boto-u)		(463)
+ Metaleioliichas	S		(ZR88)	+ Eoleonaspis	O (Ashg-u)		(690)
Metopolichas	O (Aren-u)	-O (Llde-l)	(378)	+ Gaotania	S (Ldov)		
+ Nipponarges	D (m)		(ZR84)	+ Globulaspis	S (Ldov-m)		(735)
+ Nonix	S (Wenl)		(774)	+ Guancenshania	Cm(u)		(ZR87)
+ Oinochoe	D (Gedi)		(774)	+ Haibowania	Cm(u)		(ZR88)
+ Otarozoum	O (Cara)		(774)	+ Hispaniaspis	O (Ashg)		(1268)
+ Paraleolichas	S		(ZT88)	+ Histiomona	Cm(Dres-l)		(482)
Perunaspis	D (Gedi)	-D (Eife)	(774,1106)	+ Isoprusia	D (Emsi-u)	-D (Give)	(421,1106)
Platyllichas	O (Llde-u)	-S (Ldov)	(774)	+ Ivanopleura	S		(ZR84)
+ Probolichas	O (Llde)	-O (Cara-m)	(774)	+ Kettneraspis	S (Wenl-l)	-D (Give)	(1106,1245)
+ Pseudotupolichas	S (Ldov)	-S (Wenl)	(774)	+ Koneprusia	D (Gedi)	-D (Give)	(421,1106)
Radiolichas	D (Give)		(774)	+ Laethoprusia	S (Wenl-l)	-D (Sieg)	(1106,1245)
				+ Leonaspis	O (Ashg-m)	-D (Emsi-u)	(1106)
				+ Meadowtownella	S (Wenl-u)		(1245)
				+ Meringaspis	Cm(uMid-u)	-Cm(Dres-l)	(16,483)
				+ Metaacidaspis	Cm(u)		(ZR84)
				+ Miraspis	O (Llde-u)	-S (Ludl-l)	(795)
				+ Odontopleura	O (Cara-u)?	-S (Ludl-l)	(795)
				+ Orphanaspis	O (Ashg-m)	-D (m)?	(795)
				+ Parablackwelderia	Cm(Dres-l)		(472)

Taxon	First Appearance	Last Appearance	Reference	Taxon	First Appearance	Last Appearance	Reference
+Paracidaspis	Cm(Dres)	-O (Trem)	(459)	Birmanites	O (Trem)	-O (Ashg-l)	(381)
Primaspis	O (Llde-l)	-D (Eife)	(421)	Blandicephalus	Cm(Dres-u)		
Proceratocephala	O (Ashg-m)		(795)	Bohemilla	O (Trem-u)	-O (Ashg)	(726)
+Prodamesella	Cm(uMid)	-Cm(Dres)	(459,483)	Bohemopyge	O (Aren-l)	-O (Llvi)	(726)
Radiaspis	S (Wen-l)	-D (Fras)	(2,421, 1245)	+Bohomaspis	O		(ZR87)
Selenopeltis	O (Aren-l)	-O (Ashg)	(2)	Borogothus	O (Aren)		
Selenopeltoides	S (Wen-l)			Borthaspidella	O (Trem)		
+Stelckaspis	S (Ldov-u)			Borthaspis	O (Trem)		
Stephanocare	Cm(uMid)	-Cm(Dres-l)	(16,472)	Boschekulia	Cm(u)		
+Taemasaspis	S (Ldov-u)	-S (Wen-l)	(1245)	+Brandlysops	O		(ZR87)
Whittingtonia	O (Llde-l)	-O (Ashg-m)	(795)	Briscoia	Cm(Fran-u)	-Cm(Trep-u)	(379)
+Xanionurus	S (Wen-l)	-D (Eife)	(421)	Broeggerolithus	O (Cara-l)	-O (Cara-u)	(378)
				+Bulbaspis	O (Llvi)	-O (Cara)	
				Bumastides	O (Aren)?		
Or. ASAPHIDA				Buttsia	Cm(Dres-u)	-Cm(Fran-l)	(80)
+Abharella	Cm(m)	-Cm(u)	(ZR84)	+Buttsina	Cm(Dres-u)		(618)
+Aethodionide	O (Cara-u)		(795)	+Caganaspis	O (m)		(ZR87)
+Ajacicrepida	Cm(m)		(ZR89)	+Callaspis	Cm(u)		(ZR83)
+Amginia	Cm(m)		(ZR83)	Calvinella	Cm(Fran)?	-Cm(Trep-u)	(379)
Amphitryon	O (Ashg-l)	-O (Ashg-m)		Camaraspis	Cm(Fran-l)		(697)
Ampyx	O (Aren-l)	-O (Ashg-l)	(2,80,862)	Camaropoides	Cm(Fran-l)		(379)
+Ampyxella	O (Cara-u)		(378)	+Carnocranium	Cm(u)	-O (l)	(ZR90)
Ampyxina	O (Llde-u)	-O (Ashg-u)	(690)	Catillicephala	Cm(uMid-u)	-Cm(Dres-l)	(16,80)
+Ampyxinella	O (Llde)	-O (Ashg-u)		Catuniella	Cm(uMid)		(380)
+Ampyxoides	O (Aren)	-O (Llvi-u)	(795)	+?Caulaspis	Cm(Fran-u)		(618)
Anataphrus	O (Llde)	-O (Ashg-u)	(690)	+Caznaia	Cm(Fran-u)		(16)
Anderssonella	Cm(Trep-u)		(16,464)	+?Ceratolithus	O (Aren-u)		(875)
+Anebolithus	O (Aren-l)	-O (Llvi-l)	(378)	Ceratopyge	O (Trem-u)		
Anisonotella	O (m)			+Ceronocare	Cm(Fran-u)		(16)
Anomocare	Cm(uMid-u)		(16,472)	Changia	Cm(Trep)		(464)
Anomocarina	Cm(uMid-u)			Charchaquia	Cm(Fran-u)		(484)
Anomocarioides	Cm(uMid-u)			Chondranomocare	Cm(mMid)		(468,474)
Anomocariopsis	Cm(Dres-u)		(618)	Clavatellus	O (Trem-l)	-O (Trem-u)	
Apatokephalina	Cm(Trep)		(484)	+Cloacaspis	O (Aren-l)		(795)
Apatokephalus	O (Trem-l)	-O (Trem-u)	(80,618, 927)	Cnemidopyge	O (Aren-l)	-O (Llde-u)	(378,726)
				Comanchia	Cm(Fran-l)	-Cm(Fran-u)	(379,618)
				Conaspis	Cm(Fran-u)		
Aphelaspis	Cm(Dres-u)	-Cm(Fran-l)?	(16,80)	Coreanocephalus	Cm(Trep)		
+Apheloides	Cm(Fran-l)		(380)	+Cremastoglottus	O (Llvi-l)		(378)
Araioptera	Cm(Trep-u)	-O (Aren)	(2,378)	Cryptolithoides	O (Cara-l)	-O (Cara-u)	(795)
+Aristokainella	O (Trem-l)			Cryptolithus	O (Llde-u)	-O (Ashg-u)	(2,690)
Artokephalus	Cm(u)			Cyclopyge	O (Trem-l)	-O (Ashg-u)	(80)
Asaphellina	O (Trem)			Cyphonuscus	O (Ashg)		
Asaphellus	O (Trem-l)	-O (Llvi-l)	(80,378, 726)	Dactylocephalus	O (Trem-l)		(927)
				+Deanaspis	O (Cara-l)	-O (Cara-m)	
Asaphopsis	O (l)			Declivolithus	O (Cara-m)		
Asaphopoides	O (Trem)	-O (Aren-l)		+Degamella	O (Aren-u)	-O (Ashg-m)	(726,1066)
Asaphus	O (Aren-u)	-O (Cara)		Diceratopyge	Cm(Trep-u)	-O (Trem-u)	(1075)
Aspidaeglina	O (Aren-l)			Dichelepyge	O (Trem-l)		(378)
+Atopasaphus	Cm(Fran-u)		(16)	+Diemanosaukia	Cm(Trep-u)		
+Auritama	Cm(Dres-l)		(16)	Digrypos	O (m)		
Aulacoparia	O (Trem-u)	-O (Aren-l)	(795)	Dikelocephalites	Cm(Fran-u)?		(464)
Australopyge	O (Aren)			Dikelocephalopsis	O (Trem-u)		
+Bandalaspis	Cm(Fran-l)		(380)	Dikelocephalus	Cm(Trep-l)	-O (Trem-u)	(379)
Barrandia	O (Trem)	-O (Ashg-u)	(690)	Dikelocephalina	O (Trem-l)	-O (Trem-u)	(80,378)
Basilicus	O (Trem-u)	-O (Cara-l)		Dionide	O (Aren-u)	-O (Ashg-m)	(2)
Basiliella	O (Trem-u)?	-O (Cara-l)	(795)	Dionidella	O (Aren-u)	-O (Ashg-l)	(2,862, 1066)
+Beigongia	Cm(u)		(ZR83)				
Bellaspidella	Cm(Trep)	-O (Trem-l)		Dipleuropyge	Cm(u)		
Bellefontia	O (Trem-l)			Distazeris	Cm(uMid-u)		(1017)
Bergamia	O (Aren-l)	-O (Cara-l)	(378,795)	Dolerobasilicus	O (m)		
Bernia	Cm(Fran-u)		(379)	+Doremataopsis	Cm(Dres-l)		(482)
Bettonia	O (Llvi-l)	-O (Llde-l)	(378)				

Taxon	First Appearance	Last Appearance	Reference	Taxon	First Appearance	Last Appearance	Reference
+Duibianaspis	Cm(Trep-l)			Kainella	O (Trem-l)	-O (Aren)	
Dytremacephalus	Cm(Dres-u)		(489)	Kainiella	Cm(Trep)?		
Ectenaspis	O (Cara-u)	-O (Ashg-u)	(795,1066)	Kayserspisp	O (Trem-u)	-O (Aren-l)	(565)
Edmundsonia	O (Cara-l)		(795)	Kazelia	Cm(Fran)		
Eirelithus	O (m)			Keithia	Cm(Trep)		
Elkia	Cm(Fran-u)	-Cm(Trep)		Keithiella	Cm(Fran-u)	-Cm(Trep-u)	(379,697)
Ellipsotaphrus	O (Aren-l)	-O (Ashg)	(2,378,726)	Kendallina	Cm(Fran-u)		(488,697)
+Elongatanileus	O (Cara-u)		(1268)	+Kobayashella	Cm(Fran-l)		(380,459)
+Eopatokenephalus	O (l)		(ZR83)	Kobayashia	O (Trem)		
Eosaphus	Cm(Fran-l)	-Cm(Trep)?	(81)	Kogenium	Cm(m)		
Eoisotelus	O (l)			Kokuria	Cm(Fran-u)		
Eoptychaspis	Cm(Fran-u)		(379)	Koptura	Cm(lMid)	-Cm(tuMid)?	(472,474)
Eoroergia	O (Trem-u)	-O (Llde-u)	(382,795)	Labiostria	Cm(Dres-u)		
-Eotrinucleus	O (Trem-l)			Lachnostoma	O (Aren-l)		(795)
+Eowuhia	Cm(tuMid)		(ZR85)	Lakaspis	O (l)		
-Erbenia	Cm(m)	-Cm(tu)	(ZR84)	Lannacus	O (Aren)		
Eugonocare	Cm(Dres-u)		(16,459)	Lapidaria	O (Aren)		
Euptychaspis	Cm(Trep-l)	-O (Trem-l)	(379,697)	Leimitia	O (Trem-u)		(1075)
Eurekaia	Cm(Trep-l)	-O (Trem-l)	(379)	-Liaoningella	Cm(tu)		(ZR83)
Eymekops	Cm(mMid)?	Cm(tuMid)?		Lichapyge	O (Trem-l)	-O (Trem-u)	(378)
Falanapis	O (Aren-l)			Lichengia	Cm(Trep)		
Famatinolithus	O (Aren-l)			-Linguisaukia	Cm(Trep-u)		
+Flabellocephalus	Cm(tuMid)		(ZR85)	Lingukainella	O (l)?		
-Fritchaspis	D (Emis-u)	-D (Eife)	(421)	-Lionegalaspides	O (Aren-u)	-O (Llvi-l)	(1266)
Frognaspis	O (Ashg-l)		(1066)	Lioparia	Cm(Dres-l)?		(464)
-Galerosaukia	Cm(Trep)		(16)	Liostracina	Cm(tuMid)	-Cm(Dres-l)	(16,464)
+Globampyx	O (Aren-u)		(795)	Liostracinooides	Cm(Trep-l)	-Cm(Trep-u)	
Glyphaspellus	Cm(mMid)?			-Lisogorites	O (Llde)?	-O (Cara-u)	
Glyphopeltis	Cm(m)			+Listroa	Cm(Dres-u)		(1017)
+Gog	O (Aren-l)	-O (Llvi-l)	(378,795)	Litocephalus	Cm(Dres-u)	-Cm(Fran-l)	(80)
+Gogiura	O (l)		(ZR87)	Lloydolithus	O (Llde-l)		(378)
+Golasaphus	Cm(Fran-u)		(16)	Loganellus	Cm(Trep)		
+Griphasaphus	Cm(Dres-l)		(16,482)	Lonchodomas	O (Llvi-u)	-O (Ashg-u)	(2,795)
Guandacolithus	O (Cara)			+Lophoholcus	Cm(Dres-l)		(482)
Hanchungolithus	O (Aren-l)	-O (Aren-u)	(2,875)	+Lophosaukia	Cm(Fran-u)	-Cm(Trep)	(16)
Haniwa	Cm(Fran)	-Cm(Trep)	(16,464)	-Lycophron	O (l)		(ZR85)
Haniwoides	Cm(Fran-u)		(16)	+Lynaspis	Cm(Dres-l)		(482)
+Hastiremopleurides	O (Llde-l)	-O (Ashg-l)	(381)	Macropyge	Cm(Trep-l)	-O (Trem-u)	(378,618)
Hemibarrandia	O (Trem-l)	-O (Trem-u)	(1075)	+Macropygella	O (l)		(ZR87)
+Heterocyclopyge	O (Llde-u)	-O (Ashg-m)	(795,1075)	Macrotoxus	Cm(tuMid-m)		
Hoekaspis	O (Aren-l)			Madaroccephalus	Cm(tuMid-u)	-Cm(Dres-l)	(80)
Homalopteon	O (Llde-l)	-O (Cara-u)	(378)	Maladioidella	Cm(Fran-u)	-Cm(Trep)	(16)
Homalopyge	O (Llvi)			Mansuyella	Cm(tu)		
Homotelus	O (Llde)	-O (Cara-u)		Mapanopsis	Cm		
Housia	Cm(Dres-u)?	-Cm(Fran-l)	(2,80)	+Marekolithus	O (Ashg-m)		
Hukasawia	O (l)			Marrolithoides	O (Llde-l)	-O (Cara-l)	(378)
Hungaiia	Cm(Trep)			Marrolithus	O (Llvi-u)	-O (Cara-m)	(378)
Hungioides	O (Aren-l)	-O (Llvi)		Maustonia	Cm(Fran-u)		(488)
Hunnebergia	O (Aren-l)		(795)	Meeria	Cm(Fran-u)		(379)
Hysterolenus	Cm(Trep)	-O (Trem-l)	(80,378)	Megalaspidella	O (Aren)		(378)
Idahonia	Cm(Fran-l)	-Cm(Fran-u)	(1,488)	Megalaspides	O (Aren-u)		(795)
Illaenopsis	O (Trem-l)	-O (Llvi-l)	(378)	+Megalaspis	Cm(Fran-u)	-Cm(Trep-u)	(81)
Incaia	O (Llvi-u)	-O (Llde-u)		Megistaspis	O (Trem-u)	-O (Llvi)?	
+Incisopyge	O (l)		(ZR85)	Mendolaspis	O (Aren)		
Inouyella	Cm(tuMid)		(464,472)	Menoparia	O (Trem-u)		(795)
Iranella	Cm(tu)			+Merlinia	O (Aren-l)		(378)
+Isabelinia	O (m)		(ZR91)	Metanomocare	Cm(tuMid-u)		
Isocolus	O (Aren-u)	-O (Ashg)		+Metotropis	Cm(Dres-l)		(482)
Isoteloides	O (Aren-l)	-O (Llde)	(795)	+Metayuepingia	O (Trem-u)		(927)
Isotelus	O (Llvi-l)	-O (Ashg-u)	(382,690)	Microparia	O (Aren-l)	-O (Ashg-m)	(2,378)
-Isyrakopeltis	O (l)		(ZR87)	+Mictosaukia	Cm(Trep-u)		(16)
Ityophorus	O (Ashg-m)		(1066)	+Mioptychopyge	O (Aren-u)	-O (Llvi-l)	(1266)

Taxon	First Appearance	Last Appearance	Reference	Taxon	First Appearance	Last Appearance	Reference
Monkaspis	Cm(uMid)			+Plectifer	Cm(uMid-u)	-Cm(Dres-l)	(16,482)
Monocheilus	Cm(Fran-l)	-Cm(Trep-l)	(379)	+Plesiomegalaspis	O (Aren-l)		(565)
Myida	O (Trem)			+Plesiyuepingia	O (l)		(ZR91)
+Myindella	O (Trem-l)		(378)	Portentosus	Cm(u)		
Myttonia	O (Aren-l)		(2)	Pradesia	O (Trem)		
+Nadiyella	Cm(u)		(ZR89)	+Prehousia	Cm(Dres-u)		
Nankinolithus	O (Llde-l)	-O (Ashg-m)	(875)	Presbynilæus (+ Paranilæus)			
+Nanlingia	O (m)		(ZR83)	O (Aren-l)		-O (Aren-u)	
+Neopeltis	O (l)		(ZR83)	Priecyclopyge	O (Aren-u)	-O (Llde-l)	(378,1075)
Nileoides	O (Llde-u)		(795)	+Proampyx	Cm(Alda-u)	-Cm(uMid)	(16,885)
Nileus	O (Trem-l)	-O (Ashg-m)		Proceratopyge	Cm(Dres-l)	-Cm(Fran-u)	(16,81)
Ningkianolithus	O (Aren-u)		(875)	+Promacropyge	Cm(Trep)	-O (Trem)?	(459,483)
Niobe	Cm(Fran-u)?	-O (Cara-l)	(81,795)	Promegalaspides	Cm(Fran-u)		(81,459)
Niobella	Cm(Fran-u)	-O (Llvi)	(81)	Prosaukia	Cm(Fran-u)	-Cm(Trep-u)	(16,379, 697)
Niobides	O (Aren)			+Proteuloma	Cm(Trep-l)	-O (Aren-l)	(483)
Niobina	O (Trem-l)	-O (Trem-u)		Protolloydolithus	O (Llvi-l)	-O (Llde-l)	(378)
+Nobiliasaphus	O (Llvi)	-O (Cara-m)	(378,1081)	+Protopyresbynilæus	O (Trem-u)	-O (Aren-l)	(795)
+Nomadinia	Cm(Dres-l)		(482)	Psalaspis	Cm(Fran-u)		(379)
+Norasphus	O (l)		(ZR85)	+Pseudampyxina	O (Ashg-l)		(862)
Norinia	Cm(Fran-u)		(618)	Pseudanomocarina	Cm(Mid)		(467)
+Notoaphelaspis	Cm(Dres-u)			+Pseudaphelaspis	Cm(Trep-l)		
Notopeltis	O (Trem-u)			Pseudoasaphus	O (Llvi)	-O (Cara-l)	
Novaspis	O (Cara-u)	-O (Ashg-m)		Pseudobasilæus	O (Llvi)	-O (Cara-m)	
Ogmasaphus	O (Aren-u)	-O (Cara-l)	(1266)	+Pseudocyclopyge	Cm(Fran)		(459)
Ogyginus	O (Aren-l)	-O (Llde-l)	(378)	Pseudogygites	O (Cara-u)	-O (Ashg-m)	(795)
Ogygiocarella	O (Llvi-l)	-O (Cara-l)	(378)	Pseudohysterolenus	O (Trem-l)		
Ogygiocaris	O (Aren-l)	-O (Llde)	(565)	Pseudokainella	O (Trem-l)	-O (Trem-u)	(378)
Ogygites	O (Llde)			+Pseudopycephalus	O (Llvi-l)		(565)
Ogygitoidea	O (m)			Pseudosaratogia	Cm(Dres-u)	-Cm(Fran-u)	(80)
Olenaspella	Cm(Dres-u)	-O (Trem-l)	(459,472)	+Pseudoyuepingia	Cm(Dres-u)	-Cm(Fran-l)	(721,1017)
Olentella	Cm(Dres-u)?	-Cm(Fran-u)	(618)	Psilacella	O (Aren-u)	-O (Ashg)	(726)
Omeipsis	O (Llvi)		(1066)	+Psilocara	O (Aren-l)		(795)
Omnia	O (Llde-l)	-O (Ashg-m)	(1075)	Psilocephalina	O (Trem)		
Onychopyge	O (Trem-l)			+Psilocephalinella	Cm(Trep)	-O (Trem-l)	(378)
+Opipeuter	O (Aren-l)	-O (Aren-u)	(565)	Pterocephalia	Cm(Dres-u)	-Cm(Fran-l)	(16,489)
+Opsimasaphus	O (Llde-l)	-O (Ashg-m)	(1075)	Pteroccephalops	Cm(Dres-u)		(494)
Orometopus	O (Trem-l)	-O (Aren)	(2)	+Ptychaspis	Cm(Fran-l)	-Cm(Fran-u)?	(16,464)
Orygmaspis	Cm(Fran-u)		(484,488)	Ptychocephalus	O (Trem-u)	-O (Aren-l)	(795)
Oscolia	Cm(Trep)			Ptychopyge	O (Aren)	-O (Llvi-u)	
+Paivinia	O (l)		(ZR87)	Quadricephalus	Cm(Trep)		(16,464)
Palella	Cm(m)			+Quitacetra	Cm(uMid)		(16)
Parabailiella	Cm(mMid)?	Cm(uMid)?		+Quitailia	Cm(uMid)		(16)
+Parabarrandia	O (Llvi)	-O (Llde-l)	(1075)	Raphiophorus	O (Llde-l)	-S (Ludl-l)	(1066,1075)
Parabasilæus	O (Aren-l)?	-O (Cara-m)	(378)	Raymondella	O (Llde-u)	-O (Cara-l)	(795)
Parabellefontia	O (Trem-l)		(795)	Reedolithus	O (Llde-l)	-O (Cara-l)	
Parabolinoidea	Cm(Fran-l)	-Cm(Fran-u)?	(378)	+Remopleurella	O (Cara-u)		(378)
+Parabumastides	O (Cara-m)	-O (Ashg-l)	(ZR90)	Remopleurides	O (Llvi-l)	-O (Ashg-u)	(690)
Paracoosia	Cm(Dres-l)		(16,379)	Remopleuridiella	O (Trem-l)	-O (Trem-u)	(795)
+Parahousia	Cm(Fran-l)		(384)	Rhadinopleura	O (Trem-l)		(2)
+Paramansuyella	Cm(u)			+Rhombampyx	O (Aren-u)	-O (Llde-l)	(381)
Paramegalaspis	O (Trem)			+Rhysometropus	Cm(uMid-u)	-Cm(Dres-l)	(16)
+Paraphillipsinella	O (Cara-l)	-O (Ashg-l)	(862)	Richardsonella	Cm(Fran-u)	-Cm(Trep)	(16,484)
+Parapychoyge	O (Aren-u)		(795)	Robergia	O (Llvi-u)	-O (Ashg)	(795)
Paratrinucleus	O (Llde)		(795)	+Robergiella	O (Aren-l)	-O (Ashg-u)	(690,795)
+Pedinocephalina	Cm(Dres-l)	-Cm(Dres-u)	(460)	+Roksaspis	Cm(u)		(ZR90)
+Pedinocephalites	Cm(Dres-u)		(618)	Saimachia	Cm(m)		
Pedinocephalus	Cm(Dres-u)	-Cm(Fran-l)	(380)	Salterolithus	O (Cara-l)		(378)
+Peichiashania	Cm(uMid)	-Cm(Fran-u)	(16,483)	Saratogia	Cm(Fran-l)	-Cm(Trep)	(80,379)
Pempbigaspis	Cm(Dres-l)			Saukia	Cm(Fran-u)	-Cm(Trep-u)	(379,464)
Platypeltoides	O (Trem-l)	-O (Trem-u)		Saukiella	Cm(Fran-u)	-Cm(Trep-u)	(379,472)
Plectasaphus	O (Llde)			Saukioides	Cm(Trep)		
+Plecteuloma	Cm(Fran-u)	-Cm(Trep-l)	(16)				

Taxon	First Appearance	Last Appearance	Reference	Taxon	First Appearance	Last Appearance	Reference
Scinocephalus	O (Trem-u)		(795)	Acheilus	Cm(Trep)	-O (Trem-l)	(797)
-Sciintilla	Cm(l)		(ZR88)	Acrocephalaspis	Cm(Fran-l)		(380)
-Sculptella	O (m)		(ZR91)	+ Acrocephalella	Cm(Dres-l)		(460)
Seleneceme	O (Aren-u)	-O (Llvi-l)	(2,378,726)	Acrocephalina	Cm(Fran-u)	-O (Trem-l)	(472,618, 927)
+ Sigmakainella	Cm(Fran-u)		(16)	Acrocephalites	Cm(uMid-u)	-Cm(Dres-u)	(81)
+ Sinampyxina	O (Ashg-l)		(862)	Acrocephalops	Cm(mMid-l)	-Cm(mMid-u)	(81)
Sinosaukia	Cm(Fran-u)?	-Cm(Trep)	(16)	+ Acrodirtes	Cm(Dres-l)		(16)
Stapeleyella	O (Aren-l)	-O (Llvi-l)	(378,726)	+ Aedotes	Cm(uMid-u)	-Cm(Dres-l)	(16,482)
Stenochilina	Cm(Trep)			+ Afghanocare	Cm(Dres-l)		
-Stigmacephaloides	Cm(Fran-u)		(379)	Agasso	Cm(uMid-u)		
Stigmacephalus	Cm(Fran-u)		(379,697)	+ Agelagma	Cm(uMid-u)	-Cm(Dres-l)	(16)
Stigmaspis	Cm(Fran-u)		(379)	Agraulopsis	Cm(m)		
-Stigmatoa	Cm(Dres-u)	-Cm(Fran-l)	(483,498, 1020)	Agraulos	Cm(Boto)	-Cm(uMid-u)	(81)
Symphysops	O (Llvi)	-O (Ashg-m)	(2,1075)	+ Aiaiaspis	Cm(uMid-u)		
Symphysurina	O (Trem-l)			+ Ajjirikina	Cm(uMid-u)	-Cm(Dres)	(482,483)
Symphysurus	O (Trem-l)	-O (Cara-l)	(795)	Alanisia	Cm(Atda-u)	-Cm(Boto-l)?	(923)
+ Taenicephalites	Cm(Fran-u)		(16)	+ Alataurus	Cm(Boto)?		(471)
Taenicephalus	Cm(Dres-u)	-Cm(Fran-u)	(472,494, 618)	Albansia	Cm(uMid)?		
Taihungshania	O (Aren)	-O (Llvi)		Aldanaspis	Cm(uMid)		(380)
+ Taklamakania	O (Cara-u)	-O (Ashg-l)	(862)	Aleste	O (Ashg-l)	-O (Ashg-m)	(862)
Talaomnarolithus	O (Cara-l)		(378)	Aldonaia	Cm(Boto-l)	-Cm(Tojo)	(462,474)
+ Tchukeraspis	O (l)		(ZR87)	+ Alekcinella	Cm(Fran-l)		(380)
Tellerina	Cm(Trep-l)	-Cm(Trep-u)	(379,464)	Alokistocare	Cm(Tojo-l)	-Cm(mMid-l)	(474,479)
Temnoura	O (l)			Alokistocarella	Cm(lMid)	-Cm(uMid-u)	(80)
Teratorhynchus	O (Cara-l)		(795)	+ Altioculus	Cm(mMid-u)		(1089)
Theodensia	Cm(Trep-u)	-O (Trem-l)	(379)	+ Altitudella	Cm(Boto-l)		(522)
+ Thoralcocleus	O (l)		(ZR85)	Amecephalina	Cm(Tojo-l)	-Cm(Tojo-u)	(474)
Thysanopyge	O (Aren-l)			+ Amecephalites	Cm(lMid)		
+ Toernquistina	O		(ZR87)	Amecephalus	Cm(Tojo-u)	-Cm(mMid-u)	(81)
Tramoria	O (l)?			Amiaspis	Cm(Dres-u)		(379)
Tretaspis	O (Llde-u)	-O (Ashg-u)	(2,690)	+ Amicus	O (u)		
Triarthropsis	Cm(Fran-u)	-Cm(Trep-u)	(379)	+ Amphorella	Cm(Fran-u)		(618)
+ Trigonoaspis	O (Llde-l)	-O (Ashg-l)	(862)	Anquia	Cm(Dres-l)		(80)
Trigonocerca	O (Trem-u)	-O (Aren-l)	(795)	+ Amzasskiella	O (Trem-l)		(927)
Trigonocercella	O (Aren-l)		(795)	Anabaraspis	Cm(Tojo-u)	-Cm(mMid)	(474,522)
+ Trinucleoides	O (Llvi)		(2)	+ Anaximander	O (Aren-l)		(795)
Trinucleus	O (Llvi-l)?	-O (Llde-u)	(795)	Andrarina	Cm(mMid-l)	-Cm(uMid-u)	
Tungtzuella	O (Aren)		(565)	+ Anechocephalus	Cm(Fran-l)		(1017)
Varvia	O (Trem-u)	-O (Aren-l)		+ Anemocephalops	Cm(Fran-l)		(380)
Vogdesia	O (Llde-l)	-O (Cara-m)	(382,795)	+ Anemocephalus	Cm(Fran-u)		(380)
Walcottaspis	Cm(Trep)			Angelina	O (Trem-l)	-O (Trem-u)	(80,378)
+ Wanliangtingia	O (Trem)			?Angustaeva	Cm(Atda-u)		(473)
Welleraspis	Cm(Dres-l)	-Cm(Dres-u)	(379,1017)	Ankoura	Cm(uMid-u)	-Cm(Dres-l)	(379)
Wentusia	Cm(Dres)	-Cm(Fran-u)	(16,464)	+ Ananimitella	O (Aren-l)	-O (Llde-l)	(381)
Wilbernia	Cm(Fran-l)?	-Cm(Fran-u)	(379,697)	Annamitia	Cm(uMid)		
Wuhuia	Cm(Fran-u)	-Cm(Trep)	(16,464)	Anomocarella	Cm(mMid)	-Cm(uMid-u)	
Xenasaphus	O (Llde)			+ Anopocodia	Cm(Dres)		(482)
Yuepingia	Cm(uMid)	-Cm(Dres-u)	(16,472)	Antagmus	Cm(Boto-u)	-Cm(Tojo)	(463,474)
-Yuepingioides	Cm(Trep-l)			?Antatlasia	Cm(Atda-u)	-Cm(Boto-u)?	(473,928)
+ Yumenaspis	O (Llde-l)	-O (Cara-u)	(1066)	+ Anuloides	Cm(Fran-l)		(380)
-Zhenganiites (+ Eosotyphyge)	O (Aren-u)	-O (Llvi-l)	(1266)	Apachia	Cm(Fran-l)		(379)
Zuminaspis	O (Aren)			Apatokephaloides	Cm(Trep-u)		(379)
				+ Apatokephalops	O (Trem-l)		(927)
				+ Aphelotoxon (+ Panumia)	Cm(Dres-u)	-Cm(Fran-l)	(486,489)
Or. PTYCHOPARIIDA				+ Aplexura	Cm(Dres-u)	-Cm(Fran-l)	(618)
+ Acanthometopus	Cm(u)		(ZR83)	+ Aplotaspis	Cm(Dres-u)		(16)
Acanthopleurella	O (Trem-l)		(378)	+ Apomodocia	Cm(Dres-l)		
Acerocare	Cm(Trep-u)		(81)	+ Apoplanias	O (Trem-l)		(379,697)
Acerocarina	Cm(Trep)	-O (Trem)	(81)	Aposolenopleura	Cm(Fran)	-Cm(Trep)	(484)
Acheilops	Cm(Trep-u)		(379)	Arapahoia	Cm(uMid-u)	-Cm(Dres-l)	(80)

Taxon	First Appearance	Last Appearance	Reference	Taxon	First Appearance	Last Appearance	Reference
Arcuolimbus	Cm(Dres-l)		(379)	Bolaspis	Cm(mMid-u)	-Cm(uMid)	(379)
Arellanella	Cm(m)			Bonneterina	Cm(Dres-l)		(379)
+ Argunaspis	Cm(Boto)?		(471)	+ Botrioides	O (Livi-u)	-O (Llde-l)	
Aristoharpes	S (Ldov-m)	-S (Ldov-u)		Bowmania	Cm(Trep-u)		
Arraphus	O (u)			Brachyaspidion	Cm(uMid-l)		
Asaphiscus	Cm(uMid-l)		(379)	+ Brachyhipposiderus	O (Trem-l)	-O (Trem-u)	(927)
+ Asaphoon	O (Trem-l)			Braintreeella	Cm(mMid-u)		(80)
+ Ascionepea	Cm(uMid-u)	-Cm(Dres-l)	(16,482)	Brassicicephalus	Cm(Dres-l)		(16)
+ Asiatella	Cm(Boto)?		(471)	+ Bronteus	O (Cara)	-D (Fras)	(421)
+ Asilluchus	Cm(Dres-u)		(16)	Brunswickia	Cm(mMid)?	-Cm(uMid-u)	(81)
+ Asiocephalus	Cm(Fran)			+ Brutaspis	Cm(Fran-l)		(380)
Asthenopsis	Cm(uMid)		(16)	Bucksella	Cm(u)		
Atops	Cm(Atda-u)		(80)	+ Bulnibarbi	O (Aren)		
+ Aulacodigma	Cm(Dres-l)		(16)	Burlingia	Cm(mMid-u)		(80)
Austinvilla	Cm(Boto-u)	-Cm(Tojo)	(81)	Burnetiella	Cm(Fran-l)		(80)
+ Austosinia	Cm(m)		(ZR89)	+ Bvalbardites	O (Aren-l)		(795)
Australoharpes	O (Trem-l)			Bynumia	Cm(uMid-u)	-Cm(Dres-l)	(379)
Avonina	Cm(Dres-l)		(16)	Bynumiella	Cm(Fran-l)	-Cm(Trep-u)	(379)
+ Badainjaranspis	Cm(u)		(ZR87)	Bynumina	Cm(Fran-l)	-Cm(Trep-u)	(486,1054)
+ Bagongshania	Cm(u)		(ZR83)	Bythicheilus	Cm(mMid-l)	-Cm(uMid)?	
+ Baikounuraspis	O (l)		(ZR88)	Caborcella	Cm(Tojo-u)	-Cm(mMid-l)	(81,474)
Bailiaspis	Cm(mMid-l)	-Cm(uMid-l)	(81)	Cainatops	Cm(m)		
Bailiella	Cm(mMid-l)	-Cm(uMid-m)	(81)	+ Calculites	Cm(Trep-u)	-O (Trem-l)	(795)
+ Balderia	Cm(uMid)		(ZR89)	+ Calocephalites	Cm(Fran-l)		
+ Balnibarbi	O (Aren-l)		(795)	+ Calvipelta	Cm(Trep-l)	-Cm(Trep-u)	(697)
+ Batchatiella	Cm(Trep-l)		(380)	+ Carinamala	Cm(Dres-l)		
+ Bathyocos	Cm(mMid-u)		(1089)	+ Carrickia	O (Livi-l)	-O (Ashg)	(383)
Bayfieldia	Cm(Trep-l)	-Cm(Trep-u)	(379,484)	+ Catasolenopleura	Cm(u)		(ZR83)
Bellaspis	Cm(Trep)			+ Caulaspina	Cm(Dres-u)		(618)
Belteila	Cm(Trep)	-O (Trem-l)		+ Cedarapis	Cm(Dres-l)		(380)
Bemaspis	Cm(Fran-u)		(379)	+ Cedarellus	Cm(Fran-l)		(618)
+ Beothuckia	Cm(u)		(ZR90)	Cedaria	Cm(uMid-u)	-Cm(Dres-l)	(80,379)
+ Berabichia	Cm(Atda-u)		(1221)	Cedarina	Cm(uMid-u)	-Cm(Dres-l)?	(80,379)
Bergeroniaspis	Cm(Boto-l)	-Cm(Boto-u)	(462,471)	+ Cernuolimbus	Cm(Dres-u)	-Cm(Fran-l)	
Bergeroniellus	Cm(Boto-l)	-Cm(Tojo-u)	(472,474)	Champlainia	Cm(uMid)		
+ Bergeronites (+ Palaeodotes)				Chancia	Cm(Tojo-u)	-Cm(mMid-u)	(16,80)
	Cm(uMid-u)	-Cm(Dres-l)	(16,483)	+ Chanciaopsis	Cm(mMid-u)		(1089)
+ Berkutaspis	Cm(Trep-u)			Changshania	Cm(Dres-l)	-Cm(Fran)	(472)
+ Bestjubella	Cm(Fran-l)		(380)	+ Changqingia	Cm(m)		(ZR83)
+ Biaverta	Cm(uMid-u)	-Cm(Dres-l)	(482)	+ Changshanocephalus	Cm(Dres-u)		(1020)
Bicella	Cm(Tojo)		(81)	Chariocephalus	Cm(Fran-u)		(379,697)
+ Bidjinella	Cm(Boto)?		(471)	Chelidonocephalus	Cm(m)?, Cm(u)?		
Bienvilla	Cm(Fran-u)	-O (Aren-l)	(378,795)	+ Chencunia	Cm(Trep-l)		
+ Bifodina	O (Trem-l)			+ Chondrastaulina	Cm(Boto)		(462)
Bigotina	Cm(Atda-l)	-Cm(Atda-u)	(467,472)	+ Chosenia	O (Trem-u)		
+ Bigotinella	Cm(Atda-u)?			+ Chuangiformis	Cm(Fran-u)		(618)
Bigotinops	Cm(Atda-l)		(473)	+ Chulanolenus	Cm(l)		(ZR83)
+ Binodaspis	Cm(Boto-l)	-Cm(Tojo-u)	(461,474, 522)	+ Ciliocephalus	O (Trem-u)		(927)
				+ Ciliiscutellum	S (Ldov)		(ZR88)
+ Biscoia	Cm(Trep)			+ Circuloecrania	O (Aren-u)		(726)
Blackwelderioides	Cm(Dres-l)		(464)	+ Clappaspis	Cm(mMid-l)		(500)
Blainia	Cm(m)			+ Clelandia	Cm(Trep-l)	-O (Trem-l)	(697)
Blainiopsis	Cm(m)			Cliffia	Cm(Fran-l)		(379,697)
+ Blosyropsis	O (Livi-u)		(795)	Coenaspis	Cm(Dres)		
Blountia	Cm(uMid-u)	-Cm(Dres-u)	(16,379, 1017)	Collyrolenus	Cm(Tojo-l)		(473)
				+ Conococheaquea	Cm(Trep-u)?		(697)
Blountiella	Cm(Dres-l)		(379)	Conocoryphe	Cm(mMid-u)	-Cm(uMid-m)	(81)
Boeckaspis	O (Trem-l)		(80)	Conokephalina	Cm(uMid)?	-Cm(Fran-l)	(81)
+ Bohemoharpes	S (Ldov-u)	-D (Gedi)	(1106)	Coosia	Cm(Dres-l)		(80,379)
Bolaspidella	Cm(uMid-l)	-Cm(uMid-u)	(81)	+ Coosella	Cm(Dres-l)		(80,379)
+ Bolaspidellus	Cm(Fran)		(459)	Coosina	Cm(Dres-l)		(80,379)
+ Bolaspidina	Cm(Dres-u)		(618)	+ Coosinoides	Cm(Fran-l)		(380,459)

Taxon	First Appearance	Last Appearance	Reference	Taxon	First Appearance	Last Appearance	Reference
Corbina	Cm(Trep-l)	-Cm(Trep-u)	(379,697)	Elyx	Cm(uMid-u)		(81)
Coulooumania	Cm(m)			Emmrichella	Cm(mMid)?	-Cm(uMid)	(472)
+ Craighadia	O (Cara-u)		(795)	+ Emmrichops	O (Llde-l)		(378)
Crassifimbria	Cm(Tojo-u)		(487,885)	+ Enammocephalus	Cm(Boto)		(471)
Crepicephalina	Cm(uMid)		(464)	Endymionia	O (Aren-u)	-O (Llvi-l)	(2)
Crepicephalus	Cm(Dres-l)		(80,379)	Entomaspis	Cm(Trep-l)	-Cm(Trep-u)	(379)
Crepichilella	Cm(Fran)			Eobronteus	O (Llvi-u)	-S (u)?	(795)
Croixana	Cm(Fran-l)?	-Cm(Fran-u)	(488)	Eoharpes	O (Llvi-l)	-O (Ashg-m)	
Crusoa	Cm(m)			+ Eokoataia	Cm(lMid)?		
Ctenocephalus	Cm(mMid-l)	-Cm(mMid-u)	(81,378)	+ Eokosovopeltis	O (Cara-l)	-O (u)	
Ctenopyge	Cm(Fran-u)		(81)	Eoptychoparia	Cm(Boto)	-Cm(mMid-u)	(464,474)
+ ?Culmenaspis	Cm(Tojo)		(474)	Eoshumardia	Cm(u)		
Cyclognathina	Cm(Fran-u)	-Cm(Trep-u)	(380)	?Erbia	Cm(Tojo-u)	-Cm(lMid)	(474)
+ Cyclolorenzella	Cm(uMid-u)	-Cm(Dres-l)	(459,464)	- ?Erbiella	Cm(Boto-l)		(462,468)
+ Damaiaospis	Cm(u)		(ZR83)	- Erdoradites	Cm(Fran-l)		(380)
+ Dananzhuangaspis	Cm(m)		(ZR83)	+ Erediaspis	Cm(uMid-u)		(16,482)
Dartomaspis	Cm(Fran-u)		(379,697)	+ Erixanium	Cm(Dres-u)	-Cm(Fran-l)	(16,489)
Dasometopus	Cm(uMid-l)?	-Cm(uMid-u)	(80)	Eshelmania	Cm(Dres-u)	-Cm(Fran-l)	(80)
Deadwoodia	Cm(Fran-l)		(488,697)	Etheridgaspis	O (Aren)		
Deckera	Cm(Fran-l)		(379)	Euloma	Cm(Trep-u)	-O (Aren-l)	(1081)
+ Decus	Cm(m)		(ZR83)	+ Euonchonotina	O (Trem-l)		
Deiracephalus	Cm(Dres-l)		(80,379)	Eurostina	Cm(m)		
Dellea	Cm(Fran-l)		(16,488)	Eurycare	Cm(Fran-u)		(80)
+ Delleana	Cm(Fran-l)		(380)	+ Faciura	Cm(Fran-l)		(618)
+ Deltina	Cm(mMid-u)		(1089)	+ Faillleana	O (Llde-l)	-O (Cara-u)	(378,795)
Densonella	Cm(uMid-u)	-Cm(Dres-l)	(379)	+ Fatocephalus	Cm(Trep-u)		
+ Dentaloscutellum	D (Emis-l)		(421,1106)	+ Ferenepea	Cm(uMid-u)	-Cm(Dres-l)	(16,482)
+ Diceratocephalina	Cm(Trep-l)		(618)	?Ferralsia	Cm(Atda-u)	-Cm(Tojo-u)	(80,81)
Diceratocephalus	Cm(Dres-l)		(463)	Fissocephalus	Cm(Fran)		(459)
+ Didwudina	Cm(Fran-l)		(380)	+ Forchhammeria	Cm(uMid-l)		(467)
+ Dipyrgotes	Cm(Dres-l)			+ Furalithus	O (Aren-l)		(726)
Dokimocephalus	Cm(Fran-l)		(379)	+ Galeaspis	Cm(Fran-l)		(380)
Dolgaia	Cm(u)			+ Gaotanaspis	Cm(m)		(ZR84)
+ Dolgeuloma	Cm(Trep-l)	-Cm(Trep-u)	(618)	+ Gastropolus	O (Llvi-l)		(378,726)
Dolichoharpes	O (Llde)	-O (Ashg-m)	(795)	Genevievella	Cm(uMid-u)	-Cm(Dres-l)	(81,379,1017)
Dorypygella	Cm(uMid)	-Cm(Dres)	(464)	+ Girvanopyge	O (Trem-u)?	-O (Ashg)	(726)
Drabia	Cm(Fran-l)		(486,697)	Glaphyraspis	Cm(Dres-l)	-Cm(Dres-u)	(379,1017)
Dresbachia	Cm(Dres-l)			+ Gloria	Cm(uMid)		
Drumaspis	Cm(Fran-l)	-Cm(Fran-u)	(379,488)	Glyphaspis	Cm(mMid-u)		(81,1089)
Dubhglasina	O (Llde-l)		(795)	+ Glyptometopsis	Cm(Dres-u)		
Dunderbergella	Cm(Trep)?			Glyptometopus	Cm(Trep)		
Dunderbergia	Cm(Dres-u)	-Cm(Fran-l)	(379)	+ Graciella	Cm(Fran-u)		(618)
+ Duplora	Cm(Fran-u)		(16)	Grandiocus	Cm(uMid)		(472)
+ Edithiella	Cm(Fran-l)		(384)	Groenwallia	Cm(uMid-u)	-Cm(Dres-u)	(618)
Ehmania	Cm(mMid-u)			+ Gymnostomix	O (Aren-l)		(726)
Ehmaniella	Cm(mMid-u)		(81)	+ Habrocephalus	Cm(Boto)?		(471)
+ Ejinaspis	Cm(u)		(ZR87)	Hamatolenus	Cm(Tojo)		(928)
+ Elatius	Cm(l)		(ZR85)	Hanivella	Cm(Fran-u)		(618)
Eldoradia	Cm(uMid-m)		(81)	Hardyoides	Cm(uMid-u)	-O (Trem)	(1,459)
+ Elegantaspis	Cm(Fran-l)		(380)	Harpes	D (Eife)	-D (Fras)	(421,1106)
+ Elicicola	Cm(Atda-u)		(923)	+ Harpesoides	O (u)		
+ Elkanaspis	Cm(Fran)	-Cm(Trep-u)		Harpides	Cm(Trep-u)	-O (Llvi-u)	(618,795)
Ellipsocephaloides	Cm(Fran-u)		(379,697)	+ Harpidoideis	Cm(u)	-O (l)	(ZR88)
Ellipsocephalus	Cm(Atda-u)	-Cm(uMid-l)	(80,81)	Hartshillia	Cm(uMid-l)	-Cm(uMid-m)	(80,378)
Ellipsostrenua	Cm(lMid)		(473)	Hartshillina	Cm(uMid-m)		(378)
Elrathia	Cm(mMid-u)	-Cm(uMid)	(81,379)	+ Hatangia	Cm(uMid)		
Elrathiella	Cm(mMid-u)		(81,379)	Hedinaspis	Cm(Fran-u)	-Cm(Trep)	(484)
Elrathina	Cm(lMid)	-Cm(uMid-l)	(81,379)	+ Helieranella	O (Trem)		(ZR87)
Elvinia	Cm(Fran-l)			+ Helioharpes	D (Gedi)	-D (Give)	(1106)
+ Elvinoideis	Cm(Fran-l)		(380)	+ Henadoparia	Cm(Dres-l)		(482)
+ Elviraspis	Cm(Fran-l)		(380)	+ Heptabronteus	O (Cara-l)	-O (Cara-u)?	
+ Elyaspis	Cm(Fran-l)		(384)				

Taxon	First Appearance	Last Appearance	Reference	Taxon	First Appearance	Last Appearance	Reference
Heterocaryon	Cm(Trep-l)	-Cm(Trep-u)	(484,697)	+ Kaufmannella (+ Kaufmannia)	O (Trem-l)		
Hibbertia	O (Llvi-l)	-O (Ashg-l)	(382)	+ Kazelina	Cm(Fran-l)		(618)
+Hidascutellum	D (Gedi)	-D (Eife)	(421)	+Kepisis	O (l)?		(694)
Highgatella	O (Trem-l)			+Ketyna	Cm(Fran-u)	-O (Trem)	(483,618)
Hindermeyeria	Cm(Boto)?			+Kiefania	D (Gedi)	-D (Give)	(421,1106)
Holasaphus	Cm(mMid-l)		(81)	Kijanella	Cm(Boto)?		(471)
+Holmdalia	Cm(uMid-u)		(1017)	Kindbladia	Cm(Fran-l)		(483)
Holocephalina	Cm(uMid-l)	-Cm(uMid-m)	(80,378)	Kingaspis	Cm(Boto-l)	-Cm(mMid)?	(80,885)
Holcacephalus	Cm(uMid-u)	-Cm(Dres-l)		+Kingaspidoidea	Cm(Tojo)		(473)
Holdenia	O (Cara-l)		(795)	Kingstonia	Cm(Dres-l)		(488)
Homodictya	Cm(Dres-l)			+Kirkdomina	O (Ljde-l)		(795)
+Hospes	Cm(Fran)	-O (Trem-u)	(459,483, 927)	+Kirengelia	Cm(Trep-l)		(618)
+Houmengia	Cm(m)		(ZR83)	Kistocare	Cm(mMid-l)		(81)
+Hsuaspis	Cm(Atda-u)	-Cm(Boto-u)	(463,923)	Kochaspis	Cm(Tojo-l)	-Cm(lMid)	(464,474)
+Hsuehuangia	Cm(m)		(ZR83)	Kochiella	Cm(Tojo-l)	-Cm(lMid)	(81,379)
+Huaibeia	Cm(m)		(ZR83)	Kochina	Cm(lMid)	-Cm(mMid-l)	(80,379)
+Huainania	Cm(m)		(ZR83)	+?Kodymaspis	O (Llvi)	-O (Ljde-l)	(1075,1081)
+Hunanopyge	O (Trem-l)			+Kolbinella	Cm(Boto-l)		(468,522)
Hundwarella	Cm(m)			Koldinioidia	Cm(Fran-u)	-O (Trem-l)	(1,16)
Hupeia	Cm(Boto)?		(471)	Komaspis	Cm(uMid)		
Hyperbolochilus	O (Trem-u)		(795)	+Kosovopeltis	S (Wenl)	-D (Gedi)	(421)
Hypermeaspis	O (Trem-u)	-O (Aren-u)	(378,795)	Kouamkites	Cm(mMid)		
+Hyperoparia	Cm(m)		(ZR83)	+Krolina	Cm(Boto)?		(471)
Hypothetica	O (Trem-u)		(2)	Kujandaspis	Cm(Dres-u)?		(490)
+Ichangia	Cm(Boto-l)		(463)	+Kuljumbina	Cm(Dres-u)		(618)
Iddingsia	Cm(Dres-u)	-Cm(Fran-l)	(379)	+Kulyambopeltis	Cm(Fran-l)		(618)
Idiomesus	Cm(Fran-u)	-O (Trem-l)	(379,697)	+Kuraspis	Cm(uMid-u)	-Cm(Fran-l)	(618)
Idiorapha	O (Llvi-l)?		(795)	Kyphocephalus	Cm(Fran-l)		(488)
+Ignotogregatus	Cm(mMid)	-Cm(uMid)	(ZR89)	+Labiostrella	Cm(Dres-u)	-Cm(Fran-l)	(618)
Ingiefeldia	Cm(Tojo-l)	-Cm(lMid)	(81,462)	+Lacorosalina	O (Aren-u)		(795)
+Iniotoma	Cm(uMid-u)		(16)	+Laminurus	Cm(lMid)		(522)
Inoyellaspis	Cm(m)			+Lampropeltis	Cm(uMid)		(16,482)
Inouyia	Cm(uMid)		(464)	+Langyashania	Cm(Fran-u)?		
Inouyops	Cm(m)			+Larifugula	Cm(Trep-l)	-Cm(Trep-u)	(697)
+Interalia	Cm(uMid-u)		(16,482)	Lautonella	Cm(Fran-u)?	-Cm(Trep)	(379,459)
+Iohomia	Cm(mMid-u)		(694)	+Lecanoaspis	Cm(Fran-l)		(380)
Iranoleesia	Cm(u)			Lecanopleura	Cm(uMid)	-Cm(u)	
+Irinia	Cm(uMid)			Leiobienvillia	Cm(Trep-u)	-O (Trem)	(379)
Irvingella	Cm(Dres-u)		(80,379)	Leiocoryphe	Cm(uMid)?	-Cm(Trep-u)	(379)
Irvingelloidea	O (l)			+Leioscutellum	S (Ldov-m)		(651)
Ithyektyphus	Cm(uMid)			+Leioshumardia	O (Aren-l)	-O (Llvi-u)	(726,795)
+Ivshinaspis	Cm(Trep)			+Lenacare	Cm(lMid)		(522)
+Janxilithus	O (Cara-m)	-O (Cara-u)?	(875)	+Lecephalus	Cm(Fran-l)	-Cm(Trep-u)	(380)
+Jenkinsonia	Cm(uMid-l)		(385)	Leptoplastides	O (Trem-l)	-O (Trem-u)	(80,378)
+Jessievillia	Cm(Fran-l)		(887)	Leptoplastus	Cm(Fran-u)	-O (Trem-l)	(16)
+Jiangjunshania	Cm(l)		(ZR83)	Levisaspis	O (Trem-l)		
+Jiangsuaspis	Cm(m)		(ZR83)	Levisella	Cm(Trep)		
+Jiangsucephalus	Cm(m)		(ZR83)	+Limpaina	O (l)		(ZR84)
+Jiangsuia	Cm(m)		(ZR83)	+Liocare	Cm(uMid)		
+Jiia	O (Trem-l)			Lioharpes	D (Gedi)	-D (Give)	(1106)
Jujuyaspis	O (Trem-l)		(80,697)	Lioparella	Cm(m)		
+Kabukiia	Cm(u)		(ZR89)	+Liopelta	Cm(uMid)		
+Kadyella	Cm(Boto)		(462,471)	Liosolenopleura	Cm(mMid)?		
+Kameschkoviella	Cm(Boto)?		(471)	Liostracus	Cm(Dres-l)?	-Cm(Fran-l)	(81)
Kaninia	Cm(Trep-l)		(618)	+Litaspis	Cm(Boto-u)		
+Kaotaia	Cm(mMid-l)			+Litavkaspis	Cm(m)		(ZR88)
+Karagandoides	Cm(Fran-l)		(380)	Llanoaspidella	Cm(Dres-l)		
+Karataspis	O (l)		(ZR88)	Llanoaspis	Cm(Dres-l)		
+Kasatchaspis	Cm(Fran-l)		(380)	Lobocephalina	Cm(uMid-m)	-Cm(Dres-l)?	(16,81)
+Kathleenella	Cm(Trep-l)	-Cm(Trep-u)	(697)	+Lochmanaspis	Cm(Fran-l)		(380)
+Kathrynia	Cm(Trep-u)		(697)	Loganopeltis	O (Trem)	-O (Aren)	(2)

Taxon	First Appearance	Last Appearance	Reference	Taxon	First Appearance	Last Appearance	Reference
Loganopeltoides	Cm(Trep)		(1,459)	+Munjia	Cm(u)		(ZR83)
Lonchocephalus	Cm(Dres-1)		(1,16)	Myopsolenus	Cm(Tojo)		(928)
+Loparella	Cm(Trep-u)		(618)	+Nahamia	O (Lide-u)	-O (Ashg-u)	(690,795)
+Lopeloma	Cm(Trep-u)		(618)	+Nahannicephalus	Cm(uMid-u)	-Cm(Dres-1)	(1017)
+?Lordshillia	O (Aren-l)		(726)	+Nambetella	O (Aren-l)		(565)
Lorenzella	Cm(Dres-l)		(472)	Nasocephalus	Cm(uMid)	-Cm(Dres-1)	(80)
+Lorrettina	Cm(Fran-u)		(16)	Nassovia	Cm(uMid-l)	-Cm(uMid-u)	(80)
?Luaspis	Cm(Boto)?			+Natmus	O (Trem-l)		
+Lunacephalus	Cm(Fran-l)		(380)	+Naustia	Cm(Fran)	-Cm(Trep-1)	
+Lunacrana	O (Trem-l)		(1054)	Neoacrocephalites	Cm(Fran-u)		(618)
+Luottuolingia	Cm(u)		(ZR83)	+Neoanomocrella	Cm(Dres)		(459)
Lusatiops	Cm(Boto-u)		(80,81,473)	+Neohedinaspis	O (Trem)		(ZR84)
Luxella	Cm(Tojo)	-Cm(mMid-l)	(81)	+Neoshirakiella	Cm(Fran-u)?		
+Luyanhaoia	Cm(u)		(ZR84)	+Neosolenopleurella	Cm(m)		(ZR83)
+Lydiaspis	Cm(uMid)			Neotaenicephalus	O (Trem)		
Lyriaspis	Cm(mMid)		(16)	Nepea	Cm(uMid-u)		(16,81)
Macelloura	Cm(Fran-u)		(379)	Nericia	Cm(uMid-u)		(80)
Macronoda	Cm(Trep-l)	-Cm(Trep-u)	(379)	Nericiaspis	Cm(Fran-u)		(81)
+Maduiya	Cm(Dres-u)		(618)	+Nganasanella	Cm(Dres-u)		(618)
+Magnacephalus	Cm(Trep)			+Nilgna	Cm(Dres-l)		(482)
+Magnomma	Cm		(ZR83)	+Noelaspis	Cm(u)		(ZR90)
Maiaspis	Cm(uMid)		(460)	+Nordia	Cm(Fran-u)		(618)
Maladia	Cm(Fran-l)	-Cm(Trep)	(1,488)	Norwoodella	Cm(uMid-u)	-Cm(Dres-1)	(16,379)
Maladioides	Cm(Dres-u)		(1,472)	Norwoodia	Cm(Dres-1)		(81,379)
+Malinaspis	O (m)		(ZR87)	+Novakella	O (Aren-u)	-O (Cara-u)	(795)
+Malongullia	O (Cara-u)		(386)	+Nyaya	O (Trem-l)		(618)
Manchuriella	Cm(mMid)	-Cm(uMid)	(464,472)	+Nyella	Cm(lMid)		(478)
Manchurocephalus	Cm(Dres-l)		(1066)	Obrucheviaspis	Cm(Dres-u)	-Cm(Fran-l)	(380)
+Mansiella	Cm(Trep-l)		(618)	Octobronte	O	-S (u)	
+Mantoushania	Cm(mMid-l)		(ZR90)	+Oculetus	Cm(uMid)		
+Maotunia	Cm(m)		(ZR89)	+Olegaspis	Cm(Dres-u)	-Cm(Fran-u)	(380,618)
Mapania	Cm(mMid)?	-Cm(uMid)	(16,472)	+Olenekina	Cm(mMid-u)		
Marjunia	Cm(uMid-l)		(492)	Olenus	Cm(Dres-l)	-Cm(Fran-l)	(16,81)
Maryvillia	Cm(Dres-l)		(379)	Olekmaspis	Cm(Boto)		(471,474)
Megadunderbergia	Cm(u)			+Onchocephalina	Cm(Tojo)		(474)
+Megalopsis	Cm(u)		(ZR83)	+Onchocephalites	Cm(Tojo-u)	-Cm(mMid-u)	(493)
+Megapalaolenus	Cm(Boto-u)		(463)	Onchocephalus	Cm(Tojo-l)	-Cm(lMid)	(16,81)
Mekynophrys	O (Trem)			+Onchonotellus	Cm(uMid-u)	-O (Trem-u)	(16,483)
Meneviella	Cm(mMid-l)	-Cm(uMid-m)	(81,378)	+Onchonotina	Cm(Trep-l)	-O (Trem-l)	
+Meniscocorphyne	Cm(u)		(ZR90)	Onchonotopis	Cm(uMid)	-Cm(Dres-l)	
Menocephalites	Cm(m)			Onchopeltis	Cm(Dres-u)	-Cm(Fran)	(1,494)
Menomonina	Cm(uMid-u)	-Cm(Dres-l)	(379,1017)	+Oopites	O (Aren-l)	-O (Aren-u)	(795)
+Meroperix	S (Wenl-u)			+Opoa	S (Wenl-u)		
Mesetia	Cm(Tojo)		(473)	+Opsupharus	S (Ldov)	-S (Wenl)	(735)
Metabowmania	O (Trem)?			+Oreisor	Cm(lMid)		
Metaharpes	S (Ldov)			Orlovia	Cm(Dres-u)?	Cm(Fran-l)?	(495)
Meteoraspis	Cm(Dres-l)		(16)	Orloviella	Cm(uMid)	-Cm(Dres-u)	(380,618)
Metisaspina	Cm(Dres-u)		(618)	+Ottenbyaspis	O (Trem)		
Metisaspis	Cm(Dres-l)?			Oujjania	Cm(Atda-u)		(473)
Mexicella	Cm(lMid)			Pachyaspis	Cm(Tojo)	-Cm(mMid-l)	(16,81)
+Miaopopsis	O (Cara-l)?	-O (Ashg-l)	(862)	Paenebeltella	O (Trem-u)		(795)
Micmacca	Cm(Atda-u)	-Cm(Tojo-u)	(80,462)	+Palaeolenella	Cm(Boto)?		(471)
+Michaspis	Cm(uMid)			+?Palaeolenides	Cm(Atda)		
+Minicephalus	Cm(Dres-l)		(379)	?Palaeolenus	Cm(Boto-u)		(463,885)
+Minkella	Cm(Fran-u)		(697)	+Pancus	Cm(lMid)		
+Miranda	Cm(u)		(ZR90)	Papyriaspis	Cm(uMid)		(16)
Missisquoia	O (Trem-l)			+Parabathycheilus	O (Trem-u)		
Modocia	Cm(mMid-u)	-Cm(Dres-l)	(80,379)	Parabolina	Cm(Fran-l)	-O (Trem-l)	(81)
+Monosulcatina	Cm(Fran-u)		(618)	Parabolinella	O (Trem-l)	-O (Trem-u)	(80,378)
+Morosa	Cm(Dres-u)	-Cm(Fran-l)	(489,887)	Parabolinites	Cm(Fran-u)	-Cm(Trep-u)	(81)
Moxomia	O (Trem)			Parabolinopsis	O (Trem-l)	-O (Trem-u)	(1075)
+Mundocephalina	Cm(Boto)?		(471)	Paracedaria	Cm(uMid-u)		(379)

Taxon	First Appearance	Last Appearance	Reference	Taxon	First Appearance	Last Appearance	Reference
Paracrocephalites	Cm(u)			+Poriagraulos	Cm(mMid)		(464)
+Paraenshia	Cm(u)		(ZR83)	+Poroscutellum	D (Sieg)		(421)
+Paraeosptychoparia	Cm(m)		(ZR83)	+Portaginus	O (Ashg-u)		(795)
Paraharpes	O (Llde-l)	- O (Ashg-u)	(378,795)	Porterfieldia	O (Aren-l)	- O (Cara-u)	(378)
+Pararivingella	Cm(Dres-u)	- Cm(Fran-l)	(81)	+Poulsenella	Cm(Dres-u)		(618)
+Parakingasidoides	Cm(Tojo)		(473)	Poulsenia	Cm(Tojo)	- Cm(lMid)	(81,463)
Parakoldinia	Cm(Dres-u)	- O (Trem-l)	(618)	Princetonella	Cm(Fran-u)	- Cm(Trep-l)	(697)
+Paralorenzella	Cm(u)		(ZR83)	+Prismenaspis	Cm(Dres)		(459)
Paramicmacca	Cm(Tojo-l)		(474,522)	Proapatokephaloides	Cm(Trep)		(459)
Paranorwoodia	Cm(Trep)			Proasaphiscus	Cm(Tojo-l)	- Cm(uMid)	(464,474)
+Paranumia	O (Trem-l)			Proaulacopleura	Cm(u)		
Paraolenus	Cm(u)			Probowmania	Cm(Tojo-u)		(461,464)
Paraorlovia	Cm(uMid)		(467)	+Probowmaniella	Cm(lMid)		(464)
+Parapachyaspis	Cm(m)		(ZR83)	+Proehmaniella	Cm(mMid-u)		(1089)
+Parapeishania	Cm(m)		(ZR83)	?Proerbia	Cm(Boto-u)	- Cm(Tojo-u)	(468,474)
+Paraperiomma	Cm(Tojo)		(463)	Prohedinia	Cm(uMid)		(464)
Paraplethopeltis	O (Trem-l)		(795)	Proliostracus	Cm(Tojo)	- Cm(lMid)	(464,475)
Parasolenopleura	Cm(mMid-l)	- Cm(uMid-u)	(81,378)	+Promesus	Cm(Trep-u)		(379)
Paratermierella	Cm(Boto)?			+Proptocephalops	Cm(Fran-u)		(618)
+Paratretaspis	O (Llvi-l)		(795)	Propeltura	Cm(Fran-u)	- O (Trem)	(16,494)
Pardailhanian	Cm(m)			+Proricephalus	Cm(Trep-l)	- Cm(Trep-u)	(625,697)
Parehmania	Cm(lMid)	- Cm(mMid-u)	(479,522)	Prosopiscus	O (Aren-u)	- O (Cara)	(1066)
+Pareuloma	Cm(Fran)	- O (Trem-u)	(459)	+Prospectatrix	O (Trem-u)	- O (Aren-u)	(378,726)
+Parkesolithus	O (Cara-u)			?Protagraulos	Cm(Boto)		(80,81)
+Patronaspis	Cm(Fran-l)		(380)	Protrenites	Cm(Dres-u)		(16)
+Pauciella	Cm(Dres-u)		(618)	+Protohedinia	Cm(mMid)	- Cm(uMid)	(464)
+Pedinaspis	Cm(Fran-l)		(380)	+Protolenella	Cm(Boto)		(463)
Peishania	Cm(mMid)	- Cm(uMid)	(464,472)	Protolenus	Cm(Boto-u)	- Cm(mMid)	(80,885)
+Pelicephalus	Cm(Fran-l)		(384)	Protopeltura	Cm(Fran-l)	- Cm(Trep-l)	(81)
Peltocare	O (Trem-l)	- O (Trem-u)	(80,378)	Protostygina	O (Llvi-l)		(795)
Peltura	Cm(Fran-u)	- Cm(Trep-l)	(81)	Provedoria	Cm(m)		
Pelturina	Cm(Trep-u)		(81)	Pruvostina	Cm(Aida-u)		(473)
+Peracheilus	Cm(Trep)			Pruvostinoides	Cm(Boto-u)		(928)
+Peraspis	O (Aren-u)	- O (Llde)	(383)	Pseudatops	Cm(Aida-u)		(81,885)
Periomma	Cm(Tojo)			+Pseudichangia	Cm(Boto-u)		(463,885)
Periomella	Cm(Tojo)			+Pseudoacrocephalites			
Perioura	Cm(m)				Cm(Trep-l)	- Cm(Trep-u)	(618)
Perischoclonus	O (Llvi-l)		(795)	+Pseudoalokistocare	Cm(mMid-u)		(1089)
Perneraspis	Cm(m)			+Pseudoeteraspis	Cm(Tojo)		(474)
Pesaia	Cm(Dres-u)		(618)	+Pseudokadyella	Cm(Boto)?		(471)
+Pesaiaella	Cm(Dres-u)		(618)	+Pseudokingstonia	Cm(Fran-l)		(697)
+Petruninaspis	Cm(Fran-l)		(380)	+Pseudokoldinia	Cm(Trep-l)		(618)
+Phorocephala	O (Aren-u)	- O (Ashg-l)	(381)	Pseudolenus	Cm(Tojo)		(928)
Pianaspis	Cm(lMid)	- Cm(uMid)	(1,459)	Pseudomegalaspis	O (Llde)		
Piaziella	Cm(Tojo)	- Cm(lMid)	(81,463)	+Pseudomexicella	Cm(mMid-u)		(1089)
+Pinctus	Cm(Fran-l)		(379)	+Pseudoplesiagraulos	Cm(l)		(ZR90)
+Pinglusaspis	Cm(u)		(ZR87)	Pseudosolenopleura	Cm(Dres)		(464)
+Placosema	Cm(uMid-u)	- Cm(Dres-l)	(16,482)	Ptychoparella	Cm(Tojo-u)		(497)
+Planaspis	Cm(Boto)?		(471)	Ptychoparia	Cm(lMid)	- Cm(uMid)?	(464,472)
Planiscutellum	S (Ldov-u)			Ptychoparoides	Cm(m)		
Platydiamesus	Cm(Trep-u)		(697)	Ptychoparopsis	Cm(Boto)?		
+Platyharpes	O (Cara-l)			+Ptychopleurites	Cm(Fran-l)	- O (Trem-l)	(618)
+Plectrella	Cm(u)		(ZR90)	+Pugionicauda	Cm(Fran-u)		(697)
Plesioparabolina	O (Trem)			+Pulchricapitus (+ Reagenaspis)			
Plethometopus	Cm(Fran-u)?	- O (Trem-l)	(379,472, 697)		Cm(Fran-l)		(384,697)
+Plethopeltides	Cm(Trep-u)		(618)	+Pytine	O (Aren-u)?		(795)
Plethopeltis	Cm(Trep-u)?	- O (Trem-l)	(379,464)	+Pyttrigris	Cm(Fran-l)		(887)
Plicatolina	Cm(Fran-u)	- O (Aren-l)	(795)	+Qingshuihella	Cm(u)		(ZR90)
+Polyariella	Cm(Fran-u)	- Cm(Trep-u)	(618)	Quebecaspis	Cm(Dres-u)		
+Polycertaspis	Cm(Dres-l)		(482)	+Raashellina	Cm(Dres-u)		(618)
+Populsenella	Cm(Dres-u)		(618)	+Rampartaspis	O (Trem-l)		(1054)
				+Randicephalus	Cm(Fran-l)		(380)

Taxon	First Appearance	Last Appearance	Reference	Taxon	First Appearance	Last Appearance	Reference
+Rasettaspis	Cm(Fran-l)		(380)	Stenopilus	Cm(Trep-l)	-Cm(Trep-u)	(379)
Rasettia	Cm(Trep-l)	-Cm(Trep-u)	(379,697)	Stenorhachis	O (Aren)		
Rawlinsella	Cm(uMid)			Strenuava	Cm(Atda-u)	-Cm(lMid)	(472,885, 928)
Raymondina	Cm(Trep)			Strenuella	Cm(Atda-u)		(885)
+Regina	Cm(mMid)			Sritricephala	Cm(Trep)		
-Regius	Cm(Tojo-u)			Sulcocephalus	Cm(Fran-l)	-Cm(Fran-u)	(488,697)
-Remizites	O (l)		(ZR88)	+Suludella	Cm(uMid)		
-Resimopsis	Cm(Boto)?		(471)	+Sunwaptia	Cm(Trep-u)		(625,697)
Res-seraspis	Cm(Trep)			+?Svalbardites	O (Aren)		
+Reticuloharpes	D (Emsi-l)	-D (Give)	(1106)	Syspacephalus	Cm(Tojo-l)	-Cm(lMid)	(81,475)
Reuscholithus	O (Cara-l)		(378)	Syspacheilus	Cm(Dres-l)		(80,379)
Rhodonaspis	Cm(Dres-l)		(16)	+Szechuanella (+ Paraszechuanella)	O (Trem-l)	-O (Trem-u)	(927)
Rimouskia	Cm(Atda-u)?		(458)	Taenicophalina	Cm(Fran-u)		(379)
Rinconia	Cm(Boto-u)		(928)	+Taeonora	Cm(Dres-u)	-Cm(Fran-l)	(618)
Rollia	O (Trem)?			Taishania	Cm(Fran-l)	-Cm(Fran-u)	(16,472)
+Sagavia	O (Aren-u)	-O (Cara-u)	(726,795)	Talbotina	Cm(uMid-u)	-Cm(Dres-l)	(379)
+Sagittaspis	Cm(Fran-l)		(380)	-Talbotinella	Cm(Dres-l)	-Cm(Dres-u)	(16)
-Sagitoides	Cm(Fran-l)		(380)	+Tamaranella	Cm(Dres-u)		(618)
-Salankanaspis	Cm(mMid-l)			+Tangshanaspis	Cm(Trep)		
Saltaspis	O (Trem-l)		(80)	+Taoyuania	O (Trem-l)	-O (Trem-u)	(927)
Salteria	O (Cara-l)	-O (Cara-u)	(2)	+Tasmanocephalus	O (Aren-l)		
+Sanaschtykolia	Cm(Boto)		(462)	+Tatonaspis	Cm(Fran-u)	-Cm(Trep-l)	
+Sangzhiscutellum	S (Ldov)		(ZR88)	Tatulaspis	Cm(u)		
Sao	Cm(m)			+Tatulus	Cm(uMid)		(ZR89)
+Saonella	Cm(Dres-u)		(618)	+Tchiaspis	Cm(uMid-l)		
Schmalenseeia	Cm(uMid-l)	-Cm(Dres-l)	(472)	Teinistion	Cm(uMid)	-Cm(Dres-l)	(16,472)
+Schoriecare	Cm(Dres-u)		(618)	+Termieraspis	Cm(Boto)?	(471)	
Schoriella	Cm(uMid)		(467)	Termierella	Cm(Boto-u)	-Cm(Tojo-u)	(928)
+Schylaspis	Cm(Fran-l)		(380,459)	Terranovella	Cm(Dres-l)		(379)
+Scotoharpes	O (Trem-u)	-S (Ldov-u)	(378)	+Tholus	Cm(l)		(ZR88)
Selenoharpes	O (Aren)	-S (Wen-l)	(383)	+Tolstotchichaspis	Cm(Fran-u)		(618)
+Seletella	Cm(Fran-l)		(380)	+Torifera	Cm(Dres-l)		
+Seletoides	Cm(Fran-l)		(380)	+Torriddella	Cm(uMid-u)		(379)
+Semicyclocephalus	Cm(uMid)			+Tosotychia	Cm(uMid)		(16)
Shangtungia	Cm(Dres-l)		(464)	Tostonia	Cm(Trep)?		
+Shenjiawania	O (Trem-l)			Trachycheilus	Cm(mMid-u)		(1089)
Shickshockia	Cm(Dres)			Triarthrella	Cm(Trep)		
+Shifangia	Cm(Boto)		(463)	Triarthroides	O (Trem)		
Shirakiella	Cm(Fran-u)		(464)	Triarthrus	O (Trem-l)	-O (Ashg-u)	(2,690)
Shumardia	Cm(Trep)?	-O (Ashg-m)	(2,80)	Tricrepecephalus	Cm(mMid-u)	-Cm(Dres-l)	(379)
Shumardops	O (Trem)			-Troedssonia	Cm(Trep-u)	-O (Trem-u)	(927)
-Sichuanolenus	Cm(Boto-u)		(463)	Tropidopyge	Cm(Fran-u)	-O (Aren)?	(618)
+Sismocheilus	Cm(Dres-u)		(489)	+Trymataspis	Cm(mMid-u)		(1089)
+Simulolenus	Cm(Dres-u)			-Tuberaspis	Cm(Dres-l)		(380)
+Sinocepecephalus	Cm(l)		(ZR85)	+Turgicephalus	O (Aren-u)	-O (Llvi-l)	(795)
+Sinoharpes	O (Ashg-l)		(862)	+Tuvanella	Cm(Boto)?		(471)
+Sinoptychoparia	Cm(Tojo-u)		(885)	+Tympauella	Cm(mMid-u)		(1089)
Skreiaspis	Cm(m)			Uncaspis	Cm(Dres-l)		(379)
Solenoparia	Cm(uMid)		(464)	Urbanaspis	Cm(u)		
Solenopleura (+ Jincella)	Cm(mMid-u)	-Cm(uMid-u)	(16,469)	+Urjungaspis	Cm(uMid)		
Solenopleurella	Cm(Boto-u)?	-Cm(uMid-l)	(474,479)	Utia	Cm(mMid-l)		
Solenopleurina	Cm(m)			+Uxunella	Cm(Dres-l)	-Cm(Dres-u)	
Solenopleuropsis	Cm(uMid-m)		(378)	+Varanella	Cm(Dres-u)		(379)
Sombretella	Cm(Boto)			+Verkholenella	Cm(Dres-u)		(618)
+Songtaoia	O (Trem-l)	-O (Trem-u)	(927)	Vermilionites	O (Trem)		
-Spencella	Cm(mMid-u)	-Cm(uMid-l)	(81)	Vermontella	Cm(uMid-m)	-Cm(uMid-u)	(81)
Spencia	Cm(Tojo-u)	-Cm(mMid-l)	(81)	+Vernaculina	Cm(uMid-u)		(379)
Sphaerophthalmella	O (l)			-Volocephalina	Cm(lMid)		(478)
Sphaerophthalmus	Cm(Fran-u)		(81)	+Wangzishia	Cm(Atda-u)		(463)
-Stegnopsis	O (Aren-u)	-O (Llvi-u)	(795)	+Wanwanaspis	Cm(Trep)		(16)
-Stella	Cm(uMid)						

Taxon	First Appearance	Last Appearance	Reference	Taxon	First Appearance	Last Appearance	Reference
Weeksina	Cm(Dres-l)		(379)	+ Bitumulina	C (Tour-l)		
Westergaardia	Cm(Trep)			+ Bohemiproetus	D (Sieg)	-D (Emsi-l)	(933)
Westergaardites	Cm(Fran-u)		(484)	+ Bojocoryphe	D (Sieg)		(1106)
+ Whittingtonella	Cm(u)		(ZR90)	+ Bolbocephalus	O (Aren-l)		
+ Wilcoxaspis	Cm(Trep-u)		(625,697)	+ Bolivicrania	P		(ZR87)
+ Wilsonarella	Cm(Fran-l)		(380)	+ Boliviproetus	D (Emsi-l)	-D (Emsi-u)	(1106)
Wongia	Cm(Dres-l)?		(464)	+ Bollandia	C (Tour-u)	-C (Vise-u)	
+ Wujiajiania	Cm(Trep-l)			+ Borealia	D (Emsi-l)	-D (Emsi-u)	(1106)
+ Xenochelios	Cm(Fran-l)		(379,697)	+ Brachymetopus	D (Fame-u)	-P (Guad)	(421,624)
+ Xenostegium	O (Trem-l)	-O (Trem-u)	(795)	+ Breviphilipia	C (Tour-l)		
+ Xianquianaspis	Cm(Boto)	-Cm(Tojo)	(463)	+ Buchiproetus	D (Emsi-l)	-D (Eife)	(1106)
+ Xiaomajiella	Cm(Tojo)		(463)	+ Calybole	D (Fame-m)		(802)
+ Xilingxia	Cm(Boto-u)		(463)	+ Camingella	C (Tour-l)	-C (l)	(2)
+ Xiushuilithus	O (Cara-m)	-O (Cara-u)	(875)	+ Camsellia	D (Eife)		(1106)
Yabeia	Cm(mMid)?	-Cm(uMid)	(464,472)	+ Carbonocoryphe	C (Tour-u)	-C (Vise-u)	
+ Yinpanolithus	O (Aren-u)		(875)	+ Carbonoproetus	C (Bash-l)		(ZR88)
Yohoaspis	Cm(lMid)			+ Carolinites	O (Aren-l)	-O (Llvi-u)	(795)
+ Yosimuraspis	O (Trem-l)		(927)	+ Celmus	O (Aren-u)		(1066)
+ Yuehsiezella	Cm(Boto-u)	-Cm(Tojo)	(463)	+ Ceratopeltis	O (Aren)		
Yuknessaspis	Cm(mMid-u)		(1089)	+ Ceratoproetus	D (l)		(ZR85)
+ Yukonaspis	Cm(Fran-u)	-Cm(Trep-u)		+ Chaufouraspis	D (Emsi)		(421)
+ Yurakia	Cm(Fran-u)		(618)	+ Chaunoproetus	D (Fame-m)	-D (Fame-u)	(421,802)
+ Zaozhuangaspis	Cm(m)		(ZR84)	+ Cheiropyge	P (Sakm-u)	-P (Djhu)	(389,624)
Zdicella	O (Ashg-l)	-O (Ashg-m)		+ Chomatopyge	O (Llde-u)	-O (Cara-l)	(795)
+ Ziboaspideella	Cm		(ZR90)	+ Chuanqianoproetus	S (Wen-l)		(651)
Or. PROETIDA				+ Clavibole	D (Fras)		(802)
+ Aceroproetus	S (Wen-l)		(ZR91)	+ Clypoproetus	O (Ashg)		
+ Acidiphorus (+ Goniotelus)				+ Coignops	C (Vise-u)	-C (Bash-l)	
	O (Aren-l)	-O (Llvi-l)	(795)	+ Comptonaspis	C (Tour-l)		
+ Acropyge	P (Guad-u)	-P (Dora)	(528,624,666)	+ Coniproetus	S (Prid)	-D (Emsi-l)	(933)
				+ Conophillipia	C (Tour-l)	-C (Vise-u)	
Agerina	O (Trem)	-O (Cara-l)	(2,378,795)	+ Constantina	D (Fame-u)		(387)
+ Alberticoryphe	D (Sieg)	-D (Emsi-l)	(421,1106)	+ Cordania	D (Gedi-l)	-D (Sieg)	(421)
+ Amblycranium	O (Trem-u)		(795)	+ Cornuproetus	S (Llde-u)	-D (Give-u)	(421,1106)
Ameura	C (Serp-l)?	-P (Sakm)	(624)	+ Crassiproetus	D (Sieg)	-D (Give-l)	(421,933)
+ Anpulliglabella	P (m)		(528)	+ Cummingella	C (Tour-l)	-P (Sakm)	(624)
+ Analocaspis	O (Cara)		(388)	+ Cyamella	O (Cara-u)		(1268)
+ Anisopyge	P (Leon-l)	-P (Guad-u)	(624)	+ Cyamops	O (Cara-u)	-O (Ashg)	
+ Appendicysta	C (Bash-u)		(892)	+ Cyphaspides	D (Sieg)	-D (Give-u)	(421,1106)
+ Aprathia	C (Tour-u)	-C (Vise-u)	(895)	+ Cyphasps	S (Wen-l)	-D (Fras-u)	(378,421)
+ Archegonus	D (Fras)?	-C (Vise-u)	(421)	+ Cyphinoidea	C (Vise-u)	-C (Serp-l)	
+ Acetopeltis	O (Ashg)		(933)	+ Cyphoproetus	O (Cara-m)	-S (Wen-l)	(378,388)
+ Ascopeltis	O (Ashg-l)	-O (Ashg-m)		+ Cyrtodechenella	D (Eife)	-D (Fras)?	(421,1106)
+ Asiagena	D (Gedi)		(1106)	+ Cyrtoproetus	C (Tour-l)	-C (Vise-u)	(624)
Astroproetus	O (Llde-l)	-S (Ldov-m)	(735,795)	+ Cyrtosymbole	D (Fame)	-C (Tour)?	(421)
Astycoryphe	D (Gedi)	-D (Give-u)	(421)	+ Cyrtosymboloides	D (Emsi-l)	-D (Eife)	(421,1106)
Aulacopleura	O (Trem)?	-D (Give-u)	(1106)	+ Cystospina	C (Vise)		(1045)
Aulacopleurina	D (Sieg)	-D (Eife)	(421)	+ Daihuaiia	D (Fame-m)	-D (Fame-u)	(802)
+ Australokaskia	C (Tour-l)	-C (Tour-u)		+ Dalejeproetus	D (Gedi)	-D (Emsi-u)	(1106)
+ Australosutura	C (Tour-l)			+ Dechenella	D (Gedi-l)	-D (Give-l)	(1015)
+ Baillielloides	D (Emsi)	-D (Eife)	(421)	+ Dechenellurus	D (Gedi)	-D (Emsi-l)	(1106)
+ Bapingaspis	D (Fras-u)	-D (Fame-u)	(802)	+ Decoroproetus	O (Aren-u)	-D (Emsi-l)	(388,421,1106)
Basidechenella	D (Emsi-l)	-D (Eife)	(1106)	Delaria	P (Leon-l)	-P (Guad-l)	(624)
Bathyurellus (+ Punka)				+ Deltadechenella	D (Eife)		(421)
	O (Trem-u)	-O (Llvi-l)?	(795)	+ Denemarkia	D (Sieg)		(421,1106)
+ ?Bathyriscoops	O (Aren)			+ Devonocoryphe	D (Fame-l)	-D (Fame-u)	(802)
Bathyurus	O (Llvi-l)	-O (Cara-m)	(795)	+ Devonoproetus	D (Gedi-u)	-D (Eife-l)	(933)
+ Bedicella	C (Step-l)	-P (Sakm)		+ Diacoryphe	C (Tour)		
+ Benesovella	D (Eife-l)		(421)	+ Dimeropyge	O (Llde-l)	-O (Ashg-u)	(690)
+ Benthamaspis	O (Aren-l)		(1066)	+ Dimeropygiella	O (Aren)		
+ Biolgina	O (Aren)?		(388)	+ Ditomopyge	C (Bash-l)	-P (Guad-u)	(2,624,892)

Taxon	First Appearance	Last Appearance	Reference	Taxon	First Appearance	Last Appearance	Reference
+Dixiphopyge	C (Tour-l)			Ischyrotoma	O (Aren-l)	-O (Llvi-u)	(388,795)
+Dohmiella	D (Eife-u)	-D (Give-u)	(933)	Jeffersonia	O (Trem-u)	-O (Aren-l)	(795)
+Doublatia	P (Sakm-u)		(624)	+Jimbokranion	P (m)		(528)
Drevermannia	D (Fame)	-C (Tour)?	(1106)	+Karginella	C (Serp-l)		
+Dudu	P (l)		(ZR85)	Kaskia	C (Vise)	-C (Bash)	
Eleutherocentrus	O (Aren-u)		(795)	+Kathwaia	P (Guad-u)	-P (Djhu)	(624)
Elliptophillipsia	C (Tour-l)		(2)	+Kegeliella	D (Sieg-u)	-D (Emsi-l)	(933)
+Endops	P (Guad-u)		(624)	+Khalfinella	D (Gedi-l)	-D (Eife)	(421,1106)
Eocyphinium	C (Tour-l)	-C (Serp-l)		+Kinderlania	O (l)		(ZR85)
+Eocyrtyssymbole	D (Emsi-l)		(1106)	+Kolympoeretus	D (Sieg)		(1106)
Eodrevermannia	D (Gedi)?	-D (Emsi-u)	(421,1066)	+Koneprusites	D (Emsi-u)	-D (Give-l)	(1106)
+Eoproetus	Cm(uMid)		(ZR85)	+Kulmiella	C (Vise-u)		(378)
+Erbenaspis	D (Gedi)	-D (Emsi-u)	(421,1106)	+Lacunoporaspis	S (Ldov-u)	-D (Eife-l)	(421,735)
+Erbenicoryphe	D (Fras-l)		(1106)	+Lasarchopyge	O (Llvi)	-O (Cara-l)	
+Erbenites	D (Eife)	-D (Give-u)	(1106)	-Langonbole	D (Fame)		(421)
Eremiproetus	S (Prid)?	-D (Give-u)	(421)	Lecanopyge	Cm(Trep)		
+Eudechella	D (Give)		(421)	+Lepidoproetus	D (Gedi)	-D (Emsi-l)	(1106)
+Evagena	C (Vise)			Lichnocephala	O (Trem-u)		(795)
Exochops	C (Vise-l)			Linguaphillipsia	C (Tour-l)	-C (Vise-u)	(624)
+Falcatorproetus	S (Wenl)	-S (Ludl-l)?	(933)	+Linguaproetus	D (Eife)		(421)
Formonia	D (Fame-l)		(421,1106)	Liobole	C (Vise-u)		
+Frithjofia	D (Fame-l)	-D (Fame-u)	(802)	Liobolina	C (Tour-l)	-C (Vise-l)	
+Fusciniopyge	D (Eife)		(421)	+Loeipyge	C (Bash-u)	-P (Sakm)	(624,892)
+Ganiella	D (Gedi-l)	-D (Eife)?	(421,1106)	+Longiproetus	D (Eife-u)	-D (Give-u)	(933)
+Gapevella	C (Vise-u)	-C (Serp-l)		+Lophiokephalion	D		(ZR89)
+Gerastes	D (Gedi)	-D (Give-l)	(933,1106)	+Lugalella	C (l)		(ZR83)
+Gitarra	C (Tour-u)	-C (Vise-l)	(624)	Lutesvillia	O (Aren-l)?		
+Glaphurella	O (Ashg-m)			+Macroblepharum	D (Emsi-l)	-D (Eife)	(1106)
Glaphurina	O (Llde)		(795)	+Madaraspis	O (Llvi-l)		
Glaphurus	O (Trem)	-O (Cara-l)	(2,795,1066)	+Madygenia	O (Ashg-l)		(862)
				+Mahaiella	C (l)		(ZR83)
+Globusia	C (Tour)		(1045)	+Mannopyge	D (Emsi-u)		(1106)
Goniophrys	O (Aren-l)	-O (Llvi-l)	(383,1066)	+Maurotarion	O (Ashg)	-D (Give)?	
Goniotelina	O (Aren-l)	-O (Llvi-l)	(382)	+Merebolina	C (Serp)?		(624)
Gonioteloides	O (l)			Mesotaphraspis	O (Llde-l)	-O (Cara-u)	(795)
+Gracemerea	C (Vise-l)?		(895)	+Microphillipsia	P (Guad-u)		(624)
Griffithidella	C (Tour-l)	-C (Tour-u)	(2)	+Mirabole	D (Fame-u)		(421,802)
Griffithides	C (Tour-l)	-C (Step-l)	(389)	+Miriproetus	D (Sieg)		(1106)
Grinnellaspis	O (Aren-l)			+Monodechella	D (Give-l)		(1106)
+Haasia	D (Fame-u)		(802)	+Monodechenella	D (Eife)		(1106)
+Hamioproetus	D (Sieg)	-D (Emsi-l)	(1106)	+Moravocoryphe	D (Emsi-u)		(1106)
+Hanjjiangaspis	O (Cara-u)		(1268)	+Moschoglossis	C (Tour-u)		
+Harpidella	O (Cara-l)	-D (Give)		+Myoproetus	D (Emsi-u)	-D (Eife)	(933,1106)
+Hedstroemia	S (Ldov-u)	-D (Gedi)	(933,1106)	+Mystrocephala	D (Emsi-u)	-D (Give-l)	(421,1106)
+Helioeprotoides	D (Fame-m)		(802)	+Nagaproetus	D (Sieg)	-D (Eife)	(1106)
+Helioproetus	D (Fame-u)		(802)	Namuropyge (+ Coignouina)			
+Hentigia	P (Leon)		(892)	C (Tour-l)		-C (Bash-u)	(1066)
+Hexianella	O (l)		(ZR83)	Neogriffithides	C (Bash-u)	-P (Guad-u)	(624,892)
+Hildaphillipsia	P (Guad-u)		(624)	Neoproetus	C (Bash-u)	-P (Guad-u)	
Hillyardina	O (Trem-u)		(795)	+Niachangella	O (Ashg-u)		(690)
+Hollandia	D (Gedi)	-D (Sieg)	(1106)	+Nipponaspis	C (Bash-u)	-P (Djhu)	(389)
Holotrachelus	O (Cara-m)	-O (Ashg-u)	(2,690,795)	+Nitidocare	S		(ZR85)
+Huanoproetus	C (l)		(ZR90)	+Novoameura	P (Guad-l)		
+Humeia	D (Eife)			+Oculomagnus	O (l)		
Humiligriffithides	C (Mosc)?		(624)	+Oehleria	D (Emsi)?		(933)
+Hypaproetus	S (Ldov-m)		(651)	+Oenonella	O (Aren-u)		(795)
Hystricurus	O (Trem-l)	-O (Trem-u)	(388,795)	+Oidaloproetus	S (Ldov-m)		(651)
+Ignoproetus	D (Emsi-u)	-D (Eife)	(1106)	+Orbitoproetus	D (Gedi)	-D (Give-u)	(933,1106)
+Interproetus	S (Wenl-l)	-S (Ludl)		+Ormistonella	D (Emsi-u)	-D (Eife)	(1106)
+Iranaspidium	P (Guad-u)		(528,624)	Otarion	S (Wenl-l)	-D (Eife)	(1106)
Isbergia	O (Cara-l)	-O (Ashg)?	(795)	+Otarionella	D (Gedi)	-D (Eife-u)	(421)
+Ischyrophyma	O (Aren-l)	-O (Llvi-l)		+Otarionides	D (Sieg)		(421)

Taxon	First Appearance	Last Appearance	Reference	Taxon	First Appearance	Last Appearance	Reference
Pachyranium	O (Trem-u)		(795)	+Pseudowaribole	D (Fame-m)	-C (Mosc-l)	(802,892)
+Pachyproetus	S (Prid)		(933)	+Pterocoryphe	D (Fras-l)		(421)
Paladin	C (Vise-l)	-P (Guad)	(624)	Pteroparia	D (Fras-m)	-D (Fras-u)	
Palaeophillipsia	C (l)		(2)	Pudoproetus	D (Fame-u)	-C (Mosc-l)	(933)
Palpebralia	D (Fras)		(1106)	+Pulcherproetus	S (Ludl-u)	-S (Prid)	(933)
Panarchaeogonus	O (Llde-l)	-O (Ashg-m)	(795)	+Pusillaboles	D (Fame)		(1106)
+Parachauoproetus	D (Fame-u)		(802)	+Quadratoproetus	D (Emsi-u)		(1106)
Paradechenella	D (Emsi-u)	-D (Give)	(421,1106)	+Quyuania	O (Cara-u)		(1268)
+Parafriithofia	D (Fame-m)	-D (Fame-u)	(802)	+Radnorina	O (Cara-m)	-S (Wenl-u)	
Paragriffithides	C (l)			+Radonia	S (Tour-l)		(528)
Parahystericurus	O (Trem-l)	-O (Aren-u)	(388,795)	Ranananus	O (Aren-l)?		
+Parapalebralia	D (Emsi-u)		(1106)	+Ranunculoproetus	D (Gedi)	-D (Sieg)	(1106)
Paraphillipsia	P (Asse)	-P (Djhu)	(624)	Raymondaspis	O (Aren-u)	-O (Llde-u)	
+Paraphillipsinella	O (Cara-u)		(1268)	Raymondites	O (Llvi-l)	-O (Cara-m)	(795)
+Paraproetus	O (Ashg-m)		(1082)	+Reediella	C (Tour-l)	-C (Vise-u)	(378)
+Paratoernquistia	O (Cara-l)	-O (Cara-m)		+Rhenogriffides	C (Tour-u)	-C (Vise-l)	
+Parawarburgella	D (Gedi)		(1106)	+Richteraspis	D (Fras)		(421)
+Particeps	C (Tour-u)	-C (Serp-l)	(378)	+Richterella	C (Tour-l)	-C (Vise-l)	
+Parvigena	O (Cara-u)	-O (Ashg-m)	(388,1268)	+Rorringtonia	O (Llde-l)	-O (Ashg-m)	(388)
Paryfenus	O (Llvi)?			+Ryckholtia	S (Ludl-u)		(933)
+Pedinodechenella	D (Eife)		(421)	Scharyia	O (Llde)	-D (Eife-l)	(421,795)
Peltabella	O (Trem-u)	-O (Llvi-l)	(388,795)	+Schizophillipsia	C (Tour-u)	-C (Vise)	(624)
+Perakaspis	D (Emsi-u)	-D (Eife)?	(421,1106)	+Schizoproetina	D (Gedi)	-D (Emsi-u)	(421,1106)
+Perexigopyge	C (l)		(ZR89)	+Schizoproetoides	D (Sieg)	-D (Eife)?	(421,1106)
Perlioproetus	D (Fame-u)		(2,421)	Schizoproetus	D (Emsi-l)	-D (Give-l)	(421,1106)
Petigurus	O (Aren-l)	-O (Llvi-l)	(795)	+Sculptoproetus	S (Prid)	-D (Eife-u)	(1106)
Phaetonellus	O	-D (Give)	(421)	Sevillia	C (Bash)	-C (Step-l)	
+Phaselops	O (Llvi-l)	-O (Llde)	(388,1075)	+Sinaproetus	D (Sieg)		(1106)
Phillibole	C (Tour-u)			+Sinobole	D (Fame-l)	-D (Fame-m)	(802)
+Phillibolina	C (Vise-l)			Skemmatocare	D (Fame-l)	-D (Fame-m)	(802)
Phillipsia	C (Tour-l)	-C (Vise-l)	(2)	Skemmatopyge	D (Fame-m)		(802)
Phyllaspis	D (Sieg)	-D (Emsi-u)	(421,1106)	+Solariproetus	O (Ashg-u)		(ZR87)
Piltonia	C (Tour-l)	-C (Tour-u)		+Songkania	S (Ldov-u)		
+Piriproetus	D (Emsi-u)	-D (Eife)	(1106)	+Spatulina	C (Vise-l)	-C (Vise-u)	(378,1045)
Platyantyx	O (Llvi)?			+Sperginaspis	C (l)		(ZR88)
+Podoliproetus	D (Sieg)	-D (Emsi-l)	(933)	+Spinibole	C (Vise-l)		(1045)
+Pontipalpebralia	D (Fame)		(1106)	+Stenoblepharum	O (Llde-l)	-O (Ashg-u)	(690,795)
Praedechenella	D (Sieg)	-D (Emsi-u)	(1106)	Strigenalis	O (Trem-u)	-O (Aren-u)	(2,795)
+Pragoproetus	D (Gedi-u)	-D (Sieg)	(933)	+Thaiaispis	C (Step)?		
Prantlia	S (Ldov-u)	-D (Gedi)	(421)	+Tanybregma	O (Trem-u)?		
Pribylia	D (Sieg)	(421,1106)		+Tawstockia	C (Vise)		(1045)
Prionopeltis	S (Prid)	-D (Gedi-l)	(1106)	+Tayanaella	D (Gedi)		(1106)
+Prodiacoryphe	D (Fame-m)		(802)	+Tcherkesovia	D (Gedi)		(1106)
+Prodevermannia	D (Gedi)	-D (Emsi-l)	(421,1106)	+Tekinia	S (Ludl)	-S (Prid)	
Proetidella	O (Cara-u)	-O (Ashg-u)	(795)	Telephina	O (Aren-u)	-O (Ashg-m)	(2)
Proetides	C (Tour-l)	-C (Tour-u)		+Thalabaria	C (Vise-l)		(895)
Proetina	D (Sieg)		(421,933)	+Thebanaspis	O (Ashg-m)	-S (Ldov-m)	(933)
+Protocephalus	D (Emsi-l)	-D (Emsi-u)	(933)	Thigriffides	C (Tour-l)		(2)
+Protoopeltis	D (Emsi-l)	-D (Eife)	(1106)	+Timoraspis	P (Leon-m)	-P (Guad-u)	(624)
Proetus	O (Cara-m)	-S (Prid)	(933,1066)	Toernquistia	O (Llde-u)	-O (Ashg-u)	(2,795)
+Proscharyia	O (Trem-l)	-O (Trem-u)	(927)	+Trautensteinproetus	D (Emsi-l)	-D (Eife)	(1106)
Protarchaeogonus	O (Trem-l)		(388)	+Triproetus	C (Step)?	-P (Leon-l)	
Psalikilopsis	O (Trem-u)	-O (Aren-l)	(795)	+Tropidocare	D (Gedi)		(421,1106)
Psalikilus	O (Trem-u)	-O (Aren-l)	(795)	Tropidocoryphe	S (u)?	-D (Give-u)	
Psephosthenaspis	O (Llvi-l)			Tschernyschewiella	D (Sieg)?		(1106)
+Pseudodechenella	D (Sieg)	-D (Eife)	(421,1106)	Typhloproetus	D (Fame-u)	-C (l)	(802)
+Pseudogerastus	S (Ldov-u)	-S (Wenl)	(933)	Unguliproetus	D (Sieg)	-D (Eife)	(421,933,1106)
+Pseudohystericurus	O (Trem-u)	-O (Llvi-l)?	(795)	Uromystrum	O (Trem-u)	-O (Llvi-u)	(795)
+Pseudoolenoides	O (Llvi-l)		(382)	+Vandergrachtia	C (Vise-u)		(1045)
Pseudophillipsia	C (Bash-u)	-P (Dora)	(528,892)	+Vicinoproetus	D (Sieg)		(1106)
Pseudoproetus	S (Ldov)			Vidria	P (Leon-u)	-P (Guad-u)	(624)
+Pseudotrinosus	D (Emsi-u)		(1106)				

Taxon	First Appearance	Last Appearance	Reference	Taxon	First Appearance	Last Appearance	Reference
+ Vitaella	D (Fame-m)		(421,802)	- Blanfordianites	D (Emsi)	- D (Eife)?	(421)
+ Wagnerispina	C (Serp-l)?		(624)	+ Boeckops	D (Sieg)	- D (Emsi-u)	(1106)
+ Waideggula	C (u)		(ZR91)	+ Bolbochasmps	O (Cara-l)	- O (Cara-m)	(392)
Wurburgaspis	O (Ashg)			- Bolivianaspis	D (Gedi)		(421)
Wurburgella	O (Ashg-m)	- D (Gedi-u)	(795)	+ Borelaspis	O (Cara-m)	- O (Ashg-u)	(690,795)
+ Waribole	D (Fame-m)	- C (Mosc-l)	(802,892)	+ Bornholmaspis	O (l)		(ZR85)
+ Weania	C (Tour-l)	- C (Bash-u)	(378,624,892)	Bouleia	D (Emsi-l)	- D (Eife)	(1106)
Weberides	C (l)	- C (Bash)?		+ Bradocryphaeus	D (Eife)	- D (Fras-u)	(983)
- Weberiphilippia	C (Tour-u)	- C (Vise-u)		+ Breizhops	D (Emsi-l)	- D (Fame)?	(983,ZR83)
+ Winterbergia	C (Tour-l)?	- C (Vise-u)	(895)	- Brianurus	S (Ldov-u)		(1088)
- Witryides	C (l)		(ZR88)	+ Brongniartella	O (Llde-l)	- S (Ldov-l)	(378,795)
- Wolayella	D (Gedi-u)	- D (Emsi-l)	(421,1106)	+ Bufoceraurus	O (Cara-l)	- O (Cara-m)	
+ Xenoboloides	C (l)		(ZR87)	Burmeisterella	D (Sieg-u)	- D (Emsi-l)	(1106)
- Xenocybe	O (Ashg-l)		(388)	Burmeisteria	D (Emsi-l)	- D (Emsi-u)	(421)
+ Xenodechenella	D (Emsi-u)		(1106)	- Burtonops	D (l)	- D (Eife)	(1015)
+ Xiangzhongella	C (l)		(ZR88)	Calomnia	D (Emsi-l)	- D (Emsi-u)	(1106)
Xiphogonium	D (Sieg)	- D (Emsi-u)	(1106)	- Calpmenella	O (Ashg-u)		(690)
+ Yanshanaspis	D (l)		(ZR85)	Calymene	O (Cara-m)	- D (Sieg)	(1106)
- Yichangaspis	S		(ZR91)	Calymenella	O (Aren-l)	- O (Llde-u)	(795)
+ Zhegangula	C (Bash-u)		(892)	Calymenesum	O (Llde-l)	- O (Ashg-m)	(381)
				Calymenius	Cm (Trep)	- O (Llvi-u)	(795)
				Calyptaualax	O (Llvi-l)	- O (Ashg-u)	(392,690)
				+ Celtenerinurus	O (Cara-m)	- O (Ashg-u)	(795)
				- Centauropyge	D (Eife)		(421,1106)
				Ceraurinaella	O (Aren-u)	- O (Ashg-m)	(382,1082)
				+ Ceraurinium	O (u)		(ZR85)
				Ceraurinus	O (Cara-m)	- O (Ashg-u)	(795)
				Cerauroides	S (u)		
				+ Cerauromeros	S		(ZR85)
				+ Cerauropeltis	O (m)		(ZR85)
				Ceraurus	O (Llvi-u)	- O (Ashg-u)	(690)
				+ Chacomurus	D (Emsi-l)		(1106)
				Chasmops	O (Llvi-u)	- O (Cara-u)	(392)
				Cheirurus	O (u)	- D (Give-u)	(421)
				+ Chiarumanipyge	D (Gedi)		(421,1106)
				+ Chiozoon	S (Wenl-u)		
				- Chotecops	D (Emsi-l)	- D (Fame)	(1106)
				+ Colobinion	O (Aren-u)		(795)
				Colpocoryphe	O (Aren-l)	- O (Cara-u)	
				Comura	D (Emsi-l)	- D (Emsi-u)	(983)
				- Cordapeltis	D (Eife)		(421)
				Coronura	D (Emsi-l)	- D (Eife)	(394,421,1106)
				Corycephalus	D (Gedi)		(1106)
				+ Costracheirus	S (Wenl)	- O (Cara-m)	(ZR84)
				+ Courtessolium	O (l)		(ZR85)
				Cromus	S (Ldov-u)	- S (Prid)	(2)
				- Crotalocephalides	D (Sieg)		(1106)
				+ Crotalocephalina	S (u)	- D (Sieg)	(1106)
				Crotalocephalus	D (Gedi)	- D (Give-u)	(2,1106)
				+ Crozonaspis	O (Llvi)	- O (Cara)	
				Cryphaeoides	D (Eife)	- D (Give)	(421,1106)
				+ Cryphaeus	D (Eife)		(421)
				Cryphina	D (Sieg)	- D (Emsi-l)	(1106)
				Cryphops	D (Fras)	- D (Fame-u)	(2,421,1106)
				+ Curriella	S (Ldov-l)	- S (Ldov-m)	
				Cybele	O (Llvi-l)	- O (Cara-m)	(2)
				+ Cybellella	O (Llde-u)?	- O (Cara-l)	(795)
				Cybeloides	O (Llvi-u)	- O (Ashg-u)	(690,795)
				Cybelopsis	O (Aren-l)	- O (Llvi-l)	(795)
				+ Cybelurus	O (Aren-u)	- O (Llde-u)	(795)

Or. PHACOPIIDA

Acanthoparypha	O (Llvi-u)	- O (Cara-m)	(795)
Acastava	D (Sieg)	- D (Emsi-u)	(1106)
Acaste	S (Ldov-m)	- D (Sieg)	(1106)
Acastella	S (Ludl-l)	- D (Sieg-l)	
Acastellina	D (Emsi-u)	- D (Eife)	(1106)
Acastroides	S (Wenl-l)	- D (Emsi-u)	(421,1106)
+ Acastopyge	S (Prid)		
+ Acernaspis	S (Ldov-l)	- S (Wenl-l)	(393)
Achatella	O (Llde-u)	- O (Ashg-u)	(392,690)
Actinopeltis	O (Llde-u)	- O (Ashg-m)	(1075)
Adastocephalum	D (Gedi)?	- D (Sieg)?	(421)
+ Aegrotocatellus	S (Ludl-l)		
+ Afrops	D (Gedi)?	D (Sieg)?	(1106)
+ Alcauldops	D (Eife)	- D (Give)	(1106)
+ Alcymene	S (Ludl-l)	- S (Ludl-u)	
+ Altaesajanis	D (Eife)		(1106)
+ Alwynulus	O (Llde-u)		(795)
Anacheirus	O (Trem-u)		(378)
+ Ananaspis	S (Wenl-l)	- D (Gedi)	(393,1106)
+ Anapliomerella	O (Cara-l)		(795)
Anchiopella	D (Sieg)	- D (Emsi-l)	(1106)
+ Anchiopsis	D (Sieg-l)	- D (Eife-l)	(394)
+ Andinacaste	S (Prid)	- D (Gedi-l)	(1055)
+ Apocalymene	S (Wenl-l)	- D (Sieg-l)	
+ Arcticalymene	S (Wenl-l)	- S (Wenl-u)	
- Arduennella	D (Sieg)	- D (Emsi-l)	(902,1106)
Areia	O (Llvi)	- O (Ashg-m)?	
+ Argentopyge	D (Gedi)		(421)
Asieropyge	D (Emsi-u)	- D (Eife)	(983,1106)
Atractopyge	O (Llde-l)	- O (Ashg-m)	(378)
+ Australops	D (Gedi)?		(421,1106)
+ Avalanchurus	S (Wenl-l)	- S (Ludl-u)	(1088)
Bainella	D (Emsi-l)	- D (Emsi-u)	(421,1106)
+ Baliroma	S (Wenl-u)	- S (Ludl-u)	(1088)
Bathycheilus	O (Aren)	- O (Llvi)	
+ Batocara	S (Ludl-l)	- S (Ludl-u)	(1088)
+ Batyraspis	O (l)		(ZR88)
Bavarilla	O (Trem)		
Bevanopsis	O (Llvi-u)	- O (Cara-l)	(795)

Taxon	First Appearance	Last Appearance	Reference	Taxon	First Appearance	Last Appearance	Reference
+Cydonocephalus	O (Llvi-l)		(383)	+Furacopyge	D (Emsi-u)		(1106)
Cyrometopus	O (l)			-Gabriceraurus	O (Cara-l)	-O (Ashg-m)	(795)
Dalmanites (+ Ommokris)	S (Ldov-l)	-D (Eife-l)	(421,1066)	+Gamonedaspis	D (Emsi-l)	-D (Emsi-u)	(1106)
Dalmanitina	O (Llde)	-O (Ashg-u)	(574)	+Glyptambon	S (Wenl-u)	-S (Ludl)	(574)
Dalmaniturus	S			Gourdonia	D (Emsi-u)	-D (Eife-l)	(983,1106)
+Dayongia	O (Ashg)		(ZR87)	Gravicallymene	O (Llde-u)	-D (Give)	(378,421,795)
+Daytonia	S (Ldov-u)			Greenops	D (Emsi-u)	-D (Fras)	(421,983,1106)
+Deacybele	O (Cara-l)		(795)	+Guichenia	O (Llde)		
Deiphon	S (Ldov-l)	-S (Prid)	(735)	+Gyrometopus	O (Aren)		(1066)
+Deltacephalaspis	D (Emsi-l)	-D (Emsi-u)	(1106)	Hadrohybus	O (m)		
+Delocare	D (Emsi-l)	-D (Emsi-u)	(983,1106)	+Hadromeros	O (Llde-u)	-S (Ldov-m)	(378,390)
+Delops	S (Wenl)		(574)	+Hammanopyge	O (m)		(ZR85)
+Demetrops	O (l)		(ZR85)	Hapsiceraurus	O (Cara-m)		(795)
Denckmannites	S (Ludl-u)	-D (Gedi-l)	(421)	Helioccephalus	S (Wenl-l)	-S (Ludl-l)	
+Denella	O (Cara-m)	-O (Cara-u)	(392)	Heliomera	O (Llvi-l)		(795)
+Devonodontochile	D (Emsi-l)		(1106)	Heliomeroides	O (Aren-u)	-O (Cara-m)	(795)
Diacallymene	O (Cara-u)	-S (Wenl-u)		-Heliopyge	D (Eife)	-D (Fras-u)	(983)
Dianops	D (Fame-m)?	-D (Fame-u)	(2)	Hemisphaerocoryphe	O (Cara-l)	-O (u)	
Diaphanometopus	O (Aren)	-O (Llvi)		+Hexacosta	D (Give)		(983)
+Didrepanon	S (Wenl-u)	-D (Gedi)	(1106)	Hintzeia	O (Trem-u)	-O (Aren-l)	(795)
Dienstina	D (Fame-m)		(393,1106)	Holia (+ Ainoa)	O (Llde)?	-O (Ashg-u)	(690)
Digonus	D (Gedi-l)	-D (Emsi-u)	(902,1106)	Homalonotus	S (Ludl-l)	-S (Ludl-u)	(421,902)
Dindymene	O (Aren-l)	-O (Ashg-m)	(378,726)	+Huntonia	D (Gedi)	-D (Sieg)	(421,1106)
Dipleura	S (Ludl-u)	-D (Give-l)	(1106)	Hypodicranotus	O (Llde-l)	-O (Ashg)	
+Distyrax	S (Ldov-m)	-S (Ldov-u)		+Hyroklybe (+ Shiqiania)	S (Ldov-m)	-S (Wenl-u)	(651)
+Drotops	D (Eife-u)		(1015)	+Ibexaspis	O (l)		(ZR85)
Ductina	D (Fame)		(1106)	+Illaenula	D (Emsi-u)		(1106)
+Duftonia	O (Ashg-l)	-O (Ashg-m)	(378)	Isalux	O (Cara-m)		(795)
Eccoptochile	O (Aren-u)	-O (Ashg)	(1266)	+Lasaguaditas	O (Cara-l)		
Eccoptochiloides	O (m)			+Johntempleia	S (Ldov-l)	-S (Ldov-u)	(1088)
+Echinophacops	D (Emsi-u)		(1106)	Josephulus	O (Ashg-m)		
+Echinopyge	D (Emsi-u)		(421,983)	+Kailia	S (Wenl-l)		(651)
Ectenonotus	O (Aren-u)	-O (Llvi-l)	(795)	+Kainops	D (Gedi)	-D (Sieg)	(1106)
Elasmaspis	O (Ashg)		(2)	Kanoshia	O (Aren-u)	-O (Llvi-l)	(795)
+Eldredgeops	D (Eife)	-D (Give-u)	(1015)	Kawina	O (Aren-l)	-O (Llvi-u)	(382,795)
Emsurina	Cm (Fran-u)		(618)	Kaysereps	D (Emsi-l)	-D (Emsi-u)	(421,983)
+Encrinuraspis	O (Cara-u)	-S (Prid)	(386)	+Kazachstania	S (Ludl)?	-D (Gedi-l)	
Encrinurella	O (Aren-l)	-O (Ashg-m)	(565)	Kloucekia	O (Llvi)	-O (Ashg-m)	(378)
Encrinuroides	O (Ashg)		(2)	+Kolyrella	O (Aren-u)		(795)
Encrinurus	S (Ldov-m)	-D (Gedi)	(1066,1088)	+Kozloskiaspis	D (Emsi-l)	-D (Emsi-u)	(1106)
Eocheiurus	Cm (Fran-u)		(618)	Krattaspis	O (l)		
Eocyphops	D (Emsi-u)	-D (Eife)	(421,1106)	+Ktenoura	S (Wenl-l)	-S (Ludl-u)	
+Eodalmantina	O (Llvi-l)			+Landyia	O (Trem-l)		
+Eodindymene	O (Ashg-l)			+Lansites	O (l)		(ZR85)
Eomonarachus	O (Llde)	-O (Cara-m)		+Langgoni	S		(574)
Eophacops	S (Ldov-m)	-S (Ludl-u)	(393)	Lehua	O (Aren-u)	-O (Ashg-m)	(378,383,795)
+Erratencrinurus	O (Llde)	-O (Ashg-u)	(378,795)	Lejostegina	O (Cara-m)		
+Estoniops	O (Llvi-l)	-O (Cara-u)	(392)	Lejostrototropis	O (l)		
Eudolalites	O (Llde-u)	-O (Ashg-m)	(574)	+Leviceraurus	O (Cara-m)	-O (Cara-u)	(795)
Eulomina	O (Trem-l)	-O (Trem-u)	(1075)	+Libertella	O (Cara-l)		(694)
+Evropetites	O (Aren-u)		(795)	Liocalymene	S (Ldov-u)		
+Fenestraspis	D (Emsi-l)		(421,1106)	Liocnemis	O (Ashg-l)	-O (Ashg-m)	(2)
+Feruninops	D (Emsi-u)		(421,983)	+Liolophops	D (m)		(1015)
Flexicalymene	O (Llvi-l)	-S (Ludl-l)	(378)	+Llandovacasste	S (Ldov-m)		(1055)
+Forillonaria	D (Sieg-u)		(421,1106)	+Lochkovella	S (Prid)	-D (Gedi)	(393,421)
+Forteyops	O (l)		(ZR85)	+Lygdozoon	S (Ldov-u)	-S (Ludl)	(574)
+Foulonia	O (l)		(ZR85)	+Lyrapyge	O (Aren-u)		
+Fragiscotulla	S (Ludl-l)	-S (Ludl-u)	(1088)				
Frammia	S (Ludl-u)		(1088)				
+Francovichia	D (Emsi-l)	-D (Emsi-u)	(1106)				
+Frencinuroides	O (Cara-l)						

Taxon	First Appearance	Last Appearance	Reference	Taxon	First Appearance	Last Appearance	Reference
+ Mackenziurus	S (Wenl-u)	-S (Ludl-u)	(1088)	Phacopidella	S (Wenl-u)	-S (Prid)	(393,421)
Malladaia	D (Emsi-l)	-D (Emsi-u)	(1106)	Phacopidina	O (Llde)	-O (Cara-m)	(378,1055)
+ Malvinella	D (Emsi-u)	-D (Eife)	(421,1106)	Phacopina	O (Gedi)?	-D (Emsi-u)	(1106)
Metacalymene	S (Ludl-l)			Phacops	D (Sieg)	-D (Fame-u)	(2,1106)
Metacanthina	D (Sieg)	-D (Emsi-u)	(421,983)	+ Phalangocephalus	D (Gedi)		(421,1106)
Metacryphaeus	D (Emsi-u)	-D (Give)	(421,1106)	Pharostoma	O (Llvi-l)	-O (Ashg-m)	(378)
Metapilekia	O (l)			Pharostomina	O (Trem-l)	-O (Trem-u)	(1066)
Metapliomerops	O (l)			+ Physemataspis	O (Llde-u)	-O (Cara-l)	(795)
- Mezocrotalus	D (Gedi)		(1106)	Pilekia	O (Trem-l)	-O (Aren-u)	(795)
+ Miracybele	O (Llvi)			+ Piletina	D (Sieg-u)	-D (Emsi-u)	(421,983)
Mitchellaspis	S (u)			Placoparia	O (Aren-l)	-O (Ashg-m)	(2,795)
Monorakos	O (Cara)?	-O (Ashg)	(2)	+ Placoparina	O (Llvi-l)	-O (Llde)	(378)
+ Morgatia	O (Llde)?		(1066)	Plaesiacomia	O (Llvi)	-O (Cara-u)	
+ Moroccanites	D (Emsi-u)	-D (Eife-l)	(1015)	Plagiolaria	D (Gedi)	-D (Eife)?	(421,1106)
+ Muconaspis	O (Cara-m)	-S (Ldov-m)	(574)	Plasiaspis	O (Llvi)		(1075)
- Neocalmonia	D (Fras-l)	-D (Fras-u)?	(983)	Platycalymene	O (Llvi-l)	-O (Cara-l)	(378)
- Neometacanthus	D (Eife)	-D (Give-l)	(983)	Platycooryphe	O (Aren-u)	-S (Ldov-m)?	(902)
Neoprobolium	D (Gedi-l)?	-D (Emsi-u)	(1106)	+ Plesiomavinella	D (Emsi-u)	-D (Eife)	(1106)
Nephranops	D (Give)	-D (Fame-m)	(393,421)	Pliomera	O (Trem-l)?	-O (m)	(80)
Neseuretus	O (Aren-l)	-O (Ashg-u)	(690,726)	Pliomerella	O (Llde-l)	-O (Cara-l)	(795)
Nieszkowskia	O (Aren-u)	-O (Cara-m)	(795)	+ Pliomeridius	O (Aren-l)		
- Nipponocalymene	D (Eife)?		(1106)	Pliomerina	O (Llvi-u)?	-O (Cara-u)	
- Nucleurus	S (Ldov-m)	-S (Ldov-u)	(1088)	Pliomeroides	O (Trem)	-O (Aren)	(565)
+ Obliteraspis	O (l)		(ZR84)	Pliomerops	O (Aren-u)	-O (Cara-l)	(382)
+ Oculichasmops	O		(ZR87)	+ Podolites	D (Gedi-l)	-D (Gedi-u)	
Odontoccephalus	D (Emsi-l)	-D (Eife-u)	(394,1106)	+ Podowrinella	S (Ldov-m)	-S (Wenl-l)	(392,735)
Odontochile	D (Gedi)	-D (Eife-l)	(394,421)	Pompeckia	O (Cara-m)		(795)
Oedicybele	O (Cara-u)	-O (Ashg-u)	(378,1268)	Prionocheilus	O (Llvi-l)	-O (Ashg-m)	(1075,1081)
+ Ommokris	S (Wenl-l)		(574)	- Probolium	D (Eife)		(421)
+ Onnicallymene	O (Cara-l)	-O (Ashg-l)	(378,795)	Probolops	D (Emsi-u)		(1106)
Onycopyge	S (Ludl)			+ Prodontochile	S (Ldov)	-S (Wenl)	
+ Oosthuizenella	D (Emsi-u)		(1106)	+ Prokops	D (Sieg)		(1066)
Ormathops	O (Aren-u)	-O (Cara)	(2,726)	+ Proromina	S (Ldov-l)	-S (Ldov-m)	(735)
Osekaspis	O (Llvi)	-O (Llde-u)	(390)	+ Protacanthina	D (Gedi-u)	-D (Emsi-l)	(421,983,1106)
+ Ovalocephalus (+ Hammatocnemis)	O (Aren-u)	-O (Ashg-m)	(862,1266)	+ Protocalymene	O (Llvi-l)		(795)
+ Pacificurus	S (Ldov-u)	-S (Prid)	(1088)	+ Protocerauroides	S (Wenl)		(ZR84)
+ Paciphacops	D (Gedi-l)	-D (Eife)	(421,1106)	+ Protoencrinurella	O (Aren-l)		(565)
+ Palpebrops	D (Emsi-u)		(1106)	Protoplomerella	O (Aren-l)		(795)
+ Pamirotellus	S (Wenl)			Protoplomerops	O (Trem-l)	-O (Aren-l)	(2,80)
+ Pandaspinopyga	O (Llde-l)	-O (Cara-u)	(382,795)	Pseudocheirus	S (u)		
Papillicallymene	S (Ludl-l)	-S (Prid)		Pseudocryphaeus	D (Gedi)	-D (Emsi-l)	(1106)
+ Parabouleia	D (Gedi)	-D (Emsi-l)	(1106)	Pseudocybele	O (Aren-l)	-O (Aren-u)	(795)
Paracalmonia	D (Emsi-u)	-D (Eife)	(1106)	Pseudomera	O (Trem-l)	-O (Llvi-l)	(382,618)
+ Paraceraurus	O (Llde-u)		(795)	Pseudosphærexochus			
+ Parachuangia	Cm(u)		(ZR83)		O (Llvi-l)	-S (Ldov)?	(795)
+ Paracryphaeus	S (u)?	-D (Emsi-l)	(421,983,1106)	Psychopyge	D (Emsi-u)		(983,1106)
Paracybeloides	O (Cara-u)	-O (Ashg-u)		Ptychometopus	O (Aren-u)	-O (Llvi-l)	(393)
Parahomalonotus	S (Prid)	-D (Emsi-u)	(902,1106)	Ptychometopus	O (l)		
Parapilekia	O (Trem-l)	-O (Aren-u)	(2,80)	+ Punillaspis	D (Eife)		(1106)
+ Paratzuchiatoenemis	O (Cara)		(ZR90)	+ Quinquecosta	O (Llvi-u)	-O (Llde-u)	
- Parayoungia (+ Ichiyamella)	S (Ldov-u)	-S (Wenl-l)	(ZR84)	+ Radiopyge	D (Give-u)	-D (Fras-u)	(983)
Parevenkaspis	O (Ashg)		(2)	+ Radiurus	S (Ldov-l)	-S (Ludl-l)	
+ Parisoeceraurus	O (Cara-u)	-O (Ashg-l)	(862)	+ Ravienops	D (Fame-u)		
+ Pedinopariops	D (m)		(1015)	Reacalymene	O (Cara-l)		(378)
+ Pelitilina	D (Emsi-l)	-D (Emsi-u)	(1106)	Reedocalymene	O (Llvi)?		
Pennaia	D (Emsi-u)	-D (Eife)	(1106)	Reedops	D (Gedi-u)	-D (Emsi-u)	(421,1106)
+ Perirehaedulus	S (Ludl)			Remipyga	O (u)	-O (Ashg-u)	(690)
- Perissopliomera	O (Llvi-u)		(795)	+ Renniella	D (Emsi-u)		(1106)
+ Perryus	S (Ldov-u)	-S (Wenl-l)		Reraspis	O (Llde)?	-O (u)	
				+ Reussiana	D (Gedi)	-D (Sieg)	(1106)
				Rhenops	D (Emsi-l)	-D (Emsi-u)	(983,1106)

Taxon	First Appearance	Last Appearance	Reference	Taxon	First Appearance	Last Appearance	Reference
+Rhinophacops	D (Emsi-u)		(1106)	+Xuanenia	O (Ashg-l)		(862)
+Rhinoreedops	D (Emsi-l)		(1106)	+Xylabion	O (Livi-u)	-O (Cara-u)	(795)
+Rollmops	O (Cara-m)		(392)	+Xystocrania	O (Aren-u)	-O (Livi-u)	(383,795)
+Roncellia	D (Gedi-u)	-D (Sieg)	(421,1106)	+Yankaoia	O (Livi-l)?		(1266)
+Rossaspis	O (Trem-l)	-O (Trem-u)	(795)	+Youngia	S (Ldov-m)		
+Salterocoryphe	O (Llde)			+Zeliszakella	O (Llde-l)		(1075,1081)
+Sambremeusaspis	O (Ashg)		(ZR91)				
+Sanidopyge	D (Eife)	-D (Give)?	(421,1106)	Or. UNCERTAIN			
+Scabrella	D (Sieg-u)	-D (Emsi-u)	(902,1106)	+Abakanopleura	Cm(Dres)?		
+Sceptaspis	O (Cara-l)	-O (Ashg-u)	(392,690,795)	+Abdulinaspis	Cm(Fran)	-Cm(Trep)	(459)
+Schizostylus	D (Emsi-l)	-D (Eife)	(421,1106)	+Acanthocephalus	Cm(m)		(ZR83)
+Schoharia	D (Sieg-u)	-D (Eife-u)	(394,421)	+Acantholenus	Cm(u)		
+Scopelochasmops	O (Llde-u)	-O (Ashg-m)	(392)	+Acanthonimacuca	Cm(lMid)		
+Scotiella	S (Ldov)	-D (Gedi)	(1055)	+Acrohybus	Cm(Dres)		
+Seisonia	O (l)			+Adelogonus	Cm(Dres-l)		(16)
+Signatops	D (Emsi-u)		(1106)	+Aethia	Cm(m)		(ZR84)
+Sinocybele	O (Llde)	-O (Cara)		+Aglalalia	Cm(Atda-u)	-Cm(Boto-u)	(473)
+Sinoparapleikia	O (Trem-u)		(927)	+Agraualaeva	Cm(Atda-u)		(473)
+Sokhretia	O (Cara-u)?			+Aguaraya	Cm(Boto)?		
+Songxites	O (Ashg-m)			+Aidarella	Cm(u)		
+Spathacalymene	S (Ldov-u)	-S (Ludl-l)		+Aktugaiella	Cm(Trep)		(459)
+Sphaerexochus	O (Llvi-u)	-S (Ludl-l)	(382)	+Alomataspis	Cm(uMid)		(16,482)
+Sphaerocoryphe	O (Llvi-u)	-O (Ashg-u)	(378)	+Altajaharpes	O (l)		(ZR85)
+Spinodontochile	D (l)		(ZR85)	+Amechilus	O (Trem-u)		(795)
+Staurocephalus	O (Cara-u)	-S (Ludl-l)	(1066)	+Americare	Cm(uMid-l)		
+Sthenaroclymene	D (Gedi)	-D (Sieg)	(1106)	+Amgaspis	Cm(Tojo)	-Cm(uMid)?	(467,474)
+Stiktocybele	O (Llde-u)		(795)	+Amginouyia	Cm(lMid)		
+Strotactinus	O (Aren-u)		(795)	+Anpeltatocephalina	Cm(u)		(ZR83)
+Struzia	S (Wen-l)	-S (Ludl-u)	(1088)	+Anapodia	Cm(Dres-l)		(16,482)
+Struveapis	D (Emsi-u)	-D (Eife)	(1106)	+Antagmopleura	Cm(mMid)?		(467)
+Stubblefieldia	O (Ashg-m)			+Antatlaeva	Cm(Atda-u)	-Cm(Boto-u)	(473)
+Sycophantia	O (Aren-u)		(795)	+Ascetopeltis	O (Ashg-m)		(378)
+Synhomalotus	O (Aren)?	-O (Livi)?		+Atrabesia	Cm(Trep-l)		(16)
+Synphoria	D (Sieg-l)	-D (Eife-l)	(394)	+Avalonia	Cm(l)		
+Synphoroides	D (Gedi-u)	-D (Emsi-u)	(394,1106)	+Avascutellum	Cm(m)		(ZR90)
+Tapinocalymene	S (Wen-l)	-S (Wen-l)	(378)	+Barklyella	Cm(mMid-u)		(16)
+Tarijaetinoidea	D (Emsi-l)		(1106)	+Bathynotellus	Cm(mMid)		(1066)
+Teichertops	D (Give-l)		(1015)	+Bathynotus	Cm(Tojo)	-Cm(lMid)	
+Tesselacauda	O (Trem-l)		(795)	+Bathyriscellus	Cm(Boto)		(474)
+Thulicola	O (Llde)	-O (Cara-l)	(795)	+Beikedamaspis	Cm(Dres)		(459)
+Tibagya	D (Emsi-u)	-D (Eife)	(1106)	+Bergerolimbis	Cm(Boto-u)		(473)
+Toletanaspis	O (Aren)	-O (Livi-l)	(ZR91)	+Bicornipyge	O (Trem)		
+Toxochasmops	O (Cara-m)	-O (Ashg-u)	(392,690)	+Blayucina (+Thoraltaspis)	Cm(Atda-u)	-Cm(Boto-l)	(80)
+Toxophacops	D (Emsi-u)			+Bodenbenderia	O (l)		
+Treveropyge	S (u)?	-D (Emsi-u)	(983)	+Bondarevites	Cm(u)?		(ZR91)
+Tricopelta	O (Cara-m)	-O (Ashg-m)	(392,795)	+Brackebuschia	O (l)		
+Trimeroccephalus	D (Fame-m)		(1106)	+Brevitermierella	Cm(Boto-l)	-Cm(Boto-u)	(473,928)
+Trimerus	S (Ldov-u)	-D (Emsi-u)	(1106)	+Bridgeia	Cm(Dres-l)		(379)
+Trypaulites	D (Emsi-l)	-D (Eife-u)	(394,421,1106)	+Cambrunicornia	Cm(lMid)		(928)
+Turcropyge	D (Emsi-u)		(983)	+Canningella	O (Aren-l)		(565)
+Typhloiscus	D (Emsi-u)		(1106)	+Carmon	O (Ashg-m)?		
+Uralops	O (Cara-m)	-O (Cara-u)	(392)	+Catadovides	Cm(Tojo)	-Cm(uMid-u)	(80,81)
+Valongia	O (Llde)		(ZR84)	+Cermatops	Cm(Fran-u)		(16)
+Viaphacops	D (Sieg)	-D (Eife-l)?	(1106)	+Cermataspis	Cm(uMid-u)	-Cm(Dres-l)	(16,482)
+Victorispina	O (Trem-l)			+Chakasskia	Cm(Boto)?	-Cm(lMid)	(467)
+Vietnamia	O (m)			+Chalfontia	Cm(Fran-l)		(499)
+Vogesina	D (Emsi-l)	-D (Eife)	(1106)	+Chekiangaspis	Cm(Trep)		(459,483)
+Walencrinuroidea	O (Cara-u)			+Chinensis	Cm(Dres)	-Cm(Fran)	(459)
+Wallacia	S (Ldov-u)	-S (Wen-l)	(1088)	+Chittidilla	Cm(Tojo-u)		(885)
+Whittakerites	O (Cara-m)	-O (Cara-u)	(795)	+Chondroparia	Cm(uMid)		
				+Conoides	Cm(uMid)		

Taxon	First Appearance	Last Appearance	Reference	Taxon	First Appearance	Last Appearance	Reference
+Conopolus	Cm(uMid)		(ZR89)	+Kunmingaspis	Cm(Tojo-u)		(885)
+Cornovica	O (Livi-l)		(378)	+Kunshanaspis	Cm(l)		(ZR85)
-Coronocephalus	S (Wen-l)		(651)	+Kymataspis	Cm(m)		(928)
+Costonia	O (Cara-l)		(378)	+Laticephalus	Cm(Boto-l)		(522)
-Crossoura	O (Trem)			+Latikingaspis	Cm(lMid)		(928)
+Crucicephalus	Cm(Fran-u)		(496)	+Latoucheia	Cm(lMid)		(928)
-Cryptoderaspis	Cm(uMid-u)		(80)	+Leichneyella	Cm(uMid)	-Cm(Dres-l)	(16,482)
Curiaspis	O (Trem-l)			Leptopilus	O (Trem)		
Cuyanaspis	O (l)			Levisia	Cm(m)		
-Cyclolenzellina	Cm(Dres)		(459)	+Liaoyangaspis	Cm(uMid)		(464)
-Deltacare	O (l)			+Liriarnica	Cm(Fran-u)?		(16)
-Dicanthopyge	Cm(Dres-u)		(501)	+Lomsouaspis	Cm(uMid)		(460)
+Durinia	Cm(uMid)		(ZR89)	+Lotosoides	Cm(Fran-u)		(16)
+Edganocare	Cm(Dres)		(483)	+Loxonepea	Cm(uMid)		(16)
Eilura	Cm(mMid)	-Cm(uMid)	(472)	-Luojiashania	S (Ldov-u)		(651)
+Elburgia	Cm(Dres-u)		(489)	+Lusampa	O (l)		(ZR85)
+Ellipsuella	Cm(Boto-u)		(473)	+Macrogrammus	O (Aren-l)		(378)
Ellaspis	O (l)			+Mannschreckia	O (l)		(ZR83)
Endoaspis	O (l)			+Marcasia	Cm(Atda-u)		(473)
+Entsyna	Cm(Fran-l)		(618)	Mareda	Cm(Trep)		
Eosaukia	Cm(Dres)?			Matania	Cm(Dres-l)		(80)
Esseigania	Cm(Trep)?			Mataninella	Cm(u)		
Eulomella	O (l)			+Mecophrys	Cm(Fran-l)	-Cm(Fran-u)	(16)
Fabulaspis	Cm(m)			Megagraulos	Cm(mMid)		(472)
+Feilongshania	Cm(Boto-u)		(463)	+Megalapidicus	O (l)		(ZR85)
+Follicept	Cm(uMid)		(16)	Meisterella	Cm(u)		
-Galahetes	Cm(mMid)		(16)	+Mendosina	Cm(Trep)	-O (Trem)	(483,496)
-Gelasene	Cm(Atda-u)?		(475)	Meneghinella	Cm(l)		
+Gentilaspis	Cm(Boto-u)		(473)	+Meropalla	Cm(uMid-u)	-Cm(Dres-l)	(16,482)
Gigmpeltis	O (l)			Metagraulos	Cm(lMid)	-Cm(uMid)	(472)
Gigoutella	Cm(Boto)?			+Miranella	Cm(Boto-l)		(522)
+Giordanelia	Cm(Atda-l)		(990)	+Moretarva	Cm(Atda-u)	-Cm(Boto-l)	(473)
+Gogoella	O (Aren-l)		(565)	Nannopeltis	O (l)		
+Goldfieldia	Cm(Tojo)		(476)	+Nehanniaspis	Cm(Atda-u)?		(475)
Goycoia	Cm(u)			Ninaspis	Cm(u)		
Hamashania	Cm(Trep)			+Norina	Cm(Fran-u)		(16)
+Hercantyx	Cm(Fran-l)		(498)	Oligometopus	Cm(Fran)		(494)
Hicksia	Cm(Boto)		(473)	Onchonotus	Cm(Trep)	-O (l)	(80)
-Holyoakia	Cm(Atda-u)		(1221)	+Orictocara	Cm(mMid)		(474)
+Howelluella	Cm(Boto-u)		(473)	+Orienturus	Cm(Tojo)		(474)
-Huamiocephalus	Cm(l)		(ZR83)	+Ornamentaspis	Cm(lMid)		(928)
+Ishpella	O (l)		(ZR85)	+Oreades	Cm(lMid)		(928)
+Issafenina	Cm(Boto-l)	-Cm(Boto-u)	(473)	+Otekmaspis	Cm(Boto)		(468)
+Issafeninella	Cm(Boto-l)	-Cm(Boto-u)	(928)	+Orenaspella	Cm(Fran)		(483)
+Iveria	Cm(Fran-u)		(16)	+Ourikaia	Cm(lMid)		(928)
+Iwayaspis	Cm(Dres-u)		(16,483)	+Oxygonaspis	O (l)		(ZR83)
Jangudaspis	Cm(Boto)?			+Paichianshania	Cm(Fran-u)		(16)
+Jegorovaia	Cm(Trep)		(459)	Palaeolentus	Cm(Boto-u)		(464)
Jonotus	D			+Palmeraspis	Cm(Tojo)		(474)
Jubileia	Cm(Fran)			Paragraulos	Cm(Boto)	-Cm(Tojo-u)	(472)
Judaitella	Cm(Boto)?		(467)	+Paraplagiura	Cm(m)		(ZR83)
+Jurietella	Cm(l)		(ZR83)	+Paraplesiograulos	Cm(m)		(ZR83)
-Kamlacus	O (l)		(ZR85)	+Pararaia (+ Proichangia)			
Kazellina	Cm(u)				Cm(Atda-u)	-Cm(Boto-u)	(463,923)
-Keeleaspis	Cm(Atda-u)?		(475)	Pararania	Cm(m)		
+Kerbinella	Cm(u)		(ZR90)	+Peculicephalina	Cm(u)		(ZR91)
Knechtelia	Cm(uMid-u)		(379)	+Penarosa	Cm(uMid)		(16)
Koldinia	Cm(Dres-u)	-Cm(Fran)	(618)	+Pensacola	Cm(Atda-u)		(1221)
Koldiniella	Cm(Dres-l)		(460)	Phorectropis	Cm(Trep)		
Kolpura	Cm(uMid)		(464)	Phylacterus	Cm(Trep)		
Koraispis	O (Trem)			Piliolites	D (Give)?		
Kujandina	Cm(u)			Plagiura	Cm(Tojo-u)	-Cm(lMid)	(80,379)

Taxon	First Appearance	Last Appearance	Reference	Taxon	First Appearance	Last Appearance	Reference
+ Planolimbus	Cm(m)		(928)	+ Whittardolithus	O (Llvi-u)	-O (Llde-l)	(378)
+ Poculicephalina	Cm(u)		(ZR91)	+ Winsteria	Cm(Dres-u)	-Cm(Fran-u)	(16)
+ Priceaspis	O (Aren-l)		(565)	Xystridura	Cm(Tojo-l)	-Cm(mMid)	(16)
+ Probilacunaspis	Cm(Trep)		(459)	Yunnanocephalus	Cm(Atda-u)		(463,885)
+ Prohedinella	Cm(Tojo)		(474)	Zacompus	Cm(Trep)		
+ Pseudocacicaudus	O (Llvi-l)?		(795)	+ Zigzuela	Cm(Boto-u)		(473)
+ Pseudoclelanida	O (Trem-u)	-O (Aren)	(795)				
+ Pseudocrephalaspina							
	Cm(Fran)		(459)				
Pseudoliostracina	Cm(mMid)		(472)				
Pseudosalteria	Cm(Trep)						
Pseudosaukia	Cm(Trep)						
+ Pseudotermiereilla	Cm(Atda-u)		(473)				
+ Ptytstrigis	Cm(u)		(ZR90)				
Pyraustocranium	O (Trem-u)		(795)				
+ Qijiangia	O (Ashg-u)		(ZR90)				
Redlichaspis	Cm(l)						
Resseria	Cm(u)						
+ Resseropsis	Cm(Atda-u)		(473)				
+ Rochaeva	Cm(Atda-u)		(473)				
+ Rongxiella	S (Wen-l)		(651)				
+ Rowia	Cm(uMid-l)						
+ Sailycaspis	Cm(Boto-l)		(522)				
Sarkia	O (Llde-l)		(1075)				
Schistocephalus	Cm(Tojo)	-Cm(mMid)	(474)				
Schistometopus	Cm(lMid)		(81)				
+ Sectigena	Cm(Boto-u)?		(928)				
+ Sekwiaspis	Cm(Atda-u)?		(475)				
+ Senticucullus	S (Wen-l)		(651)				
+ Serksia	Cm(Boto-u)		(473)				
+ Serksioides	Cm(Boto-u)		(473)				
+ Shipaiella	Cm(Boto)		(463)				
+ Sibiriopeltis	O (l)		(ZR85)				
Sinolenus	Cm(l)						
+ Smeathenia	O (Cara-l)		(378)				
Sphaerocare	O (l)						
+ Spirantyx	O (Llde-l)	-O (Cara-l)	(378)				
+ Strigambitus	Cm(Dres-u)		(489)				
+ Sunaspis	Cm(mMid)		(464)				
+ Tadakoustia	Cm(Boto-l)?		(928)				
+ Taidonorus	O (l)		(ZR85)				
+ Tamdaspis	Cm(Fran)	-Cm(Trep)	(459,483)				
+ Taplimella	Cm(Dres-u)	-Cm(Fran-l)	(16)				
Tasmanaspis	O (l)						
+ Tazzemmouria	Cm(Atda-l)		(473)				
+ Tholifrons	Cm(Dres-u)						
Thomondia	O (Ashg)						
+ Thoracocare	Cm(lMid)		(478)				
+ Thymurus	O (Aren-l)						
+ Tongxingaspis	O (l)		(ZR90)				
+ Townleyella	Cm(Dres-l)		(482)				
Toxotis	Cm(m)						
Trinia	Cm(uMid)						
+ Tuyunaspis	Cm(Boto-u)		(463)				
Ullaspis	Cm(m)						
Ulrickaspis	Cm(Trep)						
+ Validaspis	Cm(Boto-l)		(468,522)				
+ Variopelta	Cm(Boto)		(475)				
+ Verditerina	Cm(uMid)		(ZR89)				
Volonellus	Cm(u)						
+ Wandefella	Cm(uMid)		(ZR89)				
Westonaspis	Cm(Trep)						

CI. THYLACOCEPHALA

Or. CONCAVICARIDA

+ Ankitokazocaris	Tr(l)		
Concavicularis	D (Emis-u)	-C (Step-l)	(425)
Dollocaris	J (Call)	-J (Tith-l)	(619)
+ Harrycaris	D (Fras-l)		(619)
+ Microcaris	Tr(Ladi-u)	-Tr(Nori)	(531,619, 693)
+ Protozoe	K (Ceno)		(531,619)
?Pseudericththus	K (Ceno)		(531,619)
+ incertae sedis	S (Ldov-u)		(617)

Or. CONCHYLIOCARIDA

+ Atropicaris	Tr(Carn-l)		(619,693)
Austriocaris	Tr(Rhae)		(531,619)
Clausia	J (Call)	-J (Tith-l)	(2,619)
+ Clausocaris	J (Tith-l)		(1066)
+ Convexicaris	C (Mosc-u)		(933)
Kilianocaris	J (Call)	-J (Tith-l)	(619)
+ Ostenocaris (+ Ostenia)	Tr(Olen)?	-J (Sine-l)	(531,619)
+ Paraostenia	J (Call)		(619)
+ ?Rugocaris	J (Phe-u)		(693)
?Silesicaris	Cm(l)		
+ Yangzicaris	Tr(m)		(619)

Or. INCERTAE SEDIS

Coreocaris	P (l)		
+ Dioxycaris	Cm(Boto)?	-Cm(uMid-l)	
Galenocaris	O (Ashg-m)		
+ Nothozoe	Cm(Boto)?	-O (Cara-l)	(1075)
?Saccocaris	Cm(u)	-O (l)	
+ Tuzoia	Cm(Atda-u)	-Cm(mMid-m)	(566,883)

CRUSTACEA

CI. INCERTAE SEDIS

Or. WAPTIIDA

Waptia	Cm(mMid-u)		(1)
--------	------------	--	-----

Or. SKARACARIDA

+ Skara	Cm(Dres-l)		(132)
---------	------------	--	-------

Or. ORSTENOCARIDA

+ Bredocaris	Cm(Fran-u)		(132)
--------------	------------	--	-------

Or. UNCERTAIN

+ ?Acanthomeridion	Cm(Atda-u)		(859)
?Burgessia	Cm(mMid-u)		
+ Cambropachycope	Cm(Dres-l)		(925)
+ Goticaris	Cm(Dres-l)		(925)
+ Henningsmoenicaris	Cm(Dres-l)		(925)
Leanchoilia	Cm(mMid-u)		(1)

Taxon	First Appearance	Last Appearance	Reference	Taxon	First Appearance	Last Appearance	Reference
+?Martinssonina	Cm(Dres-l)			Hesperibalanus	T (Mi-m)	-R	
+Oelandocaris	Cm(Dres-l)		(132)	Hexelasma	T (Eo)	-R	
?Plenocaris	Cm(mMid-l)	-Cm(mMid-u)	(883)	Ilba	J (Tith)	-R	(1066)
+Rehbachiella	Cm(Dres-l)		(132)	Illilepas (= Praelepas)			
+Waloszekia	Cm(Dres-l)		(132)		C (Mosc-u)		(2)
Cl. BRACHYPODA				Kathpalmeria	T (Eo-l)	-T (Eo-u)	
				Lepas	T (Eo-m-l)	-R	
+?Dala	Cm(Fran-u)		(344)	+Lophobalanus	T (Ol-l)	-T (Mi-l-u)	(347)
Cl. BRANCHIOPODA				Loriculina	K (Ceno)	-K (Maes)	
				+McIellania	T (Mi-m)	-T (Plio)	
?Gilsonicaris	D (Emsi-l)		(1)	Megabalanus	T (Eo-m-u)	-R	(1066)
Cl. COPEPODA				+Mesolasma	T (Ol)	-R	(346)
				Mesoscalpellum	K (Camp)?	-R	
+Kabatarina	K (Apti-u)		(874)	+Neolepas	J (Sine-u)?	J (Plio-l)?	(1066)
parasitic forms	J (Call)	-R		+Neoscalpellum	K (Sant)	-R	(346)
Cl. CIRRIPEDIA				+Notobalanus	T (Ol-u)	-T (Mi-m)	
				Oxyaspis	T (Eo-m-l)	-R	
				Pachydiadema	K (Camp-l)		(2)
				Pachylasma	T (Dani)	-R	(346)
				+Palaeobalanus	T (Eo-m)	-T (Mi)	(346)
				+Paraconcavus	T (Mi-u)	-R	(1036)
				Platylepas	Q (Plei-u)	-R	
				+Poecilasma	T (Eo-m-u)	-R	(1066)
				Pollicipes	K (Sant)	-R	(346)
				+Priscaenmarinus	Cm(mMid-u)		(348)
				Proverruca	K (Ceno)	-K (Maes)?	(1066)
				Pycnolepas	J (Tith)	-T (Mi-m)	
				Pyrgoma	T (Plio)	-R	
				Rogerella	J (m)	-R	
				Scalpellum	T (Eo-l)	-R	
				Schreterella	K (Ceno)		(2)
				+Scillaelepas	J (u)	-R	
				Semibalanus	T (Mi-m)	-R	
				Smilium	T (Eo-u)	-R	(346)
				Solidobalanus	T (Eo-m-u)	-R	(346)
				Stramentum	K (Albi-m)	-K (Maes)?	
				+Tamiosoma	T (Mi-l)	-R	(1036)
				+Tasmanobalanus	T (Ol-u)	-T (Plio-u)	(346)
				Tessarelasma	T (Mi-l-u)		
				+Tesseroplax	T (Mi-l)	-T (Plio)	(346)
				Tesseropora	T (Ol)	-R	(346)
				Tetraclita	T (Mi-l)	-R	
				+Tetrinis	K (Turo-l)		
				Titanolepas	K (Ceno)	-K (Sn)	(346)
				Trilasmis	T (Eo-m-u)	-R	
				Trypetesa	C (Step)	-R	
				Ulophysema	K (Turo)?	-R	
				Verruca	K (Ceno)	-R	
				Virgiscalpellum	K (Apti-l)	-K (Maes-u)	
				+Waikalasma	T (Mi-l-l)		(346)
				+Waiparaconus	K (Camp)	-T (Eo)	
				+Zeascalpellum	T (Eo-l)	-T (Eo-m)	(346)
				Zeugmatolepas	J (u)	-T (Dani)	
Cl. REMIPEDIA							
Or. Enantiopoda							
				Cryptocaris	C (Mosc-u)		(964)
				Tesnusocaris	C (Serp-l)		(653,964)

[Classification and basic stratigraphic ranges from the TREATISE, Part Q (1961).]

Taxon	First Appearance	Last Appearance	Reference	Taxon	First Appearance	Last Appearance	Reference
CI. MALACOSTRACA				Or. STOMATOPODA			
[Classification and basic stratigraphic ranges from the TREATISE, Part O (1961).]				+Angelosquilla	T (Mi-m)		(1262)
Or. CANADASPIDIDA				+Bathysquilla	T (Eo-l)	-R	
Branchiocaris	Cm(Atda-u)	-Cm(uMid-m)	(883,1006)	+Chloridella	K (u)		(1066)
Canadaspis	Cm(mMid-l)	-Cm(mMid-u)	(883)	Gonodactylus	T (Mi-u)	-R	
Perspicaris	Cm(Atda-u)?	-Cm(uMid-l)	(349,781)	+Gorgonophontes	C (Step-l)		(352)
Odaraia	Cm(Atda-u)?	-Cm(mMid-u)	(783)	Hemisquilla	T (Mi-m)	-R	
				Lysiosquilla	K (Maes-l)?	-R	(1262)
				Palaesquilla	K (m)		
				Perimecturus	C (Vise-l)	-C (Serp-l)	
				Pseudosculda	K (u)		
Or. LEPTOSTRACA				+Pseudosquilla	T (Eo-l)	-R	(1066)
Rhabdouraea	P (Guad-l)			Sculda	J (Tith-l)	-K (Ceno)	(2,1066)
				Squilla	T (Mi-m)	-R	(1262)
Or. HYMENOSTRACA				+Topangasquilla	T (Mi-m)		(1262)
Hymenocaris	Cm(Boto)	-O (Aren)	(350)	squillid	K (u)	-R	
				Tyrannophontes	C (Serp-l)	-C (Step-l)?	
				incertae sedis	J (Sine-l)		(623)
Or. HOPLOSTRACA				Or. AESCHRONECTIDA			
Kellibrookia	C (Mosc-u)			Aenigmacaris	C (Serp-l)	-C (Step-u)	
Sairocaris	C (Vise-l)	-C (Mosc-u)		Aratidecthes	C (Mosc-u)		
				Crangopsis	C (Vise-l)	-C (Serp-l)	
Or. ARCHAEOSTRACA				Joanelia	C (Vise-l)	-C (Serp)	
Aristozoe	S (Wenl)	-D (Eife-u)	(425,1066)	Kallidecthes	C (Vise)	-C (Mosc-u)	(1066)
Baituganocaris	D (Fras)						
Callizoe	D (Sieg-l)	-D (Sieg-u)	(425)	Or. EOCARIDACEA			
Caryocaris	O (Trem-l)	-O (u)	(2)	Anthracophausia	C (Tour)	-C (Mosc-u)	
Ceratiocaris	O (Trem)	-P (u)	(1066)	Devonocaris	D (Give-l)	-D (Fame)	
Dictyocaris	S (Wenl)	-D (l)		Eocaris	D (Give)		
+Dilophaspis	D (Emsi-l)			Esoidea	C (Mosc-u)		
Dithyrocaris	D (Give-l)	-P (u)	(425,1066)	+Palaemysis	C (Vise)	-C (Bash-u)	
Echinocaris	D (Give-l)	-D (Fame-u)	(425)				
Eleutherocharis	D (Fras-m)			Or. LOPHOGASTRIDA			
Elymocaris	D (Give-u)	-D (Fame-l)	(425)	+Eucopia	J (Call)	-R	(692,1066)
Gonatocaris	S (Ludl-l)			+Lophogaster	J (Call)	-R	(692,1066)
Guerichicaris	D (Eife-u)		(425)	Peachocaris	C (Mosc-u)	-C (Step-l)	(352)
+Hebertocaris	D (Give-l)		(425)	Schimperella	Tr(Anis)		(1066)
Heroldina	D (Sieg-u)	-D (Emsi-l)	(425)				
+Kerfornecaris	S (Prid)?			Or. BELOTELSONIDEA			
Lebesconteia	O (u)	-C (l)		Belotelson	C (Tour-u)	-C (Mosc-u)	
Macrocaris	C (Tour)						
Montecaris	S (Prid)	-D (Fame-m)	(425)	Or. WATERSTONELLIDEA			
Nahecaris	D (Emsi-l)		(425)	Waterstonella	C (Vise-u)		
Ohiocharis	D (Fame-l)	-D (Fame-u)	(425)				
Orozo	D (Sieg-u)	-D (Emsi-l)	(425)	Or. DECAPODA			
Pephricaris	D (Fame-l)		(425)	Acanthocarpus	T (Ol-u)?	-R	
Ptychocaris	D (Sieg-l)	-D (Fras-m)	(425)	Acanthochirana	J (Tith-l)	-K (Ceno)	
Pygocaris	D (Gedi-u)		(425)	+Acantholambrus	T (Eo-m-u)		(1259)
Rhinocaris	D (Give-l)	-D (Fras-m)	(425)	Actaea	Q (Plei)	-R	
Schugurocaris	S (u)	-D (Fras-m)	(425)	Actaeopsis	K (Albi)		
Trigonocarys	O (u)			+Actinotocarcinus	T (Mi-m)		
Tropidocaris	D (Fras-m)	-D (Fame-m)	(425)	+Actumnus	T (Mi-m)	-R	
				Aeger	Tr(Olen-u)	-J (Tith-l)	(75)
				+Ampliura	T (Plio)		(966)
				Anapagurus	Q (Plei)	-R	
				Andorina	T (Mi)		
Or. PHYLLOCARIDA INCERTAE SEDIS				+Antarctidromia	T (Mi-l)		
Aptychopsis	O (Ashg)	-S (u)		+Antarctomithrax	T (Eo)		
Discinocaris	O (Cara-l)?	-Tr(Carn)		Antrimpos	Tr(Indu)	-K (u)	(2)
Peltocaris	S (Wenl)						
+Protocimex	O (Aren-u)						
Or. PALAEOSTOMATOPODA							
Archaeocaris	C (Tour-l)	-C (Serp-l)	(2,1066)				
Bairdops	C (Tour-l)	-C (Serp-l)					
+?Eopteridium	D (Fame)?		(351)				

Taxon	First Appearance	Last Appearance	Reference	Taxon	First Appearance	Last Appearance	Reference
Archaeocarabus	T (Eo-l)			Coelopus	J (m)	-J (Tith)	
+Archaeocyropa	T (Eo-m-l)			Coenobita	T (Mi-l)?	-R	
Archaeogeryon	T (Mi)			Colcia	J (Sine-l)	+K (l)	
Archaeoplax	T (Mi-u)			Colneptunus	T (Eo-m-l)		
Archaeopus	K (Camp-l)?	-K (Camp-u)?	(961)	+Corellicarcinus	T (Eo-u)		
+Archeosolenocera	J (Call)			+Costaeopluma	K (Coni)	-T (Pale)	
+Archithelphusa	T (Mi-u)		(1066)	+Cretachlorodus	K (Maes-u)		
Aspidogaster	Tr(Olen)?	-Tr(Anis-m)	(674)	+Cristafrons	K (Camp-l)	-K (Camp-u)	(1037)
Astacodes	J (u)	-K (Camp)		-Cristipluma	K (Maes-l)		(961)
Astacopsis	Q (Plei)	-R		Ctenocheles	K (Maes)	-R	(1220)
Astacus	J (m)	-R	(1066)	Cyamocarcinus	T (Eo-u)		
Atelecycelus	T (Eo-m-l)	-R		Cycleryon	J (l)	-J (Tith-l)	(75)
Atergatis	T (Ol-u)?	-R		Cyclocancer	T (Ol-u)	-T (Mi)	
Avitelmessus	K (Maes-l)	-K (Maes-u)	(961)	Cyclocorystes	T (Than)	-T (Eo-l)	
Axius	T (Ol)	-R		Cycloes	T (Mi)	-R	
-Bartethusa	T (Eo-u)			Cycloprosopon	J (Tith)		
Bechleja	T (Ol-u)?			Cyclothyrus	J (Tith)		
Benthesicymus	K (Sn)			Cycloanthops	T (Plio)	-R	
Binkhorstia	K (Maes-u)			Cyphonotus	J (u)	-K (Ceno)	
Blaculla	J (Tith-l)			+Cyrtrorhina	T (Eo-l)	-R	(1259)
Blepharipoda	T (Ol-l)		(2)	Dakoticaner	K (Camp-l)	-K (Maes-l)	(354,961)
Bombur	Tr(u)	-J (Tith-l)	(75)	Daira	T (Eo-u)	-R	
Brachynotus	Q (Plei)	-R		Daranyia	T (Eo-m)	-T (Eo-u)	
+Branchiocarcinus	K (Maes)			Dardanus	T (Eo)	-R	
Branchiolambrus	T (Mi)			Dialulax	J (Tith)	-K (Camp-l)	(961)
Branchioplax	T (Dani)	-T (Mi)	(1066)	Doratiopus	K (Albi-l)	-K (Maes)	(961)
Bylgia	J (Tith-l)		(75)	Dorippe	T (Mi)	-R	
Calappa	T (Eo-u)	-R		-Drachiella	T (Plio)	-R	(966)
Calappella	T (Ol)			Drobna	J (Tith-l)		(75)
Calappilla	T (Eo-m)	-R	(1259)	Dromia	T (Eo)	-R	
Callianassa	K (Apt-l)	-R		Dromilites	T (Eo-l)	-T (Mi)	
Callinectes	T (Eo)	-R		Dromiopsis	K (Ceno)	-T (Dani)	
Caloxanthus	K (Albi-u)	-T (Dani)	(1066)	Dusa	J (Tith-l)		(75)
Camarocarcinus	T (Dani)			Ebalia	T (Mi)	-R	
Cambarus	T (Eo-l)	-R		+Ekalakia	K (Camp-u)?		(354)
Campylostoma	T (Eo-l)	-T (Eo-u)		Enoploclytia	K (Apt-l)	-K (Maes)	
Cancer	T (Mi-l-l)	-R		Enoplonotus	T (Eo-m-l)		
Cancrinus	J (Tith-l)		(75)	Eocalcinus	T (Eo)		
Cancrixantho	K (Camp)			Eocarcinus	J (Pli-l)		(2)
Carcineretes	K (Turo)?	-K (Maes-u)	(961)	+Eocarpilius	T (Eo-m-u)	-T (Mi-m)	(1259)
Carcinocarcinus	T (Eo-m)			Eoinachoides	T (Eo-u)		
Carcinoplacoides	Q (Plei)?			+Eomunidopsis	K (Ceno-l)	-K (Maes-u)	(961,1225)
Carcinoplax	T (Eo-u)	-R	(922)	+Eoprosopon	J (Pli-u)		
Carcinus	T (Eo)	-R		Epaltus	T (Plio)	-R	
Cardirhynchus	K (Sn)			Eriphia	T (Ol-l)	-R	
Cardisoma	T (Plio)	-R		Eryma	J (Sine-l)	-K (Haut-l)	
Carpilius	T (Plio)	-R	(1259)	Erymastacus	J (l)	-J (Tith-l)	
Carpilodes	T (Plio)	-R		Eryon	J (m)	-K (Nc)	
Carpopenaeus	K (Ceno)			Etallonia	J (Tith-l)?	-R	
Cenomanocarcinus	K (Albi-u)	-K (Turo-l)	(961)	Etisus	T (Eo-u)	-R	
Charassocarcinus	J (Bajo)			Etyus	K (Albi)		
Charybdis	T (Ol-u)?	-R		Eumorphactaea	T (Eo-m)		
+Chasmocarcinus	T (Eo-u)	-R		Eumorphocorystes	K (Maes)?	-T (Ol-l)?	
-Cheramus	K (Maes)	-R		Euphyllax	T (Ol-u)	-R	
+Chiengphoherus	K (Sn)	-R		Euprogna	T (Mi-u)	-R	
Chinocephalus	T (Plio)			Eurycarpus	K (Sn)		
Chlorodiella	T (Mi)	-R		Euryplax	T (Ol-u)?	-R	
Chorilia	Q (Plei)	-R		Eurytium	Q (Plei)	-R	
Chibanarius	T (Eo-u)	-R		Falconoplax	T (Eo-m)	-T (Eo-u)	
Clytiella	Tr(u)			Galathea	K (Albi-u)	-R	
Clytiopsis	Tr(Olen-u)			Galene	T (Mi)	-R	
Coeloma	T (Eo-l)	-T (Mi-l)		Galenopsis	T (Eo-m)	-T (Plio)	

Taxon	First Appearance	Last Appearance	Reference	Taxon	First Appearance	Last Appearance	Reference
Gampsurus	K (Sn)			Lecythocaris	J (Tith-l)		
Gastrodorus	J (Tith-l)			+Leiolambrus	T (Eo-u)	-R	
Gastrosacus	J (Tith-l)	-K (l)		+Leptoides	K (Maes-u)		(1225)
+Gebia	K (Vala)?		(1066)	Leptomithrax	T (Eo-u)	-R	(922)
Gemellarocarcinus	T (Eo-m)			Leucosia	T (Mi)	-R	
Geryon	T (Ol-u)	-R		Leucosilia	T (Mi)	-R	
+Gillcarcinus	T (Eo-m)			Libinia	Q (Plei)	-R	
+Glabropilum	T (Mi-m)?	-R		Linoparus	K (Apti-l)	-R	
+Glaessnerella	K (Haut)	-K (Ceno)		Liocaris	J (Bajo)		
Glyphea	J (Sine-l)	-T (Eo-l)		Lissocardia	Tr(Anis-m)		(674)
Glyphithyreus	T (Tham)?	-T (Eo-u)		Lissopsis	K (u)		
Glyptodromene	K (Ceno)	-K (Maes-u)	(1225)	Lithophylax	K (Ceno)		
Goneplax	T (Mi-m)	-R		Litogaster	Tr(Olen-u)	-Tr(Anis)?	
Goniochele	T (Eo-l)	-T (Ol-l)?		Lobocarcinus	T (Eo-m-l)	-T (Eo-u)	
Goniochirus	J (u)			Lobonotus	K (Maes)	-T (Mi-u)	(1220)
Gonicyopoda	K (Maes)?	-T (Eo)		Loerentheyia	T (Eo-m)		
Goniodromites	J (Plic-l)	-K (Ceno)		+Longusorbis	K (Camp-u)		(961)
Graptocarcinus	K (Apti)	-K (Maes-u)		Lophopanopeus	T (Eo-m)	-R	
+Halice	T (Mi-m)	-R		Lophoramina	K (Maes-l)	-T (Ol-l)?	
Harpactocarcinus	T (Eo-l)	-T (Eo-u)		Lophoraminella	K (Ceno)		
Harpactoxanthopsis	T (Eo-m)	-T (Eo-u)		+Loverania	T (Eo)		
+Haumuriaegla	K (Maes)		(357)	Loxorhynchus	T (Plio)	-R	
+Hecia	K (Ceno)		(1066)	Lyreidus	T (Eo-l)	-R	
Heltriga	Tr(u)	-J (Tith-l)	(75)	Macrocheira	T (Ol-u)?	-R	
Hellerocaris	J (m)			Macrophthalmus	T (Mi-m)?	-R	
Hemioon	K (Turo-u)			Macropipus (+ Liocarcinus)			
Hemiplax	Q (Plei)	-R			T (Eo-m-l)	-R	
Hepatella	T (Ol-u)	-R		Magila	J (Toar)?	-J (Tith-l)	(75)
Hepatinulus	T (Mi)	-T (Plio)		Maja	T (Mi-l)	-R	
Hepatiscus	T (Eo-l)	-T (Eo-u)		Martinezicancer	T (Dani)		(1066)
Hepatus	T (Mi-m)	-R		Martinocarcinus	T (Eo-u)		
+Herbstia	T (Plio)	-R		+Mascarananda	K (Maes)		
Heteractaea	T (Plio)	-R		Matuta	T (Mi)	-R	
Heterocrypta	Q (Plei)	-R		+Matuties	T (Eo-m-u)		(1259)
Hexapus	T (Eo-m)	-R		+Mecochiria	J (Tith-l)		
+Hillius	K (Albi-l)		(961)	Mecochirus	J (Sine-l)	-K (Apti)	
Holcocarcinus	T (Eo-m-l)	-T (Eo-u)		Medaeus	T (Mi)	-R	
Homarus	K (Albi)	-R		Menippe	T (Eo-m-l)	-R	
Homelys	T (Mi-u)			Mesodromites	K (Albi)	-K (Ceno)	
Homolodromia	T (Eo)		(1066)	Mesogalatheia	J (u)	-K (u)	
Homolopsis	K (Albi)	-T (Dani)		Mesorhoa	T (Ol)	-R	
Hoploparia	K (Vala-l)	-T (Eo-m)		+Metanclepirops	K (Camp)	-R	(1037)
+Hubatanka	K (Albi)		(353)	+Meyerella	K (Vala-l)	-K (Apti-u)	
Hyas	T (Mi-u)	-R		Meyeria	K (Haut)	-K (Camp-u)?	(1037)
+Hyastenus	T (Mi-m)?	-R		Microcrystes	K (Comi)	-T (Mi-m)?	
Iberihomola	K (Ceno)			Micromafia	T (Eo-m-l)	-T (Ol-l)	
+Icriocarcinus	K (Camp-u)?, K (Maes-l)?			Micromithrax	T (Eo)?	-T (Mi)	
Ilia	T (Plio)	-R		Micropsalis	T (Ol)		
+Imocaris	C (Serp-l)			Mioplax	T (Mi)		
Inachus	T (Ol-u)?	-R		Mithracia	T (Eo-l)		
+Iphiculus	T (Plio)	-R	(966)	Mithracites	K (Apti-l)		
Ixa	Q (Plei)	-R		Mitrax	T (Plio)	-R	
Ixoides	T (Plio)	-R		+Monodaeus	T (Plio)	-R	
Jasus	T (Ol)	-R		Montezumella	T (Eo-m-l)	-T (Ol-u)	
Jaxea	T (Mi)	-R		Munida	T (Dani)	-R	
Kierionopsis	T (Pale)			Munidopsis	K (Camp-u)	-R	(1037)
Klytia	J (l)	-J (u)		Munitheites	J (Tith)		
Knebalia	J (Tith-l)			Mursia	T (Ol-u)?	-R	
Laevicarcinus	T (Eo-m)	-T (Plio)		Mursilia	T (Mi)		
Laeviprosopon	J (Tith-l)			Mursiopsis	T (Ol-u)		
Laeviranina	T (Eo-l)	-T (Ol-l)?		Myra	T (Mi-u)	-R	
Lambropsis	T (Eo-m)						

Taxon	First Appearance	Last Appearance	Reference	Taxon	First Appearance	Last Appearance	Reference
Necrocarcinus (+ Orthopsis)				Paratymolus	T (Mi)	-R	
Necroneetes	K (Apti-u)	-T (Eo)	(1037)	Pariphiculus	T (Mi-m)	-R	(966)
+Neopilumnoplax	T (Eo-u)	-R		Parribaculus	T (Eo-l)	-R	
Nephrops	T (Dani)	-R		Parthenope	T (Eo-m)	-R	
Nephropsis	T (Than)?	-R		Pemphix	Tr (Anis-l)	-Tr (Anis-m)	(674)
Neptocarcinus	T (Eo-u)	-R		Penaeus	K (Sn)	-R	
Nodoprosopon	J (Oxfo)	-J (Tith-l)	(75,868)	Periacanthus	T (Eo-m)	-T (Eo-u)	
Noetlingia	T (Eo-u)	-T (Ol-l)		Persephona	T (Mi-m)	-R	
+Notomithrax	T (Eo-u)	-R	(922)	Petrochirus	K (Camp-u)?	-R	(961)
Notopocorystes	K (Albi-l)	-K (Maes-l)	(354,961)	Phalangites	J (Tith-l)	-R	(75)
Notopoides	K (Camp-l)	-R	(961)	Phylira	T (Mi-m)	-R	
Notopus	T (Eo-m)	-R		+Phlyctenodes	T (Eo-m)	-T (Ol-l)	
Notosceles	K (Maes-l)	-R	(961)	Phlyctisoma	J (Sine-l)	-K (Albi-u)	
Notostomus	K (Ceno)?	-R		Pilumnus	T (Ol)?	-R	
Nucia	T (Mi-l)	-R		Pinnixa	T (Eo-l)	-R	
+Nucilobus	T (Plio)		(966)	Piratella	Tr(m)		
Ocalina	T (Eo-u)			Pisa	Q (Plei)	-R	
Ocypode	Q (Plei)	-R		Pisomaja	T (Eo-u)		
Oedisoma	T (Eo-l)			Pithonoton	J (Bajo)	-J (Tith)	(1066)
Olinaeacaris	J (Aale)		(2)	Plagiophthalmus	K (Albi-l)	-T (Dani)	
Ommatocarcinus	T (Eo)	-R		Planes	T (Ol-u)?	-R	
Oncopareia	K (Turo)	-K (Sn)		Platycheila	Tr(u)		
Ophthalmoplax	K (Ceno-l)	-K (Maes-l)	(961)	Platypleon	Tr(u)		
Ophiophorus	J (Call)	-R		Pleolobites	T (Pale)	-T (Eo)	
+Orbitoplax	T (Eo-u)			Podophthalmus	T (Ol)	-R	(966)
Orhomalus	J (m)	-J (u)		Polycnemidium	K (Coni)		
Ovalipes	T (Plio)	-R		Porcellana	K (Ceno)	-R	
Oxythyreus	J (Tith)			+Pororaria	T (Eo-m-u)?	-T (Eo-u)	(922,1259)
+Ozius	T (Mi-m)	-R		Portunus	T (Mi)	-R	
Paguristes	K (Camp-u)	-R	(961)	Portunites	T (Eo-l)	-T (Mi-l)	
Pagurus	K (Albi-l)	-R	(961)	Portumnus	T (Eo-m-l)	-R	
Palaeastacus	J (Sine-l)	-K (Turo)		+Potamonautes	T (Mi-u)	-R	(1066)
Palaeamon	T (Eo-l)?	-R		Praeteya	J (Hett)	-J (Plie)	(2)
Palaeocarpilius	T (Eo-m-l)	-T (Mi-l)?		Prehepatus	K (Albi-l)	-K (Maes-u)	
+Palaeodromites	K (Albi-l)	-R	(961)	+Prepaeduma	T (Plio)		(966)
Palaeograpsus	T (Eo-m-l)	-T (Plio)	(966)	+Prochlorodius	T (Eo-u)		
Palaeohomarus	K (Albi)	-K (Sn)		Propryon	J (Toar-l)		(1066)
Palaeomunida	T (Eo-m)	-T (Eo-u)		Propalaeomon	T (Ol-l)		
Palaeomunidopsis	J (Bajo)?			Prosopon	J (Bajo)	-K (Nc)	(1066)
Palaeomyra	T (Mi-m)			+Protaegla	K (Albi-m)?		
Palaeonephrops	K (Sn)			Protaxius	J (u)	-T (Eo-m-l)	
Palaeopagurus	J (Plie-l)	-J (Toar-l)	(2)	+Proterocarcinus	T (Dani)		(1220)
+Palaeopalaemon	D (Fame-u)		(356)	Proteocalianassa	K (Barr-u)	-T (Eo-u)	
Palaeopalinerus	J (u)			Protoclytiopsis	P (Dora)?		(2,351)
+Palaeopemphlia	P (Leon-u)		(1066)	Protomunida	T (Dani)	-T (Than)	
Palaeopentacheles	J (Tith-l)		(75)	+Protoneocarcinus	K (Ceno-u)		(961)
Palaeophoberus	J (m)			+Proxicarpilius	T (Eo-m)		
Palaeopolycheles	J (Tith-l)		(75)	Psammocarcinus	T (Eo)	-T (Ol-l)	
Palaeoanthopsis	K (Maes)			Pseudocarcinus	T (Mi)	-R	
Palehomola	T (Ol)			Pseudoglypheia	Tr(u)	-J (m)	
+Palibaculus	K (Ceno-l)			+Pseudoneocarcinus	K (Albi-l)	-K (Maes-u)	(961,1225)
Palinurina	J (l)	-J (Tith-l)	(75)	Pseudopemphix	Tr (Olen-u)	-Tr (Anis)?	
Palinurus	K (Turo)	-R		Pseudorhinella	K (Sn)	-K (Maes-u)	
Panopeus	T (Dani)	-R		Pseudorhombila	T (Mi)	-R	
Paraclythia	K (Turo)	-K (Sn)		Pugettia	Q (Plei)	-R	
Paraclytiopsis	Tr(u)			Pustulina	J (Tith-l)?		
+Paragalthea	K (Maes-u)		(1225)	Pyromia	T (Eo-l)	-R	
Paralitogaster	Tr(l)	-Tr(m)		Randallia	T (Mi)	-R	
Paraneocarcinus	K (Haut)?	-K (Camp-l)	(961)	Randina	T (Ol)	-T (Mi)	
Parapinnixa	T (Mi)	-R		Ranilia	T (Eo)	-R	
Parapirimela	T (Mi)			Ranina	T (Eo-l)	-R	
				Raninella	K (Albi-u)	-T (Pale)	(354,961)

Taxon	First Appearance	Last Appearance	Reference	Taxon	First Appearance	Last Appearance	Reference
Hesslerella	C (Mosc-u)			+ Flemingopsis	Cm(mMid-u)		(1062)
Heterosphaeroma	T (Eo-m-l)			+ Galeopsis	Cm(mMid-u)		(1062)
Isopodites	Tr			+ Gladioscutum	Cm(uMid-m)		
Palaega (+ Bathynomus)	Tr(Olen-u)?	-R		+ Guangdongella	Cm(IMid)	-Cm(mMid)	(ZR87)
Palaocrangon	P (Guad)			+ Guangyuanelia	Cm(Atda)		(131)
Palaophreatoicus	P (Guad-u)			+ ?Hanchiangella	Cm(Atda-u)		(89)
+ Proidotea	T (Ol-l)		(1066)	+ Hipponicharion	Cm(Atda-u)	-Cm(uMid)	(580)
Protamphisopus	P (Guad-l)	-Tr(Anis)?	(2)	+ ?Houlongdongella	Cm(Boto)	-Cm(mMid)	(89)
Protosphaeroma	J			Indiana (+ Indianites)			
+ Saduria	Q (Plei)	-R	(1032)		Cm(Atda-u)	-Cm(mMid)	(11,111, 580)
Sphaeroma	T (Mi-m)?	-R		- Indota	Cm(Boto)	-Cm(mMid)	(111,129, 131)
+ Triassphaeroma	Tr(Nori-u)			+ Jixinglingella	Cm(Atda-u)		(1219)
Unusuropode	K (u)			+ Konicckion	Cm(Atda-u)	-Cm(mMid)?	(131,1006)
Urda	J (Bath)	-K (Apti)		+ ?Kunmingella	Cm(Atda-u)		(89)
Or. AMPHIPODA				+ Kunyangella	Cm(Atda-u)		(131)
Acanthogammaridae	T (Ol-l)	-R		+ Leshanella	Cm(Atda-u)?		(1006)
Corophiidae	Q (Plei)	-R		+ Liangshanella	Cm(Atda-u)		(131,580)
Gammarus	T (Ol-l)	-R	(1066)	+ ?Ludvigsenites	O (m)	-S (Wenl)	
Melita	T (Ol-l)	-R		+ Majiashanella	Cm(l)		(ZR91)
Pontogammaridae	T (Mi-m)	-R		+ Malongella	Cm(Atda)		(131)
Praegmelina	T (Mi-m)			+ Mannosocmia	Cm(IMid)	-Cm(mMid)	(ZR87)
Cl. OSTRACODA				+ ?Meishucunella (+ Meishuengella)			
(Classification and basic stratigraphy from TREATISE, Pt. Q [1961].)					Cm(Atda-u)?		(89,580)
Or. ?BRADIORIIDA				Mononotella	Cm(Atda-u)	-Cm(mMid)	(89,111)
+ Acanthomeridion	Cm(Atda-u)		(1006,1019)	+ Nanchengella	Cm(Atda-u)		(131,1006)
+ Albrunnicola	Cm(uMid)?		(131)	+ Neokunmingella	Cm(Boto)		(131)
Aluta	Cm(Atda-l)	-Cm(Tojo)	(131,885)	+ Ophiosema	Cm(Tojo-u)	-Cm(mMid)	(129,131)
+ Alutella	Cm(IMid)?		(131)	+ Ovaluta	Cm(Boto)		(1006)
+ Anabarochilina	Cm(uMid)	-Cm(Dres)	(131)	+ Parakunmingella	Cm(Atda)		(131)
+ Antohipponicharion	Cm(Atda-u)		(1006)	+ Paraphaseolella	Cm(l)		(1006)
+ Aristaluta	Cm(uMid-u)		(111,131)	+ Parasherogoldopsis	Cm(mMid-u)		(1062)
+ ?Auriculatella	Cm(Atda-u)		(89)	+ Paratsunyiella	Cm(l)		(ZR91)
+ Australopsis	Cm(mMid-u)		(1062)	+ Phaseolella	Cm(Boto)		(1006)
+ ?Bajjiella	Cm(Atda-u)?		(89)	+ Phasoia	Cm(mMid-u)		(1062)
Beyrichona (+ Escasona)	Cm(Atda-l)	-Cm(Dres)		+ Plesidielymella	Cm(IMid)?		(131)
				Polyphyma (+ Cyclotron)			
+ Biaturina (+ Bradorona)	Cm(mMid-u)		(1062)	+ Pseudokunmingella	Cm(Atda-u)?	-Cm(Dres-u)	(131,1066)
Bradoria	Cm(Atda-l)	-Cm(Fran)	(111,129, 135,885)	+ Reticulocambria	Cm(u)		(1006)
+ Bullaluta	Cm(Dres-l)			+ Schallreuterina	Cm(mMid-u)		(1062)
+ Cambraechmina	Cm(mMid-u)		(1062)	Sellula	Cm(Atda-u)		(580)
Cambria	Cm(Atda-l)?		(135)	+ Septadella	O (Trem)		(1066)
+ Carnarvonina	Cm(mMid-u)			+ Shensiella	Cm(Atda-u)		(131,1006)
+ Cedocamia	Cm(mMid-u)		(1062)	+ Shergoldopsis	Cm(mMid-u)		(1062)
+ Changshabaella	Cm(Atda-u)?		(1006)	+ Songlinella	Cm(Atda-u)		(580)
+ ?Combinivalvula	Cm(Atda-u)		(781)	+ Sunella (+ Chiella, Luella)			
+ Comptaluta	Cm(Tojo-u)	-Cm(mMid)	(129,131)		Cm(Atda-u)		(131,781)
+ ?Dahaiella	Cm(Atda-u)		(580)	+ Svealuta	Cm(mMid-u)	-Cm(Dres-l)	(111,130, 131)
+ Dabashanella	Cm(Atda-u)?		(1006)	+ Tropidiana	Cm(Tojo-u)		(129,131)
+ Damaoella	Cm(IMid)?		(131)	+ Tsunyiella	Cm(Boto)		(131)
Dielymella	Cm(Atda)?	-Cm(IMid)	(131,580)	+ Utsatia	Cm(mMid-u)		(1062)
+ Dorispina	Cm(mMid-u)		(1062)	+ Voibokalina	Cm(m)		(ZR85)
+ Duibianella	Cm(Atda-u)		(1219)	Walcottella	Cm(mMid)	-Cm(Fran-u)	(131,1066)
+ Epactridion	Cm(Atda-u)		(923)	+ Waldoria	Cm(Trep)?		(1066)
Eremos	O (Trem)			+ Wuchiapingella	Cm(Atda-u)		(131)
+ Fengtaiella	Cm(l)		(ZR88)	+ Wutingella	Cm(Atda)		(131)
				+ Yaoyingella	Cm(Atda)		(131)
				+ Yaxianella	Cm(IMid)	-Cm(mMid)	(ZR87)
				+ Yeshanella	Cm(Boto)		(1006)

Taxon	First Appearance	Last Appearance	Reference	Taxon	First Appearance	Last Appearance	Reference
+Yulinella	Cm(Mid)?		(131)	+Adamezakites	O (Llvi-u)	-O (Cara-l)	(1116)
+Zhenpingella	Cm(Atda-u)	-Cm(Boto)	(1006)	+Adelphobolbina	D (Eife)?	-D (Fras-u)	
+Zhijinella	Cm(Atda-u)?		(131,580)	+Admirabilinella	S (u)		(ZRR91)
+Zhongbaoella	Cm(Atda-u)?		(1006)	+Aechmina	O (Aren)	-D (Fame-u)	(855)
Or. ?PHOSPHATOCOPDA				+Aechminaria	S (Wenl-l)	-D (Give)	
+Falites	Cm(Dres-l)	-Cm(Fran-u)	(130,134,1066)	+Aechminella	D (Give-u)	-C (Bash)	
+Flemingia	Cm(mMid-u)		(131)	+Aetholicoxototis	S (Wenl-u)		(812)
+Hesslandona	Cm(Boto)?	-Cm(Dres-l)	(132,1066)	+Ahlintella	O (Llvi-l)		(855)
+Monasterium	Cm(Boto)	-Cm(mMid-u)	(131,1006)	+Airlina	O (Llde-u)	-O (Ashg-m)	(855)
+Oecipaluta	Cm(uMid-m)		(131)	+Aitilia	S (Wenl-l)	-S (Ludl)	(ZR79, ZR91)
+Vestrogothia	Cm(Tojo)	-Cm(Dres)	(131)	+Ajchalina	O (u)		(ZR84)
+Zepaera	Cm(Atda-u)?	-Cm(mMid-u)	(131,1006)	+Akkermites	O (Cara-u)		
Or. LEPERDITICOPIDA				+Alakolites	O (Llvi-l)		(996)
+Anisochilina	O (Llvi-u)?	-O (Cara-u)?	(855)	+Alaskabolbina	S (Prid)	-D (l)	(77)
+Aristozoe	S (Ldov)	-S (Ludl)?		+Alocutia	O (Cara-m)		(855)
+Bingeria	S (Wenl-l)	-S (Prid)	(ZR85, ZR79)	+Altaecypris	C (Tour)		
+Bivia	O (l)	-O (m)	(85)	+Alveolella	S (Prid)?		
+Bispinitia	S (Wenl)	-D (l)	(85)	+Amerigobolbina	O (Llde)	-O (Cara-m)?	(999)
+Briartina	D (m)			+Amphikegelites	C (u)		(ZR91)
+Ceratoleperditia	O (Aren-u)	-O (m)	(85)	+Amphisella	D (Give-l)?	-D (Fras-m)	
+Chevroleperditia	D		(85)	+Amphisites	D (Eife-l)	-P (Dora)	(2,648)
+Dalelina	D (l)		(85)	+Amphitoxotis	S (Wenl-u)	-S (Ludl-l)	(812)
+Dihogmochilina	O (m)	-S (Wenl)		+Amphizona	D (Give-l)		
+Eoleperditia	O (Llvi-l)	-S (Wenl-l)	(85)	+Amplettochilina	O (Aren-u)	-S (Ludl)	(855,1116)
+Eomoelleritia	D (l)		(85)	+Amygdalella	S (Ldov)	-S (Prid)	
+Gibberella	S (Ldov)	-S (Wenl)		+Antiaechmia	O (Llvi-u)?	-O (Ashg-u)	(855)
+Herrmannina	S (Wenl-l)	-D (Fame-u)	(2,1066)	+Anticostiella	O (Ashg-m)		
+Heterochilina	O (Aren)			+Antischmidtella	O (Cara-u)	-O (Ashg-l)	
+Hogmochilina	S	-D (u)	(85)	+Aparchitella	O		
+Holtedahllites	D (l)		(85)	+Aparchites	O (Aren)	-C (Vise-l)	
+Isochilina	O (Aren-u)	-O (Cara-u)	(855)	+Aparchitellina	D (Gedi)	-D (Fras-m)	
+Ivia	O (Llvi-u)?	-O (Cara-u)?	(855)	+Apatobolbina	S (Ldov-u)	-S (Wenl-l)	
+Kiaeria	S (Ludl-u)	-S (Prid)		+Apatochilina	O (Cara-l)	-O (Cara-m)	(999)
+Leperditia	O (Ashg-m)	-D (Fras-u)		+Arcyzona	D (Eife-l)		
+Moelleritia	D (l)	-D (Fras)	(85)	+Ardenna	O (Cara-l)?		(855)
+Paenaequina	S (u)	-D (m)	(85)	+Arikloedenia	D (Sieg)	-D (Eife)	
+Paraeoleperditia	O?		(85)	+Arsiriina	D	-C	(ZR89)
+Paraleperditia	D (Emsi-l)	-D (Fras)	(85)	+Atterdagia	S (Ludl-l)?	-S (Ludl-u)	(812)
+Paramoelleritia	D (Emsi-u)	-D (Eife)	(85)	+Aulacopsis	O (Aren-u)	-O (Llvi-u)	(855,999)
+Pteroleperditia	S (Ldov)	-S (Wenl)		+Aurikirkbya	C (Mosc-l)	-P (Guad-l)	
+Schrenckia	S (Ludl)			+Australobolbia	S (u)		
+Sibiritia	S (Ldov)	-S (Wenl)		+Balantoides	D (Give-u)	-D (Fras-m)	
+Sinoleperditia	D (Gedi-l)	-D (Fame)		+Ballarina	O (Llvi)		(ZR89)
+Sollenella	S (Ldov)	-D (m)	(85)	+Balticella	O (Llde-u)	-O (Cara-l)	(855)
+Swartzochilina	S (u)			+Baltonotella	O (Llde-u)	-O (Cara-u)	(855,996)
+Teichoichilina	O (m)			+Barrosina	O (u)		
+Tirisochilina	O (Aren)?	-O (m)	(85,1066)	+Barymepton	S (Ldov-u)		(ZR79)
+Tollita	S	-D (l)	(85)	+Bätsleratia	O (Llvi)		(ZR89)
+Ushkarella	Cm(Tojo)		(1006)	+Bellornatia	O (Cara-m)		
+Yokopsis	S (u)		(85)	+Berdanopis	S (Prid)	-D (Emsi-u)	(77)
Or. PALAEOCOPIDA				+Berolinella	S (Prid)		
+Abditoloculina	D (Eife)?			+Beyrichia	S (Ldov-u)	-D (Eife)?	(2)
+Acanthobolbina	O (m)			+Beyrichiana	C (Serp-l)?	-P (Wc)	
+Acantonodella	D (u)			+Beyrichiella	C (l)		
+Acravinula	P (l)		(ZR88)	+Beyrichiopsis	C (Tour-l)	-C (Serp-l)	(74,670)
+Actinochilina	O (Llde-u)	-O (Cara-l)	(855)	+Bichilina	O (Llvi-l)	-O (Cara-u)	(78,855)
				+Bicornella	D (Gedi)	-D (Fras-m)	(2)
				+Bicornellina	D (u)		
				+Bideirella	D (Give-u)		(2)
				+Bilobatia	O (Cara-m)		(855)
				+Binodella	P (l)		(ZR89)

Taxon	First Appearance	Last Appearance	Reference	Taxon	First Appearance	Last Appearance	Reference
+ Binodina	D (Gedi)			Conchoprimites	O (Llvi-l)	-O (Cara-m)	
Bisacculus	D (Give)			Conchoprimitia	O (Aren-l)	-O (Llde-u)	(78,855)
+ Bisphenella	D (m)		(ZR89)	+ Consonopsis	O (Cara-l)	-O (Cara-m)	(999)
Bodenia	O (Llde)	-O (Cara-l)	(999)	+ Conspicillum	O (Llde-l)?	-O (Cara-m)	(736,855)
+ Bodenella	O (Cara-l)	-O (Cara-m)	(999)	- Copelandella	C (l)		(1066)
- Bohemobolbina	D (l)		(ZR89)	- Copelandia	O (Cara-m)	-O (Ashg-u)	(736,855)
Bolbibollia	S (Wenl)			Cornigella	D (Eife)	-P (Guad-u)	(2,136)
+ Bolbilithis	O (Cara-l)	-O (Ashg-m)	(855)	Cornikloedenia	S (Wenl)	-D (Gedi-l)	(423)
Bolbina	O (Llvi-l)	-O (Ashg-u)	(78,855)	Coronakirkbya	C (Step)	-P (Djhu)	(648)
Bolbineosia	S (Ldov-l)	-S (Wenl-l)	(1066)	Coryellina	D (Fame-m)	-P (Guad-l)?	
Bolbiprimitia	S (Prid)			- Costaegera	S (Ldov-u)		(1066)
+ Bolbopisthia	O (Cara-l)			+ Costokloedenia	D (l)		(ZR84)
Bollia	O (Ashg-m)?	-D (Give-l)	(136,855)	Craspedobolbina	S (Ldov-u)	-S (Prid)	(2,77)
+ Bolliaphores	O (Llvi-l)		(855)	- Crenabolina	O (Cara-m)	-O (Cara-u)	(ZR91)
Bonnemaia	S (Wenl)			Crescentilla	O (Llde-u)	-O (Ashg)	(736,855, 1075)
Bonneprimites	S (Wenl)			Cryptophyllus	O (Llvi-l)	-C (Vise-u)	(1066)
+ Borcobolbina	O (Cara-l)	-O (Cara-m)	(999)	+ Cryptoglyptopleura	D (u)		(ZR89)
+ Botulobolbina	S (Prid)			Ctenobolbina	O (Cara-l)	-O (Ashg-m)	
- Braderupia	O (Cara-l)	-O (Cara-m)	(855)	Ctenobolbinella	S (Prid)	-D (Eife)?	
- Brephocharies	O (Llvi-u)	-O (Cara-u)	(736,855)	Ctenoloculina	D (Emsi-u)	-D (Give)	
Brevibolbina	O (Llde-u)	-O (Ashg-m)	(78)	Ctenonotella	O (Llde-u)	-O (Cara-u)	(78)
+ Brevidorsa	O (Llvi-l)	-D (Emsi)	(855,1066)	- Cubitosulcus	D (m)		(ZR84)
+ Brevisulcina	O (Cara-l)		(999)	+ Cubitosulcus	D (Give-l)		(136)
Bromidella	O (Llde-l)	-O (Ashg-m)	(855)	Cyathus	C (Mosc)	-C (Step-u)	(2,773)
+ Bubnofiopsis	O (Cara-l)		(855)	+ Cymbabolbina	O (Llde-l)	-O (Llde-u)	(736,855)
- Bucerella	O (Cara-l)	-O (Ashg-l)	(78)	- Cystomatochilina	O (Llde)	-S (Wenl-u)	(78)
+ BuceroBolbina	O (Cara-l)		(999)	- Damiriella	O (m)		(ZR88)
+ Bulbosulculus	O (Cara-m)		(999)	+ Dawania	O (l)	-O (u)	(ZR91)
+ Bullaeferum	O (Llvi-l)	-O (Ashg-m)	(736,855)	+ Decorella	O (u)		(ZR84)
+ Bullatella	O (Cara-m)		(ZR87)	+ Deefgella	O (Ashg)		(855)
Buregia	D (Give-u)	-D (Fras-u)		+ Deloia	C (Serp-l)		(ZR87)
+ Byrsolopsina	O (Llde-u)	-O (Ashg)?	(855)	+ Delosia	S		(ZR88)
+ Caprabolbina	O (Ashg-u)		(166,855)	+ Dentopararchites	P (Djhu)		(648)
Carboprimita	D (Fame-u)			Dibolbina	S (Ludl)		
Cardiniferella	C (Serp-l)	-C (Serp-u)	(2,1066)	+ Dibolbopisthia	O (Cara-l)		
+ Carinaknightina	Tr(l)		(1066)	+ Diceratobolbina	S (Ldov-u)	-S (Wenl-l)	
Carinobolbina	O (Llde-u)	-O (Cara-m)	(78,855)	Dicranella	O (Cara-m)	-O (Cara-u)	(999)
+ Carinokloedenia	D (Sieg-l)	-D (Emsi-l)	(423)	+ Dictyotaxotis	S (Wenl-l)		(812)
+ Carubaknightina	P (Djhu)		(648)	Dilobella	O (Aren)?	-O (Ashg-l)	(78,ZR89)
+ Cavhithis	O (Llvi-u)?	-O (Cara-u)?	(855)	+ Diplopsis	O (Cara-l)	-O (Cara-m)	(999)
+ Cavopleura	O (Cara-l)		(855)	+ Drisulcinoides	O (Cara-l)	-O (Cara-u)	(855)
+ Ceratobolbina	O (Llvi-u)	-O (Cara-m)	(855,1116)	+ Disparigonya	O (Cara-m)		(855)
Ceratopsis	O (Llvi-u)	-O (Cara-u)	(736,855)	Distobolbina	O (Cara-l)	-O (Ashg-u)	(78,855)
+ Cerninella	O (Llvi-u)	-O (Cara-m)	(999)	Disculcina	O (m)	-O (u)	
+ Cershiites	O (Aren)?			+ Dogoriella	O (Ashg-u)		(855)
- Charitoxotis	S (Wenl-u)		(812)	Dolborella	O (Cara-m)	-O (Cara-u)	
+ Cherskiella	O		(ZR84)	Dolichoscaptha	S (Wenl-l)		
+ Chesterella	C (l)		(ZR87)	+ Dolichoscapthoides	D (Gedi)		
Chilobolbina	O (Aren-u)	-O (Cara-l)	(2,78,999)	+ Domaszevicella	O (Llvi-u)		(1116)
Chironiptrum	D (Emsi-l)	-D (m)		+ Dominina	O (m)		(ZR87)
+ Cincinnaticoncha	O (Cara-u)			Donekina	D (u)		
+ Circulina	O (Cara-l)	-O (Ashg-l)	(78)	Doraclatum	D (Emsi)	-D (Give-l)	(1066)
Clavofabella	S (Wenl-l)	-S (Prid)		Drepanella	O (Cara-l)	-O (Ashg-u)	(2)
+ Clavofabellina	S (Prid)	-D (Give-u)		Drepanellina	S (Ldov-u)		
+ Clintiella	S (Wenl-l)		(ZR79)	+ Dulkumella	O (Cara-u)		
Coelochilina	O (Llvi-l)	-D (Give)	(999)	+ Duplexibollia	O (Cara-u)?	-O (Ashg-u)	(855,1066)
Coeloenellina	O (Llvi-l)	-D (Give-u)		+ Duplicristatia	O (Ashg)		(166,855)
+ Coelonella	D (Fras-l)	-P (l)	(ZR89)	+ Duringia	O (Llde-l)	-O (Ashg-l)	(855)
+ Colacchilina	O (Cara-l)		(999)	+ Easchmidtella	O (Llde-l)	-O (Ashg-m)	(736,855)
+ Collobolbina	O (Aren-u)?	-O (Cara-u)	(855,996)	Echinoprimitia	O (m)		
+ Concavhithis	O (u)		(166)	Etoprimitia	O (Aren)?	-O (u)?	
+ Conchoprimitella	O (Llvi-u)	-O (Cara-l)	(736,855)				

Taxon	First Appearance	Last Appearance	Reference	Taxon	First Appearance	Last Appearance	Reference
+Ectoprimitioides	O (Llvi)		(ZR88)	+Gracquina	O (Aren-u)	-O (Llvi-u)	(736,855)
+Edenopsis	O (Cara-u)		(137)	+Gramella	Tr(m)		(ZR85)
+Effeminatopleura	D (Fame-u)		(ZR88)	+Grammolomatella	O (Cara-m)	-O (Ashg-m)	(855)
+Egorovella	O (Llde)	-O (Cara-l)?	(999)	+Gravia	D (Give-u)	-D (Fras-u)	
+Egorvellina	O (Llde-u)	-O (Cara-l)	(999)	+Gryphinswaldensia	O (Aren-u)	-O (Ashg-u)	(855)
+Ehlersia	S (u)	-D (Gedi)		+Guberites	O (Cara-m)	-O (Ashg-l)	(999)
+Elenamarginia	S (Prid)	-D (Give)		+Guericchiella	D (l)		(ZR91)
+Ellipsella	P (Leon)		(1066)	+Gyrgathella	S (Prid)	-D	(77)
+Embryotoxotis	S (Ludl-u)		(812)	+Hallatia	O (Cara-l)?	-O (u)	
+Eoquapulex	O (Ashg-m)	-O (Ashg-u)	(855)	+Halliella	D (m)		
+Eobromidella	O (Aren)?	-O (Llvi)		+Hanaites	D (Gedi-u)	-D (Give-u)	
+Eochilina	O (Aren-u)	-O (Cara-l)	(999)	+Haplobolbina	O (m)		
+Eocytherella	O (Cara-l)	-O (Ashg-u)	(855)	+Haploprimitia	O (Aren-u)	-D (u)	
+Eographiodactylus	O (m)	-O (Ashg-u)	(166,855)	+Harginisulcus	D (Give-l)		(136)
+Eogollina	O (m)	-S (u)		+Harpabollia	O (Cara-u)		(1066)
+Eokloedenia	S (Ludl)	-S (Prid)		+Hastatellina	O (Llvi-l)	-O (Ashg-l)	(166,736,999)
+Eolomatella	O (Cara-l)	-O (Cara-m)	(166,855)	+Hatangeus	S (Ldov)		(ZR88)
+Equicastanea	S (Wenl-u)		(812)	+Hebellum	S (Prid)		
+Ertangia	D (l)		(ZR85)	+Hemeaschniditella	O (Cara-l)	-O (Ashg-u)	(855)
+Estoniops	O (Llde-l)			+Hemiaechminoides	O (Cara-l)	-S (Ludl-l)	(855)
+Eukloedenella	O (u)	-D (Fras-m)	(ZR89)	+Hemiella	S (Ludl-u)	-D (Gedi)	(2,74,812)
+Euprimites	O (Aren-u)	-O (Ashg-l)	(2,78)	+Henningmoenia	O (Cara-l)	-O (Ashg-m)	(855)
+Euprimitia	O (Aren)	-S (Ldov)		+Hercynobolbina	D (m)		(ZR89)
+Eurekabolbina	D (Gedi)			+Hesperidella	O (Llde-l)	-O (Cara-m)	(855,1116)
+Eurocyamus	O (Cara-m)		(855)	+Hesslandella	O (Aren-u)	-O (Cara-l)	(855)
+Europisthia	O (Ashg)		(855)	+Hibbardia	D (Give)		(136)
+Eurychilina	O (Cara-l)	-S (Ldov)	(999)	+Hillmeria	O (Cara-l)	-O (Cara-m)	(855)
+Eylanella	D (Eife-l)	-P (Leon)	(2)	+Hintziella	O (Llvi)		(ZR89)
+Evlanovia	D (Give-u)	-D (Fame-u)		+Hippula	O (Llvi-u)	-O (Ashg-u)	(855,1116)
+Extrania	D (l)		(ZR85)	+Histina	O (Llde-l)	-O (Cara-l)	(736,855)
+Fallaticella	O (Cara-l)	-O (Ashg-m)	(855)	+Hithis	O (Cara-m)	-O (Ashg-u)	(855,999)
+Falsipollex	D (Eife)?	-D (Give)		+Hollina	D (Gedi)	-D (Give-u)	
+Famenella	D (Fame)?	-C (Tour-l)	(670)	+Hollinella	S (Wenl)	-Tr(Indu)	(1066)
+Fellerites	D (Eife)	-C (Tour-l)	(ZR83)	+Homeoceratopsis	O (Llde-l)	-O (Cara-l)	(855)
+Femerrenstia	O (Cara-m)		(166,855)	+Homeokiesowia	O (Llde-l)	-O (Cara-m)	(166,736,855)
+Fidelitella	O (Llde)	-O (Cara-l)	(999)	+Huckea	O (Cara-m)		(855)
+Fiorella	O (Llvi)		(ZR89)	+Hungarogeisina	P (Djhu)	-P (Dora)	(648)
+Flaccivulum	D (Eife-l)			+Huntonella	D (Gedi)		
+Foramenella	O (Cara-u)	-O (Ashg-m)	(78,855,999)	+Huttoniella	S (Ludl-u)	-S (Prid)	(812)
+Foveaprimittella	O (Ashg-u)		(855)	+Hypotetragona	D (Eife-l)	-C (Pn)	
+Fuscinites	O (Llde)		(999)	+Hyrsinobolbina	S (Prid)		(77)
+Fusciniullina	O (Aren-u)	-O (Llvi-l)	(999)	+Illatiavella	D (Fras-u)	-D	(ZR83)
+Gannibeyrichia	S (Ludl-u)	-S (Prid)		+Imangidites	S (Ldov)		(ZR88)
+Garniella	S (Wenl-l)	-S (Prid)	(77)	+Inisylthere	S		(ZR88)
+Gebeckeria	O (Ashg-l)	-O (Ashg-u)	(855)	+Ishmiella	O (Cara-l)		(996)
+Geffenina	C (Vise-u)	-C (Serp-l)		+Ispharaella	S (Ludl-l)		
+Geffenites	C (Ms)			+Italogeisina	P (Djhu)	-P (Dora)	(648)
+Gellensia	O (Cara-l)	-O (Ashg-m)	(166,855)	+Ivaria	O (Aren-u)	-O (Llvi-l)	(855)
+Giandites	O (Cara)	-O (Ashg)		+Jaantussonia	O (Llvi-u)?	-O (Ashg-u)	(855)
+Gibba	S		(ZR88)	+Jagatiella	S (Wenl-l)		(ZR79)
+Gillatia	S (Ldov)			+Jakutobolbina	O (u)		(ZR84)
+Glezeria	D (Fras)			+Javatus	C (u)		(ZR84)
+Glimmatobolbina	O (Cara-l)	-O (Cara-m)	(999)	+Jeanlouiseella	O (Llde-l)	-O (Llde-u)	(855)
+Glossomorphites	O (Aren-u)	-O (Llvi-l)	(855)	+Jonesella	O (m)	-O (Cara-u)	
+Glymmatobolbina	O (Cara)			+Jonesina	C (Tour-l)	-C (Vise-u)	
+Glyptopleura	C (Tour-l)	-P (Leon-u)	(2,74,773)	+Jonesites	O (Cara)?	-S (Ludl-l)	(74)
+Glyptopleurella	D (u)		(ZR89)	+Jordanites	C (u)		(ZR91)
+Glyptopleurina	C (Vise)	-C (Pn)		+Junctusina	O (Cara-u)		(996)
+Glyptopleuroides	C (Serp)?			+Kalugia	D (u)		
+Gongylostonyx	S (Wenl-u)		(812)	+Karinutatia	O (Cara-l)?		(855)
+Gotula	O (Ashg-l)	-O (Ashg-u)	(855)				

Taxon	First Appearance	Last Appearance	Reference	Taxon	First Appearance	Last Appearance	Reference
Karlsteinella	S (Ludl-l)			+Lomatopisthia	O (Llvi-u)	-O (Cara-m)	(1066)
+Kascovobolina	S (Prid)		(1047)	+Longidorsa	O (Aren-u)	-O (Llvi-l)	(855)
+Katatona	D (Fame-u)			Lophokloedenia	D (Gedi-l)		
Kayatia	O (Cara-l)	-O (Ashg)?	(1066)	+Loutriella	S (Ldov-l)		(1066)
Kayina	O (Cara-l)	-O (Cara-m)	(855)	+Lubrzankiella	O (Llvi-u)	-O (Cara-m)	(1116)
Kegelites	C (Tour)	-P (Leon)		+Luciter	S		(ZR88)
Kellettina	C (Tour)	-P (Djhu)	(2,648)	+Lysogorella	D (Eife-l)		
+Kielciella	D (l)	-D (Give)	(ZR84)	Macronotella	O (Cara-m)		(999)
Kiesowia	O (Cara-l)	-S (Ldov)	(78,855, 999)	+Maizassionis	S (u)		(ZR91)
Kindlella	C (Vise-l)	-P (Dora)	(2,74,648)	+Malguzaria	S (u)		(ZR85)
Kinnekullea	O (Cara-m)	-O (Ashg-u)	(78,855)	+Malmina	C (l)		(1066)
Kirkbya	D (Fame-u)	-P (Djhu)	(2,648)	+Mammoides	C (Vise-u)	-P (Wc)	
Kirkbyella	S (Ldov)	-C (Mosc-l)	(1066)	Maratia	O (Cara-m)		
+Kitabella	D (m)		(ZR91)	Marginia	D (Eife-l)	-D (Fame-u)	(ZR93)
Klimphores	O (Aren)	-O (Ashg-m)	(78,855, 1066)	+Marginisulcus	D (m)		(ZR84)
Kloedenella	S (Wenl-l)	-D (l)	(2)	+Marquezina	O (Llde-l)	-O (Cara-l)	(855)
Kloedenellitina	D (Give)	-C (Vise-u)		+Martinssonopsis	O (Llde)	-O (Cara-l)	(999)
Kloedenia	O (Cara)	-D (u)		+Martinssonozona	O (Ashg)		(855)
+Klonkina	S (Ludl)	-S (Prid)		+Masloviella	O (Cara-l)		
Knighitina	C (Tour)	-P (Djhu)	(648)	Mastigobolina	S (Wenl)		
Knoxina	D (Fame)?	-P (Leon-u)		Mauryella	D (Fras-l)	-C (Ms)	
Knoxites	D (Sieg)	-C (Vise-l)	(670)	+Medianella	O (Aren-u)	-O (Ashg-u)	(855)
+Kolednikella	S (u)		(ZR91)	+Melanchlenia	D (m)		(ZR89)
+Kolmodinia	S (Ludl-u)		(1066)	Mennerella	D (Fras-u)		
+Komarioella	D (m)		(ZR85)	Mesomphalus	D (Gedi)		
+Koscoviellina	S (Ludl)	-S (Prid)	(1047)	+Microaechmina	O (Ashg-l)		
Kozlovskiella	D (Emsi-l)	-D (u)	(423,ZR88)	Microchilina	S (Wenl-l)	-D (Emsi-l)	
+Kratia	O (Cara-m)		(999)	+Miehlkella	O (Aren-u)	-O (Cara-m)	(166,855)
Kyamodes	S (Wenl)	-D (Eife)?		Milanosvkyia	D (Fras-l)	-D (Fras-m)?	
+Kyhomopisthia	O (Llde)			Milleratia	O (Cara-l)?	-O (Ashg-m)	
+Judahella	P (Djhu)	-J (Hett)?	(648,674)	Miltonella	P (Leon-l)	-P (Leon-u)?	
+Labrosavetum	D (m)		(ZR89)	+Miraculum	D (Gedi)	-D (Sieg)	
Laccochilina	O (Aren-u)	-S (Ludl)	(78,855)	+Moeckowia	O (Cara-m)	-O (Ashg-m)	
Laccoprimitia	O (Aren)	-S (Wenl)		+Moerina	S (Wenl-u)	-S (Ludl-u)	
+Langdaia	Tr(l)			+Mojczella	O (Aren-u)	-O (Cara-u)?	(1116)
+Lapazites	D (l)		(ZR84)	+Monotipleura	O (Ashg-m)		(1066)
+Lardeuxella	O (Llvi-l)	-O (Llde-u)	(855)	Moorites	D (Gedi)	-P (u)	(ZR88)
+Latebina	O (Llde-u)	-O (Cara-u)	(736,855)	+Movchovitschia	Tr(m)		(ZR85)
+Laterophores	O (Aren-u)	-O (Ashg-u)	(736,855)	+Murtiella	S (Wenl-l)		(ZR79)
Leiocyamus	S (Wenl)	-S (Prid)		Myomphalis	D (Gedi-l)		
Leioprimitia	C (l)			+Naevhithis	O (u)		(166)
+Lembittes	O (Cara-m)	-O (Cara-u)	(855)	Nanopsis	O (Trem)		
+Lembitsarvella	O (Aren-u)	-O (Cara-l)	(1116)	+Neckajatia	S (Ldov-m)	-S (Ludl)?	(1066)
-Lenatella	O (Cara-u)			+Neckajella	O (Ashg-l)		
Lennukella	O (Llde-l)	-O (Cara-l)	(78,855)	+Nemuniella	S (u)		(ZR87)
Leperditella	O (Aren-u)	-O (Cara-u)	(1066)	+Neoamphisites	P (Guad-u)		(1066)
+Leperditelloides	O (Llvi)		(ZR89)	Neoparchites	O (m)?		
+Leptobolbina	S (Ldov-u)		(ZR79)	Neobeyrichia	S (Ludl-l)	-S (Ludl-u)	(74)
Leptoprimitia	D (Gedi)	-D (Emsi-u)?		Neodrepanella	D (m)	-D (Fame)	(2)
Levisulculus	O (Llde-u)	-O (Cara-m)	(855,999)	+Neokloedenella	S (u)	-C (u)	(ZR84, ZR91)
Lichvinia	C (Vise-l)	-C (Pn)		+Neoprimitiella	S (Ldov-u)	-S (Wenl-l)	(ZR79)
+Limatia	S		(ZR91)	+Neoschmidtella	O (Ashg-u)		(855)
Limbinaria	S (Prid)?			+Neotsitrella	O (Cara-m)		(78,855)
+Limbinariella	S		(ZR91)	+Neoulrichia	P (Djhu)	-P (Dora)	(648,1066)
+Lingulibolina	O (Cara-u)		(996)	+Nevadabolbina	S (Prid)		(77)
Linsayella	S (Wenl-l)			Nezamyssia	O (Llde)	-D (Give-u)	
+Loculibolbina	O (Cara-u)	-O (Ashg-u)	(855)	+Nicolina	O (u)		(ZR84)
+Loculocavata	O (Cara-l)			+Nionella	O (Llde)	-O (Cara-m)	(999)
-Lokius	C (Serp-l)			+Nobilitella	O (Cara-u)		
Lomatobolbina	O (Llde-u)	-O (Cara-m)	(855,999)	+Nodambichilina	O (Cara-m)	-O (Ashg-u)	(855,999)
				Nodella	D (Give)	-D (Fras)	(1066)

Taxon	First Appearance	Last Appearance	Reference	Taxon	First Appearance	Last Appearance	Reference
Nodibeyrichia	S (Ludl-u)	- S (Prid)	(74)	+Pectidolon	O (Aren-u)	- O (Llde)	(999,1116)
+Nonsukozona	O (Ashg-u)		(855)	+Pedomphalella	O (Llde-u)	- O (Cara-u)	(736,855)
+Norochilina	O (Cara-l)	- O (Cara-m)	(999)	+Pelycobolbina	O (Cara-m)	- O (Cara-u)	(855)
+Notoscapa	D (Fame-u)			+Pentagona	O (Llvi-u)	- O (Cara-u)	(855,1116)
+Noviportia	S (Ldov-u)		(ZR79)	+Pentagonochilina	O (Cara-m)		(999)
+Novobolbina	O (Cara-u)		(996)	+Permoyoungiella	P (Djhu)	- P (Dora)	(648)
+Novogladites	O (Ashg)			+Perprimitia	P		(ZR89)
+Nudista	S (Wenl-l)		(812)	+Perspicillum	O (Llde-u)	- O (Cara-m)	(855,999)
+Obliquisylthius	O (Ashg-l)	- O (Ashg-u)	(855)	+Petrisigmoopsis	S?		(ZR87)
+Obotritia	D (Eife)	- D (Give-u)		Phlyctiscapha	D (Gedi)	- D (Give)	(136)
+Ochesaarina	S (Wenl-u)	- D (m)		+Phyalidopisthia	O (Cara-l)		
+Ochescapa	S (u)	- D (Fame-u)		+Physcocalyptra	D (m)		(ZR89)
+Ockerella	O (Cara-u)		(996)	+Pilla	O (Trem)	- O (u)	(1066, ZR89)
+Octobolbina	O (Cara-m)		(855)	Piretella	O (Llde-l)	- O (Ashg-u)	(855,1116)
+Ocemmatobolbina	O (Llde-l)	- O (Ashg-l)	(78)	Piretia	O (Llvi-u)	- O (Ashg-u)	(855)
+Ocjlemyra	O (Ashg-m)		(ZR88)	Piretopsis	O (Cara-l)		(855)
Oepikella	O (Llde-l)	- O (Ashg-m)	(78)	Placidea	P (l)	- P (Tatr)	(1066)
Oepikium	O (Llvi-l)	- O (Ashg-u)	(78,855, 1066)	+Plagionephrodes	D (Give-u)	- D (Fras-m)	(ZR90)
Ogmoopsis	O (Aren-u)	- O (Cara-m)	(855)	+Planiprimites	O (l)		(1066)
+Ojlemyra	O (Ashg-u)		(855)	Planusella	O (Cara)		
Oliganisus	C (Vise)?	- P (Sakm)	(773)	Platybolbina	O (Llde-u)	- S (Wenl-u)	(78,855, 1066)
Opikatia	O (m)	- O (Cara-m)		Plethobolbina	S (Wenl)		
Opisthoplax	S (Wenl-l)	- D (Gedi)		+Pleurodella	O (Cara-l)	- O (Cara-u)	(855,999)
+Orcofabella	S		(ZR91)	+Podolibolbina	O (u)		(ZR88)
Ordovicja	O (l)	- O (m)	(ZR91)	Poloniella	S (Prid)	- D (Give-u)	
+Ordovizona	O (Cara-m)	- O (Ashg-u)	(855)	+Polycerataella	O (Llde-l)	- O (Cara-m)	(78,855)
+Orechina	O (Llvi-u)	- O (Ashg-l)	(855,1116)	Polytylites	C (Tour)	- P (Leon-u)	
+Orientalina	O (Llde)	- O (Cara-l)	(999)	+Porkornya	J		(ZR85)
+Orthonaria	D (Fame-u)	- C (l)	(ZR94)	+Posneratina	C		(ZR88)
+Osmotoxotis	S (Wenl-u)		(812)	+Posnerina	D (u)		(ZR89)
+Otraczetia	O (Aren-u)		(1116)	Pribylina	O (m)		
Paegnium	D (Give-l)	- D (Fame-m)		Pribylites	D (Gedi)	- C (Tour)	(2)
+Panderia	O (Llde-u)	- O (Cara-m)		Primitia	O (Aren)	- D (u)	
+Parabairdiacypris	S (Wenl)		(ZR85)	Primitiella	O (Aren-u)	- O (Ashg)?	(78,855)
Parabolbina	O (Cara-u)	- D (Fras-l)	(78)	Primitiopsella	S (Ludl)	- D (Sieg)	
+Parabouchekius	D (Fame-u)			Primitiopsis	O (Llde)	- S (Ludl-l)	(74)
+Paractenoloculina	D (Gedi)	- D (Sieg)		Protallinella	O (Aren-l)	- O (Cara-l)	(78,736, 855)
Paraechmina	S (Wenl)	- D (l)		Pseudobeyrichia	S (u)		
+Paraglyptopleura	D (m)		(ZR85)	+Pseudobeyrichiopsis	C (u)	- P (Djhu)	(648,ZR91)
Parahealdia	D (Gedi)	- D (Emsi)		+Pseudobolbia	O (Llde-u)	- O (Cara-l)	(736,855)
+Parahippa	S (Ldov)	- S (Prid)	(1047, ZR91)	+Pseudohippula	O (Ashg-u)		(855)
+Parahollinella	P (Djhu)	- P (Dora)	(648)	+Pseudokiesowia	O (u)		(ZR84)
Parajonesites	O (Cara-m)	- O (Cara-u)		Pseudoleperditia	D (Eife-l)	- C (Tour-u)	(1066)
+Parakozlowskiella	D (Eife-u)	- D (Give-l)	(423)	+Pseudomyomphalus	D (Gedi)		
+Paranoviportia	S (Prid)		(77)	Pseudonodella	D (u)		
+Paraoiganisus	C (l)		(ZR87)	+Pseudoaparchites	S (Ldov-u)	- S (Wenl-l)	(ZR79)
Paraparchitella	C (Bash)			+Pseudoprimitiella	O (Cara-m)	- O (Ashg-m)	(137)
Paraparchites	O (u)	- P (Guad-l)	(2,ZR89)	Pseudorakverella	O (Cara-m)		(855)
+Parapribylites	D (l)	- C (l)	(ZR88, ZR94)	Pseudostrepula	O (Llde-u)	- O (Cara-m)	(855)
+Paraprimitia	S (Wenl-l)		(ZR79)	Pseudotallinnella	O (Cara-m)	- O (Ashg-m)	(855,999)
Parapyxion	O (Llvi-u)	- O (Ashg-m)	(1075)	+Pseudozygobolbina	D (l)		(ZR85)
Paraschmidtella	O (Aren-u)	- D (Fras-m)		Pseudulrichia	O (Llde-l)	- S (Wenl)	(74,855)
+Parashivaella	C (l)		(ZR85)	+Psilokirkbyella	S (Ludl)?	- C (Tour-l)	(1066)
+Parasleia	S (Wenl-l)		(812)	+Punctoschmidtella	O (Llvi-l)	- O (Cara-l)	(1066)
Parenthatia	O (Cara-m)			+Pygoconcha	O (Cara-l)	- O (Ashg-u)	(855)
+Pariconchoprimitia	O (Llvi-u)	- O (Cara-l)	(736,855)	Pyxion	O (Llde-l)	- O (Cara-m)	(78,855)
+Pariphores	O (Ashg-u)		(855)	Quadricollina	S (Ldov)		
Parulrichia	O (Cara)	- D (Gedi)		+Quadridigitalis	O (Cara)		(ZR88)
+Parvirkirbya	P (Djhu)	- P (Dora)	(648)	Quadrijugator	O (Llvi-l)?	- O (Ashg-m)	(855,999)

Taxon	First Appearance	Last Appearance	Reference	Taxon	First Appearance	Last Appearance	Reference
Quadrilobella	O (Aren-u)	-O (Cara-m)	(999)	-Semilukiella	S (u)	-D (Give-u)	(ZR83, ZR85)
+Quadrifolia	O (Llvi-u)	-O (Ashg-u)	(166,855, 1116)	Semipetanus	P (l)	-P (Leon)	
*Quasiglyptoleura	D (Fame-u)		(ZR88)	+Serenida	D (Fame-u)		(ZR94)
+Raimbautina	O (Llde)		(855)	+Severella	O (Llde-l)	-O (Cara-m)	(78,999)
+Rakverella	O (Aren-u)	-O (Cara-m)	(78,855)	+Severobolbina	O (Llde-u)	-O (Cara-m)	(855)
Raymondatia	O (Cara-m)			+Severopsis	O (Llde-u)	-O (Cara-l)	(736,855)
+Rectonaria	D (Fame-l)	-D (Fame-u)	(423)	+Seviculina	O (Llde-l)	-O (Cara-m)	(ZR87)
-Rectoplacera	D (Fame-l)	-D (Fame-u)	(423)	Shidelerites	S (Ldov)	-S (Wenl)	(ZR91)
+Rectospinella	D (Fame)	-P (l)		-Shleesha	C (Vise)?	-P (l)	(ZR89)
+Refrathella	D (Give-u)		(ZR83)	+Sibiribolbina	O (Llde)	-O (Cara-u)	
+Reginea	O (Ashg)		(855)	+Sibiritella	O (Aren)?	-O (Llde)	(999,ZR84)
+Regubea	O (u)		(166)	+Sichuania	S (Ldov)		(ZR91)
Reigiopsis	O (Aren-u)		(855)	Sigmobolbina	O (Aren-u)	-O (Ashg-l)	(78)
-Rembeyrichia	D (Sieg-l)	-D (Emsi)	(166)	Sigmoopsis	O (Llde-u)	-O (Cara-u)	(78,855)
Reticestus	D (Gedi)	-C (Vise-u)		+Sigmoopsoides	O (Llvi-l)	-O (Cara-l)	(855)
+Reticulochilina	O (Cara-m)		(999)	Signetopsis	S (Wenl-l)	-S (Prid)	
+Retinoda			(ZR87)	Sigynus	D (Give-l)		
+Retisacculus	S (Wenl-l)		(ZR79)	-Sinocoelonella	C (l)		(ZR89)
-Reuentalina	O (Llde-l)	-O (Llde-u)	(855)	Sinoprimitia	O (Aren)?		
+Reviya	C (Vise)			S			(ZR88)
+Rhytiobeyrichia	D (u)		(ZR88)	+Siveteria	S		(ZR88)
Richina	S (Ludl-l)	-D (Give-l)	(1066)	-Slependia	S		(ZR88)
Rigidella	O (Aren-l)	-O (Aren-u)	(78)	+Snaidar	O (Llde-u)?	-O (Cara-m)?	(855)
-Rimabollia	D (l)	-D (Eife)	(136)	+Soanella	O (Llde)	-O (Cara-l)	(999)
+Ritatia	O (Ashg-m)	-O (Ashg-u)	(855)	Sphenicibysis	D (m)		
-Rivillina	O (Aren-u)	-O (Llvi-l)	(855)	+Spinacchmina	O (Ashg)		(855)
Roundyella	D (Emsi-u)	-P (Dora)	(648)	+Spinella	C (l)	-P (l)	(ZR88, ZR91)
+Roudestvenskayites	S (Prid)	-D (Give-u)	(77)	+Spinigerites	O (Cara-l)	-O (Cara-u)	(855)
+Rozmaniella	O (Llde)	-O (Ashg-l)	(996)	+Spinohippula	O		(ZR88)
Ruptionium	D (Give)			+Spinopleura	O (Cara-l)?	-O (Ashg-u)	(855)
Saccarchites	S (Prid)?	-D (Gedi-l)		+Steinfurtia	O (Llvi-l)		(1066)
Sacclatia	O (Cara-l)	-S (Ludl)		Steuloffia	O (Aren-u)	-O (Cara-u)	(2,78,855)
Saffordellina	O (m)			-Stictobollia	D (Eife)		(136)
+Sagittovum	O (Ashg)		(855)	Strepula	S (Wenl-u)	-D (Gedi-u)	(74)
Samarella	D (Gedi)	-C (Serp)	(ZR91)	+Stroterobolbina	S (Ldov-u)		(812)
+Samoilovaella	D		(ZR88)	Subligaculum	D (Eife)?	-D (Give)	
Sanniulus	P (Leon-l)	-P (Leon-u)?		Subtella	D (u)		
Sansabella	C (Vise-u)	-P (Sakm)?		+Sudon	O (Cara-l)	-O (Ashg-u)	(855)
Sargentina	C (Vise)?	-P (u)		-Sulcatiella	S (u)	-D (Give-u)	
-Sarmatotoxotis	S (Wenl-u)	-S (Ludl-l)	(812)	Sulcicuneus	D (Give)		
+Sarvina	O (Llde-u)	-S (Ldov)	(855,999)	+Susus	S (Wenl-l)		(1066)
+Sarytumia	O (Cara-m)		(996)	+Suvalkeilla	S (u)		(ZR87)
-Satiellina	O (Cara-m)	-O (Ashg-u)	(855)	Svantovites	D (Give)	-D (Fras-u)	
Savagellites	C (Serp-l)?			+Swantina	O (Llde-l)	-O (Ashg-u)	(855,1116)
+Scaldianella	S (Prid)			+Sylythis	O (Cara-m)	-O (Ashg-m)	(855)
+Scanipisthia	O (Ashg-u)		(855)	+Tajurina	O (u)		(ZR84)
-Scaphina	D (Gedi)			Tallinnella	O (Aren-l)	-O (Cara-u)	(78,855, 999)
-Schallreuteria	O (Llde-l)	-O (Cara-m)	(166,736, 855)	Tallinnellina	O (Aren-l)	-O (Cara-m)	(78,855, 999)
Schmidtella	O (Llvi)	-D (Eife)?	(78,ZR89)	Tallinnopsis	O (Llde-l)	-S	(78,ZR91)
Schweyerina	D (Fras)			Tambovia	D (Fame)		(2)
Scipionis	S (Prid)?			+Tegea	S (Prid)		
Scofieldia	O (Cara-m)			+Telegraphia	O (Aren-u)		(1116)
Serobicula	D (Fras-m)	-P (l)	(74,670, ZR89)	+Tenebriion	C (l)		(ZR87)
+Scrobisylthis	O (Cara-m)	-O (Cara-u)	(855)	Tetrada	O (Llde-l)	-O (Cara-m)	(855)
+Sekobolla	S		(ZR91)	Tetradella	O (Cara-m)	-O (Ashg-u)	(855)
+Selebratina	D (Give)	-C (Vise)		Tetrasacculus	D (Eife)?	-P (l)	(ZR88)
+Selon	O (u)			Tetrastorothyx	O (u)	-D (Give)	(ZR91)
-Semibolbina	O (Ashg-m)	-C (Tour-l)	(855,ZR89)	+Theriosynpecum	K (Berr)		(ZR85)
+Semikiesowia	O (Ashg-m)	-O (Ashg-u)	(855)	+Thibautina	O (Llvi-l)		(855)

Taxon	First Appearance	Last Appearance	Reference	Taxon	First Appearance	Last Appearance	Reference
Thomasatia	O (Cara-l)?	-O (Cara-m)		+Zorotoxotis	S (Wenl-u)	-S (Ludl)	(812)
+Timiskamella	O (Llde)	-O (Cara-l)	(999)	Zygobeyrichia	S (u)	-D (Emsi-u)	(423)
+Tinotoxotis	S (Wenl-u)	-S (Ludl-l)	(812)	Zygobolba	S (Wenl)		
Tmemolophus	O (u)	-D (Give)		Zygobolboides	O (l)	-O (u)	
Treposella	D (Give)			Or. MYODOCOPIDA			
Tribolbina	C (Vise-l)	-P (u)	(1066)	Bertillonella	D (Give-l)	-C (Tour-l)	(423,917)
+Tribotoxotis	S (Wenl-u)		(812)	+Bisulcoentomozone	D (Eife-l)	-D (Eife-u)	(917)
Triemilomatella	S (Wenl)			Bolbozone	S (Ldov-u)	-D (Fame)	
Trinota	D (u)			Boucia	S (Ludl)	-S (Prid)	
+Tropidotoxotis	S (Wenl-u)		(812)	-Calocaria	S (u)		(ZR88)
+Tschingizella	O (Cara-u)		(996)	+Changyangnia	D (u)		(ZR89)
Tsitrella	O (Aren-u)		(78,855)	Checontonomus	D (m)		
Tvaerenella	O (Llvi-l)	-O (Ashg-l)	(78,855)	Conchoecia	K (Albi-l)	-R	(138)
+Uchtovia	S (u)	-D (Fras-u)	(ZR91)	+Cycloberis	J (u)		(1066)
Uhakiella	O (Aren-u)	-O (Ashg-u)	(78,855)	Cyprella	C (Vise)	-P (l)	(ZR89)
+Ullehmannia	S		(ZR91)	Cypridella	D (Fras-u)	-P (l)	(1066)
Ullerella	O (Llvi-l)	-O (Cara-m)	(855)	Cypridellina	D (Fame)?	-C (Vise)?	
Ulrichia	O (Cara-l)	-D (Fras-m)	(78)	Cypridina	J (Bath)	-R	
+Undipila	S (Wenl-u)		(812)	Cypridinnella	D (Fame)?	-C (Vise)	
+Undulirete	S (Prid)?			Cyrosina	S (Prid)?	-D (Give)	(1066)
+Unisulcopeura	O (Aren-u)	-O (Cara-l)?	(855,1116)	Cyrosia	S		
+Unzhiella	P (Tatr)			Discoidella	C (Tour-l)	-P (Dora)	(648,1066)
+Uralina	D (l)			Elpeze	S (Wenl-l)?	-P (Asse)	(1066)
+Urdia	O (Cara-m)	-O (Cara-u)	(ZR91)	Elpinella	O		
+Urtella	D (Give-l)	-D (Give-u)		Entomoconchus	C (l)		
+Urgachilina	O (Ashg-l)			Entomoprimitia	D (Fras-l)	-C (Tour-u)	(423,917)
+Uscopia	O (u)		(166)	Entomoze	S (Ldov-u)	-P (Asse)	
+Uvonhachtia	O (Cara-m)			Fossrichterina	D (Fame-m)	-D (Fame-u)	(423)
+Vaivanovia	O (Cara-l)?	-O (Cara-m)?	(855)	+Franklinella	C (Tour-u)?	-C (Vise-l)?	(1066)
+Valdarella	O (Cara-m)	-O (Cara-u)	(855,ZR91)	+Kuzminaella	D (Fame-u)	-C (Tour-l)	(917)
+Varilatella	O (Llde-u)	-O (Cara-l)	(736,855)	Macrocyprina	T (Phio)?	-R	
+Vattenfallia	S (Wenl-l)		(ZR79)	Maternella	D (Fame-m)	-C (Serp-l)	(74,917)
+Ventrigrus	O (Aren)		(1066)	Nehdentomis	D (Fras-l)	-D (Fame-u)	(423,917)
+Vesticytherura	J (m)		(ZR85)	Oncotechmonus	D (m)		
+Victoria	C (Vise-u)	-P (Sakm)		Palaeophilomedes	D (Fras)	-C (Tour)?	(1066)
+Villozona	D (Sieg)?	-C (Tour-l)?	(1066)	+Parangerella	D (Fame-l)		(917)
+Vitissites	D (Emsi)		(1066)	+Permopolyclope	P (Djlu)		(648)
+Vittella	O (Aren-u)	-O (Ashg-u)	(855)	Philomedes	K (Vala)	-R	(166)
+Vogdesella	O (Llvi-u)	-O (Cara-u)	(736,855,1116)	Polyclope	J (Hett-u)	-R	(74)
+Volganella	P (Tatr)			Pseudoentomoze	S (Ludl-l)		
+Wabiella	O (Cara-l)	-O (Cara-m)	(999)	+Rabienella	D (Fras-u)		(917)
Warthinia	O (Ashg-m)			+Rabienites	D (Fame-l)	-D (Fame-u)	(917)
+Webbylla	O (u)		(ZR89)	Rhombina	C (Vise)		
+Wehrlina	O (Cara-m)		(855)	Rhombentomoze	S (Ludl-l)	-S (Prid)	(1066)
+Welchella	C (l)		(ZR91)	Richteria	S (Ludl-l)	-C (Tour-l)	
Welleria	S (u)	-D (Give)		Richterina	D (Fame-m)	-C (Vise-u)	(917)
+Welleriella	S (u)	-D (Give)	(ZR84)	+Steinachella	C (Tour)	-C (Serp-l)	(917)
Welleriopsis	S (u)	-D (l)		Sulcuna	C (Vise)?		
Winchellatia	O (Cara-m)		(999)	Svarogites	D (m)		
+Wuxuania	D (m)		(ZR85)	Thaumatoocypris	J (Bajo)	-R	(167)
+Xiangzhoulina	D (l)		(ZR85)	+Thaumatomia	P (Guad)		(1066)
Xystinotus	O (u)	-D (Give)	(ZR91)	+Triadocypris	Tr(l)		(166)
+Xystista	S		(ZR85)	+Triadogiantocypris	Tr(m)		(ZR91)
+Yichangella	O		(ZR91)	+Truyolsina	C (Serp-l)		(1066)
Youngiella	D (Give)	-C (Step-u)	(2,773)	Ungerella	D (Eife-u)	-C (Vise-l)	(423,917)
+Yukonibolbina	S (Ludl)	-S (Prid)	(77)	Vltavina	S (Ludl-l)	-S (Prid)	(1047)
Zaborovia	D			Volkina	D (Fras-l)	-D (Fame-m)?	(917)
+Zanirinella	C (l)		(ZR88)	Or. METACOPIDA			
+Zenkopsis	S (Prid)		(1066)	+Acuprisma	O		(ZR91)
+Zigobolboides	O (Ashg-l)	-O (Ashg-m)	(999)	+Amphicostella	D (Eife-l)	-D (Give-l)	
+Ziva	S (Prid)		(1047)				

Taxon	First Appearance	Last Appearance	Reference	Taxon	First Appearance	Last Appearance	Reference
Aurigerites	D (Fame-u)	-C (Pn)		Rudderina	S (Ludl)	-D (Eife)?	
Bairdites	D (m)			Scalptina	D (m)		
Barychilina	O (Cara)	-D (Fame-u)	(2)	+Semihelidoiodes	D (Give-u)	-D (Fras-l)	(ZR90)
+Beckerhealdia	D (Fame-m)			Seminolites	C (Vise-u)	-C (Step-u)	(74,773)
Bekena	D (Give)?	-D (Fras-u)		O (Llde)	O (Llde)	-P (Djhu)	(648)
Birdsallella	D (Sieg)	-C (Step)		Sibus	D (Eife)		
Bufina	D (Emsi-u)	-D (Give-u)		Strepulites	D (Gedi)	-D (Give-l)	
Bythocyproidea	D (Emsi-m)	-C (Vise-l)	(74)	Sulcella	D (Eife-l)	-P (Dora)	(74,648)
+Catacoraites	P (l)		(ZR88)	+Svatojonitella	D (l)		(ZR89)
Chapmanites	D (m)			Thlipsura	S (Ldov-u)	-D (Eife)	(2)
+Conbathella	S (Ldov-l)		(1066)	Thlipsurella	S (Ldov-l)	-D (Eife-u)	
Condrarypris	D (Gedi)	-D (Eife)?		Thlipsurina	D (Emsi)	-D (Eife)	
Cooperatia	D (m)			Thlipsuroides	S (Wenl-u)		
Coryellites	C (Vise-u)	-C (Step)		Thlipsuroopsis	S (Prid)		
Costatia	D (m)			+Timorhaldia	D (Fame-u)	-P (l)	(ZR88)
Craterellina	D (Sieg)	-D (Emsi)		Trypetera	D (m)		
Cybroconcha	C (Tour-l)	-C (Bash)	(670)	Tubulibairdia	S (Wenl)	-D (Give-u)	(2)
Cyrtocyprus	S (Ldov-m)	-S (Wenl)	(1066)	+Tumidella	O (u)		(ZR84)
Cytherellina	O (Llvi-u)	-C (Tour-l)	(78,ZR89)	Unicomites	D (m)		
+Diura	S		(ZR91)	+Valentinia	P (Leon-l)		
Endolophia	D (m)			Varicobairdia	D (m)?		
Eocypridina	D (Fras)			Venula	C (Tour)		
Eriella	D (Emsi-u)?	-C (Tour-u)	(74)	Voronina	D		
Eucraterellina	D (Gedi)			+Wangiawania	O		(ZR91)
Euglyphella	D (Give)	-D (Eife)		Waylendella	C (Tour-l)?	-P (l)?	(670)
Eustephanella	D (Eife)			+Xixionopsis	D (Emsi-u)	-C (Mosc-u)	(ZR88)
Favulella	D (Eife)	-D (Fras-m)					
Graphiadaactyllis	D (Give-u)?	-P (Guad)	(2)	Or. PODOCOPIDA			
Healdia	D (Gedi)	-J (Plie)	(167)	+Aalenella	J (l)		(ZR91)
Healdianella	S (Wenl)	-P (l)	(670,ZR89)	+Abrobairdia	P (l)		(ZR87)
Healdioides	C (Serp-l)?			+Abrocycthereis	T (Plio)		(ZR91)
+Heterma	D (Fame-u)		(ZR94)	Absonocytheropteron			
Hungarella	P (Djhu)	-J (Plie-u)	(648,715)	T (Eo-u)			
Hyphasmaphora	D (Eife)	-D (Give)		+Abyssocypris	T (Eo-m)	-R	(929)
Incisurella	D (Give-u)?	-C (Serp-l)	(74)	+Abyssocythere	T (Eo-m)	-R	(929)
Janusella	D (l)			+Abyssocythereis	K (u)	-R	
Jenningsina	D (Emsi-u)	-D (Fras-u)	(2)	Abursus	D (u)		
Krausella	O (Llde)?	-D (Fras-m)		Acanthocythere	J (Bajo)	-J (Call)	(167)
+Ledihia	Tr(Rhae)	-J (Toar-l)		+Acanthocythereis	K (Maes-l)	-R	(166)
Longiscula	O (Aren-u)	-S (Ludl)	(78)	Acanthoscapha	S (Wenl)	-P (l)	(77,1066)
+Luniprisma	O		(ZR91)	Acratia	D (Give-u)	-P (Dora)	(648,670)
+Margiohealdia	D (Fame-u)		(ZR94)	Acratina	C (Vise)	-P (Dora)	(648,773)
Menoeidina	D (Emsi-u)	-D (m)		Acratinella	C (Mosc-l)	-P (Djhu)	(648,ZR93)
Octonaria	O (Cara-u)	-S (Ludl-l)	(74)	Acrocythere	J (Sine-u)	-K (Apti-u)	(74)
Octonariellina	S (Wenl-l)	-D (Eife)?		Acronotella	O (Ashg-m)		
Ogmoconcha	Tr(Rhae)	-J (Toar-l)		Actiangulata	C (Tour-u)	-C (Vise-u)	(74)
Ogmoconchella	J (Hett-l)	-J (Plie-u)	(74)	Actinocythereis	T (Dani)	-R	
Paracavellina	C (Vise-u)	-C (Serp-l)		Acuticythereis	T (Eo-u)	-T (Plio)	
Phreatura	C (l)			+Acuticytheretta	K (Maes)		
+Planoria	O		(ZR91)	+Acvocaria	Tr		
Platychelella	C (Serp-l)?			+Adeditia	C (Vise-u)		
Polyzygia	D (Sieg)	-D (Fras-u)	(423,1066)	+Aegyptiana	K (Maes)		(ZR91)
Ponderodictya	D (Gedi)	-D (Fras-m)		+Africanicythereis	T (Than)	-T (Eo-m)	
+Poniklacella	D (Eife)		(ZR88)	+Afrocyctheridea	J (Call)		
+Primitivothlipsurella	S (Wenl)		(ZR91)	+Agrenocythere	T (Than)	-R	(929)
Pseudobythocypris	C (Vise-u)	-P (Djhu)	(74,648)	+Aguilhasina	T (Dani)	-R	(929)
Pseudohaldia	J (Hett)	-J (Plie-u)	(74)	+Aikenicythere	C (u)		(ZR84)
Reversocypris	O (Cara)	-D (l)		+Alatacavellina	D (l)	-C (l)	(ZR88)
Robsoniella	K (Apti)	-K (Albi)		Alatacythere	K (Albi)	-T (Mi)	(2)
Ropolonellus	D (Eife-u)	-D (Fras-m)?		+Alataleberis	T (Eo-u)	-T (Mi-m)	
Rothella	D (Gedi)			+Algerina	K (Apti)	-K (Ceno)	
+Rothellina	D (Gedi)			Altha	O (Aren)?	-S (Wenl)	(ZR91)

Taxon	First Appearance	Last Appearance	Reference	Taxon	First Appearance	Last Appearance	Reference
Allocythereis	Tr(Rhae)		(74)	+Baschkirina	S (Ludl-l)	-P (Dora)	(140,648)
+Allococythere	T (Dani)	-T (Mi-l)	(173)	Basslerella	D (Sieg)	-P (Leon)	(773)
Ambocythere	T (Eo-m)	-R	(929)	Basslerites	T (Eo-l)	-R	(167)
+Ambostracon	T (Plio)	-R		Batavocythere	K (Albi-m)	-K (Albi-u)	(74)
Amphicythere	J (Bath-u)	-J (Kimm-u)	(74)	+Bathocythere	T (Mi-m)	-R	(929)
Amphicytherura	K (Barr-u)	-K (Maes-u)	(74,138)	+Beatamosina	T (Ol-u)	-T (Mi)	
+Amphileberis	T (Plio)	-R		Beecherella	O (Ashg-l)	-D (Gedi)	
+Amphistegina	T (Mi-m)?	-R		+Beecheroscapha	D (Emsi-u)	-C (Mosc-l)	(ZR88)
Ampuloides	D (l)	-D (Fame-u)	(ZR89)	+Bensonia	T (Ol-u)	-T (Mi-u)	
+Anchistrocheles	T (Eo-m)	-R	(929)	+Bensonocythere	T (Mi-m)	-R	(853)
+Aneocythereis	K (Camp)	-T (Eo-u)	(171)	Berounella	S (Ludl)	-D (Gedi)	
+Aneisohealdia	J (Hett)			+Bicornucythere	T (Plio)	-R	
+Angliacytheridea	J (Bath-u)		(166)	Bisulcoypris	K (Berr)	-K (u)	(74,ZR91)
Anisocyamus	O (Livi-u)	-S	(ZR91, 1066)	+Bohlenatia	C (Tour-l)	-P (Djhu)	(648,670)
+Anommatocyther	T (Eo-l)	-T (Eo-m)	(173)	Bolbozoella	C (Vise-u)	-C (Serp-l)	(74)
Anomocytheridea	T (Mi)	-R		Boldella	T (Eo-u)		
Antibythocypris	K (Sant-u)	-T (Eo-l)	(139,169)	+?Borgerscottia	P (Djhu)	-P (Dora)	(648)
Anticythereis	K (Sant)	-T (Eo-u)	(138)	+Borovitchella	C (Vise)		
Aparchitocythere	J (Call-l)	-J (Oxfo-l)		Bosquetia	T (Mi-u-l)	-Q (Plei)	
+Apateloschizocythere				Bosquetina	T (Eo)	-R	(167)
	K (Sant)	-K (Maes)	(166,171, ZR91)	Brachyocythere	K (Albi)	-R	(167)
Apatocythere	K (Vala)	-K (Albi)	(167)	Bradleya	T (Than)?	-R	
Aphelocythere	J (Toar-u)	-J (m)	(715)	Bronsteiniana	K (Ceno)	-T (Pale)	
+Aphrikanocythere	K (Camp)?	-K (Maes-u)		+?Bueckella	P (Dora)		(648)
+Aratocypris	K (u)	-R		+Bufanchiste	D (Emsi-u)	-D (Eife-u)	
Aracythere (+ Rockallia)				+Bulbosclerites	O (Ashg-u)		(166,855)
	K (Camp)	-R		Buntonia	K (Albi)	-R	(138)
+Archeocosta	K (u)		(ZR84)	Bythoceratina	J (Plie-l)	-R	
Archeocuneocythere	J (m)	-K (l)		Bythocypris	Tr(Olen-u)	-R	(674)
Archicythereis	T (Pg)	-T (Ng)		Bythocythere	J (Bath-l)	-R	
Arcuaria	O (Lide-u)	-S (Ldov)	(78)	Bythocytheromorpha	K (Camp-u)	-K (Maes-u)	
+Argenticytheretta	T (Eo-l)	-T (Mi-l)	(166)	Calcaribeyrichia	S (Ludl-u)	-S (Prid)	(74)
Argilloecia	J (Call-u)	-R	(170)	+Calliocythere	C (u)	-Tr(Indu)	(648,ZR91)
+Argoviella	P (u)		(ZR88)	Callistocythere	T (Eo-m-u)	-R	(2,1066)
+Arrazocypris	D (Emsi-l)	-D (Eife-u)		Camdenidea	D (m)	-D (u)	
Artifacella	C (Step)			Campocythere	J (Toar-l)	-J (Aale)	(74,167)
+Aruduce	T (Mi-u)		(ZR88)	Campylocythere	T (Mi-l-u)	-R	(167)
Ascetoleberis	K (Camp-l)	-K (Maes-u)	(139)	+Capsacythere	T (Mi-u)		(ZR91)
Asciocythere	K (Berr)	-T (Than-l)	(138,942)	+Cardobairdia	J (Hett-u)	-R	(ZR88)
Asturiella	D (Give)	-C (Serp-l)	(74)	+Caribbeania	T (Mi-l)	-T (Plio)	(ZR88)
+Asymmetrythere	T (Eo-l)	-T (Eo-u)		Carinoocythereis	T (Eo-m-l)	-R	
Atjehella	T (Ng)			+Casterocythere	Q (Plei)		(ZR87)
+Atlanticythere			(ZR88)	Cativella	T (Eo-m-l)	-R	(166,169)
Aulocytheridea	T (Dani)	-T (Eo-u)	(942)	Caudites	T (Eo-m)	-R	
Aurila	T (Ol-u)	-R		+Cavussurella	Tr(u)		(ZR88)
+Australicythere	T (Eo-m)	-R		Caytonidea	J (Bath-u)	-R	(74)
+Australoecia	T (Eo-l)	-R	(929)	Centrocythere	K (Barr-l)	-K (Ceno)	(138,167)
+Aversoalva	K (Camp-u)	-R	(929)	Ceratobairdia	P (Guad-l)?	-Tr(u)	
+Aviacypris	O (Ashg)		(855)	+Ceratocratia	D (Fame-u)		(ZR94)
+Baffincythere	T (Mi-u)	-R	(1104)	+Chamishaella	D (Fame)?	-C (Mosc-u)	(ZR91)
Bairdia	O (Ashg-m)	-R	(855)	Chapmanicythereis	K (Albi-l)	-K (Albi-m)	(74)
Bairdiarella	C (Tour-l)	-P (Dora)	(648,670)	+Chejudocythere	T (Eo-l)	-R	(929)
+Bairdiohealdites	D (l)		(ZR87)	+Cistacythereis	T (Mi-l-u)	-T (Plio-l)	
Bairdiolites	D (Fame-u)	-P (l)	(ZR89)	+Christocythere	T (Mi-l)	-T (Mi-u-l)	(166,ZR91)
Bairdiocypris	O (Cara-n)	-P (Dora)	(648,1066)	Citrella	J (Bath)		
Bairdoppilata	K (l)	-R		Cladaroocythere	T (Eo-u)	-T (Mi-l)	(74,166)
+Bajacythere	T (Eo-m)			+Cleithranchiste	D (Give)		(ZR89)
Bakunella	T (Mi-u)	-Q (Plei)	(ZR91)	+Cletocythereis	T (Eo-u)	-R	
+Balowella	J (Call-u)	-J (Oxfo-l)	(868)	Climacoidea	T (Mi-l-u)?	-R	
+Barrychilina	C (Tour-l)		(ZR88)	+Clinoocythere	K (Camp)	-K (Maes)	
				Clithrocytheridea	K (Barr)	-R	

Taxon	First Appearance	Last Appearance	Reference	Taxon	First Appearance	Last Appearance	Reference
+ Cluthia	T (Eo-u)	-R		- Dumontina	K (Ceno-u)	-T (Than-l)	(138,942)
- Cnestocythere	T (Eo)	-T (Mi-u-l)	(2)	- Dutoitella	T (Eo-m)	-R	(929)
- Collisboris	K (Sant)		(172)	- Echinoscythereis	K (Turo)	-R	(138)
- Coniferina	S (Prid)	-D	(77)	- Editia	C (Tour-u)	-C (Serp-l)	(74)
+ Condomyra	O (Livi-u)	-O (Ashg)	(855,1116)	- Egenacythere	T (Mi-u-l)	-T (Mi-u-u)	
+ Cooperuna	C (Vise)?	-P (Dora)	(648,ZR91)	+ Egorovia	S (Prid)	-D (Fras)	(140)
+ Copytus	T (Eo-u)	-R		+ Egorovitina	C (Vise-u)		
+ Coquimba	T (Plio)		(ZR91)	+ Eisobairdia	Tr(u)		(ZR85)
- Cornicythereis	K (Barr)	-K (Ceno-l)	(74)	- Ekythyphocytthere	J (Hert-l)	-J (Bath-u)	(2,868)
+ Cornucoquimba	T (Mi-m)	-R	(1104)	- Ellesmerina	D		
+ Cornutobairdia	Tr(u)		(ZR88)	+ Elliptocyprites	O (l)	-O (u)	(ZR89, ZR91)
- Costa	T (Dani)	-R		- Elofonella	T (Mi-m)	-R	(1104)
- Costaveenia	K (u)		(ZR91)	- Elofsonia	Q (Plei)	-R	(167)
- Covracythere	Tr(m)			- Emphasia	J (m)		
+ ?Craspedograpylus	C (Tour-l)		(670)	- Entoprimitia	D (Fame-l)		(74)
- Crassacythere	K (Camp-l)	-K (Maes-l)	(74)	+ ?Eobuntonia	K (Coni-l)	-K (Maes-l)	(ZR94)
+ Crenaleya	T (Ol-l)	-T (Mi-l)		- Eoconchoecia	S (Ldov)	-S (Ludl)?	
- Cretaceratina	K (Sant)	-T (Eo-m)	(172)	- Eocytheridea	J (Bajo-l)	-J (Tith-u)	(74)
+ Cristaeleberis	K (Coni-l)	-T (Than)		- Eocytheropteron	J (Bajo)	-T (Plio-u)	(74)
+ Crucicormina	O (Ashg)			- Eopaijenborchella	K (Camp-u)	-R	
- Cryptobairdia	C (Vise-u)	-P (Dora)	(74,648)	+ Eoparaparchites	O (m)		(ZR85)
- Cunecoceratina	J (Ple-l)	-K (Maes-l)	(74,141)	+ Eorotundacythere	K (Sant)	-K (Camp)	(171)
- Cuneocythere	T (Eo-m-u)?	-R	(172)	+ Eostephanela	D (Eife)		
- Curfsina	K (Albi-m)	-K (Maes-u)	(74,167)	- Eridoconcha	O (Lide-l)	-D (Fame)	(736,1066)
- Cushmanidea	T (Eo-l)	-R	(942)	+ Eripleura	J (Oxfo-u)	-J (Kimm-l)	
- Cyamocytheridea	T (Dani)	-T (Mi-u-u)	(74)	+ Escharacytheridea	K (Camp-l)	-K (Maes-u)	(139)
- Cyprideis	T (Ol-u)	-R		+ ?Estonaceratella	O (Ashg-m)	-O (Ashg-u)	(855)
+ Cypridopsis	Q (Plei)	-R	(ZR84)	- Eucythere	K (Vala)	-R	(167)
+ Cystacythereis	T (Mi-u)	-Q (Plei-u)	(166)	- Eucytherura	J (Bajo-u)	-R	(868)
- Cytheralison	K (Camp)	-R	(171)	+ Eudeucacythere	J (Bath-l)	-J (Bath-m)	(ZR94)
- Cythere	T (Mi-u)	-R	(167)	- Eurytycythere	K (Vala)	-K (Haut-l)	(74)
- Cythereis	K (Haut)	-T (Than)	(74,138, 1066)	+ Euthlipsurella	S (Ldov-m)	-D (Eife)	
- Cytheretta	T (Than-l)	-R		- Eoxyphalmocythere	J (Oxfo)	-T (Dani)	(167)
- Cytheridea	T (Eo-l)	-R	(74)	- Fabalicypriis	D (Give)	-J (Ple-l)	(648)
+ Cytheridella	T (Than)	-T (Eo-l)	(ZR91)	- Fabanella	J (Bajo)	-K (Barr-u)	(74)
- Cytherissinella	Tr(Olen-u)		(674)	+ Falsocythere	T (Mi-l)	-R	(ZR91)
- Cytherois	T (Mi-l)	-R	(ZR91)	- Falunia	T (Ol-u)?	-R?	
- Cytheroma	T (Ol-u)?	-R		- Fastigastocythere	J (Bath-u)		(74)
- Cytheromorpha	J (Bajo)	-R	(2)	+ Faveolebris	T (Plio)	-R	
- Cytheropterina	J (Toar-l)	-K (Apti-u)	(2,74)	+ Finnarchinella	T (Mi-m)	-R	
- Cytheropteron	J (Toar-l)	-R	(74)	+ Fissocrocinocythere	K (Coni)	-K (Maes-u)	(139)
- Cytherura	K (u)?	-R	(171)	- Fissocythere	J (m)		
- Dahomeya	K (Maes)	-T (Eo-l)	(ZR91)	+ Flabellinitulis	T (Mi-u-l)		
- Daleiella	S (Wenl)			+ Flexuocythere	T (Mi-u-l)	-T (Mi-u-u)	
+ Dallonella	T (Mi-u)		(ZR89)	- Flexus	T (Eo-u)	-R	
- Damonella	J (Tith-u)	-K (Barr-u)	(74)	- Forbescythere	T (Eo-m-u)	-T (Eo-u)	(74)
+ Dentokriithe	T (Eo-m)	-T (Mi-l)		+ Fovoleberis	K (Maes)	-R	
+ Determania	Tr(m)	-Tr(u)	(ZR85)	- Frambocythere	K (Albi)	-T (Eo-l)	(ZR91, 1073)
+ Dicerobairdia	Tr(Carn-u)		(ZR85)	- Frostiella	S (Prid)		(74)
- Dicrotygma	J (Kimm-u)	-K (Nc)	(74)	+ Fuelocythere	P (Dora)		(648)
- Dictocythere	J (Tith-u)		(74)	- Fuhrbergiella	J (Toar-l)	-J (Bath-m)	(74,868)
+ Diebelina	T (Eo-u)		(942)	- Galliaicytheridea	J (Call-m)	-K (Berr-u)	(74)
- Digmocythere	T (Eo-m-l)	-T (Ol-l)?		+ Gammacythere	J (Ple-l)	-J (Ple-u)	(74)
- Diognompteron	K (u)			- Garnuella	S (Wenl-u)		(74)
- Disopontocypris	T (Ol-l)	-T (Mi-l-u)	(170)	- Geisina	D (Fras-l)?	-P (Leon-l)	
- Dolocythere	K (Vala)	-K (Albi)	(138)	+ Gemmanella	Tr(Olen)?	-Tr(Ladi-u)	(674)
- Dolocytheridea	K (Berr-u)	-K (Sant)	(74,167)	+ Gerbeciekites	D (Emsi-u)	-D (Give-u)	
+ Donmacythere	K (u)		(ZR87)	- Gesoriacula	J (Bath)		
+ Doratocythere	Q (Plei)		(ZR91)	+ Gibberlebeis	K (Sant)		
- Dordoniella	K (Albi-l)	-K (Turo-l)	(141,1073)	+ Gingiella	K (Turo)	-K (Sant)	(172)
+ Dornbuschia	O (Cara-l)	-O (Ashg-u)	(855)				

Taxon	First Appearance	Last Appearance	Reference	Taxon	First Appearance	Last Appearance	Reference
Glabellacythere	J (Bath-u)	-J (Oxfo-l)	(74)	+Huantraiconella	T (Pale)		
+Glenocythere	K (Albi-l)	-K (Ceno-u)	(143)	Hulingsina	T (Mi)	-R	
+Glorianella	Tr(Olen-u)	-Tr(Ladi-u)	(674)	Hutsonia	J (Call-m)?	-K (Ceno)	(138)
Glyptocythere	J (Bajo-l)	-J (Bath-u)	(74)	+Hystricyocypere	K (Sant)	-K (Camp)	(171)
+Glyptogatocythere	J (m)		(ZR88)	+latella	D (l)		(ZR89)
Glyptolichviella	D (Fame)?	-C (Vise-u)	(74)	Idiocythere	T (Eo-m-l)	-T (Mi-l)	
+Golcoythere	K (Turo-u)?		(ZR94)	+Imhotepia	K (Turo-l)	-K (Maes-u)	(141)
Gramannella	J (Sine-u)	-J (Plie-u)	(74)	Incongruella	T (Mi-l)	-Q (Plei)	
+Gramannicythere	J (Plie-l)	-J (Toar-l)		+?Indivisia	C (Vise)?	-P (Dora)?	(648,ZR89)
+Grekoffiana	T (Mi)			Iniella	P (Tat)		
+Grinoneis	T (Pg)		(ZR91)	-Ionicythere	T (Mi-m)	-Q (Plei)	
+Grundeleva	C (Serp-l)			+Iraqicythereis	K (Ceno)		(ZR88)
+Grundeleva	C (Serp-l)			-Isobuntonia	T (Eo-l)	-T (Eo-u)	
+Gruendelicypere	P (Dora)	-Tr(Rhae)?	(648)	Isobryochypis	J (Hett)	-J (Bajo-l)	
Gubkiniella	K (Barr)			Isocythereis	K (Barr)	-K (Sant)	
+Gujaratella	T (Mi-l)		(ZR91)	+Isohabrocypere	T (Dani)	-T (Eo-l)	
Gunneropsis	O (Livi-u)	-O (Cara-l)	(736,855)	+Jatella	S (Prid)		(ZR85)
+Gyrocypere	T (Eo-l)	-T (Eo-m)	(173)	+Javanella	T (Plio)	-R	
Habrocythere	K (Barr-l)	-K (Ceno-l)	(167)	+Jefina	D (Eife-l)	-D (Give-u)	
Hammatocythere	T (Eo-l)	-T (Ol-l)	(74)	+Jingguella	J (u)	-K (l)	(ZR91)
+Hanaiborchella	T (Mi-u)	-R	(1104)	Jonesia	T (Mi)	-R	
+Hanaiceratina	T (Ng)	-R		+Jugosocythereis	T (Eo-m)	-R	
+Hanaicythere	Q (Plei)		(ZR88)	Juvenix	K (Barr)		
Haplocytheridea	K (Haut-l)	-R	(74)	+Kaesleria	K (Coni-l)	-K (Maes-u)	
Harperopsis	O (Cara-l)	-O (Cara-m)	(74,166,736)	Kalyptovalva	K (Sant)?	-K (Maes)	
Hastacypris	C (Serp-l)			+Kamacythereis	K (Coni)	-K (Sant)	(ZR89)
+Haughtonileberis	K (Ceno-m)	-T (Ol-l)	(ZR91,1073)	Kangarina	K (Sn)	-R	(167)
Haworthina	C (Mosc-u)	-P (Dora)	(648)	+Karinadomella	D (Fame-u)		
Hazelina	K (Maes-u)	-T (Eo-u)	(74)	+Karsteneis	K (Turo-u)	-K (Camp)	(141,171)
Healdiacypis	C (Tour-l)	-C (Mosc)		Kassinina	T (Ol-l)	-T (Mi-u)	(170)
+Hechticythere	K (Vala)	-K (Sant)	(138)	+Kefiella	K (Maes-u)		
+Heinia	T (Eo-l)	-R	(929)	+Keijella	T (Eo-m-l)	-T (Plio)	(166)
+Heliocythere	T (Mi-u)		(ZR89)	P (Djhu)			(648)
+Hellebardia	S		(ZR91)	+Keijicythere	P (Tat)		
Hemicyprideis	T (Eo-l)	-T (Mi-m)?	(74)	Kemeroviana	P (Tat)		
Hemicythere	T (Eo-l)	-R	(169)	+Keslingiella	S		(ZR87)
Hemicytheria	T (Mi-u)	-T (Plio)	(167)	Kikliocythere	K (Turo)	-K (Maes-u)	
Hemicytheridea	T (Ol-u)?	-T (Plio)	(167)	Kingmaina	K (Sant)	-T (Eo-u)	
Hemicytherura	K (Vala)	-R		Kinkelinella	Tr(Rhae)	-J (Bath-u)	(74)
Hemikriihe	T (Plio)	-R	(167)	Kirbyellina	S (Ludl)	-C (Vise)	
+Hemingwayella	K (Haut)	-K (Sant)	(172)	Kirtonella	J (Bajo-l)	-J (Bath-m)	(74)
+Hemiparacytheridea	K (Ceno-u)	-T (Mi-m)	(141,175,929)	Klieana	J (Bath-u)	-K (Albi)	(74,167)
Henryhowella	T (Eo-m)	-R	(929)	+Klinglerella	Tr(Rhae)	-J (Sine-u)	(ZR91)
+Heptaloculites	T (Eo)			+Kloedycytherella	P (Djhu)	-P (Dora)	(648)
+Hercynocythere	D (Emis-u)	-D (Give-u)		Knoxiella	D (l)	-P (Leon-u)?	(1066)
Hermanites	K (Sant)	-R	(171)	Kobayashiina	T (Plio)	-R	
+Herrigocyther	K (Ceno-m)	-K (Ceno-u)		+Krausellina	O (Ashg)	-D (Gedi)?	
+Hesslandites	O (Aren)		(1066)	Krithe	K (Ceno-u)	-R	(167)
Heterocyprideis	Q (Plei)	-R	(166)	Kroemmelbeinia	O (Cara-l)	-O (Ashg-m)	(855)
Heterocythereis	T (Mi-u-l)	-R		Kroemmelbeinella	Q (Plei)		
+Hiatobairdia	Tr(m)		(ZR85)	+Kummerowia	D (Emis-u)	-D (Fras-u)	(ZR89)
+Hiltermannicythere	T (Mi-u-u)	-R		+?Lamellaeratia	P (Djhu)		(648)
Hirschmannia	T (Mi)	-R	(167)	+Langtonia	K (l)		(ZR91)
Hirsutocythere	T (Eo-m)	-R		+Lankacythere	T (Mi-l)		(ZR91)
+Holcopocythere	K (Maes-l)	-T (Dani)		Leguminocythereis	T (Than)	-Q (Plei)	(1066)
+Hornbrookella	K (Maes-l)	-T (Plio)		Lemicythere	K (Maes)	-T (Eo-u)	(942)
+Horrificiella	K (Sant)?	-T (Eo-m-u)		Leptocythere	T (Ol-l)	-R	
+Hourqia	K (Albi)			+Lesleya	J (Bath-u)		(166)
Howeina	T (Mi-u)	-T (Plio)	(1104)	+Leviella	Tr(Ladi-u)	-Tr(Carn-u)	
				Liasina	J (Sine-u)	-J (Toar-l)	(74)
				+Liasopteron	J (Toar-l)	-J (Aale)	
				Libumella	O (Cara-u)	-C (Vise-u)	(74,996)
				+Ligerina	S (Prid)		

Taxon	First Appearance	Last Appearance	Reference	Taxon	First Appearance	Last Appearance	Reference
+Limburgina	K (Albi)	-T (Eo-u)	(141,171)	+Moosina	T (Pale)		(ZR91)
+Lindisfarnia	T (Plio)	-R	(166)	+Morkhovenia	Q (Plei)		(ZR91)
+Liujiangia	D (l)		(ZR85)	+Morkhovenicythereis	J (Bath-l)	-J (Bath-u)	(74)
-Lixouria	T (Ol-l)	-T (Plio)		Mosaeleberis	K (Turo-l)	-K (Maes-u)	(74,138)
+Ljubimovella	J (Bajo-l)		(74)	+Mostlerella	Tr(Ladi)	-Tr(Carn-u)	
+Loculibairdia	K (u)		(ZR85)	+Muellerina	T (Eo-u)	-R	
Loculicytheretta	T (Mi-l)	-R		Munseyella	K (Sant)	-R	(172)
Londmia	S (Prid)		(74)	Murrayina	T (Mi)		
+Longyuanelia	C (l)		(ZR88)	+Murthya	T (Mi-l)		
Looneyella	K (Nc)	-K (Turo-l)		Mutilus	T (Mi-m)	-R	
Lophoctenella	S (Ludl-l)	-S (Prid)	(74,812)	+Nagyella	Tr(Anis)		(1066)
Lophocythere	J (Bajo-u)	-J (Kimm-u)	(868)	+?Namaia	C (Tour-l)		
Lophodentina	J (Hett-u)	-J (Sine-l)	(74)	+Nanacythere	J (Plei-l)	-J (Toar-l)	
+?Louza	K (Albi-u)	-K (Ceno-m)	(ZR94)	+Nanurocythereis	T (Mi-u-u)		
Loxocochea	K (Albi)	-R	(1073)	+Navarracythere	K (u)		(ZR87)
+Loxococheella	T (Mi-l)	-R	(ZR88)	Naviculina	J (Bajo)		
+Loxocorniculum	T (Ol-u)	-R		+Necrateria	D (Fame-u)	-C (Tour-l)	
Loxocythere	T (Ol)	-R		Nemoceratina	K (Ceno)	-K (Maes-l)	(74)
Lutkevichinella	Tr(Indu)	-Tr(Olen-u)		+Neobairdia	P (l)		(ZR89)
+Luvula	T (Mi-u)	-R		+Neoberounella	P		
Lycoperocypris	K (l)			+Neocaudites	T (Plio)	-R	(853)
Macrocypris	J (Oxfo)	-R	(2)	+Neoceraterellina	D (Gedi)	-D (Emsi)?	
Macrocyprides	O (m)	-O (Ashg-m)		Neocyprideis	K (Ceno-u)	-T (Plio)	
Macrodentina	J (Bath-u)	-K (Vala)	(74,167)	Neocythere	K (Barr-l)	-T (Dani)	(74,942)
+Macrosarisa	K (Apti)		(1066)	+Neocytheretta	T (Mi)	-R	(167)
Macrypsilon	S (Ludl-u)	-S (Prid)	(74)	Neocytherideis	T (Eo-u)	-R	
+Majungaella	J (Bath)	-K (Camp)	(171)	Neomonoceratina	T (Eo-l)	-R	
+Malzella	T (Mi-u)	-R	(853)	+Neonesidea	T (Than)	-R	
+Mandawacythere	J (Oxfo)?	-J (u)		+Neonyhamella	D (Emsi)		(1066)
Mandelstamia	J (Oxfo-l)	-K (Berr-u)	(74)	+Neootonaria	S (Ldov-u)	-S (Ludl)	
Mandocythere	K (Haut-l)	-K (Ceno)	(74)	+Neophreycythere	J (Bath-l)	-J (Bath-u)	(74)
Mantelliana	J (Kimm-u)	-K (Barr-u)	(74)	+Neothlipsura	D (Gedi)	-D (Eife)?	
+Margohealdia	D (Fame-l)	-C (l)	(ZR89)	+Neoveenia	T (Dani-l)		
+Margobairdia	Tr(m)	-Tr(u)	(ZR85)	Nephokirkos	T (Eo)		
+Margaropantia	O (Cara-u)		(1066)	Netrocytheridea	K (u)	-K (Maes)	
Marslatourella	J (Bath-l)	-J (Call-l)	(74,166)	+Netschajewiana	P (Djhu)?		
+Martinicythere	K (Camp)	-T (Eo-u)		Newsomites	S (Wenl)	-D (Fras-u)	
Matronella	K (Albi-u)	-K (Ceno-l)	(74)	+Nigeria	K (Ceno-m)	-K (Maes-u)	(138,139)
+Mauritsina	K (Albi)	-T (Eo-l)		+?Nigeroloxocochea	K (Albi)	-T (Than)	(ZR91, 1073)
Mediocytherideis	T (Mi)	-T (Plio)		+Nikitinella	O (m)		(ZR88)
+Megommatocythere	K (Sant)	-T (Eo-m)		+Nodobairdia	Tr(Ladi)?	-Tr(Carn-u)	(ZR85)
Mehesella	K (Maes-u)	-T (Ol-l)?		Nodophthalmocythere			
+Memoria	J (Call-l)			J (Call-l)	-J (Kimm-u)	(74)	
Merocythere	J (Bath-l)		(74)	+Nonurocythereis	T (Mi-u-u)	-T (Plio)	(ZR89)
+Messinella	T (Eo-m)	-T (Plio)		Nophreycythere	J (Call-m)	-J (Oxfo-u)	(74)
+Metacypris	K (l)		(ZR91)	Normanicycythere	T (Mi-u)	-R	
Metacytheropteron	J (Kimm)	-R	(131)	+Notocythere	Tr(Nori-l)		
Microcheilinella	S (Ludl-l)?	-Tr(l)	(648,1066)	Novocypris	T (Eo-l)	-T (Eo-m-u)	(74)
Microcythere	T (Mi-m)	-R	(1066)	+Nucleolina	K (Turo-u)	-T (Than)	
Microcytherura	T (Eo-u)	-R		+Nuguschia	P (Djhu)?		
Microparaparchites	C (Ms)	-P (l)?		+Obisafitella	D (l)		(ZR85)
Micropneumatocythere	J (Sine)	-J (Call)	(2,166)	+Oblitacythereis	T (Mi-u-u)	-R?	(ZR94)
Microxestoleberis	T (Eo)	-R		+Oculocytheropteron	K (Sant)	-T (Eo-u)	(171)
Miocytheridea	K (Vala-u)	-K (Barr-l)	(74)	+Occlusacythereis	T (Mi-u-u)		
+Mirabairdia	Tr(m)		(ZR85)	Occultocythereis	K (Coni)?	-R	(167)
Miracythere	T (Eo-u)	-R		+Octosylthere	O (Ashg-m)?	-O (Ashg-u)	(855)
+Mochella	Tr(Ladi-u)	-Tr(Carn-l)	(ZR94)	Oerthella	K (Albi-l)	-T (Eo-u)	(74,138)
Monoceratella	O (Llde)	-S (Wenl)	(78)	+Olbia	O (Ashg-u)		(855)
Monoceratina	D (Give-u)	-P (Guad-u)	(2)	Oligocythereis	J (Bajo)	-J (Kimm-u)	(2,166)
Monsmirabilia	T (Eo-l)	-T (Ol-l)?	(167)	+Olimfalunia	T (Mi-u-l)	-T (Plio)	
Moorea	P (u)		(2)	+Ommatokrithe	T (Mi-l)		(166)

Taxon	First Appearance	Last Appearance	Reference	Taxon	First Appearance	Last Appearance	Reference
+Opimocythere	T (Dani)	-T (Than-l)	(942)	Parariscus	J (Bajo-u)	-J (Call-l)	(868)
+Orbitolina	K (Albi-l)	-K (Albi-u)	(ZR94)	+?Paraschizocythere	K (Maes)		(ZR91)
+Ordoniya	K (Maes-u)	-T (Eo-l)	(ZR91, ZR94)	Paraschuleridea	J (u)		
Orionina	T (Eo)	-R		+Paraspinobairdia	P (Djhu)		(648)
+Orlovicavina	Tr(Anis-u)			+Parasterbergella	K (Berr)	-K (Ceno-u)	(138,1073)
+Ornatoleberis	T (Mi-l)		(ZR91)	Parataxodonta	K (Apti)	-K (Albi)	
+Orthobairdia	D (Give)?	-P (Sakm)?		+Paratriebelina	P (Djhu)		(648)
+Orthocypris	S (Ludl)	-D (Fras-m)		+Pariceratina	K (Ceno-u)	-T (Mi-m)	(141,929)
Orthonotacythere	J (l)	-T (Eo-l)	(167,942, ZR91)	+Parvacytthereis	K (Turo-l)	-K (Turo-u)	(ZR94)
Otocythere	J (Toar-l)	-J (m)	(74)	+Patagonocythere	T (Eo-m)	-R	(173)
+Ouachitaia	T (Eo-u)			+Patellacythere	K (Albi-u)	-R	(ZR89)
+Ovatoquasillites	D (Fame-u)	-C (Tour-l)	(ZR89)	Pavloviella	K (Haut)	-K (Barr-l)	
Ovocytheridea	K (Apti)	-K (Maes)	(138,169)	Pectocythere	T (Than)	-Q (Plei)	(ZR91)
+Ovornina	O (Cara-u)	-C (Mosc-u)?	(77,648, 996)	Pedicythere	J (Call-u)	-R	(74,172)
+Pacambocythere	T (Mi-u)	-R	(1104)	+Peleocythere	T (Eo-l)	-R	(929)
+Pachycaudites	T (Mi-l)		(ZR91)	Pellucistoma	T (Eo-u)	-R	
Pachydomeella	D (m)			+Peloriops	K (Albi-l)	-K (Maes)	
+Pachydomealloides	O (Llvi-l)	-O (Llvi-u)	(855)	+Pennyella	K (Apti-u)	-R	(166)
Paenula	K (Ceno)			+Peratocytheridea	T (Ol-u)	-R	(853)
Paijenborchellina	K (Ne)	-R		Perissocytheridea	K (Albi-u)	-R	
Paijenborchella	K (Sn)	-R	(167)	+Peraurilla	T (Mi-u-l)	-T (Mi-u-u)	
Palaecocytheridea	J (Bajo)	-R	(167)	Phacorhabdodus	K (Turo-u)	-R	(74,141)
Palaecocytheridella	J (u)	-K (l)		+Phalococythere	K (Maes-l)	-T (Eo-u)	(166,173)
+Paleocosta	K (Maes-u)	-T (Ol)?		Phanassymetria	S (Ludl)	-D (Gedj)?	
Paleomonsmirabilia	T (Eo-l)			+Philonoptunus	T (Eo-u)		(ZR93)
Palmenella	T (Mi-m)	-R		Phlyctenophora	T (Ol-u)?	-R	
+Palmoconcha	T (Than)	-R	(929)	Phlyctocythere	T (Eo)	-R	(167)
+Papillatobairdia	T (Mi-m)	-Q (Plei)	(ZR91)	+Phodeucythere	K (Barr)	-K (Turo-u)?	(141)
+Parabairdianella	P (Djhu)		(648)	+Phthanoloxoconcha	K (Albi-u)	-K (Camp)?	
+Parabrounella	D (Fame)?	-P (Djhu)	(648)	+Phyrocyclythere	K (Maes)	-T (Than)	
+Parabythocythere	C (u)	-P (Djhu)	(648,ZR91)	+Physocythere	K (Albi)	-T (Dani)	(138,942)
+Paracaudites	K (Turo-l)	-K (Sant)	(141)	Pichotia	J (Bath)		
+Paracosta	K (l)	-T (Eo-m)	(ZR91)	Pinnatullites	O (Aren-u)	-O (Llvi-l)	(78,855)
Paracyprideis	K (Vala)	-R	(138)	+Pinnoxypridea	K (l)		(ZR91)
Paracyprinotus	T (Plio)			+Pistocythereis	T (Plio)	-R	
Paracypris	Tr(Ladi)?	-R		+Plamleberis	K (Apti)?	-K (Ceno-u)	
+Paracythere	T (Mi-u)	-R		+Plantella	S (Wenl)		(ZR85)
+Paracythereis	K (Maes)		(138)	Platyeythere	J (Bath-u)		(74)
Paracytheretta	K (Sant)	-T (Than)		Platyeythereis	K (Vala)	-T (Mi-u-u)	(167)
Paracytheridea	K (u)	-R		+Platyleberis	T (Ol-l)	-R	
+Paracythereis	K (Maes-u)	-R	(1066)	Platylophocythere	J (u)		
+Paracytheroma	T (Eo-u)	-Q (Plei)	(ZR91)	+Platytrhomboides	O (Cara-m)	-O (Ashg-u)	(855)
+Paracytheromorpha	T (Ol-u)	-T (Plio)	(ZR87)	+Plavskella	D (Fame)?	-C (Mosc-l)	
Paracytheropieron	T (Mi)	-R		Pleurifera	J (Sine-u)	-J (Toar-l)	(74)
Paradoxostoma	T (Eo)	-R		Pleurocythere	J (Toar-l)	-J (Call-u)	(74,167)
Paraeocypris	T (Plio)			Pneumatocythere	J (Aale)	-J (Bajo-l)	(74)
Paraexophthalmocythere	K (Vala)	-K (Haut)		Pokornyyella	T (Eo-l)	-T (Mi-u-u)	(167)
+Paraglyptobairdia	P (Djhu)	-P (Dora)	(648)	+Porkornyyopsis	Tr(Ladi)	-J (Tith)	
+Paragrenocythere	K (Camp)	-T (Eo-u)	(166,ZR91)	Polenovula	D (Give-l)	-D (Give-u)	(2)
+Parahemingwayella	T (Than)	-R	(929)	Polydentina	J (Kimm-l)	-K (l)	(74,868)
Parakrithe	K (Ceno)	-R		Pontocyprella	J (Sine-u)	-T (Eo)	
+ParakritHELLA	T (Plio)	-R		Pontocypris	Tr(Rhae)	-R	(74)
+Paramacrocypris	P (Dora)		(648)	Pontocythere	T (Eo-u)	-R	
+Paramicrocheilina	O		(ZR91)	+Posacythere	T (Ol-l)	-R	(929)
+Paramunseyella	K (Sant)		(171)	+Poseidonamicus	T (Eo-l)	-R	
+Paranesidea	T (Than)?	-R		Posteroprotyocythere	J (Sine)	-K (u)	
Paranotacythere	J (Oxfo-u)	-K (Apti-l)	(74,868)	+Praebythoceratina	Tr	-J	
+Paraplatyrhomboides	O (m)		(ZR85)	+Praemacrocypris	J (Hett)		
				+Praelobobairdia	P (Dora)		(648)
				+Praemunseyella	K (Sant)		(1066)
				+Praephaconhabdodus	K (Albi-l)	-K (Sant)	(138)
				+Praepilatina	S (Prid)	-P (Dora)	(140,648)

Taxon	First Appearance	Last Appearance	Reference	Taxon	First Appearance	Last Appearance	Reference
Praeschuleridea	J (Toar-l)	-J (Bath-u)	(2)	+Qingjiania	K (l)		(ZR91)
+Praezabythocypris	P (Djuh)		(648)	Quadracythere	T (Than)	-R	(167)
O (l)		-O (u)	(ZR91)	Quasibuntonia	T (Plio)		
+Premunseyella	K (Sant)	-K (Camp)	(171)	Quasillites	D (Emsi-u)	-C (Ms)	
+Proabyssocypris	T (Ol-u)	-T (Mi-m)		+Racvetina	Tr		
+Processobairdia	D (Fame-m)	-D (Fame-u)	(423)	+Radimella	T (Mi)	-R	(166)
+Procythereis	T (Mi-l)		(ZR91)	Ranapeltis	D (Gedi)	-D (Eife)	
Procytheretina	K (Ceno)			+Ranicella	C		
Procytheridea	J (Hett-u)	-J (u)	(715)	+Raymoorea	K (Apti-u)?	-K (Ceno-l)?	
+Procytherideis	T (Mi-u-l)	-T (Mi-u-u)		+Rayneria	K (Sant)	-K (Camp)	(172)
Procytheropteron	J (Kimm-l)	-K (Maes)	(868)	+Rectaloides	O (Llvi-l)	-O (Cara-u)	(996)
Procytherura	J (Toar-l)	-K (Haut-u)	(74)	Rectella	O (Llde-u)	-D (Give-u)	(78)
Progoncythere	J (Aale)	-J (Oxfo-m)	(74,167)	Rectobairdia	D (Fras-m)	-P (Leon-u)	(74,773)
+*Progonoida	J (Sine-u)			+Rectobuntonia	T (Mi-u-l)	-T (Mi-u-u)	
Proparaparchites	C (Serp)?	-C (Pn)		Rectocypris	T (Plio-u)		
Proponocypris	K (Maes)	-R		Rectocythere	J (Bath-u)	-J (Kimm-u)	
+Prorectella	O (Llvi-l)		(996)	+Rectotrachyleberis	T (Plio)		(ZR89)
+Prosumia	D (Gedi)			Reginacypris	T (Mi)		
+Proteoconcha	T (Plio)	-R	(853)	Rehacythereis	K (Vala)	-K (Sant)	(138,141, ZR89)
Protoacanthocythere	J (Bajo-l)		(74)	Renngartenella	Tr(Olen)?	-Tr(Carn-u)	
Protoargilloecia	J (Bath)	-T (Mi)	(2)	+Retjculina	T (Dani)	-T (Eo-m)	(ZR94)
Protobuntonia	K (Ceno-l)	-T (Eo-l)		+Reticulocosta	K (Ceno-l)	-K (Sant)	(1073)
Procythere	J (Bajo)	-K (Ceno-m)	(167)	+Reussicythere	T (Ol)		(ZR88)
Procytheretta	T (Eo)	-R		+Revisylithere	O (Ashg-u)		(855)
+Protojonesia	K			+Reymenticosta	T (Pale)	-T (Eo)	(ZR91)
+Pseudacantoscapha	P (Dora)		(648)	+Rhadinocythere	J (Kimm-u)		
+Pseudaurilla	T (Plio)	-R		+Rhocobairdia	P (l)		(ZR89)
Pseudobothocythere	K (Barr)	-K (Albi-l)	(74,138)	Rhombocythere	Tr(Nori-l)	-R	
+Pseudocavellina	D (Gedi)			Rhysomagis	D (m)		
+Pseudoceratina	T (Ng)	-R		+Rimacytheropteron	T (Eo-l)	-R	(929)
Pseudocyproides	S (Wenl)			+Rishona	D (Emsi)	-D (Give)	(1066)
Pseudocythere	K	-R		+Robertsonites	T (Mi-m)	-R	(1104)
Pseudocytheretta	T (Plio)?	-R		+Rostrocytheridea	K (Nc)	-K (Sant)	(171,172)
Pseudocytheridea	T (Ol)	-T (Mi)		Rotundracythere	T (Eo)	-R	
Pseudocytheromorpha				Rubracea	J (Call)		
	T (Eo-u)			+Ruchholzella	Tr(Rhae)	-J (Hett)?	
Pseudocytherura	T (Ol-u)	-R	(167)	Ruggieria	T (Eo-l)	-R	
Pseudohustonia	J (Call-u)	-J (Oxfo-l)	(74)	+Ruggierella	T (Eo-l)	-R	(929)
Pseudokrithe	T (Pg)			+Rushdisaidina	K (u)		(ZR91)
+Pseudomacrocypris	T (Mi-l)		(ZR91)	Russia	D (Eife-u)	-D (Give-u)	
+Pseudomonoceratina	D (Give-u)	-P	(ZR93)	Rutlandella	J (l)	-J (Bath-m)	(ZR91)
Pseudoparaparchites	C (Ms)	-C (Step)	(773)	Ruttenella	T (Eo-u)		
Pseudoperissocytheridea				+Saalfeldella	C (Vise-u)		(ZR94)
	J (Call)	-J (Oxfo-m)	(74)	+Sagmatocythere	T (Eo-u)	-T (Mi-u-u)	(ZR94)
Pseudophanasymmetria				Sahnia	T (Eo)	-R	(167)
	K (u)	-K (Maes)		+Sahnicythere	T (Plio)?	-R	
Pseudoprotocythere	J (Bath-m)		(74)	Saida	K (Albi-l)	-R	(172)
+Pseudopsammocythere				+Sanyuania	T (Plio)	-R	
	T (Mi-u-l)	-T (Mi-u-u)	(ZR94)	+Sarlatina	K (Ceno)		(166)
+Pseudorayella	O (Llvi-u)	-P (Djuh)	(78,648, 1116)	+Sarsicytheridea	T (Plio)	-R	
Pterygocythere	K (Ceno)	-R	(138)	+?Saumella	D (Give)	-C (Vise-l)	(670)
Pterygocythereis	K (Ceno)	-R	(167)	+Saxellacythere	J		
+Ptychobairdia	Tr(Nori)	-J (Bath-u)	(166)	Scabriculocypris	J (Tith-u)		(868)
Pulviella	Tr(Olen-u)	-Tr(Rhae)	(674)	+Scaphella	S (Wenl)		(ZR85)
+Pullvillites	O (m)	-O (Ashg-m)	(855,ZR88)	+Scaphium	S (Ludl)?		
Punctaparchites	O (Llvi-l)		(855)	+Scepticythereis	K (Sant)		(171)
Punctomosea	D (Eife-l)	-D (Fras-u)		Schizocythere	K (Camp-u)	-R	
Puriana	T (Ol-u)?	-R	(166,167)	Schleesha	C (Vise-u)	-P (Leon-u)?	(74,773)
+Puricytheretta	T (Mi)			+Schneideria	D (Give-u)	-D (Fras-m)	(ZR83)
Pustulobairdia	C (Vise-u)		(74)	Schuleridea	J (Aale)	-T (Mi)	(167)
Pyocytheridea	J (Call-l)	-K (l)		Sclerochilus	T (Mi-m)?	-R	

Taxon	First Appearance	Last Appearance	Reference	Taxon	First Appearance	Last Appearance	Reference
Cytherella	Tr(Anis)	-R	(1066)	Ph. BRYOZOA	[Classification and basic stratigraphic ranges from the TREATISE, Part G (1953).]		
Cytherelloidea	Tr(Anis-m)	-R	(2,74)				
Dizygopleura	S (Wenl)	-C (Tour-l)	(2,1066)	CI. STENOLAEMATA			
Gotlandella	S (Wenl-u)		(2)	Or. CYCLOSTOMATA (= Tubuliporata)			
+Nyhammella	S (Ldov-u)	-S (Prid)	(1066)	Acanthopora	J (Sine)	-K (l)	(581)
Platella	K (Ceno-l)	-T (Mi-u)	(141)	Actinopora	J (Bath)	-R	(1241)
+Reubenella	Tr(Anis)	-Tr(Carn-u)		Actinotaxia	K (Maes-u)		(583)
Staringia	K (Maes)			+Aggregopora	K (Ceno-u)	-T (Dani-u)	(584)
+Struveopsis	D (Eife)		(ZR91)	Alveolaria (+ Blumberbachium)			
Tetratylus	C (Serp-l)?			T (Ol)		-T (Plio-u)	
Or. UNCERTAIN				+Amphimorsoniella	K (Ceno-l)		(626)
Acrossula	D (m)			+Anguisia	Q (Plei)	-R	
+Adamiczakia	O (Ashg-m)		(ZR88)	+Annectocyma	T (Mi-m)	-R	
-Anahuacia	P (l)		(ZR88)	+Apatotervia	K (Sant-l)	-K (Maes-l)	(585)
-Anfedatia	S (Ludl)			Apsendesia	J (Aale)	-T (Eo-m)	(581,1241)
+Benniviaspis	D (l)		(ZR85)	Atagma	K (Coni)	-K (Maes-u)	(586,626)
+Borodiella	T (Mi)		(ZR87)	Atelesopora	T (Plio)	-Q (Plei)	
Boucekites	D (m)			Atractosocia	J (Bath)		
Brachycytheropteron	K (l)			+Attinopora	T (Ol-l)	-R	(1015)
Budnianella	S			Berenicea	O (Cara)?	-R	
Celechovites	D (m)			Bicavea (+ Multicrisina)			
Ceratocypris	O (l)	-S		K (Turo-u)		-T (Dani)	(626)
Craspedopyxion	O (m)			+Bicoronipora	K (Vala-l)	-K (Vala-u)	
+Crescenticythere	T (Mi-l)			Bierisia	T (Eo-l)	-R	(587)
+Gelidicella	O		(ZR84)	Bicrisina	K (Turo)	-T (Mi-u)	(588,1241,1260)
+Gerubiella	D (Give)?	-D (Fras-l)		Bidiastopora	J (Bath)?	-K (Ceno-m)?	(626)
Ginella	O (m)			Biflabellaria	K (Maes)		(942)
Gipsella	D (u)			+Biovicella	T (Mi-l)	-T (Mi-u)	(1241)
Golcondella	C (Ms)			Bisidmonea	J (Bath-m)	-R?	(581)
+Hameaschmidtella	O (m)		(ZR84)	Bitubigera	T (Eo-u)	-T (Mi-u-u)	(627)
+Huanghuaella	O		(ZR91)	Bivestis	K (Maes)		
Hupehella	D (u)			+Bobiesipora	T (Mi-m)		(628)
Ilmenoindivisia	D			Brachysocia	K (Ceno)	-T (Dani)	
Jamischjewskya	C (Tour-u)	-C (Vise)		+Braiesopora	Tr(Carn)		
+Kuresaaria	S (Prid)			+Buria	Tr(Nori)		
+Lublinella	D (l)		(ZR85)	Canalipora (+ Tubulipora)			
+Maghrebeis	K (u)		(ZR88)	K (Camp)?		-T (Dani-u)	(589)
+Marginitomorites	P (l)		(ZR88)	K (Vala)		-R?	(908)
+Microcosmia	T (Eo-l)		(ZR91)	+Carinifer	K (Maes)		(942)
+Navicularina	O (u)		(ZR88)	+Cassianopora	Tr(Carn-l)		(84)
Neochilina	D			Cava	J (Bajo-u)	-J (Call-l)	(581)
+Netzkaina	S (Ludl)			Cavaria	K (Maes)		
Novakina	S			Cavarinella	K (Camp)	-T (Than-l)	(1260)
+Ochesaarina	S (Ludl-u)	-S (Prid)		+Ceata	K (Barr)	-K (Camp)	(626,1260)
Paleocythere	D (m)			+Ceidmonea	K (Camp)	-K (Maes)	(942)
+Proeditia	C (u)		(ZR91)	Cellulipora	K (Vala-u)	-K (Coni)	(590)
Pseudonodellina	D			Centronea	T (Eo-u)		
Pulvillites	O (Ashg-l)	-S		Ceriocava	J (Toar)	-K (Sant)	(581,626,1066)
Pixiprimitia	D			Ceriopora	J (Aale)?	-T (Plio)	(908)
Reversoparaparchites				Cerioporella	K (Maes)	-T (Dani)	(942)
D (u)			(ZR85)	Charixa	K (Apti)?	-K (Albi-u)	(908)
T (Pg)				Chartecyis	K (Vala-l)		(590,1066)
+Spathocystes	D (l)		(ZR87)	Chilopora	J (Bath)	-K (Camp)?	(1260)
+Tatsjell	Tr(u)		(ZR85)	+Chisma	K (Apti-l)	-K (Apti-u)	(626)
+Tegaspis	D (l)		(ZR85)	Choristopetalum	K (Apti-l)		
Tetrasulcata	D (u)			+Cinctipora	K (Camp)	-R	(1241)
+Torustilina	O (m)		(ZR88)	+Circibiopora	T (Eo-l)	-T (Eo-m-l)	(1241)
+Trapezisylthere	O (Ashg-m)		(ZR88)				
+Uthoerina	O (Ashg-m)		(ZR88)				
+Uvonhactia	O		(ZR89)				
+Venzavella	S (Wenl-l)	-S (Prid)					
+Vitella	O (m)		(ZR84)				

Taxon	First Appearance	Last Appearance	Reference	Taxon	First Appearance	Last Appearance	Reference
Clausa	K (Apti-l)	-T (Dani)	(589,908)	Elca	K (Vala)	-T (Dani)	(626,1260)
Clavicava	K (Nc)			Entalophora (+ Diastopora)	J (Bajo-l)	-R	(593)
Clavisparsa	K (Sant)?	-K (Maes)	(942)	+Eoentolophoreocia	K (Apti)?	-R	(908)
Clavitubigera	K (Apti-l)	-T (Dani-l)	(586)	+Eoheteropora	Tr(Nori-u)		
Chinopora	K (Ceno-l)	-K (Maes-u)	(589)	+Eohornera	K (Camp)	-K (Maes-u)	(589)
Clonopora	O (Llvi-l)	-D (Give)	(575,1034)	Erkosonea	T (Dani)	-T (Eo-u)	(510,942)
Clypeina	K (Coni)	-T (Eo)	(626)	+Eurystrotos	K (Vala-l)	-R	
Coelocochlea	K (Maes-u)		(942)	+Exidomonea	K (Ceno)	-R	(1241)
+Coelospiropora	K (Haut-l)			Exochoecia	T (Eo-l)	-T (Mi-u)	
+Collapora	J (Aale)	-K (Ceno)	(908)	+Fasciculinozocia	K (Sant)	-T (Dani)	(1241)
Conotubigera	K (Camp)		(942)	+Fasciculipora	J (Bath-u)	-R	(581)
+Coronidmonea	T (Dani)		(591)	+Fascigera	K (Maes)	-T (Mi-m)	(589,942, 1241)
Corymbopora	K (Ceno)	-T (Dani)	(942)	Fascipora	K (Ceno)	-K (Maes)	(1241)
Corynotrypa	O (Aren-u)	-P (Guad-l)?	(1066,1116)	Filicava	K (Camp)?	-K (Maes)	(942)
Coscinocia	T (Mi-m)			Filicea	K (Coni)	-T (Dani)	(586,626, 1066)
+Crassodiscopora	K (Maes-u)	-T (Dani-u)	(589)	Filicrisia	T (Ol-u)	-R	(587)
Crassohornera	T (Eo-m-u)	-T (Eo-u)?		Filicrisina	K (Coni)	-K (Maes)	(626,942)
+Crescis	J (Bajo-u)	-J (Call-l)	(581)	Filifascigera	K (u)?	-R	
Crisia	K (Maes-u)	-R	(587)	Filisparsa	K (Haut-l)	-R	(582)
Crisidia	K (Maes-u)	-R	(587)	Flabellotrypa	O (Ashg)?	-D (Gedi)	(575)
+Crisidmonea	K (Maes-l)	-T (Mi-m)	(1066)	Foricula	K (Apti-l)	-K (Maes-u)	(586,626)
+Crisiella	T (Mi-m)	-R	(587)	Frondipora	K (Camp)	-R	(942)
Crisina	K (Coni)	-T (Than)	(626)	Fungella	K (u)	-K (Maes-u)	(586)
Crisinella	D (Emsi)	-D (Fame)	(1034)	Globulipora	K (Camp)?	-T (Dani)	(942)
Crisiona	T (Dani-l)	-R	(587)	+Goryunovia	O (Aren-l)		
Crisisina	K (Ceno)	-R	(626,1260)	Grammanotosoecia	K (Sant)?	-K (Maes)	(942)
Crisulipora	T (Ol-l)	-R	(1066)	Grammascosoecia	K (u)	-K (Maes-u)	(586)
Cryptoglena	K (Vala-l)	-K (Maes-u)	(590)	Haploecia	J (Bajo)	-K (Vala)?	
Cuvilliera	T (Eo-l)	-T (Eo-u)	(942)	?Hederella	S (Wenl)	-C (Step-u)	(2,1066)
Cyclocites	J (Bath)		(2)	Hederopsis	D (Eife)	-D (Give)	(575,1034)
+Cylindropora	T (Plio)		(1015)	Hemicellaria	K (u)	-T (Than)	
Cyrtopora	K (Vala)	-K (Maes)	(1260)	Hernodia	S (u)	-D (Give)	(575,1034)
Cystoporella	D (Eife)			Heterocrisina	K (Ceno-u)	-T (Than)	(626)
Cytis	K (Coni)	-K (Maes)	(626,942)	+Heterohaploecia	K (Coni)	-K (Camp-l)	(1066)
Dacryopora	J			Heteropora	J (Toar-l)	-R	(1066)
+Decurella	T (Eo-u)		(942)	Heteroporella	K (u)?	-T (Plio)	
+Defrancia	T (Plio)		(1260)	Homoosolen	K (Turo-u)	-K (Maes-u)	(585,588)
Defranciopora	K (Vala-u)	-T (Ol)	(582,589)	Hornera	K (Sant-l)	-R	(589)
+Dendroecia	K (Vala-u)	-K (Barr-u)	(592)	Hyporosopora	J (Aale)	-R?	(908)
+Dentalitrypa	O (Ashg)	-D (Eife)	(575,1241)	Idmidronea	K (Camp-l)	-R	(590)
Desmotelesia	T (Mi-m)	-R	(1260)	Idmonea (+ Reptotubigera)	J (Aale)	-R	(581,589, 626)
Desmediaperoecia	K (Maes-u)	-R		Idmonella	K (Sn)		
Desmeplatioecia	K (Turo)	-R	(1241)	+Idmoneoides	T (Dani)	-R	(1241)
Desmepora	K (Ceno-l)	-K (Maes-u)	(586,588)	+Infundibulipora	K (Coni)	-R	(1241)
Diastoporina	O (Cara-l)	-S (Ldov)	(742,1241)	Koldophos	J (Aale)	-J (Bath)	(1241)
+Dichospiropora	K (Vala-l)	-K (Haut-l)		+Kuarnbyella	K (Turo)	-K (Maes-l)	(589)
Diplocava	K (Vala-u)		(590)	Kukersella (+ Crownopora)	O (Llvi-l)	-O (Ashg-u)	(742)
Diploclema	O (Cara-l)	-S (Wenl-u)	(575,742)	+Kyarnbyella	K (Turo)	-K (Maes)	(942,1241)
Diplodestmepora	K (Coni)	-K (Camp)	(626,1260)	+Lagenosypho	D (Eife)	-P (Guad-u)	(905,1034)
+Diplopetalopora	K (Maes-l)	-T (Dani-u)	(594)	Lagonoecia	T (Eo-l)	-T (Eo-u)	(942,1066)
Diplosolen	K (Coni)	-R	(626)	Laterocavea	K (Apti)	-K (Albi)	(626,908)
Discocytis	K (Ceno-u)	-K (Maes-u)	(586)	Lateroecia	K (Sn)		
Discofascigera	K (Albi)	-T (Mi)	(626)	Laterotubigera	K (Ceno)	-K (Camp)	(626,1260)
Discosparsa	K (Vala-u)	-T (Mi-l-u)	(590,1260)	Leiosoecia	K (Apti)	-T (Eo-l)	(597)
+Discotruncatulipora	K (Ceno-l)	-K (Maes-u)	(595)	Lekythionia	T (Than)	-T (Eo-u)	(942)
Discotubigera	K (Maes)	-T (Dani-u)	(589,942)	Leptopora	K (Ceno)		
Disporella	K (Coni)	-R	(589)				
Ditaxia (+ Semimultieresis)	K (Apti)	-K (Maes-u)	(586,589)				
+Diversipora	D (Eife)		(575)				
Echinocava	K (Haut-l)	-K (Albi)	(596,626)				
Elaphopora	J (Tith-u)						

Taxon	First Appearance	Last Appearance	Reference	Taxon	First Appearance	Last Appearance	Reference
Lichenopora	K (Albi)	-R	(1260)	+Polyscosoeciella	K (Camp-u)	-T (Mi-u)	(1260)
Liripora	T (Mi)	-R		+Poriceata	K (Haut-u)?	-K (Barr-u)	(1048)
Lobosoecia	K (Ceno)		(2)	+Poroplagioecia	K (Barr)		(631)
Locularia	K (Maes-u)		(583,942)	Proboscina	T (Dani)	-R	(1241)
Lopholepsis	K (Camp)?	-K (Maes-u)		+Probosciniopora	J (Bajo)	-K (Apti)	(908,1241)
Marssoniella	K (Ceno-l)	-T (Dani)	(589,626)	Prosthenoecia	T (Eo-m-l)	-T (Eo-u)	(942)
Meandropora	T (Mi-m)	-T (Plio)		+Pseudofrondipora	T (Mi-l-u)	-T (Mi-u)	(630)
Mecynoecia	J (Aale)	-R	(581)	+Pseudoseriopora	K (Sant)	-K (Maes-u)	(589)
Meliceritella (+ Nodelea)				+Pseudotervia	K (Camp-l)	-T (Dani-u)	(589)
	K (Ceno-u)	-T (Than-l)	(626)	Psilosolen	Q (Plei)	-R	
+Melicerita	T (Plio)		(1260)	Pustulopora (+ Hammia)			
Meliceritites	K (Barr-l)	-K (Maes-u)	(592,908)		K (Camp)	-T (Dani-u)	(589)
Mesenteripora (+ Cisternifera)					K (Maes)		(942)
	J (Pliu-u)	-R	(581,593,908)	+Radicipora	J (Toar-u)	-J (Oxfo)	(581,1241)
Mesonea	T (Eo)	-R		Radiocavaria	K (u)		
Mesonopora	J (Aale)	-K (Apti-u)	(581,592,596,1241)	Radiofascigera	K (Vala)	-R	
			(593)	Radiopora	K (Barr-l)	-R	(589,592)
Microecia	J (Bajo-l)	-R		Ramia	Tr(u)		
Mitoclema	O (Cara-l)	-D (l)?		+Ramofilisparsa	K (Ceno)		(1241)
Mitoclemella	O (Cara-m)?			?Reptaria	S (Lud)	-D (Give-u)	(575,1066)
+Monodesmopora	T (Mi)			Reptoceritites	K (Ceno)		(1260)
Multicavea (+ Ascosoecia)				Reptoclausa	J (Aale)	-K (Maes)	(626,908)
	K (u)?	-K (Maes-u)	(598)	Reptofascigera	K (Sant)?	-K (Maes)	(942)
Multicrescis	K (Haut-l)	-T (Mi)	(599)	Reptomultelea	K (Ceno)?		
Multifascigera	K (Vala-u)	-K (Maes)	(590,942)	Reptomulticava	K (Vala-u)	-T (Plio)	(583,1260)
Multigalea	K (Vala-u)	-K (Apti-u)	(590,592)	Reptomulticlausa	K (Ceno)	-T (Dani-u)	(589)
Multisparsa	J (Aale)	-K (Haut-l)	(581,590)	Reptomultisparsa	Tr(Nori)	-R	(1241)
Multitubigera	J (Aale)	-K (Maes)	(581)	+Reptonodiocava	Tr(Nori)	-J (Bath)?	
Multizonopora (+ Zonatula)				Retecava (+ Spiridimonea)			
	K (Haut-l)	-K (Camp)	(626,1260)		K (Vala)?	-T (Dani-u)	(589)
Nematifera	K (Nc)			Retelea	K (Turo)	-T (Dani)	(588,942,1260)
Neoretenea	T (Dani)		(942)	Retenea	K (Vala-u)	-K (l)	(590)
+Neuropora	J (Bajo)		(1260)	Reticirisina	K (Turo)	-K (Maes)	(585,588)
Neuroporella	K (u)			Reticulipora	J (Aale)	-T (Eo-m-u)	(581,629)
+Nevipanopora	K (Coni)	-R	(626)	Rhipidiopora	K (Camp)	-K (Maes)	(1241)
Notoplagioecia	K (Apti)	-K (Ceno-m)	(626)	Ripisoecia	J (Bajo-l)	-J (Call-l)	(581,593)
Oncousoecia	J (Sine-l)?	-R	(1066)	Rosacilla	J (Aale)	-K (Sant)	(1241)
Osburnostylus	O (Cara-l)			Sagenella	O (Aren)	-S (Lud-l)	(575,1230)
Osculipora	K (Ceno-u)	-T (Dani-u)	(589,626)	+Seelandia	Tr(Carn-l)		(84)
+Pachyteichopora	K (Coni)	-K (Camp-u)	(598)	Seguenziella	T (Plio)		
+Palaeocrisidia	C (Tour-l)	-C (Tour-u)	(905)	Semiceia	K (Ceno)	-K (Maes)	(588,942,1260)
+Paracrescis	K (Apti-u)		(908)	+Semicinctipora	T (Ol-l)	-T (Mi-l)	(1014)
+Paralhelderella	D (Emsi)	-D (Fras)	(1034)	Semiclausa	K (Sant)	-K (Maes)	(942,1260)
Paratretyocycloecia	T (Than-l)	-T (Eo-m-l)	(942)	+Semicytis	K (Maes)		
Parleiosoecia	T (Eo-m-u)	-T (Eo-u)	(942,1260)	Semicytella	K (Turo)	-K (Sn)	(588)
Paratretyocycloecia	T (Than-l)	-T (Ol-l)	(942)	Semielea (+ Reptelea, Semimultelea)			
Patenaria	K (Camp)?	-K (Maes-u)	(583)		K (Ceno)	-K (Maes)	(626,942)
Pennipora	K (Maes-u)		(583)	Semifascipora	K (Camp-u)	-K (Maes)	(1241)
+Perfodiasstopora	K (Haut-l)		(1048)	+Semifungella	K (Maes-u)		
Pergensella	K (Maes)		(942)	Semilaterotubigera	K (Coni)		(1260)
Peripora	K (Ceno)	-K (Maes-u)	(1241)	Semimulticavea	K (Vala)	-K (Camp)?	(596,908)
Petalopora (+ Parascosoecia, Reptocavea)				Seminodierescis	K (Apti-u)		(908)
	K (Vala-u)	-T (Than)	(589,590)	Semitubigera	K (u)?	-T (Eo)	
?Phacelopora	O (Cara-m)	-O (Ashg-u)	(742)	Serietubigera	K (Camp)	-T (Dani-u)	(589,1241)
+Phormopora	K (Maes)	-T (Dani)	(942)	+Serpentipora	K (Maes)	-R	(1241)
Plagioecia	J (Bajo)	-R	(1241)	+Silenopora	K (Maes-u)	-T (Dani-u)	(589)
Platonea	T (Eo-u)	-R		+Sphaerogypina	T (Mi-u)	-T (Plio)	(1260)
Plethopora	K (Apti-u)	-K (Maes)	(626)	Siphodictyum	K (Barr-l)	-K (Apti-u)	(592,908)
Plethoporella	K (Maes)		(942)	Siphoniotyphlus	K (Ceno-l)	-K (Maes-u)	(1066)
Pleuronea	K (Maes)	-T (Plio)		Sparsicavea	K (Apti-l)	-K (Maes)	(626)
Polyascosoecia	K (Maes)	-T (Plio)	(627,942)				

Taxon	First Appearance	Last Appearance	Reference	Taxon	First Appearance	Last Appearance	Reference
Sparsicytis	K (Coni)?	-K (Maes)	(942)	Botryllopora	D (Give-l)	-D (Fras)	(1034)
Spinopora	K (Ceno)	-K (u)		Buskopora	S (Ludl)	-D (Give)	(1034,1241)
+Spirentolophora	K (Vala)	-K (Camp)	(942)	Bythotrypa	O (Llvi-u)	-O (Ashg)	(742)
+Spirdmonea	K (Camp-u)			Canutrypa	D (Fras)		(1034)
Spiropora	J (Bajo-l)	-T (Eo-u)	(581,1066,1260)	Ceramella	D (Give)		(1034)
+Spiroporina	T (Eo-u)		(1260)	Ceramophylla	O (Llde)	-O (Ashg)	(1241)
Stathmepora	K (Maes)	-T (Mi-u)	(1260)	Ceramopora	O (Llvi)	-S (Prid)	(1241)
Stellocavea (+ Camerapora)				Ceramoporella	O (Llvi-u)	-D (Give)	(512,742,1034)
	K (Maes)		(942)	Cheilotrypa	S (Ludl)	-C (Serp-l)	(1034)
Stephanodesma	K (Maes)	-T (Than-l)		+Chiocystiramus	C (Vise-u)		(905)
Stigmatoechos	K (Camp-l)	-T (Than)	(589)	Cliotrypa	C (Tour-u)	-C (Vise-l)	(509)
Stomatopora (+ Alecto)				Coelocaulis	D (Gedi-l)	-D (Fras)	(1034)
	Tr(Carn)	-R	(908)	Constellaria	O (Llde-l)	-S (Ldov)	(1066)
+Stomatoporina	J (Bajo)	-R	(587)	Coscinum	P (Asse)	-P (Guad-l)	(1087,1241)
+Stomatoporopsis	K (Maes)		(1241)	Coscinotrypa	D (Eife)	-P (Djhu)	(571)
Sulcocava	K (Coni)	-T (Dani-u)	(589)	Cressaluna	O (Ashg-m)		
Supercytis	K (Turo-l)	-K (Maes)	(588)	Crepipora	O (Llde)	-D (Emsi)	(742,1034)
+Talmontipora	K (Camp-u)			Cyclotrypa	S (Ludl)?	-P (Guad-u)	(571,905,1034)
Telopora	T (Ol-l)	-R	(1260)	Cystiramus	D (Give)	-D (Fame)	(1034)
Tennysonia		R		+Cystitrypa	Tr(Carn)		(1066)
Terebellaria	J (Aale)	-J (Call-l)	(581)	Cystodictya	D (Emsi)	-P (Guad-u)	(905,1034)
Tervia	K (Turo)	-R	(626)	Diamesopora	O (Ashg)	-S (Ludl)	(2,1241)
+Tetragonoecia	K (Vala-u)	-K (Haut-l)		Dichotrypa	D (Give)	-P (Guad-u)	(905,1034)
Tetrapora	J (Oxfo-u)	-J (Kimm)	(2,581)	Duncanoclema	S (Prid)	-D (Gedi)	(742,1241)
Theonoo	J (Aale)	-R	(581,589)	Dybowskiella	D (Give)?	-P (Djhu)	(1034,1241)
Tholopora	K (Vala-u)	-T (Ol)	(590,626,908)	Eofistulipora	D (Eife)	-D (Fras)	(1034,1241)
Tretonea	T (Eo-u)		(1260)	Epiactinotrypa	P (Guad-u)		(571,905)
Tretocycloecia	K (Haut-l)	-T (Mi-u)	(1048)	Eridopora	S	-P (Guad-u)	(571,1034)
+Triplazoecia	K (Camp-u)	-K (Maes-l)	(589)	Etherella	P (Leon-m)	-P (Guad-u)	(571,905)
Trochilopora	K (Coni)	-K (Maes)	(942)	Evactinopora	C (Tour-l)	-P (Leon-l)	(509,571)
+Truncatula	K (Ceno)	-K (Turo)	(1260)	Evactinostella	P (Asse-u)	-P (Leon-l)	(571,905)
Truncatulipora	K (Haut-l)	-K (Maes)	(589,626,1048)	Favicella	D (Give)		(1034)
				Favositella	O (Cara-l)	-S (Prid)	(512,1000)
Tubigera	K (Maes)			Filiramoporina	P (Sakm)		(1066)
Tubigerina	K (u)?	-R		Fistulamina	C (Tour-l)	-P (Guad-u)	(509,571)
Tubulipora	K (Camp-l)?	-R	(589,1066)	+Fistulicanta	S (Ldov)	-D (Gedi)	(742,1241)
Umbrellina	K (Ceno)	-K (Maes)	(942)	Fistuliphragma	D (Sieg)	-D (Give)	(1034)
Unicrisia	K (Camp)?	-K (Maes)	(942)	Fistulipora	O (Ashg-m)	-P (Dora)	(571,1066)
Unicytis	K (Ceno-m)	-R	(626)	Fistuliporella	S (Wenl-u)	-D (Give)	(742,1034)
Unitubigera	K (Vala-l)	-T (Mi)?	(596,908)	Fistuliporidra	D (Give)		
+Voigtia	O (Aren-u)	-O (Ashg)	(1116)	Fistuliramus	O (Ashg)	-P (Djhu)	(571,742,905)
+Voigtella	T (Dani)		(942)	Fistulocladia	D (Give)	-P (Guad-u)	(905,1034)
Voigtopora	K (Apti-u)	-K (Camp-l)		Fistulotrypa	D (Give)	-P (Guad-u)	(571,1034)
+Wassyopora	K (Haut-l)	-K (Apti-l)	(1048)	Ganiella	D (Emsi)	-D (Eife)	(1034)
+Wolinella	O (Aren-u)	-S (Wenl-u)	(575)	Glyptopora	C (Tour-u)	-C (Bash-u)	(509,905)
Ybseloscoecia	T (Eo-l)	-R		Goniocladia	D (Fras)	-P (Dora)	(905,1034)
Zonopora (+ Spirofastigera)				Goniocladia	C (Tour-l)	-C (Vise-l)	(509)
	K (Albi)	-T (Eo-u)?	(942,1260)	Goniocladia	C (Tour-l)	-C (Vise-l)	(509)
				Haplortrypa	O (Ashg)	-D (Emsi)	(742,1034)
				Hemigopora	O (Ashg-m)	-S (Prid)	(742)
				Hexagonella	P (Asse-l)	-P (Djhu)	(571)
				+Inconobotopora	S (Wenl-l)		
				+Isphairamella	D (Gedi)		(1034,1241)
				Kasakhstanella	D (Fras)	-D (Fame)	(1034)
				Lamtshinopora	O (Aren)	-O (Ashg)	(742,1230,1241)
				Lichenalia	O (Cara-m)	-S (Prid)	(742)
				Lichenotrypa	D (Eife)		(1034)
				Liguloclema	P (Leon-m)	-P (Guad-u)	(571)
				Lophoclema	C (Step-u)		(1241)

Or. CYSTOPORATA

Acanthoceramoporella

	O (Llde)	-O (Ashg-u)	(742)
Acrogenia	D (Give-l)	-C (Tour)	(1241)
Actinotrypa	C (Vise-l)		
Actinotrypella	P (Asse-l)	-P (Leon-l)	(571)
Aetomacladia	P (Sakm-u)	-P (Leon)	(1241)
Altschedata	D (Give)	-D (Fras)	(1034)
Anolotichia	O (Llvi-l)	-O (Ashg-m)	(2,511)
+Balticoporellina	O (Llvi-l)		(742)
+Belorussipora	O (Cara)		(1241)

Taxon	First Appearance	Last Appearance	Reference	Taxon	First Appearance	Last Appearance	Reference
+Lunaferrimita	O (Llde-u)	-O (Cara-l)	(513)	+Asperopora	O (Ashg-u)	-D (l)?	(742,1083)
Meekopora	S (Wenl)	-P (Guad-u)	(571,1034,1241)	Aspidopora	O (Cara)	-S (Ldov-m)	(742)
Meekoporella	C (Step-u)	-P (Guad-u)	(905,1241)	+Astralochoama	C (Serp-l)		(905)
Metelipora	P (Asse-u)	-P (Leon-l)	(571)	+Astroviella	S (Ludl)	-S (Prid)	(742,1034,1241)
+Mongolodictya	C (Bash)		(1241)	+Astroviellina	S (Prid)		(742,1000)
Odonotrypa	D (Eife)	-D (Give)	(1034,1241)	Ataetopora	O (Cara-u)	-O (Ashg)	(544)
+Pakridictya	O (Llvi-l)		(742)	Ataetoporella	O (Llvi)?	-S (Wenl)	(742)
Papillalunaria	O (Llde-l)	-O (Ashg-l)	(742)	Atactotoechus	O (Llvi-u)	-D (Fame)	(544,742)
+Parametelipora	P (Guad-l)		(1241)	†Balticopora	O (Cara-m)	-O (Cara-u)	
Pholidopora	S (Wenl-u)		(742)	+Balticoporella	O (Cara-m)	-O (Ashg)	(514,742)
Phractopora	D (Eife)	-C (Vise-u)	(509,1034)	Batostoma	O (Aren-u)	-S (Prid)	(512,742,1230)
Pileotrypa	D (Eife)			Batostomella	O (Cara-m)?	-D (Give)	(1034)
Pinacotrypa	D (Give)		(1034)	Batostomellina	S (Ldov)	-S (Ludl)	(2)
+Podljassopora	S (Ludl)	-S (Prid)	(1000,1241)	+Bimuropora	O (Cara-l)	-O (Cara-m)	(1066)
Prismopora	D (Emsi)	-P (Guad-u)	(905,1034)	Bythopora	O (Cara-l)	-S (Prid)	(2,544)
Profistulipora	O (Trem)	-S (Ludl)?	(742,1230)	D (l)		-D (Give)	
Prilocella	D (Give)		(1034)	†Calacanthopora	S (Wenl-u)	-S (Ludl)	(742)
Ramipora	C (Tour-u)	-P (Guad-u)	(571,905)	Calloporella	O (Llvi-u)	-S (Wenl)	(544,742)
Ramiporalia	C (Tour-u)	-P (Sakm-u)	(509,571)	Callotrypa	D (Gedi)	-D (Eife)	(1034)
Ramiporella	C (Vise-u)	-P (Sakm-u)	(509,571,905)	+Calopora	O (Cara)	-S (Wenl)	(511)
Ramiporida	C (Tour-l)	-P (Leon-m)	(571,905)	†Capillapora	O (m)		(1241)
+Realeksella	D (Eife)		(1241)	+Champlainopora	O (Llvi-u)	-O (Cara-l)	(512)
Revalopora	O (Aren-l)	-O (Cara-u)	(742,1066)	Chondraulus	D (Gedi)	-D (Give)	(1034,1241)
Rhinopora	O (Llvi)	-S (Wenl-u)	(742,1241)	Coeloclemis	C (Serp-l)	-P (Djhu)	(571,905)
†Rhinoporella	O (Cara)		(1241)	+Crustopora	D (Emsi)	-C (Mosc-u)	(905,1034)
Scalaripora	D (Eife)	-D (Give)	(1034)	Cyclopora	D (Give)	-C (Vise-l)	(509,1034)
Scenellopora	O (Llde-u)	-O (Cara-m)		Cyclopoporella	C (Vise-l)		(509)
Selenopora	D (Eife)	-D (Give)	(1034,1241)	Cyphotrypa	O (Aren-u)	-D (Fame)	(544,1034)
Semiopora	D (Give)		(1034)	Dekayella	O (Cara)	-O (u)	
+Stellipora	O (Ashg-u)		(1083)	Dekayia	O (Llde)	-O (Ashg-m)	(544)
Stictocella	D (Give)		(1034)	Dianulites	O (Aren-u)	-O (Ashg-u)	(2,1083)
Strotopora	D (Eife)	-C (Vise-l)	(905,1034)	Diazipora	O (Llvi)	-O (Cara-m)	(544,1241)
Sulcoretepora	D (Gedi)	-P (Djhu)	(509,571,1034)	Diplostenopora	S (Prid)	-D (Gedi)	(544,742)
Taeniopora	D (Emsi)	-D (Give)	(1034)	Diplotrypa	O (Aren-u)	-S (Ludl-l)	(515,523)
Thamnotrypa	D (Eife)		(1034)	Discotrypa	O (Ashg-l)	-D (Give)	(544)
†Vasalemmapora	O (Cara)		(1241)	+Discotrypina	S (Ldov)	-S (Ludl)	(742)
Volgia	C (Step-u)	-P (Guad-u)	(509,905)	Dittopora	O (Aren-u)	-O (Ashg-u)	(544,742,1083)
Xenotrypa	O (Aren-u)	-O (Llvi-u)	(738,742)	+Dybowskiites	O (Ashg)	-S (Ldov)	(1241)
†incertae sedis	Tr(Ladi-u)	-Tr(Carn-u)		Dyoidophragma	D (Give-l)		(544,1034)
Or. TREPSTOMATA				Dyscritella	D (Gedi)	-Tr(Nori-u)	(544,1034)
†Acantholaminatus	O (Cara-m)		(742)	+Dyscritellina	P (Leon-u)	-P (Dora)	(1241)
Acanthotrypa	O (Cara)		(742)	+Eodyscritella	D (Fame)		(514)
+Acanthotrypina	S (Ldov)	-S (Wenl-l)	(514)	Eostenopora	S (Ldov-u)	-C (Serp-l)	(512,742,1066)
+Aisenvergia	D (Fame)	-C (Tour-u)	(509,905)	+Eostenoporella	O (u)		(742)
Amphiporella	C (Vise-u)?	-C (Serp-l)		Eridocamplyus	S (Ludl)	-D (Give-l)	(742)
Amplexopora	O (Aren)	-D (Fras)	(544,742,1034,1230)	Eridotrypa	O (Aren-u)	-D (Eife)	(1230,1241)
Amsassipora	O (Cara)	-C (Serp)	(742,1241)	Eridotrypella	O (Ashg-m)	-C (Vise)	(544,1241)
Anaphragma	O (Aren-u)	-S (Ludl)	(738,742)	+Eridotrypellina	O (Llde)	-D (Give)	(1241)
Anisotrypa	S (Ludl)	-C (Bash)	(1066,1241)	Esthoniopora	O (Aren-l)	-O (Cara-m)	(2,544)
†Anisotrypella	P (Sakm-u)	-P (Djhu)	(544,905)	+Esthonioporella	O (Cara-l)	-O (Ashg)	(544,742,1241)
†Annunziopora	O (Aren)	-O (Cara-m)	(742)	†Flustra	Tr(Carn)		
Anomalotoechus	S (Ldov)	-D (Fame)	(544,742,1241)	Geinitzella	P (Wc)		
Aostipora	O (Llvi)?	-O (Ashg-u)	(742,1083)	Gortanipora	O (Ashg-m)		
+Araxopora	P (Wc)	-P (Djhu)	(905,1066)	Hallopora	O (Aren)	-D (Emsi-u)	(2,742,1230)
Arcticopora	P (Guad-u)	-Tr(Nori)	(544,905)	Halloporina	O (Cara-l)	-O (Cara-m)	(544)
+Armillopora	D (Fame)		(1034,1241)	+Helenopora	C (Serp-l)		(905)

Taxon	First Appearance	Last Appearance	Reference	Taxon	First Appearance	Last Appearance	Reference
+ Arthrotrypa	O (Ashg-m)		(1000)	+ Oanduella	O (Llde)	-O (Cara-m)	(1241)
Ascopora	D (Fame)	-P (Guad-u)	(571,905)	+ Oanduellina	O (Cara-m)	O (Ldov)	(742)
+ Ascoporella	P (Asse-u)	-P (Guad)	(1087,1241)	+ Oginbopora	C (Vise-l)	-P (Guad-u)	(571,905)
+ Astroidictya	O (Cara)	-O (Ashg)	(1241)	+ ?Orectodictya	O (Cara-m)		(516)
Athrophragma	O (Llde)	-O (Ashg-m)		Orthopora	O (Ashg-m)	-C (Tour)	(742,905)
Bactropora	D (Give-l)	-C (Vise-l)?	(509)	Pachydictya	O (Llvi-u)	-S (Ludl-l)	(742)
Callocladia	C (Vise-l)	-P (Guad-u)	(509,571,905)	+ ?Palaeocoryne	C (Vise-l)	-C (Serp-u)?	(509)
Carinodictya	O (Llde)	-O (Ashg-m)		Pamirella	P (Leon-l)	-P (Guad-l)	(905,1241)
Championodictya	O (Cara-u)	-O (Ashg-m)		+ Paranickelespora	C (Vise)		(1241)
Chazydictya	O (Llvi-u)	-O (Llde-u)	(512)	+ Permoholoclema	P (Leon-m)	-P (Guad-u)	(905)
+ Cladodictya	O (Cara)		(1241)	Petaloporella	D (Sieg)	-D (Give)	(534,1034)
Clathropora	O (Ashg-l)	-S (Ldov)	(1034,1241)	Phaenopora	O (Cara-l)	-D (Gedi)	(1034,1066)
Clausotrypa	C (Step-u)	-P (Djhu)	(509,905,1241)	Phaenoporella	O (Llde)	-S (Ldov)	(742)
Coscineella	D (Give)			+ Phaenophragma	O (Ashg)	-S (Wenl)?	(742)
+ Crownopora	O (Cara-m)	-O (Cara-u)	(512)	Phragmophora	C (Step-l)	-C (Step-u)	(509)
Cuneatopora	O (Llde)	-S (Wenl)	(742)	Phylodictya	O (Aren)	-S (Prid)	(575,742,1230)
+ Dicanopora	O (Ashg-u)		(1083)	+ Pictatella	P (Leon-u)	-P (Guad-l)	(1241)
+ Eichwaldictya	O (Cara-m)	-S (Prid)	(1000,1241)	Pinogopora	P (Guad-u)		(571,905)
Ensiaphragma	D (Emis-l)		(1066)	+ Primarella	C (Step-u)	-P (Guad-u)	(1241)
Ensiopora	O (Cara)	-D (Eife)	(1034)	Proavella	O (Llvi-l)	-S (Wenl-u)	(742)
Eopachydictya	O (Llvi-u)	-O (Llde-u)		+ Promediopora	D (Fras)		(1241)
Eurydictya	O (Llde)	-O (Ashg-m)	(742)	+ Prophylodictya	O (Aren-u)	-O (Llvi-u)	(1230)
+ Europora	C (Ms)		(1241)	+ ?Protocorisina	O (Cara-m)	-O (Cara-u)	
+ Eurythyrorhombopora	C (Ms)		(1034)	+ Pseudoscopora	D (Fame)		(534)
Euspilopora	D (Give-u)		(1034)	Pseudonematopora	C (Tour-l)	-C (Vise-l)	(905)
Goldfussitrypa	O (Aren-u)	-O (Cara-m)	(742,1066)	Pseudopachydictya	O (Llde)	-O (Ashg)	(742)
Goniotrypa	O (Cara)	-S (Wenl)	(742)	Pseudostictoporella	O (Cara-l)	-O (Cara-m)	
Graptodictya	O (Llvi)	-S (Ldov)	(742)	Ptilodictya	O (Cara-l)	-D (Give)	(742,1034)
Heliotrypa	C (Vise-u)	-C (Serp-l)	(509)	Ptilotrypa	O (Cara-u)	-O (Ashg-l)	(742)
Heloclema	C (Serp-l)			Ptilotrypina	O (Cara-m)?	-O (Cara-u)	(742)
Helopora	O (Llvi-u)	-D (Give)	(742)	Rhabdomeson	D (Eife)	-P (Dora)	(905,1034,1066)
Heminematopora	O (Llvi-u)	-O (Ashg-u)	(1083,1116)	Rhombopora	D (Eife)	-P (Guad-u)	(534,571,1241)
Hemiulrichostylus	O (Cara-l)			+ Rozonovia	D (Fras)		(1241)
Hexites	C (Vise-l)	-C (Vise-u)		Saffordotaxis	D (Eife)	-C (Vise)	(1241)
Hypnasmopora	C (Tour)	-P (Djhu)	(1241)	Sceptropora	O (Cara-l)	-S (Ludl)	(742,1241)
Insignia	O (Cara-m)	-O (Ashg-m)		+ Shishoviclema	C (Step-u)		(534)
Intrapora	D (Emis)	-C (Vise-u)	(509,1034)	Sibiredictya	O (Llde-u)	-O (Cara)	(2,1241)
+ Ipmorella	D (Fame)	-C (Vise)	(534,1241)	+ Silenella	P (Leon)		(1241)
+ Kielanopora	O (Llvi-u)	-O (Cara-u)	(1116)	+ ?Spira	C (Tour-u)	-C (Vise)	
Klaucena	C (Tour-l)	-P (Guad-u)	(509,905)	+ Staffordotaxis	C (Tour-u)	-P (Guad-u)	(905)
+ ?Lanopora	C (Bash-l)	-C (Mose-u)	(509)	+ Stellationdictya	O (Llvi)	-O (Ashg)	(1241)
+ Matsutrypa	O (Cara)	-S (Wenl)	(534)	Stictopora	O (Llvi)	-D (Give)	(742,1034)
+ Maychella	P (Leon-l)	-P (Guad-u)	(905)	Stictoporella	O (Llvi-l)	-S (Wenl)	(742,1066)
+ Maychellina	C (Bash-l)	-P (Djhu)	(905)	Stictoporellina	O (Aren-u)	-O (Ashg)	(575,1241)
Mediapora	S (Ludl)	-C (Tour-u)	(509,534)	+ Stictoporina	D (Give)		(1034)
Megacanthopora	D (Fame)	-P (Leon-m)	(905)	Stictotrypa	S (Wenl-l)		(2)
+ Megacanthoporina	C (Tour)		(1241)	Streblascopora	C (Vise-l)	-P (Djhu)	(509,571,905)
+ Metadictya	O (Cara-l)	-S (Wenl-u)	(742)	Streblacladia	P (Sakm-l)	-P (Leon-l)	(571)
+ Morozoviella	P (Guad-l)	-P (Guad-u)	(905)	+ Streblpax	C (Serp-l)		(509)
Moyerella	S (Ldov)	-S (Wenl)	(534)	Streblotrypa	S (Ludl)	-P (Djhu)	(905,1066)
+ Nemaacanthoclema	C (Tour-l)	-C (Tour-u)	(509)	Streblotrypella	D (Eife)	-P (Guad-u)	(571,1241)
+ Nemaacanthopora	C (Tour)		(534)	Taeniodictya	C (Tour)	-C (Vise-l)	(905,1241)
Nemataxis	D (Emis)	-D (Give)	(1034)	+ Tamaroclema	D (Fame)?	-C (Tour)?	(1241)
Nematopora	O (Llde-l)	-C (Step-u)	(534,905)	+ Tebitopora	Tr (Anis-m)?	-Tr (Carn-u)	
+ Neorhombopora	C (Step-l)	-P (Guad-u)	(509,534,905)	Tepocryptopora	O (Aren)		(523,1230)
Nicklesopora	D (Gedi)	-P (Leon-u)	(509,571,1034)	Trigonodictya	O (Llde-u)	-S (Prid)	(742)
Nikiforovella	D (Give-l)	-P (Sakm-u)	(905)	Tropidopora	D (Eife)		(1034)
+ Nudymella	C (Bash)?		(534,1066)	Ulrichostylus	O (Llde)	-S (Ludl)	(742)

Taxon	First Appearance	Last Appearance	Reference	Taxon	First Appearance	Last Appearance	Reference
+Uralotrypa	P (Sakm)	-P (Leon)	(1241)	+Gilmouropora	P (Guad-l)		(905,1109)
+Verella	S (Ldov)	-S (Ludl)	(534)	+Girtyopora	P (Sakm)	-P (Djhu)	(571,1109)
+Veroclema	S (Ldov)	-S (Ludl)	(1241)	+Girtyoporina	P (Guad-l)	-P (Djhu)	(571,1109)
Virgatella	O (Llde)	-O (Cara-m)	(1066,1241)	Glauconomella	O (Llde)	-S (Ldov)	(742,1034,1241)
Worthenopora	C (Vise-l)	-C (Vise-u)	(509)	+Hayasakapora	C (Vise)	-P (Djhu)	(571,509,905,1241)
+Yangotrypa	O (Aren)		(1230)	Helicopora	S (Wenl)	-C (Vise)	(1241)
+incertae sedis	Tr(Ladi-u)	-Tr(Carn-u)		+Hemibashkirella	D (Eife)		(1241)
+incertae sedis	Tr(Nori-m)	-Tr(Rhae)		Hemitrypa	S (Ldov)	-P (Leon-m)	(571,742)
				+Hemitrypella	D (Eife)	-C (Vise-u)	(424,509,1034,1241)
Or. FENESTRATA							
Acanthocladia	C (Tour-l)	-P (Dora)	(905,936)	+Hinganotrypa	P (Leon-l)	-P (Guad-u)	(571,905)
+Admiratella	C (Vise)	-P (Leon)	(1241)	Hyalotoechus	D (Fras)	-D (Fame)	(1034)
+Atemifenestella	S (Prid)	-P (Djhu)	(668,905,1241)	Ichthyorachis	D (Give)	-C (Vise-l)	(509,742,1241)
+Aluverina	O (Cara-l)	-O (Cara-m)	(742)	+Ignotifenestella	C (Tour-l)	-C (Serp)	(905,1241)
+Alwynopora	O (Aren-u)		(523)	+Ignotrypa	D (Eife)	-D (Give)	(1034)
+Amalgamoprus	O (Llde)			+Ikclarchimedes	D (Eife)	-D (Give)	(1034)
+Amurodictya	D (Sieg)	-D (Eife)	(1109,1241)	Isotrypa	S (Wenl-l)	-D (Fras-l)	(424,742)
Anastomopora	C (Step-u)	-P (Asse)	(905)	+Kallodietyon	P (Asse)	-P (Leon-m)	(905)
+Apertostella	C (Vise-l)	-C (Vise-u)	(974)	+Kalvariella	P (Guad-u)	-P (Djhu)	(905)
+Arborocladia	C (Tour)	-C (Vise)	(1241)	+Kingopora	P (Sakm)	-P (Guad-u)	(905,1241)
+Archaeofenestella	S (Ldov-u)	-S (Wenl-u)	(742)	+Kazarchimedes	C (Vise-u)		(509)
Archimedes	C (Tour-u)	-P (Leon-l)	(571)	+Lanarkopora	C (Vise-u)	-C (Serp-u)	(509,905)
Arctipora	P (Dora)	-Tr(Olen)		+Laxifenestella	D (Emsi)	-P (Djhu)?	(905,1034,1241)
Arthrostylus	O (Llde)	-S (Wenl-u)	(742)	+Levifenestella	C (Tour-l)	-P (Djhu)	(509,571,905)
+Australofenestella	C (Tour-l)	-C (Mosc-u)	(905)	Linotaxis	D (Fras)	-D (Fame)	(1034)
+Australopolypora	C (Vise-u)	-P (Leon-u)	(905)	Loculipora	S (Ldov-m)	-D (Give)	(742)
+Baculopora	C (Vise-u)			Lyrocladia	C (Serp-l)	-P (Leon-m)	(509,571,905,1241)
+Banastella	C (Vise-l)	-C (Vise-u)	(974)	Lyropora	C (Tour-u)	-P (Leon-l)	(509,571)
Bashkiriella	D (Eife)	-P (Leon)	(1241)	Lyroporella	D (Give)	-C (Serp-l)	(424,509)
Bicorbis	P (Leon-u)		(1241)	+Lyporoidra	C (Vise)		(1241)
Carinophylloporina	O (Llde)	-O (Cara-l)	(742)	+Matherocladia	C (Tour-u)	-C (Vise-l)	(509,905)
+Cavernella	C (Bash)	-P (Guad-u)	(905)	Matheropora	C (Vise-l)	-P (Leon-m)	(509,571)
Cervella	P (We)			+Medisemioscinium	D (Sieg)	-D (Fras)	(1241)
Chainodictyon	C (Vise-l)	-P (Leon-m)	(2,571)	Minilya	D (Eife)	-P (Guad-u)	(905,1034,1241)
+Chasmatopora	O (Llde)	-S (Ludl)	(742)	+Mirifenestella	D (Give)		(1034)
+Chasmatorpina	O (Ashg)		(1241)	Moorephylloporina	O (Cara-l)	-O (Ashg)	(1241)
+Cricodictyum	O (Llvi-u)			+Morozovopora	C (Vise-u)		(1066,1109)
+Cubifenestella	C (Vise-l)	-C (Vise-u)	(974)	+Murengoloclema	D (Eife)		(1109)
+Cyclopelta	D (Sieg)	-D (Give)	(424,668,1034)	Nemataxidra	O (Cara-l)		(742)
+Cystostictoporus	O (Llvi-u)		(742)	Nematotrypa	O (Llvi-u)	-O (Ashg-l)	(532,742)
+Dictyoretmon	C (Vise-l)	-C (Vise-u)	(509,905)	+Neoretrepina	C (Tour)	-C (Serp)?	(1066,1241)
Diploporella	C (Tour-l)	-P (Leon-m)	(509,571,905)	Oeciophylloporina	O (Cara-l)		(742)
Enallopora	O (Llvi)	-O (Ashg-u)	(1083,1116)	Ottoseetaxis	O (Cara-l)	-O (Cara-m)	(742)
+Eosemioscinium	S (Ldov)	-D (Give)	(1241)	Paleschara	O (Cara-m)	-D (Give-u)?	(742)
Escharopora	O (Llvi)	-O (Ashg-m)	(742)	+Parachasmatorpina	O (Llvi)	-O (Ashg-m)	(1116)
+Esthonioporina	O (Llde)	-O (Ashg)	(742,1241)	+Parafenestalia	P (Sakm)	-P (Guad-u)	(571,905,1241)
+Eulyra	C (Vise-l)	-C (Vise-u)	(905)	Parafenestella	C (Vise)		(1241)
+Exfenestella	D (Emsi)	-P (Djhu)	(905,1034,1241)	+Paraseptopora	D (Fame)	-P (Leon-u)	(1241)
+Fabiifenestella	D (Emsi-l)	-P (Dora)	(668,905)	Patellipora	D (Eife)	-D (Give)	(1034)
Fenestella	S (Wenl)	-Tr(Indu)	(742,1241)	+Paucipora	C (Mosc)	-C (Step-u)	(1241)
+Fenestellata	P (Guad-u)		(571,905)	Penniretepora	S (Ludl)	-P (Djhu)	(571,905,1241)
Fenestepora	D (Eife)	-C (u)	(1034)	+Permfenestella	P (Asse)	-P (Guad-l)	(905)
+Fenestevorta	C (Serp-l)	-C (Serp-u)	(509,905)	Pesnastylus	S (Wenl)?	-S (Ludl)	(742,1241)
Fenestralia	D (Fame)	-C (Serp-u)	(509,905)				
Fenestrapora	D (Give)		(424)				
Fenestrellina	C (Vise)?	-P (Guad-u)					
Filites	D (Sieg)	-D (Emsi)	(668,1034)				
+Flexifenestella	D (Sieg)	-P (Guad-u)	(668,905)				

Taxon	First Appearance	Last Appearance	Reference	Taxon	First Appearance	Last Appearance	Reference
Phylloporina	O (Llvi-u)	-S (Wenl)	(1083,1241)	Trepotomina	O (Cara-l)		(742)
+Pinnatopora	O (Ashg-m)	-C (Ms)?	(742,1034)	+Trinella	P (Guad-u)		(571,905)
+Pinnatoporella	O (Ashg-m)			+Uldzapora	D (Give)		(1109)
+Polyfenestella	C (Vise)		(1241)	Unitrypa	D (Gedi)	-D (Give)	(1000)
Polypora	S (Wenl)	-Tr(Olen)	(1241)	Utopora	D (Gedi)	-D (Emsi-l)	(1034,1241)
+Polyporella	O (Ashg)	-P (Dora)	(1241)	+Wjatella	P (Sakm-l)	-P (Guad-u)	(571,905)
+Praesemioscinium	S (Ldov)	-D (Give)	(1241)	Or. UNCERTAIN			
Protorettopora	C (Vise-u)	-C (Mosc-l)	(509,905)	+Archacomeson	O (m)		(742)
Pseudohornera	O (Llde-u)	-S (Ldov-u)	(509,742,1066)	+Assatkinella	O (Cara-l)		(742)
Pseudoisotrypa	D (Emsi-u)		(424)	+Bajolla	D (Give)		(1034)
+Pseudoseptopora	C (Step-l)	-C (Step-u)	(509)	+Basslederella	D (Gedi)	-D (Fras)	(1034)
Pseudounitrypa	C (Tour-u)	-P (Leon-l)	(509,571,905)	+Brestopora	O (Llvi)?, O (Llde)?		(742)
Pteropora	O (Ashg-l)	-O (Ashg-u)	(1083)	+Cyclophaenopora	O (Cara-m)	-O (Ashg-m)	(742)
+Ptilofenestella	C (Vise-u)		(905)	+Glossotrypa	D (Eife)		(1034)
Ptiloporella	S (Wenl-l)	-P (Leon-m)	(571)	+Magnederella	D (Sieg)	-D (Give)	(1034)
+Ptiloporina	D (Gedi-u)	-D (Give)	(424)	+Niigaella	D (Emsi)	-D (Eife)	(1034)
+Ptilofenestella	C (Vise)		(1241)	+Pycnobasis	D (Eife)	-D (Fras)	(1034)
Ptylopora	D (Sieg)	-P (Guad-u)	(424,571,1034)	+Radiotrypa	O (Ashg-m)?	-O (Ashg-u)	(742,1083)
+Pushkinella	O (Cara-l)	-S (Ldov)	(742,1066)	+Rhenanarella	D (Emsi)		(1034)
+Quadrisesmioscinium				+Schischatella	D (Gedi)	-D (Emsi)	(1034)
	D (Emsi)	-C (Tour)	(1241)	Cl. GYMNOLAEMATA			
+Ralfina	O (Cara-l)	-O (Cara-m)	(1066,1116)	Or. CTENOSTOMATA			
+Ralfinella	O (Cara)		(1066)	Allonema	S	-C (Step-l)	(509,905)
+Rarifenestella	D (Gedi)	-D (Emsi)	(1034)	+Amathia	K (Maes)	-R	
-Rectifenestella	S (Ldov)	-P (Dora)	(905,1241)	+arachnidid	Tr(Ladi-l)		(1066)
+Reteporidra	D (Give-l)	-P (Guad-u)	(509,571)	+Arachnidium	J (Aale)	-R	(900)
Reteporina	D (Emsi)	-D (Fras)	(1241)	+Arachnoidella	J (Kimm-l)	-R	(900)
Rhombocladia	C (Vise-l)	-P (Leon-m)	(509,571)	?Ascodictyon	S (Wenl-u)	-P (Sakm-u)	(571,1066)
Rhomboporella	C (u)	-P (Sakm)	(1241)	Bascomella	C (Bash-l)	-P (Guad-u)	(509,571,905)
-Ryhopora	P (Leon-u)		(1241)	+Buskia	J (Oxfo)	-R	(1066)
Samaria	C (l)			+Cardiarachnidium	J (Oxfo-u)		(900)
Sardesonina	O (Llde)	-O (Cara-l)	(742,1066)	+Casteropora	D (Sieg-u)	-D (Eife)	(1034)
+Schiscjatella	D (Gedi)		(1241)	?Condranema	O (m)	-P (Sakm-u)	(571,905)
Semioscinium	S (Ldov)	-C (Vise-l)?	(742,1241)	+Cookobryozoon	T (Mi-m)	-T (Plio)	(710)
+Semifenestella	D (Give)		(1241)	Elisapora	S (Wenl)	-C (Ms)	(2)
+Septatopora	C (Tour-u)	-P (Guad-u)	(509,571,905)	+Fischerella	C (Vise-l)		(710)
Septopora	C (Tour-l)	-P (Dora)	(571,905,1241)	+Foraripora	K (Camp-l)	-K (Maes-l)	(518,710)
Seriopora	D			+Haimeina	Tr(Rhae)	-J (Plic)	(710)
+Shylgapora	C (Mosc)	-P (Guad-u)	(1241)	+Harmeriella	K (Maes-l)?	-R	(518)
Silvaseptopora	P			Immergentia	D (Give-l)?	-R	(517)
+Speotrypa	D (Eife)		(1241)	?Marcusodictyon	O (Trem)	-C (Mosc-u)	
Sphragiopora	C (Vise-u)	-C (Serp-l)	(509)	+Marcusopora	K (Maes-l)		(710)
-Spinofenestella	S (Prid)	-P (Dora)	(1241)	+Orbignyopora	S (Wenl-u)	-T (Plio)	(710,1066)
Spirillopora	D (l)			Penetrantia	K (Sant-l)?	-R	(710)
Subreptopora	O (Llvi-l)	-S (Wenl)?		Ropalonaria	O (Ashg-m)	-K (Apti)?	(710)
Synocladia	P (Asse)	-P (Dora)	(571,905,1241)	Spathipora	J (Call-l)	-R	(710)
Synocladiopsis	P (Leon-u)			+Stoloniceella	J (Tith-u)	-K (Maes)	(518)
Syringoclemis	C (Serp-l)	-P (Guad-u)	(509,571,905)	Terebripora	J (Tith-u)?	-R	
+Tavayzopora	P (Guad-l)	-P (Guad-u)	(571)	Vesicularia	K (Maes)?	-R	
Thamniscus	O (Cara)	-P (Guad-u)	(571,742)	Vinella	O (Cara-l)	-K (Camp)	(2)
Timanodictya	P (Asse)	-P (Guad-u)	(571,1034,1109)	Vinelloidea	J (Oxfo)		
Timanotrypa	P (Sakm)	-P (Guad-u)	(571,905,1109)	+Voigtella	K (Camp-u)	-K (Maes-u)	(710,1066)
+Tratacladia	P (Sakm)		(1241)	Or. CHEILOSTOMATA			
				Acanthocella	T (Ol-l)	-R	(1260)
				Acanthodesia	T (Eo-u)	-R	(1260)
				Acanthoporella	Q (Plei)	-R	
				Acanthoporidae	T (Eo-l)		

Taxon	First Appearance	Last Appearance	Reference	Taxon	First Appearance	Last Appearance	Reference
+Acoscinopleura	K (Sant)	-K (Maes-u)	(519)	Caberoides	T (Eo-m-l)		(629)
+Acropora	K (Maes-u)	-T (Ol-l)	(1260)	Callopora	K (Ceno-l)	-R	
+Actiseocos	T (Eo-l)?	-R	(1066)	Calloporina	T (Mi-m)	-R	
Adenifera	T (Eo-u)	-T (Ol-l)	(1260)	Calpensia	T (Eo-m-l)	-R	(633,1260)
Adeona	T (Mi-l)	-R		Calpidopora	K (Ceno-u)		(626)
Adeonella	T (Eo-m-l)	-R	(629)	Calvetina	T (Eo-m-l)		
Adeonellopsis	T (Eo-l)	-R	(2,1066)	+Calvina	T (Dani)		(1066)
Aechmella	K (Ceno-u)	-T (Plio)	(519)	Canda	T (Eo)	-R	
+Aegyptopora	T (Eo-u)		(1260)	Canupora	T (Dani)		
Aeolopora	K (Sant)	-T (Dani)	(1260)	Carydiopora	K (Sant)?	-K (Maes-u)	
Aetea	T (Eo-u)	-R	(1260)	Castanopora	K (Camp-u)	-K (Maes-u)	
Aimulosia	T (Eo-m-l)	-R		Catenariopsis	R		(1066)
Akatopora	T (Eo-m-l)	-R		-Catenicella	T (Eo-m-l)	-T (Ol-l)	(1260)
Alderina	K (Sant)	-R	(1260)	Cellaria	T (Eo-m-u)	-R	(1260)
Allantopora	K (Maes)	-R	(519)	+Cellarinella	T (Plio)	-R	(1066)
+Alysidota	T (Plio-u)		(1260)	Cellarinidra	K (Ceno-m)	-K (Turo)	(626,864)
Ammatophora	K (Maes-l)	-R	(1260)	Cellepora	K (Maes-l)?	-R	(1066)
+Amphiblestrella	K (Maes)		(1260)	+Celleporaria	T (Eo-m-u)	-R	(606,1066)
Amphiblestrum	K (Ceno)	-R	(1260)	+Celleporella	K (Maes-u)	-R	(603)
Anaptopora	K (Ceno-l)	-K (Ceno-u)	(626)	+Celleporina	T (Eo-m-l)	-R	(606)
Anarthropora	T (Dani)	-R	(1260)	Chaperia	T (Eo-u)	-R	
Andriopora	K (Ceno-l)	-T (Dani-u)	(588,601)	Characadoma	T (Mi)	-R	
Angelopora	K (Coni)	-K (Sn)	(626)	+Chasmazoom	T (Mi)		
Anornithopora	K (Camp)	-T (Dani-u)	(601)	+Cheethamia	K (Maes-l)		(1260)
Anotopora	K (Ceno-l)	-K (Ceno-u)	(626)	+Cheilohomercopsis	T (Eo-u)		(1066)
Antropora	T (Eo-u)	-R		Cheilonella	T (Eo-m-l)		(2)
Aplousina	K (u)	-R		Cheilopora	T (Than)	-R	(1260)
Arachnopusia	T (Eo-m-u)	-R	(1260)	Cheiloporina	T (Eo)	-R	
Argopora	K (Coni)	-K (Sn)	(626)	+Chelidozoum	T (Mi-m)		(1066)
Arthropoma	T (Ol-l)	-R	(1260)	+Chlidoniopsis	T (Eo-u)	-R	(634)
Aspidostoma	K (Sn)	-R		Chorizopora	T (Mi-m)	-R	
+Atacama	T (Plio-u)			+Christinella	T (Mi-u)		
Atactoporida	T (Eo-l)	-T (Ol-l)?	(1066)	Cianotremella	T (Dani)		(1066)
Auchenopora	K (u)	-T (Dani)		-Cillia	T (Mi-l-u)		(634)
Bactrellaria	K (Maes-u)		(519)	Claviporella	T (Mi-l)	-R	(2)
Bactridium	K (Sn)	-R		+Cleidochasma	T (Mi-m)	-R	(1260)
Balantiostoma	K (Maes)	-T (Than-l)	(2)	Cliothriellum	T (Ol)		
Baptopora	K (Coni)	-K (Sn)		+Codonellina	Q (Plei)	-R	(1260)
Bathosella	K (Maes-u)	-T (Than)	(1260)	Coelopora	K (Camp)	-R	(1260)
Bathystomella	K (Maes-u)		(519)	Coleopora	T (Mi)	-R	
Batopora	T (Eo-l)	-R	(1066)	Collarina	K (Sn)	-R	
Batrachopora	K (Camp-l)	-K (Maes)	(1260)	Colletosia	T (Eo-u)	-T (Mi-u)	
Beania	T (Eo-m)	-R	(602,1066)	Collura	K (u)	-K (Maes)	
Beisselina	K (Camp)	-R	(519)	Columnotheca	K (Maes-l)	-T (Than-l)	(519)
Beisselinopsis	K (Maes-l)	-T (Than-l)	(519)	Conescharellina	T (Eo-l)	-R	(1066)
+Biavicularium	T (Mi-l)	-R		Conopeum	K (Ceno-u)	-R	(605)
+Bicornifera	T (Dani)	-T (Ol-u)	(1010)	Copidozoum	T (Mi-l)	-R	
+Bifaxaria	T (Eo-l)	-R	(1066)	Corbulipora	T (Eo)	-T (Mi)	
+Bifussurinella	T (Ol-u)	-T (Mi-m)	(1010)	Cornuticella	Q (Plei)	-R	
Biflustra	T (Eo-u)	-R	(1066)	Corymboporella	K (Ceno)		
Biselenaria	T (Eo-m-u)	-T (Eo-u)	(1260)	Corynostylus	T (Mi)		
Bitectipora	T (Ol-u)	-T (Mi-m)	(2,1066)	Coscinopiopsis	T (Eo)	-R	
+Boreas	K (Camp-l)	-T (Mi-l-u)	(603)	Coscinopleura	K (Maes)	-T (Than)	(1066)
+Boreasina	K (Coni)	-K (Maes)	(603,864,1066)	Costazia	T (Ol-l)	-R	(1260)
Bracebridgia	T (Eo-m-l)	-R	(1260)	Costula	K (Sn)	-K (Maes)	
+Brydonella	K (Maes-l)	-T (Dani-u)	(601)	Cothurnicella	T (Eo-u)	-R	(602)
+Bryocyrtella	T (Mi-m)		(1260)	Cranosina	K (Camp-l)	-R	(1260)
+Bubnoffiella	K (Maes-l)		(604)	Craspedopora	T (Eo-m-l)		(1260)
+Buffonella	T (Eo-m-u)	-T (Ol-l)	(1260)	+Craspedoporina	T (Than)		(1260)
Buffonellodes	K (Sn)	-R		+Crassicellepora	T (Dani-u)		(601)
Caberea	T (Ol-l)	-R	(1260)	Crassimarginatella	T (Dani)	-R	
				Crateropora	K (Sn)	-R	

Taxon	First Appearance	Last Appearance	Reference	Taxon	First Appearance	Last Appearance	Reference
Crepidacantha	K (u)	-R		Escharicellaria	K (Sant)	-K (Maes)	(2,519)
Crepis	T (Mi-l)	-R	(602)	Eschariifora	K (Sant-u)	-K (Maes-l)	(609,1066)
Cribella	T (Mi-m)?	-R	(636)	Escharina	T (Eo-m-l)	-R	
+Cribellopora	T (Eo-u)	-R	(1066)	Escharipora	K (Maes)		(519)
Cribrendocium	T (Eo-m)	-T (Eo-u)		Escharoides	T (Eo-l)	R	(629)
Cribrilaria	K (Maes-u)	-R	(633)	Eucheilopora	K (Turo)	-K (Sn)	(588)
Cribrilina	K (Sant)	-R	(1260)	Eucratea	T (Eo-l)	-R	
Cryptostomella	K (Sant-u)	-T (Dani-u)	(2,519)	Euritina	K (Ceno-u)	T (Eo)	(588,1066)
Cryptosula	T (Mi-u-l)	-R	(1066)	Eurytomella	T (Plio-u)	-R	(1066)
Ctenopora	K (Ceno-l)	-K (Ceno-u)	(626)	Exechonella	T (Eo-m-l)?	-R	(2,1066)
Cucullipora	T (Mi)			Exochella	K (Sant)	R	(2)
Cupuladria	T (Pale)	-R	(1066)	Fenestulina	T (Mi)	R	
Cyclicopora	T (Eo-m-u)	-R	(1066)	Figularia	T (Eo)	R	
Cyclocolpota	T (Mi)	-Q (Plei)		+Fissuricella	K (Maes-u)	-T (Dani-u)	(601)
Cycloperiella	T (Mi)	-R		+Flabellipora	Q (Plei)	-R	
Cyphonella	T (Eo)			Floridina	K (Coni)	-R	(519)
Cystisella	T (Dani)	-R		Floridinella	K (Sn)	-R	
+Dacryonella	T (Eo-m-u)	-T (Ol-l)	(1260)	+Flustrella	K (Apti-u)	-K (Camp)	
Dacryoporella	K (Ceno)	-K (Sant)	(519)	Flustrellaria	K (Ceno-u)	-K (Maes)	
Dakaria	T (Eo-l)	-R	(629)	Francopora	K (Coni)	-K (Sn)	
Decurtaria	K (Camp)	-K (Maes-u)	(519)	Frurionella	K (Maes)	-T (Than-l)	(519)
Dentiporella	T (Eo)	-R	(606)	Fuscicellaria	K (Turo)	-K (Sn)	(2,1066)
Diacanthopora	K (Camp)	-T (Dani)	(1260)	+Galeopsis	T (Dani)	-T (Eo-u)?	(1260)
Diancopora	K (Coni)			Gargantua	K (Ceno)	-R	(1260)
+Dibunostoma	T (Eo-u)	-R		Gastropella	T (Dani)	-T (Eo-u)	(1260)
Diceratopora	K (Sn)			Gaudryanella	T (Eo-m-l)	-R	(2)
Dictuonia	K (Maes)		(2)	Geisopora	K (Camp)	-K (Maes)	(2)
Didymosella	T (Eo-m)	-R	(1066)	+Gemellaria	T (Eo-m-u)?		(1260)
Dightonia	T (Ol-l)?	-R		Gemellipora	T (Eo-m-u)	-R	(629)
Dimorphocella	T (Mi-m)	-R	(1260)	Gemelliporella	T (Mi-m)	-Q (Plei)	(636,1260)
Dimorphocellaria	K (Maes)			Gemelliporidra	Q (Plei)	-R	
Dimorphostylus	K (Sn)	-T (Dani)		Gemelliporina	T (Mi)	-R	
+Dionella	K (Coni)	-T (Eo-u)	(608,626)	+Geminella	T (Than-l)		
+Diplobeisselina	T (Dani)			Gephyrophora	T (Ol-u)?	-R	
+Diplopholeous	T (Eo-m-u)	-T (Ol-l)	(1260)	Gephyrotes	K (Camp-u)	-R	(1260)
+Diplorula	T (Plio)	-R		Gigantopora	T (Dani)	-R	(2)
Diplotresis	T (Dani-u)	-T (Eo-l)?	(601)	+Grammella	T (Eo-m-u)	-T (Ol-l)	(1260)
Discoflustraria	K (Coni)	-K (Maes)	(2,519,626)	+Grammothoa	K (Maes-u)		(603)
Discoporella	T (Mi-l)	-R		+Graptopora	K (Sant)		(1066)
Discosella	T (Eo-m-u)		(1260)	Graptoporella	K (Sant-u)		(2)
+Discovibracella	K (Maes)	-T (Eo)	(607)	Hagenowinella	K (Maes-u)		(609)
Dishelopora	K (Coni)	-K (Sant)	(2,626)	Haplocephalopora	T (Dani)		(519)
Distansescharella	K (Coni)	-R		Haplopoma	T (Mi-m)	-R	(1260)
Distefanella	T (Plio)			+Haplopomella	T (Mi-m)		(1260)
Disteginopora	K (Sn)	-K (Maes)		Hapsidopora	K (Ceno-l)		(519)
Ditaxipora	T (Eo-u)			+Haswellia	T (Ol-l)?		(1260)
+Ditaxiporina	T (Eo-l)	-T (Ol-u)	(1066)	+Helix	T (Ol-u)?	-R	
Dittosaria	T (Eo-l)	-T (Ol-u)	(629,1260)	+Helioxionella	T (Ol-u)	-R	
Duvergiera	T (Mi-l)			+Hemeschara	T (Plio)		(1260)
+Dysnoetocella	T (Dani)		(607)	Hemicoscinopsis	T (Mi-l)	-R	
Dysnoetopora	K (Camp-l)	-K (Maes-u)	(605)	Hemicyclopora	T (Eo-u)?	-R	
Electra	T (Than)	-R	(1260)	Hemiphactella	T (Mi-l)	-T (Mi)	
Ellisina	K (Ceno-l)	-R		Hemiseptella	T (Mi)	-R	
+Ellisinidra	T (Dani)		(1260)	Hemisittina	T (Mi-l-u)		(1260)
Emballotheca	T (Ol-l)	-R	(1260)	Hemistylus	T (Dani)		(1260)
+Encicellaria	K (Maes-u)		(637,1066)	+Herentia	T (Eo-m-u)	-R	(1260)
Enoplostomella	T (Eo-u)	-R		Herpetopora	K (Turo)	-T (Ol-l)	
+Entomaria	T (Eo-m-l)	-R	(1260)	Hesperopora	T (Dani)		
+Eohippota	K (Camp-u)		(603)	+Heteractis	T (Than)?	-T (Eo-u)	
+Eosrupocellaria	K (Maes-l)		(1066)	+Heterocella	T (Eo-u)	-T (Ol-l)	(1260)
Erinella	T (Mi)			+Heteroconopeum	K (Ceno-u)	-K (Camp-u)	
+Escharella	T (Eo-m-l)?	-R	(633)	Hexacanthopora	K (Coni)	-K (Camp)	(519)

Taxon	First Appearance	Last Appearance	Reference	Taxon	First Appearance	Last Appearance	Reference
Hiantopora	T (Dani)	-R	(1066)	Leptocheilopora	K (Sant)	-T (Dani)	(601,1066,1260)
Hincksina	K (Camp)	-R	(2)	+Lobopora	T (Eo-m-l)		(1260)
Hincksipora	T (Mi-m)?	-R	(636)	+Lunularia	T (Than)		(1260)
Hippadenella	T (Mi-l-u)	-R	(1260)	Lunulites	K (Sant-l)	-T (Plio)	(626,636)
Hippaliosina	T (Dani)	-R	(1260)	Macropora	T (Than)	-R	(1066)
Hipperechonella	T (Mi-l)			+Macroporina	T (Eo-m-l)		
Hippiopora	K (Coni)		(1260)	Magnea	T (Mi-m)		
Hippodiplosia	T (Eo-m-u)	-R	(1260)	Mamillipora	T (Eo)	-R	
Hippoexechonella	T (Mi-l-l)			Manzonella	T (Plio)		
Hippolyrula	T (Mi-l)			Marginaria	K (Albi-u)	-K (u)	(864)
Hippomenella	T (Eo-m-u)	-R	(1260)	Margaretta	T (Eo-l)	-R	(1066)
Hippomonavella	T (Mi-l-u)?	-R	(1260)	+Marquetta	T (Eo-m-l)		(1260)
Hippophylactella	T (Mi-l-l)			Marssonopora	K (Maes)	-T (Dani)	(519)
Hippopleurifera	T (Eo-m-l)	-R	(633)	+Mastigophora	T (Eo-m-u)	-T (Mi-m)	(1260)
Hippopodina	T (Eo-m-u)	-R	(1260)	Mastigophorella	T (Eo)	-R	
Hippopodinella	T (Mi-m)	-R		Melicerita	K (Sn)	-T (Plio)	
Hippoporella	T (Eo-m-l)	-R	(1260)	Membranipora	K (Albi)	-R	(1260)
Hippoporidra	T (Mi-l-u)	-R	(1066)	Membraniporella	K (Ceno)	-R	(1260)
Hippoporina	T (Dani)	-R	(1260)	Membraniporidra	K (Ceno)	-R	
Hippozoon	T (Eo-m-l)	-T (Eo-m-u)	(629,1260)	+Membraniporina	K (Maes-l)	-T (Mi-m)	(1260)
Hipposera	T (Ol-u)	-T (Mi-l-u)	(1260)	+Membrendoecium	T (Dani)	-T (Ol-l)	(1260)
Hippothesia	K (Albi)	-R	(1260)	Meniscopora	T (Than)	-T (Mi)	(1260)
+Hippozeugosella	T (Eo-m-u)	-T (Eo-u)	(1260)	Mesostomaria	T (Mi)	-R	
+Hoeverella	K (Camp-l)			Metracalposia	T (Eo-m-l)	-T (Eo-u)	(633,1260)
Holoporella	T (Eo-m-u)	-R	(1260)	Metradolium	T (Eo-m-u)	-T (Eo-u)	(633,1260)
Holostegopora	K (Sn)			+Metrarabdotos	T (Eo-u)	-R	(1066)
Homalostega	K (Camp)	-K (Maes)		+Metrocrypta	T (Eo-m)	-T (Ol-l)	(1260)
Hoplitaechmella	K (Camp-l)	-T (Than)	(519)	Micropora	K (Ceno-u)	-R	(626)
Hoplocheilina	K (Ceno)	-R?	(2)	+Metropieriella	T (Eo-m-u)	-T (Eo-u)	(1260)
Hopora	K (Ceno)	-K (u)		Microporella	T (Eo-l)?	-R	(629)
+Hormerella	T (Plio)	-R	(606)	Microporina	T (Dani)?	-R	(1260)
Houzeauina	T (Eo-m-u)	-T (Eo-u)	(1260)	Mollia	T (Dani)	-R	(1260)
Hystricopora	K (Coni)			Monoceratopora	K (Turo)	-T (Dani-u)	(588,601)
Ichnopora	K (Coni)	-K (Sant)	(519)	Monocerina	T (Mi)		
+Melicerites (+ Inversaria)				Monoporella	K (Maes)	-R	(1066)
Inversiuia	K (Camp-u)	-K (Maes-u)		Monsellia	T (Than-l)		
	T (Ol-l)	-R	(1066)	+Monticellaria	T (Dani)?		(1260)
+Jaculina	T (Plio)	-R		Morphasmnopora	K (Camp)?	-K (Maes-u)	(586)
Kankopora	K (Ceno-u)	-K (u)	(626)	+Mosathoa	K (Maes-u)		(603)
Kelestoma	K (Sn)	-T (Eo)		Mucronella	T (Dani)	-R	(601)
Kenella	T (Eo)	-R		Mumiella	K (Sant)	-K (Sn)	(1066)
Kionidella	T (Eo-m-l)	-T (Mi-u-u)	(635)	Murinopsia	K (Camp-u)?	-K (Maes-u)	
Kleidionella	K (Sn)?	-T (Ol-l)	(1066)	Myagropora	K (Coni-l)	-K (Sant-l)	(2)
+Kronothoa	K (Camp-u)		(603)	+Myriapora	T (Eo-l)	-R	(639)
+Kunradina	K (Maes-l)		(603)	Myrizoum	T (Mi)	-R	
+Kylonisa	T (Eo-m)			Mystriopora	K (Albi-u)	-K (Camp)	(1260)
Labioporella	T (Eo-m-l)	-R	(633)	Nannopora	K (Coni)	-T (Eo)	(626)
Lacerna	T (Eo-l)	-R	(629)	+Neliella	K (u)?	-R	
+Lacrimula	T (Eo-u)	-R	(638)	Nellia	K (Maes)	-R	
Lagarozoum	T (Eo)	-R		Nematoporella	T (Mi-l-u)		
Lagenipora	K (u)	-R		Nephropora	K (Maes-l)		(2)
Lagynopora	K (Turo)	-T (Dani)	(588,1260)	+Notamia	T (Than)		(1260)
Laminopora	T (Mi)	-R		+Nudonychoecella	K (Maes-u)		
+Lanceopora	T (Plio)	-R	(1066)	+Obliquoctoma	T (Mi-u-u)		(1260)
+Latereschara	K (Maes-u)		(600)	Ochetosella	T (Eo-m-l)	-T (Eo-u)	(633)
Lateroflustrellaria	K (Maes)			+Ochetosellina	T (Dani-u)		(601)
+Laterotecatia	K (Maes-u)		(603)	Odontionella	T (Plio)	-R	
Leiosella	T (Eo-u)	-R	(633)	Ogiva	K (Ceno)	-K (Coni)	(1260)
Lekythoglena	K (Maes)		(519)	Ogivalia	K (Ceno)	-R	(1260)
Lekythopora	T (Ol-u)	-R	(1066)	Ogivalina	T (Eo-m-u)	-T (Plio)	
+Lepralia	K (Sant)	-R?	(1260)	Oligotopora	K (u)		
Lepralina	T (Mi-l)		(634)				

Taxon	First Appearance	Last Appearance	Reference	Taxon	First Appearance	Last Appearance	Reference
Omalosecosa	T (Mi)	-R		+Pseudobeisselma	K (Maes-u)		
Onychocella	K (Ceno-l)	-R	(519)	+Pseudolunulites	T (Ol-u)		(ZR90)
+Onychocellaria	K (Maes-u)		(586)	Pseudostege	K (u)		
Opisthorthopora	K (Coni)	-K (Maes)		+Pseudothyrella	T (Dani)		(1260)
Orbitulipora	T (Than)	-T (Ol-l)	(1260)	Psilosecos	T (Dani)	-T (Eo)?	(519)
Osthiomisia	T (Eo-m-u)	-R	(1260)	Pterocella	T (Ol)	-R	(2)
Otionella	T (Eo-m-u)	-R	(1260)	Puellina	T (Eo-m-u)	-R	(1260)
Otopora	K (Ceno-l)		(2,864)	Puncturiella	K (Camp)	-T (Than-l)	(519)
Pachycraspedon	T (Eo)			Pyripora	K (Albi)?	-R	(2)
Pachyderia	K (Maes)	-T (Dani-u)	(519)	Pyriporella	K (u)		
Pachystomaria	T (Mi)			+Pyripopsis	J (Tith-u)	-K (Albi-u)	(611)
+Pachythea	K (Maes-u)		(1260)	Pyrulella	K (u)	-R	
Pachytheceella	K (Camp)	-T (Eo)	(519)	Quadricecellaria	K (Turo)	-K (Maes-u)	(610,626)
Palmicellaria	T (Mi-l)	-R	(1260)	+Quadriscutella	T (Ol)	-R	(1066)
Pancheilopora	K (Camp)			+Radulopora	K (Maes-l)	-K (Maes-u)	(610)
+Parasmittina	T (Plio)	-R	(1260)	Ramphonotus	K (Sant)	-R	(1260)
+Paravinella	T (Plio)		(ZR91)	+Rectonychoceella	T (Eo-m-u)	-T (Ol-l)	(1260)
Parellisina	T (Mi)	-R		+Reginella	T (Plio)	-R	(1260)
Parmularia	T	-R		+Reptadeonella	T (Mi-l-l)	-R	
+Parobeisselina	K (Maes-l)	-T (Than)	(607)	Reptescharipora	K (Sn)	-K (Maes)	
Pasythea	T (Eo-m)	-R	(602)	+Reptolunites	K (Turo)	-T (Mi-m)	(1260)
Patsyella	T (Ol-l)	-R	(2)	Retepora	T (Eo-m-u)	-R	(1260)
+Pavobeisselina	K (Maes)	-T (Than-l)		+Reteporellina	T (Eo-u)?	-R	(1066)
+Pavolunulites	K (Coni)	-T (Ol-l)?	(626)	+Reussia	T (Eo-u)	-T (Mi-u)	(1260)
Pelmatopora	K (Coni)	-T (Dani-u)	(519,601)	+Revvsirella	T (Mi-l)	-R	(640)
Perigastrella	T (Than)	-R	(2,1066)	Rhabdopora	K (Turo)		
Periporosella	K (Maes-l)	-T (Eo-u)	(608)	+Rhabdotometa	T (Eo-u)	-T (Mi-l)	(633)
+Peristomella	T (Eo-m-l)	-T (Ol-l)	(1260)	Rhacopora	K (Coni)		(2)
+Petaloconchus	Q (Plei)		(1260)	Rhagasostoma	K (Ceno)	-T (Mi-u-u)	(629,1260)
+Petalosiegas	T (Mi-m)	-R	(1066)	+Rhammatopora	K (Apt)	-K (Ceno-l)	(611,626)
Petraliella	T (Mi-u)	-R	(1260)	Rhamphostomiella	T (Ol-l)	-R	(1260)
Phidolopora	Q (Plei)	-R		Rhebasia	K (Coni)		
Phoecana	T (Eo-u)	-R	(1260)	Rhiniopora	K (Camp)?	-T (Dani-u)	(601)
Phonicosia	T (Eo)	-R		Rimulostoma	T (Mi-l)		
Phractoporella	K (Camp-l)	-T (Dani-u)	(601)	Romancheina	T (Eo-m-u)	-R	(1260)
Phrynopora	K (Camp)			Rosselliana	K (Coni)	-R	(626)
Phylactella	T (Eo-u)	-R	(1260)	Rotoporina	K (Turo-u)?	-T (Than-l)	(864)
Phylactellipora	T (Eo-u)	-R	(1260)	+Saevitella	T (Mi-u-u)		
Pithodella	K (Maes)	-T (Than-l)		+Salicornaria	T (Plio)		(1260)
Plagiosmittia	T (Eo-m-u)	-T (Eo-u)	(1260)	Sandalopora	K (Turo)	-K (Maes-l)	(2,1260)
Planicellaria	K (Maes)		(1260)	Savignyella	T (Eo-l)?	-R	(1066)
Platyglena	K (Turo)	-T (Dani)	(1066)	Schismopora	T (Eo-m-u)	-R	(1260)
Pleurolyrula	T (Eo-u)	-T (Mi)	(633)	Schismoporella	T (Mi-l-u)	-T (Mi-u-u)	
Pleuroschizella	T (Eo)			Schistacanthopora	K (u)	-K (Maes)	
Pliophloea	K (Coni)	-T (Eo-m-l)	(519,629)	Schizaropsis	T (Eo-u)		
Pnictopora	K (Coni)	-K (Sant)	(519)	Schizemiella	T (Eo-m-u)		(1260)
+Pnictopropsis	K (Sant-u)	-K (Camp-u)	(591)	+Schizemiellopsis	T (Dani)		(1260)
Polyccephalopora	K (Camp)?	-K (Maes-u)		Schizobathysella	T (Eo-u)	-T (Ol-l)	(1066,1260)
Polyceratopora	K (Ceno-u)	-K (u)	(626)	Schizobrachiella	T (Mi-l-u)	-R	(636,1260)
Porella	T (Eo-m-l)	-R	(1260)	Schizomavella	T (Eo-m-l)	-R	(633)
+Poricella	T (Eo-m-l)		(1260)	Schizoporella	T (Than)	-R	(1260)
Poricellaria	K (Maes-u)	-R	(1066)	Schizoporellopsis	T (Mi)		
Porina (+ Spiroporina)	K (Camp-l)	-R	(1066)	+Schizoretopora	T (Mi-l-u)	-R	(1260)
+Porismittina	T (Mi-m)		(1260)	Schizorthosecos	T (Eo-m-u)	-T (Eo-u)	(636,1260)
+Porometra	T (Mi-m)	-T (Plio)	(633)	Schizosmittina	T (Mi-m)		
+Poropeltarion	T (Eo-m)	-T (Eo-u)	(633)	Schizostomella	T (Eo-l)	-T (Plio)	(629,636)
Prattia	T (Eo)	-T (Eo-u)		+Schizotheca	T (Mi-u-u)	-R	
+Prenantia	T (Plio)	-R		+Schizotrema	T (Mi-m)		(1260)
Prodromopora	K (Coni)	-K (Sant)	(626)	Schizotremopora	T (Mi-l)		
Prosotopora	K (Sant)			Scorpiodina	T (Mi)		
Prostomaria	T (Mi-m-l)		(1066)	+Scuticella	T (Eo-m-l)?	-R	
				+Scruparia	K (Maes-u)	-R	(1066)

Taxon	First Appearance	Last Appearance	Reference	Taxon	First Appearance	Last Appearance	Reference
Scrupocellaria	T (Eo-m-l)	-R		Thoracopora	K (Turo)	-K (Camp)	(2,1066)
Selenaria	T (Eo-m-u)	-R	(1260)	+Thornipora	K (Maes-l)	-T (Dani-l)	
Semieschara	K (Sant)?	-K (Camp)?		Thyracella	K (Maes)		
+Semiescharinella	K (Camp)?	-T (Than-l)		Trematoecia	T (Mi)	-R	(606)
Semithaswellia	T (Eo-m-u)	-R	(1260)	Tremogasterina	T (Than)	-R	
+Sertella	T (Eo-u)	-R		Tremolyrula	T (Mi-m)		
+Setosella	T (Eo-m-l)	-R	(1260)	Trenopora	T (Eo-m-l)	-R	(629)
Setosellina	T (Dani)	-R	(1066)	+Tremosciscopoleura	K (Camp)	-K (Maes)	(1260)
Setosinella	T (Than)		(1066)	Tremoschirodina	T (Mi-l-u)	-R	(1260)
Sinupetraliella	T (Mi)	-R		Tremotoichos	T (Eo-m-u)	-T (Eo-u)	(633,1260)
Siphonoporella	T	-R		+Trepotpora	K (Maes-l)		(612)
+Skylonia	T (Eo-m)	-T (Mi-u-u)	(1066)	Tretosina	T (Mi)		
Smittina	T (Than-l)	-R	(629)	Tricephalopora	K (Coni)	-T (Than)	(519)
Smittinella	T (Mi)			Tricolopora	K (Coni)	-K (Sn)	(626)
Smittipora	K (Ceno-l)	-R		+Tricornicella	T (Than-l)	-T (Ol-l)	
Smittistoma	T (Eo-m-l)	-T (Eo-m-u)	(629)	Trigonopora	T (Eo-u)	-R	(1260)
Smittoidea	T (Eo-m-l)	-R	(633)	Trilophopora	K (u)	-T (Dani)	
+Solenonychocella	K (Sant)	-K (Camp-u)		Tripurula	T (Mi)	-R	
Solenophragma	K (Camp)	-K (Maes)	(1260)	Trochopora	T (Eo-m-l)	-T (Mi-m)	(629)
Sparsiporina	T (Eo-u)	-T (Ol-l)	(634)	Trochosodon	Q (Plei)	-R	
Sphaeropora	T (Mi)	-R		Trypematella	Q (Plei)		
+Sphaerulobryozoom	T (Plio)	-R		Trypocella	T (Mi)		
Sphenella	T (Mi-m)?			Trypostega	T (Eo-l)	-R	(1260)
+Spinicharixa	K			+Tshokrakopora	T (Mi-m)		
Stamenocella	K (Turo)	-T (Mi-l-u)	(519,1260)	+Tubescharina	T (Mi-m)		(1260)
+Staurosteginopora	K (Sant)		(1066)	Tubiporella	T	-R	
Steginopora	K (Sn)			Tubitrabecularia	T (Eo-u)	-T (Mi)	(1066)
Steginoporella	T (Eo-m-l)	-R	(629,1066)	Tubucella	T (Eo-l)	-T (Ol-u)	(633,1066,1260)
Stenopsella	T (Eo)	-R		Tubucellaria	T (Eo-m-l)	-R	(2)
+Stenopsis	T (Mi-l-u)	-R?		+Turbicellopora	T (Eo-u)	-R	(606)
Stenosipora	T (Eo-m-l)	-T (Mi-m)	(629,636)	Tylopora	K (Ceno-l)	-K (Turo)	(519)
Stephanollona	T (Mi-m)			Ubaghisia	K (Maes)		
Stephanosella	T (Ol-l)	-R	(1260)	Umbonula	T (Than)	-R	(1260)
Stephanotrema	T (Mi)			+Uniaivicularia	T (Mi-u)	-R	(633)
Steraechmella	K (Maes-u)	-R	(586)	+Velumella	T (Eo-m-u)		(1260)
Stichocados	K (Maes-l)	-T (Dani)	(519,1260)	Vermindari	T (Plio)	-R	
Stichomicropora	K (Ceno-l)	-T (Eo)?	(601,626,1066)	Vibracella	K (Sn)	-R	
Stichopora	K (Camp)	-K (Maes-u)	(2)	Vibracellina	T (Eo-l)	-R	(629)
Stichoporina	T (Ol-l)	-T (Mi-u)	(1260)	Vibraculina	T (Mi-u)	-T (Plio)	(1260)
+Stichtostega	K (Camp-l)	-K (Camp-u)	(1260)	Vincularia	K (Sant)	-R	(1260)
Stomachetosella	T (Ol-l)	-R		+Virgocella	K (Camp)	-T (Than)	
Stomhypselosaria	T (Eo)	-R		Vittaticella	T (Eo-u)	-R	
Strongylopora	T	-R		Volvivillustrellaria	K (Camp-l)	-K (Maes)	(591)
Strophipora	T (Mi-l)	-R		+Voorthuyseniella	T (Eo-l)	-R	(1010)
Stylopoma	T (Mi-l-u)	-R	(2)	+Wawalia	K (Vala-u)	-K (Albi-u)	(613)
+Sylonika	T (Eo-l)			Watersipora	T (Mi-u-u)	-R	(1066)
Synaptacella	T			Wilbertopora	K (Albi-u)		(2,864)
Synnotum	T (Mi-l-u)	-R	(602,1066)	Woodipora	K (Camp-l)	-T (Plio)	(2)
Systemostoma	K (Camp)	-T (Than-l)	(519)	+Xaveropora	T (Mi-u)		
+Taeniocellana	K (Maes-u)						
+Taenioporella	K (Maes-l)	-T (Dani)	(1066,1260)				
Taenioporina	K (Camp)	-T (Than-l)?	(519)				
Taphrostoma	T (Eo-m-u)		(629)				
Taractopora	K (Coni-l)	-K (Camp-l)	(2,1066)				
Tegella	K (u)	-R					
Teichopora	T (Than)	-T (Eo-u)	(1260)				
Tessaradoma	T (Dani)	-R	(1066)				
Tetraplaria	T (Eo-m-l)	-R	(1066)				
Teuchopora	T (Mi-u-u)	-Q (Plei)					
Thalamoporella	T (Eo-m-l)	-R	(633,1066)				
+Thecatia	K (Maes-u)	-R	(603)				
				Ph. ENTOPROCTA			
				+Barentsia	J (Kimm)	-R	(1003)
				Ph. BRACHIOPODA			
				Cl. LINGULATA			
				(Genera from Doescher, 1981; stratigraphy as listed.)			
				Or. LINGULIDA			
				+Aboriginella	Cm(u)		(881)
				Andobolus	O (Llde)		(1066)

Taxon	First Appearance	Last Appearance	Reference	Taxon	First Appearance	Last Appearance	Reference
+Anomaloglossa	O (Cara-m)?		(564)	Palaeobolus	Cm(m)	-O (Trem-l)	(1)
+Anx	O (Cara-m)	-O (Ashg-m)	(881)	Palaeoglossa	O (Trem-l)	-O (Ashg-u)	(5,401,538)
+Apatobolus	O (Cara)		(538)	+Palaeoschmidites	Cm(Boto)	-Cm(lMid)?	(932)
+Apsilingula	D (u)		(538)	+Palaeotrimerella	O (Llde-u)	-O (Cara-l)	(657)
Aulonotreta	O (Aren)		(1,538)	+Paldiskites	O (Aren-l)	-O (Llvi)	(538)
+Barbatulella	O (Ashg-l)		(402)	Paracraniopts	O (Cara-m)	-S (Ldov-l)	(6)
Barroisella	D (Give)	-Tr(l)	(538,1064)	+Paradinobolus	O (Cara-l)		
+Bicarinata (+ Liralingua)	D (Eife)	-C (Serp-l)	(400,538)	Patrula	O (Aren-u)	-D (Sieg)	(1066)
Bistramia	O			+Peritrimerella	O (u)		(881)
Broeggeria	Cm(Fran)	-O (Trem-l)	(3,11)	Plectoglossa	O (Cara-l)	-O (Cara-m)	(397)
+Canalitatus	Cm(m)		(881)	+?Plicatolingula	Cm(Tomm-u)?		(580)
+Casquella	O (Cara-u)?		(564)	Pseudobolus	O (Llde-l)	-O (Cara-l)	(1,397)
+Cositrimerella	O (Ashg-l)			Pseudodicellomus	Cm(Fran-l)	-Cm(Fran-u)	(1)
Dicellomus	Cm(uMid-u)	-Cm(Dres-l)	(1,4)	Pseudolingula	O (Aren-u)	-O (Ashg-m)	(1,5,397)
+Dictyobolus	O (Aren-u)		(396)	Pseudopholidops	O (Llde-u)	-O (Cara)	(1,1066)
Dignomia	D (m)?		(1)	Quasithambonia	O (Aren-l)		(538)
Ectenoglossa	O (Aren-u)	-O (Cara-m)	(1,397,538)	+Rafanoglossa	O (Aren-l)	-O (Ashg-m)	
Elkania	Cm(Fran)?	-O (l)	(1)	Rhynobolus	S (Wenl)		(1)
+Elkanisca	O (Trem-l)	-O (Aren-u)	(538)	+Rosobolus	O (Trem-l)		(538)
Elliptoglossa	O (Aren-u)	-O (Ashg-m)	(396,398)	Rowellella	O (Trem-u)	-O (Ashg-m)	(1,910)
+Expellobolus	O (Trem-l)		(538)	+Sanxiaella	O (Cara)?, O (Ashg)?		(538)
+Experilingula	Cm	-O (l)?	(881)	Schmidites	O (Trem-u)	-O (Aren)	(5,538)
+Fengzuella	O (Cara-l)			+Semilingula	P (Leon-u)		(1064)
+Fezzanoglossa	O (Cara)		(399)	+Shouxianella	S (Ldov)		(881)
Fordia	Cm(m)	-Cm(u)	(1)	+Sinoglossa	Cm(uMid)	-Cm(Dres-l)	
+Foveola	O (Trem)		(538)	+Sinotrimerella	O (Cara-l)		(881)
Glossella	O (Llvi-l)	-O (Cara-m)	(398)	Spiningula	O (Llvi-l)	-O (Cara-l)	(398)
Glottidia	T (Eo)	-R	(1)	+Spondylglossella	O		(881)
Glyptoglossella	O (Cara-l)		(397)	+Squamilingulella	O (l)		(ZRR2)
+Gorjanskya	O (m)		(881)	+Tarutiglossa	D		(881)
+Hyperobolus	O (Trem-l)	-O (Trem-u)	(538)	+Thysanobolus	O (Trem-l)	-O (Trem-u)	(538)
+Kyrshabakella	Cm(Boto)	-Cm(mMid)	(719)	Thysanotos	O (Trem-l)	-O (Trem-u)	(538)
Lachrymula	C (Tour-u)	-C (Pn)	(400)	+Tilasia	O (Ashg-m)		(950)
+Laima	D (m)		(881)	+Timalina	D (u)		(538)
Lamanskya	O (Trem-u)	-O (Aren-u)	(950)	Tomatina	O (l)		(1)
Langella	C (Pn)	-P (l)?	(1)	Trigonoglossa	D (Give)	-C (Step-u)	(1,400,538)
+Leontiella	O		(881)	Tropidoglossa	Cm(u)		(538)
+Leptembolon	O (Trem-u)	-O (Aren)	(538)	+Tunisiglossa	O (Trem)		(538)
Leptobolus	O (Llde-l)	-O (Ashg-l)	(397)	Volborthis	O (Aren-u)	-O (Llvi-l)	(1189)
+Libyaeglossa	O (Cara)			+Wadiglossa	O		(881)
Lingula	T (Eo)	-R	(1064)	Westonia	Cm(Boto)	-O (Cara)	(538)
Lingulapholis	O (Cara-u)	-D (m)?	(1)	+Westonisca	O (Trem-l)		(538)
+Lingularia	Tr(Olen)?	-K (Sant)?	(1064)	+Yidurella	S		(881)
Lingulasma	O (Llvi-l)	-O (Ashg-m)	(4,397, 1066)	+Zhanella	Cm(Fran)?		(719)
Lingulella	Cm(Atda-u)	-O (Ashg-u)	(12,538)				
+Lingulellotreta	Cm(Boto-l)	-Cm(Tojo)	(881,1066)	Or. ACROTRETIDA			
Lingulepis	Cm(Atda-u)	-O (Trem)?		Acanthocrania	O (Cara-l)	-P (Guad-u)	(7)
Lingulipora	O (m)?	-D (Fame-l)	(708)	Acanthambonia	O (Aren-u)	-O (Ashg-m)	(396,538)
Lingulobolus	O (Trem)	-O (Aren-u)	(396)	Acrothele	Cm(Atda-l)	-Cm(uMid-u)	(13,14,885)
Lingulops	O (Llvi)?	-S (Wenl)?		Acrothyra	Cm(Boto-l)	-Cm(lMid-u)	(885)
+Lunoglossa	P		(881)	Acrotreta	Cm(Atda-u)	-O (Ashg)	(397,921, 1050)
+Mirilingula	Cm(u)	-O (Trem)	(881)	Acrotretella	O (Cara-l)	-S (Ludl)?	(538,910)
Monobolina	O (Aren-u)	-O (Llde)	(1,950)	+Aktassia	O (Llde-l)	-O (Cara-l)	(538)
Monomerella	O (Ashg)	-S (Ldov)	(538)	+Alichovia	O (Trem-u)	-O (Cara-l)	(538)
+Notiobolus	Cm(m)		(538)	+Amictocracens	Cm(uMid-l)	-Cm(uMid-u)	(569)
Obolopsis	Cm(Boto)		(1006)	+Anabolotreta	Cm(uMid-u)	-Cm(Dres-l)	(569)
Obolus	Cm(Atda-u)	-O (Cara-u)	(5,11)	+Anatreta	Cm(Fran)		
+Oepikites	Cm(m)			Ancistrocrania	K (Turo-u)	-K (Maes)	(1)
+Ovidiella	O (Llde-u)		(657)	+Anelotreta	Cm(m)		(881)
Pachyglossella	O (Cara-l)	-O (Cara-m)	(1)	Angarella	O (u)?		
				Angulotreta	Cm(uMid)	-Cm(Fran-u)	

Taxon	First Appearance	Last Appearance	Reference	Taxon	First Appearance	Last Appearance	Reference
+Aphelotretra	Cm(m)	-Cm(Dres-l)	(538)	Lingulodiscina	D	-P (l)	(ZR70, ZR77)
Apsotretra	Cm(Dres-l)	-O (Aren-u)?	(5)	Linnarssonella	Cm(Fran-l)		
Artiotretra	S (Wenl)			Cm(Boto-l)	-Cm(uMid-u)		(1,522,885)
+Biernatia	O (Trem)?	-O (Cara)?	(910)	+Ljaschenkovia	D		
Botsfordia	Cm(Atda-u)	-Cm(mMid)	(15,16, 1066)	+Lochkothele	D (l)		(881)
+Bozshakolia	Cm(m)		(881)	+Luhotretra	Cm(m)		(1191)
+Caenotretra	S (Ldov-m)	-D (Eife)	(538)	+Lurgiticoma	O (Aren)		(538)
+Canthylotretra	Cm(m)	-Cm(uMid-u)	(538)	+Mesocrania	J (Oxfo-u)	-K (Berr)	
+Celdobolus	O (Trem-u)	-O (Aren-u)	(538)	Multispinula	O (Aren-u)	-O (Ashg-m)	(396,1066)
+Celidocrania	O		(881)	+Myloconotretra	O (Aren-u)		(396)
Ceratreta	Cm(Fran-l)	-O (Aren-u)	(1,396)	+Myotreta	O (Trem-u)	-O (Cara)	(538)
Clistotretra	O (Trem)		(1)	+Nematocrania	P (Leon-m)		(403)
Conodiscus	Cm(u)		(1,538)	Neobolus	Cm(l)		(2)
Conotretra	O (Trem-u)	-O (Cara)	(921)	+Neocrania	T	-R	(881)
-Craniotretra	Cm(m)		(ZR78)	+Neotreta	Cm(uMid-m)	-Cm(Dres-u)	(538)
Craniscus	J (Oxfo-u)	-R		+Numericoma	O (Aren-l)	-O (Llde-l)	(910)
+Cristicoma	O (m)		(538)	+Nushbiella	O (Cara-l)		(881,910)
Curticia	Cm(Boto)	-Cm(Fran)	(2,17)	Oehlertella	C (Ms)	-C (Pn)	
+Cyrbasiotretra	O (Aren-u)		(396)	+Olenotretra	Cm(Fran)		(1190)
+Cyronotretra	O (Llde-l)	-O (Cara-l)	(910)	Opisthotreta	Cm(Dres-l)		
+Dactylotretra	Cm(Dres-u)	-Cm(u)	(538,1020)	+Opisconidion	O (Ashg-l)	-D (Fras)	(1066)
+Dearbornia	Cm			Orbiculoidea	O (Trem)?	-P (Dora)	(1066,1142)
+Diandongia	Cm(Boto-l)		(885)	+Orbiculopora	D		
+Dicondyloreta	Cm(uMid)			+Orbiculothyris	O (Cara)		(399)
Discinisca	J (l)	-R	(538)	Orbithele	Cm(m)	-O (Aren-l)	(1,1066)
Discinopsis	Cm(m)		(1)	Orthisocrania	O (Aren-u)	-O (u)	(1)
Discotretra	O (l)			Oxlosia	O (Trem-l)	-O (Llvi)	
+Discradisca	J (Kimm)	-R	(538)	+Paratretra	O (Trem-u)	-O (Cara-l)	(538)
+Ditreta	O (Trem-u)		(538)	+Pegmatreta	Cm(Tojo)	-Cm(uMid)	(580)
Drabodiscina	O (Cara)		(399)	Petrocrania	O (Llvi-u)	-P (Djhu)	(5,7,397)
Dysoristus	Cm(Tojo)	-Cm(Dres-u)	(17,580)	Philhedra	O (Llvi)	-C (Vise-l)	(2,9)
+Edreja	Cm(Boto)		(881,1066)	Philhedrella	S (Ldov-l)?	-S (Ludl)?	(1,16)
Eleutheroocrania	O (Cara-m)	-S (Ldov)	(1,538)	+Phytotretra	Cm(Dres-u)	-O (Llde-l)	(910)
Eoconulus	O (Aren-u)	-O (Ashg-m)	(396,398, 910)	+Pienotretra	Cm(m)	-Cm(u)	(538)
+Eoscapheasma	Cm(Fran)		(1190)	Polylasma	O (Aren)		(538)
+Eosiphonotretra	O (Trem-l)	-O (Llde)	(538)	+Pomeraniotretra	O (Aren-l)		(881,921)
+Eothele	Cm(Boto-u)	-Cm(Tojo)	(18,932)	Prototretra	Cm(Boto)	-Cm(uMid)	(4,580)
Ehippelasma	O (Llvi-u)	-O (Ashg-m)	(1,398,910)	Pseudocrania	O (Aren-u)	-O (Cara-m)	(404,1066)
+Eurytretra	O (Trem-l)	-O (Llvi)	(398,921)	Pseudometoptoma	O (Llde)?	-S	(538,881)
+Fascicoma	O (Llvi)?, O (Llde)?		(538)	+Quadriflora	Cm(Fran)		(1190)
+Ferrobolus	O (Trem-l)		(538)	Redlichella	Cm(m)		(1)
Glyptacrothrele	Cm(mMid-l)?		(1191)	+Rhondellina	Cm(uMid-u)	-Cm(Dres-l)	
Glyptias	Cm(l)		(1)	Rhysotretra	O (Llvi-l)	-O (Cara-l)	(1,398)
+Hadrotretra	Cm(Boto)	-Cm(uMid)	(18,932)	Roemerella	D (Give-l)	-P (Leon-u)	(4,7)
+Hansotretra	O (Llvi-l)		(398)	+Satpakella	Cm(Fran)		(1190)
Helmersenian	O (Trem-u)	-O (Aren)	(1,538)	Scaphelasma	O (Aren-l)	-O (Ashg-m)	(398,921)
Hisingerella	O (Llde-l)	-O (Ashg-l)	(1)	Schizambon	Cm(Tojo)	-O (Ashg-l)	(16,397, 1066)
Homotretra	Cm(Boto-u)	-Cm(mMid)	(4,522)	Schizobolus	D (Give-l)	-D (Fame)	(4)
Isocrania	K (Turo-u)	-T (Dani-l)	(1,8,538)	Schizoecrania	O (Llvi-l)	-D (Gedi)	(1,5,1066)
+Issedonia	O (Aren)	-O (Ashg)	(538)	Schizopholis	Cm(Boto)		(1)
+Karathele	Cm(m)		(881)	Schizotretra	O (Aren-u)	-S (Wenl-u)	(5)
+Karnotretra	O (Aren-u)		(396)	+Schizotretoides	O (l)		(ZR78)
Keyserlingia	Cm(u)	-O (Trem)	(1,538)	+Semitretra	O (Trem-u)	-O (Aren-l)	(538)
+Kleithriatretra	Cm(Tojo)		(932)	+Siphonobolus	O (Trem-l)		(538)
+Kosoidea	S (u)		(881)	Siphonotretra	O (Trem-u)	-O (Cara-l)	(397,538)
+Kotujotretra	Cm(Dres-l)			+Spinulothele	Cm(Boto-l)		(19)
+Kotylotretra	Cm(mMid)?	-Cm(uMid)	(1192)	Spondylotretra	O (Trem-u)	-O (Ashg-m)	(1,398,910)
+Lepidocrania	P (Asse)	-P (Guad-l)	(7)	+Stilpnotretra	Cm(uMid-u)	-Cm(Dres-l)	(569)
Lindstroemella	D (Give-l)	-C (Mosc-u)?	(1,4)	+Tobejalotretra	Cm(Fran)		(1190)
				Torynelasma	O (Aren-u)	-O (Cara-l)	(398)

Taxon	First Appearance	Last Appearance	Reference	Taxon	First Appearance	Last Appearance	Reference
Trematis	O (Llde)	-O (Ashg-u)	(32,981)	Or. OBOLELLIDA			
+Treptotreta	Cm(uMid-m)	-Cm(Dres-u)	(569,1020)	Alisina	Cm(Boto)?		(1,580)
Undiferina	O (Llvi-l)	-O (Cara-l)	(398)	Bicia	Cm(Boto)		(1)
+Vandalotreta	Cm(mMid)?		(881)	+Brevipelta	Cm(Atda)		
+Veliseptum	O (Cara-u)	-O (Ashg-l)	(538)	+Cingulella	Cm(m)		(1191)
+Westralicrania	T (Than)		(405,538)	+Ivshinella	Cm(Boto)?		(580)
Or. PATERINIDA				+Lindinella	Cm(m)		(1191)
+Aldanotreta	Cm(Tomm-l)		(522,885)	Magnicanalis	Cm(Boto-l)		(885)
+Askepasma	Cm(Atda)?		(580)	+Monoconvexa	Cm(Atda)		(580)
+Bomina	Cm(Boto)		(1193)	+Nochorojiella	Cm(Tomm-u)	-Cm(Atda-l)	(407,522)
+Cryptotreta	Cm(Tomm-u)	-Cm(Atda-u)	(522,885)	Oboiella	Cm(Atda-l)	-Cm(Boto-l)	(19,885)
Dictyonina	Cm(Boto)?	-Cm(mMid-u)	(1)	+?Proiobolus	Cm(Tomm-u)?		(580)
Dictyonites	O (Aren-u)	-O (Cara-l)	(398,910)	+Sibiria	Cm(Atda-l)	-Cm(Boto-l)	(522)
+?Kolihiium	O (Trem-l)		(538)	Trematobolus	Cm(Atda-u)	-Cm(mMid)	(1,2,23)
+Lacunites	O (Trem-l)	-O (Aren)	(538)	Or. CHILEIDA			
Mickwitzia	Cm(Tomm-u)	-Cm(Tojo)?	(22)	+Acareorthis	Cm(Tojo-l)		(1066)
Micromitra	Cm(Tomm-l)	-Cm(Fran-l)	(10,21,569,885)	+Chile	Cm(Boto)		(1066)
Paterina	Cm(Tomm-u)	-Cm(mMid-u)	(19)	Or. NAUKATOIDEA			
Ptychopeltis	O (Llde-u)	-O (Cara-l)	(1075)	+Bynguanoia	Cm(Tojo)		(1066)
+Salanygolina	Cm(Boto)		(813)	+Naukat	Cm(Boto)		(1066)
Walcottina	Cm(Atda-l)		(580,885)	+Oina	Cm(Boto)		(1188)
Cl. INARTICULATA				+Pelmanella	Cm(Tojo-l)		
Or. CRANIOPSIDA				Or. UNCERTAIN			
Craniops	O (Cara-l)	-C (Tour)	(4,397)	+?Acidotocarena	Cm(Tomm-u)?		(580)
+Helimedusa	Cm(Atda-u)		(779)	+?Artimystella	Cm(Tomm-u)?		(580)
Or. TRIMERELLIDA				+?Dolichomocelypha	Cm(Tomm-l)		(881,1050)
+Adenus	O (Cara-u)		(720)	+?Erognia	Cm(Tomm-u)?		(89,580,951)
Dinobolus	O (Aren-u)?	-S (Ludl)	(1,2,538)	+?Heosomocelypha	Cm(Tomm-l)	-Cm(Atda-l)	(881,1050)
Eodinobolus	O (Cara-l)	-O (Ashg-m)	(1,2)	+?Khasaghia	Cm(Tomm)	-Cm(Atda)	(1006)
+Gasconia	O (Ashg-l)			+?Lathamella	Cm(Tomm-u)?		(580)
+Gyroselenella	O (Ashg-l)		(881)	+?Psamathopalass	Cm(Tomm-u)?		(580)
+Machaerocolella	O (Cara-l)	-O (Ashg-l)		+?Scambocaris	Cm(Tomm-u)?		(580)
+Prosoponella	O (Ashg-l)		(881)	+?Surindia	Cm(l)		(1006)
Trimerella	S (Ldov-l)?	-S (Ludl-l)	(1,1066)	+Tegulella	O (Aren-u)	-O (Cara-l)	(910)
+Ussunia	O (Llde)		(881,1066)	Cl. ARTICULATA			
+Vaculina	Cm(mMid)	-Cm(u)		[Genera from Doescher (1981); stratigraphy as listed.]			
Or. CRANIIDA				Or. ORTHIDA			
Crania	J (u)	-R	(ZR67)	+Aberia	O (Ashg-m)		
Cl. UNCERTAIN				+Acanthorthis	O (Aren-u)		
Or. KUTORGINIDA				+Acanthotoechia	O (Aren-u)		(396)
+Agyrekia	Cm(Boto-l)	-Cm(Tojo-l)	(1006,1050)	+Acosarina	P (Asse)	-P (Dora)	(7,150,538)
+Haupiria	Cm(uMid)		(881,1006)	+Admixtella	O (u)		(ZR78)
+Khasagina	Cm(Tomm-u)	-Cm(Atda)	(813)	+Altaeorthis	O		(538)
Kutorgina	Cm(Atda-l)?	-Cm(Tojo-u)	(19,522,1066)	+Ambardella	Cm(Dres)		(810)
Quebecia	Cm(l)		(1006)	+Ambonorthella	S (Wenl-u)		(25,408)
Rustella	Cm(Atda)	-Cm(Boto)	(1006)	+Amphiplecia	O (Cara-l)	-O (Ashg-m)	(1133)
Schuchertina	Cm(mMid-u)		(2)	Anchigonites	O (Aren)	-O (Llvi-l)	(1)
+Trematosia	Cm(Boto-l)	-Cm(Tojo)	(23,932)	Angusticardinia	O (Aren-l)	-O (Aren-u)	(2,1066)
Yorkia	Cm(Boto)	-Cm(uMid-l)	(4,23,1050)	Anomalorthis	O (Aren-u)	-O (Llvi-u)	(1)
+incertae sedis	O (Aren-u)			Antigonambonites	O (Aren-u)		(1,2)
				Apatorthis	O (Llde)?	-O (Ashg-m)	(1,1066)
				+Apatoskenidioides	O		(881)
				+Apheoorthina	O (Trem-l)		(538)
				Apheoorthis	Cm(Trep-l)	-O (Aren-u)	(1,396)
				+Apollonorthis	O (Llde-l)	-O (Llde-u)	(1134)
				Apomatella	O (Aren-u)		(1)

Taxon	First Appearance	Last Appearance	Reference	Taxon	First Appearance	Last Appearance	Reference
Archaeorthis	O (Trem-l)	-O (Llvi-l)?	(396)	+Dalejina	O (Ashg-u)	-D (Eife-u)	(24,25,27,965)
Arctohedra	Cm(Tojo)	-Cm(uMid)	(932)	Dalmanella	O (Aren-l)	-S (Ldov-l)	(5,24,25)
+Arcualla	S (Wenl-l)	-D (l)	(24,538)	+Dalmanellopsis	D (l)		(538)
+Arenorthis	O (Ashg-u)			Dedzetina	O (Cara-u)	-O (Ashg-m)	(25)
+Astraborthis	O (Aren-l)?	-O (Aren-u)	(5)	Desmorthis	O (Aren-u)	-O (Llvi-u)	(5)
+Asturorthis	S (Ldov-u)			Diceromyonia	O (Ashg-l)	-S (Ldov-l)	(764)
+Asymphylotoechia	O (Llvi)?			Dicoelosia	O (Cara-u)	-D (Emsi)	(1,25,28)
Ateleasma	O (Llvi-l)?	-O (Cara-l)	(1)	+Didymoparcium	D (Emsi)		(538)
+Ateleasmoidea	O		(881)	Dinorthis	O (Llde-l)	-O (Ashg-m)	(1)
+Atlantida	O (Cara-l)		(538)	+Diochthofera	O (Ashg)		(912)
Aulacella	D (Eife-u)	-C (Tour-l)	(1,25,538)	Diorthis	O (Cara-l)		(1)
Aulacophora	C (Tour-u)	-C (Serp-l)	(400)	Diparelasma	O (Aren-l)	-O (Llvi-l)	(4,5)
Austinella	O (Cara-u)	-O (Ashg-m)	(4,26)	+Diplonorthis	O (Ashg-m)	-O (Ashg-u)	(965)
+Austrohedra	Cm(Tojo)		(932)	Diraphora	Cm(lMid)	-Cm(Dres-l)	
+Bagnorthis	O (Ashg)			+Discomyorthis	D (Gedi-l)	-D (Emsi)	(25)
+Bajanorthis	Cm(u)		(538)	Doleroides	O (Llde)	-O (Cara-m)	(1,4)
Bancroftina	O (Cara-m)	-O (Ashg-u)	(404)	Dolerorthis	O (Cara-l)	-D (Emsi)	(5,25)
Barbarorthis	O (Ashg)		(538)	+Draborthis	O (Ashg-m)	-S (Ldov-l)	(965)
+Baturria	S (Wenl)	-D (Gedi)	(25)	Drabovia	O (Llde-u)	-O (Ashg-u)	(5,25,1075)
Bicuspina	O (Llde-u)	-O (Ashg-u)	(1,25,404,965)	Drabovinella	O (Llde)	-O (Ashg-u)	(1,965)
+Biarnatium	D (Fras)		(1066)	+Dysprosorthis	O (Ashg-u)		(881)
Billingsella	Cm(Boto)	-O (Aren)	(1,409)	Eilotretra	S (Wenl-u)		(25,764)
Bohemiella	Cm(lMid)	-Cm(u)	(1,538)	Elasmothyrus	O (Cara-l)	-O (Ashg)	(1,912)
+Boonderella	O (Cara)		(1135)	+Elegesta	S (Wenl)		(881)
Boreadorthis	O (Cara-l)	-O (Ashg-m)	(538)	+Engenella	Cm(m)		(810)
+Boticum	O (Ashg-m)		(538)	Enteletella	P (u)		(1)
+Bowanorthis	O (Cara)		(1135)	Enteles	C (Mosc)	-P (Dora)	(1,411)
Brachymimulus	O (Cara-m)?	-S (Wenl-u)	(1,25,538)	Enteletina	C (Pn)	-P (u)	(1)
+Brahmorthis	Cm(mMid)?		(538)	Eoconcha	Cm(Atda)?	Cm(Boto)?	(1)
+Brandysia	O (Llde-l)			Eodalmanella	O (Llvi)		(1)
+Caecmia	O (Llvi-u)	-O (Llde-l)		+Eodiorthis	O (Aren)?		(881)
Caeroplecia	O (Cara-m)		(5)	Eoorthis	Cm(Dres-u)	-O (Trem)	(1,16,538)
Campylorthis	O (Cara-l)	-O (Cara-m)	(1,4)	+Eorhipidomella	O (Llde)?	-O (Cara-m)	(538)
Cariniferella	D (Fras-u)		(25)	+Eoschizophoria	S (Ludl-u)	-D (Sieg)?	(881)
Chaulistomella	O (Llde)	-O (Cara-l)	(1)	+Eosophragmophora	D (Emsi-l)		(24)
+Chiidorthis	Cm(m)		(538)	Eosotrematorthis	O (Aren)		(1,2)
+Chrustenopora	O (Cara-l)		(538)	Eostrophomena	O (Trem-u)		(1)
+Cillinella	O (Llde-u)	-O (Cara-m)?	(538)	+Epitomyonia	O (Ashg-l)	-S (Wenl-u)	(25)
+Cinerorthis	S (Wenl)		(410)	Eremotoechia	O (Cara-l)		(1)
+Clavodalejina	D (Emsi)		(538)	Eremotrema	O (Cara-l)	-O (Ashg-u)	(1,965)
Cliftonia	O (Cara-u)	-S (Wenl-l)	(1,860)	Eridorthis	O (Cara-l)	-S (Wenl-u)	(25,26)
Climambon	O (Cara-l)	-O (Cara-m)	(1)	+Eripnifera	O (Ashg)		(912)
Clitambonites	O (Llvi-l)	-O (Cara)	(1,538)	Estlandia	O (Aren)	-O (Cara-m)	(538,1066)
Comatopoma	O (Ashg-m)	-O (Ashg-u)	(1)	+Euorthisina	O (Aren)	-O (Llvi)	(538,1075,1081)
+Cordatomyonia	S (Ldov-u)	-D (Gedi-u)	(25,408,538)	Evenkina	O (Cara)		(1,538)
Corineorthis	O (Llvi-u)	-O (Cara-l)	(1)	+Evenkinorthis	O (m)		(ZR77)
+Cortezorthis	D (Gedi)	-D (Eife-l)	(25,538)	+Famatiorthis	O (Aren)	-O (Cara-l)	(538)
+Costisorthis	D (Sieg)?	-D (Eife)?	(410)	Fascicostella	S (Prid)	-D (Eife-u)	(25)
Craigella	O (Cara)		(538)	Fasciulina	O (Aren)		(1)
Cremoorthis	O (Cara-l)	-O (Ashg-m)	(404,1066)	Fascifera	O (Cara-l)	-S (Ldov-l)	(1,25)
Cristiferina	O (Cara-l)		(397)	+Fascizetina	S (Wenl-l)	-D (Sieg)?	(538,860)
+Crossiskenidium	O (Aren-u)		(396)	+Ferrax	O (Aren-l)		
+Crozonorthis	O (Llde-l)	-O (Llde-u)	(1134)	Ffynnonia	O (Aren-u)		(412)
+Cycladigera	D (Emsi)		(1066)	+Fehamya	O (Ashg-u)		(881,965)
Cyclocoelia	O (Ashg-l)		(1)	Finkelburgia	Cm(Trep)	-O (Aren-u)?	(1,379)
Cyclomyonia	O (Cara-l)		(1)	+Fistulogonites	O (Aren-u)	-O (Cara)	(412,538)
Cymbithyrus	Cm(Trep-l)	-O (l)?	(1)	+Flabellitesia	S (Wenl)		(860)
+Cymbricia	Cm(Tojo)		(932)	+Fulcriphoria	D (Gedi)	-D (Emsi)	(538)
Cyrtonetella	O (Llde-l)	-O (Cara-l)	(1)	+Geliidorthidina	S (Ldov)	-S (Wenl)	(410)
				+Geliidorthis	O (Llvi-u)?	-O (Ashg-m)	(1076)

Taxon	First Appearance	Last Appearance	Reference	Taxon	First Appearance	Last Appearance	Reference
Giraldiella	O (Llde-u)	-S (Ldov-u)	(25,1075)	+Malinella	O (m)		(538)
+Glaphorthis	Cm(Tojo)	(932)		+Mapingtichia	P (l)		(881)
Glossorthis	O (Aren)	-O (Cara)	(538)	+Marcharella	Cm(u)		(538)
+Glypteria	O (Aren-u)	-S (Ldov-l)	(538)	+Marginorthis	O		(881)
+Glyptoria	Cm(Boto)?		(23)	Marionites	O (Cara-m)?		(1)
Glyptorthis	O (Llde)	-S (Wenl-u)	(397,408,912)	+Marklandella	S (Ldov-l)	-S (Ludl)?	(408,538)
Gonambonites	O (Llvi-l)		(1)	Matutella	Cm(Tojo)	-Cm(lMid-u)	(522)
+Grammoplectia	O (Cara)	-O (Ashg)	(1133)	Mcewanella	O (Llde-l)	-O (Ashg-m)	(1,4,5)
Harknessella	O (Cara-l)	-O (Cara)	(1,5)	+Megasalopina	D (Gedi-u)		(25)
Hebertella	O (Cara)	-O (Ashg-u)	(538,965)	Mendacella	O (Cara-u)	-S (Wenl-l)	(1,538,1066)
Hemipronites	O (l)		(1)	Metorthis	O (l)		(1)
Hesperonomia	O (Trem-u)	-O (Llde)	(1066)	Mimella	O (Llde-l)	-O (Cara-m)	(4)
Hesperonomiella	O (Aren-l)	-O (Aren-u)	(1,412)	+Miniprokopia	D (l)	-D (m)	(ZR71, ZR84)
Hesperorthis	O (Llvi-l)	-S (Ludl-u)	(1,3)	+Mirorthis	O (Cara)	-O (Ashg-u)	(965)
+Heterorthella	S (Ldov-l)	-S (Ludl)	(25)	+Molongella	S (Prid)	-D (Gedi)	(538)
Heterorthina	O (Llde-l)	-O (Ashg)	(1,25)	Monelasma	D (Fras)		(25)
Heterorthis	O (Llde-u)	-O (Cara-m)	(1,5)	+Monorthis	O (Aren-l)	-O (Aren-u)	(412)
Hirnantia	O (Ashg-m)	-S (Wenl-l)	(25,860)	Multicosella	O (Llde-l)	-O (Cara-m)	(4)
Hollandiella	D (Eife)		(25)	+Munhella	O (Aren-u)	-O (Cara)	(412,538)
Holderleyella	O (Llvi-u)	-O (Ashg-u)	(1,5,401,1066)	+Muriferella	D (Sieg-l)	-D (Emsi)	(24,25)
Howellites	O (Cara-l)	-S (Ldov-l)	(1,404,538)	+Murjukiana	O (Llvi)		(878)
+Hulterstadiella	O (Ashg)		(1136)	Mystrophora	D (Emsi-l)	-D (Eife-u)	(25,30)
+Humaella	O (Trem)		(881)	Nanorthis	O (Trem-l)	-O (Aren-l)	(1)
Hypsomyonia	D (Fras-u)		(1)	+Narynella	Cm(Boto)	-Cm(m)	(1006)
+Idiorthis	S (Wenl)		(25)	+Neoschizophoria	C (l)		(881)
Ilmarinia	O (Cara)	-O (Ashg-m)	(1,2,538)	+Nereidella	O (Aren-l)	-O (Cara)	(538)
+Incothris	O (Aren)		(538)	+Neumania	O (Aren-u)	-O (Llvi)	(412)
+Irhirea	O (Cara-m)		(538)	Nicollella	O (Cara-l)	-O (Ashg-u)	(1,5,397)
Iru	O (Llvi-l)		(1)	+Nicoloides	O (Cara-m)		(881)
Isothis	O (Ashg-m)	-D (Give)	(538,965)	+Nicolorthis	O (Cara-m)		(881)
+Israelaria	Cm(Boto)?		(23)	Nisusia	Cm(Atda-u)	-Cm(uMid)	(10,19,1050)
+Jaanusonites	O (Aren-u)		(412)	+Nocturneilla	O (Aren-u)		(5)
Jamesella	Cm(mMid)?		(1)	Nothorthis	O (Trem-u)	-O (Cara-l)	(1,397)
+Jercia	S (Ldov)		(1066)	+Notorthisina	O (Trem)		(538)
+Jevinellina	O (l)		(881)	+Notoscaphidia	O (Aren-u)		(396)
+Jezercia	O (Cara-m)	-O (Ashg-m)	(1075)	+Nucleorhynchia	O (m)		(881)
Jivinella	O (Trem-l)	-O (Trem-u)	(1,538)	+Nugnecella	O (m)		(ZR82)
+Kampella	S (Ldov)		(881)	+Oanduporella	O (m)	-O (Cara-l)	(538)
+Karlicium	O (Cara-u)	-O (Ashg-m)	(410)	Oenerorthis	Cm(Fran-l)	-O (Trem)	(1,4,538)
Kaysarella	D (Emsi)	-D (Eife)	(25,1066)	+Ocothis	O (l)		(881)
+Kinnella	O (Ashg-u)	-S (Ldov-l)	(25)	+Ogmoplectia	O (Cara-u)	-O (Ashg-m)	
+Koflaia	P (Leon-u)	-P (Djhu)	(1060)	+Oleothis	O (Cara-l)		
Kotujella	Cm(Atda)?, Cm(Boto)?		(1)	Oligonys	Cm(m)		(1)
+Kratorthis	O (Llvi-l)	-O (Llvi-u)	(1053)	Oligorthis	O (Aren)?		(1)
Kullervo	O (Llde-l)	-O (Ashg-u)	(1,5,965)	Onniella	O (Llde-u)	-S (Ldov-l)	(965)
+Kundiella	Cm(Tomm-u)	-Cm(Atda-l)	(885,1006)	+Onnizetina	O (Cara-m)		(410)
Lacunarites	O (Llvi-l)		(1)	Onychoplectia	O (Llvi)	-S (Ldov-l)	(2,25)
Ladogiella	O (Aren)		(1)	Onychotreta	S (Wenl-u)		(25,764)
Laticurra	O (Llvi)	-O (Ashg-m)	(1,406)	Orthambonites	O (Aren-u)	-O (Llvi-l)	(1053)
+Lebediorthis	O (l)		(881)	Orthidiella	O (Aren-u)	-O (Llvi-u)	
+Leioria	Cm(Boto-l)	-Cm(Boto-u)	(23,1050)	Orthidium	O (Aren-u)	-O (Llvi-u)	(412)
Lepidorthis	O (l)		(1)	+Orthiella	D (u)		(881)
+Leptoskelidion	O (Ashg-u)	-S (Ldov-l)	(764)	Orthis	O (Aren-l)	-O (Llvi-l)	(5)
Levenea	S (Ldov)	-D (Eife-l)	(4,24,25)	+Orthostrophella	O (Ashg-m)	-D (Gedi)	(25,764)
Linoporella	O (Cara-m)	-S (Ludl-u)	(1,27,538)	Orthostrophia	S (Wenl)	-D (Gedi-u)	(25,764)
Lissotreta	S (Wenl-u)		(25,764)	Orthotichia	C (Bash-l)	-P (Dora)	(400,411)
+Loganella	D (Sieg)		(25)	Orthotropia	S (Ludl)		(538)
+Lomatorthis	O (Aren-u)		(396)	Orusia	Cm(Fran)		(1)
Loperia	Cm(m)		(1)	Oslogonites	O (Aren-l)		(1,5)
Lordorthis	O (u)		(1)				

Taxon	First Appearance	Last Appearance	Reference	Taxon	First Appearance	Last Appearance	Reference
Otusia	Cm(Fran)?		(1)	Raunites	O (Aren-u)		(1)
Oxoplectia	O (Llvi)?	-S (Went-u)	(25,406)	+Ravozetina	O (Cara-u)	-S (Ldov-l)	(410,538, 965)
Pahlenella	O (l)		(1)	Reeftonia	D (Emsi-l)		(24,25)
+Palaeoschizophoria	S (Went)		(881)	+Replcoskenidioides	O (Ashg)		(912)
Panderina	O (Aren)		(1,538)	Resserella	S (Ldov-l)	-D (Emsi-u)	(25)
+Paradolerothis	O		(881)	Retrorsirostra	O (Cara-u)	-O (Ashg-m)	(1)
+Paralenothis	O (Aren-u)	-O (Llvi-u)	(1053)	Reuschella	O (Cara-l)	-S (Ldov-l)	(1,25,397)
+Paraoxychoplectia	O (Cara)	-S (Went)	(1137)	Rhactorthis	O (Cara-l)	-O (Ashg-u)	(1,404,965)
Parenteles	C (Step)	-P (Djhu)	(411,538)	Rhipidomella	D (Eife)	-P (Dora)	(538)
+Parmorthina	S (Went)?		(860)	+Rhipidomelloides	D (Gedi)		
+Parmorthis	S (Ldov-l)	-S (Went)	(1066)	+Rhynchorthis	O (Aren-u)		(412)
+Paterorthis	O (Llde-l)			Riograndella	O		
Paucicirura	O (Cara-l)	-O (Ashg-u)	(1)	+Robertorthis	O (Trem-l)		(538)
+Paurorthina	O (Aren)			+Saccogonum	Cm(u)		(538)
Paurorthis	O (Aren)	-O (Ashg)	(1,2,397, 912)	+Saesorthis	Cm(mMid)?		
+Peleicostella	D (l)		(538)	+Salacorthis	O (Cara-l)		(5)
+Peltichia	P (Djhu)	-P (Dora)	(881)	Salopia	O (Llde-l)	-O (Cara-u)	(1,5,1066)
Perditocardinia	C (Tour-u)	-P (Leon)	(1,34)	Salopina	O (Ashg)	-D (Eife-u)	(25,538)
+Peridalejina	D (Eife)		(538)	+Salopinella	S (Went-l)?		(24)
+Peritritoechia	O			+Saucrothis	O		
+Phacelorothis	O (Cara)		(1135)	Saukrodictya	O (Llde-u)	-O (Cara-l)	(25)
Phragmophora	D (Emsi)	-D (Eife)?	(1,538)	Scaphorthis	O (Llde-u)	-O (Ashg)	(1,912)
Phragmorthis	O (Aren-u)	-O (Ashg)	(1,396,912)	-Schalidomorthis	O (Llvi)?	O (Llde)?	(538)
Pionodema	O (Cara-l)	-S (Ldov-l)	(1,25)	-Schizonema	O (Ashg-m)	-S (Went)	(538)
Pionorthis	O (Ashg-m)		(1)	Schizophorella	O (Ashg-m)	-O (Ashg-u)	(965)
Placotriplesia	S (Ldov-m)	-S (Ludl)	(25,764, 965)	Schizophoria	S (Ldov-u)	-P (Dora)	(651,1066)
Plaesiomya	O (Cara-m)	-O (Ashg-u)	(1,4)	Schizoramma	S (Ldov-m)	-S (Went)	(25,965)
+Planicardina	D (Sieg-l)		(538)	-Septorthis	O (Ashg-m)		(1066)
Planoharknessella	O (Cara)		(1)	+Severginella	O (Cara)	-O (Ashg)	(538)
Platyorthis	S (Prid)	-D (Eife)	(25)	+Shiragia	Cm(Dres-u)		(1066)
Platystrophia	O (Aren)	-S (Went-u)	(5,25)	+Shoshonorthis	O (Aren-l)	-O (Llvi)	(1053)
Platytoechia	O (Aren)	-O (Aren-u)	(1,412)	+Sigmelasma	O (Llde)	-O (Ashg)	(912)
Plectrothis	O (Trem-u)	-O (Ashg-u)	(538,965)	+Sigopallus	O (Cara-l)		(881)
Plectroreta	S (Went-l)	-S (Ludl-l)	(25,27)	Sinorthis	O (Aren)		(1)
Pleurothis	O (Trem-u)	-O (Llvi)	(1,1066)	+Sivorthis	O (Llvi)	-O (Cara-l)	(1053)
Polytoechia	O (Aren-u)		(1,4)	Skenidioides	O (Llvi-l)	-D (Emsi)	(5,538)
Pomatotrema	O (Aren-u)		(1,4)	Skenidium	D (Gedi-l)	-D (Fras-u)	(25,764)
+?Pompeckium	Cm(Boto-l)		(413)	Smeathenella	O (Cara)		(3)
Poramborthis	O (Trem-l)	-O (Trem-u)	(1066)	+Sonculina	O (m)		(881)
Portranella	O (Ashg-m)	-O (Ashg-u)	(1,965)	Soudleyella	O (Cara-m)		
Prantlina	O (Aren)	-O (Llvi)	(1,538)	Sphenophragmus	D (Give-l)	-D (Give-u)	(25)
Productorthis	O (Aren)	-O (Cara-l)	(1,397)	Sphenorthis	S (Ldov)		(1)
Progonambonites	O (Aren-u)	-O (Llvi-l)	(1,412)	Spinorthis	O (u)		(1)
Prokopia	D (l)	-D (Eife)	(25,538)	Spondylostrophia	S (Ldov)		(538)
Proschizophoria	S (Ludl)	-D (Emsi-l)	(24,25)	+Stainbrookia	D (Fras-u)		(538,708)
+Protambonites	O (Trem-l)	-O (Trem-u)	(1066)	Streptis	O (Ashg)	-S (Went-u)	(1,25,27)
+Proteorthis	S (Went)		(410)	+Strixella	S (Ludl)	-D (Gedi-l)	(25)
+Protocortezorthis	S (Ldov-m)?	-D (Emsi)	(538)	+Sulcatorthis	O		(881)
+Protohesperonomia	O (Aren-u)		(396)	+Sulevorthis	O (Cara-u)	-O (Ashg-m)	(1053)
+Protomendacella	O (Cara-m)		(538)	+Svobodaina	O (Llde)	-O (Cara-u)	(1,25,36)
+Protophragmapora	D (l)			+Tafialtia	O (Llde-l)	-O (Cara-u)	(538)
Protorthis	Cm(uMid)		(1)	+Talentella	S (Prid)	-D (Sieg)	
+Protoskenidioides	O (Aren-l)		(5)	+Taphrothis	O (Aren-u)	-O (Cara-m)	(1,396)
Pseudodicoelosis	S (Ludl)		(25,764)	+Tarfaya	O (Aren-l)		(538)
+Pseudomendacella	S (Went-l)		(860)	+Tazzarinia	O (Llde-l)	-O (Cara-m)	(5,538)
+Pseudominella	O (Aren)		(881)	Teichertina	D (Eife)	-D (Fras)	(25)
Psiloria	Cm(Atda-u)	-Cm(Boto)		Thiemella	D (Fras-m)	-D (Fame)	(25,538)
Ptychopleurella	O (Llde-l)	-D (Emsi-l)	(35,1066)	+Tismanorthis	O (u)		(1138)
Ranorthis	O (Trem-l)	-O (Aren-u)	(1,1066)	+Tissintia	O (Llvi-u)	-O (Cara-m)	(5,538)
+Raridium	S		(881)	+Toxorthis	O (Ashg-u)	-S (Ldov-l)	(25,965)
				+Treioria	O (Aren-u)		(412)

Taxon	First Appearance	Last Appearance	Reference	Taxon	First Appearance	Last Appearance	Reference
Trematorthis	O (Aren-u)	-O (Llvi)	(1,538)	+ Ametoria	P (Leon-u)		(7)
Triplexia	O (Llvi-u)	-S (Wenl-u)	(1,5,408, 1255)	+Amosina	S (Ldov-u)	-D (Gedi-l)	(25)
Tritoechia	O (Trem-u)	-O (Aren-u)	(2,4)	+ Amphistrophia	S (Ldov-u)	-S (Prid)	(25,27)
+ Trondorthis	O (Llvi)		(412)	+ Amphistropiella	S (Wenl)	-D (Gedi)	(538)
Tropidothis	O (Cara-l)		(1)	+ Amsdenostropiella	S (Wenl)	-D (Gedi)	(538)
+ Trucizetina	O (Ashg-m)	-O (Ashg-u)	(410,965)	+ Ancylotrophia	D (Emsi-u)	-D (Eife-u)	(25)
+ Turarella	Cm(Dres)?		(810)	+ Andalucinetes	D (Emsi)		(994)
+ Tuvinia	O (m)		(538)	+ Anechophragma	O (Llvi)		(878)
Tyersella	D (Gedi-l)	-D (Gedi-u)	(538)	+ Anemonaria	P (Leon-m)	-P (Leon-u)	(7,1246)
+ Tyronella	O (Ashg-m)		(1066)	Anidanthus	P (Asse)	-P (Dora)	(963,1142)
Valcourea	O (Aren)	-O (Cara-m)	(1,4,1066)	Anisopleurella	O (Llde)	-S (Ldov-l)	(25,878)
Vallomyonia	D (Eife-l)	-D (Fras-l)	(25)	Anopia	D (Gedi-u)	-D (Emsi-l)	(25)
Vellamo	O (Llde)?	-O (Ashg-u)	(1,2,965)	Anopiopsis	C (Tour-u)	-C (Vise-l)	(1,955)
+ Villicundella	O (Ashg)		(538)	Anotambonites	O (Llde)	-O (Ashg-m)	(1,416,878, 930)
+ Virgoria	O (Aren-u)		(412)	+ Ansehia	P (Djhu)		(538)
+ Visbyella	S (Ldov-l)	-S (Wenl-l)	(25,27, 1066)	Antiquatonia	C (Tour-u)	-P (Leon-m)	(1,417)
+ Wangyua	S (Wenl-l)		(860)	Apatomorpha	O (Llde-u)	-O (Cara-l)	(1,878)
+ Whittardia	O (Cara-m)		(5)	+ Aphanomena	O (Ashg-m)	-S (Wenl)	(401,538, 965)
Wimanella	Cm(Boto)	-Cm(uMid)	(413)	+ Apiciliella	D (l)	-D (m)	(ZR79)
+ Wulongella	O (u)		(881)	Aporthophyla	O (Aren-u)	-O (Llvi)	(1,878)
+ Wysogorskiella	O (m)		(538)	+ Aporthophylina	O (Llvi)?		(878)
Xenorthis	Cm(u)	-O (l)	(1,538)	+ Apsoalymma	C (Ms)		(538)
+ Xinanorthis	O (l)		(ZR83)	+ Araksalosis	D (Fame-m)	-D (Fame-u)	(907)
+ Yichangorthis	O		(881)	+ Araxilevis	P (Djhu)		(411)
+ Zhejiangorthis	O (u)		(ZR83)	+ Arbuzostrophia	D (Emsi-u)		
+ Zichopyramis	O			+ Archeochonetes	O (Ashg-m)	-O (Ashg-u)	
Or. STROPHOMENIDA				+ Archaiosteges	C (Tour-u)		(1140)
+ Absenticosta	C (Vise-u)		(963,1246)	+ Arcticalosia	P		(881)
Acanthatia	D (Fame-m)		(25,708)	+ Arctochonetes	P (Leon-m)	-P (Leon-u)	(417)
+ Acanthocosta	C (Tour)		(963)	+ Ardiviscus	D (Fame-l)		(861)
+ Acanthalosia	C (u)	-P (l)	(881)	+ Ardmosteges	C (Bash-l)		
Acanthoplecta	C (Tour-u)	-C (Serp-l)	(400,963)	+ Areostrophia	D (Gedi)	-D (Emsi)	(25,1066)
Acanthoproductus	D (Fame-u)		(963)	+ Argentioproductus	C (Tour-l)	-C (Serp-l)	(1200,1246)
+ Acculina	O (Llde)		(878)	+ Articalosia	P (Leon-u)		
+ Achunoproductus	C (Step-u)	-P (Asse)	(963)	+ Aseptella	C (Bash-l)		(1246)
+ Acritosia	P (Asse-l)	-P (Leon-u)	(7)	+ Aseptonetes	D (Emsi)	-D (Eife)	(994)
Actinomena	O (Llde-u)	-O (Ashg-l)	(1,416)	+ Asioproductus	P (Dora)		(1142)
+ Adairia	C (Serp-l)			+ Asperlinus	P (Leon-u)	-P (Guad-u)	(538)
+ Adiaphragma	D (l)		(ZR80)	+ Aspinosella	C (Step)?		(538)
+ Adectorhynchus	C (Serp-l)		(538)	+ Astaristrophia	D (Emsi-u)		(1141)
+ Admodorogusos	C (Vise-u)		(1139)	+ Asymmetrochonetes	D (Gedi)		(994)
Aegiria (= Aegiromena)	O (Llvi-u)	-S (Wenl-u)	(878)	+ Atelestegastus	P (Asse)		(7)
+ Aegironites	O (Llde)	-O (Ashg-m)	(416,878)	+ Auchmerella	D (m)		(538)
+ Aenigmastrophia	S (Ludl)		(25)	+ Aulie	O (Cara-u)		(878)
Aesopomum	S (Ludl-u)	-D (Emsi)	(25,651)	+ Auloprotonia	C (Vise-u)		(1,955)
+ Agelesia	P (Leon-m)		(7)	+ Aulosteges	P (Wc)	-P (Djhu)	(1,411)
Agramatia	D (Fame-l)		(1,25)	+ Auricolispina	P (Asse)		(963)
Ahtuella	O (Aren-u)	-O (Llvi-u)	(1,412)	+ Australosia	D (Fame)		
Airtonia	C (Vise-l)		(1)	+ Australostrophia	D (Sieg-l)	-D (Emsi-l)	(1,538)
+ Akatchania	P		(881)	+ Austronopia	D (Emsi)	-D (Eife)	(994)
+ Akelina	O (Trem-u)		(878)	+ Avonia	C (Tour-u)	-C (Serp-u)	(1,695, 1246)
Ala	C (Tour)		(538)	+ Azygidium	C (u)	-P (l)	(881)
+ Alatoproductus	P (Sakm)?	-P (Guad-l)?	(538)	+ Babina	D (Gedi)	-D (Eife)	(881)
+ Alatorthotetina	P (u)		(881)	+ Bagrasia	D (Fame-u)		(25,963)
Alexenia	C (Mosc-l)	-C (Step-u)	(411,963)	+ Baissalosteges	P (Guad-u)	-P (Djhu)?	(1143)
+ Alitaria (= Alifera)	C (Vise-l)	-C (Serp-u)	(400,1246)	+ Bajanhongorella	O (Ashg-l)		(748)
+ Allanetes	D (Emsi-l)		(39)	+ Balakhonia	C (Vise-l)	-C (Bash-l)?	(400)
+ Altaestrophia	D (Emsi)	-D (Eife)?	(538)	+ Balkhasheconcha	C (Serp-u)	-C (Mosc)	(963)
				+ Bandoproductus	P (Asse)		(963)

Taxon	First Appearance	Last Appearance	Reference	Taxon	First Appearance	Last Appearance	Reference
+Barbaestrophia	D (Gedi)		(25,538)	+Chalimochonetes	D (Emsi-u)		(994)
+Barunkhuraya	D (Fame-u)		(1246)	Chaoiella	C (Mose)	-P (Leon)	(1,963)
Bathymyonia	P (Sakm)	-P (Guad-u)	(7,40)	+Chaoina	P (Asse)	-P (Leon-u)	(963)
+Bekkeromena	O (Cara-u)		(416)	-Chattertonia	D (Emsi-l)	-D (Emsi-u)	(861)
+Beleutella	C (Serp-l)	-C (Serp-u)	(400)	+Chelononia	P (Asse)		(7)
Bellaclathrus	O (Leon)?			+Chenxiyanoproductus	P (Djhu)	-P (Dora)	(881,1142)
Bellimurina	O (Cara-l)	-O (Ashg-m)	(1,404)	+Chianella	P (Leon-u)		(963)
+Bibatiola	P (Leon-m)		(403,1246)	+Chilianshania	P (l)		(963)
Bilobia	O (Cara-l)	-O (Cara-m)	(25,878)	+Chilidiopsis	S (Went-l)	-S (Ludl)	(38,44)
Bilotina	P (Leon-m)		(403,538)	+Chlupacina	D (Eife)		(994)
Bimuria (+ Cooperea)				+Choanodus	P (Leon-m)	-P (Leon-u)	(7)
	O (Llde)	-O (Ashg-u)	(1,878,965)	Chonetella	P (Leon-u)	-P (Dora)	(1066,1142,1246)
+Biparetis	O (Ashg-u)	-S (Ldov-l)	(538,764,975)	Chonetes	D (Sieg-l)	-C (Tour-l)	(25)
				Chonetina	P (Leon)		(538)
+Biplatyconcha	P		(881)	Chonetinella	C (Bash-l)	-Tr(Indu-l)	(7,41,400,1142)
+Bitterella	Tr(Carn)	-Tr(Nori)	(538)	+Chonetinetes	P (Leon-u)	-P (Djhu)	(7)
+Blyskavomena	O (Cara-l)			Chonetipustula	C (Tour-u)	-C (Vise-u)	(400)
+Boicinetes	D		(881)	Chonetoidea	O (Llde)	-S (Ldov-l)	(878,965)
+Bojodouvillina	D (Sieg-l)	-D (Eife)	(25,1246)	+Chonopectella	P (Dora)		(538)
+Bothrionia	P (Guad-l)		(7)	Chonopectoides	D (Fras)		(25,411)
+Bothrostegium	P (Leon-u)		(7)	Chonopectus	D (Fame)	-C (Tour-l)	(1,25)
+Borua	O (Aren-u)		(396,878)	Chonosteges	P (Sakm-u)	-P (Leon-u)	(7)
+Boucotstrophia	D (Emsi)		(538)	+Chonostegoidella	C (u)		(881)
Brachytrion	S (Ldov-m)?	-D (Emsi-u)	(25)	+Chonostegoides	P (Guad-l)	-P (Guad-u)	(411)
+Bracteoletpaena	O (Ashg)	-S (Went-l)	(25)	Chonostrophia	D (Emsi-l)	-D (Give)	(25,994)
Brasiloproductus	C (Mosc-l)		(1)	+Chonostrophicella	D (Gedi-l)	-D (Emsi-l)	(24,25,764)
+Breileenia	C (Vise-l)	-C (Serp-u)	(1246)	Christianella	O (u)		(881)
+Brochocarina	C (Tour-u)	-C (Vise-u)	(400)	Christiania	O (Aren-u)	-O (Ashg-u)	(1,397)
+Bulabdelia	C (Serp-l)		(561)	+Chynistrophia	D (l)		(538)
+Buntoxia	C (Serp)	-C (Step-u)	(963)	Cinctifera	C (Vise-u)		(1,400)
+Burovia	P (Dora)		(963)	Colaptomena	O (Cara-m)		(1)
Buxtonia	D (Fame-u)	-P (Dora)	(25,41,695,1142)	+Colletostriacia	D (Gedi-u)		(1005)
				+Collemataria	P (Leon-l)	-P (Guad-u)	(7)
+Buxtoniella	C (l)		(881)	+Collumatus	P (Leon-u)		(7)
Buxtonioides	C (Mose)	-C (Step)	(1,538)	+Companteris	C (Bash-l)	-C (Mosc-l)?	(96,3,1200)
+Bystromena	O (Cara-l)		(5)	Compressoproductus	P (Asse)	-P (Dora)	(7,538)
+Cactosteges	P (Leon-u)	-P (Guad-l)	(7)	+Comuquia	P (Leon-m)		(403)
+Caenanopia	C (Tour-l)	-C (Bash-l)	(34,42,400)	+Connectoproductus	C (Bash-l)	-C (Bash-u)	(400)
+Callicalyptella	D (Gedi)		(25)	+Contradouvillinia	D (Emsi)		(538)
+Calliomarginatia	P (Guad-u)		(963)	+Coolinia	O (Ashg-m)	-S (Ludl-u)	(25,27,764)
Calliprotonia	C (Mose-u)	-P (Sakm)	(7,41,963)	+Cooperina	C (Mosc)	-P (Guad-u)	(7,538)
+Callytharrella	P (Sakm-u)			+Corbicularia	D (Fras-l)		(994)
+Calypsolepta	O (Aren-u)	-O (Llvi)	(412)	+Coronalosia	P (l)		
Cancrinella	P (Asse)	-P (Djhu)	(7,41,411,1200)	Coscinarina	P (Leon-u)		(1)
				Coscinophora	P (Sakm-u)	-P (Leon-u)	(7)
Cancrinelloides	P (Guad-l)		(43,417)	+Costachonetes	C (Step-u)	-P (Sakm-u)	(418,994)
+Capillomesolobus	C (Pn)		(881)	+Costalosiella	P (Sakm)	-P (Leon-l)	(881)
+Capillonia	P (Leon-m)	-P (Djhu)	(418)	Costanopia	D (Emsi-u)	-D (Eife)	(24)
+Caphlropia	D (Sieg)	-D (Eife)	(994)	+Costatumulus	P		(881)
Cardinocrania	P (Djhu)		(1066)	+Costellarina	P (Sakm)	-P (Leon-u)	(538)
+Caricula	P (Leon-m)		(403,1246)	Costiferina	P (Sakm)	-P (Leon-m)	(1246)
+Carlinia	C (Serp-l)		(400)	+Costisteges	P (u)		(881)
+Carringtonia	C (Vise-l)	-C (Vise-u)	(881,955)	Costispinifera	P (Guad-l)	-P (Guad-u)	(7)
+Castellarina	S (Ldov-u)	-S (Ludl)	(25)	+Costistrophomena	O (Ashg)		(881)
+Cathaysia	P (We)	-Tr(Indu-l)	(150,1142)	+Costistrophonella	S (Ludl)	-D (Eife-l)	(538)
+Caucasiproductus	D (Eife-l)	-D (Fras-l)	(963)	Craspedalosia	P (Sakm)?	-P (Guad)	(40)
+Caucasoproductus	P (Djhu)		(1143,1246)	Craspedelia	O (Llde)	-O (Cara-u)?	(878)
+Cedulia	D (Fras)		(403)	+Craspedona	P (Guad-u)		(7)
+Celebetes	P (Leon-m)		(403)	+Crisistrophia	D (Emsi-l)		(416)
+Celtanopia	D (l)		(881)	+CROSSACANTHIA	C (Vise-u)		(1246)
+Coocypha	P (Leon-m)	-P (Djhu)	(419)				
+Chaganella	O (Llde)	-O (Cara-l)	(538)				

Taxon	First Appearance	Last Appearance	Reference	Taxon	First Appearance	Last Appearance	Reference
Crossalosis	C (Vise-u)		(400)	+Dowhatania	C (Ms)		
Ctenalosis	P (Asse)	-P (Guad-u)	(7)	+Drahanorhynchus	C (Tour-l)	-C (Bash-l)	(400)
+Ctenochonetes	D (Gedi)	-D (Emsi-l)?	(994)	+Drahanostrophia	D (Sieg-l)	-D (Give-l)	(25)
+Cubacula	C (Step-l)	-C (Step-u)	(963)	+Drummackina	O (Ashg-m)		(1066)
+Cyclantharia	D (Give)?	-P (Guad-l)	(7,538)	Duartaeta	C (Mosc-u)	-P (Sakm)	(1,1246)
+Cymbistropheodonta	D (Fras)		(538)	+Dubioleptina	S (Wen-l)		(25,878)
+Cymoproductus	P (u)		(881)	+Dulankarella	O (Cara-l)	-O (Cara-u)	(419,878)
Cymostrophia	S (Wen-l)	-D (Give)	(24,38,538)	Dyoros	P (Sakm-u)	-P (Guad-u)	(7)
+Cyndafia	P (Dora)		(1144)	+Dysechrestia	P (Leon-u)		(403,1246)
Cyphomena	O (Cara-l)	-S (Ldov-l)	(1,965)	+Dzhebaglina	O (m)		(881)
+Cyphomenoidea	S (Ldov-u)		(24,27)	Ecceentricosta	S (Ludl)	-S (Prid)	(39,994)
+Cyphotalosis	C (Tour-l)		(907)	+Echinalosis	P (Leon-m)	-P (Djhu)	(46,427)
+Cyrtalosis	P (Guad-l)	-P (Djhu)?	(403,1246)	Echinaria	P (Leon)	-P (Guad-l)	(1246)
+Cyrtoniscus	D (Sieg)?	-D (Emsi-l)	(39,538)	+Echinariella	P (Guad-l)	-P (Guad-u)	(1246)
Dactylogonia	O (Llvi-u)	-O (Cara-l)	(1,4,397)	Echimauris	P (Asse-l)	-P (Guad-u)	(7)
+Dagnachonetes	D (Eife)	-D (Give)	(994)	+Echinoconchella	C (Vise-u)	-C (Serp-l)	(881)
+Dalejodiscus	D (Sieg)	-D (Emsi-u)	(878)	Echinoconchus	C (Tour-u)	-C (Bash-l)	(955,1200)
Dalinuria	P (Asse)	-P (Sakm)	(963,1246)	Echinosteges	P (Leon-u)	-P (Guad-u)	(7)
Dasyalosis	C (Vise-u)	-P (Dora)	(1,400,538)	Edriosteges	P (Sakm)?	-P (Dora)	(7,411,1142)
+Dasyaria	P (Asse-u)	-P (Leon-u)	(7,963)	Eichwaldia	O (Cara-l)		(2,397)
+Datangia	C (Vise-u)		(963)	Elliottella (+ Pylonotus)	P (Leon-u)		(7,1246)
Daviesiella	C (Vise-l)	-C (Serp-l)	(400)	+Elliptostrophia	D (Eife)		(25)
+Davoustia	D (Sieg)		(994)	+Enigmalaria	P (Wc)		(538)
+Dawsonelloides	D (Gedi-u)	-D (Sieg-u)	(39)	+Entacanthadus	P (Leon-u)		(1060)
Delepineia	C (Tour-u)	-C (Serp-l)	(400)	+Eoamphistrophia	S (Ldov-u)		(538)
+Demonedys	P (Leon-m)	-P (Dora)	(418)	Eochonetes	O (Ashg-l)	-O (Ashg-u)	(25,878,965)
+Dengalosis	C (Ms)		(881)	+Eocramatia	O (Llvi-l)		(5)
+Densepustula	C (Bash-u)?		(963)	Eodevonaria	D (Sieg-u)	-D (Eife-l)	(4,39)
Derbyella	P (Wc)		(1,538)	Eolisochonetes	C (Serp-l)	-P (Leon)	(1,400)
Derbyia	C (Serp-l)	-P (Dora)	(7,41,400,1142)	Eolyttonia	C (Step)	-P (Guad-u)	(7)
Derbyoides	C (Pn)	-P (Asse)	(7)	+Eomaoristrophia	S (Wen-l)		(881)
+Desistrophia	S (Wenl)		(881)	Eomarginifera	C (Vise-u)		(1246)
Desmoinesia (+ Rudinia)				+Eomegastrophia	S (Ldov-m)?	-S (Wenl)	(538)
	C (Bash-l)	-C (Mosc-u)	(963,1200)	+Eopholidostrophia	O (Ashg)	-S (Ldov-u)	(25)
Devonalosis	D (Give-l)	-D (Give-u)	(25)	Eoplectodonta	O (Cara-l)	-S (Wen-l)	(1,25,878)
+Devonamphistrophia	D (Emsi)		(538)	+Eoplicanoptia	S (Ludl)		(994)
+Devonaria	D (Emsi)	-D (Fras)	(994)	+Eoprodicella	D (Sieg-u)	-D (Emsi-u)	(861)
Devonochonetes	D (Emsi-u)	-D (Fras-u)	(24)	+Eoschuchertella	D (Gedi-u)	-D (Fras-m)	(47)
Devonoproductus	D (Eife-u)	-D (Fras-u)	(24,25,861)	+Eosericioidea	O		(881)
Diambonia	O (Cara-l)	-O (Ashg-u)	(25,538)	Eostrophalosis	D (Give-u)	-D (Fras-u)	(25,708)
+Diambonioidea	O		(881)	Eostropheodonta	O (Ashg-m)	-S (Ldov-u)	(1,25)
Diaphragmus	C (Vise-l)	-C (Serp-l)	(400)	Eostrophonella	S (Ldov-m)?	-S (Ldov-u)	(25)
+Dichacaenia	D (Give-u)		(708)	+Epidioaegiria	S (Wenl)	-S (Ludl)	(538,878)
Dicoelostrophia	D (Emsi-l)	-D (Eife)	(24,25)	+Epicelia	P (Guad)		(428)
+Dictyoclostoidea	P (Guad-u)		(963)	Ericiata	D (Fame-m)	-C (Tour-u)	(1,695)
Dictyoclostus	C (Tour-u)	-P (Dora)	(1066,1142)	+Erinostrophia	S (Ldov-u)		(1145)
?Dictyonella	O (Ashg-m)	-D (Give)	(25,27,764,1066)	+Erismatina	P (u)		(881)
+Dietyostrophia	D (Emsi)		(538)	+Esilia	O (m)		(881)
Dicystoconcha	C (Pn)	-P (l)		Etheridgina	C (Vise)		(1)
Diplanus	C (Step)	-P (Guad)	(7,538)	+Falafer	P (Guad)	-P (Dora)	(428,1142)
+Dipunctella	P (l)	-P (u)	(881)	+Fallaxoproductus	P (u)		(881)
+Donalosis	D (Fras-u)	-D (Fame-m)	(907)	+Famichonetes	P (Dora)	-Tr(Indu-l)	(1142)
+Dorashamia	P (Dora)		(411)	Fardenia	O (Cara)	-S (Ldov-u)	(1,25)
+Dorsirugata	D (Fame-u)		(963,1246)	+Fascistropheodonta	D (Sieg)	-D (Eife)	(538)
+Doroscyphus	C (Vise-u)		(955)	+Fenxiangella	O (l)		(ZR87)
Douvillina	D (Eife-l)	-D (Fras-u)	(4,25)	+Ferganoproductus	C (Vise-u)	-C (Serp-l)	(963,1246)
Douvillinaria	D (Fras-m)	-D (Fras-u)	(25)	Fibulistrophia	D (Emsi-l)	-D (Emsi-u)	
Douvillinella	D (Emsi-u)	-D (Fras)	(25)	+Filiconcha	P (Guad-u)		(963)
+Douvillinoidea	D (Fras)		(538)	Fimbriaria	C (Mosc-u)	-P (Leon)	(1,963)
+Douvinnella	D (u)		(881)				

Taxon	First Appearance	Last Appearance	Reference	Taxon	First Appearance	Last Appearance	Reference
+Fimbrinia	C (Bash)	-P (Leon)	(1246)	Helaspis	D (Eife)		(963)
Flexaria	C (Tour-u)	-C (Serp-l)	(400,955)	+Heleniproductus	P (Leon-u)		(963)
+Floweria	D (Fras-u)		(708)	+Hemichonetes	P (l)		(538)
Fluctuaria	C (Tour-u)	-C (Serp-u)	(1)	+Hercosestia	P (Leon-m)	-P (Leon-u)	(7)
Foliomena	O (Cara-u)	-O (Ashg-u)	(930,965)	+Hercosia	P (Sakm)	-P (Leon-u)	(7,538)
+Forma	P			Hercostrophia	D (Emsi-u)	-D (Fras)	(24,25)
+Frankiella	D (Eife)		(994)	Hesperinia	O (Llvi)	-O (Ashg)	(1)
Furciella	O (Cara-l)	-S (Ldov)	(1,5,397)	Hesperomena	O (Llvi-u)		(1,878)
+Fuschionetes	P (Dora)	-Tr(Indu-l)	(150,1142)	Heteralosia	D (m)	-P (Guad-u)	(7,538)
+Fusiproductus	P (Guad-l)	-P (Dora)	(150,963)	+Hibernodonta	O (u)		(881)
Gacella	O (Llde)		(1066)	+Hinganela	D (l)		(881)
+Galataestrophia	D (Emsi)	-D (Give)	(538)	+Hinganoleptaena	O (u)		(881)
Galeatella	D (Fame-m)		(25,708)	Hipparionix	D (Sieg-u)		(25)
+Gamonetes	D (Sieg)	-D (Emsi)	(994)	+Hollardia	D (Gedi)		(538)
Gamphalosis	D (Fras-m)		(25)	+Holotricharina	P (Leon-m)	-P (Leon-u)	(7)
+Guangdangina	P (Guad-l)?			Holtedahlina	O (Cara-m)	-S (Ldov-l)	(1,4,965)
+Gegenella	C (u)			+Hollynetes	D (Eife)	-D (Give)	(994)
Gemmellaroia	P (Leon-u)		(1)	+Hontorialosia	C (u)		(ZR79)
+Gemmellaroialla	P (Leon-u)		(1)	Horridonia	P (Asse)	-P (Guad-u)	(963)
+Gemmulicosta	C (Mose)	-C (Step-u)	(963)	+Howseia	P (Guad)?		
Geniculifera	C (Tour-l)	-C (Tour-u)	(48,955, 1246)	+Huatangia	P (Dora)		(1142)
+Geniculina	O (Ashg-m)			+Hubeiproductus	C (l)		(881)
+Geniculomclearnites	D (Gedi)		(538)	+Hunanochonetes	D (Emsi)	-D (Eife)	(994)
Geyerella	P (l)	-P (Guad-u)	(7)	+Hunanoproductus	C (Tour-l)		(963)
+Gibberostrophia	D (Gedi-l)	-D (Gedi-u)	(538,764)	Hustediella	Tr(Olen)		(897)
+Gibbochonetes	C (Tour)	-C (Vise)	(994)	+Hypolinoproductus	P (l)		(881)
Gigantoproductus	C (Vise-u)	-C (Serp-u)	(400,1200)	+Hypopsia	P (Asse)		(974)
Girlasia	P (Guad)		(538)	+Hypselometes	S (u)		(881)
+Glabrichonetina	P (Dora)		(994)	Hystriculina	C (Mosc-u)	-P (Sakm-u)	(7,963, 1246)
+Glaidiostrophia	S (Ludl-u)	-D (Emsi)	(25)	Idioglyptus	S (Ludl)	-D (Gedi)	(24,25)
Globiella	P (Sakm)	-P (Guad-u)	(1)	+Impiacus	C (Vise-u)		(963,1246)
+Globosobucina	P (Leon)		(538)	+Incisius	P (Sakm)	-P (Dora)	(963,1142)
+Globosochonetes	C (Vise)		(994)	+Indigia	P (Sakm)		(963)
+Globosoproductus	C (Vise)		(963)	Inflatia	C (Vise-u)	-C (Bash-l)	(400,955, 1200)
+Glossoleptaena	S (Prid)	-D (Sieg-u)	(25)	+Infurca	O (Cara)		(538)
Glyptambonites	O (Llde-u)	-O (Cara-l)	(1,878)	Ingria	O (Aren-u)	-O (Llvi-u)	(412,878)
Glyptomena	O (Llde-u)	-O (Ashg)	(1,29,397)	+Iniproductus	D (Fame-u)		(963)
+Glyptosteges	P (Sakm)	-P (Leon-l)	(7)	Institella	P (Leon-m)	-P (Leon-u)	(7)
+Gondolina	C (Serp)		(963)	Institifera	C (Vise-u)	-C (Bash)	(1,400, 1246)
+Goniarina	C (u)	-P (Leon-u)	(7)	Institina	C (Vise-u)	-P (Djhu)	(1,400, 1066)
Goniotrema	O (Llvi)		(397,878)	Inversella	O (Llvi-l)	-O (Llvi-u)	(878)
+Gorgostrophia	D (Sieg)	-D (Emsi)	(416,538)	Irboskites	D (Fras)		(25)
Gorystrophia	D (Gedi)	-D (Sieg)	(25)	+Iridostrophia	S (Ludl)	-D (Sieg)	(25,1148)
Grandaurispina	P (Leon-m)	-P (Guad-u)	(7,963)	+Isochonetes	C (Bash-l)		
+Grandiproductella	D (Fame)		(963)	Isophragma	O (Cara-l)		(878)
Grorudia (+ Alwynella)	O (Cara-l)		(878)	+Jakutella	C (Bash)	-C (Step-u)	(963)
Grumantia	P (m)	-P (Guad-l)	(429)	+Jakutochonetes	C (Bash)?	-P (Guad-l)	(538)
Gubleria	P (Djhu)		(411)	Jakutoproductus	C (Step-l)	-P (Leon-u)	(417,963, 1246)
+Guistrophia	D (Emsi-l)		(881)	+Jakutostrophia	D (Eife)		
+Guizhovella	C (l)			+Janiomya	S (Prid)	-D (Gedi-l)	(25,416)
+Guangjiayanelia	P (l)		(881)	+Jielingia	O (l)		(881)
Gunnarella	O (Cara-l)	-O (Ashg-m)	(1,538)	+Jiguliconcha	C (Step-l)	-C (Step-u)	(963,1246)
+Gunningblandella	O (Cara-u)		(419,878)	+Jipuproductus	P (l)		(881)
+Guttasella	O (Llvi)		(878)	+Johnsonetes	D (Emsi)?, D (Eife)?		(881)
+Hallinetes	D (Eife)		(1146)	+Jonesea	O (Ashg-l)	-S (Prid)	(878)
Hamlingella	D (Fame-m)	-D (Fame-u)	(1)	Juresania	C (Step-l)	-P (Leon)	(7,400, 1200)
+Hanaeproductus	D (Give-l)						
Haydenella	P (Leon-m)	-P (Dora)	(150,1142)				
+Haydenoides	P (u)?						
Hedstroemia	O (Cara-l)	-O (Ashg-m)	(1)				

Taxon	First Appearance	Last Appearance	Reference	Taxon	First Appearance	Last Appearance	Reference
+Kadriliproductus	C (Tour-u)	-C (Vise-l)	(963,1246)	Leptestia	O (Aren-u)	-O (Cara-m)	(1,538,878)
+Kajnarina	O (m)		(878)	Leptestiina	O (Cara-l)	-O (Ashg-m)	(878)
+Kansuella	C (Vise-u)		(1,963)	+Leptochonetes	D (Sieg)	-D (Emsi)	(994)
+Karavankina	C (Vise-u)?	-P (Sakm)	(400,963)	Leptodonta	D (Sieg)	-D (Eife)	(25,538)
+Kasetia	P (Sakm-u)	-P (Leon-u)	(963)	Leptodontella	D (Eife)	-D (Give)	(25,538)
Kassineella (+ Durraanelia)				Leptodus	P (Leon-m)	-P (Dora)	(7,936)
+Katastrophomena	O (Cara-u)	-O (Ashg-u)	(878,965)	Leptostrophia	S (Ldov-l)	-D (Fras)	(25,27,538)
+Kavesia	O (Ashg-m)	-S (Ludl-l)	(24,25)	+Leptostrophiaella	S (Wenl)	-D (Eife)	(538)
+Kelamelia	D (Fame-u)	-C (Tour-l)	(963)	+Lercarella	P (Guad)?		(538)
+Kentronetes	C (u)		(881)	+Lethamia	P (Guad-u)		(963)
+Keokukia	D (Gedi-u)?	-D (Eife)		+Leurosina	P (Sakm-u)	-P (Guad-l)	(7)
+Keyserlingina	C (Vise-l)	-C (Vise-u)	(955)	+Levipustula	C (Serp)	-C (Step-u)	(1246)
+Khaegaestrophia	C (Step-u)	-P (Guad-l)	(1,411)	Levitusia	C (Tour-u)	-C (Vise-l)	(400,1200, 1246)
+Kiaeromena	D (Emsi-l)		(1147)	Lialosia	P (Leon)		(1)
Kiangsiella	O (Cara-l)	-O (Ashg-m)	(1,538)	+Libys	C (Vise-u)		(963)
+Kinelina	P (Leon)?	-P (Guad-u)	(411)	Liljevallia	S (Ldov-u)	-S (Wenl-l)	(25,27)
Kirkina	D (m)		(538)	Limbella	C (Step-u)	-P (Leon-u)	(1,7,1066)
Kjaerina	O (Llvi-u)		(2)	+Limbifera	C (Vise-u)		(963,1246)
Kjerulfina	O (Cara-l)	-O (Ashg-u)	(1,5,965)	Limbinurina	O (Cara-l)		(1)
Kochiproductus	O (Cara-l)	-O (Ashg-u)	(1,538)	Linoproductus	C (Vise-u)	-P (Djhu)	(4,7,411, 1066)
+Komukia	C (Vise-u)	-P (Leon-u)	(7,417)	+Linoprotonia	C (Vise-l)	-C (Vise-u)	(400)
+Kozhuchinella	C (Asse)	-P (We)	(538)	+Linosstrophomena	S (Wenl-l)		(651)
Kozłowskaia	O (Trem)		(878)	+Lioleptaena	C (Serp)	-C (Step-u)	(2,4)
Kozłowskites	C (Bash-l)	-P (Leon-m)	(400,403)	Liosotella	P (Leon-u)	-P (Guad-u)	(7)
+Krejciigratella	O (Cara-l)	-O (Ashg-m)	(25,878)	+Lipanteris	C (u)	-P (l)	(881)
+Krizistrophia	D (Eife)		(538)	+Liraplecta	P (Sakm)		(963)
Krotovia	S (Wenl)		(1148)	+Liraria	P (Sakm-u)	-P (Leon-l)	(7)
	C (Vise-u)	-C (Bash-l)	(1,40,411, 1246)	Lissochonetes	C (Serp-l)	-P (Dora)	(417,538, 1142)
+Kueichowella				+Lissoleptaena	D (Gedi)	-D (Sieg)	(1148)
+Kunlunia	C (Ms)			+Lissomarginifera	C (Serp-l)	-C (Step-u)	(400)
+Kurtomarginifera	C (Pn)	-P (l)	(881)	+Lissosia	P (Leon)	-P (Guad-u)	(538)
+Kutorginella	P (Dora)		(1142)	Lissostrophia	S (Ludl)		(25,538)
	C (Bash-l)	-P (Guad-u)	(7,963, 1200)	+Litocothia	P (Leon-m)		(403)
+Kuvelusius	+Lissostrophia			+Liveringia	P (u)		(881)
Labriproductus	P (Guad-l)		(43)	Loczyella	P (Djhu)		(963)
+Laevicyphomena	C (Vise-l)		(955,1)	+Lomatiphora	C (Tour)		(963)
+Lameispinifera	C (Vise-l)		(538)	Longispina	D (Eife-l)	-D (Fras-l)	(4,25,39)
+Lamellosia	S (Ldov)		(1246)	+Lopasnia	C (Mosc)		(963)
Laminatia	P (Guad-u)		(7)	+Lopingia	P		
+Lammimargus	D (Fame-m)	-D (Fame-u)	(25,708)	+Loreleiella	D (Sieg-u)	-D (Emsi-l)	
+Lampangella	P (Leon-u)	-P (Guad-l)	(963,1246)	+Loxophragmus	P (Leon-m)	-P (Leon-u)	(7)
+Lanipustula	P (Dora)		(963)	+Luanquella	D (Emsi)	-D (Eife)	(994)
+Lapasnia	C (Vise-u)	-C (Serp-u)	(963,1200)	+Ludfordina	O (Cara)	-S (Ludl)	(538)
+Laterispina	C (Mosc-l)		(963)	+Luhaiia	O (Cara-u)	-O (Ashg-u)	(1,965)
+Latiproductus	P (Dora)		(963)	+Luofuia	D (Eife)		(24)
Leangella	C (Vise-u)	-C (Bash-l)	(400,1200)	+Lyonia	P (Sakm)		(963)
+Leiochonetes	O (Cara-l)?	-S (Ludl-l)	(878,1066)	+Lytonia	P (Leon)	-P (Djhu)	(33,411)
Leioproduktus	C (Vise-l)		(955)	+Maakina	O (Cara-m)	-O (Cara-u)	(1,538)
+Lepidoleptaena	D (Fame-m)		(25,708)	+Mabella	O (u)		(881)
+Lepidomena	S (Wenl-u)	-D (Emsi-l)	(25,27,538)	+Mackerrovia	S (Ldov-u)		(430)
Leptaena	O (m)		(1138)	Macrocoelia	O (Llvi-u)	-O (Cara-m)	(397,406)
Leptaeniscia	O (Llde-u)	-C (Tour-u)	(4,5)	+Maemia	C (Bash)	-C (Step-u)	(1246)
Leptaenoidia	S (Ludl)	-D (Sieg)	(25,1066)	+Magadania	P (Guad-l)		(963)
+Leptaenomenclax	S (Wenl-u)		(25,27)	+Magicoestrophia	O		(881)
Leptaenopoma	D			+Magniplicatina	P (Guad-l)		(963)
Leptaenopyxis	O (Ashg-u)		(416)	+Magniventra	D (Sieg)	-D (Emsi)	(538)
Leptagonia	D (Gedi)	-D (Emsi-l)	(24,25)	+Magnumbonella	C (Tour-l)	-C (Tour-u)	(955)
Leptalosia	S (Wenl)	-C (Serp-l)	(1,25,400)	+Malayanopia	D (u)	-C (Ms)	(538)
Leptelloidea	D (Fame-u)	-C (Step-u)	(25,41)	+Malloproductus	D (Fame)		(881)
Leptella	O (Trem-l)?	-O (Aren-u)	(878,1066)				
Leptellina	O (Trem-l)?	-O (Aren-u)	(878,1066)				
Leptelloidea	O (Llvi-l)	-O (Ashg-m)	(878)				
	O (Llvi)?	-O (Cara-l)	(1,878)				

Taxon	First Appearance	Last Appearance	Reference	Taxon	First Appearance	Last Appearance	Reference
+Malurostrophia	D (Emsi)	-D (Eife)	(538)	Murinella	O (Llde-l)	-O (Cara-l)	(1,5)
+Mamutinetes	D (Eife)		(1149)	+Nabarredia	D (Gedi)	-D (Sieg)	(994)
+Mansina	O (l)		(ZR78)	+Nabiaoia	D (Eife)		(24,878)
Maoristrophia	S (Wen-l)	-D (Emsi-l)	(1)	+Nadiastrophia	D (Emsi-l)	-D (Eife)	(24,25)
+Margaritiprproductus	D (Fame-u)		(963)	+Nanambonites	O (Livi)		(878)
+Marginalosia	P (Dora)		(427)	Neochonetes	C (Bash-l)	-P (Dora)	(400,418,1142)
Marginatia	C (Tour-l)	-C (Vise-l)	(1,955,1066)	+Neocramatia	O (Cara-u)		(930)
Marginicinctus	C (Vise-u)		(1,400)	+Neokjaerina	O (Ashg)		(538)
Marginifera	P (Leon-u)	-P (Guad-l)	(1246)	+Neoplicatifera	P (Sakm)	-P (Leon-l)	(963)
Marginirugus	C (Tour-u)	-C (Vise-l)	(963,1200)	+Neoyanguania	C (l)		(881)
+Marginoproductus	C (Vise)		(963)	Nervostrophia	D (Emsi-l)	-D (Fras-u)	(25,538)
+Marginovatia	C (Vise-u)	-C (Mosc-l)		+Neumanella	S (Ludl)	-S (Prid)	(538)
+Markamia	C (Pn)		(881)	+Nigerinoplica	D (Fame-l)	-C (Tour-l)	(955)
+Matanoleptodus	P (u)		(881)	+Niutoushania	P (Guad-l)	-P (Guad-u)	(963)
+Maydenella	O (m)		(1138)	+Niviconia	P (Leon-m)	-P (Leon-u)	(7)
Mclearnites	S (Wen-l)	-D (Gedi)	(25,538)	Nix	C (Serp-l)		
+Mclearnitesella	S (Wen-l)	-D (Gedi)	(538)	+Nodella	D (u)	-C (l)	
Meckella	C (Serp-u)	-P (Dora)	(7,400,1142)	Notanopia	S (Prid)	-D (Sieg)	(538)
Megachonetes	C (Tour-u)	-C (Serp-l)	(1,24,400,1200)	+Nothokuvclousia	C (u)	-P (l)	(881)
+Megaderbyia	P (Guad)			+Nothopindax	P (Asse)		(7)
+Megalosia	P (Dora)			Notiochonetes	D (Sieg)	-D (Emsi)	(39,994)
Megamyonia	O (Cara-u)	-O (Ashg-l)	(764)	Notoleptaena	D (Gedi)	-D (Emsi)	(25)
+Megaspinochonetes	S (Wen-l)?		(24)	+Notoloslia	P (u)		(881)
+Megasteges	P (Dora)		(1066)	+Notostrophia	P (Leon-l)		(427)
Megastrophia	S (Ldov-u)	-D (Give-l)	(25,27)	+Novellinetes	D (Emsi)		(994)
+Megastropiella	D (Emsi)	-D (Eife)	(538)	+Nubialba	O (Ashg-m)		
+Megatschernyschewia	P (m)		(881)	Nudauris	P (Asse-l)	-P (Leon-u)	(7,963)
Megousia	P (We)	-P (Guad-u)	(7)	+Nudyimia	C (Vise-u)	-C (Serp)	(963)
Mercieilla	S (Ldov-m)	-S (Ldov-u)	(25,878,965)	+Nurochonetes	D (Emsi-l)	-D (Emsi-u)	(994)
Mesodouvillina	S (Wen-l)	-D (Eife-u)	(25,28)	+Odoratus	O (m)?, O (u)?		(881)
+Mesoleptostrophia	S (Ldov-m)?	-D (Gedi)	(538)	Oepikina	O (Llde)	-O (Ashg-m)	(1,397)
Mesolissostrophia	S (u)		(1)	Oepikinella	O (Cara-l)?	-O (Cara-m)?	(1)
Mesolobus	C (Bash-l)	-P (Leon-u)	(1,7,1200)	+Ogbinia	P (Guad-l)	-P (Djhu)	(411)
Mesopholidostrophia	S (Ldov-u)	-D (Give-l)	(24,25)	Oldhamina	P (Djhu)	-P (Dora)	(411,936,1142)
Mesoplica	D (Fame-m)	-D (Fame-u)	(25,955,1200)	+Oldhaminella	P (u)?		
+Mezounia	S (Wen-l)		(25,878)	Oligorachis	D (Fras-l)		(25)
+Micraphelia	P (Leon-m)	-P (Djhu)	(7)	Ombonia	C (Pn)	-P (Dora)	(7,411,538)
Microtrypa	O (Cara-l)	-O (Cara-m)	(1,397)	+Onavia	C (Tour-l)		(1246)
+Mingenewia	P (Leon-m)		(431)	+Oncosarina	P (Sakm)	-P (Leon-l)	(7)
+Minispina	C (Step)?		(538)	+Onopordumaria	C (Mosc)		(538)
+Minutostropheodontia	D (Eife)		(538)	+Opikella	S (Wen-l)	-S (Wen-l)	(25,764,860)
+Mistproductus	P (Leon)		(1150)	Orbinaria	D (Fame-u)		(25,1200,1246)
+Mitchellella	S (Ludl)		(538)	+Origostrophia	O (Ashg)		(538)
Mjosina	O (Cara-l)	-O (Ashg-m)	(1,538)	Orthopleura	D (Eife)	-D (Give)	(25)
+Moderatoproductus	C (Vise-u)		(963)	Orthotetella	P (Asse-l)	-P (Leon-m)	(7)
+Molongcola	O (Cara)		(1135)	Orthotetes	C (Mosc-l)	-P (Guad-u)	(1,4,1200)
+Mongoliella	D (Sieg)			+Orthotetoides	C (u)		(881)
+Mongoloslia	P (We)		(538)	Orthothetina	C (Serp-l)	-P (Dora)	(411,1142)
Monticulifera	P (Asse)	-P (Guad-l)?	(963)	Orthothrix	P (Djhu)		(1)
+Montsenetes	D (Give)		(1151)	+Otarieilla	P (Leon)		(538)
+Moravostrophia	D (Give-l)		(25)	+Ottadalenites	O (Livi-l)		(412,878)
+Morganella	D (Fame-l)		(963)	Ovatia	C (Tour-l)	-C (Bash-l)	(1,48,400)
+Morinorhynchus	S (Wen-l)	-D (Gedi-l)	(764,860)	Overtonia	C (Vise-u)	-C (Serp-l)	(1,400,1066,1246)
Muirwoodia	C (Step-l)	-P (Guad-u)	(40,963)	+Overtoniina	P (Leon)		(1246)
+Multiridgia	O		(881)	+?Ozora	C (Vise-l)		(1200)
				+Palaeoldhamina	P (l)		(881)
				+Palaeoleptostrophia	S (Ldov-l)	-S (Ldov-u)	(1152)

Taxon	First Appearance	Last Appearance	Reference	Taxon	First Appearance	Last Appearance	Reference
Palaeostrophomena	O (Llde-u)	-O (Ashg-m)	(1,878,930)	+Platyconcha	P (Leon-u)		(963)
+Palmerhythis	C (Vise-u)		(881)	Platymena	O (Cara-l)	-O (Ashg-u)	(1)
+Papilloilinus	C (Vise)		(963)	+Platyselma	C (Vise-u)		(1246)
+Papilostrophia	D (Sieg)?	-D (Emsi)	(416,538)	+Plebejochonetes	D (Sieg-u)	-D (Eife)	(39)
+Parabuxtonia	C (l)		(881)	Plectambonites	O (Aren-u)	-O (Cara-l)?	(878)
+Parachonetella	P (Guad-u)		(963)	Plecticella	O (Trem-u)		(878)
+Parachonetes	D (Sieg)	-D (Emsi)	(25,994)	Plectodonta	S (Ldov-m)	-D (Eife)	(25,878, 965)
+Paracostanopia	D (Emsi)		(538)	Plectodontella	D (Eife-l)		(878)
+Paraderbyia	P (l)		(881)	+Pleurochonetes	D (Sieg)		(538)
+Parademonedys	P (l)		(881)	+Plicaea	C (Vise)		(1154)
+Parageyerella	P (Dora)		(881)	+Plicanopia	D (Sieg-u)?	-D (Eife)?	(25,538)
+Parajuresania	C (Bash-l)	-C (Mosc-u)		+Plicanoplites	D (Sieg)?, D (Emsi)?		(538)
+Parakansuella	C (l)		(881)	Plicatifera	C (Vise-u)		(1246)
+Paraleptodus	P (l)		(881)	+Plicatiferina	C (Pn)		(538)
+Paraleptostrophia	D (Emsi)	-D (Eife)?	(538)	Plicatoderbya	P (l)	-P (Guad-u)	(1)
Paralyttonia	C (Pn)	-P (Guad-u)	(403,538)	Plicochonetes	D (Fame-u)	-C (Serp-l)?	(24,41,400)
Paramarginatia	P (Wc)		(538)	Plicodevonaria	D (Emsi)	-D (Eife)	(39)
Paramarginifera	P (Asse)	-P (Leon)	(963)	+Plicoproductus	D (Eife)		(963)
+Parameekella	P (Guad)?	-P (Tatr)	(881)	Plicostropheodonta	D (Sieg)	-D (Emsi-u)	(25)
+Paramesolobus	C (Bash-u)	-P (Djhu)	(418)	+Ploughsharella	P (u)		(881)
+Paramonticulifera	P			Poikilosakos	C (Step-l)	-P (Djhu)	(411)
+Paramuirwoodia	C (u)		(881)	+Polonioproductus	D (Eife-u)		(861)
+Paranisopleurella	S (Wenl)		(881)	+Polymorpharia	P (Leon-u)	-P (Guad-u)	(7,963)
+Paraothotina	P (Guad-u)		(881)	+Pomeromena	O (u)		(538)
+Parapholidostrophia	D (Emsi-l)	-D (Give-l)	(25,47)	+Pradochonetes	D (u)		(881)
+Paraplicanopia	D (Emsi-u)	-D (Eife)	(24)	+Praehorridonia	C (Serp)	-C (Mosc)	(963)
+Paraplicatifera	P (Sakm)	-P (Leon)	(963)	Prachaeogenoconcha	D (Fame-l)		(25)
+Parapulchratia	P			Probolonia	P (Guad-l)	-P (Guad-u)	(963,1246)
Parastrophonella	D (Emsi)	-D (Give)	(538)	+Proboscisambon	O (Ashg-m)		(538)
+Parmephrix	C (Vise-u)		(1153)	Proboscidella	C (Vise-u)	-C (Serp-u)	(400)
+Parmula	S (Prid)		(881)	Productella	D (Give-u)	-D (Fras-u)	(4,426,963)
+Paromalomena	O (Ashg-m)	-O (Ashg-u)	(965)	Productellana	D (Fame-u)	-C (Tour-l)	(963,1200)
+Paryphella	P (Dora)		(963,1246)	Productellina	D (Fame-u)		(1)
Paucicostella	O (Llvi)?		(1)	+Productelloides	D (Fame-m)		(963)
+Paucispinauria	P (l)		(881)	Productina	D (Fame-u)	-C (Bash-l)	(400,861)
Paucispinifera	P (Leon-u)	-P (Guad-u)	(7)	Productus	C (Vise-l)	-C (Bash-l)	(1,963)
+Paucistrophia	D (Emsi-u)		(24)	+Promarginifera	C (Vise-u)		
+Pectenoproductus	P (Guad-u)	-P (Djhu)	(963)	Prorichtofenia	P (Leon)	-P (Guad-l)	(1,2)
Pelonomia	O (Llvi)		(1,878)	+Prorugaria	C (Step)?		(538)
+Pembrostrophia	S (Wenl)		(538)	+Protanidanthus	C (Step-u)		(963)
Peniculauris	P (Sakm-u)	-P (Leon-u)	(7)	+Protoguliferina	C (Mosc-u)	-C (Step-l)	
Pentlandina	S (Ldov-l)	-S (Ludl-l)	(25,27)	Protonchetes	S (Ldov-u)	-D (Gedi)	(25,39,994)
+Perichonetes	D (Emsi-u)	-D (Eife)?	(24)	+Protocymostrophia	S (Ludl)	-D (Emsi)	(538)
Perigeyerella	P (Leon-m)	-P (Dora)	(1,403, 1142)	+Protodouvillina	S (Prid)	-D (Give)	(538)
+Permochonetes	P (Sakm)	-P (Leon-l)	(418)	+Protogarginifera	C (Vise)		(963)
+Permorthotestes	P		(538)	Prototeleptostrophia	D (Sieg)	-D (Fras)	(25,538)
+Permudaria	P (Leon-u)?	-P (Tatr)	(963)	Protomegastrophia	S (Ldov-u)	-D (Gedi)	(25)
+Petaloconchetes	C (Ms)		(881)	Protoniella	C (Vise-u)	-C (Serp-l)	(400,1246)
+Petasmaia	P (Leon-m)		(7)	+Protoshaleria	S (Wenl-u)	-D (Gedi)	(538,764)
Petroria	O (Aren-u)	-O (Llvi-l)	(878)	+Protoguliferina	C (Pn)	-P (Wc)	(538)
+Pharacidodiscus	C (Tour-u)		(963,1246)	+Pseudoanisopleurella	O		
+Philippotia	D (Emsi)		(881,994)	+Pseudoantiquatonia	P		(881)
+Pholidostrophia	S (Ldov-m)	-D (Fras)	(538,965)	+Pseudoavonia	P (l)		(881)
+Phragmostrophia	D (Emsi)	-D (Give-l)	(25,538)	+Pseudochonetes	D (l)	-D (m)	(ZR79)
+Piloricilla	C (Tour-l)	-C (Tour-u)	(881,955)	Pseudoderbyia	P (l)		(1)
Pionomena	O (Cara-l)		(1)	+Pseudodouvillina	D (Fras-u)		(538)
Pirgulia	P (Guad)		(538)	+Pseudoleptellina	O (Ashg)		(1155)
Planispina	P (l)		(1)	Pseudoleptodus	P (Asse)	-P (Guad-u)	(7)
+Planodouvillina	D (Emsi)		(538)	Pseudomarginifera	P (l)		(1)
Planoproductus	D (Fame-m)		(1,708)	+Pseudomonticulifera	P (l)		(881)
+Platycancrinella	P (u)		(881)	Pseudostrophalosia	P (Sakm-u)	-P (Leon-l)	

Taxon	First Appearance	Last Appearance	Reference	Taxon	First Appearance	Last Appearance	Reference
+Pseudostrophochonetes				+Ruthiphiala	C (Tour-l)		(955)
Pseudostrophomena	D (l)		(881)	+Rutrumella	O (Llvi)		(412,878)
+Pterostrophia	O (Cara-m)		(538)	+Saetosina	C (u)	-P (m)	(881)
Ptychoglyptus	D (Sieg-l)	-D (Sieg-u)	(881)	+Saharonetes	D		(881)
Pugilis	O (Llde)	-O (Ashg-u)?	(878)	+Sajakella	C (Vise-u)	-C (Bash)	(963,1246)
Pulchratia	C (Tour-u)	-C (Serp-u)	(400)	Sampo	O (Cara-u)	-O (Ashg-u)	(878,965)
	C (Step-l)	-C (Step-u)	(41,50,1200)	Sandia	C (Bash-l)		(41,400,963,1246)
Pulsia	C (Vise-u)	-C (Step-l)	(432)	+Sandrella	P		(881)
Pustula	C (Tour-l)	-C (Vise-u)	(1,400,955)	+Sanjuanella	O		(881)
+Pygmochonetes	P (Leon-u)		(994)	+Sanjuanetes	S (Ludl)	-D (Gedi)	
Quadratia	C (Tour-l)	-C (Serp-l)	(1)	+Sarytchevinella	P (Guad)		(963)
Quadrochonetes	C (Mosc-u)	-P (Guad-l)	(1)	Scacchinella	C (Step-u)	-P (Guad-l)	(1066)
+Quasiavonia	C (Vise-u)		(1246)	+Scamnomena	S (Wenl)		(538)
+Quasistrophonella	S (Ludl)	-D (Sieg-l)	(538,1066)	+Scapharina	P (Guad-u)		(7,1246)
+Qianjiangella	O (u)		(881)	+Sceletonia	P (Leon-l)		(7)
+Qianomena	S (Ldov-m)	-S (Ldov-u)	(881,965)	+Schedophyla	O (Aren-l)	-O (Llvi)?	(878)
+Quinquenella	P (Leon-u)	-P (Djhu)	(418)	Schellwienella	D (Gedi-u)	-C (Serp-l)	(38,48,955)
+Quondogia	O (Cara)		(1135)	+Schistochonetes	C (Vise)		(994)
Radiomena	D (Emsi)	-D (Give-l)	(25)	+Schrenkiella	P (Sakm)	-P (Leon)	(963)
Rafinesquina	O (Llvi-u)	-S (Ldov-l)	(5,32,538)	Schuchertella	D (Gedi-l)	-P (Leon-u)	(7,28,403,1060)
+Raittonella	O (m)		(1135)	Schuchertellopsis	D (Eife)	-D (Fras)	(1,538)
+Ralia	D (Emsi-u)		(811)	+Scissicosta	C (Tour-l)		(963)
Ramavectus	P (Sakm-u)	-P (Leon-m)	(7)	+Scolococoncha	C (Vise-u)		(1246)
+Ramosvina	P (m)		(881)	Scuteputula	C (Tour-u)		(955)
+Ratburia	P (Leon-u)		(418)	+Selloproductus	P (Guad)		(963)
+Reedoconcha	P (Leon)		(538)	Semenewia	C (Tour-u)	-C (Serp-l)	(400)
+Reinversella	O (Aren-u)	-O (Llvi)	(412,878)	Semicostella	C (Vise-l)	-C (Serp-u)	(1246)
+Renaudia	D (Sieg)?	D (Emsi)?	(538)	+Semileptagonia	D (u)		(538)
Retaria	C (Mosc-u)	-C (Step-u)?	(1)	+Seminuella	C (Tour-l)	-C (Tour-u)	(881,955)
Retichonetes	D (Eife)	-C (Tour-u)	(1,994)	+Semiplanella	C (Vise-u)	-C (Serp-l)	(400)
Reticulatia	C (Bash-l)	-P (Sakm)	(7,41,400)	Semiplanus	C (Vise-u)	-C (Serp-l)	(1200)
Reticulatochonetes	C (Tour)		(1)	Semiproductus	D (Fame-u)	-C (Tour-u)	(25,955)
+Retimarginifera	P (Sakm-u)	-P (Leon-u)	(403,963)	+Sentolunia	O (Ashg-l)		(416)
+Retroplexus	C (Vise-u)		(881)	Sentosia	D (Fame-m)	-C (Tour-l)	(25,708)
+Reversella	O (Ashg-m)		(878)	+Sentosiooides	C (Tour-l)		(963)
+Rhactomena	O (Ashg)		(538)	+Septachonetes	D (Emsi)		(994)
Rhamnaria	P (Sakm-u)	-P (Guad-u)	(7)	+Septapermella	D (Gedi)		(538)
Rhenostrophia	D (Gedi)	-D (Emsi)	(25,538)	Septarinia	C (Vise-u)		(1)
Rhipidomena	O (Llde)	-O (Cara-l)	(1,397)	+Septasteges	P (Leon)		
+Rhyssochonetes	D (Give-u)	-D (Fras-l)	(708)	+Septiconcha	P (Guad-l)		(963)
+Rhytialosia	D (Fras-m)		(907)	+Serbarinia	C (Vise-u)		(963)
Rhytiophora	C (Tour-l)		(955,1246)	Sericoides	O (Llde-u)	-O (Ashg-u)	(1,433,965)
+Rhytisia	P (Leon-m)	-P (Guad-l)	(7,1246)	+Seseloisi	P (Leon-u)		(1060)
+Rhytistrophia	S (Ludl)	-D (Eife-l)	(4,538)	+Serratoicrista	C (Vise-u)		(400)
Richtiofenia	P (l)	-P (Dora)	(1,2,936,1142)	+Sestropoma	P (Guad-l)	-P (Guad-u)	(7)
Rigybella	P (Leon-m)	-P (Guad-u)	(7,403)	Setigerites	C (Tour-u)	-C (Vise-u)	(1,400,955)
+Rotundostrophia	D (Sieg)	-D (Emsi-u)	(416)	+Shagamella	S (Wenl-u)	-S (Ludl)	(25)
+Rugaria	P (Sakm-u)	-P (Dora)	(7,418)	Shaleria	S (Ldov-u)	-D (Gedi)	(25)
Rugatia	C (Step-l)	-P (Leon-u)	(7,963)	+Shaleriella	S (Wenl)	-S (Prid)	(538)
Rugauris	C (Tour-l)		(955,1246)	+Shiquianella	S		
Rugicostella	C (Vise-l)	-C (Vise-u)	(400,1066)	+Shishapangmaella	C (Ms)		(881)
Rugivestis	P (Asse)	-P (Leon)	(1,963,1246)	+Shlyginia	O (m)		(881)
Rugoclostus	C (Bash-l)	-C (Bash-u)	(955,1200)	+Siberistrophia	S (Wenl)	-D (Emsi)	(538)
+Rugoconcha	C (Bash-l)		(963,1246)	Sicelia	P (Leon-u)		(1)
Rugoleptaena	S (Ludl)	-D (Eife)	(25,538)	+Sicularia	P (Leon-u)		(1060)
Rugosochonetes	C (Tour-l)	-C (Serp-u)	(1,34,994)	+Simplicarina	P (Guad-l)		(1246)
+Rugosomarginifera	P (Dora)		(1142)	+Sinochonetes	D (Sieg)		(24,994)
+Rugosowerbyella	O (Ashg-l)	-O (Ashg-u)	(878,965)	Sinoproductella	D (Fame)		(25,963)
+Rurambonites	O (Cara-u)?	-O (Ashg-u)	(878)	+Sinoshaleria	D		
				Sinostrophia	D (Emsi-l)		(24)

Taxon	First Appearance	Last Appearance	Reference	Taxon	First Appearance	Last Appearance	Reference
Sinuatella	C (Vise-u)	-C (Serp-l)	(1,400)	+Subglobosochonetes	C (Tour-l)	-C (Vise-l)	(955)
-Siphonosis	P (Leon-m)	-P (Leon-u)	(7)	+Substriatifera	P (Guad)		(963)
+Sokolskya	C (Bash-l)	-C (Bash-u)	(400,1200)	+Subtaeniothaeus	P (u)		(ZR89)
+Sommeriella	P (Sakm)	-P (Guad-l)	(538)	+Subtransmena	D (Eife)		(538)
+Songzichonetes	P (l)		(ZR89)	+Sulcataria	C (Step)	-P (Sakm)	(7,418,994)
Sowerbina	P (Leon-m)		(417)	+Sulcatostrophia	D (Fras-u)		(4,538)
Sowerbyella (+ Viruella)				+Sulcirurgia	P (u)		(881)
	O (Llvi-u)?	-S (Ldov-l)	(878,965)	+Svalbardia	P (Leon-u)	-P (Guad-u)	(538)
Sowerbyites	O (Llde-u)	-O (Cara-u)	(878)	+Svalbardoproducetus	P (Leon)	-P (Guad-u)	(963)
Spanodonta (+ Archambona)				Syndelasma	O (Llvi-l)		(1,878)
	O (Trem-u)	-O (m)?	(878)	+Syntrophodonta	D (m)		(881)
Sphenalosis	P (Leon)?	-P (Guad)	(1,40)	+Taemostrophia	D (Emsi)		(538)
Sphenosteges	P (Leon)?	-P (Guad-u)	(1,40)	+Taeniothaeus	P (Sakm)?	-P (Guad)	(538)
+Spinarella	P (Guad-l)		(1246)	Taffia	O (Aren-l)	-O (Llvi)	(878)
+Spinauris	C (Tour)		(963)	Taimyropsis	P		
Spinifrons	P (Sakm-u)	-P (Leon-m)	(7)	+Talasoproducetus	C (Vise)		(963)
+Spinocarinifera	C (Tour-l)		(34,955)	Taleoleptaena	D (Emsi-l)	-D (Eife)	(25)
+Spinochonetes	S (Ldov-m)	-S (Wen-l)	(24,651)	+Tangxiangia	D (Emsi-u)	-D (Eife)	(24)
Spinolytonia	P (u)		(1)	Tapajotia	C (Pn)	-P (l)	(1)
Spinomarginifera	P (Guad-u)	-P (Dora)	(150,963, 1142,1246)	Taphrodonta	O (Llvi-u)		(878)
				Taphroestria	P (Leon-u)		(7)
+Spinorugifera	C (Vise-u)			+Tashanomena	O (Ashg-m)		
D				+Tastaria	S (Ludl)	-D (Sieg)	(538)
Spinulicosta	D (Emsi-u)	-D (Eife-u)	(25)	+Tchadania	S (u)		(881)
Spirisiosium	P (Guad)		(538)	Tectarea	P (We)		(1,538)
+Spitzbergenia	P (Guad-u)		(963)	Teguliferina	C (Mosc-u)	-P (Leon-m)?	(7,1066)
-Spuriosa	P (Asse)		(7)	+Teichostrophia	D (Emsi)	-D (Give-l)	(25)
Spyridiophora	P (Asse)	-P (Guad-l)	(963,1066)	Telaeshaleria	D (Eife-u)	-D (Give-l)	(25)
Squamaria	P (Asse)	-P (Leon)	(963)	+Teleoproducetus	P (l)?		(881)
+Squamatina	D (Sieg)	-D (Emsi)	(994)	+Tenuichonetes	P (Guad-l)		(994)
+Stauromata	P (Leon-u)?			Teratelasma	O (Cara-l)		(397)
Stegacanthia	C (Tour-u)	-C (Vise-l)	(955)	+Teratellasmella	O (m)		(1138)
Steinhagella	D (Eife)?	-D (Fame-u)	(24,25,538)	Terrakea	P (Guad-l)	-P (Guad-u)	(427,963)
Stelckia	D (Give)		(25)	+Tesuquea	C (Bash-l)		(41,955)
+Stepanoconchus	P (Asse)	-P (Sakm)	(963)	Tetraodontella	O (Llvi-l)?	-O (Cara-m)	(878)
-Stepanoviella	P (Sakm-l)	-P (Dora)	(51,411, 1142)	+Tetragonetes	P (Leon)	-P (Guad-u)	(538)
				Tetraphalerella	O (Llde)	-O (Ashg-m)	(1)
+Stereochia	P (Sakm)	-P (Leon-u)	(963)	Thaerodonta	O (Ashg-l)	-S (Ldov-l)	(25,31,965)
+Stictozoster	P (Sakm-u)	-P (Leon-m)	(403)	+Thamnosia	P (Sakm-u)	-P (Guad-u)	(7)
Stipulina	C (Vise-u)		(1,400)	+Thecospiropsis	Tr(Carn)		(538)
+Streptopomum	C (l)			Thomasella	C (Vise-u)		(1,963,1246)
Streptorhynchus	C (Tour-l)	-P (Djhu)	(34,150)	+Thuleproductus	P (Leon-u)	-P (Guad-u)	(963)
Striatifera	C (Vise-u)	-P (Sakm)	(1,7)	Titanambonites	O (Llvi-u)	-O (Cara-l)	(1,397)
+Striatochonetes	D (Fras)		(994)	Titanium	C (Serp-l)	-C (Serp-u)	(400)
-Striatoproducetella	D (Eife-u)	-D (Fras-l)	(861)	+Titanomena	O (Ashg-u)		(401)
+Striatospica	P (Guad-u)		(963)	+Tityrophia	P (Sakm)		(963)
-Strictozoster	P (Leon-m)		(963,1246)	+Tivertonia	P (Sakm-u)	-P (Leon-l)?	(418)
-Strigospina	P (Guad)		(1246)	Tolmatchoffia	C (Tour-u)	-C (Vise-l)	(955)
+Striirichthofenia	P (l)		(881)	Tomilia	C (Vise)		(1)
-Striochonetes	P (Leon-m)	-P (Guad-l)	(418)	Toniproductus	C (Tour-u)	-C (Vise-l)	(955)
Strophalosia	P (Sakm)	-P (Guad-l)	(7)	Toquimia	O (Llvi)	-O (Cara-u)	(1,878)
Strophalosiella	P (We)		(1,538)	Torquistia	C (Tour)	-P (Leon-u)	(1,418)
Strophalosiina	P (Leon)	-P (Dora)	(4,1142)	+Tourmakeadia	O (Aren-u)		(396,878)
Strophochonetes	S (Ldov-l)?	-D (Emsi)	(25,994)	+Transennatia	P (Leon-m)	-P (Leon-u)	(403,1246)
Strophodonta	S (Prid)	-D (Fras-u)	(1,538)	+Trilobostrophia	D (Sieg)		(538)
Strophomena	O (Llvi-l)	-S (Ldov-l)	(1,965)	+Trichoconetes	C (Vise-u)		(994)
Strophonella	S (Ldov-m)	-D (Emsi)	(25,965)	Trigrammaria	O (Cara-l)	-O (Cara-m)	(1)
+Strophonellites	S (Wenl)		(25)	+Trimurellina	O (Ashg-l)?	-O (Ashg-u)	(878,965)
Strophonelloides	D (Fras-u)		(25)	+Tropidelasma	P (Asse-l)	-P (Guad-u)	(7)
-Strophopriion	S (Ldov-u)	-D (Gedi)	(538)	+Trotlandella	O (Cara)		(538)
Strophoproducetus	D (Fame)		(25)	Truncalosis	D (Give-l)	-D (Give-u)	(25)
+Strophorichthofenia	C (Pn)	-P (l)		+Truncatenia	P (u)		(881)

Taxon	First Appearance	Last Appearance	Reference	Taxon	First Appearance	Last Appearance	Reference
Tschernyschewia	P (Sakm)	-P (Dora)	(7,411, 1066,1142)	+Yunnanoleptaena	D (Gedi)		(1148)
Tubaria	C (Mose-l)	-P (Sakm)	(963)	+Zeravshania	S (Prid)	-D (Gedi)	(538)
+Tuberella	P (l)?		(881)	+Zhenania	P (l)		(881)
+Tubersulcatella	C (Bash)	-P (Leon)	(963)	+Zhexichonetes	P (l)		(881)
+Tubersulculus	C (Step-u)	-P (Leon)	(963,1246)	+Zia	C (Bash)		(41)
+Tubulostrophia	D (Sieg)	-D (Emsi)	(25)	Zophostrophia	D (Fras)		(25)
+Tudiaophomena	S			Or. PENTAMERIDA			
Tulcumbella	C (Tour-l)		(994)	+Acanthoglypha	O (Aren-u)		(396)
+Turgenostrophia	S (u)		(881)	+Aenigmastricklandia	S (Ldov-u)		(25)
+Tuvaechonetes	S (u)		(881)	Aliconchidium	S (Ludl)		(25)
+Tuvaestrophia	S (u)		(881)	Alimbella	O (Trem)		(1)
+Tylambonites	O (Cara)		(1135)	+Altumbella	O (m)		(881)
Tylopecta	P (Leon-u)	-P (Dora)	(963,1142)	+Amsdenina	S (Wenl-l)	-S (Prid)	(25,860)
+Ujukies	O (m)		(878)	Anastrophia	S (Ldov-m)	-D (Sieg-l)	(25,965)
Ukoa	O (Llvi)		(878)	Antirhynchonella	S (Ldov-m)	-S (Ludl-l)	(25,27)
+Umboactus	C (Mose-l)		(963)	+Apopentamerus	S (Ldov-u)	-S (Ludl)	(538)
Uncisteges	P (Wc)		(538)	+Aseptagypha	D (Emsi)		(538)
Undaria	C (Vise-u)		(1,400)	Barrandina	S (Wenl-l)	-S (Ludl)	(25,860)
+Undelella	P (Leon-u)	-P (Guad-u)	(994)	+Bateridium	S (Ludl)		(881)
+Undellaria	P (Sakm-u)		(7)	Biseptum	D (Eife)		(25)
+Undulella	P (Leon-u)	-P (Guad-l)	(7)	+Bisulcata	S (Prid)		(1066)
+Uraloconchus	P (Sakm)	-P (Leon-u)	(963)	+Bleshidium	S (Wenl)	-S (Prid)	(881,1066)
+Uraloproductus	P (Sakm)	-P (Leon-u)	(963)	+Bobinella	Cm(u)		(538)
Urushtenia	C (Pn)	-P (Leon)	(403,538)	+Boreadocamara	O (Aren)		
+Urushtenoidea	P (Wc)		(538)	+Borealis	S (Ldov-l)	-S (Ldov-m)	(24,25)
+Ussurichonetes	P (Guad-u)		(994)	+Boucotides	S (Wenl-u)		(25,764)
+Valdaria	S (Wenl-l)		(24,27)	Brevicamera	O (Cara-l)		(397)
+Vediproductus	P (Guad-l)		(403)	+Brevilamulella (+ Antigaleatella)	O (Ashg-m)	-S (Ldov-m)	(1264)
+Veerersalosis	D (Fras)		(907)	Brevisseptum	S		(538)
+Velostrophia	D (Emsi)		(538)	Brooksina	S (Wenl)	-S (Ludl)	(25,538)
+Verchojania	C (Bash-l)	-C (Step-u)	(963,1246)	Busulcata	S (Ludl)	-S (Prid)	(25)
Virginiana	S (Wenl-l)	-S (Wenl-u)	(24,25,764)	+Cadudium	S (Prid)		(881)
+Vituliproductus	C (Vise-u)		(ZR81)	Calliglypha	O (l)		(1)
+Viodostrophia	S (Ldov-u)			Callipentamerus	S (Ldov-u)	-S (Wenl)	(25,538)
Waagenites	P (Leon-m)	-Tr (Indu-l)	(150,403, 1142)	Cambrotrophia	Cm(mMid)		(2,16)
Waagenoconcha	P (Asse)?	-P (Dora)	(1200,1142)	Camerella	O (Aren-u)	-S (Ldov-u)	(4,35,538)
+Wardakia	C (Pn)	-P (l)		Capelliniella	S (Wenl-u)	-S (Ludl)	(25,538)
+Waterhouseiella	P (Leon-m)	-P (Leon-u)	(418)	+Carinagypha	D (Emsi-l)	-D (Emsi-u)	(25)
+Weiningia	C			+Caryogyps	S (Wenl-l)	-S (Ludl)	(538,860)
+Werrica	C (l)		(538)	Clarkella	O (Trem-u)	-O (Aren)	(1,4)
Whidbornella	D (Fras-l)	-D (Fame-u)	(538,955, 1200)	Clorinda	S (Ldov-l)	-D (Eife)	(25)
+Wimanoconcha	P		(881)	Clorindella	S (Ldov-u)	-S (Ludl)	(25)
+Wiradjuriiella	O (Cara)		(1135)	Clorindina	D (Sieg)		(25)
Wyatkina	P		(1)	Clorindinella	S (Ldov-u)?	-S (u)?	(1)
Wyndhamia	P (Sakm-u)	-P (Guad-l)	(1,46)	Conchidium	S (Wenl-l)	-S (Ludl-l)	(27,538)
Xenambonites	O (Llde)	-O (Cara-l)	(878)	Costistricklandia	S (Ldov-u)	-S (Wenl-l)	(25)
+Xenizostrophia	D (l)	-D (m)	(ZR79, ZR80)	+Cuparius	O (Llvi-l)		(538)
Xenosteges	P (Leon-m)	-P (Guad-u)	(7)	Cymbidium	S (Wenl-l)	-S (Ludl)	(25,860)
+Xenostrophia	D (Emsi-l)	-D (Emsi-u)	(24)	Diaphelasma	O (Trem-u)	-O (Aren-l)	
+Xestosia	P (Leon-m)	-P (Leon-u)	(7)	Didymelasma	O (Cara-l)		(1)
+Xinjiangiproductus	C (Serp-l)		(963)	+Disulcatella	S (Ldov-l)		(1264)
+Xinshaoproductus	C (Vise)		(963)	Doloresella	O (Aren)		(1)
+Xystostrophia	D (Eife-u)	-D (Give-l)	(25,416)	+Ectorhipidium	S (Ludl)		(25)
+Yagonia	C (Vise-l)	-C (Vise-u)	(561,994)	+Ehlersella	S (Ldov-u)		(25)
+Yakovlevia	P (Sakm-l)	-P (Guad-u)	(417,1246)	Enantiosphen	D (Give)		(25)
+Yanguania	C (Tour)		(963)	Enantiosphenella	D (Give-l)		(25)
+Ygerodiscus	S (Ldov-l)	-S (Wenl-u)	(433,878)	+Eoanastrophia	O (m)	-O (Ashg-m)	(ZR84, ZR85)
+Yuanbaella	O (l)	-O (m)	(881)	+Eoconchidium	O (Ashg-m)		(1264)
				+Eoikirkidium	S (Wenl)	-S (Ludl)	(538)

Taxon	First Appearance	Last Appearance	Reference	Taxon	First Appearance	Last Appearance	Reference
Euirostra	O (Cara)		(1)	Pentamerifera	S (Ludl)		(25)
+Galeoatagypa	S	-D	(881)	Pentameroides (+ Reveroides)	S (Ldov-u)	-S (Wenl-u)	(25,764)
+Galeatellina	O (Ashg-m)			Pentamerus	S (Ldov-m)	-S (Ldov-u)	(25,538)
+Gashaomiaoa	S (Ludl)	-D (Emsi)	(881)	Perimecocoelea	O (Cara-l)		(397)
+Geniculigypa	D (Give-l)		(1263)	+Physemella	D (Fras)		
+Glyptogypa	D (Eife-u)		(1156)	+Pinguella	S (Wenl-u)	-S (Prid)	(25,538)
Glyptotrophia	O (Trem)		(1)	Plectocamara	O (Cara-l)		(397)
Grayina	S (Wenl-l)	-D (Sieg)	(25,860)	+Plectosyntrophia	O (m)		(881)
Gypidula	S (Ldov-u)	-D (Fras-u)	(25)	Plectotrophia	Cm(Fran)?		(1)
Gypidulella	D (Eife)		(25)	Pleurodium	S (Ldov-m)		(651)
Gypidulina	D (Sieg-l)	-D (Fras-l)	(24)	+Plicidium	S (Ldov-m)		(1264)
+Gypiduloides	D (Fras-u)		(1215)	+Plicicoelina	S (Ludl)		(538)
Harpidium	S (Ldov-u)	-S (Ludl)	(24,25)	+Plicogypa	D (Emsi-u)	-D (Eife)	(11,46)
Hesperotrophia	O (Aren)		(1)	Plicostricklandia	S (Ldov-u)	-S (Wenl-u)	(25)
Holorhynchus (+ Nondia)				Porambonites	O (Aren)	-S (Ldov-u)	(1,397, 1066)
	O (Ashg-m)	-S (Ldov-m)	(1264)				
Huenella	Cm(Fran-l)	-Cm(Fran-u)	(414,618)	+Porambonitoides	O (l)		(ZR82)
Huenellina	Cm(Trep)		(1)	Procerulina	D (Sieg)	-D (Eife-u)	(25)
Idiostrophia	O (Aren-u)	-O (Llvi)	(396,397)	+Proconchidium (+ Norgium)			
Imbricatia	O (Aren-l)				O (Ashg-m)		(1264)
Ishimia	O (Cara-l)		(538)	+Prostricklandia	O (Ashg-m)		(1264)
+Isovella	S (Ldov-u)	-S (Ludl)	(538)	+Pseudocoelochidium (+ Paraconchidium)			
+Ivdelinella	D (Eife-l)		(538)		S (Ldov-m)	-S (Ldov-u)	(1264)
Ivdelinia	D (Sieg)	-D (Fras)	(1,2,538)	+Pseudoporambonites	O (l)		(ZR79)
Jolvia	S (Wenl)		(1)	+Pseudosieberella	D (Eife)		(538)
+Karakulina	O (Aren)		(538)	+Psilocamerella	O (m)		(881)
+Khodalevichia	S (Wenl)	-S (Ludl)	(25,538)	Punctolira	O (l)	-O (Aren-u)	(1)
+Kirkidium	S (Wenl-l)	-S (Prid)	(25,27)	+Rectigypidida	D (l)		
+Kokomerena	O (m)		(881)	+Rectotrophia	O (Aren-u)		(412)
Kulumbella	S (Ldov-m)		(1264)	Rhipidium	S (Wenl-l)	-S (Ludl-l)	(25,27,538)
+Kumbella	D (Give)		(538)	+Rhysselasma	O (l)		
+Lamelliconchidium	S (Ludl)		(25)	Rhyssotrophia	O (Llvi-l)		(1,538)
Levibiseptum	D (l)?, D (m)?			+Rosella	O (Aren)		(538)
Leviconchidiella	D (Eife)		(25)	+Rugolepyros	S (Wenl)		
Levigatella	S (Ludl)	-D (Fras)	(25)	+Rugostrophia	O (Aren-u)	-O (Cara)	(412,538)
+Limstrophina	O (m)		(ZR82)	Salonia	O (Cara-m)		(1)
Liostrophia	O (Cara-m)	-O (Ashg)	(1,538)	+Savageina	S (Wenl)	-S (Ludl)	(24,538)
Liricamera	O (Aren)	-O (Llvi)	(1)	+Scheguitania	D		(538)
+Lissidium	S (Wenl)			+Schizostrophina	O (m)		(ZR82)
Lissocoelina	S (Wenl-u)	-S (Ludl-l)	(25)	+Severella	S (Wenl-l)	-S (Ludl)	(25,860)
+Llanocella	D (Gedi)		(25)	+Shordolella	D (Gedi-l)		(1157)
Lycophoria	O (Aren)	-O (Llvi)	(1,1066)	Sieberella	S (Ludl)	-D (Emsi-l)	(25,38)
+Lysidium	D (Sieg)		(881)	+Spondylopyxis	S (Ldov-u)	-S (Ludl)	(25,860)
+Lysigypa	D (Eife)		(11,46)	Stenocamara	O (Aren)	-O (Cara-l)	(1,397)
+Mariannaella	S (Ldov-m)?			+Stenopentamerus	S (Wenl-u)	-S (Ludl)	(25)
Medessia	O (Trem)		(1)	Stichtrophia	O (Trem-u)	-O (Aren)	(1)
Mesonomia	Cm(u)	-O (l)	(1)	Stricklandia	S (Ldov-l)	-S (Ldov-u)	(25,538)
+Metabolipa	D (Give-u)	-D (Fras-m)		+Stricklandiella	S (Ldov-m)	-S (Ldov-u)	(538,651)
Metacamarella	O (Cara)		(25,538)	+Stricklandistrophia	S (Ldov)		(538)
Microcardinalia	S (Ldov-m)	-S (Ldov-u)	(25,1264)	+Subriana	S (Wenl-u)	-S (Ludl)	(25)
+Mogoktella	Cm(u)		(538)	+Sulcupentamerus	S		(881)
+Nanukidium	S (u)		(538)	+Supertriolobus	S (Wenl)	-S (Ludl)	(25,538)
Noetlingia	S (Ldov-l)?, S (Ldov-m)?		(25)	Syntrophia	O (Aren-u)	-O (Llvi)?	(4,25)
+Neometabolipa	D (Fras)			Syntrophia	Cm(Trep)	-O (Aren-u)	(1,4,538)
Neostrophia	O (Llvi)?	-O (Cara-m)	(397,538)	Syntrophinella	O (Aren-l)	-O (Aren-u)	(1)
+Novoemelia	D (Eife)		(538)	Syntrophopsis	O (Trem-u)	-O (Aren-u)	(1,4)
+Paleostrophia	Cm(Fran)	-O (Llvi)	(412,415)	+Tcharella	Cm(Tojo-u)	-Cm(mMid)?	(810,1066)
Parallelelasma	O (Cara-l)		(397)	+Tcherskidium	O (Ashg-m)		(1264)
+Pararhipidium	S (Wenl-u)	-S (Ludl)	(25,538)	Tetralobula	Cm(Trep-l)	-O (Aren-u)	(1,4)
Parastrophina	O (Cara-l)	-S (Ldov-u)	(24,397)	Thaumatrophia	O (l)		(1)
Parastrophinella	O (Llde-l)	-S (Ludl)	(5,25,1078)	+Trigonotrophia	O (Llvi-u)		(538)
Pentamerella	D (Emsi-l)	-D (Fras)	(24,25)				

Taxon	First Appearance	Last Appearance	Reference	Taxon	First Appearance	Last Appearance	Reference
+Triseptata	O (l)		(538)	+Asiarhynchia	D (l)		(881)
+Tscherskidium	O (Ashg-m)	-O (Ashg-u)	(965)	+Astua	D (Gedi)	-D (Emsi)	(1148)
+Tuloja	O (m)		(881)	Asutiorhynchia	S (Ludl)	-D (Emsi)	(25,538)
+Twenhofelia	S (Wenl-u)	-S (Ludl)	(25)	Athabascchia	D (Give)	-D (Fras-l)	(25)
+Vadimia	S (Ludl)			+Athyrhynchus	D (Emsi-l)	-D (Emsi-u)	(47)
+Vaga	O (Cara-u)		(538)	Atribonium	D (Eife-l)	-C (Tour-u)	(1,25,955)
+Vagranelia	S (Wenl)	-S (Ludl)	(25)	+Aucklandirhynchia	J (Plie)	-J (Call-l)?	(1068)
Virgiana (+ Platymerella)				+Aulites	T	-R	(881)
	S (Ldov-l)	-S (Ldov-m)	(1,25)	+Australirhynchia	D (Sieg-l)		(25)
+Virgianaella	S (Ldov-l)	-S (Ldov-m)	(1264)	Austriellula	Tr(Carn)	-Tr(Nori)	(538)
+Vosmiverstum	S (Wenl)		(860)	Austrirhynchia	Tr(Carn)	-Tr(Rhae)	(1)
Wyella	S (Ludl)		(25)	Axiodeaneia	C (Tour-l)	-C (Tour-u)	(955)
Xenelasma	O (Aren-l)			+Azamella	O (u)		(1138)
Xenelasmella	O (Llvi)?, O (Llde)?		(538)	+Baeorhynchia	J (Bajo-l)	-J (Bath-l)	(877)
+Xenelasmopsis	O (Ashg)		(538)	+Bailongjiangella	S (Wenl)		(881)
Xizangostrophia	O (l)		(ZR80)	Barzellinia	Tr		
Yangtzeella	O (Llvi)		(1066)	Basilicorhynchus	D (Fame-l)		(1,25)
Zdimir	D (Emsi-u)	-D (Give)	(25)	Basiliola	K (Turo)	-R	(1091)
+Zdimirella	D (Give-l)		(538)	Bathyrhynchia	D (Gedi-u)		(25)
				+Beckmannia	D (Eife-u)	-D (Give-l)	(25)
				+Beichuanella	D (m)		(ZR82)
				+Beichuanrhynchus	D (l)		(1161)
				Belbekella	K (Berr-u)	-K (Ceno-l)	(538)
				+Bergalariai	D (Fras-m)		
				+Betterbergia	D (Eife)		(538)
				+Bicepsirhynchia	J (Oxfo-l)		(1027)
				Bihendulirhynchia	J (Kimm-l)		(1)
				+Bilaminella	J (Call)		(538)
				Bodrakella	J (l)		(1)
				+Bohemirhynchia	K (Ceno)		(1091)
				+Boloria	P (Leon)		(538)
				+Boreairhynchia	D (Gedi)		(24)
				+Boucoteila	S (Prid)		(25)
				+Boucotia	D (Gedi)	-D (Eife)?	(25)
				+Bradfordirhynchia	J (Bath)		(1090)
				+Brownella	D (Emsi)		(538)
				+Brunnirhynchia	D (Fame-l)		(538)
				+Bryorhynchus	P (Guad-l)	-P (Guad-u)	(7)
				Burnirhynchia	J (Bajo-l)	-J (Kimm)	(877,1091)
				Burrirhynchia	K (Barr)	-K (Ceno)	(1,1091)
				Calcirhynchia	J (Hett-u)	-J (Plie)	(1,56,1091)
				+Caledorhynchia	J (Sine)	-J (Call-l)?	(1068)
				+Callaiaspida	C (Bash-l)	-P (Guad)	(538)
				Callipleura	D (Give-l)		(25)
				Calvinaria	D (Fras-l)	-D (Fras-u)	(25,708)
				+Calvirhynchia	J (Bajo)		(1091)
				Camarophorina	P (Wc)		(538)
				+Ancorhynchia	P (Dora)		
				+Anteriodocus	P (Sakm-u)	-P (Guad-u)	(7)
				+Antistrixia	D (Give)		(1066)
				+Antronaria	P (Sakm)	-P (Leon-u)	(7)
				+Aorhynchia	Tr(Anis-l)	-Tr(Anis-u)	(1068)
				+Aparimarhynchia	Tr(Anis-l)	-Tr(Anis-u)	(1068)
				+Apertirhynchella	Tr(Carn)		(881)
				+Aphaurosia	P (Guad-u)		(7)
				Aphelesia	T (Eo)	-T (Plio-u)	(1)
				+?Apodosia	J (Bajo)	-K (Berr)	
				+Apringia	J (Sine)	-J (Toar)	(1,55)
				+Aratanea	S		
				+Aratella	D (Fame-u)	-C (Tour-l)	(538)
				+Aratoechia	S (Wenl)		(881)
				+Arella	D (Emsi-u)	-D (Eife)	(1160)
				Aseptalum	D (Sieg)		(24)
				+Aseptirhynchia	D (Emsi)		

OR. RHYNCHONELLIDA

Taxon	First Appearance	Last Appearance	Reference	Taxon	First Appearance	Last Appearance	Reference
+Caucasorhynchia	Tr(Nori)	-Tr(Rhae)	(1)	+Druganirhynchia	J (Aale)		(1091)
+Cavatisinurostrum	D (Fame)			+Dushanirhynchia	D (Eife)		(24)
-Cenorhynchia	P (Asse)	-P (Guad-l)	(7)	+Dzhangirhynchia	J (Aale)	-J (Bath)?	(1027,1091)
-Centrorhynchus	D (Fame-l)	-D (Fame-u)	(1,695)	Eatomia	D (Gedi-l)	-D (Sieg-l)	(25,764)
+Chaeniorhynchus	P (Leon-m)	-P (Leon-u)	(7)	Eatomioides	S (Ludl)		(25)
-Changyangrhynechus	C (u)		(881)	+Echinirhynchia	J (Oxfo)	-K (Berr)	(1091)
-Cherubicornea	D (Sieg)	-D (Emsi)	(1148)	+Echyrosia	J (Bajo-u)		(877)
+Chivatschella	P (u)?		(538)	+Ellassonia	P (Sakm)	-P (Leon-u)	(7,538)
+Chlupacitoechia	D (Sieg)	-D (Emsi)	(1148)	+Eliorhynchus	D (Give-l)		(881)
Cirpa	J (Sine-u)	-J (Plie-u)	(57,538)	Eoglossinotoechia	S (Ludl)	-D (Emsi-l)	(25)
+Coeloterorhynchus	D (Fras-u)		(25)	Eoemithiris	T (Eo)	-R	(1)
Coledium	D (Eife)	-C (Serp-l)?	(25,955)	Eoparaphorhynchus	D (Fame-l)	-D (Fame-m)	(1,25,695)
-Colophragma	D (Fras-u)	-D (Fame-l)	(708)	+Eopugnax	D (Emsi)		(1001)
+Colpotoria	J (Bajo-l)	-J (Call-l)	(877)	+Eoseptaliphoria	Tr(u)		(ZR80)
-Comiotoechia	D (Fras)		(538)	Erectocephalus	D		
-Conarosa	J (Toar)	-J (Bath-u)	(877)	Eremithyris	P (Djhu)		
+Cooperhynchia	J (Tith-u)			+Erhynx	D (Eife)		(881)
-Corrugatimedorostrum				Erynnaria	T (Eo-l)	-T (Eo-u)	(1)
	C (Mosc)		(538)	Estonirhynchia	S (Wenl)	-S (Ludl)	(25)
Corvinopugnax	D (Sieg)	-D (Emsi-u)	(25,989)	Eucharitina	D (Emsi-l)		(24,25)
Costellirostra	D (Gedi-l)	-D (Emsi)	(25,764)	+Eumetabolotoechia	D (Give)		(538)
+Costinorella	Tr(Anis)		(538)	+Eurycolporhynchus	D (Give-u)		(25)
Costirhynchia	J (Aale)	-J (Bajo)	(1,1091)	+Euryssites	J (Bath-l)	-J (Call-l)	(877)
+Cratorhynchonella	D (l)		(881)	Euxinella	Tr(Nori)		(538)
Cretirhynchia	K (Albi)	-T (Dani-l)	(8,765, 1091)	+Evanescirostrum	D (Fame-l)		(25,708)
				+Evanidisinurostrum	D (Fame-l)		(881)
Crurirhynchia	Tr(Anis-u)	-Tr(Nori)	(1)	+Evenkorhynchia	O (Ashg-m)		(538)
Cryptopora	K (Maes)	-R	(8,765)	+Excavatorhynchia	Tr(Carn)		(538)
Cryptoporella	K (Camp-u)	-K (Maes-l)	(765)	Fascicosta	P (Guad-u)		(7)
Cryptorhynchia	J (Aale)	-J (Call)?	(1091)	Felinitoechia	S (Ludl)	-D (Emsi)	(25)
Cubanirhynchia	J (Toar)	-J (Bajo-l)	(538)	Fenestrirostra	S (Ldov-l)	-S (Ldov-m)	(25)
Cuncirhynchia	J (Hett)	-J (Plie-l)	(1,56,538)	Ferganella	S (Ldov-u)	-D (Sieg)	(25)
Cupularostrum	D (Give-l)	-D (Fras-u)	(25)	+Filigreenia	D (Emsi)		
Curtirhynchia	J (Aale)	-J (Bajo)	(1091)	+Fissirhynchia	Tr(Carn)	-J (Sine)?	(434)
Cyclothyrus	J (Tith-u)	-K (Maes-u)		Fitzroyella	D (Give-u)	-D (Fras-l)	(25)
Cymatorhynchia	J (Aale)	-J (Bath)	(1093)	Flabellirhynchia	J (Toar)	-J (Bajo)?	(1,1091)
+Cyphoterorhynchus	D (Fras-l)		(25,695)	Flabellulirostrum	D (Give-u)	-D (Fras-l)	(25)
Cyrolexis	C (Mosc-l)	-P (Dora)	(1,1142)	Formosarhynchia	J (Bajo)	-J (Bath-l)	(1)
Daghanirhynchia	J (Bajo)	-J (Oxfo)	(1091)	+Fortunella	J (Oxfo)	-K (Apti)	(1091)
+Dagysorhynchia	K (Haut)?, K (Barr)?		(1108)	Furcirhynchia	J (Hett)	-J (Toar-u)	(715)
+Dalerhynchus	D			+Fusirhynchia	J (Tith-u)	-K (Vala)	(538)
+Daviniirhynchia	J (Bath)		(1091)	+Gastrodetoechia	D (Fame)		(25)
Decoropugnax	S (Ludl)	-S (Prid)	(25)	Gerassimovia	P (u)		(1)
+Decurtella	Tr(Anis-m)	-Tr(Ladi)	(538)	+Gerrhynx	D (Sieg)		(1001)
-Deltarhynchia	J (Bath-l)		(877)	Gibbirhynchia	J (Sine-l)	-J (Bath-m)	(1,57,715, 877)
+Deltarina	P (Guad-u)		(7)	+Gigantorhynchus	D (m)		(ZR85)
Denticuliphoria	P (u)		(1)	+Globirhynchia	J (Toar)	-J (Bath-u)	(877,1093)
Diatobirhynchia	S (Wenl)	-S (Ludl)	(25)	+Globulirhynchia	D (Fras)		(538)
+Dierisma	Tr(Nori)		(538)	+Glosshyothyridina	D		
+Diholkorhynchia	Tr(Anis)		(538)	Glossinotoechia	D (Sieg)	-D (Emsi-u)	(25,538)
+Dimensionaequalirostrum				+Glossinulina	D (Emsi)		(538)
	D (Fame)		(538)	+Glossinulirhynchia	D (Sieg)		(1001)
Dimerella	Tr(Nori)		(538)	Glossinulus	D (Emsi-u)	-D (Eife-l)	(25)
-Disphenia	P (Djhu)	-P (Dora)	(871,881, 1066)	+Glyptorhynchia	P (Dora)		
				Gnathorhynchia	J (Aale)	-J (Call)	(1)
+Divaricosta	P (Guad-l)		(7)	+Goleomixa	P (Leon-m)		(403)
+Dogdoa	D (Sieg)?		(538)	Goniophoria	C (Tour-u)	-P (Wc)	(1,538,955)
Donella	C (l)		(1)	Goniorhynchia	J (Bath-u)		(538)
Dorsisinus	D (Fame-u)		(955)	+Gracilitoechia	D (l)		(538)
Dorytreta	O (Lvi-u)	-O (Ashg-u)	(397)	+Grammorhynchus	C (Tour-u)	-C (Vise-l)	(955)
Drepanorhynchia	O (Cara-l)	-O (Cara-m)	(397)	Grandirhynchia	J (Plie-u)		(1,715)
+Droharhynchia	D (Eife-l)	-D (Give-l)	(881)				

Taxon	First Appearance	Last Appearance	Reference	Taxon	First Appearance	Last Appearance	Reference
Granulirhynchia	J (Aale)	-J (Bajo)	(1,1091)	+Kritorhynchia	S (Ldov-m)		(24)
+Grasirhynchia	K (Ceno)		(538)	+Kutchirhynchia	J (Bath-m)	-J (Bath-u)	(538,877)
+Hadrorhynchia	D (Give-l)	-D (Give-u)	(1,708)	+Kvesanirhynchia	K (Berr)		
+Hadrotorhynchus	D (Give-u)		(881)	+Kwangsirhynchus	D (Sieg)		(24)
+Hadyrhynchia	D (Fame)		(1066)	+Lacunaerhynchia	J (Bajo-u)		(1027)
Hagabirhynchia	Tr(Nori)		(1)	Lacunosella (+ Kolhidaella, Dichatomosella)			
Halorella	Tr(Carn)	-Tr(Nori)	(1066)	J (Call)		-K (Barr-u)	(59,538)
+Halorellina	Tr			Ladogia	D (Fras-l)		(1,538,695)
Halorelloidea	Tr(Carn)	-Tr(Nori)	(1,1066)	Ladogilornix	D (Eife-l)		(25)
+Havlicekella	D (Sieg-l)		(764)	+Ladogilina	D (Fras)		(538)
Hebetoecchia	S (Ludl)	-D (Emsi)	(1,25)	+Ladogilinella	D (Fras)		(538)
+Hemileurus	P (Asse)		(7)	Ladogiodes	D (Fras-l)		(25)
Hemiplethorhynchus	C (Tour-u)	-C (Vise-l)	(955)	+Laevigaterhynchia	J (Call)		(1091)
Hemithiris	T (Mi)	-R	(1)	+Laevirhynchia	Tr(Carn)		(538)
+Hemithyropsis	K (Camp-l)	-K (Maes-u)		+Laevorhynchia	P (Dora)		
+Hemitoecchia	S (Prid)	-D (Gedi)	(25)	+Lambdarina	C (Tour-u)	-P (Djhu)	(871)
+Herangirhynchia	Tr(Nori-u)	-J (Toar)	(1068)	+Lamellarhynchia	K (Vala-u)	-K (Apti-u)	(1,538)
Hesperorhynchia	K (Turo)	-K (Sn)	(1,538)	Lanceomyonia	S (Ludl)	-S (Prid)	(538)
+Heteromychus	J (Bath-u)	-J (Call-l)	(877)	+Langkawai	D (u)	-C (Ms)	(538)
+Himalairhynchia	Tr(Nori)		(538)	Laosia	P		
+?Hircinisca	S (Wen-l)	-S (Ludl-l)	(25)	+Lapradella	D (Gedi)?	-D (Sieg-l)?	
+Hiscobeccus	O (Cara-m)	-O (Ashg-m)	(764)	+Lateralistrostrum	D (Fras)		(538)
+Hispanirhynchia	T (Eo)		(1066)	+Lairhynchia	O (u)		(881)
+Holcorhynchella	Tr(Anis)	-J (Plie)?	(1,538)	Latonotoecchia	D (Gedi)	-D (Emsi-l)	(25)
Holcorhynchia	J (Sine)	-J (Toar)	(56,538)	Leiorhynchoidea	C (Tour-l)	-P (Guad-u)	(7,400)
+Holosia	P (Leon-u)	-P (Guad-u)	(7)	Leiorhynchoidea	D (m)		(538)
+Homalirhynchia	J (Bath-l)		(1027)	Leiorhynchus	D (Give-l)	-D (Fras-u)	(25,538)
+Homeocardiiorhynchus	D (Give)		(881)	+Lenatoecchia	S (Ldov-m)	-S (Prid)	(25,965)
Homeorhynchia	Tr(Rhae)	-J (Aale)	(56,57,538)	Lepidocycloidea	O (Cara-m)	-O (Cara-u)	(1)
+Hostimex	S (Wenl)		(881)	Lepidocyclus	O (Cara-m)	-O (Ashg-m)	(1,764)
Hyborhynchella	D (Fras-u)		(25,708)	Lepidorhynchia	K (Haut-u)	-K (Ceno)	(1,538)
+Hybostenoscisma	P (Dora)		(1,128)	+Leptocaryorhynchus	D (Fame-l)	-D (Fame-m)	(25,695)
+Hybostenoscisma	P (Dora)		(1,142)	+Levipuganax	D (Fame)		(881)
+Hypoleiorhynchus	D (Fras)		(538)	+Libyairhynchus	D (Fras-l)	-D (Fame-u)	(1,163)
Hypothyridina	D (Eife-u)	-D (Fras-u)	(25)	Linguopugnoides	S (Ludl-u)	-D (Emsi-l)	(24,25,989)
+Hypselerorhynchus	D			+Lioterella	S (Prid)?		(764)
Hypsitychia	O (Ashg-l)	-O (Ashg-u)	(25,965)	+Linxiangxiella	D (u)		(881)
+Iberirhynchia	D (Emsi)	-D (Eife)	(25)	+Lirellaria	P (Leon-m)	-P (Djhu)	(1,538)
+Indorhynchia	J (Call)		(538)	+Lirellarina	J (Bajo-u)		(877)
+Innaecchia	D (l)			Lissella	C (Pn)		
+Innuiteella	D (Gedi)	-D (Emsi)	(25)	Lissopleura	D (Gedi)		(25)
+Insignitisinurostrum	D (Fame-m)		(881)	+Lissorhynchia	Tr(Anis)	-Tr(Ladi-l)	(538)
+Iotina	P (Leon-m)		(7)	+Loborina	D (Fame)		(871)
+Iowarhynchus	C (Tour-u)		(955)	+Lokutella	J (Sine)	-J (Plie)	(1091)
+Ipherron	D (Eife)		(881)	+Longdongsuia	D (Eife)		(24)
+Irgisella	D (l)			+Longxianirhynchia	O (m)		(881)
Isjuminelina	J (Oxfo)		(1)	Lorangerella	D (Fras-l)		(25)
+Isjuminella	J (Bath)		(538)	+Losvia	D (l)		(ZR80)
Isopoma	D (Eife)	-D (Give)	(25)	+Lotharingella	J (Bath-l)	-J (Call-l)	
Ivanoviella	J (Bajo)	-J (Call-u)	(1027,1091)	+Lunaria	Tr(Nori)		(538)
+Kabanoviella	K (Haut-u)		(538)	+Luterella	S (u)		(764)
Kallirhynchia	J (Aale)	-J (Call-l)	(1,877,1091)	Machaeraria	S (Prid)	-D (Eife-l)	(25)
Katunia	D (Gedi)	-D (Sieg)	(25)	+Machaerotoecchia	D (Gedi)	-D (Emsi)	(1,148)
+Kawhiarhynchia	J (Call-l)	-J (Tith-u)	(1068)	+Macropotamorhynchus	C (Tour-l)	-C (Vise-l)	(955)
+Kericesrella	J (Plie)		(1091)	+Madarosia	P (Guad-l)	-P (Guad-u)	(7)
+Kholbotchonia	D		(881)	+Makridinirhynchia	J (Plie)		(57)
+Kindleina	D (Fame-m)	-D (Fame-u)	(58)	Malwirhynchia	K (Ceno-m)	-K (Ceno-u)	(1)
+Korjakirhynchia	K (Haut)		(1091)	+Maorirhynchia	Tr(Olen-u)?	-Tr(Nori-l)?	(1068)
+Kotyxex	D (Sieg)		(1066)	Markitoecchia	D (Emsi)	-D (Eife-u)	(25)
+Kransia	D (Sieg-u)	-D (Give)	(25,651)	Maxillirhynchia	Tr(Nori)	-J (Bajo-u)	(538)
				+Mediterranirhynchia	J (Hett)	-J (Plie)	(57,538)

Taxon	First Appearance	Last Appearance	Reference	Taxon	First Appearance	Last Appearance	Reference
Meglopterorhynchus	D (Fame-m)	-D (Fame-u)	(1,695)	Orthorhynacula	O (Cara-m)	-O (Ashg-l)	(25)
+ Miaohuangrhynchus	D (l)		(ZR79)	Orthorhynchuloides	O (Cara-m)		(1,538)
Microhynchia	J (m)		(1)	-Osmarella	Tr(Nori)	-J (Plie)	(434)
Microsphaeridiorhynchus				-Otarorhynchia	O (Cara)?	-O (Ashg)	(538)
	S (Wen-l)	-S (Prid)	(25,27)	-Ovlatchania	C (l)		(881)
-Minutalirhynchia	J (Call-m)	-J (Oxfo)	(1072)	-Owenirhynchia	K (Albi)	-K (Camp)	(1091)
+Minysphenia	C (Step)		(871)	-Oxypleurohynchia	S (Prid)		(1164)
Moissevia	Tr(Nori)	-Tr(Rhae)	(1)	-Pachancorhynchia	D (Gedi)		(881)
Monadotoechia	D (Gedi-u)	-D (Emsi-l)	(25)	-Pamirorhynchia	J (Aale)?, J (Bajo)?		(1091)
-Mongolirhynchia	S (u)		(24)	-Pammegetherhynchus			
-Mongolorhynch	D (Emsi-u)	-D (Eife)	(1160)		D (Fras)		
Monticlaella	J (Call)	-K (Ceno-u)	(59,1066)	-Pampecilorhynchus	D (Fame)		(538)
Moorefieldella	C (Tour-u)	-C (Vise-u)	(955)	+Paraacanthothyrus	J (Aale)	-J (Bajo)	(1091)
-Moquellina	J (Bath-u)	-J (Call-u)	(1027,1091)	+Paraglossinulus	D (Fras)		(881)
-Morphorhynchus	D (Give-u)		(708)	Paranorella	P (Sakm-u)	-P (Guad-u)	(7)
Mosquilla	J (Tith-u)		(1)	+Paranorellina	Tr(Olen)		(538)
-Multicorhynchia	Tr(Carn)		(881)	+Paranudirostralina	Tr(Anis)		(881)
+Murihikurhynchia	Tr(Carn-u)	-J (Sine)?	(1068)	+Paraoigorhynchia	O (Cara)?	-O (u)?	(538)
-Myopugnax	P (Wc)		(538)	Paraphorhynchus	D (Fame-u)	-C (Tour-l)	(1,25,955)
+Myrmirhynch	S (Ludl)		(881)	Parapugnax	D (Fras-m)	-D (Fras-u)	(25)
-Nalivkinaria	D (Eife)		(25)	-Parahactorhynchia	J (Bajo)		(1091)
Nannirhynchia	J (Toar-l)	-J (Bajo-u)	(1,715)	+Paratetratomia	D		
Nantanelia	P (Wc)		(1,538)	+Paratribonium	D (Sieg)		(1165)
-Nasonirhynchia	D (Sieg)		(1148)	+Paromoeopygma	D (Fame)		(538)
-Nastasia	J (Bajo-u)		(877)	+Parthirhynchia	K (Turo)	-K (Maes)	(1091)
Nayunnella	D (Fras-u)	-D (Fame)	(1,25)	+Parvaltissimarostrom	D (Fras-u)		(1166)
+Neimongolella	D (Emsi)		(538)	Parvirhynchia	J (Aale)	-J (Oxfo)	(1,1091)
Nekhoroshevia	D (Give)	-D (Fras)	(25)	+Paryphorhynchopora	D	-C	
Nemesa	D (Eife-u)	-D (Give-l)	(25)	Patagorhynchia	T (Eo)		(1)
+Neocirpa	J (Bajo)		(1091)	Paurogastroderhynchus			
+Neofascicosta	Tr				D (Fame)		(25)
+Neorhynchula	O (u)		(881)	Paurorhynchia	D (Fame-m)		(1,708)
-Neowellereella	Tr(Indu-l)		(150)	Payuella	P (l)		(1)
+Nepasitoechia	C (Tour-l)		(538)	Pectorhynchia	S (Ldov-u)		(25)
+Nikolaevirhynchus	S (Ldov)		(881,965)	Pegmarhynchia	D (Gedi-u)?	-D (Emsi)	(25,1066)
+Ningbiangella	C (Tour-u)		(435,955)	+Perakia	D (Emsi)	-D (Eife)	(25)
+Niorhynch	S (Wenl)		(881)	Peregrinella	K (Vala)	-K (Haut-u)	(1)
+Nipponirhynchia	P (Sakm-l)		(881)	+Peregrinellina	K (l)		(881)
+Nordotoechia	D (Gedi)	-D (Emsi)	(25)	+Peregrinelloidea	J (Plie)		(538)
Norella	Tr(Anis-u)	-Tr(Nori)	(1,538, 1066)	+Perrarisinurostrum	D (Fame-l)		(881)
				+Petasmaria	D (Fame-m)		(708)
Notoconchidium	S (u)	-D (l)	(538)	+Petasmatherus	P (Asse-u)	-P (Guad-l)	(7)
Notosaria	T (Ol-u)	-R	(1)	+Phapsirhynchia	T (Plio)		(538)
+Nucleosorhynchia	Tr(m)		(881)	+Phlogoiderhynchus	D (Give-u)	-D (Fras-l)	(25)
+Nudirostralina	Tr(Anis)	-Tr(Ladi)	(538)	Phoenicitoechia	D (Sieg-u)	-D (Emsi-l)	(25)
-Nyalamurhynchia	J (Bajo)			+Phrenophoria	P (Sakm-u)	-P (Guad-u)	(7)
Nyge	D (Fame)		(1,25)	+Physetorhynchia	D (Fame-u)		(25)
Nymphorhynchia	D (Sieg-l)	-D (Eife)	(24,25)	+Piarorhynchella	Tr(Olen)	-Tr(Anis)	(538)
+Obscurella	D (Sieg)		(1001)	Piarorhynchia	Tr(Anis)	-J (Toar)	(538,1066)
+Obsoleterhynchia	J (Bath-u)		(1027)	Pisirhynchia	J (Sine)	-J (Plie-u)	(55)
Obturamentella	D (Gedi)	-D (Sieg)	(25,764)	Plagiiorhynchia	S (Ldov)	-S (Ludl)	(25,27)
+Ochotorhynchia	J (Sine)		(538)	-Planirhynchia	Tr(u)	-J (Plie)	(57,1091)
-Oligoptycherhynchus				+Planovatiostrum	D (Fame-u)		(25)
	D (Sieg)	-D (Eife)	(538)	+Platy glossariorhynchus			
Oligorhynchia	O (Lvi-u)	-O (Cara-l)	(397)		D (Give-u)		(25)
Omolonella	Tr(Nori)		(538)	+Platytorhynchus	D (Give-u)	-D (Fras-l)	(25)
+Omolonorhynchia	J (Toar)		(1092)	+Plectorhynchella	D (Fame)	-C (Tour)	(25,538)
-Onugorhynchia	D (Sieg)	-D (Emsi)	(1148)	?Plectothryella	O (Ashg-m)	-S (Ldov-l)?	(25,965)
-Orbiculatisurostrum	D (Fras)		(881)	Pleiolepurina	D (Gedi-u)	-D (Sieg)	(25)
Orbirhynchia	K (Apti)	-K (Camp)	(1066,1091)	Plekoneella	P (Guad)	-P (Djhu)	(427,538)
-Oriensellina	K (Berr)	-K (Vala)	(1091)	+Plekoniina	C (u)	-P (l)	(881)
+Orlovirhynchia	J (Plie)		(538)	Plethorhynchia	D (Gedi)	-D (Sieg)	(25)

Taxon	First Appearance	Last Appearance	Reference	Taxon	First Appearance	Last Appearance	Reference
Pleurocornu	S (Wenl)		(25)	Rhynchonellina	Tr(Nori)	-J (Toar)	(1,538)
+Pleuropugnoides	C (Vise-u)		(60)	Rhynchonelloidea	J (Sine-u)	-J (Bajo)	(56,715, 1091)
Plicarostrom	K (Haut)		(1)	Rhynchonelloidella	J (Toar)	-J (Call-l)	(1091)
Plicirhynchia	T (Eo-u)		(1)	Rhynchopora	D (Fame)	-P (Djhu)	(1,2,25)
+Plionoptycherhynchus	D (Fras)		(538)	Rhynchotetra	C (Tour-l)	-C (Tour-u)	(955)
+Pompeociliorhynchus	D (Fame-l)		(695)	+Rhynchotetraoides	O (Cara)		(538)
+Pontalorhynchia	J (Sine)	-J (Plie-l)		Rhynchotremia	O (Cara-m)	-S (Ldov-l)	(1,25)
+Pontisia	C (Bash)	-P (Leon-u)	(7,1066)	Rhynchotreta	S (Ldov-m)	-D (Gedi)	(25,27, 1066)
Porostictia	D (Fame-m)		(1,25)	Rhynchotretina	D (Sieg)	-D (Emsi)	(25)
Pracyclothyris	J (Bath)	-K (Haut-u)	(538,1091)	+Rhynoleichus	C (Mosc)		(538)
Praegnamtenia	D (Sieg)	-D (Emsi)	(25)	Rhytirhynchia	T (Plio)	-R	(1)
+Praelacunosella	J (Call)		(1091)	Rimirhynchia	J (Sine)	-J (Plie-l)	(1)
+Preissorhynchia	P (Dora)	-Tr(Indu-l)	(1128)	Rimirhynchopsis	Tr(Nori)	-Tr(Rhae)	(1)
+Praemonticlarella	J (Toar)	-J (Aale)	(1091)	+Rionorhynchia	K (Haut)	-K (Barr)	(1091)
+Primpilalaria	D (Eife-u)	-D (Give-l)	(1015,1156)	+Riorhynchia	T (Pale)		(538)
Prionorhynchia	J (Sine)	-J (Aale)	(55,57,715, 1091)	-Ripidiorhynchus	D (Give-u)	-D (Fame)	(25,538)
+Proatribonium	D (Sieg)		(1066)	Robinsonella	Tr(Nori)	-Tr(Rhae)	(538)
Probolarina	T (Than)	-T (Eo-m)	(1066)	Robustirhynchia	J (Call)		(1)
+Properotundirostrum	D (Eife-u)		(881)	+Rochatorhynchia	K (Maes)		(1167)
+Propriopugnus	C (Vise-u)		(435)	+Rossirhynchus	C (Tour)		
+Protegorhynchia	K (Camp)		(1066)	Rostricellula	O (Lvi-l)	-S (Ldov-l)	(1,4,24)
Proterorhynchia	K (Vala)	-K (Apti)	(1091)	+Rostirrhynchia	J (Plio)		(57,538)
Protorhynchia	O (Lvi-u)		(397)	Rotia	C (Tour-u)	-C (Vise-u)	(400)
Pseudocamarophoria	D (Emsi)	-D (Eife)	(25)	+Rozmanaria	D (Fame-u)		
+Pseudocamaratoechia	S (Ldov)		(965)	Rudirhynchia	J (Plie-l)	-J (Plie-u)	(57,715)
Pseudogibbirhynchia	J (Plie-u)	-J (Toar-u)	(56,715, 1091)	Rugaltarostrom	D (Fame-m)	-D (Fame-u)	(25,53)
+Pseudoglossirotoechia	D (Emsi)	-D (Eife)	(25)	Russirhynchia	J (Call)	-K (Haut)	(1091)
+Pseudohalorella	Tr(Nori)		(538)	+Rutorhynchia	J (Oxfo)	-J (Kimm)	(1091)
+Pseudomonticlarella	J (Tith)		(1091)	+Ryocarhynchus	D (Fras-u)		(786)
+Pseudonudirostra	D (u)		(538)	-Rzonsnickiana	D (Eife)		(538)
Pseudopugnax	P (u)		(1)	+Saccorhynchia	Tr(Nori)		(538)
+Pseudosinotectirostrum	D (Fame-l)	-D (Fame-m)		+Saguersia	D (Eife-u)	-D (Give-l)	(25)
+Pseudouncinulus	D (Emsi)	-D (Give)	(25,1001)	Sakawairhynchia	Tr(Ladi-l)	-J (Toar)	(1068)
Pseudowellerella	P (Djhu)		(411)	+Salairotoechia	D (Eife)		(25)
Pseudoyunnanella	D (u)		(ZR82)	Salgirella	J (Sine)	-J (Aale)	(1091)
Psilocamara	C (Mosc-u)	-P (Asse)	(7)	Sanjuanica	C (l)		(538)
Ptilorhynchia	J (Aale)	-K (Apti)	(1094)	+Sardorhynchia	J (Bath)	-J (Call)	(1091)
+Ptilotorhynchus	P (Guad-l)	-P (Guad-u)	(7)	Scalpellirhynchia	J (Sine)	-J (Aale)	(1091)
Ptychomaletoechia	D (Fame-l)	-D (Fame-u)	(25,955)	+Schizoria	J (Bajo-u)		(877)
Ptyctorhynchia	J (Toar)	-J (Bajo)	(1091)	Schmurella	D (Eife-u)	-D (Give-l)	(25)
+Ptygmastrum	P (Leon)	-P (Guad-l)	(7)	Sedenticellula	C (Tour-l)		(1)
+Pugnaria	D (Fame-u)		(881)	+Selennjachia	D (Eife)		(1066)
Pugnax	D (Fame)	-C (Bash-l)	(1,25,400)	+Semiotoechia	D (Fras)		(538)
Pugnoides	C (Tour-l)	-C (Bash-l)	(4,48,400)	+Seminula	C	-P	(538)
+Pyncnoria	J (Bath-m)	-J (Call-l)	(877)	Septacamera	P (Sakm)	-P (Guad-l)	(1)
+Pygmaella	D (Gedi)	-D (Emsi)	(1066)	Septalaria	D (Eife-u)	-D (Give-l)	(25)
+Qilianoconcha	Tr(Anis)		(538)	+Septalariopsis	D (Fras)		(436)
+Qilianotryma	O (m)		(ZR84)	Septaliphoria (+ Blochmanella)	J (Bajo)?	-K (Berr-u)	(1,59)
Quadratorhynchia	J (Sine)	-J (Bajo)	(1091)	+Septaliphorioides	Tr(Anis)		(1167)
+Qinlingotoechia	D (l)		(881)	+Septatoechia	K (Albi)	-K (Maes)	(1091)
+Rackirhynchia	D (Sieg)		(1066)	+Septemirostellum	C (Tour)		(538)
+Rahouairhynchia	J (Oxfo)?, J (Kimm)?		(1091)	+Septirhynchia	J (Call-l)	-J (Kimm)	(538,1066)
Rectirhynchia	J (Bajo)		(1)	+Septocamarella	P (We)		
+Remnevitoechia	D (Gedi)		(25)	Septocurella	J (Sine-u)	-J (Oxfo)	(55,1091)
Rhactorhynchia	J (Aale)	-J (Tith)	(1,538,868)	+Septocylothyris	Tr		
Rhynchonella	J (Hett)	-K (Vala)?	(1091)	+Septuldirhynchia	J (Bajo-u)		(538)
				+Serbiarhynchia	J (Bajo-u)	-J (Bath)	(1013)
				+Sharpirhynchia	J (Bajo)	-J (Bath)	(1090)
				Shumardella	C (Tour-l)	-C (Tour-u)	(4,955)

Taxon	First Appearance	Last Appearance	Reference	Taxon	First Appearance	Last Appearance	Reference
+ Sibirtoechia	D (Gedi)		(25)	+ Thliborhynchia	D (Sieg)		(25)
+ Sichuanhynchis	C (Pn)			+ Thurmannella	J (Plie)	-J (Oxfo-l)	(1,59,538)
Sicorhynchia	D (Sieg)	-D (Emsi-l)	(25,989)	+ Tichirhynchus	D (Gedi)?		
+ Sinorhynchia	Tr (Anis)		(538)	+ Timorhynchia	Tr (Ladi)	-Tr (Nori-l)	(1068)
+ Sinotectirostrum	D (Fame-m)?	-D (Fame-u)	(1,25,955)	+ Tomestoporhynchus			
+ Sinuplicorhynchia	Tr (Ladi)	-Tr (Carn)	(538)		D (Fras-l)		(1168)
+ Slovenirhynchia	J (Plie-u)		(Z(R)67)	+ Tonasirhynchia	K (Berr)		(1169)
+ Slezhnorhynchia	K (Haut)		(1091)	+ Tonsella	O (Ashg-u)		(764)
+ Solidipontirostrum	D (Eife-u)	-D (Give-l)	(25)	+ Torquirhynchia	J (Call-l)	-J (Tith-l)	(59,538)
Somalirhynchia	J (Bajo)	-J (Kimm-u)	(59,877)	Torynechus	P (Sakm-u)	-P (Leon-m)	(7)
Sphaerirhynchia	S (Ldov-u)	-D (Emsi-l)	(25,27)	+ Trasgu	C (Bash-l)		
Sphenarina	T (Plio)		(1)	+ Tretorhynchia	C (Vise-u)		(400)
Sphenorhynchia	J (Bajo-u)	-J (Call)	(1,877)	- Triasorhynchia	Tr (Anis)		(1167)
Sphenotreta	O (Livi-u)	-S (Ldov-l)	(25,397)	Trichorhynchia	J (Plie)	-J (Bajo)	(1,1091)
Squamirhynchia	J (Sine-l)	-J (Plie-l)	(1,56)	+ Tricoria	P (Sakm-u)	-P (Leon-l)	(7)
+ Stegerhynchops	S (Wenl-u)		(538,764)	+ Tridensilis	D (Sieg)	-D (Emsi)	(Z(R)67)
Stegerhynchus	O (Ashg-m)	-S (Prid)	(25,538)	Trifidorostellum	D (Fame-m)	-C (MS)	(1,25)
+ Stegocornu	S (Ldov-u)		(25)	Trigonirhynchella	Tr (Nori)		(1)
Stegorhynchella	S (Ldov-m)	-S (Ludl)	(25,965)	Trigonirhynchia	D (Sieg-u)	-D (Emsi-l)	(25)
+ Stenaulacorhynchus	D (Fame)		(538)	+ Trigonirhynchioides	S (u)		(24)
+ Stenoglossariorhynchus				- Trophisina	P (Leon-m)		(7)
	D (Give-l)		(25)	+ Tungussotoechia	S		(881)
+ Stenomeloporphynchus				+ Tuvaerhynchus	S (Wenl)		(881)
	D (Fras-l)		(881)	+ Tyrirhynchus	S (Ldov)		(Z(R)89)
+ Stenorhynchia	D (Sieg)	-D (Emsi-u)	(881,989)	- Uchtella	D (Fras)		(538)
Stenosisma	C (Toar-l)	-P (Dora)	(411,1066)	+ Ujandrella	D (l)		
Stolmorhynchia	J (Plie-l)	-J (Call)	(56,1091)	Uncinulus	D (Gedi-u)	-D (Eife-u)	(25)
Straelenia	D (Sieg)	-D (Emsi-l)	(25)	Uncinunellina	P (Sakm-l)	-P (Dora)	(403,411,1142)
Streptaria	T (Eo)	-T (Mi-m)	(1)	+ Undulorhynchia	S (u)		(764)
- Striatopugnax	D (Fras-l)		(436,538)	+ Uniplicatorhynchia	Tr (Carn)		(881)
- Striatorhynchus	D (Fame)		(881)	- Uralorhynchia	J (Tith-u)	-K (Berr)	(538)
+ Strigirhynchia	P (Guad-u)		(7)	+ Uralotoechia	S (Prid)		(25)
Strirhynchia	J (Bajo-u)		(1)	+ Urbanirhynchia	K (Ceno-m)?	-K (Turo-u)	
+ Strongyloria	J (Bajo-u)	-J (Bath-l)	(877)	+ Ussuricamara	P (u)		(1066)
+ Sufetirhynchia	S (Ludl)	-S (Prid)	(881)	- Ussurirhynchia	P		
Suiaella	K (Barr)		(1)	+ Veghirhynchia	Tr (Carn)	-Tr (Nori)	(538)
Sulcatina	S (Wenl-l)	-S (Ludl)	(25)	+ Viarhynchia	K (Camp)	-K (Maes)	(538)
+ Sulcicostula	D (Sieg-l)?			+ Vincentirhynchia	Tr (Nori-u)	-J (Toar)	(1068)
+ Sulciphoria	J (Call-m)	-J (Oxfo)	(1072)	+ Vladimirirhynchus	D (Gedi)?, D (Sieg)?		(538)
Sulciryhynchia	K (Berr)	-K (Albi)	(1091)	+ Volirhynchia	Tr (Anis)	-Tr (Ladi)?	(538)
Sulcrostra	Tr (u)	-J (Toar)	(1,538)	+ Voskoptoechia	D (Sieg)		(1148)
+ Sulcorhynchia	Tr (Ladi)	-Tr (Carn)	(538)	+ Waikatorhynchia	J (Kimm)	-J (Tith-u)	(1068)
+ Tabarhynchus	D (Fras)			Wairakiella	P (u)		(427,538)
Tadschikia	S (Wenl)	-S (Ludl-u)	(1,24,538)	+ Wairakirhynchia	Tr (Anis-l)	-Tr (Ladi)	(1068)
- Taimyrrhynch	D (Sieg)	-D (Emsi)	(1149)	Wellerella	C (Mosc-l)	-P (Dju)	(1,411)
- Tainotoechia	D (Emsi)	-D (Eife)	(25)	+ Wenxianirhynchus	D (l)		(881)
+ Tainuirhynchia	J (Bath)?	-J (Tith-u)	(1068)	+ Werneckeella	D (Sieg-u)		(25)
+ Talovkorhynchia	K (Albi-l)	-K (Albi-m)	(1108)	+ Westbroekina	D (Fras-u)		(1215)
Tanerhynchia	D (Emsi)		(25)	Wilsoniella	D (Sieg)	-D (Emsi-l)	(24,25)
+ Tangularella	J (Bath-u)	-J (Call)	(1027)	+ Wulunguia	O		(881)
+ Tasmallela	O (u)		(1138)	+ Xenioopugnax	S (Ludl)		(538)
+ Tatjamoa	D (Emsi)?, D (Eife)?			+ Xiaobangdaia	D		(881)
- Tatjania	D (Eife)		(881,1066)	+ Xinshaoella	D (u)		(Z(R)79)
+ Tautostia	P (Sakm-u)	-P (Guad-u)	(7)	+ Yakutijaella	D (Emsi)?		(1066)
- Tegulorhynchia	T (Dani)	-R	(405)	+ Yanbianella	C		
+ Tenuisurostrum	D (Fame-l)		(25)	+ Yanetechia	D (Eife)		
Terebratuloidea	C (Pn)	-P (Dora)	(1,1142)	Yanishewskiella	C (Vise-u)	-C (Bash-l)	(400)
Tetraemera	C (Vise-l)	-C (Vise-u)	(400)	+ Yairirhynchia	C (MS)		(538)
Tetrarhynchia	J (Sine-u)	-J (Bajo)	(1)	+ Yidunella	Tr (Nori)		(538)
Tetratomia	D (Eife)		(1066)	+ Ypsilorhynchus	D (Eife)	-D (Fras-l)	(25,436)
+ Thebesia	O (Ashg-m)	-S (Wenl-l)	(25,860,965)	+ Yukiangites	D (Gedi)		(1148)

Taxon	First Appearance	Last Appearance	Reference	Taxon	First Appearance	Last Appearance	Reference
+Yulongella	Tr(Nori)		(538)	+Arctomeristina	S (Ldov)	-S (Wenl-u)	(764,1239)
Yunnanella	D (Fras)	-D (Fame)	(1,25)	+Arcullina	P (m)		(881)
+Yunshanella	J (Call)	-J (Oxfo-l)	(1172)	+Arduspriifer	D (Emsi-l)	-D (Give)	
+Zanclorhynchua	O (m)		(ZR79)	+Argella	S (Prid)		(743,897)
+Zeravshanotoechia	D (m)		(ZR78)	+Argorhynch	D (Sieg-u)		(1122)
+Zhejiangella	P (l)		(881)	+Arionthia	P (Guad-l)	-P (Guad-u)	(7)
Zilimia	D (Fame-l)		(1)	+Arktikina	C (Serp)?	-C (Bash)?	(538)
+Zlichorhynchus	D (Sieg)	-D (Eife)?	(24,25)	Artospriifer	D (Fame)		(25,538)
Or. SPIRIFERIDA				+Astegosia	P (Leon-m)	-P (Guad-u)	(7)
Acambona	C (Tour-l)	-C (Serp)	(48,897, 1239)	Asyrinx	P (We)		(1,538)
+Acanthospriifer	S (Ldov-u)		(538)	Asyrinxia	C (Tour-u)?		(1)
Acanthospirina	D (Fame-u)	-C (Vise-l)	(25,400)	Athyris	D (Emsi)	-C (Serp)	(1239)
Acropriifer	D (Sieg-l)	-D (Eife)	(25)	Athyrisina	D (Eife)	-D (Fras)	(897)
Actinoconchus	D (Fame-u)	-C (Step-u)	(897,955)	+Athyrisinoides	D (Eife)	-D (Give)	(897)
+Acuminothyris	C (Vise-l)		(538)	+Athyrisinopsis	D (l)	-D (m)	(881)
Acutatheca	D (Fras-u)		(25,708)	+Atrythyris	D (Emst)	-D (Give-l)	(897)
+Acutella	D (Fras)		(538)	Attenuatella	P (Asse-l)	-P (Guad-l)	(7,417)
+Acutilineolus	S (Wenl-u)		(538,764)	+Aulidospira	O (Cara)		(1271)
+Acutoria	D (Give-u)		(708)	Australospriifer	D (Sieg)	-D (Eife)	(538)
+Admiculoria	C (Ms)			+Austrochoristites	C (Tour)		(538)
Adolfia	D (Fras-l)	-D (Fame-u)	(25,538)	Austospriifer	D (Fras)		(25)
+Adolfispriifer	D (Fras-u)		(1215)	+Avisyrinx	C (Mosc-l)	-C (Mosc-u)	
+Aequispriiferina	Tr(Ladi)?, Tr(Carn)?		(538)	+Badanjariana	D (Emsi)		(538)
+Afghanospriifer	C (Serp)		(538)	+Bajitugania	P (Guad-u)		(897)
Alaskospira	S (Ldov-u)	-S (u)	(1,538)	+Balatospira	Tr(Ladi)?	-Tr(Carn)	(538)
Alatiformia	D (Emsi)	-D (Eife-u)	(25)	+Bashkiria	C (Tour)		(538)
+Aldaniopriifer	D (l)		(538)	+Baterospriifer	S (Ludl)?		(881)
+Alipunctifera	Tr(Ladi)		(538)	+Beschevella	C (Serp-u)		(400)
Alispriifer	C (Vise-u)	-C (Serp-l)	(561)	+Biconvexiella	P		(881)
+Alispriiferella	P (Asse-u)	-P (Guad)	(881)	+Bidentatus	D (l)		(ZR78)
Allanella	D (Give)	-D (Fras)	(25)	+Biernatella	D (Give-u)	-D (Fras-u)	(538)
+Altajella	D (l)		(538)	+Birchella	P (Guad-u)?		
Altiplecus	P (Asse)	-P (Djhu)	(7,538)	+Bisinoceolia	D (Emsi-l)		(25)
+Altoplicatella	Tr(m)		(881)	Bojothyris	D (Sieg)	-D (Emsi-l)	(25)
+Alvarezites	D (m)		(1271)	+Bolilaspriifer	Tr(Nori)		(538)
Ambikella	C (Ms)		(437,538)	+Boreiospira	Tr(Carn)		(538)
Ambocoelia	D (Gedi)	-C (Vise-u)	(25,400)	+Boucotoskia	S (Wenl-u)	-S (Ludl-u)	(25,27)
+Amboglossa	D (Eife)		(538)	Brachyspriifer	D (Sieg)	-D (Emsi)	(25)
Ambothyris	D (Eife-u)	-D (Fras)	(25)	Brachythyrima	C (Vise-u)	-P (Sakm-u)	(400,432, 1172)
+Amerista	S (u)		(1271)	+Brachythyrimella	P (Sakm)		(538)
Amesopleura	C (Tour-u)			Brachythyris	D (Fame)	-C (Bash-l)	(1,25,400)
Amoensopriifer	D (Emsi)	-D (Eife)	(24,25,538)	Branikia	D (Emsi)?		(1)
Amphiolina	Tr(Carn)	-Tr(Rhae)	(2,538)	+Brantonites	D (m)		(1271)
Amphiclinodonta	Tr(Carn)	-J (Plie-u)	(538)	Brevispriifer	D (Emsi l)	-D (Eife-u)	(24,25)
Amphitomella	Tr(Carn)	-Tr(Rhae)?	(1066,1239)	+Brimethyris	D (Emsi)		(1271)
Anathyrella	D (Fras)		(897)	Buchanathyris	D (Emsi-u)	-D (Give)	(25,897)
Anathyris	D (Emsi-u)	-D (Fras)	(1,25,438, 897)	+Bullarina	P (l)		(881)
+Andreaspira	C (u)		(881)	Cadomella	J (Plie)	-J (Toar)	(11,2,1066)
+Angiospriifer	C (Vise-u)	-C (Serp-u)	(541,1200)	+Callispriifer	D (l)?		(881)
Anisactinella	Tr(Anis)	-Tr(Carn)	(538)	Callispirina	C (Step-u)	-P (Dora)	(411,432, 1128)
Anomactinella	Tr(Carn)		(538)	Callospiriferina	J (Sine)	-J (Toar)?	
+Anomaloria	P (Leon-m)	-P (Guad-u)	(7,403)	+Calvustrigis	C (Tour-u)		(881,955)
Anthracospriifer	C (Vise-l)	-C (Bash-l)	(1200)	+Calyptoria	J (Toar)		(877)
Antispriifer	D (Sieg)		(25)	Camarium	S (Wenl)	-D (Eife)	(25,1239)
Aperispriifer	P (Sakm-u)	-P (Dora)	(427,712)	+Camarophorella	D (Fame-u)	-C (Tour-u)	(2,25,955)
+Apeathyris	O (Cara)		(881,1066)	Camarospira	D (Eife-u)	-C (Tour)	(25,992)
+Apousiella	D (Give-u)	-D (Fras-m)	(25,439)	+Camadospira	Tr(Carn)		(538)
+Araspriifer	S		(881)	Cancellospriifer	P		
+Araxathyris	P (Djhu)	-P (Dora)	(1128)	+Candispriifer	D (Sieg)		(25)
				+Cantabriella	C (u)		(881)

Taxon	First Appearance	Last Appearance	Reference	Taxon	First Appearance	Last Appearance	Reference
+Capillispirifer	C (u)		(881)	+Cyrtinoides (+ Microcloipeus)			
+Carbocyrina	C (Vise-u)		(1200)	D (Eife-u)	-D (Give-u)		(881,894)
+Cardiothyris	C (Tour-l)		(955,1239)	D (Gedi)	-D (Eife)		(538)
Carinokoninckina	Tr(Nori)		(538)	Cyrtiopsis	D (Fras)	-D (Fame-u)	(25,538, 695)
+Carpinaria	D (Give-l)		(538)	+Cyrtiorina	D (Fame-l)		(708)
+Carteridina	C (Tour)	-C (Vise)	(1271)	Cyrtospirifer	D (Fras-l)	-C (Tour-l)	(1,25)
+Cartorium	P (Sakm-u)	-P (Dora)	(7,1128)	+Dabashanospira	S (Wenl)		(743)
+Cassianospira	Tr(Carn)		(1239)	+Dagyspirifer	Tr(Nori-l)		(975)
+Celsifornix	C (Tour-u)		(439,955)	+Dalaia	P (Wc)		(538)
+Changshaispirifer	D (u)		(ZR79)	+Danzania	C (Ms)		(881)
+Changtangella	D		(881)	Darvasia	P (Wc)		(1,538)
Chapinella	D (Fame-m)	-D (Fame-u)	(58)	Davidsonina	C (Vise-l)	-C (Serp-l)	(400)
Charionella	D (Sieg)	-D (Fras-l)	(25,1239)	+Deltachania	C (Mosc)		(897)
Charionoides	D (Emsi)		(25,1239)	+Deltospirifer	D (Emsi-l)		(881)
Chimaerothyris	D (Eife)		(25)	Delthyris	S (Wenl-u)	-D (Gedi-u)	(1,4,25,27)
+Chnaurocoelia	S (Ludl)		(538)	+Densalvus	C (Tour-l)	-C (Tour-u)	(955)
+Choperella	D (Give)?	-D (Fras-l)	(538)	+Dentospiriferina	Tr(Carn)		(538)
Choristitella	C (Mosc-l)	-C (Step-u)	(1200)	+Diazoma	D (Eife)	-D (Fras)	(538)
Choristites	C (Serp-u)	-P (Sakm)	(1,400)	Dicamara	D (Eife)	-D (Fras-l)	(25)
+Cingulospiriferina	J (Sine-l)	-J (Plie-l)	(1173)	+Dicamaropsis	S (Wenl-u)		(25,764)
+Cingulodermis	D (Emsi-l)	-D (Eife)	(25)	+Dichospirifer	D (Fame-m)	-D (Fame-u)	
Clavigera (+ Hectoria)	Tr(Nori)	-Tr(Rhae)	(1,1239, 1271)	+Dichozygopleura	D (Gedi-l)		(25)
Cleiothyridina (+ Cleiothyridellina)	D (Fame-l)	-P (Djhu)	(58,411)	+Dicoelospirifer	S (Wenl-l)		(860)
+Clivospirifer	D (Fras)		(538)	+Didymothyris	S (Wenl-u)	-S (Prid)	(25,27, 1239)
Collarothyris	S (Prid)		(897)	Dimegelasma	C (Tour-l)	-C (Vise-u)	(1,400)
+Colongina	D (Gedi)	-D (Sieg)	(1239)	-Dinaris-pira	Tr(Anis)	-Tr(Ladi)?	(538)
+Comelicania	P (Dora)		(411)	Dioristella	Tr(Carn)		(1239)
Composita	D (Fras-u)	-P (Guad-u)	(1,7,708, 1215)	Diplospirilla	Tr(Anis)	-Tr(Carn)	(1239)
+Compositella	Tr(l)		(881)	+Dispiriferina	J (Hett)	-J (Toar)	(538)
+Concinnispirifer	S (Wenl-u)	-D (Gedi)	(25)	+Dixonella	D (l)		(881)
+Cooperispira	D (Emsi)		(1271)	Dmitria	D (Fame-m)		(1)
+Corylispirifer	D (l)		(881)	+Dmitrispirifer	D (Fras)		(538)
+Costatispirifer	P (l)		(881)	+Doescherella (+ Crassispirifer)	C (l)		(881)
+Costellispirifer	D (Emsi)			+Dogdathyris	D (Emsi)		(1132)
+Costicrura	P		(881)	C (Bash)?	C (Mosc)?		(538)
Costispirifer	D (Sieg-l)	-D (Emsi)	(25,764)	+Domospirifer	C (Bash-u)	-C (Mosc-u)	(1200)
+Costispiriferina	Tr(m)	-J (l)?	(538)	+Duryella	D (Emsi)	-D (Eife)	(25,538)
+Crassumbo	C (Tour-u)		(955)	+Dyticospirifer	D (Sieg-l)		(25)
+Cratispirifer	P (l)		(881)	Dzieduszycia	D (Fame)		(1,25)
+Cratospirifer	C (Tour)		(881)	Echinocoelia	D (Eife)	-D (Fras-l)	(4,25)
Crenispirifer	C (Step)	-P (Djhu)	(1,411)	+Echinocoelopsis	D (u)	-C (Ms)	(538)
+Crimisaria	D (Fame-l)		(708)	+Echinospirifer	D (Fras)		(538)
+Crimisarina	D (Fame-u)	-C (Tour-u)	(897,955)	Ectochoristites	C (Tour-l)	-C (Tour-u)	(1200)
+Cruricella	C (Pn)	-P (Dora)	(538)	+Eifyris	D (Eife)		(1271)
+Cruris-pina	D (Give-u)		(894)	+Ejnespirifer	S (u)		(881)
Crurithyris	D (Eife)	-Tr(Indu-l)	(25,150, 1128)	+Elenchus	C		
Cryptospirifer	P (Leon-u)	-P (Guad-u)	(1239)	Eletherokomma	D (Give)	-D (Fras-u)?	(1,25)
Cryptothyris	O (Cara-u)	-O (Ashg)?	(538)	Elita	D (Sieg)	-D (Fras-u)	(25,708, 1066)
+Ctenokoninckina	Tr			Eliva	P (Asse-l)	-P (Dora)?	(7,417, 1128)
+Cumberlandina	D (Sieg)		(25)	Elivella	C (Step)?	-P (Sakm)	(538)
+Cyclorhynchia	O (Ashg)		(1132)	+Elivina	P (Asse-l)	-P (Guad-u)	(7,417)
Cyrrella	P (Asse)	-P (Guad-u)	(1,538,712)	Ella	P (Wc)		(1,538)
Cyrta	S (Ldov-u)	-S (Ludl)	(25,538)	+Elymospirifer	D (Emsi-l)		(24)
Cyrtna	S (Wenl)	-C (Vise-u)	(2,48,435, 1066)	Elythina	D (Emsi-u)	-D (Give)	(25)
Cyrtnaella	D (Gedi)	-D (Emsi)	(25)	Emanuella	D (Emsi-u)	-D (Fras-u)	(24,25, 1215)
				+Enchodrosipirifer	D (Fame-u)		(ZR70)

Taxon	First Appearance	Last Appearance	Reference	Taxon	First Appearance	Last Appearance	Reference
+Endospirifer	S (Wenl)		(881)	+Helenathyris	D (Gedi)	-D (Sieg)	(897)
+Eobiernatella	D (Give-u)			+Heteraria	P (Sakm)?	-P (Guad)	(538)
+Eobrachythyrida	C (Vise-u)	-C (Serp-u)	(1200)	+Himathyris	P (u)		(881,1271)
+Eobrachythyris	D (Fame-m)	-D (Fame-u)	(695)	Hindella	O (Ashg-m)	-S (Ldov-u)	(25)
+Eochoristitella	C (Ms)		(881)	Hirsutella	Tr(Anis-l)	-Tr(Ladi)?	(1,538)
Eochoristites	C (Tour-u)	-C (Vise-u)	(400)	+Hispidaria	D (Fame-m)		(708)
+Eodmitria	D (Fras-l)		(881)	+Histosyrinx	C (l)		(ZR75)
+Eohowellella	S (Ldov)		(ZR77)	+Holcospirifer	S (Wenl-u)	-S (Ludl-u)	(538)
+Eolaballa	P (Dora)		(881,1128)	+Homevalaria	P (Leon-l)		(881)
Eomartiniopsis	C (Tour-l)	-C (Vise-u)	(34,400)	Homoeospira	S (Ldov)	-D (Gedi)	(1239)
+Eoplicoplasia	S (Wenl-u)	-D (Sieg)	(1174)	+Homoeospirella	S (Ldov)	-S (Wenl-u)	(25,764,1066)
Eoreticularia	D (Emsi)		(25)	Howellella	S (Ldov-u)	-D (Emsi-u)	(25)
Eospirifer	O (Ashg-m)	-D (Eife)	(24,25)	+Howelloidea	D (l)		(881)
Eospiriferina	D (Eife)		(24)	Howittia	D (Sieg)	-D (Emsi-u)	(25)
Eosyringothyris	D (Fras)?		(25)	+Hungarispira	Tr(Carn)		(897,1271)
+Eridmatius	C (Mosc-u)	-P (Asse-l)	(7,417)	Hustedia	C (Tour-l)	-P (Dora)	(33,42,411,1128)
+Espella	S			Hyattidina	O (Cara-u)	-D (Gedi)	(25,1239)
Eudoxina	C (Tour-l)		(1,955)	+Hysterohowellella	D (Gedi-l)		(881)
Eumetria	D (Fame)	-C (Bash)	(1,4,400,1066,1239)	Hysterolites	D (Gedi-u)	-D (Sieg-l)	(25,538)
Euractinella	Tr(Ladi)	-Tr(Carn)	(1239)	+Ikella	D (Eife)		(1239)
+Eurekaspirifer	D (Emsi-l)		(25)	+Iliella	O (Ashg-u)		(881,965)
Euryspirifer	D (Emsi-l)	-D (Give-u)	(25)	Ilmenia	D (Emsi-u)	-D (Fras)	(24,25)
+Fallaxispirifer	D (Emsi)	-D (Eife)?	(ZR79, ZR83)	-Ilmenopsis	D		(881)
+Ferglenia	C (Tour-u)		(1175)	Ilmenispina	D (Give-l)		(1)
+Fidespirifer	D (Fras)		(538)	+Imacanthyrus	D (Gedi)		
Fimbrispirifer	D (Gedi)	-D (Give-l)	(1,25,1066)	Imbexia	C (Tour-u)	-C (Serp-l)	(1,1200)
+Finospirifer	C (l)		(538)	+Implexina	C (Pn)		
+Flabellocyrtia	Tr(Ladi)		(538)	Indospirifer	D (Emsi-u)	-D (Fras-u)	(24,25)
+Flexathyris	C (Vise)		(897)	+Iniathyris	C (Tour-l)		(955)
+Frechella	C (l)		(881,1271)	Ivanothyris	D (Gedi)	-D (Emsi)?	(25)
Fredericksia	C (Pn)	-P (u)	(1,538)	+Iwaspirifer	C (Ms)		(538)
Fusella	C (Tour-u)	-C (Serp-u)	(400)	Janiceps	P (Djhu)	-P (Dora)	(411,1239)
+Fusispirifer	P (Sakm-l)	-P (Guad-u)	(712)	Janius	S (Wenl-l)	-D (Eife)	(25)
+Galeatathyris	C (Vise)?		(881,1271)	+Jarovathyris	S		(881)
Georgethyris	C (Vise-u)		(400)	+Jiangdaspirifer	Tr(u)		(881)
+Gerksipira	C (Tour-u)		(881,955)	+Jilinmartinia	C (u)		(881)
+Gerolsteinites	D (Eife-u)		(1015)	+Jilinspirifer	D (u)		(881)
+Gerothyris	D (Eife-l)		(1015)	+Johnsonathyris	D (Fame-m)	-D (Fame-u)	(53)
+Gibbospirifer	C (Pn)	-P (Asse)	(538)	+Kalitvella	C (Mosc-u)		(1176)
+Gissarina	S (Prid)		(743)	+Kanospirifer	P (u)		(ZR77)
+Gjelispiniifera	C (Step-u)		(1200)	+Kasakhstania	C (Pn)		(538)
Glassina	S (Wenl-u)	-S (Ludl-l)	(25,27)	+Kalitvella	C		(881)
+Glendonina	P (Guad-u)			+Kelusia	D		
+Globispirifer	C (l)			+Khinganospirifer	D (m)		(ZR79)
+Glytospirifer	D (Emsi-l)	-D (Emsi-u)	(24)	+Kimatothyris	D (Eife)		
+Gonathyris	D (Sieg)		(1132)	+Kinghiria	C (Vise)		(538)
+Goungjuns-pirifer	D (u)		(881)	+Kintathyris	P (Sakm-u)		(1172)
Grantonia	P (Leon-l)		(62)	+Kisilia	C (Tour)		(538)
Greenfieldia	S (Ludl)	-D (Gedi)	(25,1239)	+Kitakamithyris	C (Tour-l)	-C (Bash-l)	(400)
+Gruntallina	P (Dora)		(881,1271)	+Klipsteinella	Tr(Carn)		(538)
+Guangshunia	D			+Klipsteinelloidea	Tr(Nori)		(538)
+Guangxiispirifer	D (Eife)		(24)	+Koeveskallina	Tr(Ams)	-Tr(Carn)	(538)
+Guaxa	D (Gedi-u)	-D (Sieg-l)		+Koigia	S (Ldov)		(881)
+Guicyrtia	D (Eife)		(24)	+Koniella	D (Eife-u)	-D (Fras-u)	(881)
+Guilinospirifer	C (l)		(881)	+Komispirifer	D (Fras)		(538)
+Gypospirifer	C (Serp-u)	-P (Leon-m)	(7)	Konineckina	Tr(Carn)	-J (Sine)	(2,538)
+Haplospirifer	P (l)		(ZR79)	Konineckella	Tr(Ladi-u)	-J (Sine)	(2,538,1066)
Havlicekia	S (Ludl)	-D (Emsi)	(1,25)	Konineckodonta	Tr(Rhae)	-J (Plie)	(55)
Hedeina	S (Ldov-u)	-D (Eife)	(25,538)	+Kosirium	D (Eife-u)	-D (Give)	(538)
+Hedeinopsis	S (Wenl-u)	-S (Ludl-l)					

Taxon	First Appearance	Last Appearance	Reference	Taxon	First Appearance	Last Appearance	Reference
-Kozlenia	S (Wenl)		(881)	+Moravilla	D (Give-l)		(25)
Kozlowskiellina (+ Kozlowskiella)	S (Wenl-u)	-D (Eife-u)	(27,38)	+Moumina	P (Wc)		(1,538)
+Kungaella	P (l)		(881)	+Mucrospirifer	D (Emsi-u)	-D (Give-u)	(25,538)
+Kymatothyris	D (Emsi)	-D (Eife)	(538)	+Mucrospiriferinella	C (Step)?		(538)
+Laballa	Tr(Carn)	-Tr(Rhae)	(434)	+Multispirifer	D (Sieg)		(25)
+Ladjia	D (Give)	-D (Fras)	(25)	+Myodethyrium	P (Leon-l)?		(881)
+Laevispirifer	S (Ldov)		(ZR78)	+Myriospirifer	S (Wenl)	-D (Sieg)	(5,38)
+Laioporella	C (Pn)	-P (Wc)	(538)	+Nahoniella (+ Yukonella)	P (l)		
+Lamellokoninekina	Tr(Nori)		(538)	Najadospirifer	D (Emsi)	-D (Emsi-u)	(25)
-Lamellosathyris	C (Vise)	-C (Serp-l)	(897)	+Nakazatothyris	D (m)		(538)
+Lamnaespina	P (Guad)		(538)	+Nebenothyris	C (Vise-u)		(400)
+Lanchangiangia	Tr(Nori)		(538)	+Neocyrtina	Tr		
-Larispirifer	C (Mosc-l)?	-P (Asse)	(1200)	Neodethyris	D (Eife)		(1)
+Latiptecus	P (l)		(ZR79)	+Neophricodothyris	P (Asse-l)	-P (Djhu)	(7,411)
+Latispirifer	P (l)	-P (u)	(881)	Neoretzia	Tr(Anis)	-Tr(Rhae)?	(2,434, 1271)
+Lazutkia	D (Emsi-u)	-D (Give)	(24,25)	Neospirifer	C (Vise-u)	-P (Djhu)	(400,411)
+Leiolepismatina	Tr			Nikiforovaena	S (Wenl-l)	-S (Ludl)	(24,25)
+Leiothyridina	C (Vise)	-C (Serp-l)?	(897)	+Nodaea	C (Tour)?		(538)
+Lenzia	D (Emsi)?			+Nordathyris	C (Serp)		(1239)
+Lepidospirifer	P (Leon-m)	-P (Leon-u)	(7)	+Nordella	D		
Lepismatina	Tr(Carn)?	-Tr(Nori)	(434)	Nordispirifer	D (Fras)		(538)
Leptathyris	D (Eife)	-D (Give-l)	(25,1239)	Notospirifer	C (Step-l)	-P (Guad-u)	(427,437, 712)
Leptospira	D (Gedi-u)	-D (Eife)	(25,897)	Nucleospira	S (Ldov-m)	-P (Leon-l)	(7,651)
Licharewia	P (Leon)	-P (Guad-u)	(33)	+Nudispiriferina	Tr		
Liospiriferina	J (Hett)	-J (Toar)	(877)	+Nuguschella	D		
Liraspirifer	D (Fame)	-C (Ms)	(25)	+Nurataella	S (Wenl-u)		(538)
Liriplica	C (Mosc)?			Obesaria	D (Eife)		(25)
+Lithothyris	D (Fame)		(25)	+Ochotathyris	Tr(Nori)		(1239)
+Ljudmilispirifer	D (Emsi-u)	-D (Eife-l)		+Odontospirifer	P (Guad-u)		(1,538)
Macropleuria	S (Wenl-u)	-D (Eife)	(25)	+Oiosia	D (Fame-m)		(708)
+Madoia	Tr(m)		(881)	+Olgerdia	P (u)?		(538)
+Majkopella	Tr(Carn)	-Tr(Rhae)	(1239)	+Orbicoelia	P (Leon-m)		(403)
Martinia	C (Vise-u)	-P (Dora)	(955,1128)	+Orenburgella	C (Vise)		(ZR69)
Martinella	C (l)		(ZR78)	+Orientospira	Tr(Nori)		(538)
Martinopsis	C (Pn)	-P (Djhu)	(411)	+Orientospirifer	D (Sieg)		(24)
Martinothyris	C (Vise-u)		(400)	+Ornothyrella	O (Ashg)		(1239)
Mauispirifer	D (Emsi)		(25)	+Orthospirifer	D (Give-l)	-D (Fras-u)	(64)
Mediospirifer	D (Eife-l)	-D (Give-u)	(25)	+Orulgania	C (Bash-l)	-C (Step-u)	(400)
Megakozlowskiella	S (Prid)?	-D (Give-l)	(25)	+Otospirifer	D (m)		(538)
+Mennespirifer	D (Fras)		(538)	+Oxycypella	Tr(Carn)	-Tr(Rhae)	(434,1066, 1239)
Mentzelia	Tr(Anis-l)	-Tr(Rhae)	(1,434,674)	+Pachyplax	D (Emsi-u)		
+Mentzelioides	Tr(Nori)?		(538)	+Paeckelmanella	C (Step-u)	-P (Guad-u)	(1,33)
Mentzeliopsis	Tr(Ladi)	-J (Plie)	(434)	+Palaeochoristites	C (Tour-u)	-C (Vise-l)	(1200)
Merista	S (Ldov-u)	-C (Tour-u)	(25,955)	+Palaeospirifer	D (Fame)		(25)
Meristella	D (Gedi)	-D (Fras)	(992)	+Parachoristites	C (Bash-l)	-P (Asse)	(1200)
+Meristelloides	D (Emsi)		(992)	+Paracomposita	C (l)		(881)
Meristina	S (Ldov-m)	-C (Vise)	(965,1066)	+Paracrurithyris	P (Dora)	-Tr(Indu)?	(150,1066)
+Meristorygma	C (Bash-u)	-P (Wc)?	(440,1200)	+Paracemanuella	D (m)		(ZR79)
Meristospira	D (Eife-l)	-D (Give)	(25,1239)	+Paralaballa	Tr(Nori)		(538)
Merospirifer	C (Vise-l)	-C (Vise-u)	(400)	+Paralazutkia	D (Eife)		(24)
Metaplasia	D (Gedi-l)	-D (Emsi)	(1,25)	+Paralepismatina	Tr		
+Metathyrisina	S (Ldov-m)		(743,1122)	+Parallelora	D (Fame-u)	-C (Tour-l)	(25,955)
+Metriolepis	P (Sakm)	-P (Guad-u)	(7)	+Paramentzelia	Tr		
+Mictospirifer	S (Ldov-u)		(1177)	+Paramerista	D (Gedi)	-D (Emsi)	(992)
+Mimothyra	C (Tour-l)	-C (Vise-u)	(435)	+Paraquadrithyris	D		(881)
+Mirifusella	C (Tour-u)	-C (Vise-l)	(955)	+Parareticularia	P (l)		(ZR79)
+Misolia	Tr(Nori)		(1066)	+Pararhynchospirina	D (Gedi)	-D (Emsi)	(897)
Molongia (+ Protathyrisina)	S (Ludl-l)	-D (Gedi)	(1,24,743)	Paraspirifer	D (Sieg-u)	-D (Give-l)	(25)
+Mongoliopsis	C (Ms)						
+Mongolospira	D (Sieg)		(1239)				

Taxon	First Appearance	Last Appearance	Reference	Taxon	First Appearance	Last Appearance	Reference
+Paraspiriferina	P (Asse)	-Tr(Indu-l)	(7,1128)	+Pseudoprotathyris	S (Prid)	-D (Gedi)	(897)
+Parathyrisina	D (Sieg)	-D (Give)	(24,897,1239)	+Pseudospiriferina	Tr(m)		(ZR84)
Parazyga	D (Eife)		(897)	+Pseudospondylospira	Tr(Carn-u)	-Tr(Nori-l)	(975)
+Parunicinella	C (Ms)			Pseudosyringothyris	P (We)	-P (Sakm)	(1,538)
+Patriaspirifer	D (Sieg)	-D (Emsi-l)	(1178)	Pseudosyrinx	C (Tour-u)	-P (Guad-u)	(48,400,955)
Paulonia	C (l)		(1)	+Pseudoundspirifer	D (l)		
+Pennospiriferina	Tr(Ladi)	-Tr(Carn)	(538)	Psioidea	Tr(Carn)	-Tr(Rhae)	(1,2,538)
Pentactinella	Tr(Ladi)	-Tr(Carn)	(1239)	+Psioidiella	Tr(Tr(Carn-u)?, Tr(Nori-l)?		
Pentagonia	D (Emsi-u)	-D (Give-l)	(25)	+Pteroplecta	P (u)		(1066)
+Penzhinella	P (Guad-l)		(881)	Pterospirifer	P (Asse)	-P (Guad)	(2)
+Perissothyris	C (Vise-u)		(955)	+Puanospirifer	D (Eife)		(24)
+Permasyrinx	P		(881)	+Punctocyrtella	C (Step)	-P (Sakm-u)	(538)
+Pernophricodothyris	P (Leon-m)	-P (Dora)	(403,538)	+Punctospirilla	Tr(Anis-m)	-Tr(Ladi-u)	(538)
+Pernospirifer	P (Sakm)	-P (Leon)	(417)	Punctospirifer	C (Tour-l)	-P (Guad-u)	(47,955)
+Perryspirifer	D (Emsi-u)	-D (m)	(65,441)	Punctocyrtella	C (Tour-l)	-C (Vise-u)	(400,955)
+Petshorospirifer	D (Fame-u)		(881)	Purdonella	C (Mosc-l)	-P (Djhu)	(2,1200)
Pexidella	Tr(Anis)	-Tr(Nori)	(1239)	Pustulatia	D (Emsi)	-D (Give-u)	(25,538)
+Phenacozugmayerella	Tr(Carn-u)	-Tr(Nori-m)	(975)	+Pustuloplica	P (Leon-m)	-P (Guad)	(538)
Phricodothyris	C (Vise-l)	-P (Dora)	(1,435,1128)	+Pustulospiriferina	P (Sakm-l)	-P (Guad-u)	(437)
+Pinegathyris	C (Bas-l)	-P (Guad-u)	(897,1239)	+Pyramidathyris	P (l)		(881)
+Pinguuangella	D (Eife)		(24)	+Pyramina	D		
Pinguispirifer	D (Emsi)	-D (Eife)	(25)	+Qiansispirifer	D (m)		(ZR79)
+Planalvus	C (Tour)	-C (Vise-l)	(897,1239)	-Qinghaispiriferina	Tr(m)		(881)
+Plancella	D (Sieg-l)		(764)	+Qingthyris	Tr(m)		(881)
+Planthaydenella	P		(881)	+Qingyenia	Tr(Anis)		(538)
Platyrachella	D (Give-u)	-D (Fras-u)	(4)	+Qinlingia	D (Gedi-l)		(1122)
Platyspirifer	D (Fras-l)		(1,695)	+Qispiriferina	Tr(m)		(881)
Plectospira	D (Sieg)	-C (Vise-l)	(897,955)	+Quadrifarius	S (Prid)	-D (Gedi)	(25)
+Plicatocyrtia	C (Step)			Quadrithyris	D (Eife)		(25)
+Plicatospiriferella	C (Pn)		(881)	Quadrithyris	D (Gedi-u)	-D (Give-l)	(25)
Plicatosyrinx	C (l)		(1)	Quasimartina	D (l)		(1)
Plicocyrtia	S (Wen-l)	-S (Ludl)	(24,25,538)	+Quirigites	D (Eife)		(1015,1156)
Plicocyrtina	D (Sieg-u)	-D (Eife)	(25)	+Quizhouspirifer	C (l)		
Plicoplasia	S (Wen-l)	-D (Eife)	(25,860)	+Kallacosta	P (Sakm-u)	-P (Guad-u)	(7)
+Plicotorynifer	C (Serp-u)	-C (Pn)	(400)	-Rariella	D (Gedi)	-D (Emsi)	(897)
+Podtscheremia	C (Tour-l)	-C (Serp-l)?	(955)	Rastelligera	Tr(Carn)	-Tr(Rhae)	(1,538)
+Pondospirifer	P			+Rawdonia	C (Vise)		(897)
+Posicomita	P (Leon-u)	-P (Guad-l)	(881,1239)	+Rectambitus	P (Dora)		(1128)
Pradoia	D (Sieg)	-D (Give)	(25,897,1239)	Reticularia	D (Fras)	-C (Serp-l)	(2,25,400)
+Primorewia	P (l)		(712)	Reticulariina	C (Vise-u)	-P (Djhu)	(4,400,538)
+Prochorititella	C			Reticulariopsis	S (Wen-l)	-D (Fras)	(436,538)
+Prolarutkina	D		(881)	+Retzia	S (Wen-l)	-C (Tour)	(1239)
Proreticularia	S (Ludl-l)	-D (Emsi)	(25,538,1066)	+Retziella	S (Wen-l)	-S (Prid)	(1122)
Prospira	C (Tour-l)	-C (Tour-u)	(1,400,1200)	-Retzispirifer	D (Eife)		(538)
Prosserella	D (Eife-l)		(25)	+Rhenothyris	D (l)	-D (m)	(538)
Protathyris	D (Gedi)	-D (Sieg)	(24,25,1239)	+Rhynchospirifer	D (m)		(ZR79)
Protoreticularia	S (u)		(881)	Rhynchospirina	S (L,dov)	-D (Fame)	(2,1066,1239)
Protozeuga	S (Ldov-m)	-S (Wen-l)	(25,27,965)	+Rigauxia	D (Fras-m)		(881)
+Pseudocyrtina	-Tr(Nori)			+Roctex	D (Eife)		(1149)
+Pseudohomeospira	S (Prid)		(897)	+Rotespirifer	P (Guad)		(538)
+Pseudokymatothyris	D (l)		(1161)	+Rostrospirifer	D (Emsi-l)	-D (Emsi-u)	(24)
+Pseudolaballa	Tr(Carn)		(538)	+Rowleyella	C (Tour-u)		(48,955)
+Pseudolepismatina	Tr(u)		(ZR80)	+Ruüspirifer	S		(881)
+Pseudoparazyga	D (Gedi-u)	-D (Emsi)	(25,1239)	-Sarganostega	P (Leon-l)	-P (Djhu)	(7,538)
+Pseudopentagonia	C (Tour)		(538)	+Scenesia	P (Leon-l)		(7)
				Schizospirifer	D (m)?		(1)
				+Schwagerispira	Tr(Anis)		(897)
				+Sculptospirifer	D (m)		(881)
				+Semibrachythyria	P (l)	-P (Dora)	(ZR80, ZR83,1128)

Taxon	First Appearance	Last Appearance	Reference	Taxon	First Appearance	Last Appearance	Reference
Septamphiclina	Tr(Nori)		(538)	Tangshanella	C (Bash)?	C (Mosc)?	(538)
Septathyris	D (Sieg)	-D (Emsi-l)	(25)	Tannuspirifer	S (Ldov)	-S (Ludl-u)	(538)
+Septospirifer	P (Asse)	-P (Sakm)	(538)	+Tarandrospirifer	D (Fame)?	-C (Vise-u)	(400)
-Septospirigirella	P (Guad-u)		(411)	+Tecnocyrtina	D (Give-u)	-D (Fras-l)	(25)
Septosyringothyris	C (l)		(1)	+Tegulocrea	C (Tour-u)	-C (Vise-l)	(1175)
Sergospirifer	C (Mosc-u)	-P (Leon)	(1200)	-Tenellodermis	S (Wenl)	-D (Gedi)	(25,538)
+Sergunkovia	C (l)		(ZR83)	+Tenisia	D (Fame-u)		
+Settedabania	C (Pn)			Tenticospirifer	D (Fras-m)	-D (Fras-u)	(25)
+Sikasella	C (Ms)			+Tenuicostella	D (l)		
Sinucosta	Tr(Anis)	-Tr(Rhae)	(2,434)	Tetractinella	Tr(Anis-l)	-Tr(Ladi)	(674,1239)
+Sinucostella	Tr(m)		(881)	-Tetraloba	D (Emsi)		(1271)
+Skelidorygma	D (Fame)	-C (Serp-l)	(440)	-Texathyris	C (Tour-u)		(955)
+Sphaerathyris	D (Sieg)	-D (Emsi)	(1132)	Theococyrta	Tr(Carn)		(1,2)
Sphenospira	D (Fame)	-C (Tour)?	(25,538)	-Theococyrtaeidea	Tr		
Spinella	D (Emsi-u)		(25)	-Thedusia	P (Leon-m)	-P (Guad-u)	(7)
-Spinispirifer	D (Fame)		(538)	Theodossia	D (Give)	-D (Fame)	(25)
Spinocyrtia	D (Sieg-l)	-D (Fame-u)	(1066)	Thomasaria	D (Fras-m)	-D (Fras-u)	(25)
+Spinolepismatina	Tr(Nori)?		(538)	+Timaniella	P (Leon-u)	-P (Guad-l)	(417)
-Spinomartinia	P (Sakm)	-P (Djbu)	(427,712)	+Timanospirifer	D (Fras)		(538)
Spinoplasia	D (Gedi)	-D (Sieg-l)	(25)	+Tingella	D (Give)?	-D (Fras)	(538)
+Spinospirifer	D (m)		(538)	+Tipispirifer	P (Leon-m)		(403)
Spinuliplica	C (Serp-l)	-C (Mosc)?		+Tiramnia	C (Bash-l)	-P (Wc)	(538,1200)
Spirielytha	P (Sakm-u)	-P (Guad)?	(33)	+Titanothyris	P (l)		(881)
Spirifer	C (Tour-u)	-C (Bash-l)	(1200)	Tomiospis	C (Vise)?	-P (Guad-u)	(1)
Spiriferella	C (Vise-l)	-P (Dora)	(417,1066,1142)	+Tongzithyris	P (Dora)		(1128)
Spiriferellina	C (Vise-u)	-P (Dora)	(411,435,1128)	Toryniifer	D (Fame)	-C (Serp-l)	(1,4,25)
+Spiriferelloides	P (l)		(881)	+Toryniiferella	D (Fame-m)	-D (Fame-u)	(695,708)
Spiriferina	J (Hett-u)	-J (Toar-u)	(538)	+Transversaria	P		(881)
Spiriferinaella	P (Leon)	-P (Guad-l)	(7)	+Trautscholdia	C (Mosc-l)	-P (Asse)	(1200)
Spiriferinoides	Tr(Carn)		(1,538)	Trematospira	D (Gedi-l)	-D (Eife-l)	(25,764)
Spirigerella	P (Sakm-l)	-P (Dora)	(411,1128)	Triadispira	Tr(Nori)		(1,538)
-Spirigerellina	Tr(Olen)	-Tr(Carn)	(538)	Triathyris	D (Emsi-u)		(25)
Spirinella	S (Wenl-l)	-S (Ludl-u)	(860)	-Trigonospirifer	D (Anis-l)		(881)
+Spiropunctifera	C (Vise-u)		(538)	Trigonotreta	C (Step-l)	-P (Leon)	(62,538,712)
Spondylospira	Tr(Carn-l)	-Tr(Nori-u)	(442,975)	-Trochalocyrtina	D (Eife)		(538)
+Spondylothyris	D (l)		(881)	+Tschatkalia	S (Ldov)	-S (Wenl)	(992)
+Spurispirifer	S (Wenl-l)	-D (Emsi)	(25,860)	+Tulathyris	D (Fame-u)	-C (Tour-l)	(1200)
+Squamathyris	S (Ludl)		(897)	+Tulungospirifer	Tr(Anis)		(538)
+Squamularia	P (Dora)		(1128)	+Tumarinia	P (Guad)		(538)
Squamulariina	D (m)		(1)	+Tuotalania	P (l)		(881)
+Stepanovina	P (l)		(ZR70)	+Turganiella	D (Emsi)		(1239)
Stolzenburgiella	Tr(Anis)		(1271)	+Tytospiriferina	Tr		
Strispirifer	S (Ldov-m)	-D (Eife)	(24,25)	Tylothyris	D (Fras-u)	-C (Vise-u)	(1,400)
Strophopleura	D (Fame-m)		(25,955)	+Tyrganiella	D (Emsi)		(992)
+Struveina	D (Sieg)	-D (Eife)	(25,538)	Uchtospirifer	D (Fras-l)		(538,695)
Subansiria	C (Pn)?	-P (Sakm)	(538)	+Uexothyris	D (Eife-l)		(1015,1156)
+Subcuspidella	D (Emsi)	-D (Eife)	(25)	-Ufonicocelia	D (Emsi-l)		(1122)
+Subspirifer	C (l)		(881)	+Ulhospirifer	C (Tour-l)?		(538)
Suessia	J (Plie-u)		(1066)	+Uldziathyris	C (Vise)		(1239)
+Sulcathyris	D (Eife)		(538)	Uncinella	P (Leon-m)	-P (Leon-u)	(403)
Sulcatospirifer	D (Fame)		(25)	Undispirifer	S (Pridl)	-D (Fras)	(25)
+Sulcicosta	P		(881)	+Undispiriferoides	D (m)		(ZR66)
+Sulcipleuca	P (Sakm-l)	-P (Guad-u)	(62,712)	Unispirifer	C (Tour-l)	-C (Tour-u)	(1,400,1200)
+Sulcispiriferina	P (Guad-u)	-P (Dora)	(881)	Uralospirifer	D (Emsi)	-D (Eife)?	(1)
+Svetlania	D (Emsi-l)		(897)	Urella	D (m)		(1)
+Swaicoelia	D (u)	-C (Ms)	(538)	+Ushkolia	D (Fame)		(538)
Syringospira	D (Fame-m)		(25,708)	+Vadum	S (Wenl-u)		(538)
Syringothyris	D (Fame-u)	-C (Serp-l)	(25,1200)	+Vandercammenina	D (Sieg-l)	-D (Emsi)	(25)
+Tabellina	C (Step-l)		(712)	+Verkhotomia	C (Tour-l)	-C (Tour-u)	(955)
+Taimyrella	C (u)	-P (Wc)	(538)	Verneuilia	D (Eife)	-C (Vise-u)	(1,435)

Taxon	First Appearance	Last Appearance	Reference	Taxon	First Appearance	Last Appearance	Reference
+Viligella	Tr(Nori)		(538)	+Barkolia	S		(881)
+Vitimetula	Tr(Nori-u)	-Tr(Rhae)	(975)	+Beesia	S (Ldov-l)	-S (Ldov-m)?	(1179)
+Voiseyella	C (Tour-u)	-C (Vise-l)	(955)	+Beitaia	S (Ldov-m)	-S (Ldov-u)	(24)
Warrenella	D (Emsi-l)	-D (Fras)	(25,47)	Biconostrophia	D (Sieg-u)	-D (Emsi-l)	(25,1228)
+Warrenellina	D (Eife)	-D (Fras)?	(538)	Biñda	D (Emsi)	-D (Give)	(538)
+Warsawia	C (Vise-l)		(440,955)	+Bucequia	S (Ludl)		(881)
Whitfieldella	S (Ldov)	-D (Gedi)	(25,764, 1239)	+Butkovia	D (Sieg)		
+Weibeia	O (m)		(881)	Carinatina	D (Sieg)	-D (Give-l)	(24,37,662, 989)
+Wilberrya	P (Sakm)	-P (Leon-u)	(538)	+Carinatinella	S (Ldov-u)?	-D (Emsi)	(37)
Xenomartinia	D (Sieg)	-D (Eife)	(25)	+Carinatrypa	D (Eife-u)	-D (Give-u)	(37,538, 662,1228)
+Xenosaria	P (Guad-u)		(7)	Catazyga	O (Cara-u)	-O (Ashg-u)	(25,538, 965)
+Xerospirifer	D (Sieg)		(538)	+Caratrypa	S		(881)
+Xerxespirifer	S (Wenl)		(538)	+Cerasina	S (Ldov-l)		(1179)
+Xestotrema	P (Guad-l)	-P (Guad-u)	(1066)	+Cerberatrypa	D (Eife)		(1149)
+Xinanospirifer	S (Wenl-l)		(651)	+Cherkesovaena	D (Emsi)	-D (Eife)	(1228)
+Xinjiangospirifer	D (Emsi)		(881)	+Claratrypa	S (Ludl)		(881)
+Yalongia	Tr(m)		(881)	Clarkeia	O (Ashg-u)	-D (Eife)	(1066)
+Yangkongia	Tr(m)		(881,1066)	Clintonella	S (Ldov-m)	-S (Ldov-u)	(24,965)
+Yanospira	Tr(u)		(ZR77)	Coelospira	S (Ludl-u)	-D (Eife-u)	(25,443)
+Yaonoïella	P (l)		(881)	+Coelospirella	D (Gedi)	-D (Emsi-l)	(24,538)
+Yeothyris	D (Eife)		(1015,1156)	Coelospirina	D (Emsi-u)		(25)
+Yingwuspirifer	S (Ldov-l)	-S (Ludl)	(651)	+Costatrypa	D (Fras-l)	-D (Fras-u)	(662)
+Zaïssania	C (Mosc)	-P (Wc)	(538)	+Crassatrypa	S (Ludl-u)	-S (Prid)	(1228)
+Zeugopleura	C (Tour-l)		(881,955)	+Crassipunctatrypa	D (Sieg-u)	-D (Emsi-u)	(445)
+Zhejiangospirifer	P (l)		(881)	+Cromatrypa	S (Ludl)		(881)
+Zhonghuacoelia	D (Fras-l)		(436)	Cryptatrypa	S (Wenl)		
Ziganela	C (Tour-l)	-C (Tour-u)	(1,1200)	Cyclospira	O (Cara-m)	-S (Ldov-l)	(683,965)
+Zonathyris	D (m)		(1271)	Davidsonia	D (Emsi-u)	-D (Give-u)	(1228)
Zugmayerella	Tr(Carn-u)	-Tr(Rhae)	(2,434,975)	Davidsoniatrypa	D (Sieg-u)		(25)
Or. ATRYPIDA				Dayia	S (Ludl-l)	-S (Prid)	(25,27)
+Adaptatrypa	D (Eife)		(881)	+Desatrypa	D (Eife-u)	-D (Give-u)	(37,662, 1228)
Alisipra	O (Ashg-m)	-S (Ldov-l)?	(25,965)	Desquamatia	D (Emsi)	-D (Fras-u)	(25,37)
+Altaethyrella	O (u)		(ZR78)	+Dihelictera	S (Ldov-u)	-S (Wenl)?	(1179)
Anabaia (+ Harringtonina)				+Dnestrina	S (Ludl)		(25)
	S (Ldov-l)	-S (Ludl-u)	(66,446, 538)	Dubaria	D (Gedi)	-D (Sieg)	(683)
+Anabaria	S			+Eifelatrypa	D (Eife-u)	-D (Give)	(37,1228)
Anatrypa	D (Fras-l)	-D (Fras-m)	(662)	+Endrea	S (Wenl-l)	-S (Ludl-u)	(1236)
+Anazyga	O (Cara-l)	-O (Cara-u)	(683)	Eocoelia	S (Ldov-l)	-S (Wenl-l)	(1,27)
Anoplotheca	D (Sieg)	-D (Emsi)	(25)	Eokarpinskia	S (Prid)	-D (Gedi)	(25,1228)
Anteloceelia	D (Emsi)		(538)	+Eonalivkinia	O (u)		(ZR85)
+Antizygospira	O (u)		(881)	+Eospinatrypa	S (Wenl-l)	-S (Prid)	(37)
+Anulatrypa	D (l)?		(881)	+Eospirigerina	O (Ashg-l)	-S (Ldov-u)	(24,25)
+Araneatrypa	D (Sieg)		(881,989)	+Euroatrypa	O (Cara)		(538)
+Arctispira	D (Gedi)		(881)	+Exatrypa	D (Fras-l)		(662)
+Atlanticocoelia	D (Emsi)		(881)	Falsatrypa	D (Emsi)		(25)
Atrypa	S (Ldov-u)	-D (Fras-l)	(25)	+Filiatrypa	D		(881)
+Atryparia	D (Eife)	-D (Fras-m)	(37,538)	+Fossatrypa	D (Sieg-u)	-D (Eife-l)	(538)
Atrypella	S (Ludl-l)	-D (Gedi-u)	(25,27)	Glassia	S (Ldov-m)	-S (Prid)	(25,683, 965)
+Atrypellina	S (u)		(881)	+Globatrypa	S		(881)
Atrypina	S (Ldov-m)	-D (Sieg-l)	(24,25)	+Gotatrypa	S (Ldov-m)	-S (Prid)	(37)
Atrypinella	S (Ludl-u)	-D (Gedi-u)	(37)	+Gracianella	S (Wenl-l)	-D (Gedi-l)	(25,37)
+Atrypinopsis	S (Ldov-m)	-S (Wenl)	(24,683)	Gruenewaldtia	D (Eife-l)	-D (Give-l)	(25,1228)
Atrypoidea	S (Wenl-l)	-S (Prid-l)	(24,68)	Hallina	O (Cara-l)		(397)
Atryppus	S (Ldov-u)?	-S (Wenl-l)	(37)	+Hanusatrypa	D (Emsi)		(538)
+Atryppulus	D (l)?		(881)	+Hergetatrypa	D (l)?		(881)
+Aulacatrypa	S		(881)	Holynatrypa	D (Emsi-u)	-D (Eife-l)	(24,1066)
Australina	S (Ludl-l)	-S (Prid)	(683)	+Hyponeatrypa	D (m)		(538)
+Australispiria	O (Cara)		(1135)				
Australocoelia	D (Sieg)	-D (Emsi)	(538,1066)				

Taxon	First Appearance	Last Appearance	Reference	Taxon	First Appearance	Last Appearance	Reference
+ Johnsoniatrypa	S (Wen-l)		(860)	Pentlandella	S (Ldov-m)	-S (Ldov-u)	(25,538)
+ Idrosipira	O (Cara-m)	-S (Ldov-l)	(683,965)	+ Peratos	D (Eife)	-D (Fras)	(683)
+ Imbricatospira	S (Ldov)		(881)	+ Peshiatrypa	D		(881)
+ Indentistella	D (Emsi-l)			+ Pesterevatrypa	D (m)		(ZR85)
+ Independentrypa	D (Eife)	-D (Give-u)	(37,662)	+ Planatrypa	D (Gedi)	-D (Eife)	(37)
+ Invertina	D (Give-u)		(1180)	+ Plectatrypa	O (Ashg-m)	-S (Ludl-l)	(25,66,965)
Invertrypa	D (Eife-u)		(25)	+ Plesicarinatina	S (Prid)	-D (Emsi)	(1228)
+ Iowatrypa	D (Fras-m)	-D (Fras-u)	(37,662)	+ Procarinatina	S		(881)
+ Iospinatrypa	D (Emsi-u)	-D (Fras)	(25,444)	+ Prodavidsonia	D (Emsi)	-D (Eife-l)	(25,1228)
+ Jkella	D		(538)	Protatrypa	O (Ashg-m)	-S (Ldov-m)	(25,965)
+ Joviatrypa	S (Ldov-m)	-S (Wen-l)?	(1179)	Protozyga	O (Cara-l)	-S (Ldov-l)	(2,37,447, 683,965)
+ Kaplicona	D (l)?		(881)	+ Pseudatrypa	D (Give-l)	-D (Fras-u)	(37,662)
+ Karbous	D (Gedi)	-D (Eife)	(683,989)	+ Pseudogruenewalldtia			
Karpinskia	D (Sieg)	-D (Eife)	(25,989)	+ Pseudomeristina	D (Fras-l)	-D (Fras-m)	(37,662)
Kayseria	D (Eife-l)	-D (Give)	(25,1066)	S (Wen-l)	-S (Ludl)		
Kerpina	D (Eife-u)		(1)	+ Puanatrypa	D		
- Klukatrypa	D (l)?		(881)	+ Punctatrypa	D (Gedi-u)	-D (Eife-u)	(24,25)
+ Kurzunia	O (m)	-O (u)	(881)	Punctospinatrypa	D (Sieg-u)	-D (Emsi-u)	(24)
Kwangsia	D (Emsi-u)	-D (Give)	(24,66)	+ Pusillagutta	O (m)		(881)
+ Kyrtatrypa	D (Gedi)	-D (Fras-m)	(37,538, 662)	+ Qilianotrypa	O (Ashg-m)		
Leptocoelia	D (Gedi)	-D (Eife-u)	(4,66)	+ Quanguyuania	S		
+ Leptocoelina	D (Sieg)			+ Quasidavidsonia	D (l)?		(881)
+ Levispira	D (Emsi)	-D (Eife)	(683)	+ Radiatrypa	D (Fras-l)	-D (Fras-m)	(538,662)
+ Lichnatrypa	D (Emsi-l)		(881)	+ Radimatrypa	D (Eife)		(1149)
+ Limbatrypa	S (Ldov-u)	-S (Ludl)	(37,447)	+ Reticulatrypa	S (Wen-l)	-D (Sieg)	(25,37,538)
+ Lingatrypa	S		(881)	+ Rhinotreta	O (Cara-l)	-O (Ashg-l)	(910,1181)
Lissatrypa	S (Ldov-m)	-D (Emsi-u)	(25,683, 965)	+ Rugodavidsonia	D (Eife-u)	-D (Give-l)	(1228)
- Lissatrypella	S (Wen-l)	-S (Prid)	(683)	+ Rugosatrypa	D (Gedi-u)	-D (Emsi-l)	(444)
Lissatrypoidea	S (Wen-l)	-S (Ludl)	(25)	+ Salairella	O (u)		(881)
+ Lixatrypa	D (l)?		(881)	+ Salairina	D (Sieg)	-D (Emsi)	(37)
Loilemia	S			+ Schachriomonina	O (u)	-S (Ldov-l)	(ZR87,965)
- Manespira	O (Llde-u)	-O (Cara-m)	(683)	Septatrypa	S (Ldov-m)	-D (Gedi)	(538,965)
+ Mangkeluia	D (Emsi)		(1228)	- Seratrypa	D (Give-u)	-D (Fras-l)	(37,662)
+ Megaplectatrypa	D (Emsi)		(538)	+ Seruliatrypa	D (m)		(538)
+ Megumatrypa	S (Ldov-l)?, S (Ldov-m)?		(538)	+ Shroekia	S (Ludl)		(25)
Meifodia	S (Ldov-l)	-S (Ldov-u)	(24,25, 1179)	+ Sibiratrypa	D		
Minatrypa	D (Emsi-u)	-D (Give-l)	(25,37)	+ Sibirispira	S (Ludl)	-D (Emsi)	(37)
+ Mogoliella	D (Give)		(1228)	+ Solitudinella	D (Sieg)		(1182)
+ Munieratrypa	D (Sieg-u)	-D (Eife-l)	(538)	Spinatrypa	S (Wen-l)	-D (Fras-u)	(25,27)
Nalivkinia	S (Ldov-m)	-D (Gedi)	(24,25)	+ Spinatrypa	D (Emsi)	-D (Fras-m)	(37,662)
+ Nanatrypa	S		(881)	+ Spinopunctatrypa	D (Emsi)		(538)
Nanospira	S (Wen-l)	-S (Ludl)	(25,764)	Spirigerina	S (Ldov-m)	-D (Eife)?	(25,37,538)
- Navispira	S (Ludl)	-D (Sieg-l)	(44,3,764)	+ Sulcatospira	O (Cara-u)?		(1066)
+ Neatrypa	D (Give-u)	-D (Fras-l)	(37,662)	+ Sulcificatrypa	D (m)		(881)
+ Neocoelia	D (Emsi)	-D (Eife)	(538)	+ Symmatrypa	S (Ludl)	-S (Prid)	(1228)
+ Neokarpinskia	D (Sieg)	-D (Emsi)	(1228)	+ Synatrypa	D (Eife)	-D (Give-l)	(37)
- Neospirigerina	S (Ludl)	-D (Emsi)	(538)	+ Sypharatripa	S (Ldov-l)	-S (Ludl)	(447)
- Notoparmella	S (Prid)	-D (Gedi-u)	(25,538)	+ Taouquospira	O (m)		(881)
+ Nuria	O (m)		(881)	+ Tectatrypa	S (Prid)		(1066)
- Ogilviella	D (Gedi-u)	-D (Sieg-l)	(37,1005)	+ Tenuiatrypa	D		
+ Oglu	D (Sieg)		(881,989)	+ Tibetatrypa	D (Sieg-u)?	-D (Emsi-l)	
- Oglupes	S		(881)	+ Togatrypa	D (l)?		(881)
+ Ommutakhella	S (Ldov)		(ZR77)	+ Toquimaella	D (Sieg-l)	-D (Emsi-l)	(37)
- Opisconidion	O (Ashg-l)	-D (Fras)	(1181)	+ Totia	D (l)	-D (m)	(ZR77, ZR85)
+ Orthocarina	O (u)		(881)	+ Trigonatrypa	D (Eife)		(1149)
- Ovalospira	O (u)		(ZR82)	Tuvaella	S (Ldov-m)	-S (Prid)	(37,1066)
+ Pacificocoelia	D (Gedi-u)	-D (Eife)	(25)	Uncites	D (Give)		(1)
+ Parakarpinskia	D (m)		(881)	+ Uncitospira	S (Ldov-l)		(881)
+ Peet-atrypa	D (m)		(538)	+ Undatrypa	D (Emsi)		(538)
				+ Undithyrella	O (Ashg)	-S (Ldov)	(538)

Taxon	First Appearance	Last Appearance	Reference	Taxon	First Appearance	Last Appearance	Reference
Charltoniomyces	J (Aale)	-K (Berr)	(1)	+Dilophosina	K (Ceno)		(882)
Chascothyris	D (Give)		(25)	Dinarella	Tr(Carn)		(538)
Chathamiomyces	T (Pg)			Disculina	J (m)	-J (Oxfo-u)	(1)
Chatwiniothyris	K (Sn)	-T (Dani)	(1,882)	+Dissoria	J (Call-m)		(877)
Cheirothyris	J (Oxfo)	-J (Tith-l)	(1,538)	+Dolichobrochus	J (Call)		(882)
-Cheirothyropsis	J (Call-m)		(882)	+Dolichosina	T (Ol)		(882)
Cheniomyces	J (Bajo-u)		(1)	-Dolichozygus	T (Plio)	-R	(882)
+Chondronia	P (Sakm-l)	-P (Leon-u)	(7)	-Dongbaella	C (l)		
Choristothyris	K (Sn)	-K (Maes)	(1)	-Dorsoplicathyris	J (Bath-u)	-J (Oxfo)	(872,882)
Cimicinella	D (Emsi)		(25)	-Dracius	K (Camp-u)	-K (Maes-u)	(889)
+Cimicinoides	D (Eife-u)?		(25)	-Dundrythyris	J (Bajo)		(1095)
Cincta	J (Plie-l)	-J (Aale)	(1)	Dyscolia	T (Plio)	-R	(1,882)
+Cinctopsis	J (Plie)?		(881)	+Dyscritothyris	K (Camp)?	K (Maes)?	(882)
Cistellarcula	T (Eo)		(1)	Dzirulina	K (Haut)	-K (Albi-l)	(1)
+Clathrithyris	K (Haut)	-K (Apti)?	(538)	+Ectoposia	P (Guad-l)		(7)
Cloudeella	D (Gedi-u)	-D (Sieg)	(25)	+Ectoreneselandia	D (Give)		(538)
+Cloudothyris	D (Emsi-u)		(25)	-Ectyphoria	J (Bath-u)	-J (Call-l)	(877)
Coenothyris (+ Praerhaetina)				-Elasmata	P (Wc)		(538)
	Tr(Olen-u)	-Tr(Nori-u)	(1,674)	-Elderra	T (Mi-m)		(1183)
-Colinella	K (Vala)	-K (Barr)	(1094)	Elmaria	D (Give)		(1)
-Collinithyris	K (Vala-l)	-K (Apti)	(538)	+Embolosia	T (Eo-m)		(882)
+Colosia	J (Oxfo-u)	-J (Kimm)	(882)	+Emeithyris	Tr		
+Columellithyris	J (m)		(881)	+Enalloxia	P (Sakm)		(7)
+Conarothyris (+ Pionothyris)				+Endothyris	K (Berr)	-K (Vala)	(881)
	J (Aale)	-J (Bajo-l)	(872)	-Ense	D (Give)		(1015)
Concinnithyris	K (Ceno-l)	-K (Sant-l)	(776)	-Eoantiptychia	Tr(m)		(881)
Conomimus	D (Give)		(25)	Eodallina	Tr(Nori)	-Tr(Rhae)?	(1)
-Convexothyris	K (Haut)?, K (Barr)?		(1108)	Eogryphus	T (Eo)		(1,882)
+Cooperithyris	J (l)		(881)	+Eousella	J (Call)	-J (Oxfo)	(538)
Coptothyris	T (Ol-u)?	-R	(538)	Epicyrta	J (Plie-u)		(1)
+Coriothyris	J		(881)	Epithyris	J (Bath-u)		(882)
+Costacranaena	D (m)		(538)	+Epithyroides	Tr		
+Costoconcha	Tr(Nori)		(538)	+Eristenosia	J (Kimm)		(882)
Cranaena	D (Emsi)	-C (Serp-l)	(4,25,400)	Etythyris	D (Emsi-l)		(25)
-Cricosia	K (u)		(538)	Eucalathis	T (Mi)	-R	(1)
+Cruralina	K (Berr-l)	-K (Apti)	(538)	Eudesia	J (Bajo-u)	-K (Barr)?	(1,538)
Cruratula	Tr(Ladi)	-Tr(Carn)	(1,538)	+Eudesites	J (Oxfo)		
Cryptacanthia	C (Mosc)	-P (Tatr)	(1,2,538,1066)	Euidothyris	J (Aale)		(1,882)
				+Euryphyris	J		(881)
Cryptonella	D (Sieg-u)	-P	(1066)	+Eurysina	T (Eo)?	-R	(882)
Cubanothyris	Tr(Nori)		(1)	+Euryrosia	K (l)		(882)
Cudmorella	T (Mi)		(1)	Eurythyris	D (Sieg)		(1)
+Cuersithyris	J (Sine)	-J (Toar)	(ZR82)	+Evagyrotheca	K (Berr)		
+Cymidia	D (Emsi)		(538)	Exceptothyris	J (l)	-J (Plie)	(57,882)
+Cyranoida	K (Sn)		(882)	+Faksethyris	T (Dani-u)		(538)
Cyrtothyris	K (Vala-u)	-K (Albi-m)	(776)	+Falciterula	J (u)		(881)
-Cystothyris	Tr(u)		(881)	+Ferrythyris	J (Toar-l)	-J (Bath-l)	(872)
-Dalligas	K (Maes-l)	-T (Dani-l)	(8,765)	Fimbriothyris	J (Plie-u)		(1)
Dallina	T (Mi)	-R	(1)	Flabellothyris	J (Bath-l)	-J (Call-m)	(538,877,1027)
Dallinella	T (Mi)	-R	(1)				
Dallithyris	T (Eo)	-R	(882)	+Fletcherina	P (Guad)		
Derbyina	D (Sieg)?	-D (Eife)	(538)	Fletcherithyris	P (Wc)	-Tr(Anis)	(538)
Dereta	K (Albi-u)	-K (Ceno-l)	(538)	-Fletcherithyroides	Tr(m)		(ZR77)
Dietyothyris	J (Bath-u)	-J (Kimm)	(882,1066)	Frenula	T (Mi-u)	-R	(1,538)
+Dietyothyropsis	J (Oxfo)		(868)	Gacina	D (l)	-C (Serp-l)	(400,538)
+Diedrothyris	T (Eo-u)	-T (Mi-m)	(538)	+Galliennythyris	J (Oxfo-m)	-J (Tith)	(882,1027)
Dielasma	C (Tour-l)	-Tr(Anis-l)	(2,42,955)	Gefonia	P (Leon-m)	-P (u)?	(1,538)
Dielsmella	C (Tour-l)	-C (Vise-u)	(400,955)	+Gemerithyris	Tr(Carn)		
Dielsamina	P (Guad-u)?			Gemmarcula	K (Apti-l)	-K (Maes-u)	(1,147,538)
+Dienope	J (Call)		(882,1066)	Geranocephalus	D (Give)		(25)
Diestothyris	T (Mi)	-R	(1)	Gibbithyris	K (Ceno-m)	-K (Sant-u)	(776,889)
-Digonella	J (Bath)	-J (Oxfo)	(1)	+Gigantothyris	J (Bajo-l)	-J (Bath-u)	(872)

Taxon	First Appearance	Last Appearance	Reference	Taxon	First Appearance	Last Appearance	Reference
Gilledia	C (Step-l)	-P (Guad-u)	(712)	+Kendzhilgithyrus	J		(881)
Girtyella	C (Tour-l)	-C (Serp-l)	(955)	+Keratothyrus	J (Sine)	-J (Plie)	(538)
+Gisilina	K (Camp-u)	-K (Maes-u)	(8,765,889)	Kikaithyrus	T (Plio)	-Q (Plei)	(1,538)
Globithyrus	D (Sieg)	-D (Emsi-u)	(25)	Kingena	K (Albi-l)	-K (Maes-u)	(1,8,538)
+Glosseudesia	K (Vala-u)	-K (Barr-l)	(776)	+Kingenella	K (Camp-u)	-K (Maes-u)	(538)
Glossothyropsis	P (Sakm)	-P (Djuh)	(7,33,538)	+Kolymithyrus	Tr(Carn)	-Tr(Nori)	(538)
+Glyphisaria	J (Call-m)	-J (Kimm)	(877)	+Konstantia	K (Vala)		(1096)
+Gmelinmagas	T			+Kraussina	T (Mi-u)	-R	
+Goliathyrus	J (Call-u)		(881)	+Krimargyrotheca	K (Berr)		
Goniothyrus	J (Toar)	-J (Bajo-l)	(872,1093)	Kurakithyrus	T (Plio)		(1)
+Goniothyropsis	J		(881)	Kutchithyrus	J (Bath-u)	-K (Barr-l)	(538,776,882)
Gryphus	T (Eo-l)	-R	(1)	Labaiia	P (u)		(1)
Gusarella	J (Bath-u)	-J (Tith)?	(1)	+Laevithyrus	Tr(Carn)	-Tr(Nori)	(538)
Gwynia	T (Dani-l)	-R	(8)	+Langshanthyrus	K		(881)
+Gwyniella	K (Maes)	-T (Dani-l)	(765,889)	+Laqueus	T (Mi)	-R	(1)
+Gyrosina	J (Bath-m)	-J (Call-l)	(882,1027)	+Latiflexa	P (K(u))		(881)
+Gyrosoria	K (Turo-u)	-K (Maes-u)	(538)	+Lazella	J (Bajo-u)	-J (Bath)	(1013)
Gyrothyrus	T (Mi)	-R	(1)	+Lazithyrus	J (Bajo-u)	-J (Bath)	(1013)
+Habrobrochus	J (Call-m)	-J (Kimm)	(877)	+Leiosepthathyris	D (m)		(ZR79)
+Hadrosia	K (Vala)		(882)	+Lenothyris	J (Kimm)	-J (Tith-u)	(538)
Hamburgia	D (Give)	-C (Serp-l)	(400,538)	+Leptothyrellopsis	K (Camp-l)	-K (Maes-u)	(8,765,889)
Hamptonina	J (Call-u)		(1)	+Lievinnella	D (Gedi-l)		(25)
+Harmatosia	K (Ceno)		(881)	Linguthyrus	J (Sine)	-J (Bajo)	(1,55)
Harttella	C (Serp-l)		(1,538)	+Lingshanella	D (l)		(881)
Heimia	J (Bajo)		(1,882)	Liothyrella	T (Mi)	-R	(1,882)
+Heligothyrus	K (Turo-u)		(776)	+Liramia	K (Turo)		(882)
+Helvetella	K (Vala)	-K (Haut)?	(538,1108)	+Lissajousithyrus	J (Bajo-l)	-J (Bajo-u)	(872,882)
Hemiptychina	C (Step)	-P (Djuh)	(403,411,538)	+Lissothyrus	K (Haut-l)		(881)
+Hemistringocephalus	D (Give)		(881)	+Loboidothyris (+ Duidrythyrus)	J (Plie)?	-J (Kimm)	(538,872,1120)
Hercothyris	T (Eo)	-R		Loboidothyropsis	J (Plie)		(57)
Hesperithyrus	J (Hett)?	-J (Plie-u)	(1,55,538)	Lobothyris	J (Sine)	-J (Bajo)	(538,872)
+Hesperosia	K (Albi)?		(882)	+Lobothyroides	Tr(u)		(882)
+Hessenhausia	D (Give)		(538)	+Loenithyrus	J		(882)
Heterelasma	P (Sakm)	-P (Djuh)	(7,538)	+Longithyrus	K (Ceno)		(882)
+Heterobrochus	J (Kimm)		(882)	Lophrothyrus	J (Aale)	-J (Call)	(872,1098)
Holcothyrus	J (Bajo-u)	-J (Bath-l)	(1,872)	+Loriolithyrus	K (Berr-u)	-K (Apti-u)	(776)
+Hoskingia	P (u)		(ZR85)	Lowenstamia	P (Asse)?		(1,7)
Hynniphoria	J (u)		(1)	+Lunpolia	K (Apti)	-K (Ceno)	(882)
+Iberithyrus	K (Haut-l)	-K (Barr-l)	(882)	Lutetiarcula	T (Eo)		(1)
Iheringithyrus	T (Mi)		(1)	+Lychnothyrus	J (Plie)		(881)
+Ilyinella	T (Eo-l)		(882)	Macandrevia	T (Mi)	-R	(1)
+Inaequalis	J (Plie)		(57)	Maclarenella	D (Fras)		(25)
Inopinatarcula	K (Sant)		(1,538)	Magadina	T (Ol-u)	-R	(538)
+Inversithyrus	J (Aale)	-J (Call)	(1098)	Magadinella	T (Ol-u)	-R	(1183)
+Irenothyris	J (Oxo-l)		(538)	Magas	K (Camp-u)	-K (Maes-u)	(8,538,765)
Ismenia	J (Oxo-u)		(1)	Magasella	Q (Plei)	-R	(ZR71)
Isumithyrus	T (Plio)		(1)	Magella	T (Ol-u)?	-Q (Plei)	(1,538)
Jaisalmeria	J (Tith-u)		(1)	Magellania	P (Eo-u)	-R	(1)
Japanithyrus	T (Plio)	-R	(1)	Magharithyrus	J (Bath)		(1)
Jisuina	P (Wc)	-P (u)?	(538)	Malleia	T (Ol-u)?	-T (Plio)	(538)
Jolonica	Q (Plei)?	-R	(1)	+Maltia	T (Mi)		(882)
Juralina	J (Oxo-fm)	-K (Barr-l)	(1,538,776)	+Mametothyrus	K (Barr)	-K (Albi-u)	(882)
Juvavella	Tr(Nori)		(1)	+Maorielasma	P (Sakm-l)	-P (Guad-u)	(712)
Juvavellina	Tr(Nori)		(1)	+Marinurnula	C (Step-l)	-P (Guad-u)	(712)
+Kachathyrus	K (Barr-u)	-K (Apti-l)	(538)	+Maritimithyrus	K (Berr)	-K (Vala)	(881)
Kamoica	T (Mi)	-T (Plio)	(1)	+Mayaothyrus	K (l)		(881)
+Kaplex	D (Eife)	-D (Give)	(538)	Meganterella	D (Emsi-l)		(25)
+Karadagella	J (Bajo-u)		(882)	Meganteris	D (Sieg)	-D (Emsi)	(25)
+Karadagithyrus	J (Bajo-u)	-K (Berr)	(882)	Megathyrus	K (u)	-R	(1)
+Karpatiella	J (Plie)?		(881)				
+Kedrvpvythyrus	K (Haut)		(1185)				

Taxon	First Appearance	Last Appearance	Reference	Taxon	First Appearance	Last Appearance	Reference
Megerlia	T (Mi-u)	-R	(1,2)	Ornatotheryris	K (Albi-l)	-K (Ceno-u)	(776)
Megerlina	T (Ng)	-R		Ornithella	J (Bajo)	-J (Kimm)	(1)
Mendatheryris	D (Gedi-u)		(25)	Ornithotheryris	K (Camp-u)		(882)
+Meonia	K (Maes-l)	-K (Maes-u)	(8,765)	+Ortholina	K (u)		(881)
+Merophricus	J (Sine)		(882)	Orthotheryris	K (l)		(1)
†Mexicaria	J (Oxfo)		(882)	Orthotoma (+ Orthoidea)	J (Plie-l)	-J (Toar-l)	(1,2,55, 1066)
+Micella	J (Call)		(538)	+Ovatatheryris	K (Albi)	-K (Ceno-m)	(776)
+Micidus	D (Emsi)		(538)	Pachymagas	T (Ol-u)	-T (Mi-m)	(1,538)
†Millythyris	J (Bajo-l)	-J (Bath-l)	(872)	+Pachythyris	J (Oxfo-m)		(882)
+Mimaria	P (Guad-l)		(7)	+Pamirothyris	Tr(Nori)	-Tr(Rhae)	(882)
+Mimorina	T (Ol-u)?	-T (Plio)	(882)	+Pamirothyropsis	J		
+Minithyris	J (Bajo-u)	-J (Bath)	(1013)	Pantellaria	T (Mi)	-R	(1)
Miogryphus	T (Mi)		(1,882)	+Papodina	J (Sine)	-J (Plie)	(881)
+Mirisquamea	J (Plie)		(57,882)	+Paraboubeithyris	K (Barr-u)		(776)
Miyakotheryris	T (Mi)		(1)	+Paracapillithyris	K (Ceno-u)		(882)
Modestella	K (Albi-l)		(1066)	+Paracrothyris	D (m)		
+Moeschia	J (Call)	-J (Oxfo-u)	(882)	+Paradoxotheryris	Tr		
+Monsardithyris	J (Toar-u)	-J (Bath)	(872,1093)	+Paradygella	Tr(Carn)		(538)
†Montanella	J (Call)		(538)	+Parahemipterychina	Tr(u)		(881)
+Moorelina	J (Bajo)		(1095)	+Parakingena	K (l)		(ZR81)
Moraviaturia	K (Ceno)		(1)	+Paral dingia	T (Eo-u)	-T (Mi-l)	(538)
+Morrisithyris	J (Bajo-l)	-J (Call-l)	(872)	Paranaia	D (Emsi-l)		(25)
+Moutonithyris	K (Berr-l)	-K (Ceno-l)	(776)	+Parantiptychia	Tr(m)		(881)
†Muirwoodella	J (Bajo-u)		(882)	+Paraplathyris	K (l)		(881)
Murravia	T (Mi)	-R	(1)	+Parastrungocephalus	D (Give-u)		(1015)
Musculina	K (Vala-l)	-K (Albi-u)	(776)	+Paraulcinella	Tr(m)		(881)
Mutationella	D (Gedi-l)	-D (Emsi)	(25)	Parathyridina	J (Sine-u)	-J (Bajo)	(1,882)
+Mycerosia	J (Call-m)	-J (Kimm)	(877)	+Paulinella	D (Emsi)		
+Najdinotheryris	K (Ceno-u)	-K (Camp)	(776)	+Peculneithyris	K (Barr)	-K (Apti)	(882)
Nanothyris	D (Gedi-l)	-D (Sieg-l)	(1,2,25)	Pegmatyris	T (Mi)		(1)
Naradanthyris	J (Bajo)	-J (Bath)	(1)	+Penithyris	J (Oxfo-m)	-J (Oxfo-u)	(882,1027)
+Negramithyris	J (Bajo-u)	-J (Bath-l)	(991)	+Penzhinothyris	K (Albi-l)	-K (Albi-u)	(882,1108)
+Nekvasiloveia	K (Haut)			+Periallus	Tr(l)		(538)
Neobouchardia	T (Ol-u)	-T (Mi-l-u)	(1,538)	+Peristerotheryris	J (Plie)		(538)
+Neoglobiothyris	D		(881)	+Permicola	P		
Neoliothyris	K (Camp-u)	-K (Maes-u)?	(776)	+Perrierithyris	J (Call)	-J (Oxfo-l)	(882)
Neothyris	T (Mi-m)	-R	(1)	+Petalothyris	J (Bajo-l)?		(882)
+Nerthebrochus	K (u)		(882)	+Petria	C (Pn)		
Neumayrithyris	J (m)	-J (Oxfo)	(1)	Phragmothyris	T (Eo)	-T (Ol)	(1)
+Newberria	D (Eife)	-D (Give)	(538)	+Phyllonia	D (l)		(882)
+Ninglongothyris	Tr(Carn)		(538)	Phymatotheryris	J (Sine)	-J (Toar)	(1,538)
Nipponithyris	T (Mi)	-R	(1)	Pictothyris	T (Plie)	-R	(1)
+Notosia	J (l)		(882)	+Pilkena	T (Ol-u)	-T (Mi)	(1183)
Notothyris	P (u)		(1)	+Pinaxiothyris	J (Oxfo)	-K (Vala)	(882,1098)
Notothyris	P (Leon-m)	-P (Dora)	(2,1142)	+Pionopleurum	J (Call-m)		(877)
Nucleata	J (Kimm)	-K (Albi-u)	(1,538,776)	+Pionothyris	J (Bajo)?		(882)
+Nucleatina	K (Sn)		(882)	+Prithyris	Tr(m)		(881)
Nucleatula	Tr(Carn)	-Tr(Nori)	(1,538)	+Pirorella	J (Plie)?		(881)
Oblongarcula	K (Vala)	-K (Albi-u)	(1,538)	+Pirothyris	J (l)	-J (Plie)	(57)
-Obnixia	Tr(l)			+Placothyris	J (Bajo)	-J (Kimm)?	(538)
Obovothyris	J (Bath)		(1)	+Planothyris	P (Wc)		(538)
+Odarovithyris	J (Bajo-u)		(882)	Platida	K (Sant-u)	-R	(8,889)
†Ogmusia	T (Dani)		(882)	+Platythyris	K (Barr)	-K (Sn)	(1097)
+Okathyris	J (Tith-u)	-K (Haut-l)	(538)	+Plectelasma	P (Sakm)	-P (Guad-u)	(7)
Oleneothyris	T (Than)		(1,71,538)	Plectocoma	Tr(Anis)	-Tr(Nori)	(1,538)
+Oligorhysis	J (Bajo)?		(882)	Plectoidothyris	J (Bajo-l)		(1,882)
Oligothyris	C (Mosec)	-P (Leon)?	(1,33)	Plectothyris	J (Bajo-l)		(1,882)
+Omolonia	D (Give)		(538)	Plesiothyris	J (l)	-J (Plie-u)	(1,538)
+Omolonothyrus	J (Toar)		(538)	+Pleuraloma	J (Call-m)		(877)
+Orientothyris	K (Maes)		(882)	+Pleurelasma	P (Guad-u)		(7)
Oriskania	D (Sieg-l)		(25,764)				
†Ornatotherella	Tr(Nori)		(538)				

Taxon	First Appearance	Last Appearance	Reference	Taxon	First Appearance	Last Appearance	Reference
Pleurothyrella	D (Sieg)?	-D (Emsi-l)	(70,538)	Rhynchorina	K (Camp)		(1)
+Plicatoria	T (Eo-m)		(882)	+Rhytsoria	T (Than)		(882)
+Pliothyrida	T (Mi-u)?, T (Plio)?		(538)	+Rocheithyrus	J (Bajo-u)	-J (Bath-l)	(882)
Podolella	D (Gedi-l)	-D (Gedi-u)	(25)	+Romingerina	C (Tour-u)	-C (Serp-l)	(400)
+Pontielasma	P (Leon)		(538)	+Rossithyrus	K (Camp)		(538)
+Portneutia	Tr(l)		(538)	+Rostranteris	P (Dora)		(1142)
+Postepithyrus	J (Oxfo-u)	-J (Kimm)	(1,882)	Rouillieria	J (Tith-u)	-K (Barr-l)	(1,776)
+Praeangustothyris	P (u)		(881)	-Ruegenella	K (Maes-)		(538)
+Praearythrothea	K (Berr)	-K (Ceno-l)	(538)	Rugia	K (Coni)	-T (Dani-l)	(765,889)
+Praecubanothyris	Tr(Anis)	-Tr(Ladi)?	(538)	Rugitela	J (Toar)	-K (Haut)	(1,877)
+Praegibbithyrus	K (l)		(ZR89)	Rugithyrus	J (Bajo)		(1)
+Praegoniathyris	J		(881)	+Russiella	J (Kimm)	-K (Albi-u)	(538)
Praelongithyrus	K (Berr-u)	-K (Albi-u)	(776)	+Sacothyris	Tr(Nori)		(538)
+Praeonothyris	K			+Sacothyropsis	Tr(u)		(881)
+Praeudesia	J (Bath-u)	-J (Call)	(1186)	-Sangiaothyris	Tr(Ladi)	-Tr(Nori)	(538)
Prionothyris	D (Sieg-l)	-D (Emsi)	(4,538,764)	-Sardope	K (Apti)		(882)
+Proanadyrella	Tr(l)		(881)	+Saucrobrochus	J (Bajo)?		(882)
+Proboscidea	D (Sieg)		(538)	Scaphiocoelia	D (Emsi-l)		(25)
+Prochidonophora	K (Nc)	-K (Apti)	(538)	+Scumulus	K (Camp-u)	-K (Maes-u)	(8,765,889)
Propygoe	Tr(Carn)	-J (Toar)?	(1,538)	+Securina	J (Sine)	-J (Plie)	(881)
Prorensselaeria	D (Gedi-u)		(25)	+Securithyrus	J (Plie)		(881)
Protogusarella	Tr(Olen)			Selenella	D (m)		(1)
+Prototegulithyrus	J		(881)	Sellithyrus	J (Oxfo-u)	-K (Turo)	(776)
+Psebajithyrus	J (Oxfo)		(882)	Sendaityrus	T (Mi)		(1)
+Pseudoaucalacothyrus	K (Barr)?	-K (Albi)	(1185)	-Senokosica	J (Plie)		(57,882)
+Pseudobornhardtina	D (m)		(ZR79)	Septothyris	D (Give-u)		(25)
Pseudodielasma	P (Guad-l)	-P (Tatr)	(538)	+Serbiothyris	J (l)	-J (Plie)	(57)
+Pseudoglossothyris	J (Toar)	-J (Aale)	(872)	+Siberiothyris	K (Berr)	-K (Haut)	(538)
Pseudohartina	P			Silesiathyris	Tr(Anis)		(538)
Pseudokingena	J (Sine)	-J (Plie)	(538)	+Sinusella	J (Plie)?		(881)
+Pseudolabaia	P			+Slavinithyrus	J (Plie)		
+Pseudopygoides	Tr			+Smirnovaena	K (l)		(881)
+Pseudorhaetina	Tr(Nori-u)			+Smirnovina	K (Haut)		(881)
+Pseudorostranteris	P (Wc)		(538)	+Sogxianthyris	J (m)		(881)
Pseudorugitela	Tr(Nori)		(1,538)	Somalitela	J (Kimm)?, J (Tith)?		(1,538)
+Pseudotybithyrus	J (Bath-u)		(1027)	Somalithyrus	J (Oxfo)?	-J (Kimm)	(1,877)
+Pseudowattonithyrus	J (Bath-u)		(1027)	+Spasskothyris	K (Berr)	-K (Haut)	(538)
Psilothyris	K (Berr-u)	-K (Ceno)	(1,1094)	Sphaeroidothyris	J (Toar-l)	-J (Call-m)	(1,872)
Ptycotothyris	J (Aale)	-J (Call-l)	(872)	+Sphiganaria	J (Bajo-l)	-J (Kimm)	(877)
+Pycnbrochus	T (Ol-l)		(882)	+Spinulithyrus	J (l)		(538)
Pygites	J (Tith-u)	-K (Barr-l)	(448,776)	+Squamiplana	J (Plie)		(57,882)
Pygope	J (Kimm-u)	-K (Barr-l)	(448,776)	+Stenogmus	J (Call-l)		(882,1027)
+Pyraeneica	J (Plie)		(57)	+Stenorina	J (Call-l)		(877)
+Qinglongia	P (Dora)		(1142)	+Stenosarina	T (Plio)	-R	(882)
Rectithyrus	K (Apti-l)	-K (Maes-l)		Stethothyris	T (Eo-u)	-R	(1)
Reelftonella	D (Emsi)		(25)	Stiphothyris	J (Bajo-u)		(1,872)
Rensselaeria	D (Gedi-u)	-D (Emsi)	(25,764)	Striithyrus	J (Call-l)	-J (Oxfo)	(1,877)
Rensselaeria	D (Gedi-l)		(25,38)	Stringocephalus	D (Give-l)	-D (Give-u)	(25)
Rensselaeria	D (Eife)	-D (Give-l)	(25)	+Stringodiscus	D (Give-u)		(1015)
+Rensselandioidea	D (m)		(881)	Stringomimus	D (Give)		(25)
Rhaetina	Tr(Olen)?	-J (Sine-u)	(434,538)	+Strongylobrochus	J (Bajo-u)		(882)
+Rhaetinopsis	Tr(Carn)		(538)	Stroudithyrus	J (Toar-u)	-J (Bajo-l)	(1,872)
+Rhapidothyris	J (Plie-l)	-J (Plie-u)	(882)	+Struvethyrus	J (Bajo-u)	-J (Bath)	(1013)
+Rhenorenselaeria	D (Gedi)?	-D (Emsi)	(1)	+Sturtella	D (Sieg-l)		(538)
Rhipidothyris	D (Eife-u)	-D (Give-l)	(25)	Subrensselandia	D (Eife)	-D (Give-l)	(1)
Rhizothyris	T (Ol-u)	-T (Mi-u)	(1,538)	+Subsinucephalus	D (Eife-u)	-D (Give-u)	(1015,1156)
+Rhombaria	K (Sn)		(882)	+Sulcatinephala	Tr(Anis)	-Tr(Ladi)?	(538)
+Rhomboidella	J (Plie)?		(881)	+Sulcatothyris	Tr(Carn)		(538)
Rhombothyris	K (Apti-u)	-K (Albi)	(1,776, 1097)	+Svaljavithyrus	J		
Rhynchonellopsis	T (Ol-l)		(1)	+Symphythyris	J (u)	-K (Haut-u)	(538)
Rhyncora	K (Camp)		(1,538)	+Systenothyris	J (Bajo-u)		(882)
				+Tacinia	P (Wc)		(538)

Taxon	First Appearance	Last Appearance	Reference
Or. UNCERTAIN			
+ Agastapleura	O		
+ Bajarinovia	Cm(Boto-l)	-Cm(Tojo-u)	(1006,1050)
+ Biarea	D		
+ Conispirifer	D (u)		(881)
Cornwallia	O (u)		(1)
+ Dirinus	C		
+ Dongbeispirifer	S		(881)
+ Eurothisina	O (Aren-u)		(5)
+ Imospirifer	D		
Isogramma	C (Vise-u)	-P (Leon-m)	(7,41,400)
+ Jilinia	S		(881)
Larium	P (l)		(1)
+ Liococlia	S (Prid)		(25)
+ Manosia	O (u)		(ZR83)
Megapleuronia	P (Leon-u)		(2)
+ Mesotreta	O		
Minororthis	O (m)		(1)
+ Nekvasilovella	K (Nc)		(881)
+ Neogypidula	P		
+ Obolorugia	D (m)		(881)
+ Permianella	P		
+ Pomatospirella	Tr		
+ Quinlingia	D (l)		
+ Reflexia	C		
+ Rhynchoferella	D		
+ Rictia	P (l)		(1)
+ Rugosothyris	D (l)		
+ Septoparmella	D (Gedi-u)		(24)
Socraticum	P (l)		(1)
+ Spondylobolus	S		
Swantonia	Cm(Boto-u)	-Cm(Tojo-u)	(19,1050)
Syntrophioides	Cm(m)		(1)
+ Togaella	O (u)		(ZR81)
+ Turriculum	P		
+ Venezuela	D		
+ Virbium	P		
Wynnia	Cm(Tojo)		(1050)
Yeosinella	O (u)		(1)
+ Yongjia	S		(881)

Ph. CHAETOGNATHA**Or. UNCERTAIN**

+ Paucijaculum	C (Mosc-u)		(375)
+ Titerina	O (Aren-l)		
+ Incertae sedis	Cm(mMid-l)		(1066)

Or. "protoconodontia"

+ Amphigeisina	Cm(Atda-u)	-Cm(mMid)	(885,1006)
+ ?Ganloudina	Cm(Tomm)?		(1006)
+ Gapparodus	Cm(Atda-l)	-Cm(Dres)	(655)
+ ?Kijacus	Cm(Tomm-l)	-Cm(Atda-u)	(885,1006,1244)
+ ?Leguminella	Cm(Tomm-u)?		(1006)
+ ?Maldeotaia	Cm(Tomm-l)?		(725,1006)
+ ?Mongolodus	Cm(Boto-l)		(1006)
+ Protohertzina (+ Emeidus, Hastina)	V (N-Da-l)	-Cm(Boto-l)	(1030,1244)

Taxon	First Appearance	Last Appearance	Reference
Ph. ECHINODERMATA			
Cl. CAMPTOSTROMOIDEA			
Or. CAMPTOSTROMATOIDA			
+ Camptostroma	Cm(Boto-u)		(654)
Cl. EDRIOASTEROIDEA			
[Classification from Guensburg and Sprinkle (1994).]			
Or. ISOROPHIDA			
+ Agelacrinites	D (Give-l)	-C (Step-u)	(318)
+ Angliscus	C (l)		
+ Apynodiscus	O (Ashg-l)		
+ Archaepyrigus	O (Aren-l)		(1121)
+ Argodiscus			
Bassleridiscus	O (Cara-m)		
+ Belochthus	O (Cara-m)		(318)
+ Bostryclavus	C (Vise-l)		(1237)
Carneyella	O (Llde)	-O (Ashg-m)	(318)
+ Chatsworthia	Cm(u)		(1121)
Cincinnatiidiscus	O (Cara)?	-O (Ashg-l)	
+ Clavidiscus	C (Tour-l)		(1237)
Cooperidiscus	D (Fras)		
+ Cryptogoleus	O (Cara-m)	-O (Ashg-m)	(318)
+ Curvitiordo	O (Cara-m)	-O (Ashg-m)	(318)
Cyclocystoides	O (Cara-l)	-D (Eife)	
Cystaster	O (Cara-m)	-O (Ashg-m)	(318)
+ Deltadiscus	O (Aren-l)		(1121)
Dinocystis	D (Fame)		
Discocystis	C (Serp-l)	-C (Step-u)?	(318,1066)
Edriodiscus	Cm(Tojo-u)		(318,1066)
+ Epipaston	S (Ludl)		(319)
+ Euhydrodiskos	O (Ashg-m)		
+ Fanulodiscus	O (Llvi)		(1121)
+ Floridiscus			
Foerstediscus	O (Cara-m)	-S (Ludl-u)?	(318)
+ Gigantioclavus	C (Mosc-l)		
+ Hadrochthus	D (Fras-m)		(318)
+ Hadrodiscus			
Hemicystites	S (Wen-l)		(318)
+ Hypsioclavus	C (Tour-u)	-C (Serp-l)	(1237)
+ Hystrichopsydax	O (Ashg-m)		
Isorophus	O (Cara-l)	-S (Ludl-l)	(318,319)
Isorophusella	O (Cara-l)	-O (Ashg-m)	(318)
+ Krama	D (Give-u)?		(318)
Lebetodiscus	O (Cara-m)		(318)
Lepidoconia	O (Cara-m)?		
Lepidodiscus	C (Tour-l)	-C (Serp-l)	(318)
+ Lispidecodus	C (Tour)		
+ Monocycloides	O (Aren-u)		(1066)
+ Neoisorophusella	C (Vise-u)		
+ Polytryphocycloides	D (Fras)		
+ Postibulla	D (Give-u)	-C (Tour-l)	(318)
+ Pyrgocystis	O (Cara-l)	-D (Eife)	(1066)
+ Rectitiordo	O (Cara-m)		(318)
+ Savagella	O (Ashg-m)		
+ Sievertsia	O (Cara-u)	-D (Give)	
+ Spiracclavus	C (Mosc-u)		
+ Stalticodiscus			
Streptaster	O (Cara-u)	-O (Ashg-m)	(318)
Thresherodiscus	O (Cara-m)		

Taxon	First Appearance	Last Appearance	Reference	Taxon	First Appearance	Last Appearance	Reference
Timeischytes	D (Give)?	-D (Fras-m)		Neoschi-sma	P (Asse)	-P (Guad-u)	(2,82)
Ulrichidiscus	C (Serp-l)?		(318)	Notoblastus	P (Asse)	-P (Guad-u)	(523,904)
Xenocystites	D (Fras)			Nymphaeoblastus	C (Tour)	-C (Vise-u)	(82,904)
+ Zygoecyloides	O (Ashg-l)			Orophocrius	D (Fame-u)	-C (Vise-u)	(82,1246)
Or. EDRIOASTERIDA				+ Pachyblastus	D (Emsi)		(82)
+ Aepyaster	Cm(u)		(320)	Paracadaster	P (Leon)		(2)
Astrocytites	O (Cara-l)	-O (Ashg-l)	(1121)	Pentablastus	C (Serp-u)		(82)
† Cambroblastus	Cm(Fran)			Pentremiidea	D (Emsi-l)		(2,82)
Cyathocystis	O (Llvi-u)	-O (Cara-l)	(659)	Phaenoblastus	C (Tour-l)		(82)
Cyathotheca	O (Llvi-l)	-O (Ashg-u)?	(659,1066)	Phaenoschisma	C (Tour-l)	-C (Serp-l)	(82,520,904)
Edriaster	O (Cara-l)	-O (Cara-m)	(239,318)	Pleuroschisma	D (Emsi)	-D (Give-l)	(82)
† Edriophus	O (Cara-m)		(318)	Polydeltoideus	S (Lud-l)	-S (Prid)	(82,523)
+ Lampteroblastus	O (Aren-l)		(1121)	Pteroblastus	P (Leon-u)	-P (Guad-u)	(2,82)
+ Paredriophus	O (Trem-u)		(1121)	Sagittoblastus	P (Leon)		(2)
- Rhenopyrgus	O (Ashg-m)	-D (Emsi-l)	(319)	Sphaeroschisma	P (Asse)	-P (Sakm)	(82,523)
Totiglobus	Cm(lMid)	-Cm(mMid-u)	(805)	Thaumatoblastus	P (Asse)	-P (Guad-u)	(2,82)
Or. STROMATOCYSTITIDA				Timoroblastus	P (Leon-u)	-P (Guad-u)	(2,82)
Stromatocystites	Cm(Boto-u)	-Cm(uMid)	(654)	+ Tympanoblastus	C (Step)	-P (Leon)	(82,523,904)
Or. UNCERTAIN				+ Xenoblastus	C (Tour-l)	-C (Tour-u)	(82)
† Cambraster	Cm(lMid)	-Cm(uMid)	(654,805)	Or. SPIRACULATA			
Walcottidiscus	Cm(mMid-u)	-Cm(uMid-l)	(805)	Acentrotremites	C (Vise-l)	-C (Vise-u)	(82,520)
Cl. HELICOPLACOIDEA				Ambolostoma	C (Vise-u)		(520,904)
Helicoplacus (+ Waucobella)				+ Arcuoblastus	C (Tour-u)		(324)
	Cm(Atda-u)	-Cm(Boto-l)	(654)	Auloblastus	C (Tour-u)?		(520)
Polyplacus	Cm(Atda)		(654)	Belocrinus	D (Sieg-u)		
† Westgardella	Cm(Atda-u)			Calycoblastus	P (Asse)	-P (Leon)	(2,523)
Cl. BLASTOIDEA				Carpenteroblastus	C (Tour-u)	-C (Vise-l)	(2,520,904)
Or. FISSICULATA				+ Conuloblastus	D (Emsi-u)		(523)
Agmoblastus	C (Step-l)	-P (l)	(321)	Cordylloblastus	D (Emsi)	-D (Eife)	
Angioblastus	C (Bash-u)	-P (Guad-u)	(2,82)	† Costatoblastus	C (Tour-l)		(523)
+ Angulatoblastus	D (Sieg)	-D (Emsi)	(322)	Crioblastus	C (Vise-l)?	-C (Vise-u)	(2)
Anthoblastus	P (Sakm)	-P (Guad-u)	(2,82)	Cryptoblastus	C (Tour-l)	-C (Tour-u)	(2,918)
+ Artuschisma	C (Serp-l)		(904)	+ Decemoblastus	C (Tour-u)		(324)
Astrocrinites	C (Vise-u)		(82)	+ Deliablastus	C (Vise-l)		(904)
† Astrocrinus	C (Vise-u)		(1066)	Deltoblastus	P (Guad-u)		(2,904)
+ Austroblastus	P (Leon-l)		(82)	Dentiblastus	C (Tour-u)		(2,520)
Brachyschisma	D (Emsi)	-D (Give)	(523)	Devonoblastus	D (Give)		(523)
† Caryoblastus	D (Emsi)		(82)	Diploblastus	C (Vise-u)	-C (Serp-l)	(904)
Ceratoblastus	P (Guad-u)		(2)	Doryblastus	D (Fame)		(904)
Codaster	C (Vise-u)		(82)	Elaeacrinus	D (Emsi-l)		(2)
Cryptoschisma	D (Emsi)		(2)	Ellitheroocrinus	D (Eife-l)	-D (Give)	(322)
Decaschisma	S (Wen-l)		(82)	Ellipticoblastus	C (Vise-l)		(520)
Dipteroblastus	P (Guad-u)		(2)	+ Euryoblastus	C (Vise-l)		(904)
+ Dolichoblastus	C (Serp)		(82)	Globoblastus	C (Tour-u)		(2)
Hadroblastus	C (Tour-l)	-C (Vise-u)	(82,520)	Gongyloblastus	C (Vise-l)		
Heteroschisma	D (Eife-l)	-D (Give)	(2)	Granatoocrinus	C (Vise-l)		(520,904)
Indoblastus	P (Guad-u)		(2)	Heteroblastus	C (Vise-u)		(2)
- Junggaroblastus	D (Fame-u)		(1247)	+ Houiblastus	D (Fame-l)?		(1247)
+ Katoblastus	C (Tour-u)		(82,520)	+ Kadiskoblastus	C (Tour)		(904)
† Karachstanoblastus	C (Serp)		(82)	+ Hyperoblastus	D (Emsi)	-D (Fras-l)	(904)
+ Koryschisma	C (Tour-l)	-C (Serp-l)	(918)	† Iranoblastus	C (Vise-l)		(904)
+ Leptoschisma	D (Gedi)	-D (Emsi)	(82,904)	Lophoblastus	C (Tour-u)?		(520)
+ Mastoblastus	C (Serp-l)		(82,904)	Malchiblastus	C (Bash)		(523)
Microblastus	P (Guad-u)		(2)	Mesoblastus	C (Tour-u)	-C (Vise-l)	(2,520)
Nannoblastus	P (Sakm)	-P (Guad-u)	(2,82)	Metablastus	C (Tour-l)	-C (Vise-l)	(904,918)
				Monadoblastus	C (Tour-u)		(904)
				Monoblastus	C (Tour-u)		(2,520)
				Monoschizablastus	C (Vise-u)		(2)
				+ Montanablastus	C (Tour-l)		(918)

Taxon	First Appearance	Last Appearance	Reference	Taxon	First Appearance	Last Appearance	Reference
Calix	O (Trem)	-O (Cara-u)	(2)	Or. UNCERTAIN			
Campylostoma	O (u)			Batherocystis	O (Llde)?	-O (Cara-l)	
Carpocystites	D (l)			Bockia	O (Aren-l)	-O (Cara)	(1071)
Codracystis	O (Llvi)	-O (Cara-m)	(1075)	+ ?Bolboporites	O (Aren-u)	-O (Cara)	
Dactylocystis	O (Cara-l)		(2)	- Bromidocystis	O (Cara-l)		(1066)
- Destombesia	O (Cara)	-O (Ashg)		Cardiocystites	O (Cara-m)		
Estonocystis	O (Cara-m)			?Cigara	Cm(mMid-u)	-CmtuMid	(805)
Eucystis	O (Ashg-l)	-D (Eife)	(2)	Cryptocrinites	O (Aren-u)	-O (Llvi-l)	(805,1066)
Eumorphocystis	O (Llde)	-O (Cara-u)		Cymbionites	Cm(lMid-l)		
Fungocystites	O (Llde-u)	-O (Cara-m)	(1075)	Lapillocystites	Cm(m)		
Glyptosphaerites	O (Aren-u)	-O (Cara-l)	(2,805)	- Lubocrinus	Cm(uMid)		
+ Glyptosphaerionites	O (Trem-l)			Lysocystites	S (Wenl-u)		
Gomphocystites	O (Ashg-m)	-S (Wenl-u)	(532)	+ Mandalacystis	O (Llvi-l)		
Haplophaerionis	O (Cara-l)	-O (u)		+ Marjumiocystis	Cm(uMid-m)		(539)
Hippocystis	O (m)	-O (Cara-u)		Peridionites	Cm(lMid-l)		
Holocystites	O (u)	-S (Wenl-u)		+ Petalocystites	O (Llvi-l)		
Lepidocalix	O (m)			Pilocystites	Cm(m)		
Lichenoides	Cm(uMid-l)			Polyptychella	O (m)		
Mesocystis	O (Aren-u)?	-O (Llvi-l)?	(2,1066)	+ Sinoecrinus	Cm(mMid-l)		
Metasterocystis	O (Llvi-l)?			+ Tatonkacystis	Cm(Fran)		
Pachycalix	O (Cara)			Cl. CORONATA			
Paleosphaerionites	O (Trem-u)		(805)	- Cupulocorona	O (Ashg-l)	-S (Wenl-l)	(540)
+ Pemphocystis	O (Ashg)			Mespilocystites	O (Cara-l)	-O (Ashg-u)	(540)
+ Phlyctocystis	O (Llde-l)			Paracystis	O (Cara)		
Proterocystites	D (l)			Stephanoblastus	O (Cara)	-S (Wenl)	(540)
Protocrinites	O (Aren-u)	-O (Cara-m)	(2,805)	Stephanocrinus	O (Ashg-m)	-S (Ludl-l)	(331,540)
Pseudaristocystis	O (Llde)		(2)	Tormoblastus	O (Ashg-m)?		
Pyrocystites	O (Llvi)?	-O (Llde-u)	(2)	Cl. PARACRINOIDEA			
Regnellcystis	O (Cara-l)			Or. COMAROCYSTITIDA			
Revalocystis	O (Cara-u)		(1066)	Achradocystites	O (Cara-m)		(706)
Sinocystis	O (m)			Amygdalocystites	O (Cara-m)		(706)
Sphaerionites	O (Aren-u)	-O (Ashg-m)	(805)	Billingsocystis	O (m)		
Tholocystis	O (m)			Canadocystis	O (Llde)	-O (Cara-l)	(2,706)
Trematocystis	O (Ashg-m)	-S (Wenl)	(2)	Comarocystites	O (Cara-l)	-O (Cara-m)	(706)
Cl. EOCHRINOIDEA				+ Implicaticystis	O (Cara-m)	-O (Ashg-m)	(334)
Or. IMBRICATA (= Lepidocystoidea)				+ Oklahomacystis	O (Cara-l)		(333,706)
+ Kinzercystis	Cm(Boto-u)		(654)	+ Ovulocystites	S (Ldov-u)		(333)
Lepidocystis	Cm(Boto-u)		(654)	Schuchertocystis	O (Llde-u)	-O (Cara-l)	
Or. GOGIIDA ("Order Number 1")				Sinclairocystis	O (Cara-l)	-O (Ashg-m)	(1066)
Acanthocystites	Cm(uMid-l)			Or. PLATYCYSTITIDA			
Akadocrinus	Cm(uMid)			Globulocystites	O (Cara-l)		(332)
- Curteocrinus	Cm(mMid-l)			Malocystites	O (Llvi)?	-O (Llde)	(2)
Gogia	Cm(Boto-u)	-Cm(uMid-m)?	(713)	Platycystites	O (Llde-u)	-O (Cara-l)	(2,332)
Palaeocystites	O (Llde-u)			Welleroecystis	O (Cara-l)		(706)
+ Paragogia	Cm(mMid-l)			Or. UNCERTAIN			
Rhopalocystis	O (Trem-u)			+ Bistomiacycstis	O (Cara-l)?		(1066)
Or. ASCOCYSTITIDA ("Order Number 2")				? Columboecystis	O (Cara-l)		
Ascocystites	O (Llvi)?	-O (Cara-l)	(1075)	? Foersteecystis	O (Cara-l)		
Cambrocrinus	Cm(Dres-l)			Springeroecystis	O (Cara-l)		
? Eocystites	Cm(Atda-l)	-Cm(uMid-m)	(713)	Cl. CTENOCYSTOIDEA			
Eustypocystis	Cm(uMid-m)			Ctenocystis	Cm(mMid-l)	-Cm(uMid-m)	(713)
Nolichuckia	Cm(uMid-u)			+ Etocetenocystis	Cm(uMid)		(805)
Pareocrinus	Cm(Dres-l)		(805)				
+ Ridersia	Cm(Fran)		(805)				
Or. TRACHELOCRINIDA							
- Trachelocrinus	Cm(Fran-u)						

Taxon	First Appearance	Last Appearance	Reference
CI. HOMOSTELEA			
Or. CINCTA			
Decacystis	Cm(mMid-u)?		
Gyrocyctis	Cm(mMid-u)		(805)
Trochocystites	Cm(uMid)		(805)
Trochocystoides	Cm(uMid)		(805)

CI. HOMOIOSTELEA**Or. SOLUTA**

Belemnocystites	O (Cara-m)		(248)
+Castericyctis	Cm(uMid-l)?	-Cm(uMid-m)	(539)
+Coleicarpus	Cm(uMid)		
Dalejocystis	D (Emsi-u)	-D (Eife)	
Dehmicyctis	D (Emsi-l)?		
Dendrocystites	O (Trem-u)	-O (Ashg-l)	(335)
Dendrocystoides	O (Ashg-m)		(335)
Girvanicyctis	O (Ashg-m)		(1066)
Heckericyctis	O (Llde-u)		
Iowacyctis	O (Ashg-l)		(335)
Minervaecystis	Cm(Trep)	-O (Trem-u)	
+Mycinocystites	O (Cara-l)	-O (Cara-m)	(248)
Rutrocypleus	D (Gedi)?	-D (Sieg)?	
+Scalenocystites	O (Cara-m)		(248)
Syringocrinus	O (Cara-m)		(335)
incertae sedis	Cm(Tojo)		(654)

CI. STYLOPHORA**Or. CORNUTA**

+Acuticarpus	Cm(Fran)		
+Amygdalotheca	O (Aren-l)		(744)
+Archaeoethurnus	Cm(uMid)	-Cm(Trep)	
+Babinocystis	O (Aren-u)		
+Beryllia	O (Llde)		(1066)
Bohemiaecystis	O (Llvi)	-O (Llde-l)	
Ceratocystis	Cm(lMid)	-Cm(uMid-m)	(713,805)
+Chauvelia	O (m)		(805)
+Chauvelicyctis	O (Aren-l)		(805)
Cothurnocystis	O (Aren-l)	-O (Ashg-m)	(726,1066)
+ 'Cothurnocystis' bifida	Cm(uMid-l)		(808,1066)
+Domfrontia	O (Llde)		(1066)
+Galliaecystis	O (Aren-l)		(744)
+Hanusia	O (Llvi)	-O (Llde-l)	(1066)
+Lyricocarpus	O (l)		
+Milonicyctis	O (Llde)		(1066)
+Nanocarpus	O (Aren)		
Nevadaecystis	Cm(Trep)		(1066)
+Ovocarpus	O (l)		
Phyllocystis	O (Aren-l)	-O (Llde)	(805,1066)
+Prochauvelicyctis	O (Trem-u)		(1066)
+Procothurnocystis	O (Aren-u)		
+Progalliaecystis	O (Aren)		
+Prokopicyctis	O (Llde)		(1066)
+Protocystites	Cm(uMid-m)		(744)
+Reticulocarpus	O (Llvi)	-O (Llde)?	(726,1066)
Scotiaecystis	O (Ashg-m)		(1066)
+Thoralicyctis	O (Aren-l)	-O (Aren-u)	(805)

Or. MITRATA

Allanicyctidium	S (Ldov-u)	-D (l)	
Anatiferopsis	O (Aren-u)	-O (Cara-l)	(726)
Anomalocystites	D (Gedi-l)		
+Aspidocarpus	O (Cara-l)		(1066)
Ateleocystites	O (Cara-l)	-O (Cara-m)	
Australocystis	D (Sieg)?		
Balanocystites	O (Aren-u)	-O (Llvi)	(726)
+Barrandocarpus	O (Cara-l)	-O (Ashg-u)	(336)
Basslerocystis	D (Sieg-u)		
+Bokkeveldia	D (Emsi)		
+Chaivella	O (Llde)		(1066)
Chinianocarpus	O (Aren-l)		(805,1066)
+Diamphidicyctis	O (Ashg-m)		(337)
Enoploura	O (Cara-m)	-O (Ashg-m)	(937)
+Eumitrocyctella	O (Llde)		
+Guichenocarpus	O (Trem)	-O (Llde)	(1066)
+Jaekelocarpus	C (Bash-u)		(675,937)
+Kierocystis	O (Cara-m)		(937)
+Kopicyctis	O (Cara-m)		(937)
+Lagynocystis	O (Llvi)	-O (Llde)	(726,1066)
Mitrocystella	O (Llde)		(1066)
Mitrocystites	O (Aren-l)	-O (Llvi)	(1066)
+Mongolocarpus	S (Ludl-l)		
+Notocarpus	S (Ludl-l)?		
+Occultocystis	D (l)		
Paranacyctis	D (Sieg)?		
Peltocystis	O (Aren-l)		(805,1066)
Placocystella	D (Emsi)		
Placocystites	S (Wenl)		
Rhenocystis	D (Emsi-l)		
Spermacyctis	O (m)		
+Tasmanicyctidium	S (Ldov-u)		
Victoriaecystis	S (u)		
+Vizeainocarpus	O (Aren-l)		
+Willmanocystis	O (Cara-m)		(336)
+Yachalicyctis	D (l)		

CI. OPHIOCISTIOIDEA

+Cardioserra	D (Eife)	-D (Give-l)	
Eucladia	S (Ludl-l)		
Euthemon	S (Wenl-u)		(1066)
Rotasaccus	D (Give)		
Sollasina (+ Rhenosquama)	S (Ludl-l)	-D (Eife)	(1066)
Volchovia	O (Aren-u)	-O (Ashg-u)	

CI. HOLOTHUROIDEA

[Classification and stratigraphic data from the TREATISE.
Pt. U (1966): data include both body and spicule taxa.]

Or. DENDROCHIROTIDA

+Acutiscleris	J (Hett-u)	-J (Pie)	(982,988)
Amphitriodites	J (Oxlo)		
+Andenothyone	D (l)		
Binoculites	Tr(Ams)	-R	(988)
Calclamma	Tr(Anis-l)	-T (Mi-u-l)	(687)
Calclamnoidea	Tr(Ladi-u)?	-R	(687)
+Clavallus	C (Tour-l)	-Tr(Anis)?	(988)
Costigerites	J	-T (Eo)	
Dietyothurites	T (Ol-l)	-R	(960)

Taxon	First Appearance	Last Appearance	Reference	Taxon	First Appearance	Last Appearance	Reference
Elgerius	T (Ol-l)		(960)	Micradites	J (Oxfo)		(960)
Eocaudina	C (Tour-l)	-R	(1066)	Paleochiridota	C (Tour-l)	-C (Step-u)	(768)
Fissobractites	Tr(Anis)	-Tr(Rhae)		+Porachistrum	D (Give)		(1066)
† Helfriedella	J (Bath)	-J (Oxfo)	(924)	Protheelia	P (Djhu)		(768)
† Huniella	J (Bath)	-J (Oxfo)	(924)	Rigaudites	K (l)	-T (Ol)	
+ Kuehnites	Tr(Anis)	-Tr(Nori-u)	(982,1066)	Rota	C (Tour-l)	-P (Guad)	(1066)
+ Monilipsolus	Tr(Ladi-l)		(947)	Spandelites	J (Oxfo)		(960)
Mortensenites	C (u)	-T (Mi)	(768)	Stueria	Tr(Carn-u)?	-R	(982)
Pachopsites	T (Mi)			Synapites	J (Oxfo)	-R	(2)
Paracucumarites	J (Bath-l)?	-K (Albi)		Thallatocanthus	C (Mosc-u)	-P (Guad)	(1066)
Parviotoidus	J (Oxfo)		(950)	Theelia	C (Bash)	-R	(1066)
Petropegia	C (Mosc-l)						
† Priscologula	K (Albi)			Or. MOLPADIIDA			
† Priscologatus	Tr(m)	-T (Ol-l)	(982)	Calcancorella	T (Ol-l)	-R	(960)
+ Priscopedatoides	Tr(Anis-m)		(674)	Calchgula	J (l)	-R	(768)
Priscularites	J (Oxfo)?	-R	(960)	Exlinella	J (Oxfo)	-R	(2)
+ Pseudostaurucumites	Tr(Nori-m)		(982)	-Jordanocaudina	J (Bath)		(924)
- ?Punctatites	P (Tatr)	-J (Hett-u)	(982,1066)	Pedatopriscus	J (Oxfo)	-R	(2,960)
Schlumbergites	Tr(Rhae)	-J (Oxfo)	(687,960)	+Pseudoexlinella	J (Bath-u)		(924)
+ Solopedatus	Tr(Nori-u)		(982)	Staurucumites	Tr(Anis-u)	-J (Oxfo-l)?	(2,687,988)
+ Spinopriscopedatus	J (Bajo)	-K (Albi)	(924)				
† Stichopitella	Tr(Nori-l)	-Tr(Nori-u)	(982)	Or. ARTHROCHIROTIDA			
- Strobilothylene	Tr(Ladi-l)		(947)	Etheridgella	C (Step-u)		(2)
- Uncinuloides	Tr(Nori-m)	-Tr(Nori-u)	(982)	Frizzellus	Tr	-J (Oxfo)	(2)
				Palaeocucumaria	D (Emsi-l)		(947)
Or. ASPIDOCHIROTIDA				Or. DACTYLOCHIROTIDA			
+ Bathysynactites	Tr(Ladi)?		(947)	+Palaeoypsilus	J (Hett-u)	-J (Sine-l)	(982)
Calcammella	P (Guad)	-R					
+ Collbatothuria	Tr(Ladi-l)		(947)	Or. UNCERTAIN			
Cucumarites	J (Sine)	-R	(768,960)	-Acanthocaudina	Tr(Nori-u)		(982)
+ Holothropopsis	J (Bajo-u)		(947)	Alexandrites	T (Mi-m)		(2)
Ornaticannula	J (Oxfo)	-R	(960)	Calclyra	C (Pn)	-P (Djhu)	(768)
Parvispina	C (Ms)	-T (Mi)		+Conisia	Tr(Carn-u)	-Tr(Nori-u)	(982)
Priscopedatus	C (u)	-R		+Cosmatites	Tr(m)		(982)
Proholothuria	J (Kimm-u)		(947)	+Crucivirga	Tr(Nori-l)		(982)
-Ramusites	J (u)	-K (Albi)		-Curvatella	Tr(Nori-u)		(982)
Rhabdotites	Tr(Ladi-u)?	-J (Oxfo)	(687,960)	Sclerothupites	J (Oxfo)		(960)
Stichopites	Tr(Ladi-u)	-R	(687)	-Semperites	Tr(Nori-l)	-Tr(Nori-u)	(982)
Uncinulina	C (Serp-l)	-R	(768)	+Triradites	Tr(Nori-l)	-Tr(Nori-u)	(982)
				-Uniramosa	Tr(Nori-m)	-K (Albi)	(982)
Or. ELASIPODIDA				ASTEROZOA			
+ Mercedescudina	Tr		(982)	[Classification from the Treatise, Pt. U. Blake (1987, 1989), and Gale (1987).]			
Micranthyx	C (Tour)?	-P (Guad)		Cl. SOMASTEROIDEA			
† Oneirophanites	Tr(Ladi)?		(947)	Or. GONIACTINIDA			
+ Palelpidia	Tr(Nori-l)	-Tr(Nori-u)	(982)	Ampullaster	O (Trem-u)		(2)
+ Praeacudina	Tr(Nori-l)	-Tr(Nori-u)	(982)	Archegonaster	O (Aren-u)	-O (Llvi)	(1075)
+ Praecephronides	Tr(Anis-u)	-J (Plie)	(988)	Archophiactis	O (Ashg)		(2)
Protocaudina	D (Eife)	-J (Oxfo)	(768,1066)	Chinianaster	O (Aren-l)		(805)
Tetravirga	C (Vise-u)	-Tr(Nori-u)	(2,768,982)	Lepidasterina	D (Fras)?		
				+Ophiolenikis	O (Aren-l)		
				Stuertzura	S (Ludl)		
				Villebrunaster	O (Aren-l)		(805)
Or. APODIDA				Cl. ASTEROIDEA			
Acanthocheelia	Tr(Anis-m)	-Tr(Rhae)	(687,982)	Or. PLATYASTERIDA			
Achistrum (+ Achistrolum)	C (Vise-u)	-T (Pale)?	(2,1066)	+Foliaster	D (Give-l)		
Aduncrum	Tr	-J		Palasteriscus	D (Emsi-l)		(1066)
Auricularites	J (Oxfo)		(960)				
Calcancora	Tr(Rhae)	-R	(687)				
Calcancoroidea	T (Ol-u)		(768)				
Croneisites	T (Eo)	-T (Mi-u-l)					
Hemisphaeranthos	J (Plie)?	-K (Sn)	(768)				
+ ?Kozurella	Tr(Nori-l)	-Tr(Nori-u)	(982)				

Taxon	First Appearance	Last Appearance	Reference	Taxon	First Appearance	Last Appearance	Reference
Ophiocten	J	-R		Hercocrinus	O (Llde-u)		(2)
Ophioglyphoidea	K (Albi)			+Hirneocrinus	S (Wenl-l)		(243)
+Ophiolancea	K (Vala-u)			+Kyreocrinus	S (Ldov-m)		
Ophiomusium	J (Sine)	-R		Lampteroocrinus	S (Ldov)	-S (Ludl)	
Ophiopetra	J (Kimm-u)			+Lemenoocrinus	D (Eife-u)		
Ophiopinna	J (Call)			+Luxocrinus	S (Ldov)		
+Ophiotrix	J (Oxfo-u)?		(1066)	Lyriocrinus	S (Wenl)		
Ophiotitanos	K (Ceno)			Macarocrinus	D (Emsi-l)		
Ophiotrigonum	J (Oxfo)			Maquoketocrinus	O (Ashg-l)		
Ophiura	K (Albi-u)	-R		+Monielloocrinus	D (Emsi-u)		
+Ophiurella	J (Tith-l)			Monstrocrinus	D (Emsi-u)	-D (Eife)	
Ophiurina	D (Emsi-l)			Neoarchaeocrinus	O (Cara-m)	-D (Gedi)?	
Ophiuriocoma	J (Aale)			+Nexocrinus	S (Ldov)		
Palaeocoma	J (Hett)	-J (Plie)		Nyctocrinus	S (Wenl-l)		
Silesiaster	C (Tour)			Ophiocrinus	D (l)		
+Sinusura	J (Sine)	-J (Toar)		Opsioocrinus	D (Give-l)		
Stephanoura	D (u)			Orthocrinus	D (Emsi-u)	-D (Eife)?	
+Syntomospina	C (Step-l)		(341)	Paradiabolocrinus	O (Cara-l)		
+Xanthamphiura	K (Haut-u)			Paragazacrinus	S (Wenl-l)		
				Pararchaeocrinus	O (Cara-l)	-O (Ashg-m)	
Or. UNCERTAIN				Paulocrinus	S (Wenl-l)		
+Lumectaster	C (Vise-l)			+Pelidoocrinus	S (Ludl)		(241)
				+Peremocrinus	S (Ludl)		(241)
Cl. CRINOIDEA				+Perunocrinus	D (Sieg)	-D (Emsi-l)	
				+Pidelocrinus	S (Ludl)		(241)
Or. ECHMATOCRINIDA				+Pregazacrinus	S (Ldov)		
Echmatocrinus	Cm(mMid-u)			Proexenocrinus	O (Aren-l)		(1066)
				Pterinoocrinus	D (Emsi)	-D (Fras)	
Or. DIPLOBATHRIDA				Ptychocrinus	O (Ashg-m)	-S (Ldov-u)	
Acanthocrinus	D (Emsi-l)	-D (Give)		+Rasfacrinus	O (Cara-u)?, O (Ashg-l)?		
+Allozygocrinus	S (Ldov)			Reteocrinus	O (Cara-l)	-O (Ashg-m)	(239)
Ambicocrinus	D (Gedi-l)			+Rhachicricinus	S (Ldov-m)		
+Ampuroocrinus	D (Emsi)			Rhaphaocrinus	O (Llde-u)	-O (Ashg-m)	(2)
Anthemocrinus	S (Wenl)			+Rheocrinus	O (Ashg)		
Anthracoocrinus	O (Cara-l)			Rhipidocrinus	D (Eife)	-D (Give)	
+Apuroocrinus	D (Emsi)		(242)	Rhodocrinites	C (Tour-l)?	-C (Vise-u)	(2,986)
Archaeocrinus	O (Llde)	-O (Ashg-l)		+Shidianocrinus	D (m)		
Atactocrinus	O (Ashg-m)			Siderocrinus	S (Ludl)		
Balacrinus	O (Cara-m)			+Sillfocrinus	S (Ldov-m)		
+Bromidoocrinus	O (Cara-l)			+Simplococrinus	O (Cara-u)		(240)
Cadisocrinus	D (Give-l)			Siphonocrinus	S (Wenl-u)		
Cleioocrinus	O (Llde-u)	-O (Cara-m)	(2)	Sphaerotocrinus	D (Gedi)		
+Colpodocrinus	O (Cara-l)			Spyridocrinus	D (Sieg)	-D (Emsi)	(1066)
Condylocrinus	D (Eife)			Stereoaster	S (Ldov-m)		
+Cotylacrina	O (Cara-m)			Thylacocrinus	D (l)	-D (Give)	
Cribanocrinus	C (Tour-l)	-C (Vise-l)	(986)	Trichinoocrinus	O (Llvi-u)		
+Crinocrinus	O (Cara-l)			Traskocrinus	O (Cara-l)		
Cyphocrinus	S (Wenl-l)	-S (Ludl)	(241)	Trochocrinites	O (Cara-m)?		
Deocrinus	O (Llvi-u)		(2)	+Turboocrinus	S (Ldov-m)		
Diaboloocrinus	O (Llde)	-O (Ashg-m)?		Wilsonocrinus	O (Cara-l)	-S (Wenl-l)	
Diamenocrinus	D (Sieg)	-D (Emsi)		+Xysmacrinus	S (Ldov-m)		
Dimerocrinites	S (Ldov-u)	-D (Eife)?					
Elpidocrinus	S (Ludl-l)?						
Emperocrinus	S (Wenl-l)			Or. MONOBATHRIDA			
Eudimerocrinus	S (Ludl)			Aacocrinus	C (Tour-l)		
+Euptychocrinus	O (Cara-m)	-S (Ldov)		Abacocrinus	S (Wenl)		
Gauroocrinus	O (Ashg-m)			Abactinoocrinus	C (Tour-l)		
Gazacrinus	S (Wenl-l)	-S (Ludl)		Abathocrinus	S (Wenl-l)		
Gilbertsocrinus	D (Give-l)?	-C (Vise-l)	(986)	Abatocrinus	C (Tour-l)	-C (Vise-l)	(986)
Griphocrinus	D (Eife)	-D (Give)		+Abلودoglyptocrinus	O (Cara-l)	-S (Ldov-l)	(239)
+Gustabilicrinus	O (Cara-l)		(239)	Acacocrinus	S (Ldov-m)?	-D (Give)	(703)
+Hagnocrinus	S (Ldov-u)	-S (Ludl-u)	(243)	Acroocrinus	C (Vise-u)	-C (Serp-l)	(986)
				Actinoocrinites	C (Tour-u)	-C (Mose)	(704)

Taxon	First Appearance	Last Appearance	Reference	Taxon	First Appearance	Last Appearance	Reference
Agaricocrinus	C (Tour-l)	-C (Vise-l)	(986)	Dialatocrinus	C (Tour-l)	-C (Tour-u)	(986)
Agathocrinus	D (Emsi)?	-D (Fame-u)	(1247)	Diatrocrinus	C (Vise-l)		(986)
Ahisocrinus	O (Ashg-u)	-S (Wenl)?		Dichocrinus	C (Tour-l)	-C (Mosc-u)	(660)
Allocrinus	S (Wenl-l)	-S (Ludl)		+ Dilatocrinus	C (Tour-u)		(704)
Alloprosallocrinus	C (Vise-l)		(986)	Dinacrocristus	C (Mosc-u)	-C (Step-l)	
+ Amarsupiocrinus	S (Ldov)	-S (Ludl)		+ Displodocrinus	C (Tour-l)	-C (Tour-u)	(704)
Amblacrinus	D (Eife)	-D (Give)		Dizyocristus	C (Vise-l)	-C (Vise-u)	(986)
Amonohexacristus	D (Emsi)?			Dolatocrinus	D (Emsi)	-D (Give)	
Amphocrinus (= Mitrocrinus)	C (Tour-l)	-C (Serp-l)		Dorycristus	C (Tour-l)	-C (Vise-l)	(986)
Amphocracrinus	C (Tour-u)	-C (Serp-l)?	(704)	Ectocrinus	C (Vise-u)		(986)
+ Ancalocrinus	C (Tour-l)	-C (Tour-u)	(704)	+ Eocamptocrinus	D (Eife-u)?	-D (Give-l)?	(1065)
Aorocrinus	D (Give)?	-C (Vise-l)	(986)	Eopatellocrinus	O (Cara-m)	-S (Wenl-l)	
+ Archaeocalyptocrinus	S (Ldov)	-S (Wenl)		Eretmocristus	C (Tour-l)	-C (Vise-l)	
Arthroacantha	D (Emsi-l)	-D (Fras)?		Eucalyptocristites	S (Ldov)	-D (Eife)	
Aryballocrinus	C (Tour-l)	-C (Vise-l)	(986)	Eucudocrinus	C (Tour-u)	-C (Vise-l)	(986)
Athabascacristus	C (Tour-u)		(986)	Eutelecrinus	P (Guad-u)		(2)
+ Auliskocrinus	C (Vise-l)		(986)	Eutrochocrinus	C (Tour-u)	-C (Vise-l)	(986)
Azygocrinus	C (Vise-l)		(986)	Eumorphocrinus	C (Vise-l)		
Barrandeocrinus	S (Wenl)			+ Exsulacristus	C (u)		
Batocrinus	C (Vise-l)	-C (Vise-u)	(986)	Gennaeocrinus	D (Emsi)	-D (Give)	
Beyrichocrinus	D (Sieg-l)			+ Glaphyocrinus	C (Vise-l)		
+ Bikoocrinus	S (Ldov-m)?		(526)	Globacrocristus	C (Bash-u)	-C (Mosc-u)	
Blairocristus	C (Tour-l)	-C (Tour-u)	(986)	Globoocrinus	C (Vise-u)		(986)
Bogotacristus	D (Emsi)?, D (Eife)?			Glyptocrinus	O (Cara-m)	-S (Ludl)?	(248)
Bohemioocrinus	S (u)			Hadrocristus	D (l)	-D (Eife-l)	
+ Bolicristus	S (Ldov)			Hapalocrinus	D (Emsi-l)	-D (Fras-u)	(1065)
+ Boliviacrinus	D (Eife)			+ Harrelicristus	C (Tour-l)	-C (Serp-l)	(986)
Brahmacristus	C (Tour-u)	-C (Vise-l)	(986)	Hexacristites	S (Ludl)	-C (Tour-l)	
Briarocrinus	S (Wenl)			Himerocrinus	D (l)	-D (Eife-l)	
Cactocrinus	C (Tour-u)	-C (Vise-l)	(986)	+ Hyrtanecristus	C (Vise-l)	-C (Serp-l)	(246,986)
Calliocristus	S (Wenl-u)	-D (l)		+ Ibanocrinus	S (Ldov-m)?		(703)
Camarocrinus	S (Prid)	-D (Gedi)		Iberocrinus	C (Bash)	-C (Mosc-u)	
Camptocrinus	C (Vise-l)	-C (Serp-l)		+ Ilmocristus	C (Vise-u)	-C (Serp)	
Canistrocrinus	O (Ashg-m)			+ Ivanovaeocrinus	C (Mosc-u)		
Cantharocrinus	D (Emsi-l)	-D (Eife)?		+ Krinoocrinus	S (Ldov)		
Carolicristus	S (Prid)			+ Kylixocrinus	S (Ldov)		
Carpocrinus	S (Ldov-m)	-D (Sieg)		Laurelocristus	S (Wenl-l)		
Caucacrocristus	C (Step-l)			Lenneocrinus	D (Give)	-D (u)	
+ Celtocrinus	O (Aren-l)		(1066)	Liomolgoocrinus	D (Gedi)		
Centriocrinus	D (Eife-l)			- Lobomolocristus	S (Wenl-u)	-S (Prid)	(249)
+ Cerasmocristus	D (Fras)			Lyonicristus	S (Ldov)	-S (Ludl)	
+ Chinacrinus	D (Fame-l)		(1247)	Macrocrinus	C (Tour-u)	-C (Vise-l)	(986)
Clarkeocrinus	D (Eife)	-D (Give)		Macrostyrocrinus	O (Ashg-m)	-D (Emsi)	
Clematocrinus	S (Ldov-m)	-S (Ludl-l)		Maligneocrinus	C (Tour-l)		
Clonocrinus	S (Wenl)	-S (Ludl)		Manillocrinus	C (Tour-l)		
Closteroocrinus	S (Wenl-l)			+ Mantiacristus	S (Ldov-m)		
Coelocristus	C (Tour-u)			+ Marhoumacristus	S (Prid)	-D (Gedi)	
Comanthocrinus	D (l)	-D (Give)		Marsupiocristus	S (Wenl)	-D (Gedi)	
Compsocristus	O (Ashg-m)	-O (Ashg-u)		Megaliocrinus	C (Bash-l)	-C (Mosc-u)	
Cordylocristus	S (Ludl)?	-D (Gedi)		Megistocrinus	D (Gedi)	-C (Vise-l)	(986)
Corocristus	D (Emsi)	-D (Give)		Melocristites	D (Gedi)	-D (Fras-u)	(1065)
Craterocrinus	D (Eife)			Metaacrocristus	C (Mosc-u)		
Ctenocrinus	S (Ludl)	-D (Eife)?		+ Metaeutelecrinus	P (Guad-u)?		
Culicocrinus	D (Emsi-u)			Methabocrinus	S (u)		
Cusacristus	C (Tour-l)	-C (Tour-u)	(986)	+ Nanicristus	S (Ludl)		
Cylicocrinus	S (Wenl-l)			+ Neocamptocrinus	P (Sakm)	-P (Tatr)	(247,1066)
Cytidocrinus	C (Vise-l)		(956)	Neodichocrinus	P (Guad-u)		(2)
Cyttarocrinus	D (Emsi-l)?	-D (Give-u)		Neoplaticristus	P (Sakm)	-P (Guad-u)?	
Cytocristus	S (Wenl-l)			Nunnacristus	C (Tour-u)	-C (Vise)?	(986)
Desmidocrinus	S (Ludl)			Oehltericristus	D (Gedi)	-D (Eife)	
				Oenochoacristus	D (l)	-C (Tour-u)	(704)
				+ Paiderocrinus	S (Ldov-m)?		(526)

Taxon	First Appearance	Last Appearance	Reference	Taxon	First Appearance	Last Appearance	Reference
+Pandanocrinus	D (Sieg)			Xenocrinus	O (Ashg-m)	-O (Ashg-u)	
+Paracrocrinus	C (Mose)			+Zenkericrinus	S (Prid)		
Paradihocrinus	C (Tour-u)	-C (Vise-l)	(986)	+Zirocrinus	S (Ldov-m)?		(526)
Paragariocrinus	P (Guad)		(2)				
Parahexacrinus	D (Emsi)?			Or. DISPARIDA			
+Paramegaliocrinus	C (Mose)			Abyssocrinus	S (Wenl)		(1066)
Paramelocrinus	S (Wenl-u)	-S (Prid)	(249)	Acolocrinus	O (Cara-l)		
+Paratalarocrinus	C (Vise-u)		(245)	Agostocrinus	O (Cara-l)		
Patelliocrinus	S (Ldov-m)	-S (Wenl)		Allagecrinus	D (Fame-u)	-C (Serp-l)	(906)
Periechocrinus	S (Wenl-u)	-S (Ludl-l)		Allocatillocrinus	C (Vise-u)	-C (Serp-l)	(660,906)
Periglyptocrinus	O (Cara-m)	-O (Cara-u)		Anamesocrinus	D (Give)	-D (Fras)	(1066)
+Phrygilocrinus	S (Ldov-m)?		(526)	Anomalocrinus	O (Cara-l)?	-O (Ashg-l)	(1066)
Physetocrinus	C (Tour-l)	-C (Vise-l)	(704,986)	Anulocrinus	O (Cara-l)	-O (Ashg-m)	(248,250)
Pimilicocrinus	C (Tour-u)	-C (Vise-l)	(986)	+Apodasmocrinus	O (Cara-l)		(251)
Pithocrinus	D (Emsi)	-D (Give)		+Atopocrinus	O (Llvi-u)		
Planacrocrinus	C (Bash-u)	-C (Step-l)		+Athyocrinus	O (Ashg-l)		
Platyacrocrinus	C (Bash-u)			+Aureocrinus	D (Emsi-u)		
Platytrinites	D (l)	-P (Guad-u)	(2)	Belemnocrinus	C (Tour-u)	-C (Vise-l)	(906)
Platyhexacrinus	D (Emsi)	-D (Eife)		Brachioocrinus	D (Gedi)		
Plemnoocrinus	C (Tour-u)	-C (Vise-l)	(986)	+Brutopsocrinus	D (Gedi)		
Plesioocrinus	P (Guad-u)		(2)	Caleocrinus	O (Cara-l)	-S (Ludl)	
Pleurocrinus	C (Tour-l)	-P (Guad-u)	(2,704)	Caleidocrinus	O (Llvi-u)	-O (Cara-m)	
Polypetes	S (Wenl)			Calycanthocrinus	D (Sieg)	-D (Eife)	(998)
Pradocrinus	D (Emsi-l)			+Cataraquocrinus	O (Cara-l)		
+Praedicticrinus	S (Ludl)			+Catatonocrinus	S (Ldov-l)		(1066)
Prohexacrinus	S (u)?			Cautilocrinus	C (Tour-u)	-C (Vise-l)	(704)
+Prokopocrinus	S (Wenl)	-S (Ludl)		+Changinocrinus	D (m)		
Promelocrinus	S (Wenl-u)			+Charactocrinus	S (Wenl-l)		(250)
Protacrocrinus	C (Tour-u)		(986)	Chirocrinus	S (Ldov)	-S (Wenl)	(250)
Pterotoocrinus	C (Vise-u)	-C (Serp-l)	(986)	Chiropinna	S (Wenl)	-S (Ludl)	
Pycnocrinus	O (Cara-m)	-O (Ashg-m)		Ciceroocrinus	S (Wenl)	-S (Prid)	(998)
Pyxidocrinus	D (Gedi)	-D (Give)		+Cinnamticrinus	O (Cara-m)	-O (Ashg-m)	(1066)
Sampsonocrinus	C (Tour-l)	-C (Vise-l)	(986)	+Claviculacrinus	O (Ashg-u)		
Schizocrinus	O (Cara-m)			Columbicrinus	O (Cara-l)		(239)
Scyphocrinites	S (Wenl)	-D (Gedi-u)		+Compagicrinus	O (Aren-u)		(805)
+Shimantocrinus	D (Sieg)			Cremacrinus	O (Cara-l)	-S (Ludl)	(250)
Springeracrocrinus	C (Vise-l)	-C (Serp-l)	(660)	Crinobrachiatus	S (Wenl-l)		
Stammocrinus	D (Emsi-l)	-D (Give)		Cunctocrinus	D (Give)		
Steganocrinus	C (Tour-u)	-C (Vise-l)	(986)	Daedalocrinus	O (Cara-m)		
Stelidiocrinus	S (Wenl)		(526)	Deltaocrinus	S (Ldov)	-D (Fame-l)	(1247)
+Stipatocrinus	S (Ldov)			Desmaerocrinus	D (Fame)	-C (Tour-l)	
Stiptocrinus	S (Wenl-l)?	-S (Ludl)		+Diaphrocrinus	S (Ldov)		(250)
Stomiocrinus	P (Leon-m)	-P (Guad-u)	(2)	+Difficilicrinus	O (Cara-l)		(251)
+Strimplecrinus	C (Vise-l)	-C (Serp-l)		+Dolerocrinus	D (Eife-u)		
Strotocrinus	C (Tour-u)	-C (Vise-l)	(986)	Doliocrinus	O (Cara-l)		(239)
+Struzocrinus	D (Sieg)			Drymocrinus	O (Cara-u)	-O (Ashg-l)	
Sunwaptacrinus	C (Tour-l)	-C (Tour-u)	(704)	Dystactocrinus	O (Cara-u)	-O (Ashg-l)	
Talarocrinus	C (Vise-u)		(986)	Ectenocrinus	O (Cara-l)	-O (Ashg-m)	
+Tarantocrinus	C (Tour-l)		(704)	+Eociceroocrinus	O (Ashg-m)		(1066)
Technocrinus	S (Ludl)	-D (Sieg)		Eohalysioocrinus	S (Wenl)	-D (Eife)?	(250)
Teleioocrinus	C (Tour-u)	-C (Vise-l)	(986)	Eomyelodactylus	S (Ldov-l)	-S (Ldov-u)	
Thalocrinus	D (Emsi-l)			Epihalysioocrinus	P (Leon-m)		
Thamnoocrinus	D (Give)			Espanocrinus	D (Emsi)		
+Theleproktoocrinus	S (Ldov)			Eucatillocrinus	C (Vise-l)	-C (Mose-l)	
+Thomasocrinus	S (Ldov)			Eustenocrinus	O (Cara-m)		
+Tirocrinus	S (Ldov-m)?		(703)	Geraocrinus	O (Cara-l)	-O (Cara-m)	(1066)
Trichotocrinus	D (Fras)			Glaucoocrinus	O (Cara-m)		
Tryblioocrinus	D (Emsi-l)	-D (Give)	(1065)	+Gongroocrinus	C (Bash-u)		(660)
+Tunisiacrinus	P (Guad)		(244)	Grypocrinus	S (Wenl)		(250)
+Typanocrinus	S (Ldov-m)?		(526)	Halysioocrinus	D (Give)	-C (Vise-u)	(906)
Uperocrinus	D (Fame-l)	-C (Vise-l)	(1247)	Haplocrinites	D (Eife)	-D (Fras)	(1066)
Wannerocrinus	P (Guad-u)		(2)	+Heraocrinus	D (Emsi-u)	-D (Eife)	

Taxon	First Appearance	Last Appearance	Reference	Taxon	First Appearance	Last Appearance	Reference
Anemetocrinus	C (Vise-u)		(906)	Corythocrinus	C (Vise-l)		(906)
Anobascrinus	C (Bash-u)	-C (Step-l)		Cosmetocrinus	D (Fame-m)?	-C (Serp-l)	(906,1247)
Anthiomocrinus	S (Ludl)	-D (Emsi)		Costalocrinus	D (Sieg-u)	-C (Vise-l)	
Aphelecrinus	C (Tour-l)	-C (Serp-l)		Cradeocrinus	D (Fras)	-C (Tour-l)	(906)
Apographocrinus	C (Mosc-u)	-P (Wc)		Cranocrinus	C (Bash)	-P (Guad-u)	
Arachnocrinus	D (Eife)			Criocrinus	C (Mosc-u)		
Araeocrinus	C (Mosc-l)			Cromyocrinus	C (Vise-l)	-C (Mosc-u)	(257,1056)
Arkaerinus	C (Bash-u)			Crotalocrinites	S (Wenl-u)	-S (Ludl)	
Armenocrinus	C (Vise-l)	-C (Vise-u)	(906)	Cryphiocrinus	C (Serp-l)		(906)
Arrectocrinus	C (Step-l)	-C (Step-u)		Culmicrinus	C (Tour-l)	-C (Serp-l)	
Arroyocrinus	P (Wc)			Cupressocrinites	D (l)	-D (Fras-u)	(1065)
Ascetocrinus	C (Tour-u)		(906)	Cupulocrinus	O (Cara-l)	-O (Ashg-m)	(248)
Asymmetrocrinus	P (Guad-u)			Cyathocrinites	S (Wenl)	-C (Vise-u)	
Atelestocrinus	C (Vise-l)		(906)	Cydonocrinus	C (Vise-u)	-P (Guad-u)	(906)
Athlorinus	C (Bash-u)	-C (Step-l)		Cydropocrinus	C (Vise-l)		(906)
Atokacrinus	C (Mosc-l)	-C (Mosc-u)		Cylioerinus	S (Wenl)		
Atractocrinus	D (Give)	-D (Fras)		Cymbiocrinus	C (Vise-u)	-P (Tatr)	
Atrapocrinus	C (Mosc-l)			Dasciocrinus	C (Vise-u)	-C (Serp-l)	
Atremacrinus	P (Guad-u)			Decadocrinus	D (Give)	-C (Vise-u)	
Aulocrinus	C (Vise-l)		(906)	Delocrinus	C (Mosc-u)	-P (Guad-u)	
Aulodesocrinus	C (Vise-u)		(906)	Denariocrinus	D (m)		
Bactrocrinites	S (Ludl)	-D (Give-l)		Dendrocrinus	O (Cara-l)	-S (Ludl)	(248)
Barycrinus	C (Tour-u)	-C (Vise-u)		Depaocrinus	P (Guad-u)		
Basleocrinus	P (Leon)	-P (Guad-u)		Derbiocrinus	C (Tour-u)		
Bathericrinus	S (Wenl)	-D (Emsi-l)		Dichostreblocrinus	C (Tour-u)	-P (Guad-u)	(906)
Bathronocrinus	C (Mosc-u)	-P (Wc)		Dicromyocrinus	C (Serp-l)	-C (Step-u)	(257)
Belanskicrinus	D (Fras-l)			Dictenocrinus	S (Wenl)	-D (Emsi)	
Benthocrinus	P (Guad-u)			Dinotocrinus	C (Tour-l)	-C (Vise-u)	(660)
Bicidiocrinus	C (Serp-l)			Diphuicrinus	C (Bash-u)	-C (Step-u)	
Blothocrinus	C (Tour-u)	-C (Vise-u)	(906)	Edapocrinus	C (Vise-l)		(906)
Bolboerinus	P (l)	-P (Guad-u)		Eifelocrinus	D (Emsi)		
Bollandocrinus	C (Vise-l)	-C (Vise-u)	(906)	Eireocrinus	C (Tour-l)	-C (Tour-u)	(906)
Botryocrinus	S (Wenl-u)	-D (Give)	(254)	Eirmocrinus	C (Mosc-u)		
Brabeocrinus	C (Mosc-l)	-P (Wc)		Elibatocrinus	C (Mosc-l)	-P (Asse)	
Bridgerocrinus	D (Fame-l)	-C (Tour-u)?	(1247)	Elicrinus	D (Sieg)	-D (Emsi-l)	
+ Briseocrinus	D (Emsi-u)			+ Elpasocrinus	O (Aren-l)		(1071)
Bronaughocrinus	C (Vise-u)		(906)	Embryocrinus	P (Leon)	-P (Guad-u)	
Brychiocrinus	C (Mosc-u)			Enalocrinus	S (Wenl)	-S (Ludl)	
Bursacrinus	C (Tour-u)		(906)	Endelocrinus	C (Bash-u)	-P (Sakm)	
Cadocrinus	P (Guad-u)			+ Eoindocrinus	P (Leon-m)		
Caelocrinus	S (Ldov)			+ Eoparisocrinus	O (Cara-m)	-S (Wenl)	
Caecolispongia	P (Sakm)	-P (Guad-l)		+ Eopiliocrinus	P (Leon-m)		
Carabocrinus	O (Llde-u)	-O (Ashg-m)		+ Eopinacrinus	O (Cara-l)		
Carcinocrinus	C (Serp-l)		(906)	+ Eperisocrinus	C (Step-l)		
Carlopsocrinus	C (Vise-u)		(906)	Epipetechoracrinus	P (l)		
Catactocrinus	D (Fras)			Eratocrinus	C (Tour-u)	-C (Vise-l)	(906)
+ Cathetocrinus	C (Step-u)			Eri-soerinus	C (Bash-u)	-P (Wc)	
Celonocrinus	C (Step-l)	-P (Wc)		Esthonoerinus	O (Cara-l)		(1213)
Ceratocrinus	P (Guad-u)			Ethelocrinus	C (Bash-u)	-C (Step-u)	(257)
Cercidocrinus	C (Tour-l)	-C (Tour-u)	(906)	Euerisocrinus	C (Step-l)		
Cestocrinus	C (Vise-l)		(906)	Eupachyrcrinus	C (Vise-u)	-C (Serp-l)	
Charientocrinus	D (Give)	-D (Fras)		Euspirocrinus	S (Ldov)	-S (Ludl)	
Chlidonocrinus	C (Serp-l)	-C (Step-l)		Exaetocrinus	C (Vise-u)	-P (l)	(906)
Clathrocrinus	C (Mosc-l)	-C (Step-l)		Exochoerinus	C (Vise-u)		(906)
Clistocrinus	C (Bash)	-P (Leon)		Exoerinus	C (Bash)	-P (Sakm)?	
Codiaerinus	D (l)	-D (Eife)		Exoriocrinus	C (Mosc-u)	-C (Step-u)	
Coeliocrinus	C (Tour-u)		(906)	Exterocrinus	C (Bash-u)		
Coenocystis	C (Mosc-l)	-P (Guad-u)		Fifeocrinus	C (Vise-u)	-C (Serp-l)	(660)
+ Contignatindocrinus	P (Guad-u)?			Follicrinus	D (Emsi-l)?		
Contocrinus	C (Mosc-u)	-C (Step-u)		Fortheocrinus	C (Vise-u)		(906)
Corematocrinus	D (Fras)			Galateacrinus	C (Mosc-u)	-C (Step-u)	
Corynecrinus	D (Emsi)			Gasterocoma	D (Sieg)	-D (Give)	

Taxon	First Appearance	Last Appearance	Reference	Taxon	First Appearance	Last Appearance	Reference
Gastrocrinus	D (Emsi)			Logocrinus	D (Give)	-D (Fras)	
Gilmocrinus	C (Tour-l)	-C (Vise-l)	(906)	Lopadiocrinus	P (Guad-u)		
Givsoocrinus	S (Wenl)	-P (Leon-u)	(1066)	Lophocrinus	C (Vise-u)		(906)
Glaukosocrinus	C (Vise-u)	-C (Step-u)	(906)	Malaiocrinus	P (Guad-u)		
Glossocrinus	D (Fras)			+ Mamirius	S (Wenl-u)	-S (Prid)	(255)
Goleocrinus	C (Vise-u)	-C (Mosc-l)	(257,660,906)	Mantikosocrinus	C (Vise-u)	-C (Serp-l)	(257,906)
Goniocrinus	C (Tour-l)	-C (Vise-l)	(906)	Maragnicrinus	D (Fras-u)		
Gothocrinus	S (Ludl)			Marathonocrinus	C (Bash)	-C (Mosc-l)	
Graffhamicrinus	C (Mosc-l)	-P (Asse)?		Mastigoocrinus	S (Wenl)		
Graphiocrinus (+ Missouriicrinus)	C (Tour-u)	-C (Mosc)	(906)	+ Mathericrinus	C (Bash)	-C (Mosc-l)	
Grenprisia	O (Cara-m)			- Megatocrinus	P (Leon-u)		
Haeretocrinus	C (Mosc-u)	-C (Step-u)		Melbacrinus	C (Step-l)		
Hallocrinus	D (Emsi)	-C (Vise-u)	(906)	- Menniscocrinus	C (Vise-l)		
Halogetocrinus	C (Mosc-l)	-P (Asse)		Meroocrinus	O (Llde)	-O (Cara-u)	(2)
Harmostocrinus	C (Vise-u)	-C (Serp-l)		Metabolocrinus	O (m)		
+ Harrellicrinus	P (Leon-m)			Metacromyocrinus	C (Bash-l)	-C (Step-l)	(257)
Heliosocrinus	C (Vise-u)	-C (Bash-u)		Metafinocrinus	C (Mosc-u)		
Hemindocrinus	P (Leon)			Metaindocrinus	P (Guad-l)		
Hemimollocrinus	P (Leon)			Metaperimestocrinus	C (Bash)	-C (Step-l)	
Hemistreptacron	P (l)	-P (Guad-u)		Metasyocrinus	P (Guad-u)		
Histocrinus	C (Vise-l)		(906)	Metutharocrinus	C (Bash-u)		
Holocrinus	D (Fame-l)	-C (Vise-l)	(1247)	+ Miatschikovocrinus	C (Mosc-u)	-C (Step-l)	
Hosieocrinus	C (Vise-u)		(906)	Microcaracrinus	C (Mosc-l)	-P (Sakm)	
Hydreionocrinus	C (Vise-l)	-C (Serp-l)	(906)	Mictocrinus	D (Eife)		
Hydroicrinus	C (Mosc-u)	-C (Step-l)		- Minilycrinus	P (Sakm)?	P (Leon)?	
Hydroprocrinus	P (Leon-m)			Moapocrinus	P (Asse)?	-P (Sakm)	(257)
Hylodecrinus	C (Vise-l)			Mollocrinus	P (Guad-u)		
Hypocrinus	P (Guad-u)			Monobrachiocrinus	P (Leon)	-P (Guad-u)	
Hypselocrinus	C (Tour-l)	-C (Vise-u)	(906)	Mooreocrinus	C (Bash)	-C (Step-l)	
- Idaemocrinus	D (Gedi)	-D (Sieg)		Morrowcrinus	C (Bash-u)		
Idosocrinus	C (Vise-u)		(906)	Moscovicrinus	C (Mosc)	-P (Wc)	
+ Illemocrinus	O (Cara-m)		(1213)	Moundocrinus	C (Mosc-l)	-C (Step-u)	
Imitocrinus	D (Emsi)			Myrtillocrinus	D (Eife)		
Indocrinus	P (Guad-u)			+ Nacocrinus	C (Mosc-u)		
Intermediacrinus	C (Vise-u)	-C (Serp-l)		Nactocrinus	C (Tour-u)		(906)
Iteacrinus	D (Fras)			Nanocrinus	D (Give)		
Jahnocrinus	D (Give-l)			Nassovioicrinus	D (Emsi)	-D (Fras)	
Jimbacrinus	P (Leon-m)			Nebrashaerinus	P (Sakm)		
Kalpidocrinus	D (m)			Neocataerinus	C (Step-l)		
+ Kanabinoicrinus	S (Ldov-m)?			Neolageniocrinus	C (Tour-u)	-P (Guad-u)	(906)
- Kansacrinus	C (Step-l)	-P (Wc)		Neoprotencrinus	C (Mosc-l)	-C (Step-l)	
Kopflerinus	D (Eife)			Neozeacrinus	C (Mosc-u)	-P (Guad-u)	
+ Kooptonocrinus	S (Prid)?, D (Gedi)?			Nereocrinus	P (l)	-P (Guad-u)	
Kophinocrinus	D (Give)			Notiocrinus	P (Guad-u)		
Laccocrinus	P (Guad-u)			+ Nowracrinus	P (Leon-m)	-P (Guad-u)	
Lageniocrinus	C (Tour)	-P (Leon)		+ Nuxocrinus	D (Emsi)	-D (Give-u)	(256)
Lampadosocrinus	C (Tour-u)	-C (Bash-l)?	(906)	+ Occiducrinus	P (Leon-m)	-P (Guad-u)	(1066)
- Lanecrinus	C (Vise-l)		(1056)	Oklahomacrinus	C (Mosc-l)	-C (Step-u)	
Lasanocrinus	C (Bash-l)	-C (Mosc-u)		+ Oligobrachiocrinus	P (Leon-m)		
Lasioicrinus	D (Emsi)	-C (Tour-l)	(906)	Ontarioicrinus	O (Cara-m)		
Laudonocrinus	C (Bash)	-C (Step-u)		Ophiuroicrinus	C (Tour-u)	-C (Serp-l)	(906)
Lebetocrinus	C (Vise-l)		(906)	Ottawaicrinus	O (Cara-m)		
Lecobasicrinus	C (Mosc-l)	-C (Step-u)		Oxyocrinus	C (Bash)		
Lecythiocrinus	C (Bash-u)	-C (Step-l)		Pachylocrinus	C (Tour-u)	-C (Serp-l)	(906)
Lecythocrinus	D (Eife)	-D (Give)		Pageicrinus	D (Emsi)		
- Lekocrinus	C (Vise-l)			Paianocrinus	C (Serp-l)		(906)
Linobrachiocrinus	D (u)			Palaeocrinus	O (Llde-u)	-O (Cara-m)	
Linocrinus	C (Tour-u)	-C (Serp-l)	(906)	Palmerocrinus	C (Bash-l)	-C (Mosc-l)	
Liparocrinus	D (Fras-u)			Pandoracrinus	O (Llde)		(2)
Lobalocrinus	C (Step-u)			Parabotryocrinus	D (u)		
				Parabursacrinus	P (Sakm-u)	-P (Guad-u)	
				Paracosmetocrinus	C (Tour-l)	-C (Tour-u)	

Taxon	First Appearance	Last Appearance	Reference	Taxon	First Appearance	Last Appearance	Reference
Paracromyocrinus	C (Bash)	-P (Wc)		+Pyrenocrinus	D (Emsi)	-D (Give)	(256)
Paracydonocrinus	P (Leon-m)			Quantoxocrinus	D (Give)	-D (Fras)	
Paracymbiocrinus	C (Serp-l)			+Quinquecaudex	O (Cara-l)	-O (Ashg-l)	(239)
Paradelocrinus	C (Bash)	-C (Step-l)		Ranulocrinus	C (Tour-l)	-C (Serp-l)	(660)
Paragassizocrinus	C (Bash-u)	-C (Step-u)		Retusocrinus	C (Mosc-u)	-C (Step-u)	
Paragraphiocrinus	P (Guad-u)			Rhabdocrinus	C (Vise-u)	-C (Serp)	(906)
Paraperocrinus	D (l)			Rhadiocrinus	D (Emsi)	-D (Give)	
Paraplasocrinus	P (Guad-u)			Rhenocrinus	D (Emsi-l)		
+Parascytalocrinus	C (Vise-l)		(1056)	Rhopalocrinus	D (Eife)		
Parastachyocrinus	P (Guad-u)			Rhopocrinus	C (Vise-u)	-C (Serp-l)	
Parastephanocrinus	S (Ludl)			+Rimosidocrinus	P (Guad-u)?		
Parasycoocrinus	P (Guad-u)?			Roemerocrinus	P (l)	-P (Guad-u)	
+Paratimorocidaris	P (Leon-m)			+Saccosompsis	C (Vise-l)		
Parazeacrinites	C (Vise-u)		(906)	+Sardinocrinus	C (Mosc-u)	-C (Step-u)	
Parathelocrinus	C (Bash-u)	-C (Mosc-u)	(257)	Sarocrinus	C (Vise-l)		(906)
Parindocrinus	P (Guad-u)			+Scammatoocrinus	C (Vise-l)	-C (Serp-l)	(660,906)
Parisangulocrinus	D (Gedi)	-D (Sieg-u)		Schedexocrinus	C (Mosc-u)		
Parisocrinus	D (Emsi)	-C (Vise-l)		+Schistocrinus	C (Mosc-l)	-C (Step-l)	
Parspaniocrinus	P (Wc)			Schmidtocrinus	D (Eife)		
Parulocrinus	C (Mosc-u)	-P (Wc)	(257)	Schultziocrinus	D (Eife)		
Pedinocrinus	C (Vise-u)		(906)	Sciadiocrinus	C (Bash-u)	-C (Step-u)	
Pegocrinus	C (Mosc)			Scolioocrinus	D (Give)		
Pelecocrinus	C (Tour-u)	-C (Serp-l)	(906)	Scotiocrinus	C (Vise-u)	-C (Serp-l)	(906)
Pellecrinus	C (Tour)	-C (Vise-l)		Scytalocrinus	D (Fame-u)	-C (Step-u)	
Pentaramicrinus	C (Vise-u)?	-C (Serp-l)		Sellardsicrinus	C (Bash-u)	-C (Mosc-u)	
Pentececrinus	D (Fame-u)			Separoocrinus	C (Step-u)		
Perimestocrinus	C (Mosc-u)	-P (Wc)		Sigambrocrinus	D (Gedi)	-D (Eife)	
Permiocrinus	P (Guad-u)			Simocrinus	C (Step-u)		
Pernerocrinus	D (Sieg-u)			Sinocrinus	C (Mosc-l)		
Petalambicrinus	C (Step-l)			+Sinopetalocrinus	S (Ldov)		
Petalocrinus	S (Ldov-m)	-S (Wenl)		Situlocrinus	D (Emsi-l)		
Petschoracrinus	C (Mosc)	-P (l)		+Skaiocrinus	P (Leon)		
Phacelocrinus	C (Tour-u)	-C (Serp-l)	(660)	Sostonocrinus	C (Tour-l)		(906)
Phanoocrinus	C (Vise-u)	-C (Serp-l)		Spaniocrinus	P (Guad-u)		
Piliidiocrinus	P (Guad-u)			Sphaeroocrinus	D (Give)		
Pirasoocrinus	C (Mosc-u)			Spheniscocrinus	P (Leon)	-P (Guad-u)	
Platyfundocrinus	C (Mosc-l)			Springericrinus	C (Tour-u)	-C (Vise-l)	(906)
Plaxocrinus	C (Bash)	-P (Wc)		Stachyoocrinus	P (Guad-u)		
+Plicodendrocrinus	O (Cara-m)	-O (Ashg-u)		Staphyloocrinus	C (Vise-u)		(906)
Plummericrinus	C (Serp-l)	-P (Wc)		Stellarocrinus	C (Mosc-u)		
Polusocrinus	C (Mosc-l)	-C (Step-u)		Stenopocrinus	C (Bash-l)	-P (Wc)	
Polycrinus	O (Cara-u)	-O (Ashg-m)	(1213)	Stinoocrinus	C (Vise-l)		(906)
Polygonocrinus	C (Mosc-u)	-C (Step-l)		Strebloocrinus	D (Give)		
Porocrinus	O (Cara-l)	-O (Ashg-m)		Streptocrinus	S (Wenl)		
Poteriocrinites	C (Tour-l)	-C (Vise-l)	(906)	Strongylocrinus	C (Bash-u)	-P (Guad-u)	
+Praecipulocrinus	O (Cara-m)	-O (Ashg-m)	(1213)	Stuartwellerocrinus	C (Bash-u)	-P (Wc)	
+Premanicrinus	S (Ldov-u)	-S (Wenl-l)	(255)	Subarrectocrinus	C (Step-u)	-P (Asse)	
Prininocrinus	D (u)			Sublobalocrinus	C (Step-l)	-C (Step-u)	
Proallosocrinus	C (Bash-u)	-C (Mosc-l)		Sundacrinus	P (Leon)	-P (Guad-u)	
Proampelocrinus	C (l)			Sycoerinites	C (Vise-u)		(906)
Probletoocrinus	C (Step-l)			Synarmocrinus	C (Bash)	-C (Step-l)	(257)
Prochoidiocrinus	P (Guad-u)			Syndetocrinus	S (Ludl)		
Proctothylacocrinus	D (Give)			Synphocrinus	C (Mosc)	-P (Guad-u)?	
Proindocrinus	P (Leon-m)			+Tapinocrinus	P (Sakm)	-P (Guad-u)?	
Prolobocrinus	P (Guad-u)			+Tarachiocrinus	C (Mosc-u)	-C (Step-l)	(257)
Propoteroocrinus	D (Emsi-l)			+Tasmanocrinus	P (Sakm)		
Protenerinus	C (Mosc-l)	-P (Leon)		Telikosocrinus	C (Serp-l)		
Psilocrinus	C (Mosc-u)			Tenagocrinus	P (Guad-u)		
+Pskovicrinus	D (Fras)			Terpnoocrinus	C (Step-l)		
+Pulaskicrinus	C (Serp-l)			Tetrabrachiocrinus	P (Guad)		(244)
+Pumilindocrinus	P (Guad-u)?			Tetrapleuroocrinus	D (Eife)		
Pyndaxocrinus	C (Step-u)			Texacrinus	C (Mosc-u)	-P (Wc)	

Taxon	First Appearance	Last Appearance	Reference	Taxon	First Appearance	Last Appearance	Reference
Thalamocrinus	S (Wenl-l)	-S (Ludl-l)		+Ancoracrinus	C (Tour-l)	-C (Tour-u)	(704)
Thenarocrinus	S (Wenl)			Anisocrinus	S (Wenl)	-S (Ludl)	(261)
Thetidocrinus	P (Guad-u)			Apodactylocrinus	D (Fras)		
Tholocrinus	C (Vise-u)	-C (Serp-l)		Artichthyocrinus	C (Vise-u)		(906)
Thyridocrinus	S (Wenl-l)			Asaphocrinus	S (Wenl-l)	-S (Ludl)	
Timorechinus	P (Guad-u)			Caldenocrinus	C (Vise-u)		(906)
Trautscholdocrinus	C (Mosc)			Calpiocrinus	S (Wenl-u)	-S (Ludl)	
+Treocrinus	D (Emsi-u)			Calycocrinus	C (Bash-u)	-P (Guad-u)	
Triboloporus	O (Cara-l)			Cholocrinus	S (Wenl-u)		(259)
Tribrachyocrinus	P (Leon)	-P (Guad-u)		Cibolocrinus	C (Serp-u)	-P (Guad-u)	
Triceracrinus	C (Mosc-u)	-P (Wc)		Cleistocrinus	S (Ludl)		
Trimerocrinus	P (l)	-P (Guad-u)		Clidochirus	O (Ashg-u)	-C (Tour-u)	(2,906)
Tundracrinus	C (Mosc-u)	-P (Sakm)		+Cryptanisocrinus	S (Ldov-u)		
Tyriocrinus	C (Vise-u)	-C (Serp-l)	(257)	Dactylocrinus	D (Eife)	-C (Tour-l)	(906)
Ulocrinus	C (Mosc-l)	-C (Step-l)		Dieuryocrinus	C (Vise-l)		(906)
Ulrichocrinus	C (Vise-l)	-C (Mosc-u)		Euryocrinus	D (Give)	-C (Vise-l)	(906)
Ureocrinus	C (Vise-u)	-C (Serp-l)	(257,906)	Forbesiocrinus	D (Fame-l)	-C (Vise-l)	(906,1247)
Utharocrinus	C (Bash-l)	-C (Step-l)		Gaulocrinus	C (Vise-l)		
+Vadarocrinus	D (Sieg-u)			Geroldicrinus	D (Eife)		
Vasocrinus	D (Gedi)	-D (Give)		Honalocrinus	S (Wenl)		(261)
Vertigocrinus	C (Step-l)	-C (Step-u)		Hormocrinus	S (Wenl-u)	-S (Ludl-u)	(259)
+Wetherbyocrinus	C (Serp-l)			Iethyocrinus	S (Wenl-l)	-D (Sieg)	
Woodocrinus	C (Vise-u)	-C (Serp-l)	(906)	Lecanocrinus	S (Ldov-u)	-D (Emsi)?	
†Worthenocrinus	C (Vise-l)			+Lecocrinus	S (Wenl-u)	-D (Fras-u)	(259)
+Yakovlevicrinus	P (Leon-m)			Lithocrinus	S (Wenl-u)		
Zeacrinites	C (Vise-u)	-C (Serp-l)		Loxocrinus	P (Guad-u)		
Zeusocrinus	C (Serp-l)			Mespiocrinus	C (Tour-l)	-C (Vise-u)	(906)
Zostocrinus	D (Give-l)			Metichtyocrinus	C (Tour-u)	-C (Vise-l)	(906)
Zygotocrinus	C (Tour-u)			Miracrinus	D (Gedi-l)		

Or. ?HEMISTREPTOCRINIDA

(?Cl. Hemistreptocrinoidea Arendt, 1976)

+Hemistreptocrinus	O (Llvi)		
+Nonparactocrinus	O (Llvi)		
Paractocrinus	O (Llvi)		
Parorthocrinus	O (Llvi)		
Tetractocrinus	O (Aren-u)		

Or. TAXOCRINIDA

†Archætaetaxocrinus	O (Aren-u)	-O (Llvi-u)	(258)	Pentacrinus	J (Hett)	-J (Oxfö-u)	(1066)
Enascocrinus	C (Vise-u)	-C (Serp-l)	(906)	Pernobrachypus	P (Guad-u)		
Euonychocrinus	C (Step-l)			Petrocrinus	P (Guad-u)		
Eutaxocrinus	S (Ludl)?	-C (Tour-l)		Plagiocrinus	P (Guad-u)		
Gnorimocrinus	S (Wenl)	-S (Ludl)		+Proanisocrinus	O (Ashg-m)		(261,1213)
+Haereticotaxocrinus	S (Ludl)			Proapsidocrinus	P (Guad-u)		
Meristocrinus	S (Wenl)	-S (Ludl)		Propyllocrinus	P (Guad-u)		
Nevadacrinus	P (Sakm)		(1066)	Pycnosaccus	S (Wenl-u)	-S (Prid)	(259)
Onychocrinus	C (Tour-u)	-C (Serp-l)	(906)	Rumphiocrinus	P (Guad-u)		
Parichtyocrinus	C (Tour-u)	-C (Vise-l)		Sagenocrinites	S (Wenl-l)	-S (Ludl)	
†Peptaxocrinus	S (Ludl)			+Strobocrinus	P (Guad)		(244)
†Praeocrinus	D (Eife-u)?	-D (Give-l)	(1065)	Synaptocrinus	D (Give-l)	-D (u)	
Protaxocrinus	O (Cara-m)	-D (Gedi)		Syntomocrinus	P (Guad-u)		
Synocrinus	C (Serp-l)	-C (Mosc-l)	(906)	+Tagenocrinus	D (Give-u)		(259)
Taxocrinus	D (Eife)	-C (Serp-l)		Temnocrinus	S (Wenl-u)		
				Trampidocrinus	P (Wc)		
				+Trinalicrinus	P (Guad)		(244)
				Wachsmuthicrinus	D (Fame)?	-C (Vise-u)	(906)
				Zenocrinus	C (Bash-u)		

Or. SAGENOCRINIDA

Aexitrophocrinus	C (Mosc-l)	-C (Step-u)	
Ainacrinus	C (Vise-u)		(906)
Ammonicrinus	D (Eife)	-D (Give)	
Amphicrinus	C (Vise-u)		(906)
Ancistrocrinus	P (Guad-u)		

Or. MILLERICRINIDA

†Ailsacrinus	J (Bath)		
+Amaltheoerinus	J (Sine-u)	-J (Toar-l)	
Angulocrinus	J (Call)	-J (Kimm)	

Taxon	First Appearance	Last Appearance	Reference
Apiocrinites	J (Bath)	-K (Albi-l)	(1066)
Dadocrinus	Tr(Olen-u)	-Tr(Anis-m)	(1066)
Guettardicrinus	J (Oxfo)		
Liliocrinus	J (Bath)	-J (Kimm)	
Millericrinus	J (Sine)	-K (Vala)	(1066)
+Neodadocrinus	J (Sine-u)?, J (Plie-u)		
Orbignycrinus	J (Bath)	-J (Kimm)	
Pomatocrinus	J (l)	-J (Tith-u)	
+Shroshaecrinus	J (Sine-u)	-J (Toar)	(1066)
+Souticrinus	J (Sine-u)		

Or. CYRTOCRINIDA

+Aspidocrinus	J (Tith)	-K (Nc)	
+Bileicrinus	J (Sine-u)?, J (Plie-l)?		
Brachiomonocrinus	K (Vala-l)	-K (Barr-l)	
Calamocrinus	T (Dani)	-R	
+Capsicocrinus	J (Plie-l)		(1066)
+Coollaroocrinus	K (Nc)	-K (Apti)	
Cotylederma	J (Sine-u)	-J (Toar-l)	(934)
+Crataegocrinus	J (Bajo)?	-J (Tith)	
Cyathidium	J (Tith)	-R	
?Cyclocrinus	J (Bajo)	-K (Albi)	(2)
Cyrtocrinus	J (Oxfo)	-K (Vala)	
Dibrachioocrinus	K (Vala-l)	-K (Barr-l)	
+Dinaroocrinus	J (Toar)		
Eudesicrinus	J (Plie-l)	-J (Tith)	(1066)
Eugeniacrinites	J (Plie-l)	-K (Barr-l)	(1066)
+Fisheriacrinus	J (Bajo-l)		
Gammarocrinites	J (Call)	-K (Camp-l)	
+?Gutticrinus	J (Plie-u)		(1066)
Gymnocrinus	J (Oxfo)	-R	
Hemibrachioocrinus	K (Vala-l)	-K (Barr-l)	(1066)
Hemicrinus	J (Tith-l)	-K (Albi)	(1066)
Holopus	T (Pale)?	-R	
+Hoyacrinus	J (Kimm)		
+Labiocrinus	K (Nc)		
Lonchoocrinus	J (Bajo)	-K (Vala-l)	
+Ninocrinus	J (Bajo)		
+Paracotylederma	J (Toar)		
+Paragammarocrinites	K (Camp-l)		
Phyllocrinus	J (Bajo-l)	-K (Apti)?	(1066)
Pilocrinus	J (Call)	-K (Camp-l)	
Plicatocrinus	J (Plie)	-J (Tith-u)	(1066)
Proholopus	J (Tith)	-K (Barr-l)	
Psalidocrinus	J (Tith)	-K (Vala)	
+Quenstedticrinus	J (Sine-u)	-J (Plie-u)	(1066)
Remisovicrinus	J (Bajo)	-J (Tith)	
+Sacariaocrinus	J (Sine-u)	-J (Toar)	
+Sclerocrinus	K (Barr)		(1066)
+Strambergocrinus	K (Vala-u)		
+Turoocrinus	K (Albi-u)		(1066)
Tetracrinus	J (Sine-u)	-J (Tith-u)	
+Torynocrinus	K (Nc)	-K (Albi)	

Or. BOURGUETICRINIDA

Bathycrinus (+ Palaeobothycrinus)	T (Dani-u)	-R	(864)
Bourgueticrinus	K (Turo-l)	-T (Than-l)	(864)
Conocrinus	T (Than-l)	-R	(864)
Democrinus	K (Maes-l)	-R	(864)
Dunnicrinus	K (Maes-u)		(864)
Monachocrinus	K (Sant-u)	-R	(864)
Porphyrocrinus	T (Mi-u)	-R	

Taxon	First Appearance	Last Appearance	Reference
-------	------------------	-----------------	-----------

Or. ISOCRINIDA

Austinoocrinus	K (Apti-l)	-K (Maes)	(864)
Balanocrinus	Tr(Nori-u)	-K (Haut)	
+Buchiericrinus	K (Maes-l)	-T (Eo-l)	(576)
Cainocrinus	T (Dani)	-T (Eo)	(576)
Charioocrinus	J (Toar-l)	-J (Oxfo)	(864)
Chladocrinus	Tr(Carn)	-R	(864)
+Cenocrinus	J (Plie-l)	-R	
+Denticrinus	T (Dani)	-T (Than-l)	
+Diploocrinus	T (Eo-m)	-R	
Doreckicrinus	K (Camp-u)	-T (Dani)	(576,864)
+Echicrinus	Tr(Anis-m)	-Tr(Anis-u)	
+Hispidocrinus	J (Sine-u)	-J (Oxfo)	(864)
Holoocrinus	Tr(Olen-u)	-Tr(Carn-l)	(864,980)
Isocrinus (+ Teroocrinus, Tyroleocrinus)	Tr(Ladi-u)?	-R	(864)
Isselicerinus	K (Camp-l)?	-T (Mi-m)	(864)
+Laevigatocrinus	Tr(Anis)	-Tr(Carn-l)	(576)
+Margocrinus	J (Aale)	-J (Tith)	(576)
Metacrinus (+ Taurinoocrinus)	T (Dani)?	-R	
Moenoocrinus	Tr(Anis-l)		(864)
+Neocrinus	K (Nc)	-R	
Nielsenicrinus	K (Haut-l)	-T (Ol-u)	(864)
+Percevalicrinus	J (Oxfo-l)	-K (Haut)	(576)
+Praeisselficrinus	K (Camp-u)	-K (Maes)	(576)
+Raymondicrinus	T (Ol-l)		(576)
+Rhodanometra	J (Call)		
Seiroocrinus	Tr(Nori)	-J (Bath)?	(1066)
+Sievertsia	T (Mi-m)	-T (Plie)	
+Siliesiacrinus	Tr(Anis-m)	-Tr(Anis-u)	
+Singularocrinus	Tr(Nori-l)		(576,864)
Teliocrinus	T (Mi-l-u)	-R	
+Teroocrinus	Tr(Nori)	-K (Haut)	
+?Tulipacrinus	Tr(Carn-l)	-Tr(Rhae)	(980)
+Tyroleocrinus	Tr(Anis)	-Tr(Carn)?	
+Umboocrinus	K (Berr)		

Or. COMATULIDA

Allionia	T (Mi)		
Amphorometra	K (Ceno)	-T (Eo-l)	
Archaeometra	J (Bajo)	-K (Vala)	
asterometrid	T (Plie)	-R	
Bruennichometra	T (Dani)		
Burdigalocrinus	J (Oxfo)	-K (Berr-u)	
Coelometra	K (Vala)		
Comaster	T (Mi)	-R	
Comatulina	J (Oxfo)	-K (Coni)	
+Conoideoocrinus	K (Berr-u)		
Conometra	T (Eo)	-T (Mi)	
Cypelometra	T (Mi)		
Decameros	K (Vala)	-K (Albi)	
Discometra	T (Mi)		
+Eocomatulula	Tr(Nori)	-J (Plie-u)	(934,1066)
Glenotremites	K (Vala-u)	-K (Sant)	
+Hebeticrinus	J (Tith)	-K (Haut)	(1066)
Hertha	K (Maes)	-T (Mi)	
Heterometra	T (Eo)	-R	
Himerometra	T (Eo)	-R	
Jaekelometra	K (Camp)	-T (Dani)	
Loriolicrinus	J (Oxfo)	-K (Haut)	

Taxon	First Appearance	Last Appearance	Reference	Taxon	First Appearance	Last Appearance	Reference
Loriolometra	K (Albi)	-K (Camp)		Dolichoerinus	J (Bajo)	-J (Tith)	
Microcrinus	T (Eo)			+ Dulanocrinus	O (u)		
Nemaster	T (Eo)	-R		+ Dwortsowaerinus	O (m)	-O (u)	
Notocrinus	T (Eo-l)	-R		Edriocrinus	D (Gedi)	-D (Eife)	
Palaeantodon	T (Eo)	-Q (Plei)		+ Gemmaerinus	D (Sieg)	-D (Emsi)	
Palaeocomaster	J (Hett-l)	-J (Tith-u)	(934)	Helicoerinus	S		
Paracomatula	Tr(Nori-u)	-J (Bajo-u)	(934,1066)	Kalicocrinus	D (l)		
Placometra	K (Turo)	-T (Dain)		+ Lanternocrinus	Tr(Rhae)		
-Procormaster	J (Toar-l)			Laubeocrinus	S		
Pseudoantodon	K (Vala)	-K (Barr)		+ Leocrinus	Tr(Nori-l)	-Tr(Nori-u)	
Pterocoma	J (Tith-l)	-K (Turo)		+ Lotoerinus	Tr(Rhae)		
Remesimetra	K (Albi)	-K (Ceno)		Mitrocrinus	O (Cara-l)		
Roiometra	K (Albi-m)		(1066)	- Nasutocrinus	Tr(Nori-l)		
Schlueterometra	K (Coni)	-K (Sant)		Pachyocrinus	O (Lde)		
Semiometra	J (Bath)	-K (Maes)		Pasaloerinus	C (Tour)	-C (Vise)	
Solanocrinites	J (Bath)?	-K (Albi)	(2)	Phillipsocrinus	C (l)		
Solonaerium	J (Kimm)			+ Spriocrinus	S (Ldov-m)		(651)
Stenometa	T (Mi-l)	-R		+ Tetractocrinus	O (Llvi-u)		
Stremetra	T (Mi)	-R		Tetramerocrinites	C (Tour)		
Thiollhericrinus	J (Bath)?	-K (Haut)?	(1066)	Thuringocrinus	D (u)		
Vicetiametra	T (Eo-u)			+ Torrocrinus	D (l)		
				+ Trochocrinites	O (Cara)		
Or. UINTACRINIDA				Cl. ECHINOIDEA			
Marsupites	K (Sant-u)			Or. BOTHRIOCIDAROIDA			
Uintacrinus	K (Sant-u)?			Bothriocidaris	O (Cara-l)	-O (Ashg-m)	(239,1066)
Or. ROVEACRINIDA				Neobothriocidaris	O (Llvi-u)	-O (Ashg-m)	(328,1116)
Applinocrinus	K (Camp-u)	-K (Maes-u)	(1066)	+ Unibothriocidaris	O (Cara-l)		(239)
Discoerinus	K (Albi)	-K (Ceno)		Or. ECHINOCYSTITOIDA			
+ Hyalocrinus	K (Albi)		(1066)	Albertechinus	D (u)		(956)
Orthogonocrinus	K (Albi)	-K (Coni)		+ Aptilechinus	S (Ldov-u)		
Ossicrinus	Tr(Ladi-u)	-Tr(Carn-l)	(980)	Archaecidaris	D (Fras)?	-C (Mosc-u)	(956,1066)
Osteocrinus	Tr(Ladi-l)	-Tr(Rhae)	(1066)	Aulechinus	O (Ashg-m)		(2)
Poecilocrinus	K (Albi)	-K (Ceno)		+ Cavanechinus	D (m)		(956)
Plotocrinus	K (Albi)			Cravenechinus	C (Vise-u)		(2)
Poculicrinus	Tr(Carn-l)	-Tr(Carn-u)	(980)	Deneechinus	C (Vise-l)		(956)
Roveacrinoides	K (Turo)			Devonocidaris	D (Fras)		(956)
Roveacrinus	K (Albi)	-K (Coni)		Echinocystites	S (Ludl-l)		(1066)
Saccocoma	J (Bajo)	-K (Vala)		Ectinechinus	O (Ashg-m)		(2)
+ Scotocrinus	Tr(Anis-m)			Eothuria	O (Ashg-m)		(1066)
Somphocrinus	Tr(Carn-u)		(980)	+ Fournierechinus	C (Vise-l)		(956)
Styracocrinus	K (Albi-u)	-K (Ceno-l)		Gotlandechinus	S (Ludl-l)		(2,956)
Or. ENCRINIDA				Hyattechinus	C (Tour-l)	-C (Serp)	
+ Ainimacrinus	Tr(Ladi-u)	-Tr(Carn-l)	(980)	+ Kongielechinus	D (Give)		
- Chelocrinus	Tr(Anis)	-Tr(Carn-l)	(980)	Koninckocidaris	S (u)?		
Encrinus	Tr(Anis-l)	-Tr(Rhae)?	(2,1066)	Lepidechinoides	D (Give)		(956)
Pseudosaccocoma	J (Tith)	-K (Apti-l)?		Lepidechinus	C (Tour-l)		(956)
+ Traumatocrinus	Tr(Anis)	-Tr(Carn-l)	(980)	Lepidesthes	D (m)	-C (Pn)	
- Vostocovacrinus	Tr(Carn-l)			Lepidocentrus	D (Emsi)?	-C (Vise)	(577,956,1066)
Or. UNCERTAIN				Ledidocidaris	C (Tour-u)	-C (Vise)	(956)
Acariaeocrinus	J (Sine)			Lovenechinus	C (Tour)		(956)
+ Balearocrinus	C (Vise)			Maccoya	C (l)		
Becharocrinus	C (Bash-u)?			Meekechinus	P (u)		
+ Bihaticrinus	Tr(Nori)			Melonechinus	C (Vise-u)		(1066)
Coronocrinus	D (Gedi)			Myriastiches	S (Ludl-l)		
Cosmocrinus	D (u)			Nortonechinus	D (Fras)?		(1066)
Craspedocrinus	D (l)			Oligoporus	C (Vise-l)		(956)
+ Dazhuocrinus	S (Wenl-l)		(651)	Palaechinus	C (Tour-l)	-C (Vise)	(956)
Dicriocrinus	D (l)			Palaodiscus	S (Ludl-l)		(1066)

Taxon	First Appearance	Last Appearance	Reference
Perischocidarid	C (l)		
Perischodomus	C (Vise-l)		(956)
Pholidechinus	C (Vise-l)		
+Pholidocidarid	C (Tour)		(956)
Porechinus	D (Emsi-l)?		(1066)
Polytaxicidarid	C (Tour-u)?		(956)
Pronechinus	P (Djhu)?		(2)
Proterocidarid	C (l)	- C (Pn)	
Rhenechinus	D (Emsi-l)?		
Tornquistellus	D		
Wrightia	S (Ludl)		(2)
Xenechinus	P (Asse)		(2)
Xysteria	C (l)		

Or. CIDAROIDA

Alpicidarid	K (Haut)		
Anaulocidarid	Tr(Indu-u)	- Tr(Carn-u)	(801)
Anisocidarid	J (Bajo)		
+Austrocidarid	T (Mi)	- R	(956)
Balanocidarid	J (Bajo-l)	- K (Ceno-l)	(865,956,1043)
Caenocidarid	J (Bajo)		
+Calocidarid	T (Mi-m)	- R	(709)
Chondrocidarid	T (Ol-u)	- R	
Cidarid	R		
Cyathocidarid	K (Camp)?	- T (Eo-u)	(942)
+Delocidarid	T (Mi)		(956)
Dicycloctidarid	Tr(Carn)		(801)
Diplocidarid	J (Plie-u)	- K (Haut)	(956)
+Dorocidarid	K (Maes)	- R	(709)
Eucidarid	T (Eo-m-u)	- R	
+Fellius	T (Eo-m)	- T (Eo-u)	(709)
Goniocidarid	K (Camp)?	- R	
+Hirudocidarid	K (Albi-u)	- K (Camp-u)	(865)
Histocidarid	T (Ol-u)	- R	(956)
+Lenticidarid	Tr(Olen-u)		(801)
+Leuroctidarid (+ Glyotidudadema)	Tr(Ladi-u)		(578,801,1066)
+Levicidarid	Tr(Ladi-u)		(801)
Megacidarid	J (Toar)	- J (Bajo)	
+Megaporocidarid	Tr(Ladi-u)		(801)
+Menocidarid	T (Mi)		(956)
Merocidarid	J (Bajo)	- J (Kimm)	
+Mesodiadema	Tr(Ladi-u)	- Tr(Carn-l)	(801)
Mikroctidarid	Tr(Ladi-u)		(801)
+Minicidarid	T (Mi)		(956)
Miocidarid	P (Guad-u)	- J (Plie-u)	(709,956,1066)
+Notocidarid	T (Plie)	- R	(956)
+Oedematocidarid	K (Ceno-l)	- K (Maes)	(865)
Pachycidarid	J (Plie-u)	- J (Oxfo)	(577,956)
+Palmerius	T (Eo-u)		(709)
Paracidarid	Tr(Ladi-u)	- J (Tith-u)	(801)
Parhabdocidarid	J (u)		
+Parvicidarid	Tr(Nori)?		(1120)
+Pauocidarid	Tr(Anis-m)?	- Tr(Ladi-u)	(801)
+Phalacroctidarid (+ Anomocidarid)	K (Albi-u)	- R	(984)
Phylacanthus	J (Kimm)	- R	(577)
Plegiocidarid	J (Hett-l)	- K (Haut)	(577,801)
Plococidarid	T (Eo)		
Polycidarid	J (Bajo)	- K (Albi-l)	(865)

Taxon	First Appearance	Last Appearance	Reference
Poriocidarid	K (Apti-u)	- R	(865)
+Porocidarid	T (Tham)?	- R	(956)
Prionocidarid	K (Albi-u)	- R	(865)
Proctidarid	J (Plie)	- J (m)	
+Prophyllacanthus	K (u)	- T (Eo-u)	(709)
Rhabdocidarid	J (Plie-u)	- T (Eo-u)	(956)
Sardocidarid	K (Ceno)	- T (Mi-l)?	
+Serpianotiarid	Tr(Anis-m)	- Tr(Ladi-u)	(342,801)
Sinaecidarid	K (u)?		
Stereocidarid	K (Haut)?	- R	(865)
Stylocidarid	T (Mi)	- R	
Temnocidarid	K (Maes-l)	- R	(865)
Tetracidarid	J (m)?		
Tretocidarid	T (Mi-l-u)	- R	(709)
Triadocidarid	Tr(Ladi-u)		(801)
+Triassicidarid	Tr(Nori)		(1120)
Tylocidarid (+ Psychocidarid)	K (Albi-u)	- R	(865)
+Vinchuscanechaia	J (Sine-u)?		(1120)
Xenocidarid	D (Eife)	- D (Fras)	(2,956)
+Zardinechinus	Tr(Ladi-u)	- J (Sine)?	(801,1120)

Or. ECHINOTHURIOIDA

Araeosoma	K (Maes)?	- R	
Asthenosoma	K (Maes)	- R	
Echinothuria	K (Sant-l)	- K (Maes)	(934,942)
Pelanechinus	J (Bajo-u)	- J (Oxfo-l)	

Or. DIADEMATOIDA

Ancylocidarid	J (Oxfo)?		(956)
Centrostephanus	K (Sant-l)	- R	(934)
Diadema	K (Ceno)?	- R	
Endeodiadema	J (Call)		
Engelia	J (l)		
?Eodiadema	J (Hett-u)	- J (Toar)	(2,342)
Eosalenia	J (Plie)	- J (Oxfo-l)	(1066)
+Farquharsonia	J (Call)		(342)
Helodiadema	K (Ceno)		
Heteropedina	J (Bath)		
Kierechinus	T (Eo-l)		(801)
Macrodiadema	K (u)		
Palaeodiadema	K (Ceno)	- K (Maes)	
Pedinothuria	J (Kimm-l)?		
+Pelanoidiadema	J (Bajo-u)		
Tiaridia	K (Ceno)		

Or. PEDINOIDA

Diademopsis	Tr(Nori)	- J (Kimm)	(2,801)
Echinopedina	T (Eo-l)	- T (Eo-u)	(942)
Hemipedina	Tr(Carn-u)?	- K (Ceno)	(801,1066)
Leiopedina	T (Eo-m-l)		
Leptocidarid	J (Oxfo)		
Loriolopedina	T (Eo-l)	- T (Eo-u)	(942)
Mesodiadema	J (Toar)		
?Micropedina	K (Ceno-m)	- K (Maes)	(942,984)
Palaeopedina	J (l)	- J (Bajo)	
Pedina	J (Sine)	- T (Mi)	(956)
Phalacropedina	J (Oxfo)	- J (Kimm)	
Phymopedina	J (Bath)	- J (Tith-u)	
Pseudorthopsis	T (Eo-l)	- T (Eo-u)	(942)
Pseudopedina	J (Plie-u)	- J (Oxfo)	(956)
Sienechinus	T (Eo-m)		

Taxon	First Appearance	Last Appearance	Reference	Taxon	First Appearance	Last Appearance	Reference
Or. PYGASTEROIDA				Beletechinus	K (Sant)	-K (Maes-u)	(956)
-Atlasaster	J (Sine-l)			Circopeltis	K (Turo)	-T (Eo-u)	(942)
Pileus	J (Oxfo-l)			Codechinus	K (Apti)		
Pleiechinus	J (Plie-u)	-J (Bath)	(342,1066)	Codiopsis	J (u)	-T (Eo-u)	(942)
Pygaster	J (Plie-u)	-K (Ceno)	(956)	+Coelopleurus	K (Camp)	-R	(956)
Or. SALENIOIDA (= Calycina)				Cottaldia	K (Apti)	-K (Ceno-u)	(1043)
Aerosalenia	J (Aale)	-K (Vala)	(934)	-Cotteaudia	K (Apti)		(956)
+Eurusalenia	K (Camp-u)		(956,1066)	Diplechinus	J (Plie-u)		(956)
Glyphopneustes	K (Ceno)	-K (Maes-u)	(997)	Diplotagma	K (Camp)?	-K (Maes)	(942)
Goniophorus	J (Oxfo)	-J (Kimm)		T (Eo-m)		-T (Eo-u)	
Heterosalenia	J (Bath)	-K (Maes)	(577,942)	-Echinocephus	K (Ceno-l)	-K (Turo-l)	
Hyposalenia	J (Kimm)	-T (Dani)	(577)	Echinotiara	J (Toar-l)	-K (Maes)	(342,956)
Idiocidaris	K (Ceno)			Eurypneustes	T (Eo-l)		
+Leptosalenia	K (Apti)	-K (Ceno-l)	(984)	Gauthieria	K (Turo-l)	-T (Eo-l)	(577)
Monodiadema	J (Oxfo)			-Gauthiosoma	K (Camp-u)	-K (Maes-l)	
Polysalenia	K (Camp)		(942,1066)	Glyphocyphus	K (Ceno)	-T (Eo-m)	
Poropeltaris	J (Oxfo-m)		(1066)	Glypticus	J (Call)	-J (Tith)	
Pseudosalenia	J (Bath)		(342)	Glyptocidaris	T (Eo-l)	-R	(942)
Recrosalenia	J (Bath)?, J (Call)?			Glyptocyphus	K (Ceno-l)		
Salenia	J (Oxfo-u)	-R	(577)	Gomphechinus	K (Maes)		(577)
Salenidia	K (Albi)	-T (Eo-u)		Goniopygus	J (Tith-u)	-T (Eo-u)	(942)
Trisalenia	K (Camp)?	-K (Maes)	(942)	+Hattopsis	K (Maes-u)		
Valsalenia	K (Maes)?	-T (Dani)	(577)	Hemidiadema	K (Haut-l)	-K (Ceno)	(577,934)
Or. HEMICIDAROIDA				Hemithylus	K (Camp)?	-K (Maes)	(942)
Acrocidaris	J (Bajo)	-K (Haut)	(577)	Jacquieria	J (Toar)		
Allomma	K (Ceno-l)	-K (Ceno-m)	(1043)	J (Hett-l)		-J (Call)	(801,934)
Asterocidaris	J (Aale)	-J (Oxfo)		Lambertechinus	K (Camp)?	-K (Maes)	(942)
Cidaropsis	J (Bath)			Leioechinus	J (Bath)		(342)
Colpitiara	J (Oxfo)			Leptechinus	J (Plie)	-K (Nc)	
Diplopodia	J (l)?	-K (Ceno-u)	(2,956)	Magnosia	J (Bath-m)	-K (Ceno)	(956)
Dumbea	K (l)	-K (Albi)	(342)	Micropsis	J (Toar)?	-K (Maes-u)	
Gymnocidaris	J (Bajo)	-J (Bath-u)	(577,956)	-Murravechinus	T (Mi)		(956)
Hemicidaris	J (Plie-u)	-K (Apti)?	(956)	Narindechinus	T (Eo-m-l)		
Hemitaris	J (Bath)	-J (Tith-u)	(342)	Noetingaster	K (Maes)		
Hessotiara	J (Hett)?	-J (Oxfo-l)	(1066)	Phymechinus	J (Bajo)	-K (Maes)	(942)
Heterodiadema	K (Ceno)	-K (Camp)?		Phymosoma	J (Call)	-T (Dani)	
Hypodiadema	J (Plie-l)	-K (Vala)		Phymotaxis	K (Camp)?	-T (Ol-u)	(577,1066)
Loriolia	J (Bath-u)	-K (Nc)	(956)	Pleiocephus	J (Call)		
Microdiadema	J (Plie)			Pleurodiadema	J (Bath)	-J (Oxfo)	
Pedinopsis	K (Nc)	-K (Camp)	(942)	Polycephus	J (Bath)	-J (Oxfo)?	
Plesiocidaris	J (l)	-J (Kimm)	(2)	+Polyplocida	T (Eo)		(956)
Polydiadema	J (Plie-u)	-T (Eo)	(577)	Porosoma	K (Nc)	-T (Ol-l)?	
Pseudocidaris	J (Sine)?	-K (Ceno)?	(956)	Psephechinus	J (Toar-l)	-K (l)	
Pseudodiadema	Tr(Rhae)	-K (Ceno-m)	(577,801)	Pseudarabacia	K (Turo)		
Sphaerotiaria	J (Plie-u)	-K (Nc)		Rachiosoma	K (Ceno)	-T (Dani)	(577,956)
Tetragramma	J (Call)	-K (Turo-u)	(577,956)	Stomechinus	J (Bajo)	-T (Ol-u)?	(577)
Tiaromma	K (Ceno-l)			Stomopneutes	T (Eo-m-l)	-R	(956)
Trochodiadema	K (Turo)			Thierychinus	J (Bath-l)		
Or. PHYMOSOMATOIDA				Thylachinus	K (Camp)?	-T (Ol)	
Acanthechinus	T (Than)			Tiarechinopsis	J (Bajo)		
Acropeltis	J (Call)	-K (Berr-u)?		Triadechinus	K?	-T (Eo-m)	(577)
Acrosaster	J (Bath)			Trochalosoma	K (Camp)?	-T (Eo-u)	(577)
Actinophyma	K (Camp)?	-K (Maes)	(942)	Trochotiara	J (Plie)	-K (Ceno)	
Aeolopneustes	T (Eo-l)			-Winkleria	K (Maes)		
Arbacia	T (Ol-u)	-R		-Zeugopleurus	K (Ceno)	-K (Maes-l)?	
Arbia	T (Ol-u)	-T (Mi-l)		Or. TEMNOPLEUROIDA			
Atopechinus	J (Bath)			Ambipleurus	T (Eo-l)	-T (Eo-u)	(942,956)
Baueria	T (Than)?	-T (Eo-u)	(577,942)	Amblypneustes	T (Ol-u)	-R	(956)
				Arachniopleurus	T (Eo-l)	-T (Eo-u)	(942)
				Arbacia	T (Ol-u)	-T (Plio)	(577)
				+Asaphechinus	T (Ol-u)?	-R	(956)

Taxon	First Appearance	Last Appearance	Reference	Taxon	First Appearance	Last Appearance	Reference
Brochopleurus	T (Ol-u)	- T (Mi-u-l)		Stirechinus	T (Mi)	- R	
+ Cryptechinus	T (Mi-m)		(956)	Strongylocentrotus	T (Mi-l-l)	- R	(1066)
Desmechinus	T (Mi)	- R		Toxopneustes	Q (Plei)	- R	
Dictyopleurus	T (Eo-u)		(956)	Tripeustes	T (Mi-l)	- R	
Echinocyphus	K (Turo)			Trochoechinus	K (Ceno)?	- T (Mi)	
Echinopsis	K (u)	- T (Ol-u)	(577,956)	Zenocentrotus	T (Mi)	- R	
Erbechinus	T (Mi)	- R	(577)				
Gagara	T (Than)	- T (Ol-u)		Or. PLESIOCIDAROIDA			
Glyptechinus	K (Haut-l)	- K (u)	(934)	Tiarechinus	Tr(Ladi-u)		(801)
Goniosigma	T (Ol-l)						
Grammechinus	T (Mi)			Or. ORTHOPSIDA			
Graphopleurus	T (Mi-m)?			Brochechinus	J (Oxfo)		
Irenechinus	T (Ol-l)	- T (Mi-l)		Dubarechinus	J (Plie-u)		
Leioocyphus	K (Ceno)			Gymnodiadema	J (Bath)	- J (Call)	
Leptopleurus	T (Mi-m)		(679)	Orthocidarid	K (Vala)		
Lytechinus	T (Mi-l)	- R	(577)	Orthopsis	J (Bajo)	- K (Maes)	(2,801)
Martinechinus	T (Plio)?, Q (Plei)?			Scaptodiadema	J (Oxfo)		
+ Medoecchinus	T (Eo-m-l)		(956)				
Microcyphus	T (Mi)	- R	(577)	Or. HOLECTYPOIDA			
+ Mirechinus	T (Eo-m-l)		(956)	?Amblypgus	T (Than)	- T (Ol-u)?	(956,1066)
Opechinus	T (Eo-l)	- R	(942)	Anorthopygus	K (Ceno-l)	- K (Camp-l)?	(1043)
Paradoxechinus	T (Eo-l)	- T (Mi-m)	(942,956)	Caenholectypus	K (Apti)	- K (Maes)	(577,956, 984)
+ Pentechinus	T (Ol-u)			Camerogalerus	K (Ceno-l)	- K (Ceno-m)?	
Printechinus	T (Plio)	- R		Cluniaster	K (Haut)		
Prionechinus	T (Mi-l)	- R	(956)	Conulus	K (Nc)	- K (Maes)	(1066)
Progonechinus	T (Eo-l)	- T (Eo-u)	(942)	Coptodiscus	K (Ceno-l)	- K (Sn)	(1043)
Pseudarbacina	T (Mi-l)	- T (Mi-m)		Discholectypus	K (Albi)		
Pseudechinus	T (Plio)	- R		Discoides	K (Haut)	- K (Turo-u)	(577,956)
Pseudocentrotus	T (Mi)	- R	(956)	Dixonia	K (Ceno)	- K (Camp)	
Pseudodicoptella	T (Plio)			+ Duperieria	T (Eo-m-u)		(942)
Radiocyphus	T (Eo)			Echinogalerus	K (Ceno-l)	- K (Maes-u)	(577,956, 1043)
Salmacis	T (Plio)	- R		Echinoneus	T (Ol-u)	- R	(956)
Scolecchinus	T (Ol-u)?	- T (Mi-l)		Galerites	K (Camp)	- K (Maes-u)	(2)
Scoliechinus	T (Eo)		(577)	Globator	K (Barr)	- K (Maes)	(577,1066)
Sphaerechinus	T (Mi-l-l)	- R	(577,956)	Holectypus	J (Plie-l)	- J (Kimm-l)	(868)
+ Tatechinus	T (Eo-u)		(956)	Lanieria	K (Camp)		(956)
Temnechinus	T (Plio)			Mattsechinus	K (Sn)		
Temnopleurus	T (Mi)	- R	(577)	Metholectypus	K (Camp)?, K (Maes)?		(1066)
Temnotrema	T (Pale)	- R	(577)	Neoglobator	T (Dani)	- T (Eo-l)	(942)
Triplacidia	T (Eo-m-l)	- T (Ol-l)?	(577,956)	Pygopyrina	J (Call)	- K (Ceno)	
Zeuglopleurus	K (Ceno)	- K (Turo-l)	(956)	+ Pyrina	K (Apti)	- K (Maes)	(956)
				Rhopostoma	T (Dani)	- T (Eo-l)	
Or. ECHINOIDA				Or. OLIGOPYGOIDA			
Allocentrotus	T (Plio-l)	- R	(956)	Haima	T (Eo-l)	- T (Eo-u)	(577,934)
Atactus	T (Plio)			Microlampas	T (Eo)		
Diplosalenia	T (Eo-u)		(2)	Oligopygus	T (Eo-m-l)	- T (Eo-u)	(956)
Echinometra	T (Ol-u)	- R	(1066)	?Oxulechinus	K (Sn)		
Echinostrephus	T (Mi)	- R		?Protolampas	T (Dani)		
Echinus	T (Plio)	- R		Or. CLYPEASTEROIDA			
+ Ellipsechinus	K			Abertella	T (Mi-l)	- T (Mi-m)	
Evechinus	T (Plio)?	- R	(577)	Ammotrophus	Q (Plei)	- R	
Gracilechinus	T (Plio)?	- R	(956)	Amphiope	T (Eo-u)	- T (Mi-m)	(679)
Helicoidaris	T (Mi)	- R		Arachnoides	T (Plio)	- R	
Heterocentrotus	T (Plio)	- R		Astriclepeus	T (Mi-l)	- R	
Hypochinus	T (Eo-u)	- T (Plio)		Astrodapsis	T (Mi-m)	- T (Mi-u-u)	(577)
Isechinus	T (Mi)			Clypeaster	T (Eo-m-l)?	- R	(1066)
Nudechinus	T (Mi-m)	- R	(679)	Cubanaster	T (Eo-m-u)	- T (Eo-u)	
Oligophyma	T (Mi-m)	- T (Mi-u-l)					
Parasalenia	T (Mi-l-l)	- R					
Psammechinus	T (Mi-l-u)?	- R	(1066)				
Schizechinus	T (Mi-m)	- T (Plio)	(679)				
?Spaniocyphus	K (Vala)	- K (Maes)	(942)				

Taxon	First Appearance	Last Appearance	Reference	Taxon	First Appearance	Last Appearance	Reference
Cyamidia	T (Eo-m-l)	-T (Eo-u)	(942,956)	Thagastea	T (Eo-l)	-T (Eo-u)	(942)
Dendroster	T (Plio-l)	-R		Topocyamus	T (Than-u)		(934)
†Durhamella	T (Eo-m)	-T (Eo-u)		?Tournoueraster	T (Ol-l)		
Echinarachnius	T (Mi-m)	-R		Vaquerosella	T (Mi-l)		
Echinocyamus	K (Maes)	-R		Weisbordella	T (Eo-u)		
Echinodiscus	T (Ol-l)	-R	(1066)	-Willungaster	T (Ol-u)?, T (Mi-l)?		
Encope	T (Mi-l)	-R		Wythella	T (Eo-m-u)	-T (Eo-u)	
Eoscutella	T (Eo-u)			Or. CASSIDULOIDA			
Eoscutum	T (Eo-m)	-T (Eo-u)	(942)	†Acriaster	K (Albi-u)?		(984)
Fellaster	T (Ol-l)?	-R	(1066)	Apatopygus	T (Eo-l)	-R	(577)
Fibularia	T (Eo-l)	-R	(1066)	Archiacia	K (Vala)	-K (Ceno-u)	(1043)
Fibulaster	T (Eo-l)	-T (Eo-u)	(942)	Arnaudaster	K (Ceno-l)		(1066)
Fibulina	T (Eo-u)		(2)	Astrolampus	K (Vala)	-K (Ceno)	
Fossilaster	T (Mi-l)			Astropygaulus	K (Ceno)		(577)
Heliophora	T (Mi)	-R		Australanthus	T (Eo-u)		
†Hesperaster	Q (Plei)	-R	(956)	Bothropyneutes	J (Bath)	-J (Call)	
Hupea	T (Plio)	-R		+Calilampus	T (Eo-l)		
Heringiella	T (Eo-l)?	-T (Mi)?	(1066)	Cassidulus	K (Maes-l)	-R	(577)
Jacksonaster	T (Eo-m)	-R	(956)	Catopygus	J (Kimm)	-K (Maes)	(577,942)
Karlaster	T (Mi)			†Centropygus	J (Call)		(956)
Kewia	T (Eo-u)	-T (Plio-l)		Claviaster	K (Ceno-l)	-K (Maes-u)	(997,1043)
Laganum	T (Eo-u)	-R	(2)	Clypeanthus	K		
Lenicyamidia	T (Eo-l)			Clypeolampas	K (Camp)	-K (Maes)	
†Leniechinus	T (Eo-m)		(956)	Clypeopygus	K (Nc)	-K (Maes)	(577)
Lenita	T (Eo-m)			Clypeus	J (Bajo)	-J (Kimm)	
Leodia	T (Mi-u)	-R		+Colliclypeus	K (Albi-u)?		(984)
Mellita	T (Mi-l-u)	-R		Conoclypus	T (Eo-l)	-T (Mi-m)	(956)
Mellitella	T (Mi)	-R		Daradaster	T (Than)	-T (Eo-u)	(942,1066)
Merriamaster	T (Mi-u)	-T (Plio-u)	(577)	Domechinus	K (Maes)		
Monophoraster	T (Mi-l)			+Echinanthus	K (Maes)	-T (Eo-u)	(956)
Monostychia	T (Mi)			Echinolampas	T (Than)	-R	(577)
Mortonella	T (Eo-u)			+Eogaleropygus	J (Toar-u)		(934)
Neolaganum	T (Eo-m-u)	-T (Eo-u)		Eurhodia	T (Than)	-T (Mi-m)	(577,942,956)
Neorumphia	T (Ol-u)			Eurypetalum	K (Coni)	-K (Maes)	(942)
Nipponaster	T (Mi)	-T (Plio-l)	(956)	Faujasia	K (Albi-u)	-K (Maes-u)	(577,956)
Parascutella	T (Mi-m)		(679)	Fauraster	K (Maes)		
Parmulechinus	T (Ol-l)	-T (Mi-l)		Galeropygus	J (Toar-u)	-J (Oxfo)	(934)
-Pentedium	T (Eo-m)		(956)	Gentilia	K (Ceno-u)		(956)
Periarctus	T (Eo-m-u)	-T (Eo-u)		Gitolampas	K (Camp)	-T (Mi-m)	(956)
Peronella	T (Eo)	-R	(577)	Gongrochanus	K (Sant)		(942)
Peronellites	T (Mi)			Hardouinia	K (Turo)	-K (Maes-u)	(956)
Porpitella	T (Than)	-T (Eo-m)	(956,1066)	Hemicara	K (Maes)		(942)
Proescutella	T (Eo-m)			Hypopygurus	K (Ceno)		
Protoscutella	T (Eo-m)	-T (Eo-u)		Hypopygaster	T (Dani)	-T (Than)	
+Prowillungaster	T (Mi-l)			Ilarionia	T (Eo-l)	-T (Eo-u)	(942)
Remondella	T (Mi-u)	-T (Plio-l)		Kephrenia	T (Eo-l)	-T (Eo-u)	(942)
Rotula	T (Mi-l)	-R		†Laticlypus	J (Oxfo)		(956)
Rotuloidea	T (Mi-l-u)	-T (Plio)	(956,1066)	Lefortia	K (Sant)	-K (Maes-l)	(577,942,956)
Rumphia	T (Ol-u)	-R	(577)	+Lovenilampas	K (u)		(956)
?Runa	T (Plio-u)		(956)	Mepygurus	J (Call)		(342)
Samlandaster	T (Eo-u)			Neocatopygus	T (Than)	-T (Eo-m)	(577,942)
Sanchezella	T (Eo-u)			Nucleolites	J (Bajo-u)	-T (Eo)	(577)
Scaphochinus	T (Mi)	-R	(577)	Nucleopygus	K (Nc)	-T (Mi)	(577)
Scutaster	T (Mi-l)			Ochetes	K (Albi)	-K (Ceno)	
Scutella	T (Ol-l)	-T (Mi-u-l)	(1066)	Oolopygus	K (Ceno-m)	-K (Maes)	(577,942,1043)
Scutellaster	T (Mi-u)	-Q (Plei)		Oviclypeus	T (Eo-l)	-T (Eo-u)	(942)
Scutellina	T (Eo-l)	-T (Eo-u)	(942)	Parapygus	K (Ceno)	-K (Maes)	
Scutellinoides	T (Mi)			Petalobrissus	K (Ceno)	-K (Maes)	
Scutulium	T (Ol-l)						
Sismondia	T (Eo-l)	-T (Mi-m)	(956)				
Tarphygygus	T (Eo-m)	-T (Eo-u)	(942,956)				
Temuirachnius	T (Mi-u)						

Taxon	First Appearance	Last Appearance	Reference	Taxon	First Appearance	Last Appearance	Reference
Phyllobrissus	J (Kimm)	- K (Maes)	(577)	Ganbrirretia	T (Dani)		
Plagiochasma	K (Haut)	- T (Than-l)	(942)	+ Garummaster	T (Dani)		(942)
Platipygus	T (Mi)			+ Girallaster	K (Maes)	- T (Ol-u)	(572)
Plesiolampas	T (Than)	- T (Eo-l)?	(942)	Guettaria	K (Ceno)	- K (Maes)	
Phiolampas	K (Camp)?	- T (Plio)	(577)	Hagenowia	K (Sant-u)	- K (Maes-l)	
Pseudopygaulus	T (Than)	- T (Eo-u)	(942)	Hemipeustes	K (Camp)	- K (Maes)	
Pseudopygurus	J (Call-m)	- J (Oxfo-u)	(577,956)	Holaster	K (Berr-u)	- T (Than)	(934,942)
Pseudosorella	J (Oxfo-l)			+ Huttonechinus	T (Ol-l)		(572)
Pygaulus	K (Haut)	- K (Ceno-u)	(1043)	Infulaster	K (Turo-u)	- K (Camp)	(1242)
Pygidiolampas	K (Camp)			Iranaster	K (Camp)	- K (Maes)	
Pygopistes	K (Ceno)			Ismidaster	K (Camp)?	K (Maes)?	(1242)
Pygorhynchus	K (Vala-u)	- T (Ol-u)	(577)	Jeronia	T (Dani)		
Pygurostoma	K (Coni)	- K (Maes-u)	(942,997)	Labrotaxis	K (Albi-u)	- K (Ceno)	(956)
Pygurus	J (Bajo)	- K (Sant)	(956)	Lampadaster	K (Camp)?	- K (Maes)	(577)
Rhynchotampas	T (Than)	- R	(942)	Lampadocorys	K (Ceno)	- K (Maes)	(942)
Rhynchopygus	K (Ceno)	- R	(577)	Menuthiaster	K (Camp)?	K (Maes)?	(1242)
Santeelampas	T (Eo-l)	- T (Eo-u)	(942)	Messaoudia	K (Ceno)		
+ Stegopygus	K (Ceno)		(956)	Nordenskjoldaster	K (Ceno)		
Stigmatopygus	K (Ceno)	- T (Eo-u)		Olfaster	K (Sant)	- K (Camp)	(1242)
Studeria	T (Dani)	- R		Opisopneustes	K (Camp)	- K (Maes)	(942)
Termieria	K (Maes)	- T (Dani)	(577)	Paronaster	K (u)	- K (Maes)	(942)
Vologesia	K (Ceno)	- K (Maes)		+ Pomaster	T (Than)		(942)
Zuffardia	K (Camp)	- K (Maes-u)	(577)	+ Pourtalesia	T (Mi-m)	- R	
				Pseudananchys	K (Albi)	- K (Maes)	(577)
Or. DISASTEROIDA				Pseudholaster	K (Barr)	- K (Maes)	(714,942)
Aerolusia	K (Ne)			Pseudolfaster	K (Camp)	- K (Maes-u)	(942)
Cardiolampas	J (Tith)			Rispolia	K (Camp)	- K (Maes)	
Cardiopelta	J (Call-u)	- K (Vala)		Sanchezaster	T (Eo-u)		
Collyrites	J (Bath)	- K (Albi)	(1066)	Scagliaster	K (u)	- K (Maes)	(942)
Collyropsis	J (Oxfo)	- K (Berr)	(1242)	+ Seunaster	K (Camp)	- K (Maes)	(942)
Corthyia	K (Ne)	- K (Albi)		+ Somaliaster	K (Sn)		
Cyclolampas	J (Bajo-u)	- J (Tith)	(934)	+ Spatagoides	K (Maes)		(956)
Dialyaster	K (Vala)		(1242)	Stegaster	K (Maes-l)	- K (Maes-u)	(577)
Disaster	J (Call-l)	- K (Barr)		Stenoaster	K (Turo-u)	- K (Maes)	(714)
Grasia	J (Oxfo)			Sternotaxis	K (Turo)	- K (Maes)	(942)
Hyboclypus	J (Aale)	- J (Kimm)		Taphraster	K (Ne)		
Metaporinus	J (Call-u)	- J (Oxfo)		Tholaster	K (Maes)		
Orbignyana	J (Bajo-u)	- J (Bath)	(934)	Titanaster	T (Eo-l)	- T (Eo-u)	(942)
+ Oustechnius	J (Tith)		(1242)	Toxopatagus	K (Camp)?	- T (Mi-m)	(1066)
Proholaster	J (Tith)			Zaimoffenia	K (Ceno)		
Pygomalus	J (Sine)	- J (Call)	(1242)				
Pygorhytis	J (Bajo)	- J (Call)	(1242)	Or. SPATANGOIDA			
+ Tetraramania	K (Berr)	- K (Barr)	(1242)	Abatus	T (Dani)	- R	(1242)
Tithonia	J (Bath)	- K (Vala)	(956)	Adytaster	T (Eo-l)	- T (Eo-u)	(942)
				Agassizia	T (Eo-m-l)	- R	(343)
Or. HOLASTEROIDA				Aguyaoaster	T (Eo-m)		(343)
Aurelianaster	K (Turo)			+ Allotoxaster	J (Call)	- J (Tith)	(1242)
Basseaster	K (Maes)	- T (Dani)	(942)	+ Amoraster	T (Mi-l-u)	- T (Mi-u-l)	
+ Cardabia	T (Than)		(572)	+ Anisaser	T (Eo)	- T (Ol-u)	(1242)
Cardiaster	K (Albi-u)	- K (Maes-u)	(343,956)	Antillaster	T (Eo-m-l)	- T (Mi-u-u)	(343,956)
Cardiotaxis	K (Turo)	- K (Maes-u)	(942)	Aphelaster	K (Berr-l)	- K (Haut)	(714)
Chelonechinus	T (Mi-u)?			+ Apoxyptalum	T (Ol-u)		(1242)
Cibaster	K (Ceno)	- K (Camp)	(942)	Archaechinus	T (Eo-l)		
Corechinus	T (Dani)		(577)	Asterostoma	T (Eo-m)		(343)
+ Coryslus	T (Eo-m-u)	- T (Mi-l-u)	(572)	Atelospatangus	T (Eo-m)	- T (Mi)	(956)
Duncanaster	T (Eo-l)	- T (Eo-u)	(942)	Barnumia	K (Camp)		
Echinocorys	K (Turo-u)	- T (Eo-l)		Breynia	T (Eo-u)	- R	(577)
Entomaster	K (Camp)?	- K (Maes)	(942)	Brightonia	T (Than)		(942)
+ Galeaster	K (Maes-l)	- T (Dani)	(956,1242)	Brisaster	T (Dani)	- R	(1242)
Galeraster	T (Eo-l)	- T (Mi-l)	(942)	Brissolampas	T (Ol-u)	- T (Mi-l)?	(577)
+ Galeola	K (Camp)		(942)	Brissomorpha	T (Mi)		
				Brissopatagus	T (Eo-l)	- T (Ol-u)	(577,942)

Taxon	First Appearance	Last Appearance	Reference	Taxon	First Appearance	Last Appearance	Reference
Brissopneustes	K (Camp-u)	-T (Eo-l)	(942)	+Lutetiaster	T (Eo-l)?	-T (Mi)	(1242)
Brissopsis	T (Eo-m)	-R	(577)	Macraster	K (Apti)	-K (Ceno)	
Brissus	T (Eo-m-l)	-R	(343)	Macropneustes	T (Eo-m-l)	-R	(342)
+Cagaster	T (Mi)		(956)	Maretia	T (Eo-m-l)	-R	
+Caribbaster	T (Eo-m-l)	-T (Eo-u)	(343)	Mariania	T (Ol-u)?	-T (Mi-m)	(956)
Cestobrius	T (Eo-l)	-T (Eo-u)	(942)	Mauritanaster	T (Ol-u)		(577)
Cheopsia	T (Eo-l)	-T (Eo-u)	(942)	Mazzettia	T (Mi)		
Chuniola	T (Mi)			Megapetalus	T (Mi-u-u)		(956,1242)
Cionobrius	T (Eo-l)	-R	(942)	Megapneustes	T (Eo-l)	-T (Eo-u)	(942)
Cleistechinus	T (Mi)			Meoma	T (Eo-m-l)	-R	(343)
Coraster	K (Camp-u)	-T (Than)	(942)	Metalia	T (Eo-m-l)	-R	(956)
Cotreaucorys	K (Turo-u)	-K (Maes)	(714)	Micraster	K (Ceno-l)	-K (Maes-u)	(956,1043)
Crucibrissus	T (Eo-m)	-T (Eo-u)	(956)	Migliorinia	T (Eo-m)	-T (Mi-l)	(343)
Cyclaster	K (Camp-u)	-R	(956)	Mokotibaster	K (Maes-l)		(956)
Diplodetus	K (Sant)	-T (Eo-u)	(942)	Moira	T (Eo-l)	-R	(942)
+Diploporaster	T (Mi-l)	-R	(1242)	+Moiropsis	T (Mi)	-R	(1242)
Distefanaster	K (Maes-u)	-T (Eo-u)	(577,942,956)	Moronaster	T (Eo-l)	-T (Eo-u)	(942)
				T (Eo)			(956)
				+Mortensenaster	T (Eo)		
Ditremaster	T (Eo-l)	-T (Plio)	(956)	+Mundaster	K (Ceno-u)	-K (Turo-l)	(956,1066)
Douvillaster	K (Apti)	-K (Turo)		+Neoporaster	T (Than)		(1242)
Echinocardium	T (Ol-u)?	-R		Nipponaster	K (Camp-l)	-K (Maes-l)	(714)
Enallopneustes	K (Sant)			Nudobrius	T (Eo-u)?	-T (Mi)	(577)
Enichaster	T (Ol)			Opissaster	T (Eo-l)	-T (Plio)	(577,942)
+Epiaster	K (Barr)	-K (Ceno)	(1242)	Ornithaster	K (Camp-u)	-T (Than)	(942)
Eupatagus	T (Eo-l)	-R	(577)	+Orthaster	K (Camp)	-T (Than)	(1242)
+Faorina	T (Plio)	-R	(1242)	Ovulaster	K (Camp)	-K (Maes-l)	(942)
Fernandezaster	T (Eo-l)	-T (Ol-u)?	(577,942)	Palaeostoma	T (Eo-l)	-R	(343)
Fourtaunia	T (Eo-l)	-T (Ol-l)?	(942)	+Paleopneustes	T (Ol-u)	-R	(956)
Gibbaster	K (Camp)		(942)	Palhemaster	K (Apti)	-K (Ceno)	(1242)
+Gilfechinus	T (Eo-u)		(942,956)	Palmeraster	T (Eo-u)	-T (Ol-l)?	(577)
Gonzalezaster	T (Eo-u)			Parabrissus	T (Eo-l)	-T (Eo-u)	(942)
+Granobriusoides	T (Ol-u)			+Paraheteraster	K (Barr)	-K (Albi)	(956)
Gualtieria	T (Eo-l)	-T (Mi)	(942)	+Paraster	T (Pale)	-R	(1242)
Habanaster	T (Eo-u)		(342)	Periaster	K (Ceno-l)	-T (Eo-u)	(942,1043)
Hemiasster	K (Apti-l)	-R		+Peraspatangus	T (Mi-l)	-T (Mi-m)	
Hemifaorina	T (Mi-u)			Peribrissus	T (Mi)		
Hemigymnia	T (Dani)			Pericosmus	T (Eo-l)	-R	(2)
Hernandezaster	T (Ol-l)	-T (Mi-l)	(343,577)	Pharaonaster	T (Eo-l)	-T (Eo-u)	(942)
Herreraaster	T (Ol)			Physaster	K (Albi)	-K (Maes)	(1242)
Heteraster	K (Albi)?	-K (Ceno)	(1066,1242)	+Pictaviechinus	J (Bath)		(956)
Heterobrius	T (Mi-l)?	-R		Plagiobrius	T (Eo-m-l)	-R	
Heterolampas	K (Camp)?	-K (Maes)	(942)	Platybrissus	T (Mi)	-R	
Hikelaster	T (Mi)			Plesiaster	K (Sant)	-K (Maes)	(577)
Holcopneustes	T (Dani)	-T (Ol)	(577,1242)	Plesiopatagus	T (Eo-l)	-T (Eo-m-l)	(956)
Homoeaster	K (Camp)	-T (Than)	(942,1242)	Polydesmaster	K (Ceno)		
Homoeopetalus	T			Prenaster	T (Eo-l)	-T (Eo-u)	(956,1242)
Hypsopatagus	T (Eo)	-T (Ol)		Proraster	K (Ceno)	-K (Maes)	(942)
+Hysteraster	T (Mi-l-u)		(1242)	Prostostoma	T (Ol-u)	-T (Mi)	(577)
Isaster	T (Dani)	-T (Than)	(1242)	Protenaster	T (Eo-u)	-R	
Isomicraster	K (Ceno-l)	-K (Maes-l)	(942,956)	Protobrius	T (Dani)	-T (Than)	(942)
Isopetalum	T (Ol)			+Psephoaster	T (Eo-u)	-T (Mi-l)	
Isopneustes	T (Dani)	-T (Eo-m-l)?	(942,1066)	Pseudobrius	T (Mi)		
+Kertaster	T (Than)		(942)	Pseudogibbaster	T (Dani)	-T (Than-u)	
+Kina	T (Eo-u)	-T (Ol-u)	(1242)	+Pseudolinthia	T (Dani)		(1242)
Laevipatagus	T (Eo-l)	-T (Eo-u)	(942)	+Pseudowashitaster	K (Barr-l)	-K (Albi-l)	
Lajanaster	T (Ol-u)	-T (Mi-l)?	(343)	Pusillaster	K (Maes)		
Lambertiaster	K (Sn)			Pygospatangus	T (Eo-l)	-T (Eo-u)	(942)
Lambertona	T (Eo-l)	-T (Mi)	(343)	Radiobrius	T (Mi-m)		(679)
Leiotomaster	K (Albi)?	-K (Sn)	(577,1066)	+Rhynobrius	T (Mi-u)	-R	(956)
Leviechinus	T (Than)		(942)	Rojasia	T (Eo-l)	-T (Eo-u)	(942)
Linthia	K (Ceno)	-T (Plio)	(343,956)	Royasendia	T (Eo-u)		
Lovenia	T (Eo-m-u)?	-R	(1242)	+Savaiiaster	T (Eo)	-R	(1242)

Taxon	First Appearance	Last Appearance	Reference
Schizaster	T (Than)	-R	(577)
Schizopneustes	T (Dani)		
Semipetalion	T (Eo-u)		
+Somalechinus	K (Ceno)		(956)
Spatangomorpha	T (Eo-m)	-T (Plio)	(577)
Spatangus	T (Eo-m-l)	-R	(1066)
Stomaporus	T (Eo-l)	-T (Eo-u)	(942)
+Taimanawa	T (Eo-u)	-R	(1242)
+Tessieria	K (Maes)		(956)
Toxaster	K (Berr-u)	-K (Camp)?	(934,1242)
Trachypatagus	T (Mi-m)	-T (Mi-u-l)	(679)
+Tripylus	K (Maes-u)	-T (Dani)	(956)
Turanglaster	K (Camp)		(942)
Unifascia	T (Eo-m)		
Verbeekia	T (Eo-m)?	-T (Eo-u)	(942)
+Victoriaster	T (Mi)		(1242)
Vomeraster	K (Camp)	-K (Maes)	(1242)
Washitaster	K (Barr)	-K (Albi)	(577,1066)
+Wuarnia	T (Ol-u)		(1242)

Or. NEOLAMPADOIDA

Notolampas	T (Mi-l)	-R?	
Pisolampas	T (Eo-u)		

Or. UNCERTAIN

Besairecidaris	J (Bajo)		(956)
+Bramus	P		(956)
+Crinocidaris	Tr		(956)
Desorella	J (Oxfo)		
+Firmacidaris	J (Plie-u)	-J (Tith)?	(956)
Galeroclypeus	J (Bath)		
Heterocidaris	J (Plie-u)	-J (Oxfo)	(1066)
Infraclypeus	J (Tith)		
Lanternarius	S (Wenl)		(956)
Loriollella	J (Plie-u)		
Menopygus	J (Bajo)	-J (Oxfo-l)	
+Protocidaris	P		(956)
+Radiolus	Tr(u)		(956)
Silurocidaris	S (Ludl-l)		(2,956)
+Vernius	P		(956)

Ph. HEMICHORDATA

[Classification and basic stratigraphic ranges based on the TREATISE, Part V (2nd ed.), (1970).]

Cl. ENTEROPNEUSTA

+Megaderaion	J (Sine-l)		(623)
?incertae sedis	Cm(mMid-u)		

Cl. PTEROBRANCHIA

Or. RHABDOPLEURIDA

Cylindrotheca	S		
Graptovermis	O (Trem-u)	-O (Llvi-l)	(677)
+Kystodendron	O (Aren)	-S (u)	(527,671)
Rhabdopleura	Cm(uMid)	-R	(1059)
Rhabdopleurites	O (m)		(671)
Rhabdopleuroides	O (Llvi)	-O (Ashg)	(2,671)
Rhabdotubus	Cm(mMid-u)	-Cm(uMid-m)	(677)

Taxon	First Appearance	Last Appearance	Reference
Or. CEPHALODISCIDA			
Cephalodiscus	T (Eo-m)?	-R	(527)
Eocephalodiscus	O (Trem-u)		(527)
Pterobranchites	O (Llde)		

Cl. GRAPTOLITHINA

Or. DENDROIDEA

Acanthograptus	Cm(Trep)	-S (Ludl)?	(2)
Adelograptus	O (Trem-l)	-O (Aren-l)	
Aletograptus	O (Trem-u)		
Anisograptus	O (Trem-l)		
+Aorograptus	O (Trem-u)		(946)
+Araneograptus	O (Trem-u)	-O (Aren-l)	
+Aretograptus	O (Trem-l)		
Aspidograptus	Cm(Dres-u)	-S (Ludl-u)	(931)
Bryograptus	O (Trem-l)	-O (Trem-u)	
Callograptus	Cm(Dres-l)	-C (Serp-l)	(2)
Calyxdendrum	O (Llde-u)?		
+Choristograptus	O (Trem-u)		
Clonograptus	O (Trem-l)	-O (Aren-l)	(946)
+Coremagraptus	O (Aren)	-S (Ludl)	
+Cymatograptus	O (Aren-l)		
Dendrograptus	Cm(Dres-l)	-C (Vise)?	(2)
Desmograptus	Cm(Dres-u)	-C (Serp-l)	(931)
Dictyonema	Cm(Dres-u)	-C (Serp-l)	(2,931)
Graptolodendrum	O (Llde-l)		
+Hunnegraptus	O (Trem-u)		
Kiaerograptus	O (Trem-u)		(1066)
Korenagraptus	O (l)	-D (Sieg)	
Licnograptus	O (l)		
+Ophigraptus	D (Einsi-u)?, D (Eife-l)?		
Palaeodictyota	Cm(Dres-u)	-D (Gedi)	(931,1066)
+Paradelograptus	O (Trem-u)		
+Paratemnograptus	O (Trem-u)		(946)
Polygonograptus	Cm(Dres-u)	-S (Ludl)	(931)
Psigraptus	O (Trem-u)		
Ptilograptus	O (Aren-u)?	-S (Prid)	(1066)
Ptiograptus	S	-C (Vise)	
Radiograptus	O (Trem-l)		
+Rhabdinopora	O (Trem-l)	-O (Trem-u)	(946)
Rhipidodendrum	O (Trem)		
Sagenograptus	O (l)		
Staurograptus	O (Trem-l)		
Thallograptus	Cm(Dres-u)	-S (Ludl)	(2,931)
Triograptus	O (Trem-u)		
+incertae sedis	Cm(uMid-m)		(1066)

Or. TUBOIDEA

Calycotubus	O (Trem)		
Conitubus	O (Trem)		
Cyclograptus	S (Wenl-u)		
Discograptus	O (Ashg)		
Epigraptus (+ Idiotubus)	O (Trem-l)	-S (Ludl)	(677,870)
Fasciculitubus	Cm(u)		
Galeograptus	O (u)	-S (Wenl)	
Kozlowskitubus (+ Dentrotubus)	O (Trem)	-S (Ludl)?	
Parvitubus	O (Aren)		
Reticulograptus	O (Aren)?	-S (Wenl)	
Tubidendrum	O (Trem)		

Taxon	First Appearance	Last Appearance	Reference	Taxon	First Appearance	Last Appearance	Reference
Or. CAMAROIDEA							
Bitheticocamara	O (Trem)			+ Coronograptus	S (Ldov-l)	-S (Ldov-m)	
Cysticamara	O (Trem-l)			Corynites	O (Cara-l)	-O (Cara-m)?	(1066)
Flexicollicamara	O (Trem)			Corynoides	O (Cara-l)	-O (Cara-u)	
Graptocamara	O (Trem)	-O (Aren)?	(2)	+ Crinograptus	S (Ludl-l)		
+Syringotaenia	O (Trem)		(1066)	Cryptograptus	O (Aren-u)	-O (Cara-u)	(1066)
Tubicamara	O (Trem)			Cucullograptus	S (Ludl-l)		
Or. CRUSTOIDEA							
Bulamicrusta	O (Llde-l)	-S (Wenl-u)	(870)	Cyrtograptus	S (Ldov-u)	-S (Wenl-u)	
Ellesierusta	O (Llde-l)			Cystograptus	S (Ldov-l)		(1267)
Holmicrusta	O (Llde-l)			+ Demirastrites	S (Ldov-m)	-S (Ldov-u)	(799)
Hornograptus	O (Llde-u)			Dicaulograptus	O (Llvi-u)		
Lapworthicrusta	O (Llvi)?			Dicellograptus	O (Llvi-l)	-O (Ashg-u)	(722,1066)
Reudemannicrusta	O (Llde-l)			-Diceratograptus	O (Ashg-u)		(981)
Urbanekicrusta	S (Wenl-u)		(870)	Dichograptus	O (Aren-l)	-O (Llvi)	
Wimanicrusta	O (Llde-l)			Dicranograptus	O (Llde-u)	-O (Cara-u)	(722)
Xenocyathus	O (Cara-m)	-S (Wenl)		+ Didymograptellus	O (Aren-l)		
incertae sedis	S (Ludl)			Didymograptus	O (Trem-u)	-O (Llde-u)?	
Or. STOLONOIDEA							
?Melanostrophus	O (l)	-O (tu)?		+ Dimorphograptoides	S (Ldov-l)		(1267)
Stolonodendrum	O (Trem-u)		(677)	Dimorphograptus	S (Ldov-l)		(1267)
Or. GRAPTOLOIDEA							
Abiesgraptus	D (Gedi-l)	-D (Gedi-u)	(799)	Dinemagraptus	O (Aren-u)	-O (Llde-u)	
Abrograptus	O (Llde-l)	-O (Llde-u)		+ Diplacanthograptus	O (Cara-m)	-O (Ashg-m)	(722)
Acrograptus	O (Aren-u)	-O (Llvi-l)	(726)	Diplograptus	O (Llvi-u)	-O (Ashg-u)	(722)
+Agastograptus	S (Wenl-u)	-S (Ludl-l)	(1066)	Diversograptus	S (Ldov-m)	-S (Ldov-u)	(799)
+Agetograptus	S (Ldov-m)		(1267)	+ Eisenackograptus	S (Wenl-l)	-S (Wenl-u)	(1223)
Akidograptus	O (Ashg-m)	-S (Ldov-l)	(981)	+ Eoglyptograptus	O (Aren-u)	-O (Cara-l)?	(722)
Allograptus	O (Aren-u)			+ Euclimacograptus	O (Ashg-m)		
Amphigraptus	O (Llde-u)	-O (Cara-u)		+ Exigraptus	O (Aren-u)		(1229)
Amplexograptus	O (Llde-l)	-O (Ashg-u)	(722)	+ Geitonograptus	O (Llde-u)		
Anomalograptus	O (l)			+ Geniculograptus	O (Cara-l)	-O (Ashg-m)	(722)
Anthograptus	O (Aren-l)			Glossograptus	O (Aren-u)	-O (Cara-l)	(1229)
+ Apiograptus	O (Aren-u)			Glyptograptus	S (Ldov-l)	-S (Ldov-u)	(1066,1267)
Arachniograptus	O (Ashg-m)		(981)	Goniograptus	O (Aren-l)	-O (Llvi-l)?	
+ Archielimacograptus	O (Aren-u)	-O (Cara-m)	(722)	Gothograptus	S (Ludl-l)		(1223)
Archiretiolites	O (Cara-u)		(722)	Gymnograptus	O (Llde-l)		(722)
+ Arienigraptus	O (Aren-u)	-O (Llvi-u)	(1229)	Hallograptus	O (Aren-u)	-O (Cara-l)	
+ Arnheimograptus	O (Cara-u)	-O (Ashg-m)	(722)	+ Hirsutograptus	S (Ldov-l)		(1267)
+ Atavograptus	O (Ashg)	-S (Ldov-m)	(799,1066)	Holmograptus	O (Aren-u)	-O (Llvi-l)?	
Atopograptus	O (Llvi)			Holograptus	O (Aren)		
Aulograptus	O (Llvi-l)?			Holoretiolites	S (Ludl-l)	-S (Ludl-u)	(799,1223)
Averianowograptus	S (Wenl-l)			+ Hustedograptus	O (Llvi)	-O (Cara-l)	(722,1066)
Azygograptus	O (Aren-l)	-O (Llde-u)?	(311)	Isograptus	O (Aren-u)	-O (Llvi-u)	
Barrandograptus	S (Ldov-m)	-S (Wenl-l)	(799)	Janograptus	O (Llvi-u)	-O (Llde)	
+ Bergstroemograptus	O (Llvi-l)	-O (Llvi-u)	(1229)	Joamgsjamotes	O (Llde-u)?		
+ Bohemograptus	S (Ludl-l)	-S (Ludl-l)		+ Kalpinograptus	O (Llde-l)	-O (Cara-l)	(1229)
Brachiograptus	O (Llvi)			Kinnegraptus	O (Aren-u)		
Calamograptus	O (l)			+ Lagarograptus	S (Ldov-l)	-S (Ldov-m)	(799)
Cardiograptus	O (Aren-u)	-O (Llvi-l)		Lasiograptus	O (Cara-l)	-O (Cara-m)	(722)
Cephalograptus	S (Ldov-m)		(1267)	+ ?Laxograptus	O (Aren-l)		
Climacograptus	O (Aren-u)	-O (Ashg-u)	(1066)	Leptograptus	O (Llde-u)	-O (Ashg-m)	(722,981)
-Clinoclimacograptus	S (Ldov-l)	-S (Ldov-m)	(722,799,1267)	+ Limpidograptus	S (Ldov-l)		
-Colonograptus	S (Ludl-l)		(799)	Linograptus	S (Ludl-l)	-D (Gedi-u)	
-Comograptus	S (Ldov-l)	-S (Ldov-m)	(1267)	+ Lobograptus	S (Ludl-l)		(799)
				Loganograptus	O (Aren-l)	-O (Llvi)	
				Lonchograptus	O (Llvi-u)		
				Maecandrograptus	O (Aren-u)		
				+ Metabrograptus	O (Llde-u)	-O (Cara-l)?	(1066)
				+ Metaclimacograptus	S (Ldov-l)	-S (Ldov-u)	(722,1267)
				Mimograptus	O (l)		
				Monoclimacis	S (Ldov-m)	-S (Ludl-l)	(799)
				Monograptus	S (Ldov-m)	-S (Ludl-l)	(799)
				Nanograptus	O (Llde-u)		
				Nemagraptus	O (Llde-l)	-O (Cara-l)	

Taxon	First Appearance	Last Appearance	Reference	Taxon	First Appearance	Last Appearance	Reference
+Neocolonograptus	S (Ludl-u)	-S (Prid)		Rhaphidograptus	S (Ldov-l)	-S (Ldov-m)	
+Neocucullograptus	S (Ludl-u)			+Rivagraptus	S (Ldov-l)	-S (Ldov-m)	(1267)
+Nediceillograptus	S (Ldov-l)	-S (Ldov-m)	(1267)	Sactograptus	S (Ludl-l)	-S (Prid)?	(799)
+Neodiplograptus	S (Ldov-l)		(1267)	Schizograptus	O (Aren-l)	-O (Aren-u)	(1075)
Neodiversograptus	S (Ludl-l)			+Semiplectograptus	S (Ludl-l)		(1223)
+Neogothograptus	S (Ludl-l)			Sigmagraptus	O (Aren-l)?		
+Neolobograptus	S (Ludl-u)			Sinodiversograptus	S (Ldov-m)	-S (Ldov-u)	
Neograptus	O (Cara-m)	-O (Ashg-m)	(722)	Sinograptus	O (Llvi-l)		
Nicholsonograptus	O (Llvi-l)			+Sinoreteograptus	O (Ashg-l)		(981)
+Normalograptus	O (Ashg-l)	-S (Ldov-u)	(1267)	Sinotomatograptus	S (Ldov-u)	-S (Wen-l)	(799)
Nymphograptus	O (Ashg-l)	-O (Ashg-m)	(722,981)	Skiagraptus	O (Aren-u)		
+Oelandograptus	O (Aren-u)	-O (Llvi-l)	(722)	+Sokolovograptus	S (Wen-l)	-S (Wen-u)	(1223)
Oncograptus	O (Aren-u)			Spinograptus	S (Ludl-l)		
Orthograptus	O (Llde-u)	-O (Ashg-m)	(722)	Stellatograptus	O (Aren-u)?		
Orthoretiolites	O (Cara-u)	-O (Ashg-l)	(722)	+Streptograptus (+ Globosograptus)	S (Ldov-u)		
Osoagraptus	O (Aren-u)			Stromatograptus	S (Ldov-u)	-S (Wen-u)	(799)
+Paracilmacograptus	S (Ldov-l)	-S (Ldov-m)?	(722)	+Sudburigraptus	S (Ldov-l)	-S (Ldov-m)	(1267)
Paraglossograptus	O (Aren-u)	-O (Llvi-l)		Syndyograptus	O (Llde)?		
+Parakidograptus	S (Ldov-l)		(722,1267)	+Tangyagraptus	O (Ashg-m)		(981)
+Paraothograptus	O (Ashg-m)		(722)	+Temnograptus	O (Aren-l)		
+Parapetalolithis	S (Ldov-m)	-S (Ldov-u)	(1267)	Tetragraptus	O (Aren-l)	-O (Llvi-l)	(1066)
Paraplectograptus	S (Wen-l)	-S (Wen-u)	(1223)	Thamnograptus	O (Aren-l)	-O (Llde-u)	(311,1075)
+Paraplegmatograptus	O (Ashg-l)	-O (Ashg-m)		Trianograptus	O (Aren-l)	-O (Aren-u)	
+Pararetiograptus	O (Ashg-m)		(981)	Trichograptus	O (Aren-l)	-O (Llvi)	
Parazygograptus	O (l)			Trochograptus	O (Aren-u)		
Peiragraptus	O (Ashg-m)		(722)	Tylograptus	O (Aren-u)	-O (Llvi-l)	
+?Pendeograptus	O (Aren-l)			+Uncinatograptus	S (Ludl-u)		
Petalograptus	S (Ldov-l)	-S (Ldov-u)	(722)	+Undulograptus	O (Aren-u)	-O (Llvi-l)	(722)
+Petalolithis	S (Ldov-m)	-S (Ldov-u)	(1267)	+Uralograptus	S (Wen-l)		(799)
Phormograptus	O (Cara-u)?	-O (Ashg-m)	(981)	+Urbanekograptus	O (Llde-u)		(722)
Phyllograptus	O (Aren-l)	-O (Aren-u)		+Xiphograptus	O (Aren-l)	-O (Aren-u)	
Pipigraptus	O (Cara-u)		(722)	+Yangziograptus	O (Ashg-m)	-O (Ashg-u)	(981)
+Plectodinemagraptus	S (Ludl-u)		(1223)	+Yinograptus	O (Ashg-l)	-O (Ashg-m)	
Plectograptus	S (Ludl-l)		(1223)	Yushanograptus	O (Aren-u)		
Plegmatograptus	O (Ashg-l)	-O (Ashg-m)	(981)	+Yutagraptus	O (Aren-u)		
Pleurograptus	O (Cara-u)	-O (Ashg-m)	(981)	Zyagraptus	O (Aren)	-O (Llvi)?	
+Pribylograptus	S (Ldov-l)	-S (Ldov-m)	(799)				
Pristiograptus	S (Ldov-m)	-S (Prid)	(799)				
+Prolasiograptus	O (Llvi-u)	-O (Llde-l)	(722)				
+Pseudamplexograptus							
	O (Llvi-u)	-O (Cara)	(722,1066)				
+Pseudazygograptus	O (Llde-u)			Acanthastus	O (Trem)		
+Pseudisograptus	O (Aren-u)		(1229)	Acellograptus	Cm(Dres-u)		(931)
Pseudobryograptus	O (Aren-l)	-O (Llvi-l)		+Archaeodictyota	Cm(Dres-u)	-O (Trem-u)?	
Pseudoclimacograptus				Ascograptus	S (Wen-l)		
	O (Llvi)	-O (Ashg-m)	(981,1075)	Cactograptus	S (Ldov-u)		
Pseudodichograptus	O (Aren-u)			Ceramograptus	O (u)		
+Pseudoglytograptus	S (Ldov-l)	-S (Ldov-m)	(722,1267)	Chaunograptus	Cm(mMid)	-D (Gedi)	(2)
+Pseudoisograptus	O (Aren-l)	-O (Llvi-l)	(1066)	Coelograptus	S (Wen-l)?		
+Pseudomonoclimacis	S (Ludl-u)			Crinocaulis	S (Ldov)		
+Pseudoplectograptus	S (Wen-l)		(1223)	Dithecodendrum	Cm(uMid)		
Pseudoplegmatograptus				Graptoblastoides	O (Trem)	-O (Llde)	
	S (Ldov-u)			Graptoblastus	O (Trem)		
+Pseudoretiolites	O (Ashg)	-S (Ldov-m)	(799,1066)	Haplograptus	Cm	-O	
+Pseudorthograptus	S (Ldov-l)	-S (Ldov-u)	(1267)	Leveillites	S (Ldov)		
Pseudotrigonograptus				Mastigograptus	Cm(Dres-u)	-S	(931)
	O (Aren-u)		(726,1066)	Palmatophycus	S (Wen-l)		
Pterograptus	O (Aren-u)	-O (Llde-u)	(311)	+Pillograptus	Cm(Fran-l)?		
Rastrites	S (Ldov-m)	-S (Ldov-u)		Ruedemannograptus	O		
Reteograptus	O (Llde-l)	-O (Cara-l)	(311)	Siberiodendrum	Cm(m)	-Cm(u)	
Retiolites	S (Ldov-u)	-S (Ludl-l)	(799)	Siberiograptus	Cm(u)		
				+Siryngotaepia	O (Trem-u)		

Or. UNCERTAIN

Taxon	First Appearance	Last Appearance	Reference	Taxon	First Appearance	Last Appearance	Reference
Ph. CHORDATA				-Cahabagnathus	O (Llde-l)	-O (Cara-l)	(867)
Cl. CONODONTA				Cambroistodus	Cm(Trep-l)	-Cm(Trep-u)	
[Classification and basic stratigraphic ranges based on the TREATISE, Part V (Suppl. 2), (1981) and Sweet (1988).]				Capricornognathus	C (Vise-l)		(867)
Or. ?PARACONODONTIDA				-Carinella			
Albiconus	O (Trem-l)			Carinodus	S (Ldov-u)	-S (Wenl-l)	(800,867)
Furnishina	Cm(mMid-u)	-O (Trem-l)	(2)	Cavusgnathus	C (Tour-l)	-C (Serp-l)	(315,800)
Hertzina	Cm(m)?	-Cm(Fran-l)	(2,312)	Chirodella	Tr(Anis-l)	-Tr(Nori-l)	(674,800)
+Heterodontoides	Cm(u)			Chirognathus	O (Llde-l)	-O (Cara-u)	(2,800)
Muellerodus	Cm(m)	-Cm(Dres-u)		Chosonodina	O (Trem-u)	-O (Llvi)	(1066)
Nogamiconus	Cm(m)	-O (Trem)		Clavohamulus	O (Trem-l)	-O (Trem-u)	(867)
Proacodus	Cm(m)	-O (Trem)		Cloghergnathus	C (Vise-l)		(867)
Problematoconites	Cm(Trep-l)	-O (Trem-l)		Clydagnathus	D (Fame-u)	-C (Tour-l)	(867)
Proneotodus	Cm(m)?	-O (Trem-u)		Coeloceroodontus	O (Llvi-u)	-O (Cara-u)	(313,800)
Prosagittodontus	Cm(Fran-l)	-O (Trem)		+Coleodus	O (Llvi-l)	-O (Cara-l)	(800)
Proscandodus	Cm(u)			+Complexodus	O (Llde-l)	-O (Cara-l)	(867)
Westergaardodina	Cm(mMid-u)	-O (Llde)		Cordylodus	Cm(Trep-u)	-O (Trem-u)	(800)
Or. CONODONTOPHORIDA				Cornuodus	O (Trem)	-O (Ashg)	(1066,1116)
Acanthocordylodus	O (Cara-l)	-O (Cara-u)	(800)	Coryssognathus	S (Ludl)		
Acanthodina	O (Ashg)		(800)	-Cristodus	O (Aren-l)		(800)
Acanthodus	O (Trem-l)	-O (Trem-u)	(800)	Cryptotaxis	D (Fame-u)		
Adetognathus	C (Serp-l)	-P (Sakm-u)	(867)	+Ctenognathodus*	S (Ldov-l)?	-S (Wenl-u)	(800,1066)
Aethotaxis	C (Serp-l)	-C (Step-u)	(800)	+Culumbodina	O (Llde-u)	-O (Ashg-l)	(313,800)
+Algherella	Tr(Ladi)		(800)	Coeloceroodontus	O (Llvi-u)	-O (Cara-m)	(313,800)
+Alternognathus	D (Fame-m)		(867)	Cypridodella	Tr(Olen-l)	-Tr(Rhae)	
Amorphognathus	O (Aren-u)	-O (Ashg-u)	(800)	Dapsilodus	O (Llde-u)	-D (Gedi)	(313,1066)
+Amydrotaxis	D (Gedi-l)	-D (Sieg-l)	(800)	-Declinognathodus	C (Serp-u)	-C (Mosc-l)	(800,867)
Anastrophognathus	Tr(Anis-l)		(800)	-Decoriconus	O (Cara-u)	-D (Gedi)	(800,1066)
Ancoradella	S (Ludl-l)	-S (Ludl-u)		+Denticodina	S (Ldov-u)	-D (Gedi-l)	(800)
Ancyrodella	D (Give-u)	-D (Fras-u)		Dichodella	O (Ashg)		
Ancyrodelloides	D (Gedi-u)		(800)	Diplododella	D (Fame-u)		
Ancyrognathus	D (Fras-m)	-D (Fame-l)	(867)	Diplognathodus	C (Vise)	-P (Dora)	(867,1066)
Ancyrolepis	D (Give-u)	-D (Fame-l)	(800)	+Dischidognathus	O (Aren-u)	-O (Llvi-u)	(800)
Angulodus	D (Fame)?	-C (Vise-l)	(315)	Distomodus	S (Ldov-l)	-S (Wenl-l)	(800,867)
+Ansellia	O (Llvi-l)	-O (Cara)?	(867)	Doliognathus	C (Tour-u)	-C (Vise-l)	(315)
Antognathus	D (Fame-u)			Dollymae	C (Tour-l)	-C (Tour-u)	(867)
Apatella	D (Fame-u)			Drepanodus	O (Trem-u)	-O (Cara-m)	(800,867, 1116)
Apatognathus	D (Fame-m)?	-C (Vise-u)?	(315,800)	Drepanoistodus	O (Trem-u)	-O (Ashg-u)	(313)
Aphelognathus	O (Cara-m)	-O (Ashg-u)	(313)	+Dvorakia	S (Prid)	-D (Eife-u)	(314,800)
Appalachignathus	O (Llde-u)	-O (Cara-l)	(313)	Ellisonia	C (Bash-u)	-Tr(Nori-u)?	(800,867)
Apsidognathus	S (Ldov-u)	-S (Wenl-l)	(800)	Ellsonella	D (Fras)		
Archaeognathus (+ Yongquistina)	O (Cara-l)		(316)	+Elmbaysgnathus	C (Vise-l)		(800)
+Aspeliindia (+ Pseudolonchodina)	S (Ldov-u)	-S (Wenl-l)	(800)	+Eocarniodus	O (Ashg-l)	-O (Ashg-m)	(800)
Astropentagnathus	S (Ldov-u)		(800,867)	Eoconodontus	Cm(Trep-l)	-O (Trem-l)	(867)
Aulacognathus	S (Ldov-u)		(800,867)	Eognathodus	D (Sieg-l)	-D (Give-l)	(800)
+Axiothea	Tr(Rhae)		(1066)	Eoplacognathus	O (Aren-u)	-O (Cara-l)	(313)
Bactrognathus	C (Tour-u)		(867)	Eotaphrus	C (Tour-l)	-C (Vise-l)	(867)
+Baltoniodus	O (Aren-l)	-O (Ashg-l)	(867)	Epigondolella	Tr(Ladi-u)	-Tr(Nori-u)	(800)
Belodella	S (Ldov)	-D (Fras-m)?	(800,867)	+Erika	D (Gedi)		(800)
Belodina	O (Llvi-l)	-O (Ashg-u)	(800)	Erismodus	O (Llde-l)	-O (Cara-m)	(800,867)
Bergstroemognathus	O (Aren-l)		(867)	Erraticodon	O (Aren-u)	-O (Llde-l)	(800)
+Besselodus	O (Llvi-u)	-O (Ashg-m)	(800)	Eupriododina	D (Fras-m)		
Bispathodus	D (Fame-m)	-C (Vise-u)?	(867)	Evencodus	O (Llde-l)	-O (Llde-u)	(800)
Branmelhia	D (Fame-u)	-C (Tour-l)	(800)	+Fahraeusodus	O (Aren)		(1066)
Bryantodina	O (Llde-l)	-O (Cara-u)	(313,800)	Fryxellodontus	Cm(Trep)	-O (Aren-l)	(800)
Bryantodus	D (Fras-m)	-C (Mosc-u)	(315)	+Fungulodus	D (Fame-u)		(800)
Caenodontus	P (Guad-l)	-P (Guad-u)	(1066)	Furnishius	Tr(Olen-l)		(867)
				+Gamachignathus	O (Ashg-m)	-O (Ashg-u)	(800,867)
				Geniculatus	C (Vise-l)	-C (Serp-l)	(315)
				Gladjiodolella	Tr(Anis-l)	-Tr(Carn-l)	(867)
				+Glyptoconus	O (Trem-u)	-O (Llvi-u)	(800)
				Gnathodus	C (Tour-l)	-C (Serp-l)	(315,800)

Taxon	First Appearance	Last Appearance	Reference	Taxon	First Appearance	Last Appearance	Reference
Gondolella	C (Mosc-u)	-C (Step-u)	(800)	+Neomultioistodus	O (Aren-u)	-O (Llvi-l)?	(867)
+Granatodontus	Cm (Trep)?		(1066)	Neopanderodus	D (Emsi)	-D (Give-u)	
Hadrodontina	Tr(Olen-l)	-Tr(Olen-u)		Neospathodus	Tr(Indu-u)	-Tr(Ladi)	(800,867)
Hamarodus	O (Cara-u)	-O (Ashg-u)	(867)	Neosireptognathodus	P (Leon-l)	-P (Guad-l)	(800,867)
Hemilistrona	D (Fame-u)			Nericodus	O (Trem-u)		(800)
Hibbardella	D (Eife-l)	-D (Fame-u)	(800)	+Nicoeraella	Tr(Anis-m)	-Tr(Carn-l)	(867)
Hindeodelloides	C (Tour-l)			Nodognathus	C (Tour-l)		
Hindeodina	D (Fame-m)	-C (Serp-l)	(315)	Nordiodus	O (Ashg-m)		
Hindeodus	C (Tour-l)	-Tr(Indu-u)	(867)	Oelandodus	O (Aren-l)		(867)
Hirsutodontus	Cm (Trep-u)	-O (Trem-l)		Oepikodus	O (Aren-l)	-O (Aren-u)	(867)
Histiodella	O (Aren-u)	-O (Aren-u)	(800,867, 1066)	Oistodella	O (Llvi-l)	-O (Llde-l)	(800)
+Homoiragnathus	P (l)		(867)	Oistodus	O (Trem-l)	-O (Llvi-l)	(800,867)
+Huddella	S (Wenl-u)		(800)	Oligodus	C (Tour-l)		
+Iapetognathus	O (Trem-u)		(867)	Oneotodus	Cm(mMid-u)?	-O (Trem-u)	(213,313, 800)
Icriodella	O (Llvi)	-S (Wenl-l)	(867,1066)	Oulodus	O (Cara-l)	-D (Emsi)	(800,1066)
Icriodus	S (Prid)	-D (Fame-u)		Ozarkodina	O (Cara-u)	-D (Fras-l)	(867)
+Icriospathodus	Tr(Olen-u)			Pachycladina	Tr(Olen-l)		(800)
Idiognathodus	C (Bash-l)	-C (Step-u)	(315,800)	Palmatolepis	D (Give-u)	-D (Fame-u)	(867)
Idiognathoides	C (Serp-u)	-C (Mosc-u)	(315,800)	Paltodus	O (Trem-u)	-O (Aren-l)	(867)
Idiopriionodus	C (Vise-u)	-C (Step-u)	(867)	Panderodus (+ Pseudopanderodus)			
Iranognathus	P (Dora)		(867)		O (Aren-u)	-D (Give-u)	(800)
Isarcicella	Tr(Indu-l)		(867)	Pandorinellina	D (Gedi-u)	-C (Tour-l)	(800)
Istorinus	O (Ashg)		(800)	Parabelodina	O (Ashg)		(800)
Johnognathus	S (Ldov-u)	-S (Wenl-l)		Parachirognathus	Tr(Olen-l)	-Tr(Olen-u)	(2,800)
Juanognathus (+ Aurilobus)				Paracordylodus	O (Trem-u)	-O (Aren-l)	(867)
	O (Trem-u)	-O (Llvi-l)	(800)	+Parapaltodus	O (Llvi)		(1066)
+Jumudontus	O (Aren-l)	-O (Aren-u)	(313,867)	+Parapriionodus	O (Aren-u)		(800)
Kimognathus	D (Sieg-l)			+Paraserratorgnathus	O (Aren-l)		(800)
Kladognathus (+ Lambdagnathus, Magnilaterella)				Paroi-stodus	O (Trem-l)	-O (Llvi-l)	(867)
	C (Tour-u)	-C (Serp-l)	(315,800)	+Parutabonus	O (Trem-l)		(800)
+Klapperina	D (Give-u)		(800,867)	Patrognathus	D (Fame-u)	-C (Tour-u)	
Kockella	S (Ldov-l)	-S (Ludl-u)	(867)	Pavlovites	P (Leon-m)		
+Latericriodus	S (Prid)	-D (Sieg-l)	(867)	Pedavis	S (Ludl-u)	-D (Sieg-l)	
Laterignathus	S (Prid)	-D (Give-u)	(867)	Pelekysgnathus	S (Ludl-u)?	-D (Fame-u)	(867,1066)
+Laurentoscandodus	O (Trem-u)?			Periodon	O (Aren-l)	-O (Cara-u)	(313,867)
Lenodus	O (Aren-l)	-O (Aren-u)	(1116)	Phragmodus	O (Aren-u)	-O (Ashg-u)	(313,800, 867,1116)
Leptochirognathus	O (Aren-u)	-O (Llde)	(800,867, 1066)	Pinacognathus	C (Tour-l)		
+Leutorhinion	O (Trem-u)?			Platyvillosus	Tr(Olen-l)	-Tr(Olen-u)	(867)
Ligonodina	D (Fras-m)	-D (Fras-u)	(800)	Playfordia	D (Fras-l)		(800)
+Lochricia (+ Paragnathodus)				Plectodina	O (Aren-u)	-O (Ashg-m)	(2)
	C (Vise-l)	-C (Serp-u)	(867)	Plegagnathus	O (Cara-u)	-O (Ashg-u)	(800)
Lonchodina	D (Fras-m)	-C (Serp-l)		Polonodus	O (Aren-u)	-O (Ashg-m)	(800)
Loxodus	O (Trem-l)	-O (Trem-u)		Polygnathellus	D (Fras-m)?		(800)
Macerodus	O (Trem-u)		(800,867)	Polygnathoides	S (Ludl-l)	-S (Ludl-u)	(867)
Mehlina	D (Fras-l)	-C (Tour-l)	(800,867)	Polygnathus	D (Sieg-u)	-C (Vise-l)	(867)
+Merrillina	P (Guad-u)	-P (Djh)	(800)	Polylophodonta	D (Fame-l)		(800,867)
Mesotaxis	D (Give-u)	-D (Fras-u)	(867)	Polyplacognathus	O (Cara-m)	-O (Cara-u)	(867)
Mestognathus	C (Tour-l)	-C (Serp-l)	(867)	+Pranognathus	S (Ldov)		(1066)
Metapriionodus	D (Fame)?	-C (Tour-l)		+Prattognathus	O (Llvi-u)		(800)
Microzarkodina	O (Aren-l)	-O (Llvi-l)	(867)	Pravognathus	O (Llde-u)	-O (Cara-l)	(800)
+Misikella	Tr(Nori-u)	-Tr(Rhae)	(800,867)	Priionidina	D (Fras-m)?		(800)
+Mitrellotaxis	D (Fame-u)		(800)	Priionodus	O (Trem-u)	-O (Llvi-l)	(867,1066)
Mixoconus	O (Cara-l)		(800)	Pristognathus	O (Ashg-l)	-O (Ashg-m)	(800)
Monocostodus	O (Trem-l)	-O (Trem-u)		Proconodontus	Cm(Dres)	-O (Trem-l)	
Mosherella	Tr(Carn-l)		(800,867)	Protognathodus	D (Fame-u)	-C (Tour-u)	(867)
Multioistodus	O (Aren-u)	-O (Llde-u)	(800)	Protopanderodus	O (Aren-l)	-O (Ashg-m)	(800,867)
+Neocaviteilla	Tr(Carn)		(800)	Protopriionodus	O (Aren-l)	-O (Aren-u)	(800,867)
+Neocoleodus	O (Cara-l)		(1066)	Pseudobelodina	O (Cara-l)	-O (Ashg-m)	(313)
Neognathodus	C (Bash-l)	-P (Asse)?	(800)	Pseudofurnishius	Tr(Ladi-l)	-Tr(Carn-l)	(800,867)
Neogondolella	C (Bash-u)	-Tr(Carn-u)	(800,867)	Pseudooneotodus	O (Llvi-u)	-D (Sieg)	(800,1066)

Taxon	First Appearance	Last Appearance	Reference	Taxon	First Appearance	Last Appearance	Reference
Pseudopolygnathus	D (Fame-m)	-C (Tour-u)	(315,867)	Xaniognathus	P (Leon-u)	-Tr(Nori-l)	(800)
+ Pseudosweetognathus	P (Leon-l)			+ Yaooxiognathus	O (Cara-m)?	-O (Ashg-l)	(867,1116)
Pteractiodus (= Trigonodus, Triangulodus)	O (Trem-u)	-O (Cara-m)	(867)	CHORDATA			
Pteropathodus	S (Ldov-u)	-S (Wenl-l)	(867)	[Classification and basic stratigraphic ranges based on Romer (1966).]			
Ptilognathus	C (Serp)?			Cl. CEPHALOCHORDATA (= Acrania)			
Pygodus	O (Llvi-u)	-O (Cara-l)	(867)	Pikaia	Cm(mMid-u)		(449)
Rabeignathus	P (Leon-u)		(800)	+ Palaeobranchiostoma	P (l)		(1066)
Reutterodus	O (Aren-l)		(800,867)	+ ?Yunnanozoon	Cm(Atda-u)		(1226)
Rhachistognathus	C (Vise-u)	-C (Step-l)	(867)	Cl. TUNICATA (= Ascidiacea)			
Rhipidognathus	O (Aren-u)	-O (Ashg-m)	(800)	+Cystodytes	T (Eo-l)	-R	(767)
Rhodalepus	D (Fame-u)		(800)	+ Micrasieites	T (Eo-m-l)	-R	(767)
Rhodesognathus	O (Llde)	-O (Ashg-l)	(867,1116)	+ Permosoma	P (Leon-u)		(1066)
+ Rossodus	O (Trem-u)		(867)	Cl. CEPHALASPIDOMORPHI			
+ Rotundacodina	S (Ldov-l)	-S (Prid)	(867)	Or. CEPHALASPIDIFORMES (= Osteostraci)			
Roundya	C (Serp)?	-C (Bash)		+ Aachenaspis	S (Prid)		(1066)
Sagittodontina	O (Llvi)	-O (Ashg-m)	(867,1116)	+ Darmuthia	S (Ludl-l)		(672,1066)
Sannemannia	D (Gedi-u)	-D (Give-u)	(800)	+ Didymaspis	S (Prid)	-D (Gedi)	(1066)
+ Scabbardella	O (Cara-l)	-O (Ashg-m)	(800)	+ Fieldingaspis	D (Gedi-l)		(1066)
Scalioognathus	C (Tour-u)	-C (Vise-l)	(315)	+ Illemoraspid	D (Give)?		
Scalpellodus	O (Trem-u)	-O (Cara-u)	(800)	+ Oeselaspid	S (Wenl-u)	-S (Ludl-l)	(672,1066)
Scaphignathus	D (Fame-m)		(867)	+ Procephalaspis	S (Ludl)		(1066)
Schmidtognathus	D (Give-u)		(867)	+ Saaremaaspis	S (Wenl-u)?		(672)
+ Schopfodus	O (Cara-l)	-O (Cara-m)		+ Sclerodus	S (Wenl-u)	-S (Prid)	
Scolopodus	O (Trem-u)	-O (Ashg)	(1116)	+ Tannuaspid	D (Gedi)		(1066)
Scyphiodus	O (Cara-m)			+ Thyestes (= Auchenaspis)	S (Prid)		(672)
Semiacontiodus	O (Trem-l)	-O (Cara-m)	(867)	Timanaspid	S (Prid)		(1066)
Serratognathus	O (Aren-l)	-O (Aren-u)	(800)	+ Tremataspis	S (Wenl-u)	-S (Prid)	(672)
+ Sibiriodus	O (Llde-l)		(800)	+ Tuvaspis	S (Prid)		(1066)
Siphonodella (= Dinodus Elictognathus, Falcodus)	D (Fame-u)	-C (Vise-l)	(315)	+ Tyriaspis	S (Prid)		(672,1066)
Spinodus	O (Llvi-u)	-O (Cara-l)	(1116)	+ incertae sedis	O (Cara-l)		(2)
Staufferella	O (Llvi-u)	-O (Ashg-u)	(313,800)	Or. ATELASPIDIFORMES			
Staurogathus	C (Tour-u)		(867)	+ Atelaspid	S (Wenl)		(1066)
+ Steptotaxis	D (Emsi-l)	-D (Eife-l)	(867)	+ Hemicyclaspis	S (Ludl-l)	-S (Prid)	(672)
Stereoconus	O (Llde-l)	-O (Cara-m)	(313,800)	+ Witaaspis	S (Wenl)		(1066)
Stolodus	O (Aren-l)		(800,867)	Or. BIRKENIIFORMES			
Strachanognathus	O (Aren-u)	-O (Ashg-u)	(800,1066)	+ Birkenia	S (Prid)		(1066)
Streptognathodus	C (Serp-u)	-P (Leon)	(800,867,1066)	+ Lasanius	S (Wenl)		(1066)
Subbryantodus	D (Fame)?	-C (Serp-l)	(315)	Or. ANASPIDA			
+ Sweetina	P (Leon-m)	-P (Guad-l)	(867)	Jamoytius	S (Ldov-u)	-D (Gedi-l)	(1066)
Sweetocristatus	P (Leon-m)	-P (Leon-u)	(800)	+ ?Conopiscius	C (l)		
Sweetognathus	P (Sakm-l)	-P (Guad-u)	(800)	Or. PETROMYZONIFORMES (= Cyclostomata)			
+ Tangshanodus	O (Aren-u)	-O (Llvi-l)	(800)	Hardistiella	C (Serp-l)		
+ Taoqupognathus	O (Cara-l)		(800)	Mayomyzon	C (Mosc-u)		
Taphrogathus	C (Vise-l)	-C (Vise-u)	(867)	Or. MYXINIFORMES			
Tasmanognathus	O (Cara-l)		(800)	+ Myxinikela	C (Mosc-u)		
Teridotus	Cm(Fran-u)	-O (Trem-u)	(800)				
Tortodus	D (Eife-l)	-D (Eife-u)	(867)				
+ Tripodus (= Diaphorodus)	O (Aren-l)	-O (Llvi-l)?	(867)				
+ Tropodus	O (Trem-u)	-O (Aren-u)	(800)				
+ Tuxekania	S (Ldov-u)	-S (Wenl-l)	(800)				
Ulrichodina (= Eucharodus)	O (Trem-u)	-O (Aren-u)	(800)				
Utahconus	O (Trem-l)	-O (Trem-u)	(867)				
+ Variabiloconus	O (Trem-l)	-O (Aren-l)	(867)				
+ Volgelgnathus	C (Vise-u)	-C (Serp-u)	(867)				
Walliserodus	O (Aren-l)	-S (Prid)	(800)				
+ Windsorgnathus	C (Vise-u)		(867)				

Taxon	First Appearance	Last Appearance	Reference	Taxon	First Appearance	Last Appearance	Reference
Cl. PTERASPIDOMORPHI							
Or. ASTRASPIDIFORMES							
Astraspis	O (Cara-l)	-O (Ashg-m)	(2)	Pteraspis	D (Gedi-u)	-D (Emsi-l)	(2)
+Tesakoviaspis	S (Ldov)		(1066)	Ptomaspis	S (Wenl)	-S (Ludl)?	
Or. PTERASPIDOMORPHES (= Heterostraci)							
+Alainaspis	S (Prid)			Pycnaspis	O (Cara-m)		
Alloccryptaspis	D (Sieg-l)		(2)	Pycnosteus	D (Give-u)		(689)
Americaspis	S (Prid)		(1066)	+Sacabambaspis	O (Cara-l)		
?Anatolepsis	O (Aren)	-O (Llvi-l)	(2,1066)	Sanidaspis	D (l)		
Angaraspis	D (Sieg)		(2)	Schizosteus	D (Eife)	-D (Give-u)	(689)
Anglaspis	S (Prid)?	-D (Gedi)	(718)	Seretaspis	D (Gedi)?		(1066)
+Arandaspis	O (Llvi-l)		(563)	Siberiaspis	D (Sieg)		(2)
Archegonaspis (+ Lonaspis)	S (Ludl-l)	-S (Prid)		Steinaspis	D (Gedi)		(1066)
?Archodus	O (Aren)		(2)	Strophisterus	S (u)		
Ariaspis (+ Psychaspis)	S (Wenl-u)	-D (Sieg)?		Tareyaspis	D (Sieg)		
+Asketaspis	S (Wenl)?			Tartuosteus	D (Give-u)	-D (Fras-l)	(502,689)
Aspidosteus	D (Fras)?			Tolypelepis	S (Wenl-l)	-D (Gedi-l)	(2)
+Athenaeigis	S (Wenl-u)			+Ultitaspis	S (Prid)		(1066)
Boothaspis	S (Prid)			Vernonaspis	S (Wenl-u)	-S (Prid)	
+Canadapteraspis	D (Gedi)		(1100)	Yogliinia	D (Give-u)		(689)
+Clydonaspis	D (Emsi-l)			Or. FURCACUDIFORMES			
Corvaspis	S (Ludl)	-D (Gedi-u)	(689)	-Cometicercus	D (Gedi)		
+Corveolepis	D (Gedi)		(1066)	-Drepanolepis	D (Gedi)		
Ctenaspis (+ Bothriaspis)	S (Prid)	-D (Gedi-u)	(2)	-Furcacauda	D (Gedi)		
Cyathaspis	S (u)	-D (Gedi-l)	(502)	-Pezopallichthyes	S (Wen-l)		
Dikenaspis	S (Prid)		(1066)	+Sphenonectris	D (Gedi)		
Dinaspidella	D (Gedi)		(1100)	Or. THELODONTIFORMES (= Coelolepida)			
Drepanaspis	D (Sieg-u)	-D (Emsi-l)	(502,689)	+Australolepis	D (Give-u)	-D (Fras-l)	
Dyreaspis	D (l)			Coelolepis	S (u)	-D (l)	
Edaphaspis	D (Sieg-u)			+Goniporus	S (Prid)	-D (Gedi)	(746)
Eglonaspis	D (Sieg-u)	-D (Emsi)?	(2)	+Helenolepis	S (Prid)		(746)
Empedaspis	D (Sieg-u)			+Katoporus	S (Prid)	-D (Gedi-l)	(746)
Ennosviaspis	D (l)			+Kawalepsis	S (Ludl)		
Eriptychius	O (Cara-l)	-O (Cara-u)	(2,450)	Lanarkia	S (Wenl-u)		
Glossoidaspis (+ Europrotaspis)	D (l)			+Loganellia (= Logania)	S (Ldov-u)	-D (Gedi)	(1066)
Grumantaspis	D (l)			Phlebolepis	S (Wenl)	-S (Ludl-l)	(2,1066)
Gunaspis	D (l)			Thelodus (+ Dystrovia)	S (Ldov-u)	-S (Prid)	
Homaspidella	S (Prid)	-D (Gedi)	(2)	Or. UNCERTAIN			
Irregulariaspis	D (Gedi)		(2)	+Aserotaspis	D (Gedi)		(1100)
Kallostracon	S (Ludl)	-D (Gedi-l)	(689)	Coscinodus	S (u)		
Karelosteus	D (Fras-u)		(689)	Dipnoides	S (u)		
Kiangsuaspis	S (Wenl)			Gompholepis	S (u)		
+Liliaspis	D (Gedi)			Gyropeltus	S (u)		
Listraspis	D (l)			+Lepidaspis	D (Gedi)		(1100)
+Nahanniaspis	S (Prid)	-D (Gedi)	(1066,1100)	+Neeyambaspis	D (Eife)?		
Obliaspis	D (Sieg)		(2)	Palaeospondylus	D (Give)		(2)
?Palaeodus	O (Aren)		(2)	Palaeosteus	S (u)		
Pelaspis	D (Sieg-u)			+Pituriaspis	D (Eife)?		
+Pileolepis	S (Wenl-u)			Rabdacanthus	S (u)		
Pionaspis	D (Gedi)		(1100)	Rhabdiodus	S (u)		
Poraspis	S (Prid)	-D (Gedi-u)	(2)	+Sigurdia	D (l)		(746)
+Poriferaspis	O (Llvi-l)		(563)	+Superciliaspis	D (Gedi)		(1100)
+Porophoraspis	O (Llvi-l)		(746)	Tyloodus	S (u)		
Protaspis (+ Giganthaspis)	D (l)			+Waengsjoeaspis	D (Gedi)		(1100)
Psephaspis	D (Sieg)	-D (Emsi)	(689)	Cl. PLACODERMI			
				Or. STENSIOELLIDA			
				Stensioella	D (Emsi-l)		(521)

Taxon	First Appearance	Last Appearance	Reference	Taxon	First Appearance	Last Appearance	Reference
Or. PSEUDOPETALICHTHIDA				-Arenipiscis	D (Emsi)		(568)
-Nessariostoma	D (Emsi-l)		(1066)	Aspidichthys	D (Fras-u)	-D (Fame)	(521)
Paraplesiobatis	D (Emsi-l)		(521)	+Atlantidosteus	D (Emsi-u)		
Pseudopetalichthys	D (Emsi-l)		(521)	Belemnacanthus	D (m)		(521)
Or. RHENANIDA (Gemuendinida)				Belosteus	D (Fras-u)		(521)
Asterosteus	D (Eife)		(521)	Brachydeirus	D (Fras-m)	-D (Fras-u)	(521)
+Boliosteus	D (m)		(746)	Brachyosteus	D (Fras-u)		(521)
Gemuendina	D (Emsi-l)		(521)	Braunosteus	D (Fras-u)		(521)
Jagorina	D (Fras-u)		(521)	+Bruntonichthys	D (Fras-l)		(916)
Ohioaspis	D (Emsi)	-D (Give-u)	(521,1066)	Buchanosteus	D (Emsi)		(521)
Or. PTYCTODONTIDA				+Bullerichthys	D (Fras-l)		(916)
Campbellodus	D (Fras-l)		(521)	Bungartius	D (Fame-u)		(521)
Chelyophorus	D (Fras)	-D (Fame)	(521)	+Burrinujucosteus	D (Emsi)		(568)
Ctenurella	D (Fras-l)		(521)	Callognathus	D (Fras)	-D (Fame)	(521)
+Denisonodus	D (Fras-l)			+Camaropiscis	D (Fras-l)		(916)
Desmoporella	D (Eife)	-D (Give)	(521)	Copanognathus	D (Fras-l)		(521)
Eczematotepis	D (Eife)	-D (Fras-m)	(521)	Cosmacanthus	D (Fras)?	D (Fame)?	(521)
Goniosteus	D (Eife)		(521)	Cyrtosteus	D (Fras-u)		(521)
Palaemyllus	D (Eife-l)	-D (Fras)	(521)	Deirosteus	D (Eife)?	-D (Fras)	(521)
+Ptyctodopsis	D (Fras-l)			Deveonema	D (Fras-m)		(521)
Ptyctodus	D (Eife-l)	-C (Tour-l)	(521)	Dinichthys	D (Fras-m)		(521)
Rhynchodus	D (Eife)	-C (Tour-l)	(521)	Dinomylostoma	D (Fras-l)	-D (Fras-m)	(521)
+Tollodus	D (Sieg)		(1066)	Diplognathus	D (Fame)		(521)
incertae sedis	D (Gedi)?	D (Sieg)?	(521)	Dunkleosteus	D (Give)	-D (Fame-u)	(521,1066)
Or. ACANTHOTHORACI				Eastmanosteus	D (Eife-u)	-D (Fame-l)	(521)
+Breizosteus	D (Sieg)		(1066)	+Eldenosteus	D (Fras-l)		
Dobrowlania	D (Gedi-u)		(521)	Enseosteus	D (Fras-u)		(521)
Kimaspis	D (Gedi-l)		(521)	+Erolosteus	D (Emsi)		(568)
Kolymaspis	D (Emsi)		(1066)	Erromenosteus	D (Fras-u)		(521)
Kosoraspis	D (Gedi)	-D (Sieg-l)	(521,1066)	+Eskimaspis	D (Gedi-u)		
+Murrindalaspis	D (Emsi)		(1066)	+Fallacosteus	D (Fras-l)		
Palaeacanthaspis	D (Gedi-u)		(521)	Gemuendenaspis	D (Emsi-l)		(521)
Radotina	D (Gedi)	-D (Sieg)	(521,1066)	Glyptaspis	D (Fame-u)		(521)
Romundina	D (Gedi-u)		(521)	+Goodradigbeon	D (Emsi)		(568)
+Weejasperaspis	D (Emsi)		(746,1066)	Gorgonichthys	D (Fame-u)		(521)
Or. BRINDABELLASPIDA				Grazosteus	D (m)?		(521)
+Brindabellaspis	D (Emsi)		(1066)	Groenlandaspis	D (Fras)	-D (Fame-u)?	(521)
Or. PETALICHTHIDA				Gymnotrachelus	D (Fame-u)		(521)
Diandongpetalichthys	D (Gedi)		(1066)	Gyropalacosteus	D (Fras-l)		(521)
Ellopetalichthys	D (Give)		(521)	Hadrosteus	D (Fras-m)?		(521)
Epipetalichthys	D (Fras-u)		(521)	+Harrytoombsia	D (Fras-l)		(916)
+Eurycaraspis	D (Give)			Heintzichthys	D (Fras-l)	-D (Fame-u)	(521)
+Lilipetalichthyes	D (Eife)		(1066)	Heterosteus	D (Give-u)		(521)
Lunaspis	D (Emsi-u)		(521)	Holdenius	D (Fame-u)		(521)
Macropetalichthys	D (Eife-l)	-D (Give)	(521)	Hollardosteus	D (Give-u)		(521)
Neopetalichthys	D (Emsi)		(521,1066)	Holonema	D (Eife)	-D (Fras-m)	(521)
Notopetalichthys	D (Emsi)		(521)	Hussakofia	D (Fame-u)		(521)
Quasipetalichthys	D (Give)		(521)	+Incisoscutum	D (Fras-l)		(916)
-Shearsbyaspis	D (Emsi)			+Kendrichthys	D (Fras-l)		(916)
Wijdeaspis	D (Emsi)	-D (Eife)	(521)	Kiangyosteus	D (Give)		(521)
+Xinanpetalichthyes	D (Eife)		(1066)	+Kimberia	D (Fras-l)		(916)
Or. ARTHRODIRA				+Kimberleyichthyes	D (Fras-l)		(1066)
-Africanaspis	D (Fame)			+Kweichowlepis	D (Sieg)		(1066)
Arctonema	D (Eife)		(521)	-Latocamurus	D (Fras)		(1066)
				Laurentaspis	D (Emsi)?	D (Eife)?	(521)
				Leptosteus	D (Fras-u)		(521)
				Machaerognathus	D (Fras-l)		(521)
				Malerosteus	D (Fras)		(521)
				+Mcnamaraspis	D (Fras-l)		
				Megaloplax	D (Fras)		(521)
				+Melanosteus	D (Fras-l)		(1066)
				Microsteus	D (Fras-u)		(521)

Taxon	First Appearance	Last Appearance	Reference	Taxon	First Appearance	Last Appearance	Reference
Murmur	D (Sieg)		(521)	Or. DESMIODONTIDA			
Mylostoma	D (Fame-u)		(521)	Desmiodus	C (Vise-u)		(451)
+ Operchaliosteus	D (Fras-m)			+ Heteropetalus	C (Serp-l)		(451)
Overtonaspis	D (Sieg-l)		(521)	Or. CLADOSELACHIDA			
Oxyosteus	D (Fras-m)	-D (Fras-u)	(521)	Cladoselache (= Cladodus)			
Pachyosteus	D (Fras-u)		(521)		D (Fame-u)		(2,1066)
+ Panxioosteus	D (Fras-l)		(1066)	+ Iberolepis	D (Gedi-l)	-D (Sieg-l)	(645)
Parabelosteus	D (Fras-u)		(521)	+ Lunalepis	D (Gedi-l)	-D (Sieg-l)	(645)
Parabuchanosteus	D (Emsi)		(521)	+ Monocladodus	D (Fame)		(451)
Paramylostoma	D (Fame-u)		(521)	Or. CORONODONTIDA			
Pholidosteus	D (Fras-u)		(521)	Coronodus	D (Fras-l)		(2)
Platyaspis	D (Fras)		(521)	Diademodus	D (Fame-u)		(2)
+ Plourdosteus	D (Fras-l)		(1066)	+ Siamodus	D (Fame-u)		(898)
Prescottaspis	D (Sieg-l)		(521)	Or. SYMMORIIDA			
Qataraspis	D (l)?		(521)	+ Bebhacanthus	C (Mosc-u)		
Rachioosteus	D (Give-u)?, D (Fras-l)?		(521)	+ Cobelodus	C (Mosc-u)		(451)
Rhenonema	D (Give)		(521)	Denaea	C (Vise-l)	-C (Mosc-u)	(2,451)
Rhinosteus	D (Fras-u)		(521)	- Falcatus	C (Tour-l)	-C (Serp-l)	(1066)
+ Rolfosteus	D (Fras)		(916)	+ Orestiacanthus	C (Serp-l)		(746)
Selenosteus	D (Fame-u)		(521)	- Stethacanthus	D (Fame-m)	-C (Mosc-u)	(451,898)
+ Squamatognathus	D (Eife-u)			Symmorium	D (Fame-u)	-C (Mosc-u)	(2,451,898)
Stenosteus	D (Fame-l)	-D (Fame-u)	(521)	Tamiobatis	D (Fame)	-C (Vise-u)?	(451)
Stuertzaspis	D (Emsi-l)		(521)	Or. EUGENEODONTIDA			
Synauchenia	D (Fras-u)		(521)	(= Edestida + Helicoprionida)			
Taemasosteus	D (Emsi)	-D (Fras-m)	(521)	Agassizodus	C (Serp-l)	-C (Mosc-u)	(863,1066)
Tafilalichthys	D (Fame-l)		(521)	+ Arpagodus	C (Mosc-u)		(451,1066)
Tapinosteus	D (Fras-u)		(521)	- Bobbodus	C (Mosc-u)	-C (Step-u)	(451)
Taunaspis	D (Sieg)		(521)	Camposus	C (Vise-u)	-C (Mosc)	(451)
Tiaraspis	D (Sieg-u)		(521)	Campyloprion	C (Step)		(451)
Timanosteus	D (Fras)		(521)	+ Caseodus	C (Mosc-u)		(451)
Titanichthys	D (Fame-l)	-D (Fame-u)	(521)	- Chiastodus	C (Mosc)		(451)
+ Toombososteus	D (Emsi)		(568)	Edestus	C (Serp-l)	-P (l)	
+ Torosteus	D (Fras-l)		(916)	Erikodus	P (Guad-u)		
Trachosteus	D (Fame-u)		(521)	+ Eugeneodus	C (Mosc-u)		(451)
Trematosteus	D (Fras-u)		(521)	Fadenia	C (Step-l)		(1066)
Tropidosteus	D (Give)		(521)	- Gilliodus	C (Mosc-u)		(451)
+ Tubonaspis	D (Fras-l)		(916)	Helicampodus	P (Guad-u)	-Tr (Indu)	
Wheathillaspis	D (Sieg-l)		(521)	Helicoprion	P (l)	-P (Guad-u)	(718)
Williamsaspis	D (Emsi)		(521)	Lestrodus	C (Bash-l)		(1066)
+ Yinosteus	D (Give)		(1066)	Ornithoprion	C (Mosc-u)		(451)
Or. ANTIARCHA				Parahelicampodus	Tr (Indu)		
Grossaspis	D (Give)		(521)	Parahelicoprion	P (l)	-P (Leon)	
+ Jiangxilepus	D (Fame)			Prospiraxia	D (u)		
Lepadolepis	D (Fras-u)			Pseudodontichthys	D (m)		
+ Liujiangolepis	D (Sieg)		(1066)	+ Romerodus	C (Mosc-u)		(451)
+ Phymolepis	D (Gedi)		(1066)	Sarcoprion	P (Guad-u)		
+ Qujinolepis	D (Gedi)		(1066)	Syntomodus	P (u)		
+ Sinolepis	D (Fame)		(1066)	Toxoprion	C (Pn)		
Taenirolepis	D (Fras)		(521)	Or. ORODONTIDA			
+ Xichonolepis	D (Fame)		(1066)	+ Hercynolepis	D (Fame-m)		(451,1066)
+ Yunnanolepis	D (Gedi)	-D (Sieg)	(1066)	+ Leiiodus	C (Tour-u)		(451)
+ Zhanjilepis	D (Gedi)		(1066)	Orodus	C (Tour-l)	-P (Sakm)	(451,1066)
Or. UNCERTAIN				Or. SQUATINACTIDA			
+ Antineosteus	D (Emsi-u)			+ Squatinactis	C (Serp-l)		(451)
?Nessariostoma	D (Emsi-l)		(521)				
?Oestophorus	D (Give)	-D (Fras)	(521)				
Cl. CHONDRICTHYSES							
Or. INCERTAE SEDIS							
+ Elegestolepis	S (u)						

Taxon	First Appearance	Last Appearance	Reference	Taxon	First Appearance	Last Appearance	Reference
Or. CTENACANTHIDA				Or. SQUALIFORMES			
+ Acandylacanthus	C (Tour-l)		(451)	+ Sphenodus	J (Sine)	-T (Dani)	(884)
- Acrodus	Tr(Indu-u)	-K (Camp-l)	(884)	+ Thrinax	T (Eo-m-l)		(884)
+ Acronemus	Tr(Ladi)		(884)	- Welcommia	K (Vala)		
+ Amelacanthus	D (u)		(746)	- Weltonia	T (Than)	-T (Eo-l)	(884)
+ Anaclitacanthus	C (Tour-u)		(451)	Or. SQUALIFORMES			
+ ?Arauzia	D (Gedi-l)		(645)	+ Centrophoroides	K (Sant-u)	-K (Maes)	(884)
- Arctacanthus	P (Guad-u)		(2)	Centrophorus (+ Cheirostephanus)	K (Turo)	-R	(884)
- Asteracanthus	Tr(Anis)?	-K (Maes)	(2,884)	?Centropterus	K (Apti)		(884)
+ Asteroptychius	C (l)		(451)	Centrosqualus	K (Sant-u)		(525,884)
- Bdellodus	J (l)		(884)	+ Cretascymnus	K (Sant-u)	-K (Maes-u)	(884)
- Coelosteus	C (Ms)			Dalatias	T (Eo-m-u)	-R	(453)
+ Cratoselache	C (Vise-l)?		(451)	+ Decania	T (Mi-l)	-R	(884)
- Ctenacanthus	D (Give-l)	-C (Vise-u)	(1066)	Echinorhinus	K (Camp)	-R	(884)
- Dabasacanthus	C (Mosc-u)		(451)	+ Eoetmopterus	K (Camp-u)	-K (Maes)	(1066)
+ Dierenodus (+ Carcharopsis)	C (Vise-u)	-C (Bash-u)		Etmopterus	T (Mi-l-u)	-R	(884)
Doratodus	Tr(Carn)?	-Tr(Nori)	(863)	+ Gibbechinorhinus	K (Maes-l)		(1066)
+ Echinodus	C (Pn)		(746)	Isistius	T (Than)	-R	(2,884)
Eoorodus	D (Fame-u)		(451)	+ Megasqualus	T (Than-u)	-T (Eo-l)	(884)
Goodrichthys	C (l)			+ Microetmopterus	K (Maes-l)		
+ Holmesella	C (u)	-C (Step-l)?	(451)	Oxynotus	T (Mi-l)	-R	(884)
Hyoeladodus	C (Tour-u)		(451)	+ Paraechinorhinus	T (Eo-m-u)	-T (Mi-m)	(621,884)
Hybodus	Tr(Anis)?	-K (Maes-l)	(884)	+ Proetmopterus	K (Maes-u)		
+ Hylaeobatis	K (Barr)		(884,1066)	+ Protosqualus	K (Barr)	-K (Ceno)?	(884)
Lambdodus	C (Tour-u)		(451)	+ Protosynodus	K (Camp-u)		(884)
+ Lissodus (+ Lonchidon)	C (Vise)	-K (Maes)	(746,884,1066)	+ Pseudoechinorhinus	T (Dani)		(621,884)
Mesodmodus	C (Tour-l)		(451)	+ Scymnodon	T (Ol-u)	-R	(884)
+ Moyacanthus	C (l)		(451)	- Scymnorhinus	T (Pale)?	-R	(884)
+ Onychoselache	C (Vise-l)		(451)	Sommiosus	T (Mi)	-R	(884)
- Palaeobates	Tr(Ladi-u)	-Tr(Rhae)		+ Squaliolus	T (Mi-l-u)	-R	(884)
Petrodus	C (Vise-l)	-C (Mosc-u)?	(2)	+ Squalogaleus	J (Tith-l)		(884)
Phoebodus	D (Eife-u)	-Tr(Rhae)	(884,898,1066)	Squalus	K (Camp)	-R	(884)
Polyacrodus	Tr(Indu-u)	-K (Camp-l)	(884)	Or. PRISTIOPHORIFORMES			
+ Pororhiza	K (Albi)		(884)	+ Ikamius	T (Eo-u)	-Q (Plei-l)	(884)
Priohybodus	J (u)	-K (Vala)?	(884)	Pliotrema	T (Mi)	-R	(884)
Protacodus	D (Fras-u)	-D (Fame-u)	(451,898)	Pristiophorus (+ Propristiophorus)	K (Sant-u)	-R	(884)
+ ?Pseudodalatias	Tr(Nori-u)		(863,884)	Or. SQUALOMORPHI INCERTAE SEDIS			
Ptychodus	K (Albi-u)	-K (Camp)	(884)	+ Protospinax	J (Tith-l)		(525,884)
?Raineria	Tr(Nori)	-Tr(Rhae)	(525,884)	Or. SQUATINIFORMES			
Sphenacanthus	C (Ms)	-P		Squatina (+ Pseudorhina)	J (Oxfo-u)	-R	(452,884)
+ Steinbachodus	Tr(Carn-l)		(884)	Or. HETERODONTIFORMES			
Styracodus	C (Pn)			Heterodontus	J (Toar-u)	-R	(1066)
+ ?Trichorhipis	C (Mosc-u)		(451)	Or. ORECTOLOBIFORMES			
Tristychius	C (Vise)		(451)	+ Acanthoscyllium	K (Ceno)	-K (Sant-u)	(884)
Wodnika	P (Guad-l)		(2,451)	+ Agaleus	J (Sine-l)?		(884)
+ Xystrodus	P (u)		(746)	+ Alimnascyllum	K (Sant-u)		(525,884)
Or. HEXANCHIFORMES				+ Amnea	J (Aale)		(863,884)
Chlamydoselachus	K (Camp)	-R	(884)	+ Brachaelurus	K (Barr-u)	-R	(525,884)
+ Eonotidanus	J (Oxfo-l)	-K (Haut)	(884)	Cantioscyllium	K (Ceno)	-K (Turo)	(884)
+ Heptanchias	T (Dani)	-R		+ Cederstroemia	K (Camp-l)	-K (Camp-u)	
Hexanchus	J (Sine)	-R	(884,1066)	Chiloscyllium	K (Ceno)	-R	(884)
+ ?Memuriodus	D (Eife)?	-D (Give)?	(1066)	+ Cretorectolobus	K (Camp-u)	-K (Maes-l)	(884)
Notidanodon	K (Albi)	-T (Than)	(884)	+ Eostegostoma	T (Eo-m-l)	-T (Eo-u)	(884)
+ Notorhynchus	K (Haut-u)	-R					
+ Pachyhexanchus	K (Haut-l)						
+ Parahexanchias	T (Mi-l)	-T (Mi-m)	(723,884)				

Taxon	First Appearance	Last Appearance	Reference
Ginglymostoma	K (Albi)	-R	(884)
+Hemiscyllium	T (Than)	-R	(884)
Mesiteia	K (Ceno-l)		(884)
+Nebrius	T (Dani)	-R	(884)
+Orectoloboides	J (Call)	-K (Albi-u)	(452,884)
+Palaeorhincodon	T (Eo-l)	-T (Eo-m)	(884)
Palaeoscyllium (+ Corysodon)	J (Kimm-u)	-J (Tith-l)	(863,884)
+Paleobranchselurus	J (Toar-u)	-J (Call)	(884,1066)
+Paraginglymostoma	K (Maes)		(884)
+Pararhincodon	K (Ceno-l)	-T (Eo-l)	(746,884)
Phorcynis (+ Crossorhinus)	J (Kimm)		(884)
+Protoginglymostoma	T (Eo-l)		(884)
+Rhincodon	T (Mi-m)	-R	(884)
+Squatiscyllium	T (Than)	-T (Eo-l)	(884)

Or. LAMNIFORMES

Alopias	T (Eo-l)	-R	(884)
Anomotodon	K (Apti-u)	-T (Mi-l)?	(884)
+Archaeolamna	K (Albi-u)	-K (Camp-l)	
+Carchariolamna	T (Mi)		(884)
+Carcharocles	T (Eo-m-l)	-T (Plio)	(884,958)
Carcharoides	T (Ol-l-u)	-T (Mi-m)	(884)
Carcharodon	T (Mi-l-u)	-R	(884)
Cetorhinus	T (Ol-l)	-R	(1066)
+Cretodus (+ Plicatolamna)	K (Ceno-m)	-K (Maes)	(884)
+Cretolamna	K (Albi)	-T (Eo-u)	(884)
+Cretoxyrhina	K (Ceno)	-K (Sant)	(884)
+Hispidaspis	K (Albi)	-K (Sant)	(884)
+Hypotodus	T (Eo-l)	-T (Eo-u)	(884)
+Isurolamna	T (Than)	-T (Eo-m-l)	(746,884, 958)
Isurus (+ Anotodus)	T (Than)	-R	(884)
+Jaekelotodus	T (Than)	-T (Eo-m-l)	(884,958)
Lamna	T (Dani)	-R	(958)
+Leptostyrax	K (Albi)	-K (Coni)	(884)
+Microcorax	K (Ceno)	-K (Camp)	(884)
+Misrichthys	T (Eo-m-u)	-T (Eo-u)	
+Mitsukurina	T (Eo-m)	-R	(884)
Odontaspis	K (Camp)	-R	(884)
+Otodus	T (Than)	-T (Eo-l)	(884)
Palaeocarcharias	J (Tith-l)		(525,884)
+Palaeocarcharodon	T (Than)		(884)
+Palaeohypotodus	T (Dani)	-T (Eo-l)	(884,958)
+Paracorax	K (Sant)	-K (Maes)	(884)
+Paranomotodon	K (Ceno)	-K (Camp)	(884)
Parisurus	K (Albi-m)	-K (Albi-u)	(884)
+Parotodus	T (Ol)	-T (Plio)	(884)
+Palalamna	K (Vala)	-K (Albi)	(884,1066)
Pseudocorax	K (Turo-u)	-K (Maes-u)	(863,884)
Pseudoisurus	K (Ceno)		(884)
Scapanorhynchus	K (Apti)	-K (Maes)	(884)
Squalicorax (+ Corax, Palaeocorax)	K (Albi)	-K (Maes-u)	(525,863, 884)
+Striatolamia	T (Dani)	-T (Eo-m-l)	(958)
+Synodontaspis (+ Caracharias)	K (Apti)	-R	(884)
+Xiphodolamia	T (Eo-l)	-T (Eo-m-l)	(884)

Taxon	First Appearance	Last Appearance	Reference
Or. CARCHARHINIFORMES			
+Abdouinia	T (Dani)	-T (Eo-u)	(884,958)
+Archaeotriakis	K (Camp)		(884)
Carcharhinus (+ Aprionodon, Hypopriion)	T (Eo-m-l)	-R	(884,958)
+Chaenogaleus	T (Mi-l)	-R	(884)
+Eogaleus	T (Eo-m-l)		(746,884)
Galeocerdo	T (Eo-l)	-R	(884)
Geleorhinus (+ Protogeleus)	K (Turo-l)	-R	(884)
Galeus (+ Priurius)	T (Mi-l-u)	-R	(884)
Hemipristis	T (Eo-m)	-R	(884)
+Isogomphodon	T (Eo-m-l)	-R	(884)
+Macrouroaleus	J (Tith-l)		(884)
+Megascyliorhinus	T (Eo-l)	-Q (Plei)	(453,884)
Musielus	T (Eo-l)	-R	(884)
Negaprion	T (Eo-m)	-R	(884)
+Pachygaleus	T (Eo-l)		
+Palaeogaleus	K (Camp)	-T (Than)	(884)
+Paragaleus	T (Mi-l)	-R	(884)
+Paratriakis	K (Turo)	-K (Camp)	(525,863, 884)
-Physogaleus (+ Trigonodus)	T (Than)	-T (Mi-l)	(884,958)
+Premintreia	T (Eo-l)		
Prionace (+ Prionodon)	T (Plio)	-R	(884)
+Protoscyliorhinus	K (Turo)		(884)
+Pterolamiops	T (Plio)	-R	(884)
+Pteroscylidium	K (Sant-u)	-K (Maes)	(884)
+Rhizoprionodon	T (Eo-l)	-R	(884)
Scyliorhinus (+ Scylliodus)	K (Albi-u)	-R	(525,884)
Sphyrna	T (Mi-m)	-R	(1066)
+Squatigaleus	K (Camp-u)	-K (Maes-l)	
Triakis (+ Rhaibodus)	T (Pale)	-R	
-incertae sedis	J (Bath)		(863,884, 1066)
Or. GALEOMORPHII INCERTAE SEDIS			
+Nemacanthus	Tri(l)	-Tri(Rhae)	(884)
Palaeospinax	Tri(l)	-J (Toar-l)	(1066)
+Paraorthacodus	J (Aale)	-T (Than)	(884)
+?Parasquatina	K (Maes)		(884)
+Reifia	Tri(Nori-l)		(525,884)
Synechodus	K (Apti)	-T (Dani)	(884)
Or. RAJIFORMES			
+Ankystrorhynchus	K (Sant)	-K (Camp)	(746,884)
Anoxypristis	T (Eo-m-l)	-R	(863,884)
+Arthropterus	J (Toar-l)		(884)
+Asterodermus	J (Tith-l)		(2)
Belemnobatis	J (Kimm-u)		(884)
+Breviacanthus	J (Bath)		(452,884)
Clenopristis	K (Maes)		(863,884)
Cyclobatis	K (Ceno-u)		(2,884)
+Dalpiazia	K (Maes)		(884)
+Erquitaia	K (Maes-l)		
+Euryarthra	J (Tith-l)		(884)

Taxon	First Appearance	Last Appearance	Reference	Taxon	First Appearance	Last Appearance	Reference
- Ganopristis	K (Maes)		(884)	Myliobatis (+ Promyliobatis)			
- Hypsobatis	K (Camp)	-K (Maes-l)	(1066)	T (Dani)		-R	(884)
+ Ischyrhiza	K (Ceno-u)	-K (Maes)	(884)	+ Palaeodasyatis	T (Dani)		
- Jurobates	J (Toar-u)		(452,884)	Plinthicus	T (Mi-l)	-T (Mi-m)	(884)
- Libanopristis	K (Ceno)		(746,884)	+ Pucabatis	K (Maes)		(884)
+ Mafoletia	K (Ceno-u)		(1066)	Rhinoptera	T (Than)	-R	(2,884)
Marckgrafia	K (Ceno-l)		(884)	Rhombodus	K (Maes)		(884,1066)
+ Micropristis	K (Ceno)	-K (Camp)	(746,884)	Urolophus	T (Eo-m-l)	-R	(1066)
Onchopristus (+ Platyspondylus)							
	K (Apti-u)	-K (Ceno-u)	(2,718,884)	Or. CHONDRENCHELYIFORMES			
Onchosaurus	K (Turo)	-K (Sant)	(884)	Chondrenchelys	C (Vise-l)		(454)
Parapalaebates	K (Camp)	-K (Maes-l)	(884)	+ Harpagofututor	C (Serp-l)		(454)
+ Pararaja	K (Ceno)		(884)	+ ?Platyxystrodus	C (Tour)	-C (Mosc-u)	(454)
Peyeria	K (Ceno-l)		(884)	+ ?Solenodus	C (Mosc-u)		(2)
Platyrhina (+ Narcopterus)							
	T (Eo-l)	-R	(2,884)	Or. COPODONTIFORMES			
Pristis	T (Eo-l)	-R	(2,884)	Acmoniodus	D (Fras-l)		(2)
+ Protoplathyrhina	K (Turo)	-K (Camp)	(884)	+ Copodus	C (Ms)		(746)
Propristis	T (Eo-m-u)	-T (Mi-l)	(718,863,884)				
- Pseudohypolophus	K (Albi)	-K (Camp)		Or. PSAMMODONTIFORMES			
Ptychotrygon	K (Ceno)	-K (Camp)	(884)	Lagarodus	C (Vise)		(1066)
Pucapristis	K (Maes)		(884)	Mazodus	C (Ms)		
Raja	K (Maes)	-R		Psammiodus	D (Fame-u)?	-C (Vise)	(1066)
+ Rajorhina	K (Ceno-l)		(1066)				
Rhinobatos	K (Apti)	-R	(525,884)	Or. HOLOCEPHALI INCERTAE SEDIS			
+ Rhombopterygia	K (Ceno)		(884)	Acanthorhina	J (Toar)		
Rhynchobatus	T (Eo-l)	-R	(884)	+ Alethodontus	J (Hett)		(452)
Schizorhiza	K (Maes)		(863,884)	+ Chimaeropsis	J (Sine)?	-J (Tith-l)	(2,452)
Sclerorhynchus	K (Turo)	-K (Camp)	(884)	Cochliodus	(teeth)		
+ Spathobatis	J (Aale)	-J (Kimm-u)	(884)	Cranodus	(teeth)		
Squatirhina	K (Turo)	-K (Maes)	(884)	+ ?Cymatodus	(teeth)		
+ Youssoubatis	K (Camp)	-K (Maes-u)	(1066)	Deltodus	(teeth)		
				+ Dichelodus	(teeth)		
				Diplacodus	(teeth)		
Or. TORPEDINOIDEA				Erismaacanthus	(spine)		
Eotorpedo	T (Dani)	-T (Eo-l)	(884,1066)	Helodus	(teeth)		
Narcine	T (Eo-l)	-R	(884)	Helodopsis	(teeth)		
Torpedo	T (Mi-m)	-R	(884)	Icanodus	(teeth)		
				Jimphohia	C (Mosc-u)		(451)
Or. MYLIOBATIFORMES				Macrodontacanthus	(spine)		
Aetobatus	T (Than)	-R	(884)	Menaspacanthus	(spine)		
+ Aetomylaeus	T (Plio)	-R	(884)	Menaspis	P (Guad-l)		(2)
Apocopodon	T (Than)		(2,884)	+ Metopacanthus	J (Sine)	-J (Toar)	(452)
- Archaeomanta	T (Than)	-T (Eo-m-l)	(884)	Myriacanthus	J (Hett)	-J (Bajo)	(2,452)
- Arechia	T (Eo-l)	-T (Eo-m)	(884)	Platyodus	(teeth)		
+ Brachyrhizodus	K (Camp)	-K (Maes)	(884)	Poecilodus	(teeth)		
+ Burnhamia	T (Than)	-T (Eo-m)	(884)	Psephodus	(teeth)		
+ Coupatezia	K (Maes)	-T (Eo-m)	(884)	+ Ptyktoptychion	K (Albi)		(863)
Dasyatis	K (Ceno-l)	-R	(2,884)	+ Recurvacaanthus	(spine)		
+ Eomanta	T (Ol-l)		(746)	Sandalodus	(teeth)		
+ Eomobula	T (Eo-m-l)			Synthetodus	(teeth)		
Gymnura	K (Ceno-u)	-R	(1066)	Thoraldodus	(teeth)		
+ Heterotorpedo	T (Dani)?	-T (Eo-u)	(884)	Venustodus	(teeth)		
Hypolophites	T (Dani)?	-T (Than)	(884)	Xenodus	(teeth)		
+ Hypolophodon	T (Dani)	-T (Mi)?	(884,958)				
- Igdabatis	K (Maes)		(884)	Or. CHIMAERIFORMES			
+ Jacqhermania	T (Eo-m-l)	-T (Eo-m-u)	(884)	+ Agkistracanthus	Tr(Rhae)	-J (Hett)	(452)
Manta (+ Paramesbula)				Amylodon	T (Ol)		
	T (Mi-l)	-R	(884)	Brachymylus	J (Call-u)	-J (Kimm-l)	(452,863)
+ Merabatis	T (Eo-l)	-T (Eo-m)	(884)	Callorhynchus	K (u)	-R	
Mobula	T (Ol-l)	-R	(884)	Chimaera	K (u)	-R	

Taxon	First Appearance	Last Appearance	Reference
Crassidonta	P (l)	- P (Leon)	(1066)
+Delphyodontos	C (Serp-1)?		(746)
Deltopychius	C (Vise)	- C (Serp)	(451)
+Echinochimaera	C (Serp-1)		(746,1066)
Edaphodon	K (Albi-u)	- T (Plio)	
Elasmodectes	J (Tith-l)	- K (u)	(452)
Elasmodus	K (Sant-l)	- T (Eo-m)	(863)
Ganodus	J (Bajo)	- J (Tith-l)	(452)
+Harriotta	K (Sant)		(1066)
Icthyriapus	K (u)		
Ischyodus	J (Bajo)	- T (Plio)	(718,1066)
+Marracanthus	C (Ms)		
Myledaphus	K (Camp-u)	- T (Eo-l)	(863)
Pachymylus	J (Call)		(452)
+?Similiharriotta	C (Mosc-u)		(451)
Squaloraja	J (Sine-l)		(623,1066)

Or. INIOPTERYGIA

Iniopera	C (Mosc-u)		(451)
Iniopteryx	C (Mosc-u)		(451)
Inioxyle	C (Mosc-u)?, C (Step-1)?		(451)
Promexyele	C (Mosc-u)		(451)
Sibyrhynchus	C (Mosc-u)		(451)
incertae sedis	C (Serp-1)		(451)

Or. PETALODONTIDA

Ageleodus	C (l)	- C (Pn)	
+Antliodus	C (Tour-u)	- C (Vise-u)	(451)
+Belantsea	C (Serp-1)		
Brachyrhizodus	P (l)		
Cynopodus	C (l)		
Euglossodus	C (Vise-u)		(451)
Fissodus	C (l)	- C (Pn)	
+Glyphanodus	C (Vise-u)		(451)
Janassa (+ Petalorhynchus)	C (Vise-u)	- P (Guad-u)	(1066)
Megacatenopetalus	P (Leon-u)	- P (Djhu)	(2,1066)
?Mesolophodus	C (Vise-u)		(451)
+Netsepoye	C (Serp-1)		
+Paracymatodus	C (Mosc-u)		(451)
Peripristis (= Ctenoptychius)	C (Tour-l)	- P (Guad-l)	(2)
Petalodus	C (Tour-l)	- P (l)	(2)
Polyrhizodus	C (Ms)		
+Pristodus (+ Hoplodus)	C (Vise-u)		(451)
+Serratodus	C (Vise-l)		(451)
+Siksika	C (Serp-1)		

Or. UNCERTAIN

+Anachronistes	C (Vise-u)	- P (Leon)	
Chomatodus	C (l)		
+Harpacodus	C (Vise-u)		(451)
Eucentrurus	C (Vise)		(2)
+Hueneichthys	Tr(Rhae)		(525,884)
+Leonotus	D (Gedi-l)	- D (Sieg-l)	(645,898)
+Lisgodus	C (Tour-u)		(451)
+Odontorhynchus	T (Than)	- T (Eo-u)	(884)
+Polysentor	C (Mosc-u)		(451)
+Tanaodus	C (l)	- C (Serp-1)	(451)
+Vallisia	Tr(Rhae)		(884)

Taxon	First Appearance	Last Appearance	Reference
CI. ACANTHODII			
Or. CLIMATIIFORMES			
+Cassidiceps	D (Gedi)		
-Cheiracanthoides	D (Eife-u)	- D (Fras-l)	
-Gomphonchus	S (Ludl)		(1066)
Gyracanthus	D (Sieg)	- C (Mosc-l)	(455,645)
+Hanilepis	S (Ludl)		
+Kathemacanthus	D (Gedi)		
+?Lupopyrus	D (Gedi)		(455)
Marsdenius	C (Bash-l)		(1066)
Nostolepis	S (Wenl)	- D (Give-l)	(455,645)
Pruemolepis	D (Gedi-l)	- C (Tour-l)	(645)

Or. ISCHNACANTHIDA

+Apatēcānthus	D (Fras)		(455)
Atopacanthus	D (Eife)	- D (Fras-m)	(455)
Doliiodus	S (Ludl-u)	- D (Gedi-l)	(455)
Ischnacanthus	S (Prid)	- D (Sieg-l)	(455)
Onchus	S (L.dov-u)	- D (Fame)	(455)
+Persacanthus	D (Fras-l)	- D (Fras-m)	(455)
-Poracanthodes	S (Ludl)		

Or. ACANTHODIDA

Haplacanthus	D (Emsi-u)	- D (Fras)	(455)
-Protogonacanthus	D (Fras-l)		(455)

Or. UNCERTAIN

-Brochoadmones	D (Gedi)		(1100)
-Gemuendolepis	D (Emsi-l)		(455)
+Gladiobranchus	D (Gedi)		(1100)
-Gomphacanthus	S (Prid)	- C (Mosc-u)	(455,645)
Homacanthus	D (Eife)	- C (Bash-u)	(455)
Machaeracanthus	D (Gedi-l)	- D (Fras-l)	(455,645)
Nodocosta	D (Emsi)	- D (Fras-l)	(455)
Nodonchus	D (Sieg-l)		(455)
Oracanthus	C (Tour)	- C (Serp-1)?	(455)

CI. OSTEICHTHYES

Or. DIPTERIFORMES (= Dipnoi)

Chirodipterus	D (Fras-l)		(502)
Conchodus	D (Give-u)	- D (Fame)	(2)
Devonosteus	D (u)		
-Diabolepis	D (Gedi)		(1066)
Dipnorhynchus	D (Emsi-l)	- D (Eife)?	(2)
Dipterus	D (Sieg)	- D (Fame)?	(2,1066)
Ganorhynchus	D (Give)	- D (Fame-u)	(2)
Griphonanthus	D (Fras)		(502)
Grossipierus	D (u)		
Holodipterus	D (Fras)		
Melanognathus	D (m)		
Palaedaphus	D (u)		
+Pilliarhynchus	D (Fras-l)		
Rhinodipterus	D (m)	- D (u)	
+Sponysedron	D (Emsi-l)		(1066)
Stomiatyktus	D (m)		
Uranolophus	D (Sieg)		(1066)

Or. COELOCANTHIFORMES (= Crossopterygii)

+Alcoveria	Tr(Ladi-l)		(1066)
+Allenpterus	C (Serp-l)		(456)

Taxon	First Appearance	Last Appearance	Reference	Taxon	First Appearance	Last Appearance	Reference
Axelia	Tr(Olen-l)			Or. PALAEONISCIFORMES			
Canningius	D (m)			+?Acrolepis	C (Tour)		(1066)
+ Caridosuctor	C (Serp-l)		(456)	+?Aedulla	P (Leon)		(1066)
Chagrinia	D (Fame-u)		(2)	Aegicephalichthys	Tr(m)		
+ Changxingia	P (Tatr)?			+?Aetherimion	C (l)		(1066)
+ Chrysolepis	D (Fame)			?Andreolepis	S (Ludl-l)		(1066)
Coccoderma	J (Tith-l)		(863,1066)	+?Amblypterus	P (Tatr)		(1066)
Coelacanthopsis	C (Vise-u)			+?Amblypterina	P (Tatr)		(1066)
+ Coelacanthus	P (Guad-l)		(1066)	+?Asarotus	K (Camp)		(1066)
+ Cryptolepis	D (Fame-u)			+?Atopocephala	Tr(l)		(1066)
Cualabaea	J (u)			+?Bendenius	C (l)		(1066)
Devonosteus	D (m)	- D (u)		+ Birgeria	Tr(l)	- J (l)	
Diploercides	D (Fras-m)	- C (Vise-u)	(2,1066)	+?Boreolepis	P (m)		(1066)
Ectosteorhachis	P (Asse)		(2)	+ Boreosomus	Tr(Indu)	- Tr(Ladi)	(863)
Euporoosteus	D (Give)	- D (Fras)	(2,1066)	Borichthys	C (Ms)		
Eusthenopteron	D (Give-u)	- D (Fras)	(502)	+?Brachypareion	C (Tour)		(1066)
+ Garnbergia	Tr(Anis)			+?Broovalia	Tr(l)		(1066)
Glyptolepis	D (Eife)	- D (Fras-m)	(502)	+ Browniechthys	J (Hett)		(452)
Glyptopomus	D (Fame)		(502)	+?Buronella	P (Leon)		(1066)
Graphiurichthys (+ Graphiurus)	Tr(Carn-u)			+?Canobius	C (l)		(1066)
Gyroptychius	D (Eife-l)	- D (Give)	(502)	+?Caruichthys	Tr(Anis)		(1066)
Hamodus	D (m)			Centrolepis	J (Sine)		(2,452)
+ Hadronector	C (Serp-l)		(456)	+?Charleuxia	P (Asse)		(1066)
+ Hainbergia	Tr(Ladi)		(718)	+?Cheirodopsis	C (Tour)		(1066)
Heptanema	Tr(Ladi)	- J (Tith-l)	(863,1066)	+?Chichia	P (u)		(1066)
Holophagus	J (Hett)?	- K (Berr)	(452,1066)	+ Chondrosteus	J (Sine)	- J (Toar)	(452,916)
Holoptychius	D (Give-u)	- D (Fame-u)	(2,502)	+?Coccocephalichthys	C (Serp)	- P (l)	(1066)
+ Latvius	D (Fras-l)		(502)	+ Coccolepis	J (Sine)	- K (Berr)	(452,916)
Laugia	Tr(Indu-l)		(2)	+ Cornuobiscus	C (Tour)		(1066)
Libys	J (Tith-l)		(452)	Cosmolepis	J (Hett)	- J (Sine-l)	(2,452)
Litoptychius	D (u)			+?Cosmoptychius	C (Tour)		(1066)
+ Lochmocereus	C (Serp-l)		(456)	+?Cycloptychius	C (Tour)	- C (u)	(1066)
Macropoma	K (Albi)	- K (Camp-l)	(2)	+ Cyranorhis	C (Serp-l)		
Macropomoides	K (Ceno)		(863)	+ Daedalichthys	Tr(l)		(1066)
+ Miguashaia	D (Fras-l)		(502)	+?Decazella	P (Leon)		(1066)
+ Megapomus	D (Fame-l)			Dialiipina	D (l)		
Megistolepis	D (u)			+?Dictyopype	Tr(l)		(1066)
Mylacanthus	Tr(Olen-l)			+?Dorsolepis	Tr(Anis)		(1066)
Nesides	D (Fras)		(502)	+?Drydenius	C (Tour)		(1066)
Onychodus	D (Ems-l)?	- D (Fame)	(2)	+?Dwykia	C (Vise)		(1066)
Osteolepis	D (Eife-u)	- D (Fras-m)	(502)	+?Eigilia	P (l)		(1066)
+ Panderichthys	D (Give)	- D (Fame)	(1066)	+?Elonichthys	C (Tour)		(1066)
Piveteaia	Tr(Indu-u)			+?Eurynotoides	P (Tatr)		(1066)
+ Polyosteorhynchus	C (Serp-l)		(456)	+?Evenkia	Tr(l)		(1066)
Porolepis	D (Sieg-u)	- D (Give)	(502,1066)	+?Fukangichthys	Tr(Rhae)		(1066)
Powichthys	D (Gedi-u)?			+?Gardinerichthys	P (Tatr)		
+ Rhabdoderma	C (Vise)	- C (Step-u)?	(1066)	+?Gonatodus	C (Tour)		(1066)
Rhizodus	C (Ms)	- C (Bash-u)	(2)	Gyrolepidoides	Tr(m)		
Sassenia	Tr(Indu-l)	- Tr(Olen-l)		Gyrolepis	Tr(Olen-l)	- Tr(Rhae)	
Scleracanthus	Tr(Olen-l)			+ Gyrosteus	J (Toar)	- J (Bath)	(452,916)
Sinocoelacanthus	Tr(l)			+?Haplolepis	C (Moscu)		(1066)
Strunius	D (m)	- D (u)		+ Helichthys	Tr(l)		(1066)
Synaptotylus	C (Step-l)		(1066)	+?Hulettia	J (Bath)	- J (Call)	(452)
Thursius	D (Eife-l)	- D (Give-l)	(2,502)	+?Igornella	P (Leon)		(1066)
+ Ticinopomis	Tr(Ladi-l)			+?Ilmichthys	C (Moscu)		(1066)
+ Undina	Tr(Nori)?	- K (Berr)	(452,863)	+?Inichthys	P (u)		(1066)
Whiteia	Tr(Indu-u)			Kentuckia	C (l)		
Wimania	Tr(Olen-l)			+?Korutichthys	P (Tatr)		(1066)
+ Yonngichthys	P (Dora)			Ligulalepis	S (Ludl)	- D (l)	
+ Youngolepis	D (Gedi)	- D (Sieg)	(1066)	+?Lophosteus	S (u)		(1066)
				+?Mesolepis	C (Tour)		(1066)

Taxon	First Appearance	Last Appearance	Reference	Taxon	First Appearance	Last Appearance	Reference
+Mimia	D (Fras)			Or. SAURICHTHYIFORMES			
+Moythomasia	D (Eife)	-D (Fame)	(2,502,916)	+Eosaurichthys	P (u)?		(1066)
+Naxilepis	S (Ludl)			+Saurorhynchus	J (Sine)	-J (Toar)	(452,1066)
+?Nematoptychius	C (Tour)		(1066)	Or. PHOLIDOPLEURIFORMES			
+?Neuburgella	P (u)		(1066)	+Arctosomus	Tr(l)?		(1066)
+?Nozamicthys	C (Mose-u)		(1066)	+Australosomus	Tr(l)		(916)
Orvikuina	D (Eife)	-D (Give)?	(502)	+Gracilignathichthys	Tr(Ladi-l)?		(1038)
Osorioichthys	D (u)			+Pholidopleurus	Tr(Ladi-l)	-Tr(Carn)	(916)
Palaeoniscum	P (Guad)		(2,863)	Or. PERLEIDIFORMES			
+?Palaeothrissum	P (l)		(1066)	+Aetheodontus	Tr(Ladi-l)?		(1038)
+?Paradrydenius	C (Tour)		(1066)	+Besania	Tr(Ladi-l)		(1066)
+?Paragonatodus	C (Tour)		(1066)	+Boreichthys	Tr(l)?		(1066)
+?Paralogniscus	P (u)		(1066)	+Chrotichthys	Tr(Indu)		
+?Paramblypterus	C (Bash)		(1066)	+Cleithrolepis	Tr(Anis)		(1066)
+?Paramesolepis	C (Tour)		(1066)	+Colobodus	Tr(Olen)	-Tr(Rhae)	
+?Phaneroesteon	C (l)		(1066)	+Crenolepis	Tr(Anis)		(916)
+?Platysomus	C (Tour)		(1066)	+Ctenognathichthys	Tr(Ladi-l)?		(1038)
+?Plesiococolepis	J (Sine)		(1066)	+Dimorpholepis	Tr		
+?Protamblyptera	C (Tour)		(1066)	+Dipteronotus	Tr(Olen)?	-Tr(Carn)	(1038,1066)
+?Psilichthys	K (Nc)		(1066)	+Dollopterus	Tr(Anis)		(916)
Pteronisculus	Tr(l)			+Gabanellia	Tr(Nori-m)?		
+?Rhabdolepis	P (u)		(1066)	+Gigantopterus	Tr(Carn)		(863)
+?Rhadinichthys	C (Tour)	-C (u)	(1066)	+Helmolepis	Tr(l)		
+?Sakamenchthys	Tr(l)		(1066)	+Hydrossum	Tr(l)		
+?Scanilepis	Tr(Rhae)		(1066)	+Luganoia	Tr(Ladi-l)?		(1038)
+?Sinoniscus	P (u)		(1066)	+Manlietta	Tr(Ladi)		(916)
Songanella	J (Tith-l)		(452)	+Meidichthys	Tr(l)		
+?Stegotrachelus	D (Eife)		(1066)	+Meridensia	Tr(Anis)	-Tr(Ladi-l)	(916,1038)
+Stichopterus	Tr(l)		(916)	+Peltoperleidus	Tr(Ladi-l)?		(1038)
+?Strepeoschema	C (l)		(1066)	+Perleidus	Tr(Olen)?	-Tr(Carn)	(916)
+Strongylosteus	J (Toar-l)		(916)	+Plesiopterleidus	Tr(l)?		(1066)
+Styracopterus	C (Tour)		(1066)	+Procheirichthys	Tr(m)		
+?Sundayichthys	C (l)		(1066)	+?Saurichthyes	Tr(Indu-u)	-Tr(Anis-m)?	(718,916)
Tegeolepis	D (Fame-u)		(2)	+Thoracopecterus	Tr(Olen)?	-Tr(Nori)	
+?Tienshaniscus	P (u)		(1066)	+Tripelta	Tr(l)		
Trachelacanthus	P (u)		(2)	+Zeuchthyscus	Tr(l)?		(1066)
+?Urostheneus	P (Tatr)	-Tr(Ladi)	(1066)	Or. PELTOPLEURIFORMES			
+?Uydenia	P (l)		(1066)	+Habroichthys	Tr(Ladi-l)?		(1038)
+?Wardichthys	C (Tour)		(1066)	+Nannolepis	Tr(Ladi-l)	-Tr(Carn)	(1038)
+?Watsonichthyes	C (Tour)		(1066)	+Peltopleurus	Tr(Ladi-l)	-J (Sine)	(1038,1066)
+Wendychthys	C (Serp-l)			+Peripeltopleurus	Tr(Ladi-l)?		(1038)
+?Westollia	P (Leon)		(1066)	+Placopleurus	Tr(Ladi)	-J (Sine-l)	(2,623)
+?Whiteichthys	C (Tour)		(1066)	+Platysiagum	Tr(Ladi-l)	-J (Sine)	(452,718,1038)
+?Willomoricthys	C (Vise)		(1066)	Or. CEPHALOXENIFORMES			
Or. TARRASIIIFORMES				+Cephaloxenus	Tr(Ladi-l)		(1038,1066)
?Holopterygius	D (Fras)			Or. ACIPENSERIFORMES			
+Palaeophichthys	C (Mose-u)		(1066)	?Acipenser	K (Camp)	-R	
Paratarrasius	C (Serp-l)			?Huso	T (Plio-l)	-R	
Tarrasius	C (Vise)			+Paleosephurus	K (Turo)	-K (Camp)	(916)
Or. PTYCHOLEPIFORMES				+Peipiaosteus	J (Tith)		(1066)
+Chungkingichthyes	J (Toar)		(1066)	+Protoscapirhynchus	K (Turo)?	-K (Camp)?	(2)
+Ptycholepis	Tr(Ladi-l)	-J (Toar-l)	(452,863)	Or. SEMIONOTIFORMES			
+Yachoulepis	J (Toar)		(1066)	Acentrophorus	P (Djuh)?		(1066)
Or. BOBASATRANIFORMES				Alleiolepis	Tr(m)		
+Bobasatrania	Tr(Olen)?	-Tr(Carn)	(1038,1066)				
+Ebenaqua	P (u)		(1066)				
+Ecrinesomus	Tr(Carn)		(1066)				
+Polzbergia	Tr(Carn)		(1066)				

Taxon	First Appearance	Last Appearance	Reference	Taxon	First Appearance	Last Appearance	Reference
+ Allelepidotus	Tr(m)		(1066)	+ Aphanepygus	K (Ceno-1)		(1066)
Aphelolepis	Tr(Carn)			Broughia	Tr(l)		
Archaeolepidotus	Tr(l)			Callopterus	J (Tith-l)		(452)
Asialepidotus	Tr(m)			Caturus (+ Strobilodus)			
+ Austrolepidotus	J (Toar)?		(452)		Tr(u)	- J (Tith-u)	(718)
+ Callopterus	J (Kimm)		(1066)	Eoeugnathus	Tr(Ladi)	- Tr(u)	(2)
+ Corunegenys	Tr(u)		(746)	Eusemius	J (Tith-l)		(452)
Dandya	Tr(Nori)		(863)	Furo	Tr(u)?	- J (Tith-u)	(718,863)
Dapedium	Tr(Nori)	- J (Bajo)	(452)	Heterolepidotus	Tr(Nori)	- J (Tith-l)	(452,1066)
Enigmaticichthys	Tr(m)			Ionosopus	J (Kimm-u)	- K (Apti)	(2,863)
Eosemionotus	Tr(Olen)?	- Tr(Anis-u)		Jacobulus	Tr(l)		
+ Hemicalypterus	Tr(u)		(746)	Leedsichthys (+ Leedsia)			
Heterostrophus	J (Call)	- J (Tith-l)	(452,863)		J (Call-m)	- J (Oxfo)	
Lepidotus	Tr(Carn)	- K (Maes)	(2,1066)	+ Lehmanotus	Tr(l)		(1066)
Lepisosteus	K (u)	- R		+ Liodesmus	J (Tith-l)		(452)
+ Oligopleurus	J (Kimm)		(1066)	Lophiostomus	K (Ceno)	- K (Turo)	(863)
Orthurus	Tr(Carn)			Macrepistius	K (Albi)		(1066)
+ Oshunia	K (Ceno)		(1066)	Neorhombolepis	K (l)	- K (Turo)	(2)
Paralepidosteus	K (Albi)?	- K (Camp)?	(2)	+ Omddenia	J (Toar-l)		(452)
Paralepidotus	P (Tatr)?	- Tr(Rhae)		+ Oligopleura	J (Tith-l)		(452)
+ Pericentrophus	Tr(l)		(746)	Ospia	Tr(Indu)		(863)
+ ?Plesiolepidotus	Tr(Carn)	- Tr(Nori)		Osteorachis	J (Sine)	- J (Call)	(452)
Prionoepleurus	J (l)	- J (u)		Otomitla	K (l)		
Pristiosomus	Tr(u)			Paracentrophorus	Tr(Indu)		(2)
+ ?Prolepidotus	Tr(Rhae)?			Parasemionotus	Tr(Indu)		
Sargodon	Tr(Nori)	- Tr(Rhae)	(863)	Sinoeugnathus	Tr(Ladi)		(2)
+ Semionotus	Tr(m)	- J (l)		Stensioonotus	Tr(l)		
Serrolepis	Tr(m)	- Tr(u)		Stromerichthys	K (u)		
Sinosemionotus	Tr(m)			Thomasiotus	Tr(Indu)		(863)
+ Spathiurus	K (Ceno)		(1066)	Tungusichthys	Tr(l)		
+ Tetragonolepis	J (Toar)	- J (u)	(452,746)	Watsonulus	Tr(l)		

Or. PYCNODONTIFORMES

Acrotenuus	K (u)		
Anomoecodus	K (Ceno)	- K (Maes)	(863)
Athrodon	J (Tith-l)	- K (u)	(452)
+ Brembodus	Tr(Nori)		(1066)
Coccodus	K (Ceno-1)		(718)
Coelodus	J (Kimm)	- K (Turo)	(452,718)
Eomesodon	Tr(Nori)	- J (Tith-u)	(2,452)
+ Gibbodon	Tr(Nori)		(1066)
Grypodon	K (u)		
Gyrodus	J (Bajo)	- K (u)	(452)
Gyronchus (+ Mesoda, Macromesodon, Uranoplasus)			
	J (Bajo)	- J (u)?	(452,863)
+ Ichthyoceras	K (Ceno-1)		(1066)
+ Mesturus	J (Toar)	- J (Kimm)	(452,1066)
Micropycnodon	K (Sant)		(1066)
+ Nursallia	K (Sant)	- T (Eo-m-l)	(1066)
Palaeobalistum	K (u)	- T (Eo-m-l)	(2,1066)
Polygyrodus	K (u)		
Proscinetes (+ Microdon)			
	J (Bath)	- J (Tith-u)	(452,863)
Pycnodus	J (u)	- T (Eo-m-u)	
Stemmatodus	K (l)		
Tibetodus	J (u)		
Trewavasia	K (Ceno-1)		(1066)

Or. AMIIFORMES

Allolepidotus	Tr(m)	- Tr(u)	
+ Amiopsis	J (Tith-l)	- J (Tith-u)	(452)

Or. MACROSEMIIFORMES

Enchelyolepis	J (Tith-u)	- K (Haut)	(452,1066)
Histionotus	J (Kimm)	- K (l)	(452)
Legnonotus	Tr(Carn)	- Tr(Rhae)	(1066)
Macrosemius	J (Kimm)?	- J (Tith-l)	(452,718)
Notagogus	J (Tith-l)	- K (l)	(452)
Ophiopsis	Tr(Ladi)	- J (Tith-l)	(2,718)
Petalopteryx	K (l)	- K (Ceno)	(2)
Propterus	J (Tith-l)	- K (l)	(452)
Uarbyichthys	J		

Or. PACHYCORMIFORMES

Aetheolepis	J (m)		(915)
Allotrissops	J (Kimm-u)	- J (Tith-l)	(2,915)
+ Ankylophorus	J (Kimm-u)		(915)
+ Aphelopsis	J (m)		(915)
Archaeomaene	J (Bajo)		(718,915)
+ Ascalobos	J (Tith-l)	- K (Haut-u)	(452,915)
Aspidorhynchus	J (Bath)	- J (Tith-u)	(2,452)
Asthenocormus	J (Call)	- J (Tith-l)	(452)
+ Atacamichthys	J (Oxfo)		(915)
Austroleuropholis	J (Tith-l)		(2)
+ Baleiichthys	J (m)		(915)
Belonostomus	J (Kimm)	- K (Maes)	(2,452,915)
+ Bobbichthys	J (Oxfo)		(915)
Ceramurus	J (Tith-u)		(2,452,863)
Chirocentrites (+ Spathodactyles)			
	K (Nc)	- K (Ceno)	(915)
Cladoicyclus	K (Nc)	- K (Apti)	(915)

Taxon	First Appearance	Last Appearance	Reference
?Clupavus	J (Tith-u)	-K (Ceno)	(2)
+Domeykos	J (Oxfo)		(915)
+Elpistioichthys	Tr(Carn)		(915)
+Eubiodes	K (Ceno)		(746,915)
Eugnathides	J (Oxfo)	-J (Tith-l)	(452)
+Eurycormus	J (Call)	-J (Tith-l)	(915)
Euthynotus	J (Toar-l)		(452,915)
?Eurystichthys	J (Kimm)		(863)
?Flugopterus (+ Megalopterus)	Tr(Carn)		
+Gillicus	K (Albi)	-K (Camp)	(746,915)
+Hengnania	J (l)		(915)
Hungkiiichthys	J (u)		
Hypsocormus	J (Call)	-J (Tith-u)	(452,915)
Ichthyodes	K (Albi-u)	-K (Camp)	(915)
Ichthyokentema	J (Tith-u)		(1066)
+Koonwarria	K (Apti)?, K (Albi)?		(915)
+Leptolepides	J (Tith-l)		(746,915)
Leptolepis	J (Toar-l)	-K (Apti)?	(915)
Ligulella	J (Tith-l)		(2)
Luisichthys	J (Oxfo)	-J (Tith-l)?	(452)
+Luisiella	J (Kimm)		(915)
+Madariscus	J (m)		(915)
Mesocleupea	K (l)		
+Neopachycormus	K (Ceno)		(915)
+Neopholidophoropsis	K (Apti)		(915)
	J (Bath)		(746,915)
+Oreochima	J (m)		(915)
Orthocormus	J (Kimm-u)	-J (Tith-l)	(452,915)
Pachycormus	J (Toar-l)	-J (Call)?	(452,915)
Pachytrissops	J (Tith-l)	-K (Nc)	(915)
+Parapholidophorus	Tr(Nori-m)		(915)
Parapleuropholis	J (Tith-l)		(2)
+Pholidoctenus	Tr(Nori-m)		(915)
+Pholidolepis	Tr(u)	-J (Sine-l)	(452)
+Pholidophoretetes	Tr(Carn)		(915)
Pholidophoristion	J (Tith-l)	-K (Apti)	(915)
Pholidophorooides	J (Sine-l)		(452)
+Pholidophoropsis	J (Sine)		(915)
Pholidophorus	Tr(Nori-m)	-K (Apti)	(718,915)
+Pholidorhynchodon	Tr(Nori-m)		(915)
Pleuropholis	J (Kimm-u)	-K (Apti)	(915,1066)
Prohalecites	Tr(Ladi-l)	-Tr(Carn)	(2)
+Proleptolepis	J (Sine-u)		(915)
+Prosauropsis	J (Toar-l)		(746,915)
+Protoleupea	J (Oxfo)	-J (Tith-l)	(452,915)
Protosphyraena	K (Albi)	-K (Camp)	(2,915)
Prymetes	K (u)		
Saurocephalus	K (Coni)	-K (Maes-l)	(915)
Saurodon	K (Ceno)	-K (Maes-l)	(863)
Sauropsis	J (Toar-l)	-J (Tith-l)	(915,1066)
+Saurostomus	J (Toar-l)		(915)
+Seefeldia	Tr(Nori)		(915)
?Spathiurus	K (Camp)		(2)
+Tharsis	J (Kimm)	-K (Berr)	(915)
Thrissops	J (Kimm-u)	-J (Tith-u)	(452,915)
+Todilia	J (Call)		(452)
+Varasichthys	J (Oxfo)?		(452)
+Vinctifer	K (Apti)		(915)
+Wadeichthys	K (Apti)?, K (Albi)?		(915)
Xiphactinus	K (Albi)	-K (Camp)	(915)

Taxon	First Appearance	Last Appearance	Reference
Or. OSTEOGLOSSIFORMES (mostly freshwater)			
Brychaetus	T (Than-l)	-T (Eo-l)	(915)
+Opsithrissops	T (Than)?		(915)
incertae sedis	J (Bath)		(560)

Or. ELOPIFORMES

?Anaethalion	J (Kimm-u)	-K (Vala-l)	(452,915)
+?Antofastaichthys	J (Oxfo)		(915)
?Carsothrissops	K (Ceno)		(915)
+Chongichthys	J (Oxfo)		(452)
?Coryphaenopsis	K (Turo)		(863)
Dactylopon	K (Camp)		(915)
+Davichthys	K (Ceno)	-K (Sant)	(915)
Ectasis	T (Mi-u)?		(915)
+?Eichstaettia	J (Tith-l)		(915)
Elops	T (Eo-l)	-R	(560)
?Eoprotelops	J (Kimm-u)		(915)
?Esocelops	T (Eo-l)		
?Flindersichthys	K (Albi)		(915)
-Lyrolepis	T (Eo-u)		(915)
Notelops	K (Apti-u)		(863,915)
Opistopteryx	K (Sant)		(915)
Osmeroides	K (Apti-u)	-K (Camp)	(915)
Ostariostoma	K (u)		
Pronotacanthus	K (Sant)		(915)
Protostomias	K (Ceno-l)		(2)
?Protelops	K (Ceno)	-K (Turo)	(863)
Tachynectes	K (Turo)	-K (Camp-u)	(363,915)

Or. MEGALOPIFORMES

Broweria	T (Mi)		
+Elopoidea	K (Albi-u)		(915)
Megalops	T (Mi-u)	-R	(915)
+Paratarpon	K (Camp)		(915)
+Promegalops	T (Eo-l)		(915)
+Protarpon	T (Eo-l)		(915)
Sedenhorstia	K (Ceno)	-K (Camp)	(915)

Or. ANGUILLIFORMES

Albula	K (Sant)	-R	(915)
Anguilla	T (Eo-l)	-R	(560)
Anguillavus	K (Ceno-u)		(915)
+Anguilloides	T (Eo-m-l)		(746)
Ariosoma	T (Ol-l)	-R	(503)
+Bolcanguilla	T (Eo-n)		(746)
+Bolcyrus	T (Eo-m-l)		(746)
Brannerion	K (Apti-u)		
+Casierius	K (Albi)		(915)
Conger	T (Eo-l)	-R	(915)
+Coriops	K (Maes)		(915)
+Dapiazella	T (Eo-m-l)		(746)
Deprandus	T (Mi-u)		(915)
Dinelops	K (Ceno)?, K (Turo)?		(915)
Echelus	T (Mi)	-R	(915)
Echidnocephalus	K (Camp)		(915)
+Egertonia	T (Than)	-T (Eo-m)	(746,915)
Enchelion	K (Ceno-u)		(863)
Enchelurus	K (Ceno)	-K (Camp)	(2,915)
+Eoanguilla	T (Eo-m-l)		(746)
+Eodiaphodus	K (Maes)	-T (Pale)	(915)
+Eomuraena	T (Eo-l)		(915)

Taxon	First Appearance	Last Appearance	Reference	Taxon	First Appearance	Last Appearance	Reference
?Eomyrophis	T (Eo-m)	-R	(746)	†Martineichthys	K (Coni)		(915)
+Eomyrus	T (Eo-m-l)		(915)	†Moorovillia	K (Camp)		(915)
+Gazolapodus	T (Eo-m)		(746)	Niobrara	K (Coni)?, K (Sant)?		(915)
+Gnathophis	T (Eo-l)	-R	(915)	Pachyriodus (+ Thrissoptatea)			
+Goslinophis	T (Eo-m-l)		(746)	K (Albi)	-K (Camp)		(915)
Haljulia	K (Ceno-u)		(2)	Paranogmius	K (Ceno)		(863)
+Hildebrandia	T (Eo-m-l)	-R	(560)	Platinx	T (Than)	-T (Eo-m-l)	(915)
+Hoplunnis	T (Eo-l)	-R	(915)	Plethodus	K (Albi)	-K (Turo)	(915)
Isties	K (Sant)	-K (Camp)	(915)	Protobrama	K (Ceno)		(863)
†Japonoconger	T (Plio)	-R	(915)	Rhacolepis	K (Apti-u)		(915)
Laytonia	T (Mi-u)		(915)	Syntengmodus	K (Coni)?, K (Sant)?		(915)
+Lebonichthyes	K (Ceno)	-K (Sant)	(915)	Tsellatia	K (Ceno)	-K (Turo)	(915)
Mastygoercus	T (Mi-l-u)	-R	(915)	Zanclites	K (Sant)		(915)
+Micromyrus	T (Eo-l)		(915)				
†Milananguilla	T (Eo-m-l)		(746)				
Muraena	T (Mi-u)	-R	(718,915)				
Muraenesox	T (Eo-l)	-R	(560)				
Mylomyrus	T (Eo-m-l)		(718)				
+Myroconger	T (Ol-l)?	-R	(915)				
+?Mystriophis	T (Mi)?	-R	(746)				
?Nettastoma	T (Eo-m-l)	-R					
Notacanthus	T (Eo-m-l)	-R	(560)				
+?Ophisurus	T (Mi-m)	-R	(503)				
+Palaomyrus	T (Eo-l)		(915)				
+Panturichthys	T (Mi-m)	-R	(503)				
Paralbula	K (Camp)	-T (Eo-u)	(915)				
Paranguilla	T (Eo-m-l)		(746)				
†Paraconger	T (Eo-l)	-R	(560)				
+Paracongroides	T (Eo-m-l)		(746)				
†Parechelus	T (Eo-l)		(915)				
+Patavichthys	T (Eo-m-l)		(746)				
+?Pisodonophis	T (Mi-m)	-R	(503)				
†Phyllodus	T (Dani)	-T (Eo-l)	(746,915)				
+Proserriomer	T (Ol-l)		(915)				
+Proteomyrus	T (Eo-m-l)		(746)				
+Pseudogertonia	T (Dani)?		(746)				
+Pseudoplichthyes	T (Eo-u)	-R	(503)				
+Pseudoxenomystax	T (Plio-l)	-R	(560)				
Pterothrissus	K (Camp)	-R	(915)				
+Rhechias	T (Eo-u)	-R	(503)				
†Rhynchoconger	T (Mi-m)	-R	(560)				
†Rhynchocyamba	Q (Plei)		(915)				
Rhynchorhinus	T (Eo-l)		(915)				
+Scalanago	T (Mi-m)	-R	(915)				
+?Taenioconger	T (Ol-u)	-R	(503)				
Urenchelys	K (Ceno-u)	-K (Sant)	(2,915)				
?Uroconger	T (Mi)	-R	(746)				
+Veronanguilla	T (Eo-m-l)		(746)				
+Voltaconger	T (Eo-m-l)		(746)				
+Whitapodus	T (Eo-m-l)		(746)				
Or. CROSSOGNATHIFORMES							
Apsopelix (+ Holmintholepsis)							
	K (Albi)	-K (Maes)?	(915)				
†Araripichthys	K (Apti)		(915)				
Bananogmius (+ Thryptodus)							
	K (Coni)?	-K (Camp)	(863)				
+Crossognathus	K (Barr)	-K (Albi)	(915)				
Elopopsis	K (Ceno)	-K (Camp)	(915)				
†Eni-schorhynchus	K (Turo)		(915)				
+Greenwoodella	K (Apti-l)		(915)				
†Luxilites	K (Coni)		(915)				
Or. CLUPEIFORMES							
				Alisea	T (Mi-u)		(915)
				Alosa	T (Eo-u)	-R	(560)
				+Anchoa	T (Mi-l)	-R	(560)
				Austrorlupea	T (Plio)?		
				+Chirocentrus	T (Eo-m-l)	-R	(915)
				Clupea	T (Eo-l)?	-R	(915)
				+?Daitingichthys	J (Tith-l)		(915)
				Engraulis	T (Mi-u)	-R	(746,915)
				Etringus	T (Mi-u)		(915)
				Etrumeus	T (Eo-m)	-R	(560)
				Ganoessus (+ Lembicus, Epelichthys)			
					T (Mi-u)		(915)
				Ganolytes	T (Mi-u)		(915)
				Gasterorlupea	K (Maes)		(915)
				?Hacquetia	T (Eo-m-l)		(863)
				+Harengula	T (Eo-l)	-R	(560)
				?Histiobrissa	K (Sant)		
				+Ilisha	T (Mi-l)	-R	(560)
				Knighia	T (Than)	-T (Eo-l)	(915)
				Opisthonema	T (Ol-l)	-R	(915)
				+?Ornatogulium	K (Ceno)		(915)
				Pachythrissops	J (Oxfo)	-J (Tith-l)	(452)
				Pomolobus	T (Ol-l)	-R	(915)
				Pseudohilsa	T (Mi-m)	-R?	(915)
				Quisque	T (Mi-u)		(915)
				Sardina	T (Ol-u)?	-R	(915)
				Sardinella	T (Eo-m)	-R	(560)
				+Sardinops	T (Mi-l)	-R	(503)
				Sarmatella	T (Mi-u)	-R?	(915)
				Scambroclupea	K (Ceno)		(915)
				?Stolephorus	T (Mi)	-R	
				Xyne (+ Xyrinus)	T (Mi-u)		(915)
Or. GONORHYNCHIFORMES							
				+Aethalionopsis	K (Berr)		(915)
				Caeus (+ Prochanos)	K (Apti)	-K (Ceno)?	(863,915)
				+Chanoides	T (Eo-m-l)		(746)
				Chanopsis	K (Apti)?		(915)
				Chanos	T (Eo-l)	-R	(915)
				+Charitopsis	K (Ceno-l)		
				Charitosomus	K (Ceno-u)	-K (Sant)	(2,915)
				+Coelogaster	T (Eo-m-l)		(915)
				Dastilbe (+ Parachonus)			
					K (Apti)		(915)
				+Halecopsis	T (Eo-l)		
				+Judeichthys	K (Ceno-l)		(915)

Taxon	First Appearance	Last Appearance	Reference	Taxon	First Appearance	Last Appearance	Reference
+?Lusitanichthys	K (Ceno)		(915)	Chauliodus (+ Eostomias)			
+Neohalecopis	T (Ol-l)		(915)		T (Mi-u)	-R	(915)
Notogoneus	T (Than)	-T (Ol-u)	(915)	Cyclothone	T (Mi-u)	-R	(915)
+Ramallichthys	K (Ceno-l)		(915)	+Danaphos	T (Eo-u)	-R	(915)
+Rubiesichthys	K (Vala-l)	-K (Haut-u)	(915)	Gonostoma	T (Mi-u)	-R	(915)
+?Salminops	K (Ceno)		(915)	+Ichthyococcus	T (Mi-u)	-R	(915)
Tharrhias	K (Apti)		(863,915)	Idrissa	K (Ceno-l)	-T (Ol-l)	(2,915)
Or. SILURIFORMES				+Maurolicus	T (Mi-l-u)	-R	(503)
Arius	K (Maes-l)	-R		Obuus	T (Mi-m)		(915)
Eopeyeria	T (Eo-u)		(915)	Paraviniguerria	K (Ceno-l)		(2)
+Selenaspis	T (Mi-m)	-R	(915)	Photichthys	T (Plio)	-R	(915)
+incertae sedis	K (Camp)		(915)	Polyipnoides (+ Palaeotroctes)			(915)
Or. OSMERIFORMES					T (Eo-m)		(915)
+Allosmerus	Q (Plei)	-R	(560)	Polyipnus	T (Ol-l)	-R	(2,915)
Argentina	T (Eo-l)	-R	(560)	+Polymetme	T (Eo-l)	-R	(915)
Bathylagus	T (Mi-m)	-R	(915)	+?Polymetmeaglecosus			
+Carpathichthys	T (Ol-u)		(915)		T (Mi-l)	-R	(560)
+Enoplophthalmus	T (Ol-l)		(915)	+Praewoodsia	T (Ol-l)		(915)
+Hypomesus	T (Ol-u)	-R	(915)	+Sahelinia	T (Mi-u)	-T (Plio)	(915)
Mallotus	Q (Plei)	-R	(915)	Scopeloides	T (Ol-l)		(863)
+Maulisia	T (Plio)	-R	(915)	Sternoptyx	T (Ol-l)	-R	(915)
+Nansenia	T (Mi-u)	-R	(560)	+Valenciennellus	T (Eo-l)	-R	(915)
+Nybelinoides	K (Berr)		(915)	Vinciguerria	T (Eo-m)	-R	(915)
+Ophisthoproctus	T (Eo-u)	-R	(915)	Or. ALEPISAUROFORMES			
Osmerus	T (Than)	-R	(915)	+Alepisaurus	T (Mi-m)	-R	(915)
Proargentina (+ Glossadon)				Apateodus	K (Albi)	-K (Maes-l)	(915)
	T (Eo-m)	-T (Ol-l)	(2,915)	+Apateopholis	K (Ceno-u)		(915)
+Spirinchus	T (Plio)	-R	(560)	+Argillichthys	T (Eo-l)		(915)
Or. SALMONIFORMES				+?Cheirotrix	K (Sant)	-K (Camp)	(915)
+?Barcarenichthys	K (Ceno)		(915)	Cimolichthys	K (Ceno)	-K (Maes)	(718)
+?Casieroides	K (Nc)		(915)	+Cyanichthys	K (Ceno)		(915)
+?Chardonius	K (Nc)		(915)	Dercetis (+ Trianaaspis, Benthesisikyme)			
+Eosalmo	T (Eo-m)		(915)		K (Turo)	-K (Camp-u)	(863,915)
+?Gaudryella	K (Ceno)		(915)	+Dercetoides	K (Ceno-l)		(915)
+?Gharbouria	K (Ceno)		(915)	+Drimys	T (Mi-u)		(915)
+?Ginsburgia	K (Ceno)		(915)	Enchodus (+ Hokodon)			
?Goudkoffia	K (Maes)		(2)		K (Ceno-l)	-T (Dani)	(915)
+Helgolandichthys	K (Apti)		(915)	Eurypholis	K (Ceno-u)	-K (Turo)	(915)
+Hucho	T (Mi-u)		(915)	+Evermanella	T (Plio)	-R	(560)
?Natlandia	K (Maes)		(2)	+?Exocoetoides	K (Ceno)		(915)
+Oncorhynchus	T (Plio)	-R	(915)	Halec	K (Ceno)	-K (Sant)	(915)
+Prosopium	T (Mi-u)	-R	(915)	+Hemisaurida	K (Ceno)		(915)
+?Pseudoberyx	K (Ceno)		(915)	Holosteus	T (Eo-m)	-T (Ol-l)	(915)
+?Pseudoleptepis	K (Nc)		(915)	+Ichthyotringa	K (Ceno-l)	-K (Camp)	(2,863,915)
+Rhabdofario	T (Mi-u)	-T (Plio)	(915)	Leptecodon	K (Sant)		(915)
Salmo	T (Mi-l-l)?		(718)	+Lestidiops	T (Eo-l)	R	(915)
Salvelinus	T (Mi-u)	-R	(915)	Palaeocyclus	K (Camp)		(915)
+Similodonichthys	T (Mi-u)	-T (Plio)	(915)	Pantophilus	K (Sant)		(915)
Thaumaturus (+ Prohydrocyon)				Paralepis	T (Mi-u)	-R	(915)
	T (Eo-m-l)	-T (Mi-l-l)?	(2,718)	Parascopelus	T (Mi-u)		(915)
Thymallus	Q (Plei)	-R	(915)	+Parenchodus	K (Ceno-u)		(915)
+?Umbrina	T (Mi-l-l)	-R	(503)	+Pelargothynchus	K (Camp-u)		(863)
Or. STOMIIFORMES				+Phylactoecephalus	K (Ceno-u)		(915)
+Argyripnus	T (Ol-u)	-R	(503)	Prionolepis	K (Ceno)	-K (Turo)	(915)
Argyropelecus	T (Eo-m-l)	-R	(560)	Rharbichthys	K (Ceno)		(915)
+Astronesthes	T (Eo-m)	-R	(915)	Rhynchodercetis	K (Ceno-l)	-K (Ceno-m)	(915)
				+Saurida	T (Eo-l)	-R	(560)
				+Saurorhamphus	K (Ceno-u)		(915)
				Stratodus	K (Camp)	-K (Maes)	(915)
				+Synodus	T (Mi-l)	-R	(503)
				?Telepholis	K (Ceno)	-K (Camp-u)	(863)
				Volclichthys	K (Ceno)		(915)

Taxon	First Appearance	Last Appearance	Reference	Taxon	First Appearance	Last Appearance	Reference
Or. AULOPIFORMES				+Pharmacichthys	K (Ceno-u)		(915)
+Acrognathus	K (Ceno)	-K (Sant)	(915)	Pseudotetrapterus	T (Ol-l)?	-T (Ol-u)	(863,915)
+Aulopopsis	T (Eo-l)		(915)	Or. POLYMIXIIFORMES			
+Aulopus	T (Eo-l)	-R	(560)	+Aipichthyoides	K (Ceno-l)		(915)
+Chlorophthalmus	T (Eo-u)	-R	(560)	Aipichthys	K (Ceno-l)		(2)
+Labrophagus	T (Eo-l)		(915)	+Berycopsia	K (Turo)		(915)
Nematonotus	K (Ceno-l)		(915)	Berycopsis	K (Ceno)	-K (Camp-u)	(863)
-?Notolepis	T (Plio)	-R	(560)	-Dalmatichthys	K (Sn)		(915)
-Scopelarchus	T (Ol-u)	-R	(503)	Homonotichthys	K (Ceno)		(915)
-Scopelosaurus	T (Eo-u)	-R	(560)	Omosoma	K (Ceno-l)	-K (Camp)	(2,915)
Or. "CTENOTHRISSIFORMES"				-Paraipichthys	K (Ceno-l)		(915)
Aulolepis	K (Ceno-u)		(2)	Polymixia	T (Eo-u)	-R	(915)
Ctenothrissa	K (Ceno-u)	-K (Turo)?	(2)	Pycnosterinx	K (Sant)		(915)
+Heterothrissa	K (Ceno-u)		(915)	Or. OPHIDIIFORMES			
+Humilichthys	K (Ceno-u)		(915)	-Ampheristus	T (Pale)	-T (Eo-u)	(560,915)
Pateroperca	K (Ceno-u)		(2)	-Bassozetus	T (Mi-u)	-R	(915)
+Pattersonichthys	K (Ceno-u)		(915)	+Benthocomectes	T (Eo-m)	-R	(560)
+Phoenicolepis	K (Ceno-u)		(915)	Brotula	T (Eo-l)	-R	(560)
+Protracanthus	K (Ceno-l)	-K (Ceno-u)	(2,915)	Carapus	T (Eo-m)	-R	(560)
Or. MYCTOPHIFORMES				-Chilara	T (Plio)	-R	(560)
+Benthosema	T (Mi-m)	-R	(560)	+Dannevigia	T (Eo-m)	-R	(915)
+Bolinichthys	T (Mi-l-u)?	-R	(503)	-Dermatopsis	T (Mi-m)?	-R	(915)
Ceratoscopus (+ Ceratoscopus)				+Diplacanthopoma	T (Ol-l)	-R	(560)
	K (Plio-l)	-R	(560)	+Dipulus	T (Eo-u)	-R	(915)
?Chirothrix	K (Sant)		(718)	+Echiodon	T (Ol-u)	-R	(503)
Diaphus	T (Eo-l)	-R	(915)	+Eolamprogrammus	T (Dant)		(915)
+Electrona	T (Mi-u)	-R	(560)	Glyptophidium	T (Eo-l)	-R	(560,915)
+Eokreffia	T (Pale)		(915)	+Hoplobrotula	T (Eo-m)	-R	(560)
Eomyctophum	T (Eo-m)	-T (Ol-u)	(915)	+Lepophidium	T (Mi-l)	-R	(560)
-Gymnoscopus	T (Plio)	-R	(560)	-Monomitus	T (Eo-m)	-R	(560)
+Hygophum	T (Ol-u)?	-R	(503)	Neobrythites	T (Eo-m)?	-R	(915)
+Lampadena	T (Plio)	-R	(915)	-Nolfophidion	T (Eo-m)	-T (Mi-l)	(915)
+Lampanyctodes	T (Mi-u)	-R	(560)	Ogilbia	T (Than)?	-R	(560)
Lampanyctus	T (Mi-u-l)	-R	(915)	-Oligopus	T (Eo-l)	-R	(560)
-Lampichthyes	T (Mi-u)	-R	(560)	-Onuxodon	T (Eo-l)	-R	(560)
-Lobianchia	T (Ol-u)?	-R	(503)	Ophidion	T (Eo-m-l)?	-R	(915)
Myctophum	T (Mi-u)?	-R	(915)	+Propteridium	T (Ol-l)		(915)
-Neocassandra	T (Pale)		(915)	Protobrotula	T (Ol-l)		(2,863)
+Notoscopelus	T (Mi-m)	-R	(560)	+Sacogaster	T (Eo-u)	-R	(915)
+Parvilux	T (Plio)	-R	(560)	-Siremo	T (Ol-u)	-R	(560)
+Protomyctophum	T (Plio)	-R	(560)	+incertae sedis	K (Camp)		(915)
Sardinus	K (Camp)		(915)	Or. BATRACHOIDIFORMES			
Sardinoides (+ Cassandra)				Batrachoides	T (Mi-u)	-R	(915)
	K (Ceno-l)	-K (Camp)	(2,915)	+Perulibatrachus	T (Mi)	-R	(560)
-Scopelopsis	T (Plio-l)	-R	(560)	+Porichthys	T (Mi-u)	-R	(1012)
-Stenobranchius	T (Plio)	-R	(560)	+incertae sedis	T (Eo-l)	-T (Ol-l)	(915)
-Symbolophorus	T (Mi-l-u)	-R	(503)	Or. LOPHIIFORMES			
-Tarletonbeania	T (Plio)	-R	(560)	+Antennarius	T (Eo-l)	-R	(560)
+Triphoturus	T (Plio)	-R	(560)	+Brachionichthys (+ Histonotophorus)			
Or. ACANTHOMORPHA INCERTAE SEDIS					T (Eo-m-l)	-R	(915)
-Asineops	T (Than)	-T (Eo-m-l)	(915)	+Chaunax	T (Eo-u)	-R	(560)
Blochius	T (Eo-m-l)		(2,863)	+Dibranchus	T (Eo-u)	-R	(560)
Congorhynchus	K (Maes)	-T (Eo-l)	(915)	Lophius	T (Eo-m-l)	-R	(2)
Cylindracanthus	K (Ceno-u)	-T (Eo-u)	(915)	+Ogcocephalus	T (Eo-m)	-R	(560)
-Enniskillenus	T (Eo-l)		(915)				
Homorhynchus	T (Eo-m)	-T (Ol-l)	(915)				
+Omosomopsis	K (Ceno)		(915)				
Palaeorhynchus	T (Eo-m)	-T (Mi-l)	(915)				

Taxon	First Appearance	Last Appearance	Reference	Taxon	First Appearance	Last Appearance	Reference
Or. GADIFORMES							
+ Austrophycis	T (Mi-l)	-R	(560)	Menidia	T (Plio)	-R	(915)
+ Bathygadus (= Azalois, Lygisma)	T (Eo-u)	-R	(915)	+ Palaeoatherina	T (Eo-u)	-T (Mi-u)	(915)
Bolbocara	T (Mi-u)	(2)	(915)	+ Pranesus	T (Eo-u)	-R	(560)
Bregmacerina	T (Mi-l)	(915)	(915)	+ Stenatherina	T (Ng)	-R	(560)
Bregmaceros	T (Eo-m)	-R	(560)	Or. BELONIFORMES			
+ Brosme	T (Mi-u)	-R	(560)	Belone	T (Ol-l)	-R	(915)
?Brosmius	T (Ol-u)?	-R	(915)	Cobitopsis	T (Ol-l)	-R	(915)
Coelorhynchus	T (Eo-u)	-R	(915)	Euleptorhamphus (+ Derhias)	T (Mi-u)	-R	(915)
+ Coryphaenoides	T (Ol-u)	-R	(560,915)	?Hemilampronites	K (Maes)	(2)	(915)
Eclipses	T (Mi-u)	(915)	(915)	Hemirhamphus	T (Eo-m-l)	-R	(2)
+ Eophycis	T (Ol-l)	(915)	(915)	+ Hyporhamphus	T (Mi-u)	-R	(1012)
+ Eulichthys	T (Eo-u)	-R	(560)	+ Rhamphexocoetus	T (Eo-m)	(915)	(915)
+ Gadella	T (Plio)	(915)	(915)	+ Scomberesox	T (Mi-u)	-R	(915)
+ Gadculus	T (Ol-l)	-R	(503)	+ Xiphopterus	T (Eo-m-l)	(915)	(915)
+ Gadomus	T (Mi-u)	-R	(915)	Or. BERYCIFORMES			
Gadus	T (Mi-u)	-R	(915)	Acrogaster	K (Sant)	-K (Camp-u)	(863)
+ Gaidropsarus	T (Ol-l)	-R	(560)	+ Adriacentrus	K (Turo)	(915)	(915)
Hymenocephalus	T (Ol-l)	-R?	(915)	Africentrum	T (Mi-u)	(915)	(915)
+ Laemonema	T (Mi-m)	-R	(915)	+ Alloberyx	K (Sant)	(915)	(915)
Lepidion	T (Mi-m)	-R	(915)	+ Argilloberyx	T (Eo-l)	(915)	(915)
Lota	T (Ol-l)	-R	(915)	+ Berybolicensis	T (Eo-m-l)	(746)	(746)
+ ?Lycodopsis	T (Plio)	-R	(560)	+ Berycomorus	T (Ol-l)	(915)	(915)
Macruronus	T (Eo-u)	-R	(915)	Beryx	T (Eo-u)	-R	(915)
Melanogrammus	T (Plio)	-R	(915)	+ Caproberyx	K (Turo)	-K (Sant)	(915)
Melanonus	T (Than)	-R	(915)	+ Centroberyx	T (Pale)	-R	(915)
Merlangius	T (Mi-m)	-R	(560)	+ Cryptoberyx	K (Ceno)	(915)	(915)
Merluccius	T (Eo-l)	-R	(915)	+ ?Ctenoberyx	T (Pale)	-R	(560)
+ Microgadus	T (Plio)	-R	(560)	+ Ctenocephalichthys	K (Sant)	(915)	(915)
+ Micromesistius	T (Ol-u)	-R	(560)	+ Digoria	T (Ol-l)	(915)	(915)
Molva	T (Mi-m)	-R	(915)	Dinopteryx	K (Sant)	(915)	(915)
+ Nezumia	T (Than)	-R	(560)	+ Diretmus	T (Ol-l)	-R	(915)
Palaeogadus	T (Than)	-T (Mi-m)	(560,915)	+ Eoholocentrum	T (Eo-m-l)	(746)	(746)
Palaeomolva	T (Ol-u)	-T (Mi-m)	(915)	+ Erugocentrus	K (Turo)	(915)	(915)
?Paraticthys	K (Camp)?	-K (Maes)	(2)	Gephyroberyx	T (Eo-m)	-R	(560)
+ Paratrisopterus	T (Mi-u)	-R?	(560)	+ Gnathoberyx	K (Sant)	(915)	(915)
+ Phycis	T (Ol-l)	-R	(560,915)	Holocentrites	T (Eo-u)	-T (Ol-l)	(863)
Physiculus	T (Mi-l)	-R	(503)	Holocentrus	T (Eo-l)	-R	(560)
+ Pollachius	Q (Plei)	(915)	(915)	Hoplopteryx	K (Ceno)	-K (Camp)	(2,915)
+ Pseudophycis	T (Plio)	(915)	(915)	Hoplostethus	T (Eo-l)	-R	(560)
+ Pseudoraniceps	T (Ol-u)	-T (Mi-l)	(915)	+ Inocentrus	K (Sant)	(915)	(915)
Raniceps	T (Than)	-R	(560)	+ Judeoberyx	K (Ceno)	(915)	(915)
?Rankinian	K (Sant)	-K (Camp)	(2)	Kansius	K (Sant)	(915)	(915)
Rhinocephalus	T (Than)	-T (Eo-l)	(2)	+ Kryptophaneron	T (Mi-m)	-R	(915)
+ Squalogadus	T (Ol-l)	-R	(915)	+ Libanoberyx	K (Ceno)	(915)	(915)
+ Theragra	T (Plio)	-R	(560)	+ Lissoberyx	K (Ceno)	(915)	(915)
Trachyrhynchus	T (Ol-l)?	-R	(915)	?Lobopterus	K (Ceno)	(2)	(2)
Trichiurichthys	T (Mi-u-u)	(2)	(915)	+ Melamphaes	T (Mi-u)	-R	(560)
+ Trichurides	T (Than)	-T (Eo-m)	(915)	Monocentris	T (Eo-m-l)	-R	(915)
+ Tripteryphycis	T (Eo-u)	-R	(915)	Myripristis	T (Mi-l)	-R	(915)
+ Trisopterus	T (Ol-u)	-R	(915)	+ Naupygus	T (Eo-l)	(915)	(915)
?Urophycis	T (Eo)	-R	(560,915)	+ Optivus	T (Eo-m)	-R	(560)
+ Ventrifossa	T (Mi-l)	-R	(560,915)	Paraberyx	T (Eo-l)	(915)	(915)
Or. ATHERINIFORMES							
Atherina	T (Eo-m-l)	-R	(2)	+ Parospinus	K (Sant)	(915)	(915)
+ Atherinopsis	T (Mi-u)	-R	(1012)	+ Pattersonoberyx	K (Ceno)	(915)	(915)
+ Chirostoma	T (Plio)?	-R	(915)	+ Plectrypops	T (Ol-l)	-R	(560)
Colpichthys	T (Plio)	-R	(915)	+ Plesioberyx	K (Ceno)	(915)	(915)
+ Leuresthes	Q (Plei)	-R	(560)	+ Poromitra	T (Ol-l)	-R	(915)
				+ Pseudoholocentrum	T (Ol-l)	(915)	(915)

Taxon	First Appearance	Last Appearance	Reference	Taxon	First Appearance	Last Appearance	Reference
Pycnosteroides	K (Ceno-u)		(915)	Pseudosyngnathus	T (Eo-m-l)		(746)
+ Sargocentron	T (Eo-l)	- R	(560,915)	Pungitius	T (Mi-u)	- R	(915)
- Scianenuropsis	T (Eo-l)		(915)	+ Ramphosus	T (Than)	- T (Eo-m-l)	(915)
Scopelogadus	T (Mi-u)	- R	(2)	Solenorhynchus	T (Eo-m-l)		(2)
+ Stichoberyx	K (Ceno)		(915)	?Solenostomus	T (Eo-m-l)	- R	(2)
+ Stichocentrus	K (Ceno)		(915)	Syngnathus	T (Eo-m-l)	- R	(2)
+ Stichopteryx	K (Ceno)		(915)	+ Synhypuralis	T (Eo-m-l)		(746)
+ Tenuicentrum	T (Eo-m-l)		(746)	+ Urosphen	T (Eo-m-l)		(915)
Trachichthyoides	K (Ceno)	- K (Sant)	(915)	+ Urosphenopsis	T (Than)		(915)
Tubantia	K (Camp-u)		(863)				

Or. LAMPRIDIFORMES

+ Analectis	T (Ol-l)		(915)
† Ateleopus	T (Mi-m)	- R	(560)
† Bajaichthys	T (Eo-m-l)		(915)
+ Bathysoma	T (Dani)		(915)
† Danatinia	T (Than)		(915)
† Eolophotes	T (Eo-m)		(915)
Lampris	T (Mi-u)	- R	(915)
Palaeocentrotus	T (Than)		(915)
Protolophus	T (Ol-l)	- R?	(915)
+ Turkmene	T (Than)		(915)
- Velifer	T (Eo-m-l)		(915)

Or. ZEIFORMES

† Antigonina	T (Eo-l)	- R	(915)
Capros	T (Ol-l)	- R	(915)
Caprovesposus	T (Ol-l)	- T (Mi-m)	(915)
Cytoidea	T (Ol-l)		(915)
† Microcapros	K (Ceno)		(915)
+ Palaeocyttus	K (Ceno)		(915)
+ Zenion	T (Plio)	- R	(915)
Zenopsis	T (Ol-l)	- R	(915)
Zeus	T (Ol)	- R	(915)

Or. GASTEROSTEIFORMES

+ Acanthognathus	T (Ol-l)	- R	(915)
† Aeoliscoidea	T (Eo-m-l)		(746)
Aeoliscus	T (Ol-l)	- R	(915)
+ Aulorhamphus	T (Eo-m-l)		(746)
Aulorhynchus	T (Eo-m-l)?	- R	(915)
† Aulostomoides	T (Eo-m-l)		(915)
Aulostomus	T (Eo-l)?	- R	(718)
Calamostoma	T (Eo-m-l)		(2)
Centriscus	T (Plio)	- R	(915)
+ Eoaulostomus	T (Eo-m-l)		(915)
Fistularia	T (Ol-l)	- R	(915)
+ Fistularioides	T (Eo-m-l)		(915)
+ Gasterorhamphosus	K (Camp)?		(915)
Gasterosteus	T (Mi-u)	- R	(718)
† Hippocampus	T (Plio)	- R	(915)
Hipposyngnathus	T (Ol-l)		(915)
+ Jungersenichthys	T (Eo-m-l)		(915)
+ Macroaulostomus	T (Eo-m-l)		(915)
† Nerophis	T (Ol-u)	- R	(915)
† Paraeoliscus	T (Eo-m-l)		(746)
+ Paramphisile	T (Eo-m-l)		(746)
+ Parasynarcualis	T (Eo-m-l)		(746)
+ Prosolenostomus	T (Eo-m-l)		(915)
Protaulopsis	T (Eo-m-l)	- R	(2)
+ Protorhamphosus	T (Than)		(746)

Or. DACTYLOPTERIFORMES

+ ?Dactyloptena	T (Mi-l-u)	- R	(503)
Dactylopterus	T (Plio-l)	- R	(915)
Prevolitans	T (Eo-u)		(915)
+ Pterygocephalus	T (Eo-m-l)		(746,915)

Or. SCORPAENIFORMES

Achrestogrammus	T (Mi-u)		(2,915)
Agonus	T (Ol-l)	- R	(915)
+ Artedius	T (Plio)	- R	(560)
+ Chitonotus	T (Plio)	- R	(560)
Cyclopterus	Q (Plei)	- R	
?Ctenopomichthys	T (Eo-l)	- T (Mi)	(746)
+ Enophrys	T (Plio)	- R	(560)
Eocottus	T (Eo-m-l)		(2)
Eosynanceja	T (Eo-l)		(2)
+ ?Eutrigla	Q (Plei)	- R	
+ Hoplichthys	T (Mi-m)	- R	(915)
+ Icelinus	T (Plio)	- R	(560)
Lepidocottus	T (Plio)	- R	(915)
+ Lepidotrigla	T (Eo-u)?	- R	(915)
+ ?Leptocottus	T (Plio)	- R	(560)
Lirosclees	T (Mi-u)		(915)
+ Malacocottus	T (Plio)	- R	(560)
+ Neoplatycephalus	T (Mi-l)	- R	(915)
+ Notesthes	T (Eo-u)	- R	(560)
+ Ophiodon	Q (Plei)	- R	(915)
Peristedion	T (Mi-l)	- R	(915)
+ Platycephalus	T (Eo-l)	- R	(915)
+ Podothecus	T (Eo-u)	- R	(915)
+ Pontinus	T (Ol-l)	- R	(503)
+ Prionotus	T (Plio)	- R	(1012)
+ Radulinus	T (Plio)	- R	(560)
Scorpaena (+ Rhomarchus)			
	T (Eo-u)	- R	(560)
+ Scorpaenichthys	Q (Plei)	- R	(560)
- Sebastes	T (Ol-l)	- R	(560)
Sebastodes (+ Rixator, Sebastinus, Sebastoessus)			
	T (Mi-u)	- R	(915)
Trigla	T (Ol-l)	- R	(915)
+ Zaniolepis	Q (Plei)	- R	(560)

Or. PERCIFORMES

+ Abadzekhia	T (Ol-l)		(915)
+ Absalomichthyes	T (Mi-u)		(915)
Acanthonemus	T (Eo-m-l)		(771,863)
?Acanthonotus	T (Mi)	- R	
+ Acanthopygaeus	T (Eo-m-l)	- T (Ol-l)	(915)
Acanthurus	T (Eo-m-l)?	- R	(2)
+ Acentrogobius	T (Mi-l)?	- R	(503)
Acestrus	T (Eo-l)		(746)

Taxon	First Appearance	Last Appearance	Reference	Taxon	First Appearance	Last Appearance	Reference
+ Acropoma	T (Than)	-R	(915)	+ Chalcidichthys	T (Mi-u)		(915)
+ Aglyptorhynchus	T (Eo-l)	-T (Ol-u)	(915)	+ Chanda	T (Eo-l)	-R	(560)
+ Alectis	T (Mi)	-R	(915)	+ Cheilinus	T (Ol-l)	-R	(915)
+ Alpes	T (Mi-l)	-R	(915)	+ Chelmon	T (Mi)	-R	(915)
+ Aluvarua	T (Ol-l)			+ Crenidens	T (Mi-u)	-R	(915)
Ammodytes	T (Eo-m-l)	-R	(560)	+ Chromis	T (Mi-u)	-R	(915)
Amphiperca (+ Anthracoperca)				+ Clinus	T (Mi)?	-R	(915)
	T (Eo-m-l)		(915)	+ Coryphopterus	T (Plio)	-R	(560)
+ Amphistichus	Q (Plei)	-R	(560)	+ Cottopsis	T (Ol-l)	-R	(915)
+ Anarhichas	T (Plio)	-R	(915)	+ Crenidens	T (Mi-u)	-R	(915)
+ Anarrhichthys	Q (Plei)	-R	(560)	+ Cristigerina	T (Eo-l)		(915)
+ Anisotremus	T (Plio)	-R	(560)	+ Ctenodentex	T (Eo-m-u)		(915)
+ ?Aphia	Q (Plei)	-R		+ Ctenosciaena	T (Mi-l)	-R	(560)
Aploclinotus	T (Plio)	-R	(915)	+ Cubiceps	T (Plio)	-R	(915)
Apogon	T (Eo-l)	-R	(560)	+ Cyclopoma	T (Eo-m-l)	-R?	(915)
Apogonoides (+ Arambourgia)				+ Cymatogaster	T (Plio)	-R	(560)
	T (Mi-u)		(863,915)	+ Cynoscion	T (Mi-u)	-R	(915)
+ Apolectus (+ Parastromateus)				+ Damalichthys	T (Plio)	-R	(915)
	T (Eo-m-l)	-R	(915)	+ Dapalis	T (Than)?	-T (Mi-m)	(560)
+ Apsilus	T (Eo-m-l)	-R	(560)	+ Dapalooides	T (Mi-l)	-R	(915)
+ Araeosteus	T (Mi-u)	-R	(915)	+ Decapterus	T (Mi-l)	-R	(915)
+ Aramichthys	T (Eo-m)		(915)	+ ?Delientosteus	T (Mi-l)?	-R	(503)
+ Archaephippus	T (Eo-m-l)		(771)	+ Dentex	T (Eo-l)	-R	(560)
+ Archaeus	T (Than)	-T (Ol-l)	(915)	+ Diaphyodus	T (Than)	-T (Eo-u)	(915)
+ Ardiodus	T (Than)	-T (Eo-l)	(746,915)	+ Diplodus	T (Eo-u)	-R	(915)
+ Argyrosomus	T (Mi-l-u)	-R	(503)	+ Diptericthys	T (Ol-l)		(915)
+ Ariomma	T (Mi-l)	-R	(560)	+ Ductor	T (Eo-m-l)		(746,771)
+ Asima (+ Stylopus, Taurinichthys)				+ Eastmanalepes	T (Eo-m-l)		(915)
	T (Mi)		(915)	+ Echenis	T (Ol-l)	-R	(915)
+ Avitolabrax	T (Mi-l)		(863)	+ Emmelichthys	T (Eo-m-l)	-R	(560)
+ Avitoluvarus	T (Eo-l)			+ Enoplosus	T (Eo-m-l)?	-R	(915)
+ Bairdiella	T (Mi-u)	-R	(1012)	+ Eocoelopoma	T (Than)	-T (Eo-l)	(746,915)
+ Bathylupea	T (Eo-l)	-R	(915)	+ Eolabroides	T (Eo-m-l)		(2,863)
+ Beaumontoperca	T (Ol-u)		(915)	+ Eolates	T (Eo-m-l)	-T (Ol-u)	(915)
+ Beerichthys	T (Eo-l)		(915)	+ Eoluarus	T (Eo-l)		(915)
+ Bembrops	T (Eo-u)	-R	(915)	+ Eoplatax	T (Eo-m-l)		(771)
+ Bilinia	T (Mi-l)		(915)	+ Eoserranus	T (Dani)?		(915)
+ Blabe	T (Eo-m)		(915)	+ Eothynnus	T (Eo-l)		(746)
+ Blennius	T (Mi-u)	-R	(915)	+ Eothyristes	T (Ol-u)		(915)
+ Bodianus	T (Mi-m)	-R	(915)	+ Eozanclus	T (Eo-m-l)		(915)
+ Boops	T (Mi-m)	-R	(503)	+ Epigonus	T (Eo-l)	-R	(915)
+ Brachydeuterus	T (Mi-l)	-R	(503)	+ Epinephelus	T (Eo-m-l)	-R	(560)
+ Brama	T (Plio)	-R	(915)	+ Epimula	T (Ol-l)	-R	(915)
+ Bramoides	T (Eo-l)		(915)	+ Eriquius	T (Mi-u)		(915)
+ Branchiostegus	T (Mi-u)	-R	(915)	+ Euthynnus	T (Mi-u)	-R	(915)
+ Burtinia	T (Eo-m-l)		(915)	+ Eutrichiurides	T (Dani)	-T (Ol-l)	(915)
+ Caesio	T (Eo-m-l)	-R	(915)	+ Exallias	T (Eo-m-l)	-R	(560)
+ Calamus	T (Ol-l)	-R	(915)	+ Exellia	T (Than)	-T (Eo-m-l)	(718,771, 915)
+ Callionymus	T (Eo-l)	-R	(2)				
+ Callipteryx	T (Eo-m-l)		(718)	+ Gazza	T (Eo-m-l)	-R	(915)
+ Callyodon	T (Ol-l)?	-R	(915)	+ Gempylus	T (Ol-l)?	-R	(915)
+ Calotomus	T (Mi)		(915)	+ Genyonemus	Q (Plei)	-R	(560)
+ Carangodes	T (Eo-m-l)		(771)	+ Gerres	T (Eo-l)	-R	(560)
+ Carangopsis	T (Eo-m-l)		(718,771)	+ Gillidia	T (Eo-m-l)		(915)
+ Caranx	T (Eo-m-l)	-R	(560,771)	+ Glaucosoma	T (Eo-u)	-R	(915)
+ Centracanthus	T (Eo-l)	-R	(915)	+ Gobius	T (Mi-l)	-R	(560)
+ ?Centropomus	T (Eo-l)	-R	(560)	+ Goniocranium	T (Eo-l)		(915)
+ Centroprius	T (Eo-l)	-R	(915)	+ Grammatocygnus	T (Ol-l)	-R	(915)
+ Cepola	T (Eo-l)	-R	(915)	+ Gymnosarda	T (Ol-l)	-R?	(915)
+ Ceratoichthyes	T (Eo-m-l)		(771)	+ Haliophis	T (Eo-m)	-R?	(560)
+ Chaetodon	T (Ol-u)	-R	(915)	+ Hemerocoetes	T (Ol-l)	-R	(915)
+ Chaeturichthys	Q (Plei)	-R	(560)				

Taxon	First Appearance	Last Appearance	Reference	Taxon	First Appearance	Last Appearance	Reference
Hemirhabdorhynchus				+Ostracoberyx	T (Eo-l)	-R	(915)
+Hemithyrsites	T (Ol-u)	-R	(915)	+Oxyjulius	T (Plio)	-R	(560)
Hypacanthus	T (Ol-l)	-R	(915)	Pagellus	T (Eo-m)	-R	(915)
+Hyperoglyphe	T (Mi-l-u)	-R	(503)	Pagrus	T (Eo-l)	-R	(915)
+Hyperoplus	T (Mi-m)	-R	(503)	+Palaeoperca	T (Eo-m-l)		(915)
+Hyperprotopon	Q (Plei)	-R	(560)	+Palaeoperichthys	T (Than)		(915)
Ioscion	T (Mi-u)		(915)	+Palaeothunnus	T (Than)		(915)
+Isacia	T (Than)	-R	(560,915)	Palimphyes	T (Than)	-T (Ol-l)	(863)
Istiophorus	T (Mi-m)	-R	(915)	Paracalamus	T (Mi-u)		(915)
Isurichthys	T (Ol)		(915)	+Parapercis (= Neopercis)			
Izuus	T (Mi-l)		(915)		T (Ol-l)	-R	(560)
+Kuhlia	T (Eo-l)	-R	(560)	Paraplatax	T (Ol-l)		(915)
+Kushlukia	T (Eo-l)		(915)	Parapristopoma	T (Eo-m)	-R	(560)
+Kyphosida	T (Eo-l)	-R	(915)	Parapygaeus	T (Eo-m-l)		(863)
+Labrisomus	T (Mi-u)	-R	(915)	+Pararhenanoperca	T (Eo-m)		(915)
Labrodon	T (Eo-l)	-R	(2)	+Parasphyraena	T (Mi-m)		(915)
Labrus	T (Eo-m-l)?	-R	(915)	+Paratrachinotus	T (Eo-m-l)		(771)
Lactarius	T (Eo-l)	-R	(915)	+Pasaichthyes	T (Eo-m-l)		(771)
Landanichthys	T (Dani)		(915)	+Pelates	T (Eo-m)?	-R	(915)
Larimus	T (Ol-u)	-R	(915)	+Pempheris	T (Plio)	-R	(915)
Leognathus	T (Ol-l)	-R	(915)	+Pennahia	Q (Plei)	-R	(560)
Lednevia	T (Ol-u)	-T (Mi-l)	(915)	+Pentaceros	T (Mi-m)	-R	(915)
+Lepidogobius	Q (Plei)		(915)	+?Pentaneumus	T (Mi-l)	-R	(503)
Lepidopus	T (Eo-m)	-R	(915)	+Pentaprion	T (Eo-m-l)	-R	(560)
+Leptoscopus	T (Ol-u)	-R	(915)	Percalates	T (Eo)?	-R	(915)
+Lethops	T (Plio)	-R	(560)	+Percostoma	T (Eo-l)		(915)
+Libotoniis	T (Eo-m)		(915)	+Phanerodon	Q (Plei)	-R	(560)
+Lithognathus	T (Mi-l-u)	-R	(503)	Phosphichthys	T (Eo-l)		(915)
+?Liza	T (Mi-l)	-R	(503)	+Pimelometopon	Q (Plei)	-R	(560)
Lompoquia (+ Atkinsonella)				+Pinichthys	T (Ol-l)	-T (Mi-l)	(915)
	T (Mi-u)		(915)	+Pirskenius	T (Mi-l)		(915)
+Lonchistium	T (Mi-l)	-R	(560)	+Plagiolohocentrum	T (Ol-u)?		(915)
Lophar	T (Mi-u)		(915)	Platax	T (Plio)	-R	(915)
+Luvarus	T (Ol-l)?	-R	(915)	Platyalaemus	T (Eo-m-l)		(915)
+Lycodopsis	T (Plio)	-R	(915)	+Platylates	T (Ol-l)		(915)
+Lycconectes	T (Plio)	-R	(560)	+?Plectrohinchus	T (Mi-l)	-R	(503)
Maccullochella	T (Mi)	-R	(915)	+Plectrites	T (Mi-u)		(915)
Makaira	T (Mi-u)	-R	(915)	+Plesioserranus	T (Eo-l)	-T (Eo-u)	(915)
+Malacopygaeus	T (Eo-m-l)		(915)	+Podocephalus	T (Eo-l)		(915)
Mataarchia	T (Mi)	-R		Pogonias	T (Mi)	-R	
Mene	T (Than)	-R	(915)	+Polydactylus	T (Mi-u)	-R	(1012)
+Menticirrhus	T (Mi-u)	-R	(1012)	Pomacanthus	T (Eo-m-l)	-R	(560)
+Mioplosus	T (Eo-l)	-T (Eo-m)	(915)	Pomadasyis	T (Eo-m)?	-R	(915)
Morone	T (Eo-m-l)	-R	(560)	+Priaicanthopsis	T (Ol-l)		(915)
Mugil	T (Ol-l)	-R	(2)	Priacanthus	T (Ol-l)	-R	(915)
Mullus	T (Mi-l-u)	-R	(503)	Priscacara (= Cockerellites)			
+Mupus (+ Schedophilus)					T (Eo-l)	-T (Eo-m)	(915)
	T (Eo-m-l)	-R	(560,915)	Pristigenys	T (Eo-l)	-R	(560)
Naso	T (Eo-m-l)	-R	(2)	+Progempylus	T (Eo-l)		(915)
+?Neanthias	T (Ol-l)	-R	(503)	Prolates	T (Than-l)		(863)
+Nebriis	T (Mi-l)	-R	(560)	+Proluvarus	T (Eo-l)		
Neocybium	T (Eo-u)	-T (Mi)	(915)	+Propercarina	T (Ol)		(915)
+Neoscombrops	T (Mi-l)	-R	(915)	Proserannus	T (Dani)		(2)
+Oblada	T (Eo-m)	-R	(560)	Protanthias	T (Mi-u)		(915)
Ocyrtias	T (Mi-u)		(915)	Protatoga	T (Mi)		
Odontebolca	T (Eo-m-l)		(718)	+Psenes	T (Ol-l)	-R	(915)
Oligoplites	T (Ol-l)?	-R	(915)	+Psenicubiceps	T (Ol-l)		(915)
Oncolepis	T (Eo-m-l)		(2)	+Psettops	T (Eo-m-l)		(771)
Opisthomyzon	T (Ol-l)		(915)	+Pseudohistiophorus	T (Eo)	-R	(915)
+Oplegnathus	T (Mi-l)	-R	(915)	Pseudoscaris	T (Ol-l)?	-R	(915)
Orthopristsis	T (Eo-m)	-R	(560)	Pseudoscopelus	T (Ol-l)	-R	(915)
				Pseudoseriola	T (Mi-u)		(915)

Taxon	First Appearance	Last Appearance	Reference	Taxon	First Appearance	Last Appearance	Reference
+Symphurus	Q (Plei)	-R	(915)	Catapleura	K (u)		
Turahbuglossus	T (Eo-m-l)		(2)	Chelonia	T (Ol-u)?	-R	
Or. TETRADONTIFORMES				Chelosphargis	K (Camp)		(987)
Acanthopleurus	T (Ol-l)		(915)	Chelyopsis	T (Ol)		
+Alutera	T (Plio)	-R	(915)	Corsochelys	K (Camp-u)		
+Amanses	T (Eo-l)	-R	(560)	Cosmocheilus	T (Eo-l)		(2)
+Aracana	T (Ol-u)	-R	(915)	Cratochelone	K (u)		
Balistes	T (Mi-m)	-R	(915)	Ctenochelys	K (Camp-l)	-K (Camp-u)	(987)
+Balistomorphus	T (Ol-l)		(915)	Cynocercas	K (u)		
Chilomycterus	T (Mi-u)	-R	(915)	Dermochelys	T (Mi)	-R	
+Cretatriacanthus	K (Camp-u)?, K (Maes-l)?			Desmatocheilus	K (Turo-l)	-K (Maes)	(1066,1069)
+Cryptobalistes	T (Ol-l)		(915)	+Dollochelys	K (Maes-u)	-T (Eo-l)	(987)
Diodon	T (Eo-l)	-R	(915)	Eochelone	T (Eo-m)		
Eodiiodon	T (Eo-m-l)		(915)	Eosphargis	T (Eo-l)		(1066)
+Eolactoria	T (Eo-m-l)		(746)	+Erquelinnesia	T (Eo-l)		(1066)
+Eopectus	T (Eo-m-l)		(746)	Glarichelys	T (Eo)	-T (Ol)	
+Eospinus	T (Eo-l)			Glaucochelone	K (u)		
+Eotetraodon	T (Eo-m-l)		(915)	Glyptocheilus	K (u)		
Eotrigonodon	T (Dani)?	-T (Eo-m-l)	(2,863)	Kurobecheilus	T (Mi)		
+Indotrigonodon	T (Pale)		(915)	Lembonax	T (Eo)		
+Kankatodus	K (Maes)	-T (Eo-l)	(915)	Lophochelys	K (Camp-l)	-K (Camp-u)	
Kyrtogymnodon	T (Plio)		(915)	Neptunochelys	K (u)		
Marosichthys	T (Mi)	-R		Notochelone	K (Albi)		(1066)
Mola	T (Mi-u)	-R	(915)	Oligochelone	T (Ol)		
Oligobalistes	T (Ol-l)		(915)	Osteopygis	K (Camp-u)	-T (Eo)	(987,1069)
Oligodiiodon	T (Ol-l)	-T (Mi-u)	(915)	Pachychelys	T (Plio)		
+Oligolactoria	T (Ol-l)			Peritresius	K (Maes-l)	-K (Maes-u)	(987,1069)
Ostracion	T (Than)	-R	(915)	+Plesiochelys	J (Kimm)		
+Pisdurodon	T (Pale)		(915)	+Pneumatoarthrus	K (Maes)		(1066)
+Plectoeretacicus	K (Ceno-l)		(915)	Porthochelys	K (Coni-u)		(987)
+Proaracana	T (Eo-m-l)		(746)	+Portlandemys	J (Tith-u)		(1066)
Prodiiodon	T (Eo-m-l)		(915)	Prionochelys	K (Camp-l)	-K (Camp-u)	(987)
+Progymnodon	T (Eo-m-l)	-T (Eo-u)	(915)	Procolpochelys	T (Eo-u)	-T (Mi-m)	(504)
+Protacanthodes	T (Eo-m-l)		(915)	Protremys	T (Eo)		
Protobalistium	T (Eo-m-l)		(915)	Protostega	K (Ceno-u)	-K (Camp)	(987)
Spinacanthus	T (Eo-m-l)		(915)	Psephophorus	T (Eo)	-T (Plio)	
Tetraodon	T (Mi-m)	-R	(915)	Pseudosphargis	T (Ol)		
Triacanthus	T (Eo-m)	-R	(915)	Puppigerus	T (Eo-l)	-T (Eo-u)	
Trigonodon	T (Mi-m)	-T (Plio)	(915)	Rhinochelys	K (Albi)	-K (Ceno-u)	(2)
Triodon	T (Eo-l)	-R	(2)	Syllomus	T (Mi-m)		(504)
+Zignoichthys	T (Eo-m-l)		(746)	+Tasbacka	T (Than)		
Cl. AMPHIBIA				Therezinosaurus	K (u)		
Or. TEMNOSPONDYLI				Thinochelys	K (u)		
+Tupilakosaurus	Tr(Indu-u)		(1066)	Tomochelone	K (u)		
Cl. REPTILIA				Toxochelys	K (Coni-u)?	-K (Maes-l)	(987)
Or. ANASPIDA INCERTAE SEDIS				Or. SQUAMATA			
+Mesosaurus	P (Leon)		(1066)	+Acrochordus	T (Mi-m)	-R	(505)
Or. CHELONIA				Acteosaurus	K (Turo)		(1066)
Allopleuron	K (u)			Aigialosaurus	K (Turo)		(1066)
Archelon	K (Camp-l)		(987)	Amphekepubis	K (u)		
Argillochelys	T (Eo-l)	-T (Eo-m)		Amphorosteus	K (u)		
Atlantochelys	K (u)			Angolosaurus	K (u)		
Bryochelys	T (Ol)			Anomalopsis	T (Eo-l)		(505)
Calcarichelys	K (Camp-l)		(987)	+Archaeophis	T (Eo-l)		(505)
Caretta	T (Eo)	-R		Carinodens (+ Compressidens)	K (u)	-K (Maes)	
Carolinochelys	T (Ol)			Carsosaurus	K (Turo)		(1066)
				Clidastes	K (Sant)	-K (Camp-l)	
				Coniasaurus	K (Ceno-u)	-K (Turo-u)	
				Dolichosaurus	K (Ceno)	-K (Turo-l)	
				Dollosaurus	K (u)		

Taxon	First Appearance	Last Appearance	Reference	Taxon	First Appearance	Last Appearance	Reference
Eidolosaurus	K (Turo)		(1066)	- Silvestrosaurus	Tr(Ladi-l)?		(1044)
Ectenosaurus	K (Sn)			Simosaurus	Tr(Ladi-l)	- Tr(Ladi-u)	(1044)
Globidens	K (Camp-l)?	- K (Maes)		Or. PLESIOSAURIA			
+ Goronyosaurus	K (Maes)		(1066)	Alzadasaurus	K (l)	- K (Turo)	(1069)
Hainosaurus	K (Camp-l)	- K (Maes)		Aphrosaurus	K (u)	- K (Maes-u)	(2)
Halisaurus	K (Camp-l)	- K (Maes-l)	(1069)	Aptychodon	K (u)		
Holocodus	K (u)			Archaeonectrus	J (l)		
Leiodon	K (Ceno-u)	- K (Maes)		Aristonectes	K (Maes)		(1066)
Mosasaurus (+ Moanasaurus)	K (Camp-l)?	- K (Maes-u)	(2)	+ Bishanopliosaurus	J (Toar)		(746,1269)
+ Nigerophis	T (Dani)	- T (Eo-m-l)	(505)	Brachauchenius	K (u)		
+ Opetiosaurus	K (Turo)		(1066)	Brancasaurus	K (Berr)	- K (l)	(2)
Palaeophis	K (Maes)	- T (Eo-m-l)	(505)	Brimosaurus	K (u)		
Platecarpus	K (Sant)	- K (Camp-u)	(1069)	Cimoliasaurus	K (Apti)	- K (Maes-u)	(2)
Plesiotylosaurus	K (Maes-u)		(1069)	Colymbosaurus	J (Tith-l)?		
Plioplatecarpus	K (Camp-u)	- K (Maes-l)	(1069)	Cryptoclidus	J (Call-l)		
Plotosaurus	K (Maes-u)		(1069)	Discosaurus	K (u)		
Pontosaurus	K (l)			Dolichorhynchops	K (l)	- K (Sn)	
Proaigialosaurus	J (Tith-l)		(2)	Elasmosaurus	K (Turo-l)	- K (Sn)	
Prognathodon	K (Camp-l)	- K (Maes-l)	(1069)	Embaphis	K (u)		
Pterosphenus	T (Eo-m-u)	- T (Eo-u)	(505)	Eretmosaurus	Tr(Rhae)	- J (l)	(2)
+ Russellophis	T (Eo-l)		(505)	Eurycleidus	J (Hett)		(1066)
+ Selmasaurus	K (Camp-l)	- K (Maes)?	(1069)	Eurysaurus	J (m)		
Simoliophis	K (Ceno)			Fresnosaurus	K (Maes-u)		(1069)
Taniwhasaurus	K (u)			Gymocetus	K (u)		
Tylosaurus	K (Sant-u)	- K (Camp-l)		Hexatarostinus	J (l)		
+ Vialorophis	T (Than)			Hunosaurus	K (u)		
+ Woutersophis	T (Eo-m-l)		(505)	Hydralmosaurus	K (u)		
				Hydrotherosaurus	K (u)	- K (Maes-u)	(1069)
Or. THALATTOSAURIA				Iserosaurus	K (u)		
+ Askeptosaurus	Tr(Ladi-l)?		(1066)	+ Kimmerosaurus	J (Tith-l)		
+ Clarazia	Tr(Ladi-l)?		(1066)	Kronosaurus	K (l)		
+ Hescheleria	Tr(Ladi-l)?		(1066)	Leptocleidus	K (Ne)	- K (Barr)	
+ Nectosaurus	Tr(Carn)		(1066)	Leurospondylus	K (u)	- K (Maes-l)	(2)
+ Thalattosaurus	Tr(Carn)		(1066)	Liopleurodon	J (Bath)	- J (Tith-u)	(2)
				Macroplata	J (l)		
Or. NOTOSAURIA				+ Maresaurus	J (Bajo-l)		(1269)
- Anarosaurus	Tr(Anis)		(746,1044)	Mauisaurus	K (u)	- K (Maes)?	
Ceresiosaurus	Tr(Ladi-l)		(1044)	Megalneusaurus	J (u)		
Corosaurus	Tr(Olen)		(1044)	Microcleidus	J (Toar-l)		(1066)
Cymatosaurus	Tr(Anis-l)	- Tr(Ladi-l)?	(746,1044)	Morenosaurus	K (u)	- K (Maes-u)	(1069)
+ Dactylosaurus	Tr(Anis)		(746,1044)	Muraenosaurus	J (Call)	- J (Oxfo)?	
Deirosaurus	Tr(m)			Nothosaurops	K (u)		
Elmosaurus	Tr(m)			Ogmodirus	K (u)		
+ Hupehsuchus	Tr(Anis)		(1066)	Oligosimus	K (u)		
Keichosaurus	Tr(Anis)		(1044)	Orophosaurus	K (u)		
Kwangsisaurus	Tr(Olen)			Pantosaurus	J (u)		
Lariosaurus	Tr(Anis-u)	- Tr(Ladi-u)		Peloneustes	J (l)	- J (Call)	
Metanothosaurus	Tr(Olen)			Peyerus	K (l)		
Nanchangosaurus	Tr(Anis)		(1066)	Picrocleidus	J (u)		
Neusticosaurus	Tr(Ladi-l)	- Tr(Carn-l)		Piptomerus	K (u)		
Nothosaurus	Tr(Anis-m)	- Tr(Carn-u)	(2,1044)	Piratosaurus	K (u)		
Pachypleurosaurus	Tr(Ladi-l)	- Tr(Ladi-u)		Pistosaurus	Tr(Anis-u)		(1066)
Paranothosaurus	Tr(Ladi-l)?		(1044)	Plesiosaurus	Tr(Rhae)	- J (Toar)	
Parthanosaurus	Tr(Ladi)?			Pliosaurus	J (l)	- J (Tith-l)	
+ Phygosaurus	Tr(Ladi-u)?		(746)	Polycotylus	K (Camp-l)	- K (Maes)	(1066,1069)
Pontopus	Tr(u)			Polyptychodon	K (Albi-u)	- K (Sant-l)	
Proneusticosaurus	Tr(m)			Rhæticonia	Tr(m)		
+ Psilotrachelosaurus	Tr(m)		(746)	+ Rhomaleosaurus	J (Hett)	- J (Toar-u)	(746,1269)
+ Serpianosaurus	Tr(Ladi-l)?			Scanisaurus	K (u)		
+ Shingyisaurus	Tr(m)?			Scarrisaurus	K (l)		
				Secleyosaurus	J (l)		

Taxon	First Appearance	Last Appearance	Reference	Taxon	First Appearance	Last Appearance	Reference
Simolestes	J (Bajo-u)	-J (Tith)	(1269)	+Protoichthysaurus	J (Hett-l)		
Sthenosaurus	J (l)			-Shastasaurus	Tr(Carn)	-Tr(Nori)	
Stretosaurus	J (u)	-J (Tith-l)		+Shonisaurus	Tr(Carn)	-Tr(Nori)	(746,1066)
Styxosaurus	K (Sn)			+Simbirshiasaurus	K (Haut)		
Sulmosaurus	K (u)			-Stenopterygius	J (Toar-l)		(1066)
Taphrosaurus	K (u)	-K (Maes)		+Svalbardosaurus	Tr(l)		(1066)
Thalassomedon	K (u)			Temnodontosaurus	J (Sine)?	-J (Toar)	
Thaumatosauros	J (l)	-J (m)		Toretocnemus	Tr(u)		
Tremametes	J (u)			+Utatusaurus	Tr(Olen-u)		(746)
Tricleidus	J (Call)	-J (u)					
Trinacromerum	K (Albi)		(1066)				
+Tuarangisaurus	K (Camp)?	-K (Maes)?		Or. SPHEODONTIA			
+Turneria	K (Maes)		(1066)	+Palaeopleurosaurus	J (Toar-l)		(1066)
Uronautes	K (u)			-Pleurosaurus	K (Berr)		(1066)
Woolungasaurus	K (l)						
+Yuzhoupliosaurus	J (m)		(1269)	Or. CROCODILIA			
				Aeolodon	J (Tith-l)		(620)
Or. PLACODONTIA				Angulosuchus	J (Bajo)?	-J (u)	(620)
+Chelyposuchus	Tr(Nori)?			Capellineosuchus	K (l)		
Cyamodus	Tr(Anis-l)	-Tr(Ladi-l)	(940)	+Cricosaurus	J (Kimm)		(620)
?Helveticosaurus	Tr(Anis-u)?, Tr(Ladi-l)?		(2)	Crocodylaemus	J (Kimm)		(1066)
Henodus	Tr(Carn-l)	(2,940)		Dakosaurus	J (Oxf)	-K (Haut-l)	(2,620)
+Negevodus	Tr(Anis-l)	(940)		Dyrosaurus	K (Maes)	-T (Eo-m-l)	(2)
Paraplocodus	Tr(Anis-u)	-Tr(Ladi-u)	(940)	Enaliosuchus	K (Nc)		(620)
+Placocheilus	Tr(Nori)?			Gavialinum	J (Bath)		(620)
Placocheilus	Tr(Carn-l)	(940)		Geosaurus	J (Kimm)	-K (Nc)	(620)
Placodus	Tr(Olen-u)	-Tr(Ladi-l)	(2,940)	Gnathosaurus	J (Tith-l)		(620)
+Protenodontosaurus	Tr(Carn)			Haematosaurus	J (Kimm-u)		(620)
Psephoderma	Tr(Nori)	-Tr(Rhae)	(2,940)	Heterosaurus	K (Nc)		(620)
Psephosaurus	Tr(Anis-l)	-Tr(Rhae)	(2,940)	+Hyposaurus	K (Maes)		(1066)
Saurosphargis	Tr(Anis)		(2)	+Machinosaurus	J (m)	-J (Tith)	(620)
				Metriorhynchus	J (Call-l)	-J (Tith-u)	(2,620)
				Mycterosuchus	J (Call)		(620)
Or. ICHTHYOSAURIA				Peiposuchus	J (u)		
Brachypterygius	J (Tith-l)	-J (Tith-u)		Pelagosaurus	J (Plie)	-J (Toar-l)	(620)
-Californosaurus	Tr(u)			Pholidosaurus	J (Tith-u)?	-K (Vala)?	(620)
+Caypullisaurus	J (Tith-l)			Phosphatosaurus	T (Eo)		
+Chaohusaurus	Tr(Olen)		(746)	Platysuchus	J (Plie)		(620)
+Chensaurus	Tr(Olen-u)			Rhabdognathus	T (Eo-l)		(620)
Chonespondylus	Tr(m)			+Rhytisodon	K (Nc)		(620)
Cymbospondylus	Tr(Olen)	-Tr(Ladi-l)	(1066)	+Sarcosuchus	K (l)		(620)
+Delphinosaurus	Tr(u)		(746)	Sokotosaurus	K (Maes)	-T (Eo-l)	(620,1066)
Eurhinosaurus	J (Toar-l)			Stenosaurus	J (Toar-l)	-J (Tith-u)	(2,620)
+Excalibosaurus	J (Sine-l)			Suchosaurus	K (Vala)	-K (Apti)?	(620)
+Grendelius	J (Kimm)		(746)	Sunosuchus	J (u)		
Grippia	Tr(Olen-u)		(2)	Teleidosaurus	J (Bath-l)		(620)
+Himalayosaurus	Tr(u)		(746)	Teleorhinus	K (l)	-K (u)	
+Hudsonopidia	Tr(Nori-l)			Telesaurus	J (Sine)?	-J (Tith-u)	(620)
Ichthyosaurus	J (Hett)	-J (Plie)		Wurnosaurus	T (Eo-l)		(620)
Leptopterygius	Tr(Rhae)	-J (Toar-l)					
Macropterygius	J (m)	-K (l)		Cl. AVES			
Merramia	Tr(u)			Or. HESPERORNITHIFORMES			
Mixosaurus	Tr(Anis-l)	-Tr(Ladi-u)	(2,1066)	Baptornis	K (Sant)	-K (Maes)	(1066)
-Naanchangasaurus	Tr(m)		(746)	Enaliornis	K (Albi-u)	-K (Ceno)	(1066)
Nannopterygius	J (Tith-l)			Hesperornis	K (Sant)	-K (Camp-l)	(1066)
Omphalosaurus	Tr(Olen-u)	-Tr(Anis)	(1066)	Parahesperornis	K (Sant)		(1066)
Ophthalmosaurus (+ Baptandon)	J (Call)	-J (Tith-u)?	(1066)				
Pessosaurus	Tr(m)			Or. ICHTHORNITHIFORMES			
+Phalarodon	Tr(Anis)		(746)	Apatornis	K (Coni)		(1066)
Platypterygius (+ Myobradypterygius, Myopterygius)	K (Nc)	-K (Ceno-l)		Ichthyornis	K (Turo)	-K (Camp)	(1066)
				Palintropus	K (Maes)?		(1066)

Taxon	First Appearance	Last Appearance	Reference	Taxon	First Appearance	Last Appearance	Reference
Or. SPHENISCIFORMES				Balaenotus	T (Mi-u)	-T (Plio)	(746)
Pachdyptes	T (Eo-u)		(1066)	Balaenula	T (Mi-u)	-T (Plio)	(746)
Or. PROCELLARIIFORMES				Basilosaurus	T (Eo-m-u)	-T (Eo-u)	(1022)
Diomedeoides	T (Ol-l)		(1066)	Belemnoziphius	T (Mi-u)		
Eopuffinus	T (Than)?	-T (Ol-l)	(1066)	Belosphys	T (Mi-m)		
Oceanodroma	T (Mi-u)		(1066)	Berardiopsis	T (Plio-u)		
+Pelecanoides	T (Plio)	-R	(1066)	+Brachydelphis	T (Mi-u)		(1066)
Tythostonyx	K (Maes)		(1066)	Burtinopsis	T (Mi-u)		(746)
+incertae sedis	T (Eo-u)		(1066)	Cephalotropis	T (Plio)		(1066)
Or. PELECANIFORMES				Ceterhinops	T (Mi-m)		
Empheresula	T (Ol-u)		(1066)	Cetorhynchus	T (Mi-m)	-T (Mi-u)	
Phocavis	T (Eo-u)	-T (Mi-m)?	(1066)	Cetotheriomorphis	T (Mi-m)	-T (Mi-u)	(746)
Prophaethon	T (Eo-l)		(1066)	Cetotheriopsis	T (Ol-u)	-T (Mi-l)	
Pseudodontornis	T (Than)	-T (Plio)	(1066)	Cetotherium	T (Mi-u)	-T (Plio-l)	
Sula	T (Ol-l)?	-R	(1066)	Champsodelphis	T (Mi-l)	-T (Mi-m)	(746,1066)
Or. CHARADRIIFORMES				+Chonecetus	T (Ol-u)		(746,1022)
Anatalavis	K (Maes)		(1066)	Choneziphius	T (Mi-u)	-T (Plio-u)	
Graculavus	K (Maes)		(1066)	Colophonodon	T (Mi-u)		
Laornis	K (Maes)		(1066)	Cophocetus	T (Mi-m)		
Larus	T (Mi-l-l)		(1066)	+Cylodelphis	T (Mi-l)	-T (Mi-u)	(746)
Palaeotringa	K (Maes)		(1066)	Delphinapterus	T (Mi-m)	-R	(1066)
Petralca	T (Ol-u)		(1066)	Delphinavus	T (Mi-l)	-T (Mi-u)	(746)
Phalaropus	T (Plio)	-R	(1066)	Delphinodon	T (Mi-m)		
Stercorarius	T (Mi-m)	-R	(1066)	Delphinopsis	T (Mi-u)		
Telmatornis	K (Maes)		(1066)	Delphinus	T (Plio-l)	-R	
Or. INCERTAE SEDIS				+Denebola	T (Mi-u)		(746)
Scanirnis	T (Dani)		(1066)	Diaphorocetus	T (Mi-l)		
Cl. MAMMALIA				Dinoziphius	T (Mi-m)	-T (Mi-u)	(746)
Or. CETACEA				+Diorocetus	T (Mi-m)		(746)
Acrodelphis	T (Mi-l)	-T (Mi-u)		Doliodelphis	T (Mi-l)		
+Aetiocetus	T (Ol-u)		(746)	Dorudon	T (Eo-m-u)	-T (Eo-u)	(1009)
Agabelus	T (Mi-m)			Eboroziphius	T (Mi-u)		
Aglaiocetus	T (Mi-l)		(746)	Eocetus	T (Eo-m-u)	-T (Eo-u)	(1009)
Agorophius	T (Ol-u)		(506)	Eoplataniata	T (Mi-l)		
Agriocetus	T (Ol-u)			+Eosqualodon	T (Ol-u)		(746)
+Albireo	T (Mi-u)		(746)	+Eschrichtius	T (Mi-m)	-R	(746)
+Ambulocetus	T (Eo-m)			Eubalaena	Q (Plei)	-R	
Amphicetus	T (Plio-l)			Eucetotherium	T (Mi-m)	-T (Mi-u)	(746)
+Anacharsis	T (Mi-u)		(746)	Eurhinodelphis	T (Mi-m)	-T (Mi-u)	(746)
+Andrewsiphius	T (Eo-m-l)		(506,1022)	+Ferecetotherium	T (Ol-u)		(746,1022)
Anoplonassa	T (Mi-m)	-T (Mi-u)	(746)	+Gandakasia	T (Eo-m-l)		(746,1022)
Apenophyseter	T (Mi-l)			+Georgiacetus	T (Eo-m)		
Araeodelphis	T (Mi-m)		(746)	Globicephala	Q (Plei)	-R	
Archaeodelphis	T (Ol-u)		(746)	+Hadrodelphis	T (Mi-m)		(746)
Argyrocetus	T (Mi-l)			+Haplocetus	T (Mi-u)		(746)
+Atocetus	T (Mi-m)		(1066)	Hemisyntrachelus	T (Plio)		(1066)
+Atropatenocetus	T (Ol-u)			Herpetocetus	T (Mi-u)		
+Auiophyseter	T (Mi-m)		(746)	Heterocetus	T (Mi-m)	-T (Mi-u)	(746)
Aulocetus	T (Mi)			Heterodelphis	T (Mi-m)	-T (Mi-u)	
Aulophyseter	T (Mi-m)		(1066)	Hoplocetus	T (Mi-m)		
+Australithax	T (Mi-u)		(1066)	+Ichthyocetes	T (Eo-m-l)		(746,1022)
+Australosqualodon	T (Ol-u)		(746,1022)	Idiocetus	T (Mi)	-T (Plio-u)	
Balaena	T (Plio)	-R	(746)	Idiophyseter	T (Mi-m)		
Balaenodon	T (Mi-u)		(746)	Idiorophus	T (Mi-l)		
Balaenoptera	T (Mi-u)	-R		+Imrocetus	T (Mi-u)		(746)
				+Imrodelphis	T (Mi-u)		(746)
				Incaecetus	T (Mi-m)		(746)
				+Indocetus	T (Eo-m-l)		(1022)
				Iniopsis	T (Ol-u)	-T (Mi-u)	(746)
				Isocetus	T (Mi-u)		
				Ixacanthus	T (Mi-m)		
				+Kampholophus	T (Mi-m)		(746)

Taxon	First Appearance	Last Appearance	Reference	Taxon	First Appearance	Last Appearance	Reference
Kekenodon	T (Ol-u)		(1022)	Phocaena	T (Mi-u)	-R	(746)
+Kelloggia	T (Ol-u)		(1022)	Phocaenopsis	T (Mi-l)		
Kentriodon	T (Mi-m)		(1066)	Phocageneus	T (Mi-m)		(746)
Kogia	T (Plio)	-R		Phococetus	T (Ol-l)	-T (Mi-l-u)	(2,1022)
Kogiopsis	T (Plio-l)			Physeter	T (Mi-l)	-R	
+Lagenorhynchus	T (Plio)	-Q (Plei)	(507)	Physeterula	T (Mi-l)	-T (Plio)	(746)
Lamprolithax	T (Mi-m)			Physetodon	T (Plio-l)		
Leptodelphis	T (Mi-m)		(1066)	+Pinocetus	T (Mi-m)		
Liolithax	T (Mi-m)	-T (Mi-u)	(1066)	+Piscolithax	T (Mi-u)	-T (Plio-l)	(746)
†Llanocetus	T (Eo-u)		(1022)	Pithanodelphis	T (Mi-u)		
+Lomacetus	T (Mi-u)		(1066)	Placoziphius	T (Mi-u)		
Loncodephus	T (Mi-u)		(746)	Platylithax	T (Mi-m)		
Lophocetus	T (Mi-m)			Platyosphys	T (Ol-l)		
Loxolithax	T (Mi-m)			Plesiocetopsis	T (Mi-u)	-T (Plio-l)	
Macrochirifer	T (Mi-u)			+Plesiocetus	T (Mi-l)	-T (Plio-l)	(746,1066)
Macrodelphinus	T (Mi-l)			+Pliopontes	T (Plio-l)		(746)
+Mammalodon	T (Ol-u)		(1022)	Pomatodelphis	T (Mi-m)	-T (Plio-l)	
Manicetus	T (Ol-l-u)	-T (Mi-l)	(2,746)	Pontistes	T (Plio-l)		
†Medoicinia	T (Mi-l-u)		(1066)	Pontivaga	T (Plio-l)		
+Megaptera	T (Plio-l)	-R	(746)	Pontogeneus	T (Eo-u)		
Megapteropsis	T (Plio-l)			+Potamodelphis	T (Mi-u)		(746)
Mesocetus	T (Mi-m)	-T (Mi-u)		+Praekogia	T (Mi-u)		(746)
Mesoplodon	T (Mi-u)	-R		+Prioinia	T (Mi-l)		(1066)
Mesoteria	T (Mi-u)			Prionodelphis	T (Plio-l)		
Metasqualodon	T (Ol-u)		(1022)	Priscophyseter	T (Mi-u)		(746)
Metopocetus	T (Mi-u)			+Procetis	T (Eo-m)		(1066)
Microcetus	T (Ol-u)			Prophyseter	T (Mi-u)		
+Microphocaena	T (Mi-m)		(1066)	Prororziphius	T (Mi-u)		
Microsqualodon	T (Mi-l)			Prosqualodon	T (Mi-l)		
Microzeuglodon	T (Ol-u)		(746)	Protobalaena	T (Plio-l)		
Miodelphis	T (Mi-l)		(746)	Protocetus	T (Eo-m-l)	-T (Eo-m-u)	(1022)
+Miokogia	T (Mi-l)		(1066)	Protodelphinus	T (Mi-l)		
+Mirocetus	T (Ol-u)		(746,1022)	Protophocaena	T (Mi-u)		
Mixocetus	T (Mi-u)			Prozeuglodon	T (Eo-m-l)	-T (Eo-u)	(1066)
Monodon	Q (Plei)			Pseudorca	Q (Plei-l)	-R	
Morenocetus	T (Mi-l)			+Remingtonocetus	T (Eo-m-l)		(1022)
+Nanisocetus	T (Mi-u)		(746)	+Rhabdosteus	T (Mi-m)		(507)
Namocetus	T (Mi-u)		(746)	Rhagnopsis	T (Mi-u)?	-T (Plio)	(1066)
Namolothax	T (Mi-m)			Rhytidodon	T (Mi-l)		
Neosqualodon	T (Mi-l)			+Rodhocetus	T (Eo-m)		
+Ninoziphius	T (Plio)			+Sachalinocetus	T (Mi-l)		(746)
Notiocetus	T (Plio-l)			+Sagbacetus	T (Eo-u)		(1009)
Notocetus	T (Mi-l-u)		(1066)	+Salammiphocaena	T (Mi-u)		(746)
Oedolithax	T (Mi-m)			+Sarmatodelphis	T (Mi-m)		(1066)
+Oligodelphis	T (Ol-l-u)		(746)	Saurocetus	T (Ol-u)	-T (Mi-u)?	(1022)
Ontocetus	T (Mi-m)	-T (Mi-u)		Schizodelphis	T (Mi-l)	-T (Mi-u)	(1066)
Orcinus	T (Mi-u)	-R	(746)	Siphonocetus	T (Mi-u)		(746)
Orycterocetus	T (Mi-l)		(1066)	Sormatodelphis	T (Mi-u)		
Pachycetus	T (Eo-m)		(746)	Squalodelphis	T (Mi-l-u)		(1066)
Palaeobalaena	T (Mi-m)			Squalodon	T (Ol-u)	-T (Plio)	(1066)
Palaeocetus	T (Mi-u)		(746)	+Squaloziphius	T (Mi-l)		
Palaeophocaena	T (Mi-u)			†Stenella	T (Mi-m)?	-T (Plio)	(746)
Palaeoziphius	T (Mi-u)			Steno	T (Plio-l)	-R	
Pappocetus	T (Eo-m-l)			Stenodelphis	Q (Plei)	-R	
+Parapontoparia	T (Mi-u)	-T (Plio-u)	(746)	Stereodelphis	T (Mi-m)		
Parasqualodon	T (Ol-u)		(746)	+Sulacocetus	T (Ol-u)		(746)
Parietobalaena	T (Mi-u)		(746)	Tangarasaurus	T (Mi-l)		
Patriocetus	T (Ol-u)			Thalassocetus	T (Mi-u)		
+Pelocetus	T (Mi-m)		(746)	Tiphyocetus	T (Mi-m)		
Pelodelphis	T (Mi-m)			Tretosphrys	T (Mi-m)		
Periplocetus	T (Mi-m)			Tretulias	T (Mi-u)		
Phoberodon	T (Mi-l)			Trirhizodon	T (Mi-l)	-T (Mi-m)	

Taxon	First Appearance	Last Appearance	Reference	Taxon	First Appearance	Last Appearance	Reference
Tursiops	T (Mi-m)	-R	(1066)	+ Callorhinus	T (Plio)	-R	(746)
Ulias	T (Mi-u)			Cystophora	Q (Plei)	-R	
Xenorophus	T (Ol-u)		(506)	Desmatophoca	T (Mi-l-u)	-T (Mi-m)	(746)
Ziphiodelphis	T (Mi-u)		(1066)	Dusignathus	T (Mi-u-u)		(746)
Ziphioides	T (Mi-m)			+ Enaliarctos	T (Ol-u)	-T (Mi-l-u)	
Ziphirostrum	T (Mi-u)			+ Enhydriodon	T (Mi-u)	-R	
Ziphius	T (Plio-l)?			+ Enhydriotherium	T (Mi-u)	-T (Plio)	
Zygorhiza	T (Eo-m-u)	-T (Eo-u)	(1022)	Eumetopias	T (Plio-u)	-R	
Or. SIRENIA				Gryphoca	T (Plio-u)		
† Anisosiren	T (Eo-m-l)		(746)	+ Imagotaria	T (Mi-m)	-T (Mi-u)	(746)
Anomotherium	T (Ol-l-u)	-T (Ol-u)	(746)	+ Kamtschatarctos	T (Mi-m)		
† Bharatisiren	T (Mi-l-l)			Leptophoca	T (Mi-m)		
Caribosiren	T (Ol-l-u)		(746)	Mesotaria	T (Plio-u)		
† Dioplotherium	T (Mi-l)	-T (Mi-m)	(746)	+ Monachiopsis	T (Mi-m)		(1066)
+ Dusisiren	T (Mi-m)	-T (Plio-l)	(746)	Monachus	T (Mi-u)	-R	
+ Eosiren	T (Eo-u)		(1009)	Monotherium	T (Mi-u)		
Felsinotherium	T (Plio-l)	-T (Plio-u)		Necromites	T (Mi)		
Halianassa	T (Mi-l)	-T (Mi-u)		+ Neophoca	Q (Plei)	-R	
Halitherium	T (Ol-l)	-T (Ol-u)		Neotherium	T (Mi-m)		(2)
Hesperosiren	T (Mi-l)			Odobenus	T (Plio)	-R	(746)
+ Hydrodamalis	T (Plio-l)	-R		Otaria	Q (Plei)	-R	
Indosiren	T (Mi-u)		(746)	Palaeophoca	T (Plio-u)		
+ Ishatherium	T (Eo-m)?			+ Palmidophoca	T (Mi-m)		(1066)
Lophiodolus	T (Ol-l)?		(508)	+ Pelagiartcos	T (Mi-m)		
Manatus	Q (Plei)	-R		Phoca	T (Mi-m)	-R	
+ Metaxytherium	T (Mi-l-u)	-T (Mi-u-l)	(508,746)	Phocanella	T (Plio-u)		
Miosiren	T (Plio-l)			+ Pinnartidion	T (Mi-l)		(746)
+ Paralitherium	T (Eo-u)			Pithanotaria	T (Mi-m)	-T (Mi-u)	(746)
Potamosiren	T (Mi-l)		(746)	Platyphoca	T (Plio-u)		
Prohalicore	T (Mi-m)			+ Pliopedtia	T (Mi-u)		(746)
Prorastomus	T (Eo-l)	-T (Eo-u)		Pontolis	T (Mi-u)		
Protosiren	T (Eo-m-l)	-T (Eo-m-u)	(1009)	+ Pontophoca	T (Mi-m)		(1066)
Prototherium	T (Eo-u)		(746)	+ Praepusa	T (Mi-m)		(1066)
Ribodon	T (Mi-u-u)		(508,746)	Pristiphoca	T (Mi-m)	-Q (Plei-l)	
Rytiodus	T (Mi-l)			+ Properiptychus	T (Mi-m)		(1066)
Scaldicetus	T (Mi-l)	-T (Mi-u)	(1066)	Prophoca	T (Mi-u)		
Sirenavus	T (Eo-m-l)			Prorosmarus	T (Mi-u)		
Thalattosiren	T (Mi-l)		(746)	+ Prototaria	T (Mi-m)		
+ Trichechus	T (Plio)	-R	(508)	+ Pteronarctos	T (Mi-l-u)		(1066)
+ Xenosiren	T (Plio-l)?			+ Thalassoleon	T (Mi-u-u)	-T (Plio)	(746)
				Trichechodon	T (Plio)	-Q (Plei)	
				Valenictis	T (Plio-l)		
				Zalophus	Q (Plei)	-R	
Or. CARNIVORA (Pinnipedia)							
+ Aivukus	T (Mi-u)		(746)	Or. DESMOSTYLIA			
Alachtherium	T (Plio-u)			Behemotops	T (Ol-u)		
Allodesmus	T (Mi-l)	-T (Mi-m)	(746)	Cornwallius	T (Ol-u)		
Arctocephalus	Q (Plei)	-R	(746)	Desmostylus	T (Mi-l)	-T (Mi-u)	
Atopotarus	T (Mi)	-Q (Plei)		Paleoparadoxia	T (Mi-m)	-T (Mi-u)	
Callophoca	T (Plio)						

REFERENCES CITED

1. **Moore, R.C., Teichert, C., and Robison, R.A., eds.**
1953-1984. *Treatise on Invertebrate Paleontology*. Geological Society of America and the University of Kansas Press, Lawrence, Kansas.
2. **Harland, W.B. et al.**
1967. *The Fossil Record*. Geological Society of London, London, 828 pp.
3. **Lockley, M.G.**
1983. A review of brachiopod dominated palaeocommunities from the type Ordovician. *Palaeontology*, vol. 26(1), pp. 111-146.
4. **Shimer, H.W. and Schrock, R.R.**
1944. *Index Fossils of North America*. M.I.T. Press, Cambridge, Massachusetts, 837 pp.
5. **Williams, A.**
1974. Ordovician Brachiopods from the Shelve District, Shropshire. *British Museum (Natural History) Bulletin, Geology*, Supplement 11, 163 pp.
6. **Temple, J.T.**
1968. The Lower Llandovery (Silurian) Brachiopods from Keisley, Westmorland. *Monograph of the Palaeontographical Society*, vol. 122, no. 521, 58 pp.
7. **Cooper, A.G. and Grant, R.E.**
1972-1977. Permian brachiopods of West Texas, I-VI. *Smithsonian Contributions to Paleobiology*, no. 14, pp. 1-231; no. 15, pp. 233-793; no. 19, pp. 795-1921; no. 21, pp. 1923-2607; no. 24, pp. 2609-3159; no. 32, pp. 3161-3370.
8. **Surlyk, F. and Johansen, M.B.**
1984. End-Cretaceous brachiopod extinctions in the chalk of Denmark. *Science*, vol. 223, pp. 1174-1177.
9. **Carter, J.L.**
1968. New genera and species of early Mississippian brachiopods from the Burlington Limestone. *Journal of Paleontology*, vol. 42, pp. 1140-1152.
10. **Robison, R.A.**
1964. Late Middle Cambrian faunas from western Utah. *Journal of Paleontology*, vol. 38, pp. 510-566.
11. **Rushton, A.W.A.**
1974. The Cambrian of Wales and England. In C.H. Holland, ed., *Cambrian of the British Isles, Norden, and Spitsbergen*. Wiley-Interscience, New York, pp. 43-121.
12. **Wright, A.D.**
1979. Brachiopod radiation. In M.R. House, ed., *The Origin of Major Invertebrate Groups*. Systematics Association Special Volume 12. Academic Press, London, pp. 235-252. [Cited by Sepkoski as: Wright 1974.]
13. **Cowie, J.W., Rushton, A.W.A., and Stubblefield, C.J.**
1979. A correlation of Cambrian rocks in the British Isles. *Geological Society of London, Special Report 2*, 42 pp.
14. **Pospelov, A.G., Boyarinova, A.S., Aksarina, N.A., Nadler, Yu.S., and Fedyanina, E.S.**
1979. Opornii razrez nizhnego Kembriya po r. Kiev Kuzneckom Alatau. In I.T. Zhuravleva, ed., *Problemy Biostratigrafii i Paleontologii Nizhnego Kembriya Sibiri*. "Nauka", Moscow, pp. 222-232.
15. **Keller, B.M. and Rozanov, A.Yu., eds.**
1979. Upper Precambrian and Cambrian Paleontology of East-European Platform [in Russian]. "Nauka", Moscow, 211 pp.
16. **Shergold, J.H.**
1979. Biostratigraphical synopsis Eastern Georgina Basin, QLD. (Appendix to International Geological Congress Excursion 4C Guidebook). Australian Bureau of Mineral Resources, Geological and Geophysical Record 1975/69, 50 pp.
17. **Lochman, C. and Duncan, D.**
1944. Early Upper Cambrian faunas of central Montana. *Geological Society of America Special Paper 54*, 181 pp.
18. **Rees, M.N. and Rowell, A.J.**
1980. Preble Formation, a Cambrian outer continental shelf deposit, Nevada. *Brigham Young University Geological Studies*, vol. 27, pp. 1-8.
19. **Rowell, A.J.**
1977. Early Cambrian brachiopods from the southwestern Great Basin of California and Nevada. *Journal of Paleontology*, vol. 51, pp. 68-85.
20. **Richards, R.P.**
1972. Autecology of Richmondian brachiopods (Late Ordovician of Indiana and Ohio). *Journal of Paleontology*, vol. 46, pp. 386-405.
21. **Brasier, M.D., Hewitt, R.A., and Brasier, C.J.**
1978. Of the late Precambrian-Early Cambrian Hartshill Formation of Warwickshire. *Geological Magazine*, vol. 115, pp. 21-36.
22. **Bergstrom, J.**
1981. Lower Cambrian shelly faunas and biostratigraphy in Scandinavia. In M.E. Taylor, ed., *Short Papers for the Second International Symposium of the Cambrian System*. U.S. Geological Survey Open-File Report 81-743, pp. 22-25.
23. **Cooper, G.A.**
1976. Lower Cambrian brachiopods from the Rift Valley (Israel and Jordan). *Journal of Paleontology*, vol. 50, pp. 269-289.
24. **Wang Yu, Boucot, A.J., Rong Jia-Yu, and Yany Xue-Chang**
1984. Silurian and Devonian biogeography of China. *Geological Society of America Bulletin*, vol. 95, pp. 265-279.
25. **Boucot, A.J.**
1975. *Evolution and Extinction Rate Controls*. Elsevier, Amsterdam, 427 pp.
26. **Macomber, R.W.**
1970. Articulate brachiopods from the upper Bighorn Formation (Late Ordovician) of Wyoming. *Journal of Paleontology*, vol. 44, pp. 416-450.
27. **Bassett, M.G. and Cocks, L.R.M.**
1974. A review of Silurian brachiopods from Gotland. *Fossils and Strata*, no. 3, pp. 1-56.
28. **Johnson, J.G.**
1973. Mid-Lochkovian brachiopods from the Windmill Limestone of central Nevada. *Journal of Paleontology*, vol. 47, pp. 1013-1031.
29. **Sheehan, P.M. and Lesperance, P.J.**
1979. Late Ordovician (Ashgillian) brachiopods from the Perce region of Quebec. *Journal of Paleontology*, vol. 53, pp. 950-967.
30. **Perry, D.G.**
1979. Late Early Devonian reef associated brachiopods of the Prongs Creek Formation, northern Yukon. *Journal of Paleontology*, vol. 53, pp. 1094-1111.
31. **Bayer, T.N.**
1967. Repetitive benthonic communities in the Maquoketa Formation (Ordovician) of Minnesota. *Journal of Paleontology*, vol. 41, pp. 417-422.
32. **Richards, R.P.**
1972. Autecology of Richmondian brachiopods (Late Ordovi-

- cian of Indiana and Ohio). *Journal of Paleontology*, vol. 46, pp. 386-405.
- 33. Stehli, F.G. and Grant, R.E.**
1971. Permian brachiopods from Axel Heilberg Island, Canada, and an index of sampling efficiency. *Journal of Paleontology*, vol. 45, pp. 502-521.
- 34. Carter, J.L.**
1971. Early Mississippian brachiopods from the Gilmore City Limestone of Iowa. *Journal of Paleontology*, vol. 46, pp. 473-491.
- 35. Wright, A.D.**
1982. A new species of *Prychopleurella* (Brachiopoda) from the Upper Ordovician Boda Limestone of Dalarna, Sweden. *Journal of Paleontology*, vol. 56, pp. 351-357.
- 36. Harper, C.W., Jr., Boucot, A.J., and Walmsley, V.G.**
1969. Rhipidomellid brachiopod subfamilies Heterorthisinae and Platyorthisinae. *Journal of Paleontology*, vol. 43, pp. 74-92.
- 37. Copper, P.**
1973. New Siluro-Devonian atrypoid brachiopods. *Journal of Paleontology*, vol. 47, pp. 484-500.
- 38. Amsden, T.W.**
1968. Articulate brachiopods of the St. Clair Limestone (Silurian), Arkansas, and the Clarita Formation (Silurian), Oklahoma. *Paleontological Society Memoir 1* (*Journal of Paleontology*, vol. 42, no. 3, supplement), 117 pp.
- 39. Boucot, A.J. and Harper, C.W., Jr.**
1968. Silurian to lower Middle Devonian Chonetacea. *Journal of Paleontology*, vol. 42, pp. 143-176.
- 40. Logan, A. and McGugan, A.**
1968. Biostratigraphy and faunas of the Permian Ishbel Group, Canadian Rocky Mountains. *Journal of Paleontology*, vol. 42, pp. 1123-1139.
- 41. Sutherland, P.K. and Harlow, F.H.**
1973. Pennsylvanian brachiopods and biostratigraphy in southern Sangre de Cristo Mountains, New Mexico. *New Mexico Bureau of Mines and Mineral Resources Memoir 27*, 172 pp.
- 42. Rodriguez, J. and Gutschick, R.C.**
1969. Silicified brachiopods from the lower Lodgepole Limestone (Kinderhookian), southwestern Montana. *Journal of Paleontology*, vol. 43, pp. 952-960.
- 43. Waterhouse, J.B.**
1968. New species of *Megousia* Muirwood & Cooper and allied new genus from the Permian of Australia and North America. *Journal of Paleontology*, vol. 42, pp. 1171-1185.
- 44. Chiang, K.K.**
1971. Silurian pentameracean brachiopods of the Fossil Hill Formation, Ontario. *Journal of Paleontology*, vol. 45, pp. 849-861.
- 45. Gordon, M.**
1966. New spinose early Meramec (upper Mississippian) productoid brachiopods. *Journal of Paleontology*, vol. 40, pp. 573-584.
- 46. Waterhouse, J.B.**
1969. Permian Strophalosidae (Brachiopoda) from the Canadian Arctic archipelago. *Journal of Paleontology*, vol. 43, pp. 28-40.
- 47. Jones, B. and Smith, G.P.**
1980. Lower Devonian brachiopods from the Eids Formation, southwest Ellesmere Island, Arctic Canada. *Journal of Paleontology*, vol. 54, pp. 675-695.
- 48. Carter, J.L.**
1967. An unusual spiriferacean brachiopod from the Barnett Formation (Mississippian) of central Texas. *Journal of Paleontology*, vol. 41, pp. 587-594.
- 49. Nelson, S.J. and Johnson, C.E.**
1968. Permo-Pennsylvanian brachythurid and horridonid brachiopods from the Yukon Territory, Canada. *Journal of Paleontology*, vol. 42, pp. 715-746.
- 50. Scheing, M.H. and Langenheim, R.L., Jr.**
1980. Brachiopods of the suborder Strophomenidina from the Shumway Cyclothem, Mattoon Formation, Virgilian of Illinois. *Journal of Paleontology*, vol. 54, pp. 1019-1034.
- 51. Waterhouse, J.B.**
1970. Gondwanan occurrences of the upper Paleozoic brachiopod *Srepanoviella*. *Journal of Paleontology*, vol. 44, pp. 37-50.
- 52. Beus, S.S. and Lane, N.G.**
1969. Middle Pennsylvanian fossils from Indian Springs, Nevada. *Journal of Paleontology*, vol. 43, pp. 986-1000.
- 53. Savage, N.M.**
1969. New atrypoid brachiopods from the Lower Devonian of New South Wales. *Journal of Paleontology*, vol. 44, pp. 655-668.
- 54. Tillman, C.G.**
1967. Silicified rhynchonellid brachiopods from beds of New Scotland age (Early Devonian), Virginia and West Virginia. *Journal of Paleontology*, vol. 41, pp. 1247-1255.
- 55. Voros, A.**
1983. The Pliensbachian brachiopods of the Bakony Mountains (Hungary): a stratigraphical study. *Fragmenta Mineralogica et Palaeontologica*, vol. 11, pp. 29-39.
- 56. Ager, D.V.**
1956-1957. Monograph of the British Liassic Rhynchonellidae. *Monograph of the Palaeontographical Society*, no. 476, pp. 1-51; no. 483, pp. 51-84; no. 498, pp. 85-136; no. 519, pp. 137-172.
- 57. Sucic-Profic, Z.**
1969. Mesozoic Brachiopods of Yugoslavia (middle Liassic Brachiopods of the Yugoslav Carpatho-Balkanids). University of Belgrade (Yugoslavia), Belgrade.
- 58. Savage, N.M., Eberlein, G.D., and Churkin, M.**
1978. Upper Devonian brachiopods from the Port Refugio Formation, Suemez Island, southeastern Alaska. *Journal of Paleontology*, vol. 52, pp. 370-393.
- 59. Childs, A.**
1969. Upper Jurassic rhynchonellid brachiopods from northwestern Europe. *British Museum (Natural History) Bulletin. Geology. Supplement 6*, 119 pp.
- 60. Parkinson, D.**
1969. Relative growth, variation, and evolutionary trends in a carbonate rhynchonellid brachiopod. *Journal of Paleontology*, vol. 43, pp. 95-110.
- 61. Johnson, J.G., Reso, A., and Stevens, M.**
1969. Late Upper Devonian brachiopods from the West Range Limestone of Nevada. *Journal of Paleontology*, vol. 43, pp. 1351-1368.
- 62. Clarke, M.J.**
1979. The Tasmanian Permian spiriferid brachiopods *Trigonotreta stokesi* Koenig, 1825, *Grantonia hobartensis* Brown, 1953, and *Spirifer tasmaniensis* Morris, 1845. *Journal of Paleontology*, vol. 53, pp. 197-207.
- 63. Johnson, J.G. and Klapper, G.**
1978. Devonian brachiopods and conodonts from central Oregon. *Journal of Paleontology*, vol. 52, pp. 295-299.
- 64. Pitrat, C.W.**
1977. Spiriferid brachiopods from the Traverse Group of Mich-

- igan: Orthospirifer. *Journal of Paleontology*, vol. 51, pp. 330-342.
65. **Waterhouse, J.B.**
1971. The brachiopod genus *Tomioxypis* Benedictova from the Permian of Canada. *Journal of Paleontology*, vol. 45, pp. 68-80.
66. **Boucot, A.J., Johnson, J.G., and Staton, R.D.**
1964. Of some atrypoid, retzoid and athyroid Brachiopoda. *Journal of Paleontology*, vol. 38, pp. 805-822.
67. **Titus, R.**
1982. Fossil communities of the middle Trenton Group (Ordovician) of New York State. *Journal of Paleontology*, vol. 56, pp. 477-485.
68. **Jones, B.**
1979. *Atrypoides erebus* n. sp. from the Late Silurian of Arctic Canada. *Journal of Paleontology*, vol. 53, pp. 187-196.
69. **Copper, P.**
1982. Early Silurian atrypoids from Manitoulin Island and the Bruce Peninsula, Ontario. *Journal of Paleontology*, vol. 56, pp. 680-702.
70. **Anderson, M.M., Boucot, A.J., and Johnson, J.G.**
1967. Devonian terebratulid brachiopods from the Accraian Series of Ghana. *Journal of Paleontology*, vol. 40, pp. 1365-1367.
71. **Feldman, H.R.**
1979. Palaeoecology and morphology variation of a Paleocene terebratulid brachiopod (*Oleneothlyris harlani*) from the Hornerstown Formation of New Jersey. *Journal of Paleontology*, vol. 51, pp. 86-107.
72. **Doescher, R.A.**
1981. Living and fossil brachiopod genera 1775-1979. Lists and bibliography. *Smithsonian Contributions to Paleobiology*, no. 42, 238 pp.
73. **Oravecz-Scheffer, A.**
1983. Foraminiferal stratigraphy of the Triassic in the Transdanubian central range. *Acta Geologica Hungarica*, vol. 26, pp. 213-226.
74. **Bate, R.H. and Robinson, E., eds.**
1978. *A Stratigraphical Index of British Ostracoda*. Seel House Press, Liverpool, 538 pp.
75. **Barthel, K.W.**
1978. *Solnhofen. Ein Blick in die Erdgeschichte*. Ott Verlag, Thun, 393 pp.
76. **Loeblich, A.R., Jr. and Tappan, H.**
1984. Some new proteinaceous and agglutinated genera of Foraminifera. *Journal of Paleontology*, vol. 58, pp. 1158-1163.
77. **Stone, S.M. and Berdan, J.M.**
1984. Some Late Silurian (Pridolian) ostracodes from the Roberts Mountains, central Nevada. *Journal of Paleontology*, vol. 58, pp. 977-1009.
78. **Sarv, L.**
1972. Development of Ordovician ostracodes of the East Baltic. *Proceedings of the International Paleontological Union, 23rd International Geological Congress, Prague (1968)*, pp. 203-210.
79. **Jenkins, D.G. and Murrays, J.W., eds.**
1981. *Stratigraphical Atlas of Fossil Foraminifera*. Ellis Horwood Ltd., Chichester, 310 pp.
80. **Lochman-Balk, C. and Wilson, J.L.**
1958. Cambrian biostratigraphy in North America. *Journal of Paleontology*, vol. 32, pp. 312-350.
81. **Fritz, W.H.**
1970. Cambrian faunas. In R.J.W. Douglas, ed., *Geology and Economic Minerals of Canada*. Department of Energy, Mines and Resources, Canada, pp. 593-600.
82. **Breimer, A. and Macurda, D.B., Jr.**
1972. The phylogeny of fissiculate blastoids. *Verhandelingen Koninklijke Nederlandse Akademie van Wetenschappen*, vol. 26, pp. 1-390.
83. **Bernasoni, M.P. and Robba, E.**
1982. The thecosomatous pteropods: a contribution toward the Cenozoic Tethyan paleobiogeography. *Bollettino della Società Paleontologica Italiana*, vol. 21, pp. 211-227.
84. **Bizzarini, F. and Braga, G.**
1982. The Triassic Bryozoa of the western Tethyan basin. *Bollettino della Società Paleontologica Italiana*, vol. 21, pp. 223-234.
85. **McKenzie, K.G.**
1982. Paleozoic Ostracoda of Tethys. *Bollettino della Società Paleontologica Italiana*, vol. 21, pp. 311-326.
86. **Shimanskii, V.N. and Solob'eb, A.N.**
1981. Razvitie i smena prosteishikh, kishchnopolostnich i chervei na rubche Mezozoja i Kainozoja. "Nauka", Moscow, 82 pp.
87. **Brasier, M.D. and Hewitt, R.A.**
1981. Faunal sequence within the Lower Cambrian "non-trilobite" zone (s.l.) of central England and correlated regions. In M.E. Taylor, ed., *Short Papers for the Second International Symposium on the Cambrian System*. U.S. Geological Survey Open-File Report 81-743, pp. 23-33.
88. **Jell, P.A.**
1980. Earliest known pelecypod on Earth—a new Early Cambrian genus from South Australia. *Alcheringa*, vol. 4, pp. 233-239.
89. **Luo Hulin, Jiang Zhiwen, Wu Xiche, Song Xueliang, Ouyang Lin, et al.**
1981. The Sinian-Cambrian Boundary in Eastern Yunnan, China. *Yunnan Institute of Geological Sciences*, 249 pp.
90. **MacKinnon, D.J.**
1982. *Tuarangia paparu* n. gen. and n. sp., a late Middle Cambrian pelecypod from New Zealand. *Journal of Paleontology*, vol. 56, pp. 589-598.
91. **Pojeta, J.**
1971. Review of Ordovician pelecypods. U.S. Geological Survey Professional Paper 695, 46 pp.
92. **Hallam, A.**
1976. Stratigraphic distribution and ecology of European Jurassic bivalves. *Lethaia*, vol. 9, pp. 245-259.
93. **Hallam, A.**
1977. Jurassic bivalve biogeography. *Paleobiology*, vol. 3, pp. 58-73.
94. **Hallam, A.**
1981. The end-Triassic bivalve extinction event. *Palaeogeography, Palaeoclimatology, Palaeoecology*, vol. 35, pp. 1-44.
95. **MacAlester, A.L.**
1968. Type species of Paleozoic nuculoid bivalve genera. *Geological Society of America Memoir* 105, 143 pp.
96. **Moore, E.J.**
1984. Middle Tertiary molluscan zones of the Pacific Northwest. *Journal of Paleontology*, vol. 58, pp. 718-737.
97. **Soot-Ryen, H.**
1964. Nuculoid pelecypods from the Silurian of Gotland. *Arkiv foer Mineralogi och Geologi*, vol. 3, pp. 89-519. [Cited by Sepkoski as: Soot-Ryan (sic) 1964.]
98. **Morris, N.J. and Fortey, R.A.**
1976. The significance of *Tironucula* gen. nov. to the study of

- bivalve evolution. *Journal of Paleontology*, vol. 50, pp. 701-709.
- 99. Lewy, Z.**
1982. *Gryphaelignus* n. gen. (Bivalvia, Malleidae) from the Bathonian of the Middle East. *Journal of Paleontology*, vol. 56, pp. 811-815.
- 100. Waterhouse, J.B., Campbell, J.D., and Williams, J.G.**
1982. Early Permian brachiopods and molluscs from Gondor Formation, Eglington Valley, Southland, New Zealand. *Journal of Geology and Geophysics*, vol. 6, pp. 301-307. [Cited by Sepkoski as: Waterhouse et al. 1983.]
- 101. Addicott, W.O.**
1974. Giant pectinids of the eastern North Pacific margin: significance in Neogene zoogeography and chronostratigraphy. *Journal of Paleontology*, vol. 48, pp. 180-194.
- 102. Logan, A.**
1970. The new bivalve genus *Arctomyalina* from the Pennsylvanian of the Canadian Arctic Archipelago. *Journal of Paleontology*, vol. 44, pp. 501-506.
- 103. Newell, N.D. and Boyd, D.W.**
1970. Oyster-like Permian Bivalvia. *American Museum of Natural History Bulletin*, vol. 143, pp. 217-282.
- 104. Gonzalez, C.R.**
1978. *Orbiculopecten* gen. nov. (Aviculopectinidae, Bivalvia) from the Upper Carboniferous of Patagonia, Argentina. *Journal of Paleontology*, vol. 2, pp. 1086-1092.
- 105. Hoare, R.D., Sturgeon, M.T., and Kindt, E.A.**
1978. New Pennsylvanian bivalves and occurrences of *Pseudocoenocardium* from Ohio and West Virginia. *Journal of Paleontology*, vol. 52, pp. 1023-1036.
- 106. Scott, R.W.**
1978. Paleobiology of Comanchean (Cretaceous) cardiid (Cardiidae), North America. *Journal of Paleontology*, vol. 52, pp. 881-903.
- 107. Zinsmeister, W.J.**
1983. New late Paleocene molluscs from the Simi Hills, Ventura County, California. *Journal of Paleontology*, vol. 57, pp. 1282-1303.
- 108. Runnegar, B.**
1974. Evolutionary history of the bivalve subclass Anomalodermata. *Journal of Paleontology*, vol. 48, pp. 904-939.
- 109. Batten, R.L.**
1973. The vicissitudes of the gastropods during the interval of Guadalupian-Ladinian time. In A. Logan and L.V. Hill, eds., *The Permian and Triassic Systems and Their Mutual Boundary*. Canadian Society of Petroleum Geologists, Calgary, Alberta, pp. 596-607.
- 110. Runnegar, B. and Jell, P.A.**
1976. Australian Middle Cambrian molluscs and their bearing on early molluscan evolution. *Alcheringa*, vol. 1, pp. 109-138.
- 111. Shergold, J.H.**
1976. Biostratigraphic synopsis: Eastern Georgina Basin, QLD (Appendix to International Geological Congress Excursion 4C Guidebook). Australian Bureau of Mineral Resources, Geology and Geophysics Bulletin, vol. 153, pp. 1-251.
- 112. Frederickson, E.A.**
1956. Cambrian of Oklahoma. In J. Roger, ed., *El Sistema Cambrico*, vol. 2. Report of the 20th International Geological Congress, pp. 403-508. [Cited by Sepkoski as: Frederickson, E.A. 1956.]
- 113. Runnegar, B.**
1981. Biostratigraphy of Cambrian molluscs. In M.E. Taylor, ed., *Short Papers for the Second International Symposium on the Cambrian System*. U.S. Geological Survey Open-File Report 81-743, pp. 198-202.
- 114. Gordon, M. Jr. and Yochelson, E.L.**
1983. A gastropod fauna from the *Cravenoceras hesperium* ammonoid zone (Upper Mississippian) in east-central Nevada. *Journal of Paleontology*, vol. 57, pp. 971-991.
- 115. Yin Hong-Fu and Yochelson, E.L.**
1983. Middle Triassic Gastropoda from Qingyan, Ghizhou Province, China: 1. Pleurotomariacea and Murchisoniacea. 3.—Euomphalacea and Loxonematacea. *Journal of Paleontology*, vol. 57, pp. 62-187, 1098-1127.
- 116. Day, J.E. and Beus, S.S.**
1982. *Turbonopsis apachienis*, a new species of archaeogastropod from the Devonian (Frasnian) of Arizona. *Journal of Paleontology*, vol. 56, pp. 119-123.
- 117. Hoare, R.D.**
1980. New Pennsylvanian gastropods from Ohio. *Journal of Paleontology*, vol. 54, pp. 1035-1040.
- 118. Popenoe, W.P.**
1983. Cretaceous Aporrhaidae from California: Aporrhainae and Arrhoginae. *Journal of Paleontology*, vol. 57, pp. 742-765.
- 119. Diener, C.**
1926. *Glossophora Triadica*. *Fossilium Catalogus, I: Animalia*, Pars 34, W.J. Junk, Berlin, 242 pp.
- 120. Dietrich, W.O.**
1925. *Gastropoda Mesozoica: Fam. Nerineidae*. *Fossilium Catalogus, I: Animalia*, W. Junk, Berlin, 164 pp.
- 121. Schilder, F.A.**
1932. *Cypraeacea*. *Fossilium Catalogus, I: Animalia*, Pars 55, W. Junk, Berlin, 276 pp.
- 122. Muller A.H.**
1963-1970. *Lehrbuch der Paläozoologie*. Gustav Fischer Verlag, Jena.
- 123. Moore, R.C., Lalicker, C.G., and Fischer, A.G.**
1952. *Invertebrate Fossils*. McGraw-Hill, New York, 766 pp.
- 124. Piveteau, J., ed.**
1952-1969. *Traité de Paléontologie*. Masson et Cie, Paris.
- 125. Squires, R.L.**
1983. New molluscs from the lower Middle Eocene Lajas Formation, southern California. *Journal of Paleontology*, vol. 57, pp. 354-362.
- 126. Zinsmeister, W.J. and Camacho, H.H.**
1980. Late Eocene Struthiolariidae (Mollusca: Gastropoda) from Seymour Island, Antarctic Peninsula and their significance to the biogeography of early Tertiary shallow-water faunas of the Southern Hemisphere. *Journal of Paleontology*, vol. 54, pp. 1-14.
- 127. Zinsmeister, W.J.**
1977. Note on a new occurrence of the Southern Hemisphere aporrhaid gastropod *Struthiopera* Finlay & Marwick on Seymour Island, Antarctica. *Journal of Paleontology*, vol. 51, pp. 399-404.
- 128. Marincovich, L., Jr.**
1981. *Tyrannoberingius rex*, a new genus and species of Miocene gastropod from Alaska. *Journal of Paleontology*, vol. 55, pp. 176-179.
- 129. Opik, A.A.**
1968. Ordian (Cambrian) Crustacea Bradiorida of Australia. Australian Bureau of Mineral Resources, Geology, and Geophysics, Bulletin, vol. 103, pp. 1-44.
- 130. Rushton, A.W.A.**
1978. Fossils from the Middle-Upper Cambrian transition in the Nuneaton district. *Palaentology*, vol. 21, pp. 245-284.

- 131. Jones, P.J. and McKenzie, K.G.**
1980. Queensland Middle Cambrian Bradoriida (Crustacea): new taxa, palaeobiogeography and biological affinities. *Alcheringa*, vol. 4, pp. 203–226.
- 132. Muller, K.J.**
1983. Crustacea with preserved soft parts from the Upper Cambrian of Sweden. *Lethaia*, vol. 16, pp. 93–109.
- 133. Koneva, S.S.**
1978. The first record of ostracodes in the Lower Cambrian of Kazakhstan. *Paleontological Journal*, vol. 12, pp. 137–138.
- 134. Landing, E.**
1980. Late Cambrian–Early Ordovician macrofaunas and phosphate microfaunas. St. John Group, New Brunswick. *Journal of Paleontology*, vol. 54, pp. 752–761.
- 135. Grigor'yeva, N.V., Mel'nikova, L.M., and Pel'man, Yu.L.**
1983. Brachiopods, ostracodes (bradoriids), and problematical fossils from the stratotype region of the Lower Cambrian. *Paleontological Journal*, vol. 17, pp. 51–56.
- 136. Tillman, J.R.**
1983. Ostracodes of the superfamilies Beyrichiacea and Drepanellacea from Middle Devonian rocks of central Ohio. *Journal of Paleontology*, vol. 55, pp. 885–893.
- 137. Warshauer, S.M.**
1981. *Cincinnaticoncha*, *Pseudoprimitiella* and *Edenopsis*: new generic names for Ordovician ostracodes. *Journal of Paleontology*, vol. 55, pp. 885–893.
- 138. Tambareau, V.**
1981. Ostracodes et evolution de l'Atlantique Nord au Cretace. *Société Géologique de France. Bulletin*, vol. 24, pp. 1077–1085.
- 139. Brouwers, G.M. and Hazel, J.E.**
1978. Ostracoda and correlation of the Severn Formation (Navarroan, Maestrichtian) of Maryland. *Society of Economic Paleontologists and Mineralogists Monograph No. 1*, 52 pp.
- 140. Degardin, J.-M. and Lethiers, F.**
1982. Une microfaune (Conodonta, Ostracoda) dans le Silurien terminal des Pyrenees Centrales Espagnoles. *Revista Espanola de Micropaleontologia*, vol. 14, pp. 335–358.
- 141. Colin, J.P., Lamolda, M.A., and Rodriguez Lazaro, J.M.**
1982. Los ostracodes del Cenomaniense superior y Turoniense de la Cuenca Vasco-Cantabrica. *Revista Espanola de Micropaleontologia*, vol. 14, pp. 187–220.
- 142. Neale, J.W.**
1973. *Cluthia* (Crustacea, Ostracoda), a new Pleistocene and Recent leptocytherid genus. *Journal of Paleontology*, vol. 47, pp. 683–688.
- 143. Al-Abdul-Razzaq, S.K.**
1979. *Glennocythere*, a new ostracode genus from the Ahmadi Formation (Cretaceous) of Kuwait. *Journal of Paleontology*, vol. 53, pp. 920–930.
- 144. Mamet, B.**
1977. Foraminiferal zonation of the Lower Carboniferous: methods and stratigraphic implications. In E.G. Kauffman and J.E. Hazel, eds., *Concepts and Methods of Biostratigraphy*. Dowden, Hutchinson & Ross, Stroudsburg, Pa., pp. 445–462.
- 145. Douglass, R.C.**
1977. The development of fusulinid biostratigraphy. In E.G. Kauffman and J.E. Hazel, eds., *Concepts and Methods of Biostratigraphy*. Dowden, Hutchinson & Ross, Stroudsburg, Pa., pp. 463–482.
- 146. Ross, C.A. and Ross, J.R.P.**
1979. Permian. In R.A. Robison and C. Teichert, eds., *Treatise on Invertebrate Paleontology*. Geological Society of America and the University of Kansas Press, Boulder, Colorado, and Lawrence, Kansas, pp. A291–A350.
- 147. Surlyk, F. and Birkelund, T.**
1977. An integrated stratigraphical study of fossil assemblages from the Maastrichtian White Chalk of northwestern Europe. In E.G. Kauffman and J. Hazel, eds., *Concepts and Methods of Biostratigraphy*. Hutchinson & Ross, Stroudsburg, Pa., pp. 257–281.
- 148. Shimanski, V.N. and Solob'eb, A.N.**
1981. Razvitiye i smena prosteishikh, kishchnopolostnich i chervei na rubeche Mezozoja i Kainozoja. "Nauka", Moscow, 82 pp.
- 149. Jenkins, D.G. and Murray, J.W., eds.**
1981. *Stratigraphical Atlas of Fossil Foraminifera*. British Micropaleontological Society Series. Ellis Horwood Ltd, Chichester, 310 pp.
- 150. Sheng, J.-Z., Chen, C.-Z., Wang, Y.-G., Rui, L., Liao, Z.-T., Bando, Y., Ishii, K., Nakazawa, and Nakamura, K.**
1984. Permian-Triassic boundary in middle and eastern Tethys. *Journal of the Faculty of Science, Hokkaido University, Series 4: Geology and Mineralogy*, vol. 21, pp. 133–181. [Cited by Sepkoski as: Sheng et al. 1984.]
- 151. Sirotti, A.**
1982. Phylogenetic classification of Lepidocylinidae: a proposal. *Bollettino della Societa Paleontologica Italiana*, vol. 21, pp. 99–112.
- 152. Salaj, J.**
1969. *Meadrospiranella* nov. gen., a new Mid-Triassic foraminifer from the West Carpathians, Czechoslovakia. *Journal of Paleontology*, vol. 43, pp. 1294–1295.
- 153. Masters, B.A.**
1976. Planktic Foraminifera from the Upper Cretaceous Selma Group, Alabama. *Journal of Paleontology*, vol. 50, pp. 318–330.
- 154. Gutschick, R.C. and Wuellner, D.**
1983. An unusual benthic agglutinated foraminiferan from Late Devonian anoxic basinal black shales of Ohio. *Journal of Paleontology*, vol. 57, pp. 308–320.
- 155. Blome, C.D.**
1983. Middle Jurassic (Callovian) radiolarians from carbonate concretions, Alaska and Oregon. *Micropaleontology*, vol. 30, pp. 343–389.
- 156. Pessagno, E.A., Jr., Blome, C.D., and Longoria, J.F.**
1984. A revised radiolarian zonation for the Upper Jurassic of western North America. *Bulletins of American Paleontology*, vol. 87, no. 320, pp. 5–51.
- 157. Hayami, I. and Kase, T.**
1977. A systematic survey of the Paleozoic and Mesozoic Gastropods and Paleozoic Bivalvia from Japan. University Museum, University of Tokyo, Bulletin no. 13, 156 pp.
- 158. Oyama, K., Mizuno, A., and Sakamoto, T.**
1960. *Illustrated Handbook of Japanese Paleogene Molluscs*. Geological Survey of Japan, 244 pp.
- 159. Hayami, I.**
1975. A systematic survey of the Mesozoic Bivalvia from Japan. University Museum, University of Tokyo, Bulletin, no. 10, 249 pp.
- 160. Scrutton, C.T.**
1984. Origin and early evolution of tabulate corals. *Palaeontographica Americana*, no. 54, pp. 110–118.
- 161. Sando, W.J.**
1984. Biostratigraphic utility of upper Paleozoic syringoporoid

- corals, western interior region, conterminous U.S.A. *Palaeontographica Americana*, no. 54, pp. 453-458.
- 162. Copper, P.**
1981. *Spirapora*: a new Late Ordovician tabulate coral from Manitoulin Island, Ontario, Canada. *Journal of Paleontology*, vol. 55, pp. 1071-1075.
- 163. Semenov-Tian-Chansky, P. and Sutherland, P.K.**
1981. Coral distribution near the Middle Carboniferous boundary. In W.H.C. Ramsbottom, W.B. Saunders, and B. Owens, eds., *Biostratigraphic Data for a Mid-Carboniferous Boundary*. Subcommission on Carboniferous Stratigraphy, Leeds, pp. 134-144.
- 164. Pedder, A.E.H.**
1982. *Chostophyllum*, a new genus of charactophyllid corals from the Middle Devonian of western Canada. *Journal of Paleontology*, vol. 56, pp. 559-582.
- 165. McLean, R.A. and Pedder, A.E.H.**
1984. Frasnian rugose corals of western Canada. Part I: Chonophyllidae and Kyphophyllidae. *Palaeontographica*, Abt. A, vol. 185, pp. 1-38.
- 166. Boomer, I., Lord, A.R., Horne, D.J., and Siveter, D.J., eds.**
1973-1998. *Stereo-Atlas of Ostracod Shells*, vols. 1-25. University of Newcastle, UK.
- 167. Van Morkhoven, F.P.C.M.**
1963. Post Paleozoic Ostracoda: Their Morphology, Taxonomy, and Economic Use, vol. II. Elsevier, Amsterdam, 478 pp.
- 168. Siddiqui, Q.A.**
1971. Early Tertiary Ostracoda of the Family Trachyleberididae from West Pakistan. *British Museum (Natural History)*, Bulletin, Geology, Supplement 9, 98 pp.
- 169. Neufville, E.M.H.**
1973. Upper Cretaceous-Paleogene Ostracoda from the South Atlantic. Publications of the Paleontological Institute, University of Uppsala, Special Volume 1, 205 pp.
- 170. Mandel'shtan, M.I. and Shneider, G.F.**
1968. The Fossil Ostracoda of the U.S.S.R.—Family Cypridae (E. Less, trans.). National Lending Library for Science and Technology, Boston Spa, Yorkshire, 531 pp.
- 171. Bate, R.H.**
1972. Upper Cretaceous Ostracoda from the Carnarvon Basin, Western Australia. *Palaeontological Association, Special Papers in Palaeontology* 10, 85 pp.
- 172. Neale, J.W.**
1975. The Ostracod Fauna from the Santonian Chalk (Upper Cretaceous) of Gingia, Western Australia. *Palaeontological Association, Special Papers in Palaeontology* 16, 81 pp.
- 173. Scrutton, C.T.**
1979. Early fossil cnidarians. In M.R. House, ed., *The Origin of Major Invertebrate Groups*. Systematics Association Special Volume 12. Academic Press, New York, pp. 161-208.
- 174. Pedder, A.E.H.**
1982. The rugose coral record across the Frasnian-Famennian Boundary. *Geological Society of America Special Paper* no. 190, pp. 485-490.
- 175. Davies, G.R. and Nassichuk, N.W.**
1973. The hydrozoan *Palaeoaplysina* from the upper Paleozoic of Ellesmere Island, Arctic Canada. *Journal of Paleontology*, vol. 47, pp. 251-265.
- 176. Ossian, C.R.**
1973. New Pennsylvanian scyphomedusa from western Iowa. *Journal of Paleontology*, vol. 47, pp. 990-995.
- 177. Lenz, A.C.**
1980. A planktic problematicum from the Silurian of northern Yukon, Canada. *Journal of Paleontology*, vol. 54, pp. 584-587.
- 178. Willoughby, R.H. and Robison, R.A.**
1979. Medusoids from the Middle Cambrian of Utah. *Journal of Paleontology*, vol. 53, pp. 494-500.
- 179. Wang Hongzhen, Lin Baoyu, and Liu Xiaoliang.**
1984. Cnidarian fossils from the Sinian System of China and their stratigraphic significance. *Palaeontographica Americana*, no. 54, pp. 136-140.
- 180. Bengtson, S.**
1981. *Atractosella*, a Silurian alcyonacean octocoral. *Journal of Paleontology* vol. 55, pp. 281-294.
- 181. Giammona, C.P. and Stanton, R.J., Jr.**
1980. Octocorals from the Middle Eocene Stone City Formation, Texas. *Journal of Paleontology*, vol. 54, pp. 71-80.
- 182. Stanley, G.D. and Kanie, Y.**
1985. The first Mesozoic chondrophorine (medusoid hydrozoan), from the Lower Cretaceous of Japan. *Palaeontology*, vol. 28, pp. 101-109. [Originally cited by Sepkoski as: Stanley 1984. As listed here, the paper refers to the genus for which it is cited. This paper is also cited in reference 1066 for the same stratigraphic range.]
- 183. Beauvais, I.**
1984. Evolution and diversification of Jurassic Scleractinia. *Palaeontographica Americana*, no. 54, pp. 219-224.
- 184. Cairns, S.D.**
1984. An application of phylogenetic analysis to the Scleractinia: Family Fungiidae. *Palaeontographica Americana*, no. 54, pp. 49-57.
- 185. Turnsek, D., Busc, S., and Ogorelic, B.**
1984. The role of corals in Ladinian-Carnian reef communities of Slovenia, Yugoslavia. *Palaeontographica Americana*, no. 54, pp. 201-209.
- 186. Kolbuk, D.R.**
1984. A new compound skeletal organism from the Rosella Formation (Lower Cambrian), Atan Group, Cassian Mountains, British Columbia. *Journal of Paleontology*, vol. 58, pp. 703-708.
- 187. Glaessner, M.F.**
1971. The genus *Comomedusites* Glaessner and Wade and the diversification of the Cnidaria. *Palaeontologische Zeitschrift*, vol. 45, pp. 7-17.
- 188. Wade, M.**
1971. Bilateral Precambrian chondrophores from the Ediacaran fauna, South Australia. *Proceedings of the Royal Society of Victoria*, vol. 84, pp. 183-188.
- 189. Wade, M.**
1971. Hydrozoa and Scyphozoa and other medusoids from the Precambrian Ediacara fauna, South Australia. *Palaeontology*, vol. 15, pp. 197-225.
- 190. Glaessner, M.F.**
1984. Dawn of Animal Life. Cambridge University Press, Cambridge, 244 pp.
- 191. Bischoff, G.C.O.**
1978. *Septodactium siluricum*, a representative of a new subclass Septodactaria of the Anthozoa, with partial preservation of soft parts. *Senckenbergiana Lethaica*, vol. 59, pp. 229-273.
- 192. Zhuravleva, I.T.**
1970. Marine faunas and Lower Cambrian stratigraphy. *American Journal of Science*, vol. 269, pp. 417-445.
- 193. Palij, V.M., Posti, E., and Fedonkin, M.A.**
1979. Soft-bodied Metazoa and trace fossils of the Vendian and Lower Cambrian [in Russian]. In B.M. Keller and A.Yu. Rozanov, eds., *Upper Precambrian and Cambrian Pale-*

- ontology of East-European Platform. "Nauka", Moscow, pp. 49-82.
- 194. Debrenne, F. and Naud, G.**
1981. Meduses et traces fossiles supposees precambriennes dans la formation de San Vito, Sarrabus, Sud-Est de la Sardaigne. Société Géologique de France, Bulletin, vol. 23, pp. 23-31.
- 195. Sokolov, B.S.**
1973. Vendian of northern Eurasia. In M.G. Pitcher, ed., Arctic Geology. American Association of Petroleum Geologists, Tulsa, Okla., pp. 204-218.
- 196. Fedonkin, M.A.**
1980. New representatives of Precambrian coelenterates on the north of the Russian Platform [in Russian]. Paleontologicheskii Zhurnal, vol. 1980, no. 2, pp. 7-15.
- 197. Bergstrom, S.**
1981. [This reference is not cited in the database. It is therefore not possible to determine which paper is intended.]
- 198. Briggs, D.E.G.**
1978. A new trilobite-like arthropod from the Lower Cambrian Kinzers Formation, Pennsylvania. Journal of Paleontology, vol. 52, pp. 132-140.
- 199. Conway Morris, S.**
1978. *Laggania cambria* Walcott: a composite fossil. Journal of Paleontology, vol. 52, pp. 126-131.
- 200. Rigby, J.K. and Bryant, T.L.P.**
1979. Fossil sponges of the Mississippian Fort Payne Chert in northeastern Alabama. Journal of Paleontology, vol. 53, pp. 1005-1012.
- 201. Rigby, J.K.**
1980. *Ichnospongia perplexa*, a new sponge from the Mississippian Chainman Shale near Eureka, Nevada. Journal of Paleontology, vol. 54, pp. 1278-1281.
- 202. Russo, F.**
1981. Nuove spugne calcaree triassiche di Campo (Cortina d'Ampezzo). Belluno. Società Paleontologica Italiana, Bollettino, vol. 20, pp. 3-17.
- 203. Finks, R.M.**
1960. Late Paleozoic sponge faunas of the Texas region. American Museum of Natural History Bulletin, vol. 120, pp. 1-160.
- 204. Finks, R.M.**
1971. Sponge zonation in the west Texas Permian section. In J.T. Dutro, ed., Paleozoic Perspectives: A Paleontological Tribute to G. Arthur Cooper. Smithsonian Contributions to Paleobiology, no. 3, p. 285-300.
- 205. Rigby, J.K. and Stearns, C.W.**
1983. Sponges and Spongionormorphs. Notes for a Short Course. University of Tennessee Department of Geological Sciences, Studies in Geology 7, 220 pp.
- 206. Rigby, J.K. and Gilland, J.K.**
1977. A new fossil sponge from the Ordovician Garden City Limestone of southeastern Idaho. Great Basin Naturalist, vol. 37, pp. 475-480.
- 207. Pickett, J. and Rigby, J.K.**
1983. Sponges from the Early Devonian Garra Formation, New South Wales. Journal of Paleontology, vol. 57, pp. 720-741.
- 208. Rigby, J.K.**
1973. Permian sponges from northwestern British Columbia. Canadian Journal of Earth Sciences, vol. 10, pp. 1600-1606.
- 209. Rigby, J.K. and Bayer, T.N.**
1971. Sponges of the Ordovician Maquoketa Formation in Minnesota and Iowa. Journal of Paleontology, vol. 45, pp. 608-627.
- 210. Rigby, J.K. and Chidsey, T.C., Jr.**
1976. A well-preserved *Calycococcolia typicalis* Bassler (Porifera) from the Ordovician Fort Peña Formation of western Texas. Brigham Young University Geology Studies, vol. 23, no. 3, pp. 3-8.
- 211. Rigby, J.K.**
1976. A new chiaostoclonellid sponge from the Devonian of Michigan. Journal of Paleontology, vol. 51, pp. 1215-1219.
- 212. Rigby, J.K. and Dixon, O.A.**
1979. Sponge fauna of the Upper Silurian Read Bay Formation, Somerset Island, District of Franklin, Arctic Canada. Journal of Paleontology, vol. 53, pp. 587-627.
- 213. Rigby, J.K. and Terrell, F.M.**
1973. Permian sponges from western Ellesmere Island, Arctic Canada. Canadian Journal Earth Sciences, vol. 10, pp. 1431-1443.
- 214. Rigby, J.K.**
1970. *Ellesmerespongia feildeni*, a new Permian sponge from the Canadian Arctic. Journal of Paleontology, vol. 44, pp. 1143-1145.
- 215. Rigby, J.K.**
1977. A new Middle Ordovician sponge from western Newfoundland. Canadian Journal of Earth Sciences, vol. 14, pp. 2662-2668.
- 216. Rigby, J.K. and Lenz, A.C.**
1977. A new Silurian astylospongoid sponge from Baillie-Hamilton Island, Canadian Arctic Archipelago. Canadian Journal of Earth Sciences, vol. 15, pp. 157-162.
- 217. Finks, R.M.**
1971. A new Permian eutaxicladine demosponge, mosaic evolution, and the origin of the Dicranocladina. Journal of Paleontology, vol. 45, pp. 977-997.
- 218. Hartman, W.D., Wendt, J.W., and Wiedenmayer, F.**
1980. Fossil and Living Sponges. Sedimenta VIII. University of Miami, Miami, Florida, 274 pp.
- 219. Rigby, J.K.**
1976. Some observations on occurrences of Cambrian Porifera in western North America and their evolution. Brigham Young University Geology Studies, vol. 23, no. 2, pp. 51-60.
- 220. Rigby, J.K., Schumacher, D., and Meader, S.J.**
1979. The genus *Ensisiferites*, a Devonian astraesponge of North America. Journal of Paleontology, vol. 53, pp. 475-493.
- 221. Rigby, J.K.**
1976. A new Devonian heteractinid sponge from southwestern Ellesmere Island, Arctic Canada. Canadian Journal of Earth Sciences, vol. 13, pp. 120-125.
- 222. Rigby, J.K.**
1978. Porifera of the Middle Cambrian Wheeler Shale, from the Wheeler Amphitheater, House Range, in western Utah. Journal of Paleontology, vol. 52, pp. 1325-1345.
- 223. Rigby, J.K. and Scott, R.W.**
1981. Sponges from the Lower Cretaceous Mural Limestone in Arizona and northern Mexico. Journal of Paleontology, vol. 55, pp. 552-562.
- 224. Muller, W.**
1984. Die Kalkschwämme der Unterordnung Inozoa Steinmann aus dem Oberen Jura von Württemberg (SW-Deutschland). Stuttgarter Beiträge zur Naturkunde Serie B (Geologie und Paläontologie) 100: 1-85. [Cited by Sepkoski as: Muller 1984.]
- 225. Rigby, J.K.**
1983. Sponges of the Middle Cambrian Marjum Limestone from

- the House Range and Drum Mountains of western Millard County, Utah. *Journal of Paleontology*, vol. 57, pp. 240–270.
- 226. Rigby, J.K. and Blodgett, R.B.**
1983. Early Middle Devonian sponges from the McGrath Quadrangle of west-central Alaska. *Journal of Paleontology*, vol. 57, pp. 773–786.
- 227. Finks, R.M.**
1970. The evolution and ecologic history of sponge during Palaeozoic times. Symposium of the Zoological Society of London, vol. 25, pp. 3–22.
- 228. Rigby, J.K. and Gosney, T.C.**
1983. First reported Triassic lyssakid sponges from North America. *Journal of Paleontology*, vol. 57, pp. 787–796.
- 229. Rigby, J.K., Horrocks, R.D., and Cys, J.M.**
1982. A new hexactinellid brachiopore from the Upper Permian of West Texas. *Journal of Paleontology*, vol. 56, pp. 315–323.
- 230. Rigby, J.K.**
1974. *Vauvrealispongia* and *Twenhofelella*, two new brachiopod hexactinellid sponges from the Ordovician and Silurian of Anticosti Island, Quebec. *Canadian Journal of Earth Sciences*, vol. 11, pp. 1343–1349.
- 231. Rigby, J.K. and Harris, D.R.**
1979. A new Silurian sponge fauna from northern British Columbia, Canada. *Journal of Paleontology*, vol. 53, pp. 968–980.
- 232. Rigby, J.K. and Murphy, M.A.**
1983. *Gabelia*, a new Late Devonian lyssakid protospore from the Roberts Mountains, Nevada. *Journal of Paleontology*, vol. 57, pp. 797–803.
- 233. Rigby, J.K., King, J.E., and Gunther, L.F.**
1981. The new Lower Ordovician protospore, *Asthenospongia*, from the Phi Kappa Formation in central Idaho. *Journal of Paleontology*, vol. 55, pp. 842–847.
- 234. Rigby, J.K. and Ausich, W.I.**
1981. Lower Mississippian sponges from the Edwardsville Formation, southern Indiana. *Journal of Paleontology*, vol. 55, pp. 370–382.
- 235. Rigby, J.K.**
1979. Patterns in Devonian sponge distribution. *Palaeontological Association, Special Papers in Paleontology* 23, pp. 225–228.
- 236. Rigby, J.K. and Washburn, A.T.**
1972. A new hexactinellid sponge from the Mississippian-Pennsylvanian Diamond Peak Formation in eastern Nevada. *Journal of Paleontology*, vol. 46, pp. 266–270.
- 237. Rigby, J.K. and Gutschick, R.C.**
1976. Two new lower Paleozoic hexactinellid sponges from Utah and Oklahoma. *Journal of Paleontology*, vol. 50, pp. 79–85.
- 238. Stearn, C.W.**
1983. Stromatoporoids from the Blue Fjord Formation (Lower Devonian) of Ellesmere Island, Arctic Canada. *Journal of Paleontology*, vol. 57, pp. 539–559.
- 239. Guensburg, T.E.**
1983. Echinodermata of the Middle Ordovician Lebanon Limestone, central Tennessee. *Bulletins of American Paleontology*, vol. 86, no. 319, pp. 5–100.
- 240. Kelley, S.M., Frest, T.J., and Strimble, H.L.**
1978. Additional information of *Simplococrinus persculptus*. *Journal of Paleontology*, vol. 52, pp. 1227–1232.
- 241. Frest, T.J. and Strimble, H.L.**
1981. New camarate crinoids from the Silurian of North America. *Journal of Paleontology*, vol. 55, pp. 639–655.
- 242. McIntosh, G.C.**
1981. *Apurocrinus stercra*, a new genus and species of camarate crinoid from the Lower Devonian. *Journal of Paleontology*, vol. 55, pp. 948–952.
- 243. Frest, T.J. and Strimble, H.L.**
1977. Hirneacrinidae (new), simple Silurian camarate crinoids from the North American continental interior. *Journal of Paleontology*, vol. 51, pp. 1181–1200.
- 244. Lane, N.G.**
1979. Upper Permian crinoids from Djebel Tebaga, Tunisia. *Journal of Paleontology*, vol. 53, pp. 121–132.
- 245. Strimble, H.L. and Coney, C.**
1978. *Paratalurocrinus*, a new camarate genus from the upper Mississippian of Virginia. *Journal of Paleontology*, vol. 52, pp. 484–511.
- 246. Broadhead, T.W. and Strimble, H.L.**
1980. *Hyrancrinus*, a new Carboniferous camarate crinoid genus from eastern North America. *Journal of Paleontology*, vol. 54, pp. 35–44.
- 247. Willink, R.J.**
1980. A new coil-stemmed camarate crinoid from the Permian of eastern Australia. *Journal of Paleontology*, vol. 54, pp. 15–34.
- 248. Kolata, D.R.**
1975. Middle Ordovician echinoderms from northern Illinois and southern Wisconsin. *Journal of Paleontology*, vol. 49, no. 3 (supplement), 74 pp.
- 249. Frest, T.J. and Strimble, H.L.**
1977. Three new camarates (Echinodermata: Crinoidea) from the Silurian of Oklahoma and Tennessee. *Journal of Paleontology*, vol. 51, pp. 272–281.
- 250. Ausich, W.I.**
1984. Calceocrinids from the Early Silurian (Llandoveryan) Brassfield Formation of southwestern Ohio. *Journal of Paleontology*, vol. 58, pp. 1167–1185.
- 251. Frest, T.J., Strimble, H.L., and McGinnis, M.R.**
1979. Two new crinoids from the Ordovician of Virginia and Oklahoma, with notes on pinnulation in the Disparida. *Journal of Paleontology*, vol. 53, pp. 399–415.
- 252. Brett, C.E.**
1979. *Paracolocrinus*, a new inadunate crinoid genus from Rochester Shale (Silurian, Wenlockian) of New York. *Journal of Paleontology*, vol. 54, pp. 913–922.
- 253. Kelly, S.M. and Ausich, W.I.**
1978. A new Lower Ordovician (middle Canadian) disparid crinoid from Utah. *Journal of Paleontology*, vol. 52, pp. 916–920.
- 254. McIntosh, G.C.**
1984. Devonian cladid inadunate crinoids: Family Botryoecrinidae Bather, 1899. *Journal of Paleontology*, vol. 58, pp. 1260–1281.
- 255. Frest, T.J. and Strimble, H.L.**
1982. New Manicrinidae (Crinoidea, Inadunata, Dendroaimina) from the Silurian of Illinois and Indiana. *Journal of Paleontology*, vol. 56, pp. 720–728.
- 256. McIntosh, G.C.**
1982. *Nusocrinus* and *Pyrenocrinus*, two new Devonian cladid inadunate crinoid genera. *Journal of Paleontology*, vol. 57, pp. 495–513.
- 257. Webster, G.D.**
1981. New crinoids from the Naco Formation (middle Pennsylvanian) of Arizona and a revision of the family Cromyocerinidae. *Journal of Paleontology*, vol. 57, pp. 495–513.
- 258. Lewis, R.D.**
1981. *Archataxocrinus*, new genus, the earliest known flexible

- crinoid (Whiterockian) and its phylogenetic implications. *Journal of Paleontology*, vol. 55, pp. 227-238.
- 259. McIntosh, G.C.**
1981. *Tagenocrinus* and *Lecocrinus*, two new flexible crinoid genera from the Silurian and Devonian of North America. *Journal of Paleontology*, vol. 55, pp. 1103-1108.
- 260. Strimple, H.L. and Pareyn, C.**
1981. *Cibolocrinus* from the Namurian of North Africa with notes on the genus. *Journal of Paleontology*, vol. 56, pp. 226-232.
- 261. Frest, T.J. and Strimple, H.L.**
1978. The flexible crinoid genus *Anisocrinus* (Ordovician-Silurian) in North America. *Journal of Paleontology*, vol. 52, pp. 683-696.
- 262. Rigby, J.K., Chamberlain, C.K., and Black, B.A.**
1970. Mississippian and Pennsylvanian sponges from the Ouachita Mountains of Oklahoma. *Journal of Paleontology*, vol. 44, pp. 816-832.
- 263. Rigby, J.K.**
1970. Two new Upper Devonian hexactinellid sponges from Alberta. *Journal of Paleontology*, vol. 44, pp. 7-16.
- 264. Kling, S.A. and Reif, W.-E.**
1969. The Paleozoic history of amphidisc and hemidisc sponges: new evidence from the Carboniferous of Uruguay. *Journal of Paleontology*, vol. 43, pp. 1429-1434.
- 265. Bogoyavlenskaya, O.V.**
1974. Printsipi sistematzatsii Stromatoporoidei. In B.S. Sokolov, ed., *Ancient Cnidaria*, vol. 1. "Nauka", Moscow, pp. 20-27.
- 266. Kapp, U.S. and Stearn, C.W.**
1974. Stromatoporooids of the Chazy Group (Middle Ordovician). Lake Champlain, Vermont and New York. *Journal of Paleontology*, vol. 49, pp. 163-186.
- 267. Andri, E. and Rossi, F.**
1980. *Leiochaetetes furlensis* n. gen., n. sp., un nuovo Chetetide del Passo del Furlo (Pesaro, Marche). *Societa Paleontologica Italiana. Bollettino*, vol. 19, pp. 274-280.
- 268. Rozanov, A.Yu., Missarzhevsky, V.V., Volkova, N.A., Voronova, L.G., Krylov, I.N., Keller, B.M., Korolyut, I.K., Lendzion, K., Mikhniak, P., Pykhova, N.G., and Sidorov, A.D.**
1969. Tommotsky yarus i problema nizhney granitsy Kembra. *Geological Institute of the Academy of Sciences USSR Transactions*, vol. 206, pp. 5-380.
- 269. Stinchcomb, B.L.**
1975. Paleogeology of two new species of Late Cambrian *Hypseloconus* (Monoplacophora) from Missouri. *Journal of Paleontology*, vol. 49, pp. 416-421.
- 270. Matthews, S.C. and Missarzhevsky, V.V.**
1975. Small shelly fossils of late Precambrian and Early Cambrian age: a review of recent work. *Journal of the Geological Society of London*, vol. 131, pp. 289-304.
- 271. Qian, Y.**
1977. Hyolitha and some problematica from the Lower Cambrian Meishucun Stage in central and southwestern China [in Chinese]. *Acta Palaeontologica Sinica*, vol. 16, pp. 255-278.
- 272. Berg-Madsen, V. and Peel, J.S.**
1977. Middle Cambrian monoplacophorans from Bornholm and Australia, and the systematic position of the bellerophonitiform molluscs. *Lethaia*, vol. 11, pp. 113-126.
- 273. Peel, J.S.**
1977. Relationship and internal structure of a new *Pilina* (Monoplacophora) from the Late Ordovician of Oklahoma. *Journal of Paleontology*, vol. 51, pp. 116-122.
- 274. Runnegar, B., Pojeta, J., Jr., Taylor, M.E., and Collins, D.**
1979. New species of the Cambrian and Ordovician chitons *Matthelia* and *Chelodes* from Wisconsin and Queensland: evidence for the early history of polyplacophoran mollusks. *Journal of Paleontology*, vol. 53, pp. 1374-1395.
- 275. Hoare, R.D. and Smith, A.G.**
1984. Permian Polyplacophora (Mollusca) from West Texas. *Journal of Paleontology*, vol. 58, pp. 82-103.
- 276. Laghi, G.F.**
1981. *Crenatorolica zardinii* n. gen., n. sp. of Polyplacophora from St. Cassian Beds (Dolomites, Italy). *Societa Paleontologica Italiana. Bollettino*, vol. 20, pp. 155-158.
- 277. Debrock, M.D., Hoare, R.D., and Mapes, R.H.**
1984. Pennsylvanian (Desmoinesian) Polyplacophora (Mollusca) from Texas. *Journal of Paleontology*, vol. 58, pp. 1117-1135.
- 278. Hoare, R.D., and Smith, A.G.**
1984. Permian Polyplacophora (Mollusca) from West Texas. *Journal of Paleontology*, vol. 58, pp. 82-103.
- 279. Pojeta, J., Jr. and Runnegar, B.**
1976. The paleontology of rostroconch mollusks and the early history of the phylum Mollusca. U.S. Geological Survey Professional Paper 968, 88 pp.
- 280. Kobayashi, T.**
1967. The Cambro-Ordovician formations and faunas of South Korea. Part X. Stratigraphy of the Chosen Group in Korea and South Manchuria. Section C. The Cambrian of eastern Asia and other parts of the continent. *Journal of the Faculty of Science, University of Tokyo, Sec. II*, vol. 16, pp. 381-534.
- 281. Pojeta, J., Jr., Gilbert-Tomlinson, J., and Shergold, J.H.**
1977. Cambrian and Ordovician rostroconch molluscs from northern Australia. *Australian Bureau of Mineral Resources. Bulletin* 171, pp. 1-54.
- 282. Hoare, R.D., Mapes, R.H., and Barnes, C.J.**
1982. Some Mississippian and Pennsylvanian rostroconchs from the Midcontinent region. *Journal of Paleontology*, vol. 56, pp. 123-131.
- 283. Yancey, T.E.**
1973. A new genus of Permian siphonodontalid scaphopods, and its bearing on the origin of the Siphonodontallidae. *Journal of Paleontology*, vol. 47, pp. 1062-1064.
- 284. Pojeta, J., Jr. and Runnegar, B.**
1979. *Rhytidontalium kentuckyensis*, a new genus and new species of Ordovician scaphopod, and the early history of scaphopod molluscs. *Journal of Paleontology*, vol. 53, pp. 530-541.
- 285. Churkin, M. Jr. and Carter, C.**
1970. Devonian tentaculitids of east-central Alaska, systematics and biostratigraphic significance. *Journal of Paleontology*, vol. 44, pp. 51-68.
- 286. Ormiston, A.R.**
1973. A coiled tentaculite from the Salmontrout Limestone, Alaska. *Journal of Paleontology*, vol. 47, pp. 1065-1068.
- 287. Syoiev, A.A.**
1972. Biostratigratiya i khilosity ortotetsimorly nizhnego Kembra Sibirskoi Platformy. "Nauka", Moscow, 152 pp.
- 288. Marek, L.**
1976. The distribution of the Mediterranean Ordovician Hyolitha. In M.G. Bassett, ed., *The Ordovician System: Proceedings of a Palaeontological Association Symposium*.

- Birmingham, September 1974. University of Wales Press and the National Museum of Wales, Cardiff, pp. 491-500.
- 289. Valkov, A.K.**
1975. Biostratigrafiya i khlyotilya Kembriya severovostoka Sibirskoi Platformi. "Nauka", Moscow, 137 pp.
- 290. Yochelson, E.L., Marek, L., and Flower, R.H.**
1969. Late Cambrian lyolithoid *Kygmæoceras* redescribed. *Journal of Paleontology*, vol. 43, pp. 1274-1276.
- 291. Malinsky, J.M. and Mapes, R.A.**
1983. First occurrence of *Hyolitha* (Mollusca) in the Pennsylvanian of North America. *Journal of Paleontology*, vol. 57, pp. 347-353.
- 292. Keller, B.M. and Rozanov, A.Yu., eds.**
1979. Upper Precambrian and Cambrian Paleontology of East-European Platform [in Russian]. "Nauka", Moscow, 211 pp.
- 293. Kobayashi, T.**
1967. The Cambro-Ordovician formations and faunas of South Korea. Part. X. Stratigraphy of the Chosen Group in Korea and South Manchuria. Section C. The Cambrian of eastern Asia and other parts of the continent. *Journal of the Faculty of Science, University of Tokyo, Sec. II*, vol. 16, pp. 381-534.
- 294. Taylor, M.E.**
1966. Precambrian mollusc-like fossils from Inyo County, California. *Science*, vol. 153, pp. 198-201.
- 295. North, F.K.**
1971. The Cambrian of Canada and Alaska. In C.H. Holland, ed., *Cambrian of the New World*. Wiley-Interscience, New York, pp. 219-324.
- 296. Peel, J.S. and Yochelson, E.L.**
1984. Permian Toxemorphorida from Greenland: an appraisal of the molluscan class *Xenocoelha*. *Lethaia*, vol. 17, pp. 211-222.
- 297. Chen, J.-Y. and Teichert, C.**
1983. Cambrian cephalopods. *Geology*, vol. 11, pp. 647-650.
- 298. Crick, R.E.**
1981. Diversity and evolutionary rates of Cambro-Ordovician nautiloids. *Paleobiology*, vol. 7, pp. 200-215.
- 299. Teichert, C., Glenister, B.F., and Crick, R.E.**
1979. Biostratigraphy of Devonian nautiloid cephalopods. *Palaeontological Association, Special Papers in Palaeontology* 23, pp. 259-262.
- 300. Tucker, J.K., Mapes, R.H., and Aronoff, S.M.**
1978. New coiled nautiloids from the Wewoka Formation (Pennsylvanian) of Oklahoma. *Journal of Paleontology*, vol. 52, pp. 67-72.
- 301. Whetstone, K.N. and Teichert, C.**
1978. A new genus of nautiloid cephalopods from the Mooreville Formation (Cretaceous) of Alabama. *Journal of Paleontology*, vol. 52, pp. 440-443.
- 302. House, M.R. and Senior, J.R., eds.**
1981. The Ammonoidea. *Systematics Association Special Volume 18*. Academic Press, New York.
- 303. Frest, T.J., Glenister, B.F., and Furnish, W.M.**
1981. Pennsylvanian-Permian Cheloniceratacean ammonoid families *Maximitidae* and *Pseudohaloritidae*. *Paleontological Society Memoir 11* (*Journal of Paleontology*, vol. 55, no. 3, supplement), 46 pp.
- 304. Saunders, W.B. and Swan, A.R.H.**
1984. Morphology and morphologic diversity of mid-Carboniferous (Namurian) ammonoids in time and space. *Paleobiology*, vol. 10, pp. 195-228.
- 305. Tharalson, D.B.**
1984. Revision of the Early Permian ammonoid family *Perrinitidae*. *Journal of Paleontology*, vol. 58, pp. 804-833.
- 306. Drushchits, V.V., Kabanov, G.K., and Nerodenko, V.M.**
1984. Structures of the phragmocone and rostrum in *Tauriconites* gen. nov. (Coleoidea, Diplobelata). *Paleontological Journal*, vol. 18, pp. 1-8.
- 307. Jeletzky, J.A.**
1966. Comparative morphology, phylogeny, and classification of fossil Coleoidea. *University of Kansas Paleontological Contributions*, Art. 7. 162 pp.
- 308. Stevens, G.R.**
1973. Jurassic belemnites. In A. Hallam, ed., *Atlas of Palaeobiogeography*. Elsevier, Amsterdam, pp. 257-274.
- 309. Stevens, G.R.**
1973. Cretaceous belemnites. In A. Hallam, ed., *Atlas of Palaeobiogeography*. Elsevier, Amsterdam, pp. 385-401.
- 310. Green, R.G.**
1977. *Niobrareuteuthis walkeri*, a new species of teuthid from the Upper Cretaceous Niobrara Formation of Kansas. *Journal of Paleontology*, vol. 51, pp. 992-995.
- 311. Finney, S.C.**
1980. Thamnograptid, dichograptid and abrograptid graptolites from the Middle Ordovician Athens Shale of Alabama. *Journal of Paleontology*, vol. 54, pp. 1184-1208.
- 312. Landing, E.**
1974. Early and Middle Cambrian conodonts from the Taconic allochthon, eastern New York. *Journal of Paleontology*, vol. 48, pp. 1241-1248.
- 313. Sweet, W.C.**
1984. Graphic correlation of upper Middle and Upper Ordovician rocks, North American Midcontinent Province, U.S.A. In D.L. Brunton, ed., *Aspects of the Ordovician System*. *Palaeontological Contributions*, University of Oslo, no. 295. Universitetsforlaget, pp. 23-35.
- 314. Klapper, G. and Barrick, L.E.**
1983. Middle Devonian (Eifelian) conodonts from the Spillville Formation in northern Iowa and southern Minnesota. *Journal of Paleontology*, vol. 57, pp. 1212-1243.
- 315. Ross, C.A.**
1979. Carboniferous. In R.A. Robison and C. Teichert, eds., *Treatise on Invertebrate Paleontology, Part A. Geological Society of America and the University of Kansas Press, Boulder, Colorado, and Lawrence, Kansas*, pp. A254-A290.
- 316. Klapper, G. and Bergstrom, S.M.**
1984. The enigmatic Middle Ordovician fossil *Archeognathus* and its relations to conodonts and vertebrates. *Journal of Paleontology*, vol. 58, pp. 949-976.
- 317. Repetski, J.E. and Ethington, R.L.**
1983. *Rossochis mantionensis* (Conodonta), a new Early Ordovician index fossil. *Journal of Paleontology*, vol. 57, pp. 289-301.
- 318. Bell, B.M.**
1976. A study of North American Edrioasteroidea. *New York State Museum Memoir 21*, 446 pp.
- 319. Holloway, D.J. and Jell, P.A.**
1983. Silurian and Devonian edrioasteroids from Australia. *Journal of Paleontology*, vol. 57, pp. 1001-1016.
- 320. Bell, B.M. and Sprinkle, J.**
1978. *Totiglobus*, an unusual edrioasteroid from the Middle Cambrian of Nevada. *Journal of Paleontology*, vol. 52, pp. 243-266.
- 321. Strimple, H.L. and Mapes, R.H.**
1977. A new upper Pennsylvanian fissiculate blastoid from Texas. *Journal of Paleontology*, vol. 51, pp. 357-362.
- 322. Macurda, D.B., Jr. and Breimer, A.**
1977. *Strongyloblastus*, a Mississippian blastoid from western Canada. *Journal of Paleontology*, vol. 51, pp. 693-700.

324. **Macurda, D.B., Jr.**
1977. *Arcuoblastus* and *Decemoblastus*, two new Mississippian blastoid genera from the Burlington Limestone, Iowa. *Journal of Paleontology*, vol. 51, pp. 1201-1214.
325. **Sprinkle, J.**
1975. The "arms" of *Caryocrinites*, a rhombiferan cystoid convergent on crinoids. *Journal of Paleontology*, vol. 49, pp. 1062-1073.
326. **Paul, C.R.C.**
1972. *Cheirocystella antiqua* gen. et sp. nov. from the Lower Ordovician of western Utah, and its bearing on the evolution of the Cheirocrinidae (Rhombifera: Glyptocystitida). *Brigham Young University Geology Studies*, vol. 19, pp. 15-63.
327. **Broadhead, T.W. and Strimple, H.L.**
1978. Systematics and distribution of the Callocystitidae (Echinodermata, Rhombifera). *Journal of Paleontology*, vol. 52, pp. 164-177.
328. **Paul, C.R.C.**
1967. The British Silurian cystoids. *British Museum (Natural History), Geology, Bulletin*, vol. 13, pp. 297-356.
329. **Ausich, W.L. and Schumacher, G.A.**
1984. New Lower Silurian rhombiferan cystoid (Echinodermata, Callocystitidae) from southwestern Ohio. *Journal of Paleontology*, vol. 58, pp. 9-15.
330. **Paul, C.R.C.**
1968. Morphology and function of dichopore pore-structure in cystoids. *Palaentology*, vol. 11, pp. 697-730.
331. **Brett, C.E., Frest, T.J., Sprinkle, J., and Clement, C.R.**
1983. Coronoida: a new class of blastozoan echinoderms based on taxonomic reevaluation of *Stephanocrinitus*. *Journal of Paleontology*, vol. 57, pp. 627-651.
332. **Frest, T.J., Strimple, H.L., and Coney, C.C.**
1979. Paracrinoidea (Platycystitidae) from the Benbolt Formation (Blackriverian) of Virginia. *Journal of Paleontology*, vol. 53, pp. 380-398.
333. **Frest, T.J., Strimple, H.L., and Witzke, R.J.**
1979. New Comarocystitida (Echinodermata: Paracrinoidea) from the Silurian of Iowa and Ordovician of Oklahoma. *Journal of Paleontology*, vol. 54, pp. 217-228.
334. **Frest, T.J. and Strimple, H.L.**
1982. A new comarocystitid (Echinodermata: Paracrinoidea) from the Kimmiswick Limestone (Middle Ordovician), Missouri. *Journal of Paleontology*, vol. 56, pp. 358-370.
335. **Parsley, R.L. and Caster, K.E.**
1965. North American *Soluta* (Carpoidea, Echinodermata). *Bulletins of American Paleontology*, vol. 49, pp. 109-174.
336. **Kolata, D.R. and Jollie, M.**
1982. Anomalocystitid mitrates (Stylophora-Echinodermata) from the Champlanian (Middle Ordovician) Guttenberg Formation of the upper Mississippi Valley region. *Journal of Paleontology*, vol. 56, pp. 631-653.
337. **Kolata, D.R. and Guensburg, T.E.**
1979. *Diamphidocystis*, a new mitrate "carpod" from the Cincinnati (Upper Ordovician) Maquoketa Group in southern Illinois. *Journal of Paleontology*, vol. 53, pp. 1121-1135.
338. **Blake, D.**
1979. Post-Paleozoic Asterozoa. In T.W. Broadhead and J.A. Waters, eds., *Echinoderms. Notes for a Short Course*. University of Tennessee Department of Geological Sciences, *Studies in Geology* 3, pp. 200-214.
339. **Branstrator, J.W.**
1972. *Lanthanaster cruciformis*, a new Upper Ordovician sea star from Cincinnati, Ohio. *Journal of Paleontology*, vol. 46, pp. 66-69.
340. **Harper, J.A. and Morris, R.W.**
1978. A new encrinasterid ophiuroid from the Conemaugh Group (Pennsylvanian) of western Pennsylvania, and revision of Encrinasteridae. *Journal of Paleontology*, vol. 52, pp. 155-163.
341. **Morris, R.W., Rollins, H.B., and Shaak, G.D.**
1973. A new ophiuroid from the Brush Creek Shale (Conemaugh Group, Pennsylvanian) of western Pennsylvania. *Journal of Paleontology*, vol. 47, pp. 473-478.
342. **Kier, P.M.**
1973. Evolutionary trends and their functional significance in the post-Paleozoic echinoids. *Paleontological Society Memoir* no. 5 (*Journal of Paleontology*, vol. 48, no. 3, supplement), pp. 1-95.
343. **Kier, P.M.**
1984. Fossil spatangoid echinoids of Cuba. *Smithsonian Contributions to Paleobiology*, no. 55, 336 pp.
344. **Muller, K.J.**
1981. Arthropods with phosphatized soft parts from the Upper Cambrian "Orsten" of Sweden. In M.E. Taylor, ed., *Short Papers for the Second International Symposium on the Cambrian System*. U.S. Geological Survey Open-File Report 81-743, pp. 147-151.
345. **Jaeger, H. and Martinsson, A.**
1967. Remarks on the problematic fossil *Xenusium auersvaldæ*. *Geologiska Föreningen i Stockholm, Föreläsningar*, vol. 88, pp. 435-452.
346. **Buckeridge, J.S.**
1983. Fossil barnacles (Cirripedia: Thoracica) of New Zealand and Australia. *New Zealand Geological Survey Paleontological Bulletin* 50, pp. 1-151.
347. **Zullo, V.A.**
1983. New genera and species of balanoid barnacles from the Oligocene and Miocene of North Carolina. *Journal of Paleontology*, vol. 58, pp. 1312-1338.
348. **Collins, D. and Rudkin, D.M.**
1981. *Priscansermarius barnetti*, a probable lepadomorph barnacle from the Middle Cambrian Burgess Shale of British Columbia. *Journal of Paleontology*, vol. 55, pp. 1006-1015.
349. **Robison, R.A. and Richards, B.C.**
1981. Larger bivalve arthropods from the Middle Cambrian of Utah. *University of Kansas Paleontological Contributions*, Art. 106, 19 pp.
350. **Briggs, D.E.G.**
1978. A new trilobite-like arthropod from the Lower Cambrian Kinzers Formation, Pennsylvania. *Journal of Paleontology*, vol. 52, pp. 132-140.
351. **Schram, F.R.**
1980. Miscellaneous late Paleozoic Malacostraca of the Soviet Union. *Journal of Paleontology*, vol. 54, pp. 542-547.
352. **Schram, F.R.**
1984. Fossil syncarida. *Transactions of the San Diego Society of Natural History*, vol. 20, pp. 189-246.
353. **Feldmann R.M. and West, R.R.**
1978. *Hihatanka*, a new genus of lobster (Decapoda: Mecochiridae) from the Kiowa Formation (Cretaceous: Albian) of Kansas. *Journal of Paleontology*, vol. 52, pp. 1219-1226.
354. **Bishop, G.A.**
1976. Two new crabs, *Sodakus tanakayo-tankaensis*, new genus, new species, and *Raninella oaheensis* new species

- (Crustacea, Decapoda) from the Upper Cretaceous Pierre Shale of South Dakota. *Journal of Paleontology*, vol. 52, pp. 608–617.
- 355. Schram, F.R.**
1978. *Jerometichenoria grandis* new genus, new species (Crustacea: Mysidacea) from the Lower Permian of the Soviet Union. *Journal of Paleontology*, vol. 52, pp. 605–607.
- 356. Schram, F.R., Feldmann, R.M., and Copeland, M.J.**
1978. The Late Devonian Palaeopalaemonidae and the earliest decapod crustaceans. *Journal of Paleontology*, vol. 52, pp. 1375–1387.
- 357. Feldmann, R.M.**
1984. *Haumuriægla glaessneri* new genus and species (Decapoda, Anomura, Aeglididae) from Haumurian (Late Cretaceous) rocks near Cheviot, New Zealand. *New Zealand Journal of Geology and Geophysics*, vol. 27, pp. 379–385.
- 358. Iverson, E.W. and Chivers, D.D.**
1984. A new genus of Sphaeromatidae (Crustacea: Isopoda: Flabellifera) from the Miocene of Kern County, California. *Journal of Paleontology*, vol. 58, pp. 104–108.
- 359. Fisher, D.C.**
1982. Phylogenetic and macroevolutionary patterns within the Xiphosurida. Third North American Paleontological Convention, Proceedings, vol. 1, pp. 175–180.
- 360. Plotnick, R.E.**
1982. Patterns in the Evolution of the Eurypterids. Unpubl. Ph.D. Thesis, University of Chicago, Chicago, 411 pp.
- 361. Lendzion, K.**
1975. Fauna of the *Mobergella* Zone in the Polish Lower Cambrian. *Kwartalnik Geologiczny, Warszawa*, vol. 19, pp. 237–242.
- 362. Linsley, R.M.**
1979. Gastropods of the Devonian. *Palaontological Association, Special Papers in Palaontology* 23, pp. 249–254.
- 363. Sterrn, C.W.**
1979. Biostratigraphy of Devonian stromatoporoids. *Palaontological Association, Special Papers in Palaontology* 23, pp. 229–232.
- 364. Lutke, F.**
1979. Biostratigraphical significance of the Devonian Daeryconarida. *Palaontological Association, Special Papers in Palaontology* 23, pp. 281–289.
- 365. Kielan-Jaworowska, Z.**
1966. Polychaete jaw apparatuses from the Ordovician and Silurian of Poland and a comparison with modern forms. *Palaontologica Polonica*, vol. 16, pp. 1–152.
- 366. Tangourdeau, P.**
1983. La place des Scolecodontes disperses (Annelides) dan le peuplement des mers au Paleozoïque. *Museum National d'Histoire Naturelle, Paris, Bulletin*, vol. 4, ser 5, pp. 205–212.
- 367. Mierzejewski, P. and Mierzejewska, G.**
1975. Zenognath type of polychaete jaw apparatuses. *Acta Palaontologica Polonica*, vol. 20, pp. 437–442.
- 368. Jager, M.**
1983. Serpulidae (Polychaeta sedentaria) aus der norddeutschen höheren Oberkreide—Systematik, Stratigraphie, Ökologie. *Geologisches Jahrbuch*, vol. A68, pp. 3–220. [Cited by Sepkoski as: Jager 1983.]
- 369. Yochelson, E.L.**
1971. The little known Pennsylvanian *Clavulites* reinterpreted as a "worm." *Journal of Paleontology*, vol. 45, pp. 126–129.
- 370. Robison, R.A.**
1969. Annelids from the Middle Cambrian Spence Shale of Utah. *Journal of Paleontology*, vol. 43, pp. 1169–1173.
- 371. Tynan, M.C.**
1983. Coral-like microfossils from the Lower Cambrian of California. *Journal of Paleontology*, vol. 57, pp. 1188–1211.
- 372. Rowland, S. M. and Carlson, S.J.**
1983. *Westgardia gigantea*, a new Lower Cambrian fossil from eastern California. *Journal of Paleontology*, vol. 57, pp. 1317–1320.
- 373. Bergstrom, S.M.**
1979. First report of the enigmatic microfossil *Konyrium* in North America. *Journal of Paleontology*, vol. 53, pp. 320–327.
- 374. Taylor, P.D.**
1984. *Marcusodictyon* Bassler from the Lower Ordovician of Estonia: not the earliest bryozoan but a phosphatic problematicum. *Alcheringa*, vol. 8, pp. 177–186.
- 375. Schram, F.R.**
1973. Pseudocoelomates and a nemertine from the Illinois Pennsylvanian. *Journal of Paleontology*, vol. 47, pp. 985–989.
- 376. Nitecki, M.H. and Solem, A.**
1973. A problematic organism from the Maron Creek (Pennsylvanian) of Illinois. *Journal of Paleontology*, vol. 47, pp. 903–907.
- 377. Tuftin, S.E. and Kylo, L.R.**
1978. Problematical fossils in the Ordovician of Minnesota. *Journal of Paleontology*, vol. 52, pp. 846–849.
- 378. Thomas, A.T., Owens, R.M., and Rushton, A.W.A.**
1984. Trilobites in British stratigraphy. *Geological Society of London, Special Report*, no. 16, 78 pp.
- 379. Lochman-Balk, C.**
1971. The Cambrian of the craton of the United States. In C.H. Holland, ed., *Cambrian of the New World*. Wiley-Interscience, New York, pp. 79–167.
- 380. Ivshin, N.K.**
1983. Upper Cambrian Trilobites of Kazakhstan. Pt. II. (S. Viswanathan, trans.). *Amerind Publishing Co.*, New Delhi, 432 pp.
- 381. Zhiyi Zhou, Gongzheng Yin, and Tripp, R.P.**
1983. Trilobites from the Ordovician Shihtzupu Formation, Zunyi, Guizhou Province, China. *Transactions of the Royal Society of Edinburgh: Earth Science*, vol. 75, pp. 13–36.
- 382. Shaw, F.C.**
1974. Simpson Group (Middle Ordovician) trilobites of Oklahoma. *Journal of Paleontology*, vol. 48, no. 5 (supplement), 54 pp.
- 383. Ross, R. J., Jr.**
1974. Early Paleozoic trilobites, sedimentary facies, lithospheric plates, and ocean currents. *Fossils and Strata*, no. 4, pp. 307–329 [Cited by Sepkoski as: Ross 1973.]
- 384. Kurtz, V.E.**
1975. Frasnian (Upper Cambrian) trilobite faunas from the Elvins Group of southeast Missouri. *Journal of Paleontology*, vol. 49, pp. 1009–1043.
- 385. Robison, R.A.**
1971. Additional Middle Cambrian trilobites from the Wheeler Shale of Utah. *Journal of Paleontology*, vol. 45, pp. 796–804.
- 386. Webby, B.D., Moors, H.T., and McLean, R.A.**
1970. *Malongallia* and *Encrinurus* spix, new Ordovician trilobites from New South Wales, Australia. *Journal of Paleontology*, vol. 44, pp. 881–887.
- 387. Cisne, J.**
1970. *Constantina oulchra*: an unusual proetid trilobite from the

- Devonian of Pennsylvania. *Journal of Paleontology*, vol. 44, pp. 522-523.
- 388. Fortey, R.A. and Owens, R.M.**
1975. Proetida—a new order of trilobites. *Fossils and Strata*, no. 4, pp. 227-240.
- 389. Chamberlain, C.K.**
1977. Carboniferous and Permian trilobites from Ellesmere Island and Alaska. *Journal of Paleontology*, vol. 51, pp. 758-771.
- 390. Ludvigsen, R.**
1977. The Ordovician trilobite *Ceraurimus* Barton in North America. *Journal of Paleontology*, vol. 51, pp. 959-972.
- 391. Eldredge, N.**
1972. Morphology and relationships of *Boudiea* Kozłowski, 1923 (Trilobita, Calmonidae). *Journal of Paleontology*, vol. 46, pp. 140-151.
- 392. Ludvigsen, R. and Chatterton, B.D.E.**
1982. Ordovician Pterygometopidae (Trilobita) of North America. *Canadian Journal of Earth Sciences*, vol. 19, pp. 2179-2206.
- 393. Chlupac, I.**
1975. The distribution of phacopid trilobites in space and time. *Fossils and Strata*, no. 4, pp. 399-408. [Cited by Sepkoski as: Chlupac 1975.]
- 394. Lesperance, P.J.**
1975. Stratigraphy and paleontology of the Synphoriidae (Lower and Middle Devonian dalmanitacean trilobites). *Journal of Paleontology*, vol. 49, pp. 91-137.
- 395. Chatterton, B.D.E. and Perry, D.G.**
1979. *Acanthalomina* Prantl & Pribyl, a valid subgenus of the trilobite genus *Diacanthaspis*. *Journal of Paleontology*, vol. 53, pp. 1327-1342.
- 396. Williams, A. and Curry, G.B.**
1985. Lower Ordovician Brachiopoda from the Tommakeady Limestone, Co. Mayo, Ireland. *British Museum (Natural History)*, *Geology, Bulletin*, vol. 38, pp. 183-269.
- 397. Cooper, G.A.**
1956. Chazyan and related brachiopods. *Smithsonian Miscellaneous Collections*, vol. 127, no. 1, 1024 pp.
- 398. Krause, F.F. and Rowell, A.J.**
1975. Distribution and systematics of the inarticulate brachiopods of the Ordovician carbonate mud mound of Meiklejohn Peak, Nevada. *University of Kansas Paleontological Contributions*, Art. 61, 74 pp.
- 399. Havlicek, V. and Massa, D.**
1973. Brachiopodes de l'Ordovicien Supérieur de Libye occidentale. Implications stratigraphiques regionales. *Geobios*, vol. 6, pp. 267-290.
- 400. Winkler Prins, C.F.**
1982. Brachiopods and the lower/middle Carboniferous Mississippian/Pennsylvanian Boundary. *In* W.H.C. Ramsbottom *et al.*, eds., *Biostratigraphic Data for a Mid-Carboniferous Boundary*. Leeds, pp. 61-68.
- 401. Bergstrom, J.**
1968. Upper Ordovician brachiopods from Västergötland, Sweden. *Geologica et Palaeontologica*, vol. 2, pp. 1-35.
- 402. Williams, S.H. and Lockley, M.G.**
1983. Ordovician inarticulate brachiopods from graptolitic shales at Dob's Linn, Scotland, their morphology and significance. *Journal of Paleontology*, vol. 57, pp. 391-400.
- 403. Grant, R.E.**
1976. Permian brachiopods from southern Thailand. *Paleontological Society Memoir* no. 9 (*Journal of Paleontology*, vol. 50, no. 3, supplement), 269 pp.
- 404. Williams, A.**
1963. The Caradocian brachiopod faunas of the Bala District, Merionethshire. *British Museum (Natural History)*, *Geology, Bulletin*, vol. 8, pp. 329-471.
- 405. McNamara, K.J.**
1983. The earliest *Tegulorhynchia* (Brachiopoda: Rhynchonellida) and its evolutionary significance. *Journal of Paleontology*, vol. 57, pp. 461-473.
- 406. Ross, R.J.**
1967. Some Middle Ordovician brachiopods and trilobites from the Basin Ranges, western United States. U.S. Geological Survey Professional Paper 523-D, pp. D1-D43.
- 407. Grigor'yeva, N.V., Mel'nikova, L.M., and Pel'man, Yu.L.**
1983. Brachiopods, ostracodes (bradoriids) and problematical fossils from the stratotype region of the Lower Cambrian. *Paleontological Journal*, vol. 17, pp. 51-56.
- 408. Bassett, M.G.**
1972. The articulate brachiopods from the Wenlock Series of the Welsh Borderland and south Wales. Part 2. *Palaeogeographical Society [Monogr.]*, pp. 27-78.
- 409. Fisher, D.W.**
1956. The Cambrian System of New York State. *In* J. Rogers, ed., *El Sistema Cambrico*. XX International Geological Congress, Mexico, Proceedings, pp. 321-351.
- 410. Havlicek, V.**
1974. New genera of Orthidina (Brachiopoda) in the lower Paleozoic of Bohemia. *Vestník Ustredního Ústavu Geologického*, vol. 49, pp. 167-170.
- 411. Grant, R.E.**
1970. Brachiopods from Permian-Triassic Boundary beds and age of Chhidru Formation, West Pakistan. *In* B. Kummel and C. Teichert, eds., *Stratigraphic Boundary Problems: Permian and Triassic of West Pakistan*. University of Kansas Press, Lawrence, Kansas, pp. 117-151.
- 412. Neuman, R.B.**
1984. Geology and paleobiology of islands in the Ordovician Iapetus Ocean: review and implications. *Geological Society of America Bulletin*, vol. 95, pp. 1188-1201.
- 413. Kobayashi, T.**
1967. The Cambro-Ordovician formations and faunas of South Korea. Part X. Stratigraphy of the Chosen Group in Korea and South Manchuria. Section C. The Cambrian of eastern Asia and other parts of the continent. *Journal of the Faculty of Science, University of Tokyo*, Sec. II, vol. 16, pp. 381-534.
- 414. Grant, R.E.**
1965. Faunas and stratigraphy of the Snowy Range Formation (Upper Cambrian) in southwestern Montana and north-eastern Wyoming. *Geological Society of America Memoir* 96, 171 pp.
- 415. Kobayashi, T.**
1965. The Cambro-Ordovician formations and faunas of South Korea. Part X. Stratigraphy of the Chosen Group in Korea and South Manchuria. Section B. The Chosen Group of North Korea and northeast China. *Journal of the Faculty of Science, University of Tokyo*, Sec. II, vol. 16, pp. 209-311.
- 416. Havlicek, V.**
1965. Brachiopoda of the suborder Strophomenidina in Czechoslovakia. *Ustredního Ústavu Geologického, Rozpravy*, vol. 33, pp. 1-235.
- 417. Waterhouse, J.B.**
1977. Chronologic, ecologic, and evolutionary significance of the phylum Brachiopoda. *In* E.G. Kauffman and J.E. Ha-

- zel, eds., Concepts and Methods of Biostratigraphy, Dowden, Hutchinson & Ross, Inc., Stroudsburg, Pa., pp. 497–518.
- 418. Archbold, N.W.**
1983. Permian marine invertebrate provinces of the Gondwanan Realm. *Alcheringa*, vol. 7, pp. 59–73. [Cited by Sepkoski as: Archibold (sic) (Alcheringa).]
- 419. Percival, I.G.**
1979. Ordovician plectambonitacean brachiopods from New South Wales. *Alcheringa*, vol. 3, pp. 91–116.
- 420. Johnson, J.G.**
1976. *Chattertonia* new genus (Brachiopoda), the chonetid-productid link. *Journal of Paleontology*, vol. 50, pp. 789–791.
- 421. Alberti, H.**
1979. Devonian trilobite biostratigraphy. *Palaeontological Association, Special Papers in Palaeontology* 23, pp. 313–324.
- 422. Oliver, W.A., Jr. and Pedder, A.E.H.**
1979. Rugose corals in Devonian stratigraphical correlation. *Palaeontological Association, Special Papers in Palaeontology* 23, pp. 233–248.
- 423. Gooday, A.J. and Becker, G.**
1979. Ostracods in Devonian biostratigraphy. *Palaeontological Association, Special Papers in Palaeontology* 23, pp. 193–197.
- 424. Cuffey, R.J. and McKinney, F.K.**
1979. Devonian Bryozoa. *Palaeontological Association, Special Papers in Palaeontology* 23, pp. 307–311.
- 425. Rolfe, W.D.I. and Edwards, V.A.**
1979. Devonian Arthropoda (Trilobita and Ostracoda excluded). *Palaeontological Association, Special Papers in Palaeontology* 23, pp. 325–329.
- 426. Anderson, M.M., Boucot, A.J., and Johnson, J.G.**
1969. Eifelian brachiopods from Padaukpin, northern Shan States, Burma. *British Museum (Natural History), Geology, Bulletin*, vol. 18, pp. 107–163.
- 427. Waterhouse, J.B.**
1982. Permian Pectinacea and Limacea (Bivalvia) from New Zealand. *New Zealand Geological Survey Paleontological Bulletin* 49, pp. 1–75.
- 428. Grant, R.E.**
1972. The lophophore and feeding mechanisms of the Productina (Brachiopoda). *Journal of Paleontology*, vol. 46, pp. 213–248.
- 429. Stehli, F.G. and Grant, R.E.**
1971. Permian brachiopods from Axel Heiberg Island, Canada, and an index of sampling efficiency. *Journal of Paleontology*, vol. 45, pp. 502–521.
- 430. Cocks, L.R.M.**
1968. Some strophomenacean brachiopods from the British Lower Silurian. *British Museum (Natural History), Geology, Bulletin*, vol. 15, pp. 285–324.
- 431. Archbold, N.W.**
1980. *Mingenewia* new genus (Strophalosidina, Brachiopoda) from Western Australian Permian. *Journal of Paleontology*, vol. 54, pp. 253–258.
- 432. Gauri, K.L.**
1965. Uralian stratigraphy, trilobites, and brachiopods of the western Carnic Alps (Austria). *Jahrbuch der Geologischen Bundesanstalt Sonderband*, vol. 11, pp. 1–94.
- 433. Cocks, L.R.M.**
1970. Silurian brachiopods of the Superfamily Plectambonitacea. *British Museum (Natural History), Geology, Bulletin*, vol. 19, pp. 141–203.
- 434. Pearson, A.B.**
1977. Rhaetic brachiopods of Europe. *Neue Denkschriften des Naturhistorischen Museums in Wien*, vol. 1, pp. 1–85.
- 435. Brunton, C.H.C.**
1984. Silicified brachiopods from the Visean of County Fermanagh, Ireland (III). Rhynchonellids, spiriferids and terebratulids. *British Museum (Natural History), Geology, Bulletin*, vol. 38, pp. 27–130.
- 436. Chen Yuan-Ren**
1984. Brachiopods from the Upper Devonian Tuqiaozi Member of the Longmenshan area (Sichuan, China). *Palaeontographica*, Abt. A, vol. 184, pp. 95–166.
- 437. Waterhouse, J.B., Campbell, J.D., and Williams, J.G.**
1983. Early Permian brachiopods and molluscs from Gondor Formation, Eglinton Valley, Southland, New Zealand. *Journal of Geology and Geophysics*, vol. 26, pp. 301–308.
- 438. Boucot, A.J.**
1983. Old world realm (Rhenish-Bohemian region), shallow-water, Early Devonian brachiopods from the Jauf Formation of Saudi Arabia. *Journal of Paleontology*, vol. 58, pp. 1196–1202. [Cited by Sepkoski as: Boucot 1984.]
- 439. Carter, J.L.**
1972. Two new genera of lamellose spiriferacean brachiopods. *Journal of Paleontology*, vol. 46, pp. 729–734.
- 440. Carter, J.L.**
1974. New genera of spiriferid and brachythyridid brachiopods. *Journal of Paleontology*, vol. 48, pp. 674–696.
- 441. Jones, B. and Boucot, A.J.**
1983. Spiriferids from the Lower Devonian strata of southwest Ellesmere Island, Arctic Canada. *Journal of Paleontology*, vol. 57, pp. 327–346.
- 442. Hoover, P.R.**
1983. The cooperculum: a new structure in the phylum Brachiopoda, and its functional significance. *Journal of Paleontology*, vol. 57, pp. 1017–1029.
- 443. Amsden, T.W.**
1983. *Coelospira concava* (Hall) from the Pinetop Chert (Early Devonian), Ouachita Mountains, Oklahoma. *Journal of Paleontology*, vol. 57, pp. 1244–1260.
- 444. Copper, P. and Racheboef, P.R.**
1985. Devonian atrypoid brachiopods from the Armorican Massif, northwestern France. *Palaeontographica*, Abt. A, vol. 187, pp. 58–104.
- 445. Wang Yu, Copper, P., and Rong Jia-Yu**
1983. Distribution and morphology of the Devonian brachiopod *Punctatrypa*. *Journal of Paleontology*, vol. 57, pp. 1067–1089.
- 446. Laubacher, G., Boucot, A.J. and Gray, J.**
1982. Additions to Silurian stratigraphy, lithofacies, biogeography, and paleontology of Bolivia and southern Peru. *Journal of Paleontology*, vol. 56, pp. 1138–1170.
- 447. Copper, P.**
1982. Early Silurian atrypoids from Manitoulin Island and Bruce Peninsula, Ontario. *Journal of Paleontology*, vol. 56, pp. 680–702.
- 448. Dieni, I. and Middlemiss, F.A.**
1981. Pygopid brachiopods from the Venetian Alps. *Societa Paleontologica Italiana, Bollettino*, vol. 20, pp. 19–48.
- 449. Conway Morris, S.**
1979. The Burgess Shale (Middle Cambrian) fauna. *Annual Review of Ecology and Systematics*, vol. 10, pp. 327–349.
- 450. Ossian, C.R. and Halseth, M.A.**
1976. Discovery of Ordovician vertebrates in the Arbuckle

- Mountains of Oklahoma. *Journal of Paleontology*, vol. 50, pp. 773-777.
- 451. Zangerl, R.**
1981. Chondrichthyes I. Paleozoic Elasmobranchii. Handbook of Paleoichthyology, vol. 3A. Gustav Fischer Verlag, Stuttgart, 115 pp.
- 452. Schaeffer, B. and Patterson, C.**
1984. Jurassic fishes from the western United States, with comments on Jurassic fish distribution. *American Museum Novitates*, no. 2796, 86 pp.
- 453. Keyes, I.W.**
1984. New records of fossil elasmobranch genera *Megascyliorhinus*, *Centrophorus*, and *Dalatias* (Order Selachii) in New Zealand. *New Zealand Journal of Geology and Geophysics*, vol. 27, pp. 203-216.
- 454. Lund, R.**
1982. *Harpagofututor volsellorhinus* new genus and species (Chondrichthyes, Chondrenchelyiformes) from the Namurian Bear Gulch Limestone. *Chondrenchelys problematica* Traquair (Visean) and their sexual dimorphism. *Journal of Paleontology*, vol. 56, pp. 938-958.
- 455. Denison, R.H.**
1979. Acanthodii. Handbook of Paleoichthyology, vol. 5. Gustav Fischer Verlag, Stuttgart, 62 pp.
- 456. Lund, R. and Lund, W.**
1984. New genera and species of coelacanths from the Bear Gulch Limestone (Lower Carboniferous) of Montana (U.S.A.). *Geobios*, vol. 17, pp. 237-244.
- 457. House, M.R.**
1979. Biostratigraphy of the early Ammonoidea. Palaeontological Association, Special Papers in Palaeontology 23, pp. 263-280.
- 458. Bird, J.M. and Rasetti, F.**
1968. Lower, Middle, and Upper Cambrian faunas in the Taconic sequence of eastern New York—stratigraphic and biostratigraphic significance. *Geological Society of America Special Paper* 113, 66 pp.
- 459. Ergaliev, G.Kh.**
1981. Upper Cambrian biostratigraphy of the Kyrshabakty Section, Maly Karatau, southern Kazakhstan. In M.E. Taylor, ed., Short Papers for the Second International Symposium on the Cambrian System. U.S. Geological Survey Open-File Report 81-743, pp. 82-88.
- 460. Daily, B. and Jago, J.B.**
1975. The trilobite *Lejopyge* Hawley and Corda and the Middle-Upper Cambrian Boundary. *Palaeontology*, vol. 18, pp. 527-550.
- 461. Ergaliev, G.Kh. and Pokrovskaja, N.V.**
1977. Nizhnem briiskie trilobity Malogo Karatau (Yuzhiy Kazakhstan). "Nauka", Kazakhstan CCP, 96 pp.
- 462. Repina, L.N.**
1972. Biogeography of Early Cambrian of Siberia according to trilobites. Proceedings of the International Paleontological Union, 23rd, International Geological Congress, Prague, 1968, pp. 289-300.
- 463. Zhou Zhiyi and Yuan Jinfang**
1981. The biostratigraphic distribution of Lower Cambrian trilobites in southwest China. In M.E. Taylor, ed., Short Papers for the Second International Symposium on the Cambrian System. U.S. Geological Survey Open-File Report 81-743, pp. 250-251.
- 464. Lu, Y.H., Chen, C.L., Chien, Y.Y., Lin, H.L., Chou T.Y., and Yuan, K.S.**
1974. Bio-environmental control hypothesis and its application to the Cambrian biostratigraphy and paleozoogeography. Nanking Institute of Geology and Paleontology, Memoir 5, pp. 27-110.
- 465. Resser, C.E. and Howell, B.F.**
1938. Lower Cambrian *Olenellus* Zone of the Appalachians. *Geological Society of America Bulletin*, vol. 49, pp. 195-248.
- 466. Daily, B.**
1972. The base of the Cambrian and the first Cambrian faunas. University of Adelaide, Centre for Precambrian Research, Special Paper 1, pp. 13-42.
- 467. Tchernycheva, N.E.**
1959. Systeme Cambrien. In A.P. Markovsky, ed., Structure Geologique de l'U.R.S.S. Tome 1. Stratigraphie (P. de Saint-Aubin and J. Rogers, trans.). Centre National de la Recherche Scientifique, Paris, pp. 185-244.
- 468. Repina, L.N.**
1981. Trilobite biostratigraphy of the Lower Cambrian stages in Siberia. In M.E. Taylor, ed., Short Papers for the Second International Symposium on the Cambrian System. U.S. Geological Survey Open-File Report 81-743, pp. 173-180.
- 469. Fisher, D.W.**
1956. The Cambrian System of New York State. In J. Rogers, ed., El Sistema Cambrico. XX International Geological Congress, Mexico, Proceedings, pp. 321-351.
- 470. Rozanov, A.Yu.**
1967. The Cambrian lower boundary problem. *Geological Magazine*, vol. 104, pp. 415-434.
- 471. Repina, L.N.**
1966. Trilobity nizhnego Kembriya yugo Sibiri (madsemenstuo Redlichioidea). "Nauka", Moscow, 204 pp.
- 472. Kobayashi, T.**
1971. The Cambro-Ordovician faunal provinces and the inter-provincial correlation. *Journal of the Faculty of Science, University of Tokyo, Sec. II*, vol. 18, pp. 129-299.
- 473. Hupe, P.**
1960. Sur le Cambrien inferieur du Maroc. Proceedings of the 21st International Geological Congress, Copenhagen, Pt. 8, pp. 75-85.
- 474. Repina, L.N.**
1974. K voprosu o granitse nizhnego i srednego kembriya Sibirskoy platformy i soprodel'nykh territorij. In I.T. Zhuravleva and A.Yu. Rozanov, eds., Biostratigrafiya i Paleontologiya Nizhnego Kembriya Evropy i Severnoj Azii. "Nauka", Moscow, pp. 76-103. [Cited by Sepkoski with slightly different transliteration of title.]
- 475. Fritz, W.H.**
1972. Lower Cambrian trilobites from the Sekwi Formation type section, MacKenzie Mountains, northwestern Canada. *Geological Survey of Canada Bulletin* 212, 58 pp.
- 476. Alpert, S.P.**
1976. Trilobite and star-like trace fossils from the White-Inyo Mountains, California. *Journal of Paleontology*, vol. 50, pp. 226-239.
- 477. Xiang Li-Wen**
1981. Classification and correlation of the Cambrian System in China. In M.E. Taylor, ed., Short Papers for the Second International Symposium on the Cambrian System. U.S. Geological Survey Open-File Report 81-743, pp. 240-241.
- 478. Palmer, A.R. and Halley, R.B.**
1979. Physical stratigraphy and trilobite biostratigraphy of the Carrara Formation (Lower and Middle Cambrian) in the

- southern Great Basin. U.S. Geological Survey Professional Paper 1047, 131 pp.
- 479. McKee, E.D. and Resser, C.E.**
1945. History of the Grand Canyon Region. Carnegie Institute, Washington, Publication no. 563.
- 480. Cowie, J.**
1968. Lower Cambrian faunas from Ellesmere Island, District of Franklin. Geological Survey of Canada Bulletin 163, pp. 3-27.
- 481. Borrello, A.V.**
1971. The Cambrian of South America. In C.H. Holland, ed., *Cambrian of the New World*. Wiley-Interscience, London, pp. 385-438.
- 482. Opik, A.A.**
1967. The Mindyallan Fauna of north-western Queensland. Australian Bureau of Mineral Resources, Geology and Geophysics Bulletin 74, 167 pp.
- 483. Erlinga**
1979. [This reference is not cited in the database. It is therefore not possible to determine which paper is intended.]
- 484. Taylor, M.E. and Cook, H.E.**
1976. Continental shelf and slope facies in the Upper Cambrian and lowest Ordovician of Nevada. Brigham Young University Geology Studies, vol. 23, no. 2, pp. 181-214.
- 485. Robison, R.A.**
1976. Additional Middle Cambrian trilobites from the Wheeler Shale of Utah. *Journal of Paleontology*, vol. 45, pp. 796-804.
- 486. Palmer, A.R.**
1982. Fossils of Dresbachian and Franconian (Cambrian) age from the subsurface of west-central Indiana. Indiana Department of Natural Resources, Geological Survey, Special Report 29, 12 pp.
- 487. Rasetti, F.**
1951. Middle Cambrian stratigraphy and faunas of the Canadian Rocky Mountains. Smithsonian Miscellaneous Collections, vol. 116, no. 5, pp. 1-277.
- 488. Grant, R.E.**
1965. Faunas and stratigraphy of the Snowy Range Formation (Upper Cambrian) in southwestern Montana and north-western Wyoming. Geological Society of America Memoir 96, 171 pp.
- 489. McBride, D.J.**
1976. Outer shelf communities and trophic groups in the Upper Cambrian of the Great Basin. Brigham Young University Geology Studies, vol. 23, no. 2, pp. 139-152.
- 490. Beliaevsky, N.A. et al.**
1959. Structure Geologique de l'U.R.S.S. Tome 1 Stratigraphie. Leningrad. Vsesoiuznyi Geologicheskii Institut, 803 pp.
- 491. Rosova**
1963. [This reference is not cited in the database. It is therefore not possible to determine which paper is intended.]
- 492. Chang, W.T.**
1966. On the classification of Redheliacea, with description of new families and new genera. *Acta Palaeontologica Sinica*, vol. 14, pp. 135-184.
- 493. Willoughby, R.**
1976. Lower and Middle Cambrian fossils from the Shady Formation, Austinville, Virginia. Geological Society of America Abstracts with Programs, vol. 8, pp. 301-302.
- 494. North, F.K.**
1971. The Cambrian of Canada and Alaska. In C.H. Holland, ed., *Cambrian of the New World*. Wiley-Interscience, London, pp. 219-324.
- 495. Wilson, J.L.**
1957. Geography of olenid trilobite distribution and its influence on Cambro-Ordovician correlation. *American Journal of Science*, vol. 255, pp. 321-340.
- 496. Shergold, J.H.**
1971. Late Upper Cambrian trilobites from the Gola Beds, western Queensland. Australian Bureau of Mineral Resources, Geology and Geophysics Bulletin 112, 126 pp.
- 497. Deiss, C.F.**
1940. Lower and Middle Cambrian stratigraphy of southwestern Alberta and southeastern British Columbia. Geological Society of America Bulletin, vol. 51, pp. 731-794.
- 498. Opik, A.A.**
1963. Early Upper Cambrian fossils from Queensland. Australian Bureau of Mineral Resources, Geology and Geophysics Bulletin 64, 133 pp.
- 499. Henderson, R.A.**
1976. Idamean (early Upper Cambrian) trilobites from northwestern Queensland. *Palaentology*, vol. 19, pp. 325-364.
- 500. Mavey, G.B.**
1958. Lower and Middle Cambrian stratigraphy in northern Utah and southeastern Idaho. Geological Society of America Bulletin, vol. 69, pp. 647-687.
- 501. Robison, R.A. and Palmer, A.R.**
1968. Revision of Cambrian stratigraphy, Silver Island Mountains, Utah. *American Association of Petroleum Geologists Bulletin*, vol. 52, pp. 167-171.
- 502. Westoll, T.S.**
1979. Devonian fish biostratigraphy. *Palaentological Association, Special Papers in Palaentology* 23, pp. 341-353.
- 503. Steurbaut, C.**
1984. Les otolithes de Teleosteens de l'Oligo-Miocene d'Aquitaine (Sud-ouest de la France). *Palaentographica*, Abt. A, vol. 186, pp. 1-162.
- 504. Weems, R.E.**
1974. Middle Miocene sea turtles (*Syllomus*, *Procolpochelys*, *Psephophorus*) from the Calvert Formation. *Journal of Paleontology*, vol. 48, pp. 278-303.
- 505. Rage, J.-C.**
1984. Serpentes. *Encyclopedia of Paleotherpetology*, Pt. 11. Gustav Fischer Verlag, Stuttgart, 80 pp.
- 506. Fordyce, E.R.**
1981. Systematics of the odontocete whale *Agorophius pygmaeus* and the family Agorophiidae (Mammalia: Cetacea). *Journal of Paleontology*, vol. 55, pp. 1028-1095.
- 507. Fleischer, G.**
1976. Hearing in extinct cetaceans as determined by cochlear structure. *Journal of Paleontology*, vol. 50, pp. 133-152.
- 508. Domning, D.P.**
1972. Evolution of manatees: a speculative history. *Journal of Paleontology*, vol. 56, pp. 599-619.
- 509. Ross, J.R.P.**
1984. Biostratigraphic distribution of Carboniferous Bryozoa. In P.K. Sutherland and W.L. Manger, eds., *Neuvieme Congres International de Stratigraphie et de Geologie du Carbonifere*, vol. 2. Southern Illinois Univ. Press, Carbondale, pp. 19-32.
- 510. Hinds, R.W.**
1975. Growth mode and homeomorphism in cyclostome Bryozoa. *Journal of Paleontology*, vol. 49, pp. 875-910.
- 511. Ross, J.R.P.**
1969. Champlainian (Ordovician) Ectoprocta (Bryozoa). *New*

- York state, part II. *Journal of Paleontology*, vol. 43, pp. 257-284. [Cited by Sepkoski as: Ross 1969.]
- 512. Ross, J.R.P.**
1984. Paleoeecology of Ordovician Bryozoa. In D.L. Brunton, ed., *Aspects of the Ordovician System*. Palaeontological Contributions, University of Oslo, No. 295. Universitetsforlaget, pp. 141-148.
- 513. Utgaard, J.**
1981. *Lunaferamita*, a new genus of Constellariidae (Bryozoa) with strong cystoporate affinities. *Journal of Paleontology*, vol. 55, pp. 1058-1070.
- 514. Boardman, R.S. and McKinney, F.K.**
1976. Skeletal architecture and preserved organs of four-sided zooids in convergent genera of Paleozoic Trepostomata (Bryozoa). *Journal of Paleontology*, vol. 50, pp. 25-78.
- 515. Bolton, T.E.**
1966. Illustrations of Canadian fossils. Silurian faunas of Ontario. Geological Survey of Canada Paper 66-5, 46 pp.
- 516. Karklins, O.L.**
1983. Ptilodictyoid Cryptostomata Bryozoa from the Middle and Upper Ordovician rocks of central Kentucky. *Journal of Paleontology*, vol. 57, no. 1 (supplement), 31 pp.
- 517. Richards, R.P.**
1974. A Devonian *Immergentia* (Ectoprocta: Ctenostomata) from Ohio. *Journal of Paleontology*, vol. 48, pp. 940-946.
- 518. Voigt, E. and Soule, J.D.**
1973. Cretaceous burrowing bryozoans. *Journal of Paleontology*, vol. 47, pp. 21-33.
- 519. Voigt, E.**
1959. La signification stratigraphique des bryozoaires dans le cretace superieur. *Comptes Rendus du Congres National des Sociétés Savantes*, Dijon, Section des Sciences. Colloque Cretace, pp. 701-707. [Cited by Sepkoski as: Voigt 1959.]
- 520. Waters, J.A. and Sevastopulo, G.D.**
1984. The stratigraphical distribution and paleoecology of Irish Lower Carboniferous blastoids. *Irish Journal of Earth Sciences*, vol. 6, pp. 137-154.
- 521. Denison, R.**
1978. Placodermi. *Handbook of Paleichthyology*, vol. 2. Gustav Fischer Verlag, Stuttgart, 128 pp.
- 522. Sokolov, B.S. and Zhuravleva, I.T.**
1983. Lower Cambrian subdivision of the Siberia. Atlas of fossils [in Russian]. *Transactions of the Institute of Geology and Geophysics*, vol. 558, 216 pp.
- 523. Horowitz, A.S., Blakely, R.F., and Macurda, D.B., Jr.**
1985. Taxonomic survivorship within the Blastoida (Echinodermata). *Journal of Paleontology*, vol. 59, pp. 543-550.
- 524. Yin Hongfu**
1985. Bivalves near the Permian-Triassic Boundary in South China. *Journal of Paleontology*, vol. 59, pp. 572-600.
- 525. Thies, D. and Reif, W.-E.**
1985. Phylogeny and evolutionary ecology of Mesozoic Neoselachii. *Neues Jahrbuch für Geologie und Paläontologie Abhandlungen*, vol. 169, pp. 333-361.
- 526. Ausich, W.I.**
1985. New crinoids and revision of the superfamily Glyptocrinacea (Early Silurian, Ohio). *Journal of Paleontology*, vol. 59, pp. 793-808.
- 527. Richards, R.B., Chapman, A.J., and Temple, J.T.**
1984. *Rhabdopleura hollandi*, a new pterobranch hemichordate from the Silurian of the Llandovery District, Powys, Wales. *Proceedings of the Geologists' Association*, vol. 95, pp. 23-28.
- 528. Kobayashi, T. and Hamada, T.**
1984. Permian trilobites of Japan in comparison with Asian, Pacific and other faunas. *Palaeontological Society of Japan, Special Paper No. 26*, 92 pp.
- 529. MacKinnon, D.I.**
1984. New Zealand late Middle Cambrian molluscs and the origin of Rostroconchia and Bivalvia. *Alcheringa*, vol. 9, pp. 65-81.
- 530. Darragh, T.A.**
1985. Molluscan biogeography and biostratigraphy of the Tertiary of southeastern Australia. *Alcheringa*, vol. 9, pp. 83-116.
- 531. Pinna, G., Arduini, P., Pesarini, C., and Teruzzi, G.**
1984. Comments on the recently-described crustacean class Thylacocephala and its synonymy. *Paleontological Journal*, vol. 18, pp. 109-113.
- 532. Paul, C.R.C.**
1984. British Ordovician cystoids. Part 2. *Monographs of the Palaeontographical Society*, vol. 136, no. 563, pp. 65-152.
- 533. Shuto, T.**
1984. A revision of the Burmese Tertiary turrids. *Memoirs of the Faculty of Science, Kyushu University, Ser. D, Geology*, vol. 25, pp. 115-157.
- 534. Gorjunova, R.V.**
1984. Morfologii, sistema i filogenii manok (otrid Rhabdome-sida). "Nauka", Moscow, 152 pp.
- 535. Nazarov, B.B. and Ormiston, A.R.**
1985. Radiolaria from the late Paleozoic of the southern Urals, USSR, and West Texas, USA. *Micropaleontology*, vol. 31, pp. 1-54.
- 536. Jansonius, J. and Jenkins, W.A.M.**
1978. Chitinozoa. In B.U. Haq and A. Boersma, eds., *Introduction to Marine Micropaleontology*. Elsevier, New York, pp. 341-357.
- 537. Conkin, J.E. and Conkin, B.M.**
1977. Paleozoic smaller Foraminifera of the North American Atlantic Borderlands. In F.M. Swain, ed., *Stratigraphic Micropaleontology of the Atlantic Basins and Borderlands*. Elsevier, Amsterdam, pp. 49-58.
- 538. Cowen, R.**
1985. Personal communication, September
- 539. Ubaghs, G. and Robison, R.A.**
1985. A new homioistelecan and a new eocrinoid from the Middle Cambrian of Utah. *University of Kansas Paleontological Contributions*, Art. 115, pp. 1-24.
- 540. Donovan, S.K. and Paul, C.R.C.**
1985. Coronate echinoderms from the lower Palaeozoic of Britain. *Palaeontology*, vol. 28, pp. 527-543.
- 541. Legrand-Blain, M.**
1985. A new genus of Carboniferous spiriferid brachiopod from Scotland. *Palaeontology*, vol. 28, pp. 567-575.
- 542. Pojeta, J., Jr. and Runnegar, B.**
1976. The paleontology of rostroconch mollusks and the early history of the Phylum Mollusca. *U.S. Geological Survey Professional Paper 968*, 88 pp.
- 543. Pojeta, J., Jr.**
1979. Geographic distribution of Cambrian and Ordovician rostroconch mollusks. In J. Gray and A.J. Boucot, eds., *Historical Biogeography, Plate Tectonics, and the Changing Environment*. Oregon State University Press, Corvallis, Oregon, pp. 27-36.
- 544. Astrova, G.G.**
1978. Istoriya, sistema i filogeniya mshanok Otryad Trepostomata. "Nauka", Moscow, 240 pp.

- 545. Heinberg, C.**
1978. Bivalves from the latest Maestrichtian of Stevns Klint and their stratigraphic affinities. In T. Birkelund and R.G. Bromley, eds., *Cretaceous-Tertiary Boundary Events*. Univ. Copenhagen, pp. 58-64.
- 546. Nazarov, B.B. and Ormiston, A.R.**
1985. Evolution of Radiolaria in the Paleozoic and its correlation with the development of other marine fossil groups. *Senckenbergiana Lethaea*, vol. 66, pp. 203-216.
- 547. Woodring, W.P.**
1959. Geology and paleontology of Canal Zone and adjoining parts of Panama. Description of Tertiary molluscs (gastropods: Vermetidae to Thaididae). U.S. Geological Survey Professional Paper 306B, pp. 147-239.
- 548. Woodring, W.P.**
1957. Geology and paleontology of Canal Zone and adjoining parts of Panama. U.S. Geological Survey Professional Paper 306A, pp. 1-145.
- 549. Woodring, W.P.**
1970. Geology and paleontology of Canal Zone and adjoining parts of Panama. Description of Tertiary molluscs (gastropods: Eulimidae, Marginellidae to Helminthoglyptidae). U.S. Geological Survey Professional Paper 306D, pp. 299-452.
- 550. Ladd, H.S.**
1977. Cenozoic molluscs from western Pacific Islands. Gastropods (Eratoidae through Harpidae). U.S. Geological Survey Professional Paper 533, pp. 1-75.
- 551. Woodring, W.P.**
1973. Geology and paleontology of Canal Zone and adjoining parts of Panama. Description of Tertiary molluscs (addition to gastropods, scaphopods, pelecypods: Nuculidae to Malleidae). U.S. Geological Survey Professional Paper 306E, pp. 453-539.
- 552. Moore, E.J.**
1976. Oligocene marine molluscs from the Pittsburg Bluff Formation in Oregon. U.S. Geological Survey Professional Paper 922, pp. 1-66.
- 553. Woodring, W.P.**
1964. Geology and paleontology of Canal Zone and adjoining parts of Panama. Description of Tertiary mollusks (gastropods: Columbelloidae to Volutidae). U.S. Geological Survey Professional Paper 306C, pp. 241-297.
- 554. Addicott, W.O.**
1973. Oligocene molluscan biostratigraphy and paleontology of the lower part of the Temblor Formation, California. U.S. Geological Survey Professional Paper 791, pp. 1-48.
- 555. Addicott, W.O.**
1976. Molluscan paleontology of the Lower Miocene Clallam Formation, northwestern Washington. U.S. Geological Survey Professional Paper 976, pp. 1-44.
- 556. Yochelson, E.**
1969. Revision of some of Girty's invertebrate fossils from the Fayetteville Shale (Mississippian) of Arkansas and Oklahoma—gastropods. U.S. Geological Survey Professional Paper 606D, pp. 25-33.
- 557. Ladd, H.S.**
1966. Chitons and gastropods (Haliotidae through Adeorbidae) from the western Pacific Islands. U.S. Geological Survey Professional Paper 531, pp. 1-98.
- 558. Sohl, N.**
1965. Marine Jurassic gastropods, central and southern Utah. U.S. Geological Survey Professional Paper 503D, pp. 1-29.
- 559. Ladd, H.S.**
1972. Cenozoic fossil mollusks from western Pacific islands. Gastropods (Turritellidae through Strombidae). United States Geological Survey Professional Paper 532, pp. 1-79.
- 560. Nolf, D.**
1985. *Otolithi Piscium*. Handbook of Paleooichthyology, vol. 10. Gustav Fischer Verlag, Stuttgart, 145 pp.
- 561. Roberts, J., Hunt, J.W., and Thompson, D.M.**
1976. Late Carboniferous marine invertebrate zones of eastern Australia. *Alcheringa*, vol. 1, pp. 197-225.
- 562. Freneix, S. and Avias, J.**
1976. *Caleogonia*, a new smooth trigoniacean bivalve from the Triassic of New Caledonia. *Alcheringa*, vol. 1, pp. 279-291.
- 563. Ritchie, A. and Gilbert-Tomlinson, J.**
1977. First Ordovician vertebrates from the Southern Hemisphere. *Alcheringa*, vol. 1, pp. 351-368.
- 564. Percival, I.G.**
1977. Inarticulate brachiopods from the Late Ordovician of New South Wales and their palaeoecological significance. *Alcheringa*, vol. 2, pp. 117-141.
- 565. Legg, D.P.**
1978. Ordovician biostratigraphy of the Canning Basin, Western Australia. *Alcheringa*, vol. 2, pp. 321-334.
- 566. Glassner, M.F.**
1977. Lower Cambrian Crustacea and annelid worms from Kangaroo Island, South Australia. *Alcheringa*, vol. 3, pp. 21-31.
- 567. Jell, P.A.**
1977. Two arthropods from the Lancefieldian (La1) of central Victoria. *Alcheringa*, vol. 4, pp. 37-46.
- 568. Young, G.C.**
1977. New Early Devonian brachythoracids (placoderm fishes) from the Taemas-Wee Jasper region of New South Wales. *Alcheringa*, vol. 5, pp. 245-271.
- 569. Henderson, R.A. and MacKinnon, D.I.**
1981. New Cambrian inarticulate Brachiopoda from Australasia and the age of the Tasman Formation. *Alcheringa*, vol. 5, pp. 289-309.
- 570. Vannier, J.**
1983. *Rivillina*, a new ostracode (Bradoriida?) genus from the Armorican Massif, France. *Alcheringa*, vol. 7, pp. 1-8.
- 571. Ross, J.R.P.**
1978. Biogeography of Permian ectoproct Bryozoa. *Palaeontology*, vol. 21, pp. 341-356.
- 572. Foster, R.J. and Philip, G.M.**
1978. Tertiary holasteroid echinoids from Australia and New Zealand. *Palaeontology*, vol. 21, pp. 791-822.
- 573. Clarke, M.R. and Fitch, J.E.**
1978. Staloliths of Cenozoic teuthoid cephalopods from North America. *Palaeontology*, vol. 22, pp. 479-511.
- 574. Holloway, D.J.**
1981. Silurian dalmanitacean trilobites from North America and the origins of the Dalmanitinae and Synphoriinae. *Palaeontology*, vol. 24, pp. 695-731.
- 575. Dzik, J.**
1981. Evolutionary relationships of the early Palaeozoic 'cyclostomatous' Bryozoa. *Palaeontology*, vol. 24, pp. 827-861.
- 576. Kikushin, V.G.**
1981. Taxonomic survey of fossil isocrinids with a list of the species found in the USSR. *Geobios*, vol. 15, pp. 299-325.
- 577. Kier, P.M. and Lawson, M.H.**
1978. Index of living and fossil echinoids 1924-1970. *Smithsonian Contributions to Paleobiology*, no. 34, 182 pp.

- 578. Kier, P.M.**
1984. Echinoids from the Triassic (St. Cassian) of Italy, their lantern supports, and a revised phylogeny of Triassic echinoids. *Smithsonian Contributions to Paleobiology*, no. 56, 41 pp.
- 579. Lipps, J.**
1986. Personal communication, February.
- 580. Bengtson, S.**
1988. Unpublished data base, communicated March 1988.
- 581. Walter, B.**
1969. Les bryozoaires jurassiques en France. Systematique, rapports avec la stratigraphique et la paleoecologie. Documents des Laboratoires de Geologie de la Faculte des Sciences de Lyon, vol. 35, 328 pp.
- 582. Hillmer, G.**
1971. Bryozoen (Cyclostomata) aus dem Unter-Hauterive von Nordwestdeutschland. *Mitteilungen Geologische-Paläontologische Institut, Universität Hamburg*, vol. 40, pp. 5-106.
- 583. Voigt, E.**
1953. Revision von: H. Hamm "Die Bryozoen des Maastrichter Obersenon" (1881). *Mitteilungen aus dem Geologischen Staatsinstitut in Hamburg*, vol. 22, pp. 32-75.
- 584. Voigt, E.**
1982. *Aggregopora schmidti* n.g. n. sp. (Bryoz. Cyclostomata) aus der Obermaastrichtium-Schreibkreide von Hemmoor (Niedersachsen) und einige andere verwandte Formen. *Geologisches Jahrbuch*, vol. A61, pp. 225-257.
- 585. Voigt, E.**
1985. Bryozoaires du Cretace superieur trouves dans les residus du remplissage d'une fente karstique dans les Gorges du Nant (Vercors). *Geobios*, vol. 18, pp. 621-642.
- 586. Voigt, E.**
1957. Bryozoen aus dem Kreidetuff von St. Symphorien bei Cily (Obermaastr.). *Institut Royal des Sciences Naturelles de Belgique*, vol. 33, no. 43, pp. 1-48.
- 587. Lagaaij, R.**
1975. Crisia and Crisidia (Bryozoa Cyclostomata) from the later Maastricht. *In S. Pouyet, ed., Bryozoa 1974*. Documents des Laboratoires de Geologie de la Faculte des Sciences de Lyon, vol. 3, pp. 583-594.
- 588. Voigt, E.**
1972. Sur quelques de Bryozoaires cheilostomes cretace decrites par A. d'Orbigny. *Annales de Paleontologie, Invertebres*, vol. 58, pp. 203-220.
- 589. Brood, K.**
1972. Cyclostomatous Bryozoa from the Upper Cretaceous and Danian in Scandanavia. *Stockholm Contributions to Geology*, vol. 26, pp. 1-464.
- 590. Walter, B.**
1972. Les bryozoaires Neocomiens du Jura Suisse et Francais. *Geobios*, vol. 5, pp. 277-357.
- 591. Voigt, E.**
1975. Bryozoen aus dem Campan von Misburg bei Hannover. *Berichte der Naturhistorischen Gesellschaft zu Hannover*, vol. 119, pp. 235-278.
- 592. Masse, J.-P. and Walter, B.**
1974. Les bryozoaires du Cretace Inferieur Provençal. *Biostratigraphie et Paleocologie*, vol. 7, pp. 183-210.
- 593. Walter, B. and Almeras, Y.**
1981. Bryozoaires et brachiopods des "Calcaires Bajociens a Bryozoaires" des Causses (France) et leur paleoecologie. *Geobios*, vol. 14, pp. 361-387.
- 594. Brood, K.**
1972. Cyclostomatous Bryozoa from the Upper Cretaceous and Danian in Scandanavia. *Stockholm Contributions to Geol.* vol. 26, pp. 1-464. [=589] [Cited by Sepkoski as: Brood, K. 1978.]
- 595. Flor, F.**
1975. *Discotruncatulipora corbis* n.g. n. sp. (Bryoz. Cycl.) aus der Oberen Kreide. *Mitteilungen Geologische-Paläontologische Institut, Universität Hamburg*, vol. 44, pp. 99-110.
- 596. Walter, B., Arnaud-Vanneau, A., Arnaud, H., Busnardo, R., and Ferry, S.**
1975. Les Bryozoaires Barremo-Aptiens du sud-est de la France. Gisements et paleoecologie, biostratigraphie. *Geobios*, vol. 8, pp. 83-117.
- 597. Walter, B. and Busnardo, R.**
1971. Un gisement Aptien de bryozoaires dans Les Alps Francaises (Vercors, Isere). *Geobios*, vol. 4, pp. 87-99.
- 598. Voigt, E.**
1978. *Pachyteichopora* n.g. (Bryoz. Cyclostomata) aus der oberen Kreide. *Paläont. Zeitschrift*, vol. 52, no. 3/4, pp. 257-270.
- 599. Hillmer, G.**
1971. Bryozoen (Cyclostomata) aus dem Unter-Hauterive von Nordwestdeutschland. *Mitteilungen Geologische-Paläontologische Institut, Universität Hamburg*, vol. 40, pp. 5-106. [Cited by Sepkoski as: Hillmer, G. 1957.]
- 600. Maryanska, T.**
1969. Bryozoa from the uppermost Maastrichtian and Palaeocene deposits of the middle Vistula Gorge near Pulawy. *Prace. Muzeum Ziemi*, vol. 14, pp. 85-130.
- 601. Berthelsen, O.**
1962. Cheilostome Bryozoa in the Danian deposits of east Denmark. *Danmarks Geologiske Undersoegelse, Raekke 2*, no. 83, pp. 1-290.
- 602. Lagaaij, R.**
1968. First fossil finds of six genera of Bryozoa Cheilostomata. *Atti Societa Italiana di Scienze Naturali Milano*, vol. 108, pp. 345-360.
- 603. Voigt, E. and Hillmer, G.**
1983. Oberkretazische Hippothidae (Bryozoa Cheilostomata) aus dem Campanium von Schweden und dem Maastrichtium der Niederlande. *Mitteilungen Geologische-Paläontologische Institut, Universität Hamburg*, vol. 54, pp. 169-208.
- 604. Voigt, E.**
1959. Revision der von F.V. Hagenow 1839-1850 aus der Schreibkreide von Rugen veröffentlichten Bryozoen. *Geologie Beiheft*, vol. 25, pp. 1-80.
- 605. Voigt, E.**
1971. The cheilostomatous nature of the alleged cyclostomatous bryozoan genus *Dysnoetopora*. *Lethaia*, vol. 4, pp. 79-100.
- 606. Pouyet, S.**
1973. Revision systematique des Cellepores (Bryozoa, Cheilostomata) et des especes fossiles Europeennes. Analyse de quelques populations a cellepores dans le Neogene du Bassin Rhodanien. *Documents des Laboratoires de Geologie de la Faculte des Sciences de Lyon*, vol. 55, 266 pp.
- 607. Voigt, E.**
1964. A bryozoan fauna of Dano-Montian age from Boryszew and Sochaczew in central Poland. *Acta Palaeontologica Polonica*, vol. 9, pp. 419-480.
- 608. Medd, A.W.**
1979. *Ellisia* Norman and *Periporossella* Canu & Bassler (Superfamily Membraniporacea) from the Upper Cretaceous

- of Europe. Institute of Geological Sciences, Report No. 78/25, 29 pp.
- 609. Voigt, E.**
1979. Bryozoen der Kunrader Schichten in Sud-Limburg (Ober Kreide, Ob. Maastrichtium). *Grundboor en Hamer*, vol. 2, pp. 33–88.
- 610. Voigt, E.**
1968. On the Cretaceous age of the so-called Jurassic Cheilostome Polyzoa (Bryozoa). A contribution to the knowledge of the Polozoa-fauna of the Maastrichtian in the Contentin (Manche). *British Museum (Natural History), Geology, Bulletin*, vol. 17, pp. 1–45.
- 611. Larwood, G.P.**
1975. Preliminary report on early (pre-Cenomanian) cheilostome Bryozoa. *In* S. Pouyet, *ed.*, *Bryozoa 1974*. Doc. Lab. Geol. Fac. Sci. Lyon-H.S. 3, pp. 565–582.
- 612. Voigt, E.**
1967. Ökologische und stratigraphische Untersuchungen an Bryozoen der oberen Kreide. *Berichte der Deutschen Gesellschaft für Geologisches Wissenschaftlichen A., Geologie und Palaontologie*, vol. 12, no. 5, pp. 479–491.
- 613. Dzik, J.**
1975. The origin and early phylogeny of the cheilostomatous Bryozoa. *Acta Palaontologica Polonica*, vol. 20, pp. 395–423.
- 614. Davies, A.M.**
1971. Tertiary Faunas: I. The Composition of Tertiary Faunas. Elsevier, Amsterdam, 571 pp.
- 615. Wenz, W.**
1938. *Gastropoda*. *Handbuch der Paläozoologie*, Bd. 6. Verlag von Gebrüder Borntraeger, Berlin, 1639 pp.
- 616. Broadhead, T.W.**
1984. *Macrardblastus*, a Middle Ordovician blastoid from the southern Appalachians. *University of Kansas Paleontological Contributions*, Art. 110, pp. 1–9.
- 617. Mikulic, D.G., Briggs, D.E.G., and Kluessendorf, J.**
1984. A Silurian soft-bodied biota. *Science*, vol. 228, pp. 715–717.
- 618. Rozova, A.V.**
1984. Biostratigraphic Zoning and Trilobites of the Upper Cambrian and Lower Ordovician of the Northwestern Siberian Platform. *Amerind Publ. Co.*, New Delhi, 243 pp.
- 619. Rolfe, W.D.I.**
1984. Form and function in Thylacocephala, Conchyliocarida and Concavicularia (?Crustacea): a problem of interpretation. *Transactions of the Royal Society of Edinburgh*, vol. 76, pp. 391–399.
- 620. Steel, R.**
1973. *Crocodylia*. *Encyclopedia of Paleoherpptology*, Pt. 16. Gustav Fischer Verlag, Stuttgart, 116 pp.
- 621. Pfeil, F.H.**
1983. Zahnmorphologische Untersuchungen an rezenten und fossilen Haien der Ordnungen Chlamydoselachiformes und Echinorhiniformes. *Palaeoichthyologica*, vol. 1, pp. 1–315.
- 622. Reid, R.E.H.**
1968. Hexactinellid faunas in the Chalk of England and Ireland. *Geological Magazine*, vol. 105, pp. 15–22.
- 623. Pinna, G.**
1985. Exceptional preservation in the Jurassic of Osteno. *Philosophical Transactions of the Royal Society of London B*, vol. 311, pp. 171–180.
- 624. Owens, R.M.**
1983. A review of Permian trilobite genera. *Palaontological Association, Special Papers in Palaeontology* 30, pp. 15–41.
- 625. Westrop, S.R.**
1986. New Ptychaspid trilobites from the Upper Cambrian Mistoya Formation of southern Alberta. *Canadian Journal of Earth Sciences*, vol. 23, pp. 214–221.
- 626. Voigt, E.**
1981. Upper Cretaceous bryozoan-seagrass associations in the Maastrichtian of the Netherlands. *In* G.P. Larwood and C. Nielson, *eds.*, *Recent and Fossil Bryozoa*. Olsen & Olsen, Fredensborg, Denmark, pp. 281–298.
- 627. David, L., Balleis, R., and Mongereau, N.**
1968. Première étude sur les Bryozoaires du Pliocène rhodanien. *Giornale de Geologia, Bologna*, ser. 2, vol. 35, pp. 107–116.
- 628. Vavra, N.**
1975. Cyclostomatous Bryozoa from the Austria Miocene. *In* S. Pouyet, *ed.*, *Bryozoa 1974*. *Documents des Laboratoires de Geologie de la Faculte des Sciences de Lyon*, vol. 3, pp. 519–533.
- 629. Buge, E.**
1964. Les bryozoaires du Paleogene du Bassin de Paris (Region Parisienne et Contentin): Etat actuel de nos connaissances et perspectives d'avenir. *Memoires, Bureau de Recherches Geologique et Minieres*, no. 28.
- 630. Mongereau, N.**
1970. Les bryozoaires cyclostomes branchus du Miocene du Rhone (France): Donnees nouvelles. *Geobios*, vol. 3, pp. 29–42.
- 631. Weitschat, W. and Voigt, E.**
1983. *Poroplagioecia*—ein neues Bryozoen Genus aus dem norddeutschen Barremium (Unterkreide) (Orde Cyclostomata). *Verhandlungen des Naturwissenschaftlichen Vereins in Hamburg*, vol. 26, pp. 37–46.
- 632. Mongereau, N.**
1970. Les bryozoaires cyclostomes branchus du Miocene du Bassin du Rhone (France). *Documents des Laboratoires de Geologie de la Faculte des Sciences de Lyon*, vol. 40, pp. 1–95.
- 633. Cheetham, A.H.**
1966. Cheilostomatous Polyzoa from the Upper Bracklesham Beds (Eocene) of Sussex. *British Museum (Natural History), Geology, Bulletin*, vol. 13, pp. 1–115.
- 634. Vavra, N.**
1977. *Bryozoa Tertiaria*. *Catalogus Fossilium Austriae*, Vol. 3, 210 pp.
- 635. Vavra, N.**
1979. Bryozoa from the Miocene of Styria (Austria). *In* G.P. Larwood and M.B. Abbott, *eds.*, *Advances in Bryozoology*. Academic Press, London, pp. 585–610.
- 636. David, L. and Pouyet, S.**
1974. Revision des Bryozoaires cheilostomes miocenes du Bassin de Vienne-Autriche. *Documents des Laboratoires de Geologie de la Faculte des Sciences de Lyon*, vol. 60, pp. 83–257.
- 637. Keij, A.J.**
1969. *Encicellaria*, a new cheilostome bryozoan genus from the Maastrichtian of Maastricht, Netherlands. *Proceedings Koninklijke Nederlandse Akademie van Wetenschappen, Amsterdam*, ser. B, vol. 72, pp. 211–217.
- 638. Cook, P.L. and Lagaij, R.**
1976. Some Tertiary and Recent conescharelliform Bryozoa. *British Museum (Natural History) Bulletin, Zoology*, vol. 29, pp. 317–376.

639. David, L., Mongereau, N., Pouyet, S., and Ritzowski, S.
1968. Les Bryozoaires du Chattien de la region de Kassel (Hesse-Allemagne). Atti Societa Italiana di Scienze Naturali Milano, vol. 108, pp. 327-344.
640. Baluk, W. and Radwanski, A.
1984. Free-living bryozoans from the Korytnica Clays (Middle Miocene, Holy Cross Mountains, central Poland). Acta Geologica Polonica, vol. 34, pp. 239-252.
641. Hurcewicz, H.
1968. Siliceous sponges from the Upper Cretaceous of Poland. Part II. Monaxonia and Triaxonia. Acta Palaeontologica Polonica, vol. 13, pp. 3-118.
642. Hurcewicz, H.
1966. Siliceous sponges from the Upper Cretaceous of Poland. Part I. Tetraxonia. Acta Palaeontologica Polonica, vol. 11, pp. 15-153.
643. Orlov, Yu.A., ed.
1958-1964. Osnovy Paleontologii. Moscow.
644. Stinchcomb, B.L.
1986. New Monoplacophora (Mollusca) from the Late Cambrian and Early Ordovician of Missouri. Journal of Paleontology, vol. 60, pp. 606-626.
645. Mader, H.
1986. Schuppen und Zahne von Acanthodien und Elasmobranchiern aus dem Unter-Devon Spaniens (Pisces). Gottinger Arbeiten, Geologie und Palaontologie, vol. 28, pp. 1-59.
646. Neumann, N. and Schroeder, R., eds.
1985. Les grands foraminiferes du Cretace moyen de la region Mediterranee. Geobios, Memoire Special, no. 7, 160 pp.
647. Fedonkin, M.A.
1985. Sistematičeskoe opisanie Vendskich Metazoa. In B.S. Sokolov, ed., Vendskaya Sistema, vol. 1. "Nauka", Moscow, pp. 70-106.
648. Kozur, H.
1985. Biostratigraphic evaluation of the upper Paleozoic conodonts, ostracods and holothurian sclerites of the Bukk Mts. Part II: Upper Paleozoic ostracods. Acta Geologica Hungarica, vol. 28, pp. 225-256.
649. Neagu, T.
1984. Nouvelles donnees sur la morphologie du test, sur la systematique et la nomenclature des Miliolides agatisthees du Mesozoique. Revista Espanola de Micropaleontologia, vol. 16, pp. 75-90.
650. Ponder, W.F.
1984. A revision of the genera of the Rissoidae (Mollusca: Mesogastropoda: Rissoacea). Records of the Australian Museum, Suppl. 4, 221 pp.
651. Mu Enzhi, Boucot, A.J., Chen Xu, and Rong Jia-Yu
1984. Correlation of the Silurian rocks of China. Geological Society of America Special Paper 202, 80 pp.
652. Rigby, J.K. and Potter, A.W.
1986. Ordovician sphenozoan sponges from the eastern Klamath Mountains, northern California. Journal of Paleontology, vol. 60, no. 4 (supplement), 47 pp.
653. Schram, F.R., Yager, J., and Emerson, M.J.
1986. Remipedia. Part 1. Systematics. San Diego Society of Natural History, Memoir 15, 60 pp.
654. Paul, C.R.C. and Smith, A.B.
1984. The early radiation and phylogeny of echinoderms. Biological Reviews, vol. 59, pp. 443-481.
655. Brazier, M.D.
1986. The succession of small shelly fossils (especially conoidal microfossils) from English Precambrian-Cambrian Boundary beds. Geological Magazine, vol. 123, pp. 287-256.
656. Kjellesvig-Waering, E.N.
1986. A restudy of the fossil Scorpionida of the world. Palaeontographica Americana, no. 55, 287 pp.
657. Gorjansky, W.Ju. and Popov, L.Ye.
1986. On the origin and systematic position of the calcareous-shelled inarticulate brachiopods. Lethaia, vol. 19, pp. 233-240.
658. Wells, J.W.
1986. A list of scleractinian generic and subgeneric taxa, 1758-1985. Fossil Cnidaria, vol. 15, no. 11, pp. 1-69.
659. Bockelie, J.F. and Paul, C.R.C.
1983. *Cyathotheca suecica* and its bearing on the evolution of the Edrioasteroidea. Lethaia, vol. 16, pp. 257-264.
660. Burdick, D.W. and Strimple, H.L.
1982. Genevievian and Chesterian crinoids of Alabama. Geological Survey of Alabama, Bulletin 121, 277 pp.
661. Szabo, J.
1984. Stratigraphical studies of Lower and Middle Jurassic gastropods from the Bakony Mountains, Hungary. In O. Michelsen and A. Zeiss, eds., International Symposium on Jurassic Stratigraphy, vol. III. Geological Survey Denmark, Copenhagen, pp. 848-862.
662. Copper, P.
1986. Frasnian/Famennian mass extinction and cold-water oceans. Geology, vol. 14, pp. 835-839.
663. Kelly, S.R.A.
1984. Bivalvia of the Splisby Sandstone and Sandringham Sands (Late Jurassic-Early Cretaceous) of eastern England. Part I. Monograph of the Palaeontographical Society, vol. 137, no. 566, 94 pp.
664. Calzada, S.
1979. Sobre tres lamelibranchios del Lias de Camarasa (Lerida). Cuadernos de Geologia, Universidad de Granada, vol. 10, pp. 213-218.
665. Waterhouse, J.B.
1982. Permian Pectinacea and Limacea (Bivalvia) from New Zealand. New Zealand Geological Survey, Palaeontology Bulletin 49, 75 pp.
666. Sheng, Jin-Zhang, Rui Lin, and Chen Chu-Zhen
1985. Permian and Triassic sedimentary facies and paleogeography of South China. In K. Nakazawa and J.M. Dickens, eds., The Tethys. Her Paleogeography and Paleobiogeography from Paleozoic to Mesozoic. Tokai University Press, Tokyo, pp. 59-80.
667. Okimura, Y., Idhii, K., and Ross, C.A.
1985. Biostratigraphic significance and faunal provinces of Tethyan Late Permian smaller Foraminifera. In K. Nakazawa and J.M. Dickens, eds., The Tethys. Her Paleogeography and Paleobiogeography from Paleozoic to Mesozoic. Tokai University Press, Tokyo, pp. 115-138.
668. McKinney, F.K. and Kriz, J.
1985. Lower Devonian Fenestrata (Bryozoa) of the Prague Basin, Barrandian Area, Bohemia, Czechoslovakia. Field Museum of Natural History Fieldiana (Geology), N.S., no. 15, 90 pp.
669. Hahn, G., Hahn, R., Leonardos, O.H., Pflu, H.D., and Walde, D.H.G.
1982. Koperlich erhaltene Scyphozoen-Reste aus dem Jungpräkambrium Brasiliens. Geologica et Palaeontologica, vol. 16, pp. 1-18.

- 670. Crasquin, S.**
1985. Zonation par les ostracodes dan le Mississippien de l'ouest Canadien. *Revue de Paleobiologie*, vol. 41, pp. 43-52.
- 671. Mierzejewski, P.**
1986. Ultrastructure, taxonomy and affinities of some Ordovician and Silurian microfossils. *Palaeontologica Polonica*, vol. 47, pp. 129-220.
- 672. Janvier, P.**
1985. Environmental framework of the diversification of the Osteostraci during the Silurian and Devonian. *Philosophical Transactions of the Royal Society of London B*, vol. 109, pp. 259-272.
- 673. Kriz, J.**
1979. Silurian Cardiolidae (Bivalvia). *Sbornik Geologických Ved: Palaeontologie*, vol. 22, pp. 1-157.
- 674. Malinowska, L., ed.**
1986. Geology of Poland, vol. III. Atlas of Guide and Characteristic Fossils. Part 2a. Mesozoic, Triassic. *Wydawnictwa Geologiczne*, Warsaw, 253 pp.
- 675. Frest, T.J., Kolata, D.R., and Mapes, R.H.**
1985. The youngest carpod: occurrence, affinities, and life mode of a Pennsylvanian mitrate from Oklahoma. *Geological Society of America Abstracts with Program*, vol. 17, p. 586.
- 676. Vu-Huc, D.**
1977. A revision of certain bivalve genera from the Upper Triassic of North Vietnam. *Doklady Akademii Nauk SSSR*, vol. 232, pp. 676-679.
- 677. Bengtson, S. and Urbanek, A.**
1986. *Rhabdotubus*, a Middle Cambrian rhabdopleurid hemichordate. *Lethaia*, vol. 19, pp. 293-308.
- 678. Kalvoda, J.**
1986. Upper Frasnian and lower Tournaisian events and evolution of calcareous Foraminifera—close links to climatic changes. In O.H. Walliser, ed., *Global Bio-Events*. Springer-Verlag, Berlin, pp. 255-236.
- 679. Ali, M.S.M. and Maczynska, S.**
1986. Middle Miocene echinoids in the Tethys (Egypt) and the Paratethys (Poland). *Neues Jahrbuch für Geologie und Palaeontologie Monatshefte*, vol. 1986, pp. 577-586.
- 680. Sorauf, J.E. and Pedder, A.E.H.**
1986. Late Devonian rugose corals and the Frasnian-Famennian crisis. *Canadian Journal of Earth Sciences*, vol. 23, pp. 1265-1287.
- 681. Powell, A.W.B.**
1979. *New Zealand Mollusca*. Collins, Auckland, 500 pp.
- 682. Beauvais, L.**
1986. Monographie des Madreporaires du Jurassique Inferieur du Maroc. *Palaeontographica, Abt. A*, vol. 194, pp. 1-68.
- 683. Copper, P.**
1986. Evolution of the earliest smooth spire-bearing atrypoids (Brachiopoda: Lissatrypidae, Ordovician-Silurian). *Palaeontology*, vol. 29, pp. 827-867.
- 684. Salaj, J., Borza, K., and Samuel, O.**
1983. Triassic Foraminiferas of the West Carpathians. *Geologicky Ustav Dionyza Stura, Bratislava*, 213 pp.
- 685. Sanfilippo, A. and Riedel, W.R.**
1985. Cretaceous Radiolaria. In H.M. Bolli, J.B. Saunders, and K. Perch-Nielsen, eds., *Plankton Stratigraphy*. Cambridge Univ. Press, Cambridge, pp. 573-630.
- 686. Sanfilippo, A., Westberg-Smith, M.J., and Riedel, W.**
1986. Cenozoic Radiolaria. In H.M. Bolli, J.B. Saunders, and K. Perch-Nielsen, eds., *Plankton Stratigraphy*. Cambridge Univ. Press, Cambridge, pp. 631-712.
- 687. Zawidzka, K.**
1971. Triassic holothurian sclerites from Tatra Mountains. *Acta Palaeontologica Polonica*, vol. 16, pp. 429-459.
- 688. Melnikova, G.K. and Roniewicz, E.**
1976. Contributions to the systematics and phylogeny of Amphistraeina (Scleractinia). *Acta Palaeontologica Polonica*, vol. 21, pp. 97-114.
- 689. Tarlo, L.B.H.**
1964. Psammosteiformes (Agnatha), a review with description of new material from the Lower Devonian of Poland. I. General part. *Palaeontologica Polonica*, no. 13, 135 pp.
- 690. Owen, A.W.**
1986. The uppermost Ordovician (Hirnantian) trilobites of Girvan, SU Scotland with a review of coeval trilobite faunas. *Transactions of the Royal Society of Edinburgh, Earth Sciences*, vol. 77, pp. 231-239.
- 691. Tchechmedjjeva, V.L.**
1986. Paleoeologie des Madreporaires du Cretace superieur dans le Srednogieorie de l'Ouest (Bulgarie occidentale). *Geologica Balcanica*, vol. 16(5), pp. 55-81.
- 692. Secretan, S. and Riou, B.**
1986. Les Mysidaees (Crustacea, Peracarida) du Callovien de La Vouite-sur-Rhone. *Annales de Paleontologie*, vol. 72, pp. 295-324.
- 693. Tintori, A., Bigi, E., Crugnola, G., and Danini, G.**
1986. A new Jurassic Thylacocephala *Pugocaris indunensis* Gen. n. sp. n. and its paleoecological significance. *Rivista Italiana di Paleontologia e Stratigrafia*, vol. 92, pp. 239-250.
- 694. Hu, C.H.**
1971. Ontogeny and sexual dimorphism of lower Paleozoic trilobites. *Palaeontographica Americana*, vol. 7, no. 44, pp. 31-155.
- 695. Farsan, N.M.**
1986. Faunenwandel oder Faunenkrise? Faunistische Untersuchung der Grenze Frasnium/Famennium im mittleren Sudasien. *Newsletters on Stratigraphy*, vol. 16, pp. 113-131.
- 696. Long, D.C.**
1981. Late Eocene and Early Oligocene Turridae (Gastropoda: Prosobranchiata) of the Brown's Creek and Glen Aire Clays, Victoria, Australia. *Memoirs of the National Museum of Victoria*, vol. 42, pp. 15-55.
- 697. Westrop, S.R.**
1986. Trilobites of the Upper Cambrian Sunwaptan Stage, Southern Canadian Rocky Mountains, Alberta. *Palaeontographica Americana*, no. 3, 179 pp.
- 698. Brimaud, C. and Vachard, D.**
1986. Les spongiaires siliceux du Tortonien des Betique (Miocene de l'Espagne du Sud): especes nouvelles ou peu connues I. Choriostides et Lithisides. *Bulletin, Museum National d'Histoire Naturelle (Paris)*, 4 ser., vol. 8, pp. 293-341.
- 699. Geyer, G.**
1986. Mittelkambrische Mollusken aus Marokko und Spanien. *Senckenbergiana Lethaea*, vol. 67, pp. 55-118.
- 700. Palmer, K.V.W. and Brann, D.C.**
1966. Catalogue of the Paleocene and Eocene Mollusca of the southern and eastern United States. *Bulletins of American Paleontology*, vol. 48, no. 218, 1027 pp.
- 701. Cheng Yen-Nien**
1986. Taxonomic Studies of Upper Paleozoic Radiolaria. Na-

- tional Museum of Natural Science, Taiwan, Special Publication 1, 311 pp.
- 702. Signor, P.W., Mount, J.F., and Onken, B.R.**
1986. A pre-trilobite shelly fauna from the White-Inyo Region of eastern California and western Nevada. *Journal of Paleontology*, vol. 61, pp. 425-438.
- 703. Ausich, W.I.**
1987. Brassfield Comsocrinina (Lower Silurian crinoids) from Ohio. *Journal of Paleontology*, vol. 61, pp. 552-562.
- 704. Webster, G.D. and Lane, N.G.**
1987. Crinoids from the Anchor Limestone (lower Mississippian) of the Monte Cristo Group, southern Nevada. *University of Kansas Paleontological Contributions*, Art. 119, 56 pp.
- 705. Adegoke, O.S.**
1977. Stratigraphy and paleontology of the Ewekoro Formation (Paleocene) of southwestern Nigeria. *Bulletins of American Paleontology*, vol. 71, no. 295, 379 pp.
- 706. Parsley, R.L. and Mintz, L.W.**
1975. North American Paracrinoidea: (Ordovician: Paracrinozoa, new, Echinodermata). *Bulletins of American Paleontology*, vol. 68, no. 288, 115 pp.
- 707. Blome, C.D.**
1984. Upper Triassic Radiolaria and radiolarian zonation from western North America. *Bulletins of American Paleontology*, vol. 85, no. 318, 88 pp.
- 708. Cooper, G.A. and Dutro, J.T., Jr.**
1982. Devonian brachiopods of New Mexico. *Bulletins of American Paleontology*, vol. 82, no. 315, 215 pp.
- 709. Cutress, B.M.**
1980. Cretaceous and Tertiary Cidaroida (Echinodermata: Echinozoa) of the Caribbean area. *Bulletins of American Paleontology*, vol. 77, no. 309, 221 pp.
- 710. Pohovsky, R.A.**
1978. The boring ctenostomate Bryozoa: taxonomy and paleobiology based on cavities in calcareous substrata. *Bulletins of American Paleontology*, vol. 73, no. 301, 192 pp.
- 711. Laub, R.S.**
1978. The corals of the Brassfield Formation (mid-Llandovery, Lower Silurian) in the Cincinnati Arch region. *Bulletins of American Paleontology*, vol. 75, no. 305, 457 pp.
- 712. Waterhouse, B.J.**
1987. Late Paleozoic Brachiopoda (Athyrida, Spiriferida and Terebratulida) from the southeast Bowen Basin, East Australia. *Palaontographica*, Abt. A, vol. 196, pp. 1-56.
- 713. Ubahgs, G.**
1987. Echinodermes nouveaux du Cambrien moyen de la Montagne Noire (France). *Annales de Paleontologie*, vol. 73, pp. 1-27.
- 714. Tanaka, K.**
1984. Appraisal of the Cretaceous echinoid fauna of Japan. *Bulletin of the Geological Survey of Japan*, vol. 35, pp. 389-417.
- 715. Hallam, A.**
1987. Radiations and extinctions in relation to environmental change in the marine Lower Jurassic of northwest Europe. *Paleobiology*, vol. 13, pp. 152-168.
- 716. Kennedy, W.J., Wright, C.W., and Hancock, J.M.**
1987. Basal Turonian ammonites from West Texas. *Palaentology*, vol. 30, pp. 27-74.
- 717. Patterson, R.T. and Richardson, R.H.**
1987. A taxonomic revision of the unilocular Foraminifera. *Journal of Foraminiferal Research*, vol. 17, pp. 212-226.
- 718. Muller, A.H.**
1985. *Lehrbuch der Palaozoologie*. Bd. III, Vertebraten. Teil 1, Fische im Weiteren Sinne und Amphibien. Gustav Fischer Verlag, Jena. 655 pp.
- 719. Koneva, S.P.**
1987. A new family of Cambrian inarticulate brachiopods. *Palaentological Journal*, vol. 20, pp. 28-35.
- 720. Popov, L.E. and Rukavishnikov, T.B.**
1987. A new family of gigantic inarticulate brachiopods from the Upper Ordovician of southern Kazakhstan. *Palaentological Journal*, vol. 20, pp. 36-40.
- 721. Jago, J.B.**
1987. Idamean (Late Cambrian) trilobites from the Denison Range, south-west Tasmania. *Palaentology*, vol. 30, pp. 207-231.
- 722. Mitchell, C.E.**
1987. Evolution and phylogenetic classification of the Diplograptacea. *Palaentology*, vol. 30, pp. 353-405.
- 723. Ward, D.J. and Thiers, D.**
1987. Hexanchid shark teeth (Neoselachii, Vertebrata) from the Lower Cretaceous of Germany and England. *Mesozoic Research*, vol. 1, pp. 89-106.
- 724. Schram, F.R., Sieg, J., and Malzahn, E.**
1986. Fossil Tanaidacea. *Transactions of the San Diego Society of Natural History*, vol. 21, pp. 127-144.
- 725. Brasier, M.D. and Singh, P.**
1986. Microfossils and Precambrian-Cambrian Boundary stratigraphy at Maldeota, Lesser Himalaya. *Geological Magazine*, vol. 124, pp. 323-345.
- 726. Fortey, R.A. and Owens, R.M.**
1987. The Arenig Series in South Wales: stratigraphy and paleontology I. The Arenig Series in South Wales. *British Museum (Natural History), Bulletin, Geology*, vol. 41, pp. 71-307.
- 727. Popenoe, W.R. and Saul, L.R.**
1987. Evolution and classification of the Late Cretaceous-Early Tertiary gastropod *Perissites*. *Los Angeles County Museum of Natural History, Contributions to Science*, vol. 380, pp. 37.
- 728. Hoskins, R.H., ed.**
1982. Stages of the New Zealand marine Cenozoic: a synopsis. *New Zealand Geological Survey Report 107*, 73 pp.
- 729. Bugrova, E.M.**
1986. Paleogene infusorids (composition, distribution, and facies dependence). *Palaentological Journal*, vol. 20, pp. 1-11.
- 731. Malinky, J.M.**
1987. Taxonomic revision of lower and middle Paleozoic Orthothecida (Hyalolitha) from North America and China. *Journal of Paleontology*, vol. 61, pp. 942-959.
- 732. Glenister, B.F. and Furnish, W.M.**
1987. New Permian representatives of ammonoid superfamilies Marathontaceae and Cyclolobaceae. *Journal of Paleontology*, vol. 61, pp. 982-998.
- 733. Hacobjan, V.T.**
1972. Systematics of Late Cretaceous trochactaeonids (Gastropoda). *Palaentological Journal*, vol. 6, pp. 1-12.
- 734. Djalilov, M.R.**
1972. Systematics of actaeonellids (Gastropoda). *Palaentological Journal*, vol. 6, pp. 13-19.
- 735. Howells, Y.**
1982. Scottish Silurian trilobites. *Monograph of the Palaentographical Society, London 135(561)*, pp. 1-76.
- 736. Jones, C.R.**
1984. Ordovician (Llandoveryan and Caradocian) beyrichiope Ostracoda from England and Wales. *Monograph of the*

- Palaontographical Society, London 138(569), pp. 1-76, 139(571), pp. 77-114.
- 737. Bjaly, V.I.**
1973. New Early Ordovician monoplacophorans of Siberia. *Paleontological Journal*, vol. 7, pp. 326-330.
- 738. Taylor, P.D. and Curry, G.B.**
1985. The earliest known fenestrate bryozoan from the lower Arenig of south Wales: implications of the oldest described bryozoan. *Geological Magazine*, vol. 124, pp. 367-371.
- 740. Grant-Mackie, J.A.**
1978. Subgenera of the Upper Triassic bivalve *Monotis*. *New Zealand Journal of Geology and Geophysics*, vol. 21, pp. 97-111.
- 741. Boltovskoy, E.**
1987. Tertiary benthic Foraminifera in bathyal deposits of the Quaternary world ocean. *Journal of Foraminiferal Research*, vol. 17, pp. 279-285.
- 742. Anstey, R.**
1989. Personal communication.
- 743. Menakova, G.N. and Nikiforova, O.I.**
1986. New Upper Silurian brachiopods from the Zeravshan-Gissar Mountain region. *Paleontological Journal*, vol. 20, pp. 63-75.
- 744. Jefferies, R.P.S., Lewis, M., and Donovan, S.K.**
1986. *Protocystites monevensis*—a stem-group chordate (Cordata) from the Middle Cambrian of south Wales. *Palaentology*, vol. 30, pp. 429-484.
- 745. Waterhouse, J.B.**
1987. Late Palaeozoic Mollusca and correlations from the Southeast Bowen Basin, East Australia. *Palaentographica*, Abt. A, vol. 198, pp. 129-233.
- 746. Carroll, R.**
1987. *Vertebrate Paleontology and Evolution*. W.H. Freeman & Co., San Francisco, 698 pp.
- 747. Pojarkova, Z.N.**
1977. Late Cretaceous gastropods from the northeast of Soviet central Asia. *Paleontological Journal*, vol. 11, pp. 14-28.
- 748. Rozman, Kh.S.**
1977. Pseudopunctate Davidsoniacea (Brachiopoda) from the lower Ashgill of Mongolia. *Paleontological Journal*, vol. 11, pp. 510-512.
- 749. Damborenea, S.E.**
1987. Early Jurassic Bivalvia of Argentina, Parts 1 & 2. *Palaentographica*, Abteilung A, vol. 119, pp. 23-111, 113-216.
- 750. Kusmicheva, Ye.I.**
1980. Fossil Gorgonida. *Paleontological Journal*, vol. 14, pp. 1-12.
- 751. Malinky, J.M., Linsley, R.M., and Yochelson, E.L.**
1987. Taxonomic revision of Hyolitha from the middle Paleozoic of North America. *Journal of Paleontology*, vol. 61, pp. 1173-1186.
- 752. Bozorgnia, F.**
1973. Paleozoic foraminiferal biostratigraphy of central and east Alborz Mountains, Iran. *National Iranian Oil Company, Tehran, Geological Laboratories, Publication, No. 4*, 1-185.
- 753. Pessagno, E.A., Jr.**
1977. Upper Jurassic Radiolaria and radiolarian biostratigraphy of the California Coast Range. *Micropaleontology*, vol. 23, pp. 56-113.
- 754. Pessagno, E.A., Jr., Finch, W., and Abouft, P.L.**
1979. Upper Triassic Radiolaria from the San Hipolito Formation, Baja California. *Micropaleontology*, vol. 25, pp. 160-197.
- 755. Baumgartner, P.O.**
1979. Late Jurassic Hagiastriidae and Patulibracidae (Radiolaria) from the Argolis Peninsula (Peloponnesus, Greece). *Micropaleontology*, vol. 26, pp. 274-322.
- 756. Pessagno, E.A., Jr. and Whalen, P.**
1982. Lower and Middle Jurassic Radiolaria (multicyrtid Nassellarina) from California, east-central Oregon, and the Queen Charlotte Islands, British Columbia. *Micropaleontology*, vol. 28, pp. 111-169.
- 757. Blome, C.D.**
1982. Upper Triassic Capnuchopteraeidae and Capnodocinae (Radiolaria) from east-central Oregon. *Micropaleontology*, vol. 29, pp. 11-49.
- 758. Larsson, K.**
1979. Silurian tentaculitids from Gotland and Scania. *Fossils and Strata*, no. 11, 180 pp.
- 759. Gehling, J.G.**
1987. Earliest known echinoderm—a new Ediacaran fossil from the Pound Supergroup of South Australia. *Alcheringa*, vol. 11, pp. 337-345.
- 760. Loeblich, A. and Tappan, H.**
1987. *Foraminiferal Genera and Their Classification*. Van Nostrand Reinhold Co., New York, vol. 1, 970 pp.
- 761. Wood, R.**
1987. Biology and revised systematics of some late Mesozoic stromatopora. *Palaentological Association, Special Papers in Palaentology* 37, 89 pp.
- 762. Tunnicliff, S.P.**
1987. Caradocian bivalve molluscs from Wales. *Palaentology*, vol. 30, pp. 677-690.
- 763. Yeh, Kuei-Yu**
1987. Taxonomic studies of Lower Jurassic Radiolaria from east-central Oregon. *National Museum of Natural Sciences, Taiwan, Special Publication* 2, 169 pp.
- 764. Amsden, T.W. and Barrick, J.E.**
1987. Late Ordovician through Early Devonian annotated correlation chart and brachiopod range charts for the southern Midcontinent Region, U.S.A., with a discussion of Silurian and Devonian conodont faunas. *Oklahoma Geological Survey Bulletin* 143, 66 pp.
- 765. Johansen, M.B.**
1987. Brachiopods from the Maastrichtian-Danian boundary sequence at Nye Klov, Jylland, Denmark. *Fossils and Strata*, no. 20, 99 pp.
- 766. Rigby, J.K.**
1986. Sponges of the Burgess Shale (Middle Cambrian), British Columbia. *Palaentographica Canadiana*, no. 2, 105 pp.
- 767. Monnet, F. and Buge, E.**
1971. Les spicules d'ascidies fossiles et actuelles. *Annales de Paleontologie, Invertebrés*, vol. 57, pp. 93-105.
- 768. Frizzell, D.L. and Exline, H.**
1955. Monograph of fossil holothurian sclerites. *Bulletin of the University Missouri School of Mines and Metallurgy, Technical Series*, no. 89, 204 pp.
- 769. Kozur, H.**
1970. Zur Klassifikation und phylogenetischen Entwicklung der fossilen Phyllococida und Eunocida (Polychaeta). *Freiberger Forschungshefte*, vol. 260, pp. 35-82.
- 770. Kozur, H.**
1970. Die Eunocida und Phyllococida des Mesozoikums. *Freiberger Forschungshefte*, vol. 267, pp. 73-111.
- 771. Blot, J.**
1969. Les Poissons Fossiles du Monte Bolea. *Stude Recherche sui Giacimenti Terziari di Bolea*, I. Verona, 525 pp.

772. **Gale, A.S.**
1987. Goniasteridae (Asteroidea, Echinodermata) from the Late Cretaceous of north-west Europe. The genera *Calliderma*, *Crateraster*, *Nymphaster* and *Chomataster*. Mesozoic Research, vol. 1, pp. 151-186.
773. **Melnyk, D.H. and Maddocks, R.F.**
1987. Ostracode biostratigraphy of the Permo-Carboniferous of central and north-central Texas. Part II: Ostracode zonation. Micropaleontology, vol. 34, pp. 21-40.
774. **Thomas, A.T. and Holloway, D.J.**
1988. Classification and phylogeny of the trilobite order Lichida. Philosophical Transactions of the Royal Society of London B, vol. 321, pp. 179-262.
775. **Trammer, J.**
1982. Lower and middle Oxfordian sponges of the Polish Jura. Acta Geologica Polonica, vol. 32, pp. 1-39.
776. **Michalik, J., Borza, K., Snopkova, P., and Vasicek, Z.**
1987. Sucasne trendy v stratigrafii spodnokriedovych utvarov a ich aplikacia na zapadne Karpaty. Geologicke Prace, vol. 86, pp. 179-195.
777. **Erwin, D.H.**
1987. Permian Gastropoda of the southwestern United States: Subulitacea. Journal of Paleontology, vol. 62, pp. 56-69.
778. **Hou, X.-G.**
1987. Two new arthropods from Lower Cambrian, Chengjiang, eastern Yunnan. Acta Palaeontologica Sinica, vol. 26, pp. 237-256.
779. **Sun, W.-G. and Hou, X.-G.**
1987. Early Cambrian medusae from Chengjiang, Yunnan, China. Acta Palaeontologica Sinica, vol. 26, pp. 257-271.
780. **Hou, X.-G.**
1987. Three new arthropods from Lower Cambrian, Chengjiang, eastern Yunnan. Acta Palaeontologica Sinica, vol. 26, pp. 272-285.
781. **Hou, X.-G.**
1987. Early Cambrian large bivalved arthropods from Chengjiang, eastern Yunnan. Acta Palaeontologica Sinica, vol. 26, pp. 286-298.
782. **Sun, W.-G. and Hou, X.-G.**
1987. Early Cambrian worms from Chengjiang, Yunnan, China: *Maotianshania* gen. nov. Acta Palaeontologica Sinica, vol. 26, pp. 298-305.
783. **Hou, X.-G. and Sun, W.-G.**
1987. Discovery of Chengjiang fauna at Meishucun, Jinning, Yunnan. Acta Palaeontologica Sinica, vol. 27, pp. 1-12.
784. **Dzik, J.**
1986. Turrellipadida and other Machaeridia. In A. Hoffman and M.H. Nitecki, eds., Problematic Fossil Taxa. Oxford University Press, New York, pp. 116-134.
785. **Batten, R.L. and Stokes, W.L.**
1986. Early Triassic gastropods from the Sinbad Member of the Moenkopi Formation, San Rafael Swell, Utah. American Museum of Natural History Novitates, no. 2864, 33 pp.
786. **Sartenaer, P.**
1988. A second North American representative of the middle Frasnian rhynchonellid genus *Caryorhynchus* Crickmay, C.H., 1952. Journal of Paleontology, vol. 64, pp. 539-546.
787. **Erwin, D.H.**
1988. Gastropoda of the southwestern United States: Cerithiacea, Acteonacea, and Pyramidellacea. Journal of Paleontology, vol. 62, pp. 566-575.
788. **Blake, D.B.**
1988. A first fossil member of the Ctenodiscidae (Asteroidea, Echinodermata). Journal of Paleontology, vol. 62, pp. 626-631.
789. **Dhondt, A.V. and Dieni, I.**
1988. Early Cretaceous bivalves of eastern Sardinia. Memorie di Scienze Geologiche, Padova, vol. 40, pp. 1-97.
790. **Abdel-Gawad, G.I.**
1986. Maastrichtian non-cephalopod mollusks (Scaphopoda, Gastropoda and Bivalvia) of the middle Vistula Valley, central Poland. Acta Geologica Polonica, vol. 36, pp. 69-224.
791. **Fursich, F.T.**
1982. Upper Jurassic bivalves from Milne Land, East Greenland. Gronlands Geologiske Undersogelse, Bulletin, vol. 144, 126 pp.
792. **Kollman, H.A.**
1976. Gastropoden aus den Losensteiner Schichten der Umgebung von Losenstein (Oberosterreich). 1. Teil: Eurthyneura und Prosobranchia I (Neogastropoda). Annalen. Naturhistorischen Museum Wien, vol. 80, pp. 163-206.
793. **Kollman, H.A.**
1976. Gastropoden aus den Losensteiner Schichten der Umgebung von Losenstein (Oberosterreich). 3. Teil: Cerithiacea (Mesogastropoda). Annalen, Naturhistorischen Museum Wien, vol. 82, pp. 11-51.
794. **Kollman, H.A. and Peel, J.S.**
1983. Paleocene gastropods from Nugsunaq, West Greenland. Gronlands Geologiske Undersogelse, Bulletin, vol. 146, 115 pp.
795. **Sloan, R.E.**
1988. The Deicke Ash bed and the Blackriver-Trenton boundary. Geological Society of America Abstracts with Program, vol. 20, no. 7, p. 389, and unpublished data.
796. **Chevalier, J.-P. and Beauvais, L.**
1987. Systematique. In P.-P. Grasse, ed., Traité de Zoologie. Tome III, fasc. 3. Cnidaires Anthozoaires. Masson, Paris, pp. 679-764. [Cited by Sepkoski as: Chevalier, J.-P. and L. Beauvais. 19... Systematique (new Traité) (scleractinians).]
797. **Erwin, D.**
1989. Personal communication. (January, 1989).
798. **Scrutton, C.T.**
1987. Patterns of extinction and survival in Palaeozoic corals. In G.P. Larwood, ed., Extinction and Survival in the Fossil Record. Systematics Association Special Volume No. 34. Clarendon Press, Oxford, pp. 65-88.
799. **Richards, R.B.**
1988. Anachronistic, heraldic, and echoic evolution: new patterns revealed by extinct planktonic hemichordates. In G.P. Larwood, ed., Extinction and Survival in the Fossil Record. Systematics Association Special Volume No. 34. Clarendon Press, Oxford, pp. 211-230.
800. **Aldridge, R.J.**
1988. Extinction and survival in the Conodonta. In G.P. Larwood, ed., Extinction and Survival in the Fossil Record. Systematics Association Special Volume No. 34. Clarendon Press, Oxford, pp. 231-256.
801. **Smith, A.B.**
1990. Echinoid evolution from the Triassic to lower Liassic. Cahiers Institut Catholique de Lyon, ser. Sci., vol. 3, pp. 79-115.
802. **Yuan Jiniang**
1988. Proetiden aus dem jungeren Oberdevon von Sud-China. Palaeontographica, Abt. A, vol. 201, pp. 1-102.

- 803. Kelly, S.R.A.**
1988. Cretaceous wood-boring bivalves from western Antarctica with a review of the Mesozoic Pholadidae. *Palaeontology*, vol. 31, pp. 341–372.
- 804. Briggs, D.E.G. and Collins, D.**
1988. A Middle Cambrian chelicerate from Mount Stephen, British Columbia. *Palaeontology*, vol. 31, pp. 779–798.
- 805. Smith, A.B.**
1988. Patterns of diversification and extinction in early Palaeozoic echinoderms. *Palaeontology*, vol. 31, pp. 799–828.
- 806. Reyeros De Castillo, M.M.**
1983. Algunas Formaciones cretácicas del Estado de Oaxaca. *Paleontologia Mexicana*, no. 47, 67 pp.
- 807. Toulmin, L.D.**
1977. Stratigraphic distribution of Paleocene and Eocene fossils in the eastern Gulf Coast region. *Geological Survey of Alabama Monograph* 13, 602 pp.
- 808. Ubachs, G. and Robison, R.A.**
1988. Homalozoan echinoderms of the Wheeler Formation (Middle Cambrian) of western Utah. *University of Kansas Paleontological Contributions*, Art. 120, pp. 1–18.
- 809. Conway Morris, S. and Robison, R.A.**
1988. More soft-bodied animals and algae from the Middle Cambrian of Utah and British Columbia. *University of Kansas Paleontological Contributions*, Art. 122, pp. 1–48.
- 810. Andreyeva, O.N.**
1987. The Cambrian articulate brachiopods. *Paleontological Journal*, vol. 21(4), pp. 27–38.
- 811. Lazarev, S.S.**
1987. The origins and systematic position of the main groups of productids. *Paleontological Journal*, vol. 21(4), pp. 39–47.
- 812. Siveter, D.J.**
1980. British Silurian Beyrichiacea (Ostracoda). Part I. *Monograph of the Palaeontological Society*, vol. 133, no. 556, 76 pp.
- 813. Ushatinskaya, G.T.**
1987. Unusual inarticulate brachiopods from the Lower Cambrian sequence of Mongolia. *Paleontological Journal*, vol. 21(2), pp. 59–66.
- 814. Gardner, J.**
1945. Mollusca of the Tertiary formations of northeastern Mexico. *Geological Society of America Memoir* 11, 332 pp.
- 815. Cleveley, R.J. and Morris, N.J.**
1988. Taxonomy and ecology of Cretaceous Cassiopidae (Mesogastropoda). *British Museum (Natural History). Bulletin*, *Geology*, vol. 44, pp. 233–291.
- 816. Moore, E.J.**
1983. Tertiary marine pelecypods of California and Baja California: Nuculidae through Malleidae. *U.S. Geological Survey Professional Paper* 1228-A, 108 pp.
- 817. Beauvais, L., Berthou, P.Y., and Lauverjat, X.**
1975. Le gisement campanien de Mira (Beira litorale, Portugal): sédimentologie, micropaléontologie, révision des Madreporaires. *Comunicações dos Serviços Geológicos de Portugal*, vol. 59, pp. 37–58.
- 818. Turnsek, D. and Polsak, A.**
1978. Senonijske kolonijske korale iz biolititnega kompleksa v Orešju na Medvednici. *Slovenska Akademija Znanosti in Umetnosti, Razprave, Series IV*, vol. 21, pp. 129–179.
- 819. Turnsek, D. and Mihajlovic, M.**
1981. Lower Cretaceous cnidarians from eastern Siberia. *Slovenska Akademija Znanosti in Umetnosti, Razprave*, vol. 23(1), pp. 1–54.
- 820. Rosendahl, S.**
1985. Die oberjurassische Korallenfazies von Algarve (Sudportugal). *Arbeiten, Institut Geologie und Paläontologie, Universität Stuttgart*, vol. 82, pp. 1–125.
- 821. Sikharulidze, G.**
1979. The corals of the Urgonian facies of Georgia. *Geobios, Memoire Special* 3, pp. 301–304.
- 822. Turnsek, D. and Buser, S.**
1974. Spodnejekredne korale, idrozoji in hetetide z Banjske planote in Trnovskega Gozda Slovenska Akademija Znanosti in Umetnosti, *Razprave, Series IV*, vol. 17, pp. 81–124.
- 823. Turnsek, D.**
1972. Zgoranjejurske korale iz južne Slovenije. *Slovenska Akademija Znanosti in Umetnosti, Razprave, Series IV*, vol. 15, pp. 145–265.
- 824. Geyer, O.F.**
1953. Die Fauna oolithischen Trummerkalke des oberes Malm in Württemberg und ihre Beziehungen zur korallogenen Fazies des Tithon. *Neues Jahrbuch für Geologie und Paläontologie, Monatshefte*, vol. 1953, pp. 130–140.
- 825. Turnsek, D., Seyfried, H., and Geyer, O.F.**
1975. Geologische und paläontologische Untersuchungen an einem Korallen-vorkommen im subbaltischen Unterjura von Murcia (sud-Spanien). *Dissertationes 18/5. Slovenska Akademija Znanosti in Umetnosti Academia scientiarum et artium Solvenica*.
- 826. Beauvais, L.**
1974. Quelques exemples pris dans le Malm montrant le rôle des Madreporaires dans la théorie de la mobilité continentale. *Bulletin, Société Géologique de France, 7e Ser.*, vol. 16, pp. 465–469.
- 827. Beauvais, L.**
1972. Deux nouveaux genres de Madreporaires triasiques. *Bulletin, Société Géologique de France, 7e ser.*, vol. 15, pp. 310–314.
- 828. Beauvais, L.**
1984. Evolution and diversification of Jurassic Scleractinia. *Palaontographica Americana*, no. 54, pp. 219–224.
- 829. Beauvais, L. and Bernier, P.**
1981. Nouvelles espèces de Madreporaires dans le Kimmeridgien supérieur du Jura (France). *Geobios*, vol. 14, pp. 173–189.
- 830. Geyer, O.F.**
1955. Korallen-faunen aus dem oberen Juras von Portugal. *Senckenbergiana Lethaea*, vol. 35, pp. 317–356.
- 831. Beauvais, L.**
1970. Etude de quelques polypiers Bajociens du Maroc Oriental. *Notes du Service Géologique du Maroc*, vol. 30, no. 225, pp. 39–48.
- 832. Roniewicz, E.**
1970. Scleractinia from the upper Portlandian of Tisbury, Wiltshire, England. *Acta Palaeontologica Polonica*, vol. 15, pp. 519–537.
- 833. Negus, P.E.**
1983. Distribution of the British Jurassic corals. *Proceedings of the Geologists' Association*, vol. 94, pp. 251–257.
- 834. Stanley, G.D., Jr.**
1986. Late Triassic coelenterate faunas of western Idaho and northeastern Oregon: implications for biostratigraphy and paleogeography. *U.S. Geological Survey Professional Paper* 1425.

835. **Turnsek, D. and Ramova, A.**
1986. Upper Triassic (Norian-Rhaetian) reef buildups in the northern Julian Alps (NU Yugoslavia). *Razprave, Dissertaciones* 28/2. Slovenska Akademija Znanosti in Umetnosti Academia scientiarum et artium Slovenica.
836. **Deng Zhan-Qui and Kong Lei**
1984. Middle Triassic corals and sponges from southern Guizhou and eastern Yunnan. *Acta Palaeontologica Sinica*, vol. 23, pp. 489-504.
837. **Kuz'micheva, E.I.**
1984. Cretaceous and Paleocene corals of the Ukraine. *Moscow University Geology Bulletin*, vol. 40, pp. 30-35.
838. **Barthel, K.W., Janicke, V., and Schairer, G.**
1971. Untersuchungen am Korallen-Riffkomplex von Laisacker bei Neuburg a. D. (unteres Untertithon, Bayern). *Neues Jahrbuch für Geologie und Paläontologie, Monatshefte*, vol. 1971, pp. 4-23.
839. **Osberger, R.**
1955. Jungtertiäre Korallen von Java. *Neues Jahrbuch für Geologie und Paläontologie. Abhandlungen*, vol. 101, pp. 39-74.
840. **Roniewicz, E.**
1966. Les Madreporaires du Jurassique superieur de la bordure des Monts de Sainte-Croix, Pologne. *Acta Palaeontologica Polonica*, vol. 11, pp. 157-290.
841. **Floris, S.**
1980. The coral banks of the Danian of Denmark. *Acta Palaeontologica Polonica*, vol. 25, pp. 531-540.
842. **Mariotti, N., Nicosia, G., Pallini, G., and Schiavinotto, F.**
1979. Corali ed Ammonititi nel Bajociano del sasso di Umbria). Ulteriori prove di variazioni del livello del mare. *Geologica Romana*, vol. 18, pp. 225-251.
843. **Beauvais, L.**
1966. Etude des Madreporaires Jurassiques de Sahara Tunisie. *Annales de Paleontologie (Invertebres)*, vol. 52, pp. 115-152.
844. **Beauvais, L.**
1981. Madreporaires. *Cretaceous Research*, vol. 2, pp. 271-274.
845. **Lommerzhelm, A.**
1976. Zur Paläontologie, Fazies, Paläogeographie und Stratigraphie der turonen Grünsande (Oberkreide) im Raum Mulheim/Broich/Speldorf (Westfalen) mit einer Beschreibung der Cephalopodenfauna. *Decheniana (Bonn)*, vol. 129, pp. 197-244.
846. **Beauvais, L.**
1982. Etude de quelques coelenteres de la base du Mesozoique du Canada occidental. *Canadian Journal of Earth Sciences*, vol. 16, pp. 1963-1973.
847. **Beauvais, L.**
1971. Essai de repartition stratigraphique des Madreporaires du Dogger. *Comptes Rendus. Academie de Sciences (Paris)*, vol. 272, ser. D, pp. 3256-3259.
848. **Beauvais, L. and Mrabat, A.**
1977. Les madreporaires de Berriasien superieur du Djebel Siouf (axe nord-sud, Tunisie central). *Notes du Service Geologique du Tunis*, vol. 43, pp. 103-137.
849. **Freig, C.**
1982. Paläogeographische und ökologische Bedeutung von Korallenfaunen des Unter-Okenoman und Unter-Turon am Kassenberg bei Mulheim/Ruhr. *Paläontologische Zeitschrift*, vol. 56, pp. 19-37.
850. **Pfister, T.E.**
1980. Systematische und paläoökologische Untersuchungen an oligozänen Korallen der Umgebung von San Luca (Provinz Vicenza, Norditalien). *Schweizerische Paläontologische Abhandlungen*, vol. 103, 121 pp.
851. **Beauvais, L. and Mori, K.**
1988. *Amphimeandra*, a new genus in the family Amphistraeciidae (Mesozoic Scleractinia). *Geobios*, vol. 21, pp. 103-108.
852. **MacNeil, F.S. and Dockery, D.T., III.**
1984. Lower Oligocene Gastropoda, Scaphopoda, and Cephalopoda of the Vicksburg Group in Mississippi. *Mississippi Bureau of Geology Bulletin* 124, 415 pp.
853. **Hazel, J.E.**
1983. Age and correlation of the Yorktown (Pliocene) and Croatan (Pliocene and Pleistocene) Formations at the Lee Creek Mine. *Smithsonian Contributions to Paleobiology*, no. 53, pp. 81-200.
854. **Addicott, W.D.**
1970. Miocene gastropods and biostratigraphy of the Kern River area, California. *U.S. Geological Survey Professional Paper* 642, 174 pp.
855. **Vannier, J.M.C., Siveter, D.J., and Schallreuter, R.E.L.**
1989. The composition and palaeogeographical significance of the Ordovician ostracode faunas of southern Britain, Baltoscandia, and Ibero-Armorica. *Palaeontology*, vol. 32, pp. 163-222.
856. **Stevens, C.H. and Rycerski, B.**
1989. Early Permian colonial rugose corals from the Stikine River area, British Columbia. *Journal of Paleontology*, vol. 63, pp. 158-181.
857. **Bonner, F.T. and Desai, D.**
1988. A review and revision of the Jurassic-Early Cretaceous Globigerinina, with especial reference to the Aptian assemblages of Speeton (North Yorkshire, England). *Journal of Micropaleontology*, vol. 7, pp. 143-185.
858. **Chen Jun-Yuan, Hou Xian-Guang, and Lu Hao-Zhi**
1988. Lower Cambrian leptomitids (Demospongiae), Chengjiang, Yunnan. *Acta Palaeontologica Sinica*, vol. 28, pp. 17-30.
859. **Hou Xian-Guang, Chen Jun-Yuan, and Lu Hao-Zhi**
1989. Early Cambrian new arthropods from Chengjiang, Yunnan. *Acta Palaeontologica Sinica*, vol. 28, pp. 42-57.
860. **Ning Zhang**
1989. Wenlockian (Silurian) brachiopods of the Cape Phillips Formation, Baile Hamilton Island, Arctic Canada: Parts I, II and III. *Palaeontographica, Abt. A*, vol. 206, pp. 49-135, vol. 207, pp. 1-48.
861. **Biernat, G. and Lazarev, S.S.**
1988. Genus *Poloniproducetus* nov. (Brachiopoda, Devonian). *Acta Palaeontologica Polonica*, vol. 33, pp. 59-71.
862. **Tripp, R.P., Zhou, Z., and Pan, Z.**
1988. Trilobites from the Upper Ordovician Tangtou Formation, Jiangsu Province, China. *Transactions of the Royal Society of Edinburgh: Earth Science*, vol. 80, pp. 25-68.
863. **Smith, A.B. and Patterson, C.**
1989. The influence of taxonomic method on the perception of patterns of evolution. *Evolutionary Biology*, vol. 23, pp. 127-216.
864. **Jablonski, D. and Bottjer, D.J.**
1989. Onshore-offshore trends in marine invertebrate evolution. In R.M. Ross and W.D. Allmon, eds., *Causes of Evolution: A Paleontological Perspective*. University of Chicago Press, Chicago, pp. 21-75.
865. **Smith, A.B. and Wright, C.W.**
1988. British Cretaceous echinoids. Part 1. General introduction

- and Cidaroida. Monograph of the Palaeontographical Society, pp. 1-101 (Publ. No. 578, part of Vol. 141 for 1987).
- 866. Malinky, J.M.**
1988. New early Paleozoic Hyolithida and Orthothecida (Hyolitha) from North America. *Journal of Paleontology*, vol. 63, pp. 302-319.
- 867. Sweet, W.C.**
1988. The Conodonta. Morphology, Taxonomy, Paleoecology, and Evolutionary History of a Long-Extinct Animal Phylum. Oxford Monographs. Geol. Geophys. 10. Clarendon Press, New York, 212 pp.
- 868. Malinowska, L., ed.**
1988. Geology of Poland. Vol. III. Atlas of Guide and Characteristic Fossils. Part 2b. Mesozoic, Jurassic. Publishing House Wydawnictwa Geologiczne, Warsaw, 476 pp.
- 869. Morycowa, E.**
1988. Middle Triassic Scleractinia from the Cracow-Silesia region, Poland. *Acta Palaeontologica Polonica*, vol. 33, pp. 91-121.
- 870. Mierzejewski, P.**
1988. Encrusting graptolites from the Mulde beds of Gotland. *Acta Palaeontologica Polonica*, vol. 33, pp. 261-266.
- 871. Grant, R.E.**
1988. The family Cardiarinidae (late Paleozoic rhynchonellid Brachiopoda). *Senckenbergiana Lethaea*, vol. 69, pp. 121-136.
- 872. Almeras, Y. and Moulán, G.**
1988. Les terebratulides du Bøgger Provençal (Paleontologie-biostratigraphie-phylogénie-paléocologie). Documents des Laboratoires de Géologie de la Faculté des Sciences de Lyon, vol. 101, 277 pp.
- 873. Rigby, J.K., Fan Jiasong, and Zhang Wei**
1988. Sphinctozoan sponges from the Permian reefs of South China. *Journal of Paleontology*, vol. 63, pp. 404-439.
- 874. Cressey, R. and Boxshall, G.**
1989. Kabatarina pattersoni, a fossil parasitic copepod (Dichelestiidae) from a Lower Cretaceous fish. *Micropaleontology*, vol. 35, pp. 150-167.
- 875. Zhou, Z.Y. and Hughes, C.P.**
1989. A review of trinucleid trilobites of China. *Paläontologisches Zeitschrift*, vol. 63, pp. 55-78.
- 876. Reid, D.G.**
1989. The comparative morphology, phylogeny and evolution of the gastropod family Littorinidae. *Philosophical Transactions of the Royal Society of London*, vol. 324, pp. 1-110.
- 877. Cooper, G.A.**
1989. Jurassic brachiopods of Saudi Arabia. *Smithsonian Contributions to Paleobiology*, no. 65, 213 pp.
- 878. Cocks, L.R.M. and Rong Jia-Yu**
1989. Classification and review of the brachiopod superfamily Plectambonitacea. *British Museum (Natural History), Bulletin. Geology*, vol. 45, pp. 77-163.
- 879. Hoare, R.D., Heaney, M.J., III, and Mapes, R.H.**
1989. Bivalves (Mollusca) from the Imo Formation (Mississippian, Chesterian) of north-central Arkansas. *Journal of Paleontology*, vol. 63, pp. 582-603.
- 880. Rigby, J.K. and Chatterton, B.D.E.**
1989. Middle Silurian Ludlovian and Wenlockian sponges from Bailie-Hamilton and Cornwallis Islands, Arctic Canada. *Geological Survey of Canada Bulletin* 391, 69 pp.
- 881. Doescher, R.A.**
1989. Compilation of brachiopod genera. Unpublished.
- 882. Cooper, G.A.**
1983. The Terebratulacea (Brachiopoda), Triassic to Recent: a study of the brachioida (loops). *Smithsonian Contributions to Paleobiology*, no. 50, pp. 1-445.
- 883. Conway Morris, S.**
1989. The persistence of Burgess Shale-type faunas: implications for the evolution of deeper water faunas. *Transactions of the Royal Society of Edinburgh*, vol. 80, pp. 271-284.
- 884. Cappetta, H.**
1987. Chondrichthyes II. Mesozoic and Cenozoic Elasmobranchii. *Handbook of Paleichthyology*, vol. 3B. Gustav Fischer Verlag, Stuttgart, 193 pp.
- 885. Brasier, M.D.**
1989. Towards a biostratigraphy of the earliest skeletal biotas. In J.W. Cowie and M.D. Brasier, eds., *The Precambrian-Cambrian Boundary*. Clarendon Press, Oxford, pp. 117-165.
- 886. Rigby, J.K., Fan Jiasong, and Zhang Wei**
1989. Inozoan calcareous Porifera from the Permian reefs in South China. *Journal of Paleontology*, vol. 63, pp. 778-800.
- 887. Hohensee, S.R. and Stüt, J.H.**
1989. Redeposited *Elvinia* Zone (Upper Cambrian) trilobites from the Collier Shale, Ouachita Mountains, west-central Arkansas. *Journal of Paleontology*, vol. 63, pp. 857-879.
- 888. Zinsmeister, W.J., Feldmann, R.M., Woodburne, M.O., and Elliot, D.H.**
1989. Latest Cretaceous/earliest Tertiary transition on Seymour Island, Antarctica. *Journal of Paleontology*, vol. 63, pp. 731-738.
- 889. Johansen, M.D.**
1989. Adaptive radiation, survival and extinction of brachiopods in the northwest European Upper Cretaceous-lower Paleocene chalk. *Palaeogeography, Palaeoclimatology, Palaeoecology*, vol. 74, pp. 147-204.
- 890. Jung, R.**
1989. Revision of the *Strombina*-Group (Gastropoda: Columbellidae), Fossil and Living. Distribution, Biostratigraphy, and Systematics. *Schweizerische Paläontologische Abhandlungen*, Birkhäuser Verlag, Basel, 298 pp.
- 891. Cooper, M.R.**
1989. The Gondwanic bivalve *Pisotrigonia* (family Trigonidae) with description of a new species. *Paläontologisches Zeitschrift*, vol. 63, pp. 241-250.
- 892. Hahn, G., Hahn, R., and Jin-Fang Yuan**
1989. Trilobites from the Upper Carboniferous (Westphalian A) of S-China (N-Guangxi). *Geologica et Palaeontologica*, vol. 23, pp. 113-203.
- 893. Flügel, H.W. von**
1970. Die Entwicklung der rugosen Korallen im hohen Perm. *Verhandlungen der Geologischen Bundesanstalt*, vol. 1, pp. 146-161.
- 894. Goldman, D. and Mitchell, C.E.**
1990. Morphology, systematics, and evolution of Middle Devonian Ambocoeliidae (Brachiopoda), western New York. *Journal of Paleontology*, vol. 64, pp. 79-99.
- 895. Engel, B.A. and Morris, L.N.**
1989. Early Carboniferous trilobites (Weaniinae) of eastern Australia. *Alcheringa*, vol. 13, pp. 305-346.
- 896. Yoo, E.K.**
1988. Early Carboniferous Mollusca from Gundy, Upper Hunter,

- New South Wales. Records of the Australian Museum, vol. 40, pp. 233–264.
- 897. Grunt, T.A.**
1988. Otrid Atyridida. Trudy Paleontologicheskogo Instituta. "Nauka", Moscow, 139 pp.
- 898. Long, J.A.**
1988. Late Devonian chondrichthyans and other microvertebrate remains from northern Thailand. Journal of Vertebrate Paleontology, vol. 10, pp. 59–71.
- 899. Beu, A.G. and Maxwell, P.A.**
1990. Cenozoic Mollusca of New Zealand. New Zealand Geological Survey Paleontological Bulletin, no. 58, 518 pp.
- 900. Taylor, P.D.**
1990. Bioimmured ctenostomes from the Jurassic and the origin of the cheilostome Bryozoa. Palaeontology, vol. 33, pp. 19–34.
- 901. Kennedy, W.J. and Cobban, W.A.**
1990. Cenomanian ammonite faunas from the Woodbine Formation and lower part of the Eagle Ford Group, Texas. Palaeontology, vol. 33, pp. 75–154.
- 902. Wenndorf, K.-W.**
1990. Homalonotinae (Trilobita) aus dem Rheinischen unter-Devon. Palaeontographica, Abt. A, vol. 211, pp. 1–184.
- 903. Nestor, H.**
1990. Biogeography of Silurian stromatoporoids. In W.S. McKerrow and C.R. Scotese, eds., Palaeozoic Palaeogeography and Biogeography. Geological Society of London Memoir 12, pp. 215–222.
- 904. Waters, J.A.**
1990. The palaeobiogeography of the Blastozoa (Echinodermata). In W.S. McKerrow and C.R. Scotese, eds., Palaeozoic Palaeogeography and Biogeography. Geological Society of London Memoir 12, pp. 339–352.
- 905. Ross, J.P.R. and Ross, C.A.**
1990. Late Palaeozoic bryozoan biogeography. In W.S. McKerrow and C.R. Scotese, eds., Palaeozoic Palaeogeography and Biogeography. Geological Society of London Memoir 12, pp. 353–362.
- 906. Lane, N.G. and Sevastopulo, G.D.**
1990. Biogeography of Lower Carboniferous crinoids. In W.S. McKerrow and C.R. Scotese, eds., Palaeozoic Palaeogeography and Biogeography. Geological Society of London Memoir 12, pp. 333–336.
- 907. Lazarev, S.S.**
1989. Systematics of the Devonian brachiopod suborder Strophalosioidina. Paleontological Journal, vol. 23(2), pp. 25–36.
- 908. Pitt, L.J. and Taylor, P.D.**
1989. Cretaceous Bryozoa from the Faringdon Sponge Gravel (Aptian) of Oxfordshire. British Museum (Natural History), Bulletin, Geology, vol. 46, pp. 61–152.
- 909. Signor, P.W.**
1990. Unpublished compilation of Gastropoda.
- 910. Holmer, L.E.**
1989. Middle Ordovician inarticulate brachiopods from Vastergotland and Dalarna, Sweden. Fossils and Strata, no. 26, 172 pp.
- 911. Blake, D.B.**
1989. Hettangian Asteriidae (Echinodermata: Asteroidea) from southern Germany: taxonomy, phylogeny and life habits. Palaeontologische Zeitschrift, vol. 64, pp. 103–123.
- 912. Potter, A.W.**
1990. Middle and Late Ordovician brachiopods from the eastern Klamath Mountains, northern California. Part 1. Palaeontographica, Abt. A, vol. 212, pp. 31–158.
- 913. Hall, J. and Clarke, J.M.**
1898. A memoir on the Palaeozoic reticulate sponges constituting the family Dictyospongidae. Pt. I. Fifteenth Annual Report of the State Geologist, New York, vol. II, pp. 743–984.
- 914. Neveeskaya, L.A. and Solovoyov, A.N., eds.**
1981. Development and change of molluscs at the Mesozoic-Cenozoic Boundary. "Nauka", Moscow. (trans. 1987, I. Beu and A. Beu, New Zealand Geological Survey Report PAL117)
- 915. Patterson, C.**
1990. Personal communication, September 1990 (ms. for revision of "Vertebrate Paleontology").
- 916. Gardiner, B.**
1990. Personal communication, September 1990 (ms. for revision of "Vertebrate Paleontology").
- 917. Gross-Uffenorde, H. and Schindler, E.**
1990. The effect of global events on entomozoacean Ostracoda. In R. Whately and C. Maybury, eds., Ostracoda and Global Events. Chapman & Hall, London, pp. 101–112.
- 918. Sprinkle, J. and Gutschick, R.C.**
1990. Early Mississippian blastoids from western Montana. Bulletin of the Museum of Comparative Zoology, vol. 152, no. 3, pp. 89–166.
- 919. Roniewicz, E. and Morycowa, E.**
1989. Triassic Scleractinia and the Triassic/Liassic Boundary. Association of Australasian Palaeontologists Memoir 8, pp. 347–354.
- 920. Turnsek, D.**
1989. Diversification of corals and coral reef associations in Mesozoic palaeogeographic units of northwestern Yugoslavia. Association of Australasian Palaeontologists Memoir 8, pp. 283–289.
- 921. Biernat, G. and Bednarczyk, W.**
1989. Evolutionary crisis within the Ordovician acrotetid inarticulate brachiopods of Poland. In E.G. Kauffman and O.H. Walliser, eds., Extinction Events in Earth History. Springer-Verlag, Berlin, pp. 105–114.
- 922. Feldmann, R.M. and Maxwell, P.A.**
1990. Late Eocene decapod Crustacea from North Westland, South Island, New Zealand. Journal of Paleontology, vol. 64, pp. 779–797.
- 923. Bengtson, S., Conway Morris, S., Cooper, B.J., Jell, P.A., and Runnegar, B.**
1990. Early Cambrian fossils from South Australia. Association of Australasian Palaeontologists Memoir 9, 364 pp.
- 924. Kozur, H. and Sadeddin, W.**
1990. Holothurian sclerites from the Middle Jurassic of Wadi Huni, northwest Jordan. Micropaleontology, vol. 36, pp. 353–366.
- 925. Walossek, D. and Muller, K.J.**
1990. Upper Cambrian stem-lineage crustaceans and their bearing upon the monophyletic origin of Crustacea and the position of *Agnostus*. Lethaia, vol. 23, pp. 409–427.
- 926. Allmon, W.D.**
1990. Review of the *Bullia* Group (Gastropoda: Nassariidae) with comments on its evolution, biogeography, and phylogeny. Bulletins of American Paleontology, no. 99, pp. 1–179.
- 927. Peng Shanchi**
1990. Tremadoc stratigraphy and trilobite faunas of northwestern Hunan. 2. Trilobites from the Panjiazui Formation and

- the Madaoyu Formation in Jiangnan Slope Belt, Berin-
geria, vol. 2, pp. 55–171.
- 928. Geyer, G.**
1990. Die marokkanischen Ellipsocephalidae (Trilobita: Redlichiiden). *Beringeria*, vol. 3, pp. 3–363.
- 929. Coles, G., Ayress, M., and Whitley, R.**
1990. A comparison of North Atlantic and Pacific Cainozoic deep-sea Ostracoda. *In* R. Whitley and C. Maybury, eds., *Ostracoda and Global Events*. Chapman & Hall, London, pp. 287–305.
- 930. Harper, D.A.T.**
1989. Brachiopods from the upper Ardmillan Succession (Ordovician) of the Girvan District, Scotland. Pt. 2. Monograph of the Palaeontographical Society, vol. 142, pp. 79–128.
- 931. Rickards, R.B., Baillie, P.W., and Jago, J.B.**
1989. An Upper Cambrian (Idamean) dendroid assemblage from near Smithton, northern Tasmania. *Alcheringa*, vol. 14, pp. 207–232.
- 932. Roberts, J. and Jell, P.A.**
1990. Early Middle Cambrian (Ordian) brachiopods of the Coonigan Formation, western New South Wales. *Alcheringa*, vol. 14, pp. 257–309.
- 933. Lutke, F.**
1990. Contributions to a phylogenetical classification of the subfamily Proetinae Salter, 1864 (Trilobita). *Senckenbergiana Lethaea*, vol. 71, pp. 1–83.
- 934. Jablonski, D. and Bottjer, D.J.**
1990. The origin and diversification of major groups: environmental patterns and macroevolutionary lags. *In* P.D. Taylor and G.P. Larwood, eds., *Major Evolutionary Radiations*. Clarendon Press, Oxford, pp. 17–57.
- 935. Schram, F.R.**
1990. On Mazon Creek Thylacocephala. *Proceedings San Diego Society Natural History*, no. 3, pp. 1–16.
- 936. Flugel, E. and Reinhardt, J.**
1990. Uppermost Permian reefs in Skyros (Greece) and Sichuan (China): implications for the Late Permian extinction event. *Palaios*, vol. 4, pp. 502–518.
- 937. Parsley, R.L.**
1990. Review of selected North American mitrate styloporans (Homolozoa: Echinodermata). *Bulletins of American Paleontology*, vol. 100, no. 336, pp. 1–57.
- 938. Yeh, K.-Y.**
1990. Taxonomic studies of Triassic Radiolaria from Busuanga Island, Philippines. *Bulletin, National Museum of Natural Science, Taiwan*, no. 2, pp. 1–64.
- 939. Boersma, A. and Premoli Silva, I.**
1990. Distribution of Paleogene planktonic foraminifera—analogs with the Recent? *Palaeogeography, Palaeoclimatology, Palaeoecology*, vol. 83, pp. 29–48.
- 940. Pinna, G.**
1990. Notes on stratigraphy and geographical distribution of placodonts. *Atti, Società Italiana di Scienze Naturali Milano*, vol. 131, pp. 145–156.
- 941. Senowbari-Daryan, B.**
1990. Die systematische Stellung der thalamiden Schwämme und ihre Bedeutung in der Erdgeschichte. *Münchener Geowissenschaftliche Abhandlungen: Reihe A. Geologie und Paläontologie*, vol. 21, 326 pp.
- 942. Solovev, A.N.**
1980. Razvitie i Smena Bespozvoonoiynykh na Rubezhe Mezozoia i Kainozoia. *Mshanki Chlenistonogie, Iglokozhiye. "Nauka"*, Moscow, 176 pp.
- 943. Marciniowski, R. and Wiedmann, J.**
1990. The Albian ammonites of Poland. *Palaeontologia Polonica*, no. 50, 94 pp.
- 944. Narbonne, G.M., Myrow, P., Landing, E., and Anderson, M.M.**
1990. A chondrophorine (medusoid hydrozoan) from the basal Cambrian (Placentian) of Newfoundland. *Journal of Paleontology*, vol. 65, pp. 186–191.
- 945. Bergman, C.F.**
1989. Silurian paulinitid Polychaeta from Gotland. *Fossils and Strata*, no. 25, 128 pp.
- 946. Williams, S.H. and Stevens, R.K.**
1991. Late Tremadocian graptolites from western Newfoundland. *Paleontology*, vol. 34, pp. 1–47.
- 947. Smith, A.B. and Gallemi, J.**
1991. Middle Triassic holothurians from northern Spain. *Paleontology*, vol. 34, pp. 49–76.
- 948. Babin, C. and Gutierrez-Marco, J.-C.**
1991. Middle Ordovician bivalves from Spain and their phyletic and palaeogeographic significance. *Paleontology*, vol. 34, pp. 109–147.
- 949. Scrutton, C.T. and Clarkson, E.N.K.**
1991. A new scleractinian-like coral from the Ordovician of the Southern Uplands, Scotland. *Paleontology*, vol. 34, pp. 179–194.
- 950. Holmer, L.E.**
1991. The taxonomy and shell characteristics of a new elkaniid brachiopod from the Ashgill of Sweden. *Paleontology*, vol. 34, pp. 195–204.
- 951. Qian Yi and Bengtson, S.**
1989. Paleontology and biostratigraphy of the Early Cambrian Meishucunian Stage in Yunnan Province, South China. *Fossils and Strata*, no. 24, 156 pp.
- 952. Rigby, J.K.**
1991. The new Devonian (Givetian) heteractinid sponge *Gonedekia* from Ontario, Canada, and evolution of the as-treacospungiids and eifeldiids. *Journal of Paleontology*, vol. 65, pp. 38–44.
- 953. Fan, J., Rigby, J.K., and Zhang, W.**
1991. "Hydrozoa" from Middle and Upper Permian reefs of South China. *Journal of Paleontology*, vol. 65, no. 45–68.
- 954. Riley, N.J.**
1991. A global review of mid-Dinantian ammonoid biostratigraphy. *Courier Forschungsinstitut Senckenberg*, vol. 130, pp. 133–143.
- 955. Carter, J.L.**
1991. Subdivision of the Lower Carboniferous in North America by means of articulate brachiopod generic ranges. *Courier Forschungsinstitut Senckenberg*, vol. 130, pp. 145–155.
- 956. Kier, P.M. and Lawson, M.H.**
1978. Index of living and fossil echinoids 1924–1970. *Smithsonian Contributions to Paleobiology*, no. 34, 182 pp.
- 957. Webb, G.E.**
1990. Lower Carboniferous coral fauna of the Rockhampton Group, east-central Queensland. *Association of Australasian Paleontologists Memoir* 10, pp. 1–68.
- 958. Ward, D.J. and Wiest, R.L., Jr.**
1990. A checklist of Paleocene and Eocene sharks and rays (Chondrichthyes) from the Pamunkey Group, Maryland and Virginia, USA. *Tertiary Research*, vol. 12, pp. 81–88.
- 959. Weidich, K.F.**
1990. Die kalkalpinen Unterkreide und ihre Foraminiferenfauna. *Zitteliana*, vol. 17, pp. 1–312.

- 960. Deflandre-Rigaud, M.**
1962. Contribution à la connaissance des sclerites d'Holothurides fossiles. *Memoires du Museum National d'Histoire Naturelle*, ser. c, vol. 11, pp. 1-124.
- 961. Bishop, G.A.**
1986. Occurrence, preservation, and biogeography of the Cretaceous crabs of North America. In R.H. Gore and K.L. Heck, eds., *Crustacean Biogeography*. A.A. Balkema, Rotterdam, pp. 111-142.
- 962. Conway Morris, S. and Chen Menge**
1991. Cambroclaves and paracarinaritids, early skeletal problematica from the Lower Cambrian of South China. *Palaeontology*, vol. 34, pp. 357-397.
- 963. Lazarev, S.S.**
1990. Evolution and System of Productids [in Russian]. "Nauka", Moscow, 173 pp.
- 964. Emerson, M.J. and Schram, F.R.**
1990. Remipedia. Part 2. Paleontology. *Proceedings of the San Diego Society of Natural History*, no. 7, 52 pp.
- 965. Sheehan, P.M. and Corrough, P.J.**
1991. Supplementary information for: "Brachiopod zoogeography across the Ordovician-Silurian extinction event." Unpublished (deposited with the British Library at Boston Spa, W. Yorkshire, U.K. Suppl. Publ. SUP18059).
- 966. Morris, S.F. and Collins, J.S.H.**
1991. Neogene crabs from Brunei, Sabah and Sarawak. *British Museum (Natural History)*, *Bulletin, Geology*, vol. 47, pp. 1-35.
- 967. Morris, N.J., Dickens, J.M., and Astafieva-Urbaitis, K.**
1991. Upper Palaeozoic Anomalodesmatan Bivalvia. *British Museum (Natural History)*, *Bulletin, Geology*, vol. 47, pp. 51-100.
- 968. Philip, J.M. and Airaud-Crumiere, C.**
1991. The demise of the rudist-bearing carbonate platforms at the Cenomanian/Turonian Boundary: a global control. *Coral Reefs*, vol. 10, pp. 115-125.
- 969. Stearn, C.W.**
1990. Stromatoporoids from the allochthonous reef facies of the Stuart Bay Formation (Lower Devonian), Bathurst Island, Arctic Canada. *Journal of Paleontology*, vol. 64, pp. 493-510.
- 970. Stearn, C.W.**
1990. A revision of *Anostylostroma*, *Atelodictyon*, and related genera (Paleozoic Stromatoporoida). *Journal of Paleontology*, vol. 65, pp. 611-622.
- 971. Ward, P.D.**
1990. A review of Maastrichtian ammonite ranges. *Geological Society of America Special Paper* 247, pp. 519-529.
- 972. Kauffman, E.G., Johnson, C.C., and Sohl, N.F.**
1989. Biostratigraphy of rudistid Bivalvia, Caribbean Province. Unpublished chart.
- 973. Lyssenko, N.I. and Aliev, G.A.**
1991. The systematics of phaneropyxydids (Gastropoda). *Paleontological Journal*, vol. 24, pp. 102-106.
- 974. Snyder, E.M.**
1991. Revised taxonomic procedures and paleoecological applications for some North American Mississippian Fenestellidae and Polyporidae (Bryozoa). *Palaeontographica Americana*, no. 57, 275 pp.
- 975. Hoover, P.R.**
1991. Late Triassic cyrtinoid spiriferinacean brachiopods from western North America and their biostratigraphic and biogeographic implications. *Bulletins of American Paleontology*, vol. 100, no. 337, pp. 63-109.
- 976. Bandel, K.**
1991. Über triassische Loxonematoidea und ihre Beziehungen zu rezentes und paläozoischen Schnecken. *Palaeontologische Zeitschrift*, vol. 65, pp. 239-268.
- 977. Pojeta, J., Jr.**
1988. The origin and Paleozoic diversification of solemyoid pelecypods. *New Mexico Bureau of Mines and Mineral Resources Memoir* 44, pp. 201-271.
- 978. Riedel, P. and Senowbari-Daryan, B.**
1991. Pharetronids in Triassic reefs. In J. Reitner and H. Keupp, eds., *Fossil and Recent Sponges*. Springer-Verlag, Berlin, pp. 465-476.
- 979. Marek, L. and Isaacson, P.E.**
1991. Devonian hyoliths from Bolivia. *Journal of Paleontology*, vol. 66, pp. 24-28.
- 980. Simms, M.J.**
1990. Crinoid diversity and the Triassic-Jurassic Boundary. *Cahiers de Université Catholique de Lyon*, ser. Sci., no. 3, pp. 67-77.
- 981. Chen Xu and Rong Jia-Yu**
1991. Concepts and analysis of mass extinction with the Late Ordovician event as an example. *Historical Biology*, vol. 5, pp. 107-121.
- 982. Gilliland, P.M.**
1991. Holothurian faunal changes at the Triassic-Jurassic Boundary. *Lethaia*, vol. 25, pp. 69-84.
- 983. Morzadu, P.**
1992. Evolution des Asteroptyginnæ (Trilobita) et variations eustatiques au Devonien. *Lethaia*, vol. 25, pp. 85-96.
- 984. Smith, A.B. and Bengtson, P.**
1991. Cretaceous echinoids from north-eastern Brazil. *Fossils and Strata*, no. 31, 88 pp.
- 985. Ward, L.W.**
1991. Molluscan Biostratigraphy of the Miocene, Middle Atlantic Coastal Plain of North America. *Virginia Museum of Natural History Memoir* 2, 159 pp.
- 986. Lane, N.G. and Sevastopulo, G.D.**
1987. Stratigraphic distribution of Mississippian camerate crinoid genera from North America and western Europe. *Courier Forschungsinstitut Senckenberg*, vol. 98, pp. 199-206.
- 987. Sullivan, R.M.**
1987. A reassessment of reptilian diversity across the Cretaceous-Tertiary Boundary. *Los Angeles County Natural History Museum, Contributions to Science*, no. 381, 26 pp.
- 988. Gilliland, P.M.**
1992. Holothurians in the Blue Lias of southern Britain. *Palaeontology*, vol. 35, pp. 159-210.
- 989. Latz, S.**
1992. Unterdevonische Brachiopoden aus dem Hellen Crinoidenschutt- und Riffkalk der Seawarte (zentrale Karnische Alpen/Karnten/Osterreich). *Palaeontographica*, Abt. A, vol. 220, pp. 161-201.
- 990. Pillola, G.L.**
1991. Trilobites du Cambrien inférieur du SU de la Sardigne, Italie. *Palaeontographia Italica*, vol. 78, pp. 1-174.
- 991. Jablonski, D. and Raup, D.M.**
1991. Personal communication.
- 992. Grunt, T.A.**
1989. Otryd Atripida. *Akad. Nauk SSSR Paleontologicheskii Institut Trudy*, vol. 238, 139 pp.
- 993. Christensen, W.K.**
1991. Belemnites from the Coniacian to lower Campanian

- chalks of Norfolk and southern England. *Palaentology*, vol. 34, pp. 695-749.
- 994. Afanasjeva, G.A.**
1988. Brachiopodi Otrida Chonetida. *Akademia Nauk SSSR Paleontologicheskii Institut Trudy*, vol. 228, 122 pp.
- 995. Schastlivtceva, N.P.**
1988. Triasovie Otcoceratidi i Nautilidi SSSR. *Akademia Nauk SSSR Paleontologicheskii Institut Trudy*, vol. 229, 103 pp.
- 996. Melnikova, L.M.**
1986. Ordovikijskie Ostrakodi Kazachstana. *Akademia Nauk SSSR Paleontologicheskii Institut Trudy*, vol. 218, 102 pp.
- 997. Ali, M.S.M.**
1992. Additional echinoids from the late Maestrichtian (Cretaceous) of Gebel El Rowdah, Oman—United Arab Emirates. *Neues Jahrbuch für Geologie und Palaentologie, Monatshefte*, vol. 1992, pp. 65-74.
- 998. Rozhnov, S.V.**
1981. Morskije Liliji Nadsemeistva Pisocrinacea. *Akademia Nauk SSSR Paleontologicheskii Institut Trudy*, vol. 192, 127 pp.
- 999. Ivanova, V.A.**
1979. Ostrakodi Rannego i Srednego Ordovika. *Akademia Nauk SSSR Paleontologicheskii Institut Trudy*, vol. 172, 216 pp.
- 1000. Pushkin, V.I., Nekhorosheva, L.V., Kopajevich, G.V., and Jaroshinskaya, A.M.**
1990. Przhidoliskije mshanki SSSR. "Nauka", Moscow, 125 pp.
- 1001. Baranov, V.V.**
1990. New Devonian rhynchonellid taxa from northeastern USSR. *Palaentological Journal*, vol. 25, pp. 32-41.
- 1002. Kaasa, M.E., Jr.**
1990. Late Pennsylvanian and Permian Turrellapadida (Machaerida) from the western and south-central United States. *In* S. Lidgard and P.R. Crane, eds., *Fifth North American Paleontological Convention Abstracts and Program*. The Paleontological Society Special Publication 6, p. 154.
- 1003. Taylor, P.D. and Todd, J.A.**
1992. Bioimmuration: exceptional fossil preservation made routine. *In* S. Lidgard and P.R. Crane, eds., *Fifth North American Paleontological Convention Abstracts and Program*. The Paleontological Society Special Publication 6, p. 287.
- 1004. Blodgett, R.B. and Johnson, G.**
1992. Early Middle Devonian (Eifelian) gastropods of central Nevada. *Palaentographica, Abt. A*, vol. 222, pp. 85-139.
- 1005. Farrell, J.R.**
1992. The Garra Formation (Early Devonian: late Lochkovian) between Cumnock and Larras Lee, New South Wales, Australia: stratigraphic and structural setting, faunas and community sequence. *Palaentographica, Abt. A*, 222, pp. 1-41.
- 1006. Bengtson, S.**
1992. Proterozoic and earliest Cambrian skeletal metazoans. *In* J.W. Schopf and C. Klein, eds., *The Proterozoic Biosphere. A Multidisciplinary Study*. Cambridge University Press, Cambridge, pp. 1017-1033.
- 1007. Blome, C.D. and Reed, K.M.**
1992. Permian and Early (?) Triassic radiolarian faunas from the Grindstone terrane, central Oregon. *Journal of Paleontology*, vol. 66, pp. 351-383.
- 1008. Sohl, N.D.**
1992. Upper Cretaceous gastropods (Fissurellidae, Haliotidae, Scissurellidae) from Puerto Rico and Jamaica. *Journal of Paleontology*, vol. 66, pp. 414-434.
- 1009. Gingerich, P.D.**
1992. Marine mammals (Cetacea and Sirenia) from the Eocene of Gebel Mokattam and Fayum Egypt: stratigraphy, age, and paleoenvironments. *Museum of Paleontology, University of Michigan, Papers on Paleontology*, no. 30, 84 pp.
- 1010. Szezechura, J.**
1991. Bicorniferida: cheilostomous Bryozoa with articulated colony branches. *Acta Palaentologica Polonica*, vol. 36, pp. 399-411.
- 1011. Hodgkinson, K.A., Garvie, C.L., and Be, A.W.H.**
1991. Eocene euthecosomatous Pteropoda (Gastropoda) of the Gulf and Eastern Coasts of North America. *Bulletins of American Paleontology*, vol. 103, no. 341, 62 pp.
- 1012. Noll, D. and Stringer, G.L.**
1992. Neogene paleontology in the northern Dominican Republic. 14. Otoliths of teleostean fishes. *Bulletins of American Paleontology*, vol. 102, no. 340, 81 pp.
- 1013. Radulovic, V.**
1991. Middle Jurassic brachiopods of Laz (Yugoslav part of the Carpatho-Balkan arch). *Palaentologia Jugoslavia*, vol. 40, pp. 1-365.
- 1014. Boardman, R.S., McKinney, F.K., and Taylor, P.D.**
1991. Morphology, anatomy, and systematics of the Cinctiporidae, new family (Bryozoa: Stenolaemata). *Smithsonian Contributions to Paleobiology*, no. 70, 81 pp.
- 1015. Struve, W.**
1992. Neues zur Stratigraphie und Fauna des rhenotypen Mittel-Devon. *Senckenbergiana Lethaea*, no. 71, pp. 503-624.
- 1016. Van Iken, H.**
1992. Morphology and phylogenetic significance of the corners and midlines of the conulariid test. *Palaentology*, vol. 35, pp. 335-358.
- 1017. Pratt, B.R.**
1992. Trilobites of the Marjuman and Steptoean stages (Upper Cambrian), Rabbitkettle Formation, southern Mackenzie Mountains, northwest Canada. *Palaentographica Canadiana*, no. 9, 179 pp.
- 1018. Steiger, T.**
1992. Systematik, Stratigraphie und Palökologie der Radiolarien des Oberjura-Unterkreide-Grenzbereiches in Osterhorn-Tirolikum (Nordliche Kalkalpen, Salzburg unter Bayern). *Zitteliana*, vol. 79, pp. 3-188.
- 1019. Simonetta, A.M.S. and Conway Morris, S., eds.**
1991. *The Early Evolution of Metazoa and the Significance of Problematic Taxa*. Cambridge University Press, Cambridge, 296 pp.
- 1020. Webers, G.F., Craddock, C., and Spletstoesser, J.F., eds.**
1991. *Geology and Paleontology of the Ellsworth Mountains, West Antarctica*. Geological Society of America Memoir 170, 459 pp.
- 1021. Schrammen, A.**
1924. Die Kieselspontgenien der oberen Kreide von Nordwestdeutschland. III und letzter Teil. *Monographien zur Geologie und Palaentologie*, Ser. 1, Heft 2. Verlag von Gebrüder Borntraeger, Berlin, 159 pp.
- 1022. Fordyce, R.E.**
1992. Crustacean evolution and Eocene/Oligocene environments. *In* D.R. Prothero and W.A. Berggren, eds., *Eocene-Oligocene Climatic and Biotic Evolution*. Princeton University Press, Princeton, NJ, pp. 368-381.
- 1023. Debrenne, F. and Zhuravlev, A.**
1992. Irregular Archaeocyaths. Morphology, Ontogeny, Systematics, Biostratigraphy. *Palaentology*. Cahiers de Palaentologie, CNRS Editions, Paris, 212 pp.
- 1024. Herrmann-Degan, W.**
1980. Eine Hexactinelliden-Faunula aus dem "Chalk" (Maas-

- tricht?. Palaeozoan Sudwest-Agyptens. Berliner Geowissenschaftliche Abhandlungen Reihe A, Band 24, 38 pp.
- 1025. Cashman, P.B.**
1992. Melanosclerites: first North American report of these problematic microfossils and discussion of their affinity. *Journal of Paleontology*, vol. 66, pp. 563–569.
- 1026. Lafuste, J., Debrenne, F., Gandin, A., and Gravestock, D.**
1991. The oldest tabulate coral and the associated Archaeocyatha. Lower Cambrian, Flinders Ranges, South Australia. *Geobios*, vol. 6, pp. 697–718.
- 1027. Shi, X.**
1991. Jurassic rhynchonellids from north Qinghai-Tibetan Plateau, China: a study on internal structures. *Palaontographica*, Abt. A, vol. 225, pp. 79–166.
- 1028. Muller, K.J. and Hinz, I.**
1992. Cambrogeorginidae fam. nov., soft-integumented Problematika from the Middle Cambrian of Australia. *Alcheringa*, vol. 16, pp. 333–353.
- 1029. Van Belle, R.A.**
1981. Catalogue of Fossil Chitons (Mollusca: Polyplacophora). W. Backhuys, Rotterdam.
- 1030. Khomevovskiy, V.V. and Karlova, G.A.**
1993. Biostratigraphy of the Vendian-Cambrian beds and the lower Cambrian boundary in Siberia. *Geological Magazine*, vol. 130, pp. 29–45.
- 1031. Hesselbo, S.P.**
1992. Aglaspida (Arthropoda) from the Upper Cambrian of Wisconsin. *Journal of Paleontology*, vol. 66, pp. 885–923.
- 1032. Wieder, R.W. and Feldmann, R.M.**
1992. Mesozoic and Cenozoic fossil isopods from North America. *Journal of Paleontology*, vol. 66, pp. 958–972.
- 1033. Clark, F.E. and Patterson, R.T.**
1992. An illustrated key to the identification of unilocular genera of calcareous foraminifera. *Journal of Paleontology*, vol. 67, pp. 20–28.
- 1034. Horowitz, A.L. and Pachut, J.F.**
1993. Specific, generic, and familial diversity in Devonian bryozoans. *Journal of Paleontology*, vol. 67, pp. 42–52.
- 1035. Blake, D.B. and Guensburg, T.E.**
1993. New Lower and Middle Ordovician stelleroids (Echinodermata) and their bearing on the origins and early history of the stelleroid echinoderms. *Journal of Paleontology*, vol. 67, pp. 103–113.
- 1036. Zullo, V.A.**
1992. Revision of the balanid barnacle genus *Concavus* Newman, 1982, with the description of a new subfamily, two new genera, and eight new species. *Paleontological Society Memoir 27 (Journal of Paleontology)*, vol. 66, no. 6, supplement, 46 pp.
- 1037. Feldmann, R.M., Tshudy, D.M., and Thomson, M.R.A.**
1992. Late Cretaceous and Paleocene decapod crustaceans from James Ross Basin, Antarctic Peninsula. *Paleontological Society Memoir 28 (Journal of Paleontology)*, vol. 67, no. 1, supplement, 41 pp.
- 1038. Burgin, T.**
1992. Basal ray-finned fishes (Osteichthyes, Actinopterygii) from the Middle Triassic of Monte San Giorgio (Canton Tessin, Switzerland). *Schweizerische Paläontologische Abhandlungen*, vol. 114, pp. 1–164.
- 1039. Petuch, E.J.**
1992. Patterns of diversity and extinction in Transmarian muricean, buccinacean, and conacean gastropods. *The Nautilus*, vol. 106, pp. 155–173.
- 1040. Astafieva, M.M.**
1991. The bipolar distribution of *Inoceramus*-like bivalved mollusks in the Permian. *Paleontological Journal*, vol. 25, pp. 33–39.
- 1041. Briggs, D.E.G. and Kear, A.J.**
1993. Decay and preservation of polychaetes: taphonomic thresholds in soft-bodied organisms. *Paleobiology*, vol. 19, pp. 107–135.
- 1042. Becker, R.T.**
1993. Anoxia, eustatic changes, and Upper Devonian to lowermost Carboniferous global ammonoid diversity. In M.R. House, ed., *The Ammonoidea: Environment, Ecology, and Evolutionary Change*. Clarendon Press, Oxford, pp. 115–163.
- 1043. Neraudeau, D. and Moreau, P.**
1989. Paleoeologie et paleobiogeographie des faunes d'échinides du Cenomanien Nord-Aquitain (Charente-Maritime, France). *Geobios*, vol. 22, pp. 293–324.
- 1044. Storrs, G.W.**
1993. Function and phylogeny in sauropterygian (Diapsida) evolution. *American Journal of Science*, vol. 293-A, pp. 63–90.
- 1045. Hahn, G., Hahn, R., and Brauckmann, C.**
1992. Zur Phylogenie der Cystispirinae (Trilobita, Karbon). *Senckenbergiana Lethaea*, vol. 72, pp. 91–120.
- 1046. Babin, C.**
1992. Role des plates-formes gondwaniennes dans les diversifications des mollusques bivalves durant l'Ordovicien. *Bulletin, Société Géologique de France*, vol. 164, pp. 141–153.
- 1047. Hansch, W.**
1993. The distribution of ostracodes in the Pridoli, upper Silurian, of the Prague Basin, Czechoslovakia. *Neues Jahrbuch für Geologie und Paläontologie, Abhandlungen*, vol. 187, pp. 183–198.
- 1048. Walter, B.**
1993. Les bryozoaires de l'Urgonien inferior Vaulion (Jura Vaudois, Suisse)—un premier pas vers les faunes Barremo-Aptiennes. *Palaontographica*, Abt. A, vol. 226, pp. 55–75.
- 1049. Moore, E.J.**
1992. Tertiary marine pelecypods of California and Baja California: Erycinidae through Carditidae. U.S. Geological Survey Professional Paper 1228-E, 37 pp.
- 1050. Popov, L.Ye.**
1992. The Cambrian radiation of Brachiopods. In J.H. Lipps and P.W. Signor, eds., *Origin and Early Evolution of the Metazoa*. Plenum Press, New York, pp. 399–424.
- 1051. Hemleben, C., Kaminski, M.A., Kuhnt, W., and Scott, D.B., eds.**
1990. *Paleoecology, Biostratigraphy, Paleocceanography and Taxonomy of Agglutinated Foraminifera*. Kluwer, Dordrecht, 1017 pp.
- 1052. Jager, M.**
1993. Danian Serpulidae and Spirorbidae from NE Belgium and SE Netherlands: K/T boundary extinction, survival, and origination patterns. *Contributions to Tertiary and Quaternary Geology*, vol. 29, pp. 73–137.
- 1053. Jaanusson, V. and Bassett, M.G.**
1993. *Orthambonites* and related Ordovician brachiopod genera. *Paleontology*, vol. 36, pp. 21–63.
- 1054. Loch, J.D., Stitt, J.H., and Derby, J.R.**
1993. Cambrian-Ordovician boundary interval extinctions: implications of revised trilobite and brachiopod data from Mount Wilson, Alberta, Canada. *Journal of Paleontology*, vol. 67, pp. 497–517.

- 1055. Edgecombe, G.D.**
1993. Silurian acastacean trilobites of the Americas. *Journal of Paleontology*, vol. 67, pp. 535–548.
- 1056. Kammer, T.W. and Ausich, W.I.**
1993. Advanced cladid crinoids from the middle Mississippian of the east-central United States: intermediate-grade calyces. *Journal of Paleontology*, vol. 67, pp. 614–639.
- 1057. Brook, G.A. and Cooper, B.J.**
1993. Shelly fossils from the Early Cambrian (Tojonian) Wirralpa, Aroona Creek, and Ramsay Limestones of South Australia. *Journal of Paleontology*, vol. 67, pp. 758–787.
- 1058. Zhang, R. and Yan, D.**
1993. Stratigraphic and paleobiogeographic summary of Carboniferous marine bivalves. *Journal of Paleontology*, vol. 67, pp. 850–855.
- 1059. Durman, P.N. and Sennikov, N.V.**
1993. A new rhabdopleurid hemichordate from the Middle Cambrian of Siberia. *Palaentologia*, vol. 36, pp. 283–296.
- 1060. Grant, R.E.**
1993. Permian brachiopods from Khios Island, Greece. *Paleontological Society Memoir 33* (*Journal of Paleontology*, vol. 67, no. 4, supplement), 21 pp.
- 1061. Marincovich, L., Jr.**
1993. Danian mollusks from the Prince Creek Formation, northern Alaska, and implications for Arctic Ocean paleogeography. *Paleontological Society Memoir 35* (*Journal of Paleontology*, vol. 67, no. 5, supplement), 35 pp.
- 1062. Hinz-Schallreuter, I.**
1993. Ostracodes from the Middle Cambrian of Australia. *Neues Jahrbuch für Geologie und Paläontologie, Abhandlungen*, vol. 188, pp. 305–326.
- 1063. Hedgpeth, J.W.**
1978. A reappraisal of the Palaeozoic trilobites with description of a species from the Jurassic. *Zoological Journal of the Linnean Society*, vol. 63, pp. 23–34.
- 1064. Biernat, G. and Emig, C.C.**
1993. Anatomical distinctions of the Mesozoic lingulide brachiopods. *Acta Palaentologica Polonica*, vol. 38, pp. 1–20.
- 1065. Gluchowski, E.**
1993. Crinoid assemblages in the Polish Givetian and Frasnian. *Acta Palaentologica Polonica*, vol. 38, pp. 35–92.
- 1066. Benton, M.J., ed.**
1993. *The Fossil Record 2*. Chapman & Hall, London, 845 pp.
- 1067. Saul, L.R.**
1993. Pacific Slope Cretaceous bivalves: eight venerid species. *Journal of Paleontology*, vol. 67, pp. 965–979.
- 1068. MacFarlan, D.A.B.**
1992. Triassic and Jurassic Rhynchonellacea (Brachiopoda) from New Zealand & New Caledonia. *Royal Society of New Zealand, Bulletin 31*, 310 pp.
- 1069. Russell, D.A.**
1988. A check list of North American marine Cretaceous vertebrates including freshwater fishes. *Tyrrell Museum of Paleontology Occasional Paper no. 4*, 58 pp.
- 1070. Winchester-Seeto, T. and Bell, K.N.**
1994. Microforaminiferal linings from the Early Devonian of eastern Australia, and their generic placement. *Journal of Paleontology*, vol. 68, pp. 200–207.
- 1071. Sprinkle, J. and Wahlman, G.P.**
1994. New echinoderms from the Early Ordovician of West Texas. *Journal of Paleontology*, vol. 68, pp. 324–338.
- 1072. Smirnova, T.N.**
1992. Late Mesozoic brachiopods of the Caspian Depression and the Russian Platform. *Paleontological Journal*, vol. 26, pp. 25–35.
- 1073. Andreu-Boussut, B.**
1991. Les Ostracodes du Cretace moyen (Barremien a Turonien), le long d'une Transversale Agadir-Nador (Maroc). *Strata, Actes du Laboratoire de Geologie Sedimentaire et Paleontologie de l'Universite Paul-Sabatier, Toulouse*, vol. 14, pp. 1–765.
- 1074. Roy, K.**
1994. Temporal patterns of taxonomic, morphologic and biogeographic change in stromboidean gastropods and their macroevolutionary implications. Unpubl. Ph.D. dissertation. University of Chicago, Chicago, 236 pp.
- 1075. Havlicek, V. and Varek, J.**
1966. The biostratigraphy of the Ordovician of Bohemia. *Sbornik Geologických Ved: Paleontologie*, vol. 8, pp. 769. [Cited by Sepkoski as: Havlicek and Varek (sic) 1966.]
- 1076. Storch, P. and Mergl, M.**
1989. Kralodvor/Kosoviensis boundary and the Late Ordovician environmental changes in the Prague Basin (Barrandian Area, Bohemia). *Sbornik Geologických Ved: Geologie*, vol. 44, pp. 117–153. [Cited by Sepkoski as: Storch and Mergl 1989.]
- 1077. Carter, R.M.**
1971. Revision of Arenig Bivalvia from Ramsey island, Pembroke-shire. *Palaentologia*, vol. 14, pp. 250–261. [Cited by Sepkoski as: Carter 1971.]
- 1078. Wilcox, C.J. and Lockley, M.G.**
1981. A reassessment of facies and faunas in the type Llandeilo (Ordovician), Wales. *Palaentologia, Palaoclimatologia, Palaeoecologia*, vol. 34, pp. 285–314.
- 1079. Fortey, R.A. and Owens, R.M.**
1987. The Arenig Series in South Wales: stratigraphy and paleontology I. The Arenig Series in South Wales. *British Museum (Natural History), Bulletin, Geology*, vol. 41, pp. 71–307. [=726] [Cited by Sepkoski as: Fortey and Owen (sic) 1987.]
- 1080. Harper, D.A.T., Graham, J.R., Owen, A.W., and Donovan, S.K.**
1987. An Ordovician fauna from Lough Shee, Partry Mountains, Co. Mayo, Ireland. *Geological Journal*, vol. 23, pp. 293–310.
- 1081. Havlicek, V. and Varek, J.**
1990. Ordovician invertebrate communities in black-shale lithofacies (Prague Basin, Czechoslovakia). *Vestník Ustředního Ústavu Geologického*, vol. 65, pp. 223–236. [Cited by Sepkoski as: Havlicek and Varek (sic) 1990.]
- 1082. Price, D.**
1981. Ashgill trilobite faunas from Llyn Peninsula, North Wales, U.K. *Geological Journal*, vol. 16, pp. 201–216. [Cited by Sepkoski as: Price 1981.]
- 1083. Brood, K.**
1981. Hirnantian (Upper Ordovician) Bryozoa from Baltoscandia. *In* C.P. Larwood and C. Nielsen, eds., *Recent and Fossil Bryozoa*. Olsen and Olsen, Fredensborg, pp. 19–27. [Cited by Sepkoski as: Brood 1981.]
- 1084. Rohr, D.M.**
1994. Ordovician (Whiterockian) Gastropoda of Nevada: Belerophonitoidea, Macluritoidea, and Euomphaloidea. *Journal of Paleontology*, vol. 68, pp. 473–486.
- 1085. Fursich, F.T., Palmer, T.J., and Goodyear, K.L.**
1994. Growth and disintegration of bivalve-dominated patch reefs in the Upper Jurassic of southern England. *Palaentologia*, vol. 37, pp. 131–171.

- 1086. Ezaki, Y.**
1994. Patterns and paleoenvironmental implications of end-Permian extinction of Rugosa in South China. *Palaeogeography, Palaeoclimatology, Palaeoecology*, vol. 107, pp. 165–177.
- 1087. Nakrem, H.A.**
1994. Middle Carboniferous to Early Permian bryozoans from Spitsbergen. *Acta Palaeontologica Polonica*, vol. 39, pp. 45–116.
- 1088. Edgcombe, G.D.**
1994. New Lower Silurian (Llandovery) Encrinurine trilobites from the Mackenzie Mountains, Canada. *Journal of Paleontology*, vol. 68, pp. 824–837.
- 1089. Sundberg, F.A.**
1994. Corynexochida and Ptychopariida (Trilobita, Arthropoda) of the Ehmaniella Biozone (Middle Cambrian), Utah and Nevada. Natural History Museum of Los Angeles County, Contributions in Science, no. 446, 137 pp.
- 1090. Shi, X.Y. and Grant, R.E.**
1993. Jurassic rhynchonellids; internal structures and taxonomic revisions. *Smithsonian Contributions to Paleobiology*, no. 73, pp. 1–190.
- 1091. Sulser, H.**
1993. Brachiopoda: Rhynchonellida mesozoica. *Fossilium Catalogus. Animalia*, pars 132, pp. 1–281. [Cited by Sepkoski as: Sulser 1993.]
- 1092. Ager, D.V. and Sun Donli**
1989. Distribution of Mesozoic brachiopods on the northern and southern shores of Tethys. *Paleontologia Cathayana*, vol. 4, pp. 23–51.
- 1093. Elmi, S., Almeras, Y., Ameer, M., Atrops, F., Benhamou, M., and Moulou, G.**
1982. La dislocation de plates-formes carbonates liasiques en Mediterranee Occidentale et ses implications sur les echanges fauniques. *Bulletin. Société Geologique de France*, Ser. 7, vol. 24, pp. 1007–1016. [Cited by Sepkoski as: Elmi et al. 1982.]
- 1094. Sandy, M.R.**
1990. Early Cretaceous brachiopods from Mexico and their paleobiogeographic significance. *Journal of Paleontology*, vol. 64, pp. 942–956. [Cited by Sepkoski as: Sandy 1990.]
- 1095. Walter, B. and Almeras, Y.**
1981. Bryozoaires et brachiopods des "Calcaires Bajocien a Bryozoaires" des Causses (France) et leur paleoecologie. *Geobios*, vol. 14, pp. 361–387. [= 593] [Cited by Sepkoski as: Walter and Almeras 1980.]
- 1096. Michalik, J.**
1992. The structure and distribution of the European Cretaceous brachiopod assemblages with emphasis on the Tethyan fauna. *Schriftenreihe der Erdwissenschaftlichen Kommissionen*, vol. 9, pp. 57–74. [Cited by Sepkoski as: Michalik 1992.]
- 1097. Middlemiss, F.A.**
1979. Boreal and Tethyan brachiopods in the European Early and Middle Cretaceous. *In* J. Wiedmann, ed., *Aspekte der Kreide Europas*. Stuttgart: E. Schweizerbart'sche Verlagsbuchhandlung, pp. 351–361. [Cited by Sepkoski as: Middlemiss 1979.]
- 1098. Mancenido, M.O. and Dagens, A.S.**
1992. Brachiopods of the Circum-Pacific region. *In* G.E.G. Westermann, ed., *The Jurassic of the Circum-Pacific*. Cambridge University Press, Cambridge, pp. 328–333.
- 1099. Culver, S.J.**
1994. Early Cambrian foraminifera from the southwestern Taoudeni Basin, West Africa. *Journal of Foraminiferal Research*, vol. 24, pp. 191–202.
- 1100. Adrain, J.M. and Wilson, M.V.H.**
1994. Early Devonian cephalaspids (Vertebrata: Osteostraci: Cornuata) from the southern MacKenzie Mountains, N.W.T., Canada. *Journal of Vertebrate Paleontology*, vol. 14, pp. 301–319.
- 1101. Walossek, D. and Muller, K.J.**
1994. Pentastomid parasites from the lower Palaeozoic of Sweden. *Transactions of the Royal Society of Edinburgh. Earth Sciences*, vol. 85, pp. 1–37.
- 1102. Budd, A.F., Stemann, T.A., and Johnson, K.G.**
1994. Stratigraphic distributions of genera and species of Neogene and Recent Caribbean reef corals. *Journal of Paleontology*, vol. 68, pp. 951–977.
- 1103. Yatskov, S.V.**
1994. Devonian ammonoid zonation on Novaya Zemlya. *Newsletters in Stratigraphy*, vol. 30, pp. 167–182.
- 1104. Irizuki, T.**
1994. Late Miocene ostracods from the Fujikotogawa Formation, northern Japan—with reference to cold water species involved with trans-Arctic interchange. *Journal of Micro-paleontology*, vol. 13, pp. 3–15.
- 1105. Hou X. and Bergstrom, J.**
1994. Palaeocoeloid worms may be nematomorphs rather than annelids. *Lethaia*, vol. 27, pp. 11–17.
- 1106. Chlupac, I.**
1994. Devonian trilobites—evolution and events. *Geobios*, vol. 27, pp. 487–505.
- 1107. Cooper, M.R.**
1994. Towards a phylogenetic classification of the Cretaceous ammonites. III. Scaphitaceae. *Neues Jahrbuch für Geologie und Palaeontologie. Abhandlungen*, vol. 193, pp. 165–193.
- 1108. Smirnov, T.N.**
1994. Early Cretaceous brachiopods of northwestern Kamchatka. *Paleontological Journal*, vol. 28, pp. 34–50.
- 1109. Goryunova, R.V.**
1994. The taxonomic rank and phylogeny of the timanodictyoid bryozoans. *Paleontological Journal*, vol. 28, pp. 51–70.
- 1110. Edinger E.N., and Risk, M.J.**
1994. Oligocene-Miocene extinction and geographic restriction of Caribbean corals: roles of turbidity, temperature, and nutrients. *Palaos*, vol. 9, pp. 576–598.
- 1112. Olivero, E.B. and Aguirre-Urreta, M.B.**
1994. A new tube-builder hydrocratinian, symbiotic with hermit crabs, from the Cretaceous of Antarctica. *Journal of Paleontology*, vol. 68, pp. 1169–1182.
- 1112. Jablonski, D.**
1994. Personal communication (January, 1995).
- 1113. Vachard, D., Martini, R., Rettori, R., and Zaninetti, L.**
1994. Nouvelle classification des Foraminifères Endothyroides du Trias. *Geobios*, vol. 27, pp. 543–558.
- 1114. Stinchcomb, B.L. and Darrough, G.**
1994. Some molluscan problematica from the Upper Cambrian-Lower Ordovician of the Ozark Uplift. *Journal of Paleontology*, vol. 69, pp. 52–65.
- 1115. Kelly, S.R.A.**
1995. New trigonoid bivalves from the Early Jurassic and earliest Cretaceous of the Antarctic Peninsula region: systematics and Austral paleobiogeography. *Journal of Paleontology*, vol. 69, pp. 66–84.
- 1116. Dzik, J., Olempska, E. and Pisera, A.**
1994. Ordovician carbonates platform ecosystem of the Holy

- Cross Mountains. *Palaeontologia Polonica*, no. 53, Part 1, Text, 317 pp., Part 2, Plates 1–67.
- 1117. Liljedahl, L.**
1994. Silurian nuculoid and modiomorphid bivalves from Sweden. *Fossils and Strata*, no. 33, 89 pp.
- 1118. Reitner, J.**
1992. "Coralline Spongiens." *Berliner geowissenschaftliche Abhandlungen* (E), vol. 1, pp. 1–352.
- 1119. Cadée, M.C. and Janssen, A.W.**
1994. A taxonomic revision of NW European Oligocene and Miocene Fasciolaridae traditionally included in the genus *Streptochetus* (Mollusca, Gastropoda). *Contributions to Tertiary and Quaternary Geology*, vol. 31, pp. 31–107.
- 1120. Stanley, G.D., ed.**
1994. Paleontology and stratigraphy of Triassic to Jurassic rocks in the Peruvian Andes. *Palaeontographica*, Abt. A, vol. 233, pp. 1–208.
- 1121. Guensberg, T.E. and Sprinkle, J.**
1994. Revised phylogeny and functional interpretation of the Edrioasteroidea based on new taxa from the Early and Middle Ordovician of western Utah. *Field Museum of Natural History, Fieldiana Geology*, Publ. 1463, 43 pp.
- 1122. Rony, J.-Y., Struz, D.L., Boucot, A.J., Fu, L.-P., Modzamevskaia, T.L., and Su, Y.-Z.**
1994. The Retziellidae (Silurian ribbed impunctate athyridid brachiopods). *Acta Palaeontologica Sinica*, vol. 33, pp. 546–574.
- 1123. Rigby, J.K. and Clement, C.R.**
1994. Demosponges and hexactinellid sponges from the Lower Devonian Ross Formation of west-central Tennessee. *Journal of Paleontology*, vol. 69, pp. 211–232.
- 1124. Kelly, J.R.A.**
1995. New trigonoid bivalves from the Albanian (Early Cretaceous) of Alexander Island, Antarctic Peninsula: systematics, paleoecology, and austral Cretaceous paleobiogeography. *Journal of Paleontology*, vol. 69, pp. 64–279.
- 1125. Filkorn, H.F.**
1994. Fossil scleractinian corals from James Ross Basin, Antarctica. *Antarctic Research Series*, vol. 65, 96 pp.
- 1126. Hou, X.-G. and Bergstrom, J.**
1994. Cambrian lobopodians—ancestors of extant onychophorans. *Zoological Journal of the Linnean Society*, vol. 114, pp. 3–19.
- 1127. Landing, E.**
1995. Upper Placentian-Branchian Series on mainland Nova Scotia (Middle-upper Lower Cambrian) faunas, paleoenvironments, and stratigraphic revision. *Journal of Paleontology*, vol. 69, pp. 475–495.
- 1128. Xu, G.-R. and Grant, R.E.**
1994. Brachiopods near the Permian-Triassic boundary in South China. *Smithsonian Contributions to Paleobiology*, no. 76, pp. 1–68.
- 1129. Adrain, J.M., Chatterton, B.D.E., and Blodgett, R.B.**
1994. Silurian trilobites from southwestern Alaska. *Journal of Paleontology*, vol. 69, pp. 723–736.
- 1130. Pan, H.-Z. and Erwin, D.H.**
1994. Gastropod diversity patterns in South China during the Chihsia-Ladinian and their mass extinction. *In* Jin Y., J. Utting and B.R. Wardlaw, eds., *Permian Stratigraphy, Environments and Resources*, vol. 1. *Palaeontology & Stratigraphy*. *Palaeoworld* No. 4, Nanjing University Press, Nanjing, pp. 249–262.
- 1131. Conway Morris, S.**
1993. Ediacaran-like fossils in Cambrian Burgess Shale-type fauna of North America. *Palaeontology*, vol. 36, pp. 593–635.
- 1132. Baranov, V.V.**
1993. Paleozoic athyrids (brachiopods) from Northeast Asia. *Palaeontological Journal*, vol. 28, pp. 37–49.
- 1133. Wright, A.D. and Jaanusson, V.**
1993. New genera of Upper Ordovician triplesiid brachiopods from Sweden. *Geologiska Föreningen i Stockholm, Föreläsningar*, vol. 115, pp. 93–108.
- 1134. Melou, M.**
1976. Orthida (Brachiopoda) de la Formation de Postolenne (Ordovicien), Finistère, France. *Geobios*, vol. 9, pp. 693–717.
- 1135. Percival, I.G.**
1991. Late Ordovician articulate brachiopods from central New South Wales. *Association of Australasian Paleontologists, Memoir* 11, pp. 107–177.
- 1136. Wright, A.D.**
1993. A homeomorph of the articulate brachiopod *Dicoelosia* from the Upper Ordovician Hulterstad fauna of Oland, Sweden. *Geologiska Föreningen i Stockholm, Föreläsningar*, vol. 115, pp. 65–75.
- 1137. Wright, A.D.**
1993. The triplesiid brachiopod *Brachymimulus* and its species. *Alcheringa*, vol. 18, pp. 55–57.
- 1138. Laurie, J.R.**
1991. Articulate brachiopods from the Ordovician and Lower Silurian of Tasmania. *Association of Australasian Paleontologists, Memoir* 11, pp. 1–106.
- 1139. Brunton, C.H.C. and Mundy, D.J.C.**
1993. Productellid and plicatiferid (productoid) brachiopods from the Lower Carboniferous of the Craven Reef Belt, North Yorkshire. *British Museum (Natural History), Bulletin*, *Geology*, vol. 49, pp. 99–119.
- 1140. Carter, J.L.**
1991. A new aulostegid (Brachiopoda: Aulostegoidea) from the lower Mississippian of northcentral Iowa. *Annals of the Carnegie Museum*, vol. 60, pp. 359–363.
- 1141. Garcia-Alcalde, J.L.**
1991. El Devonico de Santa Maria del Mar (Castrillon, Asturias, Espana). *Revista Espanola Paleontologia*, vol. 7, pp. 53–79.
- 1142. Xu, G.-R. and Grant, R.E.**
1994. Brachiopods near the Permian-Triassic boundary in South China. *Smithsonian Contributions to Paleobiology*, no. 76, pp. 1–68. [= 1128]
- 1143. Kotlyar, G.V., Zakharov, Yu.D., Pronina, G.P., Chediya, I.O., and Burago, V.I.**
1989. Pozdnepermnskiy etap evolutsii organicheskogo mira. "Nauka", Leningrad.
- 1144. Grant, R.E.**
1993. The brachiopod family Gemmellarioidea. *Journal of Paleontology*, vol. 67, pp. 53–60.
- 1145. Cocks, L.R.M. and Worsley, D.**
1993. Late Llandovery and early Wenlock stratigraphy and ecology in the Oslo region, Norway. *British Museum (Natural History), Bulletin*, *Geology*, vol. 49, pp. 31–46.
- 1146. Racheboeuf, P.R. and Feldman, H.R.**
1990. Chonetacean brachiopods of the "Pink Chonetes" Zone, Onondaga Limestone (Devonian, Eifelian), central New York. *American Museum Novitates*, no. 2982, 16 pp.
- 1147. Mendibajar, B.**
1994. New Early Devonian strophomenids (Brachiopoda) from Mongolia. *Palaeontological Journal*, vol. 28, pp. 45–52.

- 1148. Havlicek, V.**
1992. New Lower Devonian (Lochkovian-Zlichovian) rhynchonellid brachiopods in the Prague Basin. *Paleontologie (Prague)*, vol. 32, pp. 55–122.
- 1149. Havlicek, V. and Kukal, Z.**
1990. Sedimentology, benthic communities and brachiopods in the Suchomasty (Dalejan) and Acanthopyge (Eifelian) limestones of the Koneprusy area (Czechoslovakia). *Paleontologie (Prague)*, vol. 31, pp. 105–205.
- 1150. Yang, D.**
1990. The brachiopod fauna of Early Permian early Qixia stage, Yishan area, Guangxi and its significance. *Bulletin of the Yichang Institute of Geology and Mineral Research*, vol. 17, pp. 81–93.
- 1151. Racheboeuf, P.R.**
1990. Los chonetáceos (braquiopodos) del Devónico boliviano: bioestratigrafía y datos taxonómicos complementarios. *Revista Española Paleontología*, vol. 7, pp. 31–52.
- 1152. Rong, J.-Y. and Cocks, L.R.M.**
1994. True *Strophomena* and a revision of strophomenoid and "strophodontoid" brachiopods. *Palaentology*, vol. 37, pp. 651–694.
- 1153. Brunton, C.H.C., Racheboeuf, P.R., and Murphy, D.J.C.**
1994. Reclassification of *Semenovia concentrica* (de Koninck, 1847) (Brachiopoda, Lower Carboniferous). *Geobios*, vol. 27, pp. 51–60.
- 1154. Ayzenberg, D.E.**
1992. Novy rod vizeyskikh produktiv Donbassa. *Paleontologicheskii Zhurnal*, vol. 1992(2), pp. 130–132.
- 1155. Andreev, D.A.**
1992. Novye posdneordovskie Plectambonitacea (brachiopody) tsentral'nogo Kazakhstana. *Paleontologicheskii Zhurnal*, vol. 1992(1), pp. 112–115.
- 1156. Stuve, W.**
1992. Neues zur Stratigraphie und Fauna des rhenotypen Mittel-Devon. *Senckenbergiana Lethaea*, vol. 71, pp. 503–624.
- 1157. Rozman, Ch.S.**
1992. Novye brachiopody silura Mongolii. In L.P. Tatarinov *et al.*, eds., *Novye Taksony Iskopaemykh Bespozvonochnykh Mongolii*. "Nauka"; Moscow, pp. 15–25.
- 1158. Mancenido, M.O. and Damboreuea, S.E.**
1990. Corallophilous micromorphic brachiopods from the Lower Jurassic of west central Argentina. In D.I. MacKinnon *et al.*, eds., *Brachiopods through Time*. Balkema, Rotterdam, pp. 89–96.
- 1159. Baker, P.G.**
1990. Morphology and shell microstructure of Cretaceous thecideidine brachiopods and their bearing on the thecideidine phylogeny. *Palaentology*, vol. 34, pp. 815–836.
- 1160. Erlanger, O.A.**
1990. Novye ranne i srednedevonskie rinkhonellidy Mongolii. In L.P. Tatarinov *et al.*, eds., *Novye Taksony Iskopaemykh Bespozvonochnykh Mongolii*. "Nauka"; Moscow, pp. 41–55.
- 1161. Chen, Y.-R.**
1990. Brachiopod fauna from Tudling Member of Bailiuping Formation (Early Devonian) in the Longmenshan area of Sichuan, China. *Professional Papers of Stratigraphy and Paleontology*, vol. 23, pp. 229–271.
- 1162. Sartenaer, P.**
1994. *Cabavirila*, nouveau genre calvinariide (rhynchonellide, brachiopode) de la partie moyenne du Frasnien. *Bulletin de l'Institut Royal des Sciences Naturelles de Belgique, Sciences de la Terre*, vol. 64, pp. 96–108.
- 1163. Mergl, M. and Massa, D.**
1992. Devonian and Lower Carboniferous brachiopods and bivalves from western Libya. *Biostratigraphie du Paléozoïque*, vol. 12, pp. 1–115.
- 1164. Plodowski, G.**
1973. Rhynchonellacea aus den Zentralkarnischen Alpen. *Senckenbergiana Lethaea*, vol. 54, pp. 65–103.
- 1165. Sapelnikov, V.N. and Mizens, L.I.**
1991. Novye rannye brachiopody Stenscismatacea zapadnogo sklona srednego Urala. *Paleontologicheskii Zhurnal*, vol. 1991(2), pp. 106–110.
- 1166. Sartenaer, P. and Xu, H.-K.**
1991. Two new rhynchonellid (brachiopod) species from the Frasnian Shetienschiao Formation of central Hunan, China. *Bulletin de l'Institut Royal des Sciences Naturelles de Belgique, Sciences de la Terre*, vol. 61, pp. 123–133.
- 1167. Sulser, H.**
1993. Brachiopoda: Rhynchonellida mesozoica. *Fossilium catalogus 1: Animalia*, vol. 132, pp. 1–281.
- 1168. Sartenaer, P.**
1991. *Tomstenporhynchus*, nouveau genre Rhynchonellide (Brachiopode) du Frasnien inférieur de la plate-forme Russe. *Bulletin de l'Institut Royal des Sciences Naturelles de Belgique, Sciences de la Terre*, vol. 63, pp. 13–23. [Cited by Sepkoski as: Sartaenaer (sic) 1991.]
- 1169. Lobatscheva, S.V. and Smirnova, T.N.**
1994. A new brachiopod genus of the family Ochotorthynchiidae from the Lower Cretaceous of the Crimea. *Paleontological Journal*, vol. 288, pp. 165–171.
- 1170. Li, L. and Feng, G.**
1982. Some Jurassic brachiopods from Yunshan District, eastern Heilongjiang Province [in Chinese]. *Bulletin of the Shenyang Institute of Geology and Mineral Resources*, vol. 5, pp. 45–61.
- 1171. Martinez Chacon, M.L.**
1978. Syringothyridacea (Brachiopoda) del Carbonífero de la Cordillera cantábrica (N de España). *Trabajos de Geología (Oviedo Universidad)*, vol. 10, pp. 317–330.
- 1172. Shi, G.R. and Waterhouse, J.B.**
1991. Early Permian brachiopods from Perak, west Malaysia. *Journal of Southeast Asian Earth Sciences*, vol. 6, pp. 25–39.
- 1173. Pozza, G.C.**
1991. *Cinglospiriferina*, nuovo genere di brachiopodi nel Lias inferiore marchigiano (Italia centrale). *Bollettin Società Paleontologia Italiana*, vol. 31, pp. 207–222.
- 1174. Johnson, J.G. and Lenz, A.C.**
1992. *Eoplacoplasta*, a new genus of Silurian-Lower Devonian ambocoeliid brachiopods. *Journal of Paleontology*, vol. 66, pp. 530–531.
- 1175. Carter, J.L.**
1992. New genera of Lower Carboniferous spiriferid brachiopods (Brachiopoda: Spiriferida). *Annals of the Carnegie Museum*, vol. 61, pp. 327–338.
- 1176. Murav'ev, I.S. and Grigor'eva, A.D., eds.**
1986. Atlas fauny verkhnego Karbona i nizhney Permi Samar'skoy Luki. *Kazanskogo Universiteta: Kazan, Russia*.
- 1177. Johnson, J.G.**
1995. *Mictospirifer*, a new genus of Lower Silurian eospiriferid brachiopods. *Journal of Paleontology*, vol. 69, p. 607.
- 1178. Johnson, J.G.**
1995. *Patriaspirifer*, a new genus of Lower Devonian spiriferid brachiopods. *Journal of Paleontology*, vol. 69, p. 198.

- 1179. Copper, P.**
1995. Five new genera of Late Ordovician-Early Silurian brachiopods from Anticosta Island, eastern Canada. *Journal of Paleontology*, vol. 69, pp. 846–862.
- 1180. Copper, P. and Chen, Y.**
1995. *Invertina*, a new Middle Devonian atrypid brachiopod genus from south China. *Journal of Paleontology*, vol. 69, pp. 251–256. [Cited by Sepkoski as: Copper, P. et al. 1995.]
- 1181. Popov, L., Nolvak, J., and Holmer, L.E.**
1994. Late Ordovician brachiopods from Estonia. *Palaeontology*, vol. 37, pp. 627–650.
- 1182. Godefroid, J.**
1991. *Soliudinella hollardi* n. gen. n. sp. (Brachiopoda, Lissatrypidae) dans le Praguien du Maroc pre-saharien. *Bulletin de l'Institut Royal des Sciences Naturelles de Belgique, Sciences de la Terre*, vol. 61, pp. 107–121.
- 1183. Richardson, J.R.**
1991. Australasian Tertiary Brachiopoda. The subfamily Anakineticinae nov. Proceedings of the Royal Society of Victoria, vol. 103, pp. 29–45.
- 1184. Tkhorzhevskiy, E.S.**
1990. K. sistematičke yurskikh sul'katnykh Terebratulida (Brachiopoda). *Paleontologicheskii Sbornik*, vol. 27, pp. 31–39.
- 1185. Smirnova, T.N.**
1990. Sistema rannemelovykh brachiopod. "Nauka": Moscow.
- 1186. Hegab, A.A.A. and Tkhorzhevskiy, E.**
1990. New genus *Praeudesia* (Brachiopoda) from the Jurassic outcrops of Gebel Maghara, northern Sinai, Egypt. *Bulletin of the Faculty of Science, Assiut University*, vol. 20, pp. 1–17.
- 1187. Calzada, S., Peybernes, B., Kamoun, F., and Youssef, M.B.**
1994. *Tuneithyris*, un nouveau genre de brachiopode du Trias de Tunisie centrale. *Revue de Paléobiologie*, vol. 13, pp. 117–124.
- 1188. Popov, L.E. and Tikhonov, Yu.A.**
1990. Rannekembriyskie brachiopody i Ayuzhnoy Kirgizii. *Paleontologicheskii Zhurnal*, vol. 1990(3), pp. 33–45.
- 1189. Holmer, L.E. and Popov, L.**
1995. The elkaniide brachiopod *Volborthia* from the Lower Ordovician of Baltoscandia. *Paläontologische Zeitschrift*, vol. 69, pp. 213–221.
- 1190. Koneva, S.P., Popov, L.E., Ushatinskaya, G.T., and Esakova, N.V.**
1990. Bezzamkovyye brachiopody (akrotretidy) i mikroproblematiki iz vrkhnego kembriya Severo-Vostochnogo Kazakhstana. *Trudy Instituta Geologii i Geofiziki (Novosibirsk)*, vol. 765, pp. 158–170.
- 1191. Mergl, M. and Stehoferova, P.**
1990. Middle Cambrian inarticulate brachiopods from central Bohemia. *Paleontologie (Prague)*, vol. 31, pp. 67–104.
- 1192. Koveva, S.P.**
1990. Novye srednekembriyskie akrotretidy (brachiopody) Malogo Karatau. *Paleontologicheskii Zhurnal*, vol. 1990(3), pp. 47–56.
- 1193. Korovnikov, I.V. and Ushatinskaya, G.T.**
1994. A new lingulate genus (brachiopods) from the Lower Cambrian of Tuva. *Paleontological Journal*, vol. 28, pp. 160–164.
- 1194. Peel, J.S.**
1984. Autecology and systematics of a new Silurian anomphalid gastropod from western Greenland. *Rapport Gronlands Geoliske Undersogelse*, vol. 121, pp. 77–87.
- 1195. Jeffery, D.L., Hoare, R.D., Mapes, R.H., and Brown, C.J.**
1994. Gastropods (Mollusca) from the Ino Formation (Mississippiian, Chesterian) of north-central Arkansas. *Journal of Paleontology*, vol. 68, pp. 58–79.
- 1196. Boucot, A.J., Rohr, D.M., Gray, J., De Faria, A., and Colbath, G.K.**
1986. *Plectonotus* and *Plectonotoides*, new subgenus of *Plectonotus* (Bellerophonacea: Gastropoda) and their biogeographic significance. *Neues Jahrbuch für Geologie und Paläontologie Abteilung*, vol. 173, pp. 167–180.
- 1197. Wagner, P.R.**
1995. Generation and Maintenance of Morphologic and Phylogenetic Diversity among Early Gastropods. Unpublished Ph.D. thesis, University of Chicago, 533 pp.
- 1198. Lysenko, N.I. and Aliyev, G.A.**
1987. A revision of the genus *Diozoptysis* and a new family of gastropods. *Paleontological Journal*, vol. 1987(1), pp. 128–132.
- 1199. Tassell, C.B.**
1980. Further gastropods from the Early Devonian Lilydale Limestone. *Records of the Queen Victoria Museum*, vol. 69, pp. 3–27.
- 1200. Poletaev, V.I. and Lazarev, S.S.**
1994. General stratigraphic scale and brachiopod evolution in the Late Devonian and Carboniferous subequatorial belt. *Bulletin de la Société Belge de Géologie*, vol. 103, pp. 99–107.
- 1201. Gubanov, A.B. and Yochelson, E.L.**
1994. A Wenlockian (Early Silurian) gastropod shell and operculum from Siberia. *Journal of Paleontology*, vol. 68, pp. 486–491.
- 1202. Taboada, A. and Aliyev, G.A.**
1987. Nuevos Eotomariidae (Gastropoda) de Paleozoico superior de Argentina. *Ameghiniana*, vol. 24, pp. 175–180.
- 1203. Flower, R.H.**
1968. Fossils from the Smith Basin Limestone of the Fort Ann region, New York. *New Mexico Institute of Mining and Technology Memoir* 22, pp. 22–27.
- 1204. Lozano-Lucea, L.**
1986. New Upper Cretaceous gastropods of Camarasa, Illerda, vol. 47, pp. 207–215.
- 1205. Adler, H.K.**
1994. Silicified Permian gastropods of the Park City Formation. Unpublished MS thesis, University of Wyoming, Laramie, 189 pp.
- 1206. Cook, A.G.**
1994. A septate gastropod from the Silurian *Bungonia* Limestone, New South Wales. *Memoirs of the Queensland Museum*, vol. 35, pp. 27–30.
- 1207. Bandel, K.**
1988. Repräsentieren die Euomphaloidea eine natürliche Einheit der Gastropoden? *Mitteilungen Geologische-Paläontologische Institut, Universität Hamburg*, vol. 67, pp. 1–33.
- 1208. Colom, G.**
1986. *Falsostyliola filamentosa* nov. gen. n. sp. *Memorias de la Real Academia de Ciencias y Artes de Barcelona*, vol. 46, pp. 1–17.
- 1209. Akopyan, V.T.**
1976. Late Cretaceous Gastropods of the Armenian SSR. *Akademiya Nauk Armyanskoi SSR, Erevan*, 443 pp.
- 1210. Kollman, H.A.**
1982. Cenomanian gastropods from the ophiolitic conglomer-

- ates of Boeotia, Greece. *Annales Geologiques des Pays Helleniques*, vol. 31, pp. 33–358.
- 1211. Cleavelly, R.J.**
1980. Two new British Cretaceous Epitonidae (Gastropoda): evidence for evolution of shell morphology. *British Museum (Natural History), Bulletin, Geology*, vol. 34, pp. 235–249.
- 1212. Saul, L.R.**
1988. New Late Cretaceous and early Tertiary Perssityidae (Gastropoda) from the Pacific Slope of North America. *Natural History Museum of Los Angeles County, Contributions in Science*, no. 400, pp. 1–25.
- 1213. Brower, J.C.**
1995. Dendrocinid crinoids from the Ordovician of Northern Iowa and southern Minnesota. *Journal of Paleontology*, vol. 69, pp. 939–960.
- 1214. Rigby, J.K. and Hou, X.-G.**
1995. Lower Cambrian demosponges and hexactinellid sponges from Yunnan, China. *Journal of Paleontology*, vol. 69, pp. 1009–1019.
- 1215. Savage, N.M. and Baxter, M.**
1995. Late Devonian (Frasnian) brachiopods from the Wadleigh Limestone, southeastern Alaska. *Journal of Paleontology*, vol. 69, pp. 1029–1046.
- 1216. Dong, X. and Knoll, A.H.**
1995. Middle and Late Cambrian sponge spicules from Hunan, China. *Journal of Paleontology*, vol. 69, pp. 173–184.
- 1217. Gehling, J.G. and Rigby, J.K.**
1996. Long expected sponges from the Neoproterozoic Ediacara fauna of South Australia. *Journal of Paleontology*, vol. 70, pp. 185–195.
- 1218. Le Renard, T., Sabelli, B., and Taviani, M.**
1996. On *Candinia* (Sacoglossa: Julidiidae), a new fossil genus of bivalved gastropods. *Journal of Paleontology*, vol. 70, pp. 230–235.
- 1219. Zhang, X.-G. and Pratt, B.R.**
1996. Early Cambrian palaeoscolecid cuticles from Shaanxi, China. *Journal of Paleontology*, vol. 70, pp. 275–279.
- 1220. Feldmann, R.M., Casadio, S., Chirino-Galvez, L., and Aguirre-Urreta, M.**
1995. Fossil decapod crustaceans from the Jaguel and Roca Formations (Maastrichtian-Danian) of the Neuquen Basin, Argentina. *Paleontological Society Memoir 43 (Journal of Paleontology)*, vol. 69, no. 5, supplement, 22 pp.
- 1221. Palmer, A.R. and Rowell, A.J.**
1995. Early Cambrian trilobites from the Shackleton Limestone of the central Transantarctic Mountains. *Paleontological Society Memoir 45 (Journal of Paleontology)*, vol. 69, no. 6, supplement, 28 pp.
- 1222. Doyle, P. and Bennett, M.R.**
1995. Belemnites in biostratigraphy. *Palaentology*, vol. 38, pp. 815–829.
- 1223. Kozłowska-Dawidziuk, A.**
1995. Silurian retiolitids of the East European Platform. *Acta Palaeontologica Polonica*, vol. 40, pp. 261–326.
- 1224. Hoare, R.D. and Mapes, R.H.**
1995. Relationships of the Devonian *Strobilepis* and related Pennsylvanian problematica. *Acta Palaeontologica Polonica*, vol. 40, pp. 111–128.
- 1225. Collins, J.S.H., Fraaye, R.H.B., and Jagt, J.W.M.**
1995. Late Cretaceous anomurans and brachyurans from the Maastrichtian type area. *Acta Palaeontologica Polonica*, vol. 40, pp. 165–210.
- 1226. Dzik, J.**
1995. *Yunnanozoon* and the ancestry of chordates. *Acta Palaeontologica Polonica*, 40, pp. 341–360.
- 1227. Newell, N.D. and Boyd, D.W.**
1995. Pectinoid bivalves of the Permian-Triassic crisis. *American Museum of Natural History Bulletin*, no. 227, 95 pp.
- 1228. Copper, P.**
1995. *Davidsonia* and *Rugodavidsonia* (new genus), cryptic Devonian atrypid brachiopods from Europe and South China. *Journal of Paleontology*, vol. 70, pp. 588–602.
- 1229. Maletz, J. and Mitchell, C.E.**
1996. Evolution and phylogenetic classification of the Glosso-graptidae and Arenigraptidae (Graptoloidea): new data and remaining questions. *Journal of Paleontology*, vol. 70, pp. 641–655.
- 1230. Anstey, R.L. and Pachut, J.F.**
1995. Phylogeny, diversity history, and speciation in Paleozoic bryozoans. In D.H. Erwin and R.L. Anstey, eds., *New Approaches to Speciation in the Fossil Record*. Columbia University Press, New York, pp. 239–284.
- 1231. Robba, E.**
1995. The Rembangian (Middle Miocene) mollusk fauna of Java, Indonesia. I. Archaeogastropoda. *Rivista Italiana de Paleontologia Stratigrafia*, vol. 102, pp. 267–292.
- 1232. Hoare, R.D., Mapes, R.H., Yancey, T.E., and Nestell, M.K.**
1996. Late Paleozoic turrellepoid machaeridians from North America. *Acta Palaeontologica Polonica*, vol. 41, pp. 127–145.
- 1233. Crame, J.A.**
1996. A new oxytomid bivalve from the Upper Jurassic-Cretaceous of Antarctica. *Palaentology*, vol. 39, pp. 615–628.
- 1234. Crimes, T.P., Insole, A., and Williams, B.P.J.**
1995. A rigid-bodied Ediacaran biota from Upper Cambrian strata in Co. Wexford, Eire. *Geological Journal*, vol. 30, pp. 89–109.
- 1235. Landing, E. and Bartowski, K.E.**
1995. Oldest shelly fossils from the Taconic Allochthon and late Early Cambrian sea-levels in eastern Laurentia. *Journal of Paleontology*, vol. 70, pp. 741–761.
- 1236. Copper, P.**
1996. New and revised genera of Wenlock-Ludlow atrypids (Silurian Brachiopoda) from Gotland, Sweden, and the United Kingdom. *Journal of Paleontology*, vol. 70, pp. 913–923.
- 1237. Sumrall, C.D.**
1996. Late Paleozoic edrioasteroids (Echinodermata) from the North American midcontinent. *Journal of Paleontology*, vol. 70, pp. 969–985.
- 1238. Cope, J.C.W.**
1996. Early Ordovician (Arenig) bivalves from the Llangynog Inlier, south Wales. *Palaentology*, vol. 39, pp. 979–1025.
- 1239. Markov, A.V., Naimark, E.B., and Grunt, T.A.**
1995. Dependence of extinction of atrypid genera (Brachiopoda) on their phylogenetic age and the age of corresponding taxa [in Russian]. *Paleontologicheskii Zhurnal*, vol. 1995(2), pp. 3–15.
- 1240. Markov, A.V.**
1997. Database: Rugosa. Paleontological Institute, Russian Academy of Sciences, Moscow.
- 1241. Markov, A.V.**
1997. Database: Bryozoa. Paleontological Institute, Russian Academy of Sciences, Moscow.
- 1242. Markov, A.V. and Solov'jev, A.N.**
1997. Database: Spatangacea (Echinoidea). Paleontological Institute, Russian Academy of Sciences, Moscow.

- 1243. Markov, A.V.**
1997. Database: Regular archaeocyathids. Paleontological Institute, Russian Academy of Sciences, Moscow.
- 1244. Markov, A.V.**
1997. Database: Problematica Paleontological Institute, Russian Academy of Sciences, Moscow.
- 1245. Adrain, J.M. and Ramskold, L.**
1997. Silurian Odontopleurinae (Trilobita) from the Cape Phillips Formation, Arctic Canada. *Journal of Paleontology*, vol. 71, pp. 237–261.
- 1246. Brunton, C.H.C. and Lazarev, S.S.**
1997. Evolution and classification of the Productellidae (Productida), upper Paleozoic brachiopods. *Journal of Paleontology*, vol. 71, pp. 381–393.
- 1247. Lane, N.G., Waters, J.A., and Maples, C.G.**
1997. Echinoderm faunas of the Hongguleng Formation, Late Devonian (Famennian), Xinjiang-Uygyr Autonomous Region, People's Republic of China. *Paleontological Society Memoir 47 (Journal of Paleontology)*, vol. 71, no. 2, supplement), 43 pp.
- 1248. Garvie, C.L.**
1996. The molluscan macrofauna of the Reklaw Formation, Marquet Member (Eocene: lower Clairbornian), in Texas. *Bulletins of American Paleontology*, vol. 111, no. 352, pp. 1–177.
- 1249. Groves, J.R. and Wahlman, G.P.**
1996. Biostratigraphy and evolution of Late Carboniferous and Early Permian smaller foraminifers from the Barents Sea (offshore arctic Norway). *Journal of Paleontology*, vol. 71, pp. 758–779.
- 1250. Marek, L., Malinky, J.M., and Geyer, G.**
1997. Middle Cambrian fossils from Tizi n'Tichka, the High Atlas, Morocco. Part 2. Hyolitha. *Journal of Paleontology*, vol. 71, pp. 638–656.
- 1251. Saunders, W.B. and Work, D.M.**
1997. Evolution of shell morphology and suture complexity in Paleozoic prolecanitids, the rootstock of Mesozoic ammonoids. *Paleobiology*, vol. 23, pp. 301–325.
- 1252. Nestor, V.**
1994. Early Silurian Chitinozoans of Estonia and North Latvia. *Academia 4. Estonian Academy Publishers, Tallinn*, 163 pp.
- 1253. Nestor, H.**
1990. Biogeography of Silurian stromatoporoids. *Geological Society of America Memoir 12*, pp. 215–221.
- 1254. Szaniawski, H.**
1996. Scolecodonts. In J. Jansonius and D.C. McGregor, eds., *Palynology: Principles and Applications*. American Association of Stratigraphic Palynologists Foundation, vol. 1, pp. 337–354.
- 1255. Hints, L.**
1990. Ordovician brachiopods. In D. Kaljo and H. Nestor, eds., *Field Meeting Estonia 1990*. Estonian Academy of Sciences, pp. 58–61.
- 1256. Meidla, T. and Sarv, L.**
1990. Ostracodes. In D. Kaljo and H. Nestor, eds., *Field Meeting Estonia 1990*. Estonian Academy of Sciences, pp. 68–71.
- 1257. Puura, T.**
1990. Ordovician inarticulate brachiopods. In D. Kaljo and H. Nestor, eds., *Field Meeting Estonia 1990*. Estonian Academy of Sciences, pp. 56–57.
- 1258. Hoare, R.D., Sturgeon, M.T., and Anderson, J.R., Jr.**
1997. Pennsylvanian marine gastropods from the Appalachian Basin. *Journal of Paleontology*, vol. 71, pp. 1019–1039.
- 1259. Feldmann, R.M., Bice, K.L., Hopkins, C.S., Salva, E.W., and Pickford, K.**
1997. Decapod crustaceans from the Eocene Castle Hayne Limestone, North Carolina: paleoceanographic implications. *Journal of Paleontology*, vol. 72, no. 1 (supplement), 28 pp.
- 1260. Lidgard, S.**
1998. Bryozoan database of May 1998 (unpublished).
- 1261. Pedder, A.E.H.**
1998. New and revised Lower Devonian Rugosa from western North America and Tasmania. *Journal of Paleontology*, vol. 72, pp. 224–245.
- 1262. Hof, C.H.I. and Schram, F.R.**
1998. Stomatopoda (Crustacea: Malacostraca) from the Miocene of California. *Journal of Paleontology*, vol. 72, pp. 317–331.
- 1263. Blodgett, R.B. and Boucot, A.J.**
1998. *Gentichlypa*, a new gypidulid (Brachiopoda) genus from the Middle Devonian of Michigan. *Journal of Paleontology*, vol. 72, pp. 454–457.
- 1264. Rong, J.-Y. and Boucot, A.J.**
1998. A global review of the Viranidae (Ashgillian-Llandovery, Brachiopoda, Pentamerioidea). *Journal of Paleontology*, vol. 72, pp. 457–465.
- 1265. Blake, D.B. and Reid, R., III.**
1998. Some Albian (Cretaceous) asteroids (Echinodermata) from Texas and their paleontological implications. *Journal of Paleontology*, vol. 72, pp. 512–532.
- 1266. Zhou, Z., Dean, W.T., Yuan, W., and Zhou, T.**
1998. Ordovician trilobites from the Dowangou Formation, Kalpin, Xinjiang, north-west China. *Palaentologia*, vol. 41, pp. 693–735.
- 1267. Melchin, M.J.**
1998. Morphology and phylogeny of some Early Silurian "diplrogaptid" genera from Cornwallis Island, arctic Canada. *Palaentologia*, vol. 41, pp. 263–315.
- 1268. Fortey, R.A.**
1997. Late Ordovician trilobites from southern Thailand. *Palaentologia*, vol. 40, pp. 397–449.
- 1269. Gasparini, Z.**
1997. A new pliosaur from the Bajocian of the Neuquen Basin, Argentina. *Palaentologia*, vol. 40, pp. 135–147.
- 1270. Loser, H.**
1996. Cretaceous corals—state of knowledge and current research. *Zentralblatt für Geologie und Paläontologie*, Teil I, pp. 1475–1485.
- 1271. Alvarez, J.-Y., Rong and Boucot, A.J.**
1998. The classification of athyridid brachiopods. *Journal of Paleontology*, vol. 72, pp. 827–835.
- 1272. Vermeij, G.J.**
1998. New genera of Cenozoic muricid gastropods, with comments on the mode of formation of the labral tooth. *Journal of Paleontology*, vol. 72, pp. 855–864.
- 1273. Copper, P.**
1998. Evaluating the Frasnian-Famennian mass extinction: Comparing brachiopod faunas. *Acta Palaentologica Polonica*, vol. 43, pp. 137–154.

ALPHABETICAL LISTING OF GENERA

This list includes all genera in the preceding taxonomically-arranged compendium. Following each generic name is a set of abbreviations for Phylum, Class, and Order. Abbreviations are listed in the table on pages 556–560.

Aachenaspis	(Cd,Ce,Ce)	Acaciapora	(Cn,An,Ta)	Acanthodina	(Cd,Co,Co)
Aacocrinus	(Ec,Cr,Mo)	Acacocrinus	(Ec,Cr,Mo)	Acanthodiscus	(Mo,Ce,Am)
Aaglacrinus	(Ec,Cr,Cf)	Acadagnostus	(Ar,Tr,Ag)	Acanthodus	(Cd,Co,Co)
Aalenella	(Mo,Ga,Ar)	Acadiocaris	(Ar,Mi,Ta)	Acanthoglypha	(Br,Ar,Pe)
Aalenirhynchia	(Br,Ar,Rh)	Acadoparadoxides	(Ar,Tr,Re)	Acanthognathus	(Cd,Os,Ga)
Aatocrinus	(Ec,Cr,Cf)	Acadoparadoxis	(Ar,Tr,Ag)	Acanthograptus	(He,Gr,De)
Abacocrinus	(Ec,Cr,Mo)	Acaeniotyle	(Ac,Ra,Sp)	Acanthogyra	(Cn,An,Sc)
Abactinocrinus	(Ec,Cr,Mo)	Acalepha	(Cn,Hy,Tr)	Acanthohoplites	(Mo,Ce,Am)
Abadehella	(Fo,Fo,Fo)	Acambona	(Br,Ar,Sp)	Acantholaminatus	(Bz,St,Tr)
Abadiella	(Ar,Tr,Re)	Acamptochetus	(Mo,Ga,Ne)	Acantholenus	(Ar,Tr,Un)
Abadzekhia	(Cd,Os,Pf)	Acampogenotia	(Mo,Ga,Ne)	Acantholepis	(Ec,Rh,Rh)
Abakania	(Ar,Tr,Co)	Acandylacanthus	(Cd,Ch,Ct)	Acantholoceras	(Mo,Ce,Am)
Abakanopleura	(Ar,Tr,Un)	Acanothyra	(Po,He,Un)	Acanthomeridion	(Ar,Os,Ar)
Abathocrinus	(Ec,Cr,Mo)	Acantaloma	(Ar,Tr,Od)	Acanthomeridium	(Ar,Un,Un)
Abathomphalus	(Fo,Fo,Fo)	Acanthactinella	(Po,He,Re)	Acanthometopus	(Ar,Tr,Pt)
Abatocrinus	(Ec,Cr,Mo)	Acanthaeacites	(Mo,Ce,Am)	Acanthomicmacca	(Ar,Tr,Un)
Abatus	(Ec,Ec,Sp)	Acanthahalsites	(Cn,An,Ta)	Acanthonautilus	(Mo,Ce,Na)
Abbasites	(Mo,Ce,Am)	Acanthalosia	(Br,Ar,St)	Acanthonema	(Mo,Ga,Ar)
Abderospira	(Mo,Ga,Ce)	Acanthambonia	(Br,Li,Ac)	Acanthonemus	(Cd,Os,Pf)
Abditodentrix	(Fo,Fo,Fo)	Acanthastrea	(Cn,An,Sc)	Acanthonotus	(Cd,Os,Pf)
Abditoloculina	(Ar,Os,Pa)	Acanthastrella	(Po,De,As)	Acanthoparypha	(Ar,Tr,Ph)
Abdounia	(Cd,Ch,Ca)	Acanthastus	(He,Gr,Un)	Acanthopecten	(Mo,Bi,Pt)
Abdulinaspis	(Ar,Tr,Un)	Acanthathia	(Br,Ar,St)	Acanthophyllia	(Cn,An,Ru)
Abdullaevia	(Fo,Fo,Fo)	Acanthechinus	(Ec,Ec,Ph)	Acanthophora	(Po,De,As)
Aberia	(Br,Ar,Or)	Acanthina	(Mo,Ga,Ne)	Acanthophyllia	(Cn,An,Sc)
Abertella	(Ec,Ec,Cf)	Acanthinities	(Mo,Ce,Ce)	Acanthophyllum	(Cn,An,Ru)
Abharella	(Ar,Tr,As)	Acanthinucella	(Mo,Ga,Ne)	Acanthoplecta	(Br,Ar,St)
Abichites	(Mo,Ce,Ce)	Acanthionella	(Bz,Gy,Ch)	Acanthopleura	(Mo,Po,Ne)
Abicyathus	(Pr,Cr,Cr)	Acanthiolobina	(Ar,Os,Pa)	Acanthopleurella	(Ar,Tr,Pt)
Abiesgraptus	(He,Gr,Gr)	Acanthocardia	(Mo,Bi,Ve)	Acanthopleuroceras	(Mo,Ce,Am)
Abلودگلیپتوکریس	(Ec,Cr,Mo)	Acanthocarpus	(Ar,Mi,De)	Acanthopleurus	(Cd,Os,Te)
Abnormisphaera	(Ac,Ra,Na)	Acanthocassis	(Pr,Un,Sa)	Acanthoplites	(Mo,Ce,Am)
Aboriginella	(Br,Li,Li)	Acanthocaudina	(Ec,Ho,Un)	Acanthopora	(Bz,St,Ce)
Abra	(Mo,Bi,Ve)	Acanthocella	(Bz,Gy,Ch)	Acanthoporella	(Bz,Gy,Ch)
Abrachiocrinus	(Ec,Cr,Cf)	Acanthocephalus	(Ar,Tr,Un)	Acanthoporidae	(Bz,Gy,Ch)
Abrardia	(Fo,Fo,Fo)	Acanthoceramoporella	(Bz,Su,Cy)	Acanthoproductus	(Br,Ar,St)
Abrekia	(Br,Ar,Rh)	Acanthoceras	(Mo,Ce,Am)	Acanthopygaeus	(Cd,Os,Pf)
Abretiella	(Mo,Ga,Ne)	Acanthoceratites	(Mo,Ce,Ce)	Acanthopyge	(Ar,Tr,Li)
Abrobairdia	(Ar,Os,Pa)	Acanthochaetetes	(Po,De,Ta)	Acanthopyle	(Ac,Ra,Sp)
Abrocycthere	(Ar,Os,Pa)	Acanthochirana	(Ar,Mi,De)	Acanthopyrgus	(Po,Re,Ca)
Abrocycthereis	(Ar,Os,Pa)	Acanthochitina	(Fo,Fo,Ch)	Acanthorhaphis	(Po,De,Pa)
Abrograptus	(He,Gr,Gr)	Acanthochitonina	(Mo,Po,Ne)	Acanthorhina	(Cd,Ch,In)
Abrotocrinus	(Ec,Cr,Cf)	Acanthocircus	(Ac,Ra,Na)	Acanthorhynchia	(Br,Ar,Rh)
Abruptolopha	(Mo,Bi,Pt)	Acanthocladia	(Bz,Su,Fe)	Acanthorthis	(Br,Ar,Or)
Abrytasites	(Mo,Ce,Am)	Acanthoclava	(Pr,Un,In)	Acanthoscapa	(Ar,Os,Pa)
Absalomichthyes	(Cd,Os,Pf)	Acanthoclema	(Bz,St,Cr)	Acanthoscapites	(Mo,Ce,Am)
Absenticosta	(Br,Ar,St)	Acanthoclymenia	(Mo,Ce,Am)	Acanthoscyllium	(Cd,Ch,Os)
Abssidaticonus	(Mo,In,In)	Acanthocordylodus	(Cd,Co,Co)	Acanthosphaera	(Ac,Ra,Sp)
Absonocytheropteron	(Ar,Os,Pa)	Acanthocoryna	(Po,He,Ls)	Acanthospirifer	(Br,Ar,Sp)
Abursus	(Ar,Os,Pa)	Acanthocosta	(Br,Ar,St)	Acanthospirina	(Br,Ar,Sp)
Abylea	(Mo,Ga,Ar)	Acanthocrania	(Br,Li,Ac)	Acanthospongia	(Po,He,Ls)
Abyssamina	(Fo,Fo,Fo)	Acanthocrinus	(Ec,Cr,Di)	Acanthoteuthis	(Mo,Ce,Be)
Abyssocrinus	(Ec,Cr,Os)	Acanthocyathus	(Cn,An,Sc)	Acanthotheelia	(Ec,Ho,Ap)
Abyssocypris	(Ar,Os,Pa)	Acanthocystites	(Ec,Os,Go)	Acanthothyria	(Br,Ar,Rh)
Abyssocycthere	(Ar,Os,Pa)	Acanthocythere	(Ar,Os,Pa)	Acanthothyropsis	(Br,Ar,Rh)
Abyssocycthereis	(Ar,Os,Pa)	Acanthocythereis	(Ar,Os,Pa)	Acanthothoecia	(Br,Ar,Or)
Abyssothyris	(Br,Ar,Te)	Acanthodesia	(Bz,Gy,Ch)	Acanthotrigonia	(Mo,Bi,Tr)
Acabaria	(Cn,An,Go)	Acanthodictya	(Po,He,Re)	Acanthotrophia	(Mo,Ga,Un)

Acanthotrypa	(Bz,St,Tr)	Acidotocarena	(Br,Un,Un)	Acrodirotes	(Ar,Tr,Pt)
Acanthotrypina	(Bz,St,Tr)	Acila	(Mo,Bi,Nu)	Acrodus	(Cd,Ch,Ct)
Acanthurus	(Cd,Os,Pf)	Acilia	(Mo,Ga,Nt)	Acrogaster	(Cd,Os,Br)
Acantonodella	(Ar,Os,Pa)	Acimetopus	(Ar,Tr,Un)	Acrogenia	(Bz,St,Cy)
Acar	(Mo,Bi,Ar)	Acinetaster	(Ec,Os,St)	Acrognathus	(Cd,Os,Au)
Acareorthis	(Br,Ar,Or)	Acinophyllum	(Cn,An,Ru)	Acrograptus	(He,Gr,Gr)
Acareorthis	(Br,Un,Ch)	Acipenser	(Cd,Os,Ac)	Acrohelia	(Cn,An,Se)
Acariaeoerinus	(Ec,Cr,Un)	Acirsa	(Mo,Ga,Nt)	Acrohybus	(Ar,Tr,Un)
Acariaeoerinus	(Ec,Cr,Ct)	Acirsella	(Mo,Ga,Nt)	Acrolepis	(Cd,Os,Pa)
Acarinina	(Fo,Fo,Fo)	Acleistoceras	(Mo,Ce,On)	Acrolusia	(Ec,Ec,Ds)
Acaroceras	(Mo,Ce,El)	Achiceratia	(Mo,Ga,Nt)	Acronemus	(Cd,Ch,Ct)
Acasta	(Ar,Ci)	Achlis	(Mo,Ga,Nt)	Acronotella	(Ar,Os,Po)
Acastava	(Ar,Tr,Ph)	Achlisina	(Mo,Ga,Ar)	Acropeltis	(Ec,Ec,Ph)
Acaste	(Ar,Tr,Ph)	Acloedictya	(Po,He,Re)	Acrophyllum	(Cn,An,Ru)
Acastella	(Ar,Tr,Ph)	Acmaea	(Mo,Ga,Pa)	Acropora	(Cd,Os,Pf)
Acastellina	(Ar,Tr,Ph)	Acmahachis	(Ar,Tr,Ag)	Acropora	(Cn,An,Se)
Acastoides	(Ar,Tr,Ph)	Acmaturris	(Mo,Ga,Ne)	Acropyge	(Ar,Tr,Pr)
Acastopyge	(Ar,Tr,Ph)	Acme	(Mo,Ga,Nt)	Acroreia	(Mo,Ga,Ba)
Accordiella	(Fo,Fo,Fo)	Acmoniodus	(Cd,Ch,Cp)	Acrosalenia	(Ec,Ec,Sa)
Acculina	(Br,Ar,St)	Acmophyllum	(Cn,An,Ru)	Acrosaster	(Ec,Ec,Ph)
Accurganaxon	(Cn,An,Ru)	Acobaecardium	(Mo,Bi,Pt)	Acrosmitia	(Cn,An,Se)
Acdalina	(Cn,An,Ta)	Acoelia	(Po,Ca,Ph)	Acrosolarium	(Mo,Ga,Ar)
Acentrogobius	(Cd,Os,Pf)	Acolocrinus	(Ec,Cr,Ds)	Acrosphaera	(Ac,Ra,Sp)
Acentrophorus	(Cd,Os,Se)	Acolosia	(Br,Ar,Rh)	Acrosphaerorthoceras	(Mo,Ce,Or)
Acentrotremites	(Ec,Bi,Sp)	Acominia	(Mo,Ga,Ne)	Aerospira	(Mo,Ga,Nt)
Acerahedrina	(Ac,Ra,Na)	Acomposceras	(Mo,Ce,Am)	Acrospirifer	(Br,Ar,Sp)
Acernaspis	(Ar,Tr,Ph)	Aconeceras	(Mo,Ce,Am)	Acrospryris	(Ac,Ra,Na)
Acerocanium	(Ac,Ra,Na)	Acontheus	(Ar,Tr,Co)	Acrosstula	(Ar,Os,Un)
Acerocare	(Ar,Tr,Pt)	Acorylus	(Mo,Bi,Ve)	Acrostemma	(Mo,Ga,Ce)
Acerocarina	(Ar,Tr,Pt)	Acosarina	(Br,Ar,Or)	Acrosterigma	(Mo,Bi,Ve)
Aceroproetus	(Ar,Tr,Pr)	Acoscinopleura	(Bz,Gy,Ch)	Acrostylus	(Mo,Ga,He)
Acervoschwagerina	(Fo,Fo,Fo)	Acostina	(Fo,Fo,Fo)	Acrotelmus	(Cd,Os,Py)
Acervularia	(Cn,An,Ru)	Acotripus	(Ac,Ra,Na)	Acroteuthis	(Mo,Ce,Be)
Acervulina	(Fo,Fo,Fo)	Acratia	(Ar,Os,Po)	Acrothele	(Br,Li,Ac)
Acesta	(Mo,Bi,Pt)	Acratina	(Ar,Os,Po)	Acrothyra	(Br,Li,Ac)
Acestus	(Cd,Os,Pf)	Acratineella	(Ar,Os,Po)	Acrothyris	(Br,Ar,Ic)
Acetopeltis	(Ar,Tr,Pr)	Acravacula	(Ar,Os,Po)	Acrotreta	(Br,Li,Ac)
Acevina	(Mo,In,In)	Acravincula	(Ar,Os,Pa)	Acrotretella	(Br,Li,Ac)
Acharax	(Mo,Bi,So)	Acriaster	(Ec,Ec,Ca)	Acrulammima	(Fo,Fo,Fo)
Achatella	(Ar,Tr,Ph)	Acriclymenia	(Mo,Ce,Ct)	Acsaspedites	(Cn,Hy,Tr)
Acheilops	(Ar,Tr,Pt)	Acrilla	(Mo,Ga,Nt)	Actaea	(Ar,Ml,De)
Acheilus	(Ar,Tr,Pt)	Acrilloscala	(Mo,Ga,Nt)	Actaeon	(Mo,Ga,Ce)
Achistrulum	(Ec,Ho,Ap)	Acrimeroceras	(Mo,Ce,Go)	Actaeonella	(Mo,Ga,Ce)
Achistrum	(Ec,Ho,Ap)	Acrioceras	(Mo,Ce,Am)	Actaeonellina	(Mo,Ga,Ce)
Achiurus	(Cd,Os,Pn)	Acritosia	(Br,Ar,St)	Actaeonema	(Mo,Ga,Nt)
Achorocyathus	(Pr,Cr,Cr)	Acrobatus	(Ac,Ra,Na)	Actaeonidea	(Mo,Ga,Ce)
Achradocrinus	(Ec,Cr,Ct)	Acrobrochus	(Br,Ar,Te)	Actaeonina	(Mo,Ga,Ce)
Achradocystites	(Ec,Pe,Co)	Acrocanites	(Mo,Ce,Pl)	Actaeopsis	(Ar,Ml,De)
Achrestogrammus	(Cd,Os,Sc)	Acrocephalaspis	(Ar,Tr,Pt)	Actaeopyramis	(Mo,Ga,He)
Achrochordiella	(Po,De,Li)	Acrocephalella	(Ar,Tr,Pt)	Actaeus	(Ar,Un,Un)
Achrochordonia	(Po,De,Li)	Acrocephalina	(Ar,Tr,Pt)	Acteocina	(Mo,Ga,Ce)
Achunopductus	(Br,Ar,St)	Acrocephalites	(Ar,Tr,Pt)	Acteosaurus	(Cd,Re,Sq)
Aciconularia	(Cn,Sc,Cn)	Acrocephalops	(Ar,Tr,Pt)	Actiangulata	(Ar,Os,Po)
Aciculella	(Fo,Fo,Fo)	Acrochordiceeras	(Mo,Ce,Ce)	Actinacis	(Cn,An,Se)
Aciculiscala	(Mo,Ga,Nt)	Acrochordus	(Cd,Re,Sq)	Actinaraea	(Cn,An,Sc)
Acidaspidella	(Ar,Tr,Od)	Acrocidaris	(Ec,Ec,Hm)	Actinaraecopsis	(Cn,An,Sc)
Acidaspidites	(Ar,Tr,Od)	Acrococclites	(Mo,Ce,Be)	Actinastaeopsis	(Cn,An,Sc)
Acidaspidina	(Ar,Tr,Od)	Acrocolum	(Mo,Ga,Nt)	Actinastrea	(Cn,An,Sc)
Acidaspis	(Ar,Tr,Od)	Acrocolum	(Mo,Ga,Ce)	Actinobalanus	(Ar,Ci)
Acidiphorus	(Ar,Tr,Pr)	Acrocosmia	(Mo,Ga,Nt)	Actinocamax	(Mo,Ce,Be)
Acidiscus	(Ar,Tr,Ag)	Acrocrinus	(Ec,Cr,Mo)	Actinoceras	(Mo,Ce,Ac)
Acidnomelous	(Ac,Ra,Na)	Acrocryathus	(Cn,An,Ru)	Actinochilina	(Ar,Os,Pa)
Acidocharacus	(Pr,Un,Na)	Acrocrythere	(Ar,Os,Pa)	Actinochiloma	(Po,De,Li)
Acidolites	(Cn,An,Ta)	Acrodelfis	(Cd,Ma,Ce)	Actinoconchus	(Br,Ar,Sp)

Actinoconus	(Mo,In,In)	Acylocrinus	(Ec,Cr,Cl)	Adradosia	(Cn,An,Ru)
Actinocrinites	(Ec,Cr,Mo)	Acyrena	(Mo,Bi,Ve)	Adraheutina	(Fo,Fo,Fo)
Actinocyathus	(Cn,An,Ru)	Adaerinus	(Ec,Cr,Cl)	Adrana	(Mo,Bi,Nu)
Actinocyclus	(Fo,Fo,Fo)	Adairia	(Br,Ar,St)	Adrenia	(Br,Ar,Te)
Actinocythereis	(Ar,Os,Po)	Adamanoophyllum	(Cn,An,Ru)	Adriacentrus	(Cd,Os,Br)
Actinodesma	(Mo,Bi,Pt)	Adamczakia	(Ar,Os,Un)	Adrianelia	(Po,De,Li)
Actinodictya	(Po,He,Re)	Adamczakites	(Ar,Os,Pa)	Adriantites	(Mo,Ce,Go)
Actinodictyon	(Po,De,St)	Adamnestia	(Mo,Ga,Ce)	Adriatella	(Po,De,Ax)
Actinodonta	(Mo,Bi,Mo)	Adamsoceras	(Mo,Ce,Ac)	Adula	(Mo,Bi,Mt)
Actinofungia	(Po,De,Ax)	Adansonella	(Mo,Bi,Ve)	Adulomya	(Mo,Bi,So)
Actinoleuca	(Mo,Ga,Pa)	Adaptatrypa	(Br,Ar,At)	Aduncrum	(Ec,Ho,Ap)
Actinolithes	(Po,Ca,He)	Adastoccephalum	(Ar,Tr,Ph)	Adusta	(Mo,Ga,Nt)
Actinomena	(Br,Ar,St)	Adaverina	(Cn,An,Ta)	Advenaster	(Ec,As,Px)
Actinomma	(Ac,Ra,Sp)	Adectorhynchus	(Br,Ar,St)	Advenina	(Br,Ar,Te)
Actinomorphia	(Mo,Ce,On)	Adelitia	(Ar,Os,Po)	Adversella	(Pr,Co,Sa)
Actinopeltis	(Ar,Tr,Ph)	Adekoheastrea	(Cn,An,Se)	Adygella	(Br,Ar,Te)
Actinophrentis	(Cn,An,Ru)	Adekunbiellida	(Pg, . .)	Adygelloides	(Br,Ar,Te)
Actinophyma	(Ec,Ec,Ph)	Adeloceras	(Mo,Ce,Na)	Adygellopsis	(Br,Ar,Te)
Actinopora	(Bz,St,Ce)	Adelocoenia	(Cn,An,Se)	Adygeya	(Mo,Ce,Se)
Actinopsis	(Mo,Ga,Nt)	Adelocyrtis	(Ac,Ra,Na)	Adyshevitheca	(Hy,Or,Or)
Actinopteria	(Mo,Bi,Pt)	Adelocythara	(Mo,Ga,Ne)	Adytaster	(Ec,Ec,Sp)
Actinopterimia	(Mo,Bi,Pt)	Adelodonez	(Mo,Bi,Ve)	Aechmella	(Bz,Gy,Ch)
Actinosepia	(Mo,Ce,Te)	Adelogonus	(Ar,Tr,Un)	Aechmina	(Ar,Os,Pa)
Actinospheon	(Fo,Fo,Fo)	Adelograptus	(He,Gr,De)	Aechminaria	(Ar,Os,Pa)
Actinostreon	(Mo,Bi,Pt)	Adelomelon	(Mo,Ga,Ne)	Aechminella	(Ar,Os,Pa)
Actinostroma	(Po,De,St)	Adelophthalmus	(Ar,Me,Eu)	Aedotes	(Ar,Tr,Pt)
Actinostromaria	(Po,De,Ax)	Adelosina	(Fo,Fo,Fo)	Aedulla	(Cd,Os,Pa)
Actinostromarianina	(Po,De,Ax)	Adelphobolbina	(Ar,Os,Pa)	Aegasteroceras	(Mo,Ce,Am)
Actinostromella	(Po,De,St)	Adelphoceras	(Mo,Ce,Na)	Aeger	(Ar,Ml,De)
Actinotaxia	(Bz,St,Ce)	Adelungia	(Fo,Fo,Fo)	Aegicephalichthys	(Cd,Os,Pa)
Actinotheca	(Pr,Un,In)	Ademtila	(Mo,Ga,Ne)	Aegides	(Mo,In,In)
Actinotoecaricus	(Ar,Ml,De)	Adenifera	(Bz,Gy,Ch)	Aegilops	(Mo,Bi,Ar)
Actinotrigonia	(Mo,Bi,Tr)	Adenus	(Bi,In,Tr)	Aegiria	(Br,Ar,St)
Actinotrypa	(Bz,St,Cy)	Adeona	(Bz,Gy,Ch)	Aegiromena	(Br,Ar,St)
Actinotrypella	(Bz,St,Cy)	Adeonella	(Bz,Gy,Ch)	Aegironites	(Br,Ar,St)
Actisecos	(Bz,Gy,Ch)	Adeoneilopsis	(Bz,Gy,Ch)	Aegoceras	(Mo,Ce,Am)
Actomphalus	(Mo,Ga,Eu)	Adeorbis	(Mo,Ga,Nt)	Aegocrioceras	(Mo,Ce,Am)
Actostroma	(Po,De,Ax)	Adercotryma	(Fo,Fo,Fo)	Aegolytoceras	(Mo,Ce,Am)
Actumnus	(Ar,Ml,De)	Adesmoconularia	(Cn,Sc,Cn)	Aegospyrus	(Ac,Ra,Na)
Acuariceras	(Mo,Ce,Am)	Adetognathus	(Cd,Co,Co)	Aegrotocatellus	(Ar,Tr,Ph)
Aculatostroma	(Po,De,St)	Adetopora	(Cn,An,Ta)	Aegyptiana	(Ar,Os,Po)
Aculeochrea	(Tr,An)	Adhaerentia	(Fo,Fo,Fo)	Aehmospira	(Mo,Ga,Ar)
Aculopileus	(Mo,In,In)	Adiaphragma	(Br,Ar,St)	Aeidimylitus	(Mo,Bi,Mt)
Acumina	(Mo,Ga,Ne)	Adinocrinus	(Ec,Cr,Cl)	Aelga	(Mo,Bi,Ph)
Acuminothyris	(Br,Ar,Sp)	Adinophyllum	(Cn,An,Ru)	Aellograptus	(He,Gr,Un)
Acupurpura	(Ar,Os,Me)	Adinus	(Mo,Ga,Ne)	Aemula	(Br,Ar,Te)
Acutatheca	(Mo,Ga,Ne)	Adiozoptyxis	(Mo,Ga,Un)	Aemulophyllum	(Cn,An,Ru)
Acutatognostus	(Br,Ar,Sp)	Adkinsella	(Cn,An,Sc)	Aeneator	(Mo,Ga,Ne)
Acutella	(Ar,Tr,Ag)	Adkinsia	(Mo,Ce,Am)	Aenigmatarius	(Ar,Ml,Ae)
Acutichiton	(Br,Ar,Sp)	Adkinsites	(Mo,Ce,Am)	Aenigmatröcklandia	(Br,Ar,Pe)
Acutiouloudina	(Mo,Po,Ne)	Admete	(Mo,Ga,Ne)	Aenigmatrophia	(Br,Ar,St)
Acutiosites	(Pr,Un,Vo)	Admetopsis	(Mo,Ga,Ne)	Aenigmatectus	(Pr,Ma,He)
Acuticythereis	(Mo,Ce,Am)	Admiculorlia	(Br,Ar,Sp)	Aenigmatyris	(Br,Ar,Te)
Acuticytheretta	(Ar,Os,Pa)	Admirabilinella	(Ar,Os,Pa)	Aenigmatoceras	(Mo,Ce,Go)
Acutilineolus	(Ar,Os,Pa)	Admiratella	(Bz,St,Fe)	Aenigmocrinus	(Ec,Cr,Cl)
Acutimitoceras	(Mo,Ce,Go)	Admixtella	(Br,Ar,Or)	Aenona	(Mo,Bi,Ve)
Acutiramus	(Ar,Me,Eu)	Admorogousus	(Br,Ar,St)	Aeolisaccus	(Fo,Fo,Fo)
Acutirostriconus	(Mo,In,In)	Adnatida	(Br,Ar,Te)	Aeoliscooides	(Cd,Os,Ga)
Acutisclerulus	(Ec,Ho,De)	Adnatoceras	(Mo,Ce,Or)	Aeoliscus	(Cd,Os,Ga)
Acutitheca	(Pr,Un,In)	Adocetocystis	(Ec,Rh,Rh)	Aeolodon	(Cd,Re,Cr)
Acutoria	(Mo,Ce,Am)	Adolfia	(Br,Ar,Sp)	Aeolopneustes	(Ec,Ec,Ph)
Acutostrea	(Br,Ar,Sp)	Adolfspirifer	(Br,Ar,Sp)	Aeolopora	(Bz,Gy,Ch)
Acvocaria	(Mo,Bi,Pt)	Adontorhina	(Mo,Bi,Ve)	Aeolostreptis	(Fo,Fo,Fo)
	(Ar,Os,Po)	Adornatipecten	(Mo,Bi,Pt)	Aeora	(Mo,Bi,Ve)

Aepyaster	(Ec,Ed,Ed)	Agaricia	(Cn,An,Sc)	Agnostogonus	(Ar,Tr,Ag)
Aepystoma	(Mo,Ga,Nt)	Agaricocrinus	(Ec,Cr,Mo)	Agnostoles	(Ar,Tr,Ag)
Aequipecten	(Mo,Bi,Pt)	Agaronia	(Mo,Ga,Ne)	Agnostus	(Ar,Tr,Ag)
Aequispirrella	(Mo,Ga,Ar)	Agasoma	(Mo,Ga,Ne)	Agoniatites	(Mo,Ce,An)
Aequispiriferina	(Br,Ar,Sp)	Agassicerias	(Mo,Ga,Am)	Agonisia	(Mo,Bi,Tr)
Aeretica	(Mo,Bi,Ve)	Agassizia	(Ec,Ec,Sp)	Agonus	(Cd,Os,Sc)
Aerithyris	(Br,Ar,Te)	Agassizocrinus	(Ec,Cr,Ct)	Agorophius	(Cd,Ma,Ce)
Aerosuama	(Pr,Co,Sa)	Agassizodus	(Cd,Ch,Eu)	Agostocrinus	(Ec,Cr,DS)
Aesocrinus	(Ec,Cr,Ct)	Agasso	(Ar,Tr,Pt)	Agramatia	(Br,Ar,St)
Aesopomum	(Br,Ar,St)	Agastapleura	(Br,Ar,Un)	Agraulaeva	(Ar,Tr,Un)
Aesopus	(Mo,Ga,Ne)	Agastograptus	(He,Gr,Gr)	Agraulopsis	(Ar,Tr,Pt)
Aetea	(Bz,Gy,Ch)	Agastophyllum	(Cn,An,Ru)	Agraulos	(Ar,Tr,Pt)
Aethalionopsis	(Cd,Os,Go)	Agastrioceras	(Mo,Ce,Go)	Agrenocythere	(Ar,Os,Po)
Aethia	(Br,Ar,Rh)	Agastrocyathus	(Po,Ir,Ar)	Agrioceras	(Mo,Ce,On)
Aetheloxoceras	(Mo,Ce,Ya)	Agatha	(Mo,Ga,He)	Agriocetus	(Cd,Ma,Ce)
Aethodontia	(Cd,Os,Pe)	Agathammina	(Fo,Fo,Fo)	Agriopleura	(Mo,Bi,Hi)
Aetheolepis	(Cd,Os,Pe)	Agathamminoides	(Fo,Fo,Fo)	Agriopoma	(Mo,Bi,Ve)
Aetheretmon	(Cd,Os,Pa)	Agathelia	(Cn,An,Sc)	Aguaraya	(Ar,Tr,Un)
Aethia	(Ar,Tr,Un)	Agathicerias	(Mo,Ce,Go)	Aguayoaster	(Ec,Ec,Sp)
Aethiosolen	(Mo,Ce,Or)	Agathiphyllia	(Cn,An,Sc)	Aguilerella	(Mo,Bi,Pt)
Aethirhynchia	(Br,Ar,Rh)	Agathirses	(Mo,Ga,Nt)	Agulbasia	(Br,Ar,Te)
Aethoceras	(Mo,Ce,Ta)	Agathistoma	(Mo,Ga,Ar)	Agulbasina	(Ar,Os,Po)
Aethocrinus	(Ec,Cr,Ct)	Agathocrinus	(Ec,Cr,Mo)	Agyrekia	(Br,Un,Ku)
Aethodontide	(Ar,Tr,As)	Agathodonta	(Mo,Ga,Ar)	Agyrekoocyathus	(Po,Re,Aj)
Aetholicototaxis	(Ar,Os,Pa)	Agathotoma	(Mo,Ga,Ne)	Ahlintella	(Ar,Os,Pa)
Aethotaxis	(Cd,Co,Co)	Agatrix	(Mo,Ga,Ne)	Ahmadiura	(Ar,Os,Po)
Aetiocetus	(Cd,Ma,Ce)	Agelacrinites	(Ec,Ed,Is)	Ahrdorffia	(Cn,An,Sc)
Aetobatus	(Cd,Ch,My)	Agelagma	(Ar,Tr,Pt)	Ahtiella	(Br,Ar,St)
Aetomacladia	(Bz,St,Cy)	Agelasia	(Mo,Bi,Ve)	Ahtioconcha	(Mo,Bi,Pt)
Aetomylaeus	(Cd,Ch,My)	Ageleodus	(Cd,Ch,Pe)	Aiaiaspis	(Ar,Tr,Pt)
Aetostreon	(Mo,Bi,Pt)	Agelesia	(Br,Ar,St)	Aidarella	(Ar,Tr,Un)
Aeixitrochocrinus	(Ec,Cr,Sa)	Ageria	(Mo,Ga,Nt)	Aidynkulirhynchia	(Br,Ar,Rh)
Afer	(Mo,Ga,Ne)	Agerina	(Ar,Tr,Pr)	Aigialosaurus	(Cd,Re,Sq)
Affinetrina	(Fo,Fo,Fo)	Agerinella	(Br,Ar,Th)	Aigoceras	(Mo,Ce,Di)
Affiniptyxis	(Mo,Ga,Ar)	Agerostrea	(Mo,Bi,Pt)	Aikenicythere	(Ar,Os,Po)
Affinocrinus	(Ec,Cr,Ct)	Agetoitella	(Cn,An,Ta)	Ailsacrinus	(Ec,Cr,Mi)
Affrollonia	(Mo,Ga,Ar)	Agetolites	(Cn,An,Ta)	Aimitus	(Hy,Hy,Hy)
Afganodesma	(Mo,Bi,Nu)	Agglutinella	(Fo,Fo,Fo)	Aimulosia	(Bz,Gy,Ch)
Afghanella	(Fo,Fo,Fo)	Agglutisolena	(Fo,Fo,Fo)	Ainacrinus	(Ec,Cr,Sa)
Afghanocare	(Ar,Tr,Pt)	Aggomorphastraea	(Cn,An,Sc)	Ainia	(Cn,An,Ta)
Afghanospirifer	(Br,Ar,Sp)	Aggregopora	(Bz,St,Cc)	Ainigmacrinus	(Ec,Cr,En)
Afiacyathus	(Po,Re,Aj)	Agkistracanthus	(Cd,Ch,Cm)	Ainiktozoon	(Pr,Un,In)
Afilasma	(Br,Ar,Te)	Agladrellia	(Mo,Ga,Ne)	Ainoceras	(Mo,Ce,Am)
Aforia	(Mo,Ga,Ne)	Aglaglia	(Ar,Tr,Un)	Aioloceras	(Mo,Ce,Am)
Afossocochiton	(Mo,Po,Ne)	Aglaiocypris	(Ar,Os,Po)	Aipetoceras	(Mo,Ce,Di)
Afranticythereis	(Ar,Os,Po)	Aglaocetus	(Cd,Ma,Cc)	Aipichthyoides	(Cd,Os,Po)
Afraster	(Ec,As,Fo)	Aglaocrinus	(Ec,Cr,Ct)	Aipichthys	(Cd,Os,Po)
Africentrum	(Cd,Os,Br)	Aglaoglypta	(Mo,Ga,Be)	Aipoceras	(Mo,Ce,Na)
Afrocoryphaea	(Mo,Bi,Pt)	Aglaspella	(Ar,Me,Ag)	Aiptospira	(Mo,Ga,Be)
Africoterebellum	(Mo,Ga,Nt)	Aglaspis	(Ar,Me,Ag)	Airina	(Ar,Os,Pa)
Afriscrobs	(Mo,Ga,Nt)	Aglaspoides	(Ar,Me,Ag)	Airtonia	(Br,Ar,St)
Afrobolivina	(Fo,Fo,Fo)	Aglaurides	(An,Po,Eu)	Aisenvergia	(Bz,St,Tr)
Afrocardium	(Mo,Bi,Ve)	Agolithodictya	(Po,He,Re)	Aithriocrinus	(Ec,Cr,Ct)
Afrocornulina	(Mo,Ga,Nt)	Aglyptorhynchus	(Cd,Os,PF)	Aitilia	(Ar,Os,Pa)
Afrocypraea	(Mo,Ga,Nt)	Agnoblastus	(Ec,BI,F)	Aivukus	(Cd,Ma,Ca)
Afrocytheridea	(Ar,Os,Po)	Agnesia	(Mo,Ga,Ar)	Aizyella	(Mo,Ga,Ar)
Afrops	(Ar,Tr,Ph)	Agnewia	(Mo,Ga,Ne)	Ajaciicrepida	(Ar,Tr,As)
Afrovolutilithes	(Ec,As,Ne)	Agniesella	(Mo,Ga,Ar)	Ajaciacyathellus	(Po,Re,Aj)
Agabelus	(Cd,Ma,Ce)	Agnocardia	(Mo,Bi,Ve)	Ajaciacyathus	(Po,Re,Aj)
Agaleus	(Cd,Ch,Oc)	Agnomyax	(Mo,Bi,Ve)	Ajchalinia	(Ar,Os,Pa)
Agalmaster	(Ec,As,Pu)	Agnostaridis	(Ar,Tr,Ag)	Ajirikima	(Ar,Tr,Pt)
Aganaster	(Ec,Op,Op)	Agnostascus	(Ar,Tr,Ag)	Ajuukuzella	(Br,Ar,Te)
Agapella	(Mo,Bi,Ve)	Agnostocrinus	(Ec,Cr,Ct)	Aka	(Po,De,Ha)
Agarhynchia	(Br,Ar,Rh)	Agnostoglossa	(Ar,Tr,Ag)	Akademiophyllum	(Pr,Cr,Cr)

Akadocrinus	(Ec,Eo,Go)	Albebarania	(Ec,As,Px)	Alia	(Mo,Ga,Ne)
Akagophyllum	(Cn,An,Ru)	Albertapriion	(An,Po,Eu)	Alichovia	(Br,Li,Ac)
Akantharges	(Ar,Tr,Li)	Albertechinus	(Ec,Ee,Ey)	Aliconchidium	(Br,Ar,Pe)
Akatchania	(Br,Ar,St)	Albertella	(Ar,Tr,Co)	Aliculastrum	(Mo,Ga,Ce)
Akatopora	(Bz,Gy,Ch)	Albertellina	(Ar,Tr,Co)	Alievium	(Ac,Ra,Na)
Akburunella	(Mo,Ga,Ne)	Albertelloides	(Ar,Tr,Co)	Alifera	(Br,Ar,St)
Akelina	(Br,Ar,St)	Alberticoryphe	(Ar,Tr,Pt)	Aligena	(Mo,Bi,Ve)
Akera	(Mo,Ga,An)	Albertoceras	(Mo,Ce,El)	Aliger	(Mo,Ga,Nt)
Akidograptus	(He,Gr,Gr)	Albiconus	(Cd,Co,Pa)	Aimbella	(Br,Ar,Pe)
Akiyoshiella	(Fo,Fo,Fo)	Albireo	(Cd,Ma,Ce)	Alinkioduncanella	(Cn,An,Ru)
Akiyosiphylum	(Cn,An,Ru)	Albrunnicola	(Ar,Os,Ar)	Alidonax	(Mo,Bi,Ve)
Akkermites	(Ar,Os,Pa)	Albula	(Cd,Os,An)	Aliofusus	(Mo,Ga,Ne)
Akmilleria	(Mo,Ce,Pl)	Albumares	(Tr,Un)	Aliomactra	(Mo,Bi,Ve)
Aknisophyllum	(Cn,An,Ru)	Alcaldops	(Ar,Tr,Ph)	Alipunctifera	(Br,Ar,Sp)
Akopovorhynchia	(Br,Ar,Rh)	Alceste	(Ar,Tr,Pt)	Aliquantula	(Br,Ar,Te)
Akroceras	(Mo,Ce,Di)	Alcidellus	(Mo,Ce,Am)	Alisea	(Cd,Os,Cl)
Aksopora	(Po,De,Ax)	Alcidiella	(Mo,Ga,Nt)	Alisina	(Br,Un,Ob)
Aksuglobulus	(Pr,Un,In)	Alcimocrinus	(Ec,Cr,Cl)	Alisocrinus	(Ec,Cr,Mo)
Aktassia	(Br,Li,Ac)	Alciola	(Cd,Os,Pf)	Alispira	(Br,Ar,At)
Aktastioceras	(Mo,Ce,An)	Alcira	(Mo,Ga,Ne)	Alispirifer	(Br,Ar,Sp)
Aktinorbitoides	(Fo,Fo,Fo)	Alcthoee	(Mo,Ga,Ne)	Alispiriferella	(Br,Ar,Sp)
Aktjubochelus	(Mo,Ce,On)	Alconeracyathus	(Po,Ar,Ar)	Alitaria	(Br,Ar,St)
Aktubinskia	(Mo,Ce,Pl)	Alcoveria	(Cd,Os,Co)	Alithyris	(Br,Ar,Te)
Aktubites	(Mo,Ce,Go)	Alcymene	(Ar,Tr,Ph)	Alkenopterus	(Ar,Me,Eu)
Aktuboclymenia	(Mo,Ce,Cl)	Aldanaspis	(Ar,Tr,Pt)	Allagecrinus	(Ec,Cr,Ds)
Aktugaia	(Pr,Un,Hy)	Aldanella	(Mo,In,Pe)	Allanella	(Br,Ar,Sp)
Aktugaiella	(Ar,Tr,Un)	Aldania	(Pr,Co,Ch)	Allanetes	(Br,Ar,St)
Ala	(Br,Ar,St)	Aldaniopirifer	(Br,Ar,Sp)	Allanicytidium	(Ec,St,Mi)
Alaba	(Mo,Ga,Nt)	Aldanites	(Mo,Ce,Go)	Allanoceras	(Mo,Ce,Or)
Alabamina	(Fo,Fo,Fo)	Aldanolina	(Mo,In,In)	Allantopora	(Bz,Gy,Ch)
Alabaminoides	(Fo,Fo,Fo)	Aldanospina	(Pr,Co,Ch)	Allantospongia	(Po,De,Un)
Alabina	(Mo,Ga,Nt)	Aldanotheca	(Hy,Or,Or)	Allathea	(Hy,Or,Or)
Alabusherothyris	(Br,Ar,Te)	Aldanotreta	(Br,Un,Un)	Alleinacin	(Mo,Bi,Ve)
Alachtherium	(Cd,Ma,Ca)	Alderina	(Bz,Gy,Ch)	Alleiolepis	(Cd,Os,Se)
Alainaspis	(Cd,Pt,Pt)	Aldingia	(Br,Ar,Te)	Allelepidotus	(Cd,Os,Se)
Alaionema	(Mo,Ga,Ar)	Aldoniaia	(Ar,Tr,Pt)	Allenpterus	(Cd,Os,Co)
Alaiophyllum	(Cn,An,Ru)	Aldrichia	(Mo,Ga,Ne)	Alleynia	(Cn,An,Ru)
Alakiria	(Cn,An,Sc)	Alectis	(Cd,Os,Pf)	Alleynodictyon	(Po,De,St)
Alakolites	(Ar,Os,Pa)	Alectona	(Po,De,Hd)	Alliatina	(Fo,Fo,Fo)
Alalcomenaeus	(Ar,Un,Un)	Alectrion	(Mo,Ga,Ne)	Alliatinella	(Fo,Fo,Fo)
Alania	(Ar,Tr,Pt)	Alectryonella	(Mo,Bi,Pt)	Alligaticeras	(Mo,Ce,Am)
Alanites	(Mo,Ce,Ce)	Alekcineilla	(Ar,Tr,Pt)	Alionia	(Ec,Cr,Cm)
Alaoceras	(Mo,Ce,Go)	Alekseevaella	(Br,Ar,Rh)	Alloberyx	(Cd,Os,Br)
Alariopsis	(Mo,Ga,Nt)	Alekseites	(Mo,Cr,Te)	Allobuchia	(Mo,Bi,Pt)
Alaskabolbina	(Ar,Os,Pa)	Aleodonta	(Mo,Bi,Mo)	Allocaitlocrinus	(Ec,Cr,Ds)
Alaskacoscinus	(Po,Ir,Ar)	Aleomorphella	(Fo,Fo,Fo)	Allocentrotus	(Ec,Ec,Ec)
Alaskaspongia	(Po,De,Pe)	Alepes	(Cd,Os,Pf)	Alloceras	(Mo,Ce,On)
Alaskoceras	(Mo,Ce,Ta)	Alepisaurus	(Cd,Os,Al)	Alloceratites	(Mo,Ce,Ce)
Alaskospira	(Br,Ar,Sp)	Aletes	(Mo,Ga,Nt)	Allochiton	(Mo,Po,Ne)
Alaskozygopleura	(Mo,Ga,Nt)	Alethodontus	(Cd,Ch,In)	Alloclionites	(Mo,Ce,Ce)
Alasonia	(Po,Ca,Ph)	Alethynoceras	(Mo,Ce,Na)	Allocoenia	(Cn,An,Sc)
Alatacavellina	(Ar,Os,Pa)	Aletoceras	(Mo,Ce,Di)	Allocoeniopsis	(Cn,An,Sc)
Alatacythere	(Ar,Os,Pa)	Aletograptus	(He,Gr,De)	Allocoemia	(Mo,Ga,Nt)
Alataleberris	(Ar,Os,Pa)	Alexandrites	(Ec,Ho,Un)	Alloctoceras	(Mo,Ce,En)
Alatacyathus	(Po,Re,Ca)	Alexandronautilus	(Mo,Ce,Na)	Allocrinus	(Ec,Cr,Mo)
Alataurus	(Ar,Tr,Pt)	Alexenia	(Br,Ar,St)	Allocrioceras	(Mo,Ce,Am)
Alatiformia	(Br,Ar,Sp)	Alfeldites	(Mo,Ce,Am)	Allocryptaspis	(Cd,Pt,Pt)
Alatocoenus	(Cn,He,He)	Alfredina	(Fo,Fo,Fo)	Allocyrtium	(Ac,Ra,Sp)
Alatoproductus	(Br,Ar,St)	Algaroda	(Mo,Ga,Nt)	Allocystites	(Ec,Di,Di)
Alatorthotetina	(Br,Ar,St)	Algericeras	(Mo,Ce,Am)	Allocythereis	(Ar,Os,Pa)
Alatothyris	(Br,Ar,Sp)	Algerina	(Ar,Os,Pa)	Allodesma	(Mo,Bi,Mo)
Albaillella	(Ac,Ra,Sp)	Algerites	(Mo,Ce,Am)	Allodesmus	(Cd,Ma,Ca)
Albanites	(Mo,Ce,Ce)	Algherella	(Cd,Co,Co)	Allograptus	(He,Gr,Gr)
Albansia	(Ar,Tr,Pt)	Algomella	(Mo,In,In)	Alloiteaucoenia	(Cn,An,Sc)

Alloiteausmilvia	(Cn,An,Sc)	Altaepeltis	(Ar,Tr,Co)	Amandaraia	(Cn,An,Ru)
Allolepidotus	(Cd,Os,Am)	Altaesajanis	(Ar,Tr,Ph)	Amandophyllum	(Cn,An,Ru)
Allomactra	(Mo,Bi,Ve)	Altaestrophia	(Br,Ar,St)	Amanses	(Cd,Os,Te)
Allomera	(Po,De,Li)	Altaethyrella	(Br,Ar,At)	Amaraphyllum	(Cn,An,Ru)
Allomma	(Ec,Ec,Hm)	Altaicornus	(Hy,Hy,Hy)	Amarassites	(Mo,Ce,Ce)
Allomorphina	(Fo,Fo,Fo)	Altaicyathus	(Po,Ir,Ka)	Amarophos	(Mo,Ga,Ne)
Allomorphinella	(Fo,Fo,Fo)	Altaiophyllum	(Cn,An,Ru)	Amarsuopocrinus	(Ec,Cr,Mo)
Allonema	(Bz,Gy,Ct)	Altaipecten	(Mo,Bi,Ph)	Amathia	(Br,Gy,Ct)
Allonia	(Pr,Co,Ch)	Altaja	(Cn,An,Ru)	Amaura	(Mo,Ga,He)
Allonychia	(Mo,Bi,Pr)	Altajaharpes	(Ar,Tr,Un)	Amauellina	(Mo,Ga,Nt)
Allopagus	(Mo,Bi,Ve)	Altajella	(Br,Ar,Sp)	Amauroceras	(Mo,Ce,Am)
Allophyllum	(Cn,An,Ru)	Altaspiratella	(Mo,Ga,Th)	Amauropina	(Mo,Ga,Nt)
Allopicoceras	(Mo,Ce,En)	Altasterella	(Fo,Fo,Fo)	Amauropis	(Mo,Ga,Nt)
Allopleuron	(Cd,Re,Ch)	Alternatus	(Mo,Cr,Te)	Amauropsona	(Mo,Ga,Nt)
Allopora	(Cn,Hy,St)	Alternifenestella	(Bz,St,Fe)	Amaurotoma	(Mo,Ga,Ar)
Alloprosalocrocinus	(Ec,Cr,Mo)	Alternognathus	(Cd,Co,Co)	Amardella	(Br,Ar,Or)
Alloptychites	(Mo,Ce,Ce)	Altha	(Ar,Os,Po)	Amberleya	(Mo,Ga,Ar)
Allothynechoides	(Br,Ar,Rh)	Altinerina	(Fo,Fo,Fo)	Ambicocrinus	(Ec,Cr,Di)
Allothynechus	(Br,Ar,Rh)	Altioculus	(Ar,Tr,Pr)	Ambigostrea	(Mo,Bi,Pr)
Allosacculus	(Po,De,Li)	Altipleucus	(Br,Ar,Sp)	Ambikella	(Br,Ar,Sp)
Allosmerus	(Cd,Os,Os)	Altistoma	(Fo,Fo,Fo)	Ambipleurus	(Ec,Ec,Te)
Allosocrinus	(Ec,Cr,Ct)	Altitudella	(Ar,Tr,Pr)	Ambitropus	(Fo,Fo,Fo)
Allostrophia	(Mo,Ga,Nt)	Altivasum	(Mo,Ga,Ne)	Ambliacrinus	(Ec,Cr,Mo)
Allosyococrinus	(Ec,Cr,Ct)	Altomarginula	(Mo,Ga,Ar)	Amblyacrum	(Mo,Ga,Ne)
Allothriassops	(Cd,Os,Pe)	Altoplicatella	(Br,Ar,Sp)	Amblycranium	(Ar,Tr,Pr)
Allothaxter	(Ec,Ec,Sp)	Altrix	(Mo,Ga,Ar)	Amblygypus	(Ec,Ec,Ho)
Allothrioceras	(Mo,Ce,En)	Altschedata	(Bz,St,Cy)	Amblypneustes	(Ec,Ec,Te)
Allotropiophyllum	(Cn,An,Ru)	Altudoceras	(Mo,Ce,Go)	Amblypteria	(Cd,Os,Pa)
Allozygoocrinus	(Ec,Cr,Di)	Alturnella	(Mo,Ga,Pe)	Amblypterus	(Cd,Os,Pa)
Allumettoceras	(Mo,Ce,Or)	Alula	(Mo,Bi,Ph)	Amblyosphonella	(Po,De,Pe)
Almaena	(Fo,Fo,Fo)	Alurites	(Mo,Ce,Go)	Amblyosphonelloides	(Po,De,Pe)
Almaloceras	(Mo,Ce,On)	Aluta	(Ar,Os,Ar)	Ambocardia	(Mo,Bi,Ve)
Almascyllum	(Cd,Ch,Oc)	Alutella	(Ar,Os,Ar)	Ambocoelia	(Br,Ar,Sp)
Almerahynchia	(Br,Ar,Rh)	Alutera	(Cd,Os,Te)	Ambocythere	(Ar,Os,Po)
Almites	(Mo,Ce,Go)	Aluvarua	(Cd,Os,Pr)	Amboglossa	(Br,Ar,Sp)
Almohadites	(Mo,Ce,Am)	Aluverina	(Bz,St,Fe)	Ambolostoma	(Ec,Bi,Sp)
Almorhynchia	(Br,Ar,Rh)	Aluverooceras	(Mo,Ce,Ac)	Ambonlepidos	(Pr,Ma,Tu)
Almifia	(Mo,Bi,Pr)	Alvania	(Mo,Ga,Nt)	Ambonolium	(Ar,Tr,Co)
Alocaxis	(Mo,Ga,Nt)	Alveinus	(Mo,Bi,Ve)	Ambonorthella	(Br,Ar,Or)
Alocolytoceras	(Mo,Ce,Am)	Alveocyclammina	(Fo,Fo,Fo)	Ambonychia	(Mo,Bi,Pr)
Aloconcha	(Mo,Bi,Un)	Alveolaria	(Bz,St,Ce)	Ambonychiopsis	(Mo,Bi,Pr)
Alocopocythere	(Ar,Os,Pr)	Alveoella	(Ar,Os,Pa)	Ambostraccon	(Ar,Os,Pr)
Alocospira	(Mo,Ga,Ne)	Alveolina	(Fo,Fo,Fo)	Ambothyris	(Br,Ar,Sp)
Aloculatia	(Ar,Os,Pa)	Alveolinella	(Fo,Fo,Fo)	Ambozone	(Mo,Ga,Ar)
Alokistocare	(Ar,Tr,Pr)	Alveolites	(Cn,An,Ta)	Ambrolinevitus	(Hy,Hy,Hy)
Alokistocarella	(Ar,Tr,Pr)	Alveolocyathus	(Cn,An,Sc)	Ambtonia	(Ar,Os,Pr)
Alomataspis	(Ar,Tr,Un)	Alveolophragmium	(Fo,Fo,Fo)	Ambuloectus	(Cd,Ma,Ce)
Alopias	(Cd,Ch,La)	Alveopora	(Cn,An,Sc)	Amecephalina	(Ar,Tr,Pr)
Alosa	(Cd,Os,Cl)	Alveosepta	(Fo,Fo,Fo)	Amecephalus	(Ar,Tr,Pr)
Alosculum	(Po,He,Ly)	Alveovalulina	(Fo,Fo,Fo)	Amechilus	(Ar,Tr,Un)
Alpenachitina	(Fo,Fo,Ch)	Alvinia	(Mo,Ga,Nt)	Amecestis	(Ec,Rh,Rh)
Alpenoceras	(Mo,Ce,Di)	Alwynella	(Br,Ar,St)	Amechinomya	(Mo,Bi,Ve)
Alphacyathus	(Po,Re,Aj)	Alwynia	(Br,Ar,Te)	Amechichilus	(Mo,Ga,Nt)
Alpicidaris	(Ec,Ec,Ct)	Alwynopora	(Bz,St,Fe)	Amechicythara	(Mo,Ga,Ne)
Alpillina	(Fo,Fo,Fo)	Alwynulus	(Ar,Tr,Ph)	Amelacanthus	(Cd,Ch,Ct)
Alpinites	(Mo,Ce,Go)	Alysidotella	(Bz,Gy,Ch)	Ameranella	(Mo,Ga,Un)
Alpinophragmium	(Fo,Fo,Fo)	Alzadasaurus	(Cd,Re,Ps)	Americardia	(Mo,Bi,Ve)
Alpinophyllia	(Cn,An,Sc)	Alzonella	(Fo,Fo,Fo)	Americare	(Ar,Tr,Un)
Alpinoseris	(Cn,An,Sc)	Amaca	(Mo,Ga,Nt)	Americaspis	(Cd,Pr,Pr)
Alpinothalamia	(Po,De,Un)	Amalda	(Mo,Ga,Ne)	Amerigobolbina	(Ar,Os,Pa)
Alsatites	(Mo,Ce,Am)	Amalgamoporos	(Bz,St,Cr)	Amerirostra	(Mo,Ce,Se)
Alsopocrinus	(Ec,Cr,Ct)	Amalgamoprus	(Bz,St,Fe)	Amerycina	(Mo,Bi,Ve)
Altaecypris	(Ar,Os,Pa)	Amalthococrinus	(Ec,Cr,Mi)	Amesopleura	(Br,Ar,Sp)
Altaeorthis	(Br,Ar,Or)	Amaltheus	(Mo,Ce,Am)	Ametoria	(Br,Ar,St)

Ameura	(Ar,Tr,Pr)	Ampakabastraea	(Cn,An,Sc)	Amphipropalum	(Ac,Ra,Na)
Amgaspis	(Ar,Tr,Un)	Ampakanites	(Mo,Ce,Am)	Amphiscephala	(Mo,Ga,Eu)
Amginia	(Ar,Tr,As)	Ampellatocephalina	(Ar,Tr,Un)	Amphisella	(Ar,Os,Pa)
Amginoerbia	(Ar,Tr,Co)	Ampelocrinus	(Ec,Cr,Cl)	Amphisorus	(Fo,Fo,Fo)
Amginouyia	(Ar,Tr,Un)	Ampezzamilla	(Mo,Ga,He)	Amphisphaera	(Ac,Ra,Sp)
Amiantis	(Mo,Bi,Ve)	Ampezzoella	(Mo,Ga,He)	Amphissa	(Mo,Ga,Ne)
Amiaspis	(Ar,Tr,Pt)	Ampezzogyra	(Mo,Ga,He)	Amphisites	(Ar,Os,Pa)
Amictocracens	(Br,Li,Ac)	Ampezzopleura	(Mo,Ga,He)	Amphistegina	(Fo,Fo,Fo)
Amicula	(Mo,Fo,Ne)	Ampezzosella	(Mo,Ga,He)	Amphistephanites	(Mo,Ce,Ce)
Amicus	(Ar,Tr,Pt)	Ampezzotrochus	(Mo,Ga,Ar)	Amphisticus	(Cd,Os,Pf)
Amiella	(Ar,Mo,Li)	Ampehekepibus	(Cd,Re,Sq)	Amphistium	(Cd,Os,Pn)
Amijiella	(Fo,Fo,Fo)	Amphelia	(Cn,An,Sc)	Amphistrophia	(Br,Ar,St)
Amiopsis	(Cd,Os,Am)	Ampheristocrinus	(Ec,Cr,Cl)	Amphistrophella	(Br,Ar,St)
Amiskwia	(Pr,Un,In)	Ampheristus	(Cd,Os,Op)	Amphistylus	(Ac,Ra,Sp)
Amissopecten	(Br,Ar,Rh)	Amphiaraus	(Mo,Bi,Ve)	Amphithalamus	(Mo,Ga,He)
Ammagnostus	(Ar,Tr,Ag)	Amphiastraea	(Cn,An,Sc)	Amphitomaria	(Mo,Ga,He)
Ammatophora	(Bz,Gy,Ch)	Amphiaulastraea	(Cn,An,Sc)	Amphitomella	(Br,Ar,Sp)
Ammoastuta	(Fo,Fo,Fo)	Amphiblestrum	(Bz,Gy,Ch)	Amphitoxotis	(Ar,Os,Pa)
Ammobacularia	(Fo,Fo,Fo)	Amphibrachium	(Ac,Ra,Sp)	Amphitremoda	(Fo,Fo,Fo)
Ammobaculites	(Fo,Fo,Fo)	Amphicervicis	(Fo,Fo,Fo)	Amphitriodites	(Ec,Ho,De)
Ammobaculoides	(Fo,Fo,Fo)	Amphicetus	(Cd,Ma,Ce)	Amphitriscoelus	(Mo,Bi,Hi)
Ammocycloculina	(Fo,Fo,Fo)	Amphichaena	(Mo,Bi,Ve)	Amphitrochus	(Mo,Ga,Ar)
Ammodiscella	(Fo,Fo,Fo)	Amphiclina	(Br,Ar,Sp)	Amphitryon	(Ar,Tr,As)
Ammodiscoides	(Fo,Fo,Fo)	Amphiclinodonta	(Br,Ar,Sp)	Amphizonia	(Ar,Os,Pa)
Ammodiscus	(Fo,Fo,Fo)	Amphicoryna	(Fo,Fo,Fo)	Amphodon	(Cd,Os,Pf)
Ammodytes	(Cd,Os,Pf)	Amphicostella	(Ar,Os,Me)	Amphoracitina	(Fo,Fo,Ch)
Ammoeplithidiella	(Fo,Fo,Fo)	Amphicrinus	(Ec,Cr,Sc)	Amphoracrinus	(Ec,Cr,Mo)
Ammoglobigerina	(Fo,Fo,Fo)	Amphictene	(An,Po,Te)	Amphoracrocrinus	(Ec,Cr,Mo)
Ammolagena	(Fo,Fo,Fo)	Amphicyclia	(Ac,Ra,Sp)	Amphoracystis	(Ec,Di,Di)
Ammomarginulina	(Fo,Fo,Fo)	Amphicyrtoceras	(Mo,Ce,On)	Amphoratheca	(Fo,Fo,Fo)
Ammonellipsites	(Mo,Ce,Go)	Amphicythere	(Ar,Os,Pa)	Amphorella	(Ar,Tr,Pt)
Ammonia	(Fo,Fo,Fo)	Amphicytherura	(Ar,Os,Pa)	Amphorellina	(Ci,Pa,Sp)
Ammoniacrinus	(Ec,Cr,Sa)	Amphidema	(Mo,Bi,Ve)	Amphorithalamia	(Po,De,Pe)
Ammonitoceras	(Mo,Ce,Am)	Amphidonte	(Mo,Bi,Pt)	Amphorometra	(Ec,Cr,Cm)
Ammonoceratites	(Mo,Ce,Am)	Amphigeisina	(Ch,Pr)	Amphorosteus	(Cd,Re,Sq)
Ammopalmula	(Fo,Fo,Fo)	Amphigenia	(Br,Ar,Te)	Amphoton	(Ar,Tr,Co)
Ammoscalaria	(Fo,Fo,Fo)	Amphigraptus	(He,Gr,Gr)	Amphotonella	(Ar,Tr,Co)
Ammosiphonia	(Fo,Fo,Fo)	Amphijanira	(Mo,Bi,Pt)	Amplectoproductina	(Fo,Fo,Fo)
Ammosphaeroidina	(Fo,Fo,Fo)	Amphikegelites	(Ar,Os,Pa)	Ampletocchilina	(Ar,Os,Pa)
Ammospirata	(Fo,Fo,Fo)	Amphileberis	(Ar,Os,Pa)	Amplexiphyllum	(Cn,An,Ru)
Ammotium	(Fo,Fo,Fo)	Amphilectella	(Po,De,Li)	Amplexizaphrentis	(Cn,An,Ru)
Ammotrochoides	(Fo,Fo,Fo)	Amphilichas	(Ar,Tr,Li)	Amplexocarinia	(Cn,An,Ru)
Ammotrophus	(Ec,Ec,Cl)	Amphilites	(Cn,An,Ta)	Amplexograptus	(He,Gr,Gr)
Ammovertella	(Fo,Fo,Fo)	Amphimeandra	(Cn,An,Sc)	Amplexoides	(Cn,An,Ru)
Ammovertellina	(Fo,Fo,Fo)	Amphimenum	(Ac,Ra,Sp)	Amplexopora	(Bz,St,Tr)
Ammovolummina	(Fo,Fo,Fo)	Amphimorphina	(Fo,Fo,Fo)	Amplexus	(Cn,An,Ru)
Amnestostroma	(Po,De,St)	Amphimorsoniella	(Bz,St,Ce)	Amplicolpus	(Mo,Ga,He)
Amnicythere	(Ar,Os,Pa)	Amphinerita	(Mo,Ga,Ar)	Ampliura	(Ar,Tr,De)
Amniopora	(Cn,An,Ta)	Amphicoelia	(Mo,Bi,Pt)	Amplogladius	(Mo,Ga,He)
Amoebinella	(Pr,Un,In)	Amphiope	(Ec,Ec,Cl)	Ampliosiphon	(Mo,Ga,Ne)
Amoebites	(Mo,Ce,Am)	Amphiophiura	(Ec,Op,Op)	Amplostoma	(Mo,Ga,He)
Amoeboceras	(Mo,Ce,Am)	Amphioplus	(Ec,Op,Op)	Amphithilla	(Mo,Ce,Am)
Amoehirhynchia	(Br,Ar,Rh)	Amphipella	(Br,Ar,Rh)	Ampulla	(Mo,Ga,Ne)
Amoenspirifer	(Br,Ar,Sp)	Amphiperas	(Mo,Ga,He)	Ampullaster	(Ec,So,Go)
Amonileia	(Mo,Ga,Ar)	Amphipera	(Cd,Os,Pf)	Ampullella	(Mo,Ga,He)
Amonohexacrinus	(Ec,Cr,Mo)	Amphiphora	(Cn,An,Sc)	Ampulliglabella	(Ar,Tr,Pr)
Amonotis	(Mo,Bi,Pt)	Amphiplecia	(Br,Ar,Or)	Ampullina	(Mo,Ga,He)
Amoraster	(Ec,Ec,Sp)	Amphiplecta	(Ac,Ra,Na)	Ampullinopsis	(Mo,Ga,He)
Amorena	(Mo,Ga,Ne)	Amphipoanoceras	(Mo,Ce,Ce)	Ampullospira	(Mo,Ga,He)
Amoria	(Mo,Ga,Ne)	Amphipora	(Po,De,St)	Ampuloides	(Ar,Os,Pa)
Amorphognathus	(Cd,Co,Co)	Amphiporella	(Bz,St,Tr)	Ampulonica	(Mo,Ga,He)
Amosina	(Br,Ar,St)	Amphisalidocrinus	(Ec,Cr,Cl)	Ampurocrinus	(Ec,Cr,Di)
Amotopus	(Mo,Bi,My)	Amphipsammus	(Mo,Bi,Ve)	Ampyx	(Ar,Tr,As)
Amotapus	(Mo,Bi,Ve)	Amphipyndax	(Ac,Ra,Na)	Ampyxella	(Ar,Tr,As)

Ampyxia	(Ar,Tr,As)	Anagymnotoceras	(Mo,Ce,Ce)	Anaulocidaris	(Ec,Ec,Ci)
Ampyxina	(Ar,Tr,As)	Anahamulina	(Mo,Ce,Am)	Anavirgaites	(Mo,Ce,Am)
Ampyxinella	(Ar,Tr,As)	Anahoplites	(Mo,Ce,Am)	Anaxenaspis	(Mo,Ce,Ce)
Ampyxoides	(Ar,Tr,As)	Anahuacia	(Ar,Os,Un)	Anaximander	(Ar,Tr,Pt)
Aniquia	(Ar,Tr,Pt)	Anakinetica	(Br,Ar,Te)	Anazofa	(Mo,Ga,Ne)
Amsassia	(Po,De,Ta)	Anaklinoceras	(Mo,Ce,Am)	Anazyga	(Br,Ar,At)
Amsassipora	(Bz,St,Fr)	Anakrusa	(Ac,Ra,Sp)	Anbullina	(Mo,Ga,Ne)
Amsdenella	(Br,Ar,Rh)	Analectis	(Cd,Os,La)	Ancalagon	(Pt)
Amsdenina	(Br,Ar,Pe)	Analoocaspis	(Ar,Tr,Pr)	Ancalocrinus	(Ec,Cr,Mo)
Amsdenoides	(Cn,An,Ru)	Analox	(Ar,Tr,Un)	Anceps	(Mo,Ga,Ar)
Amsdenostropiella	(Br,Ar,St)	Analytoceras	(Mo,Ce,Am)	Ancherlotheca	(Hy,Or,Or)
Amsleroceras	(Mo,Ce,Fl)	Anamesoceras	(Mo,Ce,Di)	Anchicrinus	(Ec,Cr,Ci)
Amuletum	(Mo,Ga,Ne)	Anamesocrinus	(Ec,Cr,Os)	Anchigonites	(Br,Ar,Or)
Amurodictya	(Bz,St,Fe)	Ananaspis	(Ar,Tr,Ph)	Anchiopella	(Ar,Tr,Ph)
Amuropecten	(Mo,Bi,Pt)	Ananias	(Mo,Ga,Ar)	Anchiopsis	(Ar,Tr,Ph)
Amurothyris	(Br,Ar,Te)	Ananorites	(Mo,Ce,Ce)	Anchispirocyclina	(Fo,Fo,Fo)
Amussiopecten	(Mo,Bi,Pt)	Ananterodonta	(Mo,Bi,Mo)	Anchistrocheles	(Ar,Os,Po)
Amussium	(Mo,Bi,Pt)	Anapachydiscus	(Mo,Ce,Am)	Anchoa	(Cd,Os,Ci)
Amyclina	(Mo,Ga,Ne)	Anapagurus	(Ar,ML,De)	Anchomasa	(Mo,Bi,My)
Amydaicornus	(Hy,Hy,Hy)	Anapepta	(Mo,Ga,Ne)	Anchura	(Mo,Ga,Nt)
Amydroptychus	(Br,Ar,Rh)	Anapetopsis	(Mo,Ga,Be)	Ancienta	(Pr,Un,In)
Amydrotaxis	(Cd,Co,Co)	Anaphragma	(Bz,St,Tr)	Ancilla	(Mo,Ga,Ne)
Amygdalella	(Ar,Os,Pa)	Anaplomerella	(Ar,Tr,Ph)	Ancillarina	(Mo,Ga,Ne)
Amygdalocosta	(Br,Ar,Te)	Anapteris	(Mo,Bi,My)	Ancillina	(Mo,Ga,Ne)
Amygdalocystites	(Ec,Pe,Co)	Anaptopora	(Bz,Gy,Ch)	Ancillista	(Mo,Ga,Ne)
Amygdalophyllidium	(Cn,An,Ru)	Anaptychius	(Br,Ar,Te)	Ancillopsis	(Mo,Ga,Ne)
Amygdalophylloides	(Cn,An,Ru)	Anaptyctocyathus	(Po,Re,Aj)	Ancillotoechia	(Br,Ar,Rh)
Amygdalophyllum	(Cn,An,Ru)	Anarcestes	(Mo,Ce,Am)	Ancistroceras	(Mo,Ce,Or)
Amygdalotheca	(Ec,St,Co)	Anarchoerinus	(Ec,Cr,Ci)	Ancistrocrania	(Br,Li,Ac)
Amygdalum	(Mo,Bi,Mt)	Anarconcha	(Mo,Ga,Ar)	Ancistrocrinus	(Ec,Cr,Sa)
Amylodon	(Cd,Ch,Cm)	Anarhchia	(Cd,Os,Pl)	Ancistrorelops	(Mo,Ga,Ne)
Amyssodropa	(Mo,Ga,Ne)	Anarhynchia	(Br,Ar,Rh)	Ancistromesus	(Mo,Ga,Pa)
Amzaskiella	(Ar,Tr,Pt)	Anarosaurus	(Cd,Re,No)	Ancistrorhynchia	(Br,Ar,Rh)
Anabacia	(Cn,An,Sc)	Anarhichthys	(Cd,Os,Pl)	Ancistrosyrinx	(Mo,Ga,Ne)
Anabaia	(Br,Ar,At)	Anarthropora	(Bz,Gy,Ch)	Ancillifia	(Mo,Bi,Ve)
Anabaraceps	(Ar,Tr,Re)	Anartioerinus	(Ec,Cr,Ci)	Ancilyoceras	(Mo,Ce,Am)
Anabaraspis	(Ar,Tr,Pt)	Anartiozystis	(Ec,Rh,Cl)	Ancilloceras	(Mo,Ce,Am)
Anabarella	(Mo,He,He)	Anascaphites	(Mo,Ce,Am)	Ancoracrinus	(Ec,Cr,Sa)
Anabaria	(Br,Ar,At)	Anasibirites	(Mo,Ce,Ce)	Ancoradella	(Cd,Co,Co)
Anabarcornus	(Hy,Hy,Hy)	Anasirenites	(Mo,Ce,Ce)	Ancorellina	(Br,Ar,Th)
Anabariteilus	(Tr,An)	Anaspyroceras	(Mo,Ce,Or)	Ancorhynchia	(Br,Ar,Rh)
Anabarites	(Tr,An)	Anastes	(Mo,Ga,Ar)	Anculosa	(Mo,Ga,Nt)
Anabarochilina	(Ar,Os,Ar)	Anastomoceras	(Mo,Ce,Or)	Ancylocidaris	(Ec,Ec,Di)
Anabathron	(Mo,Ga,Nt)	Anastomopora	(Bz,St,Fe)	Ancylostrophia	(Br,Ar,St)
Anabolotreta	(Br,Li,Ac)	Anastrophia	(Br,Ar,Pe)	Ancylohiitina	(Fo,Fo,Ch)
Anacaenaspis	(Ar,Tr,Od)	Anastrophognathus	(Cd,Co,Co)	Ancyrocrinus	(Ec,Cr,Ci)
Anacharsis	(Cd,Ma,Cv)	Anatalavis	(Cd,Av,Ci)	Ancyrodella	(Cd,Co,Ci)
Anacheirurus	(Ar,Tr,Ph)	Anataphrus	(Ar,Tr,As)	Ancyrodelloides	(Cd,Co,Co)
Anachis	(Mo,Ga,Ne)	Anathrella	(Br,Ar,Sp)	Ancyrognathus	(Cd,Co,Co)
Anachronistes	(Cd,Ch,In)	Anathrysis	(Br,Ar,Sp)	Ancyrolepis	(Cd,Co,Co)
Anacithara	(Mo,Ga,Ne)	Anatibetites	(Mo,Ce,Ce)	Ancyropyge	(Ar,Tr,Od)
Anacleoniceras	(Mo,Ce,Am)	Anaticinella	(Fo,Fo,Fo)	Andalucinetes	(Br,Ar,St)
Anaclitacanthus	(Cd,Ch,Ct)	Anatiferopsis	(Ec,St,Mi)	Andalsiana	(Ar,Tr,Ol)
Anacomularia	(Cn,Se,Cn)	Anatifopsis	(Ar,Un,Un)	Andamookia	(Fo,Fo,Fo)
Anacopodia	(Ar,Tr,Un)	Anatinya	(Mo,Bi,Ph)	Andangularia	(Mo,Ga,Nt)
Anadara	(Mo,Bi,Ar)	Anatina	(Mo,Bi,Mt)	Andemantatraea	(Cn,An,Sc)
Anadesmoceras	(Mo,Ce,Am)	Anatipopecten	(Mo,Bi,Pt)	Andenothyone	(Ec,Ho,De)
Anadoxides	(Ar,Tr,Re)	Anatolepis	(Cd,Pt,Pt)	Anderkenia	(Mo,Bi,Pt)
Anadyrella	(Br,Ar,Te)	Anatoma	(Mo,Ga,Ar)	Andersenia	(Fo,Fo,Fo)
Anaethalion	(Cd,Os,El)	Anatomes	(Mo,Ce,Ce)	Andersenolina	(Fo,Fo,Fo)
Anafesta	(Tr,Un)	Anatreta	(Br,Li,Ac)	Andersonites	(Mo,Ce,Am)
Analleingites	(Mo,Ce,Ce)	Anatropites	(Mo,Ce,Ce)	Andersonella	(Ar,Tr,As)
Anagaudryceras	(Mo,Ce,Am)	Anatrypa	(Br,Ar,At)	Anderssonoceras	(Mo,Ce,Ce)
Anagymites	(Mo,Ce,Ce)	Anatsabites	(Mo,Ce,Go)	Andesites	(Mo,Ce,Am)

Andicerus	(Mo,Ce,Am)	Angrancoceras	(Mo,Ce,Go)	Anisotechnophorus	(Mo,Ro,Ri)
Andicula	(Mo,Ga,Ne)	Anguilla	(Cd,Os,An)	Anisotremus	(Cd,Os,Pf)
Andinaecaste	(Ar,Tr,Ph)	Anguillavus	(Cd,Os,An)	Anisotrypa	(Bz,St,Tr)
Andinodesmia	(Mo,Bi,Ph)	Anguilloides	(Cd,Os,An)	Anisotrypella	(Bz,St,Tr)
Anditrigonia	(Mo,Bi,Tr)	Anguillospira	(Mo,Ga,Nt)	Ankhelasma	(Cn,An,Ru)
Andivaugonia	(Mo,Bi,Tr)	Anguinella	(Mo,Ga,Nt)	Ankinatsytes	(Mo,Ce,Am)
Andobolus	(Br,Li,Li)	Anguipecten	(Mo,Bi,Pt)	Ankitokazocaris	(Ar,Th,Cc)
Andonia	(Mo,Ga,Ne)	Anguisia	(Bz,St,Cc)	Ankoura	(Ar,Tr,Pt)
Andorina	(Ar,MI,De)	Angularia	(Mo,Ga,Nt)	Ankumia	(Ar,Os,Pl)
Andrarina	(Ar,Tr,Pt)	Angulaticeras	(Mo,Ce,Am)	Ankyloceras	(Mo,Ce,On)
Andrazella	(Cn,An,Sc)	Angulatoblastus	(Ec,BI,Fi)	Ankylophorus	(Cd,Os,Pc)
Andreaea	(Po,He,He)	Angulatostroma	(Po,De,St)	Ankystorhynchus	(Cd,Ch,Rj)
Andreaspira	(Br,Ar,Sp)	Angullongia	(Po,De,Pe)	Annachlamys	(Mo,Bi,Pt)
Andreioceras	(Mo,Ce,Di)	Angulophyllum	(Cn,An,Ru)	Annaecoelia	(Po,De,Pe)
Andrejella	(Fo,Fo,Fo)	Angulobraccia	(Ac,Ra,Sp)	Annamitella	(Ar,Tr,Pt)
Andreolepis	(Cd,Os,Pa)	Anguloceras	(Mo,Ce,El)	Annamitia	(Ar,Tr,Pt)
Andrewsiphius	(Cd,Ma,Ce)	Angulocrinus	(Ec,Cr,Mi)	Annea	(Cd,Ch,Oc)
Andriopora	(Bz,Gy,Ch)	Angulodiscus	(Fo,Fo,Fo)	Annectina	(Fo,Fo,Fo)
Androgynoceras	(Mo,Ce,Am)	Angulodus	(Cd,Co,Co)	Annectocyma	(Bz,St,Cc)
Andromeda	(Ac,Ra,Na)	Angulogavelinella	(Fo,Fo,Fo)	Annepona	(Mo,Ga,Nt)
Androsina	(Fo,Fo,Fo)	Angulogerina	(Fo,Fo,Fo)	Anningella	(Mo,Bi,Pt)
Andrusella	(Mo,Bi,Ve)	Angulospira	(Mo,Pa,Hy)	Annoceras	(Mo,Ce,El)
Andrusovicardium	(Mo,Bi,Ve)	Angulotreta	(Br,Li,Ac)	Annotocyathus	(Cn,An,Sc)
Anebochtheris	(Ar,Os,Po)	Angulus	(Mo,Bi,Ve)	Annuliconcha	(Mo,Bi,Pt)
Anebolithus	(Ar,Tr,As)	Angustaeva	(Ar,Tr,Pt)	Annulinctes	(Mo,Bi,Pt)
Anechocephalus	(Ar,Tr,Pt)	Angusticardinia	(Br,Ar,Or)	Annuloceras	(Mo,Ce,Am)
Anechocrinus	(Ec,Cr,Cl)	Angusticardo	(Mo,Bi,Ve)	Annulocibicides	(Fo,Fo,Fo)
Anechophragma	(Br,Ar,St)	Angusticornus	(Hy,Hy,Hy)	Annulocyathella	(Po,Re,Aj)
Aneisoheldia	(Ar,Os,Po)	Angustiochrea	(Tr,An)	Annulocyathus	(Po,Re,Aj)
Anelotreta	(Br,Li,Ac)	Angustiphyllum	(Cn,An,Ru)	Annulofrondicularia	(Fo,Fo,Fo)
Anematina	(Mo,Ga,Ar)	Angustothyris	(Br,Ar,Te)	Annulofungia	(Po,Re,Aj)
Anemetocrinus	(Ec,Cr,Cl)	Angyomphalus	(Mo,Ga,Ar)	Annuloplatellina	(Fo,Fo,Fo)
Anemocephalops	(Ar,Tr,Pt)	Anhelkcephalon	(Ar,MI,Is)	Annunziopora	(Bz,St,Tr)
Anemocephalus	(Ar,Tr,Pt)	Anhuiaspis	(Ar,Tr,Co)	Anobasicrinus	(Ec,Cr,Cl)
Anemonaria	(Br,Ar,St)	Anhuiceras	(Mo,Ce,El)	Anodomaria	(Mo,Ga,Ar)
Anepholoceras	(Mo,Ce,Na)	Anhuiconus	(Mo,In,In)	Anodontia	(Mo,Bi,Ve)
Anetoceras	(Mo,Ce,An)	Anhuiella	(Pr,Un,Se)	Anodontopleura	(Mo,Bi,Hi)
Aneuroceras	(Mo,Ce,Am)	Aniabrochus	(Br,Ar,Te)	Anodontopsis	(Mo,Bi,Mo)
Aneurychilus	(Mo,Ga,Nt)	Anictosphaera	(Fo,Fo,Fo)	Anofia	(Mo,Bi,Ve)
Aneurystoma	(Mo,Ga,Ne)	Anidanthus	(Br,Ar,St)	Anolites	(Mo,Ce,Ce)
Anfaceras	(Mo,Ce,Ce)	Animonithyris	(Br,Ar,Te)	Anolotichia	(Bz,St,Cy)
Anfedatia	(Ar,Os,Un)	Anisactinella	(Br,Ar,Sp)	Anomalactinella	(Br,Ar,Sp)
Angaraspis	(Cd,Pt,Pt)	Anisarcestes	(Mo,Ce,Ce)	Anomalesia	(Br,Ar,Te)
Angarella	(Br,Li,Ac)	Anisaser	(Ec,Ec,Sp)	Anomalinelia	(Fo,Fo,Fo)
Angaria	(Mo,Ga,Ar)	Anisastraea	(Cn,An,Sc)	Anomalinoides	(Fo,Fo,Fo)
Angaricyathus	(Po,Re,Aj)	Anisicyrtis	(Ac,Ra,Na)	Anomalisiph	(Mo,Ga,Ne)
Angarocaris	(Ar,Me,Ag)	Anisocardia	(Mo,Bi,Ve)	Anomalocardia	(Mo,Bi,Ve)
Angastobactrites	(Mo,Ce,An)	Anisoceras	(Mo,Ce,Am)	Anomalocaris	(Pr,Di,Ra)
Angelina	(Ar,Tr,Pt)	Anisocerasites	(An,Po,Eu)	Anomaloceras	(Mo,Ce,Na)
Angelinoeras	(Mo,Ce,Or)	Anisochilina	(Ar,Os,Le)	Anomalocoelia	(Mo,Bi,Pt)
Angeliphyllia	(Cn,An,Sc)	Anisocidaris	(Ec,Ec,Cl)	Anomalocrinus	(Ec,Cr,Ds)
Angelopora	(Bz,Gy,Ch)	Anisocoenia	(Cn,An,Sc)	Anomalocystites	(Ec,St,Mi)
Angioblastus	(Ec,BI,Fi)	Anisocorbula	(Mo,Bi,My)	Anomalodiscus	(Mo,Bi,Ve)
Angiospirifer	(Br,Ar,Sp)	Anisocrinus	(Ec,Cr,Sa)	Anomalodonta	(Mo,Bi,Pt)
Anglagnostus	(Ar,Tr,Ag)	Anisocyamus	(Ar,Os,Po)	Anomalofusus	(Mo,Ga,Ne)
Anglaspis	(Cd,Pt,Pt)	Anisodonta	(Mo,Bi,Ve)	Anomaloglossa	(Br,Li,Li)
Angliaecytheridea	(Ar,Os,Po)	Anisograptus	(He,Gr,De)	Anomalograptus	(He,Gr,Gr)
Anglicornus	(Mo,Ce,Di)	Anisomyon	(Mo,Ga,Ba)	Anomalokellia	(Mo,Bi,Ve)
Anglidiscus	(Ec,Ed,Is)	Anisonotella	(Ar,Tr,As)	Anomalomya	(Mo,Ga,Sa)
Anglonautis	(Mo,Ce,Na)	Anisophyllum	(Cn,An,Ru)	Anomalopleuroides	(Mo,Bi,Ph)
Angliosuchus	(Cd,Re,Cr)	Anisopleurella	(Br,Ar,St)	Anomalopsis	(Cd,Re,Sp)
Angochitina	(Fo,Fo,Ch)	Anisopyge	(Ar,Tr,Pr)	Anomaloria	(Br,Ar,Sp)
Angolosaurus	(Cd,Re,Sq)	Anisosiren	(Cd,Ma,Si)	Anomalorthis	(Br,Ar,Or)
Angotia	(Fo,Fo,Fo)	Anisostoma	(Mo,Ga,Ar)	Anomalotoechus	(Bz,St,Tr)

Anomastraea	(Cn,An,Sc)	Antepaijenborchella	(Ar,Os,Po)	Antineosteus	(Cd,Pl,Un)
Anomeioceras	(Mo,Ce,On)	Antepepta	(Mo,Ga,Ne)	Antinoche	(Mo,Bi,Ve)
Anomia	(Mo,Bi,Pt)	Anteridocus	(Br,Ar,Rh)	Antinodulus	(Mo,Ga,Nt)
Anomianella	(Mo,Bi,Un)	Antetrichomya	(Mo,Bi,Mt)	Antinomia	(Br,Ar,Te)
Anommatocyther	(Ar,Os,Po)	Antezeilleria	(Br,Ar,Te)	Antipecten	(Mo,Bi,Pt)
Anomocare	(Ar,Tr,As)	Anthaspidella	(Po,De,Li)	Antiphragmoceras	(Mo,Ce,Di)
Anomocarella	(Ar,Tr,Pt)	Anthemocrinus	(Ec,Cr,Di)	Antiplanes	(Mo,Ga,Ne)
Anomocarina	(Ar,Tr,As)	Antheria	(Cn,An,Ru)	Antiplectoceras	(Mo,Ce,Or)
Anomocarioides	(Ar,Tr,As)	Antherolites	(Cn,An,Ta)	Antipleura	(Mo,Bi,Pr)
Anomocariopsis	(Ar,Tr,As)	Anthoblastus	(Ec,Bi,Fi)	Antipychna	(Br,Ar,Te)
Anomocidaris	(Ec,Ec,Ci)	Anthoceras	(Mo,Ce,En)	Antiquaster	(Ec,Op,St)
Anomoclonella	(Po,De,Li)	Anthochitina	(Fo,Fo,Ch)	Antiquatheca	(Hy,Or,Or)
Anomocytheridea	(Ar,Os,Po)	Anthocyrtidium	(Ac,Ra,Na)	Antiquatonia	(Br,Ar,St)
Anomoedus	(Cd,Os,Py)	Anthocyrtis	(Ac,Ra,Na)	Antiquicyprina	(Mo,Bi,Ve)
Anomopora	(Cn,An,Sc)	Anthocyrtoma	(Ac,Ra,Na)	Antiquilma	(Mo,Bi,Pt)
Anomorphites	(Po,De,Li)	Anthograptus	(Ec,Gr,Gr)	Antirhynchonella	(Br,Ar,Pe)
Anomotherium	(Cd,Ma,Si)	Antholites	(Cn,An,Ta)	Antischmidella	(Ar,Os,Pa)
Anomotodon	(Cd,Ch,La)	Anthomorpha	(Mo,Ce,On)	Antisolarium	(Mo,Ga,Ar)
Anomphalus	(Mo,Ga,Eu)	Anthonya	(Mo,Bi,Ve)	Antispira	(Mo,Pa,Hy)
Anonymoceras	(Mo,Ce,On)	Anthospyrus	(Ac,Ra,Na)	Antispirifer	(Br,Ar,Sp)
Anopaea	(Mo,Bi,Pt)	Anthostylis	(Cn,An,Sc)	Antistrix	(Br,Ar,Te)
Anopisthodon	(Mo,Bi,Tr)	Anthracaris	(Ar,MI,My)	Antistrixia	(Br,Ar,Rh)
Anoplia	(Br,Ar,St)	Anthracocaris	(Ar,MI,Ta)	Antitrochus	(Mo,Ga,Ar)
Anopliopsis	(Br,Ar,St)	Anthracoceras	(Mo,Ce,Go)	Antizafra	(Mo,Ga,Ne)
Anoploceras	(Mo,Ce,Na)	Anthracoceratites	(Mo,Ce,Go)	Antizyga	(Mo,Pa,Hy)
Anoplonassa	(Cd,Ma,Ce)	Anthracoceratoides	(Mo,Ce,Go)	Antizygospira	(Br,Ar,At)
Anoplotheca	(Br,Ar,At)	Anthracocrinus	(Ec,Cr,Di)	Antliodus	(Cd,Ch,Pe)
Anopocodia	(Ar,Tr,Pt)	Anthracoleda	(Mo,Bi,Nu)	Antofastaichthys	(Cd,Os,El)
Anopolenus	(Ar,Tr,Re)	Anthracomedusa	(Cn,Ch,Ca)	Antogonathus	(Cd,Co,Co)
Anoptambonites	(Br,Ar,St)	Anthraconeilo	(Mo,Bi,Nu)	Antohipponcharion	(Ar,Os,Ar)
Anoptychia	(Mo,Ga,Nt)	Anthracoperca	(Cd,Os,Pl)	Antoneila	(Mo,Bi,Ar)
Anoria	(Ar,Tr,Co)	Anthracophausia	(Ar,MI,Eo)	Antoniocoscinus	(Po,Re,Aj)
Anoriostoma	(Mo,Ga,Ar)	Anthracospirifer	(Br,Ar,Sp)	Antonoceras	(Mo,Ce,On)
Anornithopora	(Bz,Gy,Ch)	Anthracoscyon	(Cd,De,Li)	Antrocapophyllum	(Cn,An,Ru)
Anorhaster	(Ec,As,Ur)	Antiaechmia	(Ar,Os,Pa)	Antrimpos	(Ar,MI,De)
Anorthopygus	(Ec,Ec,Ho)	Antibythypris	(Ar,Os,Po)	Antrispongia	(Po,He,Un)
Anostylostroma	(Po,De,St)	Anticlimax	(Mo,Ga,Nt)	Antronaria	(Br,Ar,Rh)
Anoterisma	(Cd,Os,Pn)	Anticonulus	(Mo,Ga,Ar)	Antropora	(Bz,Gy,Ch)
Anotoceras	(Mo,Ce,Ce)	Anticostella	(Ar,Os,Pa)	Antrospongia	(Po,De,Li)
Anotodus	(Cd,Ch,La)	Anticythereis	(Ar,Os,Po)	Antutitrigonia	(Mo,Bi,Tr)
Anotopora	(Bz,Gy,Ch)	Antigaleatella	(Br,Ar,Pe)	Anulatrypa	(Br,Ar,At)
Anoxypristis	(Cd,Ch,Rj)	Antigona	(Mo,Bi,Ve)	Anulipecten	(Mo,Bi,Pt)
Anozyga	(Mo,Ga,Nt)	Antigonambonites	(Br,Ar,Or)	Anulocrinus	(Ec,Cr,Ds)
Ansates	(Mo,Ga,Pa)	Antigonia	(Cd,Os,Ze)	Anuloides	(Ar,Tr,Pt)
Anselhia	(Br,Ar,St)	Antigoniarcula	(Br,Ar,Te)	Anulostrea	(Mo,Bi,Pt)
Ansellia	(Cd,Co,Co)	Antiguamya	(Mo,Bi,My)	Anys	(Br,Li,Li)
Anshunopecten	(Mo,Bi,Pt)	Antiguastrea	(Cn,An,Sc)	Anzalia	(Pr,Un,In)
Antacaroceras	(Mo,Ce,El)	Antiguraleus	(Mo,Ga,Ne)	Aojia	(Ar,Tr,Co)
Antactinodion	(Mo,Bi,Nu)	Antigyra	(Mo,Pa,Hy)	Aorhynchia	(Br,Ar,Rh)
Antagnopleura	(Ar,Tr,Un)	Antigyroceras	(Mo,Ce,Di)	Aorocrinus	(Ec,Cr,Mo)
Antagnus	(Ar,Tr,Pt)	Anthomocrinus	(Ec,Cr,Ci)	Aorograptus	(He,Gr,De)
Antalis	(Mo,Sc,Sc)	Antijanira	(Mo,Bi,Pt)	Aostipora	(Bz,St,Tr)
Antalyna	(Fo,Fo,Fo)	Antikinkaidia	(Cn,An,Ru)	Aoteadrillia	(Mo,Ga,Ne)
Antarcticella	(Fo,Fo,Fo)	Antilachelus	(Mo,Ga,Ar)	Apachella	(Mo,Ga,Ar)
Antarcticocyathus	(Po,Fr,Ar)	Antillarster	(Ec,Ec,Sp)	Apachia	(Ar,Tr,Pt)
Antarctidromia	(Ar,MI,De)	Antillia	(Cn,An,Sc)	Aparchitella	(Ar,Os,Pa)
Antarctisra	(Ac,Ra,Na)	Antillocaprina	(Mo,Bi,Hi)	Aparchitellina	(Ar,Os,Pa)
Antarctodarwinella	(Mo,Ga,Nt)	Antillocyathus	(Cn,An,Sc)	Aparchites	(Ar,Os,Pa)
Antarctomithrax	(Ar,MI,De)	Antillophos	(Mo,Ga,Ne)	Aparchitocythere	(Ar,Os,Po)
Antailaeva	(Ar,Tr,Un)	Antillophyllia	(Cn,An,Sc)	Aparimarhynchia	(Br,Ar,Rh)
Antatlasia	(Ar,Tr,Pt)	Antillosarcolites	(Mo,Bi,Hi)	Apataxia	(Mo,Ga,Nt)
Anteglossia	(Mo,Ga,Nt)	Antilloseris	(Cn,An,Sc)	Apatēcathanus	(Cd,Ac,Is)
Antelocoelia	(Br,Ar,At)	Antimelatoma	(Mo,Ga,Ne)	Apatēcchia	(Br,Ar,Te)
Antennarius	(Cd,Os,Lo)	Antimitra	(Mo,Ga,Ne)	Apatella	(Cd,Co,Co)

Apateloschizocythere	(Ar.Os,Po)	Aphrosalpinx	(Po.De,Pe)	Apousiella	(Br.Ar,Sp)
Apatoides	(Cd.Os,Al)	Aphrosaurus	(Cd.Re,Ps)	Apoxypetalum	(Ec.Ec,Sp)
Apatopholis	(Cd.Os,Al)	Aphycoceras	(Mo.Ce,On)	Appalachignathus	(Cd.Co,Co)
Apatobolbina	(Ar.Os,Pa)	Aphyllum	(Cn.An,Ru)	Appendicysta	(Ar.Tr,Pr)
Apatobolus	(Br.Li,Li)	Apianurus	(Ar.Tr,Od)	Appisania	(Mo.Ga,Ne)
Apatochilina	(Ar.Os,Pa)	Apicaria	(Mo.Ga,Nt)	Applinocrinus	(Ec.Cr,Rv)
Apatocythere	(Ar.Os,Po)	Apicilirella	(Br.Ar,St)	Aprathia	(Ar.Tr,Pr)
Apatogenathus	(Cd.Co,Co)	Apioecardia	(Mo.Bi,Ve)	Apriecardia	(Mo.Bi,Hi)
Apatokephalina	(Ar.Tr,As)	Apioeceras	(Mo.Ce,On)	Apringia	(Br.Ar,Rh)
Apatokephaloides	(Ar.Tr,Pt)	Apioerinites	(Ec.Cr,Mi)	Aprionodon	(Cd.Ch,Ca)
Apatokephalops	(Ar.Tr,Pt)	Apioecypraea	(Mo.Ga,Nt)	Apsendesia	(Bz.St,Ce)
Apatokephalus	(Ar.Tr,As)	Apioecystites	(Ec.Rh,Rh)	Apsidoceras	(Mo.Ce,Ba)
Apatolichas	(Ar.Tr,Li)	Apiograptus	(He.Gr,Gr)	Apsidognathus	(Cd.Co,Co)
Apatomorpha	(Br.Ar,St)	Apionicon	(Ar.Ma,Cy)	Apsilingula	(Br.Li,Li)
Apatopygus	(Ec.Ec,Ca)	Apiotoma	(Mo.Ga,Ne)	Apsilus	(Cd.Os,Pf)
Apatornis	(Cd.Av,Ic)	Apiotrigonia	(Mo.Bi,Tr)	Apsocalymma	(Br.Ar,St)
Apatorthis	(Br.Ar,Or)	Apistocncha	(Pr.Un,In)	Apsopelix	(Cd.Os,Cr)
Apatoskenidioides	(Br.Ar,Or)	Apletosia	(Br.Ar,Te)	Apsoroceras	(Mo.Ce,Am)
Apatotervia	(Bz.St,Ce)	Apleuroceras	(Mo.Ce,Ce)	Apsotreta	(Br.Li,Ac)
Apelismilia	(Cn.An,Sc)	Aplexura	(Ar.Tr,Pt)	Apterniella	(Fo.Fo,Fo)
Apenophyseter	(Cd.Ma,Ce)	Aploceras	(Mo.Ce,Ac)	Aptilechinus	(Ec.Ec,Ey)
Aperispirifer	(Br.Ar,Sp)	Aplococeras	(Mo.Ce,Ce)	Apocyathella	(Po.Re,Aj)
Apertauroria	(Fo.Fo,Fo)	Aplocoma	(Ec.Op,Op)	Apocyathus	(Po.Re,Aj)
Apertirynchella	(Br.Ar,Rh)	Aplocus	(Mo.Ga,Ar)	Aptychodon	(Cd.Re,Ps)
Apertostella	(Bz.St,Fe)	Aplocyathus	(Cn.An,Sc)	Aptycholathyrus	(Mo.Ga,Ne)
Aphaea	(Mo.Bi,Ve)	Aplodiotus	(Cd.Os,Pf)	Aptychopsis	(Ar.Ml,In)
Aphanaia	(Mo.Bi,Pt)	Aplophyllia	(Cn.An,Sc)	Aptyxiella	(Mo.Ga,He)
Aphanepygus	(Cd.Os,Am)	Aplopsammia	(Cn.An,Sc)	Aptyxis	(Mo.Ga,Ne)
Aphanites	(Mo.Ce,Go)	Aplpsomilia	(Cn.An,Sc)	Apulites	(Mo.Bi,Hi)
Aphanomena	(Br.Ar,St)	Aplosphecion	(Po.Ca,Ph)	Apurocrinus	(Ec.Cr,Di)
Aphanoptyxis	(Mo.Ga,He)	Aplotaspis	(Ar.Tr,Pt)	Apynodiscus	(Ec.Ed,Is)
Aphanotaenia	(Mo.Ga,He)	Aplousina	(Bz.Gy,Ch)	Aquilofusus	(Mo.Ga,Ne)
Aphaurosia	(Br.Ar,Rh)	Aplustrum	(Mo.Ga,Ce)	Aquilonites	(Mo.Ce,Go)
Apheathyris	(Br.Ar,Sp)	Aplysiofibra	(Po.De,Un)	Aquitanastraea	(Cn.An,Sc)
Aphelaceras	(Mo.Ce,Na)	Apocalymene	(Ar.Tr,Ph)	Aquitanophyllia	(Cn.An,Sc)
Aphelakardia	(Mo.Ro,Co)	Apocladophyllia	(Cn.An,Sc)	Arabatia	(Br.Ar,Te)
Aphelaspis	(Ar.Tr,As)	Apocoelia	(Po.De,Pe)	Arabella	(An.Po,Eu)
Aphelaster	(Ec.Ec,Sp)	Apocopodon	(Cd.Ch,My)	Arabellites	(An.Po,Eu)
Aphelcerinus	(Ec.Cr,Cl)	Apocrinoceras	(Mo.Ce,El)	Arabia	(Mo.Ga,Nt)
Apheltesia	(Br.Ar,Rh)	Apocyathus	(Pr.Cr,Cr)	Arabica	(Mo.Ga,Nt)
Aphelocythere	(Ar.Os,Po)	Apodactylocrinus	(Ec.Cr,Sa)	Arabicella	(Br.Ar,Te)
Aphelognathus	(Cd.Co,Co)	Apodasmocrinus	(Ec.Cr,Ds)	Arabitrigonia	(Mo.Bi,Tr)
Apheloides	(Ar.Tr,As)	Apoderoceras	(Mo.Ce,Am)	Aracana	(Cd.Os,Te)
Aphelolepis	(Cd.Os,Se)	Apodosia	(Br.Ar,Rh)	Arachnastraea	(Cn.An,Ru)
Aphelotoxon	(Ar.Tr,Pt)	Apogon	(Cd.Os,Pf)	Arachnidium	(Bz.Gy,Ct)
Aphelotreta	(Br.Li,Ac)	Apogonoceras	(Mo.Ce,Na)	Arachniograptus	(He.Gr,Gr)
Apheoorthina	(Br.Ar,Or)	Apogonoides	(Cd.Os,Pf)	Arachniophyllum	(Cn.An,Ru)
Apheoorthis	(Br.Ar,Or)	Apogradioerinus	(Ec.Cr,Cl)	Arachniopleurus	(Ec.Ec,Te)
Aphera	(Mo.Ga,Ne)	Apolectus	(Cd.Os,Pf)	Arachnocrinus	(Ec.Cr,Cl)
Aphetoceras	(Mo.Ce,Ta)	Apollon	(Mo.Ga,Nt)	Arachnocystites	(Ec.Rh,Rh)
Aphia	(Cd.Os,Pf)	Apollonorthis	(Br.Ar,Or)	Arachnoidella	(Bz.Gy,Ct)
Aphlebospongia	(Po.Ca,Ph)	Apolymetis	(Mo.Bi,Ve)	Arachnoides	(Ec.Ec,Cl)
Aphnelepis	(Cd.Os,Pc)	Apomatella	(Br.Ar,Or)	Arachnolasma	(Cn.An,Ru)
Aphractus	(Mo.Ce,Na)	Apomodocia	(Ar.Tr,Pt)	Arachnolasmella	(Cn.An,Ru)
Aphragmites	(Mo.Ce,As)	Apopentamerus	(Br.Ar,Pe)	Arachnophyllum	(Cn.An,Ru)
Aphragmus	(Br.Ar,Te)	Apoplanias	(Ar.Tr,Pt)	Arachnopusia	(Bz.Gy,Ch)
Aphraxonia	(Cn.An,Ru)	Apoptoegma	(Mo.Ro,Ri)	Araecrinus	(Ec.Cr,Cl)
Aphrikaneocythere	(Ar.Os,Po)	Aporolepas	(Ar.Ci)	Araeodactylus	(Mo.Ga,Nt)
Aphrocallistes	(Po.He,He)	Aporosocyathus	(Po.Re,Aj)	Araeodellphis	(Cd.Ma,Ce)
Aphrodina	(Mo.Bi,Ve)	Aporrhais	(Mo.Ga,Nt)	Araeonema	(Mo.Ga,Ar)
Aphroelasma	(Cn.An,Ru)	Aporthophylla	(Br.Ar,St)	Araeopleura	(Mo.Bi,Hi)
Aphroidophyllum	(Cn.An,Ru)	Aporthophyllina	(Br.Ar,St)	Araeopoma	(Cn.An,Ru)
Aphrophylloides	(Cn.An,Ru)	Aposolenopleura	(Ar.Tr,Pt)	Araeopora	(Cn.An,Ta)
Aphrophyllum	(Cn.An,Ru)	Apothyris	(Br.Ar,Te)	Araeosoma	(Ec.Ec,Et)

Araosteus	(Cd,Os,Pf)	Archaeoehintinia	(Fo,Fo,Fo)	Archaiosteges	(Br,Ar,St)
Aragonella	(Fo,Fo,Fo)	Archaeochitosa	(Fo,Fo,Fo)	Archambona	(Br,Ar,St)
Aragonia	(Fo,Fo,Fo)	Archaeooidaris	(Ec,Ec,Ey)	Archarenicola	(An,Po,Dr)
Araiophyllum	(Cn,An,Sc)	Archaeoconularia	(Cn,Sc,Cn)	Archaster	(Ec,As,Vi)
Araioleura	(Ar,Tr,As)	Archaeoconus	(Mo,Te,Hy)	Archecamp	(Ac,Ra,Na)
Araiostroution	(Cn,An,Ta)	Archaeocrinus	(Ec,Cr,Di)	Archecyrtis	(Ac,Ra,Na)
Arakaevella	(Fo,Fo,Fo)	Archaeocryptolaria	(Cn,Hy,Hy)	Archecyrtum	(Ac,Ra,Na)
Arakespongia	(Po,He,LS)	Archaeocyathus	(Po,lr,Ar)	Archecyrtus	(Ac,Ra,Na)
Arakalsosia	(Br,Ar,St)	Archaeocytopoda	(Ar,MI,De)	Archegocystis	(Ec,Di,Di)
Aralocardia	(Mo,Bi,Ve)	Archaeodelphis	(Cd,Ma,Ce)	Archegonaspis	(Cd,Pt,Pt)
Arambourgia	(Cd,Os,Pf)	Archaeodictyomitra	(Ac,Ra,Na)	Archegonaster	(Ec,So,Go)
Arambourgichthys	(Cd,Os,Pf)	Archaeodictyota	(He,Gr,Un)	Archegonus	(Ar,Tr,Pr)
Aramichthys	(Cd,Os,Pf)	Archaeodoryderma	(Po,De,Li)	Archelon	(Cd,Re,Ch)
Arandaspis	(Cd,Pt,Pt)	Archaeofenestella	(Bz,St,Fe)	Archendoceras	(Mo,Ce,Ya)
Araneatrypa	(Br,Ar,At)	Archaeogeryon	(Ar,MI,De)	Archeochonetes	(Br,Ar,St)
Aranerites	(Mo,Ce,Go)	Archaeognathus	(Cd,Co,Co)	Archeocosta	(Ac,Ra,Po)
Aranegraptus	(He,Gr,De)	Archaeohagiastrum	(Ac,Ra,Sp)	Archeoemucopythere	(Ar,Os,Po)
Araneosstroma	(Po,De,St)	Archaeolafova	(Cn,Hy,Hy)	Archeocydippida	(Ct)
Arapahoia	(Ar,Tr,Pt)	Archaeolasmogyra	(Cn,An,Sc)	Archeolimulus	(Ar,Me,Xi)
Arapopleurum	(Br,Ar,Te)	Archaeolepas	(Ar,Ct)	Archeosolenocera	(Ar,MI,De)
Araratella	(Mo,Ga,Nt)	Archaeolepidotus	(Cd,Os,Se)	Archeostrum	(Ac,Ra,Na)
Araripichthys	(Cd,Os,Cr)	Archaeolynchus	(Po,Re,Mo)	Archetypum	(Ac,Ra,Na)
Araspirifer	(Br,Ar,Sp)	Archaeomaene	(Cd,Os,Pc)	Archiacia	(Ec,Ec,Ca)
Arastra	(Mo,Ga,Ar)	Archaeomianta	(Cd,Ch,My)	Archiacina	(Fo,Fo,Fo)
Aratanea	(Br,Ar,Rh)	Archaeomieson	(Bz,St,Un)	Archiacoceras	(Mo,Ce,On)
Aratella	(Br,Ar,Rh)	Archaeometra	(Ec,Cr,Cm)	Archiastrerella	(Ar,Co,Ch)
Arathecus	(Hy,Or,Ci)	Archaeonectris	(Cn,Hy,Hy)	Archicladium	(Pr,Co,Ch)
Aratidecthes	(Ar,MI,Al)	Archaeonectrus	(Cd,Re,Ps)	Archiclimacograptus	(He,Gr,Gr)
Aratoechia	(Br,Ar,Rh)	Archaeoniscus	(Ar,MI,Is)	Archicorys	(Ac,Ra,Na)
Aratrocypris	(Ar,Os,Pt)	Archaeopetastus	(Pr,Un,In)	Archicypraea	(Mo,Ga,Nt)
Arauzia	(Cd,Ch,Ct)	Archaeopharetra	(Po,lr,Ar)	Archicythereis	(Ar,Os,Po)
Araxathyrus	(Br,Ar,Sp)	Archaeophiala	(Mo,Te,Tr)	Archierato	(Mo,Ga,Nt)
Araxilevis	(Br,Ar,St)	Archaeophiomusium	(Ec,Op,Op)	Archimedes	(Bz,St,Fe)
Araxoceras	(Mo,Ce,Ce)	Archaeophis	(Cd,Re,Sq)	Archimediella	(Mo,Ga,Nt)
Araxopora	(Bz,St,Tr)	Archaeophyllia	(Cn,An,Sc)	Archinacella	(Mo,Ga,Pa)
Arayina	(Mo,Ga,Ne)	Archaeophyllum	(Pr,Cr,Cr)	Archinacellina	(Mo,In,In)
Arbacia	(Ec,Ec,Ph)	Archaeoplax	(Ar,MI,De)	Archiretiolites	(He,Gr,Gr)
Arbacina	(Ec,Ec,Te)	Archaeopraga	(Mo,Te,Tr)	Archisymplectes	(Nt)
Arbia	(Ec,Ec,Ph)	Archaeoprion	(An,Po,Et)	Architectonica	(Mo,Ga,He)
Arbizustrophia	(Br,Ar,St)	Archaeops	(Ar,Tr,Re)	Archithelphusa	(Ar,MI,De)
Arborea	(Cn,Pe,Ra)	Archaeopus	(Ar,MI,De)	Archivesica	(Mo,Bi,Ve)
Arborocladia	(Bz,St,Fe)	Archaeopyramisa	(Ac,Ra,Sp)	Archinosphaera	(Ac,Ra,Sp)
Arborohindia	(Po,De,Li)	Archaeorthis	(Br,Ar,Or)	Archoceras	(Mo,Ce,An)
Arbuscula	(Po,De,Li)	Archaeosecyphia	(Po,De,Li)	Archocyrtum	(Ac,Ra,Sp)
Arca	(Mo,Bi,Ar)	Archaeosemantis	(Ac,Ra,Sp)	Archodus	(Cd,Pt,Pt)
Arcacythere	(Ar,Os,Po)	Archaeosepia	(Mo,Ce,Se)	Archohelia	(Cn,An,Sc)
Arcanoceras	(Mo,Ce,Go)	Archaeosepta	(Fo,Fo,Fo)	Archophiactis	(Ec,So,Go)
Arcavicula	(Mo,Bi,Pt)	Archaeosomia	(Cn,An,Sc)	Archypora	(Cn,An,Ta)
Arceliniithyrus	(Br,Ar,Te)	Archaeosmilopsis	(Cn,An,Sc)	Arcinella	(Mo,Bi,Ve)
Arc neodominus	(Mo,Ro,Co)	Archaeosphaeroma	(Ar,MI,Is)	Archithea	(Pr,Un,In)
Arcestes	(Mo,Ce,Ce)	Archaeospira	(Mo,In,In)	Arcobellus	(Mo,Ce,Be)
Arcythyris	(Br,Ar,Te)	Archaeospongoprimum	(Ac,Ra,Sp)	Arcochiton	(Mo,Po,Nc)
Archaeagnostus	(Ar,Tr,Ag)	Archaeosyon	(Po,lr,Ar)	Archocyathus	(Cn,An,Ru)
Archaealveolina	(Fo,Fo,Fo)	Archaeotremaria	(Pr,Un,In)	Arcomya	(Mo,Bi,Ph)
Archaeaspis	(Ar,Tr,Ol)	Archaeotriakis	(Cd,Ch,Ca)	Arcomytilus	(Mo,Bi,Mt)
Archaeachinus	(Ec,Ec,Sp)	Archaeotritrabs	(Ac,Ra,Sp)	Arcopagella	(Mo,Bi,Ve)
Archaeacyclus	(Fo,Fo,Fo)	Archaeotrypa	(Cn,An,Un)	Arcopagia	(Mo,Bi,Ve)
Archaeadiscus	(Fo,Fo,Fo)	Archaeozaphrentis	(Cn,An,Ru)	Arcopaginula	(Mo,Bi,Ve)
Archaeoglobigerina	(Fo,Fo,Fo)	Archaehippippus	(Cd,Os,Pf)	Arcopagiopsis	(Mo,Bi,Ve)
Archaeichnium	(Cn,Pe,Un)	Archaeopyrgus	(Ec,Ed,Is)	Arcoperna	(Mo,Bi,Mt)
Archaeoantennularia	(Cn,Hy,Hy)	Archaeosphaera	(Fo,Fo,Fo)	Arcoplasma	(Cn,An,Ru)
Archaeocalyptocrinus	(Ec,Ce,Mo)	Archaeotaxocrinus	(Ec,Cr,Tx)	Arcopsis	(Mo,Bi,Ar)
Archaeocarabus	(Ar,MI,De)	Archaeus	(Cd,Os,Pf)	Arcosarina	(Br,Ar,Te)
Archaeocaris	(Ar,MI,Pa)	Archais	(Fo,Fo,Fo)	Arcoscappellum	(Ar,Ct)

Arctacanthus	(Cd,Ch,Ct)	Areia	(Ar,Tr,Ph)	Ariaspis	(Cd,Pt,Pt)
Arctangia	(Cn,An,Sc)	Arellanella	(Ar,Tr,Pt)	Aricoceras	(Mo,Ce,Go)
Arcthoplites	(Mo,Ce,Am)	Aremella	(Mo,Ga,Ar)	Aricograptus	(He,Gr,Gr)
Arctica	(Mo,Bi,Ve)	Arenaciarcula	(Br,Ar,Te)	Arietceras	(Mo,Ce,Am)
Arcticalosia	(Br,Ar,St)	Arenagula	(Fo,Fo,Fo)	Arietetes	(Mo,Ce,Am)
Arcticalymene	(Ar,Tr,Ph)	Arene	(Mo,Ga,Ar)	Arietocelites	(Mo,Ce,Ce)
Arcticeramus	(Mo,Bi,Pt)	Arenicola	(An,Po,Dr)	Arikloedenia	(Ar,Os,Pa)
Arcticlam	(Mo,Bi,Ph)	Areniconulus	(Fo,Fo,Fo)	Ariomma	(Cd,Os,Pf)
Arcticoceras	(Mo,Ce,Am)	Arenigomya	(Mo,Bi,Ph)	Arioceras	(Mo,Ce,Or)
Arcticopora	(Bz,St,Tr)	Arenipiscis	(Cd,Pl,Ar)	Arionthia	(Br,Ar,Sp)
Arctinurus	(Ar,Tr,Lt)	Arenobulimina	(Fo,Fo,Fo)	Ariosoma	(Cd,Os,An)
Arctipeltis	(Ar,Tr,Co)	Arenodosaria	(Fo,Fo,Fo)	Arisaigaster	(Ec,As,Pu)
Arctipora	(Bz,St,Fe)	Arenogaudyria	(Fo,Fo,Fo)	Arisaigia	(Mo,Bi,Nu)
Arctireta	(Br,Ar,Th)	Arenomya	(Mo,Bi,My)	Arisostoma	(Mo,Ga,Ar)
Arctispira	(Br,Ar,At)	Arenonionella	(Fo,Fo,Fo)	Arisphinctes	(Mo,Ce,Am)
Arctites	(Mo,Cr,Te)	Arenoparrella	(Fo,Fo,Fo)	Aristaluta	(Ar,Os,Ar)
Arctcephalites	(Mo,Ce,Am)	Arenorbis	(Ec,Op,Op)	Aristerella	(Mo,Bi,Mo)
Arctcephalus	(Cd,Ma,Ca)	Arenorthis	(Br,Ar,Or)	Aristerostrophia	(Mo,Ga,Nt)
Arctoceras	(Mo,Ce,Ce)	Arenosphion	(Fo,Fo,Fo)	Aristocaris	(Ar,Un,Un)
Arctochonetes	(Br,Ar,St)	Arenoturrispirillina	(Fo,Fo,Fo)	Aristoceramus	(Mo,Bi,Pt)
Arctogymnites	(Mo,Ce,Ce)	Arenovidalina	(Fo,Fo,Fo)	Aristoceras	(Mo,Ce,Go)
Arctohedra	(Br,Ar,Or)	Areopsammia	(Cn,An,Sc)	Aristoceratoides	(Mo,Ce,Go)
Arctolungarites	(Mo,Ce,Ce)	Areostrophia	(Br,Ar,St)	Aristocystites	(Ec,Di,Di)
Arctomeekoceras	(Mo,Ce,Ce)	Arestoceras	(Mo,Ce,Am)	Aristoharpes	(Ar,Tr,Pt)
Arctomelon	(Mo,Ga,Ne)	Arestorides	(Mo,Ga,Nt)	Aristokainella	(Ar,Tr,As)
Arctomercaticeras	(Mo,Ce,Am)	Aretograptus	(He,Gr,De)	Aristonectes	(Cd,Re,Ps)
Arctomeristina	(Br,Ar,Sp)	Argalista	(Mo,Ga,Ar)	Aristophyllum	(Cn,An,Ru)
Arctomyalina	(Mo,Bi,Pt)	Argella	(Br,Ar,Sp)	Aristoptychites	(Mo,Ce,Ce)
Arctonema	(Cd,Pl,Ar)	Argenocythere	(Ar,Os,Po)	Aristozoe	(Ar,Os,Le)
Arctophyllum	(Cn,An,Ru)	Argenticytheretta	(Ar,Os,Po)	Aristozoe	(Ar,ML,Ar)
Arctopratulum	(Mo,Bi,Ve)	Argentina	(Cd,Os,Os)	Arites	(An,Po,Ph)
Arctopronites	(Mo,Ce,Ce)	Argentinaster	(Ec,Op,Op)	Arius	(Cd,Os,Si)
Arctopychites	(Mo,Ce,Ce)	Argentiniceras	(Mo,Ce,Am)	Arizonella	(Mo,Ga,Ar)
Arctosirenites	(Mo,Ce,Ce)	Argentiproductus	(Br,Ar,St)	Arjamannia	(Mo,Ga,Ar)
Arctosomus	(Cd,Os,Ph)	Argentopyge	(Ar,Tr,Ph)	Arkacrinus	(Ec,Cr,Cl)
Arctostrea	(Mo,Bi,Pt)	Argillichthys	(Cd,Os,Al)	Arkanites	(Mo,Ce,Go)
Arctostroma	(Po,De,St)	Argilloberyx	(Cd,Os,Br)	Arkarua	(Cn,In,In)
Arctothyris	(Br,Ar,Te)	Argillochelys	(Cd,Re,Ch)	Arkoceras	(Mo,Ce,Ta)
Arctotrochites	(Mo,Ce,Ce)	Argilloecia	(Ar,Os,Po)	Arkonaster	(Ec,As,Un)
Arctotis	(Mo,Bi,Pt)	Arginopsis	(Mo,Bi,Ar)	Arkonoceras	(Mo,Ce,Or)
Arcturellina	(Mo,Bi,Ve)	Arginula	(Mo,Ga,Ar)	Arktikina	(Br,Ar,Sp)
Arcualla	(Br,Ar,Or)	Argobuccinum	(Mo,Ga,Nt)	Armagnostus	(Ar,Tr,Ag)
Arcuaria	(Ar,Os,Po)	Argocheilus	(Mo,Ce,On)	Armatites	(Cn,An,Ta)
Arcuatothyris	(Br,Ar,Te)	Argodiscus	(Ec,Ed,Is)	Armatheraster	(Ec,Op,Oe)
Arcuata	(Mo,Bi,Mt)	Argolites	(Mo,Ce,Ce)	Armatites	(Mo,Ce,Go)
Arcularia	(Mo,Ga,Ne)	Argonauta	(Mo,Ce,Ce)	Armatobalanus	(Ar,Ci)
Arculicythere	(Ar,Os,Po)	Argonauticeras	(Mo,Ce,Am)	Armenia	(Fo,Fo,Fo)
Arcullaea	(Mo,Bi,Ar)	Argopecten	(Mo,Bi,Pt)	Armenoceras	(Mo,Ce,Ac)
Arcullina	(Br,Ar,Sp)	Argopora	(Bz,Gy,Ch)	Armenocrinus	(Ec,Cr,Cl)
Arcuoblastus	(Ec,Bi,Sp)	Argorhynch	(Br,Ar,Sp)	Armenostoma	(Mo,Ga,Nt)
Arcuolimbus	(Ar,Tr,Pt)	Argosirenites	(Mo,Ce,Ce)	Armillopora	(Bz,St,Tr)
Arcyzona	(Ar,Os,Pa)	Argoviaster	(Ec,As,Fo)	Armstrongia	(Po,He,Re)
Ardaennella	(Ar,Tr,Ph)	Argovithyris	(Br,Ar,Te)	Arnaudastier	(Ec,Ec,Ca)
Ardeamiya	(Mo,Bi,Ve)	Argunaspis	(Ar,Tr,Pt)	Arnaudia	(Mo,Bi,Hi)
Ardennea	(Ar,Os,Pa)	Argutastrea	(Cn,An,Ru)	Arnaudiella	(Fo,Fo,Fo)
Ardiodus	(Cd,Os,Pf)	Argyrinpus	(Cd,Os,St)	Arnheimograptus	(He,Gr,Gr)
Ardiviscus	(Br,Ar,St)	Argyroceus	(Cd,Ma,Ce)	Arniocelites	(Mo,Ce,Ce)
Ardmosteges	(Br,Ar,St)	Argyromya	(Mo,Bi,Ph)	Arnioceras	(Mo,Ce,Am)
Ardrossacyathus	(Po,Ir,Ar)	Argyropeleus	(Cd,Os,St)	Arniotites	(Mo,Ce,Am)
Ardrossania	(Mo,Un,Un)	Argyropeza	(Mo,Ga,Nt)	Arnoglossus	(Cd,Os,Pn)
Arduennella	(Ar,Tr,Ph)	Argyrosomus	(Cd,Os,Pt)	Aromasithyris	(Br,Ar,Te)
Arduspirifer	(Br,Ar,Sp)	Argyroteca	(Br,Ar,Te)	Aroonia	(Pr,Un,In)
Arechia	(Cd,Ch,My)	Ariadnaria	(Mo,Ga,Nt)	Arossia	(Ar,Ci)
Areella	(Br,Ar,Rh)	Arianites	(Mo,Ce,Ce)	Arpadites	(Mo,Ce,Ce)

Arpagodus	(Cd,Ch,Eu)	Asaphechinus	(Ec,Ec,Te)	Aspella	(Mo,Ga,Ne)
Arpaoceras	(Mo,Ce,Or)	Asaphellina	(Ar,Tr,As)	Aspelundia	(Cd,Co,Co)
Arqoviella	(Ar,Os,Po)	Asaphellus	(Ar,Tr,As)	Aspenites	(Mo,Ce,Ce)
Arraphus	(Ar,Tr,Pt)	Asaphiceras	(Mo,Ce,On)	Asperconella	(Mo,He,He)
Arrazocypri	(Ar,Os,Po)	Asaphinella	(Mo,Bi,Ve)	Asperdaphne	(Mo,Ga,Ne)
Archinella	(Ac,Ra,Sp)	Asaphinoides	(Mo,Bi,Ve)	Asperilla	(Mo,Ga,Ar)
Arrectoalatus	(Ac,Ra,Sp)	Asaphis	(Mo,Bi,Ve)	Asperiscala	(Mo,Ga,Nt)
Arrectocrinus	(Ec,Cr,Cl)	Asaphiscus	(Ar,Tr,Pt)	Asperlunus	(Br,Ar,St)
Arrhoges	(Mo,Ga,Nt)	Asaphoceras	(Mo,Ce,Am)	Asperocare	(Ar,Tr,Co)
Arribazona	(Mo,Ga,Ar)	Asaphocrinus	(Ec,Cr,As)	Asperoconus	(Mo,In,In)
Arroyocrinus	(Ec,Cr,Cl)	Asapholytoceras	(Mo,Ce,Am)	Asperophyllum	(Cn,An,Ru)
Arrhythmocrinus	(Po,Ir,Ar)	Asaphoon	(Ar,Tr,Pt)	Asperopora	(Bz,St,Tr)
Arsiriina	(Ar,Os,Pa)	Asaphopsis	(Ar,Tr,As)	Asphinctites	(Mo,Ce,Am)
Artchedella	(Bz,St,Cr)	Asaphopsoides	(Ar,Tr,As)	Aspidaegлина	(Ar,Tr,As)
Artedius	(Cd,Os,Se)	Asaphus	(Ar,Tr,As)	Aspidagnostus	(Ar,Tr,Ag)
Arterioceras	(Mo,Ce,Or)	Asarotus	(Cd,Os,Pa)	Aspidaster	(Ec,As,Val)
Arthaberia	(Po,De,As)	Asbestoceras	(Mo,Ce,Di)	Aspidastraea	(Cn,An,Se)
Arthaberites	(Mo,Ce,Ce)	Ascalobos	(Mo,Ce,Am)	Aspidichthys	(Cd,Pl,Ar)
Arthraster	(Ec,As,Val)	Ascaulocardium	(Mo,Bi,Ph)	Aspidiscus	(Cn,An,Se)
Arthricocephalites	(Ar,Tr,Co)	Ascensovoluta	(Mo,Ga,Ne)	Aspidocarpus	(Ec,St,Mt)
Arthricocephalus	(Ar,Tr,Co)	Ascetocrinus	(Ec,Cr,Cl)	Aspidoceras	(Mo,Ce,Am)
Arthritica	(Mo,Bi,Ve)	Ascetoleberis	(Ar,Os,Po)	Aspidocerinus	(Ec,Cr,Cy)
Arthroacantha	(Ec,Cr,Mo)	Ascetopeltis	(Ar,Tr,Un)	Aspidodiadema	(Ec,Ec,Di)
Arthrochites	(Cn,Se,Cn)	Aschemoella	(Fo,Fo,Fo)	Aspidogaster	(Ar,Ml,De)
Arthroclema	(Bz,St,Cr)	Asciocythere	(Ar,Os,Po)	Aspidograptus	(He,Gr,De)
Arthrophyllum	(Mo,Ce,Or)	Ascionepea	(Ar,Tr,Pt)	Aspidopholas	(Mo,Bi,My)
Arthropoma	(Bz,Gy,Ch)	Ascitellina	(Mo,Bi,Ve)	Aspidopora	(Bz,St,Tr)
Arthropteris	(Cd,Ch,Rj)	Ascoceras	(Mo,Ce,As)	Aspidorhynchus	(Cd,Os,Pe)
Arthrorhachis	(Ar,Tr,Ag)	Ascocystites	(Ec,Eo,As)	Aspidostephanus	(Mo,Ce,Am)
Arthrostyleocia	(Bz,St,Cr)	Ascodictyon	(Bz,Gy,Ct)	Aspidosteus	(Cd,Pl,Pt)
Arthrostylus	(Bz,St,Fe)	Ascograptus	(He,Gr,Un)	Aspidostoma	(Bz,Gy,Ch)
Arthrotrypa	(Bz,St,Cr)	Ascolatirus	(Mo,Ga,Ne)	Aspidotheca	(Mo,Ga,Be)
Articalosia	(Br,Ar,St)	Ascoliella	(Fo,Fo,Fo)	Aspidothyris	(Br,Ar,Te)
Artioceratoidea	(Mo,Ce,Pl)	Ascopeltis	(Ar,Tr,Pt)	Aspidura	(Ec,Op,Op)
Articheilus	(Mo,Ce,Na)	Ascopora	(Bz,St,Cr)	Aspinoeras	(Mo,Ce,Am)
Artichyocrinus	(Ec,Cr,Sa)	Ascoporella	(Bz,St,Cr)	Aspinosella	(Br,Ar,St)
Articularia	(Fo,Fo,Fo)	Ascosyrinx	(Pr,Un,In)	Assatiknella	(Br,St,Un)
Articulina	(Fo,Fo,Fo)	Aseptagyppa	(Br,Ar,Pe)	Asselodiscus	(Fo,Fo,Fo)
Artifactella	(Ar,Os,Po)	Aseptalum	(Br,Ar,Rh)	Asserculinia	(Cn,An,Ru)
Artigesia	(Mo,Bi,Hi)	Aseptella	(Br,Ar,St)	Assilina	(Fo,Fo,Fo)
Artimycetella	(Br,Un,Un)	Aseptirhynchia	(Br,Ar,Rh)	Astacodes	(Ar,Ml,De)
Artinksia	(Mo,Ce,Pl)	Aseptonetes	(Br,Ar,St)	Astaculus	(Fo,Fo,Fo)
Artioceras	(Mo,Ce,Pl)	Aserotaspis	(Cd,Pl,Un)	Astaculus	(Ar,Ml,De)
Artiotreta	(Br,Li,Ac)	Ashtarotha	(Mo,Bi,Ve)	Astades	(Mo,Ga,Nt)
Artiscus	(Ac,Ra,Sp)	Asiagena	(Ar,Tr,Tr)	Astariostrophia	(Br,Ar,St)
Artocapsa	(Ac,Ra,Na)	Asialepidotus	(Cd,Os,Se)	Astare	(Mo,Bi,Ve)
Artokephalus	(Ar,Tr,As)	Asiarhynchia	(Br,Ar,Rh)	Astartella	(Mo,Bi,Ve)
Artoperina	(Ac,Ra,Na)	Asiatella	(Ar,Tr,Pt)	Astartellopsis	(Mo,Bi,Ve)
Artophormis	(Ac,Ra,Na)	Asiatotrigonia	(Mo,Bi,Tr)	Astartemya	(Mo,Bi,Ve)
Artophormis	(Ac,Ra,Sp)	Asijatheca	(Hy,Or,Ci)	Astartilla	(Mo,Bi,Ph)
Artospirifer	(Br,Ar,Sp)	Asiiluchus	(Ar,Tr,Pt)	Astartopsis	(Mo,Bi,Ve)
Artostrobium	(Ac,Ra,Na)	Asima	(Cd,Os,Pl)	Astartopsis	(Mo,Bi,Ve)
Artostrobis	(Ac,Ra,Na)	Asineops	(Cd,Os,In)	Astegosia	(Br,Ar,Sp)
Arturocyathus	(Po,Re,Aj)	Asiocephalus	(Ar,Tr,Pt)	Astele	(Mo,Ga,Ar)
Artuschisma	(Ec,Bi,Fi)	Asioproductus	(Br,Ar,St)	Astenaspis	(Ar,Tr,Re)
Aruduce	(Ar,Os,Po)	Askeatonolucidum	(Mo,Ce,Na)	Asteracanthus	(Cd,Ch,Ct)
Arutella	(Ar,Os,Po)	Askepasma	(Br,Li,Pa)	Asteracmea	(Mo,Ga,Pa)
Aryballocrinus	(Ec,Cr,Mo)	Askeptosaurus	(Cd,Re,Th)	Asteractinella	(Po,Ca,He)
Arystidictyon	(Po,He,Re)	Asketaspis	(Cd,Pl,Pt)	Asterias	(Ec,As,Fo)
Arzelella	(Mo,Bi,Tr)	Asketomorpha	(Mo,Bi,Ph)	Asterigerina	(Fo,Fo,Fo)
Asa	(Mo,Bi,Ve)	Asklepioeras	(Mo,Ce,Ce)	Asterigerinata	(Fo,Fo,Fo)
Asanoia	(Fo,Fo,Fo)	Asoella	(Mo,Bi,Pl)	Asterigerinella	(Fo,Fo,Fo)
Asanonella	(Fo,Fo,Fo)	Aspa	(Mo,Ga,Nt)	Asterigerinoides	(Fo,Fo,Fo)
Asanospira	(Fo,Fo,Fo)	Aspasmophyllum	(Cn,An,Ru)	Asteriospongia	(Po,Ca,He)

Asteroaemmonia	(Fo,Fo,Fo)	Astroconia	(Po,He,Re)	Atamarcia	(Mo,Bi,Ve)
Asteroarchaediscus	(Fo,Fo,Fo)	Astrocrinites	(Ec,BI,Fi)	Ataphropsis	(Mo,Ga,Ar)
Asterobillingsia	(Cn,An,Ru)	Astrocrinus	(Ec,BI,Fi)	Ataphrus	(Mo,Ga,Ar)
Asteroblastus	(Ec,Di,Di)	Astrocyclia	(Ac,Ra,Sp)	Atavograptus	(He,Gr,Gr)
Asterocalyx	(Po,De,Li)	Astrocystites	(Ec,Ed,Ed)	Ataxella	(Fo,Fo,Fo)
Asteroceras	(Mo,Ce,Am)	Astrodapsis	(Ec,Ec,Cl)	Ataxioceras	(Mo,Ce,Am)
Asterocidaris	(Ec,Ec,Hm)	Astroentactinia	(Ac,Ra,Sp)	Ataxiocyathus	(Po,Ir,Ar)
Asterocoelus	(Cn,He,Hc)	Astrogyra	(Cn,An,Sc)	Ataxocerithium	(Mo,Ga,Nt)
Asterocyathus	(Po,Re,Aj)	Astroides	(Cn,An,Sc)	Ataxoobignyma	(Fo,Fo,Fo)
Asterocyclina	(Fo,Fo,Fo)	Astrolampus	(Ec,Ec,Ca)	Ataxophragmium	(Fo,Fo,Fo)
Asterocystis	(Ec,Di,Di)	Astrolemma	(Po,De,Li)	Ataxotrochus	(Mo,Ga,Nt)
Asterodermus	(Cd,Ch,Rj)	Astroolithium	(Ac,Ac,Ac)	Atadabanella	(Ar,Tr,Co)
Asterodisphyllum	(Cn,An,Ru)	Astromma	(Ac,Ra,Sp)	Atadabanithes	(Hy,Hy,Hy)
Asterohedbergella	(Fo,Fo,Fo)	Astronesthes	(Cd,Os,St)	Atelaspis	(Cd,Ce,At)
Asterohelix	(Mo,Ga,Ar)	Astronomion	(Fo,Fo,Fo)	Atelecyclus	(Ar,MI,De)
Asterolepidina	(Fo,Fo,Fo)	Astropecten	(Ec,As,Px)	Atelelasma	(Br,Ar,Or)
Asteronyx	(Ec,Op,Ph)	Astropegma	(Po,He,Ly)	Atelelasmoidea	(Br,Ar,Or)
Asterophragmina	(Fo,Fo,Fo)	Astropentagnathus	(Cd,Co,Co)	Ateleocystites	(Ec,St,Mi)
Asteroptychius	(Cd,Ch,Ct)	Astrophacus	(Ac,Ra,Sp)	Ateleopus	(Cd,Os,La)
Asteropyge	(Ar,Tr,Ph)	Astroporina	(Po,De,Ax)	Atelesopora	(Bz,St,Cc)
Asterorbis	(Fo,Fo,Fo)	Astroproetus	(Ar,Tr,Pr)	Atelestegastus	(Br,Ar,St)
Asterotalia	(Fo,Fo,Fo)	Astropygaulus	(a, Ec, Ca)	Atelestocrinus	(Ec,Cr,Cl)
Asterosalpinx	(An,Po,Se)	Astrorhiza	(Fo,Fo,Fo)	Atelikamara	(Fo,Fo,Fo)
Asterosmia	(Cn,An,Sc)	Astrorotalia	(Fo,Fo,Fo)	Atelithyris	(Br,Ar,Te)
Asterospongia	(Po,De,Li)	Astrosclerida	(Po,De,Ax)	Atelodictyon	(Po,De,St)
Asterosteus	(Cd,Pl,Rh)	Astrostrum	(Ac,Ra,Sp)	Atelospatangus	(Ec,Ec,Sp)
Asterostoma	(Ec,Ec,Sp)	Astrostylopsis	(Po,De,Ax)	Atergatis	(Ar,MI,De)
Asterotumulus	(Po,Re,Aj)	Astrovidictya	(Bz,St,Cr)	Athabascacrinus	(Ec,Cr,Mo)
Asthenoceras	(Mo,Ce,Am)	Astroviella	(Bz,St,Tr)	Athabascchia	(Br,Ar,Rh)
Asthenocormus	(Cd,Os,Pc)	Astroiellina	(Bz,St,Tr)	Athabaskia	(Ar,Tr,Co)
Asthenophyllum	(Cn,An,Ru)	Astua	(Br,Ar,Rh)	Athabaskiella	(Ar,Tr,Co)
Asthenopsis	(Ar,Tr,Pt)	Asturiella	(Ar,Os,Po)	Athanoceras	(Mo,Ce,Di)
Asthenosoma	(Ec,Ec,Et)	Asturiphyllum	(Cn,An,Ru)	Athecastraea	(Cn,An,Sc)
Asthenospongia	(Po,He,LS)	Asturoceras	(Mo,Ce,Go)	Athenaegis	(Cd,Pt,Pt)
Asthenotoma	(Mo,Ga,Ne)	Asturothis	(Br,Ar,Or)	Atheresthes	(Cd,Os,Pn)
Astiericeras	(Mo,Ce,Am)	Astutorhyncha	(Br,Ar,Rh)	Atherina	(Cd,Os,At)
Astieridiscus	(Mo,Ce,Am)	Astya	(Cn,Hy,St)	Atheriopsis	(Cd,Os,At)
Astoceras	(Mo,Ce,Ac)	Astycoryphe	(Ar,Tr,Pr)	Atileta	(Mo,Ga,Ne)
Astraborthis	(Br,Ar,Or)	Astylomanon	(Po,De,Li)	Athlocrinus	(Ec,Cr,Cl)
Astractura	(Ac,Ra,Sp)	Astylopongia	(Po,De,Li)	Athlopecten	(Mo,Bi,Pt)
Astraea	(Mo,Ga,Ar)	Astylopongiella	(Po,De,Li)	Athrodon	(Cd,Os,Py)
Astraeoconus	(Po,Ca,He)	Astyris	(Mo,Ga,Ne)	Athrophragma	(Bz,St,Cr)
Astraeofungia	(Cn,An,Sc)	Asymmetricityhere	(Ar,Os,Po)	Athyrrhynchus	(Br,Ar,Rh)
Astraeomorpha	(Cn,An,Sc)	Asymmetrina	(Fo,Fo,Fo)	Athyris	(Br,Ar,Sp)
Astraeophyllum	(Cn,An,Ru)	Asymmetrochonetes	(Br,Ar,St)	Athyrisina	(Br,Ar,Sp)
Astraeospongium	(Po,Ca,He)	Asymmetrocrinus	(Ec,Cr,Cl)	Athyrisinoides	(Br,Ar,Sp)
Astralites	(Mo,Ga,Ar)	Asynphylotoechia	(Br,Ar,Or)	Athyrisinopsis	(Br,Ar,Sp)
Astralium	(Mo,Ga,Ar)	Asymptoceras	(Mo,Ce,Na)	Athyrorhynchia	(Br,Ar,Te)
Astralochoma	(Bz,St,Tr)	Asyrinx	(Br,Ar,Sp)	Atilia	(Mo,Ga,Ne)
Astrangia	(Cn,An,Sc)	Asyrinxia	(Br,Ar,Sp)	Atira	(Mo,Ga,Ar)
Astrariaea	(Cn,An,Sc)	Atacama	(Bz,Gy,Ch)	Atjehella	(Ar,Os,Po)
Astraspis	(Cd,Pt,As)	Atacamichthys	(Cd,Os,Pc)	Atkinsonella	(Mo,Ga,Ne)
Astreopora	(Cn,An,Sc)	Atacocrinus	(Ec,Cr,Di)	Atlanta	(Mo,Ga,Nt)
Astreptoceras	(Mo,Ce,Am)	Atactolituola	(Fo,Fo,Fo)	Atlanticoeolia	(Br,Ar,At)
Astreptoscolex	(An,Po,Ph)	Atactopora	(Bz,St,Tr)	Atlanticythere	(Ar,Os,Po)
Astrhelia	(Cn,An,Sc)	Atactoporella	(Bz,St,Tr)	Atlantida	(Br,Ar,Or)
Astriclypeus	(Ec,Ec,Cl)	Atactoporida	(Bz,Gy,Ch)	Atlantidosteus	(Cd,Pl,Ar)
Astrictriphylum	(Cn,An,Ru)	Atactosia	(Br,Ar,Te)	Atlantobellerophon	(Mo,Ga,Be)
Astrobolia	(Po,De,Li)	Atactotoechus	(Bz,St,Tr)	Atlantoceras	(Mo,Ce,An)
Astrocentrus	(Ac,Ra,Na)	Atactus	(Ec,Ec,Ec)	Atlantochelys	(Cd,Re,Ch)
Astrocerium	(Cn,An,Ta)	Atagma	(Bz,St,Cc)	Atlastaster	(Ec,Ec,Py)
Astrocladia	(Po,De,Li)	Ataktaspis	(Ar,Tr,Co)	Atocetus	(Cd,Ma,Ce)
Astrocoecus	(Ac,Ra,Sp)	Atalacmea	(Mo,Ga,Pa)	Atokacrinus	(Ec,Cr,Cl)
Astrocoenia	(Cn,An,Sc)	Atalantia	(Mo,Bi,Tr)	Atoma	(Mo,Ga,Ne)

Atomoceras	(Mo,Ce,On)	Aucklandirhynchia	(Br,Ar,Rh)	Aulocrinus	(Ec,Cr,Cl)
Atomodesma	(Mo,Bi,Pt)	Audaxlytoceras	(Mo,Ce,Am)	Aulocyclus	(Po,De,Pe)
Atopacanthus	(Cd,Ac,Is)	Audiensinia	(Fo,Fo,Fo)	Aulocystella	(Cn,An,Ta)
Atopasaphus	(Ar,Tr,As)	Augea	(Mo,Bi,Pt)	Aulocystis	(Cn,An,Ta)
Atopechinus	(Ec,Ec,Ph)	Augurites	(Mo,Ce,An)	Aulocytheridea	(Ar,Os,Po)
Atopocephala	(Cd,Os,Pa)	Augustoceras	(Mo,Cc,On)	Aulodesocrinus	(Ec,Cr,Cl)
Atopoceras	(Mo,Ce,On)	Auiophyseter	(Cd,Ma,Ce)	Aulodonus	(Po,He,He)
Atopocoenia	(Cn,An,Sc)	Aukides	(Cd,Os,Pf)	Aulograptus	(He,Gr,Gr)
Atopocrinus	(Ec,Cr,Ds)	Aulacatrypa	(Br,Ar,At)	Aulohelia	(Cn,An,Ta)
Atopodonta	(Mo,Bi,Ve)	Aulacella	(Br,Ar,Or)	Aulokoninckophyllum	(Cn,An,Ru)
Atopograptus	(He,Gr,Gr)	Aulacera	(Po,De,St)	Aulolepis	(Cd,Os,Ct)
Atopostroma	(Po,De,St)	Aulacoceras	(Mo,Ce,Au)	Aulonotreta	(Br,Li,Li)
Atopotarus	(Cd,Ma,Ca)	Aulacodigma	(Ar,Tr,Pt)	Aulophax	(Po,He,Ly)
Atops	(Ar,Tr,Pt)	Aulacodiscus	(Mo,Ga,Nt)	Aulophyllum	(Cn,An,Ru)
Attractites	(Mo,Ce,Au)	Aulacofusus	(Mo,Ga,Ne)	Aulophyseter	(Cd,Ma,Ce)
Attractocrinus	(Ec,Cr,Cl)	Aulacognathus	(Cd,Co,Au)	Aulopopsis	(Cd,Os,Au)
Attractopyge	(Ar,Tr,Ph)	Aulacomya	(Mo,Bi,Mt)	Aulopora	(Cn,An,Ta)
Attractosella	(Po,De,Un)	Aulacomiyella	(Mo,Bi,Pt)	Auloporella	(Cn,An,Ta)
Attractosella	(Cn,An,Al)	Aulaconautilus	(Mo,Ce,Na)	Auloprotonia	(Br,Ar,St)
Attractosocia	(Bz,St,Cc)	Aulacoparia	(Ar,Tr,As)	Aulopus	(Cd,Os,Au)
Attractotrema	(Mo,Ga,Ar)	Aulacophyllum	(Cn,An,Ru)	Aulorhamphus	(Cd,Os,Ga)
Atracura	(Mo,Pa,Hy)	Aulacopleura	(Ar,Tr,Pr)	Aulorhynchus	(Cd,Os,Ga)
Atraktoprion	(An,Po,Eu)	Aulacopleurina	(Ar,Tr,Pr)	Aulosmia	(Cn,An,Sc)
Atraktus	(Mo,Ga,Ne)	Aulacopleurum	(Mo,Bi,Tr)	Aulosoma	(Po,De,Li)
Atrapocrinus	(Ec,Cr,Cl)	Aulacopsis	(Ar,Os,Pa)	Aulospongia	(Po,De,Pe)
Atratebia	(Ar,Tr,Un)	Aulacophora	(Br,Ar,Or)	Aulosteges	(Br,Ar,St)
Atremacrinus	(Ec,Cr,Cl)	Aulacosia	(Po,He,He)	Aulostegites	(Cn,An,Ta)
Atresius	(Mo,Ga,Nt)	Aulacosphinctes	(Mo,Ce,Am)	Aulostomoides	(Cd,Os,Ga)
Atreta	(Mo,Bi,Pt)	Aulacosphinctoides	(Mo,Ce,Am)	Aulostomus	(Cd,Os,Ga)
Atribonium	(Br,Ar,Rh)	Aulacospongia	(Po,De,Li)	Aulostrotion	(Cn,An,Ru)
Atrimitra	(Mo,Ga,Ne)	Aulacostephanus	(Mo,Ce,Am)	Aulostylus	(Cn,An,Ru)
Atrina	(Mo,Bi,Mt)	Aulacostrepis	(Mo,Ga,Nt)	Aulotortus	(Fo,Fo,Fo)
Atrochaetetes	(Po,De,Ta)	Aulacoteuthis	(Mo,Ce,Be)	Aulozoa	(Cn,An,Ta)
Atropatenocetus	(Cd,Ma,Ce)	Aulacothyris	(Br,Ar,Te)	Aupouria	(Mo,Bi,Ar)
Atropicarió	(Ar,Th,Co)	Aulacothyroides	(Br,Ar,Te)	Aurelianaster	(Ec,Ec,Hs)
Atrypa	(Br,Ar,At)	Aulacothyropsis	(Br,Ar,Te)	Aurelianaella	(Mo,Ga,Nt)
Atryparia	(Br,Ar,At)	Aulactis	(Ec,Op,Oe)	Aureocrinus	(Ec,Cr,Ds)
Atrypella	(Br,Ar,At)	Aulacocidaris	(Ec,Ec,Ci)	Auriala	(Mo,Ga,Nt)
Atrypellina	(Br,Ar,At)	Aulakolepos	(Pr,Ma,Tu)	Auricolispina	(Br,Ar,St)
Atrypina	(Br,Ar,At)	Aulametaoceras	(Mo,Ce,Na)	Auricularia	(Mo,Ga,Ar)
Atrypinella	(Br,Ar,At)	Aulasimoceras	(Mo,Ce,Am)	Auricularites	(Ec,Ho,Ap)
Atrypinopsis	(Br,Ar,At)	Aulastraea	(Cn,An,Sc)	Auriculatella	(Ar,Os,Ar)
Atrypoidea	(Br,Ar,At)	Aulastraeopora	(Cn,An,Sc)	Auriculospira	(Mo,In,Pe)
Atrypopsis	(Br,Ar,At)	Aulatromoceras	(Mo,Ce,Go)	Aurigerites	(Ar,Os,Me)
Atrypunculus	(Br,Ar,At)	Aulaxinia	(Po,De,Li)	Aurikiikbya	(Ar,Os,Pa)
Atrythyris	(Br,Ar,Sp)	Aulechinus	(Ec,Ec,Ey)	Aurila	(Ar,Os,Po)
Atsabités	(Mo,Ce,Go)	Aulica	(Mo,Ga,Ne)	Aurilobus	(Cd,Co,Co)
Attenuata	(Mo,Ga,Nt)	Aulicina	(Mo,Ga,Ne)	Aurina	(Mo,Ga,Ne)
Attenuatella	(Br,Ar,Sp)	Aulie	(Br,Ar,St)	Auripygma	(Mo,Ga,Nt)
Atterdagia	(Ar,Os,Pa)	Aulielia	(Ac,Ra,Sp)	Aurisella	(Pr,Un,In)
Attiliosa	(Mo,Ga,Ne)	Aulina	(Cn,An,Ru)	Auristomia	(Mo,Ga,He)
Attinopora	(Bz,St,Cc)	Auliscocyathus	(Po,Ir,Ar)	Auritama	(Ar,Tr,As)
Attungaita	(Po,De,Li)	Auliskoerinus	(Ec,Cr,Mo)	Auroria	(Fo,Fo,Fo)
Aturia	(Mo,Ce,Na)	Aulites	(Br,Ar,Rh)	Auseria	(Mo,Ga,Ar)
Aturoidea	(Mo,Ce,Na)	Auloblastus	(Ec,Bl,Sp)	Ausia	(Cn,Pe,Un)
Atwillina	(Fo,Fo,Fo)	Aulocaulis	(Cn,An,Ta)	Aussites	(Mo,Ce,Au)
Atyphocrinus	(Ec,Cr,Ds)	Aulocetus	(Cd,Ma,Ce)	Austerum	(Mo,Ga,Eu)
Atys	(Mo,Ga,Ce)	Aulochiton	(Mo,Po,Ne)	Austinella	(Br,Ar,Or)
Aubertianella	(Ci,Po,Sp)	Auloclisia	(Cn,An,Ru)	Austiniceras	(Mo,Ce,Am)
Aubignyna	(Fo,Fo,Fo)	Auloconus	(Fo,Fo,Fo)	Austinoceras	(Mo,Ce,On)
Aucellina	(Mo,Bi,Pt)	Aulocopella	(Po,De,Li)	Austinocrinus	(Ec,Cr,Is)
Auchenaspis	(Cd,Ce,Cc)	Aulocopina	(Po,De,Li)	Austinovilla	(Ar,Tr,Pt)
Auchenopora	(Bz,Gy,Cb)	Aulocopium	(Po,De,Li)	Austosinia	(Ar,Tr,Pt)
Auchmerella	(Br,Ar,St)	Aulocricus	(Po,Re,Aj)	Austracutillaea	(Mo,Bi,Ar)

Australanthus	(Ec.Ec.Ca)	Austromegalbanus	(Ar.Ci)	Axiodeanea	(Br.Br.Rh)
Australaster	(Ec.As.Pu)	Austromitra	(Mo.Ga.Ne)	Axiopolina	(Fo.Fo.Fo)
Australiarcula	(Br.Ar.Te)	Austromytilus	(Mo.Bi.Mt)	Axiothea	(Cd.Co.Co)
Australiceras	(Mo.Ce.Am)	Austronopia	(Br.Ar.St)	Axiophoria	(Cn.An.Ru)
Australicitythere	(Ar.Os.Po)	Austrophycis	(Cd.Os.Ga)	Axius	(Ar.Ml.De)
Australimoosella	(Ar.Os.Po)	Austropleuropholis	(Cd.Os.Pc)	Axoclisia	(Cn.An.Ru)
Australina	(Br.Ar.At)	Austrossasia	(Mo.Ga.Nt)	Axocricophyllum	(Cn.An.Ru)
Australirhynchia	(Br.Ar.Rh)	Austrosalata	(Mo.Ga.Ar)	Axocyathus	(Cn.An.Sc)
Australispira	(Br.Ar.At)	Austroscentilla	(Mo.Bi.Ve)	Axogaster	(Cn.An.Go)
Australispongia	(Po.He.Un)	Austrosphaera	(Mo.Ga.Ne)	Axolasma	(Cn.An.Ru)
Australithax	(Cd.Ma.Ce)	Austrospirifer	(Br.Ar.Sp)	Axolithophyllum	(Cn.An.Ru)
Australobollia	(Ar.Os.Pa)	Austroteuthis	(Mo.Ce.Au)	Axonoceras	(Mo.Ce.Am)
Australobuchia	(Mo.Bi.Pt)	Austrothyris	(Br.Ar.Te)	Axophyllum	(Cn.An.Ru)
Australoecia	(Br.Ar.At)	Austrotoma	(Mo.Ga.Ne)	Axopora	(Cn.Hy.Mi)
Australoconularia	(Cn.Sc.Cn)	Austrotrogonia	(Mo.Bi.Tr)	Axoporella	(Cn.Hy.Mi)
Australocystis	(Ec.St.Mi)	Austrotrollina	(Fo.Fo.Fo)	Axoprumum	(Ac.Ra.Sp)
Australoecia	(Ar.Os.Po)	Austrotroton	(Mo.Ga.Nt)	Axosmilia	(Cn.An.Sc)
Australofenestella	(Bz.St.Fe)	Austrotrophon	(Mo.Ga.Ne)	Axotrochus	(Cn.An.Sc)
Australoharpes	(Ar.Tr.Pt)	Austrovenus	(Mo.Bi.Ve)	Axuolites	(Cn.An.Ta)
Australokaskia	(Ar.Tr.Pt)	Austroworthenia	(Mo.Ga.Ar)	Axymene	(Mo.Ga.Ne)
Australolaxispira	(Mo.Ga.Nt)	Autoloxolichas	(Ar.Tr.Li)	Ayalaina	(Fo.Fo.Fo)
Australolepis	(Cd.Pt.Th)	Avalanchurus	(Ar.Tr.Ph)	Aysheia	(Lo)
Australomya	(Mo.Bi.Ph)	Avalonia	(Ar.Tr.Un)	Azalais	(Cd.Os.Ga)
Australoneilo	(Mo.Bi.Nu)	Avascutellum	(Ar.Tr.Ag)	Azamella	(Br.Ar.Rh)
Australonema	(Mo.Ga.Ar)	Avellana	(Mo.Ga.Ce)	Azor	(Mo.Bi.Ve)
Australophyllum	(Cn.An.Ru)	Averianowograptus	(He.Gr.Gr)	Azorica	(Po.De.Li)
Australopolypora	(Bz.St.Fe)	Aversoalva	(Ar.Os.Po)	Azorinus	(Mo.Bi.Ve)
Australoportlandia	(Mo.Bi.Nu)	Avesnella	(Fo.Fo.Fo)	Azumapecten	(Mo.Bi.Pt)
Australops	(Ar.Tr.Ph)	Aveyronceras	(Mo.Ce.Am)	Azygidium	(Br.Ar.St)
Australopsis	(Ar.Os.Ar)	Aviacypria	(Ar.Os.Po)	Azygocrinus	(Ec.Cr.Mo)
Australopyge	(Ar.Tr.As)	Avicenia	(Cn.An.Ta)	Azygograptus	(He.Gr.Gr)
Australosia	(Br.Ar.St)	Avichlamys	(Mo.Bi.Pt)	Azyricyathus	(Pr.Cr.Cr)
Australosomus	(Cd.Os.Ph)	Avicularca	(Mo.Bi.Pt)	Azrytalia	(Po.He.Un)
Australospirifer	(Br.Ar.Sp)	Avicularium	(Mo.Bi.Ve)	Babakovia	(Ar.Tr.Co)
Australosqualodon	(Cd.Ma.Ce)	Aviculocardium	(Mo.Bi.Ve)	Babelispirillina	(Fo.Fo.Fo)
Australostrophia	(Br.Ar.St)	Aviculocephaloonus	(Mo.In.In)	Babella	(Mo.Ga.He)
Australosutura	(Ar.Tr.Pr)	Aviculolima	(Mo.Bi.Pt)	Babina	(Br.Ar.St)
Austriacopsis	(Mo.Ga.Ar)	Aviculomonotis	(Mo.Bi.Pt)	Babinka	(Mo.Bi.Mo)
Austriellula	(Br.Ar.Rh)	Aviculomya	(Mo.Bi.Un)	Babinocystis	(Ec.St.Co)
Austriocaris	(Ar.Th.Co)	Aviculomyalina	(Mo.Bi.Pt)	Babukella	(Br.Ar.Te)
Austrirhynchia	(Br.Ar.Rh)	Aviculopecten	(Mo.Bi.Pt)	Babylonella	(Mo.Ga.Ne)
Austri-saturnalis	(Ac.Ra.Sp)	Aviculoperma	(Mo.Bi.Pt)	Babylonia	(Mo.Ga.Ne)
Austroaporrhais	(Mo.Ga.Nt)	Aviculopinna	(Mo.Bi.Mt)	Babylonites	(Mo.Ga.Eu)
Austrobalanus	(Ar.Ci)	Aviculovulsa	(Mo.Bi.Pt)	Bacchites	(Mo.Ce.Ce)
Austroblastus	(Ec.Bi.Fr)	Avilionella	(Mo.Ce.Ba)	Baccispongia	(Po.He.Un)
Austrocardium	(Mo.Bi.Ve)	Avimactra	(Mo.Bi.Ve)	Bacinella	(Pr.Un.In)
Austroceratites	(Mo.Ce.Ce)	Avisyrix	(Br.Ar.Sp)	Backhausina	(Br.Ar.Th)
Austrochiton	(Mo.Po.Ne)	Avitelmessus	(Ar.Ml.De)	Bactrellaria	(Bz.Gy.Ch)
Austrochoristites	(Br.Ar.Sp)	Avitolabrax	(Cd.Os.Pf)	Bactridium	(Bz.Gy.Ch)
Austrocidaris	(Ec.Ec.Ci)	Avitoluvarus	(Cd.Os.Pf)	Bactrites	(Mo.Ce.An)
Austroclavus	(Mo.Ga.Ne)	Avoceras	(Mo.Ce.El)	Bactritimimus	(Mo.Ce.Au)
Austroclupea	(Cd.Os.Cl)	Avonia	(Br.Ar.St)	Bactroceras	(Mo.Ce.El)
Austrocochlis	(Mo.Ga.Nt)	Avonina	(Ar.Tr.Pt)	Bactrocrintites	(Ec.Cr.Cl)
Austrocolomia	(Fo.Fo.Fo)	Avonothyris	(Br.Ar.Te)	Bactrocrythara	(Mo.Ga.Ne)
Austrocominella	(Mo.Ga.Ne)	Awateria	(Mo.Ga.Ne)	Bactrognathus	(Cd.Co.Co)
Austrocypraea	(Mo.Ga.Nt)	Awhea	(Fo.Fo.Fo)	Bactronella	(Po.Ca.Ph)
Austrodosinia	(Mo.Bi.Ve)	Axagnostus	(Ar.Tr.Ag)	Bactropora	(Bz.St.Cr)
Austrodrillia	(Mo.Ga.Ne)	Axelella	(Mo.Ga.Ne)	Bactroptyxis	(Mo.Ga.He)
Austrofusus	(Mo.Ga.Ne)	Axelia	(Cd.Os.Co)	Bactrospira	(Mo.Ga.Nt)
Austroharpa	(Mo.Ga.Ne)	Axinola	(Mo.Bi.Ar)	Bactrotheca	(Hy.Or.Or)
Austrohedra	(Br.Ar.Or)	Axinolobus	(Mo.Ce.Go)	Bactrynum	(Br.Ar.Th)
Austrolepidotus	(Cd.Os.Se)	Axinopsida	(Mo.Bi.Ve)	Baculina	(Mo.Ce.Am)
Austrolithes	(Mo.Ga.Ne)	Axinulus	(Mo.Bi.Ve)	Baculites	(Mo.Ce.Am)
Austromacoma	(Mo.Bi.Ve)	Axinura	(Cn.An.Ru)	Baculocystites	(Ec.Di.Di)

Baculogypsina	(Fo,Fo,Fo)	Balabania	(Mo,Bi,Hi)	Bantfella	(Fo,Fo,Fo)
Baculogypsinoides	(Fo,Fo,Fo)	Balacrinus	(Ec,Cr,Di)	Banflia	(Fr,Un,In)
Baculopora	(Bz,St,Fe)	Balaena	(Cd,Ma,Ce)	Banis	(Mo,Ga,Nt)
Badainjarania	(Br,Ar,Sp)	Balaenodon	(Cd,Ma,Ce)	Bankia	(Mo,Bi,My)
Badainjaranspis	(Ar,Tr,Pt)	Balaenoptera	(Cd,Ma,Ce)	Banlovakia	(Mo,Ga,Ar)
Badiotella	(Mo,Bi,Pt)	Balaenotus	(Cd,Ma,Ce)	Bannerella	(Fo,Fo,Fo)
Badiotites	(Mo,Ce,Ce)	Balaenula	(Cd,Ma,Ce)	Bantamia	(Cn,An,Sc)
Badouceras	(Mo,Ce,Or)	Balakhomia	(Br,Ar,St)	Bapingaspis	(Ar,Tr,Pr)
Baelenia	(Fo,Fo,Fo)	Balangia	(Ar,Tr,Co)	Baptandon	(Cd,Re,Ic)
Baeopluoceras	(Mo,Ce,Ba)	Balanocidaris	(Ec,Ec,Ci)	Baptopora	(Bz,Gy,Ch)
Baeorhynchia	(Br,Ar,Rh)	Balanoconcha	(Br,Ar,Te)	Baptornis	(Cd,Av,He)
Baerocrinus	(Ec,Cr,Hy)	Balanocrinus	(Ec,Cr,Is)	Barbadiastraea	(Cn,An,Sc)
Baffinocythere	(Ar,Os,Po)	Balanocystites	(Ec,St,Mi)	Barbaestrophia	(Br,Ar,St)
Bagenovia	(Mo,St,St)	Balanophyllia	(Cn,An,Sc)	Barbarella	(Cn,An,Ru)
Bagenoviella	(Mo,In,In)	Balantionella	(Po,He,Ly)	Barbarofusus	(Mo,Ga,Ne)
Baggatella	(Fo,Fo,Fo)	Balantioselena	(Mo,Bi,Ve)	Barbarorthis	(Br,Ar,Or)
Baggina	(Fo,Fo,Fo)	Balantiosstoma	(Bz,Gy,Ch)	Barbarothyris	(Br,Ar,Te)
Bagginoides	(Fo,Fo,Fo)	Balantoides	(Ar,Os,Pa)	Barbatia	(Mo,Bi,Ar)
Bagnorthis	(Br,Ar,Or)	Balanus	(Ar,Ci)	Barbatulella	(Br,Li,Li)
Bagongshania	(Ar,Tr,Pt)	Balashovia	(Mo,Ce,On)	Barbierella	(Mo,Bi,Ve)
Bagotum	(Ac,Ra,Na)	Balatonia	(Po,De,As)	Barbieria	(Ec,Di,Di)
Bagrasia	(Br,Ar,St)	Balatonites	(Mo,Ce,Ce)	Barbigodithreca	(Cn,Sc,Cn)
Baikalocyathus	(Po,Re,Aj)	Balatonspira	(Br,Ar,Sp)	Barboasia	(Mo,Bi,Pt)
Baikitolites	(Cn,An,Ta)	Balcis	(Mo,Ga,Nt)	Barbotella	(Mo,Ga,Ar)
Baikonuraspis	(Ar,Tr,Pt)	Balcorcania	(Ar,Tr,Re)	Barbourinella	(Fo,Fo,Fo)
Bailiaspis	(Ar,Tr,Pt)	Balderia	(Ar,Tr,Pt)	Barcarenicthytes	(Cd,Os,Sa)
Bailiella	(Ar,Tr,Pt)	Balearites	(Mo,Ce,Am)	Barcoona	(Mo,Bi,Un)
Bailielloides	(Ar,Tr,Pr)	Baleaerocrinus	(Ec,Cr,Un)	Barchamia	(Mo,Bi,Pt)
Bailongjiangella	(Br,Ar,Rh)	Baleiichthys	(Cd,Os,Pc)	Barella	(Pr,Un,Hy)
Bailya	(Mo,Ga,Ne)	Baliactis	(Ec,As,He)	Barentsia	(En)
Bainbridgia	(Cn,An,Ta)	Balinula	(Mo,Ga,Ar)	Barkeria	(Mo,Ga,Ne)
Bainella	(Ar,Tr,Ph)	Balistes	(Cd,Os,Te)	Barkerina	(Fo,Fo,Fo)
Bairdia	(Ar,Os,Po)	Balistomorphus	(Cd,Os,Te)	Barklyella	(Ar,Tr,Un)
Bairdianella	(Ar,Os,Po)	Balizoma	(Ar,Tr,Ph)	Barbora	(Br,Ar,Al)
Bairdiella	(Cd,Os,Pf)	Balkanites	(Mo,Ce,Ce)	Barlecia	(Mo,Ga,Nt)
Bairdiocypris	(Ar,Os,Po)	Balkhamia	(Fo,Fo,Fo)	Barnadina	(Fo,Fo,Fo)
Bairdiohealdites	(Ar,Os,Po)	Balkhasheconcha	(Br,Ar,St)	Barnea	(Mo,Bi,My)
Bairdiolites	(Ar,Os,Po)	Balkoceras	(Mo,Ce,Pl)	Barnesella	(Mo,Ga,Eu)
Bairdites	(Ar,Os,Me)	Ballardina	(Ar,Os,Pa)	Barnesoceras	(Mo,Ce,El)
Bairdoppilata	(Ar,Os,Po)	Balnibarbi	(Ar,Tr,Pt)	Barnumia	(Ec,Ec,Sp)
Bairdops	(Ar,ML,Pa)	Balowella	(Ar,Os,Po)	Barocospira	(Mo,Ga,Ar)
Baisalina	(Fo,Fo,Fo)	Baltagnostus	(Ar,Tr,Ag)	Baronmites	(Mo,Ce,Am)
Baissalosteges	(Br,Ar,St)	Balticella	(Ar,Os,Pa)	Barrandecirrus	(Mo,Ga,Ar)
Baitalites	(Cn,An,Ta)	Balticeras	(Mo,Ce,Am)	Barrandeites	(Mo,Ce,Ce)
Baituganella	(Fo,Fo,Fo)	Balticoeras	(Mo,Ce,Or)	Barrandeoecarpus	(Ec,St,Mi)
Baituganocaris	(Ar,ML,Ar)	Balticopora	(Bz,St,Tr)	Barrandeoecrinus	(Mo,Ce,Ba)
Bajacythere	(Ar,Os,Po)	Balticoporella	(Bz,St,Tr)	Barrandeoerinus	(Ec,Cr,Mo)
Bajachthys	(Cd,Os,La)	Balticoporellina	(Bz,St,Cy)	Barrandeoograptus	(He,Gr,Gr)
Bajanerita	(Mo,Ga,Ar)	Baltoceras	(Mo,Ce,El)	Barrandeoilites	(Po,De,Ta)
Bajanhongorella	(Br,Ar,St)	Baltoeurypterus	(Ar,Me,EU)	Barrandeoptyllum	(Cn,An,Ru)
Bajanorthis	(Br,Ar,Or)	Baltoniodus	(Cd,Co,Co)	Barrandia	(Ar,Tr,As)
Bajarinovia	(Br,Ar,Un)	Baltonotella	(Ar,Os,Pa)	Barrandina	(Br,Ar,Pe)
Bajgolia	(Cn,An,Ta)	Baluchicardia	(Mo,Bi,Ve)	Barrealispira	(Mo,Ga,Ar)
Bajiella	(Ar,Os,Ar)	Balsia	(Mo,Ce,Go)	Barremites	(Mo,Ce,Am)
Bajkaloceras	(Mo,Ce,In)	Bambusoeras	(Mo,Ce,El)	Barrettia	(Mo,Bi,Hi)
Bajolla	(Bz,St,Un)	Bamyaniceras	(Mo,Ce,Pl)	Barroisella	(Br,Li,Li)
Bajugania	(Br,Ar,Sp)	Bananogmius	(Cd,Os,Cr)	Barroisia	(Po,Ca,Sp)
Bakeroeras	(Mo,Ce,El)	Banastella	(Bz,St,Fe)	Barrosiceras	(Cn,An,Ar)
Bakevellia	(Mo,Bi,Pt)	Bancrottina	(Br,Ar,Or)	Barrosicaulus	(Mo,Ga,Ar)
Bakevelloides	(Mo,Bi,Pt)	Bandalaspis	(Ar,Tr,As)	Barrosina	(Ar,Os,Pa)
Bakomyia	(Mo,Ga,Ar)	Bandelium	(Mo,Ga,Ar)	Barrichilina	(Ar,Os,Po)
Bakonyithyris	(Br,Ar,Te)	Bandellina	(Mo,Ga,He)	Barskovia	(Mo,In,In)
Baksanophyllia	(Cn,An,Sc)	Bandopoductus	(Br,Ar,St)	Barthusa	(Ar,ML,De)
Bakunella	(Ar,Os,Po)	Bandyella	(Fo,Fo,Fo)	Bartonia	(Mo,Ga,Ne)

Bartramella	(Fo,Fo,Fo)	Bateridium	(Br,Ar,Pe)	Baturria	(Br,Ar,Or)
Bartrumia	(Mo,Bi,Ve)	Bateroboceras	(Mo,Ce,Ta)	Batyraspis	(Ar,Tr,Ph)
Bartschella	(Mo,Ga,He)	Baterospirifer	(Br,Ar,Sp)	Bauchioceras	(Mo,Ce,Am)
Barunkhuraya	(Br,Ar,St)	Bathericrinus	(Ec,Cr,Ci)	Baueria	(Ec,Ec,Ph)
Barychilina	(Ar,Os,Me)	Batherocystis	(Ec,Fo,Un)	Baumgartneria	(Ac,Ra,Na)
Baryconites	(Mo,Bi,Hi)	Bathmoceras	(Mo,Ce,Fl)	Baunea	(Po,De,Ta)
Barycrinus	(Ec,Cr,Ci)	Bathmosmilia	(Cn,An,Sc)	Bauxia	(Mo,Ga,Nt)
Barycypraea	(Mo,Ga,Nt)	Bathosella	(Bz,Gy,Ch)	Bayarilla	(Ar,Tr,Ph)
Baryhelia	(Cn,An,Sc)	Bathotheca	(Po,De,Li)	Bayania	(Mo,Ga,Nt)
Barylasma	(Cn,An,Ru)	Bathraspira	(Mo,Ga,Nt)	Bayanoteuthis	(Mo,Ce,Be)
Barymaetra	(Mo,Bi,Ve)	Bathrocalpis	(Ac,Ra,Na)	Bayfieldia	(Ar,Tr,Pt)
Barymepton	(Ar,Os,Pa)	Bathronocrinus	(Ec,Cr,Ci)	Bayhaim	(Cn,An,Ta)
Baryphyllia	(Cn,An,Sc)	Bathropyramis	(Ac,Ra,Na)	Baykonaroceras	(Mo,Ce,Or)
Baryphyllum	(Cn,An,Ru)	Bathrotomaria	(Mo,Ga,Ar)	Baylea	(Mo,Ga,Ar)
Barysmilia	(Cn,An,Sc)	Bathyarca	(Mo,Bi,Ar)	Bayleia	(Mo,Bi,Hi)
Baryspira	(Mo,Ga,Ne)	Bathybalva	(Cn,An,Ru)	Bayleites	(Mo,Ce,Am)
Barytellina	(Mo,Bi,Ve)	Bathybembix	(Mo,Ga,Ar)	Bayleoida	(Mo,Bi,Hi)
Barytichisma	(Cn,An,Ru)	Bathycheilus	(Ar,Tr,Ph)	Bazardarella	(Br,Ar,Te)
Barzellinia	(Br,Ar,Rh)	Bathyclides	(Mo,Ga,Ar)	Bdellacomia	(Ec,Op,St)
Baschkirina	(Ar,Os,Pa)	Bathyclupea	(Cd,Os,Pf)	Bdellodus	(Cd,Ch,Ct)
Baschkirites	(Mo,Ce,Go)	Bathycoenia	(Cn,An,Sc)	Bdelloidina	(Fo,Fo,Fo)
Bascomella	(Bz,Gy,Ct)	Bathycrinus	(Ec,Cr,Bo)	Beachia	(Br,Ar,Te)
Bashkiria	(Br,Ar,Sp)	Bathycyathus	(Cn,An,Sc)	Beania	(Bz,Gy,Ch)
Bashkirielia	(Bz,St,Fe)	Bathycythere	(Ar,Os,Pa)	Beaniceras	(Mo,Ce,Am)
Bashkortoceras	(Mo,Ce,Go)	Bathydiscus	(Ar,Tr,Ag)	Beatamoošina	(Ar,Os,Pa)
Basidichenella	(Ar,Tr,Pr)	Bathygadus	(Cd,Os,Ga)	Beatites	(Mo,Ce,Ce)
Basilicorhynchus	(Br,Ar,Rh)	Bathygalea	(Mo,Ga,Nt)	Beaumontia	(Cn,An,Ta)
Basilicus	(Ar,Tr,As)	Bathylagus	(Cd,Os,Os)	Beaumontoperca	(Cd,Os,Pf)
Basiliella	(Ar,Tr,As)	Bathylasma	(Ar,Ci)	Beaussetia	(Po,He,Ly)
Basiliola	(Br,Ar,Rh)	Bathymyonia	(Br,Ar,St)	Bebhacanthus	(Cd,Ch,Sn)
Basilirata	(Mo,Ga,Nt)	Bathynomus	(Ar,MI,Is)	Becharocrinus	(Ec,Cr,Un)
Basilissa	(Mo,Ga,Ar)	Bathy notellus	(Ar,Tr,Re)	Bechleja	(Ar,MI,De)
Basilitrona	(Mo,Ga,Nt)	Bathynotus	(Ar,Tr,Co)	Beckerheldia	(Ar,Os,Me)
Basilosaurus	(Cd,Ma,Ce)	Bathynotus	(Ar,Tr,Re)	Beckmannia	(Br,Ar,Rh)
Baskanioceras	(Mo,Ce,Am)	Bathyococ	(Ar,Tr,Pt)	Becksia	(Po,He,Ly)
Basleoeras	(Mo,Ce,Go)	Bathyrhyncha	(Br,Ar,Rh)	Beckwithia	(Ar,Me,Ag)
Basleoerinus	(Ec,Cr,Ci)	Bathysiphon	(Fo,Fo,Fo)	Becchia	(Br,Ar,At)
Basleoephyllum	(Cn,An,Ru)	Bathysoma	(Cd,Os,La)	Bedeva	(Mo,Ga,Ne)
Basocephalus	(Ar,Tr,Co)	Bathysquilla	(Ar,MI,St)	Bedicella	(Ar,Tr,Pr)
Basseaster	(Ec,Ec,Hs)	Bathystomella	(Bz,Gy,Ch)	Beecherella	(Ar,Os,Pa)
Bassetbullia	(Mo,Po,Ne)	Bathysynactites	(Ec,Ho,As)	Beecheria	(Br,Ar,Te)
Bassetina	(Ar,Ci)	Bathytoma	(Mo,Ga,Ne)	Beecheroscapha	(Ar,Os,Pa)
Bassina	(Mo,Bi,Ve)	Bathytormus	(Mo,Bi,Ve)	Beedeina	(Fo,Fo,Fo)
Bassinaria	(Mo,Bi,Ve)	Bathyurellus	(Ar,Tr,Pr)	Beekmanoceras	(Mo,Ce,Ta)
Bassipterus	(Ar,Me,Eu)	Bathyuriscellus	(Ar,Tr,Re)	Beella	(Fo,Fo,Fo)
Bassius	(Cn,An,Ru)	Bathyuriscidella	(Ar,Tr,Co)	Beerichthys	(Cd,Os,Pf)
Basslederella	(Bz,St,Un)	Bathyuriscops	(Ar,Tr,Pr)	Behemotops	(Cd,Ma,De)
Bassleratia	(Ar,Os,Pa)	Bathyuriscopsis	(Ar,Tr,Co)	Beichuanella	(Br,Ar,Rh)
Basslerella	(Ar,Os,Pa)	Bathyuriscus	(Ar,Tr,Co)	Beichuania	(Mo,Bi,Un)
Bassleridiscus	(Ec,Ed,Is)	Bathyurus	(Ar,Tr,Pr)	Beichuanrhynchus	(Br,Ar,Rh)
Basslerites	(Ar,Os,Pa)	Batillaria	(Mo,Ga,Nt)	Beigongia	(Ar,Tr,As)
Bassleroceras	(Mo,Ce,El)	Batilonia	(Mo,Ga,Nt)	Beikedamaspis	(Ar,Tr,Un)
Basslerocystis	(Ec,St,MI)	Batissa	(Mo,Bi,Ve)	Beiliupora	(Cn,An,Ta)
Bassotrochus	(Mo,Ga,Eu)	Batocara	(Ar,Tr,Ph)	Beisselia	(Mo,Ga,Ne)
Bassozetus	(Cd,Os,Op)	Batocrinus	(Ec,Cr,Mo)	Beisselina	(Bz,Gy,Ch)
Basterotella	(Mo,Bi,Ve)	Batolites	(Mo,Bi,Hi)	Beisselinoopsis	(Bz,Gy,Ch)
Basterotia	(Mo,Bi,Ve)	Batopora	(Bz,Gy,Ch)	Beitaia	(Br,Ar,At)
Bastindoceras	(Mo,Ce,Na)	Batostoma	(Bz,St,Tr)	Bejrutella	(Br,Ar,Te)
Bastropia	(Mo,Ga,Ne)	Batostomella	(Bz,St,Tr)	Bekena	(Ar,Os,Me)
Batalleria	(Ec,Di,Di)	Batostomellina	(Bz,St,Tr)	Bekkeromena	(Br,Ar,St)
Batangophyllum	(Cn,An,Ru)	Batrachoides	(Cd,Os,Pa)	Beklemishevites	(Pr,Un,Hy)
Batavocythere	(Ar,Os,Pa)	Batrachopora	(Bz,Gy,Ch)	Bekoma	(Ac,Ra,Na)
Batchatiella	(Ar,Tr,Pt)	Batschykiyathus	(Po,Re,Aj)	Bela	(Mo,Ga,Ne)
Batequeus	(Mo,Bi,Pt)	Battaglia	(Po,De,Pe)	Belanskicrinus	(Ec,Cr,Ci)

Belantsea	(Cd,Ch,Pe)	Belorussipora	(Bz,St,Cy)	Bergerolimbos	(Ar,Tr,Un)
Belatomina	(Mo,Ga,Ne)	Belosepia	(Mo,Ce,Se)	Bergeroniaspis	(Ar,Tr,Pt)
Belbekella	(Br,Ar,Rh)	Belosepiella	(Mo,Ce,Se)	Bergeroniellus	(Ar,Tr,Pt)
Belemnacanthus	(Cd,Pl,Ar)	Belosphys	(Cd,Ma,Ce)	Bergeronites	(Ar,Tr,Pt)
Belemnella	(Mo,Ce,Be)	Belospirula	(Mo,Ce,Be)	Berggrenia	(Fo,Fo,Fo)
Belemnellocamax	(Mo,Ce,Be)	Belosteus	(Cd,Pl,Ar)	Bergoceras	(Mo,Ce,Or)
Belemnitella	(Mo,Ce,Be)	Belotelson	(Ar,MI,Be)	Bergstroemognathus	(Cd,Co,Co)
Belemmites	(Mo,Ce,Be)	Beloteuthis	(Mo,Ce,Te)	Bergstroemograptus	(He,Gr,Gr)
Belemnitina	(Mo,Ce,Be)	Belothyris	(Br,Ar,Te)	Beringius	(Mo,Ga,Ne)
Belemnitomimus	(Mo,Ce,Am)	Belovia	(Ar,Tr,Od)	Berkhia	(Cn,An,Ru)
Belemnobatis	(Cd,Ch,Rj)	Belowea	(Ac,Ra,Sp)	Berkutaspis	(Ar,Tr,Pt)
Belemnocamax	(Mo,Ce,Be)	Beltanacyathus	(Po,Ir,Ar)	Berlieria	(Mo,Ga,Ar)
Belemnocrinus	(Ec,Cr,Ds)	Beltanelliformis	(Cn,An,Ac)	Bermudezella	(Fo,Fo,Fo)
Belemnocystites	(Ec,Hs,So)	Beltanelloidea	(Cn,An,Ac)	Bermudezina	(Fo,Fo,Fo)
Belemnopsis	(Mo,Ce,Be)	Beltella	(Ar,Tr,Pt)	Bermudezinella	(Fo,Fo,Fo)
Belemnosella	(Mo,Ce,Se)	Belubalua	(Po,De,Pe)	Bernaya	(Mo,Ga,Ne)
Belemnospongia	(Po,De,Un)	Belubulaspongia	(Po,De,Li)	Bernia	(Ar,Tr,As)
Belemnostroma	(Po,De,St)	Bemaspis	(Ar,Tr,Pt)	Berniceras	(Mo,Ce,Am)
Belemnoteuthis	(Mo,Ce,Pm)	Bembaxia	(Mo,Ga,Ar)	Bernoullius	(Ac,Ra,Na)
Belemnoziphys	(Cd,Ma,Ce)	Bembicium	(Mo,Ga,Nt)	Beroides	(Mo,St,St)
Belemosis	(Mo,Ce,Se)	Bembicosoma	(Ar,Me,Xi)	Berolinella	(Ar,Os,Pa)
Beleutella	(Br,Ar,St)	Bembridgia	(Mo,Ga,Nt)	Berounella	(Ar,Os,Pa)
Beleutoceras	(Mo,Ce,Go)	Bembrops	(Cd,Os,Pf)	Berriavella	(Mo,Ce,Am)
Belgradeophyllum	(Cn,An,Ru)	Bemella	(Mo,He,He)	Berrosiceras	(Mo,Ce,Am)
Bellaclathrus	(Br,Ar,St)	Benacoceras	(Mo,Ce,Am)	Berryteuthis	(Mo,Ce,Te)
Bellaspidella	(Ar,Tr,As)	Bendeia	(Mo,Ga,Ne)	Berthelina	(Fo,Fo,Fo)
Bellaspira	(Mo,Ga,Ne)	Bendemacoma	(Mo,Bi,Ve)	Berthelinella	(Fo,Fo,Fo)
Bellaspis	(Ar,Tr,Pt)	Bendenius	(Cd,Os,Pa)	Berthelina	(Mo,Ga,Sa)
Bellastrea	(Mo,Ga,Ar)	Beneckastrea	(Cn,An,Sc)	Berthelinopsis	(Fo,Fo,Fo)
Bellatara	(Mo,Ga,Nt)	Beneckeia	(Mo,Ce,Ce)	Bertilionella	(Ar,Os,My)
Bellaxinaca	(Mo,Bi,Ar)	Benesovella	(Ar,Tr,Pr)	Berybolencis	(Cd,Os,Br)
Bellazona	(Mo,Ga,Ar)	Bengtsonia	(Pr,To,Mi)	Berycomorus	(Cd,Os,Br)
Bellefontia	(Ar,Tr,As)	Benniaspis	(Ar,Os,Un)	Berycopsis	(Cd,Os,Pa)
Bellerophina	(Mo,Ga,Nt)	Benoistea	(Mo,Ga,Nt)	Berycopsis	(Cd,Os,Pa)
Bellerophon	(Mo,Ga,Be)	Bensonastraea	(Cn,An,Ru)	Beryllia	(Ec,St,Co)
Belliceps	(Ar,Tr,Re)	Bensonia	(Ar,Os,Pa)	Beryx	(Cd,Os,Br)
Bellifusus	(Mo,Ga,Ne)	Bensonocythere	(Ar,Os,Pa)	Besairecidaris	(Ec,Ec,Un)
Bellimurina	(Br,Ar,St)	Benthamsaspis	(Ar,Tr,Pr)	Besania	(Cd,Os,Pe)
Bellinuroopsis	(Ar,Me,Xi)	Bentharcia	(Mo,Bi,Ar)	Beschevella	(Br,Ar,Sp)
Bellinurus	(Ar,Me,Xi)	Benthescymus	(Ar,MI,De)	Beshtashella	(Mo,In,In)
Belliscala	(Mo,Ga,Nt)	Bentheskyma	(Cd,Os,Al)	Besla	(Mo,Ga,He)
Bellocaris	(Ar,MI,My)	Benthocardiella	(Mo,Bi,Ve)	Besselodus	(Cd,Co,Co)
Belloceras	(Mo,Ce,El)	Benthocomectes	(Cd,Os,Op)	Bestjubella	(Ar,Tr,Pt)
Bellolia	(Mo,Ga,Ne)	Benthocrinus	(Ec,Cr,Cl)	Bethanophyllum	(Cn,An,Ru)
Bellornatia	(Ar,Os,Pa)	Benthomangelia	(Mo,Ga,Ne)	Betracrium	(Ac,Ra,Sp)
Bellucina	(Mo,Bi,Ve)	Benthopecten	(Ec,As,No)	Betterbergia	(Br,Ar,Rh)
Beloceras	(Mo,Ce,An)	Benthosoma	(Cd,Os,My)	Bettonia	(Ar,Tr,As)
Belochthys	(Ec,Ed,Is)	Beltoceeras	(Mo,Ce,Ta)	Betyokites	(Mo,Ce,Am)
Belocrinus	(Ec,BI,Sp)	Benueites	(Mo,Ce,Am)	Beudanticeras	(Mo,Ce,Am)
Belocurta	(Mo,Ce,Se)	Benxiceras	(Mo,Ce,Pr)	Beudantiella	(Mo,Ce,Am)
Belodella	(Cd,Co,Co)	Benxiphyllum	(Cn,An,Ru)	Beugniastrea	(Cn,An,Ru)
Belodina	(Cd,Co,Co)	Beogradophyllum	(Cn,An,Ru)	Bevahites	(Mo,Ce,Am)
Beloitoceras	(Mo,Ce,On)	Beothuckia	(Ar,Tr,Pt)	Bevanopsis	(Ar,Tr,Ph)
Belone	(Cd,Os,Be)	Berabichia	(Ar,Tr,Pt)	Beyrichia	(Ar,Os,Pa)
Belonechitina	(Fo,Fo,Ch)	Berardiopsis	(Cd,Ma,Ce)	Beyrichiana	(Ar,Os,Pa)
Belonidium	(Mo,Ga,He)	Beraua	(Mo,Ga,Ar)	Beyrichiscus	(Mo,Ga,Be)
Belonisia	(Po,He,He)	Beraunia	(Mo,Ga,Ar)	Beyrichiella	(Ar,Os,Pa)
Belonostomus	(Cd,Os,Pe)	Berbericeras	(Mo,Ce,Am)	Beyrichiopsis	(Ar,Os,Pa)
Belophos	(Mo,Ga,Ne)	Bercutia	(Pr,To,Mi)	Beyrichites	(Mo,Ce,Ce)
Beloplaxus	(Mo,Po,Ne)	Berdanopsis	(Ar,Os,Pa)	Beyrichoceras	(Mo,Ce,Go)
Beloptera	(Mo,Ce,Se)	Berenicea	(Bz,St,Ce)	Beyrichoceratoides	(Mo,Ce,Go)
Belopteridium	(Mo,Ce,Se)	Beretra	(Mo,Ga,Nt)	Beyrichocrinus	(Ec,Cr,Mo)
Belopterina	(Mo,Ce,Se)	Bergalarai	(Br,Ar,Rh)	Beyrichona	(Ar,Os,Ar)
Belorussiella	(Fo,Fo,Fo)	Bergamia	(Ar,Tr,As)	Bezania	(Mo,Ga,Nt)

Bhimaites	(Mo,Ce,Am)	Biflustra	(Bz,Gy,Ch)	Biplanispira	(Fo,Fo,Fo)
Biangularia	(Mo,Ga,Ar)	Bifodina	(Ar,Tr,Pt)	Biplatyconcha	(Br,Ar,St)
Biapertorbis	(Fo,Fo,Fo)	Bifolium	(Br,Ar,Th)	Biplex	(Mo,Ga,Nt)
Biarea	(Br,Ar,Un)	Biformispira	(Mo,Ga,Eu)	Biplica	(Mo,Ga,Ce)
Biarrizina	(Fo,Fo,Fo)	Bifossularia	(Cn,An,Ru)	Biplicatoria	(Br,Ar,Te)
Biasterigerina	(Fo,Fo,Fo)	Bifoveoceras	(Mo,Ce,Or)	Biplices	(Mo,Ce,Am)
Biaurina	(Ar,Os,Ar)	Bifurcamma	(Fo,Fo,Fo)	Bipulvina	(Mo,Tr,Tr)
Biaverta	(Ar,Tr,Pt)	Bifurcium	(Mo,Ga,Ne)	Bipygmaeus	(An,Po,Se)
Biavicularium	(Bz,Gy,Ch)	Bigalea	(Mo,Ro,Co)	Biradiolites	(Mo,Bi,Hi)
Bibatiola	(Br,Ar,St)	Bigenerina	(Fo,Fo,Fo)	Birchella	(Br,Ar,Sp)
Bibradya	(Fo,Fo,Fo)	Bighornia	(Cn,An,Ru)	Birdsallella	(Ar,Os,Me)
Bibucia	(Cn,An,Ta)	Biglobigerinella	(Fo,Fo,Fo)	Bireophax	(Fo,Fo,Fo)
Bicarina	(Mo,Ga,Ar)	Bignotella	(Ci,Po,Sp)	Birgeria	(Cd,Os,Pa)
Bicarinatina	(Br,Li,Li)	Bigotella	(Mo,Ga,Nt)	Birkena	(Cd,Ce,Bi)
Bicarinella	(Mo,Ga,Nt)	Bigotina	(Ar,Tr,Pt)	Birkenmajeria	(Ac,Ra,Na)
Bicatillus	(Mo,Ga,Nt)	Bigotinella	(Ar,Tr,Pt)	Birmanites	(Ar,Tr,As)
Bicavea	(Bz,St,Ce)	Bigotonops	(Ar,Tr,Pt)	Birostrina	(Mo,Bi,Pt)
Bicella	(Ar,Tr,Pt)	Bigotites	(Mo,Ce,Am)	Bisacculus	(Ar,Os,Pa)
Bicepsirhynchia	(Br,Ar,Rh)	Bihatirinus	(Ec,Cr,Un)	Bisatoceras	(Mo,Ce,Go)
Biceratops	(Ar,Tr,Re)	Bihendulrhynchia	(Br,Ar,Rh)	Bisceola	(Ar,Tr,Pt)
Bichilina	(Ar,Os,Pa)	Bihenduloceras	(Mo,Ce,Am)	Bisculcata	(Br,Ar,Pe)
Bicia	(Br,Un,Ob)	Bihenithyris	(Br,Ar,Te)	Biselenaria	(Bz,Gy,Ch)
Bicidiocrinus	(Ec,Cr,Ci)	Bija	(Cn,An,Un)	Bisepium	(Br,Ar,Pe)
Bicingulites	(Mo,Cr,Te)	Bikocrinus	(Ec,Cr,Mo)	Biseriammina	(Fo,Fo,Fo)
Bickmorites	(Mo,Ce,Ba)	Bilaminella	(Br,Ar,Rh)	Biseriella	(Fo,Fo,Fo)
Biconcava	(Fo,Fo,Fo)	Bilaterocoenia	(Cn,An,Sc)	Bishanopliosaurus	(Cd,Re,Ps)
Biconostrophia	(Br,Ar,At)	Bilecicrinus	(Ec,Cr,Cy)	Bisidmonea	(Bz,St,Ce)
Biconulites	(An,Po,Un)	Bilinguites	(Mo,Ce,Go)	Bisinocoella	(Br,Ar,Sp)
Biconvexiella	(Br,Ar,Sp)	Bilingulogavelinella	(Fo,Fo,Fo)	Bisonoceras	(Mo,Ce,En)
Bicorbis	(Bz,St,Fe)	Bilinia	(Cd,Os,Pt)	Bispathodus	(Cd,Co,Co)
Bicorbula	(Mo,Bi,My)	Bilicobbanoceras	(Mo,Ce,Am)	Bisphaera	(Fo,Fo,Fo)
Bicornella	(Ar,Os,Pa)	Billiemia	(Mo,Ga,Nt)	Bisphaerocephalina	(Ac,Ra,Na)
Bicornellina	(Ar,Os,Pa)	Billingsaria	(Cn,An,Ta)	Bisphenella	(Ar,Os,Pa)
Bicornifera	(Bz,Gy,Ch)	Billingsella	(Br,Ar,Or)	Bispinitia	(Ar,Os,Le)
Bicornomyge	(Ar,Tr,Un)	Billingsites	(Mo,Ce,As)	Bispranella	(Fo,Fo,Fo)
Bicornuocopina	(Mo,Bi,Hi)	Billingsocystis	(Ec,Pc,Co)	Bissulentactinia	(Ac,Ra,Sp)
Bicornuocythere	(Ar,Os,Po)	Bilobatia	(Ar,Os,Pa)	Bistarkum	(Ac,Ra,Sp)
Bicoronipora	(Bz,St,Cc)	Bilobia	(Br,Ar,St)	Bistomiacystis	(Ec,Pc,Un)
Bicoscinus	(Po,Fr,Ka)	Bilobissa	(Mo,Bi,Pt)	Bistramia	(Br,Li,Li)
Bicrenucula	(Mo,Bi,Nu)	Biloclymenia	(Mo,Ce,Ci)	Bistrialites	(Mo,Ce,Na)
Bicrenula	(Mo,Bi,Nu)	Biloculinella	(Fo,Fo,Fo)	Bisulcina	(Br,Ar,Te)
Bicrisia	(Bz,St,Cc)	Bilotina	(Br,Ar,St)	Bisulcoecypris	(Ar,Os,Po)
Bicrisina	(Bz,St,Cc)	Biltnerites	(Mo,Ce,Ce)	Bisulcoentomozeo	(Ar,Os,My)
Bicupularia	(Bz,Gy,Ch)	Bimontina	(Fo,Fo,Fo)	Bitauoniceras	(Mo,Ce,Or)
Bicuspina	(Br,Ar,Or)	Bimuria	(Br,Ar,St)	Bitaxia	(Fo,Fo,Fo)
Bideirella	(Ar,Os,Pa)	Bimuropora	(Bz,St,Tr)	Bitectipora	(Bz,Gy,Ch)
Bidentatus	(Br,Ar,Sp)	Binatisphinctes	(Mo,Ce,Am)	Bithecocamara	(He,Gr,Ca)
Bidiastopora	(Bz,St,Cc)	Bingeria	(Ar,Os,Le)	Biticinella	(Fo,Fo,Fo)
Bidjinella	(Ar,Tr,Pt)	Binkhorstia	(Ar,ML,De)	Bitraria	(Cn,An,Ru)
Bienella	(Ar,Tr,Co)	Binneyites	(Mo,Ce,Am)	Bitternella	(Br,Ar,Th)
Bienvillia	(Ar,Tr,Pt)	Binoculites	(Ec,Ho,De)	Bitiolum	(Mo,Ga,Nt)
Biernatella	(Br,Ar,Sp)	Binodaspis	(Ar,Tr,Pt)	Bittiscalea	(Mo,Ga,Nt)
Biernatia	(Br,Li,Ac)	Binodella	(Ar,Os,Pa)	Bittium	(Mo,Ga,Nt)
Biernatium	(Br,Ar,Or)	Binodina	(Ar,Os,Pa)	Bittnerella	(Br,Ar,St)
Bifarilaminella	(Fo,Fo,Fo)	Bioistodina	(Pr,Un,In)	Bituina	(Mo,Bi,Pt)
Bifarina	(Fo,Fo,Fo)	Biokovina	(Fo,Fo,Fo)	Bituberitina	(Fo,Fo,Fo)
Bifarinella	(Fo,Fo,Fo)	Biolgia	(Ar,Tr,Pr)	Bitubigera	(Bz,St,Cc)
Bifariostroma	(Po,De,St)	Biorbis	(Fo,Fo,Fo)	Bitubulogenerina	(Fo,Fo,Fo)
Bifaxaria	(Bz,Gy,Ch)	Biovicella	(Bz,St,Cc)	Bitumulina	(Ar,Tr,Pr)
Bifericeras	(Mo,Ce,Am)	Bipallicyathus	(Mo,Re,Aj)	Bivallulosa	(Ac,Ra,Sp)
Bifida	(Br,Ar,At)	Biparetis	(Br,Ar,St)	Bivestis	(Bz,St,Cc)
Bifidoscala	(Mo,Ga,Nt)	Biparietata	(Fo,Fo,Fo)	Bivetiella	(Mo,Ga,Ne)
Bifissurinella	(Bz,Gy,Ch)	Biphylum	(Cn,An,Ru)	Bivetopsia	(Mo,Ga,Ne)
Bitlabellaria	(Bz,St,Cc)	Biplanata	(Fo,Fo,Fo)	Bivia	(Ar,Os,Le)

Bivonia	(Mo,Ga,Nt)	Bodrakella	(Br,Ar,Rh)	Bolcanguilla	(Cd,Os,An)
Biwaella	(Fo,Fo,Fo)	Bodyleryskites	(Mo,Ce,Am)	Bolcyrus	(Cd,Os,An)
Blabe	(Cd,Os,Pf)	Bodzentina	(Ar,Os,Pa)	Boidea	(Ar,Os,Pa)
Blackdownia	(Mo,Ga,Ne)	Boeckaspis	(Ar,Tr,Pt)	Boldia	(Fo,Fo,Fo)
Blackwelderia	(Ar,Tr,Od)	Boeckeleriacambria	(Pn)	Boletechinus	(Ec,Ec,Ph)
Blackwelderioides	(Ar,Tr,Pt)	Boeckhia	(Mo,Ga,Ar)	Bolletzkyidae	(Mo,Ce,Bo)
Blaculla	(Ar,Ml,De)	Boeckops	(Ar,Tr,Ph)	Bolgarithyrus	(Br,Ar,Te)
Blagaveia	(Mo,Bi,Ve)	Boehmia	(Mo,Ga,He)	Bolierius	(Ec,Cr,Mo)
Blainia	(Ar,Tr,Pt)	Boehmoceras	(Mo,Ce,Am)	Bolidium	(Po,De,Li)
Blainiopsis	(Ar,Tr,Pt)	Boesites	(Mo,Ce,Pl)	Bolilaspifer	(Br,Ar,Sp)
Blairella	(Mo,Bi,Ve)	Boettgeriella	(Mo,Ga,Ne)	Bolinchthyes	(Cd,Os,My)
Blairocrinus	(Ec,Cr,Mo)	Boetuvia	(Mo,Bi,Ve)	Bolinus	(Mo,Ga,Ne)
Blakeoceras	(Mo,Ce,On)	Bogdanoceras	(Mo,Ce,Go)	Boliositeus	(Cd,Pl,Rh)
Blancia	(Mo,Ga,Ce)	Boggsia	(Mo,Ga,Nt)	Bolis	(Mo,Ga,Ne)
Blandiaspis	(Ar,Tr,Co)	Bogimbailites	(Cn,An,Ta)	Bolitesia	(Po,He,Ly)
Blandicephalus	(Ar,Tr,As)	Bogoslovskya	(Mo,Ce,Or)	Bolitesia	(Hy,Or,Or)
Blanforiderceras	(Mo,Ce,Am)	Bogotacrinus	(Ec,Cr,Mo)	Boliviacrinus	(Ec,Cr,Mo)
Blanodalmanites	(Ar,Tr,Ph)	Bogushella	(Fo,Fo,Fo)	Bolivianaspis	(Ar,Tr,Ph)
Blasicurra	(Mo,Ga,Nt)	Bohaispira	(Mo,Ga,Nt)	Bolivicrania	(Ar,Tr,Pr)
Blastamina	(Fo,Fo,Fo)	Bohaispiropsis	(Mo,Ga,Nt)	Bolivina	(Fo,Fo,Fo)
Blastinia	(Po,Ca,Ph)	Bohemaster	(Ec,As,Ur)	Bolivineilla	(Fo,Fo,Fo)
Blastinoidea	(Po,Ca,Ph)	Bohemiacystis	(Ec,St,Co)	Bolivineillina	(Fo,Fo,Fo)
Blastocerina	(Mo,Ce,Di)	Bohemioocrinus	(Ec,Cr,Mo)	Bolivinita	(Fo,Fo,Fo)
Blastochaetetes	(Po,De,Ta)	Bohemiella	(Br,Ar,Or)	Bolvinoides	(Fo,Fo,Fo)
Blastocystis	(Ec,Pa,Pa)	Bohemilla	(Ar,Tr,As)	Bolvinopsis	(Fo,Fo,Fo)
Blastoiodocrinus	(Ec,Pa,Pa)	Bohemiproetus	(Ar,Tr,Pr)	Bolvioproetus	(Ar,Tr,Pr)
Blastolepas	(Ar,Ci)	Bohemirhynchia	(Br,Ar,Rh)	Bolkarina	(Fo,Fo,Fo)
Blastosmia	(Cn,An,Sc)	Bohemites	(Mo,Ce,Or)	Bollandia	(Ar,Tr,Pr)
Blastulospongia	(Po,De,Pe)	Bohemobolbina	(Ar,Os,Pa)	Bollandites	(Mo,Ce,Go)
Blayacina	(Ar,Tr,Re)	Bohemograptus	(He,Gr,Gr)	Bollandoceras	(Mo,Ce,Go)
Blefuscuiana	(Fo,Fo,Fo)	Bohemoharpes	(Ar,Tr,Pt)	Bollandocrinus	(Ec,Cr,Cl)
Blennius	(Cd,Os,Pf)	Bohemopyge	(Ar,Tr,As)	Bollia	(Ar,Os,Pa)
Blepharipoda	(Ar,Ml,De)	Bohemoscolex	(An,Pa,Pa)	Bolliaphores	(Ar,Os,Pa)
Bleshidium	(Br,Ar,Pe)	Bohemura	(Ec,Op,Oe)	Bolliella	(Fo,Fo,Fo)
Bleta	(Mo,Bi,Un)	Bohlenatia	(Ar,Os,Pa)	Bolloceras	(Mo,Ce,On)
Blochius	(Cd,Os,In)	Bohomaspis	(Ar,Tr,As)	Bolma	(Mo,Ga,Ar)
Blochmanella	(Br,Ar,Rh)	Boicinetes	(Br,Ar,St)	Bolojerea	(Po,De,Li)
Blosyropsis	(Ar,Tr,Pt)	Boikothalamia	(Po,De,Ve)	Boloria	(Br,Ar,Rh)
Blothrocrinus	(Ec,Cr,Cl)	Boiomylus	(Mo,Bi,Pt)	Bolospongia	(Po,De,Li)
Blothrocryathus	(Cn,An,Sc)	Boiotremus	(Mo,Ga,Be)	Boltenella	(Mo,Ga,Ne)
Blothrophyllum	(Cn,An,Ru)	Bojarkaella	(Fo,Fo,Fo)	Boltovskoyella	(Fo,Fo,Fo)
Blountia	(Ar,Tr,Pt)	Bojocoryphe	(Ar,Tr,Pr)	Bomakellia	(Cn,Pe,Er)
Blountiella	(Ar,Tr,Pt)	Bojocyclus	(Cn,An,Ru)	Bombur	(Ar,Ml,De)
Blowiella	(Fo,Fo,Fo)	Bojodouvillina	(Br,Ar,St)	Bomburites	(Mo,Ce,Am)
Blumerbachium	(Br,St,Cc)	Bojoscutellum	(Ar,Tr,Co)	Bomina	(Br,Li,Pa)
Blyskavomena	(Br,Ar,St)	Bojothyris	(Br,Ar,Sp)	Bonata	(Cn,In,In)
Blysmatophyllum	(Cn,An,Ru)	Bolaspidella	(Ar,Tr,Pt)	Bondarevites	(Ar,Tr,Re)
Blystagnostus	(Ar,Tr,Ag)	Bolaspidellus	(Ar,Tr,Pt)	Bondarella	(Ar,Tr,Ol)
Bobasarania	(Cd,Os,Bb)	Bolaspidina	(Ar,Tr,Pt)	Bonellitia	(Mo,Ga,Ne)
Bobbichthys	(Cd,Os,Pe)	Bolaspis	(Ar,Tr,Pt)	Bonnaria	(Ar,Tr,Co)
Bobodus	(Cd,Ch,Eu)	Bolbibollia	(Ar,Os,Pa)	Bonnaspis	(Ar,Tr,Co)
Bobiesipora	(Bz,St,Cc)	Bolbilitis	(Ar,Os,Pa)	Bonnemaia	(Ar,Os,Pa)
Bobinella	(Br,Ar,Pe)	Bolbina	(Ar,Os,Pa)	Bonneprimites	(Ar,Os,Pa)
Bochianites	(Mo,Ce,Am)	Bolbineossia	(Ar,Os,Pa)	Bonnetella	(Mo,Ga,Ar)
Bockia	(Ec,Eo,Un)	Bolbiprimitia	(Ar,Os,Pa)	Bonneterrina	(Ar,Tr,Pt)
Bodenbenderia	(Ar,Tr,Un)	Bolboacara	(Cd,Os,Pa)	Bonnia	(Ar,Tr,Co)
Bodenia	(Ar,Os,Pa)	Bolbocephalus	(Ar,Tr,Pr)	Boniella	(Ar,Tr,Co)
Bodeniella	(Ar,Os,Pa)	Bolbochasmops	(Ar,Tr,Ph)	Bonniopsis	(Ar,Tr,Co)
Bodeurina	(Cn,An,Sc)	Bolbocrinus	(Ec,Cr,Cl)	Bontaca	(Mo,Bi,Ph)
Bodianus	(Cd,Os,Pf)	Bolboparia	(Ar,Tr,Un)	Boolelasma	(Cn,An,Ru)
Bodieceras	(Mo,Ce,Ta)	Bolbopisthia	(Ar,Os,Pa)	Boonderella	(Br,Ar,Or)
Bodoceras	(Mo,Ce,Ta)	Bolboporites	(Ec,Eo,Un)	Boonderroia	(Po,De,Li)
Bodophyllum	(Cn,An,Ru)	Bolbozoe	(Ar,Os,My)	Boops	(Cd,Os,Pf)
Bodospira	(Mo,Pa,Hy)	Bolbozoella	(Ar,Os,Pa)	Booralia	(Br,Ar,Te)

Boothaspis	(Cd,Pt,Pt)	Bostryclavus	(Ec,Ed,Is)	Bowdenathecra	(Mo,Ga,Th)
Bopoina	(Ar,Os,Jo)	Botheca	(Po,De,Li)	Bowdenia	(Mo,Bi,Ph)
Borchgrevinkium	(Ar,Me,Ag)	Bothriaspis	(Cd,Pt,Pt)	Bowenelsma	(Cn,An,Ru)
Borcobolbina	(Ar,Os,Pa)	Bothriocidaris	(Ec,Ec,Bo)	Bowlandia	(Mo,Bi,Ph)
Bordenia	(Cn,An,Ru)	Bothionia	(Br,Ar,St)	Bowmanita	(Ar,Tr,Pt)
Borealocamara	(Br,Ar,Pe)	Bothrochlaenia	(Po,De,Li)	Bozorginiella	(Fo,Fo,Fo)
Boreadorthis	(Br,Ar,Or)	Bothroclisia	(Cn,An,Ru)	Bozshakolia	(Br,Li,Ac)
Borealarges	(Ar,Tr,Li)	Bothroconis	(Po,He,Un)	Brabbinthes	(Po,He,Un)
Borealaspis	(Ar,Tr,Ph)	Bothrocorbula	(Mo,Bi,My)	Brabeocrinus	(Ec,Cr,Ct)
Borealia	(Ar,Tr,Pr)	Bothrolemma	(Po,De,Li)	Bracebridgia	(Bz,Gy,Ch)
Borealicornus	(Hy,Hy,Hy)	Bothroptoria	(Cn,An,Sc)	Brachaelurus	(Cd,Ch,Oc)
Borealirhynchia	(Br,Ar,Rh)	Bothrophyllum	(Cn,An,Ru)	Brachachenius	(Cd,Re,Ps)
Borealis	(Br,Ar,Pe)	Bothrostegium	(Br,Ar,St)	Brachiatusmilla	(Cn,An,Sc)
Boreas	(Bz,Gy,Ch)	Bothrothyris	(Br,Ar,Te)	Brachidontes	(Mo,Bi,Mt)
Boreasina	(Bz,Gy,Ch)	Bothryopneutes	(Ec,Ec,Ca)	Brachioerinus	(Ec,Cr,Ds)
Boreichthys	(Cd,Os,Pe)	Bothus	(Cd,Os,Pn)	Brachiograptus	(He,Gr,Gr)
Boreionectes	(Mo,Bi,Pt)	Botium	(Br,Ar,Or)	Brachiomonocrinus	(Ec,Cr,Cy)
Boreiospira	(Br,Ar,Sp)	Botocythus	(Po,Re,Aj)	Brachionichthys	(Cd,Os,Lo)
Boreiothyris	(Br,Ar,Te)	Botomella	(Ar,Tr,Co)	Brachiospongia	(Po,He,LS)
Borelasma	(Cn,An,Ru)	Botrioides	(Ar,Tr,Pt)	Brachiospyris	(Ac,Ra,Na)
Borelis	(Fo,Fo,Fo)	Botroclonium	(Po,He,He)	Brachisofaster	(Cn,An,Sc)
Boreloides	(Fo,Fo,Fo)	Botryceras	(Mo,Ce,En)	Brachopteraella	(Ar,Me,Eu)
Boreoceras	(Mo,Ce,En)	Botryllopora	(Bz,St,Cy)	Brachyspidion	(Ar,Tr,Pt)
Boreocomitas	(Mo,Ga,Ne)	Botryocampe	(Ac,Ra,Na)	Brachybelus	(Mo,Ce,Be)
Boreolepis	(Cd,Os,Pa)	Botryocella	(Ac,Ra,Na)	Brachycerithium	(Mo,Ga,Nt)
Boreomeekoceras	(Mo,Ce,Ce)	Botryocrinus	(Ec,Cr,Ct)	Brachycoenia	(Cn,An,Sc)
Boreoscala	(Mo,Ga,Nt)	Botryocyrtis	(Ac,Ra,Na)	Brachycyathus	(Cn,An,Sc)
Boreoscutellum	(Ar,Tr,Co)	Botryodictya	(Po,He,Re)	Brachycyloceras	(Mo,Ce,Or)
Boreosomus	(Cd,Os,Pa)	Botryopyle	(Ac,Ra,Na)	Brachycythara	(Mo,Ga,Ne)
Boretrothron	(Mo,Ga,Ne)	Botryosella	(Po,He,He)	Brachycythere	(Ar,Os,Po)
Borestus	(Mo,Ga,Ar)	Botryostrobus	(Ac,Ra,Na)	Brachycytheropteron	(Ar,Os,Un)
Borgerscottia	(Ar,Os,Po)	Botsfordia	(Br,Li,Ac)	Brachydeirus	(Cd,Pl,Ar)
Borichthys	(Cd,Os,Pa)	Bottonaeyathus	(Po,Ar,Ar)	Brachydelphis	(Cd,Ma,Ce)
Boriesia	(Mo,Bi,Ph)	Botula	(Mo,Bi,Mt)	Brachydeuterus	(Cd,Os,Pt)
Borina	(Mo,Bi,Pt)	Botulina	(Mo,Bi,Mt)	Brachydomoceras	(Mo,Ce,On)
Borissia	(Mo,Bi,Na)	Botulobolbina	(Ar,Os,Pa)	Brachyhipposiderus	(Ar,Tr,Pt)
Borissiakoceras	(Mo,Ce,Am)	Botulopsis	(Mo,Bi,Mt)	Brachylepas	(Ar,Ci)
Borkinia	(Mo,Ce,Ct)	Boubeithyris	(Br,Ar,Te)	Brachymeandra	(Cn,An,Sc)
Borkopleura	(Ar,Tr,Od)	Boucaulticeras	(Mo,Ce,Am)	Brachymeris	(Mo,Bi,Ve)
Bornemannaspis	(Ar,Tr,Re)	Boucekites	(Ar,Os,Un)	Brachymetopus	(Ar,Tr,Pr)
Bornhardtceras	(Mo,Ce,Am)	Bouchardia	(Br,Ar,Te)	Brachymimulus	(Br,Ar,Or)
Bornhardtina	(Br,Ar,Te)	Bouchardiella	(Br,Ar,Te)	Brachymylus	(Cd,Ch,Cm)
Bornhbolmaspis	(Ar,Tr,Ph)	Boucia	(Ar,Os,My)	Brachynotus	(Ar,Ml,De)
Bornia	(Mo,Bi,Ve)	Boucotella	(Br,Ar,Rh)	Brachyopterus	(Ar,Me,Eu)
Borniola	(Mo,Bi,Ve)	Boucotia	(Br,Ar,Rh)	Brachyosteus	(Cd,Pl,Ar)
Borocyathus	(Po,Re,Aj)	Boucotides	(Br,Ar,Pe)	Brachypareion	(Cd,Os,Pa)
Bordiella	(Ar,Os,Un)	Boucotunskia	(Br,Ar,Sp)	Brachyphyllia	(Cn,An,Sc)
Borodinia	(Fo,Fo,Fo)	Boucotspira	(Mo,Ga,Eu)	Brachyprion	(Br,Ar,St)
Borogothus	(Ar,Tr,As)	Boucotstrophia	(Br,Ar,St)	Brachypterygius	(Cd,Re,lc)
Borovitchella	(Ar,Os,Po)	Bouleia	(Ar,Tr,Ph)	Brachyrhizodus	(Cd,Ch,My)
Borsonella	(Mo,Ga,Ne)	Bouleiceras	(Mo,Ce,Am)	Brachyrhynchus	(Cd,Os,Pr)
Borsonia	(Mo,Ga,Ne)	Bouleignus	(Mo,Bi,Pt)	Brachyschisma	(Ec,Bl,Fi)
Borthaspidella	(Ar,Tr,As)	Boultonia	(Fo,Fo,Fo)	Brachyseris	(Cn,An,Sc)
Borthaspis	(Ar,Tr,As)	Bounyongia	(Ar,Tr,Od)	Brachysiphon	(Fo,Fo,Fo)
Borua	(Br,Ar,St)	Bourgetia	(Mo,Ga,Nt)	Brachysocia	(Bz,St,Ce)
Boschekulia	(Ar,Tr,As)	Bourgueticrinus	(Ec,Cr,Bo)	Brachyspingus	(Mo,Ga,Ne)
Bosira	(Mo,Bi,Pt)	Bournonia	(Mo,Bi,Hi)	Brachyspirifer	(Br,Ar,Sp)
Bosniella	(Fo,Fo,Fo)	Boutillieria	(Mo,Ga,Ar)	Brachystoma	(Mo,Ga,Nt)
Bosnites	(Mo,Ce,Ce)	Bouvierphyllum	(Cn,An,Ru)	Brachystomia	(Mo,Ga,He)
Bosquetella	(Br,Ar,Th)	Bovicornellum	(Pr,Un,In)	Brachythrina	(Br,Ar,Sp)
Bosquetia	(Ar,Os,Po)	Bovicornu	(Mo,Ga,Th)	Brachythyriella	(Br,Ar,Sp)
Bosquetina	(Ar,Os,Po)	Bowanophyllum	(Cn,An,Ru)	Brachythyris	(Br,Ar,Sp)
Bostrichopus	(Ar,Un,Un)	Bowanorthis	(Br,Ar,Or)	Brachytoma	(Mo,Ga,Ne)
Bostrychoceras	(Mo,Ce,Am)	Bowdenagaza	(Mo,Ga,Ar)	Brachytomaria	(Mo,Ga,Ar)

Brachytrema	(Mo,Ga,Nt)	Brenckleina	(Fo,Fo,Fo)	Brizalina	(Fo,Fo,Fo)
Brachyzya	(Br,Ar,Te)	Brephochariéis	(Ar,Os,Pa)	Brocchia	(Mo,Ga,Nt)
Brackebuschia	(Ar,Tr,Un)	Brestopora	(Bz,St,Un)	Brochinia	(Mo,Ga,Ne)
Bractea	(Cn,An,Ta)	Brevaxina	(Fo,Fo,Fo)	Brocchites	(Mo,Ga,Ne)
Bractechlamys	(Mo,Bi,St)	Breviacanthus	(Cd,Ch,Rj)	Brocchium	(Ec,Ec,Or)
Bracteoleptaena	(Br,Ar,St)	Breviarca	(Mo,Bi,Ar)	Brochidium	(Mo,Ga,At)
Bracthelia	(Cn,An,Sc)	Breviattractites	(Mo,Ce,Au)	Brochina	(Mo,Ga,Nt)
Bractocyathus	(Po,Re,Aj)	Brevibelus	(Mo,Ce,Be)	Brochodamones	(Cd,Ac,Un)
Bracytrochus	(Cn,An,Os,Pa)	Brevibolbina	(Ar,Os,Pa)	Brochocarina	(Br,Ar,St)
Braderupia	(Ar,Os,Pa)	Brevicamera	(Br,Ar,Pe)	Brochodora	(Po,De,Li)
Bradfordia	(Mo,Ce,Am)	Brevicardium	(Mo,Bi,Ve)	Brochopleurus	(Ec,Ec,Te)
Bradfordirhynchia	(Br,Ar,Rh)	Brevicoceras	(Mo,Ce,Di)	Brochosogenys	(An,Po,Eu)
Bradfordoceras	(Mo,Ce,Or)	Brevidora	(Ar,Os,Pa)	Brockocystis	(Ec,Rh,Rh)
Bradleya	(Ar,Os,Pa)	Brevikites	(Mo,Ce,Go)	Broctus	(Ac,Ra,Na)
Bradocryphaeus	(Ar,Tr,Ph)	Brevilabiatus	(Hy,Hy,Hy)	Brodekoceras	(Mo,Ce,Di)
Bradoria	(Ar,Os,Ar)	Brevilamulella	(Br,Ar,Pe)	Brodieia	(Mo,Ce,Am)
Bradorona	(Ar,Os,Ar)	Brevimaecandra	(Cn,An,Sc)	Broeckina	(Fo,Fo,Fo)
Bradyfallotaspis	(Ar,Tr,Ol)	Brevinucula	(Mo,Bi,Nu)	Broeckinella	(Fo,Fo,Fo)
Bradyina	(Mo,Fo,Fo)	Breviorrhonta	(Mo,Bi,Mt)	Broggeria	(Br,Li,Li)
Bradyospira	(Mo,Ga,Ar)	Brevipelta	(Br,Un,Ob)	Broggeroceras	(Mo,Ce,Di)
Bradyphyllum	(Cn,An,Ru)	Breviphilipsia	(Ar,Tr,Pr)	Broggerolithus	(Ar,Tr,As)
Brahcylyrodesma	(Mo,Bi,Mo)	Breviphrentis	(Cn,An,Ru)	Bromidella	(Ar,Os,Pa)
Brahimorthis	(Br,Ar,Or)	Breviphyllum	(Cn,An,Ru)	Bromidoceras	(Ec,Cr,Di)
Brahmaerinus	(Ec,Cr,Mo)	Breviredlichia	(Ar,Tr,Re)	Bromidocystis	(Ec,Eo,Un)
Brahmaites	(Mo,Ce,Am)	Breviscutellum	(Ar,Tr,Co)	Bromnaghocrinus	(Ec,Cr,Cl)
Braiesopora	(Bz,St,Cc)	Breviseptophyllum	(Cn,An,Ru)	Brongniartella	(Ar,Tr,Ph)
Braintreella	(Ar,Tr,Pt)	Breviseptum	(Br,Ar,Pe)	Bronicella	(Cn,In,In)
Brama	(Cd,Os,Pf)	Brevisiphonella	(Po,Ca,Ph)	Bronnimannia	(Fo,Fo,Fo)
Bramertonia	(Mo,Ga,Nt)	Brevispirifer	(Br,Ar,Sp)	Bronnothyrus	(Br,Ar,Te)
Bramkampella	(Fo,Fo,Fo)	Brevisulcina	(Ar,Os,Pa)	Bronsteiniana	(Ar,Os,Pa)
Bramkampia	(Mo,Ce,Am)	Brevitermierella	(Ar,Tr,Re)	Bronteopsis	(Ar,Tr,Co)
Bramoides	(Cd,Os,Pf)	Brevitermierella	(Ar,Tr,Un)	Bronteus	(Ar,Tr,Pt)
Bramus	(Ec,Ec,Un)	Brevithea	(Hy,Or,Or)	Brookesena	(Mo,Ga,Nt)
Brancaasaurus	(Cd,Re,Ps)	Brewericeras	(Mo,Ce,Am)	Brooksina	(Br,Ar,Pe)
Branchiocarcinus	(Ar,ML,De)	Breynia	(Ec,Ec,Sp)	Brookula	(Mo,Ga,Ar)
Branchiocaris	(Ar,ML,Ca)	Brianelium	(Ac,Ra,Sp)	Broovalia	(Cd,Os,Pa)
Branchiolambrus	(Ar,ML,De)	Brianiispongia	(Po,De,Li)	Brosme	(Cd,Os,Ga)
Branchioplax	(Ar,ML,De)	Briantelasma	(Cn,An,Ru)	Brosmius	(Cd,Os,Ga)
Branchiostegus	(Cd,Os,Pf)	Briantia	(Cn,An,Ru)	Brotula	(Cd,Os,Op)
Brancoeras	(Mo,Ce,Am)	Brianurus	(Ar,Tr,Ph)	Broughia	(Cd,Os,Am)
Branddysops	(Ar,Tr,As)	Briarocrinus	(Ec,Cr,Mo)	Brouwerites	(Mo,Ce,Ce)
Brandysia	(Br,Ar,Or)	Briartina	(Ar,Os,Le)	Brouzetia	(Mo,Ga,He)
Branikia	(Br,Ar,Sp)	Bridegeina	(Mo,Ga,Ar)	Broweria	(Cd,Os,Me)
Branislavia	(Mo,Bi,Hi)	Bridegeites	(Mo,Ga,Eu)	Browneella	(Br,Ar,Rh)
Branmehlia	(Cd,Co,Co)	Bridgeia	(Ar,Tr,Un)	Browneithys	(Cd,Os,Pa)
Brannerion	(Cd,Os,An)	Bridgeoceras	(Mo,Ce,El)	Bruclarkia	(Mo,Ga,Ne)
Branneroceras	(Mo,Ce,Go)	Bridgerocrinus	(Ec,Cr,Cl)	Bruennichometra	(Ec,Cr,Cm)
Branneroceratoides	(Mo,Ce,Go)	Brightia	(Mo,Ce,Am)	Bruetia	(Mo,Bi,Ve)
Bransonia	(Mo,Ro,Co)	Brightonia	(Ec,Ec,Sp)	Bruniastarte	(Mo,Bi,Ve)
Brarhyclasma	(Cn,An,Ru)	Brightonicystis	(Ec,Di,Di)	Brunnirhyncha	(Br,Ar,Rh)
Brasilia	(Mo,Ce,Am)	Brijlonella	(Mo,Ga,Ar)	Brunonia	(Mo,Ga,Nt)
Brasiliella	(Fo,Fo,Fo)	Brimosaurus	(Cd,Re,Ps)	Brunsia	(Fo,Fo,Fo)
Brasilioproductus	(Br,Ar,St)	Brindabellaspis	(Cd,Pl,Br)	Brunsiella	(Fo,Fo,Fo)
Brassiccephalus	(Ar,Tr,Pt)	Brisaster	(Ec,Ec,Sp)	Brunswickia	(Ar,Tr,Pt)
Braunosteus	(Cd,Pl,Ar)	Briscoia	(Ar,Tr,As)	Bruntonichthys	(Cd,Pl,Ar)
Brebina	(Fo,Fo,Fo)	Briseocrinus	(Ec,Cr,Cl)	Brushenodus	(Pr,Un,In)
Bredocaris	(Ar,In,Or)	Brisingella	(Ec,As,Fo)	Brutaspis	(Ar,Tr,Pt)
Bredyia	(Mo,Ce,Am)	Brissolampas	(Ec,Ec,Sp)	Brutonia	(Ar,Tr,Li)
Bregmacerinia	(Cd,Os,Ga)	Brissomorpha	(Ec,Ec,Sp)	Brutopisocrinus	(Ec,Cr,Ds)
Bregmaceros	(Cd,Os,Ga)	Brissopatagus	(Ec,Ec,Sp)	Bryantodina	(Cd,Co,Co)
Breileenia	(Br,Ar,St)	Brissopneustes	(Ec,Ec,Sp)	Bryantodus	(Cd,Co,Co)
Breizhops	(Ar,Tr,Ph)	Brissopsis	(Ec,Ec,Sp)	Bryachetus	(Cd,Os,Or)
Breizosteus	(Cd,Pl,Ac)	Brissus	(Ec,Ec,Sp)	Brychiocrinus	(Ec,Cr,Cl)
Brembodus	(Cd,Os,Py)	Bristolia	(Ar,Tr,Ol)	Brydonella	(Bz,Gy,Ch)

Brylyella	(Ar.Tr.Co)	Buglossidium	(Cd.Os.Pn)	Burdikinia	(Mo.Ga.Ar)
Bryochelys	(Cd.Re.Ch)	Bukowskites	(Mo.Ce.Ce)	Buregia	(Ar.Os.Pa)
Bryograptus	(He.Gr.De)	Bulahdelia	(Br.Ar.St)	Burenoceras	(Mo.Ce.El)
Bryopa	(Mo.Bi.Ph)	Bulaiaspis	(Ar.Tr.Re)	Burgessia	(Ar.In.Un)
Bryorhynchus	(Br.Ar.Rh)	Bulamicrusta	(He.Gr.Cr)	Burgessochaeta	(An.Po.Un)
Bubnofiella	(Bz.Gy.Ch)	Bulbaspis	(Ar.Tr.As)	Burgundia	(Po.De.Ta)
Bubnofiopis	(Ar.Os.Pa)	Bulbihastula	(Mo.Ga.Ne)	Buria	(Bz.St.Ce)
Bubovicus	(Mo.Ga.Be)	Bulbipora	(Bz.Gy.Ch)	Burijites	(Mo.Ce.Pn)
Bubupeltina	(Ar.Tr.Co)	Bulbobaculites	(Fo.Fo.Fo)	Burithes	(Hy.Hy.Hy)
Bucanella	(Mo.Ga.Be)	Bulbobuccinerata	(Fo.Fo.Fo)	Burlingia	(Ar.Tr.Pt)
Bucania	(Mo.Ga.Be)	Bulbochitina	(Fo.Fo.Ch)	Burmeisterella	(Ar.Tr.Ph)
Bucanoides	(Mo.Ga.Th)	Bulbocystis	(Ec.Di.Di)	Burmeisteria	(Ar.Tr.Ph)
Bucanophyllum	(Cn.An.Ru)	Bulbophragmium	(Fo.Fo.Fo)	Burmesia	(Mo.Bi.Ph)
Bucanopsis	(Mo.Ga.Be)	Bulbosclerites	(Ar.Os.Po)	Burmhirynchia	(Br.Ar.Rh)
Bucanospira	(Mo.Ga.At)	Bulbosulculus	(Mo.Ga.Pa)	Burnetella	(Ar.Tr.Pt)
Bucanotheca	(Hy.Or.Or)	Bulbus	(Mo.Ga.Nt)	Burnhamia	(Cd.Ch.My)
Bucardiomya	(Mo.Bi.Ph)	Bulbusoides	(Mo.Ga.Nt)	Burovia	(Br.Ar.St)
Bucardium	(Mo.Bi.Ve)	Bulimactaeon	(Mo.Ga.Ce)	Burriera	(Mo.Bi.Un)
Buccella	(Fo.Fo.Fo)	Bulimina	(Fo.Fo.Fo)	Burrijuosteus	(Cd.Pl.Ar)
Buccerenata	(Fo.Fo.Fo)	Bulminella	(Fo.Fo.Fo)	Burrihynchia	(Br.Ar.Rh)
Buccinanops	(Mo.Ga.Ne)	Bulminellita	(Fo.Fo.Fo)	Burronoceras	(Mo.Ce.Un)
Buccinaria	(Mo.Ga.Ne)	Bulminooides	(Fo.Fo.Fo)	Bursa	(Mo.Ga.Nt)
Buccinofusus	(Mo.Ga.Ne)	Bulimorpha	(Mo.Ga.Nt)	Bursachitina	(Fo.Fo.Ch)
Buccinopsis	(Mo.Ga.Ne)	Bulla	(Mo.Ga.Ce)	Bursacrinus	(Ec.Cr.Cl)
Buccinorbis	(Mo.Ga.Ne)	Bullacapsula	(Ac.Ra.Na)	Bursata	(Mo.Po.Pa)
Buccinulum	(Mo.Ga.Ne)	Bullaferum	(Ar.Os.Pa)	Burseolina	(Fo.Fo.Fo)
Buccinum	(Mo.Ga.Ne)	Bullalata	(Ar.Os.Ar)	Burtinella	(Mo.Ga.Nt)
Buccitriton	(Mo.Ga.Ne)	Bullalveolina	(Fo.Fo.Fo)	Burtinia	(Cd.Os.Pf)
Bucconia	(Mo.Ga.Ce)	Bullarina	(Br.Ar.Sp)	Burtinopsis	(Cd.Ma.Ce)
Bucequia	(Br.Ar.At)	Bullata	(Mo.Ga.Ne)	Burtonops	(Ar.Tr.Ph)
Bucerella	(Ar.Os.Pa)	Bullatella	(Ar.Os.Pa)	Buryella	(Ac.Ra.Na)
Bucerobolbina	(Ar.Os.Pa)	Bullatimorphites	(Mo.Ce.Am)	Buscotypus	(Mo.Ga.Ut)
Buchanathyrus	(Br.Ar.Sp)	Bullerichthys	(Cd.Pl.Ar)	Buskia	(Bz.Gy.Ct)
Buchanoceras	(Mo.Ce.Or)	Bullia	(Mo.Ga.Ne)	Buskopora	(Bz.St.Cy)
Buchanosteus	(Cd.Pl.Ar)	Bullina	(Mo.Ga.Ce)	Busnardoites	(Mo.Ce.Am)
Bucherina	(Fo.Fo.Fo)	Bulliopsis	(Mo.Ga.Ne)	Bussonastraea	(Cn.An.Sc)
Buchia	(Mo.Bi.Pt)	Bullopore	(Fo.Fo.Fo)	Busuanga	(Ac.Ra.Na)
Buchiceras	(Mo.Ce.Am)	Bullopsis	(Mo.Ga.Ce)	Busulcata	(Br.Ar.Pe)
Buchicrinus	(Ec.Cr.Is)	Bullothyris	(Br.Ar.Te)	Busycon	(Mo.Ga.Ne)
Buchiola	(Mo.Bi.Pr)	Bullulodictyon	(Po.De.St)	Busycoptypus	(Mo.Ga.Ne)
Buchiproetus	(Ar.Tr.Pt)	Bulnibarbi	(Ar.Tr.Pt)	Butakovicyathus	(Po.Re.Mo)
Buchnerina	(Fo.Fo.Fo)	Bulogites	(Mo.Ce.Ce)	Butkovia	(Br.Ar.At)
Buchotrigonia	(Mo.Bi.Tr)	Bulosia	(Mo.Ga.Ne)	Butovia	(Pr.Cr.Cr)
Buchozia	(Mo.Ga.Ne)	Buluniella	(Mo.Bi.Mo)	Butovicella	(Mo.Bi.Pr)
Buckmanina	(Mo.Ga.Ar)	Buluniella	(Mo.Bi.Mo)	Buttsia	(Ar.Tr.As)
Buckmanithyrus	(Br.Ar.Te)	Bulvankeriphyllum	(Cn.An.Ru)	Buttsina	(Ar.Tr.As)
Bucksella	(Ar.Tr.Pt)	Bumastides	(Ar.Tr.As)	Buttsoceras	(Mo.Ce.Or)
Budaia	(Cn.An.Sc)	Bumastoides	(Ar.Tr.Co)	Buvignieria	(Mo.Ga.Nt)
Budaiceras	(Mo.Ce.Am)	Bumastus	(Ar.Tr.Co)	Buxtonia	(Br.Ar.St)
Budashevaella	(Fo.Fo.Fo)	Bunaia	(Ar.Me.Xi)	Buxtoniella	(Br.Ar.St)
Buddhites	(Mo.Ce.Ce)	Bunburyiceras	(Mo.Ce.Am)	Buxtonioides	(Br.Ar.St)
Budnianella	(Ar.Os.Un)	Bundenbachiellus	(Ar.Un.Un)	Buzaxina	(Fo.Fo.Fo)
Buechelia	(Mo.Ga.Ar)	Bundenbachochaeta	(An.Po.Un)	Bvalbardites	(Ar.Tr.Pt)
Buehleroceras	(Mo.Ce.El)	Bungartius	(Cd.Pl.Ar)	Bykovaeina	(Fo.Fo.Fo)
Bueckella	(Ar.Os.Po)	Bungoella	(Mo.Bi.Ve)	Bykoviella	(Fo.Fo.Fo)
Buelowiteuthis	(Mo.Ce.Au)	Bunodella	(Ar.Me.Xi)	Bylgia	(Ar.Ml.De)
Buenellus	(Ar.Tr.Re)	Bunodes	(Ar.Me.Xi)	Bynguanoia	(Br.Un.Na)
Bueningia	(Fo.Fo.Fo)	Buntonia	(Ar.Os.Po)	Bynumia	(Ar.Tr.Pt)
Bufanchiste	(Ar.Os.Po)	Buntoxia	(Br.Ar.St)	Bynumiella	(Ar.Tr.Pt)
Bufalopterus	(Ar.Me.Eu)	Bunyericinus	(Cn.In.In)	Bynumina	(Ar.Tr.Pt)
Bufonellodes	(Bz.Gy.Ch)	Burbonella	(Cd.Os.Pa)	Byramia	(Mo.Ga.Nt)
Butina	(Ar.Os.Me)	Burekhardtites	(Mo.Ce.Am)	Byronia	(Pr.Un.Hy)
Bufoceraurus	(Ar.Tr.Ph)	Burekhardtia	(Mo.Bi.Pt)	Byronoceras	(Mo.Ce.On)
Bufonariella	(Mo.Ga.Nt)	Burdigalocrinus	(Ec.Cr.Cm)	Byrsolopsina	(Ar.Os.Pa)

Byssocardium	(Mo,Bi,Ve)	Calaiceras	(Mo,Ce,Ph)	Calix	(Ec,Di,Di)
Byssodesma	(Mo,Bi,Mo)	Calameastolia	(Cn,An,Se)	Callaiaspida	(Br,Ar,Rh)
Byssomesa	(Mo,Bi,Ve)	Calamocrinus	(Ec,Cr,Cy)	Callaionautilus	(Mo,Ce,Na)
Byssonychia	(Mo,Bi,Pt)	Calamograptus	(He,Gr,Gr)	Callanaitis	(Mo,Bi,Ve)
Byssopteria	(Mo,Bi,Pt)	Calamophyllia	(Cn,An,Se)	Callaspis	(Ar,Tr,As)
Bystromena	(Br,Ar,St)	Calamophylliopsis	(Cn,An,Se)	Callavia	(Ar,Tr,Ol)
Bysulcoocythere	(Ar,Os,Po)	Calamoseris	(Cn,An,Se)	Callianassa	(Ar,ML,De)
Bythiamena	(Mo,Bi,Ve)	Calamostoma	(Cd,Os,Ga)	Callianax	(Mo,Ga,Ne)
Bythichelius	(Ar,Tr,Pt)	Calamotrypa	(Bz,St,Tr)	Calliaster	(Ec,As,Va)
Bythoceratina	(Ar,Os,Po)	Calamus	(Cd,Os,Pf)	Calliasterella	(Ec,As,Ur)
Bythocypris	(Ar,Os,Po)	Calantica	(Ar,Ci,)	Callicalyptella	(Br,Ar,St)
Bythocyproidea	(Ar,Os,Me)	Calapoecia	(Cn,An,Ta)	Calliconites	(Mo,Ce,Au)
Bythocyroidea	(Ar,Os,Po)	Calappa	(Ar,ML,De)	Callicylix	(Po,He,Ly)
Bythothere	(Ar,Os,Po)	Calappella	(Ar,ML,De)	Callicythere	(Ar,Os,Po)
Bythocytheromorpha	(Ar,Os,Po)	Calappilia	(Ar,ML,De)	Calliderma	(Ec,As,Va)
Bythopora	(Bz,St,Tr)	Calathiscus	(Po,He,Ly)	Calliglypha	(Br,Ar,Pe)
Bythotrypa	(Bz,St,Cy)	Calathospongia	(Po,He,LS)	Callihoplites	(Mo,Ce,Am)
Byzantia	(Mo,Ga,Ar)	Calaurops	(Mo,Ga,Ar)	Callimira	(Ac,Ra,Na)
Cabania	(Mo,Ga,Ne)	Calcanora	(Ec,Ho,Ap)	Callinectes	(Ar,ML,De)
Caberea	(Bz,Gy,Ch)	Calcanorella	(Ec,Ho,Mo)	Calliobasis	(Mo,Ga,Ar)
Caberoides	(Bz,Gy,Ch)	Calcanoroidea	(Ec,Ho,Ap)	Calliocrinus	(Ec,Cr,Mo)
Cabestanna	(Mo,Ga,Nt)	Calcarata	(Mo,Ga,Ne)	Calliomarginata	(Br,Ar,St)
Caborcella	(Ar,Tr,Pt)	Calcaribeyrichia	(Ar,Os,Po)	Calliomphalus	(Mo,Ga,Ar)
Cabralista	(Mo,Bi,Ve)	Calcarichelys	(Cd,Re,Ch)	Callionyx	(Cd,Os,Pf)
Cabrievoceras	(Mo,Ce,An)	Calcarina	(Fo,Fo,Fo)	Calliosioma	(Mo,Ga,Ar)
Cacemia	(Br,Ar,Or)	Calceochiton	(Mo,Po,Pa)	Calliotectum	(Mo,Ga,Ne)
Cacheoceras	(Mo,Ce,En)	Calceocrinus	(Ec,Cr,Ds)	Callitropis	(Mo,Ga,Ar)
Cactocrinus	(Ec,Cr,Mo)	Calceola	(Cn,An,Ru)	Calliovarica	(Mo,Ga,Ar)
Cactograptus	(He,Gr,Un)	Calceolispongia	(Ec,Cr,Ci)	Callipentamerus	(Br,Ar,Pe)
Cactosteges	(Br,Ar,St)	Calchasiceras	(Mo,Ce,On)	Calliphylloceras	(Mo,Ce,Am)
Cadella	(Mo,Bi,Ve)	Calchicanularia	(Mo,Bi,Pt)	Calliphylloceras	(Mo,Ce,Ph)
Cadisocrinus	(Ec,Cr,Di)	Calchixactina	(Po,He,LS)	Callipleura	(Br,Ar,Rh)
Cadniacyathus	(Po,Re,Aj)	Calchirhynchia	(Br,Ar,Rh)	Calliprotionia	(Br,Ar,St)
Cadoceras	(Mo,Ce,Am)	Calcisphaerula	(Ci,Po,Sp)	Callipteryx	(Cd,Os,Pf)
Cadocrinus	(Ec,Cr,Ci)	Calciella	(Po,De,Hd)	Calliptychoceras	(Mo,Ce,Am)
Cadomella	(Br,Ar,Sp)	Calciithecra	(Hy,Uc,Uc)	Callispira	(Mo,Ga,Nt)
Cadomia	(Mo,Bi,Nu)	Calcitonella	(Fo,Fo,Fo)	Callispirifer	(Br,Ar,Sp)
Cadomites	(Mo,Ce,Am)	Calcitrappesa	(Mo,Ga,Ne)	Callispirina	(Br,Ar,Sp)
Cadomoceras	(Mo,Ce,Am)	Calcivertella	(Fo,Fo,Fo)	Callista	(Mo,Bi,Ve)
Cadudium	(Br,Ar,Pe)	Calclamna	(Ec,Ho,De)	Callistadia	(Mo,Ga,Ar)
Cadulus	(Mo,Se,Se)	Calclamella	(Ec,Ho,As)	Callistalov	(Mo,Bi,Ve)
Caecum	(Mo,Ce,Se)	Calclamnoidea	(Ec,Ho,De)	Callistele	(Mo,Ga,Ar)
Caelocrinus	(Ec,Cr,Ci)	Calcligula	(Ec,Ho,Mo)	Callistochiton	(Mo,Po,Ne)
Caenanophia	(Br,Ar,St)	Calclyra	(Ec,Ho,Un)	Callistocypraea	(Mo,Ga,Nt)
Caenoholcypus	(Ec,Ec,Ho)	Calculites	(Ar,Tr,Pt)	Callistocythere	(Ar,Os,Po)
Caenmites	(Mo,Ce,Am)	Caldenocrinus	(Ec,Cr,Sa)	Callistotapes	(Mo,Bi,Ve)
Caenocidarid	(Ec,Ec,Ci)	Caledogonia	(Mo,Bi,Tr)	Callithaca	(Mo,Bi,Ve)
Caenocyclus	(Mo,Ce,Go)	Caledorhynchia	(Br,Ar,Rh)	Callitomarid	(Mo,Ga,Ar)
Caenodontus	(Cd,Co,Co)	Calcidocrinus	(Ec,Cr,Ds)	Callitrigonia	(Mo,Bi,Tr)
Caenolyroceras	(Mo,Ce,Go)	Caleschara	(Bz,Gy,Ch)	Callizoe	(Ar,ML,Ar)
Caenotreta	(Br,Li,Ac)	Caletaster	(Ec,As,Va)	Callizoceras	(Mo,Ce,Am)
Caeroplecia	(Br,Ar,Or)	Calhounoceras	(Mo,Ce,Ac)	Calloarea	(Mo,Bi,Ar)
Caesaria	(Po,He,He)	Caliapora	(Cn,An,Ta)	Callocardia	(Mo,Bi,Ve)
Caesariella	(Mo,Bi,Nu)	Calicantharus	(Mo,Ga,Ne)	Callochiton	(Mo,Po,Ne)
Caesia	(Mo,Ga,Ne)	Calicia	(Po,Ca,Ph)	Callocladia	(Bz,St,Cr)
Caestocorbula	(Mo,Bi,My)	Caliculospongia	(Po,Un,Un)	Callocladia	(Bz,St,Tr)
Caesus	(Cd,Os,Go)	Calindrum	(Mo,Ga,Ar)	Calloconularia	(Cn,Sc,Cn)
Caganaspis	(Ar,Tr,As)	Califodesma	(Mo,Bi,Ve)	Calloconus	(Mo,He,He)
Cagaster	(Ec,Ec,Sp)	Californiceras	(Mo,Ce,Am)	Callocystites	(Ec,Rh,Rh)
Ca habagnathus	(Cd,Co,Co)	Californosaurus	(Cd,Re,Ic)	Callodictyon	(Po,He,Ly)
Cainatops	(Ar,Tr,Pt)	Caligella	(Fo,Fo,Fo)	Callodontia	(Mo,Bi,Mo)
Caioceeras	(Mo,Ce,Am)	Calilampus	(Ec,Ec,Ci)	Callonothus	(Cd,Pl,Ar)
Caioocrinus	(Ec,Cr,Is)	Calinastrea	(Cn,An,Ru)	Callograptus	(He,Gr,De)
Calacanthopora	(Bz,St,Tr)	Calipernurus	(Ar,Tr,Od)	Callolongchaeus	(Mo,Ga,He)

Callopegma	(Po,De,Li)	Calvina	(Bz,Gy,Ch)	Cambroisostodus	(Cd,Co,Co)
Callophoca	(Cd,Ma,Ca)	Calvinaria	(Br,Ar,Rh)	Cambropachycope	(Ar,In,Un)
Callopoma	(Mo,Ga,Ar)	Calvinella	(Ar,Tr,As)	Cambrophylulum	(Cn,An,Un)
Callopora	(Bz,Gy,Ch)	Calvipelta	(Ar,Tr,Pt)	Cambropodus	(Ar,My,My)
Calloporella	(Bz,Su,Tr)	Calvirhynchia	(Br,Ar,Rh)	Cambropodus	(Ar,Un,Un)
Calloporina	(Bz,Gy,Ch)	Calvustrigis	(Br,Ar,Sp)	Cambrothyrium	(Cn,In,In)
Callopteris	(Cd,Os,Am)	Calybole	(Ar,Tr,Pr)	Cambroscutum	(Mo,In,In)
Callopteus	(Cd,Os,Se)	Calycanthoerinus	(Ec,Cr,Ds)	Cambrospira	(Mo,In,In)
Callorhinus	(Cd,Ma,Ca)	Calycoblastus	(Ec,BI,Sp)	Cambrotrophia	(Br,Ar,Pe)
Callorhynchus	(Cd,Ch,Cm)	Calycoceras	(Mo,Ce,Am)	Cambrotrypa	(Cn,An,Un)
Callosphaera	(Ac,Ra,Sp)	Calycoecolia	(Po,De,Li)	Cambrotubulites	(Pr,Un,Pa)
Callospiriferina	(Br,Ar,Sp)	Calycoerinus	(Ec,Cr,Sa)	Cambrotubulus	(Tr,An)
Callotrochus	(Mo,Ga,Ar)	Calycospongia	(Po,He,Ly)	Cambunicornia	(Ar,Tr,Re)
Callotrypa	(Bz,St,Tr)	Calycotubus	(He,Gr,Tu)	Camdenidea	(Ar,Os,Po)
Callucina	(Mo,Bi,Ve)	Calymene	(Ar,Tr,Ph)	Cameleolopha	(Mo,Bi,Pt)
Callucinella	(Mo,Bi,Ve)	Calymenella	(Ar,Tr,Ph)	Camellaspongia	(Po,De,Li)
Callucinopsis	(Mo,Bi,Ve)	Calymenesum	(Ar,Tr,Ph)	Camena	(Pr,To,Mi)
Callusaria	(Mo,Ga,Nt)	Calymenidius	(Ar,Tr,Ph)	Camenella	(Pr,To,Mi)
Callyodon	(Cd,Os,Pf)	Calymmatina	(Po,De,Li)	Camerapora	(Bz,St,Cc)
Callytharella	(Br,Ar,St)	Calyptactis	(Ec,As,He)	Camarella	(Br,Ar,Pe)
Calmissiphylum	(Cn,An,Ru)	Calyptaulax	(Ar,Tr,Ph)	Camerisma	(Br,Ar,Rh)
Calmonia	(Ar,Tr,Ph)	Calyptocoryphe	(Ac,Ra,Na)	Camerocerat	(Mo,Ce,En)
Calocaria	(Ar,Os,My)	Calyptocoscinus	(Po,Re,Ca)	Camerogalerus	(Ec,Ec,Ho)
Calocephalites	(Ar,Tr,Pt)	Calyptogena	(Mo,Bi,Ve)	Camerophorina	(Br,Ar,Rh)
Caloceras	(Mo,Ce,Am)	Calyptolepta	(Br,Ar,St)	Cameroptychium	(Po,He,Ly)
Calocidaris	(Ec,Ec,Ci)	Calyptoria	(Br,Ar,Sp)	Camerospingia	(Po,He,Ly)
Calocyclas	(Ac,Ra,Na)	Calyptraea	(Mo,Ga,Nt)	Camerotheca	(Hy,Hy,Hy)
Calocyclella	(Ac,Ra,Na)	Calyptraphorus	(Mo,Ga,Nt)	Camerothyris	(Br,Ar,Te)
Calocycloma	(Ac,Ra,Na)	Calyptrella	(Po,He,Ly)	Cammingella	(Ar,Tr,Pr)
Calocyrtoceras	(Mo,Ce,Or)	Calyptrina	(Pr,Un,Sa)	Campages	(Br,Ar,Te)
Calodisculus	(Mo,Ga,He)	Calyptroides	(Mo,Ga,Nt)	Campanelle	(Mo,Ga,He)
Calodiscus	(Ar,Tr,Ag)	Calyptropsis	(Mo,Ga,Nt)	Campanellula	(Fo,Fo,Fo)
Calophos	(Mo,Ga,Ne)	Calyxdendrum	(He,Gr,De)	Campanile	(Mo,Ga,Nt)
Calophylloides	(Cn,An,Ru)	Camagueyia	(Fo,Fo,Fo)	Campanilopa	(Mo,Ga,Nt)
Calophyllum	(Cn,An,Ru)	Camarasip	(Ar,Tr,As)	Campanulithus	(Ac,Ra,Sp)
Calopora	(Bz,St,Tr)	Camarelasma	(Br,Ar,Te)	Campbelloceras	(Mo,Ce,Ta)
Calorebama	(Mo,Ga,Ne)	Camarium	(Br,Ar,Sp)	Campbellodus	(Cd,Pl,Pt)
Calorhadia	(Mo,Bi,Nu)	Camarnia	(Mo,Ga,Ne)	Campbellospira	(Mo,Ga,Ar)
Calostylis	(Cn,An,Ru)	Camarocarcinus	(Ar,MI,De)	Campendoceras	(Mo,Ce,En)
Calostylopsis	(Cn,An,Sc)	Camarocrinus	(Ec,Cr,Mo)	Campichia	(Mo,Ga,He)
Calotomus	(Cd,Os,Pf)	Camarophorella	(Br,Ar,Sp)	Campitius	(Pr,Un,Vo)
Calotrophon	(Mo,Ga,Ne)	Camarophorina	(Br,Ar,Rh)	Campodus	(Cd,Ch,Eu)
Caloxanthus	(Ar,MI,De)	Camarophorinella	(Br,Ar,Rh)	Campomaxis	(Mo,Ga,He)
Calpasia	(Bz,Gy,Ch)	Camarsospira	(Br,Ar,Sp)	Camponeilla	(Mo,Ga,He)
Calpichtina	(Fo,Fo,Ch)	Camarothyridina	(Br,Ar,Rh)	Campophyllum	(Cn,An,Ru)
Calpidium	(Bz,Gy,Ch)	Camarotoechia	(Br,Ar,Rh)	Camposcala	(Mo,Ga,Nt)
Calpidopora	(Bz,Gy,Ch)	Camarotoechiodes	(Br,Ar,Rh)	Campopallus	(Ar,Tr,Ol)
Calpiocrinus	(Ec,Cr,Sa)	Camarspoides	(Ar,Tr,As)	Campotalatus	(Ac,Ra,Sp)
Calpionella	(Ci,In,Ca)	Cambarus	(Ar,MI,De)	Camptoceratops	(Mo,Ga,Th)
Calpionellites	(Ci,In,Ca)	Cambodia	(Mo,Ga,Nt)	Camptochiton	(Mo,Po,Ne)
Calpionellopsis	(Ci,In,Ca)	Cambraechmina	(Ar,Os,Ar)	Camptochlamys	(Mo,Bi,Pt)
Calpitaria	(Mo,Bi,Ve)	Cambrastrer	(Ec,Ed,Un)	Camptoerinus	(Ec,Cr,Mo)
Calpmenella	(Ar,Tr,Ph)	Cambretina	(Mo,In,Pe)	Camptocythere	(Ar,Os,Po)
Calpurna	(Mo,Ga,Nt)	Cambria	(Ar,Os,Ar)	Camptilithus	(Cn,An,Ta)
Calstevenus	(Mo,Se,Sc)	Cambriidium	(Mo,St,St)	Camptonectes	(Mo,Bi,Pt)
Calthotia	(Mo,Ga,Ar)	Cambrioconus	(Mo,Te,Hy)	Camptosalpinx	(An,Po,Se)
Calthropella	(Po,De,As)	Cambroblastus	(Ec,Pa,Pa)	Campstroma	(Ec,Cm,Cm)
Calva	(Mo,Bi,Ve)	Cambrocassis	(Pr,Un,In)	Campylacrum	(Mo,Ga,Ne)
Calvadosiella	(Mo,Ga,Nt)	Cambroclavus	(Pr,Ca,Ca)	Campylites	(Mo,Ce,Am)
Calvaentolium	(Mo,Bi,Pt)	Cambroconus	(Mo,In,In)	Campylocephalus	(Ar,Me,Eu)
Calverturis	(Mo,Ga,Ne)	Cambrocrinus	(Ec,Eo,As)	Campyloceras	(Mo,Ce,Or)
Calvetina	(Bz,Gy,Ch)	Cambrocryathella	(Po,Ir,Ar)	Campylocythere	(Ar,Os,Po)
Calveziconus	(Fo,Fo,Fo)	Cambrogeorgina	(Pr,Un,In)	Campyloption	(Cd,Ch,Eu)
Calvezina	(Fo,Fo,Fo)	Cambromedusa	(Cn,In,In)	Campylorthis	(Br,Ar,Or)

Campylostoma	(Ec,Di,Di)	Cantalum	(Ac,Ra,Sp)	Carbonoproetus	(Ar,Tr,Pr)
Camsellia	(Ar,Tr,Pr)	Cantharidella	(Mo,Ga,Ar)	Carboprinita	(Ar,Os,Pr)
Camurophyllum	(Cn,An,Ru)	Cantharidus	(Mo,Ga,Ar)	Carbosostrius	(An,Po,Ph)
Camuropiscis	(Cd,Pl,Ar)	Cantharocrinus	(Ec,Cr,Mo)	Carcharinus	(Cd,Ch,Ca)
Canadapteraspis	(Cd,Pl,Pt)	Cantharus	(Mo,Ga,Ne)	Carchariolamna	(Cd,Ch,La)
Canadaspis	(Ar,Ml,Ca)	Cantharus	(Mo,Ga,Ne)	Carcharocles	(Cd,Ch,La)
Canadia	(An,Po,Ph)	Canthylotreta	(Br,Li,Ac)	Carcharodon	(Cd,Ch,La)
Canadiphyllum	(Cn,An,Ru)	Cantioscylium	(Cd,Ch,Co)	Carcharoides	(Cd,Ch,La)
Canadoceras	(Mo,Ce,Am)	Cantrainea	(Mo,Ga,Ar)	Carcharopsis	(Cd,Ch,Ct)
Canadocystis	(Ec,Pe,Co)	Cantrillia	(Cn,An,Ru)	Carciocaeenia	(Cn,An,Sc)
Canadospira	(Br,Ar,Sp)	Canupora	(Bz,Gy,Ch)	Carcinaspides	(Ar,Ma,Cy)
Canadotis	(Mo,Bi,Pt)	Canutrypa	(Bz,St,Cy)	Carcineretes	(Ar,Ml,De)
Canalipora	(Bz,St,Cc)	Canutus	(Ac,Ra,Na)	Carcinocarcinus	(Ar,Ml,De)
Canaliscala	(Mo,Ga,Nt)	Capedopecten	(Mo,Bi,Pt)	Carcinocrinus	(Ec,Cr,Ct)
Canalitates	(Br,Li,Li)	Capellineosuchus	(Cd,Re,Cr)	Carcinoplacoides	(Ar,Ml,De)
Canarium	(Mo,Ga,Nt)	Capelliniella	(Br,Ar,Pe)	Carcinoplax	(Ar,Ml,De)
Canavarella	(Mo,Ce,Am)	Capillapora	(Bz,St,Tr)	Carcinosoma	(Ar,Me,Eu)
Canavaria	(Mo,Ce,Am)	Capillarina	(Br,Ar,Te)	Carcinus	(Ar,Ml,De)
Canavarites	(Mo,Ce,Am)	Capillicyathus	(Pr,Cr,Cr)	Cardabia	(Ec,Ec,Hs)
Canavirilia	(Br,Ar,Rh)	Capillimya	(Mo,Bi,Ph)	Cardiaphyllum	(Cn,An,Ru)
Cancellaria	(Mo,Ga,Ne)	Capillirhynchia	(Br,Ar,Rh)	Cardiarachnidium	(Bz,Gy,Ct)
Cancellariefla	(Mo,Ga,Ne)	Capillirostra	(Br,Ar,Rh)	Cardiarina	(Br,Ar,Te)
Cancellina	(Fo,Fo,Fo)	Capillspirifer	(Br,Ar,Sp)	Cardiaster	(Ec,Ec,Hs)
Cancelloceras	(Mo,Ce,Go)	Capillithyrus	(Br,Ar,Te)	Cardiastrea	(Cn,An,Sc)
Cancellospirifer	(Br,Ar,Sp)	Capillomesolobus	(Br,Ar,St)	Cardiacarnia	(Mo,Bi,Pr)
Cancellothyris	(Br,Ar,Te)	Capillonia	(Br,Ar,St)	Cardiella	(Mo,Ce,Go)
Cancelrana	(Mo,Ga,Ne)	Capistrocardia	(Mo,Bi,My)	Cardilia	(Mo,Bi,Ve)
Cancer	(Ar,Ml,De)	Caplinoplia	(Br,Ar,St)	Cardilona	(Mo,Bi,Ve)
Cancilla	(Mo,Ga,Ne)	Capnodoce	(Ac,Ra,Sp)	Cardinalia	(Mo,Ga,Ar)
Cancrinella	(Br,Ar,St)	Capnophyllum	(Cn,An,Ru)	Cardinia	(Mo,Bi,Ve)
Cancrinelloides	(Br,Ar,St)	Capnuchosphaera	(Ac,Ra,Sp)	Cardiniotrella	(Ar,Os,Pa)
Cancrinus	(Ar,Ml,De)	Caprabolbina	(Ar,Os,Pa)	Cardinoides	(Mo,Bi,Un)
Canceris	(Fo,Fo,Fo)	Capricornognathus	(Cd,Co,Co)	Cardiniopsis	(Mo,Bi,Ve)
Cancerisiella	(Fo,Fo,Fo)	Caprina	(Mo,Bi,Hi)	Cardinirhynchia	(Br,Ar,Rh)
Cancrixantho	(Ar,Ml,De)	Caprinella	(Mo,Bi,Hi)	Cardinocrania	(Br,Ar,St)
Canda	(Bz,Gy,Ch)	Caprinula	(Mo,Bi,Hi)	Cardiobebeba	(Mo,Bi,Pr)
Candeina	(Fo,Fo,Fo)	Caprinuloidea	(Mo,Bi,Hi)	Cardiocardia	(Mo,Bi,Ve)
Candinia	(Mo,Ga,Sa)	Capriocornites	(Mo,Ce,Na)	Cardioceras	(Mo,Ce,Am)
Candispirifer	(Br,Ar,Sp)	Caproberyx	(Cd,Os,Br)	Cardiocystites	(Ec,Eo,Un)
Candona	(Ar,Os,Po)	Capros	(Cd,Os,Ze)	Cardiodictyon	(Lo)
Candorbulina	(Fo,Fo,Fo)	Caprotina	(Mo,Bi,Hi)	Cardioicia	(Bz,St,Cc)
Canepina	(Mo,Ga,Un)	Caprovesposus	(Cd,Os,Ze)	Cardiograptus	(He,Gr,Gr)
Canesium	(Ac,Ra,Na)	Capsacysthere	(Ar,Os,Po)	Cardiola	(Mo,Bi,Pr)
Caneyella	(Mo,Bi,Pt)	Capsella	(Mo,Bi,Ve)	Cardiolampas	(Ec,Ec,Ds)
Caninella	(Cn,An,Ru)	Capscocrinus	(Ec,Cr,Cy)	Cardiolaria	(Mo,Bi,Nu)
Caninia	(Cn,An,Ru)	Capsospongia	(Po,De,Li)	Cardiolinka	(Mo,Bi,Pr)
Caninophyllum	(Cn,An,Ru)	Capsulocyathus	(Po,Re,Ca)	Cardiolita	(Mo,Bi,Ar)
Caninostroton	(Cn,An,Ru)	Capulacmaea	(Mo,Ga,Nt)	Cardiolopsis	(Mo,Bi,Pr)
Canistrocrinus	(Ec,Cr,Mo)	Capulus	(Mo,Ga,Nt)	Cardiomantea	(Mo,Bi,Ve)
Canistrumella	(Po,Ca,He)	Carabocrinus	(Ec,Cr,Ct)	Cardiomorpha	(Mo,Bi,Ph)
Cannapora	(Cn,An,Ta)	Caracharius	(Cd,Ch,La)	Cardiomya	(Mo,Bi,Ph)
Cannartidium	(Ac,Ra,Sp)	Carangodes	(Cd,Os,Pl)	Cardiopeneta	(Ec,Ec,Ds)
Cannartiscus	(Ac,Ra,Sp)	Carangopsis	(Cd,Os,Pl)	Cardiophyllum	(Pr,Cr,Cr)
Cannartus	(Ac,Ra,Sp)	Carantophyllum	(Cn,An,Sc)	Cardioserra	(Ec,Oh,Oh)
Canningella	(Ar,Tr,Un)	Caranx	(Cd,Os,Pl)	Cardiotaxis	(Ec,Ec,Hs)
Canningius	(Cd,Os,Co)	Carapezzia	(Br,Ar,Rh)	Cardiothyris	(Br,Ar,Sp)
Cannobotrys	(Ac,Ra,Na)	Carapus	(Cd,Os,Op)	Cardirhynchus	(Ar,Ml,De)
Cannostomites	(Cn,Sc,Co)	Caratrypa	(Br,Ar,At)	Cardisoma	(Ar,Ml,De)
Canobius	(Cd,Os,Pa)	Carbactinoceras	(Mo,Ce,Ac)	Cardita	(Mo,Bi,Ve)
Canopoconus	(Mo,In,In)	Carboeyrtina	(Br,Ar,Sp)	Carditamera	(Mo,Bi,Ve)
Canoptum	(Ac,Ra,Na)	Carbonarca	(Mo,Bi,Ar)	Carditella	(Mo,Bi,Ve)
Cantabiella	(Br,Ar,Sp)	Carbonella	(Fo,Fo,Fo)	Carditellopsis	(Mo,Bi,Ve)
Cantabricanites	(Mo,Ce,Pl)	Carboninia	(Mo,Ga,He)	Cardies	(Mo,Bi,Ve)
Cantabrigites	(Mo,Ce,Am)	Carbonocoryphe	(Ar,Tr,Pr)	Cardiomantea	(Mo,Bi,Ve)

Carditopsis	(Mo.Bi.Ve)	Carnalpia	(Mo.Bi.Pr)	Caryorhynchus	(Br.Ar.Rh)
Cardium	(Mo.Bi.Ve)	Carnarvonia	(Ar.Os.Ar)	Caryosmilia	(Cn.An.Sc)
Cardobairdia	(Ar.Os.Po)	Carnegiea	(Po.De.Ta)	Caryosphaera	(Ac.Ra.Sp)
Careliopsis	(Mo.Ga.He)	Carneithyris	(Br.Ar.Te)	Caryospongia	(Po.De.Li)
Caretta	(Cd.Re.Ch)	Carneyella	(Ec.Ed.Is)	Caseispongia	(Po.He.He)
Caribachlamys	(Mo.Bi.Pt)	Carniaphyllum	(Cn.An.Ru)	Caseodus	(Mo.Ce.El)
Caribbaster	(Ec.Ec.Sp)	Carnicoleus	(Pr.Ma.Le)	Caseodus	(Cd.Ch.Eu)
Caribbella	(Ar.Os.Po)	Carnicoleus	(Mo.Po.Pa)	Caseyella	(Mo.Ga.Ne)
Caribeanelia	(Fo.Fo.Fo)	Carnidia	(Mo.Bi.Un)	Casieria	(Cd.Os.An)
Caribiella	(Mo.Ga.Ne)	Carniodus	(Cd.Co.Co)	Casieroides	(Cd.Os.Sa)
Caribosiren	(Cd.Ma.Si)	Carnites	(Mo.Ce.Ce)	Casimiria	(Mo.Ga.Nt)
Caricella	(Mo.Ga.Ne)	Carolastraea	(Cn.An.Sc)	Casmaria	(Mo.Ga.Nt)
Caricula	(Br.Ar.St)	Carolia	(Mo.Bi.Pt)	Caspiaza	(Ac.Ra.Sp)
Caridosuctor	(Cd.Os.Co)	Carolicrinus	(Ec.Cr.Mo)	Caspieila	(Fo.Fo.Fo)
Carinacca	(Mo.Ga.Nt)	Carolinapecten	(Mo.Bi.Pt)	Caspiactra	(Mo.Bi.Ve)
Carinachites	(Cn.Sc.Cn)	Carolinites	(Ar.Tr.Pt)	Casquilla	(Br.Li.Li)
Carinacanthus	(Po.Re.Aj)	Carolinochelys	(Cd.Re.Ch)	Cassandra	(Cd.Os.My)
Carinagypa	(Br.Ar.Pe)	Carolirhynchia	(Br.Ar.Rh)	Cassianastraea	(Cn.An.Sc)
Carinaknightina	(Ar.Os.Pa)	Carota	(Mo.Ga.Ne)	Cassianaxis	(Mo.Ga.He)
Carinamala	(Ar.Tr.Pt)	Carotites	(Ar.Ml.De)	Cassianebala	(Mo.Ga.He)
Carinaria	(Mo.Ga.Nt)	Carpathichthys	(Cd.Os.Os)	Cassianella	(Mo.Bi.Pt)
Carinaropsis	(Mo.Ga.Be)	Carpatothyris	(Br.Ar.Te)	Cassianilda	(Mo.Ga.He)
Carinasarte	(Mo.Bi.Ve)	Carpenteria	(Fo.Fo.Fo)	Cassianochaetes	(Po.De.Ax)
Carinata	(Br.Ar.At)	Carpenteroblastus	(Ec.Bl.Sp)	Cassianocirrus	(Mo.Ga.Ar)
Carinatineella	(Br.Ar.At)	Carphites	(Po.He.Re)	Cassianoides	(Mo.Bi.Pt)
Carinator	(Mo.Ga.Ar)	Carpicyathus	(Po.Re.Aj)	Cassianopora	(Bz.St.Cc)
Carinathothyris	(Br.Ar.Te)	Carpilius	(Ar.Ml.De)	Cassianospira	(Br.Ar.Sp)
Carinatrypa	(Br.Ar.At)	Carpilodes	(Ar.Ml.De)	Cassianostroma	(Po.De.Ax)
Carinella	(Cd.Co.Co)	Carpinaria	(Br.Ar.Sp)	Cassianothalamia	(Po.De.Hd)
Carinifer	(Bz.St.Cc)	Carpocanarium	(Ac.Ra.Na)	Cassianozyga	(Mo.Ga.Nt)
Cariniferella	(Br.Ar.Or)	Carpocanistrum	(Ac.Ra.Na)	Cassidiaria	(Mo.Ga.Nt)
Carinitheca	(Hy.Or.Or)	Carpocanium	(Ac.Ra.Na)	Cassidella	(Fo.Fo.Fo)
Carinobairdia	(Ar.Os.Po)	Carpocanopsis	(Ac.Ra.Na)	Cassidella	(Fo.Fo.Fo)
Carinobolbina	(Ar.Os.Pa)	Carpocrinus	(Ec.Cr.Mo)	Cassideus	(Ac.Ra.Na)
Carinocerax	(Mo.Ce.An)	Carpocystites	(Ec.Di.Di)	Cassidiceps	(Cd.Ac.Cl)
Carinoclymenia	(Mo.Ce.Cl)	Carpopenaues	(Ar.Ml.De)	Cassidia	(Mo.In.In)
Carinocoenus	(Fo.Fo.Fo)	Carpospongia	(Po.De.Li)	Cassidirostrum	(Br.Ar.Rh)
Carinocranium	(Ar.Tr.As)	Carrickia	(Ar.Tr.Pt)	Cassidulina	(Fo.Fo.Fo)
Carinocythereis	(Ar.Os.Pt)	Carringtonia	(Br.Ar.St)	Cassidulinella	(Fo.Fo.Fo)
Carinodens	(Cd.Re.Sq)	Carruthersella	(Cn.An.Ru)	Cassidulinita	(Fo.Fo.Fo)
Carinodictya	(Bz.St.Cr)	Carsosaurus	(Cd.Re.Sq)	Cassidulinoides	(Fo.Fo.Fo)
Carinodrillia	(Mo.Ga.Ne)	Carsothrissops	(Cd.Os.El)	Cassidulus	(Ec.Ec.Ca)
Carinokloedenia	(Ar.Os.Pa)	Carstenia	(Mo.Ce.Am)	Cassigerinella	(Fo.Fo.Fo)
Carinokoninekina	(Br.Ar.Sp)	Carta	(Po.De.Ax)	Cassigerinelloita	(Fo.Fo.Fo)
Carinolithes	(Hy.Hy.Hy)	Carterella	(Po.De.Li)	Cassinoceras	(Mo.Ce.En)
Carinomphalus	(Mo.Ga.Nt)	Carterina	(Fo.Fo.Fo)	Cassiope	(Mo.Ga.Nt)
Carinonautilus	(Mo.Ce.Na)	Carterochaena	(Mo.Bi.My)	Cassiopella	(Mo.Ga.Nt)
Carinonychia	(Mo.Bi.Pt)	Carteroceras	(Mo.Ce.El)	Cassipelia	(Mo.Ga.Ar)
Carinophylloceras	(Mo.Ce.Ph)	Cartlaginites	(Mo.Ce.Am)	Cassiss	(Mo.Ga.Nt)
Carinophylloporina	(Bz.St.Fe)	Cartorhium	(Br.Ar.Sp)	Cassowarioides	(Mo.Ro.Co)
Carinotachylasma	(Cn.An.Ru)	Carubaegutes	(Pr.Co.Sa)	Cassubia	(Pr.Di.Ra)
Carinotropis	(Mo.Ga.Ne)	Carubaknightina	(Ar.Os.Pa)	Castanopora	(Bz.Gy.Ch)
Carinovalvia	(Ar.Os.Po)	Caruichthys	(Cd.Os.Pa)	Castellaroina	(Br.Ar.St)
Carinowaagenophyllum	(Cn.An.Ru)	Carydiopora	(Bz.Gy.Ch)	Casterella	(Mo.Bi.Pt)
Carinthiaphyllum	(Cn.An.Ru)	Carydium	(Mo.Bi.Mo)	Castericystis	(Ec.Hs.So)
Caritodens	(Mo.Bi.Pt)	Caryoblastus	(Ec.Bl.Fi)	Casteroceras	(Mo.Ce.Na)
Carivia	(Fo.Fo.Fo)	Caryocaris	(Ar.Ml.Ar)	Casterocythere	(Ar.Os.Po)
Carlclausus	(Ar.Ml.Ta)	Caryocorbula	(Mo.Bi.My)	Casterolimulus	(Ar.Mc.Xi)
Carlinastraea	(Cn.An.Ru)	Caryocrintes	(Ec.Rh.Rh)	Casteropora	(Bz.Gy.Ct)
Carlinia	(Br.Ar.St)	Caryocystites	(Ec.Rh.Rh)	Castrum	(Ac.Ra.Na)
Carlloceras	(Mo.Ce.Na)	Caryogyps	(Br.Ar.Pe)	Catacephalus	(Br.Ar.Te)
Carlopsocrinus	(Ec.Cr.Cl)	Caryomanon	(Po.De.Li)	Cataceramus	(Mo.Bi.Pt)
Carminodonta	(Mo.Bi.Mo)	Caryona	(Br.Ar.Te)	Catacoeloceras	(Mo.Ce.Am)
Carmon	(Ar.Tr.Un)	Caryophyllia	(Cn.An.Sc)	Catacoraites	(Ar.Os.Me)

Catactocrinus	(Ec,Cr,C1)	Caveola	(Mo,Ga,Ne)	Canellipsis	(Ac,Ra,Sp)
Catactotoechus	(Cn,An,Ru)	Cavernella	(Bz,St,Fe)	Censella	(Mo,Ce,Am)
Catadoxides	(Ar,Tr,Re)	Cavernisa	(Mo,Ga,Nt)	Cenoceras	(Mo,Ce,Na)
Catamarcaia	(Mo,Bi,Ar)	Cavernolites	(Hy,Hy,Hy)	Cenocrinus	(Ec,Cr,Is)
Catantostoma	(Mo,Ga,Ar)	Cavhithis	(Ar,Os,Pa)	Cenodiscaella	(Ac,Ra,Sp)
Catapleura	(Cd,Re,Ch)	Cavilabium	(Mo,Ga,Nt)	Cenodiscus	(Ac,Ra,Sp)
Cataraquicrinus	(Ec,Cr,Ds)	Cavilasma	(Cn,An,Ru)	Cenolarcopyle	(Ac,Ra,Sp)
Catascchisma	(Mo,Ga,Ar)	Cavilentia	(Mo,Ce,Go)	Cenomanaster	(Ec,As,Va)
Catasigaloceras	(Mo,Ce,Am)	Cavilinga	(Mo,Bi,Ve)	Cenomanella	(Mo,Ga,Nt)
Catasolenopleura	(Ar,Tr,Pt)	Cavilucina	(Mo,Bi,Ve)	Cenomanina	(Cn,An,Sc)
Cataspydrax	(Fo,Fo,Fo)	Cavispongia	(Mo,He,Ly)	Cenomanocarcinus	(Ar,Ml,De)
Catastroboceras	(Mo,Ce,Na)	Caviumbonia	(Mo,Ga,Nt)	Cenorhynchia	(Br,Ar,Rh)
Cateuthis	(Mo,Ce,Be)	Cavolina	(Mo,Ga,Th)	Cenosphaera	(Ac,Ra,Sp)
Catatonocrinus	(Ec,Cr,Ds)	Cavopleura	(Ar,Os,Pa)	Centraropyge	(Ar,Tr,Ph)
Catazona	(Mo,Ga,Ar)	Cavusgnathus	(Cd,Co,Co)	Centracanthus	(Cd,Os,Pf)
Catazona	(Mo,Ga,Ar)	Cavusonella	(Po,Ca,Ph)	Centrastraea	(Cn,An,Sc)
Catazyga	(Br,Ar,At)	Cavussurella	(Ar,Os,Pa)	Centriconus	(Mo,In,In)
Catella	(Mo,Bi,Ar)	Cayogoceras	(Mo,Ce,Di)	Centrifuga	(Mo,Ga,Ne)
Catenariopsis	(Bz,Gy,Ch)	Caypulisaurus	(Cd,Re,lc)	Centrifugus	(Mo,Ga,Ne)
Catenicella	(Bz,Gy,Ch)	Caytonidea	(Ar,Os,Pa)	Centriocrinus	(Ec,Cr,Mo)
Catenipora	(Cn,An,Ta)	Cayutoceras	(Mo,Ce,Or)	Centricrus	(Cd,Os,Go)
Catenispongia	(Po,Ca,Ph)	Caznaia	(Ar,Tr,As)	Centristella	(Cn,An,Ru)
Catenoscala	(Mo,Ga,Nt)	Ceata	(Bz,St,Cc)	Centroberyx	(Cd,Os,Br)
Catenotoma	(Mo,Ga,Ne)	Ceciliaphyllum	(Cn,An,Ru)	Centrobotrys	(Ac,Ra,Na)
Cathaysia	(Br,Ar,St)	Cecrops	(Ac,Ra,Sp)	Centrocardita	(Mo,Bi,Ve)
Cathetocrinus	(Ec,Cr,C1)	Cedarapis	(Ar,Tr,Pt)	Centroceras	(Mo,Ce,Na)
Catillicephala	(Ar,Tr,As)	Cedarapellus	(Ar,Tr,Pt)	Centrocyrtoceras	(Mo,Ce,Na)
Catillocrinus	(Ec,Cr,Ds)	Cedaria	(Ar,Tr,Pt)	Centrocyrtoceraia	(Mo,Ce,El)
Catilon	(Mo,Ga,Ne)	Cedarina	(Ar,Tr,Pt)	Centrocythere	(Ar,Os,Pa)
Catimula	(Mo,Bi,Pt)	Cedarvilleoceras	(Mo,Ce,Or)	Centrolepis	(Cd,Os,Pa)
Cativella	(Ar,Os,Pa)	Cederstroemia	(Cd,Ch,Co)	Centrolitoceras	(Mo,Ce,Na)
Catoma	(Ac,Ra,Sp)	Cedocamia	(Ar,Os,Ar)	Centronaea	(Bz,St,Cc)
Catopygus	(Ec,Ec,Ca)	Cedulia	(Br,Ar,St)	Centronella	(Br,Ar,Te)
Catoraphinoceras	(Mo,Ce,El)	Ceidmonea	(Bz,St,Cc)	Centronelloidea	(Br,Ar,Te)
Catulloceras	(Mo,Ce,Am)	Cekovia	(Ar,Tr,Co)	Centroonoceras	(Mo,Ce,Or)
Catuniella	(Ar,Tr,As)	Celaeceras	(Mo,Ce,An)	Centrophoroides	(Cd,Ch,Sq)
Caturus	(Cd,Os,Am)	Celatoconus	(Mo,Ga,Ne)	Centrophorus	(Cd,Ch,Sq)
Catyrephoceras	(Mo,Ce,Ta)	Cellobolus	(Br,Li,Ac)	Centroleura	(Ar,Tr,Re)
Caucacrocrinus	(Ec,Cr,Mo)	Celebetes	(Br,Ar,St)	Centropomus	(Cd,Os,Pf)
Caucasella	(Mo,Ga,Nt)	Celechopora	(Cn,An,Ta)	Centropristis	(Cd,Os,Pf)
Caucasicus	(Ac,Ra,Sp)	Celechovites	(Ar,Os,Un)	Centropterus	(Cd,Ch,Sq)
Caucasina	(Fo,Fo,Fo)	Celidocrania	(Br,Li,Ac)	Centropygus	(Ec,Ec,Ca)
Caucasiproductus	(Br,Ar,St)	Cellana	(Mo,Ga,Pa)	Centrorhynchus	(Br,Ar,Rh)
Caucasites	(Mo,Ce,Ce)	Cellaria	(Bz,Gy,Ch)	Centrozoceras	(Mo,Ce,On)
Caucasoproductus	(Br,Ar,St)	Cellarinella	(Bz,Gy,Ch)	Centrosqualus	(Cd,Ch,Sq)
Caucasorhynchia	(Br,Ar,Rh)	Cellarinidra	(Bz,Gy,Ch)	Centrostephanus	(Ec,Ec,Di)
Caucasothyris	(Br,Ar,Te)	Cellepora	(Bz,Gy,Ch)	Centrotarphyceras	(Mo,Ce,Ta)
Caudites	(Ar,Os,Pa)	Celleporaria	(Bz,Gy,Ch)	Ceocepea	(Br,Ar,St)
Caudriella	(Fo,Fo,Fo)	Celleporella	(Bz,Gy,Ch)	Ceotinaella	(Po,Ca,Un)
Caulaspina	(Ar,Tr,Pt)	Celleporina	(Bz,Gy,Ch)	Cepatia	(Mo,Ga,Nt)
Caulaspis	(Ar,Tr,As)	Cellicyathus	(Po,Tr,Ar)	Cephalites	(Po,He,Ly)
Caulastrea	(Cn,An,Sc)	Cellonina	(Fo,Fo,Fo)	Cephalodiscus	(He,Pt,Ce)
Cauliculospongia	(Po,De,Li)	Cellulipora	(Bz,St,Cc)	Cephalograptus	(He,Gr,Gr)
Caulophacus	(Po,He,Ls)	Celmus	(Ar,Tr,Pr)	Cephalopyge	(Ar,Tr,Ag)
Caumontisphinctes	(Mo,Ce,Am)	Celonocrinus	(Ec,Cr,C1)	Cephalopyramis	(Ac,Ra,Na)
Cautotriphora	(Mo,Ga,Nt)	Celov	(Mo,Ce,Na)	Cephaloraphidites	(Po,De,As)
Cava	(Bz,St,Cc)	Celsiformix	(Br,Ar,Sp)	Cephalotropis	(Cd,Ma,Ce)
Cavanechinus	(Ec,Ec,Ey)	Celtanopia	(Br,Ar,St)	Cephaloxenus	(Cd,Os,Ce)
Cavaria	(Bz,St,Cc)	Celtenocrinus	(Ar,Tr,Ph)	Cephal	(Cd,Os,Pf)
Cavarinella	(Bz,St,Cc)	Celtoconcha	(Mo,Bi,Mo)	Cerabonusoides	(Pr,Di,Ra)
Cavaspongia	(Ac,Ra,Sp)	Celtoocrinus	(Ec,Cr,Mo)	Ceragnostus	(Ar,Tr,Ag)
Cavatisinuostrom	(Br,Ar,Rh)	Celtooides	(Mo,Bi,Ve)	Ceramaster	(Ec,As,Va)
Caveacus	(Pr,Un,In)	Celyphia	(Po,De,Pe)	Ceramella	(Bz,St,Cy)
Cavellina	(Ar,Os,Pl)	Cementula	(An,Po,Se)	Ceramisia	(Br,Ar,Te)

Ceramograptus	(He.Gr.Un)	Ceraurinus	(A.Tr,Ph)	Chabactoceras	(Mo,Ce,El)
Ceramophylla	(Bz.St,Cy)	Cerauroides	(Ar.Tr,Ph)	Chablaisia	(Fo,Fo,Fo)
Ceramopora	(Bz.St,Cy)	Cerauromeros	(Ar.Tr,Ph)	Chaceia	(Mo,Bi,My)
Ceramoporella	(Bz.St,Cy)	Cerauropeltis	(Ar.Tr,Ph)	Chacurus	(Ar.Tr,Ph)
Ceramurus	(Cd.Os,Pe)	Ceraurus	(Ar.Tr,Ph)	Chadwickoceras	(Mo,Ce,On)
Ceraostroma	(Po,De,Ax)	Cerberatrypa	(Br,Ar,At)	Chaeniorhynchus	(Br,Ar,Rh)
Cerachocyrtium	(Ac,Ra,Sp)	Cercidocrinus	(Ec,Cr,Ci)	Chaenocardia	(Mo,Bi,Pt)
Cerasina	(Br,Ar,At)	Cercomya	(Mo,Bi,Ph)	Chaenogaleus	(Cd,Ch,Ca)
Cerasmocrinus	(Ec,Cr,Mo)	Cereiophyllia	(Cn,An,Sc)	Chaenomya	(Mo,Bi,Ph)
Cerastoderma	(Mo,Bi,Ve)	Cererithyris	(Br,Ar,Te)	Chaetasterina	(Ec,As,Va)
Ceratammina	(Fo,Fo,Fo)	Ceresiosaurus	(Cd,Re,No)	Chaetetella	(Po,De,Ta)
Ceratarges	(Ar,Tr,Li)	Ceriaster	(Cn,An,Ru)	Chaetetes	(Po,De,Ta)
Ceratia	(Mo,Ga,Nt)	Ceriacava	(Bz,St,Cc)	Chaetetipora	(Po,De,Ta)
Ceratiocaris	(Ar,ML,Ar)	Cericysta	(Cn,An,Ru)	Chaetetopsis	(Po,De,Ta)
Ceratites	(Mo,Ce,Ce)	Ceriodictyon	(Po,He,Ly)	Chaetodon	(Cd,Os,Pe)
Ceratobairdia	(Ar,Os,Pe)	Ceriolasma	(Cn,An,Ru)	Chaetopleura	(Mo,Po,Ne)
Ceratoblastus	(Ec,Bi,Fi)	Cerioheterastraea	(Cn,An,Sc)	Chaetosalpina	(An,Po,Se)
Ceratobolbina	(Ar,Os,Pa)	Ceripora	(Bz,St,Cc)	Chaeturichthys	(Cd,Os,Pe)
Ceratobulimina	(Fo,Fo,Fo)	Ceriporella	(Bz,St,Cc)	Chaganella	(Br,Ar,St)
Ceratocameris	(Fo,Fo,Fo)	Ceriphyllum	(Cn,An,Ru)	Chagrinia	(Cd,Os,Co)
Ceratocera	(Ar,Tr,Od)	Ceristella	(Cn,An,Ru)	Chainodictyon	(Bz,St,Fe)
Ceratocephala	(Ar,Tr,Od)	Ceritella	(Mo,Ga,Ce)	Chaivella	(Ec,St,Mi)
Ceratocephalina	(Ar,Tr,Od)	Cerithidea	(Mo,Ga,Nt)	Chakassicryathus	(Po,Re,Aj)
Ceratocoenia	(Cn,An,Sc)	Cerithideops	(Mo,Ga,Nt)	Chakasskia	(Ar,Tr,Un)
Ceratoconcha	(Ar,Ci)	Cerithideopsilla	(Mo,Ga,Nt)	Chalalabeltus	(Mo,Ce,Be)
Ceratoconus	(Mo,In,In)	Cerithideopsis	(Mo,Ga,Nt)	Chalaroepgma	(Po,De,Li)
Ceratocratia	(Ar,Os,Pe)	Cerithidium	(Mo,Ga,Nt)	Chalaroschwagerina	(Fo,Fo,Fo)
Ceratocrinus	(Ec,Cr,Ci)	Cerithiella	(Mo,Ga,Nt)	Chalrostrepis	(Mo,Ga,Be)
Ceratocyathus	(Cn,An,Sc)	Cerithina	(Mo,Ga,Nt)	Chalasiocranos	(Pr,Un,In)
Ceratocypris	(Ar,Os,Un)	Cerithinella	(Mo,Ga,Nt)	Chalaidichthys	(Cd,Os,Pe)
Ceratocyrtis	(Ac,Ra,Na)	Cerithioclava	(Mo,Ga,Nt)	Chalcidophyllum	(Cn,An,Ru)
Ceratocystis	(Ec,St,Co)	Cerithioegya	(Mo,Ga,Nt)	Chalfontia	(Ar,Tr,Un)
Ceratodictya	(Po,He,Re)	Cerithiderma	(Mo,Ga,Nt)	Chalilovella	(Fo,Fo,Fo)
Ceratoichthyes	(Cd,Os,Pe)	Cerithioides	(Mo,Ga,Ar)	Chalimochonetes	(Br,Ar,St)
Ceratoiscum	(Ac,Ra,Sp)	Cerithiomorpha	(Mo,Ga,Nt)	Chalmasia	(Mo,Bi,Pt)
Ceratolamarckina	(Fo,Fo,Fo)	Cerithiopsis	(Mo,Ga,Nt)	Chama	(Mo,Bi,Ve)
Ceratoleperditia	(Ar,Os,Le)	Cerithiopsidella	(Mo,Ga,Nt)	Chamaesipho	(Ar,Ci)
Ceratolichas	(Ar,Tr,Li)	Cerithopsina	(Mo,Ga,Nt)	Chamelea	(Mo,Bi,Ve)
Ceratolithus	(Ar,Tr,As)	Cerithiopsis	(Mo,Ga,Nt)	Chametracia	(Mo,Bi,Ve)
Ceratomya	(Mo,Bi,Ph)	Cerithiscalca	(Mo,Ga,Nt)	Chamishaella	(Ar,Os,Pe)
Ceratomyopsis	(Mo,Bi,Ph)	Cerithium	(Mo,Ga,Nt)	Chamusetia	(Mo,Ce,Am)
Ceratonurus	(Ar,Tr,Od)	Cermataspis	(Ar,Tr,Un)	Championodictya	(Bz,St,Cr)
Ceratopea	(Mo,Ga,Eu)	Cermatop	(Ar,Tr,Un)	Champlainia	(Ar,Tr,Pt)
Ceratopeltis	(Ar,Tr,Pr)	Cerninella	(Ar,Os,Pa)	Champlainopora	(Bz,St,Tr)
Ceratophyllia	(Cn,An,Sc)	Cernuolimbus	(Ar,Tr,Pt)	Champsodelphis	(Cd,Ma,Ce)
Ceratophyllum	(Cn,An,Ru)	Cerobertina	(Fo,Fo,Fo)	Chanasia	(Mo,Ce,Am)
Ceratoporella	(Po,De,Ta)	Cerobertinella	(Fo,Fo,Fo)	Chancelloria	(Pr,Co,Ch)
Ceratoproetus	(Ar,Tr,Pr)	Ceromyella	(Mo,Bi,Ph)	Chancia	(Ar,Tr,Pt)
Ceratopsammia	(Cn,An,Sc)	Ceroniola	(Mo,Bi,Ve)	Chanciaopsis	(Ar,Tr,Pt)
Ceratopsis	(Ar,Os,Pa)	Ceronocare	(Ar,Tr,As)	Chanda	(Cd,Os,Pe)
Ceratopyge	(Ar,Tr,As)	Cershiites	(Ar,Os,Pa)	Changaspis	(Ar,Tr,Co)
Ceratospiculus	(Cd,Os,My)	Certonardoa	(Ec,As,Va)	Changshingoceras	(Mo,Ce,Go)
Ceratospicus	(Cd,Os,My)	Cerullia	(Mo,Bi,Ve)	Changia	(Ar,Tr,As)
Ceratospyrus	(Ac,Ra,Na)	Cervella	(Bz,St,Fe)	Changicyathus	(Po,Ir,Ar)
Ceratostoma	(Mo,Ga,Ne)	Cessipylorum	(Ac,Ra,Sp)	Changjianggouphyllum	(Cn,An,Ru)
Ceratostreon	(Mo,Bi,Pt)	Cestites	(Pr,Un,In)	Changkiuoceras	(Mo,Ce,En)
Ceratotheca	(Hy,Or,Or)	Cestobryssus	(Ec,Ec,Sp)	Changninocrinus	(Ec,Cr,Os)
Ceratothecia	(Cn,An,Sc)	Cestocrinus	(Ec,Cr,Ci)	Changqingia	(Ar,Tr,Pt)
Ceratotrochus	(Cn,An,Sc)	Ceterhinops	(Cd,Ma,Ce)	Changshabaella	(Ar,Os,Ar)
Ceratopheloceras	(Mo,Ce,An)	Cetorhinus	(Cd,Ch,La)	Changshaispirifer	(Br,Ar,Sp)
Ceratreta	(Br,Li,Ac)	Cetorhynchus	(Cd,Ma,Ce)	Changshania	(Ar,Tr,Pt)
Ceratunocochlis	(Mo,Ga,Nt)	Cetotheriomorphis	(Cd,Ma,Ce)	Changshanocephalus	(Ar,Tr,Pt)
Ceraurinaella	(Ar,Tr,Ph)	Cetotheriopsis	(Cd,Ma,Ce)	Changtangella	(Br,Ar,Sp)
Ceraurinium	(Ar,Tr,Ph)	Cetotherium	(Cd,Ma,Ce)	Changxingia	(Cd,Os,Co)

Changyangnia	(Ar.Os,My)	Chauffouraspis	(Ar.Tr,Pr)	Chelycyptraea	(Mo.Ga,Nt)
Changyangrhyngchus	(Br.Ar,Rh)	Chauliochiton	(Mo.Po,Ne)	Chelyophorus	(Cd,Pl,Pt)
Chankacyathus	(Po,Ir,Ar)	Chauliodius	(Cd.Os,St)	Chelyopsis	(Cd,Re,Ch)
Chanoides	(Cd.Os,Go)	Chaulistomella	(Br.Ar,Or)	Chelyposuchus	(Cd,Re,Pl)
Chanopsis	(Cd.Os,Go)	Chaunactis	(Po,De,Lo)	Chemnitria	(Mo.Ga,He)
Chanos	(Cd.Os,Go)	Chaunax	(Cd.Os,Lo)	Chemnuzia	(Ar.Tr,Pt)
Chaoaspis	(Ar.Tr,Re)	Chaunograptus	(He.Gr,Un)	Chenella	(Fo,Fo,Fo)
Chaohuceras	(Mo,Ce,En)	Chaunoproetus	(Ar.Tr,Pr)	Chenendopora	(Po,De,Li)
Chaohusaurus	(Cd,Re,Ic)	Chauvelicystis	(Ec,St,Co)	Chengjuangoconus	(Mo,In,In)
Chaoiella	(Br.Ar,St)	Chauvetia	(Mo.Ga,Ne)	Chengkouaspis	(Ar.Tr,Re)
Chaoina	(Br.Ar,St)	Chavarella	(Mo,Bi,Ve)	Chengkouia	(Ar.Tr,Co)
Chapadella	(Br.Ar,Te)	Chavancerithium	(Mo.Ga,Nt)	Chenia	(Fo,Fo,Fo)
Chaperia	(Mo,Bi,Hi)	Chavsakia	(Cn,An,Ru)	Cheniothyris	(Br.Ar,Te)
Chaperia	(Bz,Gy,Ch)	Chazydictya	(Bz,St,Cr)	Chenxianoproductus	(Br.Ar,St)
Chapinella	(Br.Ar,Sp)	Chazyoceras	(Mo,Ce,En)	Cheopsia	(Ec,Ec,Sp)
Chapmanicythereis	(Ar.Os,Po)	Checontonomus	(Ar.Os,My)	Chepuloceeras	(Mo,Ce,El)
Chapmanina	(Fo,Fo,Fo)	Chedevilla	(Mo.Ga,Nt)	Chepultapedia	(Mo.Ga,Ar)
Chapmanites	(Ar.Os,Me)	Cheilea	(Mo.Ga,Nt)	Cheramus	(Ar,MI,De)
Characodoma	(Bz,Gy,Ch)	Cheilinus	(Cd.Os,PF)	Cherkesoavaena	(Br.Ar,AT)
Charactoceras	(Mo,Ce,Ta)	Cheilocephalus	(Ar,Ti,Co)	Chernobaculites	(Fo,Fo,Fo)
Charactocerina	(Mo,Ce,Ba)	Cheiloceras	(Mo,Ce,Go)	Chernyshinella	(Fo,Fo,Fo)
Charactocrinus	(Ec,Cr,DS)	Cheilohorneropsis	(Bz,Gy,Ch)	Chernyshinellina	(Fo,Fo,Fo)
Charactophyllum	(Cn,An,Ru)	Cheilonella	(Bz,Gy,Ch)	Cherskiella	(Ar,Os,Pa)
Charadream	(Mo.Ga,Nt)	Cheilopora	(Bz,Gy,Ch)	Cherubicornea	(Br.Ar,Rh)
Charassocarcinus	(Ar,MI,De)	Cheilopora	(Bz,Gy,Ch)	Chesacardium	(Mo,Bi,Ve)
Charchaguaia	(Ar,Tr,As)	Cheilomilia	(Cn,An,Sc)	Chesaclava	(Mo.Ga,Ne)
Chardonius	(Cd.Os,Sa)	Cheilospicata	(Mo.Ga,Th)	Chesaconavus	(Ar,Ci)
Charentia	(Fo,Fo,Fo)	Cheilosporites	(Po,De,Pe)	Chesapeakella	(Mo,Ce,Am)
Chariaster	(Ec,As,Va)	Cheilotomona	(Mo.Ga,Ar)	Chesapecten	(Mo,Bi,Pt)
Charientocrinus	(Ec,Cr,Ci)	Cheilotrypa	(Bz,St,Cy)	Chesasyrinx	(Mo.Ga,Ne)
Chariocephalus	(Ar,Tr,Pt)	Cheiopteria	(Mo,Bi,Pt)	Chesathais	(Mo.Ga,Ne)
Chariocrinus	(Ec,Cr,Is)	Cheiracanthoides	(Cd,Ac,Ac)	Chestatrophon	(Mo.Ga,Ne)
Charionella	(Br.Ar,Sp)	Cheiracanthoides	(Cd,Ac,Ci)	Chesterella	(Ar,Os,Pa)
Charionoides	(Br.Ar,Sp)	Cheirocrinus	(Ec,Rh,Rh)	Chetaites	(Mo,Ce,Am)
Charisphyllum	(Cn,An,Ru)	Cheirocyrella	(Ec,Rh,Rh)	Chevalieria	(Cn,An,Sc)
Charitopsis	(Cd.Os,Go)	Cheirocystis	(Ec,Rh,Rh)	Chevalierismilia	(Cn,An,Sc)
Charitosomus	(Cd.Os,Go)	Cheirodopsis	(Cd,Os,Pa)	Chevallieria	(Mo.Ga,Nt)
Charitoxotis	(Ar,Os,La)	Cheiropteraster	(Ec,Op,Oe)	Chevroleperditia	(Ar,Os,Le)
Charixa	(Bz,St,Cc)	Cheiropyge	(Ar,Tr,Pr)	Chia	(Cn,An,Pa)
Charixa	(Bz,Gy,Ch)	Cheirostephanus	(Cd,Ch,Sq)	Chianella	(Br.Ar,St)
Charleuxia	(Cd,Os,Pa)	Cheirothrix	(Cd,Os,Al)	Chiapasella	(Mo,Bi,Hi)
Charltonina	(Fo,Fo,Fe)	Cheirothyris	(Br.Ar,Te)	Chiarumanipyge	(Ar,Tr,Ph)
Charltonithyris	(Br.Ar,Te)	Cheirothyropsis	(Br.Ar,Te)	Chiastronella	(Po,De,Li)
Charnia	(Cn,Pe,Ra)	Cheiruroides	(Ar,Tr,Co)	Chiastrodus	(Cd,Ch,Eu)
Charniodiscus	(Cn,Pe,Ra)	Cheirurus	(Ar,Tr,Ph)	Chiastrulus	(Ac,Ac,Ac)
Charonia	(Mo.Ga,Nt)	Chejudocythere	(Ar,Os,Po)	Chiastrusella	(Bz,Gy,Ch)
Chartecyris	(Bz,St,Cc)	Chekangaspis	(Ar,Tr,Un)	Chibapsetta	(Cd,Os,Pn)
Chartocardium	(Mo,Bi,Ve)	Chelediscus	(Ar,Tr,Ag)	Chicagoceras	(Mo,Ce,Or)
Chartroniella	(Mo.Ga,Ar)	Chelidonocephalus	(Ar,Tr,Pt)	Chichia	(Cd,Os,Pa)
Charybdis	(Ar,MI,De)	Chelidozoum	(Bz,Gy,Ch)	Chicoreus	(Mo.Ga,Ne)
Chascothyris	(Br.Ar,Te)	Chelmon	(Cd,Os,PF)	Chidleyenoceras	(Mo,Ce,Ba)
Chasmataspis	(Ar,Me,Ch)	Chelocrinus	(Ec,Cr,En)	Chielasma	(Cn,An,Ru)
Chasmatopora	(Bz,St,Fe)	Chelodes	(Mo,Po,Pa)	Chiella	(Ar,Os,Ar)
Chasmatoporella	(Bz,St,Fe)	Chelonechinus	(Ec,Ec,HS)	Chienaspis	(Ar,Tr,Co)
Chasmatoporina	(Bz,St,Fe)	Chelonia	(Cd,Re,Ch)	Chihlioceras	(Mo,Ce,En)
Chasmazoon	(Bz,Gy,Ch)	Chelonibia	(Ar,Ci)	Chihsiaphyllum	(Cn,An,Ru)
Chasmocarcinus	(Ar,MI,De)	Chelonicerias	(Mo,Ce,Am)	Chihngphoherus	(Ar,MI,De)
Chasmops	(Ar,Tr,Ph)	Cheloniellon	(Ar,Mo,Ch)	Chilara	(Cd,Os,Op)
Chasmotheca	(Mo.Ga,Nt)	Chelonomia	(Br.Ar,St)	Chile	(Br,Un,Ch)
Chathamithyris	(Br.Ar,Te)	Chelosphargis	(Cd,Re,Ch)	Chileutomania	(Mo.Ga,Nt)
Chatsworthia	(Ec,Ed,Is)	Chelotia	(Mo.Ga,Ar)	Chilianashania	(Br.Ar,St)
Chattertonia	(Br.Ar,St)	Chelsonella	(Hy,Or,Or)	Chiliidopsis	(Br.Ar,St)
Chattonia	(Mo,Bi,Ve)	Cheltonia	(Mo,Ce,Am)	Chilidorthis	(Br.Ar,Or)
Chatwinothyris	(Br.Ar,Te)	Chelyconus	(Mo,Ga,Ne)	Chilobolbina	(Ar,Os,Pa)

Chilocyclus	(Mo,Ga,Nt)	Chlidoniopsis	(Bz,Gy,Ch)	Chonostegites	(Cn,An,Ta)
Chilodonta	(Mo,Ga,Ar)	Chlidonocrinus	(Ec,Cr,Ci)	Chonostegoidella	(Br,Ar,St)
Chilodontoidea	(Mo,Ga,Ar)	Chlinocephalus	(Ar,MI,De)	Chonostegoides	(Br,Ar,St)
Chiloguembelina	(Fo,Fo,Fo)	Chloridiella	(Ar,MI,St)	Chonostrophia	(Br,Ar,St)
Chiloguembelitria	(Fo,Fo,Fo)	Chlorodiella	(Ar,MI,De)	Chonostrophiiella	(Br,Ar,St)
Chilometopus	(Ar,Tr,Co)	Chlorophthalmus	(Cd,Os,Au)	Choperella	(Br,Ar,Sp)
Chilomycterus	(Cd,Os,Te)	Chlorostoma	(Mo,Ga,Ar)	Choreanoceroides	(Mo,Ce,En)
Chilonorria	(Ar,Tr,Co)	Chlupacina	(Br,Ar,St)	Chorilia	(Ar,MI,De)
Chilopora	(Bz,St,Ce)	Chlupacispira	(Mo,Ga,Ar)	Choristitella	(Br,Ar,Sp)
Chiloscyllium	(Cd,Ch,Oc)	Chlupacitoechia	(Br,Ar,Rh)	Choristites	(Br,Ar,Sp)
Chilostomella	(Fo,Fo,Fo)	Chnaurocoelia	(Br,Ar,Sp)	Choristoceras	(Mo,Ce,Ce)
Chilostomelloides	(Fo,Fo,Fo)	Choanoceras	(Mo,Ce,As)	Choristograptus	(He,Gr,De)
Chilostomina	(Fo,Fo,Fo)	Choanodus	(Br,Ar,St)	Choristopetalum	(Bz,St,Ce)
Chimaera	(Cd,Ch,Cm)	Choanoplasma	(Cn,An,Ru)	Choristothyris	(Br,Ar,Te)
Chimaeropsis	(Cd,Ch,In)	Choffatia	(Fo,Fo,Fo)	Chorizopora	(Bz,Gy,Ch)
Chimaerothyris	(Br,Ar,Sp)	Choffatia	(Mo,Ce,Am)	Chorus	(Mo,Ga,Ne)
Chimela	(Mo,Bi,Ve)	Choffaticeras	(Mo,Ce,Am)	Chosenia	(Ar,Tr,Pt)
Chinacrinus	(Ec,Cr,Mo)	Choia	(Po,De,Un)	Chosonodina	(Cd,Co,Co)
Chinensis	(Ar,Tr,Un)	Choiaella	(Po,De,Un)	Chostophyllum	(Cn,An,Ru)
Chingua	(Mo,Ga,Ar)	Cholaster	(Ec,Op,Op)	Chotocypus	(Ar,Tr,Ph)
Chinianaster	(Ec,So,Go)	Cholocrinus	(Ec,Cr,Sa)	Choubertella	(Ar,Tr,Ol)
Chinianocarpus	(Ec,St,Mi)	Cholopilus	(Ar,Tr,Co)	Chouberticyathus	(Po,Ir,Ar)
Chioceras	(Mo,Ce,Ce)	Chomataster	(Ec,As,Va)	Chouteauceras	(Mo,Ce,Na)
Chion	(Mo,Bi,Ve)	Chomatodus	(Cd,Ch,In)	Christianella	(Br,Ar,St)
Chione	(Mo,Bi,Ve)	Chomatomediocris	(Fo,Fo,Fo)	Christiania	(Br,Ar,St)
Chionelasmus	(Ar,Ci)	Chomatopyge	(Ar,Tr,Pr)	Christinapecten	(Mo,Bi,Pt)
Chionella	(Mo,Bi,Ve)	Chomatoseris	(Cn,An,Sc)	Christinella	(Bz,Gy,Ch)
Chioneryx	(Mo,Bi,Ve)	Chonaxis	(Cn,An,Ru)	Chrostoceras	(Mo,Ce,Go)
Chionista	(Mo,Bi,Ve)	Chondagraulus	(Ar,Tr,Co)	Christitys	(Mo,Ga,Ne)
Chionopsis	(Mo,Bi,Ve)	Chondranomocare	(Ar,Tr,As)	Christophoceras	(Mo,Ce,Am)
Chiotites	(Mo,Ce,Ce)	Chondraustaulina	(Ar,Tr,Pt)	Chromis	(Cd,Os,Pf)
Chiozoon	(Ar,Tr,Ph)	Chondraulius	(Bz,St,Tr)	Chrotichthys	(Cd,Os,Pe)
Chippewaella	(Mo,Ga,Be)	Chondrenchelys	(Cd,Ch,Ch)	Chrustenopora	(Br,Ar,Or)
Chiralithes	(Mo,Ga,Ne)	Chondrinouvina	(Ar,Tr,Co)	Chrysalidina	(Fo,Fo,Fo)
Chiraluta	(Mo,Ga,Ne)	Chondroceras	(Mo,Ce,Am)	Chrysalidinaella	(Fo,Fo,Fo)
Chirocentrites	(Cd,Os,Pe)	Chondrocerithium	(Mo,Ga,Nt)	Chrysalidina	(Mo,Ga,He)
Chirocentrus	(Cd,Os,Ci)	Chondrocidaris	(Ec,Ec,Ci)	Chrysalogonium	(Fo,Fo,Fo)
Chirocrinus	(Ec,Cr,Ds)	Chondrocladia	(Po,De,Po)	Chrysame	(Mo,Ga,Ne)
Chirodella	(Cd,Co,Co)	Chondrocoenia	(Cn,An,Sc)	Chrysceras	(Mo,Ce,Di)
Chirodipterus	(Cd,Os,Di)	Chondrodonta	(Mo,Bi,Pt)	Chrysocythere	(Ar,Os,Po)
Chirognathus	(Cd,Co,Co)	Chondronia	(Br,Ar,Te)	Chrysodimus	(Mo,Ga,Ne)
Chirona	(Ar,Ci)	Chondroparia	(Ar,Tr,Un)	Chrysolepis	(Cd,Os,Co)
Chironiptum	(Ar,Os,Pa)	Chondroplon	(Cn,In,In)	Chrysostoma	(Mo,Ga,Ar)
Chiropinna	(Ec,Cr,Ds)	Chondrosteus	(Cd,Os,Pa)	Chrysothorammina	(Fo,Fo,Fo)
Chirospongia	(Po,He,Un)	Chondroteuthis	(Mo,Ce,Be)	Chthamalus	(Ar,Ci)
Chirostoma	(Cd,Os,At)	Chonecetus	(Cd,Ma,Ce)	Chuanbeiphyllum	(Cn,An,Ru)
Chirothrix	(Cd,Os,My)	Chonelasma	(Po,He,He)	Chuandaniella	(Ar,Un,Un)
Chisiloceras	(Mo,Ce,En)	Chonellopsis	(Po,De,Le)	Chuangia	(Ar,Tr,Co)
Chisma	(Bz,St,Ce)	Chonespondylus	(Cd,Re,Le)	Chuangiella	(Ar,Tr,Co)
Chitinodeudron	(Fo,Fo,Fo)	Chonetella	(Br,Ar,St)	Chuangiformis	(Ar,Tr,Pt)
Chitinoideella	(Ci,In,Ca)	Chonetes	(Br,Ar,St)	Chuangiopsis	(Ar,Tr,Co)
Chitinolagena	(Fo,Fo,Fo)	Chonetina	(Br,Ar,St)	Chuanqianoproetus	(Ar,Tr,Pr)
Chitinotheuthis	(Mo,Ce,Au)	Chonetinella	(Br,Ar,St)	Chubbina	(Fo,Fo,Fo)
Chiton	(Mo,Po,Ne)	Chonetinetes	(Br,Ar,St)	Chuchiaopsis	(Ar,Tr,Co)
Chitonastrum	(Ac,Ra,Sp)	Chonetipustula	(Br,Ar,St)	Chulanolenus	(Ar,Tr,Pt)
Chitonotus	(Cd,Os,Sc)	Chonetoidea	(Br,Ar,St)	Chumazites	(Mo,Ce,Go)
Chitralina	(Fo,Fo,Fo)	Choneziphus	(Cd,Ma,Ce)	Chungkingichthyes	(Cd,Os,Pr)
Chittidilla	(Ar,Tr,Un)	Chongichthys	(Cd,Os,El)	Chuniola	(Ec,Ec,Sp)
Chivatschella	(Br,Ar,Rh)	Choniocardia	(Mo,Bi,Ve)	Churanocyathus	(Po,Re,Aj)
Chladorcinus	(Ec,Cr,Is)	Chonopectella	(Br,Ar,St)	Chusenella	(Fo,Fo,Fo)
Chlamydoephyllum	(Cn,An,Ru)	Chonopectoides	(Br,Ar,St)	Chusenophyllum	(Cn,An,Ru)
Chlamydoselachus	(Cd,Ch,Hx)	Chonopectus	(Br,Ar,St)	Chuticeras	(Mo,Ce,Di)
Chlamys	(Mo,Bi,Pt)	Chonophyllum	(Cn,An,Ru)	Chynistrophia	(Br,Ar,St)
Chlathrus	(Mo,Ga,Nt)	Chonosteges	(Br,Ar,St)	Cianotremella	(Bz,Gy,Ch)

Cibaster	(Ec.Ec.Hs)	Cipliacella	(Mo.Bi.Ve)	Cladoselache	(Cd.Ch.Cl)
Cibecua	(Mo.Ga.Ar)	Ciplyella	(Mo.Bi.Ve)	Cladospira	(Ac.Ra.Na)
Cibicides	(Fo.Fo.Fo)	Circe	(Mo.Bi.Ve)	Claibornia	(Mo.Ga.Ar)
Cibicidina	(Fo.Fo.Fo)	Circeis	(An.Po.Se)	Claibornicardia	(Mo.Bi.Ve)
Cibicidoides	(Fo.Fo.Fo)	Circibiopora	(Bz.St.Cc)	Claibornites	(Mo.Bi.Ve)
Cibicorbis	(Fo.Fo.Fo)	Circinatiella	(Fo.Fo.Fo)	Clambites	(Mo.Ce.Am)
Cibolaites	(Mo.Ce.Am)	Circomphalus	(Mo.Bi.Ve)	Clanculopsis	(Mo.Ga.Ar)
Cibolites	(Mo.Ce.Ce)	Circonularia	(Cn.Sc.Cn)	Clanculus	(Mo.Ga.Ar)
Cibolocrinus	(Ec.Cr.Sa)	Circopeltis	(Ec.Ec.Ph)	Clappaspis	(Ar.Tr.Pt)
Cicatella	(Mo.Bi.Ve)	Circophyllia	(Cn.An.Sc)	Claraia	(Mo.Bi.Pt)
Cicatrea	(Mo.Bi.Ve)	Circophyllum	(Cn.An.Ru)	Claraioides	(Mo.Bi.Pt)
Cicatrites	(Mo.Ce.Am)	Circopora	(Po.De.Ax)	Claratrypa	(Br.Ar.At)
Ciceragnostus	(Ar.Tr.Ag)	Circotheca	(Hy.Or.Ci)	Clarazia	(Cd.Re.Th)
Cicerocrinus	(Ec.Cr.Ds)	Circulaforma	(Ac.Ra.Sp)	Clarella	(Ar.Tr.Re)
Ciclopecten	(Mo.Bi.Pt)	Circulina	(Ar.Os.Pa)	Clariiondia	(Ar.Tr.Re)
Cidarina	(Mo.Ga.Ar)	Circulocrania	(Ar.Tr.Pt)	Clarkeaster	(Ec.As.Pu)
Cidaris	(Ec.Ec.Ci)	Circulopsis	(Mo.Ga.Ar)	Clarkeia	(Br.Ar.At)
Cidaropsis	(Ec.Ec.Hm)	Circuloscala	(Mo.Ga.Nt)	Clarkeipterus	(Ar.Me.Eu)
Cigara	(Ec.Eo.Un)	Circulus	(Mo.Ga.Ar)	Clarkella	(Br.Ar.Pe)
Cigarella	(Mo.Bi.Pt)	Circumtextiphyllum	(Cn.An.Ru)	Clarkeocrinus	(Ec.Cr.Mo)
Cigelirina	(Mo.Ga.Ne)	Cirillia	(Mo.Ga.Ne)	Clarkeolepis	(Pr.Ma.Le)
Cilara	(Mo.Ga.Ne)	Cirolana	(Ar.Ml.Is)	Clarkesvillia	(Mo.Ce.Di)
Ciliatocardium	(Mo.Bi.Ve)	Cirpa	(Br.Ar.Rh)	Clarkoeras	(Mo.Ce.El)
Ciliocephalus	(Ar.Tr.Pt)	Cirquella	(Ar.Tr.Ol)	Claruscoscinus	(Po.Ir.Ar)
Ciliscutellum	(Ar.Tr.Pt)	Cirroceras	(Mo.Ce.Am)	Clathricoscinus	(Po.Re.Ca)
Cillia	(Bz.Gy.Ch)	Cirrodiscus	(Ac.Ra.Sp)	Clathricyathus	(Po.Re.Aj)
Cillinella	(Br.Ar.Or)	Cirrus	(Mo.Ga.Ar)	Clathrispongia	(Po.Un.Un)
Cimicinella	(Br.Ar.Te)	Cirsoeerithium	(Mo.Ga.Nt)	Clathrithalamus	(Po.Re.Aj)
Cimicinoides	(Br.Ar.Te)	Cirsochilus	(Mo.Ga.Ar)	Clathrithyrus	(Br.Ar.Te)
Cimitaria	(Mo.Bi.Ph)	Cirsonphalus	(Mo.Ga.Nt)	Clathrobaculus	(Mo.Ga.Nt)
Cimoliasaurus	(Cd.Re.Ps)	Cirsonella	(Mo.Ga.Ar)	Clathroceras	(Mo.Ce.On)
Cimolichthys	(Cd.Os.Al)	Cirsope	(Mo.Ga.Nt)	Clathrochitina	(Fo.Fo.Ch)
Cimolioecentrum	(Mo.Ga.Nt)	Cirsostylus	(Mo.Ga.Ar)	Clathrocoilona	(Po.De.St)
Cimolithium	(Mo.Ga.Nt)	Cirsotrema	(Mo.Ga.Nt)	Clathrocorys	(Ac.Ra.Na)
Cinomia	(Mo.Ce.Na)	Cisalveolina	(Fo.Fo.Fo)	Clathrocyrinus	(Ec.Cr.Cl)
Cincinnaticoncha	(Ar.Os.Pa)	Cistacythereis	(Ar.Os.Po)	Clathrocyclas	(Ac.Ra.Na)
Cincinnatiocrinus	(Ec.Cr.Ds)	Cistellarcula	(Br.Ar.Te)	Clathrodictyella	(Po.De.St)
Cincinnatiidiscus	(Ec.Ed.Is)	Cisternifera	(Bz.St.Cc)	Clathrodictyon	(Po.De.St)
Cinclidella	(Po.He.Ly)	Citharichthys	(Cd.Os.Pn)	Clathrodriella	(Mo.Ga.Ne)
Cincliderma	(Po.He.He)	Citharina	(Fo.Fo.Fo)	Clathromangalia	(Mo.Ga.Ne)
Cinclidonema	(Mo.Ga.Ar)	Citharinella	(Fo.Fo.Fo)	Clathronema	(Mo.Ga.Nt)
Cinclopyramis	(Ac.Ra.Na)	Citharus	(Cd.Os.Pn)	Clathropora	(Bz.St.Cr)
Cincoriola	(Fo.Fo.Fo)	Citrella	(Ar.Os.Po)	Clathroscala	(Mo.Ga.Nt)
Cincta	(Br.Ar.Te)	Cittarium	(Mo.Ga.Ar)	Clathrospra	(Mo.Ga.Ar)
Cinctifera	(Br.Ar.St)	Civrieuxia	(Fo.Fo.Fo)	Clathrospungia	(Po.He.Re)
Cinctipora	(Bz.St.Cc)	Cladangia	(Cn.An.Sc)	Clathrospyrus	(Ac.Ra.Na)
Cinctiscala	(Mo.Ga.Nt)	Cladaroocythere	(Ar.Os.Po)	Clathrostroma	(Po.De.St)
Cinctoceras	(Mo.Ce.Di)	Cladionophyllum	(Cn.An.Ru)	Clathrus	(Mo.Ga.Nt)
Cinctopsis	(Br.Ar.Te)	Cladiscities	(Mo.Ce.Ce)	Clathurella	(Mo.Ga.Ne)
Cinerorthis	(Br.Ar.Or)	Cladoceramus	(Mo.Bi.Pt)	Claudioncha	(Mo.Bi.Ve)
Cingentolium	(Mo.Bi.Pt)	Cladochitina	(Fo.Fo.Ch)	Claudostriatella	(Fo.Fo.Fo)
Cinglospiriferina	(Br.Ar.Sp)	Cladochonus	(Cn.An.Ta)	Clausia	(Bz.St.Cc)
Cingula	(Mo.Ga.Nt)	Cladocora	(Cn.An.Sc)	Clausastraea	(Cn.An.Sc)
Cingulella	(Br.Un.Ob)	Cladoceroopsis	(Po.De.Ax)	Clausastraeopsis	(Cn.An.Sc)
Cingulina	(Mo.Ga.He)	Cladocycclus	(Cd.Os.Pe)	Clausia	(Ar.Th.Co)
Cinguliturris	(Mo.Ga.Ne)	Cladodermia	(Po.De.Li)	Clausinella	(Mo.Bi.Ve)
Cingulochitina	(Fo.Fo.Ch)	Cladodia	(Po.De.Li)	Clausocaris	(Ar.Th.Co)
Cingulodermis	(Br.Ar.Sp)	Cladodictya	(Bz.St.Cr)	Clausotrypa	(Bz.St.Cr)
Cinguloturris	(Ac.Ra.Na)	Cladodus	(Cd.Ch.Cl)	Clava	(Mo.Ga.Nt)
Cinnabaria	(Po.De.Pe)	Cladolithosia	(Po.De.Li)	Clavachitina	(Fo.Fo.Ch)
Cinulia	(Mo.Ga.Ce)	Cladophyllia	(Cn.An.Sc)	Clavagella	(Mo.Bi.Ph)
Cionobrissus	(Ec.Ec.Sp)	Cladophylloopsis	(Cn.An.Sc)	Clavagnostus	(Ar.Tr.Ag)
Cionodendron	(Cn.An.Ru)	Cladopora	(Cn.An.Ta)	Clavallus	(Ec.Ho.De)
Ciperozea	(Fo.Fo.Fo)	Cladorhiza	(Po.De.Po)	Clavaspidella	(Ar.Tr.Co)

Clavatellus	(Ar,Tr,As)	Clidoderma	(Cd,Os,Pn)	Closia	(Mo,Ga,Ne)
Clavatorella	(Fo,Fo,Fo)	Clifdenella	(Po,De,Pe)	Closteriscus	(Mo,Ga,Ne)
Clavatulata	(Mo,Ga,Ne)	Clifdenia	(Mo,Ga,Ne)	Closterocrinus	(Ec,Cr,Mo)
Clavellofusus	(Mo,Ga,Ne)	Cliffia	(Ar,Tr,Pt)	Closteroides	(Mo,Ga,Ne)
Clavelloides	(Fo,Fo,Fo)	Cliftonia	(Br,Ar,Or)	Cloudella	(Br,Ar,Te)
Claviaster	(Ec,Ec,Ca)	Cliftonoceras	(Mo,Ce,Ba)	Cloudina	(Pr,Cr,Cr)
Clavibole	(Ar,Tr,Pr)	Climacamma	(Fo,Fo,Fo)	Cloudothyris	(Br,Ar,Te)
Clavicava	(Bz,St,Cc)	Climacina	(Mo,Ga,Nt)	Cloughtonia	(Mo,Ga,Nt)
Clavicosta	(Mo,Bi,Pt)	Climacoconus	(Cn,Sc,Cn)	Clniaster	(Ec,Ec,Ho)
Clavicularinus	(Ec,Cr,Ds)	Climacograptus	(He,Gr,Gr)	Clupavus	(Cd,Os,Pe)
Clavidietyon	(Po,De,St)	Climacoidea	(Ar,Os,Po)	Clupea	(Cd,Os,Cl)
Clavidiscus	(Ec,Ed,Is)	Climacopoma	(Mo,Ga,He)	Clustinia	(Ar,Tr,Od)
Clavidrupa	(Mo,Ga,Ne)	Climacoraphistoma	(Mo,Ga,Et)	Cluthia	(Ar,Os,Po)
Clavigellus	(Ar,Tr,Co)	Climacospongia	(Po,De,Ha)	Cluthoceras	(Mo,Ce,Go)
Clavigera	(Br,Ar,Sp)	Climacotrigonia	(Mo,Bi,Tr)	Clydagnathus	(Cd,Co,Co)
Clavigerinella	(Fo,Fo,Fo)	Clinambon	(Br,Ar,Or)	Clydomphalites	(Mo,Ce,Am)
Claviedbergella	(Fo,Fo,Fo)	Clinapertina	(Fo,Fo,Fo)	Clydonaspis	(Cd,Pt,Pt)
Clavilasma	(Cn,An,Ru)	Clinocardium	(Mo,Bi,Ve)	Clydonautilus	(Mo,Ce,Na)
Clavilithes	(Mo,Ga,Ne)	Clinoceras	(Mo,Ce,Or)	Clydoniceras	(Mo,Ce,Am)
Clavipholas	(Mo,Bi,My)	Clinoclimacograptus	(He,Gr,Gr)	Clydonites	(Mo,Ce,Ce)
Claviphylum	(Cn,An,Ru)	Clinocythere	(Ar,Os,Po)	Clymenia	(Mo,Ce,Cl)
Claviporella	(Bz,Gy,Ch)	Clinocythereis	(Ar,Os,Po)	Clymenoceras	(Mo,Ce,An)
Claviscala	(Mo,Ga,Nt)	Clinolobus	(Mo,Ce,Go)	Clymenonautilus	(Mo,Ce,Na)
Clavisparsa	(Bz,St,Cc)	Clinopagma	(Mo,Ga,Ne)	Clypeanthus	(Ec,Ec,Ca)
Claviticinella	(Fo,Fo,Fo)	Clinophyllum	(Cn,An,Ru)	Clypeaster	(Ec,Ec,Cl)
Clavitubigera	(Bz,St,Cc)	Clinopista	(Mo,Bi,Nu)	Clypeina	(Bz,St,Cc)
Clavocerithium	(Mo,Ga,Nt)	Clinopora	(Bz,St,Cc)	Clypeoceras	(Mo,Ce,Ce)
Clavodalejina	(Br,Ar,Or)	Clintiella	(Ar,Os,Pa)	Clypeola	(Mo,Ga,Nt)
Clavofabella	(Ar,Os,Pa)	Clintonella	(Br,Ar,At)	Clypeolampas	(Ec,Ec,Ca)
Clavofabellina	(Ar,Os,Pa)	Clinura	(Mo,Ga,Ne)	Clypeolum	(Mo,Ga,Ar)
Clavohamulus	(Cd,Co,Co)	Clinurella	(Mo,Ga,Ne)	Clypeomorus	(Mo,Ga,Nt)
Clavostoma	(Mo,Ga,Ne)	Clinurospis	(Mo,Ga,Ne)	Clypeopybus	(Ec,Ec,Ca)
Clavulina	(Fo,Fo,Fo)	Clinus	(Cd,Os,Pf)	Clypeorbis	(Fo,Fo,Fo)
Clavulinoides	(Fo,Fo,Fo)	Clio	(Mo,Ga,Th)	Clypeus	(Ec,Ec,Ca)
Clavulinopsis	(Fo,Fo,Fo)	Cliocystiramus	(Bz,St,Cy)	Clypidina	(Mo,Ga,Ar)
Clavulites	(An,Po,Se)	Cliona	(Po,De,Hd)	Clypoproetus	(Ar,Tr,Pr)
Clavus	(Mo,Ga,Ne)	Clionites	(Mo,Ce,Ce)	Clytiella	(Ar,ML,De)
Cleidochondrella	(Mo,Bi,Pt)	Clionyssiceras	(Mo,Ce,On)	Clytiopsis	(Ar,ML,De)
Cleidothaerus	(Mo,Bi,Ph)	Cliopectera	(Mo,Bi,Pt)	Clytoceras	(Mo,Ce,Ta)
Cleiocrinus	(Ec,Cr,Di)	Clioscapites	(Mo,Ce,Am)	Cnemaulax	(Po,De,Li)
Cleionychia	(Mo,Bi,Pt)	Cliotrypa	(Bz,St,Cy)	Cnemicopanion	(Po,Ca,Ph)
Cleiothyridellina	(Br,Ar,Sp)	Clisiophyllum	(Cn,An,Ru)	Cnemidactis	(Ec,As,Ur)
Cleiothyridina	(Br,Ar,Sp)	Clisocolus	(Mo,Bi,Ve)	Cnemidiastrum	(Po,De,Li)
Cleistechinus	(Ec,Ec,Sp)	Clisospira	(Mo,Pa,Hy)	Cnemidopyge	(Ar,Tr,As)
Cleistocrinus	(Ec,Cr,St)	Clistoceras	(Mo,Ce,Go)	Cnesterium	(Mo,Bi,Nu)
Cleistopora	(Cn,An,Ta)	Clistocrinus	(Ec,Cr,Cl)	Cnestocythere	(Ar,Os,Po)
Cleistosphinctes	(Mo,Ce,Am)	Clitotrema	(Br,Li,Ac)	Cnestriella	(Mo,Bi,Nu)
Cleithranchiste	(Ar,Os,Po)	Clitambonites	(Br,Ar,Or)	Coahuilites	(Mo,Ce,Am)
Cleithrolepis	(Cd,Os,Pe)	Clitendoceras	(Mo,Ce,En)	Coalcomana	(Mo,Bi,Hi)
Clelandia	(Ar,Tr,Pt)	Clithriellum	(Bz,Gy,Ch)	Coalingodea	(Mo,Ga,Nt)
Clelandoceras	(Mo,Ce,El)	Clithrocytheridea	(Ar,Os,Po)	Coanollonia	(Mo,Ga,Ar)
Clematocrinus	(Ec,Cr,Mo)	Clivospirifer	(Br,Ar,Sp)	Cobbanites	(Mo,Ce,Am)
Clementia	(Mo,Bi,Ve)	Clivoluturris	(Mo,Ga,Ne)	Cobbanoscapites	(Mo,Ce,Am)
Cleobula	(Mo,Ga,Ne)	Cloacaspis	(Ar,Tr,As)	Cobboldiella	(Hy,Or,Gl)
Cleodictya	(Po,He,Re)	Cloghnergathus	(Cd,Co,Co)	Cobrepophora	(Mo,Po,Pa)
Cleoniceras	(Mo,Ce,Am)	Cloioceras	(Mo,Ce,Am)	Cobelodus	(Cd,Ch,Sy)
Cleopion	(Pr,Un,Co)	Clonocrinus	(Ec,Cr,Mo)	Cobitopsis	(Cd,Os,Be)
Cleotriuvia	(Mo,Ga,Nt)	Clonograptus	(He,Gr,De)	Cocceaster	(Ec,As,Pu)
Clepsydrosporgia	(Po,He,Re)	Clonopora	(Bz,St,Cc)	Coccocephalichthys	(Cd,Os,Pa)
Cletoocythereis	(Ar,Os,Po)	Clonosmia	(Cn,An,Sc)	Coccoeyelia	(Ac,Ra,Sp)
Clibanarius	(Ar,ML,De)	Clorinda	(Br,Ar,Pe)	Coccodentalium	(Mo,Sc,Sc)
Clidastes	(Cd,Re,Sq)	Clorindella	(Br,Ar,Pe)	Coccoderma	(Cd,Os,Co)
Clidiophora	(Mo,Bi,Ph)	Clorindina	(Br,Ar,Pe)	Coccodiscus	(Ac,Ra,Sp)
Clidochirus	(Ec,Cr,St)	Clorindinella	(Br,Ar,Pe)	Coccodus	(Cd,Os,Py)

Coccolaricus	(Ac,Ra,Sp)	Coelocyclus	(Mo,Ga,Be)	Coleodus	(Cd,Co,Co)
Coccolarnacium	(Ac,Ra,Sp)	Coelocyprina	(Mo,Bi,Ve)	Coleolella	(Pr,Un,Co)
Coccolepis	(Cd,Os,Pa)	Coelocyrtoceras	(Mo,Ce,On)	Coleooides	(Pr,Un,Co)
Coccopyllum	(Cn,An,Sc)	Coelocystis	(Ec,Rh,Rh)	Coleolus	(Pr,Un,Co)
Coccopygia	(Mo,Ga,Ar)	Coeloderoceras	(Mo,Ce,Am)	Coleophyllum	(Cn,An,Ru)
Coccoseris	(Cn,An,Ta)	Coelodiscus	(Mo,Ga,Nt)	Coleopora	(Bz,Gy,Ch)
Cocculina	(Mo,Ga,Ar)	Coelodus	(Cd,Os,Py)	Colina	(Mo,Ga,Nt)
Cocculinella	(Mo,Ga,Ar)	Coeloenellina	(Ar,Os,Pa)	Colinella	(Br,Ar,Te)
Cochiolepis	(Mo,Ga,Nt)	Coelogaster	(Cd,Os,Go)	Collabrina	(Mo,Ga,Ar)
Cochlearites	(Mo,Bi,Pt)	Coelogasteroceras	(Mo,Ce,Na)	Collapora	(Bz,St,Ce)
Cochleiferoceras	(Mo,Ce,An)	Coelograptus	(He,Gr,Un)	Collarina	(Bz,Gy,Ch)
Cochleochilus	(Mo,Ga,Ar)	Coelofasma	(Cn,An,Ru)	Collarothyris	(Br,Ar,Sp)
Cochlespira	(Mo,Ga,Ne)	Coelolepis	(Cd,Pl,Th)	Collatipora	(Po,De,Li)
Cochlespirella	(Mo,Ga,Ne)	Coeloma	(Ar,Ml,De)	Collatipora	(Pr,Un,Co)
Cochlespiropsis	(Mo,Ga,Ne)	Coelomeandra	(Cn,An,Sc)	Collbatothuria	(Ec,Ho,As)
Cochliconus	(Mo,Ga,Ne)	Coelometra	(Ec,Cr,Cm)	Collectoceras	(Mo,Ce,Go)
Cochlioceras	(Mo,Ce,El)	Coelonella	(Ar,Os,Pa)	Collemataria	(Br,Ar,St)
Cochliodus	(Cd,Ch,In)	Coelopsis	(Mo,Bi,Ve)	Colletosia	(Bz,Gy,Ch)
Cochloceras	(Mo,Ce,Ce)	Coelopleurus	(Ec,Ec,Ph)	Collostroacia	(Br,Ar,St)
Cochlocrioceras	(Mo,Ce,Am)	Coelopora	(Bz,Gy,Ch)	Collibolbina	(Ar,Os,Pa)
Cochlodesma	(Mo,Bi,Ph)	Coeloptychium	(Po,He,Ly)	Collicypeus	(Ec,Ec,Ca)
Cochlograptus	(He,Gr,Ar)	Coelopus	(Ar,Ml,De)	Colliculus	(Mo,Ga,Ar)
Cockburnia	(Mo,Bi,Ve)	Coelorhynchus	(Cd,Os,Go)	Collicyrtidium	(Ac,Ra,Na)
Cockerellites	(Cd,Os,Pf)	Coeloscapha	(Mo,Ga,Ce)	Collignonastrea	(Cn,An,Sc)
Coccorota	(Fo,Fo,Fo)	Coeloscaphia	(Po,He,Ly)	Collignonicardia	(Mo,Bi,Ve)
Codakia	(Mo,Bi,Ve)	Coeloseris	(Cn,An,Sc)	Collignoniceras	(Mo,Ce,Am)
Codalucina	(Mo,Bi,Ve)	Coelosmia	(Cn,An,Sc)	Collignonites	(Mo,Ce,Ce)
Codaster	(Ec,BI,Fi)	Coelosphaeroma	(Po,De,Li)	Collina	(Mo,Ce,Am)
Codachinus	(Ec,Ec,Ph)	Coelospira	(Br,Ar,At)	Collimithyris	(Br,Ar,Te)
Codiarcinus	(Ec,Cr,Cl)	Coelospirella	(Br,Ar,At)	Collisboris	(Ar,Os,Po)
Codiacystis	(Ec,Di,Di)	Coelospirina	(Br,Ar,At)	Collisella	(Mo,Ga,Pa)
Codinella	(Mo,Ga,Ar)	Coelospiripora	(Bz,St,Cc)	Collonia	(Mo,Ga,Ar)
Codiopsis	(Ec,Ec,Ph)	Coelosteus	(Cd,Ch,Ct)	Collonista	(Mo,Ga,Ar)
Codoceras	(Mo,Ce,Di)	Coelostylina	(Mo,Ga,Nt)	Collosphaera	(Ac,Ra,Na)
Codoceras	(Mo,Ce,On)	Coelostylis	(Cn,An,Ru)	Collotia	(Mo,Ce,Am)
Codonella	(Ci,Po,Sp)	Coeloterorhynchus	(Br,Ar,Rh)	Collumatus	(Br,Ar,St)
Codonocheilus	(Mo,Ga,At)	Coeloteuthis	(Mo,Ce,Be)	Collura	(Bz,Gy,Ch)
Codonoconus	(Mo,In,In)	Coelotrochus	(Mo,Ga,Ar)	Collyrites	(Ec,Ec,Ds)
Codonofusiella	(Fo,Fo,Fo)	Coelozone	(Mo,Ga,Ar)	Collyrolenus	(Ar,Tr,Pt)
Codonophyllum	(Cn,An,Ru)	Coemansia	(Mo,Ga,He)	Collyropsis	(Ec,Ec,Ds)
Codonosmia	(Cn,An,Sc)	Coenangia	(Cn,An,Sc)	Colneptunus	(Ar,Ml,De)
Coelacanthopsis	(Cd,Os,Co)	Coenaphrodia	(Cn,An,Ru)	Colobinon	(Ar,Tr,Ph)
Coelastarte	(Mo,Bi,Ve)	Coenaspis	(Ar,Tr,Pt)	Colobodus	(Cd,Os,Pe)
Coelenteratella	(Cn,An,Un)	Coenastrea	(Cn,An,Sc)	Coloceras	(Mo,Ce,Na)
Coeliocrinus	(Ec,Cr,Cl)	Coenites	(Cn,An,Ta)	Colombiceras	(Mo,Ce,Am)
Coelobolma	(Mo,Ga,Ar)	Coenobia	(Ar,Ml,De)	Colomia	(Fo,Fo,Fo)
Coelocanthus	(Cd,Os,Co)	Coenocyathus	(Cn,An,Sc)	Colomiellia	(Ci,In,Ca)
Coelocaulis	(Bz,St,Cy)	Coenocystis	(Ec,Cr,Cl)	Colomita	(Fo,Fo,Fo)
Coelocaulus	(Mo,Ga,Ar)	Coenostella	(Po,De,Ax)	Colonommina	(Fo,Fo,Fo)
Coelocelites	(Mo,Ce,Ce)	Coenostroma	(Po,De,St)	Colongina	(Br,Ar,Sp)
Coelocentrus	(Mo,Ga,Ar)	Coenothyris	(Br,Ar,Te)	Colonograptus	(He,Gr,Gr)
Coeloceras	(Mo,Ce,Am)	Coignops	(Ar,Tr,Pr)	Colophonodon	(Cd,Ma,Ce)
Coelocerodontus	(Cd,Co,Co)	Coilopoceras	(Mo,Ce,Am)	Colophragma	(Br,Ar,Rh)
Coelochilina	(Ar,Os,Pa)	Colacchilina	(Ar,Os,Pa)	Coloradoscaphtes	(Mo,Ce,Am)
Coelochrysalis	(Mo,Ga,Nt)	Colania	(Fo,Fo,Fo)	Colosia	(Br,Ar,Te)
Coelocladia	(Po,De,Ha)	Colaniella	(Fo,Fo,Fo)	Colospongia	(Po,De,Pe)
Coelocladia	(Po,De,Pe)	Colapterochiton	(Mo,Po,Ne)	Colossaspis	(Ar,Tr,Od)
Coelocladella	(Po,De,Ha)	Colaptoconus	(Cd,Co,Co)	Colossolacis	(Po,De,Li)
Coeloclemis	(Bz,St,Tr)	Colaptomena	(Br,Ar,St)	Colostraccon	(Mo,Ga,Ce)
Coelocochlea	(Bz,St,Cc)	Colchidites	(Mo,Ce,Am)	Colpantyx	(Mo,Bi,Mo)
Coelocoenia	(Cn,An,Sc)	Coleidium	(Br,Ar,Rh)	Colpentalium	(Mo,Bi,Pt)
Coeloconia	(Po,Ca,Ph)	Coleia	(Ar,Ml,De)	Colpichthyes	(Cd,Os,At)
Coelocorypha	(Po,De,Li)	Coleiconus	(Fo,Fo,Fo)	Colpites	(Mo,Ga,Ar)
Coelocrinus	(Ec,Cr,Mo)	Coleites	(Fo,Fo,Fo)	Colpocoryphe	(Ar,Tr,Ph)

Colpodecrinus	(Ec,Cr,Di)	Comluella	(Ar,Tr,Re)	Concinnispirifer	(Br,Ar,Sp)
Colpomphalus	(Mo,Ga,Ar)	Commonozonispira	(Mo,Ga,Ar)	Concinnithyrus	(Br,Ar,Te)
Colpomya	(Mo,Bi,Mo)	Commutatophyllum	(Cn,An,Ru)	Condomyra	(Ar,Os,Po)
Colpophyllia	(Cn,An,Sc)	Communia	(Cn,An,Ru)	Condonella	(Mo,Ga,Ar)
Colposigma	(Mo,Ga,Nt)	Comophyllastraea	(Cn,An,Sc)	Condonofusella	(Fo,Fo,Fo)
Colpospira	(Mo,Ga,Nt)	Comophyllia	(Cn,An,Sc)	Condraeypis	(Ar,Os,Me)
Colpospongia	(Po,He,LS)	Comophyllospis	(Cn,An,Sc)	Condranema	(Br,Gy,Ct)
Colpostomia	(Mo,Ga,He)	Comoseris	(Cn,An,Sc)	Condraoceras	(Mo,Ce,Na)
Colpotiara	(Ec,Ec,Hm)	Compacoleus	(Pr,Ma,Le)	Condrostellata	(Fo,Fo,Fo)
Colpotoria	(Br,Ar,Rh)	Compagicrinus	(Ec,Cr,Ds)	Condylacanthus	(Po,De,As)
Colubraria	(Mo,Ga,Nt)	Companteris	(Br,Ar,St)	Condylocardia	(Mo,Bi,Ve)
Colubrella	(Mo,Ga,Ar)	Complanophyllum	(Cn,An,Ru)	Condylocrinus	(Ec,Cr,Di)
Colubrellina	(Mo,Ga,Nt)	Complexastraea	(Cn,An,Sc)	Condyllocuna	(Mo,Bi,Ve)
Columnactinastrea	(Cn,An,Sc)	Complexastraeopsis	(Cn,An,Sc)	Condylopyge	(Ar,Tr,Ag)
Columnastrea	(Cn,An,Sc)	Complexodus	(Cd,Co,Co)	Conescharellina	(Br,Gy,Ch)
Columnarium	(Mo,Ga,Ne)	Complexophyllum	(Cn,An,Ru)	Conifroma	(Ac,Ra,Na)
Columnella	(Mo,Ga,Ne)	Composita	(Br,Ar,Sp)	Confusastraea	(Cn,An,Sc)
Columnellaria	(Mo,Ga,Nt)	Compositella	(Br,Ar,Sp)	Confusastraraea	(Cn,An,Sc)
Columnellina	(Mo,Ga,Nt)	Compositocyathus	(Po,Re,Aj)	Confusiscala	(Mo,Ga,Nt)
Columnellispho	(Mo,Ga,Ne)	Compressidens	(Mo,Se,Sc)	Conger	(Cd,Os,An)
Columnellopsis	(Mo,Ga,Ne)	Compressidens	(Cd,Re,Sq)	Congeriomorpha	(Mo,Bi,Ve)
Columnicrinus	(Ec,Cr,Ds)	Compressigerina	(Fo,Fo,Fo)	Congorhynchus	(Cd,Os,In)
Columnites	(Mo,Ce,Ce)	Compressiphyllum	(Cn,An,Ru)	Congregopora	(Cn,Hy,St)
Columnitrigonia	(Mo,Bi,Tr)	Compressopoductus	(Br,Ar,St)	Coniasaurus	(Cd,Re,Sq)
Columnocystis	(Ec,Pe,Un)	Compsaspis	(Po,De,Li)	Coniatopenia	(Po,Ca,Ph)
Columnellaespongia	(Po,De,Li)	Compsaster	(Ec,As,Ur)	Conicarcella	(Ci,Po,Sp)
Columnellithyrus	(Br,Ar,Te)	Compsoccephalus	(Ar,Tr,Co)	Conicorbittolina	(Fo,Fo,Fo)
Columnellogyra	(Cn,An,Sc)	Compsocrinus	(Ec,Cr,Mo)	Conicosmiliotrochus	(Cn,An,Sc)
Columnoceras	(Mo,Ce,Or)	Compsodrillia	(Mo,Ga,Ne)	Conicospirillina	(Fo,Fo,Fo)
Columna	(Po,De,St)	Compsomyax	(Mo,Bi,Ve)	Coniculuspongia	(Po,De,Un)
Columnaphyllia	(Cn,An,Sc)	Componema	(Mo,Ga,Ar)	Coniferina	(Ar,Os,Po)
Columnaria	(Cn,An,Ru)	Comptaluta	(Ar,Os,Ar)	Conilites	(Fo,Fo,Fo)
Columnaxon	(Cn,An,Ru)	Comptonaspis	(Ar,Tr,Pr)	Coninoda	(Mo,Ga,Nt)
Columnocoenia	(Cn,An,Sc)	Comptonia	(Ec,As,Va)	Coniproetus	(Ar,Tr,Pr)
Columnogyra	(Cn,An,Sc)	Comuquia	(Br,Ar,St)	Coniscala	(Mo,Ga,Nt)
Columnolasma	(Cn,An,Ru)	Comura	(Ar,Tr,Ph)	Conisia	(Ec,Ho,Un)
Columnoporella	(Cn,An,Ta)	Comus	(Mo,Bi,Ve)	Conispirifer	(Br,Ar,Un)
Columnostroma	(Po,De,St)	Conactaeon	(Mo,Ga,Ce)	Conispongia	(Po,Ca,Ph)
Columnotheca	(Bz,Gy,Ch)	Conannulofungia	(Po,Re,Aj)	Conitubus	(He,Gr,Tu)
Colus	(Mo,Ga,Ne)	Conarchnium	(Ac,Ra,Na)	Conjectura	(Mo,Ga,Ar)
Coluzea	(Mo,Ga,Ne)	Conarosia	(Br,Ar,Rh)	Conlinoceras	(Mo,Ce,Am)
Colveraia	(Mo,Bi,Hi)	Conarothyris	(Br,Ar,Te)	Connagnostus	(Ar,Tr,Ag)
Colwellia	(Mo,Ga,Ne)	Conaspis	(Ar,Tr,As)	Connectastrea	(Cn,An,Sc)
Colymbosaurus	(Cd,Re,Ps)	Conathella	(Ar,Os,Me)	Connectopoductus	(Br,Ar,St)
Comalianma	(Fo,Fo,Fo)	Concavatotruncana	(Fo,Fo,Fo)	Conobelus	(Mo,Ce,Be)
Comanaphyllum	(Cn,An,Ru)	Concavella	(Fo,Fo,Fo)	Conocardium	(Mo,Ro,Co)
Comanchia	(Ar,Tr,As)	Concavithis	(Ar,Os,Pa)	Conocaryomma	(Ac,Ra,Sp)
Comanthocrinus	(Ec,Cr,Mo)	Concavicularis	(Ar,Th,Cc)	Conocerina	(Mo,Ce,El)
Comarmondia	(Mo,Ga,Ne)	Concavites	(Mo,Ce,Am)	Conocerithium	(Mo,Ga,Nt)
Comaroceras	(Mo,Ce,Di)	Concavodontia	(Mo,Bi,Nu)	Conochitina	(Fo,Fo,Ch)
Comarocystites	(Ec,Pe,Co)	Concavus	(Ar,Ci)	Conoclisa	(Mo,Pa,Hy)
Comaster	(Ec,Cr,Cm)	Conchicolites	(Pr,Un,Cn)	Conoclypus	(Ec,Ec,Ca)
Coniatopoma	(Br,Ar,Or)	Conchidium	(Br,Ar,Pe)	Conococheaquea	(Ar,Tr,Pt)
Comatulina	(Ec,Cr,Cm)	Conchocele	(Mo,Bi,Ve)	Conocoelia	(Po,Ca,Ph)
Combinivalvula	(Ar,Os,Ar)	Conchodon	(Mo,Bi,Hi)	Conocoryphe	(Ar,Tr,Pt)
Combophyllum	(Cn,An,Ru)	Conchodus	(Cd,Os,Di)	Conocrinus	(Ec,Cr,Bo)
Combusta	(Ac,Ra,Na)	Conchoecia	(Ar,Os,My)	Conocyathus	(Cn,An,Sc)
Comelicania	(Br,Ar,Sp)	Concholepas	(Mo,Ga,Ne)	Conodia	(Mo,In,He)
Cominella	(Mo,Ga,Ne)	Conchopeltis	(Cn,Sc,Cn)	Conodicoelites	(Mo,Ce,Be)
Cominicula	(Mo,Bi,Pr)	Conchoprimittella	(Ar,Os,Pa)	Conodiscus	(Br,Li,Ac)
Cominista	(Mo,Ga,Ne)	Conchoprimites	(Ar,Os,Pa)	Conoglobigerina	(Fo,Fo,Fo)
Cominula	(Mo,Ga,Ne)	Conchoprimitia	(Ar,Os,Pa)	Conoidacmaea	(Mo,Ga,Pa)
Comiotocchia	(Br,Ar,Rh)	Conchothyra	(Mo,Ga,Nt)	Conoidaecrinus	(Ec,Cr,Cm)
Comitas	(Mo,Ga,Ne)	Concinnispira	(Mo,Ga,Ar)	Conoidea	(Ar,Tr,Un)

Conoidocyathus	(Pr,Cr,Cr)	Conus	(Mo,Ga,Ne)	Corbariastraea	(Cn,An,Sc)
Conokephalina	(Ar,Tr,Pt)	Convexastraea	(Cn,An,Sc)	Corbicellopsis	(Mo,Bi,Ve)
Conolagena	(Fo,Fo,Fo)	Convexicaris	(Ar,Th,Co)	Corbicula	(Mo,Bi,Ve)
Conolichas	(Ar,Tr,Li)	Convexopecten	(Mo,Bi,Pt)	Corbicularia	(Br,Ar,St)
Conolithes	(Mo,Ga,Ne)	Convexothyrus	(Br,Ar,Te)	Corbiculella	(Mo,Bi,Ve)
Conomedusites	(Cn,Sc,Cn)	Convoluticeras	(Mo,Ce,An)	Corbiculopsis	(Mo,Bi,Ve)
Conometra	(Ec,Cr,Cm)	Cookia	(Mo,Ga,Ar)	Corbina	(Ar,Tr,Pt)
Conomimus	(Br,Ar,Te)	Cookobryozoon	(Bz,Gy,Ct)	Corbis	(Mo,Bi,Ve)
Conominolia	(Mo,Ga,Ar)	Coolinia	(Br,Ar,St)	Corbula	(Mo,Bi,My)
Conomitra	(Mo,Ga,Ne)	Coollarocerinus	(Ec,Cr,Cy)	Corbulamella	(Mo,Bi,My)
Conomurex	(Mo,Ga,Nt)	Cooperatia	(Ar,Os,Me)	Corbulipora	(Bz,Gy,Ch)
Conopeum	(Bz,Gy,Ch)	Cooperea	(Br,Ar,St)	Corbuloceras	(Mo,Ce,On)
Conophilipsia	(Ar,Tr,Pr)	Cooperella	(Mo,Bi,Ve)	Corbulomima	(Mo,Bi,My)
Conophyllia	(Cn,An,Sc)	Cooperellopsis	(Mo,Bi,Ve)	Corburella	(Mo,Bi,Ve)
Conopiscius	(Cd,Ce,An)	Coopericystis	(Ec,Rh,Rh)	Corcorania	(Ar,Un,Un)
Conopolus	(Ar,Tr,Un)	Cooperidiscus	(Ec,Ed,Is)	Cordania	(Ar,Tr,Pr)
Conopora	(Cn,Hy,St)	Cooperina	(Br,Ar,St)	Cordapeltis	(Ar,Tr,Ph)
Conopoterium	(Cn,An,Ta)	Cooperithyrus	(Br,Ar,Te)	Cordatella	(Fo,Fo,Fo)
Conora	(An,Po,Se)	Cooperoceras	(Mo,Ce,Na)	Cordatomyonia	(Br,Ar,Or)
Conorbina	(Fo,Fo,Fo)	Cooperrhynchia	(Br,Ar,Rh)	Cordiceramus	(Mo,Bi,Pt)
Conorbinella	(Fo,Fo,Fo)	Cooperuna	(Ar,Os,Po)	Cordiaera	(Mo,Ga,Ne)
Conorbis	(Mo,Ga,Ne)	Coosella	(Ar,Tr,Pt)	Cordiilleracyathus	(Po,Re,Aj)
Conorbitoides	(Fo,Fo,Fo)	Coosia	(Ar,Tr,Pt)	Cordiopsis	(Mo,Bi,Ve)
Conorboides	(Fo,Fo,Fo)	Coosina	(Ar,Tr,Pt)	Cordispira	(Mo,Ga,Ar)
Conoredlichia	(Ar,Tr,Re)	Coosinoides	(Ar,Tr,Pt)	Cordiula	(Mo,Bi,Ve)
Conorhytis	(Mo,Ga,Pa)	Copanognathus	(Cd,Pl,Ar)	Cordobicyathus	(Po,Re,Aj)
Conorotalites	(Fo,Fo,Fo)	Copelandella	(Ar,Os,Pa)	Cordubiceras	(Mo,Ce,Am)
Conosmia	(Cn,An,Sc)	Copelandia	(Ar,Os,Pa)	Cordyloblastus	(Ec,Bi,Sp)
Conosphaera	(Ac,Ra,Sp)	Cophocara	(Mo,Ga,Ne)	Cordylocrinus	(Ec,Cr,Mo)
Conospongocytis	(Ac,Ra,Na)	Cophocetus	(Cd,Ma,Ce)	Cordylodus	(Cd,Co,Co)
Conostichoceras	(Mo,Ce,On)	Copia	(Cn,An,Ru)	Coreanocephalus	(Ar,Tr,As)
Conoteuthis	(Mo,Ce,Be)	Copiceras	(Mo,Ce,El)	Coreanoceras	(Mo,Ce,En)
Conotheca	(Hy,Or,Ci)	Copicyntra	(Ac,Ra,Sp)	Corechinus	(Ec,Ec,Hs)
Conotoma	(Mo,Ga,Ar)	Copicyntroides	(Ac,Ra,Sp)	Corelliacarinus	(Ar,Mi,De)
Conotomaria	(Mo,Ga,Ar)	Copidens	(Mo,Bi,Mo)	Coremagraptus	(He,Gr,De)
Conotreta	(Br,Li,Ac)	Copidocatopus	(Mo,Ga,Ar)	Corematocrinus	(Ec,Cr,Cl)
Conotrochamma	(Fo,Fo,Fo)	Copidozoum	(Bz,Gy,Ch)	Coreocaris	(Ar,Th,In)
Conotrochus	(Cn,An,Sc)	Copieilinia	(Ac,Ra,Sp)	Coreospira	(Mo,He,He)
Conotubigera	(Bz,St,Ce)	Copleicyathus	(Po,Ir,Ar)	Coriandria	(Mo,Ga,Nt)
Conradoceras	(Mo,Ce,Di)	Copodus	(Cd,Ch,Cp)	Corineorthis	(Br,Ar,Or)
Conradostrea	(Mo,Bi,Pt)	Coprinosclex	(Er)	Coriops	(Cd,Os,An)
Consobrinella	(Mo,Ga,Ce)	Coprolithina	(Fo,Fo,Fo)	Coriothyris	(Br,Ar,Te)
Consonopsis	(Ar,Os,Pa)	Coptocampylodon	(Cn,An,Go)	Coripia	(Mo,Bi,Ve)
Conspicillum	(Ar,Os,Pa)	Coptochetus	(Mo,Ga,Ne)	Cornellites	(Mo,Bi,Pt)
Constantina	(Ar,Tr,Pr)	Coptodiscus	(Ec,Ec,Ne)	Corniculina	(Mo,Cr,Da)
Constellaria	(Bz,St,Cy)	Coptosipho	(Mo,Ga,He)	Corniculinooides	(Mo,Cr,Da)
Constellatospongia	(Po,Ca,He)	Coptostoma	(Mo,Ga,Ne)	Cornicythereis	(Ar,Os,Po)
Constileioceras	(Mo,Ce,Am)	Coptostomella	(Mo,Ga,Ne)	Cornigella	(Ar,Os,Pa)
Contemniscala	(Mo,Ga,Nt)	Coptothyris	(Br,Ar,Te)	Cornikloedenia	(Ar,Os,Pa)
Contignatindocrinus	(Ec,Cr,Cl)	Copytus	(Ar,Os,Po)	Cornovica	(Ar,Tr,Un)
Contitheca	(Hy,Or,Or)	Coquandia	(Mo,Bi,My)	Cornuaspongia	(Po,Ca,Ph)
Contocrinus	(Ec,Cr,Cl)	Coquimba	(Ar,Os,Po)	Cornuboniscus	(Cd,Os,Pa)
Contortella	(Mo,Ga,Nt)	Coraeophos	(Mo,Ga,Ne)	Cornucardia	(Mo,Bi,Ve)
Contortophyllum	(Cn,An,Ru)	Corallidium	(Po,De,Li)	Cornuecoquimba	(Ar,Os,Po)
Contractenus	(Mo,Cr,Te)	Corallidomus	(Mo,Bi,Mo)	Cornucrinus	(Ec,Cr,Hy)
Contradouvillinia	(Br,Ar,St)	Coralliochama	(Mo,Bi,Hi)	Cornuella	(Mo,Te,Cy)
Contusotruncana	(Fo,Fo,Fo)	Coralliochaga	(Mo,Bi,Ve)	Cornulina	(Mo,Ga,Ne)
Conuber	(Mo,Ga,Nt)	Coralliophila	(Mo,Ga,Ne)	Cornulitella	(Pr,Un,Cn)
Conularia	(Cn,Sc,Cn)	Corallites	(Po,De,Li)	Cornulites	(Pr,Un,Cn)
Conulariella	(Cn,Sc,Cn)	Corallium	(Cn,An,Go)	Cornuloculina	(Fo,Fo,Fo)
Conularina	(Cn,Sc,Cn)	Coralloceras	(Mo,Ce,Or)	Cornuodus	(Cd,Co,Co)
Conulariopsis	(Cn,Sc,Cn)	Corallopondylus	(Mo,Bi,Pt)	Cornupoetus	(Ar,Tr,Pr)
Conuloblastus	(Ec,Bi,Sp)	Coraster	(Ec,Ec,Sp)	Cornuscutellum	(Ar,Tr,Co)
Conulus	(Ec,Ec,Ho)	Corax	(Cd,Ch,La)	Cornuspira	(Fo,Fo,Fo)

Cornutella	(Ac,Ra,Na)	Coryellites	(Ar,Os,Me)	Cosmogoniophora	(Mo,Bi,Mo)
Cornutiella	(Bz,Gy,Ch)	Coryellites	(Ar,Os,Pa)	Cosmogoniophorina	(Mo,Bi,Mo)
Cornutobairdia	(Ar,Os,Pa)	Corylispirifer	(Br,Ar,Sp)	Cosmolepis	(Cd,Os,Pa)
Cornutoentolium	(Mo,Bi,Pt)	Corylocrinus	(Ec,Rh,Rh)	Cosmolithes	(Mo,Ga,Ne)
Cornutovum	(Ac,Ra,Na)	Corymbopora	(Bz,St,Cc)	Cosmomya	(Mo,Bi,Ph)
Cornwallia	(Cn,An,Ta)	Corymboporella	(Bz,Gy,Ch)	Cosmonautilus	(Mo,Ce,Na)
Cornwallia	(Br,Ar,Un)	Corymbospongia	(Po,De,Pe)	Cosmophilina	(Mo,Ga,Ce)
Cornwallis	(Cd,Ma,De)	Corynecrinus	(Ec,Cr,Cl)	Cosmoptychius	(Cd,Os,Pa)
Corocalyptra	(Ac,Ra,Na)	Corynella	(Po,Ca,Ph)	Cossmanna	(Mo,Ga,He)
Coroceras	(Mo,Ce,Ce)	Corynexochides	(Ar,Tr,Co)	Cossmannella	(Mo,Bi,Ve)
Corocrinus	(Ec,Cr,Mo)	Corynexochina	(Ar,Tr,Co)	Cossmannia	(Mo,Ga,Nt)
Coronakirkbya	(Ar,Os,Pa)	Corynexochus	(Ar,Tr,Co)	Cossmannia	(Mo,Ga,He)
Coronalosia	(Br,Ar,St)	Corynites	(He,Gr,Gr)	Costa	(Ar,Os,Pa)
Coronatica	(Mo,Ga,Nt)	Corynoides	(He,Gr,Gr)	Costacalista	(Mo,Bi,Ve)
Corongoceras	(Mo,Ce,Am)	Corynostylus	(Bz,Gy,Ch)	Costachonetes	(Br,Ar,St)
Coronia	(Mo,Ga,Ne)	Corynotrypa	(Bz,St,Cc)	Costaclymenia	(Mo,Ce,Cl)
Coroniceras	(Mo,Ce,Am)	Coryphaenoides	(Cd,Os,Pa)	Costacopluma	(Ar,MI,De)
Coronidmonea	(Bz,St,Cc)	Coryphaenopsis	(Cd,Os,El)	Costacraena	(Br,Ar,Te)
Coroniopsis	(Mo,Ga,Ne)	Coryphopterus	(Cd,Os,Pl)	Costaeara	(Ar,Os,Pa)
Coronipora	(Fo,Fo,Fo)	Coryphostoma	(Fo,Fo,Fo)	Costaegera	(Ar,Os,Pa)
Coronicala	(Mo,Ga,Nt)	Coryphyllia	(Cn,An,Sc)	Costaella	(Mo,Ga,He)
Coronites	(Mo,Ce,Am)	Coryslus	(Ec,Ec,Hs)	Costaglycymeris	(Mo,Bi,Ar)
Coronocephalus	(Ar,Tr,Un)	Corysoceras	(Mo,Ce,On)	Costagya	(Mo,Bi,Pt)
Coronochitina	(Fo,Fo,Ch)	Coryssodon	(Cd,Ch,Oc)	Costaledopsis	(Mo,Bi,Nu)
Coronocrinus	(Ec,Cr,Un)	Coryssochiton	(Mo,Po,Ne)	Costalocrinus	(Ec,Cr,Cl)
Coronocyathus	(Cn,An,Sc)	Coryssognathus	(Cd,Co,Co)	Costalosiella	(Br,Ar,St)
Coronocystis	(Ec,Rh,Rh)	Corythmelissa	(Ac,Ra,Na)	Costanopia	(Br,Ar,St)
Coronodus	(Cd,Ch,Co)	Corythocrinus	(Ec,Cr,Cl)	Costathea	(Hy,Or,Ci)
Coronograptus	(He,Gr,Gr)	Corythoecia	(Ac,Ra,Sp)	Costatia	(Ar,Os,Me)
Coronopsis	(Mo,Ga,Eu)	Cosa	(Mo,Bi,Ar)	Costaticella	(Bz,Gy,Ch)
Coronula	(Ar,Ci)	Coscinaraea	(Cn,An,Sc)	Costatiella	(Ar,Os,Pa)
Coronura	(Ar,Tr,Ph)	Coscinarina	(Br,Ar,St)	Costatispirifer	(Br,Ar,Sp)
Corophiidae	(Ar,MI,Am)	Coscinaulus	(Po,He,Ly)	Costatoblastus	(Ec,Bi,Sp)
Corosaurus	(Cd,Re,No)	Coscinella	(Bz,St,Cr)	Costaleoda	(Mo,Bi,Nu)
Corphalia	(Cn,An,Ru)	Cosciniopsis	(Bz,Gy,Ch)	Costatoria	(Mo,Bi,Tr)
Corralia	(Po,De,Li)	Coscinium	(Bz,St,Cy)	Costatrypa	(Br,Ar,At)
Corralio	(Po,De,Ha)	Coscinoeyathella	(Po,Re,Ca)	Costatumulus	(Br,Ar,St)
Corrigotubella	(Fo,Fo,Fo)	Coscinoeyathellus	(Po,Re,Ca)	Costaveenia	(Ar,Os,Pa)
Corrosina	(Fo,Fo,Fo)	Coscinoeyathus	(Po,Re,Ca)	Costayella	(Fo,Fo,Fo)
Corrugatagnostus	(Ar,Tr,Ag)	Coscinodiscus	(Po,De,Li)	Costazia	(Bz,Gy,Ch)
Corrugatella	(Fo,Fo,Fo)	Coscinodus	(Cd,Pt,Un)	Costeina	(Mo,Bi,Pt)
Corrugatimediostrum	(Br,Ar,Rh)	Coscinoecia	(Bz,St,Cc)	Costellacesta	(Mo,Bi,Pt)
Corrupecten	(Mo,Bi,Pt)	Coscinophora	(Br,Ar,St)	Costellagerina	(Fo,Fo,Fo)
Corrugopora	(Cn,An,Ta)	Coscinophragma	(Fo,Fo,Fo)	Costellamussiopecten	(Mo,Bi,Pt)
Corsania	(Mo,Ga,Ar)	Coscinopleura	(Bz,Gy,Ch)	Costellaria	(Mo,Ga,Ne)
Corsochelys	(Cd,Re,Ch)	Coscinopora	(Po,He,Ly)	Costellarina	(Br,Ar,St)
Corteorthis	(Br,Ar,Or)	Coscinoptycta	(Po,Re,Aj)	Costellipitar	(Mo,Bi,Ve)
Corthya	(Ec,Ec,De)	Coscinospira	(Fo,Fo,Fo)	Costellirostra	(Br,Ar,Rh)
Corticium	(Po,De,As)	Coscinospongia	(Po,De,Li)	Costellispirifer	(Br,Ar,Sp)
Corticospingia	(Po,He,Re)	Coscinotrypa	(Bz,St,Cy)	Costentolium	(Mo,Bi,Pt)
Corticulospongia	(Po,He,LS)	Cosjuvia	(Cn,An,Ru)	Costicamptonetes	(Mo,Bi,Pt)
Cortina	(Ac,Ra,Na)	Coskinolina	(Fo,Fo,Fo)	Costicrura	(Br,Ar,Sp)
Cortinella	(Mo,Ga,Ar)	Coskinolinoides	(Fo,Fo,Fo)	Costidiscus	(Mo,Ce,Am)
Cortinia	(Mo,Bi,Ph)	Coskinon	(Fo,Fo,Fo)	Costifera	(Fo,Fo,Fo)
Cortiniscus	(Ac,Ra,Na)	Cosmacanthus	(Cd,Pl,Ar)	Costiferina	(Br,Ar,St)
Corum	(Ac,Ra,Na)	Cosmasyrinx	(Mo,Ga,Ne)	Costigerites	(Ec,Ho,De)
Corumbella	(Cn,Se,Un)	Cosmatites	(Ec,Ho,Un)	Costigervillia	(Mo,Bi,Pt)
Corunegenys	(Cd,Os,Sc)	Cosmetalepas	(Mo,Ga,Ar)	Costileioceras	(Mo,Ce,Am)
Corvaspis	(Cd,Pt,Pt)	Cosmetocrinus	(Ec,Cr,Cl)	Costimitoceras	(Mo,Ce,Go)
Corveolepis	(Cd,Pt,Pt)	Cosmetodon	(Mo,Bi,Ar)	Costinorella	(Br,Ar,Rh)
Corvinopugnax	(Br,Ar,Rh)	Cosmiolithus	(Cn,An,Ta)	Costipellagiella	(Mo,In,Ph)
Corwenia	(Cn,An,Ru)	Cosmoecirithium	(Mo,Ga,Nt)	Costirynychia	(Br,Ar,Rh)
Corycephalus	(Ar,Tr,Ph)	Cosmochelys	(Cd,Re,Ch)	Costisorthis	(Br,Ar,Or)
Coryellina	(Ar,Os,Pa)	Cosmoerinus	(Ec,Cr,Un)	Costispinifera	(Br,Ar,St)

Costispirifer	(Br,Ar,Sp)	Cranocerinus	(Ec,Cr,Ct)	Crateroceras	(Mo,Ce,On)
Costispiriferina	(Br,Ar,Sp)	Cranodus	(Cd,Ch,In)	Craterocrinus	(Ec,Cr,Mo)
Costisteges	(Br,Ar,St)	Cranopsis	(Mo,Ga,Ar)	Crateromorpha	(Po,He,LS)
Costistricklandia	(Br,Ar,Pe)	Cranosina	(Bz,Gy,Ch)	Craterophyllum	(Cn,An,Ru)
Costistrophomena	(Br,Ar,St)	Craspedalasia	(Br,Ar,St)	Crateropora	(Bz,Gy,Ch)
Costistrophonella	(Br,Ar,St)	Craspedarges	(Ar,Tr,LI)	Craterosperis	(Cn,An,Sc)
Costitrimarella	(Br,LI,LI)	Craspedelia	(Br,Ar,St)	Craticularia	(Po,He,He)
Costoanachis	(Mo,Ga,Ne)	Craspedites	(Mo,Ce,Am)	Cratis	(Mo,Bi,Ar)
Costoconcha	(Br,Ar,Te)	Craspedobolbina	(Ar,Os,Pa)	Cratispirifer	(Br,Ar,Sp)
Costocyrena	(Mo,Bi,Ve)	Craspedochiton	(Mo,Po,Ne)	Cratochelone	(Cd,Re,Ch)
Costokidderia	(Mo,Bi,Ve)	Craspedocrinus	(Ec,Cr,Un)	Cratorhynchonella	(Br,Ar,Rh)
Costokloedenia	(Ar,Os,Pa)	Craspedodiscus	(Mo,Ce,Am)	Cratorhynchelache	(Cd,Ch,Ct)
Costonia	(Ar,Tr,Un)	Craspedoglyphylus	(Ar,Os,Po)	Cratospirifer	(Br,Ar,Sp)
Costoprimites	(Ar,Os,Pa)	Craspedona	(Br,Ar,St)	Cravenechinus	(Ec,Ec,Ey)
Costosyrnola	(Mo,Ga,He)	Craspedophyllia	(Cn,An,Sc)	Cravenia	(Cn,An,Ru)
Costracheirurus	(Ar,Tr,Ph)	Craspedopora	(Bz,Gy,Ch)	Cravenites	(Mo,Ce,Go)
Costula	(Bz,Gy,Ch)	Craspedops	(Ar,Me,Ag)	Cravenoceras	(Mo,Ce,Go)
Costulatostyliolina	(Mo,Cr,Da)	Craspedopyxion	(Ar,Os,Un)	Cravenoceratoides	(Mo,Ce,Go)
Cotaglnagnostus	(Ar,Tr,Ag)	Craspedostoma	(Mo,Ga,At)	Crawfordina	(Mo,Ga,Ne)
Cothonion	(Cn,An,Un)	Crassacythere	(Ar,Os,Po)	Crebriscaia	(Mo,Ga,Nt)
Cothurnicella	(Bz,Gy,Ch)	Crassadoma	(Mo,Bi,Pt)	Cremacrinus	(Ec,Cr,Ds)
Cothurnocystis	(Ec,St,Co)	Crassaluna	(Bz,St,Cy)	Cremastoglottus	(Ar,Tr,As)
Cotonopsis	(Mo,Ga,Ne)	Crassatella	(Mo,Bi,Ve)	Cremides	(Mo,Ga,Ar)
Cottaldia	(Ec,Ec,Ph)	Crassatellina	(Mo,Bi,Ve)	Cremnoceramus	(Mo,Bi,Pt)
Cotteaudia	(Ec,Ec,Ph)	Crassatellites	(Mo,Bi,Ve)	Creninodinatus	(Mo,In,In)
Cotteroceras	(Mo,Ce,En)	Crassatellopsis	(Mo,Bi,Ve)	Crenmorthis	(Br,Ar,Or)
Cottonia	(Mo,Ga,Ne)	Crassatina	(Mo,Bi,Ve)	Crenabolina	(Ar,Os,Pa)
Cottopsis	(Cd,Os,Pt)	Crassatrypa	(Br,Ar,At)	Crenaleya	(Ar,Os,Po)
Cottreauaster	(Ec,As,Va)	Crassialveolites	(Cn,An,Ta)	Crenamussium	(Mo,Bi,Pt)
Cottreaucorys	(Ec,Ec,Sp)	Crassiatractites	(Mo,Ce,Au)	Crenatella	(Fo,Fo,Fo)
Cottreautes	(Mo,Ce,Am)	Crassicellopora	(Bz,Gy,Ch)	Crenatolorica	(Mo,Po,Ne)
Cotylerina	(Ec,Cr,Di)	Crassiceras	(Mo,Ce,Am)	Crenatula	(Mo,Bi,Pt)
Cotyrahindia	(Po,De,LI)	Crassicollaria	(Cn,In,Ca)	Crenaturricula	(Mo,Ga,Ne)
Cotylerderma	(Ec,Cr,Cy)	Crassicconcha	(Mo,Bi,Ph)	Crenaverneuilina	(Fo,Fo,Fo)
Cotylyscus	(Po,Un,Un)	Crassicocinus	(Po,Re,Aj)	Crenella	(Mo,Bi,Mt)
Couloniceras	(Mo,Ce,Am)	Crassicyclus	(Cn,An,Ru)	Crenetocerithium	(Mo,Ga,Nt)
Couloumania	(Ar,Tr,Pt)	Crassidonta	(Cd,Ch,Cm)	Creniceras	(Mo,Ce,Am)
Coupatezia	(Cd,Ch,My)	Crassifimbria	(Ar,Tr,Pt)	Crenidens	(Cd,Os,Pf)
Courtessolium	(Ar,Tr,Ph)	Crassilasma	(Cn,An,Ru)	Crenilabium	(Mo,Ga,Ce)
Couthouya	(Mo,Ga,Nt)	Crassilina	(Mo,Cr,Da)	Crenilabrus	(Cd,Os,Pf)
Covracythere	(Ar,Os,Po)	Crassimarginata	(Mo,Ga,Ar)	Crenilunula	(Mo,Ga,Ar)
Cowiella	(An,Pa,Pa)	Crassimarginatella	(Bz,Gy,Ch)	Crenipecten	(Mo,Bi,Pt)
Cowlitzia	(Mo,Ga,Nt)	Crassimurex	(Mo,Ga,Ne)	Crenipetinnella	(Mo,Bi,Pt)
Cowperesia	(Mo,Bi,Ve)	Crassinella	(Mo,Bi,Ve)	Crenispirifer	(Br,Ar,Sp)
Cowtoniceras	(Mo,Ce,Am)	Crassiplanulites	(Mo,Ce,Am)	Crenistriella	(Mo,Ga,Be)
Coxesia	(Mo,Bi,Mt)	Crassiproetus	(Ar,Tr,Pt)	Crenisutura	(Mo,Ga,Ne)
Coxiconcha	(Mo,Bi,Mo)	Crassipunctatrypa	(Br,Ar,At)	Creniturbo	(Mo,Ga,Ar)
Coxiella	(Ci,Po,Sp)	Crassiscalca	(Mo,Ga,Nt)	Crenolepis	(Cd,Os,Pe)
Coxites	(Fo,Fo,Fo)	Crassispira	(Mo,Ga,Ne)	Crenomytilus	(Mo,Bi,Mt)
Coxiellina	(Ci,Po,Sp)	Crassispirella	(Mo,Ga,Ne)	Crenostrea	(Mo,Bi,Pt)
Cradeocrinus	(Ec,Cr,Ct)	Crassispirifer	(Br,Ar,Sp)	Crenotrapezium	(Mo,Bi,Ve)
Craftonoceras	(Mo,Ce,Ta)	Crassistella	(Cn,An,Sc)	Crenulazone	(Mo,Ga,Ar)
Craginia	(Mo,Ga,Nt)	Crassidiscospora	(Bz,St,Ce)	Crenulimopsis	(Mo,Bi,Ar)
Craigella	(Br,Ar,Or)	Crassohomera	(Bz,St,Ce)	Crenulipora	(Cn,An,Ta)
Craigheadia	(Ar,Tr,Pt)	Crassophrentis	(Cn,An,Ru)	Crenulites	(Cn,An,Ru)
Craena	(Br,Ar,Te)	Crassopleura	(Mo,Ga,Ne)	Crenulostomina	(Fo,Fo,Fo)
Crangopsis	(Ar,Ml, Ae)	Crassostrea	(Mo,Bi,Pt)	Creonella	(Mo,Ga,He)
Crania	(Br,In,Cr)	Crassotornoceras	(Mo,Ce,Go)	Crepicephalina	(Ar,Tr,Pt)
Craniella	(Po,De,As)	Crassumbo	(Br,Ar,Sp)	Crepicephalus	(Ar,Tr,Pt)
Craniops	(Br,In,Cp)	Crataegocrinus	(Ec,Cr,Cy)	Crepichilella	(Ar,Tr,Pt)
Craniotreta	(Br,LI,Ac)	Crateniophyllum	(Cn,An,Ru)	Crepidacantha	(Bz,Gy,Ch)
Craniscus	(Br,LI,Ac)	Crateraster	(Ec,As, Va)	Crepidophyllia	(Cn,An,Ru)
Cranocephalites	(Mo,Ce,Am)	Craterastraea	(Cn,An,Sc)	Crepidosome	(Ec,Op,Oe)
Cranoceras	(Mo,Ce,Na)	Craterellina	(Ar,Os,Me)	Crepidula	(Mo,Ga,Nt)

Crepipatella	(Mo,Ga,Nt)	Cricocrinus	(Ec,Cr,Cl)	Crossbitheca	(Hy,Or,Ci)
Crepipora	(Bz,St,Cy)	Cricocyathus	(Cn,An,Sc)	Crossea	(Mo,Ga,Ar)
Crepis	(Bz,Gy,Ch)	Cricodictyum	(Bz,St,Fe)	Crosseola	(Mo,Ga,Ar)
Crepispisula	(Mo,Bi,Ve)	Cricosaurus	(Cd,Re,Cr)	Crossiskeniidium	(Br,Ar,Or)
Crescentic there	(Ar,Os,Un)	Cricosia	(Br,Ar,Te)	Crossoceras	(Mo,Ga,Ar)
Crescentilla	(Ar,Os,Pa)	Crimella	(Mo,Ga,He)	Crossognathus	(Cd,Os,Cr)
Crescis	(Bz,St,Cc)	Crimites	(Mo,Ce,Go)	Crossorhinus	(Cd,Ch,Oc)
Creseis	(Mo,Ga,Th)	Crinerocrinus	(Ec,Cr,Di)	Crossostoma	(Mo,Ga,Ar)
Crespinella	(Fo,Fo,Fo)	Crinimicaminus	(An,Po,Te)	Crossotrema	(Mo,Ga,Nt)
Crespinina	(Fo,Fo,Fo)	Crinisaria	(Br,Ar,Sp)	Crossoura	(Ar,Tr,Un)
Crestjähitus	(Hy,Hy,Hy)	Crinisarina	(Br,Ar,Sp)	Crotalocephalides	(Ar,Tr,Ph)
Crestoconus	(Mo,In,In)	Crinistrophia	(Br,Ar,St)	Crotalocephalina	(Ar,Tr,Ph)
Cretaceomurex	(Mo,Ga,Ne)	Crinotograptus	(He,Gr,Gr)	Crotalocephalus	(Ar,Tr,Ph)
Cretaceratina	(Ar,Os,Po)	Crinobrachiatus	(Ec,Cr,Ds)	Crotalocrinities	(Ec,Cr,Cl)
Cretachlorodus	(Ar,Ml,De)	Crinocaulis	(He,Gr,Un)	Crownopora	(Bz,St,Cr)
Cretascymnus	(Cd,Ch,Sq)	Crinocidaris	(Ec,Ec,Un)	Crozonopsis	(Ar,Tr,Ph)
Cretatriacanthus	(Cd,Os,Te)	Criocardium	(Mo,Bi,Ve)	Crozonarthris	(Br,Ar,Or)
Cretirhynchia	(Br,Ar,Rh)	Crioceras	(Mo,Ce,Am)	Cruavicerias	(Mo,Ce,Am)
Cretiscapellum	(Ar,Ci)	Crioceratites	(Mo,Ce,Am)	Crubus	(Ac,Ra,Na)
Cretitanais	(Ar,Ml,Ta)	Crisia	(Bz,St,Cc)	Crucella	(Ac,Ra,Sp)
Cretocardia	(Mo,Bi,Ve)	Crisidia	(Bz,St,Cc)	Crucibrissus	(Ec,Ec,Sp)
Cretodus	(Cd,Ch,La)	Crisidmonea	(Bz,St,Cc)	Crucibulum	(Mo,Ga,Nt)
Cretolamna	(Cd,Ch,La)	Crisiella	(Bz,St,Cc)	Crucicephalus	(Ar,Tr,Un)
Cretorectolobus	(Cd,Ch,Oc)	Crisina	(Bz,St,Cc)	Crucicornina	(Ar,Os,Po)
Cretoxyrhina	(Cd,Ch,La)	Crisinella	(Bz,St,Cc)	Cruciella	(Mo,Bi,Un)
Creusia	(Ar,Ci)	Crisiona	(Bz,St,Cc)	Crucilobicerias	(Mo,Ce,Am)
Cribanocrinus	(Ec,Cr,Di)	Crisisina	(Bz,St,Cc)	Cruciculina	(Fo,Fo,Fo)
Cribella	(Bz,Gy,Ch)	Crispispongia	(Po,Ca,Ph)	Crucimedusina	(Cn,Hy,Hy)
Cribellopora	(Bz,Gy,Ch)	Crisposcala	(Mo,Ga,Nt)	Cruciphyllum	(Cn,An,Ru)
Cribellopsis	(Fo,Fo,Fo)	Crispus	(Pr,Cr,Cr)	Crucispongia	(Po,He,Un)
Cribranopsis	(Fo,Fo,Fo)	Crista	(Cn,An,Ru)	Crucivirga	(Ec,Ho,Un)
Cribraria	(Mo,Ga,Nt)	Cristaleberis	(Ar,Os,Po)	Crumillospongia	(Po,De,Ha)
Cribratina	(Fo,Fo,Fo)	Cristafrons	(Ar,Ml,De)	Cruralina	(Br,Ar,Te)
Cribrendoecium	(Bz,Gy,Ch)	Cristagnostus	(Ar,Tr,Ag)	Cruratala	(Br,Ar,Te)
Cribricellina	(Bz,Gy,Ch)	Cristalloella	(Mo,Ga,He)	Cruricella	(Br,Ar,Sp)
Cribricyathus	(Pr,Cr,Cr)	Cristatodus	(Pr,Un,In)	Cruirhynchia	(Br,Ar,Rh)
Cribrilaria	(Bz,Gy,Ch)	Cristellariopsis	(Fo,Fo,Fo)	Cruirispina	(Br,Ar,Sp)
Cribrilina	(Bz,Gy,Ch)	Cristicoma	(Br,Li,Ac)	Cruirithyrus	(Br,Ar,Sp)
Criboaperturata	(Fo,Fo,Fo)	Cristiferina	(Br,Ar,Or)	Crusoia	(Ar,Tr,Pt)
Criboblastus	(Ec,Bi,Sp)	Cristigerina	(Cd,Os,Pf)	Crussoliceras	(Mo,Ce,Am)
Cribroconcha	(Ar,Os,Me)	Cristipluma	(Ar,Ml,De)	Crustopora	(Bz,St,Tr)
Cribroelphidium	(Fo,Fo,Fo)	Cristodus	(Cd,Co,Co)	Crustuloides	(Mo,Bi,Ve)
Crirogenerina	(Fo,Fo,Fo)	Crisulipora	(Bz,St,Cc)	Cruziturrucula	(Mo,Ga,Ne)
Crirogloborotalia	(Fo,Fo,Fo)	Crittendenia	(Mo,Bi,Pt)	Cryoturris	(Mo,Ga,Ne)
Crirogoesella	(Fo,Fo,Fo)	Crocodilaemus	(Cd,Re,Cr)	Cryphaeoides	(Ar,Tr,Ph)
Crirohantkenina	(Fo,Fo,Fo)	Croixana	(Ar,Tr,Pt)	Cryphaeus	(Ar,Tr,Ph)
Crirohemisphaeroides	(Fo,Fo,Fo)	Crolianium	(Ac,Ra,Na)	Cryphina	(Ar,Tr,Ph)
Crirolenticulina	(Fo,Fo,Fo)	Cromatrypa	(Br,Ar,At)	Cryphiocrinus	(Ec,Cr,Cl)
Crirolinoides	(Fo,Fo,Fo)	Crommium	(Mo,Ga,Nt)	Cryphops	(Ar,Tr,Ph)
Cribronodosaria	(Fo,Fo,Fo)	Cromus	(Ar,Tr,Ph)	Crypolucina	(Mo,Bi,Ve)
Cribrononion	(Fo,Fo,Fo)	Cromyocrinus	(Ec,Cr,Cl)	Cryptanthoria	(Br,Ar,Te)
Cribroparrella	(Fo,Fo,Fo)	Cromyodruppa	(Ac,Ra,Sp)	Cryptamphorella	(Ac,Ra,Na)
Cribropleurostomella	(Fo,Fo,Fo)	Cromyodruppocarpus	(Ac,Ra,Sp)	Cryptangia	(Cn,An,Sc)
Cribrupullenia	(Fo,Fo,Fo)	Cromyomma	(Ac,Ra,Sp)	Cryptanisocrinus	(Ec,Cr,Sc)
Cribrorobulina	(Fo,Fo,Fo)	Cromyosphaera	(Ac,Ra,Sp)	Cryptatrypa	(Br,Ar,At)
Cribrorotalia	(Fo,Fo,Fo)	Cromyostaurolonche	(Ac,Ra,Sp)	Cryptaulax	(Mo,Ga,Nt)
Crirosphaeroides	(Fo,Fo,Fo)	Croneisella	(Fo,Fo,Fo)	Cryptaulia	(Mo,Bi,Hi)
Crirospira	(Fo,Fo,Fo)	Croneisigenys	(An,Po,Eu)	Cryptechinus	(Ec,Ec,Te)
Crirospongia	(Po,He,He)	Croneisites	(Ec,Ho,Ap)	Crypthelia	(Cn,Hy,Mi)
Crirostomoides	(Fo,Fo,Fo)	Cronia	(Mo,Ga,Ne)	Cryptobairdia	(Ar,Os,Po)
Crirothalamia	(Po,De,Pe)	Cronyphyllum	(Cn,An,Ru)	Cryptobalistes	(Cd,Os,Te)
Criroturretoides	(Fo,Fo,Fo)	Crossacanthia	(Br,Ar,St)	Cryptoberyx	(Cd,Os,Br)
Crickites	(Mo,Ce,An)	Crossalasia	(Br,Ar,St)	Cryptoblastus	(Ec,Bi,Sp)
Cricocosmia	(Pa)	Crossata	(Mo,Ga,Nt)	Cryptoborsonia	(Mo,Ga,Ne)

Cryptobranchia	(Mo,Ga,Ar)	Ctenaspis	(Cd,Pt,Pt)	Cucumaltina	(Po,De,Li)
Cryptocapsa	(Ac,Ra,Na)	Ctenilyria	(Mo,Ga,Ne)	Cucumarites	(Ec,Ho,As)
Cryptocarida	(Mo,Bi,Ve)	Cteniopleurium	(Mo,Bi,Pt)	Cudmorella	(Br,Ar,Te)
Cryptocaris	(Ar,Re,En)	Ctenobactrites	(Mo,Ce,An)	Cuersithyris	(Br,Ar,Te)
Cryptoccephalus	(Ac,Ra,Na)	Ctenoberyx	(Cd,Os,Br)	Cuifastrea	(Cn,An,Sc)
Cryptochiton	(Mo,Po,Ne)	Ctenobolbina	(Ar,Os,Pa)	Cuifia	(Cn,An,Sc)
Cryptochorda	(Mo,Ga,Ne)	Ctenobolbinella	(Ar,Os,Pa)	Culicia	(Cn,An,Sc)
Cryptoclidus	(Cd,Re,Ps)	Ctenocardia	(Mo,Bi,Ve)	Culicocrinus	(Ec,Cr,Mo)
Cryptoclymenia	(Mo,Ce,Go)	Ctenocephalichthys	(Cd,Os,Br)	Culipagnostus	(Ar,Tr,Ag)
Cryptocoelia	(Po,De,Pe)	Ctenocephalus	(Ar,Tr,Pt)	Culmenaspis	(Ar,Tr,Pt)
Cryptocoelopsis	(Mo,Bi,Ve)	Ctenoceras	(Mo,Ce,Or)	Culmia	(Mo,Ga,Ne)
Cryptocoenia	(Cn,An,Sc)	Ctenocheles	(Ar,ML,De)	Culmicrinus	(Ec,Cr,Cl)
Cryptoconchus	(Mo,Po,Ne)	Ctenochelys	(Cd,Re,Ch)	Cultellus	(Mo,Bi,Ve)
Cryptoconus	(Mo,Ga,Ne)	Ctenochonetes	(Br,Ar,St)	Cultripopsis	(Mo,Bi,Pt)
Cryptocordieria	(Mo,Ga,Ne)	Ctenocolpus	(Mo,Ga,Nt)	Culmbodina	(Cd,Co,Co)
Cryptocrinites	(Ec,Eo,Un)	Ctenoconularia	(Cn,Sc,Cn)	Cumberlandina	(Br,Ar,Sp)
Cryptocycloceras	(Mo,Ce,Or)	Ctenocrinus	(Ec,Cr,Mo)	Cumberloceras	(Mo,Ce,El)
Cryptoderaspis	(Ar,Tr,Un)	Ctenocystis	(Ec,Ct,Ct)	Cumingia	(Mo,Bi,Ve)
Cryptodictya	(Po,He,Re)	Ctenodentex	(Cd,Os,Pf)	Cumingsoceras	(Mo,Ce,Ba)
Cryptoglena	(Bz,St,Cc)	Ctenodonta	(Mo,Bi,Nu)	Cummingella	(Ar,Tr,Pt)
Cryptoglyptoleura	(Ar,Os,Pa)	Ctenodontella	(Mo,Bi,Nu)	Cumminsia	(Cn,An,Ru)
Cryptogoleus	(Ec,Ed,Is)	Ctenognathichthys	(Cd,Os,Pe)	Cumularia	(Mo,Bi,H)
Cryptograptus	(He,Gr,Gr)	Ctenognathodus	(Cd,Co,Co)	Cuna	(Mo,Bi,Ve)
Cryptolarancium	(Ac,Ra,Sp)	Ctenoidea	(Mo,Bi,Pt)	Cunanax	(Mo,Bi,Ve)
Cryptolepas	(Ar,Ci)	Ctenokoninckina	(Br,Ar,Sp)	Cunavella	(Mo,Bi,Ph)
Cryptolepis	(Cd,Os,Co)	Ctenoloculina	(Ar,Os,Pa)	Cunctocrinus	(Ec,Cr,Ds)
Cryptolichenaria	(Cn,An,Ta)	Ctenonotella	(Ar,Os,Pa)	Cuneamya	(Mo,Bi,Ph)
Cryptolithoides	(Ar,Tr,As)	Ctenophoraster	(Ec,As,Px)	Cunearca	(Mo,Bi,Ar)
Cryptolithus	(Ar,Tr,As)	Ctenopomichthys	(Cd,Os,Sc)	Cuneaster	(Ec,As,Px)
Cryptomactra	(Mo,Bi,Ve)	Ctenopora	(Bz,Gy,Ch)	Cuneatopora	(Bz,St,Cr)
Cryptomella	(Mo,Ga,Ne)	Ctenopristis	(Cd,Ch,Rj)	Cuneicardioceras	(Mo,Ce,Am)
Cryptomya	(Mo,Bi,My)	Ctenopterus	(Ar,Me,Eu)	Cuneigervillia	(Mo,Bi,Pt)
Cryptonatica	(Mo,Ga,Nt)	Ctenoptychius	(Cd,Ch,Pe)	Cuneirhynchia	(Br,Ar,Rh)
Cryptonella	(Br,Ar,Te)	Ctenopyge	(Ar,Tr,Pt)	Cuneoceratina	(Ar,Os,Po)
Cryptonerita	(Mo,Ga,Ar)	Ctenorbitoides	(Fo,Fo,Fo)	Cuneocorbula	(Mo,Bi,My)
Cryptopecten	(Mo,Bi,Pt)	Ctenosciaena	(Cd,Os,Pf)	Cuneocythere	(Ar,Os,Po)
Cryptophragmus	(Po,De,St)	Ctenoscolex	(An,Po,Ph)	Cuneolina	(Fo,Fo,Fo)
Cryptophyllus	(Ar,Os,Pa)	Ctenostreon	(Mo,Bi,Pt)	Cuneolinella	(Fo,Fo,Fo)
Cryptoplax	(Mo,Po,Ne)	Ctenothrissa	(Cd,Os,Ct)	Cuneus	(Mo,Bi,Ve)
Cryptoplocus	(Mo,Ga,He)	Ctenurella	(Cd,Pt,Pt)	Cuniculimella	(Fo,Fo,Fo)
Cryptopora	(Br,Ar,Rh)	Cterocardia	(Mo,Bi,Ve)	Cuniculocystis	(Ec,Rh,Rh)
Cryptoporella	(Br,Ar,Rh)	Cteroclymenia	(Mo,Ce,Cl)	Cunitoceras	(Mo,Ce,Go)
Cryptoporocyathus	(Po,Re,Ca)	Cualabaea	(Cd,Os,Co)	Cunningtoniceras	(Mo,Ce,Am)
Cryptoptyx	(Mo,Ga,Nt)	Cubacula	(Br,Ar,St)	Cunulites	(Cn,An,Sc)
Cryptorhynchia	(Br,Ar,Rh)	Cubanaster	(Ec,Ec,Cl)	Cupaniella	(Mo,Ga,Ne)
Cryptorhytis	(Mo,Ga,Ne)	Cubanina	(Fo,Fo,Fo)	Cuparius	(Br,Ar,Pe)
Cryptorthoceras	(Mo,Ce,Or)	Cubanirhynchia	(Br,Ar,Rh)	Cuphosolenus	(Mo,Ga,Nt)
Cryptoschisma	(Ec,BI,F)	Cubanothyris	(Br,Ar,Te)	Cuphotifer	(Mo,Ga,Nt)
Cryptoseptida	(Fo,Fo,Fo)	Cubaohetoceras	(Mo,Ce,Am)	Cupidoliva	(Mo,Ga,Ne)
Cryptosiphon	(An,Po,Te)	Cubestana	(Mo,Ga,Nt)	Cupithea	(Pr,Un,In)
Cryptospira	(Mo,Ga,Ne)	Cubiceps	(Cd,Os,Pf)	Cupressocrinites	(Ec,Cr,Cl)
Cryptospirifer	(Br,Ar,Sp)	Cubiculovinea	(An,Po,Se)	Cupuladria	(Bz,Gy,Ch)
Cryptostephanidium	(Ac,Ra,Na)	Cubifenestella	(Bz,St,Fe)	Cupularostrum	(Br,Ar,Rh)
Cryptostomella	(Bz,Gy,Ch)	Cubitostrea	(Mo,Bi,Pt)	Cupulina	(Po,De,Li)
Cryptosula	(Bz,Gy,Ch)	Cubitosulcus	(Ar,Os,Pa)	Cupulocorona	(Ec,Co,Co)
Cryptotaxis	(Cd,Co,Co)	Cubtosulcus	(Ar,Os,Pa)	Cupuloerinus	(Ec,Cr,Cl)
Cryptotexanites	(Mo,Ce,Am)	Cuburbita	(Fo,Fo,Fo)	Curetia	(Mo,Ga,He)
Cryptothyrella	(Br,Ar,Sp)	Cuccoceras	(Mo,Ce,Ce)	Curfina	(Ar,Os,Po)
Cryptothyris	(Br,Ar,Sp)	Cuactienophyllum	(Cn,An,Ru)	Curiaspis	(Ar,Tr,Un)
Cryptotreta	(Br,LI,Pa)	Cucullaea	(Mo,Bi,Ar)	Curionia	(Mo,Bi,Ve)
Ctena	(Mo,Bi,Ve)	Cucullaearea	(Mo,Bi,Ar)	Curriella	(Ar,Tr,Ph)
Ctenacanthus	(Cd,Ch,Ct)	Cucullaria	(Mo,Bi,Ar)	Cursina	(Fo,Fo,Fo)
Ctenactis	(Cn,An,Sc)	Cucullipora	(Bz,Gy,Ch)	Curtastrum	(Cn,An,Ru)
Ctenalasia	(Br,Ar,St)	Cucullograptus	(He,Gr,Gr)	Curteocrinus	(Ec,Eo,Go)

Curticia	(Br.Li.Ac)	Cyathus	(Ar.Os.Pa)	Cyclolipopsis	(Cn.An.Sc)
Curtirhynchia	(Br.Ar.Rh)	Cybantyx	(Ar.Tr.Co)	Cyclolituities	(Mo.Ce.Or)
Curtitheca	(Hy.Or.Or)	Cybele	(Ar.Tr.Ph)	Cyclobolus	(Mo.Ce.Go)
Curtoceras	(Mo.Ce.Ta)	Cybellela	(Ar.Tr.Ph)	Cycloculina	(Fo.Fo.Fo)
Curtognathus	(Cd.Co.Co)	Cybeloides	(Ar.Tr.Ph)	Cyclolorenzella	(Ar.Tr.Pt)
Curtiohibolites	(Mo.Ce.Be)	Cybelopsis	(Ar.Tr.Ph)	Cyclomacra	(Mo.Bi.Ve)
Curvatella	(Ec.Ho.Un)	Cybelurus	(Ar.Tr.Ph)	Cyclomedusa	(Cn.Cy.Cy)
Curvirostrum	(Mo.Bi.Ar)	Cycladicama	(Mo.Bi.Ve)	Cyclomolops	(Mo.Ga.Nt)
Curviroordo	(Ec.Ed.Is)	Cycladigera	(Br.Ar.Or)	Cyclomussa	(Cn.An.Sc)
Curvostrea	(Mo.Bi.Pt)	Cycladophora	(Ac.Ra.Na)	Cyclomyonia	(Br.Ar.Or)
Cusacrinus	(Ec.Cr.Mo)	Cyclagnostus	(Ar.Tr.Ag)	Cyclonema	(Mo.Ga.Eu)
Cushmania	(Fo.Fo.Fo)	Cyclanmina	(Fo.Fo.Fo)	Cyclopagnostus	(Ar.Tr.Ag)
Cushmanidea	(Ar.Os.Po)	Cyclanpterium	(Ac.Ra.Na)	Cyclope	(Mo.Ga.Ne)
Cushmanina	(Fo.Fo.Fo)	Cyclantharia	(Br.Ar.St)	Cyclopecten	(Mo.Bi.Pt)
Cusnia	(Mo.Ga.Ne)	Cyclaster	(Ec.Ec.Sp)	Cyclopellatia	(Mo.Bi.Ve)
Cuspicorbula	(Mo.Bi.My)	Cyclastraea	(Cn.An.Sc)	Cyclopelta	(Bz.St.Fe)
Cuspidaria	(Mo.Bi.Ph)	Cyclastrum	(Ac.Ra.Sp)	Cycloperella	(Bz.Gy.Ch)
Cussetostrea	(Mo.Bi.Pt)	Cycledomia	(Fo.Fo.Fo)	Cyclophaenopora	(Bz.St.Un)
Cutchispinctes	(Mo.Ce.Am)	Cycleryon	(Ar.Ml.De)	Cyclophyllopsis	(Cn.An.Sc)
Cuvierina	(Mo.Ga.Th)	Cyclicopora	(Bz.Gy.Ch)	Cyclopiotes	(Mo.Ce.On)
Cuvilliera	(Bz.St.Cc)	Cyclina	(Mo.Bi.Ve)	Cycloplectoceras	(Mo.Ce.Ta)
Cuvillierina	(Fo.Fo.Fo)	Cyclindroclavulina	(Fo.Fo.Fo)	Cyclopoma	(Cd.Os.Pf)
Cuyanaspis	(Ar.Tr.Un)	Cyclindroclyathus	(Cn.An.Sc)	Cyclopora	(Bz.St.Tr)
Cuyaniceras	(Mo.Ce.Am)	Cyclinella	(Mo.Bi.Ve)	Cycloprella	(Bz.St.Tr)
Cyamidia	(Ec.Ec.Cl)	Cyclinorbis	(Mo.Bi.Ve)	Cycloporidium	(Cn.Hy.Sp)
Cyamiomacra	(Mo.Bi.Ve)	Cyclites	(Mo.Ga.Ar)	Cycloptosopon	(Ar.Ml.De)
Cyamocarcinus	(Ar.Ml.De)	Cyclobacia	(Cn.An.Sc)	Cyclospuedomia	(Fo.Fo.Fo)
Cyamocephalus	(Ar.Mc.Ni)	Cyclobactries	(Mo.Ce.An)	Cyclospinella	(Fo.Fo.Fo)
Cyamocytheridea	(Ar.Os.Po)	Cyclobathmus	(Mo.Ga.Ar)	Cyclopterus	(Cd.Os.Sc)
Cyamodus	(Cd.Re.Ph)	Cyclobatis	(Cd.Ch.Rj)	Cycloptychius	(Cd.Os.Pa)
Cyamops	(Ar.Tr.Pr)	Cyclocancer	(Ar.Ml.De)	Cycloptoeolina	(Fo.Fo.Fo)
Cyanaphyllum	(Cn.An.Ru)	Cyclocarcinides	(Ar.Ma.Cy)	Cyclopyge	(Ar.Tr.As)
Cyanoeyclas	(Mo.Bi.Ve)	Cyclocardia	(Mo.Bi.Ve)	Cyclorbiculina	(Fo.Fo.Fo)
Cyanoplax	(Mo.Po.Ne)	Cycloceltites	(Mo.Ce.Ce)	Cyclorbiculinoidea	(Fo.Fo.Fo)
Cyathactis	(Cn.An.Ru)	Cycloceras	(Mo.Ce.Or)	Cyclorhynchia	(Fo.Fo.Fo)
Cyathaspis	(Cd.Pt.Pt)	Cyclochlamys	(Mo.Bi.Pt)	Cyclorhynchia	(Br.Ar.Sp)
Cyathaxonella	(Cn.An.Ru)	Cyclocites	(Bz.St.Cc)	Cyclorisma	(Mo.Bi.Ve)
Cyathaxonia	(Cn.An.Ru)	Cycloclema	(Po.De.Li)	Cyclorismina	(Mo.Bi.Ve)
Cyathelia	(Cn.An.Sc)	Cycloclymenia	(Mo.Ce.An)	Cycloscala	(Mo.Ga.Nt)
Cyathidium	(Ec.Cr.Cy)	Cycloclypeus	(Fo.Fo.Fo)	Cycloseena	(Mo.Ga.Ar)
Cyathoceras	(Cn.An.Sc)	Cyclocoelia	(Br.Ar.Or)	Cycloseris	(Cn.An.Sc)
Cyathochitina	(Fo.Fo.Ch)	Cyclocolpota	(Bz.Gy.Ch)	Cyclostigma	(Po.He.Ly)
Cyathocidaris	(Ec.Ec.Ci)	Cycloconcha	(Mo.Bi.Mo)	Cycloserpula	(An.Po.Se)
Cyathoclisia	(Cn.An.Ru)	Cycloconchoides	(Mo.In.In)	Cyclospiraeroma	(Ar.Ml.Is)
Cyathocricus	(Po.Re.Aj)	Cyclocorystes	(Ar.Ml.De)	Cyclospira	(Br.Ar.At)
Cyathocoenia	(Cn.An.Sc)	Cyclocrinus	(Ec.Cr.Cy)	Cyclosporgia	(Mo.Ga.Ar)
Cyathocrinites	(Ec.Cr.Cl)	Cyclocyathella	(Po.Re.Aj)	Cyclostomaria	(Mo.Ga.Ar)
Cyathocylindrum	(Cn.An.Ru)	Cyclocyathus	(Cn.An.Sc)	Cyclostomiceras	(Mo.Ce.El)
Cyathocystis	(Ec.Ed.Ed)	Cyclocyrtendoceras	(Mo.Ce.En)	Cyclostrema	(Mo.Ga.Ar)
Cyathodictya	(Po.He.Re)	Cyclocyrtionella	(Mo.Te.Cy)	Cyclostremela	(Mo.Ga.Ar)
Cyathodonta	(Mo.Bi.Ph)	Cyclocystoides	(Ec.Ed.Is)	Cyclostremiscus	(Mo.Ga.Nt)
Cyathopaedium	(Cn.An.Ru)	Cycloelostomia	(Mo.Ga.He)	Cyclostromella	(Mo.Ga.He)
Cyathophora	(Cn.An.Sc)	Cycloes	(Ar.Ml.De)	Cyclosunnetta	(Mo.Bi.Ve)
Cyathophycus	(Po.He.Re)	Cycloflabellum	(Cn.An.Sc)	Cyclotellina	(Mo.Bi.Ve)
Cyathophyllia	(Cn.An.Sc)	Cycloforina	(Fo.Fo.Fo)	Cyclothea	(Mo.Ga.Be)
Cyathophyllipsis	(Cn.An.Sc)	Cyclogeorgina	(Pr.Un.In)	Cyclothone	(Cd.Os.St)
Cyathophylloides	(Cn.An.Ru)	Cyclognathina	(Ar.Tr.Pt)	Cyclothyca	(Mo.Ga.Nt)
Cyathophyllum	(Cn.An.Ru)	Cyclograptus	(He.Gr.Tu)	Cyclothyreus	(Ar.Ml.De)
Cyathophycus	(Po.Un.Un)	Cyclohoicus	(Mo.In.In)	Cyclothyris	(Br.Ar.Rh)
Cyathoseris	(Cn.An.Sc)	Cyclolampus	(Ec.Ec.Ds)	Cyclotron	(Ar.Os.Ar)
Cyathosmilia	(Cn.An.Sc)	Cycloiberis	(Ar.Os.My)	Cyclotrypa	(Bz.St.Cy)
Cyathosporgia	(Po.De.Li)	Cycloienzellina	(Ar.Tr.Un)	Cycloturbo	(Mo.Ga.Ar)
Cyathotheca	(Ec.Ed.Ed)	Cyclofina	(Fo.Fo.Fo)	Cycloanthops	(Ar.Ml.De)
Cyathotrochus	(Cn.An.Sc)	Cyclolites	(Cn.An.Sc)	Cyclozyga	(Mo.Ga.Nt)

Cyclus	(Ar.Ma,Cy)	Cymbaloporella	(Fo.Fo.Fo)	Cypridella	(Ar.Os,My)
Cydonocephalus	(Ar.Tr,Ph)	Cymbaloporetta	(Fo.Fo.Fo)	Cypridellina	(Ar.Os,My)
Cydonocrinus	(Ec.Cr.Cl)	Cymbia	(Ar.Un,Un)	Cypridina	(Ar.Os,My)
Cydrocrinus	(Ec.Cr.Cl)	Cymbidium	(Br.Ar,Pe)	Cypridinella	(Ar.Os,My)
Cylichna	(Mo.Ga,Ce)	Cymbioerinus	(Ec.Cr.Cl)	Cypridodella	(Cd.Co,Cy)
Cylichnania	(Mo.Ga,Ce)	Cymbiola	(Mo.Ga,Ne)	Cypridopsis	(Ar.Os,Po)
Cylichnatis	(Mo.Ga,Ce)	Cymbionites	(Ec.Eo,Un)	Cyprilepas	(Ar.Ci)
Cylichnella	(Mo.Ga,Ce)	Cymbistropheodonta	(Br.Ar,St)	Cyprimeria	(Mo,Bi,Ve)
Cylichnina	(Mo.Ga,Ce)	Cymbites	(Mo,Ce,Am)	Cyproglobina	(Mo.Ga,Nt)
Cylichnopsis	(Mo.Ga,Ce)	Cymbithyrus	(Br.Ar,Or)	Cypropterina	(Mo.Ga,Nt)
Cylicioscapa	(Mo.Ga,Eu)	Cymbium	(Mo.Ga,Ne)	Cyprosina	(Ar.Os,My)
Cylicocrinus	(Ec.Cr,Mo)	Cymbochlaenia	(Po.De,Li)	Cyprosis	(Ar.Os,My)
Cylicoopsis	(Po.De,Ax)	Cymbophora	(Mo,Bi,Ve)	Cyptendoceras	(Mo,Ce,En)
Cylinder	(Mo.Ga,Ne)	Cymbospindylus	(Cd.Re,Ic)	Cyranichthys	(Cd.Os,Al)
Cylindracanthus	(Cd.Os,In)	Cynbricia	(Br.Ar,Or)	Cyranoia	(Br.Ar,Te)
Cylindriscala	(Mo.Ga,Nt)	Cymbularia	(Mo.Ga,Be)	Cyrbasia	(Mo.Ga,Nt)
Cylindritella	(Mo.Ga,Ce)	Cymella	(Mo,Bi,Ph)	Cyrbasiotreta	(Br,Li,Ac)
Cylindrites	(Mo.Ga,Ce)	Cymenorhynchus	(Mo.Ga,Nt)	Cyrenobonassa	(Mo,Bi,Ve)
Cylindrotopsis	(Mo.Ga,Nt)	Cynia	(Mo.Ga,Ne)	Cyrenodonax	(Mo,Bi,Ve)
Cylindrobullina	(Mo.Ga,Ce)	Cynidia	(Br.Ar,Te)	Cyrenopsis	(Mo,Bi,Ve)
Cylindrochitina	(Fo.Fo,Ch)	Cymoeceras	(Mo,Ce,Go)	Cyroxelis	(Br.Ar,Rh)
Cylindroclavulina	(Fo.Fo,Fo)	Cymodoce	(Ar,MI,Is)	Cyrtactinoceras	(Mo,Ce,Or)
Cylindrocolaniella	(Fo.Fo,Fo)	Cymoproductus	(Br.Ar,St)	Cyrtallosia	(Br.Ar,St)
Cylindromitra	(Mo.Ga,Ne)	Cymosmia	(Cn.An,Se)	Cyrtella	(Br.Ar,Sp)
Cylindrophyllia	(Cn.An,Se)	Cymostrophia	(Br.Ar,St)	Cyrtendoceras	(Mo,Ce,En)
Cylindrophyllum	(Cn.An,Ru)	Cyndalia	(Br.Ar,St)	Cyrtentactinia	(Ac,Ra,Sp)
Cylindrophylla	(Po.De,Li)	Cynisca	(Mo.Ga,Ar)	Cyrtoceratites	(Mo,Ce,On)
Cylindropora	(Br,St,Cc)	Cyniscella	(Mo.Ga,Ar)	Cyrtia	(Br.Ar,Sp)
Cylindrosmia	(Cn.An,Se)	Cynoceras	(Cd.Re,Ch)	Cyrtina	(Br.Ar,Sp)
Cylindrostylus	(Cn.An,Ta)	Cynopodius	(Cd,Ch,Pe)	Cyrtinaella	(Br.Ar,Sp)
Cylindroteuthis	(Mo,Ce,Be)	Cynoscion	(Cd.Os,Pl)	Cyrtinoides	(Br.Ar,Sp)
Cylindrotheca	(He,Pt,Rh)	Cypellia	(Po,He,Ly)	Cyrtinopsis	(Br.Ar,Sp)
Cylindrotrocholina	(Fo.Fo,Fo)	Cypellospongia	(Po,He,Ls)	Cyrtiopsis	(Br.Ar,Sp)
Cylindrot truncatum	(Mo.Ga,Ce)	Cypelometra	(Ec,Cr,Cm)	Cyrtiorina	(Br.Ar,Sp)
Cylioeceras	(Mo,Ce,Am)	Cyphaspides	(Ar.Tr,Pr)	Cyrtiphaeroneium	(Ac,Ra,Sp)
Cylocrinus	(Ec,Cr,Cl)	Cyphaspis	(Ar.Tr,Pr)	Cyrtisphaeractemium	(Ac,Ra,Sp)
Cylismilia	(Cn.An,Se)	Cyphastraea	(Cn.An,Se)	Cyrtobactrites	(Mo,Ce,An)
Cyllene	(Mo.Ga,Ne)	Cyphinooides	(Ar.Tr,Pr)	Cyrtobaltoceras	(Mo,Ce,El)
Cyllenina	(Mo.Ga,Ne)	Cyphocrinus	(Ec,Cr,Di)	Cyrtobolia	(Po,He,He)
Cymbalobina	(Ar.Os,Pa)	Cyphoma	(Mo.Ga,Nt)	Cyrtocalpis	(Ac,Ra,Na)
Cymaceras	(Mo,Ce,Am)	Cyphomena	(Br.Ar,St)	Cyrtocapsa	(Ac,Ra,Na)
Cymaclymenia	(Mo,Ce,Cl)	Cyphomenoidea	(Br.Ar,St)	Cyrtocapsella	(Ac,Ra,Na)
Cymahoplites	(Mo,Ce,Am)	Cyphonella	(Bz,Gy,Ch)	Cyrtoceras	(Mo,Ce,On)
Cymakra	(Mo.Ga,Ne)	Cyphoniscus	(Ar.Tr,As)	Cyrtoceratites	(Mo,Ce,On)
Cymatelsma	(Cn.An,Ru)	Cyphonocheilus	(Mo.Ga,Ne)	Cyrtoceria	(Mo,Ce,El)
Cymatella	(Cn.An,Ru)	Cyphonotus	(Ar,MI,De)	Cyrtocheilus	(Mo,Ce,On)
Cymatiella	(Mo.Ga,Nt)	Cyphoprotetus	(Ar.Tr,Pr)	Cyrtochetus	(Mo.Ga,Ne)
Cymatium	(Mo.Ga,Nt)	Cyphotoloxia	(Br,Ar,St)	Cyrtochelus	(Mo,Ce,Am)
Cymatoceras	(Mo,Ce,Na)	Cyphoterorhynchus	(Br.Ar,Rh)	Cyrtochilites	(Pr,Un,In)
Cymatochiton	(Mo,Po,Ne)	Cyphotrypa	(Bz,St,Tr)	Cyrtoelymenia	(Mo,Ce,Cl)
Cymatodus	(Cd,Ch,In)	Cyphoxis	(Mo,Bi,Ar)	Cyrtocrinus	(Ec,Cr,Cy)
Cymatoga	(Ar,MI,Is)	Cypraeta	(Mo.Ga,Nt)	Cyrtocyathus	(Cn.An,Se)
Cymatogaster	(Cd.Os,Pl)	Cypraecassis	(Mo.Ga,Nt)	Cyrtocypris	(Ar.Os,Me)
Cymatograptus	(He,Gr,De)	Cypraedia	(Mo.Ga,Nt)	Cyrtodaria	(Mo,Bi,My)
Cymatoica	(Mo,Bi,Ve)	Cypraerato	(Mo.Ga,Nt)	Cyrtodechenella	(Ar.Tr,Pr)
Cymatonautilus	(Mo,Ce,Na)	Cypraegemmula	(Mo.Ga,Nt)	Cyrtodelphis	(Cd,Ma,Ce)
Cymatonota	(Mo,Bi,Mo)	Cypracopsis	(Mo.Ga,Nt)	Cyrtodiscus	(Mo,In,In)
Cymatopegma	(Mo,Ro,Ri)	Cypraeorbis	(Mo.Ga,Nt)	Cyrtodonta	(Mo,Bi,Ar)
Cymatophos	(Mo.Ga,Ne)	Cypraecoriviva	(Mo.Ga,Nt)	Cyrtodontula	(Mo,Bi,Ar)
Cymatorhynchia	(Br.Ar,Rh)	Cyrella	(Ar.Os,My)	Cyrtogomphoceras	(Mo,Ce,Di)
Cymatosaurus	(Cd,Re,No)	Cypricardella	(Mo,Bi,Ve)	Cyrtogomphus	(Mo,Ce,On)
Cymatospira	(Mo.Ga,Be)	Cypricardinia	(Mo,Bi,Ve)	Cyrtograptus	(He,Gr,Gr)
Cymatosyrinx	(Mo.Ga,Ne)	Cypricardites	(Mo,Bi,Ar)	Cyrtolites	(Mo,Te,Cy)
Cymbalopora	(Fo.Fo,Fo)	Cyprideis	(Ar.Os,Po)	Cyrtomites	(Ar.Tr,Ph)

Cyrtoneλλα	(Mo, Te, Cy)	Cystothalamia	(Po, De, Pe)	Dacrocirinus	(Ec, Cr, Mi)
Cyrtoneλλοψις	(Mo, Te, Cy)	Cystothalamiella	(Po, De, Pe)	Daedalichthys	(Cd, Os, Pa)
Cyrtonicus	(Br, Ar, St)	Cystothyris	(Br, Ar, Te)	Daedalocirinus	(Ec, Cr, Ds)
Cyrtonotella	(Br, Ar, Or)	Cythara	(Mo, Ga, Ne)	Daghanirhynchia	(Br, Ar, Rh)
Cyrtonotreta	(Br, Li, Ac)	Cythereella	(Mo, Ga, Ne)	Dagmaraephyllum	(Cn, An, Ru)
Cyrtonowakia	(Mo, Cr, Da)	Cytheralison	(Ar, Os, Po)	Dagmarella	(Fo, Fo, Fo)
Cyrtonybyoceras	(Mo, Ce, Ac)	Cythere	(Ar, Os, Po)	Dagmarita	(Fo, Fo, Fo)
Cyrtophyllum	(Cn, An, Ta)	Cythereis	(Ar, Os, Po)	Dagnacnometes	(Br, Ar, St)
Cyrtopinna	(Mo, Bi, Mt)	Cythereella	(Ar, Os, Pl)	Dagnoceras	(Mo, Ce, Ce)
Cyrtopleura	(Mo, Bi, My)	Cytherellina	(Ar, Os, Me)	Daguinaspis	(Ar, Tr, Ol)
Cyrtopleurites	(Mo, Ce, Ce)	Cytherelloidea	(Ar, Os, Pl)	Daguinaspis	(Ar, Tr, Un)
Cyrtopora	(Bz, St, Ce)	Cytheretta	(Ar, Os, Po)	Dagysorhynchia	(Br, Ar, Rh)
Cyrtoproetus	(Ar, Tr, Pr)	Cytheridea	(Ar, Os, Po)	Dagyspirifer	(Br, Ar, Sp)
Cyrtorizoceras	(Mo, Ce, On)	Cytheridella	(Ar, Os, Po)	Dahaiella	(Ar, Os, Ar)
Cyrtorostra	(Mo, Bi, Pt)	Cytheriopsis	(Mo, Bi, Ve)	Daharella	(Po, Ca, Ph)
Cyrtosiceras	(Mo, Ce, Am)	Cytherissa	(Ar, Os, Po)	Daharina	(Mo, Bi, Ve)
Cyrtospira	(Mo, Ga, Nt)	Cytherissinella	(Ar, Os, Po)	Dahomeya	(Ar, Os, Po)
Cyrtospirifer	(Br, Ar, Sp)	Cytherocardia	(Mo, Bi, Ve)	Daidia	(Mo, Ga, Ar)
Cyrtospyroceras	(Mo, Ce, On)	Cytherodon	(Mo, Bi, Tr)	Daihuania	(Ar, Tr, Pr)
Cyrtosteus	(Cd, Pl, Ar)	Cytherois	(Ar, Os, Po)	Dailyatia	(Pr, To, Mi)
Cyrtostropha	(Mo, Ga, Ar)	Cytheroma	(Ar, Os, Po)	Dailycyathus	(Po, Re, Aj)
Cyrtosymbole	(Ar, Tr, Pr)	Cytheromorpha	(Ar, Os, Po)	Dainella	(Fo, Fo, Fo)
Cyrtosymboloides	(Ar, Tr, Pr)	Cytheropterina	(Ar, Os, Po)	Dainita	(Fo, Fo, Fo)
Cyrtothoracoceras	(Mo, Ce, Or)	Cytheropteron	(Ar, Os, Po)	Daintiella	(Fo, Fo, Fo)
Cyrtothyris	(Br, Ar, Te)	Cytherura	(Ar, Os, Po)	Daira	(Ar, ML, De)
Cyrtovaginoceras	(Mo, Ce, En)	Cytidocirinus	(Ec, Cr, Mo)	Daitingichthys	(Cd, Os, Cl)
Cyrtulotibia	(Mo, Ga, Nt)	Cytis	(Bz, St, Ce)	Daixina	(Fo, Fo, Fo)
Cystacysthereis	(Ar, Os, Po)	Cytcocirinus	(Ec, Cr, Mo)	Daixites	(Mo, Ce, Go)
Cystammima	(Fo, Fo, Fo)	Cytoracea	(Po, De, Li)	Dakaria	(Bz, Gy, Ch)
Cystaster	(Ec, Ed, Is)	Cyttarocirinus	(Ec, Cr, Mo)	Dakeoceras	(Mo, Ce, El)
Cystauletes	(Po, De, Pe)	Cyttaroplasma	(Cn, An, Ru)	Dakosaurus	(Cd, Re, Cr)
Cystelasma	(Cn, An, Ru)	Cytooides	(Cd, Os, Ze)	Dakoticancer	(Ar, ML, De)
Cysticamara	(He, Gr, Ca)	Czarnockia	(Cn, An, Ru)	Dala	(Ar, Bp, Bp)
Cysticonophyllum	(Cn, An, Ru)	Czekanow-skites	(Mo, Ce, Ce)	Dalaia	(Br, Ar, Sp)
Cysticyathus	(Po, Uc, Un)	Dabasacanthus	(Cd, Ch, Ct)	Dalatia	(Cd, Ch, Sq)
Cystihalysites	(Cn, An, Ta)	Dabashanella	(Ar, Os, Ar)	Dalecarlioceras	(Mo, Ce, On)
Cystihexagonaria	(Cn, An, Ru)	Dabashanites	(Pr, Co, Sa)	Daleiella	(Ar, Os, Po)
Cystilophophyllum	(Cn, An, Ru)	Dabashanospira	(Br, Ar, Sp)	Dalejeproetus	(Ar, Tr, Pr)
Cystipaliphyllum	(Cn, An, Ru)	Dacicardium	(Mo, Bi, Ve)	Dalejina	(Br, Ar, Or)
Cystiphorolites	(Cn, An, Ru)	Dacrydium	(Mo, Bi, Mt)	Dalejocystis	(Ec, Hs, So)
Cystiphylloides	(Cn, An, Ru)	Dacryomyia	(Mo, Bi, Nu)	Dalejodiscus	(Br, Ar, St)
Cystiphyllum	(Cn, An, Ru)	Dacryoperella	(Bz, Gy, Ch)	Dalelina	(Ar, Os, Le)
Cystiramus	(Bz, St, Cy)	Daeryopora	(Bz, St, Ce)	Dalerhynchus	(Br, Ar, Rh)
Cystisella	(Bz, Gy, Ch)	Dactylaraea	(Cn, An, Sc)	Dalinuria	(Br, Ar, St)
Cystispina	(Ar, Tr, Pr)	Dactylidella	(Mo, Ga, Ne)	Daljanolites	(Cn, An, Ta)
Cystispongia	(Po, He, Ly)	Dactylidia	(Mo, Ga, Ne)	Dallarca	(Mo, Bi, Ar)
Cystistroma	(Po, De, St)	Dactylioceras	(Mo, Ce, Am)	Dalliella	(Mo, Ga, Nt)
Cystitrypa	(Bz, St, Cy)	Dactyliosphaera	(Ac, Ra, Sp)	Dalligas	(Br, Ar, Te)
Cystitrypanopora	(Cn, An, Ta)	Dactylites	(Po, De, Li)	Dallina	(Br, Ar, Te)
Cystoblastus	(Ec, Rh, Rh)	Dactylocalycites	(Po, De, Li)	Dallinella	(Br, Ar, Te)
Cystocantrilla	(Cn, An, Ru)	Dactylocalyx	(Po, He, Ly)	Dalliestia	(Mo, Ga, Nt)
Cystocerium	(Po, De, St)	Dactylocalyxalus	(Ar, Tr, As)	Dallithyris	(Br, Ar, Te)
Cystodendropora	(Cn, An, Ta)	Dactylocoenia	(Cn, An, Sc)	Dallocardia	(Mo, Bi, Ve)
Cystodictya	(Bz, St, Cy)	Dactyloerinus	(Ec, Cr, Sa)	Dallonella	(Ar, Os, Po)
Cystodytes	(Cd, Tu, Tu)	Dactylocystis	(Ec, Di, Di)	Dalmanella	(Br, Ar, Or)
Cystograptus	(He, Gr, Gr)	Dactylogonia	(Br, Ar, St)	Dalmanellopsis	(Br, Ar, Or)
Cystolonsdaleia	(Cn, An, Ru)	Dactylopopon	(Cd, Os, El)	Dalmaniopsis	(Ar, Un, Un)
Cystolyriasma	(Cn, An, Ru)	Dactyloptena	(Cd, Os, Da)	Dalmanites	(Ar, Tr, Ph)
Cystomatochilina	(Ar, Os, Pa)	Dactylopterus	(Cd, Os, Da)	Dalmanitina	(Ar, Tr, Ph)
Cystophora	(Cd, Ma, Ca)	Dactylosaurus	(Cd, Re, No)	Dalmanitoides	(Ar, Tr, Ph)
Cystophrentis	(Cn, An, Ru)	Dactylosmia	(Cn, An, Sc)	Dalmanitulus	(Ar, Tr, Ph)
Cystoporella	(Bz, St, Ce)	Dactyloteuthis	(Mo, Ce, Be)	Dalmanophyllum	(Cn, An, Ru)
Cystostictoporus	(Bz, St, Fe)	Dactylotreta	(Br, Li, Ac)	Dalmasiceras	(Mo, Ce, Am)
Cystostroma	(Po, De, St)	Dactyosachites	(Pr, Co, Sa)	Dalmaticthys	(Cd, Os, Po)

Dalmatites	(Mo,Ce,Ce)	Dasyalosia	(Br,Ar,St)	Declivolithus	(Ar,Tr,As)
Dalnia	(Cn,An,Ru)	Dasyatis	(Cd,Ch,My)	Decorella	(Ar,Os,Pa)
Dalpiazzella	(Cd,Os,An)	Dasyceras	(Mo,Ce,Ph)	Decoriconus	(Cd,Co,Co)
Dalpiazia	(Cd,Ch,Rj)	Dasyconus	(Cn,Hc,He)	Decorites	(Mo,Ce,Go)
Damaiaospis	(Ar,Tr,Pt)	Dasyostoma	(Mo,Ga,Nt)	Decoritheca	(Hy,Uc,Uc)
Damalichthys	(Cd,Os,PF)	Dasyaria	(Br,Ar,St)	Decoroproetus	(Ar,Tr,Pr)
Damaoella	(Ar,Os,Ar)	Datangia	(Br,Ar,St)	Decoropugnax	(Br,Ar,Rh)
Damesella	(Ar,Tr,Od)	Datta	(Mo,Bi,Pt)	Decoroscutellum	(Ar,Tr,Co)
Damesia	(Mo,Ga,Ar)	Daucina	(Fo,Fo,Fo)	Decorospira	(Mo,Ga,Ar)
Damesicerias	(Mo,Ce,Am)	Daucinoides	(Fo,Fo,Fo)	Decurella	(Bz,St,Cc)
Damesites	(Mo,Ce,Am)	Davichthys	(Cd,Os,El)	Decurtaria	(Bz,Gy,Ch)
Damiriella	(Ar,Os,Pa)	Davidsonella	(Br,Ar,Th)	Decurtella	(Br,Ar,Rh)
Damonella	(Ar,Os,Pa)	Davidsonia	(Br,Ar,At)	Decus	(Ar,Tr,Pt)
Dampietrigonia	(Mo,Bi,Tr)	Davidsoniatrypa	(Br,Ar,At)	Dedzetina	(Br,Ar,Or)
Dananzhuangaspis	(Ar,Tr,Pt)	Davidsonina	(Br,Ar,Sp)	Deelgella	(Ar,Os,Pa)
Danaoceras	(Mo,Ce,On)	Daviesiconus	(Mo,Fo,Fo)	Deflandrecyrtium	(Ac,Ra,Na)
Danaphos	(Cd,Os,St)	Daviesiella	(Br,Ar,St)	Deflandrella	(Ac,Ra,Sp)
Danatinia	(Cd,Os,La)	Daviesina	(Fo,Fo,Fo)	Deflandrellium	(Ac,Ra,Sp)
Dandya	(Cd,Os,Se)	Davinirhynchia	(Br,Ar,Rh)	Defordia	(Po,De,Li)
Danella	(Br,Ar,Th)	Davoustia	(Br,Ar,St)	Defrancia	(Cn,An,Sc)
Dannevigia	(Cd,Os,Op)	Dawania	(Ar,Os,Pa)	Defrancipora	(Bz,St,Cc)
Danoceras	(Mo,Ce,On)	Dawsonelloides	(Br,Ar,St)	Degamella	(Ar,Tr,As)
Danubiella	(Fo,Fo,Fo)	Dawsonia	(Ar,Tr,Ag)	Degeletticyathus	(Po,Re,Aj)
Danubisphinctes	(Mo,Ce,Am)	Dawsonoceras	(Mo,Ce,Or)	Degrangia	(Mo,Bi,My)
Danubites	(Mo,Ce,Ce)	Dawsonocerinia	(Mo,Ce,Or)	Dehmicystis	(Ec,Hs,So)
Danzania	(Br,Ar,Sp)	Daxatina	(Mo,Ce,Ce)	Dehornella	(Po,De,Ar)
Danzkoceras	(Mo,Ce,Na)	Daxia	(Fo,Fo,Fo)	Dehinira	(Mo,Ga,Ar)
Daonella	(Mo,Bi,Pt)	Dayia	(Br,Ar,At)	Deiloceras	(Mo,Ce,Di)
Dapalis	(Cd,Os,PF)	Dayiceras	(Mo,Ce,Am)	Deinoceeras	(Mo,Ce,Di)
Dapaloides	(Cd,Os,PF)	Dayongia	(Ar,Tr,Ph)	Deiphon	(Ar,Tr,Ph)
Dapedium	(Cd,Os,Se)	Daytonia	(Ar,Tr,Ph)	Deiracephalus	(Ar,Tr,Pt)
Daphnella	(Mo,Ga,Ne)	Dazhuercinus	(Ec,Cr,U)	Deiracorallium	(Cn,An,Ru)
Daphnites	(Mo,Ce,Ce)	Deeruska	(Mo,Bi,Mo)	Deiradoceras	(Mo,Ce,Am)
Daphnobela	(Mo,Ga,Ne)	Deezybele	(Ar,Tr,Ph)	Deiradovelavus	(Pr,Ca,Ca)
Dapsilodus	(Cd,Co,Co)	Deadwoodia	(Ar,Tr,Pt)	Deiroceras	(Mo,Ce,Ae)
Daradaster	(Ec,Ec,Ca)	Deanaspis	(Ar,Tr,As)	Deirosaurus	(Cd,Re,No)
Daraelites	(Mo,Ce,Pl)	Deania	(Cd,Ch,Sq)	Deirostros	(Cd,Pl,Ar)
Daranyia	(Ar,MI,De)	Dearbornia	(Br,Li,Ae)	Dekayella	(Bz,St,Tr)
Darbya	(Mo,Ga,Ne)	Debarina	(Fo,Fo,Fo)	Dekayia	(Bz,St,Tr)
Darcinia	(Mo,Bi,Ve)	Debnikiella	(Cn,An,Ru)	Delagnostus	(Ar,Tr,Ag)
Dardanula	(Mo,Ga,Nt)	Decacystis	(Ec,Hm,Ci)	Delaria	(Ar,Tr,Pr)
Dardanus	(Ar,MI,De)	Decadocrinus	(Ec,Cr,Ci)	Delecticeras	(Mo,Ce,Am)
Darellia	(Mo,Ce,Am)	Decaheliocoenia	(Cn,An,Sc)	Delectopecten	(Mo,Bi,Pt)
Darendeella	(Mo,Bi,Hi)	Decameros	(Ec,Cr,Cm)	Delepineia	(Br,Ar,St)
Dariellina	(Fo,Fo,Fo)	Decaphyllum	(Cn,An,Ru)	Delepinoceras	(Mo,Ce,Go)
Dariopsides	(Fo,Fo,Fo)	Decapterus	(Cd,Os,PF)	Delgadella	(Ar,Tr,Ag)
Darjella	(Fo,Fo,Fo)	Decaschisma	(Ec,Bi,Fi)	Delheidia	(Cn,Hy,Un)
Darmuthia	(Cd,Ce,Ce)	Decatopecten	(Mo,Bi,Pt)	Delia	(Mo,Bi,Un)
Daronia	(Mo,Ga,Nt)	Decazella	(Cd,Os,Pa)	Deliablastus	(Ec,Bi,Sp)
Darteplacatula	(Mo,Bi,Pt)	Decemoblastus	(Ec,Bi,Sp)	Dellea	(Ar,Tr,Pt)
Dartoceras	(Mo,Ce,Un)	Deceptioncyathus	(Po,Re,Ap)	Delleana	(Ar,Tr,Pt)
Dartonaspis	(Ar,Tr,Pt)	Deceptrix	(Mo,Bi,Un)	Delocare	(Ar,Tr,Ph)
Dartonoceras	(Mo,Ce,En)	Dechaseauxia	(Mo,Bi,Hi)	Delocidaris	(Ec,Ec,Ci)
Darvasia	(Br,Ar,Sp)	Dechenella	(Ar,Tr,Pr)	Delocorinus	(Ec,Cr,Ci)
Darvasicerias	(Mo,Ce,Pl)	Decheneboides	(Ar,Tr,Pr)	Deloia	(Ar,Os,Pa)
Darvasites	(Fo,Fo,Fo)	Dechenellurus	(Ar,Tr,Pr)	Delops	(Ar,Tr,Ph)
Darwasophyllum	(Cn,An,Ru)	Decipia	(Mo,Ce,Am)	Delosia	(Ar,Os,Pa)
Dasbergoceras	(Mo,Ce,Na)	Decipilites	(Hy,Hy,Hy)	Delosites	(An,Po,Eu)
Dasciocrinus	(Ec,Cr,Ci)	Decipula	(Mo,Bi,Ve)	Delphinapterus	(Cd,Ma,Ce)
Dasmia	(Cn,An,Sc)	Deckera	(Ar,Tr,Pt)	Delphinavus	(Cd,Ma,Ce)
Dasmiopsis	(Cn,An,Sc)	Deckerella	(Fo,Fo,Fo)	Delphinites	(Mo,Ce,Am)
Dasmosmilia	(Cn,An,Sc)	Deckerellina	(Fo,Fo,Fo)	Delphinodon	(Cd,Ma,Ce)
Dasometopus	(Ar,Tr,Pt)	Deckeroceras	(Mo,Ce,Ba)	Delphinopsis	(Cd,Ma,Ce)
Dastilbe	(Cd,Os,Go)	Declinognathodus	(Cd,Co,Co)	Delphinosaurus	(Cd,Re,Le)

Delphinulopsis	(Mo,Ga,Ar)	Dendrophya	(Fo,Fo,Fo)	Derbyoides	(Br,Ar,St)
Delphinus	(Cd,Ma,Ce)	Dendrosmitia	(Cn,An,Sc)	Dercecis	(Cd,Os,Al)
Delphyodontos	(Cd,Ch,Cm)	Dendrosyrilla	(Ac,Ra,Na)	Dercectoides	(Cd,Os,Al)
Deltacare	(Ar,Tr,Un)	Dendrostella	(Cn,An,Ru)	Dereconchia	(Mo,Bi,Pt)
Deltacephalaspis	(Ar,Tr,Ph)	Dendrostroma	(Po,De,St)	Dereimsia	(Ar,Tr,Ph)
Deltachania	(Br,Ar,Sp)	Dendrozoum	(Cn,An,Ta)	Dereta	(Br,Ar,Te)
Deltaclavus	(Pr,Ca,Ca)	Denebola	(Cd,Ma,Ce)	Derivatolites	(Cn,An,Ta)
Deltacoleus	(Pr,Ma,Tu)	Deneechinus	(Ec,Ec,Ey)	Dermaster	(Ec,As,Fo)
Deltacrinus	(Ec,Cr,Ds)	Denella	(Ar,Tr,Ph)	Dermatopsis	(Cd,Os,Op)
Deltacystis	(Ec,Rh,Rh)	Denemarkia	(Ar,Tr,Pr)	Dermatostroma	(Po,De,St)
Deltadecohenella	(Ar,Tr,Pr)	Dengalosis	(Br,Ar,St)	Dermochelys	(Cd,Re,Ch)
Deltadiscus	(Ec,Ed,Is)	Denguiria	(Mo,Bi,Pt)	Dermomurex	(Mo,Ga,Ne)
Deltamya	(Mo,Bi,Ph)	Dengyngocoanus	(Mo,In,In)	Dermosastraea	(Cn,An,Sc)
Deltarhynchia	(Br,Ar,Rh)	Denigeria	(Po,De,Pe)	Dermoseris	(Cn,An,Sc)
Deltarina	(Br,Ar,Rh)	Denisonodus	(Cd,Pl,Pt)	Dermosmitia	(Cn,An,Sc)
Delientosteus	(Cd,Os,Pf)	Dennantia	(Mo,Ga,Ne)	Dermosmiliopsis	(Cn,An,Sc)
Delthyris	(Br,Ar,Sp)	Densalvus	(Br,Ar,Sp)	Derolytoceras	(Mo,Ce,Am)
Deltina	(Ar,Tr,Pt)	Densastroma	(Po,De,St)	Derrihas	(Cd,Os,Be)
Deltoblastus	(Ec,Bi,Sp)	Densepustula	(Br,Ar,St)	Derstolida	(Mo,Ga,Nt)
Deltoceras	(Mo,Ce,Ta)	Densigrewingkia	(Cn,An,Ru)	Dertonia	(Mo,Ga,Ne)
Deltocyathus	(Cn,An,Sc)	Densiphrentis	(Cn,An,Ru)	Derventina	(Fo,Fo,Fo)
Deltocyathoceras	(Mo,Ce,Na)	Densiphyllum	(Cn,An,Ru)	Desatrypa	(Br,Ar,At)
Deltodus	(Cd,Ch,In)	Densocyathus	(Po,Re,Aj)	Desertospira	(Mo,Ga,Ar)
Deltoideum	(Mo,Bi,Pt)	Densonella	(Ar,Tr,Pt)	Deshayesia	(Mo,Ga,Nt)
Deltoideonutilus	(Mo,Ce,Na)	Dentachites	(Pr,Un,In)	Deshayesites	(Mo,Ce,Am)
Deltopecten	(Mo,Bi,Pt)	Dentacodina	(Cd,Co,Co)	Desioceras	(Mo,Ce,El)
Deltoptychius	(Cd,Ch,Cm)	Dentalina	(Fo,Fo,Fo)	Desistropia	(Br,Ar,St)
Deltospirifer	(Br,Ar,Sp)	Dentalinella	(Fo,Fo,Fo)	Deslongchampsia	(Mo,Ga,Pa)
Denarezites	(Mo,Ce,Go)	Dentalinoides	(Fo,Fo,Fo)	Desmacrocerinus	(Ec,Cr,Ds)
Dembabaspira	(Mo,Ga,Nt)	Dentalinopsis	(Fo,Fo,Fo)	Desmatelesia	(Bz,St,Cc)
Demeterops	(Ar,Tr,Ph)	Dentalitrypa	(Bz,St,Cc)	Desmatochelys	(Cd,Re,Ch)
Deminucla	(Mo,Bi,Nu)	Dentalium	(Mo,Se,Sc)	Desmatophoca	(Cd,Ma,Ca)
Demirastrites	(He,Gr,Gr)	Dentallopoma	(Mo,Ga,Ar)	Desmechinus	(Ec,Ec,Te)
Demirina	(Fo,Fo,Fo)	Dentaloscutellum	(Ar,Tr,Pt)	Desmediaperoccia	(Bz,St,Cc)
Democrinus	(Ec,Cr,Bo)	Dentatococinus	(Po,Re,Aj)	Desmeplogioccia	(Bz,St,Cc)
Demomedys	(Br,Ar,St)	Dentex	(Cd,Os,Pf)	Desmepora	(Bz,St,Cc)
Demoulia	(Mo,Ga,Ne)	Dentiblastus	(Ec,Bi,Sp)	Desmidocrinus	(Ec,Cr,Mo)
Denaea	(Cd,Ch,Sy)	Denticelex	(Mo,Bi,Pt)	Desmidopora	(Po,De,Ta)
Denaecyathus	(Po,Re,Aj)	Denticrinus	(Ec,Cr,Is)	Desmidodus	(Cd,Ch,De)
Denagnostos	(Ar,Tr,Ag)	Denticuliphoria	(Br,Ar,Rh)	Desmoeceras	(Mo,Ce,Am)
Denariocrinus	(Ec,Cr,Cl)	Denticulites	(Mo,Cr,Te)	Desmochitina	(Fo,Fo,Ch)
Denayella	(Mo,Ga,Ar)	Dentilasma	(Cn,An,Ru)	Desmoeccladia	(Cn,An,Sc)
Denayphyllum	(Cn,An,Ru)	Dentimargo	(Mo,Ga,Ne)	Desmoecoenia	(Cn,An,Sc)
Denckmannites	(Ar,Tr,Ph)	Dentiporella	(Bz,Gy,Ch)	Desmoderma	(Po,He,Ly)
Dendostrea	(Mo,Bi,Pt)	Dentiscala	(Mo,Ga,Nt)	Desmograptus	(He,Gr,De)
Dendracis	(Cn,An,Sc)	Dentistyla	(Mo,Ga,Ar)	Desmoinesia	(Br,Ar,St)
Dendraraea	(Cn,An,Sc)	Dentitebera	(Mo,Ga,Ne)	Desmolyllites	(Mo,Ce,Am)
Dendraster	(Ec,Ec,Cl)	Dentoceras	(Mo,Ce,Na)	Desmophyllum	(Cn,An,Sc)
Dendrastraea	(Cn,An,Sc)	Dentoglobigerina	(Fo,Fo,Fo)	Desmopora	(Po,De,AX)
Dendritina	(Fo,Fo,Fo)	Dentokrithe	(Ar,Os,Po)	Desmoporella	(Cd,Pl,Pt)
Dendrocircus	(Ac,Ra,Na)	Dentonia	(Mo,Bi,Ve)	Desmorthis	(Br,Ar,Or)
Dendroclonella	(Po,De,I,i)	Dentoparaparchites	(Ar,Os,Pa)	Desmoscaphtes	(Mo,Ce,Am)
Dendrocomus	(Mo,Ga,Ne)	Dentospiriferina	(Br,Ar,Sp)	Desmospyris	(Ac,Ra,Na)
Dendrocrinus	(Ec,Cr,Cl)	Dentrimitra	(Mo,Ga,Ne)	Desmostroma	(Po,De,St)
Dendrocycathus	(Cn,An,Sc)	Dentrotubus	(He,Gr,Tu)	Desmostylus	(Cd,Ma,De)
Dendrocystites	(Ec,Hs,So)	Deocrinus	(Ec,Cr,Di)	Desorella	(Ec,Ec,Un)
Dendrocystoides	(Ec,Hs,So)	Depaocrinus	(Ec,Cr,Cl)	Desorinassa	(Mo,Ga,Ne)
Dendroecia	(Bz,St,Cc)	Depasophyllum	(Cn,An,Ru)	Despujolsia	(Ar,Tr,Re)
Dendrofavosites	(Cn,An,Ta)	Deprandus	(Cd,Os,An)	Desquamatia	(Br,Ar,At)
Dendrograptus	(He,Gr,De)	Depressiscula	(Mo,Ga,Nt)	Desumbatia	(Ec,Di,Di)
Dendrogyra	(Cn,An,Sc)	Derbiocrinus	(Ec,Cr,Cl)	Dettermania	(Ar,Os,Po)
Dendrohelia	(Cn,An,Sc)	Derbyella	(Br,Ar,St)	Deussenia	(Mo,Ga,Ne)
Dendroholmia	(Cn,An,Ru)	Derbyia	(Br,Ar,St)	Deuteronectanebos	(Pr,Un,In)
Dendrophyllia	(Cn,An,Sc)	Derbyina	(Br,Ar,Te)	Deuterospira	(Fo,Fo,Fo)

Deveonema	(Cd,Pl,Ar)	Diandongconus	(Mo,In,In)	Dicerodiscus	(Ar,Tr,Ag)
Devonalosia	(Br,Ar,St)	Diandongia	(Br,Li,Ac)	Diceromyonia	(Br,Ar,Or)
Devonamphistrophia	(Br,Ar,St)	Diandongpetalichthys	(Cd,Pl,Pe)	Dichacaenia	(Br,Ar,St)
Devonaria	(Br,Ar,St)	Dianella	(Mo,He,He)	Dichatomosella	(Br,Ar,Rh)
Devonaster	(Ec,As,Pu)	Dianops	(Ar,Tr,Ph)	Dichelepyge	(Ar,Tr,As)
Devonesteus	(Cd,Os,Di)	Dianulites	(Bz,St,Tr)	Dichelodus	(Cd,Ch,In)
Devonia	(Mo,Bi,Ve)	Diaperoecia	(Bz,St,Cc)	Dichocaeniopsis	(Cn,An,Sc)
Devoniotheca	(Hy,Or,Or)	Diaphana	(Mo,Ga,Ce)	Dichocoenia	(Cn,An,Sc)
Devonistella	(Ec,As,Pu)	Diaphanometopus	(Ar,Tr,Ph)	Dichocrinus	(Ec,Cr,Mo)
Devonobactrites	(Mo,Ce,An)	Diaphelasma	(Br,Ar,St)	Dichodella	(Cd,Co,Co)
Devonoblastus	(Ec,Bi,Sp)	Diaphoroceras	(Mo,Ce,El)	Dichograptus	(He,Gr,Gr)
Devonocaris	(Ar,Ml,Eo)	Diaphorocetus	(Cd,Ma,Ce)	Dichojerea	(Po,De,Li)
Devonocheilus	(Mo,Ce,Di)	Diaphorocrinus	(Ec,Cr,Ds)	Dichophyllia	(Cn,An,Ht)
Devonochonetes	(Br,Ar,St)	Diaphorodus	(Cd,Co,Co)	Dichospirifer	(Br,Ar,Sp)
Devonocidaris	(Ec,Ec,Ey)	Diaphragmus	(Br,Ar,St)	Dichospiropora	(Bz,St,Cc)
Devonocoryphe	(Ar,Tr,Pr)	Diaphus	(Cd,Os,My)	Dichostasia	(Mo,Ga,At)
Devonodontochile	(Ar,Tr,Ph)	Diaphodus	(Cd,Os,Ph)	Dichostreblocrinus	(Ec,Cr,Cl)
Devonopropodus	(Br,Ar,St)	Diaplectia	(Po,Ca,Ph)	Dichotomites	(Mo,Ce,Am)
Devonoproetus	(Ar,Tr,Pr)	Diaploceras	(Mo,Ce,Ce)	Diaplococeras	(Mo,Ce,Am)
Devonopronorites	(Mo,Ce,An)	Diarthema	(Mo,Ga,Nt)	Dichotomosmia	(Cn,An,Sc)
Devonospongia	(Po,De,Li)	Diartus	(Ac,Ra,Sp)	Dichotomosphinctes	(Mo,Ce,Am)
Devonosteus	(Cd,Os,Co)	Diaschophyllum	(Cn,An,Ru)	Dichotrypa	(Bz,St,Cy)
Devonozyga	(Mo,Ga,Nt)	Diasterofungia	(Po,Ca,Ph)	Dichozygopleura	(Br,Ar,Sp)
Dexiobia	(Mo,Bi,Pr)	Diastoloceras	(Mo,Ce,El)	Dicirrocrinus	(Ec,Cr,Un)
Dhosaites	(Mo,Ce,Am)	Diastoma	(Mo,Ga,Nt)	Dickersonia	(Mo,Ce,Am)
Dhrumaites	(Mo,Ce,Am)	Diastomella	(Mo,Ga,Nt)	Dickinsonella	(Mo,Ga,Ar)
Dhrumella	(Fo,Fo,Fo)	Diastopora	(Bz,St,Cc)	Dickinsonia	(Cn,Pe,Er)
Diabolepis	(Cd,Os,Di)	Diastoporina	(Bz,St,Cc)	Diclidaster	(Ec,As,Va)
Diabolirhynchia	(Br,Ar,Rh)	Diatinostoma	(Mo,Ga,Nt)	Dicoecura	(Ac,Ra,Sp)
Diaboloceras	(Mo,Ce,Go)	Diatorocrinus	(Ec,Cr,Mo)	Dicoelites	(Mo,Ce,Be)
Diabolocrinus	(Ec,Cr,Di)	Diatrypsis	(Mo,Ga,Nt)	Dicoelosia	(Br,Ar,Or)
Diacalymene	(Ar,Tr,Ph)	Diaulax	(Ar,Ml,De)	Dicoelospirifer	(Br,Ar,Sp)
Diacanthaspis	(Ar,Tr,Od)	Diaziceras	(Mo,Ce,Am)	Dicoelostrophia	(Br,Ar,St)
Diacanthocapsa	(Ac,Ra,Na)	Diazipora	(Bz,St,Tr)	Dicolocapsa	(Ac,Ra,Na)
Diacanthopora	(Bz,Gy,Ch)	Diazoma	(Br,Ar,Sp)	Dicoloboglossa	(Cd,Os,Pn)
Diacoryphe	(Ar,Tr,Pr)	Dibaphimitra	(Mo,Ga,Ne)	Dicondyliotreta	(Br,Li,Ac)
Diacria	(Mo,Ga,Th)	Dibaphus	(Mo,Ga,Ne)	Diconomorpha	(Mo,Ga,Ne)
Diactoma	(Ac,Ra,Sp)	Diberus	(Mo,Bi,Mt)	Diconularia	(Cn,Sc,Cn)
Diacyparia	(Po,De,Li)	Diblasius	(Cn,An,Sc)	Dicosmos	(Mo,Ga,Ar)
Diadeloplax	(Pr,Mu,St)	Dibolachras	(Ac,Ra,Na)	Dicostella	(Mo,Ce,Am)
Diadema	(Ec,Ec,Di)	Dibolbina	(Ar,Os,Pa)	Dicranastrum	(Ac,Ra,Sp)
Diademoceras	(Mo,Ce,Na)	Dibolbopisthia	(Ar,Os,Pa)	Dicranella	(Ar,Os,Pa)
Diademodus	(Cd,Ch,Co)	Dibrachioerapsus	(Ec,Cr,Cy)	Dicranoclonella	(Po,De,Li)
Diademopsis	(Ec,Ec,Pe)	Dibranchus	(Cd,Os,Lo)	Dicranodesma	(Mo,Bi,Ve)
Diadochoceras	(Mo,Ce,Am)	Dibunophyllum	(Cn,An,Ru)	Dicranodonta	(Mo,Bi,Ar)
Diaerecallus	(Mo,Ga,Nt)	Dibunostoma	(Bz,Gy,Ch)	Dicranognomus	(Ar,Tr,Li)
Diagoceras	(Mo,Ce,Or)	Dicamara	(Br,Ar,Sp)	Dicranograptus	(He,Gr,Gr)
Diagoniella	(Po,He,Re)	Dicamaropsis	(Br,Ar,Sp)	Dicranopeltis	(Ar,Tr,Li)
Diala	(Mo,Ga,Ne)	Dicantropyge	(Ar,Tr,Un)	Dicranopora	(Bz,St,Cr)
Dialeptophyllum	(Cn,An,Ru)	Dicaulograptus	(He,Gr,Gr)	Dicranurus	(Ar,Tr,Od)
Dialiipina	(Cd,Os,Pa)	Dicellograptus	(He,Gr,Gr)	Dicrenodus	(Cd,Ch,Ct)
Dialopsis	(Mo,Ga,Nt)	Dicellomus	(Br,Li,Li)	Dicriconconus	(Mo,Cr,Te)
Dialutocrinus	(Ec,Cr,Mo)	Dicellonema	(Mo,Ga,Be)	Dicroa	(Ac,Ra,Sp)
Dialyaster	(Ec,Ec,Ds)	Diceras	(Mo,Bi,Hi)	Dicroloma	(Mo,Ga,Nt)
Dialytophyllum	(Cn,An,Ru)	Diceratigalea	(Ac,Ra,Na)	Dicromyocrinus	(Ec,Cr,Cl)
Dialytostoma	(Mo,Ga,Nt)	Diceratobolbina	(Ar,Os,Pa)	Dicrorygma	(Ar,Os,Pa)
Diamantopora	(Cn,Hy,Mt)	Diceratocephalina	(Ar,Tr,Pt)	Dicrenocrinus	(Ec,Cr,Cl)
Diambonia	(Br,Ar,St)	Diceratocephalus	(Ar,Tr,Pt)	Dictocythere	(Ar,Os,Pa)
Diambonioidea	(Br,Ar,St)	Diceratocraptus	(He,Gr,Gr)	Dictuonia	(Bz,Gy,Ch)
Diamenocrinus	(Ec,Cr,Di)	Diceratopora	(Bz,Gy,Ch)	Dietyaraea	(Cn,An,Sc)
Diamessopora	(Bz,St,Cy)	Diceratopyge	(Ar,Tr,As)	Dietyastrum	(Ac,Ra,Sp)
Diameza	(Mo,Ga,Nt)	Dicerobairdia	(Ar,Os,Pa)	Dietyella	(Ar,Tr,Co)
Diamphidocystis	(Ec,St,Mi)	Dicerocardium	(Mo,Bi,Ve)	Dietyites	(Ar,Tr,Co)
Diancopora	(Bz,Gy,Ch)	Dicerocaris	(Ar,Un,Un)	Dietyobembix	(Mo,Ga,Ar)

Dictyobolus	(Br.Li.Li)	Didymosella	(Bz.Gy.Ch)	Dilophosina	(Br.Ar.Te)
Dictyocaris	(Ar.Ml.Ar)	Didymosphaera	(Po.De.Li)	Dimarzipecten	(Mo.Bi.Pt)
Dictyocephalus	(Ac.Ra.Na)	Didymothyris	(Br.Ar.Sp)	Dimegelasma	(Br.Ar.Sp)
Dictyoceras	(Mo.Ce.Or)	Didymotis	(Mo.Bi.Pt)	Dimelasma	(Cn.An.Ru)
Dictyoclostoides	(Br.Ar.St)	Diebelina	(Ar.Os.Po)	Dimensionaequalirostrum	(Br.Ar.Rh)
Dictyoclostus	(Br.Ar.St)	Diecithalamia	(Po.De.Pe)	Dimerella	(Br.Ar.Rh)
Dictyoceolia	(Po.De.Pe)	Diedrothyris	(Br.Ar.Te)	Dimeroceras	(Mo.Ce.Go)
Dictyoconella	(Fo.Fo.Fo)	Diegosmia	(Cn.An.Sc)	Dimeroclymenia	(Mo.Ce.Cl)
Dictyoconites	(Mo.Ce.Au)	Dielasma	(Br.Ar.Te)	Dimerocrinites	(Ec.Cr.Di)
Dictyoconoidea	(Fo.Fo.Fo)	Dielasmella	(Br.Ar.Te)	Dimeropyge	(Ar.Tr.Pr)
Dictyoconus	(Fo.Fo.Fo)	Dielasmina	(Br.Ar.Te)	Dimeropygiella	(Ar.Tr.Pr)
Dictyocoryne	(Ac.Ra.Sp)	Dielymella	(Ar.Os.Ar)	Dimidia	(Pr.Co.Ch)
Dictyocyathus	(Po.Ir.Ar)	Diemanosaukia	(Ar.Tr.As)	Diminovula	(Mo.Ga.Nt)
Dictyofavosites	(Cn.An.Ta)	Diempterus	(Mo.Ga.Nt)	Dimitobelus	(Mo.Ce.Be)
Dictyofavus	(Po.Ir.Ar)	Dieneria	(Mo.Ce.Ce)	Dimorpha	(Po.De.Li)
Dictyokathina	(Fo.Fo.Fo)	Dienope	(Br.Ar.Te)	Dimorpharaea	(Cn.An.Sc)
Dictyomitra	(Ac.Ra.Na)	Dienstina	(Ar.Tr.Ph)	Dimorphastrea	(Cn.An.Sc)
Dictyomitrella	(Ac.Ra.Na)	Dientomochilus	(Mo.Ga.Nt)	Dimorphastraeopsis	(Cn.An.Sc)
Dictyonathyrus	(Br.Ar.Sp)	Dierespongia	(Po.He.Re)	Dimorpha	(Fo.Fo.Fo)
Dictyonella	(Br.Ar.St)	Dierisma	(Br.Ar.Rh)	Dimorphinites	(Mo.Ce.Am)
Dictyonema	(He.Gr.De)	Diestoceras	(Mo.Ce.On)	Dimorphites	(Mo.Ce.Ce)
Dictyonina	(Br.Li.Pa)	Diestosphaecion	(Po.Ca.Ph)	Dimorphocella	(Bz.Gy.Ch)
Dictyonites	(Br.Li.Pa)	Diestothyris	(Br.Ar.Te)	Dimorphocellaria	(Bz.Gy.Ch)
Dictyophimus	(Ac.Ra.Na)	Dietrichia	(Mo.Bi.Ve)	Dimorphoceras	(Mo.Ce.Go)
Dictyophyton	(Po.He.Re)	Dietrichiella	(Mo.Ga.Pa)	Dimorphoceratoides	(Mo.Ce.Go)
Dictyopleurus	(Ec.Ec.Te)	Dieuryocrinus	(Ec.Cr.Sa)	Dimorphocoenia	(Cn.An.Sc)
Dictyopodium	(Ac.Ra.Na)	Difficilicrinus	(Ec.Cr.Ds)	Dimorphocoeniopsis	(Cn.An.Sc)
Dictyopora	(Cn.An.Ta)	Diffingia	(Cn.An.Ru)	Dimorphoconus	(Pr.Un.In)
Dictyopora	(Ac.Ra.Na)	Diffusolasma	(Cn.An.Ru)	Dimorphofungia	(Cn.An.Sc)
Dictyopsella	(Fo.Fo.Fo)	Difunites	(Mo.Ce.Pl)	Dimorphograptus	(He.Gr.Gr)
Dictyopselloides	(Fo.Fo.Fo)	Digenopora	(Bz.Gy.Ch)	Dimorpholepis	(Cd.Os.Pe)
Dictyoptychus	(Mo.Bi.Hi)	Digenoceras	(Mo.Ce.On)	Dimorphomeandra	(Cn.An.Sc)
Dictyoptype	(Cd.Os.Pa)	Dightonia	(Bz.Gy.Ch)	Dimorphophyllia	(Cn.An.Sc)
Dictyorbitolina	(Fo.Fo.Fo)	Digitalaria	(Mo.Bi.Ve)	Dimorphophylites	(Mo.Ce.Am)
Dictyoretmon	(Bz.St.Fe)	Digitariopsis	(Mo.Bi.Ve)	Dimorphoseris	(Cn.An.Sc)
Dictyorbhabdus	(Po.He.Re)	Digitolabrum	(Mo.Ga.Nt)	Dimorphosmia	(Cn.An.Sc)
Dictyospongia	(Po.He.Re)	Digitophyllites	(Mo.Ce.Ce)	Dimorphostylus	(Bz.Gy.Ch)
Dictyospyris	(Ac.Ra.Na)	Digitosmia	(Cn.An.Sc)	Dimorphotectus	(Mo.Ga.Ar)
Dictyostrophia	(Br.Ar.St)	Digmocythere	(Ar.Os.Po)	Dimorphotoceras	(Mo.Ce.Ce)
Dictyosycon	(Po.Ir.Ar)	Dignomia	(Br.Li.Li)	Dimya	(Mo.Bi.Pt)
Dictyothurites	(Ec.Ho.De)	Digonella	(Br.Ar.Te)	Dimyodon	(Mo.Bi.Pt)
Dictyothyris	(Br.Ar.Te)	Digonoclisia	(Cn.An.Ru)	Dinacrocrinus	(Ec.Cr.Mo)
Dictyothyropsis	(Br.Ar.Te)	Digonophyllum	(Cn.An.Ru)	Dinardocrinus	(Ec.Cr.Cy)
Dictyotomaria	(Mo.Ga.Ar)	Digonus	(Ar.Tr.Ph)	Dinarella	(Br.Ar.Te)
Dictyotoxotis	(Ar.Os.Pa)	Digoria	(Cd.Os.Br)	Dinarispira	(Br.Ar.Sp)
Dicyclina	(Fo.Fo.Fo)	Digrypos	(Ar.Tr.As)	Dinarites	(Mo.Ce.Ce)
Dicycloclidaris	(Ec.Ec.Ci)	Dihelice	(Mo.Ga.At)	Dinaspidella	(Cd.Pt.Pt)
Dicystoconcha	(Bi.Ai.St)	Dihelietera	(Br.Ar.At)	Dinaxis	(Mo.Ga.Nt)
Didactylum	(Ac.Ra.Sp)	Dihogmochilina	(Ar.Os.Le)	Dindymene	(Ar.Tr.Ph)
Dideroceras	(Mo.Ce.En)	Diholkorhynchia	(Br.Ar.Rh)	Dinlops	(Cd.Os.An)
Didianema	(Mo.Ga.Ar)	Dikelocephalites	(Ar.Tr.As)	Dinemagraptus	(He.Gr.Gr)
Didimacar	(Mo.Bi.Ar)	Dikelocephalopsis	(Ar.Tr.As)	Dinesus	(Ar.Tr.Co)
Didontogaster	(An.Po.Ph)	Dikelocephalus	(Ar.Tr.As)	Dingus	(Mo.St.St)
Didrepanon	(Ar.Tr.Ph)	Dikelocephalina	(Ar.Tr.As)	Dinichthys	(Cd.Pl.Ar)
Didwudina	(Ar.Tr.Pt)	Dikenaspis	(Cd.Pt.Pt)	Dinobolus	(Br.Li.Li)
Didymaspis	(Cd.Ce.Ce)	Dilatilabrum	(Mo.Ga.Nt)	Dinocardium	(Mo.Bi.Ve)
Didymelasma	(Br.Ar.Pe)	Dilatobactrites	(Mo.Ce.An)	Dinocystis	(Ec.Ed.Is)
Didymites	(Mo.Ce.Ce)	Dilatocrinus	(Ec.Cr.Mo)	Dinodus	(Cd.Co.Co)
Didymoceras	(Mo.Ce.Am)	Dilites	(Hy.Uc.Uc)	Dinomischus	(Pr.Un.In)
Didymocyathus	(Po.Re.Aj)	Dillerites	(Mo.Ce.An)	Dinomylostoma	(Cd.Pl.Ar)
Didymocyrtis	(Ac.Ra.Na)	Dillerium	(Cn.An.Ru)	Dinophyllum	(Cn.An.Ru)
Didymograptellus	(He.Gr.Gr)	Dilobella	(Ar.Os.Pa)	Dinopteryx	(Cd.Os.Br)
Didymograptus	(He.Gr.Gr)	Diloma	(Mo.Ga.Ar)	Dinorthis	(Br.Ar.Or)
Didymoparcium	(Br.Ar.Or)	Dilophaspis	(Ar.Ml.Ar)	Dinoscolites	(An.Po.Ph)

Dinostrophinx	(Cn.An,Ru)	Diplocyca	(Mo.Ga,Nt)	Dirceella	(Mo.Ga,Nt)
Dinotocrinus	(Ec.Cr,Ct)	Diploidesopora	(Bz.St,Cc)	Diretmus	(Cd.Os.Br)
Dinoziphius	(Cd.Ma,Ce)	Diplodetus	(Ec.Ec,Sp)	Dirhachopea	(Mo.Ga,Ar)
Diochthofera	(Br.Ar,Or)	Diplodiactyon	(Po.He,Ly)	Dirinus	(Br.Ar,Un)
Diodoceras	(Mo.Ce,Na)	Diplododella	(Cd.Co,Co)	Dirocerithium	(Mo.Ga,Nt)
Diodochoceras	(Mo.Ce,Am)	Diplodonta	(Mo.Bi,Ve)	Dirymoceras	(Mo.Ce,Am)
Diodon	(Cd.Os,Te)	Diplodus	(Cd.Os,Pf)	Disaraea	(Cn.An,Sc)
Diodora	(Mo.Ga,Ar)	Diploepora	(Cn.An,Ta)	Disaster	(Ec.Ec,Js)
Diogmopteron	(Ar.Os,Po)	Diplognathodus	(Cd.Co,Co)	Discagnostus	(Ar.Tr,Ag)
Diomedeoides	(Cd.Av,Pr)	Diplognathus	(Cd.Pl,Ar)	Discamminoides	(Fo.Fo,Fo)
Dionella	(Bz.Gy,Ch)	Diplograptus	(He.Gr,Gr)	Discanomalina	(Fo.Fo,Fo)
Dionide	(Ar.Tr,As)	Diplogrya	(Cn.An,Sc)	Dischides	(Mo.Sc,Sc)
Dionidella	(Ar.Tr,As)	Diplohelia	(Cn.An,Sc)	Dischidognathus	(Cd.Co,Co)
Dionites	(Mo.Ce,Ce)	Diplomeriza	(Mo.Ga,Ne)	Discholectypus	(Ec.Ec,Ho)
Diopatraites	(An.Po,Eu)	Diplomitra	(Mo.Ga,Ne)	Discinella	(Pr.Un,Hy)
Dioplotherium	(Cd.Ma,Si)	Diplomoceras	(Mo.Ce,Am)	Discinisa	(Br.Li,Ac)
Dioratiopus	(Ar.Ml,De)	Diplonorthis	(Br.Ar,Or)	Discinocaris	(Ar.Ml,In)
Dioristella	(Br.Ar,Sp)	Diplopetalopora	(Bz.St,Cc)	Discinopsis	(Br.Li,Ac)
Diorocetus	(Cd.Ma,Ce)	Diplophyllum	(Cn.An,Ru)	Discispongia	(Po.De,As)
Diorthelasma	(Br.Ar,Or)	Diploplegma	(Ac.Ra,Sp)	Discitoceras	(Mo.Ce,Na)
Diorugoceras	(Mo.Ce,Na)	Diplopleura	(Po.He,Un)	Discoactinoceras	(Mo.Ce,Ac)
Diorychtopora	(Cn.An,Ta)	Diplopodia	(Ec.Ec,Hm)	Discobasib	(Mo.Ga,He)
Diotis	(Mo.Bi,Pt)	Diploporaria	(Bz.St,Fe)	Discoceras	(Mo.Ce,Ta)
Dioxycaris	(Ar.Th,In)	Diploporaster	(Ec.Ec,Sp)	Discoceratites	(Mo.Ce,Ce)
Diozoptyxis	(Mo.Ga,He)	Diplopsis	(Ar.Os,Pa)	Discocoirris	(Mo.Ga,Ar)
Diparelasma	(Br.Ar,Or)	Diploria	(Cn.An,Sc)	Discoolymenia	(Mo.Ce,Go)
Dipentaspis	(Ar.Tr,Od)	Diplorhina	(Ar.Tr,Ag)	Discooella	(Po.Ca,Ph)
Dipharus	(Ar.Tr,Ag)	Diplorula	(Bz.Gy,Ch)	Discocoenia	(Cn.An,Sc)
Diphuicrinus	(Ec.Cr,Ct)	Diplosalenia	(Ec.Ec,Ec)	Discocoeniopsis	(Cn.An,Sc)
Diphyllospira	(Po.He,He)	Diploschiza	(Mo.Bi,Pt)	Discocrinus	(Ec.Cr,Ry)
Diphyphyllum	(Cn.An,Ru)	Diplosirenites	(Mo.Ce,Ce)	Discocyathus	(Cn.An,Sc)
Diplacanthograptus	(He.Gr,Gr)	Diplosolen	(Bz.St,Cc)	Discocyelina	(Fo.Fo,Fo)
Diplacanthopoma	(Cd.Os,Op)	Diplospiraerina	(Fo.Fo,Fo)	Discocystis	(Ec.Ed,Is)
Diplacmoceras	(Mo.Ce,Am)	Diplospinella	(Pr.Co,Ch)	Discocytis	(Bz.St,Cc)
Diplacodus	(Cd.Ch,In)	Diplospirella	(Br.Ar,Sp)	Discodermia	(Po.De,Li)
Diplactura	(Ac.Ra,Sp)	Diplostenopora	(Bz.St,Tr)	Discodermites	(Po.De,Li)
Diplagnostus	(Ar.Tr,Ag)	Diplostoma	(Po.Ca,Ph)	Discofascigera	(Bz.St,Cc)
Diplanus	(Br.Ar,St)	Diplostroma	(Po.De,St)	Discofustrellaria	(Bz.Gy,Ch)
Diplaraea	(Cn.An,Sc)	Diplotagma	(Ec.Ec,Ph)	Discogenus	(Mo.Ga,Ar)
Diplasioceras	(Mo.Ce,Am)	Diplothea	(Hy.Hy,Hy)	Discogonius	(Mo.Ga,Un)
Diplechinus	(Ec.Ec,Ph)	Diplotheangia	(Cn.An,Sc)	Discograptus	(He.Gr,Tu)
Diplesioceras	(Mo.Ce,Am)	Diplothemina	(Fo.Fo,Fo)	Discogypsina	(Fo.Fo,Fo)
Dipleura	(Ar.Tr,Ph)	Diplothesis	(Bz.Gy,Ch)	Discohelix	(Mo.Ga,Eu)
Dipleurites	(Mo.Bi,Pt)	Diplotrypa	(Bz.St,Tr)	Discohoplites	(Mo.Ce,Am)
Dipleurodonta	(Mo.Bi,Mo)	Diplozone	(Mo.Ga,Ar)	Discoidella	(Ar.Os,My)
Dipleuropyge	(Ar.Tr,As)	Dipnoides	(Cd.Pt,Un)	Discoids	(Ec.Ec,Ho)
Diploaspis	(Ar.Me,Ch)	Dipnorhynchus	(Cd.Os,Di)	Discoideocyathus	(Cn.An,Sc)
Diploastrea	(Cn.An,Sc)	Dipodospyris	(Ac.Ra,Na)	Discometra	(Ec.Cr,Cm)
Diplobelus	(Mo.Ce,Be)	Dipoloceras	(Mo.Ce,Am)	Discomiltha	(Mo.Bi,Ve)
Diploblastus	(Ec.Bl,Sp)	Dipoloceroides	(Mo.Ce,Am)	Discomyorthis	(Br.Ar,Or)
Diplocava	(Bz.St,Cc)	Dipterichthys	(Cd.Os,Pl)	Discophiceras	(Mo.Ce,Ce)
Diploceroides	(Cd.Os,Co)	Dipteroblastus	(Ec.Bl,Fi)	Discophyllites	(Mo.Ce,Ph)
Diplochaetetes	(Po.De,Ta)	Dipteronotus	(Cd.Os,Pe)	Discophyllum	(Cn.Hy,Hy)
Diplochilus	(Mo.Ga,Ar)	Dipterophyllum	(Mo.Ga,Ru)	Discophyma	(Po.He,Ly)
Diplochone	(Cn.An,Ru)	Dipterus	(Cd.Os,Di)	Discoporella	(Bz.Gy,Ch)
Diplocidaris	(Ec.Ec,Ci)	Diptychochilus	(Mo.Ga,Nt)	Discopsis	(Mo.Ga,Nt)
Diploclerna	(Bz.St,Cc)	Drptyxiella	(Mo.Ga,He)	Discopychites	(Mo.Ce,Ce)
Diplocoenia	(Cn.An,Sc)	Diptyxis	(Mo.Ga,Nt)	Discoramulina	(Fo.Fo,Fo)
Diploconcha	(An.Po,Se)	Dipulus	(Cd.Os,Op)	Discorbinella	(Fo.Fo,Fo)
Diploconula	(Mo.Ga,Eu)	Dipunctella	(Br.Ar,St)	Discorbis	(Fo.Fo,Fo)
Diplocrinus	(Ec.Cr,Is)	Dipyrgotes	(Ar.Tr,Pt)	Discorbitina	(Fo.Fo,Fo)
Diplocteniopsis	(Cn.An,Sc)	Dipyrgotes	(Ar.Tr,Od)	Discorbitura	(Fo.Fo,Fo)
Diploctenium	(Cn.An,Sc)	Dirachis	(Mo.Ga,Ar)	Discordichilus	(Mo.Ga,Eu)
Diplocyathellus	(Po.Re,Aj)	Diraphora	(Br.Ar,Or)	Discorinopsis	(Fo.Fo,Fo)

Discorotalia	(Fo,Fo,Fo)	Distoloceras	(Mo,Ce,Am)	Doellocoosmia	(Mo,Ga,Nt)
Discors	(Mo,Bi,Ve)	Distomodus	(Cd,Co,Co)	Doeschera	(Br,Ar,Sp)
Discosaurus	(Cd,Re,Ps)	Distorsio	(Mo,Ga,Nt)	Doeschera	(Hy,Hy,Hy)
Discoscala	(Mo,Ga,Nt)	Distriactis	(Ac,Ra,Sp)	Dogdathyrus	(Br,Ar,Sp)
Discoscaphites	(Mo,Ce,Am)	Distriatostylus	(Mo,Cr,Da)	Dogdo	(Br,Ar,Rh)
Discosella	(Bz,Gy,Ch)	Distyrax	(Ar,Tr,Ph)	Dogielina	(Fo,Fo,Fo)
Discosphonella	(Po,De,Pe)	Disulcatella	(Br,Ar,Pe)	Dogoriella	(Ar,Os,Pa)
Discosmia	(Cn,An,Sc)	Disulcinoides	(Ar,Os,Pa)	Dohaia	(Fo,Fo,Fo)
Discosorus	(Mo,Ce,Di)	Ditaxia	(Bz,St,Cc)	Dohmiella	(Ar,Tr,Pr)
Discosparsa	(Bz,St,Cc)	Ditaxipora	(Bz,Gy,Ch)	Dohmophyllum	(Cn,An,Ru)
Discosphinctes	(Mo,Ce,Am)	Ditaxiporina	(Bz,Gy,Ch)	Dokidocyathella	(Po,Re,Aj)
Discosphinctoides	(Mo,Ce,Am)	Dithecodendrum	(He,Gr,Un)	Dokidocyathus	(Po,Re,Aj)
Discospirina	(Fo,Fo,Fo)	Dithyrocaris	(Ar,MI,Ar)	Dokimocephalus	(Ar,Tr,Pt)
Discostroma	(Po,De,Ii)	Ditichia	(Mo,Bi,Nu)	Dokophyllum	(Cn,An,Ru)
Discotectonica	(Mo,Ga,He)	Ditoecholasma	(Cn,An,Ru)	Dolabella	(Mo,Ga,An)
Discotectus	(Mo,Ga,Ar)	Ditomopyge	(Ar,Tr,Pr)	Dolabra	(Mo,Bi,Tr)
Discotheca	(Mo,Ga,Ar)	Ditrabs	(Ac,Ra,Sp)	Dolatoerinus	(Ec,Cr,Mo)
Discotoma	(Mo,Ga,Ar)	Ditraenella	(Po,De,Hd)	Dolborella	(Ar,Os,Pa)
Discomaria	(Mo,Ga,Ar)	Ditremaster	(Ec,Ec,Sp)	Dolerobasiliscus	(Ar,Tr,As)
Discotreta	(Br,Li,Ac)	Ditreta	(Br,Li,Ac)	Doleroeras	(Mo,Ce,On)
Discotrochus	(Cn,An,Sc)	Ditretus	(Mo,Ga,Nt)	Doleroerinus	(Ec,Cr,Ds)
Discotropis	(Mo,Ga,Eu)	Ditrupa	(An,Po,Se)	Dolerooides	(Br,Ar,Or)
Discotropites	(Mo,Ce,Ce)	Ditrupula	(An,Po,Se)	Doleroenus	(Ar,Tr,Re)
Discotruncatulipora	(Bz,St,Cc)	Ditumarites	(Mo,Ce,Ce)	Dolerothitis	(Br,Ar,Or)
Discotrypa	(Bz,St,Tr)	Dittopora	(Bz,St,Tr)	Dolgaia	(Ar,Tr,Pt)
Discotrypina	(Bz,St,Tr)	Dittosaria	(Bz,Gy,Ch)	Dolgeuloma	(Ar,Tr,Pt)
Discotubigera	(Bz,St,Cc)	Ditypodon	(Mo,Bi,Ve)	Dolichognostus	(Ar,Tr,Ag)
Discouvermetulus	(An,Po,Se)	Diura	(Ar,Os,Me)	Dolichoblastus	(Ec,Bi,Fi)
Discovibracella	(Bz,Gy,Ch)	Divalinga	(Mo,Bi,Ve)	Dolichochochus	(Br,Ar,Te)
Discradisca	(Br,Li,Ac)	Divalucina	(Mo,Bi,Ve)	Dolichoerinus	(Ec,Cr,Un)
Disculcina	(Ar,Os,Pa)	Divaricardium	(Mo,Bi,Ve)	Dolichoeyathus	(Pr,Cr,Cr)
Disculina	(Br,Ar,Te)	Divaricella	(Mo,Bi,Ve)	Dolichoharpes	(Ar,Tr,Pt)
Disculus	(Mo,Ga,He)	Divaricospongia	(Po,He,Ls)	Dolichoholatus	(Mo,Ga,Ne)
Dishelopora	(Bz,Gy,Ch)	Divaricosta	(Br,Ar,Rh)	Dolichometopsis	(Ar,Tr,Co)
Disjectopora	(Po,De,AX)	Divarikellia	(Mo,Bi,Ve)	Dolichomocelypha	(Br,Un,Un)
Disoketa	(Mo,Ga,Nt)	Diversiphyllum	(Cn,An,Ru)	Dolichophonus	(Br,Ar,Sc)
Disolenia	(Ac,Ra,Sp)	Diversipora	(Bz,St,Cc)	Dolichoapteron	(Mo,Bi,Pt)
Disopontocypris	(Ar,Os,Po)	Diversograptus	(He,Gr,Gr)	Dolichoapterus	(Ar,Me,Eu)
Disparigonya	(Ar,Os,Pa)	Divisosphinctes	(Mo,Ce,Am)	Dolichorhynchops	(Cd,Re,Ps)
Disparilia	(Mo,Bi,Ve)	Dixieus	(Ec,Ec,Ph)	Dolichosaurus	(Cd,Re,Sq)
Disparistromaria	(Po,De,AX)	Dixiphopyge	(Ar,Tr,Pr)	Dolichoscapa	(Ar,Os,Pa)
Disphenia	(Br,Ar,Rh)	Dixonella	(Br,Ar,Sp)	Dolichoscapoides	(Ar,Os,Pa)
Disphenoceras	(Mo,Ce,En)	Dxonia	(Ec,Ec,Ho)	Dolichosina	(Br,Ar,Te)
Disphyllia	(Cn,An,Ru)	Dizerina	(Fo,Fo,Fo)	Dolichozygus	(Br,Ar,Te)
Disphyllum	(Cn,An,Ru)	Dizoniopsis	(Mo,Ga,Nt)	Dolichupis	(Mo,Ga,Nt)
Dispiriferina	(Br,Ar,Sp)	Dizygoerinus	(Ec,Cr,Mo)	Dolierassa	(Mo,Ga,Ar)
Displodoerinus	(Ec,Cr,Mo)	Dizygopleura	(Ar,Os,Pl)	Doliella	(Mo,Ga,He)
Disporella	(Bz,St,Cc)	Djurjuriceras	(Mo,Ce,Am)	Dolioecassis	(Mo,Ga,Nt)
Dispotaea	(Mo,Ga,Nt)	Dmitria	(Br,Ar,Sp)	Dolioerinus	(Ec,Cr,Ds)
Dissochilus	(Mo,Ga,Nt)	Dmitrispirifer	(Br,Ar,Sp)	Doliodelphus	(Cd,Ma,Ce)
Dissorja	(Br,Ar,Te)	Dnestrina	(Br,Ar,At)	Doliodus	(Cd,Ac,Is)
Dissostoma	(Mo,Ga,Nt)	Dnestrites	(Cn,An,Ta)	Doliognathus	(Cd,Co,Co)
Distansescharella	(Bz,Gy,Ch)	Dnestroceras	(Mo,Ce,Or)	Dolius	(Hy,Hy,Hy)
Distazeris	(Ar,Tr,As)	Dobrodgeiceras	(Mo,Ce,Am)	Dollfusia	(Mo,Bi,Ve)
Distefanaster	(Ec,Ec,Sp)	Dobrogeites	(Mo,Ce,Ce)	Dollocaris	(Ar,Th,Ce)
Distefanella	(Bz,Gy,Ch)	Dobrogelina	(Fo,Fo,Fo)	Dollochelys	(Cd,Re,Ch)
Disteginopora	(Bz,Gy,Ch)	Dobrogimaetra	(Mo,Bi,Ve)	Dollopteris	(Cd,Os,Pe)
Distichites	(Mo,Ce,Ce)	Dobrowlania	(Cd,Pl,Ac)	Dollosaurus	(Cd,Re,Sq)
Distichoceras	(Mo,Ce,Am)	Dochmocardia	(Mo,Bi,Ve)	Dollymae	(Cd,Co,Co)
Distichomeandra	(Cn,An,Sc)	Dodococeras	(Mo,Ce,Am)	Dolocythere	(Ar,Os,Co)
Distichoflabellum	(Cn,An,Sc)	Dododerma	(Po,He,Re)	Dolocytheridea	(Ar,Os,Po)
Distichophyllia	(Cn,An,Sc)	Docomphala	(Mo,Ga,Nt)	Dolomena	(Mo,Ga,Nt)
Distichopora	(Cn,Hy,St)	Dodecaactinella	(Po,Ca,Un)	Dolomitella	(Mo,Ga,He)
Distobolbina	(Ar,Os,Pa)	Dodecaeria	(An,Po,SP)	Doloresella	(Br,Ar,Pe)

Dolorthoceras	(Mo,Ce,Or)	Dorsoplanites	(Mo,Ce,Am)	Drepanaspis	(Cd,Pt,Pt)
Dolosella	(Fo,Fo,Fo)	Dorsoplicatyrhis	(Br,Ar,Te)	Drepanaster	(Ec,Op,Os)
Dolostoma	(Mo,Ga,Ne)	Dorsoscyphus	(Br,Ar,St)	Drepanella	(Ar,Os,Pa)
Dolponella	(Mo,Bi,Pt)	Dorsoserpula	(An,Po,Se)	Drepanellina	(Ar,Os,Pa)
Domaszevicella	(Ar,Os,Pa)	Dorudia	(Fo,Fo,Fo)	Drepanites	(Fo,Fo,Fo)
Domatoceras	(Mo,Ce,Na)	Dorudon	(Cd,Ma,Ce)	Drepaniotes	(Mo,Ce,Ce)
Dombargloria	(Mo,Ce,Go)	Dorvillea	(An,Po,Eu)	Drepanocheilus	(Mo,Ga,Nt)
Dombarites	(Mo,Ce,Go)	Doryagnostus	(Ar,Tr,Ag)	Drepanochites	(Pr,Co,So)
Dombarocanites	(Mo,Ce,Go)	Doryblastus	(Ec,BL,Sp)	Drepanocheono	(Mo,Ga,Ar)
Domechinus	(Ec,Ec,Ca)	Doryceras	(Mo,Ce,Go)	Drepanodus	(Cd,Co,Co)
Domerginella	(Mo,Ga,Ne)	Doryctanthidium	(Ac,Ra,Sp)	Drepanoistodus	(Cd,Co,Co)
Domeykos	(Cd,Os,Pe)	Dorycrinus	(Ec,Cr,Mo)	Drepanopterus	(Ar,Me,Eu)
Domfrontia	(Ec,St,Co)	Doryderma	(Po,De,Li)	Drepanopyge	(Ar,Tr,Re)
Dominicotrochus	(Cn,An,Sc)	Dorydictyum	(Ac,Ra,Sp)	Drepanorhynchia	(Br,Ar,Rh)
Dominina	(Ar,Os,Pa)	Dorydiscus	(Ac,Ra,Sp)	Drepanura	(Ar,Tr,Od)
Domokhotia	(Br,Ar,Sp)	Dorydruppa	(Ac,Ra,Sp)	Drepanuroides	(Ar,Tr,Re)
Donacoceras	(Mo,Ce,En)	Dorylonchidium	(Ac,Ra,Sp)	Dresbachia	(Ar,Tr,Pt)
Donacophyllum	(Cn,An,Ru)	Doryphacus	(Ac,Ra,Sp)	Drevennia	(Fo,Fo,Fo)
Donacopsis	(Mo,Bi,Ve)	Doryplegma	(Ac,Ra,Sp)	Dreverniana	(Ar,Tr,Pr)
Donacosmia	(Cn,An,Sc)	Dorypyge	(Ar,Tr,Co)	Drevöella	(Cn,Hy,Hy)
Donaldiella	(Mo,Ga,Ar)	Dorypygella	(Ar,Tr,Pt)	Dreverelasma	(Cn,An,Ru)
Donaldina	(Mo,Ga,He)	Dorypygina	(Ar,Tr,Co)	Drillia	(Mo,Ga,Ne)
Donalosa	(Br,Ar,St)	Dorysphaera	(Ac,Ra,Sp)	Drilliola	(Mo,Ga,Ne)
Donax	(Mo,Bi,Ve)	Dorytreta	(Br,Ar,Rh)	Drilluta	(Mo,Ga,Ne)
Donella	(Br,Ar,Rh)	Dosidicus	(Mo,Ce,Te)	Drilonereis	(An,Po,Eu)
Donellina	(Ar,Os,Pa)	Dosina	(Ar,Ci)	Drilonereisites	(An,Po,Eu)
Donetrites	(Cn,An,Ta)	Dosina	(Mo,Bi,Ve)	Drimys	(Cd,Os,Al)
Donetzoceras	(Mo,Ce,Go)	Dosinella	(Mo,Bi,Ve)	Drobna	(Ar,ML,De)
Dongbaella	(Br,Ar,Te)	Dosinia	(Mo,Bi,Ve)	Droharhynchia	(Br,Ar,Rh)
Dongbeispirifer	(Br,Ar,Un)	Dosiniopsella	(Mo,Bi,Ve)	Droilus	(Ac,Ra,Na)
Dongiovannia	(Mo,Ga,Ar)	Dosiniopsis	(Mo,Bi,Ve)	Dromia	(Ar,ML,De)
Dongshania	(Ar,Tr,Re)	Dosinobia	(Mo,Bi,Ve)	Dromilites	(Ar,ML,De)
Dongshanoceras	(Mo,Ce,El)	Dosinorbis	(Mo,Bi,Ve)	Dromiopsis	(Ar,ML,De)
Donispirifer	(Br,Ar,Sp)	Dostia	(Mo,Ga,Ar)	Droogeriella	(Fo,Fo,Fo)
Donnacysthere	(Ar,Os,Po)	Doubichites	(Mo,Ce,Go)	Drosodia	(Po,De,St)
Donophyllum	(Cn,An,Ru)	Doublatia	(Ar,Tr,Pr)	Drosodovia	(Po,Un,Un)
Doraclatum	(Ar,Os,Pa)	Douglasocaris	(Ar,Un,Un)	Drotops	(Ar,Tr,Ph)
Dorashamia	(Br,Ar,St)	Douvillester	(Ec,Ec,Sp)	Druganirhynchia	(Br,Ar,Rh)
Dorateuthis	(Mo,Ce,Te)	Douvilleia	(Mo,Ga,Ce)	Druidwilsonia	(Mo,Ga,Nt)
Doratocysthere	(Ar,Os,Po)	Douvilleceras	(Mo,Ce,Am)	Drulanta	(Ac,Ra,Na)
Doratodus	(Cd,Ch,Ct)	Douvilletonia	(Mo,Ga,Nt)	Drumaspis	(Ar,Tr,Pt)
Doreadospyris	(Ac,Ra,Na)	Douvillina	(Br,Ar,St)	Drummackina	(Br,Ar,St)
Doreadungula	(Mo,Bi,Pt)	Douvillinaria	(Br,Ar,St)	Drumoceras	(Mo,Ce,Ce)
Dordoniella	(Ar,Os,Po)	Douvillinella	(Br,Ar,St)	Drupa	(Mo,Ga,Ne)
Dordonophyllia	(Cn,An,Sc)	Douvillinoides	(Br,Ar,St)	Druppastylus	(Ac,Ra,Sp)
Doreckierinus	(Ec,Cr,Is)	Douvineilla	(Br,Ar,St)	Druppactraetus	(Ac,Ra,Sp)
Doremataopsis	(Ar,Tr,As)	Dowhatania	(Br,Ar,St)	Druppocarpus	(Ac,Ra,Sp)
Dorlopterus	(Ar,Me,Eu)	Dowlingoceras	(Mo,Ce,On)	Druppula	(Ac,Ra,Sp)
Doricysthereis	(Ar,Os,Po)	Doxander	(Mo,Ga,Nt)	Drydenius	(Cd,Os,Pa)
Dorikranites	(Mo,Ce,Ce)	Dozyia	(Mo,Bi,Ve)	Drymocrinus	(Ec,Cr,Ds)
Dorippe	(Ar,ML,De)	Drabia	(Ar,Tr,Pt)	Dryorhiopsis	(Fo,Fo,Fo)
Dorispina	(Ar,Os,Ar)	Drabodiscina	(Br,Li,Ac)	Dryptoscolex	(An,Po,Ph)
Dorlodotia	(Cn,An,Ru)	Draborthis	(Br,Ar,Or)	Dualina	(Mo,Bi,Pr)
Dorbuschia	(Ar,Os,Po)	Drabovaspis	(Ar,Me,Ag)	Duartea	(Br,Ar,St)
Dorocidaris	(Ec,Ec,Ci)	Drabovia	(Br,Ar,Or)	Duashoceras	(Mo,Ce,Am)
Dorothis	(Fo,Fo,Fo)	Drabovinella	(Br,Ar,Or)	Dubarechinus	(Ec,Ec,Or)
Dorsanum	(Mo,Ga,Ne)	Drachiella	(Ar,ML,De)	Dubaria	(Br,Ar,At)
Dorsatensia	(Mo,Ce,Am)	Dracius	(Br,Ar,Te)	Dubertretia	(Mo,Bi,Hi)
Dorsina	(Mo,Ga,Ne)	Dracolychnus	(Po,He,Ly)	Dubhglasina	(Ar,Tr,Pt)
Dorsirugatia	(Br,Ar,St)	Drahanorhynchus	(Br,Ar,St)	Dubioleptina	(Br,Ar,St)
Dorsisinus	(Br,Ar,Rh)	Drahanostrophita	(Br,Ar,St)	Dubius	(Pr,Cr,Cr)
Dorsojugatus	(Hy,Hy,Hy)	Drabomia	(Mo,Ce,Tr)	Dubrovia	(Cn,An,Ru)
Dorsolepis	(Cd,Os,Pa)	Drakonoceras	(Mo,Ce,Di)	Ducdonia	(Cn,An,Ta)
Dorsolineivus	(Hy,Hy,Hy)	Dreissenomya	(Mo,Bi,Ve)	Ductina	(Ar,Tr,Ph)

Ductor	(Cd,Os,Pf)	Durotrigensia	(Mo,Ce,Am)	Dzirulina	(Br,Ar,Te)
Dudleyaspis	(Ar,Tr,Od)	Durranelia	(Br,Ar,St)	Eamesiella	(Mo,Bi,Ve)
Dudu	(Ar,Tr,Pr)	Durvilleoceras	(Mo,Ce,Ce)	Earlachitina	(Fo,Fo,CH)
Duerleyoceras	(Mo,Ce,Na)	Duryella	(Br,Ar,Sp)	Earlandia	(Fo,Fo,Fo)
Dufrenoya	(Mo,Ce,Am)	Dusa	(Ar,MI,De)	Earlandiella	(Fo,Fo,Fo)
Duttonia	(Ar,Tr,Ph)	Dushanirhynchia	(Br,Ar,Rh)	Earlandinita	(Fo,Fo,Fo)
Duibianaspis	(Ar,Tr,As)	Dushanophrentis	(Cn,An,Ru)	Easchmidtella	(Ar,Os,Pa)
Duibianella	(Ar,Os,Ar)	Dusignathus	(Cd,Ma,Ca)	Eastmanalepes	(Cd,Os,Pf)
Duidrythyris	(Br,Ar,Te)	Dusisten	(Cd,Ma,St)	Eastmanosteus	(Cd,Pl,Ar)
Dukhamia	(Fo,Fo,Fo)	Duslia	(Ar,Un,Un)	Eastonastraea	(Cn,An,Ru)
Dulankarella	(Br,Ar,St)	Dutkevichella	(Fo,Fo,Fo)	Eastonerius	(Ac,Ra,Na)
Dulanocerinus	(Ec,Cr,Un)	Dutkevichites	(Fo,Fo,Fo)	Eastonia	(Mo,Bi,Ve)
Dulcineaia	(Mo,Bi,Mo)	Dutkevitchia	(Fo,Fo,Fo)	Eastonoides	(Cn,An,Ru)
Dulkumella	(Ar,Os,Pa)	Dutottella	(Ar,Os,Pol)	Eatonia	(Br,Ar,Rh)
Dulunomya	(Mo,Bi,Ph)	Dutrochus	(Mo,Ga,Ar)	Eatonicella	(Mo,Ga,Nt)
Dumassella	(Mo,Ga,Nt)	Duvalia	(Mo,Ce,Be)	Eatonoides	(Br,Ar,Rh)
Dumblea	(Ec,Ec,Hu)	Duvergiera	(Bz,Gy,Ch)	Ebala	(Mo,Ga,He)
Dumnomia	(Mo,Ga,Ne)	Dvorakia	(Cd,Co,Co)	Ebalia	(Ar,MI,De)
Dumontina	(Ar,Os,Pol)	Dwightoceras	(Mo,Ce,El)	Ebenaqua	(Cd,Os,Bb)
Dumortieria	(Mo,Ce,Am)	Dwortsowacrinus	(Ec,Cr,Un)	Ebetallites	(An,Pol,Un)
Dunbarella	(Mo,Bi,Ph)	Dwykia	(Cd,Os,Pa)	Ebianella	(Mo,In,In)
Dunbarinella	(Fo,Fo,Or)	Dyasma	(Mo,Bi,Ph)	Ebianotheca	(Hy,Or,Or)
Dunbarites	(Mo,Ce,Go)	Dybowskella	(Bz,St,Cy)	Eblanaia	(Fo,Fo,Fo)
Dunbartula	(Fo,Fo,Fo)	Dybowskinita	(Cn,An,Ru)	Ebobotrochus	(Cn,An,Se)
Duncanella	(Cn,An,Ru)	Dybowskites	(Bz,St,Tr)	Eboracicerias	(Mo,Ce,Am)
Duncania	(Cn,An,Ru)	Dyera	(Mo,Ga,Ar)	Eboroceras	(Mo,Ce,Am)
Duncaniaaster	(Ec,Ec,Hs)	Dyfrondicularia	(Fo,Fo,Fo)	Eboroziphus	(Cd,Ma,Ce)
Duncanoclema	(Bz,St,Cy)	Dymia	(Fo,Fo,Fo)	Ebrayia	(Cn,An,Se)
Duncanopora	(Cn,An,In)	Dynatoceras	(Mo,Ce,Di)	Ebrayiceras	(Mo,Ce,Am)
Duncanosammia	(Cn,An,Se)	Dyocbicides	(Fo,Fo,Fo)	Eburna	(Mo,Ga,Ne)
Duncanosmiaia	(Cn,An,Se)	Dyoconia	(Po,Ca,Ph)	Eburneopecten	(Mo,Bi,Pl)
Dunderbergella	(Ar,Tr,Pl)	Dyocopan	(Po,Ca,Ph)	Eburneotrochus	(Cn,An,Se)
Dunderbergia	(Ar,Tr,Pl)	Dyoidophragma	(Bz,St,Tr)	Eburnopsis	(Mo,Ga,Ne)
Dundrythyris	(Br,Ar,Te)	Dyoros	(Br,Ar,St)	Eburoceras	(Mo,Ce,El)
Dunedinites	(Mo,Ce,Ce)	Dyreaspis	(Cd,Pl,Pl)	Echblastia	(Po,He,He)
Dungulia	(Cn,An,Se)	Dyrosaurus	(Cd,Re,Cr)	Eccaparadoxides	(Ar,Tr,Re)
Dunhillia	(Po,De,Li)	Dyscheiloceras	(Mo,Ce,Go)	Eccentricostea	(Br,Ar,St)
Dunkeria	(Mo,Ga,He)	Dyschrestia	(Br,Ar,St)	Eccentricotheca	(Pr,To,Un)
Dunkleosteus	(Cd,Pl,Ar)	Dyscolia	(Br,Ar,Te)	Ecclimadictyon	(Po,De,St)
Dunleithoceras	(Mo,Ce,On)	Dyseritella	(Bz,St,Tr)	Ecclesiogyra	(Mo,Ga,Nt)
Dumicrinus	(Ec,Cr,Bo)	Dyseritellina	(Bz,St,Tr)	Eccoctochile	(Ar,Tr,Ph)
Dumsopteris	(Ar,Me,Eu)	Dyseritoceras	(Mo,Ce,El)	Eccoctochiloides	(Ar,Tr,Ph)
Dunveganoceras	(Mo,Ce,Am)	Dyseritothyris	(Br,Ar,Te)	Ecculiocephalus	(Mo,Ga,Eu)
Duodecimedusina	(Cn,In,In)	Dysidea	(Po,De,Di)	Eccylopteris	(Mo,Ga,Eu)
Duostomina	(Fo,Fo,Fo)	Dysnoetocella	(Bz,Gy,Ch)	Ecdyceras	(Mo,Ce,As)
Duotaxis	(Fo,Fo,Fo)	Dysnoetopla	(Mo,In,In)	Echelus	(Cd,Os,An)
Duotingia	(Ar,Tr,Co)	Dysnoetopora	(Bz,Gy,Ch)	Echeneis	(Cd,Os,Pl)
Dupericria	(Ec,Ec,Ho)	Dysondonta	(Mo,Bi,Nu)	Echierinus	(Ec,Cr,Is)
Duplella	(Fo,Fo,Fo)	Dysoristua	(Br,LI,Ac)	Echidnina	(Po,He,Un)
Duplexibollia	(Ar,Os,Pa)	Dysplanus	(Ar,Tr,Co)	Echidnocephalus	(Cd,Os,An)
Duplicaria	(Mo,Ga,Ne)	Dysprosithis	(Br,Ar,Or)	Echigonia	(Fo,Fo,Fo)
Dupliceristata	(Ar,Os,Pa)	Dystactella	(Mo,Bi,So)	Echigophyllum	(Cn,An,Ru)
Duplicatecten	(Mo,Bi,Pl)	Dystactocrinus	(Ec,Cr,De)	Echimalosia	(Br,Ar,St)
Duphloporoclythus	(Po,Re,Ap)	Dystactospongia	(Po,De,As)	Echinanthus	(Ec,Ec,Ca)
Duplocarimia	(Cn,An,Ru)	Dystrowia	(Cd,Pl,Th)	Echinarachnius	(Ec,Ec,Cl)
Duplophyllum	(Cn,An,Ru)	Dytocospirifer	(Br,Ar,Sp)	Echinaria	(Br,Ar,St)
Duplora	(Ar,Tr,Pl)	Dytremacephalus	(Ar,Tr,As)	Echinariella	(Br,Ar,St)
Durangites	(Mo,Ce,Am)	Dzhangirhynchia	(Br,Ar,Rh)	Echinaster	(Ec,As,Sp)
Durama	(Mo,Bi,Hi)	Dzhaprakoeras	(Mo,Ce,Go)	Echinasterella	(Ec,As,He)
Durga	(Mo,Bi,Hi)	Dzhebagina	(Br,Ar,St)	Echinauris	(Br,Ar,St)
Durhamella	(Ec,Ec,Cl)	Dzhinetoceras	(Mo,Ce,Na)	Echinellopsis	(Mo,Ga,Nt)
Durhamina	(Cn,Cn,Ru)	Dzhulites	(Mo,Ce,Ce)	Echinimathilda	(Mo,Ga,Nt)
Duringia	(Ar,Os,Pa)	Dzhulfoceras	(Mo,Ce,Ce)	Echininus	(Mo,Ga,Un)
Durina	(Ar,Tr,Un)	Dzieduszyckia	(Br,Ar,Sp)	Echirinynchia	(Br,Ar,Rh)

Echinobathra	(Mo,Ga,Nt)	Ectenoceras	(Mo,Ce,El)	Egdetheca	(Hy,Or,Or)
Echinocardium	(Ec,Ec,Sp)	Ectenocrinus	(Ec,Cr,Ds)	Egenayathere	(Ar,Os,Po)
Echinocaris	(Ar,MI,Ar)	Ectenodesma	(Mo,Bi,Pt)	Egerca	(Mo,Ga,Ne)
Echinocava	(Bz,St,Cc)	Ectenodietya	(Po,He,Re)	Egerella	(Mo,Bi,Ve)
Echinochimaera	(Cd,Ch,Cm)	Ectenoglossa	(Br,Li,Lj)	Egertonia	(Cd,Os,An)
Echinocirrus	(Mo,Ga,Ar)	Ectenolithes	(Mo,Ce,El)	Egesta	(Mo,Bi,Ve)
Echinocoelia	(Br,Ar,Sp)	Ectenonotus	(Ar,Tr,Ph)	Egestas	(Mo,Ga,Ne)
Echinocoeliopsis	(Br,Ar,Sp)	Ectenosaurus	(Cd,Re,Sq)	Eggerella	(Fo,Fo,Fo)
Echinocoenchella	(Br,Ar,St)	Ectillaenus	(Ar,Tr,Co)	Eggerellina	(Fo,Fo,Fo)
Echinocoynchus	(Br,Ar,St)	Ectinechinus	(Ec,Ec,Ey)	Eggerina	(Fo,Fo,Fo)
Echinocorys	(Ec,Ec,Hs)	Ectinochilus	(Mo,Ga,Nt)	Egilina	(Mo,Ga,He)
Echinocyamus	(Ec,Ec,Cl)	Ectocentrites	(Mo,Ce,Am)	Eglisia	(Mo,Ga,Nt)
Echinocyphus	(Ec,Ec,Te)	Ectochoristites	(Br,Ar,Sp)	Eglonaspis	(Cd,Pt,Pt)
Echinocystites	(Ec,Ec,Ey)	Ectocrinus	(Ec,Cr,Mo)	Egorovella	(Ar,Os,Pa)
Echinocythereis	(Ar,Os,Po)	Ectocycloceras	(Mo,Ce,El)	Egorovia	(Ar,Os,Po)
Echinodiscus	(Ec,Ec,Cl)	Ectocyrtoceras	(Mo,Ce,On)	Egorovitina	(Ar,Os,Pa)
Echinodus	(Cd,Ch,Ct)	Ectodemites	(Ar,Os,Pa)	Egorvella	(Ar,Os,Pa)
Echinoscerinites	(Ec,Rh,Rh)	Ectogrammysia	(Mo,Bi,Ph)	Egosiella	(Cn,An,Ta)
Echinofulgur	(Mo,Ga,Ne)	Ectolites	(Mo,Ga,Ce)	Egotistica	(Mo,Ga,Ne)
Echinogalerus	(Ec,Ec,Ho)	Ectomaria	(Mo,Ga,Ar)	Egrabensicerus	(Mo,Ce,Am)
Echinognathus	(Ar,Me,Et)	Ectonocorys	(Ac,Ra,Na)	Egracina	(Mo,Bi,Ve)
Echinolampas	(Ec,Ec,Ca)	Ectoposia	(Br,Ar,Te)	Egriona	(Mo,Bi,Ve)
Echinolichas	(Ar,Tr,Lj)	Ectoprimitia	(Ar,Os,Pa)	Egyngolia	(Ar,Tr,Ag)
Echinometra	(Ec,Ec,El)	Ectoprimitioides	(Ar,Os,Pa)	Ehlersella	(Br,Ar,Pe)
Echinomma	(Ac,Ra,Sp)	Ectoreusselandia	(Br,Ar,Te)	Ehlersia	(Ar,Os,Pa)
Echinoneus	(Ec,Ec,Ho)	Ectorhipidium	(Br,Ar,Pe)	Ehlersina	(Mo,Ga,Ar)
Echinopecten	(Mo,Bi,Pt)	Ectosteorthachis	(Cd,Os,Co)	Ehlersoceras	(Mo,Ce,On)
Echinopedina	(Ec,Ec,Pe)	Ectyphoria	(Br,Ar,Te)	Ehmania	(Ar,Tr,Pt)
Echinophaeops	(Ar,Tr,Ph)	Ecytherura	(Ar,Os,Po)	Ehmaniella	(Ar,Tr,Pt)
Echinophoria	(Mo,Ga,Nt)	Eczematolepis	(Cd,Pl,Pt)	Ehrenbergina	(Fo,Fo,Fo)
Echinophyllia	(Cn,An,Sc)	Edaphaspis	(Cd,Pl,Pt)	Eichbaumia	(Cn,Me,Me)
Echinopora	(Cn,An,Sc)	Edaphoceras	(Mo,Ce,Na)	Eichstaettia	(Cd,Os,El)
Echinoporina	(Fo,Fo,Fo)	Edaphodon	(Cd,Ch,Cm)	Eichwaldia	(Br,Ar,St)
Echinoprimitia	(Ar,Os,Pa)	Edaphophyllum	(Cn,An,Ru)	Eichwaldictya	(Bz,St,Cr)
Echinopsis	(Ec,Ec,Te)	Edapocernus	(Ec,Cr,Cl)	Eichwaldiella	(Mo,Ga,Nt)
Echinopyge	(Ar,Tr,Ph)	Edelsteinaspis	(Ar,Tr,Co)	Eichwaldoceras	(Mo,Ce,Ta)
Echinorbis	(Mo,Bi,Pt)	Edelsteinia	(Po,De,St)	Eidolosaurus	(Cd,Re,Sq)
Echinorhinus	(Cd,Ch,Sq)	Edenoceras	(Mo,Ce,On)	Eifelatrypa	(Br,Ar,At)
Echinosphæerites	(Ec,Rh,Rh)	Edenopsis	(Ar,Os,Pa)	Eifeloceras	(Mo,Ce,Or)
Echinospirifer	(Br,Ar,Sp)	Edestus	(Cd,Ch,Et)	Eifelocrinus	(Ec,Cr,Cl)
Echinosteges	(Br,Ar,St)	Edganocare	(Ar,Tr,Um)	Eiffelia	(Po,Ca,He)
Echinostrephus	(Ec,Ec,Ec)	Edgecombeaspis	(Ar,Tr,Od)	Eiffiarges	(Ar,Tr,Lj)
Echinothuria	(Ec,Ec,Et)	Edhemia	(Fo,Fo,Fo)	Eigilia	(Cd,Os,Pa)
Echinotiara	(Ec,Ec,Ph)	Ediacaria	(Cn,Sc,Um)	Eilottreta	(Br,Ar,Or)
Echinoturris	(Mo,Ga,Ne)	Edithaella	(Fo,Fo,Fo)	Eilura	(Ar,Tr,Um)
Echinus	(Ec,Ec,Ec)	Edithiella	(Ar,Tr,Pt)	Eirellithus	(Ar,Tr,As)
Echioeratooides	(Mo,Ce,Am)	Editia	(Ar,Os,Pa)	Eireocrinus	(Ec,Cr,Cl)
Echiocheras	(Mo,Ce,Am)	Edmondia	(Mo,Bi,Ph)	Eirlysia	(Mo,Ga,Ar)
Echiodon	(Cd,Os,Op)	Edmundites	(Mo,Ce,Ce)	Eirmocrinus	(Ec,Cr,Cl)
Echmatocrinus	(Ec,Cr,Ec)	Edmundsonia	(Ar,Tr,As)	Eiselia	(Mo,Ga,Ar)
Echyropora	(Cn,An,Ta)	Edomia	(Fo,Fo,Fo)	Eisenackiella	(Cn,Hy,Hy)
Echyrosia	(Br,Ar,Rh)	Edreja	(Br,Li,Ac)	Eisenackitina	(Fo,Fo,Ch)
Eckastraea	(Cn,An,Sc)	Edrioster	(Ec,Ed,Ed)	Eisenackirogaptus	(He,Gr,Gr)
Eclipses	(Cd,Os,Ga)	Edriocrinus	(Ec,Cr,Un)	Eisobardia	(Ar,Os,Po)
Eclusia	(Fo,Fo,Fo)	Edriodiscus	(Ec,Ed,Is)	Ejinaspis	(Ar,Tr,Pt)
Ecnomocaris	(Ar,Mo,Em)	Edriophus	(Ec,Ed,Ed)	Ejnespiriter	(Br,Ar,Sp)
Econgella	(Fo,Fo,Fo)	Edriospongria	(Po,De,Li)	Ekalakia	(Ar,MI,De)
Economolopsis	(Mo,Bi,Nt)	Edriosteges	(Br,Ar,St)	Ekaterronta	(Mo,Bi,Ar)
Echphora	(Mo,Ga,Ne)	Edwardsastraea	(Cn,An,Sc)	Ekaterrontia	(Mo,Bi,Nt)
Echphorosycon	(Mo,Ga,Ne)	Edwardsomeandra	(Cn,An,Sc)	Ekstadia	(Mo,Bi,Nt)
Eerinesomus	(Cd,Os,JB)	Edwardsosieris	(Cn,An,Sc)	Ektypophythere	(Ar,Os,Po)
Ectasis	(Cd,Os,Tr)	Edwardsosmia	(Cn,An,Sc)	Eksvosophyllum	(Cn,An,Ru)
Ectenaspis	(Ar,Tr,As)	Edwardsotrochus	(Cn,An,Sc)	Ekwanoeras	(Mo,Ce,On)
Ectenocardiomorpha	(Mo,Bi,Mo)	Eliminatopleura	(Ar,Os,Pa)	Elachorbis	(Mo,Ga,Nt)

Elachychiton	(Mo,Po,Ne)	Elgerius	(Ec,Ho,De)	Elliptocyprites	(Ar,Os,Po)
Elaeacrinus	(Ec,BI,Sp)	Elhasaella	(Fo,Fo,Fo)	Elliptoglossa	(Br,Li,Li)
Elaeocyma	(Mo,Ga,Ne)	Eliasopora	(Bz,Gy,Ct)	Elliptoidea	(Mo,Bi,Un)
Elangatanileus	(Ar,Tr,As)	Elibatocrinus	(Ec,Cr,Cl)	Elliptophyllipsia	(Ar,Tr,Pr)
Elangaspis	(Ar,Tr,Co)	Elicicola	(Ar,Tr,Pt)	Elliptoseris	(Cn,An,Sc)
Elaphoceras	(Mo,Ce,Di)	Elicerinus	(Ec,Cr,Cl)	Elliptostrophia	(Br,Ar,St)
Elaphopora	(Bz,St,Cc)	Elietognathus	(Cd,Co,Co)	Elliptotellina	(Mo,Bi,Ve)
Elasenia	(Cn,In,In)	Eligmoloxus	(Mo,Ga,Nt)	Elliptovermetus	(Mo,Ga,Nt)
Elasma	(Po,He,Ly)	Eligmus	(Mo,Bi,Pt)	Ellisella	(Mo,Ga,Eu)
Elasmalimus	(Po,De,Li)	Elimata	(Mo,Bi,Pt)	Ellisina	(Bz,Gy,Ch)
Elasmaspis	(Ar,Tr,Ph)	Eliorhynchus	(Br,Ar,Rh)	Ellisonia	(Cd,Co,Co)
Elasmata	(Br,Ar,Te)	Elioserosis	(Ar,MI,Is)	Ellopetalichthys	(Cd,Pl,Pe)
Elasmatium	(Mo,Bi,Un)	Elita	(Br,Ar,Sp)	Ellsaspis	(Ar,Tr,Un)
Elasmocoelia	(Po,Ca,Ph)	Eliva	(Br,Ar,Sp)	Ellsworthoconus	(Mo,Te,Tr)
Elasmocoenia	(Cn,An,Sc)	Elivella	(Br,Ar,Sp)	Elmaria	(Br,Ar,Te)
Elasmodectes	(Cd,Ch,Cm)	Elivina	(Br,Ar,Sp)	Elminius	(Ar,Ci)
Elasmodus	(Cd,Ch,Cm)	Elkanaspis	(Ar,Tr,Pt)	Elmosaurus	(Cd,Re,No)
Elasmotungia	(Cn,An,Sc)	Elkania	(Br,Li,Li)	Elobiceras	(Mo,Ce,Am)
Elasmogyra	(Cn,An,Sc)	Elkanisca	(Br,Li,Li)	Elofsonella	(Ar,Os,Po)
Elasmoierea	(Po,Ca,Ph)	Elkanoceras	(Mo,Ce,Di)	Elofsonia	(Ar,Os,Po)
Elasmonema	(Mo,Ga,Ar)	Elkanospina	(Pr,Co,Ch)	Elongata	(Mo,In,He)
Elasmophora	(Cn,An,Sc)	Elkia	(Ar,Tr,As)	Elongatinileus	(Ar,Tr,As)
Elasmophyllia	(Cn,An,Sc)	Ella	(Br,Ar,Sp)	Elongobula	(Fo,Fo,Fo)
Elasmophyllum	(Cn,An,Ru)	Ellassonia	(Br,Ar,Rh)	Elonichthys	(Cd,Os,Pa)
Elasmosaurus	(Cd,Re,Ps)	Ellatrvia	(Mo,Ga,Nt)	Elopoides	(Cd,Os,Me)
Elasmostoma	(Po,Ca,Ph)	Elleria	(Ar,Me,Xi)	Elopopsis	(Cd,Os,Cr)
Elasmothyris	(Br,Ar,Or)	Elleriprion	(An,Po,Eu)	Elops	(Cd,Os,El)
Elatiorella	(Mo,Ga,He)	Ellesicrusta	(He,Gy,Cr)	Elpasocrinus	(Ec,Cr,Cl)
Elatius	(Ar,Tr,Pt)	Ellesmerelasma	(Cn,An,Ru)	Elpezeo	(Ar,Os,My)
Elburgia	(Ar,Tr,Un)	Ellesmerespongia	(Po,De,Li)	Elphidiella	(Fo,Fo,Fo)
Eldenosteus	(Cd,Pl,Ar)	Ellesmerina	(Ar,Os,Po)	Elphidioides	(Fo,Fo,Fo)
Elder	(Ar,MI,My)	Ellesmeroceras	(Mo,Ce,El)	Elphidium	(Fo,Fo,Fo)
Elderra	(Br,Ar,Te)	Ellicea	(Mo,Ga,Ne)	Elpidocrinus	(Ec,Cr,Di)
Eldonia	(Pr,Un,In)	Ellinoceras	(Mo,Ce,Ac)	Elpiella	(Ar,Os,My)
Eldoradia	(Ar,Tr,Pt)	Elliottella	(Br,Ar,St)	Elpisoceras	(Mo,Ce,Di)
Eldredgeops	(Ar,Tr,Ph)	Elliottina	(Br,Ar,Th)	Elpistochthys	(Cd,Os,Pc)
Elea	(Bz,St,Cc)	Ellipsactinia	(Po,De,Ax)	Elrathia	(Ar,Tr,Pt)
Electra	(Bz,Gy,Ch)	Ellipsasteria	(Cn,An,Sc)	Elrathiella	(Ar,Tr,Pt)
Electroma	(Mo,Bi,Pt)	Ellipsechinus	(Ec,Ec,Ec)	Elrathina	(Ar,Tr,Pt)
Electrona	(Cd,Os,My)	Ellipsella	(Ar,Os,Pa)	Elrodoceras	(Mo,Ce,Ac)
Eleganella	(Mo,Ga,He)	Ellipsoidium	(Ac,Ra,Sp)	Elsonella	(Cd,Co,Co)
Elegantaspis	(Ar,Tr,Pt)	Ellipsobulimina	(Fo,Fo,Fo)	Elvinia	(Ar,Tr,Pt)
Eleganticerus	(Mo,Ce,Am)	Ellipsocephaloides	(Ar,Tr,Pt)	Elvinoides	(Ar,Tr,Pt)
Elegantilites	(Hy,Hy,Hy)	Ellipsocephalus	(Ar,Tr,Pt)	Elviraspis	(Ar,Tr,Pt)
Elegantiscala	(Mo,Ga,Nt)	Ellipsoceras	(Mo,Ce,Am)	Elyaspis	(Ar,Tr,Pt)
Elegantula	(Mo,Bi,Ve)	Ellipsocoenia	(Cn,An,Sc)	Elymocaritis	(Ar,MI,Ar)
Eleganuculana	(Mo,Bi,Nu)	Ellipsocristellaria	(Fo,Fo,Fo)	Elymospirifer	(Br,Ar,Sp)
Elegesta	(Br,Ar,Or)	Ellipsocyathus	(Cn,An,Ru)	Elysastraea	(Cn,An,Sc)
Elegestolepis	(Cd,Ch,In)	Ellipsodimorphina	(Fo,Fo,Fo)	Elythina	(Br,Ar,Sp)
Elenamarginia	(Ar,Os,Pa)	Ellipsoglandulina	(Fo,Fo,Fo)	Elyx	(Ar,Tr,Pt)
Elenchus	(Br,Ar,Sp)	Ellipsoidastraea	(Cn,An,Sc)	Emaciatceras	(Mo,Ce,Am)
Elenella	(Fo,Fo,Fo)	Ellipsoidella	(Fo,Fo,Fo)	Emanuella	(Br,Ar,Sp)
Elephantanellum	(Mo,Ga,Nt)	Ellipsoidina	(Fo,Fo,Fo)	Emarginoconus	(Mo,In,In)
Elephantaria	(Cn,An,Sc)	Ellipsolingulina	(Fo,Fo,Fo)	Emarginula	(Mo,Ga,Ar)
Elephantoceras	(Mo,Ce,Go)	Ellipsopolymorphina	(Fo,Fo,Fo)	Emarginulina	(Mo,Ga,Ar)
Elergella	(Fo,Fo,Fo)	Ellipsoscapha	(Mo,Ga,Ce)	Emarites	(Hy,Hy,Hy)
Eleusoceras	(Mo,Ce,Di)	Ellipsosmia	(Cn,An,Sc)	Emballotheca	(Bz,Gy,Ch)
Eleutherocearis	(Ar,MI,Ar)	Ellipsostreua	(Ar,Tr,Pt)	Embaphias	(Cd,Re,Ps)
Eleutheroceptrus	(Ar,Tr,Pr)	Ellipsostylus	(Ac,Ra,Sp)	Embaysgnathus	(Cd,Co,Co)
Eleutheroceania	(Br,Li,Ac)	Ellipsotaphrus	(Ar,Tr,As)	Embolophyllum	(Cn,An,Ru)
Eleutheroerinus	(Ec,BI,Sp)	Ellipsoxiphus	(Ac,Ra,Sp)	Embolosia	(Br,Ar,Te)
Eleutheroomma	(Br,Ar,Sp)	Ellipsuella	(Ar,Tr,Un)	Embryocrinus	(Ec,Cr,Cl)
Eleutherospira	(Mo,Ga,Ar)	Ellipticoblastus	(Ec,BI,Sp)	Embryotoxotis	(Ar,Os,Pa)
Elganellus	(Ar,Tr,Re)	Elliptocephala	(Ar,Tr,Ol)	Emeides	(Ch,Pr)

Emeiella	(Ar,Un,Un)	Encrinaster	(Ec,Op,Oe)	Enigmaticthys	(Cd,Os,Se)
Emeithella	(Pr,Un,In)	Encrinuraspis	(Ar,Tr,Ph)	Enigmonia	(Mo,Bi,Pt)
Emeithyris	(Br,Ar,Te)	Encrinurella	(Ar,Tr,Ph)	Enischorhynchus	(Cd,Os,Cr)
Emeraldella	(Ar,Mo,Em)	Encrinuroides	(Ar,Tr,Ph)	Enkelberghia	(Mo,Bi,Pt)
Emeritheca	(Pr,Un,In)	Encrinurus	(Ar,Tr,Ph)	Enniskillenus	(Cd,Os,In)
Emersonia	(Mo,Ga,Ar)	Encrinus	(Ec,Cr,En)	Ennosiaspis	(Cd,Pt,Pt)
Emersonius	(Ar,Ci)	Endamplexus	(Cn,An,Ru)	Ennuclia	(Mo,Bi,Nu)
Emileia	(Mo,Ce,Am)	Endelocrinus	(Ec,Cr,Cl)	Enophrys	(Cd,Os,Se)
Emilites	(Mo,Ce,Go)	Endeodiadema	(Ec,Ec,Di)	Enoploceras	(Mo,Ce,Na)
Emiluvia	(Ac,Ra,Sp)	Endianaulax	(Mo,Ga,Ar)	Enoploclytia	(Ar,Mi,De)
Emmelichthys	(Cd,Os,Ph)	Endiaplocus	(Mo,Ga,He)	Enoplocoelia	(Po,De,Pe)
Emmonsaspis	(Cn,Pe,Un)	Endiataenia	(Mo,Ga,Nt)	Enoplonotus	(Ar,Mi,De)
Emmonsia	(Cn,An,Ta)	Endiatoma	(Mo,Ga,Ne)	Enoplophthalmus	(Cd,Os,Os)
Emmonsiaella	(Cn,An,Ta)	Endiatrachelus	(Mo,Ga,He)	Enoplostomella	(Bz,Gy,Ch)
Emmonsoceras	(Mo,Ce,En)	Endoaspis	(Ar,Tr,Un)	Enoplosus	(Cd,Os,Ph)
Emmrhella	(Ar,Tr,Pt)	Endoceras	(Mo,Ce,En)	Enopoura	(Ec,St,Mi)
Emmrichops	(Ar,Tr,Pt)	Endochernella	(Fo,Fo,Fo)	Enosphinctes	(Mo,Ce,Am)
Empedaspis	(Cd,Pt,Pt)	Endocostapecten	(Mo,Bi,Pt)	Ense	(Br,Ar,Te)
Emperoceras	(Mo,Ce,Am)	Endocostea	(Mo,Bi,Pt)	Enseosteus	(Cd,Pl,Ar)
Emperocrinus	(Ec,Cr,Di)	Endocyloceras	(Mo,Ce,El)	Ensia	(Mo,Bi,Un)
Emphasia	(Ar,Os,Ph)	Endodiscosorus	(Mo,Ce,Di)	Ensiculus	(Mo,Bi,Ve)
Empheresula	(Cd,Av,Pe)	Endolobus	(Mo,Ce,Na)	Ensisferites	(Po,Ca,He)
Empleconia	(Mo,Bi,Ar)	Endolophia	(Ar,Os,Me)	Ensis	(Mo,Bi,Ve)
Emploca	(Po,He,He)	Endomargarus	(Mo,Bi,Ph)	Ensisphragma	(Bz,St,Cr)
Empodesma	(Cn,An,Ru)	Endopachychilus	(Mo,Ga,Ne)	Ensipora	(Bz,St,Cr)
Emsurella	(Ar,Tr,Co)	Endopachys	(Cn,An,Sc)	Ensispteria	(Mo,Bi,Pt)
Emsurina	(Ar,Tr,Ph)	Endophyllum	(Cn,An,Ru)	Ensis	(Mo,Bi,Ve)
Emuella	(Ar,Tr,Re)	Endoptanoceras	(Mo,Ce,Ba)	Ensisolen	(Mo,Bi,Ve)
Enaeta	(Mo,Ga,Ne)	Endoptectoceras	(Mo,Ce,Di)	Ensitellops	(Mo,Bi,Ve)
Enaliarctos	(Cd,Ma,Ca)	Endoplegma	(Po,He,Ls)	Ensitheca	(Hy,Or,Ci)
Enaliornis	(Cd,Av,He)	Endops	(Ar,Tr,Pr)	Entacanthodus	(Br,Ar,St)
Enaliosuchus	(Cd,Re,Cr)	Endoptygma	(Mo,Ga,Nt)	Entacanthus	(Mo,Ga,Ne)
Enallhelia	(Cn,An,Sc)	Endoroceras	(Mo,Ce,El)	Entactinia	(Ac,Ra,Sp)
Enalloeocenia	(Cn,An,Sc)	Endosacculus	(Ar,Ci)	Entactinosphaera	(Ac,Ra,Sp)
Enallocrinus	(Ec,Cr,Cl)	Endospirifer	(Br,Ar,Sp)	Entalina	(Mo,Sc,Se)
Enalloprenitis	(Cn,An,Ru)	Endospiroplectamina	(Fo,Fo,Fo)	Entalophora	(Bz,St,Ce)
Enallopneustes	(Ec,Ec,Sp)	Endostaffella	(Fo,Fo,Fo)	Entalophroecia	(Bz,St,Ce)
Enallopورا	(Bz,St,Fe)	Endostokesoceras	(Mo,Ce,Di)	Entapium	(Ac,Ra,Sp)
Enallopsammia	(Cn,An,Sc)	Endostoma	(Po,Ca,Ph)	Enteletella	(Br,Ar,Or)
Enallosia	(Br,Ar,Te)	Endoteba	(Fo,Fo,Fo)	Enteletes	(Br,Ar,Or)
Enallothecidea	(Br,Ar,Th)	Endotebanella	(Fo,Fo,Fo)	Enteletina	(Br,Ar,Or)
Enammocephalus	(Ar,Tr,Pt)	Endotheicum	(Cn,An,Ru)	Entelophyllia	(Cn,An,Ru)
Enantiaspis	(Ar,Tr,Re)	Endothyra	(Fo,Fo,Fo)	Entelophyllum	(Cn,An,Ru)
Enantiomorpha	(Fo,Fo,Fo)	Endothyranella	(Fo,Fo,Fo)	Entemmotrochus	(Mo,Ga,Ar)
Enantiosphena	(Br,Ar,Pe)	Endothyranopsis	(Fo,Fo,Fo)	Enterolasma	(Cn,An,Ru)
Enantiosphenella	(Br,Ar,Pe)	Endothyris	(Br,Ar,Te)	Enteropleura	(Mo,Bi,Pt)
Enantiotoma	(Mo,Ga,Ar)	Endotriada	(Fo,Fo,Fo)	Entimoceras	(Mo,Ce,Di)
Enantiotreon	(Mo,Bi,Pt)	Endotriadella	(Fo,Fo,Fo)	Entogonites	(Mo,Ce,Go)
Enascocrinus	(Ec,Cr,Tx)	Endrea	(Br,Ar,At)	Entolioides	(Mo,Bi,Pt)
Enatimene	(Mo,Ga,Ne)	Endymionia	(Ar,Tr,Pt)	Entolium	(Mo,Bi,Pt)
Enatiodeltalina	(Fo,Fo,Fo)	Engelia	(Ec,Ec,Di)	Entomaspis	(Ar,Tr,Pt)
Enaulofungia	(Po,Ca,Ph)	Engenella	(Br,Ar,Or)	Entomaster	(Ec,Ec,Hs)
Enayites	(Mo,Ce,Am)	Engina	(Mo,Ga,Ne)	Entomella	(Mo,Ga,Ar)
Enchelion	(Cd,Os,An)	Engoniophos	(Mo,Ga,Ne)	Entomocochus	(Ar,Os,My)
Enchelurus	(Cd,Os,An)	Engonoceras	(Mo,Ce,Am)	Entomonotis	(Mo,Bi,Pt)
Enchelyolepis	(Cd,Os,Ma)	Engorthoceras	(Mo,Ce,Or)	Entomope	(Mo,Ga,Nt)
Enchodrosipirifer	(Br,Ar,Sp)	Engraulis	(Cd,Os,Cl)	Entomoprimitia	(Ar,Os,My)
Enchodus	(Cd,Os,Al)	Enhydriodon	(Cd,Ma,Ca)	Entomozoe	(Ar,Os,My)
Enchostoma	(Pr,Un,In)	Enhydritrithium	(Cd,Ma,Ca)	Entoprimitia	(Ar,Os,Mo)
Enchoteuthis	(Mo,Ce,Te)	Enichaster	(Ec,Ec,Sp)	Entsyna	(Ar,Tr,Un)
Encicellaria	(Bz,Gy,Ch)	Enida	(Mo,Ga,Ar)	Ensygmophyllum	(Cn,An,Ru)
Encyclomphalus	(Mo,Ga,Ar)	Enigmaconus	(Mo,In,In)	Eoacidaspis	(Ar,Tr,.)
Encoiloceras	(Mo,Ce,Na)	Enigmalmes	(Cn,An,Ta)	Eoacrochordiceras	(Mo,Ce,Ce)
Encope	(Ec,Ec,Cl)	Enigmalosia	(Br,Ar,St)	Eoacteon	(Mo,Ga,Ce)

Eoactis	(Ec.As,Ur)	Eocomatula	(Ec.Cr,Cm)	Eofletcheria	(Cn.An,Ta)
Eoagnostus	(Ar.Tr,Ag)	Eoconcha	(Br.Ar,Or)	Eofletcheriella	(Cn.An,Ta)
Eoammosphaeroides	(Fo.Fo,Fo)	Eoconchidium	(Br.Ar,Pe)	Eoforschia	(Fo.Fo,Fo)
Eoamphistrophia	(Br.Ar,St)	Eoconchoecia	(Ar.Os,Po)	Eofusulina	(Fo.Fo,Fo)
Eoanastrophia	(Br.Ar,Pe)	Eoconodontus	(Cd.Co,Co)	Eogaleropygus	(Ec.Ec,Ca)
Eoanguilla	(Cd.Os,An)	Eoconularia	(Cn.Sc,Cn)	Eogaleus	(Cd.Ch,Ca)
Eoannularia	(Fo.Fo,Fo)	Eoconuloïdes	(Fo.Fo,Fo)	Eogaudryceras	(Mo.Ce,Am)
Eoantiptychia	(Br.Ar,Te)	Eoconulus	(Br.Li,Ac)	Eoglobigerina	(Fo.Fo,Fo)
Eoapatokephalus	(Ar.Tr,As)	Eocopea	(Ar.Ml,Is)	Eogloborites	(Tr.An)
Eoaquapulex	(Ar.Os,Pa)	Eocoryne	(Po.Un,Un)	Eoglossinotoechia	(Br.Ar,Rh)
Eoaraxoceras	(Mo.Ce,Ce)	Eocottus	(Cd.Os,Sc)	Eoglossophyllum	(Cn.An,Ru)
Eoasaphus	(Ar.Tr,As)	Eocramatia	(Br.Ar,St)	Eoglyptograptus	(He.Gr,Gr)
Eoasianites	(Mo.Ce,Go)	Eocrassina	(Mo.Bi,Ve)	Eognathodus	(Cd.Co,Co)
Eoastarte	(Mo.Bi,Tr)	Eocrioceratites	(Mo.Ce,Am)	Eogonioloboceras	(Mo.Ce,Go)
Eoatlanta	(Mo.Ga,Nt)	Eocristellaria	(Fo.Fo,Fo)	Eogorgia	(Cn.An,Go)
Eoaulostomus	(Cd.Os,Go)	Eocyphops	(Ar.Tr,Ph)	Eographiodactylus	(Ar.Os,Pa)
Eobacritates	(Mo.Ce,An)	Eocymatium	(Mo.Ga,Nt)	Eogryphus	(Br.Ar,Te)
Eobelemnites	(Mo.Ce,Be)	Eocyphinium	(Ar.Tr,Pr)	Eogunnarites	(Mo.Ce,Am)
Eobeloceras	(Mo.Ce,An)	Eocypraea	(Mo.Ga,Nt)	Eoguttulina	(Fo.Fo,Fo)
Eobiernatella	(Br.Ar,Sp)	Eocypridina	(Ar.Os,Me)	Eogymnites	(Mo.Ce,Ce)
Eobothus	(Cd.Os,Pn)	Eocyrtoceras	(Mo.Ce,On)	Eohalobia	(Mo.In,In)
Eobrachythyrina	(Br.Ar,Sp)	Eocyrtolites	(Mo.In,In)	Eohalysiocrinus	(Ec.Cr,Ds)
Eobrachythyris	(Br.Ar,Sp)	Eocyrtosymbole	(Ar.Tr,Pr)	Eoharpa	(Mo.Ga,Ne)
Eobromidella	(Ar.Os,Pa)	Eocystites	(Ec.Eo,As)	Eoharpes	(Ar.Tr,Pt)
Eobronteus	(Ar.Tr,Pt)	Eocythara	(Mo.Ga,Ne)	Eohastigerinella	(Fo.Fo,Fo)
Eobucania	(Mo.Ga,Be)	Eocytherella	(Ar.Os,Pa)	Eoheticoceras	(Mo.Ce,Am)
Eobuglossus	(Cd.Os,Pn)	Eocytheridea	(Ar.Os,Po)	Eohemithiris	(Br.Ar,Rh)
Eobuntonia	(Ar.Os,Po)	Eocytheropteron	(Ar.Os,Po)	Eoheteroceras	(Mo.Ce,Am)
Eocalcinus	(Ar.Ml,De)	Eodallina	(Br.Ar,Te)	Eoheteropora	(Bz.St,Cc)
Eocalliostoma	(Mo.Ga,Ar)	Eodalmanella	(Br.Ar,Or)	Eohippotha	(Bz.Gy,Ch)
Eocallista	(Mo.Bi,Ve)	Eodalmanitina	(Ar.Tr,Ph)	Eohollina	(Ar.Os,Pa)
Eocameroceras	(Mo.Ce,En)	Eodanubites	(Mo.Ce,Ce)	Eoholocentrum	(Cd.Os,Br)
Eocamptocrinus	(Ec.Cr,Mo)	Eoderoceras	(Mo.Ce,Am)	Eohornera	(Bz.St,Cc)
Eocamptonectes	(Mo.Bi,Pt)	Eodesmoceras	(Mo.Ce,Am)	Eohowellella	(Br.Ar,Sp)
Eocamites	(Mo.Ce,Pt)	Eodevonaria	(Br.Ar,St)	Eohyattoceras	(Mo.Ce,Go)
Eocarcinosoma	(Ar.Me,Eu)	Eodiadema	(Ec.Ec,Di)	Eohydnophora	(Cn.An,Sc)
Eocarcinus	(Ar.Ml,De)	Eodiaphragmoceras	(Mo.Ce,El)	Eoinachoides	(Ar.Ml,De)
Eocaris	(Ar.Ml,EO)	Eodiaphyodus	(Cd.Os,An)	Eoindocrinus	(Ec.Cr,Cl)
Eocarniodus	(Cd.Co,Co)	Eodiceras	(Mo.Bi,Hi)	Eoischyryna	(Mo.Ro,Ri)
Eocatenipora	(Cn.An,Ja)	Eodictyonella	(Br.Ar,St)	Eoisotelus	(Ar.Tr,As)
Eocaudina	(Ec.Ho,De)	Eodictyoptychus	(Mo.Bi,Hi)	Eokainaster	(Ec.As,Px)
Eocephalites	(Mo.Ce,Am)	Eodindymene	(Ar.Tr,Ph)	Eokalishania	(Ar.Tr,Co)
Eocephalodiscus	(He.Pt,Ce)	Eodinobolus	(Br.Li,Li)	Eokaotaia	(Ar.Tr,Pt)
Eoceratocoencha	(Ar.Ci)	Eodiodon	(Cd.Os,Te)	Eokarpinskia	(Br.Ar,At)
Eocerithium	(Mo.Ga,Nt)	Eodiorthelasma	(Br.Ar,Or)	Eokirkidium	(Br.Ar,Pe)
Eocermina	(Mo.Ga,Nt)	Eodiscus	(Ar.Tr,Ag)	Eokloedenia	(Ar.Os,Pa)
Eocetus	(Cd.Ma,Ce)	Eodmitria	(Br.Ar,Sp)	Eokosovopeltis	(Ar.Tr,Pt)
Eochaunactis	(Po.De,Li)	Eodon	(Mo.Bi,Ve)	Eokreffitia	(Cd.Os,My)
Eocheirus	(Ar.Tr,Ph)	Eodonax	(Mo.Bi,Ve)	Eolabalia	(Br.Ar,Sp)
Eochelodes	(Mo.Po,Pa)	Eodontopleura	(Ar.Tr,Od)	Eolabroides	(Cd.Os,Pf)
Eochelone	(Cd.Re,Ch)	Eodouvilleicerias	(Mo.Ce,Am)	Eolacazella	(Br.Ar,Th)
Eochetoceras	(Mo.Ce,Am)	Eodrevernannia	(Ar.Tr,Pr)	Eolactoria	(Cd.Os,Te)
Eochilina	(Ar.Os,Pa)	Eodrilla	(Mo.Ga,Ne)	Eolagina	(Fo.An,Fa)
Eochonetes	(Br.Ar,St)	Eodyscritella	(Bz.St,Tr)	Eolaminoptasma	(Cn.An,Ja)
Eochoristitella	(Br.Ar,Sp)	Eoectenolites	(Mo.Ce,El)	Eolamprogrammus	(Cd.Os,Op)
Eochoristites	(Br.Ar,Sp)	Eoendothya	(Fo.Fo,Fo)	Eolasioidiscus	(Fo.Fo,Fo)
Eochuangia	(Ar.Tr,Co)	Eoendothyranopsis	(Fo.Fo,Fo)	Eolasma	(Ar.Ci)
Eocicerocrinus	(Ec.Cr,Ds)	Eoeponidella	(Fo.Fo,Fo)	Eolates	(Cd.Os,Pf)
Eocithara	(Mo.Ga,Ne)	Eoescharopora	(Pr.Un,In)	Eoleonaspis	(Ar.Tr,Od)
Eoclarkoceras	(Mo.Ce,El)	Eoetmopterus	(Cd.Ch,Sq)	Eolepas	(Ar.Ci)
Eoclathurella	(Mo.Ga,Ne)	Eoeugnathus	(Cd.Os,Am)	Eoleperditia	(Ar.Os,Le)
Eoclavatorella	(Fo.Fo,Fo)	Eeofabiana	(Fo.Fo,Fo)	Eoleptoceras	(Mo.Ce,Am)
Eocoelia	(Br.Ar,At)	Eofallotaspis	(Ar.Tr,Re)	Eolimea	(Mo.Bi,Pt)
Eocoelopoma	(Cd.Os,Pf)	Eofistulipora	(Bz.St,Cy)	Eolimulus	(Ar.Me,In)

Eoliotina	(Mo,Ga,Ar)	Eoplacognathus	(Cd,Co,Co)	Eosipho	(Mo,Ga,Ne)
Eolissocometes	(Br,Ar,St)	Eoplacostegus	(An,Po,Se)	Eosiphonalia	(Mo,Ga,Ne)
Eolomatella	(Ar,Os,Pa)	Eoplatanista	(Cd,Ma,Ce)	Eosiphonotreta	(Br,Li,Ac)
Eolophotes	(Cd,Os,La)	Eoplataxa	(Cd,Os,Pr)	Eosiren	(Cd,Ma,Si)
Eoluarvus	(Cd,Os,Pr)	Eoplectodonta	(Br,Ar,St)	Eosoconus	(Mo,In,In)
Eolyttonia	(Br,Ar,St)	Eoplectus	(Cd,Os,Te)	Eosolariella	(Mo,Ga,Ar)
Eomactra	(Mo,Bi,Ve)	Eopleurotoma	(Mo,Ga,Ne)	Eosolarium	(Mo,Ga,Nt)
Eomadrasites	(Mo,Ce,Am)	Eoplicanopia	(Br,Ar,St)	Eosolen	(Mo,Bi,Ve)
Eomanta	(Cd,Ch,My)	Eoplicoplasia	(Br,Ar,Sp)	Eosomichelinoceeras	(Mo,Ce,Or)
Eomaoristropia	(Br,Ar,St)	Eopolychaetus	(An,Po,Un)	Eosophragmophora	(Br,Ar,Or)
Eomarginifera	(Br,Ar,St)	Eopolydiexodina	(Fo,Fo,Fo)	Eosotrematorthis	(Br,Ar,Or)
Eomarsionella	(Fo,Fo,Fo)	Eoporpita	(Cn,Hy,Un)	Eosphaeroma	(Ar,MI,Is)
Eomartiniopsis	(Br,Ar,Sp)	Eoprodromites	(Mo,Cc,Pl)	Eosphargis	(Cd,Re,Ch)
Eomathilda	(Mo,Ga,Nt)	Eoproductella	(Br,Ar,St)	Eospinatrypa	(Br,Ar,At)
Eomegalodus	(Mo,Bi,Hi)	Eoprotetus	(Ar,Tr,Pr)	Eospinus	(Cd,Os,Te)
Eomegastropia	(Br,Ar,St)	Eoprosodacna	(Mo,Bi,Ve)	Eospirifer	(Br,Ar,Sp)
Eomeretrix	(Mo,Bi,Ve)	Eoprosopon	(Ar,MI,De)	Eospiriferina	(Br,Ar,Sp)
Eomesodon	(Cd,Os,Py)	Eoprotelops	(Cd,Os,El)	Eospirigerina	(Br,Ar,At)
Eomiltha	(Mo,Bi,Ve)	Eoprotetrachyceras	(Mo,Ce,Ce)	Eospondylus	(Ec,Op,Ph)
Eomiodon	(Mo,Bi,Ve)	Eops	(Ar,Tr,Re)	Eospongia	(Po,De,Li)
Eomobula	(Cd,Ch,My)	Eopsetta	(Cd,Os,Pr)	Eosqualodon	(Cd,Ma,Cc)
Eomoelleritia	(Ar,Os,Le)	Eopsiloceras	(Mo,Cc,Ph)	Eostaffella	(Fo,Fo,Fo)
Eomonarachus	(Ar,Tr,Ph)	Eopteria	(Mo,Ro,Co)	Eostaffeloides	(Fo,Fo,Fo)
Eomonotis	(Mo,Bi,Pr)	Eopteridium	(Ar,MI,Pa)	Eostegostoma	(Cd,Ch,Oc)
Eomunidopsis	(Ar,MI,De)	Eoptychaspis	(Ar,Tr,As)	Eostella	(Ec,As,Pu)
Eomuraena	(Cd,Os,An)	Eoptychia	(Mo,Ga,Nt)	Eostenopora	(Bz,St,Tr)
Eomycophom	(Cd,Os,My)	Eoptychoparia	(Ar,Tr,Pr)	Eostenoporella	(Bz,St,Tr)
Eomyelodaetylus	(Ec,Cr,Ds)	Eopulfinus	(Cd,Av,Pr)	Eostephanela	(Ar,Os,Po)
Eomyrophis	(Cd,Os,An)	Eopugnax	(Br,Ar,Rh)	Eostichomitra	(Ac,Ra,Na)
Eomyrus	(Cd,Os,An)	Eoquasiendothyra	(Fo,Fo,Fo)	Eostomias	(Mo,Cs,St)
Eonalivkinia	(Br,Ar,At)	Eoradiolites	(Mo,Bi,Hi)	Eostrophalosida	(Br,Ar,St)
Eonapora	(Ac,Ra,Na)	Eoranela	(Mo,Ga,Nt)	Eostrophelodonta	(Br,Ar,St)
Eonavicular	(Mo,Bi,Ar)	Eoredlichia	(Ar,Tr,Re)	Eostrophomena	(Br,Ar,Or)
Eonodosaria	(Fo,Fo,Fo)	Eoreticularia	(Br,Ar,Sp)	Eostrophonella	(Br,Ar,St)
Eonomia	(Mo,Bi,Pr)	Eorhipidomella	(Br,Ar,Or)	Eostrotion	(Cn,An,Ru)
Eonomismoceras	(Mo,Ce,Go)	Eorizoceras	(Mo,Ce,On)	Eosturia	(Mo,Cc,Cc)
Eonotidanus	(Cd,Ch,Hx)	Eorobergia	(Ar,Tr,As)	Eostyloidietya	(Ac,Ra,Sp)
Eonovitatus	(Hy,Or,Or)	Eorotundracythere	(Ar,Os,Po)	Eosurcula	(Mo,Ga,Ne)
Eontia	(Mo,Bi,Ar)	Eorupertia	(Fo,Fo,Fo)	Eosynanceja	(Cd,Os,Sc)
Eoophthalmidium	(Fo,Fo,Fo)	Eosagenites	(Mo,Cc,Cc)	Eosyringothyris	(Br,Ar,Sp)
Eoorodus	(Cd,Ch,Ct)	Eosalenia	(Ec,Ec,Di)	Eotaphrus	(Cd,Co,Co)
Eoorthis	(Br,Ar,Or)	Eosalmo	(Cd,Os,Sa)	Eotebenna	(Mo,He,He)
Eopachydietya	(Bz,St,Cr)	Eosaukia	(Ar,Tr,Un)	Eotetragonites	(Mo,Cc,Am)
Eopachydiscus	(Mo,Ce,Am)	Eosaurichthys	(Cd,Os,Su)	Eotetraodon	(Cd,Os,Te)
Eopajenborchella	(Ar,Os,Po)	Eoscephalasma	(Br,Li,Ac)	Eotextularia	(Fo,Fo,Fo)
Eopalorbitolina	(Fo,Fo,Fo)	Eoscapites	(Mo,Cc,Am)	Eothalassoceras	(Mo,Cc,Go)
Eoparafusulina	(Fo,Fo,Fo)	Eoschistoceras	(Mo,Cc,Go)	Eothecidellina	(Br,Ar,Th)
Eoparalegoceras	(Mo,Cc,Go)	Eoschizodus	(Mo,Bi,Tr)	Eothele	(Br,Li,Ac)
Eoparaparchites	(Ar,Os,Po)	Eoschizophoria	(Br,Ar,Or)	Eothesbia	(Mo,Ga,Ne)
Eoparaphorhynchus	(Br,Ar,Rh)	Eoschubertella	(Fo,Fo,Fo)	Eothinites	(Mo,Cc,Go)
Eoparisocrinus	(Ec,Cr,Cl)	Foschuchertella	(Br,Ar,St)	Eothuoceras	(Mo,Cc,El)
Eopatelliocrinus	(Ec,Cr,Mo)	Foscobinella	(Mo,Ga,Ne)	Eothuria	(Ec,Ec,Ey)
Eopecten	(Mo,Bi,Pr)	Foscerupocellaria	(Bz,Gy,Ch)	Eothynnus	(Cd,Os,Pr)
Eopeyeria	(Cd,Os,Si)	Foscutella	(Ec,Ec,Cl)	Eothyrites	(Cd,Os,Pr)
Eophacops	(Ar,Tr,Ph)	Foscutellum	(Ar,Tr,Co)	Eotibia	(Mo,Ga,Nt)
Eophasma	(Nm)	Foscutum	(Ec,Ec,Cl)	Eottisotia	(Mo,Cc,Am)
Eophiura	(Ec,Op,St)	Fosemicosecinium	(Bz,St,Fe)	Eotomaria	(Mo,Ga,Ar)
Eopholidostropia	(Br,Ar,St)	Fosemionotus	(Cd,Os,Se)	Eotomopteris	(An,Po,Ph)
Eophycis	(Cd,Os,Ga)	Fosentalphorita	(Br,Ar,Rh)	Eotorpedo	(Cd,Ch,To)
Eophyllites	(Mo,Cc,Ph)	Fosericoida	(Br,Ar,St)	Eotournayella	(Fo,Fo,Fo)
Eophyema	(Mo,Bi,Ve)	Foserranus	(Cd,Os,Pr)	Eotrapezium	(Mo,Bi,Ve)
Eopiliocrinus	(Ec,Cr,Cl)	Foshumardia	(Ar,Tr,Pr)	Eotrigonia	(Mo,Bi,Tr)
Eopinctada	(Mo,Bi,Pr)	Fosignomilina	(Fo,Fo,Fo)	Eotrigonodon	(Cd,Os,Te)
Eopinnacrinus	(Ec,Cr,Cl)	Fosinica	(Mo,Ga,Um)	Eotrimeroceras	(Mo,Cc,On)

Eotrunculus	(Ar,Tr,As)	Epidomatoceras	(Mo,Ce,Na)	Epulotrochus	(Mo,Ga,Ar)
Eotripteroceras	(Mo,Ce,Or)	Epifaxis	(Mo,Ga,Ar)	Equicastanea	(Ar,Os,Pa)
Eotrivia	(Mo,Ga,Nt)	Epiglyphioceras	(Mo,Ce,Go)	Equichlamys	(Mo,Bi,Pr)
Eotrochactaeon	(Mo,Ga,Ce)	Epiglyptoxoceras	(Mo,Ce,Am)	Equisotra	(Br,Ar,Pe)
Eotrochus	(Mo,Ga,Ar)	Epigondolella	(Cd,Co,Co)	Erato	(Mo,Ga,Nt)
Eotrophonia	(An,Po,Un)	Epigonoceras	(Mo,Ce,Am)	Eratoerinus	(Ec,Cr,Cl)
Eotropitoides	(Mo,Ce,Am)	Epigonites	(Mo,Ce,Am)	Eratoidea	(Mo,Ga,Ne)
Eotuberitina	(Fo,Fo,Fo)	Epigonus	(Cd,Os,Pl)	Eratopsis	(Mo,Ga,Nt)
Eoturrus	(Mo,Ga,Ne)	Epigraptus	(He,Gr,Tu)	Eratotrivia	(Mo,Ga,Nt)
Eotympanotonus	(Mo,Ga,Nt)	Epigygnites	(Mo,Ce,Ce)	Erbechinus	(Ec,Ec,Te)
Eoursiviva	(Mo,Bi,My)	Epihalysiocerinus	(Ec,Cr,Ds)	Erbenaspis	(Ar,Ti,Pr)
Eousella	(Br,Ar,Te)	Epilopites	(Mo,Ce,Am)	Erbenia	(Ar,Tr,As)
Eouvigerina	(Fo,Fo,Fo)	Epijuresanites	(Mo,Ce,Go)	Erbenicoryphe	(Ar,Tr,Pr)
Eovasum	(Mo,Ga,Ne)	Epileyeriella	(Mo,Ce,Am)	Erbenites	(Ar,Tr,Pr)
Eoverbeekina	(Fo,Fo,Fo)	Epilucina	(Mo,Bi,Ve)	Erbenoceras	(Mo,Ce,An)
Eoverruca	(Ar,Ci)	Epimayaites	(Mo,Ce,Am)	Erbia	(Ar,Tr,Pr)
Eovolutilithes	(Mo,Ga,Ne)	Epimorphoceras	(Mo,Ce,Am)	Erbiella	(Ar,Tr,Pr)
Eovolutina	(Fo,Fo,Fo)	Epinephelus	(Cd,Os,Pl)	Erbiopsidella	(Ar,Tr,Co)
Eovolva	(Mo,Ga,Nt)	Epinnula	(Cd,Os,Pl)	Erbiopsis	(Ar,Tr,Co)
Eowacringella	(Fo,Fo,Fo)	Epipalasciceras	(Mo,Ce,Am)	Erbocysathus	(Po,Re,Aj)
Eowedekindellina	(Fo,Fo,Fo)	Epipaston	(Ec,Ed,Js)	Erdona	(Mo,Bi,My)
Eowellerites	(Mo,Ce,Go)	Epipeltoeras	(Mo,Ce,Am)	Erdoradites	(Ar,Tr,Pr)
Eowluhia	(Ar,Tr,As)	Epipetalichthys	(Cd,Pl,Pe)	Erectocephalus	(Br,Ar,Rh)
Eoxancus	(Mo,Ga,Ne)	Epipetshoraerinus	(Ec,Cr,Cl)	Erediaspis	(Ar,Tr,Pr)
Eozanclus	(Cd,Os,Pl)	Epiphanoptyllum	(Cn,An,Ru)	Eremactis	(Pr,Co,Ch)
Eozellia	(Fo,Fo,Fo)	Epiphaxum	(Cn,An,He)	Eremiprotetus	(Ar,Tr,Pr)
Epacerochordiceras	(Mo,Ce,Ce)	Epiphyllina	(Cn,Sc,Co)	Eremitiacyathus	(Po,Ir,Ar)
Epactridion	(Ar,Os,Ar)	Epiphyllum	(Cn,An,Sc)	Eremites	(Mo,Ce,Ce)
Epadianites	(Mo,Ce,Go)	Epipiastospingia	(Po,De,Li)	Eremithyrus	(Br,Ar,Rh)
Epaxis	(Mo,Ga,Ne)	Epipythia	(Mo,Ga,Ar)	Eremoceras	(Mo,Ce,El)
Epancyloceras	(Mo,Ce,Am)	Episageceras	(Mo,Ce,Pl)	Eremochitina	(Fo,Fo,Ch)
Eparietites	(Mo,Ce,Am)	Episculites	(Mo,Ce,Ce)	Eremos	(Ar,Os,Ar)
Epaspidoceras	(Mo,Ce,Am)	Episcynia	(Mo,Ga,Nt)	Eremotoechia	(Br,Ar,Or)
Epelichthys	(Cd,Os,Cl)	Episiphon	(Mo,Sc,Sc)	Eremotrema	(Br,Ar,Or)
Epelidoaegiria	(Br,Ar,St)	Epismilia	(Cn,An,Sc)	Eremocrinus	(Ec,Cr,Mo)
Epengonoceras	(Mo,Ce,Am)	Epismiliopsis	(Cn,An,Sc)	Eremosaurus	(Cd,Re,Ps)
Eperisocrinus	(Ec,Cr,Cl)	Epistomaria	(Fo,Fo,Fo)	Erettopterus	(Ar,Me,Eu)
Epetrium	(Mo,Ga,Nt)	Epistomella	(Po,De,Li)	Ergenia	(Mo,Bi,Ve)
Epeudea	(Po,Ca,Un)	Epistomina	(Fo,Fo,Fo)	Erginus	(Mo,Ga,Ar)
Epheria	(Mo,Ga,Nt)	Epistominella	(Fo,Fo,Fo)	Eribotrys	(Ac,Ra,Na)
Ephippelasma	(Br,Li,Ac)	Epistominita	(Fo,Fo,Fo)	Ericatia	(Br,Ar,St)
Ephippoceras	(Mo,Ce,Na)	Epistominitella	(Fo,Fo,Fo)	Ericina	(Cn,An,Ru)
Ephippiothoceras	(Mo,Ce,Or)	Epistominoides	(Fo,Fo,Fo)	Ericusa	(Mo,Ga,Ne)
Epiactinotrypa	(Bz,St,Cy)	Epistrenoceras	(Mo,Ce,Am)	Eridites	(Mo,Ce,Or)
Epialtus	(Ar,Ml,De)	Epistreptophyllum	(Cn,An,Sc)	Eridmatas	(Br,Ar,Sp)
Epiannularia	(Fo,Fo,Fo)	Epistroboceras	(Mo,Ce,Na)	Eridocamplysus	(Bz,St,Tr)
Epiaster	(Ec,Ec,Sp)	Epithalassoceras	(Mo,Ce,Go)	Eridococoncha	(Ar,Os,Po)
Epicanites	(Mo,Ce,Pl)	Epitheles	(Po,Ca,Ph)	Eridophyllum	(Cn,An,Ru)
Epicefia	(Br,Ar,St)	Epithemella	(Fo,Fo,Fo)	Eridopora	(Bz,St,Cy)
Epichelites	(Mo,Ce,Ce)	Epithyrus	(Br,Ar,Te)	Eridorthis	(Br,Ar,Or)
Epichelitoides	(Mo,Ce,Ce)	Epithyroides	(Br,Ar,Te)	Eridotrypa	(Bz,St,Tr)
Epicephalites	(Mo,Ce,Am)	Epitomyonia	(Br,Ar,Or)	Eridotrypella	(Bz,St,Tr)
Epiceratites	(Mo,Ce,Ce)	Epitonium	(Mo,Ga,Nt)	Eridotrypellina	(Bz,St,Tr)
Epicheloniceras	(Mo,Ce,Am)	Epitornoceras	(Mo,Ce,Go)	Eriella	(Ar,Os,Me)
Epicodakia	(Mo,Bi,Ve)	Epitrachys	(An,Po,Un)	Erieopteris	(Ar,Me,Eu)
Epicosmoceras	(Mo,Ce,Am)	Epitrochus	(Cn,An,Sc)	Erika	(Cd,Co,Co)
Epicymatoceras	(Mo,Ce,Na)	Epivirgatites	(Mo,Ce,Am)	Erikodus	(Cd,Ch,Eu)
Epicyprina	(Mo,Bi,Ve)	Epivocklumeria	(Mo,Ce,Cl)	Erinella	(Bz,Gy,Ch)
Epicyrta	(Br,Ar,Te)	Eponidella	(Fo,Fo,Fo)	Erineum	(Po,He,He)
Epideira	(Mo,Ga,Ne)	Eponides	(Fo,Fo,Fo)	Erinoceras	(Mo,Ce,Go)
Epideroceras	(Mo,Ce,Am)	Epopella	(Ar,Ci)	Erinocystis	(Ec,Rh,Rh)
Epiderceras	(Mo,Bi,Hi)	Epophioceras	(Mo,Ce,Am)	Erinostrophia	(Br,Ar,St)
Epidirella	(Mo,Ga,Ne)	Epitingium	(Ac,Ra,Sp)	Erioliceras	(Mo,Ce,Am)
Epidirona	(Mo,Ga,Ne)	Eptitauroceras	(Mo,Ce,Go)	Eripachya	(Mo,Ga,Ne)

Eriphia	(Ar,Ml,De)	Escornebovina	(Fo,Fo,Fo)	Eubaculites	(Mo,Ce,Am)
Eriphyla	(Mo,Bi,Ve)	Escumasia	(Cn,Un,Un)	Eubalena	(Cd,Ma,Ce)
Eriphyloopsis	(Mo,Bi,Ve)	Esclaeovitrigonia	(Mo,Bi,Tr)	Eubela	(Mo,Ga,Ne)
Eripleura	(Ar,Os,Po)	Esericeras	(Mo,Ce,Am)	Eubiodesctes	(Cd,Os,Pe)
Eriplifera	(Br,Ar,Or)	Eshelmania	(Ar,Tr,Pt)	Eubostrychoceras	(Mo,Ce,Am)
Eriptycha	(Mo,Ga,Ce)	Esilia	(Br,Ar,St)	Eubranoceras	(Mo,Ce,Am)
Eriptychius	(Cd,Pt,Pl)	Eskimaspis	(Cd,Pl,Ar)	Eubrochis	(Po,He,He)
Eriquius	(Cd,Os,Pl)	Eskimoceras	(Mo,Ce,Ac)	Eubrochus	(Po,He,He)
Erismacanthus	(Cd,Ch,In)	Esmeraldina	(Ar,Tr,Re)	Eubulimella	(Fo,Fo,Fo)
Erismacoscinus	(Po,Re,Aj)	Esmeria	(Mo,Ga,Ar)	Eucalathis	(Br,Ar,Te)
Erismatina	(Br,Ar,St)	Esocelops	(Cd,Os,El)	Eucallista	(Mo,Bi,Ve)
Erismodus	(Cd,Co,Co)	Esopoceras	(Mo,Ce,Or)	Eucalycoceras	(Mo,Ce,Am)
Erisocrinus	(Ec,Cr,Cl)	Espanocrinus	(Ec,Cr,Ds)	Eucalyptocrinites	(Ec,Cr,Mo)
Eristavites	(Mo,Ce,Am)	Espella	(Br,Ar,Sp)	Eucatilocrinus	(Ec,Cr,Ds)
Eristenosia	(Br,Ar,Te)	Esperites	(Po,De,Ha)	Euceeryphalus	(Ac,Ra,Na)
Eritropsis	(Mo,Bi,Nu)	Esseigania	(Ar,Tr,Un)	Euecenturus	(Cd,Ch,In)
Erixanium	(Ar,Tr,Pt)	Essexella	(Cn,Sc,Rh)	Eucetotherium	(Cd,Ma,Ce)
Erkosonea	(Bz,St,Cc)	Essoidea	(Ar,Ml,Es)	Euecharitina	(Br,Ar,Rh)
Erlangbapora	(Cn,An,Ta)	Estea	(Mo,Ga,Nt)	Euecharodus	(Cd,Co,Co)
Ermoceras	(Mo,Ce,Am)	Esthonia	(Cn,An,Ta)	Euehasma	(Mo,Ro,Co)
Ermietta	(Cn,Pe,Er)	Esthoniopora	(Bz,St,Tr)	Euehasmella	(Mo,Ro,Ri)
Ermogía	(Br,Un,Un)	Esthonioparina	(Bz,St,Fe)	Eueheilodon	(Mo,Ga,Ne)
Erosaria	(Mo,Ga,Nt)	Esthonioporella	(Bz,St,Tr)	Eueheilopora	(Bz,Gy,Ch)
Erphyllum	(Pr,Cr,Cr)	Esthonocrinus	(Ec,Cr,Cl)	Euehelus	(Mo,Ga,Ar)
Erquefnnesia	(Cd,Re,Ch)	Estlandia	(Br,Ar,Or)	Euehilotheca	(Mo,Ga,Th)
Erquitaia	(Cd,Ch,Rj)	Estonaceraella	(Ar,Os,Po)	Euehitonia	(Ac,Ra,Sp)
Erratencrinurus	(Ar,Tr,Ph)	Estonielaena	(Cn,An,Ru)	Euehondria	(Mo,Bi,Pt)
Erraticodon	(Cd,Co,Co)	Estonioceras	(Mo,Ce,Ta)	Euechrysalis	(Mo,Ga,Nt)
Erraticornus	(Hy,Hy,Hy)	Estoniops	(Ar,Tr,Ph)	Euecidaris	(Ec,Ec,Ci)
Erthyx	(Br,Ar,Rh)	Estonirhynchia	(Br,Ar,Rh)	Euephidoceras	(Mo,Ce,Na)
Errina	(Cn,Hy,St)	Estonocystis	(Ec,Di,Di)	Eueladia	(Ec,Oh,Oh)
Errolosteus	(Cd,Pl,Ar)	Estraingia	(Ar,Tr,Pt)	Eueladocrinus	(Ec,Cr,Mo)
Eromenosteus	(Cd,Pl,Ar)	Etacystis	(Pr,Un,In)	Euelathurella	(Mo,Ga,Ne)
Eronea	(Mo,Ga,Nt)	Etalia	(Mo,Bi,Pt)	Euelia	(Mo,Ga,Ne)
Ertangia	(Ar,Os,Pa)	Etallonasteria	(Cn,An,Sc)	Euelimacograptus	(He,Gr,Gr)
Erugatocyathus	(Po,Re,Aj)	Etallonia	(Cn,An,Sc)	Eueochlis	(Mo,Ga,Ar)
Erugocentrus	(Cd,Os,Br)	Etalloniella	(Po,He,Ly)	Euecominia	(Mo,Ga,Ne)
Erugonia	(Mo,Bi,Tr)	Etea	(Mo,Bi,Ve)	Eueconactaeon	(Mo,Ga,Ce)
Ervillia	(Mo,Bi,Ve)	Ethalia	(Mo,Ga,Ar)	Eueconchitina	(Fo,Fo,Ch)
Erycina	(Mo,Bi,Ve)	Ethelocrinus	(Ec,Cr,Cl)	Eueconia	(Mo,Ga,Ar)
Erycinella	(Mo,Bi,Ve)	Etherella	(Bz,St,Cy)	Eueconospira	(Mo,Ga,Ar)
Erycinopsis	(Mo,Bi,Ve)	Etheridgaspis	(Ar,Tr,Pt)	Euecopia	(Ar,Ml,Lo)
Erycites	(Mo,Ce,Am)	Etheridgella	(Ec,Mo,Ar)	Eueconomiceras	(Mo,Ce,Am)
Erylus	(Po,De,As)	Etheridgia	(Po,He,He)	Euecoronis	(Ac,Ra,Na)
Eryma	(Ar,Ml,De)	Etheridgina	(Br,Ar,St)	Euecrassatella	(Mo,Bi,Ve)
Erymarella	(Mo,Ga,Ar)	Etheripeecten	(Mo,Bi,Pt)	Euecratea	(Bz,Gy,Ch)
Erymastacus	(Ar,Ml,De)	Ethmocardium	(Mo,Bi,Ve)	Euecraterellina	(Ar,Os,Me)
Erymnaria	(Br,Ar,Rh)	Ethmocoscinus	(Po,Re,Aj)	Euecryptocaris	(Ar,Ml,Ta)
Erymnoceras	(Mo,Ce,Am)	Ethmocycathus	(Po,Re,Aj)	Euecycloceras	(Mo,Ce,Am)
Erymnocerites	(Mo,Ce,Am)	Ethmophyllum	(Po,Re,Aj)	Euecycloidea	(Mo,Ga,Nt)
Eryon	(Ar,Ml,De)	Etitus	(Ar,Ml,De)	Euecyclophialus	(Mo,Ga,Ar)
Escasona	(Ar,Os,Ar)	Etmopterus	(Cd,Ch,Sq)	Euecycloscala	(Mo,Ga,Ar)
Escharacytheridea	(Ar,Os,Po)	Etoctenocystis	(Ec,Ct,Ct)	Euecyclus	(Mo,Ga,Ar)
Escharella	(Bz,Gy,Ch)	Etrema	(Mo,Ga,Ne)	Euecymatoceras	(Mo,Ce,Na)
Escharendoceras	(Mo,Ce,En)	Etrempopsis	(Mo,Ga,Ne)	Euecymba	(Mo,Ga,Ne)
Escharicellaria	(Bz,Gy,Ch)	Etringus	(Cd,Os,Cl)	Euecypraedia	(Mo,Ga,Nt)
Escharifora	(Bz,Gy,Ch)	Etrumeus	(Cd,Os,Cl)	Euecyrtidellum	(Ac,Ra,Na)
Escharina	(Bz,Gy,Ch)	Etymothyris	(Br,Ar,Te)	Euecyrtidium	(Ac,Ra,Na)
Escharipora	(Bz,Gy,Ch)	Etyus	(Ar,Ml,De)	Euecyrtes	(Ac,Ra,Na)
Escharoides	(Bz,Gy,Ch)	Euaetaeonina	(Mo,Ga,Ce)	Euecystis	(Ec,Di,Di)
Escharopora	(Bz,St,Cr)	Euagassioceras	(Mo,Ce,Am)	Euecythere	(Ar,Os,Po)
Eschrichtius	(Cd,Ma,Ce)	Euagnostus	(Ar,Ti,Ag)	Euecytherura	(Ar,Os,Po)
Escoffieria	(Mo,Ga,Nt)	Euaeptoceras	(Mo,Ce,Am)	Eudea	(Po,Ca,Ph)
Esconites	(An,Ph,Ph)	Euaspidoceras	(Mo,Ce,Am)	Eudecacythere	(Ar,Os,Po)

Eudechella	(Ar.Tr.Pr)	Eumitra	(Mo.Ga.Ne)	Eurissolina	(Mo.Ga.Nt)
Eudesella	(Br.Ar.Th)	Eumitrocystella	(Ec.St.Mi)	Eurites	(Mo.Ce.Go)
Eudesia	(Br.Ar.Te)	Eumorphactaea	(Ar.Ml.De)	Euritia	(Bz.Gy.Ch)
Eudesicrinus	(Ec.Cr.Cy)	Eumorphoceras	(Mo.Ce.Go)	Euroatrypa	(Br.Ar.At)
Eudesites	(Br.Ar.Te)	Eumorphocrystes	(Ar.Ml.De)	Euroceras	(Mo.Ce.Go)
Eudictyon	(Po.He.Un)	Eumorphocrinus	(Ec.Cr.Mo)	Eurocyamus	(Ar.Os.Pa)
Eudimerocrinus	(Ec.Cr.Di)	Eumorphocystis	(Ec.Di.Di)	Europicardium	(Mo.Bi.Ve)
Eudisoceras	(Mo.Ce.Ce)	Eumorpholites	(Hy.Uc.Uc)	Europisthia	(Ar.Os.Pa)
Eudmetoceras	(Mo.Ce.Am)	Eumorphotis	(Mo.Bi.Pt)	Europora	(Bz.St.Cr)
Eudoceras	(Mo.Ce.On)	Eunatica	(Mo.Ga.Nt)	Europrotaspis	(Cd.Pt.Pt)
Eudolatites	(Ar.Tr.Ph)	Eunaticina	(Mo.Ga.Nt)	Eurothisina	(Br.Ar.Un)
Eudolium	(Mo.Ga.Nt)	Eunema	(Mo.Ga.Ar)	Eurostina	(Ar.Tr.Pt)
Eudoxina	(Br.Ar.Sp)	Eunemopsis	(Mo.Ga.Ar)	Eurudagnostus	(Ar.Tr.Ag)
Eudoxochiton	(Mo.Po.Ne)	Eunice	(An.Po.Eu)	Euryalox	(Mo.Ga.Ar)
Euepirrhysia	(Po.Ca.Ph)	Eunicites	(An.Po.Eu)	Euryamphipora	(Po.De.St)
Euerisocrinus	(Ec.Cr.Cl)	Euninella	(Mo.Ga.Ar)	Euryarthra	(Cd.Ch.Rj)
Eufistulina	(Mo.Bi.My)	Euomphaloceras	(Mo.Ce.Am)	Eurycaraspis	(Cd.Pl.Pe)
Euflemingites	(Mo.Ce.Ce)	Euomphalopsis	(Mo.Ga.Eu)	Eurycare	(Ar.Tr.Pt)
Eugabrielona	(Mo.Ga.Ar)	Euomphalopterus	(Mo.Ga.Eu)	Eurycarpus	(Ar.Ml.De)
Eugeneodus	(Cd.Ch.Eu)	Euomphalus	(Mo.Ga.Eu)	Eurycephalites	(Mo.Ce.Am)
Eugeniacrinites	(Ec.Cr.Cy)	Euonchonotina	(Ar.Tr.Pt)	Eurycheilostoma	(Fo.Fo.Fo)
Euglossodus	(Cd.Ch.Pe)	Euonychocrinus	(Ec.Cr.Tx)	Eurychilina	(Ar.Os.Pa)
Euglyphella	(Ar.Os.Me)	Euorthisina	(Br.Ar.Or)	Eurycleidus	(Cd.Re.Ps)
Eugnathides	(Cd.Os.Pe)	Eupachyrinus	(Ec.Cr.Cl)	Eurycolporhynchus	(Br.Ar.Rh)
Eugonocare	(Ar.Tr.As)	Eupachydiscus	(Mo.Ce.Am)	Eurycornus	(Cd.Os.Pc)
Eugyra	(Cn.An.Sc)	Euparthenia	(Mo.Ga.He)	Eurydesma	(Mo.Bi.Pt)
Eugyropsis	(Cn.An.Sc)	Eupatagus	(Ec.Ec.Sp)	Eurydictya	(Bz.St.Cr)
Euhelia	(Cn.An.Sc)	Euphemitella	(Mo.Ga.Be)	Eurydike	(Mo.Ga.Ne)
Euhomaloceras	(Mo.Ce.Am)	Euphemites	(Mo.Ga.Be)	Eurydiscites	(Po.De.Ha)
Euhoplites	(Mo.Ce.Am)	Euphemitopsis	(Mo.Ga.Be)	Euryntemema	(Mo.Ga.Ne)
Euhoploceras	(Mo.Ce.Am)	Euphenax	(Mo.Bi.Pt)	Euryentome	(Mo.Ga.Ne)
Euhydrodiskos	(Ec.Ed.Is)	Euphyllax	(Ar.Ml.De)	Euryitycythere	(Ar.Os.Po)
Euhystriochoceras	(Mo.Ce.Am)	Euphyllia	(Cn.An.Sc)	Eurymya	(Mo.Bi.Mo)
Euidothyris	(Br.Ar.Te)	Euphylloceras	(Mo.Ce.Ph)	Eurymyella	(Mo.Bi.Mo)
Euisculites	(Mo.Ce.Ce)	Euphyllon	(Mo.Ga.Ne)	Eurynoticeras	(Mo.Ce.Am)
Eukloedenella	(Ar.Os.Pa)	Eupinacoceras	(Mo.Ce.Ce)	Eurynotoides	(Cd.Os.Pa)
Eulachyichiton	(Mo.Po.Ne)	Euplectella	(Po.He.I.s)	Euryoblastus	(Ec.Bl.Sp)
Eulepidina	(Fo.Fo.Fo)	Eupleura	(Mo.Ga.Ne)	Euryochetus	(Mo.Ga.Ne)
Euleptoichiton	(Mo.Po.Ne)	Eupleuroceras	(Mo.Ce.Go)	Euryocrinus	(Ec.Cr.Sa)
Euleptonhamphus	(Cd.Os.Be)	Euplica	(Mo.Ga.Ne)	Eurypetalum	(Ec.Ec.Ca)
Euleraphe	(Po.Tr.As)	Euporosteus	(Cd.Os.Co)	Eurypholis	(Cd.Os.Al)
Eulichthys	(Cd.Os.Ga)	Euprimites	(Ar.Os.Pa)	Euryphyllum	(Cn.An.Ru)
Eulima	(Mo.Ga.He)	Euprimitia	(Ar.Os.Pa)	Euryplax	(Ar.Ml.De)
Eulimastoma	(Mo.Ga.He)	Euprioniodina	(Cd.Co.Co)	Eurypneustes	(Ec.Ec.Ph)
Eulimella	(Mo.Ga.He)	Euprionoceras	(Mo.Ce.Am)	Euryprion	(An.Po.Eu)
Eulimene	(Mo.Ga.Nt)	Euprogatha	(Ar.Ml.De)	Eurypterus	(Ar.Me.Eu)
Eulinderina	(Fo.Fo.Fo)	Euprotomus	(Mo.Ga.Nt)	Euryptyris	(Br.Ar.Te)
Eulithota	(Cn.Sc.Se)	Eupsammia	(Cn.An.Sc)	Eurypyrene	(Mo.Ga.Ne)
Euloma	(Ar.Tr.Pt)	Euptera	(Mo.Bi.Pt)	Euryrizoceras	(Mo.Ce.On)
Eulomella	(Ar.Tr.Un)	Euptychaspis	(Ar.Tr.As)	Eurysalenia	(Ec.Ec.Sa)
Eulomina	(Ar.Tr.Ph)	Euptychoceras	(Mo.Ce.Am)	Eurysaurus	(Cd.Re.Ps)
Eulophoceras	(Mo.Ce.Am)	Euptychocrinus	(Ec.Cr.Di)	Eurysina	(Br.Ar.Te)
Euloxa	(Mo.Bi.Ve)	Eupycnodonte	(Mo.Bi.Pt)	Eurysites	(Br.Ar.Rh)
Euloxoceras	(Mo.Ce.Or)	Euractinella	(Br.Ar.Sp)	Eurysoria	(Br.Ar.Te)
Euloxostomum	(Fo.Fo.Fo)	Eurekabolbina	(Ar.Os.Pa)	Euryspirifer	(Br.Ar.Sp)
Eulyra	(Bz.St.Fe)	Eurekapegma	(Mo.He.He)	Eurystichthys	(Cd.Os.Pc)
Eulytoceras	(Mo.Ce.Am)	Eureka spirifer	(Br.Ar.Sp)	Eurytomella	(Bz.Gy.Ch)
Eumarcia	(Mo.Bi.Ve)	Eurekaia	(Ar.Tr.As)	Eurystomites	(Mo.Ce.Ta)
Eumedlicottia	(Mo.Ce.Pl)	Eurette	(Po.He.He)	Eurystrotos	(Bz.St.Ce)
Eumetabolotoecchia	(Br.Ar.Rh)	Eurhinodelphis	(Cd.Ma.Ce)	Eurytellina	(Mo.Bi.Ve)
Eumetadrillia	(Mo.Ga.Ne)	Eurhinosaurus	(Cd.Re.Ic)	Eurythyrrhombopora	(Bz.St.Cr)
Eumetopias	(Cd.Ma.Ca)	Eurhodia	(Ec.Ec.Ca)	Eurythyris	(Br.Ar.Te)
Eumetria	(Br.Ar.Sp)	Eurhomalea	(Mo.Bi.Ve)	Eurytium	(Ar.Ml.De)
Eumetula	(Mo.Ga.Nt)	Euriclanculus	(Mo.Ga.Ar)	Eurytorus	(Mo.Ga.Un)

Eurytreta	(Br,Li,Ac)	Evalea	(Mo,Ga,He)	Exocrinus	(Ec,Cr,Ci)
Euryzone	(Mo,Ga,Ar)	Evanescirostrum	(Br,Ar,Rh)	Exocyroceras	(Mo,Ce,Di)
Eusagenites	(Mo,Ce,Ce)	Evanidisinurostrum	(Br,Ar,Rh)	Exodictydia	(Po,De,Li)
Euscalpellum	(Ar,Ci)	Evansaspis	(Ar,Tr,Co)	Exogyra	(Mo,Bi,Pt)
Euscenarium	(Ac,Ra,Na)	Evarnula	(Mo,Ga,Ne)	Exomiliopsis	(Mo,Ga,Ne)
Euscobinella	(Mo,Ga,Ne)	Evechinus	(Ec,Ee,Ec)	Exomilus	(Mo,Ga,Ne)
Euseila	(Mo,Ga,Nt)	Evelynella	(Mo,Ga,He)	Exophthalmocythere	(Ar,Os,Po)
Eusemius	(Cd,Os,Am)	Evencoceras	(Mo,Ce,In)	Exoriocrinus	(Ec,Cr,Ci)
Eushantungoceras	(Mo,Ce,Ac)	Evencodus	(Cd,Co,Co)	Exospirna	(Mo,Bi,Mt)
Eusiphonella	(Po,Ca,Ph)	Evenia	(Mo,Bi,Pt)	Exostega	(Cn,An,Ru)
Eusmilta	(Cn,An,Sc)	Evenkia	(Cd,Os,Pa)	Exotica	(Mo,Bi,Ve)
Eusmiliopsis	(Cn,An,Sc)	Evenkiella	(Cn,An,Ru)	Exotornoceras	(Mo,Ce,Go)
Euspilopora	(Bz,St,Cr)	Evenkina	(Br,Ar,Or)	Expellobolus	(Br,Li,Li)
Euspira	(Mo,Ga,Nt)	Evenkinorthis	(Br,Ar,Or)	Experlingula	(Br,Li,Li)
Euspirocrinus	(Ec,Cr,Ci)	Evenkorhynchia	(Br,Ar,Rh)	Exputens	(Mo,Bi,Pt)
Euspirocrommium	(Mo,Ga,Nt)	Evermanella	(Cd,Os,Al)	Exsculptina	(Fo,Fo,Fo)
Eustenocrinus	(Ec,Cr,Ds)	Everticyclamma	(Fo,Fo,Fo)	Exsulacrinus	(Ec,Cr,Mo)
Eustephanella	(Ar,Os,Me)	Evesthes	(Cd,Os,Pn)	Extendilabrum	(Mo,Ga,Be)
Eusthenoceras	(Mo,Ce,Or)	Eviakia	(Cn,In,In)	Extentithea	(Hy,Or,Ci)
Eusthenopteron	(Cd,Os,Co)	Evlanella	(Ar,Os,Pa)	Exterocrinus	(Ec,Cr,Ci)
Eusthenotrochus	(Cn,An,Sc)	Evlania	(Fo,Fo,Fo)	Extrania	(Ar,Tr,Co)
Eustoma	(Mo,Ga,Nt)	Evlanoceras	(Mo,Ce,On)	Eygalerina	(Fo,Fo,Fo)
Eustomia	(Mo,Ga,He)	Evlanovia	(Ar,Os,Pa)	Eymarella	(Mo,Ga,Ar)
Eustrobilus	(Po,De,Li)	Evolutinella	(Fo,Fo,Fo)	Eymekops	(Ar,Tr,As)
Eustrombus	(Mo,Ga,Nt)	Evolutonion	(Fo,Fo,Fo)	Ezhuangia	(Ar,Tr,Co)
Eustypocystis	(Ec,Eo,As)	Evolsocassidulina	(Fo,Fo,Fo)	Ezilloella	(Mo,Ce,Am)
Eusyringium	(Ac,Ra,Na)	Evropites	(Ar,Tr,Ph)	Ezonoculana	(Mo,Bi,Nu)
Eutactostomium	(Po,He,He)	Ewaldocoenia	(Cn,An,Sc)	Fabagella	(Mo,Bi,Ph)
Eutaxocrinus	(Ec,Cr,Tx)	Ewekoroia	(Mo,Ga,Nt)	Fabaliocypris	(Ar,Os,Po)
Eutelecrinus	(Ec,Cr,Mo)	Ewekorolaxis	(Mo,Ga,Nt)	Fabarella	(Ar,Os,Po)
Euthemon	(Ec,Oh,Oh)	Ewingella	(Ac,Ra,Na)	Fabella	(Mo,Bi,Ve)
Euthlipsurella	(Ar,Os,Po)	Exaetocrinus	(Ec,Cr,Ci)	Faberoceras	(Mo,Ce,Di)
Euthria	(Mo,Ga,Ne)	Exallias	(Cd,Os,Pf)	Faberolasma	(Cn,An,Ru)
Euthriofusus	(Mo,Ga,Ne)	Exanthesis	(Po,He,Ly)	Faberophyllum	(Cn,An,Ru)
Euthydesma	(Mo,Bi,Pr)	Exastipyx	(Ar,Tr,Co)	Fabiania	(Fo,Fo,Fo)
Euthymella	(Mo,Ga,Nt)	Exatrypa	(Br,Ar,At)	Fabifenestella	(Bz,St,Fe)
Euthymipecten	(Mo,Bi,Pt)	Excalibosaurus	(Cd,Re,Je)	Fabularia	(Fo,Fo,Fo)
Euthynnus	(Cd,Os,Pf)	Excavatorhynchia	(Br,Ar,Rh)	Fabulaspis	(Ar,Tr,Un)
Euthynotus	(Cd,Os,Pc)	Excellichlamys	(Mo,Bi,Pt)	Fabulina	(Mo,Bi,Ve)
Euthyrachis	(Mo,Ga,Ar)	Exceptothyris	(Br,Ar,Te)	Faciledictyon	(Po,De,St)
Euthystylus	(Mo,Ga,Nt)	Exechestoma	(Mo,Ga,Nt)	Faciura	(Ar,Tr,Pt)
Eutinocbilus	(Mo,Ga,Ar)	Exechocrinus	(Mo,Ga,Nt)	Facivermis	(Lo)
Eutomoceras	(Mo,Ce,Ce)	Exechonella	(Bz,Gy,Ch)	Fadaiella	(Mo,Ga,Un)
Eutrepoceras	(Mo,Ce,Na)	Exellia	(Cd,Os,Pf)	Fadenia	(Cd,Ch,Eu)
Eutretocystis	(Ec,Rh,Rh)	Exfenestella	(Bz,St,Fe)	Fagesia	(Mo,Ce,Am)
Eutrichiurides	(Cd,Os,Pf)	Exidomonea	(Bz,St,Cc)	Fahraeusodus	(Cd,Co,Co)
Eutrigla	(Cd,Os,Sc)	Exigraptus	(He,Gr,Gr)	Failleama	(Ar,Tr,Pt)
Eutrochocrinus	(Ec,Cr,Mo)	Exilia	(Mo,Ga,Ne)	Fainella	(Cn,An,Ta)
Euturrilites	(Mo,Ce,Am)	Exilifrons	(Cn,An,Ru)	Faksephyllia	(Cn,An,Sc)
Eutylys	(Mo,Bi,My)	Exililusius	(Mo,Ga,Ne)	Faksethyris	(Br,Ar,Te)
Euvigerina	(Fo,Fo,Fo)	Exilitheca	(Hy,Or,Ex)	Falater	(Br,Ar,St)
Euvola	(Mo,Bi,Pt)	Exiloidea	(Mo,Ga,Ne)	Falamapis	(Ar,Tr,As)
Euxinella	(Br,Ar,Rh)	Exiteloceras	(Mo,Ce,Am)	Falcatotontia	(Mo,Bi,Ar)
Euxinita	(Fo,Fo,Fo)	Exlessia	(Mo,Ga,Nt)	Falcatoprotus	(Ar,Tr,Pr)
Euxinocythere	(Ar,Os,Po)	Exlmella	(Ec,Ho,Mo)	Falcatus	(Cd,Ch,Sy)
Euzaphleges	(Cd,Os,Pf)	Exochella	(Bz,Gy,Ch)	Falcilymenia	(Mo,Ce,Ci)
Euzittelia	(Po,Ca,Ph)	Exochoceras	(Mo,Ce,Di)	Falciferella	(Mo,Ce,Am)
Euzkadiella	(Po,De,Ha)	Exochocrinus	(Ec,Cr,Ci)	Falciferula	(Br,Ar,Te)
Euzone	(Mo,Ga,Ar)	Exochocia	(Bz,St,Cc)	Falcimylitus	(Mo,Bi,Mt)
Euzonosoma	(Ec,Op,Oe)	Exochopora	(Po,De,Li)	Falcispongus	(Ac,Ra,Na)
Evactinopora	(Bz,St,Cy)	Exochops	(Ar,Tr,Pr)	Falcitornoceras	(Mo,Ce,Go)
Evactinostella	(Bz,St,Cy)	Exochorhynchus	(Mo,Bi,Ph)	Falcodus	(Cd,Co,Co)
Evagena	(Ar,Tr,Pt)	Exocoetoides	(Cd,Os,Al)	Falconoplax	(Ar,Mi,De)
Evagyrotheca	(Br,Ar,Te)	Exocoenularia	(Cn,Sc,Cn)	Faltes	(Ar,Os,Ar)

Falkosites	(An,Po,Eu)	Fasciculicardia	(Mo,Bi,Ve)	Felinotoechia	(Br,Ar,Rh)
Fallacites	(Mo,Ce,Go)	Fasciculiconcha	(Mo,Bi,Pt)	Felixaraea	(Cn,An,Sc)
Fallacosteus	(Cu,Pl,Ar)	Fasciculina	(Br,Ar,Or)	Felixastraea	(Cn,An,Sc)
Fallagnostus	(Ar,Tr,Ag)	Fasciculinopora	(Bz,St,Cc)	Felixigyra	(Cn,An,Sc)
Fallaticella	(Ar,Os,Pa)	Fasciculipora	(Bz,St,Cc)	Felixium	(Po,De,Di)
Fallaxispirifer	(Br,Ar,Sp)	Fasciculitubus	(He,Gr,Tu)	Fellaster	(Ec,Ec,Cl)
Fallaxopproductus	(Br,Ar,St)	Fasciculoerans	(Mo,Ce,An)	Fellerites	(Ar,Os,Pa)
Fallocyathus	(Po,Re,Aj)	Fasciculophyllum	(Cn,An,Ru)	Fellius	(Ec,Ec,Cl)
Fallotaspis	(Ar,Tr,Re)	Fasciculus	(Ct)	Felsinella	(Fo,Fo,Fo)
Fallotella	(Fo,Fo,Fo)	Fascifera	(Br,Ar,Or)	Felsinothorium	(Cd,Ma,Si)
Fallotia	(Fo,Fo,Fo)	Fascigera	(Bz,St,Cc)	Femerensia	(Ar,Os,Pa)
Falloticerans	(Mo,Ce,Am)	Fascinewellipecten	(Mo,Bi,Pt)	Feneoniana	(Mo,Ga,Ar)
Faloriella	(Mo,Ga,Nt)	Fasciolaria	(Mo,Ga,Ne)	Fenestella	(Bz,St,Fe)
Falospongia	(Po,De,Ha)	Fascioplex	(Mo,Ga,Ne)	Fenestellata	(Bz,St,Fe)
Falsatrypa	(Br,Ar,At)	Fascipericyclus	(Mo,Ce,Go)	Fenestepora	(Bz,St,Fe)
Falsicatnipora	(Cn,An,Ta)	Fasciphyllum	(Cn,An,Ru)	Fenesteverta	(Bz,St,Fe)
Falsicolus	(Mo,Ga,Ne)	Fascipora	(Bz,St,Cc)	Fenestralia	(Bz,St,Fe)
Falsifusus	(Mo,Ga,Ne)	Fasciseris	(Cn,An,Sc)	Fenestrapora	(Bz,St,Fe)
Falsipollex	(Ar,Os,Pa)	Fascistropheodonta	(Br,Ar,St)	Fenestraspis	(Ar,Tr,Ph)
Falsobentonia	(Ar,Os,Po)	Fascivelvata	(Mo,Ga,Ar)	Fenestrellina	(Bz,St,Fe)
Falsocibicides	(Fo,Fo,Fo)	Fascizetina	(Br,Ar,Or)	Fenestricardita	(Mo,Bi,Ve)
Falcoythere	(Ar,Os,Po)	Fastigastocytthere	(Ar,Os,Po)	Fenestrirostra	(Br,Ar,Rh)
Falsogaudryinella	(Fo,Fo,Fo)	Fastigiella	(Mo,Ga,Nt)	Fenestrocyathus	(Po,Ar,Ar)
Falsoguttulina	(Fo,Fo,Fo)	Fastuosocolex	(An,Po,Ph)	Fenestrosporgia	(Po,De,Li)
Falsopalmula	(Fo,Fo,Fo)	Fatocephalus	(Ar,Tr,Pt)	Fenestrosyrinx	(Mo,Ga,Ne)
Falsoplanulina	(Fo,Fo,Fo)	Faujasia	(Ec,Ec,Ca)	Fenestruina	(Bz,Gy,Ch)
Falsostyliola	(Mo,Ga,He)	Faujasina	(Fo,Fo,Fo)	Fengjiachonia	(Mo,Bi,Ve)
Falsotruncana	(Fo,Fo,Fo)	Fauraster	(Ec,Ec,Ca)	Fengtaiella	(Ar,Os,Ar)
Falsurgonina	(Fo,Fo,Fo)	Fautor	(Mo,Ga,Ar)	Fengzuella	(Br,Li,Li)
Falunia	(Ar,Os,Po)	Favartia	(Mo,Ga,Ne)	Fensiangia	(Pr,Un,In)
Faluniella	(Mo,Ga,He)	Favelloides	(Ci,Po,Sp)	Fenxiangella	(Br,Ar,St)
Famatinolithus	(Ar,Tr,As)	Faveolebris	(Ar,Os,Po)	Ferayia	(Fo,Fo,Fo)
Famatinorthis	(Br,Ar,Or)	Favia	(Cn,An,Sc)	Ferecetotherium	(Cd,Ma,Ce)
Famaxonia	(Cn,An,Ru)	Favicella	(Bz,St,Cy)	Ferenepea	(Ar,Tr,Pt)
Famenella	(Ar,Os,Pa)	Favilyntus	(Po,Re,Mo)	Ferestromatopora	(Po,De,St)
Famennelasma	(Cn,An,Ru)	Favistina	(Cn,An,Ru)	Ferganella	(Br,Ar,Rh)
Fangxianites	(Pr,Cc,Ch)	Favites	(Cn,An,Sc)	Fergania	(Mo,Bi,Pt)
Fania	(Po,De,Pe)	Favitopsis	(Cn,An,Sc)	Ferganoceras	(Mo,Ce,Go)
Faniathalamia	(Po,De,Pe)	Favocassidulina	(Fo,Fo,Fo)	Ferganoproductus	(Br,Ar,St)
Fanichonetes	(Br,Ar,St)	Favoschiaetetes	(Po,De,Ta)	Fernandezaster	(Ec,Ec,Sp)
Fanninoceras	(Mo,Ce,Am)	Favositella	(Bz,St,Cy)	Ferngenia	(Br,Ar,Sp)
Fansycyathus	(Po,Re,Aj)	Favosites	(Cn,An,Ta)	Ferralsia	(Ar,Tr,Pt)
Fantus	(Ac,Ra,Na)	Favosyringium	(Ac,Ra,Na)	Ferrax	(Br,Ar,Or)
Fanulodiscus	(Ec,Ed,Is)	Favrella	(Mo,Ce,Am)	Ferresium	(Ac,Ra,Sp)
Faorina	(Ec,Ec,Sp)	Favria	(Mo,Ga,He)	Ferrobolus	(Br,Li,Ac)
Farabophyllum	(Cn,An,Ru)	Favriella	(Mo,Ga,Ne)	Ferrogrya	(Mo,Pa,Hy)
Faraudiella	(Mo,Ce,Am)	Favulella	(Ar,Os,Me)	Ferrya	(Cn,An,Sc)
Farbesiceras	(Mo,Ce,Am)	Favulina	(Fo,Fo,Fo)	Ferrythyris	(Br,Ar,Te)
Farcus	(Ac,Ra,Na)	Favusella	(Fo,Fo,Fo)	Feruminops	(Ar,Tr,Ph)
Fardenia	(Br,Ar,St)	Fax	(Mo,Ga,Ne)	Feurillia	(Fo,Fo,Fo)
Farisia	(Mo,Bi,Ve)	Faxsephyllia	(Cn,An,Sc)	Fezzanoglossa	(Br,Li,Li)
Farnhamia	(Mo,Ce,Am)	Faxxia	(Mo,Ga,Nt)	Flynnonia	(Br,Ar,Or)
Farquharsonia	(Ec,Ec,Di)	Fayetteville	(Mo,Ce,Go)	Fibrosopecten	(Mo,Bi,Pt)
Farraia	(Mo,Bi,Ph)	Fayettoceras	(Mo,Ce,On)	Fibula	(Mo,Ga,Nt)
Farrea	(Po,He,He)	Fayoumaster	(Ec,As,Va)	Fibularia	(Ec,Ec,Cl)
Farreopsis	(Po,He,Un)	Fedora	(Bz,Gy,Ch)	Fibulaster	(Ec,Ec,Cl)
Farroceras	(Mo,Ce,En)	Fedorowskicyathus	(Cn,An,Ru)	Fibulella	(Mo,Ga,He)
Fartulum	(Mo,Ga,Nt)	Fedorowskiella	(Cn,An,Ru)	Fibulina	(Ec,Ec,Cl)
Fascianella	(Ar,Os,Pa)	Fehamya	(Br,Ar,Or)	Fibulistrophia	(Br,Ar,St)
Fasciatiphyllia	(Cn,An,Sc)	Fehlmannites	(Mo,Ce,Am)	Fibuloptygmatis	(Mo,Ga,He)
Fascicoma	(Br,Li,Ac)	Feifelia	(Po,He,He)	Fibuloptyx	(Mo,Ga,He)
Fascicosta	(Br,Ar,Rh)	Feilongshania	(Ar,Tr,Un)	Picariastrea	(Cn,An,Sc)
Fascicostella	(Br,Ar,Or)	Felaniella	(Mo,Bi,Ve)	Ficheuria	(Mo,Ce,Am)
Fasciculiamplexus	(Cn,An,Ru)	Felica	(Mo,Bi,Ar)	Ficopsis	(Mo,Ga,Nt)

Fictoaecteon	(Mo,Ga,Ce)	Fissoelphidium	(Fo,Fo,Fo)	Flexaria	(Br,Ar,St)
Fictonoba	(Mo,Ga,Nt)	Fissurella	(Mo,Ga,Ar)	Flexathyris	(Br,Ar,Sp)
Ficulomorpha	(Mo,Ga,Ne)	Fissurellidea	(Mo,Ga,Ar)	Flexicalymene	(Ar,Tr,Ph)
Ficulopsis	(Mo,Ga,Ne)	Fissuricella	(Bz,Gy,Ch)	Flexiclymenia	(Mo,Ce,Cl)
Ficus	(Mo,Ga,Ne)	Fissurina	(Fo,Fo,Fo)	Flexicollicamara	(He,Gr,Ca)
Fidelitella	(Ar,Os,Pa)	Fissurisepia	(Mo,Ga,Ar)	Flexicorbula	(Mo,Bi,My)
Fidera	(Mo,Bi,Nu)	Fistellaspongia	(Po,He,LS)	Flexifenestella	(Bz,St,Fe)
Fidespirifer	(Br,Ar,Sp)	Fistulacanta	(Bz,St,Cy)	Flexihydra	(Cn,Hy,Hy)
Fieldaspis	(Ar,Tr,Co)	Fistulamina	(Bz,St,Cy)	Flexiostroma	(Po,De,St)
Fieldia	(Pa)	Fistularia	(Cd,Os,Ga)	Flexispinites	(Mo,Ce,Am)
Fieldingaspis	(Cd,Ce,Ce)	Fistularioides	(Cd,Os,Ga)	Flexispecten	(Mo,Bi,Pt)
Fieldospongia	(Po,De,LI)	Fistulicanta	(Bz,St,Cy)	Flexopteron	(Mo,Ga,Ne)
Fifeocrinus	(Ec,Cr,Cl)	Fistulimurina	(Po,De,Ta)	Flexoptychites	(Mo,Ce,Ce)
Figularia	(Bz,Gy,Ch)	Fistuliphragma	(Bz,St,Cy)	Flexuocythere	(Ar,Os,Po)
Fijnonion	(Fo,Fo,Fo)	Fistulipora	(Bz,St,Cy)	Flexus	(Ar,Os,Po)
Fikaïtes	(Mo,Ce,Am)	Fistuliporella	(Bz,St,Cy)	Flickia	(Mo,Ce,Am)
Filiatrypa	(Br,Ar,At)	Fistuliporida	(Bz,St,Cy)	Flindersiethys	(Cd,Os,El)
Filicava	(Bz,St,Cc)	Fistuliramus	(Bz,St,Cy)	Flindersipora	(Cn,An,Ta)
Filicea	(Bz,St,Cc)	Fistulispongia	(Po,De,Pe)	Flintinella	(Fo,Fo,Fo)
Filiconcha	(Br,Ar,St)	Fistulobalanus	(Ar,Ci)	Florbertia	(Ar,Me,Ag)
Filicrisia	(Bz,St,Cc)	Fistulocladia	(Bz,St,Cy)	Floria	(Cn,An,Sc)
Filicrisina	(Bz,St,Cc)	Fistulogonites	(Br,Ar,Or)	Floribella	(Mo,Ga,Un)
Filifascigera	(Bz,St,Cc)	Fistulotrypa	(Bz,St,Cy)	Floridina	(Bz,Gy,Ch)
Filigreenia	(Br,Ar,Rh)	Fitzroyella	(Br,Ar,Rh)	Floridinella	(Bz,Gy,Ch)
Filiramoporina	(Bz,St,Cy)	Flabellammina	(Fo,Fo,Fo)	Floridiscus	(Ec,Ed,Is)
Filisparsa	(Bz,St,Cc)	Flabellamminopsis	(Fo,Fo,Fo)	Florimetis	(Mo,Bi,Ve)
Filites	(Bz,St,Fe)	Flabellimutilus	(Ar,Os,Po)	Floripatella	(Mo,Ga,Pa)
Filodrilla	(Mo,Ga,Ne)	Flabellinella	(Fo,Fo,Fo)	Flosculinella	(Fo,Fo,Fo)
Filograna	(An,Po,Se)	Flabellipecten	(Mo,Bi,Pt)	Flosculus	(Po,He,Un)
Filogranula	(An,Po,Se)	Flabellirhynchia	(Br,Ar,Rh)	Flourensina	(Fo,Fo,Fo)
Filopecten	(Mo,Bi,Pt)	Flabellisphinctes	(Mo,Ce,Am)	Floweria	(Br,Ar,St)
Filosina	(Mo,Bi,Ve)	Flabellispongia	(Po,He,Ly)	Flowerites	(Mo,Ce,Di)
Fimbria	(Mo,Bi,Ve)	Flabellitesia	(Br,Ar,Or)	Floweroceras	(Mo,Ce,Ac)
Fimbriaria	(Br,Ar,St)	Flabellocephalus	(Ar,Tr,As)	Floyda	(Mo,Ga,Ar)
Fimbriatella	(Mo,Ga,Nt)	Flabellocycolina	(Fo,Fo,Fo)	Flucticularia	(An,Po,Se)
Fimbrinia	(Br,Ar,St)	Flabellocyrtia	(Br,Ar,Sp)	Fluctuaria	(Br,Ar,St)
Fimbriothyris	(Br,Ar,Te)	Flabellopora	(Bz,Gy,Ch)	Flugopterus	(Cd,Os,Pe)
Fimbrispirifer	(Br,Ar,Sp)	Flabellomilia	(Cn,An,Sc)	Flustra	(Bz,St,Tr)
Finiclymenia	(Mo,Ce,Cl)	Flabellothrypa	(Br,Ar,Te)	Flustrella	(Bz,Gy,Ch)
Finkelmburgia	(Br,Ar,Or)	Flabellotrypa	(Bz,St,Cc)	Flustrellaria	(Bz,Gy,Ch)
Finksella	(Po,De,LI)	Flabellulirostrum	(Br,Ar,Rh)	Foegia	(Mo,Bi,Ph)
Finlayella	(Mo,Bi,Ve)	Flabellum	(Cn,An,Sc)	Foerstecystis	(Ec,Pe,Un)
Finlayina	(Fo,Fo,Fo)	Flabthecca	(Pr,Un,In)	Foerstediscus	(Ec,Ed,Is)
Finlayola	(Mo,Ga,He)	Flaccivelum	(Ar,Os,Pa)	Foerstella	(Po,He,LS)
Finnarchinella	(Ar,Os,Po)	Flacilla	(Mo,Ga,Nt)	Foerstellites	(Mo,Ce,En)
Finospirifer	(Br,Ar,Sp)	Flagellophyllum	(Cn,An,Ru)	Foersteoceras	(Mo,Ce,Di)
Fiorella	(Ar,Os,Pa)	Flagrosipora	(Fo,Fo,Fo)	Foersteotheca	(Hy,Or,Or)
Firmacidarid	(Ec,Ec,Un)	Flatopia	(Mo,Bi,Tr)	Foerstephyllum	(Cn,An,Ta)
Firmicornus	(Hy,Hy,Hy)	Flaventia	(Mo,Bi,Ve)	Folia	(Mo,Ga,Ar)
Fischerella	(Bz,Gy,Ct)	Flectcheriathyris	(Br,Ar,Te)	Foliaster	(Ec,As,Pl)
Fischericardium	(Mo,Bi,Ve)	Flectoconularia	(Cn,Sc,Cn)	Folina	(Mo,Ga,Nt)
Fischeriella	(Mo,Ga,Ar)	Flectospira	(Fo,Fo,Fo)	Folioceras	(Mo,Ce,Or)
Fischerina	(Fo,Fo,Fo)	Flemingia	(Ar,Os,Ar)	Foliomena	(Br,Ar,St)
Fisherocrinus	(Ec,Cr,Cy)	Flemingites	(Mo,Ce,Ce)	Follicalena	(Po,De,Pe)
Fissidentalium	(Mo,Sc,Sc)	Flemingopsis	(Ar,Os,Ar)	Folliceps	(Ar,Tr,Un)
Fissilobicerias	(Mo,Ce,Am)	Flemingostrea	(Mo,Bi,Pt)	Follicrinus	(Ec,Cr,Cl)
Fissilunula	(Mo,Bi,Ve)	Flemmingia	(Mo,Ga,Nt)	Follicucullus	(Ac,Ra,Sp)
Fissirhynchia	(Br,Ar,Rh)	Fletcheria	(Cn,An,Ru)	Follmannia	(Mo,Bi,Pt)
Fissispongia	(Po,Ca,Ph)	Fletcheriella	(Cn,An,Ta)	Fomichevia	(Cn,An,Ta)
Fissobractites	(Ec,Ho,De)	Fletcherina	(Cn,An,Ru)	Fomichevella	(Cn,An,Ru)
Fissocephalus	(Ar,Tr,Pt)	Fletcheripecten	(Mo,Bi,Pt)	Fomitchella	(Pr,Un,In)
Fissocrinocythere	(Ar,Os,Po)	Fletcherithyroides	(Br,Ar,Te)	Fontanelliceras	(Mo,Ce,Am)
Fissocythere	(Ar,Os,Po)	Fletcheriaviewia	(Mo,Ga,EU)	Fontannesia	(Mo,Ce,Am)
Fissodus	(Cd,Ch,Pe)	Flexanulus	(Po,Re,Aj)	Fontannesella	(Mo,Ce,Am)

Fontbotia	(Fo,Fo,Fo)	Frambocythere	(Ar,Os,Po)	Fujispira	(Mo,Ga,Eu)
Foodiceras	(Mo,Ce,Na)	Frammia	(Ar,Tr,Ph)	Fukanglichthys	(Cd,Os,Pa)
Fooidites	(Mo,Ce,An)	Francesita	(Fo,Fo)	Fulcrella	(Mo,Bi,Ve)
Foramenella	(Ar,Os,Pa)	Francocharis	(Ar,Ml,My)	Fulcrifloria	(Br,Ar,Or)
Foraripora	(Bz,Gy,Ct)	Francopora	(Bz,Gy,Ch)	Fulgerca	(Mo,Ga,Ne)
Foratiscala	(Mo,Ga,Nt)	Francoviahia	(Ar,Tr,Ph)	Fulgoraria	(Mo,Ga,Ne)
Forator	(Mo,Ga,Nt)	Frankiella	(Br,Ar,St)	Fulguroficus	(Mo,Ga,Nt)
Forbesiceras	(Mo,Ce,Am)	Frankites	(Mo,Ce,Ce)	Fulgurofusius	(Mo,Ga,Ne)
Forbescythere	(Ar,Os,My)	Franklinella	(Ar,Os,My)	Fulpia	(Mo,Bi,Ve)
Forbesiaster	(Ec,As,Va)	Franklinoceras	(Mo,Ce,Di)	Fulvia	(Mo,Bi,Ve)
Forbesiocrinus	(Ec,Cr,Sa)	Fransonia	(Mo,Bi,Pt)	Fundinia	(Mo,Bi,Hi)
Forcepia	(Po,De,Po)	Franusuaecyathus	(Po,Re,Ca)	Fungella	(Bz,St,Ce)
Forchhammeria	(Ar,Tr,Pt)	Frechastrea	(Cn,An,Ru)	Fungia	(Cn,An,Sc)
Fordaspis	(Ar,Tr,Co)	Frechella	(Br,Ar,Sp)	Fungiacara	(Mo,Bi,Mt)
Fordilla	(Mo,Bi,Mo)	Frechiella	(Mo,Ce,Am)	Fungiacyathus	(Cn,An,Sc)
Fordinia	(Br,Li,Li)	Frechites	(Mo,Ce,Ce)	Fungiastraea	(Cn,An,Sc)
Foremanella	(Ac,Ra,Sp)	Fredenia	(Mo,Ga,Ne)	Funginella	(Cn,An,Sc)
Foremanellina	(Ac,Ra,Na)	Fredericksia	(Br,Ar,Sp)	Funginellastrea	(Cn,An,Sc)
Foremanina	(Ac,Ra,Na)	Freiastarte	(Mo,Bi,Ve)	Fungochitina	(Fo,Fo,Ch)
Foricula	(Bz,St,Ce)	Freixialina	(Fo,Fo,Fo)	Fungocystites	(Ec,Di,Di)
Forillonaria	(Ar,Tr,Ph)	Freja	(Mo,Bi,Nu)	Fungophyllia	(Cn,An,Sc)
Forma	(Br,Ar,St)	Fremontella	(Ar,Tr,Ol)	Fungulodus	(Cd,Co,Co)
Formanhelena	(Ac,Ra,Sp)	Fremontia	(Ar,Tr,Ol)	Funis	(Mo,Ga,Nt)
Formonia	(Ar,Tr,Pt)	Fremontoceras	(Mo,Ce,Ba)	Funiscula	(Mo,Ga,Nt)
Formosarhynchia	(Br,Ar,Rh)	Frencriuroides	(Ar,Tr,Ph)	Furacopyge	(Ar,Tr,Ph)
Formosocyathus	(Po,Re,Aj)	Freneixita	(Mo,Bi,Pt)	Furcalithus	(Ar,Tr,Pt)
Formosulus	(Mo,Bi,My)	Freneivostrea	(Mo,Bi,Pt)	Furcaster	(Ec,Op,Oe)
Forolina	(Po,De,St)	Frenguelliceras	(Mo,Ce,Am)	Furcirhynchia	(Br,Ar,Rh)
Forreria	(Mo,Ga,Ne)	Frenguellia	(Mo,Bi,Tr)	Furcitella	(Br,Ar,St)
Forresteria	(Mo,Ce,Am)	Frenula	(Br,Ar,Te)	Furnishina	(Cd,Co,Pa)
Forschia	(Fo,Fo,Fo)	Frescocyathus	(Cn,An,Sc)	Furnishius	(Cd,Co,Co)
Forschiella	(Fo,Fo,Fo)	Fresnosaurus	(Cd,Re,Ps)	Furo	(Cd,Os,Am)
Forsia	(Mo,Ga,Ne)	Fresvillia	(Mo,Ce,Am)	Fursenkoina	(Fo,Fo,Fo)
Forskaelena	(Mo,Ga,Ar)	Friedbergia	(Cn,An,Ru)	Fusarchaias	(Fo,Fo,Fo)
Forteyops	(Ar,Tr,Ph)	Frigichione	(Mo,Bi,Ve)	Fusibuccinum	(Mo,Ga,Ne)
Forthocrinus	(Ec,Cr,Cl)	Frigidocardium	(Mo,Bi,Ve)	Fusciniopyge	(Ar,Tr,Pr)
Fortipecten	(Mo,Bi,Pt)	Friginatica	(Mo,Ga,Nt)	Fuscinites	(Ar,Os,Pa)
Fortowensia	(Mo,Bi,Mo)	Frinalicyathus	(Po,Re,Aj)	Fuscinullina	(Ar,Os,Pa)
Fortunella	(Br,Ar,Rh)	Fritchaspis	(Ar,Tr,As)	Fuscocardium	(Mo,Bi,Ve)
Fossacallista	(Mo,Bi,Ve)	Frithjofia	(Ar,Tr,Pr)	Fuscoscala	(Mo,Ga,Nt)
Fossacypraea	(Mo,Ga,Nt)	Frizzellus	(Ec,Ho,Ar)	Fusella	(Br,Ar,Sp)
Fossaphyllia	(Cn,An,Ht)	Frogdenites	(Mo,Ce,Am)	Fusiaphera	(Mo,Ga,Ne)
Fossariopsis	(Mo,Ga,Ar)	Frognaspis	(Ar,Tr,As)	Fusicellaria	(Bz,Gy,Ch)
Fossarius	(Mo,Ga,Nt)	Frombachia	(Mo,Ga,Ar)	Fusichonetes	(Br,Ar,St)
Fossatrivia	(Mo,Ga,Nt)	Fromentellia	(Cn,An,Sc)	Fuscoceras	(Mo,Ce,Or)
Fossatrypa	(Br,Ar,At)	Fromentelligyra	(Cn,An,Sc)	Fusiella	(Fo,Fo,Fo)
Fossrichteria	(Ar,Os,My)	Fromeophyllum	(Cn,An,Ru)	Fusifarella	(Po,De,As)
Fossopora	(Cn,An,Ta)	Froncularia	(Fo,Fo,Fo)	Fusiguraleus	(Mo,Ga,Ne)
Fossoporella	(Cn,An,Ta)	Fronculinata	(Fo,Fo,Fo)	Fusimilis	(Mo,Ga,Ne)
Fossilaster	(Ec,Ec,Cl)	Frondilina	(Fo,Fo,Fo)	Fusimira	(Mo,Ga,Ne)
Fossilites	(Mo,Bi,Hi)	Fronkina	(Fo,Fo,Fo)	Fusinus	(Mo,Ga,Ne)
Fossundecima	(An,Po,Ph)	Fron dipora	(Bz,St,Ce)	Fusiproductus	(Br,Ar,St)
Fosterella	(Ar,Ci)	Fron dovaginulina	(Fo,Fo,Fo)	Fusipyxis	(Mo,Ga,He)
Foulonia	(Ar,Tr,Ph)	Frostiella	(Ar,Os,Po)	Fusirhynchia	(Br,Ar,Rh)
Fournierechinus	(Ec,Ec,Ey)	Fruehwirthia	(Cn,An,Ru)	Fusispira	(Mo,Ga,Nt)
Fournierella	(Mo,Ce,Am)	Frumentella	(Fo,Fo,Fo)	Fusispirifer	(Br,Ar,Sp)
Fourtauna	(Ec,Ec,Sp)	Frurionella	(Bz,Gy,Ch)	Fusiteuthis	(Mo,Ce,Be)
Foveaprimittella	(Ar,Os,Pa)	Fryxellodontus	(Cd,Co,Co)	Fusitoma	(Mo,Ga,Ne)
Foveola	(Br,Li,Li)	Fuchouia	(Ar,Tr,Co)	Fusitron	(Mo,Ga,Nt)
Foveoleberis	(Ar,Os,Po)	Fuchungopora	(Cn,An,Ta)	Fusitron	(Mo,Ga,Nt)
Fractoceramus	(Mo,Bi,Pt)	Fuciniceras	(Mo,Ce,Am)	Fusiturricula	(Mo,Ga,Ne)
Fragilicyathus	(Po,Ir,Ar)	Fueloepicythere	(Ar,Os,Po)	Fusiturris	(Mo,Ga,Ne)
Fragiscutum	(Ar,Tr,Ph)	Fugleria	(Mo,Bi,Ar)	Fusoficula	(Mo,Ga,Nt)
Fragum	(Mo,Bi,Ve)	Fuhrbergiella	(Ar,Os,Po)	Fusoidella	(Mo,Ga,Nt)

Fusoterebra	(Mo,Ga,Ne)	Galeraster	(Ec,Ec,Hs)	Gardnerella	(Mo,Bi,Ve)
Fustiaria	(Mo,Sc,Sc)	Galericulus	(Mo,Ga,Nt)	Gargania	(Mo,Ga,Ar)
Fustichitina	(Fo,Fo,Ch)	Galerites	(Ec,Ec,Ho)	Gargantua	(Bz,Gy,Ch)
Fusuconcharium	(Pr,Un,In)	Galeroclypeus	(Ec,Ec,Un)	Gargasiceras	(Mo,Ce,Am)
Fusulina	(Fo,Fo,Fo)	Galeropsis	(Mo,Ga,Ne)	Gari	(Mo,Bi,Ve)
Fusulinella	(Fo,Fo,Fo)	Galeropygus	(Ec,Ec,Ca)	Garnbergia	(Cd,Os,Co)
Fusus	(Mo,Ga,Ne)	Galerosaukia	(Ar,Tr,As)	Garniella	(Ar,Os,Pa)
Futhystylus	(Mo,Ga,Nt)	Galeus	(Cd,Ch,Ca)	Garniericeras	(Mo,Ce,Am)
Fuxianhuia	(Ar,Mo,In)	Galicornus	(Hy,Hy,Hy)	Garnierisphinctes	(Mo,Ce,Am)
Fyfea	(Mo,Ga,Ne)	Gallagnostoides	(Ar,Tr,Ag)	Garnotia	(Mo,Ga,Nt)
Fylgia	(Mo,Bi,Pt)	Gallagnostus	(Ar,Tr,Ag)	Garnuella	(Ar,Os,Po)
Gabanella	(Cd,Os,Pe)	Galliaecystis	(Ec,St,Co)	Garraconularia	(Cn,Sc,Cn)
Gabbioceras	(Mo,Ce,Am)	Galliaecytheridea	(Ar,Os,Po)	Garramites	(Mo,Ga,Ar)
Gabelia	(Po,He,Re)	Galliennithyris	(Br,Ar,Te)	Garracongia	(Po,De,Li)
Gabillytes	(Mo,Ce,Am)	Gallitherina	(Fo,Fo,Fo)	Garryoceras	(Mo,Ce,Or)
Gablonzeria	(Cn,An,Sc)	Gallitella	(Fo,Fo,Fo)	Garum	(Mo,Bi,Ve)
Gabonita	(Fo,Fo,Fo)	Galloredlichia	(Ar,Tr,Re)	Garumnaster	(Ec,Ec,Hs)
Gabriceraurus	(Ar,Tr,Ph)	Gallowaina	(Fo,Fo,Fo)	Gasconadeoconus	(Mo,Te,Cy)
Gabriellus	(Ar,Tr,Ol)	Galtoeras	(Mo,Ce,On)	Gasconadia	(Mo,Ga,Ar)
Gabrielona	(Mo,Ga,Ar)	Galwayella	(Fo,Fo,Fo)	Gasconsia	(Br,In,Tr)
Gabrieloscyathus	(Po,Ir,Ar)	Gamachignathus	(Cd,Co,Co)	Gasconsoceras	(Mo,Ce,Ba)
Gacella	(Br,Ar,St)	Gamagyangnella	(Ar,Os,Po)	Gaschaomiaolia	(Br,Ar,Pe)
Gacina	(Br,Ar,Te)	Gamizyga	(Mo,Ga,Nt)	Gaspeleichas	(Ar,Tr,Li)
Gadella	(Cd,Os,Ga)	Gammacythere	(Ar,Os,Po)	Gaspongia	(Po,Ca,Un)
Gadiculus	(Cd,Os,Ga)	Gammadiscus	(Mo,Ga,Be)	Gaspoecyroceras	(Mo,Ce,Or)
Gadila	(Mo,Sc,Sc)	Gammarocrinites	(Ec,Cr,Cy)	Gasteroclupea	(Cd,Os,Cl)
Gadilina	(Mo,Sc,Sc)	Gammarus	(Ar,ML,Am)	Gasterocoma	(Ec,Cr,Cl)
Gadomus	(Cd,Os,Ga)	Gammascoclex	(An,Pa,Pa)	Gasterorhamphosus	(Cd,Os,Ga)
Gadus	(Cd,Os,Ga)	Gamonedaspis	(Ar,Tr,Ph)	Gasterosteus	(Cd,Os,Ga)
Gaetanoceras	(Mo,Ce,Go)	Gamonetes	(Br,Ar,St)	Gastrana	(Mo,Bi,Ve)
Gafrarium	(Mo,Bi,Ve)	Gamopleura	(Mo,Ga,Th)	Gastranopsis	(Mo,Bi,Ve)
Gagara	(Ec,Ec,Te)	Gamphalasia	(Br,Ar,St)	Gastrochrea	(Tr,An)
Gagariniccyathus	(Po,Re,Aj)	Gampsurus	(Ar,ML,De)	Gastrioceras	(Mo,Ce,Go)
Gagaticeras	(Mo,Ce,Am)	Ganbirretia	(Ec,Ec,Hs)	Gastroamma	(Fo,Fo,Fo)
Gaidropsarus	(Cd,Os,Ga)	Gandakasia	(Cd,Os,Ch)	Gastrobellus	(Mo,Ce,Be)
Gaimardia	(Mo,Bi,Ve)	Gandinella	(Fo,Fo,Fo)	Gastrochaena	(Mo,Bi,My)
Galahetes	(Ar,Tr,Un)	Ganella	(Fo,Fo,Fo)	Gastrochaenopsis	(Mo,Bi,My)
Galataestrophia	(Br,Ar,St)	Ganesa	(Mo,Ga,Ar)	Gastrochonus	(Cn,Hc,He)
Galateacrinus	(Ec,Cr,Cl)	Gangadharites	(Mo,Ce,Ce)	Gastrocrinus	(Ec,Cr,Cl)
Galathea	(Ar,ML,De)	Gangamophyllum	(Cn,An,Ru)	Gastrodoctoechia	(Br,Ar,Rh)
Galaticeras	(Mo,Ce,Ph)	Gangshanoceras	(Mo,Ce,Or)	Gastrodorus	(Ar,ML,De)
Galaxea	(Cn,An,Sc)	Ganiella	(Bz,St,Cy)	Gastropella	(Bz,Gy,Ch)
Galbagnostus	(Ar,Tr,Ag)	Ganineella	(Ar,Tr,Pr)	Gastrolites	(Mo,Ce,Am)
Galbanites	(Mo,Ce,Am)	Ganloudina	(Ch,Pr)	Gastropolus	(Ar,Tr,Pt)
Galeanella	(Fo,Fo,Fo)	Gannania	(Br,Ar,Sp)	Gastrosacus	(Ar,ML,De)
Galeaspis	(Ar,Tr,Pt)	Ganniberyichia	(Ar,Os,Pa)	Gatagacyathus	(Po,Ir,Ar)
Galeaster	(Ec,Ec,Hs)	Ganodus	(Cd,Ch,Cm)	Gattendorfia	(Mo,Ce,Go)
Galeatathyrus	(Br,Ar,Sp)	Ganoessus	(Cd,Os,Cl)	Gattenpleura	(Mo,Ce,Go)
Galeatella	(Br,Ar,St)	Ganolytes	(Cd,Os,Cl)	Gaudryanella	(Bz,Gy,Ch)
Galeatellina	(Br,Ar,Pe)	Ganopristis	(Cd,Ch,Rj)	Gaudryceras	(Mo,Ce,Am)
Galene	(Ar,ML,De)	Ganorhynchus	(Cd,Os,Di)	Gaudryella	(Cd,Os,Sa)
Galenocaris	(Ar,Th,In)	Gansserina	(Fo,Fo,Fo)	Gaudryina	(Fo,Fo,Fo)
Galenopsis	(Ar,ML,De)	Gansuella	(Mo,Bi,Ve)	Gaudryinella	(Fo,Fo,Fo)
Galeoatagypa	(Br,Ar,Pe)	Ganxiella	(Mo,Bi,Ve)	Gaudryinoides	(Fo,Fo,Fo)
Galeocerdo	(Cd,Ch,Ca)	Gaofengophyllum	(Cn,An,Ru)	Gaudryinopsis	(Fo,Fo,Fo)
Galeodaria	(Mo,Ga,Nt)	Gaoqiaioella	(Ar,Un,Un)	Gaulocrinus	(Ec,Cr,Sa)
Galeodea	(Mo,Ga,Nt)	Gaotanaspis	(Ar,Tr,Pt)	Gaurites	(Mo,Ce,An)
Galeodina	(Mo,Ga,Nt)	Gaotania	(Ar,Tr,Od)	Gaurocrinus	(Ec,Cr,Di)
Galeodinopsis	(Mo,Ga,Nt)	Gapeevella	(Ar,Tr,Pr)	Gauthieria	(Ec,Ec,Ph)
Galeograptus	(He,Gr,Tu)	Gapparodus	(Ch,Pr)	Gauthiericeras	(Mo,Ce,Am)
Galeola	(Ec,Ec,Hs)	Garantella	(Fo,Fo,Fo)	Gauthiosoma	(Ec,Ec,Ph)
Galeolaria	(An,Po,Se)	Garantiana	(Mo,Ce,Am)	Gavelinella	(Fo,Fo,Fo)
Galeocorys	(Mo,Ga,Nt)	Gardinerichthys	(Cd,Os,Pa)	Gavelinopsis	(Fo,Fo,Fo)
Galeopsis	(Ar,Os,Ar)	Gardineroseris	(Cn,An,Sc)	Gaviatinum	(Cd,Re,Cr)

Gaynaphyllum	(Cn, An, Ru)	Genevieveella	(Ar, Tr, Pt)	Gervilleella	(Mo, Bi, Pt)
Gazacrinus	(Ec, Cr, Di)	Genicularia	(An, Po, Se)	Gervilletia	(Mo, Bi, Pt)
Gazameda	(Mo, Ga, Ni)	Geniculus	(Cd, Co, Co)	Gervillia	(Mo, Bi, Pt)
Gazdaganites	(Mo, Ce, Am)	Geniculicyathus	(Po, Re, Aj)	Geryon	(Ar, Mi, De)
Gazimuria	(Cn, An, Ru)	Geniculifera	(Br, Ar, St)	Gesoriacula	(Ar, Os, Po)
Gazolapodus	(Cd, Os, An)	Geniculograptus	(He, Gr, Gr)	Geukenia	(Mo, Bi, Mt)
Gazza	(Cd, Os, Pf)	Geniculomclearnites	(Br, Ar, St)	Gevanites	(Mo, Ce, Ce)
Gdowia	(Ar, Me, In)	Genkaimurex	(Mo, Ga, Ne)	Gevreya	(Po, He, He)
Gebeckeria	(Ar, Os, Pa)	Gennaocrinus	(Ec, Cr, Mo)	Geyerella	(Br, Ar, St)
Gebia	(Ar, Mi, De)	Genota	(Mo, Ga, Ne)	Geyeroceras	(Mo, Ce, Ph)
Geffenina	(Ar, Os, Pa)	Gentilapsis	(Ar, Tr, Un)	Geyronaotia	(Cn, An, Ru)
Geffenites	(Ar, Os, Pa)	Gentilia	(Ec, Ec, Ca)	Geyerophyllum	(Cn, An, Ru)
Gefonia	(Br, Ar, Te)	Gentoniceras	(Mo, Ce, Am)	Gharbouria	(Cd, Os, Sa)
Gegania	(Mo, Ga, Ni)	Genuclymenia	(Mo, Ce, Cl)	Gheorghianina	(Fo, Fo, Fo)
Gegenella	(Br, Ar, St)	Genyonemus	(Cd, Os, Pf)	Ghiroboeyathus	(Cn, An, Sc)
Geinitzella	(Bz, St, Tr)	Genypteris	(Cd, Os, Op)	Giandites	(Ar, Os, Pa)
Geinitzina	(Fo, Fo, Fo)	Geocoma	(Ec, Op, Op)	Gibba	(Ar, Os, Pa)
Geisina	(Ar, Os, Po)	Geocyathus	(Po, Re, Aj)	Gibbaspira	(Mo, In, In)
Geisonoceras	(Mo, Ce, Or)	Geodia	(Po, De, As)	Gibbaster	(Ec, Ec, Sp)
Geisonocerina	(Mo, Ce, Or)	Geodiopsis	(Po, De, As)	Gibbechinorhinus	(Cd, Ch, Sq)
Geisonoceroides	(Mo, Ce, Or)	Geodites	(Po, De, As)	Gibberella	(Ar, Os, Le)
Geisopora	(Bz, Gy, Ch)	Geoffbondia	(Mo, Bi, Ve)	Gibberlebeis	(Ar, Os, Po)
Geitonoceras	(Mo, Ce, Na)	Geolcomia	(Mo, Ga, Ni)	Gibberostrophia	(Br, Ar, St)
Geitonograptus	(He, Gr, Gr)	Geopeltis	(Mo, Ce, Te)	Gibbertula	(Mo, Ga, Ne)
Gelagna	(Mo, Ga, Ni)	Georgethyris	(Br, Ar, Sp)	Gibberulina	(Mo, Ga, Ne)
Gelase	(Ar, Tr, Un)	Georgia	(Mo, Ga, Ni)	Gibberulus	(Mo, Ga, Ni)
Gelasinostoma	(Mo, Ga, Ar)	Georgina	(Mo, Ce, Ac)	Gibbirhynchia	(Br, Ar, Rh)
Gelenptron	(Cn, Hy, Hy)	Georgioceras	(Mo, Ce, Am)	Gibbithyris	(Br, Ar, Te)
Geleorhinus	(Cd, Ch, Ca)	Geosaurus	(Cd, Re, Cr)	Gibbochonetes	(Br, Ar, St)
Gelidicella	(Ar, Os, Un)	Geoteuthinus	(Mo, Ce, Te)	Gibboconcha	(Mo, Bi, Un)
Gelidorthidina	(Br, Ar, Or)	Gephyroberyx	(Cd, Os, Br)	Gibbodon	(Cd, Os, Py)
Gelidorthis	(Br, Ar, Or)	Gephyrophora	(Bz, Gy, Ch)	Gibbolucina	(Mo, Bi, Ve)
Gellensia	(Ar, Os, Pa)	Gephyrotres	(Bz, Gy, Ch)	Gibbomodiola	(Mo, Bi, Mt)
Geloina	(Mo, Bi, Ve)	Geragnostella	(Ar, Tr, Ag)	Gibbonucula	(Mo, Bi, Nu)
Geltena	(Mo, Bi, Ve)	Geragnostus	(Ar, Tr, Ag)	Gibbospirifer	(Br, Ar, Sp)
Gemaspira	(Mo, Ga, Ne)	Geraldinella	(Ar, Tr, Re)	Gibbula	(Mo, Ga, Ar)
Gemellides	(Fo, Fo, Fo)	Geranocephalus	(Br, Ar, Te)	Giganostrea	(Mo, Bi, Pt)
Gemellipora	(Bz, Gy, Ch)	Geracrinus	(Ec, Cr, Ds)	Giganthaspis	(Cd, Pt, Pt)
Gemelliporella	(Bz, Gy, Ch)	Gerassimovia	(Br, Ar, Rh)	Giganti clavus	(Ec, Ed, Is)
Gemelliporida	(Bz, Gy, Ch)	Gerastes	(Ar, Tr, Pr)	Gigantocapulus	(Mo, Ga, Ni)
Gemelliporina	(Bz, Gy, Ch)	Geratrignia	(Mo, Bi, Tr)	Gigantocyclus	(Mo, Bi, Ve)
Gemerithyris	(Br, Ar, Te)	Gerbeckites	(Ar, Os, Po)	Gigantocypraea	(Mo, Ga, Ni)
Geminella	(Bz, Gy, Ch)	Geresia	(Pr, To, Mi)	Gigantogonia	(Mo, Ga, Ni)
Geminospira	(Fo, Fo, Fo)	Gergovia	(Mo, Ga, Ne)	Gigantopecten	(Mo, Bi, Pt)
Gemma	(Mo, Bi, Ve)	Gerkeina	(Fo, Fo, Fo)	Gigantopora	(Bz, Gy, Ch)
Gemmacrinus	(Ec, Cr, Un)	Gerkispira	(Br, Ar, Sp)	Gigantoproductus	(Br, Ar, St)
Gemmanella	(Ar, Os, Po)	Gerlus	(Mo, Bi, Pt)	Gigantopterus	(Cd, Os, Pe)
Gemmarcula	(Br, Ar, Te)	Germanasterias	(Ec, As, Fo)	Gigantopygus	(Ar, Tr, Re)
Gemmaterebra	(Mo, Ga, Ne)	Germanonautilus	(Mo, Ce, Na)	Gigantorhynchus	(Br, Ar, Rh)
Gemmellaroecarinus	(Ar, Mi, De)	Germaniceras	(Mo, Ce, Am)	Gigantospingia	(Po, Ca, Ph)
Gemmellaroeceras	(Mo, Ce, Am)	Gerodia	(Ar, Os, Po)	Gigantostylis	(Cn, An, Sc)
Gemmellaroia	(Mo, Ga, He)	Geroldicrinus	(Ec, Cr, Sa)	Gigantothyris	(Br, Ar, Te)
Gemmellaroialla	(Br, Ar, St)	Gerolsteinites	(Br, Ar, Sp)	Gigasbia	(Fo, Fo, Fo)
Gemmoliva	(Mo, Ga, Ne)	Gerothyris	(Br, Ar, Sp)	Gigi	(Ac, Ra, Na)
Gemmula	(Mo, Ga, Ne)	Gerres	(Cd, Os, Pf)	Gigmpeltis	(Ar, Tr, Un)
Gemmulicosta	(Br, Ar, St)	Gerrhynx	(Br, Ar, Rh)	Gignouxia	(Po, De, Li)
Gemmuloborsonia	(Mo, Ga, Ne)	Gerronodictyon	(Po, De, St)	Gigoutella	(Ar, Tr, Re)
Gempylus	(Cd, Os, Pf)	Gerronostroma	(Po, De, St)	Gilbertharrisella	(Mo, Bi, Ve)
Gemuendenaspis	(Cd, Pl, Ar)	Gerthia	(Cn, An, Ru)	Gilbertina	(Mo, Ga, Ce)
Gemuendina	(Cd, Pl, Rh)	Gertholites	(Cn, An, Ta)	Gilbertsocrinus	(Ec, Cr, Di)
Gemuendolepis	(Cd, Ac, Un)	Gerubiella	(Ar, Os, Un)	Gilbertsonia	(Mo, Bi, Ph)
Genabacia	(Cn, An, Sc)	Gervillaria	(Mo, Bi, Pt)	Gilbertturricula	(Mo, Ga, Ne)
Genaxinus	(Mo, Bi, Ve)	Gervilleiogoma	(Mo, Bi, Pt)	Gillastrea	(Cn, An, Sc)
Gendrotella	(Fo, Fo, Fo)	Gervilleioeperna	(Mo, Bi, Pt)	Gillatia	(Ar, Os, Pa)

Gillearcinus	(Ar,Ml,De)	Gladiostrophia	(Br,Ar,St)	Globigerinella	(Fo,Fo,Fo)
Gillechinus	(Ec,Ec,Sp)	Glaesseria	(Ar,Ml,De)	Globigerinelloides	(Fo,Fo,Fo)
Gilledia	(Br,Ar,Te)	Glaesserella	(Ar,Ml,De)	Globigerinita	(Fo,Fo,Fo)
Gilletta	(Po,De,Li)	Glaesserina	(Cn,Pe,Ra)	Globigerinoides	(Fo,Fo,Fo)
Gillicus	(Cd,Os,Pc)	Glamocites	(Mo,Ce,Ce)	Globigerinoidesella	(Fo,Fo,Fo)
Gillidia	(Cd,Os,Pf)	Glandulina	(Fo,Fo,Fo)	Globigerinoita	(Fo,Fo,Fo)
Gilliodus	(Cd,Ch,Eu)	Glandulinoidea	(Fo,Fo,Fo)	Globigerinopsis	(Fo,Fo,Fo)
Gilmocrinus	(Ec,Cr,Cf)	Glandulopleurostomella	(Fo,Fo,Fo)	Globigerinopsoides	(Fo,Fo,Fo)
Gilmouropora	(Bz,St,Fe)	Glans	(Mo,Bi,Ve)	Globigeritria	(Fo,Fo,Fo)
Gilsonicaris	(Ar,Br,Br)	Glansicystis	(Ec,Rh,Rh)	Globimorphina	(Fo,Fo,Fo)
Ginebis	(Mo,Ga,Ar)	Glaphurella	(Ar,Tr,Pr)	Globiomorpha	(Mo,Ga,Nt)
Ginella	(Ar,Os,Un)	Glaphurina	(Ar,Tr,Pr)	Globirhynchia	(Br,Ar,Rh)
Ginginella	(Ar,Os,Po)	Glaphurochiton	(Mo,Po,Ne)	Globisium	(Mo,Ga,Nt)
Ginglymostoma	(Cd,Ch,Oc)	Glaphurus	(Ar,Tr,Pr)	Globispirifer	(Br,Ar,Sp)
Ginkgospungia	(Po,De,Un)	Glaphyocrinus	(Ec,Cr,Mo)	Globispiroplectammina	(Fo,Fo,Fo)
Ginospina	(Pr,Co,Ch)	Glaphyorthis	(Br,Ar,Or)	Globithyris	(Br,Ar,Te)
Ginsburgia	(Cd,Os,Sa)	Glaphyraspis	(Ar,Tr,Pt)	Globivalvulina	(Fo,Fo,Fo)
Giordanelia	(Ar,Tr,Re)	Glaphyrina	(Mo,Ga,Ne)	Globivenus	(Mo,Bi,Ve)
Gipsella	(Ar,Os,Un)	Glaphyrites	(Mo,Ce,Go)	Globoblastus	(Ec,Bf,Sp)
Giraffospyris	(Ac,Ra,Na)	Glaphyrocystis	(Ec,Rh,Rh)	Globobulimina	(Fo,Fo,Fo)
Giraldiella	(Br,Ar,Or)	Glariachelys	(Cd,Re,Ch)	Globocardium	(Mo,Bi,Ve)
Giraliapecten	(Mo,Bi,Pt)	Glassia	(Br,Ar,At)	Globocassidulina	(Fo,Fo,Fo)
Giraliarella	(Fo,Fo,Fo)	Glassina	(Br,Ar,Sp)	Globochernella	(Fo,Fo,Fo)
Giraliaster	(Ec,Ec,Hs)	Glassoceras	(Mo,Ce,Go)	Globoconusa	(Fo,Fo,Fo)
Girandia	(Ar,Tr,Co)	Glatziella	(Mo,Ce,Cf)	Globocrinus	(Ec,Cr,Mo)
Girardevia	(Ar,Me,Ag)	Glaucichelone	(Cd,Re,Ch)	Globodrillia	(Mo,Ga,Ne)
Girardotia	(Mo,Bi,Ph)	Glaucocrinus	(Ec,Cr,Ds)	Globodenthyra	(Fo,Fo,Fo)
Girlasia	(Br,Ar,St)	Glaucolithites	(Mo,Ce,Am)	Globofissurella	(Fo,Fo,Fo)
Girtycoelia	(Po,De,Pe)	Glauconia	(Mo,Ga,Nt)	Globomorpha	(Pr,Un,In)
Girtyella	(Br,Ar,Te)	Glauconiella	(Mo,Ga,Nt)	Globonema	(Mo,Ga,Ar)
Girtyoceras	(Mo,Ce,Go)	Glauconomella	(Bz,St,Fe)	Globoquadrina	(Fo,Fo,Fo)
Girtyopora	(Bz,St,Fe)	Glaucosoma	(Cd,Os,Pf)	Globoreticulina	(Fo,Fo,Fo)
Girtyoporina	(Bz,St,Fe)	Glauderia	(Ar,Un,Un)	Globorilus	(Hy,Or,Gf)
Girtypecten	(Mo,Bi,Pt)	Glaukosocrinus	(Ec,Cr,Cf)	Globoriturbulus	(Hy,Or,Gf)
Girtyspira	(Mo,Ga,Ce)	Glayderia	(Pr,Un,Co)	Globorosalina	(Fo,Fo,Fo)
Girvanagnostus	(Ar,Tr,Ag)	Glawzewska	(Br,Ar,Th)	Globorotalia	(Fo,Fo,Fo)
Girvanaster	(Ec,As,Pu)	Gleboceras	(Mo,Ce,Go)	Globorotalites	(Fo,Fo,Fo)
Girvania	(Mo,Ga,Nt)	Gleboscoceras	(Mo,Ce,Am)	Globorotaloides	(Fo,Fo,Fo)
Girvanicystis	(Ec,Hs,So)	Glenaraea	(Cn,An,Sc)	Globosobucina	(Br,Ar,St)
Girvanopyge	(Ar,Tr,Pt)	Glendella	(Mo,Bi,Pt)	Globosochonetes	(Br,Ar,St)
Gisilina	(Br,Ar,Te)	Glendonina	(Br,Ar,Sp)	Globosograptus	(He,Gr,Gr)
Gisortia	(Mo,Ga,Nt)	Glenisteroceras	(Mo,Ce,Or)	Globosoproductus	(Br,Ar,St)
Gispyrella	(Mo,Ga,He)	Genocythere	(Ar,Os,Po)	Globospirillina	(Fo,Fo,Fo)
Gissarina	(Br,Ar,Sp)	Glenodictyum	(Po,Un,Un)	Globostroma	(Cn,Hy,Sp)
Gissarophyllum	(Cn,An,Ru)	Glenotremites	(Ec,Cr,Cm)	Globotetratrix	(Fo,Fo,Fo)
Gissocrinus	(Ec,Cr,Cf)	Gleviceras	(Mo,Ce,Am)	Globoturuncana	(Fo,Fo,Fo)
Gitarra	(Ar,Tr,Pr)	Glezzeria	(Ar,Os,Pa)	Globoturuncanella	(Fo,Fo,Fo)
Gitolampas	(Ec,Ec,Ca)	Glibertia	(Mo,Bi,Ve)	Globoturuncanita	(Fo,Fo,Fo)
Gitonia	(An,Po,Se)	Glimmatobolbina	(Ar,Os,Pa)	Globoturborotalita	(Fo,Fo,Fo)
Gjellispinifera	(Br,Ar,Sp)	Gloaassamophorous	(Mo,Bi,Hi)	Globozygia	(Mo,Ga,Nt)
Glabella	(Mo,Ga,Ne)	Globacrocyrinus	(Ec,Cr,Mo)	Globularia	(Mo,Ga,Nt)
Glabbellacythere	(Ar,Os,Po)	Globampyx	(Ar,Tr,As)	Globulaspis	(Ar,Tr,Od)
Glaberagnostus	(Ar,Tr,Ag)	Globanomalina	(Fo,Fo,Fo)	Globuligerina	(Fo,Fo,Fo)
Glabrattella	(Fo,Fo,Fo)	Globator	(Ec,Ec,Ho)	Globulina	(Fo,Fo,Fo)
Glabrattellina	(Fo,Fo,Fo)	Globatrypa	(Br,Ar,At)	Globulipora	(Bz,St,Ce)
Glabriconetes	(Br,Ar,St)	Globicephala	(Cd,Ma,Ce)	Globulirhynchia	(Br,Ar,Rh)
Glabriconetina	(Br,Ar,St)	Globiconcha	(Mo,Ga,Ce)	Globuloerithium	(Mo,Ga,Nt)
Glabripecten	(Mo,Bi,Pt)	Globicuniculus	(Fo,Fo,Fo)	Globulocystites	(Ec,Pc,Pf)
Glabcroingulum	(Mo,Ga,Ar)	Globidens	(Cd,Re,Sq)	Globulospinella	(Fo,Fo,Fo)
Glabcroinguloceras	(Mo,Ce,Am)	Globiella	(Br,Ar,St)	Globusia	(Ar,Tr,Pr)
Glabcropilium	(Ar,Ml,De)	Globigerapsis	(Fo,Fo,Fo)	Glochiceras	(Mo,Ce,Am)
Gladigondolella	(Cd,Co,Co)	Globigerina	(Fo,Fo,Fo)	Glochynomorpha	(Mo,Ce,Te)
Glabdiobanchus	(Cd,Ac,Un)	Globigerinatella	(Fo,Fo,Fo)	Glonalveolina	(Fo,Fo,Fo)
Glabdiocutum	(Ar,Os,Ar)	Globigerinathea	(Fo,Fo,Fo)	Glomocystospongia	(Po,De,Pe)

Glomodiscus	(Fo,Fo,Fo)	Glyptocidaris	(Ec,Ec,Ph)	Gnathoberyx	(Cd,Os,Br)
Glomospira	(Fo,Fo,Fo)	Glyptacrothrele	(Br,Li,Ac)	Gnathodus	(Cd,Co,Co)
Glomospiranella	(Fo,Fo,Fo)	Glyptagnostus	(Ar,Tr,Ag)	Gnathophis	(Cd,Os,An)
Glomospirella	(Fo,Fo,Fo)	Glyptambon	(Ar,Tr,Ph)	Gnathorhynchia	(Br,Ar,Rh)
Glomospiroides	(Fo,Fo,Fo)	Glyptambonites	(Br,Ar,St)	Gnathosaurus	(Cd,Re,Cr)
Glomotrocholina	(Fo,Fo,Fo)	Glyptarca	(Mo,Bi,Mo)	Gnidiella	(Mo,Bi,Ve)
Gloria	(Ar,Tr,Pt)	Glyptarpites	(Mo,Ce,Am)	Gnomohalorites	(Mo,Ce,Ce)
Glorianella	(Ar,Os,Po)	Glyptaspis	(Cd,Pl,Ar)	Gnorimocrinus	(Ec,Cr,Tx)
Glorioscyathus	(Po,Re,Aj)	Glyptechinus	(Ec,Ec,Te)	Gobiella	(Mo,Bi,Tr)
Gloripallium	(Mo,Bi,Pt)	Glypterina	(Br,Ar,Or)	Gobius	(Cd,Os,Pf)
Glosia	(Mo,Ga,Nt)	Glyptias	(Br,Li,Ac)	Gobraeus	(Mo,Bi,Ve)
Glossadon	(Cd,Os,Os)	Glypticus	(Ec,Ec,Ph)	Gochtia	(Pr,Un,In)
Glossaulax	(Mo,Ga,Nt)	Glyptoactis	(Mo,Bi,Ve)	Goesella	(Fo,Fo,Fo)
Glossella	(Br,Li,Li)	Glyptocephalus	(Cd,Os,Pn)	Goestringella	(Ac,Ra,Na)
Glosseudesia	(Br,Ar,Te)	Glyptoceras	(Mo,Ce,Am)	Goethemia	(Mo,Bi,Ve)
Glosshypothyridina	(Br,Ar,Rh)	Glyptochelone	(Cd,Re,Ch)	Gog	(Ar,Tr,Pt)
Glossinoctechia	(Br,Ar,Rh)	Glyptochiton	(Mo,Po,Ne)	Gogia	(Ec,Eo,Go)
Glossinulina	(Br,Ar,Rh)	Glyptochrysalis	(Mo,Ga,Nt)	Gogiura	(Ar,Tr,As)
Glossinulirhynchia	(Br,Ar,Rh)	Glyptoconcha	(Mo,Bi,Ph)	Gogoceras	(Mo,Ce,An)
Glossinulus	(Br,Ar,Rh)	Glyptoconularia	(Cn,Sc,Cn)	Gogoella	(Ar,Tr,Un)
Glossites	(Mo,Bi,Ph)	Glyptoconus	(Cd,Co,Co)	Golasaphus	(Ar,Tr,As)
Glossocardia	(Mo,Bi,Ve)	Glyptocrinus	(Ec,Cr,Mo)	Golcocythere	(Ar,Os,Po)
Glossoceras	(Mo,Ce,As)	Glyptocypus	(Ec,Ec,Ph)	Golcondella	(Ar,Os,Un)
Glossocrinus	(Ec,Cr,Cl)	Glyptocystella	(Ec,Rh,Rh)	Goldfieldia	(Ar,Tr,Un)
Glossograptus	(He,Gr,Gr)	Glyptocysites	(Ec,Rh,Rh)	Goldfussastrea	(Cn,An,Sc)
Glossoidaspis	(Cd,Pr,Pt)	Glyptocythere	(Ar,Os,Po)	Goldfussitrypa	(Bz,St,Cr)
Glossoleptacna	(Br,Ar,St)	Glyptodendron	(Mo,Ce,Di)	Goldringia	(Mo,Ce,Na)
Glossomorphites	(Ar,Os,Pa)	Glyptodnomene	(Ar,Ml,De)	Goleocrinus	(Ec,Cr,Cl)
Glossophyllium	(Cn,An,Ru)	Glyptogatocythere	(Ar,Os,Po)	Goleomixa	(Br,Ar,Rh)
Glossopleura	(Ar,Tr,Co)	Glyptoglossella	(Br,Li,Li)	Goliathiceras	(Mo,Ce,Am)
Glossorthis	(Br,Ar,Or)	Glyptograptus	(He,Gr,Gr)	Goliathites	(Mo,Ce,Am)
Glossothyropsis	(Br,Ar,Te)	Glyptogypa	(Br,Ar,Pe)	Goliathyris	(Br,Ar,Te)
Glossotyra	(Bz,St,Un)	Glyptoleda	(Mo,Bi,Nu)	Gomboeceras	(Mo,Ce,Am)
Glossus	(Mo,Bi,Ve)	Glyptolepis	(Cd,Os,Co)	Gomberella	(Ac,Ra,Na)
Glottidia	(Br,Li,Li)	Glyptolichvinella	(Ar,Os,Po)	Gombertphyllia	(Cn,An,Sc)
Glottotychinites	(Mo,Ce,Am)	Glyptomaria	(Mo,Ga,Ar)	Gomphacanthus	(Cd,Ac,Un)
Glubokoevella	(Fo,Fo,Fo)	Glyptomena	(Br,Ar,St)	Gomphechinus	(Ec,Ec,Ph)
Glycera	(An,Po,Ph)	Glyptomietopsis	(Ar,Tr,Pt)	Gomphina	(Mo,Bi,Ve)
Glycerites	(An,Po,Ph)	Glyptomietopus	(Ar,Tr,Pt)	Gomphinella	(Mo,Bi,Ve)
Glycobtrys	(Ac,Ra,Na)	Glyptonychia	(Mo,Bi,Pt)	Gomphites	(Po,De,Hd)
Glycydonta	(Mo,Bi,Ve)	Glyptophidium	(Cd,Os,Op)	Gomphoceras	(Mo,Ce,Di)
Glycymerella	(Mo,Bi,Ar)	Glyptopleura	(Ar,Os,Pa)	Gomphocystites	(Ec,Di,Di)
Glycymeris	(Mo,Bi,Ar)	Glyptopleurella	(Ar,Os,Pa)	Gompholepis	(Cd,Pt,Un)
Glycymerita	(Mo,Bi,Ar)	Glyptopleurina	(Ar,Os,Pa)	Gompholites	(Hy,Hy,Hy)
Glycymerula	(Mo,Bi,Ar)	Glyptopleuroides	(Ar,Os,Pa)	Gomphomarcia	(Mo,Bi,Ve)
Glymmatobolbina	(Ar,Os,Pa)	Glyptopomus	(Cd,Os,Co)	Gomphonchus	(Cd,Ac,Cl)
Glyotidudadema	(Ec,Ec,Ci)	Glyptopora	(Bz,St,Cy)	Gomphopages	(Mo,Ga,Un)
Glyphanodus	(Cd,Ch,Pe)	Glyptorhynchia	(Br,Ar,Rh)	Gonambonites	(Br,Ar,Or)
Glypharthrus	(Ar,Me,Ag)	Glyptoria	(Br,Ar,Or)	Gonamella	(Pr,Un,In)
Glyphaspellus	(Ar,Tr,As)	Glyptorthis	(Br,Ar,Or)	Gonamispongia	(Po,He,Un)
Glyphaspis	(Ar,Tr,Pt)	Glyptosceptron	(Cn,An,Pe)	Gonathyrus	(Br,Ar,Sp)
Glyphea	(Ar,Ml,De)	Glyptosphaerites	(Ec,Di,Di)	Gonatocaris	(Ar,Ml,Ar)
Glyphidites	(Mo,Ce,Ce)	Glyptosphaerontes	(Ec,Di,Di)	Gonatocyrtoceras	(Mo,Ce,On)
Glyphiolobus	(Mo,Ce,Go)	Glyptospira	(Mo,Co,Ar)	Gonatodus	(Cd,Os,Pa)
Glyphisaria	(Br,Ar,Te)	Glyptosteges	(Br,Ar,St)	Gonatospaera	(Fo,Fo,Fo)
Glyphiteuthis	(Mo,Ce,Te)	Glyptostromoides	(Po,De,St)	Gondaconularia	(Cn,Sc,Cn)
Glyphithyreus	(Ar,Ml,De)	Glyptostyla	(Mo,Ga,Ne)	Gondekia	(Po,Ca,He)
Glyphocyphus	(Ec,Ec,Ph)	Glyptotoma	(Mo,Ga,Ne)	Gondolella	(Cd,Co,Co)
Glyphodeta	(Mo,Ga,Ar)	Glyptotrophia	(Br,Ar,Pe)	Gondolina	(Br,Ar,St)
Glyphopeltis	(Ar,Tr,As)	Glyptoxoceras	(Mo,Ce,Am)	Gondwanella	(Mo,Bi,Pt)
Glyphopneustes	(Ec,Ec,Sa)	Glyptozaria	(Mo,Ga,Nt)	Goneplax	(Ar,Ml,De)
Glyphostoma	(Mo,Ga,Ne)	Glyptospirifer	(Br,Ar,Sp)	Gongrochanus	(Ec,Ec,Ca)
Glyphostomella	(Fo,Fo,Fo)	Gmelinmagas	(Br,Ar,Te)	Gongrocrinus	(Ec,Cr,Ds)
Glyphoturris	(Mo,Ga,Ne)	Gnaltacyathus	(Po,Re,Aj)	Gongyloblastus	(Ec,Bi,Sp)

Gongylospongia	(Po,He,Re)	Goniotrypa	(Bz,St,Cr)	Goycoia	(Ar,Tr,Un)
Gongylostonyx	(Ar,Os,Pa)	Gonipodus	(Cd,Pt,Th)	Grabauphyllum	(Cn,An,Ru)
Gongylothorax	(Ac,Ra,Na)	Gonodactylus	(Ar,ML,St)	Grabella	(Mo,Bi,Pt)
Goniacardia	(Mo,Bi,Ve)	Gonolkites	(Mo,Ce,Am)	Gracemera	(Ar,Tr,Pr)
Goniada	(An,Po,Ph)	Gonostoma	(Cd,Os,St)	Gracianella	(Br,Ar,At)
Goniagnostus	(Ar,Tr,Ag)	Gonysycon	(Mo,Ga,Nt)	Graciella	(Ar,Tr,Pt)
Goniarina	(Br,Ar,St)	Gonzagia	(Mo,Ga,He)	Gracilechinus	(Ec,Ec,Ec)
Goniasma	(Mo,Ga,Ar)	Gonzalezaster	(Ec,Ec,Sp)	Graciliala	(Mo,Ga,Nt)
Goniastrea	(Cn,An,Sc)	Goodallia	(Mo,Bi,Ve)	Gracilignathichthys	(Cd,Os,Ph)
Goniatites	(Mo,Ce,Go)	Goodalliopsis	(Mo,Bi,Ve)	Gracilipurpura	(Mo,Ga,Ne)
Goniatogyra	(Mo,Ga,Nt)	Goodhallites	(Mo,Ce,Am)	Gracilisphinctes	(Mo,Ce,Am)
Gonilia	(Mo,Bi,Ve)	Goodradigbeeon	(Cd,Pl,Ar)	Gracilispira	(Mo,Ga,Ne)
Gonimyrtea	(Mo,Bi,Ve)	Goodrichthys	(Cd,Ch,Ct)	Gracilites	(Mo,Ce,An)
Goniocardium	(Mo,Bi,Ve)	Goossenia	(Mo,Bi,Ve)	Gracilitheca	(Hy,Or,Ex)
Gonioceras	(Mo,Ce,Ac)	Gorbachikella	(Fo,Fo,Fo)	Graciloceras	(Mo,Ce,On)
Gonioclasma	(Mo,Bi,My)	Gorbyoceras	(Mo,Ce,Or)	Gracilocyathus	(Pr,Cr,Cr)
Goniocheila	(Mo,Ga,Nt)	Gordonicyathus	(Po,Re,Aj)	Gracilopora	(Cn,An,Ta)
Goniochele	(Ar,ML,De)	Gordonifungia	(Po,Re,Aj)	Gracilocoelia	(Br,Ar,Rh)
Goniochirus	(Ar,ML,De)	Gordonoceeras	(Mo,Ce,Or)	Graciloquina	(Ar,Os,Pa)
Goniocidaris	(Ec,Ec,Ci)	Goreauella	(Po,De,Ta)	Graculavus	(Cd,Av,Ch)
Goniocladia	(Bz,St,Cy)	Gorgansium	(Ac,Ra,Sp)	Gradiella	(Mo,Ga,Nt)
Goniocladella	(Bz,St,Cy)	Gorgonichthys	(Cd,Pl,Ar)	Graffhamierinus	(Ec,Cr,Cl)
Gonioclymenia	(Mo,Ce,Cl)	Gorgonoceras	(Mo,Ce,Or)	Gratfonoceras	(Mo,Ce,Ta)
Goniococha	(Mo,Ga,Nt)	Gorgonophontes	(Ar,ML,St)	Gramannella	(Ar,Os,Pa)
Goniocora	(Cn,An,Sc)	Gorgospyris	(Ac,Ra,Na)	Gramannicythere	(Ar,Os,Po)
Goniocornus	(Hy,Hy,Hy)	Gorgostrophia	(Br,Ar,St)	Grambergia	(Mo,Ce,Ce)
Gonioceranion	(Cd,Os,Pf)	Gorisella	(Fo,Fo,Fo)	Gramella	(Ar,Os,Pa)
Goniocrinus	(Ec,Cr,Cl)	Gorizdronia	(Cn,An,Ru)	Graminospongia	(Po,De,Pe)
Goniocyclus	(Mo,Ce,Go)	Gorjanovia	(Mo,Bi,Hi)	Grammanotosoecia	(Bz,St,Ce)
Goniocylichna	(Mo,Ga,Ce)	Gorjanskya	(Br,Li,Li)	Grammascosoecia	(Bz,St,Ce)
Goniocylindrites	(Mo,Ga,Ce)	Goronosaurus	(Cd,Re,Sq)	Grammatodon	(Mo,Bi,Ar)
Goniocypoda	(Ar,ML,De)	Gorskyella	(Cn,An,Ru)	Grammatodonax	(Mo,Bi,Ve)
Goniodostomia	(Mo,Ga,He)	Gorskyites	(Cn,An,Ta)	Grammatorcynus	(Cd,Os,Pf)
Goniodromites	(Ar,ML,De)	Gortanipora	(Bz,St,Tr)	Grammechinus	(Ec,Ec,Te)
Gonioglyphoceras	(Mo,Ce,Go)	Gorystrophia	(Br,Ar,St)	Grammocerias	(Mo,Ce,Am)
Goniograptus	(He,Gr,Gr)	Goryunovia	(Bz,St,Ce)	Grammolomatella	(Ar,Os,Pa)
Goniogyra	(Mo,Ga,Nt)	Gosavia	(Mo,Ga,Ne)	Grammoplecia	(Br,Ar,Or)
Gonioloboceras	(Mo,Ce,Go)	Gosaviaraea	(Cn,An,Sc)	Grammorynchus	(Br,Ar,Rh)
Gonioloboceratoides	(Mo,Ce,Go)	Goshoraia	(Mo,Bi,Ve)	Grammothoa	(Bz,Gy,Ch)
Goniomya	(Mo,Bi,Ph)	Goslinophis	(Cd,Os,An)	Grammysia	(Mo,Bi,Ph)
Gonionaedyceras	(Mo,Ce,Di)	Gossetia	(Mo,Bi,Pt)	Grammysioidea	(Mo,Bi,Ph)
Gonionautilus	(Mo,Ce,Na)	Gossetina	(Mo,Ga,Ar)	Gramatocrinus	(Ec,Bi,Sp)
Gonionotites	(Mo,Ce,Ce)	Gotatrypa	(Br,Ar,At)	Gramatodontus	(Cd,Co,Co)
Goniophora	(Mo,Bi,Mo)	Gothicispira	(Mo,Ga,Nt)	Grandagnostus	(Ar,Ti,Ag)
Goniophoria	(Br,Ar,Rh)	Gothocrinus	(Ec,Cr,Cl)	Grandalveolites	(Cn,An,Ta)
Goniophorina	(Mo,Bi,Mo)	Gothograptus	(He,Gr,Gr)	Grandaurispina	(Br,Ar,St)
Goniophorus	(Ec,Ec,Sa)	Goticaris	(Ar,In,Un)	Grandavinea	(Mo,Bi,Ar)
Goniophrys	(Ar,Tr,Pr)	Gotlandechinus	(Ec,Ec,Ey)	Grandiarca	(Mo,Bi,Ar)
Goniophyllum	(Cn,An,Ru)	Gotlandella	(Ar,Os,Pl)	Grandicornus	(Hy,Or,Or)
Goniopora	(Cn,An,Sc)	Gotlandellites	(Mo,Cr,Te)	Grandidierceras	(Mo,Ce,Am)
Goniptyxis	(Mo,Ga,Ne)	Gotlandites	(An,Po,Eu)	Grandifavia	(Cn,An,Sc)
Goniopygus	(Ec,Ec,Ph)	Gotlandochitina	(Fo,Fo,Ch)	Grandiculus	(Ar,Ti,Pt)
Goniorynchia	(Br,Ar,Rh)	Gotlandochiton	(Mo,Po,Pa)	Grandiproductella	(Br,Ar,St)
Gonioseris	(Cn,An,Sc)	Gotodonta	(Mo,Bi,Na)	Grandirynchia	(Br,Ar,Rh)
Goniosigma	(Ec,Ec,Te)	Gotula	(Ar,Os,Pa)	Grandostoma	(Mo,Ga,Be)
Goniospira	(Mo,Ga,Nt)	Goudkoffia	(Cd,Os,Sa)	Granobrissoides	(Ec,Ec,Sp)
Gonios-teus	(Cd,Pl,Pt)	Gouetina	(Mo,Ga,Nt)	Granocardium	(Mo,Bi,Ve)
Goniotelina	(Ar,Tr,Pr)	Gougerotia	(Mo,Ga,Sa)	Granoconus	(Mo,In,In)
Gonioteloides	(Ar,Tr,Pr)	Gouldia	(Mo,Bi,Ve)	Granosolarium	(Mo,Ga,Nt)
Goniotelus	(Ar,Tr,Pr)	Gouldoceras	(Mo,Ce,Di)	Grantitheca	(Hy,Hy,Hy)
Goniotethus	(Mo,Ce,Be)	Goungjunsperifer	(Br,Ar,Sp)	Grantlandospira	(Mo,Ga,Ar)
Goniothyris	(Br,Ar,Te)	Goupillaudina	(Fo,Fo,Fo)	Grantonia	(Br,Ar,Sp)
Goniothyropsis	(Br,Ar,Te)	Gourdonia	(Ar,Tr,Ph)	Granula	(Mo,Ga,Ne)
Goniotrema	(Br,Ar,St)	Gourmya	(Mo,Ga,Nt)	Granularapis	(Ar,Tr,Co)

Granularia	(Ar.Tr,Co)	Grigelis	(Fo,Fo,Fo)	Guangyuanaspis	(Ar.Tr,Re)
Granulidictyum	(Cn,An,Ta)	Grillina	(Fo,Fo,Fo)	Guangyuanella	(Ar,Os,Ar)
Granuliferella	(Fo,Fo,Fo)	Grillita	(Fo,Fo,Fo)	Guangyuanoceras	(Mo,Ce,On)
Granuliferelloides	(Fo,Fo,Fo)	Grimbyoceras	(Mo,Ce,On)	Guangyuanoceroides	(Mo,Ce,On)
Granulina	(Cn,An,Ta)	Grimsdaleinella	(Fo,Fo,Fo)	Guanyiaopora	(Cn,An,Ta)
Granulirhynchia	(Br,Ar,Rh)	Griioneis	(Ar,Os,Po)	Guaaxa	(Br,Ar,Sp)
Granulitorina	(Mo,Ga,Nt)	Grimnellaspis	(Ar,Tr,Pr)	Gubbera	(Cn,An,Ru)
Granulochlamys	(Mo,Bi,Pt)	Griphasaphus	(Ar,Tr,As)	Guberites	(Ar,Os,Pa)
Granulolabium	(Mo,Ga,Nt)	Griphocerinus	(Ec,Cr,Di)	Gubkinella	(Fo,Fo,Fo)
Graphopleurus	(Ec,Ec,Te)	Griphodictya	(Po,He,Re)	Gubkiniella	(Ar,Os,Pa)
Graphidiactyllis	(Ar,Os,Me)	Griphognathus	(Cd,Os,Di)	Gubleria	(Br,Ar,St)
Graphidula	(Mo,Ga,Ne)	Grippia	(Cd,Re,Ic)	Gublerina	(Fo,Fo,Fo)
Graphiocomassa	(Mo,Ga,Ne)	Groebericeras	(Mo,Ce,Am)	Guebhardia	(Mo,Bi,Un)
Graphiocrinus	(Ec,Cr,Cl)	Groenlandaspis	(Cd,Pl,Ar)	Guelphinacella	(Mo,Ga,Pa)
Graphis	(Mo,Ga,Nt)	Groenlandibelus	(Mo,Ce,Se)	Guembeltes	(Mo,Ce,Ce)
Graphiurichthys	(Cd,Os,Co)	Groenlandites	(Mo,Ce,Ce)	Guembeltritia	(Fo,Fo,Fo)
Graphiurus	(Cd,Os,Co)	Groenlandophylum	(Cn,An,Ru)	Guembeltritiella	(Fo,Fo,Fo)
Graphoceras	(Mo,Ce,Am)	Groenwallia	(Ar,Tr,Pt)	Guembeltritioides	(Fo,Fo,Fo)
Graphoscyphus	(Po,Ir,Ar)	Groessensia	(Cn,An,Ta)	Guerangeria	(Mo,Bi,Mo)
Graphularia	(Cn,An,Pe)	Groomodiscus	(Mo,Ga,Be)	Guerichicaris	(Ar,MI,Ar)
Graptacme	(Mo,Sc,Sc)	Grorudia	(Br,Ar,St)	Guerichiella	(Ar,Os,Pa)
Graptoblastoides	(He,Ga,Un)	Grossaspis	(Cd,Pl,An)	Guerichia	(Mo,Cr,Da)
Graptoblastus	(He,Ga,Un)	Grossipterus	(Cd,Os,Di)	Guerrichiphylum	(Cn,An,Ru)
Graptocamara	(He,Ga,Ca)	Grossopterus	(Ar,Me,Eu)	Guerrericeras	(Mo,Ce,Am)
Graptocarcinus	(Ar,MI,De)	Grossotubenella	(Po,Ca,Ph)	Guettardierinus	(Ec,Cr,Mi)
Graptocythere	(Ar,Os,Pa)	Grossoutria	(Mo,Ce,Am)	Guettardiscyphia	(Po,He,He)
Graptodictya	(Bz,St,Cr)	Grossouvirites	(Mo,Ce,Am)	Guettaria	(Ec,Ec,Hs)
Graptogeitonia	(Cn,Hy,Un)	Grottriana	(Mo,Bi,Ve)	Guexella	(Ac,Ra,Na)
Graptolodendrum	(He,Gr,De)	Gruendelella	(Ar,Os,Pa)	Guhsania	(Mo,Ce,Am)
Graptopora	(Bz,Gy,Ch)	Gruendelicy there	(Ar,Os,Pa)	Guichenia	(Ar,Tr,Ph)
Graptoporella	(Bz,Gy,Ch)	Gruenewaldia	(Mo,Bi,Tr)	Guichenocarpus	(Ec,St,Mi)
Graptovermis	(He,Pt,Rh)	Gruenewaldtia	(Br,Ar,At)	Guichiella	(Mo,Bi,Pt)
Grasia	(Ec,Ec,Ds)	Grumantaspis	(Cd,Pt,Pt)	Guicyrtia	(Br,Ar,Sp)
Grasirhynchia	(Br,Ar,Rh)	Grumantia	(Br,Ar,St)	Guidonia	(Mo,Ga,Ar)
Grateloupia	(Mo,Bi,Ve)	Grumphyllia	(Cn,An,Sc)	Guilfordia	(Mo,Ga,Ar)
Gravellina	(Fo,Fo,Fo)	Grundelella	(Ar,Os,Pa)	Guildingia	(Mo,Pa,Ne)
Gravestia	(Mo,Ce,Am)	Grundensia	(Mo,Bi,Ve)	Guilinospirifer	(Br,Ar,Sp)
Gravesicerithium	(Mo,Ga,Nt)	Gruntallina	(Br,Ar,Sp)	Guineana	(Mo,Bi,Tr)
Gravestockia	(Po,Ca,He)	Gryngwinkia	(Cn,An,Ru)	Guistropia	(Br,Ar,St)
Gravia	(Ar,Os,Pa)	Gryphaea	(Mo,Bi,Pt)	Guitarra	(Po,De,Ha)
Gravicalymene	(Ar,Tr,Ph)	Gryphaeligmus	(Mo,Bi,Pt)	Guizhouchaetetes	(Po,De,Ta)
Graverosanma	(Cn,An,Sc)	Gryphaeostrea	(Mo,Bi,Pt)	Guizhoudiscus	(Ar,Tr,Ag)
Graviscalpellum	(Ar,Ci)	Gryphellina	(Mo,Bi,Pt)	Guizhouia	(Mo,Ga,Ar)
Grayiceras	(Mo,Ce,Am)	Gryphiswaldensia	(Ar,Os,Pa)	Guizhoupecten	(Mo,Bi,Pt)
Grayina	(Br,Ar,Pe)	Gryphoca	(Cd,Ma,Ca)	Guizhoustriatopora	(Cn,An,Ta)
Graysonites	(Mo,Ce,Am)	Gryphochiton	(Mo,Pa,Ne)	Guizhovella	(Br,Ar,St)
Grazosteus	(Cd,Pl,Ar)	Gryphus	(Br,Ar,Te)	Guizospira	(Mo,Ga,Ar)
Greenfieldia	(Br,Ar,Sp)	Grypoceras	(Mo,Ce,Na)	Gujaratella	(Ar,Os,Pa)
Greenlandoceras	(Mo,Ce,Di)	Grypocerinus	(Ec,Cr,Ds)	Gujocardia	(Mo,Bi,Ve)
Greenops	(Ar,Tr,Ph)	Grypodon	(Cd,Os,Py)	Gulelimites	(Mo,Ce,Am)
Greenwoodella	(Cd,Os,Cr)	Gryponautilus	(Mo,Ce,Na)	Gulemiceras	(Mo,Ce,Am)
Gregariella	(Mo,Bi,Mt)	Grypophyllum	(Cn,An,Ru)	Gulielmina	(Mo,Ce,Am)
Gregorioiscala	(Mo,Ga,Nt)	Grzegorzewska	(Mo,Ce,Na)	Gumbelastreae	(Cn,An,Sc)
Gregoryceras	(Mo,Ce,Am)	Gshelia	(Cn,An,Ru)	Gumbycyathus	(Po,Re,Aj)
Gregorycoenia	(Cn,An,Sc)	Gsolbergella	(Fo,Fo,Fo)	Gumina	(Mo,Ga,He)
Grekotiana	(Ar,Os,Pa)	Guadalupia	(Po,De,Gu)	Gunaspis	(Cd,Pt,Pt)
Grendelius	(Cd,Re,Ic)	Gualteria	(Ec,Ec,Sp)	Gundarina	(Cn,An,Ru)
Grenprisia	(Ec,Cr,Cl)	Guancenshania	(Ar,Tr,Od)	Gunnarella	(Br,Ar,St)
Gresslya	(Mo,Bi,Ph)	Guandacolithus	(Ar,Tr,As)	Gunnarites	(Mo,Ce,Am)
Grewiphyllum	(Cn,An,Ru)	Guangdangina	(Br,Ar,St)	Gunneropsis	(Ar,Os,Pa)
Grewinkia	(Cn,An,Ru)	Guangdongella	(Ar,Os,Ar)	Gunningblandella	(Br,Ar,St)
Griesbachites	(Mo,Ce,Ce)	Guangjiayanelia	(Br,Ar,St)	Gunteria	(Fo,Fo,Fo)
Grithidella	(Ar,Tr,Pr)	Guangshunia	(Br,Ar,Sp)	Guppyella	(Fo,Fo,Fo)
Grithidites	(Ar,Tr,Pr)	Guangxiispirifer	(Br,Ar,Sp)	Guraleus	(Mo,Ga,Ne)

Gurieuskiella	(Cn,An,Ru)	Gyronema	(Mo,Ga,Ar)	Hagenowella	(Fo,Fo,Fo)
Gusarella	(Br,Ar,Te)	Gyronites	(Mo,Ce,Ce)	Hagenowia	(Ec,Ec,Hs)
Gustabilicrinus	(Ec,Cr,Di)	Gyropeltus	(Cd,Pt,Un)	Hagenowina	(Fo,Fo,Fo)
Gutnicella	(Fo,Fo,Fo)	Gyroplacosteus	(Cd,Pl,Ar)	Hagenowinella	(Bz,Gy,Ch)
Guttasella	(Br,Ar,St)	Gyropleura	(Mo,Bi,Hi)	Hagiastrum	(Ac,Ra,Sp)
Gutticonus	(Mo,In,In)	Gyroptychius	(Cd,Os,Co)	Hagnocrinus	(Ec,Cr,Di)
Gutticrinus	(Ec,Cr,Cy)	Gyroskala	(Mo,Ga,Nt)	Hahazimania	(Mo,Ga,Nt)
Guttulina	(Fo,Fo,Fo)	Gyrosellenella	(Br,Li,Li)	Haiibowania	(Ar,Fr,Od)
Gutturnium	(Mo,Ga,Nt)	Gyrosina	(Br,Ar,Te)	Haidingerites	(Mo,Ce,Ce)
Guynia	(Cn,An,Sc)	Gyrosoria	(Br,Ar,Te)	Haileya	(An,Po,Un)
Gwynia	(Br,Ar,Te)	Gyrosopira	(Mo,Ga,Be)	Haimasiella	(Fo,Fo,Fo)
Gwyniella	(Br,Ar,Te)	Gyrosteus	(Cd,Os,Pa)	Haima	(Ec,Ec,Ol)
Gyaloceras	(Mo,Ce,Am)	Gyrostrea	(Mo,Bi,Pt)	Haimeicyclus	(Cn,An,Sc)
Gyalophyllum	(Cn,An,Ru)	Gyrothyris	(Br,Ar,Te)	Haimeina	(Bz,Gy,Ct)
Gyaloplasma	(Cn,An,Ru)	Gyrotropis	(Mo,Ga,Nt)	Haimesastraea	(Cn,An,Sc)
Gymnagnostus	(Ar,Tr,Ag)	Gyrovalvulina	(Fo,Fo,Fo)	Haimesiphyllia	(Cn,An,Sc)
Gymnarus	(Mo,Ga,Nt)	Gythemon	(Mo,Bi,Ve)	Hainbergia	(Cd,Os,Co)
Gymnentome	(Mo,Ga,Nt)	Gzheloceras	(Mo,Ce,Na)	Hainosaurus	(Cd,Re,Sq)
Gymnites	(Mo,Ce,Ce)	Haasia	(Ar,Tr,Pr)	Halec	(Cd,Os,Al)
Gymnocerithium	(Mo,Ga,Nt)	Haastina	(Mo,Bi,Ve)	Halecopsis	(Cd,Os,Go)
Gymnocidaris	(Ec,Ec,Hm)	Habanaster	(Ec,Ec,Sp)	Halenia	(Fo,Fo,Fo)
Gymnocrinus	(Ec,Cr,Cy)	Habelia	(Ar,Un,Un)	Halesium	(Ac,Ra,Sp)
Gymnodiadema	(Ec,Ec,Or)	Habonucula	(Mo,Bi,Nu)	Halia	(Mo,Ga,Ne)
Gymnodiscoceras	(Mo,Ce,Am)	Habrobrochus	(Br,Ar,Te)	Halianassa	(Cd,Ma,St)
Gymnograptus	(He,Gr,Gr)	Habrocephalus	(Ar,Tr,Pt)	Halicalyptra	(Ac,Ra,Na)
Gymnophyllum	(Cn,An,Ru)	Habrocythere	(Ar,Os,Po)	Halice	(Ar,Ml,De)
Gymnoplites	(Mo,Ce,Am)	Habroichthys	(Cd,Os,Pl)	Halichondrites	(Po,De,Ha)
Gymnosarda	(Cd,Os,Pf)	Habrosium	(Po,He,He)	Haliclona	(Po,De,Ha)
Gymnoscopelus	(Cd,Os,My)	Habrostroma	(Po,De,St)	Halicyne	(Ar,Ma,Cy)
Gymnotomix	(Ar,Tr,Pt)	Hacobjanella	(Mo,Bi,Hi)	Halidictyum	(Ac,Ra,Sp)
Gymnotoceras	(Mo,Ce,Ce)	Hacobjania	(Mo,Ga,Ce)	Halilucites	(Mo,Ce,Ce)
Gymnotrachelus	(Cd,Pl,Ar)	Hacquetia	(Cd,Os,Cl)	Halima	(Po,De,As)
Gymnotropites	(Mo,Ce,Ce)	Haddonina	(Fo,Fo,Fo)	Haliodyctya	(Ac,Ra,Sp)
Gymnura	(Cd,Ch,My)	Hadimopanella	(An,Pa,Pa)	Haliomma	(Ac,Ra,Sp)
Gymocetus	(Cd,Re,Pt)	Hadoceras	(Mo,Ce,On)	Haliommura	(Ac,Ra,Sp)
Gypidula	(Br,Ar,Pe)	Hadragnostus	(Ar,Tr,Ag)	Haliophis	(Cd,Os,Pt)
Gypidulella	(Br,Ar,Pe)	Hadranderaster	(Ec,As,Va)	Haliotiomorpha	(Mo,Ga,Ar)
Gypidulina	(Br,Ar,Pe)	Hadriania	(Mo,Ga,Ne)	Haliotius	(Mo,Ga,Ar)
Gypiduloides	(Br,Ar,Pe)	Hadroblastus	(Ec,Bl,Fr)	Haliphobeus	(Mo,Ga,Nt)
Gypospirifer	(Br,Ar,Sp)	Hadrochithus	(Ec,Ed,Is)	Haliphormis	(Ac,Ra,Na)
Gypsinia	(Fo,Fo,Fo)	Hadrocerinus	(Ec,Cr,Mo)	Halisaurus	(Cd,Re,Sq)
Gyracanthus	(Cd,Ac,Cl)	Hadrocestis	(Ec,Rh,Rh)	Halistylus	(Mo,Ga,Ar)
Gyrgathella	(Ar,Os,Pa)	Hadrodelpbis	(Cd,Ma,Ce)	Halitherium	(Cd,Ma,St)
Gyrineum	(Mo,Ga,Nt)	Hadrodiscus	(Ec,Ed,Is)	Haljulia	(Cd,Os,An)
Gyrispongia	(Po,He,Ly)	Hadrodontina	(Cd,Co,Co)	Halkieria	(Pr,Co,Sa)
Gyroceras	(Mo,Ce,On)	Hadrohybus	(Ar,Tr,Ph)	Halkyardia	(Fo,Fo,Fo)
Gyroceratites	(Mo,Ce,An)	Hadromeros	(Ar,Tr,Ph)	Halla	(An,Po,Eu)
Gyroclymenia	(Mo,Ce,Cl)	Hadronector	(Cd,Os,Co)	Hallaster	(Ec,Op,Oe)
Gyroconulina	(Fo,Fo,Fo)	Hadrophyllum	(Cn,An,Ru)	Hallatia	(Ar,Os,Pa)
Gyrocestis	(Ec,Hm,Ci)	Hadrothylichia	(Br,Ar,Rh)	Hallia	(Cn,An,Ru)
Gyrocythere	(Ar,Os,Pa)	Hadrosia	(Br,Ar,Te)	Hallicystis	(Ec,Rh,Rh)
Gyrodendron	(Cn,An,Sc)	Hadrossteus	(Cd,Pl,Ar)	Hallidaya	(Cn,Cy,Cy)
Gyrodus	(Mo,Ga,Nt)	Hadrotrochynchus	(Br,Ar,Rh)	Halliella	(Ar,Os,Pa)
Gyrodoma	(Mo,Ga,Ar)	Hadrotreta	(Br,Li,Ac)	Hallina	(Br,Ar,At)
Gyrodus	(Cd,Os,Py)	Hadyrhyntcha	(Br,Ar,Rh)	Hallinetes	(Br,Ar,St)
Gyroidina	(Fo,Fo,Fo)	Haeggochiton	(Mo,Po,Pa)	Hallipterus	(Ar,Me,Eu)
Gyroidinella	(Fo,Fo,Fo)	Haematosaurus	(Cd,Re,Cr)	Hallirhoa	(Po,De,Li)
Gyroidinoides	(Fo,Fo,Fo)	Haenleinia	(Mo,Bi,Pt)	Halloceras	(Mo,Ce,Na)
Gyrolepidoides	(Cd,Os,Pa)	Haerella	(Fo,Fo,Fo)	Hallocrinus	(Ec,Cr,Cl)
Gyrolepis	(Cd,Os,Pa)	Haereticotaxocrinus	(Ec,Cr,Tx)	Hallodictya	(Po,He,Re)
Gyroma	(Mo,Ga,Ar)	Haeretocrinus	(Ec,Cr,Cl)	Hallfograptus	(He,Gr,Gr)
Gyrometopus	(Ar,Tr,Ph)	Haeuslerella	(Fo,Fo,Fo)	Hallopora	(Bz,St,Tr)
Gyronaedyceras	(Mo,Ce,Di)	Hafinercambria	(Pn)	Halloporina	(Bz,St,Tr)
Gyronchus	(Cd,Os,Py)	Hagabirhynchia	(Br,Ar,Rh)	Hallotheca	(Hy,Hy,Hy)

Halloysia	(Mo, Ga, Nt)	Hanetia	(Mo, Ga, Ne)	Haptophyllum	(Cn, An, Ru)
Hallstadria	(Mo, Ga, Nt)	Hanielites	(Mo, Ce, Ce)	Hardaghia	(Mo, Bi, Hi)
Hallucigenia	(Lo)	Hanilepis	(Cd, Ac, Cl)	Hardieopteris	(Ar, Me, Eu)
Haloanuis	(Mo, Bi, Ar)	Hanivella	(Ar, Tr, Pt)	Hardistiella	(Cd, Ce, Pe)
Halobia	(Mo, Bi, Pt)	Haniwa	(Ar, Tr, As)	Hardmanoceras	(Mo, Ce, Ta)
Halochitina	(Fo, Fo, Ch)	Haniwoides	(Ar, Tr, As)	Hardouinia	(Ec, Ec, Ca)
Halogetocrinus	(Ec, Cr, Cl)	Hankaxis	(Cn, An, Ru)	Hardyia	(Ar, Tr, Co)
Haloginella	(Mo, Ga, Ne)	Hanleya	(Mo, Po, Ne)	Hardyoides	(Ar, Tr, Pt)
Halomitra	(Cn, An, Sc)	Hannoaceras	(Mo, Ce, Ce)	Harengula	(Cd, Os, Cl)
Halonympha	(Mo, Bi, Ph)	Hanostaffella	(Fo, Fo, Fo)	Haresiceras	(Mo, Ce, Am)
Halorella	(Br, Ar, Rh)	Hansenisca	(Fo, Fo, Fo)	Harfordia	(Mo, Ga, Ne)
Halorellina	(Br, Ar, Rh)	Hanshuieella	(Mo, In, In)	Harginisulcus	(Ar, Os, Pa)
Halorelloidea	(Br, Ar, Rh)	Hansotreta	(Br, Li, Ac)	Harknessella	(Br, Ar, Or)
Halorites	(Mo, Ce, Ce)	Hantkeniceras	(Mo, Ce, Ph)	Harmatia	(Mo, Ga, Ne)
Halysicyathus	(Po, Re, Aj)	Hantkenina	(Fo, Fo, Fo)	Harmatosia	(Br, Ar, Te)
Halysiocrinus	(Ec, Cr, Ds)	Hanusatrypa	(Br, Ar, At)	Harmeria	(Mo, Ga, Nt)
Halysitatraea	(Cn, An, Sc)	Hanusia	(Ec, St, Co)	Harmeriella	(Bz, Gy, Ct)
Halysites	(Cn, An, Ta)	Hanzawaia	(Fo, Fo, Fo)	Harmostocrinus	(Ec, Cr, Cl)
Hamacantha	(Po, De, Po)	Haoella	(Fo, Fo, Fo)	Harpa	(Mo, Ga, Ne)
Hamacuna	(Mo, Bi, Ve)	Hapalocrinus	(Ec, Cr, Mo)	Harpabollia	(Ar, Os, Pa)
Hamariolopora	(Cn, An, Ta)	Hapalopegma	(Po, He, Ly)	Harpacodus	(Cd, Ch, In)
Hamarodus	(Cd, Co, Co)	Hapalopleura	(Mo, Ce, Ph)	Harpactocarcinus	(Ar, Ml, De)
Hamashania	(Ar, Tr, Un)	Hapalorbis	(Mo, Ga, Nt)	Harpactoxanthopsis	(Ar, Ml, De)
Hamatoconus	(Mo, In, In)	Haplacanthus	(Cd, Ac, Ac)	Harpago	(Mo, Ga, Nt)
Hamatolenus	(Ar, Tr, Pt)	Haplaraera	(Cn, An, Sc)	Harpagodes	(Mo, Ga, Nt)
Hamburgia	(Br, Ar, Te)	Haplentactinia	(Ac, Ra, Sp)	Harpagofututor	(Cd, Ch, Ch)
Hameaschmidtdella	(Ar, Os, Un)	Haplistion	(Po, De, Li)	Harpella	(Mo, Ga, Ne)
Haminoea	(Mo, Ga, Ce)	Haplistionella	(Po, De, Li)	Harperopsis	(Ar, Os, Po)
Hamiroproetus	(Ar, Tr, Pr)	Haplobolbina	(Ar, Os, Pa)	Harpes	(Ar, Tr, Pt)
Hamites	(Mo, Ce, Am)	Haplocephalopora	(Fo, Gy, Ch)	Harpesoides	(Ar, Tr, Pt)
Hamiticeras	(Mo, Ce, Am)	Haploceras	(Mo, Ce, Am)	Harpidella	(Ar, Tr, Pr)
Hamitoides	(Mo, Ce, Am)	Haplocetus	(Cd, Ma, Ce)	Harpides	(Ar, Tr, Pt)
Hamingella	(Br, Ar, St)	Haplocochlias	(Mo, Ga, Nt)	Harpidium	(Br, Ar, Pe)
Hamlinia	(Mo, Ga, Ce)	Haplocrinities	(Ec, Cr, Ds)	Harpidoidea	(Ar, Tr, Pt)
Hammanopyge	(Ar, Tr, Ph)	Haplocytheridea	(Ar, Os, Po)	Harpillaenus	(Ar, Tr, Co)
Hammatoceras	(Mo, Ce, Am)	Haplodiacanthus	(Ac, Ra, Sp)	Harpoceras	(Mo, Ce, Am)
Hammatocnemis	(Ar, Tr, Ph)	Haplograptus	(He, Gr, Un)	Harpoceratoides	(Mo, Ce, Am)
Hammatocyclus	(Mo, Ce, Go)	Haplohelia	(Cn, An, Sc)	Harpohildoceras	(Mo, Ce, Am)
Hammatocythere	(Ar, Os, Po)	Haplolasma	(Cn, An, Ru)	Harpophylloceras	(Mo, Ce, Ph)
Hammatopsis	(An, Po, Un)	Haplolepis	(Cd, Os, Pa)	Harpula	(Mo, Ga, Ne)
Hammatospira	(Mo, Ga, Ar)	Haplooechia	(Bz, St, Cc)	Harrelicrinus	(Ec, Cr, Mo)
Hammatostroma	(Po, De, St)	Haplophragmella	(Fo, Fo, Fo)	Harrelicrinus	(Ec, Cr, Cl)
Hammia	(Bz, St, Cc)	Haplophragmina	(Fo, Fo, Fo)	Harringtonia	(Br, Ar, At)
Hamodus	(Cd, Os, Co)	Haplophragmium	(Fo, Fo, Fo)	Harriotta	(Cd, Ch, Cm)
Hampilina	(Mo, In, In)	Haplophragmoides	(Fo, Fo, Fo)	Harrisianella	(Mo, Ga, Nt)
Hamptonia	(Po, De, Po)	Haplophrentis	(Hy, Hy, Hy)	Harrisoceras	(Mo, Ce, Or)
Hamptoniella	(Mo, Ga, Pa)	Haplophylloceras	(Mo, Ce, Ph)	Harrycaris	(Ar, Th, Ce)
Hamptonina	(Br, Ar, Te)	Haplopleuroceras	(Mo, Ce, Am)	Harrytoombsia	(Cd, Pl, Ar)
Hamulina	(Mo, Ce, Am)	Haplopoima	(Bz, Gy, Ch)	Hartmanina	(Po, Ca, Ph)
Hamulinites	(Mo, Ce, Am)	Haploprimitia	(Ar, Os, Pa)	Hartshillia	(Ar, Tr, Pt)
Hamulispinctes	(Mo, Ce, Am)	Haploptyxis	(Mo, Ga, He)	Hartshillina	(Ar, Tr, Pt)
Hamulus	(An, Po, Se)	Haploscaphites	(Mo, Ce, Am)	Harttella	(Br, Ar, Te)
Hamusella	(Mo, In, In)	Haplosphaeronis	(Ec, Di, Di)	Harttites	(Pr, Un, In)
Hamusina	(Mo, Ga, Ar)	Haplospira	(Mo, Ga, Ar)	Hartungia	(Mo, Ga, Nt)
Hanaeproductus	(Br, Ar, St)	Haplospirifer	(Br, Ar, Sp)	Hartwellia	(Mo, Bi, Ve)
Hanaiborchella	(Ar, Os, Po)	Haplothecia	(Cn, An, Ru)	Haruspex	(Mo, Ce, Or)
Hanaibursa	(Mo, Ga, Nt)	Haplotrypa	(Bz, St, Cy)	Hastacypris	(Ar, Os, Po)
Hanaiceratina	(Ar, Os, Po)	Haplovoluta	(Mo, Ga, Ne)	Hastagnostus	(Ar, Tr, Ag)
Hanaicythere	(Ar, Os, Po)	Hapsiceraurus	(Ar, Tr, Ph)	Hastatellina	(Ar, Os, Pa)
Hanaispira	(Mo, Ga, Ar)	Hapsidocare	(Ar, Tr, Co)	Hastigerina	(Fo, Fo, Fo)
Hanaites	(Ar, Os, Pa)	Hapsidopora	(Bz, Gy, Ch)	Hastigeriella	(Fo, Fo, Fo)
Hanburia	(Ar, Tr, Un)	Hapsiphyllum	(Cn, An, Ru)	Hastigerinoides	(Fo, Fo, Fo)
Hanchiangella	(Ar, Os, Ar)	Hapsizaphrentis	(Cn, An, Ru)	Hastigerinopsis	(Fo, Fo, Fo)
Hanchungolithus	(Ar, Tr, As)	Haptaphyllina	(Cn, An, Ht)	Hastimima	(Ar, Me, Eu)

Hastina	(Ch,Pr)	Heckericystis	(Ec,Hs,So)	Helicorboides	(Fo,Fo,Fo)
Hastiremopleurides	(Ar,Tr,As)	Hecticoceras	(Mo,Ce,Am)	Helicospira	(Mo,Ga,Ar)
Hastites	(Mo,Ce,Be)	Hectioceras	(Mo,Ce,Am)	Helicostegina	(Fo,Fo,Fo)
Hastula	(Mo,Ga,Ne)	Hectioceratoides	(Mo,Ce,Am)	Helicosteginopsis	(Fo,Fo,Fo)
Hataiyoldia	(Mo,Bi,Nu)	Hectoroceras	(Mo,Ce,Am)	Helicotis	(Mo,Pa,Hy)
Hatangeus	(Ar,Os,Pa)	Hedbergella	(Fo,Fo,Fo)	Helicotoma	(Mo,Ga,Ar)
Hatangia	(Ar,Tr,Pt)	Hedecardium	(Mo,Bi,Ve)	Helicities	(Mo,Ce,Ce)
Hatasia	(Mo,Bi,My)	Hedeina	(Br,Ar,Sp)	Helieranella	(Ar,Tr,Pt)
Hatayin	(Mo,Bi,Hi)	Hedeinopsis	(Br,Ar,Sp)	Heligmina	(Mo,Bi,Pt)
Hatchericeras	(Mo,Ce,Am)	Hedeliastrea	(Cn,An,Sc)	Heligmope	(Mo,Ga,Nt)
Hattonia	(Cn,An,Ta)	Hedenstroemia	(Mo,Ce,Ce)	Heligmopsis	(Mo,Bi,Pt)
Hattopsis	(Ec,Ec,Ph)	Hederella	(Bz,St,Ce)	Heligmostylus	(Mo,Ga,Nt)
Hauericeras	(Mo,Ce,Am)	Hederopsis	(Bz,St,Ce)	Heligmotema	(Mo,Ga,Ne)
Hauerina	(Fo,Fo,Fo)	Hedinaspis	(Ar,Tr,Pt)	Heligmotoma	(Mo,Ga,Ne)
Hauerites	(Mo,Ce,Ce)	Hedraites	(Fo,Fo,Fo)	Heligothyris	(Br,Ar,Te)
Haughtonileberis	(Ar,Os,Po)	Hedstroemia	(Ar,Tr,Pr)	Heliocephalus	(Ar,Tr,Ph)
Haugia	(Mo,Ce,Am)	Hedstroemina	(Br,Ar,St)	Heliocidaris	(Ec,Ec,Ec)
Haumea	(Mo,Bi,Pt)	Hedstroemoceras	(Mo,Ce,Or)	Heliocladus	(Ac,Ra,Sp)
Haumuriaegla	(Ar,MI,De)	Hedstroemiophyllum	(Cn,An,Ru)	Heliocrinites	(Ec,Rh,Rh)
Haupiria	(Br,Un,Ku)	Hefriga	(Ar,MI,De)	Heliocryptocapsa	(Ac,Ra,Na)
Haurakia	(Mo,Ga,Nt)	Heftastylis	(Po,De,Ax)	Heliocythere	(Ar,Os,Po)
Haurania	(Fo,Fo,Fo)	Hefteria	(Fo,Fo,Fr)	Heliocenia	(Cn,An,Sc)
Haustator	(Mo,Ga,Nt)	Hegleria	(Ac,Ra,Sp)	Heliodiscus	(Ac,Ra,Sp)
Haustellum	(Mo,Ga,Ne)	Heida	(Mo,Ga,He)	Helioinactinia	(Ac,Ra,Sp)
Hautura	(Mo,Ga,Ne)	Heikeya	(Mo,Bi,Ar)	Heliofungia	(Cn,An,Sc)
Havlicekella	(Br,Ar,Rh)	Heilprinia	(Mo,Ga,Ne)	Helioharpes	(Ar,Tr,Pt)
Havlicekia	(Br,Ar,Sp)	Heimia	(Br,Ar,Te)	Heliolites	(Cn,An,Ta)
Hawaiarca	(Mo,Bi,Ar)	Heinia	(Ar,Os,Po)	Heliomedusa	(Br,In,Cp)
Haworthina	(Ar,Os,Po)	Heintzella	(Cn,An,Ru)	Heliomera	(Ar,Tr,Ph)
Hawthorneachiton	(Mo,Os,Pa)	Heintzichthys	(Mo,Pl,Ar)	Heliomeroidea	(Ar,Tr,Ph)
Hayamiella	(Mo,Ga,Ar)	Heinzia	(Mo,Ce,Am)	Heliophora	(Ec,Ec,Ct)
Hayasakaia	(Cn,An,Ta)	Helaspis	(Br,Ar,St)	Heliophyllum	(Cn,An,Ru)
Hayasakaina	(Fo,Fo,Fo)	Helcion	(Mo,Ga,Pa)	Helioplasma	(Cn,An,Ta)
Hayasakapecten	(Mo,Bi,Pt)	Helcionella	(Mo,He,He)	Helioplasmolites	(Cn,An,Ta)
Hayasakapora	(Bz,St,Fe)	Helcionopsis	(Mo,Te,Tr)	Heliopora	(Cn,An,He)
Haydenella	(Br,Ar,St)	Helenathyris	(Br,Ar,Sp)	Helioproetoides	(Ar,Tr,Pr)
Haydenia	(Mo,Ga,Nt)	Helenia	(Hy,Jy,Hy)	Helioproetus	(Ar,Tr,Pr)
Haydenoceras	(Mo,Ce,Ba)	Helenifore	(Mo,Ce,Sp)	Heliopora	(Ar,Tr,Ph)
Haydenoides	(Br,Ar,St)	Heleniproductus	(Br,Ar,St)	Heliosartnaris	(Ac,Ra,Sp)
Haynesina	(Fo,Fo,Fo)	Helenites	(Mo,Ce,Or)	Heliosocrinus	(Ec,Cr,Ct)
Hazelia	(Po,De,Ha)	Helenolepis	(Cd,Pt,Th)	Heliosoma	(Ac,Ra,Sp)
Hazulina	(Ar,Os,Po)	Helenolites	(Cn,An,Ta)	Heliosphaera	(Ac,Ra,Sp)
Healdia	(Ar,Os,Me)	Helenopora	(Bz,St,Tr)	Heliospongia	(Po,De,Ha)
Healdiacypriis	(Ar,Os,Po)	Helentappanella	(Fo,Fo,Fo)	Heliostrea	(Cn,An,Sc)
Healdianella	(Ar,Os,Me)	Helepagetia	(Ar,Tr,Ag)	Heliostylina	(Cn,An,Sc)
Healdioides	(Ar,Os,Me)	Hellfriedella	(Ec,Ho,De)	Helioseris	(Cn,An,Sc)
Hebediscina	(Ar,Tr,Ag)	Helgolandichthys	(Cd,Os,Sa)	Heliostylus	(Ac,Ra,Sp)
Hebediscus	(Ar,Tr,Ag)	Heliacus	(Mo,Ga,St)	Heliotrypa	(Bz,St,Cr)
Hebellum	(Ar,Os,Pa)	Helianthaster	(Ec,As,He)	Helix	(Bz,Gy,Ch)
Hebertella	(Br,Ar,Or)	Heliaster	(Ec,As,Fo)	Helixotionella	(Bz,Gy,Ch)
Hebertocaris	(Ar,MI,Ar)	Helicacanthus	(Mo,Ga,Ar)	Helladophyllia	(Cn,An,Sc)
Hebesella	(Mo,Ga,Nt)	Helicampodus	(Cd,Ch,Eu)	Hellebardia	(Ar,Os,Po)
Hebetierinus	(Ec,Cr,Cm)	Helicancylus	(Mo,Ce,Am)	Hellenocyclusina	(Fo,Fo,Fo)
Hebetoceras	(Mo,Ce,As)	Helicaulax	(Mo,Ga,Nt)	Hellerocaris	(Ar,MI,De)
Hebetocchia	(Br,Ar,Rh)	Helicelasma	(Cn,An,Ru)	Helloceras	(Cn,An,Sc)
Hebetoxyites	(Mo,Ce,Am)	Helichthys	(Cd,Os,Pa)	Helmersenian	(Br,LI,Ac)
Hebexius	(Ar,Os,Pa)	Helicoerinus	(Ec,Cr,Un)	Helmetia	(Ar,Mo,In)
Hebra	(Mo,Ga,Ne)	Helicocryptus	(Mo,Ga,Ar)	Helminthidium	(Cn,An,Ru)
Hebukophyllum	(Cn,An,Ru)	Helicocylus	(Mo,Ce,Go)	Helminthochiton	(Mo,Po,Ne)
Hecatoceras	(Mo,Ce,Di)	Helicodictya	(Po,He,Re)	Helminthophyllum	(Po,De,As)
Hechticythere	(Ar,Os,Po)	Helicolepidina	(Fo,Fo,Fo)	Helminthozoga	(Mo,Ga,Nt)
Hechtina	(Fo,Fo,Fo)	Helicoplacus	(Ec,He,He)	Helmolopsis	(Cd,Os,Pe)
Hecia	(Ar,MI,De)	Helicopora	(Bz,St,Fe)	Helobranchium	(Po,De,LI)
Heckericyathus	(Po,Re,Aj)	Helicopron	(Cd,Ch,Eu)	Heloceras	(Mo,Ce,Or)

Heloclema	(Bz,St,Cr)	Hemigymnia	(Ec,Ec,Sp)	Hemithyropsis	(Br,Ar,Rh)
Helodiadema	(Ec,Ec,Di)	Hemihaploceras	(Mo,Ce,Am)	Hemithyrasites	(Cd,Os,Pf)
Helodopsis	(Cd,Ch,In)	Hemihoplites	(Mo,Ce,Am)	Hemitiaris	(Ec,Ec,Hm)
Helodus	(Cd,Ch,In)	Hemiindocrinus	(Ec,Cr,Cl)	Hemitiassotia	(Mo,Ce,Am)
Helopora	(Bz,St,Cr)	Hemikaolishania	(Ar,Tr,Co)	Hemitoechia	(Br,Ar,Rh)
Heloraphinia	(Po,De,Li)	Hemikrithie	(Ar,Os,Po)	Hemitomata	(Mo,Ga,Eu)
Heloringulum	(Ac,Ra,Na)	Hemilampronites	(Cd,Os,Be)	Hemitrochiscus	(Ar,Ma,Cy)
Helotholus	(Ac,Ra,Na)	Hemilecanites	(Mo,Ce,Ce)	Hemitrypa	(Bz,St,Fe)
Helvetella	(Br,Ar,Te)	Hemilepton	(Mo,Bi,Ve)	Hemitrypella	(Bz,St,Fe)
Helveticosaurus	(Cd,Re,Pl)	Hemileurus	(Br,Ar,Rh)	Hemiulrichostylus	(Bz,St,Cr)
Helvetoglobatruncana	(Fo,Fo,Fo)	Hemiliroceras	(Mo,Ce,Na)	Hemizyga	(Mo,Ga,Nt)
Hematites	(Mo,Ce,Au)	Hemilistrona	(Cd,Co,Co)	Hemlebenia	(Fo,Fo,Fo)
Hemiaeschnidella	(Ar,Os,Pa)	Hemilytoceras	(Mo,Ce,Am)	Hemsiella	(Ar,Os,Pa)
Hemerocoetes	(Cd,Os,Pf)	Hemimactra	(Mo,Bi,Ve)	Henadoparia	(Ar,Tr,Pt)
Hemiacirsa	(Mo,Ga,Nt)	Hemimollocrinus	(Ec,Cr,Cl)	Henaniodus	(Pr,Un,In)
Hemiaechminoides	(Ar,Os,Pa)	Heminajas	(Mo,Bi,Tr)	Hengesites	(Mo,Ce,Am)
Hemiarges	(Ar,Tr,Li)	Heminautilus	(Mo,Ce,Na)	Hengnania	(Cd,Os,Pc)
Hemiaspenites	(Mo,Ce,Ce)	Heminematopora	(Bz,St,Cr)	Heniasstoma	(Mo,Ga,Ar)
Hemiaster	(Ec,Ec,Sp)	Hemingwayella	(Ar,Os,Po)	Hennigopora	(Bz,St,Cy)
Hemiaulacophyllum	(Cn,An,Rt)	Hemioon	(Ar,Ml,De)	Henningsmoenia	(Ar,Os,Pa)
Hemibaculites	(Mo,Ce,Am)	Hemiparacystheridea	(Ar,Os,Po)	Henningsmoenicaris	(Ar,In,Un)
Hemibarrandia	(Ar,Tr,As)	Hemipeecten	(Mo,Bi,Pt)	Hennoquia	(Mo,Ga,Pa)
Hemibashkirella	(Bz,St,Fe)	Hemipedina	(Ec,Ec,Pe)	Henodus	(Cd,Re,Pl)
Hemibeloitoceras	(Mo,Ce,On)	Hemiphactella	(Bz,Gy,Ch)	Henricellum	(Po,De,Pe)
Hemibrachioerinus	(Ec,Cr,Cy)	Hemiphragma	(Bz,St,Tr)	Henricia	(Ec,As,Sp)
Hemicalypterus	(Cd,Os,Se)	Hemiphragmoceras	(Mo,Ce,On)	Henryhowella	(Ar,Os,Po)
Hemicara	(Ec,Ec,Ca)	Hemipiloceras	(Mo,Ce,En)	Hensonella	(Pr,Un,In)
Hemicellaria	(Bz,St,Cc)	Hemiplasmopora	(Cn,An,Ta)	Hensonia	(Fo,Fo,Fo)
Hemicerithium	(Mo,Ga,Nt)	Hemiplx	(Ar,Ml,De)	Hensonina	(Fo,Fo,Fo)
Hemichenopus	(Mo,Ga,Nt)	Hemiplethorhynchus	(Br,Ar,Rh)	Hentigia	(Ar,Tr,Pr)
Hemichoanella	(Mo,Ce,El)	Hemipleurotoma	(Mo,Ga,Ne)	Heosomocelypha	(Br,Un,Un)
Hemichonetes	(Br,Ar,St)	Hemplicatula	(Mo,Ga,Sa)	Hepatella	(Ar,Ml,De)
Hemicidaris	(Ec,Ec,Hm)	Hemipneustes	(Ec,Ec,Hs)	Hepatulinus	(Ar,Ml,De)
Hemicoonus	(Mo,Ga,Ne)	Hemiporites	(Cn,An,Se)	Hepaticus	(Ar,Ml,De)
Hemicorbicula	(Mo,Bi,Ve)	Hemipristis	(Cd,Ch,Ca)	Heptatus	(Ar,Ml,De)
Hemicosciniopsis	(Bz,Gy,Ch)	Hemipronites	(Br,Ar,Or)	Heptabronteus	(Ar,Tr,Pt)
Hemicosmites	(Ec,Rh,Rh)	Hemiptychina	(Br,Ar,Te)	Heptaloculites	(Ar,Os,Po)
Hemicosmophyllum	(Cn,An,Rt)	Hemiptychoceras	(Mo,Ce,Am)	Heptanema	(Cd,Os,Co)
Hemicosmorhoceras	(Mo,Ce,Or)	Hemirhabdorhynchus	(Cd,Os,Pf)	Heptastylis	(Po,De,Ax)
Hemicrius	(Mo,Cr,Te)	Hemirhanphus	(Cd,Os,Be)	Heptanchias	(Cd,Ch,Hx)
Hemicrinus	(Ec,Cr,Cy)	Hemirhodon	(Ar,Tr,Co)	Heraclites	(Mo,Ce,Ce)
Hemicyrtocapsa	(Ac,Ra,Na)	Hemirobulina	(Fo,Fo,Fo)	Heracloceras	(Mo,Ce,Ba)
Hemicyclammina	(Fo,Fo,Fo)	Hemisaurida	(Cd,Os,Al)	Heraeracrus	(Ec,Cr,Ds)
Hemicyclaspis	(Cd,Ce,At)	Hemisicyllium	(Cd,Ch,Oc)	Herangirhynchia	(Br,Ar,Rh)
Hemicyclonosta	(Mo,Bi,Ve)	Hemiseptella	(Bz,Gy,Ch)	Heraulitpegma	(Mo,Ro,Ri)
Hemicyclonophyllum	(Bz,Gy,Ch)	Hemisimoceras	(Mo,Ce,Am)	Herbstia	(Ar,Ml,De)
Hemicyprideis	(Ar,Os,Po)	Hemismitina	(Bz,Gy,Ch)	Hercantyx	(Ar,Tr,Un)
Hemicystites	(Ec,Ed,Is)	Hemisphaerammina	(Fo,Fo,Fo)	Hercoceras	(Mo,Ce,Na)
Hemicythere	(Ar,Os,Os)	Hemisphaeranthos	(Ec,Ho,Ap)	Hercocithina	(Fo,Fo,Ch)
Hemicytheria	(Ar,Os,Po)	Hemisphaerocoryphe	(Ar,Tr,Ph)	Hercocrius	(Ec,Cr,Di)
Hemicytheridea	(Ar,Os,Po)	Hemisquilla	(Ar,Ml,St)	Hercocryptoceras	(Mo,Ce,On)
Hemicytherura	(Ar,Os,Po)	Hemisterias	(Mo,Bi,Un)	Hercodon	(Mo,Bi,Ve)
Hemidiadema	(Ec,Ec,Ph)	Hemistreptacron	(Ec,Cr,Cl)	Hercoglossa	(Mo,Ce,Na)
Hemidiscella	(Po,He,Hm)	Hemistretocrinus	(Ec,Cr,He)	Hercoglossoceras	(Mo,Ce,Na)
Hemidiscus	(Fo,Fo,Fo)	Hemistringocephalus	(Br,Ar,Te)	Hercolepas	(Pr,Ma,He)
Hemidonax	(Mo,Bi,Ve)	Hemistylus	(Bz,Gy,Ch)	Hercophyllum	(Cn,An,Ru)
Hemieridotrypa	(Bz,St,Tr)	Hemisurcula	(Mo,Ga,Ne)	Hercorhynchus	(Mo,Ga,Ne)
Hemieuryllae	(Ec,Op,Op)	Hemisyntrachelus	(Cd,Ma,Ce)	Hercosestria	(Br,Ar,St)
Hemifaorina	(Ec,Ec,Sp)	Hemitetragonites	(Mo,Ce,Am)	Hercosia	(Br,Ar,St)
Hemifusulina	(Fo,Fo,Fo)	Hemithalamocyathus	(Po,Re,Aj)	Hercostrophia	(Br,Ar,St)
Hemifusulinella	(Fo,Fo,Fo)	Hemithecella	(Mo,Po,Pa)	Hercothyris	(Br,Ar,Te)
Hemifusius	(Mo,Ga,Ne)	Hemithiris	(Br,Ar,Rh)	Hercynella	(Mo,Bi,Pr)
Hemigarantia	(Mo,Ce,Am)	Hemithurrammina	(Fo,Fo,Fo)	Hercynobolbina	(Ar,Os,Pa)
Hemigordius	(Fo,Fo,Fo)	Hemithylus	(Ec,Ec,Ph)	Hercynocythere	(Ar,Os,Po)

Hercynolepis	(Cd,Ch,Or)	Heteractaea	(Ar,Ml,De)	Heterophyllia	(Cn,An,Ht)
Here	(Mo,Bi,Ve)	Heteractis	(Bz,Gy,Ch)	Heterophylloides	(Cn,An,Ht)
Herella	(Mo,Bi,Ve)	Heterallosia	(Br,Ar,St)	Heteropis	(Mo,Bi,Ve)
Herentia	(Bz,Gy,Ch)	Heterantyx	(Fo,Fo,Fo)	Heteropora	(Bz,St,Cc)
Hergetatrypa	(Br,Ar,At)	Heteraria	(Br,Ar,Sp)	Heteroporella	(Bz,St,Cc)
Hergottella	(Fo,Fo,Fo)	Heteraster	(Ec,Ec,Sp)	Heteropsammia	(Cn,An,Sc)
Heritschiella	(Cn,An,Ru)	Heterastraea	(Cn,An,Sc)	Heteropygmatis	(Mo,Ga,Un)
Heritschioides	(Cn,An,Ru)	Heterastridium	(Cn,Hy,Mi)	Heteroraphidites	(Po,De,As)
Herkimeroceras	(Mo,Ce,On)	Heterodontoides	(Cd,Co,Pa)	Heterorthella	(Br,Ar,Or)
Hermania	(Mo,Ga,Ce)	Heterelasma	(Br,Ar,Te)	Heterorthina	(Br,Ar,Or)
Hermanites	(Ar,Os,Po)	Heterellina	(Fo,Fo,Fo)	Heterorthis	(Br,Ar,Or)
Hermatoporella	(Po,De,St)	Heterma	(Ar,Os,Me)	Heterosalenia	(Ec,Ec,Sa)
Hermatostroma	(Po,De,St)	Heteroaspis	(Ar,Me,Ch)	Heterosaurus	(Cd,Re,Cr)
Hermatostromella	(Po,De,St)	Heteroblastus	(Ec,Bi,Sp)	Heteroschisma	(Ec,Bi,Fi)
Hernandezaster	(Ec,Ec,Sp)	Heterobrissus	(Ec,Ec,Sp)	Heteroschizodus	(Mo,Bi,Tr)
Hernodia	(Bz,St,Cc)	Heterobrochus	(Br,Ar,Te)	Heterosculptotheca	(Pr,Un,In)
Heroldina	(Ar,Ml,Ar)	Heterocania	(Cn,An,Ru)	Heterostrum	(Ac,Ra,Sp)
Heronallenia	(Fo,Fo,Fo)	Heterocaryon	(Ar,Tr,Pt)	Heterospaeroma	(Ar,Ml,Is)
Herouvalia	(Mo,Bi,Ve)	Heterocentrotus	(Ec,Ec,Ec)	Heterospira	(Mo,Ga,Nt)
Herpetocetus	(Cd,Ma,Ce)	Heteroceras	(Mo,Ce,Am)	Heterospongia	(Po,De,Li)
Herpetocrinus	(Ec,Cr,Ds)	Heterocerithiopsis	(Mo,Ga,Nt)	Heterospongophyllum	(Cn,An,Ru)
Herpetopoma	(Mo,Ga,Ar)	Heterocetus	(Cd,Ma,Ce)	Heterostegina	(Fo,Fo,Fo)
Herpetopora	(Bz,Gy,Ch)	Heterochilina	(Ar,Os,Le)	Heterostella	(Po,Ca,He)
Herpolitha	(Cn,An,Sc)	Heterochiton	(Mo,Po,Ne)	Heterosteus	(Cd,Pl,Ar)
Herreraaster	(Ec,Ec,Sp)	Heterocidaris	(Ec,Ec,Un)	Heterostinia	(Po,De,Li)
Herrigocythere	(Ar,Os,Po)	Heterocidihara	(Mo,Ga,Ne)	Heterostomella	(Fo,Fo,Fo)
Herrmannia	(Ar,Os,Le)	Heterocolidius	(Mo,Bi,Ph)	Heterostrea	(Mo,Bi,Pt)
Hertha	(Ec,Cr,Cm)	Heterocoenia	(Cn,An,Sc)	Heterostrophus	(Cd,Os,Sc)
Hertleinites	(Mo,Ce,Am)	Heterocoenites	(Cn,An,Ta)	Heterotrissia	(Cd,Os,Ct)
Hertzina	(Cd,Co,Pa)	Heteroconopeum	(Bz,Gy,Ch)	Heterotissotia	(Mo,Ce,Am)
Herznachites	(Mo,Ce,Am)	Heterocoskinolina	(Fo,Fo,Fo)	Heterotroperdo	(Cd,Ch,My)
Herzogina	(Mo,Bi,Ve)	Heterocrinus	(Ec,Cr,Ds)	Heterotrema	(Mo,Ga,Ne)
Hescheleria	(Cd,Re,Th)	Heterocrisina	(Bz,St,Cc)	Heterotrichina	(Ci,Po,Sp)
Hesionites	(An,Po,Un)	Heterocrypta	(Ar,Ml,De)	Heterotrigonia	(Mo,Bi,Tr)
Heslingtonia	(Mo,Bi,Tr)	Heterocyathus	(Cn,An,Sc)	Heterotrypa	(Bz,St,Tr)
Hesperaster	(Ec,Ec,Ci)	Heterocyclopyge	(Ar,Tr,As)	Hexacanthopora	(Bz,Gy,Ch)
Hespererato	(Mo,Ga,Nt)	Heterocyprideis	(Ar,Os,Po)	Hexachorda	(Mo,Ga,Ne)
Hesperibalans	(Ar,Ci)	Heterocystites	(Ec,Rh,Rh)	Hexacladus	(Ac,Ra,Sp)
Hesperidella	(Ar,Os,Pa)	Heterocythereis	(Ar,Os,Po)	Hexaclinymenia	(Mo,Ce,Ci)
Hesperiella	(Mo,Ga,Ar)	Heterodolphis	(Cd,Ma,Ce)	Hexacantium	(Ac,Ra,Sp)
Hesperinia	(Br,Ar,St)	Heterodiadema	(Ec,Ec,Hm)	Hexacorbula	(Mo,Bi,My)
Hesperithyris	(Br,Ar,Te)	Heterodiscus	(Mo,Bi,Hi)	Hexacosta	(Ar,Tr,Ph)
Hesperiturris	(Mo,Ga,Ne)	Heterodonax	(Mo,Bi,Ve)	Hexacrinites	(Ec,Cr,Mo)
Hesperoceras	(Mo,Ce,Or)	Heterodontus	(Cd,Ch,Ht)	Hexacromyium	(Ac,Ra,Sp)
Hesperocirrus	(Mo,Ga,Ar)	Heterogyra	(Cn,An,Sc)	Hexactinella	(Po,He,He)
Hesperocoelia	(Po,De,Li)	Heterogyrella	(Mo,Ga,Nt)	Hexadoris	(Ac,Ra,Sp)
Hesperocystis	(Ec,Rh,Rh)	Heterohaplloecia	(Bz,St,Cc)	Hexaglauconia	(Mo,Ga,Nt)
Hesperomena	(Br,Ar,St)	Heterohelix	(Fo,Fo,Fo)	Hexagonaria	(Cn,An,Ru)
Hesperonomia	(Br,Ar,Or)	Heterolampas	(Ec,Ec,Sp)	Hexagonella	(Bz,St,Cy)
Hesperonomiella	(Br,Ar,Or)	Heterolasma	(Cn,An,Ru)	Hexagonites	(Mo,Ce,Na)
Hesperopora	(Bz,Gy,Ch)	Heterolepa	(Fo,Fo,Fo)	Hexaheliocienia	(Cn,An,Sc)
Hesperorhynchia	(Br,Ar,Rh)	Heterolepidotus	(Cd,Os,Am)	Hexalasma	(Cn,An,Ru)
Hesperornis	(Cd,Av,He)	Heterolimulus	(Ar,Me,Xi)	Hexaloxcharium	(Ac,Ra,Sp)
Hesperorthis	(Br,Ar,Or)	Heteromacoma	(Mo,Bi,Ve)	Hexalonche	(Ac,Ra,Sp)
Hesperosia	(Br,Ar,Te)	Heterometra	(Ec,Cr,Cm)	Hexameroceras	(Mo,Ce,On)
Hesperosiren	(Cd,Ma,Si)	Heteromorphina	(Fo,Fo,Fo)	Hexanchus	(Cd,Ch,Hx)
Hesperotrophia	(Br,Ar,Pe)	Heteromychus	(Br,Ar,Rh)	Hexangulaconularia	(Cn,Sc,Cn)
Hessenhausia	(Br,Ar,Te)	Heteronodosus	(Mo,Ga,Eu)	Hexapetalum	(Cn,An,Sc)
Hesslandella	(Ar,Os,Pa)	Heteropecten	(Mo,Bi,Pt)	Hexaphyllia	(Cn,An,Ht)
Hesslandites	(Ar,Os,Po)	Heteropedina	(Ec,Ec,Di)	Hexaplex	(Mo,Ga,Ne)
Hesslandona	(Ar,Os,Ar)	Heteropetalus	(Cd,Ch,De)	Hexaporites	(Bz,St,Tr)
Hesslerella	(Ar,Ml,Is)	Heterophaulactis	(Cn,An,Ru)	Hexapus	(Ar,Ml,De)
Hessotiara	(Ec,Ec,Hm)	Heteropholas	(Mo,Bi,My)	Hexapyramies	(Ac,Ra,Na)
Hetcochitina	(Fo,Fo,Ch)	Heteroprentis	(Cn,An,Ru)	Hexasaturnalis	(Ac,Ra,Sp)

Hexaspyris	(Ac,Ra,Na)	Himeraelites	(Mo,Bi,Hi)	Hippoporina	(Bz,Gy,Ch)
Hexastylarium	(Ac,Ra,Sp)	Himerocrius	(Ec,Cr,Mo)	Hippopozoon	(Bz,Gy,Ch)
Hexastylstroma	(Po,De,St)	Himerometra	(Ec,Cr,Cm)	Hippopus	(Mo,Bi,Ve)
Hexastylus	(Ac,Ra,Sp)	Himispiiticerias	(Mo,Ce,Am)	Hipposera	(Bz,Gy,Ch)
Hexatarastinus	(Cd,Re,Ps)	Hina	(Mo,Bi,Ve)	Hipposynathus	(Cd,Os,Ga)
Hexelasma	(Ar,Ci)	Hinaclema	(Bz,St,Tr)	Hippothoa	(Bz,Gy,Ch)
Hexianella	(Ar,Tr,Pr)	Hincksina	(Bz,Gy,Ch)	Hippula	(Ar,Os,Pa)
Hexismia	(Cn,An,Ta)	Hincksipora	(Bz,Gy,Ch)	Hippuritella	(Mo,Bi,Hi)
Hexites	(Bz,St,Cr)	Hindeastraea	(Cn,An,Sc)	Hippurites	(Mo,Bi,Hi)
Hexitheca	(Hy,Or,Or)	Hindella	(Br,Ar,Sp)	Hircinisca	(Br,Ar,Rh)
Heymonsicambria	(Pn)	Hindenites	(An,Po,Eu)	Hiregiroceras	(Mo,Ce,On)
Heyuncnoceras	(Mo,Ce,Un)	Hindeoceras	(Mo,Ce,Na)	Hirnantia	(Br,Ar,Or)
Hezhangophyllum	(Cn,An,Ru)	Hindeodelloides	(Cd,Co,Co)	Hirneacrinus	(Ec,Cr,Di)
Hezhouphyllum	(Cn,An,Ru)	Hindeodina	(Cd,Co,Co)	Hiramurex	(Mo,Ga,Ne)
Hiantopora	(Bz,Gy,Ch)	Hindeodus	(Cd,Co,Co)	Hiroshimaphyllum	(Cn,An,Ru)
Hiatella	(Mo,Bi,My)	Hindeoprius	(An,Po,Eu)	Hirotyphis	(Mo,Ga,Ne)
Hiatobairdia	(Ar,Os,Pa)	Hindeosphaera	(Ac,Ra,Sp)	Hirschmannia	(Ar,Os,Pa)
Hiatula	(Mo,Bi,Ve)	Hindermeyeria	(Ar,Tr,Pt)	Hirsonella	(Mo,Ga,Ne)
Hibbardella	(Cd,Co,Co)	Hindia	(Po,De,Li)	Hirsutella	(Br,Ar,Sp)
Hibbardia	(Ar,Os,Pa)	Hindsiella	(Mo,Bi,Ve)	Hirsutocythere	(Ar,Os,Pa)
Hibbertia	(Ar,Tr,Pt)	Hinemoana	(Mo,Bi,Ve)	Hirsutodontus	(Cd,Co,Co)
Hibbertopteris	(Ar,Me,Eu)	Hinganastraea	(Cn,An,Ru)	Hirsutospirella	(Fo,Fo,Fo)
Hibernioceras	(Mo,Ce,Go)	Hingarella	(Br,Ar,St)	Hirtoscala	(Mo,Ga,Ne)
Hibernodonta	(Br,Ar,St)	Hinganotrypa	(Bz,St,Fe)	Hirudocidaris	(Ec,Ec,Ci)
Hibolites	(Mo,Ce,Be)	Hingganoleptaena	(Br,Ar,St)	Hirudopsis	(An,Po,Un)
Hicetes	(An,Po,Se)	Hinia	(Mo,Ga,Ne)	Hiscobecus	(Br,Ar,Rh)
Hicksia	(Ar,Tr,Re)	Hinnites	(Mo,Bi,Pt)	Hisingerella	(Br,Li,Ac)
Hidaella	(Fo,Fo,Fo)	Hintzeia	(Ar,Tr,Ph)	Hispaniastraea	(Cn,An,Sc)
Hidascutellum	(Ar,Tr,Pt)	Hintzesnonaia	(Po,He,Un)	Hispanirhynchia	(Br,Ar,Rh)
Hidina	(Fo,Fo,Fo)	Hintzespongia	(Po,He,Re)	Hispanosinuities	(Mo,Ga,Be)
Hiemalora	(Cn,In,In)	Hintziella	(Ar,Os,Pa)	Hispidiaria	(Br,Ar,Sp)
Highgateella	(Ar,Tr,Pt)	Hippadenella	(Bz,Gy,Ch)	Hispidaspis	(Cd,Ch,La)
Higumastra	(Ac,Ra,Sp)	Hippalimus	(Po,De,Li)	Hispidocrinus	(Ec,Cr,Is)
Hijitrigonia	(Mo,Bi,Tr)	Hippaliosina	(Bz,Gy,Ch)	Hispidofusus	(Mo,Ga,Ne)
Hikelaster	(Ec,Ec,Sp)	Hipparionix	(Br,Ar,St)	Hispidopetra	(Po,De,Ha)
Hilarisirex	(Ac,Ra,Na)	Hipparionoceras	(Mo,Ce,On)	Histiastrium	(Ac,Ra,Sp)
Hilberia	(Mo,Bi,Pt)	Hippasteria	(Ec,As,Va)	Histina	(Ar,Os,Pa)
Hilda	(Mo,Ga,Ne)	Hipperechonella	(Bz,Gy,Ch)	Histiodyella	(Cd,Co,Co)
Hildaites	(Mo,Ce,Am)	Hippiopora	(Bz,Gy,Ch)	Histiomona	(Ar,Tr,Od)
Hildaphillipsia	(Ar,Tr,Pr)	Hippocampoides	(Mo,Ga,Ar)	Histionotophorus	(Cd,Os,Lo)
Hildebrandia	(Cd,Os,An)	Hippocampus	(Cd,Os,Ga)	Histionotus	(Cd,Os,Ma)
Hildoceras	(Mo,Ce,Am)	Hippocardia	(Mo,Ro,Co)	Histiothrisa	(Cd,Os,Cl)
Hildoceratoides	(Mo,Ce,Am)	Hippochaeta	(Mo,Bi,Pt)	Histocidaris	(Ec,Ec,Ci)
Hildoglochicerias	(Mo,Ce,Am)	Hippochrene	(Mo,Ga,Ne)	Histocrinus	(Ec,Cr,Cl)
Hilgardella	(Mo,Bi,Mt)	Hippocrepinia	(Fo,Fo,Fo)	Histopomphus	(Fo,Fo,Fo)
Hilgardia	(Mo,Bi,Na)	Hippocrepinella	(Fo,Fo,Fo)	Historbitoides	(Fo,Fo,Fo)
Hillaepora	(Cn,An,Ta)	Hippocystis	(Ec,Di,Di)	Histosyrinx	(Br,Ar,Sp)
Hillaxon	(Cn,An,Ru)	Hippodiplosia	(Bz,Gy,Ch)	Hithis	(Ar,Os,Pa)
Hillites	(Mo,Ga,Ne)	Hippoexechonella	(Bz,Gy,Ch)	Hiwia	(Mo,Ga,Ne)
Hillius	(Ar,MI,De)	Hippoglossoides	(Cd,Os,Pn)	Hlwiceras	(Mo,Ce,Am)
Hillmeria	(Ar,Os,Pa)	Hippolyrula	(Bz,Gy,Ch)	Hodsia	(Po,Ca,Ph)
Hillophyllum	(Cn,An,Ru)	Hippomenella	(Bz,Gy,Ch)	Hodsonites	(Mo,Ce,Go)
Hillyardina	(Ar,Tr,Pr)	Hippomonavella	(Bz,Gy,Ch)	Hoegisphaera	(Fo,Fo,Ch)
Hiltermannella	(Fo,Fo,Fo)	Hippomya	(Mo,Bi,Mo)	Hoeglundina	(Fo,Fo,Fo)
Hiltermannicythere	(Ar,Os,Pa)	Hipponicharion	(Ar,Os,Ar)	Hoekaspis	(Ar,Tr,As)
Hima	(Mo,Ga,Ne)	Hipponix	(Mo,Ga,Ne)	Hoeloceras	(Mo,Ce,Ac)
Himalairhynchia	(Br,Ar,Rh)	Hippopharangites	(Pr,Co,Sa)	Hoeninghausia	(Mo,Ce,An)
Himalayites	(Mo,Ce,Am)	Hippophylactella	(Bz,Gy,Ch)	Hoepnites	(Mo,Ce,Am)
Himalayosaurus	(Cd,Re,Je)	Hippoleurifera	(Bz,Gy,Ch)	Hoernesarca	(Mo,Bi,Ar)
Himantoceras	(Mo,Ce,Am)	Hippopodina	(Bz,Gy,Ch)	Hoernesia	(Mo,Bi,Pt)
Himantonia	(Mo,Ga,Ar)	Hippopodinaella	(Bz,Gy,Ch)	Hoernesella	(Mo,Bi,Pt)
Himatella	(Po,Ca,Ph)	Hippopodium	(Mo,Bi,Ve)	Hoeverella	(Bz,Gy,Ch)
Himathyris	(Br,Ar,Sp)	Hippoporella	(Bz,Gy,Ch)	Hoferia	(Mo,Bi,Ar)
Himavatites	(Mo,Ce,Ce)	Hippoporidra	(Bz,Gy,Ch)	Hoffetella	(Ar,Tr,Cr)

Hoffmannia	(Mo,Ce,Go)	Holocüsdöiö	(Cn,An,Sc)	Homoceratoides	(Mo,Ce,Go)
Hofkerina	(Fo,Fo,Fo)	Holodictyon	(Po,De,Li)	Homocrinus	(Ec,Cr,Ds)
Hofkeruva	(Fo,Fo,Fo)	Holodipterus	(Cd,Os,Di)	Homocrenowakia	(Mo,Cr,Da)
Hogmochilina	(Ar,Os,Le)	Holoeciscus	(Ac,Ra,Sp)	Homocetus	(Mo,Cr,Ho)
Hokodon	(Cd,Os,Al)	Holograptus	(He,Gr,Gr)	Homocystites	(Ec,Rh,Rh)
Hokouia	(Mo,Bi,Pt)	Hologyra	(Mo,Ga,Ar)	Homocythere	(Ar,Os,Po)
Holacanthopora	(Cn,An,Ta)	Holonema	(Cd,Pl,Ar)	Homodictya	(Ar,Tr,Pt)
Holasaphus	(Ar,Tr,Pt)	Holopea	(Mo,Ga,Eu)	Homoeaster	(Ec,Ec,Sp)
Holaster	(Ec,Ec,Hs)	Holophagus	(Cd,Os,Co)	Homoeoparonaella	(Ac,Ra,Sp)
Holasterella	(Po,He,Re)	Holophragma	(Cn,An,Ru)	Homoeopetalus	(Ec,Ec,Sp)
Holacephalus	(Ar,Tr,Pt)	Holoporella	(Bz,Gy,Ch)	Homoeoplanulites	(Mo,Ce,Am)
Holcobelus	(Mo,Ce,Be)	Holopterygius	(Cd,Os,Ta)	Homoeosolen	(Bz,St,Cc)
Holcocarcinus	(Ar,MI,De)	Holoptychus	(Cd,Os,Co)	Homoeospira	(Br,Ar,Sp)
Holcocrinus	(Ec,Cr,Cy)	Holopus	(Ec,Cr,Cy)	Homoeospirella	(Br,Ar,Sp)
Holcodiscoides	(Mo,Ce,Am)	Holoretiolites	(He,Gr,Gr)	Homoiranognathus	(Cd,Co,Co)
Holcodiscus	(Mo,Ce,Am)	Holorhynchus	(Br,Ar,Pe)	Homolodromia	(Ar,MI,De)
Holcolissoceras	(Mo,Ce,Ph)	Holosalenia	(Ec,Ec,Sa)	Homolopsis	(Ar,MI,De)
Holcolytoceras	(Mo,Ce,Am)	Holosia	(Br,Ar,Rh)	Homomyia	(Mo,Bi,Ph)
Holconautilus	(Mo,Ce,Na)	Holostegopora	(Bz,Gy,Ch)	Homonotichthys	(Cd,Os,Po)
Holcophylloceras	(Mo,Ce,Ph)	Holosteus	(Cd,Os,Al)	Homophyllia	(Cn,An,Sc)
Holcopneustes	(Ec,Ec,Sp)	Holothuropsis	(Ec,Ho,As)	Homorhynchus	(Cd,Os,In)
Holcopocythere	(Ar,Os,Po)	Holotrachelus	(Ar,Tr,Pr)	Homotelus	(Ar,Tr,As)
Holcoptychites	(Mo,Ce,Am)	Holotricharina	(Br,Ar,St)	Homotrema	(Fo,Fo,Fo)
Holcorhynchella	(Br,Ar,Rh)	Holtedahlna	(Br,Ar,St)	Homotreta	(Br,LI,Ac)
Holcorhynchia	(Br,Ar,Rh)	Holtedahllites	(Ar,Os,Le)	Homotrypa	(Bz,St,Tr)
Holcospirifer	(Br,Ar,Sp)	Holteria	(Ar,Tr,Co)	Homotrypella	(Bz,St,Tr)
Holcospongia	(Po,Ca,Ph)	Holubaspis	(Ar,Tr,Pt)	Homoyeya	(Mo,Bi,Pt)
Holcothyris	(Br,Ar,Te)	Holynatrypa	(Br,Ar,At)	Honggulosma	(Cn,An,Ru)
Holcotrochus	(Cn,An,Sc)	Holynetes	(Br,Ar,St)	Hontorialesia	(Br,Ar,St)
Holdenia	(Ar,Tr,Pt)	Holynocrinus	(Ec,Cr,Ds)	Hopkinsiana	(Mo,Ga,Nt)
Holdenius	(Cd,Pl,Ar)	Holyoakia	(Ar,Tr,Re)	Hopkinsina	(Fo,Fo,Fo)
Holcetypus	(Ec,Ec,Ho)	Holzapfelia	(Mo,Ga,Ne)	Hopkinsinella	(Fo,Fo,Fo)
Holia	(Ar,Tr,Ph)	Holzapfeloceras	(Mo,Ce,An)	Hoplichthys	(Cd,Os,Sc)
Holkieria	(Fo,Fo,Fo)	Holzbergia	(Mo,Ce,Am)	Hoplikasmokas	(Mo,Ce,Am)
Hollandina	(Fo,Fo,Fo)	Homacanthus	(Cd,Ac,Un)	Hoplitaechnella	(Bz,Gy,Ch)
Hollandites	(Mo,Ce,Ce)	Homagnostoides	(Ar,Tr,Ag)	Hoplites	(Mo,Ce,Am)
Hollandia	(Ar,Tr,Pr)	Homagnostus	(Ar,Tr,Ag)	Hoplitoides	(Mo,Ce,Am)
Hollandiella	(Br,Ar,Or)	Homalophrynchida	(Br,Ar,Rh)	Hoplitoplacenticeras	(Mo,Ce,Am)
Hollandina	(Br,Ar,St)	Homalina	(Mo,Bi,Ve)	Hoplobrotula	(Cd,Os,Op)
Hollandosteus	(Cd,Pl,Ar)	Homaloceras	(Mo,Ce,Na)	Hoplocardioceras	(Mo,Ce,Am)
Hollina	(Ar,Os,Pa)	Homalocrinus	(Ec,Cr,Sa)	Hoplocetus	(Cd,Ma,Ce)
Hollinella	(Ar,Os,Pa)	Homalodora	(Po,De,LI)	Hoplocheilina	(Bz,Gy,Ch)
Holmanella	(Fo,Fo,Fo)	Homalohedra	(Fo,Fo,Fo)	Hoplocrinus	(Ec,Cr,Hy)
Holmdalia	(Ar,Tr,Pt)	Homalonotus	(Ar,Tr,Ph)	Hoplocrioceras	(Mo,Ce,Am)
Holmesella	(Cd,Ch,Ct)	Homalophyllites	(Cn,An,Ru)	Hoplodus	(Cd,Ch,Pe)
Holmia	(Ar,Tr,Ol)	Homalophyllum	(Cn,An,Ru)	Hoplolichas	(Ar,Tr,LI)
Holmiceras	(Mo,Ce,Ta)	Homalopoma	(Mo,Ga,Ar)	Hoploparia	(Ar,MI,De)
Holmicrusta	(He,Gr,Cr)	Homalopteon	(Ar,Tr,As)	Hoplopteryx	(Cd,Os,Br)
Holmiella	(Ar,Tr,Ol)	Homalopyge	(Ar,Tr,As)	Hoploscaphtes	(Mo,Ce,Am)
Holmintholepsis	(Cd,Os,Cr)	Homalostega	(Bz,Gy,Ch)	Hoplostethus	(Cd,Os,Br)
Holmipterus	(Ar,Me,Eu)	Homaloteuthis	(Mo,Ce,Be)	Hoplotropites	(Mo,Ce,Ce)
Holmitheca	(Hy,Or,Ex)	Homaphrodites	(An,Po,Ph)	Hoplunnis	(Cd,Os,An)
Holmograptus	(He,Gr,Gr)	Homarus	(Ar,MI,De)	Hoplochthoides	(Ar,Tr,LI)
Holmogphyllum	(Cn,An,Ru)	Homaspidella	(Cd,Pl,Pt)	Hopora	(Bz,Gy,Ch)
Holocentrites	(Cd,Os,Br)	Homelys	(Ar,MI,De)	Hordeleyella	(Br,Ar,Or)
Holocentrus	(Cd,Os,Br)	Homcoarcticorys	(Ac,Ra,Na)	Hordeulima	(Mo,Ga,Nt)
Holococephalina	(Ar,Tr,Pt)	Homeocardiorhynchus	(Br,Ar,Rh)	Horioceras	(Mo,Ce,Am)
Holocodus	(Cd,Re,Sp)	Homeoceratopsis	(Ar,Os,Pa)	Horiopleura	(Mo,Bi,Hi)
Holocoelia	(Po,Ca,Ph)	Homeokiesowia	(Ar,Os,Pa)	Horiostomella	(Mo,Ga,Ar)
Holoconularia	(Cn,Sc,Cn)	Homeorhynchia	(Br,Ar,Rh)	Horizostoma	(Mo,Ga,Nt)
Holocrinus	(Ec,Cr,Is)	Homerites	(Mo,Ce,Ce)	Hormathospongia	(Po,He,He)
Holocryptocapsa	(Ac,Ra,Na)	Homevalaria	(Br,Ar,Sp)	Hornerella	(Bz,Gy,Ch)
Holocryptocanium	(Ac,Ra,Na)	Homoadelphoceras	(Mo,Ce,Na)	Hormocrinus	(Ec,Cr,Sa)
Holocystites	(Ec,Di,Di)	Homoceras	(Mo,Ce,Go)	Hormograptus	(He,Gr,Cr)

Hormomya	(Mo,Bi,Mt)	Huantraiconella	(Ar,Os,Po)	Huniella	(Ec,Ho,De)
Hormosina	(Fo,Fo,Fo)	Huasha	(Ac,Ra,Sp)	Hunkydora	(Mo,Bi,Ph)
Hormosinella	(Fo,Fo,Fo)	Huatangia	(Br,Ar,St)	Hunnanocephalus	(Ar,Tr,Co)
Hormospongia	(Po,De,Pe)	Huayunophyllum	(Cn,An,Ru)	Hunnebergia	(Ar,Tr,As)
Hormotoma	(Mo,Ga,Ar)	Hubeiella	(Fo,Fo,Fo)	Hunnegraptus	(He,Gr,De)
Hormotomina	(Mo,Ga,Ar)	Hubeinella	(Mo,In,In)	Hunosaurus	(Cd,Re,Ps)
Hornera	(Bz,St,Cc)	Hubeipora	(Bz,St,Tr)	Hunsrueckaster	(Ec,As,Pu)
Hornbrookella	(Ar,Os,Po)	Hubeiproductus	(Br,Ar,St)	Huntonella	(Ar,Os,Pa)
Hornsundia	(Cn,An,Ru)	Hubeispira	(Mo,In,In)	Huntonia	(Ar,Tr,Ph)
Horologium	(Mo,Ga,Ar)	Hubertoceras	(Mo,Ce,Am)	Hunyuenoceras	(Mo,Ce,El)
Horridonia	(Br,Ar,St)	Hubertschenekia	(Mo,Bi,Ve)	Hupea	(Ec,Ec,Cl)
Horrieciella	(Ar,Os,Po)	Hucho	(Cd,Os,Sa)	Hupecyathellus	(Po,Re,Aj)
Hosieocrinus	(Ec,Cr,Cl)	Huckea	(Ar,Os,Pa)	Hupecyathus	(Po,Re,Ta)
Hoskingia	(Br,Ar,Te)	Huddlella	(Cd,Co,Co)	Hupehella	(Ar,Os,Un)
Hospes	(Ar,Tr,Pt)	Hudlestonella	(Mo,Ga,Nt)	Hupehsuchus	(Cd,Re,No)
Hospitiella	(Fo,Fo,Fo)	Hudlestonia	(Mo,Ce,Am)	Hupeia	(Ar,Tr,Pt)
Hostimex	(Br,Ar,Rh)	Hudsonaster	(Ec,As,Pu)	Hupeidiscus	(Ar,Tr,Ag)
Hottingerella	(Fo,Fo,Fo)	Hudsonella	(Po,De,AX)	Hupeolenus	(Ar,Tr,Re)
Hottingeria	(Fo,Fo,Fo)	Hudsonelpidia	(Cd,Re,lc)	Hurdia	(Pr,Di,Ra)
Hottingerita	(Fo,Fo,Fo)	Hudsonoceras	(Mo,Ce,Go)	Huronia	(Mo,Ce,Ac)
Houdasia	(Mo,Ga,Ar)	Hudsonospongia	(Mo,De,Li)	Huronella	(Mo,Ce,Ac)
Houershanophyllum	(Cn,An,Ru)	Huenichthys	(Cd,Ch,In)	Huso	(Cd,Os,Ac)
Houiblastus	(Ec,BI,Sp)	Huenella	(Br,Ar,Pe)	Hussakofia	(Cd,Pl,Ar)
Houlongdongella	(Ar,Os,Ar)	Huenellina	(Br,Ar,Pe)	Hustedia	(Br,Ar,Sp)
Houmengia	(Ar,Tr,Pt)	Hughmilleria	(Ar,Me,Eu)	Hustedograptus	(He,Gr,Gr)
Hourecquia	(Mo,Ce,Am)	Huhatanka	(Ar,MI,De)	Hustedtiella	(Br,Ar,St)
Hourqia	(Ar,Os,Po)	Huiihecercina	(Mo,Ce,El)	Hutsonia	(Ar,Os,Po)
Houscolex	(An,Pa,Pa)	Huishca	(Pr,Un,In)	Huttonechinus	(Ec,Ec,Hs)
Housia	(Ar,Tr,As)	Huishuites	(Mo,Ce,Ce)	Huttoniella	(Ar,Os,Pa)
Houzeauia	(Mo,Ga,Ne)	Huizenodus	(Pr,Un,In)	Huxleyia	(Mo,Bi,So)
Houzeauina	(Bz,Gy,Ch)	Hujiagouella	(Mo,In,In)	Huyella	(Mo,Bi,Pt)
Howchinella	(Fo,Fo,Fo)	Hukasawia	(Ar,Tr,As)	Hwaania	(Mo,Ga,Nt)
Howchinia	(Fo,Fo,Fo)	Hulenites	(Mo,Ce,Am)	Hyalia	(Mo,Ga,Nt)
Howeina	(Ar,Os,Po)	Huletta	(Cd,Os,Pa)	Hyalina	(Mo,Ga,Ne)
Howellella	(Br,Ar,Sp)	Hulingsina	(Ar,Os,Po)	Hyalinea	(Fo,Fo,Fo)
Howellites	(Br,Ar,Or)	Hulterstadia	(Br,Ar,Or)	Hyalinonetrium	(Fo,Fo,Fo)
Howellitubus	(An,Po,Se)	Humaella	(Br,Ar,Or)	Hyalocrinus	(Ec,Cr,Rv)
Howelloidea	(Br,Ar,Sp)	Humboldtchaeta	(Pr,Un,In)	Hyalocyclus	(Mo,Bi,Th)
Howelluella	(Ar,Tr,Un)	Humeia	(Ar,Tr,Pr)	Hyaloderma	(Po,De,Li)
Howittia	(Br,Ar,Sp)	Humeceras	(Mo,Ce,En)	Hyalonemia	(Po,He,Am)
Howseia	(Br,Ar,St)	Humilaria	(Mo,Bi,Ve)	Hyalopecten	(Mo,Bi,Pt)
Hoyacrinus	(Ec,Cr,Cy)	Humilichthys	(Cd,Os,Ct)	Hyalorisia	(Mo,Ga,Nt)
Hoyenella	(Fo,Fo,Fo)	Humiliworthenia	(Mo,Ga,Ar)	Hyaloscala	(Mo,Ga,Nt)
Hoyoceras	(Mo,Ce,En)	Humilogriifithides	(Ar,Tr,Pr)	Hyalospongia	(Po,De,Li)
Hozmadia	(Ac,Ra,Na)	Hunanela	(Mo,Bi,Ve)	Hyalostelia	(Po,Ca,He)
Hsuaspis	(Ar,Tr,Pt)	Hunamites	(Mo,Ce,Go)	Hyalotrochus	(Bz,St,Fe)
Hsuehuangia	(Ar,Tr,Pt)	Hunanoceras	(Mo,Ce,Na)	Hyalotragos	(Po,De,Li)
Hsuum	(Ac,Ra,Na)	Hunanochonetes	(Br,Ar,St)	Hyas	(Ar,MI,De)
Huaibeia	(Ar,Tr,Pt)	Hunanopecten	(Mo,Bi,Pt)	Hyastenus	(Ar,MI,De)
Huaihecercas	(Mo,Ce,El)	Hunanophrentis	(Cn,An,Ru)	Hyatechinus	(Ec,Ec,Ep)
Huainanella	(Pr,Cr,Cr)	Hunanopora	(Bz,St,Tr)	Hyattidina	(Br,Ar,Sp)
Huainania	(Ar,Tr,Pt)	Hunanoproductus	(Br,Ar,St)	Hyattites	(Mo,Ce,Ce)
Huaiyuanelia	(Pr,Un,Pa)	Hunanopyge	(Ar,Tr,Pt)	Hyattoceras	(Mo,Ce,Go)
Huamiocephalus	(Ar,Tr,Un)	Huanospongia	(Po,He,Un)	Hyboaspis	(Ar,Tr,Co)
Huananaxonia	(Cn,An,Ru)	Hundwarella	(Ar,Tr,Pt)	Hybochelus	(Mo,Ga,Ar)
Huanghuachangoceras	(Mo,Ce,Di)	Hungaiia	(Ar,Tr,As)	Hybocladodus	(Cd,Ch,Ct)
Huanghuacella	(Ar,Os,Un)	Hungarella	(Ar,Os,Me)	Hyboclypus	(Ec,Ec,Ds)
Huangia	(Cn,An,Ru)	Hungariella	(Mo,Ga,Ar)	Hybocrinus	(Ec,Cr,Hy)
Huanglingella	(Mo,In,In)	Hungarispira	(Br,Ar,Sp)	Hybocystites	(Ec,Cr,Hy)
Huanglongophyllum	(Cn,An,Ru)	Hungarites	(Mo,Ce,Ce)	Hybodus	(Cd,Ch,Ct)
Huangophyllum	(Cn,An,Ru)	Hungaritheca	(Br,Ar,Th)	Hybolophus	(Mo,Bi,Ve)
Huangshandongia	(Ar,Un,Un)	Hungarogeisina	(Ar,Os,Pa)	Hybonotoceras	(Mo,Ce,Am)
Huangshandongoconus	(Mo,In,In)	Hungioides	(Ar,Tr,As)	Hyborhynchella	(Br,Ar,Rh)
Huanoproetus	(Ar,Tr,Pr)	Hungkiichthys	(Cd,Os,Pc)	Hybostenoscisma	(Br,Ar,Rh)

Hydatina	(Mo,Ga,Ce)	Hypermecaspis	(Ar,Tr,Pt)	Hyrokybe	(Ar,Tr,Ph)
Hyderia	(Fo,Fo,Fo)	Hyperobolus	(Ec,Bi,Sp)	Hyrsinobolbina	(Ar,Os,Pa)
Hydnoangulus	(Po,He,LS)	Hyperobolus	(Br,LI,LI)	Hyrtanacrinus	(Ec,Cr,Mo)
Hydnoceras	(Po,He,Re)	Hyperoglyphe	(Cd,Os,Pr)	Hysteraerinus	(Ec,Ec,Sp)
Hydnocerina	(Po,He,Re)	Hyperoparia	(Ar,Tr,Pt)	Hysterocheras	(Mo,Ce,Am)
Hydnodictya	(Po,He,Re)	Hyperoplus	(Cd,Os,Pr)	Hysteroconcha	(Mo,Bi,Ve)
Hydnophora	(Cn,An,Sc)	Hyperprosopon	(Cd,Os,Pr)	Hysterohowellella	(Br,Ar,Sp)
Hydnophorabacia	(Cn,An,Sc)	Hyperstrophema	(Mo,Pa,Hy)	Hysterolenus	(Ar,Tr,As)
Hydnophoracæ	(Cn,An,Sc)	Hyphantoceras	(Mo,Ce,Am)	Hysterolites	(Br,Ar,Sp)
Hydnophoromeandratea	(Cn,An,Sc)	Hyphantosoma	(Mo,Bi,Ve)	Hystriochoprydrax	(Ec,Ed,Is)
Hydnophorozeris	(Cn,An,Sc)	Hyphantozya	(Mo,Ga,Nt)	Hystriocla	(An,Po,Ph)
Hydnophyllia	(Cn,An,Sc)	Hyphasmaphora	(Ar,Os,Me)	Hystrioceras	(Mo,Ga,Eu)
Hydnophyllon	(Cn,An,Sc)	Hyphasmopora	(Bz,St,Cr)	Hystriococythere	(Ar,Os,Po)
Hydnoseris	(Cn,An,Sc)	Hypholites	(Mo,Ce,Am)	Hystriocopora	(Bz,Gy,Ch)
Hydractinia	(Cn,Hy,Hy)	Hypisculites	(Mo,Ce,Ce)	Hystrioculina	(Br,Ar,St)
Hydrallmania	(Cn,Hy,Hy)	Hypocassis	(Mo,Ga,Nt)	Hystriocurus	(Ar,Tr,Pr)
Hydralimosaurus	(Cd,Re,Ps)	Hypocladiscites	(Mo,Ce,Ce)	Hystriogaster	(Ec,As,He)
Hydrania	(Fo,Fo,Fo)	Hypocrinus	(Ec,Cr,Cl)	Hystrioyasterias	(Ec,As,Fo)
Hydreionocrinus	(Ec,Cr,Cl)	Hypodema	(Mo,Ga,Ar)	laera	(Mo,Bi,Ve)
Hydriocrinus	(Ec,Cr,Cl)	Hypodiadema	(Ec,Ec,Hmi)	Ianthinopsis	(Mo,Ga,Nt)
Hydriodictya	(Po,He,Re)	Hypodicranotus	(Ar,Tr,Ph)	Iapetognathus	(Cd,Co,Co)
Hydroconus	(Cn,He,He)	Hypoleiorhynchus	(Br,Ar,Rh)	latella	(Ar,Os,Po)
Hydrocaspodota	(Cn,Hy,Tr)	Hypolinoproductus	(Br,Ar,St)	Ibanocrinus	(Ec,Cr,Mo)
Hydrodamalis	(Cd,Ma,Si)	Hypolophites	(Cd,Ch,My)	Iberihomola	(Ar,MI,De)
Hydroides	(An,Po,Se)	Hypolophodon	(Cd,Ch,My)	Iberirhynchia	(Br,Ar,Rh)
Hydropesum	(Cd,Os,Pe)	Hypomesus	(Cd,Os,Os)	Iberites	(Mo,Ce,Ce)
Hydroprocrinus	(Ec,Cr,Cl)	Hypomphalocirrus	(Mo,Pa,Hy)	Iberitryris	(Br,Ar,Te)
Hydrotherosaurus	(Cd,Re,Ps)	Hyponeatrypa	(Br,Ar,At)	Iberocrinus	(Ec,Cr,Mo)
Hydrotribulus	(Mo,Ga,Ne)	Hypophylloceras	(Mo,Ce,Ph)	Iberolepis	(Cd,Ch,Cl)
Hygophum	(Cd,Os,My)	Hypopriion	(Cd,Ch,Ca)	Iberomeia	(Br,Ar,St)
Hylkelyphillum	(Cn,An,Sc)	Hypopsia	(Br,Ar,St)	Ibexaspis	(Ar,Tr,Ph)
Hylaeobatis	(Cd,Ch,Cl)	Hypopygurus	(Ec,Ec,Ca)	Ibexocrinus	(Ec,Cr,Ds)
Hylodecrinus	(Ec,Cr,Cl)	Hyporhamphus	(Cd,Os,Be)	Ibotrogia	(Mo,Bi,Tr)
Hymedesmia	(Po,De,Po)	Hyporosopora	(Bz,St,Ce)	Ibukiphylum	(Cn,An,Ru)
Hymenactura	(Ac,Ra,Sp)	Hyposalenia	(Ec,Ec,Sa)	Icanodus	(Cd,Ch,In)
Hymeniastrum	(Ac,Ra,Sp)	Hyposaurus	(Cd,Re,Cr)	Icanotia	(Mo,Bi,Ve)
Hymenocaris	(Ar,MI,Hy)	Hypotetragona	(Ar,Os,Pa)	Icaunhelia	(Cn,An,Sc)
Hymenoccephalus	(Cd,Os,Hy)	Hypothetica	(Ar,Tr,Pt)	Icelinus	(Cd,Os,Sc)
Hynniphoria	(Br,Ar,Te)	Hypothyra	(Po,De,LI)	Ichangia	(Ar,Tr,Ph)
Hyolithellus	(Pr,Un,Hy)	Hypothyridina	(Br,Ar,Rh)	Ichiyamella	(Ar,Tr,Ph)
Hyolithes	(Hy,Hy,Hy)	Hypotodus	(Cd,Ch,La)	Ichnopora	(Bz,Gy,Ch)
Hyostragulum	(Cn,An,Ta)	Hypotrema	(Mo,Bi,Pt)	Ichnospongia	(Po,De,Un)
Hytotissa	(Mo,Bi,Pt)	Hypotrichina	(Ci,Po,Sp)	Ichnusocyathus	(Po,Re,Aj)
Hypacanthoplites	(Mo,Ce,Am)	Hypoturrillites	(Mo,Ce,Am)	Ichthyoceras	(Cd,Os,Py)
Hypacanthus	(Cd,Os,Pr)	Hypoxynoticeras	(Mo,Ce,Am)	Ichthyococcus	(Cd,Os,St)
Hypagnostus	(Ar,Tr,Ag)	Hypoxytoma	(Mo,Bi,Pt)	Ichthyodectes	(Cd,Os,Ce)
Hypanis	(Mo,Bi,Ve)	Hypselenotoma	(Mo,Ga,Ar)	Ichthyokentema	(Cd,Os,Pe)
Hypaprotus	(Ar,Tr,Pr)	Hypselenotus	(Mo,Te,Hy)	Ichthyolaria	(Fo,Fo,Fo)
Hyparpadites	(Mo,Ce,Ce)	Hypselocrinus	(Ec,Cr,Cl)	Ichthyoletes	(Cd,Ma,Ce)
Hyphechinus	(Ec,Ec,Ec)	Hypselonetes	(Br,Ar,St)	Ichthyorachis	(Bz,St,Fe)
Hypelasma	(Mo,Bi,Hi)	Hypseloterorhynchus	(Br,Ar,Rh)	Ichthyornis	(Cd,Av,lc)
Hypenonoceras	(Mo,Ce,Am)	Hypselclavus	(Ec,Ed,Is)	Ichthyosarcolites	(Mo,Bi,Hi)
Hyperacanthus	(Mo,Ga,Ar)	Hypsipleura	(Mo,Ga,Nt)	Ichthyosaurus	(Cd,Re,lc)
Hyperagnostus	(Ar,Tr,Ag)	Hypsitycha	(Br,Ar,Rh)	Ichthyotringa	(Cd,Os,Al)
Hyperamma	(Fo,Fo,Fo)	Hypsobatis	(Cd,Ch,Rj)	Ieriocarinus	(Ar,MI,De)
Hyperamminita	(Fo,Fo,Fo)	Hypsocormus	(Cd,Os,Pr)	Ieriodella	(Cd,Co,Co)
Hyperamminoidea	(Fo,Fo,Fo)	Hypsocrinus	(Ec,Cr,Ds)	Ieriodus	(Cd,Co,Co)
Hyperbathoides	(Fo,Fo,Fo)	Hypsomyonia	(Br,Ar,Or)	Ierioma	(Ac,Ra,Sp)
Hyperbolochilus	(Ar,Tr,Pt)	Hypsopatagus	(Ec,Ec,Sp)	Ieriospathodus	(Cd,Co,Co)
Hyperchilarina	(Ar,Os,Pa)	Hypsopygaster	(Ec,Ec,Ca)	Iethyocrinus	(Ec,Cr,Sa)
Hyperderoceras	(Mo,Ce,Am)	Hypterita	(Mo,Ga,Nt)	Iethyriaprus	(Cd,Ch,Cm)
Hypergonia	(Mo,Ga,Ar)	Hypthiotheca	(Hy,Hy,Hy)	Idaemocrinus	(Ec,Cr,Cl)
Hypergoniatites	(Mo,Ce,Go)	Hypthyocyathus	(Po,Re,Aj)	Idahoia	(Ar,Tr,As)
Hyperioceras	(Mo,Ce,Am)	Hyrcaenites	(Mo,Ce,Ce)	Idalina	(Fo,Fo,Fo)

Idamea	(Ar,Tr,Co)	Ilella	(Br,Ar,Sp)	Inanibigutta	(Ac,Ra,Sp)
Idasola	(Mo,Bi,Mt)	Ilioichione	(Mo,Bi,Ve)	Inanigutta	(Ac,Ra,Sp)
Iddingsia	(Ar,Tr,Pt)	Ilisha	(Cd,Os,Cl)	Inanihella	(Ac,Ra,Sp)
Idiocetus	(Cd,Ma,Ce)	Ilijinella	(Mo,Ga,Nt)	Inaria	(Cn,In,In)
Idiocidarid	(Ec,Ec,Sa)	Ilijinicyathus	(Po,Re,Aj)	Inauris	(Fo,Fo,Fo)
Idioelema	(Bz,St,Tr)	Illaenoides	(Ar,Tr,Co)	Incardium	(Mo,Bi,Ve)
Idiocycloceras	(Mo,Ce,Am)	Illaenopsis	(Ar,Tr,As)	Incaetus	(Cd,Ma,Ce)
Idiocythere	(Ar,Os,Po)	Illaenula	(Ar,Tr,Po)	Incaia	(Ar,Tr,As)
Idiodictyon	(Po,He,Un)	Illaenurus	(Ar,Tr,Co)	Incanopsis	(Mo,Bi,Ar)
Idioglyptus	(Br,Ar,St)	Illaenus	(Ar,Tr,Co)	Incilaster	(Mo,Ga,Ar)
Idiognathodus	(Cd,Co,Co)	Illativella	(Ar,Os,Pa)	Incisilabium	(Mo,Ga,Ar)
Idiognathoides	(Cd,Co,Co)	Illemnocrinus	(Ec,Cr,Cl)	Incisius	(Br,Ar,St)
Idiohamites	(Mo,Ce,Am)	Illesca	(Mo,Bi,Ve)	Incisopyge	(Ar,Tr,As)
Idiomesus	(Ar,Tr,Pt)	Illigata	(Fo,Fo,Fo)	Incisoseutum	(Cd,Pl,Ar)
Idiophyllum	(Cn,An,Ru)	Illilepas	(Ar,Ci)	Incisurella	(Ar,Os,Me)
Idiophyseter	(Cd,Ma,Ce)	Illiniichthys	(Cd,Os,Pa)	Inclytoceras	(Mo,Ce,Ta)
Idiopriomodus	(Cd,Co,Co)	Illionia	(Mo,Bi,Ve)	Incongruellina	(Ar,Os,Po)
Idiorapha	(Ar,Tr,Pt)	Illusioliudida	(Ec,As,Ur)	Incorthis	(Br,Ar,Or)
Idioraphe	(Mo,Ga,Nt)	Illyanassa	(Mo,Ga,Ne)	Incurvocyathus	(Po,Re,Aj)
Idiorophus	(Cd,Ma,Ce)	Ilmarina	(Br,Ar,Or)	Independatrypa	(Br,Ar,At)
Idiorthis	(Br,Ar,Or)	Ilmenia	(Br,Ar,Sp)	Indiana	(Ar,Os,Ar)
Idiospira	(Br,Ar,At)	Ilmeniopsis	(Br,Ar,Sp)	Indianites	(Ar,Os,Ar)
Idiostroma	(Po,De,St)	Ilmenispina	(Br,Ar,Sp)	Indiaster	(Ec,As,Va)
Idiostrophia	(Br,Ar,Pe)	Ilmenoindivisia	(Ar,Os,Un)	Indigia	(Br,Ar,St)
Idiotrochus	(Cn,An,Sc)	Ilmocrinus	(Ec,Cr,Mo)	Indigirites	(Mo,Ce,Ce)
Idiotrypa	(Bz,St,Tr)	Ilmospirifer	(Br,Ar,Un)	Indigirophyllites	(Mo,Ce,Ph)
Idiotubus	(He,Gr,Tu)	Ilowaiskyia	(Mo,Ce,Am)	Indigophyllum	(Cn,An,Ru)
Idmidronea	(Bz,St,Ce)	Ilisanella	(Mo,In,In)	Indivisia	(Ar,Os,Po)
Idmonea	(Bz,St,Ce)	Ilyinella	(Br,Ar,Te)	Indoblastus	(Ec,Bi,Fi)
Idmonella	(Bz,St,Ce)	Ilymatogyra	(Mo,Bi,Pt)	Indocelites	(Mo,Ce,Ce)
Idmoneoides	(Bz,St,Ce)	Imacanthyrus	(Br,Ar,Sp)	Indocephalites	(Mo,Ce,Am)
Idoceras	(Mo,Ce,Am)	Imagotaria	(Cd,Ma,Ca)	Idoceras	(Mo,Ce,Am)
Idolagnostus	(Ar,Tr,Ag)	Imangidites	(Ar,Os,Pa)	Idocerithium	(Mo,Ga,Nt)
Idonearca	(Mo,Bi,Ar)	Imbrexia	(Br,Ar,Sp)	Idocoetus	(Cd,Ma,Ce)
Idosocrinus	(Ec,Cr,Cl)	Imbricaria	(Mo,Ga,Ne)	Idocerassatella	(Mo,Bi,Ve)
Idrissa	(Cd,Os,St)	Imbricatia	(Br,Ar,Pe)	Idocrinus	(Ec,Cr,Cl)
Igdabatis	(Cd,Ch,My)	Imbricatocoelia	(Po,De,Pe)	Idoculana	(Mo,Bi,Nu)
Iglesiaella	(Ar,Tr,Re)	Imbricatospira	(Br,Ar,At)	Indogrammatodon	(Mo,Bi,Ar)
Ignara	(Mo,Bi,Pt)	Imdentistella	(Br,Ar,At)	Idoculana	(Mo,Bi,Nu)
Ignoceras	(Mo,Ce,En)	Imerocetus	(Cd,Ma,Ce)	Indogrammatodon	(Mo,Bi,Ar)
Ignoproetus	(Ar,Tr,Pr)	Imerodelphis	(Cd,Ma,Ce)	Indojuvavites	(Mo,Ce,Ce)
Ignotifenestella	(Bz,St,Fe)	Imhoffius	(Cd,Os,Ph)	Indomya	(Mo,Bi,Ph)
Ignotogregatus	(Ar,Tr,Pt)	Imhotepia	(Ar,Os,Po)	Indonautilus	(Mo,Ce,Na)
Ignotrypa	(Bz,St,Fe)	Imitotocrinus	(Ec,Cr,Cl)	Indonectes	(Mo,Bi,Pt)
Igorella	(Mo,In,In)	Imitoceras	(Mo,Ce,Go)	Indonesites	(Mo,Ce,Ce)
Igorellina	(Mo,In,In)	Imlayiceras	(Mo,Ce,Am)	Indopecten	(Mo,Bi,Pt)
Igorina	(Fo,Fo,Fo)	Immanitas	(Mo,Bi,Hi)	Indophyllia	(Cn,An,Sc)
Igornella	(Cd,Os,Pa)	Immenovia	(Cn,An,Ru)	Indoplaeuna	(Mo,Bi,Pt)
Iheringiella	(Ec,Ec,Cl)	Immergentia	(Bz,Gy,Ct)	Indorhynchia	(Br,Ar,Rh)
Iheringinuclula	(Mo,Bi,Nu)	Immersothorax	(Ac,Ra,Na)	Indoscapites	(Mo,Ce,Am)
Iheringithyrus	(Br,Ar,Te)	Imocaris	(Ar,MI,De)	Indosiren	(Cd,Ma,Si)
Ihungia	(Mo,Ga,Nt)	Imocella	(Mo,Bi,Pt)	Indosmilia	(Cn,An,Sc)
Iiola	(Mo,Bi,Pr)	Imperatoria	(Po,Ca,Un)	Indospinectes	(Mo,Ce,Am)
Ikamuius	(Cd,Ch,Pr)	Impiacus	(Br,Ar,St)	Indospirifer	(Br,Ar,Sp)
Ikelarehmedes	(Bz,St,Fe)	Implexina	(Br,Ar,Sp)	Indota	(Ar,Os,Ar)
Ikella	(Br,Ar,Sp)	Implicatocyathus	(Ec,Pe,Co)	Indotrigonia	(Mo,Bi,Tr)
Ilanga	(Mo,Ga,Ar)	Implicophyllum	(Cn,An,Ru)	Indotrigonodon	(Cd,Os,Te)
Ilarionia	(Ec,Ec,Ca)	Imponodictyon	(Po,De,St)	Indovoluta	(Mo,Ga,Ne)
Ilariosmilina	(Cn,An,Sc)	Inachus	(Ar,MI,De)	inella	(Ar,Tr,Re)
Ilba	(Ar,Ci)	Inacynthella	(Po,Re,Aj)	Inessocyathellus	(Po,Re,Aj)
Ilidraites	(An,Po,Ph)	Inaequalina	(Fo,Fo,Fo)	Inessocyathus	(Po,Re,Aj)
Ilemoraspis	(Cd,Ce,Ce)	Inaequalis	(Br,Ar,Te)	Inefixiostella	(Po,De,Un)
Iledorthis	(Fo,Fo,Fo)	Inaequidens	(Mo,Bi,Nu)	Inflatia	(Br,Ar,St)
Iliia	(Ar,MI,De)	Inaigymnites	(Mo,Ce,Ce)	Inflaticornus	(Hy,Or,Or)

Inflatobolivinella	(Fo,Fo,Fo)	Intoceras	(Mo,Ce,Go)	Iredalina	(Mo,Ga,Ne)
Inflatomonotis	(Mo,Bi,Pt)	Intodesma	(Mo,Bi,Pt)	Iredalina	(Mo,Ga,Ne)
Infraclypeus	(Ec,Ec,Un)	Intormites	(Mo,Ce,Ce)	Irenechulus	(Ec,Ec,Te)
Infracoronia	(Mo,Ga,Ne)	Intranodites	(Mo,Ce,Am)	Irenita	(Fo,Fo,Fo)
Infalaster	(Ec,Ec,Hs)	Intrapora	(Bz,St,Cr)	Irenothyris	(Br,Ar,Te)
Infundibulipora	(Bz,St,Cc)	Intrasporoecolia	(Mo,De,Pe)	Irgisella	(Br,Ar,Rh)
Infundibulops	(Mo,Ga,Ar)	Intratubospongia	(Po,Ca,Ph)	Irhirea	(Br,Ar,Or)
Infurca	(Br,Ar,St)	Inversaria	(Bz,Gy,Ch)	Irianoceras	(Mo,Ce,El)
Ingentiolutus	(Po,De,Li)	Inversella	(Br,Ar,St)	Iridostrophia	(Br,Ar,St)
Inglefieldia	(Ar,Tr,Pt)	Inversithyris	(Br,Ar,Te)	Irifera	(Cd,Os,Pf)
Inglisella	(Mo,Ga,Ne)	Inversula	(Bz,Gy,Ch)	Irinaecyathus	(Po,Re,Aj)
Ingolitotheca	(Hy,Hy,Hy)	Inversoceras	(Mo,Ce,On)	Irinia	(Ar,Tr,Pt)
Ingria	(Br,Ar,St)	Invertina	(Br,Ar,At)	Irinites	(Mo,Ce,On)
Iniathyris	(Br,Ar,Sp)	Invertospira	(Mo,Pa,Hy)	Irinoceras	(Mo,Ce,Go)
Inichthys	(Cd,Os,Pa)	Invertrypa	(Br,Ar,At)	Ironella	(Cn,An,Sc)
Iniella	(Ar,Os,Pa)	Involuta	(Mo,Ga,Ne)	Irregulariaspis	(Cd,Pt,Pt)
Iniopera	(Cd,Ch,Ip)	Involutaria	(Fo,Fo,Fo)	Irregularina	(Fo,Fo,Fo)
Iniopsis	(Cd,Ma,Ce)	Involuticeras	(Mo,Ce,Am)	Irregularitopora	(Po,De,AX)
Iniopteryx	(Cd,Ch,Ip)	Involutina	(Fo,Fo,Fo)	Irridinites	(Cn,In)
Iniotoma	(Ar,Tr,Pt)	Involvina	(Fo,Fo,Fo)	Iru	(Br,Ar,Or)
Inioxyle	(Cd,Ch,Ip)	Inyocrinus	(Ec,Cr,Ds)	Irus	(Mo,Bi,Ve)
Iniproductus	(Br,Ar,St)	Inyoites	(Mo,Ce,Ce)	Irusella	(Mo,Bi,Ve)
Inisylthere	(Ar,Os,Pa)	Inzeroceras	(Mo,Ce,Go)	Irvingella	(Ar,Tr,Pt)
Inkrylovia	(Cn,Fe,Er)	Iocrinus	(Ec,Cr,Ds)	Irvingelloides	(Ar,Tr,Pt)
Innaechia	(Br,Ar,Rh)	Iodictyon	(Bz,Gy,Ch)	Isacia	(Cd,Os,Pf)
Innapora	(Cn,An,Ta)	Iohomia	(Ar,Tr,Pt)	Isahelinia	(Ar,Tr,As)
Innitagnostus	(Ar,Tr,Ag)	Iolaea	(Mo,Ga,He)	Isalau	(Ar,Tr,Ph)
Innuitella	(Br,Ar,Rh)	Ionicythere	(Ar,Os,Po)	Isanda	(Mo,Ga,Ar)
Inobolia	(Po,Ca,Ph)	Ionoscopus	(Cd,Os,Am)	Isarcicella	(Cd,Co,Co)
Inocaulis	(Cn,Hy,Hy)	Iophon	(Po,De,Pe)	Isaster	(Ec,Ec,Sp)
Inocentrus	(Cd,Os,Br)	Iorubaelia	(Ar,Os,Pe)	Isastraea	(Cn,An,Sc)
Inoceramus	(Mo,Bi,Pt)	Ioscion	(Cd,Os,Pf)	Isastrocoenia	(Cn,An,Sc)
Inoceramyia	(Mo,Bi,Pt)	Iothia	(Mo,Ga,Ar)	Isbergia	(Ar,Tr,Pr)
Inodia	(Po,De,Li)	Iotina	(Br,Ar,Rh)	Iscafius	(Mo,Ga,Ne)
Inoperna	(Mo,Bi,Mt)	Iotrigonia	(Mo,Bi,Tr)	Ischadia	(Po,De,Li)
Inopinatarcula	(Br,Ar,Te)	Iouea	(Po,De,Li)	Ischadium	(Mo,Bi,Mt)
Inordinatosphaera	(Fo,Fo,Fo)	Iowacystis	(Ec,Hs,So)	Ischnacanthus	(Cd,Ac,Is)
Inouyella	(Ar,Tr,As)	Iowanella	(Fo,Fo,Fo)	Ischnochiton	(Mo,Po,Ne)
Inouyia	(Ar,Tr,Pt)	Iowaphyllum	(Cn,An,Ru)	Ischnoptygma	(Mo,Ga,Nt)
Inouyina	(Ar,Tr,Co)	Iowarhynchus	(Br,Ar,Rh)	Ischyodus	(Cd,Ch,Cm)
Inouyops	(Ar,Tr,Pt)	Iowaspongia	(Po,He,Re)	Ischyrrhiza	(Cd,Ch,Rj)
Inoyellaspis	(Ar,Tr,Pt)	Iowatrypa	(Br,Ar,At)	Ischyrimia	(Mo,Ro,Ri)
Inquisitor	(Mo,Ga,Ne)	Iowoceras	(Mo,Ce,On)	Ischyrodonta	(Mo,Bi,Mo)
Insculptarenula	(Fo,Fo,Fo)	Ipherron	(Br,Ar,Rh)	Ischyrophyma	(Ar,Ti,Pr)
Insignia	(Bz,St,Cr)	Iphiaana	(Mo,Ga,He)	Ischyrotoma	(Ar,Tr,Pr)
Insignicornus	(Hy,Hy,Hy)	Iphiculus	(Ar,Mi,De)	Isculites	(Mo,Ce,Ce)
Insignitiinurostrum	(Br,Ar,Rh)	Iphigenia	(Mo,Bi,Ve)	Isculitoides	(Mo,Ce,Ce)
Insolentia	(Mo,Ga,Ne)	Ipmorella	(Bz,St,Cr)	Isechinus	(Ec,Ec,Ec)
Insolentithea	(Fo,Fo,Fo)	Ipsiphyllum	(Cn,An,Ru)	Iselica	(Mo,Ga,He)
Insoliphylum	(Cn,An,Ru)	Iquitosia	(An,Po,Se)	Iserosaurus	(Cd,Re,Ps)
Institella	(Br,Ar,St)	Iraidina	(Bz,St,Tr)	Isfarispira	(Mo,Ga,Eu)
Institifera	(Br,Ar,St)	Iranaspidion	(Ar,Tr,Pr)	Ishatherium	(Cd,Ma,Si)
Institina	(Br,Ar,St)	Iranaspis	(Ar,Tr,Co)	Ishigaconus	(Ac,Ra,Sp)
Insulicorypha	(An,Po,Un)	Iramiaster	(Ec,Ec,Hs)	Ishigaum	(Ac,Ra,Sp)
Insulipora	(Po,De,Li)	Irannella	(Ar,Tr,As)	Ishimia	(Br,Ar,Pe)
Integricardium	(Mo,Bi,Ve)	Iranoblastus	(Ec,Bl,Sp)	Ishmiella	(Ar,Os,Pa)
Intejoceras	(Mo,Ce,In)	Iranoceras	(Mo,Ce,Go)	Ishnula	(Mo,Ga,Ne)
Interalia	(Ar,Tr,Pt)	Iranognathus	(Cd,Co,Co)	Ishpella	(Ar,Tr,Un)
Intermediacrinus	(Ec,Cr,Cl)	Iranoleesia	(Ar,Tr,Pt)	Isis	(Cn,An,Go)
Interproetus	(Ar,Tr,Pr)	Iranophyllum	(Cn,An,Ru)	Isispongia	(Po,De,Li)
Intersmitia	(Cn,An,Sc)	Iraqia	(Fo,Fo,Fo)	Isistius	(Cd,Ch,Sq)
Intexodictyon	(Po,De,St)	Iraqiyythereis	(Ar,Os,Po)	Isitiacyathus	(Po,Re,Aj)
Intexodictyonella	(Po,De,St)	Iravadia	(Mo,Ga,Nt)	Isitiella	(Mo,In,In)
Intextum	(Po,He,He)	Irboskites	(Br,Ar,St)	Isitiithea	(Hy,Or,Or)

Isuminellina	(Br,Ar,Rh)	Issedonia	(Br,Li,Ac)	Jacksonarca	(Mo,Bi,Ar)
Isuminella	(Br,Ar,Rh)	Isselia	(Mo,Ga,Nt)	Jacksonaster	(Ec,Ec,C1)
Islandiella	(Fo,Fo,Fo)	Isselicrinus	(Ec,Cr,Is)	Jacobella	(Ar,Os,Po)
Islipia	(Mo,Ga,Ar)	Issolites	(Cn,An,Ta)	Jacobites	(Mo,Ce,Am)
Ismailia	(Fo,Fo,Fo)	Isteries	(Mo,Ce,Am)	Jacobulus	(Cd,Os,Am)
Ismenia	(Br,Ar,Te)	Istieus	(Cd,Os,An)	Jacquerhania	(Cd,Ch,My)
Ismidaster	(Ec,Ec,Hs)	Istiophorus	(Cd,Os,Pf)	Jacquesia	(Mo,Bi,Ph)
Ismidites	(Mo,Ce,Ce)	Istorinus	(Cd,Co,Co)	Jacquertia	(Ec,Ec,Ph)
Isoallagecrinus	(Ec,Cr,Ds)	Istreites	(Mo,Ce,Ce)	Jaculella	(Fo,Fo,Fo)
Isoarca	(Mo,Bi,Ar)	Istrilocolina	(Fo,Fo,Fo)	Jaculina	(Bz,Gy,Ch)
Isoabuntonia	(Ar,Os,Po)	Isumithyrus	(Br,Ar,Te)	Jacuticornus	(Hy,Hy,Hy)
Isoathyocypris	(Ar,Os,Po)	Isurichthys	(Cd,Os,Pf)	Jacutolithus	(Hy,Hy,Hy)
Isocardia	(Mo,Bi,Ve)	Iurulamma	(Cd,Ch,La)	Jadammina	(Fo,Fo,Fo)
Isocatilloerinus	(Ec,Cr,Ds)	Isurus	(Cd,Ch,La)	Jaekelcrinus	(Ec,Cr,Ds)
Isocetus	(Cd,Ma,Ce)	Isyrakopeltis	(Ar,Tr,As)	Jaekelocarpus	(Ec,St,Mi)
Isochilina	(Ar,Os,Le)	Italogeisina	(Ar,Os,Pa)	Jaekelocystis	(Ec,Rh,Rh)
Isochonetes	(Br,Ar,St)	Italoptygmatis	(Mo,Ga,He)	Jaekelometra	(Ec,Cr,Cm)
Isoclaves	(Pr,Ca,Ca)	Itararella	(Po,He,Am)	Jaekelopteris	(Ar,Me,Eu)
Isocolus	(Ar,Tr,As)	Iteacrinus	(Ec,Cr,C1)	Jaekelotodus	(Cd,Ch,La)
Isoerania	(Br,Li,Ac)	Ithacadietya	(Po,He,Re)	Jagatiella	(Ar,Os,Pa)
Isoerassina	(Mo,Bi,Ve)	Ithycephalus	(Ar,Tr,Co)	Jagolucina	(Mo,Bi,Ve)
Isoerinus	(Ec,Cr,Is)	Ithythythara	(Mo,Ga,Ne)	Jagonoma	(Mo,Bi,Ve)
Isoeyprina	(Mo,Bi,Ve)	Ithyektyphus	(Ar,Tr,Pt)	Jagorina	(Cd,Pl,Rh)
Isoeythereis	(Ar,Os,Po)	Itia	(Mo,Ga,Ne)	Jahnocrinus	(Ec,Cr,C1)
Isoedomella	(Mo,Bi,Ve)	Itieria	(Mo,Ga,He)	Jaisalmeria	(Br,Ar,Te)
Isoegnomon	(Mo,Bi,Pt)	Itomelania	(Mo,Ga,Nt)	Jakutella	(Br,Ar,St)
Isoegmophodon	(Cd,Ch,Ca)	Itruvia	(Mo,Ga,He)	Jakutiocbrea	(Tr,An)
Isogramma	(Br,Ar,Un)	Ityophorus	(Ar,Tr,As)	Jakutobobina	(Ar,Os,Pa)
Isograptus	(He,Gr,Gr)	Iulusina	(Fo,Fo,Fo)	Jakutocarinus	(Po,Re,Aj)
Isohabrocythere	(Ar,Os,Po)	Ivanopleura	(Ar,Tr,Od)	Jakutochonetes	(Br,Ar,St)
Isohomoceras	(Mo,Ce,Go)	Ivanothyris	(Br,Ar,Sp)	Jakutoproductus	(Br,Ar,St)
Isohoplites	(Mo,Ce,Am)	Ivanovaecrius	(Ec,Cr,Mo)	Jakutostrophia	(Br,Ar,St)
Isomicraster	(Ec,Ec,Sp)	Ivanovella	(Fo,Fo,Fo)	Jakutus	(Ar,Tr,Co)
Isonema	(Mo,Ga,Ar)	Ivanovia	(Cn,An,Ru)	Jamesella	(Br,Ar,Or)
Isoptalum	(Ec,Ec,Sp)	Ivanoviella	(Br,Ar,Rh)	Jamischewskyia	(Ar,Os,Un)
Isoptagma	(Br,Ar,St)	Ivanovipecten	(Mo,Bi,Pt)	Jamoytius	(Cd,Ce,An)
Isophyllastrea	(Cn,An,Sc)	Ivanovites	(Pr,Un,Hy)	Janacus	(Mo,Ga,Nt)
Isophyllia	(Cn,An,Sc)	Ivara	(Mo,Ga,He)	Janassa	(Cd,Ch,Pe)
Isoptneustes	(Ec,Ec,Sp)	Ivaria	(Ar,Os,Pa)	Janeia	(Mo,Bi,So)
Isopodites	(Ar,ML,Is)	Ivdelephyllum	(Cn,An,Ru)	Jansenschites	(Mo,Ce,Am)
Isoopoma	(Br,Ar,Rh)	Ivdelina	(Fo,Fo,Fo)	Jangudacyathus	(Po,Re,Aj)
Isofristis	(Mo,Bi,Ve)	Ivdelinella	(Br,Ar,Pe)	Jangudaspis	(Ar,Tr,Un)
Isoprusia	(Ar,Tr,Od)	Ivdelinia	(Br,Ar,Pe)	Jangzicerias	(Mo,Ce,Or)
Isoopsetta	(Cd,Os,Pn)	Iveria	(Ar,Tr,Un)	Janiiceps	(Br,Ar,Sp)
Isoraphinia	(Mo,De,Li)	Ivia	(Ar,Os,Le)	Janiomya	(Br,Ar,St)
Isoorophus	(Ec,Ed,Is)	Ividella	(Mo,Ga,He)	Janiopsis	(Mo,Ga,Ne)
Isoorophusella	(Ec,Ed,Is)	Ivoechiton	(Mo,Po,Pa)	Janischewskina	(Fo,Fo,Fo)
Isoorthis	(Br,Ar,Or)	Ivshinagnostus	(Ar,Tr,Ag)	Janita	(An,Po,Se)
Isoorthoceras	(Mo,Ce,Or)	Ivshinaspis	(Ar,Tr,Pt)	Janius	(Br,Ar,Sp)
Isospinatrypa	(Br,Ar,At)	Ivshinella	(Br,Un,Ob)	Janograptus	(He,Gr,Gr)
IsoSPIra	(Mo,Ga,Be)	Iwaispirifer	(Br,Ar,Sp)	Janopecten	(Mo,Bi,Pt)
Isoptancredia	(Mo,Bi,Ve)	Iwayaspis	(Ar,Tr,Un)	Janospira	(Mo,In,In)
Isoptoloides	(Ar,Tr,As)	Ixa	(Ar,ML,De)	Janschinnella	(Mo,Bi,My)
Isotelus	(Ar,Tr,As)	Ixacanthus	(Cd,Ma,Ce)	Janthina	(Mo,Ga,Nt)
Isoptomocrinus	(Ec,Cr,Ds)	Ixogyra	(Cn,An,Sc)	Janupecten	(Mo,Bi,Pt)
Isostrypa	(Bz,St,Cy)	Ixooides	(Ar,ML,De)	Janusella	(Ar,Os,Me)
Isovella	(Br,Ar,Pe)	Iyouella	(Ar,Tr,Ol)	Janxilitus	(Ar,Tr,Pt)
Isoxys	(Ar,Un,Un)	Izumia	(Mo,Bi,Ve)	Japanithyrus	(Br,Ar,Te)
Isphairamella	(Bz,St,Cy)	Izumiocardia	(Mo,Bi,Ve)	Japelion	(Mo,Ga,Ne)
Ispbararella	(Ar,Os,Pa)	Izuus	(Cd,Os,Pf)	Japhaniccyathus	(Po,Re,Aj)
Ispbarina	(Mo,Ga,Nt)	Jaanussonia	(Ar,Os,Pa)	Japonisaturnalis	(Ac,Ra,Sp)
Israelaria	(Br,Ar,Or)	Jaanussonites	(Br,Ar,Or)	Japonites	(Mo,Ce,Ce)
Issafenia	(Ar,Tr,Re)	Jablonskyia	(Po,De,Un)	Japonoconger	(Cd,Os,An)
Issafenella	(Ar,Tr,Re)	Jaccardiella	(Mo,Ga,He)	Jaregoceras	(Mo,Ce,Di)

Jarovathyris	(Br.Ar.Sp)	Jiia	(Ar.Tr.Pt)	Juanognathus	(Cd.Co.Co)
Jarvisella	(Fo.Fo.Fo)	Jilinia	(Br.Ar.Un)	Jubilea	(Ar.Tr.Un)
Jascottella	(Fo.Fo.Fo)	Jilimartinia	(Br.Ar.Sp)	Judabella	(Ar.Os.Pa)
Jasperia	(Ar.Tr.Li)	Jilinospirifer	(Br.Ar.Sp)	Judiella	(Ar.Tr.Un)
Jasperoceras	(Mo.Ce.Ta)	Jillua	(Cn.Hy.Un)	Juddicerias	(Mo.Ce.Am)
Jasus	(Ar.ML.De)	Jima	(Po.He.Ly)	Judeichthys	(Cd.Os.Go)
Jatella	(Ar.Os.Po)	Jimbacrinus	(Ec.Cr.Cl)	Judeoberyx	(Cd.Os.Br)
Jaton	(Mo.Ga.Ne)	Jimboiceras	(Mo.Ce.Am)	Judeocarites	(Mo.Ce.Ce)
Jauberticeras	(Mo.Ce.Am)	Jimbokranion	(Ar.Tr.Pr)	Judomia	(Ar.Tr.Ol)
Javanella	(Ar.Os.Po)	Jimenesinus	(Ec.Cr.Cl)	Judoniella	(Ar.Tr.Ol)
Javatus	(Ar.Os.Pa)	Jimenes	(Mo.Ce.Am)	Jugaleyathus	(Po.Ir.Ar)
Jawonya	(Po.Ca.He)	Jimpolilia	(Cd.Ch.In)	Juglandocrinus	(Ec.Rh.Rh)
Jaworskiella	(Mo.Bi.Tr)	Jincella	(Ar.Tr.Pt)	Jugosocythereis	(Ar.Os.Po)
Javea	(Ar.ML.De)	Jingguella	(Ar.Os.Po)	Jujubinus	(Mo.Ga.Ar)
Jaycea	(Pr.To.Un)	Jinonicella	(Mo.In.In)	Jujuyaspis	(Ar.Tr.Pt)
Jeanlouiseella	(Ar.Os.Pa)	Jintingophyllum	(Cn.An.Ru)	Julia	(Mo.Ga.Sa)
Jeannetia	(Ec.Ec.Ph)	Jipaolasma	(Cn.An.Ru)	Juliacorbula	(Mo.Bi.My)
Jeanneticeras	(Mo.Ce.Am)	Jipuroductus	(Br.Ar.St)	Junala	(Mo.Ga.Ne)
Jeanvogericeras	(Mo.Ce.Am)	Jisuina	(Br.Ar.Te)	Jumudontus	(Cd.Co.Co)
Jebileticoscinus	(Po.Re.Aj)	Jiucunella	(Ar.Un.Un)	Junctusina	(Ar.Os.Pa)
Jedria	(Mo.Ga.Ar)	Jivinella	(Br.Ar.Or)	Jungersenchthys	(Cd.Os.Ga)
Jeffersonia	(Ar.Tr.Pr)	Jixinglingella	(Ar.Os.Ar)	Junggaroblastus	(Ec.Bl.Fi)
Jeffreysina	(Mo.Ga.Nt)	Jkella	(Br.Ar.At)	Junggarochondria	(Mo.Bi.Pt)
Jefina	(Ar.Os.Po)	Joachimilites	(Hy.Hy.Hy)	Jungghunia	(Mo.Ga.Ne)
Jegorovaia	(Ar.Tr.Un)	Joachimoceras	(Mo.Ce.Or)	Junjagiana	(Mo.Bi.Mo)
Jeletzkiella	(Mo.Bi.Pt)	Joamgsjathotes	(He.Gr.Gr)	Junocrinus	(Ec.Cr.Ds)
Jeletzkytes	(Mo.Ce.Am)	Joanacyathus	(Po.Re.Aj)	Jupiteria	(Mo.Bi.Nu)
Jeletzkyteuthis	(Mo.Ce.Te)	Joanelia	(Ar.ML.Ae)	Joralina	(Br.Ar.Te)
Jellia	(Mo.Bi.Mo)	Joannites	(Mo.Ce.Ce)	Juramegalodus	(Mo.Bi.Hi)
Jellinekites	(Mo.Ce.Ce)	Jogiacartanus	(Mo.Ga.Nt)	Juranomia	(Mo.Bi.Pt)
Jenkinochitina	(Fo.Fo.Pt)	Johannaia	(Mo.Ga.Ne)	Juraphyllites	(Mo.Ce.Ph)
Jenkinsonia	(Ar.Tr.Ch)	Johnmartinia	(Mo.Bi.Nu)	Jurapseudes	(Ar.ML.Ta)
Jenneria	(Mo.Ga.Nt)	Johnognathus	(Cd.Co.Co)	Jurassicardium	(Mo.Bi.Ve)
Jenningsina	(Ar.Os.Me)	Johnsonathyris	(Br.Ar.Sp)	Jurassicorbula	(Mo.Bi.My)
Jercia	(Br.Ar.Or)	Johnsonetes	(Br.Ar.St)	Jurassiphorus	(Mo.Ga.Nt)
Jerea	(Po.De.Li)	Johnsoniatrypa	(Br.Ar.At)	Jurella	(Fo.Fo.Fo)
Jereica	(Po.De.Li)	Johnstrupia	(Mo.Ga.Nt)	Juresania	(Br.Ar.St)
Jereina	(Po.De.Li)	John templeia	(Ar.Tr.Ph)	Juresanites	(Mo.Ce.Go)
Jereminella	(An.Po.Se)	Joldagiroceras	(Mo.Ce.Or)	Jurrietella	(Ar.Tr.Un)
Jeremorphia	(Po.De.Li)	Joleaudichthys	(Cd.Os.Pn)	Jurobates	(Cd.Ch.Rj)
Jereopsis	(Po.De.Li)	Jolietoceras	(Mo.Ce.Ba)	Justium	(Ac.Ra.Sp)
Jerjesia	(Mo.Bi.Hi)	Jolonia	(Br.Ar.Te)	Juvavaionautilus	(Mo.Ce.Na)
Jerometichenoria	(Ar.ML.My)	Jolvia	(Br.Ar.Pe)	Juvavella	(Br.Ar.Te)
Jeronia	(Ec.Ec.Hs)	Jomesea	(Br.Ar.St)	Juvavellina	(Br.Ar.Te)
Jersonia	(Mo.Bi.Ve)	Jonesella	(Ar.Os.Pa)	Juvavites	(Mo.Ce.Ce)
Jessievillia	(Ar.Tr.Pt)	Jonesia	(Ar.Os.Po)	Juvenites	(Mo.Ce.Ce)
Jetwoodsia	(Mo.Ga.Nt)	Jonesina	(Ar.Os.Pa)	Juvenix	(Ar.Os.Po)
Jevinellina	(Br.Ar.Or)	Jonesites	(Ar.Os.Pa)	Jyxiella	(Cn.In.In)
Jezercia	(Br.Ar.Or)	Jonesoceras	(Mo.Ce.Or)	Kaawatina	(Mo.Ga.Ar)
Jiagouceras	(Mo.Ce.El)	Jonotus	(Ar.Tr.Un)	Kabakovitchiella	(Cn.An.Ru)
Jianchuania	(Mo.Bi.Pt)	Jordanites	(Ar.Os.Pa)	Kabanoviella	(Br.Ar.Rh)
Jianfengia	(Ar.Un.Sp)	Jordanocaudina	(Ec.Ho.Mo)	Kabatarina	(Ar.Co.Co)
Jiangdaspirifer	(Br.Ar.Sp)	Jordanopora	(Bz.St.Tr)	Kablikia	(Ar.Un.Un)
Jianghania	(Po.De.Li)	Josepha	(Mo.Ga.Ne)	Kabukiia	(Ar.Tr.Pt)
Jiangjunshania	(Ar.Tr.Pt)	Josephella	(An.Po.Se)	Kabyaipecten	(Mo.Bi.Pt)
Jiangnania	(Ar.Tr.Un)	Josephulus	(Ar.Tr.Ph)	Kabyrites	(Mo.Ce.Am)
Jiangshanodus	(Pr.Un.In)	Jouaniceras	(Mo.Ce.Am)	Kachathyris	(Br.Ar.Te)
Jiangshanolites	(Cn.An.Ta)	Jouannetia	(Mo.Bi.My)	Kachpurites	(Mo.Ce.Am)
Jiangsuaspis	(Ar.Tr.Pt)	Joufia	(Ar.Tr.Hi)	Kadaroceras	(Mo.Ce.Di)
Jiangsuephalus	(Ar.Tr.Pt)	Jousseemea	(Mo.Ga.Nt)	Kadiskoblastus	(Ec.Bl.Sp)
Jiangsuia	(Ar.Tr.Pt)	Jovellania	(Mo.Ce.On)	Kadralipoductus	(Br.Ar.St)
Jiangxilepus	(Cd.Pl.An)	Joviatrypa	(Br.Ar.At)	Kadyella	(Ar.Tr.Pt)
Jielingia	(Br.Ar.St)	Jovites	(Mo.Ce.Ce)	Kaessleria	(Ar.Os.Po)
Jiguliconcha	(Br.Ar.St)	Juaboceras	(Mo.Ce.En)	Kaeveria	(Fo.Fo.Po)

Kafanella	(Ac,Ra,Na)	Kangarina	(Ar,Os,Po)	Kasachstanodiscus	(Fo,Fo,Fo)
Kahlerina	(Fo,Fo,Fo)	Kangilacyathus	(Cn,An,Sc)	Kasakhstanella	(Bz,St,Cy)
Kahlerosphaera	(Ac,Ra,Sp)	Kangilioptera	(Mo,Ga,Nt)	Kasakhstania	(Br,Ar,Sp)
Kahua	(Mo,Ga,Nt)	Kangvarella	(Fo,Fo,Fo)	Kasatchaspis	(Ar,Tr,Pt)
Kaibabella	(Mo,Bi,Ve)	Kangxianospira	(Mo,Ga,Nt)	Kaschkadakia	(Mo,St,St)
Kailia	(Ar,Tr,Ph)	Kaninia	(Ar,Tr,Pt)	Kasetia	(Br,Ar,St)
Kailicerias	(Mo,Ce,Un)	Kaniniella	(Ar,Tr,As)	Kashiwara	(Ac,Ra,Sp)
Kailuanoceras	(Mo,Ce,En)	Kaninospirifer	(Br,Ar,Sp)	Kashmirites	(Mo,Ce,Ce)
Kaimenella	(An,Pa,Pa)	Kankatodus	(Cd,Os,Te)	Kaskia	(Ar,Tr,Pr)
Kainella	(Ar,Tr,As)	Kankopora	(Bz,Gy,Ch)	Kasovobolina	(Ar,Os,Pa)
Kainops	(Ar,Tr,Ph)	Kanosbia	(Ar,Tr,Ph)	Kassabiana	(Fo,Fo,Fo)
Kaiparapelta	(Mo,Ga,Ar)	Kansacrinus	(Ee,Cr,Cl)	Kassina	(Ac,Ra,Na)
Kaipingoceras	(Mo,Ce,En)	Kansanella	(Fo,Fo,Fo)	Kassinella	(Br,Ar,St)
Kaisalia	(Cn,Sc,Un)	Kansasteuthis	(Mo,Ce,Te)	Kassinina	(Ar,Os,Pa)
Kaitangata	(Mo,Ga,Nt)	Kansius	(Cd,Os,Br)	Kassinus	(Ar,Tr,Co)
Kaitoa	(Mo,Ga,Ce)	Kansuella	(Br,Ar,St)	Kasyrieyathus	(Po,Re,Aj)
Kaiyangites	(Pr,Un,In)	Kantollum	(Ac,Ra,Sp)	Katacanites	(Mo,Ce,Pl)
Kajnarina	(Br,Ar,St)	Kaolishania	(Ar,Tr,Co)	Katageioceras	(Mo,Ce,Di)
Kakahuia	(Mo,Bi,Ve)	Kaolishaniella	(Ar,Tr,Co)	Katarocrinus	(Ee,Cr,Un)
Kakisaphyllum	(Cn,An,Ru)	Kaotaia	(Ar,Tr,Pt)	Katastrophomena	(Br,Ar,St)
Kalamopsis	(Fo,Fo,Fo)	Kapal	(Mo,Ce,Co)	Katatona	(Ar,Os,Pa)
Kalayoldia	(Mo,Bi,Nu)	Kaparachlamys	(Mo,Bi,Pt)	Katelsyia	(Mo,Bi,Ve)
Kalbyella	(Mo,Te,Tr)	Kaplex	(Br,Ar,Te)	Katharina	(Mo,Os,Ne)
Kalentera	(Mo,Bi,Ve)	Kaplicona	(Br,Ar,At)	Kathemacanthus	(Cd,Ac,Cl)
Kalevipora	(Bz,St,Tr)	Kapua	(Mo,Ga,Nt)	Katherinella	(Mo,Bi,Ve)
Kalimnasphaera	(Ac,Ra,Sp)	Karaburunia	(Fo,Fo,Fo)	Kathina	(Fo,Fo,Fo)
Kalimnospongia	(Po,He,Am)	Karaclymenia	(Mo,Ce,Cl)	Kathleenella	(Ar,Tr,Pt)
Kalitvella	(Br,Ar,Sp)	Karadagella	(Br,Ar,Te)	Kathpalmeria	(Ar,Ci)
Kaljasma	(Cn,An,Ru)	Karadagithyris	(Br,Ar,Te)	Kathrynia	(Ar,Tr,Pt)
Kallholnoceras	(Mo,Ce,On)	Karadzharoceras	(Mo,Ce,Di)	Kathwaia	(Ar,Tr,Pr)
Kallidecthes	(Ar,Ml,Ae)	Karagandoceras	(Mo,Ce,Go)	Katoblastus	(Ee,Bi,Fi)
Kallimorphocrinus	(Ee,Cr,Di)	Karagandoids	(Ar,Tr,Pt)	Katoporus	(Cd,Pt,Th)
Kallirhynchia	(Br,Ar,Rh)	Karagemia	(Cn,An,Ta)	Katoptychia	(Mo,Ga,Nt)
Kallocalymenia	(Mo,Ce,Cl)	Karaisella	(Fo,Fo,Fo)	Katosira	(Mo,Ga,Nt)
Kallocalytion	(Bz,St,Fe)	Karakulina	(Br,Ar,Pe)	Katranophyllum	(Cn,An,Ru)
Kallopriion	(An,Po,Eu)	Karamaiceras	(Mo,Ce,Am)	Katrolicerias	(Mo,Ce,Am)
Kallostracon	(Cd,Pt,Pt)	Karamaites	(Mo,Ce,Am)	Katrolites	(Mo,Ce,Am)
Kalochitina	(Fo,Fo,Ch)	Karangatites	(Mo,Ce,Ce)	Katroma	(Ac,Ra,Na)
Kaloshia	(Fo,Fo,Fo)	Karapadites	(Mo,Ce,Am)	Katunia	(Br,Ar,Rh)
Kalpidocrinus	(Ee,Cr,Cl)	Karataspis	(Ar,Tr,Pt)	Katunioides	(Mo,St,St)
Kalpinella	(Po,De,Li)	Karatchastraea	(Cn,An,Sc)	Katzeria	(Mo,Bi,Hi)
Kalpinograptus	(He,Gr,Gr)	Karathele	(Br,Li,Ac)	Kaufmannella	(Ar,Tr,Pt)
Kaltatocyathus	(Po,Re,Aj)	Karatubulus	(Po,De,Un)	Kaufmannia	(Ar,Tr,Pt)
Kalugia	(Ar,Os,Pa)	Karavankina	(Br,Ar,St)	Kaunhonia	(Mo,Ga,Nt)
Kaluginella	(Cn,An,He)	Karbous	(Br,Ar,At)	Kaurnella	(Mo,Ga,Ar)
Kalvariella	(Bz,St,Fe)	Kardailites	(Mo,Ce,Go)	Kavesia	(Br,Ar,St)
Kalyptovalva	(Ar,Os,Po)	Karelosteus	(Cd,Pt,Pt)	Kawalepsis	(Cd,Pt,Th)
Kamajytheris	(Ar,Os,Po)	Karginella	(Ar,Tr,Pr)	Kawanamia	(Mo,Ga,Ar)
Kamerunoceras	(Mo,Ce,Am)	Karinadomella	(Ar,Os,Po)	Kawasakicerias	(Mo,Ce,En)
Kameschkoviella	(Ar,Tr,Pt)	Karinutatia	(Ar,Os,Pa)	Kaweka	(Mo,Ga,Ne)
Kamlacus	(Ar,Tr,Un)	Karlaster	(Ee,Ec,Cl)	Kawhiarhynchia	(Br,Ar,Rh)
Kammerkaroceras	(Mo,Ce,Am)	Karlicium	(Br,Ar,Or)	Kawina	(Ar,Tr,Ph)
Kamoica	(Br,Ar,Te)	Karlsteinella	(Ar,Os,Pa)	Kayaitia	(Ar,Os,Pa)
Kampella	(Br,Ar,Or)	Karlwaageites	(Mo,Ce,Am)	Kayina	(Ar,Os,Pa)
Kampholophus	(Cd,Ma,Ce)	Karnotreta	(Br,Li,Ac)	Kayoceras	(Mo,Ce,Di)
Kamptoclymenia	(Mo,Ce,Cl)	Karoceras	(Mo,Ce,On)	Kayseraspis	(Ar,Tr,As)
Kamptokephalites	(Mo,Ce,Am)	Karpatiella	(Br,Ar,Te)	Kaysereella	(Br,Ar,Or)
Kamitshatactos	(Cd,Ma,Ca)	Karpinskia	(Br,Ar,At)	Kayseria	(Br,Ar,At)
Kamurana	(Fo,Fo,Fo)	Karrerria	(Fo,Fo,Fo)	Kaysereops	(Ar,Tr,Ph)
Kanabiceras	(Mo,Ce,Am)	Karrerriella	(Fo,Fo,Fo)	Kayutocephas	(Mo,Ce,Go)
Kanabinoerinus	(Ee,Cr,Cl)	Karrerroxtularia	(Fo,Fo,Fo)	Kazachiphyllum	(Cn,An,Ru)
Kanakaia	(Fo,Fo,Fo)	Karsteneis	(Ar,Os,Po)	Kazachstania	(Ar,Tr,Ph)
Kaneharaia	(Mo,Bi,Ve)	Karsteniceras	(Mo,Ce,Am)	Kazachstanoblastus	(Ee,Bi,Fi)
Kangapaya	(Mo,Ga,Ar)	Kasachia	(Mo,Bi,Nu)	Kazachoceras	(Mo,Ce,Go)

Kazakhoclymenia	(Mo,Ce,Cl)	Kepinospira	(Mo,In,In)	Kiaeromena	(Br,Ar,St)
Kazakhstania	(Mo,Ce,Go)	Kepisis	(Ar,Tr,Pt)	Kiaeromphalus	(Mo,Ga,Eu)
Kazakhstanites	(Mo,Ce,Ce)	Kepplerites	(Mo,Ce,Am)	Kiaeroperius	(Ar,Me,Eu)
Kazakhstanotubulus	(Pr,Un,In)	Keraiaceras	(Mo,Ce,El)	Kiangsiella	(Br,Ar,St)
Kazania	(Po,De,Li)	Keramosphæarina	(Fo,Fo,Fo)	Kiangsuaspis	(Cd,Pt,Pt)
Kazanskyella	(Mo,Ce,Am)	Keration	(Mo,Ga,Ar)	Kiangyousteus	(Cd,Pl,Ar)
Kazarchimedes	(Bz,St,Fe)	Keratothyris	(Br,Ar,Te)	Kidderia	(Mo,Bi,Ve)
Kazelia	(Ar,Tr,As)	Kerberites	(Mo,Ce,Am)	Kidjasocyathus	(Po,Re,Aj)
Kazelina	(Ar,Tr,Pt)	Kerbinella	(Ar,Tr,Un)	Kiehnenus	(Pr,Un,In)
Kazellina	(Ar,Tr,Un)	Kereia	(Mo,Bi,Ve)	Kielania	(Ar,Tr,Pt)
Kechenotiske	(Fo,Fo,Fo)	Kerfornecaris	(Ar,MI,Ar)	Kielanopora	(Bz,St,Cr)
Kechikacyathus	(Po,Ir,Ar)	Kerforneidictyum	(Cn,An,Ta)	Kielanopriion	(An,Po,Eu)
Keдррррррррр	(Br,Ar,Te)	Kericserella	(Br,Ar,Rh)	Kielcensia	(Mo,Ce,Cl)
Keleaspis	(Ar,Tr,Un)	Keriocoelia	(Po,De,Ta)	Kielcephyllum	(Cn,An,Ru)
Keenaea	(Mo,Bi,Ve)	Keriocyathus	(Po,Ir,Ar)	Kielcepora	(Bz,St,Tr)
Keeneia	(Mo,Ga,Ar)	Keriogastrospongia	(Po,He,LS)	Kielciella	(Ar,Os,Pa)
Keenocardium	(Mo,Bi,Ve)	Kerionammina	(Fo,Fo,Fo)	Kierechinus	(Ec,Ec,Di)
Keepingia	(Mo,Ga,Ne)	Keriophyllia	(Cn,An,Se)	Kierionopsis	(Ar,MI,De)
Kefiella	(Ar,Os,Po)	Keriophylloides	(Cn,An,Ru)	Kierocystis	(Ec,St,MI)
Kegeliella	(Ar,Tr,Pr)	Kermadysmea	(Mo,Bi,Ve)	Kiesowia	(Ar,Os,Pa)
Kegelites	(Ar,Os,Pa)	Kerocthere	(Ar,Os,Po)	Kijacus	(Ch,Pr)
Keichousaurus	(Cd,Re,NO)	Kerpina	(Br,Ar,At)	Kijacyathus	(Po,Re,Aj)
Keijella	(Ar,Os,Po)	Kertaster	(Ec,Ec,Sp)	Kijanella	(Ar,Tr,Pt)
Keijicythere	(Ar,Os,Po)	Kerygmachela	(Pr,Di,Ra)	Kijoceras	(Mo,Ce,On)
Keilorites	(An,Po,SP)	Keslingiella	(Ar,Os,Po)	Kikaiara	(Mo,Bi,Ar)
Keilostoma	(Mo,Ga,Nt)	Ketemecornus	(Hy,Hy,Hy)	Kikaiithyris	(Br,Ar,Te)
Keimanelasma	(Cn,An,Ru)	Ketophylloides	(Cn,An,Ru)	Kiklochytère	(Ar,Os,Po)
Keithia	(Ar,Tr,As)	Ketophyllum	(Cn,An,Ru)	Kilbuchophyllum	(Cn,An,Ki)
Keithiella	(Ar,Tr,As)	Kettnerammina	(Fo,Fo,Fo)	Kilianella	(Mo,Ce,Am)
Kekenodon	(Cd,Ma,Ce)	Kettneraspis	(Ar,Tr,Od)	Kilianina	(Fo,Fo,Fo)
Kelaeno	(Mo,Ce,Te)	Kettnerites	(An,Po,Eu)	Kilianocaris	(Ar,Th,Co)
Kelamelia	(Br,Ar,St)	Ketyna	(Ar,Tr,Pt)	Kimasip	(Cd,Pl,Ac)
Kelanella	(Pr,To,MI)	Kewia	(Ec,Ec,Cl)	Kimatothyris	(Br,Ar,Sp)
Kelostoma	(Bz,Gy,Ch)	Keyserlingia	(Br,LI,Ac)	Kimberella	(Cn,In,In)
Kellawaysites	(Mo,Ce,Am)	Keyserlingina	(Br,Ar,St)	Kimberia	(Cd,Pl,Ar)
Kellericyathus	(Po,Re,Aj)	Keyserlingites	(Mo,Ce,Ce)	Kimberleyichthytes	(Cd,Pl,Ar)
Kelletia	(Mo,Ga,Ne)	Keyserlingophyllum	(Cn,An,Ru)	Kimbleia	(Mo,Bi,Hi)
Kelletina	(Ar,Os,Pa)	Khairkhania	(Mo,In,In)	Kimilites	(Cn,An,Ta)
Kellia	(Mo,Bi,Ve)	Khalifinaea	(Po,De,Pe)	Kimina	(Mo,Ga,He)
Kellibrookia	(Ar,MI,HO)	Khalfinella	(Ar,Tr,Pr)	Kimmosaurus	(Cd,Re,Ps)
Kelliella	(Mo,Bi,Ve)	Khangastrophia	(Br,Ar,St)	Kimoceras	(Mo,Ce,An)
Kellnerites	(Mo,Ce,Ce)	Khangailites	(Cn,An,Ta)	Kimognathus	(Cd,Co,Co)
Kelloggia	(Cd,Ma,Ce)	Khankaspis	(Ar,Me,Ag)	Kimoppegma	(Mo,Ro,Ki)
Kelteroceras	(Mo,Ce,Ce)	Khasaghia	(Br,Un,Un)	Kina	(Ec,Ec,Sp)
Kelusia	(Br,Ar,Sc)	Khasaginta	(Br,Un,Ku)	Kinaschukoceras	(Mo,Ce,Ta)
Kemeroviana	(Ar,Os,Po)	Khasaktia	(Po,De,St)	Kindbladlia	(Ar,Tr,Pt)
Kendallina	(Ar,Tr,As)	Khatyspytia	(Cn,Pe,Ra)	Kindbladochiton	(Mo,Po,Ne)
Kendrichthys	(Cd,Pl,Ar)	Khemisina	(An,Po,Un)	Kinderkaella	(Mo,Bi,Pt)
Kendzhlighithyris	(Br,Ar,Te)	Kheraiceras	(Mo,Ce,Am)	Kinderlania	(Ar,Tr,Pr)
Kenelasma	(Cn,An,Ru)	Kheraites	(Mo,Ce,Am)	Kindleina	(Br,Ar,Rh)
Kenella	(Bz,Gy,Ch)	Khetatheca	(Hy,Or,Ci)	Kindlella	(Ar,Os,Pa)
Kennardia	(Pr,To,MI)	Khetella	(Mo,Ga,Nt)	Kindleoceras	(Mo,Ce,On)
Kenophyllum	(Cn,An,Ru)	Khinganospirifer	(Br,Ar,Sp)	Kinehina	(Br,Ar,St)
Kensyoceras	(Mo,Ce,Go)	Khmeria	(Cn,An,Ta)	Kingaspidoides	(Ar,Tr,Pt)
Kentlandoceras	(Mo,Ce,On)	Khodalevichia	(Br,Ar,Pe)	Kingaspa	(Ar,Tr,Pt)
Kentriodon	(Cd,Ma,Ce)	Kholbotchonia	(Br,Ar,Rh)	Kingaspis	(Br,Ar,Te)
Kentronetes	(Br,Ar,St)	Khumerspira	(Mo,Ga,Be)	Kingenella	(Br,Ar,Te)
Kentrosia	(Po,He,LY)	Khvalynites	(Mo,Ce,Ce)	Kinghiiria	(Br,Ar,Sp)
Kentrospondylus	(Ec,Op,Ph)	Kiaclymenia	(Mo,Ce,Cl)	Kingites	(Mo,Ce,Ce)
Kentuckia	(Cd,Os,Pa)	Kiaeria	(Ar,Os,Le)	Kingmaina	(Ar,Os,Po)
Kenziana	(Mo,Bi,Ar)	Kiaerites	(Cn,An,Ta)	Kingoceras	(Mo,Ce,Ce)
Keokukia	(Br,Ar,St)	Kiaeroceras	(Mo,Ce,Di)	Kingopora	(Bz,St,Fe)
Kephrenia	(Ec,Ec,Ca)	Kiaerograptus	(He,Gr,De)	Kingstomia	(Ar,Tr,Pt)
Keppingophyllum	(Cn,An,Ru)	Kiaerolites	(Cn,An,Ta)	Kinishbia	(Mo,Ga,Nt)

Kinkaidia	(Cn,An,Ru)	Klaucena	(Bz,St,Cr)	Kohaticeras	(Mo,Ce,Am)
Kinkelinelia	(Ar,Os,Po)	Kleidionella	(Bz,Gy,Ch)	Koigia	(Br,Ar,Sp)
Kinkelineras	(Mo,Ce,Am)	Kleinacteon	(Mo,Ga,Ce)	Koilocoenia	(Cn,An,Sc)
Kinnegraptus	(He,Gr,Gr)	Kleithriatreta	(Br,Li,Ac)	Koilotrochus	(Cn,An,Sc)
Kinnekullea	(Ar,Os,Pa)	Klematosphinctes	(Mo,Ce,Am)	Kokanostrea	(Mo,Bi,Pt)
Kinnella	(Br,Ar,Or)	Kleopatrina	(Cn,An,Ru)	Kokenella	(Mo,Ga,Ar)
Kintathyris	(Br,Ar,Sp)	Klieana	(Ar,Os,Po)	Kokenia	(Mo,Ce,An)
Kinzercysmia	(Ec,Eo,Im)	Klimphores	(Ar,Os,Pa)	Kokenospira	(Mo,Ga,Be)
Kionelasma	(Cn,An,Ru)	Klinghardites	(Mo,Bi,Hi)	Kokomerenia	(Br,Ar,Pe)
Kionidella	(Bz,Gy,Ch)	Klinglerella	(Ar,Os,Po)	Kokomopteris	(Ar,Me,Eu)
Kionoceras	(Mo,Ce,Or)	Klipsteinella	(Br,Ar,Sp)	Koksodus	(Pr,Un,In)
Kionophyllum	(Cn,An,Ru)	Klipsteinelloidea	(Br,Ar,Sp)	Koksuja	(Pr,Un,Hy)
Kionotrochus	(Cn,An,Sc)	Klipsteinia	(Mo,Ce,Ce)	Kokuria	(Ar,Tr,As)
Kiotoceras	(Mo,Ce,En)	Kloedcytherella	(Ar,Os,Po)	Kolbicyathus	(Po,Re,Aj)
Kiowain	(Ar,Tr,Co)	Kloeddenella	(Ar,Os,Pa)	Kolbinella	(Ar,Tr,Pt)
Kiparisovia	(Mo,Ce,Ce)	Kloeddenellitina	(Ar,Os,Pa)	Kolchidina	(Fo,Fo,Fo)
Kiparisovites	(Mo,Ce,Ce)	Kloedenia	(Ar,Os,Pa)	Koldimia	(Ar,Tr,Un)
Kipia	(Mo,Bi,Hi)	Klonkina	(Ar,Os,Pa)	Koldiniella	(Ar,Tr,Un)
Kirengelia	(Ar,Tr,Pt)	Klotziella	(Ar,Tr,Co)	Koldinioidia	(Ar,Tr,Pt)
Kirengella	(Mo,Te,Hy)	Kloueckia	(Ar,Tr,Ph)	Koldophos	(Bz,St,Cc)
Kirkbya	(Ar,Os,Pa)	Klubonibelia	(Fo,Fo,Fo)	Kolednikella	(Ar,Os,Pa)
Kirkbyella	(Ar,Os,Pa)	Klubovella	(Fo,Fo,Fo)	Koleostoma	(Po,He,He)
Kirkbyellina	(Ar,Os,Po)	Klukatrypa	(Br,Ar,At)	Kolesnikovella	(Fo,Fo,Fo)
Kirkdomina	(Ar,Tr,Pt)	Klytia	(Ar,Mi,De)	Kolhidaella	(Br,Ar,Rh)
Kirkidium	(Mo,Ce,Pe)	Knebalia	(Ar,Mi,De)	Kolihaja	(Pr,Un,Cn)
Kirkina	(Br,Ar,St)	Knechtelia	(Ar,Tr,Un)	Kolihapeltis	(Ar,Tr,Co)
Kirkoceras	(Mo,Ce,En)	Knefastia	(Mo,Ga,Ne)	Kolihium	(Br,Li,Pa)
Kirsoceras	(Mo,Ce,Go)	Knemiceras	(Mo,Ce,Am)	Kolmodinia	(Ar,Os,Pa)
Kirtonella	(Ar,Os,Po)	Knightella	(Mo,Ga,Ni)	Koloceras	(Mo,Ce,Am)
Kisacacyathus	(Po,Re,Aj)	Knightsia	(Cd,Os,Cl)	Kologya	(Cn,An,Sc)
Kishinewia	(Mo,Ga,Ar)	Knightina	(Ar,Os,Pa)	Kolpura	(Ar,Tr,Un)
Kisilia	(Br,Ar,Sp)	Knighties	(Mo,Ga,Be)	Kolymaspis	(Cd,Pl,Ac)
Kiskinella	(Ar,Tr,Ag)	Knighthoceras	(Mo,Ce,Na)	Kolymella	(Ar,Tr,Ph)
Kistassella	(Mo,In,In)	Knighthoconus	(Mo,Te,Hy)	Kolymia	(Mo,Bi,Pt)
Kistocare	(Ar,Tr,Pt)	Knoxiella	(Ar,Os,Po)	Kolymithyris	(Br,Ar,Te)
Kitabella	(Ar,Os,Pa)	Knoxina	(Ar,Os,Pa)	Kolymonectes	(Mo,Bi,Pt)
Kitakamijia	(Cn,An,Ta)	Knoxites	(Ar,Os,Pa)	Kolymopora	(Cn,An,Ta)
Kitakamiphyllum	(Cn,An,Ru)	Kobayashella	(Ar,Tr,As)	Kolymoproetus	(Ar,Tr,Pr)
Kitakamithyris	(Br,Ar,Sp)	Kobayashia	(Ar,Tr,As)	Komaroiella	(Ar,Os,Pa)
Kitatites	(Mo,Ce,Di)	Kobayashiella	(Mo,Pa,Hy)	Komaspidella	(Ar,Tr,Co)
Kitehinites	(Mo,Ce,Am)	Kobayashiina	(Ar,Os,Po)	Komaspis	(Ar,Tr,Pt)
Kitsonia	(Mo,Bi,Ve)	Kobayashipeltis	(Ar,Tr,Co)	Komia	(Po,De,Ax)
Kittlia	(Mo,Ga,Nt)	Kobayshites	(Mo,Bi,Pt)	Komiella	(Br,Ar,Sp)
Kittliconcha	(Mo,Ga,Nt)	Kobeha	(Cn,An,Ru)	Komioceras	(Mo,Ce,An)
Kittlidiscus	(Mo,Ga,Ar)	Kobyia	(Cn,An,Sc)	Komispirifer	(Br,Ar,Sp)
Kittlistylus	(Mo,Ga,Nt)	Kobyastraea	(Cn,An,Sc)	Kompsasteria	(Cn,An,Sc)
Kittlitrochus	(Mo,Ga,Ar)	Kobycoenia	(Cn,An,Sc)	Komukia	(Br,Ar,St)
Kiviasukkaan	(Mo,Ga,Ar)	Kochaspis	(Ar,Tr,Pt)	Konbostrea	(Mo,Bi,Pt)
Kiwetionkia	(Po,He,Re)	Kochia	(Mo,Bi,Pt)	Koneprusia	(Ar,Tr,Od)
Kiwicyathus	(Po,Re,Aj)	Kochiella	(Ar,Tr,Pt)	Koneprusites	(Ar,Tr,Pr)
Kizilia	(Cn,An,Ru)	Kochina	(Ar,Tr,Pt)	Kongielechinus	(Ec,Ec,Ey)
Kjaerina	(Br,Ar,St)	Kochiproductus	(Br,Ar,St)	Konglungenoceras	(Mo,Ce,Di)
Kjerulfia	(Ar,Tr,Ol)	Kochoceras	(Mo,Ce,Ac)	Koniakaua	(Mo,Ga,Ar)
Kjerulfina	(Br,Ar,St)	Kockelella	(Cd,Co,Co)	Konicaktion	(Ar,Os,Ar)
Kjerulfonema	(Mo,Ga,Nt)	Kodonophyllum	(Cn,An,Ru)	Koninckella	(Br,Ar,Sp)
Klaamannipora	(Cn,An,Ta)	Kodymaspis	(Ar,Tr,Pt)	Koninckina	(Br,Ar,Sp)
Kladisoceras	(Mo,Ce,Di)	Kodymirus	(Ar,Me,Ag)	Koninckites	(Mo,Ce,Ce)
Kladognathus	(Cd,Co,Co)	Kodymites	(Mo,Ga,Be)	Koninckocarina	(Cn,An,Ru)
Klakesia	(An,Po,Un)	Koenenia	(Mo,Bi,Nu)	Koninckocidaris	(Ec,Ec,Ey)
Klamathastrea	(Cn,An,Ru)	Koenenites	(Mo,Ce,An)	Koninckodontia	(Br,Ar,Sp)
Klamathina	(Fo,Fo,Fo)	Koeveskallina	(Br,Ar,Sp)	Koninckophylloides	(Cn,An,Ru)
Klamathites	(Mo,Ce,Ce)	Kogenium	(Ar,Tr,As)	Koninckophyllum	(Cn,An,Ru)
Klapperina	(Cd,Co,Co)	Kogia	(Cd,Ma,Ce)	Konstantia	(Br,Ar,Te)
Klasmura	(Ec,Op,St)	Kogiopsis	(Cd,Ma,Ce)	Konyrium	(Po,He,Un)

Koonwarria	(Cd.Os.Pe)	Kozloskiaspis	(Ar.Tr.Ph)	Kuglerina	(Fo.Fo.Fo)
Kooptoonocrinus	(Ec.Cr.Cl)	Kozłowska	(Br.Ar.St)	Kuhlia	(Cd.Os.Pf)
Kootenia	(Ar.Tr.Co)	Kozłowskiella	(Br.Ar.Sp)	Kuhnstraeta	(Cn.An.Sc)
Kooteniella	(Ar.Tr.Co)	Kozłowskiellina	(Br.Ar.Sp)	Kuia	(Mo.Bi.Ve)
Kooteniellina	(Ar.Tr.Co)	Kozłowskinia	(Cn.An.Ru)	Kuibisia	(Cn.In.In)
Kopficrinus	(Ec.Cr.Cl)	Kozłowskicystia	(Cn.An.Ta)	Kuiperiana	(Ar.Os.Po)
Kopficystis	(Ec.St.Mi)	Kozłowskispungia	(Po.De.Li)	Kujandaspis	(Ar.Tr.Pt)
Kophinoceras	(Mo.Ce.On)	Kozłowskites	(Br.Ar.St)	Kujandina	(Ar.Ii.Un)
Kophinocrinus	(Ec.Cr.Cl)	Kozłowskitubus	(He.Gr.Tu)	Kukersella	(Bz.St.Cc)
Koptura	(Ar.Tr.As)	Kozurella	(Ec.Ho.Ap)	Kuljumbina	(Ar.Tr.Pt)
Koraispis	(Ar.Tr.Un)	Krachia	(Mo.Ga.Nt)	Kullervo	(Br.Ar.Or)
Kordecyathus	(Po.Re.Aj)	Krafftoceras	(Mo.Ce.Go)	Kullingia	(Cn.Hy.Hy)
Koremagraptus	(He.Gr.De)	Kraflia	(Ar.Os.Pa)	Kullmannophyllum	(Cn.An.Ru)
Korilacus	(Pr.Un.In)	Kraikhania	(Mo.In.In)	Kulmiella	(Ar.Tr.Pr)
Korilithes	(Hy.Hy.Hy)	Krama	(Ec.Ed.Is)	Kulparina	(Pr.To.Un)
Korjakirhynchia	(Br.Ar.Rh)	Kranaosphinctes	(Mo.Ce.Am)	Kulumbella	(Br.Ar.Pe)
Kormagnostella	(Ar.Tr.Ag)	Kransia	(Br.Ar.Rh)	Kulyambopeltis	(Ar.Tr.Pt)
Kormagnostus	(Ar.Tr.Ag)	Krasnopeevacyathus	(Po.Re.Aj)	Kumatostephanus	(Mo.Ce.Am)
Korobkovella	(Fo.Fo.Fo)	Krattaspis	(Ar.Tr.Ph)	Kumatrigonia	(Mo.Bi.Tr)
Korobkovia	(Mo.Bi.Pt)	Krattorthis	(Br.Ar.Or)	Kumbella	(Br.Ar.Pe)
Korobkoviella	(Mo.Bi.Ve)	Krausella	(Ar.Os.Me)	Kumbiopsammia	(Cn.An.Sc)
Korobkovitrigonia	(Mo.Bi.Tr)	Krausellina	(Ar.Os.Po)	Kummiella	(Mo.Bi.My)
Korobovia	(Ar.Tr.Ag)	Kraussina	(Br.Ar.Te)	Kummeloceras	(Mo.Ce.Na)
Korovinella	(Po.Ir.Ka)	Krebsia	(Mo.Ga.Nt)	Kummerowia	(Ar.Os.Po)
Korovina	(Mo.Ga.Nt)	Krejcirgrafella	(Br.Ar.St)	Kumpanophyllum	(Cn.An.Ru)
Korshunovicyathus	(Po.Re.Ca)	Krepelinella	(Ac.Ra.Na)	Kundatella	(Br.Ar.Or)
Korutichthys	(Cd.Os.Pa)	Kreyzstella	(Ac.Ra.Sp)	Kungealla	(Br.Ar.Sp)
Koryschisma	(Ec.Bl.Fi)	Krikoumbilica	(Fo.Fo.Fo)	Kungejophyllum	(Cn.An.Ru)
Korythoceras	(Mo.Ce.Am)	Krimargyrotheca	(Br.Ar.Te)	Kunklerina	(Fo.Fo.Fo)
Kosocoviella	(Ar.Os.Pa)	Krimella	(Cn.An.Go)	Kunlunia	(Br.Ar.St)
Kosirium	(Br.Ar.Sp)	Krinocrinus	(Ec.Cr.Mo)	Kuningaspis	(Ar.Tr.Un)
Koskinobigenierina	(Fo.Fo.Fo)	Kristinella	(Cn.Hy.Hy)	Kuningella	(Ar.Os.Ar)
Koskinotextularia	(Fo.Fo.Fo)	Krithe	(Ar.Os.Po)	Kunradia	(Bz.Gy.Ch)
Kosmermoceras	(Mo.Ce.Am)	Kritorhynchia	(Br.Ar.Rh)	Kunshanagnostus	(Ar.Tr.Ag)
Kosmoceras	(Mo.Ce.Am)	Krizistrophia	(Br.Ar.St)	Kunshanaspis	(Ar.Tr.Re)
Kosmoclymenia	(Mo.Ce.Cl)	Kroemmelbeinella	(Ar.Os.Po)	Kunthia	(Cn.An.Ru)
Kosoidea	(Br.Li.Ac)	Kroemmelbeinia	(Ar.Os.Po)	Kunyangella	(Ar.Os.Ar)
Kosoraspis	(Cd.Pl.Ac)	Krolina	(Ar.Tr.Pt)	Kunyangotheca	(Hy.Or.Ci)
Kosovoceras	(Mo.Ce.Ta)	Kronosaurus	(Cd.Re.Ps)	Kuonamkicornus	(Hy.Hy.Hy)
Kosovopeltis	(Ar.Tr.Pt)	Kronothoa	(Bz.Gy.Ch)	Kupenga	(Mo.Bi.Tr)
Kossmatella	(Mo.Ce.Am)	Krotovia	(Br.Ar.St)	Kurakithyris	(Br.Ar.Te)
Kossmatia	(Mo.Ce.Am)	Krumbeckia	(Mo.Bi.Hi)	Kuraspis	(Ar.Tr.Pt)
Kossmaticeras	(Mo.Ce.Am)	Krumbeckiella	(Mo.Bi.Pt)	Kuresaaria	(Ar.Os.Un)
Kotakaia	(Mo.Ga.Un)	Kruseicnema	(Po.Ir.Ar)	Kurnubia	(Fo.Fo.Fo)
Kotelnyoceras	(Mo.Ce.Di)	Krykyloceras	(Mo.Ce.Na)	Kurnubiella	(Mo.Ce.Am)
Kotisopeltis	(Ar.Tr.Co)	Kryptophaneron	(Cd.Os.Br)	Kurobechelys	(Cd.Re.Ch)
Kotlaia	(Br.Ar.Or)	Ksiazkiewiczia	(Cn.An.Sc)	Kuroshioturris	(Mo.Ga.Ne)
Kotoceras	(Mo.Ce.En)	Ktenoura	(Ar.Tr.Ph)	Kurtinia	(Mo.Bi.Hi)
Kotoracythere	(Ar.Os.Po)	Kuamaia	(Ar.Mo.In)	Kurtomarginifera	(Br.Ar.St)
Kotuites	(Tr.An)	Kuanchuanella	(Mo.In.In)	Kurtziella	(Mo.Ga.Ne)
Kotujella	(Br.Ar.Or)	Kuangxiastraeta	(Cn.An.Ru)	Kurzunia	(Br.Ar.At)
Kotujotreta	(Br.Li.Ac)	Kuanyangia	(Ar.Tr.Re)	Kusbassophyllum	(Cn.An.Ru)
Kotuyicosocinus	(Po.Re.Aj)	Kuarnbyella	(Bz.St.Cc)	Kushanites	(Mo.Ce.Go)
Kotuyitheca	(Hy.Or.Ci)	Kuehnia	(Mo.Bi.Hi)	Kushliukia	(Cd.Os.Pf)
Kotykanites	(Tr.An)	Kuehnites	(Ec.Ho.De)	Kutatissites	(Mo.Ce.Am)
Kotylotreta	(Br.Li.Ac)	Kueichouphyllum	(Cn.An.Ru)	Kutchirhynchia	(Br.Ar.Rh)
Kotyx	(Br.Ar.Rh)	Kueichowella	(Br.Ar.St)	Kutchithyris	(Br.Ar.Te)
Kotysium	(Mo.In.In)	Kueichowia	(Ar.Tr.Re)	Kutorgina	(Br.Un.Ku)
Kounamkites	(Ar.Tr.Pt)	Kueichowpora	(Cn.An.Ta)	Kutorginella	(Br.Ar.St)
Kowalaephyllum	(Cn.An.Ru)	Kufengoceras	(Mo.Ce.Go)	Kutorgoceras	(Mo.Ce.En)
Kozahuria	(Mo.Bi.Ve)	Kufuralaria	(Mo.Bi.Nu)	Kutsevelia	(Fo.Fo.Fo)
Kozhimites	(Mo.Ce.Go)	Kugdatheca	(Hy.Or.Ci)	Kuvelousia	(Br.Ar.St)
Kozhuchinella	(Br.Ar.St)	Kugeloceras	(Mo.Ce.En)	Kuzminaella	(Ar.Os.My)
Kozlenia	(Br.Ar.Sp)	Kugleria	(Mo.Bi.Hi)	Kvesanirhynchia	(Br.Ar.Rh)

Kwangsia	(Br.Ar,At)	Labyrinthus	(Pr.Un,In)	Laevidentalium	(Mo.Sc,Sc)
Kwangsiophyllum	(Cn.An,Ru)	Lacazella	(Br.Ar,Th)	Laevigaterhynchia	(Br.Ar,Rh)
Kwangsiirhynchus	(Br.Ar,Rh)	Lacazina	(Fo.Fo,Fo)	Laevigatocrinus	(Ec.Cr,Is)
Kwangsisaurus	(Cd.Re,No)	Lacazinella	(Fo.Fo,Fo)	Laevihastula	(Mo.Ga,Ne)
Kwantoella	(Fo.Fo,Fo)	Laccinum	(Mo.Ga,Ne)	Laevinerinea	(Mo.Ga,He)
Kweichowlepis	(Cd.Pl,Ar)	Laccophilina	(Ar.Os,Pa)	Laevipatagus	(Ec.Ec,Sp)
Kyamodes	(Ar.Os,Pa)	Laccocrinus	(Ec.Cr,Cl)	Laevipeneroplis	(Fo.Fo,Fo)
Kyarnbyella	(Bz.St,Cc)	Laccophyllum	(Cn.An,Ru)	Laeviprosopon	(Ar.Ml,De)
Kyarocyathus	(Po.Re,Mo)	Laccoprimitia	(Ar.Os,Pa)	Laeviramina	(Ar.Ml,De)
Kygmaeoceras	(Hy.Or,Or)	Laceratus	(Pr.Cr,Cr)	Laevirhynchia	(Br.Ar,Rh)
Kylixocrinus	(Ec.Cr,Mo)	Lacripora	(Cn.An,Ta)	Laeviselica	(Mo.Ga,He)
Kylonisa	(Bz.Gy,Ch)	Lacerna	(Bz.Gy,Ch)	Laevispirifer	(Br.Ar,Sp)
Kymagnostus	(Ar.Tr,Ag)	Lacertasterias	(Ec.As,Pu)	Laevistrombus	(Mo.Ga,Nt)
Kymataspis	(Ar.Tr,Re)	Lachnostoma	(Ar.Tr,As)	Laeviterebrum	(Mo.Ga,Ne)
Kymatothyris	(Br.Ar,Sp)	Lachryma	(Mo.Ga,Nt)	Laevithyris	(Br.Ar,Te)
Kymbecyathus	(Po.Re,Aj)	Lachrymula	(Br.Li,Li)	Laevitornaria	(Mo.Ga,Ar)
Kyminoceras	(Mo.Ce,El)	Lacinia	(Mo.Ga,Ne)	Laevitrigonia	(Mo.Bi,Tr)
Kyndalina	(Mo.Ga,Ar)	Laciolina	(Mo.Bi,Ve)	Laevityphis	(Mo.Ga,Ne)
Kyphocephalus	(Ar.Tr,Pt)	Lacorsalina	(Ar.Tr,Pt)	Laevirhynchia	(Br.Ar,Rh)
Kyphoclonella	(Po.De,Li)	Lacosteina	(Fo.Fo,Fo)	Lafittea	(Fo.Fo,Fo)
Kyphomopisthia	(Ar.Os,Pa)	Lacriforma	(Mo.Ga,He)	Laganoclymenia	(Mo.Ce,Cl)
Kyphophyllum	(Cn.An,Ru)	Lacrimula	(Bz.Gy,Ch)	Laganum	(Ec.Ec,Cl)
Kyphopyxa	(Fo.Fo,Fo)	Lactarius	(Cd.Os,Pf)	Lagarodus	(Cd.Ch,Ps)
Kyphosida	(Cd.Os,Pf)	Laculatina	(Fo.Fo,Fo)	Lagarograptus	(He.Gr,Gr)
Kyraster	(Ec.As,Ur)	Laculina	(Mo.Po,Ne)	Lagarozoom	(Bz.Gy,Ch)
Kyreocrinus	(Ec.Cr,Di)	Lacuna	(Mo.Ga,Nt)	Lagena	(Fo.Fo,Fo)
Kyrshabaktella	(Br.Li,Li)	Lacunaerhynchia	(Br.Ar,Rh)	Lagenaconularia	(Cn.Sc,Cn)
Kyrtatrypa	(Br.Ar,At)	Lacunaria	(Mo.Ga,Nt)	Lagenammia	(Fo.Fo,Fo)
Kyrtogymnodon	(Cd.Os,Te)	Lacunarites	(Br.Ar,Or)	Lagenicyathus	(Pr.Cr,Cr)
Kystodendron	(He.Pt,Rh)	Lacunella	(Mo.Ga,Nt)	Lageniocrinus	(Ec.Cr,Cr)
Kysylagathophyllum	(Cn.An,Ru)	Lacunina	(Mo.Ga,Nt)	Lagenipora	(Bz.Gy,Ch)
Kysylschinopora	(Bz.St,Tr)	Lacunites	(Br.Li,Pa)	Lagenochitina	(Fo.Fo,Ch)
Labaila	(Br.Ar,Te)	Lacunoporaspis	(Ar.Tr,Pr)	Lagenoglandulina	(Fo.Fo,Fo)
Laballa	(Br.Ar,Sp)	Lacunosella	(Br.Ar,Rh)	Lagenorhynchus	(Cd.Ma,Ce)
Labeceras	(Mo.Ce,Am)	Lacunospira	(Mo.Ga,Ar)	Lagenosypho	(Bz.St,Cc)
Labechia	(Po.De,St)	Lacurnaria	(Mo.Ga,Nt)	Laggani	(Pr.Di,Ra)
Labechiella	(Po.De,St)	Ladadiscus	(Ar.Tr,Ag)	Lagnea	(Fo.Fo,Fo)
Labechiellata	(Cn.An,Ru)	Ladaecyathus	(Po.Re,Aj)	Lagonibelus	(Mo.Ce,Be)
Labiocrinus	(Ec.Cr,Cy)	Ladatheca	(Hy.Or,Ci)	Lagonoecia	(Bz.St,Cc)
Labioporella	(Bz.Gy,Ch)	Ladinotrochus	(Mo.Ga,Ar)	Lagowites	(Mo.Ce,Go)
Labiostoma	(Fo.Fo,Fo)	Ladinula	(Mo.Ga,Nt)	Lagunitus	(Mo.Ga,Nt)
Labiostrella	(Ar.Tr,Pt)	Ladja	(Br.Ar,Sp)	Lagynocystis	(Ec.St,Mi)
Labiostria	(Ar.Tr,As)	Ladogia	(Br.Ar,Rh)	Lagynopora	(Bz.Gy,Ch)
Labiostrombus	(Mo.Ga,Nt)	Ladogiella	(Br.Ar,Or)	Lahlileona	(Mo.Bi,Ve)
Labis	(Mo.Bi,Mt)	Ladogifornix	(Br.Ar,Rh)	Lahlilia	(Mo.Bi,Ve)
Laboceras	(Mo.Ce,Ce)	Ladogilina	(Br.Ar,Rh)	Laima	(Br.Li,Li)
Labradoria	(Ar.Tr,Co)	Ladogilinella	(Br.Ar,Rh)	Laiocoehlis	(Mo.Ga,Nt)
Labridens	(Mo.Ga,Nt)	Ladogiodes	(Br.Ar,Rh)	Laioporella	(Br.Ar,Sp)
Labriproductus	(Br.Ar,St)	Ladoronia	(Fo.Fo,Fo)	Lajanaster	(Ec.Ec,Sp)
Labrisomus	(Cd.Os,Pf)	Laemonema	(Cd.Os,Ga)	Lajonkairia	(Mo.Bi,Ve)
Labrocuspis	(Mo.Ga,Ar)	Laegyra	(Mo.Pa,Hy)	Lakaspis	(Ar.Tr,As)
Labrodon	(Cd.Os,Pf)	Laethoprusia	(Ar.Tr,Od)	Lamanskya	(Br.Li,Li)
Labrophagus	(Cd.Os,Au)	Laetifaotur	(Mo.Ga,Ar)	Lamarckella	(Fo.Fo,Fo)
Labrosavelum	(Ar.Os,Pa)	Laevella	(Mo.Ga,Nt)	Lamarckina	(Fo.Fo,Fo)
Labrospira	(Fo.Fo,Fo)	Laevibaculus	(Mo.Ga,Nt)	Lamarmorella	(Fo.Fo,Fo)
Labrostrea	(Mo.Bi,Pt)	Laevibuccinum	(Mo.Ga,Ne)	Lambagnathus	(Cd.Co,Co)
Labrotaxis	(Ec.Ec,Hs)	Laevicarcinus	(Ar.Ml,De)	Lambdarina	(Br.Ar,Rh)
Labrus	(Cd.Os,Pf)	Laevicardium	(Mo.Bi,Ve)	Lambdodus	(Cd.Ch,Ct)
Labyrinthidoma	(Fo.Fo,Fo)	Laevichlamys	(Mo.Bi,Pt)	Lambelasma	(Cn.An,Ru)
Labyrinthina	(Fo.Fo,Fo)	Laeviciree	(Mo.Bi,Ve)	Lambeoceras	(Mo.Ce,Ac)
Labyrinthites	(Cn.An,Ta)	Laeviconulus	(Mo.Ga,Ar)	Lambeophyllum	(Cn.An,Ru)
Labyrinthoceras	(Ar.Os,Am)	Laevicordia	(Mo.Bi,Ph)	Lambericeras	(Mo.Ce,Am)
Labyrinthochitinia	(Fo.Fo,Fo)	Laevicyphomena	(Br.Ar,St)	Lambertechinus	(Ec.Ec,Ph)
Labyrinthotuba	(Pr.Un,In)	Laevidentalina	(Fo.Fo,Fo)	Lambertella	(Ec.As,Px)

Lambertiaster	(Ec,Ec,Sp)	Lanarkopora	(Bz,St,Fe)	Larospira	(Ac,Ra,Sp)
Lambertona	(Ec,Ec,Sp)	Lanarkopterus	(Ar,Me,Eu)	Lardeuxella	(Ar,Os,Pa)
Lambis	(Mo,Ga,Nt)	Lancastria	(Ar,Tr,Co)	Larifugula	(Ar,Tr,Pt)
Lambropsis	(Ar,Ml,De)	Lancedellia	(Mo,Ga,Ar)	Larimus	(Cd,Os,Pf)
Lamcispinifera	(Br,Ar,St)	Lanceolaities	(An,Po,Eu)	Lariosaurus	(Cd,Re,No)
Lamellacratia	(Ar,Os,Po)	Lanceolites	(Mo,Ce,Ce)	Larispirifer	(Br,Ar,Sp)
Lamellaoporella	(Cn,An,Ta)	Lanceoloboceras	(Mo,Ce,Go)	Larium	(Br,Ar,Un)
Lamellaerhynchia	(Br,Ar,Rh)	Lanceomyonia	(Br,Ar,Rh)	Larkinia	(Mo,Bi,Ar)
Lamellaria	(Mo,Ga,Nt)	Lanceopora	(Bz,Gy,Ch)	Larma	(Mo,Bi,Ve)
Lamellastraea	(Cn,An,Sc)	Lanchangjiangia	(Br,Ar,Sp)	Larnacalpis	(Ac,Ra,Sp)
Lamellata	(Po,De,AX)	Landanichthys	(Cd,Os,Pf)	Larnacantha	(Ac,Ra,Sp)
Lamelliconcha	(Mo,Bi,Ve)	Landercyathus	(Po,Ir,Ar)	Larrazetia	(Fo,Fo,Fe)
Lamelliconchidium	(Br,Ar,Pe)	Landeroceeras	(Mo,Ce,Di)	Larus	(Cd,Av,Ch)
Lamelliconus	(Fo,Fo,Fo)	Landinia	(Mo,Bi,Ve)	Lasaea	(Mo,Bi,Ve)
Lamellinucula	(Mo,Bi,Nu)	Landyia	(Ar,Tr,Ph)	Lasacina	(Mo,Bi,Ve)
Lamelliphorus	(Mo,Ga,Nt)	Lanecrinus	(Ec,Cr,Cf)	Lasaeokellya	(Mo,Bi,Ve)
Lamellistroma	(Po,De,St)	Laneites	(Ar,Tr,Ph)	Lasaeoneaera	(Mo,Bi,Ve)
Lamellofungia	(Cn,An,Sc)	Langdaia	(Ar,Os,Pa)	Lasanius	(Cd,Ce,Bl)
Lamelloinonkina	(Br,Ar,Sp)	Langeita	(An,Po,Eu)	Lasanocrinus	(Ec,Cr,Cl)
Lamellomeandra	(Cn,An,Sc)	Langella	(Fo,Fo,Fo)	Lascoa	(Cn,Sc,Se)
Lamellophyllia	(Cn,An,Sc)	Langenhemia	(Cn,An,Ru)	Lasiocladia	(Po,De,Li)
Lamellopora	(Po,De,St)	Langensolenia	(Fo,Fo,Fo)	Lasioerinus	(Ec,Cr,Cl)
Lamellothoereras	(Mo,Ce,Or)	Langgonbole	(Ar,Tr,Pr)	Lasiodiscus	(Fo,Fo,Fo)
Lamellosathyris	(Br,Ar,Sp)	Langgoni	(Ar,Tr,Ph)	Lasiograptus	(He,Gr,Gr)
Lamellosia	(Br,Ar,St)	Langkawai	(Br,Ar,Rh)	Lasiothrix	(Po,He,LS)
Lamellospira	(Mo,Ga,Ar)	Langshanthyrus	(Br,Ar,Te)	Lasiotrochus	(Fo,Fo,Fo)
Lamina	(Fo,Fo,Fo)	Langsonella	(Mo,Bi,Pe)	Lasmosmilia	(Cn,An,Sc)
Laminatia	(Br,Ar,St)	Langtonia	(Ar,Os,Po)	Latanarcestes	(Mo,Ce,An)
Laminocyathus	(Cn,An,Sc)	Langvophorus	(Mo,Bi,Ve)	Latebina	(Ar,Os,Pa)
Laminononion	(Fo,Fo,Fo)	Langyashania	(Ar,Tr,Pt)	Latentidiota	(Ac,Ra,Sp)
Laminoplasma	(Cn,An,Ta)	Lanicyathus	(Po,Re,Ca)	Latentifistula	(Ac,Ra,Sp)
Laminopora	(Bz,Gy,Ch)	Lanieria	(Ec,Ec,Ho)	Lateralatirostrum	(Br,Ar,Rh)
Laminurus	(Ar,Tr,Pt)	Lanipustula	(Br,Ar,St)	Latereschara	(Bz,Gy,Ch)
Lamna	(Cd,Ch,La)	Lankacythere	(Ar,Os,Po)	Latericriodus	(Cd,Co,Co)
Lamnaespina	(Br,Ar,Sp)	Lankesterina	(Fo,Fo,Fo)	Laterignathus	(Cd,Co,Co)
Lamnimargus	(Br,Ar,St)	Lannaacus	(Ar,Tr,As)	Laterispina	(Br,Ar,St)
Lamontopteris	(Ar,Me,Eu)	Lanopora	(Bz,St,Cr)	Laternula	(Mo,Bi,Ph)
Lamotia	(Cn,An,Ta)	Lanternarius	(Ec,Ec,Un)	Lateroavea	(Bz,St,Ce)
Lamottoceeras	(Mo,Ce,En)	Lanternocrinus	(Ec,Cr,Un)	Laterocea	(Bz,St,Ce)
Lamottopora	(Bz,St,Tr)	Lanthanaster	(Ec,As,He)	Lateroflustraria	(Bz,Gy,Ch)
Lampadaster	(Ec,Ec,Hs)	Lantschichites	(Fo,Fo,Fe)	Laterophores	(Ar,Os,Pa)
Lampadena	(Cd,Os,My)	Lantus	(Ac,Ra,Na)	Laterophyllia	(Cn,An,Sc)
Lampadocorys	(Ec,Ec,Hs)	Laocaetis	(Po,He,He)	Laterostomella	(Fo,Fo,Fo)
Lampadosocrinus	(Ec,Cr,Cl)	Laornis	(Cd,Av,Ch)	Laterotectatia	(Bz,Gy,Ch)
Lampanela	(Mo,Ga,Nt)	Laosia	(Br,Ar,Rh)	Laterotubigera	(Bz,St,Ce)
Lampangella	(Br,Ar,St)	Lapasnia	(Br,Ar,St)	Lathamella	(Br,Un,Un)
Lampantactodes	(Cd,Os,My)	Lapazites	(Ar,Os,Pa)	Lathyrulus	(Mo,Ga,Ne)
Lampantactus	(Cd,Os,My)	Lapeirousella	(Mo,Bi,Hi)	Latiata	(Mo,Ga,Nt)
Lampasopsis	(Mo,Ga,Nt)	Lapeirousia	(Mo,Bi,Hi)	Laticarca	(Mo,Bi,Ar)
Lampichthytes	(Cd,Os,My)	Laperousecythere	(Ar,Os,Po)	Latiastrea	(Cn,An,Sc)
Lampris	(Cd,Os,La)	Lapidaria	(Ar,Tr,As)	Latiavis	(Mo,Ga,Ne)
Lamprocyclus	(Ac,Ra,Na)	Lapidopiscum	(Ac,Ra,Sp)	Latibolivina	(Fo,Fo,Fo)
Lamprocyrtis	(Ac,Ra,Na)	Lapillocytites	(Ec,Eo,Un)	Laticarinina	(Fo,Fo,Fo)
Lamprodoma	(Mo,Ga,Ne)	Lapparia	(Mo,Ga,Ne)	Laticephalus	(Ar,Tr,Un)
Lamprodomina	(Mo,Ga,Ne)	Lapradeia	(Br,Ar,Rh)	Laticlypus	(Ec,Ec,Ca)
Lamprolithax	(Cd,Ma,Ce)	Lapworthella	(Pr,To,Un)	Laticocrinus	(Hy,Hy,Hy)
Lampropeltes	(Ar,Tr,Pt)	Lapworthicrurata	(He,Gr,Cr)	Laticurra	(Br,Ar,Or)
Lampterium	(Ac,Ra,Na)	Lapworthura	(Ec,Op,Oe)	Latiendothyra	(Fo,Fo,Fo)
Lampteroblastus	(Ec,Ed,Ed)	Laqueoceras	(Mo,Ce,Am)	Latiendothyranopsis	(Fo,Fo,Fo)
Lampterocrinus	(Ec,Cr,Di)	Laqueoserpula	(An,Po,Se)	Latiflexa	(Br,Ar,Te)
Lamptonium	(Ac,Ra,Na)	Laquetus	(Br,Ar,Te)	Latifusus	(Mo,Ga,Ne)
Lampusia	(Mo,Ga,Nt)	Laratheca	(Hy,Or,Ci)	Latikingspis	(Ar,Tr,Re)
Lamtschinopora	(Bz,St,Cy)	Larcidium	(Ac,Ra,Sp)	Latinewaagia	(Mo,Bi,Pt)
Lanarkia	(Cd,Pt,Th)	Larcopyle	(Ac,Ra,Sp)	Latiphyllia	(Cn,An,Sc)

Latiplecus	(Br.Ar,Sp)	Lecanites	(Mo,Ce,Ce)	Leiodorella	(Po,De,Li)
Latiproductus	(Br.Ar,St)	Lecanoaspis	(Ar.Tr,Pt)	Leiodus	(Cd,Ch,Or)
Latiredlichia	(Ar.Tr,Re)	Lecanocrinus	(Ec,Cr,St)	Leiodysodonta	(Mo,Bi,Nu)
Latirhynchia	(Br.Ar,Rh)	Lecanopleura	(Ar.Tr,Pt)	Leioechinus	(Ec,Ec,Ph)
Latirolagena	(Mo,Ga,Ne)	Lecanopyge	(Ar.Tr,Pt)	Leiognathus	(Cd,Os,Ph)
Latirostratus	(Mo,In,In)	Lecanospira	(Mo,Ga,Eu)	Leiolambrus	(Ar,Ml,De)
Latirus	(Mo,Ga,Ne)	Lecathylus	(An,Po,Un)	Leiolepismatina	(Br.Ar,Sp)
Latisageceras	(Mo,Ce,Pl)	Lecfedites	(Cn,An,Ta)	Leiolichas	(Ar.Tr,Li)
Latisipho	(Mo,Ga,Ne)	Leclites	(Mo,Ce,Am)	Leionucula	(Mo,Bi,Nu)
Latispirifer	(Br.Ar,Sp)	Lechritrochoceras	(Mo,Ce,Ba)	Leiopathes	(Cn,An,An)
Latitaenia	(Mo,Ga,Ar)	Leckhamptonia	(Mo,Bi,Ve)	Leiopecten	(Mo,Bi,Pt)
Latitrigonia	(Mo,Bi,Tr)	Lecobasicrinus	(Ec,Cr,Cl)	Leiopedia	(Ec,Ec,Pe)
Latium	(Ac,Ra,Na)	Lecocrinus	(Ec,Cr,Sa)	Leiophyllites	(Mo,Ce,Ph)
Latocamurus	(Cd,Pl,Ar)	Lecointraceras	(Mo,Ce,Am)	Leiophyllum	(Po,De,Li)
Latomeandra	(Cn,An,Sc)	Lecomptella	(Po,De,St)	Leioprimitia	(Ar,Os,Pa)
Latona	(Mo,Bi,Ve)	Lecompteus	(Mo,Bi,Mt)	Leioproductus	(Br.Ar,St)
Latontoechia	(Br.Ar,Rh)	Leconteiceras	(Mo,Ce,Ce)	Leiopteria	(Mo,Bi,Pt)
Latoucheia	(Ar.Tr,Re)	Leconteites	(Mo,Ce,Am)	Leioptyrga	(Mo,Ga,Ar)
Latouchella	(Mo,He,He)	Leconychia	(Mo,Bi,Pt)	Leiorhinus	(Mo,Ga,Nt)
Latrunculia	(Po,De,Hd)	Lecythiocrinus	(Ec,Cr,Cl)	Leiorhynchoidea	(Br.Ar,Rh)
Latusastrea	(Cn,An,Sc)	Lecythioscopa	(Pa)	Leiorhynchoidea	(Br.Ar,Rh)
Latvius	(Cd,Os,Co)	Lecythocaris	(Ar,Ml,De)	Leiorhynchus	(Br.Ar,Rh)
Laubeia	(Mo,Bi,Un)	Lecythocrinus	(Ec,Cr,Cl)	Leioria	(Br.Ar,Or)
Laubella	(Mo,Ga,Ar)	Leda	(Mo,Bi,Nu)	Leioscutellum	(Ar.Tr,Pt)
Laubenfelsia	(Po,De,Li)	Ledabia	(Ar,Os,Me)	Leiosella	(Bz,Gy,Ch)
Laubeocrinus	(Ec,Cr,Un)	Ledella	(Mo,Bi,Nu)	Leioseptathyris	(Br.Ar,Te)
Laubriereia	(Mo,Bi,Ve)	Ledidocidaris	(Ec,Ec,Ey)	Leioshumardia	(Ar.Tr,Pt)
Laudonia	(Ar,Tr,Ol)	Ledina	(Mo,Bi,Nu)	Leiosocia	(Bz,St,Cc)
Laudonoerinus	(Ec,Cr,Cl)	Lednevia	(Cd,Os,Pl)	Leiosolenus	(Mo,Bi,Mt)
Laufeldochitina	(Fo,Fo,Ch)	Ledopsis	(Mo,Bi,Nu)	Leiospongia	(Po,De,AX)
Laugeites	(Mo,Ce,Am)	Leedsia	(Cd,Os,Am)	Leiostegina	(Ar,Tr,Ph)
Laugia	(Cd,Os,Co)	Leedsichthys	(Cd,Os,Am)	Leiostegium	(Ar,Tr,Co)
Laumontoceras	(Mo,Ce,On)	Leeites	(Mo,Ce,Go)	Leiostromaster	(Ec,Ec,Sp)
Laureloceras	(Mo,Ce,On)	Leella	(Fo,Fo,Fo)	Leiostraca	(Mo,Ga,Nt)
Laurelocrinus	(Ec,Cr,Mo)	Leeporina	(Bz,St,Tr)	Leiostracosia	(Po,He,Ly)
Laurentaspis	(Cd,Pl,Ar)	Lefortia	(Ec,Ec,Ca)	Leiostratotropis	(Ar.Tr,Ph)
Laurentoscandodus	(Cd,Co,Co)	Lefroyella	(Po,He,Ly)	Leiothyridina	(Br.Ar,Sp)
Lauriopteris	(Ar,Me,Eu)	Legonotus	(Cd,Os,Ma)	Leiotrochus	(Mo,Ga,Ar)
Lautoconus	(Mo,Ga,Ne)	Legrandella	(Ar,Me,Xi)	Leislingites	(Mo,Ce,Ce)
Lauzonella	(Ar,Tr,Pt)	Legumen	(Mo,Bi,Ve)	Lejopyge	(Ar.Tr,Ag)
Lavaloceras	(Mo,Ce,Di)	Leguminella	(Ch,Pr)	Lekanophyllum	(Cn,An,Ru)
Lavenachiton	(Mo,Po,Ne)	Leguminocythereis	(Ar,Os,Po)	Leki-kochiton	(Mo,Po,Ne)
Lawrenceoceras	(Mo,Cc,El)	Lehmaniceras	(Mo,Ce,Am)	Lekoerinus	(Ec,Cr,Cl)
Laxifenestella	(Bz,St,Fe)	Lehmanotus	(Cd,Os,Am)	Lekythionia	(Bz,St,Cc)
Laxispira	(Mo,Ga,Nt)	Lehua	(Ar,Tr,Ph)	Lekythoglena	(Bz,Gy,Ch)
Laxoendothyra	(Fo,Fo,Fo)	Leiagnostus	(Ar,Tr,Ag)	Lekythopora	(Bz,Gy,Ch)
Laxograptus	(He,Gr,Gr)	Leibaella	(Pr,Cr,Cr)	Lembicus	(Cd,Os,Cl)
Laxoseptabrunsiina	(Fo,Fo,Fo)	Leibotheca	(Hy,Or,Ci)	Lembitites	(Ar,Os,Pa)
Laytonia	(Cd,Os,An)	Leichneyella	(Ar,Tr,Un)	Lembitsarvella	(Ar,Os,Pa)
Lazaricella	(Mo,Bi,Ve)	Leimitria	(Ar,Tr,As)	Lembonax	(Cd,Re,Ch)
Lazella	(Br,Ar,Te)	Leinia	(Po,Ca,Un)	Lembulus	(Mo,Bi,Nu)
Lazithyris	(Br,Ar,Te)	Leinzia	(Mo,Bi,Ph)	Lemdadella	(Ar.Tr,Re)
Lazutkinia	(Br,Ar,Sp)	Leiobienvillea	(Ar,Tr,Pt)	Lemnocrinus	(Ec,Cr,Di)
Leaella	(Mo,Ga,Nt)	Leiocarenus	(Po,De,Li)	Lemintina	(Mo,Ga,Nt)
Leancholia	(Ar,In,Un)	Leioceras	(Mo,Ce,Am)	Lemniscollitorina	(Mo,Ga,Nt)
Leangella	(Br,Ar,St)	Leiochaetetes	(Po,De,Ta)	Lemonea	(Po,De,Gu)
Lebedictya	(Po,He,Re)	Leiochonetes	(Br,Ar,St)	Lemuroceras	(Mo,Ce,Am)
Lebediorthis	(Br,Ar,Or)	Leiochonia	(Po,De,Li)	Lenacare	(Ar.Tr,Pt)
Lebesconteia	(Ar,Ml,Ar)	Leioclema	(Bz,St,Tr)	Lenadiscus	(Ar.Tr,Ag)
Lebetoceras	(Mo,Ce,En)	Leiocoryphe	(Ar,Tr,Pt)	Lenaeffa	(Mo,In,In)
Lebetocrinus	(Ec,Cr,Cl)	Leiocyamus	(Ar,Os,Pa)	Lenalitus	(Hy,Hy,Hy)
Lebetodiscus	(Ec,Ed,Is)	Leiocyphus	(Ec,Ec,Te)	Lenargyriion	(An,Pa,Pa)
Lebonichthyes	(Cd,Os,An)	Leiodermatium	(Po,De,Li)	Lenaspis	(Ar.Tr,Co)
Lecanella	(Po,De,Li)	Leiodon	(Cd,Re,Sq)	Lenastella	(Po,Ca,He)

Lenatella	(Ar,Os,Pa)	Lepidion	(Cd,Os,Ga)	Leptelasma	(Cn,An,Ru)
Lenathea	(Hy,Or,Ex)	Lepidites	(Mo,In,In)	Leptella	(Br,Ar,St)
Lenatocchia	(Br,Ar,Rh)	Lepidocalix	(Ec,Di,Di)	Leptellina	(Br,Ar,St)
Lenella	(Mo,Bi,Pt)	Lepidocardia	(Mo,Bi,Ve)	Leptelloidea	(Br,Ar,St)
Lenica	(Po,De,Po)	Lepidocentrus	(Ec,Ec,Ey)	Leptembolon	(Br,Li,Li)
Lenicyamidia	(Ec,Ec,Cl)	Lepidochitona	(Mo,Po,Ne)	Leptesthes	(Mo,Bi,Ve)
Leniechinus	(Ec,Ec,Cl)	Lepidocolenus	(Pr,Ma,Le)	Leptestia	(Br,Ar,St)
Leniocythere	(Ar,Os,Po)	Lepidoconia	(Ec,Ed,Is)	Leptestiina	(Br,Ar,St)
Lenita	(Ec,Ec,Cl)	Lepidocottus	(Cd,Os,Se)	Lepteviella	(Mo,Bi,Nu)
Lenitropon	(Mo,Ga,Ne)	Lepidocrania	(Br,Li,Ac)	Leptophobites	(Mo,Ce,Am)
Lenneocrinus	(Ec,Cr,Mo)	Lepidocyclus	(Fo,Fo,Fo)	Leptobolbina	(Ar,Os,Pa)
Lennukella	(Ar,Os,Pa)	Lepidocyclides	(Br,Ar,Rh)	Leptobolus	(Br,Li,Li)
Lenobelus	(Mo,Ce,Be)	Lepidocycylus	(Br,Ar,Rh)	Leptobranchites	(Cn,Sc,Rh)
Lenocyathus	(Po,Re,Aj)	Lepidocystis	(Ec,Eo,Im)	Leptocardia	(Mo,Bi,Ve)
Lenodus	(Cd,Co,Co)	Lepidodiscus	(Ec,Ed,Is)	Leptocaryorhynchus	(Br,Ar,Rh)
Lenothyris	(Br,Ar,Te)	Lepidogobius	(Cd,Os,Pf)	Leptoceras	(Mo,Ce,Am)
Lenotropies	(Mo,Ce,Ce)	Lepidoleptaena	(Br,Ar,St)	Leptoceratoides	(Mo,Ce,Am)
Lenticeras	(Mo,Ce,Am)	Lepidomena	(Br,Ar,St)	Leptocheilopora	(Bz,Gy,Ch)
Lenticidaris	(Ec,Ec,Ci)	Lepidophyllia	(Cn,An,Sc)	Leptochilodiscus	(Ar,Tr,Ag)
Lenticocelites	(Mo,Ce,Ce)	Lepidophylliopsis	(Cn,An,Sc)	Leptochirognathus	(Cd,Co,Co)
Lenticorbula	(Mo,Bi,My)	Lepidopleurus	(Mo,Po,Ne)	Leptochiton	(Mo,Po,Ne)
Lenticularis	(Mo,Ga,Be)	Lepidoproetus	(Ar,Tr,Pr)	Leptochondria	(Mo,Bi,Pt)
Lenticulina	(Fo,Fo,Fo)	Lepidopus	(Cd,Os,Pf)	Leptochonetes	(Br,Ar,St)
Lenticulinella	(Fo,Fo,Fo)	Lepidorbitoides	(Fo,Fo,Fo)	Leptocidaris	(Ec,Ec,Pe)
Lentidium	(Mo,Bi,My)	Lepidorhombus	(Cd,Os,Pn)	Leptocleides	(Cd,Re,Ps)
Lentigo	(Mo,Ga,Nt)	Lepidorhynchia	(Br,Ar,Rh)	Leptocollella	(Br,Ar,At)
Lentigodentalium	(Mo,Sc,Sc)	Lepidorthis	(Br,Ar,Or)	Leptocolina	(Br,Ar,At)
Lentilla	(Mo,Bi,Pt)	Lepidosemicyclina	(Fo,Fo,Fo)	Leptocolpus	(Mo,Ga,Nt)
Lentipecten	(Mo,Bi,Pt)	Lepidospirifer	(Br,Ar,Sp)	Leptoconus	(Mo,Ga,Ne)
Lentithea	(Hy,Or,Or)	Lepidospongia	(Po,He,Ly)	Lepidocottus	(Cd,Os,Se)
Lenzia	(Br,Ar,Sp)	Lepidotrigla	(Cd,Os,Se)	Leptocyathus	(Cn,An,Sc)
Leocephalus	(Ar,Tr,Pt)	Lepidotrochus	(Mo,Ga,Ar)	Leptocystis	(Ec,Rh,Rh)
Leochlamys	(Mo,Bi,Pt)	Lepidotus	(Cd,Os,Se)	Leptocythere	(Ar,Os,Po)
Leocrinus	(Ec,Cr,Un)	Lepidozona	(Mo,Po,Ne)	Leptodelphis	(Cd,Ma,Ce)
Leodia	(Ec,Fc,Cl)	Lepismatina	(Br,Ar,Sp)	Leptodesma	(Mo,Bi,Pt)
Leolasma	(Cn,An,Ru)	Lepisosteus	(Cd,Os,Se)	Leptodonta	(Br,Ar,St)
Leolites	(Hy,Hy,Hy)	Lepitites	(Mo,In,In)	Leptodontella	(Br,Ar,St)
Leonardoceras	(Mo,Ce,On)	Lepochites	(Pr,Un,In)	Leptodus	(Br,Ar,St)
Leonardophyllum	(Cn,An,Ru)	Lepocrinites	(Ec,Rh,Rh)	Leptogonium	(Ec,As,Va)
Leonaspis	(Ar,Tr,Od)	Lepophidium	(Cd,Os,Op)	Leptograptus	(He,Gr,Gr)
Leonotus	(Cd,Ch,In)	Leporemax	(Mo,Ga,Ne)	Leptoides	(Ar,Ml,De)
Leontiella	(Br,Li,Li)	Leporicypraea	(Mo,Ga,Nt)	Leptolacis	(Po,He,He)
Leopecten	(Mo,Bi,Pt)	Leporimetus	(Mo,Bi,Ve)	Leptolepides	(Cd,Os,Pe)
Leopoldia	(Mo,Ce,Am)	Lepralina	(Bz,Gy,Ch)	Leptolepis	(Cd,Os,Pe)
Lepadocystis	(Ec,Rh,Rh)	Leproconcha	(Mo,Bi,Pt)	Leptolima	(Mo,Bi,Pt)
Lepadolepis	(Cd,Pl,An)	Lepsiella	(Mo,Ga,Ne)	Leptomactra	(Mo,Bi,Ve)
Lepas	(Ar,Ci)	Lepsithais	(Mo,Ga,Ne)	Leptomaria	(Mo,Ga,Ar)
Leperditella	(Ar,Os,Pa)	Leptadrillia	(Mo,Ga,Ne)	Leptomitella	(Po,De,Po)
Leperditelloides	(Ar,Os,Pa)	Leptaena	(Br,Ar,St)	Leptomithrax	(Ar,Ml,De)
Leperditiia	(Ar,Os,Le)	Leptaenisca	(Br,Ar,St)	Leptomitus	(Po,De,Po)
Lepeta	(Mo,Ga,Pa)	Leptaenoidia	(Br,Ar,St)	Leptomphalus	(Mo,Ga,Eu)
Lepetella	(Mo,Ga,Ar)	Leptaenomenclax	(Br,Ar,St)	Leptomurex	(Mo,Ga,Ne)
Lepetopsis	(Mo,Ga,Pa)	Leptaenopoma	(Br,Ar,St)	Leptomussa	(Cn,An,Sc)
Lepiconus	(Cn,An,Sc)	Leptaenopyxis	(Br,Ar,St)	Leptomya	(Mo,Bi,Ve)
Lepicythara	(Mo,Ga,Ne)	Leptagonia	(Br,Ar,St)	Lepton	(Mo,Bi,Ve)
Lepidactis	(Ec,As,Pu)	Leptaleoceras	(Mo,Ce,Am)	Leptonotoceras	(Mo,Ce,Am)
Lepidaspis	(Cd,Pt,Un)	Leptalosia	(Br,Ar,St)	Leptopecten	(Mo,Bi,Pt)
Lepidaster	(Ec,As,Pu)	Leptastrea	(Cn,An,Sc)	Leptophoca	(Cd,Ma,Ca)
Lepidasterella	(Ec,As,He)	Leptathyris	(Br,Ar,Sp)	Leptophragma	(Po,He,He)
Lepidasterina	(Ec,So,Go)	Leptaxinus	(Mo,Bi,Ve)	Leptophyllaraea	(Cn,An,Sc)
Lepidochinoides	(Ec,Ec,Ey)	Leptechinus	(Ec,Ec,Ph)	Leptophyllastraea	(Cn,An,Sc)
Lepidochinus	(Ec,Ec,Ey)	Leptechioceras	(Mo,Ce,Am)	Leptophyllia	(Cn,An,Sc)
Lepidenteron	(An,Po,Te)	Leptecodon	(Cd,Os,Al)	Leptophyllon	(Cn,An,Sc)
Lepidesthes	(Ec,Ec,Ey)	Leptegauana	(Mo,Ga,Ne)	Leptopilus	(Ar,Tr,Un)

Leptoplastides	(Ar.Tr,Pt)	Leukoma	(Mo,Bi,Ve)	Libodiscus	(Pr.Un,In)
Leptoplastus	(Ar.Tr,Pt)	Leukomoides	(Mo,Bi,Ve)	Libotoniis	(Cd,Os,Pf)
Leptopleurus	(Ec,Ec,Te)	Leupoldina	(Fo,Fo,Fo)	Librovitschicerias	(Mo,Ce,Na)
Leptopora	(Bz,St,Cc)	Leurelasma	(Cn,An,Ru)	Libumella	(Ar,Os,Po)
Leptopoterion	(Po,Ca,He)	Leuresthes	(Cd,Os,At)	Libyaconchus	(Mo,Bi,Un)
Leptoprimitia	(Ar,Os,Pa)	Leuroactis	(Mo,Bi,Ve)	Libyaeglossa	(Br,Li,Li)
Leptopriion	(An,Po,Eu)	Leuroceras	(Mo,Ce,Na)	Libyaerhynchus	(Br,Ar,Rh)
Leptopterygius	(Cd,Re,Ic)	Leurocidarius	(Ec,Ec,Ci)	Libyceerithium	(Mo,Ga,Nt)
Leptotygyma	(Mo,Ga,NT)	Leurocylocerases	(Mo,Ce,Or)	Libyocerases	(Mo,Ce,Am)
Leptoria	(Cn,An,Sc)	Leurothoerases	(Mo,Ce,Ac)	Libys	(Cd,Os,Co)
Leptorima	(Mo,Ga,Ar)	Leurosina	(Br,Ar,St)	Lichakephalina	(Ar,Tr,Li)
Leptosalenia	(Ec,Ec,Sa)	Leurospondylus	(Cd,Re,Ps)	Lichakephalus	(Ar,Tr,Li)
Leptoscapa	(Mo,Ga,Ne)	Leurotrochoceras	(Mo,Ce,Ta)	Lichapyge	(Br,Ar,As)
Leptoschisma	(Ec,BI,Fi)	Leutorhinion	(Cd,Co,Co)	Licharewia	(Br,Ar,Sp)
Leptoscopus	(Cd,Os,Pf)	Leveillites	(He,Gr,Un)	Lichas	(Ar,Tr,Li)
Leptoseris	(Cn,An,Sc)	Levella	(Mo,Ga,Ar)	Lichenalia	(Bz,St,Cy)
Leptoskelidion	(Br,Ar,Or)	Levenea	(Br,Ar,Or)	Lichenaria	(Cn,An,Ta)
Leptosocyathellus	(Po,Re,Aj)	Levenia	(Mo,Ga,NT)	Lichengia	(Ar,Tr,As)
Leptosocyathus	(Po,Re,Aj)	Leviathania	(Mo,Ga,NT)	Lichenoides	(Ec,Di,Di)
Leptosolen	(Mo,Bi,Ve)	Levibisepium	(Br,Ar,Pe)	Lichenopora	(Bz,St,Ce)
Leptosphinctes	(Mo,Ce,Am)	Leviceraurus	(Ar,Tr,Ph)	Lichenotrypa	(Bz,St,Cy)
Leptospira	(Br,Ar,Sp)	Levicidaris	(Ec,Ec,Ci)	Lichnatrypa	(Br,Ar,At)
Leptostega	(Mo,He,He)	Leviconchidiella	(Br,Ar,Pe)	Lichnocephala	(Ar,Tr,Pr)
Leptosteus	(Cd,Pl,Ar)	Levicayathus	(Cn,An,Sc)	Lichuanopora	(Po,De,Ax)
Leptostrophia	(Br,Ar,St)	Leviechinus	(Ec,Ec,Sp)	Lichuanospongia	(Mo,De,Pe)
Leptostrophhiella	(Br,Ar,St)	Leviella	(Ar,Os,Po)	Lichvinia	(Ar,Os,Pa)
Leptostyrax	(Cd,Ch,La)	Levifenestella	(Bz,St,Fe)	Licmosinion	(Po,He,Ly)
Leptosarcula	(Mo,Ga,Ne)	Levifusus	(Mo,Ga,Ne)	Licnograptus	(He,Gr,De)
Leptotetragonites	(Mo,Ce,Am)	Levigatella	(Br,Ar,Pe)	Lidaconus	(Pr,Un,In)
Leptoteuthis	(Mo,Ce,Te)	Levimyrtaea	(Mo,Bi,Ve)	Liebea	(Mo,Bi,Pt)
Leptothyra	(Mo,Ga,Ar)	Levipugnax	(Br,Ar,Rh)	Liebusella	(Fo,Fo,Fo)
Leptothyrellopsis	(Br,Ar,Te)	Levipustula	(Br,Ar,St)	Lienardia	(Mo,Ga,Ne)
Leptothyropsis	(Mo,Ga,Ar)	Levisaspis	(Ar,Tr,Pt)	Lievinella	(Br,Ar,Te)
Leptotrigonia	(Mo,Bi,Tr)	Levisella	(Ar,Tr,Pt)	Ligatella	(Mo,Ga,NT)
Leptotriticeites	(Fo,Fo,Fo)	Levisettius	(An,Po,Ph)	Ligerina	(Ar,Os,Po)
Leptotrypa	(Bz,St,Tr)	Levisia	(Ar,Tr,Un)	Ligiscus	(Ar,Tr,Co)
Leptotrypella	(Bz,St,Tr)	Levisoceras	(Mo,Ce,El)	Ligonodina	(Cd,Co,Co)
Leptozone	(Mo,Ga,Ar)	Levispira	(Br,Ar,At)	Ligulalepis	(Cd,Os,Pa)
Leptozyga	(Mo,Ga,NT)	Levisulculus	(Ar,Os,Pa)	Ligulella	(Cd,Os,Pe)
Lepyriactis	(Ec,As,He)	Levitusia	(Br,Ar,St)	Liguloclema	(Bz,St,Cy)
Lercarella	(Br,Ar,St)	Lewesiceras	(Mo,Ce,Am)	Ligyrokala	(Mo,In,In)
Lercaritubus	(An,Po,Un)	Lewinia	(Po,De,Li)	Likinia	(Cn,Hy,Un)
Lermontovia	(Ar,Tr,Re)	Lewinskia	(Mo,Ga,NT)	Lilangina	(Mo,Bi,Pt)
Lernella	(Fo,Fo,Fo)	Lewisella	(Mo,Ga,Ar)	Lilax	(Mo,Ga,NT)
Lerouxia	(Po,De,Li)	Lewyites	(Mo,Ce,Am)	Liliaspis	(Cd,Pt,Pt)
Leshanella	(Ar,Os,Ar)	Leymeriella	(Mo,Ce,Am)	Lilicrinus	(Ec,Cr,Mi)
Lesleya	(Ar,Os,Po)	Liagnshanella	(Ar,Os,Ar)	Liljevallia	(Br,Ar,St)
Lesliella	(Cn,An,Ru)	Lialosia	(Br,Ar,St)	Liljevallospira	(Mo,Ga,Be)
Lesperonia	(Mo,Ga,Ar)	Liangshanophyllum	(Cn,An,Ru)	Lilliputiabella	(Fo,Fo,Fo)
Lessnikovaea	(Cn,An,Ta)	Liantuoconus	(Mo,In,In)	Lilloetia	(Mo,Ce,Am)
Lestidiops	(Cd,Os,Al)	Liantuoa	(Ar,Un,Un)	Liloa	(Mo,Ga,Ce)
Lestrodus	(Cd,Ch,Eu)	Liaohenia	(Mo,Ga,NT)	Lima	(Mo,Bi,Pt)
Lesueirilla	(Mo,Ga,Eu)	Liaoningella	(Ar,Tr,As)	Limacina	(Mo,Ga,Th)
Lethamia	(Br,Ar,St)	Liaoyangaspis	(Ar,Tr,Un)	Limaites	(Mo,Ce,Am)
Lethops	(Cd,Os,Pf)	Liardiphyllum	(Cn,An,Ru)	Limanda	(Cd,Os,Pn)
Leuconia	(Po,Ca,Ca)	Liardites	(Mo,Ce,Ce)	Limanomia	(Mo,Bi,Pt)
Leucorhynchia	(Mo,Ga,Ar)	Liasina	(Ar,Os,Po)	Limarca	(Mo,Bi,Ar)
Leucosia	(Ar,MI,De)	Liasopteron	(Ar,Os,Po)	Limaria	(Mo,Bi,Pt)
Leucosilia	(Ar,MI,De)	Liauria	(Cn,An,Ru)	Limatia	(Ar,Os,Pa)
Leucosyrinx	(Mo,Ga,Ne)	Libanoberyx	(Cd,Os,Br)	Limatuella	(Mo,Bi,Pt)
Leucotina	(Mo,Ga,Ne)	Libanopristis	(Cd,Ch,Rj)	Limatula	(Mo,Bi,Pt)
Leucozonia	(Mo,Ga,Ne)	Libanoteuthis	(Mo,Ce,Te)	Limatulella	(Mo,Bi,Pt)
Leufroyia	(Mo,Ga,Ne)	Libertella	(Ar,Tr,Ph)	Limatulina	(Mo,Bi,Pt)
Leukadiella	(Mo,Ce,Am)	Libinia	(Ar,MI,De)	Limbatorypa	(Br,Ar,At)

Limbella	(Br,Ar,St)	Lingyunites	(Mo,Ce,Ce)	Liosotella	(Br,Ar,St)
Limbifera	(Br,Ar,St)	Liniaxis	(Mo,Ga,Ne)	Liosphaera	(Ac,Ra,Sp)
Limbimurina	(Br,Ar,St)	Linnarssonella	(Br,Li,Ac)	Liosphinctes	(Mo,Ce,Am)
Limbinaria	(Ar,Os,Pa)	Linnarssonina	(Br,Li,Ac)	Liospira	(Mo,Ga,Ar)
Limbinariella	(Ar,Os,Pa)	Linobrachiocrinus	(Ec,Cr,Cl)	Liospiriferina	(Br,Ar,Sp)
Limburgina	(Ar,Os,Po)	Linochitina	(Fo,Fo,Ch)	Liostracina	(Ar,Tr,As)
Limea	(Mo,Bi,Pt)	Linochone	(Po,De,Li)	Liostracinoides	(Ar,Tr,As)
Limipecten	(Mo,Bi,Pt)	Linocrinus	(Ec,Cr,Cl)	Liostracus	(Ar,Tr,Pt)
Limneria	(Mo,Ga,Nt)	Linograptus	(He,Gr,Gr)	Liostrea	(Mo,Bi,Pt)
Limopsis	(Mo,Bi,Ar)	Linonema	(Po,He,He)	Liostrophia	(Br,Ar,Pe)
Limoptera	(Mo,Bi,Pt)	Linoporella	(Br,Ar,Or)	Liotella	(Mo,Ga,Ar)
Limpeina	(Ar,Tr,Pt)	Linoproductus	(Br,Ar,St)	Liot euthis	(Mo,Ce,Te)
Limpidograptus	(He,Gr,Gr)	Linoprotonia	(Br,Ar,St)	Liothyrella	(Br,Ar,Te)
Limstrophina	(Br,Ar,Pe)	Linopyrga	(Mo,Ga,He)	Liothyris	(Mo,Bi,Ve)
Limulatys	(Mo,Ga,Ce)	Linostrophomena	(Br,Ar,St)	Liotia	(Mo,Ga,Ar)
Limultella	(Ar,Me,Xi)	Linotaxis	(Bz,St,Fe)	Liotina	(Mo,Ga,Ar)
Limuloides	(Ar,Me,Xi)	Linotrigonia	(Mo,Bi,Tr)	Liotrigonia	(Mo,Bi,Tr)
Limulus	(Ar,Me,Xi)	Linsayella	(Ar,Os,Pa)	Lipanteris	(Br,Ar,St)
Linaresia	(Fo,Fo,Fo)	Linsdallia	(Mo,Bi,Pt)	Liparoceras	(Mo,Ce,Am)
Linatella	(Mo,Ga,Nt)	Linsleyella	(Mo,Ga,Eu)	Liparocrinus	(Ec,Cr,Cl)
Linchengoceras	(Mo,Ce,En)	Linstroemoceras	(Mo,Ce,As)	Lipinella	(Fo,Fo,Fo)
Linckia	(Ec,As,Va)	Linter	(Mo,Bi,Ar)	Lipinella	(Fo,Fo,Fo)
Linderina	(Fo,Fo,Fo)	Linterella	(Br,Ar,Rh)	Lipmanium	(Ac,Ra,Na)
Lindinella	(Br,Un,Ob)	Linthia	(Ec,Ec,Sp)	Lipopora	(Cn,An,Un)
Lindisfarnia	(Ar,Os,Po)	Linucula	(Mo,Bi,Nu)	Lippistes	(Mo,Ga,Nt)
Lindstroemella	(Br,Li,Ac)	Linuparus	(Ar,Ml,De)	Lippisa	(Fo,Fo,Fo)
Lindstroemia	(Cn,An,Ru)	Linxiangxiella	(Br,Ar,Rh)	Lipsanoecystis	(Ec,Rh,Rh)
Lindstroemophyllum	(Cn,An,Ru)	Lioberus	(Mo,Bi,Mt)	Liptodendron	(Cn,An,Sc)
Linearia	(Mo,Bi,Ve)	Liobole	(Ar,Tr,Pr)	Lipuites	(Mo,Ce,Ce)
Lineastroma	(Po,De,St)	Liobolina	(Ar,Tr,Pr)	Liracassis	(Mo,Ga,Nt)
Linemera	(Mo,Ga,Nt)	Liocalymene	(Ar,Tr,Ph)	Lirachiton	(Mo,Po,Ne)
Lineta	(Mo,Bi,Ve)	Liocarcinus	(Ar,Ml,De)	Liracraea	(Mo,Ga,Ne)
Linevitus	(Hy,Hy,Hy)	Liocare	(Ar,Tr,Pt)	Liralingua	(Br,Li,Li)
Linga	(Mo,Bi,Ve)	Liocarenus	(Mo,Ga,Ce)	Liramia	(Br,Ar,Te)
Lingatrypa	(Br,Ar,At)	Liocaris	(Ar,Ml,De)	Liraplecta	(Br,Ar,St)
Linglingella	(Mo,Ga,Ar)	Lioceratoides	(Mo,Ce,Am)	Liraria	(Br,Ar,St)
Lingshanella	(Br,Ar,Te)	Liocerithium	(Mo,Ga,Nt)	Liraspirifer	(Br,Ar,Sp)
Linguaclymenia	(Mo,Ce,Cl)	Liochlamys	(Mo,Ga,Ne)	Lirastrombina	(Mo,Ga,Ne)
Linguagnostus	(Ar,Tr,Ag)	Liocium	(Mo,Ga,Nt)	Lirasyrinx	(Mo,Ga,Ne)
Linguaphillipsia	(Ar,Tr,Pt)	Lioclemella	(Bz,St,Tr)	Liratalia	(Mo,Ga,Ne)
Linguaproetus	(Ar,Tr,Pr)	Liocnemis	(Ar,Tr,Ph)	Liratolina	(Mo,Ga,Ne)
Linguatornoceras	(Mo,Ce,Go)	Liocoelia	(Br,Ar,Un)	Lirellaria	(Br,Ar,Rh)
Linguchuangia	(Ar,Tr,Co)	Liococha	(Mo,Bi,Ve)	Lirellarina	(Br,Ar,Rh)
Linguisaukia	(Ar,Tr,As)	Liocyma	(Mo,Bi,Ve)	Liriamnica	(Ar,Tr,Un)
Linguithyris	(Br,Ar,Te)	Liodesmus	(Cd,Os,Am)	Liricamera	(Br,Ar,Pe)
Lingukainella	(Ar,Tr,As)	Liodonax	(Mo,Bi,Ve)	Liriospyris	(Ac,Ra,Na)
Lingula	(Br,Li,Li)	Lioglyphostoma	(Mo,Ga,Ne)	Liriplica	(Br,Ar,Sp)
Lingulapholis	(Br,Li,Li)	Lioharpes	(Ar,Tr,Pt)	Liripora	(Bz,St,Ce)
Lingularia	(Br,Li,Li)	Liokootenia	(Ar,Tr,Co)	Lirobitium	(Mo,Ga,Nt)
Lingulasma	(Br,Li,Li)	Lioleptaena	(Br,Ar,St)	Liroceras	(Mo,Ce,Na)
Lingulella	(Br,Li,Li)	Liolithax	(Cd,Ma,Ce)	Lirocingula	(Mo,Ga,Nt)
Lingulellotreta	(Br,Li,Li)	Liolophops	(Ar,Tr,Ph)	Lirodiscus	(Mo,Bi,Ve)
Lingulepis	(Br,Li,Li)	Liomesus	(Mo,Ga,Ne)	Lirofusius	(Mo,Ga,Ne)
Lingulibolina	(Ar,Os,Pa)	Liomolgoerinus	(Ec,Cr,Mo)	Liromytilus	(Mo,Bi,Mo)
Lingulina	(Fo,Fo,Fo)	Liomphalus	(Mo,Pa,Hy)	Lironoba	(Mo,Ga,Nt)
Lingulipora	(Br,Li,Li)	Lioparella	(Ar,Tr,Pt)	Lirophora	(Mo,Bi,Ve)
Lingulobolus	(Br,Li,Li)	Lioparia	(Ar,Tr,As)	Liroseceles	(Cd,Os,Se)
Lingulocystis	(Ec,Rh,Rh)	Liopelta	(Ar,Tr,Pt)	Lirosoma	(Mo,Ga,Ne)
Lingulodiscina	(Br,Li,Ac)	Liopelium	(Mo,Ga,Ne)	Lirotheca	(Hy,Hy,Hy)
Lingulogavelinella	(Fo,Fo,Fo)	Liopistha	(Mo,Bi,Ph)	Lirularia	(Mo,Ga,Ar)
Lingulonodosaria	(Fo,Fo,Fo)	Liopleurodon	(Cd,Re,Ps)	Lisania	(Ar,Tr,Co)
Lingulops	(Br,Li,Li)	Lioporida	(Bz,St,Tr)	Lisaniella	(Ar,Tr,Co)
Lingulosmilia	(Cn,An,Sc)	Liorichita	(Mo,In,In)	Lisbonia	(Mo,Ga,Ne)
Linguopugnoides	(Br,Ar,Rh)	Liosolenopleura	(Ar,Tr,Pt)	Lischkeia	(Mo,Ga,Ar)

Liscombea	(Cn,An,Ta)	Lithocampana	(Ac,Ra,Na)	Lixatrypa	(Br,Ar,At)
Liscombispongia	(Po,He,Am)	Lithoecampe	(Ac,Ra,Na)	Lixouria	(Ar,Os,Po)
Lisgodus	(Cd,Cl,In)	Lithoecarpium	(Ac,Ra,Na)	Liza	(Cd,Os,Pl)
Liskeardia	(Mo,Ce,En)	Lithochytrix	(Ac,Ra,Na)	Ljaschenkovia	(Br,Li,Ac)
Lisogoragnostus	(Ar,Tr,Ag)	Lithoconus	(Mo,Ga,Ne)	Ljaschenkovites	(Mo,Cr,Te)
Lisogorites	(Ar,Tr,As)	Lithocrius	(Ee,Cr,Sa)	Ljubimovella	(Ar,Os,Po)
Lispidecodus	(Ee,Ed,Is)	Lithocyelia	(Ac,Ra,Sp)	Ljudmilispirifer	(Br,Ar,Sp)
Lispoceras	(Mo,Ce,Na)	Lithodolina	(Mo,Bi,Mt)	Llandeilochiton	(Mo,Po,Ne)
Lispodesthes	(Mo,Ga,Nt)	Lithognathus	(Cd,Os,Pl)	Llandovacaste	(Ar,Tr,Ph)
Lissajousithyris	(Br,Ar,Te)	Lithomelissa	(Ac,Ra,Na)	Llanoaspidella	(Ar,Tr,Pl)
Lissanucula	(Mo,Bi,Nt)	Lithomespilus	(Ac,Ra,Sp)	Llanoaspis	(Ar,Tr,Pl)
Lissapiopsis	(Mo,Ga,Ne)	Lithomitra	(Ac,Ra,Na)	Llanoceras	(Mo,Ce,El)
Lissarca	(Mo,Bi,Ar)	Lithopera	(Ac,Ra,Na)	Llanocetus	(Cd,Ma,Ce)
Lissatrypa	(Br,Ar,At)	Lithophaga	(Mo,Bi,Mt)	Llanoella	(Br,Ar,Pe)
Lissatrypella	(Br,Ar,At)	Lithophylax	(Ar,Ml,De)	Lloydofithus	(Ar,Tr,As)
Lissatrypoidea	(Br,Ar,At)	Lithophyllon	(Cn,An,Sc)	Llobalocrinus	(Ee,Cr,Cl)
Lissella	(Br,Ar,Rh)	Lithophysema	(Mo,Ga,Ce)	Llobantale	(Mo,Sc,Se)
Lissidium	(Br,Ar,Pe)	Lithopoma	(Mo,Ga,Ar)	Llobatula	(Fo,Fo,Fo)
Lissoberyx	(Cd,Os,Br)	Lithopora	(Po,De,AX)	Llobendoceras	(Mo,Ce,En)
Lissocardia	(Ar,Ml,De)	Lithorhadia	(Mo,Bi,Nu)	Llobianchia	(Cd,Os,My)
Lissoceras	(Mo,Ce,Am)	Lithornithium	(Ac,Ra,Na)	Llobiochrea	(Tr,An)
Lissoceratoides	(Mo,Ce,Am)	Lithostrobilis	(Po,De,Li)	Llobites	(Mo,Ce,Ce)
Lissochilus	(Mo,Ga,Ar)	Lithostrobos	(Ac,Ra,Na)	Lloboarochiton	(Mo,Po,Ne)
Lissochlamis	(Mo,Bi,Pl)	Lithostrotion	(Cn,An,Ru)	Llobobactrites	(Mo,Ce,An)
Lissochonetes	(Br,Ar,St)	Lithostrotionella	(Cn,An,Ru)	Llobobarcinus	(Ar,Ml,De)
Lissochymenia	(Mo,Ce,Cl)	Lithostrozionioides	(Cn,An,Sc)	Lloboccephalina	(Ar,Tr,Pl)
Lissocoelia	(Po,De,Li)	Lithotractus	(Ac,Ra,Na)	Llobocorallium	(Cn,An,Ru)
Lissocoelina	(Br,Ar,Pe)	Lithotrochus	(Mo,Ga,Ar)	Llobocyclendoceras	(Mo,Ce,En)
Lissodus	(Cd,Ch,Ct)	Lithotroftionioides	(Cn,An,Sc)	Llobograptus	(He,Gr,Gr)
Lissopletaena	(Br,Ar,St)	Litugiella	(Mo,Bi,Ve)	Lloboidothyris	(Br,Ar,Te)
Lissomarginifera	(Br,Ar,St)	Litlpetalichthyes	(Cd,Pl,Pe)	Lloboidothyropsis	(Br,Ar,Te)
Lissomuricopsis	(Mo,Ga,Ne)	Litiopa	(Mo,Ga,Nt)	Llobokosmokeras	(Mo,Ce,Am)
Lissonia	(Mo,Ce,Am)	Litocephalus	(Mo,Tr,As)	Llobolytoceras	(Mo,Ce,Am)
Lissonites	(Mo,Ce,Ce)	Litoceras	(Mo,Ce,Ta)	Llobomelocrinus	(Ee,Cr,Mo)
Lissopecten	(Mo,Bi,Pl)	Litochthia	(Br,Ar,St)	Llobomseenteripora	(Bz,St,Cc)
Lissopleura	(Br,Ar,Rh)	Litocrinus	(Ee,Cr,DS)	Llobonotus	(Ar,Ml,De)
Lissopsis	(Ar,Ml,De)	Litogaster	(Ar,Ml,De)	Llobophyllia	(Cn,An,Sc)
Lissorhynchia	(Br,Ar,Rh)	Litogyroceras	(Mo,Ce,Na)	Llobopsammia	(Cn,An,Sc)
Lissosia	(Br,Ar,St)	Litophyllum	(Po,De,Ta)	Llobopterus	(Cd,Os,Br)
Lissospira	(Mo,Ga,Ar)	Litoptychius	(Cd,Os,Co)	Llobopyge	(Ar,Tr,Li)
Lissostrophia	(Br,Ar,St)	Litothyris	(Br,Ar,Sp)	Lloborina	(Br,Ar,Rh)
Lisstesta	(Mo,Ga,Ar)	Litotrigonia	(Mo,Bi,Tr)	Lloboseris	(Cn,An,Sc)
Lissotestella	(Mo,Ga,Ar)	Litschkovitrignonia	(Mo,Bi,Tr)	Llobosiphon	(Mo,Ce,En)
Lissothyris	(Br,Ar,Te)	Littoraria	(Mo,Ga,Un)	Llobosocythereis	(Ar,Os,Po)
Lissozotra	(Br,Ar,Or)	Littorina	(Mo,Ga,Nt)	Llobosocia	(Bz,St,Cc)
Listraspis	(Cd,Pl,Pl)	Littorinides	(Mo,Ga,Ar)	Llobosphinctes	(Mo,Ce,Am)
Listroa	(Ar,Tr,As)	Littorinolacuna	(Mo,Ga,Nt)	Llobothyris	(Br,Ar,Te)
Listrotheuthis	(Mo,Ce,Te)	Littorinopsis	(Mo,Ga,Nt)	Llobothyroides	(Br,Ar,Te)
Litagnostoides	(Ar,Tr,Ag)	Littorniscala	(Mo,Ga,Nt)	Llobotornoceras	(Mo,Ce,Go)
Litagnostus	(Ar,Tr,Ag)	Lituites	(Mo,Ce,Or)	Lochkothele	(Br,Li,Ac)
Litaspis	(Ar,Tr,Pl)	Lituola	(Fo,Fo,Fo)	Lochkovella	(Ar,Tr,Ph)
Litavina	(Mo,In,In)	Lituolipora	(Fo,Fo,Fo)	Lochmaeosmilina	(Cn,An,Sc)
Litavkaspis	(Ar,Tr,Pl)	Lituonelloides	(Fo,Fo,Fo)	Lochmanaspis	(Ar,Tr,Pl)
Lithacoceras	(Mo,Ce,Am)	Lituotuba	(Fo,Fo,Fo)	Lochmocereres	(Cd,Os,Co)
Lithancyclus	(Mo,Ce,Am)	Lituotubella	(Fo,Fo,Fo)	Lochria	(Cd,Co,Co)
Lithapium	(Ac,Ra,Sp)	Lituyapecten	(Mo,Bi,Pl)	Lochkartia	(Fo,Fo,Fo)
Litharaeopsis	(Cn,An,Sc)	Litvolasma	(Cn,An,Ru)	Lockportia	(An,Po,Un)
Lithatractus	(Ac,Ra,Sp)	Liujiangolepis	(Cd,Pl,An)	Locularia	(Bz,St,Cc)
Lithelius	(Ac,Ra,Sp)	Liujingina	(Ar,Os,Po)	Loculibairdia	(Ar,Os,Po)
Lithioperma	(Mo,Bi,Pl)	Livarella	(Ac,Ra,Na)	Loculibolbina	(Ar,Os,Pa)
Lithiotis	(Mo,Bi,Pl)	Liveringia	(Br,Ar,St)	Loculicyathus	(Po,Ir,Ar)
Lithisthis	(Mo,Bi,Pl)	Livia	(Ar,Tr,Na)	Loculicytheretta	(Ar,Os,Po)
Lithobotrys	(Ac,Ra,Na)	Livonia	(Mo,Ga,Ne)	Loculipora	(Bz,St,Fe)
Lithocalamus	(Mo,Bi,Hi)	Liwia	(Ar,Tr,Na)	Loculitheca	(Hy,Or,Ci)

Loculocavata	(Ar.Os.Pa)	Longicyathus	(Pr.Cr.Cr)	Lophogaster	(Ar.Mi.Lo)
Loecyceras	(Mo.Ce.Am)	Longidaonella	(Mo.Bi.Pt)	Lopholobus	(Ar.Tr.As)
Loeczella	(Br.Ar.St)	Longidorus	(Ar.Os.Pa)	Lophokloedenia	(Ar.Os.Pa)
Lodanaria	(Mo.Ga.Ar)	Longimactra	(Mo.Bi.Ve)	Lopholasma	(Cn.An.Ru)
Lodderena	(Mo.Ga.Ar)	Longioceera	(Tr.An)	Lopholepsis	(Bz.St.Cc)
Lodderia	(Mo.Ga.Ar)	Longiproetus	(Ar.Tr.Pr)	Lopholobites	(Mo.Ce.Am)
Loeblichia	(Fo.Fo.Fo)	Longiscula	(Ar.Os.Me)	Lophonema	(Mo.Ga.Eu)
Loeipyge	(Ar.Tr.Pr)	Longispina	(Br.Ar.St)	Lophonopeus	(Ar.Mi.De)
Loemmelia	(Mo.Bi.Pt)	Longithyris	(Br.Ar.Te)	Lophopaena	(Ac.Ra.Na)
Loenthyris	(Br.Ar.Te)	Longitubus	(An.Po.Se)	Lophoprentis	(Cn.An.Ru)
Loerenthya	(Ar.Mi.De)	Longinophyllia	(Cn.An.Ht)	Lophophyllia	(Cn.An.Sc)
Loffa	(Ac.Ra.Sp)	Longobardites	(Mo.Ce.Ce)	Lophophyllidium	(Cn.An.Ru)
Lofusia	(Fo.Fo.Fo)	Longobarditoides	(Mo.Ce.Ce)	Lophophyllum	(Cn.An.Ru)
Loganella	(Br.Ar.Or)	Longoconcha	(Mo.Ga.Ne)	Lophoprothyris	(Mo.Bi.Ph)
Loganellia	(Cd.Pt.Th)	Longstaffia	(Mo.Ga.Ar)	Lophoranina	(Ar.Mi.De)
Loganellus	(Ar.Tr.As)	Longtanella	(Ac.Ra.Sp)	Lophoraminella	(Ar.Mi.De)
Logania	(Cd.Pt.Th)	Longulatus	(Mo.Cr.Te)	Lophosaukia	(Ar.Tr.As)
Loganiella	(Po.De.As)	Longusorbis	(Ar.Mi.De)	Lophosmia	(Cn.An.Sc)
Loganoceras	(Mo.Ce.On)	Longxianirhynchia	(Br.Ar.Rh)	Lophospira	(Mo.Ga.Ar)
Loganograptus	(He.Gr.Gr)	Longyuanelia	(Ar.Os.Po)	Lophospyris	(Ac.Ra.Na)
Loganopeltis	(Ar.Tr.Pt)	Lonsda	(Po.He.He)	Lophosteus	(Cd.Os.Pa)
Loganopeltoides	(Ar.Tr.Pt)	Lonsdaleia	(Cn.An.Ru)	Lophotheca	(Hy.Or.Or)
Logocrinus	(Ec.Cr.Cl)	Lonsdaleiastraea	(Cn.An.Ru)	Lophotichium	(Cn.An.Ru)
Loilemia	(Br.Ar.Au)	Lonsdaleoides	(Cn.An.Ru)	Lophrothyris	(Br.Ar.Te)
Loisthostomata	(Fo.Fo.Fo)	Loomberaphyllum	(Cn.An.Ru)	Lopingia	(Br.Ar.St)
Lokius	(Ar.Os.Pa)	Looneyella	(Ar.Os.Po)	Lopingoceras	(Mo.Ce.Or)
Lokutella	(Br.Ar.Rh)	Lopadiocrinus	(Ec.Cr.Cl)	Lopochites	(Pr.Co.Sa)
Loliginites	(Mo.Ce.Te)	Lopadophorus	(Po.De.Li)	Lorangerella	(Br.Ar.Rh)
Loligo	(Mo.Ce.Te)	Lopanela	(Po.He.He)	Lordorthis	(Br.Ar.Or)
Loligosepia	(Mo.Ce.Te)	Loparella	(Ar.Tr.Pt)	Lordshillia	(Ar.Tr.Pt)
Lomacetus	(Cd.Ma.Ce)	Loparia	(Mo.Bi.Ve)	Loreleiella	(Br.Ar.St)
Lomasulcachites	(Pr.Co.Sa)	Lopasnia	(Br.Ar.St)	Lorensella	(Ar.Tr.Pt)
Lomatiocyathus	(Pr.Cr.Cr)	Lopatinia	(Mo.Bi.Ar)	Lorenziella	(Ci.In.Ca)
Lomatiphora	(Br.Ar.St)	Loperia	(Br.Ar.Or)	Lorenzina	(Cn.Sc.Co)
Lomatobolbina	(Ar.Os.Pa)	Lopeuloma	(Ar.Tr.Pt)	Lorenzinites	(Cn.In.In)
Lomatopisthia	(Ar.Os.Pa)	Lopha	(Mo.Bi.Pt)	Lorica	(Mo.Po.Ne)
Lomatorthis	(Br.Ar.Or)	Lophamplexus	(Cn.An.Ru)	Loricella	(Mo.Po.Ne)
Lombardia	(Pr.Un.In)	Lophar	(Cd.Os.Pf)	Loriculina	(Ar.Ci)
Lomia	(Mo.Ga.Th)	Lophaster	(Ec.As.Va)	Lorieroceras	(Mo.Ce.On)
Lomirosa	(Mo.Ga.Ne)	Lophelia	(Cn.An.Sc)	Loriolaster	(Ec.Op.Oe)
Lomonossovella	(Mo.Ce.Am)	Lophidiaster	(Ec.As.Px)	Loriollella	(Ec.Ec.Un)
Lompoquia	(Cd.Os.Pf)	Lophiodolus	(Cd.Ma.Si)	Loriolia	(Ec.Ec.Hm)
Lomsucaspis	(Ar.Tr.Un)	Lophiokephalion	(Ar.Tr.Pr)	Loriolierinus	(Ec.Cr.Cm)
Lonaspis	(Cd.Pt.Pt)	Lophiostomus	(Cd.Os.Am)	Loriolipedia	(Ec.Ec.Pe)
Lonchidium	(Mo.Cr.Te)	Lophiostroma	(Po.De.St)	Loriolithyris	(Br.Ar.Te)
Lonchidon	(Cd.Ch.Ct)	Lophioturris	(Mo.Ga.Ne)	Loriolyceras	(Mo.Ce.Am)
Lonchistium	(Cd.Os.Pf)	Lophius	(Cd.Os.Lo)	Loriolometra	(Ec.Cr.Cm)
Lonchocephalus	(Ar.Tr.Pt)	Lophobalanus	(Ar.Ci)	Loripes	(Mo.Bi.Ve)
Lonchocrinus	(Ec.Cr.Cy)	Lophoblastus	(Ec.Bl.Sp)	Loripinus	(Mo.Bi.Ve)
Lonchodina	(Cd.Co.Co)	Lophocardium	(Mo.Bi.Ve)	Loretina	(Ar.Tr.Pt)
Lonchodomas	(Ar.Tr.As)	Lophocarinophyllum	(Cn.An.Ru)	Losvia	(Br.Ar.Rh)
Lonchograptus	(He.Gr.Gr)	Lophoceras	(Mo.Ce.Na)	Lota	(Cd.Os.Ga)
Lonchosaccus	(Pr.Un.In)	Lophocetus	(Cd.Ma.Ce)	Lotagnostus	(Ar.Tr.Ag)
Loncodelphis	(Cd.Ma.Ce)	Lophochelys	(Cd.Re.Ch)	Lotharingella	(Br.Ar.Rh)
Londinia	(Ar.Os.Po)	Lophoclema	(Bz.St.Cy)	Lotocrinus	(Ec.Cr.Un)
Longaeviceras	(Mo.Ce.Am)	Lophocochlias	(Mo.Ga.Nt)	Lotoides	(Ar.Tr.Un)
Longaevus	(Pr.Cr.Cr)	Lophoconcha	(Mo.Bi.Nu)	Lottia	(Mo.Ga.Pa)
Longchaesus	(Mo.Ga.He)	Lophoconus	(Ac.Ra.Na)	Lotzeites	(Mo.Ce.Am)
Longdongshuia	(Br.Ar.Rh)	Lophocorys	(Ac.Ra.Na)	Louisella	(Pa)
Longduia	(Ar.Tr.Co)	Lophocrinus	(Ec.Cr.Cl)	Louissetta	(Fo.Fo.Fo)
Longianda	(Ar.Tr.Re)	Lophoctenella	(Ar.Os.Po)	Loutriella	(Ar.Os.Pa)
Longiapertina	(Fo.Fo.Fo)	Lophocyrtis	(Ac.Ra.Na)	Louza	(Ar.Os.Po)
Longicerithium	(Mo.Ga.Nt)	Lophocythere	(Ar.Os.Po)	Lovarina	(Ar.Mi.De)
Longiclavata	(Cn.An.Ru)	Lophodentina	(Ar.Os.Po)	Lovcenipora	(Cn.Hy.Un)

Lovenechinus	(Ec.Ec.Ey)	Lugalella	(Ar.Tr.Pr)	Lutetiarcula	(Br.Ar.Te)
Lovenia	(Ec.Ec.Sp)	Luganoia	(Cd.Os.Pe)	Lutetiaster	(Ec.Ec.Sp)
Lovenicystis	(Ec.Rh.Rh)	Lugoviella	(Pr.To.Mi)	Lutima	(Mo.Ga.Un)
Lovenilampas	(Ec.Ec.Ca)	Lugtonia	(Fo.Fo.Fo)	Lutkevichinella	(Ar.Os.Po)
Lovetchenia	(Mo.Bi.Hi)	Luhaia	(Br.Ar.St)	Lutraria	(Mo.Bi.Ve)
Lowenstamia	(Br.Ar.Te)	Luhocrinus	(Ec.Eo.Un)	Luvarus	(Cd.Os.Pf)
Lowoceras	(Mo.Ce.Di)	Luhops	(Ar.Tr.Re)	Luvula	(Ar.Os.Po)
Lovixonia	(Mo.Ga.Ar)	Luhotreta	(Br.Li.Ac)	Luxella	(Ar.Tr.Pt)
Lovo	(Mo.Bi.Ve)	Luidia	(Ec.As.Px)	Luxilites	(Cd.Os.Cr)
Lovobidens	(Mo.Ga.Th)	Luisichthys	(Cd.Os.Pe)	Luxocrinus	(Ec.Cr.Di)
Lovocardium	(Mo.Bi.Ve)	Luisiella	(Cd.Os.Pe)	Luxuridacna	(Mo.Bi.Ve)
Lovocaspia	(Ar.Os.Po)	Lukatiella	(Pr.Un.In)	Luyanhaochiton	(Pr.Un.In)
Lovocauda	(Ar.Os.Po)	Lumbriconereis	(An.Po.Eu)	Luyanhaeia	(Ar.Tr.Pt)
Loxoceras	(Mo.Ce.Or)	Lumbriconereites	(An.Po.Eu)	Lycettia	(Mo.Bi.Mt)
Loxochoanella	(Mo.Ce.En)	Lumbricopsis	(An.Po.Un)	Lycetticeras	(Mo.Ce.Am)
Loxoconcha	(Ar.Os.Po)	Lumectaster	(Ec.Op.Un)	Lychmiscalus	(Po.He.Ly)
Loxoconchella	(Ar.Os.Po)	Lumectospongia	(Po.He.Re)	Lychnocanium	(Ac.Ra.Na)
Loxocorniculum	(Ar.Os.Po)	Lunacephalus	(Ar.Tr.Pt)	Lychnocanoma	(Ac.Ra.Na)
Loxocrinus	(Ec.Cr.Sa)	Lunachites	(Pr.Un.In)	Lychnoceras	(Mo.Ce.On)
Loxocythere	(Ar.Os.Po)	Lunacrania	(Ar.Tr.Pt)	Lychnodietyum	(Ac.Ra.Na)
Loxodus	(Cd.Co.Co)	Lunaferramita	(Bz.St.Cy)	Lychnothyris	(Br.Ar.Te)
Loxolypta	(Mo.Bi.Ve)	Lunalepis	(Cd.Ch.Cl)	Lychholmoceras	(Mo.Ce.On)
Loxolithax	(Cd.Ma.Ce)	Lunanceras	(Mo.Ce.El)	Lycodopsis	(Cd.Os.Pf)
Lxonema	(Mo.Ga.Nt)	Lunarca	(Mo.Bi.Ar)	Lyonectes	(Cd.Os.Pf)
Loxonepea	(Ar.Tr.Un)	Lunaria	(Br.Ar.Rh)	Lycophoria	(Br.Ar.Pe)
Loxophragma	(Bz.St.Tr)	Lunaspis	(Cd.Pl.Pe)	Lycophron	(Ar.Tr.As)
Loxophragmus	(Br.Ar.St)	Lunatia	(Mo.Ga.Nt)	Lycoprocypis	(Ar.Os.Po)
Loxoplocus	(Mo.Ga.Ar)	Lunatica	(Mo.Ga.Ar)	Lydiaspis	(Ar.Tr.Pt)
Loxoptychodon	(Mo.Bi.Ve)	Lunatriella	(Fo.Fo.Fo)	Lydiiphis	(Mo.Ga.Nt)
Loxoxyxis	(Mo.Ga.He)	Lunella	(Mo.Ga.Ar)	Lyeoceras	(Mo.Ce.Or)
Loxorhynchus	(Ar.Ml.De)	Luniprisma	(Ar.Os.Me)	Lyelliceras	(Mo.Ce.Am)
Lovostomia	(Fo.Fo.Fo)	Lunilicardia	(Mo.Bi.Ve)	Lygdozoon	(Ar.Tr.Ph)
Lovostomoides	(Fo.Fo.Fo)	Lunoglossa	(Br.Li.Li)	Lygisma	(Cd.Os.Ga)
Lovostomum	(Fo.Fo.Fo)	Lunolenus	(Ar.Tr.Re)	Lyidium	(Po.De.Lj)
Lovotaphrus	(Mo.Ga.Ne)	Lunolia	(Br.Ar.Te)	Lyliophyllum	(Cn.An.Ru)
Lovotoma	(Mo.Ga.Ar)	Lunucammina	(Fo.Fo.Fo)	Lymnoea	(Po.Ca.Ph)
Loyolophyllum	(Cn.An.Ru)	Lunulacardium	(Mo.Bi.Pr)	Lymnorella	(Po.Ca.Ph)
Luanquilla	(Br.Ar.St)	Lunulacyathus	(Po.Re.Aj)	Lynaspis	(Ar.Tr.As)
Luaspis	(Ar.Tr.Pt)	Lunularia	(Bz.Gy.Ch)	Lyncina	(Mo.Ga.Nt)
Lublinella	(Ar.Os.Un)	Lunulazona	(Mo.Ga.Ar)	Lyonia	(Br.Ar.St)
Lublinophyllum	(Cn.An.Ru)	Lunulites	(Bz.Gy.Ch)	Lyonocrinus	(Ec.Cr.Mo)
Lubowastraea	(Cn.An.Sc)	Lunuloceras	(Mo.Ce.Am)	Lyonsia	(Mo.Bi.Ph)
Lubrzankiella	(Ar.Os.Pa)	Luofuia	(Br.Ar.St)	Lyopora	(Cn.An.Ta)
Lucapina	(Mo.Ga.Ar)	Luojiashania	(Ar.Tr.Un)	Lyopsetta	(Cd.Os.Pn)
Lucapinella	(Mo.Ga.Ar)	Luolishania	(Lo)	Lyosoma	(Mo.Ga.Ar)
Lucerapex	(Mo.Ga.Ne)	Luottoulingia	(Ar.Tr.Pt)	Lyraliclas	(Ar.Tr.Li)
Lucidestea	(Mo.Ga.Nt)	Lupherella	(Mo.Bi.Pt)	Lyrapyge	(Ar.Tr.Ph)
Luciella	(Mo.Ga.Ar)	Lupherites	(Mo.Ce.Am)	Lyratellina	(Mo.Bi.Ve)
Luciellina	(Mo.Ga.Ar)	Lupherium	(Ac.Ra.Na)	Lyreidus	(Ar.Ml.De)
Lucina	(Mo.Bi.Ve)	Lupira	(Mo.Ga.Ne)	Lyria	(Mo.Ga.Ne)
Lucinaxinus	(Mo.Bi.Ve)	Lupitschia	(Cn.An.Sc)	Lyrrianella	(Mo.Ga.Ne)
Lucinella	(Mo.Bi.Ve)	Luponovula	(Mo.Ga.Nt)	Lyriaspis	(Ar.Tr.Pt)
Luciniola	(Mo.Bi.Ve)	Lupospyris	(Cd.Ac.Cl)	Lyrielasma	(Cn.An.Ru)
Lucinisca	(Mo.Bi.Ve)	Luppovella	(Mo.Ce.Am)	Lyrioceras	(Mo.Ce.Ba)
Lucinoma	(Mo.Bi.Ve)	Lurgiticoma	(Br.Li.Ac)	Lyriochlamys	(Mo.Bi.Pt)
Luciploma	(Mo.Bi.Ve)	Luria	(Mo.Ga.Nt)	Lyriocrinus	(Ec.Cr.Di)
Luciter	(Ar.Os.Pa)	Lusampa	(Ar.Tr.Un)	Lyriomyophoria	(Mo.Bi.Tr)
Ludbrookia	(Mo.Bi.Ve)	Lusatipis	(Ar.Tr.Pt)	Lyriopecten	(Mo.Bi.Pt)
Ludfordina	(Br.Ar.St)	Lusitanichthys	(Cd.Os.Go)	Lyrischapa	(Mo.Ga.Ne)
Ludictyon	(Po.De.St)	Lusitanites	(Mo.Ce.Go)	Lyrocadium	(Mo.Bi.Ve)
Ludvigsenites	(Ar.Os.Ar)	Lutema	(Mo.Ga.Ne)	Lyrocladia	(Bz.St.Fe)
Ludvigsevella	(Ar.Tr.Pr)	Luterella	(Br.Ar.Rh)	Lyrodasma	(Mo.Bi.Mo)
Ludwigia	(Mo.Ce.Am)	Lutesvillia	(Ar.Tr.Pr)	Lyrodictya	(Po.He.Re)
Luella	(Ar.Os.Ar)	Lutetia	(Mo.Bi.Ve)	Lyrodobankia	(Mo.Bi.My)

Lyrogoniatites	(Mo,Ce,Go)	Macilentos	(Mo,Ga,Ni)	Macroporina	(Bz,Gy,Ch)
Lyrolepis	(Cd,Os,El)	Mackenzia	(Cn,An,Ac)	Macropotamorhynchus	(Br,Ar,Rh)
Lyromangelia	(Mo,Ga,Ne)	Mackenziecyathus	(Po,Re,Aj)	Macropoterygius	(Cd,Re,lc)
Lyropecten	(Mo,Bi,Pt)	Mackenziella	(Mo,In,In)	Macropyge	(Ar,Tr,As)
Lyropora	(Bz,St,Fe)	Mackenziephyllum	(Cn,An,Ru)	Macropygella	(Ar,Tr,As)
Lyroporella	(Bz,St,Fe)	Mackenziurus	(Ar,Tr,Ph)	Macrosarisia	(Ar,Os,Po)
Lyroporidra	(Bz,St,Fe)	Mackerrovia	(Br,Ar,St)	Macroscaphites	(Mo,Ce,Am)
Lyropurpura	(Mo,Ga,Ne)	Mackinnonia	(Mo,In,In)	Macroscenella	(Mo,In,In)
Lyroschizodus	(Mo,Bi,Tr)	Maclarenella	(Br,Ar,Te)	Macrosemium	(Cd,Os,Ma)
Lyrosurcula	(Mo,Ga,Ne)	Maclurina	(Mo,Ga,Mc)	Macrosinus	(Mo,Ga,Ne)
Lyrotyphis	(Mo,Ga,Ne)	Macluritella	(Mo,Ga,Eu)	Macrosolen	(Ar,Os,Ve)
Lysactinella	(Po,He,Un)	Macluritites	(Mo,Ga,Mc)	Macrostylocrinus	(Ec,Cr,Mo)
Lysagoroceras	(Mo,Ce,On)	Macnamaratylus	(Ec,Cr,Ds)	Macrotheca	(Hy,Un,To)
Lysaretides	(An,Po,Eu)	Macoma	(Mo,Bi,Ve)	Macrotoxa	(Ar,Tr,As)
Lysella	(Fo,Fo,Fo)	Macomona	(Mo,Bi,Ve)	Macrotrigonia	(Mo,Bi,Tr)
Lysidium	(Br,Ar,Pe)	Macopoma	(Mo,Bi,Ve)	Macrotrougaleus	(Cd,Ch,Ca)
Lysigyra	(Br,Ar,Pe)	Macraster	(Ec,Ec,Sp)	Macrozafra	(Mo,Ga,Ne)
Lysiogyrus	(Mo,Ga,Ni)	Macrepistius	(Cd,Os,Am)	Macurella	(Mo,Ga,Ne)
Lysiosquilla	(Ar,MI,St)	Macridiscus	(Mo,Bi,Ve)	Macuronus	(Cd,Os,Ga)
Lysis	(Mo,Ga,Nt)	Macroaulostomus	(Cd,Os,Ga)	Macrypilson	(Ar,Os,Po)
Lysocystites	(Ec,Eo,Un)	Macroblepharum	(Ar,Tr,Pr)	Mactomyella	(Mo,Bi,Ve)
Lysogorella	(Ar,Os,Pa)	Macrobrochus	(Po,De,Li)	Mactra	(Mo,Bi,Ve)
Lytectinus	(Ec,Ec,Te)	Macrocallista	(Mo,Bi,Ve)	Mactrellona	(Mo,Bi,Ve)
Lytheoceras	(Mo,Ce,Go)	Macrocaris	(Ar,MI,Ar)	Mactrinula	(Mo,Bi,Ve)
Lythophyllum	(Cn,An,Ru)	Macrocephalites	(Mo,Ce,Am)	Mactrodesma	(Mo,Bi,Ve)
Lyticoceras	(Mo,Ce,Am)	Macrocheira	(Ar,MI,De)	Mactromeris	(Mo,Bi,Ve)
Lytoceras	(Mo,Ce,Am)	Macrochirifer	(Cd,Ma,Ce)	Mactromya	(Mo,Bi,Ve)
Lytocrioceras	(Mo,Ce,Am)	Macrochlamis	(Mo,Bi,Pt)	Mactromyopsis	(Mo,Bi,Ve)
Lytodiscoides	(Mo,Ce,Am)	Macrocoelia	(Br,Ar,St)	Mactrona	(Mo,Bi,Ve)
Lytogyroceras	(Mo,Ce,Am)	Macrocrinus	(Ec,Cr,Mo)	Mactropistis	(Mo,Bi,Ve)
Lytohoplites	(Mo,Ce,Am)	Macroculites	(Ar,Tr,Pt)	Macurdablastus	(Ec,Bl,Un)
Lytospira	(Mo,Ga,Eu)	Macrocypraea	(Mo,Ga,Nt)	Madagascarites	(Mo,Ce,Am)
Lyttonia	(Br,Ar,St)	Macrocyprina	(Ar,Os,My)	Madarsaspis	(Ar,Tr,Pr)
Lytvolasma	(Cn,An,Ru)	Macrocypris	(Ar,Os,Po)	Madarsicus	(Cd,Os,Pe)
Lytvophyllum	(Cn,An,Ru)	Macrocyproides	(Ar,Os,Po)	Madarocephalus	(Ar,Tr,As)
Lywcea	(Mo,Bi,Pt)	Macrocystellia	(Ec,Rh,Rh)	Madarsia	(Br,Ar,Rh)
Maakina	(Br,Ar,St)	Macrodelphinus	(Cd,Ma,Ce)	Maddocksella	(Ar,Os,Po)
Mabella	(Br,Ar,St)	Macrodentina	(Ar,Os,Po)	Madiella	(Mo,Ga,Ne)
Mabellarca	(Mo,Bi,Ar)	Macrodidema	(Ec,Ec,Di)	Madiganella	(Mo,Ce,Di)
Mabiania	(Pr,Un,In)	Macrodiceras	(Mo,Bi,Hi)	Madigania	(Cn,Hy,Un)
Mabianocollus	(Cn,Sc,Cn)	Macrodomoceras	(Mo,Ce,On)	Madoia	(Br,Ar,Sp)
Macalia	(Mo,Bi,Ve)	Macrodon	(Mo,Bi,Ar)	Madonia	(Po,De,Pe)
Macaliopsis	(Mo,Bi,Ve)	Macrodonax	(Mo,Bi,Ve)	Madraeis	(Cn,An,Sc)
Macandrewia	(Br,Ar,Te)	Macrodontacanthus	(Cd,Ch,In)	Madrepora	(Cn,An,Sc)
Macandrewia	(Po,De,Li)	Macrodontella	(Mo,Bi,Ar)	Maduiya	(Ar,Tr,Pt)
Macandrewites	(Po,De,Li)	Macrodotomia	(Mo,Ga,He)	Madygenia	(Ar,Tr,Pr)
Macrocrinus	(Ec,Cr,Di)	Macrogrammus	(Ar,Tr,Un)	Maeadramorpha	(Cn,An,Sc)
Maccoya	(Ec,Ec,Ey)	Macroloxoceras	(Mo,Ce,Or)	Maeadrograptus	(He,Gr,Gr)
Maccoyella	(Mo,Bi,Pt)	Macromesodon	(Cd,Os,Py)	Maeadropolydora	(An,Po,SP)
Maccoyoceras	(Mo,Ce,Na)	Macromphalus	(Mo,Ga,Un)	Maelonoceras	(Mo,Ce,On)
Maccullochella	(Cd,Os,Pr)	Macron	(Mo,Ga,Ne)	Maemia	(Br,Ar,St)
Macelloura	(Ar,Tr,Pt)	Macroniscus	(Mo,Ga,Ne)	Maendrosaris	(Cn,An,Sc)
Macerodus	(Cd,Co,Co)	Macronoda	(Ar,Tr,Pt)	Maendrostylis	(Cn,An,Sc)
Maegaea	(Cn,An,Ru)	Macronotella	(Ar,Os,Pa)	Maenirostis	(Mo,Ce,An)
Maegopsis	(Cn,An,Sc)	Macropetalichthys	(Cd,Pl,Pe)	Maennilicrinus	(Ec,Cr,Ds)
Machaeraacanthus	(Cd,Ac,Un)	Macrophthalmus	(Ar,MI,De)	Mafoletia	(Cd,Ch,Rj)
Machaeraria	(Br,Ar,Rh)	Macropipus	(Ar,MI,De)	Magadania	(Br,Ar,St)
Machaerocollella	(Br,Li,Li)	Macroplata	(Cd,Re,Ps)	Magadiceramus	(Mo,Bi,Pt)
Machaerodonax	(Mo,Bi,Ve)	Macropleura	(Br,Ar,Sp)	Magadina	(Br,Ar,Te)
Machaerognathus	(Cd,Pl,Ar)	Macropneustes	(Ec,Ec,Sp)	Magadinella	(Br,Ar,Te)
Machaerotoechia	(Br,Ar,Rh)	Macropoma	(Cd,Os,Co)	Magaretti	(Bz,Gy,Ch)
Machairagnostus	(Ar,Tr,Ag)	Macropomoides	(Cd,Os,Co)	Magas	(Br,Ar,Te)
Machinosaurus	(Cd,Re,Cr)	Macropora	(Bz,Gy,Ch)	Magasella	(Br,Ar,Te)
Machomya	(Mo,Bi,Ph)	Macroporaster	(Ec,As,Pa)	Magdoceras	(Mo,Ce,Ta)

Magella	(Br.Ar,Te)	Malea	(Mo,Ga,Nt)	Manespira	(Br.Ar,At)
Magellania	(Br.Ar,Te)	Malerosteus	(Cd,Pl,Ar)	Mangelia	(Mo,Ga,Ne)
Magharina	(Mo,Ce,Am)	Malguzaria	(Ar,Os,Pa)	Mangeroceras	(Mo,Ce,Go)
Magharithyris	(Br.Ar,Te)	Maligneocrinus	(Ec,Cr,Mo)	Mangiliella	(Mo,Ga,Ne)
Maghrebeis	(Ar,Os,Un)	Malinaspis	(Ar,Tr,Pt)	Mangkeluia	(Br.Ar,At)
Maghrebella	(Mo,Bi,Ve)	Malinella	(Br.Ar,Or)	Manicetus	(Cd,Ma,Ce)
Magiostrophia	(Br.Ar,St)	Malinowskiella	(Po,De,Li)	Manicina	(Cn,An,Sc)
Magila	(Ar,MI,De)	Malladaia	(Ar,Tr,Ph)	Manicrinus	(Ec,Cr,Cl)
Magilus	(Mo,Ga,Ne)	Malladaites	(Mo,Ce,Am)	Manilocrinus	(Ec,Cr,Mo)
Magnacephalus	(Ar,Tr,Pt)	Mallagnostus	(Ar,Tr,Ag)	Manipora	(Cn,An,Ja)
Magnatica	(Mo,Ga,Nt)	Malleia	(Br.Ar,Te)	Manitoulinoceras	(Mo,Ce,On)
Magnea	(Bz,Gy,Ch)	Malletia	(Mo,Bi,Nu)	Manitouoceras	(Mo,Ce,En)
Magnederella	(Bz,St,Un)	Malletophychites	(Mo,Ce,Ce)	Manjoceras	(Mo,Ce,Di)
Magnella	(Mo,Ga,Ne)	Malloproductus	(Br.Ar,St)	Mankenziella	(Mo,In,In)
Magnesoina	(Fo,Fo,Fo)	Mallotus	(Cd,Os,Os)	Manlietta	(Cd,Os,Pe)
Magnicanalis	(Br,Un,Ob)	Malluviospongia	(Po,Ca,He)	Mannopyge	(Ar,Tr,Pr)
Magnicapulus	(Mo,Ga,Ar)	Malluvium	(Mo,Ga,Nt)	Mannosocmia	(Ar,Os,Ar)
Magnilaterella	(Cd,Co,Co)	Malnina	(Ar,Os,Pa)	Mannschreckia	(Ar,Tr,Un)
Magniplicatina	(Br.Ar,St)	Malocystites	(Ec,Pe,Pl)	Manoloviceras	(Mo,Ce,Am)
Magniventra	(Br.Ar,St)	Malongella	(Ar,Os,Ar)	Manorella	(Fo,Fo,Fo)
Magnomma	(Ar,Tr,Pt)	Malongullia	(Ar,Tr,Pt)	Manosia	(Br.Ar,Un)
Magnosia	(Ec,Ec,Ph)	Maltaia	(Br.Ar,Te)	Mansella	(Ar,Tr,Pt)
Magnumbonella	(Br.Ar,St)	Maltoniceras	(Mo,Ce,Am)	Mansina	(Br.Ar,St)
Mahaiella	(Ar,Tr,Pr)	Malumispongium	(Po,He,LS)	Mansuyella	(Ar,Tr,As)
Mahoningoceras	(Mo,Ce,Na)	Malungia	(Mo,Ga,Ne)	Mansuya	(Ar,Tr,Co)
Maiandroclyathus	(Po,Ir,Ar)	Malurostrophia	(Br.Ar,St)	Mansuyites	(Ar,Tr,Co)
Maiaspis	(Ar,Tr,Pt)	Malvinella	(Ar,Tr,Ph)	Mansuyphyllum	(Cn,An,Ru)
Maichelina	(Fo,Fo,Fo)	Malvufundus	(Mo,Bi,Pt)	Manta	(Cd,Ch,My)
Maidipingoconus	(Mo,In,In)	Malwirhynchia	(Br.Ar,Rh)	Mantelliana	(Ar,Os,Po)
Maikhanella	(Mo,In,In)	Malykania	(Ar,Tr,Co)	Mantellieceras	(Mo,Ce,Am)
Maikottaphyllum	(Cn,An,Ru)	Malykanotheca	(Hy,Or,Or)	Mantellina	(Mo,Bi,Pt)
Maikottia	(Cn,An,Ru)	Malzella	(Ar,Os,Pa)	Manticoceras	(Mo,Ce,Am)
Maioteuthis	(Mo,Ce,Te)	Mamayocaris	(Ar,MI,My)	Manticrinus	(Ec,Cr,Mo)
Maihuconconus	(Mo,In,In)	Mambriina	(Mo,Ga,Nt)	Mantacula	(Mo,Bi,Pt)
Maitaia	(Mo,Bi,Pt)	Mamelohindia	(Po,De,Li)	Mantikosocrinus	(Ec,Cr,Cl)
Maiassionis	(Ar,Os,Pa)	Mametothyris	(Br.Ar,Te)	Mantoushania	(Ar,Tr,Pt)
Maja	(Ar,MI,De)	Mamiconus	(Mo,Ga,Ne)	Manuaniceras	(Mo,Ce,Am)
Majatheca	(Hy,Or,Or)	Mamilodus	(Pr,Un,In)	Manulica	(Mo,Bi,Pr)
Majiangia	(Ar,Tr,Co)	Mamillopora	(Bz,Gy,Ch)	Manupecten	(Mo,Bi,Pt)
Majiaobaphyllum	(Cn,An,Ru)	Maminka	(Mo,Bi,Pt)	Manzanella	(Mo,Bi,So)
Majjashanella	(Ar,Os,Ar)	Mammalodon	(Cd,Ma,Ce)	Manzanospira	(Mo,Ga,Ar)
Majkopella	(Br.Ar,Sp)	Mammilla	(Mo,Ga,Nt)	Manzonella	(Bz,Gy,Ch)
Majoceras	(Mo,Ce,In)	Mammities	(Mo,Ce,Am)	Manzonia	(Mo,Ga,Nt)
Majungaella	(Ar,Os,Pa)	Mammoides	(Ar,Os,Pa)	Maoricardium	(Mo,Bi,Ve)
Makaira	(Cd,Os,Pl)	Mamutinetes	(Br.Ar,St)	Maoricolpus	(Mo,Ga,Nt)
Makarakia	(Mo,In,In)	Manacyathus	(Pr,Cr,Cr)	Maoricypta	(Mo,Ga,Nt)
Makarskiana	(Fo,Fo,Fo)	Manaia	(Mo,Bi,Ar)	Maorielasma	(Br.Ar,Te)
Makiyama	(Mo,De,Pa)	Manambolites	(Mo,Ce,Am)	Maorimactra	(Mo,Bi,Ve)
Makiyamaia	(Mo,Ga,Ne)	Manatus	(Cd,Ma,Si)	Maorionotis	(Mo,Bi,Pt)
Maklaya	(Fo,Fo,Fo)	Manawatawhia	(Mo,Ga,Nt)	Maorirhynchia	(Br.Ar,Rh)
Makridmirhynchia	(Br.Ar,Rh)	Manchuriella	(Ar,Tr,Pt)	Maoriscaphander	(Mo,Ga,Ce)
Malacocottus	(Cd,Os,Sc)	Manchurocephalus	(Ar,Tr,Pt)	Maoristrophia	(Br.Ar,St)
Malacopygaeus	(Cd,Os,Pl)	Manchuroceras	(Mo,Ce,En)	Maorites	(Mo,Ce,Am)
Maladia	(Ar,Tr,Pt)	Mancikella	(Mo,Bi,Ve)	Maorithyas	(Mo,Bi,Ve)
Maladioidella	(Ar,Tr,As)	Mancorus	(Mo,Ga,Ne)	Maoritomella	(Mo,Ga,Ne)
Maladioides	(Ar,Tr,Pt)	Mancosceras	(Mo,Ce,Am)	Maoritrigonina	(Mo,Bi,Tr)
Malagastrigonia	(Mo,Bi,Tr)	Mandalacystis	(Ec,Eo,Un)	Maorivetia	(Mo,Ga,Ne)
Malaiocrinus	(Ec,Cr,Cl)	Mandaloceras	(Mo,Ce,Di)	Maotianshanis	(Pa)
Malayanoplia	(Br.Ar,St)	Mandawacythere	(Ar,Os,Pa)	Maotunia	(Ar,Tr,Pt)
Malayaspira	(Mo,Ga,Eu)	Mandelstamia	(Ar,Os,Pa)	Mapania	(Ar,Tr,Pt)
Malayites	(Mo,Ce,Ce)	Mandjina	(Fo,Fo,Fo)	Mapanopsis	(Ar,Tr,As)
Malayomaorica	(Mo,Bi,Pt)	Mandocythere	(Ar,Os,Pa)	Mapingichia	(Br.Ar,Or)
Malchiblastus	(Ec,BI,Sp)	Mandolina	(Mo,Ga,Nt)	Maquoketocrinus	(Ec,Cr,Di)
Maldeotaia	(Ch,Pr)	Mandorovella	(Fo,Fo,Fo)	Maragnicrinus	(Ec,Cr,Cl)

Marama	(Mo,Bi,Ve)	Marianoceras	(Mo,Ce,Go)	Martinottiella	(Fo,Fo,Fo)
Marathonites	(Mo,Ce,Go)	Mariasalpinx	(Mo,Ga,Ne)	Martinssonina	(Ar,In,Un)
Marathonocrinus	(Ee,Cr,Cl)	Mariassvelina	(Mo,Ga,Ne)	Martinssonopsis	(Ar,Os,Pa)
Maratia	(Ar,Os,Pa)	Mariaturrucula	(Mo,Ga,Ne)	Martinssonozona	(Ar,Os,Pa)
Marbodecia	(Mo,Ga,Pa)	Mariceras	(Mo,Ce,Or)	Martolites	(Mo,Ce,Ce)
Marcaisia	(Ar,Tr,Un)	Marieta	(Fo,Fo,Fo)	Marvacrassatella	(Mo,Bi,Ve)
Marcharella	(Br,Ar,Or)	Mariella	(Mo,Ce,Am)	Marwickara	(Mo,Ga,Ne)
Marchia	(Mo,Ga,Ne)	Marinoum	(Ac,Ra,Na)	Marwickkythereis	(Ar,Os,Pa)
Marcia	(Mo,Bi,Ve)	Marinauris	(Mo,Ga,Ar)	Marwickia	(Mo,Bi,Ve)
Marekgrafia	(Cd,Ch,Rj)	Marinduqueia	(Po,De,Ve)	Maryodiscia	(Ar,Tr,Ag)
Marcusodictyon	(Bz,Gy,Ct)	Marinopecten	(Mo,Bi,Pt)	Maryonychia	(Mo,Bi,Pt)
Marcusopora	(Bz,Gy,Ct)	Marinurnula	(Br,Ar,Te)	Maryvillia	(Ar,Tr,Pt)
Mareda	(Ar,Tr,Un)	Mariochrea	(Tr,An)	Marywadea	(Ar,Pa,Pa)
Marekolithus	(Ar,Tr,As)	Mariomites	(Br,Ar,Or)	Mascarananda	(Ar,ML,De)
Maretia	(Ee,Ec,Sp)	Mariothia	(Mo,Ga,Ar)	Mashania	(Cn,In,In)
Marevalvata	(Mo,Ga,Ar)	Mariotia	(Mo,Ga,Un)	Masiaposites	(Mo,Ce,Am)
Margachitina	(Fo,Fo,Ch)	Marisastrum	(Cn,An,Ru)	Maslinella	(Fo,Fo,Fo)
Margarastrea	(Cn,An,Sc)	Maritimella	(Ar,Tr,Na)	Masloviella	(Ar,Os,Pa)
Margarastreopsis	(Cn,An,Sc)	Maritimithyrus	(Br,Ar,Te)	Masonites	(Mo,Ce,Am)
Margarella	(Mo,Ga,Ar)	Mariusulites	(Cn,An,Ta)	Massilina	(Fo,Fo,Fo)
Margaretta	(Bz,Gy,Ch)	Marjuma	(Ar,Tr,Pt)	Massyia	(Mo,Ga,Ne)
Margaritaria	(Mo,Bi,Ph)	Marjumicystis	(Ee,Eo,Un)	Mastakhella	(Mo,In,In)
Margaritella	(Mo,Ga,Nt)	Markamia	(Br,Ar,St)	Mastaster	(Ee,As,Va)
Margarites	(Mo,Ga,Ar)	Markitoechia	(Br,Ar,Rh)	Mastigaetis	(Ee,Op,Oe)
Margaritiproductus	(Br,Ar,St)	Marklandella	(Br,Ar,Or)	Mastigobolbina	(Ar,Os,Pa)
Margaritropites	(Mo,Ce,Ce)	Markocyathus	(Po,Ir,Ar)	Mastigocrinus	(Ee,Cr,Cl)
Margarophyllia	(Cn,An,Sc)	Marlenites	(An,Po,Eu)	Mastigograptus	(He,Gr,Un)
Margarosmia	(Cn,An,Sc)	Marmarostoma	(Mo,Ga,Ar)	Mastigophiura	(Ee,Op,Oe)
Marginalosia	(Br,Ar,St)	Marmolatella	(Mo,Ga,Ar)	Mastigophora	(Mo,Ce,Te)
Marginara	(Fo,Fo,St)	Marocella	(Mo,In,In)	Mastigophorella	(Bz,Gy,Ch)
Marginaria	(Bz,Gy,Ch)	Marosichthys	(Cd,Os,Te)	Mastigospira	(Mo,Ga,Eu)
Marginaster	(Ee,Op,Oe)	Marphysates	(An,Po,Un)	Mastoblastus	(Fc,BI,Fi)
Marginatia	(Br,Ar,St)	Marquezinga	(Ar,Os,Pa)	Mastoceras	(Mo,Ce,Pr)
Marginella	(Mo,Ga,Ne)	Marracanthus	(Cd,Ch,Cm)	Mastodictya	(Po,He,Re)
Margineulima	(Mo,Ga,Nt)	Marrella	(Ar,Ma,Mi)	Mastodyctyum	(Po,He,He)
Marginia	(Ar,Os,Pa)	Marrolithoides	(Ar,Tr,As)	Mastophorus	(Po,De,Li)
Marginicinctus	(Br,Ar,St)	Marrolithus	(Ar,Tr,As)	Mastophyma	(Po,De,Li)
Marginifera	(Br,Ar,St)	Marsdenius	(Cd,Ac,Cl)	Mastopora	(Cn,An,Ta)
Marginirugus	(Br,Ar,St)	Marshallana	(Mo,Ga,Ne)	Mastosia	(Po,De,Li)
Marginisulcus	(Ar,Os,Pa)	Marshallaria	(Mo,Ga,Ne)	Mastygocercus	(Cd,Os,An)
Marginohealdia	(Ar,Os,Pa)	Marshallena	(Mo,Ga,Ne)	Matania	(Ar,Tr,Un)
Marginopora	(Fo,Fo,Fo)	Marshallia	(Po,He,Ly)	Mataninella	(Ar,Tr,Un)
Marginoproductus	(Br,Ar,St)	Marshallites	(Mo,Ce,Am)	Matanoleptodus	(Br,Ar,St)
Marginorthis	(Br,Ar,Or)	Marsipella	(Fo,Fo,Fo)	Matanzia	(Fo,Fo,Fo)
Marginospongia	(Po,De,Li)	Marstatourella	(Ar,Os,Pa)	Matarchia	(Cd,Os,Pt)
Marginotimories	(Ar,Os,Un)	Marssonella	(Fo,Fo,Fo)	Matata	(Mo,Ga,Ne)
Marginotruncana	(Fo,Fo,Fo)	Marssoniella	(Bz,St,Cc)	Matejka	(Cn,An,Sc)
Marginovatia	(Br,Ar,St)	Marssonopora	(Bz,Gy,Ch)	Maternella	(Ar,Os,My)
Marginulina	(Fo,Fo,Fo)	Marsupina	(Mo,Ga,Nt)	Maternoceras	(Mo,Ce,An)
Marginulinita	(Fo,Fo,Fo)	Marsupiocrinus	(Ee,Cr,Mo)	Matherella	(Mo,Pa,Hy)
Marginulinospis	(Fo,Fo,Fo)	Marsuptes	(Ee,Cr,Ui)	Matherellina	(Mo,Pa,Hy)
Marginohealdia	(Ar,Os,Me)	Martesia	(Mo,Bi,My)	Matheria	(Mo,Bi,Ve)
Margobairdia	(Ar,Os,Pa)	Marticia	(Mo,Ga,Nt)	Mathericrinus	(Ee,Cr,Cl)
Margocrinus	(Ee,Cr,Is)	Martiguesia	(Fo,Fo,Fo)	Matherocladia	(Bz,St,Fe)
Margoplantia	(Ar,Os,Pa)	Martinechinus	(Ee,Ec,Te)	Matheronia	(Mo,Bi,Hy)
Margostrea	(Mo,Bi,Pt)	Martinezicancer	(Ar,ML,De)	Matheropora	(Bz,St,Fe)
Marhoumacrinus	(Ee,Cr,Mo)	Martinia	(Br,Ar,Sp)	Mathilda	(Mo,Ga,Nt)
Mariacassia	(Mo,Ga,Ne)	Martinichthys	(Cd,Os,Cr)	Mathoceras	(Mo,Ce,Am)
Mariacolpus	(Mo,Ga,Nt)	Martincythere	(Ar,Os,Pa)	Mathoceratites	(Mo,Ce,Am)
Mariadrillia	(Mo,Ga,Ne)	Martiniella	(Br,Ar,Sp)	Mathurifusus	(Mo,Ga,Nt)
Mariafusus	(Mo,Ga,Ne)	Martinopsis	(Br,Ar,Sp)	Matronella	(Ar,Os,Pa)
Marianarona	(Mo,Ga,Ne)	Martinocarcinus	(Ar,ML,De)	Matsumotoa	(Mo,Bi,Ar)
Mariania	(Ee,Ec,Sp)	Martinophyllum	(Cn,An,Ru)	Matsutrypa	(Bz,St,Cr)
Mariannaella	(Br,Ar,Pe)	Martinothyris	(Br,Ar,Sp)	Mattajacyathus	(Po,Re,Aj)

Mattaspongia	(Po,He,LS)	Meandrororia	(Cn,An,Sc)	Megadesmus	(Mo,Bi,Ph)
Matthavia	(Mo,Po,Pa)	Meandrosimilia	(Cn,An,Sc)	Megadiceras	(Mo,Bi,Hi)
Matthewscyathus	(Po,Uc,Un)	Meandrospira	(Fo,Fo,Fo)	Megadicososorus	(Mo,Ce,Ac)
Mattsechinus	(Ec,Ec,Ho)	Meandrospiranella	(Fo,Fo,Fo)	Megadunderbergia	(Ar,Tr,Pt)
Matuta	(Ar,Ml,De)	Meandrospongia	(Po,He,Ly)	Megaglossoceras	(Mo,Ce,Na)
Matutella	(Br,Ar,Or)	Meandrostia	(Po,Co,Ph)	Megagraulons	(Ar,Tr,Un)
Maudrillia	(Mo,Ga,Ne)	Meandrostylis	(Cn,An,Sc)	Megagrypha	(Mo,Bi,Un)
Mausisaurus	(Cd,Re,Ps)	Meandrovoltzia	(Cn,An,Sc)	Megakozlowskiella	(Br,Ar,Sp)
Mausispirifer	(Br,Ar,Sp)	Mecloudius	(Cn,An,Ru)	Megalaspidella	(Ar,Tr,As)
Mauithoe	(Mo,Ga,Ne)	Mecochiria	(Ar,Ml,De)	Megalaspides	(Ar,Tr,As)
Maulisia	(Cd,Os,Os)	Mecochirus	(Ar,Ml,De)	Megalaspidicus	(Ar,Tr,Un)
Maurea	(Mo,Ga,Ar)	Mecolotia	(Mo,Ga,He)	Megalaspis	(Ar,Tr,As)
Maurenia	(Cn,An,Ta)	Mecophrys	(Ar,Tr,Un)	Megalatractus	(Mo,Ga,Ne)
Mauria	(Mo,Ga,Ne)	Mecraster	(Ec,Ec,Sp)	Megalelasma	(Po,Un,Un)
Mauricia	(Mo,Bi,Mt)	Mecynoceras	(Mo,Ce,Di)	Megalioerinus	(Ec,Cr,Mo)
Mauritanaster	(Ec,Ec,Sp)	Mecynodon	(Mo,Bi,Ve)	Megalisania	(Ar,Tr,Co)
Mauritia	(Mo,Ga,Nt)	Mecynoecia	(Bz,St,Ce)	Megalithistida	(Po,De,Li)
Mauritsina	(Ar,Os,Po)	Medaeva	(Ar,Ml,De)	Megalneusaurus	(Cd,Re,Ps)
Maurolucius	(Cd,Os,St)	Medeela	(Mo,Bi,Hi)	Megalocardia	(Mo,Bi,Ve)
Maurotarion	(Ar,Tr,Pr)	Medessia	(Br,Ar,Pe)	Megaloceras	(Mo,Ce,On)
Mauryella	(Ar,Os,Pa)	Medianella	(Ar,Os,Pa)	Megalocypraea	(Mo,Ga,Nt)
Mauryna	(Mo,Ga,Nt)	Mediapora	(Bz,St,Cr)	Megalodon	(Mo,Bi,Hi)
Maussetia	(Mo,Ga,Nt)	Mediargo	(Mo,Ga,Nt)	Megalograptus	(Ar,Me,Eu)
Maustonia	(Ar,Tr,As)	Mediaster	(Ec,As,Va)	Megalomoidea	(Mo,Bi,Hi)
Mawsonicoscinius	(Po,Re,Ca)	Medinophyllum	(Cn,An,Ru)	Megalomphala	(Mo,Ga,Be)
Maxillirhynchia	(Br,Ar,Rh)	Mediocris	(Fo,Fo,Fo)	Megalomphalus	(Mo,Ga,Nt)
Maximities	(Mo,Ce,Go)	Medioeutherideis	(Ar,Os,Po)	Megalonoda	(Mo,Ga,Ar)
Maxwellia	(Mo,Ga,Ne)	Medionapus	(Mo,Ga,Ne)	Megaloplax	(Cd,Pl,Ar)
Mayaites	(Mo,Ce,Am)	Mediopsis	(Fo,Fo,Fo)	Megalops	(Cd,Os,Me)
Mayaothyris	(Br,Ar,Te)	Mediospirifer	(Br,Ar,Te)	Megalopsis	(Ar,Tr,Pt)
Maychella	(Bz,St,Cr)	Medipsia	(Fo,Fo,Fo)	Megalopteris	(Cd,Os,Pe)
Maychellina	(Bz,St,Cr)	Mediraon	(Mo,Bi,Ve)	Megaloraphium	(Po,De,As)
Maydenella	(Br,Ar,St)	Medisemicoscinius	(Bz,St,Fe)	Megalosia	(Br,Ar,St)
Mayeria	(Mo,Ga,Ne)	Mediterraneotrigonia	(Mo,Bi,Tr)	Megalytoceras	(Mo,Ce,Am)
Mayiella	(Ar,Tr,Re)	Mediterraneirhynchia	(Br,Ar,Rh)	Megambonia	(Mo,Bi,Mo)
Maylisoria	(Fo,Fo,Fo)	Medlicottia	(Mo,Ce,Pl)	Megamyonia	(Br,Ar,St)
Mayncina	(Fo,Fo,Fo)	Medoecchinus	(Ec,Ec,Te)	Megangulus	(Mo,Bi,Ve)
Mayomyzon	(Cd,Ce,Pe)	Medocia	(Fo,Fo,Fo)	Meganterella	(Br,Ar,Te)
Mazaphyllum	(Cn,An,Ru)	Medoicinia	(Cd,Ma,Ce)	Meganteris	(Br,Ar,Te)
Mazapilites	(Mo,Ce,Am)	Medoriopsis	(Mo,Ga,Nt)	Megantocrinus	(Ec,Cr,Ct)
Mazodus	(Cd,Ch,Ps)	Medusaephyllum	(Cn,An,Ru)	Megapalaolenus	(Ar,Tr,Pt)
Mazohydra	(Cn,Hy,Hy)	Medusaster	(Ec,Op,St)	Megapetalus	(Ec,Ec,Sp)
Mazzalina	(Mo,Ga,Ne)	Medusinites	(Cn,Cy,Cy)	Megaphyllites	(Mo,Ce,Ce)
Mazzettia	(Ec,Ec,Sp)	Medusytes	(Cn,In,In)	Megapitaria	(Mo,Bi,Ve)
Mccloudia	(Fo,Fo,Fo)	Meekchinus	(Ec,Ec,Ey)	Megaplectatrypa	(Br,Ar,At)
Mcewanella	(Br,Ar,Or)	Meekella	(Br,Ar,St)	Megapleuronia	(Br,Ar,Un)
Mclearnia	(Mo,Bi,Pt)	Meekia	(Mo,Bi,Ve)	Megapeustes	(Ec,Ec,Sp)
Mclearnites	(Br,Ar,St)	Meekoceras	(Mo,Ce,Ce)	Megapomus	(Cd,Os,Co)
Mclearnitesella	(Br,Ar,St)	Meekopinna	(Mo,Bi,Mt)	Megaporocidaris	(Ec,Ec,Ci)
Mclellania	(Ar,Ci)	Meekopora	(Bz,St,Cy)	Megapraeconia	(Mo,Bi,Ve)
Meleodea	(Cn,An,Ta)	Meekoporella	(Bz,St,Cy)	Megapronites	(Mo,Ce,Pl)
Mcmerdodus	(Cd,Ch,Hx)	Meekospira	(Mo,Ga,Nt)	Megaptera	(Cd,Ma,Ce)
Mcnamaraspis	(Cd,Pl,Ar)	Meeria	(Ar,Tr,As)	Megapteropsis	(Cd,Ma,Ce)
Mcqueenoceras	(Mo,Ce,En)	Megabalanus	(Ar,Ci)	Megarhiza	(Po,De,Li)
Meadowtownella	(Ar,Tr,Od)	Megacanthopora	(Bz,St,Cr)	Megasalopia	(Br,Ar,Or)
Meandaranea	(Cn,An,Sc)	Megacanthoporina	(Bz,St,Cr)	Megasylorhinus	(Cd,Ch,Ca)
Meandrastrea	(Cn,An,Sc)	Megacardia	(Mo,Bi,Ve)	Megasphaera	(Pr,Un,In)
Meandrella	(Mo,Ga,Ar)	Megachonetes	(Br,Ar,St)	Megasphaeroceras	(Mo,Ce,Am)
Meandrina	(Cn,An,Sc)	Megacidaris	(Ec,Ec,Ci)	Megaspinochonetes	(Br,Ar,St)
Meandripetra	(Po,De,Ta)	Megacrenella	(Mo,Bi,Mt)	Megasqualus	(Cd,Ch,Sq)
Meandroloculina	(Fo,Fo,Fo)	Megactenopetalus	(Cd,Ch,Pe)	Megasteges	(Br,Ar,St)
Meandrophylia	(Cn,An,Sc)	Megacucullaea	(Mo,Bi,Ar)	Megastomella	(Fo,Fo,Fo)
Meandropora	(Bz,St,Ce)	Megaderaion	(He,En,En)	Megastomia	(Mo,Ga,He)
Meandropsina	(Fo,Fo,Fo)	Megaderbyia	(Br,Ar,St)	Megastroma	(Po,De,Ax)

Megastrophia	(Br,Ar,St)	Melaxinaea	(Mo,Bi,Ar)	Menocephalites	(Ar,Tr,Pt)
Megastropiella	(Br,Ar,St)	Melbacrinus	(Ec,Cr,Cl)	Menocidaris	(Ec,Ec,Ci)
Megastylia	(Po,He,Re)	Melchiorites	(Mo,Ce,Am)	Menoidinia	(Ar,Os,Me)
Megasurcula	(Mo,Ga,Ne)	Meleagriniella	(Mo,Bi,Pt)	Menola	(Cn,Me,Me)
Megatebennus	(Mo,Ga,Ar)	Melicerita	(Bz,Gy,Ch)	Menonomia	(Ar,Tr,Pt)
Megateuthis	(Mo,Ce,Be)	Meliceritella	(Bz,St,Cc)	Menoparia	(Br,Ar,As)
Megathura	(Mo,Ga,Ar)	Meliceritites	(Bz,St,Cc)	Menophyllum	(Cn,An,Ru)
Megathyris	(Br,Ar,Te)	Melikerona	(Cn,An,Sc)	Menopygus	(Ec,Ec,Un)
Megatrigonia	(Mo,Bi,Tr)	Melita	(Ar,MI,Am)	Menthafonia	(Mo,Ga,Nt)
Megatschernyschewia	(Br,Ar,St)	Melithaea	(Cn,An,Go)	Menticirrhus	(Cd,Os,Pf)
Megatyloceras	(Mo,Ce,Am)	Melittosphaera	(Ac,Ra,Sp)	Mentzelia	(Br,Ar,Sp)
Megaxinus	(Mo,Bi,Ve)	Melkaniocyathus	(Po,Re,Mo)	Mentzeloides	(Br,Ar,Sp)
Megayoldia	(Mo,Bi,Nu)	Mellarium	(Mo,Ga,Ar)	Mentzeliopsis	(Br,Ar,Sp)
Megerlia	(Br,Ar,Te)	Mellevilla	(Mo,Ga,Nt)	Menuites	(Mo,Ce,Am)
Megerlina	(Br,Ar,Te)	Mellita	(Ec,Ec,Cl)	Menuthiaster	(Ec,Ec,Hs)
Meghystrichosphaeridium	(Pr,Un,In)	Mellitella	(Ec,Ec,Cl)	Menuthiocrioceras	(Mo,Ce,Am)
Meginoceras	(Mo,Ce,Ce)	Melliteryx	(Mo,Bi,Ve)	Menuthionautlis	(Mo,Ce,Na)
Megistaspis	(Ar,Tr,As)	Mellopegma	(Mo,He,He)	Meoma	(Ec,Ec,Sp)
Megistocrinus	(Ec,Cr,Mo)	Meloceras	(Mo,Ce,On)	Meomia	(Br,Ar,Te)
Megistolepis	(Cd,Os,Co)	Melocrintes	(Ec,Cr,Mo)	Meotolia	(Mo,Bi,Pt)
Megistostoma	(Mo,Ga,Ce)	Melonanchora	(Po,De,Po)	Mephiarges	(Ar,Tr,Li)
Meglopterorhynchus	(Br,Ar,Rh)	Melonechinus	(Ec,Ec,Ey)	Mepygurus	(Ec,Ec,Ca)
Megommatocythere	(Ar,Os,Po)	Melonella	(Po,De,Li)	Merabatis	(Cd,Ch,My)
Megousia	(Br,Ar,St)	Melongena	(Mo,Ga,Ne)	Mercaticeras	(Mo,Ce,Am)
Megumatrypa	(Br,Ar,At)	Melonis	(Fo,Fo,Fo)	Mercedescaudina	(Ec,Ho,El)
Mehesella	(Ar,Os,Po)	Melonites	(Mo,Ce,An)	Mercenaria	(Mo,Bi,Ve)
Mehlina	(Cd,Co,Co)	Melopetatus	(Pr,Un,In)	Merciella	(Br,Ar,St)
Meidamonella	(Fo,Fo,Fo)	Melosia	(Mo,Bi,Ve)	Mercierella	(An,Po,Se)
Meidiichthys	(Cd,Os,Pe)	Melrosia	(Cn,An,Ru)	Mercionia	(Mo,Bi,Ve)
Meifodia	(Br,Ar,At)	Melvilloceras	(Mo,Ce,Go)	Merebolina	(Ar,Tr,Pr)
Meikeloceras	(Mo,Ce,El)	Membranacyathus	(Po,Re,Aj)	Merelina	(Mo,Ga,Nt)
Meiocardia	(Mo,Bi,Ve)	Membranipora	(Bz,Gy,Ch)	Meretrissa	(Mo,Bi,Ve)
Meioceras	(Mo,Ga,Nt)	Membraniporella	(Bz,Gy,Ch)	Meretrix	(Mo,Bi,Ve)
Meisenia	(Mo,Bi,Ve)	Membraniporida	(Bz,Gy,Ch)	Merica	(Mo,Ga,Ne)
Meishucuchiton	(Mo,In,In)	Membraniporina	(Bz,Gy,Ch)	Mericella	(Mo,Ga,Ne)
Meishucunella	(Ar,Os,Ar)	Memriptyocapsa	(Ac,Ra,Na)	Mericoceras	(Mo,Ce,Or)
Meishuengella	(Ar,Os,Ar)	Memoria	(Ar,Os,Po)	Meridensia	(Cd,Os,Pe)
Meisterella	(Ar,Tr,Un)	Menabites	(Mo,Ce,Am)	Merignacia	(Mo,Bi,Ve)
Meitanoceras	(Mo,Ce,Ac)	Menabonites	(Mo,Ce,Am)	Meringaspsis	(Ar,Tr,Od)
Meitanopora	(Cn,An,Ta)	Menaspanthus	(Cd,Ch,In)	Meringosoma	(An,Po,Am)
Meitanovitus	(Hy,Hy,Hy)	Menaspis	(Cd,Ch,In)	Merisca	(Mo,Bi,Ve)
Mekynophrys	(Ar,Tr,Pt)	Mendacella	(Br,Ar,Or)	Merismococha	(Mo,In,In)
Melagathiceras	(Mo,Ce,Ce)	Mendathyris	(Br,Ar,Te)	Merisompteria	(Mo,Bi,Pt)
Melagraphia	(Mo,Ga,Ar)	Mendolaspis	(Ar,Tr,As)	Merista	(Br,Ar,Sp)
Melamphaes	(Cd,Os,Br)	Mendosina	(Ar,Tr,Un)	Meristella	(Br,Ar,Sp)
Melanatria	(Mo,Ga,Nt)	Mendospidella	(Ar,Tr,Co)	Meristelloides	(Br,Ar,Sp)
Melanchlenia	(Ar,Os,Pa)	Mene	(Cd,Os,Pf)	Meristina	(Br,Ar,Sp)
Melanella	(Mo,Ga,Nt)	Meneghinella	(Ar,Tr,Un)	Meristocrinus	(Ec,Cr,Tx)
Melaniptyxis	(Mo,Ga,He)	Meneghiniceras	(Mo,Ce,Ph)	Meristorygma	(Br,Ar,Sp)
Melanofurcata	(Cn,Me,Me)	Menestho	(Mo,Ga,He)	Meristoschisma	(Ec,Pa,Pa)
Melanognathus	(Cd,Os,Di)	Meneviella	(Ar,Tr,Pt)	Meristosoma	(Ar,Un,Un)
Melanogrammus	(Cd,Os,Ga)	Menidia	(Cd,Os,At)	Meristospira	(Br,Ar,Sp)
Melanonus	(Cd,Os,Ga)	Menippe	(Ar,MI,De)	Merklinia	(Mo,Bi,Pt)
Melanophyllidium	(Cn,An,Ru)	Menisoceras	(Mo,Ce,En)	Merklinicardium	(Mo,Bi,Ve)
Melanophyllum	(Cn,An,Ru)	Meniscocorphyte	(Ar,Tr,Pt)	Merlangius	(Cd,Os,Ga)
Melanoraphia	(An,Po,Ph)	Meniscophyllum	(Cn,An,Ru)	Merlewoodia	(Cn,An,Ru)
Melanosteus	(Cd,Pl,Ar)	Meniscopora	(Bz,Gy,Ch)	Merlia	(Po,De,Ta)
Melanostrophus	(He,Gr,St)	Menneraspis	(Ar,Tr,Re)	Merlingina	(Fo,Fo,Fo)
Melanostylus	(Cn,Me,Me)	Mennerella	(Ar,Os,Pa)	Merlinia	(Ar,Tr,As)
Melapium	(Mo,Ga,Ne)	Mennericyathus	(Po,Re,Aj)	Merluccius	(Cd,Os,Ga)
Melaraphe	(Mo,Ga,Nt)	Menneroceria	(Mo,Bi,Nu)	Merocanites	(Mo,Ce,Pl)
Melathrokerion	(Fo,Fo,Fo)	Mennespertia	(Br,Ar,Sp)	Menocidaris	(Ec,Ec,Ci)
Melatella	(Fo,Fo,Fo)	Menessieria	(Mo,Ga,Un)	Merocrinus	(Ec,Cr,Cl)
Melatoma	(Mo,Ga,Ne)	Menniscocrinus	(Ec,Cr,Cl)	Merocythere	(Ar,Os,Po)

Meroena	(Mo, Bi, Ve)	Mesonea	(Bz, St, Cc)	Metaconulus	(Mo, Ga, Ar)
Meropalla	(Ar, Tr, Un)	Mesoneilo	(Mo, Bi, Nu)	Metacrinus	(Ec, Cr, Is)
Meroperix	(Ar, Tr, Pt)	Mesoneritina	(Mo, Ga, Ar)	Metacrocinus	(Ec, Cr, Mo)
Merophricus	(Br, Ar, Te)	Mesonomia	(Br, Ar, Pe)	Metacromyocrinus	(Ec, Cr, Cl)
Merospirifer	(Br, Ar, Sp)	Mesonopora	(Bz, St, Cc)	Metacryphaeus	(Ar, Tr, Ph)
Merriamaster	(Ec, Ec, Cl)	Mesopalaeaster	(Ec, As, Pu)	Metactinoceras	(Mo, Ce, Ac)
Merriamia	(Cd, Re, Ic)	Mesopeplum	(Mo, Bi, Pt)	Metacymbites	(Mo, Ce, Am)
Merriamites	(Mo, Ga, Be)	Mesopholidostrophia	(Br, Ar, St)	Metacyptris	(Ar, Os, Po)
Merrillina	(Cd, Co, Co)	Mesophyllum	(Cn, An, Ru)	Metacyptheropteron	(Ar, Os, Po)
Merulina	(Cn, An, Sc)	Mesopleura	(Mo, Bi, Ve)	Metadagnoceras	(Mo, Ce, Ce)
Mesaktoceras	(Mo, Ce, Ac)	Mesoplica	(Br, Ar, St)	Metaderoceras	(Mo, Ce, Am)
Mesalia	(Mo, Ga, Ni)	Mesoplodon	(Cd, Ma, Ce)	Metadictya	(Bz, St, Cr)
Mesammina	(Fo, Fo, Fo)	Mesoprosopon	(Ar, Ma, Cy)	Metadimorphoceras	(Mo, Ce, Go)
Mescalites	(Mo, Ce, Go)	Mesopuzosia	(Mo, Ce, Am)	Metadinarites	(Mo, Ce, Ce)
Meschedea	(Ac, Ra, Sp)	Mesorbitolina	(Fo, Fo, Fo)	Metadiscus	(Ar, Tr, Ag)
Mesenteripora	(Bz, St, Cc)	Mesorhoea	(Ar, Ml, De)	Metadololina	(Fo, Fo, Fo)
Mesetaia	(Ar, Tr, Pt)	Mesorhytis	(Mo, Ga, Ne)	Metadolines	(Ar, Tr, Re)
Mesiteia	(Cd, Ch, Oc)	Mesosacella	(Mo, Bi, Nu)	Metaetelecrinus	(Ec, Cr, Mo)
Mesnaquaceras	(Mo, Ce, Or)	Mesosaurus	(Cd, Re, An)	Metafinocrinus	(Ec, Cr, Cl)
Mesobeloceras	(Mo, Ce, An)	Mesoscalpellum	(Ar, Ci)	Metagraulus	(Ar, Tr, Un)
Mesoblastus	(Ec, Bl, Sp)	Mesoschubertella	(Fo, Fo, Fo)	Metagravesia	(Mo, Ce, Am)
Mesocallista	(Mo, Bi, Ve)	Mesosimoceras	(Mo, Ce, Am)	Metahamites	(Mo, Ce, Am)
Mesoceras	(Mo, Ce, Di)	Mesosolenia	(Cn, An, Ta)	Metahaploceras	(Mo, Ce, Am)
Mesocetus	(Cd, Ma, Ce)	Mesospira	(Mo, Ga, Ni)	Metaharpes	(Ar, Tr, Pt)
Mesochasmoceras	(Mo, Ce, Na)	Mesosiomaria	(Mo, Gy, Ch)	Metahendestroemia	(Mo, Ce, Ce)
Mesochilotoma	(Mo, Ga, Ne)	Mesotaphraspis	(Ar, Tr, Pr)	Metahoplites	(Mo, Ce, Am)
Mesochione	(Mo, Bi, Ve)	Mesotaria	(Cd, Ma, Ca)	Metaindocrinus	(Ec, Cr, Cl)
Mesochiton	(Mo, Po, Ne)	Mesotaxis	(Cd, Co, Co)	Metakootenia	(Ar, Tr, Co)
Mesocladiscites	(Mo, Ce, Ce)	Mesoterax	(Cd, Ma, Ce)	Metalaespira	(An, Po, Se)
Mesocleupa	(Cd, Os, Pe)	Mesoteuthis	(Mo, Ce, Be)	Metaldetes	(Po, Ir, Ar)
Mesoclymenia	(Mo, Ce, Cl)	Mesotremaster	(Ec, As, Un)	Metalegoceras	(Mo, Ce, Go)
Mesocoelia	(Mo, Ga, Ar)	Mesotreta	(Br, Ar, Un)	Metaleioliclas	(Ar, Tr, Li)
Mesococularia	(Cn, Sc, Cn)	Mesotrigonia	(Mo, Bi, Tr)	Metalia	(Ec, Ec, Sp)
Mesocystis	(Ec, Di, Di)	Mesotrochactaeon	(Mo, Ga, Ce)	Metalisania	(Ar, Tr, Co)
Mesoda	(Cd, Os, Py)	Mesotrypa	(Bz, St, Tr)	Metallagecrinus	(Ec, Cr, Ds)
Mesodema	(Ar, Tr, Re)	Mesotrypina	(Bz, St, Tr)	Metalytoceras	(Mo, Ce, Am)
Mesodentalina	(Fo, Fo, Fo)	Mesoturillites	(Mo, Ce, Am)	Metamelon	(Mo, Ga, Ne)
Mesodesma	(Mo, Bi, Ve)	Mesouralina	(Cn, An, Ru)	Metamassia	(Po, De, Ta)
Mesodiadema	(Ec, Ec, Ci)	Mesovallulus	(Ac, Ra, Sp)	Metanephrops	(Ar, Ml, De)
Mesodiceras	(Mo, Bi, Hi)	Mesovalvata	(Mo, Ga, Ni)	Metanomocare	(Ar, Tr, As)
Mesodmodus	(Cd, Ch, Ct)	Mesopilocrinus	(Ec, Cr, Sa)	Metanothosaurus	(Cd, Re, No)
Mesodouvillina	(Br, Ar, St)	Mespilocystites	(Ec, Co, Co)	Metapadia	(Mo, Bi, Ar)
Mesodromites	(Ar, Ml, De)	Messaoudia	(Ec, Ec, Hs)	Metapalaconeilo	(Mo, Bi, Nu)
Mesoendothyra	(Fo, Fo, Fo)	Messinella	(Ar, Os, Po)	Metapatoceras	(Mo, Ce, Am)
Mesofavosites	(Cn, An, Ta)	Mestognathus	(Cd, Co, Co)	Metapeltoceeras	(Mo, Ce, Am)
Mesogalatheia	(Ar, Ml, De)	Mesturus	(Ar, Cd, Os, Py)	Metaperimostocrinus	(Ec, Cr, Cl)
Mesogaudryceras	(Mo, Ce, Am)	Metaacidaspis	(Ar, Tr, Od)	Metaphragmoceras	(Mo, Ce, On)
Mesogena	(Mo, Ga, Ar)	Metabaltoceras	(Mo, Ce, El)	Metapilekia	(Ar, Tr, Ph)
Mesoglaucania	(Mo, Ga, Ni)	Metabelemnites	(Mo, Ce, Au)	Metaplacenticeras	(Mo, Ce, Am)
Mesohalina	(Mo, Ga, Ni)	Metablastus	(Ec, Bl, Sp)	Metaplasia	(Br, Ar, Sp)
Mesohibolites	(Mo, Ce, Be)	Metabolipa	(Br, Ar, Pe)	Metapiromerops	(Ar, Tr, Ph)
Mesokylix	(Cn, Hy, Hy)	Metabolocrinus	(Ec, Cr, Cl)	Metapolymorphina	(Fo, Fo, Fo)
Mesolasma	(Ar, Ci)	Metabowmania	(Ar, Tr, Pt)	Metaporinus	(Ec, Ec, Ds)
Mesolepis	(Cd, Os, Pa)	Metabrograptus	(He, Gr, Gr)	Metaproniodus	(Cd, Co, Co)
Mesoleptostrophia	(Br, Ar, St)	Metacalymene	(Ar, Tr, Ph)	Metapronorites	(Mo, Ce, Pl)
Mesolimulus	(Ar, Me, Xi)	Metacamarella	(Br, Ar, Pe)	Metapyhoceras	(Mo, Ce, Am)
Mesolinga	(Mo, Bi, Ve)	Metacantites	(Mo, Ce, Pl)	Metareidlichioides	(Ar, Tr, Re)
Mesolissostrophia	(Br, Ar, St)	Metacanthina	(Ar, Tr, Ph)	Metarioceras	(Mo, Ce, On)
Mesolites	(Cn, An, Ta)	Metacarinites	(Mo, Ce, Ce)	Metarmenoceras	(Mo, Ce, Ac)
Mesolobus	(Br, Ar, St)	Metacatillocrinus	(Ec, Cr, Ds)	Metarnioceras	(Mo, Ce, Am)
Mesolophodus	(Cd, Ch, Pe)	Metacerithium	(Mo, Ga, Ni)	Metascutellum	(Ar, Tr, Co)
Mesomitha	(Mo, Bi, Ve)	Metaclichacograptus	(He, Gr, Gr)	Metasbirites	(Mo, Ce, Ce)
Mesomorpha	(Cn, An, Sc)	Metacoceras	(Mo, Ce, Na)	Metasigaloceras	(Mo, Ce, Am)
Mesomphalus	(Ar, Os, Pa)	Metacoenularia	(Cn, Sc, Cn)	Metaspyroceras	(Mo, Ce, Or)

Metasqualodon	(Cd,Ma,Ce)	Miamoceras	(Mo,Ce,On)	Microcorystes	(Ar,Ml,De)
Metassuria	(Mo,Ce,Ce)	Mianxiandiscus	(Ar,Tr,Ag)	Microcosmia	(Ar,Os,Un)
Metasterocystis	(Ec,Di,Di)	Miaohuangrhyncbus	(Br,Ar,Rh)	Miocorinus	(Ec,Cr,Cm)
Metastromatoceras	(Mo,Ce,Or)	Miaooposis	(Ar,Tr,Pt)	Microcubus	(Ac,Ra,Na)
Metastylifolia	(Mo,Cr,Da)	Miatschkovocrinus	(Ec,Cr,Cf)	Microcyathus	(Cn,An,Ta)
Metasycoerinus	(Ec,Cr,Cf)	Micantapex	(Mo,Ga,Ne)	Microcyclus	(Cn,An,Ru)
Metathyrissina	(Br,Ar,Sp)	Micatheca	(Hy,Or,Ex)	Microcyphus	(Ec,Ec,Te)
Metatibetites	(Mo,Ce,Ce)	Miccephalites	(Mo,Ce,Am)	Microcyprina	(Mo,Bi,Ve)
Metatissotia	(Mo,Ce,Am)	Micella	(Br,Ar,Te)	Microcythere	(Ar,Os,Po)
Metavermilia	(An,Po,Se)	Michaletia	(Mo,Ga,Ar)	Microcytherura	(Ar,Os,Po)
Metaxia	(Mo,Ga,Nt)	Michalskia	(Mo,Ce,Am)	Microdactylites	(Mo,Ce,Am)
Metaxytherium	(Cd,Ma,Si)	Michaspis	(Ar,Tr,Pt)	Microdactylophora	(An,Po,Eu)
Metayuepingia	(Ar,Tr,As)	Michela	(Mo,Ga,Ne)	Microdendron	(Po,De,Li)
Metelipora	(Bz,St,Cy)	Michelia	(Mo,Ga,Ar)	Microderoceras	(Mo,Ce,Am)
Metengonoceras	(Mo,Ce,Am)	Michelinaraea	(Cn,An,Sc)	Microdiadema	(Ec,Ec,Hm)
Meteoraspis	(Ar,Tr,Pt)	Michelinia	(Cn,An,Ta)	Microdietyon	(Lo)
Metephippiorhoceras	(Mo,Ce,On)	Michelinoceras	(Mo,Ce,Or)	Microdiscus	(Ar,Tr,Ag)
Methabocrinus	(Ec,Cr,Mo)	Micheliopsis	(Mo,Ga,Ar)	Micrododa	(Mo,Ga,Ar)
Metholectypus	(Ec,Ec,Ho)	Michelotophyllia	(Cn,An,Sc)	Mierodon	(Cd,Os,Py)
Metichthyocrinus	(Ec,Cr,Sa)	Michiganites	(Mo,Ce,Go)	Microdrillia	(Mo,Ga,Ne)
Metinyoites	(Mo,Ce,Ce)	Michniakia	(Mo,In,In)	Microecia	(Bz,St,Cc)
Metisaspina	(Ar,Tr,Pt)	Micidus	(Br,Ar,Te)	Microemtopterus	(Cd,Ch,Sq)
Metisaspis	(Ar,Tr,Pt)	Mickwitzia	(Br,Li,Pa)	Microfragum	(Mo,Bi,Ve)
Metioceras	(Mo,Ce,Am)	Micmacca	(Ar,Tr,Pt)	Microfulgur	(Mo,Ga,Ne)
Metopacanthus	(Cd,Ch,In)	Micmaccopsis	(Ar,Tr,Co)	Microfusum	(Mo,Ga,Ne)
Metopaster	(Ec,As,Va)	Micrabacia	(Cn,An,Sc)	Microgadus	(Cd,Os,Ga)
Metopocetus	(Cd,Ma,Ce)	Micracanthoceras	(Mo,Ce,Am)	Microgaza	(Mo,Ga,Ar)
Metoplichas	(Ar,Tr,Li)	Micraclathurella	(Mo,Ga,Ne)	Microhemidiscia	(Po,He,Hm)
Metopotropis	(Ar,Tr,As)	Micradites	(Ec,Ho,Ap)	Mirolacuna	(Mo,Ga,Nt)
Metoptoma	(Mo,Ga,Pa)	Micragnostus	(Ar,Tr,Ag)	Mirolampas	(Ec,Ec,Ol)
Metorthis	(Br,Ar,Or)	Micranellium	(Mo,Ga,Nt)	Microlotia	(Mo,Ga,Nt)
Metorthonema	(Mo,Ga,Nt)	Micraphelia	(Br,Ar,St)	Microloripes	(Mo,Bi,Ve)
Metoxynoticeras	(Mo,Ce,Am)	Micraseites	(Cd,Tu,Tu)	Microloxococoncha	(Ar,Os,Po)
Metracolpasa	(Bz,Gy,Ch)	Micraster	(Ec,Ec,Sp)	Micromia	(Ar,Ml,De)
Metradolium	(Bz,Gy,Ch)	Micrelenchus	(Mo,Ga,Ar)	Micromeris	(Mo,Bi,Ve)
Metrarabdotos	(Bz,Gy,Ch)	Micrentoma	(Mo,Ga,Ar)	Micromesistius	(Cd,Os,Ga)
Metriceras	(Mo,Ce,Di)	Miereschara	(Mo,Ga,Nt)	Micromitrax	(Ar,Ml,De)
Metrielepis	(Br,Ar,Sp)	Micrina	(Pr,To,Mi)	Micromitra	(Br,Li,Pa)
Metriumphalus	(Mo,Ga,Ar)	Microaechmina	(Ar,Os,Pa)	Micromphalina	(Mo,Ga,Nt)
Metrixonax	(Cn,An,Ru)	Microancientia	(Pr,Un,In)	Micromphalites	(Mo,Ce,Am)
Metriophyllum	(Cn,An,Ru)	Microantyx	(Ec,Ho,El)	Micromphalus	(Mo,Ga,Eu)
Metrioplexus	(Cn,An,Ru)	Microbactrites	(Mo,Ce,An)	Micromyrus	(Cd,Os,An)
Metriorhynchus	(Cd,Re,Cr)	Microbaltoceras	(Mo,Ce,El)	Micronectes	(Mo,Bi,Pt)
Metrocrypta	(Bz,Gy,Ch)	Microbiplices	(Mo,Ce,Am)	Micronoceras	(Mo,Ce,Di)
Metrolytoceras	(Mo,Ce,Am)	Microblastidium	(Po,He,Ly)	Microparaparchites	(Ar,Os,Po)
Metschnikowia	(Po,De,Un)	Microblastus	(Ec,Bf,Fi)	Microparia	(Ar,Tr,As)
Metula	(Mo,Ga,Ne)	Microcallista	(Mo,Bi,Ve)	Micropedina	(Ec,Ec,Pe)
Metulella	(Mo,Ga,Ne)	Microcampylus	(Bz,St,Tr)	Microphillipsia	(Ar,Tr,Pr)
Metussuria	(Mo,Ce,Ce)	Microcapros	(Cd,Os,Ze)	Microphocaena	(Cd,Ma,Ce)
Metutharocrinus	(Ec,Cr,Cf)	Microcaracrinus	(Ec,Cr,Cf)	Micropbyllia	(Cn,An,Sc)
Metyacayathellus	(Po,Tr,Ar)	Microcardinalia	(Mo,Bi,Ve)	Micropbyllopsis	(Cn,An,Sc)
Mexicaprina	(Mo,Bi,Hi)	Microcardium	(Mo,Bi,Ve)	Micropileus	(Mo,Te,Tr)
Mexicardia	(Mo,Bi,Ve)	Microcaris	(Ar,Th,Ce)	Micropilina	(Mo,Te,Tr)
Mexicaria	(Br,Ar,Te)	Microcetus	(Cd,Ma,Ce)	Microplasma	(Cn,An,Ru)
Mexicaspis	(Ar,Tr,Co)	Microcheilinelia	(Ar,Os,Po)	Micropneumatocythere	(Ar,Os,Po)
Mexicella	(Ar,Tr,Pt)	Microcheilus	(Mo,Ga,Ar)	Micropora	(Bz,Gy,Ch)
Mexioceras	(Mo,Ce,Go)	Microchilina	(Ar,Os,Pa)	Microporella	(Bz,Gy,Ch)
Mexicotrochaetaeon	(Mo,Ga,Ce)	Microchirus	(Cd,Os,Pn)	Microporina	(Bz,Gy,Ch)
Meyendorffina	(Fo,Fo,Fo)	Microcholmys	(Mo,Bi,Pt)	Micropristis	(Cd,Ch,Rj)
Meyerella	(Ar,Ml,De)	Microcirce	(Mo,Bi,Ve)	Micropsalis	(Ar,Ml,De)
Meyera	(Ar,Ml,De)	Microcleidus	(Cd,Re,Ps)	Micropsis	(Ec,Ec,Ph)
Mezocrotalus	(Ar,Tr,Ph)	Microcorax	(Cd,Ch,La)	Micropycthis	(Mo,Ga,Nt)
Mezounia	(Br,Ar,St)	Microcornus	(Hy,Hy,Hy)	Micropycnodon	(Cd,Os,Py)
Mialsemia	(Cn,Pe,Er)	Microcoryne	(Po,Un,Un)	Micropygus	(Ec,Ec,Di)

Micropylepora	(Pr.Un.In)	Milleaster	(Cn.Hy.Mi)	Minussina	(Bz.St.Tr)
Microrhizophora	(Po.De.Li)	Millepes	(Mo.Ga.Nt)	Minutalirhynchia	(Br.Ar.Rh)
Microrhynchia	(Br.Ar.Rh)	Millepora	(Cn.Hy.Mi)	Minutiscala	(Mo.Ga.Nt)
Microrhytis	(Mo.Ga.Ne)	Milleporella	(Po.De.Ax)	Minutostrophodontia	(Br.Ar.St)
Microsachites	(Pr.Co.Sa)	Milleporidium	(Po.De.Ax)	Minyaichme	(Fo.Fo.Fo)
Microschedia	(Pr.Un.In)	Milleratia	(Ar.Os.Pa)	Minymerisma	(Mo.In.In)
Microschiza	(Mo.Ga.Nt)	Millerella	(Fo.Fo.Fo)	Minysphenia	(Br.Ar.Rh)
Microsciadiocapsa	(Ac.Ra.Na)	Millericrinus	(Ec.Cr.Mi)	Minythra	(Br.Ar.Sp)
Microscutellum	(Ar.Tr.Co)	Milikonienkioceras	(Mo.Ce.Na)	Miowateria	(Mo.Ga.Ne)
Microseria	(Cn.An.Sc)	Millosevichia	(Mo.Ga.Ce)	Miocardiella	(Mo.Bi.Ve)
Microsmilia	(Cn.An.Sc)	Millythyris	(Br.Ar.Te)	Miocardiopsis	(Mo.Bi.Ve)
Microsolena	(Cn.An.Sc)	Milneria	(Mo.Bi.Ve)	Miocenebra	(Mo.Ga.Ne)
Microsolenastraea	(Cn.An.Sc)	Milonicystis	(Ec.St.Co)	Miocidaris	(Ec.Ec.Ci)
Microsphaeriodiorhynchu	(Br.Ar.Rh)	Milovanovicia	(Mo.Bi.Hi)	Miocyprideis	(Ar.Os.Po)
Microspongia	(Po.De.Li)	Miltha	(Mo.Bi.Ve)	Miocytheridea	(Ar.Os.Po)
Microsqualodon	(Cd.Ma.Ce)	Milthona	(Mo.Bi.Ve)	Miodelphis	(Cd.Ma.Ce)
Microstagon	(Mo.Bi.Ve)	Miltites	(Mo.Ce.Ce)	Miodomeris	(Mo.Bi.Ve)
Microstaura	(Po.He.Re)	Miltonella	(Ar.Os.Pa)	Miodontiscus	(Mo.Bi.Ve)
Microstelma	(Mo.Ga.Nt)	Mimachlamys	(Mo.Bi.Pt)	Mioerycina	(Mo.Bi.Ve)
Microsteus	(Cd.Pl.Ar)	Mimagoniatiites	(Mo.Ce.An)	Miofractarmilla	(Mo.Ga.Ar)
Microstomus	(Cd.Os.Pn)	Mimanarcestes	(Mo.Ce.An)	Miogryphus	(Br.Ar.Te)
Microsurcula	(Mo.Ga.Ne)	Mimaria	(Br.Ar.Te)	Miogypsina	(Fo.Fo.Fo)
Microtophrus	(Mo.Ga.Nt)	Mimella	(Br.Ar.Or)	Miogypsinita	(Fo.Fo.Fo)
Microthyca	(Mo.Ga.Nt)	Mimerodonta	(Mo.Bi.Mo)	Miogypsinoidea	(Fo.Fo.Fo)
Microtrigonia	(Mo.Bi.Tr)	Mimetaster	(Ar.Ma.Mi)	Miokogia	(Cd.Ma.Ce)
Microtropites	(Mo.Ce.Ce)	Mimeticosia	(Po.He.He)	Miolepidocyclina	(Fo.Fo.Fo)
Microtrypa	(Br.Ar.St)	Mimia	(Cd.Os.Pa)	Miolyncina	(Mo.Ga.Nt)
Microtubus	(An.Po.Un)	Mimikonstantia	(Br.Ar.Th)	Miomelon	(Mo.Ga.Ne)
Microvoluta	(Mo.Ga.Ne)	Mimimitoerases	(Mo.Ce.Go)	Miopentagonaster	(Ec.As.Va)
Microxestolebris	(Ar.Os.Ph)	Mimocystites	(Ec.Rh.Rh)	Miophora	(Cn.An.Sc)
Microzarkodina	(Cd.Co.Co)	Mimograptus	(He.Gr.Gr)	Miopiola	(Mo.Ga.Nt)
Microzeuglodon	(Cd.Ma.Ce)	Mimolychnoceras	(Mo.Ce.On)	Mioplax	(Ar.Ml.De)
Mictocrinus	(Ec.Cr.Cl)	Mimorina	(Br.Ar.Te)	Miopleiona	(Mo.Ga.Ne)
Mictocystis	(Cn.An.Ru)	Mimosphinctes	(Mo.Ce.An)	Mioplous	(Cd.Os.Pf)
Mictophyllum	(Cn.An.Ru)	Mimospira	(Mo.Pa.Hy)	Mioprotomya	(Mo.Bi.Ph)
Mictosaukia	(Ar.Tr.As)	Minatou	(Cn.An.Ru)	Miorangia	(Mo.Bi.Ve)
Mictospirifer	(Br.Ar.Sp)	Minatolites	(Cn.An.Ta)	Mioscapophyllia	(Cn.An.Sc)
Micula	(Cn.An.Ru)	Minatrypa	(Br.Ar.At)	Mioseris	(Cn.An.Sc)
Miculiella	(Cn.An.Ru)	Minepharus	(Mo.Bi.Ve)	Miosiren	(Cd.Ma.Si)
Middendorffia	(Mo.Po.Ne)	Minervaeystis	(Ec.Hs.So)	Miosorites	(Fo.Fo.Fo)
Miehlkella	(Ar.Os.Pa)	Minervapecten	(Mo.Bi.Pt)	Miospondylus	(Ec.Op.Oe)
Migliorinia	(Ec.Ec.Sp)	Minetrigonia	(Mo.Bi.Tr)	Mirabairdia	(Ar.Os.Po)
Migmatophyllum	(Cn.An.Ru)	Minganoerases	(Mo.Ce.On)	Mirabella	(Mo.In.In)
Migros	(Fo.Fo.Fo)	Mingenevia	(Br.Ar.St)	Mirabiloceras	(Mo.Ce.En)
Miguashaia	(Cd.Os.Co)	Miniacina	(Fo.Fo.Fo)	Mirabole	(Ar.Tr.Pr)
Mikadotrochus	(Mo.Ga.Ar)	Minicephalus	(Ar.Tr.Pt)	Mirachelus	(Mo.Ga.Ar)
Mikhailovella	(Fo.Fo.Fo)	Minicidaris	(Ec.Ec.Ci)	Miraclothurella	(Mo.Ga.Ne)
Mikhnoxyathus	(Po.Ir.Ar)	Minicrinus	(Ec.Cr.Ds)	Miracrinus	(Ec.Cr.Sa)
Mikkwaphyllum	(Cn.An.Ru)	Minilya	(Bz.St.Fe)	Miraculum	(Ar.Os.Pa)
Miklukhoceras	(Mo.Ce.Pl)	Minilyacrinus	(Ec.Cr.Cl)	Miracybele	(Ar.Tr.Ph)
Mikrocidiario	(Ec.Ec.Ci)	Minipropkia	(Br.Ar.Or)	Miraclythere	(Ar.Os.Po)
Mila	(Mo.Bi.Pt)	Minispina	(Br.Ar.St)	Miralda	(Mo.Ga.He)
Milaculum	(An.Pa.Pa)	Minitheca	(Hy.Or.Or)	Miranda	(Ar.Tr.Pt)
Milananguilla	(Cd.Os.An)	Minithyris	(Br.Ar.Te)	Miranella	(Ar.Tr.Un)
Milanovskaya	(Ar.Os.Pa)	Miniuva	(Fo.Fo.Fo)	Mirapecten	(Mo.Bi.Pt)
Milax	(Ac.Ra.Na)	Minkella	(Ar.Tr.Pt)	Mirascapha	(Mo.Ga.Ce)
Milda	(Mo.Ga.He)	Minnivola	(Mo.Bi.Pt)	Miraspis	(Ar.Tr.Od)
Miliammellus	(Fo.Fo.Fo)	Minocapsa	(Ac.Ra.Na)	Miratheca	(Pr.Un.In)
Miliammina	(Fo.Fo.Fo)	Minojapanella	(Fo.Fo.Fo)	Mirechinus	(Ec.Ec.Te)
Miliola	(Fo.Fo.Fo)	Minolia	(Mo.Ga.Ar)	Miricardium	(Mo.Bi.Ve)
Milolechina	(Fo.Fo.Fo)	Minororthis	(Br.Ar.Un)	Miriella	(Pr.Co.Sa)
Milolinella	(Fo.Fo.Fo)	Minouxia	(Fo.Fo.Fo)	Mirifenestella	(Bz.St.Fe)
Miliolipora	(Fo.Fo.Fo)	Minusella	(Ar.Tr.Re)	Mirifica	(Fo.Fo.Fo)
Miliospirella	(Fo.Fo.Fo)	Minussiella	(Cn.An.Ru)	Mirifusella	(Br.Ar.Sp)

Mirifusus	(Ac,Ra,Na)	Mixogonaria	(Cn,An,Ru)	Mojszella	(Ar,Os,Pa)
Mirilientia	(Mo,Ce,Go)	Mixomanticoceras	(Mo,Ce,An)	Mojsarcoceras	(Mo,Ce,Na)
Mirilingula	(Br,Li,Li)	Mixopterus	(Ar,Me,Eu)	Mojsisovicites	(Mo,Ce,Ce)
Miriproetus	(Ar,Tr,Pr)	Mixosaurus	(Cd,Re,Je)	Mojsisovicteuthis	(Mo,Ce,Au)
Mirisquamea	(Br,Ar,Te)	Mixosiphonoceras	(Mo,Ce,On)	Mojsisoviczia	(Mo,Ce,Am)
Miriolaminatus	(Mo,Ga,Nt)	Mixtacondona	(Ar,Os,Po)	Mojsvarities	(Mo,Ce,Ph)
Mirocetus	(Cd,Ma,Ce)	Mixtipecten	(Mo,Bi,Pt)	Mokattamia	(Mo,Bi,Ve)
Mirochiliticus	(Mo,Ga,Be)	Mixtustictyon	(Po,De,St)	Mokotibaster	(Ec,Ec,Sp)
Miroclymenia	(Mo,Ce,Cl)	Miyagipecten	(Mo,Ce,Pt)	Mola	(Cd,Os,Te)
Miroelasma	(Cn,An,Ru)	Miyakoceras	(Mo,Ce,Am)	Molaria	(Ar,Un,Un)
Mirojuvavites	(Mo,Ce,Ce)	Miyakosimilia	(Cn,An,Sc)	Moleculospina	(Po,De,Hd)
Mironovella	(Fo,Fo,Fo)	Miyakothyris	(Br,Ar,Te)	Molengraafia	(Po,Ca,Ph)
Mirothis	(Br,Ar,Or)	Mizuhopecten	(Mo,Bi,Pt)	Molinicola	(Mo,Bi,Pt)
Mirosphinctes	(Mo,Ce,Am)	Mjandymoceras	(Mo,Ce,Di)	Mollia	(Bz,Gy,Ch)
Mirua	(Mo,Ga,Ne)	Mjoesina	(Br,Ar,St)	Mollisomia	(Ar,Un,Un)
Mirula	(Mo,Ga,Un)	Mnemoceras	(Mo,Ce,On)	Mollocrinus	(Ec,Cr,Cl)
Miscellanea	(Fo,Fo,Fo)	Mnestia	(Mo,Ga,Ce)	Molongola	(Br,Ar,St)
Miscellosmilia	(Cn,An,Sc)	Mnestocyclidnella	(Mo,Ga,Ce)	Molongella	(Br,Ar,Or)
Miscia	(Mo,Bi,Hi)	Moanasaurus	(Cd,Re,Sq)	Molonga	(Br,Ar,Sp)
Misellina	(Fo,Fo,Fo)	Moapocrinus	(Ec,Cr,Cl)	Molophyllum	(Cn,An,Ru)
Misikella	(Cd,Co,Co)	Mobergella	(Pr,Un,Hy)	Molopophorus	(Mo,Ga,Ne)
Misistella	(Cn,An,Sc)	Mobula	(Cd,Ch,My)	Moltkia	(Cn,An,Go)
Misolia	(Br,Ar,Sp)	Mochella	(Ar,Os,Po)	Molukkana	(Mo,Bi,Ph)
Misrichthys	(Cd,Ch,La)	Mochlophyllum	(Cn,An,Ru)	Molukia	(Cn,An,Se)
Missisquoia	(Ar,Tr,Pt)	Mochtyella	(An,Po,Eu)	Molva	(Cd,Os,Ge)
Mississippina	(Fo,Fo,Fo)	Modelia	(Mo,Ga,Ar)	Molybdocyathus	(Po,Ir,Ar)
Missouricrinus	(Ec,Cr,Cl)	Moderatoproductus	(Br,Ar,St)	Monacanthites	(Mo,Ce,Ce)
Misteia	(Mo,Ga,Ne)	Modesta	(Cn,An,Ru)	Monachiopsis	(Cd,Ma,Ca)
Mistia	(Ec,As,Px)	Modestella	(Br,Ar,Te)	Monachocrinus	(Ec,Cr,Bo)
Mistostigma	(Mo,Ga,Un)	Modestospira	(Mo,Ga,Be)	Monachus	(Cd,Ma,Ca)
Mistproductus	(Br,Ar,St)	Modiella	(Mo,Bi,Ve)	Monadoblastus	(Ec,Bi,Sp)
Mita	(Ac,Ra,Na)	Modiodonta	(Mo,Bi,Mo)	Monadotechia	(Br,Ar,Rh)
Mitchellaspis	(Ar,Tr,Ph)	Modiolarca	(Mo,Bi,Mt)	Monalaria	(Mo,Ga,Nt)
Mitchellella	(Br,Ar,St)	Modiolaria	(Mo,Bi,Mt)	Monaster	(Ec,As,Pr)
Mithracia	(Ar,ML,De)	Modiolatus	(Mo,Bi,Mt)	Monasterium	(Ar,Os,Ar)
Mithracites	(Ar,ML,De)	Modiolina	(Mo,Bi,Ve)	Moncharmontia	(Fo,Fo,Fo)
Mitoclema	(Bz,St,Cc)	Modiolodon	(Mo,Bi,Mo)	Monelasma	(Br,Ar,Or)
Mitoclemella	(Bz,St,Cc)	Modiolopsis	(Mo,Bi,Mo)	Monetaria	(Mo,Ga,Nt)
Mitonia	(Mo,Ce,Am)	Modiolula	(Mo,Bi,Mt)	Mongoceras	(Mo,Ce,Or)
Mitorthoceras	(Mo,Ce,Or)	Modiolus	(Mo,Bi,Mt)	Mongoliacus	(Pr,Un,In)
Mitra	(Mo,Ga,Ne)	Modiolusia	(Mo,Bi,Mt)	Mongoliella	(Br,Ar,St)
Mitracalpis	(Ac,Ra,Na)	Modiomorpha	(Mo,Bi,Mo)	Mongoliolites	(Cn,An,Ta)
Mitriaria	(Mo,Ga,Ne)	Modiomylus	(Mo,Bi,Mt)	Mongoliopsis	(Br,Ar,Sp)
Mitratoma	(Mo,Ga,Ne)	Modocia	(Ar,Tr,Pt)	Mongolirhynchia	(Br,Ar,Rh)
Mitrax	(Ar,ML,De)	Modulus	(Mo,Ga,Nt)	Mongolitestia	(Pr,Un,In)
Mitrella	(Mo,Ga,Ne)	Moeckowia	(Ar,Os,Pa)	Mongolitubulus	(Pr,Un,In)
Mitrellostaxis	(Cd,Co,Co)	Moelleria	(Mo,Ga,Ar)	Mongolocarpus	(Ec,St,Mi)
Mitrellosturis	(Mo,Ga,Ne)	Moelleritia	(Ar,Os,Le)	Mongoloceras	(Mo,Ce,Go)
Mitreola	(Mo,Ga,Ne)	Moenocrinus	(Ec,Cr,Is)	Mongoloclema	(Bz,St,Tr)
Mitridomus	(Mo,Ga,Ne)	Moerckeia	(Mo,Ga,Nt)	Mongolodictya	(Bz,St,Cy)
Mitrihara	(Mo,Ga,Ne)	Moerella	(Mo,Bi,Ve)	Mongolodiscus	(Ar,Tr,Ag)
Mitrocappina	(Mo,Bi,Hi)	Moeschia	(Br,Ar,Te)	Mongolodus	(Ch,Pr)
Mitroceras	(Mo,Ce,On)	Moesiloculina	(Fo,Fo,Fo)	Mongolorhynch	(Br,Ar,Rh)
Mitrocinus	(Ec,Cr,Un)	Mofitites	(Mo,Ce,Am)	Mongolostia	(Br,Ar,St)
Mitrocystella	(Ec,St,Mi)	Mogoktella	(Br,Ar,Pe)	Mongolospira	(Br,Ar,Sp)
Mitrocystites	(Ec,St,Mi)	Mogoliella	(Br,Ar,At)	Monia	(Mo,Bi,Pt)
Mitrodendron	(Cn,An,Sc)	Mohrensternia	(Mo,Ga,Nt)	Monillocrinus	(Ec,Cr,Di)
Mitrodrillia	(Mo,Ga,Ne)	Moierina	(Ar,Os,Pa)	Monilea	(Mo,Ga,Ar)
Mitrolumna	(Mo,Ga,Ne)	Moiria	(Ec,Ec,Sp)	Moniliopsis	(Mo,Ga,Ne)
Mitromorpha	(Mo,Ga,Ne)	Moiropsis	(Ec,Ec,Sp)	Monilipolus	(Ec,Ho,De)
Mitsukurina	(Cd,Ch,La)	Moissevieia	(Br,Ar,Rh)	Monilirretusa	(Mo,Ga,Ce)
Mixastrea	(Cn,An,Sc)	Mojezalepas	(Pr,Ma,Tu)	Monilispingia	(Po,He,Ly)
Mixocetus	(Cd,Ma,Ce)	Mojezatheca	(Hy,Or,Ci)	Moniiflora	(Mo,Bi,Ve)
Mixoconus	(Cd,Co,Co)	Mojezatrypa	(Bz,St,Tr)	Monitorella	(Mo,Ga,Me)

Monkaspis	(Ar.Tr.As)	Monspeliensina	(Fo.Fo.Fo)	Morgania	(Mo.Ga.Nt)
Monnieria	(Mo.Bi.Hi)	Monsteraphyllum	(Cn.An.Ru)	Morgatia	(Ar.Tr.Ph)
Monoblastus	(Ec.Bl.Sp)	Monstrocrinus	(Ec.Cr.Di)	Moridunia	(Mo.Bi.Mo)
Monobolina	(Br.Li.Li)	Montacuta	(Mo.Bi.Ve)	Morinorhynchus	(Br.Ar.St)
Monobrachiocrinus	(Ec.Cr.Cl)	Montanablastus	(Ec.Bl.Sp)	Morionella	(Mo.Ga.Nt)
Monocentris	(Cd.Os.Br)	Montanaria	(Mo.Bi.Ve)	Morkhovenia	(Ar.Os.Po)
Monoceratella	(Ar.Os.Po)	Montanella	(Br.Ar.Te)	Morkhovencythereis	(Ar.Os.Po)
Monoceratina	(Ar.Os.Po)	Montastrea	(Cn.An.Sc)	Mormula	(Mo.Ga.He)
Monoceratopora	(Bz.Gy.Ch)	Montecaris	(Ar.Ml.Ar)	Morocoenites	(Ar.Tr.Ph)
Monocerina	(Bz.Gy.Ch)	Montezumella	(Ar.Ml.De)	Moronaster	(Ec.Ec.Sp)
Monocheilus	(Ar.Tr.As)	Montfortella	(Fo.Fo.Fo)	Morone	(Cd.Os.Pf)
Monochirus	(Cd.Os.Pn)	Montfortia	(Mo.Ga.Ar)	Morosa	(Ar.Tr.Pt)
Monocircus	(Mo.Ga.Nt)	Montfortula	(Mo.Ga.Ar)	Morosyringium	(Ac.Ra.Na)
Monocladodus	(Cd.Ch.Cl)	Montia	(Mo.Ga.Ne)	Moroteuthis	(Mo.Ce.Te)
Monocliniacis	(He.Gr.Gr)	Monticlarella	(Br.Ar.Rh)	Morozovapora	(Bz.St.Fe)
Monococonvexa	(Br.Un.Ob)	Monticulifera	(Br.Ar.St)	Morozovella	(Fo.Fo.Fo)
Monocostodus	(Cd.Co.Co)	Monticuliopora	(Bz.St.Tr)	Morozoviella	(Bz.St.Cr)
Monocuphus	(Mo.Ga.Nt)	Monticyathus	(Cn.An.Sc)	Morphaspopora	(Bz.Gy.Ch)
Monocyclusaetraea	(Cn.An.Sc)	Monticuliphyllia	(Cn.An.Sc)	Morphastrea	(Cn.An.Sc)
Monocycloides	(Ec.Ed.Is)	Montiparus	(Fo.Fo.Fo)	Morphoceras	(Mo.Ce.Am)
Monocyrtoceras	(Mo.Ce.Ac)	Montipora	(Cn.An.Sc)	Morphorhynchus	(Br.Ar.Rh)
Monodaeus	(Ar.Ml.De)	Montivaltia	(Cn.An.Sc)	Morphotropis	(Mo.Ga.Ar)
Monodechella	(Ar.Tr.Pr)	Montospira	(Mo.Ga.Ar)	Morrisiceras	(Mo.Ce.Am)
Monodechenella	(Ar.Tr.Pr)	Montsecchiana	(Fo.Fo.Fo)	Morrisipecten	(Mo.Bi.Pt)
Monodentella	(Mo.Ga.Ar)	Montsenetes	(Br.Ar.St)	Morrisithyrus	(Br.Ar.Te)
Monodesmopora	(Bz.St.Ce)	Montyoceras	(Mo.Ce.As)	Morrowcrinus	(Ec.Cr.Cl)
Monodiadema	(Ec.Ec.Sa)	Moorea	(Ar.Os.Po)	Morrowites	(Mo.Ce.Am)
Monodioxodina	(Fo.Fo.Fo)	Moorefieldella	(Br.Ar.Rh)	Mortensenaster	(Ec.Ec.Sp)
Monodilepas	(Mo.Ga.Ar)	Mooreinella	(Fo.Fo.Fo)	Mortensenites	(Ec.Ho.De)
Monodon	(Cd.Ma.Ce)	Moorelina	(Br.Ar.Te)	Mortieria	(Po.De.Li)
Monodonta	(Mo.Ga.Ar)	Moorellina	(Br.Ar.Th)	Mortinella	(Ec.Ec.Cl)
Monogonoceras	(Mo.Ce.El)	Mooreocrinus	(Mo.Ce.Or)	Mortonoceras	(Mo.Ce.Am)
Monograptus	(He.Gr.Gr)	Mooreoceras	(Ec.Cr.Cl)	Morula	(Mo.Ga.Ne)
Monolene	(Cd.Os.Pn)	Moorephylloporina	(Bz.St.Fe)	Morum	(Mo.Ga.Nt)
Monomerella	(Br.Li.Li)	Moorevillia	(Cd.Os.Cr)	Morunella	(Mo.Ga.Ne)
Monomitopus	(Cd.Os.Op)	Moorites	(Ar.Os.Pa)	Morycastraea	(Cn.An.Sc)
Monomuchites	(Mo.Ce.Or)	Mooritheca	(Hy.Or.Or)	Mosaeleberis	(Ar.Os.Po)
Monomyces	(Cn.An.Sc)	Moosrowipora	(Cn.An.Ta)	Mosasaurus	(Cd.Re.Sq)
Mononotella	(Ar.Os.Ar)	Moosina	(Ar.Os.Po)	Mosathoa	(Bz.Gy.Ch)
Monophoraster	(Ec.Ec.Cl)	Mootvingeeyathus	(Po.Re.Aj)	Moschoglossis	(Ar.Tr.Pr)
Monophyllites	(Mo.Ce.Ph)	Mopalia	(Mo.Po.Ne)	Moscovicrinus	(Ec.Cr.Cl)
Monopleura	(Mo.Bi.Hi)	Mopsea	(Cn.An.Go)	Moselopterus	(Ar.Me.Eu)
Monoplex	(Mo.Ga.Nt)	Moquellina	(Br.Ar.Rh)	Mosherella	(Cd.Co.Co)
Monopophorus	(Mo.Ga.Ne)	Morania	(Cn.An.Nt)	Moskovia	(Po.De.Ta)
Monoporella	(Bz.Gy.Ch)	Moravammina	(Fo.Fo.Fo)	Mosquilla	(Br.Ar.Rh)
Monopteria	(Mo.Bi.Pt)	Moravatturia	(Br.Ar.Te)	Mosquoceras	(Mo.Ce.Na)
Monoptygma	(Mo.Ga.Ne)	Moravilla	(Br.Ar.Sp)	Mostlerella	(Ar.Os.Po)
Monorakos	(Ar.Tr.Ph)	Moravocoryphe	(Ar.Tr.Pr)	Mostlerium	(Ac.Ra.Sp)
Monorthis	(Br.Ar.Or)	Moravophyllum	(Cn.An.Ru)	Motina	(Ar.Un.Un)
Monoschizablastus	(Ec.Bl.Sp)	Moravostrophia	(Br.Ar.St)	Motyris	(Mo.Ga.Nt)
Monosera	(Ac.Ra.Na)	Moravurus	(Ar.Me.Xi)	Moumina	(Br.Ar.Sp)
Monospinites	(Pr.Co.Sa)	Morchellastraea	(Cn.An.Sc)	Moundocrinus	(Ec.Cr.Cl)
Monostychia	(Ec.Ec.Cl)	Morchella	(Mo.Ga.Nt)	Mourlonia	(Mo.Ga.Ar)
Monosulcatina	(Ar.Tr.Pt)	Morea	(Mo.Ga.Ne)	Mourlonopsis	(Mo.Ga.Nt)
Monotaxinoides	(Fo.Fo.Fo)	Moreauoceras	(Mo.Ce.Ta)	Moussonella	(Mo.Bi.Pt)
Monotherium	(Cd.Ma.Ca)	Moremanoceras	(Mo.Ce.Am)	Moutonoceras	(Mo.Ce.Am)
Monothyra	(Mo.Bi.My)	Morencyathus	(Po.Re.Aj)	Moutonithyrus	(Br.Ar.Te)
Monotiopleura	(Ar.Os.Pa)	Morenocetus	(Cd.Ma.Ce)	Movchovitschia	(Ar.Os.Pa)
Monotis	(Mo.Bi.Pt)	Morenosaurus	(Cd.Re.Ps)	Movomia	(Ar.Tr.Pt)
Monotrypa	(Bz.St.Tr)	Moretarva	(Ar.Tr.Un)	Moyacanthus	(Cd.Ch.Ct)
Monotrypella	(Bz.St.Tr)	Moretia	(Po.He.Ly)	Moyerella	(Bz.St.Cr)
Monsardithyrus	(Br.Ar.Te)	Moretiaella	(Po.He.Ly)	Moyerokania	(Mo.In.In)
Monsella	(Bz.Gy.Ch)	Moretispongia	(Po.De.Li)	Moythomasia	(Cd.Os.Pa)
Monsmirabilia	(Ar.Os.Po)	Morganella	(Br.Ar.St)	Mrsasiella	(Mo.Bi.Pt)

Mrsosocyathus	(Po,Re,Aj)	Mundaster	(Ec,Ec,Sp)	Mutationella	(Br,Ar,Te)
Mrbilaia	(Mo,Ga,He)	Mundiitia	(Mo,Ga,Ar)	Mutiella	(Mo,Bi,Ve)
Mstikhinoceras	(Mo,Ce,Ac)	Mundiitiella	(Mo,Ga,Nt)	Mutilus	(Ar,Os,Po)
Mstinia	(Fo,Fo,Fo)	Mundocephalina	(Ar,Tr,Pt)	Mya	(Mo,Bi,My)
Mstiniella	(Fo,Fo,Fo)	Munhella	(Br,Ar,Or)	Myadesma	(Mo,Bi,Ve)
Muchattoocyathus	(Po,Re,Aj)	Munjida	(Ar,MI,De)	Myadora	(Mo,Bi,Ph)
Muconalia	(Mo,Ga,Nt)	Muniodopsis	(Ar,MI,De)	Myadoropsis	(Mo,Bi,Ph)
Mucophyllum	(Cn,An,Ru)	Munieratrypa	(Br,Ar,At)	Myagropora	(Bz,Gy,Ch)
Mucroclipeus	(Br,Ar,Sp)	Muniericeras	(Mo,Ce,Am)	Myagrostoma	(Mo,Ga,Ar)
Mucrodactylites	(Mo,Ce,Am)	Munjija	(Ar,Tr,Pt)	Myalina	(Mo,Bi,Pt)
Mucronaspis	(Ar,Tr,Ph)	Munithites	(Ar,MI,De)	Myalinella	(Mo,Bi,Pt)
Mucronella	(Bz,Gy,Ch)	Munseyella	(Ar,Os,Po)	Myalinopterella	(Mo,Bi,Pt)
Mucronina	(Fo,Fo,Fo)	Mupus	(Cd,Os,Pl)	Myapalmula	(Mo,Bi,Mt)
Mucrospirifer	(Br,Ar,Sp)	Muraena	(Cd,Os,An)	Mycedium	(Cn,An,Sc)
Mucrospiriferinella	(Br,Ar,Sp)	Muraenesox	(Cd,Os,An)	Mycerosia	(Br,Ar,Te)
Muehlerina	(Ar,Os,Po)	Muraenosaurus	(Cd,Re,Ps)	Mycetaraea	(Cn,An,Sc)
Muellerithalamia	(Po,De,Pe)	Murania	(Mo,Ce,AX)	Mycetophyllia	(Cn,An,Sc)
Muellerodus	(Cd,Co,Pa)	Murchisonella	(Mo,Ga,Nt)	Mycetophyllopsis	(Cn,An,Sc)
Muensterella	(Mo,Ce,Te)	Murchisonia	(Mo,Ga,Ar)	Mycetoserries	(Cn,An,Sc)
Muensterites	(Mo,Ce,Ce)	Murchisoniceras	(Mo,Ce,Or)	Mychostomina	(Fo,Fo,Fo)
Muensteroceras	(Mo,Ce,Go)	Murciella	(Fo,Fo,Fo)	Mycocrinus	(Ec,Cr,Ds)
Mufushanella	(Fo,Fo,Fo)	Murengoloclema	(Cd,Os,An)	Myceterosuchus	(Cd,Re,Cr)
Mugil	(Cd,Os,Pl)	Murex	(Mo,Ga,Ne)	Mycetophum	(Cd,Os,My)
Muiroceras	(Mo,Ce,Na)	Murexiella	(Mo,Ga,Ne)	Myeinocestites	(Ec,Hs,So)
Muirwoodella	(Br,Ar,Te)	Murexsul	(Mo,Ga,Ne)	Myelastrium	(Ac,Ra,Sp)
Muirwoodia	(Br,Ar,St)	Murgeina	(Fo,Fo,Fo)	Myelodactylus	(Ec,Cr,Ds)
Mulceodens	(Mo,Ro,Co)	Murgella	(Fo,Fo,Fo)	Mygallia	(Mo,Bi,Ve)
Mulinia	(Mo,Bi,Ve)	Murguthalamia	(Po,De,Ve)	Myinda	(Ar,Tr,As)
Mulinoides	(Mo,Bi,Ve)	Muricanthus	(Mo,Ga,Ne)	Myindella	(Ar,Tr,As)
Mulletia	(Mo,Bi,Pt)	Muricassis	(Mo,Ga,Nt)	Mykosmilia	(Cn,An,Sc)
Mullus	(Cd,Os,Pl)	Muriceras	(Mo,Ce,El)	Mylacanthus	(Cd,Os,Co)
Multicameroceras	(Mo,Ce,El)	Muricoglobigerina	(Fo,Fo,Fo)	Myledaphus	(Cd,Ch,Cm)
Multicarinophyllum	(Cn,An,Ru)	Muricopsis	(Mo,Ga,Ne)	Myliobatis	(Cd,Ch,My)
Multicaeva	(Bz,St,Ce)	Muricetrochus	(Mo,Ga,Ar)	Myliusia	(Po,He,He)
Multicolamnastraea	(Cn,An,Sc)	Muriferella	(Br,Ar,Or)	Myllia	(Mo,Bi,Ve)
Multiconus	(Mo,Cr,Te)	Murihikurhynchia	(Br,Ar,Rh)	Myllitella	(Mo,Bi,Ve)
Multicorhynchia	(Br,Ar,Rh)	Murinella	(Br,Ar,St)	Mylocecion	(Ac,Ra,Na)
Multicostella	(Br,Ar,Or)	Murinopsis	(Bz,Gy,Ch)	Mylocomotreta	(Br,Ii,Ac)
Multicrescis	(Bz,St,Ce)	Murjukiana	(Br,Ar,Or)	Myloceras	(Mo,Ce,Di)
Multicrisina	(Bz,St,Ce)	Murmur	(Cd,Pl,Ar)	Mylomyrus	(Cd,Os,An)
Multifarites	(Mo,Ga,Be)	Muroserpula	(An,Po,Se)	Mylostoma	(Cd,Pl,Ar)
Multifascigera	(Bz,St,Ce)	Murotriton	(Mo,Ga,Ne)	Myobarbium	(Mo,Ga,Ne)
Multiidella	(Fo,Fo,Fo)	Murphitys	(Mo,Ga,Ne)	Myobradypterygius	(Cd,Re,Ic)
Multigalea	(Bz,St,Ce)	Murravehinus	(Ec,Ec,Ph)	Myocaris	(Mo,Ro,Ri)
Multiloqua	(Po,He,He)	Murruvia	(Br,Ar,Te)	Myochama	(Mo,Bi,Ph)
Multioistodus	(Cd,Co,Co)	Murrayina	(Ar,Os,Po)	Myoconcha	(Mo,Bi,Ve)
Multiphragma	(Bz,St,Tr)	Murrayinella	(Fo,Fo,Fo)	Myodakryotus	(Mo,Bi,Ar)
Multipocula	(Po,De,Li)	Murrayoceras	(Mo,Ce,El)	Myodethyrum	(Br,Ar,Sp)
Multiprion	(An,Po,Eu)	Murrindalaspis	(Cd,Pl,Ac)	Myoforiceps	(Mo,Bi,Mt)
Multipxyxis	(Mo,Ga,He)	Mursia	(Ar,MI,De)	Myofossa	(Mo,Bi,Ph)
Multiridia	(Br,Ar,St)	Mursilia	(Ar,MI,De)	Myomphalis	(Ar,Os,Pa)
Multiseptida	(Fo,Fo,Fo)	Mursiopsis	(Ar,MI,De)	Myona	(Mo,In,Tu)
Multisolenia	(Cn,An,Ta)	Murthya	(Ar,Os,Po)	Myonia	(Mo,Bi,Ph)
Multisparsa	(Bz,St,Ce)	Murtiella	(Ar,Os,Pa)	Myopholas	(Mo,Bi,Ph)
Multispinula	(Br,Li,Ac)	Musashia	(Mo,Ga,Ne)	Myophorella	(Mo,Bi,Tr)
Multispirifer	(Br,Ar,Sp)	Muscochitina	(Fo,Fo,Ch)	Myophoria	(Mo,Bi,Tr)
Multispirina	(Fo,Fo,Fo)	Musculina	(Br,Ar,Te)	Myophoricardium	(Mo,Bi,Ve)
Multistella	(Po,De,Li)	Muscultiopsis	(Mo,Bi,Ve)	Myophorigonia	(Mo,Bi,Tr)
Multithecopora	(Cn,An,Ta)	Musculista	(Mo,Bi,Mt)	Myophoriopsis	(Mo,Bi,Ve)
Multitubigera	(Bz,St,Ce)	Musculus	(Mo,Bi,Mt)	Myoplusia	(Mo,Bi,Nu)
Multivasculatus	(Po,He,Re)	Muscirinus	(Ec,Cr,Ds)	Myoproetus	(Ar,Tr,Pr)
Multizonopora	(Bz,St,Ce)	Mussa	(Cn,An,Sc)	Myopsolenus	(Ar,Tr,Pt)
Mumiella	(Bz,Gy,Ch)	Mussivillia	(Cn,An,Sc)	Myopterygius	(Cd,Re,Ic)
Mummaspis	(Ar,Tr,Ol)	Mustelus	(Cd,Ch,Ca)	Myopugnax	(Br,Ar,Rh)

Myoscolex	(Pr.Di,Ra)	Nadiyella	(Ar.Tr,As)	Nannopeltis	(Ar.Tr,Un)
Myotreta	(Br.Li,Ac)	Nadotia	(Cn.An,Ru)	Nannopora	(Bz.Gy,Ch)
Myra	(Ar.Ml,De)	Naedyceras	(Mo.Ce,Di)	Nannopterygius	(Cd.Re,Ic)
Myrakeena	(Mo.Bi,Pt)	Naefia	(Mo.Ce,Se)	Nannopyrgula	(Mo.Ga,Nt)
Myrene	(Mo.Bi,Ve)	Naevithis	(Ar.Os,Pa)	Nannostephanus	(Mo.Ce,Am)
Myriacanthus	(Cd.Ch,In)	Nagaella	(Mo.Bi,Ve)	Nannovascoceras	(Mo.Ce,Am)
Myriapora	(Bz.Gy,Ch)	Nagaproetus	(Ar.Tr,Pr)	Nannubasa	(Mo.Ga,Ar)
Myriastiches	(Ec.Ec,Ey)	Nagatoella	(Fo.Fo,Fo)	Nanocarpus	(Ec.St,Co)
Myriophyllia	(Cn.An,Sc)	Nagatophyllum	(Cn.An,Ru)	Nanocrinus	(Ec.Cr,Cl)
Myriophyllum	(Cn.An,Sc)	Nagyella	(Ar.Os,Po)	Nanograptus	(He.Gr,Gr)
Myriopora	(Po.De,Ax)	Nahannagnostus	(Ar.Tr,Ag)	Nanogyra	(Mo.Bi,Pt)
Myriospirifer	(Br.Ar,Sp)	Nahannia	(Ar.Tr,Pt)	Nanohalus	(Mo.Bi,Ar)
Myriozoom	(Bz.Gy,Ch)	Nahanniaspis	(Cd,Pt,Pt)	Nanonavis	(Mo.Bi,Ar)
Myripristis	(Cd.Os,Br)	Nahannicephalus	(Ar.Tr,Pt)	Nanopitar	(Mo.Bi,Ve)
Myristica	(Mo.Ga,Ne)	Nahecaris	(Ar.Ml,Ar)	Nanopsis	(Ar.Os,Pa)
Myrmecidium	(Po.Ca,Ph)	Nairiella	(Mo.Ga,Nt)	Nanorthis	(Br.Ar,Or)
Myrmecioophyrum	(Po.De,Li)	Nairites	(Mo.Ce,Ce)	Nanospira	(Br.Ar,At)
Myrmecioptychium	(Po.He,Ly)	Naivis	(Mo.Ce,Or)	Nanothyris	(Br.Ar,Te)
Myrmirhyx	(Br.Ar,Rh)	Najaceras	(Mo.Ce,En)	Nansenia	(Cd.Os,Os)
Myrocongier	(Cd.Os,An)	Najadospirifer	(Br.Ar,Sp)	Nanshanophyllum	(Cn.An,Ru)
Myrsopsis	(Mo.Bi,Ve)	Najidomithyris	(Br.Ar,Te)	Nantaella	(Br.Ar,Rh)
Myrtea	(Mo.Bi,Ve)	Nakanotrigonia	(Mo.Bi,Tr)	Nanukidium	(Br.Ar,Pe)
Myrteopsis	(Mo.Bi,Ve)	Nakazathyris	(Br.Ar,Sp)	Nanurocythereis	(Ar.Os,Po)
Myrtillocrinus	(Ec.Cr,Cl)	Nalivkinaria	(Br.Ar,Rh)	Naoides	(Cn.An,Ru)
Myrtucina	(Mo.Bi,Ve)	Nalivkinella	(Cn.An,Ru)	Naos	(Cn.An,Ru)
Mysella	(Mo.Bi,Ve)	Nalivkinia	(Br.Ar,At)	Napaeana	(Po.He,Ly)
Mysia	(Mo.Bi,Ve)	Nalivkinicyathus	(Po.Re,Aj)	Napora	(Ac.Ra,Na)
Mysidae	(Ar.Ml,My)	Namaia	(Ar.Os,Po)	Naptile	(Ar.Un,Un)
Mysidiella	(Mo.Bi,Mt)	Namalia	(Cn,Pe,Er)	Napulus	(Mo.Ga,Nt)
Mysidoptera	(Mo.Bi,Pt)	Namanoia	(Ar.Tr,Co)	Naquetia	(Mo.Ga,Ne)
Mysterioceras	(Mo.Ce,Or)	Nambetella	(Ar.Tr,Pt)	Naradanithyris	(Br.Ar,Te)
Mysterium	(Po.He,He)	Namnetia	(Mo.Bi,Ve)	Naraoia	(Ar.Tr,Na)
Mystioceras	(Mo.Ce,En)	Namropyge	(Ar.Tr,Pr)	Narayania	(Fo.Fo,Fo)
Mysticocrinus	(Ec.Cr,St)	Nanacythere	(Ar.Os,Po)	Narcine	(Cd.Ch,To)
Mystriophis	(Cd.Os,An)	Nanahughmilleria	(Ar.Me,Eu)	Narcopterus	(Cd.Ch,Rj)
Mystriopora	(Bz.Gy,Ch)	Nanambonites	(Br.Ar,St)	Naricava	(Mo.Ga,Nt)
Mystrocephala	(Ar.Tr,Pr)	Nanaochlamys	(Mo.Bi,Pt)	Naricospina	(Mo.Ga,Nt)
Mystrophora	(Br.Ar,Or)	Nanatrypa	(Br.Ar,At)	Narindecchinus	(Ec.Ec,Ph)
Mytella	(Mo.Bi,Mt)	Nanchangosaurus	(Cd.Re,No)	Narona	(Mo.Ga,Ne)
Mytilarca	(Mo.Bi,Pt)	Nanchengella	(Ar.Os,Ar)	Nartheoceras	(Mo.Ce,En)
Mytilaster	(Mo.Bi,Mt)	Nanggulania	(Mo.Ga,Nt)	Narynella	(Br.Ar,Or)
Mytilidesmatella	(Mo.Bi,Pt)	Naniceella	(Fo.Fo,Fo)	Nasepia	(Cn,Pe,Er)
Mytilisepa	(Mo.Bi,Mt)	Nanierinus	(Ec.Cr,Mo)	Naso	(Cd.Os,Pt)
Mytilocerasmus	(Mo.Bi,Pt)	Namillaenus	(Ar.Tr,Co)	Nasocephalus	(Ar.Tr,Pt)
Mytiloides	(Mo.Bi,Pt)	Namisocetus	(Cd.Ma,Ce)	Nasonirhynchia	(Br.Ar,Rh)
Mytilon	(Mo.Bi,Mt)	Nankat	(Br.Un,Na)	Nassa	(Mo.Ga,Ne)
Mytiloperna	(Mo.Bi,Pt)	Nankinella	(Fo.Fo,Fo)	Nassaria	(Mo.Ga,Ne)
Mytilops	(Mo.Bi,Mt)	Nankinolithus	(Ar.Tr,As)	Nassarina	(Mo.Ga,Ne)
Mytilus	(Mo.Bi,Mt)	Nanlingella	(Mo.Bi,Pt)	Nassarius	(Mo.Ga,Ne)
Myttonia	(Ar.Tr,As)	Nanlingia	(Ar.Tr,As)	Nassauoceras	(Mo.Ce,Na)
Myurella	(Mo.Ga,Ne)	Nannamorina	(Mo.Ga,Ne)	Nassichukites	(Mo.Ce,Ce)
Myurellina	(Mo.Ga,Ne)	Nannastacus	(Ar.Ml,Cu)	Nassicola	(Mo.Ga,Ne)
Myxilla	(Po.De,Po)	Nannirhynchia	(Br.Ar,Rh)	Nassovia	(Ar.Tr,Pt)
Myxinikela	(Cd,Ce,My)	Nannites	(Mo.Ce,Ce)	Nassovocrinus	(Ec.Cr,Cl)
Myzostomites	(An.My,My)	Nanno	(Mo.Ce,En)	Nastasia	(Br.Ar,Rh)
Naanchangasaurus	(Cd.Re,Ic)	Nannobelus	(Mo.Ce,Be)	Nasutoerinus	(Ec.Cr,Un)
Nabarredia	(Br.Ar,St)	Nannoblastus	(Ec.Bi,Fi)	Nataliella	(Cn.An,Ru)
Nabaviella	(Po.Un,Un)	Nannocardioceras	(Mo.Ce,Am)	Natalophyllum	(Cn.An,Ta)
Nabiaioia	(Br.Ar,St)	Nannocetus	(Cd.Ma,Ce)	Natella	(Mo.Ga,Nt)
Nacca	(Mo.Ga,Nt)	Nannoconus	(Pr.Un,In)	Nathorstella	(Mo.Bi,Pt)
Nacella	(Mo.Ga,Pa)	Nannodiella	(Mo.Ga,Ne)	Nathorstia	(Ar.Mo,In)
Nactocerinus	(Ec.Cr,Cl)	Nannolepis	(Cd.Os,Pl)	Nathorstites	(Mo.Ce,Ce)
Nadalina	(Cn.In,In)	Nannolithax	(Cd.Ma,Ce)	Natica	(Mo.Ga,Nt)
Nadiastrophia	(Br.Ar,St)	Nannolytoceras	(Mo.Ce,Am)	Naticarius	(Mo.Ga,Nt)

Naticonema	(Mo,Ga,Ar)	Negevodus	(Cd,Re,Pl)	Neoaethleta	(Mo,Ga,Ne)
Naticopsis	(Mo,Ga,Ar)	Negramithyris	(Br,Ar,Te)	Neobactrotheca	(Hy,Or,Or)
Natiria	(Mo,Ga,At)	Nehalemia	(Ec,As,Va)	Neobairdia	(Ar,Os,Po)
Natitaria	(Mo,Ga,Nt)	Nehanniaspis	(Ar,Tr,Un)	Neobeatricea	(Po,De,St)
Natlandia	(Cd,Os,Sa)	Nehdentomis	(Ar,Os,My)	Neobellemnella	(Mo,Ce,Be)
Natmus	(Ar,Tr,Pt)	Nehedia	(Mo,Ro,Co)	Neobeliniuropis	(Ar,Me,Xi)
Natoba	(Ac,Ra,Na)	Neilo	(Mo,Bi,Nu)	Neobernaya	(Mo,Ga,Nt)
Natraglia	(Ac,Ra,Sp)	Neiloides	(Mo,Bi,Nu)	Neoberouella	(Ar,Os,Po)
Naulia	(Mo,Bi,Ve)	Neilonella	(Mo,Bi,Nu)	Neobeyrichia	(Ar,Os,Pa)
Naupliella	(Fo,Fo,Fo)	Neilsonia	(Mo,Ga,Ar)	Neobibolites	(Mo,Ce,Am)
Naupygus	(Cd,Os,Br)	Neimongolella	(Br,Ar,Rh)	Neobistrialites	(Mo,Ce,Na)
Naustia	(Ar,Tr,Pt)	Neithea	(Mo,Bi,Pt)	Neobolus	(Br,Li,Ac)
Nautellipsites	(Mo,Ce,Go)	Neithella	(Mo,Bi,Pt)	Neobothriocidaris	(Ec,Ec,Bo)
Nautiloceras	(Mo,Ce,Na)	Neitheops	(Mo,Bi,Pt)	Neobouchardia	(Br,Ar,Te)
Nautilocolina	(Fo,Fo,Fo)	Nejdia	(Mo,Ce,Am)	Neobrachiylasma	(Cn,An,Ru)
Nautilus	(Mo,Ce,Na)	Nekewis	(Mo,Ga,Ne)	Neobrunsiina	(Fo,Fo,Fo)
Navarella	(Fo,Fo,Fo)	Nekhoroshevia	(Br,Ar,Rh)	Neobulimina	(Fo,Fo,Fo)
Navarracysthere	(Ar,Os,Po)	Nekhoroshoiella	(Br,St,Tr)	Neoburmesia	(Mo,Bi,Ph)
Navicularina	(Ar,Os,Un)	Nekvasiloveia	(Br,Ar,Te)	Neobythites	(Cd,Os,Op)
Naviculina	(Ar,Os,Po)	Nekvasilovella	(Br,Ar,Un)	Neocaeniopsis	(Cn,An,Sc)
Navispira	(Br,Ar,At)	Neliella	(Bz,Gy,Ch)	Neocalmionia	(Ar,Tr,Ph)
Navoites	(Cn,An,Ta)	Nellia	(Bz,Gy,Ch)	Neocantocrinus	(Ec,Cr,Mo)
Nawenia	(Mo,Ga,Ne)	Nellitia	(Mo,Bi,Ve)	Neocantrella	(Cn,An,Ru)
Nawnites	(An,Po,Un)	Neltneria	(Ar,Tr,Ol)	Neocaprina	(Mo,Bi,Hi)
Naxilepis	(Cd,Os,Pa)	Nelumbia	(Po,De,Li)	Neocarcinoceras	(Mo,Ce,Am)
Nayadina	(Mo,Bi,Pt)	Nelumbifolium	(Po,He,Ly)	Neocarpenteria	(Fo,Fo,Fo)
Nayunnella	(Br,Ar,Rh)	Nemacantholema	(Bz,St,Cr)	Neocassandra	(Cd,Os,My)
Nazarovella	(Ac,Ra,Sp)	Nemacanthopora	(Bz,St,Cr)	Neocatacrinus	(Ec,Cr,Ci)
Neaeromya	(Mo,Bi,Ve)	Nemacanthus	(Cd,Ch,In)	Neocatillocrinus	(Ec,Cr,Ds)
Neaguites	(Fo,Fo,Fo)	Nemagraptus	(Ho,Gr,Gr)	Neocatopygus	(Ec,Ec,Ca)
Neamphitomaria	(Mo,Ga,Ar)	Nemaster	(Ec,Cr,Cm)	Neocaudites	(Ar,Os,Po)
Neancyloceras	(Mo,Ce,Am)	Nemataxidra	(Bz,St,Fe)	Neocavittella	(Cd,Co,Co)
Neanthias	(Cd,Os,Pl)	Nemataxis	(Bz,St,Cr)	Neoceras	(Mo,Ce,On)
Nearoporomya	(Mo,Bi,Ph)	Nematifera	(Bz,St,Cc)	Neochetoceras	(Mo,Ce,Am)
Neatrypa	(Br,Ar,At)	Nematinion	(Po,De,Li)	Neochilina	(Ar,Os,Un)
Neaxon	(Cn,An,Ru)	Nematocrania	(Br,Li,Ac)	Neochilonorria	(Ar,Tr,Co)
Neaxonella	(Cn,An,Ru)	Nematotonus	(Cd,Os,Au)	Neochonetes	(Br,Ar,St)
Nebenthyrus	(Br,Ar,Sp)	Nematopora	(Bz,St,Cr)	Neocirpa	(Br,Ar,Rh)
Nebespecha	(Ac,Ra,Na)	Nematoporella	(Bz,Gy,Ch)	Neocladiscites	(Mo,Ce,Ce)
Nebidella	(Ar,Tr,Re)	Nematoptychius	(Cd,Os,Pa)	Neoclavulina	(Fo,Fo,Fo)
Nebrashacrinus	(Ec,Cr,Ci)	Nematosalpinx	(Po,De,Pe)	Neocliessiophyllum	(Cn,An,Ru)
Nebraskites	(Mo,Ce,Am)	Nematotrypa	(Bz,St,Fe)	Neoclypites	(Mo,Ce,Ce)
Nebriis	(Cd,Os,Pl)	Nematrochus	(Mo,Ga,Ar)	Neocobboldia	(Ar,Tr,Ag)
Nebrius	(Cd,Ch,Oc)	Nemesa	(Br,Ar,Rh)	Neocoelia	(Br,Ar,At)
Nebroceras	(Mo,Ce,Or)	Nemetia	(Mo,Bi,Ve)	Neocoenia	(Cn,An,Sc)
Nebrodites	(Mo,Ce,Am)	Nemiana	(Cn,An,Un)	Neocola	(Mo,Ga,Ne)
Nebularia	(Mo,Ga,Ne)	Nemistium	(Cn,An,Ru)	Neocolodius	(Cd,Co,Co)
Neckajatia	(Ar,Os,Pa)	Nemocardium	(Mo,Bi,Ve)	Neocolumbites	(Mo,Ce,Ce)
Neckajella	(Ar,Os,Pa)	Nemoceratina	(Ar,Os,Po)	Neocolumnaria	(Cn,An,Ru)
Necklandia	(Mo,Bi,Pr)	Nemodon	(Mo,Bi,Ar)	Neocomites	(Mo,Ce,Am)
Necrateria	(Ar,Os,Po)	Nemrac	(Mo,Ga,Ar)	Neocoonophyllia	(Cn,An,Sc)
Necrocarcinus	(Ar,MI,De)	Nemuniella	(Ar,Os,Pa)	Neocoonularia	(Cn,Sc,Cn)
Necrogammarus	(Lo)	Neocarinaria	(Fo,Fo,Fo)	Neocosmoceras	(Mo,Ce,Am)
Necromites	(Cd,Ma,Ca)	Neoacrocephalites	(Ar,Tr,Pt)	Neocramatia	(Br,Ar,St)
Necronectes	(Ar,MI,De)	Neogaganides	(Mo,Ce,Go)	Neocerania	(Br,Li,Ac)
Necroteuthis	(Mo,Ce,Te)	Neogagnostus	(Ar,Tr,Ag)	Neoceraspedites	(Mo,Ce,Am)
Nectocaris	(Pr,Un,In)	Neoalballella	(Ac,Ra,Sp)	Neocrassina	(Mo,Bi,Ve)
Nectosaurus	(Cd,Re,Th)	Neoamphossites	(Ar,Os,Pa)	Neocraterellina	(Ar,Os,Po)
Neepaliphyllum	(Cn,An,Ru)	Neoanomicerella	(Ar,Tr,Pt)	Neocribrella	(Fo,Fo,Fo)
Neeyambaspis	(Cd,Pt,Un)	Neoparchites	(Ar,Os,Pa)	Neocrimites	(Mo,Ce,Go)
Nefocoenia	(Cn,An,Sc)	Neoarchaediscus	(Fo,Fo,Fo)	Neocrinus	(Ec,Cr,Is)
Nefophyllia	(Cn,An,Sc)	Neoarchaeocrinus	(Ec,Cr,Di)	Neocrioceras	(Mo,Ce,Am)
Negapriion	(Cd,Ch,Ca)	Neoarchaesphaera	(Fo,Fo,Fo)	Neocucullograptus	(He,Gr,Gr)
Negebites	(Mo,Ce,Ce)	Neospongophyllum	(Cn,An,Ru)	Neocybium	(Cd,Os,Pl)

Neocyloceras	(Mo,Ce,Or)	Neoisorophusella	(Ec,Ed,Is)	Neophylloceras	(Mo,Ce,Ph)
Neocylindrites	(Mo,Ga,Ce)	Neojanacus	(Mo,Ga,Ni)	Neopilumnoplax	(Ar,Mi,De)
Neocylindrus	(Mo,Ga,Ne)	Neokaipingoceras	(Mo,Ce,En)	Neoplanorbulinella	(Fo,Fo,Fo)
Neocymatoceras	(Mo,Ce,Na)	Neokarpinskia	(Br,Ar,At)	Neoplatycerphalus	(Cd,Os,Sc)
Neocypricardinia	(Mo,Bi,Ve)	Neokentoceras	(Mo,Ce,Am)	Neoplatytrichus	(Ec,Cr,Mo)
Neocyprideis	(Ar,Os,Po)	Neokeyserlingophyllum	(Cn,An,Ru)	Neoplatytaichum	(Mo,Ga,Ar)
Neocyrtina	(Br,Ar,Sp)	Neokjaerina	(Br,Ar,St)	Neopleurofusua	(Mo,Ga,Ne)
Neocyrtilites	(Mo,In,In)	Neokloedenella	(Ar,Os,Pa)	Neoplicatifer	(Br,Ar,St)
Neocystiphyllum	(Cn,An,Ru)	Neokoninckophyllum	(Cn,An,Ru)	Neopopanceras	(Mo,Ce,Ce)
Neocythere	(Ar,Os,Po)	Neokunmingella	(Ar,Os,Ar)	Neoprimitiella	(Ar,Os,Pa)
Neocytheretta	(Ar,Os,Po)	Neokypophyllum	(Cn,An,Ru)	Neoprobolium	(Ar,Tr,Ph)
Neocytherideis	(Ar,Os,Po)	Neolaganum	(Ec,Ec,Cl)	Neoproetus	(Ar,Tr,Pr)
Neodadoerinus	(Ec,Cr,Mi)	Neolageniocerinus	(Ec,Cr,Cl)	Neopronorites	(Mo,Ce,Pl)
Neodelthyris	(Br,Ar,Sp)	Neolatirus	(Mo,Ga,Ne)	Neoporaster	(Ec,Ec,Sp)
Neodexiospira	(An,Po,Se)	Neolenticulina	(Fo,Fo,Fo)	Neoprotencrinus	(Ec,Cr,Cl)
Neodichocrinus	(Ec,Cr,Mo)	Neolepas	(Ar,Ci)	Neoprotachyeras	(Mo,Ce,Ce)
Neodimorphoceras	(Mo,Ce,Go)	Neolepton	(Mo,Bi,Ve)	Neopychites	(Mo,Ce,Am)
Neodiscoeyclina	(Fo,Fo,Fo)	Neolimulus	(Ar,Me,Xi)	Neopytyxis	(Mo,Ga,He)
Neodiscosorus	(Mo,Ce,Di)	Neolioceratoides	(Mo,Ce,Am)	Neopulchellia	(Mo,Ce,Am)
Neodiversograptus	(He,Gr,Gr)	Neoliothyria	(Br,Ar,Te)	Neopycnodonte	(Mo,Bi,Pt)
Neodomatoceras	(Mo,Ce,Na)	Neolissoceras	(Mo,Ce,Am)	Neoradiolites	(Mo,Bi,Hi)
Neodrepanella	(Ar,Os,Pa)	Neolobites	(Mo,Ce,Am)	Neorbitolinopsis	(Fo,Fo,Fo)
Neolonograptus	(He,Gr,De)	Neolobograptus	(He,Gr,Gr)	Neoredlichia	(Ar,Tr,Re)
Neoeponides	(Fo,Fo,Fo)	Neoloculicyathus	(Po,Ir,Ar)	Neoretenoa	(Bz,St,Ce)
Neoeriodocampilus	(Bz,St,Tr)	Neololigosepia	(Mo,Ce,Te)	Neoreteporina	(Bz,St,Fe)
Neoeriodotrypella	(Bz,St,Tr)	Neomantelliceras	(Mo,Ce,Am)	Neoretzia	(Br,Ar,Sp)
Neofasciocosta	(Br,Ar,Rh)	Neomanticoceras	(Mo,Ce,An)	Neorhombolepis	(Cd,Os,Am)
Neoflabellina	(Fo,Fo,Fo)	Neomegalodon	(Mo,Bi,Hi)	Neorhombopora	(Bz,St,Cr)
Neofletcheriella	(Cn,An,Ta)	Neometabolipa	(Br,Ar,Pe)	Neorhynchula	(Br,Ar,Rh)
Neofordilla	(Mo,Bi,Mo)	Neometacanthus	(Ar,Tr,Ph)	Neorhomeria	(Cn,An,Ta)
Neofusulina	(Fo,Fo,Fo)	Neomicroceras	(Mo,Ce,Am)	Neorotalia	(Fo,Fo,Fo)
Neofusulinella	(Fo,Fo,Fo)	Neomicrorbis	(An,Po,Se)	Neorthoceras	(Mo,Ce,Or)
Neogaimardia	(Mo,Bi,Ve)	Neomiodon	(Mo,Bi,Ve)	Neorumphia	(Ec,Ec,Cl)
Neogastropiles	(Mo,Ce,Am)	Neomiodonoides	(Mo,Bi,Ve)	Neosaynoceras	(Mo,Ce,Am)
Neogauthiericeras	(Mo,Ce,Am)	Neomisellina	(Fo,Fo,Fo)	Neoscalpellum	(Ar,Ci)
Neogeoceras	(Mo,Ce,Pl)	Neomonoceratina	(Ar,Os,Po)	Neoschisma	(Ec,Bi,Fi)
Neoglaphyrites	(Mo,Ce,Go)	Neomorphoceras	(Mo,Ce,Am)	Neoschizodus	(Mo,Bi,Tr)
Neoglobator	(Ec,Ec,Go)	Neomorphotis	(Mo,Bi,Pt)	Neoschizophoria	(Br,Ar,Or)
Neoglobithyris	(Br,Ar,Te)	Neomphyma	(Cn,An,Ru)	Neoschmidtella	(Ar,Os,Pa)
Neoglobobuadrina	(Fo,Fo,Fo)	Neomultiostodus	(Cd,Co,Co)	Neoschubertella	(Fo,Fo,Fo)
Neogloborilus	(Hy,Or,Gi)	Neomultithecopora	(Cn,An,Ta)	Neoschwagerina	(Fo,Fo,Fo)
Neoglyphioceras	(Mo,Ce,Go)	Neonerinea	(Mo,Ga,He)	Neosciadiocapsa	(Ac,Ra,Na)
Neoglytotoxiceras	(Mo,Ce,Am)	Neonesidea	(Ar,Os,Po)	Neoscombrops	(Cd,Os,Pf)
Neognathodus	(Cd,Co,Co)	Neontolium	(Mo,Bi,Pt)	Neoselwynoceras	(Mo,Ce,Am)
Neogondolella	(Cd,Co,Co)	Neonyhamnella	(Ar,Os,Po)	Neosemantis	(Ac,Ra,Na)
Neogoniatis	(Mo,Ce,Go)	Neooctonaria	(Ar,Os,Po)	Neoshirakiella	(Ar,Tr,Pt)
Neogothograptus	(He,Gr,Gr)	Neopachycormus	(Cd,Os,Pe)	Neoshumardites	(Mo,Ce,Go)
Neograhamites	(Mo,Ce,Am)	Neopagetina	(Ar,Tr,Ag)	Neosichuanoceras	(Mo,Ce,Or)
Neogriffithides	(Ar,Tr,Pr)	Neopalaeaster	(Ec,As,Pu)	Neosilesites	(Mo,Ce,Am)
Neogualdapia	(Po,De,Pe)	Neopaliphyllum	(Cn,An,Ru)	Neosimnia	(Mo,Ga,Ni)
Neoguraleus	(Mo,Ga,Ne)	Neopanderodus	(Cd,Co,Co)	Neosirenites	(Mo,Ce,Ce)
Neogypidula	(Br,Ar,Un)	Neoparadainella	(Fo,Fo,Fo)	Neosolenopleurella	(Ar,Tr,Pt)
Neogyroidina	(Fo,Fo,Fo)	Neopauxillites	(Hy,Hy,Hy)	Neospathodus	(Cd,Co,Co)
Neohalecopsis	(Cd,Os,Go)	Neopelta	(Po,De,Li)	Neospirifer	(Br,Ar,Sp)
Neoharpoceras	(Mo,Ce,Am)	Neopeltis	(Ar,Tr,As)	Neospirigerina	(Br,Ar,Ar)
Neohedinaspis	(Ar,Tr,Pt)	Neopercis	(Cd,Os,Pf)	Neospongophylloides	(Cn,An,Ru)
Neohibolites	(Mo,Ce,Be)	Neopericyclus	(Mo,Ce,Go)	Neosqualodon	(Cd,Ma,Ce)
Neohimavatites	(Mo,Ce,Ce)	Neopetalichthys	(Cd,Pl,Pe)	Neostaffella	(Fo,Fo,Fo)
Neohindia	(Po,De,Li)	Neophariceras	(Mo,Ce,An)	Neostlingoceras	(Mo,Ce,Am)
Neohoplaceras	(Mo,Ce,Am)	Neophlycticeras	(Mo,Ce,Am)	Neostrabops	(Ar,Me,Ag)
Neoioceras	(Mo,Ce,Go)	Neophoca	(Cd,Ma,Ce)	Neostreptognathodus	(Cd,Co,Co)
Neoimbricaria	(Mo,Ga,Ne)	Neopholidophoropsis	(Cd,Os,Pe)	Neostrophophylloides	(Cn,An,Ru)
Neoinoceramus	(Mo,Bi,Pt)	Neophrecythere	(Ar,Os,Po)	Neostrophia	(Br,Ar,Pe)
Neoiraqia	(Fo,Fo,Fo)	Neophricadothyris	(Br,Ar,Sp)	Neosyringopora	(Cn,An,Ta)

Neosyringostroma	(Po,De,St)	Nericia	(Ar,Tr,Pt)	Nevenulora	(Mo,Bi,Ve)
Neotabularia	(Cn,An,Ru)	Nericiaspis	(Ar,Tr,Pt)	Neverita	(Mo,Ga,Nt)
Neotaenicephalus	(Ar,Tr,Pt)	Nericodus	(Cd,Co,Co)	Neviaopora	(Bz,St,Ce)
Neotapes	(Mo,Bi,Ve)	Neridomus	(Mo,Ga,Ar)	Nevillella	(Fo,Fo,Fo)
Neotemnophyllum	(Cn,An,Ru)	Nerinatica	(Mo,Ga,Nt)	Newaagia	(Mo,Bi,Pt)
Neothailandina	(Fo,Fo,Fo)	Nerinea	(Mo,Ga,He)	Newberria	(Br,Ar,Te)
Neothecidella	(Br,Ar,Th)	Nerinella	(Mo,Ga,He)	Newboldicerias	(Mo,Ce,Am)
Neotherium	(Cd,Ma,Ca)	Nerineopsis	(Mo,Ga,Nt)	Newellia	(Po,De,Ha)
Neothlipsura	(Ar,Os,Po)	Nerineoptyxis	(Mo,Ga,He)	Newellipecten	(Mo,Bi,Pt)
Neothyris	(Br,Ar,Te)	Nerinoides	(Mo,Ga,Nt)	Newmarracaroceras	(Mo,Ce,Am)
Neothibettes	(Mo,Ce,Ce)	Nerita	(Mo,Ga,Ar)	Newportopora	(Bz,St,Tr)
Neotrapezium	(Mo,Bi,Ve)	Neritaria	(Mo,Ga,Ar)	Newsomella	(Mo,Bi,Pt)
Neotrematopora	(Bz,St,Tr)	Neritina	(Mo,Ga,Ar)	Newsomites	(Ar,Os,Po)
Neotreta	(Br,Li,Ac)	Neritoma	(Mo,Ga,Ar)	Nexocrinus	(Ec,Cr,Di)
Neotrigonia	(Mo,Bi,Tr)	Neritoplica	(Mo,Ga,Ar)	Nezamyslia	(Ar,Os,Pa)
Neotrochaetaeon	(Mo,Ga,Ce)	Neritopsis	(Mo,Ga,Ar)	Nezumia	(Cd,Os,Ga)
Neotryplasma	(Cn,An,Ru)	Neritoptyx	(Mo,Ga,Ar)	Nezzazata	(Fo,Fo,Fo)
Neotsirella	(Ar,Os,Pa)	Neritra	(Mo,Bi,Ve)	Nezzazatinella	(Fo,Fo,Fo)
Neoudenites	(Mo,Ce,Pl)	Neritrema	(Mo,Ga,Nt)	Nganasanella	(Ar,Tr,Pt)
Neoulrichia	(Ar,Os,Pa)	Nerophis	(Cd,Os,Ga)	Niachangella	(Ar,Tr,Pr)
Neouvigenna	(Fo,Fo,Fo)	Nerthastrea	(Cn,An,Sc)	Niajuphyllum	(Cn,An,Ru)
Neovallus	(Ac,Ra,Sp)	Nerthebrochus	(Br,Ar,Te)	Nibionia	(Po,De,Pe)
Neoveenia	(Ar,Os,Po)	Nervolites	(Hy,Uc,Uc)	Nicaeotrochus	(Cn,An,Sc)
Neovenerella	(Mo,Bi,Ve)	Nervophyllum	(Cn,An,Ru)	Nicaisolopha	(Mo,Bi,Pt)
Neovenericor	(Mo,Bi,Ve)	Nervostrophia	(Br,Ar,St)	Nicania	(Mo,Bi,Ve)
Neovpresiphyllum	(Cn,An,Ru)	Neseuretus	(Ar,Tr,Ph)	Nicaniella	(Mo,Bi,Ve)
Neovermilia	(An,Po,Se)	Nesides	(Cd,Os,Co)	Niceforoceras	(Mo,Ce,Am)
Neowellerella	(Br,Ar,Rh)	Nesobornia	(Mo,Bi,Ve)	Nicella	(Cn,An,Go)
Neowormsipora	(Cn,An,Ja)	Nessariostoma	(Cd,Pl,Ps)	Nicema	(Mo,Ga,Ne)
Neowrangellium	(Ac,Ra,Na)	Netastoma	(Mo,Bi,My)	Nicholsonella	(Bz,St,Tr)
Neoyanguania	(Br,Ar,St)	Netrocytheridea	(Ar,Os,Po)	Nicholsoniella	(Cn,An,Ru)
Neozaphrentis	(Cn,An,Ru)	Netschajewia	(Mo,Bi,Ve)	Nicholsonograptus	(He,Gr,Gr)
Neozeacrinus	(Ec,Cr,Cl)	Netschajewiana	(Ar,Os,Po)	Niecklesia	(Mo,Ce,Am)
Neozeba	(Mo,Ga,Nt)	Netsepoye	(Cd,Ch,Pe)	Niecklesopora	(Bz,St,Cr)
Nepasitoechia	(Br,Ar,Rh)	Nettastoma	(Cd,Os,An)	Nioellella	(Br,Ar,Or)
Nepea	(Ar,Tr,Pt)	Nettastomella	(Mo,Bi,My)	Nicolia	(Mo,Ga,Ne)
Nepheliospongia	(Po,De,Ha)	Netzkaia	(Ar,Os,Un)	Nicolina	(Ar,Os,Pa)
Nepheliospongia	(Po,He,Un)	Neuburgella	(Cd,Os,Pa)	Nicolioidea	(Br,Ar,Or)
Nephelophyllum	(Cn,An,Ru)	Neumanella	(Br,Ar,St)	Nicolorthis	(Br,Ar,Or)
Nephokirkos	(Ar,Os,Po)	Neumania	(Br,Ar,Or)	Nicomedites	(Mo,Ce,Ce)
Nephranomma	(Ar,Tr,Ph)	Neumatoceras	(Mo,Ce,On)	Nicoraella	(Cd,Co,Co)
Nephranops	(Ar,Tr,Ph)	Neumayrithyris	(Br,Ar,Te)	Nicosiaella	(Mo,Ga,Un)
Nephriticeras	(Mo,Ce,Ba)	Neuqueninitrigonia	(Mo,Bi,Tr)	Nidarica	(Mo,Bi,Ve)
Nephriticerina	(Mo,Ce,Ba)	Neuquenicerias	(Mo,Ce,Am)	Nielsenicrinus	(Ec,Cr,Is)
Nephrolepidina	(Fo,Fo,Fo)	Neurograptus	(He,Gr,Gr)	Nielsenceras	(Mo,Ce,Ce)
Nephrooides	(Pr,Un,In)	Neuropora	(Po,De,Ja)	Nieszkowskia	(Ar,Tr,Ph)
Nephropora	(Bz,Gy,Ch)	Neuroporella	(Bz,St,Cc)	Nigerapana	(Mo,Ga,Ne)
Nephrops	(Ar,Mi,De)	Neusticosaurus	(Cd,Re,No)	Nigeria	(Ar,Os,Po)
Nephropsis	(Ar,Mi,De)	Nevadabolbina	(Ar,Os,Pa)	Nigericerias	(Mo,Ce,Am)
Nephrosphaera	(Fo,Fo,Fo)	Nevadacrinus	(Ec,Cr,Tx)	Nigerinoplica	(Br,Ar,St)
Nephrospyris	(Ac,Ra,Na)	Nevadaecystis	(Ec,St,Co)	Nigerithium	(Mo,Ga,Nt)
Nephrotheca	(Hy,Or,Or)	Nevadaphyllum	(Cn,An,Ru)	Nigeroloxoconcha	(Ar,Os,Po)
Nephthea	(Cn,An,Al)	Nevadaspira	(Mo,Ga,Eu)	Nigerophis	(Cd,Re,Sq)
Nephtya	(Cn,An,Al)	Nevadathalamia	(Po,De,Pe)	Nihonia	(Mo,Ga,Ne)
Nepotilla	(Mo,Ga,Ne)	Nevadatubulus	(Pr,Un,In)	Niigaella	(Bz,St,Un)
Neptocarinus	(Ar,Mi,De)	Nevadella	(Ar,Tr,Ol)	Nikatheca	(Hy,Or,Or)
Neptunagnostella	(Ar,Tr,Ag)	Nevadia	(Ar,Tr,Ol)	Nikenautilus	(Mo,Ce,Na)
Neptunea	(Mo,Ga,Ne)	Nevadisculites	(Mo,Ce,Ce)	Nikiforopora	(Bz,St,Tr)
Neptunoceras	(Mo,Ce,Or)	Nevadites	(Mo,Ce,Ce)	Nikiforovaena	(Br,Ar,Sp)
Neptunochelys	(Cd,Re,Ch)	Nevadoceras	(Mo,Ce,Go)	Nikiforovella	(Bz,St,Cr)
Nereidavus	(An,Po,Eu)	Nevadocoelia	(Po,De,Li)	Nikitinella	(Fo,Fo,Fo)
Nereidella	(Br,Ar,Or)	Nevadocrinus	(Ec,Cr,Sa)	Nikolaevirhynchus	(Br,Ar,Rh)
Nereina	(Mo,Ga,Ar)	Nevadophyllites	(Mo,Ce,Ph)	Nikolarites	(Pr,Ca,Ca)
Nereocrinus	(Ec,Cr,Cl)	Nevadotheca	(Hy,Hy,Hy)	Nilegna	(Ar,Tr,Pt)

Nileoides	(Ar,Tr,As)	Nix	(Br,Ar,St)	Noixodontus	(Cd,Co,Co)
Nileus	(Ar,Tr,As)	Nixonella	(Ar,Tr,Co)	Nolanicerias	(Mo,Ce,Am)
Nilobia	(Mo,Bi,Ve)	Nobiliasaphus	(Ar,Tr,As)	Nolfophidion	(Cd,Os,Op)
Nimbia	(Cn,Cy,Cy)	Nobilitella	(Ar,Os,Pa)	Nolichuckia	(Ec,Eo,As)
Nina	(Mo,Ga,Nt)	Nochoroicyathus	(Po,Re,Aj)	Nomadinis	(Ar,Tr,As)
Ninaspis	(Ar,Tr,Un)	Nochoroieila	(Br,Un,Ob)	Nomgoliella	(Mo,In,In)
Ninella	(Mo,Ga,Ar)	Nocturneilla	(Br,Ar,Or)	Nomisnoceras	(Mo,Ce,Go)
Ningbingella	(Br,Ar,Rh)	Nodaea	(Br,Ar,Sp)	Nonacteonina	(Mo,Ga,Ce)
Ninghuaphyllum	(Cn,An,Ru)	Nodambichilina	(Ar,Os,Pa)	Nondia	(Br,Ar,Pe)
Ningkianolithus	(Ar,Tr,As)	Nodasperodiscus	(Fo,Fo,Fo)	Nonion	(Fo,Fo,Fo)
Ninglongothyrus	(Br,Ar,Te)	Nodelea	(Bz,St,Cc)	Nonionella	(Fo,Fo,Fo)
Ningnanophyllum	(Cn,An,Ru)	Nodelia	(Br,Ar,St)	Nonionellata	(Fo,Fo,Fo)
Ningqiangolites	(Cn,An,Ta)	Nodellum	(Fo,Fo,Fo)	Nonionellina	(Fo,Fo,Fo)
Ningqiangsclerites	(Pr,Un,In)	Nodibeyrichia	(Ar,Os,Pa)	Nonix	(Ar,Tr,Li)
Ningquiangophyllum	(Cn,An,Ru)	Nodiceps	(Ar,Tr,Co)	Nonparactocerinus	(Ec,Cr,He)
Ninocrinus	(Ec,Cr,Cy)	Nodilitorina	(Mo,Ga,Nt)	Nonsuko/zona	(Ar,Os,Pa)
Ninoziphus	(Cd,Ma,Ce)	Nodiocoeleceras	(Mo,Ce,Am)	Nonurocythereis	(Ar,Os,Po)
Niobe	(Ar,Tr,As)	Nodipecten	(Mo,Bi,Pt)	Nophtreocythere	(Ar,Os,Po)
Niobella	(Ar,Tr,As)	Nodiscalia	(Mo,Ga,Nt)	Nopora	(Ac,Ra,Na)
Niobides	(Ar,Tr,As)	Nodisurculina	(Mo,Ga,Ne)	Noradonta	(Mo,Bi,Un)
Niobina	(Ar,Tr,As)	Noditerebra	(Mo,Ga,Ne)	Noramya	(Mo,Bi,Ar)
Niobrara	(Cd,Os,Cr)	Nodobacularia	(Ar,Os,Pa)	Norasphus	(Ar,Tr,As)
Niobraraateuthis	(Mo,Ce,Te)	Nodobaculariella	(Fo,Fo,Fo)	Norcottia	(Fo,Fo,Fo)
Nionella	(Ar,Os,Pa)	Nodobairdia	(Ar,Os,Po)	Nordastrea	(Cn,An,Ru)
Niorhynch	(Br,Ar,Rh)	Nodoblastus	(Ec,Bi,Sp)	Nordathyrus	(Br,Ar,Sp)
Niotha	(Mo,Ga,Ne)	Nodobolivina	(Fo,Fo,Fo)	Nordella	(Br,Ar,Sp)
Nipageroceras	(Mo,Ce,Di)	Nodochernysinella	(Fo,Fo,Fo)	Nordenskjoldaster	(Ec,Ec,Hs)
Niphadus	(Po,Ca,He)	Nodocosta	(Cd,Ac,Un)	Nordenskjoldia	(Mo,Bi,Ar)
Nipponarges	(Ar,Tr,Li)	Nododelphinula	(Mo,Ga,Ar)	Nordia	(Ar,Tr,Pt)
Nipponaspis	(Ar,Tr,Pr)	Nodogenerina	(Fo,Fo,Fo)	Nordiceras	(Mo,Ce,An)
Nipponaster	(Ec,Ec,Sp)	Nodognathus	(Cd,Co,Co)	Nordioidus	(Cd,Co,Co)
Nipponicorbula	(Mo,Bi,My)	Nodogordiospira	(Fo,Fo,Fo)	Nordispirifer	(Br,Ar,Sp)
Nipponirhynchia	(Br,Ar,Rh)	Nodoinvolutaria	(Fo,Fo,Fo)	Nordopliceras	(Mo,Ce,Ce)
Nipponitella	(Fo,Fo,Fo)	Nodomorphina	(Fo,Fo,Fo)	Nordospira	(Mo,Ga,Ar)
Nipponites	(Mo,Ce,Am)	Nodonchus	(Cd,Ac,Un)	Nordotoechia	(Br,Ar,Rh)
Nipponithyrus	(Br,Ar,Te)	Nodonema	(Mo,Ga,Ar)	Norella	(Br,Ar,Rh)
Nipponitrigonia	(Mo,Bi,Tr)	Nodonychia	(Mo,Bi,Pt)	Norfordia	(Po,He,Ls)
Nipponitys	(Mo,Ga,Ne)	Nodophthalmidium	(Fo,Fo,Fo)	Nordiscites	(Mo,Ce,Ce)
Nipponocalymene	(Ar,Tr,Ph)	Nodophthalmocythere	(Ar,Os,Po)	Norina	(Ar,Tr,Un)
Nipponocrassatella	(Mo,Bi,Ve)	Nodophyllum	(Cn,An,Ru)	Norinia	(Ar,Tr,As)
Nipponolimopsis	(Mo,Bi,Ar)	Nodoprosopon	(Ar,MI,De)	Norites	(Mo,Ce,Ce)
Nipponomarcia	(Mo,Bi,Ve)	Nodosageceras	(Mo,Ce,Pl)	Noritus	(Ac,Ra,Na)
Nipponophyllum	(Cn,An,Ru)	Nodosarchaediscus	(Fo,Fo,Fo)	Normalograptus	(He,Gr,Gr)
Nipponstenopora	(Bz,St,Tr)	Nodosarella	(Fo,Fo,Fo)	Normanicitythere	(Ar,Os,Po)
Nipteraxis	(Mo,Ga,He)	Nodosaria	(Fo,Fo,Fo)	Normannites	(Mo,Ce,Am)
Nipterella	(Po,De,Li)	Nodosinella	(Fo,Fo,Fo)	Norochilina	(Ar,Os,Pa)
Nipterocrinus	(Ec,Cr,Sa)	Nodosinelloides	(Fo,Fo,Fo)	Norrisella	(Mo,Ga,Ar)
Nisaclis	(Mo,Ga,Nt)	Nodosoclymenia	(Mo,Ce,Cl)	Norrisia	(Mo,Ga,Ar)
Nisiturrus	(Mo,Ga,He)	Nodosohoplites	(Mo,Ce,Am)	Northia	(Mo,Ga,Ne)
Niso	(Mo,Ga,Nt)	Nodospira	(Mo,Ga,Ar)	Nortonechinus	(Ec,Ec,Ey)
Nisostomia	(Mo,Ga,He)	Nodotetraedra	(Ac,Ra,Sp)	Norwoodella	(Ar,Tr,Pt)
Nisusia	(Br,Ar,Or)	Nodotibetites	(Mo,Ce,Ce)	Norwoodia	(Ar,Tr,Pt)
Nitanoceras	(Mo,Ce,Ce)	Nodulipora	(Po,De,Ta)	Nostoceras	(Mo,Ce,Am)
Nitidavenus	(Mo,Bi,Ve)	Nodulus	(Mo,Ga,Nt)	Nostolepis	(Cd,Ac,Cl)
Nitidella	(Mo,Ga,Ne)	Noelaspis	(Ar,Tr,Pt)	Nostrocyathus	(Po,Uc,Un)
Nitidiscala	(Mo,Ga,Nt)	Noetca	(Mo,Ga,Ce)	Notablitus	(Hy,Hy,Hy)
Nitidittellina	(Mo,Bi,Ve)	Noetia	(Mo,Bi,Ar)	Notacanthus	(Cd,Os,An)
Nitidocare	(Ar,Tr,Pr)	Noetiella	(Mo,Bi,Ar)	Notacirsa	(Mo,Ga,Nt)
Nitidus	(Po,He,He)	Noetiopsis	(Mo,Bi,Ar)	Notadusta	(Mo,Ga,Nt)
Nitkvicepora	(Cn,An,Ta)	Noetlingaster	(Ec,Ec,Ph)	Notagogus	(Cd,Os,Ma)
Nitoricornus	(Hy,Hy,Hy)	Noetlingia	(Br,Ar,Pe)	Notanopia	(Br,Ar,St)
Niutoushania	(Br,Ar,St)	Noetlingites	(Mo,Ce,Ce)	Notasaphus	(Ar,Tr,Co)
Niveria	(Mo,Ga,Nt)	Nogamiconus	(Cd,Co,Pa)	Notelops	(Cd,Os,El)
Niviconia	(Br,Ar,St)	Nogrobs	(An,Po,Se)	Notesithes	(Cd,Os,Sc)

Nothamysium	(Mo,In,In)	Notoparmella	(Br,Ar,At)	Nucha	(Po,De,Pe)
Nothaphrophyllum	(Cn,An,Ru)	Notopeltis	(Ar,Tr,As)	Nucia	(Ar,Mi,De)
Nothia	(Fo,Fo,Fo)	Notopeplum	(Mo,Ga,Ne)	Nucibolus	(Ar,Mi,De)
Nothocephalites	(Mo,Ce,Am)	Notopetalichthys	(Cd,Pl,Pe)	Nucinella	(Mo,Bi,So)
Nothoceras	(Mo,Ce,On)	Notophyllia	(Cn,An,Sc)	Nuclea	(Mo,Ce,Di)
Nothokavelousia	(Br,Ar,St)	Notoplagioecia	(Bz,St,Cc)	Nuclearia	(Mo,Ga,Nt)
Nothophyllum	(Cn,An,Ru)	Notoplanulina	(Fo,Fo,Fo)	Nucleata	(Br,Ar,Te)
Nothopindax	(Br,Ar,St)	Notoplax	(Mo,Po,Ne)	Nucleatina	(Br,Ar,Te)
Nothorthis	(Br,Ar,Or)	Notoplejona	(Mo,Ga,Ne)	Nucleatula	(Br,Ar,Te)
Nothosaurus	(Cd,Re,Ps)	Notopocorystes	(Ar,Mi,De)	Nucleocrinus	(Ec,Bi,Sp)
Nothosaurus	(Cd,Re,No)	Notopoides	(Ar,Mi,De)	Nucleolina	(Ar,Os,Po)
Nothosporadoceras	(Mo,Ce,Go)	Notopus	(Ar,Mi,De)	Nucleolites	(Ec,Ec,Ca)
Nothostephanus	(Mo,Ce,Am)	Notorhynchus	(Mo,Cs,Hx)	Nucleopsis	(Mo,Ga,Ce)
Nothozoe	(Ar,Th,In)	Notorotalia	(Fo,Fo,Fo)	Nucleopygus	(Ec,Ec,Ca)
Nothrites	(An,Po,Eu)	Notorthisina	(Br,Ar,Or)	Nucleorhynchia	(Br,Ar,Or)
Notidanodon	(Cd,Ch,Hx)	Notosaria	(Br,Ar,Rh)	Nucleospira	(Br,Ar,Sp)
Notiobolus	(Br,Li,Li)	Notoscabrotrogonia	(Mo,Bi,Tr)	Nucleurus	(Ar,Tr,Ph)
Notioatillocrinus	(Ec,Cr,Ds)	Notoscapha	(Ar,Os,Pa)	Nucleusorhynchia	(Br,Ar,Rh)
Notioceus	(Cd,Ma,Ce)	Notoscaphidia	(Br,Ar,Or)	Nucula	(Mo,Bi,Nu)
Notiochonetes	(Br,Ar,St)	Notosceles	(Ar,Mi,De)	Nuculana	(Mo,Bi,Nu)
Notiocrinus	(Ec,Cr,Cl)	Notoscopelus	(Cd,Os,My)	Nuculavus	(Mo,Bi,Nu)
Notirus	(Mo,Bi,Ve)	Notoscrobs	(Mo,Ga,Nt)	Nuculites	(Mo,Bi,Nu)
Notoacmea	(Mo,Ga,Pa)	Notoseila	(Mo,Ga,Nt)	Nuculoceeras	(Mo,Ce,Go)
Notoaphelaspis	(Ar,Tr,As)	Notosia	(Ar,Tr,As)	Nuculodonta	(Mo,Bi,Nu)
Notobalanus	(Ar,Ci)	Notosinister	(Mo,Ga,Nt)	Nuculoidea	(Mo,Bi,Nu)
Notoblastus	(Ec,Bi,Fi)	Notospirifer	(Br,Ar,Sp)	Nuculoma	(Mo,Bi,Nu)
Notobotula	(Mo,Bi,Mt)	Notostomus	(Ar,Mi,De)	Nuculopsis	(Mo,Bi,Nu)
Notocallista	(Mo,Bi,Ve)	Notostrea	(Mo,Bi,Pt)	Nucumdata	(Mo,Bi,Nu)
Notocaris	(Ar,Mi,My)	Notostrophia	(Br,Ar,St)	Nucunella	(Mo,Bi,Ar)
Notocarpus	(Ec,St,Mi)	Nototeredo	(Mo,Bi,My)	Nudangarita	(Mo,Ga,Ar)
Notoceras	(Mo,Ce,Am)	Notothyrima	(Br,Ar,Te)	Nudarchaedicus	(Fo,Fo,Fo)
Notocetus	(Cd,Ma,Ce)	Notothyris	(Br,Ar,Te)	Nudauris	(Br,Ar,St)
Notochelone	(Cd,Re,Ch)	Nototrigonia	(Mo,Bi,Tr)	Nudechinus	(Ec,Ec,Ec)
Notochione	(Mo,Bi,Ve)	Nototrivia	(Mo,Ga,Nt)	Nudirostralina	(Br,Ar,Rh)
Notochlamy	(Mo,Bi,Pt)	Notovola	(Mo,Bi,Pt)	Nudispiriferina	(Br,Ar,Sp)
Notocidaris	(Ec,Ec,Ci)	Notovoluta	(Mo,Ga,Ne)	Nudista	(Ar,Os,Pa)
Notocirrus	(An,Po,Eu)	Nouria	(Fo,Fo,Fo)	Nudivagus	(Mo,Ga,Nt)
Notocoenidium	(Br,Ar,Rh)	Novakella	(Ar,Tr,Pt)	Nudobrissus	(Ec,Ec,Sp)
Notoconorbina	(Fo,Fo,Fo)	Novakina	(Ar,Os,Un)	Nudonychoella	(Bz,Gy,Ch)
Notoconularia	(Cn,Sc,Cn)	Novakotheca	(Hy,Hy,Hy)	Nudymia	(Br,Ar,St)
Notocorbula	(Mo,Bi,My)	Novallesia	(Fo,Fo,Fo)	Nudymiella	(Bz,St,Cr)
Notocerater	(Mo,Ga,Ar)	Novaspis	(Ar,Tr,As)	Nugnecella	(Br,Ar,Or)
Notocrinus	(Ec,Cr,Cm)	Novathuca	(Mo,Bi,Ve)	Nuguschella	(Br,Ar,Sp)
Notocyathus	(Cn,An,Sc)	Novella	(Fo,Fo,Fo)	Nuguschia	(Ar,Os,Po)
Notocycloceras	(Mo,Ce,En)	Novellinetes	(Br,Ar,St)	Nullamphiura	(Ec,Op,Op)
Notocypraea	(Mo,Ga,Nt)	Noviaster	(Ec,As,Va)	Numella	(Mo,Bi,Ve)
Notocythereella	(Mo,Ga,Ne)	Novichuskaia	(Cn,An,Ru)	Numericoma	(Br,Li,Ac)
Notocythere	(Ar,Os,Po)	Noviportia	(Ar,Os,Pa)	Numidiaphyllum	(Cn,An,Ru)
Notodonax	(Mo,Bi,Ve)	Novitatus	(Hy,Or,Or)	Nummicrinus	(Ec,Cr,Sa)
Notogenota	(Mo,Ga,Ne)	Novitella	(Po,De,St)	Nummocalcar	(Mo,Ga,Ar)
Notogoneus	(Cd,Os,Go)	Novixitus	(Ac,Ra,Na)	Nummoceratas	(Mo,Ce,Go)
Notogrammatodon	(Mo,Bi,Ar)	Novoameura	(Ar,Tr,Pr)	Nummodiscorbis	(Fo,Fo,Fo)
Notohaliotis	(Mo,Ga,Ar)	Novobolbina	(Ar,Os,Pa)	Nummofallotia	(Fo,Fo,Fo)
Notolampas	(Ec,Ec,Ne)	Novocypris	(Ar,Os,Po)	Nummofoculina	(Fo,Fo,Fo)
Notolepis	(Cd,Os,Au)	Novogladites	(Ar,Os,Pa)	Nummotectus	(Mo,Ga,Ar)
Notoleptaena	(Br,Ar,St)	Novozemelia	(Br,Ar,Pe)	Nummulites	(Fo,Fo,Fo)
Notolimea	(Mo,Bi,Pt)	Nowakia	(Mo,Cr,Da)	Nunnacrinus	(Ec,Cr,Mo)
Notolimopsis	(Mo,Bi,Ar)	Nowakites	(Mo,Ce,Am)	Nuratactiocyon	(Po,De,St)
Notolosia	(Br,Ar,St)	Nowraerinus	(Ec,Cr,Cl)	Nurataella	(Br,Ar,Sp)
Notoluponia	(Mo,Ga,Nt)	Nozamicthys	(Cd,Os,Pa)	Nuria	(Br,Ar,At)
Notomella	(Mo,Ga,Ar)	Nozeba	(Mo,Ga,Nt)	Nurochonetes	(Br,Ar,St)
Notomithrax	(Ar,Mi,De)	Nubecularia	(Fo,Fo,Fo)	Nursallia	(Cd,Os,Py)
Notonucula	(Mo,Bi,Nu)	Nubialba	(Br,Ar,St)	Nushbiella	(Br,Li,Ac)
Notopaphia	(Mo,Bi,Ve)	Nucella	(Mo,Ga,Ne)	Nutricola	(Mo,Bi,Ve)

Nutricula	(Mo,Bi,Pr)	Obtusocoenus	(Mo,In,In)	Odontaster	(Ec,As,Va)
Nuttallia	(Mo,Bi,Ve)	Ocalina	(Ar,MI,De)	Odonteaolca	(Cd,Os,Pf)
Nuttallides	(Fo,Fo,Fo)	Occidentoschwagerina	(Fo,Fo,Fo)	Odontionella	(Bz,Gy,Ch)
Nuttallina	(Mo,Po,Ne)	Occiducrinus	(Ec,Cr,Cl)	Odontobasis	(Mo,Ga,Ne)
Nuttallinella	(Fo,Fo,Fo)	Occithrissops	(Cd,Os,Pc)	Odontocephalus	(Ar,Tr,Ph)
Nuttallus	(Fo,Fo,Fo)	Occlusacythereis	(Br,Os,Po)	Odontochile	(Ar,Tr,Ph)
Nuxocrinus	(Ec,Cr,Cl)	Occlusocytheropteron	(Ar,Os,Po)	Odontocyathus	(Cn,An,Sc)
Nyalamurhynchia	(Br,Ar,Rh)	Occultocystis	(Ec,St,Mi)	Odontocyathoides	(Cn,An,Sc)
Nyaya	(Ar,Tr,Pt)	Occultocythereis	(Ar,Os,Mo)	Odontodiscoceras	(Mo,Ce,Am)
Nybelinoides	(Cd,Os,Os)	Oceanodroma	(Cd,Av,Pr)	Odontofusus	(Mo,Ga,Ne)
Nybyoceras	(Mo,Ce,Ac)	Ocellaria	(Po,De,Li)	Odontogriphus	(Pt,Un,In)
Nyctocrinus	(Ec,Cr,Di)	Ocenebra	(Mo,Ga,Ne)	Odontogryphaea	(Mo,Bi,Pt)
Nyctopora	(Cn,An,Ta)	Ochesaarina	(Ar,Os,Pa)	Odontomaria	(Mo,Ga,Ar)
Nyege	(Br,Ar,Rh)	Ochescapha	(Ar,Os,Pa)	Odontophyllum	(Cn,An,Ru)
Nyella	(Ar,Tr,Un)	Ochetes	(Ec,Ec,Ca)	Odontopleura	(Ar,Tr,Od)
Nyhamnella	(Ar,Os,Pl)	Ochetoceras	(Mo,Ce,Am)	Odontopolys	(Mo,Ga,Ne)
Nymphaeoblastus	(Ec,Bi,Fi)	Ochetochilus	(Mo,Ga,Ne)	Odontorhynchus	(Cd,Ch,In)
Nymphalucina	(Mo,Bi,Ve)	Ochetoclava	(Mo,Ga,Ne)	Odontospirifer	(Br,Ar,Sp)
Nymphaster	(Ec,As,Px)	Ochetosella	(Bz,Gy,Ch)	Odontoturbo	(Mo,Ga,Ar)
Nymphograptus	(He,Gr,Gr)	Ochetosellina	(Bz,Gy,Ch)	Odoratus	(Br,Ar,St)
Nymphorhynchia	(Br,Ar,Rh)	Ochmazochiton	(Mo,Po,Ne)	Odomtomella	(Mo,Ga,He)
Nyuella	(Mo,He,He)	Ochotathyris	(Ar,Os,Pa)	Odostomia	(Mo,Ga,He)
Oamarua	(Mo,Ga,Ne)	Ochotoceras	(Mo,Ce,Am)	Odostomidea	(Mo,Ga,He)
Oanduelia	(Bz,St,Cr)	Ochotochlamys	(Mo,Bi,Pt)	Oecematobolbina	(Ar,Os,Pa)
Oanduelina	(Bz,St,Cr)	Ochotorhynchia	(Br,Ar,Rh)	Oeciophylloporina	(Bz,St,Fe)
Oanduporella	(Br,Ar,Or)	Ocinobrellus	(Mo,Ga,Ne)	Oecoptychius	(Mo,Ce,Am)
Oberhauserella	(Fo,Fo,Fo)	Ocinebrina	(Mo,Ga,Ne)	Oecoptychoceras	(Mo,Ce,Am)
Obesacapsula	(Ac,Ra,Na)	Ockerella	(Ar,Os,Pa)	Oecotraustes	(Mo,Ce,Am)
Obesaria	(Br,Ar,Sp)	Ocnerorthis	(Br,Ar,Or)	Oedalmia	(Cn,An,Sc)
Obex	(Mo,Ga,Ne)	Ocorthis	(Br,Ar,Sp)	Oedematocidaris	(Ec,Ec,Ci)
Obexomia	(Mo,Ga,He)	Ocurranus	(Mo,In,In)	Oedicybele	(Ar,Tr,Ph)
Obinautilus	(Mo,Ce,Cc)	Octamerella	(Mo,Ce,Di)	Oedisoma	(Ar,MI,De)
Obisafitella	(Ar,Os,Po)	Octatormentum	(Ac,Ra,Sp)	Oedolithax	(Cd,Ma,Ce)
Oblada	(Cd,Os,Pf)	Ocelliaenus	(Ar,Tr,Co)	Oedorhachis	(Ar,Tr,Ag)
Obliaepis	(Cd,Pt,Pt)	Octobolbina	(Ar,Os,Pa)	Oehlertella	(Br,LI,Ac)
Oblicarina	(Mo,Bi,Ph)	Octobronteus	(Ar,Tr,Pt)	Oehlertia	(Mo,Ga,Ar)
Obliquatheca	(Hy,Or,Ex)	Octobrum	(Po,He,He)	Oehlerticrinus	(Ec,Cr,Mo)
Obliquina	(Fo,Fo,Fo)	Octoheliocoenia	(Cn,An,Sc)	Oejlemyra	(Ar,Os,Pa)
Obliquipecten	(Mo,Bi,Pt)	Octomedusa	(Cn,Sc,Co)	Oelandia	(Mo,He,He)
Obliquisylthis	(Ar,Os,Pa)	Octonaria	(Ar,Os,Me)	Oelandiella	(Mo,He,He)
Oblicornus	(Hy,Hy,Hy)	Octonariellina	(Ar,Os,Me)	Oelandocaris	(Ar,In,Un)
Obliacythereis	(Ar,Os,Po)	Octosylthere	(Ar,Os,Po)	Oelandoceras	(Mo,Ce,El)
Obliteraspis	(Ar,Tr,Ph)	Ocotremacis	(Cn,An,He)	Oelandodus	(Cd,Co,Co)
Oblongarcula	(Br,Ar,Te)	Octotympanum	(Ac,Ra,Na)	Oelandograptus	(He,Gr,Gr)
Oblongiprion	(An,Po,Eu)	Oculagnostus	(Ar,Tr,Ag)	Oenochocarinus	(Ec,Cr,Mo)
Obmixia	(Br,Ar,Te)	Oculeus	(Ar,Tr,Pt)	Oenonella	(Ar,Tr,Pr)
Oboedalites	(Hy,Hy,Hy)	Oculichasmops	(Ar,Tr,Ph)	Oenonites	(An,Po,Eu)
Obolella	(Br,Un,Ob)	Oculina	(Cn,An,Sc)	Oenopota	(Mo,Ga,Ne)
Obolopsis	(Br,LI,LI)	Oculinella	(Cn,An,Ta)	Oepikaluta	(Ar,Os,Ar)
Obolorugia	(Br,Ar,Un)	Oculipora	(Cn,An,Ta)	Oepikella	(Ar,Os,Pa)
Obolus	(Br,LI,LI)	Oculomagnus	(Ar,Tr,Pr)	Oepikila	(Mo,Ro,Ri)
Obornella	(Mo,Ga,Ar)	Oculospongia	(Po,Ca,Ph)	Oepikina	(Br,Ar,St)
Obotrita	(Ar,Os,Pa)	Ocypode	(Ar,MI,De)	Oepikinella	(Br,Ar,St)
Obovothyris	(Br,Ar,Te)	Ocystias	(Cd,Os,Pf)	Oepikites	(Br,LI,LI)
Obrimia	(Mo,Bi,Ph)	Odaraia	(Ar,MI,Ca)	Oepikiuum	(Ar,Os,Pa)
Obrucheviaspis	(Ar,Tr,Pt)	Odaroviathyris	(Br,Ar,Te)	Oepikodus	(Cd,Co,Co)
Obruchevites	(Mo,Ce,Ce)	Oderoceras	(Mo,Ce,En)	Oertiella	(Ar,Os,Po)
Obscurella	(Br,Ar,Rh)	Odessites	(Mo,Cr,Te)	Oertlispongus	(Ac,Ra,Sp)
Obsoletes	(Fo,Fo,Fo)	Odetta	(Mo,Ga,He)	Oeselaspis	(Cd,Ce,Ce)
Obsoletirhynchia	(Br,Ar,Rh)	Odmdenia	(Cd,Os,Am)	Oesia	(Pr,Un,In)
Obtorio	(Mo,Ga,Ne)	Odoardia	(Mo,Ga,Ar)	Oestophorus	(Cd,Pl,Un)
Obturamentella	(Br,Ar,Rh)	Odobenus	(Cd,Ma,Ca)	Offadesma	(Mo,Bi,Ph)
Obtusella	(Mo,Ga,Ne)	Odontotrypa	(Bz,St,Cy)	Offaster	(Ec,Ec,Hs)
Obtusicosites	(Mo,Ce,Am)	Odontaspis	(Cd,Ch,La)	Offella	(Po,De,Un)

Offleya	(Mo,Ga,Be)	Olesia	(Mo,Bi,Ve)	Olivula	(Mo,Ga,Ne)
Offleyoceras	(Mo,Ce,Or)	Olcostephanus	(Mo,Ce,Am)	Olkenbachia	(Po,De,Li)
Offlyeotrochus	(Mo,Ga,Eu)	Oldhamina	(Mo,La,Su)	Ollachitina	(Fo,Fo,Ch)
Offneria	(Mo,Bi,Hi)	Oldhaminella	(Br,Ar,St)	Olssonella	(Mo,Bi,Ve)
Ogbinia	(Br,Ar,St)	Olegaspis	(Ar,Tr,Pt)	Olssonia	(Fo,Fo,Fo)
Ogbinopora	(Bz,St,Cr)	Olekmaspis	(Ar,Tr,Pt)	Omalaxis	(Mo,Ga,He)
Ogcocephalus	(Cd,Os,Lo)	Olenaspella	(Ar,Tr,As)	Omalenlina	(Mo,In,In)
Ogilbia	(Cd,Os,Op)	Olenekina	(Ar,Tr,Pt)	Omalogyra	(Mo,Ga,He)
Ogilviastrea	(Cn,An,Sc)	Olenekoceras	(Mo,Ce,Ce)	Omalosecosa	(Bz,Gy,Ch)
Ogilviella	(Br,Ar,At)	Olenellus	(Ar,Tr,Ol)	Omanimaria	(Mo,Ga,Ar)
Ogilvilasma	(Cn,An,Ru)	Olenoethyris	(Br,Ar,Te)	Ombonia	(Br,Ar,St)
Ogilvinella	(Cn,An,Sc)	Olenikites	(Mo,Ce,Ce)	Omeipsis	(Ar,Tr,As)
Ogiva	(Bz,Gy,Ch)	Olenoides	(Ar,Tr,Co)	Omiphylum	(Cn,An,Ru)
Ogivalia	(Bz,Gy,Ch)	Olenoidestranas	(Ar,Tr,Co)	Ommastrepes	(Mo,Ce,Te)
Ogivalina	(Bz,Gy,Ch)	Olentella	(Ar,Tr,As)	Ommatartus	(Ac,Ra,Sp)
Ogivia	(Mo,Ga,Nt)	Olentotreta	(Br,Li,Ac)	Ommatocampe	(Ac,Ra,Sp)
Oglu	(Br,Ar,At)	Olenus	(Ar,Tr,Pt)	Ommatocarcinus	(Ar,Ml,De)
Oglupes	(Br,Ar,At)	Oleorthis	(Br,Ar,Or)	Ommatodiscus	(Ac,Ra,Sp)
Ogmasaphus	(Ar,Tr,As)	Olequahia	(Mo,Ga,Nt)	Ommatokrithe	(Ar,Os,Po)
Ogmoconcha	(Ar,Os,Me)	Olgacocyathus	(Po,Re,Aj)	Ommatospyrus	(Ac,Ra,Sp)
Ogmoconchella	(Ar,Os,Me)	Olgardia	(Br,Ar,Sp)	Ommokris	(Ar,Tr,Ph)
Ogmodirus	(Cd,Re,Ps)	Oliganinus	(Ar,Os,Pa)	Omnivenus	(Mo,Bi,Ve)
Ogmoopsis	(Ar,Os,Pa)	Oligobalistes	(Cd,Os,Te)	Omnutakella	(Br,Ar,At)
Ogmoplecia	(Br,Ar,Or)	Oligobrachyocerinus	(Ec,Cr,C1)	Omogymna	(Mo,Ga,Ne)
Ogmusia	(Br,Ar,Te)	Oligoceras	(Mo,Ce,On)	Omoiosia	(Bz,Gy,Ch)
Ogyginus	(Ar,Tr,As)	Oligochelone	(Cd,Re,Ch)	Omolonella	(Br,Ar,Rh)
Ogygiocarella	(Ar,Tr,As)	Oligochiton	(Mo,Os,Ne)	Omolonia	(Br,Ar,Te)
Ogygiocaris	(Ar,Tr,As)	Oligocythereis	(Ar,Os,Po)	Omolonorynchia	(Br,Ar,Rh)
Ogygites	(Ar,Tr,As)	Oligodelphis	(Cd,Ma,Ce)	Omolonothyris	(Br,Ar,Te)
Ogygitoides	(Ar,Tr,As)	Oligodioidon	(Cd,Os,Te)	Omosoma	(Cd,Os,Po)
Ogygoceras	(Mo,Ce,El)	Oligodus	(Cd,Co,Co)	Omosomopsis	(Cd,Os,In)
Ogygopsis	(Ar,Tr,Co)	Oligolactoria	(Cd,Os,Te)	Omospira	(Mo,Ga,Ar)
Oharaia	(Cn,An,Ta)	Oligometopus	(Ar,Tr,Un)	Omphalius	(Mo,Ga,Ar)
Ohioaspis	(Cd,Pl,Rh)	Oligomys	(Br,Ar,Or)	Omphalocirrus	(Mo,Pa,Hy)
Ohiocaris	(Ar,Ml,Ar)	Oligophylloides	(Cn,An,Ht)	Omphalocyclus	(Fo,Fo,Fo)
Ohioceras	(Mo,Ce,Or)	Oligophyllum	(Cn,An,Ru)	Omphalonema	(Mo,Ga,Ar)
Ohiocrinus	(Ec,Cr,Ds)	Oligophyma	(Ec,Ec,Ec)	Omphalophyllia	(Cn,An,Sc)
Ohnopora	(Cn,An,Ta)	Oligoplagia	(Po,Ca,Un)	Omphalophylliopsis	(Cn,An,Sc)
Ohuus	(Cd,Os,St)	Oligopleura	(Cd,Os,Am)	Omphaloptycha	(Mo,Ga,Nt)
Oidalgnostus	(Ar,Tr,Ag)	Oligopleurus	(Cd,Os,Se)	Omphalosaurus	(Cd,Re,lc)
Oidaloproetus	(Ar,Tr,Pr)	Oligoplites	(Cd,Os,Pl)	Omphalotis	(Fo,Fo,Fo)
Oikozetetes	(Pr,Co,Sa)	Oligoporus	(Ec,Ec,Ey)	Omphalotrochus	(Mo,Ga,Eu)
Oina	(Br,Un,Na)	Oligoptycha	(Mo,Ga,Ce)	Omphalotropis	(Mo,Ga,Nt)
Oinochoe	(Ar,Tr,Li)	Oligoptycherhynchus	(Br,Ar,Rh)	Omulites	(Mo,Cr,Te)
Oiophyllites	(Mo,Ce,Am)	Oligoptyxis	(Mo,Ga,He)	Onaraspis	(Ar,Tr,Re)
Otosis	(Br,Ar,Sp)	Oligopus	(Cd,Os,Op)	Onavia	(Br,Ar,St)
Oistoceras	(Mo,Ce,Am)	Oligopygus	(Ec,Ec,Ol)	Onchocephalina	(Ar,Tr,Pt)
Oistodella	(Cd,Co,Co)	Oligorachis	(Br,Ar,St)	Onchocephalites	(Ar,Tr,Pt)
Oistodus	(Cd,Co,Co)	Oligorhynchia	(Br,Ar,Rh)	Onchocephalus	(Ar,Tr,Pt)
Oistotrigonia	(Mo,Bi,Tr)	Oligorhythisia	(Br,Ar,Te)	Onchonotellus	(Ar,Tr,Pt)
Ojlemyra	(Ar,Os,Pa)	Oligorthis	(Br,Ar,Or)	Onchonotina	(Ar,Tr,Pt)
Okathyris	(Br,Ar,Te)	Oligosimus	(Cd,Re,Ps)	Onchonotopis	(Ar,Tr,Pt)
Oketaella	(Fo,Fo,Fo)	Oligothyryna	(Br,Ar,Te)	Onchonotus	(Ar,Tr,Un)
Okinawanoarca	(Mo,Bi,Ar)	Oligotopora	(Bz,Gy,Ch)	Onchopeltis	(Ar,Tr,Pt)
Okinawavoluta	(Mo,Ga,Ne)	Olimfalunia	(Ar,Os,Po)	Onchopristus	(Cd,Ch,Rj)
Oklahomacrinus	(Ec,Cr,C1)	Olinaccaris	(Ar,Ml,De)	Onchosaurus	(Cd,Ch,Rj)
Oklahomacystis	(Ec,Pc,Co)	Olingeichiton	(Mo,Os,Pa)	Onchotrochus	(Cn,An,Sc)
Okopites	(Cn,An,Ta)	Oliva	(Mo,Ga,Ne)	Onchus	(Cd,Ac,Is)
Okribites	(Mo,Ce,Am)	Olivancillaria	(Mo,Ga,Ne)	Oncoeras	(Mo,Ce,On)
Oktavites	(He,Gr,Gr)	Oliveirania	(An,Os,Un)	Oncochilus	(Mo,Ga,Ar)
Okulitchicyathus	(Po,Tr,Ar)	Olivella	(Mo,Ga,Ne)	Oncocladia	(Po,De,Li)
Okulitchina	(Po,De,Li)	Olivieria	(Cn,An,Ru)	Oncodona	(Po,De,Li)
Olangocoelea	(Po,De,Pe)	Olivia	(Mo,Ga,Ar)	Oncograptus	(He,Gr,Gr)
Olbia	(Ar,Os,Po)	Olivooides	(Pr,Un,In)	Oncolepis	(Cd,Os,Pl)

Oncoporeia	(Ar.MI.De)	Oosthuizenella	(Ar.Tr.Ph)	Opikella	(Br.Ar.St)
Oncophora	(Po.De.Li)	Oostrombus	(Mo.Ga.Nt)	Opimaria	(Mo.Bi.Ve)
Oncorhynchus	(Cd.Os.Sa)	Ootomaria	(Mo.Ga.Ar)	Opimilda	(Mo.Ga.Nt)
Oncosarina	(Br.Ar.St)	Ootomella	(Mo.Ga.Ne)	Opimocythere	(Ar.Os.Po)
Oncosella	(Po.He.Ls)	Opabinia	(Pr.Di.Ra)	Opiotoptera	(Mo.Bi.Pt)
Oncotechmonus	(Ar.Os.My)	Opalia	(Mo.Ga.Nt)	Opipeuter	(Ar.Tr.As)
Oncoteochus	(Po.He.Ly)	Opaliopsis	(Mo.Ga.Nt)	Opiphyllum	(Cn.An.Ru)
Oncousoecia	(Bz.St.Cc)	Opeamorphus	(Po.He.Ls)	Opis	(Mo.Bi.Ve)
Ondadiptoeniopsis	(Cn.An.Sc)	Opechinus	(Ec.Ec.Te)	Opisconidion	(Br.Ar.At)
Onega	(Ar.Pa.Pa)	Opella	(Mo.Ga.Ar)	Opisoma	(Mo.Bi.Ve)
Oneirophanites	(Ec.Ho.El)	Operchaliosteus	(Cd.Pl.Ar)	Opisopneustes	(Ec.Ec.Hs)
Oneooceras	(Mo.Ce.El)	Operculina	(Fo.Fo.Fo)	Opissaster	(Ec.Ec.Sp)
Oneotodus	(Cd.Co.Co)	Opertochasma	(Mo.Bi.My)	Opisthocoeelus	(Mo.Bi.Pr)
Onestia	(Mo.Bi.Ve)	Opertorbitolites	(Fo.Fo.Fo)	Opisthomyzon	(Cd.Os.Pf)
Ongleya	(Mo.Ga.Ce)	Opertum	(Fo.Fo.Fo)	Opisthonema	(Mo.Ga.Ar)
Oniscidia	(Mo.Ga.Nt)	Opetionella	(Po.De.Un)	Opisthoxylax	(Ar.Os.Pa)
Onithochiton	(Mo.Po.Ne)	Opetiosaurus	(Cd.Re.Sq)	Opisthoptera	(Mo.Bi.Pt)
Onitshoceras	(Mo.Ce.Am)	Ophiaacanth	(Ec.Op.Op)	Opisthornithopora	(Bz.Gy.Ch)
Onkogrypha	(Mo.Bi.Un)	Ophiaulax	(Ec.Op.Op)	Opisthotreta	(Br.Li.Ac)
Onkospira	(Mo.Ga.Ar)	Ophiceras	(Mo.Ce.Ce)	Opisthotrigonia	(Mo.Bi.Tr)
Onnia	(Ar.Tr.As)	Ophidioceras	(Mo.Ce.Or)	Opistopteryx	(Cd.Os.El)
Onnicalymene	(Ar.Tr.Ph)	Ophidion	(Fo.Fo.Fo)	Opleganthus	(Cd.Os.Pf)
Onniella	(Br.Ar.Or)	Ophigraptus	(He.Gr.De)	Oplophorus	(Ar.MI.De)
Omnizetina	(Br.Ar.Or)	Ophileta	(Mo.Ga.Eu)	Opoa	(Ar.Tr.Pt)
Onoba	(Mo.Ga.Nt)	Ophiletina	(Mo.Ga.Eu)	Oppelia	(Mo.Ce.Am)
Onopordumaria	(Br.Ar.St)	Ophilyroceras	(Mo.Ce.Go)	Oppellisilia	(Cn.An.Sc)
Ontariocrinus	(Ec.Cr.Cl)	Ophioceras	(Mo.Ce.Or)	Oppenheimopecten	(Mo.Bi.Pt)
Ontocetus	(Cd.Ma.Ce)	Ophiocnida	(Ec.Op.Op)	Oppligeria	(Po.De.Po)
Onugorhynchia	(Br.Ar.Rh)	Ophiocoma	(Ec.Op.Op)	Opisconidion	(Br.Li.Ac)
Onuphionella	(Pr.Un.In)	Ophiocrinus	(Ec.Cr.Di)	Opsidiscus	(Ar.Tr.Ag)
Onuphis	(An.Po.Eu)	Ophiocrossota	(Ec.Op.Op)	Opsimasaphus	(Ar.Tr.As)
Onuxodon	(Cd.Os.Op)	Ophiocten	(Cd.Os.Op)	Opsiocrinus	(Ec.Cr.Di)
Onychaster	(Ec.Op.Ph)	Ophiodemella	(Mo.Ga.Ne)	Opsiosoryctocephalus	(Ar.Tr.Co)
Onychia	(Pr.Co.Ch)	Ophiodesia	(Po.De.Po)	Opsithrissops	(Cd.Os.Or)
Onychoella	(Bz.Gy.Ch)	Ophiodon	(Cd.Os.Sc)	Opsupharus	(Ar.Tr.Pt)
Onychocellaria	(Bz.Gy.Ch)	Ophioglyphoida	(Ec.Op.Op)	Optivus	(Cd.Os.Br)
Onychoceras	(Mo.Ce.Am)	Ophiolancea	(Ec.Op.Op)	Optoturris	(Mo.Ga.Ne)
Onychochilus	(Mo.Pa.Hy)	Ophiomusium	(Ec.Op.Op)	Oracanthus	(Cd.Ac.Un)
Onychocrinus	(Ec.Cr.Tx)	Ophionautilus	(Mo.Ce.Na)	Orania	(Mo.Ga.Ne)
Onychodictyon	(Lo)	Ophiopetra	(Ec.Op.Op)	Oraniceras	(Mo.Ce.Am)
Onychodus	(Cd.Os.Co)	Ophiopinna	(Ec.Op.Op)	Oratoceras	(Mo.Ce.On)
Onychophyllum	(Cn.An.Ru)	Ophiopsis	(Cd.Os.Ma)	Orbiasterocyathus	(Po.Re.Aj)
Onychoplecia	(Br.Ar.Or)	Ophiosema	(Ar.Os.Ar)	Orbiblastus	(Ec.Bl.Sp)
Onychopterella	(Ar.Me.Eu)	Ophiotrix	(Ec.Op.Op)	Orbicoelia	(Br.Ar.Sp)
Onychopyge	(Ar.Tr.As)	Ophiotitanos	(Ec.Op.Op)	Orbicoscimus	(Po.Re.Aj)
Onychoselache	(Cd.Ch.Ct)	Ophiotrigonum	(Ec.Op.Op)	Orbiculatisiurostrum	(Br.Ar.Rh)
Onychotreta	(Br.Ar.Or)	Ophioxenikos	(Ec.So.Go)	Orbiculiforma	(Ac.Ra.Sp)
Onycoppyge	(Ar.Tr.Ph)	Ophiraphidites	(Po.De.As)	Orbiculoidea	(Br.Li.Ac)
Onymagnostus	(Ar.Tr.Ag)	Ophisthoproctus	(Cd.Os.Os)	Orbiculopecten	(Mo.Bi.Pt)
Onyxites	(Mo.Ce.Di)	Ophisurus	(Cd.Os.An)	Orbiculopora	(Br.Li.Ac)
Oocerina	(Mo.Ce.On)	Ophiura	(Ec.Op.Op)	Orbiculothyris	(Br.Li.Ac)
Oochiton	(Mo.Po.Ne)	Ophiurella	(Ec.Op.Op)	Orbicycathellus	(Po.Re.Aj)
Oocorys	(Mo.Ga.Nt)	Ophiurina	(Ec.Op.Op)	Orbicynathus	(Po.Re.Aj)
Oocystis	(Ec.Rh.Rh)	Ophiurocoma	(Ec.Op.Op)	Orbignya	(Mo.Bi.Hi)
Oolina	(Fo.Fo.Fo)	Ophiurocrinus	(Ec.Cr.Cl)	Orbignyana	(Ec.Ec.Ds)
Oolitea	(Fo.Fo.Fo)	Ophryaster	(Ec.As.Va)	Orbignyoenia	(Cn.An.Sc)
Ooliticia	(Mo.Ga.Ar)	Ophryotrocha	(An.Po.Eu)	Orbignycrinus	(Ec.Cr.Mi)
Oolopygus	(Ec.Ec.Ca)	Ophryostoma	(Po.He.Ly)	Orbignyella	(Bz.St.Tr)
Oonendoceras	(Mo.Ce.Ya)	Ophthalmapseudes	(Ar.MI.Ta)	Orbignygyra	(Cn.An.Sc)
Oonia	(Mo.Ga.Nt)	Ophthalmidium	(Fo.Fo.Fo)	Orbignyna	(Fo.Fo.Fo)
Oonocarcinus	(Ar.Ma.Cy)	Ophthalmipora	(Fo.Fo.Fo)	Orbignyopora	(Bz.Gy.Ct)
Oonoceras	(Mo.Ce.On)	Ophthalmoplax	(Ar.MI.De)	Orbinaria	(Br.Ar.St)
Oopsites	(Ar.Tr.Pt)	Ophthalmosaurus	(Cd.Re.Ic)	Orbipora	(Bz.St.Tr)
Oosterella	(Mo.Ce.Am)	Opikatia	(Ar.Os.Pa)	Orbirhynchia	(Br.Ar.Rh)

Orbitammina	(Fo,Fo,Fo)	Orithopsis	(Ar,MLDe)	Orthochilus	(Mo,Ga,Nt)
Orbitella	(Mo,Bi,Ve)	Orithostella	(Fo,Fo,Fo)	Orthooidaris	(Ec,Ec,Or)
Orbitestella	(Mo,Ga,He)	Oriudogutta	(Ac,Ra,Sp)	Orthoconcorca	(An,Po,Se)
Orbithele	(Br,Li,Ac)	Orlovina	(Ar,Tr,Pt)	Orthocomus	(Mo,In,In)
Orbitoclypeus	(Fo,Fo,Fo)	Orlovicavina	(Ar,Os,Po)	Orthocomus	(Cd,Os,Pe)
Orbitocyclina	(Fo,Fo,Fo)	Orloviella	(Ar,Tr,Pt)	Orthocriurus	(Ec,Cr,Di)
Orbitoides	(Fo,Fo,Fo)	Orlovirynchia	(Br,Ar,Rh)	Orthocyathus	(Cn,An,Ru)
Orbitokathina	(Fo,Fo,Fo)	Ormastrilium	(Mo,Ga,Ar)	Orthocycloceras	(Mo,Ce,Or)
Orbitolina	(Fo,Fo,Fo)	Ormathops	(Ar,Tr,Ph)	Orthocypris	(Ar,Os,Po)
Orbitolinella	(Fo,Fo,Fo)	Ormistonella	(Ac,Ra,Sp)	Orthodesma	(Ml, Bi, Mt)
Orbitolinopsis	(Fo,Fo,Fo)	Ormistoniella	(Ar,Tr,Pr)	Orthodiscus	(Po,He,Ly)
Orbitolites	(Fo,Fo,Fo)	Ormoceras	(Mo,Ce,Ac)	Orthodochnioceras	(Mo,C, Un)
Orbitoplax	(Ar,MLDe)	Ornamentaria	(Mo,Ga,Nt)	Orthogarrantiana	(Mo,Ce,Am)
Orbitoproetus	(Ar,Tr,Pr)	Ornamentaspis	(Ar,Tr,Re)	Orthogonium	(Cn,In,In)
Orbitopsella	(Fo,Fo,Fo)	Ornatonomalina	(Fo,Fo,Fo)	Orthogonocriurus	(Ec,Cr,Rv)
Orbitremites	(Ec,Bi,Sp)	Ornategulum	(Cd,Os,Cl)	Orthograptus	(He,Gr,Gr)
Orbitulipora	(Bz,Gy,Ch)	Ornaticannula	(Ec,Ho,As)	Orthoidea	(Br,Ar,Te)
Orbula	(Ac,Ra,Na)	Ornatoclymenia	(Mo,Ce,Cl)	Orthokarstenia	(Fo,Fo,Fo)
Orbulina	(Fo,Fo,Fo)	Ornatoleberis	(Ar,Os,Po)	Ortholina	(Br,Ar,Te)
Orbulinoides	(Fo,Fo,Fo)	Ornatophyllum	(Cn,An,Ru)	Ortholites	(Cn,An,Ta)
Orcadia	(Fo,Fo,Fo)	Ornatoporta	(An,Po,Se)	Orthomorphina	(Fo,Fo,Fo)
Orcinus	(Cd,Ma,Ce)	Ornatoptygmatitis	(Mo,Ga,Ne)	Orthomyalina	(Mo,Bi,Pt)
Orcofabella	(Ar,Os,Pa)	Ornatospira	(Mo,Ga,Ar)	Orthonaria	(Ar,Os,Pa)
Ordinatuts	(Po,He,He)	Ornatothyrella	(Br,Ar,Te)	Orthonema	(Mo,Ga,Nt)
Ordoniya	(Ar,Os,Po)	Ornatothyris	(Br,Ar,Te)	Orthonota	(Mo,Bi,Ph)
Ordosia	(Ar,Tr,Co)	Ornatus	(Po,He,Ly)	Orthonotacythere	(Ar,Os,Po)
Ordosoceras	(Mo,Ce,Ac)	Ornithaster	(Ec,Ec,Sp)	Orthonyococeras	(Mo,Ce,Ac)
Ordovicina	(Ar,Os,Pa)	Ornithella	(Br,Ar,Te)	Orthonychia	(Mo,Ga,Ar)
Ordovicina	(Fo,Fo,Fo)	Ornithopecten	(Mo,Bi,Pt)	Orthopelta	(An,Po,Eu)
Ordovizona	(Ar,Os,Pa)	Ornithoprion	(Cd,Ch,Eu)	Orthophyllum	(Cn,An,Ru)
Orechina	(Ar,Os,Pa)	Ornithothyris	(Br,Ar,Te)	Orthopleura	(Br,Ar,St)
Oreocopia	(Mo,Ga,Eu)	Ornopis	(Mo,Ga,Ne)	Orthopora	(Bz,St,Cr)
Orectodictya	(Bz,St,Cr)	Ornothyrella	(Br,Ar,Sp)	Orthopristis	(Cd,Os,Pl)
Orectoloboides	(Cd,Ch,Oc)	Orocystites	(Ec,Rh,Rh)	Orthopsis	(Ec,Ec,Or)
Orectospira	(Mo,Ga,Nt)	Orodes	(Ar,Tr,Re)	Orthoptychus	(Mo,Bi,Hi)
Orecyta	(Po,De,Li)	Orodus	(Cd,Ch,Or)	Orthoptychus	(Mo,Ga,Ce)
Oreisor	(Ar,Tr,Co)	Orometopus	(Ar,Tr,As)	Orthoretiolites	(He,Gr,Gr)
Orenburgella	(Br,Ar,Sp)	Orophocriurus	(Ec,Bi,Fi)	Orthorhynchuloides	(Ar,Ar,Rh)
Oreochima	(Cd,Os,Pe)	Orophosaurus	(Cd,Re,Ps)	Orthorhynchula	(Br,Ar,Rh)
Orestia	(Mo,Bi,Hi)	Orospeiciom	(Po,De,Li)	Orthospiinctes	(Mo,Ce,Am)
Orestiacanthus	(Cd,Ch,Sy)	Orospira	(Mo,Ga,Eu)	Orthospirifer	(Br,Ar,Sp)
Orestites	(Mo,Ce,Ce)	Orosaurus	(Ac,Ra,Sp)	Orthostomia	(Mo,Ga,Nt)
Oretia	(Mo,Bi,Pt)	Orozoe	(Ar,ML,Ar)	Orthostrophella	(Br,Ar,Or)
Organoceras	(Mo,Ce,Am)	Orphanaspis	(Ar,Tr,Od)	Orthostrophia	(Br,Ar,Or)
Orhomalus	(Ar,ML,De)	Orria	(Ar,Tr,Co)	Orthosurecula	(Mo,Ga,Ne)
Orietocara	(Ar,Tr,Un)	Orriella	(Ar,Tr,Co)	Orthotetella	(Br,Ar,St)
Oriodorsalis	(Fo,Fo,Fo)	Orthacodus	(Cd,Ch,Hx)	Orthotetes	(Br,Ar,St)
Oriensellina	(Br,Ar,Rh)	Orthambonites	(Br,Ar,Or)	Orthotetoides	(Br,Ar,St)
Orientalina	(Ar,Os,Pa)	Orthaspidoceras	(Mo,Ce,Am)	Orthotheca	(Hy,Or,Or)
Orienticyathus	(Po,Re,Aj)	Orthaster	(Ec,Ec,Sp)	Orthothetina	(Br,Ar,St)
Orientina	(Fo,Fo,Fo)	Orthaulax	(Ar,Os,Nt)	Orthothrix	(Br,Ar,St)
Orientospira	(Br,Ar,Sp)	Orthella	(Fo,Fo,Fo)	Orthothyris	(Br,Ar,Te)
Orientospirifer	(Br,Ar,Sp)	Orthidiella	(Br,Ar,Or)	Orthotichia	(Br,Ar,Or)
Orientothyris	(Br,Ar,Te)	Orthidium	(Br,Ar,Or)	Orthotoma	(Br,Ar,Te)
Orienturus	(Ar,Tr,Un)	Orthiella	(Br,Ar,Or)	Orthotrigonia	(Mo,Bi,Tr)
Orietalia	(Fo,Fo,Fo)	Orthildaides	(Mo,Ce,Am)	Orthotrionacia	(Fo,Fo,Fo)
Origostrophia	(Br,Ar,St)	Orthis	(Br,Ar,Or)	Orthotropia	(Br,Ar,Or)
Orinella	(Mo,Ga,He)	Orthisocrania	(Br,Li,Ac)	Orthovertella	(Fo,Fo,Fo)
Oriocrassatella	(Mo,Bi,Ve)	Orthobardia	(Ar,Os,Po)	Orthoyldia	(Mo,Bi,Nu)
Orionastraea	(Cn,An,Ru)	Orthocardium	(Mo,Bi,Ve)	Orthurus	(Cd,Os,Se)
Orionina	(Ar,Os,Po)	Orthocarina	(Br,Ar,At)	Ortmannia	(Po,De,As)
Orionoides	(Mo,Ce,Am)	Orthocellites	(Mo,Ce,Ce)	Ortmannispongia	(Po,De,Li)
Oriostoma	(Mo,Te,Cy)	Orthoceras	(Mo,Ce,Or)	Ortonella	(Mo,Bi,Ar)
Oriskania	(Br,Ar,Te)	Orthochetus	(Mo,Ga,Nt)	Orulgania	(Br,Ar,Sp)

Orulganites	(Mo,Ce,Go)	Otekmaspis	(Ar,Tr,Un)	Ovinotis	(Mo,Ga,Ar)
Orusia	(Br,Ar,Or)	Otenaspella	(Ar,Tr,Un)	Ovirissoa	(Mo,Ga,Nt)
Orvikuina	(Cd,Os,Pa)	Othneiocrinus	(Ec,Cr,Ds)	Ovlatchania	(Br,Ar,Rh)
Orycteroctetus	(Cd,Ma,Ce)	Otionella	(Bz,Gy,Ch)	Ovoceras	(Mo,Ce,Di)
Oryctocare	(Ar,Tr,Co)	Otocelrites	(Mo,Ce,Ce)	Ovocerina	(Mo,Ce,Di)
Oryctocephalina	(Ar,Tr,Co)	Otoceras	(Mo,Ce,Ce)	Ovocytheridea	(Ar,Os,Po)
Oryctocephalites	(Ar,Tr,Co)	Otocythere	(Ar,Os,Po)	Ovornina	(Ar,Os,Po)
Oryctocephalops	(Ar,Tr,Co)	Otodus	(Cd,Ch,La)	Ovulactaeon	(Mo,Ga,Ce)
Oryctocephalus	(Ar,Tr,Co)	Otohoplites	(Mo,Ce,Am)	Ovulaster	(Ec,Ec,Sp)
Oryctoderma	(Fo,Fo,Fo)	Otoites	(Mo,Ce,Am)	Ovulechinus	(Ec,Ec,OI)
Oryctomya	(Mo,Bi,Ve)	Otollonia	(Mo,Ga,Ar)	Ovulocystites	(Ec,Pe,Co)
Orygmaspis	(Ar,Tr,As)	Otomitla	(Cd,Os,Am)	Ovulopsis	(Mo,Ga,Ce)
Orygmophyllum	(Cn,An,Ru)	Otomphalus	(Mo,Ga,Ar)	Ovum	(Ac,Ra,Na)
Osangularia	(Fo,Fo,Fo)	Otopleura	(Mo,Ga,He)	Owenella	(Mo,Ga,Be)
Osbornoceras	(Mo,Ce,On)	Otopora	(Bz,Gy,Ch)	Owenirhynchia	(Br,Ar,Rh)
Osburnostylus	(Bz,St,Cc)	Otoscapites	(Mo,Ce,Am)	Owenites	(Mo,Ce,Ce)
Osecolia	(Ar,Tr,As)	Otospirifer	(Br,Ar,Sp)	Owenoceras	(Mo,Ce,Go)
Osculigera	(Mo,Bi,Hi)	Otostoma	(Mo,Ga,Ar)	Oxfordoceras	(Mo,Ce,Or)
Osculipora	(Bz,St,Ce)	Otracvetia	(Ar,Os,Pa)	Oxinosis	(Fo,Fo,Fo)
Osculocystis	(Ec,Rh,Rh)	Ottadalenites	(Br,Ar,St)	Oxintoceras	(Mo,Ce,Go)
Osekaspis	(Ar,Tr,Ph)	Ottawacrinus	(Ec,Cr,Cl)	Oxlosia	(Br,Li,Ac)
Oshunia	(Cd,Os,Se)	Ottawella	(An,Po,EU)	Oxoplecia	(Br,Ar,Or)
Osilinus	(Mo,Ga,Ar)	Ottawina	(An,Po,Ph)	Oxyacrum	(Mo,Ga,Ne)
Oslodictyon	(Po,De,St)	Ottenbyaspis	(Ar,Tr,Pt)	Oxyagnostus	(Ar,Tr,Ag)
Oslonmites	(Br,Ar,Or)	Ottoia	(Pa)	Oxybeloceras	(Mo,Ce,Am)
Oslograptus	(He,Gr,Gr)	Otoino	(Mo,Ga,Nt)	Oxycerites	(Mo,Ce,Am)
Osmarella	(Br,Ar,Rh)	Otoseetaxis	(Bz,St,Fe)	Oxycolpella	(Br,Ar,Sp)
Osmeroidea	(Cd,Os,El)	Otukaia	(Mo,Ga,Ar)	Oxycypraea	(Mo,Ga,Nt)
Osmerus	(Cd,Os,Os)	Otusia	(Br,Ar,Or)	Oxydisclites	(Mo,Ce,Am)
Osmotoxotis	(Ar,Os,Pa)	Ouachitaia	(Ar,Os,Po)	Oxygnaspis	(Ar,Tr,Un)
Osoinia	(Mo,Bi,Ve)	Ouaka	(Ac,Ra,Sp)	Oxygnoceras	(Mo,Ce,Di)
Osooriochthys	(Cd,Os,Pa)	Ouamouia	(Mo,Bi,Ph)	Oxygyrus	(Mo,Ga,Nt)
Ospia	(Cd,Os,Am)	Oudardia	(Mo,Bi,Ve)	Oxyjullis	(Cd,Os,Pr)
Ospriasolen	(Mo,Bi,Ve)	Ouijiania	(Ar,Tr,Pt)	Oxymericeras	(Mo,Ce,Am)
Ossiania	(Mo,Ga,Ce)	Oulanga	(Cn,An,Sc)	Oxylentis	(Mo,Ga,Ne)
Osscrinus	(Ec,Cr,Rv)	Oulastrea	(Cn,An,Sc)	Oxynaspis	(Ar,Ci)
Ostariostoma	(Cd,Os,El)	Oulodus	(Cd,Co,Co)	Oxynautilus	(Mo,Ce,Na)
Ostenia	(Ar,Th,Co)	Oulophyllia	(Cn,An,Sc)	Oxynocrinus	(Ec,Cr,Cl)
Ostenocaris	(Ar,Th,Co)	Ourikaia	(Ar,Tr,Re)	Oxynotoceras	(Mo,Ce,Am)
Osteocrinus	(Ec,Cr,Rv)	Oustechnius	(Ec,Ec,Ds)	Oxynotus	(Cd,Ch,Sq)
Osteolepis	(Cd,Os,Co)	Ovactaeonina	(Mo,Ga,Ce)	Oxyosteus	(Cd,Pl,Ar)
Osteomya	(Mo,Bi,Ph)	Ovalarca	(Mo,Bi,Ar)	Oxyparoniceras	(Mo,Ce,Am)
Osteopygis	(Cd,Re,Ch)	Ovalastrea	(Cn,An,Sc)	Oxyperas	(Mo,Bi,Ve)
Osteorachis	(Cd,Os,Am)	Ovalastraecopsis	(Cn,An,Sc)	Oxypleurorhynchia	(Br,Ar,Rh)
Osthimosia	(Bz,Gy,Ch)	Ovalipes	(Ar,Mi,De)	Oxyprion	(An,Po,EU)
Ostioma	(Mo,Ga,Ar)	Ovalithea	(Hy,Uc,Uc)	Oxypteria	(Mo,Bi,Pt)
Ostlingoceras	(Mo,Ce,Am)	Ovalocephalus	(Ar,Tr,Ph)	Oxyrhizium	(Po,He,He)
Ostomya	(Mo,Bi,Ph)	Ovalospira	(Br,Ar,AU)	Oxyspira	(Mo,Ga,Nt)
Ostracion	(Cd,Os,Te)	Ovaluta	(Ar,Os,Ar)	Oxysteles	(Mo,Ga,Ar)
Ostracoberyx	(Cd,Os,Pr)	Ovalveolina	(Fo,Fo,Fo)	Oxyteuthis	(Mo,Ce,Be)
Ostrea	(Mo,Bi,Pt)	Ovatathyris	(Br,Ar,Te)	Oxythyreus	(Ar,Mi,De)
Ostreavicula	(Mo,Bi,Un)	Ovatia	(Br,Ar,St)	Oxytoma	(Mo,Bi,Pt)
Ostreinella	(Mo,Bi,Pt)	Ovatoceras	(Mo,Ce,Am)	Oxytornoceras	(Mo,Ce,Go)
Ostreofa	(Mo,Bi,Pt)	Ovatipsa	(Mo,Ga,Nt)	Oxytropidoceras	(Mo,Ce,Am)
Ostreoneella	(Mo,Bi,Pt)	Ovatoconcha	(Mo,Bi,So)	Oxytus	(Hy,Hy,Hy)
Otapiria	(Mo,Bi,Pt)	Ovatoquasillites	(Ar,Os,Po)	Oxyuropoda	(Ar,Un,Un)
Otaria	(Cd,Ma,Ca)	Ovatoscutum	(Cn,Hy,Un)	Oyonnaxstraea	(Cn,An,Sc)
Otariella	(Br,Ar,St)	Overtonaspis	(Cd,Pl,Ar)	Ozakiphyllum	(Cn,An,Ru)
Otarion	(Ar,Tr,Pr)	Overtonia	(Br,Ar,St)	Ozarkina	(Mo,Ga,EU)
Otarionella	(Ar,Tr,Pr)	Overtoniina	(Br,Ar,St)	Ozarkispira	(Mo,Ga,Ar)
Otarionides	(Ar,Tr,Pr)	Ovicardium	(Mo,Bi,Ve)	Ozarkocoelia	(Po,De,Li)
Otarorhynchia	(Br,Ar,Rh)	Oviclypeus	(Ec,Ec,Ca)	Ozarkoconus	(Mo,Te,Hy)
Otarozoum	(Ar,Tr,Li)	Ovidiella	(Br,Li,Li)	Ozarkodina	(Cd,Co,Co)
Otatara	(Mo,Ga,Nt)	Ovilia	(Mo,Ga,Ne)	Ozarkplina	(Mo,In,In)

Ozawainella	(Fo,Fo,Fo)	Pachyhelioplasma	(Cn,An,Ta)	Pachytrissops	(Cd,Os,Pc)
Ozius	(Ar,MI,De)	Pachyhexanchus	(Cd,Ch,Hx)	Pachyvascoceras	(Mo,Ce,Am)
Ozodochilus	(Mo,Ga,Ar)	Pachykellya	(Mo,Bi,Ve)	Pacificoecolia	(Br,Ar,At)
Ozopora	(Cn,An,Ta)	Pachylasma	(Ar,Ci)	Pacificor	(Mo,Bi,Ve)
Ozora	(Br,Ar,Si)	Pachylepisma	(Po,He,Un)	Pacificurus	(Ar,Tr,Ph)
Ozopongia	(Po,He,Re)	Pachylites	(Cn,An,Ta)	Pacimonotis	(Mo,Bi,Pt)
Ozotrachelus	(Po,De,Li)	Pachylocrinus	(Ec,Cr,Ci)	Pacimonion	(Fo,Fo,Fo)
Ozourina	(Fo,Fo,Fo)	Pachylocroceras	(Mo,Ce,Go)	Pacipecten	(Mo,Bi,Pt)
Paalzowella	(Fo,Fo,Fo)	Pachylytoceras	(Mo,Ce,Am)	Paciphacops	(Ar,Tr,Ph)
Paibianocrinus	(Ec,Cr,So)	Pachymagas	(Br,Ar,Te)	Pacitrigonia	(Mo,Bi,Tr)
Pacambocthere	(Ar,Os,Po)	Pachymegalodon	(Mo,Bi,Hi)	Pacymoorellina	(Br,Ar,Th)
Pachancorhynchia	(Br,Ar,Rh)	Pachymelton	(Mo,Ga,Ne)	Pacyoncus	(Ac,Ra,Sp)
Pachastrella	(Po,De,As)	Pachymura	(Po,Ca,Ph)	Padagrosites	(Mo,Ce,Am)
Pachdypetes	(Cd,Av,Sp)	Pachymya	(Mo,Bi,Ph)	Padragosiceras	(Mo,Ce,Am)
Pachecoa	(Mo,Bi,Ar)	Pachymyulus	(Cd,Ch,Cm)	Padunoceras	(Mo,Ce,In)
Pachendoceras	(Mo,Ce,El)	Pachymyonia	(Mo,Bi,Ph)	Paeckelmannella	(Br,Ar,Sp)
Pachopsites	(Ec,Ho,De)	Pachymytilus	(Mo,Bi,Pt)	Paeckelmannopora	(Cn,An,Ta)
Pachotoceras	(Mo,Ce,On)	Pachynion	(Po,De,Li)	Paedumius	(Ar,Tr,Ol)
Pachus	(Ac,Ra,Na)	Pachyocrinus	(Ec,Cr,Un)	Paegnium	(Ar,Os,Pa)
Pachyascus	(Po,He,He)	Pachyomphalus	(Mo,Ga,Ar)	Paenaequina	(Ar,Os,Le)
Pachyaspis	(Ar,Tr,Pt)	Pachyopis	(Mo,Bi,Ve)	Paenubellula	(Ar,Tr,Pt)
Pachyblastus	(Ec,Bi,Fi)	Pachyosteus	(Cd,Pl,Ar)	Paenula	(Ar,Os,Po)
Pachycalix	(Ec,Di,Di)	Pachypherna	(Mo,Bi,Pt)	Pagea	(Ar,Me,Eu)
Pachycalyptma	(Po,De,Li)	Pachyphloia	(Fo,Fo,Fo)	Pagecrinus	(Ec,Cr,Ci)
Pachycanzlicula	(Cn,An,Ta)	Pachyphragma	(Cn,An,Ta)	Pagellus	(Cd,Os,Pf)
Pachycardia	(Mo,Bi,Un)	Pachyphyllia	(Cn,An,Sc)	Pagetia	(Ar,Tr,Ag)
Pachycardioceras	(Mo,Ce,Am)	Pachyptictonia	(Mo,Ce,Am)	Pagetides	(Ar,Tr,Ag)
Pachycardium	(Mo,Bi,Ve)	Pachyplax	(Br,Ar,Sp)	Pagetiellus	(Ar,Tr,Ag)
Pachycaudites	(Ar,Os,Po)	Pachypleurosauros	(Cd,Re,No)	Pagodea	(Mo,Ga,Ar)
Pachyceras	(Mo,Ce,Am)	Pachypora	(Cn,An,Ta)	Pagodia	(Ar,Tr,Co)
Pachycetus	(Cd,Ma,Ce)	Pachypoterion	(Po,De,Li)	Pagodina	(Mo,Ga,Ar)
Pachychelys	(Cd,Re,Ch)	Pachyproetus	(Ar,Tr,Pr)	Pagodospira	(Mo,Ga,Ar)
Pachycidaris	(Ec,Ec,Ci)	Pachypsechia	(Po,De,Li)	Pagodula	(Mo,Ga,Ne)
Pachycladina	(Cd,Co,Co)	Pachypteria	(Mo,Bi,Pt)	Pagrus	(Cd,Os,Pf)
Pachyclymenia	(Mo,Ce,Ci)	Pachyrachis	(Po,He,Ly)	Paguristes	(Ar,MI,De)
Pachycoenia	(Cn,An,Sc)	Pachyredlichia	(Ar,Tr,Re)	Pagurus	(Ar,MI,De)
Pachycormus	(Cd,Os,Pc)	Pachyrisma	(Mo,Bi,Hi)	Pahlenella	(Br,Ar,Or)
Pachycorynea	(Po,De,Li)	Pachyrismella	(Mo,Bi,Ve)	Pahvantia	(Ar,Un,Un)
Pachycoosinus	(Po,Re,Aj)	Pachyrissolina	(Mo,Ga,Nt)	Paianocrinus	(Ec,Cr,Ci)
Pachycothon	(Po,De,Li)	Pachyritzodus	(Cd,Os,Cr)	Paichia shania	(Ar,Tr,Un)
Pachycranium	(Ar,Tr,Pr)	Pachysalax	(Po,De,Li)	Paiderocrinus	(Ec,Cr,Mo)
Pachycraspedon	(Bz,Gy,Ch)	Pachysceptron	(Cn,An,Pe)	Paijenborchella	(Ar,Os,Po)
Pachycrommium	(Mo,Ga,Nt)	Pachyseris	(Cn,An,Sc)	Paijenborchellina	(Ar,Os,Po)
Pachycyathus	(Cn,An,Sc)	Pachysolenia	(Cn,An,Sc)	Paititubulites	(Pr,Un,Pa)
Pachycymbiola	(Mo,Ga,Ne)	Pachysphinctes	(Mo,Ce,Am)	Paivinia	(Ar,Tr,As)
Pachycythara	(Mo,Ga,Ne)	Pachystelliporella	(Cn,An,Ta)	Pajamites	(Ar,Os,Po)
Pachydedrion	(Cn,An,Sc)	Pachystomaria	(Bz,Gy,Ch)	Pakistania	(Mo,Ga,Ar)
Pachydera	(Bz,Gy,Ch)	Pachystriatopora	(Cn,An,Ta)	Pakriditya	(Bz,St,Cy)
Pachydesma	(Mo,Bi,Ve)	Pachystrophia	(Mo,Ga,Eu)	Pakrioceras	(Mo,Ce,Ta)
Pachydesmoceras	(Mo,Ce,Am)	Pachystylostroma	(Po,De,St)	Palaeantholithus	(Ac,Ra,Sp)
Pachydiadema	(Ar,Ci)	Pachysyrnola	(Mo,Ga,He)	Palachemomella	(Fo,Fo,Fo)
Pachydietya	(Bz,St,Cr)	Pachyteichisma	(Po,He,Ly)	Palacorona	(Ar,Tr,Co)
Pachydiscoides	(Mo,Ce,Am)	Pachyteichopora	(Bz,St,Cc)	Paladin	(Ar,Tr,Pr)
Pachydiscus	(Mo,Ce,Am)	Pachyteuthis	(Mo,Ce,Be)	Paladmete	(Mo,Ga,Nt)
Pachydomella	(Ar,Os,Po)	Pachytherius	(Mo,Bi,Ve)	Palaeacanthaspis	(Cd,Pl,Ac)
Pachydomelloides	(Ar,Os,Po)	Pachytherca	(Po,De,Ta)	Palaeacis	(Cn,An,Ta)
Pachydon	(Mo,Bi,My)	Pachytheccalis	(Cn,An,Sc)	Palaeacmea	(Cn,Hy,Hy)
Pachydontella	(Mo,Ga,Ar)	Pachytheccopna	(Cn,An,Sc)	Palaeantedon	(Ec,Cr,Cm)
Pachyduvalia	(Mo,Ce,Be)	Pachythercella	(Bz,Gy,Ch)	Palaeareae	(Cn,An,Ru)
Pachyerymnoceras	(Mo,Ce,Am)	Pachythrissops	(Cd,Os,Ci)	Palaeastacus	(Ar,MI,De)
Pachyfavosites	(Cn,An,Ta)	Pachythurammina	(Fo,Fo,Fo)	Palaeaster	(Ec,As,Pt)
Pachygalcus	(Cd,Ch,Ca)	Pachythyris	(Br,Ar,Te)	Palaeastraea	(Cn,An,Sc)
Pachyglossella	(Br,Li,Li)	Pachytilodia	(Po,Ca,Ph)	Palaeattractus	(Mo,Ga,Ne)
Pachygyra	(Cn,An,Sc)	Pachytraga	(Mo,Bi,Hi)	Palaechinus	(Ec,Ec,Ey)

Palaeodaphus	(Cd,Os,Di)	Palaeoentelophyllum	(Cn,An,Ru)	Palaeoiphis	(Cd,Re,Sq)
Palaeaga	(Ar,MI,Is)	Palaeoentolium	(Mo,Bi,Pt)	Palaeoiphura	(Ec,Op,Oe)
Palaeoaphnacmaea	(Cn,Hy,Hy)	Palaeoephippium	(Ac,Ra,Sp)	Palaeoiphobertus	(Ar,MI,De)
Palaeamon	(Ar,MI,De)	Palaeofavosipora	(Cn,An,Ta)	Palaeoiphoca	(Cd,Ma,Ca)
Palaeamysis	(Ar,MI,EO)	Palaeofusulina	(Fo,Fo,Fo)	Palaeoiphococena	(Cd,Ma,Ce)
Palaeanigma	(Cn,Sc,Cn)	Palaeogadus	(Cd,Os,Ga)	Palaeoiphonus	(Ar,Ar,Sc)
Palaeoaphrodite	(An,Po,Ph)	Palaeogaleus	(Cd,Ch,Ca)	Palaeoiphragmodictya	(Po,He,Re)
Palaeoaplysina	(Po,De,Ax)	Palaeoglossa	(Br,Li,Li)	Palaeoiphreaticus	(Ar,MI,Is)
Palaeoatherina	(Cd,Os,At)	Palaeoionitites	(Mo,Ce,An)	Palaeiomussa	(Cn,An,Sc)
Palaeobalaena	(Cd,Ma,Ce)	Palaeograpsus	(Ar,MI,De)	Palaeoiphyllia	(Cn,An,Sc)
Palaeobalanus	(Ar,Ci)	Palaeohelia	(Cn,An,Sc)	Palaeoiphyllites	(Mo,Ce,Ph)
Palaeobalistum	(Cd,Os,Py)	Palaeoholopus	(Ec,Cr,Sa)	Palaeoiphylum	(Cn,An,Ru)
Palaeobates	(Cd,Ch,Ct)	Palaeohomarus	(Ar,MI,De)	Palaeoiphyma	(Po,De,Li)
Palaeobelemnopsis	(Mo,Ce,Au)	Palaeohydantina	(Mo,Ga,Ce)	Palaeoipinna	(Mo,Bi,Pt)
Palaeobigenerina	(Fo,Fo,Fo)	Palaeohypotodus	(Cd,Ch,La)	Palaeoiplatoda	(Cn,Pe,Er)
Palaeobolus	(Br,Li,Li)	Palaeoisopus	(Ar,Py,Pa)	Palaeoiplesiastraea	(Cn,An,Sc)
Palaeobothyrinus	(Ec,Cr,Bo)	Palaeojerea	(Po,De,Li)	Palaeoipleurosaurus	(Cd,Re,Sp)
Palaeobotryllus	(Pr,Un,In)	Palaeokazachstanites	(Mo,Ce,Ce)	Palaeoipolycheles	(Ar,MI,De)
Palaeobranchiostoma	(Cd,Cp,Cp)	Palaeokylix	(Cn,Hy,Hy)	Palaeoporites	(Cn,An,Ta)
Palaeocampa	(An,Po,Am)	Palaeoldhamina	(Br,Ar,St)	Palaeopsammia	(Cn,An,Sc)
Palaeocancellaria	(Mo,Ga,Ne)	Palaeolenella	(Ar,Tr,Pt)	Palaeosephaea	(Mo,Ga,Ne)
Palaeocarcharias	(Cd,Ch,La)	Palaeolenides	(Ar,Tr,Pt)	Palaeoteria	(Mo,Bi,Pt)
Palaeocarcharodon	(Cd,Ch,La)	Palaeolentus	(Ar,Tr,Re)	Palaeopyramidium	(Ac,Ra,Sp)
Palaeocardia	(Mo,Bi,Pt)	Palaeolentus	(Ar,Tr,Pt)	Palaeoreichelina	(Fo,Fo,Fo)
Palaeocardita	(Mo,Bi,Ve)	Palaeoleptostrophia	(Br,Ar,St)	Palaeorhaphis	(Mo,Ga,Ne)
Palaeocarpilius	(Ar,MI,De)	Palaeolima	(Mo,Bi,Pt)	Palaeorhincodon	(Cd,Ch,Ce)
Palaeocentrotus	(Cd,Os,La)	Palaeolithostrotion	(Cn,An,Ru)	Palaeorhynchus	(Cd,Os,In)
Palaeoceras	(Mo,Ce,Pl)	Palaeolithuonella	(Fo,Fo,Fo)	Palaeorubus	(Ac,Ra,Sp)
Palaeocetus	(Cd,Ma,Ce)	Palaeololigo	(Mo,Ce,Te)	Palaeosaccus	(Po,He,Is)
Palaeochaeta	(An,Po,Ph)	Palaeolucina	(Mo,Bi,Ve)	Palaeosatturalis	(Ac,Ra,Sp)
Palaeochoristites	(Br,Ar,Sp)	Palaeolycus	(Cd,Os,Al)	Palaeoscenidium	(Ac,Ra,Sp)
Palaeocollonia	(Mo,Ga,Ar)	Palaeomanon	(Po,De,Li)	Palaeosceptron	(Cn,An,Pe)
Palaeocoma	(Ec,Op,Op)	Palaeomiliolina	(Fo,Fo,Fo)	Palaeoschada	(Po,De,Pe)
Palaeocomaster	(Ec,Cr,Cm)	Palaeomillepora	(Cn,Hy,Mi)	Palaeoschisma	(Mo,Ga,Ar)
Palaeocomcha	(Mo,Bi,Nu)	Palaeomoera	(Mo,Bi,Ve)	Palaeoschizophoria	(Br,Ar,Or)
Palaeocomularia	(Po,Re,Mo)	Palaeomolva	(Cd,Os,Ga)	Palaeoschmidrites	(Br,Li,Li)
Palaeocorax	(Cd,Ch,La)	Palaeomunida	(Ar,MI,De)	Palaeoscolecida	(An,Pa,Pa)
Palaeocorbula	(Mo,Bi,Ph)	Palaeomunidopsis	(Ar,MI,De)	Palaeoscolex	(An,Pa,Pa)
Palaeocorolites	(Cn,An,Ta)	Palaeomya	(Mo,Bi,Ve)	Palaeoscomber	(Cd,Os,Pf)
Palaeocoryne	(Bz,St,Cr)	Palaeomyulus	(Cd,Pl,Pt)	Palaeoscorpis	(Ar,Ar,Sc)
Palaeocrangon	(Ar,MI,Is)	Palaeomyra	(Ar,MI,De)	Palaeoscurria	(Mo,In,In)
Palaeocrinus	(Ec,Cr,Ci)	Palaeomyrus	(Cd,Os,An)	Palaeoscyllium	(Cd,Ch,Oc)
Palaeocrisidia	(Bz,St,Ce)	Palaeonarica	(Mo,Ga,Nt)	Palaeosigma	(An,Po,Eu)
Palaeoactopus	(Mo,Ce,Oc)	Palaeonectris	(Cn,Hy,Hy)	Palaeosmia	(Cn,An,Ru)
Palaeoocumaria	(Ec,Ho,Ar)	Palaeoneilo	(Mo,Bi,Nu)	Palaeosolaster	(Ec,As,He)
Palaeocuma	(Ar,MI,Cu)	Palaeonephrops	(Ar,MI,De)	Palaeosolemia	(Mo,Bi,So)
Palaeocyathus	(Cn,An,Ru)	Palaeonisco	(Mo,Ga,Nt)	Palaeosolen	(Mo,Bi,Mi)
Palaeocyathoceras	(Mo,Ce,En)	Palaeoniscum	(Cd,Os,Pa)	Palaeospinax	(Cd,Ch,In)
Palaeocycloceras	(Mo,Ce,Or)	Palaeonubercularia	(Fo,Fo,Fo)	Palaeospirifer	(Br,Ar,Sp)
Palaeocyclus	(Cn,An,Ru)	Palaeonucula	(Mo,Bi,Nu)	Palaeospiroplectamina	(Fo,Fo,Fo)
Palaeocypraea	(Mo,Ga,Nt)	Palaeopagurus	(Ar,MI,De)	Palaeosporyulus	(Cd,Pt,Un)
Palaeocystites	(Ec,EO,Go)	Palaeopalaemon	(Ar,MI,De)	Palaeosquilla	(Ar,MI,St)
Palaeocytheridea	(Ar,Os,PO)	Palaeopalinurus	(Ar,MI,De)	Palaeostaffella	(Fo,Fo,Fo)
Palaeocytheridella	(Ar,Os,PO)	Palaeopantopus	(Ar,Py,PP)	Palaeostauronema	(Po,He,He)
Palaeocythus	(Cd,Os,Ze)	Palaeopecten	(Mo,Bi,Pt)	Palaeostella	(Ec,As,Pu)
Palaeodactylophora	(An,Po,EU)	Palaeopedina	(Ec,Ec,Pe)	Palaeosteus	(Cd,Pt,Un)
Palaeodasyatis	(Cd,Ch,My)	Palaeopelyx	(An,Po,EU)	Palaeostoma	(Ec,Ec,Sp)
Palaeodecaradium	(Ac,Ra,Sp)	Palaeopemphix	(Ar,MI,De)	Palaeostrophomena	(Br,Ar,St)
Palaeodiadema	(Ec,Ec,Di)	Palaeopentacheles	(Ar,MI,De)	Palaeostylus	(Mo,Ga,Nt)
Palaeodictyota	(He,Gr,De)	Palaeoperca	(Cd,Os,Pf)	Palaeosulcochites	(Pr,Co,Sa)
Palaeodiscus	(Ec,Ec,Ey)	Palaeopericichthys	(Cd,Os,Pf)	Palaeotanasia	(Ar,MI,TA)
Palaeodotes	(Ar,Tr,Pt)	Palaeopichthys	(Cd,Os,TA)	Palaeotetraphyle	(Ac,Ra,Sp)
Palaeodromites	(Ar,MI,De)	Palaeophilipsia	(Ar,Tr,Pr)	Palaeotextularia	(Fo,Fo,Fo)
Palaeodus	(Cd,Pt,Pt)	Palaeophilomedes	(Ar,Os,My)	Palaeothalonnus	(Ac,Ra,Sp)

Palaeothea	(Ar.Py,Pt)	Paleoxiphosphaera	(Pr.Un.In)	Pamirothyris	(Br.Ar,Te)
Palaeotrissum	(Cd,Os,Pa)	Palermites	(Mo,Ce,Go)	Pamirothropsis	(Br.Ar,Te)
Palaeothunnus	(Cd,Os,Pf)	Palermocoelia	(Po,De,Pe)	Pammegeterhynchus	(Br.Ar,Rh)
Palaeotridifidus	(Ac,Ra,Sp)	Paleschara	(Bz,St,Fe)	Pamphagoisirenites	(Mo,Ce,Ce)
Palaeotrimerella	(Br,Li,Li)	Paleunema	(Mo,Ga,Ar)	Pampocilorhynchus	(Br.Ar,Rh)
Palaeotringa	(Cd,Av,Ch)	Paleuphemites	(Mo,Ga,Be)	Panacoma	(Mo,Bi,Ve)
Palaeotripus	(Ac,Ra,Sp)	Paleyoidia	(Mo,Bi,Nu)	Panamurex	(Mo,Ga,Ne)
Palaeotrochactaeon	(Mo,Ga,Ce)	Palhemiaster	(Ec,Ec,Sp)	Panarchaegonus	(Ar,Tr,Pr)
Palaeotrochus	(Mo,Ga,Ar)	Palibacus	(Ar,MI,De)	Pancheilopora	(Bz,Gy,Ch)
Palaeotroctes	(Cd,Os,St)	Palicites	(Mo,Ce,Ce)	Panchione	(Mo,Bi,Ve)
Palaeotuba	(Cn,Hy,Hy)	Paliimphyes	(Cd,Os,Pf)	Pancornus	(Mo,Ce,Di)
Palaeoxanthopsis	(Ar,MI,De)	Paliintropus	(Cd,Av,Le)	Pandaglandulina	(Fo,Fo,Fo)
Palaeoypsilus	(Ec,Ho,Da)	Palinurina	(Ar,MI,De)	Pandancornus	(Ec,Cr,Mo)
Palaeoziphus	(Cd,Ma,Ce)	Palimurus	(Ar,MI,De)	Pandaspiniyuga	(Ar,Tr,Ph)
Palaeozygopleura	(Mo,Ga,Nt)	Paliophyllum	(Cn,An,Ru)	Panderia	(Ar,Tr,Co)
Palaura	(Ec,Op,St)	Paliurus	(An,Po,Se)	Panderichthys	(Cd,Os,Co)
Palangaria	(Mo,Ga,Ar)	Pallacera	(Mo,Ga,Ne)	Panderina	(Br,Ar,Or)
Palaskensis	(Mo,Ce,Ne)	Pallaimorphina	(Fo,Fo,Fo)	Panderodus	(Cd,Co,Co)
Palasterina	(Ec,As,He)	Palliocypraea	(Mo,Ga,Nt)	Panderopora	(Bz,St,Tr)
Palasteriscus	(Ec,As,Pf)	Palliolatella	(Fo,Fo,Fo)	Pandora	(Mo,Bi,Ph)
Palastraea	(Cn,An,Ru)	Palliolum	(Mo,Bi,Pt)	Pandoracrinus	(Ec,Cr,Cl)
Palastroepora	(Cn,An,Sc)	Palliseria	(Mo,Ga,Mc)	Pandorella	(Mo,Bi,Ph)
Paldiskites	(Br,Li,Li)	Palmadusta	(Mo,Ga,Nt)	Pandorinellina	(Cd,Co,Co)
Palehomola	(Ar,MI,De)	Palmatohindia	(Po,De,Li)	Paneka	(Mo,Bi,Pr)
Palelialia	(Mo,Ce,Na)	Palmatolepis	(Cd,Co,Co)	Pangoa	(Mo,Ga,Ne)
Palella	(Ar,Tr,As)	Palmatophycus	(He,Gr,Un)	Panis	(Mo,Bi,Pt)
Palelpidia	(Ec,Ho,El)	Palmenella	(Ar,Os,Po)	Panitheca	(Hy,Or,Or)
Paleolvania	(Mo,Ga,He)	Palmeraspis	(Ar,Tr,Un)	Pannellaina	(Fo,Fo,Fo)
Paleoalvolites	(Cn,An,Ta)	Palmeraster	(Ec,Ec,Sp)	Panomya	(Mo,Bi,My)
Paleoastroides	(Cn,An,Sc)	Palmerhytis	(Br,Ar,St)	Panopea	(Mo,Bi,My)
Paleoatactoechus	(Bz,St,Tr)	Palmericyathus	(Po,Re,Aj)	Panopeus	(Ar,MI,De)
Paleobrachselurus	(Cd,Ct,Oc)	Palmerinella	(Fo,Fo,Fo)	Panormella	(Mo,Ga,Ne)
Paleocenosphaera	(Pr,Un,In)	Palmerius	(Ec,Ec,Ci)	Panormida	(Po,De,Pe)
Paleoehiridota	(Ec,Ho,Ap)	Palmeroceras	(Mo,Ce,Or)	Pantanelium	(Ac,Ra,Sp)
Paleoehiton	(Mo,Po,Pa)	Palmerocrinus	(Ec,Cr,Cl)	Pantellaria	(Br,Ar,Te)
Paleoconus	(Mo,Ce,Au)	Palmettaspis	(Ar,Tr,Or)	Pantoicoceras	(Mo,Ce,Di)
Paleocosta	(Ar,Os,Po)	Palmicellaria	(Bz,Gy,Ch)	Pantokratoria	(Po,De,Ax)
Paleoconodiscus	(Ec,As,Px)	Palmidophoca	(Cd,Ma,Ca)	Pantophilus	(Cd,Os,Al)
Paleoconophora	(Ct)	Palmoconcha	(Ar,Os,Po)	Pantophyllum	(Cn,An,Ru)
Paleocythere	(Ar,Os,Un)	Palmoxytoma	(Mo,Bi,Pt)	Pantosaurus	(Cd,Re,Ps)
Paleodictyoconus	(Fo,Fo,Fo)	Palmula	(Fo,Fo,Fo)	Panturichthys	(Cd,Os,An)
Paleofavosites	(Cn,An,Ta)	Palnerostephanus	(Mo,Ce,Am)	Panumia	(Ar,Tr,Pt)
Paleofossus	(Ar,Tr,Co)	Palocyathus	(Cn,An,Sc)	Panxinella	(Cn,An,Co)
Paleofusimitra	(Mo,Ga,Ne)	Palomelon	(Mo,Ga,Ne)	Panxioseus	(Cd,Pl,Ar)
Paleogaudryina	(Fo,Fo,Fo)	Palorbitolina	(Fo,Fo,Fo)	Paokannia	(Ar,Tr,Re)
Paleogrypophyllum	(Cn,An,Ru)	Palorbitolinoides	(Fo,Fo,Fo)	Paoshanella	(Pr,Un,Co)
Paleolimulus	(Ar,Me,Xi)	Palpebralia	(Ar,Tr,Pr)	Paphia	(Mo,Bi,Ve)
Paleolina	(Pr,Un,Sa)	Palpebrops	(Ar,Tr,Ph)	Paphies	(Mo,Bi,Ve)
Paleomarcia	(Mo,Bi,Ve)	Paltaopites	(Mo,Ce,Am)	Paphirus	(Mo,Bi,Ve)
Paleomerus	(Ar,Me,Ag)	Paltechioceras	(Mo,Ce,Am)	Papiliolinus	(Br,Ar,St)
Paleomonsmirabilia	(Ar,Os,Po)	Paltodus	(Cd,Co,Co)	Papiliophyllum	(Cn,An,Ru)
Paleonereites	(An,Po,Ph)	Palumicorbula	(Mo,Bi,My)	Papillanaria	(Bz,St,Cy)
Paleononites	(An,Po,Eu)	Palurites	(An,Po,Eu)	Papillatbairdia	(Ar,Os,Po)
Paleoparadoxia	(Cd,Ma,De)	Palus	(Mo,Bi,Hi)	Papillicalymene	(Ar,Tr,Ph)
Paleopatellina	(Fo,Fo,Fo)	Pamirella	(Bz,St,Cr)	Papilliscardium	(Mo,Bi,Ve)
Paleopfenderina	(Fo,Fo,Fo)	Pamirina	(Fo,Fo,Fo)	Papillina	(Mo,Ga,Ne)
Paleopneustes	(Ec,Ec,Sp)	Pamirochaetetes	(Po,De,Ta)	Papillocyathus	(Po,Re,Aj)
Paleopolymorphina	(Fo,Fo,Fo)	Pamirophyllum	(Cn,An,Ru)	Papillostrophia	(Br,Ar,St)
Paleopsephurus	(Cd,Os,Ac)	Pamiropora	(Po,De,Ax)	Papodina	(Br,Ar,Te)
Paleopupa	(Mo,Pa,Hy)	Pamirohrhynchia	(Br,Ar,Rh)	Pappocetus	(Cd,Ma,Ce)
Paleosphaerites	(Ec,Di,Di)	Pamiroseris	(Cn,An,Sc)	Paprobites	(Mo,Ce,Go)
Paleostraba	(Mo,Bi,Nu)	Pamirostroma	(Po,De,Ax)	Papyriaspis	(Ar,Tr,Pt)
Paleostrophia	(Br,Ar,Pe)	Pamirotellus	(Ar,Tr,Ph)	Papyridea	(Mo,Bi,Ve)
Paleowaagia	(Mo,Bi,Pt)	Pamirotheca	(Br,Ar,Th)	Paquetoceras	(Mo,Ce,Ba)

Paquiericeras	(Mo,Ce,Am)	Paracarruthersella	(Cn,An,Ru)	Paracremacrinus	(Ec,Cr,Ds)
Paraacanthothyris	(Br,Ar,Rh)	Paracassidulina	(Fo,Fo,Fo)	Paracrescis	(Bz,St,Cc)
Paraacrochordiceras	(Mo,Ce,Ce)	Paracatillocrinus	(Ec,Cr,Ds)	Paracroceras	(Mo,Ce,Am)
Paraaldenella	(Mo,In,Pe)	Paracaudites	(Ar,Os,Po)	Paracrocephalites	(Ar,Tr,Pt)
Paraaplysinosifibria	(Po,De,Un)	Paracavellina	(Ar,Os,Me)	Paracrocrinus	(Ec,Cr,Mo)
Paraarctica	(Mo,Bi,Ve)	Paracedaria	(Ar,Tr,Pt)	Paracroomyocrinus	(Ec,Cr,Cl)
Paraaulina	(Cn,An,Ru)	Paracelites	(Mo,Ce,Ce)	Paracrothyris	(Br,Ar,Te)
Parabactrites	(Mo,Ce,An)	Paracencroceras	(Mo,Ce,Na)	Paracrurithyris	(Br,Ar,Sp)
Parabadiella	(Ar,Tr,Re)	Paracentrophorus	(Cd,Os,Am)	Paracryphaeus	(Ar,Tr,Ph)
Parabailiella	(Ar,Tr,As)	Paraceratites	(Mo,Ce,Ce)	Paractenolocolina	(Ar,Os,Pa)
Parabairdiacypris	(Ar,Os,Pa)	Paraceratitoides	(Mo,Ce,Ce)	Paractinoceras	(Mo,Ce,Ac)
Parabairdianella	(Ar,Os,Po)	Paraceratoconus	(Mo,In,In)	Paractocrinus	(Ec,Cr,He)
Parabarrandia	(Ar,Tr,As)	Paraceraurus	(Ar,Tr,Ph)	Paracuarciceras	(Mo,Ce,Am)
Parabasilius	(Ar,Tr,As)	Paracerithium	(Mo,Ga,Nt)	Paracucumarites	(Ec,Ho,De)
Parabathycheilus	(Ar,Tr,Pt)	Paracharnia	(Cn,Pe,Ra)	Paracunofolites	(Cn,An,Sc)
Parabdinoides	(Ar,Os,Pa)	Parachasmatopora	(Bz,St,Fe)	Paracyanthus	(Cn,An,Sc)
Parabelhavites	(Mo,Ce,Am)	Parachaunoproetus	(Ar,Tr,Pr)	Paracybantyx	(Ar,Tr,Co)
Parabellefontia	(Ar,Tr,As)	Parachirognathus	(Cd,Co,Co)	Paracybeloides	(Ar,Tr,Ph)
Parabelodina	(Cd,Co,Co)	Parachonetella	(Br,Ar,St)	Paracyclammima	(Fo,Fo,Fo)
Parabelopeltis	(Mo,Ce,Te)	Parachonetes	(Br,Ar,St)	Paracyclas	(Mo,Bi,Ve)
Parabelosteus	(Cd,Pl,Ar)	Parachonus	(Cd,Os,Go)	Paracyclendoceras	(Mo,Ce,En)
Paraberounella	(Ar,Os,Po)	Parachorisites	(Br,Ar,Sp)	Paracycloseries	(Cn,An,Sc)
Paraberriasella	(Mo,Ce,Am)	Parachuangia	(Ar,Tr,Ph)	Paracyclostomiceras	(Mo,Ce,El)
Paraberyx	(Cd,Os,Br)	Paracidaris	(Ec,Ec,Ci)	Paracydomocrinus	(Ec,Cr,Cl)
Parabevalites	(Mo,Ce,Am)	Paracidaspis	(Ar,Tr,Od)	Paracymatoceras	(Mo,Ce,Na)
Parabifolium	(Br,Ar,Th)	Paracirculus	(Mo,Ga,Ar)	Paracymatodus	(Cd,Ch,Pe)
Parablackwelderia	(Ar,Tr,Od)	Paracladiscites	(Mo,Ce,Ce)	Paracymbiocrinus	(Ec,Cr,Cl)
Parabolbina	(Ar,Os,Pa)	Paraclathurella	(Mo,Ga,Ne)	Paracymbites	(Mo,Ce,Am)
Parabolbinella	(Ar,Os,Pa)	Paraclausastraea	(Cn,An,Sc)	Paracyprideis	(Ar,Os,Po)
Parabolbozoe	(Ar,Os,My)	Paracleistoceras	(Mo,Ce,On)	Paracyprinotus	(Ar,Os,Po)
Parabolliceras	(Mo,Ce,Am)	Paraclidochirus	(Ec,Cr,Sa)	Paracypris	(Ar,Os,Po)
Parabolliceratoides	(Mo,Ce,Am)	Paraclimacograptus	(He,Gr,Gr)	Paracystiphylloides	(Cn,An,Ru)
Parabolina	(Ar,Tr,Pt)	Paraclythia	(Ar,Mi,De)	Paracystis	(Ec,Co,Co)
Parabolinella	(Ar,Tr,Pt)	Paraclytiopsis	(Ar,Mi,De)	Paracythere	(Ar,Os,Po)
Parabolinites	(Ar,Tr,Pt)	Paracodaster	(Ec,BI,Fi)	Paracythereis	(Ar,Os,Po)
Parabolinoides	(Ar,Tr,As)	Paracolocrinus	(Ec,Cr,Ds)	Paracytheretta	(Ar,Os,Po)
Parabolinopsis	(Ar,Tr,Pt)	Paracolunnaria	(Cn,An,Ru)	Paracytheridea	(Ar,Os,Po)
Paraborsonia	(Mo,Ga,Ne)	Paracomatula	(Ec,Cr,Cm)	Paracytherois	(Ar,Os,Po)
Parabotryocrinus	(Ec,Cr,Cl)	Paracomitias	(Mo,Ga,Ne)	Paracytheroma	(Ar,Os,Po)
Paraboubeithyris	(Br,Ar,Te)	Paracomminia	(Mo,Ga,Ne)	Paracytheromorpha	(Ar,Os,Po)
Parabouchekius	(Ar,Os,Pa)	Paracomposita	(Br,Ar,Sp)	Paracytheropteron	(Ar,Os,Po)
Parabouleia	(Ar,Tr,Ph)	Paraconcaucus	(Ar,Ci)	Paradagmarita	(Fo,Fo,Fo)
Parabournoia	(Mo,Bi,Hi)	Paraconchidium	(Br,Ar,Pe)	Paradainella	(Fo,Fo,Fo)
Parabrachyellasma	(Cn,An,Ru)	Paraconger	(Cd,Os,An)	Paradakoceras	(Mo,Ce,El)
Parabrissus	(Ec,Ec,Sp)	Paracongroides	(Cd,Os,An)	Paradanubites	(Mo,Ce,Ce)
Parabuchanosteus	(Cd,Pl,Ar)	Paraconlinoceras	(Mo,Ce,Am)	Paradasyceras	(Mo,Ce,Ph)
Parabumastitides	(Ar,Tr,As)	Paraconradoceras	(Mo,Ce,On)	Paradechenella	(Ar,Tr,Pr)
Parabursacrinus	(Ec,Cr,Cl)	Paraconularia	(Cn,Sc,Cn)	Paradeltoocyathus	(Cn,An,Sc)
Parabuxtonia	(Br,Ar,St)	Paraconularoides	(Cn,Sc,Cn)	Paradelocrinus	(Ec,Cr,Cl)
Parabythocthere	(Ar,Os,Po)	Paracoosia	(Ar,Tr,As)	Paradelograptus	(He,Gr,De)
Paracaeoceras	(Mo,Ce,Am)	Paracorax	(Cd,Ch,La)	Parademonedys	(Br,Ar,St)
Paracalamus	(Cd,Os,Pl)	Paracorbicula	(Mo,Bi,Ve)	Paradeningeria	(Po,De,Pe)
Paracaligella	(Fo,Fo,Fo)	Paracordylodus	(Cd,Co,Co)	Paradentalium	(Mo,Sc,Sc)
Paracalmonia	(Ar,Tr,Ph)	Paracoriceras	(Mo,Ce,Am)	Paraderbyia	(Br,Ar,St)
Paracaealycoeras	(Mo,Ce,Am)	Paracoscinus	(Po,Je,Ar)	Paradiablocrinus	(Ec,Cr,Di)
Paracaunia	(Cn,An,Ru)	Paracoskinolina	(Fo,Fo,Fo)	Paradiceras	(Mo,Bi,Hi)
Paracanoptum	(Ac,Ra,Na)	Paracosmetocrinus	(Ec,Cr,Cl)	Paradichocrinus	(Ec,Cr,Mo)
Paracanthodus	(Pr,Un,In)	Paracosta	(Ar,Os,Po)	Paradicidia	(Mo,Ce,Am)
Paracanthoplitis	(Mo,Ce,Am)	Paracostanoplia	(Br,Ar,St)	Paradimroceras	(Mo,Ce,Go)
Paracapillithyris	(Br,Ar,Te)	Paracotylederma	(Ec,Cr,Cy)	Paradimrochoceras	(Mo,Ce,Go)
Paracaprinnula	(Mo,Bi,Hi)	Paracraniops	(Br,Li,Li)	Paradinarites	(Mo,Ce,Ce)
Paracarcinosoma	(Ar,Me,Eu)	Paracraspedites	(Mo,Ce,Am)	Paradinobolus	(Br,Li,Li)
Paracardium	(Mo,Bi,Pr)	Paracraicularia	(Po,He,He)	Paradisoceras	(Mo,Ce,Ta)
Paracarinachites	(Pr,Un,In)	Paracravenoceras	(Mo,Ce,Go)	Paradisphyllum	(Cn,An,Ru)

Paradistichites	(Mo,Ce,Ce)	Paraglobivalvulinoides	(Fo,Fo,Fo)	Parakionoceras	(Mo,Ce,Or)
Paradistichophylum	(Cn,An,Sc)	Paragloboritus	(Tr,An)	Parakoldinia	(Ar,Tr,Pt)
Paradiversograptus	(He,Gr,Gr)	Paragloborotalia	(Fo,Fo,Fo)	Parakorolithes	(Hy,Hy,Hy)
Paradnatoceras	(Mo,Ce,Or)	Paraglossinulus	(Br,Ar,Rh)	Parakozlowskiella	(Ar,Os,Pa)
Paradolerorthis	(Br,Ar,Or)	Paraglossograptus	(He,Gr,Gr)	Parakrithie	(Ar,Os,Pa)
Paradolphia	(Mo,Ce,Am)	Paraglycerites	(An,Po,Ph)	Parakrithella	(Ar,Os,Pa)
Paradomatoceras	(Mo,Ce,Na)	Paraglyptobairdia	(Ar,Os,Pa)	Parakunmingella	(Ar,Os,Ar)
Paradonax	(Mo,Bi,Ve)	Paraglyptopleura	(Ar,Os,Pa)	Paralabalia	(Br,Ar,Sp)
Paradoxaphyllia	(Cn,An,Ru)	Paragnathites	(An,Po,Eu)	Paralabamina	(Fo,Fo,Fo)
Paradoxechinus	(Ec,Ec,Te)	Paragnathodus	(Cd,Co,Co)	Paralaeospira	(An,Po,Se)
Paradoxia	(Mo,Bi,Un)	Paragoceras	(Mo,Ce,Ce)	Paralazutkinia	(Br,Ar,Sp)
Paradoxides	(Ar,Tr,Re)	Paragogia	(Ec,Eo,Go)	Paralbertella	(Ar,Tr,Co)
Paradoxiella	(Fo,Fo,Fo)	Paragonaster	(Ec,As,Vi)	Paralbulia	(Cd,Os,An)
Paradoxipecten	(Mo,Bi,Pt)	Paragonatodus	(Cd,Os,Pa)	Paralcidia	(Mo,Ce,Am)
Paradoxocrinus	(Ec,Cr,Ds)	Paragoniozonia	(Mo,Ga,Ar)	Paraldingia	(Br,Ar,Te)
Paradoxostoma	(Ar,Os,Pa)	Paragouldia	(Mo,Bi,Ve)	Paralegoceras	(Mo,Ce,Go)
Paradoxothyris	(Br,Ar,Te)	Paragraphiocrinus	(Ec,Cr,Cl)	Paralejurus	(Ar,Tr,Co)
Paradrilla	(Mo,Ga,Ne)	Paragraulus	(Ar,Tr,Un)	Paralenorthis	(Br,Ar,Or)
Paradrilonereigenys	(An,Po,Ph)	Paragrenocythere	(Ar,Os,Pa)	Paralenticeras	(Mo,Ce,Am)
Paradrydenius	(Cd,Os,Pa)	Paragriffithides	(Ar,Tr,Pr)	Paraleoichthas	(Ar,Tr,Li)
Paradunbarula	(Fo,Fo,Fo)	Paragumbelites	(Mo,Ce,Ce)	Paraleperiditha	(Ar,Os,Le)
Paraduplophyllum	(Cn,An,Ru)	Paragymnites	(Mo,Ce,Ce)	Paralepidosteus	(Cd,Os,Se)
Paradygella	(Br,Ar,Te)	Parahalobia	(Mo,Bi,Pt)	Paralepidotus	(Cd,Os,Se)
Paraechinorhinus	(Cd,Ch,Sq)	Parahalomitra	(Cn,An,Sc)	Paralepis	(Cd,Os,Al)
Paraechmina	(Ar,Os,Pa)	Paraharpes	(Ar,Tr,Pt)	Paralepismatina	(Br,Ar,Sp)
Paraemanuella	(Br,Ar,Sp)	Parahastites	(Mo,Ce,Be)	Paraleptoceras	(Mo,Ce,Am)
Paraendoceras	(Mo,Ce,En)	Parahauerites	(Mo,Ce,Ce)	Paraleptodus	(Br,Ar,St)
Paraendothyra	(Fo,Fo,Fo)	Parahaldia	(Ar,Os,Pa)	Paraleptomitella	(Po,De,Pa)
Paraenshia	(Ar,Tr,Pt)	Parahelicampodus	(Cd,Ch,Eu)	Paraleptostrophia	(Br,Ar,St)
Paraeofusulina	(Fo,Fo,Fo)	Parahelicoprion	(Cd,Ch,Eu)	Paralevisia	(Ar,Tr,Co)
Paraeoleperiditha	(Ar,Os,Le)	Parahemingwayella	(Ar,Os,Pa)	Paralhederella	(Bz,St,Cc)
Paraeoliscus	(Cd,Os,Ga)	Parahemiptychina	(Br,Ar,Te)	Paralichthys	(Cd,Os,Ph)
Paraeosoptychoparia	(Ar,Tr,Pt)	Parahelipiranchias	(Cd,Ch,Hx)	Paralingulina	(Fo,Fo,Fo)
Paraesa	(Mo,Bi,Ve)	Paraheritichoides	(Cn,An,Ru)	Paralioclema	(Bz,St,Tr)
Paraeucypris	(Ar,Os,Pa)	Parahesperornis	(Cd,Av,He)	Paraliospira	(Mo,Ga,Ar)
Paraexophthalmocythere	(Ar,Os,Pa)	Paraheteraster	(Ec,Ec,Sp)	Paralisaniella	(Ar,Tr,Co)
Parafallotaspis	(Ar,Tr,Ol)	Parahexacrinus	(Ec,Cr,Mo)	Paralithierium	(Cd,Ma,Si)
Parafavella	(Cl,Pa,Sp)	Parahibolites	(Mo,Ce,Be)	Paralithostrotion	(Cn,An,Ru)
Parafenestalia	(Bz,St,Fe)	Parahildaites	(Mo,Ce,Am)	Paralitogaster	(Ar,MI,De)
Parafissurina	(Fo,Fo,Fo)	Parahippa	(Ar,Os,Pa)	Parallelelasma	(Br,Ar,Pe)
Parafletcheria	(Cn,An,Ru)	Parahollinella	(Ar,Os,Pa)	Parallelodon	(Mo,Bi,Ar)
Parafollicucullus	(Ac,Ra,Sp)	Parahomalonotus	(Ar,Tr,Ph)	Paralieldodus	(Mo,Bi,Mo)
Parafornichella	(Mo,In,In)	Parahomoceras	(Mo,Ce,Go)	Parallelopora	(Po,De,St)
Parafriithjofia	(Ar,Tr,Pr)	Parahoplites	(Mo,Ce,Am)	Parallelopora	(Br,Ar,Sp)
Parafriidularia	(Fo,Fo,Fo)	Parahousia	(Ar,Tr,As)	Parallelostroma	(Po,De,St)
Parafusulina	(Fo,Fo,Fo)	Parahsuum	(Ac,Ra,Na)	Paralleynia	(Cn,An,Ru)
Parafusulinella	(Fo,Fo,Fo)	Parahughmilleria	(Ar,Me,Eu)	Paralobites	(Mo,Ce,Ce)
Parafusus	(Mo,Ga,Ne)	Parahyolithes	(Hy,Uc,Uc)	Paralogonicus	(Cd,Os,Pa)
Paragalathea	(Ar,MI,De)	Parahystericurus	(Ar,Tr,Pr)	Paralorenella	(Ar,Tr,Pt)
Paragalerus	(Mo,Pa,Hy)	Parailsanella	(Mo,In,In)	Paraloxoceras	(Mo,Ce,Or)
Paragaleus	(Cd,Ch,Ca)	Parainoceramus	(Mo,Bi,Pt)	Paralucinella	(Mo,Bi,Ve)
Paragammarocrinites	(Ec,Cr,Cy)	Paraipepilyllum	(Cn,An,Ru)	Paralytoceras	(Mo,Ce,Go)
Paraganides	(Mo,Ce,Ce)	Paraipichthys	(Cd,Os,Pa)	Paralytonia	(Br,Ar,St)
Paragaricocrinus	(Ec,Cr,Mo)	Parairvingella	(Ar,Tr,Pt)	Paramacrocypris	(Ar,Os,Pa)
Paragassizocrinus	(Ec,Cr,Cl)	Parajaubertella	(Mo,Ce,Am)	Paramalungia	(Ar,Tr,Re)
Paragastrioceras	(Mo,Ce,Go)	Parajonesites	(Ar,Os,Pa)	Paramammites	(Mo,Ce,Am)
Paragattendorfia	(Mo,Ce,Go)	Parajuresania	(Br,Ar,St)	Paramansuyella	(Ar,Tr,As)
Paragaudryina	(Fo,Fo,Fo)	Parajuvavites	(Mo,Ce,Ce)	Paramarginatia	(Br,Ar,St)
Paragazacrinus	(Ec,Cr,Di)	Parakansuella	(Br,Ar,St)	Paramarginifera	(Br,Ar,St)
Parageyerella	(Br,Ar,St)	Parakarpinskia	(Br,Ar,At)	Paramarria	(Ar,Ma,MI)
Paraginglymostoma	(Cd,Ch,Os)	Parakellnerites	(Mo,Ce,Ce)	Paramarshallena	(Mo,Ga,Ne)
Paraglans	(Mo,Bi,Ve)	Parakidograptus	(He,Gr,Gr)	Paramartesia	(Mo,Bi,My)
Paraglauconia	(Mo,Ga,Nt)	Parakingasidoids	(Ar,Tr,Pt)	Paramblypterus	(Cd,Os,Pa)
Paraglobivalvulina	(Fo,Fo,Fo)	Parakingena	(Br,Ar,Te)	Paramblypsiphonella	(Po,De,Pe)

Paramecynoceras	(Mo,Ce,Di)	Paranorites	(Mo,Ce,Ce)	Paraplatax	(Cd,Os,Pf)
Parameekella	(Br,Ar,St)	Paranoritoides	(Mo,Ce,Ce)	Paraplatycosta	(Ar,Os,Po)
Paramegalaspis	(Ar,Tr,As)	Paranorwoodia	(Ar,Tr,Pt)	Paraplatyrrhomboides	(Ar,Os,Po)
Paramegalioerinus	(Ec,Cr,Mo)	Paranotacythere	(Ar,Os,Po)	Paraplatyschisma	(Mo,Ga,Ar)
Paramegalodus	(Mo,Bi,Hi)	Paranotosaurus	(Cd,Re,No)	Paraplatythriss	(Br,Ar,Te)
Paramegateuthis	(Mo,Ce,Be)	Paranoviportia	(Ar,Os,Pa)	Paraplectograpthus	(He,Gr,Gr)
Paramelocrinus	(Ec,Cr,Mo)	Paranowakia	(Mo,Cr,Da)	Paraplectoeyra	(Fo,Fo,Fo)
Paramentzella	(Br,Ar,Sp)	Paranptychia	(Br,Ar,Te)	Paraplectonoceras	(Mo,Ce,El)
Paramerista	(Br,Ar,Sp)	Paranudirostralina	(Br,Ar,Rh)	Paraplegmatograpthus	(He,Gr,Gr)
Paramesbula	(Cd,Ch,My)	Paranumia	(Ar,Tr,Pt)	Paraplesiobatis	(Cd,Pl,Ps)
Paramesolepis	(Cd,Os,Pa)	Paraolenoides	(Ar,Tr,Co)	Paraplesiograpuloides	(Ar,Tr,Un)
Paramesolobus	(Br,Ar,St)	Paraolentus	(Ar,Tr,Pt)	Paraplesioteuthis	(Mo,Ce,Te)
Parametacoceras	(Mo,Ce,Na)	Paraoliganisus	(Ar,Os,Pa)	Paraplethopeltis	(Ar,Tr,Pt)
Parametaria	(Mo,Ga,Ne)	Paraoligorhyncha	(Br,Ar,Rh)	Parapleuropholis	(Cd,Os,Pc)
Parametelipora	(Bz,St,Cy)	Paraonychoplecia	(Br,Ar,Or)	Parapleurosmelia	(Cn,An,Sc)
Paramichelina	(Cn,An,Ta)	Paraophthalmidium	(Fo,Fo,Fo)	Paraplicanopia	(Br,Ar,St)
Paramicmaea	(Ar,Tr,Pt)	Paraorlovia	(Ar,Tr,Pt)	Paraplicatifera	(Br,Ar,St)
Paramicrocheliniella	(Ar,Os,Po)	Paraorthacodus	(Cd,Ch,In)	Parapodocapsa	(Ac,Ra,Na)
Paramixogonaria	(Cn,An,Ru)	Paraorthograpthus	(He,Gr,Gr)	Parapokomyella	(Ar,Os,Po)
Parammatoceras	(Mo,Ce,Am)	Paraorthotetina	(Br,Ar,St)	Parapoliella	(Ar,Tr,Co)
Paramobergella	(Pr,Un,In)	Paraostenia	(Ar,Th,Co)	Parapolytremacis	(Cn,An,He)
Paramodiola	(Mo,Bi,Mo)	Parapachyaspis	(Ar,Tr,Pt)	Parapontaria	(Cd,Ma,Ce)
Paramoelleritina	(Ar,Os,Le)	Parapachytraga	(Mo,Bi,Ph)	Parapanonoceras	(Mo,Ce,Ce)
Paramoltkia	(Cn,An,Go)	Parapalaebates	(Cd,Ch,Rj)	Parapoulpus	(Ac,Ra,Na)
Paramonopleura	(Mo,Bi,Hi)	Parapalaoceras	(Mo,Ce,El)	Parapribylites	(Ar,Os,Pa)
Paramonticulifera	(Br,Ar,St)	Parapalebralia	(Ar,Tr,Pr)	Paraprimitia	(Ar,Os,Pa)
Paramooreoceras	(Mo,Ce,Or)	Parapallasiceras	(Mo,Ce,Am)	Parapriionodus	(Cd,Co,Co)
Paramorea	(Mo,Ga,Ne)	Parapaltodus	(Cd,Co,Co)	Parapristopoma	(Cd,Os,Pf)
Paramphicrinus	(Ec,Cr,Sa)	Paraparchitella	(Ar,Os,Pa)	Paraproetus	(Ar,Tr,Pr)
Paramphipora	(Po,De,St)	Paraparchites	(Ar,Os,Pa)	Parapronorites	(Mo,Ce,Pl)
Paramphisidie	(Cd,Os,Go)	Parapassaloteuthis	(Mo,Ce,Be)	Paraprothyriss	(Mo,Bi,Ph)
Paramplexoides	(Cn,An,Ru)	Parapatoceras	(Mo,Ce,Am)	Paraptychopyge	(Ar,Tr,As)
Paramuirwoodia	(Br,Ar,St)	Parapavona	(Cn,An,Ru)	Parapugnax	(Br,Ar,Rh)
Paramunseyella	(Ar,Os,Po)	Parapeishania	(Ar,Tr,Pt)	Parapulchratia	(Br,Ar,St)
Paramiya	(Mo,Bi,My)	Parapelagiella	(Ar,In,Pe)	Parapunctella	(Ar,Un,Un)
Paramylostoma	(Cd,Pl,Ar)	Parapeltoceras	(Mo,Ce,Am)	Parapuractaeon	(Mo,Ga,Ce)
Paramysis	(Ar,MI,My)	Parapercis	(Cd,Os,Pf)	Parapuzosia	(Mo,Ce,Am)
Paramytilarca	(Mo,Bi,Pt)	Paraperiomma	(Ar,Tr,Pt)	Parapygaeus	(Cd,Os,Pf)
Paranacyathus	(Po,Tr,Ar)	Parapermerocrinus	(Ec,Cr,Cl)	Parapygus	(Ec,Ec,Ca)
Paranacystis	(Ec,St,MI)	Paraperrinites	(Mo,Ce,Go)	Parapyxion	(Ar,Os,Pa)
Paranaia	(Br,Ar,Te)	Paraphaseolella	(Ar,Os,Ar)	Paraquadrithyriss	(Br,Ar,Sp)
Parananlingella	(Fo,Fo,Fo)	Paraphillipsia	(Ar,Tr,Pr)	Paraquataia	(Bz,St,Cc)
Paranannites	(Mo,Ce,Ce)	Paraphillipsinella	(Ar,Tr,As)	Pararachnastraea	(Cn,An,Ru)
Paranassa	(Mo,Ga,Ne)	Parapholas	(Mo,Bi,My)	Pararacoonus	(Mo,In,In)
Paranautilus	(Mo,Ce,Na)	Parapholidophorus	(Cd,Os,Pc)	Pararaja	(Cd,Ch,Rj)
Paranclyoceras	(Mo,Ce,Am)	Parapholidostrophia	(Br,Ar,As)	Pararania	(Ar,Tr,Un)
Parandiceras	(Mo,Ce,Am)	Paraphorhynchus	(Br,Ar,Rh)	Pararaphispira	(Mo,Ga,Ar)
Paranditrigonia	(Mo,Bi,Tr)	Paraphragmites	(Mo,Ce,Or)	Pararaphistoma	(Mo,Ga,Eu)
Paraneocarcinus	(Ar,MI,De)	Paraphrontia	(Mo,Bi,Mo)	Pararasenia	(Mo,Ce,Am)
Paraneistrolepis	(Mo,Ga,Ne)	Paraphyllites	(Mo,Ce,An)	Pararcestes	(Mo,Ce,Ce)
Paranereites	(An,Po,Ph)	Paraphyllogyra	(Cn,An,Sc)	Pararachaocrinus	(Ec,Cr,Di)
Paranesidea	(Ar,Os,Po)	Parapilekia	(Ar,Tr,Ph)	Pararedlichia	(Ar,Tr,Re)
Parangarenga	(Mo,Ga,Ne)	Parapiloceras	(Mo,Ce,En)	Parareichelina	(Fo,Fo,Fo)
Paranguilla	(Cd,Os,An)	Parapinacoceras	(Mo,Ce,Ce)	Pararenicola	(Pr,Un,In)
Parangularia	(Mo,Ga,Nt)	Parapinnixa	(Ar,MI,De)	Parareticularia	(Br,Ar,Sp)
Paranicklespora	(Bz,St,Cr)	Parapirimela	(Ar,MI,De)	Pararetiograpthus	(He,Gr,Gr)
Paranileus	(Ar,Tr,As)	Parapisocrinus	(Ec,Cr,Ds)	Pararhactorhynchia	(Br,Ar,Rh)
Parapisocrinus	(Ec,Cr,Sa)	Paraplicites	(Mo,Ce,Ce)	Pararhenanoperca	(Cd,Os,Pf)
Paranisopleurella	(Br,Ar,St)	Paraplaocodus	(Cd,Re,Pl)	Pararhinodon	(Cd,Ch,Os)
Paranogmuis	(Cd,Os,Cr)	Paraplaocuna	(Mo,Bi,Pt)	Pararhiphaoceras	(Mo,Ce,Na)
Paranomia	(Mo,Bi,Pt)	Paraplaocoenia	(Cn,An,Sc)	Pararhippidium	(Br,Ar,Pe)
Paranomotodon	(Cd,Ch,La)	Paraplagiura	(Ar,Tr,Un)	Pararhynchospirina	(Br,Ar,Sp)
Paranorella	(Br,Ar,Rh)	Paraplagusia	(Cd,Os,Pn)	Pararinoceras	(Mo,Ce,Na)
Paranorellina	(Br,Ar,Rh)	Paraplasocrinus	(Ec,Cr,Cl)	Parariscus	(Ar,Os,Po)

Paramioceras	(Mo,Ce,Am)	Parastraeoiorpha	(Cn,An,Sc)	Paratriebelina	(Ar,Os,Po)
Pararotalia	(Fo,Fo,Fo)	Parasōraeopora	(Cn,An,Sc)	Paratrinucleus	(Ar,Tr,As)
Parasabellidites	(Pr,Un,So)	Parastenoceras	(Mo,Ce,Am)	Paratrisopterus	(Cd,Os,Ga)
Parasageceras	(Mo,Ce,Ce)	Parastriatopora	(Cn,An,Ta)	Paratrochamminoides	(Fo,Fo,Fo)
Parasalenia	(Ec,Ec,Ec)	Parastriatoporella	(Cn,An,Ta)	Paratrophon	(Mo,Ga,Ne)
Parasarcinula	(Cn,An,Ta)	Parastringeocephalus	(Br,Ar,Te)	Paratropites	(Mo,Ce,Ce)
Parasaturnalis	(Ac,Ra,Sp)	Parastroma	(Mo,Bi,Hi)	Paratsunyiella	(Ar,Os,Ar)
Parasauvagesia	(Mo,Bi,Hi)	Parastromateus	(Cd,Os,Pf)	Paratungusella	(Ar,Tr,Re)
Parasaynoceras	(Mo,Ce,Am)	Parastromatopora	(Po,De,Ax)	Paraturbo	(Mo,Ga,Ar)
Parascenella	(Mo,In,In)	Parastrophina	(Br,Ar,Pe)	Paraturrilites	(Mo,Ce,Am)
Paraschartymites	(Mo,Ce,Go)	Parastrophinella	(Br,Ar,Pe)	Paratymolus	(Ar,Mi,De)
Paraschistoceras	(Mo,Ce,Go)	Parastrophonella	(Br,Ar,St)	Paratuzchiatocenemis	(Ar,Tr,Ph)
Paraschizocythere	(Ar,Os,Po)	Parasturgia	(Mo,Ce,Ce)	Paraucellina	(Mo,Bi,Pt)
Paraschizodus	(Mo,Bi,Tr)	Parastylonurus	(Ar,Me,Eu)	Paraungerella	(Ar,Os,My)
Paraschmidella	(Ar,Os,Pa)	Parasulcatinella	(Br,Ar,Te)	Paravaginoceras	(Mo,Ce,En)
Paraschuleridea	(Ar,Os,Po)	Parasycoerinus	(Br,Ar,Ce)	Paravascoceras	(Mo,Ce,Am)
Paraschwagerina	(Fo,Fo,Fo)	Parasynarcualis	(Cd,Os,Ga)	Paravesicocaulis	(Po,De,Pe)
Parascoceras	(Mo,Ce,As)	Parasynastraea	(Cn,An,Sc)	Paravinciguerra	(Cd,Os,St)
Parascombrops	(Cd,Os,Pf)	Parasyngenechilus	(Mo,Ga,Ne)	Paravinella	(Bz,Gy,Ch)
Parascopelus	(Cd,Os,Al)	Parasyrix	(Mo,Ga,Ne)	Paravirgaites	(Mo,Ce,Am)
Parascutella	(Ec,Ec,Cl)	Paraszchuanella	(Ar,Tr,Pt)	Paraviviana	(Mo,Ga,Ar)
Parascytalocrinus	(Ec,Cr,Cl)	Paratalarocrinus	(Ec,Cr,Mo)	Paravulvulina	(Fo,Fo,Fo)
Parasemonotus	(Cd,Os,Am)	Paratancredia	(Mo,Bi,Ve)	Parawarburgella	(Ar,Tr,Pr)
Paraseptopora	(Bz,St,Fe)	Parataphrus	(Mo,Ga,Ar)	Parawedekindia	(Mo,Ce,Am)
Paraseraphs	(Mo,Ga,Nt)	Paratarpon	(Cd,Os,Me)	Parawelekindellina	(Fo,Fo,Fo)
Paraserratognathus	(Cd,Co,Co)	Paratarrasius	(Cd,Os,Ta)	Parawentzeella	(Cn,An,Ru)
Parashergoldopsis	(Ar,Os,Ar)	Parataxodonta	(Ar,Os,Po)	Parawentzellophyllum	(Cn,An,Ru)
Parashivaella	(Ar,Os,Pa)	Paratemnograptus	(He,Gr,De)	Parawestonoceras	(Mo,Ce,Di)
Parashumardites	(Mo,Ce,Go)	Paraterebella	(An,Po,Te)	Parawoeklumeria	(Mo,Ce,Cl)
Parasibirites	(Mo,Ce,Ce)	Paraterebra	(Mo,Ga,Ne)	Parayakutoceras	(Mo,Ce,Go)
Parasilesites	(Mo,Ce,Am)	Paratermiella	(Ar,Tr,Pt)	Parayoungia	(Ar,Tr,Ph)
Parasinplotyxis	(Mo,Ga,He)	Paratetradium	(Cn,An,Ta)	Parazeacrinites	(Ec,Cr,Cl)
Parasiphonophyllia	(Cn,An,Ru)	Paratetradomia	(Br,Ar,Rh)	Paravebinella	(Mo,Ga,Nt)
Parasleia	(Ar,Os,Pa)	Paratutodopsis	(Mo,Ce,Te)	Parazolophyllia	(Cn,An,Ru)
Parasmilia	(Cn,An,Sc)	Paratexanites	(Mo,Ce,Am)	Parazonophyllum	(Cn,An,Ru)
Parasmithiphyllum	(Cn,An,Ru)	Paratextularia	(Fo,Fo,Fo)	Parazophocrinus	(Ec,Cr,Ds)
Parasociophyllum	(Cn,An,Ru)	Parathecidia	(Br,Ar,Th)	Parazyga	(Br,Ar,Sp)
Parasolenoceras	(Mo,Ce,Am)	Parathecosmia	(Cn,An,Sc)	Parazygograptus	(He,Gr,Gr)
Parasolenopleura	(Ar,Tr,Pt)	Parathetidites	(Mo,Ce,Ce)	Pardailhanmia	(Ar,Tr,Pt)
Parasolia	(Cn,In,In)	Parathisbites	(Mo,Ce,Ce)	Parechelus	(Cd,Os,An)
Parasorites	(Fo,Fo,Fo)	Parathuramina	(Fo,Fo,Fo)	Paredriophus	(Ec,Ed,Ed)
Paraspelaum	(Po,De,Li)	Parathuraminites	(Fo,Fo,Fo)	Parehmania	(Ar,Tr,Pt)
Parasphaerorthoceras	(Mo,Ce,Or)	Parathyasira	(Mo,Bi,Ve)	Parellisina	(Bz,Gy,Ch)
Parasphyraena	(Cd,Os,Pf)	Parathyridina	(Br,Ar,Te)	Parenchodus	(Cd,Os,Al)
Paraspidites	(Mo,Ce,Ce)	Parathyrisina	(Br,Ar,Sp)	Parengonoceras	(Mo,Ce,Am)
Paraspidoceras	(Mo,Ce,Am)	Parathysanophyllum	(Cn,An,Ru)	Parentactinia	(Ac,Ra,Sp)
Parasinobairdia	(Ar,Os,Po)	Paratibites	(Mo,Ce,Ce)	Parenteletes	(Br,Ar,Or)
Paraspirifer	(Br,Ar,Sp)	Paratichthys	(Cd,Os,Ga)	Parentanthes	(Ar,Os,Pa)
Paraspiriferina	(Br,Ar,Sp)	Paratikhinella	(Fo,Fo,Fo)	Parentites	(Mo,Ce,An)
Paraspticeras	(Mo,Ce,Am)	Paratimorocidaris	(Ec,Cr,Cl)	Pareocrinus	(Ec,Eo,As)
Parasqualodon	(Cd,Ma,Ce)	Paratirolites	(Mo,Ce,Ce)	Parapisiolia	(Cn,An,Sc)
Parasquatina	(Cd,Ch,In)	Paratissolia	(Mo,Ce,Am)	Pareops	(Ar,Tr,Re)
Parastachyoerinus	(Ec,Cr,Cl)	Paratorleyoceras	(Mo,Ce,Go)	Pareora	(Mo,Ga,Nt)
Parastarte	(Mo,Bi,Ve)	Paratiornoceras	(Mo,Ce,Go)	Paretallonia	(Cn,An,Sc)
Parastauria	(Cn,An,Ru)	Paratrachinotus	(Cd,Os,Pf)	Parethelocrinus	(Ec,Cr,Cl)
Parastegnammina	(Fo,Fo,Fo)	Paratrachyceras	(Mo,Ce,Ce)	Parethmophyllum	(Po,Re,Aj)
Parastelliporella	(Cn,An,Ta)	Paratrachytoechus	(Bz,St,Tr)	Pareuchelus	(Mo,Ga,Ar)
Parastenodiscus	(Bz,St,Tr)	Paratrematoceras	(Mo,Ce,Or)	Pareuloma	(Ar,Tr,Pt)
Parastenopoceras	(Mo,Ce,Na)	Paratreta	(Br,Li,Ac)	Pareuryalox	(Mo,Ga,Ar)
Parastephanocrinus	(Ec,Cr,Cl)	Paratretaspis	(Ar,Tr,Pt)	Parevenkaspis	(Ar,Tr,Ph)
Paraster	(Ec,Ec,Sp)	Paratretoycloecia	(Bz,St,Ce)	Parevianoceras	(Mo,Ce,Di)
Parasterbergella	(Ar,Os,Po)	Paratrisina	(Cd,Ch,Ca)	Parevophthalmocythere	(Ar,Os,Po)
Parasterophrentis	(Cn,An,Ru)	Paratrisina	(Fo,Fo,Fo)	Pareynia	(Cn,An,Ru)
Parastertia	(Mo,Ce,Am)	Paratribonium	(Br,Ar,Rh)	Parhabdodiaris	(Ec,Ec,Ci)

Pariceratina	(Ar.Os,Po)	Parphia	(Fo.Fo,Fo)	Pascocetes	(Mo.Ce,Am)
Parichthyocrinus	(Ec,Cr,Tx)	Parphores	(Ar.Os,Pa)	Pasitheola	(Mo.Ga,Nt)
Pariconchoprimitia	(Ar.Os,Pa)	Parrellina	(Fo.Fo,Fo)	Paskenites	(Mo.Ce,Am)
Paridium	(Ac,Ra,Na)	Parrelloides	(Fo.Fo,Fo)	Passalocrinus	(Ec,Cr,Un)
Parietiplicatum	(Mo,Ga,Ce)	Parribacus	(Ar.MI,De)	Passaloteuthis	(Mo.Ce,Be)
Parietobalaena	(Cd,Ma,Ce)	Parryoceras	(Mo.Ce,Di)	Passendorferia	(Mo.Ce,Am)
Parillaenus	(Ar,Tr,Co)	Parsimonia	(An,Po,Se)	Passya	(Mo,Bi,Ve)
Parindocrinus	(Ec,Cr,Cl)	Parspaniocerinus	(Ec,Cr,Cl)	Pasternakevia	(Ar,Me,Xi)
Parinodiceras	(Mo,Ce,Am)	Parthanosaurus	(Cd,Re,No)	Pastrikella	(Fo,Fo,Fo)
Parinomya	(Mo,Bi,Pt)	Parthenina	(Mo,Ga,He)	Pasythea	(Bz,Gy,Ch)
Parinotus	(Mo,Ga,Ne)	Parthenope	(Ar,MI,De)	Patagiosites	(Mo,Ce,Am)
Parinvolutina	(Fo,Fo,Fo)	Parthirynchia	(Br,Ar,Rh)	Patagocardia	(Mo,Bi,Ve)
Parioerinus	(Ec,Cr,Ds)	Particeps	(Ar,Tr,Pr)	Patagonacythere	(Ar,Os,Po)
Pariphiculus	(Ar,MI,De)	Particoma	(Mo,Bi,My)	Patagonibelus	(Mo,Ce,Be)
Parisanguinolocinus	(Ec,Cr,Cl)	Partisania	(Fo,Fo,Fo)	Patagorhynchia	(Br,Ar,Rh)
Parisastrea	(Cn,An,Sc)	Partretocyeloecia	(Cn,Bz,Ce)	Patagopyris	(Ac,Ra,Na)
Parisiella	(Mo,Bi,Ve)	Partschiceras	(Mo,Ce,Ph)	Patanacta	(Cn,In,In)
Parisis	(Cn,An,Go)	Partubiola	(Mo,Ga,Ar)	Patanophyma	(Po,De,LI)
Parisoceraurus	(Ar,Tr,Pt)	Partulida	(Ar,MI,De)	Patavihychys	(Cd,Os,An)
Parisochitina	(Fo,Fo,Ch)	Parulocrinus	(Ec,Cr,Cl)	Patella	(Mo,Ga,Pa)
Parisocrinus	(Ec,Cr,Cl)	Parulrichia	(Ar,Os,Pa)	Patellacythere	(Ar,Os,Po)
Parisurus	(Cd,Ch,La)	Parunicinella	(Br,Ar,Sp)	Patellastra	(Mo,Ga,Pa)
Parkaspis	(Ar,Tr,Co)	Parurgonina	(Fo,Fo,Fo)	Patelliconus	(Mo,In,In)
Parkeria	(Cn,Hy,Sp)	Parussuria	(Mo,Ce,Ce)	Patellilabia	(Mo,Ga,Be)
Parkesolithus	(Ar,Tr,Pt)	Parutachonus	(Cd,Co,Co)	Patellina	(Fo,Fo,Fo)
Parkinsonia	(Mo,Ce,Am)	Paruvanella	(Po,De,Pe)	Patellinella	(Fo,Fo,Fo)
Parksia	(Po,De,Ax)	Parvaemea	(Mo,Ga,Pa)	Patelliocerinus	(Ec,Cr,Mo)
Parkula	(Hy,Hy,Hy)	Parvacythereis	(Ar,Os,Po)	Patellipora	(Bz,St,Fe)
Parleosocia	(Bz,St,Ce)	Parvaltissimarostrium	(Br,Ar,Rh)	Patellispungia	(Po,De,LI)
Parleria	(Cn,Hy,Hy)	Parvamussium	(Mo,Bi,Pt)	Patelloida	(Mo,Ga,Pa)
Parmephrix	(Br,Ar,St)	Parvancorina	(Ar,Pa,Pa)	Patellopsis	(Mo,Ga,Ba)
Parmicorbula	(Cn,An,Ru)	Parvaxon	(Mo,An,Ru)	Patellostium	(Mo,Ga,Be)
Parmophorella	(Mo,In,In)	Parvicardium	(Mo,Bi,Ve)	Patellovalvulina	(Fo,Fo,Fo)
Parmorthina	(Br,Ar,Or)	Parvicidarid	(Ec,Ec,Ci)	Patellula	(Ac,Ra,Sp)
Parmorthis	(Br,Ar,Or)	Parvicingula	(Ac,Ra,Na)	Patenaria	(Bz,St,Ce)
Parmula	(Br,Ar,St)	Parvicorbis	(Mo,Bi,Ve)	Paterimitra	(Pr,To,Mi)
Parmularia	(Bz,Gy,Ch)	Parvicuspis	(Ac,Ra,Sp)	Paterina	(Br,LI,Pa)
Parmulechinus	(Ec,Ec,Cl)	Parvigena	(Ar,Tr,Pr)	Pateroperca	(Cd,Os,Ct)
Parmulophora	(Mo,Bi,Ve)	Parvikirbya	(Ar,Os,Pa)	Paterophyllum	(Cn,An,Ru)
Parobeisselina	(Bz,Gy,Ch)	Parvilucina	(Mo,Bi,Ve)	Paterorthis	(Br,Ar,Or)
Parodiceras	(Mo,Ce,Go)	Parviltux	(Cd,Os,My)	Paterrula	(Br,LI,LI)
Parodontoceras	(Mo,Ce,Am)	Parvimitra	(Mo,Ga,Ne)	Patholites	(Hy,Hy,Hy)
Parodospongia	(Po,De,LI)	Parvioctoidus	(Ec,Ho,De)	Patinopecten	(Mo,Bi,Pt)
Paroecotraustes	(Mo,Ce,Am)	Parvirhynchia	(Br,Ar,Rh)	Patriaspirifer	(Br,Ar,Sp)
Paroertlispongus	(Ac,Ra,Sp)	Parvirota	(Mo,Ga,Ar)	Patriocetus	(Cd,Ma,Ce)
Paroistodus	(Cd,Co,Co)	Parviscala	(Mo,Ga,Nt)	Patro	(Mo,Bi,Pt)
Paromalomena	(Br,Ar,St)	Parvisetia	(Mo,Ga,Nt)	Patrocardia	(Mo,Bi,Pt)
Paromaeopygma	(Br,Ar,Rh)	Parvisiphio	(Mo,Ga,Ne)	Patrocardia	(Mo,Bi,Pt)
Paronaella	(Mo,Ga,Un)	Parvispina	(Ec,Ho,As)	Patrognathus	(Cd,Co,Co)
Paronaria	(Cn,Hy,Sp)	Parvithracia	(Mo,Bi,Ph)	Patronaspis	(Ar,Tr,Pt)
Paronaster	(Ec,Ec,Hs)	Parvitubus	(He,G,Tu)	Patsyella	(Bz,Gy,Ch)
Paronastrara	(Cn,An,Sc)	Parviveneus	(Mo,Bi,Ve)	Pattersonia	(Po,He,Am)
Paronaula	(Ac,Ra,Sp)	Parviviana	(Mo,Ga,Ar)	Pattersonichthys	(Cd,Os,Ct)
Paronella	(Mo,Bi,Hi)	Parvivoluta	(Mo,Ga,Ne)	Pattersonoberyx	(Cd,Os,Br)
Paroniceras	(Mo,Ce,Am)	Parvochlamys	(Mo,Bi,Pt)	Pattalophyllia	(Cn,An,Sc)
Parooeceria	(Mo,Ce,On)	Parvohallopora	(Bz,St,Tr)	Pattalophylliopsis	(Cn,An,Sc)
Parophrys	(Cd,Os,Pn)	Parvularugoglobigerina	(Fo,Fo,Fo)	Patulibracchium	(Ac,Ra,Sp)
Paropsites	(Po,De,As)	Parvulites	(Mo,Cr,Te)	Patulula	(Ac,Ra,Na)
Paropsonema	(Cn,Hy,SI)	Parvulonoda	(Pr,Un,In)	Patuxentrophon	(Mo,Ga,Ne)
Parormoceras	(Mo,Ce,Ac)	Paryfenus	(Ar,Tr,Pr)	Paua	(Mo,Ga,Ar)
Parorthocerinus	(Ec,Cr,He)	Paryphella	(Br,Ar,St)	Paucicostella	(Br,Ar,St)
Parospinus	(Cd,Os,Br)	Paryphoceras	(Mo,Ce,Am)	Paucicrura	(Br,Ar,Or)
Parotodus	(Cd,Ch,La)	Paryphorhynchopora	(Br,Ar,Rh)	Paucicella	(Ar,Tr,Pt)
Paroxynoticeras	(Mo,Ce,Am)	Pasaichthyes	(Cd,Os,Pf)	Paucijaculum	(Ch,Un)

Paucipodia	(Lo)	Peculator	(Mo,Ga,Ne)	Pelittina	(Ar,Tr,Ph)
Paucipora	(Bz,St,Fe)	Peculicephalina	(Ar,Tr,Un)	Pellasinmia	(Mo,Ga,Nt)
Paucispinauria	(Br,Ar,St)	Peculneithyrus	(Br,Ar,Te)	Pellatispira	(Fo,Fo,Fo)
Paucispinifera	(Br,Ar,St)	Pedanochiton	(Mo,Po,Ne)	Pellatispirella	(Fo,Fo,Fo)
Paucistropia	(Br,Ar,St)	Pedasiola	(Mo,Ga,Be)	Pellax	(Mo,Ga,Ar)
Paulbronnimannella	(Fo,Fo,Fo)	Pedatopriscus	(Ec,Ho,Mo)	Pellecrinus	(Ec,Cr,Cl)
Paulckella	(Mo,Bi,Tr)	Pedavis	(Cd,Co,Co)	Pellucistoma	(Ar,Os,Po)
Paulina	(Fo,Fo,Fo)	Pedderelasma	(Cn,An,Ru)	Pelmatopora	(Bz,Gy,Ch)
Paulinea	(Mo,Bi,Nu)	Pedicularia	(Mo,Ga,Nt)	Pelocetus	(Cd,Ma,Ce)
Paulinella	(Br,Ar,Te)	Pedicythere	(Ar,Os,Po)	Pelodelphis	(Cd,Ma,Ce)
Paulinites	(An,Po,Eu)	Pedina	(Ec,Ec,Pe)	Peloneustes	(Cd,Re,Ps)
Paulocaris	(Ar,MI,My)	Pedinaspis	(Ar,Tr,Pt)	Pelonomia	(Br,Ar,St)
Paulocrinus	(Ec,Cr,Di)	Pedinocephalina	(Ar,Tr,As)	Peloriops	(Ar,Os,Po)
Paulonaria	(Mo,Ga,Nt)	Pedinocephalites	(Ar,Tr,As)	Pelosina	(Fo,Fo,Fo)
Paulonia	(Br,Ar,Sp)	Pedinocephalus	(Ar,Tr,As)	Peltabellia	(Ar,Tr,Pr)
Paulotropites	(Mo,Ce,Ce)	Pedinocrinus	(Ec,Cr,Cl)	Peltacrinus	(Ec,Cr,Ds)
Paurinella	(Ac,Ra,Sp)	Pedinodochenella	(Ar,Tr,Pr)	Peltichia	(Br,Ar,Or)
Paurocidaris	(Ec,Ec,Ci)	Pedinopariops	(Ar,Tr,Ph)	Peltocare	(Ar,Tr,Pt)
Paurogastroderhynchus	(Br,Ar,Te)	Pedinopsis	(Ec,Ec,Hm)	Peltocaris	(Ar,MI,In)
Pauropegma	(Mo,Ro,Ri)	Pedinothuria	(Ec,Ec,Di)	Peltoceras	(Mo,Ce,Am)
Paurorhyncha	(Br,Ar,Rh)	Pedicerias	(Mo,Ce,Am)	Peltoceratoides	(Mo,Ce,Am)
Paurorhina	(Br,Ar,Or)	Pedipes	(Mo,Ga,Un)	Peltocystis	(Ec,St,Mi)
Paurorthis	(Br,Ar,Or)	Pedomphalella	(Ar,Os,Pa)	Peltoytoceras	(Mo,Ce,Am)
Pauxillites	(Hy,Hy,Hy)	Pedrogopora	(Bz,St,Tr)	Peltomorphites	(Mo,Ce,Am)
Pavastephyllum	(Cn,An,Ru)	Peclerophon	(Mo,Ga,Be)	Peltopterleidus	(Cd,Os,Pe)
Pavlovectina	(Fo,Fo,Fo)	Peetzatrypa	(Br,Ar,At)	Peltopleurus	(Cd,Os,Pl)
Pavlovina	(Mo,Ce,Am)	Pegastier	(Ec,As,Fo)	Peltura	(Ar,Tr,Pt)
Pavloviceras	(Mo,Ce,Am)	Pegidia	(Fo,Fo,Fo)	Pelturina	(Ar,Tr,Pt)
Pavloviella	(Ar,Os,Po)	Pegma	(Mo,Bi,Pt)	Pelycobolbina	(Ar,Os,Pa)
Pavlovites	(Cd,Co,Co)	Pegmarhynchia	(Br,Ar,Rh)	Pembrostropia	(Br,Ar,St)
Pavloviteuthis	(Mo,Ce,Be)	Pegmathyrus	(Br,Ar,Te)	Pempheris	(Cd,Os,Pf)
Pavobeisselina	(Bz,Gy,Ch)	Pegmatula	(An,Po,Se)	Pemphigaspis	(Ar,Tr,As)
Pavofunites	(Bz,Gy,Ch)	Pegmatreta	(Br,Li,Ac)	Pemphix	(Ar,MI,De)
Pavona	(Cn,An,Sc)	Pegmaulvalva	(Mo,Bi,Pt)	Pemphocystis	(Ec,Di,Di)
Pavonaria	(Cn,An,Pe)	Pegocomptus	(Mo,Ga,Ne)	Penaeus	(Ar,MI,De)
Pavonina	(Fo,Fo,Fo)	Pegocrinus	(Ec,Cr,Cl)	Penarosia	(Ar,Tr,Un)
Pavoninoides	(Fo,Fo,Fo)	Pegophysema	(Mo,Bi,Ve)	Pendeograptus	(He,Gr,Gr)
Pavonitina	(Fo,Fo,Fo)	Pegusa	(Cd,Os,Pn)	Peneauia	(Mo,Cr,Da)
Pavopsammia	(Fo,Fo,Fo)	Peichiashania	(Ar,Tr,As)	Peneckiella	(Cn,An,Ru)
Pavora	(Mo,Ga,Ne)	Peilinia	(Mo,Bi,Pt)	Peneroplis	(Fo,Fo,Fo)
Paxula	(Mo,Ga,Ne)	Peipesuchus	(Cd,Re,Cr)	Penetrantia	(Bz,Gy,Ct)
Payradeautia	(Mo,Ga,Nt)	Peipiaosteus	(Cd,Os,Ac)	Penhsioceras	(Mo,Ce,En)
Payuella	(Br,Ar,Rh)	Peiragraptus	(He,Gr,Gr)	Penicillirinus	(Ec,Cr,Ds)
Paziella	(Mo,Ga,Ne)	Peishania	(Ar,Tr,Pt)	Peniculus	(Mo,Bi,Ph)
Pehelincevella	(Mo,Ga,Ce)	Peismoceras	(Mo,Ce,Ta)	Peniculauris	(Br,Ar,St)
Peachella	(Ar,Tr,Ol)	Pelagiartectos	(Cd,Ma,Ca)	Peniculocrinus	(Ec,Cr,Ds)
Peachocaris	(Ar,MI,Lo)	Pelagiella	(Mo,In,Pe)	Penion	(Mo,Ga,Ne)
Pealerina	(Fo,Fo,Fo)	Pelagoceras	(Mo,Ce,Di)	Penitella	(Mo,Bi,My)
Pearylandites	(Mo,Ce,Ce)	Pelagosaurus	(Cd,Re,Cr)	Pennahia	(Cd,Os,Pf)
Peasiella	(Mo,Ga,Nt)	Pelanechinus	(Ec,Ec,Et)	Pennaia	(Ar,Tr,Ph)
Pecchiolia	(Mo,Bi,Ph)	Pelanodiadema	(Ec,Ec,Di)	Pennastroma	(Po,De,St)
Pecten	(Mo,Bi,Pt)	Pelargorhynchus	(Cd,Os,Al)	Pennipora	(Bz,St,Cc)
Pectenoproductus	(Br,Ar,St)	Pelaspis	(Cd,Pt,Pt)	Penniretepora	(Bz,St,Fe)
Pectidolon	(Ar,Os,Pa)	Pelates	(Cd,Os,Pf)	Pennoceras	(Mo,Ce,Go)
Pectinaria	(An,Po,Te)	Pelecanoides	(Cd,Av,Pr)	Pennospiriferina	(Br,Ar,Sp)
Pectinatites	(Mo,Ce,Am)	Peleccrinus	(Ec,Cr,Cl)	Pennyella	(Ar,Os,Po)
Pectinia	(Cn,An,Sc)	Pelecocythere	(Ar,Os,Po)	Penoperculoides	(Fo,Fo,Fo)
Pectinoceras	(Mo,Ce,On)	Pelecyora	(Mo,Bi,Ve)	Pensacola	(Ar,Tr,Un)
Pectinodonta	(Mo,Ga,Pa)	Peleicostella	(Br,Ar,Or)	Pensarnia	(Mo,Bi,Nu)
Pectinucula	(Mo,Bi,Nu)	Pelekyognathus	(Cd,Co,Co)	Pentablastus	(Ec,BL,Fi)
Pectinula	(Mo,Bi,Pt)	Peliscaria	(Mo,Ga,Nt)	Pentaceros	(Cd,Os,Pf)
Pectocythere	(Ar,Os,Po)	Pelicaspongia	(Po,He,Am)	Pentacoenia	(Cn,An,Sc)
Pectorhyncha	(Br,Ar,Rh)	Pelicephalus	(Ar,Tr,Pt)	Pentacrinities	(Ec,Cr,Sa)
Pectunculus	(Mo,Bi,Ve)	Pelidocrinus	(Ec,Cr,Di)	Pentactinella	(Br,Ar,Sp)

Pentactinocapus	(Ac.Ra.Sp)	Peregrinellina	(Br.Ar.Rh)	Perischoclonus	(Ar.Tr.Pt)
Pentactura	(Ac.Ra.Sp)	Peregrinelloidea	(Br.Ar.Rh)	Perischodomus	(Ec.Ec.Ey)
Pentaditripa	(An.Po.Se)	Peregrinicyathus	(Po.Re.Aj)	Perischodory	(Ar.Tr.Co)
Pentagnostus	(Ar.Tr.Ag)	Pereiraea	(Mo.Ga.Nt)	Periseris	(Cn.An.Sc)
Pentagona	(Ar.Os.Pa)	Peremocrinus	(Ec.Cr.Di)	Perisphinctes	(Mo.Ce.Am)
Pentagonalia	(Ar.Tr.Ag)	Perexigupye	(Ar.Tr.Pr)	Perispyridium	(Ac.Ra.Na)
Pentagonia	(Br.Ar.Sp)	Perfodiastopora	(Bz.St.Cc)	Perissity	(Mo.Ga.Nt)
Pentagonoceras	(Mo.Ce.Cc)	Pergamidia	(Mo.Bi.Pt)	Perissocoelia	(Po.De.Li)
Pentagonochilina	(Ar.Os.Pa)	Pergensella	(Bz.St.Cc)	Perissocrinus	(Ec.Cr.Ds)
Pentagonodiscus	(Mo.Ga.Ar)	Pergensia	(Bz.St.Cc)	Perissocytheridea	(Ar.Os.Po)
Pentagrammysia	(Mo.Bi.Ph)	Periacanthus	(Ar.Ml.De)	Perissodonta	(Mo.Ga.Nt)
Pentalastrum	(Ac.Ra.Sp)	Periallus	(Br.Ar.Te)	Perissolax	(Mo.Ga.Nt)
Pentalina	(Mo.In.In)	Periarchus	(Ec.Ec.Cl)	Perissopliomera	(Ar.Tr.Ph)
Pentamerella	(Br.Ar.Pe)	Periaster	(Ec.Ec.Sp)	Perissoptera	(Mo.Ga.Nt)
Pentamerifera	(Br.Ar.Pe)	Periaulax	(Mo.Ga.Ar)	Perissothyris	(Br.Ar.Sp)
Pentameroceras	(Mo.Ce.On)	Peribositra	(Mo.Bi.Pt)	Peristedion	(Cd.Os.Sc)
Pentameroides	(Br.Ar.Pe)	Peribrissus	(Ec.Ec.Sp)	Peristernia	(Mo.Ga.Ne)
Pentamerus	(Br.Ar.Pe)	Pericarinata	(Mo.Ga.Nt)	Peristerothyris	(Br.Ar.Te)
Pentamplexus	(Cn.An.Ru)	Pericarinoceras	(Mo.Ce.Cc)	Peritresius	(Cd.Re.Ch)
Pentanemus	(Cd.Os.Pf)	Pericentrophus	(Cd.Os.Se)	Peritimerella	(Br.Li.Li)
Pentapalacopycon	(Ar.Py.Pt)	Perichlamydidium	(Ac.Ra.Sp)	Peritrochia	(Br.Ar.Or)
Pentaphyllia	(Cn.An.Ru)	Perichonetes	(Br.Ar.St)	Peritrochia	(Mo.Ce.Go)
Pentaphyllum	(Cn.An.Ru)	Periclaria	(Mo.Bi.Pt)	Peritrophon	(Mo.Ga.Ne)
Pentapion	(Cd.Os.Pf)	Pericleites	(Mo.Ce.Go)	Peritroblastus	(Ec.Bl.Sp)
Pentaptyxis	(Mo.Ga.He)	Pericosmus	(Ec.Ec.Sp)	Perkinsoceras	(Mo.Ce.En)
Pentaramicrinus	(Ec.Cr.Cl)	Pericyclus	(Mo.Ce.Go)	Perleidus	(Cd.Os.Pe)
Pentaspheera	(Ac.Ra.Sp)	Peridalejina	(Br.Ar.Or)	Perlioprotus	(Ar.Tr.Pr)
Pentasteria	(Ec.As.Pa)	Peridionites	(Ec.Eo.Un)	Permanomia	(Mo.Bi.Pt)
Pentececrinus	(Ec.Cr.Cl)	Peridipsaccus	(Mo.Ga.Ne)	Permartella	(Mo.Bi.Ve)
Pentechinus	(Ec.Ec.Te)	Periechocrinus	(Ec.Cr.Mo)	Permaster	(Ec.As.Ur)
Pentidium	(Ec.Ec.Cl)	Perigastrella	(Bz.Gy.Ch)	Permasyrinx	(Br.Ar.Sp)
Pentephyllum	(Ec.Bl.Sp)	Perigeyerella	(Br.Ar.St)	Permanella	(Br.Ar.Un)
Pentithyris	(Br.Ar.Te)	Periglypta	(Mo.Bi.Ve)	Permicola	(Br.Ar.Te)
Pentlandella	(Br.Ar.At)	Periglyptocrinus	(Ec.Cr.Mo)	Permiocrinus	(Ec.Cr.Cl)
Pentlandina	(Br.Ar.St)	Periloculina	(Fo.Fo.Fo)	Permiobrachypus	(Ec.Cr.Sa)
Pentoperia	(Mo.Bi.Ar)	Perimeoceras	(Mo.Ce.On)	Permoceras	(Mo.Bi.Pt)
Pentremites	(Ec.Bl.Sp)	Perimeocoelia	(Br.Ar.Pe)	Permoceras	(Mo.Ce.Na)
Pentremiidea	(Ec.Bl.Fi)	Perimecturus	(Ar.Ml.St)	Permochoiton	(Mo.Po.Ne)
Pentremoblastus	(Ec.Bl.Sp)	Perimera	(Po.De.Li)	Permoconetes	(Br.Ar.St)
Penzhiella	(Br.Ar.Sp)	Perimestocrinus	(Ec.Cr.Cl)	Permodiscus	(Fo.Fo.Fo)
Penzhiothyris	(Br.Ar.Te)	Peringiella	(Mo.Ga.Nt)	Permodomatoceras	(Mo.Ce.Na)
Peonza	(Mo.Ga.Ne)	Periodon	(Cd.Co.Co)	Permofofenestella	(Bz.St.Fe)
Petoconus	(Mo.In.In)	Periodanoceras	(Mo.Ce.On)	Permoheleclema	(Bz.St.Cr)
Pephracaris	(Ar.Ml.Ar)	Periomma	(Ar.Tr.Pt)	Permoheleclema	(Bz.St.Tr)
Pepitaxoncrinus	(Ec.Cr.Tx)	Periomella	(Ar.Tr.Pt)	Permonautilus	(Mo.Ce.Na)
Peplosmilia	(Cn.An.Sc)	Perioura	(Ar.Tr.Pt)	Permorphorus	(Mo.Bi.Ph)
Peponocyathus	(Cn.An.Sc)	Peripaedium	(Cn.An.Ru)	Permorphricodothyris	(Br.Ar.Sp)
Pepta	(Mo.Ga.Ne)	Peripeltopleurus	(Cd.Os.Pl)	Permorphycoppe	(Ar.Os.My)
Peracheilus	(Ar.Tr.Pt)	Peripetoceras	(Mo.Ce.Na)	Permorphora	(Bz.St.Tr)
Peracle	(Mo.Ga.Th)	Periphacelopora	(Cn.An.Ta)	Permorphothestes	(Br.Ar.St)
Perakia	(Br.Ar.Rh)	Periphæna	(Ac.Ra.Sp)	Permosoma	(Cd.Tu.Tu)
Peramplifata	(Mo.Bi.Ve)	Periphragella	(Po.He.He)	Permospirifer	(Br.Ar.Sp)
Peraspatangus	(Ec.Ec.Sp)	Periplectum	(Po.He.He)	Permot euther	(Mo.Ce.Pm)
Peraspis	(Ar.Tr.Pt)	Peripleurites	(Mo.Ce.Ce)	Permoyoungiella	(Ar.Os.Pa)
Peratagnostus	(Ar.Tr.Ag)	Periplocetus	(Cd.Ma.Ce)	Permundaria	(Br.Ar.St)
Peratobelus	(Mo.Ce.Be)	Periploma	(Mo.Bi.Ph)	Perna	(Mo.Bi.Mt)
Peratocytheridea	(Ar.Os.Po)	Periplomya	(Mo.Bi.Ph)	Perneraspis	(Ar.Tr.Pt)
Peratos	(Br.Ar.At)	Periplomya	(Mo.Bi.My)	Pernericirrus	(Mo.Ga.Ar)
Percalates	(Cd.Os.Pf)	Peripora	(Bz.St.Cc)	Pernerina	(Fo.Fo.Fo)
Percevalicrinus	(Ec.Cr.Is)	Periporosella	(Bz.Gy.Ch)	Pernerites	(An.Po.Eu)
Percostoma	(Cd.Os.Pf)	Peripristis	(Cd.Ch.Pe)	Permeritrochus	(Mo.Ga.Ar)
Percultazonaria	(Fo.Fo.Fo)	Peripriaterocyathus	(Pr.Cr.Cr)	Permerocrinus	(Ec.Cr.Cl)
Perditocardinia	(Br.Ar.Or)	Perirehaedulus	(Ar.Tr.Ph)	Pernoceras	(Mo.Ce.Go)
Peregrinella	(Br.Ar.Rh)	Perischochidaris	(Ec.Ec.Ey)	Pernomylitus	(Mo.Bi.Mt)

Pernopecten	(Mo,Bi,Pt)	Pesnastylus	(Bz,St,Fe)	Petroria	(Br,Ar,St)
Pernostrea	(Mo,Bi,Pt)	Pessosaurus	(Cd,Re,lc)	Petrosistroma	(Po,De,Ha)
Peromelissa	(Ac,Ra,Na)	Pesierevatrypa	(Br,Ar,At)	Petrosites	(Po,De,Ha)
Peronaea	(Mo,Bi,Ve)	Petalambicrinus	(Ec,Cr,Ct)	Petrostroma	(Po,Ca,Ph)
Peronella	(Ec,Ec,Ct)	Petalavis	(Cn,An,Ru)	Petrozium	(Cn,An,Ru)
Peronellites	(Ec,Ec,Ct)	Petalites	(Pr,Un,In)	Petruninaspis	(Ar,Tr,Pt)
Peroniceras	(Mo,Ce,Am)	Petaloblastus	(Ec,Bt,Sp)	Petryoceras	(Mo,Ce,Or)
Peronidella	(Po,Ca,Ph)	Petalobriassus	(Ec,Ec,Ca)	Petschoracrinus	(Ec,Cr,Ct)
Peronidia	(Mo,Bi,Ve)	Petalocardia	(Mo,Bi,Ve)	Petschorospirifer	(Br,Ar,Sp)
Peronoceras	(Mo,Ce,Am)	Petalochonetes	(Br,Ar,St)	Petteroceras	(Mo,Ce,An)
Peronochaeta	(An,Po,Un)	Petalococonchus	(Mo,Ga,Nt)	Pettersia	(Mo,Bi,Ar)
Peronophyllum	(Cn,An,Ru)	Petalocrinus	(Ec,Cr,Ct)	Pexidella	(Br,Ar,Sp)
Peronopora	(Bz,St,Tr)	Petalocystites	(Ec,Eo,Un)	Pexiphyllum	(Cn,An,Ru)
Peronopsis	(Ar,Tr,Ag)	Petalodontia	(Mo,Bi,Hi)	Peyeria	(Cd,Ch,Rj)
Perotrochus	(Mo,Ga,Ar)	Petalodus	(Cd,Ch,Pe)	Peyerus	(Cd,Re,Ps)
Perouvianella	(Fo,Fo,Fo)	Petalograpus	(He,Gr,Gr)	Peyrotia	(Mo,Ga,Nt)
Perplexostroma	(Po,De,St)	Petalope	(Po,He,He)	Peytonoceras	(Mo,Ce,Go)
Perplicaria	(Mo,Ga,Ne)	Petalopora	(Bz,St,Cc)	Pezantia	(Mo,Ga,Nt)
Perprimitia	(Ar,Os,Pa)	Petaloporella	(Bz,St,Cr)	Pfenderella	(Fo,Fo,Fo)
Perrarisinurostrom	(Br,Ar,Rh)	Petalopteryx	(Cd,Os,Ma)	Pfendericonus	(Fo,Fo,Fo)
Perrierina	(Mo,Bi,Ve)	Petalorhynchus	(Cd,Ch,Pe)	Pfenderina	(Fo,Fo,Fo)
Perrierithyris	(Br,Ar,Te)	Petalostegus	(Bz,Gy,Ch)	Phacelapsimilia	(Cn,An,Sc)
Perrinia	(Mo,Ga,Ar)	Petalothyris	(Br,Ar,Te)	Phacellastraea	(Cn,An,Sc)
Perrinites	(Mo,Ce,Go)	Petalotrypa	(Bz,St,Tr)	Phacellocoenia	(Cn,An,Sc)
Perrinoceras	(Mo,Ce,Ce)	Petasisforma	(Ac,Ra,Na)	Phacellopegma	(Po,De,Li)
Perritocrinus	(Ec,Cr,Ds)	Petasmaia	(Br,Ar,St)	Phacellophyllum	(Cn,An,Ru)
Perrona	(Mo,Ca,Ne)	Petasmaria	(Br,Ar,Rh)	Phacelloplasma	(Cn,An,Ru)
Perryspirifer	(Br,Ar,Sp)	Petasmatherus	(Br,Ar,Rh)	Phacelocrinus	(Ec,Cr,Ct)
Perryus	(Ar,Tr,Ph)	Petasothea	(Hy,Or,Ct)	Phaceloorthis	(Br,Ar,Or)
Persacanthus	(Cd,Ac,Is)	Petchorina	(Fo,Fo,Fo)	Phacellophyllia	(Cn,An,Sc)
Perse	(Mo,Ga,Ne)	Peteraurilla	(Ar,Os,Po)	Phacelopora	(Bz,St,Cc)
Persephona	(Ar,Ml,De)	Pettersia	(Mo,Ga,Nt)	Phacelostylophyllum	(Cn,An,Sc)
Persicitheca	(Hy,Uc,Uc)	Peterygocytheresis	(Ar,Os,Po)	Phacoceras	(Mo,Ce,Na)
Persicula	(Mo,Ga,Ne)	Pethopecten	(Mo,Bi,Pt)	Phacodiscus	(Ac,Ra,Sp)
Persikima	(Mo,Bi,Ve)	Petigopora	(Bz,St,Tr)	Phacopidella	(Ar,Tr,Ph)
Persimedesites	(Cn,In,In)	Petigurus	(Ar,Tr,Pr)	Phacopidina	(Ar,Tr,Ph)
Persiopora	(Bz,St,Tr)	Petitclercia	(Mo,Ce,Am)	Phacopina	(Ar,Tr,Ph)
Personella	(Mo,Ga,Nt)	Petkovicia	(Mo,Bi,Hi)	Phacops	(Ar,Tr,Ph)
Personopsella	(Ar,Tr,Ag)	Petratixia	(Mo,Ga,Ne)	Phacorhabdotus	(Ar,Os,Po)
Personopsis	(Mo,Ga,Un)	Petraia	(Cn,An,Ru)	Phacosoma	(Mo,Bi,Ve)
Perspicas	(Ar,Ml,Ca)	Petraiella	(Cn,An,Ru)	Phacostylus	(Ac,Ra,Sp)
Perspiciillum	(Ar,Os,Pa)	Petralca	(Cd,Av,Ch)	Phacotriactis	(Ac,Ra,Sp)
Perssuakiella	(Mo,He,He)	Petraliella	(Bz,Gy,Ch)	Phaedrysmocheilus	(Mo,Ce,Na)
Peruardia	(Mo,Bi,Ar)	Petraphyllum	(Cn,An,Ru)	Phaenoblastus	(Ec,Bt,Fi)
Perucardia	(Mo,Bi,Ve)	Petrasma	(Mo,Bi,So)	Phaenocalpis	(Ac,Ra,Na)
Perucerithium	(Mo,Ga,Nt)	Petraster	(Ec,As,Pu)	Phaenodesmia	(Mo,Bi,Na)
Peruchilus	(Mo,Ga,Nt)	Petria	(Br,Ar,Te)	Phaenophragma	(Bz,St,Cr)
Peruficus	(Mo,Ga,Ne)	Petricola	(Mo,Bi,Ve)	Phaenopora	(Bz,St,Cr)
Perulibatrachus	(Cd,Os,Ba)	Petricolaria	(Mo,Bi,Ve)	Phaenoporella	(Bz,St,Cr)
Perulithes	(Mo,Ga,Ne)	Petricolirus	(Mo,Bi,Ve)	Phaenoscenium	(Ac,Ra,Na)
Peruluta	(Mo,Ga,Ne)	Petricovenica	(Mo,Bi,Ve)	Phaenoschisma	(Ec,Bt,Fi)
Perunaspis	(Ar,Tr,Li)	Petridictyum	(Cn,An,Ta)	Phaetonellus	(Ar,Tr,Pr)
Perunautilus	(Mo,Ce,Na)	Petrisigmoopsis	(Ar,Os,Pa)	Phalacrocidaris	(Ec,Ec,Ct)
Perunicus	(Mo,Ga,Ar)	Petrochirus	(Ar,Ml,De)	Phalacroma	(Ar,Tr,Ag)
Perunocrinus	(Ec,Cr,Di)	Petrocerania	(Br,Li,Ac)	Phalacropedina	(Ec,Ec,Pe)
Perustrombus	(Mo,Ga,Nt)	Petrocrinus	(Ec,Cr,Sa)	Phalagnostus	(Ar,Tr,Ag)
Peruviella	(Mo,Ga,Ce)	Petrodus	(Cd,Ch,Ct)	Phalangites	(Ar,Ml,De)
Peruvispira	(Mo,Ga,Ar)	Petrodistroma	(Po,De,St)	Phalangium	(Po,De,Li)
Pervertina	(Mo,Pa,Hy)	Petrolytoceras	(Mo,Ce,Am)	Phalangocephalus	(Ar,Tr,Ph)
Pervicacia	(Mo,Ga,Ne)	Petromactra	(Mo,Bi,Ve)	Phalarodon	(Cd,Re,lc)
Pervinquieria	(Mo,Ce,Am)	Petronella	(Cn,An,Ru)	Phalaropus	(Cd,Av,Ch)
Pesaia	(Ar,Tr,Pt)	Petropegia	(Ec,Ho,De)	Phalcoocythere	(Ar,Os,Po)
Pesaiella	(Ar,Tr,Pt)	Petrophylliella	(Cn,An,Sc)	Phalium	(Mo,Ga,Nt)
Peshiatrypa	(Br,Ar,At)	Petropoma	(Mo,Ga,Ar)	Phanassymetria	(Ar,Os,Po)

Phandella	(Mo,Ga,Ne)	Phillipsia	(Ar,Tr,Pr)	Pholidopleurus	(Cd,Os,Ph)
Phaneroceras	(Mo,Ce,Go)	Phillipsinella	(Ar,Tr,Co)	Pholidopora	(Bz,St,Cy)
Phanerochiderma	(Po,He,Ly)	Phillipsoceras	(Mo,Ce,Go)	Pholidorhynchodon	(Cd,Os,Pc)
Phanerodon	(Cd,Os,Pf)	Phillipsocrinus	(Ec,Cr,Un)	Pholidosaurus	(Cd,Re,Cr)
Phanerolepida	(Mo,Ga,Ar)	Philobrya	(Mo,Bi,Ar)	Pholidosteus	(Cd,Pl,Ar)
Phaneroptyxis	(Mo,Ga,He)	Philomedes	(Ar,Os,My)	Pholidostrophia	(Br,Ar,St)
Phanerotheon	(Cd,Os,Pa)	Philoneptunus	(Ar,Os,Po)	Pholidotoma	(Mo,Ga,Ne)
Phanerothephanus	(Mo,Ce,Am)	Philovene	(Mo,Ga,Eu)	Phonicosia	(Bz,Gy,Ch)
Phanerotinus	(Mo,Ga,Eu)	Philovenella	(Mo,In,Pe)	Phoracanthus	(Mo,Ga,Ne)
Phanerotrema	(Mo,Ga,Ar)	Philyra	(Ar,MI,De)	Phorculus	(Mo,Ga,Ar)
Phanocrinus	(Ec,Cr,Cl)	Phimocrinus	(Ec,Cr,Ds)	Phorcus	(Mo,Ga,Ar)
Phapsirhynchia	(Br,Ar,Rh)	Phineus	(Cn,An,Ru)	Phorcynis	(Cd,Ch,Oc)
Pharaonaster	(Ec,Ec,Sp)	Phiops	(An,Po,Eu)	Phoretropis	(Ar,Tr,Un)
Pharaonella	(Mo,Bi,Ve)	Phlebolepis	(Cd,Pt,Th)	Phormedites	(Mo,Ce,Ce)
Pharciceras	(Mo,Ce,An)	Phlogocardia	(Mo,Bi,Ve)	Phormocrytis	(Ac,Ra,Na)
Pharcidoconcha	(Mo,Bi,Ar)	Phlogoiderhynchus	(Br,Ar,Rh)	Phormograptus	(He,Gr,Gr)
Pharcidodiscus	(Br,Ar,St)	Phloioceras	(Mo,Ce,Na)	Phormopora	(Bz,St,Cc)
Pharella	(Mo,Bi,Ve)	Phlyctaeonium	(Po,He,Ly)	Phormosella	(Po,He,Re)
Pharetrolites	(Mo,Ga,Be)	Phlyctenodes	(Ar,MI,De)	Phormospyris	(Ac,Ra,Na)
Pharetrospongia	(Po,Ca,Ph)	Phlyctenophora	(Ar,Os,Po)	Phormostichoartus	(Ac,Ra,Na)
Pharkidonotus	(Mo,Ga,Be)	Phlyctia	(Po,De,Li)	Phorocephala	(Ar,Tr,Pt)
Pharmacichthys	(Cd,Os,In)	Phlycticeras	(Mo,Ce,Am)	Phorticum	(Ac,Ra,Sp)
Pharodina	(Mo,Bi,Ve)	Phlycticerioceras	(Mo,Ce,Am)	Phos	(Mo,Ga,Ne)
Pharostoma	(Ar,Tr,Ph)	Phlyctiderma	(Mo,Bi,Ve)	Phosinella	(Mo,Ga,Nt)
Pharostomiina	(Ar,Tr,Ph)	Phlyctiscapha	(Ar,Os,Pa)	Phosphannulus	(Pr,Un,Hy)
Pharus	(Mo,Bi,Ve)	Phlyctisoma	(Ar,MI,De)	Phosphatosaurus	(Cd,Re,Cr)
Phaseliforma	(Ac,Ra,Sp)	Phlyctocystis	(Ec,Di,Di)	Phosphichthys	(Cd,Os,Pf)
Phaselops	(Ar,Tr,Pr)	Phlyctocytthere	(Ar,Os,Po)	Photichthys	(Cd,Os,St)
Phaseolella	(Ar,Os,Ar)	Phlyseogrammocera	(Mo,Ce,Am)	Phractopora	(Bz,St,Cy)
Phasianella	(Mo,Ga,Ar)	Phoberodon	(Cd,Ma,Ce)	Phractoporella	(Bz,Gy,Ch)
Phasianema	(Mo,Ga,He)	Phobetractinia	(Po,Ca,Un)	Phragmactis	(Ec,Op,St)
Phasianochilus	(Mo,Ga,Ar)	Phoca	(Cd,Ma,Ca)	Phragmoceras	(Mo,Ce,Di)
Phasianotrochus	(Mo,Ga,Ar)	Phocaena	(Cd,Ma,Ce)	Phragmocerina	(Mo,Ce,Di)
Phasoia	(Ar,Os,Ar)	Phocaenopsis	(Cd,Ma,Ce)	Phragmocoelia	(Po,De,Pe)
Phaulactis	(Cn,An,Ru)	Phocagenus	(Cd,Ma,Ce)	Phragmodictya	(Po,He,Re)
Phaularptites	(Mo,Ce,Am)	Phocanella	(Cd,Ma,Ca)	Phragmodus	(Cd,Co,Co)
Phaulostephanus	(Mo,Ce,Am)	Phocavis	(Cd,Av,Pe)	Phragmolites	(Mo,Ga,Be)
Phaulozigzag	(Mo,Ce,Am)	Phoceana	(Bz,Gy,Ch)	Phragmophera	(Bz,St,Cr)
Phaxas	(Mo,Bi,Ve)	Phocidaster	(Ec,As,Va)	Phragmophora	(Br,Ar,Or)
Phelopteria	(Mo,Bi,Pt)	Phococetus	(Cd,Ma,Ce)	Phragmopora	(Bz,St,Tr)
Phenacocyclus	(Mo,Bi,Ve)	Phodeucythere	(Ar,Os,Po)	Phragmorisma	(Mo,Bi,Ph)
Phenacophragma	(Fo,Fo,Fo)	Phoebodus	(Cd,Ch,Ct)	Phragmorthis	(Br,Ar,Or)
Phenacovolva	(Mo,Ga,Nt)	Phoenicoechia	(Br,Ar,Rh)	Phragmosalpinx	(An,Po,Se)
Phenacozugmayerella	(Br,Ar,Sp)	Phoenicolepis	(Cd,Os,Ct)	Phragmosiphon	(Mo,Ce,En)
Phenatoma	(Mo,Ga,Ne)	Phoenixites	(Mo,Ce,Go)	Phragmosmillia	(Cn,An,Sc)
Pheronema	(Po,He,Am)	Phoidagnostoides	(Ar,Tr,Ag)	Phragmosphaera	(Mo,Ga,Be)
Phestia	(Mo,Bi,Nu)	Phoidagnostus	(Ar,Tr,Ag)	Phragmostoma	(Mo,Ga,Be)
Phestioides	(Mo,Bi,Nu)	Pholadella	(Mo,Bi,Ph)	Phragmostrophia	(Br,Ar,St)
Phialaspongia	(Po,De,Li)	Pholadidea	(Mo,Bi,My)	Phragmoteuthis	(Mo,Ce,Pm)
Phialopecten	(Mo,Bi,Pt)	Pholadomorpha	(Mo,Bi,Mt)	Phragmotrypis	(Br,Ar,Tr)
Phidolopora	(Bz,Gy,Ch)	Pholadomya	(Mo,Bi,Ph)	Phragmotrypa	(Bz,St,Tr)
Philbertia	(Mo,Ga,Ne)	Pholadomyocardia	(Mo,Bi,Ph)	Phreagena	(Mo,Bi,Ve)
Philhedra	(Br,Li,Ac)	Pholadopsis	(Mo,Bi,My)	Phreatura	(Ar,Os,Me)
Philhedrella	(Br,Li,Ac)	Pholas	(Mo,Bi,My)	Phrenophoria	(Br,Ar,Rh)
Philine	(Mo,Ga,Ce)	Pholideechinus	(Ec,Ec,Ey)	Phricodoceras	(Mo,Ce,Am)
Philippia	(Mo,Ga,He)	Pholidocidaris	(Ec,Ec,Ey)	Phricodothyris	(Br,Ar,Sp)
Philippinactinia	(Cn,Hy,Hy)	Pholidoeladia	(Po,De,Li)	Phrissospongia	(Po,De,Li)
Philippinarea	(Mo,Bi,Ar)	Pholidoctenus	(Cd,Os,Pc)	Phrontis	(Mo,Ga,Ne)
Philippotia	(Br,Ar,St)	Pholidolepis	(Cd,Os,Pc)	Phrygiocrinus	(Ec,Cr,Mo)
Phillibole	(Ar,Tr,Pr)	Pholidophoretetes	(Cd,Os,Pc)	Phrynopora	(Bz,Gy,Ch)
Phillibolna	(Ar,Tr,Pr)	Pholidophoristion	(Cd,Os,Pc)	Phryx	(Mo,Ga,Pa)
Phillipaster	(Ec,As,Ur)	Pholidophoroides	(Cd,Os,Pc)	Phthanoloxoconcha	(Ar,Os,Po)
Phillipites	(Mo,Ce,Ce)	Pholidophoropsis	(Cd,Os,Pc)	Phthanoncoceras	(Mo,Ce,On)
Phillipsastrea	(Cn,An,Ru)	Pholidophorus	(Cd,Os,Pc)	Phthonia	(Mo,Bi,Mt)

Phycis	(Cd.Os.Ga)	Physetodon	(Cd.Ma.Ce)	Pillararhynchus	(Cd.Os.Di)
Phygosaurus	(Cd.Re.No)	Physetorhynchia	(Br.Ar.Rh)	Pilletina	(Ar.Tr.Ph)
Phygraea	(Mo.Bi.Pt)	Physiculus	(Cd.Os.Ga)	Pillucina	(Mo.Bi.Ve)
Phylactella	(Bz.Gy.Ch)	Physioceras	(Mo.Ce.Di)	Piloceras	(Mo.Ce.En)
Phylactellina	(Bz.Gy.Ch)	Physocalpia	(Po.De.Li)	Pilocrinus	(Ec.Cr.Cy)
Phylactellipora	(Bz.Gy.Ch)	Physocardia	(Mo.Bi.Ve)	Pilocystites	(Ec.Eo.Un)
Phylacterus	(Ar.Tr.Un)	Physocythere	(Ar.Os.Po)	Pilograptus	(He.Gr.Un)
Phylacteocephalus	(Cd.Os.Al)	Physodoloceras	(Mo.Ce.Am)	Pilolepis	(Cd.Pt.Pt)
Phyletripes	(Ac.Ra.Sp)	Physogaleus	(Cd.Ch.Ca)	Pilophyllia	(Cn.An.Ru)
Phyllacanthus	(Ec.Ec.Ci)	Physogyra	(Cn.An.Sc)	Pilophylloides	(Cn.An.Ru)
Phyllangia	(Cn.An.Sc)	Physoida	(Mo.Bi.My)	Pilophyllum	(Cn.An.Ru)
Phyllaspis	(Ar.Tr.Pr)	Physoseris	(Cn.An.Sc)	Piloricella	(Br.Ar.St)
Phyllobrissus	(Ec.Ec.Ca)	Physospongia	(Po.He.Re)	Pilotoceras	(Mo.Ce.Ta)
Phylloceras	(Mo.Ce.Ph)	Physotreta	(Br.Li.Ac)	Piltonia	(Ar.Tr.Pr)
Phyllocheilus	(Mo.Ga.Nt)	Phytogyra	(Cn.An.Sc)	Pilumnus	(Ar.Ml.De)
Phyllochites	(Pr.Un.In)	Phytopsis	(Cn.An.Ta)	Pimelites	(Mo.Ce.Am)
Phyllochiton	(Pr.Ca.Ca)	Piallina	(Fo.Fo.Fo)	Pimelometopon	(Cd.Os.Pf)
Phyllocadiscites	(Mo.Ce.Ce)	Piamaecyathellus	(Po.Re.Aj)	Pimlicocrinus	(Ec.Cr.Mo)
Phyllocoenia	(Cn.An.Sc)	Pianaspis	(Ar.Tr.Pt)	Pinacites	(Mo.Ce.An)
Phyllocoeniopsis	(Cn.An.Sc)	Piarorhynchella	(Br.Ar.Rh)	Pinaclymenia	(Mo.Ce.Cl)
Phyllocrinus	(Ec.Cr.Cy)	Piarorhynchia	(Br.Ar.Rh)	Pinacoceras	(Mo.Ce.Ce)
Phyllocystis	(Ec.St.Cr)	Piaziella	(Ar.Tr.Pt)	Pinacognathus	(Cd.Co.Co)
Phylloidermia	(Po.De.Li)	Piceaphyllum	(Cn.An.Ru)	Pinacophyllum	(Cn.An.Sc)
Phylloidietya	(Bz.St.Cr)	Pichlostroma	(Po.De.St)	Pinacoplacites	(Mo.Ce.Ce)
Phylloдина	(Mo.Bi.Ve)	Pichlerella	(Mo.Bi.Pt)	Pinacotrypa	(Bz.St.Cy)
Phylloдus	(Cd.Os.An)	Pichottia	(Ar.Os.Po)	Pinaria	(Fo.Fo.Fo)
Phyllograptus	(He.Gr.Gr)	Pichynella	(Mo.In.In)	Pinaxiothyris	(Br.Ar.Te)
Phyllogyra	(Cn.An.Sc)	Picnotreta	(Br.Li.Ac)	Pinctada	(Mo.Bi.Pt)
Phyllohelia	(Cn.An.Sc)	Picounina	(Fo.Fo.Fo)	Pinctus	(Ar.Tr.Pt)
Phyllonia	(Br.Ar.Te)	Picrocleidus	(Cd.Re.Ps)	Pindosmia	(Cn.An.Sc)
Phyllonotus	(Mo.Ga.Ne)	Pictatella	(Bz.St.Cr)	Pinegathyrus	(Br.Ar.Sp)
Phyllopachyceras	(Mo.Ce.Ph)	Pictavia	(Mo.Ga.Nt)	Pinegia	(Cn.In.In)
Phylloporina	(Bz.St.Fe)	Pictaviechinus	(Ec.Ec.Sp)	Pinegopora	(Bz.St.Cr)
Phylloptychoceras	(Mo.Ce.Am)	Pictetia	(Mo.Ce.Am)	Pinghuangella	(Br.Ar.Sp)
Phylloseriopsis	(Cn.An.Sc)	Pictetoceras	(Mo.Ce.El)	Pinglusapis	(Ar.Tr.Pt)
Phylloseris	(Cn.An.Sc)	Pictiformes	(Mo.Ga.Ar)	Pinguaella	(Br.Ar.Pe)
Phyllosmia	(Cn.An.Sc)	Pictonia	(Mo.Ce.Am)	Pinguispirifer	(Br.Ar.Sp)
Phyllozoon	(Cn.Pe.Er)	Pictoscala	(Mo.Ga.Nt)	Pinguitellina	(Mo.Bi.Ve)
Phyllytoceras	(Mo.Ce.Ce)	Pictothyris	(Br.Ar.Te)	Pinichthys	(Cd.Os.Pf)
Phymaplectia	(Po.De.Li)	Pidelocrinus	(Ec.Cr.Di)	Pinna	(Mo.Bi.Mt)
Phymaplectia	(Po.De.Li)	Pieckonia	(An.Po.Ph)	Pinnarctidion	(Cd.Ma.Ca)
Phymaraphinia	(Po.De.Li)	Piersaloceras	(Mo.Ce.On)	Pinnatispongia	(Po.He.Un)
Phymatella	(Po.De.Li)	Piestochilus	(Mo.Ga.Ne)	Pinnatopora	(Bz.St.Fe)
Phymatoceras	(Mo.Ce.Am)	Piettea	(Mo.Ga.Nt)	Pinnatulites	(Ar.Os.Po)
Phymatophyllum	(Cn.An.Ru)	Pijpersia	(Fo.Fo.Fo)	Pinnatoporella	(Bz.St.Fe)
Phymatopleura	(Mo.Ga.Ar)	Pikaia	(Cd.Cp.Cp)	Pinnixa	(Ar.Ml.De)
Phymatothyris	(Br.Ar.Te)	Pilamina	(Fo.Fo.Fo)	Pinnocaris	(Mo.Ro.Ri)
Phymechinus	(Ec.Ec.Ph)	Pilaminella	(Fo.Fo.Fo)	Pinnoxypridea	(Ar.Os.Po)
Phymolepis	(Cd.Pl.An)	Pilecomus	(Mo.In.In)	Pinocetus	(Cd.Ma.Ce)
Phymopedina	(Ec.Ec.Pe)	Pilekia	(Ar.Tr.Ph)	Pinquiggemula	(Mo.Ga.Ne)
Phymosoma	(Ec.Ec.Ph)	Pileochama	(Mo.Bi.Hi)	Pinzonella	(Mo.Bi.Hi)
Phymotaxis	(Ec.Ec.Ph)	Pileochiton	(Mo.Po.Ne)	Pionaspis	(Cd.Pt.Pt)
Phyrocythere	(Ar.Os.Po)	Pileolaria	(An.Po.Se)	Pionoceras	(Mo.Ce.Ta)
Physalactinoceras	(Mo.Ce.Pr)	Pileolites	(Po.He.He)	Pionodema	(Br.Ar.Or)
Physalidopisthia	(Ar.Os.Pa)	Pileolus	(Mo.Ga.Ar)	Pionomena	(Br.Ar.St)
Physaster	(Ec.Ec.Sp)	Pileospongia	(Po.He.Ls)	Pionopleurum	(Br.Ar.Te)
Physoacalypta	(Ar.Os.Pa)	Pileotrypa	(Bz.St.Cy)	Pionorthis	(Br.Ar.Or)
Physemataspis	(Ar.Tr.Ph)	Pileus	(Ec.Ec.Py)	Pionothyris	(Br.Ar.Te)
Physematites	(Mo.Ce.Go)	Pilidiocrinus	(Ec.Cr.Cl)	Pipedentalium	(Mo.Sc.Sc)
Physemella	(Br.Ar.Pe)	Pilina	(Mo.Te.Tr)	Pipetta	(Ac.Ra.Sp)
Physeogrammoceras	(Mo.Ce.Am)	Pilinopsis	(Mo.In.In)	Pipettaria	(Ac.Ra.Sp)
Physeter	(Cd.Ma.Ce)	Piliolites	(Ar.Tr.Un)	Piograptus	(He.Gr.Gr)
Physeterula	(Cd.Ma.Ce)	Pilkena	(Br.Ar.Te)	Piptomerus	(Cd.Re.Ps)
Physetocrinus	(Ec.Cr.Mo)	Pilla	(Ar.Os.Pa)	Pirania	(Po.De.Hd)

Pirasoerinus	(Ec,Cr,Cf)	Placites	(Mo,Ce,Ce)	Planacrocrinus	(Ec,Cr,Mo)
Piratella	(Ar,Ml,De)	Placoblastus	(Ec,Bi,Sp)	Planalveolitella	(Cn,An,Ta)
Piratoceeras	(Mo,Ce,Na)	Placochelyanus	(Cd,Re,Pl)	Planalveolites	(Cn,An,Ta)
Piratosaurus	(Cd,Re,Ps)	Placochelys	(Cd,Re,Pl)	Planalvus	(Br,Ar,Sp)
Pirena	(Mo,Ga,Nt)	Placochlaenia	(Po,He,He)	Planannatoceras	(Mo,Ce,Am)
Pirenella	(Mo,Ga,Nt)	Placocoenia	(Cn,An,Sc)	Planariomya	(Mo,Bi,Ph)
Piretella	(Ar,Os,Pa)	Placocoeniopsis	(Cn,An,Sc)	Planaspis	(Ar,Tr,Pt)
Piretia	(Ar,Os,Pa)	Placocorythus	(Cn,An,Sc)	Planatrypa	(Br,Ar,At)
Piretopsis	(Ar,Os,Pa)	Placocystella	(Ec,St,Mi)	Planaxis	(Mo,Ga,Nt)
Pirgos	(Mo,Ga,Ne)	Placocystites	(Ec,St,Mi)	Plancella	(Br,Ar,Sp)
Pirgulia	(Br,Ar,St)	Placodus	(Cd,Re,Pl)	Planes	(Ar,Ml,De)
Piriclymenia	(Mo,Ce,Cf)	Placogyra	(Cn,An,Sc)	Planetoceras	(Mo,Ce,Na)
Pirileberis	(Ar,Os,Pa)	Placogyropsis	(Cn,An,Sc)	Planetophyllum	(Cn,An,Ru)
Piriproctus	(Ar,Tr,Pr)	Placojerea	(Po,De,Li)	Planicardina	(Br,Ar,Or)
Pirithyrus	(Br,Ar,Te)	Placometra	(Ec,Cr,Cm)	Planicardium	(Mo,Bi,Ve)
Pirocystella	(Ec,Rh,Rh)	Placonella	(Cd,Re,Pl)	Planicellaria	(Bz,Gy,Ch)
Pironaea	(Mo,Bi,Hi)	Placoparia	(Ar,Tr,Ph)	Planicolonia	(Mo,Ga,Ar)
Pironastrea	(Cn,An,Sc)	Placoparina	(Ar,Tr,Ph)	Planihaydenella	(Br,Ar,Sp)
Pirotella	(Br,Ar,Te)	Placopecten	(Mo,Bi,Pt)	Planinioluta	(Fo,Fo,Fo)
Pirotothyris	(Br,Ar,Te)	Placophora	(Cn,An,Sc)	Planikella	(Mo,Bi,Ve)
Pirper	(Mo,Ga,Ar)	Placophyllia	(Cn,An,Sc)	Planileberis	(Ar,Os,Pa)
Pirsila	(Mo,Ga,Ce)	Placopleurus	(Cd,Os,Pl)	Planiprimites	(Ar,Os,Pa)
Pirskenius	(Cd,Os,Pl)	Placopsilina	(Fo,Fo,Fo)	Planirhynchia	(Br,Ar,Rh)
Pisa	(Ar,Ml,De)	Placopterina	(Mo,Bi,Pt)	Planiscutellum	(Ar,Tr,Pt)
Pisanella	(Mo,Ga,Ne)	Placosecytus	(Po,De,Li)	Planisphinctes	(Mo,Ce,Am)
Pisania	(Mo,Ga,Ne)	Placosema	(Ar,Tr,Pt)	Planispina	(Br,Ar,St)
Pisiananura	(Mo,Ga,Ne)	Placosmilia	(Cn,An,Sc)	Planispirillina	(Fo,Fo,Fo)
Piscolithax	(Cd,Ma,Ce)	Placostegus	(An,Po,Se)	Planispirina	(Fo,Fo,Fo)
Pisdurodon	(Cd,Os,Te)	Placotelia	(Po,He,Ly)	Planispirinella	(Fo,Fo,Fo)
Pisinna	(Mo,Ga,Nt)	Placothyris	(Br,Ar,Te)	Planitvela	(Mo,Bi,Ve)
Pisirhynchia	(Br,Ar,Rh)	Placotrema	(Po,He,He)	Planitrochus	(Mo,Ga,Eu)
Pisocrinus	(Ec,Rh,Ds)	Placotriplexia	(Br,Ar,Or)	Planioarchaediscus	(Fo,Fo,Fo)
Pisodonophis	(Cd,Os,An)	Placotrochus	(Cn,An,Sc)	Planocaprina	(Mo,Bi,Hi)
Pisolampas	(Ec,Ec,Ne)	Placoziphus	(Cd,Ma,Ce)	Planocoenites	(Cn,An,Ta)
Pisolina	(Fo,Fo,Fo)	Placuna	(Mo,Bi,Pt)	Planodouvillina	(Br,Ar,St)
Pisomaja	(Ar,Ml,De)	Placunanomia	(Mo,Bi,Pt)	Planoeudothyra	(Fo,Fo,Fo)
Pisostrigilla	(Mo,Bi,Ve)	Placunopsis	(Mo,Bi,Pt)	Planoglabratella	(Fo,Fo,Fo)
Pisothalamia	(Po,De,Pe)	Plaesiocomia	(Ar,Tr,Ph)	Planoglobulina	(Fo,Fo,Fo)
Pisotrigonia	(Mo,Bi,Tr)	Plaesiomya	(Br,Ar,Or)	Planogypsina	(Fo,Fo,Fo)
Pistillachitina	(Fo,Fo,Ch)	Plafkerium	(Ac,Ra,Sp)	Planoharknessella	(Br,Ar,Or)
Pistocythereis	(Ar,Os,Pa)	Plagiarca	(Mo,Bi,Ar)	Planolateralus	(Mo,Ga,Ar)
Pistopriion	(An,Po,Eu)	Plagiobrissus	(Ec,Ec,Sp)	Planolimbus	(Ar,Tr,Rc)
Pistosaurus	(Cd,Re,Ps)	Plagiocardium	(Mo,Bi,Ve)	Planolindrina	(Fo,Fo,Fo)
Pisulina	(Mo,Ga,Ar)	Plagioceras	(Mo,Ce,Di)	Planomalina	(Fo,Fo,Fo)
Pitar	(Mo,Bi,Ve)	Plagioclasma	(Ec,Ec,Ca)	Planomedusites	(Cn,Cy,Cy)
Pitarella	(Mo,Bi,Ve)	Plagiocrinus	(Ec,Cr,Sa)	Planomiliola	(Fo,Fo,Fo)
Pitarina	(Mo,Bi,Ve)	Plagioecia	(Bz,St,Cc)	Planoproductus	(Br,Ar,St)
Piichleria	(Mo,Bi,Ar)	Plagiolypta	(Mo,Sc,Sc)	Planopulvinulina	(Fo,Fo,Fo)
Pithanodelphis	(Cd,Ma,Ce)	Plagiolithocentrum	(Cd,Os,Pl)	Planorbulina	(Fo,Fo,Fo)
Pithanotaria	(Cd,Ma,Ca)	Plagiolaria	(Ar,Tr,Ph)	Planorbulinella	(Fo,Fo,Fo)
Pithocrinus	(Ec,Cr,Mo)	Plagionephrodes	(Ar,Os,Pa)	Planoria	(Ar,Os,Me)
Pithodea	(Mo,Ga,Ar)	Plagionium	(Ac,Ra,Na)	Planorotalites	(Fo,Fo,Fo)
Pithodella	(Bz,Gy,Ch)	Plagiophthalmus	(Ar,Ml,De)	Planospirina	(Mo,Ga,Ar)
Pithonoton	(Ar,Ml,De)	Plagiopora	(Bz,Gy,Ch)	Planospirites	(Mo,Bi,Pt)
Pittella	(Mo,Ga,Ne)	Plagiopychus	(Mo,Bi,Hi)	Planospiridiscus	(Fo,Fo,Fo)
Pittfordipterus	(Ar,Me,Eu)	Plagiographie	(Fo,Fo,Fo)	Planotectus	(Mo,Ga,Eu)
Pitturiaspis	(Cd,Pt,Un)	Plagioryncha	(Br,Ar,Rh)	Planotheca	(Hy,Hy,Hy)
Pityusina	(Fo,Fo,Fo)	Plagiosmittia	(Bz,Gy,Ch)	Planothyris	(Br,Ar,Te)
Piveteaia	(Cd,Os,Co)	Plagiosstoma	(Mo,Bi,Pt)	Planovastrotrum	(Br,Ar,Rh)
Placamen	(Mo,Bi,Ve)	Plagiotomella	(Fo,Fo,Fo)	Planozone	(Mo,Ga,Ar)
Placentamma	(Fo,Fo,Fo)	Plagiotomoceras	(Mo,Ce,Or)	Planopyrgiscus	(Mo,Ga,He)
Placenticerus	(Mo,Ce,Am)	Plagiothyra	(Mo,Ga,Ar)	Plantella	(Ar,Os,Pa)
Placidea	(Ar,Os,Pa)	Plagiura	(Ar,Tr,Un)	Planularia	(Fo,Fo,Fo)
Placiphorella	(Mo,Po,Ne)	Plakina	(Po,De,Ho)	Planulina	(Fo,Fo,Fo)

Planulinoides	(Fo,Fo,Fo)	Platygoniatites	(Mo,Ce,Go)	Plebidonax	(Mo,Bi,Ve)
Planusella	(Ar,Os,Pa)	Platygrammatodon	(Mo,Bi,Ar)	Plectanium	(Fo,Fo,Fo)
Planuspira	(Pr,Un,In)	Platygyra	(Cn,An,Sc)	Plectambonites	(Br,Ar,St)
Planutenia	(Mo,In,In)	Platyharpes	(Ar,Tr,Pt)	Plectasaphus	(Ar,Tr,As)
Plasiaspis	(Ar,Tr,Ph)	Platyhelvia	(Cn,An,Sc)	Plectastus	(Po,He,Ly)
Plasmiadictyon	(Cn,An,Ta)	Platyhexacrinus	(Ec,Cr,Mo)	Plectatrypa	(Br,Ar,At)
Plasmatoceras	(Mo,Ce,Am)	Platyla	(Mo,Ga,Nt)	Plectelasma	(Br,Ar,Te)
Plasmophyllum	(Cn,An,Ru)	Platylaemus	(Cd,Os,Pf)	Plectella	(Br,Ar,St)
Plasmpora	(Cn,An,Ta)	Platylates	(Cd,Os,Pf)	Plecteuloma	(Ar,Tr,As)
Plasmporella	(Cn,An,Ta)	Platyleberis	(Ar,Os,Po)	Plecteurette	(Po,He,He)
Plasmuscolex	(An,Pa,Pa)	Platylenticeras	(Mo,Ce,Am)	Plectifer	(Ar,Tr,As)
Plassenia	(Po,De,Ta)	Platylepas	(Ar,Ci)	Plectina	(Fo,Fo,Fo)
Plastomiltha	(Mo,Bi,Ve)	Platylchas	(Ar,Tr,Li)	Plectinella	(Fo,Fo,Fo)
Platanaster	(Ec,As,Pl)	Platylithax	(Cd,Ma,Ce)	Plectinia	(Po,Ca,Ph)
Platax	(Cd,Os,Pf)	Platylophocythere	(Ar,Os,Po)	Plectocamara	(Br,Ar,Pe)
Platecarpus	(Cd,Re,Sq)	Platylyron	(Mo,Ga,Ar)	Plectoceras	(Mo,Ce,Ba)
Platella	(Ar,Os,Pl)	Platymena	(Br,Ar,St)	Plectochiitina	(Fo,Fo,Ch)
Platichthys	(Cd,Os,Pn)	Platymerella	(Br,Ar,Pe)	Plectocion	(Mo,Ga,Ne)
Platidia	(Br,Ar,Te)	Platymyoidea	(Mo,Bi,Ph)	Plectoconcha	(Br,Ar,Te)
Platiferostroma	(Po,De,St)	Platynoticeras	(Mo,Ce,Am)	Plectoeretaeicus	(Cd,Os,Te)
Platillaenus	(Ar,Tr,Co)	Platyodon	(Mo,Bi,My)	Plectodermata	(Po,He,Re)
Platinx	(Cd,Os,Cr)	Platyodus	(Cd,Ch,In)	Plectodermatium	(Po,He,Ly)
Platipygus	(Ec,Ec,Ca)	Platyoptera	(Mo,Ga,Nt)	Plectodina	(Cd,Co,Co)
Platisporgia	(Po,De,Li)	Platyorthis	(Br,Ar,Or)	Plectodinemagraptus	(He,Gr,Gr)
Platonea	(Bz,St,Cc)	Platyosphyx	(Cd,Ma,Ce)	Plectodiscus	(Cn,Hy,Hy)
Platotropites	(Mo,Ce,Ce)	Platypeltoides	(Ar,Tr,As)	Plectodon	(Mo,Bi,Ph)
Platyacra	(Mo,Ga,Ar)	Platyphoca	(Cd,Ma,Ca)	Plectodonta	(Br,Ar,St)
Platyacrocrinus	(Ec,Cr,Mo)	Platyplina	(Mo,In,In)	Plectodontella	(Br,Ar,St)
Platyantyx	(Ar,Tr,Pr)	Platypleon	(Ar,ML,De)	Plectofronidularia	(Fo,Fo,Fo)
Platyaspis	(Cd,Pl,Ar)	Platypleuroceras	(Mo,Ce,Am)	Plectofusulina	(Fo,Fo,Fo)
Platyaxum	(Cn,An,Ta)	Platypterygius	(Cd,Re,Ic)	Plectoglossa	(Br,Li,Li)
Platybassis	(Mo,Ga,Ar)	Platyrachella	(Br,Ar,Sp)	Plectograpus	(He,Gr,Gr)
Platybolbina	(Ar,Os,Pa)	Platyrhina	(Cd,Ch,Rj)	Plectogyranopsis	(Fo,Fo,Fo)
Platybrissus	(Ec,Ec,Sp)	Platyrhomboides	(Ar,Os,Po)	Plectoidothyris	(Br,Ar,Te)
Platybursa	(Ac,Ra,Na)	Platyschisma	(Mo,Ga,Ar)	Plectolites	(Mo,Ce,Ta)
Platycalymene	(Ar,Tr,Ph)	Platyscutellum	(Ar,Tr,Co)	Plectomediocris	(Fo,Fo,Fo)
Platycancrinella	(Br,Ar,St)	Platyselma	(Br,Ar,St)	Plectomillerella	(Fo,Fo,Fo)
Platycardia	(Mo,Bi,Ve)	Platysiagum	(Cd,Os,Pl)	Plectomya	(Mo,Bi,Ph)
Platycephalus	(Cd,Os,Sc)	Platysiphon	(Mo,Ce,En)	Plectonotoides	(Mo,Ga,Be)
Platyceramus	(Mo,Bi,Pl)	Platysolenites	(Fo,Fo,Fo)	Plectonotus	(Mo,Ga,Be)
Platyceras	(Mo,Ga,Ar)	Platysomus	(Cd,Os,Pa)	Plectopyramis	(Ac,Ra,Na)
Platycheila	(Ar,ML,De)	Platyspinites	(Pr,Co,Ch)	Plectorecurvoides	(Fo,Fo,Fo)
Platycheilella	(Ar,Os,Me)	Platyspirifer	(Br,Ar,Sp)	Plectorhynchus	(Cd,Os,Pf)
Platycheilina	(Mo,Ga,Ar)	Platyspondylus	(Cd,Ch,Rj)	Plectorhynchella	(Br,Ar,Rh)
Platychnonia	(Po,De,Li)	Platystrophia	(Br,Ar,Or)	Plectorthis	(Br,Ar,Or)
Platyclymenia	(Mo,Ce,Cl)	Platysuchus	(Cd,Re,Cr)	Plectosolen	(Mo,Bi,Ve)
Platycoenia	(Cn,An,Sc)	Platyteichum	(Mo,Ga,Ar)	Plectospira	(Br,Ar,Sp)
Platyconcha	(Br,Ar,St)	Platyterorhynchus	(Br,Ar,Rh)	Plectospyris	(Po,He,He)
Platycnoceras	(Mo,Ce,Di)	Platythalamiaella	(Po,De,Pe)	Plectostroma	(Po,De,St)
Platyconus	(Mo,Ga,Ar)	Platythyris	(Br,Ar,Te)	Plectosyntrophia	(Br,Ar,Pe)
Platycorphe	(Ar,Tr,Ph)	Platytoechia	(Br,Ar,Or)	Plectothyrella	(Br,Ar,Rh)
Platycosta	(Ar,Os,Po)	Platytyrochopsis	(Cn,An,Sc)	Plectothyris	(Br,Ar,Te)
Platycrinites	(Ec,Cr,Mo)	Platytyrochus	(Cn,An,Sc)	Plectotreta	(Br,Ar,Or)
Platyuccoceras	(Mo,Ce,Ce)	Platyvillosus	(Cd,Co,Co)	Plectotrochammina	(Fo,Fo,Fo)
Platycyathus	(Cn,An,Sc)	Platyworthenia	(Mo,Ga,Ar)	Plectotrophia	(Br,Ar,Pe)
Platycystites	(Ec,Pe,Pl)	Platyxytrodus	(Cd,Ch,Ch)	Plectrella	(Ar,Tr,Pt)
Platycythara	(Mo,Ga,Ne)	Platyzona	(Mo,Ga,Ar)	Plectrites	(Cd,Os,Pf)
Platycythere	(Ar,Os,Po)	Plavecchia	(Cn,An,Sc)	Plectronia	(Po,Ca,Ph)
Platycythereis	(Ar,Os,Po)	Plavskella	(Ar,Os,Po)	Plectronoceras	(Mo,Ce,Pl)
Platydiamesus	(Ar,Tr,Pt)	Plaxiphora	(Mo,Po,Ne)	Plectrypops	(Cd,Os,Br)
Platyfundocrinus	(Ec,Cr,Cl)	Plaxocrinus	(Ec,Cr,Cl)	Pleesus	(Ac,Ra,Na)
Platygena	(Mo,Bi,Pt)	Playfordia	(Cd,Co,Co)	Plegagnathus	(Cd,Co,Co)
Platyglena	(Bz,Gy,Ch)	Playfordites	(Mo,Ce,An)	Plegiocidaris	(Ec,Ec,Ci)
Platygllossariorhynchus	(Br,Ar,Rh)	Plebejochonetes	(Br,Ar,St)	Plegmatograptus	(He,Gr,Gr)

Plegmosphaera	(Ac,Ra,Sp)	Plesiothamasteria	(Cn,An,Sc)	Pleuromphalus	(Mo,Ga,Eu)
Pleia	(Mo,Ga,Ne)	Plesiothyreus	(Mo,Ga,Ar)	Pleuromya	(Mo,Bi,Ph)
Pleiechinus	(Ec,Ec,Py)	Plesiothyris	(Br,Ar,Te)	Pleuromysidia	(Mo,Bi,Pt)
Pleioocyptus	(Ec,Ec,Ph)	Plesiotisotia	(Mo,Ce,Am)	Pleuronautilus	(Mo,Ce,Na)
Pleioleuрина	(Br,Ar,Rh)	Plesiotriton	(Mo,Ga,Nt)	Pleuronoceras	(Mo,Ce,Na)
Pleioptygma	(Mo,Ga,Ne)	Plesiotrochus	(Mo,Ga,Nt)	Pleuronea	(Br,St,Cc)
Pleioritytis	(Mo,Bi,Ve)	Plesioturritiles	(Mo,Ce,Am)	Pleuronecites	(Mo,Bi,Pt)
Plekonella	(Br,Ar,Rh)	Plesiotylosaurus	(Cd,Re,Sq)	Pleuronicthys	(Cd,Os,Pn)
Plekonina	(Br,Ar,Rh)	Plesiovasoceras	(Mo,Ce,Am)	Pleuronodoceras	(Mo,Ce,Ce)
Plemnocrinus	(Ec,Cr,Mo)	Plesiyuepingia	(Ar,Tr,As)	Pleuronotus	(Mo,Ga,Eu)
Plenocaris	(Ar,In,Un)	Plethobolbina	(Ar,Os,Pa)	Pleurope	(Po,He,Ly)
Plentaria	(Mo,Ga,Ne)	Plethocardia	(Mo,Bi,Pt)	Pleuropegma	(Mo,Ro,Ri)
Pleolobites	(Ar,MI,De)	Plethodus	(Cd,Os,Cr)	Pleuropholis	(Cd,Os,Pe)
Pleophyllum	(Cn,An,Ru)	Plethometopus	(Ar,Tr,Pt)	Pleurophopsis	(Mo,Bi,Ve)
Pleramplexus	(Cn,An,Ru)	Plethopeltella	(Ar,Tr,Co)	Pleurophorella	(Mo,Bi,Ph)
Plerodiffia	(Cn,An,Ru)	Plethopeltides	(Ar,Tr,Pt)	Pleurophorina	(Mo,Bi,Ph)
Pleroma	(Po,De,Li)	Plethopeltis	(Ar,Tr,Pt)	Pleurophyllia	(Cn,An,Sc)
Plesiacanthoceras	(Mo,Ce,Am)	Plethopora	(Br,St,Cc)	Pleurophyllum	(Cn,An,Ru)
Plesiacanthoides	(Mo,Ce,Am)	Plethoporella	(Br,St,Cc)	Pleurophymia	(Po,De,Li)
Plesiastarte	(Mo,Bi,Ve)	Plethorhynga	(Br,Ar,Rh)	Pleuropinacoceras	(Mo,Ce,Ce)
Plesiaster	(Ec,Ec,Sp)	Plethoschisma	(Ec,Rh,Rh)	Pleuroploca	(Mo,Ga,Ne)
Plesiastrea	(Cn,An,Sc)	Plethosphonia	(Po,De,Li)	Pleuropodia	(Cn,An,Sc)
Plesiastropecten	(Ec,As,Px)	Plethospira	(Mo,Ga,Ar)	Pleuropugnoides	(Br,Ar,Rh)
Plesicarinata	(Br,Ar,At)	Pleuraeme	(Mo,Ga,Nt)	Pleuropyge	(Po,He,Ly)
Plesidielymella	(Ar,Os,Ar)	Pleuratoma	(Br,Ar,Te)	Pleuropyramis	(Mo,Ga,Ne)
Plesioacirsa	(Mo,Ga,Nt)	Pleuratella	(Mo,Ga,Ar)	Pleurorima	(Mo,Ga,Ar)
Plesioastropecten	(Ec,As,No)	Pleurelasma	(Br,Ar,Te)	Pleurorthis	(Br,Ar,Or)
Plesioberyx	(Cd,Os,Br)	Pleureterites	(Mo,Bi,Un)	Pleurorthisceras	(Mo,Ce,Or)
Plesiocaryophyllia	(Cn,An,Sc)	Pleurifera	(Ar,Os,Po)	Pleurosaurus	(Cd,Re,Sp)
Plesiocerithium	(Mo,Ga,Ne)	Pleurikodonta	(Mo,Bi,Ph)	Pleuroschisma	(Ec,Bi,Fi)
Plesiocectopsis	(Cd,Ma,Ce)	Pleurinodus	(Ar,Tr,Ag)	Pleuroschiella	(Br,Gy,Ch)
Plesiocetus	(Cd,Ma,Ce)	Pleurocardia	(Mo,Bi,Ve)	Pleurosiphonella	(Cn,An,Ta)
Plesiochelys	(Cd,Re,Ch)	Pleuristratoentactinia	(Ac,Ra,Sp)	Pleuroskelidion	(Fo,Fo,Fo)
Plesiocidaris	(Ec,Ec,Hm)	Pleuroacanthites	(Mo,Ce,Am)	Pleurostoma	(Po,He,He)
Plesiooccolopsis	(Cd,Os,Pa)	Pleurobelus	(Mo,Ce,Be)	Pleurostomella	(Fo,Fo,Fo)
Plesioecenia	(Cn,An,Sc)	Pleurocephalites	(Mo,Ce,Am)	Pleurostomelloides	(Fo,Fo,Fo)
Plesioerinus	(Ec,Cr,Mo)	Pleuroceras	(Mo,Ce,Am)	Pleurostylina	(Cn,An,Sc)
Plesiocunoltops	(Cn,An,Sc)	Pleurochonetes	(Br,Ar,St)	Pleurotexasites	(Mo,Ce,Am)
Plesioocyprina	(Mo,Bi,Ve)	Pleurochorium	(Po,He,He)	Pleurothyrella	(Br,Ar,Te)
Plesioocyprinella	(Mo,Bi,Ph)	Pleuroconcha	(Mo,Bi,Ve)	Pleurotomaria	(Mo,Ga,Ar)
Plesiodiceras	(Mo,Bi,Hi)	Pleurocora	(Cn,An,Sc)	Pleurotomella	(Mo,Ga,Ne)
Plesiodiploteniopsis	(Cn,An,Sc)	Pleurocornu	(Br,Ar,Rh)	Pleurotomoides	(Mo,Ga,Ne)
Plesiodiploria	(Cn,An,Sc)	Pleurocrinus	(Ec,Cr,Mo)	Pleurotrigonia	(Mo,Bi,Tr)
Plesiofavia	(Cn,An,Sc)	Pleuroctenium	(Ar,Tr,Ag)	Plexituba	(Cn,An,Ta)
Plesiohamites	(Mo,Ce,Am)	Pleurocystites	(Ec,Rh,Rh)	Plexodictyon	(Po,De,St)
Plesiolampas	(Ec,Ec,Ca)	Pleurocythere	(Ar,Os,Po)	Pleydellia	(Mo,Ce,Am)
Plesiolepidotus	(Cd,Os,Se)	Pleurodapis	(Mo,Bi,Ph)	Plicacesta	(Mo,Bi,Pt)
Plesiomalvinella	(Ar,Tr,Ph)	Pleurodella	(Ar,Os,Pa)	Plicacoleus	(Pr,Ma,Tu)
Plesiomegalaspis	(Ar,Tr,As)	Pleurodesma	(Mo,Bi,My)	Plicaea	(Br,Ar,St)
Plesiomontivalvata	(Cn,An,Sc)	Pleurodiadema	(Ec,Ec,Ph)	Plicafoliosa	(Mo,Ga,Ar)
Plesioptarabolina	(Ar,Tr,Pt)	Pleurodictyum	(Cn,An,Ta)	Plicanopia	(Br,Ar,St)
Plesioptagus	(Ec,Ec,Sp)	Pleurodistichites	(Mo,Ce,Ce)	Plicanoplites	(Br,Ar,St)
Plesiopterleidus	(Cd,Os,Pe)	Pleurodium	(Br,Ar,Pe)	Plicarcularia	(Mo,Ga,Ne)
Plesioptyllia	(Cn,An,Sc)	Pleurofusua	(Mo,Ga,Ne)	Plicarostrium	(Br,Ar,Rh)
Plesioptyllum	(Cn,An,Sc)	Pleurogrammatodon	(Mo,Bi,Ar)	Plicatiella	(Mo,Bi,Tr)
Plesiopinna	(Mo,Bi,Mt)	Pleurograptus	(He,Gr,Gr)	Plicatifera	(Br,Ar,St)
Plesioptygmatis	(Mo,Ga,He)	Pleurohoplites	(Mo,Ce,Am)	Plicatiferina	(Br,Ar,St)
Plesiosaurus	(Cd,Re,Ps)	Pleuroimmaea	(Mo,Ga,Ba)	Plicatoeras	(Mo,Ce,Or)
Plesioserranus	(Cd,Os,Pf)	Pleuroliria	(Mo,Ga,Ne)	Plicatoerinus	(Ec,Cr,Cy)
Plesiosiderastraea	(Cn,An,Sc)	Pleurolucina	(Mo,Bi,Ve)	Plicatocyrtia	(Br,Ar,Sp)
Plesiosmilia	(Cn,An,Sc)	Pleurolyrula	(Br,Gy,Ch)	Plicatoderbya	(Br,Ar,St)
Plesiospidiscus	(Mo,Ce,Am)	Pleurolytoceras	(Mo,Ce,Am)	Plicatoflamna	(Cd,Ch,La)
Plesiosytilina	(Cn,An,Sc)	Pleuromera	(Po,De,Li)	Plicatolina	(Ar,Tr,Pt)
Plesiot euthis	(Mo,Ce,Te)	Pleuromeris	(Mo,Bi,Ve)	Plicatolingula	(Br,Li,Li)

Plicatomorpha	(Mo,Bi,Mo)	Plotocrinus	(Ec,Cr,Rv)	Polenovula	(Ar,Os,Po)
Plicatomurus	(Cn,An,Ta)	Platophylops	(Mo,Ga,Th)	Poletaevella	(Ar,Tr,Re)
Plicatomytilus	(Mo,Bi,Mt)	Plotosaurus	(Cd,Re,Sq)	Poleumita	(Mo,Ga,Eu)
Plicatoria	(Br,Ar,St)	Ploughsharella	(Br,Ar,St)	Poliella	(Ar,Tr,Co)
Plicatospiriferella	(Br,Ar,Sp)	Plourdosteus	(Cd,Pl,Ar)	Poliellaspis	(Ar,Tr,Co)
Plicatostylus	(Mo,Bi,Pt)	Plumalina	(Cn,Hy,Un)	Policellina	(Ar,Tr,Co)
Plicatosyrinx	(Br,Ar,St)	Plumaster	(Ec,As,Va)	Polimella	(Mo,Ga,Nt)
Plicatula	(Mo,Bi,Pt)	Plumatalina	(Po,De,St)	Polinices	(Mo,Ga,Nt)
Plicidium	(Br,Ar,Pe)	Plummericrinus	(Ec,Cr,Cl)	Poliniella	(Mo,Ga,Ne)
Plicifusus	(Mo,Ga,Ne)	Plummerinella	(Fo,Fo,Fo)	Poliphyllum	(Cn,An,Ru)
Plicirhynchia	(Br,Ar,Rh)	Plummerita	(Fo,Fo,Fo)	Politiceras	(Mo,Ce,Go)
Pliciscala	(Mo,Ga,Nt)	Plummeroceras	(Mo,Ce,Na)	Pollachius	(Cd,Os,Ga)
Plicithea	(Hy,Or,Or)	Plumulites	(Pr,Ma,Le)	Pollex	(Mo,Bi,Ve)
Plicobulla	(Mo,Ga,Ce)	Plurigenis	(Mo,Bi,Ve)	Pollia	(Mo,Ga,Ne)
Plicochonetes	(Br,Ar,St)	Pneumataphorous	(Cd,Os,Pf)	Polliaxis	(Ar,Tr,Co)
Plicocoelina	(Br,Ar,Pe)	Pneumatoothis	(Cd,Re,Ch)	Pollicina	(Mo,Te,Cy)
Plicocyathus	(Po,Re,Aj)	Pneumatocythere	(Ar,Os,Po)	Pollicipes	(Ar,Ci)
Plicocyrta	(Br,Ar,Sp)	Pnictopora	(Bz,Gy,Ch)	Pollingeria	(Pr,Un,In)
Plicocyrtrina	(Br,Ar,Sp)	Pnictoporopsis	(Bz,Gy,Ch)	Poloniella	(Ar,Os,Pa)
Plicodendrocrinus	(Ec,Cr,Cl)	Pobum	(Ac,Ra,Sp)	Poloniproductus	(Br,Ar,St)
Plicodevonaria	(Br,Ar,St)	Pocillopora	(Cn,An,Sc)	Polonites	(Mo,Ce,Go)
Plicogypa	(Br,Ar,Pe)	Pocillosporgia	(Po,De,I,I)	Polonoceras	(Mo,Ce,Go)
Pliconacca	(Mo,Ga,Nt)	Poculicephalina	(Ar,Tr,Un)	Polonodus	(Cd,Co,Co)
Plicoplasia	(Br,Ar,Sp)	Poculicrinus	(Ec,Cr,Rv)	Polusocrinus	(Ec,Cr,Cl)
Plicopora	(Bz,Gy,Ch)	Poculisphinctes	(Mo,Ce,Am)	Polyacrodus	(Cd,Ch,Ct)
Plicoproductus	(Br,Ar,St)	Podabacia	(Cn,An,Sc)	Polyactinella	(Po,Ca,Un)
Plicostriklania	(Br,Ar,Pe)	Podapsis	(Po,De,I,I)	Polyadelphia	(Cn,An,Ru)
Plicostropheodonta	(Br,Ar,St)	Podjassopora	(Bz,St,Cy)	Polyariella	(Ar,Tr,Pt)
Plicotorynifer	(Br,Ar,Sp)	Podobursa	(Ac,Ra,Na)	Polyascosocia	(Bz,St,Ce)
Plictetia	(Mo,Ce,Am)	Podocapsa	(Ac,Ra,Na)	Polyastropsis	(Cn,An,Sc)
Pliogatella	(Po,De,Li)	Podoccephalus	(Cd,Os,Pf)	Polyblastidium	(Po,He,Ly)
Pliendoceras	(Mo,Ce,En)	Podocoronis	(Ac,Ra,Na)	Polycephalopora	(Bz,Gy,Ch)
Plinthicus	(Cd,Ch,My)	Podocyrtilis	(Ac,Ra,Na)	Polyceratella	(Ar,Os,Pa)
Plinthodermatium	(Po,De,Li)	Pododermis	(Mo,Bi,Te)	Polyceratopora	(Bz,Gy,Ch)
Plinthokonium	(Pr,Un,In)	Podolella	(Br,Ar,Pe)	Polycertaspis	(Ar,Tr,Pt)
Plinthosella	(Po,De,Li)	Podolia	(Fo,Fo,Fo)	Polychaetaspis	(An,Po,Eu)
Pliobolia	(Po,De,Li)	Podolibolbina	(Ar,Os,Pa)	Polychaetus	(An,Po,Eu)
Pliobolopsis	(Po,De,Li)	Podoliceris	(Mo,Ce,Or)	Polychasmina	(Fo,Fo,Fo)
Pliobothrus	(Cn,Hy,St)	Podoliproetus	(Ar,Tr,Pr)	Polycidaris	(Ec,Ec,Ci)
Pliocardia	(Mo,Bi,Ve)	Podolites	(Ar,Tr,Ph)	Polycnemidium	(Ar,ML,De)
Pliolampas	(Ec,Ec,Ca)	Podollites	(Cn,An,Ta)	Polycnemiseudea	(Po,Ca,Ph)
Pliomera	(Ar,Tr,Ph)	Podophthalmus	(Ar,ML,De)	Polyconites	(Mo,Bi,Hi)
Pliomerella	(Ar,Tr,Ph)	Podoseris	(Cn,An,Sc)	Polycope	(Ar,Os,My)
Pliomerina	(Ar,Tr,Ph)	Podothecus	(Cd,Os,Sc)	Polycoscinus	(Po,Re,Aj)
Pliomeroides	(Ar,Tr,Ph)	Podowrinella	(Ar,Tr,Ph)	Polycosmites	(Ec,Rh,Rh)
Pliomerops	(Ar,Tr,Ph)	Podischeremia	(Br,Ar,Sp)	Polycotylus	(Cd,Re,Ps)
Plionema	(Mo,Bi,Ve)	Poecilasma	(Ar,Ci)	Polycrinus	(Ec,Cr,Cl)
Plionoptycherhynchus	(Br,Ar,Rh)	Poecilocrinus	(Ec,Cr,Rv)	Polyicylindricus	(Bz,St,Tr)
Pliopedia	(Cd,Ma,Ca)	Poecilodus	(Cd,Ch,In)	Polyicylindrites	(Mo,Cr,Ho)
Pliophloea	(Bz,Gy,Ch)	Poecilomorphus	(Mo,Ce,Am)	Polyicyphus	(Ec,Ec,Ph)
Plioplatecarpus	(Cd,Re,Sq)	Pogonias	(Cd,Os,Pf)	Polycystocoelia	(Po,De,Pe)
Pliopontos	(Cd,Ma,Ce)	Pogonipocrinus	(Ec,Cr,Ds)	Polydactylus	(Cd,Os,Pf)
Pliosaurus	(Cd,Re,Ps)	Pogonochitina	(Fo,Fo,Ch)	Polydeltoideus	(Ec,Bl,Fr)
Pliothyrida	(Br,Ar,Te)	Pohlia	(Fo,Fo,Fo)	Polydentina	(Ar,Os,Po)
Pliotrema	(Cd,Ch,Pr)	Poikilosakos	(Br,Ar,St)	Polydesmaster	(Ec,Ec,Sp)
Plocezyga	(Mo,Ga,Nt)	Poirieria	(Mo,Ga,Ne)	Polydesmia	(Mo,Ce,Ac)
Plochelaea	(Mo,Ga,Ne)	Pojarkovella	(Fo,Fo,Fo)	Polydiadema	(Ec,Ec,Hm)
Plocoastraea	(Cn,An,Sc)	Pojetaconcha	(Mo,Ro,Co)	Polydixodina	(Fo,Fo,Fo)
Plococidaris	(Ec,Ec,Ci)	Pojetia	(Mo,Bi,Nu)	Polydilasma	(Cn,An,Ru)
Plococonia	(Po,De,Li)	Pokornyella	(Ar,Os,Po)	Polydora	(An,Po,Sp)
Ploconema	(Mo,Ga,Ar)	Polaricyclus	(Mo,Ce,Go)	Polyedra	(Po,De,Pe)
Plocoscyphia	(Po,He,Ly)	Polaroplasma	(Cn,An,Ru)	Polyelasmoceras	(Mo,Ce,On)
Plocostoma	(Mo,Ga,Ar)	Polehemia	(Mo,Ga,Eu)	Polyendostoma	(Po,Ca,Ph)
Plocostylus	(Mo,Ga,Ar)	Polenovia	(Ar,Os,My)	Polyentactinia	(Ac,Ra,Sp)

Polyfenestella	(Bz.St.Fe)	Polysphinctes	(Mo.Ce.Am)	Pontocypris	(Ar.Os.Po)
Polyfistula	(Ac.Ra.Sp)	Polyspinopora	(Bz.St.Tr)	Pontocythere	(Ar.Os.Po)
Polygnathellus	(Cd.Co.Co)	Polystigmatium	(Po.He.He)	Pontogeneus	(Cd.Ma.Ce)
Polygnathoides	(Cd.Co.Co)	Polystira	(Mo.Ga.Ne)	Pontolis	(Cd.Ma.Ca)
Polygnathus	(Cd.Co.Co)	Polystoma	(Po.De.Li)	Pontophoca	(Cd.Ma.Ca)
Polygonaria	(Cn.An.Ru)	Polystomellina	(Fo.Fo.Fo)	Pontopus	(Cd.Re.No)
Polygonatium	(Po.He.Ly)	Polystylidium	(Cn.An.Sc)	Pontosaurus	(Cd.Re.Sq)
Polygonocrinus	(Ec.Cr.Cl)	Polysyge	(Po.He.He)	Popanites	(Mo.Ce.Am)
Polygonograptus	(He.Gr.De)	Polytaxicidarid	(Ec.Ec.Ey)	Popanoceras	(Mo.Ce.Go)
Polygrammoceras	(Mo.Ce.Or)	Polytaxis	(Fo.Fo.Fo)	Popenella	(Mo.Ga.Nt)
Polygyreulima	(Mo.Ga.Nt)	Polyteichus	(Bz.St.Tr)	Popenoem	(Mo.Ga.Ne)
Polygyrina	(Mo.Ga.Nt)	Polythecalis	(Cn.An.Ru)	Popigaia	(Ar.Tr.Co)
Polygyrodus	(Cd.Os.Py)	Polythecalloides	(Cn.An.Ru)	Popofskyellum	(Ac.Ra.Sp)
Polyipnoides	(Cd.Os.St)	Polytholosa	(Po.De.Pe)	Poporites	(Mo.Ce.Ce)
Polyipnus	(Cd.Os.St)	Polythyra	(Po.De.Li)	Popovia	(Fo.Fo.Fo)
Polylasma	(Br.Li.Ac)	Polythyris	(Po.He.He)	Populsenella	(Ar.Tr.Pt)
Polylepidina	(Fo.Fo.Fo)	Polytoechia	(Br.Ar.Or)	Poracanthodes	(Cd.Ac.Is)
Polylophidium	(Po.He.Re)	Polytremacis	(Cn.An.He)	Porachistrum	(Ec.Ho.Ap)
Polylophodonta	(Cd.Co.Co)	Polytremaria	(Mo.Ga.Ar)	Porambonites	(Br.Ar.Pe)
Polylophia	(Pr.Un.Co)	Polytretia	(Po.De.As)	Porambonitoides	(Br.Ar.Pe)
Polymesoda	(Mo.Bi.Ve)	Polytryphocloides	(Ec.Ed.Is)	Poramborthis	(Br.Ar.Or)
Polymetme	(Cd.Os.St)	Polytylies	(Ar.Os.Pa)	Poraspis	(Cd.Pt.Pt)
Polymetmeglareosus	(Cd.Os.St)	Polyzygia	(Ar.Os.Me)	Poratites	(Pr.Un.In)
Polymixia	(Cd.Os.Po)	Polzbergia	(Cd.Os.Bb)	Porcaconus	(Mo.In.In)
Polymorpharia	(Br.Ar.St)	Pomacanthus	(Cd.Os.Pf)	Porcauricula	(Pr.To.Mi)
Polymorphastraea	(Cn.An.Sc)	Pomadasy	(Cd.Os.Pf)	Porcellana	(Ar.Ml.De)
Polymorphina	(Fo.Fo.Fo)	Pomahakia	(Mo.Ga.Ne)	Porcellia	(Mo.Ga.Ar)
Polymorphinella	(Fo.Fo.Fo)	Pomarangina	(Mo.Bi.Hi)	Porechinus	(Ec.Ec.Ey)
Polymorphites	(Mo.Ce.Am)	Pomaster	(Ec.Ec.Hs)	Porefieldia	(Po.De.Pe)
Polymenamussium	(Mo.Bi.Pt)	Pomatias	(Mo.Ga.Nt)	Porella	(Bz.Gy.Ch)
Polyosepia	(Po.He.He)	Pomatoceros	(An.Po.Se)	Porfirievella	(Cn.An.Ru)
Polyosteorhynchus	(Cd.Os.Co)	Pomatocrinus	(Ec.Cr.Mi)	Porigraulus	(Ar.Tr.Pt)
Polypeltes	(Ec.Cr.Mo)	Pomatodelphis	(Cd.Ma.Ce)	Poriceata	(Bz.St.Ce)
Polyperibola	(Fo.Fo.Fo)	Pomatospirella	(Br.Ar.Un)	Poricellaria	(Bz.Gy.Ch)
Polyphyloseris	(Cn.An.Sc)	Pomatotrema	(Br.Ar.Or)	Porichthys	(Cd.Os.Ba)
Polyphyma	(Ar.Os.Ar)	Pomaulax	(Mo.Ga.Ar)	Poriferaspis	(Cd.Pt.Pt)
Polyplacida	(Ec.Ec.Ph)	Pomerania	(Mo.Ce.Am)	Poriferella	(Po.He.He)
Polyplacognathus	(Cd.Co.Co)	Pomeraniotreta	(Br.Li.Ac)	Porina	(Bz.Gy.Ch)
Polyplacus	(Ec.He.He)	Pomeromena	(Br.Ar.St)	Porioicidarid	(Ec.Ec.Ci)
Polyplectella	(Po.He.Re)	Pomiropecten	(Mo.Bi.Pt)	Porites	(Cn.An.Sc)
Polyplectites	(Mo.Ce.Am)	Pomolobus	(Cd.Os.Cl)	Porkornya	(Ar.Os.Pa)
Polyplectus	(Mo.Ce.Am)	Pomorina	(Cn.In.In)	Porkornyopsis	(Ar.Os.Po)
Polypleuraspis	(Ar.Tr.Co)	Pompeckia	(Ar.Tr.Ph)	Porkunites	(Cn.An.Ta)
Polypora	(Bz.St.Fe)	Pompeckioceras	(Mo.Ce.Am)	Pornosis	(Mo.Ga.Ne)
Polyporella	(Bz.St.Fe)	Pompeckium	(Br.Ar.Or)	Poroarticulina	(Fo.Fo.Fo)
Polyptychella	(Ec.Eo.Un)	Pompeckjina	(Mo.Bi.Pt)	Poroblastus	(Ec.Bl.Sp)
Polyptychites	(Mo.Ce.Am)	Pompeckjites	(Mo.Ce.Ce)	Porochonia	(Po.He.Ly)
Polyptychoceras	(Mo.Ce.Am)	Pompholigina	(Mo.Bi.Ve)	Porocidarid	(Ec.Ec.Ci)
Polyptychodon	(Cd.Re.Ps)	Pompoecilorhynchus	(Br.Ar.Rh)	Porocoscinus	(Po.Re.Aj)
Polyrhypidium	(Po.De.Li)	Ponderia	(Mo.Ga.Ne)	Porocrinus	(Ec.Cr.Cl)
Polyrhizodus	(Cd.Ch.Pe)	Ponderodietya	(Ar.Os.Me)	Porocyathellus	(Po.Re.Aj)
Polyrhizophora	(Po.De.Li)	Pondospirifer	(Br.Ar.Sp)	Porocypellia	(Po.He.Ly)
Polyrophe	(Cn.An.Ru)	Poniklacella	(Ar.Os.Me)	Porocystis	(Pr.Un.In)
Polysalenia	(Ec.Ec.Sa)	Ponocyclus	(Mo.Ga.Nt)	Porodiscus	(Ac.Ra.Sp)
Polyschema	(Po.He.He)	Ponteixites	(Mo.Ce.Am)	Poroepoides	(Fo.Fo.Fo)
Polyschides	(Mo.Sc.Sc)	Ponticeras	(Mo.Ce.An)	Porolelda	(Mo.Bi.Nu)
Polysentor	(Cd.Ch.In)	Pontielasma	(Br.Ar.Te)	Porolepis	(Cd.Os.Co)
Polyseries	(Cn.An.Sc)	Pontinus	(Cd.Os.Sc)	Porometra	(Bz.Gy.Ch)
Polysiphon	(Po.Ca.Un)	Pontipalpebralia	(Ar.Tr.Pr)	Poromitra	(Cd.Os.Br)
Polysiphonella	(Po.De.Pe)	Pontisia	(Br.Ar.Rh)	Poromya	(Mo.Bi.Ph)
Polysiphonidia	(Pr.Un.In)	Pontistes	(Cd.Ma.Ce)	Poropeltarion	(Bz.Gy.Ch)
Polysiphospongia	(Po.De.Pe)	Pontivaga	(Cd.Ma.Ce)	Poropeltaris	(Ec.Ec.Sa)
Polysiponeudea	(Po.De.Li)	Pontobdellopsis	(An.Po.Un)	Porophoraspis	(Cd.Pt.Pt)
Polysolenia	(Ac.Ra.Sp)	Pontocyrella	(Ar.Os.Po)	Poroplagioecia	(Bz.St.Ce)

Poroproteron	(Mo,Ga,Ne)	Poulsenia	(Ar,Tr,Pt)	Praekurnubia	(Fo,Fo,Fo)
Pororaria	(Ar,Ml,De)	Pourtalesia	(Ec,Ec,Hs)	Praelacazella	(Br,Ar,Th)
Pororhiza	(Cd,Ch,Ct)	Pourtalocyathus	(Cn,An,Sc)	Praelacazella	(Fo,Fo,Fo)
Poroscutellum	(Ar,Tr,Pt)	Powellisetia	(Mo,Ga,Nt)	Praelacunosella	(Br,Ar,Rh)
Porosoma	(Ec,Ec,Ph)	Powichthys	(Cd,Os,Co)	Praelamelloodonta	(Mo,In,In)
Porosorotalia	(Fo,Fo,Fo)	Pradesia	(Ar,Tr,As)	Praelapeirusia	(Mo,Bi,Hi)
Porosphaera	(Po,Ca,Ph)	Pradesura	(Ec,Op,St)	Praelepas	(Ar,Ci)
Porosphaerella	(Po,Ca,Ph)	Pradochonetes	(Br,Ar,St)	Praellitorina	(Mo,Ga,Ar)
Porospongia	(Po,He,He)	Pradocrinus	(Ec,Cr,Mo)	Praelobobairdia	(Ar,Os,Po)
Porostictia	(Br,Ar,Rh)	Pradoia	(Br,Ar,Sp)	Praelongithyrus	(Br,Ar,Te)
Porphyrocrinus	(Ec,Cr,Bo)	Praevalveolina	(Fo,Fo,Fo)	Praelumbrineris	(An,Po,Eu)
Porpitella	(Ec,Ec,Cl)	Praeammoastuta	(Fo,Fo,Fo)	Praemacrocypris	(Ar,Os,Po)
Porpoceras	(Mo,Ce,Am)	Praeamonotis	(Mo,Bi,Pt)	Praemanambolites	(Mo,Ce,Am)
Portaginus	(Ar,Tr,Pt)	Praeangustothyris	(Br,Ar,Te)	Praematuratropis	(Mo,Ga,Be)
Portalia	(Pr,Un,In)	Praeanomalodonta	(Mo,Bi,Pt)	Praemerocheras	(Mo,Ce,Go)
Portentosus	(Ar,Tr,As)	Praecaryotheca	(Br,Ar,Te)	Praemonticellarella	(Br,Ar,Rh)
Porterfieldia	(Ar,Tr,Pt)	Praecatya	(Ar,Ml,De)	Praemuniericeras	(Mo,Ce,Am)
Porterius	(Mo,Bi,Ar)	Praeaucellina	(Mo,Bi,Pt)	Praemunsyella	(Ar,Os,Po)
Porthochelys	(Cd,Re,Ch)	Praebarretia	(Mo,Bi,Hi)	Praemurica	(Fo,Fo,Fo)
Porticulasphaera	(Fo,Fo,Fo)	Praebigotites	(Mo,Ce,Am)	Praemyonia	(Mo,Bi,Ph)
Portlandemys	(Cd,Re,Ch)	Praebuchia	(Mo,Bi,Pt)	Praemytilus	(Mo,Bi,Mt)
Portlandia	(Mo,Bi,Nu)	Praebulimina	(Fo,Fo,Fo)	Praenatica	(Mo,Ga,Ar)
Portlockiella	(Mo,Ga,Ar)	Praebullavalveolina	(Fo,Fo,Fo)	Praeneoathyris	(Br,Ar,Te)
Portneufia	(Br,Ar,Te)	Praebythoceratina	(Ar,Os,Po)	Praenucula	(Mo,Bi,Nu)
Portorica	(Mo,Ga,Nt)	Praecambridium	(Cn,Pe,Er)	Praeophthalmidium	(Fo,Fo,Fo)
Portranella	(Br,Ar,Or)	Praecanthochiton	(Mo,Po,Pa)	Praeorbitolina	(Fo,Fo,Fo)
Portunites	(Ar,Ml,De)	Praecaprina	(Mo,Bi,Hi)	Praeorbulina	(Fo,Fo,Fo)
Portunus	(Ar,Ml,De)	Praecaprotina	(Mo,Bi,Hi)	Praerocrinus	(Ec,Cr,Tx)
Posacythere	(Ar,Os,Po)	Praecardiomya	(Mo,Bi,Un)	Praecrostra	(Mo,Bi,Mt)
Posidonamicus	(Ar,Os,Po)	Praecardium	(Mo,Bi,Pr)	Praecoxyteuthis	(Mo,Ce,Be)
Posicomta	(Br,Ar,Sp)	Praecaudina	(Ec,Ho,El)	Praeparafusulina	(Fo,Fo,Fo)
Posidonia	(Mo,Bi,Pt)	Praechlamys	(Mo,Bi,Pt)	Praeparkinsonia	(Mo,Ce,Am)
Posidoniella	(Mo,Bi,Pt)	Praechrysalidina	(Fo,Fo,Fo)	Praepeneroplis	(Fo,Fo,Fo)
Posidonotis	(Mo,Bi,Pt)	Praeconia	(Mo,Bi,Ve)	Praephacorhabdodus	(Ar,Os,Po)
Posneratina	(Ar,Os,Pa)	Praeconocaryomma	(Ac,Ra,Sp)	Praepilatina	(Ar,Os,Po)
Posnerina	(Ar,Os,Pa)	Praectenodonta	(Mo,Bi,Nu)	Praepleurocystis	(Ec,Rh,Rh)
Postacanthella	(Mo,In,In)	Praecubanothyris	(Br,Ar,Te)	Praepseudofusulina	(Fo,Fo,Fo)
Postalia	(Mo,Ga,Nt)	Praecupulocrinus	(Ec,Cr,Cl)	Praeputa	(Cd,Ma,Ca)
Postendothyra	(Fo,Fo,Fo)	Praecyclothyris	(Br,Ar,Rh)	Praeradiolites	(Mo,Bi,Hi)
Postepithyris	(Br,Ar,Te)	Praecystamina	(Fo,Fo,Fo)	Praerangia	(Mo,Bi,Ve)
Posterodonta	(Mo,Bi,So)	Praedaraelites	(Mo,Ce,Pl)	Praereticulinella	(Fo,Fo,Fo)
Posteroprotythere	(Ar,Os,Po)	Praedeehenella	(Ar,Tr,Pr)	Praerhaetina	(Br,Ar,Te)
Postestopochonus	(Mo,In,In)	Praedellandrella	(Ac,Ra,Sp)	Praerhapydionina	(Fo,Fo,Fo)
Postfallotaspis	(Ar,Tr,Re)	Praedicticrinus	(Ec,Cr,Mo)	Praesacella	(Mo,Bi,Nu)
Postglatzliella	(Mo,Ce,Cl)	Praedietyrbotolina	(Fo,Fo,Fo)	Praeschuleridea	(Ar,Os,Po)
Postibulla	(Ec,Ed,Is)	Praeephronides	(Ec,Ho,El)	Praesemicosinium	(Bz,St,Fe)
Postligata	(Mo,Bi,Ar)	Praeexogyra	(Mo,Bi,Pt)	Praesiderolites	(Fo,Fo,Fo)
Postrugoglobigerina	(Fo,Fo,Fo)	Praegibbithyris	(Br,Ar,Te)	Praesondylopecten	(Mo,Bi,Pt)
Posttornoceras	(Mo,Ce,Go)	Praeglobobulimina	(Fo,Fo,Fo)	Praesphaeroceras	(Mo,Ce,Am)
Potamides	(Mo,Ga,Nt)	Praeglobotruncana	(Fo,Fo,Fo)	Praestomatia	(Mo,Ga,Ar)
Potamidopsis	(Mo,Ga,Nt)	Praeglycyera	(An,Po,Ph)	Praestorsella	(Fo,Fo,Fo)
Potamodolphis	(Cd,Ma,Ce)	Praeglyphoceras	(Mo,Ce,Go)	Praestrigites	(Mo,Ce,Am)
Potamomya	(Mo,Bi,Ve)	Praegmelina	(Ar,Ml,Am)	Praestylosphaera	(Ac,Ra,Sp)
Potamonautes	(Ar,Ml,De)	Praegnantenia	(Br,Ar,Rh)	Praethalamiopora	(Po,De,Pe)
Potamosiren	(Cd,Ma,Si)	Praegonia	(Mo,Bi,Tr)	Praetintinnopsella	(Ci,Po,Sp)
Poterioceras	(Mo,Ce,On)	Praegoniothyris	(Br,Ar,Tr)	Praetollia	(Mo,Ce,Am)
Poteriocerina	(Mo,Ce,On)	Praehedbergella	(Fo,Fo,Fo)	Praetorretites	(Mo,Bi,Hi)
Poteriocrinites	(Ec,Cr,Cl)	Praeheliosaurus	(Ac,Ra,Sp)	Praeudesia	(Br,Ar,Te)
Poterionella	(Po,De,Li)	Praehorridonia	(Br,Ar,St)	Praeundulomya	(Mo,Bi,Ph)
Potidoma	(Mo,Bi,Ve)	Praechyalocyllis	(Mo,Ga,Th)	Praevicula	(Mo,Bi,Un)
Potoceras	(Mo,Ce,Na)	Praediostroma	(Po,De,St)	Praewaagenoconcha	(Br,Ar,St)
Poularia	(Ar,Os,Po)	Praeisselcrinus	(Ec,Cr,Is)	Praewetzelella	(Cn,An,Ru)
Poulpus	(Ac,Ra,Na)	Praekaraisella	(Fo,Fo,Fo)	Praewoodsia	(Cd,Os,St)
Poulsenella	(Ar,Tr,Pt)	Praekogia	(Cd,Ma,Ce)	Praeabythocypris	(Ar,Os,Po)

Pragmotheca	(Pr,Un,In)	Prinnos	(Cn,An,Go)	Pristiosomus	(Cd,Os,Se)
Pragnellia	(Cn,An,Tu)	Primorella	(Bz,St,Tr)	Pristiphoca	(Cd,Ma,Ca)
Pragoprotus	(Ar,Tr,Pr)	Primorewia	(Br,Ar,Sp)	Pristis	(Cd,Ch,Rj)
Pragsoconus	(Fo,Fo,Fo)	Primoriina	(Fo,Fo,Fo)	Pristiurus	(Cd,Ch,Ca)
Pranesus	(Cd,Os,At)	Primovula	(Mo,Ga,Nt)	Pristodus	(Cd,Ch,Pe)
Pranognathus	(Cd,Co,Co)	Princetonella	(Ar,Tr,Pt)	Pristognathus	(Cd,Co,Co)
Prantlia	(Ar,Tr,Pr)	Prinonocrinus	(Ec,Cr,Cl)	Proabyssocypris	(Ar,Os,Po)
Prantlina	(Br,Ar,Or)	Printechinus	(Ec,Ec,Te)	Proacrisa	(Mo,Ga,Nt)
Prasopora	(Bz,St,Tr)	Priohyodus	(Cd,Ch,Ct)	Proacodus	(Cd,Co,Pa)
Prasoporina	(Bz,St,Tr)	Prionia	(Cd,Ma,Ce)	Proadusta	(Mo,Ga,Nt)
Prattia	(Bz,Gy,Ch)	Prionace	(Cd,Ch,Ca)	Proagnostus	(Ar,Tr,Ag)
Pratognathus	(Cd,Co,Co)	Prionechinus	(Ec,Ec,Te)	Proagialosaurus	(Cd,Re,Sq)
Pratum	(Mo,Bi,Ve)	Prioniodina	(Cd,Co,Co)	Proallosocrinus	(Ec,Cr,Cl)
Pravitoceras	(Mo,Ce,Am)	Prioniodus	(Cd,Co,Co)	Proampelocrinus	(Ec,Cr,Cl)
Pravitoschwagerina	(Fo,Fo,Fo)	Prionites	(Mo,Ce,Ce)	Proanypys	(Ar,Tr,As)
Pravognathus	(Cd,Co,Co)	Prionoceras	(Mo,Ce,Go)	Proanadyrella	(Br,Ar,Te)
Pravoslavlevia	(Fo,Fo,Fo)	Prionocheilus	(Ar,Tr,Ph)	Proanisocrinus	(Ec,Cr,Sa)
Preangeria	(Mo,Ga,Ne)	Prionocheilus	(Cd,Re,Ch)	Proapatokephaloides	(Ar,Tr,Pt)
Precaratoropella	(Po,De,Ta)	Prionocidaris	(Ec,Ec,Ct)	Proapophyllia	(Cn,An,Sc)
Precorynella	(Po,Ca,Ph)	Prionocycloceras	(Mo,Ce,Am)	Proapsidocrinus	(Ec,Cr,Sa)
Predarwinula	(Ar,Os,Po)	Prionocycloides	(Mo,Ce,Am)	Proaracana	(Cd,Os,Te)
Preflorianites	(Mo,Ce,Ce)	Prionocylus	(Mo,Ce,Am)	Proarcestes	(Mo,Ce,Ce)
Preflorianitoides	(Mo,Ce,Ce)	Prionodelphis	(Cd,Ma,Ce)	Proargentina	(Cd,Os,Os)
Pregazacrinus	(Ec,Cr,Di)	Prionodoceras	(Mo,Ce,Am)	Proasphiscus	(Ar,Tr,Pt)
Prehepatus	(Ar,ML,De)	Prionodon	(Cd,Ch,Ca)	Proatribonium	(Br,Ar,Rh)
Prehousia	(Ar,Tr,As)	Prionolepis	(Cd,Os,Al)	Proaulacopleura	(Ar,Tr,Pt)
Prelissorhynchia	(Br,Ar,Rh)	Prionopeltis	(Ar,Tr,Pr)	Proavella	(Bz,St,Cr)
Premacrinus	(Ec,Cr,Cl)	Prionopleurus	(Cd,Os,Se)	Proavites	(Mo,Ce,Ce)
Premintreia	(Cd,Ch,Ca)	Prionorhynchia	(Br,Ar,Rh)	Probeloceras	(Mo,Ce,An)
Premunseyella	(Ar,Os,Po)	Prionothyrus	(Br,Ar,Te)	Probilacunaspis	(Ar,Tr,Un)
Prenantia	(Bz,Gy,Ch)	Prionotus	(Cd,Os,Sc)	Probillingsites	(Mo,Ce,As)
Prenaster	(Ec,Ec,Sp)	Prionovulva	(Mo,Ga,Nt)	Problematicum	(Pr,Un,In)
Prenkites	(Mo,Ce,Ce)	Priotrochus	(Mo,Ga,Ar)	Problematocoenites	(Cd,Co,Pa)
Prepaeduma	(Ar,ML,De)	Priscacara	(Cd,Os,Pt)	Probletoerinus	(Ec,Cr,Cl)
Presbynius	(Ar,Is,As)	Priscanermarinus	(Ar,Ci)	Probolaeum	(Mo,Po,Pa)
Prescottaspis	(Cd,Pl,Ar)	Priscaphander	(Mo,Ga,Ce)	Probolarina	(Br,Ar,Rh)
Preshumardites	(Mo,Ce,Go)	Priseella	(Fo,Fo,Fo)	Probolichas	(Ar,Tr,Li)
Presimoceras	(Mo,Ce,Am)	Priscachiton	(Mo,Po,Pa)	Probolionia	(Br,Ar,St)
Prestrombus	(Mo,Ga,Nt)	Priscoclius	(Mo,Ga,Nt)	Probolium	(Ar,Tr,Ph)
Presumatrina	(Fo,Fo,Fo)	Priscofusus	(Mo,Ga,Ne)	Probolops	(Ar,Tr,Ph)
Pretlimiophyllum	(Po,Re,Aj)	Priscogilula	(Ec,Ho,De)	Probooscicaris	(Pr,Di,Ra)
Preverticillites	(Po,De,Pe)	Priscolongatus	(Ec,Ho,De)	Proboiscidella	(Br,Ar,St)
Prevolitans	(Cd,Os,Da)	Priscomaetra	(Mo,Bi,Ve)	Proboiscidina	(Br,Ar,Te)
Priacanthopsis	(Cd,Os,Pf)	Priscopedatoides	(Ec,Ho,De)	Proboiscina	(Bz,St,Ce)
Priacanthus	(Cd,Os,Pf)	Priscopedatus	(Ec,Ho,As)	Proboiscinopora	(Bz,St,Ce)
Priapulites	(Pa)	Priscophyseter	(Cd,Ma,Ce)	Proboiscisambon	(Br,Ar,St)
Pribyllia	(Ar,Tr,Pr)	Priscosolenia	(Cn,An,Ta)	Probowmania	(Ar,Tr,Pt)
Pribylina	(Ar,Os,Pa)	Priscularites	(Ec,Ho,De)	Probowmaniella	(Ar,Tr,Pt)
Pribylites	(Ar,Os,Pa)	Prismatomorpha	(Fo,Fo,Fo)	Procalpurnus	(Mo,Ga,Nt)
Pribylograptus	(He,Gr,Gr)	Prismatophyllum	(Cn,An,Ru)	Procampanile	(Mo,Ga,Nt)
Priceaspis	(Ar,Tr,Un)	Prismatro	(Mo,Bi,Pt)	Procancellaria	(Mo,Ga,Ar)
Pricella	(Mo,Ce,Cl)	Prismenaspis	(Ar,Tr,Pt)	Procardia	(Mo,Bi,Ph)
Pricyclopyge	(Ar,Tr,As)	Prismodietya	(Po,He,Re)	Procarinaria	(Mo,Te,Cy)
Priene	(Mo,Ga,Nt)	Prismopora	(Bz,St,Cy)	Procarinatina	(Br,Ar,At)
Primaconulariella	(Pr,Un,In)	Prisogaster	(Mo,Ga,Ar)	Procarmites	(Mo,Ce,Ce)
Primarella	(Bz,St,Cr)	Pristeroceras	(Mo,Ce,Di)	Procephalaspis	(Cd,Ce,Ce)
Primaspis	(Ar,Tr,Od)	Pristes	(Mo,Bi,Ve)	Procerapex	(Mo,Ga,Ne)
Primipilaria	(Br,Ar,Rh)	Pristigenys	(Cd,Os,Pt)	Proceratocephala	(Ar,Tr,Od)
Primitia	(Ar,Os,Pa)	Pristimerica	(Mo,Ga,Ne)	Proceratopyge	(Ar,Tr,As)
Primitiella	(Ar,Os,Pa)	Pristinacca	(Mo,Ga,Nt)	Procerites	(Mo,Ce,Am)
Primitiopsella	(Ar,Os,Pa)	Pristinoseptrella	(Fo,Fo,Fo)	Procerithiopsis	(Mo,Ga,Nt)
Primitiopsis	(Ar,Os,Pa)	Pristiograptus	(He,Gr,Gr)	Procerithium	(Mo,Ga,Nt)
Primitivolithiopsella	(Ar,Os,Me)	Pristiophorus	(Cd,Ch,Pr)	Procerolagena	(Fo,Fo,Fo)
Primitophyllum	(Cn,An,Ru)	Pristiophyllia	(Cn,An,Ht)	Procerozigzag	(Mo,Ce,Am)

Procerulina	(Br,Ar,Pe)	Productella	(Br,Ar,St)	Proholopus	(Ec,Cr,Cy)
Processobairdia	(Ar,Os,Pe)	Productellana	(Br,Ar,St)	Proholothuria	(Ec,Ho,As)
Processopriion	(An,Po,Eu)	Productelloides	(Br,Ar,St)	Prohungarites	(Mo,Ce,Ce)
Procetus	(Cd,Ma,Ce)	Productina	(Br,Ar,St)	Prohydrocyon	(Cd,Os,Sa)
Prochanos	(Cd,Os,Go)	Productorthis	(Br,Ar,Or)	Prohystreroceas	(Mo,Ce,Am)
Prochauvelcystis	(Ec,St,Co)	Productus	(Br,Ar,St)	Proichangia	(Ar,Tr,Re)
Procheirichthys	(Cd,Os,Pe)	Produvalia	(Mo,Ce,Be)	Proidotea	(Ar,MI,Is)
Procheloniceras	(Mo,Ce,Am)	Proeditia	(Ar,Os,Un)	Proindocrinus	(Ec,Cr,Cl)
Prochlidonophora	(Br,Ar,Te)	Prochmaniella	(Ar,Tr,Pt)	Projovellania	(Mo,Ce,Om)
Prochlorodius	(Ar,MI,De)	Proendoceas	(Mo,Ce,En)	Projuvavites	(Mo,Ce,Ce)
Prochoidiocrinus	(Ec,Cr,Cl)	Proerbia	(Ar,Tr,Pt)	Prokaliapits	(Po,De,LI)
Prochoristitella	(Br,Ar,Sp)	Proeryon	(Ar,MI,De)	Prokoootenia	(Ar,Tr,Co)
Prochorites	(Mo,Ce,An)	Proescutella	(Ec,Ec,Cl)	Prokopia	(Br,Ar,Or)
Prochuangia	(Ar,Tr,Co)	Proetidella	(Ar,Tr,Pr)	Prokopierinus	(Ec,Cr,Mo)
Procidaris	(Ec,Ec,Ci)	Proetides	(Ar,Tr,Pr)	Prokopycystis	(Ec,St,Co)
Procladiscites	(Mo,Ce,Ce)	Proetina	(Ar,Tr,Pr)	Prokops	(Ar,Tr,Ph)
Procladocora	(Cn,An,Sc)	Proetmopterus	(Cd,Ch,Sq)	Prolaria	(Mo,Bi,Ph)
Proclava	(Mo,Ga,Nt)	Proetocephalus	(Ar,Tr,Pr)	Profasiograptus	(He,Gr,Gr)
Procliviceras	(Mo,Ce,Ph)	Proetopeltis	(Ar,Tr,Pr)	Prolates	(Cd,Os,Pf)
Proclydonautilus	(Mo,Ce,Na)	Proetus	(Ar,Tr,Pr)	Prolationus	(Mo,Cr,Te)
Procolpochelys	(Cd,Re,Ch)	Proeuplectella	(Po,He,LS)	Prolazutkina	(Br,Ar,Sp)
Procolumbites	(Mo,Ce,Ce)	Proeurete	(Po,He,He)	Prolecanites	(Mo,Ce,Pl)
Procomaster	(Ec,Cr,Cin)	Proexenocrinus	(Ec,Cr,Di)	Proleopoldia	(Mo,Ce,Am)
Procominula	(Mo,Ga,Ne)	Profallotaspis	(Ar,Tr,Ol)	Prolepidotus	(Cd,Os,Sc)
Proconchidium	(Br,Ar,Pe)	Proficus	(Mo,Ga,Nt)	Proleptochiton	(Mo,Po,Ne)
Proconodontus	(Cd,Co,Co)	Profistulipora	(Bz,St,Cy)	Proleptolepis	(Cd,Os,Pc)
Proconulus	(Mo,Ga,Ar)	Profragum	(Mo,Bi,Ve)	Proleptophyllia	(Cn,An,Sc)
Proconus	(Mo,In,In)	Profulvia	(Mo,Bi,Ve)	Prolemyeriella	(Mo,Ce,Am)
Procopievskia	(Mo,Bi,Pt)	Profundalvania	(Mo,Ga,Nt)	Prolopsiera	(Mo,Ga,Pe)
Procorallites	(Po,De,LI)	Profusulinella	(Fo,Fo,Fo)	Proliosiracus	(Ar,Tr,Pt)
Procostaria	(Mo,Bi,Tr)	Progabbia	(Mo,Ga,Ne)	Prolisserpula	(An,Po,Se)
Proctothronocystis	(Ec,St,Co)	Progadilina	(Mo,Sc,Se)	Prolobella	(Mo,Bi,Pt)
Procraspedites	(Mo,Ce,Am)	Progalbanites	(Mo,Ce,Am)	Prolobites	(Mo,Ce,An)
Procrucibulum	(Mo,Pa,Hy)	Progaleurus	(Mo,Pa,Hy)	Prolobocrinus	(Ec,Cr,Cl)
Procteria	(Cn,An,Ta)	Progalliacystis	(Ec,St,Co)	Prolotaria	(Cd,Ma,Ca)
Proctothylacocrinus	(Ec,Cr,Cl)	Progempylus	(Cd,Os,Pf)	Proluvarus	(Cd,Os,Pf)
Procyathellus	(Po,Re,Aj)	Progeronia	(Mo,Ce,Am)	Prolyliceras	(Mo,Ce,Am)
Procyathopora	(Cn,An,Sc)	Prognathodon	(Cd,Re,Sq)	Promacropyge	(Ar,Tr,As)
Procycolites	(Cn,An,Sc)	Progonambonites	(Br,Ar,Or)	Promacrurus	(Mo,Bi,Ph)
Procymatoceras	(Mo,Ce,Na)	Progonocythere	(Ar,Os,Po)	Promantelliceras	(Mo,Ce,Am)
Procyprina	(Mo,Bi,Ve)	Progonechinus	(Ec,Ec,Te)	Promarginifera	(Br,Ar,St)
Procytheres	(Ar,Os,Pe)	Progonioclymenia	(Mo,Ce,Cl)	Promartynia	(Mo,Ga,Ar)
Procytherettina	(Ar,Os,Po)	Progonoceratites	(Mo,Ce,Ce)	Promathilda	(Mo,Ga,He)
Procytheridea	(Ar,Os,Po)	Progonoidea	(Ar,Os,Po)	Promediapora	(Bz,St,Cr)
Procytherideis	(Ar,Os,Po)	Prographularia	(Cn,An,Pe)	Promegalaspides	(Ar,Tr,As)
Procytheropterion	(Ar,Os,Po)	Prograyiceras	(Mo,Ce,Am)	Promegalops	(Cd,Os,Me)
Procytherura	(Ar,Os,Po)	Progyimnodon	(Cd,Os,Te)	Promelocrinus	(Ec,Cr,Mo)
Productylloceras	(Mo,Ce,Am)	Progyrosmilia	(Cn,An,Sc)	Prometus	(Ar,Tr,Pt)
Prodamesella	(Ar,Tr,Od)	Prohalecites	(Cd,Os,Pc)	Promexyle	(Cd,Ch,Ip)
Prodarwinia	(Cn,An,Ru)	Prohalicore	(Cd,Ma,Si)	Promicroceras	(Mo,Ce,Am)
Prodavidsonia	(Br,Ar,At)	Proharpoceras	(Mo,Ce,Ce)	Promillepora	(Po,De,Ax)
Prodentalina	(Fo,Fo,Fo)	Prohauericeras	(Mo,Ce,Am)	Promopalaecaster	(Ec,As,Pt)
Prodentalium	(Mo,Sc,Se)	Prohctioceras	(Mo,Ce,Am)	Promourlonia	(Mo,Ga,Ar)
Prodeshayesites	(Mo,Ce,Am)	Prohedinella	(Ar,Tr,Un)	Promyalina	(Mo,Bi,Pt)
Prodiacoryphe	(Ar,Tr,Pr)	Prohedinia	(Ar,Tr,Pt)	Promylobatis	(Cd,Ch,My)
Prodioides	(Cd,Os,Te)	Prohelicoceras	(Mo,Ce,Am)	Promyophorella	(Mo,Bi,Tr)
Prodiozoptyxis	(Mo,Ga,He)	Prohelicotoma	(Mo,Ga,Eu)	Promytilus	(Mo,Bi,Mt)
Prodonacosmilina	(Cn,An,Sc)	Proheliolites	(Cn,An,Ta)	Pronajaceras	(Mo,Ce,En)
Prodontochile	(Ar,Tr,Ph)	Proheliopora	(Cn,An,He)	Pronechinus	(Ec,Ec,Ey)
Prodreissensia	(Mo,Bi,Ve)	Prohexacrinus	(Ec,Cr,Mo)	Pronereites	(An,Po,Ph)
Prodrevermannia	(Ar,Tr,Pr)	Prohexactinella	(Po,He,He)	Pronesticosaurus	(Cd,Re,No)
Prodromites	(Mo,Ce,Pl)	Prohexagonaria	(Cn,An,Ru)	Proniceras	(Mo,Ce,Am)
Prodromopora	(Bz,Gy,Ch)	Prohimntes	(Mo,Bi,Pt)	Proninella	(Fo,Fo,Fo)
Productea	(Mo,Bi,Un)	Proholaster	(Ec,Ec,Ds)	Pronocella	(Mo,Bi,Ve)

Pronoetlingites	(Mo,Ce,Ce)	Prorsisphinctes	(Mo,Ce,Am)	Protageulus	(Mo,Bi,Ve)
Pronorites	(Mo,Ce,Pl)	Prurugaria	(Br,Ar,St)	Protagraulus	(Ar,Tr,Pt)
Pronotacanthus	(Cd,Os,El)	Prosgaitodontus	(Cd,Co,Pa)	Protallinnella	(Ar,Os,Pa)
Pronucula	(Mo,Bi,Nu)	Prosaphites	(Mo,Ce,Am)	Protalochiton	(Mo,Po,Ne)
Prooneotodus	(Cd,Co,Pa)	Prosaukia	(Ar,Tr,As)	Protamblyptera	(Cd,Os,Pa)
Proostrea	(Mo,Bi,Pt)	Prosauropsis	(Cd,Os,Pc)	Protambonites	(Br,Ar,Or)
Propachastrella	(Po,De,As)	Proscala	(Mo,Ga,Nt)	Protamphisopus	(Ar,Ml,Is)
Propalaemon	(Ar,Ml,De)	Proscandodus	(Cd,Co,Pa)	Protamphyceras	(Mo,Ce,Am)
Proparaparchites	(Ar,Os,Po)	Proscharyia	(Ar,Tr,Pr)	Protanidanthus	(Br,Ar,St)
Propatokephalops	(Ar,Tr,Pt)	Proschizophoria	(Br,Ar,Or)	Protanisoceras	(Mo,Ce,Am)
Propeamusium	(Mo,Bi,Pt)	Proscinetes	(Cd,Os,Py)	Protanthias	(Cd,Os,Pf)
Propectinaites	(Mo,Ce,Am)	Proscorpius	(Ar,Ar,Sc)	Protapes	(Mo,Bi,Ve)
Propeleda	(Mo,Bi,Nu)	Proscutum	(Mo,Ga,Ar)	Protarabellites	(An,Po,Eu)
Propeltura	(Ar,Tr,Pt)	Proselicothoon	(Mo,Ce,Am)	Protaraea	(Cn,An,Ta)
Propemurchisonia	(Mo,Ga,Nt)	Proserrianus	(Cd,Os,Pf)	Protarca	(Mo,Bi,Ar)
Propercarina	(Cd,Os,Pf)	Proserriovomer	(Cd,Os,An)	Protarchaegonus	(Ar,Tr,Pr)
Properiptychus	(Cd,Ma,Ca)	Proshumardites	(Mo,Ce,Go)	Protarpon	(Cd,Os,Me)
Properisphinctes	(Mo,Ce,Am)	Prosiceras	(Mo,Ce,Am)	Protarthraster	(Ec,As,Ur)
Properotundirostrum	(Br,Ar,Rh)	Prosimmia	(Mo,Ga,Nt)	Protaspis	(Cd,Pt,Pt)
Properirinites	(Mo,Ce,Go)	Prosipho	(Mo,Ga,Ne)	Protaster	(Ec,Op,Oe)
Properycina	(Mo,Bi,Ve)	Prosiphonella	(Po,Ca,Un)	Protathysisina	(Br,Ar,Sp)
Prophaethon	(Cd,Av,Pe)	Prosmilia	(Cn,An,Ru)	Protathyrus	(Br,Ar,Sp)
Prophetilora	(Mo,Bi,Ve)	Prosochasma	(Mo,Bi,Pt)	Protatrypa	(Br,Ar,At)
Prophoca	(Cd,Ma,Ca)	Prosoceogeton	(Mo,Bi,Ve)	Protaulopsis	(Cd,Os,Ga)
Prophyllacanthus	(Ec,Ec,Ci)	Prosocoelus	(Mo,Bi,Ve)	Protautoga	(Cd,Os,Pf)
Prophylocrinus	(Ec,Cr,Sa)	Prosogyrotrogonia	(Mo,Bi,Tr)	Protaxius	(Ar,Ml,De)
Prophyllodictya	(Bz,St,Cr)	Prosolarium	(Mo,Ga,Ar)	Protaxocrinus	(Ec,Cr,Tx)
Prophyseter	(Cd,Ma,Ce)	Prosolenostomus	(Cd,Os,Ga)	Protectoconorca	(An,Po,Se)
Propilidium	(Mo,Ga,Ar)	Prosoleptus	(Mo,Bi,Nu)	Protetuliferina	(Br,Ar,St)
Propilina	(Mo,Te,Tr)	Prosopticus	(Ar,Tr,Pt)	Protetulorhynchia	(Br,Ar,Rh)
Propinacoceras	(Mo,Ce,Pl)	Prosoptium	(Cd,Os,Sa)	Protelops	(Cd,Os,El)
Proplacentoceras	(Mo,Ce,Am)	Prosopton	(Ar,Ml,De)	Protelphidium	(Fo,Fo,Fo)
Proplanulites	(Mo,Ce,Am)	Prosoptonella	(Br,Li,Li)	Protemnites	(Ar,Tr,Pt)
Propleroma	(Po,De,Li)	Prosoptychus	(Mo,Ga,Be)	Protemys	(Cd,Re,Ch)
Propolynoe	(An,Po,Un)	Prosoosphinctes	(Mo,Ce,Am)	Protenaster	(Ec,Ec,Sp)
Propomatoceros	(An,Po,Se)	Prosoosphinctoides	(Mo,Ce,Am)	Protengonoceras	(Mo,Ce,Am)
Propontocypris	(Ar,Os,Po)	Prostoma	(Ec,Ec,Sp)	Protendonotosaurus	(Cd,Re,Pl)
Propopanoceras	(Mo,Ce,Go)	Prostopora	(Bz,Gy,Ch)	Protentella	(Fo,Fo,Fo)
Propora	(Cn,An,Ta)	Prospectatrix	(Ar,Tr,Pt)	Proteoceras	(Mo,Ce,Or)
Proporella	(Cn,An,Ta)	Prospheeroidinella	(Fo,Tr,Fo)	Proteocncha	(Ar,Os,Po)
Propotericrinus	(Ec,Cr,Ci)	Prospingites	(Mo,Ce,Ce)	Proteomyrus	(Cd,Os,An)
Propriolythus	(Po,Re,Mo)	Prospira	(Br,Ar,Sp)	Proteorhynchia	(Br,Ar,Rh)
Propriopugnus	(Br,Ar,Rh)	Prospiraxis	(Cd,Ch,Eu)	Proteorthis	(Br,Ar,Or)
Propristiophorus	(Cd,Ch,Pr)	Prospondylus	(Mo,Bi,Pt)	Proterato	(Mo,Ga,Nt)
Propristis	(Cd,Ch,Rj)	Prosqalodon	(Cd,Ma,Ce)	Proterebella	(An,Po,Te)
Propteridium	(Cd,Os,Op)	Prosserella	(Br,Ar,Sp)	Proterocameroceras	(Mo,Ce,En)
Propterus	(Cd,Os,Ma)	Prostacheoceras	(Mo,Ce,Go)	Proterocarcinus	(Ar,Ml,De)
Proptychites	(Mo,Ce,Ce)	Prosthenodon	(Mo,Ga,Nt)	Proterocidaris	(Ec,Ec,Ey)
Proptychitoides	(Mo,Ce,Ce)	Prosthenocia	(Bz,St,Ce)	Proterocoelus	(Mo,In,In)
Propustularia	(Mo,Ga,Nt)	Prostomaria	(Bz,Gy,Ch)	Proteroctopus	(Mo,Ce,Oc)
Propygope	(Br,Ar,Te)	Prostricklandia	(Br,Ar,Pe)	Proterocystites	(Ec,Di,Di)
Prorasenia	(Mo,Ce,Am)	Prosumia	(Ar,Os,Po)	Proterophyllum	(Cn,An,Ru)
Proraster	(Ec,Ec,Sp)	Prosynphysurus	(Ar,Tr,Co)	Proterovaginoceras	(Mo,Ce,En)
Prorastomus	(Cd,Ma,St)	Protacanthina	(Ar,Tr,Ph)	Protula	(An,Po,Se)
Prorectella	(Ar,Os,Po)	Protacanthoceras	(Mo,Ce,Am)	Prothetmos	(Cn,An,Sc)
Prorensselaeria	(Br,Ar,Te)	Protacanthodes	(Cd,Os,Te)	Protraclis	(Mo,De,Li)
Proreticularia	(Br,Ar,Sp)	Protacanthodiscus	(Mo,Ce,Am)	Protetragonites	(Mo,Ce,Am)
Proreicephalus	(Ar,Tr,Pt)	Protacanthoplites	(Mo,Ce,Am)	Proteuloma	(Ar,Tr,As)
Proriehofenia	(Br,Ar,St)	Protachilleum	(Po,De,Li)	Protesuites	(Mo,Ce,Ce)
Prorokia	(Mo,Bi,Ve)	Protacodus	(Cd,Ch,Ct)	Protexanites	(Mo,Ce,Am)
Proromma	(Ar,Tr,Ph)	Protaconeceras	(Mo,Ce,Am)	Prothalassoceras	(Mo,Ce,Go)
Prorosmarus	(Cd,Ma,Ca)	Protacrocrinus	(Ec,Cr,Mo)	Protheelia	(Ec,Ho,Ap)
Prorotrigonia	(Mo,Bi,Tr)	Protactinoceras	(Mo,Ce,Pr)	Prothyris	(Mo,Bi,Ve)
Proroziphium	(Cd,Ma,Ce)	Protaetoclymenia	(Mo,Ce,Ci)	Prothysanostoma	(Cn,Sc,Rh)

Protimanites	(Mo,Ce,An)	Protoecotrausites	(Mo,Ce,Am)	Protopliomerella	(Ar,Tr,Ph)
Protoacanthcythere	(Ar,Os,Po)	Protoencrinurella	(Ar,Tr,Ph)	Protopliomerops	(Ar,Tr,Ph)
Protoaibailella	(Ac,Ra,Sp)	Protoentolium	(Mo,Bi,Pt)	Protopopanoceeras	(Mo,Ce,Go)
Protoarenicola	(Pr,Un,In)	Protofusus	(Mo,Ga,Nt)	Protopora	(Cn,An,Ta)
Protoargilloecia	(Ar,Os,Po)	Protogamginifera	(Br,Ar,St)	Protopresbyneilus	(Ar,Tr,As)
Protoarmstrongia	(Po,He,Re)	Protogeelus	(Cd,Ch,Ca)	Protoprioniodus	(Cd,Co,Co)
Protoatlanta	(Mo,Ga,Nt)	Protoginglymostoma	(Cd,Ch,Co)	Protopsetta	(Cd,Os,Pn)
Protoaulacoceras	(Mo,Ce,Au)	Protoglobbulimina	(Fo,Fo)	Protopsium	(Ac,Ra,Sp)
Protoaulacophyllum	(Cn,An,Ru)	Protognathodus	(Cd,Co,Co)	Protopterygotheca	(Pr,Un,In)
Protoaulopora	(Cn,An,Un)	Protogonacanthus	(Cd,Ac,Ac)	Protoramulophyllum	(Cn,An,Ru)
Protobactrites	(Mo,Ce,Or)	Protogrammoceras	(Mo,Ce,Am)	Protorcula	(Mo,Ga,Nt)
Protobalana	(Cd,Ma,Ce)	Protogusarella	(Br,Ar,Te)	Protoretetpora	(Bz,St,Fe)
Protobalanus	(Pr,Ma,He)	Protolahcium	(Cn,Hy,Hy)	Protoreticularia	(Br,Ar,Sp)
Protobalistium	(Cd,Os,Te)	Protohedinia	(Ar,Tr,Pt)	Protorhamphosus	(Cd,Os, Ga)
Protobalteeia	(Mo,Ga,Nt)	Protohelilites	(Cn,An,Ta)	Protorhyncha	(Br,Ar,Rh)
Protobolus	(Br,Un,Ob)	Protohertzina	(Ch,Pr)	Protornoceras	(Mo,Ce,Go)
Protobrama	(Cd,Os,Cr)	Protohesperonomia	(Br,Ar,Or)	Protorotella	(Mo,Ga,Ar)
Protobrissus	(Ec,Ec,Sp)	Protoheteraestrea	(Cn,An,Sc)	Protorthis	(Br,Ar,Or)
Protobrotula	(Cd,Os,Op)	Protohoplites	(Cd,Co,Am)	Protoryctocephalus	(Ar,Tr,Co)
Protobuntonia	(Ar,Os,Po)	Protohyalostelia	(Po,De,Un)	Protosageceras	(Mo,Cc,Pl)
Protobusyon	(Mo,Ga,Ne)	Protoichthyosaurus	(Cd,Re,lc)	Protoscaevogyra	(Mo,Pa,Hy)
Protocallianassa	(Ar,ML,De)	Protojonesia	(Ar,Os,Po)	Protoscapirhynchus	(Cd,Os,Ac)
Protocalithacea	(Mo,Bi,Ve)	Protokionoceras	(Mo,Ce,Or)	Protoscolex	(An,Pa,Pa)
Protocalymene	(Ar,Tr,Ph)	Protolamna	(Cd,Ch,La)	Protoscutella	(Ec,Ec,Cl)
Protocalypptaea	(Mo,Ga,Ar)	Protolampas	(Ec,Ec,Ol)	Protoseyliorhinus	(Cd,Ch,Ca)
Protocaninia	(Cn,An,Ru)	Protolenella	(Ar,Tr,Pt)	Protoseris	(Cn,An,Sc)
Protocanites	(Mo,Ce,Pl)	Protolenus	(Ar,Tr,Pt)	Protoshalaria	(Br,Ar,St)
Protocarcinophyllum	(Cn,An,Ru)	Protoleptostrophia	(Br,Ar,St)	Protosiren	(Cd,Ma,Si)
Protocardia	(Mo,Bi,Ve)	Protoleucon	(Po,Ca,Ca)	Protoskenioides	(Br,Ar,Or)
Protocaris	(Ar,Un,Un)	Protolloydolithus	(Ar,Tr,As)	Protoskenioides	(Pr,Un,In)
Protocaudina	(Ec,Ho,El)	Protolon-daleiastraea	(Cn,An,Ru)	Protosphaeroma	(Ar,ML,Is)
Protoceras	(Mo,Ce,Ce)	Protolophotus	(Cd,Os,La)	Protosphyraena	(Cd,Os,Pe)
Protocerauroides	(Ar,Tr,Ph)	Protolyella	(Cn,Hy,Si)	Protospinax	(Cd,Ch,In)
Protocetus	(Cd,Ma,Ce)	Protoma	(Mo,Ga,Nt)	Protospira	(Mo,In,Pe)
Protolithon	(Mo,Po,Ne)	Protomaegea	(Cn,An,Ru)	Protospirialis	(Mo,Ga,Ar)
Protolithonetes	(Br,Ar,St)	Protomegalodon	(Mo,Bi,Hi)	Protospongia	(Po,He,Re)
Protocidarid	(Ec,Ec,Un)	Protomegastrophia	(Br,Ar,St)	Protosqualus	(Cd,Ch,Sq)
Protocimex	(Ar,ML,In)	Protomelission	(Pr,Un,In)	Protostega	(Cd,Re,Ch)
Protoclupaea	(Cd,Os,Pe)	Protomendacella	(Br,Ar,Or)	Protostichocapsa	(Ac,Ra,Na)
Protoclytiopsis	(Ar,ML,De)	Protomichelina	(Cn,An,Ta)	Protostomias	(Cd,Os,El)
Protoconchioides	(Mo,In,In)	Protomunidia	(Ar,ML,De)	Protostygina	(Ar,Tr,Pt)
Protoconus	(Mo,Te,Cy)	Protomya	(Mo,Bi,Ph)	Protostylifera	(Mo,Ga,Nt)
Protocortezorthis	(Br,Ar,Or)	Protomyctophum	(Cd,Os,My)	Protostylus	(Mo,Ga,Nt)
Protocosta	(Ar,Os,Po)	Protonecrocarcinus	(Ar,ML,De)	Protosurcula	(Mo,Ga,Ne)
Protocrinites	(Ec,Di,Di)	Protonema	(Mo,Ga,Nt)	Protosycon	(Po,Ca,Ca)
Protocrisina	(Bz,St,Cr)	Protoniella	(Br,Ar,St)	Prototeguliferina	(Br,Ar,St)
Protocyathactis	(Cn,An,Ru)	Protonodosaria	(Fo,Fo,Fo)	Prototegulithyrus	(Br,Ar,Te)
Protocyathophyllum	(Cn,An,Ru)	Prtonoetia	(Mo,Bi,Ar)	Protothaca	(Mo,Bi,Ve)
Protocyclendoceras	(Mo,Ce,En)	Protonympha	(An,Po,Ph)	Prototherium	(Cd,Ma,Si)
Protocycloceras	(Mo,Cc,El)	Protopalliolum	(Mo,Bi,Ph)	Protothermannia	(Mo,Ce,Am)
Protocymostrophia	(Br,Ar,St)	Protopanderodus	(Cd,Co,Co)	Prototrochoceras	(Mo,Ce,Ce)
Protocypraea	(Mo,Ga,Nt)	Protopeltura	(Ar,Tr,Pt)	Prototretia	(Br,Li,Ac)
Protocypraedia	(Mo,Ga,Nt)	Protopeneroplis	(Fo,Fo,Fo)	Prototryplasma	(Cn,An,Ru)
Protocyclendoceras	(Mo,Ce,En)	Protoperispyridium	(Ac,Ra,Na)	Prototurbo	(Mo,Ga,Ar)
Protocystis	(Ec,Rh,Rh)	Protophætra	(Po,Ir,Ar)	Prototyphis	(Mo,Ga,Ne)
Protocystites	(Ec,St,Co)	Protophiles	(Mo,Ce,Am)	Protovallulus	(Ac,Ra,Sp)
Protocythere	(Ar,Os,Po)	Protophocaena	(Cd,Ma,Ce)	Protowenella	(Mo,He,He)
Protocytheretta	(Ar,Os,Po)	Protophragmapora	(Br,Ar,Or)	Protowentellia	(Cn,An,Ru)
Protodelphinus	(Cd,Ma,Ce)	Protophragmoceras	(Mo,Ce,Di)	Protoxiphtractus	(Ac,Ra,Sp)
Protodicerias	(Mo,Bi,Hi)	Protopilophyllum	(Cn,An,Ru)	Protocyclus	(Mo,Ce,Cl)
Protodolium	(Mo,Ga,Nt)	Protopirula	(Mo,Ga,Nt)	Prototoxynotus	(Cd,Ch,Sq)
Protodonax	(Mo,Bi,Ve)	Protopis	(Mo,Bi,Mt)	Prototaxiprentis	(Cn,An,Ru)
Protodouvillina	(Br,Ar,St)	Protoplatyrhina	(Cd,Ch,Rj)	Protozeuga	(Br,Ar,Sp)
Protodurhamina	(Cn,An,Ru)	Protoplatytes	(Mo,Ce,Ce)	Protozoe	(Ar,Th,Cc)

Protozyga	(Br,Ar,At)	Psammodonax	(Mo,Bi,Ve)	Pseudarisphinctes	(Mo,Ce,Am)
Protrachyceras	(Mo,Ce,Ce)	Psammomulus	(Mo,Ga,Nt)	Pseudaristocystis	(Ec,Di,Di)
Protrachypora	(Cn,An,Ta)	Psammodus	(Cd,Ch,Ps)	Pseudarthron	(Ar,Un,Un)
Protremadictyon	(Po,He,He)	Psammogyra	(Cn,An,Sc)	Pseudasaphis	(Mo,Bi,Ve)
Protremaster	(Ec,As,Va)	Psammohelia	(Cn,An,Sc)	Pseudaspidites	(Mo,Ce,Ce)
Protriacanthus	(Cd,Os,Ct)	Psammoica	(Mo,Bi,Ve)	Pseudaspidoceras	(Mo,Ce,Am)
Protriticites	(Fo,Fo,Fo)	Psammolingulina	(Fo,Fo,Fo)	Pseudastarte	(Mo,Bi,Ve)
Protrochiscolithus	(Cn,An,Ta)	Psammomilulus	(Ar,Me,Xi)	Pseudastorhiza	(Fo,Fo,Fo)
Protrochocyathus	(Cn,An,Sc)	Psammophax	(Fo,Fo,Fo)	Pseudatops	(Ar,Tr,Pt)
Protropites	(Mo,Ce,Ce)	Psammosphon	(An,Po,Te)	Pseudatrypa	(Br,Ar,At)
Protuba	(Mo,Ga,Nt)	Psammospiraera	(Fo,Fo,Fo)	Pseudaturoidea	(Mo,Ce,Na)
Protula	(An,Po,Se)	Psammotaena	(Mo,Bi,Ve)	Pseudaucella	(Mo,Bi,Pt)
Protulites	(An,Po,Se)	Psammotellina	(Mo,Bi,Ve)	Pseudaulicina	(Mo,Ga,Ne)
Protulophila	(Cn,Hy,Hy)	Psammotreta	(Mo,Bi,Ve)	Pseudavena	(Mo,Ga,Ce)
Protunuma	(Ac,Ra,Na)	Psarodictyon	(Po,De,Li)	Pseudavicula	(Mo,Bi,Pt)
Proturboella	(Mo,Ga,Nt)	Psathura	(Mo,Bi,Ve)	Pseudaviculopecten	(Mo,Bi,Pt)
Proturrilitoides	(Mo,Ce,Am)	Psebajithyris	(Br,Ar,Te)	Pseudazygograptus	(He,Gr,Gr)
Proturritelia	(Mo,Ga,Ar)	Pselicoceras	(Mo,Ce,Na)	Pseudechinus	(Ec,Ec,Te)
Protypus	(Ar,Tr,Co)	Psenes	(Cd,Os,Pf)	Pseudedomia	(Fo,Fo,Fo)
Prouddenites	(Mo,Ce,Pl)	Psenicubiceps	(Cd,Os,Pf)	Pseudendoceras	(Mo,Ce,El)
Prouktaspis	(Ar,Tr,Co)	Psephaea	(Mo,Ga,Ne)	Pseudentolium	(Mo,Bi,Pt)
Protella	(Bz,St,Tr)	Psephaspis	(Cd,Pt,Pt)	Pseuderichthys	(Ar,Th,Ce)
Proveedoraia	(Ar,Tr,Pt)	Psephechinus	(Ec,Ec,Ph)	Pseudharpoceras	(Mo,Ce,Ce)
Proveniella	(Mo,Bi,Ve)	Psephidia	(Mo,Bi,Ve)	Pseudhelicoceras	(Mo,Ce,Am)
Proventocitum	(Ac,Ra,Sp)	Psephoaster	(Ec,Ec,Sp)	Pseudhimalayites	(Mo,Ce,Am)
Provermicularia	(Mo,Ga,Nt)	Psephoderma	(Cd,Re,Pl)	Pseudholaster	(Ec,Ec,Hs)
Proverruca	(Ar,Ci)	Psephodus	(Cd,Ch,In)	Pseudholocentrum	(Cd,Os,Br)
Provinciastraea	(Cn,An,Sc)	Psephophorus	(Cd,Re,Ch)	Pseudichangia	(Ar,Tr,Pt)
Provisocyntra	(Ac,Ra,Sp)	Psephosaurus	(Cd,Re,Pl)	Pseudinvalticeras	(Mo,Ce,Am)
Prowillungaster	(Ec,Ec,Cl)	Psephothenaspis	(Ar,Tr,Pr)	Pseudisastreae	(Cn,An,Sc)
Proxicarpillus	(Ar,Mi,De)	Psephosyllogus	(Po,He,He)	Pseudisocardia	(Mo,Bi,Ve)
Proxicharonia	(Mo,Ga,Nt)	Psetodes	(Cd,Os,Pn)	Pseudisograptus	(He,Gr,Gr)
Proxichione	(Mo,Bi,Ve)	Psetopsis	(Cd,Os,Pf)	Pseudoacicaudus	(Ar,Tr,Un)
Proxifrons	(Fo,Fo,Fo)	Pseudacantoscapha	(Ar,Os,Po)	Pseudoaclinis	(Mo,Ga,He)
Proximitra	(Mo,Ga,Ne)	Pseudaesta	(Mo,Bi,Pt)	Pseudoacrocephalites	(Ar,Tr,Pt)
Proxiuber	(Mo,Ga,Nt)	Pseudacompsoceras	(Mo,Ce,Am)	Pseudoactinodictyon	(Po,De,St)
Prozacanthoides	(Ar,Tr,Co)	Pseudactinoceras	(Mo,Ce,Or)	Pseudoactinostroma	(Po,De,St)
Prozeuglodon	(Cd,Ma,Ce)	Pseudaetomoceras	(Mo,Ce,Am)	Pseudoaganides	(Mo,Ce,Am)
Pruemolepis	(Cd,Ac,Cl)	Pseudaganides	(Mo,Ce,Na)	Pseudoagathiceras	(Mo,Ce,Go)
Prunobrachiium	(Ac,Ra,Sp)	Pseudagnostina	(Ar,Tr,Ag)	Pseudoalbaillella	(Ac,Ra,Sp)
Prunocarpus	(Ac,Ra,Sp)	Pseudagnostus	(Ar,Tr,Ag)	Pseudoalokistocare	(Ar,Tr,Pt)
Prunocystites	(Ec,Rh,Rh)	Pseudalaria	(Mo,Ga,Nt)	Pseudoaluco	(Mo,Ga,Nt)
Prunopyle	(Ac,Ra,Sp)	Pseudallotropiophyllum	(Cn,An,Ru)	Pseudoamblysiphonella	(Po,De,Pe)
Prunum	(Mo,Ga,Ne)	Pseudamura	(Mo,Ga,Nt)	Pseudoammodiscus	(Fo,Fo,Fo)
Pruvostastraea	(Cn,An,Sc)	Pseudamiantis	(Mo,Bi,Ve)	Pseudoamplexus	(Cn,An,Ru)
Pruvostina	(Ar,Tr,Pt)	Pseudammatoceras	(Mo,Ce,Am)	Pseudoamylgdalophyllum	(Cn,An,Ru)
Pruvostinoides	(Ar,Tr,Pt)	Pseudamplexograptus	(He,Gr,Gr)	Pseudoanisopleurella	(Br,Ar,St)
Prymnetes	(Cd,Os,Pe)	Pseudamphoxyphyllum	(Cn,An,Ru)	Pseudoaquaetonia	(Br,Ar,St)
Psalaspis	(Ar,Tr,As)	Pseudamplexus	(Cn,An,Ru)	Pseudoaparchites	(Ar,Os,Pa)
Psalikilopsis	(Ar,Tr,Pr)	Pseudampyxina	(Ar,Tr,As)	Pseudoaptyxis	(Mo,Ga,Ne)
Psalikilus	(Ar,Tr,Pr)	Pseudamussium	(Mo,Bi,Pt)	Pseudoarcopagia	(Mo,Bi,Ve)
Psamathopalass	(Br,Un,Un)	Pseudananchys	(Ec,Ec,Hs)	Pseudoarctolepis	(Ar,Un,Un)
Psammacoma	(Mo,Bi,Ve)	Pseudancistroceras	(Mo,Ce,Ta)	Pseudoasaphus	(Ar,Tr,As)
Psammactinia	(Cn,Hy,Hy)	Pseudanomicarina	(Ar,Tr,As)	Pseudoasopora	(Bz,St,Cr)
Psamatodendron	(Fo,Fo,Fo)	Pseudantalis	(Mo,Sc,Sc)	Pseudoaspidoceras	(Mo,Ce,Am)
Psammechinus	(Ec,Ec,Ec)	Pseudaphelaspis	(Ar,Tr,As)	Pseudoathyrina	(Br,Ar,Sp)
Psammimopelta	(Fo,Fo,Fo)	Pseudaphrodina	(Mo,Bi,Ve)	Pseudoaulacothyrus	(Br,Ar,Te)
Psammiphora	(Cn,An,Sc)	Pseudarbacia	(Ec,Ec,Ph)	Pseudoaulophacus	(Ac,Ra,Sp)
Psammobella	(Mo,Bi,Ve)	Pseudarbacina	(Ec,Ec,Te)	Pseudoaurila	(Ar,Os,Po)
Psammobia	(Mo,Bi,Ve)	Pseudarca	(Mo,Bi,Mo)	Pseudoavonia	(Br,Ar,St)
Psammocarcinus	(Ar,Mi,De)	Pseudarcella	(Ci,Po,Sp)	Pseudobaculites	(Mo,Ce,An)
Psammocoencha	(Mo,Bi,Un)	Pseudarchaster	(Ec,As,Va)	Pseudobaculites	(Mo,Ce,Am)
Psammocora	(Cn,An,Sc)	Pseudargentinceras	(Mo,Ce,Am)	Pseudobaisalina	(Fo,Fo,Fo)
Psammocyathus	(Cn,An,Sc)	Pseudarictites	(Mo,Ce,Go)	Pseudobarroisiceras	(Mo,Ce,Am)

Pseudobasilicus	(Ar,Tr,As)	Pseudoclararia	(Mo,Bi,Pt)	Pseudodontornis	(Cd,Av,Pe)
Pseudobatosomella	(Bz,St,Tr)	Pseudoclathrochitina	(Fo,Fo,Ch)	Pseudodontodolida	(Cn,An,Ru)
Pseudobaylea	(Mo,Ga,Ar)	Pseudoclaviphylum	(Cn,An,Ru)	Pseudodooovittia	(Br,Ar,St)
Pseudobeiselmia	(Bz,Gy,Ch)	Pseudoclavulina	(Fo,Fo,Fo)	Pseudoechinorhinus	(Cd,Ch,Sq)
Pseudobelodina	(Cd,Co,Co)	Pseudoclavus	(Pr,Ca,Ca)	Pseudoeogertia	(Cd,Os,An)
Pseudobelus	(Mo,Ce,Be)	Pseudoclelanida	(Ar,Tr,Un)	Pseudoendothyra	(Fo,Fo,Fo)
Pseudoberyx	(Cd,Os,Pa)	Pseudoclimacograptus	(He,Gr,Gr)	Pseudoentomozoe	(Ar,Os,My)
Pseudobeyrichia	(Ar,Os,Pa)	Pseudoclymenia	(Mo,Ce,Go)	Pseudopistominaella	(Fo,Fo,Fo)
Pseudobeyrichiopsis	(Ar,Os,Pa)	Pseudocobboldia	(Ar,Tr,Ag)	Pseudoeponides	(Fo,Fo,Fo)
Pseudobigalea	(Mo,Ro,Co)	Pseudocoenia	(Cn,An,Sc)	Pseudoeobia	(Ar,Tr,Co)
Pseudoblothrophylum	(Cn,An,Ru)	Pseudocoeniopsis	(Cn,An,Sc)	Pseudoeteraspis	(Ar,Tr,Pt)
Pseudobolivina	(Fo,Fo,Fo)	Pseudocolpomya	(Mo,Bi,Mt)	Pseudoeuchasma	(Mo,Ro,Ri)
Pseudobollia	(Ar,Os,Pa)	Pseudocominella	(Mo,Ga,Ne)	Pseudoeucyrtis	(Ac,Ra,Na)
Pseudobolloceras	(Mo,Ce,Di)	Pseudoconchidium	(Br,Ar,Pe)	Pseudoexlinella	(Ec,Ho,Mo)
Pseudobolus	(Br,Li,Li)	Pseudoconocardium	(Mo,Ro,Co)	Pseudofabularia	(Fo,Fo,Fo)
Pseudobornhardtina	(Br,Ar,Te)	Pseudoconularia	(Cn,Sc,Cn)	Pseudofavaria	(Cn,An,Sc)
Pseudobradyna	(Fo,Fo,Fo)	Pseudocorax	(Cd,Ch,La)	Pseudofavites	(Cn,An,Sc)
Pseudobradypodium	(Cn,An,Ru)	Pseudocorbula	(Mo,Bi,Ve)	Pseudofavosites	(Cn,An,Te)
Pseudobrechites	(Mo,Bi,Ph)	Pseudocosmoceras	(Mo,Ce,Am)	Pseudofavarella	(Mo,Ce,Am)
Pseudobrevicoceras	(Mo,Ce,On)	Pseudocostatoria	(Mo,Bi,Pr)	Pseudofax	(Mo,Ga,Ne)
Pseudobrightia	(Mo,Ce,Am)	Pseudocrania	(Br,Li,Ac)	Pseudofaster	(Ec,Ec,Hs)
Pseudobrissus	(Ec,Ec,Sp)	Pseudocrocephalaspina	(Ar,Tr,Un)	Pseudofissurella	(Mo,Ga,Ar)
Pseudobrochidium	(Mo,Ga,Nt)	Pseudocrotinites	(Ec,Rh,Rh)	Pseudofissurina	(Fo,Fo,Fo)
Pseudobroeckinella	(Fo,Fo,Fo)	Pseudocruella	(Ac,Ra,Sp)	Pseudoflecteria	(Cn,An,Te)
Pseudobryograptus	(He,Gr,Gr)	Pseudocryphaeus	(Ar,Tr,Ph)	Pseudoflemingites	(Mo,Ce,Ce)
Pseudobuccinum	(Mo,Ga,Ne)	Pseudocryptaenia	(Mo,Ga,Ar)	Pseudofloridites	(Mo,Ce,Am)
Pseudobulimina	(Fo,Fo,Fo)	Pseudocryptophyllum	(Cn,An,Ru)	Pseudofrondicularia	(Fo,Fo,Fo)
Pseudobulminella	(Fo,Fo,Fo)	Pseudocucullaea	(Mo,Bi,Ar)	Pseudofrondipora	(Bz,St,Ce)
Pseudobythocypris	(Ar,Os,Me)	Pseudocuspidiaria	(Mo,Bi,Ph)	Pseudofulgur	(Mo,Ga,Ne)
Pseudobythocythere	(Ar,Os,Pe)	Pseudocybele	(Ar,Tr,Ph)	Pseudofurmihius	(Cd,Co,Co)
Pseudocadoceras	(Mo,Ce,Am)	Pseudocycloceras	(Mo,Ce,Or)	Pseudofusua	(Mo,Ga,Un)
Pseudocalvinella	(Ar,Tr,Co)	Pseudocyclopyge	(Ar,Tr,As)	Pseudofusulina	(Fo,Fo,Fo)
Pseudocalycoceras	(Mo,Ce,Am)	Pseudocycloseris	(Cn,An,Sc)	Pseudofusulinella	(Fo,Fo,Fo)
Pseudocamaratoechia	(Br,Ar,Rh)	Pseudocyclammina	(Fo,Fo,Fo)	Pseudogalatea	(Ar,MI,My)
Pseudocamarophoria	(Br,Ar,Rh)	Pseudocyma	(Mo,Ga,Nt)	Pseudogaleodea	(Mo,Ga,Nt)
Pseudocampophyllum	(Cn,An,Ru)	Pseudocyproides	(Ar,Os,Pe)	Pseudogarantiana	(Mo,Ce,Am)
Pseudocancilla	(Mo,Ga,Ne)	Pseudocyrena	(Mo,Bi,Ve)	Pseudogarnieria	(Mo,Ce,Am)
Pseudocarcinus	(Ar,MI,De)	Pseudocyrina	(Br,Ar,Sp)	Pseudogastroceras	(Mo,Ce,Go)
Pseudocardia	(Mo,Bi,Ve)	Pseudocyrtoceras	(Mo,Ce,Or)	Pseudogatheria	(Cn,An,Sc)
Pseudocardioceras	(Mo,Ce,Ce)	Pseudocystiphylum	(Cn,An,Ru)	Pseudogaudryina	(Fo,Fo,Fo)
Pseudocardium	(Mo,Bi,Ve)	Pseudocythere	(Ar,Os,Pe)	Pseudogaudryinella	(Fo,Fo,Fo)
Pseudocarnites	(Mo,Ce,Ce)	Pseudocytheretta	(Ar,Os,Pe)	Pseudogavelinella	(Fo,Fo,Fo)
Pseudocassidulinoides	(Fo,Fo,Fo)	Pseudocytheridea	(Ar,Os,Pe)	Pseudogasteros	(Ar,Tr,Pr)
Pseudocassis	(Mo,Ga,Ce)	Pseudocytheromorpha	(Ar,Os,Pe)	Pseudogibbaster	(Ec,Ec,Sp)
Pseudocastroboceras	(Mo,Ce,Na)	Pseudocytherura	(Ar,Os,Pe)	Pseudogibbirhynchia	(Br,Ar,Rh)
Pseudocavellina	(Ar,Os,Pa)	Pseudodalatias	(Cd,Ch,Ct)	Pseudoglyphyrhites	(Mo,Ce,Go)
Pseudocelites	(Mo,Ce,Ce)	Pseudodontabites	(Mo,Ce,Ce)	Pseudoglaucina	(Mo,Ga,Nt)
Pseudocenceras	(Mo,Ce,Na)	Pseudodechenella	(Ar,Tr,Pr)	Pseudogloborotalia	(Fo,Fo,Fo)
Pseudocentrotus	(Ec,Ec,Te)	Pseudoderbyia	(Br,Ar,St)	Pseudoglomospira	(Fo,Fo,Fo)
Pseudoceratina	(Ar,Os,Pa)	Pseudodiartema	(Mo,Ga,Nt)	Pseudoglossirotoechia	(Br,Ar,Rh)
Pseudochaetetes	(Po,De,Te)	Pseudodicelillum	(Br,Li,Li)	Pseudoglossothyris	(Br,Ar,Te)
Pseudochama	(Mo,Bi,Ve)	Pseudodichograptus	(He,Gr,Gr)	Pseudoglyphea	(Ar,MI,De)
Pseudocheirurus	(Ar,Tr,Ph)	Pseudodicelites	(Mo,Ce,Be)	Pseudoglyptograptus	(He,Gr,Gr)
Pseudochernyshinella	(Fo,Fo,Fo)	Pseudodicelolosa	(Br,Ar,Or)	Pseudogomphoceras	(Mo,Ce,Di)
Pseudochoffatella	(Fo,Fo,Fo)	Pseudodicoptella	(Ec,Ec,Te)	Pseudogrammatodon	(Mo,Bi,Ar)
Pseudochonetes	(Br,Ar,St)	Pseudodictyomitra	(Ac,Ra,Na)	Pseudogrammoceras	(Mo,Ce,Am)
Pseudochonophyllum	(Cn,An,Ru)	Pseudodictyophimus	(Ac,Ra,Na)	Pseudogregoryceras	(Mo,Ce,Am)
Pseudochrysalidina	(Fo,Fo,Fo)	Pseudodictymotis	(Mo,Bi,Pt)	Pseudogruenewaldtia	(Br,Ar,At)
Pseudochrysalis	(Mo,Ga,Nt)	Pseudodielasma	(Br,Ar,Te)	Pseudogrypophyllum	(Cn,An,Ru)
Pseudocibicides	(Fo,Fo,Fo)	Pseudodigonophyllum	(Cn,An,Ru)	Pseudogualupia	(Po,De,Pe)
Pseudocidaris	(Ec,Ec,Hm)	Pseudodiloma	(Mo,Ga,Ar)	Pseudogumbelina	(Fo,Fo,Fo)
Pseudocirsipe	(Mo,Ga,Nt)	Pseudodiplocoenia	(Cn,An,Sc)	Pseudoguettardia	(Po,De,Li)
Pseudoclimbites	(Mo,Ce,Am)	Pseudodoliolina	(Fo,Fo,Fo)	Pseudogygites	(Ar,Tr,As)
Pseudoclanculus	(Mo,Ga,Ar)	Pseudodontichthys	(Cd,Ch,Eu)	Pseudogyra	(Mo,Bi,Pt)

Pseudohagiastrium	(Ac.Ra.Sp)	Pseudolepismatina	(Br.Ar,Sp)	Pseudomytiloides	(Mo.Bi,Pt)
Pseudohalorella	(Br.Ar,Rh)	Pseudoleptellina	(Br.Ar,St)	Pseudonautulus	(Mo.Ce,Na)
Pseudohalorites	(Mo.Ce,Go)	Pseudoleptopodus	(Br.Ar,St)	Pseudoneocarcinus	(Ar.Ml,De)
Pseudohaploceras	(Mo.Ce,Am)	Pseudoleptolepis	(Cd,Os,Sa)	Pseudonematopora	(Bz.St,Cr)
Pseudohartina	(Br.Ar,Te)	Pseudolepton	(Mo.Bi,Ve)	Pseudoneoptychites	(Mo.Ce,Am)
Pseudohastigerina	(Fo.Fo,Fo)	Pseudoleptomeriella	(Mo.Ce,Am)	Pseudoneptunea	(Mo.Ga,Ne)
Pseudohastites	(Mo.Ce,Be)	Pseudolillia	(Mo.Ce,Am)	Pseudonerinea	(Mo.Ga,Ce)
Pseudohaureina	(Fo.Fo,Fo)	Pseudolimea	(Mo.Bi,Pt)	Pseudonina	(Mo.Ga,Ar)
Pseudoheldia	(Ar.Os,Me)	Pseudolingula	(Br.Li,Li)	Pseudoninella	(Mo.Ga,Ar)
Pseudohelenia	(Fo.Fo,Fo)	Pseudolinthia	(Ec.Ec,Sp)	Pseudoniscus	(Ar.Me,Xi)
Pseudoheliastrea	(Cn.An,Sc)	Pseudolioceras	(Mo.Ce,Am)	Pseudonodella	(Ar.Os,Pa)
Pseudoheligmus	(Mo.Bi,Pt)	Pseudoliomesus	(Mo.Ga,Ne)	Pseudonodellina	(Ar.Os,Un)
Pseudoheliodiscus	(Ac.Ra,Sp)	Pseudoliostacina	(Ar.Tr,Un)	Pseudonodosaria	(Fo.Fo,Fo)
Pseudohercynella	(Mo.Ga,Ba)	Pseudoliotina	(Mo.Ga,Ar)	Pseudonomisoceras	(Mo.Ce,Go)
Pseudohexagonaria	(Cn.An,Ru)	Pseudolissoceras	(Mo.Ce,Am)	Pseudononion	(Fo.Fo,Fo)
Pseudohibolites	(Mo.Ce,Be)	Pseudolituonella	(Fo.Fo,Fo)	Pseudonovella	(Fo.Fo,Fo)
Pseudohilsa	(Cd,Os,Cf)	Pseudolituotuba	(Fo.Fo,Fo)	Pseudonucula	(Mo.Bi,Nu)
Pseudohippula	(Ar.Os,Pa)	Pseudolituotubella	(Fo.Fo,Fo)	Pseudonuculana	(Mo.Bi,Nu)
Pseudohistiophorus	(Cd,Os,Pf)	Pseudoliva	(Mo.Ga,Ne)	Pseudonudirostra	(Br.Ar,Rh)
Pseudohomeospira	(Br.Ar,Sp)	Pseudolomchodina	(Cd.Co,Co)	Pseudooides	(Pr.Un,In)
Pseudohornera	(Bz.St,Fe)	Pseudolucinisa	(Mo.Bi,Ve)	Pseudoolenoides	(Ar.Tr,Pr)
Pseudouangia	(Cn.An,Ru)	Pseudolunulites	(Bz.Gy,Ch)	Pseudoolina	(Fo.Fo,Fo)
Pseudohustonia	(Ar.Os,Po)	Pseudolyria	(Mo.Ga,Ne)	Pseudooneotodus	(Cd.Co,Co)
Pseudohydroceras	(Po.He,Re)	Pseudomacrocypris	(Ar.Os,Po)	Pseudoostrella	(Mo.Ce,Am)
Pseudohyperammia	(Fo.Fo,Fo)	Pseudomalaxis	(Mo.Ga,He)	Pseudopachydictya	(Bz.St,Cr)
Pseudohypolophus	(Cd.Ch,Rj)	Pseudomantelliceras	(Mo.Ce,Am)	Pseudopachymytilus	(Mo.Bi,Pt)
Pseudohysterolenus	(Ar.Tr,As)	Pseudomarginifera	(Br.Ar,St)	Pseudopalaeoaplysina	(Po.De,Ax)
Pseudohystricurus	(Ar.Tr,Pr)	Pseudomarsionella	(Fo.Fo,Fo)	Pseudopalmula	(Fo.Fo,Fo)
Pseudoinperatgoria	(Po.De,Pe)	Pseudomatthevia	(Mo.In,In)	Pseudopanderodus	(Cd.Co,Co)
Pseudoinvoluciteras	(Mo.Ce,Am)	Pseudomaaura	(Mo.Ga,Ne)	Pseudopantanelium	(Ac.Ra,Sp)
Pseudoironealla	(Cn.An,Sc)	Pseudomegalaspis	(Ar.Tr,Pt)	Pseudoparalegoceras	(Mo.Ce,Go)
Pseudoirus	(Mo.Bi,Ve)	Pseudomelania	(Mo.Ga,Nt)	Pseudoparaparchites	(Ar.Os,Po)
Pseudoischnochiton	(Mo.Po,Ne)	Pseudomelatoma	(Mo.Ga,Ne)	Pseudoparazyga	(Br.Ar,Sp)
Pseudoisograptus	(He.Gr,Gr)	Pseudomendacella	(Br.Ar,Or)	Pseudoparrella	(Fo.Fo,Fo)
Pseudoisotrypa	(Bz.St,Fe)	Pseudomenutites	(Mo.Ce,Am)	Pseudopatellinella	(Fo.Fo,Fo)
Pseudoisurus	(Cd.Ch,La)	Pseudomera	(Ar.Tr,Ph)	Pseudopatellinoides	(Fo.Fo,Fo)
Pseudojacobites	(Mo.Ce,Am)	Pseudomercatoceras	(Mo.Ce,Am)	Pseudopavona	(Cn.An,Ru)
Pseudojerera	(Po.De,Li)	Pseudomeristina	(Br.Ar,At)	Pseudopecten	(Mo.Bi,Pt)
Pseudokadyella	(Ar.Tr,Pt)	Pseudomesalia	(Mo.Ga,Nt)	Pseudopedina	(Ec.Ec,Pe)
Pseudokahlerina	(Fo.Fo,Fo)	Pseudometis	(Mo.Bi,Ve)	Pseudopeltoceras	(Mo.Ce,Am)
Pseudokainella	(Ar.Tr,As)	Pseudometoptoma	(Br.Li,Ac)	Pseudopemmatites	(Po.He,He)
Pseudokatrolliceras	(Mo.Ce,Am)	Pseudometula	(Mo.Ga,Ne)	Pseudopemphix	(Ar.Ml,De)
Pseudokiesowia	(Ar.Os,Pa)	Pseudomexicella	(Ar.Tr,Pt)	Pseudopentagonia	(Br.Ar,Sp)
Pseudokingena	(Br.Ar,Te)	Pseudomicrocroplasma	(Cn.An,Ru)	Pseudoperisphinctes	(Mo.Ce,Am)
Pseudokingstonia	(Ar.Tr,Pt)	Pseudomiltha	(Mo.Bi,Ve)	Pseudoperissitys	(Mo.Ga,Ne)
Pseudokionoceras	(Mo.Ce,Or)	Pseudomimella	(Br.Ar,Or)	Pseudoperissocytheridea	(Ar.Os,Po)
Pseudokoldinia	(Ar.Tr,Pt)	Pseudomonoceratina	(Ar.Os,Po)	Pseudoperissolax	(Mo.Ga,Ne)
Pseudokossmaticeras	(Mo.Ce,Am)	Pseudomonotis	(Mo.Bi,Pt)	Pseudoperimorphus	(Mo.Bi,Ve)
Pseudokriihe	(Ar.Os,Po)	Pseudomonticlarella	(Br.Ar,Rh)	Pseudoperna	(Mo.Bi,Pt)
Pseudokunmingella	(Ar.Os,Ar)	Pseudomonticulifera	(Br.Ar,St)	Pseudopetalichthys	(Cd.Pl,Ps)
Pseudokymatites	(Mo.Ce,Ce)	Pseudomorea	(Mo.Ga,Ne)	Pseudopetria	(Cn.An,Ht)
Pseudokymatothyris	(Br.Ar,Sp)	Pseudompalatrochus	(Mo.Ga,Eu)	Pseudopfenderina	(Fo.Fo,Fo)
Pseudolabaia	(Br.Ar,Te)	Pseudomphalocyclus	(Fo.Fo,Fo)	Pseudophacoceras	(Mo.Ce,Na)
Pseudolaballa	(Br.Ar,Sp)	Pseudomucophyllum	(Cn.An,Ru)	Pseudophalacroma	(Ar.Tr,Ag)
Pseudolabechnia	(Po.De,St)	Pseudomulcodens	(Mo.Ro,Co)	Pseudophanasymmetria	(Ar.Os,Po)
Pseudolacazina	(Fo.Fo,Fo)	Pseudomurchisonia	(Mo.Ga,Nt)	Pseudophasianus	(Mo.Ga,Ar)
Pseudolacuna	(Mo.Ga,Nt)	Pseudomurex	(Mo.Ga,Ne)	Pseudophaulactis	(Cn.An,Ru)
Pseudolamarckina	(Fo.Fo,Fo)	Pseudomya	(Mo.Bi,Un)	Pseudophichthyes	(Cd.Os,An)
Pseudolancastria	(Ar.Tr,Co)	Pseudomyalina	(Mo.Bi,Pt)	Pseudophillipsia	(Ar.Tr,Pr)
Pseudolatirus	(Mo.Ga,Ne)	Pseudomyoconcha	(Mo.Bi,Ve)	Pseudopholidops	(Br.Li,Li)
Pseudoleda	(Mo.Bi,Nu)	Pseudomyomphalus	(Ar.Os,Pa)	Pseudophorus	(Mo.Ga,Eu)
Pseudolenus	(Ar.Tr,Pt)	Pseudomyona	(Mo.In,Tu)	Pseudophragmina	(Fo.Fo,Fo)
Pseudoleperditia	(Ar.Os,Pa)	Pseudomyophorella	(Mo.Bi,Tr)	Pseudophragmoceras	(Mo.Ce,Di)
Pseudolepidina	(Fo.Fo,Fo)	Pseudomyriophyllia	(Cn.An,Sc)	Pseudophycis	(Cd.Os,Ga)

Pseudophyllites	(Mo,Ce,Am)	Pseudorhaphydionina	(Fo,Fo,Fo)	Pseudospondylospira	(Br,Ar,Sp)
Pseudopliophyllum	(Cn,An,Ru)	Pseudorhina	(Cd,Ch,St)	Pseudosquilla	(Ar,Ml,St)
Pseudopironaea	(Mo,Bi,Hi)	Pseudorhynchidionina	(Fo,Fo,Fo)	Pseudostaffella	(Fo,Fo,Fo)
Pseudopis	(Mo,Bi,Ve)	Pseudorhizostomites	(Cn,In,In)	Pseudostaurocmites	(Ec,Ho,De)
Pseudopisania	(Mo,Ga,Ne)	Pseudorhombia	(Ar,Ml,De)	Pseudostege	(Bz,Gy,Ch)
Pseudopisthophyllum	(Cn,An,Sc)	Pseudorhytidopilus	(Mo,Ga,Ar)	Pseudostenopoceras	(Mo,Ce,Na)
Pseudoplacenteras	(Mo,Ce,Am)	Pseudoristolta	(Ac,Ra,Na)	Pseudostictoporella	(Bz,St,Cr)
Pseudoplacuna	(Mo,Bi,Pt)	Pseudoroemeria	(Cn,An,Ta)	Pseudostomatella	(Mo,Ga,Ar)
Pseudoplacunopsis	(Mo,Bi,Pt)	Pseudoroemeripora	(Cn,An,Ta)	Pseudostreptograptus	(He,Gr,Gr)
Pseudoplaneoendothyra	(Fo,Fo,Fo)	Pseudoromingeria	(Cn,An,Ta)	Pseudostrepula	(Ar,Os,Pa)
Pseudoplanglobulina	(Fo,Fo,Fo)	Pseudorostranteris	(Br,Ar,Te)	Pseudostromatoporella	(Po,De,St)
Pseudoplanulinella	(Fo,Fo,Fo)	Pseudorotalia	(Fo,Fo,Fo)	Pseudostrophalosia	(Br,Ar,St)
Pseudoplasmapora	(Cn,An,Ta)	Pseudorotalia	(Mo,Ga,Nt)	Pseudostrophochonetes	(Br,Ar,St)
Pseudoplatyceras	(Mo,Ga,Ar)	Pseudorothoceras	(Mo,Ce,Or)	Pseudostrophomena	(Br,Ar,St)
Pseudoplectograptus	(He,Gr,Gr)	Pseudorhopsis	(Ec,Ec,Pe)	Pseudostygina	(Ar,Tr,Co)
Pseudoplectograpturn	(He,Gr,Gr)	Pseudorothotheca	(Pr,Un,Hy)	Pseudostylodictyon	(Po,De,St)
Pseudoplesiagraulos	(Ar,Tr,Pt)	Pseudorugitela	(Br,Ar,Te)	Pseudostylosphaera	(Ac,Ra,Sp)
Pseudopleurophorus	(Mo,Bi,Ve)	Pseudoruttenia	(Fo,Fo,Fo)	Pseudosweetognathus	(Cd,Co,Co)
Pseudoplocezyga	(Mo,Ga,Ne)	Pseudosaccoceras	(Mo,Ce,Ce)	Pseudosyngnathus	(Cd,Os,Ga)
Pseudoplocoscypbia	(Po,De,Li)	Pseudosalenia	(Ec,Ec,Sa)	Pseudosyringocnema	(Po,Ar,Ar)
Pseudopollicina	(Mo,In,In)	Pseudosalteria	(Ar,Tr,Un)	Pseudosyringothyris	(Br,Ar,Sp)
Pseudopolyconites	(Mo,Bi,Hi)	Pseudosanguinolites	(Mo,Bi,Ve)	Pseudosyrinx	(Br,Ar,Sp)
Pseudopolygnathus	(Cd,Co,Co)	Pseudosaracenia	(Fo,Fo,Fo)	Pseudotallinnella	(Ar,Os,Pa)
Pseudopolymerphina	(Fo,Fo,Fo)	Pseudosarotegia	(Ar,Tr,As)	Pseudotaphrus	(Mo,Ga,Nt)
Pseudopolymorphinoides	(Fo,Fo,Fo)	Pseudosaturnalis	(Ac,Ra,Sp)	Pseudotaxis	(Fo,Fo,Fo)
Pseudopolyplectus	(Mo,Ce,Am)	Pseudosaturniforma	(Ac,Ra,Na)	Pseudotealliocaris	(Ar,Ml,My)
Pseudopolythecalis	(Cn,An,Ru)	Pseudosaukia	(Ar,Tr,Un)	Pseudotechnophorus	(Mo,Ro,Ri)
Pseudopolytremacis	(Cn,An,He)	Pseudosaxicanda	(Ar,Tr,Re)	Pseudotectus	(Mo,Ga,Ar)
Pseudoporambonites	(Br,Ar,Pe)	Pseudosaxicava	(Mo,Bi,My)	Pseudotemnocheilus	(Mo,Ce,Na)
Pseudoporfieldia	(Po,De,Pe)	Pseudosaxynella	(Mo,Ce,Am)	Pseudotemperoceras	(Mo,Ce,Or)
Pseudoportlandia	(Mo,Bi,Nu)	Pseudoscalites	(Mo,Ga,Nt)	Pseudotermierella	(Ar,Tr,Un)
Pseudopoulpus	(Ac,Ra,Na)	Pseudoscaris	(Cd,Os,Pf)	Pseudotervia	(Bz,St,Cc)
Pseudopoppelia	(Mo,Ce,Am)	Pseudoschistoceras	(Mo,Ce,Go)	Pseudotetrapterus	(Cd,Os,In)
Pseudoprimitiella	(Ar,Os,Pa)	Pseudoschizogonium	(Mo,Ga,Ar)	Pseudotoxularia	(Fo,Fo,Fo)
Pseudopronites	(Mo,Ce,Pl)	Pseudoschloenbachia	(Mo,Ce,Am)	Pseudotoxulariella	(Fo,Fo,Fo)
Pseudoproboloceras	(Mo,Ce,An)	Pseudoschwagerina	(Fo,Fo,Fo)	Pseudotheoampe	(Ac,Ra,Na)
Pseudoproetus	(Ar,Tr,Pr)	Pseudoscolpelus	(Cd,Os,Pf)	Pseudothetidites	(Mo,Ce,Ce)
Pseudoprotathyris	(Br,Ar,Sp)	Pseudosculda	(Ar,Ml,St)	Pseudothurmannia	(Mo,Ce,Am)
Pseudoprotocythere	(Ar,Os,Po)	Pseudoscythalia	(Po,De,Li)	Pseudotibetites	(Mo,Ce,Ce)
Pseudopsammocythere	(Ar,Os,Po)	Pseudoscliscthon	(Po,De,Li)	Pseudotimania	(Cn,An,Ru)
Pseudoptera	(Mo,Bi,Pt)	Pseudosepia	(Mo,Ce,Se)	Pseudotindaria	(Mo,Bi,Nu)
Pseudopterocephalus	(Ar,Tr,As)	Pseudoseptifer	(Po,De,Ta)	Pseudotirilites	(Mo,Ce,Ce)
Pseudopugnax	(Br,Ar,Rh)	Pseudoseptopora	(Bz,St,Fe)	Pseudotissotia	(Mo,Ce,Am)
Pseudopuzosia	(Mo,Ce,Am)	Pseudoseriola	(Cd,Os,Pf)	Pseudotitanoceras	(Mo,Ce,Na)
Pseudopygaulus	(Ec,Ec,Ca)	Pseudoseriopora	(Bz,St,Cc)	Pseudotoceras	(Mo,Ce,Ce)
Pseudopygoides	(Br,Ar,Te)	Pseudoseris	(Cn,An,Sc)	Pseudotoites	(Mo,Ce,Am)
Pseudopygurus	(Ec,Ec,Ca)	Pseudosetia	(Mo,Ga,Nt)	Pseudotoma	(Mo,Ga,Ne)
Pseudopythina	(Mo,Bi,Ve)	Pseudosiderastraea	(Cn,An,Sc)	Pseudotornia	(Mo,Ga,He)
Pseudorakverella	(Ar,Os,Pa)	Pseudosiderolites	(Fo,Fo,Fo)	Pseudotormentus	(Ac,Ra,Sp)
Pseudoraniceps	(Cd,Os,Ga)	Pseudosieberella	(Br,Ar,Pe)	Pseudotoucasia	(Mo,Bi,Hi)
Pseudoraniella	(Ar,Ml,De)	Pseudosigmoilina	(Fo,Fo,Fo)	Pseudotoxoeuma	(Hy,Un,To)
Pseudorapa	(Mo,Ga,Ne)	Pseudosimoceras	(Mo,Ce,Am)	Pseudotrapezium	(Mo,Bi,Ve)
Pseudoraphitoma	(Mo,Ga,Ne)	Pseudosinotectirostrum	(Br,Ar,Rh)	Pseudotribrachia	(Fo,Fo,Fo)
Pseudorayella	(Ar,Os,Po)	Pseudosiphonella	(Fo,Fo,Fo)	Pseudotrigonograptus	(He,Gr,Gr)
Pseudorbitoides	(Fo,Fo,Fo)	Pseudosirenites	(Mo,Ce,Ce)	Pseudotrioculina	(Fo,Fo,Fo)
Pseudorbitolina	(Fo,Fo,Fo)	Pseudosolenina	(Fo,Fo,Fo)	Pseudotrinodus	(Ar,Tr,Pr)
Pseudorca	(Cd,Ma,Ce)	Pseudosolenopleura	(Ar,Tr,Pt)	Pseudotriplasia	(Fo,Fo,Fo)
Pseudoredlichia	(Ar,Tr,Re)	Pseudosonnerriata	(Mo,Ce,Am)	Pseudotritix	(Fo,Fo,Fo)
Pseudoreichelina	(Fo,Fo,Re)	Pseudosorella	(Ec,Ec,Ca)	Pseudotriticeites	(Fo,Fo,Fo)
Pseudoreophax	(Fo,Fo,Fo)	Pseudosphaerexochus	(Ar,Tr,Ph)	Pseudotritonium	(Mo,Ga,Nt)
Pseudoresserops	(Ar,Tr,Re)	Pseudosphaerodon	(Cd,Os,Pf)	Pseudotrivia	(Mo,Ga,Nt)
Pseudoretiolites	(He,Gr,Gr)	Pseudosphargis	(Cd,Re,Ch)	Pseudotropites	(Mo,Ce,Am)
Pseudorhabdophyllum	(Cn,An,Ru)	Pseudospiriferina	(Br,Ar,Sp)	Pseudotruncatella	(Mo,Ga,Nt)
Pseudorhaetina	(Br,Ar,Te)	Pseudospirocyclina	(Fo,Fo,Fo)	Pseudotrupetostroma	(Po,De,St)

Pseudotryplasma	(Cn,An,Ru)	Psilokirkbyella	(Ar,Os,Pa)	Pterolytoceras	(Mo,Ce,Am)
Pseudotubina	(Mo,Ga,Ar)	Psilomelissa	(Ac,Ra,Na)	Pteromeris	(Mo,Bi,Ve)
Pseudotubithyrus	(Br,Ar,Te)	Psilomya	(Mo,Bi,Ph)	Pteromya	(Mo,Bi,Ph)
Pseudotupolichas	(Ar,Tr,Li)	Psilonotus	(Br,Ar,St)	Pteromyrtea	(Mo,Bi,Ve)
Pseudotybithyrus	(Br,Ar,Te)	Psilonychia	(Mo,Bi,Pt)	Pteronarcus	(Cd,Ma,Ca)
Pseudotylostoma	(Mo,Ga,Nt)	Psilophyllites	(Mo,Ce,Am)	Pteronisculus	(Cd,Os,Pa)
Pseudoumbriina	(Cd,Os,Pl)	Psiloria	(Br,Ar,Or)	Pteroniella	(Mo,Bi,Pt)
Pseudouncinulus	(Br,Ar,Rh)	Psilosecos	(Bz,Gy,Ch)	Pteronites	(Mo,Bi,Mt)
Pseudoundispirifer	(Br,Ar,Sp)	Psilosolen	(Bz,St,Cc)	Pteronitina	(Mo,Bi,Pt)
Pseudounitrypa	(Bz,St,Fe)	Psilosturia	(Mo,Ce,Ce)	Pteronychia	(Mo,Bi,Pt)
Pseudouvirgerina	(Fo,Fo,Fo)	Psilothyrus	(Br,Ar,Te)	Pteroparia	(Ar,Tr,Pr)
Pseudovaccinites	(Mo,Bi,Hi)	Psilotissotia	(Mo,Ce,Am)	Pteropelta	(An,Po,Eu)
Pseudovaricia	(Mo,Ga,Ne)	Psilotrachelosaurus	(Cd,Re,No)	Pteroperina	(Mo,Bi,Pt)
Pseudovermilia	(An,Po,Se)	Psilotrigrionia	(Mo,Bi,Tr)	Pterophrentis	(Cn,An,Ru)
Pseudoverruculina	(Po,De,Li)	Psioidea	(Bt,Ar,Sp)	Pteroplecta	(Br,Ar,Sp)
Pseudovertagus	(Mo,Ga,Nt)	Psioidiella	(Br,Ar,Sp)	Pteropora	(Bz,St,Fe)
Pseudovidalina	(Fo,Fo,Fo)	Psikovierinus	(Ec,Cr,Cl)	Pteroprella	(Mo,Bi,Ve)
Pseudovidrioceras	(Mo,Ce,Go)	Psychopyge	(Ar,Tr,Ph)	Pteropurpura	(Mo,Ga,Ne)
Pseudovirgatites	(Mo,Ce,Am)	Psydracophyllum	(Cn,An,Ru)	Pteroredlichia	(Ar,Tr,Re)
Pseudovirgula	(Po,De,Li)	Ptarmigania	(Ar,Tr,Co)	Pterorhiza	(Cn,An,Ru)
Pseudovola	(Mo,Bi,Pt)	Ptarmiganoides	(Ar,Tr,Co)	Pterorytis	(Mo,Ga,Ne)
Pseudovomer	(Cd,Os,Pl)	Ptenoceras	(Mo,Ce,Na)	Pteroscaphites	(Mo,Ce,Am)
Pseudowaagenia	(Mo,Ce,Am)	Pteracontiodtus	(Cd,Co,Co)	Pteroscylidium	(Cd,Ch,Ca)
Pseudowanganella	(Fo,Fo,Fo)	Pteramma	(Fo,Fo,Fo)	Pterosirenites	(Mo,Ce,Ce)
Pseudowanerophyllum	(Cn,An,Ru)	Pteraspis	(Cd,Pt,Pt)	Pterospathodus	(Cd,Co,Co)
Pseudowaribole	(Ar,Tr,Pr)	Pteraulima	(Mo,Ga,Nt)	Pterosphenus	(Cd,Re,Sq)
Pseudowartha	(Mo,Ga,Be)	Pteria	(Mo,Bi,Pt)	Pterospira	(Mo,Ga,Ne)
Pseudowashitaster	(Ec,Ec,Sp)	Pteridinium	(Cn,Pe,Er)	Pterospirifer	(Br,Ar,Sp)
Pseudowattonithyrus	(Br,Ar,Te)	Pterigotheca	(Hy,Hy,Hy)	Pterostrophia	(Br,Ar,St)
Pseudowedekindellina	(Fo,Fo,Fo)	Pterinea	(Mo,Bi,Pt)	Pterotheca	(Mo,Ga,Be)
Pseudowellerella	(Br,Ar,Rh)	Pterinella	(Mo,Bi,Pt)	Pterothrissus	(Cd,Os,An)
Pseudowoodella	(Fo,Fo,Fo)	Pterinoactinodesma	(Mo,Bi,Pt)	Pterotoblastus	(Ec,Bi,Fi)
Pseudoxenomystax	(Cd,Os,An)	Pterinoacrinus	(Ec,Cr,Di)	Pterotocrinus	(Ec,Cr,Mo)
Pseudoxybeloceras	(Mo,Ce,Am)	Pterinopecten	(Mo,Bi,Pt)	Pterotrachea	(Mo,Ga,Nt)
Pseudoxyperas	(Mo,Bi,Ve)	Pterinopectinella	(Mo,Bi,Pt)	Pterotrigrionia	(Mo,Bi,Tr)
Pseudoyangtzespira	(Mo,In,In)	Pterobranchites	(He,Pt,Ce)	Pterotyphis	(Mo,Ga,Ne)
Pseudoyatsengia	(Cn,An,Ru)	Pterocalpia	(Po,De,Li)	Pterpinus	(Pr,Un,In)
Pseudoyuepingia	(Ar,Tr,As)	Pterocanium	(Ac,Ra,Na)	Pterygia	(Mo,Ga,Ne)
Pseudoyunnanella	(Br,Ar,Rh)	Pterocardia	(Mo,Bi,Hi)	Pterygocephalus	(Cd,Os,Da)
Pseudozaphrentoides	(Cn,An,Ru)	Pterocella	(Bz,Gy,Ch)	Pterygochiton	(Mo,Po,Ne)
Pseudozonaria	(Mo,Ga,Nt)	Pterocephalia	(Ar,Tr,As)	Pterygocythere	(Ar,Os,Po)
Pseudozygobolbina	(Ar,Os,Pa)	Pterocephalops	(Ar,Tr,As)	Pterygocythereis	(Ar,Os,Po)
Pseudozygopleura	(Mo,Ga,Nt)	Pterocera	(Mo,Ga,Nt)	Pterygometopus	(Ar,Tr,Ph)
Pseudulrichia	(Ar,Os,Pa)	Pterocerella	(Mo,Ga,Nt)	Pterynotus	(Mo,Ga,Ne)
Pseuduptionia	(Mo,Ce,Am)	Pterochaenia	(Mo,Bi,Pt)	Ptililaenus	(Ar,Tr,Co)
Psiaoceras	(Mo,Ce,On)	Pterochelios	(Mo,Ga,Ar)	Ptilocella	(Bz,St,Cy)
Psigraptus	(He,Gr,De)	Pterochelus	(Mo,Ga,Ne)	Ptiliodictya	(Bz,St,Cr)
Psilacella	(Ar,Tr,As)	Pterochitina	(Fo,Fo,Ch)	Ptilofenestella	(Bz,St,Fe)
Psilarius	(Mo,Ga,Ne)	Pterochiton	(Mo,Po,Ne)	Ptilognathus	(Cd,Co,Co)
Psilaxis	(Mo,Ga,He)	Pterocodon	(Ac,Ra,Na)	Ptilograptus	(He,Gr,De)
Psilichthys	(Cd,Os,Pa)	Pterocomma	(Ec,Cr,Cm)	Ptilonaster	(Ec,Op,St)
Psilocalyx	(Po,He,He)	Pterocoryphe	(Ar,Tr,Pr)	Ptiloncodus	(Pr,Un,In)
Psilocamara	(Br,Ar,Rh)	Pterocorys	(Ac,Ra,Na)	Ptiloporella	(Bz,St,Fe)
Psilocamerella	(Br,Ar,Pe)	Pterocorythus	(Pr,Cr,Cr)	Ptiloporina	(Bz,St,Fe)
Psilocara	(Ar,Tr,As)	Pterodontia	(Mo,Ga,Nt)	Ptilorhynchia	(Br,Ar,Rh)
Psiloccephalina	(Ar,Tr,As)	Pterodonticeras	(Mo,Ga,Nt)	Ptilorhynchus	(Br,Ar,Rh)
Psiloccephalineella	(Ar,Tr,As)	Pteroeides	(Cn,An,Pe)	Ptilotrigrionia	(Mo,Bi,Tr)
Psiloceras	(Mo,Ce,Am)	Pterograptus	(He,Gr,Gr)	Ptilotypha	(Bz,St,Cr)
Psilolitharella	(Fo,Fo,Fo)	Pterolabrella	(Mo,Ga,Nt)	Ptilotyppina	(Bz,St,Cr)
Psiloladiscites	(Mo,Ce,Ce)	Pterolamiops	(Cd,Ch,Ca)	Ptiograptus	(He,Gr,De)
Psilocoehlis	(Mo,Ga,Ne)	Pteroleperditia	(Ar,Os,Le)	Ptomaspis	(Cd,Pt,Pt)
Psilocoehcha	(Mo,Bi,So)	Pteroloxa	(Ar,Os,Po)	Ptomatis	(Mo,Ga,Be)
Psilocrinus	(Ec,Cr,Cl)	Pterolucina	(Mo,Bi,Ve)	Ptretiosocyathus	(Po,Re,Aj)
Psilohamites	(Mo,Ce,Am)	Pteroluter	(Mo,Bi,Ve)	Ptychagnostus	(Ar,Tr,Ag)

Ptycharecstes	(Mo,Ce,Ce)	Puanophyllum	(Cn,An,Ru)	Punjabia	(Mo,Ga,Nt)
Ptychaspis	(Ar,Tr,As)	Puanospirifer	(Br,Ar,Sp)	Punka	(Ar,Tr,Pr)
Ptychatractus	(Mo,Ga,Ne)	Pubericycathus	(Pr,Cr,Cr)	Pupa	(Mo,Ga,Ce)
Ptycheulimella	(Mo,Ga,He)	Pucabatis	(Cd,Ch,My)	Pupatonia	(Mo,Ga,Nt)
Ptychites	(Mo,Ce,Ce)	Pucapristis	(Cd,Ch,Rj)	Puperita	(Mo,Ga,Ar)
Ptychobairdia	(Ar,Os,Po)	Puchastrea	(Cn,An,Se)	Pupillaea	(Mo,Ga,Ar)
Ptychobellerophon	(Mo,Ga,Be)	Puchenquia	(Mo,Ce,Am)	Pupillaria	(Mo,Ga,Ar)
Ptychoblastus	(Ec,BI,Sp)	Pudoproetus	(Ar,Tr,Pr)	Puposyrnola	(Mo,Ga,He)
Ptychoceras	(Ar,Mi,Ar)	Puebloites	(Mo,Ce,Am)	Puppigerus	(Cd,Re,Ch)
Ptychocaulus	(Mo,Ga,Ar)	Puellina	(Bz,Gy,Ch)	Purdonella	(Br,Ar,Sp)
Ptychocephalus	(Ar,Tr,As)	Pugettia	(Ar,Mi,De)	Purella	(Mo,In,In)
Ptychoceras	(Mo,Ce,Am)	Pugilina	(Mo,Ga,Ne)	Puriana	(Ar,Os,Po)
Ptychocerithium	(Mo,Ga,Nt)	Pugilis	(Br,Ar,St)	Puricytheretta	(Ar,Os,Po)
Ptychochaetetes	(Po,De,Ta)	Pugionicauda	(Ar,Tr,Pr)	Purisiphonia	(Po,He,He)
Ptychocladia	(Fo,Fo,Fo)	Pugnaria	(Br,Ar,Rh)	Purmanaroceras	(Mo,Ce,El)
Ptychocosomes	(Ec,Rh,Rh)	Pugnax	(Br,Ar,Rh)	Purpura	(Mo,Ga,Ne)
Ptychocrinus	(Ec,Cr,Di)	Pugnellus	(Mo,Ga,Nt)	Purpuradusta	(Mo,Ga,Nt)
Ptychochyndrites	(Mo,Ga,Ce)	Pugnoides	(Br,Ar,Rh)	Purpurellus	(Mo,Ga,Ne)
Ptychodesia	(Po,He,He)	Puha	(Mo,Ga,Ne)	Purpurina	(Mo,Ga,Nt)
Ptychodesma	(Mo,Bi,Ar)	Pulaskicrinus	(Ec,Cr,Ci)	Purpurocardia	(Mo,Bi,Ve)
Ptychodus	(Cd,Ch,Ct)	Pulchellia	(Mo,Ce,Am)	Purpuroidea	(Mo,Ga,Nt)
Ptychoglyptus	(Br,Ar,St)	Pulcherproetus	(Ar,Tr,Pr)	Puruiana	(Mo,Ga,Ne)
Ptychogyra	(Mo,Ga,Ba)	Pulchrastele	(Mo,Ga,Ar)	Puruinella	(Mo,Ga,Ar)
Ptycholepis	(Cd,Os,Pt)	Pulchratia	(Br,Ar,St)	Purshkinella	(Bz,St,Fe)
Ptycholytoceras	(Mo,Ce,Am)	Pulchricapitus	(Ar,Tr,Pr)	Pusia	(Mo,Ga,Ne)
Ptychomaltoechia	(Br,Ar,Rh)	Pulchri laminia	(Po,De,St)	Pusillaboles	(Ar,Tr,Pr)
Ptychometopus	(Ar,Tr,Ph)	Pulchritama	(Mo,Ga,Ne)	Pusillagutta	(Br,Ar,At)
Ptychomphalina	(Mo,Ga,Ar)	Pullenia	(Fo,Fo,Fo)	Pusillaster	(Ec,Ec,Sp)
Ptychomphalus	(Mo,Ga,Ar)	Pulleniatina	(Fo,Fo,Fo)	Pusillina	(Mo,Ga,Nt)
Ptychomya	(Mo,Bi,Ve)	Pullenoides	(Fo,Fo,Fo)	Pusiolina	(Mo,Ga,Ne)
Ptychoparella	(Ar,Tr,Pt)	Pullvillites	(Ar,Os,Po)	Pusionella	(Mo,Ga,Ne)
Ptychoparia	(Ar,Tr,Pt)	Pulsellum	(Mo,Sc,Sc)	Pustula	(Br,Ar,St)
Ptychoparoides	(Ar,Tr,Pt)	Pulsia	(Br,Ar,St)	Pustularia	(Mo,Ga,Nt)
Ptychoparopsis	(Ar,Tr,Pt)	Pulsidis	(Mo,Bi,My)	Pustulatia	(Br,Ar,Sp)
Ptychopegma	(Mo,Ro,Ri)	Pulsiphonina	(Fo,Fo,Fo)	Pustulifer	(Mo,Ga,Nt)
Ptychopeltis	(Br,Li,Pa)	Pulviella	(Ar,Os,Po)	Pustulina	(Ar,Mi,De)
Ptychophylloceras	(Mo,Ce,Ph)	Pulvillites	(Ar,Os,Un)	Pustulobairdia	(Ar,Os,Po)
Ptychophyllum	(Cn,An,Ru)	Pulvinies	(Mo,Bi,Pt)	Pustuloplica	(Br,Ar,Sp)
Ptychopfeurella	(Br,Ar,Or)	Pulvinostrea	(Mo,Bi,Pt)	Pustulopora	(Bz,St,Ce)
Ptychopleurites	(Ar,Tr,Pt)	Pumilindocrinus	(Ec,Cr,Ci)	Pustulospiriferina	(Br,Ar,Sp)
Ptychopotamides	(Mo,Ga,Nt)	Pumilocytheridea	(Ar,Os,Po)	Pusula	(Mo,Ga,Nt)
Ptychopteria	(Mo,Bi,Pt)	Punctaparchites	(Ar,Os,Po)	Putapacyathus	(Po,Re,Aj)
Ptychopyge	(Ar,Tr,As)	Punctatites	(Ec,Ho,De)	Putealicerus	(Mo,Ce,Am)
Ptychoris	(Mo,Ga,Ne)	Punctatrypa	(Br,Ar,At)	Putilla	(Mo,Ga,Ar)
Ptychosalpinx	(Mo,Ga,Ne)	Punctatus	(Pr,Un,In)	Putillovoerinus	(Ec,Cr,Ds)
Ptychosphaera	(Mo,Ga,Be)	Punctella	(Pr,Un,In)	Putrella	(Fo,Fo,Fo)
Ptychospirina	(Mo,Ga,Ar)	Punctiscala	(Mo,Ga,Nt)	Putzeysia	(Mo,Ga,Ar)
Ptychostolis	(Mo,Bi,Nu)	Punctobolivella	(Fo,Fo,Fo)	Puyseguria	(Mo,Bi,Ve)
Ptychostoma	(Mo,Ga,Nt)	Punctocyrtella	(Br,Ar,Sp)	Puzosia	(Mo,Ce,Am)
Ptychosyca	(Mo,Ga,Ne)	Punctolira	(Br,Ar,Pe)	Puzosigella	(Mo,Ce,Am)
Ptychosyrinx	(Mo,Ga,Ne)	Punctomosea	(Ar,Os,Po)	Pyanomya	(Mo,Bi,Mo)
Ptychotrygon	(Cd,Ch,Rj)	Punctoprimitia	(Ar,Os,Pa)	Pychaspis	(Cd,Pt,Pt)
Ptychozone	(Mo,Ga,Ar)	Punctoschmidtella	(Ar,Os,Pa)	Pycnaster	(Ec,As,Va)
Ptyctodopsis	(Cd,Pl,Pt)	Punctospira	(Mo,Ga,Nt)	Pycnactis	(Cn,An,Ru)
Ptyctodus	(Cd,Pl,Pt)	Punctospirella	(Br,Ar,Sp)	Pycnactoides	(Cn,An,Ru)
Ptyctorhynchia	(Br,Ar,Rh)	Punctospirifer	(Br,Ar,Sp)	Pycnaspis	(Cd,Pt,Pt)
Ptyctothyris	(Br,Ar,Te)	Punctothyris	(Br,Ar,Sp)	Pycnobasis	(Bz,St,Un)
Ptygmactrum	(Br,Ar,Rh)	Punctopsintrypa	(Br,Ar,At)	Pycnobrochus	(Br,Ar,Te)
Ptygmatis	(Mo,Ga,He)	Puncturella	(Mo,Ga,Ar)	Pycnocalyptra	(Po,He,He)
Ptyktoptychion	(Cd,Ch,In)	Puncturellopsis	(Mo,Ga,Ar)	Pycnoceras	(Mo,Ce,Ta)
Ptylopora	(Bz,St,Fe)	Puncturiella	(Bz,Gy,Ch)	Pycnoclonaella	(Po,De,Li)
Ptyssoceras	(Mo,Ce,Na)	Pungitius	(Cd,Os,Os)	Pycnocrinus	(Ec,Cr,Mo)
Ptytstrigis	(Ar,Tr,Un)	Punillaspis	(Ar,Tr,Ph)	Pycnodesma	(Po,De,Li)
Puanatrypa	(Br,Ar,At)	Punipagia	(Mo,Bi,Ve)	Pycnodonte	(Mo,Bi,Pt)

Pycnodus	(Cd.Os.Py)	Pyrazella	(Mo.Ga.Nt)	Qilianotryma	(Br.Ar.Rh)
Pycnoidocoseinus	(Po.Ir.Ar)	Pyrazisinus	(Mo.Ga.Nt)	Qinghaiophyllum	(Cn.An.Ru)
Pycnoidocyathus	(Po.Ir.Ar)	Pyrazus	(Mo.Ga.Nt)	Qinghaipiriferina	(Br.Ar.Sp)
Pycnolepas	(Ar.Ci)	Pyrene	(Mo.Ga.Ne)	Qingjiania	(Ar.Os.Po)
Pycnolithus	(Cn.An.Ta)	Pyrenina	(Fo.Fo.Fo)	Qingkouia	(Ar.Tr.Re)
Pycnomphalus	(Mo.Ga.Eu)	Pyrenocrinus	(Ec.Cr.Cl)	Qinglongia	(Br.Ar.Te)
Pycnopenema	(Po.De.Li)	Pyrenomitra	(Mo.Ga.Ne)	Qingshuihella	(Ar.Tr.Pt)
Pycnopora	(Bz.St.Tr)	Pyrenoturris	(Mo.Ga.Ne)	Qingthyris	(Br.Ar.Sp)
Pycnoria	(Br.Ar.Rh)	Pyrgiscilla	(Mo.Ga.He)	Qingyenia	(Br.Ar.Sp)
Pycnosaccus	(Ec.Cr.Sa)	Pyrgiscus	(Mo.Ga.He)	Qinlingia	(Br.Ar.Sp)
Pycnospongia	(Po.De.Li)	Pyrgites	(Pr.Un.In)	Qinlingophyllum	(Cn.An.Ru)
Pycnosterinx	(Cd.Os.Po)	Pyrgo	(Fo.Fo.Fo)	Qinlingotoecchia	(Br.Ar.Rh)
Pycnosteroides	(Cd.Os.Br)	Pyrgocystis	(Ec.Ed.Is)	Qiongzhouia	(Mo.Bi.Nu)
Pycnosteus	(Cd.Pt.Pt)	Pyrgocythara	(Mo.Ga.Ne)	Qispiriferina	(Br.Ar.Sp)
Pycnostylus	(Cn.An.Ru)	Pyrgoella	(Fo.Fo.Fo)	Qishougouceras	(Mo.Ce.El)
Pycnotrochus	(Mo.Ga.Ar)	Pyrgolampros	(Mo.Ga.He)	Qiyangia	(Mo.Bi.Pt)
Pygaeus	(Cd.Os.Pf)	Pyrgolidium	(Mo.Ga.He)	Quadracythere	(Ar.Os.Po)
Pygaster	(Ec.Ec.Py)	Pyrgonia	(Ar.Ci)	Quadragnostus	(Ar.Tr.Ag)
Pygaulus	(Ec.Ec.Ca)	Pyrgopolon	(An.Po.Se)	Quadrans	(Mo.Bi.Ve)
Pygocystis	(Ec.Rh.Rh)	Pyrgotrochus	(Mo.Ga.Ar)	Quadrapsus	(Ac.Ra.Sp)
Pygidiolampas	(Ec.Ec.Ca)	Pyrgozyga	(Mo.Ga.Nt)	Quadratrapora	(Pr.Un.In)
Pygites	(Br.Ar.Te)	Pyrgulina	(Mo.Ga.He)	Quadratia	(Br.Ar.St)
Pygmaella	(Br.Ar.Rh)	Pyricavea	(Bz.St.Cc)	Quadraticephalus	(Ar.Tr.As)
Pygmaeoconus	(Mo.In.In)	Pyrifusus	(Mo.Ga.Ne)	Quadratiphyllia	(Cn.An.Ht)
Pygmaeoocrinus	(Ec.Cr.Ds)	Pyrina	(Ec.Ec.Ho)	Quadratirhynchia	(Br.Ar.Rh)
Pygmaeostron	(Fo.Fo.Fo)	Pyripora	(Bz.Gy.Ch)	Quadratobuliminella	(Fo.Fo.Fo)
Pygmochoetes	(Br.Ar.St)	Pyriporella	(Bz.Gy.Ch)	Quadratojaworskiella	(Mo.Bi.Tr)
Pygocardia	(Mo.Bi.Ve)	Pyripopsis	(Bz.Gy.Ch)	Quadratoucuella	(Mo.Bi.Nu)
Pygocaris	(Ar.Ml.Ar)	Pyritonema	(Po.He.Ls)	Quadratoprotus	(Ar.Tr.Pr)
Pygocephalus	(Ar.Ml.My)	Pyrocystites	(Ec.Di.Di)	Quadratotrigonia	(Mo.Bi.Tr)
Pygoconcha	(Ar.Os.Pa)	Pyrocysteridea	(Ar.Os.Po)	Quadricarina	(Mo.Ga.Ar)
Pygodus	(Cd.Co.Co)	Pyrogochomia	(Po.De.Li)	Quadricellaria	(Bz.Gy.Ch)
Pygolia	(Mo.Bi.Pr)	Pyromaia	(Ar.Ml.De)	Quadricollina	(Ar.Os.Pa)
Pygomalus	(Ec.Ec.Ds)	Pyropsis	(Mo.Ga.Ne)	Quadrigitalis	(Ar.Os.Pa)
Pygope	(Br.Ar.Te)	Pyrospongia	(Po.He.Ly)	Quadrifarius	(Br.Ar.Fa)
Pygopistes	(Ec.Ec.Ca)	Pyruchia	(Mo.Ga.Ne)	Quadrjugator	(Ar.Os.Pa)
Pygopyrina	(Ec.Ec.Ho)	Pyrulella	(Bz.Gy.Ch)	Quadrilatera	(Mo.Bi.Ar)
Pygorhynchus	(Ec.Ec.Ca)	Pyrulina	(Fo.Fo.Fo)	Quadrilobella	(Ar.Os.Pa)
Pygorhytis	(Ec.Ec.Ds)	Pyrulinoidea	(Fo.Fo.Fo)	Quadrinmedusina	(Cn.Ch.Ca)
Pygospatangus	(Ec.Ec.Sp)	Pyrulofusus	(Mo.Ga.Ne)	Quadrinmorphina	(Fo.Fo.Fo)
Pyguropsis	(Ec.Ec.Ca)	Pyrunculus	(Mo.Ga.Ce)	Quadrinmorphinella	(Fo.Fo.Fo)
Pygurostoma	(Ec.Ec.Ca)	Pyruspongia	(Po.He.Ls)	Quadrinervus	(Mo.Ga.Nt)
Pygurus	(Ec.Ec.Ca)	Pythina	(Mo.Bi.Ve)	Quadrinermis	(Ac.Ra.Sp)
Pyktes	(Mo.Ga.Nt)	Pythmenema	(Mo.Ga.Ar)	Quadriscutella	(Bz.Gy.Ch)
Pyntonema	(Ac.Ra.Sp)	Pythonoceras	(Mo.Ce.Or)	Quadrismicoscinium	(Bz.St.Fe)
Pyloctostylus	(Ac.Ra.Sp)	Pytime	(Ar.Tr.Pt)	Quadrisonia	(Br.Li.Ac)
Pylostephanidium	(Ac.Ra.Na)	Pyttstrigis	(Ar.Tr.Pt)	Quadrithyrina	(Br.Ar.Sp)
Pyndaxocrinus	(Ec.Cr.Cl)	Pyxidocrinus	(Ec.Cr.Mo)	Quadrithyris	(Br.Ar.Sp)
Pyraeneica	(Br.Ar.Te)	Pyxidocyathus	(Pr.Cr.Cr)	Quadritia	(Ar.Os.Pa)
Pyramblastus	(Ec.Bi.Sp)	Pyxion	(Ar.Os.Pa)	Quadrochones	(Pr.Co.Sa)
Pyramidathyrus	(Br.Ar.Sp)	Pyxiopoma	(Mo.Ga.Nt)	Quadrochonetes	(Br.Ar.St)
Pyramidella	(Mo.Ga.He)	Pyxiprimitia	(Ar.Os.Un)	Quadrolaminella	(Po.De.Un)
PyramideHloides	(Mo.Ga.Nt)	Qataraspis	(Cd.Pl.Ar)	Quadrorites	(Pr.Un.In)
Pyramidina	(Fo.Fo.Fo)	Qataria	(Fo.Fo.Fo)	Quadrrochophogonuchites	(Cn.Sc.Cn)
Pyramidoceras	(Mo.Ce.On)	Qianbeilites	(Cn.An.Ta)	Quadrostrea	(Mo.Bi.Pt)
Pyramidulina	(Fo.Fo.Fo)	Qianjiangella	(Br.Ar.St)	Quadrotheca	(Hy.Hy.Hy)
Pyramimitra	(Mo.Ga.Ne)	Qiannanites	(Mo.Ce.Go)	Quangyuania	(Br.Ar.At)
Pyramina	(Br.Ar.Sp)	Qiannanophyllum	(Cn.An.Ru)	Quantoxocrinus	(Ec.Cr.Cl)
Pyramisasteria	(Cn.An.Sc)	Qianomena	(Br.Ar.St)	Quasiavonia	(Br.Ar.St)
Pyramispongia	(Ac.Ra.Sp)	Qianspirifer	(Br.Ar.Sp)	Quasibolivineella	(Fo.Fo.Fo)
Pyramistomia	(Mo.Ga.He)	Qiaotingaspis	(Ar.Tr.Re)	Quasiborelis	(Fo.Fo.Fo)
Pyramitoma	(Mo.Ga.Ne)	Qijiangia	(Ar.Tr.Un)	Quasibuntonia	(Ar.Os.Po)
Pyramus	(Mo.Bi.Ph)	Qilianconcha	(Br.Ar.Rh)	Quasicaris	(Ar.Un.Un)
Pyraustocranium	(Ar.Tr.Un)	Qilianopora	(Bz.St.Tr)	Quasicraenoceras	(Mo.Ce.Go)

Quasicyclammina	(Fo,Fo,Fo)	Rabilimis	(Ar,Os,Po)	Rahbahthalmia	(Po,De,Pe)
Quasidavidsonia	(Br,Ar,At)	Racemiguembelina	(Fo,Fo,Fo)	Rahouiarhynchia	(Br,Ar,Rh)
Quasiendothyra	(Fo,Fo,Fo)	Rachaniephyllum	(Cn,An,Ru)	Raibosammia	(Fo,Fo,Fo)
Quasifusulina	(Fo,Fo,Fo)	Rachiosoma	(Ec,Ec,Ph)	Railtonella	(Br,Ar,St)
Quasifusulinoides	(Fo,Fo,Fo)	Rachiosteus	(Cd,Pl,Ar)	Raimbautina	(Ar,Os,Pa)
Quasiglyptopleura	(Ar,Os,Pa)	Rachycentron	(Cd,Os,Pf)	Raimondiceras	(Mo,Ce,Am)
Quasihermanites	(Ar,Os,Po)	Rackirhynchia	(Br,Ar,Rh)	Raina	(Mo,Bi,Ve)
Quasiirregularina	(Fo,Fo,Fo)	Rackovskia	(Po,De,St)	Raincourtia	(Mo,Ga,Ce)
Quasilitotuba	(Fo,Fo,Fo)	Racodiscula	(Po,De,Li)	Raineria	(Cd,Ch,Ct)
Quasillites	(Ar,Os,Po)	Raevetina	(Ar,Os,Po)	Raja	(Cd,Ch,Rj)
Quasimartina	(Br,Ar,Sp)	Radiaspis	(Ar,Tr,Od)	Rajorhina	(Cd,Ch,Rj)
Quasintoceras	(Mo,Ce,Go)	Radiastrea	(Cn,An,Ru)	Rakhia	(Mo,Bi,Ve)
Quasipetalichthys	(Cd,Pl,Pe)	Radiatodonta	(Mo,Bi,Mo)	Rakusites	(Mo,Ce,Am)
Quasipetosus	(Ac,Ra,Na)	Radiatrypa	(Br,Ar,At)	Rakverella	(Ar,Os,Pa)
Quasirotalia	(Fo,Fo,Fo)	Radiaxialia	(Pr,Un,In)	Ralfina	(Bz,St,Fe)
Quasipiroplectammina	(Fo,Fo,Fo)	Radicenalspongia	(Po,Ca,Ph)	Ralfinella	(Bz,St,Fe)
Quasistrophonella	(Br,Ar,St)	Radicicyathus	(Pr,Cr,Cr)	Ralia	(Br,Ar,St)
Quasithambonia	(Br,Li,Li)	Radiciphyllia	(Cn,An,Hu)	Rallacosta	(Br,Ar,Sp)
Quasiverbeckina	(Fo,Fo,Fo)	Radicipora	(Fo,St,Cc)	Ramacrinus	(Ec,Cr,Ds)
Quassisipho	(Mo,Ga,Ne)	Radicispongia	(Po,Ca,Ph)	Ramalliththys	(Cd,Os,Go)
Quebecaspis	(Ar,Tr,Pt)	Radimetrypa	(Br,Ar,At)	Ramalmarina	(Po,He,He)
Quebecia	(Br,Un,Ku)	Radimella	(Ar,Os,Po)	Ramavectus	(Br,Ar,St)
Quebecoceras	(Mo,Ce,El)	Radinista	(Mo,Ga,Nt)	Ramellina	(Cn,Pe,Un)
Quendreda	(Mo,Bi,Mt)	Radiobrisus	(Ec,Ec,Sp)	Ramenta	(Mo,In,In)
Quenstedtia	(Mo,Bi,Ve)	Radiocavaria	(Bz,St,Cc)	Ramesses	(An,Po,Un)
Quenstedticrinus	(Ec,Cr,Cy)	Radiocondyla	(Mo,Bi,Ve)	Ramia	(Bz,St,Cc)
Quenstedtiphyllia	(Cn,An,Sc)	Radiocomus	(Cn,He,He)	Ramifer	(Pr,Cr,Cr)
Quenstedtoceras	(Mo,Ce,Am)	Radiocyclopeus	(Fo,Fo,Fo)	Ramina	(Mo,Ga,Nt)
Quepora	(Cn,An,Ta)	Radiocyphus	(Ec,Ec,Te)	Ramiphyllum	(Cn,An,Ru)
Queraltina	(Fo,Fo,Fo)	Radiofascigera	(Bz,St,Cc)	Ramipora	(Bz,St,Cy)
Quidnipagus	(Mo,Bi,Ve)	Radiograptus	(He,Gr,De)	Ramporalia	(Bz,St,Cy)
Quimalea	(Mo,Ga,Ne)	Radiolichas	(Ar,Tr,Li)	Ramporella	(Bz,St,Cy)
Quiniocrinus	(Ec,Cr,Ds)	Radiolittella	(Mo,Bi,Hi)	Ramiporida	(Bz,St,Cy)
Quinlingia	(Br,Ar,Un)	Radiolites	(Mo,Bi,Hi)	Ramispongia	(Po,He,He)
Quinmites	(Mo,Ce,Go)	Radiolus	(Ec,Ec,Un)	Ramochitina	(Fo,Fo,Ch)
Quinquecapsularia	(Ac,Ra,Sp)	Radiomena	(Br,Ar,St)	Ramofilisparsa	(Bz,St,Cc)
Quinquecaudex	(Ec,Cr,Cl)	Radiopecten	(Mo,Bi,Pt)	Ramosites	(Mo,Ce,Go)
Quinquecosta	(Ar,Tr,Ph)	Radiophyllum	(Cn,An,Ru)	Ramovsia	(Fo,Fo,Fo)
Quinquelithes	(Hy,Hy,Hy)	Radioplica	(Po,He,Ly)	Ramovsina	(Br,Ar,St)
Quinqueloculina	(Fo,Fo,Fo)	Radiopora	(Bz,St,Cc)	Rampartaspis	(Ar,Tr,Pt)
Quinquenella	(Br,Ar,St)	Radiopyge	(Ar,Tr,Ph)	Ramphonotus	(Bz,Gy,Ch)
Quinqueremis	(Ac,Ra,Sp)	Radioscuttelum	(Ar,Tr,Cc)	Ramphopriion	(An,Po,Eu)
Quiriagites	(Br,Ar,Sp)	Radiostroma	(Po,De,St)	Ramphosus	(Cd,Os,Ga)
Quiricobelus	(Mo,Ce,Be)	Radiothalamos	(Po,De,Pe)	Ramsetia	(Mo,Bi,My)
Quisque	(Cd,Os,Cl)	Radiotrabeculopora	(Po,De,Ac)	Ramseyocrinus	(Ec,Cr,Ds)
Quitacetra	(Ar,Tr,As)	Radiotrypa	(Bz,St,Un)	Ramulina	(Fo,Fo,Fo)
Quititalia	(Ar,Tr,As)	Radiurus	(Ar,Tr,Ph)	Ramulinella	(Fo,Fo,Fo)
Quitmannites	(Mo,Ce,Am)	Radnorria	(Ar,Tr,Pr)	Ramulocrinus	(Ec,Cr,Cl)
Quizhouspirifer	(Br,Ar,Sp)	Radoceras	(Mo,Ce,Di)	Ramulophyllum	(Cn,An,Ru)
Qujinolepis	(Cd,Pl,An)	Radonia	(Ar,Tr,Pr)	Ramusites	(Ec,Ho,As)
Quoiechia	(Mo,Bi,Tr)	Radotina	(Cd,Pl,Ac)	Ramussenoceras	(Mo,Ce,On)
Quoondogia	(Br,Ar,St)	Radotruncana	(Fo,Fo,Fo)	Rananastus	(Ar,Tr,Pr)
Quoyia	(Mo,Ga,Ne)	Radstockiceras	(Mo,Ce,Am)	Ranapelitis	(Ar,Os,Po)
Quydatella	(Fo,Fo,Fo)	Radulimus	(Cd,Os,Sc)	Randallia	(Ar,ML,De)
Raadshoovenia	(Fo,Fo,Fo)	Radulonectites	(Mo,Bi,Pt)	Randicephalus	(Ar,Tr,Pt)
Raanespongia	(Po,De,Li)	Radulopecten	(Mo,Bi,Pt)	Randia	(Mo,In,In)
Raashellina	(Ar,Tr,Pt)	Radulopora	(Bz,Gy,Ch)	Ranelia	(Mo,Ga,Nt)
Rabanitina	(Fo,Fo,Fo)	Raeta	(Mo,Bi,Ve)	Ramellina	(Mo,Ga,Nt)
Rabdacanthus	(Cd,Pt,Un)	Raetomya	(Mo,Bi,My)	Rangea	(Cn,Pe,Ra)
Rabdastrea	(Cn,An,Sc)	Rafanoglossa	(Br,Li,Li)	Rangeroceras	(Mo,Ce,El)
Rabeignathus	(Cd,Co,Co)	Rafinesquina	(Br,Ar,St)	Rangia	(Mo,Bi,Ve)
Rabicea	(Mo,Ga,Ne)	Ragadina	(Po,De,Li)	Rangimata	(Mo,Ga,Ar)
Rabienella	(Ar,Os,My)	Ragozinia	(Mo,Bi,Ve)	Ranicella	(Ar,Os,Po)
Rabienites	(Ar,Os,My)	Raha	(Mo,Ga,Nt)	Ranceps	(Cd,Os,Ga)

Ranidina	(Ar,Ml,De)	Raymondiceras	(Mo,Ce,Go)	Redlichaspis	(Ar,Tr,Re)
Ranikothalia	(Fo,Fo,Fo)	Raymondicrinus	(Ec,Cr,Is)	Redlichella	(Br,Li,Ac)
Ranilia	(Ar,Ml,De)	Raymondina	(Ar,Tr,De)	Redlichia	(Ar,Tr,Re)
Raniliformis	(Ar,Ml,De)	Raymondites	(Ar,Tr,Pr)	Redlichina	(Ar,Tr,Re)
Ranina	(Ar,Ml,De)	Raymoorea	(Ar,Os,Po)	Redlichops	(Ar,Tr,Re)
Raninella	(Ar,Ml,De)	Rayneria	(Ar,Os,Po)	Redmondina	(Fo,Fo,Fo)
Raninoides	(Ar,Ml,De)	Rayonnoceras	(Mo,Ce,Ac)	Redocla	(Mo,Ga,Nt)
Rankenella	(Po,De,Li)	Reacalymene	(Ar,Tr,Ph)	Redonia	(Mo,Bi,Mo)
Rankinian	(Cd,Os,Ga)	Reagenaspis	(Ar,Tr,Pt)	Redoubtia	(Pr,Un,In)
Ranorthis	(Br,Ar,Or)	Realeksella	(Bz,St,Cy)	Redpathoceras	(Mo,Ce,As)
Ranularia	(Mo,Ga,Nt)	Rebeccapecten	(Mo,Bi,Pt)	Redstonea	(Cn,An,Ru)
Ranunculoopretus	(Ar,Tr,Pr)	Rebusum	(Mo,Bi,Un)	Reedella	(Fo,Fo,Fo)
Raoulius	(Ac,Ra,Na)	Recilites	(Hy,Hy,Hy)	Reediella	(Ar,Tr,Pr)
Rapana	(Mo,Ga,Ne)	Recrosalenia	(Ec,Ec,Sa)	Reedocalymene	(Ar,Tr,Ph)
Rapanecephora	(Mo,Ga,Ne)	Rectaloides	(Ar,Os,Po)	Reedocochia	(Br,Ar,St)
Raphanites	(Mo,Ce,Di)	Rectambitus	(Br,Ar,Sp)	Reedolithus	(Ar,Tr,As)
Phanconillia	(Fo,Fo,Fo)	Rectannulus	(Po,Re,Aj)	Reedops	(Ar,Tr,Ph)
Raphibelus	(Mo,Ce,Be)	Rectella	(Ar,Os,Po)	Reedsoconera	(Mo,Ce,Di)
Raphidiphorus	(An,Po,Am)	Recticardo	(Mo,Bi,Ve)	Reeftonia	(Br,Ar,Te)
Raphidociliclus	(Ac,Ra,In)	Recticostratraea	(Cn,An,Sc)	Reeftonia	(Br,Ar,Or)
Raphidonema	(Po,Ca,Ph)	Rectifenestella	(Bz,St,Fe)	Reesidites	(Mo,Ce,Am)
Raphiophorus	(Ar,Tr,As)	Rectigrewingkia	(Cn,An,Ru)	Reflexia	(Br,Ar,Un)
Raphischisma	(Mo,Ga,Ar)	Rectigypidida	(Br,Ar,Sp)	Refratiella	(Ar,Os,Pa)
Raphispira	(Mo,Ga,Ar)	Rectiplanes	(Mo,Ga,Ne)	Regalilima	(Mo,Bi,Pt)
Raphistoma	(Mo,Ga,Eu)	Rectirhynchia	(Br,Ar,Rh)	Regardrella	(Po,He,LS)
Raphistomina	(Mo,Ga,Eu)	Rectithyris	(Br,Ar,Te)	Regina	(Ar,Tr,Pt)
Raphitoma	(Mo,Ga,Ne)	Rectitordio	(Ec,Ed,Is)	Reginacypris	(Ar,Os,Po)
Rapopsis	(Mo,Ga,Ne)	Rectoavesmella	(Fo,Fo,Fo)	Reginea	(Ar,Os,Pa)
Raricardium	(Mo,Bi,Pt)	Rectobairdia	(Ar,Os,Po)	Regispongia	(Po,Ca,He)
Raridium	(Br,Ar,Or)	Rectobolivina	(Fo,Fo,Fo)	Regius	(Ar,Tr,Pt)
Rariella	(Br,Ar,Sp)	Rectobuntonia	(Ar,Os,Po)	Regnardia	(Po,De,Li)
Rarifienestella	(Br,St,Fe)	Rectochevnyshinella	(Fo,Fo,Fo)	Regnellocrinus	(Ec,Cr,Ds)
Rarisimetus	(Hy,Hy,Hy)	Rectocibicides	(Fo,Fo,Fo)	Regnellcystis	(Ec,Di,Di)
Rarocyathus	(Pr,Cr,Cr)	Rectoelmenia	(Mo,Ce,Cl)	Regoria	(Mo,Bi,Mt)
Rasenia	(Mo,Ce,Am)	Rectocornuspira	(Fo,Fo,Fo)	Regozara	(Mo,Bi,Ve)
Rasenoidea	(Mo,Ce,Am)	Rectocyclammia	(Fo,Fo,Fo)	Regubea	(Ar,Os,Pa)
Rasettaspis	(Ar,Tr,Pt)	Rectocypris	(Ar,Os,Po)	Regulaecystis	(Ec,Rh,Rh)
Rasettia	(Ar,Tr,Pt)	Rectocythere	(Ar,Os,Po)	Regulifer	(Mo,Bi,Mt)
Rasetticyathus	(Po,Re,Aj)	Rectodictyoconus	(Fo,Fo,Fo)	Rehacythereis	(Ar,Os,Po)
Rasfacrinus	(Ec,Cr,Di)	Rectoelphidiella	(Fo,Fo,Fo)	Rehbachiaella	(Ar,In,Un)
Rasia	(Mo,Bi,Ar)	Rectoendothyra	(Fo,Fo,Fo)	Rehmannia	(Mo,Ce,Am)
Rasmussenoceras	(Mo,Ce,Or)	Rectoepistominoides	(Fo,Fo,Fo)	Reichelina	(Fo,Fo,Fo)
Rastelligera	(Br,Ar,Sp)	Recteoponides	(Fo,Fo,Fo)	Reichelinella	(Fo,Fo,Fo)
Rastellum	(Mo,Bi,Pt)	Rectoglomospira	(Fo,Fo,Fo)	Reifia	(Cd,Ch,In)
Rastrites	(He,Gr,Gr)	Rectomillerella	(Fo,Fo,Fo)	Reiflingites	(Mo,Ce,Ce)
Ratburia	(Br,Ar,St)	Rectonaria	(Ar,Os,Pa)	Reigiopsis	(Ar,Os,Pa)
Ratcliffespongia	(Po,He,Re)	Rectoplacera	(Ar,Os,Pa)	Reimanelasma	(Cn,An,Ru)
Rathbunopon	(Ar,Ml,De)	Rectoseptaglomospirane	(Bu,Os,Sc)	Reimaniphyllia	(Cn,An,Sc)
Ratifusus	(Mo,Ga,Ne)	Rectoseptatourmayella	(Fo,Fo,Fo)	Reimanophyllum	(Cn,An,Ru)
Raufia	(Po,Ca,Ph)	Rectospinella	(Ar,Os,Pa)	Reineckea	(Mo,Ce,Am)
Raulinia	(Mo,Ga,He)	Rectostipulina	(Fo,Fo,Fo)	Reineckites	(Mo,Ce,Am)
Rauna	(Ar,Ml,De)	Rectotornamentum	(Ac,Ra,Sp)	Reinholdella	(Fo,Fo,Fo)
Raunites	(Br,Ar,Or)	Rectotourmayellina	(Fo,Fo,Fo)	Reinversella	(Br,Ar,St)
Rauserella	(Fo,Fo,Fo)	Rectotrachyleberis	(Ar,Os,Po)	Reisocyathus	(Cn,An,Sc)
Rauserina	(Fo,Fo,Fo)	Rectotrophia	(Br,Ar,Pe)	Reissella	(Fo,Fo,Fo)
Ravienops	(Ar,Tr,De)	Rectseptoceras	(Mo,Ce,El)	Reiswigia	(Po,De,Li)
Ravitrona	(Mo,Ga,Nt)	Rectuvigerina	(Fo,Fo,Fo)	Reitlingerina	(Fo,Fo,Fo)
Ravnostomia	(Mo,Ga,He)	Recurvacanthus	(Cd,Ch,In)	Rejkocephalus	(Ar,Tr,Re)
Ravozetina	(Br,Ar,Or)	Recurvaster	(Ec,As,Va)	Relanus	(Ac,Ra,Na)
Rawdonia	(Br,Ar,Sp)	Recurvella	(Mo,Bi,Ve)	Remaniella	(Ci,Po,Sp)
Rawlinsella	(Ar,Tr,Pt)	Recurvina	(Mo,Ga,Ne)	Remera	(Mo,Ga,Ne)
Raymondaspis	(Ar,Tr,Pr)	Recurvoidea	(Fo,Fo,Fo)	Remesella	(Fo,Fo,Fo)
Raymondatia	(Ar,Os,Pa)	Redicire	(Mo,Bi,Ve)	Remesia	(Cn,An,Ta)
Raymondella	(Ar,Tr,As)	Redkinia	(Pr,Un,In)	Remesimetra	(Ec,Cr,Cm)

Remingtonocetus	(Cd,Ma,Ce)	Reteosciscus	(Po,Re,Aj)	Retrorsichela	(Ar,MLDe)
Remipygia	(Ar,Tr,Ph)	Retelea	(Bz,St,Cc)	Retrorsirostra	(Br,Ar,Or)
Remismilia	(Cn,An,Sc)	Retenoa	(Bz,St,Cc)	Retusa	(Mo,Ga,Cc)
Remisovicrinus	(Ec,Cr,Cy)	Reteocrinus	(Ec,Cr,Di)	Retusocrinus	(Ec,Cr,Ci)
Remizites	(Ar,Tr,Pt)	Reteograptus	(He,Gr,Gr)	Retzia	(Br,Ar,Sp)
Remnevitoechia	(Br,Ar,Rh)	Retepora	(Bz,Gy,Ch)	Retziella	(Br,Ar,Sp)
Remnita	(Mo,Ga,Ne)	Reteporellina	(Bz,Gy,Ch)	Retzispirifer	(Br,Ar,Sp)
Remondella	(Ec,Ec,Ci)	Reteporidae	(Bz,St,Cc)	Reubenella	(Br,Ar,Pl)
Remondia	(Mo,Bi,Ve)	Reteporidra	(Bz,St,Fe)	Reubenia	(Mo,Bi,Pt)
Remopleurella	(Ar,Tr,As)	Reteporina	(Bz,St,Fe)	Reudemannicrusta	(He,Gr,Cr)
Remopleurides	(Ar,Tr,As)	Retetumulus	(Po,Re,Aj)	Reuentalina	(Ar,Os,Pa)
Remopleuridiella	(Ar,Tr,As)	Retha	(Mo,Bi,Hi)	Reuschella	(Br,Ar,Or)
Renaudia	(Br,Ar,St)	Reticestus	(Ar,Os,Pa)	Reuschia	(Cn,An,Ta)
Renea	(Mo,Ga,Nt)	Reticionetes	(Br,Ar,St)	Reuscholithus	(Ar,Tr,Pt)
Remibeyrichia	(Ar,Os,Pa)	Reticaticularia	(Po,He,He)	Reusella	(Fo,Fo,Fo)
Reniera	(Po,De,Un)	Reticrisina	(Bz,St,Cc)	Reussangia	(Cn,An,Sc)
Renirsmilia	(Cn,An,Sc)	Reticulacella	(Mo,Ga,Un)	Reussia	(Bz,Gy,Ch)
Renites	(Mo,Ce,An)	Reticulaconularia	(Cn,Sc,Cn)	Reussiana	(Ar,Tr,Ph)
Renitheca	(Hy,Or,Or)	Reticularia	(Br,Ar,Sp)	Reussicoenia	(Cn,An,Sc)
Rennensismilia	(Cn,An,Sc)	Reticulariina	(Br,Ar,Sp)	Reussicythere	(Ar,Os,Pa)
Renngartenella	(Ar,Os,Pa)	Reticulariopsis	(Br,Ar,Sp)	Reussiphylia	(Cn,An,Sc)
Renniella	(Ar,Tr,Ph)	Reticulata	(Br,Ar,St)	Reussiphylion	(Cn,An,Sc)
Rensselaeleria	(Br,Ar,Te)	Reticulatochonetes	(Br,Ar,St)	Reussoolina	(Fo,Fo,Fo)
Rensselaelerina	(Br,Ar,Te)	Reticulatoconus	(Mo,In,In)	Reussopsammia	(Cn,An,Sc)
Rensselandia	(Br,Ar,Te)	Reticulatrypa	(Br,Ar,At)	Reutterodus	(Cd,Co,Co)
Rensselandioides	(Br,Ar,Te)	Reticuloceia	(Po,Ca,Ph)	Revalocrinus	(Ec,Cr,Hy)
Renulina	(Fo,Fo,Fo)	Reticulina	(Ar,Os,Pa)	Revalocystis	(Ec,Di,Di)
Renzicerias	(Mo,Ce,Am)	Reticulinella	(Fo,Fo,Fo)	Revalopora	(Bz,St,Cy)
Renziium	(Ac,Ra,Sp)	Reticulipora	(Bz,St,Cc)	Revalotrypa	(Bz,St,Tr)
Reophaella	(Fo,Fo,Fo)	Reticullina	(Po,De,Ax)	Reveroides	(Br,Ar,Pe)
Reophax	(Fo,Fo,Fo)	Reticulocambria	(Ar,Os,Ar)	Reversacapha	(Ar,Os,Pa)
Repicoskenidioides	(Br,Ar,Or)	Reticulocarpus	(Ec,St,Cc)	Reversella	(Br,Ar,St)
Repmanina	(Fo,Fo,Fo)	Reticuloceeras	(Mo,Ce,Go)	Reversocypris	(Ar,Os,Me)
Reposia	(Mo,Ce,Cc)	Reticulochilina	(Ar,Os,Pa)	Reversoparaparchites	(Ar,Os,Un)
Reptadeonella	(Bz,Gy,Ch)	Reticulocosta	(Ar,Os,Pa)	Revisylhere	(Ar,Os,Pa)
Reptaria	(Bz,St,Cc)	Reticulograptus	(He,Gr,Tu)	Revija	(Ar,Os,Pa)
Reptelea	(Bz,St,Cc)	Reticulogyra	(Fo,Fo,Fo)	Revissirella	(Bz,Gy,Ch)
Reptescharipora	(Bz,Gy,Ch)	Reticuloharpes	(Ar,Tr,Pt)	Rexea	(Cd,Os,Pl)
Reptocavea	(Bz,St,Cc)	Reticulomedusa	(Cn,Sc,Rh)	Rexithaerus	(Mo,Bi,Ve)
Reptocerites	(Bz,St,Cc)	Reticulopalmula	(Fo,Fo,Fo)	Reymentella	(Mo,Ga,Nt)
Reptoclausa	(Bz,St,Cc)	Reticulophragmium	(Fo,Fo,Fo)	Reymenticosta	(Ar,Os,Pa)
Reptofascigera	(Bz,St,Cc)	Reticulophragmoids	(Fo,Fo,Fo)	Reynesella	(Mo,Ce,Am)
Reptolunites	(Bz,Gy,Ch)	Reticuloturris	(Mo,Ga,Ne)	Reynesoceras	(Mo,Ce,Am)
Reptomultelea	(Bz,St,Cc)	Reticycloceras	(Mo,Ce,Or)	Reynesoceloceras	(Mo,Ce,Am)
Reptomulticava	(Bz,St,Cc)	Retifacies	(Ar,Mo,In)	Rhabdactinia	(Po,De,Pe)
Reptomulticlausa	(Bz,St,Cc)	Retilaskeya	(Mo,Ga,Nt)	Rhabdammina	(Fo,Fo,Fo)
Reptomultisparsa	(Bz,St,Cc)	Retillamina	(Po,Il,Ar)	Rhabdelasma	(Cn,An,Rt)
Reptonodicava	(Bz,St,Cc)	Retimarginifera	(Br,Ar,St)	Rhabdiferous	(Mo,Ce,El)
Requienia	(Mo,Bi,Hi)	Retinoda	(Ar,Os,Pa)	Rhabdinopora	(He,Gr,De)
Reraspis	(Ar,Tr,Ph)	Retiolites	(He,Gr,Gr)	Rhabdiodus	(Cd,Pl,Un)
Resabulum	(Mo,Ga,Ne)	Retiophyllia	(Cn,An,Sc)	Rhabdites	(Mo,Ce,Or)
Resania	(Mo,Bi,Ve)	Retiophyllum	(Cn,An,Ru)	Rhabdobelus	(Mo,Ce,Be)
Resatrix	(Mo,Bi,Ve)	Retiopustula	(Mo,Ga,Ar)	Rhabdoceras	(Mo,Ce,Cc)
Resegia	(Pr,Un,In)	Retipilina	(Mo,In,In)	Rhabdochites	(Pr,Un,In)
Resetocrinus	(Ec,Cr,Ds)	Retipirula	(Mo,Ga,Ne)	Rhabdochitina	(Fo,Fo,Ch)
Resigia	(Fo,Fo,Fo)	Retisacculus	(Ar,Os,Pa)	Rhabdoicidaris	(Ec,Ec,Ci)
Resimopsis	(Ar,Tr,Pt)	Retispira	(Mo,Ga,Be)	Rhabdocolpus	(Mo,Ga,Nt)
Resseraspis	(Ar,Tr,Pt)	Retites	(Mo,Ce,Go)	Rhabdoconcha	(Mo,Ga,Nt)
Resserella	(Br,Ar,Or)	Retizafra	(Mo,Ga,Ne)	Rhabdocora	(Cn,An,Sc)
Resseria	(Ar,Tr,Un)	Retroceramus	(Mo,Bi,Pt)	Rhabdoerinus	(Ec,Cr,Ci)
Resserops	(Ar,Tr,Re)	Retroclitendoceras	(Mo,Ce,En)	Rhabdoeyclus	(Cn,An,Ru)
Resseropis	(Ar,Tr,Re)	Retrocypoda	(Ar,ML,De)	Rhabdoeodermia	(Cd,Os,Co)
Retaria	(Br,Ar,St)	Retroplexus	(Br,Ar,St)	Rhabdofario	(Cd,Os,Pa)
Retecava	(Bz,St,Cc)	Retropluma	(Ar,ML,De)	Rhabdofavita	(Cn,An,Sc)

Rhabdognathus	(Cd,Re,Cr)	Rhampidoceras	(Mo,Ce,Am)	Rhipidium	(Br,Ar,Pe)
Rhabdohydra	(Cn,Hy,Hy)	Rhappopleura	(He,Pt,Rh)	Rhipidocrinus	(Ec,Cr,Di)
Rhabdolepis	(Cd,Os,Pa)	Rhaphaocrinus	(Ec,Cr,Di)	Rhipidocystis	(Ec,Rh,Rh)
Rhabdololithis	(Ac,Ra,Na)	Rhaphidograptus	(He,Gr,Gr)	Rhipidodendrum	(He,Gr,De)
Rhabdolythrus	(Po,Re,Ca)	Rhaphidora	(Po,De,Ta)	Rhipidognathus	(Cd,Co,Co)
Rhabdomeson	(Bz,St,Cr)	Rhaphischisma	(Mo,Ga,Ar)	Rhipidogyra	(Cn,An,Sc)
Rhabdonelloides	(Ci,Po,Sp)	Rhaphistomella	(Mo,Ga,Ar)	Rhipidomella	(Br,Ar,Or)
Rhabdophyllia	(Cn,An,Sc)	Rhaphidophyllum	(Cn,An,Ta)	Rhipidomelloides	(Br,Ar,Or)
Rhabdophylliopsis	(Cn,An,Sc)	Rhaphidothyris	(Br,Ar,Te)	Rhipidomena	(Br,Ar,St)
Rhabdopitaria	(Mo,Bi,Ve)	Rhaptagnostus	(Ar,Tr,Ag)	Rhipidophyllum	(Cn,An,Ru)
Rhabdopleurites	(He,Pt,Rh)	Rhapydionina	(Fo,Fo,Fo)	Rhipidomilia	(Cn,An,Sc)
Rhabdopleuroides	(He,Pt,Rh)	Rharbichthys	(Cd,Os,Al)	Rhipidothyris	(Br,Ar,Te)
Rhabdopora	(Bz,Gy,Ch)	Rhaxella	(Mo,De,As)	Rhipsites	(Mo,Ce,Or)
Rhabdorbitoides	(Fo,Fo,Fo)	Rhaxelloides	(Po,De,As)	Rhizammina	(Fo,Fo,Fo)
Rhabdosispongia	(Po,He,Re)	Rhebasia	(Bz,Gy,Ch)	Rhizangia	(Cn,An,Sc)
Rhabdospongia	(Po,De,As)	Rhechias	(Cd,Os,An)	Rhizocheton	(Po,He,Ly)
Rhabdotetradium	(Cn,An,Ta)	Rhectomyax	(Mo,Bi,Ve)	Rhizodus	(Cd,Os,Co)
Rhabdotites	(Ec,Ho,As)	Rhedensia	(Mo,Bi,Hi)	Rhizophylloides	(Cn,An,Ru)
Rhabdotocochlis	(Mo,Ga,Ar)	Rhegmaphyllum	(Cn,An,Ru)	Rhizophyllum	(Cn,An,Ru)
Rhabdotometra	(Bz,Gy,Ch)	Rhengenopsis	(Cd,Ma,Ce)	Rhizoplegma	(Ac,Ra,Sp)
Rhabdotubus	(He,Pt,Rh)	Rhenanarella	(Bz,St,Un)	Rhizopoterionopsis	(Po,He,Ly)
Rhabdotum	(Po,De,Li)	Rhenania	(Mo,Bi,Tr)	Rhizopoterion	(Cd,Ch,Ca)
Rhabdouraea	(Ar,MI,Le)	Rhenanomya	(Mo,Bi,Un)	Rhizopsis	(Po,De,Un)
Rhabdus	(Mo,Sc,Sc)	Rhenanoperca	(Cd,Os,Pf)	Rhizopteron	(Po,He,Ly)
Rhabdosteus	(Cd,Ma,Ce)	Rhenaster	(Ec,As,Pu)	Rhizorus	(Mo,Ga,Ce)
Rhacheopora	(Bz,Gy,Ch)	Rhenechinus	(Ec,Ec,Ey)	Rhizostele	(Po,De,Li)
Rhachiosoma	(Ar,MI,De)	Rhencrinus	(Ec,Cr,Cl)	Rhizostomites	(Cn,Sc,Li)
Rhachistognathus	(Cd,Co,Co)	Rhencystis	(Ec,St,MI)	Rhizostomella	(Cn,Hy,Un)
Rhachicrinus	(Ec,Cr,Di)	Rhenogriffides	(Ar,Tr,Pr)	Rhizotetraclis	(Po,De,Li)
Rhacochilus	(Cd,Os,Pf)	Rhenonema	(Cd,Pl,Ar)	Rhizothyris	(Br,Ar,Te)
Rhacolepis	(Cd,Os,Cr)	Rhenops	(Ar,Tr,Ph)	Rhocobairdia	(Ar,Os,Po)
Rhacophyllites	(Mo,Ce,Ph)	Rhenopterus	(Ar,Me,Eu)	Rhodalepis	(Cd,Co,Co)
Rhacopora	(Cn,An,Ta)	Rhenopyrgus	(Ec,Ed,Ed)	Rhodanicaris	(Ar,MI,De)
Rhactomena	(Br,Ar,St)	Rhenorenselaria	(Br,Ar,Te)	Rhodanometra	(Ec,Cr,Is)
Rhactorhynchia	(Br,Ar,Rh)	Rhenosquama	(Ec,Oh,Oh)	Rhodanopeza	(Fo,Fo,Fo)
Rhactorthis	(Br,Ar,Or)	Rhenostrophia	(Br,Ar,St)	Rhodanospongia	(Po,He,He)
Rhadinichthys	(Cd,Os,Pa)	Rhenothyra	(Fo,Fo,Fo)	Rhodanella	(Fo,Fo,Fo)
Rhadinites	(Mo,Ce,Go)	Rhenothyris	(Br,Ar,Sp)	Rhodesognathus	(Cd,Co,Co)
Rhadinoceras	(Mo,Ce,Ta)	Rheocrinus	(Ec,Cr,Di)	Rhodocrinites	(Ec,Cr,Di)
Rhadinocrinus	(Ec,Cr,Cl)	Rhincodon	(Cd,Ch,Ce)	Rhodonaspis	(Ar,Tr,Pt)
Rhadinocythere	(Ar,Os,Po)	Rhinipora	(Bz,Gy,Ch)	Rhodospaera	(Ac,Ra,Sp)
Rhadinopleura	(Ar,Tr,As)	Rhinobatos	(Cd,Ch,Rj)	Rhodospyrus	(Ac,Ra,Na)
Rhaeboceras	(Mo,Ce,Am)	Rhinocarcinosoma	(Ar,Me,Eu)	Rhogostomium	(Po,He,He)
Rhaeta	(Mo,Bi,Ve)	Rhinocaris	(Ar,MI,Ar)	Rhomaleosaurus	(Cd,Re,Ps)
Rhaetavacuila	(Mo,Bi,Pt)	Rhinocephalus	(Cd,Os,Ga)	Rhomarchus	(Cd,Os,Sc)
Rhaetiastrea	(Cn,An,Sc)	Rhinochelys	(Cd,Re,Ch)	Rhombampyx	(Ar,Tr,As)
Rhaeticonia	(Cd,Re,Ps)	Rhinoclavus	(Mo,Ga,Nt)	Rhombaria	(Br,Ar,Te)
Rhaetidia	(Mo,Bi,Ve)	Rhinocypris	(Ar,Os,Po)	Rhombodanidium	(Po,He,He)
Rhaetina	(Br,Ar,Te)	Rhinoderma	(Mo,Ga,Ar)	Rhombella	(Mo,Ga,Ar)
Rhaetinopsis	(Br,Ar,Te)	Rhinodipterus	(Cd,Os,Di)	Rhombicalvaria	(Ar,Mo,In)
Rhaetomegalodon	(Mo,Bi,Hi)	Rhinophacops	(Ar,Tr,Ph)	Rhombifera	(Ec,Rh,Rh)
Rhagosostoma	(Bz,Gy,Ch)	Rhinopora	(Bz,St,Cy)	Rhombina	(Ar,Os,My)
Rhagnura	(Pr,Un,In)	Rhinoporella	(Bz,St,Cy)	Rhombobotivinnella	(Fo,Fo,Fo)
Rhagospolecion	(Po,De,Li)	Rhinopoupinia	(Ar,MI,De)	Rhomboceras	(Mo,Ce,On)
Rhaiphale	(Mo,Bi,Ve)	Rhinoptera	(Cd,Ch,My)	Rhombocladia	(Bz,St,Fe)
Rhakistella	(Po,He,Re)	Rhinoreedops	(Ar,Tr,Ph)	Rhombocomiculuf	(Pr,Un,In)
Rhammatopora	(Bz,Gy,Ch)	Rhinosteus	(Cd,Pl,Ar)	Rhombocythere	(Ar,Os,Po)
Rhamnaria	(Br,Ar,St)	Rhinotreta	(Br,Ar,At)	Rhombodictyon	(Po,He,Re)
Rhamphegenys	(An,Po,Eu)	Rhioidogyra	(Cn,An,Sc)	Rhombodus	(Cd,Ch,My)
Rhamphexocoetus	(Cd,Os,Be)	Rhiphaeceras	(Mo,Ce,Na)	Rhombotentozoe	(Ar,Os,My)
Rhamphognathus	(Cd,Os,Pf)	Rhiphaeoclymenia	(Mo,Ce,Cl)	Rhomboidella	(Br,Ar,Te)
Rhamphonostus	(Bz,Gy,Ch)	Rhiphaeoclytus	(Mo,Ce,Go)	Rhomboidestoma	(Mo,Ga,Ne)
Rhamphopyge	(Ar,Tr,Pt)	Rhiphaeconautilus	(Mo,Ce,Na)	Rhombopora	(Bz,St,Cr)
Rhamphostomella	(Bz,Gy,Ch)	Rhipidiopora	(Bz,St,Cc)	Rhomboporella	(Bz,St,Fe)

Rhombopsis	(Mo,Ga,Ne)	Rhysomagus	(Ar,Os,Po)	Rimulopsis	(Mo,Ga,Ar)
Rhombopteria	(Mo,Bi,Pt)	Rhysostrophia	(Br,Ar,Pe)	Rimulostoma	(Bz,Gy,Ch)
Rhombotrygia	(Cd,Ch,Rj)	Rhysotreta	(Br,Li,Ac)	Rinaldocoynchus	(Mo,Ga,He)
Rhombostoma	(Mo,Ga,Nt)	Rhyssochonetes	(Br,Ar,St)	Rinaldomphalus	(Mo,Ga,Ar)
Rhombothyris	(Br,Ar,Te)	Rhysosmetropus	(Ar,Tr,As)	Rinconia	(Ar,Tr,Pt)
Rhombotrypa	(Bz,St,Tr)	Rhyssomytiodes	(Mo,Bi,Pt)	Rincereras	(Mo,Ce,Na)
Rhombotrypella	(Bz,St,Tr)	Rhyssoplax	(Mo,Po,Ne)	Rinetrigonia	(Mo,Bi,Tr)
Rhondellina	(Br,Li,Ac)	Rhythmias	(Cd,Os,Pf)	Ringicula	(Mo,Ga,Ce)
Rhopalastrum	(Ac,Ra,Sp)	Rhytialosia	(Br,Ar,St)	Ringiculella	(Mo,Ga,Ce)
Rhopalica	(Po,He,He)	Rhytidoderma	(Po,De,Li)	Ringiculina	(Mo,Ga,Ce)
Rhopalites	(Mo,Ga,Ne)	Rhytidohoplites	(Mo,Ce,Am)	Ringiculocosta	(Mo,Ga,Ce)
Rhopaloblastus	(Ec,BI,Sp)	Rhytidolasma	(Cn,An,Ru)	Ringiculopsis	(Mo,Ga,Ce)
Rhopalocanium	(Ac,Ra,Na)	Rhytidophyllum	(Cn,An,Ru)	Ringiculoptycha	(Mo,Ga,Ce)
Rhopalocoelia	(Po,De,Li)	Rhytidopilus	(Mo,Ga,Ar)	Ringiculospingia	(Mo,Ga,Ce)
Rhopalocoma	(Ec,Op,St)	Rhytimya	(Mo,Bi,Ph)	Ringifungia	(Po,Re,Aj)
Rhopaloconus	(Po,De,Hd)	Rhytiobeyrichia	(Ar,Os,Pa)	Ringinella	(Mo,Ga,Ce)
Rhopalocrinus	(Ec,Cr,Cl)	Rhytidentalium	(Mo,Sc,Sc)	Ringoceras	(Mo,Ce,On)
Rhopalocystis	(Ec,Eo,Go)	Rhytiophora	(Br,Ar,St)	Ringsteadia	(Mo,Ce,Am)
Rhopalodictyum	(Ac,Ra,Sp)	Rhytipirion	(An,Po,Eu)	Rioceras	(Mo,Ce,El)
Rhopalophyllia	(Cn,An,Sc)	Rhytirhynchia	(Br,Ar,Rh)	Riograndella	(Br,Ar,Or)
Rhopalospongia	(Po,De,Li)	Rhytisia	(Br,Ar,St)	Rionorhynchia	(Br,Ar,Rh)
Rhopalosyringium	(Ac,Ra,Na)	Rhytisodon	(Cd,Ma,Ce)	Riorhynchia	(Br,Ar,Rh)
Rhopaloteuthis	(Mo,Ce,Be)	Rhytisoria	(Br,Ar,Te)	Rjoulina	(Br,Ar,Th)
Rhopocrinus	(Ec,Cr,Cl)	Rhytistrophia	(Br,Ar,St)	Ripacubana	(Fo,Fo,Fo)
Rhopostoma	(Ec,Ec,Ho)	Riasanites	(Mo,Ce,Am)	Riphaeolites	(Cn,An,Ta)
Rhoptrum	(Po,De,Li)	Riasanospongia	(Po,De,Un)	Ripidiorhynchus	(Br,Ar,Rh)
Rhymmoceras	(Mo,Ce,Go)	Ribeiria	(Mo,Ro,Ri)	Ripisoecia	(Bz,St,Ce)
Rhynchobatus	(Cd,Ch,Rj)	Riberina	(Mo,Ro,Ri)	Ripleyella	(Mo,Ga,Ne)
Rhynchoceras	(Mo,Ce,Di)	Ribodon	(Cd,Ma,Si)	Risella	(Mo,Ga,Nt)
Rhynchoerithium	(Ac,Ra,Na)	Richardsonella	(Ar,Tr,As)	Rissolopsis	(Mo,Ga,Nt)
Rhynchoconger	(Cd,Os,An)	Richardsonites	(Mo,Ce,Go)	Rishona	(Ar,Os,Po)
Rhynchocymba	(Cd,Os,An)	Richardsonoceras	(Mo,Ce,On)	Rispolia	(Ec,Ec,Hs)
Rhynchocypraea	(Mo,Ga,Nt)	Riehina	(Ar,Os,Pa)	Risselloidea	(Mo,Ga,Ar)
Rhynchoderectis	(Cd,Os,Al)	Richterarges	(Ar,Tr,Li)	Rissoo	(Mo,Ga,Nt)
Rhynchodus	(Cd,Pl,Pt)	Richteraspis	(Ar,Tr,Pr)	Rissocerithium	(Mo,Ga,Nt)
Rhynchoferella	(Br,Ar,Un)	Richterella	(Ar,Tr,Pr)	Rissoina	(Mo,Ga,Ne)
Rhyncholampas	(Ec,Ec,Ca)	Richterina	(Ar,Os,My)	Rissolina	(Mo,Ga,Nt)
Rhynchomytilus	(Mo,Bi,Mt)	Richterina	(Ar,Os,My)	Rissomangalia	(Mo,Ga,Ne)
Rhynchonella	(Br,Ar,Rh)	Richthofenia	(Br,Ar,St)	Rissopsetta	(Mo,Ga,He)
Rhynchonellina	(Br,Ar,Rh)	Ricinella	(Mo,Ga,Nt)	Ristacrinus	(Ec,Cr,Ds)
Rhynchonelloidea	(Br,Ar,Rh)	Rietaxis	(Mo,Ga,Ce)	Ristola	(Ac,Ra,Na)
Rhynchonelloidella	(Br,Ar,Rh)	Rictia	(Br,Ar,Un)	Ritatia	(Ar,Os,Pa)
Rhynchonellopsis	(Br,Ar,Te)	Rictocyma	(Mo,Bi,Ve)	Ritena	(Mo,Ga,Ar)
Rhynchopora	(Br,Ar,Rh)	Ridderia	(Cn,An,Ru)	Riuguhdrillia	(Mo,Ga,Ne)
Rhynchopteris	(Mo,Bi,Pt)	Ridersia	(Ec,Eo,As)	Riveroinella	(Fo,Fo,Fo)
Rhynchopygus	(Ec,Ec,Ca)	Rigaudites	(Ec,Ho,Ap)	Rivillina	(Ar,Os,Pa)
Rhynchorina	(Br,Ar,Te)	Rigauxia	(Br,Ar,Sp)	Rixator	(Cd,Os,Sc)
Rhynchorinus	(Cd,Os,An)	Rigbyella	(Br,Ar,St)	Riyadhella	(Fo,Fo,Fo)
Rhynchorthis	(Br,Ar,Or)	Rigbyetia	(Po,De,Pe)	Rizoceras	(Mo,Ce,On)
Rhynchorthoceras	(Mo,Ce,Or)	Rigbyspongia	(Po,De,Pe)	Robergia	(Ar,Tr,As)
Rhynchospirifer	(Br,Ar,Sp)	Rigidella	(Ar,Os,Pa)	Robergiella	(Ar,Tr,As)
Rhynchospirina	(Br,Ar,Sp)	Rimabollia	(Ar,Os,Pa)	Robertella	(Mo,Bi,Hi)
Rhynchostreon	(Mo,Bi,Pt)	Rimacytheropteron	(Ar,Os,Pa)	Robertina	(Fo,Fo,Fo)
Rhynchotetra	(Br,Ar,Rh)	Rimalina	(Fo,Fo,Fo)	Robertinoides	(Fo,Fo,Fo)
Rhynchotetraoides	(Br,Ar,Rh)	Rimella	(Mo,Ga,Nt)	Robertiolythus	(Po,Re,Mo)
Rhynchotrema	(Br,Ar,Rh)	Rimirhynchia	(Br,Ar,Rh)	Robertocyathus	(Po,Re,Aj)
Rhynchotreta	(Br,Ar,Rh)	Rimirhynchopsis	(Br,Ar,Rh)	Robertorthis	(Br,Ar,Or)
Rhynchotretina	(Br,Ar,Rh)	Rimkinites	(Mo,Ce,Ce)	Robertsonites	(Ar,Os,Po)
Rhynchozon	(Bz,Gy,Ch)	Rimmyjminia	(Mo,Bi,Ve)	Robinsonella	(Br,Ar,Rh)
Rhyncora	(Br,Ar,Te)	Rimmyjmina	(Mo,Bi,Mo)	Robotium	(Ac,Ra,Sp)
Rhynobolus	(Br,Li,Li)	Rimosiodocrinus	(Ec,Cr,Cl)	Robsoniella	(Ar,Os,Me)
Rhynobrissus	(Ec,Ec,Sp)	Rimosodaphnella	(Mo,Ga,Ne)	Robsonoceras	(Mo,Ce,El)
Rhynoleichus	(Br,Ar,Rh)	Rimouskia	(Ar,Tr,Pt)	Robuloides	(Fo,Fo,Fo)
Rhyselasma	(Br,Ar,Pe)	Rimula	(Mo,Ga,Ar)	Robus	(Mo,Ga,Ar)

Robustirhynchia	(Br.Ar,Rh)	Roperia	(Mo.Ga,Ne)	Rotundocyathus	(Po.Re,Aj)
Robustocyathellus	(Po.Re,Aj)	Ropolonellus	(Ar.Os,Me)	Rotundostrophia	(Br.Ar,St)
Robustocyathus	(Po.Re,Aj)	Rorespirifer	(Br.Ar,Sp)	Rotundrostrophya	(Ar.Os,Po)
Robustopachyphloia	(Fo.Fo,Fo)	Rorringtonia	(Ar.Tr,Pr)	Roudairia	(Mo.Bi,Ve)
Robustoschwagerina	(Fo.Fo,Fo)	Rosacilla	(Bz.St,Cc)	Rouillieria	(Br.Ar,Te)
Robustum	(Mo.In,He)	Rosalina	(Fo.Fo,Fo)	Roundyia	(Cd.Co,Co)
Rocalebris	(Ar.Os,Po)	Rosella	(Br.Ar,Pe)	Roundyella	(Ar.Os,Pa)
Rochaeva	(Ar.Tr,Un)	Roselletona	(Cn.An,Un)	Roussanofoceras	(Mo.Ce,Na)
Rochatorhynchia	(Br.Ar,Rh)	Rosenella	(Po.De,St)	Rousseauspira	(Mo.Ga,Me)
Rochefortia	(Mo.Bi,Ve)	Rosenellinella	(Po.De,St)	Rousselia	(Mo.Bi,Hi)
Rochefortula	(Mo.Bi,Ve)	Roseoporella	(Cn.Hy,Un)	Roveacrinoides	(Ec.Cr,Rv)
Rocheithyris	(Br.Ar,Te)	Rosobolus	(Br.Li,Li)	Roveacrinus	(Ec.Cr,Rv)
Rochella	(Mo.Bi,Ve)	Rossalites	(Mo.Ce,Am)	Rowellella	(Br.Li,Li)
Rochia	(Mo.Ga,Ar)	Rossaspis	(Ar.Tr,Ph)	Rowia	(Ar.Tr,Un)
Rochtex	(Br.Ar,Sp)	Rosseliana	(Bz.Gy,Ch)	Rowleyella	(Br.Ar,Sp)
Rockallia	(Ar.Os,Po)	Rossicoeras	(Mo.Ce,En)	Roxania	(Mo.Ga,Ce)
Rodentilites	(Hy.Hy,Hy)	Rossiites	(Mo.Cr,Te)	Roxaniella	(Mo.Ga,Ce)
Rodhocetus	(Cd.Ma,Ce)	Rossirhynchus	(Br.Ar,Rh)	Roxoa	(Mo.Bi,My)
Rodinosmilia	(Cn.An,Sc)	Rossieria	(Mo.Ga,Ar)	Roya	(Mo.Ga,Ar)
Roemerella	(Br.Li,Ac)	Rossithyris	(Br.Ar,Te)	Royasendia	(Ec.Ec,Sp)
Roemia	(Cn.An,Ta)	Rossoeras	(Mo.Ce,In)	Rozanovicoscinus	(Po.Re,Aj)
Roemeripora	(Cn.An,Ta)	Rossocyathella	(Po.Re,Aj)	Rozanovicyathus	(Po.Re,Aj)
Roemerispongia	(Po,He,Re)	Rossodus	(Cd.Co,Co)	Rozanoviella	(Mo.In,In)
Roemerocrinus	(Ec.Cr,Ci)	Rossopora	(Cn.An,Ta)	Rozdestvenskayites	(Ar.Os,Pa)
Roemerolites	(Cn.An,Ta)	Rostellaca	(Mo.Ga,Ne)	Rozkovskaella	(Cn.An,Ru)
Roemerus	(Ar.Mi,De)	Rostellaria	(Mo.Ga,Nt)	Rozkovskia	(Cn.An,Ru)
Rogerella	(Ar,Ci)	Rostellinda	(Mo.Ga,Ne)	Rozmanaria	(Br.Ar,Rh)
Roglicia	(Fo.Fo,Fo)	Rostranteris	(Br.Ar,Te)	Rozmaniella	(Ar.Os,Pa)
Rogueus	(Ar.Mi,De)	Rostreulima	(Mo.Ga,Nt)	Rozonovia	(Bz.St,Cr)
Rohea	(Mo.Bi,Ve)	Rostriellula	(Br.Ar,Rh)	Ruakituria	(Fo.Fo,Fo)
Rohini	(Mo.Bi,Ve)	Rostrihynchia	(Br.Ar,Rh)	Ruatoria	(Fo.Fo,Fo)
Roiometra	(Ec.Cr,Cm)	Rostrocardia	(Mo.Bi,Ve)	Rubiesichthys	(Cd.Os,Go)
Rojasia	(Ec.Ec,Sp)	Rostrocerithium	(Mo.Ga,Nt)	Rubracea	(Ar.Os,Po)
Roksaspis	(Ar.Tr,As)	Rostroconus	(Mo,Ro,Ri)	Rubroceras	(Mo.Ce,Am)
Rolandomphalus	(Mo.Ga,Ar)	Rostrocystheridea	(Ar.Os,Po)	Ruchholzella	(Ar.Os,Po)
Rolfëia	(Ar.Me,Xi)	Rostroperna	(Mo.Bi,Pt)	Rudagnostus	(Ar.Tr,Ag)
Rolfosteus	(Cd,Pl,Ar)	Rostrospirifer	(Br.Ar,Sp)	Rudakites	(Cn.An,Ta)
Rollandiana	(Mo.Ga,Ar)	Rota	(Ec.Ho,Ap)	Rudanulus	(Po.Re,Aj)
Rollerites	(Mo.Ce,Am)	Rotadiscoides	(Mo.Ga,Be)	Rudderina	(Ar.Os,Me)
Rollia	(Ar.Tr,Pt)	Rotadiscus	(Cn.Hy,Si)	Rudicardium	(Mo.Bi,Ve)
Rollierella	(Mo.Bi,Ve)	Rotafirma	(Ac.Ra,Na)	Rudinia	(Br.Ar,St)
Rollieria	(Mo.Bi,Nu)	Rotaita	(Br.Ar,Rh)	Rudirhynchia	(Br.Ar,Rh)
Rollmops	(Ar.Tr,Ph)	Rotalia	(Fo.Fo,Fo)	Rudiscala	(Mo.Ga,Nt)
Roloboceras	(Mo.Ce,Am)	Rotaliatina	(Fo.Fo,Fo)	Ruditapes	(Mo.Bi,Ve)
Rolombus	(Ac.Ra,Na)	Rotaliatinopsis	(Fo.Fo,Fo)	Rudolfoceras	(Mo.Ce,El)
Rolycladium	(Pr.Co,Ch)	Rotalidium	(Fo.Fo,Fo)	Ruedemannaella	(An.Po,Un)
Romancheima	(Bz.Gy,Ch)	Rotalinoides	(Fo.Fo,Fo)	Ruedemannaia	(Mo.Ga,Ar)
Romaniceras	(Mo.Ce,Am)	Rotalipora	(Fo.Fo,Fo)	Ruedemanniapterus	(Ar.Me,Eu)
Romaniella	(Mo.Te,Tr)	Rotamorphina	(Fo.Fo,Fo)	Ruedemannoceras	(Mo.Ce,Di)
Romanites	(Mo.Ce,Ce)	Rotasaccus	(Ec.Oh,Oh)	Ruedemannograptus	(He.Gr,Un)
Romaniteuthis	(Mo.Ce,Te)	Rotasphaera	(Ac.Ra,Sp)	Ruegenella	(Br.Ar,Te)
Romerodus	(Cd,Ch,Eu)	Rothella	(Ar.Os,Me)	Ruella	(Mo.Bi,Ve)
Romingeria	(Cn.An,Ta)	Rothellina	(Ar.Os,Me)	Ruesticyrtium	(Ac.Ra,Na)
Romingerina	(Br.Ar,Te)	Rothina	(Fo.Fo,Fo)	Rufilla	(Mo.Ga,Ar)
Romingoceras	(Mo.Ce,On)	Rothpeltzia	(Mo.Ga,Nt)	Rufispirifer	(Br.Ar,Sp)
Romundina	(Cd,Pl,Ac)	Rothpletzella	(Mo.Ga,Ar)	Rugafarius	(Ar.Mi,De)
Roncador	(Cd,Os,Pf)	Rotiphyllum	(Cn.An,Ru)	Rugaltarostrium	(Br.Ar,Rh)
Roncana	(Mo.Bi,Pt)	Rotodiscoceras	(Mo.Ce,Ce)	Rugaria	(Br.Ar,St)
Roncellia	(Ar.Tr,Ph)	Rotopericyclus	(Mo.Ce,Go)	Rugatia	(Br.Ar,St)
Rondocephalus	(Ar.Tr,Co)	Rotoporina	(Bz.Gy,Ch)	Rugatiscala	(Mo.Ga,Nt)
Rongxiella	(Ar.Tr,Un)	Rotula	(Ec.Ec,Ci)	Rugatotheca	(Pr.Un,In)
Rontrippia	(Ar.Tr,Li)	Rotularia	(An.Po,Se)	Rugauris	(Br.Ar,St)
Ropaloceras	(Mo.Ce,Di)	Rotuloidea	(Ec.Ec,Ci)	Ruggieria	(Ar.Os,Po)
Ropalonaria	(Bz.Gy,Ct)	Rotundacodina	(Cd.Co,Co)	Ruggieriella	(Ar.Os,Po)

Rugia	(Br,Ar,Te)	Rutrumella	(Br,Ar,St)	Sadleria	(Po,De,Li)
Rugicostella	(Br,Ar,St)	Rutenella	(Ar,Os,Po)	Saduria	(Ar,Mi,Is)
Rugifera	(Mo,Ga,He)	Ruzhencovia	(Bz,St,Tr)	Saetorthis	(Br,Ar,Or)
Rugiferites	(Mo,Ce,Am)	Ruzhencvispongas	(Ac,Ra,Sp)	Saetophyllia	(Cn,An,Sc)
Rugitela	(Br,Ar,Te)	Ryadhella	(Fo,Fo,Fo)	Saeta-spongia	(Po,He,Re)
Rugithyris	(Br,Ar,Te)	Ryckholtia	(Ar,Tr,Pt)	Saetograptus	(He,Gr,Gr)
Rugivestis	(Br,Ar,St)	Ryderia	(Mo,Bi,Nu)	Saetosina	(Br,Ar,St)
Rugobela	(Mo,Ga,Ne)	Ryderophyllum	(Cn,An,Ru)	Saeviella	(Bz,Gy,Ch)
Rugobolivinella	(Fo,Fo,Fo)	Ryenella	(Mo,Bi,Mt)	Saffordellina	(Ar,Os,Pa)
Rugocaris	(Ar,Th,Co)	Ryhopora	(Bz,St,Fe)	Saffordia	(Mo,Bi,Mo)
Rugoclostus	(Br,Ar,St)	Rylstonia	(Cn,An,Ru)	Saffordoceras	(Mo,Ce,Ac)
Rugoconcha	(Br,Ar,St)	Ryocarhynchus	(Br,Ar,Rh)	Saffordophyllum	(Cn,An,Ta)
Rugoconites	(Cn,In,In)	Rytiodus	(Cd,Ma,Si)	Saffordotaxis	(Bz,St,Cr)
Rugocythereis	(Ar,Os,Po)	Ryugasella	(Mo,Ce,Am)	Sagavia	(Ar,Tr,Pt)
Rugodavidsonia	(Br,Ar,At)	Rzehakia	(Mo,Bi,Ve)	Sageceras	(Mo,Ce,Ce)
Rugoglobigerina	(Fo,Fo,Fo)	Rzehakina	(Fo,Fo,Fo)	Sagenachitina	(Fo,Fo,Ch)
Rugoleptaena	(Br,Ar,St)	Rzonsnickiana	(Br,Ar,Rh)	Sagenella	(Mo,Ga,Ne)
Rugolepyros	(Br,Ar,Pe)	Saalfeldella	(Ar,Os,Po)	Sagenina	(Fo,Fo,Fo)
Rugosatriypa	(Br,Ar,At)	Saaremaaspis	(Cd,Ce,Ce)	Sagenites	(Mo,Ce,Ce)
Rugosochonetes	(Br,Ar,St)	Saaremolites	(Cn,An,Ta)	Sagenocrinites	(Ec,Cr,Sa)
Rugosochusenella	(Fo,Fo,Fo)	Saarina	(Pr,Un,Sa)	Sagenograptus	(He,Gr,De)
Rugosomarginifera	(Br,Ar,St)	Saauropsis	(Cd,Os,Pe)	Saghaectus	(Cd,Ma,Ce)
Rugososchwagerina	(Fo,Fo,Fo)	Sabatia	(Mo,Ga,Ce)	Saghalinities	(Mo,Ce,Am)
Rugosothyris	(Br,Ar,Un)	Sabaudia	(Fo,Fo,Fo)	Sagittaspis	(Ar,Tr,Pt)
Rugosowerbyella	(Br,Ar,St)	Sabaziella	(Mo,Ga,An)	Sagitioides	(Ar,Tr,Pt)
Rugostrophia	(Br,Ar,Pe)	Sabellaria	(An,Po,SP)	Sagittastraea	(Cn,An,Sc)
Rugotruncana	(Fo,Fo,Fo)	Sabellidites	(Pr,Un,Sa)	Sagittitheca	(Pr,Un,In)
Rugotyphis	(Mo,Ga,Ne)	Sabellivoluta	(Fo,Fo,Fo)	Sagittoblastus	(Ec,Bi,Fi)
Rugulina	(Mo,Ga,Ar)	Sabinella	(Mo,Ga,Nt)	Sagittodontina	(Cd,Co,Co)
Rukhinia	(Cn,An,Ru)	Sabinia	(Mo,Bi,Hi)	Sagittovum	(Ar,Os,Pa)
Rumerloella	(Mo,Ga,Ar)	Sablea	(Mo,Ga,Ar)	Sagittularia	(Po,Ca,Ph)
Rumphia	(Ec,Ec,Cl)	Sabrinella	(Mo,Ga,Ar)	Sagmatocythere	(Ar,Os,Po)
Rumphiocrinus	(Ec,Cr,Sa)	Sabulina	(Fo,Fo,Fo)	Sagoplecta	(Fo,Fo,Fo)
Runa	(Ec,Ec,Cl)	Sacabambaspis	(Cd,Pt,Pt)	Sagrina	(Fo,Fo,Fo)
Runnegaria	(Mo,Bi,Mo)	Sacariacrinus	(Ec,Cr,Cy)	Sagrinopsis	(Fo,Fo,Fo)
Runnegarochiton	(Mo,In,In)	Saccamina	(Fo,Fo,Fo)	Sagueresia	(Br,Ar,Rh)
Rupellaria	(Mo,Bi,Ve)	Saccaminis	(Fo,Fo,Fo)	Saharonetes	(Br,Ar,St)
Rupertina	(Fo,Fo,Fo)	Saccaminoides	(Fo,Fo,Fo)	Sahelinia	(Cd,Os,St)
Ruptivelum	(Ar,Os,Pa)	Saccarchites	(Ar,Os,Pa)	Sahnia	(Ar,Os,Po)
Rurambonites	(Br,Ar,St)	Saccarena	(Fo,Fo,Fo)	Sahnicythere	(Ar,Os,Po)
Rursiceras	(Mo,Ce,Am)	Saccaroturris	(Mo,Ga,Ne)	Sahraja	(Po,De,Pe)
Rushdisaidina	(Ar,Os,Po)	Saccelatia	(Ar,Os,Pa)	Saida	(Ar,Os,Po)
Rushtonia	(Pr,Un,Hy)	Saccella	(Mo,Bi,Nu)	Saidovina	(Fo,Fo,Fo)
Rushtonites	(Pr,Un,In)	Sacchararena	(Fo,Fo,Fo)	Saikracomecha	(Mo,Bi,Pt)
Rusoceras	(Mo,Ce,Am)	Sacciconus	(Mo,In,In)	Sailycaspis	(Ar,Tr,Un)
Russellophs	(Cd,Re,Sq)	Sacciella	(Cn,Sc,Cn)	Saimachia	(Ar,Tr,As)
Russia	(Ar,Os,Po)	Saccocaris	(Ar,Th,In)	Sainschandia	(Mo,Bi,Il)
Russiella	(Fo,Fo,Fo)	Saccocoma	(Ec,Cr,Rv)	Saintia	(Mo,Bi,Pt)
Russirhynchia	(Br,Ar,Rh)	Saccogaster	(Cd,Os,Op)	Saintiopsis	(Mo,Bi,Pt)
Russocyathus	(Po,Re,Aj)	Saccogonum	(Br,Ar,Or)	Sairocaris	(Ar,Mi,Ho)
Russospongia	(Po,De,Pe)	Saccoina	(Mo,Ga,He)	Saitoum	(Ac,Ra,Na)
Rustella	(Br,Un,Ku)	Saccorhina	(Fo,Fo,Fo)	Sajakella	(Br,Ar,St)
Rustia	(Ac,Ra,Sp)	Saccorhiza	(Fo,Fo,Fo)	Sajanaspis	(Ar,Tr,Ol)
Rutellifrons	(An,Po,Ph)	Saccorhynchia	(Br,Ar,Rh)	Sajanoocyathus	(Po,Re,Aj)
Ruthenoceras	(Mo,Ce,El)	Saccosompis	(Ec,Cr,Cl)	Sajanolythnus	(Po,Re,Mo)
Rutherfordoides	(Fo,Fo,Fo)	Saccospongia	(Po,De,Li)	Sakalavastraea	(Cn,An,Sc)
Ruthiphiala	(Br,Ar,St)	Saccostrea	(Mo,Bi,Pt)	Sakalavastraeopsis	(Cn,An,Sc)
Rutitrigonia	(Mo,Bi,Tr)	Sachalinocetus	(Cd,Ma,Ce)	Sakalavicyathus	(Cn,An,Sc)
Rutkowskiella	(Po,De,Li)	Sachites	(Pr,Co,Sa)	Sakamenichthys	(Cd,Os,Pa)
Rutlandella	(Ar,Os,Po)	Sachsibelus	(Mo,Ce,Be)	Sakawairhynchia	(Br,Ar,Rh)
Rutoceras	(Mo,Ce,Na)	Sacothyris	(Br,Ar,Te)	Sakawanella	(Mo,Bi,Ve)
Rutonia	(Mo,Bi,Hi)	Sacothyropsis	(Br,Ar,Te)	Sakesaria	(Fo,Fo,Fo)
Rutorhynchia	(Br,Ar,Rh)	Sactoceras	(Mo,Ce,Or)	Sakhacyathus	(Po,Tr,Ar)
Rutroclypeus	(Ec,Hs,So)	Sactorthoceras	(Mo,Ce,Or)	Sakhaites	(Mo,Ce,Ce)

Sakhiella	(Fo,Fo,Fo)	Sampsonocrinus	(Ec,Cr,Mo)	Sardinoides	(Cd,Os,My)
Sakmarites	(Mo,Ce,Pl)	Samsonofoclavus	(Pr,Ca,Ca)	Sardinops	(Cd,Os,Cl)
Salacorchis	(Br,Ar,Or)	Sanarkocystus	(Po,Re,Aj)	Sardocidaris	(Ec,Ec,Ci)
Salalirella	(Po,De,St)	Sanarkophyllum	(Po,Re,Aj)	Sardope	(Br,Ar,Te)
Salairia	(Cn,An,Ta)	Sanaschtykogia	(Ar,Tr,Pt)	Sardoredlichia	(Ar,Tr,Re)
Salairina	(Br,Ar,At)	Sanchezaster	(Ec,Ec,Hs)	Sardorhynchia	(Br,Ar,Rh)
Salairocystus	(Po,Re,Aj)	Sanchezella	(Ec,Ec,Cl)	Sardospongia	(Po,Ca,Un)
Salairophyllum	(Cn,An,Ru)	Sanctacarus	(Ar,Me,In)	Sarepta	(Mo,Bi,Nu)
Salairotoecchia	(Br,Ar,Rh)	Sanda	(Mo,Bi,Mt)	Sargaella	(Mo,St,St)
Salanacus	(Pr,Un,In)	Sandalodus	(Cd,Ch,In)	Sargana	(Mo,Ga,Ne)
Salankanaspis	(Ar,Tr,Pt)	Sandalolitha	(Cn,An,Sc)	Sarganostega	(Br,Ar,Sp)
Salanyella	(Mo,In,In)	Sandalopora	(Bz,Gy,Ch)	Sargentina	(Ar,Os,Pa)
Salanyolina	(Br,Un,Un)	Sandbergeria	(Mo,Ga,Nt)	Sargocentron	(Cd,Os,Br)
Salanytheca	(Tr,An)	Sandbergeroceras	(Mo,Ce,An)	Sargodon	(Cd,Os,Se)
Salaputium	(Mo,Bi,Ve)	Sanderella	(Fo,Fo,Fo)	Sargus	(Cd,Os,Pf)
Salazicerus	(Mo,Ce,Am)	Sandia	(Br,Ar,St)	Sarkachiton	(Mo,Po,Pa)
Salaeclasma	(Cn,An,Ru)	Sandlingites	(Mo,Ce,Ce)	Sarkia	(Ar,Tr,Un)
Salenia	(Ec,Ec,Sa)	Sandomingia	(Ar,MI,De)	Sarla	(Ac,Ra,Sp)
Salenidia	(Ec,Ec,Sa)	Sandoveria	(Ar,Tr,Co)	Sarlatina	(Ar,Os,Po)
Salenocidaris	(Ec,Ec,Sa)	Sandrella	(Br,Ar,St)	Sarmatella	(Cd,Os,Cl)
Salfeldiella	(Mo,Ce,Am)	Sangiaothyris	(Br,Ar,Te)	Sarmates	(Mo,Ga,Ar)
Salgirella	(Br,Ar,Rh)	Sanguinolaria	(Mo,Bi,Ve)	Sarmatiocardium	(Mo,Bi,Ve)
Sallya	(Mo,Ga,Ar)	Sanguinolites	(Mo,Bi,Ph)	Sarmaticus	(Mo,Ga,Ar)
Salmacina	(An,Po,Se)	Sangzhiscutellum	(Ar,Tr,Pt)	Sarmatidonax	(Mo,Bi,Ve)
Salmacis	(Ec,Ec,Te)	Sangzhitos	(Mo,Ce,Go)	Sarmatimacra	(Mo,Bi,Ve)
Salminops	(Cd,Os,Go)	Sanhaliotis	(Mo,Ga,Ar)	Sarmatodelphis	(Cd,Ma,Ce)
Salmo	(Cd,Os,Su)	Sanidaspis	(Cd,Pt,Pt)	Sarmatotoxitis	(Ar,Os,Pa)
Salonia	(Br,Ar,Pe)	Sanidophyllum	(Cn,An,Ru)	Sarmaturbo	(Mo,Ga,Ar)
Salopia	(Br,Ar,Or)	Sanidopyge	(Ar,Tr,Ph)	Sarocrinus	(Ec,Cr,Cl)
Salopiella	(Pr,Un,Hy)	Sanjuaneella	(Br,Ar,St)	Sarophora	(Po,He,Ly)
Salopina	(Br,Ar,Or)	Sanjuanetes	(Br,Ar,St)	Sarsicytheridea	(Ar,Os,Po)
Salopinella	(Br,Ar,Or)	Sanjuania	(Br,Ar,Rh)	Sarvina	(Ar,Os,Pa)
Salopochitina	(Fo,Fo,Ch)	Sanmartinoceras	(Mo,Ce,Am)	Sarytchevinella	(Br,Ar,St)
Salpingellina	(Cn,Po,Sp)	Sannemannia	(Cd,Co,Co)	Sarytunia	(Ar,Os,Pa)
Salpingium	(Cn,An,Ta)	Sanniolus	(Ar,Os,Pa)	Sassendalia	(Cn,An,Ru)
Salpingocapsa	(Ac,Ra,Na)	Sannionites	(Mo,Ce,Or)	Sassenia	(Cd,Os,Co)
Salpingostoma	(Mo,Ga,Be)	Sansabaina	(Fo,Fo,Fo)	Sassia	(Mo,Ga,Nt)
Salpingoteuthis	(Mo,Ce,Be)	Sansabella	(Ar,Os,Pa)	Satiellina	(Ar,Os,Pa)
Salpingthurammina	(Fo,Fo,Fo)	Santeelampas	(Ec,Ec,Ca)	Satorina	(Fo,Fo,Fo)
Saltaspis	(Ar,Tr,Pt)	Santia	(Mo,Ga,Sa)	Satpakella	(Br,Li,Ac)
Saltastraea	(Cn,An,Sc)	Sanxiaella	(Br,Li,Li)	Saturnalis	(Ac,Ra,Sp)
Salteraster	(Ec,As,Ur)	Sanyangites	(Mo,Ce,Ce)	Saturnia	(Mo,Bi,Nu)
Salterella	(Pr,Un,Vu)	Sanyuania	(Ar,Os,Po)	Saturniforma	(Ac,Ra,Sp)
Salteria	(Ar,Tr,Pt)	Sao	(Ar,Tr,Pt)	Saucrobrochus	(Br,Ar,Te)
Saltericeras	(Mo,Ce,Am)	Saonella	(Ar,Tr,Pt)	Saucrophyllum	(Cn,An,Ru)
Salterites	(Mo,Ce,Ce)	Sapenion	(Ar,Tr,Na)	Saucrothys	(Br,Ar,Or)
Salterocoryphe	(Ar,Tr,Ph)	Sapporipora	(Cn,An,Ta)	Saudia	(Fo,Fo,Fo)
Salterolithus	(Ar,Tr,As)	Saracenaria	(Fo,Fo,Fo)	Saukia	(Ar,Tr,As)
Salteropterus	(Ar,Me,Eu)	Saracenella	(Fo,Fo,Fo)	Saukianda	(Ar,Tr,Re)
Salterospira	(Mo,Ga,Ar)	Sarasinella	(Mo,Ce,Am)	Saukiandops	(Ar,Tr,Re)
Saltocuma	(Mo,Bi,Ve)	Saraswati	(Fo,Fo,Fo)	Saukiella	(Ar,Tr,As)
Saltovskajina	(Fo,Fo,Fo)	Saratogia	(Ar,Tr,As)	Saukioides	(Ar,Tr,As)
Salumniphocaena	(Cd,Ma,Ce)	Sarcinella	(An,Po,Se)	Saukrodictya	(Br,Ar,Or)
Salvadorea	(Cn,An,Ru)	Sarcinula	(Cn,An,Ta)	Saulella	(Mo,Bi,Ve)
Salvelinus	(Cd,Os,Sa)	Sarcionata	(An,Po,Un)	Saumella	(Ar,Os,Po)
Salzburgia	(Po,De,Pe)	Sarcopriion	(Cd,Ch,Eu)	Saurichthyes	(Cd,Os,Pe)
Samacar	(Mo,Bi,Ar)	Sarcosuchus	(Cd,Re,Cr)	Saurida	(Cd,Os,Al)
Samarella	(Ar,Os,Pa)	Sarda	(Cd,Os,Pf)	Saurocephalus	(Cd,Os,Pe)
Samaria	(Bz,St,Fe)	Sardaspis	(Ar,Tr,Re)	Saurocetus	(Cd,Ma,Ce)
Samarites	(Mo,Cr,Te)	Sardesonina	(Bz,St,Fe)	Saurodon	(Cd,Os,Pe)
Sambremeusapis	(Ar,Tr,Ph)	Sardina	(Cd,Os,Cl)	Sauropsis	(Cd,Os,Pe)
Samlandaster	(Ec,Ec,Cl)	Sardinella	(Cd,Os,Cl)	Saurorhamphus	(Cd,Os,Al)
Samoilovaella	(Ar,Os,Pa)	Sardinus	(Cd,Os,My)	Saurorhynchus	(Cd,Os,Su)
Sampo	(Br,Ar,St)	Sardinocrinus	(Ec,Cr,Cl)	Saurosphargis	(Cd,Re,Pl)

Saurostomus	(Cd.Os.Pc)	Scanipisthia	(Ar.Os.Pa)	Scheielloides	(Po.De.Li)
Sauvagesia	(Mo.Bi.Hi)	Scanirmis	(Cd.Av.In)	Schellwienella	(Br.Ar.St)
Savagesia	(Br.Ar.Pe)	Scanisaurus	(Cd.Re.Ps)	Scherochorella	(Fo.Fo.Fo)
Savagella	(Ec.Ed.Ls)	Scanochiton	(Mo.Po.Pa)	Schilderia	(Mo.Ga.Nt)
Savagellites	(Ar.Os.Pa)	Scapanorhynchus	(Cd.Ch.La)	Schimperella	(Ar.Mi.Lo)
Savageoceras	(Mo.Ce.Ba)	Scaphamites	(Mo.Ce.Am)	Schindewolfia	(Cn.An.Ru)
Saviniaster	(Ec.Ec.Sp)	Scaphander	(Mo.Ga.Ce)	Schindewolfites	(Mo.Ce.Am)
Savignyella	(Bz.Gy.Ch)	Scapharca	(Ar.Os.Ar)	Schindewolfoceras	(Mo.Ce.An)
Sawkinsia	(Mo.Bi.Ve)	Scapharina	(Br.Ar.St)	Schiosia	(Mo.Bi.Hi)
Saxellacythere	(Ar.Os.Po)	Scaphechinus	(Ec.Ec.Cl)	Schischatella	(Bz.St.Un)
Saxicavella	(Mo.Bi.My)	Scaphelasma	(Br.Li.Ac)	Schischkatella	(Bz.St.Fe)
Saxidomus	(Mo.Bi.Ve)	Scaphella	(Mo.Ga.Ne)	Schismopora	(Bz.Gy.Ch)
Saxoceras	(Mo.Ce.Am)	Scaphellina	(Mo.Bi.Tr)	Schismoporella	(Bz.Gy.Ch)
Saxolucina	(Mo.Bi.Ve)	Scaphellopsis	(Mo.Ga.Ne)	Schistacanthopora	(Bz.Gy.Ch)
Saynella	(Mo.Ce.Am)	Scaphignathus	(Cd.Co.Co)	Schistocephalus	(Ar.Tr.Re)
Saynoceras	(Mo.Ce.Am)	Scaphina	(Ar.Os.Pa)	Schistoceras	(Mo.Ce.Go)
Saynospongia	(Po.He.He)	Scaphiocoelia	(Br.Ar.Te)	Schistochonetes	(Br.Ar.St)
Scabbardella	(Cd.Co.Co)	Scaphites	(Mo.Ce.Am)	Schistocrinus	(Ec.Cr.Cl)
Scabrella	(Mo.Ga.Ne)	Scaphitoides	(Mo.Ce.Am)	Schistodictyon	(Po.De.St)
Scabricola	(Mo.Ga.Ne)	Scaphium	(Ar.Os.Po)	Schistometopos	(An.Po.Eu)
Scabriculocypris	(Ar.Os.Po)	Scaphogonia	(Mo.Bi.Tr)	Schistometingus	(Ar.Tr.Un)
Scabriscuttellum	(Ar.Tr.Co)	Scaphorella	(Mo.Bi.Tr)	Schistophylloceras	(Mo.Ce.Ph)
Scabrotrigonia	(Mo.Bi.Tr)	Scaphorthis	(Br.Ar.Or)	Schizambon	(Br.Li.Ac)
Scacchia	(Mo.Bi.Ve)	Scaphotrigonia	(Mo.Bi.Tr)	Schizaropsis	(Bz.Gy.Ch)
Scacchinella	(Br.Ar.St)	Scaptodiadema	(Ec.Ec.Or)	Schizaster	(Ec.Ec.Sp)
Scaeochlamys	(Mo.Bi.Pt)	Scarburgiceras	(Mo.Ce.Am)	Schizaechinus	(Ec.Ec.Ec)
Scaeoella	(Mo.Bi.Nu)	Scarificatina	(Fo.Fo.Fo)	Schizemiella	(Bz.Gy.Ch)
Scaeovogyra	(Mo.Pa.Hy)	Scarrisaurus	(Cd.Re.Ps)	Schizobasis	(Mo.Ga.Nt)
Scaevola	(Mo.Ga.Ar)	Scarus	(Cd.Os.Pf)	Schizobathysella	(Bz.Gy.Ch)
Scagliaster	(Ec.Ec.Hs)	Scatophagus	(Cd.Os.Pf)	Schizoblastus	(Ec.Bl.Sp)
Scala	(Mo.Ga.Nt)	Sceletonia	(Br.Ar.St)	Schizobolus	(Br.Li.Ac)
Scalaetrochus	(Mo.Ga.Ar)	Scenella	(Mo.He.He)	Schizobrachiella	(Bz.Gy.Ch)
Scalanago	(Cd.Os.An)	Scenellopora	(Bz.St.Cy)	Schizocardita	(Mo.Bi.Ve)
Scalaria	(Mo.Ga.Nt)	Scenellopsis	(Mo.In.In)	Schizochiton	(Mo.Po.Ne)
Scalariocardita	(Mo.Bi.Ve)	Scenesia	(Br.Ar.Sp)	Schizoclymenia	(Mo.Ce.Cl)
Scalariogyra	(Cn.An.Sc)	Scenophyllum	(Cn.An.Ru)	Schizoecrania	(Br.Li.Ac)
Scalariopora	(Bz.St.Cy)	Sceptaspis	(Ar.Tr.Ph)	Schizoerinus	(Ec.Cr.Mo)
Scalariites	(Mo.Ce.Am)	Sceptiocythereis	(Ar.Os.Po)	Schizocystis	(Ec.Rh.Rh)
Scaloronoba	(Mo.Ga.Nt)	Sceptrites	(Mo.Ce.Or)	Schizocythere	(Ar.Os.Po)
Scalaspira	(Mo.Ga.Ne)	Sceptropora	(Bz.St.Cr)	Schizodelphis	(Cd.Ma.Ce)
Scaldia	(Mo.Bi.Ph)	Sceptrum	(Mo.Ga.Ne)	Schizodiscus	(Ar.Un.Un)
Scaldianella	(Ar.Os.Pa)	Schachriomonia	(Br.Ar.At)	Schizodus	(Mo.Bi.Tr)
Scaldicetus	(Cd.Ma.Si)	Schackoia	(Fo.Fo.Fo)	Schizogonium	(Mo.Ga.Ar)
Scalenocystites	(Ec.Hs.So)	Schackoimella	(Fo.Fo.Fo)	Schizograpus	(He.Gr.Gr)
Scalenostoma	(Mo.Ga.Nt)	Schadefussdurus	(Ac.Ra.Na)	Schizolites	(Po.De.Ta)
Scalina	(Mo.Ga.Nt)	Schalhaeutlia	(Mo.Bi.Ve)	Schizolopha	(Mo.Ga.Ar)
Scaliognathus	(Cd.Co.Co)	Schagonaria	(Ar.Tr.Re)	Schizomavella	(Bz.Gy.Ch)
Scaliola	(Mo.Ga.Nt)	Schalidomorthis	(Br.Ar.Or)	Schizomena	(Br.Ar.Or)
Scalites	(Mo.Ga.Eu)	Schallreuteria	(Ar.Os.Pa)	Schizopea	(Mo.Ga.Ar)
Scalitina	(Mo.Ga.Ar)	Schallreuterina	(Ar.Os.Ar)	Schizophaulactis	(Cn.An.Ru)
Scalituba	(Mo.Ga.Nt)	Scharkovaelites	(Cn.An.Ta)	Schizophillipsia	(Ar.Tr.Pr)
Scalpellirhynchia	(Br.Ar.Rh)	Schartymites	(Mo.Ce.Go)	Schizopholis	(Br.Li.Ac)
Scalpellodus	(Cd.Co.Co)	Scharyia	(Ar.Tr.Pr)	Schizophorella	(Br.Ar.Or)
Scalpellum	(Ar.Ci)	Schaumellus	(Ac.Ra.Na)	Schizophoria	(Br.Ar.Or)
Scalpomactra	(Mo.Bi.Ve)	Schedehalysites	(Cn.An.Ta)	Schizophonites	(Cn.An.Ta)
Scalptia	(Mo.Ga.Ne)	Schedexocrinus	(Ec.Cr.Cl)	Schizopneustes	(Ec.Ec.Sp)
Scalptina	(Ar.Os.Me)	Schedocardia	(Mo.Bi.Ve)	Schizoporella	(Bz.Gy.Ch)
Scambocris	(Br.Un.Un)	Schedophilus	(Cd.Os.Pf)	Schizoporellopsis	(Bz.Gy.Ch)
Scamboscamma	(Mo.In.In)	Schedophylla	(Br.Ar.St)	Schizoproboscina	(An.Po.Un)
Scambula	(Mo.Bi.Ve)	Schedotrapezium	(Mo.Bi.Ve)	Schizoproetina	(Ar.Tr.Pr)
Scammatocrinus	(Ec.Cr.Cl)	Schegultania	(Br.Ar.Pe)	Schizoproetoides	(Ar.Tr.Pr)
Scamnomena	(Br.Ar.St)	Scheia	(Po.De.Li)	Schizoprotus	(Ar.Tr.Pr)
Scandonea	(Fo.Fo.Fo)	Scheibnerova	(Fo.Fo.Fo)	Schizoramma	(Br.Ar.Or)
Scanilepis	(Cd.Os.Pa)	Scheiella	(Po.De.Li)	Schizorelepora	(Bz.Gy.Ch)

Schizorhiza	(Cd,Ch,Rj)	Schwagerispira	(Br,Ar,Sp)	Scomberesox	(Cd,Os,Be)
Schizoria	(Br,Ar,Rh)	Schwandorfia	(Mo,Ce,Am)	Scomberoides	(Cd,Os,Pf)
Schizorthosecos	(Bz,Gy,Ch)	Schwarzziella	(Mo,Ga,Nt)	Scomberomorus	(Cd,Os,Pf)
Schizosmilgia	(Cn,An,Sc)	Schwegleria	(Mo,Ce,Be)	Scombramphodon	(Cd,Os,Pf)
Schizosmillopsis	(Cn,An,Sc)	Schweyerina	(Ar,Os,Pa)	Scombrinus	(Cd,Os,Pf)
Schizosmittina	(Bz,Gy,Ch)	Schyilaspis	(Ar,Tr,Pt)	Scombroclopea	(Cd,Os,Cl)
Schizospirifer	(Br,Ar,Sp)	Sciadiocapsa	(Ac,Ra,Na)	Scombrops	(Cd,Os,Pf)
Schizosteus	(Cd,Pt,Pt)	Sciadiocrinus	(Ec,Cr,Cl)	Scombrosarda	(Cd,Os,Pf)
Schizostomella	(Bz,Gy,Ch)	Sciaena	(Cd,Os,Pf)	Scombrosphyraena	(Cd,Os,Pf)
Schizostrophina	(Br,Ar,Pe)	Sciaenops	(Cd,Os,Pf)	Sconsia	(Mo,Ga,Nt)
Schizostylus	(Ar,Tr,Ph)	Sciaenurus	(Cd,Os,Pf)	Scopelarchus	(Cd,Os,Au)
Schizotheca	(Bz,Gy,Ch)	Scianenuropsis	(Cd,Os,Br)	Scopelochasmops	(Ar,Tr,Ph)
Schizotremites	(Ec,BI,Sp)	Scillaelepas	(Ar,Ci)	Scopelogadus	(Cd,Os,Br)
Schizotremopora	(Bz,Gy,Ch)	Scinocephalus	(Ar,Tr,As)	Scopeloides	(Cd,Os,St)
Schizotreta	(Br,Li,Ac)	Scintilla	(Mo,Bi,Ve)	Scopelopsis	(Cd,Os,My)
Schizotretoides	(Br,Li,Ac)	Scintillona	(Mo,Bi,Ve)	Scopelosaurus	(Cd,Os,Au)
Schleesha	(Ar,Os,Po)	Sciophyllum	(Cn,An,Ru)	Scophthalmus	(Cd,Os,Pn)
Schloenbachia	(Mo,Ce,Am)	Sciotopirion	(An,Po,Eu)	Scoptonodus	(Pr,Un,In)
Schlosserina	(Fo,Fo,Am)	Scipionis	(Ar,Os,Pa)	Scorbinidola	(Mo,Ga,Un)
Schlotheimia	(Mo,Ce,Am)	Sciponoceras	(Mo,Ce,Am)	Scorpaena	(Cd,Os,Sc)
Schlotheimophyllum	(Cn,An,Ru)	Scissicosta	(Br,Ar,St)	Scorpaenichthys	(Cd,Os,Sc)
Schlueteria	(Ar,MI,De)	Scissotheca	(Pr,Un,In)	Scorpiodina	(Bz,Gy,Ch)
Schlueteriphyllum	(Cn,An,Ru)	Scissula	(Mo,Bi,Ve)	Scotiocrinus	(Ec,Cr,Cl)
Schlueterometra	(Ec,Cr,Cm)	Scissulina	(Mo,Bi,Ve)	Scotiacystis	(Ec,St,Co)
Schlumbergerella	(Fo,Fo,Fo)	Scissuradentalium	(Mo,Sc,Sc)	Scoticardioceras	(Mo,Ce,Am)
Schlumbergites	(Ec,Ho,De)	Scissurella	(Mo,Ga,Ar)	Scotiella	(Ar,Tr,Ph)
Schmalenseieia	(Ar,Tr,Pt)	Scissurona	(Mo,Ga,Ar)	Scotocrinus	(Ec,Cr,Rv)
Schmidtia	(Fo,Fo,Fo)	Scitilla	(Mo,Bi,Ve)	Scotoharpes	(Ar,Tr,Pt)
Schmidtella	(Ar,Os,Pa)	Scleracanthus	(Cd,Os,Co)	Scribroporella	(Po,Ca,Un)
Schmidtellus	(Ar,Tr,Ol)	Scleritoderma	(Po,De,Li)	Scriinium	(Mo,Ga,Ne)
Schmidtillites	(Cn,An,Ta)	Sclerochilus	(Ar,Os,Po)	Scrobicula	(Ar,Os,Pa)
Schmidtites	(Br,Li,Li)	Sclerocoelia	(Po,De,Ta)	Scrobiculabra	(Mo,Bi,Ve)
Schmidtoceras	(Mo,Ce,En)	Scleroocrinus	(Ec,Cr,Cy)	Scrobisylthis	(Ar,Os,Pa)
Schmidtocrinus	(Ec,Cr,Cl)	Sclerocyathus	(Po,Re,Aj)	Scrobs	(Mo,Ga,Nt)
Schmidtognathus	(Cd,Co,Co)	Sclerodus	(Cd,Ce,Ce)	Srtella	(Bz,Gy,Ch)
Schneideria	(Ar,Os,Po)	Sclerokalia	(Po,He,Ly)	Scruparia	(Bz,Gy,Ch)
Schnurella	(Br,Ar,Rh)	Sclerophyllum	(Cn,An,Ru)	Scrupocellaria	(Bz,Gy,Ch)
Schoenaster	(Ec,Op,Oe)	Scleroplegma	(Po,He,Ly)	Scrupus	(Mo,Ga,Nt)
Schoenophyllum	(Cn,An,Ru)	Sclerorhynchus	(Cd,Ch,Rj)	Scruttonia	(Cn,An,Ru)
Schoharia	(Ar,Tr,Ph)	Sclerosmilia	(Cn,An,Sc)	Sculda	(Ar,MI,St)
Schondorfia	(Ec,As,Pu)	Sclerostyla	(An,Po,Se)	Sculptella	(Ar,Tr,As)
Schopodus	(Cd,Co,Co)	Sclerothamnopsis	(Po,He,He)	Sculptobaculites	(Fo,Fo,Fo)
Schoriecare	(Ar,Tr,Pt)	Sclerothupites	(Ec,Ho,Un)	Sculptoproetus	(Ar,Tr,Pr)
Schoriella	(Ar,Tr,Pt)	Scydolithus	(Cn,An,Sc)	Sculptospirifer	(Br,Ar,Sp)
Schrammeniella	(Po,De,Li)	Scobinella	(Mo,Ga,Ne)	Sculpturea	(Mo,Ga,Nt)
Schrenckia	(Ar,Os,Le)	Scobinodola	(Mo,Ga,Ce)	Scumulus	(Br,Ar,Te)
Schrenkiella	(Br,Ar,St)	Scobinopholas	(Mo,Bi,My)	Scurria	(Mo,Ga,Pa)
Schreteria	(Cn,An,Ru)	Scofieldia	(Ar,Os,Pa)	Scurriopsis	(Mo,Ga,Pa)
Schreteriella	(Ar,Ci)	Scofieldoceras	(Mo,Ce,On)	Scutarcopagia	(Mo,Bi,Ve)
Schroederoceras	(Mo,Ce,Ta)	Scolecchinus	(Ec,Ec,Te)	Scutaster	(Ec,Ec,Cl)
Schubertella	(Fo,Fo,Fo)	Scolecicellus	(Pr,Un,Hy)	Scutatesstomaconus	(Mo,In,In)
Schuchertella	(Br,Ar,St)	Scolecoderma	(An,Po,Te)	Scutella	(Ec,Ec,Cl)
Schuchertellopsis	(Br,Ar,St)	Scolecofura	(Pa)	Scutellaster	(Ec,Ec,Cl)
Schuchertia	(Ec,As,Pl)	Scolecocia	(Po,He,Ly)	Scutellastra	(Mo,Ga,Pa)
Schuchertina	(Br,Un,Ku)	Scoliechinus	(Ec,Ec,Te)	Scutellina	(Ec,Ec,Cl)
Schuchertoceras	(Mo,Ce,As)	Scolioocrinus	(Ec,Cr,Cl)	Scutellinoides	(Ec,Ec,Cl)
Schuchertoecystis	(Ec,Pe,Co)	Scolioecystis	(Ec,Rh,Rh)	Scutellum	(Ar,Tr,Co)
Schugurocaris	(Ar,MI,Ar)	Scoliopora	(Cn,An,Ta)	Scuteupstula	(Br,Ar,St)
Schuichengoceras	(Mo,Ce,Go)	Scolioraphis	(Po,De,As)	Scuticella	(Bz,Gy,Ch)
Schuleridea	(Ar,Os,Po)	Scoliostoma	(Mo,Ga,At)	Scutulium	(Ec,Ec,Cl)
Schulgina	(Bz,St,Tr)	Scolococoncha	(Br,Ar,St)	Scutus	(Mo,Ga,Ar)
Schultzicrinus	(Ec,Cr,Cl)	Scolopodus	(Cd,Co,Co)	Scyllorhinus	(Cd,Ch,Ca)
Schumyicyathus	(Po,Re,Aj)	Scolymia	(Cn,An,Sc)	Scylla	(Ar,MI,De)
Schwagerina	(Fo,Fo,Fo)	Scomber	(Cd,Os,Pf)	Scyllarella	(Ar,MI,De)

Scyllarides	(Ar,Ml,De)	Selenariopsis	(Bz,Gy,Ch)	Semicytella	(Bz,St,Ce)
Scyllarus	(Ar,Ml,De)	Selenaspis	(Cd,Os,Si)	Semicytheretta	(Ar,Os,Po)
Scylliodus	(Cd,Ch,Ca)	Seleneceme	(Ar,Tr,As)	Semicytheridea	(Ar,Os,Po)
Scymnodon	(Cd,Ch,Sq)	Selenegyra	(Cn,An,Sc)	Semicytherura	(Ar,Os,Po)
Scymnorhinus	(Cd,Ch,Sq)	Selenella	(Br,Ar,Te)	Semicythis	(Bz,St,Ce)
Scyphioma	(Ac,Ra,Na)	Selenimyalina	(Mo,Bi,Pt)	Semidisticophyllum	(Cn,An,Sc)
Scyphiodus	(Cd,Co,Co)	Selenisca	(Ar,Ml,De)	Semielea	(Bz,St,Cc)
Scyphoceras	(Mo,Ce,Na)	Selennjachia	(Br,Ar,Rh)	Semiellipithoecha	(Hy,Or,Or)
Scyphocodon	(Fo,Fo,Fo)	Selenoceras	(Mo,Ce,Di)	Semiendothyra	(Fo,Fo,Fo)
Scyphoconcha	(Mo,Bi,Nu)	Selenoharpes	(Ar,Tr,Pt)	Semierycina	(Mo,Bi,Ve)
Scyphocrinites	(Ec,Cr,Mo)	Selenopeltis	(Ar,Tr,Od)	Semieschara	(Bz,Gy,Ch)
Scyphophyllum	(Cn,An,Ru)	Selenopeltoides	(Ar,Tr,Od)	Semiescharinella	(Bz,Gy,Ch)
Scyphopodium	(Cn,An,St)	Selenoplax	(Pr,Un,In)	Semifascipora	(Bz,St,Cc)
Scyra	(Ar,Ml,De)	Selenopora	(Bz,St,Cy)	Semifenestella	(Bz,St,Fe)
Scytalia	(Po,De,Li)	Selenosteus	(Cd,Pl,Ar)	Semiformiceras	(Mo,Ce,Am)
Scytalocrinus	(Ec,Cr,Cl)	Seletella	(Ar,Tr,Pt)	Semifungella	(Bz,St,Cc)
Scythemtolium	(Mo,Bi,Pt)	Seletinicus	(Pr,Un,In)	Semihasswellia	(Bz,Gy,Ch)
Scythilocolina	(Fo,Fo,Fo)	Seletoides	(Ar,Tr,Pt)	Semihelidioides	(Ar,Os,Me)
Scythophyma	(Po,De,Li)	Selindeochrea	(Tr,An)	Semiinvoluta	(Fo,Fo,Fo)
Seabrookia	(Fo,Fo,Fo)	Seliscotho	(Po,De,Li)	Semikiesowia	(Ar,Os,Pa)
Searlesia	(Mo,Ga,Ne)	Selkirkia	(Pa)	Semilaterotubigera	(Bz,St,Cc)
Sebargasia	(Po,De,Pe)	Selkirkoceras	(Mo,Ce,Ac)	Semileptagonia	(Br,Ar,St)
Sebastes	(Cd,Os,Sc)	Sellaclymenia	(Mo,Ce,Cl)	Semilingula	(Br,Li,Li)
Sebastinus	(Cd,Os,Sc)	Sellaea	(Mo,Bi,Hi)	Semilukiella	(Ar,Os,Pa)
Sebastodes	(Cd,Os,Sc)	Sellagoniatites	(Mo,Ce,An)	Semimodiola	(Mo,Bi,Mt)
Sebastoessus	(Cd,Os,Sc)	Sellanarcestes	(Mo,Ce,An)	Semimultiea	(Bz,St,Cc)
Sechurina	(Mo,Bi,Ve)	Sellardiscerinus	(Ec,Cr,Cl)	Semimulticaeva	(Bz,St,Cc)
Sectiarcia	(Mo,Bi,Ar)	Sellinema	(Mo,Ga,Ar)	Seminulteriersis	(Bz,St,Cc)
Sectigena	(Ar,Tr,Re)	Sellithyris	(Br,Ar,Te)	Seminoritina	(Mo,Ga,Ar)
Sectipecten	(Mo,Bi,Pt)	Selloproductus	(Br,Ar,St)	Seminodiresciscis	(Bz,St,Cc)
Secuiofoliata	(Ac,Ra,Sp)	Sellula	(Ar,Os,Ar)	Seminola	(Mo,Ga,Ne)
Securella	(Mo,Bi,Ve)	Selmasaurus	(Cd,Re,Sq)	Seminolites	(Ar,Os,Me)
Securiconus	(Mo,He,He)	Selon	(Ar,Os,Pa)	Seminovella	(Fo,Fo,Fo)
Securina	(Br,Ar,Te)	Selwynoceras	(Mo,Ce,Am)	Seminucella	(Br,Ar,St)
Securithyris	(Br,Ar,Te)	Semaestomites	(Cn,Sc,Se)	Seminula	(Br,Ar,Rh)
Sedenhorstia	(Cd,Os,Me)	Semahana	(Mo,Ga,Ne)	Semiometra	(Ec,Cr,Cm)
Sedenticellula	(Br,Ar,Rh)	Semantrum	(Ac,Ra,Na)	Semionotus	(Cd,Os,Se)
Sedgwickia	(Mo,Bi,Ph)	Sematheos	(Cn,An,Sc)	Semiopora	(Bz,St,Cy)
Sediliopsis	(Mo,Ga,Ne)	Semelangulus	(Mo,Bi,Ve)	Semiortites	(Mo,Ce,Ce)
Sedjulina	(Br,Ar,Sp)	Semele	(Mo,Bi,Ve)	Semiotoechia	(Br,Ar,Rh)
Seebachia	(Mo,Bi,Ve)	Semefina	(Mo,Bi,Ve)	Semipallium	(Mo,Bi,Pt)
Seefeldia	(Cd,Os,Pc)	Semeloidea	(Mo,Bi,Ve)	Semipetalion	(Ec,Ec,Sp)
Seelandia	(Bz,St,Cc)	Semeloseris	(Cn,An,Sc)	Semipetatus	(Ar,Os,Pa)
Seeleyosaurus	(Cd,Re,Ps)	Semenewia	(Br,Ar,St)	Semipirum	(Mo,Ga,Ne)
Seelya	(Mo,Ga,Ar)	Semenola	(Cn,Me,Me)	Semiplanella	(Br,Ar,St)
Seelyoceras	(Mo,Ce,Ta)	Semenovites	(Mo,Ce,Am)	Semiplanus	(Br,Ar,St)
Seendia	(Mo,Bi,Ve)	Semiacontiodus	(Cd,Co,Co)	Semiplectograptus	(He,Gr,Gr)
Segdianophyllum	(Cn,An,Ru)	Semiactaeon	(Mo,Ga,Ce)	Semiproductus	(Br,Ar,St)
Segmentagnostus	(Ar,Tr,Ag)	Semibalanus	(Ar,Ci)	Semiranina	(Ar,Ml,De)
Segmina	(Ar,Os,Po)	Semibittium	(Mo,Ga,Nt)	Semirosalina	(Fo,Fo,Fo)
Seguenzia	(Mo,Ga,Ar)	Semibolbina	(Ar,Os,Pa)	Semiserpula	(An,Po,Se)
Seguenziella	(Bz,St,Cc)	Semibrachythyria	(Br,Ar,Sp)	Semisolarium	(Mo,Ga,He)
Seila	(Mo,Ga,Nt)	Semicassis	(Mo,Ga,Nt)	Semistylifer	(Mo,Ga,Nt)
Seiocrinis	(Ec,Cr,Is)	Semicea	(Bz,St,Cc)	Semiterebellum	(Mo,Ga,Nt)
Seisa	(Mo,Ga,Ar)	Semichitinoidella	(Ci,In,Ca)	Semitetularia	(Fo,Fo,Fo)
Seisonia	(Ar,Tr,Ph)	Semicinctipora	(Bz,St,Cc)	Semitreta	(Br,Li,Ac)
Sekobolla	(Ar,Os,Pa)	Semiclausa	(Bz,St,Cc)	Semitriton	(Mo,Ga,Nt)
Sektionites	(Mo,Cr,Te)	Semicorallidomus	(Mo,Bi,Mo)	Semitrivia	(Mo,Ga,Nt)
Sekwia	(Cn,Cy,Cy)	Semicorbula	(Mo,Bi,My)	Semitubigera	(Bz,St,Cc)
Sekwiaspis	(Ar,Tr,Un)	Semicoscium	(Bz,St,Fe)	Semitubina	(Mo,Ga,Ar)
Sekwicyathus	(Po,Re,Aj)	Semicostella	(Br,Ar,St)	Semityphis	(Mo,Ga,Ne)
Selar	(Cd,Os,Pl)	Semicyclocephalus	(Ar,Tr,Pt)	Semivalvulina	(Fo,Fo,Fo)
Selebratina	(Ar,Os,Pl)	Semicyclus	(Mo,Cr,Te)	Semivertagus	(Mo,Ga,Nt)
Selenaria	(Bz,Gy,Ch)	Semicypraea	(Mo,Ga,Nt)	Semperella	(Po,He,Am)

Semperia	(Mo,Ga,Ar)	Seranella	(Po,De,Pe)	Sestrodiclyon	(Po,He,He)
Semperites	(Ec,Ho,Un)	Serania	(Mo,Bi,Pt)	Sestronophora	(Fo,Fo,Fo)
Semuridia	(Mo,Bi,Pt)	Seraphis	(Mo,Ga,Nt)	Sestrophyllyum	(Cn,An,Ru)
Senalveolina	(Fo,Fo,Fo)	Seratrypa	(Br,Ar,At)	Sestropoma	(Br,Ar,St)
Senarioerinus	(Ec,Cr,Ds)	Serbarinia	(Br,Ar,St)	Sestrostomella	(Po,Ca,Ph)
Sendaitrysis	(Br,Ar,Te)	Serbiarhynchia	(Br,Ar,Rh)	Setaspis	(Ar,Me,Ag)
Senilia	(Mo,Bi,Ar)	Serbiothyris	(Br,Ar,Te)	Sethocapsa	(Ac,Ra,Na)
Senis	(Mo,Bi,Ve)	Serendipocrinus	(Ec,Cr,Ds)	Sethochytris	(Ac,Ra,Na)
Senokosica	(Br,Ar,Te)	Serenida	(Ar,Os,Pa)	Sethocytris	(Ac,Ra,Na)
Senowbaridaryana	(Po,De,Pe)	Seretaspis	(Cd,Pt,Pt)	Sethodiscinus	(Ac,Ra,Sp)
Senticucullus	(Ar,Tr,Un)	Seretites	(Mo,Cr,Te)	Sethodiscus	(Ac,Ra,Na)
Sentinella	(Po,De,Un)	Sergaelites	(Po,De,St)	Sethopera	(Ac,Ra,Na)
Sentolunia	(Br,Ar,St)	Sergipella	(Ar,Os,Po)	Sethopium	(Ac,Ra,Na)
Sentosia	(Br,Ar,St)	Sergipia	(Mo,Bi,Pt)	Sethostaurus	(Ac,Ra,Sp)
Sentosoioides	(Br,Ar,St)	Sergospirifer	(Br,Ar,Sp)	Sethostylus	(Ac,Ra,Sp)
Sentularia	(Mo,Ga,Nt)	Sergunkovia	(Br,Ar,Sp)	Setigerites	(Br,Ar,St)
Separocrinus	(Ec,Cr,Cl)	Seriastraea	(Cn,An,Sc)	Setosella	(Bz,Gy,Ch)
Sepia	(Mo,Ce,Se)	Seriatopora	(Cn,An,Sc)	Setosellina	(Bz,Gy,Ch)
Septa	(Mo,Ga,Nt)	Sericoidea	(Br,Ar,St)	Setosinella	(Bz,Gy,Ch)
Septabrunkiina	(Fo,Fo,Fo)	Serietubigera	(Bz,St,Cc)	Setotrigonia	(Mo,Bi,Tr)
Septacamera	(Br,Ar,Rh)	Seriola	(Cd,Os,Pl)	Settedabanina	(Br,Ar,Sp)
Septachonetes	(Br,Ar,St)	Seriopora	(Bz,St,Fe)	Settsassia	(Mo,Ga,Nt)
Septadella	(Ar,Os,Ar)	Seriphis	(Cd,Os,Pf)	Seumaster	(Ec,Ec,Hs)
Septaforschia	(Fo,Fo,Fo)	Serksia	(Ar,Tr,Un)	Sevanella	(Mo,Ga,Ce)
Septagathammina	(Fo,Fo,Fo)	Serksioides	(Ar,Tr,Un)	Severella	(Br,Ar,Pe)
Septalaria	(Br,Ar,Rh)	Serovaina	(Fo,Fo,Fo)	Severginella	(Br,Ar,Or)
Septalariopsis	(Br,Ar,Rh)	Serpentiopora	(Bz,St,Cc)	Severobolbina	(Ar,Os,Pa)
Septaliphoria	(Br,Ar,Rh)	Serpentubina	(Mo,Ga,Ar)	Severopsis	(Ar,Os,Pa)
Septaliphorioides	(Br,Ar,Rh)	Serpentula	(An,Po,Se)	Seviculina	(Ar,Os,Pa)
Septamphiclina	(Br,Ar,Sp)	Serpenulina	(Fo,Fo,Fo)	Sevillia	(Ar,Tr,Pr)
Septapernella	(Br,Ar,St)	Serpianites	(Mo,Ce,Ce)	Sewardoceras	(Mo,Ce,En)
Septarinia	(Br,Ar,St)	Serpianosaurus	(Cd,Re,No)	Sexta	(Mo,Bi,Ve)
Septasteges	(Br,Ar,St)	Serpianotiarius	(Ec,Ec,Ci)	Seymourites	(Mo,Ce,Am)
Septastrea	(Cn,An,Sc)	Serpula	(An,Po,Se)	Seymourisphaera	(Mo,Ga,Ne)
Septathyris	(Br,Ar,Sp)	Serpularia	(An,Po,Se)	Seymourula	(Mo,Bi,Pt)
Septatoechia	(Br,Ar,Rh)	Serpulites	(An,Po,Se)	Shabaella	(Ar,Tr,Co)
Septatopora	(Bz,St,Fe)	Serpulopsis	(Fo,Fo,Fo)	Shabaktiella	(Mo,In,In)
Septatourmayella	(Fo,Fo,Fo)	Serpulorbis	(Mo,Ga,Nt)	Shafferia	(Ar,Un,Un)
Septatrypa	(Br,Ar,At)	Serpulospira	(Mo,Ga,Eu)	Shagamella	(Br,Ar,St)
Septemchiton	(Mo,Po,Pa)	Serracaris	(Ar,Un,Un)	Shakraceras	(Mo,Ce,Am)
Septemirostellum	(Br,Ar,Rh)	Serramanticoceras	(Mo,Ce,An)	Shalera	(Br,Ar,St)
Septentrionites	(Cn,An,Ta)	Serranopsis	(Cd,Os,Pl)	Shaliella	(Br,Ar,St)
Septeuilia	(Mo,Bi,Ve)	Serranus	(Cd,Os,Pf)	Shamattawaceras	(Mo,Ce,As)
Septiconcha	(Br,Ar,St)	Serrata	(Mo,Ga,Ne)	Shanghaia	(Ar,Tr,Co)
Septifer	(Mo,Bi,Mt)	Serratifusus	(Mo,Ga,Ne)	Shanghaiaspis	(Ar,Tr,Co)
Septiferina	(Ar,Os,Po)	Serratina	(Mo,Bi,Ve)	Shangraoceras	(Mo,Ce,Go)
Septigerina	(Fo,Fo,Fo)	Serratocerithium	(Mo,Ga,Nt)	Shangtungia	(Ar,Tr,Pt)
Septihoernesia	(Mo,Bi,Pt)	Serratocrista	(Br,Ar,St)	Shanina	(Mo,Bi,Pr)
Septimyalina	(Mo,Bi,Pt)	Serratodus	(Cd,Ch,Pe)	Shaninopsis	(Mo,Bi,Mt)
Septirhynchia	(Br,Ar,Rh)	Serratognathus	(Cd,Co,Co)	Shanita	(Fo,Fo,Fo)
Septiocamarella	(Br,Ar,Rh)	Serratotrochus	(Mo,Ga,Ar)	Shansiella	(Mo,Ga,Ar)
Septocardia	(Mo,Bi,Ve)	Serratula	(An,Po,Eu)	Shansiphyllum	(Cn,An,Ru)
Septochaetetes	(Po,De,Ta)	Serrifusus	(Mo,Ga,Ne)	Shantungaspis	(Ar,Tr,Un)
Septocurella	(Br,Ar,Rh)	Serripecten	(Mo,Bi,Pt)	Shantungendoceras	(Mo,Ce,El)
Septocyclothyrus	(Br,Ar,Rh)	Serripes	(Mo,Bi,Ve)	Shanxipora	(Cn,An,Ta)
Septoparnella	(Br,Ar,Un)	Serrodiscus	(Ar,Tr,Ag)	Shanxitheca	(Pr,Un,In)
Septopora	(Bz,St,Fe)	Serrolepis	(Cd,Os,Se)	Shaoyangoceras	(Mo,Ce,Go)
Septorthis	(Br,Ar,Or)	Serrula	(Mo,Bi,Ve)	Sharpeiceras	(Mo,Ce,Am)
Septospirifer	(Br,Ar,Sp)	Serrulategyra	(Br,Ar,At)	Sharpirhynchia	(Br,Ar,Rh)
Septospirigirella	(Br,Ar,Sp)	Sertella	(Bz,Gy,Ch)	Shastaphyllum	(Cn,An,Ru)
Septosyringothyris	(Br,Ar,Sp)	Servatrina	(Mo,Bi,Mt)	Shastasaurus	(Cd,Re,Ic)
Septothyris	(Br,Ar,De)	Sesarma	(Ar,ML,De)	Shasticoceras	(Mo,Ce,Am)
Septulirhynchia	(Br,Ar,Rh)	Seseloiis	(Br,Ar,St)	Shastoceras	(Mo,Ce,Am)
Sequania	(Mo,Ga,He)	Sestrocladia	(Po,He,Ly)	Shastrina	(Fo,Fo,Fo)

Shatania	(Ar.Tr,Re)	Siberiograpus	(He.Gr,Un)	Sigmakainella	(Ar.Tr,As)
Shearsbyaspis	(Cd.Pl,Pe)	Siberionautilus	(Mo,Ce,Na)	Sigmavirgulina	(Fo,Fo,Fo)
Shelbyoceras	(Mo,Te,Hy)	Siberiothyris	(Br,Ar,Te)	Sigmelmasma	(Br,Ar,Or)
Sheldonella	(Mo,Bi,Ar)	Siberiptychites	(Mo,Ce,Am)	Sigmella	(Fo,Fo,Fo)
Shemonaella	(Ar,Os,Pa)	Siberistrophia	(Br,Ar,St)	Sigmessalia	(Mo,Ga,Nt)
Shengella	(Fo,Fo,Fo)	Sibiratrypa	(Br,Ar,At)	Sigmobolbina	(Ar,Os,Pa)
Shengoceras	(Mo,Ce,Go)	Sibirecyathus	(Po,Re,Aj)	Sigmocheilus	(Ar.Tr,Pt)
Shenjiawanina	(Ar.Tr,Pt)	Sibiredictya	(Bz,St,Cr)	Sigmocoscinus	(Po,Re,Aj)
Shensiella	(Ar,Os,Ar)	Sibiria	(Br,Un,Ob)	Sigmocyathus	(Po,Re,Aj)
Shensiphyllum	(Cn,An,Ru)	Sibiriaspis	(Ar,Tr,Ol)	Sigmocycloceras	(Mo,Ce,Or)
Sherbornina	(Fo,Fo,Fo)	Sibiriobolbina	(Ar,Os,Pa)	Sigmofungia	(Po,Ir,Ar)
Shergoldopsis	(Ar,Os,Ar)	Sibiriodus	(Cd,Co,Co)	Sigmoideella	(Fo,Fo,Fo)
Shickshockia	(Ar,Tr,Pt)	Sibiriolitella	(Cn,An,Ta)	Sigmoihauerina	(Fo,Fo,Fo)
Shidelerites	(Ar,Os,Pa)	Sibiriolites	(Cn,An,Ta)	Sigmoilina	(Fo,Fo,Fo)
Shideleroceras	(Mo,Ce,El)	Sibiriopeltis	(Ar,Tr,Un)	Sigmoilinita	(Fo,Fo,Fo)
Shidianocrinus	(Ec,Cr,Di)	Sibirispira	(Br,Ar,At)	Sigmoilopsis	(Fo,Fo,Fo)
Shifangia	(Ar,Tr,Pt)	Sibiritella	(Ar,Os,Pa)	Sigmomorphina	(Fo,Fo,Fo)
Shikamacirrus	(Mo,Ga,Ar)	Sibirites	(Mo,Ce,Ce)	Sigmoopsis	(Ar,Os,Pa)
Shikamaia	(Mo,Bi,Pt)	Sibiritia	(Ar,Os,Le)	Sigmoosoides	(Ar,Os,Pa)
Shikhanites	(Mo,Ce,Pl)	Sibiritoechia	(Br,Ar,Rh)	Sigmatops	(Ar,Tr,Ph)
Shikhanoceras	(Mo,Ce,Or)	Sibiroctenia	(Mo,Bi,Nu)	Signetopsis	(Ar,Os,Pa)
Shikokuspira	(Mo,Ga,Ar)	Sibyllites	(Mo,Ce,Ce)	Signohealdia	(Ar,Os,Me)
Shimantocrinus	(Ec,Cr,Mo)	Sibyllonautilus	(Mo,Ce,Na)	Sigopallus	(Br,Ar,Or)
Shingyisaurus	(Cd,Re,No)	Sibyrynychus	(Cd,Ch,Ip)	Sigurdia	(Cd,Pt,Un)
Shinteinella	(Pr,Un,In)	Sicanites	(Mo,Ce,Pl)	Sigyus	(Ar,Os,Pa)
Shipaiella	(Ar,Tr,Re)	Sicelia	(Br,Ar,St)	Sikasella	(Br,Ar,Sp)
Shiqiana	(Ar,Tr,Ph)	Sichotenella	(Fo,Fo,Fo)	Siksika	(Cd,Ch,Pe)
Shiquianella	(Br,Ar,St)	Sichuanaceras	(Mo,Ce,Or)	Silberlingites	(Mo,Ce,Ce)
Shiragia	(Br,Ar,Or)	Sichuania	(Mo,Bi,Pt)	Silenella	(Bz,St,Cr)
Shirakiella	(Ar,Tr,Pt)	Sichuanolenus	(Ar,Tr,Pt)	Silenis	(Ar,Os,Me)
Shirbuirnia	(Mo,Ce,Am)	Sichuanospira	(Mo,In,In)	Silenites	(Ar,Os,Pa)
Shirdagopora	(Po,De,St)	Sichuanrhynchis	(Br,Ar,Rh)	Silenopora	(Bz,St,Ce)
Shishaella	(Ar,Os,Pa)	Sichunoceras	(Mo,Ce,Un)	Silenticeras	(Mo,Ce,Ce)
Shishapangmaella	(Br,Ar,St)	Sicelloceras	(Mo,Ce,An)	Silesiaster	(Ec,Op,Op)
Shishoviclema	(Bz,St,Cr)	Sicorhynchia	(Br,Ar,Rh)	Silesiastraea	(Cn,An,Sc)
Shivaella	(Ar,Os,Pa)	Sicularia	(Br,Ar,St)	Silesiathyris	(Br,Ar,Te)
Shivelicus	(Ar,Tr,Ag)	Siculites	(Mo,Ce,Ce)	Silesicaris	(Ar,Th,Co)
Shiveligocyathus	(Po,Ir,Ar)	Siculocosta	(Fo,Fo,Fo)	Silesites	(Mo,Ce,Am)
Shizudiscus	(Ar,Tr,Ag)	Sicyonia	(Ar,Mi,De)	Silesitoides	(Mo,Ce,Am)
Shleesha	(Ar,Os,Pa)	Siderastrea	(Cn,An,Sc)	Silfonocrinus	(Ec,Cr,Di)
Shlyginia	(Br,Ar,St)	Siderocoenia	(Cn,An,Sc)	Silicomassilina	(Fo,Fo,Fo)
Sholacoceras	(Mo,Ce,Na)	Siderocrinus	(Ec,Cr,Di)	Silicosigmoilina	(Fo,Fo,Fo)
Shonisaurus	(Cd,Re,Je)	Siderofungia	(Cn,An,Sc)	Silicotuba	(Fo,Fo,Fo)
Shordolella	(Br,Ar,Pe)	Siderolites	(Fo,Fo,Fo)	Silicunculus	(Po,He,Un)
Shoshonorthis	(Br,Ar,Or)	Sideroseris	(Cn,An,Sc)	Siliesiacrinus	(Ec,Cr,Is)
Shouchangoceras	(Mo,Ce,Go)	Siderosmia	(Cn,An,Sc)	Siliningastraea	(Cn,An,Sc)
Shouguania	(Fo,Fo,Fo)	Sidneyia	(Ar,Mo,Li)	Siliqua	(Mo,Bi,Ve)
Shouxianella	(Br,Li,Li)	Sieberella	(Br,Ar,Pe)	Siliquaria	(Mo,Ga,Nt)
Shrockia	(Br,Ar,At)	Sieberina	(Fo,Fo,Fo)	Siliquimya	(Mo,Bi,Ph)
Shroshaecrinus	(Ec,Cr,Mi)	Siedleckia	(Cn,An,Ru)	Sillaginoides	(Cd,Os,Pl)
Shuguria	(Fo,Fo,Fo)	Siemiradzka	(Mo,Ce,Am)	Sillago	(Cd,Os,Pl)
Shumardella	(Br,Ar,Rh)	Sievertsia	(Ec,Ed,Is)	Siluraemaea	(Mo,Ga,Be)
Shumardia	(Ar,Tr,Pt)	Sigalia	(Fo,Fo,Fo)	Siluraster	(Ec,As,Pu)
Shumardites	(Mo,Ce,Go)	Sigalituncana	(Fo,Fo,Fo)	Silurina	(Mo,Bi,Pr)
Shumardoceras	(Mo,Ce,Ta)	Sigaloceras	(Mo,Ce,Am)	Siluriphorus	(Mo,Ga,Et)
Shumardops	(Ar,Tr,Pt)	Sigambrocrinus	(Ec,Ce,Cl)	Silurocidaris	(Ec,Un)
Shuqraia	(Po,De,Ax)	Siganopygaeus	(Cd,Os,Pl)	Silurozodus	(Mo,Bi,Tr)
Shuranoceras	(Mo,Ce,On)	Sigapatella	(Mo,Ga,Nt)	Silvaseptopora	(Bz,St,Fe)
Shwedagonia	(Mo,Ga,Ar)	Sigaretopsis	(Mo,Ga,Nt)	Silvestriella	(Fo,Fo,Fo)
Shylgapora	(Bz,St,Fe)	Sigaretotrema	(Mo,Ga,Nt)	Silvestrosaurus	(Cd,Re,No)
Siamodus	(Cd,Ch,Co)	Sigatica	(Mo,Ga,Nt)	Simacia	(Mo,Bi,Hi)
Sibertiaspis	(Cd,Pl,Pt)	Sigelophyllum	(Cn,An,Ru)	Simaproetus	(Ar,Tr,Pr)
Siberioceras	(Mo,Ce,Or)	Sigillum	(Ar,Os,Un)	Simardoceras	(Mo,Ce,Dr)
Siberiodendrum	(He,Gr,Un)	Sigmagraptus	(He,Gr,Gr)	Simaspdoceras	(Mo,Ce,Am)

Simbirshiasaurus	(Cd,Re,Ic)	Sinococlonella	(Ar,Os,Pa)	Sinuobactrites	(Mo,Ce,An)
Simbirskites	(Mo,Ce,Am)	Sinocrepecephalus	(Ar,Tr,Pt)	Sinuocornu	(An,Po,Se)
Simeonella	(Ar,Os,Po)	Sinocrinus	(Ar,Os,Pa)	Sinuoepa	(Mo,Ga,Ar)
Simichelloceras	(Ar,Ce,Go)	Sinocybele	(Ar,Tr,Ph)	Sinuospigalia	(Mo,Bi,Ve)
Simicypris	(Ar,Os,Po)	Sinocystis	(Ec,Di,Di)	Sinuosiphylia	(Cn,An,Sc)
Similihariotta	(Cd,Ch,Cm)	Sinocytheridea	(Ar,Os,Po)	Sinuozyga	(Mo,Ga,Nt)
Similipecten	(Mo,Bi,Pt)	Sinodictyon	(Po,De,St)	Sinupetraliella	(Bz,Gy,Ch)
Similivenus	(Mo,Bi,Ve)	Sinodiopsis	(Mo,Bi,Ve)	Sinuplicorhynchia	(Br,Ar,Rh)
Similococoncha	(Mo,Bi,Nu)	Sinodiscus	(Ar,Tr,Ag)	Sinuvella	(Br,Ar,Te)
Similodonta	(Mo,Bi,Nu)	Sinodisphyllum	(Cn,An,Ru)	Sinuspira	(Mo,Ga,Ar)
Simionescella	(Fo,Fo,Fo)	Sinodiversograptus	(He,Gr,Gr)	Sinustomia	(Mo,Ga,He)
Simioceras	(Mo,Ce,Go)	Sinodora	(Mo,Bi,Ph)	Sinustella	(Ar,Os,Po)
Siminia	(Mo,Ga,Nt)	Sinoocrinus	(Ec,Eo,Un)	Sintropis	(Mo,Ga,Eu)
Simobaculites	(Fo,Fo,Fo)	Sinoeremoceras	(Mo,Ce,Pl)	Sinzovia	(Mo,Ce,Am)
Simoceras	(Mo,Ce,Am)	Sinocognathus	(Cd,Os,Am)	Sinzowella	(Fo,Fo,Fo)
Simocosmoceras	(Mo,Ce,Am)	Sinoglossa	(Br,Li,Li)	Sinzowia	(Mo,Ga,Ar)
Sinocrinus	(Ec,Cr,Cl)	Sinograptus	(He,Gr,Gr)	Sipho	(Mo,Ga,Ne)
Simolestes	(Cd,Re,Ps)	Sinoharpes	(Ar,Tr,Pt)	Siphocampe	(Ac,Ra,Na)
Simoliophis	(Cd,Re,Sq)	Sinolebetoeras	(Mo,Ce,El)	Siphocampium	(Ac,Ra,Na)
Simonella	(Ar,MI,De)	Sinolenus	(Ar,Tr,Re)	Siphocypraea	(Mo,Ga,Nt)
Simonyceras	(Mo,Ce,Ph)	Sinoleperditia	(Ar,Os,Le)	Siphodictyum	(Bz,St,Ce)
Simorthoceras	(Mo,Ce,Or)	Sinolepis	(Cd,Pl,An)	Siphogaudryina	(Fo,Fo,Fo)
Simosaurus	(Cd,Re,No)	Sinonia	(Mo,Bi,Ve)	Siphogenerina	(Fo,Fo,Fo)
Simosphinctes	(Mo,Ce,Am)	Sinonicus	(Cd,Os,Pa)	Siphogenerinoides	(Fo,Fo,Fo)
Simotoichites	(Mo,Ce,Am)	Sinonovacula	(Mo,Bi,Ve)	Siphoglobulina	(Fo,Fo,Fo)
Simplexovalina	(Fo,Fo,Fo)	Sinoparapilekia	(Ar,Tr,Ph)	Siphogonuchites	(Pr,Co,Sh)
Simplexodictyon	(Po,De,St)	Sinopetaloblastus	(Ec,Bi,Sp)	Siphogrammysia	(Mo,Bi,Ph)
Simplicarina	(Br,Ar,St)	Sinopetalocrinus	(Ec,Cr,Cl)	Sipholagena	(Fo,Fo,Fo)
Simplicibrachia	(Cn,Sc,Rh)	Sinopora	(Cn,An,Ta)	Siphonacmea	(Mo,Ga,Ba)
Simplicioceras	(Mo,Ce,Na)	Sinoporella	(Cn,An,Ta)	Siphonalia	(Mo,Ga,Ne)
Simplococrinus	(Ec,Cr,Di)	Sinoprimitia	(Ar,Os,Pa)	Siphonaperta	(Fo,Fo,Fo)
Simplorbites	(Fo,Fo,Fo)	Sinoproductella	(Br,Ar,St)	Siphonaria	(Mo,Ga,Ba)
Simplorbitolina	(Fo,Fo,Fo)	Sinopsammobia	(Mo,Bi,Ve)	Siphonia	(Po,De,Li)
Simpsonibelus	(Mo,Ce,Be)	Sinoptychoparia	(Ar,Tr,Pt)	Siphonides	(Fo,Fo,Fo)
Simulolenus	(Ar,Tr,Pt)	Sinoreteograptus	(He,Gr,Gr)	Siphonina	(Fo,Fo,Fo)
Sinaeacidaris	(Ec,Ee,Ci)	Sinorhynchia	(Br,Ar,Rh)	Siphoninella	(Fo,Fo,Fo)
Sinaglaspis	(Ar,Me,Ag)	Sinoriificium	(Mo,Ga,Nt)	Siphoninoides	(Fo,Fo,Fo)
Sinaimeandra	(Cn,An,Sc)	Sinorthis	(Br,Ar,Or)	Siphoniotyphlus	(Bz,St,Ce)
Sinampyxina	(Ar,Tr,As)	Sinosabellidites	(Pr,Cr,Cr)	Siphonobesis	(Mo,Ga,Nt)
Sinasteria	(Cn,An,Sc)	Sinosachites	(Pr,Co,So)	Siphonobolus	(Br,Li,Ac)
Sinaxila	(Mo,Ga,Ne)	Sinosaukia	(Ar,Tr,As)	Siphonocetus	(Cd,Ma,Ce)
Sinclairioceras	(Mo,Ce,Di)	Sinosemionotus	(Cd,Os,Se)	Siphonochelus	(Mo,Ga,Ne)
Sinclairiocystis	(Ec,Pc,Co)	Sinoshaleria	(Br,Ar,St)	Siphonochitina	(Fo,Fo,Ch)
Sincola	(Mo,Ga,Ne)	Sinospira	(Mo,Ga,Nt)	Siphonocoelia	(Po,De,Li)
Sindeites	(Mo,Ce,Am)	Sinostomatograptus	(He,Gr,Gr)	Siphonocrinus	(Ec,Cr,Di)
Sinectenolium	(Mo,Bi,Pt)	Sinostrophia	(Br,Ar,St)	Siphonodella	(Cd,Co,Co)
Sinestites	(Ar,Os,Pa)	Sinosura	(Ec,Op,Op)	Siphonodendron	(Cn,An,Ru)
Sinezona	(Mo,Ga,Ar)	Sinotectrostrum	(Br,Ar,Rh)	Siphonodentalium	(Mo,Sc,Sc)
Singularocrinus	(Ec,Cr,Is)	Sinotites	(Mo,Ce,Go)	Siphonodosaria	(Fo,Fo,Fo)
Singulitubus	(Mo,Ga,Be)	Sinotrimerella	(Br,Li,Li)	Siphonofera	(Fo,Fo,Fo)
Siniastrea	(Cn,An,Sc)	Sinotubulites	(Pr,Un,In)	Siphonoflasma	(Cn,An,Ru)
Sinjanelia	(Ar,Tr,Co)	Sinskia	(Ar,Tr,Re)	Siphonophrentis	(Cn,An,Ru)
Sinistracrisa	(Mo,Pa,Hy)	Sinuatella	(Br,Ar,St)	Siphonophyla	(Mo,Ga,Nt)
Sinistrella	(Mo,Ga,Ne)	Sinucongeria	(Mo,Bi,Ve)	Siphonophyllia	(Cn,An,Ru)
Sinistrospira	(Mo,Ga,Eu)	Sinuconus	(Mo,In,In)	Siphonoporella	(Bz,Gy,Ch)
Sinkiangopora	(Cn,An,Ta)	Sinucosta	(Br,Ar,Sp)	Siphonorbis	(Mo,Ga,Ne)
Sinoactaeocheus	(Bz,St,Tr)	Sinucostella	(Br,Ar,Sp)	Siphonoscutula	(Fo,Fo,Fo)
Sinobelemnites	(Mo,Ce,Be)	Sinuella	(Mo,Ga,Be)	Siphonosisa	(Br,Ar,St)
Sinobole	(Ar,Ti,Pr)	Sinuina	(Mo,Ga,Ne)	Siphonosphaera	(Ac,Ra,Sp)
Sinoceras	(Mo,Ce,Or)	Sinuitella	(Mo,Te,Cy)	Siphonostomites	(An,Po,Ph)
Sinochlamydeophyllum	(Cn,An,Ru)	Sinuites	(Mo,Ga,Be)	Siphonotreta	(Br,Li,Ac)
Sinochonetes	(Br,Ar,St)	Sinuitina	(Mo,Ga,Be)	Siphopatella	(Mo,Ga,Nt)
Sinoclaves	(Pr,Ca,Ca)	Sinuitopsis	(Mo,Te,Cy)	Siphostichartus	(Ac,Ra,Na)
Sinocoelacanthus	(Cd,Os,Co)	Sinum	(Mo,Ga,Nt)	Siphostroma	(Po,De,Ax)

Siphotextularia	(Fo,Fo,Fo)	Smilium	(Ar,Ci)	Solecortus	(Mo,Bi,Ve)
Siphouigerina	(Fo,Fo,Fo)	Smilodonichthys	(Cd,Os,Sa)	Solemya	(Mo,Bi,So)
Siratoria	(Mo,Bi,Ve)	Smilostylia	(Cn,An,Sc)	Solemyarina	(Mo,Bi,So)
Siratus	(Mo,Ga,Ne)	Smilooörochus	(Cn,An,Sc)	Solen	(Mo,Bi,Ve)
Sirembo	(Cd,Os,Op)	Smirnovaena	(Br,Ar,Te)	Solena	(Mo,Bi,Ve)
Sirenavus	(Cd,Ma,Si)	Smirnovina	(Br,Ar,Te)	Solenastrea	(Cn,An,Sc)
Sirenites	(Mo,Ce,Ce)	Smithicyathus	(Cn,An,Ru)	Solenihalsites	(Cn,An,Ta)
Sirenotrachyceras	(Mo,Ce,Ce)	Smithiellia	(Mo,Ga,Ne)	Soleniscoetra	(Mo,Bi,Pt)
Siriella	(Ar,MI,My)	Smithiphyllum	(Cn,An,Ru)	Soleniscus	(Mo,Ga,Nt)
Sirius	(Mo,Ga,Nt)	Smithvilloceras	(Mo,Ce,El)	Solenocaris	(Mo,Po,Pa)
Sirtina	(Fo,Fo,Fo)	Smittina	(Bz,Gy,Ch)	Solenoceras	(Mo,Ce,Am)
Siryngotania	(He,Gr,Un)	Smittinella	(Bz,Gy,Ch)	Solenochilus	(Mo,Ce,Na)
Sisenna	(Mo,Ga,Ar)	Smittipora	(Bz,Gy,Ch)	Solenocoelia	(Po,Ca,Ph)
Siskyouspira	(Mo,Ga,Ar)	Smittistoma	(Bz,Gy,Ch)	Solenocoenia	(Cn,An,Sc)
Sismondia	(Ec,Cc,Cl)	Smittoidea	(Bz,Gy,Ch)	Solenodendron	(Cn,An,Ru)
Sita	(Mo,Bi,Ve)	Smoutina	(Fo,Fo,Fo)	Solenodus	(Cd,Ch,Ch)
Sitella	(Fo,Fo,Fo)	Smythina	(Cn,An,Ta)	Solenolmia	(Po,De,Pe)
Situlacrinus	(Ec,Cr,Cl)	Snaidar	(Ar,Os,Pa)	Solenomorpha	(Mo,Bi,Ph)
Siunguedella	(Mo,Bi,Ve)	Snezhnorhynchia	(Br,Ar,Rh)	Solenonychocella	(Bz,Gy,Ch)
Sivajiceras	(Mo,Ce,Am)	Snoopyia	(Mo,Bi,Pr)	Solenoparia	(Ar,Tr,Pt)
Sivasella	(Fo,Fo,Fo)	Soakinautilus	(Mo,Ce,Na)	Solenophragma	(Bz,Gy,Ch)
Siveteria	(Ar,Os,Pa)	Soanella	(Ar,Os,Pa)	Solenopleura	(Ar,Tr,Pt)
Sivorthis	(Br,Ar,Or)	Soapularca	(Mo,Bi,Ar)	Solenopleurella	(Ar,Tr,Pt)
Sizilites	(Mo,Ce,Go)	Sobolewia	(Mo,Ce,An)	Solenopleurina	(Ar,Tr,Pt)
Skaiocrinus	(Ec,Cr,Cl)	Sochkinophyllum	(Cn,An,Ru)	Solenopleuropis	(Ar,Tr,Pt)
Skalenoprión	(An,Po,Eu)	Sociophyllum	(Cn,An,Ru)	Solenorhynchus	(Cd,Os,Ga)
Skania	(Ar,Un,Un)	Socotora	(Mo,Ga,Nt)	Solenosphaera	(Ac,Ra,Sp)
Skaptotion	(Mo,Ga,Th)	Socraticum	(Br,Ar,Un)	Solenosteira	(Mo,Ga,Ne)
Skara	(Ar,In,Sk)	Sodakus	(Ar,MI,De)	Solenostomus	(Cd,Os,Ga)
Skarlatella	(Mo,Bi,Mt)	Soetenia	(Cn,An,Ru)	Solenotia	(Pr,Un,In)
Skelidorygma	(Br,Ar,Sp)	Sogamosa	(Mo,Bi,Ve)	Solenotryma	(Ac,Ra,Na)
Skemmatocare	(Ar,Tr,Pr)	Sogdiana	(Mo,Cr,Da)	Soletellina	(Mo,Bi,Ve)
Skemmatopyge	(Ar,Tr,Pr)	Sogdianella	(Mo,Ga,Ce)	Solgerites	(Mo,Ce,Am)
Skena	(Mo,Ga,Ar)	Sogdianina	(Fo,Fo,Fo)	Soliclymenia	(Mo,Ce,Cl)
Skenidioides	(Br,Ar,Or)	Sogdianophyllum	(Cn,An,Ru)	Solidicorbula	(Mo,Bi,My)
Skenidium	(Br,Ar,Or)	Sogxianthyris	(Br,Ar,Te)	Solidipontirostrum	(Br,Ar,Rh)
Skiagraptus	(He,Gr,Gr)	Sohlella	(Mo,Ga,Nt)	Solidobalanus	(Ar,Ci)
Skinnera	(Tr,Un)	Sohlia	(Mo,Ga,Ne)	Solipetra	(Cn,An,Ru)
Skinnerina	(Fo,Fo,Fo)	Sohliteila	(Mo,Ga,Nt)	Solitudinella	(Br,Ar,At)
Skirroceras	(Mo,Ce,Am)	Sohlites	(Mo,Ce,Am)	Sollarixis	(Mo,Ga,He)
Skolekophyllum	(Cn,An,Ru)	Sokhretia	(Ar,Tr,Ph)	Sollasia	(Po,De,Pe)
Skolekostephanus	(Mo,Ce,Am)	Sokolites	(Mo,Cr,Te)	Sollasina	(Ec,Oh,Oh)
Skoliophyllum	(Cn,An,Ru)	Sokolophocoleus	(Pr,Ma,Le)	Sollnella	(Ar,Os,Le)
Skreiaspis	(Ar,Tr,Pt)	Sokoloviella	(Cn,An,Ru)	Solonaerium	(Ec,Cr,Cm)
Skwarkoella	(Mo,Bi,Tr)	Sokoloviina	(Pr,Un,Sa)	Solopedatus	(Ec,Ho,De)
Skylonia	(Bz,Gy,Ch)	Sokolovites	(Pr,Un,Hy)	Solutofusus	(Mo,Ga,Ne)
Sladenia	(Ec,As,Va)	Sokolovitheca	(Hy,Or,Ex)	Solyma	(Mo,Bi,Ve)
Slapyllites	(Hy,Hy,Hy)	Sokolovograptus	(He,Gr,Gr)	Somalacchinus	(Ec,Ec,Sp)
Slatterites	(Mo,Ce,Am)	Sokolowia	(Mo,Bi,Pt)	Somalaster	(Ec,Ec,Hs)
Slava	(Mo,Bi,Pr)	Sokolskyia	(Br,Ar,St)	Somalibelus	(Mo,Ce,Be)
Slavinithyris	(Br,Ar,Te)	Sokotosaurus	(Cd,Re,Cr)	Somalicerus	(Mo,Ce,Am)
Slavinka	(Mo,Bi,Pr)	Solamen	(Mo,Bi,Mt)	Somalina	(Fo,Fo,Fo)
Slecia	(Ar,Os,Po)	Solanocrinities	(Ec,Cr,Cm)	Somalinautilus	(Mo,Ce,Na)
Slependia	(Ar,Os,Pa)	Solariaxis	(Mo,Ga,Nt)	Somalirhynchia	(Br,Ar,Rh)
Slimonia	(Ar,Me,Eu)	Solariaella	(Mo,Ga,Ar)	Somalitela	(Br,Ar,Te)
Slimoniphyllum	(Cn,An,Ru)	Solarioconulus	(Mo,Ga,Ar)	Somalites	(Mo,Ce,Am)
Slocomoceras	(Mo,Ce,On)	Solariorbis	(Mo,Ga,Nt)	Somalithyris	(Br,Ar,Te)
Slovenirhynchia	(Br,Ar,Rh)	Solariproetus	(Ar,Tr,Pr)	Somapecten	(Mo,Bi,Pt)
Sluha	(Mo,Bi,Nu)	Solarium	(Mo,Ga,Nt)	Somapteria	(Mo,Bi,Pt)
Slurovella	(Cn,Hy,Hy)	Solaster	(Ec,As,Va)	Somarctica	(Mo,Bi,Ve)
Smaragdia	(Mo,Ga,Ar)	Solatia	(Mo,Ga,Ne)	Somareoides	(Mo,Bi,Ph)
Smeathenella	(Br,Ar,Or)	Solea	(Cd,Os,Pn)	Sombrerella	(Ar,Tr,Pt)
Smeathenia	(Ar,Tr,Un)	Soleachiton	(Mo,Po,Ne)	Somersetella	(Po,De,Li)
Smileoceras	(Mo,Ce,Di)	Solecardia	(Mo,Bi,Ve)	Sommerella	(Br,Ar,St)

Somniosus	(Cd.Ch,Sq)	Sparisoma	(Cd.Os,Pf)	Sphaerodomites	(Mo.Ce,Am)
Somnolites	(Mo.Ce,Go)	Sparnodus	(Cd.Os,Pf)	Sphaerogypsina	(Bz.St,Cc)
Somphaentactinia	(Ac.Ra,Sp)	Sparsicavea	(Bz.St,Cc)	Sphaeroidina	(Fo.Fo,Fo)
Somphocrinus	(Ec.Cr,Rv)	Sparsicytis	(Bz.St,Cc)	Sphaeroidinella	(Fo.Fo,Fo)
Somphopora	(Cn.An,Ta)	Sparsiporina	(Bz.Gy,Ch)	Sphaeroidinellopsis	(Fo.Fo,Fo)
Sonculina	(Br.Ar,Or)	Sparsivolenia	(Cn.An,Ta)	Sphaeroidothyris	(Br.Ar,Te)
Sondagella	(Ar.Os,Po)	Sparus	(Cd.Os,Pf)	Sphaeroleberis	(Ar.Os,Po)
Sonella	(Pr.To,Mi)	Spasskothyrus	(Br.Ar,Te)	Sphaeroma	(Ar.MI,Is)
Songanella	(Cd.Os,Pa)	Spasskyella	(Cn.An,Ru)	Sphaeromanticoceras	(Mo.Ce,An)
Songdaella	(Mo.Bi,Pt)	Spatagoides	(Ec.Ec,Hs)	Sphaeronassa	(Mo.Ga,Ne)
Songkania	(Ar.Tr,Pr)	Spatangomorpha	(Ec.Ec,Sp)	Sphaeronites	(Ec.Di,Di)
Songkanoceras	(Mo.Ce,Un)	Spatangopsis	(Cn.Un,Un)	Sphaeropegma	(Po.De,Li)
Songlinella	(Ar.Os,Ar)	Spatangus	(Ec.Ec,Sp)	Sphaerophthalmella	(Ar.Tr,Pt)
Songlingella	(Mo.In,In)	Spathacalymene	(Ar.Tr,Ph)	Sphaerophthalmus	(Ar.Tr,Pt)
Songtaoia	(Ar.Tr,Pt)	Spathella	(Mo.Bi,Mo)	Sphaeropora	(Bz.Gy,Ch)
Songxites	(Ar.Tr,Ph)	Spathelopsis	(Mo.Bi,Un)	Sphaeroptychius	(Mo.Ce,Am)
Songzichonetes	(Br.Ar,St)	Spathiceras	(Mo.Ce,Am)	Sphaeropyle	(Ac.Ra,Sp)
Sonneratia	(Mo.Ce,Am)	Spathipora	(Bz.Gy,Ct)	Sphaeroschisma	(Ec.Bi,Fi)
Sonninia	(Mo.Ce,Am)	Spathites	(Mo.Ce,Am)	Sphaeroschwagerina	(Fo.Fo,Fo)
Sonninopora	(Bz.St,Tr)	Spathiurus	(Cd.Os,Ch)	Sphaerospyris	(Ac.Ra,Na)
Sontheimia	(Po.De,Li)	Spathobatis	(Cd.Ch,Rj)	Sphaerostylus	(Ac.Ra,Sp)
Sontonaella	(Ac.Ra,Sp)	Spathochlamys	(Mo.Bi,Pt)	Sphaerotiariis	(Ec.Ec,Hm)
Soomaspis	(Ar.Tr,Na)	Spathodactyles	(Cd.Os,Pc)	Sphaerotocum	(Ec.Cr,Di)
Sootrynella	(Mo.Bi,Mt)	Spatiopora	(Bz.St,Tr)	Sphaerozoum	(Ac.Ra,Sp)
Sophoceras	(Mo.Ce,Di)	Spatulina	(Ar.Tr,Pr)	Sphaerueaprina	(Mo.Bi,Hi)
Sorapisella	(Mo.Ga,Ar)	Spatuloconus	(Mo.In,In)	Sphaerulina	(Fo.Fo,Fo)
Soriella	(Fo.Fo,Fo)	Spectamen	(Mo.Ga,Ar)	Sphaerulites	(Mo.Bi,Hi)
Soris	(An.Po,Un)	Specula	(Mo.Ga,Nt)	Sphaerulobryozoon	(Bz.Gy,Ch)
Sorites	(Fo.Fo,Fo)	Speetonoceras	(Mo.Ce,Am)	Spathiurus	(Cd.Os,Se)
Sormatodelphis	(Cd.Ma,Ce)	Speightia	(Mo.Ga,Ne)	Sphenacanthus	(Cd.Ch,Ct)
Sormayceras	(Mo.Ce,Am)	Spelaenacca	(Mo.Ga,Nt)	Sphenalosis	(Br.Ar,St)
Sornayina	(Fo.Fo,Fo)	Speluncella	(Ar.Os,Po)	Sphenarina	(Br.Ar,Rh)
Sornyacyceramus	(Mo.Bi,Pt)	Spencella	(Ar.Tr,Pt)	Sphenarpites	(Mo.Ce,Am)
Sororcula	(Mo.Ga,Ar)	Spenceraster	(Ec.As,Va)	Sphenaulax	(Po.He,He)
Sorosphaera	(Fo.Fo,Fo)	Spenceria	(Ec.As,Va)	Sphenella	(Bz.Gy,Ch)
Sorosphaerella	(Fo.Fo,Fo)	Spencia	(Ar.Tr,Pt)	Sphenia	(Mo.Bi,My)
Sorosomasphaera	(Fo.Fo,Fo)	Spengleria	(Mo.Bi,My)	Sphenicibysis	(Ar.Os,Pa)
Soshkinolites	(Cn.An,Ru)	Speocarcinus	(Ar.MI,De)	Spheniopsis	(Mo.Bi,My)
Sosioceras	(Mo.Ce,Go)	Speotrypa	(Bz.St,Fe)	Spheniscocrinus	(Ec.Cr,Cf)
Sosiolytes	(Mo.Ce,Ph)	Sperginaspis	(Ar.Tr,Pr)	Spheniocephalus	(Cd.Os,Pf)
Sostronocrinus	(Ec.Cr,Cl)	Spermacystis	(Ec.St,Mi)	Sphenocerasum	(Mo.Bi,Pt)
Soudanella	(Ar.Os,Po)	Sphaera	(Mo.Bi,Ve)	Sphenoclymenia	(Mo.Ce,Cl)
Soudleyella	(Br.Ar,Or)	Sphaeractinia	(Po.De,Ax)	Sphenocytheridea	(Ar.Os,Po)
Sourimis	(Mo.Bi,Ve)	Sphaeragnostus	(Ar.Tr,Ag)	Sphenodiscus	(Mo.Ce,Am)
Souticrinus	(Ec.Cr,Mi)	Sphaerathyrus	(Br.Ar,Sp)	Sphenodus	(Cd.Ch,Hx)
Sowerbina	(Br.Ar,St)	Sphaerarchinus	(Ec.Ec,Te)	Sphenoeccium	(Cn.Hy,Hy)
Sowerbya	(Mo.Bi,Ve)	Sphaerexochus	(Ar.Tr,Ph)	Sphenophragmus	(Br.Ar,Or)
Sowerbyceras	(Mo.Ce,Ph)	Sphaerriaster	(Ec.As,Va)	Sphenorhynchia	(Br.Ar,Rh)
Sowerbyella	(Br.Ar,St)	Sphaeriella	(Po.De,Un)	Sphenorthis	(Br.Ar,Or)
Sowerbyites	(Br.Ar,St)	Sphaeriodiscus	(Ec.As,Va)	Sphenosolen	(Mo.Bi,Mt)
Sowteria	(Mo.Bi,Ar)	Sphaeriola	(Mo.Bi,Ve)	Sphenosphaera	(Mo.Ga,Be)
Spadentaline	(Mo.Sc,Sc)	Sphaerirhynchia	(Br.Ar,Rh)	Sphenospira	(Br.Ar,Sp)
Spandelinoides	(Fr.Fo,Fo)	Sphaerocare	(Ar.Tr,Un)	Sphenosteges	(Br.Ar,St)
Spandelites	(Ec.Ho,Ap)	Sphaeroceras	(Mo.Ce,Am)	Sphenothallus	(Cn.Sc,Cn)
Spantaster	(Ec.As,Pu)	Sphaerochitina	(Fo.Fo,Ch)	Sphenotomorpha	(Mo.Bi,Mo)
Spanila	(Mo.Ce,Ph)	Sphaerocina	(Mo.Ga,Th)	Sphenotreta	(Br.Ar,Rh)
Spanioceras	(Mo.Ce,On)	Sphaerocladiscites	(Mo.Ce,Ce)	Sphenotrigonia	(Mo.Bi,Tr)
Spaniocrinus	(Ec.Cr,Cl)	Sphaeroeolia	(Po.Ca,Sp)	Sphenotrochopsis	(Cn.An,Sc)
Spaniocyphus	(Ec.Ec,Ec)	Sphaeroeoloceras	(Mo.Ce,Am)	Sphenotrochus	(Cn.An,Sc)
Spaniodontella	(Mo.Bi,Ve)	Sphaeroocyphus	(Ar.Tr,Ph)	Spherolichaeetes	(Po.De,Ta)
Spanionema	(Mo.Ga,Nt)	Sphaerocrinus	(Ec.Cr,Cf)	Sphinctonella	(Po.Ca,Sp)
Spaniorinus	(Mo.Bi,Ve)	Sphaeroeypraea	(Mo.Ga,Nt)	Sphingites	(Mo.Ce,Ce)
Spanodonta	(Br.Ar,St)	Sphaerocystites	(Ec.Rh,Rh)	Sphooceras	(Mo.Ce,Or)
Sparella	(Mo.Ga,Ne)	Sphaerodictya	(Po.Hc,Re)	Sphragiopora	(Bz.St,Fe)

Sphriganaria	(Br.Ar,Te)	Spinoplasia	(Br.Ar,Sp)	Spirocyclina	(Fo,Fo,Fo)
Sphyradoceras	(Mo,Ce,Ba)	Spinopleura	(Ar,Os,Pa)	Spirocyclus	(Mo,Ga,He)
Sphyraena	(Cd,Os,Pf)	Spinopora	(Bz,St,Cc)	Spirocyrus	(Ac,Ra,Na)
Sphyraenodus	(Cd,Os,Pf)	Spinopriscoapedatus	(Ec,Ho,De)	Spirodentalium	(Mo,Ga,Eu)
Sphyraenops	(Cd,Os,Pf)	Spinopunctatrypa	(Br.Ar,At)	Spiroecus	(Mo,Ga,Nt)
Sphyryna	(Cd,Ch,Ca)	Spinoredlichia	(Ar,Tr,Re)	Spirofascigera	(Bz,St,Cc)
Spia	(Mo,Bi,Pt)	Spinorthis	(Br.Ar,Or)	Spirofrondicularia	(Fo,Fo,Fo)
Spicara	(Cd,Os,Pf)	Spinorigifera	(Br.Ar,St)	Spirogalerus	(Mo,Ga,Nt)
Spicia	(Po,De,Pe)	Spinosocyathus	(Po,Ir,Ar)	Spiroglyphus	(Mo,Ga,Nt)
Spinacanthus	(Cd,Os,Te)	Spinospirifer	(Br.Ar,Sp)	Spirogmoceras	(Mo,Ce,Ce)
Spinachitina	(Fo,Fo,Ch)	Spinospongia	(Po,Ca,Ph)	Spirographites	(Mo,Ra,Se)
Spinacnmina	(Ar,Os,Pa)	Spinostrophia	(Br.Ar,St)	Spirolaxis	(Mo,Ga,He)
Spinagnostus	(Ar,Tr,Ag)	Spinothyra	(Fo,Fo,Fo)	Spirolegoceras	(Mo,Ce,Go)
Spinammatocheras	(Mo,Ce,Am)	Spinotournayella	(Fo,Fo,Fo)	Spirolina	(Fo,Fo,Fo)
Spinarcella	(Ci,Po,Sp)	Spinulicosta	(Br.Ar,St)	Spirolingulina	(Fo,Fo,Fo)
Spinarella	(Br.Ar,St)	Spinuliplica	(Br.Ar,Sp)	Spiroloculina	(Fo,Fo,Fo)
Spinaspira	(Mo,Ga,Ne)	Spinulitheca	(Hy,Or,Ci)	Spirolophia	(Po,Un,Un)
Spinatrypa	(Br.Ar,At)	Spinulothele	(Br,Li,Ac)	Spiroloxostoma	(Fo,Fo,Fo)
Spinatrypina	(Br.Ar,At)	Spinulothyris	(Br,Ar,Te)	Spiromphalus	(Mo,Ga,Nt)
Spinauris	(Br.Ar,St)	Spinulrichospira	(Mo,Ga,Ar)	Spiromema	(Mo,Ga,Nt)
Spinearca	(Mo,Bi,Ar)	Spira	(Bz,St,Cr)	Spiromella	(Mo,Ga,Ar)
Spineilo	(Mo,Ce,Nu)	Spiraclusus	(Ec,Ed,Is)	Spironium	(Ac,Ra,Sp)
Spineilla	(Br.Ar,Sp)	Spiractaeon	(Mo,Ga,Ce)	Spirophyllum	(Cn,An,Ru)
Spineoterebra	(Mo,Ga,Ne)	Spiracnella	(Po,He,Re)	Spiropecta	(Fo,Fo,Fo)
Spineria	(Cn,An,Ru)	Spiraculinella	(Mo,Ga,Ar)	Spiropectammina	(Fo,Fo,Fo)
Spinibole	(Ar,Tr,Pr)	Spiradaphne	(Mo,Ga,Ne)	Spiropectina	(Fo,Fo,Fo)
Spinicharixa	(Bz,Gy,Ch)	Spiralella	(Pr,Un,In)	Spiropectinata	(Fo,Fo,Fo)
Spinicharybdis	(Mo,Ga,Eu)	Spiralocnulus	(Fo,Fo,Fo)	Spiropectinella	(Fo,Fo,Fo)
Spinicythere	(Ar,Os,Po)	Spiralta	(Mo,Ga,Ne)	Spirapora	(Bz,St,Cc)
Spinifrons	(Br.Ar,St)	Spirantyx	(Ar,Tr,Un)	Spiroporina	(Bz,Gy,Ch)
Spinigera	(Mo,Ga,Nt)	Spirapertolina	(Fo,Fo,Fo)	Spiropsammia	(Fo,Fo,Fo)
Spinigerites	(Ar,Os,Pa)	Spirapora	(Cn,An,Ta)	Spiropunctifera	(Br,Ar,Sp)
Spinileberis	(Ar,Os,Po)	Spiraserpula	(An,Po,Se)	Spirobis	(An,Po,Se)
Spinilingula	(Br,Li,Li)	Spirelytha	(Br.Ar,Sp)	Spirobula	(An,Po,Se)
Spiniscalca	(Mo,Ga,Nt)	Spirentolophora	(Bz,St,Cc)	Spiroscala	(Mo,Ga,Ar)
Spiniscutellum	(Ar,Tr,Co)	Spirgvaleira	(Mo,Ga,Nt)	Spirosigmoilina	(Fo,Fo,Fo)
Spinispirifer	(Br.Ar,Sp)	Spiriamphorella	(Fo,Fo,Fo)	Spirosigmoilinaella	(Fo,Fo,Fo)
Spinobairdia	(Ar,Os,Po)	Spiridmonea	(Bz,St,Cc)	Spirosolenites	(Fo,Fo,Fo)
Spinobrunsiina	(Fo,Fo,Fo)	Spirifer	(Br.Ar,Sp)	Spirospongia	(Po,He,Ly)
Spinocarinifera	(Br.Ar,St)	Spiriferella	(Br.Ar,Sp)	Spirostylus	(Mo,Ga,Nt)
Spinoceras	(Pr,Un,In)	Spiriferellina	(Br.Ar,Sp)	Spirotecta	(Fo,Fo,Fo)
Spinochernella	(Fo,Fo,Fo)	Spiriferelloides	(Br.Ar,Sp)	Spirotomaria	(Mo,Ga,Ar)
Spinochonetes	(Br.Ar,St)	Spiriferina	(Br.Ar,Sp)	Spirotrocholina	(Fo,Fo,Fo)
Spinocladia	(Po,De,Li)	Spiriferinaella	(Br.Ar,Sp)	Spirotropis	(Mo,Ga,Ne)
Spinocypris	(Ar,Os,Po)	Spiriferinoides	(Br.Ar,Sp)	Spirula	(Mo,Ce,Se)
Spinocyrtia	(Br.Ar,Sp)	Spirigerella	(Br.Ar,Sp)	Spirulirostra	(Mo,Ce,Se)
Spinodiscorbis	(Fo,Fo,Fo)	Spirigerellina	(Br.Ar,Sp)	Spirulirostrella	(Mo,Ce,Se)
Spinodontochile	(Ar,Tr,Ph)	Spirigerina	(Br,Ar,At)	Spirulirostridium	(Mo,Ce,Se)
Spinodus	(Cd,Cc,Co)	Spirilicyathella	(Po,Ir,Ar)	Spirulirostrina	(Mo,Ce,Se)
Spinoendothyra	(Fo,Fo,Fo)	Spirillina	(Fo,Fo,Fo)	Spissatella	(Mo,Bi,Ve)
Spinofenestella	(Bz,St,Fe)	Spirillopora	(Bz,St,Fe)	Spissophyllum	(Cn,An,Ru)
Spinograptus	(He,Gr,Gr)	Spirina	(Mo,Ga,At)	Spisula	(Mo,Bi,Ve)
Spinohippula	(Ar,Os,Pa)	Spirinclus	(Cd,Os,Os)	Spisulona	(Mo,Bi,Ve)
Spinokosmoceras	(Mo,Ce,Am)	Spirinella	(Br.Ar,Sp)	Spitceeras	(Mo,Ce,Am)
Spinolaxina	(Fo,Fo,Fo)	Spirisiosum	(Br.Ar,St)	Spiditiscus	(Mo,Ce,Am)
Spinoleberis	(Ar,Os,Pa)	Spirobolovina	(Fo,Fo,Fo)	Spiitspirifer	(Br,Ar,Sp)
Spinoleiophyllites	(Mo,Ce,Ph)	Spirocampe	(Ac,Ra,Na)	Spitsbergenia	(Po,De,Un)
Spinolepismatina	(Br.Ar,Sp)	Spiroceras	(Mo,Ce,Am)	Spitzbergenia	(Br,Ar,St)
Spinolyttonia	(Br,Ar,St)	Spirochrysalis	(Mo,Ga,Nt)	Splendrilla	(Mo,Ga,Ne)
Spinomarginifera	(Br,Ar,St)	Spirocirrus	(Mo,Ga,Ar)	Spoelia	(Mo,Ga,Ne)
Spinomartina	(Br,Ar,Sp)	Spirocladus	(Cn,An,Ta)	Spondeoceras	(Mo,Ce,Di)
Spinomelon	(Mo,Ga,Ne)	Spiroclypeus	(Fo,Fo,Fo)	Spondyloglossella	(Br,Li,Li)
Spinomicrotheiinelina	(Ar,Os,Pa)	Spirocolpus	(Mo,Ga,Nt)	Spondylobolus	(Br,Ar,Un)
Spinophyllum	(Cn,An,Ru)	Spirocrypta	(Mo,Ga,Nt)	Spondylopecten	(Mo,Bi,Pt)

Spondylopyxis	(Br.Ar,Pe)	Spuriosa	(Br.Ar,St)	Staphylaea	(Mo.Ga,Nt)
Spondylospira	(Br.Ar,Sp)	Spuriospirifer	(Br.Ar,Sp)	Staphylocrinus	(Ec,Cr,Cl)
Spondylostrophia	(Br.Ar,Or)	Spyridiocrinus	(Ec,Cr,Di)	Staphylopora	(Po,De,Ta)
Spondylothyrus	(Br.Ar,Sp)	Spyridiophora	(Br.Ar,St)	Stapicyathus	(Po,Re,Aj)
Spondylotreta	(Br,Li,Ac)	Spyridoceramus	(Mo,Bi,Pt)	Stappyersella	(Mo,Bi,Pt)
Spondylus	(Mo,Bi,Pt)	Spyridopecten	(Mo,Bi,Pt)	Staringia	(Ar,Os,Pl)
Spongarium	(Cn,An,Un)	Spyroceras	(Mo,Ce,Or)	Statanulocathus	(Po,Re,Aj)
Spongaster	(Ac,Ra,Sp)	Spytlnhevites	(Ar,Os,Un)	Stathmepora	(Bz,St,Ce)
Spongasteriscus	(Ac,Ra,Sp)	Squalicorax	(Cd,Ch,La)	Staufenia	(Mo,Ce,Am)
Spongastrea	(Cn,An,Ru)	Squaliolus	(Cd,Ch,Sq)	Stauferella	(Cd,Co,Co)
Spongatractus	(Ac,Ra,Sp)	Squalodelphis	(Cd,Ma,Ce)	Stautferoceras	(Mo,Ce,On)
Spongelites	(Po,De,Di)	Squalodon	(Cd,Ma,Ce)	Stauracantium	(Ac,Ra,Sp)
Spongectactinella	(Ac,Ra,Sp)	Squalogadus	(Cd,Os,Ga)	Stauractinella	(Po,He,Us)
Spongectactinia	(Ac,Ra,Sp)	Squalogaleus	(Cd,Ch,Sq)	Stauralastrum	(Ac,Ra,Sp)
Spongeoliomorpha	(Po,De,Di)	Squaloraja	(Cd,Ch,Cm)	Staurancistra	(Ac,Ra,Sp)
Spongicythere	(Ar,Os,Po)	Squaloziphus	(Cd,Ma,Ce)	Stauranderaster	(Ec,As,Val)
Spongielasma	(Cn,An,Ru)	Squalus	(Cd,Ch,Sq)	Stauria	(Cn,An,Ru)
Spongioalveolites	(Cn,An,Ta)	Squamalinia	(Mo,Ga,Sa)	Staurimidia	(Cn,In,In)
Spongiomorpha	(Po,De,As)	Squamaria	(Br,Ar,St)	Staurcephalites	(An,Po,Eu)
Spongiothecopora	(Po,De,Ta)	Squamathyrus	(Br,Ar,Sp)	Staurcephalus	(Ar,Tr,Ph)
Spongoacanthus	(Ac,Ra,Sp)	Squamatina	(Br,Ar,St)	Staurcoccura	(Ac,Ra,Sp)
Spongobranchium	(Ac,Ra,Sp)	Squamealveolites	(Cn,An,Ta)	Staurocromyum	(Ac,Ra,Sp)
Spongoapsula	(Ac,Ra,Na)	Squameofavosites	(Cn,An,Ta)	Staurcomites	(Ec,Ho,Mo)
Spongoceelia	(Ac,Ra,Sp)	Squameolites	(Cn,An,Ta)	Staurocyclia	(Ac,Ra,Sp)
Spongocone	(Ac,Ra,Sp)	Squameophyllum	(Cn,An,Ta)	Staurocystis	(Ec,Rh,Rh)
Spongodiscus	(Ac,Ra,Sp)	Squameopora	(Cn,An,Ta)	Stauroderma	(Po,He,He)
Spongolena	(Ac,Ra,Sp)	Squamilingulella	(Br,Li,Li)	Staurodictya	(Ac,Ra,Sp)
Spongolonche	(Ac,Ra,Sp)	Squamiplana	(Br,Ar,Te)	Staurodoras	(Ac,Ra,Sp)
Spongomelissa	(Ac,Ra,Na)	Squamirhynchia	(Br,Ar,Rh)	Staurodrappa	(Ac,Ra,Sp)
Spongonaria	(Cn,An,Ru)	Squamosocyathus	(Po,Re,Aj)	Staurognathus	(Cd,Co,Co)
Spongopallium	(Ac,Ra,Sp)	Squamularia	(Br,Ar,Sp)	Staurograptus	(He,Gr,De)
Spongophacus	(Ac,Ra,Sp)	Squamulariina	(Br,Ar,Sp)	Staurolonche	(Ac,Ra,Sp)
Spongophylloides	(Cn,An,Ru)	Squamuliferipecten	(Mo,Bi,Pt)	Stauromata	(Br,Ar,St)
Spongophyllum	(Cn,An,Ru)	Squarrosus	(Mo,Ga,Be)	Stauromatidium	(Cn,An,Ru)
Spongoplegma	(Ac,Ra,Sp)	Squatigaleus	(Cd,Ch,Ca)	Stauronema	(Po,He,Ly)
Spongoprunum	(Ac,Ra,Sp)	Squatina	(Cd,Ch,Sf)	Stauronereisites	(An,Po,Ph)
Spongopyle	(Ac,Ra,Sp)	Squatinactis	(Cd,Ch,St)	Staurophyllum	(Cn,An,Ru)
Spongosaturnalis	(Ac,Ra,Sp)	Squatirhina	(Cd,Ch,Rj)	Stauroplegma	(Ac,Ra,Sp)
Spongosaturnaloides	(Ac,Ra,Sp)	Squatiscyllium	(Cd,Ch,Oc)	Staurospaera	(Ac,Ra,Sp)
Spongosilicarmiger	(Ac,Ra,Na)	Squillidae	(Ar,Ml,St)	Staurosteginopora	(Bz,Gy,Ch)
Spongostaurus	(Ac,Ra,Sp)	Squinabolella	(Ac,Ra,Na)	Staurostylus	(Ac,Ra,Sp)
Spongotripus	(Ac,Ra,Sp)	Squinabolum	(Ac,Ra,Na)	Stazzania	(Mo,Ga,Ne)
Spongotrochus	(Ac,Ra,Sp)	Stacheites	(Mo,Ce,Ce)	Stchepinskya	(Mo,Bi,Ve)
Spongoxiphus	(Ac,Ra,Sp)	Stachella	(Mo,Ga,Be)	Stearnsia	(Mo,Bi,Ve)
Spongurus	(Ac,Ra,Sp)	Stacheoceras	(Mo,Ce,Go)	Stearoceras	(Mo,Ce,Na)
Sponiolepis	(Cd,Os,Se)	Stachyocrinus	(Ec,Cr,Cl)	Stedumia	(Fo,Fo,Fo)
Sponysedron	(Cd,Os,Di)	Stachyodes	(Po,De,St)	Stefania	(Pr,Un,In)
Sporadoceras	(Mo,Ce,Go)	Stachyspongia	(Po,De,Li)	Stefania	(Mo,Bi,Pt)
Sporadopora	(Cn,Hy,St)	Staffella	(Fo,Fo,Fo)	Stefaniella	(Mo,Bi,Pt)
Sporadoporiidum	(Po,De,Av)	Staffinella	(Mo,Bi,Ve)	Stegacanthia	(Br,Ar,St)
Sporadopyle	(Po,He,Ly)	Staffinia	(Mo,Ga,Ar)	Steganocrinus	(Ec,Cr,Mo)
Sporadoscintia	(Po,He,Ly)	Staffordotaxis	(Bz,St,Cr)	Stegaster	(Ec,Ec,Hs)
Sporadotrema	(Fo,Fo,Fo)	Stagonites	(Mo,Ce,Di)	Stegerhynchops	(Br,Ar,Rh)
Sporobulimina	(Fo,Fo,Fo)	Stahlia	(Mo,Bi,Ve)	Stegerhynchus	(Br,Ar,Rh)
Sporobulimella	(Fo,Fo,Fo)	Stainbrookia	(Br,Ar,Or)	Steginopora	(Bz,Gy,Ch)
Sportella	(Mo,Bi,Ve)	Stainforthia	(Fo,Fo,Fo)	Steginoporella	(Bz,Gy,Ch)
Spridmonaea	(Bz,St,Ce)	Stalticodiscus	(Ec,Ed,Is)	Stegnammina	(Fo,Fo,Fo)
Spriggia	(Cn,Hy,Un)	Stamenocella	(Bz,Gy,Ch)	Stegnopis	(Ar,Tr,Pt)
Spriggina	(Cn,Pe,Er)	Stannia	(Po,He,Ly)	Stegochiton	(Mo,Po,Ne)
Springeracrocrinus	(Ec,Cr,Mo)	Stannocrinus	(Ec,Cr,Mo)	Stegocoelia	(Mo,Ga,Ar)
Springericrinus	(Ec,Cr,Cl)	Standardoceras	(Mo,Ce,Or)	Stegoconcha	(Mo,Bi,Mt)
Springerocystis	(Ec,Pe,Un)	Stantonella	(Mo,Ga,Ne)	Stegocornu	(Br,Ar,Rh)
Spruocrinus	(Ec,Cr,Un)	Stantonoceras	(Mo,Ce,Am)	Stegopygus	(Ec,Ec,Ca)
Spumealites	(Cn,An,Ta)	Stapeleyella	(Ar,Tr,As)	Stegorhynchella	(Br,Ar,Rh)

Stegospira	(Br,Ar,Sp)	Stenocyclus	(Mo,Ce,Go)	Stephanoblastus	(Ec,Co,Co)
Stegotrachelus	(Cd,Os,Pa)	Stenodactylina	(Ar,Ml,De)	Stephanocare	(Ar,Tr,Od)
Stegoxyites	(Mo,Ce,Am)	Stenodelphina	(Cd,Ma,Ce)	Stephanoceras	(Mo,Ce,Am)
Steimannia	(Mo,Bi,Pt)	Stenodiscus	(Bz,St,Tr)	Stephanocoenia	(Cn,An,Sc)
Steinachella	(Ar,Os,My)	Stenodromia	(Ar,Ml,De)	Stephanoconus	(Mo,Ga,Ne)
Steinaspis	(Cd,Pt,Pt)	Stenoglyphyrites	(Mo,Ce,Go)	Stephanocosmia	(Mo,Ga,Nt)
Steinbachodus	(Cd,Ch,Ct)	Stenoglossariorhynchus	(Br,Ar,Rh)	Stephanocrinus	(Ec,Co,Co)
Steinerella	(Po,De,AX)	Stenogmus	(Br,Ar,Te)	Stephanocyathus	(Cn,An,Sc)
Steineria	(Po,De,AX)	Stenogomphoceras	(Mo,Ce,On)	Stephanodesma	(Bz,St,Ce)
Steinetella	(Fo,Fo,Fo)	Stenohelia	(Cn,Hy,Mi)	Stephanollona	(Bz,Gy,Ch)
Steinfurtia	(Ar,Os,Pa)	Stenoloron	(Mo,Ga,Ar)	Stephanometopon	(Ar,Ml,De)
Steinbagella	(Br,Ar,St)	Stenomometoprhynchus	(Br,Ar,Rh)	Stephanophyllia	(Cn,An,Sc)
Steinmanella	(Mo,Bi,Tr)	Stenometra	(Ec,Cr,Cm)	Stephanosalpinx	(Mo,Ga,Ne)
Steinmannites	(Mo,Ce,Ce)	Stenopareia	(Ar,Tr,Co)	Stephanoscolex	(An,Po,Un)
Stelckaspis	(Ar,Tr,Od)	Stenopeccrinus	(Ec,Cr,Cl)	Stephanosella	(Bz,Gy,Ch)
Stelckia	(Br,Ar,St)	Stenopentamerus	(Br,Ar,Pe)	Stephanosmilia	(Cn,An,Sc)
Stelchophyllum	(Cn,An,Ru)	Stenopharcciceras	(Mo,Ce,An)	Stephanotrema	(Bz,Gy,Ch)
Stelidiocrinus	(Ec,Cr,Mo)	Stenophragmidium	(Bz,St,Tr)	Stephanoura	(Ec,Op,Op)
Steliella	(Po,De,Li)	Stenopilus	(Ar,Tr,Pt)	Stephanoryza	(Mo,Ga,Nt)
Stella	(Ar,Tr,Pt)	Stenoplax	(Mo,Po,Ne)	Stephenaspis	(Ar,Tr,Co)
Stellahevaformis	(Bz,St,Tr)	Stenopoceras	(Mo,Ce,Na)	Stephenospongia	(Po,He,Re)
Stellaria	(Mo,Ga,Nt)	Stenopopanoceras	(Mo,Ce,Ce)	Steptotaxis	(Cd,Co,Co)
Stellarispongia	(Po,Ca,He)	Stenopora	(Bz,St,Tr)	Steraechmella	(Bz,Gy,Ch)
Stellarocrinus	(Ec,Cr,Cl)	Stenoporella	(Bz,St,Tr)	Stercorarius	(Cd,Av,Ch)
Stellarticulina	(Fo,Fo,Fo)	Stenopronorites	(Mo,Ce,Pl)	Stereoaster	(Ec,Cr,Di)
Stellatodictya	(Bz,St,Cr)	Stenopsella	(Bz,Gy,Ch)	Stereobrachiocrinus	(Ec,Cr,Ds)
Stellatograptus	(He,Gr,Gr)	Stenopsis	(Bz,Gy,Ch)	Stereochia	(Br,Ar,St)
Stellatophyllum	(Cn,An,Ru)	Stenopterygius	(Cd,Re,Je)	Stereocidaris	(Ec,Ec,Ci)
Stellaxis	(Mo,Ga,He)	Stenorhachis	(Ar,Tr,Pt)	Stereoecoenia	(Cn,An,Sc)
Stelletta	(Po,De,As)	Stenorhynchia	(Br,Ar,Rh)	Stereoconus	(Cd,Co,Co)
Stellettites	(Po,De,Li)	Stenorhytis	(Mo,Ga,Nt)	Stereocorypha	(Cn,An,Ru)
Stellipora	(Bz,St,Cy)	Stenorina	(Br,Ar,Te)	Stereodolphis	(Cd,Ma,Ce)
Stelliporella	(Cn,An,Ta)	Stenosarinia	(Br,Ar,Te)	Stereodespasophyllum	(Cn,An,Ru)
Stellispinella	(Pr,Co,Ch)	Stenosaurus	(Cd,Re,Cr)	Stereodictyum	(Po,He,Re)
Stellispongia	(Po,Ca,Ph)	Stenoscisma	(Br,Ar,Rh)	Stereokion	(Mo,Ga,Nt)
Stellocavea	(Bz,St,Ce)	Stenosemellopsis	(Ci,Po,Sp)	Stereolasma	(Cn,An,Ru)
Stellopora	(Po,De,St)	Stenosphon	(Mo,Ce,En)	Stereomactra	(Mo,Bi,Ve)
Stelloria	(Cn,An,Sc)	Stenospira	(Bz,Gy,Ch)	Stereophrentis	(Cn,An,Ru)
Stellostomites	(Pr,Un,In)	Stenosteus	(Cd,Pl,Ar)	Stereophyllum	(Cn,An,Ru)
Stelodictyon	(Po,De,St)	Stenotheca	(Mo,He,He)	Stereoplasmoceras	(Mo,Ce,Or)
Stelzneria	(Mo,Ga,Nt)	Stenothecella	(Mo,St,St)	Stereopsammia	(Cn,An,Sc)
Stemmatoceras	(Mo,Ce,Am)	Stenothecoides	(Mo,St,St)	Stereospyroceras	(Mo,Ce,Or)
Stemmatodus	(Cd,Os,Py)	Stenothecopsis	(Pr,To,Un)	Stereostylus	(Cn,An,Ru)
Stemtonoceras	(Mo,Ce,El)	Stenotitis	(Mo,Ga,Nt)	Stereotoceras	(Mo,Ce,Di)
Stenarcestes	(Mo,Ce,Ce)	Stenozone	(Mo,Ga,Ar)	Stereotocchus	(Bz,St,Tr)
Stenaster	(Ec,Op,St)	Stensioella	(Cd,Pl,St)	Sterictophyllum	(Cn,An,Ru)
Stenatherina	(Cd,Os,At)	Stensioina	(Fo,Fo,Fo)	Sternberga	(Ar,Os,Po)
Stenaulacorhynchus	(Br,Ar,Rh)	Stensioonotus	(Cd,Os,Am)	Sternoptyx	(Cd,Os,St)
Stenechinus	(Ec,Ec,Pe)	Stenzelia	(Mo,Bi,Ar)	Sternotaxis	(Ec,Ec,Hs)
Stenella	(Cd,Ma,Ce)	Stenzeloceras	(Mo,Ce,Na)	Steromphala	(Mo,Ga,Ar)
Stenestroemia	(Ar,Os,Po)	Stepanoconchus	(Br,Ar,St)	Stethacanthus	(Cd,Ch,Sy)
Steno	(Cd,Ma,Ce)	Stepanoviella	(Br,Ar,St)	Stethothyris	(Br,Ar,Te)
Stenoaster	(Ec,Ec,Hs)	Stepanoviina	(Br,Ar,Sp)	Stetsiona	(Fo,Fo,Fo)
Stenoblepharum	(Ar,Tr,Pr)	Stephaconus	(Pr,Un,In)	Steusloflia	(Ar,Os,Pa)
Stenobrachiis	(Cd,Os,My)	Stephanastrum	(Ac,Ra,Sp)	Steusloflina	(Ar,Os,Po)
Stenocodoceras	(Mo,Ce,Am)	Stephanella	(Po,He,Re)	Steyocyathus	(Po,lr,Ar)
Stenocamara	(Br,Ar,Pe)	Stephanicyathus	(Po,Re,Aj)	Stewartia	(Mo,Bi,Ve)
Stenochilina	(Ar,Tr,As)	Stephaniscus	(Ac,Ra,Na)	Stewartophyllum	(Cn,An,Ru)
Stenochirus	(Ar,Ml,De)	Stephanites	(Mo,Ce,Ce)	Sthenarocalymene	(Ar,Tr,Ph)
Stenocionops	(Ar,Ml,De)	Stephanium	(Ac,Ra,Na)	Sthenarosaurus	(Cd,Re,Ps)
Stenocladia	(Bz,St,Tr)	Stephanaria	(Cn,An,Sc)	Sthenelaïtes	(An,Po,Ph)
Stenoclymenia	(Mo,Ce,Cl)	Stephanasörea	(Cn,An,Sc)	Sthenoceras	(Mo,Ce,Di)
Stenociathus	(Cn,An,Sc)	Stephanaxocoenia	(Cn,An,Sc)	Sthenodontia	(Mo,Bi,Ne)
Stenocyclus	(Fo,Fo,Fo)	Stephanaxophyllia	(Cn,An,Sc)	Sthenorytis	(Mo,Ga,Ne)

Sthent euthis	(Mo,Ce,Te)	Stioderma	(Po,He,Am)	Straparella	(Mo,Ga,Ar)
Stibaraster	(Ec,As,Ur)	Stiodermiella	(Po,He,Un)	Straparollina	(Mo,Ga,Ar)
Stibarocrinus	(Ec,Cr,Ds)	Stipatorcinus	(Ec,Cr,Mo)	Straparollus	(Mo,Ga,Eu)
Stibastrea	(Cn,An,Sc)	Stiphromactra	(Mo,Bi,Ve)	Stratispongia	(Po,Ca,Ph)
Stiboria	(Cn,An,Sc)	Stiphrothyris	(Br,Ar,Te)	Stratodictyon	(Po,De,St)
Stibus	(Ar,Os,Me)	Stiptocrinus	(Ec,Cr,Mo)	Stratodus	(Cd,Os,Al)
Stichmptyx	(Po,He,He)	Stipulina	(Br,Al,St)	Stratophyllum	(Cn,An,Ta)
Stichoberyx	(Cd,Os,Br)	Stiracolpus	(Mo,Ga,Nt)	Stratphythoceratina	(Ar,Os,Po)
Stichocados	(Bz,Gy,Ch)	Stirechinus	(Ec,Ec,Ec)	Stravia	(Ar,Os,Po)
Stichocampe	(Ac,Ra,Na)	Stiremetra	(Ec,Cr,Cm)	Streblaseopora	(Bz,St,Cr)
Stichocapsa	(Ac,Ra,Na)	Stirpulina	(Mo,Bi,Ph)	Streblites	(Mo,Ce,Am)
Stichocassidulina	(Fo,Fo,Fo)	Stoibostrombus	(Pr,Un,In)	Strebliticeras	(Mo,Ce,Am)
Stichoentrus	(Cd,Os,Br)	Stokesoceras	(Mo,Ce,Di)	Streblloceras	(Mo,Ga,Nt)
Stichocibicides	(Fo,Fo,Fo)	Stolbovoceras	(Mo,Ce,Ae)	Streblochondria	(Mo,Bi,Pt)
Stichocorys	(Ac,Ra,Na)	Stolephorus	(Cd,Os,Cl)	Streblochladia	(Bz,St,Cr)
Stichoecystis	(Ec,Rh,Rh)	Stoliconus	(Pr,Un,In)	Streblocrinus	(Ec,Cr,Cl)
Stichomicropora	(Bz,Gy,Ch)	Stoliczkaia	(Mo,Ce,Am)	Streblopax	(Bz,St,Cr)
Stichomitra	(Ac,Ra,Na)	Stoliczkaria	(Cn,Hy,Un)	Streblopteria	(Mo,Bi,Pt)
Stichophormis	(Ac,Ra,Na)	Stoliczkiella	(Cn,Hy,Un)	Streblosoma	(An,Po,Fe)
Stichophyma	(Po,De,Li)	Stolidotus	(Mo,Bi,Pr)	Streblotrypa	(Bz,St,Cr)
Stichopilidium	(Ac,Ra,Na)	Stolleites	(Mo,Ce,Ce)	Streblotrypella	(Bz,St,Cr)
Stichopitella	(Ec,Ho,De)	Stolleya	(Po,De,As)	Strenoceras	(Mo,Ce,Am)
Stichopites	(Ec,Ho,As)	Stolmorhynchia	(Br,Ar,Rh)	Strenuava	(Ar,Tr,Pt)
Stichopora	(Bz,Gy,Ch)	Stolodus	(Cd,Co,Co)	Strenuella	(Ar,Tr,Pt)
Stichoporina	(Bz,Gy,Ch)	Stolonicella	(Bz,Gy,Ct)	Strepeoschema	(Cd,Os,Pa)
Stichopsammia	(Cn,An,Sc)	Stolonodendrum	(He,Gr,St)	Strephimia	(Po,He,He)
Stichopteris	(Cd,Os,Pa)	Stolzenburgiella	(Br,Ar,Sp)	Strephona	(Mo,Ga,Ne)
Stichopteryx	(Cd,Os,Br)	Stoma	(An,Po,Un)	Strephonella	(Mo,Ga,Ne)
Stichotrophia	(Br,Ar,Pe)	Stomachetosella	(Bz,Gy,Ch)	Strephophyllum	(Cn,An,Ru)
Stichtostega	(Bz,Gy,Ch)	Stomaporus	(Ec,Ec,Sp)	Strepsidura	(Mo,Ga,Ne)
Stictobollia	(Ar,Os,Pa)	Stomasphaera	(Fo,Fo,Fo)	Streptacis	(Mo,Ga,He)
Stictocella	(Bz,St,Cy)	Stomatella	(Mo,Ga,Ar)	Streptaleveolina	(Fo,Fo,Fo)
Stictoconus	(Pr,Un,In)	Stomatia	(Mo,Ga,Ar)	Streptaria	(Br,Ar,Rh)
Stictopora	(Bz,St,Cr)	Stomatodiscus	(Ac,Ra,Sp)	Streptaster	(Ec,Ed,Is)
Stictoporella	(Bz,St,Cr)	Stomatopora	(Bz,St,Cc)	Streptelasma	(Cn,An,Ru)
Stictoporellina	(Bz,St,Cr)	Stomatoporina	(Bz,St,Cc)	Streptendytes	(An,Po,Se)
Stictoporina	(Bz,St,Cr)	Stomatopropis	(Bz,St,Cc)	Streptis	(Br,Ar,Or)
Stictostroma	(Po,De,St)	Stomatorbina	(Fo,Fo,Fo)	Streptocarina	(Mo,Ga,Ne)
Stictotrypa	(Bz,St,Cr)	Stomatostoecha	(Fo,Fo,Fo)	Streptoceras	(Mo,Ce,On)
Stictozoster	(Br,Ar,St)	Stomechinus	(Ec,Ec,Ph)	Streptochetus	(Mo,Ga,Ne)
Stigmacephaloides	(Ar,Tr,As)	Stomhypselosaria	(Bz,Gy,Ch)	Streptochilus	(Fo,Fo,Fo)
Stigmacephalus	(Ar,Tr,As)	Stomiathykus	(Cd,Os,Di)	Streptocrinus	(Ec,Cr,Cl)
Stigmaspis	(Ar,Tr,As)	Stomiocrinus	(Ec,Cr,Mo)	Streptocyathopsis	(Cn,An,Sc)
Stigmatella	(Bz,St,Tr)	Stomiosphaera	(Ct,Po,Sp)	Streptocyclus	(Cn,An,Sc)
Stigmatoa	(Ar,Tr,As)	Stomohamites	(Mo,Ce,Am)	Streptocyclammia	(Fo,Fo,Fo)
Stigmatocythere	(Ar,Os,Po)	Stomoloculina	(Fo,Fo,Fo)	Streptodictyon	(Mo,Ga,Ne)
Stigmatoechos	(Bz,St,Cc)	Stomopneutes	(Ec,Ec,Ph)	Streptodiscus	(Mo,Ga,Be)
Stigmatopygus	(Ec,Ec,Ca)	Stoppniceras	(Mo,Ce,Ce)	Streptognathodus	(Cd,Co,Co)
Stigmaulax	(Mo,Ga,Nt)	Storrsella	(Fo,Fo,Fo)	Streptograptus	(He,Gr,Gr)
Stigmosphaera	(Ac,Ra,Sp)	Storthingocrinus	(Ec,Cr,Ds)	Streptolathyris	(Mo,Ga,Ne)
Stigmosphaerostylus	(Ac,Ra,Sp)	Storthodon	(Mo,Bi,Ve)	Streptomytilus	(Mo,Bi,Pt)
Stikineastraea	(Cn,An,Ru)	Storthosphaera	(Fo,Fo,Fo)	Streptopelma	(Mo,Ga,Ne)
Stikinoceras	(Mo,Ce,Ce)	Stortophyllum	(Cn,An,Ru)	Streptophyllum	(Cn,An,Ru)
Stiktocybele	(Ar,Tr,Ph)	Stosicia	(Mo,Ga,Nt)	Streptopiinna	(Mo,Bi,Mt)
Stilbe	(Mo,Ga,Nt)	Strabops	(Ar,Me,Ag)	Streptopomus	(Br,Ar,St)
Stilbophyllum	(Cn,An,Ru)	Strachanognathus	(Cd,Co,Co)	Streptorhynchus	(Br,Ar,St)
Stilifer	(Mo,Ga,Nt)	Straelania	(Br,Ar,Rh)	Streptosolen	(Po,De,Li)
Stilla	(Mo,Ga,Ne)	Stralopecten	(Mo,Bi,Pt)	Streptospongia	(Po,De,Li)
Stillicidocyathus	(Po,Ke,Aj)	Strambergocrinus	(Ec,Cr,Cy)	Streptotrochus	(Mo,Ga,Eu)
Stillina	(Ar,Os,Po)	Stramentella	(Po,De,Un)	Streptula	(Ar,Os,Pa)
Stilostomella	(Fo,Fo,Fo)	Stramentum	(Ar,Ci)	Streptulites	(Ar,Os,Me)
Stilpnoretta	(Br,Li,Ac)	Stramonita	(Mo,Ga,Ne)	Stretosaurus	(Cd,Re,Ps)
Stimulitheca	(Hy,Or,Ci)	Strandoceras	(Mo,Ce,Di)	Strettonia	(Ar,Tr,Co)
Stinoerinus	(Ec,Cr,Cl)	Strangulites	(Mo,Ga,Be)	Striacallista	(Mo,Bi,Ve)

Striacoceras	(Mo,Ce,Or)	Strixella	(Br,Ar,Or)	Strophopleura	(Br,Ar,Sp)
Striactaeonina	(Mo,Ga,Ce)	Strobeus	(Mo,Ga,Nt)	Strophoprion	(Br,Ar,St)
Striamodiolus	(Mo,Bi,Mt)	Strobilepis	(Pr,Mu,St)	Strophoproductus	(Br,Ar,St)
Striarcia	(Mo,Bi,Ar)	Strobiloceras	(Mo,Ce,Di)	Strophorichthofenia	(Br,Ar,St)
Striataella	(Fo,Fo,Fo)	Strobilocystites	(Ec,Rh,Rh)	Strophostylus	(Mo,Ga,Ar)
Striatesta	(Mo,Ga,Nt)	Strobilodus	(Cd,Os,Am)	Strotactinus	(Ar,Tr,Ph)
Striatocostatum	(Mo,Ga,Nt)	Strobilopterus	(Ar,Mo,Eu)	Stroterobolbina	(Ar,Os,Pa)
Striatifera	(Br,Ar,St)	Strobilothyrone	(Ec,Ho,De)	Strotocrinus	(Ec,Cr,Mo)
Striaticscala	(Mo,Ga,Nt)	Stroboceras	(Mo,Ce,Na)	Strotogyra	(Cn,An,Sc)
Striatobythoceratina	(Ar,Os,Po)	Strobocrinus	(Ec,Cr,Sa)	Strotopora	(Bz,St,Cy)
Striatoceramus	(Mo,Bi,Pt)	Stroggyloceras	(Mo,Ce,Di)	Strotospongia	(Po,De,Li)
Striatochonetes	(Br,Ar,St)	Stromactinia	(Cn,Hy,Sp)	Strotostoma	(Mo,Ga,Ar)
Striatocyathus	(Pr,Cr,Cr)	Stromaporidium	(Po,De,Ax)	Stroudithyris	(Br,Ar,Te)
Striatolamia	(Cd,Ch,La)	Stromateus	(Cd,Os,PF)	Strungia	(Mo,Ce,Am)
Striatopora	(Cn,An,Ta)	Stromatidium	(Po,De,Li)	Strunius	(Cd,Os,Co)
Striatoporella	(Cn,An,Ta)	Stromatoaxinellia	(Po,De,Ax)	Struszia	(Ar,Tr,Ph)
Striatoproductella	(Br,Ar,St)	Stromatoceras	(Mo,Ce,Or)	Struszocrinus	(Ec,Cr,Mo)
Striatopugnax	(Br,Ar,Rh)	Stromatocerium	(Po,De,St)	Struthiolenopus	(Mo,Ga,Nt)
Striatorhynchus	(Br,Ar,Rh)	Stromatocystites	(Ec,Ed,St)	Struthiolarella	(Mo,Ga,Nt)
Striatosirenites	(Mo,Ce,Ce)	Stromatodictyon	(Po,De,St)	Struthiolaria	(Mo,Ga,Nt)
Striatospica	(Br,Ar,St)	Stromatograptus	(He,Gr,Gr)	Struthiolariopsis	(Mo,Ga,Ne)
Striatostyliolina	(Mo,Cr,Da)	Stromatomorpha	(Po,De,Ax)	Struthioptera	(Mo,Ga,Nt)
Stribalocystites	(Ec,Rh,Rh)	Stromatopora	(Po,De,St)	Struveapis	(Ar,Tr,Ph)
Stricklandia	(Br,Ar,Pe)	Stromatoporella	(Po,De,St)	Struveina	(Br,Ar,Sp)
Stricklandiella	(Br,Ar,Pe)	Stromatoporellata	(Po,De,Ax)	Struveopsis	(Ar,Os,Pl)
Stricklandistropia	(Br,Ar,Pe)	Stromatoporellina	(Po,De,Ax)	Struvethyris	(Br,Ar,Te)
Strictocorniculum	(Pr,Un,In)	Stromatoporina	(Po,De,Ax)	Stuartwellerocrinus	(Ec,Cr,Ci)
Strictocostella	(Fo,Fo,Fo)	Stromatorhaxella	(Po,De,Ax)	Stubblefieldia	(Ar,Tr,Ph)
Strictohumerus	(Mo,Ga,Ar)	Stromatorhiza	(Po,De,Ax)	Stuckenbergia	(Po,De,Li)
Strictozoster	(Br,Ar,St)	Stromatospongia	(Po,De,Ta)	Studeria	(Ec,Ec,Ca)
Strigambitus	(Ar,Tr,Un)	Stromatosstroma	(Po,De,Ax)	Stueria	(Ec,Ho,Ap)
Strigatella	(Mo,Ga,Ne)	Stromatotrypa	(Bz,St,Tr)	Stuertzaspis	(Cd,Pl,Ar)
Strigialifusus	(Fo,Fo,Fo)	Strombiformis	(Mo,Ga,Nt)	Stuertzaster	(Ec,Op,St)
Strigenalis	(Ar,Tr,Pr)	Strombina	(Mo,Ga,Ne)	Stuertzura	(Ec,So,Go)
Strigilla	(Mo,Bi,Ve)	Strombinella	(Mo,Ga,Ne)	Stuorella	(Mo,Ga,Ar)
Strigillibuccinum	(Mo,Ga,Ne)	Strombinophos	(Mo,Ga,Ne)	Stuoresia	(Cn,An,Sc)
Strigirhynchia	(Br,Ar,Rh)	Stromboconus	(Mo,Ga,Nt)	Stuoresimorpha	(Cn,An,Sc)
Strigoceras	(Mo,Ce,Am)	Strombodes	(Cn,An,Ru)	Sturgeosompira	(Mo,Ga,Nt)
Strigocythere	(Ar,Os,Po)	Strombolaria	(Mo,Ga,Nt)	Sturia	(Mo,Ce,Ce)
Strigogoniatites	(Mo,Ce,Go)	Strombopugnellus	(Mo,Ga,Nt)	Sturtella	(Br,Ar,Te)
Strigosella	(Mo,Ga,Ar)	Strombus	(Mo,Ga,Nt)	Stutchburia	(Mo,Bi,Ve)
Strigospina	(Br,Ar,St)	Stromerichthys	(Cd,Os,Am)	Stygina	(Ar,Tr,Co)
Striirhynchia	(Br,Ar,Rh)	Strominella	(Mo,Ga,Ne)	Stylangia	(Cn,An,Sc)
Striirichthofenia	(Br,Ar,St)	Strongyloblastus	(Ec,BI,Sp)	Stylaster	(Cn,Hy,St)
Striispirifer	(Br,Ar,Sp)	Strongylobrochus	(Br,Ar,Te)	Stylastraea	(Cn,An,Ru)
Striithyris	(Br,Ar,Te)	Strongylocentrotus	(Ec,Ec,Ec)	Stylactractus	(Ac,Ra,Sp)
Strimodiolus	(Mo,Bi,Mt)	Strongylocera	(Mo,Ga,Ne)	Stylidium	(Mo,Ga,Nt)
Strimplecrinus	(Ec,Cr,Mo)	Strongylocrinus	(Ec,Cr,Ci)	Stylina	(Cn,An,Sc)
Stringocephalus	(Br,Ar,Te)	Strongylopora	(Bz,Gy,Ch)	Styliola	(Mo,Cr,Da)
Stringodiscus	(Br,Ar,Te)	Strongyloria	(Br,Ar,Rh)	Styliolina	(Mo,Cr,Da)
Stringomimus	(Br,Ar,Te)	Strongylosteus	(Cd,Os,Pa)	Stylocapsa	(Ac,Ra,Na)
Stringophylloides	(Cn,An,Ru)	Strophalosia	(Br,Ar,St)	Stylochlamydidium	(Ac,Ra,Sp)
Stringophyllum	(Cn,An,Ru)	Strophalosiella	(Br,Ar,St)	Stylocidaris	(Ec,Ec,Ci)
Striocadulus	(Mo,Sc,Se)	Strophalosiina	(Br,Ar,St)	Stylococenia	(Cn,An,Sc)
Striocarinata	(Mo,Ga,Nt)	Strophiceras	(Mo,Ce,Na)	Stylococeniella	(Cn,An,Sc)
Striochondria	(Mo,Bi,Pt)	Strophipora	(Bz,Gy,Ch)	Stylocora	(Cn,An,Sc)
Striochonetes	(Br,Ar,St)	Strophisterus	(Cd,Pt,Pt)	Stylocrinus	(Ec,Cr,Ds)
Striodostomia	(Mo,Ga,He)	Strophocardia	(Mo,Bi,Ve)	Stylocryptocapsa	(Ac,Ra,Na)
Striolucina	(Mo,Bi,Ve)	Strophochonetes	(Br,Ar,St)	Stylocyathus	(Cn,An,Sc)
Strionautilus	(Mo,Ce,Na)	Strophodonta	(Br,Ar,St)	Stylocyclia	(Ac,Ra,Sp)
Striostrea	(Mo,Bi,Pt)	Strophomena	(Br,Ar,St)	Stylodictya	(Ac,Ra,Sp)
Strioterebrum	(Mo,Ga,Ne)	Strophonella	(Br,Ar,St)	Styloides	(Cd,Os,Pl)
Strioturbonilla	(Mo,Ga,He)	Strophonellites	(Br,Ar,St)	Stylonema	(Mo,Ga,Nt)
Striticephala	(Ar,Tr,Pt)	Strophonelloides	(Br,Ar,St)	Stylonites	(Cn,An,Ta)

Stylonurella	(Ar.Me.Eu)	Subligaculum	(Ar.Os.Pa)	Sulcagloborilus	(Hy.Or.Gl)
Stylonuroides	(Ar.Me.Eu)	Sublithacoceras	(Mo.Ce.Am)	Sulcastrella	(Po.De.Li)
Stylonurus	(Ar.Me.Eu)	Sublobaloceras	(Ec.Cr.Cl)	Sulcetagnostus	(Ar.Ti.Ag)
Stylopegma	(Po.De.Pe)	Sublunuloceras	(Mo.Ce.Am)	Sulcataria	(Br.Ar.St)
Stylophora	(Cn.An.Sc)	Submantelliceras	(Mo.Ce.Am)	Sulcathyris	(Br.Ar.Sp)
Stylophylopsis	(Cn.An.Sc)	Submeekoceras	(Mo.Ce.Ce)	Sulcatiella	(Ar.Os.Pa)
Stylophyllum	(Cn.An.Sc)	Submesofavosites	(Cn.An.Ru)	Sulcatina	(Br.Ar.Rh)
Stylopleura	(Cn.An.Ru)	Submortoniceras	(Mo.Ce.Am)	Sulcatinella	(Br.Ar.Te)
Styloplocus	(Mo.Ga.Nt)	Subnebrodites	(Mo.Ce.Am)	Sulcatopinna	(Mo.Bi.Mt)
Stylopoma	(Bz.Gy.Ch)	Subneumayria	(Mo.Ce.Am)	Sulcatorthis	(Br.Ar.Or)
Styloporella	(Po.De.St)	Subninella	(Mo.Ga.Ar)	Sulcatospira	(Br.Ar.At)
Stylopsammia	(Cn.An.Sc)	Subolenekites	(Mo.Ce.Ce)	Sulcatospirifer	(Br.Ar.Sp)
Stylosmia	(Cn.An.Sc)	Suboosterella	(Mo.Ce.Am)	Sulcatostrophia	(Br.Ar.St)
Stylosphaera	(Ac.Ra.Sp)	Subpenhsioceras	(Mo.Ce.En)	Sulcatothyris	(Br.Ar.Te)
Stylospongia	(Ac.Ra.Sp)	Subperrinites	(Mo.Ce.Go)	Sulcavitus	(Hy.Hy.Hy)
Stylostaurus	(Ac.Ra.Sp)	Subplanites	(Mo.Ce.Am)	Sulcella	(Ar.Os.Me)
Stylostroma	(Po.De.St)	Subprionoicyelus	(Mo.Ce.Am)	Sulcicosta	(Br.Ar.Sp)
Stylotheuthis	(Mo.Ce.Te)	Subpterynotus	(Mo.Ga.Ne)	Sulcicostula	(Br.Ar.Rh)
Stylothalamia	(Po.De.Ve)	Subpuchellia	(Mo.Ce.Am)	Sulcicuneta	(Ar.Os.Pa)
Stylostrochus	(Cn.An.Sc)	Subrensellandia	(Br.Ar.Te)	Sulciferites	(Mo.Ce.Am)
Styptosphaera	(Ac.Ra.Sp)	Subretepora	(Bz.St.Fe)	Sulcilioconcha	(Mo.Bi.Ve)
Styracoceras	(Mo.Ce.Am)	Subriana	(Mo.Ce.Am)	Sulcimiticeras	(Mo.Ce.Go)
Styracocrinus	(Ec.Cr.Rv)	Subsajnella	(Mo.Ce.Am)	Sulciphoria	(Br.Ar.Rh)
Styracodus	(Cd.Ch.Ct)	Subshumardites	(Mo.Ce.Go)	Sulcipleca	(Br.Ar.Sp)
Styracopterus	(Cd.Os.Pa)	Subsinuecephalus	(Br.Ar.Te)	Sulciplecatatrypa	(Br.Ar.At)
Styracoteuthis	(Mo.Ce.Se)	Subspirifer	(Br.Ar.Sp)	Sulcironchia	(Br.Ar.Rh)
Styrionautilus	(Mo.Ce.Na)	Subspsyroceras	(Mo.Ce.Or)	Sulcirostra	(Br.Ar.Rh)
Styrioplax	(Ar.Ml.De)	Substeuoceras	(Mo.Ce.Am)	Sulcirurgia	(Br.Ar.St)
Styrites	(Mo.Ce.Ce)	Substreblites	(Mo.Ce.Am)	Sulcispiriferina	(Br.Ar.Sp)
Styxosaurus	(Cd.Re.Ps)	Substriatifa	(Br.Ar.St)	Sulcoactaeon	(Mo.Ga.Ce)
Suavodrililla	(Mo.Ga.Ne)	Substuozeis	(Cn.An.Sc)	Sulcoecardia	(Mo.Bi.Ve)
Subalpinites	(Mo.Ce.Am)	Subtaeniothraerus	(Br.Ar.St)	Sulcoecarina	(Mo.St.St)
Subalveolina	(Fo.Fo.Fo)	Subtella	(Ar.Os.Pa)	Sulcoecava	(Bz.St.Ce)
Subalveolitella	(Cn.An.Ta)	Subthurmannia	(Mo.Ce.Am)	Sulcocephalus	(Ar.Tr.Pt)
Subalveolites	(Cn.An.Ta)	Subtilicyathus	(Cn.An.Sc)	Sulcoelymenia	(Mo.Ce.Cl)
Subanarcestes	(Mo.Ce.Am)	Subtilocyathus	(Po.Re.Aj)	Sulcoeypraea	(Mo.Ga.Nt)
Subansiria	(Br.Ar.Sp)	Subtissotia	(Mo.Ce.Am)	Sulcodimorphoceras	(Mo.Ce.Go)
Subarecthoplites	(Mo.Ce.Am)	Subtransmena	(Br.Ar.St)	Sulcodirtyoceras	(Mo.Ce.Go)
Subarectocrinus	(Ec.Cr.Cl)	Subula	(Mo.Ga.Ne)	Sulcogladius	(Mo.Ga.Nt)
Subascosymplegma	(Po.De.Pe)	Subulacypris	(Ar.Os.Po)	Sulcohamites	(Mo.Ce.Am)
Subastiera	(Mo.Ce.Am)	Subulatachlamys	(Mo.Bi.Pt)	Sulcohamitoides	(Mo.Ce.Am)
Subaxopora	(Cn.Hy.Mi)	Subuliscala	(Mo.Ga.Nt)	Sulcohoplites	(Mo.Ce.Am)
Subbarroisiceras	(Mo.Ce.Am)	Subulites	(Mo.Ga.Nt)	Sulconatica	(Mo.Ga.Nt)
Subbelloidina	(Fo.Fo.Fo)	Subutaratua	(Cn.An.Ru)	Sulcopeculina	(Fo.Fo.Fo)
Subbonarella	(Mo.Ce.Am)	Subvenericardia	(Mo.Bi.Ve)	Sulcorbitoides	(Fo.Fo.Fo)
Subbotina	(Fo.Fo.Fo)	Subvertebriceras	(Mo.Ce.Am)	Sulcoretepora	(Bz.St.Cy)
Subbryantodus	(Cd.Co.Co)	Subvestinautilus	(Mo.Ce.Na)	Sulcoretusa	(Mo.Ga.Ce)
Subcaliapor	(Cn.An.Ta)	Subvishnutes	(Mo.Ce.Ce)	Sulcorhynchia	(Br.Ar.Rh)
Subcancilla	(Mo.Ga.Ne)	Suchium	(Mo.Ga.Ar)	Sulcorinella	(Mo.Ga.He)
Subclimax	(Mo.Ga.Nt)	Suchosaurus	(Cd.Re.Cr)	Sulcorphyllum	(Cn.An.Ru)
Subclymenia	(Mo.Ce.Na)	Sucia	(Ec.As.Va)	Sulcosipho	(Mo.Ga.Ne)
Subcollina	(Mo.Ce.Am)	Sudetia	(Cn.An.Ru)	Sulcosubularia	(Mo.Ga.Nt)
Subcolumbites	(Mo.Ce.Ce)	Sudeticeris	(Mo.Ce.Go)	Sulcotrivia	(Mo.Ga.Nt)
Subcraspedites	(Mo.Ce.Am)	Sudon	(Ar.Os.Pa)	Sulcotarbonilla	(Mo.Ga.He)
Subcuspidella	(Br.Ar.Sp)	Suecoceras	(Mo.Ce.En)	Sulculus	(Mo.Ga.Ar)
Subdichotomoceras	(Mo.Ce.Am)	Suessia	(Br.Ar.Sp)	Sulcuna	(Ar.Os.My)
Subditotectarius	(Mo.Ga.Nt)	Suessonia	(Mo.Ga.Ne)	Sulcupentamerus	(Br.Ar.Pe)
Subglobozononetes	(Br.Ar.St)	Sufetirhyncha	(Br.Ar.Rh)	Sulevorthis	(Br.Ar.Or)
Subgrossovoria	(Mo.Ce.Am)	Sugaïtes	(Pr.Ca.Ca)	Sullivania	(Mo.Ga.Ne)
Subinyoites	(Mo.Ce.Ce)	Suggrunda	(Fo.Fo.Fo)	Sulmosaurus	(Cd.Re.Ps)
Subitoceras	(Mo.Ce.Go)	Sugiyamaella	(Cn.An.Ru)	Suludella	(Ar.Tr.Pt)
Subkossmatia	(Mo.Ce.Am)	Suiaella	(Br.Ar.Rh)	Sumatrina	(Fo.Fo.Fo)
Sublamarekella	(Fo.Fo.Fo)	Sula	(Cd.Av.Pe)	Summitkaraea	(Cn.An.Sc)
Sublandinia	(Mo.Bi.Ve)	Sulakocetus	(Cd.Ma.Ce)	Sumsarophyllum	(Cn.An.Ru)

Sunaspis	(Ar.Tr.Un)	Sweetocristatus	(Cd.Co.Co)	Syndielasma	(Br.Ar.St)
Sundabittium	(Mo.Ga.Nt)	Sweetognathus	(Cd.Co.Co)	Syndosmya	(Mo.Bi.Ve)
Sundacrinus	(Ec.Cr.Cl)	Swittopecten	(Mo.Bi.Pt)	Syndogyrapus	(He.Gr.Gr)
Sundaïtes	(Mo.Ce.Pl)	Sychnoelasma	(Cn.An.Ru)	Synechodus	(Cd.Ch.In)
Sundayichthys	(Cd.Os.Pa)	Sycoceras	(Mo.Ce.On)	Syneck	(Mo.Bi.Mt)
Sunella	(Ar.Os.Ar)	Sycocrinites	(Ec.Cr.Cl)	Synrocirus	(Ec.Cr.Tx)
Sunetta	(Mo.Bi.Ve)	Sycodes	(Mo.Ga.Ne)	Synetoceras	(Mo.Ce.Di)
Sunettina	(Mo.Bi.Ve)	Sycodictya	(Po.He.Re)	Syngastroceras	(Mo.Ce.Go)
Sunia	(Ar.Tr.Co)	Sycophantia	(Ar.Tr.Ph)	Syngenochelus	(Mo.Ga.Ne)
Sunicyathus	(Pr.Cr.Cr)	Sycopsis	(Mo.Ga.Ne)	Syngnathus	(Cd.Os.Ga)
Sunites	(Mo.Ce.Go)	Sycospira	(Mo.Ga.Ne)	Synhelia	(Cn.An.Sc)
Sunaginina	(Pr.To.Un)	Sycostoma	(Mo.Ga.Ne)	Synhomalonotus	(Ar.Tr.Ph)
Sunophyllum	(Cn.An.Ru)	Sycotypus	(Mo.Ga.Ne)	Synhypuralis	(Cd.Os.Ga)
Sunosuchus	(Cd.Re.Cr)	Sydaphera	(Mo.Ga.Ne)	Synnotum	(Bz.Gy.Ch)
Sunwaptacrinus	(Ec.Cr.Mo)	Sygcauloerinus	(Ec.Cr.Ds)	Synocladia	(Bz.St.Fe)
Sunwaptia	(Ar.Tr.Pt)	Sylithis	(Ar.Os.Pa)	Synocladopsis	(Bz.St.Fe)
Superciliaspis	(Cd.Pt.Un)	Syllomus	(Cd.Re.Ch)	Synodontaspis	(Cd.Ch.La)
Supercytis	(Bz.St.Ce)	Sylonika	(Bz.Gy.Ch)	Synodontites	(Mo.Bi.Hi)
Superstes	(Mo.Ga.Ce)	Sylthere	(Ar.Os.Po)	Synodus	(Cd.Os.Al)
Supertrilobus	(Br.Ar.Pe)	Syltherella	(Ar.Os.Po)	Synopella	(Po.Ca.Ph)
Supervallpus	(Ac.Ra.Sp)	Syltispungia	(Po.De.Li)	Synphariceras	(Mo.Ce.An)
Supplanaxis	(Mo.Ga.Nt)	Sylvestra	(Ar.Os.Po)	Synphoria	(Ar.Tr.Ph)
Suprazonalis	(Mo.Ga.Ar)	Sylvestrosphaera	(Mo.Ga.Be)	Synphoroides	(Ar.Tr.Ph)
Surcula	(Mo.Ga.Ne)	Sylviacoscinus	(Po.Re.Aj)	Syntactactinia	(Ac.Ra.Sp)
Surculina	(Mo.Ga.Ne)	Symbiangia	(Cn.An.Sc)	Syntengmodus	(Cd.Os.Cr)
Surculites	(Mo.Ga.Ne)	Symbolophorus	(Cd.Os.My)	Synthetodus	(Cd.Ch.In)
Surculoma	(Mo.Ga.Ne)	Symethis	(Ar.ML.De)	Synthetostroma	(Po.De.St)
Surenites	(Mo.Ce.Go)	Symmatrypa	(Br.Ar.At)	Syntomocrinus	(Ec.Cr.Sa)
Suriekovella	(Ar.Os.Po)	Symmetrocapsulus	(Mo.Ga.Pa)	Syntomodrillia	(Mo.Ga.Ne)
Surindia	(Br.Un.Un)	Symmetropirion	(An.Po.Eu)	Syntomodus	(Cd.Ch.Eu)
Susus	(Ar.Os.Pa)	Symmoirium	(Cd.Ch.Sy)	Syntomopterius	(Ar.Me.Eu)
Sutherlandia	(Cn.An.Ta)	Symmorphomactra	(Mo.Bi.Ve)	Syntomospina	(Ec.Op.Op)
Sutneria	(Mo.Ce.Am)	Symphodus	(Cd.Os.Pf)	Syntrophia	(Br.Ar.Pe)
Suttonoceras	(Mo.Ce.On)	Symphurus	(Cd.Os.Pn)	Syntrophina	(Br.Ar.Pe)
Suvalkeilla	(Ar.Os.Pa)	Symphyllia	(Cn.An.Sc)	Syntrophinaella	(Br.Ar.Pe)
Suzinia	(Ar.Os.Po)	Symphiphyllum	(Cn.An.Ru)	Syntrophioidea	(Br.Ar.Un)
Svalbardia	(Br.Ar.St)	Symphysops	(Ar.Tr.As)	Syntrophodonta	(Br.Ar.St)
Svalbardiceras	(Mo.Ce.Ce)	Symphysurina	(Ar.Tr.As)	Syntrophopsis	(Br.Ar.Pe)
Svalbardites	(Ar.Tr.Pt)	Symphysurus	(Ar.Tr.As)	Synualoceras	(Mo.Ce.Go)
Svalbardoproductus	(Br.Ar.St)	Symphylthyris	(Br.Ar.Te)	Synwocklumeria	(Mo.Ce.Cl)
Svalbardosaurus	(Cd.Re.Ic)	Symplectophyllum	(Cn.An.Ru)	Synphocrinus	(Ec.Cr.Cl)
Svalbardophyllum	(Cn.An.Ru)	Symplectoteuthis	(Mo.Ce.Te)	Sypharatomya	(Br.Ar.At)
Svaljavithyris	(Br.Ar.Te)	Sympolycyclus	(Mo.Ce.Ce)	Syphax	(Ar.ML.De)
Svantovites	(Ar.Os.Pa)	Synagrops	(Cd.Os.Pf)	Syrdentis	(Mo.Ce.Pl)
Svarogites	(Ar.Os.My)	Synamplexoides	(Cn.An.Ru)	Syringaxon	(Cn.An.Ru)
Svatojonitella	(Ar.Os.Me)	Synamplexus	(Cn.An.Ru)	Syringium	(Ac.Ra.Na)
Svealuta	(Ar.Os.Ar)	Synaptaella	(Bz.Gy.Ch)	Syringolalycon	(Cn.An.Ta)
Sveltella	(Mo.Ga.Ne)	Synaptites	(Ec.Ho.Ap)	Syringocapsa	(Ac.Ra.Na)
Sveltia	(Mo.Ga.Ne)	Synaptocochlea	(Mo.Ga.Ar)	Syringoceras	(Mo.Ce.Na)
Svenia	(Fo.Fo.Fo)	Synaptocrinus	(Ec.Cr.Sa)	Syringoclemis	(Bz.St.Fe)
Sverdrupites	(Mo.Ce.Go)	Synaptophyllum	(Cn.An.Ru)	Syringocnema	(Po.Ir.Ar)
Sverigophyllum	(Cn.An.Ru)	Synaptotylus	(Cd.Os.Co)	Syringocolumna	(Cn.An.Ta)
Svetlania	(Cn.An.Ru)	Synarmocrinus	(Ec.Cr.Cl)	Syringocrinus	(Ec.Hs.So)
Svetlanoceras	(Mo.Ce.Go)	Synartinskia	(Mo.Ce.Pl)	Syringocyathus	(Po.Re.Aj)
Svetlanocyathus	(Po.Re.Aj)	Synastraea	(Cn.An.Sc)	Syringodictyon	(Po.De.St)
Svobodaina	(Br.Ar.Or)	Synatrypa	(Br.Ar.At)	Syringoheliolites	(Cn.An.Ta)
Svratkina	(Fo.Fo.Fo)	Synauchenia	(Cd.Pl.Ar)	Syringolites	(Cn.An.Ta)
Swaicoelia	(Br.Ar.Sp)	Synaulia	(Po.He.He)	Syringonautilus	(Mo.Ce.Na)
Swaincoythere	(Ar.Os.Po)	Synbathocrinus	(Ec.Cr.Ds)	Syringopora	(Cn.An.Ta)
Swainsonia	(Mo.Ga.Ne)	Syncera	(Mo.Ga.Nt)	Syringoporella	(Cn.An.Ta)
Swantina	(Ar.Os.Pa)	Synchirocrinus	(Ec.Cr.Ds)	Syringoporiella	(Cn.An.Ta)
Swantonia	(Br.Ar.Un)	Syncyclonema	(Mo.Bi.Pt)	Syringoporiinus	(Cn.An.Ta)
Swartzochilina	(Ar.Os.Le)	Syndetocrinus	(Ec.Cr.Cl)	Syringospira	(Br.Ar.Sp)
Sweetina	(Cd.Co.Co)	Syndianella	(Ar.Tr.Re)	Syringostroma	(Po.De.St)

Syringostromella	(Po,De,St)	Taeniopora	(Bz,St,Cy)	Tallinnoceras	(Mo,Ce,En)
Syringostromina	(Po,De,Ax)	Taenioporella	(Bz,Gy,Ch)	Tallinnopsis	(Ar,Os,Pa)
Syringotaenia	(He,Gr,Ca)	Taenioporina	(Bz,Gy,Ch)	Talmontipora	(Bz,St,Ce)
Syringothalamus	(Po,Ir,Ar)	Taeniospira	(Mo,Ga,Ar)	Talocodakia	(Mo,Bi,Ve)
Syringothyris	(Br,Ar,Sp)	Taeniothaerus	(Br,Ar,St)	Talopena	(Mo,Ga,Ar)
Syrionautilus	(Mo,Ce,Na)	Taenora	(Ar,Tr,Pt)	Talostolida	(Mo,Ga,Nt)
Synola	(Mo,Ga,He)	Taffertia	(Mo,Ce,Am)	Talovkorhynchia	(Br,Ar,Rh)
Syrotrogonia	(Mo,Bi,Tr)	Taftia	(Br,Ar,St)	Talparia	(Mo,Ga,Nt)
Syreghmatoceras	(Mo,Ce,Na)	Tafilalichthys	(Cd,Pl,Ar)	Talpaspongia	(Po,Ca,He)
Syspacephalus	(Ar,Tr,Pt)	Tafilaltia	(Br,Ar,Or)	Talpinella	(Fo,Fo,Fo)
Syspacheilus	(Ar,Tr,Pt)	Tagelus	(Mo,Bi,Ve)	Tamaranella	(Ar,Tr,Pt)
Systemocythere	(Ar,Os,Po)	Tagenocrinus	(Ec,Cr,Sa)	Tamarella	(Br,Ar,Te)
Systemostoma	(Bz,Gy,Ch)	Tahudrilla	(Mo,Ga,Ne)	Tamarites	(Mo,Ce,An)
Systemothyris	(Br,Ar,Te)	Tahusyrix	(Mo,Ga,Ne)	Tamaroclema	(Bz,St,Cr)
Systrochoceras	(Mo,Ce,Ta)	Taidocrinus	(Ec,Cr,Ds)	Tambegiroceras	(Mo,Ce,Or)
Sytovaellites	(Cn,An,Ta)	Taidonorus	(Ar,Tr,Un)	Tambovia	(Ar,Os,Pa)
Syzranella	(Fo,Fo,Fo)	Taieria	(Mo,Ga,Nt)	Tamdaspis	(Ar,Tr,Un)
Syzrania	(Fo,Fo,Fo)	Taihungshania	(Ar,Tr,As)	Tamiobatis	(Cd,Ch,Ct)
Syzygophyllia	(Cn,An,Se)	Taimanawa	(Ec,Ec,Sp)	Tamiosoma	(Ar,Ci)
Szechuanaspis	(Ar,Tr,Ag)	Taimyrella	(Br,Ar,Sp)	Tampsia	(Mo,Bi,Hi)
Szechuanella	(Ar,Tr,Pt)	Taimyria	(Mo,Bi,Ph)	Tanblastus	(Ec,Bi,Sp)
Szechuanophyllum	(Cn,An,Ru)	Taimyrophyllum	(Cn,An,Ru)	Tanakura	(Br,Ar,Te)
Tabantalites	(Mo,Ce,Go)	Taimyropsis	(Br,Ar,St)	Tanalopsis	(Mo,Ga,Ar)
Tabantoloceras	(Mo,Ce,An)	Taimyothyris	(Br,Ar,Te)	Tanaocystis	(Ec,Rh,Rh)
Tabarhynchus	(Br,Ar,Rh)	Taimyrrhynch	(Br,Ar,Rh)	Tanaodon	(Mo,Bi,Mo)
Tabatopygellina	(Ar,Tr,Co)	Taimionautilus	(Mo,Ce,Na)	Tanaodus	(Cd,Ch,In)
Tabellaephyllum	(Cn,An,Ta)	Tainoceras	(Mo,Ce,Na)	Tanbaella	(Cn,An,Ru)
Tabellina	(Br,Ar,Sp)	Tainotoechia	(Br,Ar,Rh)	Tanbaotites	(Pr,Ca,Ca)
Taberina	(Fo,Fo,Fo)	Tainuirhynchia	(Br,Ar,Rh)	Tanchintongia	(Mo,Bi,Pt)
Tabulacomus	(Cn,He,He)	Taioima	(Mo,Ga,Ne)	Tancredia	(Mo,Bi,Ve)
Tabulacysthelus	(Po,Li,Ar)	Taishania	(Ar,Tr,Pt)	Tancrediopsis	(Mo,Bi,Nu)
Tabulacysthus	(Po,Re,Aj)	Taisyakophyllum	(Cn,An,Ru)	Tancretella	(Mo,Bi,Ve)
Tabularia	(Cn,An,Ru)	Taita	(Mo,Ga,Ce)	Tanea	(Mo,Ga,Nt)
Tabulopora	(Bz,St,Tr)	Taitia	(Pr,Un,In)	Tanella	(Ar,Os,Po)
Tabuloporella	(Bz,St,Tr)	Taitzehoella	(Fo,Fo,Fo)	Tanerhynchia	(Br,Ar,Rh)
Tabulophyllum	(Cn,An,Ru)	Taitzia	(Ar,Tr,Co)	Tangarasaurus	(Cd,Ma,Ce)
Tachylasma	(Cn,An,Ru)	Taiwanocorbicula	(Mo,Bi,Ve)	Tangchiashanites	(Mo,Ce,Na)
Tachyneetes	(Cd,Os,El)	Taiwanobarnea	(Mo,Bi,Ve)	Tangkularella	(Br,Ar,Rh)
Tachyneetes	(Cd,Os,My)	Taizitheophyllum	(Cn,An,Ru)	Tangshanaspis	(Ar,Tr,Pt)
Tachyphyllum	(Cn,An,Ru)	Tajaroceras	(Mo,Ce,Or)	Tangshanella	(Br,Ar,Sp)
Tachypleus	(Ar,Me,Xi)	Tajinella	(Hy,Hy,Hy)	Tangshanodus	(Cd,Co,Co)
Tachyrhynchella	(Mo,Ga,Nt)	Tajurina	(Ar,Os,Pa)	Tangxiangia	(Br,Ar,St)
Tachyrhynchus	(Mo,Ga,Nt)	Takakkawia	(Po,De,Ha)	Tangyagraptus	(He,Gr,Gr)
Tacinia	(Br,Ar,Te)	Takayanagia	(Fo,Fo,Fo)	Taniella	(Mo,Ga,Nt)
Tadakoustia	(Ar,Tr,Re)	Takia	(Mo,Ga,Ne)	Tanimasanoria	(Mo,Ga,Ne)
Tadschikia	(Br,Ar,Rh)	Taklamakania	(Ar,Tr,As)	Taniwhasaurus	(Cd,Re,Sq)
Taemasaspis	(Ar,Tr,Od)	Talabrica	(Mo,Bi,Ve)	Tannuas-pis	(Cd,Ce,Ce)
Taemasosteus	(Cd,Pl,Ar)	Talaeomarroolithus	(Ar,Tr,As)	Tannuella	(Mo,He,He)
Taemasotrochus	(Mo,Ga,Ar)	Talahabia	(Mo,Ga,Ce)	Tannuolina	(Pr,To,Mi)
Taemostrophia	(Br,Ar,St)	Talantodiscus	(Mo,Ga,Ar)	Tannuspira	(Mo,In,In)
Taeniactis	(Ec,As,He)	Talarocrinus	(Ec,Cr,Mo)	Tannuspirifer	(Br,Ar,Sp)
Taeniaeacyathellus	(Po,Ir,Ar)	Talaspoductus	(Br,Ar,St)	Tantunia	(Mo,Ga,Ne)
Taeniarcia	(Mo,Bi,Ar)	Talassoceras	(Mo,Ce,En)	Tanuchitina	(Fo,Fo,Ch)
Taeniaster	(Ec,Op,Oe)	Talattoceras	(Mo,Ce,On)	Tanybregma	(Ar,Tr,Pr)
Taeniatumbo	(Mo,Ga,Ar)	Talbotina	(Ar,Tr,Pt)	Tanycameroceras	(Mo,Ce,El)
Taenicephalina	(Ar,Tr,Pt)	Talbotinella	(Ar,Tr,Pt)	Tanyoscapa	(Br,Ar,Te)
Taenicephalites	(Ar,Tr,As)	Talestroma	(Po,De,St)	Tanyothyris	(Br,Ar,Te)
Taenicephalus	(Ar,Tr,As)	Talentella	(Br,Ar,Or)	Tanzanicythere	(Ar,Os,Po)
Taenioceclana	(Bz,Gy,Ch)	Talentoceras	(Mo,Ce,An)	Taopuoceras	(Mo,Ce,Di)
Taenioconger	(Cd,Os,An)	Taleoleptaena	(Br,Ar,St)	Taopuognathus	(Cd,Co,Co)
Taeniodyctya	(Bz,St,Cr)	Talimuella	(Fo,Fo,Fo)	Taopuospira	(Br,Ar,At)
Taeniodon	(Mo,Bi,Un)	Talitiyphis	(Mo,Ga,Ne)	Taosia	(Mo,Ga,Ar)
Taeniolepis	(Cd,Pl,An)	Tallinnella	(Ar,Os,Pa)	Taoyuania	(Ar,Tr,Pt)
Taenioletes	(Cn,An,Ta)	Tallinnellina	(Ar,Os,Pa)	Tapajotia	(Br,Ar,St)

Tapashanites	(Mo,Ce,Ce)	Tasmanocephalus	(Ar,Tr,Pt)	Tebitopora	(Bz,St,Cr)
Tapes	(Mo,Bi,Ve)	Tasmanoceras	(Mo,Ce,En)	Techinitella	(Fo,Fo,Fo)
Taphraster	(Ec,Ec,Hs)	Tasmanoconularia	(Cn,Sc,Cn)	Technocrinus	(Ec,Cr,Mo)
Taphrodonta	(Br,Ar,St)	Tasmanocrinus	(Ec,Cr,C)	Technophorus	(Mo,Ro,Ri)
Taphrognathus	(Cd,Co,Co)	Tasmanognathus	(Cd,Co,Co)	Tecnocytina	(Br,Ar,Sp)
Taphrorthis	(Br,Ar,Or)	Tasselia	(Pg)	Tectamichelina	(Cn,An,Ta)
Taphrosaurus	(Cd,Re,Ps)	Tastaria	(Br,Ar,St)	Tectaplicia	(Mo,Ga,Ne)
Taphroestria	(Br,Ar,St)	Tatara	(Mo,Ga,Nt)	Tectarea	(Br,Ar,St)
Taphrostoma	(Bz,Gy,Ch)	Tatariella	(Ar,Os,Un)	Tectariopsis	(Mo,Ga,Ar)
Taphrostomia	(Mo,Ga,He)	Tateana	(Cn,In,In)	Tectarius	(Mo,Ga,Nt)
Tapinocalymene	(Ar,Tr,Ph)	Tatechinus	(Ec,Ec,Te)	Tectatrypa	(Br,Ar,At)
Tapinocrinus	(Ec,Ce,C)	Tateiwaia	(Mo,Ga,Nt)	Tectifusus	(Mo,Ga,Ne)
Tapinogyra	(Mo,Pa,HY)	Tatella	(Mo,Bi,Un)	Tectiritites	(Mo,Ce,Go)
Tapinosteus	(Cd,Pl,Ar)	Tatjamao	(Br,Ar,Rh)	Tectonatica	(Mo,Ga,Nt)
Tapinotomaria	(Mo,Ga,Ar)	Tatjania	(Br,Ar,Rh)	Tectospira	(Mo,Ga,Ar)
Taplimella	(Ar,Tr,Un)	Tatjanophyllum	(Cn,An,Ru)	Tectura	(Mo,Ga,Pa)
Taplowia	(Po,De,Li)	Tatonaspis	(Ar,Tr,Pt)	Tectus	(Mo,Ga,Ar)
Tappanella	(Fo,Fo,Fo)	Tatulaspis	(Ar,Tr,Pt)	Teganium	(Po,He,Re)
Tappanina	(Fo,Fo,Fo)	Taucatillocrinus	(Ec,Cr,Ds)	Tegaspis	(Ar,Os,Un)
Tarachiocrinus	(Ec,Ce,C)	Taunaspis	(Cd,Pl,Ar)	Tegea	(Ar,Os,Pa)
Taractopora	(Bz,Gy,Ch)	Taurasia	(Mo,Ga,Ne)	Tegella	(Bz,Gy,Ch)
Taracythere	(Ar,Os,Po)	Tauraxinus	(Mo,Bi,Ve)	Tegeolepis	(Cd,Os,Pa)
Taralasma	(Cn,An,Ru)	Tauricella	(Mo,Ga,He)	Tegerocyathus	(Po,Re,Aj)
Taramellia	(Mo,Ga,Nt)	Tauriconites	(Mo,Ce,Be)	Tegillarca	(Mo,Bi,Ar)
Taramelliceras	(Mo,Ce,Am)	Taurinichthys	(Cd,Os,Pf)	Tegmenia	(Ar,Os,Po)
Tarandrospirifer	(Br,Ar,Sp)	Taurinocrinus	(Ec,Cr,Is)	Tegoceras	(Mo,Ce,Am)
Taranis	(Mo,Ga,Ne)	Tauroceras	(Mo,Ce,Go)	Tegopelte	(Ar,Tr,Na)
Tarantinaea	(Mo,Ga,Ne)	Taurocrinus	(Ec,Cr,Cy)	Tegula	(Mo,Ga,Ar)
Tarantocrinus	(Ec,Cr,Mo)	Tauromenia	(Br,Ar,Te)	Tegulella	(Br,Un,Un)
Taras	(Mo,Bi,Ve)	Taurotapes	(Mo,Bi,Ve)	Teguliferina	(Br,Ar,St)
Taraxaculum	(Po,Ca,He)	Taurothyris	(Br,Ar,Te)	Tegulithyris	(Br,Ar,Te)
Tarbagatailites	(Cn,An,Ta)	Tauschia	(Mo,Ga,Ar)	Tegulooera	(Br,Ar,Sp)
Tarbellastraea	(Cn,An,Sc)	Tautosia	(Br,Ar,Rh)	Tegulorhynchia	(Br,Ar,Rh)
Tardeceras	(Mo,Ce,Ce)	Tavanicythere	(Ar,Os,Po)	Tehuacana	(Ar,ML,De)
Tareyaspis	(Cd,Pl,Pt)	Tavayzopora	(Bz,St,Fe)	Teichaster	(Ec,As,Va)
Tarfaya	(Br,Ar,Or)	Tavsenia	(Ar,Tr,Pt)	Teichertia	(Mo,Ce,Na)
Tarijaetinoidea	(Ar,Tr,Ph)	Tawera	(Mo,Bi,Ve)	Teicherticeras	(Mo,Ce,An)
Tarletonbeania	(Cd,Os,My)	Tawstockia	(Ar,Tr,Pr)	Teichertina	(Br,Ar,Or)
Taron	(Mo,Ga,Ne)	Tawuphyllum	(Cn,An,Ru)	Teichertoceras	(Mo,Ce,Di)
Tarphophragma	(Bz,St,Tr)	Taxocrinus	(Ec,Cr,Tx)	Teichertops	(Ar,Tr,Ph)
Tarphyceras	(Mo,Ce,Ta)	Taxodiella	(Ar,Os,Po)	Teichoelilina	(Ar,Os,Le)
Tarphyphyllum	(Cn,An,Ru)	Taxogyra	(Cn,An,Sc)	Teichopora	(Bz,Gy,Ch)
Tarphypygus	(Ec,Ec,C)	Taxonia	(Mo,Ga,Nt)	Teichostrophia	(Br,Ar,St)
Tarraconogyra	(Cn,An,Sc)	Taxyceras	(Mo,Ce,Di)	Teichispira	(Mo,Ga,Mc)
Tarrantoceras	(Mo,Ce,Am)	Tayamaia	(Fo,Fo,Fo)	Teilostoma	(Mo,Ga,Nt)
Tarrasius	(Cd,Os,Ta)	Tayanaella	(Ar,Tr,Pr)	Teinistion	(Ar,Tr,Pt)
Tarricoia	(Ar,Tr,Na)	Taylorcyathus	(Po,Re,Aj)	Teinostoma	(Mo,Ga,Nt)
Tarricola	(Ar,Tr,Un)	Tayshira	(Pr,Un,In)	Teinostomopsis	(Mo,Ga,Ar)
Tarsopterella	(Ar,Me,Eu)	Tazzarinia	(Br,Ar,Or)	Tejonina	(Mo,Ga,Nt)
Tartaroceras	(Mo,Ce,Or)	Tazzemmouria	(Ar,Tr,Un)	Tekina	(Ar,Tr,Pr)
Tartuosteus	(Cd,Pl,Pt)	Tchadania	(Br,Ar,St)	Telaoshaleria	(Br,Ar,St)
Tarturia	(Mo,Bi,Pt)	Tchaispis	(Ar,Tr,Pt)	Telasco	(Mo,Ga,Ne)
Taruphyllum	(Cn,An,Ru)	Tchangshichiton	(Pr,Un,In)	Telegraphia	(Ar,Os,Pa)
Tarutiglossa	(Br,Li,Li)	Tcharatheca	(Hy,Or,Or)	Teleidosaurus	(Cd,Re,Cr)
Tarynaspis	(Ar,Tr,Co)	Tcharella	(Br,Ar,Pe)	Teleiocrinus	(Ec,Cr,Mo)
Tasbaeka	(Cd,Re,Ch)	Tehegemithyris	(Br,Ar,Te)	Teleiophyllia	(Cn,An,Sc)
Tashanomena	(Br,Ar,St)	Teherkesovia	(Ar,Tr,Pr)	Teleochilits	(Mo,Ga,Ne)
Taskanites	(Mo,Ce,An)	Tchernyshvioides	(Ar,Tr,Ag)	Teleoproductus	(Br,Ar,St)
Taskanoceras	(Mo,Ce,Di)	Tchizhovaella	(Ar,Os,Po)	Teleptyxis	(Mo,Ga,He)
Tasmalella	(Br,Ar,Rh)	Tchojacyathus	(Po,Ir,Ar)	Teleurhinus	(Cd,Re,Cr)
Tasmanammina	(Fo,Fo,Fo)	Tchukeraspis	(Ar,Tr,As)	Teleosaurus	(Cd,Re,Cr)
Tasmanaspis	(Ar,Tr,Un)	Tchuranitheca	(Hy,Or,Or)	Telephina	(Ar,Tr,Pt)
Tasmanicytidium	(Ec,St,Mi)	Tealba	(Mo,Bi,Ve)	Telepholis	(Cd,Os,Al)
Tasmanobalanus	(Ar,Ci)	Tebagathalamia	(Po,De,Pe)	Telermoceras	(Mo,Ce,Am)

Telescopium	(Mo,Ga,Nt)	Tentidonox	(Mo,Bi,Ve)	Terminaster	(Ec,As,Fo)
Telikosocrinus	(Ec,Cr,Cl)	Tentifrons	(Fo,Fo,Fo)	Terminvoluta	(Mo,Ga,Ne)
Teliocihilus	(Mo,Ga,Nt)	Tentilenticulina	(Fo,Fo,Fo)	Terrocrinus	(Ec,Cr,Is)
Teliocrinus	(Ec,Cr,Is)	Tenuiaetaeon	(Mo,Ga,Ce)	Terpnocrinus	(Ec,Cr,Cl)
Telistrophis	(Mo,Bi,Un)	Tenuiatrypa	(Br,Ar,At)	Terquemia	(Mo,Bi,Pt)
Telleria	(Mo,Ga,Nt)	Tenuicentrum	(Cd,Os,Br)	Terquemula	(Ar,Os,Po)
Tellerina	(Ar,Tr,As)	Tenuicerithium	(Mo,Ga,Nt)	Terraia	(Mo,Bi,Ve)
Telleroceras	(Mo,Ce,En)	Tenuichonetes	(Br,Ar,St)	Terrakea	(Br,Ar,St)
Tellidora	(Mo,Bi,Ve)	Tenuicorbula	(Mo,Bi,My)	Terranovella	(Ar,Tr,Pt)
Tellidorella	(Mo,Bi,Ve)	Tenuicostella	(Br,Ar,Sp)	Terranovia	(Ar,Tr,Li)
Tellimya	(Mo,Bi,Ve)	Tenuilasma	(Cn,An,Ru)	Tervia	(Bz,St,Cc)
Tellina	(Mo,Bi,Ve)	Tenuimactra	(Mo,Bi,Ve)	Tesakoviaspis	(Cd,Pt,As)
Tellinella	(Mo,Bi,Ve)	Tenuipeltis	(Ar,Tr,Co)	Tesella	(Pr,To,Mi)
Tellinidella	(Mo,Bi,Ve)	Tenuiphyllum	(Cn,An,Ru)	Teshioites	(Mo,Ce,Am)
Tellinides	(Mo,Bi,Ve)	Tenuipteria	(Mo,Bi,Pt)	Tesnusocaris	(Ar,Re,En)
Tellinimactra	(Mo,Bi,Ve)	Tenuirachnius	(Ec,Ec,Cl)	Tessaradoma	(Bz,Gy,Ch)
Tellinimera	(Mo,Bi,Ve)	Tenuiscalia	(Mo,Ga,Nt)	Tessarastrum	(Ac,Ra,Sp)
Tellinocyclus	(Mo,Bi,Ve)	Tenuisinurostrum	(Br,Ar,Rh)	Tessarelasma	(Ar,Ci)
Tellinomorphia	(Mo,Bi,Ph)	Tepeyacia	(Mo,Bi,Hi)	Tessarolax	(Mo,Ga,Nt)
Tellinopsis	(Mo,Bi,Nu)	Tephlon	(Mo,Ga,Nt)	Tesselacauda	(Ar,Tr,Ph)
Tellinota	(Mo,Bi,Ve)	Terataspis	(Ar,Tr,Li)	Tesseracme	(Mo,Sc,Se)
Tellipiura	(Mo,Bi,Ve)	Teratelsasma	(Br,Ar,St)	Tesseroplax	(Ar,Ci)
Tellurimya	(Mo,Bi,Ve)	Teratelsasmella	(Br,Ar,St)	Tesseropora	(Ar,Ci)
Telmatornis	(Cd,Av,Ch)	Teratichthys	(Cd,Os,Pf)	Tessieria	(Ec,Ec,Sp)
Teloceras	(Mo,Ce,Am)	Teratorhynchus	(Ar,Tr,As)	Testacarinata	(Fo,Fo,Fo)
Telodactylus	(Mo,Ce,Am)	Tercyathellus	(Po,Re,Aj)	Testispongia	(Po,He,Ls)
Telopora	(Bz,St,Cc)	Tercyathus	(Po,Re,Aj)	Tetudinalia	(Mo,Ga,Ar)
Telothyris	(Br,Ar,Te)	Terebella	(An,Po,Te)	Tetudinaaster	(Ec,As,Va)
Temanella	(Mo,Ga,Nt)	Terebellaria	(Bz,St,Cc)	Tetsuquea	(Br,Ar,St)
Temblornia	(Mo,Bi,Ve)	Terebellites	(An,Po,Te)	Tetamocornu	(Mo,Te,Cy)
Tembrockia	(Mo,Ga,Nt)	Terebellolites	(An,Po,Te)	Tethocyathus	(Cn,An,Sc)
Temnechinus	(Ec,Ec,Te)	Terebellopsis	(Mo,Ga,Nt)	Tethyaster	(Ec,As,Px)
Temnocheilus	(Mo,Ce,Na)	Terebellum	(Mo,Ga,Nt)	Tettilopsis	(Po,De,As)
Temnocidaris	(Ec,Ec,Ci)	Terebra	(Mo,Ga,Ne)	Tetinka	(Mo,Bi,Pt)
Temnoconcha	(Mo,Bi,Ve)	Terebralia	(Mo,Ga,Nt)	Tetjuchithyris	(Br,Ar,Te)
Temnocrinus	(Ec,Cr,Sa)	Terebraliopsis	(Mo,Ga,Nt)	Tetoria	(Mo,Bi,Ve)
Temnodiscus	(Mo,Ga,Be)	Terebratalia	(Br,Ar,Te)	Tetrimya	(Mo,Bi,Ph)
Temnodontosaurus	(Cd,Re,Ic)	Terebrataliopsis	(Br,Ar,Te)	Tetrabelus	(Mo,Ce,Be)
Temnograptus	(He,Gr,Gr)	Terebratella	(Br,Ar,Te)	Tetrabrachiocrinus	(Ec,Cr,Cl)
Temnophyllum	(Cn,An,Ru)	Terebratula	(Br,Ar,Te)	Tetracamera	(Br,Ar,Rh)
Temnopleurus	(Ec,Ec,Te)	Terebratulina	(Br,Ar,Te)	Tetracapsa	(Ac,Ra,Na)
Temnoptychites	(Mo,Ce,Am)	Terebratuloidea	(Br,Ar,Rh)	Tetracarcinus	(Ar,Ml,De)
Temnospira	(Mo,Ga,At)	Terebrellina	(Mo,Ga,Ne)	Tetrachelus	(Ar,Ml,De)
Temnotrema	(Ec,Ec,Te)	Terebrifusius	(Mo,Ga,Ne)	Tetracidaris	(Ec,Ec,Ci)
Temnotropis	(Mo,Ga,Ar)	Terebrimya	(Mo,Bi,My)	Tetracionites	(Mo,Bi,Hi)
Temnoura	(Ar,Tr,As)	Terebripora	(Bz,Gy,Ct)	Tetracionocrinus	(Ec,Cr,Ds)
Temperoceras	(Mo,Ce,Or)	Terebrirostra	(Br,Ar,Te)	Tetracircinata	(Ac,Ra,Sp)
Tenagocrinus	(Ec,Cr,Cl)	Terebritoma	(Mo,Ga,Ne)	Tetracilita	(Ar,Ci)
Tenagodus	(Mo,Ga,Nt)	Terechtaspis	(Ar,Tr,Re)	Tetracrinus	(Ec,Cr,Cy)
Tenaturris	(Mo,Ga,Ne)	Teredina	(Mo,Bi,My)	Tetractinella	(Br,Ar,Sp)
Tendagurium	(Mo,Bi,Ve)	Teredinopsis	(Mo,Bi,My)	Tetractocrinus	(Ec,Cr,Un)
Tenea	(Mo,Bi,Ve)	Teredo	(Mo,Bi,My)	Tetracystis	(Ec,Rh,Rh)
Tenebriion	(Ar,Os,Pa)	Terefundus	(Mo,Ga,Ne)	Tetracytherurua	(Ar,Os,Po)
Tenedocythere	(Ar,Os,Po)	Terekites	(Mo,Ce,Go)	Tetradia	(Ar,Os,Pa)
Tenellodermis	(Br,Ar,Sp)	Terelimeella	(Mo,Ga,He)	Tetradella	(Ar,Os,Pa)
Teneposita	(Mo,Ga,Nt)	Teremelon	(Mo,Ga,Ne)	Tetraditryma	(Ac,Ra,Sp)
Tenisia	(Br,Ar,Sp)	Teretia	(Mo,Ga,Ne)	Tetradium	(Cn,An,Ta)
Tenisonina	(Fo,Fo,Fo)	Teretrina	(Mo,Ga,Nt)	Tetrafoissularia	(Cn,An,Ru)
Tenka	(Mo,Bi,Pt)	Tergrigorjanzaella	(Fo,Fo,Fo)	Tetragonetes	(Br,Ar,St)
Tennericyathus	(Po,Re,Aj)	Tergulina	(Mo,Bi,Ph)	Tetragonites	(Mo,Ce,Am)
Tennutella	(Fo,Fo,Fo)	Teridontus	(Cd,Co,Co)	Tetragonoceras	(Mo,Ce,Na)
Tennysonia	(Bz,St,Cc)	Termieraspis	(Ar,Tr,Pt)	Tetragonocrinus	(Ec,Cr,Ds)
Tentaculites	(Mo,Cr,Te)	Termierella	(Ar,Tr,Pt)	Tetragonoecia	(Bz,St,Cc)
Tenticospirifer	(Br,Ar,Sp)	Termieria	(Ec,Ec,Ca)	Tetragonolepis	(Cd,Os,Se)

Tetragonulina	(Fo,Fo,Fo)	Textivenus	(Mo,Bi,Ve)	Thanamites	(Mo,Ce,Ce)
Tetragonurus	(Cd,Os,Pf)	Textularia	(Fo,Fo,Fo)	Thanarla	(Ac,Ra,Na)
Tetragramma	(Ec,Ec,Hm)	Textulariella	(Fo,Fo,Fo)	Thanetinnassa	(Mo,Ga,Ne)
Tetragraptus	(He,Gr,Gr)	Textulariopsis	(Fo,Fo,Fo)	Tharriasis	(Cd,Os,Go)
Tetragregnon	(Ac,Ra,Sp)	Textulina	(Fo,Fo,Fo)	Tharsiella	(Mo,Ga,Ar)
Tetrahoplites	(Mo,Ce,Am)	Texturiphyllum	(Cn,An,Ru)	Tharsis	(Cd,Os,Pe)
Tetrahoplitoides	(Mo,Ce,Am)	Tezaquina	(Fo,Fo,Fo)	Thatcheria	(Mo,Ga,Ne)
Tetralasma	(Cn,An,Ru)	Thadomocenia	(Cn,An,Sc)	Thaumatocoelesia	(Po,De,Pe)
Tetralobula	(Br,Ar,Pe)	Thaeroeythere	(Ar,Os,Po)	Thaumastoplax	(Ar,MI,De)
Tetrameroceras	(Mo,Ce,On)	Thaerodonta	(Br,Ar,St)	Thaumatoblastus	(Ec,BI,Ii)
Tetramerocrinites	(Ec,Cr,Un)	Thagastea	(Ec,Ec,Cl)	Thaumatocypris	(Ar,Os,My)
Tetraminouxia	(Fo,Fo,Fo)	Thaiaspis	(Ar,Tr,Pr)	Thaumatolites	(Cn,An,Ta)
Tetranodoceras	(Mo,Ce,Na)	Thailandina	(Fo,Fo,Fo)	Thaumatomma	(Ar,Os,My)
Tetranota	(Mo,Ga,Be)	Thais	(Mo,Ga,Ne)	Thaumatosaurus	(Cd,Re,Ps)
Tetraodon	(Cd,Os,Te)	Thaisella	(Mo,Ga,Ne)	Thaumatophria	(Br,Ar,Pe)
Tetraodontella	(Br,Ar,St)	Thala	(Mo,Ga,Ne)	Thaumaturus	(Cd,Os,Sa)
Tetraphalerella	(Br,Ar,St)	Thalabaria	(Ar,Tr,Pr)	Thaumoptilon	(Cn,Pe,Ra)
Tetraphormis	(Ac,Ra,Na)	Thalamnohalielona	(Po,De,Ha)	Thaymastoceras	(Mo,Ce,Na)
Tetraplaria	(Bz,Gy,Ch)	Thalamocrinus	(Ec,Cr,Cl)	Theamataspis	(Ar,Tr,Co)
Tetrapleuroceras	(Mo,Ce,Or)	Thalamocyathus	(Po,Re,Aj)	Thebanaspis	(Ar,Tr,Pr)
Tetrapleurocrinus	(Ec,Cr,Cl)	Thalamophaga	(Fo,Fo,Fo)	Thebesia	(Br,Ar,Rh)
Tetraplica	(Mo,Ga,Ne)	Thalamopora	(Po,Ca,Sp)	Thebecristatus	(Cn,An,Ru)
Tetrapora	(Bz,St,Cc)	Thalamoporella	(Bz,Gy,Ch)	Thecactinastreae	(Cn,An,Sc)
Tetraporella	(Cn,An,Ta)	Thalassicola	(Ac,Ra,Sp)	Thecatia	(Bz,Gy,Ch)
Tetraporinus	(Cn,An,Ta)	Thalassina	(Ar,MI,De)	Thecaxon	(Cn,An,Ru)
Tetraprion	(An,Po,Eu)	Thalassocetus	(Cd,Ma,Ce)	Thecia	(Cn,An,Ta)
Tetrapterus	(Cd,Os,Pf)	Thalassoleon	(Cd,Ma,Cu)	Thecidea	(Br,Ar,Th)
Tetrapyxis	(Mo,Ga,Nt)	Thalassomedon	(Cd,Re,Ps)	Thecidella	(Br,Ar,Th)
Tetrapyle	(Ac,Ra,Sp)	Thalattorhynchus	(Cd,Os,Pf)	Thecidellina	(Br,Ar,Th)
Tetrapylonium	(Ac,Ra,Sp)	Thalattosaurus	(Cd,Re,Th)	Thecidiopsis	(Br,Ar,Th)
Tetramania	(Ec,Ec,Ds)	Thalattosiren	(Cd,Ma,Sh)	Thecipora	(Cn,An,Ta)
Tetraectangulum	(Ac,Ra,Sp)	Thalenessites	(An,Po,Ph)	Thecoactantina	(Ac,Ra,Sp)
Tettrahynchia	(Br,Ar,Rh)	Thaleops	(Ar,Tr,Co)	Thecocyathus	(Cn,An,Sc)
Tettrahabda	(Ac,Ra,Na)	Thallassoceras	(Mo,Ce,Go)	Thecocyrtella	(Br,Ar,Sp)
Tetrasacculus	(Ar,Os,Pa)	Thallatocanthus	(Ec,Ho,Ap)	Thecocyrtelloidea	(Br,Ar,Sp)
Tetraserpula	(An,Po,Se)	Thallocrinus	(Ec,Cr,Mo)	Thecomendra	(Cn,An,Sc)
Tetraspidoceras	(Mo,Ce,Am)	Thallograptus	(He,Gr,De)	Thecopsella	(Mo,Ga,Th)
Tetrastorhynch	(Ar,Os,Pa)	Thallospongia	(Po,Ca,Ph)	Thecoseria	(Cn,An,Sc)
Tetrastulcata	(Ar,Os,Un)	Thalmannammina	(Fo,Fo,Fo)	Thecoseriopsis	(Cn,An,Sc)
Tetrataxis	(Fo,Fo,Fo)	Thalmania	(Ar,Os,Po)	Thecosiphonia	(Po,De,Li)
Tetratheca	(Hy,Or,Or)	Thalmannita	(Fo,Fo,Fo)	Thecosmilia	(Cn,An,Sc)
Tetraoechus	(Bz,St,Tr)	Thalotia	(Mo,Ga,Ar)	Thecosphaera	(Ac,Ra,Sp)
Tetratomia	(Br,Ar,Rh)	Thambetolepis	(Pr,Co,Sa)	Thecospira	(Br,Ar,Th)
Tetratormentum	(Ac,Ra,Sp)	Thambites	(Mo,Ce,Am)	Thecospirella	(Br,Ar,Th)
Tetratrabs	(Ac,Ra,Sp)	Thamboceras	(Mo,Ce,Am)	Thecospiropsis	(Br,Ar,St)
Tetratubispira	(Mo,Ga,Be)	Thaminocrinus	(Ec,Cr,Ds)	Thecostegites	(Cn,An,Ta)
Tetratylus	(Ar,Os,Pl)	Thamnasteria	(Cn,An,Sc)	Thedusia	(Br,Ar,Sp)
Tetravaccinites	(Mo,Bi,Hi)	Thamnasteriamorpha	(Cn,An,Sc)	Theelia	(Ec,Ho,Ap)
Tetravirga	(Ec,Ho,El)	Thamnastraea	(Cn,An,Sc)	Theganoceras	(Mo,Ce,Am)
Tetrentactinia	(Ac,Ra,Sp)	Thaminiscus	(Bz,St,Fe)	Thekammina	(Fo,Fo,Fo)
Tetrinis	(Ar,Ci)	Thamnicrinus	(Ec,Cr,Mo)	Thelecarcinus	(Ar,MI,De)
Tetrocycloecia	(Bz,St,Cc)	Thamnodictya	(Po,He,Re)	Thelecythara	(Mo,Ga,Ne)
Teuchopora	(Bz,Gy,Ch)	Thamnograptus	(He,Gr,Gr)	Theleproctocrinus	(Ec,Cr,Mo)
Teudopsis	(Mo,Ce,Te)	Thamnonema	(Po,Ca,Ph)	Theliostyla	(Mo,Ga,Ar)
Tewoella	(Fo,Fo,Fo)	Thamnophyllum	(Cn,An,Ru)	Thelodus	(Cd,Pt,Th)
Texacrinus	(Ec,Cr,Cl)	Thamnopora	(Cn,An,Ta)	Theloreus	(Ec,Cr,Ds)
Texanites	(Mo,Ce,Am)	Thamnoporella	(Cn,An,Ta)	Thelxiopie	(Ar,Mo,Em)
Texarina	(Br,Ar,Te)	Thamnopychia	(Cn,An,Ta)	Thenarocrinus	(Ec,Cr,Cl)
Texastrea	(Cn,An,Sc)	Thamnoseria	(Cn,An,Sc)	Theneopsis	(Po,De,As)
Texathyris	(Br,Ar,Sp)	Thamnosia	(Br,Ar,St)	Theocalyptra	(Ac,Ra,Na)
Texicaprina	(Mo,Bi,Hi)	Thamnosmilia	(Cn,An,Sc)	Theocampe	(Ac,Ra,Na)
Texigryphaea	(Mo,Bi,Pt)	Thamnospongia	(Po,De,Li)	Theocapsa	(Ac,Ra,Na)
Texoceras	(Mo,Ce,Go)	Thamnotropis	(Cn,An,Sc)	Theocontus	(Ac,Ra,Na)
Textispongia	(Po,He,Un)	Thamnotrypa	(Bz,St,Cy)	Theocorys	(Ac,Ra,Na)

Theocotyle	(Ac.Ra.Na)	Thomelites	(Mo.Ce.Am)	Thyrsocyrtis	(Ac.Ra.Na)
Theocotylyssa	(Ac.Ra.Na)	Thomondia	(Ar.Tr.Un)	Thyrtrophyllum	(Cn.An.Ru)
Theocyrtis	(Ac.Ra.Na)	Thompsonella	(Fo.Fo)	Thysanobolus	(Br.Li.Li)
Theodensia	(Ar.Tr.As)	Thoosa	(Po.De.Hd)	Thysanodictya	(Po.He.Re)
Theodiscus	(Ac.Ra.Sp)	Thoracocare	(Ar.Tr.Un)	Thysanopeltella	(Ar.Tr.Co)
Theodossia	(Br.Ar.Sp)	Thoracoceras	(Mo.Ce.Or)	Thysanopeltis	(Ar.Tr.Co)
Theonella	(Po.De.Li)	Thoracopora	(Bz.Gy.Ch)	Thysanophyllum	(Cn.An.Ru)
Theonoa	(Bz.St.Cc)	Thoracopterus	(Cd.Os.Pe)	Thysanopyge	(Ar.Tr.As)
Theopera	(Ac.Ra.Na)	Thoralia	(Mo.Bi.Nu)	Thysanotos	(Br.Li.Li)
Theophormis	(Ac.Ra.Na)	Thoralaspis	(Ar.Tr.Re)	Thysanus	(Cn.An.Sc)
Theora	(Mo.Bi.Ve)	Thoralicystis	(Ec.St.Co)	Tianjinia	(Ar.Os.Po)
Theragra	(Cd.Os.Ga)	Thoralocoleus	(Ar.Tr.As)	Tianjinospira	(Mo.Ga.Nt)
Therezinosaurus	(Cd.Re.Ch)	Thoralodus	(Cd.Ch.In)	Tianshanopecten	(Mo.Bi.Pt)
Therium	(Mo.Ga.Nt)	Thorista	(Mo.Ga.Ar)	Tianzhushanella	(Pr.Un.In)
Therioceras	(Mo.Ce.Di)	Thoristella	(Mo.Ga.Ar)	Tianzhushania	(Pr.Co.Sa)
Theriosynoecum	(Ar.Os.Po)	Thornipora	(Bz.Gy.Ch)	Tianzhushanospira	(Mo.In.In)
Therioxynpecum	(Ar.Os.Pa)	Thorslundella	(Pr.Un.Hy)	Tiara	(Mo.Ga.Ne)
Thersita	(Mo.Ga.Nt)	Thorslundia	(Mo.Bi.Ar)	Tiaracanthium	(Mo.Ga.Nt)
Thesbia	(Mo.Ga.Ne)	Thorsteinssynoeceras	(Mo.Ce.Am)	Tiaracrinus	(Ec.Cr.Ds)
Theskeloceras	(Mo.Ce.El)	Thouelasma	(Cn.An.Ru)	Tiaradendron	(Cn.An.Sc)
Thestyleda	(Mo.Bi.Nu)	Thovana	(Mo.Bi.My)	Tiarasmilia	(Cn.An.Sc)
Thetidicrinus	(Ec.Cr.Cl)	Thracia	(Mo.Bi.Ph)	Tiaraspis	(Cd.Pl.Ar)
Thetidites	(Mo.Ce.Ce)	Thrallella	(Ar.Os.Po)	Tiarechinopsis	(Ec.Ec.Ph)
Thetiopsis	(Mo.Bi.Ve)	Thraxites	(Mo.Ce.Am)	Tiarechinus	(Ec.Ec.Pl)
Thetis	(Mo.Bi.Ve)	Threacoceras	(Mo.Ce.Na)	Tiarellacanthium	(Mo.Ga.Nt)
Thiarinella	(Mo.Ga.Ne)	Threaivia	(Mo.Ga.Ar)	Tiarethyris	(Br.Ar.Te)
Thibautina	(Ar.Os.Pa)	Thresherodiscus	(Ec.Ed.Is)	Tiaridia	(Ec.Ec.Di)
Thiemella	(Br.Ar.Or)	Thrinax	(Cd.Ch.Hx)	Tiaromma	(Ec.Ec.Hm)
Thierachella	(Mo.Ga.Nt)	Thrinoceras	(Mo.Ce.Na)	Tibagya	(Ar.Tr.Ph)
Thierichinus	(Ec.Ec.Ph)	Thrisspatea	(Cd.Os.Cr)	Tiberia	(Mo.Ga.He)
Thigrifides	(Ar.Tr.Pr)	Thriossos	(Cd.Os.Pc)	Tibersyrnola	(Mo.Ga.He)
Thinochelys	(Cd.Re.Cl)	Thrombus	(Po.De.As)	Tibetatrypa	(Br.Ar.At)
Thiolliericrinus	(Ec.Cr.Cm)	Throopella	(Mo.Sc.Sc)	Tibetites	(Mo.Ce.Ce)
Thisbites	(Mo.Ce.Ce)	Thryptodus	(Cd.Os.Cr)	Tibetodus	(Cd.Os.Py)
Thliborhynchia	(Br.Ar.Rh)	Thuleproductus	(Br.Ar.St)	Tibethothyris	(Br.Ar.Te)
Thlipsoshealdia	(Ar.Os.Po)	Thulicola	(Ar.Tr.Ph)	Tibia	(Mo.Ga.Nt)
Thlipsorothella	(Ar.Os.Po)	Thulioicyclus	(Cn.An.Ru)	Tibiaporrhais	(Mo.Ga.Nt)
Thlipsura	(Ar.Os.Me)	Thunus	(Cd.Os.Pf)	Tibiella	(Mo.Ga.Th)
Thlipsurella	(Ar.Os.Me)	Thuramina	(Fo.Fo.Fo)	Tiborella	(Ac.Ra.Sp)
Thlipsurina	(Ar.Os.Me)	Thuraminoides	(Ar.Fo.Fo)	Tiburinus	(Mo.Ga.Ar)
Thlipsuroides	(Ar.Os.Me)	Thuraminopsis	(Fo.Fo.Fo)	Tiche	(Ar.Ml.De)
Thlipsuropis	(Ar.Os.Me)	Thuriaantha	(Cn.An.Ru)	Tichirhynchus	(Br.Ar.Rh)
Thoe	(Ar.Ml.De)	Thuringionautilus	(Mo.Ce.Na)	Tichkaella	(Mo.In.In)
Tholaster	(Ec.Ec.Hs)	Thuringocrinus	(Ec.Cr.Un)	Tichosina	(Br.Ar.Te)
Tholiasterella	(Po.Ca.He)	Thurmannela	(Br.Ar.Rh)	Ticinella	(Fo.Fo.Fo)
Tholifrons	(Ar.Tr.Un)	Thurmannia	(Mo.Ce.Am)	Ticinopomis	(Cd.Os.Co)
Tholitoma	(Mo.Ga.Ne)	Thurmanniceras	(Mo.Ce.Am)	Ticinites	(Mo.Ce.Ce)
Tholocrinus	(Ec.Cr.Cl)	Thursius	(Cd.Os.Co)	Tickalacythere	(Ar.Os.Po)
Tholocystis	(Ec.Di.Di)	Thyasira	(Mo.Bi.Ve)	Tiddalickia	(Po.He.Re)
Thololasma	(Cn.An.Ru)	Thyestes	(Cd.Ce.Ce)	Tienoceras	(Mo.Ce.Or)
Tholonium	(Ac.Ra.Sp)	Thylacoceras	(Mo.Ce.En)	Tienodictyon	(Po.De.St)
Tholopora	(Bz.St.Cc)	Thylacocrinus	(Ec.Cr.Di)	Tienshaniscus	(Cd.Os.Pa)
Tholosina	(Fo.Fo.Fo)	Thylacus	(Mo.Ga.Nt)	Tikhinella	(Fo.Fo.Fo)
Tholospyrus	(Ac.Ra.Na)	Thylechinus	(Ec.Ec.Ph)	Tikia	(Mo.Bi.Ve)
Tholus	(Ar.Tr.Pt)	Thymallus	(Cd.Os.Sa)	Tiksitheca	(Tr.An)
Thomacystis	(Ec.Rh.Rh)	Thymurus	(Ar.Tr.Un)	Tilasia	(Br.Li.Li)
Thomasaria	(Br.Ar.Sp)	Thyracella	(Bz.Gy.Ch)	Tillocheles	(Ar.Ml.De)
Thomasatia	(Ar.Os.Pa)	Thyrastylon	(Mo.Bi.Hi)	Tiltoniceras	(Mo.Ce.Am)
Thomasella	(Br.Ar.St)	Thyratyria	(Br.Ar.Te)	Timalina	(Br.Li.Li)
Thomasinella	(Fo.Fo.Fo)	Thyridocrinus	(Ec.Cr.Cl)	Timanaspis	(Cd.Ce.Ce)
Thomasinotus	(Cd.Os.Am)	Thyroidium	(Po.He.He)	Timanella	(Fo.Fo.Fo)
Thomasites	(Mo.Ce.Am)	Thyrson	(Cd.Os.Pf)	Timania	(Cn.An.Ru)
Thomasocrinus	(Ec.Cr.Mo)	Thyrsocephalus	(Cd.Os.Pf)	Timaniella	(Br.Ar.Sp)
Thomastus	(Ar.Tr.Co)	Thyrsoeles	(Cd.Os.Pf)	Timanites	(Mo.Ce.An)

Timanoceras	(Mo,Ce,An)	Tidonia	(Ec,Ec,Ds)	Tomochelone	(Cd,Re,Ch)
Timanodictya	(Bz,St,Fe)	Tithonoceras	(Mo,Ce,Na)	Tomopleura	(Mo,Ga,Ne)
Timanospirifer	(Br,Ar,Sp)	Tithonohomola	(Ar,ML,De)	Tomotoma	(Mo,Ga,Ar)
Timanosteus	(Cd,Pl,Ar)	Tithopeltoceras	(Mo,Ce,Am)	Tomponautilus	(Mo,Ce,Na)
Timanotrypa	(Bz,St,Fe)	Tithocorys	(Cl,Co,Sp)	Tomphiceras	(Mo,Ce,Ce)
Timeischytes	(Ec,Ed,Is)	Titusvillia	(Po,He,Re)	Tomyris	(Mo,Ga,Nt)
Timidella	(Po,De,Li)	Tityrophia	(Br,Ar,St)	Tonasirhynchia	(Br,Ar,Rh)
Timidonella	(Fo,Fo,Fo)	Tivela	(Mo,Bi,Ve)	Tongacythere	(Ar,Os,Po)
Timiriasevia	(Ar,Os,Po)	Tivellina	(Mo,Bi,Ve)	Tongluceras	(Mo,Ce,Go)
Timisia	(Mo,Ga,Ar)	Tiverina	(Po,De,Ta)	Tongoboroceras	(Mo,Ce,Am)
Timiskamella	(Ar,Os,Pa)	Tivertonia	(Br,Ar,St)	Tongxingaspis	(Ar,Tr,Un)
Timoclea	(Mo,Bi,Ve)	Tiza	(Mo,Bi,My)	Tongzithyris	(Br,Ar,Sp)
Timoraspis	(Ar,Tr,Pr)	Tizilites	(Hy,Hy,Hy)	Tonicella	(Mo,Po,Ne)
Timorechinus	(Ec,Cr,Cl)	Tjanshanophyllum	(Cn,An,Ru)	Tonicia	(Mo,Po,Ne)
Timorella	(Po,De,Li)	Tjururpites	(Mo,Ce,Ce)	Tonkinaria	(Cn,An,Ru)
Timorhealdia	(Ar,Os,Me)	Tmaegoceras	(Mo,Ce,Am)	Tonkinella	(Ar,Tr,Co)
Timorhynchia	(Br,Ar,Rh)	Tmaegophoceras	(Mo,Ce,Am)	Tonna	(Mo,Ga,Nt)
Timorina	(Br,Ar,Te)	Tmemolophus	(Ar,Os,Pa)	Tonoceras	(Mo,Ce,Am)
Timorites	(Mo,Ce,Go)	Tmetoceras	(Mo,Ce,Am)	Tonsella	(Br,Ar,Rh)
Timoroblastus	(Ec,BL,Fi)	Tmetonema	(Mo,Ga,Nt)	Toolongella	(Ar,Os,Po)
Timorphyllum	(Cn,An,Ru)	Tobarum	(Mo,Bi,Ve)	Toombsosteus	(Cd,Pl,Ar)
Timothyus	(Mo,Bi,Ve)	Tobejalotreta	(Br,Li,Ac)	Toomeyospongia	(Po,He,Ls)
Tindaria	(Mo,Bi,Nu)	Tobolia	(Fo,Fo,Fo)	Topalodiscorbis	(Fo,Fo,Fo)
Tingella	(Ar,Tr,Co)	Todilia	(Cd,Os,Pe)	Toplinocyathus	(Pr,Cr,Cr)
Tingocephalus	(Ar,Tr,Co)	Toechastreaea	(Cn,An,Sc)	Toquimaella	(Br,Ar,At)
Tinophodella	(Fo,Fo,Fo)	Toechomya	(Mo,Bi,Tr)	Toquimaphyllum	(Cn,An,Ru)
Tinotoxitis	(Ar,Os,Pa)	Toernquistia	(Ar,Tr,Pr)	Toquimia	(Br,Ar,St)
Tinsithea	(Tr,An)	Toernquistina	(Ar,Tr,As)	Toquimiella	(Po,Ca,He)
Tintinnoidella	(Pr,Un,In)	Tofangoceras	(Mo,Ce,Or)	Toragnostus	(Ar,Tr,Ag)
Tintinnopsella	(Cl,Co,Sp)	Togaella	(Br,Ar,Un)	Torastarte	(Mo,Bi,Ve)
Tintorium	(Mo,Ga,Nt)	Togatrypa	(Br,Ar,At)	Torcaepella	(Mo,Ce,Am)
Tioria	(Mo,Ga,Nt)	Togocyamus	(Ec,Ec,Cl)	Torcaula	(Mo,Ga,Nt)
Tipheophyllum	(Cn,An,Ru)	Togoina	(Ar,Os,Po)	Torculoidella	(Mo,Ga,Nt)
Tiphotrocha	(Fo,Fo,Fo)	Tolanaspis	(Ar,Tr,Co)	Torella	(Ar,Os,Pa)
Tiphycetus	(Cd,Ma,Ce)	Toledonia	(Mo,Ga,Ce)	Torelloella	(Pr,Un,Hy)
Tipispirifer	(Br,Ar,Sp)	Toletanaspis	(Ar,Tr,Ph)	Toretelloides	(Pr,Un,Hy)
Tipua	(Mo,Ga,Ar)	Tollaspis	(Ar,Tr,Co)	Toretocnemus	(Cd,Re,Je)
Tiramnia	(Br,Ar,Sp)	Tollia	(Mo,Ce,Am)	Torgnellus	(Mo,Ga,Nt)
Tirasiana	(Cn,Sc,Un)	Tollicyathus	(Po,Ir,Ar)	Toricellites	(Mo,Ce,Am)
Tirisoehilina	(Ar,Os,Le)	Tollina	(Cn,An,Ta)	Torifera	(Ar,Tr,Pt)
Tirocrinus	(Ec,Cr,Mo)	Tollita	(Ar,Os,Le)	Torinia	(Mo,Ga,He)
Tirodella	(Ac,Ra,Sp)	Tollmannia	(Fo,Fo,Fo)	Torinosuella	(Fo,Fo,Fo)
Tirolidia	(Mo,Bi,Pt)	Tollodus	(Cd,Pl,Pt)	Torinosulcatella	(Mo,Bi,Ar)
Tirolites	(Mo,Ce,Ce)	Tolmachovia	(Mo,Ro,Ri)	Toriscodermia	(Po,De,Ha)
Tirolonautilus	(Mo,Ce,Na)	Tolmatchollia	(Br,Ar,St)	Torista	(Mo,Ce,Pa)
Tironucula	(Mo,Bi,Nu)	Tolminothalamia	(Po,De,Pe)	Toriyamaia	(Fo,Fo,Fo)
Tismanorthis	(Br,Ar,Or)	Tologoiyathus	(Po,Re,Aj)	Torlessia	(An,Po,Se)
Tissintia	(Br,Ar,Or)	Tolstotichaspis	(Ar,Tr,Pt)	Torleyoceras	(Mo,Ce,Go)
Tissotia	(Mo,Ce,Am)	Tolypamma	(Fo,Fo,Fo)	Tormentum	(Ac,Ra,Sp)
Titabia	(An,Po,Te)	Tolypceeras	(Mo,Ce,Am)	Tornoblastus	(Ec,Co,Co)
Titanarbonites	(Br,Ar,St)	Tolypelepis	(Cd,Pl,Pt)	Tornatellaea	(Mo,Ga,Ce)
Titanaria	(Br,Ar,St)	Tomagnostella	(Ar,Tr,Ag)	Tornatiicerinus	(Ec,Cr,Ds)
Titanaster	(Ec,Ec,Hs)	Tomagnostus	(Ar,Tr,Ag)	Tornia	(Mo,Ce,Go)
Titanichthys	(Cd,Pl,Ar)	Tomasina	(Br,Li,Li)	Tornoceras	(Mo,Ce,Go)
Titanites	(Mo,Ce,Am)	Tomellana	(Mo,Ga,Ne)	Tornquistes	(Mo,Ce,Am)
Titanocarcinus	(Ar,ML,De)	Tomestenoporhynchus	(Br,Ar,Rh)	Tornquistellus	(Ec,Ec,Ey)
Titanocardium	(Mo,Bi,Ve)	Tomiella	(Ar,Os,Po)	Tornquistia	(Br,Ar,St)
Titanoceras	(Mo,Ce,Na)	Tomiellina	(Ar,Os,Po)	Tornquistites	(Mo,Ce,Ce)
Titanolepas	(Ar,Ci)	Tomilia	(Br,Ar,St)	Tornus	(Mo,Ga,Nt)
Titanomena	(Br,Ar,St)	Tomiopsis	(Br,Ar,Sp)	Torohealdia	(Ar,Os,Me)
Titanosarcolites	(Mo,Bi,Hi)	Tomiproductus	(Br,Ar,St)	Torosocyathus	(Po,Re,Aj)
Titanothyris	(Br,Ar,Sp)	Tommasina	(Mo,Bi,Mt)	Torosteus	(Cd,Pl,Ar)
Titaonpecten	(Mo,Bi,Pt)	Tommotia	(Pr,Fo,Mi)	Torpedo	(Cd,Ch,To)
Tierina	(Ch,Un)	Tommotitubulus	(Pr,Un,In)	Torquaiscala	(Mo,Ga,Nt)

Torquatisphinctes	(Mo,Ce,Am)	Toxopriion	(Cd,Ch,Eu)	Tragolytoceras	(Mo,Ce,Am)
Torquatoceras	(Mo,Ce,On)	Toxorthis	(Br,Ar,Or)	Tragophylloceras	(Mo,Ce,Ph)
Torquesia	(Mo,Ga,Nt)	Toxotes	(Cd,Os,Pt)	Tragula	(Mo,Ga,He)
Torquesiella	(Mo,Ga,Nt)	Toxotis	(Ar,Tr,Un)	Trajana	(Mo,Ga,Ar)
Torquifer	(Mo,Ga,Ne)	Tozerites	(Mo,Ce,Ce)	Trajanella	(Mo,Ga,Nt)
Torquirhynchia	(Br,Ar,Rh)	Trabeculata	(Mo,Bi,Pt)	Trammeria	(Po,Ca,Ph)
Torreina	(Fo,Fo,Fo)	Trabeculites	(Cn,An,Ta)	Tramoria	(Ar,Tr,As)
Torreites	(Mo,Bi,Hi)	Trachelacanthus	(Cd,Os,Pa)	Trampidocrinus	(Ec,Cr,Sa)
Torreiroella	(Fo,Fo,Fo)	Trachelinella	(Fo,Fo,Fo)	Transennatia	(Br,Ar,St)
Torresina	(Fo,Fo,Fo)	Trachelochetus	(Mo,Ga,Ne)	Transennella	(Mo,Bi,Ve)
Torridella	(Ar,Tr,Pt)	Trachelocrinus	(Ec,Eo,Un)	Transicoeloceras	(Mo,Ce,Am)
Torrocricrus	(Ec,Cr,Un)	Trachicarrax	(Cd,Os,Pf)	Transitolites	(Cn,An,Ta)
Tortaguttus	(Fo,Fo,Fo)	Trachichthyoides	(Cd,Os,Br)	Transmariaturris	(Mo,Ga,Ne)
Tortartica	(Mo,Bi,Ve)	Trachinus	(Cd,Os,Pf)	Transovlia	(Mo,Ga,Nt)
Tortisipho	(Mo,Ga,Ne)	Trachocetus	(Mo,Ga,Nt)	Transversaria	(Br,Ar,Sp)
Tortocyathus	(Pr,Cr,Cr)	Trachosteus	(Cd,Pl,Ar)	Transversigerina	(Fo,Fo,Fo)
Tortodus	(Cd,Co,Co)	Trachurus	(Cd,Os,Pf)	Transylvanella	(Mo,Ga,Ar)
Tortollabellum	(Cn,An,Sc)	Trachybaculites	(Mo,Ce,Am)	Trapezicardita	(Mo,Bi,Ve)
Tortoliva	(Mo,Ga,Ne)	Trachybembix	(Mo,Ga,Ar)	Trapezisyllithere	(Ar,Os,Un)
Tortonella	(Fo,Fo,Fo)	Trachycarcinus	(Ar,MI,De)	Trapezium	(Mo,Bi,Ve)
Tortophyllum	(Cn,An,Ru)	Trachycardium	(Mo,Bi,Ve)	Trapezochites	(Pr,Co,Sa)
Toriucardia	(Mo,Bi,Ve)	Trachyceras	(Mo,Ce,Ce)	Trapezophyllum	(Cn,An,Ru)
Torulumbonina	(Fo,Fo,Fo)	Trachycheilus	(Ar,Tr,Pt)	Trapezotheca	(Hy,Or,Or)
Torusilina	(Ar,Os,Un)	Trachycythere	(Ar,Os,Po)	Trapezovitus	(Hy,Hy,Hy)
Torynechus	(Br,Ar,Rh)	Trachydictya	(Po,De,Li)	Trasgu	(Br,Ar,Rh)
Torynelasma	(Br,Li,Ac)	Trachydomia	(Mo,Ga,Ar)	Traskina	(Cn,An,Ru)
Toryniifer	(Br,Ar,Sp)	Trachylasma	(Cn,An,Ru)	Traskites	(Mo,Ce,Ce)
Toryniiferella	(Br,Ar,Sp)	Trachyleberidea	(Ar,Os,Po)	Traskocrinus	(Ec,Cr,Di)
Torynocrinus	(Ec,Cr,Cy)	Trachyleberis	(Ar,Os,Po)	Tratacladia	(Bz,St,Fe)
Torynomma	(Ar,MI,De)	Trachylytoceras	(Mo,Ce,Am)	Traumatocrinus	(Ec,Cr,En)
Tosaia	(Fo,Fo,Fo)	Trachynautilus	(Mo,Ce,Na)	Trautensteinproectus	(Ar,Tr,Pr)
Tosalorbis	(An,Po,Un)	Trachynerita	(Mo,Ga,Ar)	Trauscholdia	(Mo,Bi,Ve)
Tosapecten	(Mo,Bi,Pt)	Trachynoton	(Po,De,Li)	Trautscholdicrinus	(Ec,Cr,Cl)
Tosarca	(Mo,Bi,Ph)	Trachynotus	(Ar,MI,De)	Trechmannaria	(Cn,An,Sc)
Tosastroma	(Po,De,Ax)	Trachypatagus	(Ec,Ec,Sp)	Trechpura	(Cn,An,Ta)
Tosotychia	(Ar,Tr,Pt)	Trachyphlyctia	(Po,Ca,Ph)	Treioria	(Br,Ar,Or)
Tostonia	(Ar,Tr,Pt)	Trachyphyllia	(Cn,An,Sc)	Tremabolites	(Po,He,Ly)
Tosuhuthyris	(Br,Ar,Te)	Trachyphyllum	(Cn,An,Ru)	Tremachora	(Fo,Fo,Fo)
Totia	(Br,Ar,At)	Trachypleura	(Mo,Po,Ne)	Tremadictyon	(Po,He,He)
Totiglobus	(Ec,Ed,Ed)	Trachypleuraspidites	(Mo,Ce,Ce)	Tremamascleis	(Cd,Re,Ps)
Toucasia	(Mo,Bi,Hi)	Trachypollia	(Mo,Ga,Ne)	Tremanotus	(Mo,Ga,Be)
Toulminia	(Po,He,Ly)	Trachypsammia	(Cn,An,Ta)	Tremaphorus	(Po,He,He)
Tourmakeadia	(Br,Ar,St)	Trachyrhynchus	(Cd,Os,Ga)	Tremataspis	(Cd,Ce,Ce)
Tournarchaediscus	(Fo,Fo,Fo)	Trachysagenites	(Mo,Ce,Ce)	Tremataster	(Ec,Op,Oe)
Tournayella	(Fo,Fo,Fo)	Trachyscapites	(Mo,Ce,Am)	Trematella	(Bz,St,Tr)
Tournayellina	(Fo,Fo,Fo)	Trachysinia	(Po,Ca,Ph)	Trematiconcha	(Mo,Bi,Pt)
Tournoueraster	(Ec,Ec,Cl)	Trachysma	(Mo,Ga,Ar)	Trematis	(Br,Li,Ac)
Tournouerella	(Mo,Ga,Ar)	Trachysoma	(Ar,MI,De)	Trenatobolus	(Br,Un,Ob)
Touroconcha	(Ar,Os,Po)	Trachyspecion	(Po,Ca,Ph)	Trematoceras	(Mo,Ce,Or)
Touzinia	(Mo,Ga,Nt)	Trachyspira	(Mo,Ga,Ar)	Trematocystis	(Ec,Di,Di)
Tovebirkelundites	(Mo,Ce,Am)	Trachystenoceras	(Mo,Ce,Ce)	Trematodiscus	(Mo,Ce,Na)
Towapteria	(Mo,Bi,Pt)	Trachysycon	(Po,De,Li)	Trematofusus	(Mo,Ga,Ne)
Townleyella	(Ar,Tr,Un)	Trachyteuthis	(Mo,Ce,Te)	Trematoeocia	(Bz,Gy,Ch)
Toxamblyites	(Mo,Ce,Am)	Trachytilia	(Po,Ca,Ph)	Trematopora	(Bz,St,Tr)
Toxaster	(Ec,Ec,Sp)	Trachytoechus	(Bz,St,Tr)	Trematoporina	(Bz,St,Tr)
Toxumorphora	(Hy,Un,To)	Trachytriton	(Mo,Ga,Nt)	Trematorthis	(Br,Ar,Or)
Toxochasmops	(Ar,Tr,Ph)	Trachyum	(Po,De,Li)	Trematosia	(Br,Un,Ku)
Toxocheilus	(Cd,Re,Ch)	Tractabilis	(Mo,Cr,Te)	Trematospira	(Br,Ar,Sp)
Toxoconcha	(Mo,Ga,Nt)	Tractabilopsis	(Mo,Cr,Te)	Trematosteus	(Cd,Pl,Ar)
Toxolioceras	(Mo,Ce,Am)	Tractoliria	(Mo,Ga,Ne)	Trematotrochus	(Cn,An,Sc)
Toxonelasma	(Br,Ar,Te)	Tragalimus	(Po,De,Li)	Tremoscocinopleura	(Bz,Gy,Ch)
Toxopatagus	(Ec,Ec,Hs)	Tragoceras	(Mo,Ce,Ta)	Tremogasterina	(Bz,Gy,Ch)
Toxopacops	(Ar,Tr,Ph)	Tragodesmoceras	(Mo,Ce,Am)	Tremolyrula	(Bz,Gy,Ch)
Toxopneustes	(Ec,Ec,Ec)	Tragodesmoceroides	(Mo,Ce,Am)	Tremopora	(Bz,Gy,Ch)

Tremoschizodina	(Bz,Gy,Ch)	Triaphorus	(Mo,Bi,Ve)	Tricopelta	(Ar,Tr,Ph)
Tremospongia	(Po,Ca,Ph)	Triaracerithium	(Mo,Ga,Nt)	Tricordis	(Ar,Os,Po)
Tremotochus	(Bz,Gy,Ch)	Triarthrella	(Ar,Tr,PT)	Tricoria	(Br,Ar,Rh)
Trentonia	(An,Po,Eu)	Triarthroides	(Ar,Tr,PT)	Tricornicella	(Bz,Gy,Ch)
Treocrinus	(Ec,Cr,Cl)	Triarthropsis	(Ar,Tr,As)	Tricornina	(Ar,Os,Po)
Trepeilopsis	(Fo,Fo,Fo)	Triarthrus	(Ar,Tr,PT)	Tricornis	(Mo,Ga,Nt)
Trepocryptopora	(Bz,St,Cr)	Triasiglyphea	(Ar,MI,De)	Tricosmites	(Ec,Rh,Rh)
Treposella	(Ar,Os,Pa)	Triasina	(Fo,Fo,Fo)	Tricriepicephalus	(Ar,Tr,PT)
Trepospira	(Mo,Ga,Ar)	Triasorhynchia	(Br,Ar,Rh)	Tricycloseris	(Cn,An,Sc)
Trepotomina	(Bz,St,Fe)	Triassicidaris	(Ec,Ec,Ci)	Tridaena	(Mo,Bi,Ve)
Treptoceras	(Mo,Ce,Am)	Triassinella	(Ar,Os,Po)	Tridactylus	(Mo,Ga,Nt)
Treptopora	(Bz,Gy,Ch)	Triassistophanidchus	(Ac,Ra,Sp)	Tridensilis	(Br,Ar,Rh)
Tretotreta	(Br,Li,Ac)	Triassistophanidium	(Ac,Ra,Sp)	Tridentites	(Mo,Ce,Pl)
Tresus	(Mo,Bi,Ve)	Triassocampe	(Ac,Ra,Na)	Tridonta	(Mo,Bi,Ve)
Tretaspis	(Ar,Tr,As)	Triassocirrus	(Mo,Ga,Eu)	Triebacylether	(Ar,Os,Po)
Tretocalia	(Po,Ca,Ph)	Triassocypis	(Ar,Os,Po)	Triebelina	(Ar,Os,Po)
Tretoceras	(Mo,Ce,Or)	Triassocythere	(Ar,Os,Po)	Triemilomatella	(Ar,Os,Pa)
Tretocidaris	(Ec,Ec,Ci)	Triassphaeroma	(Ar,MI,Is)	Triendoceras	(Mo,Ce,En)
Tretodictyum	(Po,He,He)	Triathyris	(Br,Ar,Sp)	Trietteia	(Mo,Ga,Nt)
Tretoechus	(Po,De,Li)	Triibia	(Mo,Ga,Ne)	Trifricardium	(Mo,Bi,Ve)
Tretonea	(Bz,St,Ce)	Tribolbina	(Ar,Os,Pa)	Trifarina	(Fo,Fo,Fo)
Tretorhynchia	(Br,Ar,Rh)	Tribolocephalus	(Ar,MI,De)	Trifidarcula	(Br,Ar,Te)
Tretosina	(Bz,Gy,Ch)	Triboloceras	(Mo,Ce,Na)	Trifidorostellum	(Br,Ar,Rh)
Tretosphrys	(Cd,Ma,Ce)	Triboloporus	(Ec,Cr,Cl)	Triforis	(Mo,Ga,Nt)
Tretospira	(Mo,Ga,Nt)	Tribotoxotis	(Ar,Os,Pa)	Trifurcatoceras	(Mo,Ce,En)
Trettinoceras	(Mo,Ce,Go)	Tribrachia	(Fo,Fo,Fo)	Trigerastreae	(Cn,An,Sc)
Tretulias	(Cd,Ma,Ce)	Tribrachidium	(Tr,Un)	Trigerastreaeopsis	(Cn,An,Sc)
Treveropyge	(Ar,Tr,Ph)	Tribrachyocrinus	(Ec,Cr,Cl)	Triginglymus	(Ar,Os,Po)
Trewavasia	(Cd,Os,Py)	Tricarinaella	(Fo,Fo,Fo)	Trigla	(Cd,Os,Sc)
Triacanthus	(Cd,Os,Te)	Tricassastreae	(Cn,An,Sc)	Trigonactura	(Ac,Ra,Sp)
Triacartus	(Ac,Ra,Na)	Tricephalopora	(Bz,Gy,Ch)	Trigonarca	(Mo,Bi,Ar)
Triaclymenia	(Mo,Ce,Cl)	Triceracrinus	(Ec,Cr,Cl)	Trigonostarte	(Mo,Bi,Ve)
Triacrinus	(Ec,Cr,Ds)	Triceratina	(Ar,Os,Po)	Trigonatrypa	(Br,Ar,At)
Triactis	(Ac,Ra,Sp)	Trichasteropsis	(Ec,As,Tr)	Trigonella	(Cn,An,Ru)
Triactofenestrella	(Ac,Ra,Sp)	Trichechodon	(Cd,Ma,Ca)	Trigonellina	(Br,Ar,Te)
Triactoma	(Ac,Ra,Sp)	Trichechus	(Cd,Ma,Si)	Trigonia	(Mo,Bi,Tr)
Triadaspis	(Ar,Tr,Ag)	Trichichama	(Mo,Bi,Ve)	Trigoniocardia	(Mo,Bi,Ve)
Triadechinus	(Ec,Ec,Ph)	Trichinocrinus	(Ec,Cr,Di)	Trigonirhynchella	(Br,Ar,Rh)
Triadispira	(Br,Ar,Sp)	Trichiaplata	(Mo,Bi,Pl)	Trigonirhynchia	(Br,Ar,Rh)
Triadithyris	(Br,Ar,Te)	Trichites	(Mo,Bi,Mt)	Trigonirhynchoidea	(Br,Ar,Rh)
Triadocidaris	(Ec,Ec,Ci)	Trichiurichthys	(Cd,Os,Ga)	Trigonithyris	(Br,Ar,Te)
Triadocoelia	(Po,He,Ly)	Trichiurus	(Cd,Os,Pl)	Trigonospis	(Ar,Tr,As)
Triadocypis	(Ar,Os,My)	Trichochonetes	(Br,Ar,St)	Trigonocallista	(Mo,Bi,Ve)
Triadodiscus	(Fo,Fo,Fo)	Trichoerinus	(Ec,Cr,Ds)	Trigonocarys	(Ar,MI,Ar)
Triadogigantocypis	(Ar,Os,My)	Trichograpus	(He,Gr,Gr)	Trigonoceras	(Mo,Ce,Na)
Triadonereis	(An,Po,Ph)	Trichohylas	(Fo,Fo,Fo)	Trigonocerca	(Ar,Tr,As)
Triadophylum	(Cn,An,Sc)	Trichomusculus	(Mo,Bi,Mt)	Trigonocercella	(Ar,Tr,As)
Triadoskenae	(Mo,Ga,Ar)	Trichomya	(Mo,Bi,Mt)	Trigonocrassatella	(Mo,Bi,Ve)
Triadoteuthis	(Mo,Ce,Te)	Trichomyella	(Mo,Bi,Ph)	Trigonocyclia	(Ac,Ra,Sp)
Trianaaspis	(Cd,Os,Al)	Trichopaltarion	(Ar,MI,De)	Trigonodesma	(Mo,Bi,Ar)
Trianograpus	(He,Gr,Ct)	Trichorhipis	(Cd,Ch,Ct)	Trigonodictya	(Bz,St,Cr)
Trianosphaera	(Ac,Ra,Sp)	Trichorhynchia	(Br,Ar,Rh)	Trigonodon	(Cd,Os,Te)
Triangolytoceras	(Mo,Ce,Am)	Trichosirius	(Mo,Ga,Nt)	Trigonodus	(Cd,Ch,Ca)
Triainoceras	(Mo,Ce,Am)	Trichospongia	(Po,De,Un)	Trigonogastrioceras	(Mo,Ce,Go)
Triakis	(Cd,Ch,Ca)	Trichothyris	(Br,Ar,Te)	Trigonoglossa	(Br,Li,Li)
Trialatus	(Ac,Ra,Na)	Trichotoerinus	(Ec,Cr,Mo)	Trigonopis	(Mo,Bi,Ve)
Trianglospira	(Mo,Ga,Nt)	Trichotropis	(Mo,Ga,Nt)	Trigonopora	(Bz,Gy,Ch)
Triangope	(Br,Ar,Te)	Trichurides	(Cd,Os,Ga)	Trigonosemus	(Br,Ar,Te)
Triangularia	(Mo,Ga,Ar)	Tricleidus	(Cd,Re,Ps)	Trigonospirifer	(Br,Ar,Sp)
Triangulaspis	(Ar,Tr,Ag)	Tricoelocrinus	(Ec,BI,Sp)	Trigonostoma	(Mo,Ga,Ne)
Trianguligenys	(An,Po,Eu)	Tricolia	(Mo,Ga,Ar)	Trigonostroma	(Po,De,St)
Triangullina	(Ar,Tr,Ag)	Tricolocampe	(Ac,Ra,Na)	Trigonotreta	(Br,Ar,Sp)
Triangulodus	(Cd,Co,Co)	Tricolocapsa	(Ac,Ra,Na)	Trigonotrophia	(Br,Ar,Pe)
Trianguloschmidella	(Ar,Os,Po)	Tricolpopora	(Bz,Gy,Ch)	Trigonucula	(Mo,Bi,Nu)

Trigonulina	(Mo,Bi,Ph)	Triplicosta	(Mo,Bi,Ph)	Triversus	(Ac,Ra,Na)
Trigrammaria	(Br,Ar,St)	Triploca	(Mo,Ga,Ce)	Trivia	(Mo,Ga,Nt)
Trigyra	(Mo,Ce,Cy)	Triplocoeras	(Mo,Ce,Ba)	Triviella	(Mo,Ga,Nt)
Trilacertus	(Ac,Ra,Sp)	Triplophyllum	(Cn,An,Ru)	Trivirostra	(Mo,Ga,Nt)
Trilacinoceeras	(Mo,Ce,Or)	Triplopورا	(Bz,St,Tr)	Triznella	(Bz,St,Fe)
Trilasmis	(Ar,Ci)	Triplozoecia	(Bz,St,Ce)	Trizonoceras	(Mo,Ce,Go)
Trillus	(Ac,Ra,Sp)	Tripneustes	(Ec,Ec,Ec)	Trobus	(Mo,Ga,Nt)
Trilobagnostus	(Ar,Tr,Ag)	Tripocalpis	(Ac,Ra,Na)	Trochacanthus	(Mo,Ga,Ar)
Trilobiticeras	(Mo,Ce,Am)	Tripoclyelia	(Ac,Ra,Sp)	Trochactaeon	(Mo,Ga,Ce)
Trilobostrophia	(Br,Ar,St)	Tripocytis	(Ac,Ra,Na)	Trochactaeonina	(Mo,Ga,Ce)
Triloculina	(Fo,Fo,Fo)	Tripodictya	(Ac,Ra,Sp)	Trochalia	(Mo,Ga,He)
Triloculinella	(Fo,Fo,Fo)	Tripodiscium	(Ac,Ra,Na)	Trochalocyrtina	(Br,Ar,Sp)
Triloculinoides	(Fo,Fo,Fo)	Tripodocytis	(Ac,Ra,Na)	Trochabosoma	(Ec,Ec,Ph)
Triloculinopsis	(Fo,Fo,Fo)	Tripodonium	(Ac,Ra,Na)	Trochammaina	(Fo,Fo,Fo)
Trilonche	(Ac,Ra,Sp)	Tripodospyris	(Ac,Ra,Na)	Trochaminoides	(Fo,Fo,Fo)
Trilophopora	(Bz,Gy,Ch)	Tripodus	(Cd,Co,Co)	Trochamminula	(Fo,Fo,Fo)
Trimanticoceras	(Mo,Ce,An)	Tripodhaenoscenium	(Ac,Ra,Na)	Trocharea	(Cn,An,Sc)
Trimarginia	(Mo,Ce,Am)	Triporula	(Bz,Gy,Ch)	Trochifera	(Br,Ar,Te)
Trimarginites	(Mo,Ce,Am)	Triproetus	(Ar,Tr,Pr)	Trochilipora	(Bz,St,Cc)
Trimalaxis	(Mo,Ga,He)	Tripteroceeras	(Mo,Ce,On)	Trochiscolithus	(Cn,An,Ta)
Trimeraster	(Ec,As,Pu)	Tripteroceerina	(Mo,Ce,On)	Trochita	(Mo,Ga,Nt)
Trimerella	(Br,In,Tr)	Tripteroceroides	(Mo,Ce,Or)	Trochleiceras	(Mo,Ce,Am)
Trimerocephalus	(Ar,Tr,Ph)	Tripteroptychis	(Cd,Os,Ga)	Trochobolus	(Po,He,Ly)
Trimeroceras	(Mo,Ce,On)	Triptertyphis	(Mo,Ga,Ne)	Trochoceeramus	(Mo,Bi,Pt)
Trimerocrinus	(Ec,Cr,Ci)	Tripterygion	(Cd,Os,Pf)	Trochoceras	(Mo,Ce,Na)
Trimerolichas	(Ar,Tr,Li)	Triptychus	(Mo,Ga,He)	Trochocerithium	(Mo,Ga,Nt)
Trimerus	(Ar,Tr,Ph)	Tripylus	(Ec,Ec,Sp)	Trochoclisia	(Mo,Pa,Hy)
Trimurellina	(Br,Ar,St)	Triradites	(Ec,Ho,Un)	Trochoclymenia	(Mo,Ce,Cl)
Trimusculus	(Mo,Ga,Ba)	Triragonella	(Cn,An,Ru)	Trochoerinites	(Ec,Cr,Di)
Trinacria	(Mo,Bi,Ar)	Trirrhizodon	(Cd,Ma,Ce)	Trochocyathus	(Cn,An,Sc)
Trinacriacythere	(Ar,Os,Po)	Trisalenia	(Ec,Ec,Sa)	Trochocystites	(Ec,Hm,Ci)
Trinacromerum	(Cd,Re,Ps)	Trisepata	(Br,Ar,Pe)	Trochocystoides	(Ec,Hm,Ci)
Trinalicrinus	(Ec,Cr,Sa)	Triseptothyris	(Br,Ar,Te)	Trochodiadema	(Ec,Ec,Hm)
Trinia	(Ar,Tr,Un)	Trisidos	(Mo,Bi,Ar)	Trochodictyoceras	(Mo,Ce,Ta)
Trininaecyathus	(Po,Re,Aj)	Trisolenia	(Ac,Ra,Sp)	Trochodiscus	(Ac,Ra,Sp)
Trinitasia	(Mo,Bi,Ve)	Trisopterus	(Cd,Os,Ga)	Trochodon	(Mo,Ga,Ar)
Trinitella	(Fo,Fo,Fo)	Trispectes	(Mo,Ce,Or)	Trochoechinus	(Ec,Ec,Ec)
Trinitoceras	(Mo,Ce,En)	Trispirina	(Fo,Fo,Fo)	Trochograptus	(He,Gr,Gr)
Trinodus	(Ar,Tr,Ag)	Trissopilium	(Ac,Ra,Na)	Trochoidomeandra	(Cn,An,Sc)
Trinota	(Ar,Os,Pa)	Tristichograptus	(He,Gr,Gr)	Trocholites	(Mo,Ce,Ta)
Trinucleoides	(Ar,Tr,As)	Tristichotrochus	(Mo,Ga,Ar)	Trocholiticeras	(Mo,Ce,Ta)
Trinucleus	(Ar,Tr,As)	Tristix	(Fo,Fo,Fo)	Trochomphalus	(Mo,Ga,Eu)
Triodon	(Cd,Os,Te)	Tristratocoelia	(Po,De,Pe)	Trochonema	(Mo,Ga,Ar)
Triograptus	(He,Ge,De)	Tristychius	(Cd,Ch,Ct)	Trochonemella	(Mo,Ga,Ar)
Triopus	(Ar,Me,Ag)	Tristylospyris	(Ac,Ra,Na)	Trochonemopsis	(Mo,Ga,Ar)
Triozites	(Mo,Ce,Am)	Trisulcathea	(Tr,An)	Trochonerita	(Mo,Ga,Ar)
Tripartites	(Mo,Cr,Te)	Tritaxia	(Fo,Fo,Fo)	Trochophyllum	(Cn,An,Ru)
Tripatocrinus	(Ec,Cr,Hy)	Tritaxilina	(Fo,Fo,Fo)	Trochoplegma	(Cn,An,Sc)
Tripelta	(Cd,Os,Pe)	Tritiaria	(Mo,Ga,Ne)	Trochoplegmopsis	(Cn,An,Sc)
Triphora	(Mo,Ga,Nt)	Triticispongia	(Po,He,Re)	Trochopora	(Bz,Gy,Ch)
Triphoturus	(Cd,Os,My)	Triticites	(Fo,Fo,Fo)	Trochopsidea	(Mo,Ga,Ar)
Triphyllia	(Cn,An,Ru)	Tritoechia	(Br,Ar,Or)	Trochoseris	(Cn,An,Sc)
Tripia	(Mo,Ga,Ne)	Tritonalia	(Mo,Ga,Ne)	Trochosomeilia	(Cn,An,Sc)
Tripidotomaria	(Mo,Ga,Ar)	Tritonactractus	(Mo,Ga,Ne)	Trochosodon	(Bz,Gy,Ch)
Tripidium	(Ac,Ra,Na)	Tritonidea	(Mo,Ga,Ne)	Trochospira	(Fo,Fo,Fo)
Triplaccephalus	(Ar,Tr,Pt)	Tritonoceras	(Mo,Ce,Di)	Trochospirillina	(Fo,Fo,Fo)
Triplacera	(Ar,Os,Po)	Tritonomangilia	(Mo,Ga,Ne)	Trochotectus	(Mo,Ga,Ar)
Triplacidia	(Ec,Ec,Te)	Tritonoophon	(Mo,Ga,Ne)	Trochotiara	(Ec,Ec,Ph)
Triplanospongos	(Ac,Ra,Sp)	Tritonopsis	(Mo,Ga,Ne)	Trochotoma	(Mo,Ga,Ar)
Triplasia	(Fo,Fo,Fo)	Tritrabs	(Ac,Ra,Sp)	Trochotomaria	(Mo,Ga,Ar)
Triplesia	(Br,Ar,Or)	Tritropidoceras	(Mo,Ce,Ce)	Trochotrochus	(Mo,Ga,Ar)
Tripleura	(Mo,Bi,Ve)	Trituba	(Mo,Ga,Nt)	Trochotugurium	(Mo,Ga,Nt)
Tripleuroceras	(Mo,Ce,On)	Tritubulogenerina	(Fo,Fo,Fo)	Trochoturbella	(Mo,Ga,Nt)
Triplacatella	(Pr,Un,In)	Triumphis	(Mo,Ga,Ne)	Trochulina	(Fo,Fo,Fo)

Trochurus	(Ar.Tr,Li)	Truncatoflabellum	(Cn.An,Sc)	Tubericyathus	(Po.Re,Ca)
Trochus	(Mo,Ga,Ar)	Truncatulipora	(Bz,St,Ce)	Tuberitina	(Fo,Fo,Fo)
Trochylina	(Fo,Fo,Fo)	Truncaticarulum	(Cn.An,Ru)	Tuberleviathana	(Mo,Ga,Ar)
Troedssonella	(Mo,Ce,Or)	Truncoconus	(Cn.An,Sc)	Tuberoceratina	(Ar,Os,Po)
Troedssonina	(Ar,Tr,Pt)	Truncorotalia	(Fo,Fo,Fo)	Tuberoconus	(Mo,In,In)
Troedssonites	(Cn.An,Ta)	Truncorotaloides	(Fo,Fo,Fo)	TuberoDISCOIDES	(Mo,Ce,Am)
Troedssonoceras	(Mo,Ce,Ac)	Trunculariopsis	(Mo,Ga,Ne)	Tubersulcatella	(Br,Ar,St)
Trolliceras	(Mo,Ce,Am)	Truncatoconus	(Mo,In,In)	Tubersulculus	(Br,Ar,St)
Tromelinodonta	(Mo,Bi,Mo)	Trupetostroma	(Po,De,St)	Tubicamara	(He,Gr,Ca)
Trominina	(Mo,Ga,Ne)	Truyolsina	(Ar,Os,My)	Tubicauda	(Mo,Ga,Ne)
Trona	(Mo,Ga,Nt)	Truyoloceras	(Mo,Ce,Go)	Tubicora	(Cn.An,Sc)
Trondorthis	(Br,Ar,Or)	Tryblidium	(Mo,Tc,Tr)	Tubicoscinus	(Po,Re,Aj)
Troostella	(Mo,Ga,Ce)	Trybliocrinus	(Ec,Cr,Mo)	Tubidendrum	(He,Gr,Tu)
Troosticrinus	(Ec,BI,Sp)	Trymataspis	(Ar,Tr,Pt)	Tubiferoceras	(Mo,Ce,Di)
Troostoceras	(Mo,Ce,Ac)	Tryonella	(Mo,Ga,Ne)	Tubigeorgina	(Pr,Un,In)
Tropaeas	(Mo,Ga,He)	Trypacystiphyllum	(Cn.An,Ru)	Tubigera	(Bz,St,Ce)
Tropaeum	(Mo,Ce,Am)	Trypanaxis	(Mo,Ga,Nt)	Tubigerina	(Bz,St,Ce)
Tropoethyris	(Br,Ar,Te)	Trypanoocochlea	(Mo,Ga,Ar)	Tubina	(Mo,Ga,Ar)
Trophisina	(Br,Ar,Rh)	Trypanostylus	(Mo,Ga,Nt)	Tubinacis	(Cn.An,Sc)
Trophocrinus	(Ec,Cr,Ds)	Trypanotoma	(Mo,Ga,Ne)	Tubinella	(Fo,Fo,Fo)
Trophon	(Mo,Ga,Ne)	Trypanotopsis	(Mo,Ga,Ne)	Tubiola	(Mo,Ga,Ar)
Trophonopsis	(Mo,Ga,Ne)	Trypanotrochus	(Mo,Ga,Ar)	Tubiphytes	(Pr,Un,In)
Trophosycon	(Mo,Ga,Nt)	Trypaulites	(Ar,Tr,Ph)	Tubipora	(Cn.An,St)
Tropiastrea	(Cn.An,Sc)	Trypematella	(Bz,Gy,Ch)	Tubiporella	(Bz,Gy,Ch)
Tropicellites	(Mo,Ce,Ce)	Trypetera	(Ar,Os,Me)	Tubispiridiscus	(Fo,Fo,Fo)
Tropicolpus	(Mo,Ga,Nt)	Trypetesa	(Ar,Ci)	Tubispongia	(Po,Ca,Ph)
Tropidaster	(Ec,As,Va)	Trypherocrinus	(Ec,Cr,Ds)	Tubithyris	(Br,Ar,Te)
Tropidelasma	(Br,Ar,St)	Tryplasma	(Cn.An,Ru)	Tubitrabecularia	(Bz,Gy,Ch)
Tropidendron	(Cn.An,Sc)	Trypocella	(Bz,Gy,Ch)	Tuboculops	(Ar,Me,Ag)
Tropidiana	(Ar,Os,Ar)	Trypostega	(Bz,Gy,Ch)	Tubomphalus	(Mo,Ga,Ar)
Tropidocare	(Ar,Tr,Pr)	Tryssocrinus	(Ec,Cr,Ds)	Tubonastus	(Cul,Pl,Ar)
Tropidocaris	(Ar,MI,Ar)	Tschatkalia	(Br,Ar,Sp)	Tuborecta	(Fo,Fo,Fo)
Tropidoceras	(Mo,Ce,Am)	Tscherdynzeviana	(Ar,Os,Po)	Tubocella	(Bz,Gy,Ch)
Tropidocoryphe	(Ar,Tr,Pr)	Tschernyschewia	(Br,Ar,St)	Tubocellaria	(Bz,Gy,Ch)
Tropidocyathus	(Cn.An,Sc)	Tschernyschewiella	(Ar,Tr,Pr)	Tubulella	(Pr,Un,In)
Tropidodiscus	(Mo,Ga,Be)	Tscherskidium	(Br,Ar,Pe)	Tubulelloides	(An,Po,Un)
Tropidoglossa	(Br,Li,Li)	Tschingizella	(Ar,Os,Pa)	Tubulibairdia	(Ar,Os,Me)
Tropidoleptus	(Br,Ar,Te)	Tschokrakella	(Fo,Fo,Fo)	Tubuliella	(Po,De,AX)
Tropidophora	(Mo,Ga,Nt)	Tschussovskenia	(Cn.An,Ru)	Tubulipora	(Bz,St,Ce)
Tropidophyllum	(Cn.An,Ru)	Tselfatia	(Cd,Os,Cr)	Tubuliporella	(Po,De,St)
Tropidopora	(Bz,St,Cr)	Tshemsarythyris	(Br,Ar,Te)	Tubulitrypa	(Bz,St,Tr)
Tropidopyge	(Ar,Tr,Pt)	Tshingizoceras	(Mo,Ce,On)	Tubulogenerina	(Fo,Fo,Fo)
Tropidosteus	(Cd,Pl,Ar)	Tshokrakopora	(Bz,Gy,Ch)	Tubulostrophia	(Br,Ar,St)
Tropidostropha	(Mo,Ga,Ar)	Tsinania	(Ar,Tr,Co)	Tucetilla	(Mo,Bi,Ar)
Tropidothyris	(Br,Ar,Or)	Tsitrella	(Ar,Os,Pa)	Tucetona	(Mo,Bi,Ar)
Tropidotaxotis	(Ar,Os,Pa)	Tskanorella	(Cn.An,Sc)	Tucetonella	(Mo,Bi,Ar)
Tropifer	(Ar,MI,De)	Tsnyidiscus	(Ar,Tr,Ag)	Tudiaophomena	(Br,Ar,St)
Tropigastrites	(Mo,Ce,Ce)	Tsnyiella	(Ar,Os,Ar)	Tudicla	(Mo,Ga,Ne)
Tropigymites	(Mo,Ce,Ce)	Tsnylichas	(Ar,Tr,Li)	Tudiclana	(Mo,Ga,Ne)
Tropinuculites	(Mo,Bi,Nu)	Tsvetkovites	(Mo,Ce,Ce)	Tudicula	(Mo,Ga,Ne)
Tropiphyllum	(Cn.An,Sc)	Tuangia	(Mo,Bi,Ve)	Tudorella	(Mo,Ga,Nt)
Tropisurcula	(Mo,Ga,Ne)	Tuarangia	(Mo,In,Tu)	Tugali	(Mo,Ga,Ar)
Tropites	(Mo,Ce,Ce)	Tuarangisaurus	(Cd,Re,Ps)	Tugonia	(Mo,Bi,My)
Tropitoides	(Mo,Ce,Am)	Tuarkyria	(Mo,Bi,Ar)	Tugonopsis	(Mo,Bi,My)
Tropodus	(Cd,Co,Co)	Tubantia	(Cd,Os,Br)	Tugurites	(Mo,Ce,Am)
Trotlandella	(Br,Ar,St)	Tubaria	(Br,Ar,St)	Tugurium	(Mo,Ga,Nt)
Trubosta	(Mo,Ga,Ne)	Tubegatanella	(Br,Ar,Te)	Tulathyris	(Br,Ar,Sp)
Trucizetina	(Br,Ar,Or)	Tubena	(Mo,Ga,Nt)	Tulcumbella	(Br,Ar,St)
Truncacila	(Mo,Bi,Nu)	Tubeporella	(Fo,Fo,Fo)	Tulenicornus	(Hy,Hy,Hy)
Truncalosis	(Br,Ar,St)	Tubeporina	(Fo,Fo,Fo)	Tulipacrinus	(Ec,Cr,Is)
Truncaria	(Mo,Ga,Ne)	Tuberaspis	(Ar,Tr,Pt)	Tulipina	(Br,Ar,Te)
Truncatenia	(Br,Ar,St)	Tubercolocythere	(Ar,Os,Po)	Tulites	(Mo,Ce,Am)
Truncatiramus	(Ar,Me,Eu)	Tuberella	(Br,Ar,St)	Tullimonstrum	(Pr,Un,In)
Truncatocyathus	(Cn.An,Sc)	Tuberendothyra	(Fo,Fo,Fo)	Tulochilus	(Mo,Ga,Nt)

Tuloja	(Br,Ar,Pe)	Turbonopsis	(Mo,Ga,Ar)	Tuvaerhynchus	(Br,Ar,Rh)
Tulogcardium	(Mo,Bi,Ve)	Turbopecten	(Mo,Bi,Pt)	Tuvaestrophia	(Br,Ar,St)
Tulongella	(Mo,Bi,Un)	Turbophyllum	(Cn,An,Ru)	Tuvanella	(Ar,Tr,Pt)
Tulungospirifer	(Br,Ar,Sp)	Turborotalia	(Fo,Fo,Fo)	Tuvaspis	(Cd,Ce,Ce)
Tumanophyllum	(Cn,An,Ru)	Turborotalia	(Fo,Fo,Fo)	Tuvinia	(Br,Ar,Or)
Tumarina	(Br,Ar,Sp)	Turcica	(Mo,Ga,Ar)	Tuvekania	(Cd,Co,Co)
Tumaroceras	(Mo,Ce,Go)	Turcmeniella	(Fo,Fo,Fo)	Tuyloceras	(Mo,Ce,Di)
Tumidella	(Ar,Os,Me)	Turcopsyge	(Ar,Tr,Ph)	Tuyunaspis	(Ar,Tr,Un)
Tumidiacirsa	(Mo,Ga,Nt)	Turcutheca	(Hy,Or,Ci)	Tuzoia	(Ar,Th,In)
Tumidocarcinus	(Ar,MI,De)	Turehua	(Mo,Ga,Ne)	Tvaerenella	(Ar,Os,Pa)
Tumidoceras	(Mo,Ce,On)	Turganiella	(Br,Ar,Sp)	Twenhofellella	(Po,He,Am)
Tumidoleberis	(Ar,Os,Po)	Turgenostrophia	(Br,Ar,St)	Twenhofelia	(Br,Ar,Pe)
Tumidonautilus	(Mo,Ce,Na)	Turgicephalus	(Ar,Tr,Pt)	Tychobracea	(Mo,Ga,Eu)
Tumilites	(Mo,Ce,Go)	Turgidittia	(Cn,An,Ru)	Tychonia	(Mo,Ga,Ar)
Tumsucophyllum	(Cn,An,Ru)	Turia	(Mo,Bi,Ve)	Tyersella	(Br,Ar,Or)
Tumulduria	(Pr,Un,In)	Turiella	(Ar,Os,Po)	Tylambonites	(Br,Ar,St)
Tumulifungia	(Po,Re,Aj)	Turio	(Cd,Os,Pl)	Tylasteria	(Ec,As,Va)
Tumuliolythus	(Po,Re,Mo)	Turkestanella	(Mo,Bi,Tr)	Tylerichthys	(Cd,Os,Pl)
Tumulocoscinus	(Po,Re,Aj)	Turkmene	(Cd,Os,La)	Tylerocaris	(Ar,MI,My)
Tumulocyathus	(Po,Re,Aj)	Turkmenella	(Fo,Fo,Fo)	Tylocassis	(Mo,Ga,Nt)
Tumulus	(Mo,Ga,Ar)	Turkmenia	(Mo,Bi,Pt)	Tylochilus	(Mo,Ga,Nt)
Tundora	(Mo,Ga,Nt)	Turkmenithyris	(Br,Ar,Te)	Tylochidaris	(Ec,Ec,Ci)
Tundracrinus	(Ec,Cr,Cl)	Turkostrea	(Mo,Bi,Pt)	Tylocyathus	(Po,Re,Ca)
Tunestites	(Mo,Ce,Am)	Turmaekrithe	(Ar,Os,Po)	Tyloidinella	(Mo,Ga,Um)
Tunethyris	(Br,Ar,Te)	Turmalites	(Mo,Cr,Te)	Tylodisoceras	(Mo,Ce,Na)
Tunglantites	(Mo,Ce,Ce)	Turnacipora	(Cn,An,Pa)	Tyloodus	(Cd,Pl,Un)
Tungschuania	(Ar,Os,Po)	Turneria	(Cd,Re,Ps)	Tylograptus	(He,Gr,Gr)
Tungtingichthys	(Cd,Os,Pl)	Turnoceras	(Mo,Ce,On)	Tylo-nautilus	(Mo,Ce,Na)
Tungtzuella	(Ar,Tr,As)	Turnus	(Mo,Bi,My)	Tylophora	(Mo,Bi,Mo)
Tungusella	(Ar,Tr,Re)	Turoceras	(Mo,Ce,Di)	Tylopecta	(Br,Ar,St)
Tungusichthys	(Cd,Os,Am)	Turonia	(Po,De,Li)	Tylopora	(Bz,Gy,Ch)
Tunguskoceras	(Mo,Ce,Or)	Turriclavus	(Mo,Ga,Ne)	Tylopterella	(Ar,Me,Eu)
Tunguskocrinus	(Ec,Cr,Ds)	Turricolumbus	(Mo,Ga,Ne)	Tylothoeceras	(Mo,Ce,Na)
Tungusotoechia	(Br,Ar,Rh)	Turricula	(Mo,Ga,Ne)	Tylosaurus	(Cd,Re,Sq)
Tunisiacrinus	(Ec,Cr,Mo)	Turriculina	(Mo,Ga,Nt)	Tylospira	(Mo,Ga,Nt)
Tunisiaglossa	(Br,Li,Li)	Turriculum	(Br,Ar,Un)	Tylospiriferina	(Br,Ar,Sp)
Tunita	(Cd,Os,Pl)	Turricyathus	(Pr,Cr,Cr)	Tylostoma	(Mo,Ga,Nt)
Tuoidachithes	(Hy,Hy,Hy)	Turritulger	(Mo,Ga,Ne)	Tylothyris	(Br,Ar,Sp)
Tuoraconus	(Mo,In,In)	Turritilepas	(Pr,Ma,Le)	Tylotrochus	(Mo,Ga,Ar)
Tuotalania	(Br,Ar,Sp)	Turritina	(Fo,Fo,Fo)	Tylozone	(Mo,Ga,Ar)
Tupilakosaurus	(Cd,Am,Te)	Turritites	(Mo,Ce,Am)	Tylthocorys	(Ci,Po,Sp)
Turabuglossus	(Cd,Os,Pl)	Turrititoides	(Mo,Ce,Am)	Tympaneides	(Ac,Ra,Sp)
Turanglaster	(Ec,Ec,Sp)	Turrina	(Mo,Ga,Ne)	Tympanoblastus	(Ec,BI,Fi)
Turanta	(Ac,Ra,Na)	Turrinosyrinx	(Mo,Ga,Ne)	Tympanoceras	(Mo,Ce,Go)
Turarella	(Br,Ar,Or)	Turriola	(Mo,Ga,Nt)	Tympanomma	(Ac,Ra,Na)
Turbicellopora	(Bz,Gy,Ch)	Turris	(Mo,Ga,Ne)	Tympanotomus	(Mo,Ga,Nt)
Turbinaria	(Cn,An,Sc)	Turriscala	(Mo,Ga,Nt)	Tympanuella	(Ar,Tr,Pt)
Turbinatocanina	(Cn,An,Ru)	Turrispirillina	(Fo,Fo,Fo)	Typanocrinus	(Ec,Cr,Mo)
Turbinea	(Mo,Ga,Nt)	Turrispiroides	(Fo,Fo,Fo)	Typhina	(Mo,Ga,Ne)
Turbiniella	(Mo,Ga,Ne)	Turritella	(Mo,Ga,Nt)	Typhinellus	(Mo,Ga,Ne)
Turbinia	(An,Po,Se)	Turritella	(Fo,Fo,Fo)	Typhis	(Mo,Ga,Ne)
Turbiniopsis	(Mo,Ga,Ar)	Turritellopsis	(Mo,Ga,Nt)	Typhlocythere	(Ar,Os,Po)
Turbinolia	(Cn,An,Sc)	Turritoma	(Mo,Ga,Ar)	Typhloeocythera	(Ar,Os,Po)
Turbinopsis	(Mo,Ga,Nt)	Turritriton	(Mo,Ga,Nt)	Typhloiscus	(Ar,Tr,Ph)
Turbitrigonia	(Mo,Bi,Tr)	Tursiops	(Cd,Ma,Ce)	Typhlomangalia	(Mo,Ga,Ne)
Turbo	(Mo,Ga,Ar)	Turtonia	(Mo,Bi,Ve)	Typhlopleura	(Po,He,He)
Turbocheilus	(Mo,Ga,Eu)	Tusayana	(Mo,Bi,Ve)	Typhloproetus	(Ar,Tr,Pr)
Turbocrinus	(Ec,Cr,Di)	Tuscaritellum	(Ac,Ra,Sp)	Typiobius	(Ar,MI,De)
Turboella	(Mo,Ga,Nt)	Tusoteuthis	(Mo,Ce,Te)	Tyrranites	(Mo,Ce,Am)
Turboidea	(Mo,Ga,Ar)	Tutcheria	(Mo,Bi,Ve)	Tyrannoberingius	(Mo,Ga,Ne)
Turbonefina	(Mo,Ga,Ar)	Tuvacnema	(Po,Ir,Ar)	Tyrannophontes	(Ar,MI,St)
Turbonilla	(Mo,Ga,He)	Tuvaechonetes	(Br,Ar,St)	Tyrganiella	(Br,Ar,Sp)
Turbonitella	(Mo,Ga,Ar)	Tuvaconus	(Cn,Hc,Hc)	Tyrganolithes	(Cn,An,Pa)
Turbonomaria	(Mo,Ga,Ar)	Tuvaella	(Br,Ar,At)	Tyriaspis	(Cd,Ce,Ce)

Tyriocrinus	(Ec,Cr,Cf)	Ulrichospira	(Mo,Ga,Ar)	Ungulites	(An,Po,Ph)
Tyrioceras	(Mo,Ce,Ta)	Ulrichostylus	(Bz,St,Cr)	Uniaicularia	(Bz,Gy,Ch)
Tyrolecrinus	(Ec,Cr,Is)	Ulrichotrypa	(Bz,St,Tr)	Unibothriocidaris	(Ec,Ec,Bo)
Tyronella	(Br,Ar,Or)	Ulrichotrypella	(Bz,St,Tr)	Unica	(Mo,Bi,Pt)
Tyrhenocythere	(Ar,Os,Po)	Ulrickaspis	(Ar,Tr,Un)	Unicapeltis	(Ar,Tr,Co)
Tyrridiocystis	(Ec,Rh,Rh)	Ultrapanora	(Ac,Ra,Na)	Unicardiopsis	(Mo,Bi,Ve)
Tyrsoecus	(Mo,Ga,Nt)	Umbeloceras	(Mo,Ce,Di)	Unicardium	(Mo,Bi,Ve)
Tyrrhyrchus	(Br,Ar,Rh)	Umbetoceras	(Mo,Ce,Go)	Unicarinata	(Mo,Ga,Nt)
Tythostonyx	(Cd,Av,Pr)	Umbilia	(Mo,Ga,Nt)	Uniconus	(Mo,Cr,Te)
Tyttocrinus	(Ec,Cr,Cf)	Umboanctus	(Br,Ar,St)	Unicornites	(Ar,Os,Me)
Uarbychthys	(Cd,Os,Ma)	Umbocrinus	(Ec,Cr,Is)	Unicosiphonia	(Fo,Fo,Mo)
Uarthrus	(Ar,Me,Ag)	Umbonellina	(Mo,Ga,At)	Unicrisia	(Bz,St,Ce)
Ubaghisia	(Bz,Gy,Ch)	Umbonium	(Mo,Ga,Ar)	Unicytis	(Bz,St,Ce)
Uberella	(Mo,Ga,Nt)	Umbonula	(Bz,Gy,Ch)	Unifascia	(Ec,Ec,Sp)
Uberinterna	(Ac,Ra,Sp)	Umbospira	(Mo,Ga,Ar)	Uniformites	(Mo,Cr,Te)
Ubiquiradius	(Po,He,He)	Umbotrochus	(Mo,Ga,Ar)	Uniformithea	(Hy,Or,Ci)
Uca	(Ar,Ml,De)	Umbotropis	(Mo,Ga,Ar)	Unionites	(Mo,Bi,Un)
Uchauxia	(Mo,Ga,Nt)	Umbra	(Cd,Os,Sa)	Unipeltoceras	(Mo,Ce,Am)
Uchtella	(Br,Ar,Rh)	Umbraiculum	(Mo,Ga,Um)	Uniplicatorhynchia	(Br,Ar,Rh)
Uchites	(Mo,Ce,An)	Umbrellina	(Bz,St,Ce)	Uniramosa	(Ec,Ho,Un)
Uchtospirifer	(Br,Ar,Sp)	Umbrina	(Cd,Os,Pl)	Uniretepora	(Bz,Gy,Ch)
Uchtovia	(Ar,Os,Pa)	Umburra	(Mo,Bi,Pt)	Unispirifer	(Br,Ar,Sp)
Uddenia	(Mo,Bi,Ve)	Umiates	(Mo,Ce,Am)	Unisulcopleura	(Ar,Os,Pa)
Uddenites	(Mo,Ce,Pl)	Umpquaia	(Mo,Ga,Ne)	Unitas	(Mo,Ga,Ne)
Uddenoceras	(Mo,Ce,Pl)	Uncaspis	(Ar,Tr,Pt)	Unitendina	(Fo,Fo,Fo)
Udora	(Ar,Ml,De)	Uncina	(Ar,Ml,De)	Unitrypa	(Bz,St,Fe)
Udorella	(Ar,Ml,De)	Uncinaspira	(Mo,In,In)	Unitubigera	(Bz,St,Ce)
Udzhaites	(Tr,An)	Uncinotograptus	(He,Gr,Gr)	Unklesbyella	(Mo,Bi,Ph)
Uexothyris	(Br,Ar,Sp)	Uncinella	(Br,Ar,Sp)	Unodentina	(Ar,Os,Po)
Ufimia	(Cn,An,Ru)	Uncinogenys	(An,Po,Eu)	Unquatoceras	(Mo,Ce,Go)
Ufonicoclia	(Br,Ar,Sp)	Uncinulina	(Ec,Ho,As)	Unusuropode	(Ar,Ml,Ja)
Uhakiella	(Ar,Os,Pa)	Uncinuloides	(Ec,Ho,De)	Unzhiella	(Ar,Os,Pa)
Uhligella	(Mo,Ce,Am)	Uncinulus	(Br,Ar,Rh)	Upella	(Mo,Ga,He)
Uhligia	(Mo,Ce,Am)	Uncinunellina	(Br,Ar,Rh)	Uperocrinus	(Ec,Cr,Mo)
Uhligites	(Mo,Ce,Am)	Uncisteges	(Br,Ar,St)	Upantina	(Po,He,Re)
Uintacrinus	(Ec,Cr,Ui)	Uncites	(Br,Ar,At)	Upogebia	(Ar,Ml,De)
Ujandinella	(Br,Ar,Rh)	Uncitospira	(Br,Ar,At)	Uptonia	(Mo,Ce,Am)
Ujukites	(Br,Ar,St)	Undaria	(Br,Ar,St)	Utrakawites	(Mo,Ce,Am)
Ukhtoceras	(Mo,Ce,Di)	Undastriatostyliolina	(Mo,Cr,Da)	Uralella	(Br,Ar,Te)
Ukoa	(Br,Ar,St)	Undatimusculus	(Mo,Bi,Mt)	Uralichas	(Ar,Tr,Li)
Ukrainites	(Mo,Cr,Te)	Undatrypa	(Br,Ar,At)	Uralina	(Ar,Os,Pa)
Uktaspis	(Ar,Tr,Co)	Undelella	(Br,Ar,St)	Uralinella	(Fo,Fo,Fo)
Ulanophyllum	(Cn,An,Ru)	Undellaria	(Br,Ar,St)	Uralinia	(Cn,An,Ru)
Ulbospirifer	(Br,Ar,Sp)	Undiferina	(Br,Li,Ac)	Uraloceras	(Mo,Ce,Go)
Uldzapora	(Bz,St,Fe)	Undina	(Cd,Os,Co)	Uraloclymenia	(Mo,Ce,Cf)
Uldziathyris	(Br,Ar,Sp)	Undipila	(Ar,Os,Pa)	Uraloconchus	(Br,Ar,St)
Ulia	(Mo,Ga,He)	Undiscala	(Mo,Ga,Nt)	Uralodiscus	(Fo,Fo,Fo)
Ulias	(Cd,Ma,Ce)	Undispirifer	(Br,Ar,Sp)	Uralofusulinella	(Fo,Fo,Fo)
Uliitaspis	(Cd,Pt,Pt)	Undispiriferoides	(Br,Ar,Sp)	Uralograptus	(He,Gr,Gr)
Ullaspis	(Ar,Tr,Un)	Undithyrella	(Br,Ar,At)	Uralonema	(Po,He,Un)
Ullehmannia	(Ar,Os,Pa)	Undopecten	(Mo,Bi,Pt)	Uralopora	(Cn,An,Ta)
Ullerella	(Ar,Os,Pa)	Undospira	(Mo,Pa,Hy)	Uralopoductus	(Br,Ar,St)
Ullermelasma	(Cn,An,Ru)	Undulabucania	(Mo,Ga,Be)	Uralopronorites	(Mo,Ce,Pl)
Uloceras	(Mo,Ce,Na)	Undularia	(Mo,Ga,Nt)	Uralops	(Ar,Tr,Ph)
Ulocrinus	(Ec,Cr,Cf)	Undulella	(Br,Ar,St)	Uralopteria	(Mo,Bi,Pt)
Ulophysema	(Ar,Ci)	Undulirete	(Ar,Os,Pa)	Uralorhynchia	(Br,Ar,Rh)
Ulrichaster	(Ec,As,Ur)	Undulograptus	(He,Gr,Gr)	Uralorthoceras	(Mo,Ce,Or)
Ulrichella	(Ar,Os,Po)	Undulomya	(Mo,Bi,Ph)	Uraloscutellum	(Ar,Tr,Co)
Ulrichia	(Ar,Os,Pa)	Undulorhynchia	(Br,Ar,Rh)	Uralospira	(Br,Ar,At)
Ulrichicrinus	(Ec,Cr,Cf)	Undulostrea	(Mo,Bi,Pt)	Uralospirifer	(Br,Ar,Sp)
Ulrichidiscus	(Ec,Ed,Is)	Unedogemmula	(Mo,Ga,Ne)	Uralotochia	(Br,Ar,Rh)
Ulrichoceras	(Mo,Ce,Di)	Ungerella	(Ar,Os,My)	Uralotrypa	(Bz,St,Cr)
Ulrichocystis	(Ec,Rh,Rh)	Ungulina	(Mo,Bi,Ve)	Uramulelerina	(Ar,Os,Po)
Ulrichodina	(Cd,Co,Co)	Unguliproetus	(Ar,Tr,Pr)	Uranaster	(Ec,As,Pu)

Uranoceras	(Mo,Ce,Ba)	Ussurichonetes	(Br,Ar,St)	Valenagnostus	(Ar,Tr,Ag)
Uranolophus	(Cd,Os,Di)	Ussuricyathus	(Po,Re,Aj)	Valenciennellus	(Cd,Os,St)
Uranoplasmus	(Cd,Os,Py)	Ussurirhynchia	(Br,Ar,Rh)	Valenticis	(Cd,Ma,Ca)
Uranoscopus	(Cd,Os,Pf)	Ussurites	(Mo,Ce,Ph)	Valentinia	(Ar,Os,Me)
Uranosphaera	(Po,Ca,He)	Utagnostus	(Ar,Tr,Ag)	Valettaster	(Ec,As,Va)
Urasterella	(Ec,As,Ur)	Utahcaris	(Ar,Un,Un)	Valfinia	(Mo,Ga,Ar)
Urbanaspis	(Ar,Tr,Pt)	Utahconus	(Cd,Co,Co)	Valhalla	(Po,De,Li)
Urbanekicrusta	(He,Gr,Cr)	Utahphospha	(An,Pa,Pa)	Valhallites	(Mo,Ce,Na)
Urbanekograptus	(He,Gr,Gr)	Utaraitua	(Cn,An,Ru)	Valhalloceras	(Mo,Ce,On)
Urbanella	(Fo,Fo,Fo)	Utatusaurus	(Cd,Re,Je)	Validaspis	(Ar,Tr,Re)
Urbanirhynchia	(Br,Ar,Rh)	Utaturiceras	(Mo,Ce,Am)	Vallatotheca	(Mo,Te,Tr)
Urbnsia	(Mo,Bi,Ve)	Utharocrinus	(Ec,Cr,Cl)	Valletia	(Mo,Bi,Hi)
Ureolabrum	(Mo,Ga,Nt)	Uthocerina	(Ar,Os,Un)	Valliculastraea	(Cn,An,Sc)
Ureopora	(Cn,An,Ta)	Utia	(Ar,Tr,Pt)	Vallimeadra	(Cn,An,Sc)
Ureyathella	(Po,Re,Aj)	Utica	(Ar,ML,De)	Vallimeandropsis	(Cn,An,Sc)
Ureyathus	(Po,Re,Aj)	Utoceras	(Mo,Ce,En)	Valliseris	(Cn,An,Sc)
Urda	(Ar,ML,Is)	Utropora	(Bz,St,Fe)	Vallisia	(Cd,Ch,In)
Urdia	(Ar,Os,Pa)	Utsatia	(Ar,Os,Ar)	Vallites	(Mo,Ce,Go)
Urella	(Br,Ar,Sp)	Uttleya	(Mo,Ga,Ne)	Vallomyonia	(Br,Ar,Or)
Urenchelys	(Cd,Os,An)	Uvacoelia	(Po,De,Pe)	Valloria	(Cn,An,Sc)
Ureocrinus	(Ec,Cr,Cl)	Uvanella	(Po,Ca,Un)	Vallupus	(Ac,Ra,Sp)
Urftella	(Ar,Os,Pa)	Uvanilla	(Mo,Ga,Ar)	Valangia	(Ar,Tr,Ph)
Urgachilina	(Ar,Os,Pa)	Uviella	(Fo,Fo,Fo)	Valospongia	(Po,He,LS)
Urgonella	(Mo,Ga,Nt)	Uvigerina	(Fo,Fo,Fo)	Valsalenia	(Ec,Ec,Sa)
Urgonia	(Fo,Fo,Fo)	Uvigerinammina	(Fo,Fo,Fo)	Valserina	(Fo,Fo,Fo)
Uripes	(Ar,Tr,Li)	Uvigerinella	(Fo,Fo,Fo)	Valumoceratina	(Ar,Os,Po)
Urjungaspis	(Ar,Tr,Pt)	Uvonhachtia	(Ar,Os,Pa)	Valvalabamina	(Fo,Fo,Fo)
Urkutitoma	(Mo,Ga,Ar)	Uvonhactia	(Ar,Os,Un)	Valvoreussella	(Fo,Fo,Fo)
Urnacristata	(Po,De,Li)	Uvothalamia	(Po,De,Pe)	Valvulamina	(Fo,Fo,Fo)
Urmulinella	(Fo,Fo,Fo)	Uxia	(Mo,Ga,Ne)	Valvulina	(Fo,Fo,Fo)
Urobairdia	(Ar,Os,Po)	Uxunella	(Ar,Tr,Pt)	Valvulinella	(Fo,Fo,Fo)
Urochitina	(Fo,Fo,Ch)	Uydenia	(Cd,Os,Pa)	Valvulinoides	(Fo,Fo,Fo)
Uroconger	(Cd,Os,An)	Uyugroblastus	(Ec,Bi,Sp)	Vandaites	(Mo,Ce,Ce)
Urocyrts	(Ac,Ra,Na)	Uzita	(Mo,Ga,Ne)	Vandalotreta	(Br,Li,Ac)
Urocyrthere	(Ar,Os,Po)	Vaccinites	(Mo,Bi,Hi)	Vandelcoaster	(Ec,Op,Oe)
Urocyrthereis	(Ar,Os,Po)	Vacekia	(Mo,Ce,Am)	Vandenbroeckia	(Fo,Fo,Fo)
Urokodia	(Ar,Un,Un)	Vaceletia	(Po,De,Ve)	Vanderbeekia	(Fo,Fo,Fo)
Uroleberis	(Ar,Os,Po)	Vachonisia	(Ar,Ma,Ac)	Vanderbenderia	(Br,Ar,Sp)
Urolophus	(Cd,Ch,My)	Vacoea	(Cn,An,Ru)	Vandergrachtia	(Ar,Tr,Pr)
Uromitra	(Mo,Ga,Ne)	Vaculina	(Br,In,Tr)	Vandiemencythera	(Ar,Os,Po)
Uromystrum	(Ar,Tr,Pr)	Vacunella	(Mo,Bi,Ph)	Vandobiella	(Br,Ar,Te)
Uronautes	(Cd,Re,Ps)	Vacuopora	(Cn,An,Ta)	Vania	(Fo,Fo,Fo)
Urophycis	(Cd,Os,Ga)	Vacuovalvulina	(Fo,Fo,Fo)	Vaniella	(Br,Ar,Te)
Urosalpinx	(Mo,Ga,Ne)	Vadarocrinus	(Ec,Cr,Cl)	Vanikoro	(Mo,Ga,Nt)
Urosoma	(Ec,Op,Oe)	Vaderos	(Mo,Ga,Nt)	Vanikoropsis	(Mo,Ga,Nt)
Urosphen	(Cd,Os,Ga)	Vadimia	(Br,Ar,Pe)	Vaningenoceras	(Mo,Ce,En)
Urosphenopsis	(Cd,Os,Ga)	Vadum	(Br,Ar,Sp)	Vanitrochus	(Mo,Ga,Ar)
Urostheneis	(Cd,Os,Pa)	Vaga	(Br,Ar,Pe)	Vanpalmer	(Mo,Ga,Ne)
Ursirivus	(Mo,Bi,My)	Vaginella	(Mo,Ga,Th)	Vanua	(Ar,ML,De)
Urtasymoceras	(Mo,Ce,Di)	Vaginoceras	(Mo,Ce,En)	Vanuxemella	(Ar,Tr,Co)
Uruma	(Ac,Ra,Na)	Vaginulina	(Fo,Fo,Fo)	Vanuxemia	(Mo,Bi,Ar)
Urushtenia	(Br,Ar,St)	Vaginulinopsis	(Fo,Fo,Fo)	Vaquerosella	(Ec,Ec,Cl)
Urushtenoida	(Br,Ar,St)	Vagranelia	(Br,Ar,Pe)	Varanella	(Ar,Tr,Pt)
Uzbekistania	(Fo,Fo,Fo)	Vagrania	(Br,Ar,At)	Varasichthys	(Cd,Os,Pe)
Uscopia	(Ar,Os,Pa)	Vaivanovia	(Ar,Os,Pa)	Variabilifavia	(Cn,An,Sc)
Ushbaspis	(Ar,Tr,Re)	Vatanginella	(Mo,Ga,He)	Variabiliconus	(Cd,Co,Co)
Ushkarella	(Ar,Os,Le)	Valanginites	(Mo,Ce,Am)	Variatrypa	(Br,Ar,At)
Ushkolia	(Br,Ar,Sp)	Valcourea	(Br,Ar,Or)	Varicardium	(Mo,Bi,Ve)
Usloncyathus	(Po,Je,Ar)	Valcouroceras	(Mo,Ce,On)	Varicobairdia	(Ar,Os,Me)
Uslonia	(Fo,Fo,Fo)	Valdainia	(Cn,Pe,Er)	Varicobela	(Mo,Ga,Ne)
Ussunia	(Br,In,Tr)	Valdanchella	(Fo,Fo,Fo)	Varicorbula	(Mo,Bi,My)
Ussuria	(Mo,Ce,Ce)	Valdarella	(Ar,Os,Pa)	Varicosipho	(Mo,Ga,Ne)
Ussuricamara	(Br,Ar,Rh)	Valdaria	(Br,Ar,St)	Varicospira	(Mo,Ga,Nt)
Ussuricavina	(Ar,Os,Po)	Valdorsella	(Mo,Ce,Am)	Varidentella	(Fo,Fo,Fo)

Variatella	(Ar.Os.Pa)	Velezicerias	(Mo.Ce.Am)	Vermetus	(Mo.Ga.Nt)
Varinucula	(Mo.Bi.Nu)	Velicucullus	(Ac.Ra.Na)	Vermiceras	(Mo.Ce.Am)
Variopelta	(Ar.Tr.Un)	Velifer	(Cd.Os.La)	Vermicularia	(Mo.Ga.Nt)
Variostoma	(Fo.Fo.Fo)	Velisepalum	(Br.Li.Ac)	Vermiculissimum	(Po.De.Li)
Variseptophyllum	(Cn.An.Ru)	Vellaena	(Fo.Fo.Fo)	Vermiculothecidea	(Br.Ar.Th)
Varithea	(Pr.Un.In)	Vellamo	(Br.Ar.Or)	Vermilia	(An.Po.Se)
Varneycoelia	(Po.De.Li)	Veloritina	(Mo.Bi.Ve)	Vermilionites	(Ar.Tr.Pt)
Varpalmeria	(Mo.Ga.Ne)	Velostrophia	(Br.Ar.St)	Vermiliopsis	(An.Po.Se)
Varuna	(Ar.Mi.De)	Velutina	(Mo.Ga.Nt)	Verninaria	(Bz.Gy.Ch)
Varvaria	(Mo.Bi.Pt)	Velubrella	(Ca.Hy.Hy)	Vernisphinctes	(Mo.Ce.Am)
Varvia	(Ar.Tr.As)	Venatoroceras	(Mo.Ce.Na)	Vermitexta	(Mo.Bi.Ve)
Vasalemmapora	(Bz.St.Cy)	Vendia	(Cn.Pe.Er)	Vermontella	(Ar.Tr.Pt)
Vasalemnoceras	(Mo.Ce.Ta)	Vendomia	(Cn.Pe.Er)	Vernaculina	(Ar.Tr.Pt)
Vasoceras	(Mo.Ce.Am)	Veneficoceras	(Mo.Ce.El)	Vernedia	(Mo.Ga.Nt)
Vasconella	(Mo.Bi.Ar)	Venerella	(Mo.Bi.Ve)	Vernelia	(Mo.Ga.Ar)
Vascothalamia	(Po.De.Ve)	Venericardia	(Mo.Bi.Ve)	Verneulia	(Br.Ar.Sp)
Vascothalamia	(Po.De.Pe)	Venericardiella	(Mo.Bi.Ve)	Verneulina	(Fo.Fo.Fo)
Vasulicrinus	(Ec.Cr.Rv)	Venericor	(Mo.Bi.Ve)	Verneulinella	(Fo.Fo.Fo)
Vasculum	(Mo.Ga.Ba)	Venericyprina	(Mo.Bi.Ve)	Verneulinoides	(Fo.Fo.Fo)
Vasicekia	(Fo.Fo.Fo)	Veneritapes	(Mo.Bi.Ve)	Verneulites	(Mo.Ce.Go)
Vasicostella	(Fo.Fo.Fo)	Venerupis	(Mo.Bi.Ve)	Vernius	(Ec.Ec.Un)
Vasiglobulina	(Fo.Fo.Fo)	Venezolicerias	(Mo.Ce.Am)	Vernonaspis	(Cd.Pt.Pt)
Vasocrinus	(Ec.Cr.Cl)	Venezuelia	(Br.Ar.Un)	Vernoniella	(Ar.Os.Po)
Vassaroceras	(Mo.Ce.El)	Venidia	(Mo.Bi.Ve)	Vernonina	(Fo.Fo.Fo)
Vasseuria	(Mo.Ce.Se)	Veniella	(Mo.Bi.Ve)	Veroclema	(Bz.St.Cr)
Vasticardium	(Mo.Bi.Ve)	Venificardia	(Mo.Bi.Ve)	Verolites	(Cn.An.Ta)
Vasum	(Mo.Ga.Ne)	Ventalium	(Mo.Bi.Pt)	Veromanguilla	(Cd.Os.An)
Vattenfallia	(Ar.Os.Pa)	Ventilabrella	(Fo.Fo.Fo)	Verniacycathus	(Po.Re.Aj)
Vaughania	(Cn.An.Ta)	Ventricaria	(Mo.Ga.Ar)	Verrillofungia	(Cn.An.Sc)
Vaughanina	(Fo.Fo.Fo)	Ventricolaria	(Mo.Bi.Ve)	Verruca	(Ar.Ci)
Vaughanites	(Mo.Ga.Ne)	Ventriculoidea	(Mo.Bi.Ve)	Verrucella	(Cn.An.Go)
Vaughanoseris	(Cn.An.Sc)	Ventriculites	(Po.He.Ly)	Verrucocoeilia	(Po.He.He)
Vaugonia	(Mo.Bi.Tr)	Ventrifossa	(Cd.Os.Ga)	Verrucospongia	(Po.De.Li)
Vaupelia	(Mo.Ce.On)	Ventrigrurus	(Ar.Os.Pa)	Verruculina	(Po.De.Li)
Vaurealispongia	(Po.He.Ls)	Ventrilia	(Mo.Ga.Ne)	Verruturris	(Mo.Ga.Ne)
Vautrinia	(Mo.Bi.Hi)	Ventroyctheris	(Ar.Os.Po)	Verseya	(Ar.Os.Po)
Vauxia	(Po.De.Vr)	Ventroloboceras	(Mo.Ce.En)	Verseyella	(Fo.Fo.Fo)
Vauzutsinia	(Cn.Pe.Ra)	Ventroloboceras	(Mo.Ce.El)	Versispira	(Mo.Pa.Hy)
Vauzutsubua	(Cn.Pe.Un)	Ventrostoma	(Fo.Fo.Fo)	Vertebriceras	(Mo.Ce.Am)
Vavilovites	(Mo.Ce.Ce)	Venula	(Ar.Os.Me)	Vertebrices	(Mo.Ce.Am)
Veatchia	(Mo.Ga.Nt)	Venus	(Mo.Bi.Ve)	Verticillites	(Po.De.Ve)
Vectella	(Br.Ar.Te)	Venustodus	(Cd.Ch.In)	Verticpronus	(Mo.Bi.Ve)
Vectianella	(Mo.Bi.Ve)	Venzavella	(Ar.Os.Un)	Verticoceras	(Mo.Ce.Di)
Vectibelus	(Mo.Ce.Be)	Vepreculina	(An.Po.Se)	Verticordia	(Mo.Bi.Ph)
Vectis	(Ar.Mi.De)	Vepresiphylum	(Cn.An.Ru)	Vertigocrinus	(Ec.Cr.Cl)
Vectorbis	(Mo.Bi.Ve)	Vepresiosciophyllum	(Cn.An.Ru)	Vertinomia	(Mo.Bi.Pt)
Vediproductus	(Br.Ar.St)	Vepricardium	(Mo.Bi.Ve)	Vertipecten	(Mo.Bi.Pt)
Veenia	(Ar.Os.Po)	Veraephyllum	(Cn.An.Ru)	Vetrorhizoceras	(Mo.Ce.Na)
Veeniacytheris	(Ar.Os.Po)	Verancoceras	(Mo.Ce.Go)	Vertumnia	(Mo.Bi.Pt)
Veeniceratina	(Ar.Os.Po)	Verbeekia	(Ec.Ec.Sp)	Vesacula	(Mo.Ga.Ne)
Veerersalosis	(Br.Ar.St)	Verbeekiella	(Cn.An.Ru)	Vesicocaulis	(Po.De.Pe)
Veghicyclia	(Ac.Ra.Sp)	Verbeekina	(Fo.Fo.Fo)	Vesicomya	(Mo.Bi.Ve)
Veghirhynchia	(Br.Ar.Rh)	Verchojania	(Br.Ar.St)	Vesicularia	(Bz.Gy.Ct)
Velainella	(Mo.Ga.Ar)	Verchojanogrammysia	(Mo.Bi.Ve)	Vesiculophyllum	(Cn.An.Ru)
Velapertina	(Fo.Fo.Fo)	Vercorsella	(Fo.Fo.Fo)	Vesiculotubus	(Cn.An.Ru)
Velapezoides	(Ar.Os.Po)	Verditerrina	(Ar.Tr.Un)	Vesporeras	(Mo.Ce.Di)
Velarocythere	(Ar.Os.Po)	Verella	(Bz.St.Cr)	Vestieytherura	(Ar.Os.Pa)
Velatachiina	(Fo.Fo.Ch)	Veremolpa	(Mo.Bi.Ve)	Vestigiphylum	(Cn.An.Ru)
Velatella	(Mo.Ga.Ar)	Vergnesia	(Mo.Ga.Ar)	Vestinautilus	(Mo.Ce.Na)
Velates	(Mo.Ga.Ar)	Vericeras	(Mo.Ce.Or)	Vestrogothia	(Ar.Os.Ar)
Veldidentella	(Mo.Bi.Pt)	Verilarca	(Mo.Bi.Ar)	Vestulia	(Mo.Ga.Ar)
Velebites	(Mo.Ce.Ce)	Verilitus	(Cd.Os.Pf)	Veteranella	(Mo.Bi.Nu)
Velellosporgia	(Po.De.Li)	Verkholenella	(Ar.Tr.Pt)	Vetator	(Mo.Ga.Nt)
Veletuceta	(Mo.Bi.Ar)	Verkhotomia	(Br.Ar.Sp)	Vetricardiella	(Mo.Bi.Ve)

Vetoarca	(Mo,Bi,Ar)	Vincenturris	(Mo,Ga,Ne)	Vitrinellops	(Mo,Ga,Nt)
Vetridrillia	(Mo,Ga,Ne)	Vinchuscanchaia	(Ec,Ec,Ci)	Vitriwebbina	(Fo,Fo,Fo)
Vetulicola	(Ar,Un,Un)	Vinciguerra	(Cd,Os,St)	Vitta	(Mo,Ga,Ar)
Vetulina	(Po,De,Li)	Vinctifer	(Cd,Os,Pe)	Vittaticella	(Bz,Gy,Ch)
Vetustoytheridea	(Ar,Os,Po)	Vinularia	(Bz,Gy,Ch)	Vittella	(Ar,Os,Pa)
Vetustovermis	(An,Po,SP)	Vinella	(Bz,Gy,Ct)	Vittia	(Po,De,St)
Veveysiceras	(Mo,Ce,Am)	Vinelloidea	(Fo,Fo,Fo)	Vitularia	(Mo,Ga,Ne)
Vevoda	(Mo,Bi,Pr)	Vinnalochitina	(Fo,Fo,Ch)	Vivanella	(Mo,Ga,Ar)
Vex	(Br,Ar,Te)	Viodostrophia	(Br,Ar,St)	Vivesastraea	(Cn,An,Sc)
Vexillita	(Mo,Ga,Ne)	Viratellina	(Mo,Cr,Da)	Vjalovites	(Mo,Cr,Te)
Vexillum	(Mo,Ga,Ne)	Virbium	(Br,Ar,Un)	Vladimirella	(Br,Ar,Te)
Vexinia	(Mo,Ga,Ar)	Virgaloceras	(Mo,Ce,Na)	Vladimirirhynchus	(Br,Ar,Rh)
Vexilhara	(Mo,Ga,Ne)	Virgaspongia	(Po,De,Li)	Vlasta	(Mo,Bi,Pr)
Viaderella	(Mo,Bi,Ve)	Virgataxiceras	(Mo,Ce,Am)	Vltavina	(Ar,Os,My)
Viallithyris	(Br,Ar,Te)	Virgatella	(Bz,St,Cr)	Vnagripecten	(Mo,Bi,Pt)
Vialorophis	(Cd,Re,Sq)	Virgaites	(Mo,Ce,Am)	Voehringerites	(Mo,Ce,Go)
Vialovella	(Fo,Fo,Fo)	Virgatoxypris	(Ar,Os,Po)	Vogdesella	(Ar,Os,Pa)
Vialovia	(Fo,Fo,Fo)	Virgatopavlovina	(Mo,Ce,Am)	Vogdesia	(Ar,Tr,As)
Viaphacops	(Ar,Tr,Ph)	Virgatosimoceras	(Mo,Ce,Am)	Vogesina	(Ar,Tr,Ph)
Viarhynchia	(Br,Ar,Rh)	Virgatosphinctes	(Mo,Ce,Am)	Voibokalina	(Ar,Os,Ar)
Vibracella	(Bz,Gy,Ch)	Virgatospinctoides	(Mo,Ce,Am)	Voigtella	(Bz,Gy,Ct)
Vibracellina	(Bz,Gy,Ch)	Virgatotheca	(Hy,Hy,Hy)	Voigtia	(Bz,St,Cc)
Vibraculina	(Bz,Gy,Ch)	Virgella	(Mo,Ga,Nt)	Voigtella	(Bz,St,Cc)
Vicarya	(Mo,Ga,Nt)	Virgiana	(Br,Ar,Pe)	Voigtopora	(Bz,St,Cc)
Vicaryella	(Mo,Ga,Nt)	Virgianella	(Br,Ar,Pe)	Voiseyella	(Br,Ar,Sp)
Vicetia	(Mo,Ga,Nt)	Virginiata	(Br,Ar,St)	Vojnovskija	(Cn,An,Ru)
Vicetiometra	(Ec,Cr,Cm)	Virgiscalpellum	(Ar,Ci)	Vokesella	(Mo,Bi,Ve)
Vicinesphaera	(Fo,Fo,Fo)	Virgoella	(Bz,Gy,Ch)	Vokesula	(Mo,Bi,My)
Vicinia	(Ar,Os,Po)	Virgoceras	(Mo,Ce,Or)	Volachlamys	(Mo,Bi,Pt)
Viciniodiceras	(Mo,Ce,Am)	Virgola	(Po,Ca,Ph)	Volborthella	(Pr,Un,Vo)
Vicinocerithium	(Mo,Ga,Nt)	Virgoria	(Br,Ar,Or)	Volborthia	(Br,Li,Li)
Vicinoproetus	(Ar,Tr,Ph)	Virgotrigonia	(Mo,Bi,Tr)	Volchovia	(Ec,Oh,Oh)
Vickohlerites	(Mo,Ce,Ce)	Virgula	(Po,De,Li)	Volcichthys	(Cd,Os,Al)
Victalimulus	(Ar,Me,Xi)	Virgularia	(Cn,An,Pe)	Volema	(Mo,Ga,Ne)
Victoria	(Ar,Os,Pa)	Virgulaxonaria	(Hy,Hy,Hy)	Volganella	(Ar,Os,Pa)
Victoriacystis	(Ec,St,Mi)	Virgulinea	(Fo,Fo,Fo)	Volgathyris	(Br,Ar,Te)
Victoriaster	(Ec,Ec,Sp)	Virguloides	(Fo,Fo,Fo)	Volgelgnathus	(Cd,Co,Co)
Victoriella	(Fo,Fo,Fo)	Virgulopsis	(Fo,Fo,Fo)	Volgia	(Bz,St,Cy)
Victorilites	(Cn,An,Ta)	Viriatella	(Mo,Cr,Da)	Volgobelus	(Mo,Ce,Be)
Victorisipina	(Ar,Tr,Ph)	Viridibuccinum	(Mo,Ga,Ne)	Volirhynchia	(Br,Ar,Rh)
Victorithyris	(Br,Ar,Te)	Viriola	(Mo,Ga,Nt)	Volkina	(Ar,Os,My)
Vicunostachyodes	(Po,De,St)	Virmula	(Po,Ca,Ph)	Volnovachia	(Bz,St,Tr)
Vidalina	(Fo,Fo,Fo)	Virucrinus	(Ec,Cr,Ds)	Voloccephalina	(Ar,Tr,Un)
Vidria	(Ar,Tr,Pr)	Viruella	(Br,Ar,St)	Vologdinella	(Pr,Un,Vo)
Vidrioceras	(Mo,Ce,Go)	Visbyella	(Br,Ar,Or)	Vologdinocyathellus	(Po,Re,Aj)
Vielicyathus	(Cn,An,Sc)	Visbylites	(Cn,An,Ta)	Vologdinocyathus	(Po,Re,Aj)
Vietnamia	(Ar,Tr,Ph)	Vischeria	(Cn,An,Ru)	Vologdinophyllum	(Pr,Cr,Cr)
Vietnamocardium	(Mo,Bi,Ve)	Visediscus	(Fo,Fo,Fo)	Vologesia	(Ec,Ec,Ca)
Vigescentis	(Mo,Ga,Ar)	Viseina	(Fo,Fo,Fo)	Volonellus	(Ar,Tr,Un)
Vigorniella	(Mo,Bi,Ar)	Vishnuites	(Mo,Ce,Ce)	Voloshinoides	(Fo,Fo,Fo)
Vikingia	(Po,De,St)	Visitor	(Mo,Ga,Ar)	Voloshinovella	(Fo,Fo,Fo)
Viligella	(Br,Ar,Sp)	Visnyoella	(Ar,Os,Po)	Volsellina	(Mo,Bi,Mt)
Viligothyris	(Br,Ar,Te)	Vissariotaxis	(Fo,Fo,Fo)	Voltaconger	(Cd,Os,An)
Villania	(Mo,Ce,Am)	Vistularia	(Ac,Ra,Na)	Volupia	(Mo,Bi,Ve)
Villebrunaster	(Ec,So,Go)	Vistulella	(An,Po,Eu)	Volupicuna	(Mo,Bi,Ve)
Villicundella	(Br,Ar,Or)	Vistulia	(Mo,Ga,Ar)	Voluspa	(Mo,Ga,He)
Villorita	(Mo,Bi,Ve)	Vitaella	(Ar,Tr,Pr)	Voluta	(Mo,Ga,Ne)
Villozona	(Ar,Os,Pa)	Vitella	(Ar,Os,Un)	Voluticella	(Mo,Ga,Ne)
Vimentum	(Mo,Bi,Ve)	Vitiliproductus	(Br,Ar,St)	Volutilithes	(Mo,Ga,Ne)
Viminohelia	(Cn,An,Sc)	Vitimetula	(Br,Ar,Sp)	Volutoconus	(Mo,Ga,Ne)
Vinalesites	(Mo,Ce,Am)	Vitissites	(Ar,Os,Pa)	Volutocorbis	(Mo,Ga,Ne)
Vinalesphinctes	(Mo,Ce,Am)	Vitjasieffa	(Ar,Os,Po)	Volutoderma	(Mo,Ga,Ne)
Vincella	(Ar,Tr,Re)	Vitorfus	(Ac,Ra,Sp)	Volutolithes	(Mo,Ga,Ne)
Vincentirhynchia	(Br,Ar,Rh)	Vitrinella	(Mo,Ga,Nt)	Volutomitra	(Mo,Ga,Ne)

Volutomorpha	(Mo.Ga.Ne)	Waiparaconus	(Ar.Ci)	Warsawia	(Br.Ar.Sp)
Volutopsis	(Mo.Ga.Ne)	Waiparia	(Br.Ar.Ic)	Warthia	(Mo.Ga.Be)
Volutospina	(Mo.Ga.Ne)	Wairakiella	(Br.Ar.Rh)	Warthinia	(Ar.Os.Pa)
Volva	(Mo.Ga.Ni)	Wairakirhynchia	(Br.Ar.Rh)	Wasatchites	(Mo.Cc.Ce)
Volvaria	(Mo.Ga.Ne)	Waisiella	(Mo.Ga.Ar)	Washtaster	(Ec.Ec.Sp)
Volvariella	(Mo.Ga.Ne)	Waisiuconcha	(Mo.Bi.Ve)	Washitella	(Fo.Fo.Fo)
Volvarina	(Mo.Ga.Ne)	Waisiuthyrina	(Br.Ar.Te)	Wassypora	(Bz.St.Cc)
Volvarinella	(Mo.Ga.Ne)	Waitara	(Mo.Ga.Ne)	Wateletia	(Mo.Ga.Nt)
Volviceramus	(Mo.Bi.Pt)	Wakullina	(Mo.Bi.Pt)	Waterhouseiella	(Br.Ar.St)
Volvillustrellaria	(Bz.Gy.Ch)	Walcottaspis	(Ar.Tr.As)	Watersipora	(Bz.Gy.Ch)
Volvocylindrites	(Mo.Ga.Ce)	Walcottella	(Po.He.He)	Waterstonella	(Ar.Ml.Wa)
Volvulella	(Mo.Ga.Ce)	Walcottidiscus	(Ec.Ed.Un)	Watnocoeras	(Mo.Cc.Am)
Volynites	(Mo.Cr.Te)	Walcottina	(Br.Li.Pa)	Watsonella	(Mo.Ro.Ri)
Volzeia	(Cn.An.Sc)	Walcottoceras	(Mo.Cc.El)	Watsonia	(Mo.Ga.Nt)
Vomeraster	(Ec.Ec.Sp)	Walcottoma	(Mo.Ga.Eu)	Watsonichthyes	(Cd.Os.Pa)
Vomeropsis	(Cd.Os.Pf)	Waldoria	(Ar.Os.Ar)	Watsonulus	(Cd.Os.Am)
Voorthuyseniella	(Bz.Gy.Ch)	Waldthausenites	(Mo.Cc.Ce)	Wattonithyrus	(Br.Ar.Te)
Voorwindia	(Mo.Ga.Nt)	Walencrinurides	(Ar.Tr.Ph)	Waucobella	(Ec.He.He)
Vorkutella	(Mo.Bi.So)	Walkerithyrus	(Br.Ar.Te)	Wawahia	(Bz.Gy.Ch)
Vorkutopecten	(Mo.Bi.Pt)	Wallacia	(Ar.Tr.Ph)	Waylendella	(Ar.Os.Me)
Voronina	(Ar.Os.Me)	Walliospongia	(Po.He.Am)	Weania	(Ar.Tr.Pr)
Vorticina	(Mo.Ga.Ar)	Walliserodus	(Cd.Co.Co)	Webbinella	(Fo.Fo.Fo)
Vosekocrinus	(Ec.Cr.Ds)	Wallucina	(Mo.Bi.Ve)	Webbineoidea	(Fo.Fo.Fo)
Voskopella	(Mo.Pa.Hy)	Walnichollsia	(Mo.Ga.Ar)	Webbylla	(Ar.Os.Pa)
Voskopioechia	(Br.Ar.Rh)	Walossekia	(Ar.In.Un)	Webbyspira	(Br.Ar.At)
Vosmiverstum	(Br.Ar.Pe)	Walterparria	(Fo.Fo.Un)	Weberides	(Ar.Tr.Pr)
Vostocovacrinus	(Ec.Cr.En)	Waltonia	(Br.Ar.Te)	Weberiphilipsia	(Ar.Tr.Pr)
Vostokovella	(Fo.Fo.Fo)	Waluia	(Mo.Ga.Nt)	Weberithyrus	(Br.Ar.Te)
Vouastia	(Mo.Ga.Nt)	Wandlella	(Ar.Tr.Un)	Weberocoeras	(Mo.Cc.Ta)
Vredenburgites	(Mo.Cc.Ce)	Wanella	(Po.De.Pe)	Weberopeltis	(Ar.Tr.Co)
Vulsella	(Mo.Bi.Pt)	Wangacteon	(Mo.Ga.Ce)	Wedekindella	(Mo.Cc.Am)
Vulsellina	(Mo.Bi.Pt)	Wangaloo	(Mo.Ga.He)	Wedekindellina	(Fo.Fo.Fo)
Vultogryphaea	(Mo.Bi.Pt)	Wangia	(Cd.Os.Pf)	Weejasperaspis	(Cd.Pl.Ac)
Vulvulina	(Fo.Fo.Fo)	Wangiawania	(Ar.Os.Me)	Weeksia	(Mo.Ga.Ar)
Waagenia	(Mo.Cc.Go)	Wangocoeras	(Mo.Cc.Ce)	Weeksina	(Ar.Tr.Pt)
Waagenites	(Br.Ar.St)	Wanguya	(Br.Ar.Or)	Wehrlina	(Ar.Os.Pa)
Waagenium	(Po.De.Pe)	Wangzishia	(Ar.Tr.Pt)	Weibeia	(Br.Ar.Sp)
Waagenocoeras	(Mo.Cc.Go)	Wanliangtingia	(Ar.Tr.As)	Weinbergina	(Ar.Me.Xi)
Waagenoconcha	(Br.Ar.St)	Wanneria	(Ar.Tr.Ol)	Weiningia	(Br.Ar.St)
Waagenoperna	(Mo.Bi.Pt)	Wannerocrinus	(Ec.Cr.Mo)	Weiningophyllum	(Cn.An.Ru)
Waagenophyllum	(Cn.An.Ru)	Wanwanaspis	(Ar.Tr.Pt)	Weisbordella	(Ec.Ec.Cl)
Wabiella	(Ar.Os.Pa)	Wanwanella	(Mo.Ro.Co)	Weishanhuceras	(Mo.Cc.El)
Wachsmuthicrinus	(Ec.Cr.Sa)	Wanwania	(Mo.Ro.Ri)	Weissermelia	(Cn.An.Ru)
Waconella	(Br.Ar.Te)	Wanwanoceras	(Mo.Cc.Pl)	Weizhouella	(Br.Ar.At)
Wadeichthys	(Cd.Os.Pc)	Wanwanoides	(Mo.Ro.Co)	Welchella	(Ar.Os.Pa)
Wadella	(Fo.Fo.Fo)	Wapitiphyllum	(Cn.An.Ru)	Welcommia	(Cd.Ch.Hx)
Wadeoceras	(Mo.Cc.On)	Wapkia	(Po.De.Ha)	Weldouithyrus	(Br.Ar.Te)
Wadeopsammia	(Cn.An.Sc)	Wapkiosa	(Po.He.He)	Welirella	(Ar.Ra.Sp)
Wadiglossa	(Br.Li.Li)	Wapta	(Ar.In.Wa)	Wellandia	(Ar.Os.Po)
Wahnerocoeras	(Mo.Cc.Am)	Warburgaspis	(Ar.Tr.Pr)	Welleraspis	(Ar.Tr.As)
Waengsjoeaspis	(Cd.Pt.Un)	Warburgella	(Ar.Tr.Pr)	Wellerella	(Br.Ar.Rh)
Waeringella	(Fo.Fo.Fo)	Warburgia	(Mo.Bi.Ar)	Welligy	(Mo.Ga.Ar)
Waeringopterus	(Ar.Me.Eu)	Wardakia	(Br.Ar.St)	Welleria	(Ar.Os.Pa)
Waeringscorpia	(Ar.Ar.Sc)	Wardichthys	(Cd.Os.Pa)	Welleriella	(Ar.Os.Pa)
Wagima	(Po.Ca.He)	Wardocoeras	(Mo.Cc.Or)	Welleriopsis	(Ar.Os.Pa)
Wagnericeras	(Mo.Cc.Am)	Wareembra	(Po.He.Am)	Wellerites	(Mo.Cc.Go)
Wagnerispina	(Ar.Tr.Pr)	Wareiella	(Po.De.Un)	Wellerocoeras	(Mo.Cc.On)
Waideggula	(Ar.Tr.Pr)	Waribole	(Ar.Tr.Pr)	Wellerocystis	(Ec.Pc.Pl)
Waihaoria	(Mo.Ga.Ne)	Warantella	(Fo.Fo.Fo)	Wellmanella	(Fo.Fo.Fo)
Waikalasma	(Ar.Ci)	Warnea	(Mo.Bi.Ph)	Wellsites	(Mo.Cc.An)
Waikatorhynchia	(Br.Ar.Rh)	Warrella	(Br.Ar.Sp)	Wellsoceeras	(Mo.Cc.Na)
Waikura	(Mo.Ga.He)	Warrenellina	(Br.Ar.Sp)	Wellsothrochus	(Cn.An.Sc)
Waimatea	(Mo.Ga.Ne)	Warrigalia	(Po.De.Li)	Welteria	(Po.De.Pe)
Waipaoa	(Mo.Ga.Ne)	Warriootacyathus	(Po.Tr.Ar)	Welterites	(Mo.Cc.Ce)

Weltonia	(Cd.Ch.Hx)	Wicherella	(Ar.Os.Po)	Wolburgia	(Ar.Os.Po)
Wendella	(Mo.Ga.Nt)	Wichitoceras	(Mo.Ce.Ta)	Wolinella	(Bz.St.Cc)
Wenkehemnia	(Ar.Tr.Co)	Wichmannella	(Ar.Os.Po)	Willemannia	(Po.He.He)
Wenlockia	(Cn.An.Ru)	Wichmanniceras	(Mo.Ce.Am)	Wolungoceras	(Mo.Ce.Or)
Wentusia	(Ar.Tr.As)	Wiedeyoceras	(Mo.Ce.Go)	Wongaspungia	(Po.He.Ls)
Wentzelella	(Cn.An.Ru)	Wiesneria	(Fo.Fo.Fo)	Wongia	(Ar.Tr.Pt)
Wentzelellites	(Cn.An.Ru)	Wijdeaspis	(Cd.Pl.Pe)	Woodbinax	(Ar.Ml.De)
Wentzeloides	(Cn.An.Ru)	Wilbernia	(Ar.Tr.As)	Woodella	(Fo.Fo.Fo)
Wentzelophyllum	(Cn.An.Ru)	Wilberrya	(Br.Ar.Sp)	Woodipora	(Bz.Gy.Ch)
Wenxianirhynchus	(Br.Ar.Rh)	Wilbertopora	(Bz.Gy.Ch)	Woodocrinus	(Ec.Cr.Cl)
Wenxianophyllum	(Cn.An.Ru)	Wilcoxaspis	(Ar.Tr.Pt)	Woodringina	(Fo.Fo.Fo)
Werneckella	(Br.Ar.Rh)	Wilfordia	(Fo.Fo.Fo)	Woodsalia	(Mo.Ga.Nt)
Werneckelasma	(Cn.An.Ru)	Wilkingia	(Mo.Bi.Ph)	Woodsella	(Mo.Ga.Ne)
Werneroceras	(Mo.Ce.An)	Willemoesiocaris	(Ar.Ml.De)	Woodwardella	(Cd.Os.Pf)
Werrica	(Br.Ar.St)	Williamia	(Mo.Ga.Ba)	Woolungosaurus	(Cd.Re.Ps)
Werthenoceras	(Mo.Ce.Un)	Williamicyathus	(Po.Jr.Ar)	Woosteroceras	(Mo.Ce.El)
Westbroekina	(Br.Ar.Rh)	Williamsaspis	(Cd.Pl.Ar)	Wopingites	(Mo.Ce.Ph)
Westergaardia	(Ar.Tr.Pt)	Williamsoceras	(Mo.Ce.En)	Wordieoceras	(Mo.Ce.Ce)
Westergaardites	(Ar.Tr.Pt)	Willimactra	(Ar.Tr.Ve)	Wormsipora	(Cn.An.Ta)
Westergaardodina	(Cd.Co.Pa)	Williriedellum	(Ac.Ra.Na)	Worobievella	(Br.Ar.Te)
Westerna	(Mo.Ga.Ar)	Willmanocystis	(Ec.St.Mi)	Worthenella	(Pr.Un.In)
Westgardella	(Ec.He.He)	Willomorichthys	(Cd.Os.Pa)	Worthenia	(Mo.Ga.Ar)
Westgardia	(Pr.Un.In)	Willungaster	(Ec.Ec.Cl)	Wortheniella	(Mo.Ga.Ar)
Westheadocrinus	(Ec.Cr.Ds)	Willungia	(Mo.Ga.Nt)	Worthenopsis	(Mo.Ga.Ar)
Westmontia	(Ar.Os.Pa)	Willwerthia	(Ar.Me.Eu)	Worthenoceras	(Mo.Ce.On)
Westollia	(Cd.Os.Pa)	Wilsonarella	(Ar.Tr.Pt)	Worthenocrinus	(Ec.Cr.Cl)
Westonaspis	(Ar.Tr.Un)	Wilsonastraea	(Cn.An.Ru)	Worthenopora	(Bz.St.Cr)
Westonia	(Br.Li.Li)	Wilsoniconcha	(Mo.Ga.Ar)	Worthoceras	(Mo.Ce.Am)
Westonisca	(Br.Li.Li)	Wilsonicrinus	(Ec.Cr.Di)	Woutersophis	(Cd.Re.Sq)
Westonoceras	(Mo.Ce.Di)	Wilsoniella	(Br.Ar.Rh)	Wrangellium	(Ac.Ra.Na)
Westralicrania	(Br.Li.Ac)	Wilsonoceras	(Mo.Ce.Ba)	Wrightia	(Ec.Ec.Ey)
Wetherbyocrinus	(Ec.Cr.Cl)	Wimanelia	(Br.Ar.Or)	Wrighticyathus	(Po.Re.Aj)
Wetherellus	(Cd.Os.Pf)	Wimania	(Cd.Os.Co)	Wrightoceras	(Mo.Ce.Am)
Wewokella	(Po.Ca.He)	Wimanicrusta	(He.Gr.Cr)	Wrightocrinus	(Ec.Cr.Ds)
Wewokites	(Mo.Ce.Go)	Wimanoconcha	(Br.Ar.St)	Wuarnia	(Ec.Ec.Sp)
Wexfordia	(Mo.Ga.Nt)	Winchellatia	(Ar.Os.Pa)	Wuchiapingella	(Ar.Os.Ar)
Wexolina	(Cn.An.Ru)	Winchelloceras	(Mo.Ce.Go)	Wuhuia	(Ar.Tr.As)
Weyerelasma	(Cn.An.Ru)	Windelasma	(Cn.An.Ru)	Wujajiania	(Ar.Tr.Pt)
Weyla	(Mo.Bi.Pt)	Windermeria	(Cn.Pe.Er)	Wulongella	(Br.Ar.Or)
Weymouthia	(Ar.Tr.Ag)	Windhausenoceras	(Mo.Ce.Am)	Wulungguia	(Br.Ar.Rh)
Wheatillaspis	(Cd.Pl.Ar)	Windsorgnathus	(Cd.Co.Co)	Wurnosaurus	(Cd.Re.Cr)
Wheatleyites	(Mo.Ce.Am)	Winkleria	(Ec.Ec.Ph)	Wushichites	(Pr.Ca.Ca)
Wheelerella	(Fo.Fo.Fo)	Winnipegoceras	(Mo.Ce.Di)	Wushichites	(Pr.Un.In)
Whidbornella	(Br.Ar.St)	Winslowoceras	(Mo.Ce.Go)	Wutingaspis	(Ar.Tr.Re)
Whippella	(Ar.Os.Pa)	Winsteria	(Ar.Tr.Un)	Wutingella	(Ar.Os.Ar)
Whitapodus	(Cd.Os.An)	Winstonoceras	(Mo.Ce.En)	Wutinoceras	(Mo.Ce.Ac)
Whitbyoceras	(Mo.Ce.Am)	Winterbergia	(Ar.Tr.Pr)	Wutubulakia	(Br.Ar.At)
Whiteavesia	(Mo.Bi.Mo)	Wintonia	(Mo.Ce.Am)	Wutuella	(Fo.Fo.Fo)
Whiteavesites	(Mo.Ce.Or)	Wintunastraea	(Cn.An.Ru)	Wuxuania	(Ar.Os.Pa)
Whitecliffia	(Mo.Ga.Ne)	Winwoodia	(Po.Ca.Ph)	Wuxuanites	(Mo.Bi.Pt)
Whiteia	(Cd.Os.Co)	Wiradjuriella	(Br.Ar.St)	Wyatella	(Mo.Ga.Nt)
Whiteichthys	(Cd.Os.Pa)	Wisonsinella	(Mo.Ga.Ar)	Wyatkina	(Br.Ar.St)
Whiteinella	(Fo.Fo.Fo)	Wissenbachia	(Mo.Ce.Di)	Wyella	(Br.Ar.Pe)
Whiteocrinus	(Ec.Cr.Ds)	Witaaspis	(Cd.Ce.At)	Wyndhamia	(Br.Ar.St)
Whitfieldella	(Br.Ar.Sp)	Witchellia	(Mo.Ce.Am)	Wynnia	(Br.Ar.Un)
Whitfieldoceras	(Mo.Ce.Or)	Withersella	(Ar.Ml.De)	Wyomingites	(Mo.Ce.Ce)
Whitneya	(Mo.Ga.Ne)	Witryides	(Ar.Tr.Pr)	Wysogorskiella	(Br.Ar.Or)
Whitneyella	(Mo.Ga.Ne)	Wittenburgella	(Br.Ar.Te)	Wythella	(Ec.Ec.Cl)
Whitspakia	(Br.Ar.Te)	Wiwaxia	(Pr.Co.Sa)	Xainzhanoceras	(Mo.Ce.On)
Whittakerites	(Ar.Tr.Ph)	Wjatella	(Bz.St.Fe)	Xana	(Br.Ar.Te)
Whittardia	(Br.Ar.Or)	Wocklumeria	(Mo.Ce.Cl)	Xancus	(Mo.Ga.Ne)
Whittardolithus	(Ar.Tr.Un)	Wodnika	(Cd.Ch.Cl)	Xandaros	(Ar.Ml.De)
Whittingtonella	(Ar.Tr.Pt)	Woehrmannia	(Mo.Ga.Ar)	Xandarosaster	(Ec.As.Px)
Whittingtonia	(Ar.Tr.Od)	Wolayella	(Ar.Tr.Pr)	Xaniognathus	(Cd.Co.Co)

Xanionurus	(Ar,Tr,Od)	Xenothyris	(Br,Ar,Te)	Xiphostylus	(Ac,Ra,Sp)
Xaniopion	(An,Po,Eu)	Xenotrophon	(Mo,Ga,Ne)	Xiphotheca	(Ac,Ra,Na)
Xanthamphura	(Ec,Op,Op)	Xenotrypa	(Bz,St,Cy)	Xiphroceras	(Mo,Ce,Am)
Xanthea	(Br,Ar,At)	Xenuroturris	(Mo,Ga,Ne)	Xisoallogecrinus	(Ec,Cr,Ds)
Xanthilites	(Ar,MI,De)	Xenusion	(Lo)	Xitus	(Ac,Ra,Na)
Xantho	(Ar,MI,De)	Xerospirifer	(Br,Ar,Sp)	Xiushuilithus	(Ar,Tr,Pt)
Xanthochorus	(Mo,Ga,Ne)	Xerxespirifer	(Br,Ar,Sp)	Xixionopsis	(Ar,Os,Me)
Xanthodius	(Ar,MI,De)	Xestagnostus	(Ar,Tr,Ag)	Xizangospira	(Mo,Ga,Ne)
Xanthosia	(Ar,MI,De)	Xestecyathus	(Po,Re,Aj)	Xizangostrophia	(Br,Ar,Pe)
Xaveropora	(Bz,Gy,Ch)	Xestias	(Cd,Os,Pr)	Xizangotromatopora	(Po,De,Ax)
Xela	(Ar,Tr,Re)	Xestoconcha	(Mo,Bi,Mo)	Xuanenia	(Ar,Tr,Ph)
Xenambonites	(Br,Ar,St)	Xestoleberis	(Ar,Os,Po)	Xuigiella	(Ar,Tr,Co)
Xenasaphus	(Ar,Tr,As)	Xestosis	(Br,Ar,St)	Xuvenospira	(Mo,Ga,Ne)
Xenaster	(Ec,As,Pu)	Xestosina	(Br,Ar,Te)	Xyeleblastus	(Ec,BI,Sp)
Xenechinus	(Ec,Ec,Ey)	Xestosurcula	(Mo,Ga,Ne)	Xylabion	(Ar,Tr,Ph)
Xenelasma	(Br,Ar,Pe)	Xestotrema	(Br,Ar,Sp)	Xylocythere	(Ar,Os,Po)
Xenelasmella	(Br,Ar,Pe)	Xiadongoconus	(Mo,In,In)	Xylophaga	(Mo,Bi,My)
Xenelasmopsis	(Br,Ar,Pe)	Xiadongtubulus	(Hy,Or,Gl)	Xylophagella	(Mo,Bi,My)
Xeniopugnax	(Br,Ar,Rh)	Xiajiangella	(Ar,Os,Po)	Xylophomya	(Mo,Bi,My)
Xenistius	(Cd,Os,Pf)	Xianfengella	(Mo,In,In)	Xylosporgia	(Po,He,Ly)
Xenium	(Mo,Bi,Pt)	Xianfengconcha	(Mo,In,In)	Xymene	(Mo,Ga,Ne)
Xenizostrophia	(Br,Ar,St)	Xianguangia	(Cn,An,Ae)	Xymenella	(Mo,Ga,Ne)
Xenoblastus	(Ec,BI,Fi)	Xiangzhongella	(Ar,Tr,Pr)	Xyne	(Cd,Os,Cl)
Xenoboloides	(Ar,Tr,Pr)	Xiangzhouina	(Ar,Os,Pa)	Xyocax	(Ar,Tr,Ag)
Xenocardita	(Mo,Bi,Ve)	Xiangzhouinia	(Br,Ar,Te)	Xyrinus	(Cd,Os,Cl)
Xenocatlinoerinus	(Ec,Cr,Ds)	Xiangzhouphyllum	(Cn,An,Ru)	Xysila	(Br,Ar,At)
Xenoceltites	(Mo,Ce,Ce)	Xianquianaspis	(Ar,Tr,Pt)	Xysmaacrinus	(Ec,Cr,Di)
Xenocephalites	(Mo,Ce,Am)	Xiaobangdaia	(Br,Ar,Rh)	Xysteria	(Ec,Ec,Ey)
Xenoceras	(Mo,Ce,On)	Xiaomajella	(Ar,Tr,Pt)	Xystinotus	(Ar,Os,Pa)
Xenoechilos	(Ar,Tr,Pt)	Xiaoshaoceras	(Mo,Ce,El)	Xystista	(Ar,Os,Pa)
Xenoechilus	(Mo,Ce,Na)	Xiaos-huisulcra	(Mo,Bi,Na)	Xystocrania	(Ar,Tr,Ph)
Xenocidaris	(Ec,Ec,Ci)	Xichonolepis	(Cd,Pl,An)	Xystostrophia	(Br,Ar,St)
Xenocrinus	(Ec,Ce,Mo)	Xilingxia	(Ar,Tr,Pt)	Xystrella	(Mo,Ga,Ne)
Xenocryptonella	(Br,Ar,Te)	Xilingxiaconus	(Mo,In,In)	Xystridura	(Ar,Tr,Re)
Xenocyathellus	(Cn,An,Ru)	Xinanorthis	(Br,Ar,Or)	Xystrigona	(Cn,An,Ru)
Xenocyathus	(He,Gr,Cr)	Xinanospirifer	(Br,Ar,Sp)	Xystriphyloides	(Cn,An,Ru)
Xenocyste	(Ar,Tr,Pr)	Xinanpetalichthytes	(Cd,Pl,Pe)	Xystriphyllum	(Cn,An,Ru)
Xenocystites	(Ec,Ed,Is)	Xinjiangiproductus	(Br,Ar,St)	Xystrodus	(Cd,Ch,Ct)
Xenodechenella	(Ar,Tr,Pr)	Xinjiangoblastus	(Ec,BI,Sp)	Yaadia	(Mo,Bi,Tr)
Xenodiscus	(Mo,Ce,Ce)	Xinjiangopecten	(Mo,Bi,Pt)	Yabea	(Mo,Bi,Ve)
Xenodrepanites	(Mo,Ce,Ce)	Xinjiangospirifer	(Br,Ar,Sp)	Yabeia	(Ar,Tr,Pt)
Xenodus	(Cd,Ch,In)	Xinjiangthyris	(Br,Ar,Te)	Yabeiceras	(Mo,Ce,Am)
Xenocmonnsia	(Cn,An,Tr)	Xinnanospira	(Mo,In,In)	Yabeina	(Fo,Fo,Fo)
Xenogalea	(Mo,Ga,Ne)	Xinshaella	(Br,Ar,Rh)	Yabeiphyllum	(Cn,An,Ru)
Xenoleveris	(Ar,Os,Po)	Xinshaoproductus	(Br,Ar,St)	Yabeithyris	(Br,Ar,Te)
Xenoloupia	(Mo,Bi,Ve)	Xintania	(Fo,Fo,Fo)	Yabeodictyon	(Po,De,St)
Xenomartinia	(Br,Ar,Sp)	Xipha	(Ac,Ra,Na)	Yabepecten	(Mo,Bi,Pt)
Xenophalium	(Mo,Ga,Ne)	Xiphachistrella	(Ac,Ra,Sp)	Yaberinella	(Fo,Fo,Fo)
Xenophora	(Mo,Ga,Ne)	Xiphactinus	(Cd,Os,Pe)	Yachalicystis	(Ec,St,Mi)
Xenophthalmus	(Ar,MI,De)	Xiphactractus	(Ac,Ra,Sp)	Yacutiopora	(Cn,An,Tr)
Xenorina	(Br,Ar,Te)	Xiphelasma	(Cn,An,Ru)	Yacutolithuus	(Hy,Hy,Hy)
Xenorophus	(Cd,Ma,Ce)	Xiphias	(Cd,Os,Pf)	Yagonia	(Br,Ar,St)
Xenorthis	(Br,Ar,Or)	Xiphiorhynchus	(Cd,Os,Pf)	Yagudinella	(Mo,Bi,Ve)
Xenorurum	(Ac,Ra,Sp)	Xiphocabrium	(Ac,Ra,Sp)	Yakounia	(Mo,Ce,Am)
Xenosaria	(Br,Ar,Sp)	Xiphoceras	(Mo,Ce,Di)	Yakovlevia	(Br,Ar,St)
Xenoschrammenus	(Po,He,He)	Xiphocladiaella	(Ac,Ra,Sp)	Yakovlevicrinus	(Ec,Cr,Cl)
Xenosiren	(Cd,Ma,Si)	Xiphodictya	(Ac,Ra,Sp)	Yakovliella	(Cn,An,Ru)
Xenostaffella	(Fo,Fo,Fo)	Xiphodolamia	(Cd,Ch,La)	Yakutijaella	(Br,Ar,Rh)
Xenostege	(Br,Ar,St)	Xiphogonium	(Ar,Tr,Pr)	Yakutinautilus	(Mo,Ce,Na)
Xenostegium	(Ar,Tr,Pt)	Xiphograptus	(He,Gr,Gr)	Yakutoceras	(Mo,Ce,Go)
Xenostephanus	(Mo,Ce,Am)	Xiphogymites	(Mo,Ce,Ce)	Yakutoglypharites	(Mo,Ce,Go)
Xenostina	(Br,Ar,Te)	Xiphopteris	(Cd,Os,Be)	Yalongia	(Br,Ar,Sp)
Xenostrobis	(Mo,Bi,MI)	Xiphosphaera	(Ac,Ra,Sp)	Yanbianella	(Br,Ar,Rh)
Xenostrophia	(Br,Ar,St)	Xiphostaurus	(Ac,Ra,Sp)	Yanbianophyllum	(Cn,An,Ru)

Yanetechia	(Br.Ar,Rh)	Yochelcionella	(Mo,He,He)	Yunnanotheca	(Pr.To,Mi)
Yangchienia	(Fo,Fo,Fo)	Yochelsonella	(Mo,Te,Hy)	Yunnanozoon	(Cd,Cp,Cp)
Yangella	(Mo,Bi,Tr)	Yochelsonia	(Br,Ar,Te)	Yunshanella	(Br,Ar,Rh)
Yangkongia	(Br,Ar,Sp)	Yochelsonospira	(Mo,Ga,Ar)	Yurakia	(Ar,Tr,Pt)
Yangocoutlaria	(Cn,Sc,Cn)	Yogliuia	(Cd,Pl,Pt)	Yurievstiella	(Cn,An,Ru)
Yangotrypa	(Bz,St,Cr)	Yohoaspis	(Ar,Tr,Pt)	Yushanograptus	(He,Gr,Gr)
Yangtzechiton	(Pr,Un,In)	Yohoia	(Ar,Un,Un)	Yutagraptus	(Mo,Pa,Hy)
Yangtzeonus	(Mo,In,In)	Yohophyllum	(Cn,An,Ru)	Yuwenia	(Mo,Bi,Hi)
Yangtzedonta	(Mo,Bi,Mo)	Yokopsis	(Ar,Os,Le)	Yvaniella	(Ci,Po,Sp)
Yangtzeella	(Br,Ar,Pe)	Yokoyamaella	(Cn,An,Ru)	Zaborovia	(Ar,Os,Pa)
Yangtzeimerisma	(Mo,In,In)	Yokoyamaina	(Mo,Bi,Ve)	Zabythocypris	(Ar,Os,Co)
Yangtzesclerites	(Pr,Un,In)	Yokoyamaeras	(Mo,Ce,Am)	Zacanthoides	(Ar,Tr,Co)
Yangtzespira	(Mo,In,In)	Yoldia	(Mo,Bi,Nu)	Zacanthopsis	(Mo,Ga,Nt)
Yanguania	(Br,Ar,St)	Yoldiella	(Mo,Bi,Ar)	Zacampus	(Mo,Ce,Go)
Yangzicaris	(Ar,Th,Co)	Yonginella	(Br,Ar,Un)	Zadel'sdorfia	(Mo,Ga,Ne)
Yangzigraptus	(He,Gr,Gr)	Yongjia	(Cd,Os,Co)	Zafra	(Ar,Os,Pa)
Yanheceras	(Mo,Ce,Ya)	Yongquistina	(Ar,Tr,Re)	Zaissania	(Br,Ar,Sp)
Yanishewskiella	(Br,Ar,Rh)	Yonggichthys	(Br,Un,Ku)	Zakowia	(Cn,An,Ru)
Yankongovitus	(Hy,Hy,Hy)	Yorkella	(Mo,Ce,En)	Zaletrigonia	(Mo,Bi,Tr)
Yannanoceras	(Mo,Ce,Un)	Yorkia	(Ar,Tr,Pt)	Zalipais	(Mo,Ga,Ar)
Yanospira	(Br,Ar,Sp)	Yorloceras	(Po,De,As)	Zalophus	(Cd,Ma,Ca)
Yanshanaspis	(Ar,Tr,Pr)	Yosimuraspis	(Ar,Tr,Ph)	Zalozone	(Mo,Ga,Ar)
Yaonoiaella	(Br,Ar,Sp)	Youngella	(Ar,Os,Pa)	Zanassarina	(Mo,Ga,Ne)
Yaioxianognathus	(Cd,Co,Co)	Youngia	(Cd,Os,Co)	Zancletites	(Br,Ar,Rh)
Yaioxianopora	(Cn,An,Ta)	Youngibelus	(Cd,Ch,Rj)	Zanclorhyncha	(Cd,Os,Sc)
Yaoyingella	(Ar,Os,Ar)	Youngiella	(Br,Ar,Rh)	Zanclus	(Mo,Cr,Te)
Yarirhynchia	(Br,Ar,Rh)	Youngolepis	(Po,De,Li)	Zandadjanites	(Po,Ca,He)
Yarravaster	(Ec,As,Ur)	Yousoubatis	(Cn,An,Ru)	Zangerliispongia	(Cd,Os,Sc)
Yasila	(Mo,Ga,Ne)	Ypsilorhynchus	(Cn,An,Ru)	Zaniorlepis	(Ar,Os,Pa)
Yassia	(Cn,An,Ru)	Yrrhiza	(Cd,Os,Pt)	Zanirinnella	(Po,De,Pe)
Yatsengia	(Cn,An,Ru)	Yuanbaella	(Po,Re,Aj)	Zanklithalamia	(Ar,Mi,De)
Yaucorotalia	(Fo,Fo,Fo)	Yuanophylloides	(Ar,Tr,Pt)	Zanthopsis	(Ar,Tr,Pt)
Yavorskia	(Cn,An,Ta)	Yuanophyllum	(Ar,Tr,As)	Zaozhuangaspis	(Cd,Os,Pl)
Yavorskiina	(Po,De,St)	Yuchoulepis	(Ar,Tr,As)	Zaphlegulus	(Mo,Ga,Ne)
Yaxianella	(Ar,Os,Ar)	Yudjiacyathus	(Bi,Ar,Te)	Zaphon	(Cn,An,Ru)
Ybselosocia	(Bz,St,Cc)	Yuehsieszella	(Br,Ar,Rh)	Zaphrentis	(Cn,An,Ru)
Yeharaia	(Ac,Ra,Na)	Yuepingia	(Ar,Tr,Pt)	Zaphrentites	(Cn,An,Ru)
Yeharella	(Mo,Bi,Tr)	Yuepingioides	(Ar,Tr,Pt)	Zaphrentoides	(Cn,An,Ru)
Yehioceras	(Mo,Ce,En)	Yuezhuela	(Ar,Tr,Pe)	Zaphrentula	(Cn,An,Ru)
Yekerpene	(Br,Ar,Te)	Yukiangites	(Ar,Tr,Ag)	Zaphriphyllum	(Mo,Ce,Am)
Yeosinella	(Br,Ar,Un)	Yuknessaspis	(Ar,Os,Pa)	Zaraskites	(Ec,Ec,Ci)
Yeothyris	(Br,Ar,Sp)	Yukonaspis	(Ar,Tr,Un)	Zardinechinus	(Po,Ca,Un)
Yeshanella	(Ar,Os,Ar)	Yukonella	(Po,Re,Aj)	Zardinia	(Mo,Ga,Nt)
Yezoites	(Mo,Ce,Am)	Yukonia	(Ar,Os,Ar)	Zardinistylus	(Cn,An,Sc)
Ygerodiscus	(Br,Ar,St)	Yukonibolbina	(Pr,Un,In)	Zardinoephyllum	(Mo,Ga,Ar)
Yichangaspis	(Ar,Tr,Pr)	Yukonides	(Br,Ar,Rh)	Zardubinihelix	(Mo,Ga,Nt)
Yichangella	(Ar,Os,Pa)	Yukonoclyathus	(Ar,Tr,Os)	Zaria	(Ar,Os,Co)
Yichangoceras	(Mo,Ce,Un)	Yulinella	(Ar,Tr,Re)	Zarinia	(Fo,Fo,Fo)
Yichangopora	(Bz,St,Tr)	Yulunia	(Ar,Tr,Re)	Zarodella	(Ac,Ra,Sp)
Yichangorthis	(Br,Ar,Or)	Yulongella	(Br,Ar,Rh)	Zartus	(Ar,Tr,Co)
Yiduella	(Ar,Os,Po)	Yumenaspis	(Mo,Ga,Ar)	Zbirovia	(Ar,Tr,Pt)
Yidunella	(Br,Ar,Rh)	Yunnanaspis	(Ar,Tr,Re)	Zdicella	(Br,Ar,Pe)
Yidurella	(Br,Li,Li)	Yunnanaspis	(Pr,Un,In)	Zdimir	(Br,Ar,Pe)
Yiliangella	(Ar,Tr,Re)	Yunnanella	(Pr,Un,In)	Zdimirella	(Ec,Cr,Cl)
Yiliangellina	(Ar,Tr,Re)	Yunnanmia	(Cd,Pl,An)	Zeacrinites	(Mo,Ga,Nt)
Yingicus	(Mo,Ga,Ar)	Yunnanoecephalus	(Br,Ar,St)	Zeacolpus	(Mo,Ga,Nt)
Yingwuspisrifer	(Br,Ar,Sp)	Yunnanoconus	(Pr,Un,In)	Zeacrypta	(Mo,Ga,Nt)
Yinites	(Ar,Tr,Re)	Yunnanodus	(Pr,Un,In)	Zeacumanthus	(Mo,Ga,Ne)
Yinoceras	(Mo,Ce,Go)	Yunnanolepis	(Cd,Pl,An)	Zeacuminia	(Mo,Ga,Ne)
Yinograptus	(He,Gr,Gr)	Yunnanoleptaena	(Br,Ar,St)	Zeadmete	(Mo,Ga,Ne)
Yinosteus	(Cd,Pl,Ar)	Yunnanomedusa	(Pr,Un,In)	Zeafhorius	(Fo,Fo,Fo)
Yinpanolithus	(Ar,Tr,Pt)	Yunnanopleura	(Mo,In,In)		
Yishanophyllum	(Cn,An,Ru)	Yunnanopora	(Bz,St,Tr)		
Yneziella	(Fo,Fo,Fo)	Yunnanospira	(Mo,In,In)		

Zeagopleurus	(Ec.Ec,Ph)	Zeugmatolepas	(Ar,Ci)	Ziva	(Ar.Os,Pa)
Zealandites	(Mo,Ce,Am)	Zeugopleura	(Br.Ar,Sp)	Ziyunites	(Mo,Ce,Ce)
Zealeda	(Mo,Bi,Nu)	Zeugopleurus	(Ec.Ec,Ph)	Ziziphinus	(Mo,Ga,Ar)
Zeapollia	(Mo,Ga,Ne)	Zeus	(Cd,Os,Ze)	Zlambachella	(Po,De,Av)
Zeascalpiflum	(Ar,Ci)	Zeuschneria	(Br.Ar,Te)	Zlambachia	(Bz,St,Tr)
Zeauvigerina	(Fo,Fo,Fo)	Zeuschnerina	(Ar.Os,Po)	Zlichopyramis	(Br.Ar,Or)
Zebina	(Mo,Ga,Nt)	Zeusocrinus	(Ec,Cr,Cl)	Zlichorhynchus	(Br.Ar,Rh)
Zebittium	(Mo,Ga,Nt)	Zeuxis	(Mo,Ga,Ne)	Zoaceras	(Cd,Os,Ph)
Zechania	(Mo,Bi,Nu)	Zexilia	(Mo,Ga,Ne)	Zoila	(Mo,Ga,Nt)
Zeehanoceras	(Mo,Ce,Or)	Zhamoidellum	(Ac,Ra,Na)	Zolotysia	(Cn,Pe,Un)
Zefallacia	(Mo,Ga,Nt)	Zhanjilepis	(Cd,Pl,An)	Zonacoscinus	(Po,Re,Aj)
Zegalerus	(Mo,Ga,Nt)	Zhantella	(Br,Li,Li)	Zonacyathus	(Po,Re,Aj)
Zeidora	(Mo,Ga,Ar)	Zhegangula	(Ar,Tr,Pr)	Zonaria	(Mo,Ga,Nt)
Zeilleria	(Br.Ar,Te)	Zhejiangella	(Br.Ar,Rh)	Zonarina	(Mo,Ga,Nt)
Zeillerina	(Br.Ar,Te)	Zhejiangorthis	(Br.Ar,Or)	Zonatula	(Bz,St,Cc)
Zekilla	(Mo,Ga,Ne)	Zhejiangospirifer	(Br.Ar,Sp)	Zonodigonophyllum	(Cn,An,Ru)
Zelamarckina	(Fo,Fo,Fo)	Zhenania	(Br.Ar,St)	Zonodiscus	(Ac,Ra,Sp)
Zelandiella	(Mo,Ga,Ne)	Zhenaspis	(Ar,Tr,Re)	Zonophyllum	(Cn,An,Ru)
Zeliaphyllum	(Cn,An,Ru)	Zhenpingella	(Ar.Os,Ar)	Zonopora	(Bz,St,Cc)
Zeliszella	(Ar,Tr,Ph)	Zhexichonetes	(Br.Ar,St)	Zonovia	(Mo,Ce,Am)
Zelithophaga	(Mo,Bi,Mt)	Zhidothyris	(Br.Ar,Te)	Zooceras	(Mo,Ce,Di)
Zellania	(Br.Ar,Te)	Zhifangia	(Mo,Bi,Un)	Zophocrinus	(Ec,Cr,Ds)
Zellerina	(Fo,Fo,Fo)	Zhijinella	(Ar.Os,Ar)	Zophostrophia	(Br.Ar,St)
Zellia	(Fo,Fo,Fo)	Zhijinites	(Pr,Ca,Ca)	Zoroaster	(Ec,As,Fo)
Zelocystiphyllum	(Cn,An,Ru)	Zhongbaoella	(Ar.Os,Ar)	Zorototaxis	(Ar.Os,Pa)
Zelolasma	(Cn,An,Ru)	Zhonghuacuolia	(Br.Ar,Sp)	Zorrita	(Mo,Bi,Ve)
Zelophyllia	(Cn,An,Ru)	Zhongpingia	(Br.Ar,Te)	Zosterospira	(Mo,Ga,Ar)
Zelophyllum	(Cn,An,Ru)	Zhuibianoceras	(Mo,Ce,El)	Zostocrinus	(Ec,Cr,Cl)
Zemacies	(Mo,Ga,Ne)	Zhuozishanospira	(Mo,Ga,Mc)	Zotheculifida	(Fo,Fo,Fo)
Zemira	(Mo,Ga,Ne)	Zhuralevia	(Mo,Ce,Or)	Zozariella	(Bz,St,Tr)
Zemistephanus	(Mo,Ce,Am)	Zhuravlevacyathus	(Po,Re,Aj)	Zozella	(Mo,Bi,Ve)
Zemitrella	(Mo,Ga,Ne)	Zhushanophyllum	(Cn,An,Ru)	Zuercherella	(Mo,Ce,Am)
Zemyllita	(Mo,Bi,Ve)	Zhuxiella	(Ar,Tr,Pt)	Zuffardia	(Ec,Ec,Ca)
Zemysia	(Mo,Bi,Ve)	Zia	(Br.Ar,St)	Zugmayerella	(Br.Ar,Sp)
Zemysina	(Mo,Bi,Ve)	Ziboaspidella	(Ar,Tr,Pt)	Zugmayeria	(Br.Ar,Te)
Zenatia	(Mo,Bi,Ve)	Ziganella	(Br.Ar,Sp)	Zugmontites	(Mo,Ce,Am)
Zenatiopsis	(Mo,Bi,Ve)	Zignoichthys	(Cd,Os,Te)	Zugodactylites	(Mo,Ce,Am)
Zenatraria	(Mo,Bi,Ve)	Zigobolboides	(Ar.Os,Pa)	Zugokosmoceras	(Mo,Ce,Am)
Zenbinostoma	(Mo,Ga,Nt)	Ziguiella	(Fo,Fo,Fo)	Zuluiceras	(Mo,Ce,Am)
Zenepos	(Mo,Ga,Ne)	Zigzagella	(Po,Ca,Un)	Zuluscapites	(Mo,Ce,Am)
Zenion	(Cd,Os,Ze)	Zigzagiceras	(Mo,Ce,Am)	Zulitrigonia	(Mo,Bi,Tr)
Zenkerjerinus	(Ec,Cr,Mo)	Ziguella	(Ar,Tr,Un)	Zumoffenia	(Ec,Ec,Hs)
Zenkopsis	(Ar.Os,Pa)	Zikkuratia	(Mo,Ga,Ce)	Zuninaspis	(Ar,Tr,As)
Zenkovaelina	(Ar.Os,Po)	Zilimia	(Br.Ar,Rh)	Zunyicyathus	(Po,Ir,Ar)
Zenocentrotus	(Ec,Ec,Ec)	Zinolita	(Mo,Ga,Nt)	Zurcherella	(Mo,Ce,Am)
Zenocrinus	(Ec,Cr,Sa)	Zinsitys	(Mo,Ga,Ne)	Zurcheria	(Mo,Ce,Am)
Zenoites	(Mo,Ce,Ce)	Ziphiodelphis	(Cd,Ma,Ce)	Zygastracarcinus	(Ar,MI,De)
Zenophilia	(Cn,An,Ru)	Ziphioides	(Cd,Ma,Ce)	Zygatrypa	(Br.Ar,At)
Zenopsis	(Cd,Os,Ze)	Ziphrostrum	(Cd,Ma,Ce)	Zygites	(Mo,Ga,Ar)
Zepaera	(Ar.Os,Ar)	Ziphius	(Cd,Ma,Ce)	Zygobeyrichia	(Ar.Os,Pa)
Zephos	(Mo,Ga,Ne)	Zircia	(Mo,Ga,Ar)	Zygobolba	(Ar.Os,Pa)
Zephyroceras	(Mo,Ce,Go)	Zirfaea	(Mo,Bi,My)	Zygobolboides	(Ar.Os,Pa)
Zeradina	(Mo,Ga,Nt)	Zirlona	(Mo,Bi,My)	Zygochlamys	(Mo,Bi,Pt)
Zerashanoceras	(Mo,Ce,Ac)	Zirocrinus	(Ec,Cr,Mo)	Zygochlamys	(Ac,Ra,Na)
Zeravschania	(Cn,An,Ru)	Zittlella	(Po,De,Li)	Zygotocrinus	(Ec,Cr,Cl)
Zeravshanella	(Po,De,St)	Zittleus	(Po,De,Li)	Zygochlamys	(Ec,Ed,Is)
Zeravshania	(Br.Ar,St)	Zittelina	(Mo,Ga,Nt)	Zygotrapus	(He,Gr,Gr)
Zeravshanotoechia	(Br.Ar,Rh)	Zittelina	(Br.Ar,Te)	Zygotrapus	(Mo,Ga,Nt)
Zethalia	(Mo,Ga,Ar)	Zittelispungia	(Po,He,Ly)	Zygorhiza	(Cd,Ma,Ce)
Zetoceras	(Mo,Ce,Ph)	Zitteloceras	(Mo,Ce,Or)	Zygospira	(Br.Ar,At)
Zeuchthiscus	(Cd,Os,Pe)	Zittelofungia	(Cn,An,Sc)	Zygospirella	(Br.Ar,At)
Zeuglopleurus	(Ec,Ec,Te)	Zittelospongia	(Po,He,He)	Zygotstephanus	(Ac,Ra,Na)

Codes	Linnean Classification of Higher Taxa	Codes	Linnean Classification of Higher Taxa
Ac	Ph. ACTINOPODA	Er	Or. ERNIETAMORPHA
Ac	Cl. ACANTHARIA	Ra	Or. RANGEOMORPHA
Ra	Cl. RADIOLARIA	Un	Or. UNCERTAIN
Sp	Or. SPUMELLARIA	Cy	Cl. CYCLOZOA
Na	Or. NASSELLARIA	Me	Cl. MELANCLERITES
In	Or. INCERTAE SEDIS	Sc	Cl. SCYPHOZOA
Fo	Ph. FORAMINIFERIDA	Co	Or. CORONATIDA
Fo	Cl. FORAMINIFERIDA	Se	Or. SEMAEOSTOMATIDA
Fo	Or. FORAMINIFERIDA	Li	Or. LITHORHIZOSTOMATIDA
Ch	Or. CHITINOZOA	Rh	Or. RHIZOSTOMATIDA
Ci	Ph. CILIOPHORA	Cn	Or. CONULARIIDA
Po	Cl. POLYHYMENOPHORA	Un	Or. UNCERTAIN
Sp	Or. SPIROTRICHIA	Cb	Cl. CUBOZOA
In	Cl. INCERTAE SEDIS	Ca	Or. CARYBDEIDA
Ca	Or. CALPIONELLIDA	Hy	Cl. HYDROZOA
Po	Ph. PORIFERA	Tr	Or. TRACHYLINIDA
De	Cl. DEMOSPONGIA	Hy	Or. HYDROIIDA
Po	Or. POECHLOSCLERIDA	Si	Or. SIPHONOPHORIDA
Ha	Or. HAPLOSCLERIDA	Mi	Or. MILLEPORINA
Di	Or. DICTYOCERATIDA	St	Or. STYLAETERINA
Vr	Or. VERONGHIDA	Sp	Or. SPHAERACTINIDA
Ve	Or. VERTICILLITIDA	Un	Or. UNCERTAIN
As	Or. ASTROPHORIDA	In	Cl. INCERTAE SED
Li	Or. LITHISTIDA	Hc	Cl. HYDROCONOZOA
Hd	Or. HADROMERIDA	An	Cl. ANTHOZOA
St	Or. STROMATOPOROIDEA	An	Or. ANTIPATHARIA
Gu	Or. GUADALUPIIDA	St	Or. STOLONIFERA
Ax	Or. AXINELLIDA	Al	Or. ALCYONACEA
Ta	Or. TABULOSPONGIDA	He	Or. HELIOPORACEA
Ho	Or. HOMOSCLEROMORPHA	Go	Or. GORGONIDA
Pe	Or. PERMOSPHINCTA	Pe	Or. PENNATULACEA
Un	Or. UNCERTAIN	Ta	Or. TABULATA
Ca	Cl. CALCAREA	Ru	Or. RUGOSA
He	Or. HETERACTINIDA	Ht	Or. HETEROCORALLIA
Ca	Or. CALCARONEA	Sc	Or. SCLERACTINA
Ph	Or. PHARETRONIDA	Ki	Or. KILBUCHOPHYLLIDA
Sp	Or. SPHAEROCOELIDA	Ac	Or. ACTINIARIA
Un	Or. UNCERTAIN	Un	Or. UNCERTAIN
He	Cl. HEXACTINELLIDA	Un	Cl. UNCERTAIN
Hc	Or. HEXACTINOSA	Ct	Ph. CTENOPHORA
Ly	Or. LYCHNISCOSA	Nt	Ph. NEMERTINA
Ls	Or. LYSSACINOSIDA	Nm	Ph. NEMATODA
Re	Or. RETICULOSA	Pr	Ph. PROBLEMATICA
Am	Or. AMPHIDISCOSA	Ca	Cl. CAMBROCLAVIDA
Hm	Or. HEMIIDISCOSA	Co	Cl. COELOSCLERITOPHORA
Un	Or. UNCERTAIN	Sa	Or. SACHITIDA
Un	Cl. UNCERTAIN	Ch	Or. CHANCELLORIIDA
Re	Cl. REGULARES	Cr	Cl. CRIBRICYATHEA
Mo	Or. MONOCYATHIDA	Di	Cl. DINOCARDIA
Aj	Or. AJACICYATHIDA	Ra	Or. RADIODONTA
Ca	Or. CAPSULOCYATHIDA	Ma	Cl. MACHAERIDIA
Ta	Or. TABULACYATHIDA	Tu	Or. TURRILEPADIDA
Ir	Cl. IRREGULARES	Le	Or. LEPIDOCOLEOMORPHA
Ar	Or. ARCHAEOCYATHIDA	He	Or. HERCOLEPADIDA
Ka	Or. KAZAKHSTANICYATHIDA	Mu	Cl. MULTIPLACOPHORA
Uc	Cl. UNCERTAIN	St	Or. STROBILEPIDA
Ar	Or. ARCHAEOPHYLLIDA	To	Cl. TOMMOTIDA
Un	Or. UNCERTAIN	Mi	Or. MITROSAGOPHORA
Tr	Ph. TRILOBOZOA	Un	Or. UNNAMED
Un	Or. UNNAMED	Un	Cl. UNCERTAIN
An	Or. ANABARITIDA	Co	Or. COLEOLOIDA
Cn	Ph. CNIDARIA	Cn	Or. CORNULTIDAE
Pe	Cl. PETALONAMAE	Hy	Or. HYOLITHELMINTHES

Codes	Linnean Classification of Higher Taxa	Codes	Linnean Classification of Higher Taxa
Pa	Or. PAIUTIDA	Ph	Or. PHYLLOCERATIDA
Sa	Or. SABELLIDITIDA	Am	Or. AMMONOIDEA
Vo	Or. VOLBORTHELLIDA	Be	Or. BELEMNITIDA
In	Or. INCERTAE SEDIS	Oc	Or. OCTOPIIDA
Pa	Ph. PRIAPULIDA	Se	Or. SEPIIDA
Ch	Ph. CHAETOGNATHA	Te	Or. TEUTHIDA
Un	Or. UNCERTAIN	Pm	Or. PHRAGMOTEUETHIDA
Pr	Or. PROTOCONODONTIDA	Bo	Or. BOLETZKIDA
Er	Ph. ECHIURIDA	Au	Or. AULACOCERIDA
Pg	Ph. POGONOPHORA	Un	Or. UNCERTAIN
Mo	Ph. MOLLUSCA	Ro	Cl. ROSTROCONCHIA
Po	Cl. POLYPLACOPHORA	Ri	Or. RIBEIROIDA
Pa	Or. PALEOLORICATA	Co	Or. CONOCARDIOIDA
Ne	Or. NEOLORICATA	Bi	Cl. BIVALVIA
Eo	Cl. TERGOMYA	So	Or. SOLEMYOIDA
Tr	Or. TRYBLIDIIDA	Nu	Or. NUCULOIDA
Cy	Or. CYRTONELLIDA	Pr	Or. PRAECARDIOIDA
Hy	Or. HYPSELOCONIDA	Mt	Or. MYTILOIDA
He	Cl. HELCIONELLOIDA	Ar	Or. ARCOIDA
In	Cl. INCERTAE SEDIS	Pt	Or. PTERIOIDA
Pe	Or. PELAGIELLIDA	Un	Or. UNIONOIDA
Tu	Or. TUARANGIIDA	Tr	Or. TRIGONIOIDA
He	Or. HEMITHECELLITINA	Ve	Or. VENEROIDA
In	Or. INCERTAE SEDIS	My	Or. MYOIDA
Pa	Cl. PARAGASTROPODA	Hi	Or. HIPPURITOIDA
Hy	Or. HYPERSTROPHINA	Mo	Or. MODIOMORPHOIDA
Ga	Cl. GASTROPODA	Ph	Or. PHOLADOMYOIDA
Be	Or. BELLEROPHONTIDA	Un	Or. UNCERTAIN
Eu	Or. EUOMPHALINA	Sc	Cl. SCAPHOPODA
Pa	Or. PATELLOGASTROPODA	Un	Cl. UNCERTAIN
Mc	Or. MACLURITINA	St	Cl. STENOTHECOIDEA
Ar	Or. ARCHAEOGASTROPODA	Cr	Cl. CRICOCONARIDA
Ar	Or. ARCHITAEENOGLLOSSA	Te	Or. TENTACULITIDA
Ni	Or. NEOTAENIOGLLOSSA	Ho	Or. HOMOTENIDA
Ne	Or. NEOGASTROPODA	Da	Or. DACRYOCONARIDA
He	Or. HETEROSTROPHIA	Hy	Ph. HYOLITHA
Ce	Or. CEPHALASPIDA	Or	Cl. ORTHOTHECIMORPHA
An	Or. ANASPIDEA	Ci	Or. CIRCOTHECIDA
Th	Or. THECOSOMATA	Ex	Or. EXLITHECIDA
Sa	Or. SACOGLLOSSA	Gl	Or. GLOBORILIDA
On	Or. UMBRACULOMORPHA	Or	Or. ORTHOTHECIDA
Ba	Or. BASOMMATOPHORA	Hy	Cl. HYOLITHOMORPHA
Un	Or. UNCERTAIN	Hy	Or. HYOLITHIDA
Ce	Cl. CEPHALOPODA	Un	Cl. UNCERTAIN
Pl	Or. PLECTONOCERIDA	To	Or. TOXEURMORPHORIDA
El	Or. ELLESROCERIDA	Uc	Or. UNCERTAIN
Pr	Or. PROACTINOCERIDA	An	Ph. ANNELIDA
Ya	Or. YANHECERIDA	Po	Cl. POLYCHAETA
Or	Or. ORTHOCERIDA	Am	Or. AMPHINOMORPHA
As	Or. ASCOCERIDA	Eu	Or. EUNICEMORPHA
In	Or. INTEJOCERIDA	Ph	Or. PHYLLODOCEMORPHA
Ac	Or. ACTINOCERIDA	Sp	Or. SPIOMORPHA
En	Or. ENDOCERIDA	Dr	Or. DRILOMORPHA
Di	Or. DISCOSORIDA	Te	Or. TEREBELLOMORPHA
On	Or. ONCOCERIDA	Se	Or. SERPULIMORPHA
Na	Or. NAUTILIDA	Un	Or. UNCERTAIN
Ta	Or. TARPHYCERIDA	My	Cl. MYZOSTOMARIA
Ba	Or. BARRANDEOCERIDA	Pa	Cl. PALAEOSCOLECIDA
An	Or. ANARCESTIDA	Ph	Ph. PENTASTOMIDA
Cl	Or. CLYMENIIDA	Lo	Ph. LOBOPODA
Go	Or. GONIATITIDA	Ar	Ph. ARTHROPODA
Pl	Or. PROLECANITIDA	Ma	Cl. MARRELOMORPHA
Ce	Or. CERATITIDA	Mi	Or. MIMETASTERIDA

Codes	Linnean Classification of Higher Taxa	Codes	Linnean Classification of Higher Taxa
Ac	Or. ACERCOSTRACA	Ae	Or. AESCHRONECTIDA
Cy	Or. CYCLINA	Eo	Or. EOCARIDACEA
Me	Cl. MEROSTOMATA	Lo	Or. LOPHOGASTRIDA
Ag	Or. AGLASPIDA	Be	Or. BELOTELSONIDEA
Xi	Or. XIPHOSURIDA	Wa	Or. WATERSTONELLIDEA
In	Or. INCERTAE SEDIS	De	Or. DECAPODA
Ch	Or. CHASMATASPIDIDA	My	Or. MYSIDACEA
Ea	Or. EURYPTERIDA	Cu	Or. CUMACEA
Ar	Cl. ARACHNIDA	Ta	Or. TANAIIDACEA
Sc	Or. SCORPIONIDA	Is	Or. ISOPODA
Py	Cl. PYCNOGONIDA	Am	Or. AMPHIPODA
Pp	Or. PALAEOPANTOPODA	Ma	Cl. MYRIAPODA
Pa	Or. PALAEOISOPODA	Th	Cl. THYLACOCEPHALA
Pt	Or. PANTOPODA	Cc	Or. CONCAVICARIDA
Pa	Cl. PARATRILOBITA	Co	Or. CONCHYLIOCARIDA
Un	Cl. UNCERTAIN	In	Or. INCERTAE SEDIS
Tr	Cl. TRILOBITA	Bz	Ph. BRYOZOA
Na	Or. NARAOHIDA	St	Cl. STENOLAEMATA
Oi	Or. OLENELLIDA	Cc	Or. CYCLOSTOMATA
Ag	Or. AGNOSTIDA	Cy	Or. CYSTOPORATA
Re	Or. REDLICHIIIDA	Tr	Or. TREPOSTOMATA
Co	Or. CORYNEXOCHIDA	Cr	Or. CRYPTOSTOMATA
Li	Or. LICHIDA	Fe	Or. FENESTRATA
Od	Or. ODONTOPLEURIDA	Un	Or. UNCERTAIN
As	Or. ASAPHIDA	Gy	Cl. GYMNOLAEMATA
Pt	Or. PTYCHOPARIIDA	Ct	Or. CTENOSTOMATA
Pr	Or. PROETIDA	Ch	Or. CHEILOSTOMATA
Ph	Or. PHACOPIIDA	En	Ph. ENTOPROCTA
Un	Or. UNCERTAIN	Br	Ph. BRACHIOPODA
Mo	Cl. MEROSTOMOIDEA	Li	Cl. LINGULATA
Em	Or. EMERALDELLIDA	Li	Or. LINGULIDA
Li	Or. LIMULAVIDA	Ac	Or. ACROTRETIDA
Ch	Or. CHELONIELLIDA	Pa	Or. PATERINIDA
In	Or. INCERTAE SEDIS	In	Cl. INARTICULATA
Re	Cl. REMIPEDIA	Cp	Or. CRANIOPSIDA
En	Or. ENANTIOPODA	Tr	Or. TRIMERELLIDA
In	Cl. INCERTAE SEDIS	Cr	Or. CRANIIDA
Sk	Or. SKARACARIDA	Un	Cl. UNCERTAIN
Or	Or. ORSTENOCARIDA	Ku	Or. KUTORGINIDA
Wa	Or. WAPTIIIDA	Ob	Or. OBOLELLIDA
Un	Or. UNCERTAIN	Ch	Or. CHILEIDA
Bp	Cl. BRACHYPODA	Na	Or. NAUKATOIDEA
Br	Cl. BRANCHIOPODA	Un	Or. UNCERTAIN
Os	Cl. OSTRACODA	Ar	Cl. ARTICULATA
Ar	Or. ARCHAEOCOPIIDA	Or	Or. ORTHIDA
Le	Or. LEPERDITICOPIDA	St	Or. STROPHOMENIDA
Pa	Or. PALAEOCOPIIDA	Pe	Or. PENTAMERIDA
My	Or. MYODOCOPIIDA	Rh	Or. RHYNCHONELLIDA
Me	Or. METACOPIIDA	Sp	Or. SPIRIFERIDA
Po	Or. PODOCOPIIDA	At	Or. ATRYPIDA
Pl	Or. PLATYCOPIIDA	Te	Or. TEREBRATULIDA
Un	Or. UNCERTAIN	Th	Or. THECIDEIDA
Co	Cl. COPEPODA	Un	Or. UNCERTAIN
Ci	Cl. CIRRIPIIDA	Ec	Ph. ECHINODERMATA
Ml	Cl. MALACOSTRACA	Ct	Cl. CTENOCYSTOIDEA
Cu	Or. CANADASPIDIDA	St	Cl. STYLOPHORA
Le	Or. LEPTOSTRACA	Co	Or. CORNUTA
Hy	Or. HYMENOSTRACA	Mi	Or. MITRATA
Ho	Or. HOPLOSTRACA	Hm	Cl. HOMOSTELEA
Ar	Or. ARCHAEOSTRACA	Ci	Or. CINCTA
In	Or. INCERTAE SEDIS	Hs	Cl. HOMIOSTELEA
Pa	Or. PALAEOSTOMATOPODA	So	Or. SOLUTA
St	Or. STOMATOPODA	He	Cl. HELICOPLACOIDEA

Codes	Linnean Classification of Higher Taxa	Codes	Linnean Classification of Higher Taxa
Eo	Cl. EOCRINOIDEA	Hs	Or. HOLASTEROIDEA
Im	Or. IMBRICATA	Sp	Or. SPATANGOIDEA
Go	Or. GOGIIDA	Nc	Or. NEOLAMPADOIDEA
As	Or. ASCOCYSTITIDA	Un	Or. UNCERTAIN
Un	Or. UNCERTAIN	Oh	Cl. OPHIOCISTIOIDEA
Cr	Cl. CRINOIDEA	Ho	Cl. HOLOTHUROIDEA
Ec	Or. ECHMATOCRINIDA	De	Or. DENDROCHIROTIDA
Di	Or. DIPLOBATHRIDA	As	Or. ASPIDOCHEIROTIDA
Mo	Or. MONOBATHRIDA	El	Or. ELASIPODIDA
Di	Or. DISPARIDA	Ap	Or. APODIDA
Hy	Or. HYBOCRINIDA	Mo	Or. MOLPADIIDA
Cl	Or. CLADIDA	Ar	Or. ARTHROCHIROTIDA
He	Or. HEMISTREPTOCRINIDA	Da	Or. DACTYLOCHIROTIDA
Tv	Or. TAXOCRINIDA	uN	Or. UNCERTAIN
Sa	Or. SAGENOCRINIDA	So	Cl. SOMASTEROIDEA
Mi	Or. MILLERICRINIDA	Go	Or. GONIACTINIDA
Cy	Or. CYTROCRINIDA	As	Cl. ASTEROIDEA
Bo	Or. BOURGUETICRINIDA	Pl	Or. PLATYASTERIDA
Is	Or. ISOCRINIDA	Pu	Or. PUSTULOSIDA
Cm	Or. COMATULIDA	He	Or. HEMIZONIDA
Ui	Or. UINTACRINIDA	Ur	Or. URACTINIDA
Rv	Or. ROVEACRINIDA	Tr	Or. TRICHASTEROPSIDA
En	Or. ENCRINIDA	Fo	Or. FORCIPULATIDA
Un	Or. UNCERTAIN	Va	Or. VALVATIDA
Rh	Cl. RHOMBIFERA	No	Or. NOTOMYOTIDA
Di	Cl. DIPLOPORITA	Px	Or. PAXILLOSIDA
Pa	Cl. PARABLASTOIDEA	Sp	Or. SPINULOSIDA
Pc	Cl. PARACRINOIDEA	Un	Or. UNCERTAIN
Co	Or. COMAROCYSTITIDA	Op	Cl. OPHIUROIDEA
Pl	Or. PLATYCYSTITIDA	St	Or. STENURIDA
Un	Or. UNCERTAIN	Oe	Or. OEGOPHIURIDA
Co	Cl. CORONOIDEA	Ph	Or. PHRYNOPHIURIDA
Bl	Cl. BLASTOIDEA	Op	Or. OPHIURIDA
Fi	Or. FISSICULATA	Un	Or. UNCERTAIN
Sp	Or. SPIRACULATA	He	Ph. HEMICHORDATA
Un	Or. UNCERTAIN	En	Cl. ENTEROPNEUSTA
Cm	Cl. CAMPTOSTROMOIDEA	Pt	Cl. PIEROBRANCHIA
Cm	Or. CAMPTOSTROMATOIDEA	Rh	Or. RHABDOPLEURIDA
Ed	Cl. EDRIOASTEROIDEA	Ce	Or. CEPHALODISCIDA
Is	Or. ISOROPHIDA	Gr	Cl. GRAPTOLITHINA
Ed	Or. EDRIOASTERIDA	De	Or. DENDROIDEA
St	Or. STROMATOCYSTITIDA	Tu	Or. TUBOIDEA
Un	Or. UNCERTAIN	Ca	Or. CAMAROIDEA
En	Cl. ECHINOIDEA	Cr	Or. CRUSTOIDEA
Bo	Or. BOTHRIOCIDAROIDEA	St	Or. STOLONOIDEA
Ey	Or. ECHINOCYSTITOIDEA	Gr	Or. GRAPTOLOIDEA
Ci	Or. CIDAROIDEA	Un	Or. UNCL...AIN
Et	Or. ECHINOTHURIOIDEA	Cd	Ph. CHORDATA
Di	Or. DIADEMATOIDEA	Tu	Cl. TUNICATA
Pe	Or. PEDINOIDEA	Cp	Cl. CEPHALOCHORDATA
Py	Or. PYGASTEROIDEA	Co	Cl. CONODONTA
Sa	Or. SALENOIDEA	Pa	Or. PARACONODONTIDA
Hm	Or. HEMICIDAROIDEA	Co	Or. CONODONTOPHORIDA
Ph	Or. PHYMOSOMATOIDEA	Pt	Cl. PTERASPIDOMORPHI
Te	Or. TEMNOPLEUROIDEA	As	Or. ASTRASPIDIFORMES
Ec	Or. ECHINOIDEA	Pt	Or. PTERASPIDOMORPHES
Pl	Or. PLESIOCIDAROIDEA	Th	Or. THELODONTIFORMES
Or	Or. ORTHOPSIDA	Un	Or. UNCERTAIN
Ho	Or. HOLECTYPOIDA	Ce	Cl. CEPHALASPIDOMORPHI
OI	Or. OLIGOPYGOIDEA	Ce	Or. CEPHALASPIDIFORMES
Cl	Or. CLYPEASTEROIDEA	At	Or. ATELASPIDIFORMES
Ca	Or. CASSIDULOIDEA	Bi	Or. BIRKENIFORMES
Ds	Or. DISASTEROIDEA	An	Or. ANASPIDA

Codes	Linnean Classification of Higher Taxa	Codes	Linnean Classification of Higher Taxa
Pe	Or. PETROMYZONIFORMES	Ma	Or. MACROSEMIIFORMES
My	Or. MYXINIFORMES	Pc	Or. PACHYCORDIFORMES
Pl	Cl. PLACODERMI	Ot	Or. OSTEOGLOSSIFORMES
St	Or. STENSIOELLIDA	El	Or. ELOPIIFORMES
Ps	Or. PSEUDOPETALICHTHIDA	Me	Or. MEGALOPIIFORMES
Rh	Or. RHENANIDA	An	Or. ANGUILLIFORMES
Pt	Or. PTYCTODONTIDA	Cr	Or. CROSSOGNATHIFORMES
Ac	Or. ACANTHOTHORACI	Cl	Or. CLUPEIFORMES
Br	Or. BRINDABELLASPIDA	Go	Or. GONORHYNCHIFORMES
Pe	Or. PETALICHTHIDA	Si	Or. SILURIFORMES
Ar	Or. ARTHRODIRA	Os	Or. OSMERIFORMES
An	Or. ANTIARCHA	Sa	Or. SALMONIFORMES
Un	Or. UNCERTAIN	St	Or. STOMIIFORMES
Ch	Cl. CHONDRICTHYES	Al	Or. ALEPISAUIFORMES
In	Or. INCERTAE SEDIS	Au	Or. AULOPIIFORMES
De	Or. DESMIODONTIDA	Ct	Or. CTENOTHRISIFORMES
Cl	Or. CLADOSELACHIDA	My	Or. MYCTOPHIFORMES
Co	Or. CORONODONTIDA	In	Or. INCERTAE SEDIS
Sy	Or. SYMMORIIDA	Po	Or. POLYMIXIIFORMES
Eu	Or. EUGENEODONTIDA	Op	Or. OPHIDIIFORMES
Or	Or. ORODONTIDA	Ba	Or. BATRACHODIFORMES
St	Or. SQUATINACTIDA	Lo	Or. LOPHIIFORMES
Ct	Or. CTENACANTHIDA	Gd	Or. GADIFORMES
Hx	Or. HEXANCHIFORMES	At	Or. ATHERINIFORMES
Sq	Or. SQUALIFORMES	Be	Or. BELONIFORMES
Pr	Or. PRISTIOPHORIFORMES	Br	Or. BERYCIFORMES
Sl	Or. SQUATINIFORMES	La	Or. LAMPRIDIFORMES
Ht	Or. HETERODONTIFORMES	Ze	Or. ZEIFORMES
Oc	Or. ORECTOLOBIFORMES	Ga	Or. GASTEROSTEIFORMES
La	Or. LAMNIFORMES	Da	Or. DACTYLOPTERIFORMES
Ca	Or. CARCHARHINIFORMES	Sc	Or. SCORPAENIFORMES
Rj	Or. RAJIFORMES	Pf	Or. PERCIFORMES
To	Or. TORPEDINOIDEA	Pn	Or. PLEURONECTIFORMES
My	Or. MYLIOBATIFORMES	Te	Or. TETRADONTIFORMES
Ch	Or. CHONDRENCHELYIFORMES	Am	Cl. AMPHIBIA
Cp	Or. COPODONTIFORMES	Te	Or. TEMNOSPONDYLI
Ps	Or. PSAMMODONTIFORMES	Re	Cl. REPTILIA
Cm	Or. CHIMAERIFORMES	An	Or. ANASPIDA INCERTAE SE
Ip	Or. INIOPTERYGIA	Ch	Or. CHELONIA
Pe	Or. PETALODONTIDA	Sq	Or. SQUAMATA
Ac	Cl. ACANTHODII	Th	Or. THALATTOSAURIA
Cl	Or. CLIMATIIFORMES	No	Or. NOTOSAURIA
Is	Or. ISCHNACANTHIDA	Ps	Or. PLESIOSAURIA
Ac	Or. ACANTHODIDA	Pl	Or. PLACODONTIA
Un	Or. UNCERTAIN	Ic	Or. ICHTHYOSAURIA
Os	Cl. OSTEICHTHYES	Sp	Or. SPHEODONTIA
Di	Or. DIPTERIFORMES	Cr	Or. CROCODILIA
Co	Or. COELOCANTHIFORMES	Av	Cl. AVES
Pa	Or. PALAEONISCIFORMES	He	Or. HESPERORNITHIFORMES
Ta	Or. TARRASIIFORMES	Ic	Or. ICHTHORNITHIFORMES
Pt	Or. PTYCHOLEPIIFORMES	Sp	Or. SPHENISCIFORMES
Bb	Or. BOBASATRANIFORMES	Pr	Or. PROCELLARIIFORMES
Su	Or. SAURICHTHYIFORMES	Pe	Or. PELECANIFORMES
Ph	Or. PHOLIDOPLEURIFORMES	Ch	Or. CHARADRIIFORMES
Pe	Or. PERLEIDIFORMES	In	Or. INCERTAE SEDIS
Pl	Or. PELTOPLEURIFORMES	Ma	Cl. MAMMALIA
Ce	Or. CEPHALOXENIFORMES	Ce	Or. CETACEA
Ac	Or. ACIPENSERIFORMES	Si	Or. SIRENIA
Se	Or. SEMIONOTIFORMES	Ca	Or. CARNIVORA
Pyc	Or. PYCNODONTIFORMES	De	Or. DERMOSTYLIA
Am	Or. AMIIFORMES		

PREPARATION OF MANUSCRIPTS

Bulletins of American Paleontology usually comprises two or more separate papers in two volumes each year. The series is a publication outlet for significant, longer paleontological monographs (*i.e.*, more than approximately 50 printed pages), for which high quality photographic illustrations and the large quarto format are required.

Submissions are welcome from any author, regardless of institutional or organizational affiliation. Authors must, however, be members of the Paleontological Research Institution at time of publication; annual membership is currently US\$25.00. Publication costs of the *Bulletins* are heavily subsidized by the Institution, but authors are currently required to pay illustration charges at a rate of \$120.00 per plate and \$35.00 per text-figure.

Important references for style and format are 1) *Bulletins of American Paleontology* "Instructions for Authors" (volume 108, number 3-47, pages 149-153); 2) *Chicago Manual of Style* (fourteenth edition) 1993. Recent issues of the *Bulletins* provide useful guides but note changes with the "Instructions for Authors" mentioned above.

Manuscripts must be typewritten, and double-spaced *throughout* (including direct quotations, tables and references). All manuscripts should contain a table of contents, lists of text-figures and or tables, and a short, informative abstract that includes names of all new taxa. Format should follow that of recent numbers in the series. All measurements must be given in the metric system, alone or in addition to their English system equivalents. The maximum dimensions for photographic plates are 178 mm \times 229 mm (7 inches \times 9 inches; outlined on this page). Single-page text-figures should be drafted for reproduction as single column (82 mm; 3 $\frac{1}{2}$ inches) or full page (178 mm; 7 inches) width, but arrangements can be made to publish text-figures that must be larger.

Authors must provide three (3) printed copies of the text and accompanying illustrative material. Authors are *strongly* encouraged to prepare their manuscripts on word processors, as this considerably expedites publication. On initial submission, however, only printed copies of the manuscript should be sent; the disk copy should be retained so that revisions can be made after the review process. The text and line-drawings may be reproduced xerographically, but glossy prints at publication size must be supplied for all half-tone illustrations and photographic plates. These prints should be identified clearly on the back.

Referenced publication titles *must be spelled out in their entirety*. Particular care should be given to reference format. Consult the "Instructions for Authors," referred to above, as several changes have been introduced with that issue. Citations of illustrations within the text bear initial capitals (*e.g.*, Plate, Text-figure), but citations of illustrations in other works appear in lower-case letters (*e.g.*, plate, text-figure).

Format of systematic descriptions should follow that in any recent number of the *Bulletins*.

Original plate photomounts should have oversize cardboard backing and strong tracing paper overlays. These photomounts should be retained by the author until the manuscript has been formally accepted for publication. The approximate position of each text-figure in the text should be indicated. Explanations of plates and text-figures should follow the References Cited.



Gilbert Dennison Harris
(1864 - 1952)

Founder of the *Bulletins of American Paleontology* (1895)

701
38 X
UH



Bulletins of American Paleontology

Begun in 1895

NUMBER 364

JULY 10, 2003

The Oldest Known Crinoids (Early Ordovician, Utah) and a
New Crinoid Plate Homology System

by

Thomas E. Guensburg

and

James Sprinkle

Paleontological Research Institution
1259 Trumansburg Road
Ithaca, New York, 14850 U.S.A.

PALEONTOLOGICAL RESEARCH INSTITUTION

Officers

PRESIDENT	CHRISTOPHER G. MAPLES
FIRST VICE-PRESIDENT	JOHN POJETA, JR.
SECOND VICE-PRESIDENT	HOWARD P. HARTNETT
SECRETARY	SHIRLEY K. EGAN
TREASURER	PATRICIA A. JOHNSON
DIRECTOR	WARREN D. ALLMON

Trustees

JOHN D. ALLEN	PHILIP PROCIANSKY
CARLTON E. BRETT	MEGAN D. SHAY
WILLIAM L. CREPET	MARY M. SHUFORD
W. MICHAEL DRISCOLL	CONSTANCE M. SOJA
J. THOMAS DUTRO, JR.	JOHN C. STEINMETZ
PATRICIA HAUGEN	PETER B. STIFFI
ROBERT M. HORN, JR.	DAVID H. TAUBI
HARRY G. LEF	SALLY T. TRUE
AMY R. McCUNE	ARTHUR WATERMAN

Trustees Emeritus

HARRY A. LEHNINGWILL
ROBERT M. LINSLEY
SAMUEL T. PEES
EDWARD B. PICOU, JR.
JAMES E. SORAUF
RAYMOND VAN HOUTTE
WILLIAM P. S. VENTRESS
THOMAS E. WHITELEY

BULLETINS OF AMERICAN PALEONTOLOGY and PALAEONTOGRAPHICA AMERICANA

WARREN D. ALLMON EDITOR

A list of titles in both series, and available numbers and volumes are available online at www.priweb.org. Volumes 1-23 of *Bulletins of American Paleontology* are available from Periodicals Service Company, 11 Main St., Germantown, New York 12526 USA. Volume 1 of *Palaeontographica Americana* has been reprinted by Johnson Reprint Corporation, 111 Fifth Ave., New York, NY 10003 USA.

Subscriptions to *Bulletins of American Paleontology* are available for US \$165 per year (individual or institution) plus postage. Issues are available and priced individually. Numbers of *Palaeontographica Americana* are priced individually.

for additional information, contact:

Paleontological Research Institution
1259 Trumansburg Road
Ithaca, NY 14850 USA
(607) 273-6623
FAX (607) 273-6620
www.priweb.org



Bulletins of American Paleontology

Begun in 1895

NUMBER 364

JULY 10, 2003

The Oldest Known Crinoids (Early Ordovician, Utah) and a
New Crinoid Plate Homology System

by

Thomas E. Guensburg

and

James Sprinkle



Paleontological Research Institution
1259 Trumansburg Road
Ithaca, New York, 14850 U.S.A.

ISSN 0007-5779
ISBN 0-87710-458-1

Library of Congress Control Number: 2003107017

Note: Beginning with issue number 356, *Bulletins of American Paleontology* is no longer designating volumes. The journal will continue to publish approximately 2-4 issues per year, each of which will continue to be individually numbered.

Printed in the United States of America
Allen Press, Inc.
Lawrence, KS 66044 U.S.A.

CONTENTS

	Page
Abstract	5
Acknowledgments	5
Introduction	5
Age, Geologic Setting, and Stratigraphy	6
Early Crinoid Record	7
Protoerinoids	7
Primary Cup Plate Homologies	
Historical Review	7
Single Reference System Failings	8
Dual Reference System	12
Anal Plate Homologies	13
Early Crinoid Phylogeny	
Methods	13
Other Early Crinoid Phylogenies	14
Present Interpretation	15
Principal Findings	16
Systematic Paleontology	
Introduction	16
Systematics	
Subphylum Crinozoa	16
Class Crinoidea	16
Order Protoerinoida n. ord.	16
Family Titanocrinidae n. fam.	18
Genus <i>Titanocrinus</i> , n. gen.	18
Genus <i>Glenocrinus</i> , n. gen.	19
Subclass Camerata	20
Order? Diplobathrida	21
Family Reteocrinidae	21
Genus <i>Cnemecrinus</i> , n. gen.	21
Order? Monobathrida	22
Family Eknomocerimidae, n. fam.	22
Genus <i>Eknomocrinus</i> , n. gen.	22
Family uncertain	23
Genus <i>Adelphocrinus</i> , n. gen.	23
Family Habrotecrimidae, n. fam.	24
Genus <i>Habrotecrinus</i> , n. gen.	24
Systematic Position Uncertain	25
Stem A	25
Stem B	25
Appendix: Detailed Collection Data	25
References Cited	27
Plates	31
Index	41

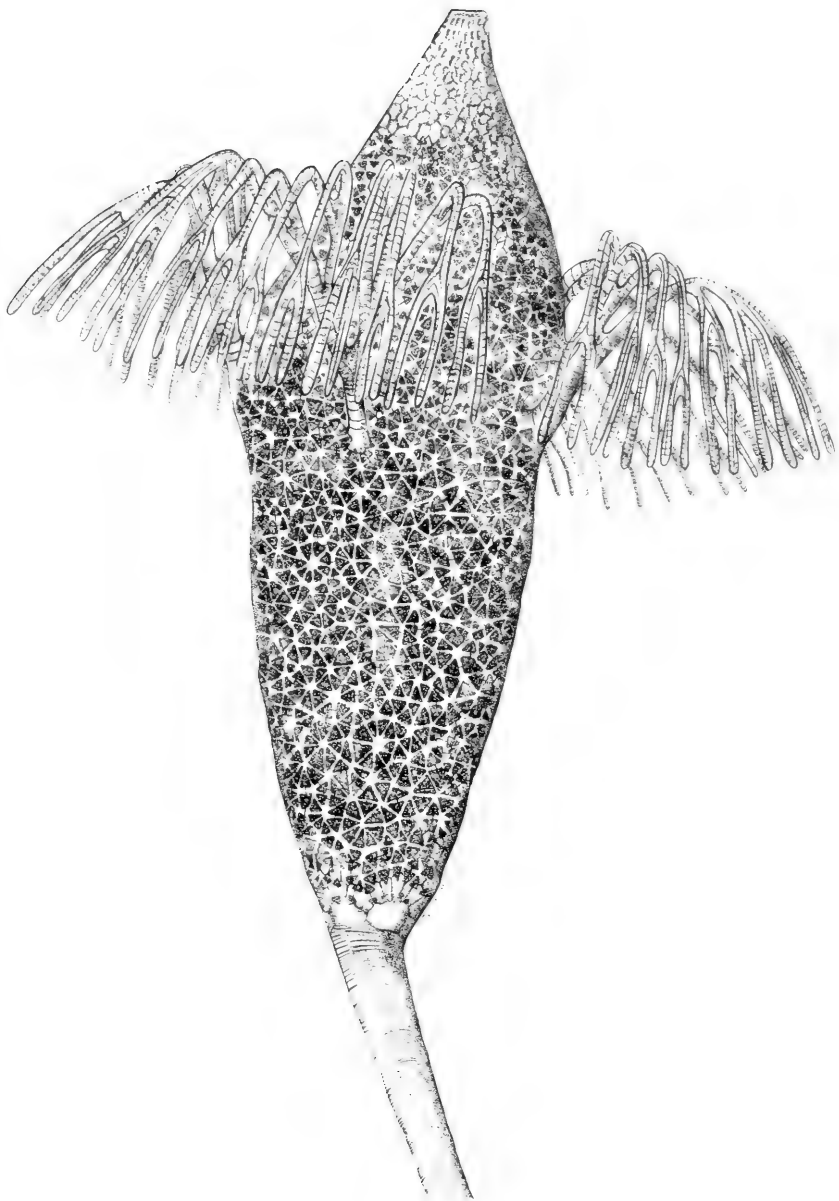

Frontispiece: Reconstruction of *Titanocrinus sumralli* new genus and species by Julianna Durst, primarily after a preliminary pencil sketch by Guensburg. This drawing is based on the holotype PE 52720 and paratype PE 52721 and is approximately natural size. The crown is shown in D-ray orientation.

THE OLDEST KNOWN CRINOIDS (EARLY ORDOVICIAN, UTAH) AND A NEW CRINOID PLATE HOMOLOGY SYSTEM

THOMAS E. GUENSBURG
Physical Science Division
Rock Valley College
Rockford, Illinois 61114 U. S. A.

AND

JAMES SPRINKLE
Department of Geological Sciences
Jackson School of Geosciences
University of Texas
Austin, Texas 78712 U. S. A.

ABSTRACT

Six new primitive genera from the Early Ordovician of western Utah significantly advance our understanding of early crinoid history. Two of the new genera are the oldest crinoids (early Ibxian, early Tremadoc) and represent a previously unknown protocrinoid evolutionary grade, differing from other crinoids in having a nonstandardized dorsal cup and arms bearing ambulacral floor plates. *Titanocrinus sumralli*, new genus and species, has hundreds of unorganized mid-cup and interbrachial plates separating the cup-base basal circling and the ray plates. *Glenocrinus globularis*, new genus and species, has similar plating with a more compact globular cup and fewer mid-cup plates, and is near the origin of diplobathrid camerates. A third taxon, *Ekuonocrinus wahwahensis*, new genus and species, from the same lower stratigraphic interval, is a stem-group monocyclic camerate crinoid with standardized but irregular cup plating and other emergent crinoid traits shared with protocrinoids. Three new camerates from higher in the section are more derived. *Cnemecrinus fillmorensis*, new genus and species, middle Ibxian (latest Tremadoc), is a retocrinid camerate, and *Adelphicrinus fortuitus*, new genus and species, and *Habrotecrinus ibexensis*, new genus and species, both latest Ibxian (middle Arenig), are monocyclic camerates. The latter taxon has unique accessory plates and major cup plate shapes. The fossil record indicates rapid diversification of disparid, cladid, and camerate crinoids by the end of the middle Ibxian (late Tremadoc), each arising independently from the protocrinoid stem group.

Evidence from ontogeny, cup-stem and radial orientation, and now, early morphologic transitions necessitates revision of long used skeletal terminology. Dual ray and cup-base references for plate homologies, rather than the traditional ray-only model, are consistent with this evidence. Consequently, infrabasals are redefined as the cup-base circling of both dicyclic and monocyclic crinoids. The use of basals is restricted to plates between infrabasals and radials of dicyclic (and tricyclic) crinoids. Traditional classifications emphasizing cup plate circling number is unreliable early in the crinoid record; instead, posterior and interray cup morphology provides the most consistent phylogenetic information.

ACKNOWLEDGMENTS

We thank Sandy Hogan, Chris Mann, and Sherri Pritz for their help in preparing illustrations. Colin Sumrall, Fred Siewers, Terry Abbott, Sergei Rozhnov, Ronald Johns, Jennifer Martin, Brian Exton, David Sprinkle, Anita Brosius, Mike Slattery, Cindy Mauk, and Lisa Tarde aided us in the field between 1989 and 1998. Raymond Ethington, University of Missouri, Columbia, processed conodont samples for age determinations. Tomasz Baumiller (University of Michigan) and Dave Meyer (University of Cincinnati) reviewed the completed manuscript and made many helpful suggestions. Funding for field work, travel, and preparation, drafting, and publication expenses were provided by NSF Grants BSR-8906568 (1989–1991, Sprinkle)

and EAR-9304253 (1993–1994, Sprinkle and Guensburg), by a PRF-ACS Grant to Mark Wilson (1989–1990, Guensburg), by CRDF Cooperative Research Grant RG1-242 (1997–1998, Rozhnov, Sprinkle, and Guensburg), and by the Geology Foundation, University of Texas at Austin, by Southern Illinois University, Edwardsville, and by Rock Valley College, Rockford, IL. This is a contribution to IGCP Project 410, The Great Ordovician Biodiversification Event.

INTRODUCTION

Crinoids have a long and rich fossil record, but their origin, like other extant echinoderm classes, has been mysterious (Ubahgs, 1978; Simms, 1994; Ausich, 1998a). Crinoid diversity exceeds that of any other echinoderm class from the Late Ordovician (Mohaw-

kian, mid-Caradoc) through the remainder of the Paleozoic Era. Prior to that time, however, their record is much less diverse.

Most Early Ordovician crinoids are morphologically similar to later crinoid crown groups, providing little information for phylogenetic analyses aimed at understanding the relationships of crown groups and origin of crinoids. The fossils described here enrich and extend the Early Ordovician crinoid record and they contain previously unknown early crinoid morphology enabling reassessment of plate homology systems and phylogeny.

Nine weeks of field work between 1989 and 1999 on the Ibexian-aged (lower Tremadoc to middle Arenig) Fillmore and Wah Wah formations of western Utah yielded many crinoid specimens, including the 20 described below. These fossils are a relatively small part of a large diverse echinoderm collection from that area. Almost all the specimens were variously encased in highly indurated carbonate matrix, requiring hundreds of hours of hand preparation with fine needles under a stereomicroscope.

AGE, GEOLOGIC SETTING, AND STRATIGRAPHY

The six new genera and species were found as isolated occurrences in four horizons of the thick, long-ranging, Fillmore and Wah Wah formations at the Ibex section, Millard County, western Utah (Appendix 1) (Hintze, 1973). The Lower Ordovician part of the Ibex section is exceptionally complete, fossiliferous, and has recently been correlated to a newly derived Ordovician Standard Section. All of the new crinoid taxa described here occur in single trilobite biozones that range in age from time slices 1b to 2c of the Ordovician Standard Section (Webby *et al.*, 2003) (Text-fig. 1; see also Appendix for detailed collection data). Two new stem-group crinoids and a stem-group monocyclic camerate occur here, near the base of the Ordovician, and represent the oldest crinoids (excepting the problematic *Echmatocrinus*) yet described (Text-fig. 1). Other crinoids previously reported from the Ibex area (Lane, 1970; Kelly and Ausich, 1978), are middle Ibexian or Whiterockian (late Tremadoc to Llanvirnian) in age. The remaining crinoids described here overlap in age with previously described Early Ordovician taxa and include one early Ibexian (late Tremadoc) and two latest Ibexian (middle Arenig) taxa.

All crinoids described here occur on or near hard-ground surfaces developed on intraformational conglomerates, echinoderm grainstones, and sponge-algal mound layers as part of the shallow water carbonate-dominated Fillmore and Wah Wah formations (Sprinkle and Guensburg, 1995, for additional information).

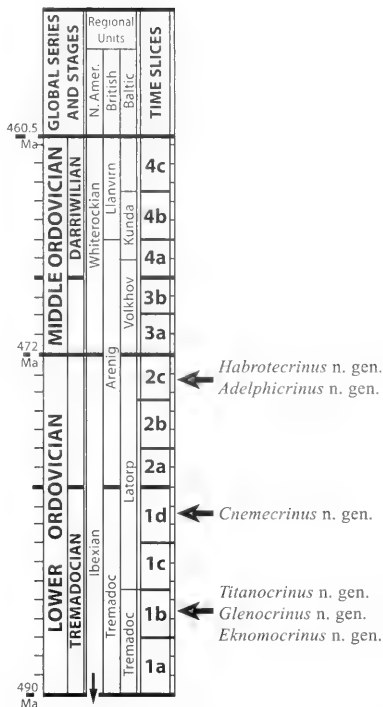

Text-figure 1. Stratigraphic occurrence of the six new protocrinoid and camerate crinoid genera within the recently established Ordovician global correlation time slices based on radiometric dates and conodont and graptolite biozonation; note radiometric dates for series boundaries. *Aethocrinus*, a widely recognized basal cladid, occurs in time slice 2a for comparison (modified from Webby *et al.*, 2003).

Echinoderm holdfasts, including *Podolithus*-type crinoid and solid blastozoan, are attached to the hard-ground surfaces. These lithofacies are resistant to weathering and dominate natural slope exposures. Sedimentary structures in this sequence include rippled and interference rippled calcisiltites and fine grainstones. Starved ripples and small-scale megaripples with hummocky cross-stratification characterize coarser facies. Thin wavy beds and laminae occur in intervening less resistant clastic shales and lime muds. Coarser crinoid-bearing lithofacies are storm generated (Dattilo, 1993; Sprinkle and Guensburg, 1995) and articulated specimens are generally rare (see Guensburg and Sprinkle, 1992).

Lower Fillmore fossils co-occur with a variety of other echinoderms including edrioasteroids and stemmed blastozoans including asteroblastids and

"eocrinoids." Unattached rhombiferans also occur nearby in the section, though rarely in direct association with crinoids. Other aspects of the fauna have more of a "Cambrian character": many trilobites, few articulate brachiopods, no bryozoans, bivalves, or corals. Asteroblastids and rhombiferans continue into the middle Fillmore, but the hardground fauna there is clearly dominated by crinoids, particularly iocrinids, and this trend continues up-section to the highest occurrences where more abundant and diverse articulate brachiopods and the earliest bryozoans in the section are found.

EARLY CRINOID RECORD

The early crinoid record was summarized by Donovan (1988). Few new taxa have been added since that time, and several are younger than thought, Middle Ordovician. Only approximately 20 species have been described. The Middle Cambrian *Echmatocrinus* is considered a basal crinozoan by some workers, but this taxon has only one apomorphy, large uniserial arms, linking it to other crinoids (Sprinkle and Collins, 1998). Other authors do not consider *Echmatocrinus* to be a crinoid (Ausich and Babcock, 1998). Widely accepted crinoids are first recorded in Lower Ordovician rocks. The oldest described Ordovician crinoid prior to this study is the disparid *Pogonipocrinus* from the middle Ibexian, western Utah. *Ramseyocrinus*, another disparid, is from the middle Ibexian (early Arenig) (Cope, 1988). The middle Ibexian (early Arenig) *Aethocrinus* (Vizcaino and Lefebvre, 1999) has been cited as the most primitive crinoid (Ausich, 1996, 1998a), but this taxon is more widely recognized as a stem-group cladid (Ubahgs, 1978; Kelly, 1986; Donovan, 1988). Two other cladids, *Compagierinus*, and *Elpasocrinus*, are also late Ibexian (middle Arenig) (Jobson and Paul, 1979; Sprinkle and Wahlman, 1994). The earliest camerate crinoids are late Ibexian (middle Arenig) in age and include *Proxenocrinus* and *Celtoocrinus* (Ausich, 1986; Donovan and Cope, 1989). These are remarkable for their similar construction to later Ordovician taxa. Perittocrinids and other crinoids from Russia, were for many years considered Early Ordovician, but are now placed in the Middle Ordovician (Whiterockian, or Llanvirnian) (Webby *et al.*, 2003).

PROTOCRINOIDS

We could not have predicted finding two of the new taxa described here. At first glance, we were not fully convinced what kind of echinoderms these fossils were (Plates 1–3). A close look, however, revealed fundamental structures of crinoids: erect branched ambulacra or arms supported by extraxial (Mooi and David,

1997) uniserial aboral ray plating arising from the lower theca or cup, wide specialized posterior or CD interray plating containing the anus, and strong pentamerality in rays and thecal (calyx) plating, and pentamerity stem. These traits also separate the fossils from other stemmed echinoderms. But these fossils have free arms with ambulacral floor plates, a basal echinoderm trait (Mooi and David, 1997), and unorganized cup (thecal) plating similar to that of Cambrian stem-group echinoderms (edriasteroids, early eocrinoids), morphology not found in other crinoids. The new fossils also share traits with other early and sometimes later crinoids (Table 1). This combination of basic crinoid construction together with emergent crinoid and earlier echinoderm characteristics are evidence of a previously unrecognized stem-group crinoid stock. We recognize these fossils as protocrinoids. Protocrinoids are crinoids with: 1) nonpinnulate uniserial arms bearing ambulacral floor plates, 2) a conical tegmen, 3) a cup with extensive nonstandardized plating except for the infrabasal circlet articulating to the stem and fixed ray plates, and 4) a pentamerity stem at the cup juncture.

PRIMARY CUP PLATE HOMOLOGIES

HISTORICAL REVIEW

The dorsal cup contains a disproportionately large portion of morphologic data typically used for crinoid classification and phylogenetic studies. Crinoid plate homologies systems were and continue to be founded on traditional serial, positional, and developmental evidence. Here, new information gained from this addition to the early crinoid fossil record prompts a reinterpretation of basic cup plate homologies.

The familiar cup plate homology system of Carpenter (1879), has been the widely accepted standard for over a century, and was virtually unquestioned until recently (Text-fig. 2, Table 2). This system is founded on a single positional reference, the radial plates. Radials are located by tracing erect arms and their recumbent rays downward into the cup to the lowest plate aligned with the arms. Larger size and specialized upper articular facets help distinguish radials in many crownward taxa where they bound the cup top, but among stem-group and most camerate taxa, the radials are below the cup edge and are morphologically similar to fixed brachials above. Bather (1892) later added biradial terminology, inferradial and superradial, to the Carpenter system, accommodating certain disparid inadunates with ray plating extending two plates downward into the cup. Plates subjacent to and alternating with (interradially positioned) radials are termed basals. Basals form the cup base of mono-

Table 1.—Procteroicoid trait distribution among Ordovician crown group crinoids. Abbreviations: Ca = camerates, Cl = cladids, D = disparids, W = widespread, all.

Character	Distribution
Arms	
uniseriate, nonpinnulate	Cl, D, few Ca
isotomous branching	W
branch plate webs	Rare Ca (<i>Reteocrinus</i> , <i>Stipato-</i> <i>crinus</i>)
imperforate biserial ambulacral floor plates	None
Tegmen	
protruding anal cone in expanded CD interray, submerged mouth offset anteriorly	W
Cup	
Gradational merging of cup and arms (radial articular facet lacking)	Ca, few D, Cl
infrabasals	W
infrabasal gap plate	Rare Ca (<i>Eknomo-</i> <i>crinus</i> n. gen.), D (<i>Anomalocrinus</i>)
basals	Cl, dicyclic Ca
nonstandardized mid- and interradial cup plating	Rare*
wide CD interray	Ca, Cl
multiple fixed ray plates (3 or more)	Ca, few Cl, D
unbranched fixed ray plates	Cl, D, rare early Ca (<i>Eknomo-</i> <i>crinus</i> n. gen.)
Stem and holdfast	
pentamerous proximal stem	Few early Ca, Cl, D
large lumen	W
" <i>Podolithus</i> "-type holdfast—multiplated upper surface and fused attachment disc below, pentamerous primary and subsidiary secondary internal partitions	D, rare early Ca, ?Cl

* = Reappears (?reversion) in acrocrinid camerates, and the cladid *Belanskicrinus* from the Devonian and Mississippian.

cyclic crinoids. The cup circlet beneath and alternating with basals (radially positioned), if present, is termed infrabasals. In the case of dicyclic crinoids, it is the infrabasals that form the cup base.

Simms (1994) offered an alternative cup-plate homology system based on the cup-stem landmark (Text-fig. 2, Table 2). Carpenter's terminology was conserved, but redefined. The cup-base circlet is always designated infrabasals by this system, except for certain monobathrids with nonpentamerous cup-base plating. Basal and radial terminology is that of the traditional Carpenter system for dicyclic crinoids, but differs in monocyclic taxa where radials in Carpenter's

system are designated basals. The initial ray plates, of Simms' system, are either radials or basals.

Ausich (1996) proposed a third system, a modified version of the traditional Carpenter scheme based on a tricyclic (four circlet) cup (Text-fig. 2, Table 2). The term lintel was proposed for the cup circlet beneath infrabasals found in the early crinoid *Aethocrinus*. Terminology applied to cladids and camerates follows Carpenter, but disparids are considered to have lintels at the cup base followed either by infrabasals and radials or infrabasals alone, depending on whether "biradials" or single radials are found in the cup.

All of the systems discussed above adopt a single reference point for establishing homologies, but this has not always been the case. A dual reference homology system (here DRHS) for crinoid cup plates consistent with cup-stem and ray reference points was widely used in the mid-19th century prior to adoption of Carpenter's radial reference system. Initial ray plates were designated radials, but the cup-base circlet, regardless of whether monocyclic or dicyclic, was termed basals (de Koninck and Le Hon, 1854; Zittel, 1879; Miller, 1890; see also Wachsmuth and Springer, 1897, p. 52–68 for a review). Plates subjacent to radials among dicyclic crinoids were referred to as "parabasals" or "subradials." S.A. Miller (1890) continued to use this system into the late nineteenth century. Jaekel (1894, 1918) applied a similar approach to dicyclic camerate crinoids and introduced the term "epibasals" for intervening cup plates between radials and basals.

SINGLE REFERENCE SYSTEM FAILINGS

The traditional Carpenter system is a convenient and established method for identifying homologies within crown groups, but positional and developmental evidence conflict with these interpretations of plate homologies. Some of this evidence has long been known, but its significance was re-recognized only recently (Wachsmuth and Springer 1897; Clark, 1915; Simms, 1994). Other contradictory evidence is provided by procteroicoids.

Stem and lumen lobes and angles of dicyclic crinoids are offset 36 degrees relative to radials or rays, but are aligned with the rays of monocyclic taxa, hence the differing terminology as infrabasals or basals for the cup-base circlet of these two patterns. This pattern should be the case if the crinoid cup developed from radials downward, but radials are added relatively late in crinoid ontogeny, after the cup-base circlet and stem below, and the orals above are fixed (Clark, 1915; Brower, 1974; Breimer, 1978; others). From the perspective of the cup-stem juncture, stem lobes and angles generally (exceptions discussed below) alternate

Traditional—Carpenter (1879), Bather (1892)

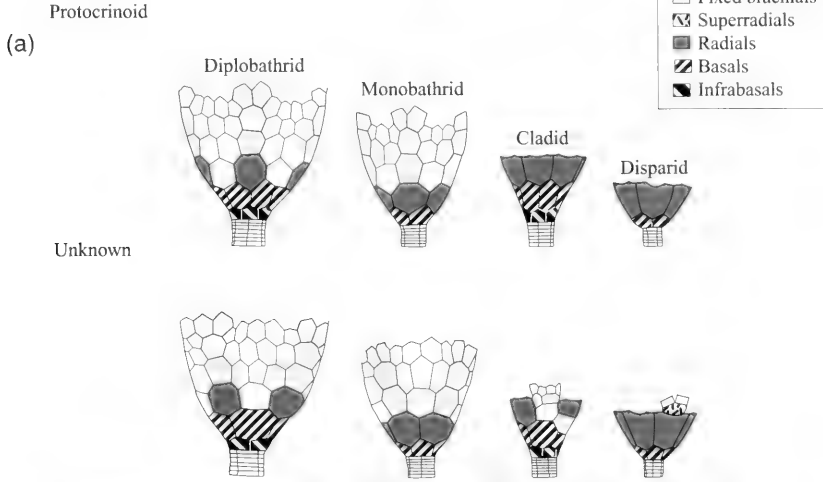

Simms (1994)

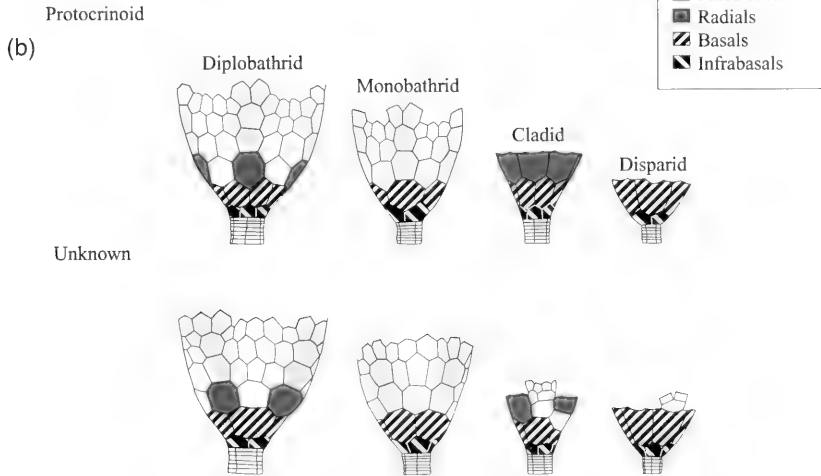

Text-figures 2A–D.—Schematic drawings of cup plating in Early Ordovician crinoid clades illustrating plate homologies. Competing systems are labeled, anterior views are presented above and posteriors below for each system. The cup-base circlet of protocrinoids is considered infrabasals because it alternates with stem meres and, in *Glenocrinus* n. gen. and sp., is aligned with radials above. Lowest or initial fixed ray plates constitute radials. Potential basals in the protocrinoid mid-cup are marked but other examples are possibilities as well. Drawings coded according to the system put forth by Simms (1994). We have labeled the cup-base circlet infrabasals based on evidence presented in the text.

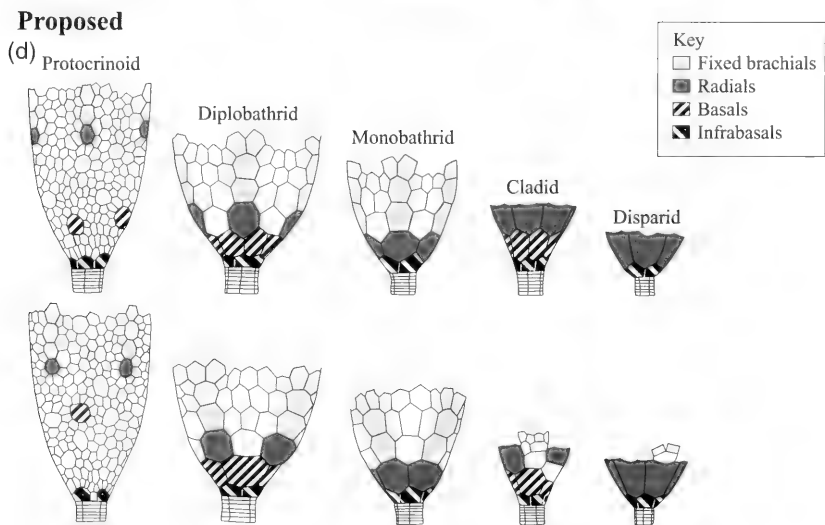
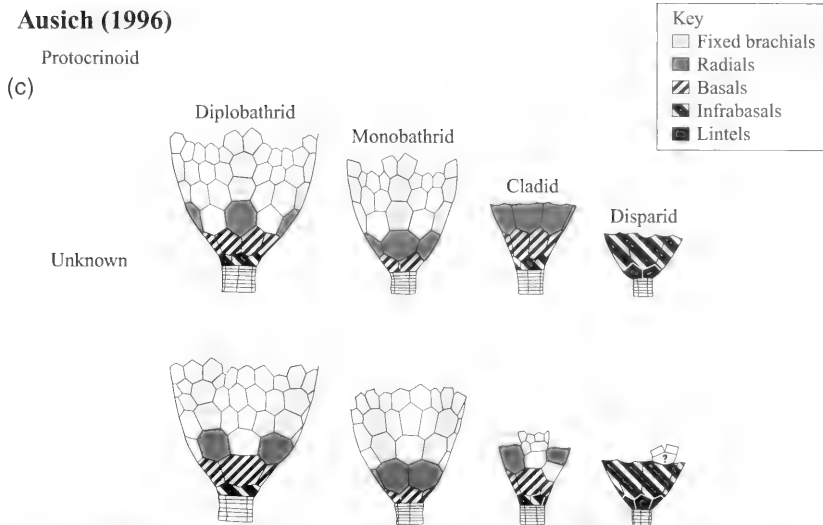

Text-figures 2A-D.—Continued.

with the cup-base plate cirlet regardless of whether the cup is monocyclic or dicyclic (Text-fig. 3). First reported by Wachsmuth and Springer (1897), this relationship was later referred to as the "Law of Wachsmuth and Springer" (herein after referred to as LWS) (Moore and Laudon, 1943; Ubahgs, 1978; Ausich,

1996). Consistent orientation of stem and cup-base cirlet and developmental evidence indicate that the cup-base cirlet is homologous (see discussion below).

Ausich (1996) questioned whether the stem angle or lobe to cup-base cirlet is sufficiently consistent to constitute a reliable criterion for establishing cup plate

Table 2.—Crinoid cup plate homologies.

Topology	Traditional*	Simms, 1994	Ausich, 1996	Proposed
primary cup-base plate circlet	basals, infrabasals	infrabasals	lintels, infrabasals, basals	infrabasals
circlet(s) between cup-base	basals	basals	basals	basals
circlet and radials (if present)				
initial ray plates	radials, inferradials	radials, basals	radials, infrabasals	radials
second fixed ray plates	fixed brachials	fixed brachials	fixed brachials, radials**	fixed brachials
posterior or CD interray	anals	anals	anals	anals**

* Primarily Carpenter, 1879; also Bather, 1892, for biradial, inferradial-superradial terminology.

** Disparids.

*** Partly or not homologous among crown groups.

homologies, citing several exceptions to the LWS. We find exceptions result from one of two circumstances, neither of which negate the importance of the cup base-stem relationships for establishing cup plate homologies.

Stem lobes or angles are actually indicators for a more fundamental relationship; alternation of stem pentameres with cup-base circlet plates. Pentamere-bearing crinoids include the vast majority of Early Ordovician taxa including proto-crinoids (see many examples documented here), but they are absent by the mid-Paleozoic. Many Late Ordovician crinoids have pentamere distal stems that transition upward into holomeric columnals in ontogenetic sequence (the disparids *Apodasmocrinus* and *Columbicrinus* and the cladid *Quinquecaudex* are examples [see Guensburg, 1984, pls. 7, 8]). Each lobe or angle of the distal stem is formed by a separate pentamere distally, but they fuse proximally into holomeric columnals. Exceptionally, however, lobes or angles are positioned along, rather than between, pentameres (see *Habrotracrinus* n. gen., and *Cnemecrinus* n. gen.). In these cases, pentamere positions are in accordance with the LWS, but the lobes or angles are not. We have not comprehensively surveyed cited exceptions to the LWS for evidence of mere orientation (Ausich, 1996), but in the genus *Retecrinus*, a weathered example has mere traces bisecting external lobes (see Guensburg, 1984, pl. 4, fig. 9).

Instances where the cup-base circlet plates of crinoids are aligned with stem pentameres comprise the second exceptional circumstance. Evidence from other parts of the cup, particularly the posterior plating, indicates this condition arises when the original cup-base circlet is either secondarily lost or a stem pentamere or tetramere circlet is added to the cup base. The former case results in a "pseudomonocyclic" cup (Warn, 1975). Hybocrinids and articulate crinoids have this arrangement. The early crinoids *Aethocrinus* and *Colpodecrinus* represent the alternative situation. *Aethocrinus* is tricyclic (three cup circlets below the radials) with distinctly cladid-type posterior morphology. *Colpodecrinus* has radials in contact all around and interbrachial fields similar to monobathrids, but with two sub-ray circlets in a "pseudocyclic" pattern (Sprinkle and Kolata, 1982). The origins of these cup plate patterns are puzzling (for instance, see alternative interpretations of *Aethocrinus* cup plate homologies [Ubahgs, 1969; Phillip and Strimple, 1971; Ausich, 1996]), but shifting of the generative zone at the cup-stem boundary downward seems a possibility.

Lintel terminology (Ausich, 1996) is based on the assumption that a tricyclic cup is the ancestral pattern among crinoids, typified by the Early Ordovician *Aethocrinus*. This conclusion is not supported by proto-crinoid morphology. Proto-crinoids have largely nonstandardized cup plating with only one circlet at the cup base. The proto-crinoid cup-base circlet alternates with stem meres below and in the case of *Glenocrinus*, is radially oriented, in contrast with that of *Aethocrinus*. Extension by Ausich (1996, 1998a) of lintel terminology to taxa other than *Aethocrinus* is questionable. For instance, Ausich (1998a) considered the cup of peritocrinoids to be tricyclic, like *Aethocrinus*. Small plates intercalated between major cup plates were considered diminutive basals and infrabasals, together with radials comprising three cup circlets above "lintels" at the cup base (see Ausich, 1998a). Other authors have considered these plates to be secondary intercalates (see Ubahgs, 1978). Positional evidence consistent with proto-crinoid secondaries and intercalates

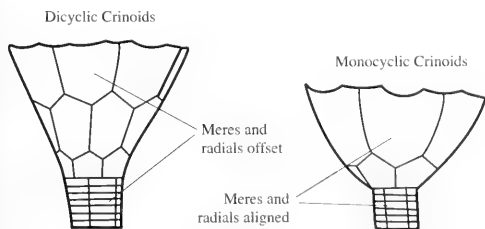

Text-figure 3.—Schematic diagram illustrating the "Law of Wachsmuth and Springer" with the cup in lateral view.

of *Habrotercrinus* n. gen. favor this latter interpretation (compare Text-fig. 13 with Ausich, 1998a, fig. 8).

Ausich (1996) extended use of lintels to disparids, claiming "biradials" are evidence of secondary loss of an intervening interradial circlet, the basals, but no supporting examples of disparids with intermediate reduced "basals" are known. Eckert and Brett (2001) questioned use of biradial terminology (Bather, 1892; Moore, 1962) among myelodactylid disparids, noting that minor differences in the relative heights of plates in different rays lead to differing interpretations of terminology. This is typical of crinoids such as these lacking a sharp boundary between the cup and free arms. We share this view and question the use of "biradial" terminology at all. Biradial terminology (inferradials, superradials) was proposed (Bather, 1892) for certain disparids where there are distinct differences in differential depth of insertion of ray plating in the cup and polygonal shapes other than the typical rectangular shape of brachials (cincinnaticrinids and homocrinids, for example). There is no evidence that this morphology evolved by the splitting of a normal radial or fusion of "biradials" to form single larger radials (Wilson, 1916; Ubaghs, 1978). Instead, simpler myelodactylid and eustenocrinid cup morphology is evidence that progressively greater differences in ray plate depths produced these cup plate patterns. Cup plates subsequent to radials, by serial homology, are fixed brachials, just as they occur in protocrinoids. Jim Brower (personal communication, 2001) has expressed a similar opinion.

The proposed system of Simms (1994) resolves the inconsistency of Carpenter's terminology at the cup-stem juncture but creates another at the radial reference point. Initial ray or arms plates are not homologous plates by Simms' interpretation, yet consistent insertion at corners of orals and the subjacent cup plates during crinoid ontogeny is evidence to the contrary.

Cup plate homology systems founded on a single reference point are inherently flawed by inconsistencies in plate orientations at the cup-stem juncture or at the radials. In practical terms referring to the cup-base circlet as "basals" and "infrabasals" by the traditional radial landmark system is inconsistent, as is reference to the lowest ray plates as radials and basals by Simms' cup-stem landmark system.

DUAL REFERENCE SYSTEM

We propose a dual reference homology system (DRHS) (Table 2; Text-fig. 2) that incorporates both Carpenter's radial and Simms' cup-base circlet-stem reference points while eliminating the inconsistencies of each. Existing cup plate terminology is conserved as much as possible, although a concern is voiced be-

low in doing so. The use of lintels could be justified for rare cases where an apparent stem mere circlet is incorporated to the cup base. *Aethocrinus* and *Colpodicrinus* are the only taxa we can identify where this is apparently the case. Infrabasals, by the DRHS, form the cup base in all but a few Paleozoic crinoids (see Single Reference System Failings above). This usage includes plate circlets that have traditionally been designated as "basals" of monocyclic crinoids. Basal terminology, as introduced here, applies only to dicyclic (and tricyclic) crinoids and presents no change in usage for those groups. Initial ray plates remain radials in the DRHS but subsequent plates are termed fixed brachials regardless of relative heights or more cup-like plate shapes: "biradial" terminology does not apply to the fossils described here and should be eliminated (see Single Reference System Failings above).

We cite early crinoid morphology and transitional morphologic series as evidence for the DRHS. Organized plating in the cup of the protocrinoid *Titanocrinus* n. gen. occurs at the cup base and at fixed ray plates by the proposed homologies here. This morphology is retained in crown group taxa while other nonstandardized cup plating of the mid-cup is nearly always absent. Mid-cup plating is reduced to a single circlet in dicyclic taxa. *Glenocrinus* n. gen. is a morphologic intermediate (see Text-fig. 8) and the Devonian *Belanskicrinus* (Moore and Strimple, 1978, p. T623) is a reversal. The mid-cup is entirely eliminated in monocyclic crinoids, but here again, acrocrinids (Ubaghs, 1978, p. T479) represent a reversal.

Carpenter (1879) criticized nineteenth century authors' use of a dual reference system because, he argued, a homologous plate circlet could not be in a radial position in dicyclic crinoids and interradial in monocyclic crinoids. However, the LWS is evidence to the contrary (see Single Reference System Failings above). Additionally, small posterior gap plates marking the primary cup-base circlet of protocrinoids and early monocyclic crinoids such as *Eknomocrinus* n. gen., sometimes *Anomalocrinus*, and *?Fresnedacrinus* (Ausich *et al.*, 2002) provide further evidence of homology. The cup-base circlet of the protocrinoid *Glenocrinus* is radially oriented (see Text-fig. 8), but those of the monocyclic taxa are interradial (see Text-fig. 10). Twisting of the mid-cup region accommodated offset plating of adjacent radials and infrabasals of monocyclic crinoids.

Generally, the number of sub-ray cup plate circlets remains a distinguishing trait of crinoid crown groups, but there are exceptions, particularly early, during the Ordovician (see Text-fig. 5). Perittocrinids and an undescribed Early Ordovician taxon from the El Paso Group, Texas, are normal monocyclic crinoids, but

posterior plates originating beneath the C-ray and a diminutive C-ray radial support inclusion in the characteristically dicyclic cladids. *Aethocrinus*, previously discussed, is by key posterior morphology a cladid but with a tricyclic cup. The Late Ordovician *Merocrinus* is dicyclic, but an anal tube supported by the C-ray indicates inclusion in the disparids. Wachsmuth and Springer (1897) commented on the overall similarity in construction of monocyclic *Glyptocrinus* and dicyclic archaeocrinoids.

Infrabasals, by our usage, are positionally equivalent to basals of blastozoan echinoderms. At the same time, we recognize that there is a question of whether these plates are homologous. We previously proposed (Guensburg and Sprinkle, 2001a) use of basals to define the primary cup-base circlelet of crinoids (and epibasals for basals of dicyclic crinoids) to infer this possibility, but to do so would necessitate significant disruption of long-used terms. We agree with Tom Baumiller (reviewer) who suggested conserving but redefining existing terminology.

ANAL PLATE HOMOLOGIES

A wide, symmetrical, CD or posterior interray characterizes protocrinoids and early camerates, reflecting the 2-1-2 ambulacral symmetry of stem-group echinoderms (Sprinkle, 1973) and the fundamental bilateral symmetry of echinoderms defined as the crinoidal plane. Three patterns of upward shifting, reduction, and even elimination of CD interray plating occur among crinoid crown groups (Ubahgs, 1978). Camerates retain the basic pattern, with posterior plating confined to the CD interray, but gap plates are eliminated and sub-ray circlelets are uninterrupted. Posterior plating of cladids includes both CD interray and sub-C-ray plating reduced to relatively few plates and confined by well-organized circlelets. These "anals" are therefore only partly homologous to those of camerates. The "radial," sometimes "anal X," and other deeply inserted plates are in the sub-ray position, consistent with mid-cup plating of protocrinoids, whereas higher plates exiting through the interray region are of CD interray origin. Patterns of changes in these remaining few plates are used to construct higher cladid phylogeny (Moore and Laudon, 1943; Brower, 1995, for instance). The majority of disparids (homocrinids, calceocrinids, heterocrinids, myelodactylocrinids) have lost the CD interray plating entirely; instead an arm-like brachial off the proximal C-ray (anibrachial of Ubahgs, 1978) supports an anal tube. *Fresnedacrinus* from the Middle Ordovician has a disparid-like C-ray anal tube and a few plesiomorphic CD interray plates (Ausich et al., 2002). Specific anal plating homologies within but not among crown groups are well supported

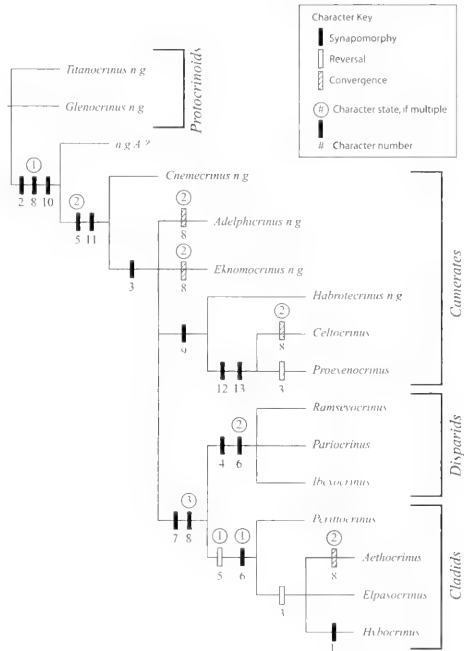

Text-figure 4.—Early crinoid phylogeny developed from Table 5 data matrix. Crinoid labeled n. g. A is not assigned to either stem or crown group.

(see Ubahgs, 1978 for a similar conclusion) but no specific posterior plate homologies link crinoid crown groups. The term "anal X" is used for cladid and disparid crinoids, but we apply it only to cladids and related hybocrinids and perritocrinids.

EARLY CRINOID PHYLOGENY

METHODS

Sixteen taxa constituting most Early Ordovician crinoid diversity were incorporated into the present analysis (Tables 3, 5; Text-fig. 4). *Titanocrinus n. gen.* was chosen as the outgroup because it is essentially complete (except for the distal stem and holdfast), among the earliest of crinoids and, most importantly, has a combination of echinoderm stem-group plesiomorphies and emergent crinoid synapomorphies (see Protocrinoids, Cup Plate Homologies above). The protocrinoid *Glenocrinus n. gen.* is morphologically close to *Titanocrinus n. gen.*, but we consider this taxon to represent a transitional stage to dicyclic or diplobathrid camerate crinoids (see Present Interpretation below). We chose to omit *Echmatocrinus*, a possible Cambrian

crinozoan (Sprinkle and Collins, 1998), because pyritized preservation is difficult to interpret and plesiomorphic construction (other than uniserial arms) provides few characters for analysis. Many characters of earlier analyses (Donovan, 1988; Ausich, 1996, 1998a) were not applicable given our choice of outgroup and the changes in terminology adopted here or for other reasons provided in Table 4. Admittedly, this approach does not constitute a rigorous parsimony analysis. The phylogeny presented here includes 13 characters that we interpret to be relevant at this level of the crinoid evolutionary tree (Table 3). These were assembled into a cladogram (Text-fig. 4). Characters were unweighted and unordered.

OTHER EARLY CRINOID PHYLOGENIES

Previous early crinoid phylogenies are few and, from the perspective of the new information afforded to us by protocrinoids, lacking in evidence for character selection and polarities. Early workers' views on the origin and early evolution of crinoids are summarized by Ubahgs (1978). Historically, the fossil record has presented a significant problem. The earliest representatives of the various crown groups available to early researchers were well differentiated and morphologically distinct. This omission has persisted to the present study, although a few early taxa such as *Aethocrinus* provide a modest amount of morphologic data that hint at early crinoid evolutionary history (Ubahgs, 1969). Some early workers (Wachsmuth and Springer, 1885; Bather, 1900) cited modern crinoid ontogeny to infer that crinoids originated from small ancestors with simple cup plating. Groups with more complex plating, such as camerates, were taken to be more derived. Others disagreed (Jaekel, 1918), stating that crinoids originated from a more general ancestor with irregular plating. These divergent views are similar to our present differences with those of Ausich (1996, 1998a) regarding crinoid ancestry and early history.

Kelly (1986) provided crinoid phylogenies based on *Echmatocrinus* as outgroup and traditional subclass-level taxa as crownward taxa, and Donovan (1988) presented a cladogram incorporating all Early Ordovician taxa known at that time, again with *Echmatocrinus* as outgroup. These studies were based on re-examination of previous material and results did not differ significantly from early crinoid phylogeny provided in the Treatise on Invertebrate Paleontology classification (Ubahgs, 1978) except that the Subclass Inadunata was concluded to be polyphyletic.

Ausich (1998a, b) provides the most comprehensive treatment of early crinoid phylogeny, and in a significant departure from the previously mentioned studies,

Table 3.—Early crinoid phylogeny characters. The outgroup, *Titanocrinus* n. gen. on left is scored as 0. (H = homoplastic, but asynchronous acquisition of derived state provides signal at the base of the crinoid tree.)

PRIMITIVE	DERIVED
CUP	
1. Infrabasal cirlet present	Infrabasal cirlet lacking
2. Infrabasal cirlet interrupted by small CD interray gap plates	Gap plates lacking—H
3. Basals present	Basals lacking
4. Posterior (CD) interray plating present	Posterior interray plating absent
5. Irregular plating beneath C-ray	1) few more or less standardized plates beneath C-ray above cirlets or 2) no plating beneath C-ray above cirlets
6. All radials of similar size, shape, and position	1) C-ray radial smaller, offset upward in cup 2) C-ray radial smaller, top offset downward in cup
7. Three or more fixed plates per ray (includes radial)	Two or one fixed plate(s) per ray—H
8. Anterior interray plates unorganized, separating rays, and confluent with unorganized plating below	Anterior interray plates organized in separated fields, bordered below by 1) sub-ray cirlet, 2) radials, or 3) lacking—H
ARMS	
9. Branching outside the cup exclusively	Lower branching within the cup
10. Arm branch web plates	Web plates lacking
11. Biserial imperforate floor plates	Floor plates reduced or absent—H
12. Brachials quadrangular	Brachials cuneate—H
COLUMN	
13. Stem polymeric at cup juncture	Stem holomeric—H

adopted a rhombiferan blastozoan outgroup. Derivation of crinoids from some blastozoan echinoderm, such as eocrinoids or their descendants such as glyptocystitid or caryocystitid rhombiferans has long been advocated (Bather, 1900; Jaekel, 1918; Yakovlev, 1918; Moore, 1954; Smith, 1990; Ausich, 1998a). Blastozoans preceded crinoids in the record, appearing in the Early Cambrian; both were stemmed echinoderms with feeding appendages extending from the theca.

Ausich (1998a) interpreted *Aethocrinus* as the nearest crinoid ancestor to rhombiferans. The four-cirlet cup of *Aethocrinus* was considered homologous to four-cirlet theca plating of rhombiferans. Character selection differs significantly from that used by Kelly (1986), Donovan (1988), and here (see Ausich, 1998a, appendix B). Results, though, were similar to those of

Table 4.—Characters not included in early crinoid phylogenetic tree.

Character	Rationale for deletion
1. Cup shape	Homoplastic, nonspecific
2. Cup plate circlet number	Homoplastic, nonspecific, same as characters 1, 3, above
3. Pinnulation	Homoplastic, same as character 12 above
4. Arm branching style	Uninformative, single taxa derived states
5. Tegmen morphology	Insufficient data
6. Cup plate ornament	Homoplastic, outgroup primitive and derived
7. Radial facet shape	Homoplastic
8. C-radial size	Nonspecific, same as characters 4–6 above
9. Lumen diameter	Homoplastic, nonspecific
10. Symplectial articular facets	Homoplastic
11. Stem shape	Homoplastic
12. Holdfast morphology	Insufficient data

Kelly (1986) and Donovan (1988), except that *Aethocrinus* and perittocrinids clustered separately near the base of the tree and, accordingly, a new subclass, the Aethocrinina, was proposed. We object to the use of a rhombiferan outgroup and the Aethocrinina (see below).

PRESENT INTERPRETATION

Few characters resolve each node in this analysis, and, while we consider evidence for maintaining camerate, cladid, and disparid crown groups compelling, we do not advocate evolution of crinoid crown groups in the stepwise pattern implied in the tree (Text-fig. 4).

Glenocrinus n. gen. and *Titanocrinus* n. gen. scored equally at the base of the tree, although the shorter globular cup and relatively large basals of the former taxon suggest a more derived position closer to diplobathrids. Camerate taxa branched low on the tree, above protocrinoids, followed by disparids and cladids. Camerates generally resemble protocrinoids but they differ from cladids and disparids by their extensive interbrachial plating and anal plating confined to the CD interray (see characters 6, 8). But unlike protocrinoids, much camerate cup plating often occurs at or above fixed ray branches while the mid-cup is substantially reduced similar to cladids and disparids. Camerates are a well-defined crown-group clade whose autapomorphies beyond this analysis include: thin holomeric columnals with smooth internodals and nodals bearing flange-like epifacets, coiled distal stem lacking a holdfast (with exceptions), tessellate plated domal tegmen, fixed secundibrachs and intersecundibrachs, cup-ray branching from primibrach two, and cuneate or biserial pinnulate arms. Monobathrid and diplobathrid camerate clades are unresolved here (Text-fig. 4) (see also Wachsmuth and Springer, 1897). Both disparids and cladids have greatly reduced cup plating (see characters 7, 8), linking them higher in the tree. But we consider their very different posterior morphology (see characters 4–6, Table 2) to be phylogenetically more significant and their sister-group relationship implied in the tree the product of convergence. Disparid and camerate crinoids appear stratigraphically early, by the lower Ibexian, in association with protocrinoids (our collections). Cladids appear only slightly later in the early Arenig (Ubahghs, 1969).

Table 5.—Character matrix for early crinoid phylogeny. States: 0 = primitive, 1, 2, 3 = derived. * Undescribed new genus, early Ibexian (early Tremadoc), Idaho.

Taxon	Characters												
	1	2	3	4	5	6	7	8	9	10	11	12	13
<i>Titanocrinus</i> n. g.	0	0	0	0	0	0	0	0	0	0	0	0	0
<i>Adelphocrinus</i> n. g.	0	1	1	0	2	0	0	2	0	1	1	0	0
<i>Aethocrinus</i>	0	1	0	0	1	1	1	2	0	1	1	0	0
<i>Celtocrinus</i>	0	1	1	0	2	0	0	2	1	1	1	1	1
<i>Cnemecrinus</i> n. g.	0	1	0	0	2	0	0	1	0	1	1	0	0
<i>Eknomocrinus</i> n. g.	0	0	1	0	2	0	0	2	0	1	1	0	0
<i>Elpasocrinus</i>	0	1	0	0	1	1	1	3	0	1	1	0	0
<i>Glenocrinus</i> n. g.	0	0	0	0	0	0	0	0	0	0	0	0	0
<i>Hybocrinus</i>	1	1	0	0	1	1	1	3	0	1	1	0	0
<i>Ibexocrinus</i>	0	1	1	1	2	2	1	3	0	1	1	0	0
n.g. A*	0	1	0	0	?	0	0	1	0	1	0	0	0
<i>Pariocrinus</i>	0	1	1	1	2	2	1	3	0	1	1	0	0
<i>Perittocrinus</i>	0	1	1	0	1	1	1	3	0	1	1	0	0
<i>Proexocrinus</i>	0	1	0	0	2	0	0	1	1	1	1	1	1
<i>Habrotecrinus</i> n. g.	0	1	1	0	2	0	0	1	1	1	1	0	0
<i>Ramseyocrinus</i>	0	1	1	1	2	2	1	3	0	1	1	0	0

We find no well-supported synapomorphies linking camerates, disparids, and cladids (Text-fig. 4) and their posterior morphologies are distinctive in the earliest occurrences. This evidence suggests separate origins for each of these crown groups from protocrinoid ancestors.

This analysis does not support a rhombiferan (or other blastozoan) sister-group to crinoids. Most characters of Ausich (1998a), for instance, plot as derived when applied to protocrinoids, the opposite of what might be expected assuming a close phylogenetic connection. Protocrinoids lack a periproct, pore rhombs, xenomorphic column, holomeric columnals, and "globe-shaped" theca, but do have standard crinoid characters such as a wide CD interray, fixed ray plates including brachials and radials, branched uniserial arms, and pentameric stem. No synapomorphies linking protocrinoids and blastozoans can be identified where such links should be expected. A four-circling cup is a general feature, not supported by many other traits (Ausich, 1998a; Guensburg and Sprinkle, 1997; Sumrall, 1998; Guensburg and Sprinkle, 2001b) and the present analysis did not resolve the "Aethocrinina," although both *Aethocrinus* and perittocrinids group within the cladids (Text-fig. 4).

Our interpretation of what taxa group together within cladids and disparids differs significantly from that of the Treatise on Invertebrate Paleontology presentation (Ubahgs, 1978) and more recent studies of Kelly (1986), Donovan (1988), and Ausich (1998b). Hybocrinids and perittocrinids are grouped with cladids, because of similarities in posterior morphology to cladids. Previous workers have suggested such a relationship (Broadhead, 1988; Sevastopulo and Lane, 1988).

PRINCIPAL FINDINGS

1. Among the earliest crinoids are two new taxa characterized by free arms bearing ambulacral floor plates, and a largely unorganized cup (theca). A combination of these plesiomorphic echinoderm and long-recognized crinoid characteristics justifies their interpretation as protocrinoids. In addition, a set of emergent crinoid characters is identified by their distribution among protocrinoids and stem crown-group taxa.

2. Evidence from: 1) consistent stem mere-basal offset, the LWS, 2) ontogeny, 3) distribution of gap plates in the primary cup-base circling of protocrinoids and early crown-group crinoids, and 4) the progressive top-down, bottom-up pattern of cup-plate standardization among stem-group crinoids all support a dual reference homology DRHS system incorporating both cup-stem and radial positions.

3. Changes in cup plate terminology usage are needed to accommodate the new evidence. The term

infrabasal is redefined to denote the primary cup-base circling. Rarely, early crinoids apparently add a circling from stem meres below (*Aethocrinus*, *Colpodecrinus*), or secondarily lose the primary cup-base circling (hybocrinids, articulates). Basals refer to the circling between radials and infrabasals, if present. Three standardized posterior patterns characterized early crown-group crinoids: plating confined to the CD interray (protocrinoids and camerates), reduced plating arising from beneath the C-ray (cladids, perittocrinids, hybocrinids), and posterior plating replaced by an arm-like branch of the C-ray (disparids).

4. Adjustment at the mid-cup resulted in the 36 degree offset between radials and infrabasals of monocyclic versus dicyclic crinoids, except those, such as articulates, that are "pseudomonocyclic" where infrabasals are secondarily lost. Other exceptions are rare.

5. Within traditional high-rank taxa, cup circling number (monocyclic, dicyclic, tricyclic patterns) continues to be a reliable phylogenetic character except early in crinoid history when significant variation occurred.

6. Cladids, disparids, and camerates are deeply rooted in crinoid phylogeny and apparently evolved rapidly and independently from protocrinoid ancestry. *Aethocrinus* and *Eknomocrinus* n. gen. share ephemeral emergent crinoid traits with protocrinoids, justifying their stem-group placement (*Aethocrinus*-cladid, *Eknomocrinus* n. gen.-camerate). Evidence for monobathrids and disparids having evolved through diplobathrid or cladid ancestors, respectively, is lacking.

SYSTEMATIC PALEONTOLOGY

INTRODUCTION

All specimens described here have been deposited in the type invertebrate fossil collection at the Field Museum of Natural History, Chicago (PE---). Terminology and abbreviations follow that of the Treatise on Invertebrate Paleontology (Ubahgs, 1978) but usages conform to the dual reference homology system introduced above (see Cup Plate Homologies above). Briefly, infrabasals are redefined as the cup-base circling plates for all Paleozoic crinoids, monocyclic or dicyclic, except in rare cases not applicable here. Basals are retained for plates between infrabasals and radials of dicyclic crinoids. Radials are the first ray plates, and all subsequent ray plates are fixed brachials.

Subphylum **CRINOZOA** Matsumoto, 1929

Class **CRINOIDEA** Miller, 1821

Order (Plesion) **PROTOCRINOIDA**, new order

Diagnosis.—Crinoids with infrabasals and fixed rays separated by nonstandardized cup plates; infra-

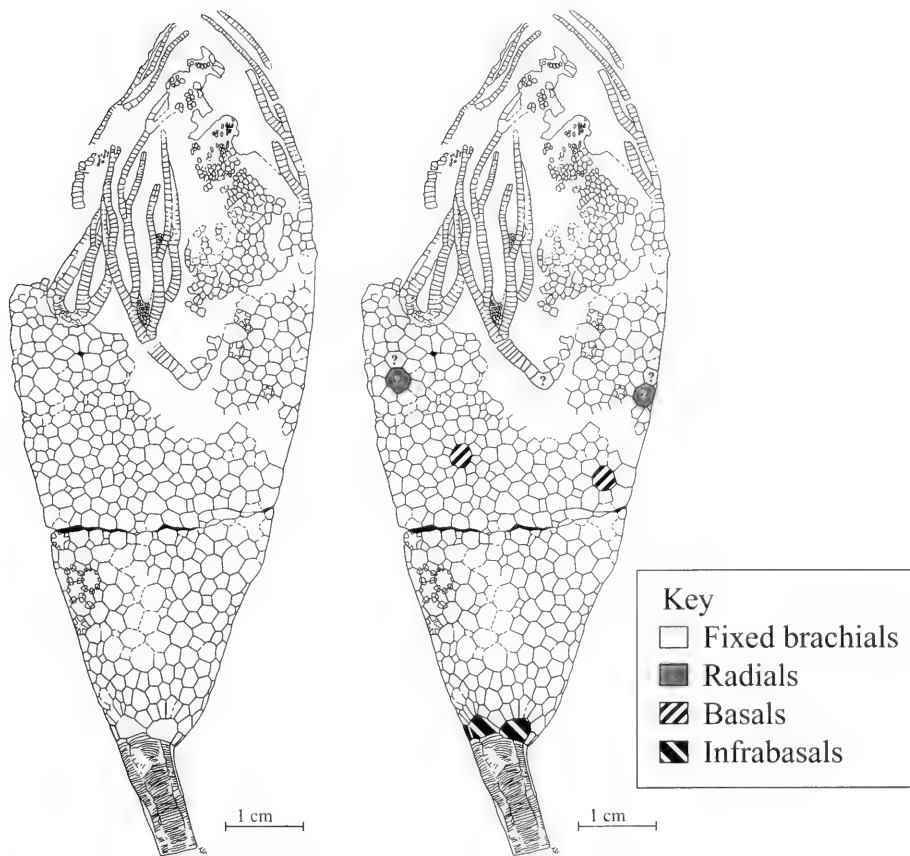

Text-figure 5.—*Titanocrinus sunralli*, n. gen. and sp., holotype PE 52720, plate tracing, D-ray orientation, interpreted (*right*) and uninterpreted (*left*) versions, distal crown flattened; pentameric stem, gap plate partly shown at right, some arms detached from the cup, diminutive web plates preserved between D-ray arm branchings. Infrabasals, tentative fixed brachials, radials, and plausible basals are located on interpreted version; other mid-cup primaries could be interpreted to be basals. Fixed ray plate arrangement is better preserved in paratype PE 52721.

basal circlelet interrupted by small posterior gap plates, rays extending down into mid-cup region, numerous irregularly arranged primary, secondary, and tertiary mid-cup and interray plates, anal plating confined to wider posterior interray; arms uniserial, nonpinnulate, branchings isotomous above cup, biseries of imperforate floor plates lining relatively large deep food grooves, laterally appressed brachials above axillaries, accessory web plating above branchings; conical anal cone atop domal tegmen, no exposed ambulacral cover plates; stem pentameres extending to cup.

Occurrence.—Lower Ordovician, lower Ibexian (lower Tremadocian), western Utah.

Discussion.—Protocrinoids are accommodated within the diagnosis for the Class Crinoidea provided by Ubachs (1978, p. T405), but lack autapomorphies of crown group subclasses. We do not assign protocrinoids to subclass at this time. *Titanocrinus* n. gen. and *Glenocrinus* n. gen. are currently the taxa placed in the protocrinoids. *Titanocrinus* n. gen. is considered the more plesiomorphic because it lacks differentiated basals. An undescribed third taxon, n. gen. A (included

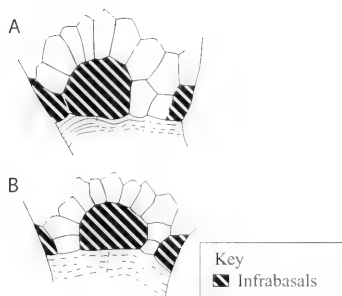

Text-figure 6.—*Titanocrinus sumralli*, n. gen. and sp., lower posterior cup tracings, with infrabasals and gap plates, stem columnals approximated: A) holotype PE 52720, B) paratype PE 52721, much enlarged.

in the phylogeny, Table 5), has similar plesiomorphic arm and stem construction, but appears to have a more organized cup.

Family TITANOCRINIDAE, new family

Diagnosis.—As for the order.

Occurrence.—Lower Ordovician, western Utah, U. S. A.

Genus TITANOCRINUS, new genus

Type species.—*Titanocrinus sumralli* Guensburg and Sprinkle, new species.

Diagnosis.—Protoocrinoida with a large conical cup, cup predominantly composed of unorganized plating; approximately 5–6 fixed brachials per ray, arms inclined outward from cup at cup juncture, plate webs at arm branches, arms branching isotomously at least four times, high conical tegmen extending above quartibrachs, large round stem with thin pentameres.

Occurrence.—Lower Ordovician, western Utah, U. S. A.

Etymology.—Latinized form of the Greek *Titan*, mythologic primordial giants, reflecting both the large relative size, early occurrence, and ancestral position of the fossils.

Discussion.—*Titanocrinus* is large, with a known crown length of over 11 cm. The distal stem and holdfast of *Titanocrinus* are not known but complete individuals were more than 30 cm long. Only *Glenocrinus* n. gen. has similar morphology to *Titanocrinus* n. gen., but this taxon has a smaller globular cup, differentiated basals, fewer irregular plates in the mid-cup, and a proportionately narrower pentalobate stem.

TITANOCRINUS SUMRALLI, new species

Text-figures 5–7; Plates 1–3

Diagnosis.—As for the genus.

Description.—Crown elongate, holotype 109 mm

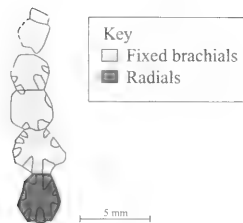

Text-figure 7.—*Titanocrinus sumralli*, n. gen. and sp., paratype 52721, C-ray fixed ray plating; compare to right side of Plate 3, figure 3 for photograph of same, much enlarged.

tall; cup 67–70 mm tall, 8.5 mm wide at base, 44 mm wide at flattened top, paratypes slightly to considerably smaller; cup steeply conical, sides diverging at approximately 55–70 degrees in flattened specimens, exposed surface of holotype cup having approximately 500 plates; attenuated distinct stellate plate ornament with small oval depressions in lower cup, ridges becoming thinner and more prominent, extending across sutures to plate centers higher up, depressed areas thinly plated; infrabasals (IBB) five, interrupted by smaller pentagonal to rectangular gap plate(s) beneath the C- to D-ray; IBB orientation uncertain, perhaps radial, IBB wider than tall but varying considerably in size (Table 6), approximately pentagonal but with slightly convex lower surfaces and scalloped convex upper surfaces articulating with 6–7 small diverging plates above, holotype with two adjacent gap plates in the CD interray, paratype PE 52721 with gap plate on either side of D-ray IB; irregularly plated mid-cup region having scattered larger thicker primaries (see interior view, Pl. 1, fig. 4) surrounded by several (8–13 in examples) smaller secondaries, basals (BB) undifferentiated from other mid-cup primaries, secondaries triangular to pentagonal with acute ridges; interbrachial (iBr) areas continuing up from mid-cup, irregular hexagonal plates, cup plates forming large, slightly convex iBr areas, and merging into edge of tegmen approximately at level of first arm bifurcation; ray ridges inclined, upward protruding, extending variable distance into cup, 2 cm in paratype PE 52721, averaging 6–7 plates including 3–4 cup-like fixed brachials (Brr) and 2–3 arm-like; ray ridges prominent at arm juncture; radials (RR) undifferentiated from fixed Brr;

Table 6.—*Titanocrinus sumralli* n. gen. and sp. basals height/width.

Specimen	A-ray	B-ray	C-ray	D-ray	E-ray
PE 52720	—	—	—	4.0/4.8	3.5/5.0
PE 52721	—/3.6	3.6/4.0	3.0/4.0	3.7/4.7	3.0/3.6

posterior interray approximately twice width of other interrays, plating irregular, like other interrays in holotype but apparently larger plating centered between fixed ray plates of paratype PE 52721; tegmen raised, conical, with numerous, small, plates, anal cone at summit.

Arm length approximately $\frac{1}{2}$ cup height, 40.5 mm in holotype; arms thin, nonpinnulate, branching isomomously at least four times, primaxillary (IAX) at second or third free Br, located just above cup-free arm juncture, first 2–5 secundibrachials (IIBrr) laterally articulating above axillaries (Axx), ?4–8 IIBrr; tegmen extensions to mid-region of IIBrr; 10–12 tertibrachials (IIBrr); 12–17 quartibrachials (IVBrr); and several quintibrachials (VBrr), arm tips unknown; webs of tiny plates in notches above arm branchings, lower Brr with large deep food groove; two floor plates per brachial, small biserial cover plates.

Stem round, wide, holotype 8.0 mm diameter at cup, tapering to 5.0 mm diameter 40 mm below; paratype PE 52721 stem 7.6 mm wide at cup, decreasing to 3.8 mm diameter 187 mm below crown; cryptopentamerism in unweathered specimens, cup-stem axes forming an obtuse angle in holotype; mere boundaries aligned with cup IBB, center of the lower IB surface and two adjacent meres below form triple juncture; pentameres curved, slanted slightly relative to (not perpendicular to) stem axis, irregular pattern of alternating nodals, internodals, or nodal and two to three internodals, low relief epifacets, some pentameres near crown wedge shaped, pinching out laterally before reaching opposite side of mere column; articular facets smooth, perhaps cryptosymplectical outer cortex; lumen large and round proximally, much smaller and pentagonal distally.

Occurrence.—Time slice 1b (see Text-fig. 1), trilobite zone E, lower Fillmore Formation, lower Ibexian (lower Tremadoc), Lower Ordovician (see Appendix).

Type material.—Holotype PE 52720, paratypes PE 52721 and 52724.

Etymology.—In recognition of Colin D. Sumrall, who found the two paratypes.

TITANOCRINUS species

Plate 4; Plate 9, figure 4

Discussion.—Six specimens are tentatively assigned to *Titanocrinus* n. gen. but not the type species (see Appendix 1 for comments regarding preservation and stratigraphic position), being too incomplete, poorly preserved, or distinct from *T. sumralli* n. gen. and sp.

PE 52722 differs from other *Titanocrinus* specimens in having dual rather than single ray ridges. PE 52723 has coarse cup-plate ornament, thick arms, and no visible arm branch web plating, all contrasting with *T. sumralli* specimens. There are at least four fixed brachials in one preserved cup ray, two or three free primibrachs, eight or nine secundibrachs, 11–13 tertibrachs, 10–14 quartibrachs, and several quintibrachs. The distal tip of the anal cone is exposed above the arm tips. Small lenticular intercalate brachials are located medially between typical brachials. There is a single perforation in the cup plates near the preserved ray. PE 52525 is very small and interpreted as a juvenile. There are small circular pores at plate corners. There are three or four fixed ray plates in one instance. PE 52726 preserves a lower cup with the infrabasal circlet and smaller unorganized plates above. The left side basal is 3.0 mm high and 3.3 mm wide; the middle basal is 2.8 mm high and 3.0 mm wide. The crushed stem is 7 mm in diameter at the cup boundary. There appears originally to have been an irregular lobate tetrameric or pentameric stem; lobes and basals are aligned. Exposed lateral mere boundaries on right side are discontinuous, in part aligned with lobe boundaries. Meres are slanted slightly relative to stem axis. There is an irregular pattern of nodals with one to three internodals. Epifacets are lacking and articular facets are flat to cryptosymplectical. PE 52727 has initial arm branching apparently at cup-arm juncture. Large deep food grooves are lined with biseries of laterally exposed floor plates, averaging 2.5 floor plates per brachial, and there is one set of domed triangular cover plates above each floor plate. Circular pores occur at tegmen plate junctures.

Material.—PE 52722, 52723, 52725–52727, and 52731.

Occurrence.—All specimens are from time slice 1b, trilobite zone E, lower Fillmore Formation, lower Ibexian (lower Tremadocian), Lower Ordovician (see Appendix 1).

Material.—PE 52722, 52723, 52725–52727, and 52731.

Occurrence.—All specimens are from time slice 1b, trilobite zone E, lower Fillmore Formation, lower Ibexian (lower Tremadocian), Lower Ordovician (see Appendix 1).

Genus GLENOCRINUS, new genus

Type species.—*Glenocrinus globularis* Guensburg and Sprinkle, new species.

Diagnosis.—Protocrinoida with a wide globular calyx, single small gap plate in CD interray, basals differentiated by their larger size, but surrounded by non-standardized mid-cup plates, mid-cup approximately half of cup height, two or three fixed Brr; arms arising vertically from cup, branching above cup on IBrr 3–5, small plate webs above branchings; stem narrow, pentalobate, rapidly tapering just below cup, then nearly constant width.

Occurrence.—Lower Ordovician, western Utah, U. S. A.

Discussion.—See *Titanocrinus* Discussion and Early Crinoid Phylogeny above. The pentameric stem, mostly nonstandardized mid-cup, presence of a gap plate, lack of fixed axillaries, ray branching above the

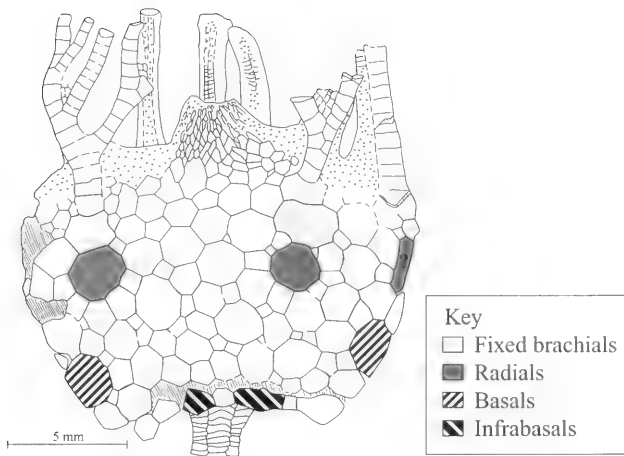

Text-figure 8.—*Glenocrinus globularis*, n. gen. and sp., holotype PE 52733, plate tracing, CD orientation, specimen flattened; small gap plate, large thick basals, central anal cone atop tegmen, plate webs at two lower arm branches.

cup, and nonpinnulate arms are all plesiomorphies unlike crown-group camerates. The distribution of lower cup plates, together with shape of the calyx, is reminiscent of rhodocrinitids such as *Diabolocrinus*.

Etymology.—*Glenos*, from Greek, meaning wonder, something to stare at, in reference to this aesthetically pleasing fossil.

GLENOCRINUS GLOBULARIS, new species

Text-figure 8; Plate 5

Diagnosis.—As for the genus.

Description.—Calyx globular; cup wide bowl shaped, slightly wider than tall, 14.5 mm wide as preserved, 11 mm high, cup plates numerous, more than 100 per side, mostly unorganized, with heavy rounded stellate ridges; apparently 5 IBB (only two exposed), apparently pentagonal (one well exposed), approximately as wide as high, alternating with pentameres, one small subpentagonal gap plate centered in posterior interray, less than half size of IBB; mid-cup plating irregular, consisting of large thick primaries, smaller secondaries, and tiny tertiary plates; interradially positioned BB slightly larger, thicker than other mid-cup primaries; three or four fixed ray plates including RR, low rounded ray ridges; R plates and first two fixed Br plates cup-like; tegmen low domal, with numerous small irregular polygonal plates, large anal cone offset toward posterior interray, posterior interray occupying most of exposed side, undifferentiated anals.

Arms incomplete, full length (based on impressions)

estimated to have been approximately 16 mm, possibly heterotomous branching, nonpinnulate, 2–5 free IBrr, 3–6 IIBrr, first two C-ray pairs in lateral contact, 5–8 IIIBrr, 5–6 IVBrr; Br: uniserial, large deep food groove, biserial cover plates over food groove, diminutive floor plates exposed laterally, interiors visible on D-ray arm where brachials broken away and in cross section of A-ray; small web plate fields one C- and one D-ray branching.

Proximal 23 mm of stem preserved, 2.7 mm wide at cup, 2.1 mm wide at distal end, rounded pentalobate at cup, becoming distinctly pentalobate distally, proximal stem strongly heteromorphic with wider nodals and thinner internodals, more distal stem less heteromorphic, nodals with lower epifacets, having lumen pentagonal with angles at pentamere boundaries.

Type material.—Holotype PE 52733.

Occurrence.—Time slice 1b, trilobite biozone E, lower Fillmore Formation, lower Ibexian (lower Tremadoc), Lower Ordovician (see Appendix)

Etymology.—*Globularis*, in reference to the rounded calyx shape.

Subclass CAMERATA Wachsmuth and Springer, 1885

Discussion.—Camerate crinoids are defined by a fully organized cup, relatively large interbranchial fields, and branching cup rays. They apparently acquired pinnulation, holomeric columnals, and a coiling distal stem (without holdfast) earlier than other crown groups.

Order ?**DIPOBATHRIDA**

Moore and Laudon, 1943

Discussion.—Diplobathrid camerates are defined by a single trait, a dicyclic cup, that we find to be inconsistent early in crinoid phylogeny (see Primary Cup Plate Homologies).

Family **RETEOCRINIDAE** Wachsmuth and Springer, 1885

Emended diagnosis.—Dicyclic camerate crinoids with heavy cup plate ridges forming a trusswork, deeply depressed pockets or fenestra between ridges and in interray regions, infrabasals overhanging stem, radials separated all around, wide posterior interray, isotomously branched nonpinnulate arms, brachials with lateral protuberances, sac-like tegmen consisting of plates similar to interbrachials, not extending beyond arm tips, and long thick stem with thin pentameritic to holomeric wafer-like columnals.

Genus **CNEMECRINUS**, new genus

Type species.—*Cnemecrinus fillmorensis* Guensburg and Sprinkle, new species.

Diagnosis.—Reteocrinids with wide conical cup, thinly plated pockets between pronounced cup plate ridging, interbrachial areas occupied by tessellate stellate plates, single large interbrachial contacting basals, CD interray wider than others, merging with sac-like tegmen (but lacking a sagittal anal ray-like ridge); arms nonpinnulate, isotomously branched at least four times, free Brr with rounded lateral protuberances; stem long, rounded pentalobate near crown, heteromorphic, tapering distally, cryptopentameritic.

Occurrence.—Lower Ordovician, western Utah, U. S. A.

Etymology.—From the Greek *kneme*, spoke of a wheel, in reference to the heavy radiating ridges of cup plates.

Discussion.—*Cnemecrinus* n. gen. has cup plating similar to other dicyclic camerates. The sac-like tegmen, stellate lower cup plates, large interbrachial areas, fixed lower arms up through the primibrachs or low in the secundibrachs, the lower primibrachs strongly articulated with adjacent interbrachials, long nonpinnulate arms, and thin tightly articulating columnals link *Cnemecrinus* n. gen. to the Late Ordovician *Reteocrinus*, but that taxon is more derived with inverted Y-shaped radials, cup fenestra, uniform stellate or pustular platelets in fenestra and interray areas, and ray-like median anal ridge. *Cnemecrinus* n. gen. morphology indicates reteocrinids are an early branch within the camerate crown group. *Reteocrinus* has arm branch web plating, a crinoid plesiomorphy, but we

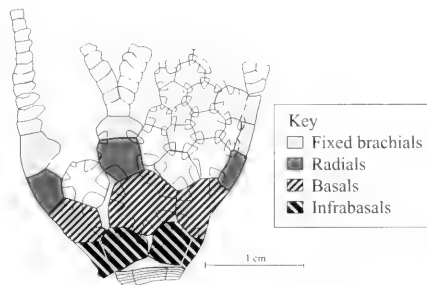

Text-figure 9. *Cnemecrinus fillmorensis*, n. gen. and sp., holotype PE 52735, plate tracing, D-ray orientation.

have not observed this character in *Cnemecrinus* n. gen.

CNEMECRINUS FILLMORENSIS, new species

Text-figure 9; Plate 6, Plate 9, figures 1, 2

Diagnosis.—As for the genus.

Description.—Largest crown lacking arm tips 72 mm long, complete holotype crown 56 mm long; cup wide conical, convex sided in flattened specimens, dicyclic; stellate, relatively thick, ridged cup plates forming a trusswork pattern, deeply depressed, thinly plated, triangular plate pockets between ridges; IBB five, small, pentagonal, radially-positioned, protruding rounded lip adjacent to large stem facet, each with a pair of diverging ridges to overlying BB; BB five, largest plates in cup, heptagonal, with two diverging ridges extending downward to adjacent IBB, ridge extending laterally to each adjacent B, another extending diagonally upward one iBr, and one ridge to radials above, B situated nearly beneath D-ray R, others in usual alternating positions; RR five, relatively large, typically heptagonal(?), separated all around by single iB, with two laterally downward ridges to BB, usually four smaller lateral ridges to adjacent iBr, and large upward ray ridge to iBr1; iBrr with stellate ornament, mostly hexagonal or pentagonal, seven observed in one interray, lowest iBr relatively large, two iBr laterally above in anterior interray; CD interray wide with two, four, then five smaller iBr, at least 15 total posterior interray plates in holotype; vertical plate ridge sequences extending upward into tegmen; arms five, approximately 2.5 times as long as cup height in holotype, nonpinnulate, branching isotomously at least three, probably four times, Ibr 2 axillary, 7–13 IIBr, Brr with rounded lateral protuberances, food grooves roofed with cover plate biseries?; stem rounded pentalobate, at least 15 cm long, with fine longitudinal striations, tapering away from crown, then nearly parallel sided distally,

cryptopentameric, pentameres visible in weathered holotype and paratype PE52738, alternating with BB above, lateral pentamere boundaries at axes of (rather than between) lobes; pentameres thin, wafer-like, with low medial notches (marking lobe boundaries), articulae synostosomal, tightly articulating, nodals with low rounded epifacets, internodals inserted approximately 2–4 mm below cup juncture, smooth-sided or with slightly rounded epifacets, axial canal large rounded pentalobate, internodes irregular, with several primary and secondary internodals.

Occurrence.—Time slice 1d, trilobite biozone G1, middle Fillmore Formation, lower Ibexian (upper Tremadoc), Lower Ordovician.

Type material.—Holotype PE 52735 and paratypes 52736–52738

Etymology.—*Fillmorensis* is the latinized form of the Fillmore Formation, from which most of the fossils described here were collected.

Order ?MONOBATHRIDA,

Moore and Laudon, 1943

Discussion.—The two monocyclic camerate clades, glyptocrinines and compsocrinines, have different cup base construction (see Family Eknomocrinidae Discussion below) and their linkage by a single trait, monocycly, to comprise the monobathrids, is weak (see Cup Plate Homologies above).

Family EKNOMOCRINIDAE, new family

Diagnosis.—Plesiomorphic camerates characterized by IBB interrupted by a small rectangular gap plate, a monocyclic cup, alignment irregularities in cup plating, exposed ambulacral grooves on tegmen with small anal cone in CD interray, nonpinnulate arms branching above cup, and pentameric stem.

Occurrence.—Lower Ordovician, western Utah, U. S. A.

Discussion.—The new family comprises the earliest monocyclic camerate crinoids. Ray branching above the cup, pentameric stem, and nonpinnulate arms are plesiomorphic, unlike crown-group camerates. We do not assign the Eknomocrinidae to either compsocrinine or glyptocrinine suborders. The five infrabasals plus one gap plate of *Eknomocrinus* n. gen. hint at derivation of the unusual hexagonal basal circler of compsocrinine camerates from protocrinoids by retention and enlargement of the gap plate.

Genus EKNOMOCRINUS, new genus

Type species.—*Eknomocrinus wahwahensis* Guensburg and Sprinkle, new species.

Diagnosis.—Eknomocrinidae with three or four fixed brachials, normal interbrachial areas arranged in

a one, two pattern, and the larger CD interray having one followed by three plates; arms relatively thick and round in cross section, branching at least three times; the narrow stem is rounded pentalobate near the crown.

Occurrence.—Lower Ordovician, western Utah, U. S. A.

Etymology.—From the Greek *eknomos* meaning unusual, marvelous, in reference to the standardized but oddly shaped cup plates.

EKNOMOCRINUS WAHWAHENSIS,

new species

Text-figure 10; Plate 7

Diagnosis.—As for the genus.

Description.—Cup wide, bowl shaped, 20 mm wide, 12.5 mm high; plates relatively thick, smooth with low ray ridges, monocyclic; IBB five, relatively small, rapidly expanding, varying considerably in shape, CD IB hexagonal, 4.0 mm wide and 2.9 mm high, DE IB hexagonal, 3.5 mm wide, 3.1 mm high, EA IB about 4 mm wide, 3.4 mm high, apparent AB IB only partly visible, small rectangular gap plate interrupting IB circler on right edge below C-ray radial, approximately 1.6 mm wide, 2.0 mm high; RR large, four visible, varying considerably in size and shape, in lateral contact except across CD interray, C-ray R pentagonal, about 4 mm wide, 3.9 mm high, D-ray R asymmetrical hexagonal, 5.0 mm wide, 4.5 mm high, E-ray R heptagonal, 6.5 mm wide, about 5.1 mm high, A-ray R heptagonal, about 6.5 mm wide, 5 mm high; three or four fixed Brr, first fixed Br much larger than succeeding ones, forming irregular fixed ray plate series, fixed Brr smaller and narrower in C ray; E-ray IBr 1 hexagonal, 3.8 mm high, 4.4 mm wide, A-ray IBr 1 triangular, 4 mm high, 3 mm wide; interbrachial areas having 1–2–3 plate pattern, irregular; tegmen apparently flat or slightly arched, includes small plates above interrays, exposed cover plates from arms visible on tegmen surface, anal cone in CD interray, about 3.5 mm high and 4.2 mm wide, with many small plates.

Arms long, thick, nonpinnulate, isotomous branching exclusively at least 3, probably 4 times (based on impressions), branches rapidly diverging from Axx; arms free above IBr 3 in D, E rays, IBr ?4 in C ray, first branching on IBr 3–5; Brr uniserial, quadrangular, stout, decreasing in size upward, IIBrr four in one case, ranging from wider than high to higher than wide, IIIBrr number uncertain, all higher than wide, cover plates small, rectangular, in single median biseries, flanked by small irregular plate mosaic along Brr, more columns of plates approaching arm base, food grooves small, shallow.

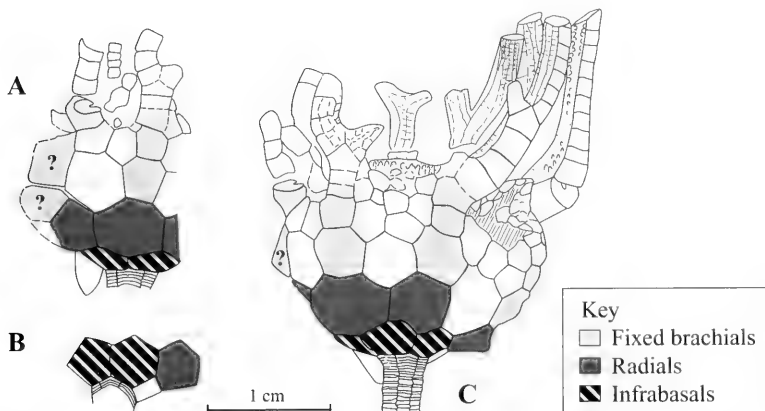

Text-figure 10.—*Eknomocrinus wahwahensis*, n. gen. and sp., holotype PE 52734, plate tracings; A) EA orientation, odd irregular plate shapes, A-ray fixed brachial articulating to EA interbrachial along long suture, B) D-ray orientation, gap plate just visible on cup lower right, cup largely standardized, C) DE interray portion of lower cup, gap plate, fixed brachials, and free arm bases.

Proximal stem 4.0 mm diameter at cup juncture, tapering to 3 mm by 4 mm below cup; pentameric pentalobate, heteromorphic with internodes consisting of one priminternodal with two secundinternodals on either side, articulae between columnals cryptocrenulate, meres slightly offset across lateral boundaries, lumen pentagonal, moderate sized, 1.3 mm diameter at preserved distal tip.

Occurrence.—Time slice 1b and trilobite biozone E, lower Fillmore Formation, lower Ibxian (lower Tremadocian), Lower Ordovician (see Appendix).

Type material.—The holotype and only specimen is PE 52734

Etymology.—*Wahwahensis*, in reference to the collection locality, the Wah Wah Mountains.

FAMILY UNCERTAIN

Discussion.—*Adelphicrinus* n. gen. is not assigned to family. The only specimen lacks most of the arms and stem and the cup posterior is unexposed. The organized and symmetrical cup containing relatively large interbrachial fields bounded by regular cup plating justifies incorporation within the camerate crown group. Interbrachial fields of *Adelphicrinus* n. gen. are somewhat atypical in being relatively high in the cup. Arm branching outside the cup like that of *Adelphicrinus* n. gen. is atypical of crownward camerates but found in protocrinoids, disparids, and cladids.

Genus **ADELPHICRINUS**, new genus

Type species.—*Adelphicrinus fortuitus* Guensburg and Sprinkle, new species.

Diagnosis.—A monocyclic camerate with arm branching above cup, radials in lateral contact, five primibrachs, arms free above primibrach two, interbrachial fields small, with small plates arranged in a 1-3 pattern in one case, interbrachials with small pores at plate corners; free arms branch at least twice, isotomous, no pinnules observed, Brr uniserial; proximal stem relatively large, circular, pentameric, with large circular lumen.

Occurrence.—Lower Ordovician, western Utah, U. S. A.

Etymology.—From the Greek *adelphe*, sister, because of generalized cup construction similar to many glyptocrinid monobathrid crinoids, to which it may be the sister group.

ADELPHICRINUS FORTUITUS, new species

Text-figure 11, Plate 9, figures 6-8

Diagnosis.—As for the genus.

Description.—Preserved crown length 21.5 mm. Cup conical, cup height 7.5 mm, maximum width 9.6 mm at IBr 1; IBB five, equal-sized, pentagonal, all approximately 2.5 mm high and wide; RR five, in lateral contact, heptagonal, largest plates in cup, all approximately 3.8 mm high and wide; IBrr five in all rays observed, IBrr 1-2 fixed, decreasing in size upward, IBr 1 height and width approximately 1.8 mm, IBrr 2-5 wider than high, higher IBrr slightly wider than high; iBrr relatively small, filling interradial areas from top of R to IBr 2, containing 12 small pustular plates in 1-3-4-4 arrangement, apparent small pores visible in immersed specimen at weathered plate cor-

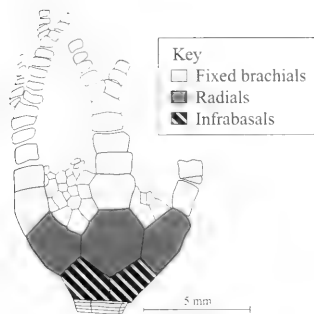

Text-figure 11.—*Adelphecrinus fortuitus*, n. gen. and sp., holotype PE 52739, plate tracing, anterior orientation.

ners. Anal sac elongate with small smooth plates, apparently attached to IBrr and perhaps lower IIBrr.

Distal arms incomplete, branching isotomously at least twice, apparently nonpinnulate; IIBrr seven, decreasing in size distally, becoming slightly deeper than wide; IIIBrr at least 14 in arm from back of calyx.

Stem facet 2.9 mm in diameter, stem segment approximately 0.5 mm long with four thin pentameric columnals, lumen large, circular, about 2.0 mm in diameter.

Occurrence.—Time slice 2c, trilobite zone I, upper Fillmore Formation, uppermost Ibexian (middle Ar enig), uppermost Lower Ordovician (see Appendix).

Type material.—The single specimen is holotype PE 52739.

Etymology.—*Fortuitus*, Latin, refers to the chance occurrence of this well-exposed complete calyx in deeply weathered, faulted, and fractured rocks.

Family HABROTECRINIDAE, new family

Diagnosis.—Monocyclic camerate crinoids with extensive accessory plating at primary plate triple junctures in interrays, beneath radials, and above infrabasals; radials with long lateral extensions, respiratory folds and pores at plate corners, and rectangular basals; pentalobate pentameric stem with mere boundaries at lobe crests.

Occurrence.—Lower Ordovician, western Utah, U. S. A.

Discussion.—The new family contains only *Habrotecrinus* n. gen. This new genus is known only from one fragmentary specimen, but its construction is unusual. Large interbrachial areas and ray branching within the cup are camerate traits, but accessory cup plating and laterally attenuated radials are distinctive. Accessory cup plates are plesiomorphic, found in stem-group crinoids, but there it does not occur within

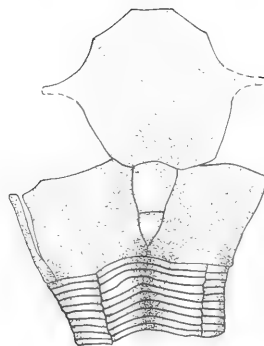

Text-figure 12.—*Habrotecrinus ibexensis*, n. gen. and sp., holotype PE 52740, lower cup drawing, two intercalate plates in wedge-shaped space between infrabasals, laterally attenuated radials, stem pentameres located on stem lobe crests, sutural pores not indicated, approximately $\times 3$.

well-defined circlets. This arrangement is present in peritocrinids, but these crinoids are cladids (disparids of others) with arms free above radials. *Celtoecrinus* is approximately the same age of *Habrotecrinus* n. gen., but is a more typical camerate, lacking accessory cup plating, and with pinnulate arms.

Genus HABROTECRINUS, new genus

Type species.—*Habrotecrinus ibexensis* Guensburg and Sprinkle, new species.

Diagnosis.—Habrotecrinidae with small triangular bosses on small intercalate cup plating, respiratory folds along cup plate margins, nearly square infrabasals contacting one accessory plate and two radials above, three or four fixed primibrachs, primaxillary approximately at top of cup, web-like extension of tegmen extending upward to tertibrach branches.

Occurrence.—Lower Ordovician, western Utah, U. S. A.

Etymology.—From the Greek *habrotēs*, luxury, in reference to the abundant accessory cup plates and complex cup ornament.

HABROTECRINUS IBEXENSIS, new species

Text-figures 12, 13; Plate 8

Diagnosis.—As for the genus.

Description.—Cup monocyclic, conical, with prominent ray ridges, attenuated plate ridges on primary cup plates, prominent rounded ray ridges, small intercalate cup plates with rounded to triangular protuberances, respiratory folds and pores around plate margins; IBB five large, nearly square, each with upright V-shaped plate ridge, each articulating with adjacent IBB later-

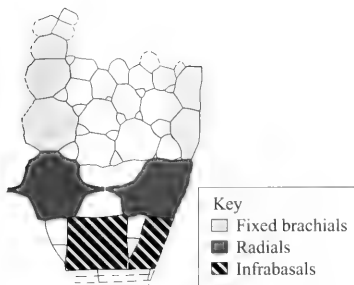

Text-figure 13.—*Habrotecrinus ibexensis* n. gen. and sp., holotype PE 52740, plate tracing (solid lines) and reconstructed (dashed) ray-interray area (see Pl. 8), secondary interbrachials, sutural pores not indicated, plating in proximal interbrachial area and in triangular space between radials and infrabasals uncertain, approximately $\times 1.8$.

ally only near cup base, two accessory plates in narrow crescentic gap away from cup base, two RR laterally above; larger distal accessory plate of this lowest gap also contacting R medially above; ?five RR (two preserved), slightly taller than wide, 11 or 12 sided, laterally attenuated resulting in very narrow R-R suture, each R with ray ridges forming X shape, adjacent R pairs and B frame large triangular gaps below interbrachial fields, gaps occupied by ?one or two intercalate plate(s); large interbrachial areas each with many primaries and small secondary intercalate plates bearing rounded bosses, merging distally into tegmen; four IBrr, three in cup, large, shorter fourth armlike, axillary, rays branching near cup top, coarse rugose ornament extending up arms; 5–6 IIBrr, IIIBrr more than eight, plate webs between IIBrr and IIIBrr branches; stem wide, pentalobate, pentameric, lateral mere boundaries at lobe crests, lumen pentalobate, large.

Occurrence.—Time slice 2c, trilobite biozone J, basal Wah Wah Formation, uppermost Ibebian, middle Arenig, uppermost Lower Ordovician (see Appendix).

Type material.—The single specimen is holotype PE 52740.

Etymology.—*Ibexensis*, in reference to Ibej Well, the source of water near the collecting locality.

Discussion.—See genus Discussion.

SYSTEMATIC POSITION UNCERTAIN

STEM A

Plate 9, figures 3, 4

Discussion.—These stem segments are pentameric and originally pentalobate in cross section. The larger flattened specimen is 1 cm wide, 10.5 cm long (including partial mold), and nontapering. Pentameres are thin and arranged as alternating nodals and internodals.

There are small medial raised ridges centered on each nodal; internodals lack epifacets, and the lumen is large and ?pentalobate. Articular facets are noncrenulate and flat. These specimens occurred in the same stratigraphic interval with *Titanocrinus* n. gen., but differ from specimens of that taxon in having pentamer ridges.

Occurrence.—Within or adjacent to Hintze's Reef, time slice 1b, trilobite zone E, lower Fillmore Formation, lower Ibebian (lower Tremadoc), Lower Ordovician.

Material.—PE 52729 and 52730.

STEM B

Plate 9, figure 5

Description.—The stem is round or rounded pentalobate. It is 1.4 cm wide as presently flattened, 3.8 cm long, nontapering, and pentameric over most of its length. Pentameres form acute angle with (they are not perpendicular to) the longitudinal stem axis. Pentameres become offset and grade into a plate mosaic at distal end. Nodal every third or fourth pentamere circlet, with slightly raised rounded epifacets; internodals are lacking epifacets. The lumen is large, and ?pentalobate judging by its small inwardly projecting angles.

Discussion.—This specimen occurred in the same stratigraphic interval with *Titanocrinus* n. gen.

Occurrence.—Within or adjacent to Hintze's Reef, time slice 1b, trilobite zone E, lower Fillmore Formation, lower Ibebian (lower Tremadoc), Lower Ordovician.

Material.—PE 52728

APPENDIX

Detailed collection data.—All specimens collected from Millard County, Utah, U. S. A. Stratigraphic and temporal data follow the zonal framework established by Hintze (1973) and time framework established in Webby *et al.* (2003). Data are compiled below in ascending stratigraphic order of occurrence. Collector and date of collection are noted.

Titanocrinus, *Glenocrinus*, and *Eknomocrinus*, and taxa uncertain stems A and B occur in graptolite-conodont time slice 1b (Webby *et al.*, 2003), trilobite zone E (Hintze, 1973), lower Ibebian (lower Tremadoc), Lower Ordovician. Most specimens were collected within or slightly below two prominent sponge-algal mound horizons in the basal ledge-forming limestone member, Fillmore Formation, informally designated by us as Miller's Reef and Hintze's Reef. Miller's Reef occurs 55.5 m (182 feet) above the base of the Fillmore and is typically 1 to 1.5 m in thickness. Hintze's Reef is the most prominent bioherm interval in the Fillmore ranging from 5 to 7 m in thickness. It

occurs at 110 m (360 ft.) above the base where it typically consists of upper and lower mound horizons with intervening thinly bedded limestones. Hintze's Reef is readily accessible at the east end of the roadcut series along highway 6–50 at Skull Rock Pass, NE NW NW 32, 20S–13W.

Titanocrinus sumralli.—Holotype. PE 52720—NE SE NE 18, 22S–13W, intraformational conglomerate, *in situ*, 0.5 m below base of Hintze's Reef, crushed crown and proximal stem, locally corroded and with syntaxial overgrowths, associated with another poorly preserved crinoid, Guensburg, 1997.

Paratypes.—PE 52721—SW SE NE 30, 22S–13W, echinoderm grainstone-intraformational conglomerate, *in situ*, 0.2 m below base of Hintze's Reef, calyx with arm bases and long stem, local syntaxial overgrowths, Sumrall, 1991. PE 52724—NE NE SE 19, 22S–13W, intraformational conglomerate, loose block approximately 6 m below Hintze's Reef, fragmentary arm, upper cup, and tegmen, weathered, Sumrall, 1993.

Titanocrinus sp.—PE52722—NW NE NE 31, 22S–13W, ?dolomitic intraformational conglomerate superjacent to Miller's Reef, crushed cup and stem and associated but separate arm and tegmen bundle, locally corroded, associated with other partial echinoderms, Guensburg, 1999. PE 52723—shaly parting, thin-bedded interreef, Hintze's Reef, Skull Rock Pass (see above), exact horizon unknown, road ballast on north side, partial arm set, tegmen, and ray-bearing cup section, well preserved, Guensburg, 1999. PE 52725—shaly interbed on intraformational conglomerate, near or in Hintze's Reef, Skull Rock Pass north side road ballast approximately ½ km west of source cut, exact horizon unknown, small crushed upper cup with arm bases, associated crinoid stems, well preserved, Sprinkle, 1990. PE 52726—shaly interbed on intraformational conglomerate, near or in Hintze's Reef, Skull Rock Pass, south side road ballast, approximately ½ km west of source cut, exact horizon unknown, crushed lower cup and proximal stem, well preserved, Sprinkle, 1990. PE 52727—SE SE NE 23 (unsurveyed), 20S–14W, calcisiltite, approximately 22 m below Hintze's Reef, partial arm and few attached cup plates, arm deeply weathered, exposing floor plates from below, Sprinkle, 1997. PE 52731—shaly interbed on intraformational conglomerate, (legal location above) near or in Hintze's Reef, road ballast, south side, Skull Rock Pass, proximal stem with attached infrabasals, Guensburg, 1991.

Glencrinus globularis.—Holotype. PE 52733—calcisiltite, approximately 3 m below Miller's Reef, west side of Hintze's (1973) Red Tops section, NE SE NW 31, 22S–13W, well preserved calyx, arm bases, proximal stem, Sprinkle, 1998.

Eknomocrinus wahwahensis.—Holotype. PE 52734—trilobite-echinoderm wackestone, *in situ*, pocket between 0.3 m tall stromatolite "heads," base of Hintze's Reef, Middle Mountain section, Wah Wah Mountains, NE SW SW 21, 23S–16W, partly weathered calyx, partial arms, proximal stem, Guensburg, 1997.

Taxa Uncertain (see above for Skull Rock Pass legal location).

Stem A.—PE 52729, 527230—Shaly interbeds on intraformational conglomerate, approximately 1/3 km west of and mined from Hintze's Reef roadcut at Skull Rock Pass, Sprinkle and Guensburg, 1991, 1993.

Stem B.—PE 52728—shaly interbed on intraformational conglomerate, near or in Hintze's Reef, Skull Rock Pass, north side road ballast, approximately 1/3 km west of source cut, exact horizon unknown, crushed distal stem segment, David Sprinkle, 1991.

Cnemecrinus fillmorensis occurs in time slice 1d, lower trilobite biozone G2, middle Ibexian (uppermost Tremadoc), Lower Ordovician. All specimens are from the light-grey ledge-forming member of the Fillmore Formation. Holotype PE 52735 and paratypes PE 52736–52737 were collected on or stratigraphically near a discontinuous large scale rippled echinoderm intraformational conglomerate, informally referred to as the "Giza Peak megaripple bed," 253 m (824 ft.) above the base of the Fillmore.

Holotype.—PE 52735—micritic limestone, float, at megaripple bed horizon, NW NE NW 25, 20S–14W (unsurveyed), slightly weathered crown and proximal stem, Siewers and Guensburg, 1989.

Paratypes.—PE 52736—shaly interbed atop megaripple bed, *in situ*, NW NE NW 25, 20S–14W, cup, partial arms, and proximal stem, Guensburg, 1989. PE 52737—shaly interbed, *in situ*, NW NW NE 25, 20S–14W, largely disarticulated crown with proximal stem, Sprinkle and Johns, 1990. PE 52738—shaly interbed, *in situ*, approximately 300 m above the base of the Fillmore, SW SE NW 30, 20S–13W, well-preserved long stem segment, Johns and Sprinkle, 1989.

Adelphicrinus and *Habrotracrinus* are from time slice 2c, upper trilobite zone I and basal zone J, upper Ibexian (middle Arenig), Lower Ordovician.

Adelphicrinus fortuitus.—Holotype. PE 52739, intraformational conglomerate, float, approximately 20 m below the top of the Fillmore Formation in the *Calathium*-calcisiltite member, informal Guen section, SW NE NW 29, 21S–13W, cup, arm bases, and short proximal stem, Sumrall, 1991.

Habrotracrinus ibexensis.—Holotype. PE 52740, shaly interbed over megaripple, *in situ*, Wah Wah Formation, approximately 2 m above base, Square Top East section, SE SW NW 32, 21S–13W, much disarticulated flattened cup, proximal arms, and proximal stem, Guensburg, 1997.

REFERENCES CITED

- Ausich, W.I.**
 1986. The crinoids of the Al Rose Formation (Early Ordovician, Inyo County, California, U. S. A.). *Alcheringa*, vol. 10, pp. 217–224.
 1996. Crinoid plate circlet homologies. *Journal of Paleontology*, vol. 70, pp. 955–964.
 1998a. Early Phylogeny and subclass division of the Crinoidea (Phylum Echinodermata). *Journal of Paleontology*, vol. 72, pp. 499–510.
 1998b. Phylogeny of Arenig to Caradoc crinoids (Phylum Echinodermata) and suprageneric classification of the Crinoidea. University of Kansas Paleontological Contributions, new series, no. 9, 36 p.
- Ausich, W.I., and Babcock, L.E.**
 1998. Phylogenetic position of *Echmatocrinus brachiatus* Sprinkle, 1973. *Palaentology*, vol. 41, pp. 193–202.
- Ausich, W.I., Gil Cid, M.D., and Dominguez Alonso, P.**
 2002. Ordovician [Dobrotivian (Llandeillian Stage) to Ashgill] crinoids (Phylum Echinodermata) from the Montes De Toledo and Sierra Morena, Spain with implications for paleogeography of Peri-Gondwana. *Journal of Paleontology*, vol. 76, pp. 975–992.
- Bather, F.A.**
 1892. Suggested terms in crinoid morphology. *Annals and Magazine of Natural History*, series 6, vol. 9, pp. 51–66.
 1900. The Echinodermata. In Lankester, E.R., ed., *A Treatise on Zoology*, Part 3. Adam and Charles Black, London, pp. 3–204.
- Breimer, A.**
 1978. Recent crinoids. In Moore, R.C., and Teichert, C., eds., *Treatise on Invertebrate Paleontology*, Part T, Echinodermata 2(1). Geological Society of America and University of Kansas Press, Lawrence, pp. T9–T58.
- Broadhead, T.W.**
 1988. Heterochrony, a pervasive influence in the evolution of Paleozoic Crinoidea. In Burke, R.D., Mladenov, P.V., Lambert, P., and Parsley, R.L., eds., *Echinoderm Biology*. Balkema, Rotterdam, pp.115–123.
- Brower, J.C.**
 1974. Ontogeny of the camerate crinoids. University of Kansas Paleontological Contributions, Paper 72, 53 p.
 1995. Dendrocrinid crinoids from the Ordovician of northern Iowa and southern Minnesota. *Journal of Paleontology*, vol. 69, pp. 939–960.
- Carpenter, P.H.**
 1879. Oral and apical systems of echinoderms. *Quarterly Journal of Microscopic Science*, vol. 8, pp. 351–383.
- Clark, A.H.**
 1915. A monograph of the existing crinoids. Vol. 1, The Comatulids, pt. 1. U. S. National Museum Bulletin, no. 82, 406 p.
- Cope, J.C.P.**
 1988. A reinterpretation of the Arenig crinoid *Ramsyocrinus*. *Palaentology*, vol. 31, pp.229–235.
- Dattilo, B.**
 1993. The Lower Ordovician Fillmore Formation of Western Utah: Storm-dominated sedimentation on a passive margin. Brigham Young University, *Geology Studies*, vol. 39, pp. 71–100.
- Donovan, S.K.**
 1988. The early evolution of the Crinoidea. In Paul, C.R.C. and Smith, A.B., eds., *Echinoderm Phylogeny and Evolutionary Biology*. Clarendon Press, Oxford, pp. 235–244.
- Donovan, S.K., and Cope, J.P.C.**
 1989. A new camerate crinoid from the Arenig of south Wales. *Palaentology*, vol. 32, pp. 101–107.
- Eckert, J., and Brett, C.E.**
 2001. Early Silurian (Llandovery) crinoids from the Lower Clinton Group, western New York State. *Bulletins of American Paleontology*, no. 360, 88 p.
- Guenzburg, T.E.**
 1984. Echinodermata of the Middle Ordovician Lebanon Limestone, central Tennessee. *Bulletins of American Paleontology*, vol. 86, 100 p.
 1992. Paleoecology of hardground encrusting and commensal crinoids, Middle Ordovician, Tennessee. *Journal of Paleontology*, vol. 66, pp.129–147.
- Guenzburg, T.E., and Sprinkle, J.**
 1992. Rise of echinoderms in the Paleozoic evolutionary fauna: significance of paleoenvironmental controls. *Geology*, vol. 20, pp. 407–410.
 1994. Revised phylogeny and functional interpretation of the Edrioasteroidea based on new taxa from the Early Ordovician of western Utah. *Fieldiana (Geology)*, New Series no. 29, 43 p.
 1997. Rhombiferans are not the ancestors of crinoids. *Geological Society of America Abstracts with Programs*, vol. 29, p. A-341.
 2001a. Origin of standardized cup and posterior plating in early crinoids. *Geological Society of America, Abstracts with Programs*, 33(6): A247.
 2001b. Earliest crinoids: new evidence for the origin of the dominant Paleozoic echinoderms. *Geology*, vol. 29, pp.131–134.
- Hintze, L.**
 1973. Lower and Middle Ordovician stratigraphic sections in the Ibox area, Millard County, Utah. Brigham Young University *Geology Studies*, vol. 20, pp. 3–36.
- Jaekel, O.**
 1894. Entwurf einer morphologie und phylogenie der crinoiden. *Gesellschaft Naturf. Freunde Sitzungsberger*, pp. 101–121.
 1918. Phylogenie und system der pelmatozoen. *Palaentologische Zeitschrift*, vol. 3, 128 p.
- Jobson, L., and Paul, C.R.C.**
 1979. *Compagierinus fenestratus*, a new Lower Ordovician crinoid from north Greenland. *Rapport Gronlands Geologiske Undesogelse*, vol. 91, pp. 71–81.
- Kelly, S.M.**
 1986. Classification and evolution of the Class Crinoidea. Abstracts of the Fourth North American Paleontological Convention, p. A23.
 1978. A new Lower Ordovician (middle Canadian) disparid crinoid from Utah. *Journal of Paleontology*, vol. 52, pp. 916–920.
- Koninck, L.G. de, and Le Hon, H.S.**
 1854. Recherches sur les crinoïdes du terrain carbonifere de la Belgique. *Academie Royale Belgique, Memoirs*, vol. 28, 217 p.
- Lane, N.G.**
 1970. Lower and Middle Ordovician crinoids from west-central Utah. Brigham Young University *Geology Studies*, vol. 17, pp.3–18.
 1978. Inadunates. In Moore, R.C., and Teichert, C., eds., *Treatise on Invertebrate Paleontology*, Part T, Echinodermata

- 2(1). Geological Society of America and University of Kansas Press, Lawrence, pp. T265–T268.
- Lane, N.G. and Sevastopulo, G.D.**
1982. Microcrinoids from the Middle Pennsylvanian of Indiana. *Journal of Paleontology*, vol. 56, pp. 103–115.
- Matsumoto, H.**
1929. Outline of a classification of the Echinodermata. *Tohoku University Scientific Reports*, series 2, vol. 13, pp. 27–33.
- Miller, J.S.**
1821. A natural history of the Crinoidea or lily-shaped animals, with observations on the genera *Asteria*, *Euryale*, *Comatula*, and *Marsuptes*. Bryan and Company, Bristol, 150 p.
- Miller, S.A.**
1890. The structure, classification, and arrangement of American Palaeozoic crinoids into families. *American Geologist*, vol. 6, pp. 275–286, 340–357.
- Mooi, R., and David, B.**
1997. Skeletal homologies of echinoderms. In Waters, J.A., and Maples, C.L., eds., *Geobiology of Echinoderms*. Paleontological Society Papers, vol. 3, pp. 305–335.
- Moore, R.C.**
1954. Status of invertebrate paleontology, 1953. IV. Echinodermata: Pelmatozoa. *Bulletins of the Museum of Comparative Zoology*, Harvard University, vol. 112, pp. 125–149.
1962. Ray structures of some inadunate crinoids. *The University of Kansas Paleontological Contributions*, Echinodermata, Article 5, 47 p.
- Moore, R.C., and Laudon, L.R.**
1943. Evolution and Classification of Paleozoic Crinoids. Geological Society of America, Special Paper no. 46, 153 p.
- Moore, R.C., and Strimple, H.L.**
1978. Family Acrocrinidae Wachsmuth & Springer, 1885. In Moore, R.C., and Teichert, C., eds., *Treatise on Invertebrate Paleontology*, Part T, Echinodermata 2(1). Geological Society of America and University of Kansas Press, pp. T479–T487.
- Phillip, G.M., and Strimple, H.L.**
1971. An interpretation of the crinoid *Aethocrinus moorei* Ubahgs. *Journal of Paleontology*, vol. 45, pp. 491–493.
- Rozhnov, S.V.**
2002. Morphogenesis and evolution of crinoids and other pelmatozoan echinoderms in the Early Paleozoic. *Paleontological Journal*, vol. 36, Supplementary Issue 6, pp. S525–S674.
- Sevastopulo, G.D., and Lane, N.G.**
1988. Ontogeny and phylogeny of disparid crinoids. In Paul, C.R.C., and Smith, A.B., eds., *Echinoderm Phylogeny and Evolutionary Biology*. Clarendon Press, Oxford, pp. 245–253.
- Simms, M.J.**
1994. Reinterpretation of thecal plate homology and phylogeny in the Class Crinoidea. *Lethaia*, vol. 26, pp. 303–312.
- Simms, M.J., and Sevastopulo, G.D.**
1993. The origin of articulate crinoids. *Palaeontology*, vol. 36, pp. 91–109.
- Smith, A.B.**
1990. Evolutionary diversification of echinoderms during the early Palaeozoic. In Taylor, P.D., and Larwood, G.P., eds., *Major Evolutionary Radiations* (Systematics Association Special Volume No. 42). Clarendon Press, Oxford, pp. 265–286.
- Sprinkle, J.**
1973. Morphology and evolution of blastozoan echinoderms. Special Publication, Museum of Comparative Zoology, Harvard University, 283 pp.
- Sprinkle, J., and Collins, D.E.**
1998. Revision of *Echmatocrinus* from the Middle Cambrian Burgess Shale of British Columbia. *Lethaia*, vol. 31, pp. 267–288.
- Sprinkle, J., and Guensburg, T.E.**
1995. Origin of echinoderms in the Paleozoic Evolutionary Fauna: the role of substrates. *Palaios*, vol. 10, pp. 437–453.
1997. Early radiation of echinoderms. In Waters, J.A., and Maples, C.L., eds., *Geobiology of Echinoderms*. Paleontological Society Papers, vol. 3, pp. 205–224.
2001. Growing a stalked echinoderm within the extraxial-axial theory. In Barker, M.F., ed., *Echinoderms 2000*. A. A. Balkema, Lisse, Netherlands, pp. 59–65.
- Sprinkle, J., and Kolata, D.R.**
1982. "Rhomb-bearing" camerate. In Sprinkle, J., ed., *Echinoderm Faunas from the Bromide Formation (Middle Ordovician) of Oklahoma*. University of Kansas Paleontological Contributions, Monograph 1, pp. 206–211.
- Sprinkle, J., and Wahlman, G.P.**
1994. New echinoderms from the Early Ordovician of west Texas. *Journal of Paleontology*, vol. 68, pp. 324–338.
- Sumrall, C.D.**
1998. A phylogenetic test of the glyptocystitid origin of crinoids. Geological Society of America Abstracts with Programs, vol. 30, no. 7, p. A-94.
- Ubahgs, G.**
1969. *Aethocrinus moorei* Ubahgs. n. gen., n. sp., le plus ancien crinoïde dicyclique connu. University of Kansas Paleontological Contributions, Paper 38, 25 p.
1978. Skeletal morphology of fossil crinoids. In Moore, R.C., and Teichert, C., eds., *Treatise on Invertebrate Paleontology*, Echinodermata, 2(1). Geological Society of America and University of Kansas Press, pp. T58–T216.
- Vizcaino, D., and Lefebvre, B.**
1999. Les échinodermes du Paléozoïque inférieur de Montagne Noire: biostratigraphie et paléodiversité. *Geobios*, vol. 32, pp. 353–364.
- Wachsmuth, C., and Springer, F.**
1885. Revision of the Palaeocrinoidea, part 3, section 1. Discussion of the Classification of relations of brachiata crinoids, and conclusion of the generic descriptions. *Academy of Natural Sciences of Philadelphia, Proceedings*, pp. 223–364.
1897. The North American Crinoidea Camerata. *Museum of Comparative Zoology*, Harvard College, *Memoirs*, vol. 20, vol. 21, 897 p.
- Warn, J.M.**
1975. Monocyclism vs. dicyclism, a primary schism in crinoid phylogeny? In Pojeta, J., and Pope, J.K., eds., *Studies in Paleontology and Stratigraphy*. *Bulletins of American Paleontology*, vol. 67, pp. 57–69.
- Warn, J. and Strimple, H.L.**
1977. The disparid superfamilies Homocrinacea and Cincinnatiacea (Echinodermata: Crinoidea), Ordovician-Silurian, North America. *Bulletins of American Paleontology*, vol. 72, 138 p.
- Webby, B.D., Cooper, R.A., Bergstrom, S.M., and Paris, F.**
2003. Stratigraphic framework and times slices. In Webby, B.D., Droser, M.L., Paris, F. and Percival, I., eds., *The Great Ordovician Biodiversification Event*. Columbia University Press, New York. In press.

Wilson, H.E.

1916. Evolution of the basal plates in monocyclic Crinoidea Camerata. *Journal of Geology*, vol. 24, pp. 488–510, 533–553, 665–684.

Yakovlev, N.N.

1918. New data on the genus *Cryptocrinus* and the connection between the Crinoidea and Cystoidea. *Annals of the Russian Palaeontologic Society*, vol. 2, pp. 7–26.

Zittel, K.A. von.

1879. *Handbuch der Palaeontologie*, Band 1, Paleozoologie. R. Oldenbourg (Munchen und Leipzig), 765 p.

ADDENDUM

The English translation of a Russian monograph by S. V. Rozhnov (Rozhnov, 2002) became available to us during galley proofing. Time prevents a full critique of this comprehensive work emphasizing, though not limited to, Russian material. However, we think it is necessary to comment on the most important relevant issues. Rozhnov proposes a plate homology system for all stemmed echinoderms or ‘pelmatozoans’, in particular a proposal for uniting crinoid terminology to other stemmed echinoderms. Our objections to the usage of ‘pelmatozoans’ are recently detailed elsewhere (Guenzburg and Sprinkle, 2001b). In short, we inter-

pret crinoids and blastozoans to have evolved separately from edrioasteroid ancestors and not one from the other.

Despite this fundamental difference of interpretation, there are some important points of agreement with Rozhnov’s as regard crinoid plate homologies. We agree that the cup base circlet is nearly always homologous (see also Simms, 1994). We agree that use of superradial terminology with disparids should be dropped and that the anal series of this clade comprises the first left branch of the C-ray. We also agree that, in a few cases, meres are incorporated into the cup base forming an added circlet (lintels).

Points of departure are also apparent. Rozhnov’s homology model assumes a single, not dual, reference point (see Single Reference System Failings, p. 8). Additionally, we find evidence for, not against, radial plate homology among crinoids (see Dual Reference System, p. 12). We don’t agree posterior plating of cladids and their flexible and articulate descendants is homologous to that of disparids or a branch of the C-ray (see Anal Plate Homologies, p. 13), or that the anal structure of hybocrinids points to a closer relationship to eocrinoids.

PLATES

EXPLANATION OF PLATE 1

Figure	Page
1-4. <i>Titanocrinus sumralli</i> , new genus and species	18
1, 2. Holotype PE 52720, D ray view, coated, locally corroded and with thick syntaxial calcite overgrowths: 1. Partly crushed crown and proximal stem. $\times 1.5$; 2. Detail of upper crown, tegmen, corroded thin arms; disjunct arm at top right. $\times 2.1$.	
3, 4. Paratype PE 52724, coated: 3. Detail, upper right of 4., deeply corroded, floor plates lining large food groove, partly preserved cover plates approximately in one-to-one correspondence with floor plates. $\times 9.1$; 4. Interior partial cup, exterior tegmen, proximal arms: numerous small tegmen plates, large and thick primary cup plate. $\times 2.4$.	

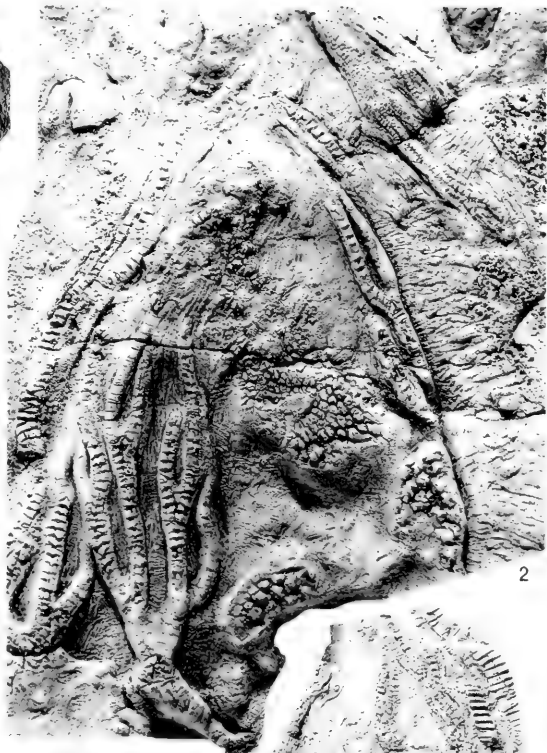

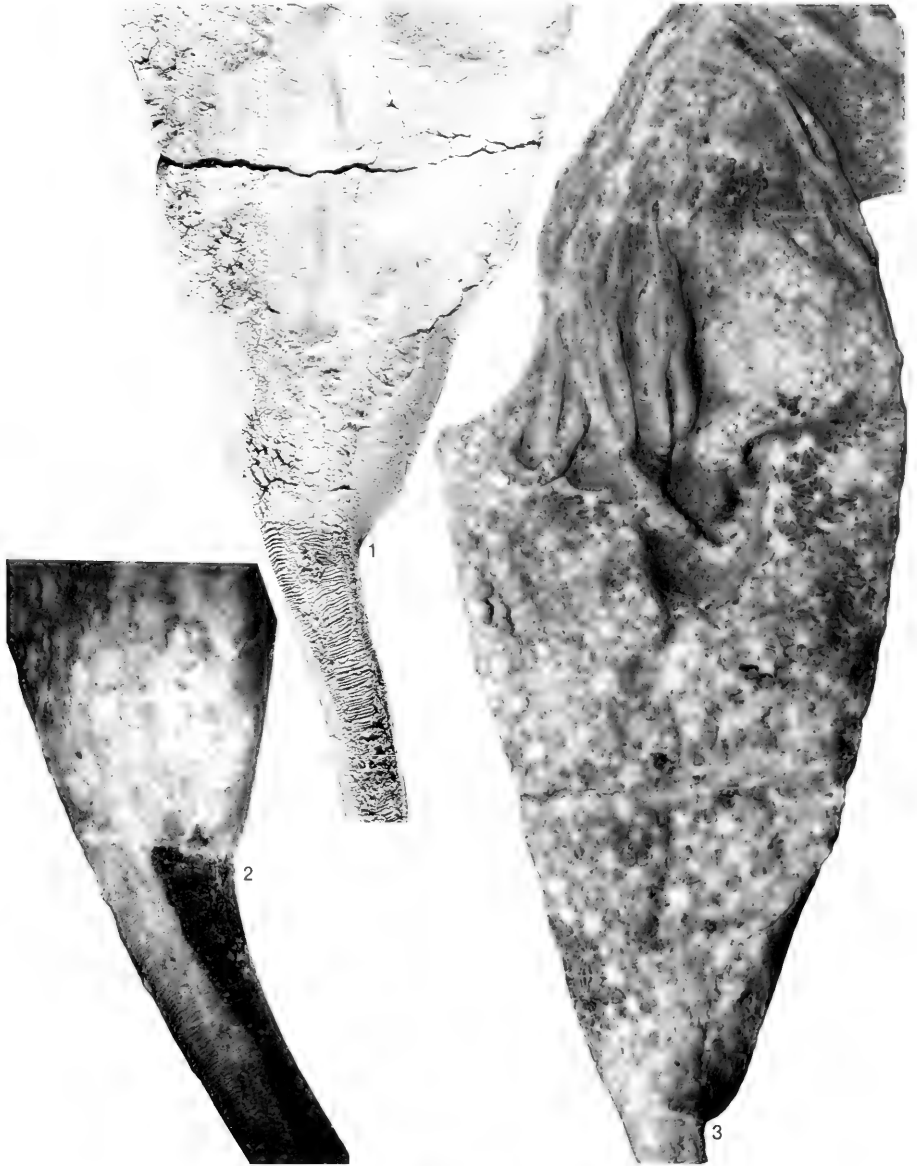

EXPLANATION OF PLATE 2

Figure	Page
1-3. <i>Titanocrinus sumralli</i> new genus and species	18
<p>Holotype PE 52720 (see Text-fig. 5): 1. Coated D-ray view detail of lower cup and stem; corroded stem with thin curved pentameres, pentameres alternating with two infrabasals, irregular mid-cup plating $\times 2.1$; 2. Proximal stem and lower cup, immersed, oriented to show CD interarray view; large infrabasal on left at cup base, two small gap plates on right (see Text-fig. 6A), dark areas on stem unweathered, $\times 3.0$; 3. Immersed D ray view of crown, cup plating, ornamentation, CD interarray plating, irregular mid-cup, infrabasals, tegmen (see Text-fig. 5), $\times 2.0$.</p>	

EXPLANATION OF PLATE 3

Figure	Page
1-5. <i>Titanocrinus sumralli</i> new genus and species	18
Paratype PE 52721: 1. Coated calyx, mostly deeply weathered, well preserved fixed ray and interray plating on upper left, $\times 1.8$;	
2. Coated calyx and stem, $\times 0.8$; 3. Coated C-ray and CD interray portion of cup, reverse side of 1, C-ray fixed brachials and radial	
on right, apparent enlarged CD interray plates at upper left, $\times 3.1$; 4. Immersed CD interray view of lower cup and proximal stem,	
large infrabasal and gap plates on either side (see Text-fig. 6B), $\times 3.9$; 5. Immersed D-ray first arm branching at cup-free arm	
boundary, web plating in notch between branches, $\times 6.0$.	



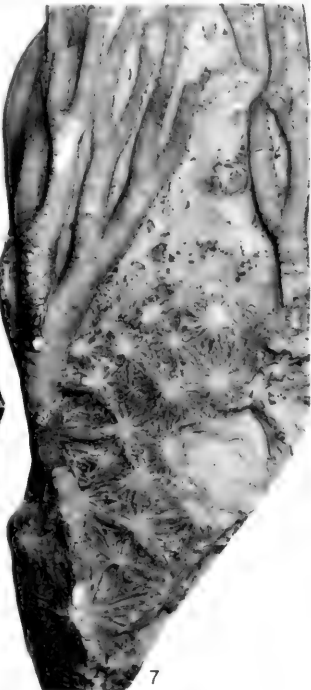
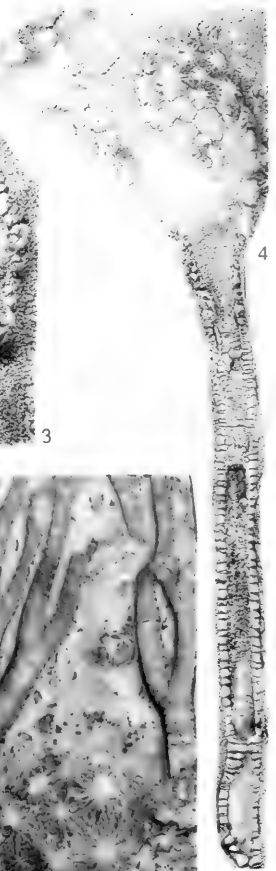
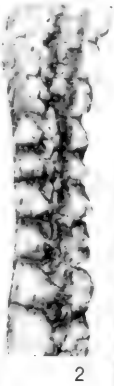

EXPLANATION OF PLATE 4

Figure	Page
1-7. <i>Titanocrinus</i> species, new genus,	19
PE 52727, Coated: 1. Weathered partial arm and few cup plates, abutting brachials at arm branchings, $\times 2.3$; 2. Detail, upper right branch of 1, weathered-away backs of brachials exposing biserial floor plates beneath, $\times 7.8$.	
PE 52722, Coated, weathered, dismembered partial crown and stem; 3. Upper calyx and arms, $\times 2.8$; 4. Lower cup and stem, cup plates with double ray ridges, $\times 2.4$.	
PE 52726, Coated: 5. Crushed cup and proximal stem, stem meres, lobes? aligned above with infrabasals, thin, discontinuous, slanting meres, $\times 2.7$.	
PE 52723, Upper crown and three partial arms; 6. Coated, abutting brachials but no plate webs at arm branches, fixed ray plates at lower left, small wedge-shaped intercalate brachials on free arms most visible on IIBr; coarse plate ornament, anal cone above incomplete arm tips, $\times 2.2$; 7. Immersed, arm, cup plating detail, $\times 2.7$.	

EXPLANATION OF PLATE 5

Figure	Page
1-5. <i>Glenocrinus globularis</i> , new genus and species	20
<p>Holotype PE 52733, CD interray view (see Text-fig. 8): 1. Coated partial crown and stem, irregular mid-cup plating, possible basals on either side, anal cone at CD tegmen apex, arm molds in matrix at top, $\times 5.3$; 2. Wetted, tilted, gap plate with infrabasal on either side, $\times 6.2$; 3. Coated, offset pentameres, pentamere columns aligned with infrabasals, $\times 9.0$; 4. Coated, distal stem, pentameres, $\times 9.0$; 5. Immersed, calyx plating, primary and smaller secondary intercalate plates, $\times 6.8$.</p>	

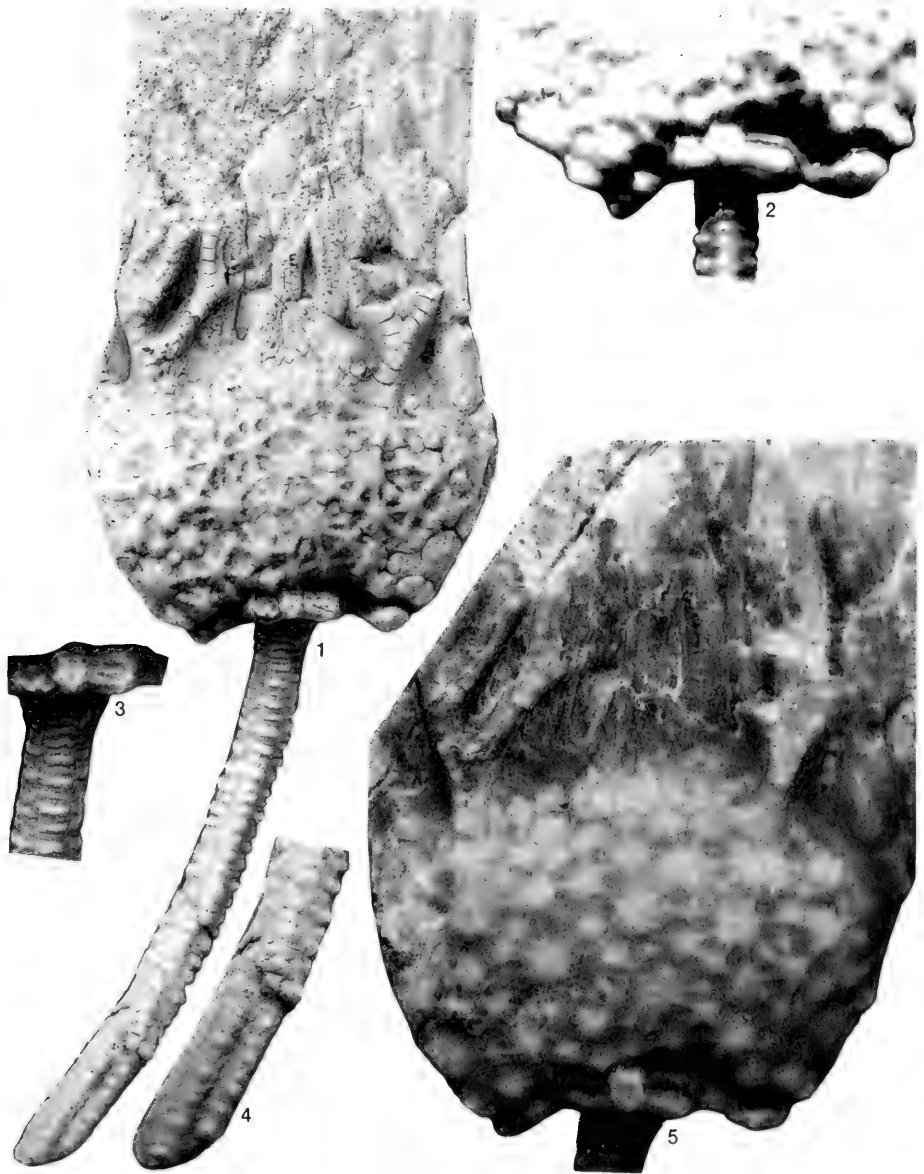

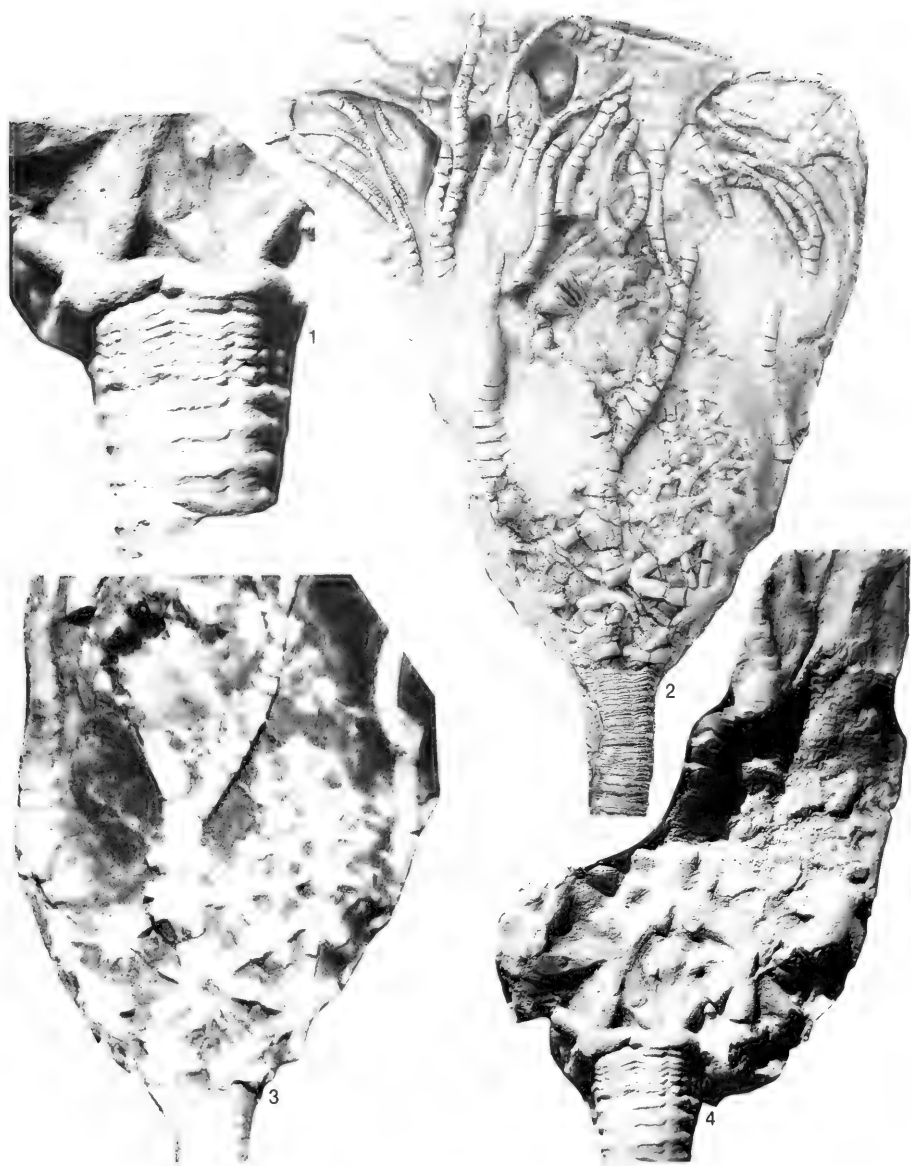

EXPLANATION OF PLATE 6

Figure	Page
1-4. <i>Cnemecrinus fillmorensis</i> new genus and species	21
1, 4. Paratype PE 52736: 1. Coated, proximal stem, infrabasals, offset pentameres at stem lobes aligned with infrabasals. $\times 4$; 1: 4. Coated, largely unprepared, thick ray ridges on cup plates. $\times 2$; 2.	
2, 3. Holotype PE 52735: 2. D-ray view, coated, crown and proximal stem, posterior plating (see Text-fig. 9). $\times 2$; 9; 3. Immersed, cup and proximal arms, damaged tegmen at center. $\times 3$; 6.	

EXPLANATION OF PLATE 7

Figure	Page
1-5. <i>Eknomocrinus wahwahensis</i> new genus and species	22
Holotype PE 52734: 1. D ray view, coated, partial crown and stem, exposed surface deeply corroded, large uniserial arms, arm molds impressed into trilobite fragment at top (see Text-fig. 10C), $\times 3.5$; 2. E-ray view, coated, EA interray, irregular A ray cup plates (see Text-fig. 10A), $\times 4.9$; 3. Immersed, tilted for basal view, infrabasals, gap plate on right adjacent to stem (see Text-fig. 10B), $\times 2.5$; 4. Coated proximal stem, offset pentameres alternating with infrabasals, $\times 6.4$; 5. Coated CD interray, anal cone, $\times 7.5$.	

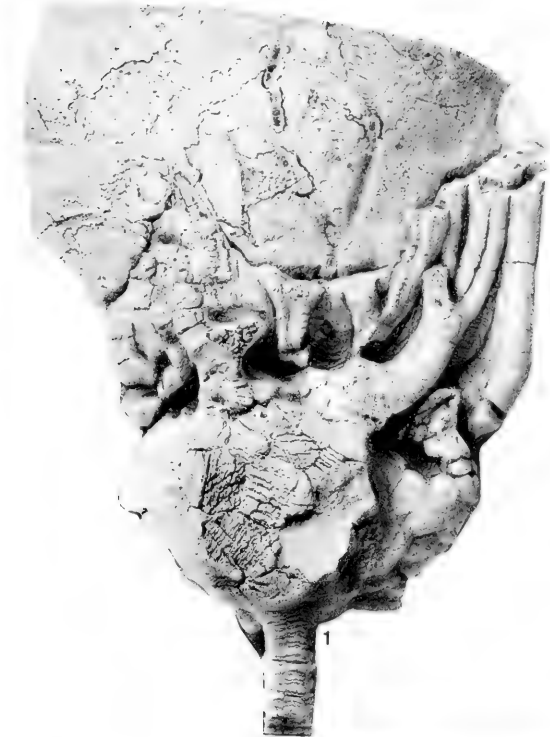



EXPLANATION OF PLATE 8

Figure	Page
1-5. <i>Habrotecrinus ibexensis</i> , new genus and species	24
Holotype PE 52740: 1. Uncertain orientation, coated, cup and proximal arms, partly disarticulated and crushed, cup ray ridge, fine cup plate ornament, square infrabasals (see Text-fig. 13), $\times 2.7$; 2. Coated pentalobate stem facet, large lumen, $\times 3.0$; 3. Coated reverse side from 1, disarticulated, wedge-shaped gap between infrabasals, pentamere boundaries bisecting stem lobes, alternating with infrabasals, $\times 3.3$; 4. Immersed, articulated infrabasals and radial, accessory plates beneath radials, between infrabasals, attenuated lateral radial projection preserved on left broken off on right, pentamere boundaries bisecting stem lobes (see Text-fig. 12), $\times 4.0$; 5. Immersed, fixed ray plating on left, radial collapsed downward at lower left, interbrachial area, accessory plating, pores at plate boundaries, $\times 4.0$.	

EXPLANATION OF PLATE 9

Figure	Page
1, 2. <i>Cnemocrinus fillmorensis</i> , new genus and species	21
Paratype PE 52738: 1. Coated stem, proximal portion crushed, nodals with low epifaets separated by few internodals, $\times 2.0$; 2. Coated distal segment, approximately 1 cm missing gap from 1, $\times 2.0$	
3, 4. Stem A	25
3. PE 52730, coated, crushed, pentameric, spiraling pentameric columns, pentamere ribs, $\times 2.7$.	
4. PE 52729 (left), large, pentameric, pentamere ribs, $\times 2.3$	
4. (upper right) <i>Titanocrinus</i> species, new genus	19
PE 52725, partial juvenile crown, poorly preserved.	
5. Stem B	25
PE 52728, coated, crushed, large distal stem, thin pentameres transition into mosaic below, spiralling pentamere columns, $\times 2.3$.	
6, 8. <i>Adelphocrinus fortuitus</i> , new genus and species	23
Holotype PE 52739: 6. Coated, weathered crown, small interbranchial fields, arm branching above cup, $\times 4.0$; 7. Cup, basal view, large stem lumen, pentameres alternating with infrabasals, $\times 4.0$; 8. Immersed, small interbranchials with possible small respiratory pores at plate corners, $\times 6.0$.	

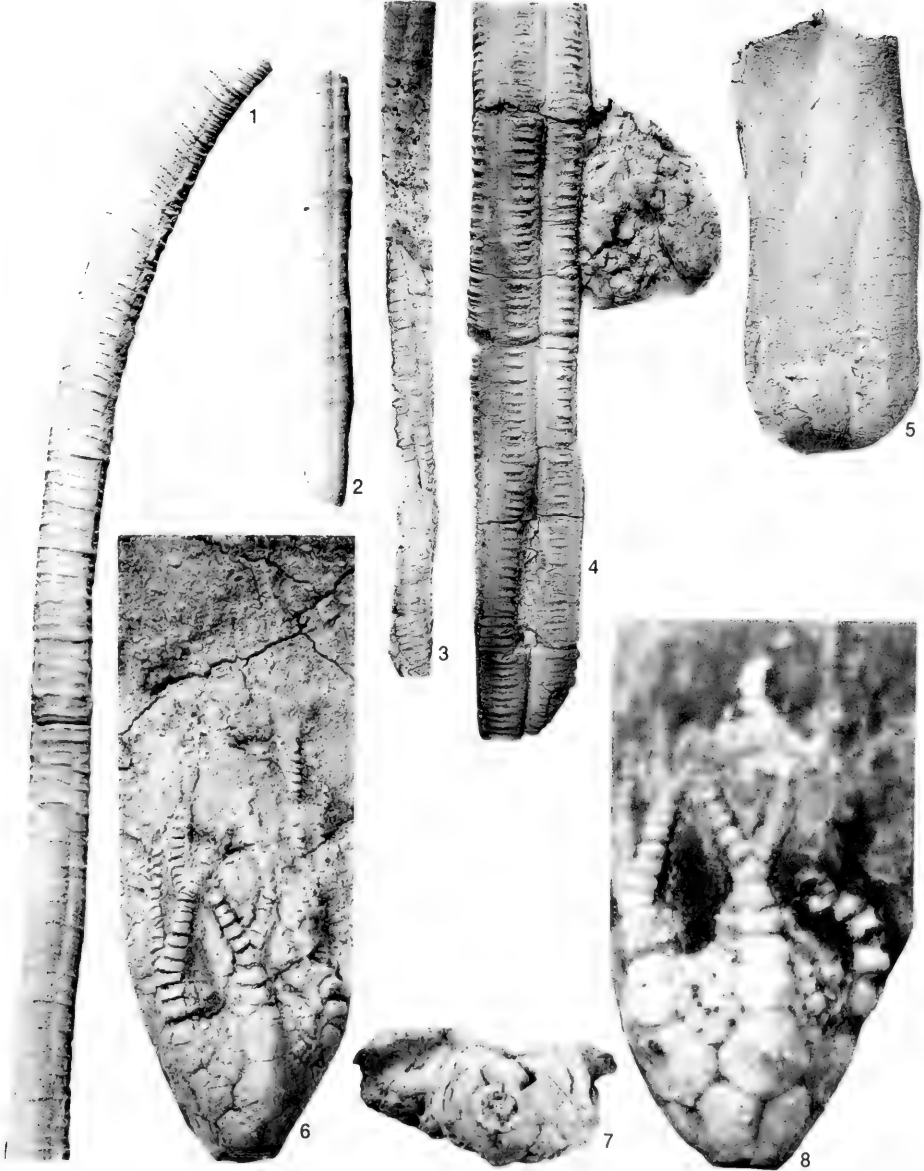

INDEX

Note: Page numbers for descriptions of genera and species are shown in **bold type**.

Abbott, Terry	5
acrocrinids	12
<i>Adelphicrinus</i> , n. gen.	13, 15, 23 , 24 , 26
<i>A. fortuitus</i> , n. sp.	5, 23, 24 , 26 , 40
Aethocrinina	15, 16
<i>Aethocrinus</i>	6, 7, 11, 12, 13, 14, 15, 16, 17
age	6
ambulacral floor plates	7, 8
anal(s), anal plates(ing)	11, 13, 16
anal cone	8, 17, 19, 35, 36, 38
anal X	13
anal plate homologies	13
anibrachial	13
<i>Anomalocrinus</i>	8, 12
<i>Apodasmocrinus</i>	11
archaeocrinids	13
Arrenig	5, 6, 7, 15, 24, 25, 26
arm(s)	7, 8, 14, 17, 18, 19, 20, 21, 22, 23, 32, 34, 35, 36, 37, 38, 39, 40
articular facet (on radial)	7, 8
articulate brachiopods	7
articulate crinoids	11
asteroblastids	7
autapomorphies	15, 17
Ausich, W.L.	5, 6, 7, 10, 11, 12, 14, 16, 27
Babeock, L.E.	7, 27
basal(s), basal plates	5, 8, 9, 10, 11, 12, 13, 14, 16, 17, 18, 19, 20, 21, 22, 36
basal ledge-forming limestone member	26
Bather, F.A.	7, 9, 11, 12, 14, 27
Baumiller, Tomasz	5, 13
<i>Belanskicrinus</i>	8, 12
Bergstrom, S.M.	6, 7, 26, 28
biradial(s)	11, 12
blastozoan(s)	6, 7, 13, 14, 16
brachial(s), brachial plates	12, 14, 16, 17, 19, 20
Breimer, A.	8, 27
Brett, C.E.	12, 27
Broadhead, T.W.	16, 27
Brosius, Anita	5
Brower, J.C.	12, 13, 27
bryozoans	7
<i>Calathium</i> -calcisillite member	26
calceocrinids	13
Cambrian	14
Camerata, Wachsmuth and Springer, 1885	20
camerate(s), camerate crinoids	5, 13, 14, 15, 16, 22, 23
Caradoc	6
Carpenter, P.H.	7, 9, 11, 12
Carpenter system (or terminology)	7, 12
caryocystiid (rhomberans)	14
CD interray (plating)	8, 11, 13, 14, 15, 16, 18, 21, 22, 33, 34, 35, 36
<i>Celtocrinus</i>	7, 13, 15
character (data) matrix (and unused characters)	14, 15
Cincinnati, University of	5
cincinnatiocrinids	12
cladid(s), cladid crinoids	5, 6, 7, 8, 9, 10, 11, 13, 15, 16, 23, 24
cladogram	14
Clark, A.H.	8, 27
<i>Cnemecrinus</i> , n. gen.	11, 13, 15, 21
<i>C. fillmorensis</i> , n. sp.	5, 21 , 26, 37, 40
Collins, D.E.	7, 14, 27
<i>Colpodocrinus</i>	11, 12, 16
<i>Columbicrinus</i>	11
<i>Compagicrinus</i>	7
conodont (samples)	5, 6, 26
Cooper, R.A.	6, 7, 25, 28
Cope, J.C.P.	7, 27
C-ray radial	14, 15, 22
CRDF Cooperative Research Grant RGI-242	5
crinoidal plane (of symmetry)	13
Crinoidea, Miller, 1821	16
crinoid(s)	5, 6, 7, 11, 12, 13, 14, 15, 16
Crinozoa, Matsumoto, 1929	16
crinozoan	7, 14
crown group(s) or taxa or clades)	11, 12, 13, 14, 15, 16
cup-base (plate) circlet	5, 9, 10, 11, 12, 13, 16
cup-plate circlet number	15
cup plate homologies	7, 9-10, 11, 12, 13
cup-stem boundary (or juncture)	11, 12, 14
data matrix	13
Dattilo, B.	6, 27
David, B.	7, 28
Devonian	12
<i>Diaboloocrinus</i>	20
dicyche (crinoid)	5, 10, 12, 13, 16, 21
?Diplobathrida, Moore and Laudon, 1943	21
diplobathrid(s) camerate	5, 9, 10, 13, 15, 16, 21
disparid(s), disparid crinoids	5, 7, 8, 9, 10, 11, 12, 13, 15, 16, 23
Domiguez Alonzo, P.	12, 27
Donovan, S.K.	7, 14, 15, 16, 2
Droser, M.L.	28
Dual Reference Homology System (DRHS)	12, 16
Early Cambrian	14
early crinoid phylogeny(ies) or record	7, 13, 14, 15, 16
Early Ordovician	5, 7, 9, 11, 13, 14
<i>Echmatocrinus</i>	6, 13, 14
Eckert, J.	12, 27
edrioasteroids	7
Eknomocrinidae, n. fam.	22
<i>Eknomocrinus</i> , n. gen.	12, 13, 15, 16, 22 , 26
<i>E. waldwahnensis</i> , n. sp.	5, 22 , 26, 38
<i>Elpavocrinus</i>	7, 13, 15
El Paso Group (Texas)	12
eocrinoids	7, 14
"epibasals"	13
Ethington, Raymond	5
eustenoocrinid	12
Exton, Brian	5
extrarail	7
Field Museum	16

- Fillmore Formation 6, 7, 19, 20, 21, 22, 23, 24, 25, 26
 fixed brachials 7, 9, 10, 11, 12, 14, 16, 17, 18, 20, 22, 23, 24, 25, 34
 fixed ray(s) (plates) 7, 8, 9, 11, 12, 14, 16, 17, 18, 34, 35, 39
 floor plates 14, 17, 19, 20, 32, 35
 four-circle cup 14, 16
Fremocidarinus 12, 13
 tunding 5
 gap plate(s) 8, 12, 13, 14, 16, 17, 18, 19, 20, 22, 33, 34, 35, 36
 geologic setting 6
 Gil Cid, D. 12, 27
 Giza Peak 26
Glenocrinus, n. gen. 9, 11, 12, 13, 15, 17, 18, 19, 26
G. globularis, n. sp. 5, 20, 26, 36
Glyptocrinus 13
 glyptocystitid (rhombiferans) 14
 grainstone(s) 6
 graptolite(s) 6, 25
 Great Ordovician Biodiversification Event 5
 Guen 26
 Guensburg, T.E. 5, 6, 11, 13, 16, 26, 27
 Habrotrocrinidae, n. fam. 24
Habrotrocrinus, n. gen. 11, 12, 13, 15, 24, 26
H. ibexensis, n. sp. 5, 24, 25, 26, 39
 hardground (surface) 6, 7
 heterocrinids 13
 Hintze, L. 6, 25, 27
 Hintze's Reef 26
 historical review 7
 Hogan, Sandy 5
 holdfast(s) 6, 8, 15, 18
 holomeric columnals 11, 14, 16
 homocrinids 12, 13
 homologous (plates, cup designs) 12, 13, 14
 homology(ies) 7
 homoplastic (character) 14, 15
 hummocky cross stratification 6
 hyboerimids 11, 13, 16
Hyboerimus 13, 15
 Ibebian 5, 6, 7, 15, 17, 19, 20, 22, 23, 24, 25, 26
 Ibeix area 6
Ibeixocrinus 13, 15
 Ibeix section 6
 IGCP Project 410 5
 inadunates, inadunate crinoids, Inadunata 7, 12, 15
 inferradial(s) 7, 11, 12
 infrabasal(s), infrabasal plates 5, 7, 8, 9, 10, 11, 12, 13, 14, 16, 17, 18, 19, 20, 21, 22, 23, 24, 25, 33, 34, 35, 36, 37, 38, 39, 40
 infrabasal circlet 6, 8, 14
 interbrachial(s) plates(ing), fields, or areas 11, 18, 20, 21, 22, 23, 24, 25, 39, 40
 intercalates 11, 24, 25, 36
 internal partitions (of attachment disc) 8
 intraray (plates) 13, 16
 intraformational conglomerate 6, 26
 iocrinids 7
 Jaekel, O. 14, 15, 27
 Johnson, L. 7, 27
 Johns, Ronald 5, 26
 Kelly, S.M. 6, 7, 15, 16, 27
 Kolata, D.R. 11, 27
 Koninek, L.G. de 8, 27
 Lane, N.G. 6, 16, 27
 Late Ordovician 6, 11, 13
 Laudon, L.R. 10, 13, 27
 "Law of Wachsmuth and Springer" (LWS) 10, 11, 12, 16
 Lefebvre, B. 7, 28
 Le Hon, H.S. 8, 27
 light-grey ledge-forming member 26
 litellid(s) 9, 10, 11, 12
 Llanvirnian 6, 7
 Lower Ordovician 7, 17, 18, 19, 20, 21, 22, 23, 24, 25, 26
 lumen 8, 15, 19, 20, 23, 24, 25, 39, 40
 Mann, Chris 5
 Martin, Jennifer 5
 matrix 6
 Matsumoto, H. 16, 28
 Mauk, Cindy 5
 megaripple(s) 6, 26
 meret(s) 9, 11, 12
Meroocrinus 13
 Meyer, Dave 5
 Michigan, University of 5
 mid-cup (plating or region) 12, 13, 16, 17, 18, 19, 33, 36
 Middle Ordovician 7, 13
 Miller, J.S. 16, 28
 Miller, S.A. 8, 28
 Miller's Reef 26
 Missouri (Columbia), University of 5
 Mohawkian 6
 ?Monobathrida, Moore and Laudon, 1943 22
 monobathrid(s), monobathrid camerate 9, 10, 11, 15, 16
 monocyclic (crinoid) 5, 10, 11, 12, 13, 16
 monocyclic camerate 5, 6, 22, 23, 24
 Mooi, R. 7, 28
 Moore, R.C. 10, 12, 13, 14, 28
 myelodactylid (disparids) 12
 n. gen. A 13, 15, 17
 nonpinnulate 7, 8, 17, 19, 20, 21, 22, 24
 nonstandardized plating 7
 NSF Grant BSR-8906568 5
 NSF Grant EAR-9304253 5
 ontogenetic sequence 11
 ontogeny 5, 12, 14, 16
 oral(s), oral plates 12
 outgroup 13, 14, 15
 Paleozoic (Era) 6, 12, 17
Panocrinus 13, 15
 Paris, F. 6, 7, 25, 28
 parsimony analysis 14
 Paul, C.R.C. 7, 27
 pentamer(s) 11, 17, 19, 24, 25, 33, 36, 37, 38, 39, 40
 pentamerie (stem) 7, 14, 16, 23, 24, 40
 peritocrinids 7, 12, 13, 15, 16, 24
Peritocrinus 13, 15
 Percival, I. 7, 28
 periproct 16
 Phillip, G.M. 11, 28
 pinnulate 15, 20
 plesiomorphies(ic) 13, 14, 16, 17, 20

- Podolithus* 6, 8
Pogonipocrinus 7
 polymeric columnals 14
 polyphyletic (taxon) 14
 pore rhombs 16
 posterior plating (or morphology) 11, 13, 16, 36
 preparation 6
 PRF-ACS Grant 5
 primary(ies or plates) 14, 17, 18, 19, 21, 32, 36
 primibrach(jial), primibrachial plates 19, 20, 21, 22, 23, 24, 25
 Pritz, Sherri 5
Proexenocrinus 7, 13, 15
 Protocrinoidea, new order 16
 protocrinoid(s) 5, 7, 8, 9, 10, 11, 12, 13, 14, 16, 17, 22
 pseudodicyclic (cup or pattern) 11
 pseudomonocyclic (cup or pattern) 11, 16
- Quinquecaudex* 11
- radial(s), radial plates 7, 9, 10, 11, 12, 13, 14, 16, 17, 18, 20, 21, 22, 23, 24, 25, 34, 39
 radial facet shape 15
 radianal 13
 radiometric dates 6
Ramsvoerinus 7, 13, 15
 ray plating (or plates) 7, 11, 12, 17
 ray ridges 18, 37, 39
 recumbant ray(s) 7
 Red Tops 26
 Reteocrinidae Wachsmuth and Springer, 1885 21
 reteocrinid camerate 5
Reteocrinus 8, 11
 reversal 12, 13
 rhombiferan(s) 7, 16
 Rock Valley College 5
 Rozhnov, Sergei 5, 28, 29
 Russia 7
- secondary(ies or plates) 12, 17, 18, 19, 20, 25, 36
 secundibrachs 19, 20, 21, 22, 23, 24
 Sevastopulo, G.D. 16, 28
 Siewers, Fred 5, 26
 Simms, M.J. 5, 9, 11, 12, 28
 single reference point (or system) 8, 12
 Skull Rock Pass 26
 Slattery, Mike 5
 Smith, A.B. 14, 28
 Southern Illinois University (Edwardsville) 5
 sponge-algal mound (layers) 6, 26
 Springer, E. 10, 13, 14, 15, 28
 Sprinkle, David 5, 26
- Sprinkle, James 5, 6, 7, 11, 13, 14, 16, 25, 26, 27
 Square Top East 26
 starved ripples 6
 Stem A 25, 26, 40
 stem angle(s) 10, 11
 Stem B 25, 26, 40
 stem-group crinoid 6, 7, 13, 16
 stem-group echinoderm(s) 7, 13
 stem lobe(s) 10, 11, 35, 37, 39
 storm generated 6
 stromatolites 26
 stratigraphy, stratigraphic occurrence or position 6, 25, 26
 Strimple, H.E. 11, 12, 28
 Sumrall, Cohn 5, 16, 19, 25, 26, 28
 superradial(s) 7, 9, 10, 11, 12
 synapomorphy(ies) 13, 16
- Tarde, Lisa 5
 tegmen 7, 8, 15, 17, 18, 19, 20, 21, 22, 32, 33, 36, 37
 tertiary(ies or plates) 17, 20
 tetramere 11
 Texas (Austin), University of 5
 Titanocrinidae, n. fam. 17
Titanocrinus, n. gen. 12, 13, 14, 15, 17, 18, 19, 26
T. sumralli, n. sp. 5, 18–19, 26, 32, 33, 34
T. species 19, 35, 40
 Treatise on Invertebrate Paleontology 14, 16
 Tremadocian) 5, 15, 17, 19, 20, 22, 23, 25
 tricyclic (cup or crinoid) 11, 12, 16
 trilobite(s) 6, 7, 19, 20, 22, 23, 24, 25, 26, 38
 twisting (in cup) 12
 2 1 2 ambulacral symmetry 13
- Ubaghs, G. 5, 10, 11, 12, 13, 14, 15, 16, 17, 28
 Utah 5, 17, 19, 20, 21, 23, 25
- Viscaino, D. 7, 28
- Wachsmuth, C. 10, 13, 14, 15, 28
 Wah Wah Formation 6, 25, 26
 Wah Wah Mountains 23, 26
 Wahlman, G.P. 7, 28
 Warn, J.M. 11, 28
 Webby, B.D. 6, 7, 25, 28
 webs, web plating) 8, 14, 17, 18, 19, 20, 34, 35
 Whiterockian 6, 7
 Wilson, H.E. 12, 28
 Wilson, Mark 5
- Yakovlev, N.N. 14, 28
- Zittel, K.A. von 8, 28



PREPARATION OF MANUSCRIPTS

Bulletins of American Paleontology usually comprises two or more separate papers in two volumes each year. The series is a publication outlet for significant, longer paleontological monographs (*i.e.*, more than approximately 50 printed pages), for which high quality photographic illustrations and the large quarto format are required.

Submissions are welcome from any author, regardless of institutional or organizational affiliation. Authors must, however, be members of the Paleontological Research Institution at time of publication; annual membership is currently US\$25.00. Publication costs of the *Bulletins* are heavily subsidized by the Institution, but authors are currently required to pay illustration charges at a rate of \$120.00 per plate and \$35.00 per text-figure.

Important references for style and format are 1) *Bulletins of American Paleontology* "Instructions for Authors" (volume 108, number 347, pages 149-153); 2) *Chicago Manual of Style* (fourteenth edition) 1993. Recent issues of the *Bulletins* provide useful guides but note changes with the "Instructions for Authors" mentioned above.

Manuscripts must be typewritten, and double-spaced *throughout* (including direct quotations, tables and references). All manuscripts should contain a table of contents, lists of text-figures and/or tables, and a short, informative abstract that includes names of all new taxa. Format should follow that of recent numbers in the series. All measurements must be given in the metric system, alone or in addition to their English system equivalents. The maximum dimensions for photographic plates are 178 mm × 229 mm (7 inches × 9 inches; outlined on this page). Single-page text-figures should be drafted for reproduction as single column (82 mm; 3½ inches) or full page (178 mm; 7 inches) width, but arrangements can be made to publish text-figures that must be larger.

Authors must provide three (3) printed copies of the text and accompanying illustrative material. Authors are *strongly* encouraged to prepare their manuscripts on word processors, as this considerably expedites publication. On initial submission, however, only printed copies of the manuscript should be sent; the disk copy should be retained so that revisions can be made after the review process. The text and line-drawings may be reproduced xerographically, but glossy prints at publication size must be supplied for all half-tone illustrations and photographic plates. These prints should be identified clearly on the back.

Referenced publication titles *must be spelled out in their entirety*. Particular care should be given to reference format. Consult the "Instructions for Authors," referred to above, as several changes have been introduced with that issue. Citations of illustrations within the text bear initial capitals (*e.g.*, Plate, Text-figure), but citations of illustrations in other works appear in lower-case letters (*e.g.*, plate, text-figure).

Format of systematic descriptions should follow that in any recent number of the *Bulletins*.

Original plate photomounts should have oversize cardboard backing and strong tracing paper overlays. These photomounts should be retained by the author until the manuscript has been formally accepted for publication. The approximate position of each text-figure in the text should be indicated. Explanations of plates and text-figures should follow the References Cited.



Gilbert Dennison Harris
(1864 - 1952)

Founder of the *Bulletins of American Paleontology* (1895)



SMITHSONIAN INSTITUTION LIBRARIES



3 9088 01457 1285