

1824

HARVARD UNIVERSITY.

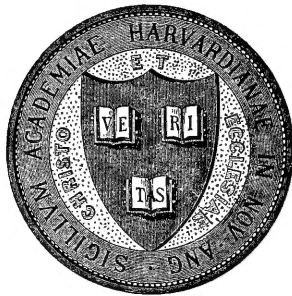

LIBRARY

OF THE

MUSEUM OF COMPARATIVE ZOOLOGY

35,343

Bought

February 26, 1923 - January 26, 1925.

35,343

FEB 26 1924

VOL. XXXVIII, No. 1

JANUARY, 1924



THE CANADIAN
FIELD-NATURALIST

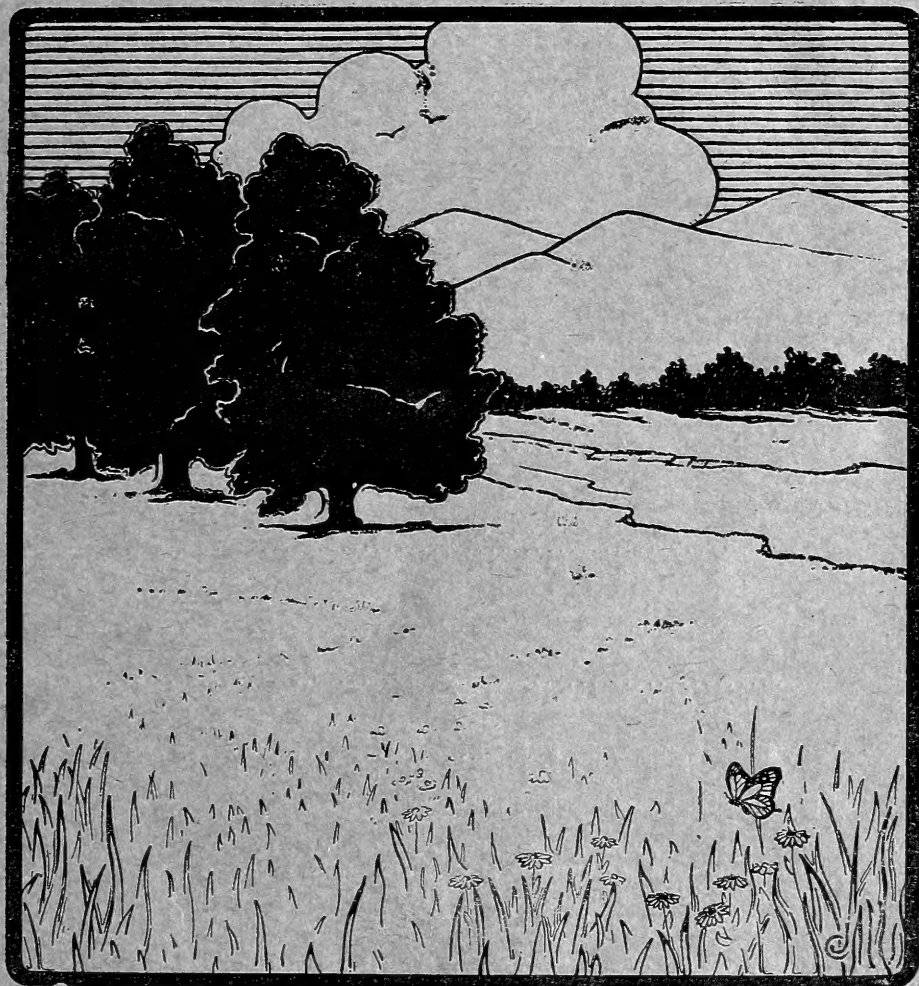

PUBLISHED BY
OTTAWA FIELD-NATURALISTS' CLUB

ISSUED FEBRUARY 15, 1924

Entered at the Ottawa Post Office as second-class matter

THE OTTAWA FIELD-NATURALISTS' CLUB

President: HOYES LLOYD.

1st Vice-President: G. A. MILLER.

2nd Vice-President: NORMAN CRIDDLE

Secretary:

J. F. WRIGHT
(Geological Survey, Ottawa.)

Treasurer:

B. A. FAUVEL,
(Mounted Police Headquarters,
113 Rideau St., Ottawa.)

Additional Members of Council: W. T. MACOUN; MISS M. E. COWAN; C. M. STERNBERG; H. I. SMITH; F. W. WAUGH; P. A. TAVERNER; E. SAPIR; E. M. KINDLE; W. J. WINTENBERG; R. E. DELURY; ARTHUR GIBSON; M. O. MALTE; R. M. ANDERSON; H. GROH; MISS F. FYLES; C. B. HUTCHINGS; H. M. AMI; CLYDE L. PATCH; D. JENNESS; V. W. JACKSON; R. O. MERRIMAN; W. N. KELLY; C. H. SNELL; J. R. MCLEOD; JOHN DAVIDSON; L. MCL. TERRILL; R. MEREDITH; FRANCIS KERMODE; PROF. R. B. THOMSON; THE EDITOR.

Editor:

HARRISON F. LEWIS,
Canadian National Parks Branch,
Dept. of the Interior, Ottawa.

Associate Editors:

E. SAPIR.....	<i>Anthropology</i>	A. G. HUNTSMAN.....	<i>Marine Biology</i>
M. O. MALTE.....	<i>Botany</i>	P. A. TAVERNER.....	<i>Ornithology</i>
F. R. LATCHFORD.....	<i>Conchology</i>	E. M. KINDLE.....	<i>Palaeontology</i>
M. Y. WILLIAMS.....	<i>Geology</i>	R. M. ANDERSON.....	<i>Zoology</i>
ARTHUR GIBSON.....	<i>Entomology</i>	CLYDE L. PATCH.....	<i>Herpetology</i>

CONTENTS.

	PAGE
Further Notes on Canadian Euphyllopods. By Frits Johansen.....	1
Nesting Habits of the American Goshawk. By A. D. Henderson.....	8
The Concentration of Migratory Birds at Sault Ste. Marie, Ontario, in the Spring. By W. H. A. Preece.....	9
The Birds of Ottawa, 1923—Revised to March 20, 1923. By Hoyes Lloyd. (<i>Concluded from Vol. XXXVII, page 156</i>).....	10
Notes and Observations:—	
Christmas Bird Census at London, Ontario. By E. M. S. Dale.....	16
Christmas Bird Census, 1923, Hamilton Ontario, Canada. By The Hamilton Bird Protection Society Inc.....	17
Christmas Bird Census, 1923, at Toronto, Ontario. By Stuart L. Thompson.....	17
The Christmas Bird Census, Ottawa District, 1923. By Hoyes Lloyd.....	17
A Cardinal in Ottawa. By Lois R. Kingston.....	18
Acknowledgements for 1923. By Clyde L. Patch, <i>Secretary (1923)</i>	18
Editor's Note.....	18
Financial Statements of the Ottawa Field-Naturalists' Club, 1922-23.....	19
Book Review:—	
The Condor, Vol. XXIV, 1922. By P. A. T.....	19

THE CANADIAN FIELD-NATURALIST, lately THE OTTAWA NATURALIST, established thirty-six years ago, "to publish the results of original research or investigation in all departments of natural history," is issued monthly, excepting for the months of June, July and August.

Papers, notes and photographs should be addressed to the Editor. Manuscript should be typewritten.

Subscriptions cover the current year, except those taken out during last quarter, when they will be applied on the following year, the remaining numbers of current year being sent free. Payments should be made to the Treasurer, Mr. B. A. Fauvel, Mounted Police Headquarters, 113 Rideau St., Ottawa. Price of this volume, \$1.50; single copies 20c each.

The Topley Co.

Photographic Material
Scientific Apparatus
Eastman Kodaks



132 Sparks Street
OTTAWA

EXPLORATIONS in Western Canada

The Ottawa Field-Naturalists' Club
has just published an interesting vol-
ume of over 300 pages, entitled:

Autobiography of John Macoun, M.A.

Canadian Explorer and Naturalist, Assistant
Director and Naturalist to the Geological Survey
of Canada—1831-1920.

This volume is an account of the life of this veteran
naturalist. Agriculturists generally, in fact all
interested in the development of Canada, will find
this book of much interest and value.

The edition is limited. The price is \$3.00 with
15c added for bank exchange, if remittance is forwarded
by personal cheque.

Applications for the volume should be made to

Mr. Arthur Gibson

Birks Building : Ottawa, Ont.

Grant-Holden- Graham Limited

Outfitters to
Surveyors & Engineers

Manufacturers of
High-Grade Tents
Tarpaulins & Sleeping Bags

WRITE FOR CATALOGUES

147 Albert Street
OTTAWA

Fine Diamonds

Sterling Silver, Fine
Cut Glass, Electro-
Plated Ware

*The Store of
Moderate Prices*

C. A. Olmsted & Son
*Jewellers, Opticians, Watchmakers and
Engravers*

208 Sparks Street, Ottawa

Lyman's Limited

(Established 1800)

MANUFACTURING CHEMISTS

Importers and Dealers in
CHEMICAL AND
ASSAY APPARATUS

344 St. Paul St. West, Montreal

THE Bank of Nova Scotia

Capital.....\$ 9,700,000
Reserve Fund and Divi-
dend Profits, over.... 18,000,000
Total Assets over..... 230,000,000

SEVENTEEN BRANCHES IN
OTTAWA AND HULL



GROW GOOD CROPS

SEEDS PLANTS BULBS

Our rigorous system of testing eliminates loss
and disappointment from your garden

Kenneth McDonald & Sons, Limited
Seed and Bulb Merchants
Market Square :: Ottawa, Ont

W. A. Rankin, Ltd.

Hammocks
Refrigerators
Builders' Hardware

410-412 Bank Street, Ottawa
Phones—Queen 1023-1024

L. C. Smith & Bro.

Typewriter

*Ball bearings in every frictional part of
the L. C. Smith insure long life, light
touch and easy operation*

Ottawa Typewriter Co. Limited
191 QUEEN ST., OTTAWA

Inspected Milk Ice Cream

Ottawa Dairy

Fresh Butter Buttermilk

Ward's NATURAL SCIENCE ESTABLISHMENT

Rochester, New York, U.S.A.

Manufacturers of the genuine Schmitt boxes,
exhibition cases and cabinets, also of the American
Entomological Company's insect pins.

Riker Mounts and botanical mounts always on
hand, also Riker botanical presses.

Send for our supply catalogue and other lists of
interest to collectors.

Headquarters for Entomological Supplies
and Specimens

"Say it with Flowers"

Sunnyside Greenhouses

Chas. Craig, Florist

Phone R. 566 Rideau Terrace OTTAWA

Kindly mention *The Canadian Field-Naturalist* to advertisers

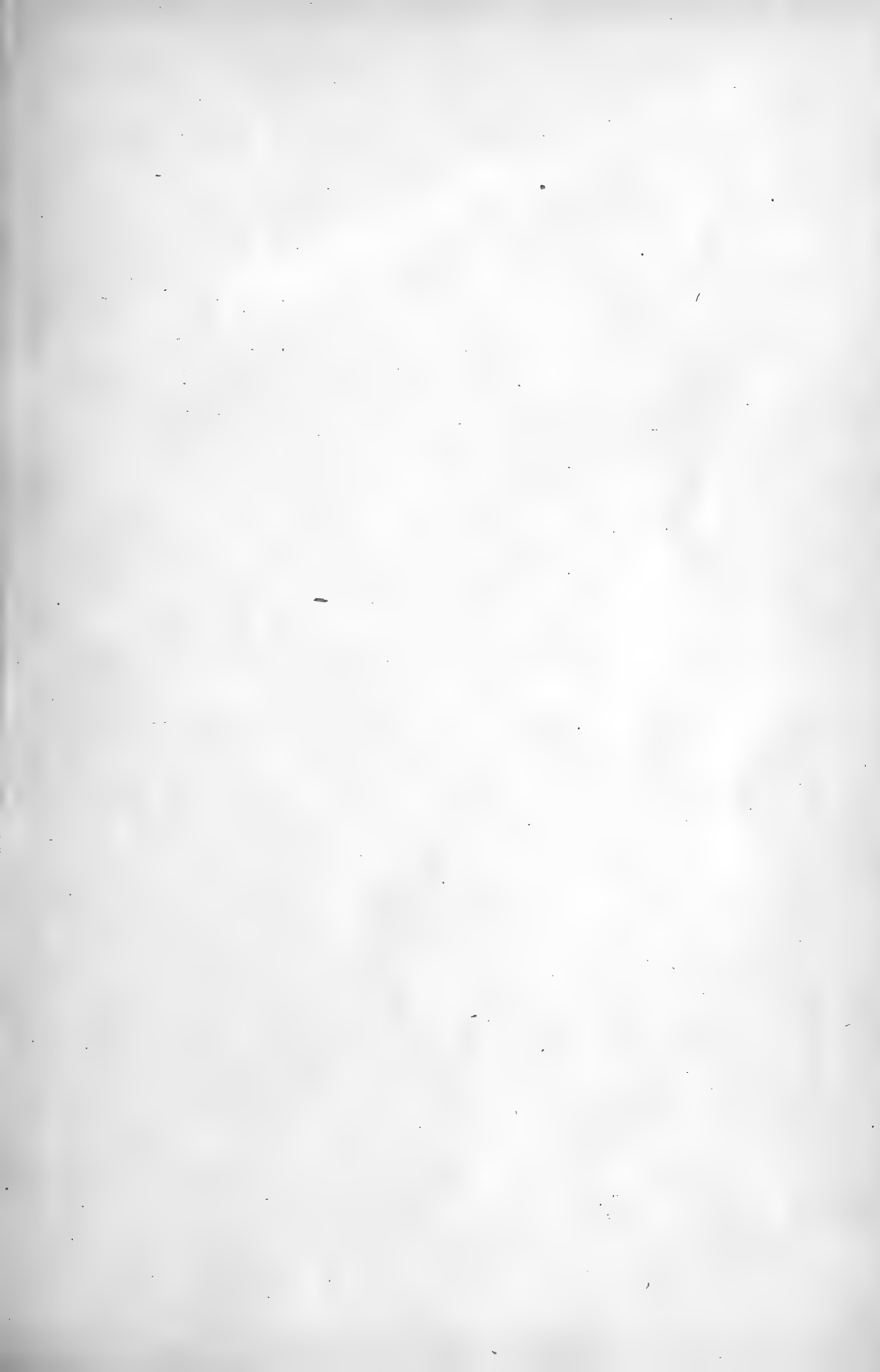

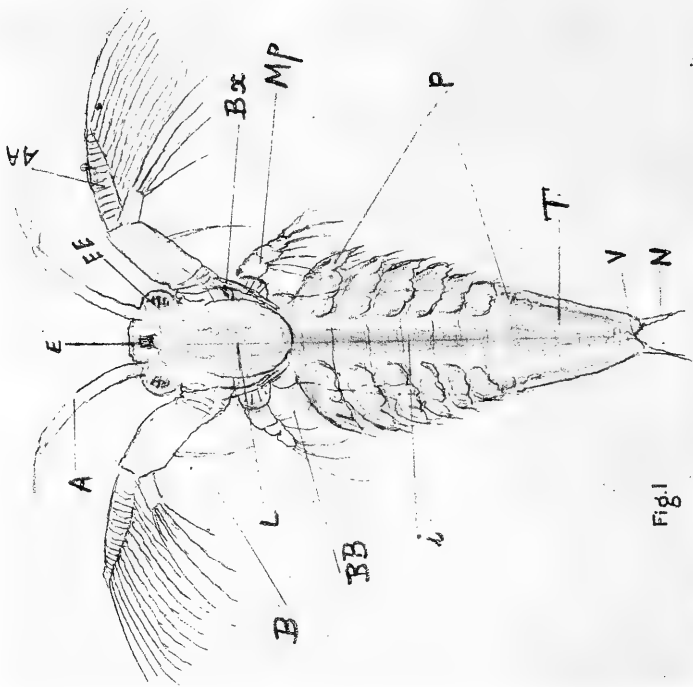

Fig. 1

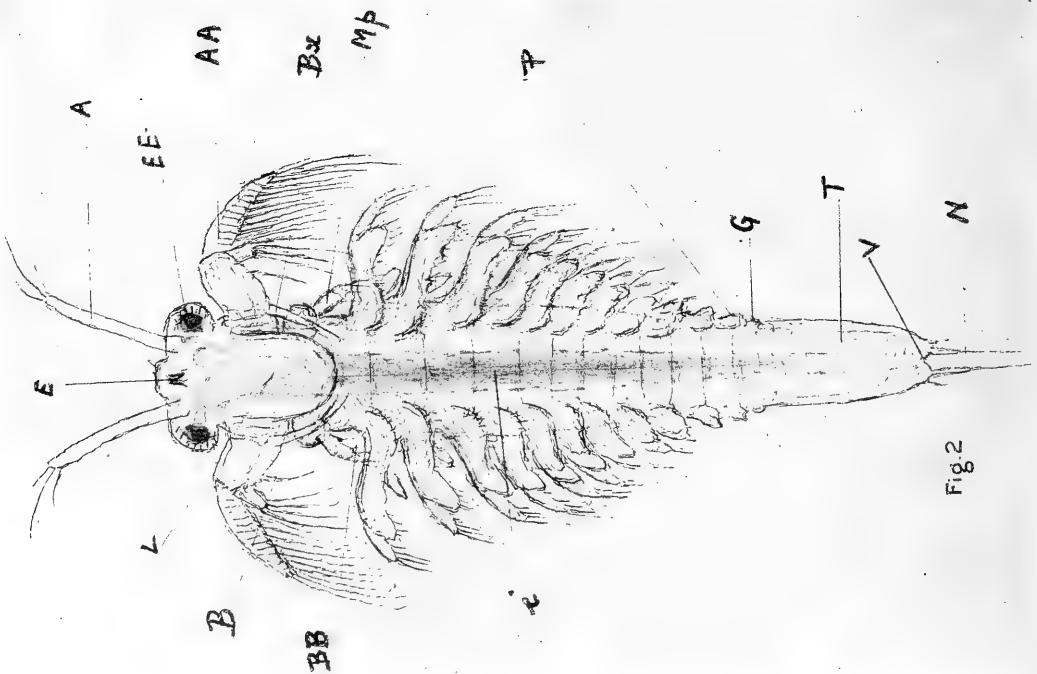

Fig. 2

G. O. SAERS, delin.

PRINTED BY PHOTOGRAPHIC ENGRAVING CO., LTD., OTTAWA.

The Canadian Field-Naturalist

VOL. XXXVIII

OTTAWA, ONT., JANUARY, 1924

No. 1

FURTHER NOTES ON CANADIAN EUPHYLLOPODS

By FRITS JOHANSEN



THE following are my observations on this group of Crustaceans, made after the publication of my article in *The Canadian Field-Naturalist* for January, 1923.

The cold weather during the first eighteen or nineteen days of April, 1923, when the temperature was mostly below the freezing point, delayed the arrival of spring around Ottawa, and consequently also the hatching and development of PhyllopoDS. Thus on April 8th I went to the collecting locality on the fields at Billings' Bridge and found them all flooded by the overflow of the Rideau River, now breaking up, making them impossible of approach. The cold weather at this period would, however, prevent the hatching of any Phyllopod eggs; nor were there any pools formed yet by the water receding. On April 15th I went out to Fairy Lake and examined the pools on the fields north of it where fairy-shrimps generally occur. Though the land was practically free of snow, the ponds had new ice an inch thick, a result of the last cold days, although the winter ice had apparently melted during the mild weather around April 10th. I examined particularly the deep pond where the fairy-shrimps are so numerous later in the year, but there were no signs of hatched eggs or of larvæ. The water had a temperature of 36°F. (air 34°F.) under the ice, at 4 p.m. Overcast, slight wind.

On the 19th of April the weather was clear and the maximum temperature rose to 48°F., and the minimum was just above freezing, owing to southerly winds; and the next day clear, warm weather came on suddenly, the maximum temperature reaching 76°F., though the minimum was only 28°F. The result was the immediate hatching of the eggs of *Eubbranchipus gelidus* in certain ice-free ponds on April 19-20th; but the eggs of *Limnætis gouldii* did not hatch until the last three days of the month, though the temperatures during the intervening week were between 30° and 70°F.

It will thus be seen that in 1923 the fairy-shrimps first appeared about 10 days later than in 1922, and the clam-shrimps almost a week later than in the preceding year. Furthermore, the last specimens of both species were found five to eight days later in 1923 than in 1922;

viz., *E. gelidus* on May 27th, and *L. gouldii* on June 26, 1923. It is one of the puzzles of nature why *Limnætis gouldii*, around Ottawa, hatches a week or two later than *Eubbranchipus gelidus*, even in the same pool, though its growth to maturity takes a longer time (about a month) than *E. gelidus*, which latter becomes ripe in a fortnight.

Eubbranchipus gelidus.

As mentioned, this species hatched in 1923 around Ottawa on April 19th and 20th, and by an excursion to Fairy Lake on April 21st I secured definite proof of this. It was a lovely, clear day, about as warm as the preceding one, and with a fresh breeze. I examined the various pools on the pasture fields north of the lake, but, even though Copepods were numerous, I saw no Cladocera nor Ostracods, and fairy-shrimps in one pool only, the one nearest Wrightville, where I have never found them before. The fairy-shrimps (*E. gelidus*) were now all in the metanauplius stage and of a size from 1½ to 4 mm. long, and far fewer than the Copepods also occurring here. Owing to their transparency they were difficult to see, and they were found only in the deeper parts of the pond where the water was 1 foot to 1½ feet deep, and where there were many dead leaves on the grass-bottom. Standing in the pool in my rubber boots, I secured a number of them by the aid of a pipette. Temperature of air and water at 6.30 p.m. was 60°F.

We are again greatly indebted to Professor G. O. Sars of Christiania, Norway, for the two beautiful figures of the youngest and the middle-sized metanauplii from this pool and date, shown on the plate accompanying this article. These represent stages of *Eubbranchipus gelidus* never before recorded or described; ones 3 mm. long being the earliest stage hitherto known. It will be seen that the youngest larvæ (1½ mm. long, Fig. 1), of which only a couple of specimens were found, are similar to the corresponding stages of its arctic relative, *Branchinecta paludosa*, so well described and figured already (see G.O. Sars: *Fauna Norvegiæ, I, Phyllocarida et Phyllopora*, Kristiana, 1896, p. 53, Tab. VIII, figs. 15, 16, and F. Johansen; *Euphyllpod Crustacea of the American Arctic, Rep. Can. Arctic Exped.*

1913-18, Vol. VII, Part G., Ottawa, 1922, pp. 17-20). The main difference lies, as Prof. Sars points out in his letter of September 24, 1923, to me, in the first pair of antennæ (*A*), which in the *Eubbranchipus* larva are much larger, heavier, and longer* than in the *Branchinecta* larva. It will, however, be seen that the *Eubbranchipus* larva represents a stage between the two larvæ figured (1896) by Sars, having the same relative size of the two pairs of antennæ (*A* and *AA*); the same small number (6-7) of foliaceous legs (*P*), with the hindmost 4-5 ones hardly indicated on the tapering, clumsy abdomen (*T*), which ends in a pair of simple (not double or triple) spines (*N*), and the same general shape of the whole larva as the youngest stage figured in Sars' Fig. 15 (1896).

On the other hand, this youngest *Eubbranchipus* larva known is similar to the larva figured in Sars' Fig. 16 (1896) in several particulars. Thus both paired eyes (*EE*) are similarly and well indicated; the labrum (*L*) is of a similar† shape (spoon-shaped), though comparatively larger than in Sars' Fig. 16, and the innermost pair of the two pairs of separate stylets or spike-bristles (*B*), originating on the base of the second pair of antennæ and paralleling the labrum on each side are cleft at the hairy end. Each of the half-a-dozen foliaceous legs developed is also similar to the foliaceous legs developed in Sars' older larva (Fig. 16), though the latter has about nine foliaceous legs out. The outermost pair of the two pairs of stylets mentioned, on the base of the second antennæ, are long, pointed and slender and end in about ten hairs on the inner side; there are also two pairs of similar, but shorter spike-bristles (*BB*), the innermost pair shortest, on the mandibular palp (*Mp*), besides its three terminal spines. The short branch of the second antenna has four terminal spines and its long branch 4-5 times as many, covering its whole length. The first pair of antennæ end in one short and two long hair-spines; and the upper (first) foliaceous legs have five short, terminal spines and four similar spines above the "gill" or respiratory lobe, the number of these spines decreasing on the succeeding, foliaceous legs.

At the time of collecting these *Eubbranchipus* larvæ I made a sketch of what I considered the youngest stage (1½ mm. long), which sketch differs from Prof. Sars' drawing reproduced here in a few minor details, which I venture to set forth. In my drawing of the larva the paired eyes are

*In addition I would suggest that in the *Eubbranchipus* larva (youngest stage) the abdomen-tail (*T*) behind the foliaceous legs (*P*) is thicker (more clumsy and cone-shaped), and the two spines (*N*) in which it ends, longer, than in the *Branchinecta* larva.

†The shape of the labrum seems to be more spoon-shaped in the *Eubbranchipus* larva, and more oval in the *Branchinecta* larva.

better developed and set off; the labrum more slender or narrow and decidedly spoon-shaped (as is the bill of *Ornithorhynchus* seen from above) and the abdomen-tail comparatively shorter and more rounded above than in Prof. Sars' drawing. I also find a tiny spine on the outside of each of the 2 long spines in which the abdomen-tail ends; and eight, instead of six or seven, foliaceous legs free of the abdomen-tail, with only one, instead of two or three, more foliaceous legs indicated. Nor was I able to discover the innermost pair of the two pairs of spike-bristles on the base of the second antennæ; but Prof. Sars' drawing is probably more correct than mine, which was made by magnifying about 100 times, ventral view. The larva figured by Sars is probably a little younger than the one I sketched.

When collecting these *Eubbranchipus* metanauplii, I noticed that the youngest individuals, described above, had a paler, more whitish and transparent general colour than the older ones, apart from the paired eyes and the large, orange maxillary gland inside the labrum. These youngest individuals were very lively in their movements, jumping in the water by the aid of the large swimming antennæ (*AA*) and holding themselves in more of a vertical than a horizontal position during this, a characteristic of all Phyllopo-nauplii. They were also quite tenacious to life, being still alive in the corked vial when I reached my office several hours after collecting them.

The second drawing made by Prof. Sars (Fig. 2 on the plate) shows a little older stage, when the metanauplius is about 2 mm. long. It will be seen at a glance that the paired eyes (*EE*) are now much better developed and set off than in Fig. 1, also the second pair of antennæ (*AA*) and mandibular palps (*Mp*) are much smaller in proportion, while the foliaceous legs (*P*) are much better developed both as to number, hairs (spines) and branches, the total number (eleven) of the adults being present, though the two hindmost pairs are as yet rudimentary. Behind the last pair will be seen on each side of the abdomen-tail a similar swelling or rounded process, the beginning to the genital organs (*G*). The abdomen-tail (*T*) is thick and almost cylindrical, not cone-shaped as in the younger stage, and ends in two long, single spines, longer than in the younger stage, each one with a small, single spine on the outside (*N*). It will also be seen that the length of the head, including labrum, is only one-fourth of the total length, while in the younger stage (Fig. 1) it is one-third. This is, of course, due, not to any great decrease in the size of the head, but to a considerable lengthening of body and tail. The first pair of antennæ (*A*) are still large, almost as long as the head.

These 2 mm. long metanauplii of *Eubranchipus* thus correspond almost exactly to the stage of *Branchinecta* mentioned and figured by Sars (1896, p. 55, Tab. VIII, Fig. 17); but the *Eubranchipus* larvæ are readily distinguished from the *Branchinecta* metanauplii by the much longer and thicker first pair of antennæ (*A*); by the more spatulate than oval-shaped labrum (*L*), and by the different number and shape of the spines (*N*) in which the tail (*T*) ends (see above). Although Sars (1896) does not include the body and tail in his Fig. 17, it is clear from the little younger

stage (Fig. 16) of *Branchinecta*, that the cercopods (paired process) (*C*), in which the tail ends, develop much earlier in *Branchinecta* than in *Eubranchipus* (where they are first found at a length of 3 mm.), and carry at least 3 spines, as compared to the two spines (*N*) protruding directly from the tail-end of *Eubranchipus* larvæ 2 mm. long.

The colouration of these 2 mm. long metanauplii of *Eubranchipus*, when alive, was more vivid orange than in the $1\frac{1}{2}$ mm. stage, but less so than in the ones 3-4 mm. long. It need hardly be added that the position, when swimming, is partly vertical, partly horizontal, and that the movements are effected both by the second pair of antennæ and by the foliaceous legs, the tail not yet being sufficiently long and movable to be of much assistance.

To illustrate the appearance of *Eubranchipus gelidus* at the stage where it is 3 mm. long, I reproduce a rough sketch of the youngest specimen collected by Dr. A. G. Huntsman in a pond near Bond Lake, at Toronto, Ontario, on April 10, 1920 (see *The Canadian Field-Naturalist* for February, 1921, p. 28). The same stage was collected by myself at Billings' Bridge, Ottawa, Ontario, on April 13, 1922 (see the same publication for January, 1923, p. 1), and, as mentioned, on April 21, 1923, near Wrightville (Hull), Quebec, (see below).

It will be seen from my sketch (Fig. 3), about 100x, that the two pairs of antennæ (*A* and *AA*) are still fairly large (1 mm. long), and the paired eyes (*EE*) still better set off on peduncles and developed; but that the mandibular palps (*Mp*) and labrum (*L*) are now much smaller, and the latter more oval in shape than formerly. On the other hand, the mouth-parts (maxillæ and mandibulæ) and particularly the foliaceous legs (*P*) are better developed, all eleven of the latter ones now being free of the abdomen-tail (*T*) and practically as in the adults, except the last 1-2 pairs. The head and body occupy exactly two-thirds of the total length, and the genital region is better indicated than in the younger stages. Apart from

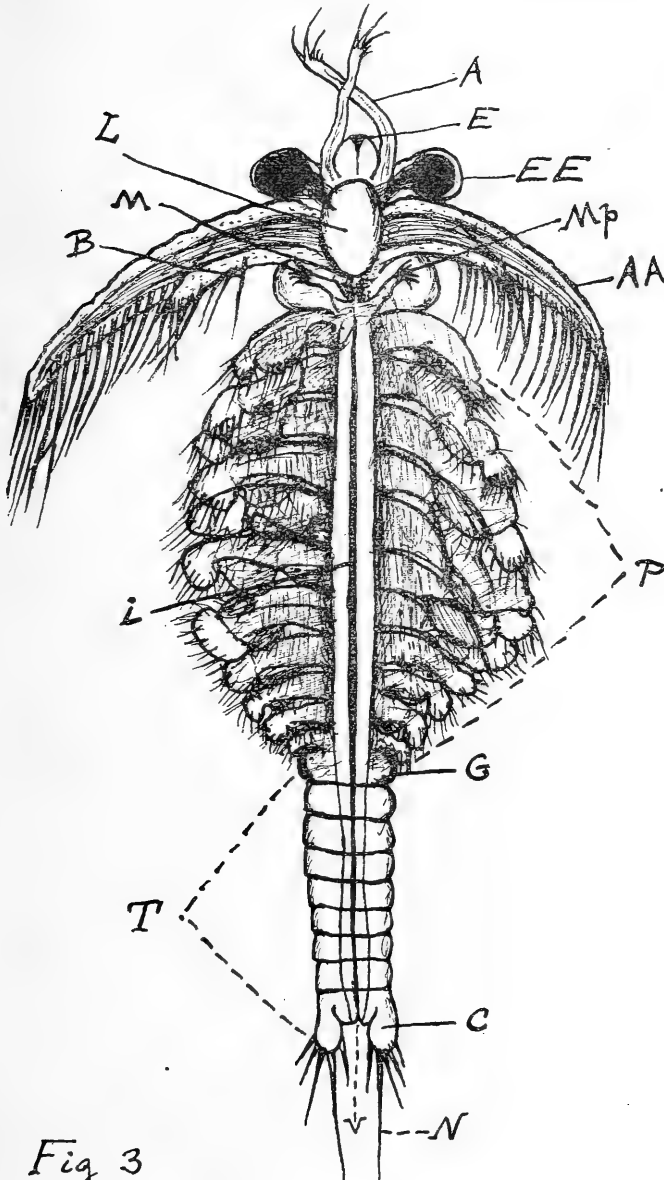

Fig 3

the genital segment (*G*) the tail (*T*) consists of eight segments or rings, the last one of which runs out laterally into a pair of oval lobes or cercopods (*C*), supplied with five rather long spines, and the whole shape of the tail is oblong-cylindrical and square "cut" at both ends, as in the adults, though shorter.

As for coloration, when alive, the back, tail (including cercopods) and two pairs of antennæ are pale; the nauplius-eye (*E*) black, and the paired (composite) eyes (*EE*) red-purple; the intestine (*I*) shows green contents (algæ), and the foliaceous legs have their free ends of a rose-orange colour, while the labrum (*L*) is red-brown (maxillary gland).

It will thus be seen that this 3 mm. long stage of *Eubbranchipus gelidus* has still a few of the larval characters (large antennæ and long spines on cercopods, paler coloration, etc.), though most of the adult characters. I also observed that in life they swim in the water *horizontally*, with either the dorsal or the ventral side uppermost, by the aid of the foliaceous legs almost entirely; and they showed also by their other movements (sudden jerks with the tail, seeking the bottom when disturbed, and circling in the water) that they had acquired most of the habits of the adults.

The stage which is 4 mm. long is, of course, still nearer the adult, and can hardly be called a metanauplius any more. The main differences from the preceding stage (3 mm. long) are the still smaller antennæ and labrum, and the better development of the foliaceous legs, genitalia and tail. The latter is longer and more slender, as are the cercopods; the latter assuming the oblong, lanceolate form so characteristic of certain genera of adult fairy-shrimps. The general coloration is of course also more vivid than in the younger stages.

At a size of half a centimeter *E. gelidus* is practically as the adults, the long spines on the cercopods falling off and being replaced by the many short, fine hairs which fringe the margin of the cercopods in the adult. The second pair of antennæ and mandibular palps also lose their appendages (spike-bristles) and long hairs, and the former are in the male transformed into the large claspers used for copulation.

At a length of 1½ cm. *E. gelidus* is sexually mature and developed (female with dorsal processes, etc.), though they keep growing for 2-3 weeks longer.

On April 22, 1923, it rained heavily until evening, and the two following days were cloudy. April 22-25, 1923, around Ottawa, had temperatures between 34° and 60° F., and on the last-mentioned day, when the weather was clear and warm, I went to the same collecting-locality

(Wrightville) where I had gone ten and four days before. I now found the same pool that I examined on April 25 full of young *E. gelidus*, now measuring 4-12 mm. in length, though the great bulk of them were less than 10 mm. long. The large, shallow pond a little south of it, where *E. gelidus* generally occurs, contained on this occasion, only a few fairy-shrimps, measuring between 5 and 9 mm., but in the deep pond west of it (see April 15, 1923, etc.), where they seem to be so much more numerous every year, many more of the same lengths were collected, though they were found only in the deeper parts. In this latter pond the water had a temperature of about 60° F. at 7 p.m. (Air 50° F.)

The next day was also clear and warm (temperatures between 30° and 68° F.), and I went to Billings' Bridge. Most of the overflow from the Rideau River had now receded from the fields south of the road so that the pools in the depressions here were now distinct. The same water hole in which I found *Limnetis gouldii* nauplii and fairy-shrimps four days earlier last year was now teeming with *E. gelidus* 5-10 mm. long; the water had a temperature of about 60° F. at 7 p.m. (air about the same temperature). In two larger pools or ponds nearby were found fewer, but generally larger (up to 12 mm. long) fairy-shrimps. Though Copepods and Ostracods in all sizes were common in the different pools there were no signs of *Limnetis gouldii* yet.

April 27, 1923, was warm and overcast (temperature between 36° and 70° F.) and the next day was rainy. In the afternoon of April 28, I again went out to the fields at Billings' Bridge and found in the smaller pools (not the ones examined two days before), a few more specimens of *E. gelidus*, besides the first nauplius and metanauplii of *Limnetis gouldii* (see later). I have now assured myself that the fairy-shrimps occur in practically all the ponds and pools on the inner part of the fields here but not in those of the part of the pasture nearest the road.

April 29 was warm and clear (36° to 64° F.), and the next day overcast with rain-showers. On April 30 (temperatures between 36° and 56° F.) I was along the Gatineau River, and visited the large pond on the fields at Tenaga where I have formerly found both fairy-shrimps and clam-shrimps so numerous. Also, on that day, I found *E. gelidus* (5-13 mm. long) in great numbers swimming around in the deeper parts of the marginal water; and also secured nauplii and metanauplii of *Limnetis gouldii* (see later).

The next three days were clear and warm (temperatures on May 1, between 40° and 58° F.); and on May 2, I went again to Billings' Bridge. All the pools on the inner part of the pasture

were now teeming with *E. gelidus*, even the ones almost dried up. Some of the pools were already dried up completely; and it thus seems as if a great many fairy-shrimps are killed before their time is up, when they occur in very small pools. In size, they were between 10 and 15 mm. long, and mostly sexually mature (females with ripe eggs, males with big claspers, etc.). I kept some of the specimens collected alive until 16 days after, the females living the longest.

May 4 began rainy, but the next three days were clear and warm (temperatures on May 7 between 44° and 76° F.); then followed two rainy days (temperatures on May 8 between 44° and 78° F.), and colder (24°-46° F.), snowy and windy weather on May 10, and overcast weather the two following days.

On May 13 it was clear and warm (34°-62° F.); and the day after was similar, a real summer day. I was along the Gatineau and in two pools in the depressions among the trees on the rocky hill near the river, between Tenaga and Kirk's Ferry, I found a great many full-grown *E. gelidus* of both sexes (females with ripe eggs, males with big claspers). The fairy-shrimps had almost more brilliant, metallic, greenish and red-brown colours than I had ever seen before, probably a result of the deep colours of the many dead leaves and the vegetation (algæ, etc.) in the water. The latter had a temperature of 43° F. at noon (air 55° F.). These two pools were several feet deep and were probably the result of melting snow. The river in the first two weeks of May rose far

beyond its normal level, inundating all the lower land on both sides, but the pools were found beyond its reach. Fairy-shrimps have not before been observed in these pools. In the pond examined two weeks earlier, many adult *E. gelidus* were also found on this date (females with ripe eggs); both in this pond and in the 2 pools nearer Kirk's Ferry a few immature individuals were collected.

The next 3 days were rainy, May 16 being warm (50°-72° F.), the two other days cooler (40°-56° F.). Then followed two clear and warm days and on May 20 much rain fell from noon on. That day I went again to Billings' Bridge but found no fairy-shrimps in the smaller (almost dried up) pools on the inner part of the pasture, though these had been partly filled again by rain-water. Full-grown specimens of both sexes, 1½ cm. long, were, however, common in the large pools, and the females had mostly ripe eggs, although I secured one immature female, 10 mm. long. I kept some of them alive for five days afterwards.

May 21 began overcast (temperatures between 48° and 56° F.); but then came a longer period with clear and warm weather, (temperatures on May 28: 48°-68° F.), lasting until the beginning of June, when it changed to hot and sultry (June 3), followed by a thunderstorm and rain-showers (June 4-5). On May 27 I was at Westborough and in the pool in the woods along the new Drive-way from Richmond Road to the Rapids I observed a couple of full-grown female *E. gelidus* (with eggs), swimming around in the deeper part



Photograph by D. Jenness

Pond at Tenaga, Quebec, May, 1921



Photograph by F. Johansen

Ponds at Billings' Bridge, Ontario, May, 1921

of the pool, and quickly hiding themselves among the dead leaves at the bottom when I tried to catch them. These must have been the very last fairy-shrimps still alive this year, because in spite of careful looking only 2-3 specimens were seen in this pool. They had not formerly been observed there; and the pool is apparently formed by melting water from the surrounding drier swamp, dammed up by the building of the new driveway. This is the latest date in the spring upon which *E. gelidus* has been observed around Ottawa.

I have given the meteorological data for Ottawa during April and May, 1923, in such detail, because they are of vital importance to an understanding of the biology of *Limnetis gouldii*, and particularly of *Eubbranchipus gelidus*. Indeed, it may be said that the fairy-shrimps are as important a presage of spring as are certain birds and the frogs, and in addition, by their complete disappearance in the middle or the end of May, signify the advent of summer weather. It is my hope that in the future they may be included in phenological observations, and studied in detail also at places in Canada other than Ottawa.

Limnetis gouldii (*L. brachyurus*.)

It has been mentioned above that in 1923 this species did not occur around Ottawa until the end of April, though careful search was made for it, and *Eubbranchipus gelidus* occurred from the middle of the month on.

On April 28 I went to the same pools at Billings' Bridge, Ontario, where I secured *L. gouldii* last year (see *The Canadian Field-Naturalist* for

January, 1923, p. 2), and in a small pool similar to the one in which I had secured *E. gelidus* two days before, I now found one nauplius and 2 metanauplii of *L. gouldii*. I used the same method as last year; but though I kept at it for an hour I did not get any more larvæ, which indicated that the eggs had only just begun to hatch. The water in this pool had a temperature of 50° F. at 7 p.m. (Air 57° F.; misty rain.)

The nauplius had a length of $\frac{1}{2}$ mm. and the two metanauplii each a length of $\frac{3}{4}$ mm. The former had the characteristic appearance (lateral, cephalic "horns", nauplius-eye and "turtle-shell", etc.) already described by me and figured by Sars (*C. F.-N.* for January, 1923), though the one secured this year seemed to be a little younger than the nauplii found last year here, while the metanauplii already had the paired eyes, the double carapace ("clam-shell"), several foliaceous legs, etc. These 3 specimens have been presented to the U.S. National Museum. I kept them alive for awhile in a vial and noticed that the nauplius, when swimming in the water, holds itself mostly vertically, with the hind-end downwards; uses during this the second pair of antennæ and mandibular palps simultaneously; and after each forward movement (stroke) the larva falls back a little, as is the case with the corresponding stages of fairy- and tadpole-shrimps (see *Meddel. om Grönland*, Vol. XLV, p. 336, and *Rep. Can. Arct. Exped.*, 1913-18, Vol. VII, Part G., p. 18.)

The pond on the fields at Tenaga, Quebec, was visited on April 30, and *L. gouldii* was also common this year in the shallow, marginal water of it,

together with *E. gelidus*. The water had a temperature of 52° F. at 4.30 p.m. (Air 46° F.; rainy.). Only one of the larvæ found on this date was in the nauplius stage ("turtle-shell", etc.) and measured $\frac{1}{2}$ mm.; the others, though not much larger (up to $\frac{3}{4}$ mm.), all had the double carapace ("clam-shell", etc.), and were thus in the metanauplius stage. They occurred particularly at places where dead leaves covered the bottom of the pond, and quite a few were secured.

On May 20 I again went to Billings' Bridge and examined the pools here carefully, but though Copepods, Ostracods and *Eubranchipus gelidus* occurred in thousands, I secured only four larvæ of *L. gouldii* (all metanauplii), three of which measured $\frac{3}{4}$ mm., and one 1 mm. in length. The water in the pool where they occurred had a temperature of 60° F. at 7.45 p.m. (Air 50°F.; clear).

It will thus be seen that in 1923 *L. gouldii* hatched around Ottawa in the last days of April and the first days of May. Apparently, however, some of the eggs hatch before the others in the same pool, and they hatch better in some ponds, as in those at Tenaga, than in others, such as those at Billings' Bridge.

I was surprised not to find any *L. gouldii* in the two pools between Tenaga and Kirk's Ferry where *E. gelidus* and other Entomostraca were so common on May 14, as it seemed an ideal place for them. They were, however, common enough in the pond at Tenaga where I secured them two weeks before; they now measured 1-1 $\frac{1}{2}$ mm. in greatest diameter.

By visiting Billings' Bridge again on May 20, I found *L. gouldii* to be very common in the large pools or ponds on the pasture. The specimens secured measured from 1 $\frac{1}{2}$ to 2 mm. in longest diameter, and (particularly the smallest ones) had a vivid, orange colour, the foliaceous legs and head being strongest colored. The water in these pools had a temperature of about 60° F. at 6 p.m. (Air 58° F.; rainy). The other smaller pools on the pasture had dried up completely or nearly so, and though they had been partly filled again by the heavy rainfall of last week, no Euphyllopoda were found in them now. The young *Limnetis* observed today were moulting frequently; but, although I kept a number of them alive and isolated two of the size-extremes, I was not able to get definite data about this, as they died before the shell was moulted. From my observations I would, however, suggest that the moulting of the shell, involving the change from a nauplius into a metanauplius, takes place in 1-2 days; the next moulting 2-3 days later; then another in 3-4 days, and so on fairly regularly, with longer and longer intervals between two successive moultings.

On June 5 I again visited Tenaga, and the *L. gouldii* were still numerous in the pond where they were collected three weeks before. The animals were keeping to the vegetation along the margin of the pond, but there were no *Eubranchipus gelidus* at all to be seen. The twenty specimens of clam-shrimps collected measured from 2 $\frac{1}{4}$ to 3 mm., and had a brilliant orange colour, paler when seen in the water. Both sexes were represented; and the females had dorsally, on each side inside the shell, about fifteen olive-green eggs, which fell out when the mother animal died. The two sexes were frequently seen in copulation, the male being by far the most energetic during this (see below).

On June 16 I again visited the fields at Billings' Bridge, and found *L. gouldii* common enough in several of the pools on the inner part of the pasture. Both sexes were present and frequently found in copulation, the females carrying eggs. Their size was now 2-3 mm., the females being the larger. Some of them were bright orange, others were brownish, and this difference in colour was not according to size or sex, but accidental.

On June 26, I was along the Gatineau and found a few living, full-grown *L. gouldii* in the usual pond at Tenaga. The eight specimens secured all had a bright orange-red-brown colour, with a growth of white Infusoria and green Alga-mould on the shell, foliaceous legs, etc. Four of them were females with eggs, which copulated freely with the four males, which latter had the same size as the females. This is the last occurrence of the species around Ottawa in 1923, and a week later than in the two preceding years; probably their late occurrence can be explained by the delay in the hatching of the eggs two months earlier. The weather during June, 1923, was mostly clear and warm with half a dozen rainy days scattered through the month.

A number of clam-shrimps collected during June, 1923, were kept alive for study, and I made the following additional observations of them.

During the copulation the male grasps, by the aid of the "hand" (modified, first pair of foliaceous legs) the female's shell, attaching themselves on the middle part of the free margin of one of the valves (carapace-shell); thus assuming a position vertical to that of the female, and with the beak of the head pressed against the "umbo" of this valve. It then moves its foliaceous legs continuously, and keeps the two valves of its own shell open, and when the female opens its two valves, the male bends the hindpart of its body in between the valves of the female shell, keeps it there for about five seconds and withdraws it again. This takes place a couple of times each minute, unless the female keeps its shell closed, swims vigorously

around alone, or the pair is disturbed by a third, visiting clam-shrimp. During the act of copulating the tail-end or abdomen of the male is bent back and protrudes from the female shell, and thus forces the valve of her shell opposite to the one to which his "hand" is attached to remain open as long as the copulation lasts. The genital organs have their aperture ventrally, between the thorax (foliaceous legs) and the last body-segments (abdomen); and it is therefore this part of the male's body which is inserted between the last pairs of foliaceous legs of the female, during the copulation. The latter takes place almost as soon as a male meets a female, even if the latter one carries eggs in the form of an olive-green colored mass on each side of the body, dorsally.

When these clam-shrimps were kept alive in water, many of the eggs would fall out from the females, thus showing that they were ripe; and both Prof. Sars and I have gone to much trouble

to try to hatch them artificially, but without any success so far, though both dead mother-animals, deposited eggs, and mud from the ponds in which they were found were kept for years. These remarks hold good for *Eubbranchipus gelidus* too; and the only way to get hold of the nauplii of these two Euphyllopoda thus seems to be to examine particular ponds carefully on the day the eggs hatch in nature.

EXPLANATIONS TO THE FIGURES

Ventral views of *Eubbranchipus gelidus* metanauplii (Originals). Fig. 1, a larva 1.41 mm. long (youngest stage observed); fig. 2, a larva 2.15 mm. long.

Both figures drawn by Prof. G. O. Sars, from specimens collected at Ottawa on April 21, 1923, by F. Johansen. Fig. 3, sketch by the author of a larva 3 mm. long, collected by Dr. A. G. Huntsman, near Toronto, on April 10, 1920.

Legend: A, first pair of antennæ; AA, second pair of antennæ; E, the single nauplius-eye; EE, the paired, composite eyes; L, labrum; B, spike-bristles on base of second pair of antennæ, with X, the cheliform process; Mp, mandibular palps, with BB, spike-bristles on their base; P, foliaceous legs; I, intestine; G, genitalia-segment; T, abdomen-tail, ending in spines, N, and (later) a paired process, the cercopods; C; V, vent (anus); M, maxilla.

NESTING HABITS OF THE AMERICAN GOSHAWK

By A. D. HENDERSON

IN THE vicinity of Belvedere, Alberta, the American Goshawk is a regular resident, but is not numerous and is yearly becoming scarcer, as it is a bold hunter and is often shot when it comes around the farms in pursuit of pigeons and poultry. Its main food, however, is Ruffed Grouse and hares. The usual breeding place is in heavy poplar woods containing a scattered growth of spruce.

I have seen these birds in mid-winter in the Clear Hills, in the Peace River country, and also observed a nest with bird sitting near White Mud Prairies on April 28th, 1916. At Belvedere it is the earliest breeding Hawk and eggs can be taken throughout April and into May.

The first nest I ever examined was about twenty miles south of Belvedere on April 14th, 1903. It was in the crotch of a tall poplar and contained one egg and the bird was sitting. On April 18th, 1906, I observed a Goshawk sitting on a nest in the forks of a large poplar. On climbing to the nest I found it contained one egg. This nest was the usual structure built by a large Hawk, and was made of dead sticks with a lining of strips of dry poplar bark and a few green spruce twigs. It was about thirty feet from the ground. All the nests of the Goshawk I have examined were of similar construction, except that in most cases the green spruce twigs were omitted. The height of the nests varied from about twenty-five to seventy-five feet.

When a nest is being taken both birds usually remain in the vicinity uttering cries of *Kek, Kek,*

Kek and *Quee, Quee, Quee*. Sometimes only one bird is seen at the nest. Often a bird will swoop fiercely at the climber's head and has to be warded off or it would surely strike. On one occasion one hit my hat a hard blow. After the eggs are taken the bird will often return and sit on the edge of the nest or resume sitting.

The Goshawk usually uses the old nest of another Hawk, building it up on top and relining it, but often builds a complete nest of its own. It seems to be attached to the locality in which it breeds and will sometimes occupy the same nest for a number of years. If the same nest is not occupied, the bird will probably be found breeding in the same belt of timber not far away. I have never found a nest in an evergreen tree. When I first started looking for Hawks' and Owls' nests I examined every spruce with care, but as a matter of fact few nests are found in them in this locality.

Nesting dates of the Goshawk at Belvedere are as follows: April 11th, 1913, three eggs, fresh. April 24th, 1913, two eggs, fresh. May 1st, 1913, two eggs, fresh. May 27th, 1913, two eggs, fresh. April 5th, 1914, three eggs, fresh. April 6th, 1914, two eggs, fresh. May 9th, 1914, six eggs, incubation advanced. April 21st, 1915, four eggs, incubation advanced. April 24th, 1915, three eggs, incubation slight. May 1st, 1922, four eggs, incubation slight. April 19th, 1923, three eggs, incubation slight.

The Goshawk does not like intruders near its nest and I have seen a pair of Goshawks noisily drive a Great Horned Owl out of a grove, two hundred yards from their nest. On another

occasion a Crow which happened to fly over the nest was promptly attacked and driven off, and once while I was taking a Horned Owl's nest a Goshawk appeared on the scene and swooped several times at the Owls; probably its own nest was not far away.

The Goshawk's liking for the farmer's poultry will probably lead to its extirpation in the settled districts before many years have passed and a like

fate threatens the Great Horned Owl for the same reason. This is a pity, as the presence of these fine birds adds much to the interest of the nature-lover on his strolls through the woods, especially in winter when birds are few. This point of view, however, has no appeal to the irate farmer and I am afraid these birds will continue to be shot at sight whenever they approach the farms.

THE CONCENTRATION OF MIGRATORY BIRDS AT SAULT STE. MARIE, ONTARIO, IN THE SPRING

By W. H. A. PREECE



IT IS believed that, in the case of many species of migratory birds, the district around Sault Ste. Marie, Ontario, is the natural point for concentration of the lines of migration between the 81st and 88th degrees of longitude W., which come north of the 42nd degree of latitude. If the map is consulted it will be seen that the meridian of 81° more or less bisects Lake Erie and the meridian of 88° Lake Superior.

It is well known that many species of migratory birds will not cross large bodies of water so that, though the general trend of spring migration is northerly, when such species reach an obstacle like Lake Erie or Lake Superior they are turned from their course. It then becomes necessary for them to travel east or west along the shore until the obstacle is encircled and they can resume their way northward. In view of this it may be taken for granted that a very considerable proportion of the birds whose lines of travel lead them to the southern shore of Lake Erie between 81° W. longitude and the western shore of the lake will turn their course westward until the western shore of the lake is reached, when they will head north again through Michigan. The lines of migration between the western shore of Lake Erie and the south eastern shore of Lake Michigan will continue northward through Michigan, gradually converging near Mackinaw.

The lines striking the southern shore of Lake Michigan will divide as do those striking Lake Erie, some following up the eastern shore, others the western. Those following the eastern route will converge around Mackinaw with the lines that have come direct and those that were diverted from their original course by Lake Erie. Obviously, nearly all those that converge at Mackinaw will cross the Straits of Mackinac and reach Sault Ste. Marie, Ontario, by way of Mackinaw and Chipewewa counties, Michigan.

The lines of migration striking the southern shore of Lake Superior, east of the 88° longitude together with those that were diverted by Lake

Michigan and followed the western shore of that lake northwards, will likewise be diverted on reaching Lake Superior and those coming east will likewise reach Sault Ste. Marie, Ontario, before a road to the north will lie open to them. It would therefore seem that once the lines of migration between 81° and 88° W. longitude have come north of 42° N. latitude, the vast majority of the migrants must pass through Sault Ste. Marie, Ontario. The loss at the western border of the area may be taken as negligible; some birds may have a tendency to fly west of north but presumably their places will be taken by others with a tendency to bear slightly east. The two chief avenues of escape to be considered are Essex and Lambton counties of Southern Ontario. Of those that escape through Essex, most if not all are certainly lost so far as Sault Ste. Marie is concerned. It may not be so, however, with those that take the Lambton trail as, owing to the migrants' habit of following a shore line, many will probably follow up the eastern shore of Lake Huron to Cape Hurd and eventually reach Sault Ste. Marie by way of Cove, Fitzwilliam, Manitoulin, Cockburn, Drummond, St. Joseph and Sugar Islands.

Owing to this concentration or converging of the lines of migration at Sault Ste. Marie, several effects should be discerned there. Firstly and most obviously, a vast concourse of birds should appear there during the spring migrations. Secondly, owing to the diversion of eastern lines, the occurrence of eastern species and subspecies is to be expected. Thirdly, we should find the occurrence of western species and subspecies, due to the concentration from the west. Fourthly and lastly, there should be an occurrence of southern species and subspecies forced north of their natural range, since, owing to the concentration, there would be congregated a larger number of birds than the available range in their normal latitude could accommodate for breeding purposes.

From such observations as have been made and from information gleaned from other observers, it

has been concluded that these phenomena do actually occur in the vicinity of Sault Ste. Marie. It is very plain to all observers that an extraordinary number of birds actually do pass through this district during the spring migration. The second and third effects are not very discernable, partly because eastern species are those which would normally be expected here and partly because in most cases "collection" is necessary for the certain identification of subspecies. No collecting has yet been done here. The occurrence of western species may be instanced by Mr. M. J. Magee's records of the Clay-coloured and Harris Sparrows, the Chestnut-collared Longspur and the Orange-crowned Warbler. Of southern birds north of their natural habitat we have many records, mostly made by Mr. M. J. Magee. These records include those of the Least Bittern, Yellow-billed Cuckoo, Woodcock, Mourning Dove, Red-bellied and Red-headed Woodpeckers, Scarlet Tanager, Towhee, Acadian and Crested Flycatchers, Wood Thrush, Yellow-throated Vireo, Golden-winged Warbler, and Blue-gray Gnat-catcher. A proper station here for the purpose of bird observation and banding would doubtless obtain many useful and interesting data about bird migration which cannot be obtained by two or three observers who can devote only Sundays to the study.

The above was written without thought of publication and was submitted to Mr. P. A. Taverner

for an opinion. His reply was most encouraging. He said: "Have read the manuscript with interest and quite agree with it. Have long realized that just such conditions must prevail at the Sault for it is the narrow neck of the bottle through which many paths lead. It is a locality that will stand intensive study."

In his reply Mr. Taverner also referred to his article, "A Hyperlaken Migration Route," published in the *Michigan Ornithological Club Bulletin* of March-June, 1905, dealing with the fall migration and accounting for the occurrence of western species around Toronto and in Southern Ontario. He states: "It seems evident then, that these birds (various western species) do not cross Michigan to reach southeastern Ontario, and another route must be sought for. As there is no indication of the birds across Indiana and Ohio they must take a hyperlaken route along the north shores of Lake Superior and Huron, around the great indentation of Georgian Bay and then south to Lake Ontario. This would bring them directly to the Toronto locality where so many specimens have been taken." In that article, Mr. Taverner assumed that most of the migrants in the fall missed the crossing at Sault Ste. Marie. His assumption appears to have been correct, for the comparative scarcity of birds here during the fall migration is in striking contrast to their abundance during the spring, and since Lake Superior blocks their way west they have no choice but to travel east.

THE BIRDS OF OTTAWA, 1923

Revised to March 20, 1923

By HOYES LLOYD

(Concluded from Vol. XXXVII, page 156)

160. *Passer domesticus* (Linnæus). HOUSE SPARROW.—Abundant resident, introduced here in 1870. (*O.N.*, IV, p. 149-154.)

161. *Plectrophenax nivalis nivalis* (Linnæus.) SNOW BUNTING.—Abundant migrant and winter resident. It is interesting to read in W. L. Scott's account of the winter birds of Ottawa, *Auk*, 1, 1884, p. 159, that the Snowbird lives principally on the refuse of the streets, for many years must have passed since these birds came into the city to any extent.

162. *Calcarius lapponicus lapponicus* (Linnæus.) LAPLAND LONGSPUR.—Probably a rare migrant. The only occasion on which it was found here in numbers was in the spring of 1890¹ (F. A. Saunders), although it was reported in the fall of the same year. There are several specimens in the White collection.

163. *Poæetes gramineus gramineus* (Gmelin). VESPER SPARROW.—Abundant summer resident; breeds. C. L. Patch took a nest for the Museum on June 23, 1916.

164. *Passerculus sandwichensis savanna* (Wilson). SAVANNAH SPARROW.—Abundant summer resident; breeds. C. E. Johnson reports adults feeding young on June 3, 1921.

165. *Ammodramus savannarum australis* Maynard. GRASSHOPPER SPARROW.—Probably a very rare summer resident; three occurrences. It has been found by F. A. Saunders¹ at Hull and at the Experimental Farm, and by Eifrig² at the Farm some years later. One was shot by F. A. Saunders at the Farm on June 28, 1898. The species is given under the name *Coturniculus passerinus* (Wils.) (Bp.), in an early list³, but this is an error, and the record was dropped in the 1891 list⁴.

Hypothetical.

Passerherbulus caudacutus (Gmelin). SHARPTAILED SPARROW.—Recorded by Eifrig⁵ using the 1883 list as a basis. For comments see next entry this list. The reported specimen is not available.

166. *Passerherbulus nelsoni nelsoni* (Allen). NELSON'S SPARROW.—Accidental. G. R. White shot one at Lochaber, Que., on September 23, 1922, and saw another on October 2, 1922.

I am in a quandary as to the proper treatment of the following account in *O.F.N.C. Trans.*, 4, p. 84: "240. *Ammodramus caudacutus* (Wils.) Sw. SHARPTAILED FINCH.—One specimen of this

¹*O.N.*, XII, pp. 87 and 265.

²*O.N.*, XXIV, p. 201, also *Auk*, XXVI, 1909, p. 432, and *Ibid.*, XXVII, 1910, p. 84.

³*O.F.N.C. Trans.*, 4, p. 85.

⁴*O.N.*, V, p. 31.

⁵*O.N.*, XXIV, p. 201.

bird was shot here last season, and sent to Dr. Coues, who remarked that this locality was both north and west of its usual range." The present location of this specimen is not known, and the puzzle the record offers may never be solved. G. R. White thinks that the bird referred to was of the same kind as the one he took in 1922, but the fact remains that, regardless of names, which may or may not have been given correctly in the 1883 list referred to, the eminent ornithologist was evidently considering this early Ottawa record to be referable to an Atlantic coast species and not to a western one.

167. *Zonotrichia leucophrys leucophrys* (J. R. Forster). WHITE-CROWNED SPARROW.—A common migrant, spring and fall.

168. *Zonotrichia albicollis* (Gmelin). WHITE-THROATED SPARROW.—An abundant migrant and common summer resident, accidental in winter; breeds. There is a local nest in the Museum, and it nested in the Whites' garden in 1922. On December 24, 1922, C. E. Johnson found one south of the city and C. L. Patch and D. Blakely found another on the same day east of the city. The former bird, believed to be a male, was watched for ten minutes at a distance of fifteen feet while it fed upon weed seeds (*Polygonum* sp.) in a clump of juniper. It was found at 12.30 p.m. and was still there at 1.45 p.m. There is a record of one being seen on December 8, 1898, at Russell, Ont., by W. A. D. Lees.¹

169. *Spizella monticola monticola* (Gmelin). TREE SPARROW.—An abundant migrant and common winter resident. Frank Hennessey and I found it at Hull on December 24, 1920, and there are December and February specimens in the White collection.

170. *Spizella passerina passerina* (Bechstein). CHIPPING SPARROW.—A common summer resident; breeds. A nest with eggs, No. 999, was taken by C. L. Patch at Meach's Lake, June 23, 1914.

171. *Spizella pusilla pusilla* (Wilson). FIELD SPARROW.—Has been found several times within the last thirty years or so, and is probably a very rare summer resident. F. A. Saunders found it four miles south-east of King's Mountain on July 2, 1892,² and again at Kazubazua, 40 miles north of Ottawa, on July 4, 1898.³ It has been noted by others as well, notably by W. E. Saunders, at Kazubazua, Que., July 27, 1899, and August 31, 1905; Ottawa vicinity, August 7, 1899, two in song. The only specimen I have seen is in the White collection—one that was taken by E. G. White near Hurdman's Bridge, October 20, 1905. He secured another this day and saw several on the 9th and 10th of the same month.

172. *Junco hyemalis hyemalis* (Linnæus). SLATE-COLORED JUNCO.—Abundant migrant and tolerably common summer resident. Eifrig⁴ reports finding a nest with four eggs at Meach's Lake on July 6, 1908, and at Rockcliffe Patch found one with young on May 24, 1920. It probably nests on Parliament Hill, as I have seen adults there on July 1st.

173. *Melospiza melodia melodia* (Wilson). SONG SPARROW.—An abundant summer resident; breeds. Nest with eggs May 15, 1921. A nest with eggs, taken June 16, 1889, by W. A. D. Lees, is No. 76, Victoria Memorial Museum.

174. *Melospiza lincolni lincolni* (Audubon). LINCOLN'S SPARROW.—Certainly a rare migrant, but just how rare is not definitely known. G. R. White took the only specimen of which I am aware, on May 16, 1884. (*O.F.N. C. Trans.* 6, p. 273.)

175. *Melospiza georgiana* (Latham). SWAMP SPARROW.—A common summer resident. Undoubtedly breeds, but I have no definite data.

176. *Passerella iliaca iliaca* (Merrem.) FOX SPARROW.—The history of this species at Ottawa shows that it is a moderately common migrant which occurs chiefly in April, May, September, October, and November.

177. *Pipilo erythrophthalmus erythrophthalmus* (Linnæus). TOWHEE.—Of rare and irregular occurrence in spring and summer. I have nothing to add to the published accounts,¹ never having found the species here, nor heard of it recently. The June 28, 1908, date in the 1910 list has been checked with the Whites.

178. *Hedymeles ludoviciana* (Linnæus). ROSE-BREADED GROSBREAK.—A moderately common summer resident; breeds. A specimen in the White collection, dated May 25, 1885, has the rose colour of the breast continuing up to the chin. On May 24, 1904, J. H. Fleming found a nest with four eggs at Rockcliffe and C. L. Patch has observed young in the nest at Meach's Lake, Que., during the last week of June, 1914. A male in fall plumage was taken by me at Hull, Que., on September 12, 1921.

179. *Passerina cyanea* (Linnæus). INDIGO BUNTING.—A rare summer resident, locally distributed, breeds. The species is mentioned in the three previous lists. An occasional bird may still be found west of Hull, Quebec—one of the stations mentioned by Eifrig. On July 9, 1922, C. L. Patch and I found three adults and a nest with four young some five miles east of the city. The nest was empty on July 19th.

Hypothetical.

Cardinalis cardinalis cardinalis (Linnæus.) CARDINAL.—One was seen on Wilbrod Street, Ottawa, during the spring of 1888 by H. B. Small.² Another was observed in the vicinity of Col. Wm. P. Anderson's place, Cooper Street, in June, 1911.³ These may have been escaped cage-birds.

180. *Spiza americana* (Gmelin). DICKCISSEL.—Accidental—a single male spent the summer of 1895 at the Experimental Farm.⁴ It was identified by F. A. and W. E. Saunders.

181. *Piranga erythromelas* Vieillot. SCARLET TANAGER.—A migrant which is also found regularly in summer—in my experience it is not common although a wave of migration may bring numbers to our district at one time. A male in

¹*Rept. of Orn.* 1893, *O.F.N.*, VIII, 1894-95, p. 67.

O.N., XXIII, 1909, pp. 113-14.

O.N., XXIV, 1911, p. 203.

Auk, XXIII, 1906, pp. 317-8.

²*O.N.*, IV, pp. 65-6.

³*O.N.*, XXV, p. 121.

⁴*O.N.*, IX, 1895-96, pp. 92-93, and 213-4.

O.N., XXVII, 1903, p. 29.

O.N., XXIV, 1910-11, p. 203.

¹*O.N.*, XII, 1898-99, p. 190.

²*O.N.*, VII, p. 61.

³*O.N.*, XII, p. 104.

cf. *Auk*, XXIII, 1906, p. 317.

O.N., XX, 1906-7, p. 113.

⁴*O.N.*, XXIV, p. 202.

the White collection taken August 26, 1885, is in changing plumage. The 1891 and 1910 lists give it as a breeding species, which is almost certainly true, but no details have been published and I know of no nests.

182. *Progne subis subis* (Linnæus.) PURPLE MARTIN.—A common summer resident; breeds. There are numerous colonies in Ottawa. A single male arrived at P. A. Taverner's bird-house on April 7, 1922, the earliest date for the district. For information concerning Taverner's Martin-house see *O.N.*, XXXII, 1918-19, pp. 119-123. On July 26, 1922, I took a number of fully grown young from a local bird-house and banded them.

183. *Petrochelidon lunifrons lunifrons* (Say.) CLIFF SWALLOW.—An uncommon summer resident irregularly distributed. Barns that once had scores of nests now have one or two. In the summer of 1922 I found two places where from one to three pairs were breeding and Johnson, Blakely and Patch reported another.

184. *Hirundo erythrogastra* Boddært. BARN SWALLOW.—A common summer resident; breeds. Carp, Ont., May 29, 1909, 1 nest with 7 eggs, 2 with 2. (Eifrig, *O.N.*, XXIII, 1909-10, p. 83.)

185. *Iridoprocne bicolor* (Vieillot). TREE SWALLOW.—An abundant migrant and summer resident; breeds. Young left nest June 30, 1922. Nest with six eggs, Meach's Lake, Que., No. 867, Victoria Memorial Museum. The most reliable occupant of Ottawa bird-houses.

186. *Riparia riparia* (Linnæus). BANK SWALLOW.—A common summer resident, colonies being found in suitable sand banks. The one near McKay's Lake, Rockcliffe, was destroyed during the breeding season of 1922, because of a demand for sand. Although the foreman spared the nests as long as possible, it is not probable that many young escaped. In 1921 an excursion party of the Club found this species nesting in sawdust banks near a saw-mill in the vicinity of Aylmer, Que.

187. *Stelgidopteryx serripennis* (Audubon). ROUGH-WINGED SWALLOW.—C. L. Patch was the first to find this species at Ottawa. On June 28, 1917,¹ he found two pairs nesting in the bank of the Rideau River only a few miles south of the city, and again on June 5, 1918, he found a nest with six eggs² in the same locality. These are the only occurrences, except that P. A. Taverner saw the species at the same place on June 11, 1918.

188. *Bombycilla garrula* Linnæus. BOHEMIAN WAXWING.—An irregular winter visitor, often missing for years at a time. It has been observed as follows: five seen November 11, 1883;³ one flock from January 8th on in 1895;⁴ abundant January to April, 1897;⁵ seen December 13, 1904 (G. R. White MS); one seen December 2, 1906;⁶ December, 1908, to March, 1909⁷; March 19th to 23rd, 1912, several seen almost daily (G. R. White, MS); and no records since then were made until R. E. DeLury found them here in February and March, 1917.⁸

189. *Bombycilla cedrorum* Vieillot. CEDAR WAXWING.—A common summer resident; breeds. Found occasionally in winter. Bred in the Whites' garden, June 10, 1888, and eggs have been taken for the Museum collection by C. L. Patch at Meach's Lake on June 23, 1914 (No. 1000). W. T. Macoun¹ reports its occurrence with the Bohemian Waxwing from the middle of January to April, 1897; specimens were taken by G. R. White. Eifrig² gives winter dates, viz., December 1, 1906, and February 22, 1908. A curious habit, the eating of apple-blossoms, is recorded by Mr. J. Craig.³

190. *Lanius borealis* Vieillot. NORTHERN SHRIKE.—A regular but sparsely distributed winter resident, occurring from November to March. In February, 1922, I found one singing with great abandon from the top of a tall tree near the Rideau River, Ottawa South. The song was musical and with its numerous pauses rather resembled that of the Brown Thrasher.

191. *Lanius ludovicianus migrans* W. Palmer. MIGRANT SHRIKE.—Believed to be a regular but not very common summer resident which breeds where found. I have seen one of these birds remain on a thorn twig while several people passed a few feet under its perch. On June 28, 1885, two young of the year are said to have been shot by W. L. Scott on the Quebec side of the River near Ottawa.⁴ The Northern Shrike breeding record for the Experimental Farm, 1903,⁵ undoubtedly refers to this species, as does the report of two nests of the Northern Shrike found at City View.⁶

A nest was taken for the Museum by C. L. Patch and C. H. Young took a nest with 6 eggs, No. 962, near the city on April 1, 1903.

192. *Vireosylva olivacea* (Linnæus). RED-EYED VIREO.—An abundant summer resident, occurring in almost all deciduous woods and throughout the city; breeds. A nest was taken for the Museum on June 23, 1916, by C. E. Johnson. In the Whites' garden on November 4, 1922, E. G. White and I watched one for some time at close range.

193. *Vireosylva philadelphica* Cassin. PHILADELPHIA VIREO.—Probably a rare migrant, not yet known to breed. I have preferred to treat sight records of this species with caution, but have found examples of the species in the local collections. These are as follows: May 13, 1886, two in White collection; May 30, 1906, a female taken at Ottawa by C. W. G. Eifrig, now No. 6446 in the Victoria Memorial Museum collection. Some other captures have been recorded, but I have not had an opportunity to examine the specimens.

194. *Vireosylva gilva gilva* (Vieillot). WARBLING VIREO.—A common summer resident; undoubtedly breeds, although I have no nesting date before me. This species is probably passed by more than any other bird that frequents the city shade trees; it may be heard singing at almost any part of the city, but many ears seem to be tuned to miss such bird music. In the White collection

¹*O.N.*, XXXI, 1917-18, p. 46.

²*O.N.*, XXXII, 1918-19, p. 77.

³*Rept. Orn. & Ool. Br., O.F.N.C. Trans.* 5, p. 146.

⁴A. G. Kingston, *O.N.*, IX, p. 22.

⁵W. T. Macoun, *O.N.*, XI, p. 31.

⁶C. W. G. Eifrig, *O.N.*, XX, p. 219 and G. R. White, MS.

⁷C. W. G. Eifrig, *O.N.*, XXII, p. 262 and G. R. White MS.

⁸*O.N.*, XXXII, 1918-19, p. 38.

¹*O.N.*, XI, 1897-98, pp. 30-31.

²*O.N.*, XXIV, 1910-11, p. 205.

³*O.N.*, X, 1896-97, p. 72.

⁴*O.F.N.C. Trans.*, 1884-5, 6, p. 273.

⁵*O.N.*, XVII, p. 30.

⁶*O.N.*, XII, 1898-99, p. 44.

Cf. *Auk*, XXII, 1905, p. 314.

there are specimens dated May 26, 1884, and May 25, 1885; while the Victoria Memorial Museum has specimens taken by John Macoun on May 29, 1888, No. 454; and by F. A. Saunders on May 23, 1891, No. 2200. Some early Ottawa ornithologists called this the Least Vireo in error.

195. *Lanivireo flavifrons* (Vieillot). YELLOW-THROATED VIREO.—Of rare occurrence; spring records are the most numerous. The two specimens in the White collection are dated May 26, 1884, and May 25, 1885. It is written¹ that W. L. Scott secured a female at Pelissier (near Kirk's Ferry, Que.) on July 21, 1884, and that G. R. White took two on May 15th of the same year. There is also an account of one having been taken the middle of June, 1883,² by whom is not stated. Eifrig³ records four in six years, and collected a female at Meach's Lake, Que., on July 20, 1905, now No. 6445, Victoria Memorial Museum. G. R. White also has the following dates in his notes; May 11, 1906 and May 18, 1914.

196. *Lanivireo solitarius solitarius* (Wilson). BLUE-HEADED VIREO.—A rather rare migrant; has been seen quite late in fall. It is recorded that Miss Gertrude Harmer found a partially completed nest at Chelsea, Que., on May 28, 1898⁴ but no details are given concerning the identification. There are specimens of the bird in the Museum and in the White collection.

Hypothetical.

Vireo pusillus Coues. LEAST VIREO.—is given in the list of 1881-82⁵ and this is changed to "*Vireo gilvus* Bp., WARBLING VIREO" later.⁶

197. *Mniotilta varia* (Linnaeus). BLACK AND WHITE WARBLER.—A common migrant which is believed to breed fairly commonly in the district. J. H. Fleming advises me that he saw a pair feeding young at Rockcliffe on August 16, 1900, and C. E. Johnson saw adult birds similarly engaged at Hog's Back during the summer of 1914, while H. Groh records⁷ a nest with 5 eggs on June 2, 1909. About mid-August a number of these birds may be seen in the city shade trees, either juveniles on their first wanderings, or possibly adults beginning the fall migration.

198. *Vermivora ruficapilla ruficapilla* (Wilson). NASHVILLE WARBLER.—A fairly common migrant, and regular summer resident; breeds. G. R. White and W. L. Scott record carefully the finding of a nest in Dow's Swamp on July 13, 1881.⁸ In 1898 it was found breeding there again by F. A. Saunders,⁹ who found it breeding at the Mer Bleue and at Chelsea, Que., as well. Eifrig also gives breeding localities in the neighbourhood of the city. The nest with four eggs in the Victoria Memorial Museum collection was taken by C. H. Young on June 10, 1906, at Meach's Lake, Que., No. 841.

199. *Vermivora celata celata* (Say). ORANGE-CROWNED WARBLER.—Accidental. I have examined only one specimen, a male shot by E. G. White

near the city on September 27, 1885.¹ It has been observed in 1898 on May 18th by G. R. White,² and he tells me that he secured one on May 28th, 1909, which I have not seen.

200. *Vermivora peregrina* (Wilson). TENNESSEE WARBLER.—As yet known only as a migrant in spring and fall, but may be found to breed. There are specimens in the local collections.

201. *Compsothlypis americana pusilla* (Wilson). NORTHERN PARULA WARBLER.—From available records to which I have nothing to add this species seems to be a regular migrant, and a rare breeder. Eifrig reports it in summer, and F. A. Saunders found it breeding near Low, Que., on July 2, 1898.³

202. *Dendroica tigrina* (Gmelin). CAPE MAY WARBLER.—Although this handsome Warbler is a regular migrant in the district, the observer who finds it, for the first few times at any rate, will thrill with the pleasure of discovery. Strangely enough there do not seem to be any fall occurrences reported, and the species is not yet known to breed. Specimens have been examined in local collections.

203. *Dendroica aestiva aestiva* (Gmelin). YELLOW WARBLER.—Very common resident in summer, when its nest may be found in any suitable locality both in city and in country. Nesting dates are: Whites' garden, May 12, 1888; J. H. Fleming, Rockcliffe, May 23, 1904.

204. *Dendroica coronata* (Linnaeus). MYRTLE WARBLER.—An abundant migrant, which has been observed in summer, notably at the Mer Bleue (1891 list), and probably breeds. E. G. White reports it as doing so near Berry's Wharf, South March Tp., Ont., during the summer of 1921.

205. *Dendroica magnolia* (Wilson). MAGNOLIA WARBLER.—Fairly common as a migrant, probably a regular breeder. Reported in summer by W. E. Saunders, 1890,⁴ and by C. G. Eifrig in the 1910 list. On May 25, 1922, I took an almost fully developed egg from the ovary of one shot at Aylmer, Que., that day. F. A. Saunders records this Warbler as breeding near Low, Que., on July 2, 1898.⁵

206. *Dendroica caerulescens caerulescens* (Gmelin). BLACK-THROATED BLUE WARBLER.—A common migrant, known to breed. F. A. Saunders found nests in a grove at Chelsea, Que., on June 16, 1898,⁶ and C. G. Eifrig reports the presence of the species in summer.

207. *Dendroica cerulea* (Wilson). CERULEAN WARBLER.—Apparently the southern influence which reaches toward Ottawa via the Rideau waterway has again been indicated by the discovery of this species some 22 miles south of the city during the spring of 1922. R. E. DeLury, who found two or three of the birds there, gives a most circumspect account of the occurrence⁷ and understood at the time that the bird was either new or very rare in the district. The bird, a male, was watched for over an hour by him, and knowing his training as a scientist, I am prepared to credit the record. It appears to be as certain as a sight

¹O.F.N.C. Trans., 6, 1885, p. 275.

²Ibid. 5, 1884, p. 142.

³O.N., XXIV, 1910-11, p. 205.

⁴O.N., XII, 1898-99, p. 72.

⁵O.F.N.C. Trans., 3, p. 30.

⁶Ibid. 4, p. 86, & O.N., V, p. 31.

⁷O.N., XXIII, 1909-10, p. 131.

⁸O.F.N.C. Trans., 3, 1881, p. 28.

⁹O.N., XII, 1898-99, p. 88.

¹O.F.N.C. Trans., 7, 1885-6, p. 355.

²O.N., XII, 1898-99, p. 71.

³O.N., XII, 1898-99, p. 104.

⁴O.N., V, 1891-92, pp. 79 & 86.

⁵O.N., XII, 1898-9, p. 104.

⁶O.N., XII, 1898-99, p. 88.

⁷C.F.N., XXXVI, 1922, p. 120.

record of a bird can be. The finding of the bird at a place so far removed from its previously known range should have been confirmed by the taking of a specimen, but this was not done, and so the matter rests for the present. The Cerulean in my opinion is hard to miss rather than difficult to find and other observers should easily locate this Warbler again if it has really moved into our district to stay.

208. *Dendroica pensylvanica* (Linnaeus). CHEST-NUT-SIDED WARBLER.—Fairly common both as migrant and as breeder. Most observers report it in summer. C. G. Eifrig and the 1891 list give it as breeding, and C. E. Johnson found a nest with four young here on June 23, 1916.

209. *Dendroica castanea* (Wilson). BAY-BREAST-ED WARBLER.—A fairly common migrant spring and fall.

210. *Dendroica striata* (J. R. Forster). BLACK-POLL WARBLER.—A common migrant spring and fall.

211. *Dendroica fusca* (Müller). BLACKBURNIAN WARBLER.—A common migrant and probably a regular breeder. Often observed in summer. F. A. Saunders found it breeding at Chelsea, Que., June 24, 1898, and commonly near Low, Que., on July 2 and 3, 1898,¹ and in the summer of 1912 P. A. Taverner found a female feeding a young Cowbird at Rockcliffe.

212. *Dendroica virens* (Gmelin). BLACK-THROAT-ED GREEN WARBLER.—A fairly common migrant and probably a regular breeder. C. G. Eifrig gives it as breeding, and J. H. Fleming saw a pair feeding young at Rockcliffe on August 16, 1900.

213. *Dendroica vigrors* (Audubon). PINE WARBLER.—Probably a rare summer resident. The specimen taken on May 8, 1884, by E. G. White is still in the White collection. It was said to be the fifth record for the species at Ottawa.² The Whites have spring dates for 1885 and E. G. White took another on August 27th³ of that year. There are several other sight records and probably more specimens. F. A. Saunders records the species as breeding at the Experimental Farm in June, 1898.⁴

214a *Dendroica palmarum palmarum* (Gmelin). PALM WARBLER.—A common migrant, breeds. With respect to the sub-species here my check of the available specimens causes me to reach exactly opposite conclusions to those of C. G. Eifrig as expressed in the 1910 list.⁵ This places me in agreement with the 1891 list in this respect.⁶ The local specimens I have examined are very largely almost typical *D. p. palmarum*, certainly much nearer to it than to *D. p. hypochrysea*, being only slightly yellower below than typical examples of the sub-species *palmarum*. The following specimens in the collection of the Victoria Memorial Museum are placed here.

Number	Sex	Collector	Date
6439	?	Eifrig	August 5, 1909.
14717	?	W. E. Saunders	September 2, 1891.
14718	?	"	"
14738	f	"	June 11, 1892.
6438	f	A. G. Kingston	May 5, 1892.
14644	?	W. E. S. ?	about 1890.

¹O.N., XII, 1898-99, pp. 88 and 104.

²O.F.N.C. Trans., 6, 1884-5, p. 274.

³Ibid. 7, 1885-6, p. 356.

⁴O.N., XII, p. 87.

⁵O.N., XXIV, 1910-11, pp. 223-4, also *vide ibid.*, p. 22.

⁶O.N., V, 1891-2, p. 46.

I have a single specimen in my own collection.

The breeding form may be determined from the adult male and two juvenals taken the same day at the Mer Bleue by W. E. Saunders. The adult is number 14667 in the Museum collection and proves to be almost typical *palmarum*. The juvenals, also dated July 3, 1890, are numbers 14665-6 (cf. O.N., v, 46 and 78).

Two nests with four eggs each, taken by C. H. Young at the Mer Bleue on May 25th and July 6th, 1908, are referred here as well.

214b. *Dendroica palmarum hypochrysea* (Ridgway). YELLOW PALM WARBLER.—Probably a regular migrant. Not known to breed, the breeding form being *D. p. palmarum*. Nearly typical specimens of *hypochrysea* were taken at Ottawa on May 28, 1892, by A. G. Kingston, and may be found in the Museum collection, where they are catalogued as follows: m. 6442, f. 6641, f. 6440. A male taken at the Mer Bleue by C. H. Young on July 3, 1907, No. 3846 Victoria Memorial Museum, is plainly an intermediate, being much browner on the back than *hypochrysea*, but having yellower under parts than *palmarum*. The available records make it appear that Ottawa is about on the dividing line between this sub-species and the preceding, but the commoner form and the breeding one is nearer *palmarum* than *hypochrysea*.

215. *Seiurus aurocapillus* (Linnaeus). OVEN-BIRD.—A moderately common migrant and summer resident. Breeds. C. H. Young collected a nest with four eggs for the Museum, No. 858, June 24, 1907, at Meach's Lake, Que.

216. *Seiurus noveboracensis noveboracensis* (Gmelin). WATER-THRUSH.—A moderately common migrant and summer resident. This bird is as persistent a singer as the Oven-bird, but its performance does not generally attract the same attention. A singing male moves very regularly in a circle when disturbed, continuing his song from one perch after another, and finally returning to his starting place. This is believed to be the local sub-species, although specimens approaching *notabilis* are found. A male in my collection taken at Aylmer, Que., on May 25, 1922, is typical *noveboracensis*; and so is a female, No. 6026, Victoria Memorial Museum, taken by F. C. Hennessey at Ottawa on July 31, 1912, although this latter one has a dark back resembling that of *notabilis*. With respect to its status as a breeding species, summer specimens are fairly common, it is reported to breed in Dow's Swamp,¹ and Eardley Young took a nest with five eggs for the Museum at Meach's Lake, Que., on May 20, 1916, No. 1156.

Hypothetical.
Oporornis formosus (Wilson). KENTUCKY WARBLER.—Recorded² in error and error corrected.³

Hypothetical.
Oporornis agilis (Wilson). CONNECTICUT WARBLER.—The occurrence of this species at Ottawa has yet to be proved definitely, in my opinion. A few sight records have been reported, the evidence in no particular case appearing to be sufficiently conclusive. Eifrig⁴ states that he has seen it on two occasions, and also records⁵ that Fleming once saw

¹O.N., XII, 1898-99, p. 87.

²O.N., XX, 1906-7, p. 66.

³Ibid., p. 78.

⁴O.N., XXIV, p. 224.

⁵O.N., XX, p. 78.

⁶O.N., XVIII, p. 39.

one here. Mr. Fleming advises me that he believes that he saw one at Rockcliffe on August 15, 1898.

217. *Oporornis philadelphia* (Wilson). MOURNING WARBLER.—A regular migrant and probably breeding species, not very common. There are several specimens which have been taken during the breeding season, and C. G. Eifrig gives localities where it is said to breed—omitting any details. F. A. Saunders records it as breeding in Dow's Swamp.¹

218. *Geothlypis trichas trichas* (Linnaeus). MARYLAND YELLOW-THROAT.—A moderately common migrant and regular summer resident; breeds. Nests are reported as being found in the Mer Bleue, June 22, 1898, and at Dow's Swamp, June 23, 1898.² One nest with four eggs was taken for the Museum on June 23, 1916, near Ottawa, by C. L. Patch. C. H. Young took 2 nests for the Museum, each with four eggs, June 8 and 11, 1908, (Nos. 868-9).

219. *Wilsonia pusilla pusilla* (Wilson). WILSON'S WARBLER.—A moderately common migrant, not yet known to breed, but it has been found here in the breeding season.

220. *Wilsonia canadensis* (Linnaeus). CANADA WARBLER.—Tolerably common migrant and summer resident. F. A. Saunders records it as breeding in Dow's Swamp and elsewhere during June, 1898.³ C. G. Eifrig also gives it status as a breeder.

221. *Setophaga ruticilla* (Linnaeus). RED-START.—Common migrant and summer resident. C. G. Eifrig reports it as nesting at Lovers' Walk, Parliament Hill. This probably refers to the nest found by G. R. White on June 24, 1894. C. E. Johnson found one building at Dow's Swamp on May 27, 1919, and located another nest near the Rideau River in the vicinity of Billings' Bridge.

222. *Anthus rubescens* (Tunstall). PIPIT.—A common migrant, passing spring and fall in large flocks to and from its nesting ground far to the north.

223. *Dumetella carolinensis* (Linnaeus). CATBIRD.—Common summer resident, breeds. Young birds just from the nest were found near Aylmer, Que., on July 16, 1922. Every prospective critic of Canadian song birds should hear a really good Catbird sing before reaching a final judgment.

224. *Toxostoma rufum* (Linnaeus). BROWN THRASHER.—Moderately common summer resident; breeds. On June 14, 1884, the Whites found a nest at Beechwood which contained three Thrasher eggs and one of the Cowbird. Another nest at the Experimental Farm is reported for June 16, 1898.⁴ Those who cannot go far into the country to hear one of our finest bird soloists can depend upon hearing at least one of these birds near the end of the street-car line at the Farm.

Hypothetical.

Harporhynchus cinereus Bd. CINEREOUS THRUSH.—Equals San Lucas Thrasher, is given in an early list⁵ and later removed.⁶

225. *Troglodytes aëdon aëdon* Vieillot. HOUSE WREN.—A common summer resident, breeding in bird boxes and natural cavities everywhere in the district, even coming well into the city to nest.

226. *Nannus hiemalis hiemalis* (Vieillot). WINTER WREN.—A fairly common migrant, and moderately common in suitable localities in summer. Recorded from Dow's Swamp in June, 1898, by F. A. Saunders¹ and undoubtedly breeds in the district. Specific breeding occurrences are needed.

227. *Cistothorus stellaris* (Naumann). SHORT-BILLED MARSH WREN.—The specimen taken by F. A. Saunders at the Mer Bleue on June 17, 1898,² is in the collection of the Victoria Memorial Museum, where I have examined it (No. 14784). Two were seen and possibly the species may breed rarely. C. G. Eifrig records the capture of one specimen at the same place on June 16, 1905.³ G. R. White has been consulted concerning the specimen credited to him in *O.F.N.C. Trans.* 5, 1884, p. 141, and states, January 14, 1922, that he did not secure a Short-billed Marsh Wren as recorded, and has none in his collection.

228. *Telmotodytes palustris palustris* (Wilson). LONG-BILLED MARSH WREN.—Common summer resident in suitable marshes, as at Kemptville, where Taverner secured specimens in 1918. A set of 6 eggs, No. 597, Victoria Memorial Museum, was taken by W. E. Saunders at the Farm on June 13, 1898.

229. *Certhia familiaris americana* Bonaparte. BROWN CREEPER.—Common as a migrant, not common in summer and winter. F. A. Saunders found it at Kazubazua, Que., on July 3, 1898⁴, and it may ultimately be found to breed, which one would expect.

230. *Sitta carolinensis carolinensis* Latham. WHITE-BREADED NUTHATCH.—Moderately common at all seasons, least so in summer. Breeds. The nest and 11 eggs in the habitat group of the Museum were taken near Billings' Bridge, over the Rideau River, by Taverner and Young on May 19, 1911.

231. *Sitta canadensis* Linnaeus. RED-BREADED NUTHATCH.—A moderately common resident at all seasons; seems to be more erratic in its movements than the White-bread. On February 18, 1923, at Fairy Lake, Hull, Que., I heard one calling in a peculiarly persistent fashion, and went to investigate. He was really shouting "murder", for a Richardson's Owl had been found peacefully resting in the lower branches of an evergreen. The hue and cry had attracted another Red-bread and a White-bread.

Summer occurrences are the only evidence of breeding of which I am aware.

232. *Penthestes atricapillus atricapillus* (Linnaeus). CHICKADEE.—A common resident, especially noticeable in winter, and an abundant migrant. Breeds. G. R. White and Norman Lett found a nest with young at Chelsea, Que., May 26, 1894. C. H. Young took a nest with six eggs near Eastman's Springs on June 1, 1908. Victoria Memorial Museum, No. 864.

¹O.N., XII, 1898-9, p. 87.

²O.N., XII, 1898-99, p. 88.

³O.N., XII, 1898-9, p. 87.

⁴O.N., XII, 1898-9, p. 88.

⁵O.F.N.C. Trans., 3, p. 29.

⁶Ibid., 4, p. 85 and O.N., V, p. 31.

¹O.N., XII, 1898-9, p. 87.

²O.N., XII, 1898-99, pp. 87 and 265.

³O.N., XXIV, 1910-11, p. 225.

⁴O.N., XII, 1898-9, p. 104.

Hypothetical.

Parus rufescens Townsend. CHESTNUT-BACKED CHICKADEE.—Reported in error,¹ and the error corrected.²

233. *Penthestes hudsonicus hudsonicus* (J. R. Forster). HUDSONIAN CHICKADEE.—Rare fall migrant. There are specimens in the White collection and they report the species in spring. It has seldom been found in the winter.

234. *Regulus satrapa satrapa* Lichtenstein. GOLDEN-CROWNED KINGLET.—A common migrant which may ultimately be found to breed, for the birds have been observed in summer.

235. *Regulus calendula calendula* (Linnæus). RUBY-CROWNED KINGLET.—Common as a migrant both spring and fall.

Hypothetical.

Poikoptila cærulea. BLUE-GRAY GNATCATCHER.—G. R. White tells me that he is not at all sure of the identity of the specimen which he is said to have taken previous to 1881, and as the specimen is not available for examination it is considered that the species should be removed from the list of the birds of Ottawa. In this Mr. White concurs. Cf. *O.F.N.C. Trans.* 3, 1881-2, p. 29. *O.N.*, V, 1891-2, p. 47. *O.N.*, VII, p. 61.

236. *Hylocichla mustelina* Gmelin). WOOD THRUSH.—Rare in summer, and only found in a few locations. There is a specimen in the White collection, taken here on May 14, 1889, as noted in migration dates, *O.N.*, III, p. 72. Several other observers have found it and F. A. Saunders³ reports one or two pairs breeding on the southern face of King's Mountain.

237. *Hylocichla fuscescens fuscescens* (Stephens). VEERY.—Common summer resident; breeds. On June 21, 1919, I found a nest at Hull, Que., in a juniper. The young were just ready to fly on that date. Another nest at Aylmer, Que., contained two Veery's eggs and two Cowbird's eggs on May 27, 1922. A third Veery's egg had been rolled out of the nest.

238. *Hylocichla alicia alicia* (Baird.) GRAY-CHEEKED THRUSH.—Probably a regular migrant, but not enough specimens have been taken to determine the relative number of this species passing as compared with the next. W. E. Saun-

ders advises me that he has a specimen from King's Mountain which is the same in measurement as *H. a. bicknelli*, but which he considers is doubtless *H. a. alicia*. A specimen in my collection was taken five miles west of Hull, Que., on September 10, 1921.

239. *Hylocichla ustulata swainsoni* (Tschudi). OLIVE-BACKED THRUSH.—Common as a migrant; may breed. There are specimens in the local collections. F. A. Saunders reports this¹ as the commonest Thrush near Low, Que., in July, 1898.

240. *Hylocichla guttata pallasii* (Cabanis). HERMIT THRUSH.—Common migrant and less common summer resident. C. E. Johnson has observed birds with building material in bill at Rideau Park. I found them at King's Mountain on July 1, 1922.

241. *Planesticus migratorius migratorius* (Linnæus). ROBIN.—Abundant summer resident, nesting everywhere in the district. Winter records at least up to Christmas are fairly common, but not many of these wintering birds are likely to survive. Found at time of the Club's Christmas bird census in 1921 and 1922. I saw one near the Printing Bureau on December 15, 1918. Eifrig reports four as wintering near the City Hall from December 21, 1908, to March 4, 1909.² In *The Auk*³ the same author says "no doubt they were frozen to death by one of the few short cold spells which occurred during the winter." R. E. DeLury recently had one bird out of several winter safely when fed.

242. *Sialia sialis sialis* (Linnæus). BLUEBIRD.—Common migrant and moderately common breeder. C. E. Johnson found a nest with five eggs not far from the city on June 3, 1921. Tree Swallows had been building in the same cavity on May 24th. For an account of young birds infested with fly larvæ vide *C.F.N.*, XXXVI, 1922, p. 116.

ERRATA:

P. 104. For *Dafila acuta tzitzihoa* (Linnæus) read *Dafila acuta tzitzihoa* (Vieillot).

P. 127. For *Calidris canutus* Linnæus read *Calidris canutus* (Linnæus).

P. 127. For *Squatarola squatarola cynosuræ* (Linnæus) read *Squatarola squatarola cynosuræ* Thayer and Bangs.

¹*O.F.N.C. Trans.*, 3, 1881-2, p. 29.

²*Ibid.* 4, 1882-3, p. 85.

³*O.N.*, XI, 1897-8, p. 119.

¹*O.N.*, XII, 1898-9, p. 104.

²*O.N.*, XXII, 1908-9, p. 265, and *O.N.*, XXIV, 1910-11, p. 228.

³*Auk*, XXVII, 1910, p. 58.

NOTES AND OBSERVATIONS

Subscriptions for 1924 are now due; by paying promptly you will assist greatly in the publishing of the magazine.

CHRISTMAS BIRD CENSUS AT LONDON, ONTARIO.—It is customary each year during Christmas week for the members of the McIlwraith Ornithological Club to take a census of the birds in the vicinity of London. This year (1923) the day set apart was December 22nd, and the territory adjacent to the city was divided into districts with two or three observers allotted to each. The total number of parties was six, some of

whom were out most of the day, the others working in the afternoon only. The list as compared with 1922 is rather a poor one, but is even better than we expected (knowing the few birds that were around the city this winter) and is quite up to the average of other Christmas lists, 1922 being very exceptional. The weather was quite mild, the thermometer registering 38° at 8 a.m., rising to 43° at midday, and falling to 40° at 8 p.m. There was a slight easterly wind and the sky was overcast all day, which tended to make observation difficult and to keep the birds quiet. The ground was entirely bare, in fact, not even frozen, a farmer being busy plowing in one

field we passed. The list follows:

Herring Gull, 6; American Golden-eye, 2; Ruffed Grouse, 7; Sparrowhawk, 1; Screech Owl, 2; Belted Kingfisher, 1; Hairy Woodpecker, 5; Downy Woodpecker, 14; Blue Jay, 13; Crow, 23; Bronzed Grackle, 3; Purple Finch, 17; Goldfinch, 2; Tree Sparrow, 43; Junco, 23; Song Sparrow, 1; Cardinal, 9; Brown Creeper, 9; White-breasted Nuthatch, 20; Red-breasted Nuthatch, 2; Black-capped Chickadee, 88; Golden-crowned Kinglet, 43.

Total, 22 species, 334 individuals.—E. M. S. DALE.

CHRISTMAS BIRD CENSUS, 1923.—*Hamilton, Ontario, Canada.*—December 26; 9 a.m. to 1 p.m. Bright sun; light covering of snow on ground, cold north-west wind; 32° at start, 38° at return. Fifteen miles on foot. Five parties working in different directions along mountain brow, under mountain brow, around marsh; same territory as last year. Herring Gull, 563; Hawk (sp?), 2; Hairy Woodpecker, 2; Downy Woodpecker, 8; Horned Lark, 1; Crow, 2; Pine Grosbeak, 1; Tree Sparrow, 28; Junco, 4; Song Sparrow, 2; Brown Creeper, 2; White-breasted Nuthatch, 10; Black-capped Chickadee, 24. Total, 13 species, 649 individuals. Others seen recently: Screech Owl; Black-billed Cuckoo (C. D. Cook, brought in December 27, injured but able to fly, died later); Blue Jay; Robin; Bluebird (C. D. Cook, December 21). Mrs. F. E. MacLoughlin, Mrs. C. D. Cook, Misses Bauer, Malcolm, Mills and Smith; Donald Baxter, Roland Brown, C. D. Cook, M. Johnstone, G. O. McMillan, C. McQuestion.—THE HAMILTON BIRD PROTECTION SOCIETY INC.

CHRISTMAS BIRD CENSUS, 1923, AT TORONTO, ONTARIO.—Christmas, 1923, dawned at Toronto so bleak and dreary a day that it promised little to a bird observer. All day the sky was more or less overcast, while a light breeze brought an occasional wet snowfall, which later turned to a drizzling rain. However, I spent the entire morning afield, for even at this slack season there is no telling what may be seen.

Strange to say, the first object of interest observed was not a bird. At the place in the Don valley where, during the Christmas census of 1922, I saw a Golden-eye on smooth water in the river, I peeped over the bank to see if I might observe the species again. But this time I found myself within fifteen feet or so of a fine muskrat, which was nibbling away at some grass roots on the edge of a tiny gravel island in mid-stream. His back was toward me, so that I could stand and watch him at leisure. I was just thinking what a

cold, comfortless breakfast it was—grass roots eaten while half in the icy water on such a day—when he half turned and saw me and instantly disappeared with a splash, swimming rapidly under water to the river bank.

I went on up the valley, crossing it and passing through an open bit of woodland. I thought I heard a White-breasted Nuthatch, but failed to locate the bird. Suddenly I caught the familiar note again and, following the sound, saw a solitary Nuthatch making his way around a thick limb high up. Next I entered a thick cedar grove where I heard and saw two Juncos. Three Chickadees were seen in open woods not far away. Then as I scrambled up the bank I saw by merest chance two silent Blue Jays, which entered the net-work of limbs overhead and moved stealthily through the woods by short flights. As I gained the top of the bank I came upon a solitary Downy Woodpecker, working in silence upon a dead tree trunk at the edge of the field.

For several seasons past I had known this field to be a great resort for Ring-billed and Herring Gulls, which congregate there to feed upon garbage spread on the field. They did not disappoint me in this instance for at once I saw several in the distance and later they flew overhead in ones and twos. As far as I could see as they sailed overhead they were all adult Ring-bills. I had hoped to see Snow Buntings upon this field, but saw none on this occasion. As I skirted the weedy edge of the field I saw a flock of small birds very busy on a weed. I trained my glasses on them at a distance of thirty or forty feet and found to my surprise that they were not Redpolls but Goldfinches—exactly thirteen in number. One large plant of lamb's quarters (*Chenopodium*) was carrying and feeding the entire picnic.

By this time the wind had brought on a drizzly rain, and, as there was little to encourage any further observation, I turned and picked my way down the wooded bank. In one spot farther on I flushed a small flock of Juncos, twelve or fifteen in number, many of which were in splendid plumage, and when I came out in the open valley below I noted a large Hawk circling and sailing westward. Although I watched it until it was far away I was unable to identify it definitely.

Time afield—8.00 a.m. to 12.30 p.m.

Birds seen—Ring-billed Gull (probably), approx. 15; Hawk (sp?) 1; Downy Woodpecker, 1; Blue Jay, 2; American Goldfinch, 13; Junco, 15 approx.; White-breasted Nuthatch, 1; Chickadee, 3. Total, 8 species, 51 individuals.—STUART L. THOMPSON.

THE CHRISTMAS BIRD CENSUS, OTTAWA DISTRICT, 1923.—The Christmas census taken by the

Ottawa bird students this year was marked by the finest turnout of observers that we have yet had. Nineteen people in all took part, and the routes were planned and allotted at a preliminary meeting, thus avoiding duplication of records so far as possible. Two parties, consisting of three observers, were out on December 22nd, confining their attention to the shores of the Ottawa River and of Lake Deschenes, the Ontario-Quebec boundary westward from the city. On the 23rd, six other parties, containing the sixteen remaining observers, radiated from the city in every direction, omitting of course the territory covered on the previous day.

The weather was remarkable for the district, the ground being free from snow, and the temperature mild on both days. The parties observing on the 22nd were troubled somewhat by fog. There was no such obstruction to vision on the 23rd, but the muddy roads impeded progress a little. After lunch at least one member used a running brook for a finger bowl without discomfort. The eight parties covered an estimated distance of 108 miles. It is worthy of note that both the Gatineau River at Kirk's Ferry and the Ottawa River at Gatineau Point were crossed by boat.

In the following list the observations of all parties are consolidated.

Herring Gull.....	Dec. 23	51
Merganser (sp.).....	" 23	7
Ruffed Grouse.....	" 23	5
Screech Owl.....	" 23	1
Hairy Woodpecker.....	" 23	5
Downy Woodpecker.....	" 23	9
Blue Jay.....	" 22, 23	6
Crow.....	" 22, 23	88
Bronzed Grackle.....	" 22	2
Evening Grosbeak.....	" 23	16
Pine Grosbeak.....	" 22	5
Redpoll.....	" 22	85
Goldfinch.....	" 23	22
Northern Shrike.....	" 22, 23	2
Myrtle Warbler.....	" 22	1
White-breasted Nuthatch.....	" 22, 23	19
Red-breasted Nuthatch.....	" 22	1
Black-capped Chickadee.....	" 22, 23	120
Robin.....	" 22	1

Total, 19 species, 446 individuals.

The absence of the Pine Siskin, more than 1300 of which were seen in the census of 1922, was notable. The Herring Gulls were a natural corollary to the open water present. There seemed to be a movement of them northward along the Rideau River. The Screech Owl was captured by hand, its attention being distracted during the stalk by the presence of a small dog. Messrs. B. A. Fauvel and R. E. DeLury, who were responsible for the capture, took the bird

home with them, banded and photographed it, and returned it by motor car to its chosen hunting ground. The Bronzed Grackles have been observed feeding for some time at the residences of Miss F. Von Charles and Mr. Maxwell Graham at Britannia. It is possible that there are more than two. The presence of the Myrtle Warbler, found by the party of Messrs. Waugh and Lewis, was an event not noted before and not likely to be noted again in many years. It may have remained because of the unusually fine weather of the past fall and early winter. The recent heavy snows and zero weather may have claimed it, unless it was so fortunate as to have moved on ahead of the storms. Chickadees were the most abundant birds, and seemed to be centred about the river valleys, particularly that of the Ottawa.

—HOYES LLOYD.

A CARDINAL IN OTTAWA.—On the 28th and 29th of November, 1923, a Cardinal (*C. cardinalis*.) was seen several times flitting about the neighborhood of the Victoria Memorial Museum and the Catherine St. Railway Station. Associating with a small flock of House Sparrows and feeding with them on weed seeds and berries of the Virginia creeper, he did not seem to suffer the persecution that these little rascals usually inflict upon solitary birds of other species. Perhaps they respected him as a distinguished stranger from a far country. Certainly his brilliant red mantle, black choker and kingly crest made him a conspicuous personage against the greys and browns of the November gardens.

I was fortunate in being able to point out this unexpected find to Mr. Claude Johnson and Mr. D. Blakeley of the Museum staff, so that there can be no doubt regarding the identification.—LOIS R. KINGSTON.

ACKNOWLEDGEMENTS FOR 1923.—In addition to the annual increase in trust funds from the R. B. White estate, two other contributions to the Ottawa Field-Naturalists' Club are well worthy of note. Mr. T. L. Thacker, of Hope, B.C., contributed a sum of money to the publications fund, and Mr. P. B. Symes, of Ottawa, presented a nearly complete set of *Transactions* and back volumes of the Club's publication, most of which are bound. This set of back volumes, valued at \$80 unbound, will be placed in the care of the Editor and preserved as the Club's set of original issues. It should also be stated that from time to time minor contributions toward the improvement of *The Canadian Field-Naturalist* have been made.—CLYDE L. PATCH, Sec.

This number of *The Naturalist* continues the policy of publishing an increased number of illustrations. Those appearing in this issue are published through the kind assistance of Mr. Frits Johansen.—EDITOR.

STATEMENT OF THE FINANCIAL STANDING OF THE OTTAWA FIELD-NATURALISTS' CLUB AT THE CLOSE OF THE CLUB YEAR 1922-23

LIABILITIES:		ASSETS:	
Ottawa Monotype Comp. Co.....	\$512.30	Cash on hand.....	\$ 26.10
Editor's honorarium, 1921.....	50.00	Unpaid membership dues, 1922.....	55.00
Editor's honorarium, 1923.....	50.00	" " 1923.....	137.50
		Grant from Ontario Government.....	200.00
		Bills receivable.....	46.83
		Deficit.....	146.87
	<hr/>		<hr/>
	\$612.30		\$612.30

This statement does not include trust funds.
Audited and found correct, December 14, 1923.

(Sgd:) W. H. COURTICE,
C. R. TWINN.

THE OTTAWA FIELD-NATURALISTS' CLUB, OTTAWA, CANADA

FULL STATEMENT OF RECEIPTS AND DISBURSEMENTS FOR THE CLUB YEAR, 1922-23

RECEIPTS		DISBURSEMENTS:	
Jan. 1, 1923:—		To Ottawa Monotype Comp. Co. a/c	
By Balance on hand.....	\$ 21.23	printing <i>Naturalist</i>	\$ 926.32
Membership Dues:—		Garden Vale Press, Final Settlement a/c	
Current.....	\$ 528.00	1921.....	50.00
Affiliated Societies, 1923.....	57.50	Ottawa Monotype Comp. Co., Reprints.....	90.25
Arrears.....	182.00	" " " " Illustrations.....	153.95
Advance.....	72.00	Ottawa Monotype Comp. Co., Authors' reprints.....	90.00
	<hr/>	Ottawa Monotype Comp. Co., Comm. on Collecting for adv. in <i>Naturalist</i>	45.00
Advertisement in <i>Naturalist</i>	839.50	Ottawa Monotype Comp. Co., Sales Tax 4½%.....	43.98
Back Nos. and Vols. Sold.....	142.00	Job Printing and Stationery.....	47.75
Authors' reprints and illustrations.....	106.05	Postage and Exchange.....	29.49
Illustrations.....	370.89	Telegrams.....	2.52
Donations.....	20.69	Balance.....	26.10
	5.00		
	<hr/>		<hr/>
	\$1505.36		\$1505.36

OTTAWA FIELD-NATURALISTS' CLUB,
(Sgd.) C. B. HUTCHINGS,
Treas.

Audited and found correct, December 14, 1923.
(Sgd.) W. H. COURTICE,
C. R. TWINN. } Auditors.

BOOK REVIEW

THE CONDOR, Vol. XXIV, 1922.

The Condor for 1922 contains the following articles of particular interest to Canadian Naturalists.

Magpies versus Livestock: An unfortunate Chapter in Avian Depredations. By S. Stillman Berry. with two photographs. Pp. 13-17.

An account of Magpies attacking sheep, cattle and hogs in Montana. Usually this was begun by picking at shearing cuts, branding-wounds or other previously existing sores but, in some cases at least, wounds were originated by the birds. Like the historic Kea Parrot of New Zealand, the Magpies soon learned the delicacy of kidney fat and the ease with which it can be reached through the small of the back. Some animals were killed by these attacks, others more or less seriously injured. The habit seems sporadic, local, and perhaps individual, as it is only in occasional localities that it develops and, when a

small percentage of the birds, probably the worst offenders, are killed off, the losses are reduced.

Notes on The Dipper in Yellowstone National Park.

By M. P. Skinner. *Park Naturalist*. Pp. 18-20.

A good account of the habits, etc., of this interesting species.

On The Occurrence of the Buffle-head at Eagle Lake.

By Allan Brooks. Pp. 25-26.

A short note correcting the identification of pictures supposed to be of this species and published in the *Condor* for November, 1921. The writer points out that the bird in question is an undoubted American Merganser and that the breeding of the Buffle-head in north-eastern California, while probable, still remains to be verified.

Bird Fatalities Resulting from a Shipwreck. By

Ernest P. Walker. Pp. 26-27.

Reporting the loss of sea-bird life from floating oil from the fuel tanks of the wreck of the *Princess*

Sophia on the Lynn Canal, Alaska, October 26, 1918. The writer was patrolling the shores of Admiralty Island, twenty to forty miles from the scene of the disaster, in search of bodies of the 343 passengers and crew lost on the occasion. He reports many Murres and Gulls dead or helpless with oil-soaked plumage. In one case an oil-stained Glaucous Gull was seen at Wrangell, some 200 miles south of the wreck.

The White Gyrfalcon in Montana. By J. Hooper Bowles. P. 28.

Reporting the capture of a specimen near Fort Benton, Montana. This record is of interest to the bird people of our western prairies as suggestive of what to expect.

A Correction. Brewer Blackbird Not Occurring in Northern British Columbia. By P. A. Taverner. P. 31.

Correcting a record made by the writer in *The Summer Birds of Hazelton, British Columbia, Condor*, March, 1919. The specimens in question prove to be Rusty Blackbirds in juvenile and worn plumages, among the first records for the species in the province.

Anthony Vireo Not a Tenable Subspecies. By J. Grinnell. Pp. 32-33.

Dr. Grinnell expresses the opinion that Anthony's Vireo, *Vireo huttoni obscurus*, the form accredited to southern Vancouver Island, is based upon fresh, unfaded specimens of *Vireo huttoni huttoni* and is therefore untenable as a distinct subspecies. He raises the question as to whether *Vireo huttoni insularis* should be recognized as the Vancouver Island bird but suggests that the dark, sooty appearance upon which Mr. Rhoades based that form may be due to smoke stains from the city near which the types were taken.

Albino Robin Returning to Former Nesting Site. By J. A. Munro. P. 62.

A partial albino male Robin with particular recognizable markings returned and nested for three successive years at Summerland, British Columbia.

Kamchatka Sea Eagle at Kodiak, Alaska. By Charles H. Gilbert. P. 66.

Report of capture, supported by photograph, of bird taken August 10, 1921, at Kodiak. The picture shows the white fore-wings very plainly.

Notes on The American Pine Grosbeak with Description of a New Subspecies. By Allan Brooks. Pp. 86-88.

The principal part of this paper consists of the description of the Queen Charlotte Grosbeak, *Pinicola enucleator carlottæ*, a new subspecies. This is the smallest and the most scarlet of the American Pine Grosbeaks and, in the opinion of the reviewer, the most distinct of any of the geographical races of the species that have been

described. In the discussion of the species incident to this description, the writer reviews his specimens from various parts of Canada, is undecided as to their subspecific determination and hopes some one will revise the group.

Yellow-headed Blackbird in Company with Brewer Blackbirds. By J. A. Munro. Pp. 93-94.

Such an association noted in the streets of Penticton, British Columbia, October 19, 1921.

What Color are the Feet of the Western Gull? By Allan Brooks. Pp. 94-95.

Major Brooks cites authorities to the effect that the feet of the Western Gull are yellow but states that fresh adults examined by him had them flesh-colored. He also calls attention to the old, impossible record of the species breeding in the Similkameen Valley, British Columbia, once more perpetuated in Ridgway's *Birds of North and Middle America*. He states that, in spite of the general report that it is a common bird of the British Columbian coast, he knows of but three authentic records for the province. He stresses the importance of noting the colors of the soft parts of all *Laridæ* as in many cases these colors are the most reliable recognition characters of the species.

Crossbills Eating Aphis. By P. A. Taverner. P. 36.

A short note on the subject suggested by some remarks by Mr. Storer in a previous number of the *Condor*. The method by which Crossbills split leaf galls and remove aphids from their interior is described.

On P. 102 the Editor calls attention to a recent article in the *Ibis* on the sense of smell in birds and urges that some one seriously investigate this subject and, with properly conducted experiment, replace the hap-hazard observation and inconclusive "experiment" upon which our present conflicting ideas are based. Here is a field for some ambitious worker.

On P. 138, announcement is made of a distributional and systematic list of the Birds of British Columbia in course of preparation by Allan Brooks and Harry S. Swarth. This is a most important and much needed work and no stronger collaboration of authorship could be named for it. It will be looked for with interest by others as well as by the ornithologists of that province.

Our English Nomenclature. By A. D. Dubois. Pp. 158-162.

This is a plea for a more accurate and scientific formation of vernacular names in our Check-list. The writer urges the use of binomial and trinomial systems of common names, and that subspecific names be constructed so that their subordinate racial character be clear, and deprecates the use of the specific name for any of the included subspecies.

(Concluded in February issue)

Henry Birks & Sons, Limited

*Gold and
Silversmiths*

BIRKS BUILDING
103-105 Sparks Street
OTTAWA

The Crabtree Co.

Artists and
Designers

BLUEPRINTERS
ENGRAVERS
COMMERCIAL
PHOTOGRAPHERS
: PHOTO :
LITHOGRAPHERS

228 Albert Street
Ottawa, Ont.



Card Filing Systems for Naturalists

As makers of the Library Bureau line of Card Filing Devices in Canada, we are in a position to supply all Naturalists with cards and trays where they can readily index all their observations and notes

Lowe-Martin Ltd.
OTTAWA, CANADA

*Printers of The Canadian Field-Naturalist
Publishers of the Autobiography of John Macoun, M.A.*

COAL C. C. Ray Company Limited

BEST QUALITY LOWEST PRICES

46 Sparks St.—Phone Q. 461
OTTAWA

Geo. E. Preston & Sons MERCHANT TAILORS

*We make everything we sell and
guarantee everything we sell*

217-219 Rideau Street, Ottawa

Dr. Mark G. McElhinney
*Dentist to certain of the
cognoscenti*

252 LISGAR STREET, OTTAWA

Telephone Queen 2438

Kindly mention The Canadian Field-Naturalist to advertisers

Prices of Separates

Notes to Contributors, Etc.

Papers for publication should be addressed to the Editor, Mr. Harrison F. Lewis, Parks Branch, Ottawa, or to the appropriate Associate Editor.

Manuscript should be plainly written, typed if possible, on one side of the paper only, with wide spaces between the lines and ample margins. It is urged that special care be used that scientific names are legible, properly formed, and correctly spelled and capitalized.

Galley proof will be submitted to authors resident in Ottawa and proof of leading articles to any other author if requested when manuscript submitted. It is requested that it be corrected and returned to the Editor as quickly as possible.

Authors of leading articles are entitled to twenty-five copies of the number in which they appear, free of charge on application.

Separates of articles as they appear on the page, without any change of make-up will be supplied at the following rates:—

	25	50	100	200	300
1 page.....	\$2.00	\$2.25	\$2.50	\$2.75	\$3.00
2 ".....	3.00	3.25	3.75	4.00	4.25
3 ".....	3.50	3.75	4.00	4.25	4.50
4 ".....	3.50	3.75	4.00	4.25	4.50
5 ".....	4.50	4.75	5.00	5.25	5.50
6 ".....	4.50	4.75	5.00	5.25	5.50
7 ".....	6.00	6.25	6.50	6.75	7.00
8 ".....	6.00	6.25	6.50	6.75	7.00
9 ".....	7.50	8.00	8.75	10.25	11.75
10 ".....	7.50	8.00	8.75	10.25	11.75
Covers extra.....	3.00	3.00	3.00	4.00	5.00

If removal of matter on the pages non-pertinent to the article or changes of make-up are desired, or if insets or other extra work are necessary, special rates will be furnished on application to the Editor.

Applications for separates should be made to the Editor and must reach him not later than with the return of the corrected proof.

Rubber Stamps

FOR

Listing Your Specimens

The more consistent use of rubber stamps will materially assist you in cataloguing the collection of specimens you have spent so much time and trouble in securing. Let us help you.

CAPITAL RUBBER STAMP WORKS

175 NEPEAN STREET
OTTAWA, CANADA

Many More are Wanted on the Subscription Lists

The Membership Committee of The Ottawa Field-Naturalists' Club is making a special effort to increase the subscription list of *The Canadian Field-Naturalist* and we are asking every reader to assist in making the campaign the success it should be.

We would particularly urge the Secretary of each Affiliated Society to bring this matter up at EVERY meeting and secure as many subscribers as they possibly can to a Canadian Publication devoted to the study of Natural History in all its phases.

Use the blank below and forward it to the Treasurer.

———— CUT OFF HERE ————

MR. B. A. FAUVEL,
Treasurer, Ottawa Field-Naturalists' Club,
Mounted Police Headquarters,
113 Rideau St., Ottawa.

I enclose One Dollar and Fifty Cents as my subscription to The Canadian Field-Naturalist for one year.

Name.....
(Mr., Mrs. or Miss)

Address.....

City and Province.....

Kindly mention The Canadian Field-Naturalist to advertisers

Affiliated Societies

NATURAL HISTORY SOCIETY OF MANITOBA

1923

Hon. Presidents: H. M. SPEECHLY, M.D.; W. G. SCOTT;
President: PROF. V. W. JACKSON; *Vice-Presidents:* NORMAN
CRIDDLE; J. J. GOLDEN; MRS. C. P. ANDERSON; PROF. C. H.
O'DONOGHUE; PROF. F. W. BRODRICK; *Treasurer:* MISS
HELEN R. CANNON. ORNITHOLOGICAL SECTION:—
Chairman: A. G. LAWRENCE; *Secretary:* B. W. CARTWRIGHT;
Leaders: H. M. SPEECHLY, M.D.; J. J. GOLDEN; C. E. KEIGH-
LEY; K. GRANT MCDUGAL; R. M. THOMAS. ENTOMOLO-
GICAL SECTION:—*Chairman:* J. B. WALLIS, B.A.; *Secre-
tary:* G. SHIRLEY BROOKS; *Leaders:* L. H. ROBERTS; A. V.
MITCHENER, B.S.A.; J. D. SUFFIELD; J. D. DUTHIE. BOTANI-
CAL SECTION:—*Chairman:* C. W. LOWE, M.Sc.; *Secre-
tary:* MRS. K. J. MCDUGAL; *Leaders:* JAMES COCKS;
PROF. F. W. BRODRICK; DR. G. R. BISBY; H. F. ROBERTS,
M. Sc.; SUBSECTION—MYCOLOGY:—*Leader:* DR. G. R.
BISBY; GEOLOGICAL SECTION:—*Chairman:* PROF. R. C.
WALLACE; *Secretary:* A. A. MCCOUBREY; SUBSECTION—
PALAEOLOGY:—*Leader:* W. CUTLER; *General Secre-
tary:* A. M. DAVIDSON, M.D., 6 Medical Arts Building.

THE HAMILTON BIRD PROTECTION SOCIETY (Incorporated)

Hon. President: MR. ADAM BROWN; *President:* MR. R. O.
MERRIMAN; *1st Vice-President:* DR. H. G. ARNOTT; *2nd Vice-
President:* MR. C. D. COOK; *Secretary-Treasurer:* MISS RUBY
R. MILLS, Public Library, Hamilton; *Directors:* DR. H. G.
ARNOTT; C. D. COOK; DR. J. A. DICKSON; MISS M. E. GRA-
HAM; MISS RUBY R. MILLS; M. HOLTON; M. JOHNSTON;
MRS. F. E. MACLOGHLIN; R. O. MERRIMAN.

NATURAL HISTORY SOCIETY OF BRITISH COLUMBIA, VICTORIA, B.C.

The Officers for the above Society for the year ending
March 31st, 1923, are as follows:—

President: W. N. KELLY; *1st Vice-President:* A. R. SHERWOOD;
2nd Vice-President: C. C. PEMBERTON; *Secretary:* H. T.
NATION; *Treasurer:* MISS S. M. THORNTON. *Committee:*—
MISS C. G. FOX, MISS A. F. GARDINER, MISS I. CATHCART,
WM. DOWNES, A. HALKETT. *Auditors:*—J. KEITH WILSON
AND F. W. GODSAL. *Trustees:*—REV. R. CONNELL, DR. C. F.
NEWCOMBE AND G. HARVEY.

ALBERTA NATURAL HISTORY SOCIETY

Hon. President: HON. GEO. HOADLEY; *Hon. Vice-President:*
H. A. CRAIG; G. W. SMITH, M.P.P.; J. J. GAETZ; *President:*
C. H. SNELL; *Vice-Presidents:* MRS. W. A. CASSELS; DR.
HENRY GEORGE; *Secretary-Treasurer:* MRS. S. PAMELY, Red
Deer; *Directors:* MRS. H. GEORGE, Red Deer; MRS. G. F.
ROOT, Wetaskiwin; K. BOWMAN, Edmonton; F. S. CARR,
Edmonton; D. MACKIE, Edmonton; W. A. CASSELS, Red
Deer; S. PAMELY, Red Deer; C. G. S. CROSBY, Red Deer;
W. F. HARRIS, Red Deer; H. R. ORAM, Red Deer. *Members
qualified to answer enquiries:* *Birds:* MRS. W. A. CASSELS, Red
Deer; DR. H. GEORGE, Red Deer; *Mammals:* DR. H. GEORGE,
Red Deer; *Fishes:* F. C. WHITEHOUSE, Red Deer; *Flowers:*
MRS. H. GEORGE, Red Deer; *Insects:* Coleoptera, F. C. CARR,
11050 123rd St., Edmonton; Lepidoptera, K. BOWMAN, 9914
115th St., Edmonton; Odonata, F. C. WHITEHOUSE, Red Deer.

The meetings of this Society are held in Red Deer on
the last Friday of each month except during July and August and
perhaps September. The annual meeting is held in Red Deer
on the last Friday in November.

McILWRAITH ORNITHOLOGICAL CLUB, LONDON, ONT.

President: J. R. McLEOD; *Secretary:* C. G. WATSON, 201
Ridout St. South, London; *Member:* qualified to answer ques-
tions: W. E. SAUNDERS, 240 Central Ave.; C. G. WATSON,
201 Ridout St. South; J. R. McLEOD, 355 Wortley Road,
J. F. CALVERT, 461 Tecumseh Ave.; E. M. S. DALE, 297
Hyman St.

VANCOUVER NATURAL HISTORY SOCIETY

Hon. President: L. S. KLINCK, LL.D., Pres. University of B.C.;
President: JOHN DAVIDSON, F. L. S., University of B.C.;
Vice-President: FRED PERRY; *Hon. Secretary:* C. F. CONNOR,
M.A., 3529-W. 2nd Ave., Vancouver, B.C.; *Hon. Treasurer:*
A. H. BAIN, 2302 York St., Vancouver, B.C.

Fortnightly meetings in the University Buildings from
September to April (inclusive). Semi-monthly excursions
from May to August (inclusive).

PROVINCE OF QUEBEC SOCIETY FOR THE PROTECTION OF BIRDS

Hon. President: I. GAMMELL; *President:* L. MCI. TERRILL;
Vice-Presidents: ALEX MACSWEEN, NAPIER SMITH, E. ARNOLD;
Hon. Corresponding Secretary: W. S. HART, P.O. Box 1185,
Montreal; *Hon. Recording Secretary:* MISS H. STONE;
Hon. Treasurer: MISS M. ARMITAGE, 63 Arlington Ave.,
Westmount; *Directors:* MISS EDITH MORROW; MISS LOUISE
MURPHY; MISS EMILY LUKE; MR. AND MRS. C. F. DALB;
MRS. J. T. AYERS; MISS JEAN MCCONNELL; W. A. OSWALD;
A. F. WINN; MR. AND MRS. WALLACE H. ROBB; W. G.
WRIGHT. *Members qualified to answer questions:* L. MCI.
TERRILL, 44 Stanley Ave., St. Lambert, Que.; NAPIER SMITH,
Bank of Montreal, Magog, Que.; E. ARNOLD, 64 Durocher St.,
Montreal; W. A. OSWALD, 301 Wilson Ave., N.D.G., Montreal;
C. N. ROBERTSON, c-o Ross Realty Co., Room 805, Lewi
Bldg., St. John St., Montreal, Que.; DR. ARTHUR WILBY,
McGill University, Montreal; W. J. BROWN, 250 Oliver Ave.,
Westmount, Que.; MISS EDITH MORROW AND MISS EMILY
LUKE, c-o Secretary.

SOCIÉTÉ PROVANCHER D'HISTOIRE NATURELLE DU CANADA

Bureau de direction pour 1923

Président: R. MEREDITH, N.P.; *1er vice-président:* ABBE
ALEX. VACHON, M.A.; *2ème vice-président:* DOCTEUR A. DERY;
Secrétaire-trésorier: JOS. MATTE, 18 avenue Maisonneuve,
Québec; *Chef de la section scientifique:* COLONEL OSCAR PELLET-
TIER; *Chef de la section de propagande éducationnelle:* DOC-
TEUR S. GAUDREAU; *Chef de la section de protection:* C.-E.
DIONNE, M.A.; *Chef de la section d'information scientifique et
pratique:* DOCTEUR J.-E. BERNIER; *Directeurs:* A.-R.-M.
BOULTON, FRANK W. ROSS, A.-A. GOUBOUT.

THE BRITISH COLUMBIA ORNITHOLO- GISTS' UNION

Officers for 1923

Hon. President: HON. MINISTER OF AGRICULTURE, Victoria;
President: FRANCIS KERMODE, Provincial Museum, Victoria
Vice-President: T. L. THACKER, Hope; *Secretary-Treasurer:*
J. W. WINSON, Huntingdon; *Directors:* J. A. MUNRO, Okanagan
Landing; DR. KELSO, Arrow Lakes; R. GLENDENING,
Agassiz; K. RACEY, Vancouver; T. PEARSE, Courtenay;
W. N. KELLY, Victoria.

THE TORONTO FIELD-NATURALISTS' CLUB

President: PROFESSOR R. B. THOMSON; *Vice-Presidents:*
PROFESSOR E. M. WALKER, DR. A. COSENS, J. H. FLEMING;
Secretary: W. F. GREGORY, 151 Ellsworth Ave., Toronto;
Treasurer: F. H. BRIDGEN; *Honorary Librarian:* C. W. NASH;
Librarian: DR. LYMAN B. JACKES. BIRD GROUP:—
Chairman: STUART THOMPSON; *Secretary:* JAMES BAILLIE.
FLOWER GROUP:—*Chairman:* DR. H. B. SIFTON; *Secretary:*
MISS J. G. WRIGHT, Ph.D.; INSECT GROUP:—*Chair-
man:* PROFESSOR WALKER; *Secretary:* MISS NORMA FORD,
Ph.D. MAMMAL GROUP:—*Chairman:* J. R. DYMOND;
Secretary: L. SNYDER. REPTILE, FISH AND AMPHIBIAN
GROUP:—*Chairman:* SHELLY LOGIER; *Secretary:* T. B.
KURATA. PROGRAM COMMITTEE:—*Chairman:* DR.
W. A. CLEMENS. WILD LIFE PRESERVATION COM-
MITTEE:—*Chairman:* RUSSELL G. DINGMAN. EDUCA-
TIONAL COMMITTEE:—*Chairman:* TAYLOR STATTEN.

We would ask the Officers, and more
particularly the Secretaries, of all the
Affiliated Societies to assist us in our
task of building up the circulation of
this magazine. By securing every
member as a subscriber we can truly
make this magazine into one of the
leading Natural History publications
of America



THE CANADIAN
FIELD-NATURALIST



PUBLISHED BY
OTTAWA FIELD-NATURALISTS' CLUB

ISSUED FEBRUARY 29, 1924

Entered at the Ottawa Post Office as second-class matter

THE OTTAWA FIELD-NATURALISTS' CLUB

Patrons:

THEIR EXCELLENCIES THE GOVERNOR-GENERAL AND THE LADY BYNG OF VIMY

President: HOYES LLOYD.
1st Vice-President: G. A. MILLER.
Secretary: J. F. WRIGHT, (Geological Survey, Ottawa.)
2nd Vice-President: NORMAN CRIDDLE
Treasurer: B. A. FAUVEL, (Mounted Police Headquarters, Laroque Bldg., Rideau and Dalhousie Sts., Ottawa)

Additional Members of Council: W. T. MACOUN; MISS M. E. COWAN; C. M. STERNBERG; H. I. SMITH; F. W. WAUGH; P. A. TAVERNER; E. SAPIR; E. M. KINDLE; W. J. WINTEMBERG; R. E. DELURY; ARTHUR GIBSON; M. O. MALTE; R. M. ANDERSON; H. GROH; MISS F. FYLES; C. B. HUTCHINGS; H. M. AMI; CLYDE L. PATCH; D. JENNESS; V. W. JACKSON; R. O. MERRIMAN; W. N. KELLY; C. H. SNELL; J. R. MCLEOD; JOHN DAVIDSON; L. MCL. TERRILL; R. MEREDITH; FRANCIS KERMODE; PROF. R. B. THOMSON; THE EDITOR.

Editor:

HARRISON F. LEWIS,
 Canadian National Parks Branch,
 Dept. of the Interior, Ottawa.

Associate Editors:

E. SAPIR.....	<i>Anthropology</i>	A. G. HUNTSMAN.....	<i>Marine Biology</i>
M. O. MALTE.....	<i>Botany</i>	P. A. TAVERNER.....	<i>Ornithology</i>
F. R. LATCHFORD.....	<i>Conchology</i>	E. M. KINDLE.....	<i>Palaeontology</i>
M. Y. WILLIAMS.....	<i>Geology</i>	R. M. ANDERSON.....	<i>Zoology</i>
ARTHUR GIBSON.....	<i>Entomology</i>	CLYDE L. PATCH.....	<i>Herpetology</i>

CONTENTS

	PAGE
Some Experiences in Bird-Banding. By Ralph E. DeLury.....	21
W. H. Hudson, The Naturalist (1841-1922). By Frank Morris.....	24
Whistling Swans in Ontario. By W. E. Saunders.....	26
Range of the Moose Extending Northward. By Rudolph Martin Anderson.....	27
In Memoriam—Napoléon A. Comeau. Born 1848. Died 1923.....	29
Correspondence:—	
Letter from Wm. Rowan, Edmonton, Alberta.....	30
Letter from Allan Brooks, Okanagan Landing, B.C.....	33
Letter from Elsie Cassels, Red Deer, Alta.....	34
Letter from Frank G. Speck, Philadelphia, Pa.....	34
Letter from Charles W. Townsend, Boston, Mass.....	35
Editorial.....	35
Notes and Observations:—	
New Records for Point Pelee. By W. E. Saunders.....	36
The Pine Mouse in Ontario. By W. E. Saunders.....	37
An Unusual Sight Description of a Bird Verified. By Hoyes Lloyd.....	38
The Collection of North American Birds in the Royal Ontario Museum of Zoology. By L. Snyder.....	38
The Plaint of the Robin. By W. A. D. Lees.....	38
Leaflets of The National Association of Audubon Societies. By J. F. Wright.....	38
Editor's Note.....	39
Book Review:—	
The Condor. By P. A. T.....	39
Roosevelt Wild Life Bulletin, Vol. I, Nos. 3 and 4. By A. B. K.....	40
Publications Received.....	40

THE CANADIAN FIELD-NATURALIST, lately THE OTTAWA NATURALIST, established thirty-six years ago, "to publish the results of original research or investigation in all departments of natural history," is issued monthly, excepting for the months of June, July and August.

Papers, notes and photographs should be addressed to the Editor. Manuscript should be typewritten.

Subscriptions cover the current year, except those taken out during last quarter, when they will be applied on the following year, the remaining numbers of current year being sent free. Payments should be made to the Treasurer, Mr. B. A. Fauvel, Mounted Police Headquarters, Laroque Building, Ottawa. Price of this volume, \$1.50; single copies 20c each.



This Style is a CANOE TENT—Weight 6 lbs.

WOODS
FEATHERWEIGHT
SILK
TENTS

Light as Air
STRONG
SERVICEABLE
WATERPROOF
BUG-PROOF

*Ideal for Field Work and Over-Night Trips.
Can be carried in your pocket—Accommodating 2 to 4 men*

WOODS MANUFACTURING CO.
OTTAWA

EXPLORATIONS
in Western Canada

The Ottawa Field-Naturalists' Club has just published an interesting volume of over 300 pages, entitled:

Autobiography of
John Macoun, M.A.

Canadian Explorer and Naturalist, Assistant Director and Naturalist to the Geological Survey of Canada—1831-1920.

This volume is an account of the life of this veteran naturalist. Agriculturists generally, in fact all interested in the development of Canada, will find this book of much interest and value.

The edition is limited. The price is \$3.00 with 15c added for bank exchange, if remittance is forwarded by personal cheque.

Applications for the volume should be made to

Mr. Arthur Gibson

Birks Building : Ottawa, Ont.

The
Topley Co.

Photographic Material
Scientific Apparatus
Eastman Kodaks



132 Sparks Street
OTTAWA

Kindly mention The Canadian Field-Naturalist to advertisers

Lyman's Limited

(Established 1800)

MANUFACTURING CHEMISTS

Importers and Dealers in
[CHEMICAL AND
ASSAY APPARATUS

344 St. Paul St. West, Montreal

THE
Bank of Nova Scotia

Capital.....\$ 9,700,000
Reserve Fund and Divi-
dend Profits, over.... 18,000,000
Total Assets over..... 230,000,000

SEVENTEEN BRANCHES IN
OTTAWA AND HULL



GROW GOOD CROPS

SEEDS PLANTS BULBS

Our rigorous system of testing eliminates loss
and disappointment from your garden

Kenneth McDonald & Sons, Limited
Seed and Bulb Merchants

Market Square :: Ottawa, Ont

W. A. Rankin, Ltd.

Hammocks
Refrigerators
Builders' Hardware

410-412 Bank Street, Ottawa

Phones—Queen 1023-1024

L. C. Smith & Bro.

Typewriter

*Ball bearings in every frictional part of
the L. C. Smith insure long life, light
touch and easy operation*

Ottawa Typewriter Co. Limited

191 QUEEN ST., OTTAWA

Inspected Milk

Ice Cream

Ottawa Dairy

Fresh Butter

Buttermilk

Ward's NATURAL SCIENCE ESTABLISHMENT

Rochester, New York, U.S.A.

Manufacturers of the genuine Schmitt boxes,
exhibition cases and cabinets, also of the American
Entomological Company's insect pins.

Riker Mounts and botanical mounts always on
hand, also Riker botanical presses.

Send for our supply catalogue and other lists of
interest to collectors.

Headquarters for Entomological Supplies
and Specimens

*"Say it with
Flowers"*

Sunnyside Greenhouses

Chas. Craig, Florist

Phone R. 566 Rideau Terrace OTTAWA

Kindly mention The Canadian Field-Naturalist to advertisers

The Canadian Field-Naturalist

VOL. XXXVIII

OTTAWA, ONTARIO, FEBRUARY, 1924

No. 2

SOME EXPERIENCES IN BIRD-BANDING

By RALPH E. DeLURY

THOUGH the countryside offers to the bird-bander undoubtedly advantages over the city, nevertheless interesting experiences are in store for the city dweller who undertakes the fascinating work of banding birds. He will naturally commence with the banding of nestlings and their parents, such work promising him rich results in regard to the ages of birds, their marriage relationships, their parasites and their returns from year to year, especially for such kinds as House Wrens, Tree Swallows, Bluebirds and Crested Flycatchers, whose nests usually permit of their easy capture. But surprising opportunities await him if he uses traps supplied with food and water to attract many kinds of resident and migrating birds. The more tempting the food and the more attractively and naturally it is displayed the greater will be his success. He will add considerably to the pleasure and the value of his work if he makes photographic records at every good opportunity. His banding station should become a sanctuary with cafeterias, bathing places and safety coverts, so managed that his guests will enjoy themselves, pose for portraits, accept rings as souvenirs and return again and again. He will have difficulties and responsibilities, the greatest of which is the absolute protection of the little feathered friends whom he has attracted to his premises. He will very soon find that the cats of the neighborhood constitute the greatest menace to the success of his station. But he will enjoy a delightful recreation in the work, and he will have his spare time well filled with pleasant adventures and will learn things about the living birds that can scarcely be found out in any other way.

Bird-banding operations were commenced in the summer of 1921 at the writer's home, which is fortunately situated for this work very near the Experimental Farm, Ottawa; the Farm with its open fields, clumps of trees, beautiful lawns and wooded parks offering great attractions to birds. During a residence of thirteen years about 75 species of birds have been seen within the writer's garden, and within a mile of it—including Dow's Lake, the Experimental Farm and its canal boundary—some 60 additional species have been noted during the same time. There is a fair

prospect of capturing for banding about 40 species in the garden and a total of 50 if the Farm grounds are included. Up to the present 235 birds have been banded, nearly 200 of which have been taken at home. Of the 28 species banded, the Song Sparrow leads with 67, the House Wren follows with 41, Robin 23, Chipping Sparrow 16, Tree Swallow 15, Downy Woodpecker, Brown Thrasher, and Whitebreasted Nuthatch 8 each, while among the rarer kinds are Indigo Bunting 4, Lincoln's Sparrow 1 and Golden-crowned Kinglet 1. There have been about 160 recaptures, five of which were after an interval of a year. A few experiences will be briefly mentioned.

SONG SPARROW.—Of the 67 banded 38 were recaptured from 1 to 13 times. Two returned after a year, one of which, a female, had nested in the garden the preceding year. These birds displayed great individuality, some squealing and fighting the hand when captured, while others took the treatment philosophically. One bird had a toe missing, another had lost the right foot. One pair nested twice in the garden. One day Song Sparrow feathers were found near one of the baths and this pair were not captured again—no doubt a cat was responsible for this break in our acquaintance. However, the accompanying photograph (1) and others recall many pleasant memories of these old friends.

HOUSE WREN.—Of the 41 banded, mainly fledglings, not one has returned in another season, thus weakening the belief in the springtime expression, "our little Wrens have come back again". The fledglings are the hardest birds to band, struggling continuously and keeping up their constant chatter, *chick-a-rick-chick-chick*. They usually have many minute parasites crawling on them and share them liberally with the bird-bander. Some of the birds taken in nests on metal posts seemed to have very few of these pests.

ROBIN.—Of the 23 birds banded, 4 of the adults were recaptured, one as many as 6 times from April to October. Family relationships are recorded in some cases, so that interesting returns are expected in the present year. One immature bird, captured in a drop trap, squealed so horribly



No. 1—Above
*An Old Friend in a Favorite
Corner*



No. 2
*An Odd Place to Find
Sunflower Seeds*



No. 3—To Left
Grasshopper au Naturel



No. 4—To Right
The Sunbath

that all the birds of the neighborhood came to see what murderer was at work, their looks plainly saying what they thought of the trap and the trapper. No birds ventured into the trap for two days.

CHIPPING SPARROW.—Of the 16 banded, one returned after a year. He and his mate had a nest in the garden the preceding year. He was captured then by placing his 4 young in one of the traps. Only two Chippies were found having swollen toes, a nail being lost from one of these. This is a considerably lower proportion than for those banded in Georgia.

DOWNY WOODPECKER.—These birds were captured by placing suet on an elm tree in front of the house and having a wire basket over it provided with a lid which was pulled over the opening by rubber bands after a prop was released by pulling a string. Some fought and screeched savagely, but one or two were quite tame after the first capture, one being captured three times in three hours. One bird returned after a year, and is feeding this winter at the suet, usually in company with a Nuthatch who was his pal last year.

WHITEBREASTED NUTHATCH.—The Nuthatches repeat frequently at the tree trap. The one who was about during last winter is shown in the photograph (2). He has learned that capture is not a serious thing, though he is wary when the trapper is about. These birds will usually accept a bit of suet and take it away and eat it when released, as do also some of the Downy Woodpeckers.

INDIGO BUNTING.—A very unusual opportunity came last summer, resulting in the banding of a pair of Indigo Buntings and their two fledglings, just within the southwest corner of the city. The old ones were captured by placing the two young under a hemispherical kitchen strainer within a "pull-front" trap. Pictures of these rare

visitors were secured, one of which is reproduced here (3), showing the band on the leg of the fledgling. Grasshoppers, whole and living, were brought to the young ones, chiefly by the mother. These are the first Indigo Buntings the writer has seen about Ottawa. Several occurrences have been reported within the past two years, so that possibly the species may be increasing in this district.

HAIRY WOODPECKER.—As the writer was looking from his window at the Observatory one day a Hairy Woodpecker, seeing a nesting box beside the window, swerved in suddenly and flew 40 feet straight toward the observer's face, striking the glass with considerable force. She was evidently planning to alight and then inspect the hole in the box. She was taken home, fed, photographed, banded and released, little the worse for her adventure.

GOLDEN-CROWNED KINGLET.—A Golden-crowned Kinglet was found, apparently stunned from flying against the large plate-glass front of the photographic studio of the observatory. Previously, in other years, one dead and one living Kinglet were picked up in the same place. This last one was taken home, fed and banded. He was very gentle and tame, always striving to perch on the hand or the head of the writer. While being photographed he flew up time after time to perch in front of the writer's face on the observing hood of the camera. He enjoyed a sunbath, but was not completely satisfied unless perching on a finger (4). In the late afternoon, standing on the writer's head, he was carried down two flights of stairs and outdoors, where, after a pause and a little chirp, he reluctantly flew to a cedar, then up high to an elm, when, getting his bearings, he flew back towards the observatory to join his migrating relatives. He wears a neatly fitting band trimmed to as small a size as possible, and he has left one of the most delightful memories.

W. H. HUDSON, THE NATURALIST (1841-1922)*

By FRANK MORRIS

I. "The Child is Father of the Man."

W. H. Hudson was born in August, 1841, on the Pampas of La Plata. His father was an Englishman who had married a New England wife and come to the Argentine, where they settled on a stock ranch near Buenos Ayres. Both parents, we learn from their son, were remarkable; the father hard-working, affectionate, tender with all living things, trustful to a fault, and absolutely devoid of fear; the mother cultured, religious, devoted to husband and children, beloved by all

the neighbours and passionately fond of flowers.

Hudson had several brothers and sisters, some older and some younger than himself. From childhood, however, he formed the habit of playing alone; and it made his mother very uneasy until she found that the boy spent his time with flowers and insects, and living creatures of all kinds—especially birds. His childhood, in fact, as he looked back on it, seemed one long revel of the senses, even from the earliest dawn of memory. He was *born*, as it were, with an extraordinary delicacy and sensibility for the beauties of living Nature, beauties of sound and scent and sight,

*Address delivered at the Annual Meeting of The Ottawa Field-Naturalists' Club, December, 1923.

colour, form and motion. The smell of the earth, the fragrance of leaves and flowers, the sound of wind and rain and running water, the brightness of butterflies and blossoms, the plumage, flight and melody of birds, the ways of all living creatures between the blue sky and the green mansions of earth—these were as food and drink and music to his soul.

Before he was eight years old, he became conscious of something more than this. A mystical sense of the supernatural in Nature awoke in him, to sweeten and somehow disturb this revel of the senses. It grew so strong as at times even to terrify; and peace of mind came to him only when in manhood he learned that the mystic writers of the XVIIth century and in his own day the poet Wordsworth and the Nature-lover, Richard Jefferies, had suffered the same fiery baptism as he.

He felt it most in Spring, with the revival of life on the earth, the return of flowers and insects and birds, and it filled him with pure delight; he felt it, too, at the autumn migration of birds, when the whole air was full of rushing wings flying northward in the night. Often, it overawed him in the solitude of the illimitable Pampas, in sunsets, and in the moonlight among the still shadows of the trees.

He had one abiding fear in boyhood, borne in on him by observation of his elder brothers, and indeed of all around him, when they grew to manhood; that there would come a time when he would have to put away childish things and adopt a calling. He thought that gradually his joy in living things and the mystic sense of communion with nature would droop and die. It was only when he was fifteen and came to read Gilbert White's *Natural History of Selborne* and the writings of Wordsworth and Jefferies, that he learned Nature might occupy a man's serious thoughts for life and the joy in living things be a solace until his dying hour. And no sooner did he learn this than he made a fierce resolve that he would never put away these childish things, even at the cost of food and drink for his body. How well he kept this vow his whole life from 18 to 80 and his 24 volumes of intimate self-expression are a proof that cannot lie.

The years of his boyhood ended in tragedy and disaster. His over-trustful father was ruined, his boyhood's home was broken up, his mother died, and he himself was struck down first by typhus and then by rheumatic fever. The doctors gave him a few weeks or (at most) months to live. To bodily distress was added torture of mind and spirit. But the miracle that no doctor could perform was wrought by Nature herself, for almost as soon as he could crawl out-of-doors his health

returned, very slowly, however; it was years before he outgrew the racking spasms of his heart.

He was about 20 years of age when his eldest brother returned home from a visit to Europe, and it is not too much to say that his home-coming proved the turning-point in Hudson's life, for he brought with him tidings of a new doctrine and a copy of Darwin's *Origin of Species*.

II. *The Naturalist in La Plata.*

As soon as the new doctrine of descent overcame the natural prejudice of earlier opinions, Hudson accepted it as infallibly true; all his field observations went to confirm it and he became filled with wonder that the world had waited so long for a revelation which now seemed self-evident. Why, he asked, had men not discovered this long before they read the motions of the stars or the shape of the earth? But, in point of fact, evolution, as a theory, has always been accepted as inevitable by philosophers ever since the days of Thales and the Pre-Socratics. It was the process of it that had baffled, and that still baffles in many details, despite Darwin's twin-props of Natural and Sexual Selection, with their corollaries of Variation and Adaptation to Environment. Hudson had altogether too strong a mentality to accept Darwin's explanations off-hand and he offered many shrewd criticisms of evolutionary argument. His width of field-observations and the soundness of his reflections made him easily the peer of such men as Darwin and Wallace; while his intuitions and imaginative power actually lifted him to a higher plane. In his aesthetic sense and power of expression he has no equal in the field of Natural History.

It was not diversity of form in the animal kingdom that drew him, still less the structure and anatomy of the carcase or the skeleton. It was the unity of the spirit that pervades living nature; the flame of life that flickers, however low, even in the flowers of the field, the tiny spark of intelligence that burns in the butterfly, the adder, the Sparrow, and the puma, no less than in the insect tribes of men.

His records of fully 20 years as a field naturalist in South America were entered in log-books day by day from the time he was 15, and we know from *Far Away and Long Ago* that in his memory they went back 10 years earlier still. They have many of them been given to the world in scattered pages of such books as *Birds and Man*, *Adventures Among Birds* and *A Hind in Richmond Park*. But the bulk of them appeared in Hudson's famous trilogy—*Birds of La Plata*, *The Naturalist in La Plata*, and *Idle Days in Patagonia*.

A close study of these three books and the order in which they were written will more than repay us the time spent. The *Birds of La Plata* as

first published under the forbidding title of *Argentine Ornithology* was in fact a systematic and severe work of science. It was written in collaboration with Philip Lutley Sclater, at that time the leading authority on South American birds. Its publication made Hudson recognized as one of the greatest naturalists in Europe. It serves to show that his master passion in nature study was bird life, and also that the systematic side of the science was not his forte or he would never have sought a collaborator. Probed a little more deeply it also reveals to us what Hudson's true forte was. For whereas the whole work consists of over 200 bird portraits and vignettes—in length only 2 or 3 pages apiece—there are two kinds of bird that so intrigued Hudson as to engross an entirely disproportionate space, the Carancho or Carrion Hawk dominating a territory of 30 pages and three parasitic Cowbirds 45 pages. These two chapters show Hudson at his very best and are far the most interesting in the whole book. Readers of *Far Away and Long Ago* will already have guessed the reason. Hudson thought emotionally and in order to write he must have lots of elbow room and perfect freedom. These birds were associated with his boyish days and his earliest discoveries, and they lifted him to the very pitch of his powers. In these two chapters he struggled free from the fetters of systematic science. He must have realized even while writing his *Argentine Ornithology* that it cramped him hopelessly and, as it were, clogged the wings of his poetic flights. Hardly was the work published before he gathered the overflow of his feeling for Nature in the famous volume of *The Naturalist*

in *La Plata*. A great man of science once remarked of this book that on the scientific side alone it was worthy of a place beside Darwin's *Voyage of H.M.S. Beagle*. As a literary achievement, of course, it leaves Darwin far behind, and Wallace, and Belt, and Bates. It takes in all Nature and in such wonderful chapters as *The Puma*, *Facts and Thoughts About Spiders*, *The Crested Screamer*, *Music and Dancing in Nature*, we see the Naturalist at his best.

But not even yet the Simon-pure W. H. Hudson. For his crowning excellence is surely psychological insight. He loved to interpret the soul of living nature, the feelings, emotions and thoughts of living creatures—insects, reptiles, birds and beasts—as he watched their behaviour; and no less, the re-actions of Nature upon man as he focussed the light of reason inwardly on his own soul. This last and supreme faculty of Hudson's was revealed for the first time in *Idle Days in Patagonia*. This work, we are told, made such an impression on William James, the great psychologist, that he never tired of quoting from it, especially from the three closing chapters *Concerning Eyes*, *The Plains of Patagonia*, and *The Perfume of an Evening Primrose*.

The dry-as-dust professors of Science no doubt viewed the successive parts of this first trilogy of Hudson's with diminishing favour, but we as amateurs will gladly reverse the process and recognize the *Birds of La Plata* and *The Naturalist in La Plata* as merely the larval and pupal stages of the glorious winged butterfly that emerges into the summer sun of *Idle Days in Patagonia*.

(Continued in the March issue)

WHISTLING SWANS IN ONTARIO

By W. E. SAUNDERS



HE recent catastrophe at Niagara, when numbers of these birds met their death, was referred to by Hoyes Lloyd in *The Canadian Field-Naturalist* for October, 1923, page 138, and it is thought that some further attention should be called to certain phases of this matter and the possibilities involved.

Residents at Niagara know that Swans pass over the falls to their death each year, though as a rule the loss of life is slight, but this year, if newspaper reports are to be credited, hundreds met disaster there. When the birds go over the Falls, about twenty-five per cent are killed outright, and a smaller percentage of the remainder are so injured that they must die, but the majority survive their rashness, if such a term may be applied to an accident, and remain in the open water, or on the shore, for some days, recuperating;

and when they feel able, they fly down the canyon towards the bridges, then turn south again, and thus fly back and forth till they have surmounted the height of the Falls, when they pass on up the river for perhaps a mile, when they again alight in the river, and unless luck favors them strongly they pass over again. This procedure may be followed two or three times, but at that time of the year there are frequent runs of ice over the cataract, and when one such arrives, the Swans below are soon caught between the larger pieces and bruised to death. In this way, so I am credibly informed by the man who seems to know most about this matter, the total loss of life usually amounts to 90 or 95 per cent of those birds that go over. He has seen them washed down by the current and sucked under the ice-bridge, where, of course, there was no further

hope for them. The fact that ice-runs are of frequent occurrence at that time of the year leaves the birds little chance, once they have injured themselves by the great plunge. And the only way in which it now appears possible to save their lives is to produce some human interference. Two good men with a boat might easily catch most of the half-dazed birds, and remove them to a place of safety where they might have their health restored, and I am informed that the authorities have practically completed arrangements for this necessary work in 1924.

In 1923, six of these birds were caught and sent to Jack Miner, at whose place they still are at the time of writing, apparently comfortable, happy, content and, contrary to the reports one hears of the Mute Swans of the parks, *gentle*. Men who have attempted to keep the Mute Swan along with other waterfowl have little good to say of the disposition of these big birds, but Jack Miner tells me that he has no more peaceable birds on his ponds than these six Whistlers.

When these birds were taken there were a good many more that might have been saved, if plans had been laid for the purpose. But now the plans have been laid, and one may hope that 1924 will tell a different story.

Jack Miner has for years had a dream of Swans coming to his place as the Geese do, and on the very day when the Niagara birds arrived at Kingsville sixteen wild ones flew over, calling as usual. The captives honked loudly, but the migrants did not alight, but when the captives have had a year's experience of Miner's kindness, they may be able to produce more effective arguments to their wild brethren. At Niagara I was told that in former times, ten or fifteen years ago, Canada Geese went over the Falls in hundreds each spring, but that now not a single Goose is found. The reason is obvious. They have a refuge at Kingsville, and do not stop at or near Niagara, where so many have met their death in the past. Fifteen years ago Miner began to carry out plans which have resulted in the present astounding aggregation of Geese at his place each and every

spring. He is now hoping that he can duplicate his Goose experience, with Swans as the objective the second time.

For three miles west of Kingsville pier there is an area of shallow water nearly half a mile wide, with a sand-bar separating it from the lake, making an ideal resting place for wild fowl of all kinds. And it is there that the three thousand Geese that I counted on the morning of April 19th had spent the night. On this shallow water Swans have been in the habit of resting for a few days during many spring migrations, but until 1921 their numbers were few, perhaps ten, or twenty, or even thirty in a year. But in 1921 a more prolonged stay was made by 280 Swans, which left after a visit two weeks long. It is not known that any considerable number came in 1922, but in 1923 they began to arrive towards the end of March, and by April 10th it was estimated that they numbered nearly a thousand, but this larger number stayed only for a few days. It is understood that the authorities are now tackling the problem of giving these birds a real sanctuary, with special protection, and perhaps even food, if they come again in 1924, and if this can be done successfully, who knows but that in a few years it may be possible to see nearly the whole Swan population of the Atlantic coast gathered in sanctuary at Kingsville, and staying even as long as the Geese do. They will, without doubt, find their way to the corn around Jack Miner's ponds, and the double attraction of food and safety may have the same result with the Swans as it has had already with the Geese. The latter have been staying later and later each fall and returning earlier and earlier each spring, until, in the winter of 1922-23, a company of 150 stayed all winter, and I understand that double that number were there to greet the new year of 1924.

A fairly complete resumé of Swans at Niagara was published by Fleming in *The Auk* for 1908, pp. 306-9, and for 1912, pp. 445-448, in which special reference is made to the death of a large number of Swans, from which Mr. Fleming obtained many specimens for his collection.

RANGE OF THE MOOSE EXTENDING NORTHWARD

By RUDOLPH MARTIN ANDERSON



AS THE moose (*Alces americanus* Jardine) is pre-eminently a browsing animal, feeding by preference on twigs and shrubs, records of its occurrence either on the prairie or on the northern tundras are rare. I have been told of a number of instances where natives have seen moose thirty or forty miles

north of the timber line in the vicinity of the Mackenzie River delta and one was killed on the mainland just across from Richard Island a few years ago. An Eskimo named Kenneth Ninakshak shot a fairly large moose a few miles up the creek near Escape Reef, Shoalwater Bay, Yukon

Territory, early in May, 1914, and I saw the skin shortly afterwards at Herschel Island.

Mr. Joseph Hodgson, a retired Hudson's Bay Company factor, who was for many years in charge of posts at Rampart House, Fort McPherson, Fort Norman, and other far northern points, told me that up to about sixty years ago moose were very rarely seen east of the lower Mackenzie and that up to about 1905 moose were virtually unknown on the east side of Great Bear Lake. In 1911 we found moose to be not rare on the Dease River, northeast of Great Bear Lake, and the Indians reported that moose were fairly numerous on the great peninsula between Dease Bay and McTavish Bay known locally as Caribou Point.

Mr. D'Arcy Arden, a well-known trapper and trader of that region, told me in May, 1916, that the Indians shot five moose on Caribou Point and three on Dease River during the winter of 1915-1916.

While the moose are not very common at the edge of the scantily forested region and very rarely venture out on the Barren Grounds, a Copper Eskimo told us that he had seen two moose near the mouth of Rae River, west end of Coronation Gulf, in 1909 or 1910. He said they had small antlers and he supposed they were cows for that reason, a natural inference for a hunter familiar with the Barren Ground Caribou. These people had some knowledge of the moose from their occasional hunts to the edge of the Great Bear Lake timber, but few of them had actually ever seen a moose. Captain Joseph F. Bernard also heard a report among the Eskimos of a moose being killed in 1910 somewhere in the region between Cockburn Point and Cape Krusenstern. This is not very far from the Rae River record and perhaps is another version of the same story.

Farther east, Mr. E. T. Blundell, in a letter dated February 2, 1920, from Island Lake Post, via West Selkirk and Norway House, Manitoba, writes:—

"I have made frequent enquiries of the Indians regarding Moose and Deer, and find that forty years ago or thereabouts, Moose were unknown in this region [northeastern Manitoba]. Since then they have gradually appeared in increasing numbers and in some of the places more remote from the main lake are in fair numbers (mostly to the southeast, a better feeding country). I am inclined to believe that the reason for the appearance of the Moose is due to the animals having been driven from the South by hunting. During the past two years Wolves have been on the increase and appear in numbers this winter If Wolves increase at the present rate I think that the Moose will rapidly vanish."

An interesting record of the occurrence of the moose in the region northwest of Hudson Bay was

given to Dr. M. O. Malte by Inspector E. G. Frere, Royal Canadian Mounted Police, November 27, 1923, with permission to have it published in *The Canadian Field-Naturalist*:—

"I am afraid I cannot give you much detail as to the two moose being killed by natives near Chesterfield Inlet. I know this, that two moose were shot at about 40 or 50 miles southwest of the Police detachment which is situated on south shore opposite Fairway Island at the mouth of the Inlet. Moreover, they were not both shot at the same time, but some weeks passed in between. I believe the first was shot in January and the other in February, 1923.

"The natives did not seem to know what kind of an animal it was and were a little afraid. They were shown pictures of various animals and then picked on the moose. Eventually both heads were brought into the Hudson Bay Post and there I saw them. Later we were given one and the horns are still there on the detachment though they have been sawn from the head which we ate, there being a scarcity of fresh meat. The horns are not large and are just losing the moss."

A photograph indicates that these animals were bulls about four or five years old, and presumably they strayed from the timbered areas along the course of the Kazan River or the Dubrawnt river to the southwest. The fact that the moose was not familiar to the native hunters shows that its occurrence is rare in that region.

The moose is perhaps second to the white-tailed deer among our big game animals in intelligence in adapting itself to changing conditions, but is much more apt to shift its range if molested too much. The moose can exist in comparatively large numbers close to civilization if it has some forest cover where it is not too much harried, as is well shown in parts of Quebec and New Brunswick where the moose becomes familiar enough with the sight and sound of settlers and lumbermen and their teams, so as not to be very wild. Many of those moose have seen so many people who have not attempted to molest them that moose are often very easy to hunt near the settlements. The moose in many of the most remote districts seem to be much more timid, probably because they learn to consider man as an enemy at all seasons.

Fifteen years ago, in 1908, the concensus of opinion of the old residents was that the moose was increasing all along the Mackenzie River valley, mainly because the Northern Indians had decreased at a very rapid rate, more than enough to compensate for the increased killing power of their more modern weapons. In more recent years, the belief is that the moose are decreasing all along this main travel route, owing to the increased number of traders and trappers who have gone into that region, attracted by the high prices of fur. At the same time, in some districts away from the main arteries of travel in Yukon

and the North West Territories, moose are said to be more numerous than ever before. Owing to the solitary habits of the moose and its preference for the thick bush, it cannot be slaughtered in such a wholesale manner as can the Barren

Ground caribou and the musk-ox, so that, considering its aptitude in occupying new ranges, there is every probability that moose will continue to exist in some of the back districts long after some of our other species have become extinct.



IN MEMORIAM

Napoléon A. Comeau

Born 1848

Died 1923

By the death, a few months ago, at Godbout, of the late Napoléon A. Comeau, natural history in Canada has lost one of its oldest and most devoted investigators. His was a remarkable and a most useful life. Born nearly four score years ago at one of the small Hudson Bay posts at Jérémie Island, Hudson Bay, long since abandoned, where his father was the Hudson's Bay Company's agent, Comeau was appointed private guardian of the Godbout salmon river in 1860 and resided there practically up to the time of his death in the autumn of 1923. He had few opportunities for schooling, but possessed a consuming desire for knowledge, and was largely a self-educated man. From the book of Nature he learned much, for of other books, in his early life, he had but few.

In the autumn of 1882 he was the companion of Baron de la Grange on a hunting trip in the mountains of Wyoming. He was an occasional visitor to Quebec, but was not particularly fond of life beyond the limits of his native Canadian Labrador, though in October, 1922, upon the special invitation of the Honourable Honoré Mercier, Minister of Lands and Forests of the Province of Quebec, and at that time president of the International Association of Game, Fish and Conservation Commissioners, he attended the annual convention of the Association held at Madison, Wisconsin, to read a paper on the Wild Life of the Canadian Labrador, with special reference to the birds of that coast. Upon that occasion he received quite an ovation, all those present crowding around him, eager not to lose a word of what he had to say to them, and Mr. F. C. Walcott, of Norfolk, Connecticut, rose immediately after Mr. Comeau had spoken, and offered a resolution to express gratitude for Mr. Comeau's coming this long "distance so that we "might not only hear him but see him. I want to "say just this word," he continued. "About ten "years ago when Frederic Selous came over to "hunt in Newfoundland, he stopped with me on "his way back just before he sailed, and said he

"had found a marvellous man up there in the "person of Mr. Comeau, who knew the natural "history of his country as few men did, and had "the gift of telling it. A little later, I read that "book, 'Life and Sport on the North Shore'. I "immediately bought fifteen or eighteen copies "and sent them to friends of mine. Sheldon and "Chapman and myself all had had the marvellous "privilege of being with Warburton Pike at one "time or another; and Warburton Pike got this "book, looking upon it as a classic. So in offering "our thanks to Mr. Comeau, I personally appreciate more than I can tell you the privilege of "looking at his face and hearing him talk."

For years and years he was the only man with any knowledge of medicine along a coastline of many hundreds of miles. In the families of the scattered residents in the various fishing settlements along the coast, "the Stork" invoked Mr. Comeau's assistance over 230 times, and without a single fatality. The surgical skill which he acquired by years of practice, following a hospital course of only one month, the medical knowledge which was his by virtue of the private study and reading of a lifetime, his surgical instruments, dental and other forces, stock of drugs, and the diphtheria and other serum supplied by the Government in times of epidemic were always freely at the disposal not only of the people of his immediate territory, but also of all those whom he could claim as neighbors for hundreds of miles around.

This sketch cannot be made long enough to contain a reference to all of Mr. Comeau's many activities. At Godbout, where he resided, he was postmaster, telegrapher, deputy coroner, Dominion Government fishery overseer, and guardian of the salmon fishing. He has served as agent for the Hudson's Bay Company, and he spoke the language of the Montagnais Indians as well as he did English and French. Having lived practically all his life upon the coast, his knowledge of many tragic scenes and incidents was acquired at first

hand, and these were described in his book "Life and Sport on the North Shore", in the native simplicity of language and manner characteristic of the author.

Special urging was necessary to induce Mr. Comeau to tell of his heroic crossing of the lower St. Lawrence, with his brother, in an open canoe in mid-winter, through forty miles of ice, exposed to a temperature of many degrees below zero for two days and a night, in the successful effort to save the lives of two of his friends. Only for the purpose of correcting earlier and erroneous reports of this dramatic event did Mr. Comeau consent to tell of it, as he has done in the chapters of his book modestly entitled "Across the St. Lawrence" and "Our Return Journey"; notwithstanding that all the newspapers of Canada and the United States sounded the praises of the rescuers, and that the Governor-General, the Lieut.-Governor, the Royal Humane Society, the Government of the Dominion, and the Société des Chevaliers Sauvateurs des Alpes Maritimes of Nice, vied with each other in showering honors upon them.

To the cause of science Mr. Comeau has rendered signal service. His text-book has been that of Nature. Other works—of which his library at Godbout contains a useful selection—and occasional visits to museums have aided him in his studies of comparative anatomy. In original

research he has done much good work, for which he has received the thanks of officials of the Smithsonian Institution and of members of various learned societies. His list of the birds of the North Shore, published in his book, is a scientific work of permanent value.

The chapters devoted to the natural history of the North Shore, and especially to trapping and salmon fishing, are the work of an expert, and there is scarcely an angler anywhere who will not be interested in Mr. Comeau's description of the salmon rivers of the North Shore, and of the various salmon problems, which he discusses out of the fullness of a life-long experience. What salmon fisherman will not be attracted by the scores—faithfully preserved for the last fifty years—of the salmon killed by rod and line in the Godbout river, and by the extraordinary kill of 57 salmon in one day, to Mr. Comeau's own rod, on the 9th July, 1874?

The life story of the trapper and the folk-lore of the Indian hunters of the North Shore are contributions to our national literature that are destined to live, and not the least charm of Mr. Comeau's volume lies in the fact that it is a sane and instructive book, conveying a graphic yet modest recital of fifty years' work for humanity and science in one of the least-known but most interesting sections of Northern Canada.—E. T. D. C.

CORRESPONDENCE

EDITOR OF *The Canadian Field-Naturalist*,
Ottawa, Canada.

Sir,

I read with considerable interest the article in the November issue of your paper by J. A. Munro on *The Necessity of Vermin Control on Bird Sanctuaries* and your note of dissent which followed it. I should like to take exception to the arguments that you present in the latter, which appear to me to be entirely fallacious.

In referring to bird sanctuaries below, I mean the kind of sanctuary that is being established everywhere to-day. If I take a particular example of the type, say Lake Ministic in this Province, a bird sanctuary with which I am particularly familiar, I do so only for the sake of clarity and so that there can be no misunderstanding as to the thing I mean. My arguments apply to all other sanctuaries of a similar character and they are becoming almost legion. There are seven in the Province of Alberta alone, besides Federal and Provincial parks, which achieve the same objects with certain modifications.

The impression one gains and is meant to gain

from government and other literature is that these reserves are established for the preservation and protection of birds. They are being established in an age of excessive legislation in which all birds in the Dominion, with the exception of those species generally known as vermin, are protected during at least some time of the year. Outside the vermin class, with the exception of game birds on which there is a regulated open season, all others are protected by law throughout the entire year. Making the perfectly legitimate assumption that these laws are in the main observed, it stands to reason that to establish sanctuaries for the protection of this class of bird is fatuous and entirely useless, for they are already protected in any and every part of their range within the Dominion from January to December. Many generations hence, when the day comes that this country is really thickly populated, there may be some pretext for such reserves. Till then there is none.

Under present conditions bird sanctuaries can in fact be of service only to two classes of birds, vermin and game. The latter are protected

throughout the year except during the legitimate open season and a sanctuary therefore has significance to them only during the shooting months. They can find there a haven of refuge and we know from experience that they do not take long to discover and use it. During the rest of the year the area is meaningless to them. Any lake, under existing legislation, serves them for breeding purposes equally well, for they are safe from human interference on one and all alike.

There remains then only the vermin class to be considered. It includes certain Hawks and Owls as well as Crows. (Mammalian vermin should strictly be included, for it enjoys an equal measure of immunity within the sanctuary.) But on these there are no closed seasons. Farmers and others shoot them all the year 'round without relenting. To them, and to them alone, has a bird sanctuary any meaning at all during the spring, when all living things are endeavouring to reproduce their kind and rear young. They alone are attracted to the reserves, for them the only gun-free areas. Your sanctuary, as you define it in your editorial, is in fact at this time of year a sanctuary for vermin, for vermin alone and for nothing else whatever.

Under these conditions a sanctuary, so far from being one for all birds without preference or prejudice, is for the major part of the year, which includes the critical period of a bird's life-history, the breeding season, a veritable trap for the majority. The reasons are self-evident. A visit to Lake Ministic in May always presents the same aspect. It is the nearest conceivable thing to a vermin farm in existence. Here, there and everywhere are Crows, seeking shelter from possible death on some neighbouring farm. Here they can breed unmolested and enjoy with impunity their favourite diet, Ducks' and other birds' eggs. As one cruises about in a canoe locating Duck nests to see how the birds are faring, one finds one clutch after another either partially or completely sucked, for the Crows have found them. If one pays a visit later, in June, one sees the first fruits of such a haven of concentrated vermin. On every hand are drakes, in partial eclipse, remating with ducks that should be tending broods of young instead of indulging in love flights with mates in circus garb. It is the most unnatural and ridiculous spectacle and might even be funny, but one's laugh dies on one's lips when one thinks of the old days on Ministic before it became a sanctuary, when it was one of the great strongholds for breeding Ducks.

Yet later in the season one realises still more the utter futility of such a sanctuary as Lake Ministic. If one goes to it in August as I have done, immediately after visiting other lakes that

are not reserves, where every young Duck noted has been strong on the wing, and sees here old birds followed by a few downy ducklings, sometimes by only one and very often by none at all, one does not know whether to laugh or to cry. But when one stops to consider that these same little ducklings are practically doomed to certain death and that they represent the second or third or possibly even the fourth attempts of the old birds to rear young, a strain that no wild birds can stand, tears are surely the logical thing. Yet this is the kind of sanctuary that you are advocating. One can only regret that you should feel "that we ought not to publish this paper (Mr. Munro's) without expressing at the same time marked dissent from its premises and conclusions".

With regard to other species Ministic presents much the same spectacle. Of the scores of Holboell's and Western Grebes that breed on it, or perhaps attempt to breed would be more correct, I have not yet known a single one to bring off a complete brood, while birds with single chicks or none at all are extremely common. For them it is no sanctuary. It is a death trap. One has only to watch Crows a few times dropping down from the blue, apparently aiming for the head of a Grebe sitting on her exposed nest, and see her sit up and raise one wing in self defence while the marauder quietly glides by the nest and grabs an exposed egg, to find an excellent reason for the fact that so few Grebes are ever reared on Lake Ministic, a sanctuary of exactly the kind you recommend.

For the small birds that are generally not molested by Crows the place is not a sanctuary in any case for there is nothing to make it one. The whole surrounding neighbourhood offers the same attractions. The birds are protected by law and can breed anywhere. If there is a difference in any one direction it is certainly in favour of the outside where Crows, Hawks, weasels, etc., are of course less abundant than they are on the ground set aside for their special protection. But with regard to small birds the situation is deceptive in any case for a peculiar reason—the ability of birds to find new mates when they have lost the old. The situation is well described in a very able and suggestive article by A. A. Allen on the Screech Owl, in the January number of *The Auk*. It deals with the life-history of a pair of these birds on a small private sanctuary in Ithaca, N.Y. In spite of the depredations of these two Owls, the "birds nesting in the sanctuary in 1923 showed a slight increase", a fact that would surely make excellent advertising for the protection of vermin. But unfortunately there is a fly in the ointment. The author demonstrates in

detail in his paper what he finally sums up in the following words: (7) "When both birds of a pair were killed on the same night by the Owls, that pair ceased to be represented in the sanctuary, but if only one was taken, the survivor secured a mate almost immediately so that *the destructiveness of the Owls was in this way covered up.*"

There is no doubt that this sort of thing goes on all the time in every sanctuary. It is a point in which I have been interested for some time. Last summer I had nesting outside my window a pair of Western Wood Pewees, the male of which I shot in June. Five hours later a new one had replaced him. During a week I shot four cocks and the fifth was left in peace to rear the brood with the bird that laid the eggs. Suppose that these birds had been breeding on a reserve and that instead of my gun being the instrument of death it was a pair of Sharp-shinned Hawks. They would certainly not have confined their destructive activities to a week, but would have continued them throughout the season. It is interesting to speculate as to the number of Wood Pewees that would have been lured into that Sanctuary to certain death. Yet the young might have flown in the end to the credit of the sanctuary and the cheers of the idealist, blind to the underlying carnage and destruction. But the same pair of Hawks would of course be preying on other small birds at the same time. These too would have to be taken into account. So would those other hundreds being killed simultaneously by all the other Hawks, Owls, Crows, weasels, squirrels, etc., in this retreat for vermin. It could hardly be called a paradise for small birds, this sanctuary of yours.

There are two solutions to the problem. Either one can protect the Crow and other vermin throughout the country and eliminate any attraction that a sanctuary might have for them, in which case its sole remaining function would be the protection of game birds during the shooting season, or one can take measures not merely to reduce the vermin in the sanctuary, but to keep it out altogether. The first alternative is on the face of it out of the question. The second is the reasonable and only possible solution. A sanctuary, so I learn from the dictionary, means "a haven of refuge" which, I take it, signifies a spot safe from harm of all sorts. So long as an area remains a home of rest and plenty for Crows and other vermin, together constituting the worst natural enemies that other birds know, it can not, by any stretch of the imagination, be termed a sanctuary for any but the predatory species that have all the others at their mercy.

In England, crowded as it is, where practically every farm is a virtual game preserve and vermin

is systematically destroyed by every possible means, not on small localised areas alone, but all over the country, Sparrow Hawks (the British equivalent of our Sharp-shinned and Cooper's Hawks) and Crows, the most relentlessly persecuted of all, are still to be found anywhere and everywhere. In this country with its countless thousands of square miles of unsettled territory, there is no excuse at all for not converting the so-called sanctuaries into real ones by systematically exterminating all vermin that sets foot or wing inside their boundaries. If the time should ever come that these birds show decrease to such an extent that their existence is imperiled, they could, for a reasonable period, be again permitted to use the sanctuaries. The reappearance of the Bittern, and the steady increase in recent years of the Peregrine Falcon and other predatory species that were on the verge of extermination in England, are evidence of what can be done to save a bird race in the eleventh hour by legislation that is reasonably enforced.

If those people who derive greater satisfaction from seeing a Great Horned Owl sitting on a tree than from shooting and eating a Grouse know that they cannot see it by going onto a sanctuary, they can find it almost anywhere outside over thousands of miles if they are prepared to take the trouble. There is no doubt great satisfaction to be derived from motoring to an advertised sanctuary and being shown in comfort and with a minimum expenditure of energy a Horned Owl that has grown fat and tame and sleek at the expense of game and other birds, but it is a satisfaction that not a soul has the right to enjoy. The bird there means only one thing, that the sanctuary is one for vermin, and hence, for nothing else. It is a haven of refuge for 5% of the avian population against the 95% for which it is a veritable trap. Whether we consider it from the point of view of the appropriation of public funds, or of what is best for birds as a whole, or of the dictionary meaning of the word sanctuary, or of aesthetics or of anything else, the just thing is to make it a refuge for the 95% at the expense of the remaining 5%.

To infer that because some people like to see Great Horned Owls, therefore the species is as useful to mankind as is the Grouse, is entirely fallacious. It would be just as sound to argue that because the village idiot is somebody's darling, and has to buy food and clothing from the village store, therefore he is as beneficial to the village community as the local schoolmaster. Yet the idiot is not only considered useless from any other aspect but sufficiently undesirable for special legislation to be enacted restraining him from marrying, for instance, and from other activities

that the rest enjoy. And even though some leading light, like the village parson, might think that the idiot should be free to do as he liked because he is a human being like the others, what right would the parson have of enforcing his opinion? None whatever. And because unreasoning sentimentalists wish Crows, Horned Owls and other undesirable birds to have a free run of the sanctuaries there is still no reason why they should get their way, for the admittance of these birds is incompatible with the whole idea and object of a sanctuary. I am quite prepared to believe that in heaven the lion and the lamb will lie down together and the Sharp-shinned Hawk and the Sparrow will nest in peace side by side, but that a government sanctuary notice can produce the same effect is more than I can credit.

While I agree that it would be a pity to confound bird sanctuaries and game farms, it seems to me that to confound bird sanctuaries and vermin farms is an incomparably graver error.

Yours,

Department of Zoology, WM. ROWAN,
University of Alberta,
Edmonton, Alberta,
January 19, 1924. _____

EDITOR OF *The Canadian Field-Naturalist*,
Ottawa, Canada.

Sir:

May I ask you to kindly allow me some space to express my opinion of your criticism of Mr. J. A. Munro's excellent article in the November number on Vermin Control in Government Sanctuaries.

Your editorial expresses the extreme view of many of the protectionists of to-day, that predatory birds and mammals should be protected for their æsthetic value in direct opposition to the doctrine of the greatest possible good to the greatest possible number.

There are many upholders of your theory, which is largely based on that ancient phantasy—the so-called Balance of Nature. That anyone, like yourself, who has travelled in the Canadian wilderness and witnessed the fearful scarcity of bird life away from man's influence should hold this view is only a small degree more inexplicable than that it should have its advocates among men whom we have been led to regard as our leading authorities in bird-lore. In an editorial in the last *Auk* (January, 1924) there occurs the following passage in reference to a proposed campaign against the Crow. "Most ornithologists will differ on this latter statement while the publications of the U.S. Dept. of Agriculture (Biological Survey) show that the Common Crow does as much good as harm. By all means let the farmer kill Crows

when damaging crops but do not let us *exterminate* an extremely interesting species of bird on the advice of ammunition manufacturers."

Exterminate! (the italics are not mine). Does this editor realize that in the densely populated island of England every effort has been made for centuries to exterminate the Crow, together with the Old World equivalent of our Sharp-shinned Hawk, and yet these two pests still exist everywhere in the British Isles? True, their numbers are held in check, resulting in a wealth of bird-life to be seen nowhere else in the world, but the most ardent game-protectionists know only too well that their extermination is an absolute impossibility. This bogey of extermination is now being worked too hard; at a recent meeting of the American Ornithologists' Union a member seriously advocated the protection of the Sharp-shinned Hawk; they laid such beautiful eggs.

As to the Crow, it now presents what is probably the most serious menace to bird-life in North America, and its numbers are increasing at an extraordinary rate, especially on the prairies. The investigation by the Biological Survey, alluded to above, wholly dealt with its relation to agriculture. No consideration was given to its effect on game and other bird life, nor was any analysis made to detect the presence of eggs in the stomach contents. If this had been done, especially with stomachs from game-producing regions, the verdict would have been so overwhelmingly against the Crows of all sorts that no thinking man would be able to defend them.

We are now at the parting of the ways. There are many intelligent bird-lovers, neither sportsmen nor collectors, who advocate vermin control wherever possible, just as they would advocate the "extermination" of noxious weeds, despite the howls of some fanatic who finds esthetic pleasure in a thistle or a cockle-burr.

The reading of Mabel Osgood Wright's *Stories from Bird-Craft Sanctuary* affords a most encouraging sign of the times. Here we have a sane protection, and I would especially refer to Dr. Chapman's comment on these (*Bird-Lore*, September-October 1922, p. 293). Two quotations from this editorial are apposite. "The Sanctuary has become not only a home for harmless birds but a well-stocked hunting ground for predaceous ones." "It seems to us that basing our actions on the principles of justice and fair play . . . we should protect our native birds from the English Sparrow, our poultry from marauding Hawks, our fish-ponds from murderous Herons, and make our sanctuaries true havens of refuge."

To the advocates of the principles of leaving birds entirely to Nature's mercies, protecting them only from man, I can cite two recent ex-

amples at the opposite ends of the large territory under the advisory jurisdiction of the Audubon Society. First the Heath Hen on Martha's Vineyard. After many years of protection and the expenditure of large sums this splendid game bird may be classed as wiped out, the last reports giving a total of 40 males and no females.

After reading the reports outlining the factors that have resulted in this condition, one is driven to the conclusion that the employment of one or two European gamekeepers at a very moderate cost would have resulted in the perpetuation of the Heath Hen. These keepers would have known from experience what would be the result of leaving a reduced number of the females of a polygamous bird to the mercies of a preponderance of males. Also they would be under no delusions as to the utility of the Marsh Hawk—that arch-enemy of all ground-nesting birds during the breeding season.

Second example, the effort to protect the Murres of the Farallones. At present, after years of protection, these are reduced to one-fifth of their former abundance when they were entirely un-protected by law and their eggs were used as a source of food supply for San Francisco.

The eggers in those days systematically raided the colonies of Western Gulls, keeping them in check. Now, under absolute protection the Gulls have increased prodigiously, to the detriment and possible future "extermination" of the very birds it was proposed to protect. Even Dr. Nelson, the Chief of the Biological Survey, is unable to get any legislation passed removing the protection from such destructive birds as the larger Gulls, although he strongly advocates this removal.

But California is a wonderful State—it absolutely protects Crows and Magpies at all seasons and places, and further expends large sums in the importation and propagation of game birds to provide the Crows with their favorite food.

However there are a great many sensible bird-lovers in that State who have used their own eyes, and are now ready to break away from the blighting influence of the fanatical protectionist who views with equanimity any bird destruction, however serious, as long as he is left to damage in every way the activities of his two bugbears—the sportsman and the ornithological collector.

Had I space I would have liked to conclude with an account of the making of a true bird-sanctuary, where no illusions as to Nature's protecting ægis were allowed to influence a system which resulted in thirty-four species of birds nesting on less than five acres. It is doubtful if such a condition exists anywhere else on this continent; but I have already taken up more space than I care to, and will conclude with the heartfelt wish that

Government Sanctuaries be made into actual havens of refuge, and that the vast outside wilderness be considered sufficient refuge to prevent the extermination of predatory birds.

Yours faithfully,

ALLAN BROOKS.

Okanagan Landing, B.C.

January 25, 1924.

EDITOR OF *The Canadian Field-Naturalist*,
Ottawa, Canada.

Dear Sir:

In a recent issue of *The Canadian Field-Naturalist* I read with great interest an article by J. A. Munro on Vermin Control in Bird Sanctuaries and your reply to same. Although no one could be more averse to taking life than I am, yet I am bound to confess that I fail to see how a bird sanctuary can be operated successfully if Crows, Magpies, squirrels, etc., are to be allowed to prey on the birds for which our sanctuaries were primarily created. Since our Alberta Natural History Society—of which I am a member—acquired the right to operate a half-section of land as a Bird Sanctuary, I have seen how futile it is to hope for an increase of the birds we had in mind to protect especially—on account of the vermin already mentioned. Our notice boards inform the public that no shooting is allowed and such wise birds as the Crow and the Magpie are quick to learn where they are safe from molestation, more's the pity. Crows, of late years, have been nesting in a park which adjoins our lawn, and it is heartbreaking to see them coming into our gardens and taking young birds out of the nests to feed their broods. Even domestic chicks are taken, and this happens in town! Perhaps you can imagine what it must be like in the quiet of a Sanctuary. Twenty years ago the Magpie was rare here—to-day it is a menace, and it and the Crow constitute the deadliest enemies of our Ducks and other birds during the nesting period.

ELSIE CASSELS.

Red Deer, Alberta.

EDITOR OF *The Canadian Field-Naturalist*,
Ottawa, Canada.

Dear Sir:

The recent number of *The Naturalist* has just come to my hands, and I am pleased to see your well-expressed and liberal editorial on Bird Sanctuaries. Your point is well taken, for, after all, vermin, if native, are as much a part of the wild life and fully as interesting as many of the preferred life forms whose interest is enhanced by sentiment.

The experiment of passive protection, similar

to Henshaw's (cited by Munro), brought forth most interesting results upon my own small summer location on the barren shores of Cape Ann, Massachusetts. Near extensive salt marshes, where a grove of beeches and scarlet oaks have gained a foothold, my observations for some 15 years have shown that small bird life can be slightly increased by providing artificial food and shelter in the usual ways, and of course by fighting the domestic cats and rats. Yet in the same grove, Screech Owls and Crows have taken up their abode; skunks and squirrels have maintained their presence, and even snakes (*Thamnophis* and *Ophibolus*) have increased noticeably—which might seem to the bird sentimentalist rather atrocious! Yet the smaller birds have maintained their happiness and numbers as well, while the grand surprise of the year (1923) was the recurrence of the House Wren as a nesting resident after having been reported by Townsend as a missing form from this cape for the past twenty years or more. After all, it is nature that the naturalist wants, not animal propaganda evoked by sentiment or fancy for this songster or that insectivorous bird. We are apt to become too pragmatic in respect to pest-producing or pest-killing birds and their utility, overlooking the broader aspects of natural history at large. If we did the same in human history we should have to focus interest and study upon one or another of the dominant racial types and ignore the natural aboriginal ones, or vice-versa.

Yours very truly,

FRANK G. SPECK.

Assistant Professor of Anthropology,

University of Pennsylvania,

December 11, 1923

Philadelphia, Pa.

EDITOR OF *The Canadian Field-Naturalist*,
Ottawa, Canada.

Dear Sir:

I was much interested in your editorial on Bird Sanctuaries in the November number of *The Canadian Field-Naturalist*, and thoroughly agree with your assertion that bird sanctuaries and game farms should not be treated in the same way.

The extermination of Hawks and Owls, Crows and squirrels because many of them destroy insectivorous birds or their young, besides sadly interfering with the "balance of nature" in the weeding out of weaklings and unfit, would deprive us of much enjoyment in nature. Hudson in England says: "For who that has ever looked at nature in other regions, where this perpetual hideous war of extermination against all noble feathered life is not carried on, does not miss the great soaring bird in the scene—eagle, or vulture, or buzzard, or kite, or harrier—floating at ease on the broad vans, or rising heavenwards in vast and ever vaster circles? . . . But the great soaring bird is nowhere in our lonely sky, and missing it, we remember the reason of its absence and realize what the modern craze for the artificially reared pheasant has cost us."

Furthermore, it is very doubtful whether if these "vermin" were exterminated, there would be any notable increase in the number of insectivorous birds. Dr. Arthur A. Allen's thoughtful paper on the food habits of a pair of Screech Owls in a small bird sanctuary, in the January *Auk* is worth considering in this connection.

I therefore agree with you that bird sanctuaries will best fulfil their purpose if the evil effects of man and all his works together with his domestic cat are excluded, and I believe that these sanctuaries are no places for the indiscriminate extermination of birds and beasts whose æsthetic value add to our interest and joy in life, not to mention their own feelings in the matter.

Yours very truly,

CHARLES W. TOWNSEND,

98 Pinckney St.,

Boston, Mass.

January 14, 1924.

EDITORIAL

Control of Predatory Birds and Small Mammals

In this number are printed several letters which have been received as a result of the publication, in our issue for November last, of Mr. J. A. Munro's paper on *The Necessity for Vermin Control on Bird Sanctuaries*, with accompanying editorial comment. These letters show a decided difference of opinion among our readers and are evidence of a strong and widespread interest in the

subject discussed.

Nevertheless, we believe that the differences of opinion between those who have contributed to this discussion are not actually as great as may at first appear. We confess with regret that we lack a first-hand acquaintance with those conditions in sanctuaries in western Canada upon which apparently are based the conclusions of

those correspondents who object to the statements made in our November editorial on this subject, but a careful perusal of the letters of those correspondents leads to the belief that the unsatisfactory conditions which they describe very clearly were provided against in our previous remarks. In support of this belief we quote the following sentence from our editorial in the November *Naturalist*:

"In most sanctuaries birds need be protected only against man and unnatural enemies for which he is responsible, such as, in North America, domestic cats, 'English' Sparrows, and a civilization-created surplus of native predators." (Italics not in original.) It appears from our correspondents' letters that the over-abundance of Crows, Magpies, Hawks, Western Gulls and similar predatory species, of which they justly complain, has resulted directly from the intervention of man and his civilization. To destroy this undesirable surplus of native predators, leaving only the original and normal numbers of these species, would in no way conflict with the opinions which we previously expressed.

The subject of predatory species in bird sanctuaries is only a small part of the general subject of our relations with them.

There can be no doubt that the Crow, for example, has increased greatly in numbers over the greater part of North America since the cultivation of the land increased his food supply manyfold. While the Crow in natural numbers was probably chiefly a useful destroyer of insects and small mammals and a harmless eater of wild fruit and sea food, in his present abundance he is an important menace to many of our most desirable game and insectivorous birds. This situation requires neither an attempt to exterminate the Crow nor absolute protection for it, but a policy of control, under which surplus Crows may be destroyed and the Crow population may be kept normal in number, so that the maximum benefit may be obtained from it. Organized Crow "shoots" and poisonings and similar methods of wholesale destruction may occasionally be necessary in giving effect to such a policy, but they should not be permitted except under intelligent supervision, preferably governmental. Similar methods of control should be applied to such partly predatory species as the Bronzed Grackle, the Magpie, some Gulls, and Squirrels, and also to the Cowbird.

Such great differences in food habits exist among our native Hawks and Owls that all the members of these groups cannot be treated alike. It is known that some of these species are almost altogether beneficial to man's activities, that the economic status of others, such as the Osprey, is practically neutral, and that others do some harm and much good. A few species, such as the Accipiters, are economically very injurious. None of them attain the abundance of the Crow or the Bronzed Grackle.

Those native Hawks and Owls which are found to be wholly beneficial or neutral should enjoy legal protection at all times. Those which are chiefly beneficial, but which are responsible for a certain amount of harm to useful wild or domestic birds should also be protected by law, with a provision that they might be shot when found actually destroying or attempting to destroy domestic fowl, or wild birds in a sanctuary area. Such a provision, although it might be subject to a certain amount of unpreventable abuse, is necessary, for legislation which would penalize an owner of domestic fowl for protecting them against a marauding Hawk or Owl in case of actual attack would lessen popular approval of bird protection in general. Moreover, destruction caused by Hawks and Owls which are generally useful is often the work of certain individual birds which have "gone wrong," and if these birds are killed the relative amount of good done by the species as a whole will be increased.

The few species of Hawks and Owls whose habits are largely injurious to human interests need, generally speaking, neither protection nor special efforts aimed at their extermination. If they become locally over-abundant, in a bird sanctuary or elsewhere, their numbers should be reduced to normal, and if there appears to be real danger of the extermination of any species it should be protected temporarily. So long as the kinds of birds commonly ranked as useful and desirable continue to increase in numbers we should not begrudge the fact that some of their *individuals* are taken for the maintenance, in modest numbers, of the *species* of Accipiters and their like.

To sum up, we should decide on the abundance desired in the case of each species, and give to each its place, keeping it within limits. Both artificial conditions in some areas and "natural" conditions in other areas must be maintained by human control.

NOTES AND OBSERVATIONS

NEW RECORDS FOR POINT PELEE.—Ornithological study at Point Pelee has shown some surprises in the way of absence of species which

ought reasonably to occur. Perhaps the most striking of these are Pine Grosbeak (in spite of the casual abundance of Evening Grosbeaks,

Purple Finches and Crossbills), Arctic 3-Toed and Red-bellied Woodpeckers, Acadian and Alder Flycatchers, and Louisiana Water-Thrush.

The Arctic Three-toed Woodpecker is a rare migrant at London, but the Red-bellied is rarely suspected to migrate. The two Flycatchers, however, certainly do migrate, and that every year, and many a Least has lost its life on account of our effort to learn something of the migration of the other species. On August 17, 1923, success at last crowned our efforts, and an Alder Flycatcher was secured by W. E. and F. A. Saunders, working together at the Point. We suspected two Flycatchers of being Alders, but one of them was a Least with a yellowish tinge below. It seemed strange after nineteen years of work, to take, as a new species on the Point, such a common bird as the Alder Flycatcher, which is not only locally abundant, but is spread over so wide a territory that many thousands of individuals must pass through that region each year.

But perhaps this is no more remarkable than the vagaries of the Olive-sided Flycatcher, which is moderately common in much of the spruce country to the north, and is seen only in the most surprisingly sparse numbers in the migrations. Any observer who sees half a dozen in a season is doing remarkably well, and indeed, he is much more likely to see none at all. Even at Point Pelee, the best place in the whole world (?) for migrations, there are records of two periods of four days each in August and September in which not a single Olive-sided Flycatcher was recorded, though we saw 6 Duck Hawks in that time (perhaps the Flycatchers were inside?).

The other bird which has been added to the Point List is the Louisiana Water-Thrush. Northern Water-Thrushes are very abundant at times, one friend even going so far as to say he saw more of them in a couple of days at the Point than he had seen in all the rest of his life, and every year, spring and fall, but especially the latter, there are days when they are common. But the Louisiana Water-Thrush, though fairly common in much of the country immediately north and north-east of the Point, has succeeded in eluding us for many years, though we always felt that it *must* be taken some day, and that day came on April 23, 1920, when, hunting alone, I saw a Water-Thrush in the wet area known as "Bert's east ridge", a ridge running north and south, wooded with second growth, and having on each side of it a low-lying tract which is full of water in wet seasons. The bird was feeding busily, and I was attracted by its note, which is different only when one is fairly familiar with both species. Careful study with the glass resulted in the capture of the bird and it was, as was expected, a Louisiana

Water-Thrush. In the breeding season, it is likely that one could collect a dozen birds of this species within twenty miles of the Point, but their travels are conducted with such secrecy that they eluded all efforts to place them on the Pelee visiting list till this date. So far as known, this species is sparingly distributed, perhaps a pair to every few square miles, over all the country for thirty miles north of Lake Erie, this distance probably becoming less as the latitude rises at the east end of the lake. Canadian specimens are scarce, as it is almost impossible to find them in the migrations and one has the greatest reluctance to collect specimens of breeding birds near their northern limit, where they are always rare.—W. E. SAUNDERS.

THE PINE MOUSE IN ONTARIO.—Ever since Robert Elliott, whose memory is ever green in Middlesex County, Ontario, added this species, *Pitymys pinetorum scalopsoides* (Audubon and Bachman), to the Canadian faunal list, by taking a few specimens at the farm of Joseph Beck, near Thorndale, the writer has been desirous of emulating the feat, and many and many a trapping expedition has been made, under Joe's competent guidance, to the very corner of the very woods where the first ones were taken, but all to no avail. The fall of 1923 was no exception. A line of traps was laid down on October 26th and faithfully tended till November 4th, but while *Microtus* were abundant, and *Peromyscus* common, no Pine Mice were to be had. The very first visit produced a surprise in the form of the rare little Lemming Mouse, *Synaptomys fatuus*, and after several days another was added to the spoils, but all the Pine Mice might have been a hundred miles away for all we could prove about them.

On November 9th, in an effort to convert J. Dewey Soper to the idea that Ontario country was really enjoyable, we set a line of traps about 25 miles southwest of Joe Beck's farm, and at the very first visit on November 12th, found a Pine Mouse almost in the first trap. It was entirely unexpected; in fact, the location was chosen for the double purpose of possibly adding the Red-backed Mouse to the county fauna, and of getting a few Smoky Shrews—and one of the latter was actually taken on the same day—and the puzzle now is to find out more of the distribution of this rare little mouse. The location of Robert Elliott's specimens was a level woods of beech and maple, and the mice were suspected of eating the bark off the exposed roots of the beech trees, but the last one was found on the side of a ravine, clothed with hemlock, oak, poplar, and shrubs, the two situations being just about as different as they possibly could be. The mouse was taken under

thin hemlock brush, and right beside it was a wet spot where a slow spring oozed down the bank. Further trapping on both sides failed of success, and there we are left for the present.—W. E. SAUNDERS.

AN UNUSUAL SIGHT DESCRIPTION OF A BIRD VERIFIED.—Most people who are reputed to know something about the birds of their home district must sooner or later have anomalies described to them by amateur observers. It requires some adroitness of wit to dissuade the amateur from his belief in the strange feathered creature he describes with such care, and a certain skill and power in argument to convince such an observer without offence that the bird described has not yet been evolved.

All will admit that sight identification of birds has its pitfalls, and although I tremble to add to the troubled state of mind of those who must honestly endeavour to lead the beginner in his first ornithological steps, this little story of a weird bird that really occurred must be told in the interest of truth, and because it bears a little moral for both observer and mentor.

On October 28th last Master Robert Lockwood reported seeing a strange bird in our garden in Ottawa, and mentioned that it had a yellow head and wings. The next day Mrs. Lloyd reported seeing a bird in the garden for which she described the outstanding points as being a yellow rump, a yellow head, and a beak like that of a House Sparrow. Incredulity, however cautiously expressed, and even cross-questioning did not cause her to alter the details of description one iota. Bird books and pictures in them seemed to centre her attention on the Myrtle Warbler, and fall specimens were produced. After careful examination by the observer these were pronounced like the unknown, but the unknown had a beak like that of a House Sparrow. The usual deadlock familiar to all who identify birds from descriptions of others had been reached.

On October 30th I saw the unknown at fairly close range, but in poor light, and was inclined to question my own eye-sight for a moment, for, to judge from its appearance, it was a strange new kind of bird that I was viewing. Examination in the hand showed it to be a Purple Finch which possibly had escaped from captivity, for every part of the plumage which should be purple was yellow. Needless to say, "it had a beak like that of a House Sparrow", and certainly I learned to be very cautious about discarding sight identifications, however improbable they might seem. In this instance it gives me great pleasure to confirm a strange but true sight description by an amateur, and to state beyond peradventure

that doubts cast upon the sight of the observer were without foundation.—HOYES LLOYD.

THE COLLECTION OF NORTH AMERICAN BIRDS IN THE ROYAL ONTARIO MUSEUM OF ZOOLOGY.—Since the inception of the Royal Ontario Museum in 1913, various small collections of bird-skins have become accessions of the department of Zoology. Heretofore no information has been given out regarding the size or nature of this study material and it seems advisable at the present time to call attention to the collection of North American forms so they may be referred to by the workers in Ornithology.

The total number of specimens, exclusive of foreign or mounted material, is 4,966. There are 243 genera and 534 species of North American birds represented. Although there are at present many gaps in the collection, some groups are fairly complete and a large series may be found in certain species.

The collection is gradually being augmented from time to time by Museum expeditions and by additional acquisitions from collectors. It seems particularly opportune at this time to make a plea to collectors to provide that their collections will ultimately find their way to institutions where the necessary care is insured and where they will be available to ornithologists in general.

Further information concerning the Museum's collections will gladly be given at any time. Address inquiries to Mr. J. R. Dymond, Secretary.—L. L. SNYDER, *Royal Ontario Museum of Zoology, Toronto, Ont.*

THE PLAINT OF THE ROBIN

W. A. D. LEES

When they found me here on American soil,
 In the time of George the glorious,
 They thought me a Thrush and gave me the name
 Of *Turdus migratorius*.
 And then the A. O. U. arose,
 In the reign of Queen Victoria,
 And they, in their wisdom, changed my name
 To *Merula migratoria*.
 And now the committee on names of birds,
 Becoming more censorious,
 Decided to hazard another guess,
Planesticus migratorius.
 Oh! when will they place my rightful name
 Among the insectivorous?
 They surely know that it ought to be
Redbreasticus vermivorus.

LEAFLETS OF THE NATIONAL ASSOCIATION OF AUDUBON SOCIETIES.—The Club has been advised

that the Audubon Societies' leaflets for the following species are available in French:

Bluebird	Song Sparrow
Blue Jay	Catbird
Robin	Flicker

This should especially interest our readers who desire to utilize these leaflets in educational work.

New leaflets of the Audubon Societies have also been issued for Lewis's Woodpecker, Western Meadowlark and Varied Thrush. As the Western Meadowlark is so common throughout the Prairies and southern British Columbia, this leaflet should be in great demand for schools in our west, for literature upon western birds has been scarce and difficult to procure in the past. Lewis's Woodpecker and the Varied Thrush are typical western

species and the leaflets concerning them will, no doubt, prove of special value for schools in British Columbia. The fact that these three leaflets of western birds are illustrated with colored pictures by Major Allan Brooks should increase their popularity with Canadians. These leaflets may be secured for five cents each by writing to the National Association of Audubon Societies, 1974 Broadway, New York City, N.Y.—J. F. WRIGHT, *Secretary, Ottawa Field-Naturalists' Club.*

The illustrations in this number of *The Canadian Field-Naturalist* have been provided through the generosity and assistance of Dr. R. E. De Lury.—EDITOR.

BOOK REVIEW

THE CONDOR (Concluded from p. 20)

He very thoroughly summarizes his suggestions in a final paragraph which is here reproduced:—

(A) The trinomial system should be followed consistently for English as for latin names.

(1) Every species in the A.O.U. list should have an English name whether the species is divided into races or not.

(2) Wherever subspecies are involved, each subspecies should be designated by the English name of the species preceded by an English subspecific term.

(3) Specific common names are preferably descriptive, while subspecific names may more properly refer to localities or the names of persons, as well as to minor characteristics.

(4) The possessive form should be used for subspecific names; not for the names of species.

(5) A misleading or distinctly false "popular" designation is very unfortunate from an educational standpoint and should not be permitted by the A.O.U. to stand as its officially recognized English name of a species or genus.

(B) Each species in the A.O.U. list should retain its permanent number, without letters affixed, as at present.

(C) Every race or subspecies, of a given species, should have assigned to it a letter of the alphabet, to be used in conjunction with the number assigned to the species.

(1) For the first described or type race of a species, assign the letter z.

(2) For all other races of a species retain the letters a, b, c, d, etc., as at present assigned, using the next succeeding letter of the alphabet for each new race.

(D) The abridged check-list should be so arranged that all species will stand out distinctly from their subdivisions. Species and subspecies

should not occupy columns of equal importance.

With very few reservations the reviewer heartily approves of all these proposals. They embody reforms that he has long urged.

Notes on the Yellow-billed Loon. By Alfred M. Bailey. Pp. 204-205.

In view of the very restricted known range of this species and the mystery that surrounds its breeding and migratory movements, Mr. Bailey's experience with it, April to June and in October, 1920, between Admiralty Island and Wrangell, Alaska, is interesting. About forty-five were seen during the spring, on one occasion thirty in a flock, and about thirty-four in the fall. A number of specimens were taken in corroboration of identification. Either this occurrence was an unusual irruptive migration such as occasionally takes place in many species, or the similarity of the bird to the Common Loon has caused it to be overlooked in waters that have been comparatively well worked in the past.

In an Open Letter to The Editor, Mr. A. J. Van Rossem, Pp. 215-216, discusses some of the much argued aspects of the present status of the subspecies. Mr. Van Rossem remarks, "If the rank and file of bird students would . . . think of the determined "subspecies" as admittedly short but still definite steps along the evolutionary highway, not only would the science of ornithology be benefitted by a new interest, but we would be spared much of the ranting about 'hair-splitting. . . .". We agree with the fundamental principles expressed but still hold that there is a limit to the fineness of splitting, beyond which it is impractical to go. Forms that are too faintly characterized to be demonstrable to those of reasonably acute perceptions and training, may well be studied by particularly gifted experts; but we do question the wisdom of naming them with

the full subspecific formality that demands their general recognition and use. He also questions the criterion of intergradation as a test for subspecific status and finally decides that "The criteria of isolation for the use of the binomial and of actual blood fusion for the use of the trinomial will, I believe, prove the ultimate ones to be adopted" To the criterion of isolation unaccompanied by evidences of differentiation, we take exception. That isolation always does produce immediate specific differentiation is an unwarranted conclusion. Geographic isolation does not prove genetic isolation. The only acceptable evidence of the latter is its observed fact, i.e., the lack of intergrades. That subspecies should be blood relationship groups seems to the present reviewer too obvious to require special statement but the question is, how are we to recognize blood relationship between variants unless a connection between them is demonstrated by intergradation? There are situations where such intergradation is physically impossible yet where subspecific relation is the most reasonable conclusion. Intergradation where demonstrated is an almost perfect proof of blood relationship; its apparent absence indicates only the greater or lesser probability of the opposite. It is therefore admittedly more or less of a convention, not quite perfect perhaps, but the best test we have and its indications should be followed except where other evidence points in a contrary direction.—P. A. T.

Roosevelt Wild Life Bulletin, Vol. 1, Nos. 3 and 4, New York State College of Forestry, Syracuse University. March, 1923.

These two bulletins contain some of the most noteworthy contributions which have yet been made to the ecology of birds. In No. 3, Aretas A. Saunders deals with "The Summer Birds of the Alleghany State Park", treating of them under the headings "Birds of the Upland Thickets", "Birds of the Forest Floor", "Birds of the Forest Trees",

"Birds of the Marshes", etc., etc., and giving a "key", a most excellent feature of which is the inclusion of females and young, and not only adult males as is unfortunately done in the case of so many intended "keys" for the identification of birds. In the same number Edmund J. Sawyer writes on "The Ruffed Grouse, with Special Reference to its Drumming." In this paper Mr. Sawyer first briefly reviews the various theories as to how the Ruffed Grouse drums. He then states that he has watched at a distance of a dozen feet the beginning, progress and ending of at least a hundred drummings, and found that each instance was a demonstration of the fact that the forceful, sound-producing blow was the *outward* and *upward* (not the downward and inward) motion of the wings. The remainder of the paper is devoted to the nesting, family life, and life of the Ruffed Grouse in winter. This article is illustrated with a good series of photographs of drumming Grouse.

In No. 4 the first paper is "The Relation of Summer Birds to the Western Adirondack Forest" by Perley M. Silloway, in which not only are the general forest habitats discussed, but the influence of certain forest trees on bird life is dealt with. Mr. Silloway presents a census of the birds found on areas varying from 4 to 10 acres in each habitat, a very difficult undertaking on the carrying out of which he is to be congratulated. In "Notes on the Relation of Birds to Adirondack Forest Vegetation", C. C. Adams presents some very interesting data, especially in regard to reforestation by birds. Dr. Adams states that, "We must therefore look upon the scattering of seeds by birds and other wild animals as a method of reforestation done without charge. This is a very valuable service, which supplements the wind-blown seeds of the aspens and birches."

Each number contains four full-page plates of birds in colours by E. J. Sawyer, the poses, colouration and grouping of the birds being excellent.—A. B. K.

PUBLICATIONS RECEIVED

Bird-Lore of the Northern Indians by Frank G. Speck. Reprint from Volume VII, Public Lectures by University of Pennsylvania Faculty, 1919-20. Philadelphia, Pa., 1921.

Ethnobotany of the Menomini Indians by Huron H. Smith. Bulletin of the Public Museum of the City of Milwaukee. Vol. 4, No. 1, December 10, 1923.

Reptile and Amphibian Notes from Intervale, New Hampshire, by Frank G. Speck. *Copeia*, No. 70, pp. 46-48. June 23, 1919.

The Origin of the Belief that Snakes Swallow their Young for Protection by Frank G. Speck. *Copeia*, No. 98, pp. 51-54. September 1, 1921.

*Notes on *Thamnophis sirtalis* from Cape Ann, Massachusetts*, by Frank G. Speck. *Copeia*, No. 37, pp. 91-92. November 24, 1916.

Testing Folk-Lore by Observations on Butler's Garter Snake by Frank G. Speck. *Copeia*, No. 57, pp. 56-60. May 15, 1918.

Le Gerfaut, 1923, Fascicule III-IV. Bruxelles, Belgique.

Revista do Museu Paulista Tomo XIII. Sao Paulo, Brasil.

Report of the Canadian Arctic Expedition 1913-18. Volume IV: Botany. Part A: Freshwater Algae and Freshwater Diatoms by Charles W. Lowe. Ottawa, February 20, 1923.

Report of the Canadian Arctic Expedition 1913-18. Volume IV: Botany. Part C: Fungi by John Dearness. Ottawa, June 1, 1923.

Report of the Secretary of Agriculture, 1923. Washington, 1923.



Henry Birks & Sons, Limited

*Gold and
Silversmiths*

BIRKS BUILDING
103-105 Sparks Street
OTTAWA

The Crabtree Co.

Artists and
Designers

BLUEPRINTERS
ENGRAVERS
COMMERCIAL
PHOTOGRAPHERS
: PHOTO :
LITHOGRAPHERS

228 Albert Street
Ottawa, Ont.



Card Filing Systems for Naturalists

As makers of the Library Bureau line of Card Filing Devices in Canada, we are in a position to supply all Naturalists with cards and trays where they can readily index all their observations and notes

Lowe-Martin Ltd.
OTTAWA, CANADA

*Printers of The Canadian Field-Naturalist
Publishers of the Autobiography of John Macoun, M.A*

COAL C. C. Ray Company Limited

BEST QUALITY LOWEST PRICES

46 Sparks St.—Phone Q. 461
OTTAWA

Geo. E. Preston & Sons MERCHANT TAILORS

*We make everything we sell and
guarantee everything we sell*

217-219 Rideau Street, Ottawa

Dr. Mark G. McElhinney

*Dentist to certain of the
cognoscenti*

252 LISGAR STREET, OTTAWA
Telephone Queen 2438

Kindly mention The Canadian Field-Naturalist to advertisers

Prices of Separates

Notes to Contributors, Etc.

Papers for publication should be addressed to the Editor, Mr. Harrison F. Lewis, Parks Branch, Ottawa, or to the appropriate Associate Editor.

Manuscript should be plainly written, typed if possible, on one side of the paper only, with wide spaces between the lines and ample margins. It is urged that special care be used that scientific names are legible, properly formed, and correctly spelled and capitalized.

Galley proof will be submitted to authors resident in Ottawa and proof of leading articles to any other author if requested when manuscript submitted. It is requested that it be corrected and returned to the Editor as quickly as possible.

Authors of leading articles are entitled to twenty-five copies of the number in which they appear, free of charge on application.

Separates of articles as they appear on the page, without any change of make-up will be supplied at the following rates:—

	25	50	100	200	300
1 page	\$2.00	\$2.25	\$2.50	\$2.75	\$3.00
2 "	3.00	3.25	3.75	4.00	4.25
3 "	3.50	3.75	4.00	4.25	4.50
4 "	3.50	3.75	4.00	4.25	4.50
5 "	4.50	4.75	5.00	5.25	5.50
6 "	4.50	4.75	5.00	5.25	5.50
7 "	6.00	6.25	6.50	6.75	7.00
8 "	6.00	6.25	6.50	6.75	7.00
9 "	7.50	8.00	8.75	10.25	11.75
10 "	7.50	8.00	8.75	10.25	11.75
Covers extra.....	3.00	3.00	3.00	4.00	5.00

If removal of matter on the pages non-pertinent to the article or changes of make-up are desired, or if insets or other extra work are necessary, special rates will be furnished on application to the Editor.

Applications for separates should be made to the Editor and must reach him not later than with the return of the corrected proof.

Rubber Stamps

FOR

Listing Your Specimens

The more consistent use of rubber stamps will materially assist you in cataloguing the collection of specimens you have spent so much time and trouble in securing. Let us help you.

CAPITAL RUBBER STAMP WORKS

175 NEPEAN STREET
OTTAWA, CANADA

Kindly mention *The Canadian Field-Naturalist* to advertisers

Many More are Wanted on the Subscription Lists

The Membership Committee of The Ottawa Field-Naturalists' Club is making a special effort to increase the subscription list of *The Canadian Field-Naturalist* and we are asking every reader to assist in making the campaign the success it should be.

We would particularly urge the Secretary of each Affiliated Society to bring this matter up at EVERY meeting and secure as many subscribers as they possibly can to a Canadian Publication devoted to the study of Natural History in all its phases.

Use the blank below and forward it to the Treasurer.

CUT OFF HERE

MR. B. A. FAUVEL,
Treasurer, Ottawa Field-Naturalists' Club,
Mounted Police Headquarters,
Laroque Building,
Rideau and Dalhousie Sts.,
Ottawa, Canada.

I enclose One Dollar and Fifty Cents as my subscription to The Canadian Field-Naturalist for one year.

Name.....
(Mr., Mrs. or Miss)

Address.....

City and Province.....

Affiliated Societies

NATURAL HISTORY SOCIETY OF MANITOBA

1923

Hon. Presidents: H. M. SPEECHLY, M.D.; W. G. SCOTT; *President:* PROF. V. W. JACKSON; *Vice-Presidents:* NORMAN CRIDDLE; J. J. GOLDEN; MRS. C. P. ANDERSON; PROF. C. H. O'DONOGHUE; PROF. F. W. BRODRICK; *Treasurer:* MISS HELEN R. CANNON. ORNITHOLOGICAL SECTION:—*Chairman:* A. G. LAWRENCE; *Secretary:* B. W. CARTWRIGHT; *Leaders:* H. M. SPEECHLY, M.D.; J. J. GOLDEN; C. E. KEIGHLEY; K. GRANT MCDUGAL; R. M. THOMAS. ENTOMOLOGICAL SECTION:—*Chairman:* J. B. WALLIS, B.A.; *Secretary:* G. SHIRLEY BROOKS; *Leaders:* L. H. ROBERTS; A. V. MITCHENER, B.S.A.; J. D. SUFFIELD; J. D. DUTHIE; BOTANICAL SECTION:—*Chairman:* C. W. LOWE, M.Sc.; *Secretary:* MRS. K. J. MCDUGAL; *Leaders:* JAMES COCKS; PROF. F. W. BRODRICK; DR. G. R. BISBY; H. F. ROBERTS, M. Sc.; SUBSECTION—MYCOLOGY:—*Leader:* DR. G. R. BISBY; GEOLOGICAL SECTION:—*Chairman:* Prof. R. C. WALLACE; *Secretary:* A. A. MCCOUBREY; SUBSECTION—PALAEONTOLOGY:—*Leader:* W. CUTLER; *General Secretary:* A. M. DAVIDSON, M.D., 6 Medical Arts Building.

THE HAMILTON BIRD PROTECTION SOCIETY (Incorporated)

Hon. President: MR. ADAM BROWN; *President:* MR. R. O. MERRIMAN; *1st Vice-President:* DR. H. G. ARNOTT; *2nd Vice-President:* MR. C. D. COOK; *Secretary-Treasurer:* MISS RUBY R. MILLS, Public Library, Hamilton; *Directors:* DR. H. G. ARNOTT; C. D. COOK; DR. J. A. DICKSON; MISS M. E. GRAHAM; MISS RUBY R. MILLS; M. HOLTON; M. JOHNSTON; MRS. F. E. MACLOGHLIN; R. O. MERRIMAN.

NATURAL HISTORY SOCIETY OF BRITISH COLUMBIA, VICTORIA, B.C.

The Officers for the above Society for the year ending March 31st, 1923, are as follows:—*President:* W. N. KELLY; *1st Vice-President:* A. R. SHERWOOD; *2nd Vice-President:* C. C. PEMBERTON; *Secretary:* H. T. NATION; *Treasurer:* MISS S. M. THORNTON. *Committee:*—MISS C. G. FOX, MISS A. F. GARDINER, MISS I. CATHCART, WM. DOWNES, A. HALKETT. *Auditors:*—J. KEITH WILSON AND F. W. GODSAL. *Trustees:*—REV. R. CONNELL, DR. C. F. NEWCOMBE AND G. HARVEY.

ALBERTA NATURAL HISTORY SOCIETY

Hon. President: HON. GEO. HOADLEY; *Hon. Vice-President:* H. A. CRAIG; G. W. SMITH, M.P.P.; J. J. GAETZ; *President:* C. H. SNELL; *Vice-Presidents:* MRS. W. A. CASSELS; DR. HENRY GEORGE; *Secretary-Treasurer:* MRS. S. PAMELY, Red Deer; *Directors:* MRS. H. GEORGE, Red Deer; MRS. G. F. ROOT, Wetaskiwin; K. BOWMAN, Edmonton; F. S. CARR, Edmonton; D. MACKIE, Edmonton; W. A. CASSELS, Red Deer; S. PAMELY, Red Deer; C. G. S. CROSBY, Red Deer; W. F. HARRIS, Red Deer; H. R. ORAM, Red Deer. *Members qualified to answer enquiries:* *Birds:* MRS. W. A. CASSELS, Red Deer; DR. H. GEORGE, Red Deer; *Mammals:* DR. H. GEORGE, Red Deer; *Fishes:* F. C. WHITEHOUSE, Red Deer; *Flowers:* MRS. H. GEORGE, Red Deer; *Insects:* *Coleoptera,* F. C. CARR, 11050 123rd St., Edmonton; *Lepidoptera,* K. BOWMAN, 9914 115th St., Edmonton; *Odonata,* F. C. WHITEHOUSE, Red Deer.

The meetings of this Society are held in Red Deer on the last Friday of each month except during July and August and perhaps September. The annual meeting is held in Red Deer on the last Friday in November.

McILWRAITH ORNITHOLOGICAL CLUB, LONDON, ONT.

President: J. R. MCLEOD; *Secretary:* C. G. WATSON, 201 Ridout St. South, London; *Members qualified to answer questions:* W. E. SAUNDERS, 240 Central Ave.; C. G. WATSON, 201 Ridout St. South; J. R. MCLEOD, 355 Wortley Road, J. F. CALVERT, 461 Tecumseh Ave.; E. M. S. DALE, 297 Hyman St.

VANCOUVER NATURAL HISTORY SOCIETY

Hon. President: L. S. KLINCK, LL.D., Pres. University of B.C.; *President:* JOHN DAVIDSON, F. L. S., University of B.C.; *Vice-President:* FRED PERRY; *Hon. Secretary:* C. F. CONNOR, M.A., 3529-W. 2nd Ave., Vancouver, B.C.; *Hon. Treasurer:* A. H. BAIN, 2302 York St., Vancouver, B.C.

Fortnightly meetings in the University Buildings from September to April (inclusive). Semi-monthly excursions from May to August (inclusive).

PROVINCE OF QUEBEC SOCIETY FOR THE PROTECTION OF BIRDS

Hon. President: I. GAMMELL; *President:* L. MCL. TERRILL; *Vice-Presidents:* ALEX. MACSWEENEY, NAPIER SMITH, E. ARNOLD; *Hon. Corresponding Secretary:* W. S. HART, P.O. Box 1185, Montreal; *Hon. Recording Secretary:* MISS H. STONE; *Hon. Treasurer:* MISS M. ARMITAGE, 63 Arlington Ave., Westmount; *Directors:* MISS EDITH MORROW; MISS LOUISE MURPHY; MISS EMILY LUKE; MR. AND MRS. C. F. DALB; MRS. J. T. AYERS; MISS JEAN MCCONNELL; W. A. OSWALD; A. F. WINN; MR. AND MRS. WALLACE H. ROBB; W. G. WRIGHT. *Members qualified to answer questions:* L. MCL. TERRILL, 44 Stanley Ave., St. Lambert, Que.; NAPIER SMITH, Bank of Montreal, Magog, Que.; E. ARNOLD, 64 Durocher St., Montreal; W. A. OSWALD, 301 Wilson Ave., N.D.G., Montreal; C. N. ROBERTSON, c-o Ross Realty Co., Room 305 Lewi Bldg., St. John St., Montreal, Que.; DR. ARTEUR WILLET, McGill University, Montreal; W. J. BROWN, 250 Oliver Ave., Westmount, Que.; MISS EDITH MORROW AND MISS EMILY LUKE, c-o Secretary.

SOCIÉTÉ PROVANCHER D'HISTOIRE NATURELLE DU CANADA

Bureau de direction pour 1923

Président: R. MEREDITH, N.P.; *1er vice-président:* ABBE ALEX. VACHON, M.A.; *2ème vice-président:* DOCTEUR A. DERY; *Secrétaire-trésorier:* JOS. MATTE, 18 avenue Maisonneuve, Québec; *Chef de la section scientifique:* COLONEL OSCAR PELLETIER; *Chef de la section de propagande éducationnelle:* DOCTEUR S. GAUDREAU; *Chef de la section de protection:* C.-E. DIONNE, M.A.; *Chef de la section d'information scientifique et pratique:* DOCTEUR J.-E. BERNIER; *Directeurs:* A.-R.-M. BOULTON, FRANK W. ROSS, A.-A. GODBOUT.

THE BRITISH COLUMBIA ORNITHOLOGISTS' UNION

Officers for 1923

Hon. President: HON. MINISTER OF AGRICULTURE, Victoria; *President:* FRANCIS KERMODE, Provincial Museum, Victoria; *Vice-President:* T. L. THACKER, Hope; *Secretary-Treasurer:* J. W. WINSON, Huntingdon; *Directors:* J. A. MUNRO, Okanagan Landing; DR. KELSO, Arrow Lakes; R. GLENDENING, Agassiz; K. RACEY, Vancouver; T. PEARSE, Courtenay; W. N. KELLY, Victoria.

THE TORONTO FIELD-NATURALISTS' CLUB

President: PROFESSOR R. B. THOMSON; *Vice-Presidents:* PROFESSOR E. M. WALKER, DR. A. COSENS, J. H. FLEMING; *Secretary:* W. F. GREGORY, 151 Ellsworth Ave., Toronto; *Treasurer:* F. H. BRIGDEN; *Honorary Librarian:* C. W. NASH; *Librarian:* DR. LYMAN B. JACKES. BIRD GROUP:—*Chairman:* STUART THOMPSON; *Secretary:* JAMES BAILLIE. FLOWER GROUP:—*Chairman:* DR. H. B. SIFTON; *Secretary:* MISS J. G. WRIGHT, PH.D.; INSECT GROUP:—*Chairman:* PROFESSOR WALKER; *Secretary:* MISS NORMA FORD, PH.D. MAMMAL GROUP:—*Chairman:* J. R. DYMOND; *Secretary:* L. SNYDER. REPTILE, FISH AND AMPHIBIAN GROUP:—*Chairman:* SHELLEY LOGIER; *Secretary:* T. B. KURATA. PROGRAM COMMITTEE:—*Chairman:* DR. W. A. CLEMENS. WILD LIFE PRESERVATION COMMITTEE:—*Chairman:* RUSSELL G. DINGMAN. EDUCATIONAL COMMITTEE:—*Chairman:* TAYLOR STATEN.

We would ask the Officers, and more particularly the Secretaries, of all the Affiliated Societies to assist us in our task of building up the circulation of this magazine. By securing every member as a subscriber we can truly make this magazine into one of the leading Natural History publications of America



FOR SALE

Back Numbers of The Ottawa Naturalist

The Club has for sale complete sets of its publications. Enquiries regarding price should be addressed to the Secretary of the Club, Dr. J. F. Wright, Geological Survey, Ottawa, Canada.

Any member having copies of the March, 1896, January, February, March and August, 1898, and December, 1900, issues of *The Ottawa Naturalist*, and who desires to dispose of the same, is requested to communicate with the Secretary.



Grant-Holden- Graham Limited

Outfitters to
Surveyors & Engineers

Manufacturers of
High-Grade Tents
Tarpaulins & Sleeping Bags

WRITE FOR CATALOGUES

147 Albert Street
OTTAWA

Fine Diamonds

Sterling Silver, Fine
Cut Glass, Electro-
Plated Ware

*The Store of
Moderate Prices*

C. A. Olmsted & Son

*Jewellers, Opticians, Watchmakers and
Engravers*

208 Sparks Street, Ottawa

WHY NOT ADVERTISE
YOUR PRODUCTS IN

The
Canadian
Field-Naturalist

*The Leading Canadian
Natural History Publication*

WRITE FOR RATE CARD

ADVERTISING DEPARTMENT
THE CANADIAN FIELD-NATURALIST

175 Nepean Street

OTTAWA

Kindly mention The Canadian Field-Naturalist to advertisers



THE CANADIAN FIELD-NATURALIST



PUBLISHED BY
OTTAWA FIELD-NATURALISTS' CLUB

ISSUED MARCH 14, 1924

Entered at the Ottawa Post Office as second-class matter

THE OTTAWA FIELD-NATURALISTS' CLUB

Patrons:

THEIR EXCELLENCIES THE GOVERNOR-GENERAL AND THE LADY BYNG OF VIMY

1st Vice-President: G. A. MILLER. President: HOYES LLOYD. 2nd Vice-President: NORMAN CRIDDLE

Secretary: J. F. WRIGHT, (Geological Survey, Ottawa.) Treasurer: B. A. FAUVEL, (Mounted Police Headquarters, (Laroque Bldg., Rideau and Dalhousie Sts., Ottawa))

Additional Members of Council: W. T. MACOUN; MISS M. E. COWAN; C. M. STERNBERG; H. I. SMITH; F. W. WAUGH; P. A. TAVERNER; E. SAPIR; E. M. KINDLE; W. J. WINTERBERG; R. E. DELURY; ARTHUR GIBSON; M. O. MALTE; R. M. ANDERSON; H. GROH; MISS F. FYLES; C. B. HUTCHINGS; H. M. AMI; CLYDE L. PATCH; D. JENNESS; V. W. JACKSON; R. O. MERRIMAN; W. N. KELLY; C. H. SNELL; J. R. MCLEOD; JOHN DAVIDSON; L. MCL. TERRILL; R. MEREDITH; FRANCIS KERMODE; PROF. R. B. THOMSON; THE EDITOR.

Editor:

HARRISON F. LEWIS,
Canadian National Parks Branch,
Dept. of the Interior, Ottawa.

Associate Editors:

E. SAPIR.....	Anthropology	A. G. HUNTSMAN.....	Marine Biology
M. O. MALTE.....	Botany	P. A. TAVERNER.....	Ornithology
F. R. LATCHFORD.....	Conchology	E. M. KINDLE.....	Palaeontology
M. Y. WILLIAMS.....	Geology	R. M. ANDERSON.....	Zoology
ARTHUR GIBSON.....	Entomology	CLYDE L. PATCH.....	Herpetology

CONTENTS.

	PAGE
Some Littoral Barnacles from William Head, British Columbia. By Ira E. Cornwall, F.G.S.	41
List of Birds Recorded from the Island of Anticosti, Quebec. By Harrison F. Lewis.	43
Intelligence Behaviour in Lizards. By Frank G. Speck.	47
Notes on the Relation of the Dipper (<i>Cinclus mexicana unicolor</i>) to Fishing Interests in British Columbia and Alberta. By J. A. Munro.	48
Further Notes on the Ferns of Hatley, Que. By Henry Mousley.	50
W. H. Hudson, The Naturalist (1841-1922). By Frank Morris (<i>Concluded</i>).	51
Some Holothurians from British Columbia. By Hubert Lyman Clark.	54
Notes and Observations:	
Trumpeter Swans (<i>with illustration</i>). By Hoyes Lloyd.	57
The Starling at Hamilton. By Calvin McQuesten.	58
Notes on Prairie Warbler and Starling. By Paul Harrington.	58
Occurrence of the Starling in the Montreal District. By L. Mcl. Terrill.	58
A Bat Active in Winter. By E. M. S. Dale.	58
Editor's Notes.	59
Book Review:—	
Jack Miner and the Birds. By R. O. M.	59
Bird-Lore of the Northern Indians. By F. W.	60
Beach Grass. By H. F. L.	60

THE CANADIAN FIELD-NATURALIST, lately THE OTTAWA NATURALIST, established thirty-six years ago, "to publish the results of original research or investigation in all departments of natural history," is issued monthly, excepting for the months of June, July and August.

Papers, notes and photographs should be addressed to the Editor. Manuscript should be typewritten.

Subscriptions cover the current year, except those taken out during last quarter, when they will be applied on the following year, the remaining numbers of current year being sent free. Payments should be made to the Treasurer, Mr. B. A. Fauvel, Mounted Police Headquarters, Laroque Building, Ottawa. Price of this volume, \$1.50; single copies 20c each.



This is Another
WOODS' PRODUCTS

One of those handy convenient little Silk Tents for an over night trip.

ABSOLUTELY MOSQUITO PROOF and WATER TITE

SILK HIKER TENT—THE PACKER'S FRIEND
Length 8' Height 4' Width 4'0" Weight 4 lbs.

CAMP EQUIPMENT OF QUALITY

WOODS MANUFACTURING CO.
OTTAWA

EXPLORATIONS
in Western Canada

The Ottawa Field-Naturalists' Club has just published an interesting volume of over 300 pages, entitled:

Autobiography of John Macoun, M.A.

Canadian Explorer and Naturalist, Assistant Director and Naturalist to the Geological Survey of Canada—1831-1920.

This volume is an account of the life of this veteran naturalist. Agriculturists generally, in fact all interested in the development of Canada, will find this book of much interest and value.

The edition is limited. The price is \$3.00 with 15c added for bank exchange, if remittance is forwarded by personal cheque.

Applications for the volume should be made to

Mr. Arthur Gibson

Birks Building : Ottawa, Ont.

The
Topley Co.

**Photographic Material
Scientific Apparatus
Eastman Kodaks**



**132 Sparks Street
OTTAWA**

Lyman's Limited

(Established 1800)

MANUFACTURING CHEMISTS

Importers and Dealers in
CHEMICAL AND
ASSAY APPARATUS

344 St. Paul St. West, Montreal



GROW GOOD CROPS

SEEDS PLANTS BULBS

Our rigorous system of testing eliminates loss
and disappointment from your garden

Kenneth McDonald & Sons, Limited
Seed and Bulb Merchants

Market Square :: Ottawa, Ont

L. C. Smith & Bro.

Typewriter

Ball bearings in every frictional part of
the L. C. Smith insure long life, light
touch and easy operation

Ottawa Typewriter Co. Limited

191 QUEEN ST., OTTAWA

Ward's NATURAL SCIENCE ESTABLISHMENT

Rochester, New York, U.S.A.

Manufacturers of the genuine Schmitt boxes
exhibition cases and cabinets, also of the American
Entomological Company's insect pins.

Riker Mounts and botanical mounts always on
hand, also Riker botanical presses.

Send for our supply catalogue and other lists of
interest to collectors.

Headquarters for Entomological Supplies
and Specimens

THE

Bank of Nova Scotia

Capital.....\$ 9,700,000

Reserve Fund and Divi-
dend Profits, over.... 18,000,000

Total Assets over..... 230,000,000

SEVENTEEN BRANCHES IN
OTTAWA AND HULL

W. A. Rankin, Ltd.

Hammocks

Refrigerators

Builders' Hardware

410-412 Bank Street, Ottawa

Phones—Queen 1023-1024

Inspected Milk

Ice Cream

Ottawa Dairy

Fresh Butter

Buttermilk

*“Say it with
Flowers”*

Sunnyside Greenhouses

Chas. Craig, Florist

Phone R. 566 Rideau Terrace OTTAWA

Kindly mention *The Canadian Field-Naturalist* to advertisers

The Canadian Field-Naturalist

VOL. XXXVIII

OTTAWA, ONTARIO, MARCH, 1924

No. 3

SOME LITTORAL BARNACLES FROM WILLIAM HEAD, BRITISH COLUMBIA

BY IRA E. CORNWALL, F.G.S.



SINCE Darwin's Monograph on the Sub-Class Cirripedia and Dr. H. A. Pilsbry's Monographs on the American species have covered the subject so thoroughly there seems very little left for the amateur to do. But an investigation of the species found on almost any part of the coast may produce results of value. When beginning the study of this interesting subclass one is struck by their great variability of form; they vary to such an extent that it is rarely safe to rely on external form alone for identification of the species, and it may occasionally be difficult to recognize the genus of some old eroded specimen. In most cases the only safe method of identification is to make an examination of the interior of the shell and opercular plates, dissect the animal, and examine the cirri and mouth parts. The plates forming the shell can be separated by boiling in a strong solution of caustic potash, and ground to expose the structure of the walls and basis, if there is one.

The most common species here, in the littoral zone, is *Balanus cariosus*. It is a good example of variability, as it is found in all the intermediate forms between a broad-based cone with well marked sculpture on its thick walls, fig. 1, E., to a long narrow tube with thin walls, and not a trace of the sculpture, which is characteristic of an uneroded conic specimen, fig. 1, C. These barnacles cover the rocks from about two feet above the lowest tide mark to within three feet of the highest tide; those growing near the upper limits of their zone are all small. Half-tide mark seems to be their favorite station, as it is there that they reach their greatest size. Some specimens that have been taken from protected situations were very large, for this species; one of these measured 59 mm. in diameter, and was 47 mm. high.

The uneroded shell of *Balanus cariosus* has a very rough appearance, as the walls are marked by many narrow, deep, irregular ribs, which have long projections pointing downward. This gives the shell the "thatched appearance" described by Darwin. Fig. 1, E. The shell of a conic specimen is remarkably thick, and is permeated by many irregular pores. These pores have cross septa and they appear like rows of long cells

extending from the base to the top of the walls. The orifice is small, and the opercular plates, or scuta and terga, are set well down in the deep sheath. This species does not have a calcareous basis, but the bases of the compartments forming the walls are firmly cemented to the rock. Between the body of the animal and the rock there is a layer of membrane, the membranous basis, which is like a carpet put down in a floorless tent. Some specimens taken from exposed places are eroded to such an extent that the opercular plates project above the margin of the orifice, fig. 1, D. When several individuals grow in a group, their outside walls are thick and have the usual thatched sculpture of conic specimens, but the walls between them may be very thin, and in some cases are poreless. If much crowded, they gain space by lengthening their walls, and become cylindrical, fig. 1, A, B, C. They may reach a length of 75 mm. or more, and have a diameter of only 15 to 20 mm. In a cylindrical specimen the orifice is of the same diameter as the body-chamber, and its margin is very irregular. The opercular plates are set deep in the sheath. Occasionally specimens are found with patches of thatch on their walls, fig. 1, B. Fig. 1, A, shows a thick-walled specimen from Bella Bella, B.C. The color of specimens taken from the littoral zone is light gray; under the microscope the surface of the upper part of the shell has a rough eroded appearance that is quite different from the appearance of the new growth exposed at the base. The surface of the new growth is smooth and white. Evidently the normal color of the shell is white, as specimens taken from other localities, where they grow below low tide mark, do not have the gray, weathered appearance. This is also true of some of the cylindrical specimens taken from under a wharf, where they were protected from weathering, even when uncovered by the tide.

Balanus cariosus growing in the littoral zone keep their opercular valves almost closed when uncovered by the tide, as more water is retained in the shell if the valves are not tightly pressed together. If disturbed they will close them with considerable force, squeezing out some water and making the faint grating noise so often heard when one is walking over barnacle-covered rocks.

Specimens taken from the floats of a boat-house, where they were never uncovered by the tide, kept on opening their valves and protruding their cirri for some time after being taken from the water.

About the middle of April enormous numbers of young barnacles, in the free-swimming stage, are to be seen in the water. Occasionally they are so plentiful that they look like clouds of dust floating near the surface. These are evidently the young of *Balanus cariosus*, as within a short time of their appearance all the rocks in the littoral zone are covered with them, and they soon develop the little star-like shell which is characteristic of that species.

A variety of *Balanus rostratus* is found beyond the littoral zone, but a few small specimens have been collected here during the lowest tides; they are found only in well-protected situations where there is a dense growth of seaweed.

Only one littoral species of pedunculate, or goose, barnacle has been found on the western coast of North America, and none on the eastern coast. This barnacle, *Mytella polymerus*, grows here in dense groups at about two feet above the lowest tide mark. Their favorite station is in narrow clefts in the rocks where they are at least partly protected from the action of drift-wood, but are well washed by the tide. They do not grow where there is seaweed, but are frequently grouped with the mussel, *Mytilus edulis*. They have a habit of opening their valves and protruding their cirri as soon as they are splashed by the

first waves of the incoming tide. The specimens found here do not seem to reach their greatest size, as they rarely exceed four or five inches in length.

There is another barnacle found here which might easily escape the notice of collectors, owing to its small size. This is *Chthamalus dalli* var. The usual size of this species is from 6 to 8 mm. in diameter, and 2 to 3 mm. high; it is exclusively littoral, and grows even higher on the rocks than

Balanus cariosus, some mature specimens being found at a height of eight feet or more above low tide mark. As the range of the tide, here, is only ten feet, this means that they are uncovered for long periods. The color of the shell is pale gray, where it is eroded; there is a narrow band of lighter colored new growth at the base. The orifice is small and the basis is membranous; there are six compartments, which are more equal in size than in *Balanus*; the right and left scuta and terga are equal.

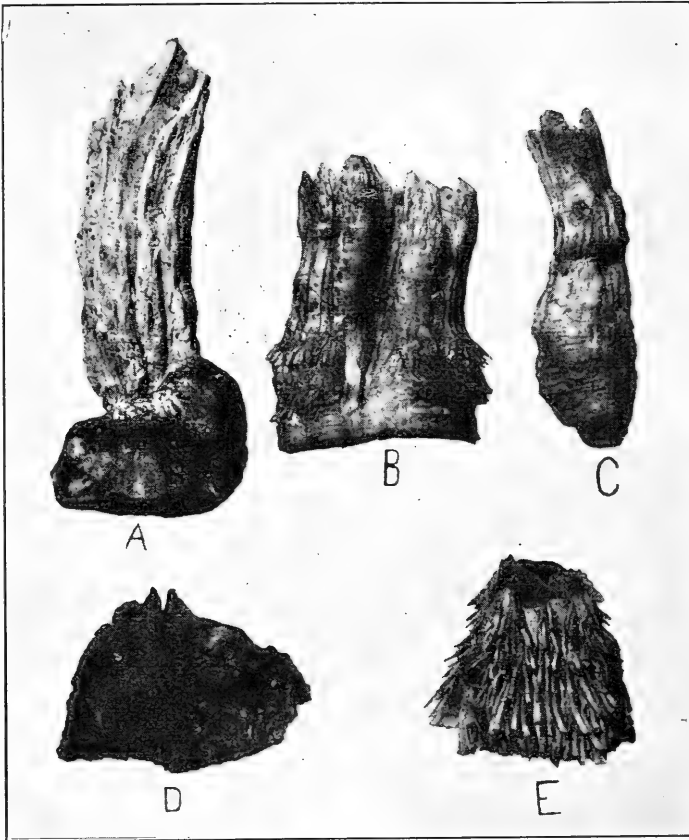

FIGURE 1. *Balanus cariosus*. Cylindric and conic forms. Photograph $\frac{3}{4}$ natural size.

There were eggs in many of the specimens examined, but they were of a larger size, compared with the size of the animal, and were less numerous, than the eggs found in other species. Several full-sized specimens of this species were found without eggs, and in each case there was a Crustacean parasite in the space under the body of the barnacle. In one barnacle there were two parasites of the same species; evidently male and female.

It is astonishing what an amount of exposure to direct sunlight and consequent great variations

of temperature the littoral barnacles can stand. Temperatures of nearly 80°F. have been recorded on a thermometer placed at the half-tide mark, and the sea-water temperature at the same time was 47°F. This is a big variation of temperature for a marine animal, and is greater than the seasonal variation of the sea-water here. Owing to the peculiar tides on this part of the coast, the half-tide mark may be uncovered from six to nine hours per day, when there are very low tides. From the hourly tide records of Victoria it was found that the half-tide mark was uncovered for more than two thousand hours during 1922. This information was obtained through the courtesy of Mr. A. Halkett, of Victoria.

The barnacles in the littoral zone are exposed to many destructive agencies, and have many enemies. Large numbers are destroyed by drift-wood carried against the rocks by the waves. The large quantities of oil which are now thrown into the sea drift ashore, coat the rocks in the littoral zone and kill many barnacles. This oil also destroys many other forms of marine life. There are fish that live partly on barnacles, and at least one species of crab is known to break them from the rocks for food.

An examination of the empty mollusk shells cast up on the beaches seems to show that barnacles prefer the shells of certain species. *Chryso-domus tabulatus* is usually covered with large and small *Balanus crenatus*. This species is also found on *Cardium corbis*, and it frequently has the sculpture of shell continued on its walls. A smooth shelled variety of *B. rostratus* growing on *Pecten hastatus* is also marked by the ribs of the shell on which it is growing. *Perlene oregonensis* may have a few barnacles on it, but they seem to grow only where the epidermis has been broken off. Living limpets are sometimes found completely covered with young barnacles, but they evidently get rid of them, as they are not found here with mature ones on them. The most common shell here, living or empty, is *Purpura crispata*, yet only one specimen has been found here with barnacles on it.

Barnacles are of considerable economic value; during their free-swimming larval stage they furnish a large amount of food for small fish and mollusks. During the last few years a large number of small herring have been caught, and the contents of their stomachs examined, and in many of them there were young barnacles in various stages of development.

LIST OF BIRDS RECORDED FROM THE ISLAND OF ANTICOSTI, QUEBEC BY HARRISON F. LEWIS

ALTHOUGH our knowledge of the bird-life of the Island of Anticosti is still regrettably incomplete, it seems desirable at this time to publish a brief list of birds recorded from the island, including much unpublished information, and correcting certain published errors. Thus there will be provided, in readily available form, and wholly in English, a résumé of the present state of our knowledge of Anticosti birds, which should make a better starting-point for the future student than would the same information in its previous scattered condition, partly in French and partly in English, partly unpublished, and partly uncorrected error.

Anticosti, the well-known island in the northern part of the Gulf of St. Lawrence, is a part of the Province of Quebec. It is about 122 miles long and has a maximum breadth of 30 miles, and nowhere exceeds 700 feet in height. Much of the surface is forested, chiefly with conifers, and streams and lakes are numerous. The rock of the island is limestone. The cultivated area is very small.

Anticosti was discovered by Jacques Cartier in 1534, and was granted as a seigniory by the crown of France to Louis Jolliet, the explorer of the Mississippi, in 1680. The present owner of the

island is Senator Gaston Menier, of Paris, France. The population is about 500.

I had the pleasure of visiting Ellis Bay, Anticosti, from June 10 to 16, 1922. Mr. Georges Martin-Zédé, Director of the island, and an ardent conserver of valuable wild life, spared no pains to make my stay a pleasant one and to assist me in observing the interesting birds and animals of the vicinity of Ellis Bay.

Besides the works referred to in the bibliography accompanying this list, and my own field notes, I have used, in compiling the list, the unpublished MS. of W. Sprague Brooks, who visited Anticosti from August 23 to September 15, 1919, and who has most kindly placed his records at my disposal, for which my sincere thanks are here expressed. Thanks are also due to F. Johansen and P. A. Taverner, for the privilege of using notes made by them at Anticosti in 1923 and in 1915, respectively, and to Lt.-Col. W. P. Anderson, W. La Brie, Capt. Oscar Mercier, and Prof. A. E. Verrill for information furnished in correspondence. I prize particularly and am particularly grateful for the privilege which I have had of corresponding with Prof. Verrill, the first real worker in Anticosti ornithology, who has taken the trouble of searching for additional information through the pages

of his original field-diary, written nightly by him in Anticosti in 1861, at which time he was already prominent among American ornithologists.

Specimens collected by Verrill and by Brooks have been deposited in the Museum of Comparative Zoology, Cambridge, Massachusetts.

The most pretentious of the lists of birds of Anticosti already published is that of Schmitt, who was resident physician on the island from 1896 to 1904. In the introduction to this list (p. 290) Schmitt says, "Except for Olor and Camptolaimus, I possess one or several specimens of all the birds listed below, which I obtained on the island, by means of a gun, or by means of a silk net spread in the forest. Their identification has been made by the aid of Ridgway's work [Manual] and, in addition, through review by Mr. C. E. Dionne, the very competent ornithologist of Laval University, who has been pleased to examine them one by one and to compare them with the specimens in that University. I ask him to accept my most sincere thanks for his extreme kindness."

In spite of this detailed statement, Schmitt's list itself contains internal evidence to the contrary, as in the case of his record of the White-fronted Goose, where he evidently speaks of a species which he thought he saw in the field, but of which he had no specimen. I have discussed this matter at length with Mr. Dionne, who assured me that Schmitt's list contained several species of which no specimens were presented to him for identification. Mr. Dionne and I later went over Schmitt's list carefully together, and he informed me as to the individual species included therein of which Schmitt had not shown him any specimens. I noted these in writing at the time and have included the notations in the following list. These form a most valuable means of correcting Schmitt's errors, and I am greatly indebted to Mr. Dionne for them.

The list published by Mr. Dionne himself is based entirely upon observations made by Mr. Willie La Brie, of Kamouraska, Quebec, who resided on Anticosti in 1913, 1916 and 1917. I have had the pleasure of meeting Mr. La Brie and seeing his Anticosti specimen of the Dickcissel, and have also had a correspondence with him concerning some of his Anticosti records, in the course of which correspondence he has kindly furnished me with much additional valuable information, which is included in this list, and for which I thank him sincerely.

The nomenclature used herein is that of the 1910 edition of the A.O.U. "Check-List", with supplements published to date.

As the paper will be published in instalments,

the bibliography is inserted here for convenience of reference.

BIBLIOGRAPHY

Bell, Robert. Catalogue of Animals and Plants collected and observed, on the south-east side of the St. Lawrence from Quebec to Gaspé, and in the Counties of Rimouski, Gaspé, and Bonaventure. *Geol. Surv. of Canada., Rept. of Progr. for the year 1858.* Montreal, 1859. Page 246. (Only Anticosti material is in reference to Red-throated Loon.)

Verrill, A. E. Catalogue of the Birds observed at Anticosti and Vicinity. *Proc. Boston Soc. Nat. Hist.,* Vol. IX, pp. 137-143. Boston, 1865.

Samuels, Edward A. Our Northern and Eastern Birds. New York, 1883. (Only Anticosti material is in reference to Canada Goose.)

Brewster, William. Notes on the Birds observed during a Summer Cruise in the Gulf of St. Lawrence. *Proc. Boston Soc. Nat. Hist.,* Vol. XXII, pp. 364-412. Boston, 1884.

Turner, L. M. List of the Birds of Labrador, including Ungava, East Main, Moose and Gulf Districts of the Hudson Bay Company, together with the Island of Anticosti. *Proc. U.S. Nat. Mus.,* VIII, pp. 233-254. 1885. (Contains no original material on Anticosti; the Anticosti records contained in it being taken from the publications of Verrill and Brewster.)

Brewster, William. The Ptarmigan of Anticosti—a Correction. *The Auk,* Vol. II, pp. 220-221, 1885.

Anon. The Settler and Sportsman in Anticosti. London, 1885. (Contains list of birds which is unreliable and altogether valueless.)

Anon. Brief Notes on the Island of Anticosti in the Gulf of St. Lawrence, Dominion of Canada. London, 1886. (Also unreliable and valueless, so far as its list of birds is concerned.)

Combes, Paul. Exploration de l'Île d'Anticosti. Paris, 1896. (Contains brief list of birds. In French.)

Schmitt, Joseph. A Summer Colony at Anticosti. *The Auk,* Vol. XIX, pp. 181-183. 1902.

Schmitt, Joseph. Monographie de l'Île d'Anticosti. Paris, 1904. Chap. XXV, Oiseaux, pp. 289-309. (In French.)

Brooks, W. Sprague. A New Jay from Anticosti Island. *Proc. New Engl. Zool. Club,* Vol. VII, March 11, 1920, p. 49. (The Anticosti representative of *Perisoreus canadensis* described as *P. barbouri* sp. nov.)

Dionne, C. E. Liste des Oiseaux de l'Île d'Anticosti. *Le Naturaliste Canadien,* Vol. XLVII, No. 2, pp. 25-29. Quebec, August, 1920. (Based on the observations of Mr. Willie LaBrie. In French.)

Anderson, W. P. Place-Names on Anticosti Island, Que. Ottawa, 1922. (Contains first published statement of the nesting of the Gannet on the east coast of Anticosti.)

1. *Colymbus auritus.* HORNED GREBE.

Schmitt: A single young specimen was killed in October at Sanatorium Bay. *Dionne:* Two specimens were seen in 1916. *Brooks:* A few noted about Ellis Bay, including a female and 3 downy young upon Lake Gamache. *Lewis:* A pair observed in courting antics at Ellis Bay, June 14, 1922, and another pair observed at Ellis Bay that day and the next.

2. *Gavia immer.* LOON.—*Verrill:* Very common. Breeds. *Brewster:* Of general distribution in the Gulf. *Schmitt:* Fairly common. Breeds. Young hatched July 7, 1901. *Dionne:* Very common. *Brooks:* Common. During second week of September seen flying from interior to waters of Ellis Bay. *Lewis:* Observed rather commonly at Ellis Bay.

3. *Gavia stellata.* RED-THROATED LOON.—*Bell:* Skins of this bird were procured by Mr. Richardson in Anticosti. *Verrill:* Very common. Breeds on little islands in interior lakes. *Brewster:* Seen at Anticosti. *Schmitt:* Fairly common. *Dionne:* Very common. *Brooks:* Did not see it, but was shown by M. Gagnon, the game warden, a skin recently taken by him.

4. *Fratercula arctica arctica.* PUFFIN.—*Verrill:* Breeds in considerable numbers along the

eastern and northern shores. *Brewster*: Observed them at Wreck Bay. *Combes*: Fairly abundant, especially at Gull Cliff. *Schmitt*: Nests in great numbers at Bird Bay. *Dionne*: Common. *Brooks*: Informed by M. Gagnon that they still breed in considerable numbers about N.E. end of island. *Johansen*: Seen flying at Fox Point, August 5, 1923.

5. *Cepphus grylle*. BLACK GUILLEMOT.—*Verrill*: Very common. Breeds. *Schmitt*: Common. Occurs throughout the year. Breeds. More common in winter. *Dionne*: Very common. *Brooks*: Several near the island, August 23. *Lewis*: Four near Ellis Bay, June 10. Four or five near West Point, June 16. *Johansen*: Recorded at High Cliff Point, August 4, 1923.

6. *Uria troille troille*. MURRE.—*Verrill*: Breeds in large numbers along the eastern and northern shores of Anticosti. About $\frac{1}{2}$ *ringvia*. *Brewster*: Saw none at eastern end of Anticosti. *Schmitt*: Very common. All winter. Greatest numbers present from autumn to May. Some nest at Bird Bay. Sometimes die in great numbers at approach of winter. *Dionne*: Formerly common, now very rare. *Johansen*: Recorded at High Cliff Point, August 4, 1923, and on the cliffs east of Cape Sandtop, August 6, 1923. Recorded as nesting at Fox Point, August 5, 1923.

Probably some of the winter birds recorded by Schmitt were *U. lomvia*, a species which is not specifically mentioned by him.

7. *Alca torda*. RAZOR-BILLED AUK.—*Verrill*: Common. Breeds on east and north shores. *Brewster*: Numerous at Wreck Bay. *Schmitt*: Found only in autumn. Rather rare. *Brooks*: Saw only a single specimen, an adult taken by M. Gagnon near North Cape, September 13, 1919. *Lewis*: One seen near West Point, June 16, 1922. *Johansen*: Nesting on cliffs between Reef and Wreck Points, August 6, 1923, and observed same day on high, perpendicular cliffs east of Cape Sandtop. Seen flying at Fox Point, August 5, 1923.

The statement by Schmitt presumably describes his experience with this species near Ellis Bay. It is certain that it does not correctly describe the status of the species on the east and north shores of Anticosti.

8. *Alle alle*. DOVEKIE.—*Schmitt*: Common all winter, from September to May. *Dionne*: Common in autumn and winter.

9. *Stercorarius parasiticus*. PARASITIC JAEGER.—*Verrill*: Not seen immediately about the island but frequent in the gulf. *Schmitt*: Rather rare. July-September. I possess three specimens of three different ages, which made the determination difficult, but it was solved, thanks

to the help of M. Dionne, by comparison with the examples of Laval University, of Quebec.

10. *Stercorarius longicaudus*. LONG-TAILED JAEGER.—*Schmitt*: A single specimen, killed in August, 1900. Very rare.

11. *Pagophila alba*. IVORY GULL.—*Combes*: Very abundant at Gull Cliff, where it nests on the ledges on the face of the cliff. *Schmitt*: A single specimen, killed in October, 1902. Very rare.

The statement by Combes is clearly incorrect, as applied to this species. The birds at Gull Cliff that he took to be Ivory Gulls were presumably Kittiwakes. The Ivory Gull remains in the list by virtue of Schmitt's record.

12. *Rissa tridactyla tridactyla*. KITTIWAKE.—*Verrill*: Breeding in immense numbers on east and north shores of the island, particularly on cliffs from East Point to Gull Cove. *Brewster*: Large breeding colony at Wreck Bay. *Schmitt*: Common. May to October. Nests in great numbers at Bird Bay. *Dionne*: Very common. *Taverner*: A number at Fox Bay, July 12, 1915. *Brooks*: Saw a few about Ellis Bay.

Schmitt published a description and photograph of the Bird Bay colony in his paper in *The Auk*.

13. *Larus hyperboreus*. GLAUCOUS GULL.—*Schmitt*: Arrives at the end of August or the first of September and departs only in the following spring. With rare exceptions it is the only Gull which winters in our locality.

14. *Larus leucopterus*. ICELAND GULL.—*Schmitt*: Rare in autumn; occasional in winter.

15. *Larus marinus*. GREAT BLACK-BACKED GULL.—*Verrill*: Common. Not found breeding at Anticosti, although it appeared to have nests about the island. *Brewster*: Numerous and generally distributed. Found young at Wreck Bay a week old. *Schmitt*: First of March to first of December. Fairly common. Some nest on the island. At the end of June, 1897, on the border of Lake Lacroix, I found a nest containing three newly-hatched young. *Dionne*: Fairly common, especially in the autumn. *Brooks*: Very common about Ellis Bay. *Lewis*: One to three observed daily at Ellis Bay, June 10-15, 1922.

16. *Larus argentatus*. HERRING GULL.—*Verrill*: Very abundant. Numerous nests on débris at foot of cliffs near east end of island. *Brewster*: Abundant, nesting among the woods. *Schmitt*: Very common. May-October. Some do not leave until November. Nests on the island. *Dionne*: Very common. *Brooks*: An abundant breeding bird. *Lewis*: At Ellis Bay, in 1922, saw 15 June 10 and 1 June 11, but none thereafter.

17. *Larus delawarensis*. RING-BILLED

GULL.—*Schmitt*: Rather rare. One specimen, killed September 18, 1901.

18. *Larus philadelphia*. BONAPARTE'S GULL.—*Schmitt*: Rather common. Summer. The first arrive in the first fortnight of May. Seen here and there (recorded in his paper in *The Auk*.) *Brooks*: A few seen August 22 and 23, on my way down St. Lawrence River and Gulf, en route to Anticosti.

19. *Sterna hirundo*. COMMON TERN.—*Schmitt*: Very common. Summer and autumn. Some pairs nest on the island. Many seen at Gull Cliff (recorded in his paper in *The Auk*.) *Dionne*: Common, especially in the autumn. *Brooks*: Quite a few Terns were seen about Ellis Bay, and the few I determined proved to be *hirundo*. *Lewis*: Terns, either Common or Arctic, occurred regularly in small numbers at Ellis Bay, June 10-16, 1922.

20. *Puffinus griseus*. SOOTY SHEARWATER.—*Schmitt*: Summer. Rather rare. Seen sometimes offshore from the island.

Mr. Dionne informs me that *Schmitt* showed him no specimens of this species, but I accept *Schmitt*'s definite statement in this case, as the species is easily identifiable and is known to occur in the Gulf of St. Lawrence in summer.

[Hypothetical. *Hydrobates pelagicus*. STORM PETREL.—*Schmitt*: Summer. Rather rare. Occurs preferably offshore from the southern and eastern parts of the island.

Mr. Dionne informs me that *Schmitt* showed him no specimens of this species, and it seems best to leave the species in the hypothetical list until confirmation of its occurrence about Anticosti is obtained.]

21. *Oceanodroma leucorhoa*. LEACH'S PETREL.—*Verrill*: Often seen about Anticosti; none found breeding. *Schmitt*: Summer. Rather common.

Mr. Dionne informs me that *Schmitt* showed him no specimens of this species.

22. *Oceanites oceanicus*. WILSON'S PETREL.—*Brewster*: Common and generally distributed in the Gulf of St. Lawrence. A day rarely passed at sea when more or less of these Petrels were not seen. *Schmitt*: Summer. Rather rare. This Petrel is found very irregularly along the coast.

Mr. Dionne informs me that *Schmitt* showed him no specimens of this species.

23. *Moris bassana*. GANNET.—*Verrill*: Quite common about the island, but none found breeding there. *Schmitt*: May. September. Common. A specimen killed June 5, 1896, off Anse aux Fraises, had in the oviduct two eggs of the size of a nut. *Dionne*: Very common. *Anderson*: "Gannet, brook . . . at east extreme of Gull Cliff Bay . . . A number of gannets nest

here." (p. 9). *Brooks*: Saw a considerable number flying off the Ellis Bay region and was told by M. Gagnon that a colony bred this summer on the cliffs near Wreck Point, at the east end of the island. *Lewis*: Seen in small companies and singly from the Gaspé coast to Ellis Bay, June 10. Numerous near West Point, June 16. *Johansen*: First Gannets seen at High Cliff Point, August 4, 1923. "A score or so of Gannets are nesting on the south-east side of Table Head, between the ascent to the light-house and the latter one itself—sitting on their nests on the small ledges of the higher part of the cliff. Apart from Gull Cliff Bay farther east, this is the only place on Anticosti Island where the gannets nest"—(August 5, 1923). "It was, however, when we reached past Cape Sandtop that I saw the greatest sight of the whole trip. On the perpendicular high cliffs following Cape Sandtop were . . . hundreds of Gannets nesting, . . . only on the south side of the cliff for a limited stretch, and only on the highest part. Here they were sitting as thick as on Bonaventure Island (where I saw them a year ago) as beds of large white flowers; and as we sailed past and shouted, the air above was filled with these large, white birds"—(August 6, 1923).

The first publication of the fact that Gannets nest on the eastern coast of Anticosti is apparently that of Lt.-Col. W. P. Anderson, quoted above. *Frits Johansen*'s field notes, also quoted above, show clearly that there are two breeding colonies of Gannets on Anticosti, and give the location and approximate size of each colony. In a letter dated December 3, 1923, Lt.-Col. W. P. Anderson says that he does not know when Gannets first began to nest on the island. In a letter dated November 22, 1923, Capt. Oscar Mercier, Master of the C.G.S. *Loos*, states, "I have noted the presence of these birds when anchored in the bay close to Heath Point lightstation, where they can be seen most any time during the summer months feeding off this point. To the best of my knowledge these birds nest on the high cliff, 'Gull Cliff,' between Heath Point and Fox bay. I have been [engaged in] navigation in the district of Anticosti for the past ten years and to the best of my memory I venture to state that these birds were present on my first trip there, although I have never seen them in any numbers elsewhere on the island."

The Gannet is now known to breed in North America at Bird Rocks; Bonaventure Island; Cape St. Mary's, Newfoundland (*Ottawa Nat.*, Vol. XXXII, p. 98); and Anticosti (two colonies).

(To be continued)



INTELLIGENCE BEHAVIOUR IN LIZARDS

By FRANK G. SPECK

EVIDENCES of a certain type of thought process have been noted and published occasionally by observers of the habits of lizards. One of the manifestations, several times recorded, is a certain apparent ability to discriminate between futile and possibly successful resistance when endeavouring to escape from the grasp of a captor. This applies to lizards of several unrelated genera. Ditmars, for example, records of the Gila Monster:

"After a few months this nervousness wears away, when they are the personification of good nature, permitting themselves to be handled in the most unceremonious fashion, without the least show of temper. A warm sand bank, in undiluted out-door sunshine, produces curious psychological phenomena. If left in a place like this for a few minutes they become different creatures, fiercely snapping from side to side, resenting the least hint of interference with sharp hisses, while they keep their jaws gaping, ready to close upon anything coming within reach Curiously enough, the temperature outside differed little from that of their artificially warmed cage. It is the sunlight which appears to produce the exhilarating effects." (*Reptiles of the World*, p. 164.)

He described similarly prompted behaviour for the Kabara-goya or Monitor, *Varanus salvator* (*op. cit.*, pp. 169-70).

Having had the opportunity of observing the behavior of a number of species and genera of captive lizards maintained in terraria equipped with natural surroundings, where the animals have lived healthily for some time, the following additions to the facts already recorded by others seem worth placing at the disposal of those who may still be interested in the problems of animal psychology, despite the blow that research in this field has suffered by the negative attitude of the professional psychologists within the last decade.

The following remarks apply to *Gerrhonotus scincicauda scincicauda* and *G. S. webbi* (Plated lizards). Several splendid specimens were kept under observation in as near an approach to their natural environment as is possible in a terrarium. These lizards are in general deliberate and in a sense intelligent. This is shown by the attention they bestow on objects which they approach with what appears to be a degree of discrimination. The creatures were completely tame, never showing the slightest resentment at being taken in the hand, though the temperature was warm, even coming to take insects and raw beef from the fingers. Upon the occasion of being placed out-

side the terrarium upon grass or earth, a striking contrast in behavior becomes manifest. Immediately a slinking posture is assumed and with sudden lurches or stealthy creeping toward the grass roots, the lizard heads for freedom. If the hand is stretched forth to grasp it, an attitude of crouching defiance is taken with half-open mouth. It may then bite the hand extended to seize it, applying the full force of its strength and thrashing wildly with tail and claws. It is a complete transformation of temperament. Upon a number of occasions when the animals were warm and active the same experiment was tried with similar results.

Upon being replaced in the terrarium the show of resistance was discontinued and the creature resumed its docility and contentment.

Another rather remarkable instance of the intelligence of this splendid lizard has already been put on record by Van Dénburg (*Reptiles of Western North America* [1922] p. 460,) where, quoting Dr. and Mrs. Grinnell, he says: "We have known of a pair of alligator lizards which lived under a beehive, coming out mornings and evenings to feed on the bees. In this case, as far as our observations went, the drone bees were selected by the lizards almost, but not quite, exclusively, in preference to the worker bees."

It is only with the saurians of the larger genera, which are generally more intelligent, that these signs of environment discrimination may be witnessed, not with the smaller genera of lizards, whose habits are of the highly sensitive, nervous and restless character. This interesting behavior is quite emphatically illustrated among other lizards, besides the *Gerrhonotus* whose case was selected for presentation. The same remarks might cover the conduct of a number, among whom I have especially in mind captives of *Ophisaurus apus* (Glass "snake") and *Lacerta ocellatus* (Eyed lizard) of Europe, and *Tiliqua scincoides* (*Cyclodus gigas*) the Giant Skink, of Australia. Ordinarily tame specimens of these reptiles actually show viciousness when seized after being placed free upon open land, even though their captive quarters are dressed with natural fittings. Mr. D. D. H. March, who has observed many lizards in captivity, informs me that he has also witnessed similar environment perception in *Phrynosoma blainvillei* (Horned "toad") of California.

If, as Morgan, the animal psychologist, said, animal activities are purely perceptual, their ideas involved being prompted only by action in its execution, then the behavior of the lizards is

very keenly adjusted to environment values. The case becomes a striking one. It seems clear that previous experience cannot have taught the animals in question, because if the attempted escape had ever resulted in success no subsequent experiments could have been made on the same individuals by the observer. Yet the mental reactions to the human captor may be similar in pattern to those in the reptile's wild life when it is confronted or seized by a carnivorous enemy.

In the instances referred to it seemed that the lizards were cognizant of the removal of the glass or wire barriers separating them from freedom and that they regulated their behavior in accordance with the perception of difference. The perception, if our interpretation of the circumstances is correct, is by no means simple. And if intelligence is what Witmer thinks, an ability to cope with problems of environment which have not been experienced before, what circumlocution is to be employed by the naturalist to avoid the use of the term intelligence in such instances?

The question involved here is one which seems to imply an ability, on the part of the larger lizards, to estimate, with apparently some correctness of judgment, the difference between environments. In short the behavior observed seems to

present a means of experimentation on a rather fine point of discrimination between futility of effort and practicability. The advantage of previous experience can hardly be attributed to the animal's re-action because previous experience can only have had one conclusion; that of unsuccessful effort and a return to the familiar quarters of the terrarium. There would seem to be something evidently more subtle here in mental process, the investigation of which field has been perhaps unfortunately ignored by recent students of animal conduct since the contributions of the English naturalist-philosopher, W. H. Hudson.

It may even be considered somewhat out of place to bring up again the now almost tabooed psychological problem of animal intelligence, in the accepted technical sense of the term, but if we do yield to standard professional prejudices by ignoring observations of controllable phenomena, we are not getting nearer to truth in natural history in a field which has been ignored of late by nearly every student. Whether the interpretation of the circumstances has been psychologically correct or not, through observation of the outer conduct of the animals, it is evident that beneath the surface here lies a fundamental problem of Saurian potential intelligence.

NOTES ON THE RELATION OF THE DIPPER (*Cinclus mexicana unicolor*) TO FISHING INTERESTS IN BRITISH COLUMBIA AND ALBERTA

By J. A. MUNRO



OMPLAINTS of damage to fishing interests, caused by Dippers eating the spawn and the fry of trout and salmon, have been received during recent years by the Commissioner of Canadian National Parks and, with a view to obtaining information on this question, the co-operation of the Department of Marine and Fisheries was secured. As a result the following notes, compiled from data submitted by officers of that Department, were prepared by Mr. W. A. Found, Assistant Deputy Minister:

"SKEENA RIVER HATCHERY

Twenty-one of these birds were examined and in nineteen cases the stomach was found to contain sockeye fry, and it is stated that these birds had been seen feeding in the vicinity of the retaining ponds. Two specimens killed about one-half mile above the hatchery contained aquatic insects and larvæ but no fry, fingerlings or fish.

The Superintendent is of opinion that this bird is harmless in that district so long as it does not discover a pond in which fry are being held. It is

most abundant in the fast mountain streams up to the timber line, and is rarer on the slower valley streams and spawning grounds. He is of opinion that, if naturally it eats a few salmon fry and ova, it will balance this by eating ova and fry of the salmon enemies.

BANFF HATCHERY.

Fall of 1921 this bird was seen taking five fish in about half an hour, also catching and eating a fish nearly three inches long; and during the winter of 1921-22 not less than 10,000 advanced Cut-Throat trout fry were taken from the ponds and destroyed by these birds.

During the week of October 30, 1922, three rainbow trout, four inches in length, were taken from the ponds by these birds, but they were unable to swallow these fish as they were too large but carried them on the bank where they died.

COWICHAN LAKE HATCHERY.

The Superintendent states that the American Dipper is not very plentiful in immediate vicinity of hatchery and gives the opinion that they are

destructive to fish life but not nearly so destructive as the Kingfisher.

CULTUS LAKE HATCHERY.

Superintendent states that there are very few American Dippers in the vicinity of the hatchery during the spring, summer and early fall. They are more plentiful during the winter months. None have been killed and examined but he reports that in the cold weather infertile eggs were scattered in the creek near the hatchery and these birds were seen taking the eggs.

ANDERSON LAKE HATCHERY.

Superintendent reports that out of 16 American Dippers shot between October 13th and November 12th, 1922, 8 were found to contain no eggs or fry, 4 were found to contain an average of 6 eggs each, 1 found to contain 4 eggs, 1 shot but was not secured and 2 were turned over to the Chief Federal Migratory Bird Officer for the Western Provinces.

BABINE LAKE HATCHERY.

Superintendent reports 8 American Dippers shot in vicinity of hatchery, stomachs examined and found to contain no fry, eggs or young fish. He states he has no doubt the absence of fry or eggs is owing to the season being too far advanced when the birds were shot.

PEMBERTON HATCHERY.

No American Dippers have been shot at this hatchery owing to the fact that they have been unusually scarce during the past winter.

PITT LAKE HATCHERY.

Quite a number of American Dippers have been destroyed but on examination of the stomachs, no fry were found. Superintendent states that he has seen these birds carrying fry away from the ponds to their nests when their young were newly hatched."

Analyses of the stomach contents of Dippers have also been conducted by the writer when opportunity offered. Four sock-eye eggs were found in the stomach of a male taken at Henderson Lake on November 21st, 1923. Of the ten other stomachs examined, from specimens taken in various parts of British Columbia, one contained portions of a trout fry and the balance held insect remains only.

In reading the above notes it will be noted that little evidence has been presented in reference to their consumption of spawn and this is evidently not considered serious by the Fishery Officials. It is known, however, that spawn is taken when occasion offers. Some years ago on the Goldstream, Vancouver Island, Dippers were observed feeding on the drifting eggs of Dog salmon which were then spawning in large numbers. But their

stomach and gullet capacity is not large—10 sock-eye eggs would constitute a full meal—and when it is considered that drifting infertile eggs form the largest percentage of those consumed, it will be realized that the damage to fishing interests caused by Dippers in this respect is of little importance.

The destruction of fry is perhaps a more serious offense but we have little evidence that this takes place to an alarming degree under natural conditions, the complaints having reference to the destruction of artificially propagated fry after they have been placed in the retaining ponds. It has been noted that these small fish swim continually along the shores of the ponds, seeking an outlet perhaps, and so fall an easy prey to Dippers, Kingfishers or other birds that may be attracted to this bountiful supply of food. Even Robins have been observed catching fry under similar conditions. It can be expected, therefore, that the Dippers which frequent retaining ponds become fish-eaters to a much greater extent than do those living on mountain streams, where their diet is largely insectivorous.

Dippers are usually solitary in their habits; occasionally two or three are seen together, but single birds are the rule after the breeding season. Each bird or each couple feed along certain portions of a stream or lake shore and their feeding grounds are guarded from the intrusion of others of their kind. When a Dipper is killed on its feeding ground another usually takes its place and if this bird be killed it will be succeeded by others. Thus a large number of Dippers may be killed at a retaining pond during the season without stopping the destruction of fry.

The experience of the Superintendent of the Banff Hatchery is a case in point. In this case, not less than ten thousand advanced Cut-Throat fry were taken from the retaining ponds by Dippers during one winter, in spite of the fact that every effort was made to kill these birds as they appeared. It seems clear therefore that the protection afforded fry through the shooting of Dippers is negligible and some other method of protection must be found. To meet this situation it has been suggested that the ponds be screened with fine mesh wire netting. This could be done at a nominal cost and prevent any further trouble from that source.

SUMMARY.

The Dipper, primarily an insectivorous bird, will feed on fish spawn and fry when such food is easily obtained.

The destruction of the spawn of trout and salmon is slight and can have little effect on the supply of these fish.

Under the artificial conditions existing at the Government Fish Hatcheries, where fry are placed in open retaining ponds, Dippers become fish-eaters through force of circumstances and are capable of doing considerable damage.

The practice of shooting these birds in order to protect the fry has not had the desired effect.

The obvious remedy is to screen the surface of retaining ponds with fine mesh wire netting. This will adequately protect the fry and render it unnecessary to destroy a song-bird of high aesthetic value.

For, apart from any economic aspect of the question, the Dipper is a bird we can ill afford to

lose. He is a songster of rare talent and a friend to every lover of the mountains. The solitary angler knows him as a restless, eccentric little chap who may be seen teetering on a spray-drenched rock in the rush of a boiling current, or walking submerged on the bed of the stream in its quiet reaches. To the trapper he is the "grey singing Wren", for he is lavish with his music in the winter months, whether he be found along swollen coast torrents which slide past moss-draped rocks, sodden bracken and rain-drenched alders; or whether he be found on the ice-rimmed edge of some up-country stream, half buried in snow in the heart of a jack-pine forest.

FURTHER NOTES ON THE FERNS OF HATLEY, QUE.

By HENRY MOUSLEY

THE FINDING of the Little Grape Fern (*Botrychium simplex*) at Hatley, and the pleasure of being able to extend considerably the known range of that curious little fern, the Walking Fern (*Camptosorus rhizophyllus*), as well as that of the Ebony Spleenwort (*Asplenium platyneuron*), in eastern Canada, will ever make the season of 1923 a memorable one.

The addition of the first-named species, together with the var. *europæum* of the Rattlesnake Fern (*Botrychium virginianum*), and the var. *etatus* of the Lady Fern (*Athyrium angustum*), brings my list of Hatley Ferns up to fifty-one species and varieties, irrespective of the hybrids in the *Thelypteris* (*Dryopteris*) family. It is said that one cannot serve two masters, but from repeated successes whilst serving not two, but many masters, I am beginning somewhat to lose faith in the saying. Certain it is, that whilst searching more especially for orchids on August 11, I came upon a little colony of *B. simplex* under cedars, in a low-lying damp wood about a mile to the north of Hatley village. Many of the plants were very small indeed, similar to those found by Mr. A. A. Eaton in New Hampshire in 1898, and figured on page 62 of Clute's *Our Ferns in their Haunts*. Another interesting *Botrychium* met with was *B. obliquum* var. *oneidense* on September 14, which was growing down one side of a logging road, in a rich, mixed wood, which also produced examples of the Rattlesnake Fern (*Botrychium virginianum*) with two and three fruiting panicles. Just about this time (August 12) I received word from Mr. C. H. Knowlton that Mr. E. B. Chamberlain, whilst searching for mosses near St. Cyr, Richmond Co., Que., in late July of the present year (1923), had come upon a colony of the Walking Fern (*Camptosorus rhizophyllus*). Naturally this aroused my enthusiasm, as the distribution of this little fern in the Province of Quebec is very

imperfectly known. So far as I am aware, the only stations for the species at this date were in the west, on the calcareous formations of Montreal, Hemmingford, and perhaps Sorel, so that the discovery of the above station has extended the range some 75 miles farther east, although I have since learned from Mr. Knowlton that he found the species (also this year) at Philipsburg, Missisquoi Co., Que., in early August, which reduces the above seventy-five miles to fifty, as Philipsburg is 25 miles farther east than Hemmingford. Thanks to the directions given me by these gentlemen, I was enabled, after a long search on August 30, to locate the very boulder on which Mr. Chamberlain had found the species. This boulder was situated in a rich deciduous wood, and it was on the western side, which was covered with moss, that quite a large colony of *Camptosorus* was growing. Later on in this same wood, I found quite a number of plants of the Maiden-hair Spleenwort (*Asplenium Trichomanes*), another little fern whose distribution in the Province is very imperfectly known at present, and which I can only presume Mr. Chamberlain did not notice, as nothing was said about its being there. The Ebony Spleenwort (*Asplenium platyneuron*) was found by Mr. Knowlton during his visit to Philipsburg in early August, when he also discovered the second station for the Walking Fern (*Camptosorus rhizophyllus*), as already mentioned. So far as I am aware, there are only two known stations for the Ebony Spleenwort in the Province, Vaudreuil, and Ile de Montreal, so that the discovery of the one mentioned extends its range eastward about fifty miles. On July 11 I climbed Owl's Head Mountain (2,484 ft.), on the western shore of Lake Memphremagog, which I have already referred to in a previous paper, *Can. Field-Nat.*, Vol. XXXVI, 1922, No. 8, p. 151. At the very foot of the trail, near a sugar-house,

which stood on the edge of the woods almost in the open, I found Braun's Holly Fern (*Polystichum Braunii*), and this species persisted almost to the summit on the right side of the trail, where there was a water course. Examples more or less pronounced of the var. *aleuticum* of the Maidenhair Fern (*Adiantum pedatum*) were also noted, and on the very summit of the mountain a second station for the Three-toothed Cinquefoil (*Potentilla tridentata*) was found, the previous one being on the top of Barnston Pinnacle (2,150 ft.), as already recorded. Just below the summit, the same as on Mt. Orford, I found quite a bed of *Thelypteris spinulosa* var. *americana*, and most of the common ferns were also met with during the day.

On July 20 I went on a visit into northern Vermont after the White Fringed Orchis (*Habenaria blephariglottis*), and, whilst there, had the satisfaction of becoming acquainted with the var. *cambricum* of the Common Polypody (*Polypodium vulgare*) as it has hitherto been called in this country, although as shown by Prof. Fernald, *Rhodora*, Vol. XXIV, 1922, No. 283, pp. 125-142, it should now be known as *Polypodium virginianum* forma *bipinnatifidum*. A new experience also awaited me in the finding of the Rusty Woodsia (*Woodsia ilvensis*), growing on exposed rocks only a little above the surface of the ground, and right

out in the open in grazing fields. The Maidenhair Spleenwort (*Asplenium Trichomanes*) was also found in a similar situation, but in the shade of some trees.

About the middle of the month of August, I went with some friends for a picnic to Orford Lake, and whilst there had a look for Mrs. Jolley's station for the Alpine Maidenhair Fern (*Adiantum pedatum* var. *aleuticum*), which, however, I failed to find, owing, I think, to a recent deviation of the road, which has swept away the site. However, I have found this variety, in a more or less pronounced form, to be fairly well distributed all around Hatley. It was whilst looking for the above variety on the southern shore of the lake that I came across a second station for that delicate little flower, the Pale Corydalis (*Corydalis sempervirens*), the previous record being from the summit of Barnston Pinnacle.

In conclusion may I suggest that the book "Les Filicinées du Québec," by Fr. Marie-Victorin, published in March, 1923, be translated into English, as a Government publication, in order to give it a wider circulation, and thus stir up a more general interest and desire on the part of the rising generation to extend our knowledge of the range of many of the rarer species in the Province, of which we know very little at present.

W. H. HUDSON, THE NATURALIST (1841-1922)

By FRANK MORRIS

(Concluded from p. 26)

III. "By the Waters of Babylon."

Throughout his life, as I have said, Hudson was ruled by his emotions. He was certainly a man of great intellectual powers, but the æsthetic side of his nature was even greater; and in this strange combination of Naturalist and Artist he was quite unique. He loved passionately the unspoiled life of the Pampas, even to the rude Indians and Spanish gauchos; he loved, too, the home and the days of his boyhood; and he set up in his heart a romantic worship for the land of his ancestors, the little old England that his father loved to speak of and that he himself insisted always on calling "home," much to the amusement of his more matter-of-fact brothers.

When Hudson was about 35 the first signs of a momentous change might be noticed in his beloved Argentine: Progress (with a capital "P") began to advance across the Atlantic like a tidal wave, destined in a few years to drown the plains and their primitive life beneath a flood of European immigrants. With its distant roar already in his ears, Hudson determined to visit the home of his ancestors and settled presently in London, Eng-

land. That he might preserve in his heart unspoiled to the end his boyhood's picture of the Pampas, Hudson never returned to the land of his birth.

Without friends and without means in the wilderness of London, Hudson trusted for support to that frailest of reeds,—a reed that only too often pierces the hand that leans on it—the pen of an author. He lived in a garret, one of the poorest of all the poor denizens of Grub Street.

"Stone walls do not a prison make, nor iron bars a cage"—in his London garret Hudson built for his soul a lordly pleasure house; a 3-story building, if you will pardon the pun; the first was built of memories—*The Purple Land*, where the imagined hero gallops through the Argentine in a series of romantic adventures, enjoying all the sights and sounds, the sunshine and simplicity, of the land that Hudson loved; the second was built of pure fancy—*A Crystal Age*, one of those never-never lands of the spirit, where the human race has attained its finest flower of culture without ever outgrowing the primitive family life, pure, passionless, and beautiful. In the third, he forced his soul into contact with all it loathed in the

unlovely and degenerate ways of Modern Babylon, a race no more of noble savages but of artificial apes—*Fan, the Story of a Young Girl*. He probably knew by now that he could never make a success of novel-writing; a popular novelist must be more of a mixer than Hudson ever had been or ever cared to be; and he hid the authorship of this third romance under an-assumed name.

It is unimaginable that so subtle a thinker as Hudson could ever have mistaken his own powers as a writer. The reason he ventured into fiction was no doubt that other kinds of writing bring so little gist to the mill. No sooner had he launched his third romance than he turned in despair from the starvation of a "stickit" novelist to what he knew meant a life of penury, the writing of Natural History.

We have already spoken of his first trilogy of books on Nature. These volumes brought him in so little and at such long intervals that he was driven to write magazine articles on various aspects of Nature as he observed it around him—chiefly birds, his life-passion, creatures that few could watch to such good purpose as he or interpret so well.

The quickness of a bird's life had always made a tremendous appeal to Hudson, as it must to most emotional natures, and his wonderfully delicate sense of beauty was stirred to ecstasy by bird melody, bird plumage and bird flight. "Properly speaking," says St. George Mivart, the Catholic scientist, "there is no such thing as a dead bird," and Hudson quotes him with warm approval. The life is the bird; when the spirit passes out of it, there's nothing left but a bundle of feathers, an empty case. Fancy Ariel dead! God never made a creature of more quick and quivering eager life than a bird's; it spreads its pinions and soars into the blue, showering down music upon the earth and leaving us, the only other biped of account, to wring our hands in despair or fashion biplanes. It is strange to think of this airy sprite as a little sister of the cold dumb adder of the dust, yet so it is.

There can be no better proof of Hudson's magnificent equipment for his task than the fact that he was able to write well and to write with authority on British bird life within a few years of first setting foot on English soil.

But he was so poor that he could barely afford to spend one short week each year in the country; most of his early observations were made in London and its suburbs. Whenever he had gathered enough articles to fill a volume, he would publish his papers in book form, and thus we have his first trilogy on British Bird Life—*Birds of a Village*, *British Birds*, and *Birds in London*.

IV. *The Naturalist in Wessex.*

Hudson's powers ripened slowly, like the poet Dryden's, and remained ripe with practically no trace of decay—only a rich mellowing—till his death at the age of 81. Quite his greatest work in all fields of literary achievement was between the ages of 60 and 75. Of this long span of 15 years the first six are the most remarkable; they represent the absolute peak of Hudson's long life; in them he had better health than ever before or after, and in them he met his happiest adventures and discoveries in the field. This gave such stimulus and exaltation to his spirit that nothing seemed too great to attempt or to achieve. In these six years he wrote his famous *Tales of the Pampas*, of which *El Ombu* is far the greatest, one of the most powerful short stories in the English language; he wrote *Green Mansions*, the romance which came nearest to popular success; a wonderful story, as beautiful as strange, in which Hudson's intense passion for tropical nature and bird life find almost lyric utterance; he wrote *A Little Boy Lost*, that charming child's fantasy of Nature; and in his own special line he wrote *Birds and Man*, the greatest of his books devoted wholly to birds, and the two volumes which in my humble judgment are among quite the greatest of all his books: *Nature in Downland*—the flora and fauna of Sussex—and *Hampshire Days*, in which he painted the whole life of his favourite county, all its varied scenery, its lanes and rivers and woods and heaths, with their flowers and insects, birds and beasts, even to the hamlets and their peasant folk, the children and gaffers and gammers of this old-world Arcady: everything and everyone in their natural setting, described, interpreted and told in winged words, by this wizard of Nature and Man. *Hampshire Days*, like *Nature in Downland*, was so composed as to run the whole gamut of living Nature; it had the harmony of a piece of music—

"Through the whole compass of the notes it ran,
The diapason closing full in man."

Though the bird was Hudson's special favorite, and his volume of *Birds and Man* probably the greatest of his bird books; it is not the greatest of his nature books, not nearly the equal of his books of a county; and this for several reasons, one of which Hudson himself points out: into the middle of his book *Birds and Man* he foists a chapter called *The Charm of Wild Flowers*, remarking that there is one trouble about books of birds—they have too much about birds in them; and he meant, of course, too little about other creatures, so that the interest is narrowed down. But a far more serious fault about bird books is that the birds are taken out of their natural environment, almost

as though they had been captured one by one and confined in cages, instead of playing their part in Nature, with the flowers and insects and beasts and men, about the woods and fields and water haunts they love. But even so, Hudson's *Birds and Man* is full of happy thoughts and the rich lore of experience in the field, as well as wide acquaintance with all the best literature on the subject. And others besides bird-lovers will be glad to know that he completed a second trilogy of bird books by adding *Adventures Among Birds* and *Birds in Town and Village* to this book of his prime.

Soon after Hudson's wonderful survey of Hampshire, he visited Cornwall and recorded his impressions in a volume called *The Land's End*. Intensely interesting as the book is, one misses in it what its author missed in the Delectable Duchy, that richness of bird and other animal life which sweetens the pages of his Downland and Hampshire studies. Those who are not fond of Natural History will find this book of great human interest, for it abounds in studies of the Cornishman. Indeed the human element in the book for the first time outweighs all the others, and probably gave a new trend to Hudson's thought, for his next two books, *A Foot in England* and *A Shepherd's Life*, are almost entirely character studies of the human kind. To these two books he added in extreme old age a third, a most entertaining series of pen-sketches, portraits and vignettes called *A Traveller in Little Things*. Far the greatest of these three is *A Shepherd's Life*, a wonderful piece of objective psychology that few but Hudson could have written. While Hudson hated civilization and the civilized as warped away from nature, joyless and blind, he was very fond of simple people, far fonder perhaps than they could ever be of him, for his was the aloofest of natures; he was intensely interested in the life of the gauchos and Indians of his native pampas, and when he settled in England the peasants and the little children found their way into the loneliness of his heart.

V. "The Harvest of a Quiet Eye."

We have seen that Hudson had a highly emotional temperament and also that his supreme interest in nature was psychological. His own personal experience taught him that whatever sense impressions came to him linked with strong emotions remained branded, as it were, indelibly in the brain; now, all Hudson's study of nature was of this emotional sort and we shall naturally guess that his memory would be unusually good. Just how good it was I shall endeavour to show.

When Hudson was 60 years of age and had lived continuously in England for a period of 26

years, he sat down to write some chapters of a book to be called *Adventures Among Birds*. The first chapter was an incident of his childhood more than 50 years before; and in recalling it and others almost as distant, he subjected himself to an experiment. Remember in estimating the result these two facts (1) he had neither seen nor heard the birds of South America for 26 years (2) for 26 years his eyes and ears had been drinking in the images and songs of British birds, many of them closely resembling and therefore confusing the original records, as in a palimpsest MS.

Hudson sat down with pencil and note book and made a list of the birds he had observed in La Plata and Patagonia. The list comprised 226 species which he had seen; of these birds the sight-images of 10 had become indistinct and one image entirely forgotten; the remaining 215 he could still describe accurately and in detail. His list of those that had been heard amounted to 192; of these, the language of 31 had grown more or less indistinct, and 7 voices had passed entirely from his memory; the remaining 154 still rang clear as a bell in his mind when he thought about them, their cries, calls, songs, and other sounds. Few observers could even approach this sight-record, none but a highly trained musician could match the sound-record; I am certain no man living but Hudson could have stood the double test.

Hudson's explanation is the simple truth: whatever enters the mind emotionally makes a lasting impression and needs no effort of memory. And further, as we know from dozens of authentic records, practically nothing is ever really blotted out from the pages of the human mind.

Of this strange truth Hudson himself affords an extraordinary example. Feeling strangely depressed and weary in November 1916 (his age was 75) he went down for the week-end from London to Brighton, and while watching the afterglow of a beautiful sunset from the pier in an east wind, he caught cold and for six weeks lay at death's door with rheumatic fever. On the second day of his illness, while thinking of his early days, he suddenly found himself staring at a bright and sharply outlined vision of his childhood. At first he didn't dare to move for fear it would fade away; but when he found it lasted on and on, growing brighter as he fixed his looks upon it, he called for a pencil and a writing pad, and at intervals, as his strength allowed, by day and by night for six weeks, he transcribed the bright vision into words as glowing—the panorama of his boyhood from three years old to twenty, his masterpiece of all, *Far Away and Long Ago*, published when he was seventy-eight.

"It was to me," he writes, "a marvellous experience: to be here, propped up with pillows

"in a dimly-lighted room, the night-nurse idly "dozing by the fire, the sound of the everlasting "wind in my ears, howling outside and dashing the "rain like hailstones against the window panes; "to be awake to all this, feverish and ill and sore, "conscious of my danger too, and at the same time "to be thousands of miles away, out in the sun "and wind, rejoicing in other sights and sounds, "happy again with that ancient, long-lost and now "recovered happiness!"

In the last 4 years of his life Hudson enlarged his *Birds in a Village* and reissued it as *Birds in Town and Village*; he recast his *Argentine Ornithology* in more popular form under the title of *Birds of La Plata*; he wrote a volume of delightful pen-sketches and anecdotes—*A Traveller in Little Things*; he composed two short stories, one of which, he tells us, sprang full-grown from his brain in an instant after long hours of concentration: *Dead Man's Pluck*, a Hampshire legend of King Edgar and Athelwold, the bosom friend whom he sew with his own hand.

Immediately after publishing *Far Away and Long Ago*, he followed it up with *The Book of a Naturalist*, one of the most racy and genial of all

his books of Natural History. In 1922, with weakened frame to be sure, but mental vigour unabated, he turned to grapple with the problems of sense, instinct and presentiment in the wonderful volume of *A Hind in Richmond Park*, which ranges from the sense of smell and bird migrations to the origin of art and psychic phenomena. Late in August 1922, the month of his birth, he handed over to a friend the MS. of the last chapter and went to bed tired but happy as a little child; and so, in the night, he slept away.

BIBLIOGRAPHY

- W. H. HUDSON, August, 1841-August, 1922.
The Purple Land (1885), *A Crystal Age* (1887), *Fan, A Novel* (1892);
Tales of the Pampas, etc. (1902-21), *Green Mansions* (1904),
A Little Boy Lost, (1905).
Birds of La Plata (1888-9), *The Naturalist in La Plata* (1892),
Idle Days in Patagonia (1893).
Birds in a Village (1893), *British Birds* (1895), *Birds in London* (1898);
Birds and Man (1901), *Adventures Among Birds* (1913), *Birds in Town and Village* (1919).
Nature in Downland (1900), *Hampshire Days* (1903), *The Land's End* (1908).
Afoot in England (1909), *A Shepherd's Life* (1910), *A Traveller in Little Things* (1921).
Far Away and Long Ago (1916-18), *The Book of a Naturalist* (1919), *A Hind in Richmond Park* (1922).

SOME HOLOTHURIANS FROM BRITISH COLUMBIA

BY HUBERT LYMAN CLARK



SMALL collection of holothurians from British Columbia from the Victoria Memorial Museum, Ottawa, has been placed in my hands for identification and, as they are of more than ordinary interest, it seems proper to publish these notes upon the species represented.* Nine of the eleven species belong to the already heterogeneous and overcrowded genus *Cucumaria* and two of them fail to conform to the description of any known species and hence must be given new names here. The variety of *Cucumarias* occurring along the western American coast is remarkable and more information about their size, colour and habits in life is greatly to be desired. Unfortunately there are no notes with these specimens that throw any light upon such matters. All the specimens treated here are in the Victoria Memorial Museum, Ottawa, Ont., except certain duplicates retained for the Museum of Comparative Zoölogy.

Leptosynapta inhaerens Verrill

Holothuria inhaerens, O. F. MULLER, 1776. *Zool. Dan. Prod.*, p. 232.

Leptosynapta inhærens, VERRILL, 1867. *Trans. Conn. Acad.*, Vol. I, p. 325.

*I take pleasure in extending my thanks to Mr. Frits Johansen, who attended to the packing and transfer of the specimens, when dealing with material collected by the Canadian Arctic Expedition, 1913-18.

A small synaptid, only about 10 mm. long, seems to represent this species. It was taken on August 6, 1885, by G. M. Dawson, in 10 fathoms of water, sand and mud, at Alert Bay, Queen Charlotte Sound, B.C.

Cucumaria californica Semper

SEMPER, 1868; *Holothurien* p. 235.

There is a large specimen, 150 mm. or so in length, from Farewell Harbour, Queen Charlotte Sound, B.C., 8-12 fathoms, gravel. It was collected by G. M. Dawson on September 7, 1885. This is apparently Whiteaves' "*Pentacta frondosa* Gunner," (1886, p. 117).*

Dr. Dawson also collected on September 4, 1885, off False Head, Queen Charlotte Sound, 30 fathoms, sand, gravel and dead shells, the anterior ends of four large *Cucumarias*, which probably belong to this species, but of course are not determinable with certainty. There are four more or less poor and decalcified *Cucumarias*, from Ucluelet, west side of Vancouver Island, low tide, which probably are *californica*. They were taken in May-July, 1909, by Young and Spreadborough.

Trans. Roy. Soc. Can., Vol. IV, Sect. 4, 1886, pp. 111-137

Cucumaria chronhjelmi Théel

THÉEL, 1886. *Challenger, Holos.*, pt. 2, p. 105.

This species is well represented in the collection by the following specimens:

Two specimens, 12 and 20 mm. long respectively, from Queen Charlotte Sound, off False Head, 30 fathoms, sand, gravel and dead shells, September 4, 1885, G. M. Dawson coll.

Fifty-five specimens, a few in good condition, but mostly very much contracted, 6-40 mm. long. They were taken by G. M. Dawson on August 6, 1885, in 10 fathoms, sand and mud, in Alert Bay, Queen Charlotte Sound, B.C.

Four specimens, 30-50 mm. long, much contracted, unusually white, from Ucluelet, west side of Vancouver Island, low tide, May-July, 1909. Young and Spreadborough coll.

One specimen, 55 mm. long, very good condition, from Comox, east side of Vancouver Island, between tides, July, 1915. W. Spreadborough coll.

Cucumaria lissoplaca sp. nov.

*λίσσος = smooth + πλακά = plate, in reference to the smooth calcareous plates in the skin.

Length along midventral radius, about 35 mm. along middorsal interradius, about 25 mm.; diameter of body near middle, dorsoventral, 10 mm.; lateral, 9mm. Body distinctly curved and more or less tapered posteriorly; in the least contracted specimens the form is markedly elongated into a caudal portion. Tentacles strongly contracted but presumably 10. Pedicels confined to ambulacra in very distinct, somewhat crowded double series; they are so full of calcareous rods they are not badly contracted but seem rather long. Calcareous ring rather high, the anterior points of the radial and interrarial pieces about equal; interrarial pieces about 2 mm. high and half as wide, concave behind; radial pieces with long posterior prolongations; measured from the interrarial margin these prolongations are about 2 mm. long but the radial piece is so deeply cleft posteriorly that they are 3 mm. long on the radial side. No madreporic canal was found but what appeared to be a collapsed Polian vessel was detected. Genital glands well developed.

Calcareous particles in two layers; the outer consists of somewhat scattered, very delicate plates only 30-50 μ in diameter, while the inner is a dense crowded layer of smooth, more or less button-like plates. The outer layer tends to be easily rubbed off and might readily be overlooked. The plates that compose it may be likened to the disk of the tables of some holothurians; in fact, the figure of the disk of a table of a young *Stichopus badinotus* recently published by me (H. L. Clark, 1922, *Bull. M.C.Z.*, Vol. 65, No. 3, pl. 2, fig. 18) gives a very good idea of their form.

Few, however, are so symmetrically developed as this figure and they all have minute blunt spinelets or tubercles more or less numerous on the upper surface.

The plates of the inner layer show considerable diversity of form but typically they may be described as short fusiform in outline, or elongated diamond-shaped with rounded angles, thus approaching the shape of a flattened spindle. In the expanded part are four moderately large perforations and in each of the elongated angles, which are opposite each other of course, is another smaller perforation. Such plates are about 90-100 μ long and 40 μ wide. From this typical form variation occurs in three ways; the plates may become more elongated and have still another perforation distal to those mentioned; such plates may be 150 μ -200 μ long and only 30-40 μ wide at the middle. Or the plates lose their projecting angles and become irregular rounded plates, which may be only 60x40 μ or even smaller, and sometimes are nearly circular; such plates have only four or five perforations. Again the plates become widened and the number of perforations increases, so that they are 120-130 μ long, 40-50 μ wide and have 10-15 perforations, but they may be much larger; the largest plate measured was 175 μ by 90 μ and had about 40 perforations.

The supporting rods of the pedicels are merely modifications of the fusiform bodies. They become more flattened and thinner, the ends are more truncate and the whole plate is curved into about a fourth or a third of a circle. Distally in the pedicel, the plates tend to develop a rudimentary spire and this becomes fairly conspicuous at the tip of the foot.

Colour, if any were ever present, is quite bleached out; the alcoholic material is now yellowish-white.

There are ten specimens of this little holothurian in the collection, taken in 10 fathoms, sand and mud, in Alert Bay, Queen Charlotte Sound, B.C., by G. M. Dawson on August 6, 1885. It was taken along with *lubrica*, *chronhjelmi*, *populifera* and *trachyplaca*, species which it closely resembles. Its tendency to develop a caudal appendage and its very characteristic calcareous particles will distinguish it, however, on careful examination. (Catalogue number 583, Radiata, Victoria Memorial Museum, Ottawa; *Cotypes.*)

Cucumaria lubrica H. L. Clark

H. L. CLARK, 1901, *Proc. Boston Soc. Nat. Hist.*, Vol. 29, p. 334.

This species seems to be abundant in Alert Bay, Queen Charlotte Sound, B.C., in about 10 fathoms,

sand and mud, for there are some 80 specimens in the collection made there on August 6, 1885, by G. M. Dawson. Museum No. 85-4. They are all very much contracted, 6-26 mm. long and in poor condition.

Cucumaria miniata (Brandt)

Cladodactyla (Polyclados) miniata BRANDT, 1835, *Prodromus*, p. 44.

Cucumaria miniata SELENKA, 1867. *Zeit. f. w. Zool.*, vol. 17, p. 350.

I am referring to this species 7 specimens 10-50 mm. long, ranging in colour from white to dark brown, whose small size and poor condition make their identification somewhat dubious. The calcareous particles indicate *miniata* and the largest specimen has two Polian vessels and a number of stone canals. No full grown specimen of *miniata* is in the collection. The small individuals were collected at the following places:

Vancouver Island, Ucluelet, low tide, May-July, 1909. Young and Spreadborough colls.

Vancouver Island, east side, Comox; between tides, July 1915. Spreadborough coll.

Cucumaria piperata (Stimpson)

Pentacta piperata STIMPSON, 1864. *Proc. Phila. Acad. Nat. Sci.*, p. 161.

Cucumaria piperata, H. L. CLARK, 1901. *Zool. Anz.*, vol. 24, p. 171.

It is unfortunate that all of the material which is apparently to be referred to this species is in poor condition and more or less decalcified. Hence the identification is largely based on the characteristic black spots and is not confirmed by calcareous particles. There are 5 specimens 12-35 mm. long, taken at the following points:

British Columbia, Queen Charlotte Islands, 1910, Spreadborough coll.

Vancouver Island, west side, Ucluelet, 9 fathoms, August, 1909. Young and Spreadborough colls.

Same place, low tide, May-July, 1909. Same collectors.

Cucumaria populifera (Stimpson)

Pentacta populifer STIMPSON, 1864. *Proc. Phila. Acad. Nat. Sci.*, p. 161.

Cucumaria populifer THÉEL, 1886. *Challenger Holos.*, p. 103.

All of the 14 *Cucumarias* that I refer to this species are small and strongly contracted, 10-25 mm. long; many are in poor condition and some are decalcified, making their identity uncertain. The four specimens from Cortez and Hernandez Islands show a very interesting diversity in the calcareous particles. The two largest specimens have the typical tables. The smallest has the

disks of the tables more or less cruciform while the next larger specimen shows a similar but not so well-marked condition. The tables are largest in the smallest specimen and smallest in the largest. Apparently we have here fragmentary evidence of interesting growth changes but obviously more detailed observations are needed to enable us to understand them.

The fourteen specimens are from the following places:

Cortez and Hernandez Islands, 8-20 fathoms, sandy bottom, July 6-8, 1885, G. M. Dawson coll.

Queen Charlotte Sound, Alert Bay, 10 fathoms, sand and mud, August 6, 1885, G. M. Dawson coll.

Vancouver Island, Queen Charlotte Sound, off False Head, 30 fathoms, sand, gravel and dead shells, September 4, 1885, G. M. Dawson coll.

Vancouver Island, east side, Departure Bay, 20 fathoms, September 17, 1908, W. Spreadborough, coll.

*Cucumaria trachyplaca** sp. nov.

**τραχύς* = rough + *πλάξ* = plate, in reference to the ridged and knobbed outer surface of the plates in the skin.

Length 18 mm., diameter 5 mm. Body not curved, but in the strongly contracted condition of all the specimens straight and not much larger at the middle than at the blunt and subequal ends. Tentacles strongly contracted, 10, of which the ventral pair are much the smallest and the dorsal four evidently larger than the others. Pedicels rather short, confined to ambulacra in two very distinct somewhat crowded series. Calcareous ring moderate; interradial pieces about 1.5 mm. high, pointed anteriorly, slightly concave posteriorly; radial pieces with long posterior prolongations, the piece itself a little narrower and more pointed than the interradial, not cleft posteriorly, the prolongations as long as the piece, the two together about 3 mm. Neither madreporic canal nor Polian vessel was found in the specimens. Genital glands moderately developed.

Calcareous particles all of one kind. I cannot find any outer epidermal layer of more delicate plates or "baskets" but the skin is more or less crowded with knobbed, perforated plates. Normally the plates are so numerous as to overlap freely and make a continuous layer, but in places where the skin is stretched the plates may be found well spaced and not in contact with each other. The plates occur in all stages of development from rods about 33μ long, widened and a little forked at each end, up to the complete plate, 200μ long (or more) and $60-70\mu$ wide, with 20 or more perforations, and on the outer surface a complicated and very irregular combination of ridges and knobs, making the plates very rough on that side. In partly developed plates, there are half a dozen or more low rounded knobs regularly

arranged with reference to the holes in the plate but as the plate develops it soon loses its symmetry, one side usually developing more than the other, the knobs are more numerous, no longer regularly distributed, and connected with each other by crooked ridges. As the ridges become higher, knobs and low spinelets develop on them, and thus the rough outer surface of the plate is formed. In the pedicels the plates become more elongated, narrower and curved, the ridges and knobs are confined to the central part, and thus the supporting rods arise.

Colour of preserved specimens, yellowish-white; tentacles darker. There is no clue as to what the colour in life may have been.

There are 25 specimens of this little *Cucumaria* before me. All were taken in 10 fathoms, sand and mud, in Alert Bay, Queen Charlotte Sound, British Columbia, by G. M. Dawson, August 6, 1885. They were taken in company with *lubrica*, *chronhjelmi*, *lissoplaca* and *populifera*, and all five species were preserved together. It is hardly probable that the five actually live in such close relationship as this indicates. Probably field study in Alert Bay will show that each species has its own particular habitat. (Catalogue No. 594,

Radiata, Victoria Memorial Museum, Ottawa. *Cotypes*.)

Cucumaria vegae Théel.

THÉEL, 1886, *Challenger, Holos.*, p. 114.

There are four little *Cucumarias* 10-20 mm. long which were taken in 10-20 fathoms, sand and gravel, at Discovery Passage, on the Vancouver Island side of Johnstone Strait, by G. M. Dawson in 1885. I have compared them with specimens of *vegæ* from St. Paul's Island and find they are immature examples of that species. As yet only the largest has pedicels on the dorsal interambulacra and, in that case, the extra pedicels are all middorsal.

Psolus chitonoides H. L. Clark

H. L. CLARK, 1902. *Proc. Boston Soc. Nat. Hist.*, vol. 29, p. 335.

There are two specimens of this holothurian from Ucluelet, Vancouver Island, B.C., taken at low tide in the early summer ("May-July") of 1909, by Young and Spreadborough. They are about 40x35 mm. and are in poor condition. The dorsal plates are imbricated and the characteristic calcareous particles in the "Sole" are well developed.

NOTES AND OBSERVATIONS

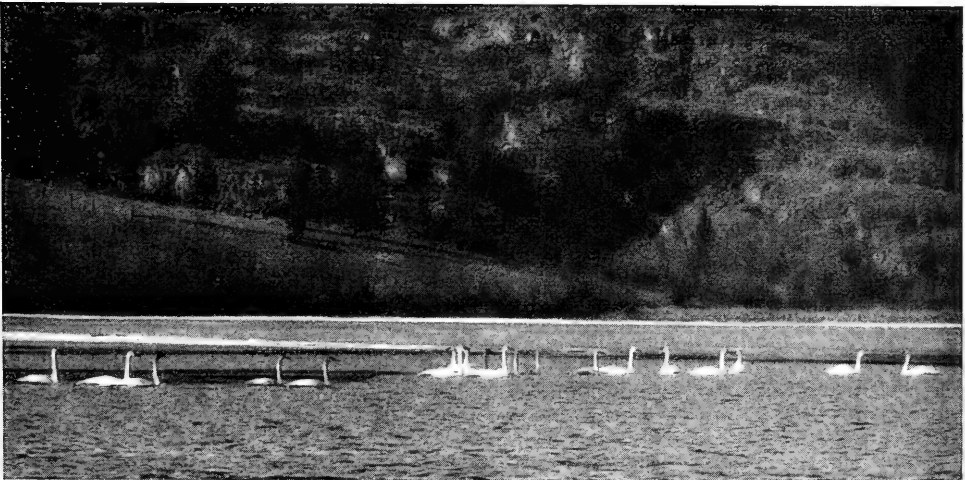

A FLOCK OF TRUMPETER SWANS

Photo by BYRON HARMON, February, 1920

Courtesy of Canadian National Parks

TRUMPETER SWANS.—The picture shows nineteen Trumpeter Swans. This species is one of the largest and rarest of Canadian birds. There are seven young birds in the flock shown, which is encouraging, since it indicates of course that we have not here a flock of birds past breeding age.

Every effort is being made for the protection of the species, but, if the species is to be saved, the co-operation of sportsman, hunter and trapper in Alberta, the Northwest Territories, British Columbia and the Yukon is essential. Swans are protected by law at all times in these areas, and in

the case of the Trumpeter every single bird must be left unmolested if this magnificent species is not to follow the Great Auk and the Labrador Duck to the oblivion of extinction.—HOYES LLOYD.

THE STARLING AT HAMILTON.—On January 10, 1923, I succeeded in satisfactorily identifying a couple of Starlings in our garden, which is just three blocks from the main corner of Hamilton.

These two birds have been seen about here for some three or four weeks. But, although one day I got a good look at one from in front and below, so as to see his black breast and yellow bill quite distinctly, it was not till January 10 that I was able to observe one thoroughly from above and with a side view. It was eating an apple still hanging to the tree; and from a distance of 15 feet I could distinctly see the yellow bill, the black head with dark cheek and eye, the speckled back and wings and the short tail, so that I have no doubt of its identity.—CALVIN McQUESTEN.

NOTES ON PRAIRIE WARBLER AND STARLING.—*Dendroica discolor* (Prairie Warbler).—In Vol. XXXVI, No. 9, of *The Canadian Field-Naturalist*, I gave an account of the Prairie Warbler summering at Nottawasaga Beach, Georgian Bay. In the summer of 1923 this bird was very scarce, no doubt due to the unusually late season, ice being piled up on the shore as late as June 10th. This retarded growth and kept the temperature below normal in the district where the Prairie Warbler commonly breeds. On June 14th, after a long search, we discovered a nest containing three fresh eggs and two of the Cowbird. The nest was in a large patch of Juniper, well concealed, two feet above the ground on the outer branch of one of the bordering Junipers. This nest and eggs are, I believe, the first to be taken in Canada.

Sturnus vulgaris (Starling).—On December 3rd, 1922; at West Toronto, Dr. Starr and myself saw five of these birds. It was not until December 19th, 1923, that this species was again observed. Mr. J. S. Baillie was driving with me along a road north of Toronto when a large flock of birds attracted our attention. At first glance they appeared to be Meadowlarks, but on closer inspection they proved to be Starlings. There were approximately one hundred in the flock and they were exceedingly wary. This same day we also saw two Flickers, feeding on the ground, and a Migrant Shrike and heard a Bluebird.—PAUL HARRINGTON.

OCCURRENCE OF THE STARLING IN THE MONTREAL DISTRICT.—My first introduction to this

species occurred on April 21st, 1923, when I saw three individuals about a group of elm trees in an old field bordering a country road a short distance from St. Lambert.

Some Junco-like notes first drew my attention to one of the birds, as it squatted lengthwise, wings aflutter, on a limb forty feet from the ground. These notes (song?) can be fairly accurately imitated by a sucking motion of the tongue in contact with the roof of the mouth.

Presently the bird took flight, followed by two others, when the striking similarity to the flight of the Meadowlark was apparent.

Later I had opportunity to observe the peculiar plumage and the long, straight bill which suggests the bill of a Woodpecker in its general appearance.

These birds were again noted on April 28th and on other occasions thereafter, and I have no doubt that they bred in the vicinity, as a single bird, apparently a juvenile, was seen there on September 30th.

Another report, coming from Montreal South, about two miles from St. Lambert, indicates that at least one flock of Starlings is wintering here. This flock, numbering seven individuals, was seen repeatedly until January 6th by Mr. W. Morgan, of Montreal South, and another gentleman who had been familiar with the Starling in England. Mr. Morgan told me, moreover, that two pairs of Starlings reared their young during the past summer in a small tower on top of his neighbor's house.

In addition to these records Mr. Napier Smith saw an individual on the outskirts of the City, near Verdun, about the 15th of May last.—L. MCI. TERRILL.

A BAT ACTIVE IN WINTER.—On January 29th, 1923, when coming home from work about 5.30 p.m., I was looking around to see if I could locate the Screech Owl that lives in our neighborhood in London, Ontario, and which is frequently to be seen just about dusk in some of the trees near the park. I was very much surprised indeed to see instead a bat fly between the trees, go across the road and finally disappear over the way. The temperature at the time was 16° and during the night went to 1° below zero, Fahrenheit. It would certainly find no insects flying around that night and one can only presume that it must have been disturbed from its winter sleep and started out into the world not knowing the conditions that there awaited it.—E. M. S. DALE.

The illustrations in this number of *The Canadian Field-Naturalist* appear through the assistance of Mr. Ira Cornwall and the Canadian National Parks Branch, to whom we express our thanks and appreciation.—EDITOR.

The list of our subscribers paid up to December 31, 1923, will appear in the issue of *The Can-*

adian Field-Naturalist for May, 1924. If our subscribers will inform us as to the natural science or sciences in which they individually are particularly interested, this information will be published with their names. Widespread action on this suggestion will make the list much more valuable to all concerned.—EDITOR.

BOOK REVIEW

JACK MINER AND THE BIRDS *and Some Things I Know About Nature. By Jack Miner, of Kingsville, Ontario, Canada. Toronto, The Ryerson Press, (Manly F. Miner, Kingsville, sole agent and distributor.) PP. 12 plus 178. 53 illustrations. Preface by J. Earle Jenner, M.D.*

Jack Miner's book, long awaited, has now been issued; and it will be eagerly read wherever "Uncle Jack's" fame has spread and wherever intimate studies of nature are appreciated. Its title, *Jack Miner and the Birds*, is aptly chosen; for it indicates the twofold interest of the book, in which—as in his lectures—the author's unique and attractive personality illuminates the nature-lore that he unfolds. His humour, his love of nature, and his reverence for the directing Power that he finds in nature, all are here, in telling phrases such as we have heard him use so often.

The book is a record of the response "wild" birds will make to the advances of friendly man. The chief feature is, of course, the well-known story of winning the confidence of the Canada Goose. From the four years of waiting after the first live decoys were secured, through the first visit of a wild flock in the spring of 1908, to the present annual visit of thousands of birds, this tale is told in detail. Not only Geese, but also Ducks and insectivorous birds lose their fears, confident in the protection of Jack Miner's sanctuary. The whole book illustrates the author's admonition: "Remember that it is the human race that is wild, not the birds. Birds are wild because they have to be, and we are wild because we prefer to be. Any creature that is intelligent enough to fly or run from you for self-preservation, will come to you for food and protection from all other enemies." (P. 16.)

Besides many miscellaneous observations of the habits and life-histories of birds, this book records the results of Jack Miner's investigations into the migrations of Ducks and Geese by "tagging". Of 440 ducks "tagged", 154 returns have been reported from birds that have been shot, a ratio of 34.8%. The location of these returns is given on a map and in a list; but unfortunately no distinction is made between the different species of Ducks. Many returns have been obtained by

retrapping birds at the sanctuary which had been caught and marked in previous seasons; but, although the histories of certain individuals are given, there is not a complete account of returns from this source. Geese have proved more difficult to trap than Ducks, but many returns have been secured from them also. A map shows thirty-six returns from James Bay and the eastern side of Hudson's Bay; one from Hamilton Inlet, Labrador; one each from Quebec (near the Ontario line), Indiana, Michigan, Illinois, and New Jersey; two from Maryland, three from Virginia, and fourteen from North Carolina. With the larger and more successful traps which he has recently installed, Jack is confident of securing more data on the migration of this species in the near future.

Jack Miner has hunted with a gun for the market, for the pot, and for sport; and now hunts chiefly without a gun. Just as he was too true a sportsman to continue long as a market hunter, he is now too true a sportsman to advocate the prohibition of hunting and shooting; but, like all true sportsmen, he is an ardent conservationist. His whole book is an argument for the preservation of our wild life, and especially our game. The claims of selfish men to all the game they want is answered by the claims of non-shooters to a right to the pleasures of nature and by the claims of future generations of shooters to an unimpaired breeding stock of game. Explicit suggestions are made for reformed game laws and for reformed methods of enforcement; but the author adds, "Personally I have more confidence in a thimbleful of education than I have in a barrelful of bayonet-point compulsion", (p. 149) and his book is no mean contribution to education for game protection.

To find fault with Jack Miner or his book is rather like complaining about the sun because of the sun-spots; but one could wish for a little more tolerance for predatory birds and mammals. A great deal of evidence is here advanced as to the destructiveness of such birds as Crow, Grackle, the Shrikes, Owls, accipitrine Hawks, etc.; and detailed methods are given for killing them. Without questioning "Uncle Jack's" observations or the necessity for reducing the numbers of

predators where special work with game birds or insectivorous birds is to be attempted, one can doubt whether wholesale warfare against Hawks and Owls is necessary and one can wish that the author had given greater prominence to his modification (p. 24), "I would not like to see these cannibal birds become extinct". He seems to overlook the possibility that those who enjoy the plaintive mystery of a Screech Owl or the dashing boldness of a Sharp-shinned Hawk may use against the lovers of game birds the same arguments that these have used against the wanton destroyers of game.

The book is well bound and printed, and at every point it is illustrated with excellently reproduced photographs. Dr. Jenner has contributed an appreciative preface, making the personality of Jack Miner more real for the reader. As a personal record, for the information it contains, and as a plea for the protection of wild-life, this book is valuable and should be read by all who find joy in Nature.—R. O. M.

BIRD-LORE OF THE NORTHERN INDIANS. By Frank G. Speck, Assistant Professor of Anthropology; reprinted from Vol. VII, Public Lectures by University of Pennsylvania Faculty, 1919-20; Philadelphia, Pa.; published by the University, 1921.

In the publication mentioned, Dr. Speck has gathered a considerable quantity of highly interesting aboriginal bird-lore which he has arranged in a manner as acceptable to the general public as to specialists in ornithology and anthropology.

Penobscot Indian names and beliefs have been taken as a basis, but considerable Malecite, Micmac and Abenaki material has also been included. This suggests that "Northeastern Indians", or "Eastern Indians", might have given the title somewhat more accuracy.

Dr. Speck is an enthusiastic naturalist on the side, and, as an anthropologist, has personally visited the Penobscot and a number of other eastern tribes, so that he combines the requisite abilities to do justice to a subject of the sort.

Mention is made in the paper of the large body of ornithological folk-lore in general which is current among eastern Algonkians, as well as the almost innumerable references of the kind in native mythology.

An interpretative tendency among the eastern Algonkians is noted, this being an attitude more or less opposed to exact or scientific observation.

Quite a number of the names applied to birds are onomatopœic. Others, again, are descriptive of some habit or humorous characteristic. A certain amount of reduplication is also observable,

as in "kwikwimessu", which reminds one of Iroquois bird names.

Not all the birds are noted in folk-lore, but the native names are of interest to compare with our own, or with those of neighboring aborigines.

Among the birds around which considerable folk-lore and mythology have gathered are: the Loon, Crow, Chickadee, Eagle, Owl, and some others in a lesser degree, birds which are noted in the same connection, not only among widely-separated Algonkians, but throughout the eastern woodlands in general.

Still another feature of interest to the ethnologist is the wide Algonkian distribution of several bird names, either in almost identical, or in very similar form.—F. W.

BEACH GRASS, by Charles Wendell Townsend. Boston. Marshall Jones Company. 1923. Pages XII plus 319, with many half-tone illustrations. Price, \$3.50.

This is a very attractive volume by an author who is well known as a gifted interpreter of the natural history of north-eastern North America. As in a previous volume, *Sand Dunes and Salt Marshes*, the area dealt with is the sandy sea-shore region in the vicinity of Ipswich, Massachusetts, the location of the author's country home. The plants, the mammals, the birds, the weather, the ice and snow, the sand itself, and some of the characteristic human residents receive in turn that careful and sympathetic treatment for which the author is justly celebrated and which makes the subject under consideration delightfully real to the reader. Such chapter titles as "Tracks in the Sand", "Ice and Snow in the Sand Dunes", "A Winter Crow Roost", "The Forest", "Hawking", and "Courtship in Birds" give only a slight inkling of the large amount of natural history detail which has here been gathered together. Clear and pleasing photographs abound throughout the volume.

The account of the planting, on upland near the marshes, of an artificial "forest" of native trees, and of its struggle upward until it became a true woodland bower, full of greenery and birds and flowers, is particularly interesting, and presents an example worthy of repeated imitation.

The reviewer cannot but regret the occasional solecism, such as "the lisping notes and distinctive calls, so familiar to the ornithologist, that comes showering down from the sky", and the occasional misspelling, such as the repeated use of "lea" for "lee", but in general the story flows smoothly and the style has the peculiar attractive quality familiar to Dr. Townsend's host of readers.

A very useful index completes the volume.—H. F. L.

CLASSIFIED NOTICES

"THE CONDOR" is a bi-monthly illustrated magazine of Western Ornithology—started in 1899 and now better than ever. Edited by Dr. Joseph Grinnell and published by The Cooper Ornithology Club. \$3.25 per year. *The Condor* is an essential to any student of American Birds. W. Lee Chambers, Business Manager, Eagle Rock, Drawer 123, Los Angeles, Cal.

Use the Advertising Columns of

The Canadian Field-Naturalist

*to bring your products before the
Nature Lovers of America*

ADVERTISING DEPARTMENT
The Canadian Field-Naturalist
175 NEPEAN STREET



Card Filing Systems for Naturalists

As makers of the Library Bureau line of Card Filing Devices in Canada, we are in a position to supply all Naturalists with cards and trays where they can readily index all their observations and notes

Lowe-Martin Ltd.
OTTAWA, CANADA

Printers of The Canadian Field-Naturalist
Publishers of the Autobiography of John Macoun, M.A.

The Crabtree Co.

Artists and
Designers

BLUEPRINTERS
ENGRAVERS
COMMERCIAL
PHOTOGRAPHERS
: PHOTO :
LITHOGRAPHERS

228 Albert Street
Ottawa, Ont.

COAL C. C. Ray Company
Limited

BEST QUALITY LOWEST PRICES

46 Sparks St.—Phone Q. 461
OTTAWA

Geo. E. Preston & Sons
MERCHANT TAILORS

*We make everything we sell and
guarantee everything we sell*

217-219 Rideau Street, Ottawa

Dr. Mark G. McElhinney
*Dentist to certain of the
cognoscenti*

252 LISGAR STREET, OTTAWA
Telephone Queen 2438

Kindly mention *The Canadian Field-Naturalist* to advertisers

Prices of Separates

Notes to Contributors, Etc.

Papers for publication should be addressed to the Editor, Mr. Harrison F. Lewis, Parks Branch, Ottawa, or to the appropriate Associate Editor.

Manuscript should be plainly written, typed if possible, on one side of the paper only, with wide spaces between the lines and ample margins. It is urged that special care be used that scientific names are legible, properly formed, and correctly spelled and capitalized.

Galley proof will be submitted to authors resident in Ottawa and proof of leading articles to any other author if requested when manuscript submitted. It is requested that it be corrected and returned to the Editor as quickly as possible.

Authors of leading articles are entitled to twenty-five copies of the number in which they appear, free of charge on application.

Separates of articles as they appear on the page, without any change of make-up will be supplied at the following rates:—

	25	50	100	200	300
1 page.....	\$2.00	\$2.25	\$2.50	\$2.75	\$3.00
2 ".....	3.00	3.25	3.75	4.00	4.25
3 ".....	3.50	3.75	4.00	4.25	4.50
4 ".....	3.50	3.75	4.00	4.25	4.50
5 ".....	4.50	4.75	5.00	5.25	5.50
6 ".....	4.50	4.75	5.00	5.25	5.50
7 ".....	6.00	6.25	6.50	6.75	7.00
8 ".....	6.00	6.25	6.50	6.75	7.00
9 ".....	7.50	8.00	8.75	10.25	11.75
10 ".....	7.50	8.00	8.75	10.25	11.75
Covers extra.....	3.00	3.00	3.00	4.00	5.00

If removal of matter on the pages non-pertinent to the article or changes of make-up are desired, or if insets or other extra work are necessary, special rates will be furnished on application to the Editor.

Applications for separates should be made to the Editor and must reach him not later than with the return of the corrected proof.

Rubber Stamps

FOR

Listing Your Specimens

The more consistent use of rubber stamps will materially assist you in cataloguing the collection of specimens you have spent so much time and trouble in securing. Let us help you.

CAPITAL RUBBER STAMP WORKS

175 NEPEAN STREET
OTTAWA, CANADA

Many More are Wanted on the Subscription Lists

The Membership Committee of The Ottawa Field-Naturalists' Club is making a special effort to increase the subscription list of *The Canadian Field-Naturalist* and we are asking every reader to assist in making the campaign the success it should be.

We would particularly urge the Secretary of each Affiliated Society to bring this matter up at EVERY meeting and secure as many subscribers as they possibly can to a Canadian Publication devoted to the study of Natural History in all its phases.

Use the blank below and forward it to the Treasurer.

CUT OFF HERE

MR. B. A. FAUVEL,
Treasurer, Ottawa Field-Naturalists' Club,
Mounted Police Headquarters,
Laroque Building,
Rideau and Dalhousie Sts.,
Ottawa, Canada.

I enclose One Dollar and Fifty Cents as my subscription to The Canadian Field-Naturalist for one year.

Name.....
(Mr., Mrs. or Miss)

Address.....

City and Province.....

Kindly mention *The Canadian Field-Naturalist* to advertisers

Affiliated Societies

NATURAL HISTORY SOCIETY OF MANITOBA

1923

Hon. Presidents: H. M. SPEECHLY, M.D.; W. G. SCOTT; *President:* PROF. V. W. JACKSON; *Vice-Presidents:* NORMAN CRIDDLE; J. J. GOLDEN; MRS. C. P. ANDERSON; PROF. C. H. O'DONOGHUE; PROF. F. W. BRODRICK; *Treasurer:* MISS HELEN R. CANNON. **ORNITHOLOGICAL SECTION:**—*Chairman:* A. G. LAWRENCE; *Secretary:* B. W. CARTWRIGHT; *Leaders:* H. M. SPEECHLY, M.D.; J. J. GOLDEN; C. E. KEIGHLEY; K. GRANT McDUGAL; R. M. THOMAS. **ENTOMOLOGICAL SECTION:**—*Chairman:* J. B. WALLIS, B.A.; *Secretary:* G. SHIRLEY BROOKS; *Leaders:* L. H. ROBERTS; A. V. MITCHENER, B.S.A.; J. D. SUFFIELD; J. D. DUTHIE; **BOTANICAL SECTION:**—*Chairman:* C. W. LOWE, M.Sc.; *Secretary:* MRS. K. J. McDUGAL; *Leaders:* JAMES COCKS; PROF. F. W. BRODRICK; DR. G. R. BISBY; H. F. ROBERTS, M. Sc.; **SUBSECTION—MYCOLOGY:**—*Leader:* DR. G. R. BISBY; **GEOLOGICAL SECTION:**—*Chairman:* Prof. R. C. WALLACE; *Secretary:* A. A. MCCOUBREY; **SUBSECTION—PALAEOLOGY:**—*Leader:* W. CUTLER; *General Secretary:* A. M. DAVIDSON, M.D., 6 Medical Arts Building.

THE HAMILTON BIRD PROTECTION SOCIETY

(Incorporated)

Hon. President: MR. ADAM BROWN; *President:* MR. R. O. MERRIMAN; *1st Vice-President:* DR. H. G. ARNOTT; *2nd Vice-President:* MR. C. D. COOK; *Secretary-Treasurer:* MISS RUBY R. MILLS, Public Library, Hamilton; *Directors:* DR. H. G. ARNOTT; C. D. COOK; DR. J. A. DICKSON; MISS M. E. GRAHAM; MISS RUBY R. MILLS; M. HOLTON; M. JOHNSTON; MRS. F. E. MACGLOHLIN; R. O. MERRIMAN.

NATURAL HISTORY SOCIETY OF BRITISH COLUMBIA, VICTORIA, B.C.

The Officers for the above Society for the year ending March 31st, 1923, are as follows:—

President: W. N. KELLY; *1st Vice-President:* A. R. SHERWOOD; *2nd Vice-President:* C. C. PEMBERTON; *Secretary:* H. T. NATION; *Treasurer:* MISS S. M. THORNTON. *Committee:*—MISS C. G. FOX, MISS A. F. GARDINER, MISS I. CATHCART, WM. DOWNES, A. HALKETT. *Auditors:*—J. KEITH WILSON AND F. W. GODSAL. *Trustees:*—REV. R. CONNELL, DR. C. F. NEWCOMBE AND G. HARVEY.

ALBERTA NATURAL HISTORY SOCIETY

Hon. President: HON. GEO. HOADLEY; *Hon. Vice-President:* H. A. CRAIG; G. W. SMITH, M.P.P.; J. J. GAETZ; *President:* C. H. SNELL; *Vice-Presidents:* MRS. W. A. CASSELS; DR. HENRY GEORGE; *Secretary-Treasurer:* MRS. S. PAMELY, Red Deer; *Directors:* MRS. H. GEORGE, Red Deer; MRS. G. F. ROOT, Wetaskiwin; K. BOWMAN, Edmonton; F. S. CARR, Edmonton; D. MACKIE, Edmonton; W. A. CASSELS, Red Deer; S. PAMELY, Red Deer; C. G. S. CROSBY, Red Deer; W. F. HARRIS, Red Deer; H. R. ORAM, Red Deer. *Members qualified to answer enquiries:* *Birds:* MRS. W. A. CASSELS, Red Deer; DR. H. GEORGE, Red Deer; *Mammals:* DR. H. GEORGE, Red Deer; *Fishes:* F. C. WHITEHOUSE, Red Deer; *Flowers:* MRS. H. GEORGE, Red Deer; *Insects: Coleoptera,* F. C. CARR, 11050 123rd St., Edmonton; *Lepidoptera,* K. BOWMAN, 9914 115th St., Edmonton; *Odonata,* F. C. WHITEHOUSE, Red Deer.

The meetings of this Society are held in Red Deer on the last Friday of each month except during July and August and perhaps September. The annual meeting is held in Red Deer on the last Friday in November.

McILWRAITH ORNITHOLOGICAL CLUB, LONDON, ONT.

President: T. D. PATTERSON, 562 Waterloo Street; *Recording Secretary:* MRS. E. H. MCKONE, Worthy Road; *Corresponding Secretary and Treasurer:* E. M. S. DALE, 297 Hyman St.; *Members qualified to answer questions:* W. E. SAUNDERS, 240 Central Ave.; C. G. WATSON, 201 Ridout St. South; J. R. MCLEOD, 355 Wortley Road; J. F. CALVERT, 461 Tecumseh Ave.; E. M. S. DALE, 297 Hyman St.

VANCOUVER NATURAL HISTORY SOCIETY

Hon. President: L. S. KLINCK, LL.D., Pres. University of B.C.; *President:* JOHN DAVIDSON, F. L. S., University of B.C.; *Vice-President:* FRED PERRY; *Hon. Secretary:* C. F. CONNOR, M.A., 3629 W. 2nd Ave., Vancouver, B.C.; *Hon. Treasurer:* A. H. BAIN, 2302 York St., Vancouver, B.C.

Fortnightly meetings in the University Buildings from September to April (inclusive). Semi-monthly excursions from May to August (inclusive).

PROVINCE OF QUEBEC SOCIETY FOR THE PROTECTION OF BIRDS

Hon. President: I. GAMMELL; *President:* L. MCI. TERRILL; *Vice-Presidents:* ALEX MACSWEEN, NAPIER SMITH, E. ARNOLD; *Hon. Corresponding Secretary:* W. S. HART, P.O. Box 1185, Montreal; *Hon. Recording Secretary:* MISS H. STONE; *Hon. Treasurer:* MISS M. ARMITAGE, 63 Arlington Ave., Westmount; *Directors:* MISS EDITH MORROW; MISS LOUISE MURPHY; MISS EMILY LUKE; MR. AND MRS. C. F. DALE; MRS. J. T. AYERS; MISS JEAN MCCONNELL; W. A. OSWALD; A. F. WINN; MR. AND MRS. WALLACE H. ROBB; W. G. WRIGHT. *Members qualified to answer questions:* L. MCI. TERRILL, 44 Stanley Ave., St. Lambert, Que.; NAPIER SMITH, Bank of Montreal, Magog, Que.; E. ARNOLD, 64 Durocher St., Montreal; W. A. OSWALD, 301 Wilson Ave., N.D.G., Montreal; C. N. ROBERTSON, c-o Ross Realty Co., Room 805, Lewi Bldg., St. John St., Montreal, Que.; DR. ARTHUR WILLEY, McGill University, Montreal; W. J. BROWN, 250 Oliver Ave., Westmount, Que.; MISS EDITH MORROW AND MISS EMILY LUKE, c-o Secretary.

SOCIÉTÉ PROVANCHER D'HISTOIRE NATURELLE DU CANADA

Bureau de direction pour 1923

Président: R. MEREDITH, N.P.; *1er vice-président:* ABBE ALEX. VACHON, M.A.; *2ème vice-président:* DOCTEUR A. DERY; *Secrétaire-trésorier:* JOS. MATTE, 13 avenue Maisonneuve, Québec; *Chef de la section scientifique:* COLONEL OSCAR PELLETIER; *Chef de la section de propagande éducationnelle:* DOCTEUR S. GAUDREAU; *Chef de la section de protection:* C.-E. DIONNE, M.A.; *Chef de la section d'information scientifique et pratique:* DOCTEUR J.-E. BERNIER; *Directeurs:* A.-R.-M. BOULTON, FRANK W. ROSS, A.-A. GOUBOUT.

THE BRITISH COLUMBIA ORNITHOLOGISTS' UNION

Officers for 1923

Hon. President: HON. MINISTER OF AGRICULTURE, Victoria; *President:* FRANCIS KERMODE, Provincial Museum, Victoria; *Vice-President:* T. L. THACKER, Hope; *Secretary-Treasurer:* J. W. WINSON, Huntingdon; *Directors:* J. A. MUNRO, Okanagan Landing; DR. KELSO, Arrow Lakes; R. GLENDENING, Agassiz; K. RACEY, Vancouver; T. PEARSE, Courtenay; W. N. KELLY, Victoria.

THE TORONTO FIELD-NATURALISTS' CLUB

President: PROFESSOR R. B. THOMSON; *Vice-Presidents:* PROFESSOR E. M. WALKER, DR. A. COSENS, J. H. FLEMING; *Secretary:* W. F. GREGORY, 151 Ellsworth Ave., Toronto; *Treasurer:* F. H. BRIGDEN; *Honorary Librarian:* C. W. NASH; *Librarian:* DR. LYMAN B. JACKES. **BIRD GROUP:**—*Chairman:* STUART THOMPSON; *Secretary:* JAMES BAILLIE. **FLOWER GROUP:**—*Chairman:* DR. H. B. SIFTON; *Secretary:* MISS J. G. WRIGHT, Ph.D.; **INSECT GROUP:**—*Chairman:* PROFESSOR WALKER; *Secretary:* MISS NORMA FORD, Ph.D. **MAMMAL GROUP:**—*Chairman:* J. R. DYMOND; *Secretary:* L. SNYDER. **REPTILE, FISH AND AMPHIBIAN GROUP:**—*Chairman:* SHELLEY LOGIER; *Secretary:* T. B. KURATA. **PROGRAM COMMITTEE:**—*Chairman:* DR. W. A. CLEMENS. **WILD LIFE PRESERVATION COMMITTEE:**—*Chairman:* RUSSELL G. DINGMAN. **EDUCATIONAL COMMITTEE:**—*Chairman:* TAYLOR STATTON.

We would ask the Officers, and more particularly the Secretaries, of all the Affiliated Societies to assist us in our task of building up the circulation of this magazine. By securing every member as a subscriber we can truly make this magazine into one of the leading Natural History publications of America.



FOR SALE

Back Numbers of The Ottawa Naturalist

The Club has for sale complete sets of its publications. Enquiries regarding price should be addressed to the Secretary of the Club, Dr. J. F. Wright, Geological Survey, Ottawa, Canada.

Any member having copies of the March, 1896, January, February, March and August, 1898, and December, 1900, issues of *The Ottawa Naturalist*, and who desires to dispose of the same, is requested to communicate with the Secretary.



Grant-Holden- Graham Limited

Outfitters to
Surveyors & Engineers

Manufacturers of

High-Grade Tents

Tarpaulins & Sleeping Bags

WRITE FOR CATALOGUES

147 Albert Street
OTTAWA

Fine Diamonds

Sterling Silver, Fine
Cut Glass, Electro-
Plated Ware

*The Store of
Moderate Prices*

C. A. Olmsted & Son

*Jewellers, Opticians, Watchmakers and
Engravers*

208 Sparks Street, Ottawa

WHY NOT ADVERTISE
YOUR PRODUCTS IN

The
Canadian
Field-Naturalist

*The Leading Canadian
Natural History Publication*

WRITE FOR RATE CARD

ADVERTISING DEPARTMENT
THE CANADIAN FIELD-NATURALIST

175 Nepean Street

OTTAWA

Kindly mention The Canadian Field-Naturalist to advertisers

35,343

APR 18 1924

VOL. XXXVIII, No. 4

APRIL, 1924



THE CANADIAN FIELD-NATURALIST



PUBLISHED BY
OTTAWA FIELD-NATURALISTS' CLUB

ISSUED APRIL 11, 1924

Entered at the Ottawa Post Office as second-class matter

THE OTTAWA FIELD-NATURALISTS' CLUB

Patrons:

THEIR EXCELLENCIES THE GOVERNOR-GENERAL AND THE LADY BYNG OF VIMY

1st Vice-President: G. A. MILLER. *President:* HOYES LLOYD. *2nd Vice-President:* NORMAN CRIDDLE
Secretary: J. F. WRIGHT, (Geological Survey, Ottawa.) *Treasurer:* B. A. FAUVEL,
(Mounted Police Headquarters,
(Laroque Bldg., Rideau and Dalhousie Sts., Ottawa)

Additional Members of Council: W. T. MACOUN; MISS M. E. COWAN; C. M. STERNBERG; H. I. SMITH;
F. W. WAUGH; P. A. TAVERNER; E. SAPIR; E. M. KINDLE; W. J. WINTENBERG; R. E. DELURY;
ARTHUR GIBSON; M. O. MALTE; R. M. ANDERSON; H. GROH; MISS F. FYLES; C. B. HUTCHINGS;
H. M. AMI; CLYDE L. PATCH; D. JENNESS; V. W. JACKSON; R. O. MERRIMAN; W. N. KELLY;
C. H. SNELL; J. R. MCLEOD; JOHN DAVIDSON; L. MCI. TERRILL; R. MEREDITH; FRANCIS
KERMODE; PROF. R. B. THOMSON; THE EDITOR.

Editor:

HARRISON F. LEWIS,
Canadian National Parks Branch,
Dept. of the Interior, Ottawa.

Associate Editors:

E. SAPIR.....	<i>Anthropology</i>	A. G. HUNTSMAN.....	<i>Marine Biology</i>
M. O. MALTE.....	<i>Botany</i>	P. A. TAVERNER.....	<i>Ornithology</i>
F. R. LATCHFORD.....	<i>Conchology</i>	E. M. KINDLE.....	<i>Palaeontology</i>
M. Y. WILLIAMS.....	<i>Geology</i>	R. M. ANDERSON.....	<i>Zoology</i>
ARTHUR GIBSON.....	<i>Entomology</i>	CLYDE L. PATCH.....	<i>Herpetology</i>

CONTENTS.

	PAGE
Further Notes on the Orchids of Hatley, Stanstead County, Quebec, 1923. By Henry Mousley	60
Dean's Bibliography of Fishes. By A. Willey	63
The Black-Billed Cuckoo in Manitoba. By H. H. Pittman	64
Notes on the Lance Formation of Southern Saskatchewan. By Charles M. Sternberg	66
The Canada Goose at Home. By A. D. Henderson	70
List of Birds Recorded from the Island of Anticosti, Quebec. By Harrison F. Lewis. (Continued)	72
Notes and Observations:—	
Another Mystery Band. By Hoyes Lloyd	76
Bats in Winter. By P. A. Taverner	76
Breeding of the Turkey Vulture in Eastern Manitoba. By J. F. Wright	76
Change in Name of Toronto Naturalists' Club. By J. R. Dymond	76
Note on the Food of the Ruffed and Spruce Grouse. By L. MCI. Terrill	77
Dr. Ami's Lecture on Prehistoric Man. By J. F. Wright	77
Note on <i>Papilio cresphontes</i> . By (Mrs.) Ethel G. Dale	77
Communication from S. Travers, Grouard, Alta.	78
Editor's Note	78
Book Review:—	
Ethnobotany of the Menomini Indians. By H. I. S.	78
Canadian National Parks Association, Bulletin No. 1. By H. F. L.	80

THE CANADIAN FIELD-NATURALIST, lately THE OTTAWA NATURALIST, established thirty-six years ago, "to publish the results of original research or investigation in all departments of natural history," is issued monthly, excepting for the months of June, July and August.

Papers, notes and photographs should be addressed to the Editor. Manuscript should be typewritten.

Subscriptions cover the current year, except those taken out during last quarter, when they will be applied on the following year, the remaining numbers of current year being sent free. Payments should be made to the Treasurer, Mr. B. A. Fauvel, Mounted Police Headquarters, Laroque Building, Ottawa. Price of this volume, \$1.50; single copies 20c each.

HIVERSACKS

We manufacture 30 different styles of Haversacks for the Canadian trade—a Haversack to suit every requirement.

Two of our popular styles are shown here

When buying a Haversack, Pack Bag or any article of outdoor equipment, ask for

WOODS' PRODUCTS

Quality is built into every article made in our Camp Equipment Department.



De Luxe



Canadian

Woods Manufacturing Co.

Dept. D

OTTAWA

EXPLORATIONS in Western Canada

The Ottawa Field-Naturalists' Club has just published an interesting volume of over 300 pages, entitled:

Autobiography of John Macoun, M.A.

Canadian Explorer and Naturalist, Assistant Director and Naturalist to the Geological Survey of Canada—1831-1920.

This volume is an account of the life of this veteran naturalist. Agriculturists generally, in fact all interested in the development of Canada, will find this book of much interest and value.

The edition is limited. The price is \$3.00 with 15c added for bank exchange, if remittance is forwarded by personal cheque.

Applications for the volume should be made to

Mr. Arthur Gibson

Birks Building : Ottawa, Ont.

The Topley Co.

Photographic Material
Scientific Apparatus
Eastman Kodaks



132 Sparks Street
OTTAWA

Kindly mention The Canadian Field-Naturalist to advertisers

Lyman's Limited

(Established 1800)

MANUFACTURING CHEMISTS

Importers and Dealers in
 CHEMICAL AND
 ASSAY APPARATUS

344 St. Paul St. West, Montreal



GROW GOOD CROPS

SEEDS PLANTS BULBS

Our rigorous system of testing eliminates loss
 and disappointment from your garden

Kenneth McDonald & Sons, Limited

Seed and Bulb Merchants

Market Square :: Ottawa, Ont

Ward's NATURAL SCIENCE ESTABLISHMENT

Rochester, New York, U.S.A.

Manufacturers of the genuine Schmitt boxes
 exhibition cases and cabinets, also of the American
 Entomological Company's insect pins.

Riker Mounts and botanical mounts always on
 hand, also Riker botanical presses.

Send for our supply catalogue and other lists of
 interest to collectors.

Headquarters for Entomological Supplies
 and Specimens

Inspected Milk Ice Cream

Ottawa Dairy

Fresh Butter Buttermilk

THE

Bank of Nova Scotia

Capital.....\$ 9,700,000

Reserve Fund and Divi-
 dend Profits, over.... 18,000,000

Total Assets over..... 230,000,000

SEVENTEEN BRANCHES IN
 OTTAWA AND HULL

W. A. Rankin, Ltd.

Hammocks
 Refrigerators
 Builders' Hardware

410-412 Bank Street, Ottawa

Phones—Queen 1023-1024

JACK MINER and THE BIRDS

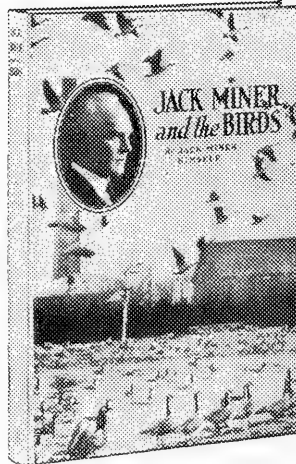

*A New
 Book You
 Will Be
 Specially
 Interested
 In*

184 pages,
 53 photos,
 printed on
 finest coated
 paper.

*If your Book-
 seller cannot
 supply you
 ORDER
 DIRECT*

\$3
 Postpaid

Cash must
 accompany
 order—if paid
 by cheque,
 add 15c for
 exchange

MANLY F. MINER
 KINGSVILLE, ONT.

Kindly mention *The Canadian Field-Naturalist* to advertisers

The Canadian Field-Naturalist

VOL. XXXVIII

OTTAWA, ONTARIO, APRIL, 1924

No. 4

FURTHER NOTES ON THE ORCHIDS OF HATLEY, STANSTEAD COUNTY, QUEBEC, 1923

BY HENRY MOUSLEY

TO MOST orchid enthusiasts I am afraid the summer of 1923 has been a disappointing one. In the early Spring, the weather was cold, and most of the wild flowers were ten days to a fortnight behind time, an instance in the orchids being *Calypso bulbosa*, which did not appear until May 27, although it was fully out on May 7, 1921. This, however, is exceptionally early, the middle of the month being more of an average date for the species, which is always our earliest orchid to appear here. Later on, when it did begin to warm up, there was not sufficient rain and moisture for the best development of most of the species. Notwithstanding all these drawbacks, the season of 1923 will ever remain a memorable one to me, if not the most memorable, for, although my list had nearly reached the limit of possibilities, I was enabled to add the White Fringed Orchis (*Habenaria blephariglottis*) and its variety *holopetala*, the variety *media* of the Northern White Bog Orchis (*Habenaria dilatata*), the variety *ochroleuca* of the Nodding Ladies' Tresses (*Spiranthes cernua*), and the Downy Rattlesnake Plantain (*Epipactis pubescens*), all of which will be dealt with hereafter, in an annotated list, as before.

The addition of the above five species and varieties to my list brings the total up to forty-one, but from this must now be deducted the hybrid Andrew's Fringed Orchis (x *Habenaria Andrewsii*), in view of Prof. Oakes Ames' revised opinion, upon examination of a further supply of this supposed hybrid from this locality. Even with this deduction, my total of forty for such a limited area is well ahead of any other competitor, I imagine, in eastern North America. My list of possibilities is now reduced to a minimum, the following three species being all that I ever am likely to find, viz.; the Ram's Head Lady's Slipper (*Cypripedium arietinum*), the Tubercled Orchis (*Habenaria flava*), and the Auricled Twayblade (*Listera auriculata*.)

Making the acquaintance of the first named, in its natural habitat in northern Vermont, on June 5 last, alone stamps the season as a memorable one for me. There, under cedars, on some rising

ground bordering a swamp, some twenty plants were found in full bloom. Later on in July, also in northern Vermont, I was introduced to the White Fringed Orchis (*Habenaria blephariglottis*), prior to my finding it in the large swamp near Beebe in August. But the crowning point of the whole season lies in the fact that I have been enabled to study the underground growth of most of the orchids found here, thanks to the encouragement and assistance given me by Dr. M. O. Malte, through whose instrumentality it has been possible to secure photos of the roots as I obtained them, at various stages of the plant's life, without which it would have been useless for me to have taken up the subject, which it is proposed to deal with later on, as opportunities occur. In passing, I may just mention that these studies have revealed the coralloid rhizome which sometimes occurs at the base of the tubers of *Calypso bulbosa*, but which few orchid hunters have seen, or are even aware of, as nothing is said about the matter in the textbooks, not even in Gray's *Manual*, 7th edition. This rhizome is found not only in young vegetative plants, but also in full grown ones, contrary to what one would expect. Irmisch describes the tuber in his *Beiträge zur Biologie und Morphologie der Orchideen*, Leipzig, 1853, and calls attention to the coralloid palmate body by quoting a description of it given by Liboschitz and Trinius in their *Flore des environs de St. Petersbourg et de Moscow*, 1818, p. 214. In order to secure examples of this interesting phenomenon, as well as other particulars of the underground growth of *Calypso*, I have visited its haunts during every month of the year.

In *Rhodora*, Vol. VI, 1904, No. 64, p. 79, there is a short note by Harriet A. Nye, entitled *Bulblets of Microstylis ophioglossoides*, in other words, the Green Adder's Mouth (*Malaxis unifolia*), in which she described the finding of several bulblets on a very fine plant of the above species. *The Orchid Review*, Vol. XXIX, 1921, No. 340, p. 112, refers to this article as follows: "Orchids which propagate by bulbils are not common, but the North American *Microstylis ophioglossoides* seems to come under this heading".

Not only was I fortunate in finding these bulblets or bulbils on one plant, but on many, and in various stages of development. I also think I have sufficient proof to substantiate what Drummond said in 1810, regarding the underground development of the Hooded Ladies' Tresses (*Spiranthes Romanzoffiana*) in Ireland, viz., that the bud precedes the tuber, and that each bud puts forth a pair of tubers. This appears to be questioned in the *Orchid Review*; see *Spiranthes Romanzoffiana* by Colonel M. J. Godfery, *Orchid Review*, Vol. XXX, 1922, No. 351, pp. 216-64, who, if I read him aright, maintains that there is only one tuber, and that this precedes the bud, which latter does not open until the following spring. All I can say at present is that I have photos which I think clearly show that Colonel Godfery is mistaken, and that Drummond is correct in the main in what he says, but this will no doubt appear more fully described later on, in the *Orchid Review*.

The mention of bulblets, a moment ago, put me in mind that in the next edition of Gray's *Manual* the heights given for some of our orchids will have to be considerably increased. In the case in question the fine plant of *Malaxis unifolia*, spoken of by Harriet A. Nye, measured 28 cm. in height, and one I collected this season measured 23 cm., whereas the extreme given in Gray's for this species is only 22 cm., and 15 cm. for the White Adder's Mouth (*Malaxis monophyllos*), although a specimen in my Herbarium, taken in 1922, measures 22.50 cm. and another 18.50 cm. An even wider discrepancy exists in the case of the Broad-leaved Epipactis (*Serapias Helleborine*), whose extreme height is given as 60 cm., whereas I received a plant this fall which measured 72.50 cm. Again, on August 22 and September 5 of the present year, I collected a fine plant of the large Coral Root (*Corallorhiza maculata*) and one of Loesel's Twayblade (*Liparis Loeselii*), the former measuring 44 cm., and the latter 22.50 cm. in height, as against 40 cm. and 22 cm., the extremes given in Gray's *Manual*. The differences in these cases is not so very great, but there are several others which call for attention, and in some no heights whatever are given.

Although the season, as I have said, was against the proper development of many species, it seems to have suited some of the Cypripediums, for I never saw the Showy Lady's Slipper (*C. hirsutum*) in greater profusion, and instead of the usual single bloom a large proportion of the plants bore two; in one case the second blossom being snow-white, without any crimson magenta whatever. Speaking of this genus reminds me of another important event of the season, namely, the flowering of the White Moccasin Flower (*Cypripedium passerinum*),

five plants of which were sent me from near Banff in Alberta in September, 1922. These I planted in a low-lying, damp deciduous wood to the south of Hatley, and out of the five, three bloomed and were photographed on June 20 by Mr. Edwin H. Lincoln, of Pittsfield, Mass., who had been instrumental in obtaining them. It is an interesting species, about which apparently nothing much is known. The flowers, which are small and solitary, have been described as white, and also as pale magenta, but mine were a cream colour, rather than white, with purple spots inside at the base of the labellum. The dorsal sepal, which is yellowish, instead of standing almost erect, as it does in the other species of *Cypripedium* growing here, bends downwards, thus forming a little hood, as it were, to the mouth of the labellum, which is only about half an inch long. The lateral petals are the same colour as the labellum, and very small, spreading, and, like the labellum, only about half an inch long. The height of the plants varied from 21 to 24 cm. In the Rockies it is said to bloom in July, but here it was fully out on June 18.

Other interesting species that I have planted here this fall, in the hope that they may do well and bloom next year, are the Crane Fly Orchis (*Tipularia discolor*), the Putty-root or Adam and Eve (*Aplectrum hymale*), and Helleborine or the Broad-leaved Epipactis (*Serapias Helleborine*). With regard to the first two, they, like *Calypso*, put forth their new leaves in September, but the flower-buds, unlike those of *Calypso*, are not in evidence until the following spring. Helleborine is a very curious and interesting orchid, which I hope to be able to study next year, as it is not at all clear from our text-books what we really have here, two synonyms being given for the species in Gray's *Manual*, viz., *Epipactis latifolia* and *E. viridiflora*. Now these two are not one and the same thing, judging from the discussion that has been taking place in England lately in the *Journal of Botany*, wherein it is contended that *E. viridiflora* should be considered as a true and distinct species, owing to the position of the stigma and the absence of a true rostellum, which allows of self-fertilization, a thing impossible in *E. latifolia*, where the stigma is pushed forward, so that the pollen masses cannot fall upon it, the rostellum also being large, and playing an important part in cross-fertilization. From an enlarged coloured drawing I have received from Mr. Robert Holmes, of Toronto, of the labellums, etc., of the plants that grow there, it looks to me as though our plant is *E. latifolia*, or some form of it, and not *E. viridiflora*, but this I shall hope to determine for myself next year. As pointed out by Bro. Marie-Victorin in his paper, *Random Botanical Notes from Isle-*

aux-Coudres, Que., The Can. Field-Nat., Vol. XXXIII, 1919, No. 6, p. 116, Serapias Helleborine was the only instance in the Province of an introduced orchidaceous plant that he was aware of. It was brought over by the first settlers, the missionaries, the "Médecins du Roi", the nuns, who were far from being "minus habens", as Bro. M.

Victorin says, and Helleborine being of medicinal value, the gardens inside the palisades usually contained a supply of the plants, which have persisted on Mount Royal, Montreal Island, to the present day.

(To be concluded.)

DEAN'S BIBLIOGRAPHY OF FISHES

BY A. WILLEY

DR. BASHFORD DEAN'S *Bibliography*, comprising over forty thousand titles, brings the literature of fishes, living and extinct, from lancelets to lungfishes, up to the end of the epochal year 1914. For the first twenty years of the enterprise, from 1890 to 1910, he worked practically alone. Then the American Museum of Natural History, under its distinguished and untiring President, Professor Henry Fairfield Osborn, ever appreciative of disinterested efforts for the advancement of science, came to the rescue and assured the ultimate success of the project.

Dr. Dean has not been an armchair bibliographer nor a fanatical bibliophile, but a great traveller, ransacking the whole world for the titles which are enshrined in three massive octavo volumes. The first volume of seven hundred and eighteen pages, with Authors' Titles A-K, was issued in 1916. The second volume of seven hundred and two pages contains Authors' Titles L-Z and a List of Anonymous Titles; it was issued in 1917.

The third volume, published in 1923, crowns the herculean task. It consists of seven hundred and seven pages and includes a long list of Addenda, a catalogue of Pre-Linnæan Publications, references to general bibliographies, voyages and expeditions, periodicals relating to fish and fish-culture. The eighth chapter is the Subject Index, covering more than three hundred pages, and divided into a Morphological Section and a Systematic Section, the whole concluding with a general index.

As explained in the preface to the first volume, the references, with this bibliography in hand, are simplified; the example given is "Jordan, 1891.4", which means the fourth paper published by David Starr Jordan in 1891. Probably this method could not have been improved upon under the circumstances; but it may be remarked that the Zoological Record effected a great improvement in its annual register by the introduction of serial numbers. As an example we may quote Bruno Hofer's experimental studies on the integumentary sense-organs of fishes, which is number 201 in the

Zoological Record for 1908 (Z.R. 1908, 201); in Dean's Bibliography the reference is: "Hofer 1908.1."

In the Addenda in the third volume, there are included some articles later than 1914 by authors who have died and whose bibliographies are completed as far as possible.

Next to the Titles, the most ambitious feature of the work is the Subject Index and in this connection it may be mentioned that wherever an outstanding work has appeared since 1914, such as Dr. Johannes Schmidt's memoir on *The Breeding Places of the Eel* (1922), it has been inserted in the Index. A particularly valuable portion of the Subject Index is that which is devoted to the Fauna of the World (pp. 420-457). If one wants, for example, to consult the references to Tanganyika or Titicaca, it is only necessary to glance at the "Finding Index" and the information is at once forthcoming. Incidentally of course there will be found in these volumes a virtually complete bibliography of Canadian Fishes to 1914.

By applying various simple tests, one may readily be convinced of the high standard of accuracy achieved. Such minor typographical inadvertences as *Malopterurus* for *Malapterurus* are rare indeed; and there is no telling whether in this instance we are not confronted with a "reformed" nomenclature. This marked freedom from errors and omissions is largely due, as Dr. Dean explains, to the very efficient collaboration on the part of his colleagues at the American Museum. The title-pages of the first two volumes bear the name of the late Dr. C. R. Eastman as co-editor. The third volume is edited by Dr. E. W. Gudger, with the co-operation of Mr. Arthur W. Henn. In the preface to this volume. Dr. Dean sets forth very fully how the work was built up. The seven pages of Errata and Corrigenda (pp. 354-360), far from being regarded as a blemish, are calculated to inspire the utmost confidence in the work as a whole; and as often as not the items requiring correction are attributable to ambiguities in the originals. A few others, however, will doubtless be added when a supplementary volume appears in the dim future. Sir

James Emerson Tennet should read Tennent; and Mr. Thomas Southwell who has written on some Ceylon fishes bears no relationship to the Norfolk naturalist of the same name.

The attempt to provide, for the general reader, an epitome of the subject-matter treated of in the enormous literature of fishes would tax the powers of an Owen or a Huxley. Nor would it be possible for anyone to compress our knowledge of the twelve thousand estimated species of fishes within a nutshell. Hardly any other class of the animal kingdom presents such a wealth of adaptation, from ocean depths to river sources; as is to be found among fishes.

Leaving out of consideration for the moment their immense antiquity and their utility, as affording a well-nigh inexhaustible food-supply to mankind, from the earliest prehistoric hunters and fishers to the man in the street of to-day, the vast range of interest which their study evokes may be illustrated by the entries under the names of Sir Humphry Davy, Michael Faraday, Walter Gaskell, and William Patten. There are other equally remote extremes, all bearing their testi-

mony to the influence which the contemplation of the fish type has exercised upon the inquisitive human intellect from ancient Greece to modern America.

For untold ages the American Ganoids, Cyclostomes, and Chimæroids had successfully guarded the secrets of their spawning habits until Bashford Dean, with consummate wizardry, laid them bare. And now, with the completion of his wonderful bibliography, he may be congratulated upon having fairly landed his fish; and it certainly is a big catch.

A word of acknowledgment is due to Dr. Gudger, himself an ichthyologist of note, with many titles to his credit, and imbued with a profound knowledge of ancient and modern fish-lore.

But mere words can hardly do justice to an arduous undertaking such as this, although its merits are conspicuous. It must suffice to add that no zoological library and no biological station can afford to be without Dean's *Bibliography of Fishes* published by the American Museum of Natural History.

THE BLACK-BILLED CUCKOO IN MANITOBA

BY H. H. PITTMAN



BY THE end of May, in Manitoba, one feels that all the migrants have arrived, for the prairie is alive with birds and the air is filled with their calls and songs, but about the second of June another note is heard—loud, clear, ringing over the plains. The Black-billed Cuckoo has arrived and is "telling the world". It is probable that he has been here a little while already, skulking in the bush, for I have found eggs as early as June 6th, but if so he does not commence to sing as soon as he arrives.

The Black-billed Cuckoo is somewhat slovenly in manner and constantly perches with drooping wings, and altogether suggests that he is wearing a suit of feathers a size too large. Compared with a bird of about similar size, such as the Bronzed Grackle, he seems like a raw recruit beside a highly-trained soldier.

I photographed a Cuckoo sitting on five eggs on June 14th, 1923, in a nest among some dead twigs on the trunk of a small poplar in a rather dark thicket of poplar, willow and cherry in south-west Manitoba, and on the 16th she was sitting closely and near to hatching.

On June 17th a great windstorm came up, destroying barns, silos and trees in this district. It tore great branches off my maples, blew a building over and carried away my water-tank,

but not far away it tore the roofs off houses, knocked down barns and blew granaries to pieces. This and the storm which came nearly a month later are two of the worst windstorms I have been in for a long time.

All the smaller trees were bent almost flat and the Cuckoo's nest was upset just as she was hatching. On June 19th, when I passed again, the nest was empty, but the Cuckoo rose from the ground and, after a search, I found an egg, some shells and one chick scattered around. The bird had not deserted, but was taking care of her solitary chick upon the ground beneath the nest.

Unfortunately, among wild creatures, any departure from the normal often ends in failure, as it did in this case, for a week later I was unable to find any trace of the young bird or the egg. Some passing weasel or Crow, perhaps, had found the helpless chick and made a meal and the egg, possibly, had been trodden upon by the bush-rabbits and the remains lost among the dead leaves.

Nestlings, as a rule, are not very pretty until they get their feathers, but young Cuckoos are uglier than most birds of their age. Their skin is black and their beaks and feet a bright blue, as though enamelled.

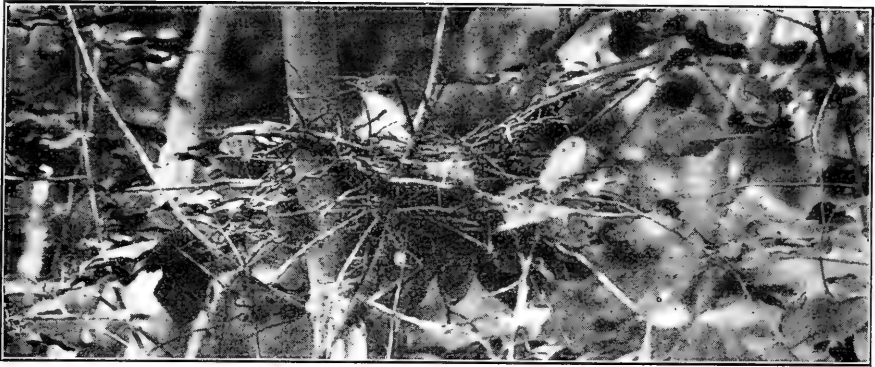

Above
Black-billed
Cuckoo
on Nest



At Left
Nest of
Black-billed
Cuckoo

Photographs
Copyrighted by
H. H. Pittman.

The wind on the prairie is frequently very strong and is quite a serious factor for the birds to contend with sometimes. The storms of 1923 destroyed many nests and I knew of many pairs of birds which presumably went south with the

fall migration without raising a single young one, even after making two attempts. There must have been hundreds if not thousands in similar plight.

NOTES ON THE LANCE FORMATION OF SOUTHERN SASKATCHEWAN*

By CHARLES M. STERNBERG

DURING a part of the field season of 1921 the writer was sent by the Director of the Geological Survey of Canada to Rocky Creek, Saskatchewan, for the purpose of making a systematic collection of vertebrate fossils and collecting specimens for museum purposes.

Rocky Creek is a small stream which heads on the southern face of Wood Mountain plateau and runs south, emptying into Milk River in Montana. Near the head of this creek in township 1, ranges 4 and 5, west of the third meridian, the country is broken into rugged "badlands". The beds are composed largely of clays, sandy clays, and sands and bear a close resemblance to the upper part of the Belly River series as exposed farther west in Alberta. They are sombre in colour, but individual beds seldom continue for any great distance without change. The beds are soft and absorb great quantities of water during the season of spring rains, thus aiding in the rapid denudation. There are very few areas of hard sandstone, but in some places the clay has been indurated by the combustion of lignite beds, which are to be found in the upper portion, and forms a resistant layer which serves as a protecting cap for isolated buttes. This combustion evidently took place long ago, as widely separated red topped buttes are all that is left to mark what was once the level of the plain. This red brick layer is on the same plane as the existing lignite beds.

Fossil vertebrates were first reported from these badlands in 1875 by Dr. G. M. Dawson, who at the same time described the geology of the region¹ and proposed the following divisions of the rocks.

"Taking first the highest beds seen, the order is as follows. α Yellowish sands and arenaceous clay, sometimes indurated in certain layers and forming a soft sandstone. It forms the flat plateau-like tops of the highest hills seen. About 50 feet.

" β Clays and arenaceous-clays, with a general purplish-gray colour when viewed from a distance. About 150 feet.

" γ Yellowish and rusty sands, in some places approaching arenaceous clays, often nodular. About 80 feet.

" δ Grayish-black clays, rather hard and very homogeneous, breaking into small angular fragments on weathering, and forming earthy banks. About 40 feet seen.

"The whole of the beds appear to be conformable and, disregarding minor irregularities, are quite horizontal to the eye.

"The clays and arenaceous clays of the upper part of the Division are very regularly bedded, and include a lignite-bearing zone. Three lignite beds, of from one to two feet each in thickness, were observed, but they are separated from each other by rather wide clay partings, and are not pure or of good quality. A bed, rich in the remains of plants, immediately overlies the upper lignite. It is composed of a very fine, and nearly white, indurated clay in which the most delicate structures are perfectly preserved. From its soft and crumbling character it is almost impossible to obtain or keep good specimens; but in the fragments which were preserved a few very interesting plants appear. Of these, some are characteristic of the Fort Union group, and identical with those of Porcupine Creek. The association of remains is that of a fresh-water pond or lake, and a fine new species of *Lemna* occurs abundantly About one-third from the base of this division a bed was found, in which curious fruits have been preserved, referable to a new species of *Æsculus*.

"The most interesting feature of this part of the section, however, is the occurrence of the remains of vertebrate animals. They are found exclusively in the lower portion of this division, and most of them below the fruit-bed just mentioned.

"Professor Cope has kindly examined the vertebrate fossils obtained in connection with the expedition. Those from this place include fragments of several species of turtles, scales of a garp-ike, and broken bones of dinosaurian reptiles."

Though Dawson placed divisions α and β both in the Lignite-Tertiary he recognized a distinction between the two, as well as the importance of dinosaurian remains contained in the lower division, even though what he collected were not determinable as to genus or species. While Dawson did not place a definite line for the separation between divisions α and β it seems quite clear that he considered the top of the uppermost coal seam as representing the top of division β and this corresponds with the thickness he gave for the division.

In his *Report on the Cypress Hills, Wood Mountain and Adjacent Country*, McConnell² says, "The Laramie³ may be separated, lithologically, over most of the district, into two distinct divisions.

*Published with the permission of the Director of the Geological Survey of Canada.

¹Dawson, G. M.—*Geology and Resources of the Region in the Vicinity of the 49th parallel*. Montreal, 1875, p. 103.

²McConnell, R. G.—*Geol. and Nat. Hist. Surv. of Canada Ann. Rept.*, 1885, pp. 67-68c.

³The term Laramie was used to include the series of deposits which follow the Fox Hill sandstone.

The lower one, which succeeds the Fox Hill conformably wherever the contact plane of the two formations was observed, bears a strong resemblance to the upper part of the Belly River series, and consists of about 150 feet of feebly coherent, grayish and pure white clays, sandy clays, and sands, with occasional bed of carbonaceous shales and lignite. . . . In the badlands south of Wood Mountain this division consists almost exclusively of clay. The upper division is more arenaceous and is predominately yellowish in colour.

"The Laramie, in this district, is remarkably deficient in fossils of any value. Silicified trunks of trees are abundant in some localities, and specimens of them, with a few almost indeterminate fragments of leaves and silicified bones, comprise the whole collection obtained from it."

Though both Dawson and McConnell recognized a lower division of the beds overlying the Fox Hill, it was left to Rose to recognize it as Lance. It was largely on the strength of the dinosaurian remains collected by Dawson that he classified the beds as Lance, for, as he points out, there was no great break, but a gradual merging from marine to fresh-water conditions. It was in the lakes and swamps and on the shores of the retreating Cretaceous seas that the last remnant of that great order of Mesozoic reptiles, the dinosaurs, persisted for a while and then passed out and their passing marks the close of the Lance period.

Rose made a study of the section on Rocky Creek in 1914 and in his report⁴ he says "From Dawson's description it is quite clear that division δ of the section is the top of the Pierre formation, division γ is the Fox Hills sandstone, and divisions α and β , which he calls the Lignite-Tertiary belong to what has been mapped as Laramie, and is here divided into Lance and Fort Union formations.

"Whether the whole of division β of the section should be classed as Lance or not is questionable. Since the Lance cannot be distinguished from the Fort Union lithologically in many places, and in this section division β grades into division α , it is impossible to mark an exact division line. The Lance certainly includes that part of division β up to the location of the vertebrate remains, which, according to Dawson's diagram, is about 30 feet from the bottom. It will be noted that Dawson says that in the lower part of this division the beds are more sombre in tint and this is also a characteristic of the Lance. The writer examined this section in the field but found no vertebrate remains. The sombre tints of the beds immediately overlying the Fox Hills sandstone were noted, however, and the upper part of division β was

found to be lithologically like the Fort Union. Holding then to the definition of the Lance as the non-marine, dinosaur-bearing beds of sombre colour which overlie the Fox Hills sandstone, the thickness of the formation along Rock Creek is placed at 50 = feet.

"There is, however, a lower division of the beds that are classed with the Fort Union formation and the probability of these belonging to the Lance is here noted. . . . This lower division is very noticeable both north and south of the Wood Mountain plateau on account of the white colour of its beds, which distinguish it from the yellow beds of the upper division. It is very striking where it overlies the Fox Hills sandstone along Twelve Mile lake and outcrops to the east along Big Muddy valley for a distance of 50 miles. It was also noted in the bottom of the branch of Big Muddy valley now occupied by Willowbunch lake and Lake of the Rivers; so that, should it be classed as Lance, that formation would have a wide distribution in southern Saskatchewan. But as no dinosaurian remains have been found in these white beds and as they differ lithologically so much from the typical sombre-coloured beds of the Lance, it is preferable to include them as a lower division of the Fort Union. However, it is probable that the lower 150 feet of the lignite-bearing beds throughout the area may be referred to the Lance formation."

It will be seen that Rose believed that the lower 150 feet of the Fort Union should be classed as Lance, but as he did not have the evidence of dinosaurian remains he hesitated in doing so.

The writer collected dinosaurian and other vertebrate remains at various levels from the base of the formation to within 12 feet of the lowest coal seam, which is approximately 131 feet above the Lance-Fox Hills contact, making the range of the dinosaurian fauna at least 119 feet. They were very abundant at about 75 feet above the base of the formation and from this horizon the writer collected parts of skeletons of *Thespesius*, *Triceratops*, and others.

Taking, then, the definition as given by Rose⁵ for the Lance formation as "The non-marine, dinosaur-bearing beds of sombre colour which overlie the Fox Hills sandstone", we are able to extend the thickness of the Lance, in this region, to include at least 119 feet. It would seem best, however, to place the top of the Lance at the top of the uppermost coal seam, which everywhere in this region seems to be the natural dividing line. Though these coal seams vary in thickness and in the quality of the lignite, they occupy the same

⁴Rose, B.—*Geol. Surv. of Can. Mem.* 89., 1916, pp. 38-40.

⁵*Loc. cit.*, p. 39.

relative position and are the only good horizon markers in the upper part of the beds.

The base of the Lance is placed at the base of a brownish-gray coarse-grained sandstone which is 150 feet below the top of the uppermost coal seam, and is underlain by yellowish-gray, arenaceous clays merging into yellowish sand.

The following section was measured by the writer in a coulee which heads in the centre of the badlands in Sec. 15, T. 1, R. 5, W. of the 3rd principal meridian (Rocky Creek, Sask.).

Beginning at the highest beds seen:

	Ft.	Ins.
Yellowish-gray arenaceous clays.....	34	3
(Plant remains in hard brown ironstone at 28 ft. from top.)		
TOP OF LANCE		
Lignite, poor grade (uppermost coal seam)	1	6
Yellowish-brown, friable clay.....	7	—
Lignite.....	—	4
Yellowish-brown, friable clay.....	9	9
Lignite, lowest coal seam.....	—	4
Brown, friable clay.....	4	6
Gray clay—caudal vertebra of hadrosaur from this bed.....	14	4
Yellowish-gray arenaceous clay.....	2	—
Gray clay.....	4	6
Brown shaley clay (clay-ironstone irregularly distributed, plants collected from this layer.).....	2	—
Yellowish-gray clay.....	13	4
Gray sandstone (Dinosaurian remains abundant at base).....	16	6
Gray clay with yellowish-brown tinge, some ironstone scattered through...	40	—
Yellowish arenaceous clay.....	3	6
Brownish friable clay.....	2	9
Gray arenaceous clay.....	14	6
Yellowish arenaceous clay.....	10	—
Brownish-gray coarse-grained sandstone, quite hard in places.....	3	—
BASE OF LANCE		
Yellowish-gray arenaceous clay, merging into yellowish sand, more clay in upper part and more sand in lower part.....	25	—
Brownish-yellow, fine-grained, friable sandstone or loosely consolidated sand.....	35	—

BOTTOM OF COULEE

The uppermost 34 feet of the section approximately corresponds to division α , the lower 60 feet to division γ , and the intermediate 150 feet to division β , of Dawson's original section.

Following is a list of the vertebrate remains collected by the writer at various levels, from the base of the Lance up to within 12 feet of the lowest coal seam, Rocky Creek, Saskatchewan, with a brief review of the same, kindly given by Mr. C. W. Gilmore, of the U.S. National Museum.

Pisces

- Lepisosteus occidentales* Leidy
- Myliadephus bipartitus* Cope
- Pappichthys* sp.
- Platacodon* sp.

Batrachia

Scapherpeton tectum Cope

Reptilia

Tustudines

- Baena* sp.
- Baena* sp.
- Basilemys* sp.
- Adocus* sp.
- Thescelus* sp.
- Aspiderites* sp.
- Aspiderites* sp.
- Aspiderites* sp.

Rhynchchocephalia

- Champsosaurus* sp.

Sauria

Iguanavus sp., undescribed lizard jaw; several specimens of same species from the Lance of Wyoming are now being studied by Mr. C. W. Gilmore.

Dinosauria

- Thespesius* n.sp.
- Thescelosaurus neglectus* Gilmore
- Triceratops prorsus?* Marsh
- Triceratops* sp.
- Ornithomimus* sp.
- Carnivorous dinosaur.

Crocodylia

- Crocodylus* sp.

All identified or verified by C. W. Gilmore.

REVIEW BY MR. GILMORE

"The fish remains as represented in the above faunal list, with one exception, have a wide geologic range and are valueless as horizon indicators. *Platacodon* at this time has been reported only from the Lance formation of Wyoming.

"Likewise the batrachia, represented by the single genus *Scapherpeton*, are of little use because of the fragmentary nature of the known materials, and also since this genus occurs in the Judith River formation of Montana.

"None of the turtle specimens are sufficiently well preserved to be identified specifically, all of the genera recognized have a wide geological range and none are distinctive of the Lance fauna.

"The single rhynchocephalian reptile, *Champsosaurus*, has a wider geologic range than any other of the extinct reptilia listed, with the exception of some of chelonian genera. *Champsosaurus* remains have been found in the Judith River, Belly River, Two Medicine, Edmonton, Lance, Puerco and Ft. Union formations.

"The dinosaur remains furnish the most conclusive evidence of the age of the beds in which they were found as being equivalent to the Lance as that formation is known in Wyoming, Montana, and the Dakotas.

"This is shown by the presence of *Thescelosaurus neglectus* Gilmore and *Triceratops prorsus?* Marsh, both typical Lance forms and unknown elsewhere.

"A Hadrosaurian reptile, probably a new species, which clearly has its closest affinities with the Lance, *Thespesius annectens* (Marsh), and the presence of the genus *Ornithomimus* furnish cor-

roborative evidence of the Lance faunas of this fauna.

"This brief review of the above faunal list of the vertebrate remains found in southern Saskatchewan shows that, while only a few of its recognized members are confined exclusively to the Lance formation, the faunal list as a whole may be considered typically representative of that formation."

The following report was given by Professor Edward E. Berry, of the John Hopkins University, on plant remains collected by the writer from Secs. 14 and 15, T. 1, R. 5, W. of 3 (Rocky Creek Sask.).

Lance formation. Below lowest coal seam.

Platanus guillelmæ heerii Knowlton (25 ft. below lowest coal).

Laurus sp. (25 feet below lowest coal seam.)

Equisetum arcticum Heer (Rhizomes with large starch-filled tubers that may have been an item on the dinosaur's bill of fare.) (75 feet below lowest coal seam.)

Above uppermost coal seam. Fort Union(?) formation.

Platanus nobilis Newberry

Paliurus pulcherrium Ward (a *Ceanothus* and not a *Paliurus*.)

Populus speciosa Ward

Sparganium stygium Heer

Platanus aceroides latifolia Knowlton? (this may be only a somewhat different appearing leaf of the *Platanus* here listed.)

Aralia coloradensis Knowlton

Phragmites sp.

"I see no reason for doubting the age determinations of Lance and Fort Union as given by the collector. The difference between the two floras as developed in the States is very slight, according to Knowlton's work on very large collections from both, made in the United States."

The following species of plants were collected by Dr. G. M. Dawson from the badlands on Rocky Creek, and described in the appendix of his report⁶, by J. W. Dawson.

Lemna (Spidodela) scutata Dawson

Phragmites? sp.

Scirpus sp.

Sapindus affinis Newberry

Aesculus antiquus Dawson

Trapa borealis? Heer

Carpolithes sp.

With the exception of *Aesculus antiquus* all were probably collected from above the uppermost coal seam.

In travelling west through the Cypress Hills the writer met Mr. V. B. Lackey, of Eastend, Sask., who had in his possession a supra-orbital horn core of *Triceratops* which had been collected on Mr. Crawford's ranch, about 3½ miles north of Eastend, Sask., in the north-east quarter of Sec. 17, T. 7, R. 21, W. of 3. The writer visited the

spot and found fragments of the skull of *Triceratops*, evidently from the same individual. Time did not permit further searching or the measuring of the section, but it was from the arenaceous clay which directly overlies the Fox Hills sandstone and below a red brick layer where a coal seam has been burnt out. From nearby and at about the same level were collected some invertebrates which have been identified by Dr. F. H. McLearn as *Compeloma producta* and *Unio danæ*.

In the collection of the Geological Survey is a dinosaurian tibia which was collected by Weston from near the head waters of Swift Current Creek. This specimen had not previously been recognized as dinosaurian. No doubt it is from the same horizon as the *Triceratops*, as Weston was collecting from the Oligocene beds which immediately overlie these beds in this locality. The specimen compares very closely with the tibia of *Thespesius* sp. from the Rocky Creek badlands, and there seems to be no question of their identity.

The occurrence of *Triceratops* and *Thespesius* in the beds immediately overlying the Fox Hills sandstone in the Cypress Hills region and the proof of the occurrence of the Lance formation in the Wood Mountain region, coupled with the lithological differences between the upper and lower parts of the "Laramie" as pointed out by McConnell, and others, seem to point to the probability of the lower part of the beds succeeding the Fox Hills in southern Saskatchewan being of Lance age. It is quite probable that if systematic collecting were done over all of the area more dinosaurian remains would be found.

Davis⁷ recently divided the Fort Union into three divisions which he calls Estevan beds, Whitemud beds, and Ravenscrag beds. The Estevan beds directly overlie the Fox Hills from Wood Mountain plateau east to Estevan, Sask., and include the Lance formation on Rocky Creek, but are, he believed, absent in the Cypress Hills region. The Whitemud beds succeed the Estevan beds in the east but lie directly on the Pierre and Fox Hills in the Cypress Hills region. The Ravenscrag beds correspond to the upper division throughout the region. He says, "Whether the lower beds belong to the Lance formation has yet to be definitely established".

If Davis is correct in making this separation the two lower divisions should appear in the Cypress Hills, although the lower one, the Estevan beds, has not been recognized, but its presence seems proven by the discovery of *Triceratops* as noted above, in beds recognized as Whitemud. It is possible that the character of both divisions has

⁷Davis, N. B.—*Rept. of the Clay Resources of Southern Saskatchewan*, Dept. of Mines, Ottawa, Mines Br., No. 486, 1918, pp. 7-11.

⁶Loc. cit., pp. 327-331.

changed in the western extension so that the separation which was made at Estevan can not so clearly be made there. Therefore the Whitemud beds as well as the Estevan beds must, on palæontological grounds, be considered of Lance age.

The occurrence of the Lance formation in Saskatchewan marks the most northerly extent of that formation so far reported. The most recent

brackish water deposits to the north and west of the Cypress Hills are the Edmonton formation, the fauna of which has an older aspect than that of the Lance. This seems to indicate that by Lance time the Cretaceous sea had retreated considerably to the south, with only a small area extending north of what is now the international boundary.

THE CANADA GOOSE AT HOME

BY A. D. HENDERSON



HE Canada Goose is such a well-known bird that perhaps little that is new can be written of its habits. I have found these birds breeding on the Saskatchewan, Pembina and Athabasca Rivers, but my best opportunity of observing them occurred in 1917 and 1918 in the Battle River District, about eighty miles north of Peace River town; and I found some of their actions extremely interesting.

At Battle River the arrival of the Canada Geese was an event eagerly looked forward to in the spring. The date of arrival, according to reports made to me, was the first week in April, though April 8th is my own record for first arrival in 1918. For days before their coming the Indian and halfbreed children can be heard practicing the honk, which they imitate to perfection. *Ah-unk! Ah-unk!*

However, though Goose is a change from the staple diet of moose meat, they are tough and dry eating in the spring, and on our hunting trips we would never waste a .30-30 shell on them as long as we could get Beaver, which to my notion is the best meat to be had in the woods. The Geese breed on the small gravelly islands in the Battle River and its two tributaries, known at that time as the Second and Third Battle Rivers. Since then the country has been surveyed and new names given to all three. Another favorite breeding place is in old beaver dams, where they nest on the old sunken beaver-houses, which in course of time have flattened down into small, grass-covered islets. Even inhabited beaver-houses are used as nesting sites, as my halfbreed hunting partner on one of our trips took five eggs from a nest on a large beaver-house in an old river-bed of the Third Battle, which we repeatedly saw entered and left by a family of beaver, showing that the Geese and beaver live together in amity.

They also nest in trees, as he told me that on one occasion while watching for beaver higher up on the Third Battle he saw a Goose fly to a large nest in a spruce tree. A halfbreed's interest in

eggs of any kind lies wholly in his stomach, so he climbed to the nest and had eggs to eat for several meals.

The 28th of April, 1917, is the earliest record I have of eggs. A nest was found on that date, containing two eggs, on a low, grassy islet in a flooded beaver meadow. The 12th of May was the date my partner took the five eggs from the nest on the inhabited beaver-house mentioned before. On May 18th I found a nest containing seven eggs, on a low, grassy islet, probably a very old beaver-house, in the same flooded beaver meadow. The nest was made of grass and was lined with finer grasses and feathers. The sitting bird permitted a near approach, with her head and neck stretched out straight in front of her and lying flat along the ground, watching my approach. This appears to be the usual behaviour when the nest is approached during incubation. We saw two other nests on this day, one containing three eggs, on a small grassy islet in the same beaver meadow, and another on an island in the Third Battle, with six eggs.

These great birds are very tame on the breeding grounds compared with the wary birds we see during the migrations. On one occasion I went up the Third Battle to an old river bed to watch for beaver, arriving there about four o'clock in the afternoon. When I arrived there were eleven Canada Geese sitting in the end of the river bed. I selected a favorable spot and sat down near the beaver-house, about eighty yards from them. In a few minutes another Goose alighted at the other end of the river bed and swam down to within forty yards of me, calling all the time and being answered by one of the eleven. They all flew, however, at the report of my .30-30, when a beaver suddenly appeared on the surface. In a few minutes another pair came sailing in, flying past me at less than twenty yards, and alighting about thirty yards away. They then swam up to within twenty yards, calling occasionally. As it was now getting late and I had seen very fresh grizzly diggings on my way up I concluded it was

time for me to return to camp as I had no great hankering to meet his majesty in the dark.

On June 4th, while walking up the river bank looking for bear, we met a pair of Geese and four goslings on shore and got within twenty yards before they moved. The old birds made a great fuss and flew down to the foot of a rapid and waited on the still water about sixty yards below. The goslings took to the water, which was tumbling and boiling over the stones; swimming and diving, they went down the rapid, under water most of the time, and joined their fond parents below.

On the 12th of June we saddled our two riding horses, threw the hitch on the three pack ponies and started on our last trip around our bear traps. Bear remain prime until about June 15th and it was in the course of bear and beaver hunts in the springs of 1917 and 1918 that I had the opportunity of observing the ways of the Canada Goose here set forth.

On the 16th, just opposite our camp on the Third Battle, I saw two pairs of Geese with four and six goslings each, on a gravel bar below a rapid. (The three Battle Rivers are very swift and full of rocks and rapids.) On seeing me, the old birds swam and waded up the rapid, along the edge where there was little current, the young following, strung out in line behind.

The spring of 1918 found me again on a bear hunt, and one evening, May 23rd, I and my wife camped for the night on a beautiful little flat covered with new green grass just below the mouth of the Second Battle. After taking off the saddles and packs, making camp and having supper, I rode down the river a short distance to where I had noticed a pair of Geese alight and soon saw one standing on a gravelly island. Making a short detour and riding closer I saw both birds lying flat on the gravel, heads and necks outstretched along the ground, precisely as they do on the nest. They were hiding right in the open without the slightest cover. Though I have what is called the hunter's eye pretty well developed, it is doubtful if I would have noticed them if I had not previously known they were there. They remained perfectly motionless and resembled pieces of water-worn driftwood so perfectly that I now understood how it was that, in descending rivers in a canoe, I had so often failed to observe them until they took wing. It was the most beautiful example of protective colouring I have ever seen. As I rode up to the river bank, in plain sight and making a good deal of noise, one bird remained perfectly still and the other moved its head slightly to watch me. I then rode out into the river to within thirty-five yards before they broke the pose and took to flight. I discovered the nest of three

eggs on the lower end of the island. It was a hollow in the sand, lined with small twigs, crumbled leaves and down and the eggs were covered.

On May 26th I examined another nest in a beaver dam about a mile up the river from the last mentioned nest. It was on a very old, flattened-down beaver-house, which formed a small island, and was only a few yards away from an occupied beaver-house. On my approach the sitting bird watched me with head and neck stretched out flat on the ground, as usual. The nest was built on flattened-down marsh hay and was composed of pieces of hay about an inch long and down.

On the 28th, while walking up the gravel banks of the Third Battle hunting bear, I came on a pair of Geese with six goslings, also three other Geese about one hundred yards upstream from them. The three Geese flew on my approach, and the female took her brood across the stream to a point about thirty yards distant. Her mate went upstream, flapping along the water, pretending to be crippled. He would allow me to approach to about forty yards and then flap along the water again for a few yards and wait for me again. He repeated this performance several times, until he thought he had enticed me far enough around the next bend, when he had a marvellous recovery, flying away and giving me the merry *honk! honk!* for being so easy. I am sure he enjoyed the ease with which he fooled me and I enjoyed watching him and letting him think so.

The next day, while riding up the river and making many crossings from bar to bar, I rode within fifteen yards of a Goose before she flushed from her nest of six eggs. This nest was on a gravelly point of the river and not on an island as usual. The eggs seemed just about to hatch. Around the next bend I flushed a Mallard from her nest of ten eggs, also on the point of hatching. This was the only Duck's nest I found in the Battle River District, it being one of the poorest Duck countries I have seen.

Having disposed of my interests at Battle River, I returned to my old home on the Pembina River in July. At one time, beaver must have been very plentiful here, judging by the numerous dams and houses found along every watercourse. Sometimes, when out hunting, I like to sit down near one of these old beaver meadows for a rest and smoke, and try to visualize the scene as it used to be. Instead of the grass-grown meadow, dam and house, I recreate the scene as it was; the miniature lake, the mud-plastered house and dam, the sunken mounds of food sticks, with the beaver swimming among them. Then comes the mighty splash as he slaps the water with his broad tail and dives to safety when he gets your wind.

Also it is not likely that his summer neighbor, the Canada Goose, was absent from the scene.

In 1899, when I first came to the Pembina District, there were still a few pairs of Geese breeding along the river, but now they are practically all gone. I believe that the young always return to breed in the district they were born in and when the Geese on any river are all killed their place is not taken by others, so that when this occurs they are gone for good; and this is

evidently what has happened on the Pembina. Otherwise, we would see them arriving about the first week in April and alighting on river, slough and prairie, the same as they do in the Battle River country, but this is not the case, as only a few stragglers visit us and then pass on to the north. As settlement advances no doubt the same thing will happen in the Battle River country and the Geese and beaver will be things of the past.

LIST OF BIRDS RECORDED FROM THE ISLAND OF ANTICOSTI, QUEBEC

By HARRISON F. LEWIS

(Continued from page 46)

24. *Phalacrocorax carbo*. CORMORANT.—*Verrill*: Breeding in large numbers on cliffs at East Point, Anticosti. No Double-crested Cormorants identified with them. *Brewster*: Found a breeding colony of about 20 nests at Wreck Bay. *Schmitt*: Summer. Rather common. With *P. auritus*. Found especially in the eastern part of the island. Fox Bay.

The present status of this species on Anticosti is uncertain, but it is probable that some breeding colonies still exist there.

25. *Phalacrocorax auritus auritus*. DOUBLE-CRESTED CORMORANT.—*Verrill*: None identified at Anticosti, but may possibly breed there. *Brewster*: Not found breeding. *Schmitt*: May-September. Fairly common. Nests on the island, at the top of the cliff at Bird Bay. *Dionne*: Fairly common. *Brooks*: The few Cormorants I noted were at such a distance that identification was impossible.

26. *Mergus americanus*. MERGANSER.—*Combes*: Lists this species without comment. *Schmitt*: Summer. Rather rare. *Brooks*: A few were noted in the summer of 1919 by Prof. W. H. Twenhofel, of the University of Wisconsin, during his paleontological expedition around the island.

27. *Mergus serrator*. RED-BREASTED MERGANSER.—*Verrill*: Very common. Nest with 6 eggs found July 17. Young seen by July 3 and some captured August 12. *Brewster*: Abundant. *Schmitt*: Arrives on the coast in May and disappears almost at once; reappearing only in September. In the interval it has nested in the interior of the island, where all summer long it is very numerous along the rivers. At Jupiter River, at the 51st kilometer, found a nest with fresh eggs, July 20, 1903. Some Mergansers remain all winter around the island. *Dionne*: Common. *Brooks*: A common bird in Anticosti, breeding in all suitable parts of the island.

28. *Lophodytes cucullatus*. HOODED MER-

GANSER.—*Brooks*: Several seen in the summer of 1919 by Prof. W. H. Twenhofel.

29. *Anas rubripes*. BLACK DUCK.—*Verrill*: Very abundant. Young seen by July 3rd. *Brewster*: Common. A brood of young with mother seen at Wreck Bay. *Schmitt*: March-October. Very common. Some always winter at points on the rivers kept open by water from springs. *Dionne*: Very common. *Brooks*: Very common. *Lewis*: At Ellis Bay saw 4 June 14 and 5 June 15. *Johansen*: A flock of Black Ducks at Shallop Creek, August 7, 1923.

30. *Chaulelasmus streperus*. GADWALL.—*Verrill*: A few specimens were seen. A young one, about half grown, was caught near the middle of July.

In a letter dated December 6, 1923, Prof. Verrill says that the young Gadwall mentioned above was presumably preserved as an alcoholic specimen in the Museum of Comparative Zoology, Cambridge, Massachusetts. He considers it likely that this specimen was destroyed during the years following the American Civil War, owing to the high price at that time of the alcohol necessary for replenishment of the supply in the containers. The director of the Museum of Comparative Zoology courteously informs me that he is unable to trace this specimen at present.

In a letter dated February 25, 1924, Prof. Verrill says, concerning the field-diary containing notes made on his visit to Anticosti in 1861, "... on Aug. 6 ... I recorded that he [the captain] and Mr. Upham Treat, one of our party, had shot ... 'one gray duck (*Chaulelasmus streperus*)' ". That, he makes clear, was not the young one mentioned in his printed list. The diary does not say what was done with it.

31. *Nettion carolinense*. GREEN-WINGED TEAL.—*Schmitt*: Summer. Rare. On the southern coast, principally between South-west Point and East Point. *Dionne*: Rare; found only one

pair with 9 young. *Brooks*: On August 26, 1919, near Little River, a flock of about 30 flew very close to me.

[Hypothetical. *Querquedula discors*. BLUE-WINGED TEAL.—*Brewster*: Fishermen at Fox Bay said it occurred in small numbers during migration.

This does not appear to me to furnish sufficient basis for the inclusion of this species in the formal list.]

32. *Dafila acuta tzitzihoa*. AMERICAN PINTAIL.—*Schmitt*: End of April-beginning of November. Rare. Especially on the coast at South Point. Nests on the island.

Prof. Verrill, in a letter dated February 25, 1924, states that in the field-diary containing notes made on his visit to Anticosti in 1861 the list of Ducks shot by the Captain of his vessel on August 6 includes "Two pin-tail ducks (*Dafila acuta*)".

33. *Marila americana*. REDHEAD.—*Schmitt*: In migration. Rare.

34. *Marila marila*. SCAUP DUCK.—*Schmitt*: Seen only in spring, for nearly a month, associating with the Old-Squaw. *Lewis*: On Lake Gamache, at Ellis Bay, I saw 12 Scaup Ducks (sp.?) on June 10 and 5 on June 14.

35. *Marila affinis*. LESSER SCAUP DUCK.—*Schmitt*: Autumn. Winter. Spring. Rather rare. Some nest on the island.

Mr. Dionne assures me that *Schmitt* submitted specimens of both Greater and Lesser Scaup Ducks to him for identification.

36. *Marila collaris*. RING-NECKED DUCK.—*Schmitt*: May. Rare. One specimen killed May 26, 1902.

37. *Glaucionetta clangula americana*. GOLDEN-EYE.—*Verrill*: Common. Young ones, about one-third grown, were caught July 19. *Schmitt*: Fairly common throughout the year. *Dionne*: Common. *Brooks*: Noted several on Lake Gamache at Ellis Bay during the last week of August.

38. *Glaucionetta islandica*. BARROW'S GOLDEN-EYE.—*Schmitt*: Autumn. Winter. Spring. Fairly common. Some always nest on the island in spring. More numerous spring and autumn than in winter.

Mr. Dionne assures me that *Schmitt* submitted specimens of both the American Golden-eye and Barrow's Golden-eye to him for identification. Confirmation of *Schmitt*'s statement that the latter species nests on Anticosti is desirable.

39. *Clangula hyemalis*. OLD-SQUAW.—*Verrill*: Very common. Breeds abundantly. The males were seen in small flocks by themselves during the whole time that we were at the island. *Brewster*: A few individuals, doubtless barren birds, observed at East Point, July 7. *Schmitt*: Arrives in September, passes the winter, and

leaves at the end of April. Does not nest on the island. *Dionne*: Common transient. *Lewis*: One at Ellis Bay, June 13, 1922.

Doubtless this species was more common at Anticosti at the time of *Verrill*'s visit than it is to-day, but evidence to substantiate his assumption that the species breeds on the island appears to be still lacking.

40. *Histrionicus histrionicus histrionicus*. HARLEQUIN DUCK.—*Brewster*: Residents of Fox Bay said it occurred there in winter. *Schmitt*: Summer. Rare. A few in the South Point region.

[Hypothetical. *Camptorhynchus labradorius*. LABRADOR DUCK.—*Combes*: Lists this species; gives no supporting evidence. *Schmitt*: Undoubtedly occurred formerly, since we are on its migration route. In 1903 *Schmitt* showed a plate of the species to Placide Duguay, formerly a fisher at Anse aux Fraises, who said that his father (deceased at the time of the conversation) had killed a drake like that 15 years before. It was in company with a gray Duck, supposed to be its mate. He stuffed the drake, but some years later it was destroyed by a cat. It had been killed early in the spring. Duguay later claimed to recognize a water-color of the species.

I do not find this evidence sufficient for the inclusion of the species in the list. Of course, no specimen of this species was submitted to Mr. Dionne for identification.]

41. *Somateria mollissima borealis*. NORTHERN EIDER.—*Schmitt*: Arrives in September and leaves at the end of April or beginning of May. Fairly common.

41a. *Somateria mollissima dresseri*. EIDER.—*Verrill*: Common about Anticosti. *Combes*: Was given the skin of a female by M. Malouin, keeper of West Point light. *Schmitt*: Like the preceding. Very common. *Dionne*: Very common, especially in autumn and winter.

42. *Somateria spectabilis*. KING EIDER.—*Verrill*: Saw a skin in the possession of the light-keeper at South-west Point, who said they were not uncommon. *Brewster*: Described by residents of Anticosti as common in winter. *Schmitt*: Like the preceding. Fairly common. *Dionne*: Fairly common.

43. *Oidemia americana*. SCOTER.—*Schmitt*: Arrives end of May or beginning of June and remains about a month. Rather rare. *Dionne*: Observed several times.

44. *Oidemia deglandi*. WHITE-WINGED SCOTER.—*Brewster*: Observed at East Point. *Schmitt*: Arrives and leaves like the preceding. Fairly common. *Lewis*: One at Ellis Bay, June 13, 1922.

45. *Oidemia perspicillata*. SURF SCOTER.—*Schmitt*: Like the preceding. Fairly common. *Dionne*: Common spring and fall. *Lewis*: One at Ellis Bay, June 13, 1922.

46. *Chen hyperboreus nivalis*. GREATER SNOW GOOSE.—*Schmitt*: Summer. Rather rare. Observed from time to time on any part of the coast, but always young birds in gray plumage.

Mr. Dionne assures me that Schmitt submitted specimens of this subspecies to him for identification. See also below under White-fronted Goose.

[Hypothetical. *Anser albifrons gambeli*. WHITE-FRONTED GOOSE.—Schmitt: September 10, 1902, I was at Ellis Bay when a flock of Canada Geese (*Branta canadensis*) passed a short distance above my head. Among them was a white Goose with a little black in the wings. I thought that it was a specimen of the White-fronted Goose, although I would not be positive about it.

No specimen of this species was submitted to Mr. Dionne for identification. The bird described above by Schmitt was presumably an adult Snow Goose.]

47. *Branta canadensis canadensis*. CANADA GOOSE.—Verrill: Breeds in large numbers in interior, about shores of lakes. Brewster: Breeds abundantly in interior. Samuels: I conclude here with Mr. [William] Couper's notes on the following species, made at Quebec, Lower Canada: "*Bernicla canadensis*. . . . A few breed in Anticosti." Combes: Listed, with the statement that some are kept in domesticity. Schmitt: End of March to first fortnight of November. Very common. Nests in the interior of the island. Dionne: Very common in summer. Brooks: Breeds abundantly and during my stay many were flying back and forth between Ellis Bay and the interior. Lewis: Saw 16 at Ellis Bay, June 10.

48. *Branta bernicla glaucogastra*. BRANT.—Schmitt: Occurs from Bescsie River to Ellis Bay. Fairly common. Arrives at the end of May and leaves at the first spring tides in June, when it goes due North. Dionne: Migrant spring and fall. Lewis: At Ellis Bay saw large flocks, totalling 3,000-4,000 birds, on migration on the evening of June 10, 1922.

[Hypothetical. *Olor columbianus*. WHISTLING SWAN.—Schmitt: A fisherman thought he saw a Swan in a lake near the sea, but the occurrence, which was not repeated, lacks certainty.

This species is not entitled to be included in the list without further evidence. No specimen of this species was submitted to Mr. Dionne.]

49. *Botaurus lentiginosus*. BITTERN.—Verrill: Common. A young one caught August 4. Schmitt: Summer. Rather common. Nests on the island. Dionne: Common. Brooks: Not uncommon summer resident.

50. *Ardea herodias herodias*. GREAT BLUE HERON.—Verrill: A large Heron, which appeared to be of this species, was seen at Ellis Bay. Schmitt: Summer. Rare. One killed at Ellis Bay, another seen at Shallop River. Dionne: Very rare, observed only one.

51. *Porzana carolina*. SORA.—Schmitt: Summer. Rare. One specimen, killed by M. Malouin, who gave it to me, on the plains at West Point. Dionne: Rather rare, only one seen.

52. *Gallinula chloropus cachinnans*. FLORIDA GALLINULE.—Schmitt: Summer. Rather rare. Borders of creeks and lakes.

One or more specimens submitted to Mr. Dionne for identification.

53. *Fulica americana*. COOT.—Schmitt: Summer. Rare. Borders of bodies of water.

One or more specimens submitted to Mr. Dionne for identification.

[Hypothetical. *Phalaropus fulicarius*. RED PHALAROPE.—Schmitt: Summer. Rare.

No specimens of this species were submitted to Mr. Dionne for identification. Under the circumstances it seems best to record it as hypothetical until further evidence is available.]

54. *Lobipes lobatus*. NORTHERN PHALAROPE.—Brewster: A flock seen and specimens taken between Cape Rosier (Gaspé) and Anticosti "about thirty miles to the northward of Cape Rosier". Schmitt: Irregular. Rather common. Not seen at all in certain summers. One specimen, killed June 9, 1902.

55. *Steganopus tricolor*. WILSON'S PHALAROPE.—Schmitt: June. Very rare.

Mr. Dionne assures me that Schmitt submitted a specimen of this species to him for identification. Its occurrence on Anticosti must have been purely accidental.

[Hypothetical. *Rubicola minor*. WOODCOCK.—Brewster: Mr. E. G. Gardiner thought he flushed one near Fox Bay, but the foliage was so dense that he did not get a clear sight of it.

This species is to be expected on Anticosti, but it should not be included in the list without stronger evidence than that given above.]

56. *Gallinago delicata*. WILSON'S SNIPE.—Combes: Saw several near River and Lake Gamache and near Great Salt Lake. Schmitt: Occurs particularly from the beginning of August to the end of October. Common. Dionne: Common. Brooks: I flushed a considerable number of Snipe in various boggy situations. Lewis: One observed at Ellis Bay, June 10.

57. *Calidris canutus*. KNOT.—Schmitt: September. Rare.

58. *Pisobia maculata*. PECTORAL SANDPIPER.—Schmitt: End of August to end of September. Some remain longer. Has been observed November 12, 1902. Dionne: Very common.

59. *Pisobia fuscicollis*. WHITE-RUMPED SANDPIPER.—Verrill: Abundant in large flocks on beach, August 14. Probably breed in interior. Schmitt: Autumn. Fairly common. Dionne: Very common. Brooks: I noted this species in abundance during the last week in August.

Verrill's surmise that this species breeds in Anticosti, for which there appears to be no sufficient basis, is probably incorrect.

60. *Pisobia minutilla*. LEAST SANDPIPER.—Verrill: Large number seen near Ellis Bay, where thought to be nesting. Brewster: A few observed daily along the beaches at Fox Bay. Schmitt: August 15 to September 15. Very common. Brooks: During the latter part of August and early September they were quite common along the shores of Ellis Bay and vicinity.

61. *Ereunetes pusillus*. SEMIPALMATED SANDPIPER.—Schmitt: Seen occasionally in June, but much more common in autumn. Fairly common.

62. *Crocethia alba*. SANDERLING.—Schmitt: End of August to end of September. Some nest on the island. Dionne: Very common.

Schmitt's statement that this species nests on Anticosti cannot be accepted without supporting evidence.

63. *Totanus melanoleucus*. GREATER YELLOW-LEGS.—Verrill: Common. Brewster: Abundant. Circumstantial evidence of breeding. Schmitt: End of April to end of September. Nests on the island. Dionne: Common. Brooks: Noted great numbers about Ellis Bay, especially August 26 and 27. Lewis: Not common at Ellis Bay June 10-16, 1922. Johansen: Flocks in lagoon at Fox River, August 6, 1923.

64. *Tringa solitaria solitaria*. SOLITARY SANDPIPER.—Schmitt: Seen about the borders of the marshes in the spring. Rather rare. Brooks: Saw one individual on a small stream running into Ellis Bay on August 28.

65. *Actitis macularia*. SPOTTED SANDPIPER.—Verrill: Common. Breeds. Brewster: Abundant. Combes: Lists this species without comment. Schmitt: May-October. Fairly common. Nests on the island. Brooks: Common. "On one occasion a bird flying along the shore about twenty yards off the beach was attacked by a Pigeon Hawk that had swooped down from a nearby spruce. The Sandpiper in great terror alighted upon the water, diving just as the Hawk thrust down its talons. Remaining under water four or five seconds it came to the surface, and, seeing the Hawk flying on its way, swam leisurely to the beach." Lewis: Not common at Ellis Bay, June 10-16, 1922.

66. *Numenius hudsonicus*. HUDSONIAN CURLEW.—Brewster: Several large flocks of Curlew, supposed to be of this species, seen at East Point, July 7. Schmitt: Arrives in groups of 20 to 30 at the end of August and remains 2 or 3 weeks. Rather rare. Does not come every year. Dionne: Fairly common.

Mr. Dionne informs me that Schmitt submitted no specimens of this species to him for identification.

[Hypothetical. *Numenius borealis*. ESKIMO CURLEW.—Schmitt: Beginning of September. Rare.

Mr. Dionne informs me that Schmitt submitted no specimens of this species to him for identification, and in view of the ease with which this species may be confused with the preceding it seems best to leave this species as hypothetical for the present.]

67. *Squatarola squatarola cynosuæ*. AMERICAN BLACK-BELLIED PLOVER.—Schmitt: End of August. Commencement of October. Fairly common. Dionne: Fairly common. Brooks: Black-bellied Plovers were seen in considerable number about Ellis Bay during the last week of August.

68. *Pluvialis dominica dominica*. GOLDEN PLOVER.—Schmitt: End of August—end of September. Fairly common. Dionne: Fairly common.

69. *Oxyechus vociferus vociferus*. KILL-DEER.—Dionne: A single one seen.

In a letter dated January 11, 1924, Mr. Willie LaBrie has kindly furnished me with the following details of the observation recorded by Dionne: "I saw one only, which was in company with ten Semipalmated Plovers, on the beach at Anse aux Fraises. I no longer recall the exact date, but it seems to me that it was toward the end of August, 1913. I have no doubts about its identification, for I saw this bird near enough to observe its size and the large rufous area on the rump and tail."

70. *Charadrius semipalmatus*. SEMIPALMATED PLOVER.—Dionne: Common, especially in autumn. Brooks: A small flock of these Plover was seen near Little River on August 26.

[Hypothetical. *Charadrius melodus*. PIPING PLOVER.—Combes: At Gamache (Ellis) Bay and at Fox Bay. Schmitt: End of August—end of September. Rather rare. Dionne: Rare, observed in autumn only.

Mr. Dionne informs me that Schmitt submitted no specimens of this species to him for identification. Neither Combes nor Schmitt mention the Semipalmated Plover, upon observation of which species it is not improbable that their records of the Piping Plover are based. In a letter dated January 11, 1924, Mr. Willie LaBrie has kindly furnished me with the following details concerning the observation, made by him, upon which the record published by Dionne is founded: "I saw a flock of 15 or 20 individuals of this species at Anse aux Fraises, about October 15, 1916, during a strong north-west storm, accompanied by snow. I recognized these little Plovers by their being much paler in color than the Semipalmated (which has already departed by that date) and by the black patches on the sides of the breast. These Plovers were not shy and I was able to approach to within a dozen paces of them." This species is known to occur in the Magdalen Islands and at Natashquan, on the north shore of the Gulf, so that it ought to visit Anticosti, and Mr. LaBrie's detailed observation inclines me to its acceptance. But as the date of the observation is unusually late in the year, and as Mr. LaBrie had apparently had no previous field experience with the Piping Plover, it seems best to leave the species in the hypothetical list for the present.]

71. *Arenaria interpres morinella*. RUDDY TURNSTONE.—Schmitt: End of August—end of September. Fairly common. Dionne: Common in autumn. Brooks: Several were seen August 26, a few miles east of Ellis Bay.

(To be continued)

NOTES AND OBSERVATIONS



ANOTHER MYSTERY BAND.—The Canadian National Parks Branch, which is keeping the file of Canadian Bird Banding Records, has recently received a band of a kind differing from the official bands being used in Canada and the United States, and an endeavour is being made to trace the origin of this band.

It is made of aluminum and has the number "57" stamped on it. Mr. Arthur Shuttleworth, of Plummer, Ontario, is the person who made the recovery in this instance, finding the band on a young "Teal Duck," which he shot on Cariboo Lake, in the Township of Plummer, District of Algoma, Ontario, on September 12, 1923.

A sketch of the band is shown with this article and the band itself will be lent to responsible persons who consider that they may be able to furnish information concerning it.—HOYES LLOYD.

BATS IN WINTER.—January 11th, 1924, on leaving my office in the Victoria Memorial Museum at noon I noticed a bat flying about the upper stories and cornice of the large laundry building on Argyle Ave., near Bank Street, Ottawa. The day was fairly cold but clear and bright. Perhaps the unseasonable mild weather and bright sun combined had penetrated its recess and awakened it from its usual hibernation—or workmen may have disturbed it. As I approached, it disappeared about the corner of the building; when I arrived at a point where I could view the other wall it could be seen clinging to the brickwork and uneasily hunching about as if searching for a more comfortable spot. In a moment it dropped away and fluttered to the front of the building where, as I left, it was still vainly searching for a crevice in the solid galvanized cornice, whose irregular surface seemed to offer prospects of snug crannies.

That bats do not always hibernate continuously through the winter or do occasionally awaken is evident from experiences that we have had with them in the house. In our residence, bats gain access in some way to the space between the attic floor and the ceiling below. Irregularly through the winter we can hear them stirring about overhead, not always in the milder weather but often

when it is coldest. The attic itself is always very cold, the rooms below at living temperature. What it is between the joists I do not know; probably somewhere between the two, and in this modified temperature the sleep of the animals is obviously not very sound and they have periods of activity. Occasionally one works into the attic and down into the rooms below, when it flies about with full strength as in summer. The noise made by them in the floor space is sometimes remarkably loud and at times we have found it hard to convince ourselves that there were no rats running about on the lath. Lately, however, when one was seen and heard literally running over the floor of a bedroom, the same sound was made, which laid at rest any slight doubt that remained. All these winter bats that I have seen seem to be the common Brown Bat, *Myotis lucifugus* (Le Conte), and no other species has been recognized by me here in the winter.—P. A. TAVERNER.

BREEDING OF THE TURKEY VULTURE IN EASTERN MANITOBA.—From July 2 to July 25, 1923, near the eastern end of Long Lake, Township 22, Range 15, east of the Principal Meridian, and about 100 miles northeast of Winnipeg, I observed two large birds, black to bluish black, with bald red heads and medium long crooked bills. They had a wing spread of 3 feet or more, and when flying they glided a great deal, instead of flapping their wings as most other birds do. They used to roost on top of a rampike or some other high tree in the mornings and evenings, sometimes both together, but generally only one at a time.

The local prospectors called them "Turkey Buzzards" and told me that two similar birds were in this region in 1916, and that in that year they hatched three young ones. Information that I obtained from local Indians was to the effect that these birds are not very frequent visitors to this part of Manitoba.

The rocks of this area are pre-Cambrian, and this appears to be the first known breeding of the Turkey Vulture on the great pre-Cambrian "shield" of North America.—J. F. WRIGHT.

CHANGE IN NAME OF TORONTO NATURALISTS' CLUB.—In *The Canadian Field-Naturalist* for March, 1922, the organization of the Toronto Naturalists' Club was announced. More recently there has been founded a Toronto Field-Naturalists' Club, affiliated with the Ottawa Field-Naturalists' Club. The two clubs have no official connection, although most of the members of the earlier club are also members of the Toronto Field-Naturalists' Club. To avoid confusion the To-

ronto Naturalists' Club has adopted the name The Brodie Club. Dr. William Brodie, after whom the club is named, was one of the best loved of the earlier Toronto naturalists. By profession he was a dentist, but every minute he could spare from his profession was spent in the study of natural history and in building up a collection of natural history specimens. In 1903 he gave up his professional work to take charge of the Biological Department of the Provincial Museum. He died in 1909 at the age of seventy-eight. He left little in the way of published works but he had the gift of inspiring others, especially the young, with a love for nature, so that many working naturalists of to-day owe their early inspiration to him. The Brodie Club is a small organization, the membership being limited to twenty. It meets every other week from September to May in the Royal Ontario Museum of Zoology. Following are the present members: J. L. Baillie, N. K. Bigelow, J. R. Dymond, J. L. Hart, T. B. Kurata, A. Leonard, W. LeRay, E. B. S. Logier, H. H. MacKay, Chas. Richards, L. L. Snyder, L. Sternberg, Stuart Thompson. Corresponding member, W. J. K. Harkness. Honorary members, Prof. B. A. Bensley, J. H. Fleming, C. W. Nash, Prof. E. M. Walker, W. E. Saunders.—J. R. DYMOND.

NOTE ON THE FOOD OF THE RUFFED AND SPRUCE GROUSE.—During the past two seasons I had opportunity to examine the crops of a number of Ruffed Grouse and one Spruce Grouse, and as the results appear to be worth recording I append them. These birds were all shot within a thirty-five mile radius in the vicinity of La Barriere and St. Michel des Saints, in Berthier County, Que.

Approximate percentages of the crop contents of six Ruffed Grouse shot between October 14 and October 24, 1922: wintergreen berries, 40%; beech nuts, 30%; birch seeds and buds, 15%; leaf particles, 5%; moosewood samaras, 5%; undetermined, 5%.

Approximate percentages of the crop contents of ten Ruffed Grouse shot between October 20 and November 10, 1923: birch seeds, 50%; birch buds, 20%; alder seeds, 10%; poplar buds, 5%; fern leaves (spinulose Wood Fern)*, 5%; wood sorrel leaves, 5%; undetermined, 5%.

One Spruce Grouse shot in jack pine growth near St. Michel, on November 8th, 1923, had been feeding entirely on jack pine needles. On this date there was a little snow on the ground, which may have had an influence on this bird's choice of food; otherwise the light snowfall prior to this date could scarcely have had any great bearing on

the food supply of the Ruffed Grouse during either season, although crops of birds secured in October of this year held a greater proportion of green leaves than those secured later. Undoubtedly, however, the contrast in the nature of the food taken during the two periods reflects conditions pertaining to the seasons under consideration—an abundance of berries and seeds in the autumn of 1922, and a corresponding dearth following the dry summer of 1923.—L. MCI. TERRILL.

DR. AMI'S LECTURE ON PREHISTORIC MAN.—In the Normal School Auditorium, Ottawa, on Monday evening, February 25th, 1924, Dr. H. M. Ami gave an interesting and educational address on "Prehistoric Man, His Habitations and Arts." This lecture was under the auspices of the Ottawa Field-Naturalists' Club, and Mr. Hoyes Lloyd, President of the Club, was chairman. By way of introduction, Dr. Ami briefly described a few of the activities of the Ottawa Field-Naturalists' Club some 20 or 30 years ago, and showed about 15 coloured lantern slides taken on the various excursions of the Club at that time.

Dr. Ami has recently returned from France, Spain and England, where he has been investigating the sites of the homes of Prehistoric Man. On this investigation, Dr. Ami collected and brought back for the Victoria Memorial Museum a great many specimens, as well as many photographs. This lecture was illustrated by more than 100 colored lantern slides showing the rock-shelters which were the homes of Prehistoric Man, the important skeletons found to date in or near these rock-shelters, and the numerous implements, carvings, and drawings of these very old men. The Chateau des Eyzies, in the Dordogne country, was described in detail, as this locality has been called "the palæolithic capital of Western Europe" and Dr. Ami emphasized that this was certainly one of the cradles of modern man, of modern culture, and of modern art. The recent important investigations and advances in the study of human palæontology were also briefly outlined. Dr. Ami's lecture gave a very clear, brief statement of this branch of research, and of the important conclusions to date.—J. F. WRIGHT, *Secretary*.

NOTE ON *Papilio cresphontes*.—During the summer of 1922 I spent a few days at the country home of a friend who is an enthusiastic collector of butterfly-fies. She told of having seen a Giant Swallowtail (*Papilio cresphontes*) in the garden a short time before, hovering over a plant of *Dictamnus fraxinella*. We went up to see if it had laid any eggs and were delighted to find a number of caterpillars which we put into a box and which in due time hatched out.

*Identified by Mr. H. Mousley.

This summer (1923) a friend here in London, Ontario, knowing I was interested in butterflies, told me one day of having seen a Giant Swallow-tail in his garden. As he had a number of clumps of the Gas Plant I went around in the course of a few days and found, as I had hoped, a number of the larvæ busily engaged on it. I brought some of them home and they duly spun and hatched. I am sorry I kept no data as to the time between spinning and hatching, which might perhaps have been of interest.

From the foregoing it would appear that this butterfly, which has been extending its range northward, has found in the Gas Plant (*Dictamnus fraxinella*), in our neighborhood, at least, a plant to its liking.—(MRS.) ETHEL G. DALE.

The following letter is published as being of interest because of the unusual lateness of the records given.—EDITOR.

EDITOR, *The Canadian Field-Naturalist*,
Ottawa, Ont.

Dear Sir:—

As Honorary Game Guardian for this part of Northern Alberta, I recently reported to the Canadian National Parks, Wild Life Division, that I had noted grey Geese and Mallard Ducks on the lakes in this district as late as the 17th day of December.

The Supervisor of this Department has written me suggesting that I write you a few lines in regard to same, giving details of such, which may be of interest to your publication.

On December the 11th, whilst making Fisheries patrol of the Whitefish Lakes, some forty miles north of Lesser Slave Lake, I noted a flock of about 20 Mallard Ducks, at the outlet of Little Whitefish Lake, which is the head of Narrows Creek, and connects with Big Whitefish Lake. This Creek was open at the time, although the lake was frozen over. There were a number of smaller Ducks there also, but I was not close enough to distinguish what species.

On December the 17th, on the south shore of Lesser Slave Lake, east of the Narrows, I was informed that a flock of grey Geese had been seen there in the open water as a part of the lake there had not yet frozen over.

I personally saw a large number of grey Geese on December the 4th in Auger Bay, Lesser Slave Lake; there must have been at least 200 in this flock.

Yours truly,

S. TRAVERS,

Fishery Overseer.

Grouard, Alta.,

January 24th, 1924.

The splendid pictures of the Black-billed Cuckoo and its nest in this number of *The Canadian Field-Naturalist* were provided through the generous financial assistance of Mr. P. A. Taverner. The illustration of a "mystery band" was kindly provided by the Canadian National Parks Branch. Our thanks in both cases are hereby tendered.—EDITOR.

BOOK REVIEW

ETHNOBOTANY OF THE MENOMINI INDIANS, by
*Huron H. Smith. Bulletin of the Public
Museum of the City of Milwaukee, No. 1, Vol.
4, pp. 1-174, plates 1-36. December 10, 1923.*

Ethnobotany of the Menomini Indians gives a list of plants found in the Menomini country. Plants not known to have Menomini names or uses are included, as it is probable that further investigation will disclose both names and uses, especially medical, for many of them. Where possible, the literal translation of the Indian name is given. The Menomini have Indian names for certain species that have only been recently discovered as valid species by the white man. The Menomini, for instance, have from time immemorial given the Juneberry (*Amelanchier canadensis*) two names, showing that they recognized the difference in the tree long before we did.

The plants have been listed under their Menomini uses as follows: Medicines, foods, fibres, dyes and miscellaneous. Under each of these

captions they are arranged alphabetically by families. In regard to each plant listed the Menomini uses, supposed properties and any known myths are given, also the white man's estimate of the value of the plant as a drug. There is also a finding list of plants arranged by both scientific and English names.

The writer of this monograph having often been called upon to identify plants or parts of plants used by various Indian tribes became interested in the Indian uses. The following contains much material quoted directly from Mr. Smith's interesting bulletin. This may help to characterize it. The use of many plants is rapidly being abandoned by most tribes and knowledge of their ethnobotany will soon be no longer even a memory. Four field trips, each of three weeks' duration, were made to the Menomini reservation in Shawano County, Wisconsin. These periods were in June, October, May and September, in 1921 and 1922. Different periods were necessary because the Indian usually does not recognize the species

he uses at all seasons of the year, any more than most white men recognize plants when they are not in bloom.

Several groups of Menomini talked over the plants obtained, thus affording a check on the Indian name as well as on its different uses. The writer lays no claim to being a linguist, but was able to pronounce the words so that Mr. Alanson Skinner could give him the correct phonetic spelling.

The introduction gives a brief picture of the Menomini, touching on many other subjects as a setting for that of ethnobotany.

The Menomini are of Algonkian stock, and number at present about 1,745. They are typical forest Indians, versed in woodcraft, hunting and agriculture. They are known as the wild rice men. Since our first knowledge of them they have been largely dependent on plants for food and many other uses. Their present reservation contains about 230,400 acres, is well wooded with a large variety of conifers and hardwood, and is well supplied with streams and lakes.

While these Indians are known to be progressive in agriculture, there are yet a number of pagans among them who are well versed in the aboriginal uses of plants for foods, textiles, medicines and various other uses. The outstanding advisors of the tribe are fine old pagans.

Many of the Medicines are worthless, so far as drug value is concerned, but others are valued as drugs by the white man. He even obtained his use of some of them from the Indian. Medicinal history in Menomini lore is inextricably bound up with their religion. The secrets of the medicine lodge are in many ways similar to those of Masonry. Since the Menomini have been taught that the medicines are very valuable, and that it would offend the various spirits to value them lightly, they guard the lore jealously. Though a remedy may be for a trifling ailment, the patient must pay well for the information, even though he be a close friend or relative. For the song, which accompanies the digging of one of the simplest remedies, two ponies and a rig were demanded in one case. There is a proper season for obtaining each medicine, which, so far as the writer observed, coincided closely with the proper time of the white man for gathering drugs when the medicinal ingredients are at their best.

When securing remedies songs are chanted. For instance, "I am inserting my hand into your bosom, Grandmother Earth, to get this root." The medicine man repeats this four times, tells Grandmother Earth why the root was chosen, and how he intends to use it, at the same time asking that she lend her power to the medicine, that it may heal and that she be not displeased. In the

cavity from which the root was taken is left a gift of a little tobacco. Some plants were more powerful than others, and the greater number of plants in a medicine, other things being equal, the more powerful it was supposed to be.

Because of the sanctity of most Menomini medical knowledge, it is difficult to obtain full information on the uses of plants as medicines. The author, like others who have worked on Indian ethnobotany, has come to the conclusion that no white man will ever get all of the data, names and uses of plants from the Indians. No one Menomini has a full knowledge of the uses of plants in his tribe. To get this one would need the co-operation of every pagan family, for they all have different lore handed down to them by word of mouth from their parents. The reviewer has found this to be true among both the neighboring Ojibwa and the far distant Bellacoola of the Pacific coast. That certain plants have been given no Indian names or uses does not necessarily mean that they have no Menomini names and are not used by those Indians. It is a common experience that many such plants are later identified by other individuals of the tribe as powerful medicines.

The foods include nearly every native edible plant, except some of the mushrooms. Several Menomini still gather and make good use of the old-time foods. They prize them above store food. Many old Menomini take pride in telling about the palatable dishes formerly made from native herbs and berries. They say that, in aboriginal times, the food of the tribe was closer to nature and was the same as medicine in that it contained the pure substances occurring in nature. The old people believe that because they have taken up store food they have the white man's diseases. Especially in the spring, they gather native foods and consider them a tonic. This is not confined to Indians.

These foods are becoming harder to find as civilization encroaches on the Menomini, and are becoming of greater monetary value to them. Even wild rice cannot be gathered in large enough quantities to last over the winter. As a consequence, they do not like to sell it and when they do, it sells for ninety cents a pound.

The fibres used from native plants have become almost a thing of the past, being replaced by the white man's manufactured materials, which are usually better and cheaper. The author believes that some of them are not known to the present Menomini and that another ten years will see the end of the native fibre industry among a people who use many automobiles and sewing machines. It is refreshing to learn that the Indian children are encouraged in their art and craft work at the

government industrial school on their reservation to preserve the Indian designs, and the author believes it likely that the government schools rather than Indian parents may be expected to perpetuate Indian art and design.

Strictly speaking, the use of woods for houses, utensils and implements, is not a fibre use, but the author has thought best to list such uses in this section of his paper. The leaf of the Mountain Maple (*Acer spicatum* Lam.) was used for the maple leaf design found in Menomini bead-work and appliqué work. The outer bark of the Spreading Dogbane (*Apocynum androsæmifolium* L.) furnished their finest thread, and Slender Nettle (*Urtica gracilis* Ait.) and Wood Nettle (*Laportea canadensis* (L.)) were used for twine. Nettle and Dogbane were widely used for string in North America, even as far as the Pacific coast.

Plant dyes were apparently all obtained by boiling the part of the plant that yielded the colour—leaves, root or bark. While the use of native fibre has been replaced by the use of the white man's materials, the native plant dyes are still depended upon to a large extent for red, yellow and black.

Under miscellaneous uses the author considers plants used in tanning, for love charms and for sacred or ceremonial uses. In the latter class, much of the information might be regarded as superstition. Much of the tanning was not done with plant material but with animal and mineral matter, yet there are roots and herbs that were used in the preparation of skins with the fur left on to prevent moths and other insects from injuring the furs. The leaf sprays of the cedar (*Thuja occidentalis* L.) were used as we use moth balls, that is, they were put in layers among clothes when they were stored away.

The author frequently exhibits his sympathy for the Indians. In fact his conclusion does not relate to his subject, Ethnobotany, but laments the passing of the old Indian life which he considers was in many respects a happier one than that of the whites.

With this bulletin as a basis, he expects to investigate in like manner the ethnobotany of the Chippewa, Winnebago, Oneida, Sauk and Potawatomi Indians, all of whom are now or were formerly in Wisconsin. Such studies will certainly be welcome. The reviewer for one hopes the author will eventually give us a complete tabulation or cross reference, including a classification, from the standpoint of material culture, to these lists of plants, showing for instance a list of diseases with all the remedies for each. The various decoctions, the various uses of bark, etc., would be of interest. The 36 plates include pictures of typical Menomini Indians and characteristic views of their country. Most of them, however, are

beautiful representations of plants. The paper, printing and book-making are good. The chief use of the bulletin will doubtless be as a book of reference.—H. I. S.

CANADIAN NATIONAL PARKS ASSOCIATION BULLETIN, Number 1. January 1st, 1924.

This interesting Bulletin is devoted to the preservation of the National Parks of Canada. It sets forth clearly that various commercial interests are putting forth great efforts to exploit certain resources in our National Parks, the property of the Canadian people, in the expectation of private pecuniary gain. The application of the Calgary Power Company to dam Spray River and thus flood the basin of the Spray Lakes for a reservoir to be used for power purposes is dealt with in particular, as being the most imminent of such efforts. The granting of such an application to destroy for commercial purposes some of the marvellous scenery of our National Parks would create a precedent which would open the way for the granting of further concessions, thus leading to the spoiling of the National Parks for the purposes for which they were created, namely, the providing of great natural recreation areas, and the keeping inviolate of the wonderful scenery and wild life which they contain.

To assist in meeting this situation the Canadian National Parks Association was formed, with a membership from coast to coast. This Association aims at the preservation of the National Parks of Canada in their entirety for the use of the people of Canada and of the world and at the preservation of their natural beauties for the benefit of mankind, and of the fauna and the flora intact, for educational, scientific, artistic and recreational purposes. The President is Lt.-Col. W. W. Foster, D.S.O., Vancouver, B.C.; the Secretary is Arthur O. Wheeler, Sidney, B.C.; and the Treasurer is Andrew S. Sibbald, Saskatoon, Saskatchewan. Provision is made for various classes of membership for individuals, clubs and associations, with fees ranging from one dollar a year for annual members to fifty dollars in one payment for life members.

An appeal is made in this number of the *Bulletin* for financial support, to enable the Association to become strongly organized and to carry on necessary publicity work. It is also requested that all who favor the preservation of our National Parks in their entirety should make this very clear to their representatives in Parliament.

The cause of the Association is a most meritorious one and the need for its activities is great and urgent. It is sincerely to be hoped that it will obtain the assistance and the success which it deserves.—H. F. L.

CLASSIFIED NOTICES

"THE CONDOR" is a bi-monthly illustrated magazine of Western Ornithology—started in 1899 and now better than ever. Edited by Dr. Joseph Grinnell and published by The Cooper Ornithology Club. \$3.25 per year. *The Condor* is an essential to any student of American Birds. W. Lee Chambers, Business Manager, Eagle Rock, Drawer 123, Los Angeles, Cal.

L. C. Smith & Bro.

Typewriter

Ball bearings in every frictional part of the L. C. Smith insure long life, light touch and easy operation

Ottawa Typewriter Co. Limited

191 QUEEN ST., OTTAWA

Use the Classified Notices to a greater extent.

Eight Lines—One Insertion—One Dollar



Card Filing Systems for Naturalists

As makers of the Library Bureau line of Card Filing Devices in Canada, we are in a position to supply all Naturalists with cards and trays where they can readily index all their observations and notes

Lowe-Martin Ltd.
OTTAWA, CANADA

Printers of The Canadian Field-Naturalist

Publishers of the Autobiography of John Macoun, M.A.

The Crabtree Co.

Artists and
Designers

BLUEPRINTERS
ENGRAVERS
COMMERCIAL
PHOTOGRAPHERS
: PHOTO :
LITHOGRAPHERS

228 Albert Street
Ottawa, Ont.

COAL C. C. Ray Company Limited

BEST QUALITY LOWEST PRICES

46 Sparks St.—Phone Q. 461
OTTAWA

Geo. E. Preston & Sons MERCHANT TAILORS

*We make everything we sell and
guarantee everything we sell*

217-219 Rideau Street, Ottawa

Dr. Mark G. McElhinney

*Dentist to certain of the
cognoscenti*

252 LISGAR STREET, OTTAWA
Telephone Queen 2438

Kindly mention The Canadian Field-Naturalist to advertisers

Prices of Separates

Notes to Contributors, Etc.

Papers for publication should be addressed to the Editor, Mr. Harrison F. Lewis, Parks Branch, Ottawa, or to the appropriate Associate Editor.

Manuscript should be plainly written, typed if possible, on one side of the paper only, with wide spaces between the lines and ample margins. It is urged that special care be used that scientific names are legible, properly formed, and correctly spelled and capitalized.

Galley proof will be submitted to authors resident in Ottawa and proof of leading articles to any other author if requested when manuscript submitted. It is requested that it be corrected and returned to the Editor as quickly as possible.

Authors of leading articles are entitled to twenty-five copies of the number in which they appear, free of charge on application.

Separates of articles as they appear on the page, without any change of make-up will be supplied at the following rates:—

	25	50	100	200	300
1 page.....	\$2.00	\$2.25	\$2.50	\$2.75	\$3.00
2 ".....	3.00	3.25	3.75	4.00	4.25
3 ".....	3.50	3.75	4.00	4.25	4.50
4 ".....	3.50	3.75	4.00	4.25	4.50
5 ".....	4.50	4.75	5.00	5.25	5.50
6 ".....	4.50	4.75	5.00	5.25	5.50
7 ".....	6.00	6.25	6.50	6.75	7.00
8 ".....	6.00	6.25	6.50	6.75	7.00
9 ".....	7.50	8.00	8.75	10.25	11.75
10 ".....	7.50	8.00	8.75	10.25	11.75
Covers extra.....	3.00	3.00	3.00	4.00	5.00

If removal of matter on the pages non-pertinent to the article or changes of make-up are desired, or if insets or other extra work are necessary, special rates will be furnished on application to the Editor.

Applications for separates should be made to the Editor and must reach him not later than with the return of the corrected proof.

Rubber Stamps

FOR

Listing Your Specimens

The more consistent use of rubber stamps will materially assist you in cataloguing the collection of specimens you have spent so much time and trouble in securing. Let us help you.

CAPITAL RUBBER STAMP WORKS

175 NEPEAN STREET
OTTAWA, CANADA

Many More are Wanted on the Subscription Lists

The Membership Committee of The Ottawa Field-Naturalists' Club is making a special effort to increase the subscription list of *The Canadian Field-Naturalist* and we are asking every reader to assist in making the campaign the success it should be.

We would particularly urge the Secretary of each Affiliated Society to bring this matter up at EVERY meeting and secure as many subscribers as they possibly can to a Canadian Publication devoted to the study of Natural History in all its phases.

Use the blank below and forward it to the Treasurer.

CUT OFF HERE

MR. B. A. FAUVEL,
Treasurer, Ottawa Field-Naturalists' Club,
Mounted Police Headquarters,
Laroque Building,
Rideau and Dalhousie Sts.,
Ottawa, Canada.

I enclose One Dollar and Fifty Cents as my subscription to The Canadian Field-Naturalist for one year.

Name.....
(Mr., Mrs. or Miss)

Address.....

City and Province.....

Kindly mention *The Canadian Field-Naturalist* to advertisers

Affiliated Societies

NATURAL HISTORY SOCIETY OF MANITOBA 1923

Hon. Presidents: H. M. SPEECHLY, M.D.; W. G. SCOTT; *President:* PROF. V. W. JACKSON; *Vice-Presidents:* NORMAN CRIDDLE; J. J. GOLDEN; MRS. C. P. ANDERSON; PROF. C. H. O'DONOGHUE; PROF. F. W. BRODRICK; *Treasurer:* MISS HELEN R. CANNOM. **ORNITHOLOGICAL SECTION:**—*Chairman:* A. G. LAWRENCE; *Secretary:* B. W. CARTWRIGHT; *Leaders:* H. M. SPEECHLY, M.D.; J. J. GOLDEN; C. E. KEIGLEY; K. GRANT McDUGAL; R. M. THOMAS. **ENTOMOLOGICAL SECTION:**—*Chairman:* J. B. WALLIS, B.A.; *Secretary:* G. SHIRLEY BROOKS; *Leaders:* L. H. ROBERTS; A. V. MITCHENER, B.S.A.; J. D. SUFFIELD; J. D. DUTHIE; **BOTANICAL SECTION:**—*Chairman:* C. W. LOWE, M.Sc.; *Secretary:* MRS. K. J. MCDUGAL; *Leaders:* JAMES COCKS; PROF. F. W. BRODRICK; DR. G. R. BISBY; H. F. ROBERTS, M. Sc.; **SUBSECTION—MYCOLOGY:**—*Leader:* DR. G. R. BISBY; **GEOLOGICAL SECTION:**—*Chairman:* Prof. R. C. WALLACE; *Secretary:* A. A. MCCOUBREY; **SUBSECTION—PALAEONTOLOGY:**—*Leader:* W. CUTLER; *General Secretary:* A. M. DAVIDSON, M.D., 6 Medical Arts Building.

THE HAMILTON BIRD PROTECTION SOCIETY (Incorporated)

Hon. President: MR. ADAM BROWN; *President:* MR. R. O. MERRIMAN; *1st Vice-President:* DR. H. G. ARNOTT; *2nd Vice-President:* MR. C. D. COOK; *Secretary-Treasurer:* MISS RUBY R. MILLS, Public Library, Hamilton; *Directors:* DR. H. G. ARNOTT; C. D. COOK; DR. J. A. DICKSON; MISS M. E. GRAHAM; MISS RUBY R. MILLS; M. HOLTON; M. JOHNSTON; MRS. F. E. MACLOGHLIN; R. O. MERRIMAN.

NATURAL HISTORY SOCIETY OF BRITISH COLUMBIA, VICTORIA, B.C.

The Officers for the above Society for the year ending March 31st, 1923, are as follows:—

President: W. N. KELLY; *1st Vice-President:* A. R. SHERWOOD; *2nd Vice-President:* C. C. PEMBERTON; *Secretary:* H. T. NATION; *Treasurer:* MISS S. M. THORNTON. *Committee:* MISS C. G. FOX, MISS A. F. GARDINER, MISS I. CATHCART, WM. DOWNES, A. HALKETT. *Auditors:*—J. KEITH WILSON AND F. W. GODSAL. *Trustees:*—REV. R. CONNELL, DR. C. F. NEWCOMBE AND G. HARVEY.

ALBERTA NATURAL HISTORY SOCIETY

Hon. President: HON. GEO. HOADLEY; *Hon. Vice-President:* H. A. CRAIG; G. W. SMITH, M.P.P.; J. J. GAETZ; *President:* C. H. SNELL; *Vice-Presidents:* MRS. W. A. CASSELS; DR. HENRY GEORGE; *Secretary-Treasurer:* MRS. S. PAMELY, Red Deer; *Directors:* MRS. H. GEORGE, Red Deer; MRS. G. F. ROOT, Wetaskiwin; K. BOWMAN, Edmonton; F. S. CARR, Edmonton; D. MACKIE, Edmonton; W. A. CASSELS, Red Deer; S. PAMELY, Red Deer; C. G. S. CROSBY, Red Deer; W. F. HARRIS, Red Deer; H. R. ORAM, Red Deer. *Members qualified to answer enquiries:* *Birds:* MRS. W. A. CASSELS, Red Deer; DR. H. GEORGE, Red Deer; *Mammals:* DR. H. GEORGE, Red Deer; *Fishes:* F. C. WHITEHOUSE, Red Deer; *Flowers:* MRS. H. GEORGE, Red Deer; *Insects:* Coleoptera, F. C. CARR, 11050 123rd St., Edmonton; Lepidoptera, K. BOWMAN, 9914 115th St., Edmonton; Odonata, F. C. WHITEHOUSE, Red Deer.

The meetings of this Society are held in Red Deer on the last Friday of each month except during July and August and perhaps September. The annual meeting is held in Red Deer on the last Friday in November.

McILWRAITH ORNITHOLOGICAL CLUB, LONDON, ONT.

President: T. D. PATTERSON, 562 Waterloo Street; *Recording Secretary:* MRS. E. H. MCKONE, Worthy Road; *Corresponding Secretary and Treasurer:* E. M. S. DALE, 297 Hyman St.; *Members qualified to answer questions:* W. E. SAUNDERS, 240 Central Ave.; C. G. WATSON, 201 Ridout St. South; J. R. McLEOD, 355 Worthy Road; J. F. CALVERT, 461 Tecumseh Ave.; E. M. S. DALE, 297 Hyman St.

VANCOUVER NATURAL HISTORY SOCIETY

Hon. President: L. S. KLING, LL.D., Pres. University of B.C.; *President:* JOHN DAVIDSON, F. L. S., University of B.C.; *Vice-President:* FRID PERRY; *Hon. Secretary:* C. F. CONNOR, M.A., 3529-W. 2nd Ave., Vancouver, B.C.; *Hon. Treasurer:* A. H. BAIN, 2302 York St., Vancouver, B.C.

Fortnightly meetings in the University Buildings from September to April (inclusive). Semi-monthly excursions from May to August (inclusive).

PROVINCE OF QUEBEC SOCIETY FOR THE PROTECTION OF BIRDS

Hon. President: I. GAMMELL; *President:* L. McI. TERRILL; *Vice-Presidents:* ALEX MACSWEN, NAPIER SMITH, E. ARNOLD; *Hon. Corresponding Secretary:* W. S. HART, P.O. Box 1185, Montreal; *Hon. Recording Secretary:* MISS H. STONE; *Hon. Treasurer:* MISS M. ARMITAGE, 63 Arlington Ave., Westmount; *Directors:* MISS EDITH MORROW, MISS LOUISE MURPHY; MISS EMILY LUKE; MR. AND MRS. C. F. DALE; MRS. J. T. AYERS; MISS JEAN MCCONNELL; W. A. OSWALD; A. F. WINN; MR. AND MRS. WALLACE H. ROBB; W. G. WRIGHT. *Members qualified to answer questions:* L. McI. TERRILL, 44 Stanley Ave., St. Lambert, Que.; NAPIER SMITH, Bank of Montreal, Magog, Que.; E. ARNOLD, 64 Durocher St., Montreal; W. A. OSWALD, 301 Wilson Ave., N.D.G., Montreal; C. N. ROBERTSON, c-o Ross Realty Co., Room 305, Lewis Bldg., St. John St., Montreal, Que.; DR. ARTHUR WILLEY, McGill University, Montreal; W. J. BROWN, 250 Oliver Ave., Westmount, Que.; MISS EDITH MORROW AND MISS EMILY LUKE, c-o Secretary.

SOCIÉTÉ PROVANCHER D'HISTOIRE NATURELLE DU CANADA

Bureau de direction pour 1923

Président: R. MEREDITH, N.P.; *1er vice-président:* ABBE ALEX. VACHON, M.A.; *2ème vice-président:* DOCTEUR A. DERY; *Secrétaire-trésorier:* JOS. MATTE, 18, avenue Maisonneuve, Québec; *Chef de la section scientifique:* COLONEL OSCAR PELLIER; *Chef de la section de propagande éducative:* DOCTEUR S. GAUDREAU; *Chef de la section de protection:* C.-E. DIONNE, M.A.; *Chef de la section d'information scientifique et pratique:* DOCTEUR J.-E. BERNIER; *Directeurs:* A.-R.-M. BOULTON, FRANK W. ROSS, A.-A. GOUBOUT.

THE BRITISH COLUMBIA ORNITHOLOGISTS' UNION

Officers for 1923

Hon. President: HON. MINISTER OF AGRICULTURE, Victoria; *President:* FRANCIS KERMODE, Provincial Museum, Victoria; *Vice-President:* T. L. THACKER, Hope; *Secretary-Treasurer:* J. W. WINSON, Huntingdon; *Directors:* J. A. MUNRO, Okanagan Landing; DR. KELSO, Arrow Lakes; R. GLENDENING, Agassiz; K. RACEY, Vancouver; T. PEARSE, Courtenay; W. N. KELLY, Victoria.

THE TORONTO FIELD-NATURALISTS' CLUB

President: PROFESSOR R. B. THOMSON; *Vice-Presidents:* PROFESSOR E. M. WALKER, DR. A. COSENS, J. H. FLEMING; *Secretary:* W. F. GREGORY, 151 Ellsworth Ave., Toronto; *Treasurer:* F. H. BRIDGEN; *Honorary Librarian:* C. W. NASH; *Librarian:* DR. LYMAN B. JACKS. **BIRD GROUP:**—*Chairman:* STUART THOMPSON; *Secretary:* JAMES BALLIE. **FLOWER GROUP:**—*Chairman:* DR. H. B. SIFTON; *Secretary:* MISS J. G. WRIGHT, PH.D.; **INSECT GROUP:**—*Chairman:* PROFESSOR WALKER; *Secretary:* MISS NORMA FORD, PH.D. **MAMMAL GROUP:**—*Chairman:* J. R. DYMOND; *Secretary:* L. SNYDER. **REPTILE, FISH AND AMPHIBIAN GROUP:**—*Chairman:* SHELLEY LOGIER; *Secretary:* T. B. KURATA. **PROGRAM COMMITTEE:**—*Chairman:* DR. W. A. CLEMENS. **WILD LIFE PRESERVATION COMMITTEE:**—*Chairman:* RUSSELL G. DINGMAN. **EDUCATIONAL COMMITTEE:**—*Chairman:* TAYLOR STATTON.

We would ask the Officers, and more particularly the Secretaries, of all the Affiliated Societies to assist us in our task of building up the circulation of this magazine. By securing every member as a subscriber we can truly make this magazine into one of the leading Natural History publications of America



FOR SALE

Back Numbers of The Ottawa Naturalist

The Club has for sale complete sets of its publications. Enquiries regarding price should be addressed to the Secretary of the Club, Dr. J. F. Wright, Geological Survey, Ottawa, Canada.

Any member having copies of the March, 1896, January, February, March and August, 1898, and December, 1900, issues of *The Ottawa Naturalist*, and who desires to dispose of the same, is requested to communicate with the Secretary.



Grant-Holden- Graham Limited

Outfitters to
Surveyors & Engineers

Manufacturers of
High-Grade Tents
Tarpaulins & Sleeping Bags

WRITE FOR CATALOGUES

147 Albert Street
OTTAWA

Fine Diamonds

Sterling Silver, Fine
Cut Glass, Electro-
Plated Ware

*The Store of
Moderate Prices*

C. A. Olmsted & Son

*Jewellers, Opticians, Watchmakers and
Engravers*

208 Sparks Street, Ottawa

Bird Houses

for
Blue Birds,
Tree
Swallows
and Wrens

*Will add a
little touch of
beauty to any
surround-
ings — and
conserve our
native birds*

Model 1 (shown)
made of Ruberoid
Round

Model 1
Made of Wood,
Square

\$1 Each Mailed C.O.D. or Express Collect
All remittances payable at par at Ottawa

PHILIP F. FORAN

147 Wilbrod St., OTTAWA

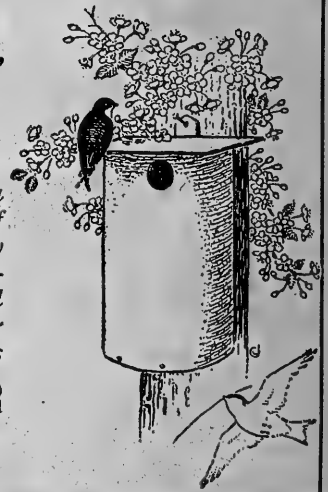

Kindly mention The Canadian Field-Naturalist to advertisers



THE CANADIAN FIELD-NATURALIST



PUBLISHED BY
OTTAWA FIELD-NATURALISTS' CLUB

ISSUED MAY 9, 1924

Entered at the Ottawa Post Office as second-class matter

THE OTTAWA FIELD-NATURALISTS' CLUB

Patrons:

THEIR EXCELLENCIES THE GOVERNOR-GENERAL AND THE LADY BYNG OF VIMY

President: HOYES LLOYD.

1st Vice-President: G. A. MILLER.

2nd Vice-President: NORMAN CRIDDLE

Secretary:

J. F. WRIGHT.

(Geological Survey, Ottawa.)

Treasurer:

B. A. FAUVEL,

(Mounted Police Headquarters,
Laroque Bldg., Rideau and Dalhousie Sts., Ottawa)

Additional Members of Council: W. T. MACOUN; MISS M. E. COWAN; C. M. STERNBERG; H. I. SMITH; F. W. WAUGH; P. A. TAVERNER; E. SAPIR; E. M. KINDLE; W. J. WINTENBERG; R. E. DELURY; ARTHUR GIBSON; M. O. MALTE; R. M. ANDERSON; H. GROH; MISS F. FYLES; C. B. HUTCHINGS; H. M. AMI; CLYDE L. PATCH; D. JENNESS; V. W. JACKSON; R. O. MERRIMAN; W. N. KELLY; C. H. SNELL; J. R. MCLEOD; JOHN DAVIDSON; L. MCI. TERRILL; R. MEREDITH; FRANCIS KERMODE; PROF. R. B. THOMSON; THE EDITOR.

Editor:

HARRISON F. LEWIS,
Canadian National Parks Branch,
Dept. of the Interior, Ottawa.

Associate Editors:

E. SAPIR.....	Anthropology	A. G. HUNTSMAN.....	Marine Biology
M. O. MALTE.....	Botany	P. A. TAVERNER.....	Ornithology
F. R. LATCHFORD.....	Conchology	E. M. KINDLE.....	Palaeontology
M. Y. WILLIAMS.....	Geology	R. M. ANDERSON.....	Zoology
ARTHUR GIBSON.....	Entomology	CLYDE L. PATCH.....	Herpetology

CONTENTS.

	PAGE
The Tiger Salamander at Ninette, Manitoba. By Clyde L. Patch and D. A. Stewart, M.D.	81
Further Notes on the Rhopalocera or Butterflies of Hatley, Stanstead County, Quebec, 1923. By Henry Mousley.....	82
Killer Whales at Green Island Lighthouse. By J. Moran.....	84
New and Rare Records of Certain Freshwater Fishes in Canada. By Philip Cox.....	85
Further Notes on the Orchids of Hatley, Stanstead County, Quebec, 1923. By Henry Mousley.....	86
List of Birds Recorded from the Island of Anticosti, Quebec. By Harrison F. Lewis.....	88
Prosecutions Under the Migratory Birds Convention Act.....	90
Official Canadian Record of Bird-Banding Returns.....	91
Notes and Observations:	
Two Interesting Nests. By P. A. Taverner.....	94
Least Bush Tit (<i>Psaltriparus minimus</i>). By K. Racey.....	94
Winter Activity of Bats. By L. L. Snyder.....	95
Conference of Provincial and Federal Officials. By H. L.....	95
The Toronto Meeting of the British Association.....	95
Statement of Trusts Fund Committee.....	96
Treasurer's Acknowledgement.....	96
Secretary's Note.....	96
Editor's Notes.....	96
Book Review:—	
Life Histories of North American Petrels and Pelicans and Their Allies and Life Histories of North American Wild Fowl. By H. F. L.....	96
Publications Received.....	97
List of Subscribers.....	97

THE CANADIAN FIELD-NATURALIST, lately THE OTTAWA NATURALIST, established thirty-seven years ago, "to publish the results of original research or investigation in all departments of natural history," is issued monthly, excepting for the months of June, July and August.

Papers, notes and photographs should be addressed to the Editor. Manuscript should be typewritten.

Subscriptions cover the current year, except those taken out during last quarter, when they will be applied on the following year, the remaining numbers of current year being sent free. Payments should be made to the Treasurer, Mr. B. A. Fauvel, Mounted Police Headquarters, Laroque Building, Ottawa. Price of this volume, \$1.50; single copies 20c each.



De Luxe

are the comfortable carrying kind made to fit—Order from your sporting goods dealer

YES— We Make Rucksacks

Seven different kinds—to suit almost every kind of work and for Field Naturalists—either of the two illustrated are suitable.

Woods' Rucks

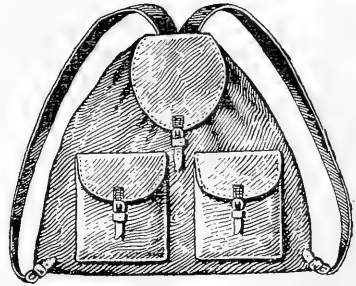

Alpine

WOODS MANUFACTURING CO.
OTTAWA

EXPLORATIONS in Western Canada

The Ottawa Field-Naturalists' Club has just published an interesting volume of over 300 pages, entitled:

Autobiography of John Macoun, M.A.

Canadian Explorer and Naturalist, Assistant Director and Naturalist to the Geological Survey of Canada—1831-1920.

This volume is an account of the life of this veteran naturalist. Agriculturists generally, in fact all interested in the development of Canada, will find this book of much interest and value.

The edition is limited. The price is \$3.00 with 15c added for bank exchange, if remittance is forwarded by personal cheque.

Applications for the volume should be made to

Mr. Arthur Gibson
Birks Building : Ottawa, Ont.

The Topley Co.

Photographic Material
Scientific Apparatus
Eastman Kodaks



132 Sparks Street
OTTAWA

Kindly mention The Canadian Field-Naturalist to advertisers

Lyman's Limited

(Established 1800)

MANUFACTURING CHEMISTS

Importers and Dealers in
CHEMICAL AND
ASSAY APPARATUS

344 St. Paul St. West, Montreal



GROW GOOD CROPS

SEEDS PLANTS BULBS

Our rigorous system of testing eliminates loss
and disappointment from your garden

Kenneth McDonald & Sons, Limited
Seed and Bulb Merchants

Market Square :: Ottawa, Ont

Ward's NATURAL SCIENCE ESTABLISHMENT

Rochester, New York, U.S.A.

Manufacturers of the genuine Schmitt boxes
exhibition cases and cabinets, also of the American
Entomological Company's insect pins.

Riker Mounts and botanical mounts always on
hand, also Riker botanical presses.

Send for our supply catalogue and other lists of
interest to collectors.

Headquarters for Entomological Supplies
and Specimens

Inspected Milk

Ice Cream

Ottawa Dairy

Fresh Butter

Buttermilk

THE

Bank of Nova Scotia

Capital.....\$ 9,700,000
Reserve Fund and Divi-
dend Profits, over.... 18,000,000
Total Assets over..... 230,000,000

SEVENTEEN BRANCHES IN
OTTAWA AND HULL

W. A. Rankin, Ltd.

Hammocks
Refrigerators
Builders' Hardware

410-412 Bank Street, Ottawa

Phones—Queen 1023-1024

WHY NOT ADVERTISE
YOUR PRODUCTS IN

The Canadian Field-Naturalist

*The Leading Canadian
Natural History Publication*

WRITE FOR RATE CARD

ADVERTISING DEPARTMENT
THE CANADIAN FIELD-NATURALIST

175 Nepean Street

OTTAWA

Kindly mention The Canadian Field-Naturalist to advertisers

The Canadian Field-Naturalist

VOL. XXXVIII

OTTAWA, ONTARIO, MAY, 1924

No. 5

THE TIGER SALAMANDER AT NINETTE, MANITOBA*

By CLYDE L. PATCH and D. A. STEWART, M.D.

DURING the month of September, 1923, Dr. D. A. Stewart kindly sent me several dozen Tiger Salamanders, *Ambystoma tigrinum*, collected in the vicinity of Manitoba Sanatorium, Ninette, of which Dr. Stewart is Medical Superintendent.

The specimens measure from six and one-half to eight inches in length, excepting one outstanding individual which measures ten and one-half inches. A few of the specimens still retain a small portion of the gills.

On September 24th Dr. Stewart sent in a larval specimen of *A. tigrinum* measuring ten inches in length.

I trust that a brief account of the adult and the larval forms of the Tiger salamander may prove worthy of space.

The range of this salamander—often incorrectly called "lizard"—extends eastward from Edmonton, Alberta, through the southern portions of Saskatchewan, Manitoba and Ontario, and southward into Mexico. *A. tigrinum* is the most widely distributed of the fifteen or more salamanders inhabiting Canada.

The adult form has a stout body, flat head and compressed tail. The color is dull yellow, marked with black blotches, which frequently have the form of vertical stripes; hence the name, Tiger salamander. The larval form is very stout, with a broad, flat head. On each side at the base of the skull there are three branching, external gills. A fin-like border extends around the tail and up the back to the base of the skull. This tadpole form somewhat resembles the Mudpuppy, *Nec-*

turus maculosus, but the gills are longer and there are five toes on the hind foot, while in *Necturus* there are only four toes on the hind foot and the dermal border ends back of the pelvis.

In the spring the Tiger salamanders come from their places of hibernation on land and migrate to water, where they deposit their gelatinous egg masses, which adhere to submerged vegetation. In several weeks the tadpoles, which breathe by means of the before-mentioned gills, hatch, and feed on minute plant and animal life. In the course of two or three years the young salamanders

have usually developed lungs, the gills and dermal border have been absorbed, and they are able to come on land in the fall to hibernate in burrows made by themselves or other animals.

At one time the larval form of

this salamander was thought to constitute a distinct genus (*Axolotes*), because of the fact that in moderately cold lakes development from the larval to the semi-aquatic form is indefinitely retarded. In this aquatic form the branching gills are retained, reproduction takes place, and adult size is attained or surpassed.

The manuscript for the balance of this article was supplied by Dr. Stewart.

I have lived in Manitoba for thirty years and on the banks of Pelican Lake here for thirteen, but I do not remember having seen any of these so-called "lizards"; or at any rate not more than two or three, until about six years ago, when they began to be very common in this district. Perhaps



TIGER SALAMANDER
Ambystoma tigrinum

All salamanders are harmless, and, though there are myths which would lead us to believe otherwise, they do not possess super-natural powers. Salamanders, like toads, frogs, lizards, snakes and turtles, are beneficial, as they feed on insects.

*Published by permission of the Director, Victoria Memorial Museum.

the sewage we dump into the lake may have something to do with their increased numbers.

The Sanatorium is built upon a slope about forty-five feet above the lake. In spring and summer we see scarcely one of these salamanders on land, but see them in the water. During the fall their instinct seems to be to get under cover of sticks and stones and leaves for the winter. Every rain in the late summer or fall would seem to them a warning of winter, and so during every such rain they come from the lake in great numbers and climb the hill in search of cover. The morning after a rain, when the sun is shining again, back they go to the lake. It has been a false alarm. Like Napoleon and his hundred thousand men, and almost in the same numbers, they march up the hill thus and then march down again. Getting under cover for every fall rain storm, they are under cover for the winter when a snow-fall finally comes. In these marches they have become troublesome to us by their being trapped in open areas and trenches. In these they are found sometimes by hundreds. After a late fall rain, especially at night, it is the morning job of somebody always to look over all areas, and we have on many occasions removed sala-

manders with shovel and wheel barrow. A number manage to crawl into corners, where, after a time, they attract attention in unpleasant ways. When building work was going on in the fall of 1918 there were certainly thousands buried in trenches. I think there have not been quite so many in the last year or two, and perhaps numbers have been somewhat reduced by their unfortunate habit of crawling into trenches.

I believe this batrachian or a similar one is known as the Water Dog in the Western States, and I have a clipping from an old copy of the *Scientific American* telling of their having been put into some ponds near Corvallis, Oregon, to clean up mosquito larvæ.

After a rain, when these so-called "lizards" crawl all over the place, over roads as well as over safer places, many are crushed by passing autos. A ridiculous report got out a few years ago and travelled over the whole world, coming back to me from papers as remote as South Africa, that they had become so plentiful at Ninette that chains had to be put on autos in order to get through them. Certainly the road after a fall of rain shows stray carcasses, but the chain story is a myth.

FURTHER NOTES ON THE RHOPALOCERA OR BUTTERFLIES OF HATLEY, STANSTEAD COUNTY, QUEBEC, 1923

By HENRY MOUSLEY

FROM an entomological point of view, the season of 1923, I imagine, will not go down to history as a very remarkable one.

The early part of the summer was cold and cheerless, and later on too dry at times for the proper development of chrysalids, with the result that many species were very restricted in numbers. Of course there were exceptions, Tiger Swallow-tails (*Papilio glaucus canadensis*) and Monarchs (*Danaus archippus*) being even more abundant, if anything, than last year, as recorded in *The Canadian Field-Naturalist*, Vol. XXXVI, 1922, No. 8, p. 142. Reverting to this paper for a moment, I find that, at the end of 1922, my list of species and varieties for Hatley and district stood at fifty-five, to which total I have been unable to add anything new this year, although on September 17 I took a female example of the Bronze Copper (*Heodes thoë*) near Hatley, this species never having been seen by me before, although it appeared in my list as having been taken by Mr. A. F. Winn, at East Bolton, on the western side of Lake Memphremagog, about 18 miles west of Hatley. The specimen in question was flying, with a number of the American Copper

(*Heodes hypophlæas*), round a clump of Asters (*Aster puniceus*) on the roadside, its somewhat larger size and the bluish grey of the underside of the hind wings attracting my attention as it settled on one of the flowers of the above species of aster. I was pleased to see again the Least Copper (*Heodes epixanthe*) in the large swamp near Beebe, where it is very plentiful. Of the six Hairstreaks included in my list, I saw only the Brown Elfin (*Incisalia augustus*), which was likewise very plentiful in the large swamp above mentioned. Fire and the deadly axe have done their work, and apparently done it well, as already recorded, for I have not seen a single Acadian or Striped Hairstreak (*Strymon acadica* and *S. liparops*) since 1920, the year when the bushes were cut down and burnt on the roadside which they frequented. The Skippers were not in their usual numbers, although they were not scarce by any means, and I had the pleasure of seeing again the rare one, The Arctic (*Carterocephalus palæmon*). This pretty little insect goes under the name of The Chequered Skipper in England, where it was first noticed by Dr. Abbott in Buckinghamshire in 1798. In 1823, it was found at Castor

Hanglands wood near Peterborough, and there I first took it many years ago, at the flowers of the ground ivy (*Nepeta glechoma*). It is just as rare and local in England as it is in these parts, and is a prize to the collector.

The larger Fritillaries were not quite as abundant as usual, and of the smaller ones neither the Baltimore (*Euphydryas phaeton*) or Harris' Checkerspot (*Melitæa harrisi*) were seen at all. On July 11, I climbed Owl's Head Mountain (2,484 ft.), on the summit of which the Banded Purple (*Basilarchia arthemis*) was flying in some profusion. The sight of this handsome butterfly put me in mind of a smaller one, the White Admiral (*Limenitis sibylla*), which flies in the New Forest, Hampshire, England, and which might almost be described as a miniature of the Banded Purple. Both have the white bands crossing the dark fore and hind wings, and in both the ornamentation of the undersides is far more beautiful than that of the upper sides. The larva of *sibylla* passes the winter in a little hibernaculum or retreat, which it constructs by fastening a growing leaf of the Honeysuckle (its food plant) to the twig, with silken threads, to prevent its falling to the ground, and then, with more silk, drawing the edges of the leaf together, thus forming a little chamber. There it passes the winter months until the following spring, when it emerges and is able to start feeding on the young growing foliage around its domicile. The remembrance of these things set me wondering whether the larva of *B. arthemis* does likewise, and I find it does, the only difference being that the hibernaculum out here is usually placed within three feet of the ground and is thus covered with snow during the winter months. The eggs are laid singly on the tips of the leaves of birch, poplar, willow, wild plum and apple trees. As in former years, the rare and beautiful Pearly Eye (*Enodia portlandia*) was seen on two occasions only, but on each of these two specimens were noted, which is two in excess of 1922.

The genus *Polygonia* was poorly represented, with the exception of the smallest member, The Grey Comma (*Polygonia progne*), which was noted in more or less abundance all through the season, and of which several larvæ were obtained feeding on wild gooseberry. These remained in the chrysalis stage for fourteen days. The largest and handsomest, The Violet Tip (*P. interrogationis*), I have not seen for some years, in fact, not since 1919, when all the members of this interesting family were unusually abundant, with the exception of the Green Comma (*P. faunus*), which was recorded by Gosse at Compton about 1837, but

which, strange to say, I have never come across so far, although Mr. Winn has taken it at East Bolton, which place, as well as Compton, is in my territory. Before leaving this family, it might be well to mention the fact that another member, *P. satyrus*, is recorded in Mr. Winn's *A Preliminary List of the Insects of the Province of Quebec*, 1912, as having been taken by the Rev. C. J. S. Bethune in Brome County (the exact locality not being given), part of which county, however, comes under my twenty miles radius, and for this reason, I feel inclined to include the species in my list, thus making the total fifty-six species and varieties, instead of fifty-five, as previously mentioned. The American Tortoise-shell (*Aglais milberti*), which was so scarce last year, appeared in fair numbers again this year, and I found many larvæ, as well as those of the Red Admiral (*Vanessa atalanta*), feeding on nettles. The larvæ also of the Mourning Cloak or Camberwell Beauty (*Aglais antiopa*), were unusually abundant, and I found many large colonies on willow. This fine butterfly is very rare in England, and more especially so in Ireland, and the examples that are recorded from time to time are usually immigrants from Germany or the Scandinavian Peninsula, where it is common. Kane, in his *Catalogue of the Lepidoptera of Ireland*, mentions an example having been seen by a friend of his near Trillick, County Tyrone. The insect was "settled on the roadside but not captured, it being Sunday". I wonder how many rare insects would be immune from capture in this enlightened age! because it was a Sunday?

Not a single example of Hunter's Butterfly (*Vanessa virginiensis*), or the Painted Lady (*Vanessa cardui*) was seen, in fact it is four years since I saw the former, and three years since I saw the latter, and then only one example in each case. In contrast to this, The Viceroy (*Basilarchia archippus*) was very plentiful, as was also that common butterfly, the Clouded Sulphur (*Eurymus philodice*). As regards this species, I cannot call to mind ever having seen an albino female in the first brood, but in the second, and more especially in the third, which appears in October, they are usually very numerous and were especially so this year.

In conclusion, now that the list of butterflies is about complete, I feel I should like to pay some attention to the moths, if only for the sake of finding out the present status of that exquisite little Noctua, the Pink Arches (*Habrosyne scripta*), which Gosse aptly describes as the most delicately beautiful of the small moths that he had ever seen, and which was common here in his day.

KILLER WHALES AT GREEN ISLAND LIGHTHOUSE

By J. MORAN



ABOUT five months after I had taken up my duties at Green Island, on which is the most northerly lighthouse in British Columbia, and which is situated in Chatham Sound, we had our first view of the orca, or killer whale. It was in mid-afternoon of a clear day in May, 1919, that, accompanied by my daughter, Rose, aged ten years, I was walking along the beach close to the house. We heard a noise, as of some animal snorting nearby, and, looking seaward, in the direction from which the noise appeared to come, we saw a huge black dorsal fin cleaving the water close inshore. Hurrying down to the water's edge to get a better view of the animal, and speculating as to what the creature could be, we saw several other huge fins approaching, and all apparently making for a little cove on the south side of the island. We made our way as closely as I deemed prudent to this little cove, which is a mere indentation in the rocky shore, and were for a time able to stand above the animals and observe their graceful movements in the clear water below. We marvelled that so many huge creatures could find room in such small space.

At first I thought that our presence might frighten the killers away, but as they seemed to take no notice of us, I sent the little girl up to the lighthouse to tell her mother to come down to see the big "fish". The tide was rising, and I soon had to move back a few yards, and when my wife arrived we took our stand on a rock that offered the best view for the time being.

For some twenty or thirty minutes we watched the animals, hearing them "blow" and noticing the mist-like spray they emitted. There were probably six in the little cove, others appearing some little way offshore.

Suddenly there was a great commotion among them, and their graceful and leisurely movements were turned to swift and apparently angry surgings this way and that, accompanied by loud snortings. Believing that we were witnesses to a battle royal between the monsters, we were determined to see the fight at as close quarters as possible; but the great amount of spray they caused made us beat a hasty retreat to another rock out of reach of the "wash". We were now about 100 feet from the brutes, and could see their huge bulk as they seemed to jump upon each other, and try by sheer weight to conquer. Then we saw them stand, as it were, on their heads, and "bore" into the crevices of the rocks

below them, thrashing the water into foam as they did so.

Then, right from under the noses of the big killers we saw a hair seal spring over a small rock and with many flops make its way towards us, and eventually stop at our very feet. It looked up at us as though asking protection and seemed in no way afraid of us. It kept a watchful eye on its enemies, but seemed to feel itself safe from them. We could see its labored breathing, and noted how tightly its nostrils closed as it held its breath. We retreated as the tide rose, and the seal followed us, until the killers disappeared, when it made off to deeper water.

What we took for a fight between the killers was most probably their endeavors to catch the seal, which had the advantage in the confined space of the cove. Be that as it may, the killers ceased their turmoil after the seal escaped.

Several times during the summer of 1919 schools of killers came close inshore, often making a circuit of the island, searching the nooks and crannies among the rocks.

A favorite place for them to disport themselves is a narrow passage just below the front of the house. This passage, which is about 100 feet wide, at high water cuts us off from the islet whereon the Gulls nest. Standing on the bluff, we can see the killers in the clear water fifty feet below us.

A picnic party visited the island in August, 1921, coming from Port Simpson, 12 miles to the east. I was showing a party of two ladies and a gentleman the lantern when I saw a school of killers approaching the passage. As they came nearer we could see their movements very clearly from the platform, and as the ladies had each a camera I asked them to try to get some snapshots. Unfortunately, just as the ladies were focussing their cameras, some one below fired a shot at the killers, which immediately made off.

A few weeks afterwards we saw a killer rise from below a Black Duck that was swimming in the passage and swallow it.

In June, 1922, we noticed a school of killers at the north-west corner of the island, not more than 50 feet from the island. After a while we saw two of them thrashing the water, as though fighting, and watched them through binoculars. We saw then that they were apparently searching for something, for they both began to "stand on end", their huge flukes standing clear out of the water. They were "boring" below the surface, and we were astonished to see how long they remained in

this erect position before coming up to breathe. After blowing they both again turned up-end, and we had an excellent opportunity to take pictures, but found that we were out of films. These manoeuvres occupied more than fifteen minutes, and then the big brutes began to strike the water with their tails, causing resounding smacks that we could plainly hear from our position on the steps of the house. This was, indeed, a rare sight, as they continued to do this for fully five minutes.

Two sea-lions were close inshore, watching the huge fish, but were well out of reach of the killers, as a small sand-bar cut them off. The balance of the school—there were about fifteen in all—were cruising leisurely at some distance from the two above-mentioned, and did not appear to take any notice of their movements.

On May 11, 1923, accompanied by my wife and son, I was cruising about the island in our little launch, when we saw a school of killers near Grey Island, an islet about half a mile to the north of us. There were probably ten of them. While we were debating whether it would be safe to approach them in an open launch, we saw several of them jump clear of the water. We decided to approach closer to see, if possible, the cause of this extraordinary behavior; but as we got nearer they disappeared.

August 23 was a rather dull day, the sky being overcast, with a little fine rain. Shortly after noon we saw killers approaching from the northwest. We had a young lady from California visiting us; and I had been wishing the killers would appear, as I was anxious to show off our "big game" to our guest. This was one of my lucky days, for there were probably fifteen in the school, and six of them came leisurely disporting themselves right below the bluff on which the house stands. I called to the girls, and my wife and daughter accompanied our guest to the edge

of the bluff, where for fully twenty minutes we were able to watch the monsters as they swam in and about the passage. We could count six of them below us. One was a huge one; the next in size being but two-thirds its bulk. Then two others were but half its size; and there were two small ones—and one was all white; even the fin was white. Naturally, the white one was the centre of interest, for we were able to see its every movement. As it disported itself, we noticed that it invariably swam in corkscrew fashion. It came up to blow fin-up; would then turn on its side as it swam, turn over, swim on the other side, and come up again fin-up to blow. It did this so often that we wondered if this was the normal way these brutes swam when disporting themselves; for, watching the others, we often saw the flash of the white underside as they swam.

Eventually the school made off to the southwest, and long after the other members of the school were (all but their fins) invisible, we could see the white one swimming under the water.

Hair seals often visit the island. We have counted twenty-three heads out of the water at one time. Frequently, as my daughter played on the beach and began to sing, seals would appear as if by magic, and, swimming close inshore, would raise head and neck out of the water to try to locate the singer.

Occasionally sea-lions pay us a visit, but their visits are very infrequent.

On one occasion we shot a hair seal, and, upon dressing it, we found an unborn seal that could not have been more than a few hours from parturition. This has led us to wonder if there is a rookery in the neighborhood. Last August my son took his mother and the girls for a picnic to a little bay south of North Dundas Island, and they reported having seen hundreds of seals in the water, many of them being very young ones.

NEW AND RARE RECORDS OF CERTAIN FRESHWATER FISHES IN CANADA

By PHILIP COX

Apomotis cyanellus (Raf.).

The Green Sun-fish, Little Red Eye. Locality: Yoho Lake, York Co., N.B., July 12, 1923.

Rare. Not deposited yet in any museum by the collector.

No previous Canadian record of this species can be found. It is not included in *Check List of the Freshwater Fishes of Canada*, by B. W. Evermann and E. L. Goldsborough, Washington, 1907; nor was C. W. Nash able to record an undoubted occurrence in Ontario (vide *Manual of Vertebrates of Ontario*, Toronto, 1908) but thought it might turn up in Lake Erie.

Five years later appeared *Check List of the Fishes of the Dominion of Canada and Newfoundland*, by Andrew Halkett, Ottawa, 1913, in which the author follows Nash in assigning it a hypothetical occurrence. In their well-known standard work, *Fishes of North and Middle America*, Washington, 1896, Drs. Jordan and Evermann did not include Canada in the range of this species, "From the Great Lake Region to Mexico . . . not found east of the Alleghanies;" Vol. I, p. 996. Moreover, Dr. W. C. Kendall failed to collect it in the State of Maine, whose inland waters he and his associates combed so thoroughly for many years (vide

Annotated Catalogue of the Fishes of Maine, Portland, 1914).

Yoho is a small lake about three miles long by a half a mile wide and is situated in the southern part of the parish of Kingsclear, York County, and about twenty miles from Fredericton. Its outlet of the same name is a wild, boisterous brook with a succession of rapids and falls, which eventually tumbles into the Oromocto, a tributary of the St. John River. The shores of the lake are bold and rocky, the water cool and clear; and there is a general absence of conditions, such as shallow water and weedy flats, usually associated with the presence of sunfishes.

Eupomotis auritus Lunn. The Long-eared Sunfish. Locality, Yoho Lake, York Co., N.B.

July 12, 1923.

Abundant. Many specimens taken. Sample deposited in Museum of N.B. Nat. Hist. Soc., St. John, N.B.

This species was credited to New Brunswick by Dr. A. Leith Adams in *Field and Forest Rambles*, London, 1873; and for half a century its claim as a Canadian fish depended on this solitary record. Since that time and on this authority it has found a place in almost every list of Canadian fishes, the writer himself having listed it as a New Brunswick

fish in *History and Present State of the Ichthyology of New Brunswick*, St. John, 1895.

Adams assigned no station for the species, nor was he known to have deposited a specimen in any museum; and, as years rolled by without any confirmation of the occurrence, years of considerable activity in ichthyological research, the accuracy of the record began to be questioned. Moreover, Dr. Adams, in common with Gill and other eminent zoologists of that time, was known to be a believer in the doctrine of "Zoological Provinces", by which, whenever a species is known to occur in any part of a so-called "province", it is attributed to the whole. As Maine and New Brunswick were regarded as one such province by the author (see p. 214), and, as the Long-eared Sunfish had been reported from Maine, it was naturally credited to New Brunswick. Now, however, as it is known to occur in the province, it seems pretty certain that Dr. Adams had actually collected it; the more, in that his researches afield were principally carried on in that section of the province.

Both the Green Sunfish and the Long-eared Sunfish seem to be dwarfed in Yoho, for no specimen of either was seen over five inches in length, whereas throughout the usual range in the United States they are said to attain a length of seven inches or more.

FURTHER NOTES ON THE ORCHIDS OF HATLEY, STANSTEAD COUNTY, QUEBEC, 1923

By **HENRY MOUSLEY**

(Concluded from page 63)

On July 11, I climbed Owl's Head Mountain (2,484 ft.) and found a large station for the Long-bracted Orchis (*Habenaria bracteata*), the plants extending nearly all up the right-hand side of the trail, where there was a water-course. Later on, towards the end of September, the 24th, I think it was, I climbed the Massawippi Hills (which are part of the Notre Dame range), on the western shore of Lake Massawippi, and found Hooker's Orchid (*Habenaria Hookeri*) to be well distributed, the same as it is on the eastern shore. I also came across plants of the beautiful Wild Columbine (*Aquilegia canadensis*), which I had hitherto failed to locate, although I had been told it grew on the western shore of the lake, a section of the country I have done very little collecting in so far, but one which promises good results, I think, as regards both birds and flowers. There is really so much yet to be done nearer home that I do not often get to the other side of the lake. As an instance of this, on May 23 I located a second station for that little gem of an orchid, *Calypso*, only about

a mile from my house, and yet again on June 18 a third station, some few hundred yards from number two, but $3\frac{1}{2}$ miles from station No. 1, which was discovered on May 15, 1918. Certainly there were not more than half a dozen plants in each, but it only shows how orchids suddenly appear in new localities. I had been over and over this ground on many occasions, not only after orchids but after birds as well, and I know they were not there a year or two ago. Another similar instance happened to me on October 2, when I found my fifth station for the Tall White Bog Orchis (*Habenaria dilatata*). I owe my luck to the fact that some of the plants, even at this late date, bore faded blooms, which enabled me to make sure of their identity. This station was to the north of the village, and was near a house that I had been living in from May 10, 1917, to October 14, 1918, during which time I had been over the ground scores of times, and I can safely say the species was not there then; yet by October, 1923, a colony, certainly only a very small

one, had become established, as well as one of the Showy Lady's Slipper (*Cypripedium hirsutum*); which was also not there in 1918. In connection with the new stations I might mention that two more were found for the Slender Ladies' Tresses (*Spiranthes gracilis*), one at Coaticook, and the other near Hatley, but with only one plant in each of them, and as the only other station produces not more than three or four plants each year, the species can truly be said to be somewhat rare here. The large Coral Root (*Corallorrhiza maculata*) seems to be more generally distributed than I at first thought, several new stations having been found for it, but in most of them only one plant was in evidence. One of these, however, was a particularly fine specimen, being 44 cm. in height, thus exceeding the extreme given in Gray's *Manual* by 4 cm. A few new stations were found for the Large Round-leaved Orchis (*Habenaria orbiculata*, and *H. macrophylla*), as also for the various Rattlesnake Plantains (*Epipactis*), but this latter family was evidently taking a rest this year, as very few plants bloomed, in comparison with the prolific year of 1922. I paid six visits this year to the large swamp at Beebe, adding six new species and varieties to the already existing list of eighteen, thus bringing the total up to twenty-four, which I imagine must be nearly, if not actually, a record for any one swamp, besides which there are still possibilities, as the high ground has yet to be worked.

When I think of all the Government has done for the conservation of the wild life of Canada, as set forth in that interesting book of the late Dr. C. Gordon Hewitt, *The Conservation of the Wild Life of Canada*, 1921, it strikes me as strange that never a thought has apparently been given to the necessity of conserving our rare native orchids, ferns, and wild flowers, before it is too late. There are no laws to protect them, nor yet reservations in which to conserve them, such as there are for the birds and mammals, and yet we owe it to future generations to see to these matters, just as much as we are doing with regard to our other wild life. What a fine thing it would be if this swamp at Beebe, with some of the surrounding ground, could be acquired and converted into a bird and wild plant reservation. Most of the other reservations scattered throughout Canada would be useless for the purpose, because they contain the larger mammals, which would do no end of damage to the plants, by trampling them out of recognition in many cases, just as the cattle do in this district, whenever they are allowed to roam in the woods and swamps. Many a rare plant have I lost through their depredations. At one end of the above swamp there is a treacherous little bog, which Ducks, Herons and Bitterns

frequent, and there many of the rarer birds are to be found breeding, such as the Olive-sided Flycatcher (*Nuttallornis borealis*), Northern Parula Warbler (*Compothlypis americana pusilla*), Brown Creeper (*Certhia familiaris americana*), and Golden-crowned Kinglets (*Regulus satrapa satrapa*), besides which White-winged Crossbills (*Loxia leucoptera*) have been noted on many occasions and possibly breed there also.

As an orchid reservation the place would be hard to beat, as there is every class of ground suitable to their requirements, as will be gathered from the number of species I have already found there. In the United States this matter of Plant Conservation is no longer "a thing in the air", it is becoming an accomplished fact. The State of Vermont already has its Game Laws, for the protection of the rarer Ferns and Wild Flowers, whereby no person shall take in any one year more than a single uprooted specimen, or two cuttings, of each of the plants named in the protected list. Any person violating the provisions of the act is liable to a fine not exceeding ten dollars for each plant or additional cutting so taken. At Fairfield, Connecticut, I believe there is just such a sanctuary as I have outlined. May I suggest that our Government give this matter its serious consideration, before it is too late, as every year with its forest fires, drainage of swamps and low-lying grounds, making of new roads, growing up of rank vegetation and undergrowth, and activities of lumbermen, is driving out many of our rarer plants. Only a few days ago I received word that a gang of lumbermen were busy in the wood in northern Vermont which I visited in June for the little Ram's Head Lady's Slipper (*Cypripedium arietinum*), and that the site was now unrecognizable! "*Sic transit noster thesauri.*"

After the above remarks, I now pass on to the annotated list of the five new species and varieties discovered this season, viz.:

WHITE FRINGED ORCHIS, *Habenaria blephariglottis* (Willd.) Torr., and var. *holopetala* (Lindl.) Gray.—As already recorded, I was first introduced to this handsome species in a delightful little swamp in northern Vermont, where grew also *Calopogon* (*Calopogon pulchellus*) and *Pogonia* (*Pogonia ophioglossoides*) in endless profusion, the latter more especially so, as it was nearly impossible to walk about without treading it under foot in some places. This was on July 21, but it was not until over a month later that, in company with Prof. Pelham Edgar, of Toronto, who was anxious to see my famous swamp, and offered to motor me over, I again visited it, on August 23. It was while on our way to the treacherous little bog at the far end of the swamp that I espied a small colony of the above species, one bloom of

which was in perfect condition, and proved to be the var. *holopetala*. It is doubtful whether this variety will be recognized in the next edition of Gray's *Manual*, for I see in *Orchidaceæ*, Ames, Fascicle IV, 1910, p. 164, the following footnote, viz., "The consensus of opinion of those who have done close field-work is that var. *holopetala* is untenable, all conditions of petals from entire to fringed sometimes being found on the same spike." See *Bulletin of the Torrey Botanical Club*, 20:86. On July 21, in northern Vermont, the species was only just coming into bloom, and I had no opportunity of going into this matter, but shall hope to do so at some future date. In the meantime I can only say that my example had no evidence of having the two kinds of petals, entire and toothed, only the first-named being in evidence, with the tip considerably less fringed than in the type.

NORTHERN WHITE ORCHIS, *Habenaria dilatata* var. *media* (Rydb.) Ames.—I first came across this variety in the large swamp above mentioned, on August 6, when it was just coming into bloom with the species, and it was still quite fresh when I paid it a second visit on the 23rd of the month. There was no mistaking its affinity to *dilatata*, the only difference being in the colour of its flowers, which were of course greenish, instead of pure white. Many fine specimens were obtained, one of which was 95 cm. in height, whilst others ranged from 90 to 60 cm., and less. Irrespective of the colour, the rhomboidal base of the lip proclaimed it as being a form of *dilatata*, and not *Habenaria hyperborea*.

NODDING LADIES' TRESSES, *Spiranthes cernua* var. *ochroleuca* (Rydb.) Ames.—This is a very distinctive variety and the wonder to me is that I have never noticed it before. The plants as a rule are much taller than those of the species that grow about here, besides which the flowers are of a decided yellowish tinge instead of white, and the raceme is longer and more lax than in the species. In addition to this, although the two were always found growing together, the species was in the lower and damper portion of the ground, whilst the variety was in the higher and drier ground. However, to make doubly sure, I carefully ex-

amined the labellums of many of the flowers, and always found that the calli at the base were perceptibly longer and more curved than in the species. This difference is well shown in Prof. Oakes Ames' paper, *Notes on New England Orchids, Rhodora*, Vol. XXIII, 1921, plate 127, fig. 13. In this paper, Prof. Ames tells us how difficult it is sometimes to distinguish *Spiranthes cernua* from the variety *ochroleuca*, and that the only sure guide is polyembryonic seeds for the species, and normal seeds for the variety. To discover this, however, requires a compound microscope and other paraphernalia which all of us do not possess, so that unless the variety can be distinguished by the means I have found sufficiently near enough for all practical purposes, I am afraid not many will trouble about the matter.

DOWNY RATTLESNAKE PLANTAIN, *Epipactis pubescens* (Willd.) A. A. Eaton.—For the addition of this orchid to my list I am indebted to Mr. C. H. Knowlton, who found a small colony of the plants growing in some rich woods at Lake Park, Sherbrooke Co., Que., on July 22 of the present year (1923). Lake Park is situated at the head of Little Magog Lake, about fifteen miles to the north of Hatley, and is a district that I have not yet worked. The plants were not fully out at this date, but the two examples taken by Mr. Knowlton were presented to the Gray Herbarium.

In conclusion, since the appearance of my last paper on the Orchids, *Can. Field-Nat.*, Vol. XXXVI, 1922, No. 9, pp. 173-74, I have been sitting on the stool of repentance, for in that paper I said that doubtless it was then more up to date to revert to *Goodyera* for the generic name of the Rattlesnake Plantains, in place of *Epipactis*. Now I understand that further delving into the archives of ancient history has revealed the fact that *Goodyera* must be put on the shelf again, and that *Epipactis* is now the order of the day, and this, mark you, is final, i.e., until it is altered again. Truly, the juggling with scientific names surpasses anything I have ever seen. The passes are so swift that one is left more than bewildered as to how it is all done, and is tempted to remark, which no doubt many of us do, "*cui bono?*"

LIST OF BIRDS RECORDED FROM THE ISLAND OF ANTICOSTI, QUEBEC

By HARRISON F. LEWIS

(Continued from page 75)

[Hypothetical. *Lagopus lagopus lagopus*. WILLOW PTARMIGAN.—Verrill: Was told this was to be found in interior, but he saw none. Brewster: An adult female in summer plumage with a chick about 10 days old, recorded as taken by Mr. Gardiner (of Brewster's party) near Fox Bay on July 10. Dionne: Formerly common, now very rare.

In a note published in *The Auk*, Vol. II, 1885, pp. 220-221, Brewster reverses his identification of Ptarmigan specimens taken in Anticosti, which careful study showed to be Rock Ptarmigan. The birds of which Verrill was told may well have

been Rock Ptarmigan also. As for the observations of Willie LaBrie, upon which Dionne's record is based, Mr. LaBrie, in a letter dated January 11, 1924, has furnished me with the following information concerning them: He saw a Ptarmigan on Anticosti in June, 1913, "which appeared to me ochre-colored or rust-colored, with wings white or nearly white." He saw another individual in October, 1917, which appeared paler than the bird seen in 1913, but was not entirely white. He was not able to be sure of the species of Ptarmigan, because of the briefness of his observations, the distance at which the

birds were observed, and his personal unfamiliarity with the species.

[There seems no reason to regard this species as other than hypothetical at present.]

72. *Lagopus rupestris rupestris*. ROCK PTARMIGAN.—Brewster has recorded two specimens taken on Anticosti by Mr. Gardiner, of his party. (See under Willow Ptarmigan.) Schmitt: Resident. Fairly common. The only Partridge occurring, but found at all times of the year. In early summer parents with 10 to 12 young are often seen.

Mr. Dionne assures me that the Ptarmigan specimens which Schmitt submitted to him for identification were of this species. Ptarmigan are apparently now very rare, perhaps extinct, on Anticosti, due, in all probability, to the great numerical increase of wild foxes under the protection and encouragement given them by the present owner of the island.

73. *Ectopistes migratorius*. PASSENGER PIGEON.—Verrill: Saw one at Heath Point. Was told they were very rare. Schmitt: Refers to Verrill's record. States individuals of the species were seen exceptionally later, but none had been seen for the 10 years immediately prior to 1904.

Now extinct. Mr. Dionne informs me that no specimens of this species were submitted to him by Schmitt for identification.

74. *Zenaidura macroura carolinensis*. MOURNING DOVE.—Schmitt: October-November. Rather rare. Several arrive in November each year, and frequent the same place near the houses at English Bay.

Specimens submitted by Schmitt were identified by Mr. Dionne.

75. *Circus hudsonius*. MARSH HAWK.—Schmitt: Summer. Rather rare. Dionne: Rather rare.

76. *Accipiter velox*. SHARP-SHINNED HAWK.—Verrill: One seen near Salmon River, July 3. Presumed from actions to be nesting. Schmitt: Summer. Fairly common. Dionne: Common. Brooks: Thought he saw one at English Bay, September 15.

77. *Astur atricapillus atricapillus*. GOSHAWK.—Schmitt: Throughout the year. Rather rare. Dionne: Not common. Brooks: Common about Ellis Bay, especially the young.

78. *Buteo borealis borealis*. RED-TAILED HAWK.—Schmitt: Throughout the year. Rather rare. One killed June 15, 1901, at English Bay.

79. *Archibuteo lagopus sancti-johannis*. ROUGH-LEGGED HAWK.—Schmitt: Arrives in June. Fairly common in some years, rather rare in others.

80. *Aquila chrysaetos*. GOLDEN EAGLE.—Combes: Possesses a foot of one, gift of Mr. Gibsone, keeper of the light at Heath Point. Schmitt: Throughout the year. Rather rare.

Some taken every fall in fox-traps. Found a nest in the interior of the island on a cliff beside the Jupiter River.

81. *Haliaeetus leucocephalus alascanus*. NORTHERN BALD EAGLE.—Verrill: One or two seen at Ellis Bay, in July. Schmitt: Throughout the year. Rather rare. Nests in trees in June and July. Dionne: Fairly common. Brooks: Saw one or two every day during his stay on Anticosti.

82. *Falco islandus*. WHITE GYRFALCON.—Schmitt: This Falcon occurs irregularly in summer. Rare.

Mr. Dionne assures me that Schmitt submitted this species to him for identification. Schmitt's statement that the season of its occurrence was summer seems, however, surprising.

83. *Falco rusticolus obsoletus*. BLACK GYRFALCON.—Schmitt: Some seen each summer. Less rare than the preceding. Dionne: One seen in 1916.

Mr. Dionne informs me that Schmitt submitted no specimen of this species to him for identification.

In a letter dated February 29, 1924, Mr. W. LaBrie gives the following information concerning the bird recorded by Dionne: As for the Black Gyrfalcon, the only one that came to my notice on Anticosti is an individual which was killed about November 15, 1916, at Anse aux Fraises, by the game warden, Francis Boudreau, of Ellis Bay. According to Mr. Boudreau, this Gyrfalcon . . . occurs from time to time near the shore in pursuit of sea-birds, principally Ducks, which it captures easily."

84. *Falco peregrinus anatum*. DUCK HAWK.—Dionne: Seen fairly often.

85. *Falco columbarius columbarius*. PIGEON HAWK.—Schmitt: Summer. Rather rare. Dionne: Very common. Brooks: Quite common about Ellis Bay.

86. *Cerchneis sparveria sparveria*. SPARROW HAWK.—Schmitt: Summer. Rather rare. Appears early in spring, before the snow is entirely melted. Chases small Sandpipers in late August. Dionne: One observed.

87. *Pandion haliaëtus carolinensis*. OSPREY.—Verrill: A few seen, but no nests. Brewster: Seen daily, but not numerous, at Fox and Ellis Bays. Schmitt: Summer, fairly common. Nests on the island, in the trees. Dionne: Very common. Brooks: Saw one or more every day about Ellis Bay. Lewis: At least one resident pair at Ellis Bay in June, 1922. Occupied nest in tree on east side of Bay seen June 15.

88. *Asio flammeus*. SHORT-EARED OWL.—Schmitt: Summer. Fairly common.

89. *Strix varia varia*. BARRED OWL.—*Schmitt*: Summer. Rather rare.

90. *Cryptoglaux funerea richardsoni*. RICHARDSON'S OWL.—*Schmitt*: Throughout the year. Rather rare. One lived throughout January, 1904, in a barn at English Bay.

91. *Cryptoglaux acadica acadica*. SAWWHET OWL.—*Schmitt*: Throughout the year. Rather rare. One found, January 10, 1903, in the camp at the Big McCarthy.

92. *Nyctea nyctea*. SNOWY OWL.—*Combes*: One killed by M. Malouin, keeper of West Point light. *Schmitt*: Winter. Appears irregularly. Very great flight in 1901-1902.

93. *Surnia ulula caparoch*. HAWK OWL.—*Schmitt*: Autumn. Winter. Spring. Common. Very common in October, 1902. *Dionne*: Very common in 1913, not seen in later years.

[Hypothetical. *Coccyzus erythrophthalmus*. BLACK-BILLED CUCKOO.—*Schmitt*: Summer. Rare. Sometimes heard. In view of the fact that Mr. Dionne informs me that *Schmitt* submitted no specimens of this species to him for identification, the available evidence does not warrant including it in this list except as hypothetical.]

94. *Ceryle alcyon alcyon*. BELTED KINGFISHER.—*Verrill*: Seen at various times, but not frequently. *Combes*: Recorded this species at Beescie River. *Schmitt*: Summer. Fairly common. Nests on the island. *Dionne*: Fairly common. *Brooks*: Saw quite a few at Ellis Bay. *Lewis*: Saw one at Ellis Bay, June 14.

95. *Dryobates villosus* (subsp.?). HAIRY WOODPECKER.—*Schmitt*: Listed without comment. *Dionne*: Fairly common.

96. *Dryobates pubescens medianus*. DOWNY WOODPECKER.—*Verrill*: Common. *Brewster*: A pair seen and their nest, containing young nearly large enough to fly, found near Fox Bay, July 11. *Schmitt*: Throughout the year. Fairly common. *Dionne*: Fairly common. *Brooks*: Five Downy Woodpeckers were seen; four males and one female being secured. My observations would indicate that it is the most common Woodpecker.

97. *Picoides arctius*. ARCTIC THREE-TOED WOODPECKER.—*Schmitt*: Throughout the year,

but more common after the end of May. Fairly common. *Dionne*: Apparently rare. *Brooks*: Saw a pair, which he secured and found typical. *Lewis*: Saw one near Ellis Bay, June 13.

98. *Picoides americanus americanus*. THREE-TOED WOODPECKER.—*Brewster*: An adult female, accompanied by a brood of young, seen at Ellis Bay, July 24. One young secured. *Schmitt*: Throughout the year. Fairly common. *Brooks*: One pair seen and taken.

99. *Sphyrapicus varius varius*. YELLOW-BELLIED SAPSUCKER.—*Dionne*: Fairly common. *Brooks*: One pair seen, September 6, about 2 miles from the shore of Ellis Bay. Two more seen, September 9, at a considerable distance from this spot. *Lewis*: Saw two, at least one an adult male, near Ellis Bay, June 13.

100. *Colaptes auratus borealis*. BOREAL FLICKER.—*Brewster*: One or two seen at Fox Bay. *Schmitt*: Summer. Fairly common. *Dionne*: Rather rare. *Brooks*: Several seen near Ellis Bay. *Lewis*: Not common at Ellis Bay, June 10-16, 1922.

101. *Chordeiles virginianus virginianus*. NIGHTHAWK.—*Schmitt*: Summer. Fairly common. *Dionne*: Not common. *Brooks*: Saw one, August 24, at Ellis Bay; on August 28 saw what was no doubt the same bird.

102. *Chaetura pelagica*. CHIMNEY SWIFT.—*Schmitt*: Summer. Rather rare. On June 9, 1901, one fell down my chimney, and several flew around the house.

103. *Archilochus colubris*. RUBY-THROATED HUMMINGBIRD.—*Schmitt*: Had seen only 2 females. One July 18, 1898, at English Bay, in his garden; the other August 15, 1901, beside Ellis Bay Road. He had previously seen Hummingbirds in Brazil, at Ottawa and at Toronto.

104. *Tyrannus tyrannus*. KINGBIRD.—*Schmitt*: Summer. Rather rare. Two taken May 7, 1902, at English Bay.

(To be continued)

PROSECUTIONS—MIGRATORY BIRDS CONVENTION ACT

BY OFFICERS OF THE CANADIAN NATIONAL PARKS AND ROYAL CANADIAN MOUNTED POLICE

Reported during the period July 23, 1923—January 18, 1924.

ALLAN, Stephen, Bayfield, Westmoreland Co., N.B. Molesting Canada Geese in close season. Fine: \$20.00.

VIBERT, Frank C., Miscou Point, Gloucester Co., N.B. Having in possession Canada Geese in close season. Fine: \$10.00.

TAYLOR, Edgar, Big Stick, Sask. Having in possession two Pintail Ducks in close season. Fine: \$10.00. Seizure; The wings of two Ducks.

MORIN, Gaspard, Meadow Lake, Sask. Molesting migratory non-game birds in close season. Fine: \$10.00.

MOORE, George, Carievale District, Sask. Having in possession portions of migratory game birds in close season. Fine: \$10.00.

ARSENEAU, Samuel, Amherst, N.S. Shooting Ducks in close season. Fine: \$25.00.

ARSENEAU, Stephen, Amherst, N.S. Shooting Ducks in close season. Fine: \$25.00.

SMITH, T. J., Cherrill, Alta. Having in possession wild Ducks in close season. Fine: \$10.00.

JUVENILE, Newcastle, N.B. Molesting migratory game birds during the night. Fine: \$20.00.

JUVENILE, Newcastle, N.B. Molesting migratory game birds during the night. Fine: \$20.00.

INRIG, George, 145 Homewood Ave., Hamilton, Ont. Having in possession a Wood Duck in close season. Fine: \$15.00.

WALKER, James D., Sydney, N.S. Hunting Canada Geese at night. Fine: \$10.00.

ANDREWS, Walter, Sydney, C.B. Hunting Canada Geese at night. Fine: \$10.00.

COOLEN, Norman, Fox Point, Halifax Co., N.S. Killing migratory game birds with the use of an automatic gun. Fine: \$10.00.

COOLEN, Norman, Fox Point, Halifax Co., N.S. Possession of migratory non-game bird—Horned Grebe—in close season. Fine: \$10.00.

Provincial Officers have brought the following prosecutions under the Migratory Birds Convention Act.

DOMINICK, Thomas, Squirrel Cove, B.C. Having in possession Gull's eggs. Fine: \$10.00. Seizure: A number of Gull's eggs.

DOMINICK, F., Squirrel Cove, B.C. Having in possession Gulls' eggs. Fine: \$10.00. Seizure: A number of Gulls' eggs.

ASE, N., Nanaimo, B.C. Hunting migratory game birds with the use of a gas-boat. Fine: \$10.00.

CRIPPS, B., Vancouver, B.C. Having in possession migratory game birds—Eleven Sandpipers. Fine: \$10.00.

MUSQUIN, T., Point Grey, Vancouver, B.C. Possession of migratory game birds—Ducks—during close season. Fine: \$10.00.

KARIYA, Y., New Westminster, B.C. Having in possession Gulls' eggs. Fine: \$15.00.

JOHNSON, M., New Westminster, B.C. Having in possession Gulls' eggs. Fine: \$15.00.

BIRD, J., New Westminster, B.C. Having in possession Gulls' eggs. Fine: \$15.00.

HENDRICKSON, T., New Westminster, B.C. Having in possession Gulls' eggs. Fine: \$15.00.

FAKEY, L., Langley, B.C. Shooting migratory insectivorous birds—Robins. Fine: \$10.00.

DRAESEKI, G. C., Vancouver, B.C. Shooting migratory insectivorous birds—Robins. Fine: \$10.00.

SING, Lan, Invermere, B.C. Possession of migratory game birds during close season. Fine: \$10.00.

HART, F., Nanaimo, B.C. Shooting migratory game birds during close season. Fine: \$25.00.

MOORE, T., Nanaimo, B.C. Shooting migratory game birds during close season. Fine: \$25.00.

BENNETT, C., Nanaimo, B.C. Shooting migratory game birds during close season. Fine: \$25.00.

CRUTCHLEY, C. F., Nanaimo, B.C. Shooting migratory game birds during close season. Fine: \$25.00.

COOK, Wm., Nanaimo, B.C. Shooting migratory game birds during close season. Fine: \$25.00.

BELLAS, F., Massett, B.C. Molesting migratory game birds by the use of an unplugged pump-gun. Fine: \$15.00.

MILNER, P., Kerrisdale, B.C. Molesting migratory game birds by the use of an unplugged pump-gun. Fine: \$10.00.

KENMAN, A. L., Howtham South, B.C. Shooting migratory game birds during close season. Fine: \$10.00.

MCCLELLAND, R., 3610—11th Ave. W., Vancouver, B.C. Possession of migratory game birds during close season. Fine: \$10.00.

A JAP (No other name given), Quathiaski Cove, B.C. Having in possession 4 Gulls' eggs. Fine: \$15.00.

COTER, W. H., 3878—11th Ave. E., Vancouver, B.C. Having in possession migratory game birds in close season. Fine: \$10.00.

HUNTER, T. S., Vancouver, B.C. Having in possession migratory game birds in close season. Fine: \$10.00.

HARTLEY, T. S., Kerrisdale, B.C. Having in possession migratory game birds in close season. Fine: \$10.00.

HOY, Wm., Kerrisdale, B.C. Having in possession migratory game birds in close season. Fine: \$10.00.

OFFICIAL CANADIAN RECORD OF BIRD-BANDING RETURNS



THE Canadian National Parks Branch, Department of the Interior, has been keeping the record of those returns upon banded birds which are of interest to Canada because either the bird has been banded in Canada and found elsewhere or banded elsewhere and found in Canada.

In order that these returns may be of the maximum value to Canadian naturalists and the public generally, the Department has decided to publish each return of interest to Canada in *The Canadian Field-Naturalist*. This procedure has, as well, the consent of practically all Canadian bird-banding operators. It is suggested that bird-banding

operators publish on their own initiative accounts of new or interesting occurrences at their bird-banding stations.

RETURN FROM BIRD BANDED IN 1915

GREAT BLACK-BACKED GULL, No. 36,340 (A.B.B.A.), banded by Dr. Chas. W. Townsend, at Old Romaine, Southern Labrador Coast, during the month of July, 1915, was two weeks afterwards collected for the pot, by a Montagnais Indian, at a place four miles from where it was banded.

RETURNS FROM BIRDS BANDED IN 1920

BLACK DUCK, No. 4531, banded by H. S. Osler, at Lake Scugog, Ontario, on September 14, 1920, was recaptured by him on September 24, 1920.

BLUE-WINGED TEAL, No. 4577, banded by H. S. Osler, at Lake Scugog, Ontario, on September 24, 1920, was killed on September 30, 1923, at Mallard's Slough, Turton, South Dakota, U.S.A.

BLACK DUCK, No. 4606, banded by H. S. Osler, at Lake Scugog, Ontario, on September 25, 1920, was shot at Pearl Beach, Michigan, during the fall of 1922.

BLACK DUCK, No. 4620, banded by H. S. Osler, at Lake Scugog, Ontario, on September 27, 1920, was shot on Cedar Island, at the mouth of the South Santee River, South Carolina, on November 16, 1923.

BLACK DUCK, No. 4659, banded by H. S. Osler, at Lake Scugog, Ontario, on October 1, 1920, was caught and found dead in a muskrat trap, just below Finn's Point Jettie, New Jersey, about December 16, 1922.

BLACK DUCK, No. 4685, banded by H. S. Osler, at Lake Scugog, Ontario, on October 4, 1920, was killed on the Bull River, near Savannah, Georgia, during the season of 1922.

RETURNS FROM BIRDS BANDED IN 1921

HOUSE WREN No. 21,128, banded by Howard F. Cant, at 35 Lansdowne Road North, Galt, Ontario, on August 6, 1921, at 2.10 p.m., was re-caught by Mr. Cant on July 6, 1922, at 7 p.m.

WHITE PELICAN, No. 100,553, banded by A. F. Wolther, at Morse, Saskatchewan, on October 30, 1921, was retagged and released by F. L. Norman, on the Cheyenne River, South Dakota, on November 1, 1921.

BLUE-WINGED TEAL, No. 5,184, banded by H. S. Osler, at Lake Scugog, Ontario, on September 15, 1921, was killed at Lake Carrier, Mississippi—no date given, but reported on April 28, 1923.

BLACK DUCK, No. 4,734, banded by H. S. Osler, at Lake Scugog, Ontario, on September 16, 1921, was killed at Clarksville, Montgomery County, Tennessee, on December 25, 1922.

BLUE-WINGED TEAL, No. 4,838, banded by H. S. Osler, at Lake Scugog, Ontario, on September 28, 1921, was shot at Elizabeth, Minnesota, on October 16, 1923.

BLACK DUCK, No. 4,893, banded by H. S. Osler, at Lake Scugog, Ontario, on September 28, 1921, was "taken" at the Pine Island Duck Club, Poplar Branch, North Carolina, on December 11, 1922.

BLACK DUCK, No. 37,322 (A.B.B.A.), banded by H. S. Osler, at Lake Scugog, Ontario, on October 1, 1921, was shot at Revels Island, off the east shore of Virginia, on January 3, 1924.

BLACK DUCK, No. 37,326 (A.B.B.A.), banded by H. S. Osler, at Lake Scugog, Ontario, on Octo-

ber 1, 1921, was killed at Lake Providence, Louisiana—no date given, but reported on February 20, 1923.

BLACK DUCK, No. 37,369 (A.B.B.A.), banded by H. S. Osler, at Lake Scugog, Ontario, on October 2, 1921, was killed at Henderson, Texas, during the winter of 1922-23.

RETURNS FROM BIRDS BANDED IN 1922

SLATE-COLORED JUNCO, No. 21,716, banded by K. G. McDougal, at East Kildonan, Manitoba (about two miles north of Winnipeg), on April 25, 1922, repeated several times until April 27, 1922.

SONG SPARROW, No. 26,701, banded by K. G. McDougal, at East Kildonan, Manitoba, on April 25, 1922, repeated until May 3, 1922. It returned to the same place on April 24, 1923.

SONG SPARROW, No. 26,702, banded by K. G. McDougal, at East Kildonan, Manitoba, on April 25, 1922, repeated until June 21, 1922.

SONG SPARROW, No. 26,704, banded by K. G. McDougal, at East Kildonan, Manitoba, on April 26, 1922, repeated several times until May 24, 1922.

SLATE-COLORED JUNCO, No. 26,707, banded by K. G. McDougal, at East Kildonan, Manitoba, on April 28, 1922, repeated on that day and also on April 29, 1922.

WHITE-THROATED SPARROW, No. 11,735, banded by K. G. McDougal, at East Kildonan, Manitoba, on May 3, 1922, repeated on that day and also on May 4, 1922.

WHITE-THROATED SPARROW, No. 11,736, banded by K. G. McDougal, at East Kildonan, Manitoba, on May 4, 1922, repeated on that day and also on May 5, 1922.

WHITE-THROATED SPARROW, No. 11,741, banded by K. G. McDougal, at East Kildonan, Manitoba, on May 6, 1922, repeated twice on May 7, 1922.

WHITE-THROATED SPARROW, No. 11,744, banded by K. G. McDougal, at East Kildonan, Manitoba, on May 8, 1922, repeated on that day and also on May 9, 1922.

ROBIN, No. 15,195, banded by Howard F. Cant, at Galt, Ontario, on May 24, 1922, raised three broods in 1922 and returned to the same place on April 10, 1923. It repeated on May 14, 1923.

ROBIN, No. 16,102, banded by Philip F. Foran, at Green Park, Hull, Quebec, on June 7, 1922, returned to the same place on July 1, 1922.

TREE SWALLOW, No. 11,652, banded by Philip F. Foran, at Station 173, Ottawa, Ontario, on June 19, 1922, returned to the same station on June 13, 1923.

BANK SWALLOW, No. 75,873, banded by Philip F. Foran, at Station 5, Rocky Mountains Park, Banff, Alberta, on July 15, 1922, returned to the same station on July 13, 1923.

GALLINULE, No. 101,224, banded by H. S. Osler, at Lake Scugog, Ontario, on August 25, 1922, was recaptured at the same station on September 8, 1923.

WHITE-THROATED SPARROW, No. 26,403, banded by B. W. Cartwright, at Sturgeon Creek (3 miles west of Winnipeg limits), Manitoba, on September 17, 1922, repeated until September 20, 1922.

BLACK DUCK, No. 37,415 (A.B.B.A.), banded by H. S. Osler, at Lake Scugog, Ontario, on Sep-

tember 24, 1922, repeated several times until October 22, 1922.

BLUE-WINGED TEAL, No. 43,871, banded by H. S. Osler, at Lake Scugog, Ontario, on September 24, 1922, was recaptured at the same station on October 3, 1922.

BLACK DUCK, No. 37,499 (A.B.B.A.), banded by H. S. Osler, at Lake Scugog, Ontario, on September 27, 1922, was recaptured at the same station on October 1, 1922.

BLACK DUCK, No. 228,413, banded by H. S. Osler, at Lake Scugog, Ontario, on October 7, 1922, was recaptured at the same station on September 3, 1923.

BLACK DUCK, No. 228,511, banded by H. S. Osler, at Lake Scugog, Ontario, on October 10, 1922, was caught alive in the Chester River, Maryland—no date given, but reported on December 27, 1923.

BLACK DUCK, No. 228,585, banded by H. S. Osler, at Lake Scugog, Ontario, on October 20, 1922, was recaptured at the same station on November 1, 1923.

MALLARD, No. 101,365, banded by Jos. Pulitzer, at Cuivre Island, Perouque, Missouri, on January 11, 1922, was shot on Lake Manitoba Marsh, on October 4, 1922.

RING-NECKED DUCK, No. 101,407, banded by E. A. McIlhenny, at Avery Island, Louisiana, on February 17, 1922, was killed at Isle à la Crosse Lake, Saskatchewan, on May 12, 1923.

MALLARD, No. 101,757, banded by E. A. McIlhenny, at Belle Isle Lake, Louisiana, on February 21, 1922, was caught in a trap at The Barrier, a point about forty miles west up the Saskatchewan River (?) no date given, but reported on July 17, 1923.

GREEN-WINGED TEAL, No. 43,080, banded by E. A. McIlhenny, at Avery Island, Louisiana, on March 4, 1922, was killed at Lac La Ronge, Saskatchewan, on June 1, 1923.

MALLARD, No. 102,426, banded by F. C. Lincoln, at the Sanganois Club, on the Illinois River, near Browning, Illinois, on March 6, 1922, was shot at Quill Lake, Saskatchewan, on October 4, 1922.

MALLARD, No. 102,464, banded by F. C. Lincoln, at the Sanganois Club, Browning, Illinois, on March 7, 1922, was shot at Red Earth, Saskatchewan (one hundred miles in a straight line from The Pas, Manitoba), during the month of July, 1922.

MALLARD, No. 102,770, banded by F. C. Lincoln, at Browning, Illinois, on March 12, 1922, was killed near Cedar Lake Post, Manitoba, on August 14, 1923.

BLUE-WINGED TEAL, No. 102,245, banded by E. A. McIlhenny, at Avery Island, Louisiana, on March 21, 1922, was killed at Chipewyan, Northwest Territories, during the month of September, 1922.

ROBIN, No. 13,591, banded by R. W. Tufts, at Wolfville, Nova Scotia, on June 11, 1922, was picked up dead on June 20, 1922, within two hundred yards of the place where it was liberated. The bird was sickly when it was banded.

TREE SWALLOW, No. 11,646, banded by Philip F. Foran, near the corner of Gilmour and Elgin Streets, Ottawa, on June 19, 1922, was captured near the Rideau River, Ottawa South, Ontario, on May 28, 1923, and died the same night. The bird was found to have a broken clavicle.

BLACK DUCK, No. 10,505, banded by R. W. Tufts, at Seal Island, Yarmouth County, Nova Scotia (about twenty miles off the coast from Goose Bay, the nearest mainland in Yarmouth County), on June 21, 1922, was shot at Goose Bay, Nova Scotia, on November 8, 1922.

BLACK DUCK, No. 10,509, banded by R. W. Tufts, at Seal Island, Yarmouth County, Nova Scotia, on June 21, 1922, was caught and killed by a dog, within a half mile from the place where it was banded, on August 26, 1922.

BLACK-POLL WARBLER, No. 7,917, banded by R. W. Tufts, at Seal Island, Yarmouth County, Nova Scotia, on June 23, 1922, was a fledgling one week old, and was found dead in its nest on June 30, 1922.

PINTAIL, No. 202,404, banded by Harry H. Felt, at Findlater, Saskatchewan, on July 9, 1922, was killed at Crook, South Dakota, on November 4, 1922.

GLAUCOUS-WINGED GULL, No. 200,994, banded by Theed Pearse, at Mittenatch Island north of the 50th Parallel, in the Gulf of Georgia, British Columbia, on July 30, 1922, was shot at Redonda Bay, British Columbia, on December 15, 1922.

ROBIN, No. 104,146, banded by Hoyes Lloyd at 406 Queen Street, Ottawa, Ontario, on July 31, 1922, was eaten by a cat in the same vicinity, on August 1, 1922.

GANNET, No. 207,105, banded by H. L. Stoddard, at Bonaventure Island, Quebec, on July 31, 1922, was found dead on the Kildare Sandhills, near Alberton, Prince Edward Island, on or about May 7, 1923. The body of the bird was then partly decomposed.

GANNET, No. 207,269, banded by H. L. Stoddard, at Bonaventure Island, Quebec, on July 31, 1922, was caught in a herring net at Neil's Harbour, Nova Scotia, on November 27, 1922.

NIGHTHAWK, No. 104,155, banded by Hoyes Lloyd, at 406 Queen Street, Ottawa, Ontario, on August 4, 1922, flew in through a window and died at a place two blocks from where it was banded, on August 6, 1922. Death was due to starvation.

GANNET, No. 207,482, banded by Wm. M. Duval, at Bonaventure Island, Quebec, on August 14, 1922, was captured in Shelburne County, Nova Scotia—no date given, but reported on October 17, 1923.

GADWALL, No. 202,471, banded by Jas. C. Silver, at Unity, Saskatchewan, on August 15, 1922, was killed in Crittenden County, Arkansas, on November 27, 1922.

GADWALL, No. 202,473, banded by Jas. C. Silver, at Unity, Saskatchewan, on August 15, 1922, was killed at Kill Squaw Lake, Saskatchewan (three miles east of the place where it was banded), on September 23, 1922.

GADWALL, No. 202,474, banded by Jas. C. Silver, at Unity, Saskatchewan, on August 15, 1922, was killed at Pabo Duro Canyon, Texas, on November 16, 1922.

PINTAIL, No. 202,476, banded by Jas. C. Silver, at Unity Saskatchewan, on August 15, 1922, was killed at Kill Squaw Lake, Saskatchewan, on September 23, 1922.

BLACK DUCK, No. 101,131, banded by H. S. Osler, at Lake Scugog, Ontario, on August 18, 1922, was shot at the foot of Strawberry Island, in the Niagara River, New York, on November 18, 1922.

(To be continued)

NOTES AND OBSERVATIONS

TWO INTERESTING NESTS.—The summer of 1923 brought two very interesting nesting situations to my attention. One was that of a Ruby-throated Hummingbird on the rear porch of the residence of Mr. E. Hawken, 184 Carling Ave., Ottawa. The cord of a common electric drop light had been tied in a knot to shorten it and raise the light socket higher from the floor. The nest was built up from a loop of this knot and, when seen, the female was incubating. She was very shy and it was possible to photograph her only under the worst possible conditions, i.e., in the heavy shade and from inside the door of the house against a brilliantly bright sky. A silhouette was all that was possible but it shows all the essential facts of the case.



In the spring, in opening a boathouse at Blue Sea Lake, seventy miles north from Ottawa up the Gatineau valley, a pair of old overalls was found hanging over a brace of the framework inside. Beneath it, on the floor, was a pile of fresh green moss fragments, nearly two quarts in bulk. It was evident from bits still adhering in the folds of the garment that some bird was attempting to build a nest in them and the material was falling through as fast as it was placed. The only bird likely to inhabit such a place that was noted in the vicinity was a Phoebe. We remained only a day or so, but before we left a safety pin was placed through the overalls to make a stop for the nesting material. On our next visit, the nest was built and occupied. The owner was—a Winter Wren. The nest site was not three feet from the well of the boat house and every time we entered the boats we had to brush the nest as we passed. We even installed an engine and tested it into running condition within the well, but in spite of the confusion, the coming and going, the hammering, the loud explosions, and the gasoline fumes, the Wren remained in possession. Sometimes she would dash off and out through the opening between the roof boards and the plate at the top of the wall, but in a few minutes she would cautiously come back and steal quietly into the nest, whence she would watch the strange proceedings through the side opening

with her black, beady little eyes. She finally hatched and raised her brood and led them away through the deep woods to places where gas engines cease from troubling and Winter Wrens are at ease. At no time was any other Winter Wren seen anywhere about. If she had a mate he took no share in the household work as does the male House Wren. Continually, back in the bush or on either hand, the glorious song of the species was heard, but never was its author detected within a hundred yards of the boat house nor was there anything to indicate that he had the slightest interest in this courageous little female or the nest she occupied. After the young had left, the nest was collected. It is composed of a great mass of green moss fragments with a few sticks in the center and completely enclosing the egg cup except for the entrance hole in the side. House and Bewick's Wrens often build in such unusual situations, but I can find no previous record of a Winter Wren doing so.—P. A. TAVERNER.

LEAST BUSH TIT (*Psaltriparus minimus*).—Considerable interest has been aroused during recent months regarding the Least Bush Tits (*Psaltriparus minimus*), which birds have been under observation by several persons for some time in Point Grey and South Vancouver.

Some ten years ago, during the month of May or June, a nest of this Tit was found by Mr. B. R. Harrison, on Kitsilano hill, where Vine Street now crosses; this nest was in a Willow tree about 12 feet from the ground; the nest was not examined for eggs, etc.

About this time a nest was also found by Mr. J. W. Winson, where the town of Marpole, Point Grey, is now located.

On November 20th, 1922, I secured two male birds through the kindness of Mr. R. C. Cummins, also a male bird on December 9th of the same year, all being taken in South Vancouver, B.C. These were taken from a flock of about 40 birds which wintered in that neighbourhood.

On June 4th, 1923, a nest was found in Point Grey, from which I secured three eggs. This nest was in a spruce tree, and was hanging from the end of a branch between 22 and 25 feet above the ground, with entrance to nest facing east. The locality was a low, swampy place with thick undergrowth. A visit to the same place on June 20th disclosed two other nests, one, an old one from last year, and the other partially destroyed; only fragments of it remained hanging to the branch. Both these nests were hanging from the ends of spruce tree branches, about 15 feet above the ground.

It is noteworthy that all three nests were within one hundred yards of each other, all were in spruce trees, pendulous, and hanging in full view above the dense swampy undergrowth and brush.

A brief description of the completed nest may be of interest. Outside dimensions are as follows:

Length over all.....	16 in.
Length from top of roof to bottom of nest.....	13½ in.
Diam. of nest at opening.....	4¼ in.
Diam. below opening.....	2½ in.
Diam. 8 in below top of roof.....	4 in.
Diam. of entrance opening, about.....	1 in.

The opening of this bottle-shaped nest points downward, and is perfectly roofed over in verandah-like style, the roofing material being securely fastened to two small branches above the top of the nest to give perfect weather protection.

The material composing the nest is green moss, lichens, leaves and a few feathers and quantities of silk from cocoons; all these being securely interwoven with long dry grass and cocoon silk. The interior, as far as discernable, is all lined with cocoon silk.—K. RACEY.

WINTER ACTIVITY OF BATS.—A note by E. M. S. Dale in *The Canadian Field-Naturalist*, March, 1924, concerning "A Bat Active in Winter", prompts me to record similar observations from Toronto. On December 8, 1923, J. L. Baillie saw a bat flying near the Biological Building of the University of Toronto. This was at 5.00 p.m., the evening being dark, with a drizzling rain. Again on February 26, 1924, at 8.30 p.m., a bat flew into the Museum Building when the door had been opened for an instant. The temperature at the time was about 30° F. Again, on the following evening another bat was seen near the Biological Building by Prof. E. M. Walker.

The second specimen here mentioned was captured and is now in the Museum collection. Most of the measurements as taken from the flesh are slightly below those given by Miller (North American Fauna, No. 13) for *Eptesicus fuscus fuscus* but the specimen agrees with that form in its dental formula and in other characters.

Mr. C. W. Nash of the Provincial Museum, Toronto, tells me that he has several records of this species being active in winter. This seems to open up the question as to whether this species is the only one occasionally seen active in winter or if other species may also be found. As it is not likely that such movements are associated with feeding, some other explanation is necessary. Also, if active bats have merely been disturbed from hibernation, one would expect to find species other than *Eptesicus fuscus* flying about in winter.—L. L. SNYDER.

NOTE: Since the above was written, Mr. P. A. Taverner's note in *The Canadian Field-Naturalist* for April, 1924, shows that *Myotis lucifugus* is also to be found active in winter. The habit, then, is not peculiar to *Eptesicus fuscus*, but both this species and *Myotis lucifugus* are "light sleepers."—L. L. S.

CONFERENCE OF PROVINCIAL AND FEDERAL OFFICIALS.—The Conference of Provincial and Federal Officials who are connected with the

administration of wild life protection throughout the Dominion has become an annual event and the winter's session was held at Ottawa on February 6th, 7th, and 8th, 1924.

The Conference was opened by the Honourable Charles Stewart, Minister of the Interior, who extended a welcome to the members and attendants and spoke from experience respecting wild life, its value and the need for its protection. He mentioned especially the pleasure and benefits to be derived from hunting and the need for the protection of fur bearers and game so that these may remain an important support for the Indians of Canada.

Resolutions on many important phases of wild life protection were adopted, and among the subjects dealt with were the following:

Jurisdiction of Provincial Game Officers;

An amendment to the Customs Act with respect to the export of game;

A reconnaissance concerning species of birds other than those protected by the Migratory Birds Convention Act;

The licensing and registration of trappers and hunters;

Leasing of Crown Lands;

The adoption of measures for the suppression of the dumping of oil into navigable waters; and the shortening of the open season for Woodcock.

A resolution was passed expressing appreciation of the great service rendered by the late Napoleon A. Comeau, of Godbout, Quebec, to the Province of Quebec, and to the world-wide movement for wild life conservation, and sincere sorrow was expressed by the conference at the recent loss suffered because of the death of so prominent a personality.—H. L.

THE TORONTO MEETING OF THE BRITISH ASSOCIATION.—The preliminary program of the annual meeting of the British Association in 1924, to be held in Toronto, Ontario, on August 6-13, under the presidency of Sir David Bruce, has been issued and is abstracted in *Nature*. Three meetings have previously been held in Canada (Montreal, 1884; Toronto, 1897; Winnipeg, 1909). Active measures are being taken to ensure that the meeting shall afford an exceptional opportunity for intercourse between British, Canadian, American and European workers in science. The University of Toronto will be the principal center of the meeting.

The inaugural general meeting will be held on Wednesday, August 6, in the Convocation Hall of the University of Toronto, when Sir David Bruce will deliver his presidential address.

A preliminary program of excursions after the meeting is also being arranged. For those able to devote the maximum time, an excursion across Canada to Vancouver, and possibly also to Prince Rupert and Victoria, is contemplated.

STATEMENT TRUST FUNDS COMMITTEE
Cash on Hand, Dec. 31, 1923. \$497.51
W. T. MACOUN, *Chairman*.

The Club acknowledges the receipt of a cheque for One hundred and twenty-five dollars from the Province of Quebec Society for the Protection of Birds. It is understood that this gift is for the improvement of our publication, and the Club appreciates fully the gift, as well as the spirit of co-operation that inspired it.—B. A. FAUVEL, *Treasurer*.

PRIZES FOR OTTAWA NATURAL HISTORY COLLECTIONS.—The Trust Funds Committee has recommended that the interest on funds received from the Kearns and R. B. Whyte estates this year be applied to the donation of prizes for local natural history collections and this recommendation has been adopted by the Club. The subjects covered are botany, entomology, and photography. Furthermore, two present members of the Council, Drs. Ami and Malte, have donated three special

prizes for local collections in archæology, botany, and geology. Full information can be had from the Secretary.—J. F. WRIGHT, *Secretary*.

If any subscriber does not receive his copy of *The Naturalist* within a reasonable time, notification should be sent to the Secretary of the Ottawa Field-Naturalists' Club, so that another copy may be sent, and so that a check may be kept on the extent to which copies are lost in the mails. Apparently some copies have failed to be delivered because of loss of the address en route to the subscriber. Steps are being taken to prevent this in future.—EDITOR.

Our thanks for the illustrations in this issue of *The Naturalist* are due to Mr. P. A. Taverner and The Victoria Memorial Museum.—EDITOR.

Through an arrangement between the Ottawa Field-Naturalists' Club and the Province of Saskatchewan, each of our subscribers will receive in the near future a copy of an extra number of *The Canadian Field-Naturalist*, containing an annotated list entitled *The Birds of Saskatchewan*, by H. Hedley Mitchell. This list will be illustrated by several half-tones and a map, and will be a valuable addition to the ornithological literature of Canada.—EDITOR.

BOOK REVIEW

LIFE HISTORIES OF NORTH AMERICAN PETRELS AND PELICANS AND THEIR ALLIES. *Smithsonian Institution. United States National Museum Bulletin 121. Order Tubinares and Order Steganopodes. By Arthur Cleveland Bent of Taunton, Massachusetts. Washington. Government Printing Office, 1922.*

LIFE HISTORIES OF NORTH AMERICAN WILD FOWL. *Smithsonian Institution. United States National Museum Bulletin 126. Order Anseres (Part). By Arthur Cleveland Bent of Taunton, Massachusetts. Washington. Government Printing Office, 1923.*

These valuable volumes continue the Life Histories of North American Birds, which Mr. Bent has been working for many years to produce. A tremendous amount of interesting and important information concerning the species dealt with has here been gathered together from published and unpublished sources, carefully assorted, and made readily available for consultation. No one, either amateur or professional, who takes a serious interest in North American birds should be without these standard reference works.

Bulletin 126 contains the life histories of North American Anseres, in the order of the A.O.U. 'Check-List', from the American Merganser to the Ring-necked Duck.

For some reason not stated the beautiful colored plates of eggs which appeared in the previous volumes of this series are not continued in the volumes under review.

The author does not adhere to the nomenclature of the A.O.U. 'Check-List' and published supplements in these volumes, as he did in the ones previously published. Instead, he uses, in Bulletin 121, "the names that will probably appear in the new check list", as understood by him, and, in Bulletin 126, scientific names furnished by Dr. Charles W. Richmond and Dr. Harry C. Oberholser. This is a regrettable departure from uniformity in a work whose direct concern is not nomenclature, but life histories. In such a work the purpose of names is simply to afford the readiest possible means of distinguishing the form under discussion, and in the opinion of the reviewer this purpose can best be fulfilled by using a standard and familiar nomenclature, already published, and widely adopted.

The life history of the Gannet is, perhaps, of

unusual interest to Canadian readers. Two breeding colonies on Anticosti must now be added to those listed by Mr. Bent.

The Albatross which was taken at the mouth of the Moisie River, Quebec, in 1885, and which is now preserved as a mounted specimen in the museum of Laval University, Quebec, is recorded under *Thalassogeron chryostomus culminatus* (Gould), although it has yet to be identified by a specialist in the Tubinares.

In the case of the Green-winged Teal the statement is made, under the caption "Breeding Range," "Ungava and Labrador records doubt-

ful." This presumably refers to records of the actual nesting, for the Green-winged Teal certainly occurs in the Labrador peninsula in the breeding season.

Scaup breeding records from the Gulf of St. Lawrence and New Brunswick are all placed under the Greater Scaup, although in the present state of our knowledge it can hardly be considered certain that some at least of the breeding Scaups which have been found in those regions were not Lesser Scaups.

Additional volumes of the series are awaited with great interest.—H. F. L.

PUBLICATIONS RECEIVED

Beach Grass. By Charles Wendell Townsend. Marshall Jones Company, 212 Summer Street, Boston, Massachusetts. Price \$3.50.

Bulletin de la Ligue Française pour la Protection des Oiseaux. Treizième Année. No. 1, Janvier, 1924.

Canadian National Parks Association Bulletin. Number 1. Jan. 1st, 1924.

Aus Natur und Museum. 53 Bericht. Heft 4. Frankfurt am Main, 1923.

Rivista Italiana di Ornitologia. Messina, 1923.

La Science Moderne. Numéro 1, Janvier, 1924.

Food and Economic Relations of North American Grebes. By Alexander Wetmore. United States Department of Agriculture. Department Bulletin No. 1196. Washington, D.C. January, 1924.

La Science Moderne. Numéro 2. Février, 1924.

SUBSCRIBERS TO "THE CANADIAN FIELD-NATURALIST" IN GOOD STANDING, JAN., 1924

Branches of Natural History in which individual subscribers are especially interested are indicated by numbers accompanying their names and referring to the following legend.

- 1—Anthropology;
- 2—Botany;
- 3—Conchology
- 4—Geology
- 5—Entomology
- 6—Marine Biology

- 7—Ornithology
- 8—Palaeontology
- 9—Mammalogy
- 10—Herpetology
- 11—Ichthyology

ACADEMY OF NATURAL SCIENCES, 1900 Race St., Philadelphia, Pa.

ACADIA UNIV. LIBRARY, Wolfville, N.S.

ADAMS, JOHN, Central Exp. Farm, Ottawa.

ALBERTA NAT. HIST. SOCIETY, 2nd Street N.E., Red Deer, Alta.

ALCOCK, F. J., Geological Survey, Ottawa.

ALLAN, K. F., 9 Poplar Plains Rd., Toronto, Ont.

ALLEN, E. C., 150 South Street, Halifax, N.S.

AM. MUSEUM OF NAT. HIST., 77th St. and Central Park W., New York City.

AMES, J. H., 96 Bay St., Toronto, Ont.

AMI, DR. H. M., 4, 8, 453 Laurier Ave. E., Ottawa, Ont.

ANDEN, K. F., Dept. of Zoology, Univ. of B.C., Vancouver, B.C.

ANDERSON, R. M., 7, 9, 58 Driveway, Ottawa, Ont.

ANDERSON, DR. W. G., Steveston, Alta.

ANDERSON, LT.-COL. W. P., 64 Cooper Street, Ottawa, Ont.

ANDREWS, A. W., 133 Tyler Ave., Detroit, Mich.

ANSLEY, J. W., 63 Gothic Ave., Toronto, Ont.

ARBIC, G., 2, Can. Nat. Parks Branch, Ottawa, Ont.

ARCHER, HELEN, 360 Main St. East, Hamilton, Ont.

ARMSTRONG, M. W., 7, Bridgetown, N.S.

ARMSTRONG, N. A. D., Westhouse, Shawing Lake, B.C.

ARNOLD ARBORETUM, Jamaica Plain, Mass.

ARNOTT, DR. H. G., 18 Ontario Ave., Hamilton, Ont.

AUCHMACHIE, A. C., 839 Euclid Ave., Toronto, Ont.

BAILEY, MRS. H. M., 2109 Nebraska St., Sioux City, Iowa, U.S.A.

BAILLIE, JAMES L., 7, 9, c-o Royal Ontario Museum of Zoology, Toronto, Ont.

BAKER, FRANK C., Natural History Bldg., Urbana, Ill.

BALDWIN, L. C., 4 Old Forest Hill Rd., Toronto, Ont.

BALM, H., 7 Oriole Parkway, Toronto, Ont.

BALLANTYNE, JAS., 54 Main St., Ottawa, Ont.

BARBER, R. E., 280 Palmer St., Guelph Ont.

BARBEAU, C. M., Victoria Museum, Ottawa, Ont.

BARTMAN, G. M., 2453 Yonge St., Toronto, Ont.

BATTERSBY, HERMAN, Oak Lake, Man.

BEAN, THOS. E., P.O. Box 441, Galena, Ill.

BEAUPRE, EDWIN, Kingston, Ont.

BELL, H., Box 1001, Pembroke, Ont.

BELL, GARNET S., 406 C.P.R. Bldg., Toronto, Ont.

BENT, A. C., 140 High St., Taunton, Mass.

BERGEN'S MUSEUM, Bergen, Norway.

BERGSTEDT, DR. J. A., Royal Swedish Academy of Sciences, Stockholm, Sweden.

BIGELOW, N. K., Royal Ontario Museum, Toronto, Ont.

BILL, J. PHILIP, 64 Carling Ave., Ottawa, Ont.

BIRD, M. L., Court House, Vancouver B.C.

BISHOP, LOUIS B., c-o L. E. Wyman, Los Angeles Museum, Exposition Park, Los Angeles, Cal.

BISSETT, E. D. R., Beausejour, Man.

BLIZARD, W. H., 70 Duggan Ave., Deer Park, Toronto, Ont.

BOGART, MRS. E. B., 147 Borden St., Toronto, Ont.

BOSTON SOCIETY OF NAT. HIST., 234 Berkeley St., Boston, Mass.

BOUCHARD, GEO., M.P., Ste. Anne de la Pocatiere, P.Q.

BOWMAN, KENNETH, 9917—113th St., Edmonton, Alta.

BRADSHAW, F., Chief Game Warden, Regina, Sask.

BRIDGEN, F. H., 15 Oswald Cres., Toronto, Ont.

BRIMLEY, J. F., Wellington, Ont.

B.C. NAT. HIS. SOCIETY, Victoria, B.C.

B.C. ORNITHOLOGISTS' UNION, Huntingdon, B.C.

BROOKS, MAJOR ALLAN, Okanagan Landing, B.C.

BROWN, MRS. R. D., 388 Main St., Ottawa, Ont.

BROWN, W. J., 250 Oliver Ave., Westmount, P.Q.

BRUNT, R. A., P.O. Box 235, Windsor, Ont.

BUCHANAN, PROF. M. M., 75 Heithdale Road, Toronto, Ont.

BUCKLE, J. W., c-o Thos. Robertson & Co., 134 Craig St. W., Montreal, P.Q.

BULLER, PROF. A. H. R., Dept. of Botany, Univ. of Manitoba, Winnipeg, Man.

BURGESS, T. J. W., (M.D.), Suite 91, Laurentian Apts., 29 Cote des Neiges Road, Montreal, P.Q.

BURWASH, ARMON, Box 120, Arnprior, Ont.

CAL. ACADEMY OF SCIENCES, San Francisco, Cal.

CALVERT, J. FLETCHER, Collegiate Institute, London, Ont.

CALVERT, E. W., c-o J. F. Calvert, 461 Tecumseh Ave., London, Ont.

CAMERON, E. R., Registrar, Supreme Court, Ottawa, Ont.

CAMERON, J. H., 355 Dufferin Ave., London, Ont.

- CAMERON, D. A., 162 Isabella St., Toronto, Ont.
- CAMPBELL, M. M., 95 Broadway Ave., Montreal East, P.Q.
- CAMPBELL, J. A., 17 Elm St., Toronto, Ont.
- CAMPBELL, R. H., 225 Clemow Ave., Ottawa, Ont.
- THE CANADIAN BOY, Banque Nationale Building, Rideau Street, Ottawa, Ont.
- CARNEGIE LIBRARY, Ottawa, Ont.
- CARTWRIGHT, E. W., 374 Donald St., Winnipeg, Man.
- CASSELS, MRS. W. A., Red Deer, Alta.
- CHAMBERS, W. LEE, Eagle Rock, Los Angeles, Cal.
- CHAMBERLAIN, C. W., Hotel Hemenway, Boston, Mass.
- CHEVERTON, GEO. H., Trossacks, Sask.
- CHISHOLM, H. E. M., Press Gallery, Parliament Bldgs., Ottawa.
- CHRISTIE, R. T., Windsor, N.S.
- CHURCHILL, ALLEN, 237 Itherville St., Montreal, P.Q.
- CLEMENS, W. A., Biological Laboratory, University of Toronto, Toronto, Ont.
- COLE, J. E., Westboro, Ont.
- COLE, MISS MINA, Red Deer, Alta.
- COLUMBIA UNIV. LIBRARY, New York, N.Y.
- COMMISSIONER DOMA. PARKS, Dept. of Interior, Ottawa, Ont.
- CONNELL, REV. ROBT., 1057 Chamberlain St., Victoria, B.C.
- CONNOLLY, C. J., St. Francis Xavier College, Antigonish, N.S.
- COOK, C. D., 7, 64 Flatt Ave., Hamilton, Ont.
- COOK, H. C., Geological Survey, Ottawa, Ont.
- CORNELL UNIVERSITY LIBRARY, Ithaca, N.Y.
- CORNWALL, IRA E., Box 799, William Head, Victoria, B.C.
- COSENS, DR. A., Parkdale Collegiate Inst., Toronto, Ont.
- COWAN, MISS EDITH, 97 Stanley Ave., Ottawa, Ont.
- COX, PROF. PHILIP, 329 St. John St., Fredericton, N.B.
- CRAMP, MISS E. B., 44 Sussex St., Rochdale, Yorkshire, England.
- CRAWFORD, H. C., Entomological Branch, Dept. of Agriculture, Ottawa, Ont.
- CREWS, A. C., Wesley Building, Toronto, Ont.
- CRERAR LIBRARY, The John, Chicago, Ill.
- CRICKMAY, CHAS. H., 234—15th St. East, N. Vancouver, B.C.
- CRIDDLE, NORMAN, Treesbank, Man.
- CRIDDLE, STUART, Treesbank, Man.
- CROSSLEY, F., Bashaw, Alta.
- CROSBY, G. C. S., Red Deer, Alta.
- CUSTANCE, P. L., 6221—19th St., S.E., Calgary, Alta.
- DAIGNEAU, DR. P. L., Theford Mines, P.Q.
- DALE, CHAS. F., 625 Cote St. Antoine Road, Westmount, P.Q.
- DALE, E. M. S., 297 Hyman St., London, Ont.
- DAVIDSON, JOHN, Provincial Botanist, University of B.C., Vancouver, B.C.
- DAWSON, W. H., 35 Delisle Ave., Toronto, Ont.
- DEAM, CHAS. C., 103 Main St., Bluffton, Indiana.
- DEPT. OF AGRICULTURE, Regina, Sask.
- DE LURY, DR. RALPH E., Dominion Observatory, Ottawa, Ont.
- DE LURY, GEORGE, Alliance, Alta.
- DE LURY, PROF. JUSTIN S., Dept. of Geology, Univ. of Man., Winnipeg, Man.
- DEMPSEY, J. H. C., P.O. Department, Hamilton, Ont.
- DEMETRIO, REV. C. H., Emma, Lafayette, Missouri.
- DENNISON, MISS H., 27 Elgin Ave., Toronto, Ont.
- DE VANY, J. L., 7, Annapolis Royal, N.S.
- DEXTER, JOHN SMITH, Hotel Miramar, Santurce, Porto Rico.
- DICE, LEO R., University of Michigan, Ann Arbor, Mich.
- DICKEY, D. R., 514 Lester Ave., Pasadena, Cal.
- DINGMAN, RUSSELL G., 98 Woodlawn Ave., Toronto, Ont.
- DOBIE, DR. W. H., 2 Hunter St., Chester, Eng.
- DOBBIE, MRS. W. J., Glenwyld, Weston, Ont.
- DOOLITTLE, E. A., Painesville, Ohio.
- DUCHARME, G., Pres. Bourget College, Rigaud, P.Q.
- DUNLOP, JAMES, Woodstock, Ont.
- DUSTAN, A. G., Entomological Branch, Dept. of Agriculture, Birks Bldg., Ottawa, Ont.
- DWIGHT, J., 43 West 70th St., New York City, N.Y.
- DYER, MRS. W. E. L., 12 Willow Ave., Westmount, P.Q.
- DYMOND, J. R., Royal Ont. Museum Zoology, Toronto, Ont.
- DYSON, J. S., Alexis Creek, Chilcotin, B.C.
- EASTHAM, J. W., Court House, Vancouver, B.C.
- EDDY, E. D., 65 Lynwood Ave., Toronto, Ont.
- EDMONTON PUBLIC LIBRARY, Edmonton, Alta.
- EIFRIG, REV. G., Oak Park, Ill.
- EMERTON, J. H., 30 Ipswich St., Boston, Mass.
- ENTOMOLOGICAL BRANCH LIB., Birks Bldg., Ottawa, Ont.
- EVANS, MISS E. L., c-o Preventorium, Queen Alexandra Sanatorium, R.R. No. 7, London, Ont.
- EVANS, JOHN D., Trenton, Ont.
- FACULTY CLUB, McGill University, 822 University St., Montreal, P.Q.
- FARLEY, F. L., Camrose, Alta.
- FARR, H. Y., 243 Wright Ave., Toronto, Ont.
- FAUTEUX, AEGIDIUS, 340 Rue St. Denis, Montreal, P.Q.
- FAUVEL, B. A., 321 McLeod St., Ottawa, Ont.
- FERRIER, W. F., 52 St. Andrews Gardens, Toronto, Ont.
- FIELD MUSEUM, Natural History Library, Chicago, Ill.
- FELLOWS, K., Income Tax Office, Daly Building, Ottawa, Ont.
- FISK, H. H. S., 17 John St., Montreal, P.Q.
- FLECK, A. W., 500 Wilbrod St., Ottawa, Ont.
- FLEMING, J. H., 7, 267 Rusholme Road, Toronto, Ont.
- FOERSTE, DR. AUG. F., 129 Wroe Ave., Dayton, Ohio.
- FORD, MISS NORMA, 96 Dunn Ave., Toronto, Ont.
- FORSEY, MRS. F. E., Library, Geological Survey, Ottawa, Ont.
- FRASER, MISS A. M., 667 McDermott Ave., Winnipeg, Man.
- FRASER, C. MCLEAN, University of B.C., Vancouver, B.C.
- FYLES, MISS F., Central Exp. Farm, Ottawa, Ont.
- GAGNON, T. P., Theford Mines, Que.
- GALVIN, E. R., Sporting Powder Div., E. I. du Pont de Nemours & Co., Wilmington, Del., U.S.A.
- GARRETT, C. B., Box 512, Cranbrook, B.C.
- GARTRELL, GEO. N., Summerland, B.C.
- GEOLOGICAL SURVEY LIBRARY, Ottawa, Ont.
- GIBSON, ARTHUR, 5, Entomological Branch, Dept. of Agriculture, Ottawa, Ont.
- GIBSON, A. R., 199 Heath St. W., Toronto, Ont.
- GILLESPIE, C., Parry Sound, Ont.
- GLADWISH, W. E., 132 Eaton Ave., Montreal West, P.Q.
- GLENDENNING, R., Entomologica Branch, Agassiz, B.C.
- GOODRICH, CALVIN, c-o Toledo Blade, Toledo, Ohio.
- GORMLEY, LIGUORI, 7, Annprior, Ont.
- GOUDIE, MISS MARIE J., Alexander High School, Medicine Hat, Alta.
- GOULD, HARRY, High River, Alta.
- GOULDING, A. M., Dentonia Park, East Toronto, Ont.
- GRAHAM, MISS M. E., c-o Educational Dept., Spring Street, Melbourne, Australia.
- GRANT, MRS. M. C., 24 Blackburn Ave., Ottawa, Ont.
- GRANT, A. W., 16 Powell Ave., Ottawa, Ont.
- GRINNELL, J., University of California, Berkeley, Cal.
- GRISDALE, J. H., Deputy Minister Agric., Ottawa, Ont.
- GRIST, MISS MARY L., 251 Laurier Ave. E., Ottawa, Ont.
- GROH, H. P., Botanical Division, Can. Exp. Farm, Ottawa, Ont.
- GUNDY, MRS. S. W., 73 Spadina R., Toronto, Ont.
- GUNDY, MR. N. F., 16 Oriole Rd., Toronto, Ont.
- GUSSOW, H. T., Central Exp. Farm, Ottawa, Ont.
- HALKETT, ANDREW, 216 Lyon St., Ottawa, Ont.
- HAMBLY, FRED J., Buckingham, P.Q.
- HAMERSLEY, MRS. W. H., P.O. Box 24, Hafford, Sask.
- HAMILTON, DR. B. A., Highland Park, Ill.
- HAMILTON BIRD PROT. SOCIETY, 36 Robinson St., Hamilton, Ont.
- HAMILTON, DR. F. W. L., 318 Somerset Building, Winnipeg, Man.
- HAHN, EMANUEL, 32 Adelaide St. E., Toronto, Ont.
- HAHN, MISS FREYA, 9 Washington Ave., Toronto, Ont.
- HANHAM, A. W., R.M.D. No. 1, Duncan, B.C.
- HANNA, MISS L., 20 Wychwood Park, Toronto, Ont.
- HARDY, CAPT. C. P., 300 Bank of Hamilton Bldg., Hamilton, Ont.
- HARKIN, J. B., Can. Natl. Parks Branch, Ottawa, Ont.
- HARPER, FRANCIS, Zoological Library, Cornell University, Ithaca, N.Y.
- HARRINGTON, A. JEROME, 813 Bathurst St., Toronto, Ont.
- HARRISON, W. J., 81 Montcalm St., Hull, P.Q.
- HARROLD, C. G., 177 Smith St., Winnipeg, Man.
- HART, THOMAS P., R.R. No. 8, Woodstock, Ont.
- HART, N. C., Western University, St. George St., London, Ont.
- HAULTAIN, C. F., 7, Port Hope, Ont.
- HAYES, A. O., 560 Avenida de Mayo, Buenos Aires, Argentina.
- HENDERSON, A. D., Belvedere, Alta.
- HILLGARDNER, GORDON, 27 Lafayette St., Brockport, N.Y.
- HODGSON, ANGUS, 714 Pine Ave., Montreal, P.Q.
- HOLDON, REV. M. W., The Vicarage, Surrey Centre, B.C.
- HOLMES, ROBT., 24 Isabella St., Toronto, Ont.
- HOWELL, MR. GEO., Wychwood Park, Toronto, Ont.
- HUARD, CANON V. A., No. 2 Richelieu St., Quebec, P.Q.
- HUDSON, PROF. G. H., 39 Brook St., Plattsburgh, N.Y.
- HUDSON, H. F., Entomological Laboratory, Strathroy, Ont.
- HUGHES, HERBERT F., Dollard, Sask.
- HUME, G. S., Geological Survey, Ottawa, Ont.
- HUNTER, ANGUS, 512 Wellington St., London, Ont.
- HUNTSMAN, A. G., 6, Biological Department, University of Toronto, Toronto, Ont.

- HURST, MR. F., 476 Russell Hill Rd., Toronto, Ont.
- HUTCHINGS, C. B., Entomological Branch, Dept. of Agriculture, Ottawa, Ont.
- HUTTON, W. S., Geological Survey, Ottawa, Ont.
- INGLIS, R. A., Div. of Botany, Experimental Farm, Ottawa, Ont.
- INTERNATIONAL INST. LIBRARY, Dept. of Agriculture, Ottawa, Ont.
- JACKES, LYMAN B., Huron Ave., Toronto, Ont.
- JACKSON, H. A. C., 35 Campbell Ave., Montreal West, P.Q.
- JAMES, MRS. FREDERICK, Percé, County Gaspé, P.Q.
- JARVIS, GERALD, Bank of Ottawa, Arnprior, Ont.
- JENKINS, J. D., Charlottetown, P.E.I.
- JENNESS, D., Geological Survey, Ottawa, Ont.
- JENNINGS, OTTO E., Carnegie Museum, Pittsburgh, Pa.
- JONES, NELSON T., R.R. No. 2, Port Stanley, Ont.
- JOHANSEN, F., 6, 114 Vittoria St., Ottawa, Ont.
- JOHNSON, A. S. JR., Thetford Mines, P.Q.
- JOHNSON, C. E., Geological Survey, Ottawa, Ont.
- JOHNSON, MRS. G. E., 70 Flora St., St. Thomas, Ont.
- KEALEY, MISS LULU, 14 Blackburn Ave., Ottawa, Ont.
- KENNARD, FREDERIC H., Dudley Road Newton Centre, Mass.
- KINDLE, E. M., 8, Geological Survey, Ottawa, Ont.
- KING, W. C., 31 Gilmour St., Ottawa, Ont.
- KINGSTON, A. G., Dept. of Public Works, Ottawa, Ont.
- KITTO, V., 317 Queen St., Ottawa, Ont.
- KLUGH, A. B., Queen's University, Kingston, Ont.
- KURATA, T. B., "Arcady", Swansea, Ont.
- LA BRIE, W., 7, Kamouraska, P.Q.
- LAING, H. M., Comox, B.C.
- LANGELIER, GUS., 7, Cap Rouge, P.Q.
- LAMBERT, MRS. A. J. F., Carmagh, Sask., via Piapot.
- LATCHFORD, HON. F. R., 3, Osgoode Hall, Toronto, Ont.
- LAUGHLIN, A. W., 87 Elm St., Toronto, Ont.
- LAW, J. EUGENE, 2370 Altadena Drive, Altadena, Cal.
- LAWRENCE, A. G., 7, City Health Dept., Winnipeg, Man.
- LAWSON, RALPH, 88 Washington Sq., Salem, Mass.
- LAWTON, BENJ., Chief Game Warden, Edmonton, Alta.
- LEES, W. A. D., Camrose, Alta.
- LEES, MISS J., Erindale, Ont.
- LEIM, A. H., Biological Department, University of Toronto, Toronto, Ont.
- LEONARD, MRS. R. W., Springbank, St. Catharines, Ont.
- LETT, MRS. R. C. W., 12920 Stoney Plain Rd., Edmonton, Alta.
- LEWIS, HARRISON F., 7, Can. Natl. Parks Branch, Ottawa, Ont.
- LIBRARY OF PARLIAMENT, Ottawa, Ont.
- LIBRARY LEG. ASSEMBLY, Toronto, Ont.
- LIBRARY, Univ. of Kansas, Lawrence, Kan.
- LLOYD, PROF. F. E., McGill University, Montreal, P.Q.
- LLOYD, HYPES, 7, 9, 406 Queen St., Ottawa, Ont.
- LLOYD, MRS. WILMOT, 7, 406 Queen St., Ottawa, Ont.
- LLOYD LIBRARY, Cincinnati, Ohio.
- LOCHHEAD, PROF. W., MacDonald College, P.Q.
- LOGIER, SHELLY, 5, 10, 11, Royal Ontario Museum, Toronto, Ont.
- LOWE, CHAS. W., Dept. of Botany, University of Manitoba, Winnipeg, Man.
- LUNN, HERBERT, Hillier, Ont.
- MACCLEMENT, W. T., Queen's University Grounds, Kingston, Ont.
- MACDONALD, MISS R. H., 38 Herkimer St., Hamilton, Ont.
- MACKAY, DR. A. H., 61 Queen St., Dartmouth, N.S.
- MACLAUGHLIN, MRS. F. E., 452 Main St. E., Hamilton, Ont.
- MACNAMARA, CHAS., Arnprior, Ont.
- MACSWEEN, A., 375 Jean Mance St., Montreal, P.Q.
- MACOUN, W. T., Experimental Farm Ottawa, Ont.
- MAGEE, M. J., 603 South St., Sault Ste. Marie, Mich.
- MAHEUX, GEORGES, Department of Agriculture, Quebec City, P.Q.
- MALCOLM, MISS E., 124 Herkimer St., Hamilton, Ont.
- MALTE, DR. M. O., 2, Geological Survey Museum, Ottawa, Ont.
- MARCOTTE, REV. LEON, St. Charles Seminary, Sherbrooke, P.Q.
- MARSHALL, A. G., 15 O'Connor St., Ottawa, Ont.
- MARTIN, A. W., Can. Nat. Ry. Agt., Port Arthur, Ont.
- MARTIN-ZEDEL, GEO., Directeur de l'Île d'Anticosti, Baie Ellis, Anticosti, P.Q.
- MASSACHUSETTS HORT. SOCIETY, 300 Massachusetts Ave., Boston, Mass.
- MATHER, KIRTLEY F., Denison University, Granville, Ohio.
- MCCULLOCH, DR. E. A., 165 St. Clair Ave. W., Toronto, Ont.
- MCLELLINEY, DR. M. G., 252 Lisgar St., Ottawa, Ont.
- MCGILL UNIVERSITY LIBRARY, 65 McTavish St., Montreal, P.Q.
- MCILWRAITH ORNITH. CLUB, c-o C. G. Watson, Secretary, 201 Ridout St., South, London, Ont.
- MCINNES, WM., Geological Survey, Ottawa, Ont.
- MCKEOUGH, DR. GEO. T., R.R. No. 1, Blenheim, Ont.
- MCLACHLIN, DAN., Arnprior, Ont.
- MCLAINE, L. S., Entomological Branch, Dept. of Agriculture, Ottawa, Ont.
- MCKINLEY, DR. J. N., 94 Inglewood Drive, Toronto, Ont.
- MCLEOD, J. R., 345 Wortley Road, London, Ont.
- MERRIAM, DR. C. HART, 1919 16th St., Washington, D.C.
- MERRIMAN, R. O., 7, 96 West 2nd St., Hamilton, Ont.
- MIDDLETON, MRS., 13 Washington Ave., Toronto, Ont.
- MIDDLETON, J. C., 38 Ridgway St., London, Ont.
- MIDDLETON, MISS, 10 McMaster Ave., Toronto, Ont.
- DE MIFFONIS, H., 355c Elgin St., Ottawa, Ont.
- MILLER, G. A., Normal School, Ottawa, Ont.
- MILLER, PROF. W. G., 21 Howland Ave., Toronto, Ont.
- MILLEN, MISS C., Hull, P.Q.
- MINER, JOHN T., Kingsville, Ont.
- MISSOURI BOTANICAL GARDEN, St. Louis, Mo.
- MOE, G. G., University of B.C., Vancouver, B.C.
- MOORE, REV. G. W., D.S.O., 2 Park Villas, Barnstaple, N. Devon, England.
- MORRIS, F., 643 Aylmer St., Peterborough, Ont.
- MORRIS, ROBERT T., 114 East 54th St., New York City, N.Y.
- MORROW, MISS EDITH, 90 Durocher St., Montreal, P.Q.
- MORSE, EDWARD S., 12 Linden St., Salem, Mass.
- MOUSLEY, H., 2, 7, Hatley, P.Q.
- MUNRO, J. A., 7, 1060 St. David St., Oak Bay, Victoria, B.C.
- MURRAY, JAS. M., 406 Simcoe St., Woodstock, Ont.
- MURPHY, JOHN, 174 McLaren St., Ottawa, Ont.
- MUSEUM OF CITY OF MILWAUKEE Library Department, Milwaukee, Wis.
- MUSEUM OF COMP. ZOOLOGY, Cambridge, Mass.
- NALDER, R. F., East Kelowna, B.C.
- NASH, C. W., Provincial Museum, St. James Square, Toronto, Ont.
- NAT. HIS. SOCIETY OF MAN., c-o Dr A. M. Davidson, 6 Medical Arts Bldg., Winnipeg, Man.
- NELSON, DENYS, General Hospital, Vancouver, B.C.
- NEWCOMBE, C. F. (M.D.), 138 Dallas Road, Victoria, B.C.
- N.Y. BOTANICAL GARDEN, Bronx Park, New York City, N.Y.
- N.Y. STATE FORESTRY COL., Syracuse, N.Y.
- N.Y. STATE LIBRARY, Albany, N.Y.
- N.Y. ZOOLOGICAL SOCIETY, 185th St. & Southern Bo., Bronx, New York, N.Y.
- NICOLLS, REV. G. G., 7 Gladstone Ave., Westmount, P.Q.
- NOBERT, JULIAN, Cluny, Alta.
- NORDBYE, F. A., Camrose, Alta.
- NORMAL SCHOOL, Brandon, Man.
- NORMAL SCHOOL, Camrose, Alta.
- NORMAL SCHOOL, Elgin St., Ottawa, Ont.
- NORMAL SCHOOL, London, Ont.
- NORMAN, ERNEST S., Kalevala, Man.
- NORTON, MRS. HARRY A., Edgewater Farm, Ayers Cliff, P.Q.
- NUNN, R. C., 56 Alpine Ave., Hamilton, Ont.
- O'DONOGHUE, CHAS. H., University of Manitoba, Winnipeg, Man.
- OGLIVY, A. S., Civil Service Comm., Hunter Bldg., Ottawa, Ont.
- ONTARIO AGRICULTURAL COLLEGE, Library, Guelph, Ont.
- ORDE, J. F., 64 Walmer Road, Toronto, Ont.
- PACK, ARTHUR N., 1214 16th St., Washington, D.C.
- PARDIDGE, J. A., 153 Clendennan Ave., Toronto, Ont.
- PAYNE, F. F., Meteorological Office, Bloor St. W., Toronto, Ont.
- PATCH, CLYDE L., 10, Geological Survey, Ottawa, Ont.
- PATTERSON, ARNOLD M., HumberSide Ave., Toronto, Ont.
- PATERSON, A. J., 60 Brock Ave., Montreal West, Que.
- PATERSON, T. D., 562 Waterloo St., London, Ont.
- PATRICK, JAMES, Yorkton, Man.
- PEARSE, THEED., Box 158, Courtney, B.C.
- PEARSON, T. GILBERT, 1974 Broadway, New York, N.Y.
- PEMBER, KARL A., Woodstock, Vt.
- PEMBERTON, C. C., 606 Sayward Bldg., Victoria, B.C.
- PERKINS, E., Box 52, Waterville, Maine
- PERLEY, MRS. W. B., Ojibway, Essex Co., Ont.
- PETCH, C. E., Hemmingford, P.Q.
- PHILIP, P. B., 220 Broadway, New York City, N.Y.
- PICHER, R. H., Mines Branch, Sussex St., Ottawa, Ont.
- PIERSOL, PROF. W. H., 35 Dunvegan Rd., Toronto, Ont.
- PORTE, T. Y., c-o H. Birks & Sons, Winnipeg, Man.
- POTTER, LAWRENCE B., Gower Ranch, East End, Sask.
- POWELL, DR., 167 College St., Toronto, Ont.
- PREECE, W. H. A., 5, 7, 21 Wellington St., Sault Ste. Marie, Ont.
- PRICE, MISS E., 27 Irwin St., Toronto.
- PRINCE, Prof. E. E., Dept. of Marine & Fisheries, Ottawa, Ont.
- PRINGLE, J. D., 273 Wright Ave., Toronto, Ont.
- PUGSLEY, E., 8 Ahrens St. E., Kitchener, Ont.
- PUGSLEY, E., R.R. No. 3, Kitchener.
- PUGET SOUND BIOL. STATION, c-o Univ. of Washington, Seattle, Wash.

- QUEBEC SOCIETY PROT. BIRDS, 66 Arlington Ave., Westmount, P.Q.
- QUEENS UNIVERSITY LIBRARY, Kingston, Ont.
- RACEY, KENNETH, 3262 1st Ave. West, Vancouver, B.C.
- RAINE, W., 7, Waverley Villa, Kew Beach, Toronto, Ont.
- RANDALL, T. E., Box 239, Castor, Alta.
- RAYMO, W. A., 30 St. Mary St., Clarkson, Toronto, Ont.
- RAYMOND, P. E., Harvard University, Cambridge, Mass.
- REED, GUILFORD W., 150 Frontenac St., Kingston, Ont.
- REED, MONTAGUE, 2660 Park Ave., Apt. 11, Montreal, P.Q.
- REID, T. A., 12 Gibson Ave., Hamilton, Ont.
- REYNOLDS, DR., 445 Colborne St., London, Ont.
- REYNOLDS, MISS G. B., Auditor General's Office, Ottawa, Ont.
- RICHARDSON, W. D., Chief Chemist, Swift & Co., Union Stock Yards, Chicago, Ill.
- ROBB, WALLACE H., Cazenovia, N.Y.
- ROBERTSON, A. D., Western University, London, Ont.
- ROBERTSON, CARL T., 1626 Hollyrood Rd. N., Cleveland, Ohio.
- ROBERTSON, C. N., c-o Ross Realty Co., Room 805 Lewis Bldg., 17 St. John St., Montreal, P.Q.
- ROPER, RIGHT REV. J. C., 140 Bay St., Ottawa, Ont.
- ROSS, W. A., Vineland Station, Ont.
- ROWAN, WM., University of Alberta, Edmonton, Alta.
- ROWE, T. C., 27 Gwynne Ave., Ottawa, Ont.
- ROYAL CANADIAN INSTITUTE, 198 College St., Toronto, Ont.
- RUSH, M. L., 224 Driveway, Ottawa, Ont.
- RUSSELL, L. S., University of Alberta, Edmonton, Alta.
- SAISON, N. B., Banff, Alta.
- SAPIR, E., 1, Victoria Museum, Ottawa, Ont.
- SAUNDERS, W. E., 240 Central Ave., London, Ont.
- SCHANTZ, ORPHEUS M., 10 South La-salle St., Chicago, Ill.
- SCOTT, R. BRUCE, 214 Poplar Plains, Toronto, Ont.
- SCOTT, REV. C. T., 127 Westminster Ave., Toronto, Ont.
- SCOTT, C. W., 2760 Hutchison St., Montreal, P.Q.
- SCOTT, MISS MARY MCK., Interior Department, Ottawa, Ont.
- SCOTT, W. L., 383 Stewart St., Ottawa, Ont.
- SEQUIN, C., Haileybury, Ont.
- SETON, ERNEST T., Lake Ave., Greenwich, Conn.
- SHAW, MRS. F. R., 56 Homewood Ave., Toronto, Ont.
- SHAW, W. T., State College, Washington, Pullman, Wash.
- SHERMAN, MISS A. R., Route No. 2, McGregor, Iowa.
- SHIRAS 3RD., GEO., Stoneleigh Court, Washington, D.C.
- SHUTT, F. T., Central Exp. Farm, Ottawa, Ont.
- SIFTON, DR. H. B., 10 Tathnally Ave., Toronto, Ont.
- SINCLAIR, D. M., Eckville, Alta.
- SMALL, DR. H. B., 150 Laurier Ave. W., Ottawa, Ont.
- SMITH, A. G., Wainwright, Alta.
- SMITH, FRANK, Natural History Bldg., Urbana, Ill.
- SMITH, HARLAN I., Geological Survey, Ottawa, Ont.
- SMITH, NAPIER, c-o Bank of Montreal, Verdun, Que.
- SNELL, C. H., Red Deer, Alta.
- SNYDER, L. L., 7, 9, Royal Ont. Museum Zoology, Toronto, Ont.
- SOCIETE PROVANCHER D'HISTOIRE NATURELLE DU CANADA, Quebec, P.Q.
- SOPER, J. D., 10527 85th Ave., Edmonton, Alta.
- SOWTER, T. W. E., Cont. Surveyors Office, Department of Interior, Ottawa, Ont.
- SPECK, F. G., Univ. of Pennsylvania, Museum, Univ. of Pa., Philadelphia, Pa.
- SPEECHLY, DR. H. M., 299 Enderton Bldg., Winnipeg, Man.
- SPENCELEY, PROF. J. G., Western Univ., London, Ont.
- SPREADBOROUGH, WM., 859 Phoenix St., Victoria, B.C.
- SPROT, G. D., R.R. Cobble Hill, Vancouver Isld., B.C.
- SQUIRES, MRS. NATHAN C., 7, Fredericton, N.B.
- STAPLES, OWEN, Hogarth Ave., Toronto, Ont.
- STATTEN, TAYLOR, 14 McMaster Ave., Toronto, Ont.
- STEPHEN, REV. BRO., Longueil, P.Q.
- STERNBERG, CHAS. M., Geological Survey, Ottawa, Ont.
- STEVENS & BROWN, 4 Trafalgar Sq., London, England.
- STEWART, MR. JOHN, 28 South Street, Halifax, N.S.
- STEWART, R. M., Dominion Observatory, Ottawa, Ont.
- STEWART, RONALD, Comox, B.C.
- STOHR, REV. M. L., St. Alexander College, Ironside, P.Q.
- STRICKLAND, E. H., University of Alberta, Edmonton, Alta.
- SWALES, B. H., U.S. National Museum, Division of Birds, Washington, D.C.
- SWIFT, H. F., 110A Grand Boulevard, Notre Dame de Grace, Montreal, P.Q.
- SYMES, P. B., 499 Somerset St., Ottawa, Ont.
- TAVERNER, P. A., Geological Survey, Ottawa, Ont.
- TAYLOR, A. W., 68 Yale St., St. Catharines, Ont.
- TAYLOR, W., 2301 Trinity St., Vancouver, B.C.
- TEMPLE, PETER, 438 Gladstone Ave., Toronto, Ont.
- TERRILL, LEWIS M., 44 Stanley Ave., St. Lambert, P.Q.
- THACKER, T. L., Little Mountain, Hope, B.C.
- THOMAS, R. M., 298 Garry St., Winnipeg, Man.
- THOMPSON, STUART, 529 Roxton Road, Toronto, Ont.
- THOMSON, PROF. R. B., Botanical Laboratories, University of Toronto, Toronto, Ont.
- THURSTON, J., 613 7th Ave. W., Calgary, Alta.
- TISDALE, PAUL, Kenton, Mar.
- TOPELY, MRS. W. J., 272 Somerset St., Ottawa, Ont.
- TORONTO FIELD-NATURALISTS' CLUB, 151 Ellsworth Ave., Toronto, Ont.
- TOWNSEND, DR. CHAS. W., 98 Pinckney St., Boston, Mass.
- TURNBULL, J. F., Box 1097, North Bay, Ont.
- TURNBULL, J. D., 48th Ave. West, Vancouver, B.C.
- TYRRELL, J. B., Room 534, Confederation Life Bldg., Toronto, Ont.
- U.S. DEPT. OF AGRIC., LIBRARY, Washington, D.C.
- U.S. GEOLOG. SURVEY LIBRARY, Dept. of Interior, Washington, D.C.
- UNIV. OF ALBERTA LIBRARY, Edmonton South, Alta.
- UNIV. OF CALIFORNIA LIBRARY, Berkeley, Cal.
- UNIVERSITY OF CHICAGO, General Library, Chicago, Ill.
- UNIV. OF HARVARD LIBRARY, Cambridge, Mass.
- UNIV. OF ILLINOIS LIBRARY, Urbana, Ill.
- UNIV. LAVAL BIBLIOTHEQUE, Quebec City, P.Q.
- UNIV. OF MANITOBA LIBRARY, Kennedy St., Winnipeg, Man.
- UNIV. OF MICHIGAN LIBRARY, Ann Arbor, Mich.
- UNIVERSITY OF MONTREAL, Botanical Lab., St. Denis St., Montreal, P.Q.
- UNIVERSITY OF OHIO, The Library, Columbus, Ohio.
- UNIVERSITY OF TORONTO, The Library, Toronto, Ont.
- VANCOUVER NAT. HIS. SOCIETY, c-o C. F. Connor, 3529 2nd Ave. W., Vancouver, B.C.
- VAN HORNE, MISS, 515 Sherbrooke St. W., Montreal, P.Q.
- VEBERT, E. P., 45 Robert Ave., Outremont, P.Q.
- WALLES, G. H., 1472 Charles St., Vancouver, B.C.
- WALLIS, J. B., School Board Office, William St., Winnipeg, Man.
- WALKER, BRYANT, 1306 Dime Bank Bldg., Detroit, Mich.
- WALKER, DR. E. M., 67 Alcina Ave., Toronto, Ont.
- WALKER, P.S., 2127 Cypress St., Vancouver, B.C.
- WARREN, DR. B. H., 220 West Market St., Westchester, Pa., U.S.A.
- WARDELL, MISS E. B., 94 Gloucester St., Toronto, Ont.
- WARWICK, F. W., 36 Blenheim Road, Galt, Ont.
- WAUGH, F. W., Geological Survey, Victoria Museum, Ottawa, Ont.
- WINCH, F., Sporting Powder Div., E. I. du Pont de Nemours Coy., Wilmington, Del., U.S.A.
- WHITE, ED. F. G., 185 Wurtemberg St., Ottawa, Ont.
- WHITE, G. R., 185 Wurtemberg St., Ottawa, Ont.
- WHITE, H. C., Queen's University, Kingston, Ont.
- WHITE, JAS., Snelgrove, Ont.
- WHITE, J. H., Faculty of Forestry, University of Toronto, Toronto, Ont.
- WHITEHOUSE, F. C., Canadian Bank Commerce, Nelson, B.C.
- WHITTAKER, E. J., Geological Survey, Ottawa, Ont.
- WICKHAM, PROF. H. F., State University, Iowa City, Iowa.
- WILLEY, PROF. ARTHUR, McGill University, Montreal, P.Q.
- WILLIAMS, M. Y., University of B.C., Vancouver, B.C.
- WILLIAMS, J. L., Laurentian Club, Ottawa, Ont.
- WILSON, MISS ALICE E., Geological Survey, Ottawa, Ont.
- WILSON, MISS E., Acacia Ave., Rock-cliffe, Ottawa, Ont.
- WILSON, JOHN T., 178 Rideau Terrace, Ottawa, Ont.
- WINCHESTER, H. S., 35 Willard Ave., Ottawa, Ont.
- WINSON, J. W., Huntingdon, B.C.
- WINTENBURG, W. J., 32 Grosvenor Ave., Ottawa, Ont.
- WOOD, A. A., R.R. No. 2, Ilderton, Ont.
- WOOD, C. RODNEY, Boy Scouts' Assn., 203 Wellington St., Ottawa, Ont.
- WOOD, MISS KING, 29 Alcina Ave., Toronto, Ont.
- WOOD, COL. WM., 59 Grand Allee, Quebec City, P.Q.
- WOLFE, WM., 102nd St., Edmonton, Alta.
- WRIGHT, A. H., Zoological Department, Cornell University, Ithaca, N.Y.
- WRIGHT, J. FRANK, Victoria Mem. Museum, Ottawa, Ont.
- WRIGHT, MISS ERTA, 34 Rockcliffe, Ottawa, Ont.
- WRIGHT, MISS S. E., 317 Queen St., Ottawa, Ont.
- YEOMANS, MISS N. A., 137 Isabella St., Toronto, Ont.
- YOUNG, C. H., Victoria Memorial Museum, Ottawa, Ont.
- ZOOLOGICAL MUSEUM, Christiana, Norway.
- ZOOLOGICAL MUSEUM, Copenhagen, Denmark.
- ZOOLOGICAL SOCIETY, LONDON, Regents Park, London N.W. 8, England.

CLASSIFIED NOTICES

"THE CONDOR" is a bi-monthly illustrated magazine of Western Ornithology—started in 1899 and now better than ever. Edited by Dr. Joseph Grinnell and published by The Cooper Ornithology Club. \$3.25 per year. *The Condor* is an essential to any student of American Birds. W. Lee Chambers, Business Manager, Eagle Rock, Drawer 123, Los Angeles, Cal.

L. C. Smith & Bro. **Typewriter**

Ball bearings in every frictional part of the L. C. Smith insure long life, light touch and easy operation

Ottawa Typewriter Co. Limited
191 QUEEN ST., OTTAWA

*Use the Classified Notices to
a greater extent.*

Eight Lines—One Insertion—One Dollar



Card Filing Systems for Naturalists

As makers of the Library Bureau line of Card Filing Devices in Canada, we are in a position to supply all Naturalists with cards and trays where they can readily index all their observations and notes

Lowe-Martin Ltd.
OTTAWA, CANADA

*Printers of The Canadian Field-Naturalist
Publishers of the Autobiography of John Macoun, M.A.*

The Crabtree Co.

Artists and
Designers

BLUEPRINTERS
ENGRAVERS
COMMERCIAL
PHOTOGRAPHERS
: PHOTO :
LITHOGRAPHERS

228 Albert Street
Ottawa, Ont.

COAL C. C. Ray Company Limited

BEST QUALITY LOWEST PRICES

46 Sparks St.—Phone Q. 461
OTTAWA

Geo. E. Preston & Sons MERCHANT TAILORS

*We make everything we sell and
guarantee everything we sell*

217-219 Rideau Street, Ottawa

Dr. Mark G. McElhinney

*Dentist to certain of the
cognoscenti*

252 LISGAR STREET, OTTAWA
Telephone Queen 2438

Kindly mention The Canadian Field-Naturalist to advertisers

Prices of Separates

Notes to Contributors, Etc.

Papers for publication should be addressed to the Editor, Mr. Harrison F. Lewis, Parks Branch, Ottawa, or to the appropriate Associate Editor.

Manuscript should be plainly written, typed if possible, on one side of the paper only, with wide spaces between the lines and ample margins. It is urged that special care be used that scientific names are legible, properly formed, and correctly spelled and capitalized.

Galley proof will be submitted to authors resident in Ottawa and proof of leading articles to any other author if requested when manuscript submitted. It is requested that it be corrected and returned to the Editor as quickly as possible.

Authors of leading articles are entitled to twenty-five copies of the number in which they appear, free of charge on application.

Separates of articles as they appear on the page, without any change of make-up will be supplied at the following rates:—

	25	50	100	200	300
1 page	\$2.00	\$2.25	\$2.50	\$2.75	\$3.00
2 "	3.00	3.25	3.75	4.00	4.25
3 "	3.50	3.75	4.00	4.25	4.50
4 "	3.50	3.75	4.00	4.25	4.50
5 "	4.50	4.75	5.00	5.25	5.50
6 "	4.50	4.75	5.00	5.25	5.50
7 "	6.00	6.25	6.50	6.75	7.00
8 "	6.00	6.25	6.50	6.75	7.00
9 "	7.50	8.00	8.75	10.25	11.75
10 "	7.50	8.00	8.75	10.25	11.75
Covers extra	3.00	3.00	3.00	4.00	5.00

If removal of matter on the pages non-pertinent to the article or changes of make-up are desired, or if insets or other extra work are necessary, special rates will be furnished on application to the Editor.

Applications for separates should be made to the Editor and must reach him not later than with the return of the corrected proof.

Rubber Stamps

FOR

Listing Your Specimens

The more consistent use of rubber stamps will materially assist you in cataloguing the collection of specimens you have spent so much time and trouble in securing. Let us help you.

CAPITAL RUBBER STAMP WORKS

175 NEPEAN STREET
OTTAWA, CANADA

Many More are Wanted on the Subscription Lists

The Membership Committee of The Ottawa Field-Naturalists' Club is making a special effort to increase the subscription list of *The Canadian Field-Naturalist* and we are asking every reader to assist in making the campaign the success it should be.

We would particularly urge the Secretary of each Affiliated Society to bring this matter up at EVERY meeting and secure as many subscribers as they possibly can to a Canadian Publication devoted to the study of Natural History in all its phases.

Use the blank below and forward it to the Treasurer.

— CUT OFF HERE —

MR. B. A. FAUVEL,
Treasurer, Ottawa Field-Naturalists' Club,
Mounted Police Headquarters,
Laroque Building,
Rideau and Dalhousie Sts.,
Ottawa, Canada.

I enclose One Dollar and Fifty Cents as my subscription to The Canadian Field-Naturalist for one year.

Name.....
(Mr., Mrs. or Miss)

Address.....

City and Province.....

Kindly mention *The Canadian Field-Naturalist* to advertisers

Affiliated Societies

NATURAL HISTORY SOCIETY OF MANITOBA

1923

Hon. Presidents: H. M. SPEECHLY, M.D.; W. G. SCOTT;
President: PROF. V. W. JACKSON; *Vice-Presidents:* NORMAN
CRIDDLE; J. J. GOLDEN; MRS. C. P. ANDERSON; PROF. C. H.
O'DONOGHUE; PROF. F. W. BRODRICK; *General Secretary:*
A. M. DAVIDSON, M.D., 6 Medical Arts Building; *Treasurer:*
MISS HELEN R. CANNON. ORNITHOLOGICAL SECTION—
Chairman: A. G. LAWRENCE; *Secretary:* B. W. CART-
WRIGHT; *Leaders:* H. M. SPEECHLY, M.D.; J. J. GOLDEN;
C. E. KEIGHLEY; K. GRANT MCDUGAL; R. M. THOMAS;
ENTOMOLOGICAL SECTION—*Chairman:* J. B. WALLIS,
B.A.; *Secretary:* G. SHIRLEY BROOKS; *Leaders:* L. H. ROBERTS,
B.A.; A. V. MITCHENER, B.S.A.; J. D. SUFFIELD; J. D.
DUTHIE. BOTANICAL SECTION—*Chairman:* C. W.
LOWE, M.Sc.; *Secretary:* MRS. K. J. MCDUGAL; *Leaders:*
JAMES COCKS; PROF. J. W. BRODRICK; DR. G. R. BISBY;
H. F. ROBERTS, M.Sc.; SUBSECTION—MYCOLOGY—
Leader: DR. R. G. BISBY; GEOLOGICAL SECTION—
Chairman: PROF. R. C. WALLACE; *Secretary:* A. A. MC-
COUBREY; SUBSECTION—PALAEOLOGY—*Leader:*
W. CUTLER.

THE HAMILTON BIRD PROTECTION SOCIETY (Incorporated)

Hon. President: MR. ADAM BROWN; *President:* MR. R. O.
MERRIMAN; *1st Vice-President:* DR. H. G. ARNOTT; *2nd Vice-*
President: MR. C. D. COOK; *Secretary-Treasurer:* MISS RUBY
R. MILLS, Public Library, Hamilton; *Directors:* DR. H. G.
ARNOTT; C. D. COOK; DR. J. A. DICKSON; MISS M. E. GRA-
HAM; MISS RUBY R. MILLS; M. HOLTON; M. JOHNSTON;
MRS. F. E. MACLOGHLIN; R. O. MERRIMAN.

NATURAL HISTORY SOCIETY OF BRITISH COLUMBIA, VICTORIA, B.C.

The Officers for the above Society for the year ending
March 31st, 1923, are as follows—

President: W. N. KELLY; *1st Vice-President:* A. R. SHERWOOD;
2nd Vice-President: C. C. PEMBERTON; *Secretary:* H. T.
NATION; *Treasurer:* MISS S. M. THORNTON. *Committee:*—
MISS C. G. FOX, MISS A. F. GARDINER, MISS I. CATHCART,
WM. DOWNES, A. HALKETT. *Auditors:*—J. KEITH WILSON
AND F. W. GODSAL. *Trustees:*—REV. R. CONNELL, DR. C. F.
NEWCOMBE AND G. HARVEY.

ALBERTA NATURAL HISTORY SOCIETY

Hon. President: HON. GEO. HOADLEY; *Hon. Vice-President:*
H. A. CRAIG; G. W. SMITH, M.P.P.; J. J. GARTZ; *President:*
C. H. SNELL; *Vice-Presidents:* MRS. W. A. CASSELS; DR.
HENRY GEORGE; *Secretary-Treasurer:* MRS. S. PAMELY, Red
Deer; *Directors:* MRS. H. GEORGE, Red Deer; MRS. G. F.
ROOT, Wetaskiwin; K. BOWMAN, Edmonton; F. S. CARR,
Edmonton; D. MACKIE, Edmonton; W. A. CASSELS, Red
Deer; S. PAMELY, Red Deer; C. G. S. CROSBY, Red Deer;
W. F. HARRIS, Red Deer; H. R. ORAM, Red Deer. *Members*
qualified to answer enquiries: *Birds:* MRS. W. A. CASSELS, Red
Deer; DR. H. GEORGE, Red Deer; *Mammals:* DR. H. GEORGE,
Red Deer; *Fishes:* F. C. WHITEHOUSE, Red Deer; *Flowers:*
MRS. H. GEORGE, Red Deer; *Insects:* *Coleoptera,* F. C. CARR,
11050 123rd St., Edmonton; *Lepidoptera,* K. BOWMAN, 9914
115th St., Edmonton; *Odonata,* F. C. WHITEHOUSE, Red Deer.

The meetings of this Society are held in Red Deer on the
last Friday of each month except during July and August and
perhaps September. The annual meeting is held in Red Deer
on the last Friday in November.

McILWRAITH ORNITHOLOGICAL CLUB, LONDON, ONT.

President: T. D. PATTERSON, 562 Waterloo Street; *Recording*
Secretary: MRS. E. H. MCKONE, Worthey Road; *Correspond-*
ing Secretary and Treasurer: E. M. S. DALE, 297 Hyman St.;
Members qualified to answer questions: W. E. SAUNDERS, 240
Central Ave.; C. G. WATSON, 201 Ridout St. South; J. R.
MCLEOD, 355 Wortley Road; J. F. CALVERT, 461 Tecumseh
Ave.; E. M. S. DALE, 297 Hyman St.

VANCOUVER NATURAL HISTORY SOCIETY

Hon. President: L. S. KLINCK, LL.D., Pres. University of B.C.;
President: JOHN DAVIDSON, F. L. S., University of B.C.;
Vice-President: FRED PERRY; *Hon. Secretary:* C. F. CONNOR,
M.A., 3529-W. 2nd Ave., Vancouver, B.C.; *Hon. Treasurer:*
A. H. BAIN, 2302 York St., Vancouver, B.C.

Fortnightly meetings in the University Buildings from
September to April (inclusive). Semi-monthly excursions
from May to August (inclusive).

PROVINCE OF QUEBEC SOCIETY FOR THE PROTECTION OF BIRDS

Hon. President: I. GAMMELL; *President:* L. MCI. TERRILL;
Vice-Presidents: ALEX MACSWEEN, NAPIER SMITH, E. ARNOLD;
Hon. Corresponding Secretary: W. S. HART, P.O. Box 1185,
Montreal; *Hon. Recording Secretary:* MISS H. STONE;
Hon. Treasurer: MISS M. ARMITAGE, 63 Arlington Ave.,
Westmount; *Directors:* MISS EDITH MORROW; MISS LOUISE
MURPHY; MISS EMILY LUKE; MR. AND MRS. C. F. DALE;
MRS. J. T. AYERS; MISS JEAN MCCONNELL; W. A. OSWALD;
A. F. WINN; MR. AND MRS. WALLACE H. ROBB; W. G.
WRIGHT. *Members qualified to answer questions:* L. MCI.
TERRILL, 44 Stanley Ave., St. Lambert, Que.; NAPIER SMITH,
Bank of Montreal, Magog, Que.; E. ARNOLD, 64 Durocher St.,
Montreal; W. A. OSWALD, 301 Wilson Ave., N.D.G., Montreal;
C. N. ROBERTSON, c-o Ross Realty Co., Room 805, Lewis
Bldg., St. John St., Montreal, Que.; DR. ARTHUR WILBY,
McGill University, Montreal; W. J. BROWN, 250 Oliver Ave.,
Westmount, Que.; MISS EDITH MORROW AND MISS EMILY
LUKE, c-o Secretary.

SOCIÉTÉ PROVANCHER D'HISTOIRE NATURELLE DU CANADA

Bureau de direction pour 1923

President: DOCTEUR S. GAUDREAU; *1er vice-président:* ABBE
A. VACHON, M.A.; *2ème vice-président:* A.-R.-M. BOULTON;
Secrétaire-trésorier: LOUIS-B. LAVOIE; *Chef de la section*
scientifique: A.-A. GOUBOUT; *Chef de la section de propagande*
éducative: DOCTEUR A. DERY; *Chef de la section de protection*
éducative: R. MEREDITH, N.P.; *Chef de la section d'information*
scientifique et pratique: DOCTEUR J.-E. BERNIER; *Directeurs:*
R.-F. LINDSAY; JOS. MATTE; G.-S. AHERN.

THE BRITISH COLUMBIA ORNITHOLO- GISTS' UNION

Officers for 1923

Hon. President: HON. MINISTER OF AGRICULTURE, Victoria;
President: FRANCIS KERMODE, Provincial Museum, Victoria
Vice-President: T. L. THACKER, Hope; *Secretary-Treasurer:*
J. W. WINSON, Huntingdon; *Directors:* J. A. MUNRO, Okanagan
Landing; DR. KELSO, Arrow Lakes; R. GLENDENING,
Agassiz; K. RACEY, Vancouver; T. PEARSE, Courtenay;
W. N. KELLY, Victoria.

THE TORONTO FIELD-NATURALISTS' CLUB

President: PROFESSOR R. B. THOMSON; *Vice-Presidents:*
PROFESSOR E. M. WALKER, DR. A. COSENS, J. H. FLEMING;
Secretary: W. F. GREGORY, 151 Ellsworth Ave., Toronto;
Treasurer: F. H. BRIGDEN; *Honorary Librarian:* C. W. NASH;
Librarian: DR. LYMAN B. JACKES. BIRD GROUP—
Chairman: STUART THOMPSON; *Secretary:* JAMES BAILLIE.
FLOWER GROUP—*Chairman:* DR. H. B. SIFTON; *Secretary:*
MISS J. G. WRIGHT, PH.D.; INSECT GROUP—
Chairman: PROFESSOR WALKER; *Secretary:* MISS NORMA FORD,
PH.D. MAMMAL GROUP—*Chairman:* J. R. DYMOND;
Secretary: L. SNYDER. REPTILE, FISH AND AMPHIBIAN
GROUP—*Chairman:* SHELLEY LOGIER; *Secretary:* T. B.
KURATA. PROGRAM COMMITTEE—*Chairman:* DR.
W. A. CLEMENS. WILD LIFE PRESERVATION COM-
MITTEE—*Chairman:* RUSSELL G. DINGMAN. EDUCA-
TIONAL COMMITTEE—*Chairman:* TAYLOR STATEN.

We would ask the Officers, and more
particularly the Secretaries, of all the
Affiliated Societies to assist us in our
task of building up the circulation of
this magazine. By securing every
member as a subscriber we can truly
make this magazine into one of the
leading Natural History publications
of America



FOR SALE

Back Numbers of The Ottawa Naturalist

The Club has for sale complete sets of its publications. Enquiries regarding price should be addressed to the Secretary of the Club, Dr. J. F. Wright, Geological Survey, Ottawa, Canada.

Any member having copies of the March, 1896, January, February, March and August, 1898, and December, 1900, issues of *The Ottawa Naturalist*, and who desires to dispose of the same, is requested to communicate with the Secretary.



Grant-Holden- Graham Limited

Outfitters to
Surveyors & Engineers

Manufacturers of
High-Grade Tents
Tarpaulins & Sleeping Bags

WRITE FOR CATALOGUES

147 Albert Street
OTTAWA

Fine Diamonds

Sterling Silver, Fine
Cut Glass, Electro-
Plated Ware

*The Store of
Moderate Prices*

C. A. Olmsted & Son
*Jewellers, Opticians, Watchmakers and
Engravers*

208 Sparks Street, Ottawa

Bird Houses

for
Blue Birds,
Tree
Swallows
and Wrens



Will add a
little touch of
beauty to any
surround-
ings — and
conserve our
native birds

Model 1 made of Ruberoid Round	Model 2 (shown) Made of Wood, Square
\$1.00 Each	\$2.00 Each
	3 for \$5.00

Mailed C.O.D. or Express Collect
All remittances payable at par. at Ottawa

PHILIP F. FORAN
147 Wilbrod St., OTTAWA

Kindly mention The Canadian Field-Naturalist to advertisers



THE CANADIAN FIELD-NATURALIST



OTTAWA FIELD-NATURALISTS' CLUB

ISSUED MAY 28, 1924

Entered at the Ottawa Post Office as second-class matter

THE OTTAWA FIELD-NATURALISTS' CLUB

Patrons:

THEIR EXCELLENCIES THE GOVERNOR-GENERAL AND THE LADY BYNG OF VIMY

President: HOYES LLOYD.

1st Vice-President: G. A. MILLER.

2nd Vice-President: NORMAN CRIDDLE

Secretary:

J. F. WRIGHT,
(Geological Survey, Ottawa.)

Treasurer:

B. A. FAUVEL,
(Mounted Police Headquarters,
Laroque Bldg., Rideau and Dalhousie Sts., Ottawa)

Additional Members of Council: W. T. MACOUN; MISS M. E. COWAN; C. M. STERNBERG; H. I. SMITH; F. W. WAUGH; P. A. TAVERNER; E. SAPIR; E. M. KINDLE; W. J. WINTEMBERG; R. E. DELURY; ARTHUR GIBSON; M. O. MALTE; R. M. ANDERSON; H. GROH; MISS F. FYLES; C. B. HUTCHINGS; H. M. AMI; CLYDE L. PATCH; D. JENNESS; V. W. JACKSON; R. O. MERRIMAN; W. N. KELLY; C. H. SNELL; J. R. MCLEOD; JOHN DAVIDSON; L. MCL. TERRILL; R. MEREDITH; FRANCIS KERMODE; PROF. R. B. THOMSON; THE EDITOR.

Editor:

HARRISON F. LEWIS,
Canadian National Parks Branch,
Dept. of the Interior, Ottawa.

Associate Editors:

E. SAPIR.....	<i>Anthropology</i>	A. G. HUNTSMAN.....	<i>Marine Biology</i>
M. O. MALTE.....	<i>Botany</i>	P. A. TAVERNER.....	<i>Ornithology</i>
F. R. LATCHFORD.....	<i>Conchology</i>	E. M. KINDLE.....	<i>Palaeontology</i>
M. Y. WILLIAMS.....	<i>Geology</i>	R. M. ANDERSON.....	<i>Zoology</i>
ARTHUR GIBSON.....	<i>Entomology</i>	CLYDE L. PATCH.....	<i>Herpetology</i>

CONTENTS.

	PAGE
Birds of Saskatchewan. By H. Hedley Mitchell.....	101
Notes and Observations:—	
Note to Librarians.....	119
Large Numbers of Mallards Remain in Buffalo Lake, Alberta, Throughout Winter. By Frank L. Farley.....	119
Notes on Crossbills. By E. M. S. Dale.....	119
Mystery Bands. By J. A. Munro.....	120
Birds Mobbing Felting on a Fence-post. By C. E. Johnson.....	120
Occurrence of the Least Bittern in Manitoba. By B. J. Hales.....	120

THE CANADIAN FIELD-NATURALIST, lately THE OTTAWA NATURALIST, established thirty-seven years ago, "to publish the results of original research or investigation in all departments of natural history," is issued monthly, excepting for the months of June, July and August.

Papers, notes and photographs should be addressed to the Editor. Manuscript should be typewritten.

Subscriptions cover the current year, except those taken out during last quarter, when they will be applied on the following year, the remaining numbers of current year being sent free. Payments should be made to the Treasurer, Mr. B. A. Fauvel, Mounted Police Headquarters, Laroque Building, Ottawa. Price of this volume, \$1.50; single copies 20c each.



De Luxe

are the comfortable carrying kind made to fit—Order from your sporting goods dealer

YES— We Make Rucksacks

Seven different kinds—to suit almost every kind of work and for Field Naturalists either of the two illustrated are suitable.

Woods' Rucks

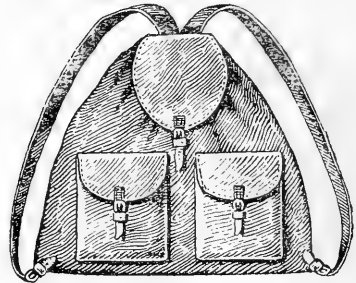

Alpine

WOODS MANUFACTURING CO.
OTTAWA

EXPLORATIONS in Western Canada

The Ottawa Field-Naturalists' Club has just published an interesting volume of over 300 pages, entitled:

Autobiography of John Macoun, M.A.

Canadian Explorer and Naturalist, Assistant Director and Naturalist to the Geological Survey of Canada—1831-1920.

This volume is an account of the life of this veteran naturalist. Agriculturists generally, in fact all interested in the development of Canada, will find this book of much interest and value.

The edition is limited. The price is \$3.00 with 15c added for bank exchange, if remittance is forwarded by personal cheque.

Applications for the volume should be made to

Mr. Arthur Gibson
Birks Building : Ottawa, Ont.

The Topley Co.

Photographic Material
Scientific Apparatus
Eastman Kodaks



132 Sparks Street
OTTAWA

Lyman's Limited

(Established 1800)

MANUFACTURING CHEMISTS

Importers and Dealers in
CHEMICAL AND
ASSAY APPARATUS

344 St. Paul St. West, Montreal

THE Bank of Nova Scotia

Capital.....\$ 9,700,000
Reserve Fund and Divi-
dend Profits, over.... 18,000,000
Total Assets over..... 230,000,000

SEVENTEEN BRANCHES IN
OTTAWA AND HULL



GROW GOOD CROPS

SEEDS PLANTS BULBS

Our rigorous system of testing eliminates loss
and disappointment from your garden

Kenneth McDonald & Sons, Limited
Seed and Bulb Merchants

Market Square :: Ottawa, Ont

W. A. Rankin, Ltd.

Hammocks
Refrigerators
Builders' Hardware

410-412 Bank Street, Ottawa

Phones—Queen 1023-1024

Ward's NATURAL SCIENCE ESTABLISHMENT

Rochester, New York, U.S.A.

Manufacturers of the genuine Schmitt boxes,
exhibition cases and cabinets, also of the American
Entomological Company's insect pins.

Riker Mounts and botanical mounts always on
hand, also Riker botanical presses.

Send for our supply catalogue and other lists of
interest to collectors.

Headquarters for Entomological Supplies
and Specimens

WHY NOT ADVERTISE
YOUR PRODUCTS IN

The Canadian Field-Naturalist

*The Leading Canadian
Natural History Publication*

WRITE FOR RATE CARD

ADVERTISING DEPARTMENT
THE CANADIAN FIELD-NATURALIST

175 Nepean Street

OTTAWA

Inspected Milk Ice Cream

Ottawa Dairy

Fresh Butter Buttermilk

Kindly mention *The Canadian Field-Naturalist* to advertisers

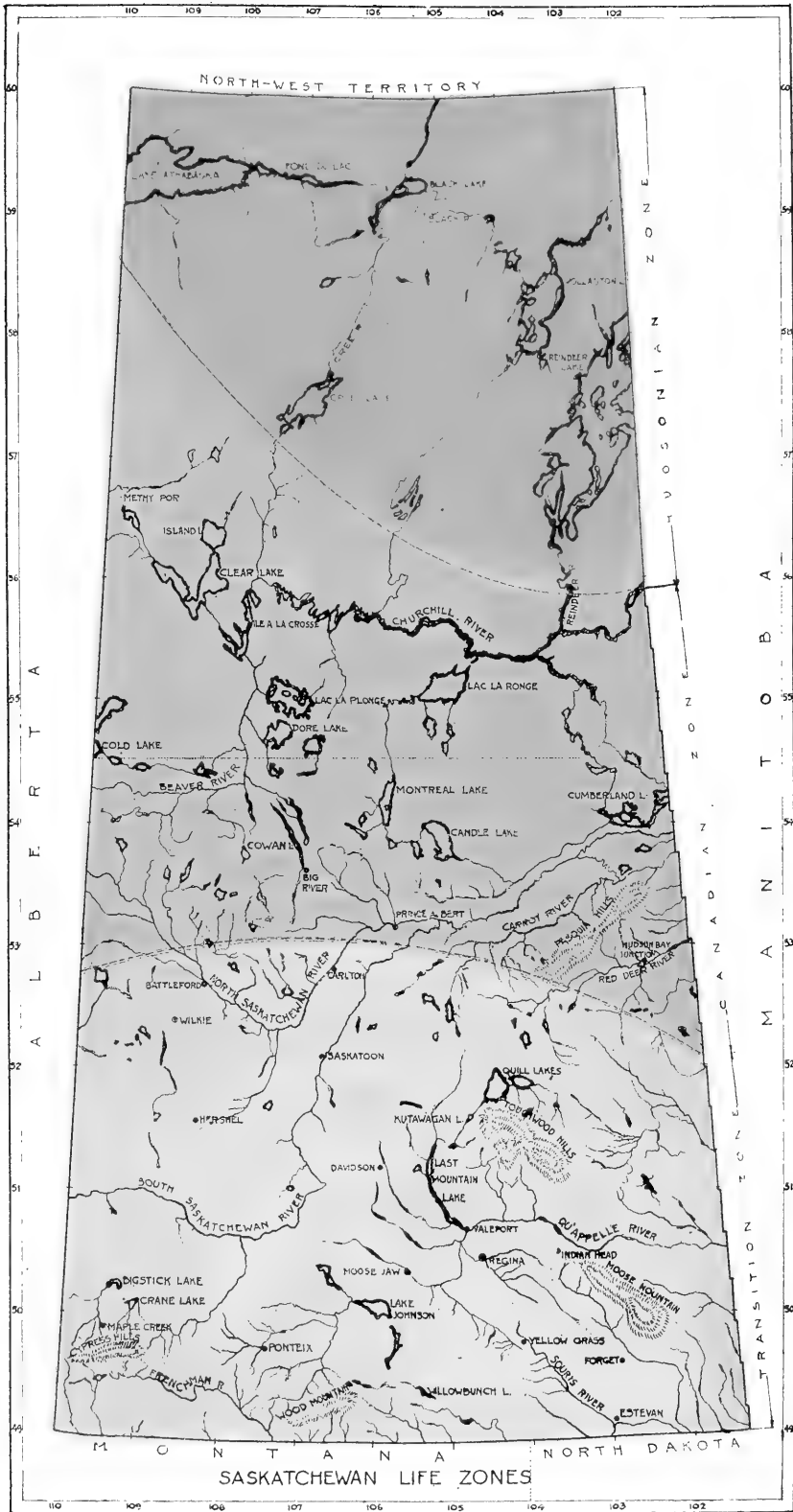

The Canadian Field-Naturalist

SPECIAL NUMBER
Vol. XXXVIII

OTTAWA, ONT., MAY, 1924

No. 6



BIRDS OF SASKATCHEWAN

By H. HEDLEY MITCHELL

Regina, 1923

INCORPORATED a province in 1905, Saskatchewan was known, previous to that time, as Assiniboia, a comparatively small area of the south of which extended westward into what is now part of the Province of Alberta; the northern boundary was finally extended to include a part of the old Northwest Territory in 1912. The changed boundaries of the province as it is to-day comprise an area of about 250,000 square miles, a region twice the size of the British Isles, or equal to the combined areas of the States of North Dakota, South Dakota and Nebraska. Though it is generally spoken of as one of the "prairie provinces", by far the greater part is wooded. From the southern, or Montana-North Dakota boundary, the open prairie extends to a line approximately 50 miles south of the city of Prince Albert. This prairie belt is, however, more or less wooded in parts, as in the Cypress Hills, Moose Mountain and other districts northward. In the extreme south, bordering on Montana, is a semi-arid zone of rolling prairie where the sage-brush and cactus are found; a ranching or stock-raising district. To the north-east is the great "Regina Plain", a level, treeless, wheat-producing prairie, while across the centre of the province is the principal forest zone of merchantable timber, mainly coniferous, extending to the north boundary, where it becomes stunted as it approaches the Barren Grounds beyond. The land slopes, for the most part, from west to east, with an elevation above sea level of from 1,500 to 3,000 feet.

The occurrence of a few groups of low wooded hills, in places, is all that varies the general flatness of the whole province, the most important of these being the Cypress Hills in the southwest, extending from east to west about 80 miles and from north to south some 25 miles, their highest

point being 4,240 feet above sea level. They bear jackpine, spruce, poplar and other trees along the northern slopes and in the coulees. The principal rivers are the North and the South Saskatchewan Rivers and the Churchill River. The larger lakes, such as Athabaska, Reindeer, La Ronge and Wollaston Lakes, are found in the north, and are all well stocked with fish. In the south the waters of the lakes are more or less alkaline, though Last Mountain Lake and the Qu'Appelle Lakes contain fish. The accompanying map embraces only the principal lakes, rivers and hills, no attempt being made to show the innumerable "sloughs" of the prairie and the corresponding "muskegs" of the timbered regions. It is divided into three parts by "life zones"; in the north we have the Hudsonian zone, in the centre the Canadian zone and in the south the Transition zone (with possibly a small portion of the Upper Austral zone in the extreme south), which are some of the subdivisions of the Austral and Boreal Regions as used by ornithologists in recent years in mapping the distribution or range of North American birds. The dotted line across the centre shows that the dividing line between north and south comes near the north end of Montreal Lake, so that Prince Albert, which is generally spoken of as being "in the north", is in the southern half of the province. Thus when a species (referred to in the following list) is noted as "common through the south to upper Transition zone", this would indicate that its approximate range (within the province) is from the United States boundary to about the latitude of Saskatoon, and so on, as the case may be. Probably the first knowledge we have of the ornithology of Saskatchewan was furnished by Captain Blackiston, who collected specimens at the old Fort Carlton and elsewhere in the Prince Albert region in 1858. Later on specimen records

were made available by James M. Macoun¹, who traversed the province by way of the Churchill River in 1888; by Messrs. Bent, Bishop and Dwight, who made collections in the south-western part of the province in 1905 and 1906; by Angus Buchanan, who travelled down the Beaver and Churchill Rivers to Reindeer Lake and beyond in 1914 (whose collections were reported on by J. H. Fleming), and by Messrs. Harper, Laing and Loring, members of the U.S. Biological Survey (Washington, D.C.) party, who collected at Lake Athabaska—within the province—in 1920². Other collectors and observers in the south have rendered valuable aid in the preparation of the present list by supplying both specimen records and hypothetical, or sight records, as C. G. Harrold, Winnipeg; L. B. Potter, Eastend; F. Bradshaw, Regina; Neil Gilmour, Moose Jaw; Geo. Lang, Indian Head; Hugh McCrae, Expanse; and others, to all of whom the writer's thanks are due, and especially so to Messrs. J. H. Fleming, Toronto; and P. A. Taverner, Ottawa, for identifying specimens and for assistance in the general preparation of the list. During the few seasons that time has been available for field work the writer has, in recent years, been able to collect specimens of some 18 or 20 species hitherto unrecorded in the province, as far as known, so that it will be readily understood that there is still much to learn of the bird life of this extensive and interesting region. The number preceding each species listed, commonly known as the A.O.U. number, and the nomenclature, are in accordance with the American Ornithologists' Union 'Check-list'; the A.O.U. numbers are a great convenience to the student in looking up any particular species in standard works on North American Birds with reference to colour, size or economic status, etc.

The economic status of species is but briefly touched upon here as nearly all of our birds are beneficial to agriculture; it is stressed in the case of Hawks, on account of the unfortunate but prevalent idea, especially in some rural districts, that all Hawks are harmful. The terms *common*, *not common*, or *uncommon*, *rare*, etc., denote the comparative abundance of the species, while the terms *winter visitant* (applied to a bird found in the province only in winter), *summer visitant* (migrating from the south and remaining during the summer or breeding season), *transient visitant* (migrating through but not remaining within the province winter or summer) and *resident* (one permanently remaining within the province winter and summer) indicate the seasonal status of the species recorded. With but few exceptions

the species listed beyond are represented by specimens in the Provincial Museum, Regina, barring those in brackets, which are "Hypothetical", a term used in recording species of which no specimen is available, but reported seen within the region concerned; i.e., "sight records"; doubtful records and birds that may well be expected to be met with sooner or later in the province are also included as hypothetical; this arrangement has been followed mainly for the convenience of the less advanced student, though it is customary to arrange the Hypothetical list entirely apart from the main list. Where the word specimen or specimens appears (applied to the more uncommon birds), followed by acquisition numbers, it indicates that there is one or more specimens in the Provincial Museum, unless otherwise stated. No previous attempt has been made to record systematically the birds of the province as a whole, and while the present list is not claimed to be exhaustive, it is hoped it will be a basis for further research and meet an increasing demand by teachers and students for "a work on Saskatchewan Birds." That provincial and state lists for the whole of North America would be very desirable, even if no more complete than the present, may be readily understood. Obviously one of their many uses would be in suggesting birds to be expected in adjacent parts of neighbouring states and provinces whose avifauna is less known; apparently some provinces, and states too, are comparatively neglected in this respect, while others are intensively studied by counties, or as recorded in "local lists".

Interest in bird study has increased greatly in recent years, nature study is becoming more widespread in this province, as it is elsewhere, and fortunately so, as with added knowledge of birds and their relation to agriculture will surely come a better sentiment towards these feathered friends of ours and of the farmer especially; the hitherto reckless killing of beneficial birds, largely at the hands of thoughtless boys with the deadly .22 rifle, can be stopped only by education along the lines of nature study in our schools throughout the province. The beginner, whether desiring to study birds as a scientist or simply as a lover of nature, must needs first of all learn to name them, to know them by their correct names; this identification of birds is often discouraging at first, but patience, frequent reference to local lists and bird books, and careful study of mounted birds in museums, when possible, will soon enable a student who has sufficient enthusiasm to go on, to name correctly and with surprising readiness the birds he sees. While a coloured illustration of each species is a most desirable aid to the beginner, it is impossible to provide this in a work such as the

¹With whom was associated W. Spreadborough.

²Notes kindly furnished by Dr. E. W. Nelson, Washington, D.C.

present, but the need of it can be greatly overcome by using the *Bird Guide* by C. K. Reed, parts 1 and 2, in conjunction with the provincial list, or the *Colour Key and Guide to the Birds of Eastern North America*, by F. M. Chapman and C. K. Reed. The *Handbook of Birds of the Western United States*, by Florence Merriam Bailey, though lacking coloured plates, will be found very instructive and helpful, especially with some few species omitted in the other works mentioned, such as Say's Phoebe, Bullock's Oriole, Pink-sided Junco, Western Tanager, etc., or birds which are peculiar to the west, and which occur in Saskatchewan. The list of "hypotheticals", gathered together for ready reference on the back page, will suggest species to be looked for, which are as yet unrecorded through the actual taking of specimens in the province. Some of these are rare, while others apparently are not rare, but have been overlooked or not secured when seen.

It is not too much to hope that the Provincial Museum will, in time to come, contain *all* of the species herein listed.

H. HEDLEY MITCHELL

Provincial Museum,

Regina,

January, 1924.



A.O.U. No.

1. *Aechmophorus occidentalis*. WESTERN GREBE.—Common summer visitant through the south to upper transition zone; noted breeding in small colonies near Big Stick, Cypress, Quill and Last Mountain Lakes.

2. *Colymbus holboelli*. HOLBOELL'S GREBE.—Not common summer visitant, noted throughout the province; found breeding near Moose Mountain and northward to Lake Athabaska.

3. *Colymbus auritus*. HORNED GREBE.—Common summer visitant, breeding most commonly through the south to Canadian zone.

4. *Colymbus nigricollis californicus*. EARED GREBE.—Fairly common summer visitant, breeding through most of south, more sparingly northward.

6. *Podilymbus podiceps*. PIED-BILLED GREBE.—Not common, found breeding near Quill Lake and sparingly through the south into Hudsonian zone.

7. *Gavia immer*. COMMON LOON.—Fairly common summer visitant, noted during breeding seasons in the Moose Mountain district, at Big River and on Reindeer Lake; probably breeds mostly in Canadian and Hudsonian zones.

[10. *Gavia adamsi*. YELLOW-BILLED LOON.—Apparently rare migrant in upper Hudsonian zone, this species of limited range to the northwest of the province is recorded by R. Macfarlane as taken at Fond du Lac, Lake Athabaska, spring of 1885. The specimen was sent to J. J. Dalgleish, of Edinburgh, Scotland (E. A. Preble, *Athabaska-Mackenzie Report, North American Fauna No. 27*). Hypothetical.]

[10. *Gavia pacifica*. PACIFIC LOON.—Probably uncommon visitant in Hudsonian zone. Found breeding at west end of Lake Athabaska—Fort Chipewyan, N.W. Alberta—June, 1885, by R. Macfarlane; the bird and eggs were sent to J. J. Dalgleish, Scotland. No doubt this species, which closely resembles the Black-throated Loon, also occurs in the eastern (larger) part of the lake within the province. Hypothetical]

11. *Gavia stellata*. RED-THROATED LOON.—Uncommon transient visitant; one specimen (830) was taken on Waskana Creek, East Regina, November 18, 1916.

36. *Stercorarius pomarinus*. POMARINE JAEGER.—Rare transient visitant; one specimen (1477) taken near Yellow Grass, November 9, 1922. Probably not as rare in Upper Hudsonian zone.

[37. *Stercorarius parasiticus*. PARASITIC JAEGER.—Probably uncommon visitant in upper Hudsonian zone. Recorded at Fort Chipewyan, west end of Lake Athabaska, by Harper. It may well be expected to occur at eastern parts of the lake within the province and as a rare migrant southward. Hypothetical.]

51. *Larus argentatus*. HERRING GULL.—Apparently uncommon through most of province. Only known specimens within the province were taken at Lake Athabaska, July 26, 1920, by U.S. Biological Survey party. Birds reported at Qu' Appelle Lakes and Crane Lake are probably referable to *L. californicus*.

53. *Larus californicus*. CALIFORNIA GULL.—Fairly common summer visitant, mostly so southwest in transition zone. Found breeding at Johnston, Last Mountain and Big Stick Lakes, more sparingly northward.

54. *Larus delawarensis*. RING-BILLED GULL.—Common summer visitant, breeding at Johnston, Quill, and Last Mountain Lakes, more sparingly northward.

55. *Larus brachyrhynchus*. SHORT-BILLED GULL.—Uncommon north, recorded only in Hudsonian zone. One specimen (755) from Reindeer Lake, July 9 1914—Buchanan. One taken at Lake Athabaska, August 18, 1920, by U.S. Biological Survey party.

59. *Larus franklini*. FRANKLIN'S GULL.—Common summer visitant through the south, in

transition zone. A large colony found breeding at Kutawagan Lake.

60. *Larus philadelphia*. BONAPARTE'S GULL.—Not common in migrations in the south; small flocks noted in Moose Mountain district, and found apparently breeding near Big River, June, 1922.

62. *Xema sabini*. SABINE'S GULL.—Not noted in the south. Two specimens (738-769) taken at Sandy Lake, Churchill River, June 9, 1914.

[64. *Sterna caspia imperator*. CASPIAN TERN.—Apparently not rare and breeding along upper Hudsonian zone. Recorded by Seton at Delta of Athabaska River, Alberta, June 4, 1904. Found common in same district and apparently about to breed, June 2-9, 1914, by Harper. There is no doubt whatever this species occurs, at least in northern Saskatchewan, but no specimens are available. Hypothetical.]

69. *Sterna forsteri*. FORSTER'S TERN.—"Rare; a few birds were seen at Many Island Lake (*on the interprovincial boundary*), on June 18, 1906, and on July 9 two specimens were taken here by Dr. Bishop." Bent, *Auk*, 1907, XXIV, p. 420.

70. *Sterna hirundo*. COMMON TERN.—Common summer visitant, breeding at larger bodies of water in transition zone, more sparingly to upper Hudsonian zone.

71. *Sterna paradisæa*. ARCTIC TERN.—Probably uncommon north in Hudsonian zone. Only known Saskatchewan specimens were taken at Lake Athabaska, August 7, 1920, by U.S. Biol. Survey party; these were noted as evidently on their breeding ground.

77. *Chlidonias nigra surinamensis*. BLACK TERN.—Common summer visitant, breeding in sloughs through the south; noted at Big River and northward into Hudsonian zone.

120. *Phalacrocorax auritus*. DOUBLE-CRESTED CORMORANT.—Common summer visitant, breeding from Lake Johnston and other larger lakes of the south, more sparingly northward to Hudsonian zone.

125. *Pelecanus erythrorhynchos*. WHITE PELICAN.—Common summer visitant; breeds in large colonies at Johnston, Quill and Dore lakes and northward.

129. *Mergus americanus*. AMERICAN MERGANSER.—Not common summer visitant. Noted breeding in Cypress Hills; at Hudson Bay Junction, Churchill River and Lake Athabaska. Mergansers are locally known as "Saw-billed Ducks".

130. *Mergus serrator*. RED-BREASTED MERGANSER.—Fairly common; noted at Willowbunch Lake in early spring migration, breeds mostly northward to upper Hudsonian zone.

131. *Lophodytes cucullatus*. HOODED MERGANSER.—Not common. Specimens (902-1376) from Qu'Appelle Lakes. Probably breeds sparingly over entire province.

132. *Anas platyrhynchos*. MALLARD.—Common, most numerous of the Ducks, breeding all through the south, more sparingly northward to upper Hudsonian zone.

133. *Anas rubripes*. BLACK DUCK.—Uncommon south in transition zone; reported more numerous in Cumberland Lake region. One specimen (895), Last Mountain Lake, October 25, 1917. R. Lloyd, Davidson. Another from the same lake was examined, autumn of 1918.

135. *Chaulelasmus streperus*. GADWALL.—Fairly common; a prairie Duck, breeding mostly in transition zone.

137. *Mareca americana*. AMERICAN WIDGEON.—The "Baldpate", as this Duck is usually called, is common all through the south, breeding about the sloughs and more sparingly northward.

139. *Nettion carolinense*. GREEN-WINGED TEAL.—Fairly common summer visitant, noted chiefly as such in Cypress Hills and Moose Mountain districts, breeding northward to upper Hudsonian zone; this is the smallest of our Ducks.

140. *Querquedula discors*. BLUE-WINGED TEAL.—Common summer visitant, breeding all through the south and more sparingly northward.

141. *Querquedula cyanoptera*. CINNAMON TEAL.—Rare summer visitant south in lower transition zone. A pair found evidently breeding on small lake 17 miles southwest of Moose Jaw, on May 22, 1923, by Neil Gilmour, who secured the male—now specimen 1484. Two reported taken by Geo. Lang of Indian Head, in that district during spring of 1885, and noted as seen in Maple Creek district in 1905 by A. C. Bent.

142. *Spatula clypeata*. SHOVELLER.—Common, breeding at sloughs through the south in transition zone; fewer northward. Locally called "Spoonbill Duck".

143. *Dafila acuta tzitzihoa*. AMERICAN PINTAIL.—Common; breeds all through the south, more sparsely to the north. One of the commonest prairie Ducks.

144. *Aix sponsa*. WOOD DUCK.—Now rare. Two specimens (23-24) taken by G. Lang at Qu'Appelle Lakes, October 18, 1899, who states he also "found a pair breeding in a hollow tree at Deep Lake, 7 miles south of Indian Head, in 1888; since 1899 none have been seen". Recently three have been seen at Hudson Bay Junction.

146. *Marila americana*. REDHEAD.—Fairly common summer visitant south in transition zone; a Duck of more local and southern distribution than other common species.

147. *Marila valisineria*. CANVASBACK.—Common; a Duck of the larger bodies of water, breeding through the south mostly in transition zone.

[148. *Marila marila*. GREATER SCAUP DUCK.—Apparently rare, even in migrations; no specimens or reliable data available, but probably occurs in the province, no doubt breeding in Hudsonian zone. Hypothetical.]

149. *Marila affinis*. LESSER SCAUP DUCK.—Common summer visitant, breeding throughout the province, but mostly in the south.

150. *Marila collaris*. RING-NECKED DUCK.—Apparently not common in the south, but probably more numerous in Canadian zone northward. A pair positively identified near Hudson Bay Junction, May 26, 1923. Recorded taken in Qu'Appelle Valley in 1891, "in company with Lesser Scaup Ducks", by Geo. Lang.

151. *Glaucionetta clangula americana*. AMERICAN GOLDEN-EYE.—A fairly common Duck in larger bodies of water, from Last Mountain Lake northward; noted breeding at Big River.

153. *Charitonetta albeola*. BUFFLE-HEAD.—Not common; specimens (30-31) from Qu'Appelle Lakes. Noted in Moose Mountain district, Hudson Bay Junction and northward into Hudsonian zone. Smallest of our Ducks except the Teals.

154. *Clangula hyemalis*. OLD-SQUAW DUCK.—Apparently rare transient visitant. Two specimens (33-35) taken at Lake Katepwa, Qu'Appelle Valley, October 20, 1912, by Geo. Lang, who states that several were taken from fishermen's nets in that lake.

165. *Oidemia deglandi*. WHITE-WINGED SCOTER.—Fairly common summer visitant in all larger lakes. Found breeding at Last Mountain Lake and Quill Lake. Locally known as "Black Duck", but very different from that species.

166. *Oidemia perspicillata*. SURF SCOTER.—Not common; records available only from the north. One specimen (575) taken at Lake Isle à la Crosse, May 31, 1914, by Buchanan. Found breeding at Lake Athabaska; downy young taken August 19, 1920, by U.S. Biological Survey party.

167. *Erismatura jamaicensis*. RUDDY DUCK.—Fairly common summer visitant, noted breeding mostly through the south.

169. *Chen hyperboreus hyperboreus*. LESSER SNOW GOOSE.—Common transient visitant locally; at times in great numbers at Lakes Buf-

falo, Willowbunch and Johnston. Reports regarding occurrence of subspecies *C. h. nivalis*—Greater Snow Goose—in Saskatchewan apparently have little foundation.

[169.1. *Chen caerulescens*. BLUE GOOSE.—Probably not rare in migration. E. T. Seton, in *Auk*, 1908, p. 451, records a specimen in his collection, taken at Fort Chipewyan, Lake Athabaska (Alberta end). Geo. Lang, Indian Head, reports it as occurring in the Qu'Appelle Valley lakes. As this species is not rare in Manitoba, it will, no doubt, be taken in Saskatchewan eventually. Hypothetical.]

170. *Chen rossii*. ROSS'S SNOW GOOSE.—Apparently rare in the south. One taken one and one-half miles south-west of Caron (Moose Jaw district), in company with Snow Geese, October 9, 1905, by W. B. Mershon, of Saginaw, Michigan. No doubt occurs more abundantly in Hudsonian zone, as numbers have been noted at west end of Lake Athabaska. See *Mackenzie-Athabaska Report, North American Fauna*, 27, p. 302—Preble.

171a. *Anser albifrons*. WHITE-FRONTED GOOSE.—Common transient visitant through the south; noted most abundant in spring migration. Locally called "Brant" by hunters, although that is a species as yet unrecorded in Saskatchewan.

172. *Branta canadensis canadensis*. CANADA GOOSE.—Common in migrations. Many still breed through the south, but in decreasing numbers.

172a. *Branta canadensis hutchinsi*. HUTCHIN'S GOOSE.—Fairly common transient visitant. A large flock in Willowbunch Lake, in open water where ice had drifted out, April 20, 1917. Specimens taken from these showed plainly the sub-specific form by their uniformly small size and noticeably small bills.

180. *Cygnus columbianus*. WHISTLING SWAN.—Common transient visitant. Most abundant at Lake Johnston in spring migration, and at Crane and Big Stick Lakes in fall migration.

181. *Cygnus buccinator*. TRUMPETER SWAN.—Apparently now rare, but doubtless still occurs. "One killed by Capt. Blakiston at Fort Carlton, Sask., March 30, 1858. ♂, length 60½ ins., wing 26½ ins., extent 8 ft. 3 in., weight 23 lbs." *Ibis*, 1863, pp. 136-7. Geo. Lang, of Indian Head, writes, "I have shot these birds years ago, but have seen none till this last fall, when, on November 10, 1921, I saw 8 at Deep Lake, south of here. I am sure of these as I heard them calling before I located them." At a later date he writes ". . . noted a small bunch of Trumpeter Swans on October 26, 1922, passing down the Qu'Appelle valley; . . . their call was easily distinguished from the Whistling Swan."

190. *Botaurus lentiginosus*. AMERICAN BITTERN.—Common summer visitant, noted as breeding mostly south in transition zone. Occurs at Big River, Hudson Bay Junction and more sparingly northward.

[191. *Ixobrychus exilis*. LEAST BITTERN.—Possibly accidental in extreme south. One reported seen at Crane Lake, June, 1894, by Spreadborough—not "taken" as in *Catalogue of Canadian Birds*). A species to be looked for in marshes along, or near, the southern boundary of the province. Hypothetical.]

194. *Ardea herodias*. GREAT BLUE HERON.—Fairly common through the south; found breeding on the ground at Lake Johnston, in low willows at Quill Lake and in large trees in Moose Mountain and Big River districts. Birds of subspecific form may be found to occur in extreme south (*A. h. treganzai?*).

202. *Nycticorax nycticorax naevius*. BLACK-CROWNED NIGHT HERON.—Not common; found breeding in transition zone. A colony of about 30 pairs in the Moose Mountain district nests in poplar trees at edge of a slough; other small colonies in the Qu'Appelle Valley and at Deep Lake. A few birds noted at Quill Lake.

204. *Grus americana*. WHOOPING CRANE.—Regarded as rare, but probably not as scarce as generally supposed. Two specimens (376-1025) taken at Forget, October, 1914 (the mounted specimen, No. 1025, became the property of the museum some years later). Prior to strict game law enactment many records for the province are available, and numbers are still seen each year. R. Lloyd, Davidson, found nest of 2 eggs 20 miles north of that town in 1911. Geo. Lang saw 9 passing over Indian Head, April 11, 1920. Neil Gilmour, Provincial Game Guardian, of Moose Jaw, found a pair breeding and a nest with 2 eggs on May 19, 1922; some few days later F. Bradshaw, Chief Game Guardian, Regina, found a second nest in same district with 3 eggs, two of which were just hatching, the third addled—now No. 1348.b. in museum—this measured less in size than the two other, fertile eggs. Both nests in transition zone; it is deemed advisable for the present to withhold exact locality of these breeding grounds. Probably breeds more commonly in unexplored parts of Canadian and Hudsonian zones.

[205. *Grus canadensis*. LITTLE BROWN CRANE.—While no specimens of this Arctic bird are available, it may be found in this province as a rare migrant. Several reports of its occurrence in the Qu'Appelle Valley and elsewhere probably apply to small Sandhill Cranes which may not be typical *G. canadensis*. Hypothetical.]

206. *Grus mexicana*. SANDHILL CRANE.—Common in migration, especially so in Quill Lake district. As summer visitant, found breeding sparingly in upper transition zone and lower Canadian zone. Data lacking as to northern occurrence.

212. *Rallus virginianus*. VIRGINIA RAIL.—Uncommon summer visitant through the south. Nest and eggs found near Quill Lake, June 23, 1915; birds not secured, but male positively identified. "An adult male found dead at Experimental Farm, Indian Head, May 27, 1921", Geo. Lang.

214. *Porzana carolina*. SORA RAIL.—Common summer visitant as noted through the south, and probably so throughout the province.

[215. *Coturnicops noveboracensis*. YELLOW RAIL.—Probably uncommon visitant, mainly in the north. Noted as evidently occurring in Manitoba by Seton (*Birds of Manitoba*) and recorded as seen westward as far as Moose Jaw by Macoun (*Catalogue of Canadian Birds*). Also reported in Alberta by W. E. Saunders. "This is the most expert of the Rails in skulking and hiding. As it is almost impossible to flush it, it may be far more common than we have reason to otherwise suspect."—P. A. Taverner in *Birds of Eastern Canada*. It will doubtless be taken in the province eventually. Hypothetical.]

221. *Fulica americana*. AMERICAN COOT.—Common summer visitant, breeding through the south and less commonly northward. Locally known as "Mud-hen".

222. *Phalaropus fulicarius*. RED PHALAROPE.—Rare transient visitant inland. A specimen (No. 741) from Sandfly Lake, Churchill River, taken June 11, 1914, by A. Buchanan.

223. *Lobipes lobatus*. NORTHERN PHALAROPE.—Fairly common as noted in migrations through the south; large flocks are to be seen at Lake Johnston spring and fall. No known records of its breeding in the province.

224. *Steganopus tricolor*. WILSON'S PHALAROPE.—Common summer visitant, noted breeding through the south mostly in lower transition zone. All Phalaropes are of peculiar habits in sex relationship; the female is larger and more brightly coloured than the male, the latter incubating the eggs and otherwise taking the place of the female in the usual nesting habits of other birds.

225. *Recurvirostra americana*. AMERICAN AVOCET.—Fairly common summer visitant, found breeding mostly in transition zone. Probably also breeds sparingly to upper Hudsonian zone. Notes on peculiar nesting habits of this species were published in the *Condor*, May-June, 1917, p. 101.

[228. *Rubicola minor*. AMERICAN WOODCOCK.—Probably rare visitant. No reliable records for the province, but its occurrence in south Manitoba and north-east North Dakota would indicate that reports of its appearance at Oxbow and Moose Mountain may have some foundation. A bird to be looked for in extreme south-east. Hypothetical.]

230. *Gallinago delicata*. WILSON'S SNIBE.—Fairly common summer visitant all through south, breeding more sparingly to northern boundary. Snipe and such like "small fry" are rarely molested by hunters in this province, where Ducks and Geese are abundant and satisfy their sporting proclivities.

231. *Limnodromus griseus griseus*. DOWITCHER.—Not common transient visitant. Specimens (552-739-777) from Beaver River and Crooked Lake, May, 1914, have been examined and referred to this form by J. H. Fleming, *Canadian Field-Naturalist*, XXXIII, 1919, p. 110.

232. *Limnodromus griseus scolopaceus*. LONG-BILLED DOWITCHER.—Not common transient visitant. One taken at Lake Athabaska, August 7, 1920—U.S. Biol. Survey. Taken at Hay Creek, Cypress Hills district, on July 3 and at Big Stick Lake, July 22, 1906—Bent, *Auk*, XXIV, 1907, p. 425. "By some ornithologists *scolopaceus* is considered merely a western subspecies of *griseus*, with intergrades between and probably a continuous breeding range across the arctic regions", etc. Vernon Bailey in *Handbook of Birds of the Western United States*, 3rd edition, p. 90.

233. *Micropalama himantopus*. STILT SANDPIPER.—Uncommon transient visitant as noted in the south, a specimen (1057) taken at Kutawagan Lake by C. Young, June 14, 1920. One taken—6 seen—at Lake Lenore by P. A. Taverner, August 27, 1921, and one at Lake Johnston, by C. G. Harrold, May 11, 1922.

[234. *Calidris canutus*. KNOT.—Probably rare transient visitant. One reported seen at Lake Johnston, May 13 and three May 20, 1923, by H. McCrae. Hypothetical.]

239. *Pisobia maculata*. PECTORAL SANDPIPER.—Fairly common transient visitant, as noted south in transition zone.

240. *Pisobia fuscicollis*. WHITE-RUMPED SANDPIPER.—Apparently rare transient visitant. Specimen (760) from Churchill River, June 11, 1914; also taken at Kutawagan Lake, June 9, 1920, by P. A. Taverner.

241. *Pisobia bairdi*. BAIRD'S SANDPIPER.—Common transient visitant through most of south, and especially over prairie belt.

242. *Pisobia minutilla*. LEAST SANDPIPER.—Common as migrant through the south; probably breeds within the province in Hudsonian zone.

243a. *Pelidna alpina sakhalina*. RED-BACKED SANDPIPER.—Apparently rare transient visitant; a specimen (758) taken on Churchill River, June 8, 1914, by Buchanan, and one secured at Lake Athabaska, August 9, 1920, by U.S. Biol. Survey party.

246. *Ereunetes pusillus*. SEMIPALMATED SANDPIPER.—Common transient visitant; usually seen in company with Least Sandpipers at Lake Johnston and other larger bodies of water, when it is difficult to distinguish one species from the

other; which also applies to other members of the Sandpiper family.

248. *Crocethia alba*. SANDERLING.—Fairly common transient visitant as noted in transition zone. This species differs from the other Sandpipers in having three toes instead of four.

249. *Limosa fedoa*. MARBLED GODWIT.—Common summer visitant all through the south in prairie districts. These birds are often confused with, and called, Curlews.

251. *Limosa haemastica*. HUDSONIAN GODWIT.—Rare; a specimen—now in possession of J. Wilson, Indian Head—taken by Geo. Lang in Qu'Appelle Valley, May 17, 1912, has been examined. Four recorded seen with flock of Marbled Godwits in marsh, Waskana Lake, Regina, May 11, 1919, by F. Bradshaw.

254. *Totanus melanoleucus*. GREATER YELLOW-LEGS.—Uncommon; a specimen (933) from Last Mountain Lake, August 26, 1918; one seen on Souris River, August, 1913, and one at Waskana Lake, August, 1922.

255. *Totanus flavipes*. LESSER YELLOW-LEGS.—Common in migrations in transition zone, noted as evidently breeding at Big River and at Hudson Bay Junction.

256. *Tringa solitaria solitaria*. SOLITARY SANDPIPER.—Fairly common summer visitant as noted in Canadian zone. Found breeding (eggs in old nest of Robin) at Big River, June 5, 1922; also at Hudson Bay Junction and on Beaver River.

256a. *Tringa solitaria cinnamomea*. WESTERN SOLITARY SANDPIPER.—A. C. Bent, in *Auk*, XXIV, 1907, p. 426, records this subspecies as "tolerably common migrant; adults first seen at Maple Creek on June 30, young first seen at Maple Creek on July 30, (Bishop)".

258a. *Catoptrophorus semipalmatus inornatus*. WESTERN WILLET.—Common summer visitant, breeding through the south in prairie regions.

261. *Bartramia longicauda*. UPLAND PLOVER.—Fairly common summer visitant, breeding through the south in transition zone and sparingly northward. This species is also called Bartramian Sandpiper.

262. *Tryngites subruficollis*. BUFF-BREASTED SANDPIPER.—Not common. Four taken at Lake Johnston, August 26, 1921, were all males. Three also taken at that lake; May 23, 1922, by C. G. Harrold. Transient visitant.

263. *Actitis macularia*. SPOTTED SANDPIPER.—Common summer visitant, breeding all

through the south, more sparingly to Hudsonian zone.

264. *Numenius americanus*. LONG-BILLED CURLEW.—Not common summer visitant as noted in lower transition zone. Apparently decreasing in numbers in some parts.

270. *Squatarola squatarola cynosuæ*. AMERICAN BLACK-BELLIED PLOVER.—Fairly common transient visitant as noted south in transition zone.

272. *Pluvialis dominica dominica*. AMERICAN GOLDEN PLOVER.—Not common transient visitant through the south; specimen records from Lake Johnston, Regina, Quill Lake and Churchill River.

273. *Oxyechus vociferus*. KILLDEER.—Common summer visitant, breeding all through south and more sparingly northward.

274. *Charadrius semipalmatus*. SEMI-PALMATED PLOVER.—Not common in migrations through the south. Possibly breeds in Hudsonian zone.

277. *Charadrius melodus*. PIPING PLOVER.—Fairly common summer visitant through the south in transition zone; found breeding at Quill, Johnston and Last Mountain Lakes.

[281. *Podasocys montanus*. MOUNTAIN PLOVER.—While no records for the province are available, this species will probably be found to occur eventually. To be looked for in the extreme south, or may wander into Saskatchewan from Montana. Hypothetical.]

283a. *Arenaria interpres morinella*. RUDDY TURNSTONE.—Uncommon transient visitant as noted through the south. Specimens from Lake Johnston, Last Mountain Lake and Churchill River.

Perdix perdix. HUNGARIAN PARTRIDGE.—Native of Europe; introduced into Alberta from Hungary about 1908 and now spreading into Saskatchewan as noted in western parts of transition zone. Two specimens (1240-1) from Wilkie, January 5, 1922. This alien species is now (1924) apparently successfully (?) established in the province.

298. *Canachites canadensis*. SPRUCE GROUSE.—Usually common resident in Canadian zone and probably less so in Hudsonian zone; like other Grouse, has periods of scarcity. Often called "Partridge", as "Hudsonian Spruce Partridge" and (subspecies *C. c. canace*) "Canada Spruce Partridge".

300a. *Bonasa umbellus togata*. CANADA RUFFED GROUSE.—Usually common resident in wooded areas south, (except in Cypress Hills, where it is apparently entirely absent). Less common northward in Hudsonian zone. Commonly called "Partridge".

301. *Lagopus lagopus lagopus*. WILLOW PTARMIGAN.—Not common winter visitant in Canadian and Hudsonian zones. Specimens from Prince Albert and Reindeer Lake districts. Some winters migrates southward into upper transition zone, and rarely south to the Qu'Appelle Valley. A Grouse locally called "White Partridge".

305. *Tympanuchus americanus americanus*. PINNATED GROUSE.—Usually fairly common resident in transition zone, apparently extending its range northwestward. Locally called "Prairie Hen" and "Prairie Chicken".

308b. *Pediœetes phasianellus campestris*. PRAIRIE SHARP-TAILED GROUSE.—Usually common resident all through transition zone, and numbers noted in large muskegs and clearings of the forest area in Canadian zone; these more northern birds may be referable to *P. p. phasianellus*. Locally known as "Prairie Chicken".

309. *Centrocercus urophasianus*. SAGE GROUSE.—Uncommon resident southwest in lower transition zone. Specimens from Wood Mountain and westward along the Frenchman River.

315. *Ectopistes migratorius*. PASSENGER PIGEON.—Regarding this now extinct species Mr. Fleming writes: "The Earl of Southesk notes a few Pigeons in a little grove at Qu'Appelle Fort, Saskatchewan, July 2, 1859 (*Saskatchewan and the Rocky Mountains*, Edinburgh, 1875). There are other old references to this bird in Saskatchewan but I doubt if it was ever very common."

316. *Zenaidura macroura carolinensis*. MOURNING DOVE.—Common summer visitant south in lower transition zone, especially southeast; noted as scarce in lower Canadian zone.

325. *Cathartes aura septentrionalis*. TURKEY VULTURE.—Fairly common summer visitant south in lower transition zone, especially southeast. Found breeding in Qu'Appelle Valley and one seen at Hudson Bay Junction, 1923.

[327. *Elanoides forficatus*. SWALLOW-TAILED KITE.—Regarding this species of rare, or accidental occurrence in parts of lower transition zone, Geo. Lang writes: "During my observations, covering 35 years in this province, I have only seen three Swallow-tailed Kites; one at Fort Qu'Appelle, May 24, 1890, one near Lake Katepwa, June 9, 1898, and one near Regina, June 20, 1906." Hypothetical.]

331. *Circus hudsonius*. MARSH HAWK.—Common summer visitant, breeding all through the south, more sparingly northward.

332. *Accipiter velox*. SHARP-SHINNED HAWK.—Fairly common; noted in south mostly in migrations, reported breeding in Cypress Hills and in Wood Mountain, northward into Hudsonian zone. Harmful.

[333. *Accipiter cooperi*. COOPER'S HAWK.—Probably occurs sparingly south in Transition zone; recorded in Manitoba and Alberta, but not, as yet, in Saskatchewan. Hypothetical.]

334. *Astur atricapillus atricapillus*. GOSHAWK.—Usually uncommon winter visitant as noted in the south. Seen near Prince Albert in October and at Regina in February. Found breeding near Beaver River, May 16, 1914, by Buchanan. Harmful.

337. *Buteo borealis*. RED-TAILED HAWK.—Red-tailed Hawks are only fairly common, as observed through the south, Moose Mountain to Big River, ranging more sparingly northward. Owing to lack of comparable material, subspecific forms are not definitely established. Specimens from Qu'Appelle Valley are referred to *B. b. calurus*, Western Red-tailed Hawk (apparently the most common form occurring in the province), by J. H. Fleming. A specimen from Lake Lenore is regarded as being referable to *B. b. krideri* (a subspecies of very light coloration), by P. A. Taverner. Mainly beneficial.

342. *Buteo swainsoni*. SWAINSON'S HAWK.—Common summer visitant, mostly so through the south in transition zone. Wholly beneficial.

343. *Buteo platypterus platypterus*. BROAD-WINGED HAWK.—Not common as noted in the south. Two specimens from Crooked and Beaver Rivers, 1914, two from Moose Mountain district, 1922, and one from Hudson Bay Junction (2 pairs seen), 1923. Beneficial.

347a. *Archibuteo lagopus sancti-johannis*. AMERICAN ROUGH-LEGGED HAWK.—Apparently rare transient visitant. A specimen in the museum at Ottawa was taken at Indian Head, May 6, 1892.

348. *Archibuteo ferrugineus*. FERRUGINOUS ROUGH-LEGGED HAWK.—Fairly common summer visitant south in lower transition zone. Unfortunately becoming more scarce yearly, with other large beneficial Hawks, owing to persistent persecution by misguided settlers.

349. *Aquila chrysaetos*. GOLDEN EAGLE.—Usually uncommon as noted through the south in transition zone, but probably occurs sparingly throughout the province. Specimens from Qu'Appelle Valley and Cypress Hills. "Eggs and adult birds taken north of Indian Head in May, 1889; they remain here all winter."—Geo. Lang.

352a. *Haliaeetus leucocephalus alascanus*. NORTHERN BALD EAGLE.—Not common; noted in the south at Last Mountain Lake, near Lake Johnston and north of Maple Creek, and, in the north, on Churchill River and as breeding at Reindeer Lake.

353. *Falco islandus*. WHITE GYRFALCON.—Accidental winter visitant. A specimen taken at Indian Head, December 25, 1897, by Geo. Lang,

and now in his possession, has been examined by P. A. Taverner. (The Gray Gyrfalcon, *Falco rusticolus rusticolus*, and the Gyrfalcon, *F. r. gyrfalco*, may also possibly occur rarely in the province.)

355. *Falco mexicanus*. PRAIRIE FALCON.—Fairly common through south in lower transition zone, noted mostly so in fall migration; no known breeding records for Saskatchewan. Harmful.

356a. *Falco peregrinus anatum*. DUCK HAWK.—Apparently uncommon. One specimen taken at Lake Johnston, May 2, 1922 (later sent to England); "its stomach contained two Northern Phalaropes."—C. G. Harrold. Probably occurs throughout the province.

357. *Falco columbarius columbarius*. PIGEON HAWK.—Not common; specimens from Lake Johnston and Reindeer Lake. Not recorded breeding south of the Churchill River. Destructive to small beneficial birds.

357b. *Falco columbarius richardsoni*. RICHARDSON'S PIGEON HAWK.—Not common; of local occurrence in mainly lower transition zone. Young and adults taken at Wood Mountain July 10, 1915; eggs and adult birds at Cypress Hills, June 10, 1921. Also called Richardson's Merlin.

360. *Cerchneis sparveria sparveria*. AMERICAN SPARROW HAWK.—Common summer visitant all through the south, and breeding more or less throughout the province. Mainly beneficial.

364. *Pandion haliaëtus carolinensis*. AMERICAN OSPREY.—Uncommon; occurs sparingly throughout the province. Several have been taken in Qu'Appelle Valley; found breeding at Lake Isle à la Crose and near Big River. Also known as Fish Hawk.

[365. *Tyto alba pratincola*. AMERICAN BARN OWL.—Concerning this rare or accidental visitant to the south, Geo. Lang writes: "I saw this bird on April 29, 1910, on the Experimental Farm (Indian Head); two days later a man brought a fine male in from Balcarres, which I am almost sure was my bird, and Harvey mounted it for him." Hypothetical.]

366. *Asio wilsonianus*. LONG-EARED OWL.—Fairly common summer visitant in the south and more sparingly through the north. Mainly beneficial.

367. *Asio flammeus*. SHORT-EARED OWL.—Common summer visitant south in prairie regions, at times locally resident; occurs sparingly northward. Beneficial.

[370. *Scotiaptex nebulosa nebulosa*. GREAT GRAY OWL.—Apparently rare winter visitant. A few recorded by Geo. Lang during winters of 1890, 1916, 1917. No doubt occurs throughout the province, but no specimens available. Also known as Cinereous Owl. Hypothetical.]

371. *Cryptoglaux funerea richardsoni*. RICHARDSON'S OWL.—Uncommon winter visitant

in the south; probably breeds north, at least in Hudsonian zone. A specimen (1478) taken near Mistatim (west of Hudson Bay Junction), February 25, 1923, by C. Owen. Two taken at Indian Head, April 30, 1891, and October 7, 1894, by Geo. Lang.

372. *Cryptoglaux acadica*. SAW-WHET OWL.—Fairly common as noted in transition zone; found breeding in Qu'Appelle Valley and the Cypress Hills. Smallest of our Owls, *richardsoni* being slightly larger.

[373. *Otus asio*. SCREECH OWL.—Apparently rare south in transition zone. Heard at Gainsborough, 1922, and reported seen at Oxbow, 1920. Recording a bird (probably of subspecific form) as seen near Eastend, 1904, L. B. Potter writes: "I surprised this bird at close quarters, almost at arm's length—saw the 'ears' distinctly". Hypothetical.]

375. *Bubo virginianus*. GREAT HORNED OWL.—Great Horned Owls are fairly common, breeding throughout the province. The majority of Saskatchewan specimens are apparently referable to *B. v. subarcticus*, Arctic Horned Owl; some others to *B. v. pallescens*. Evidently much comparable material is needed to establish definitely subspecific forms.

376. *Nyctea nyctea*. SNOWL OWL.—Fairly common winter visitant most years, arriving in the south usually during October from far North.

377a. *Surnia ulula caparoch*. AMERICAN HAWK OWL.—Uncommon as noted in transition zone, more numerous northward. Three specimens (1486-7-8) from Hudson Bay Junction, May 29, 1923. Two pairs seen; one had 7 young of varying sizes on that date. Reported taken near Indian Head in 1896 and 1899.

378. *Speotyto cunicularia hypogaea*. BURROWING OWL.—Not common summer visitant, but more numerous in extreme south-east; not noted breeding north of Davidson.

388. *Coccyzus erythrophthalmus*. BLACK-BILLED CUCKOO.—Not common summer visitant south in lower transition zone; breeds through Qu'Appelle Valley and other wooded areas.

390. *Ceryle alcyon*. BELTED KINGFISHER.—Fairly common summer visitant through the south; occurs more sparingly northward into Hudsonian zone.

393a. *Dryobates villosus leucomelas*. NORTHERN HAIRY WOODPECKER.—Not common south in transition zone, but more numerous northward. Noted breeding in Cypress Hills and at Big River.

394. *Dryobates pubescens*. DOWNY WOODPECKER.—Downy Woodpeckers are fairly common throughout the province. Found breeding in Cypress Hills and Moose Mountain and at Big River; noted during some winters in Qu'Appelle

Valley. Birds of at least north part of province are apparently referable to *D. p. nelsoni* Oberholser, Nelson's Downy Woodpecker, while those breeding in lower transition zone may be of other form. With more material available, subspecific forms will probably be definitely determined eventually.

400. *Picoides arcticus*. ARCTIC THREE-TOED WOODPECKER.—Not common resident in Canadian and Hudsonian zones. Specimens from Prince Albert and Big River.

[401. *Picoides americanus*. AMERICAN THREE-TOED WOODPECKER.—"Rare between Lake Methye and Isle a la Crosse", Macoun, *Catalogue of Canadian Birds*. Nearest specimen recorded is one taken in Manitoba, north end of Reindeer Lake, 1914, examined and referred to *P. a. fasciatus* by J. H. Fleming, *Canadian Field-Naturalist*, XXXIII, 1919, p. 112, which form no doubt occurs at least in Hudsonian zone, and is the one probably referred to by Macoun. Hypothetical.]

402. *Sphyrapicus varius*. YELLOW-BELLIED SAPSUCKER.—Common summer visitant throughout the province in suitable areas, but noted as mostly so in lower Canadian zone.

405a. *Phlæotomus pileatus abieticola*. NORTHERN PILEATED WOODPECKER.—Uncommon, probably most numerous in central Canadian zone. Noted at Big River and Hudson Bay Junction as scarce. A resident species, generally called "Cock-of-the-woods".

406. *Melanerpes erythrocephalus*. RED-HEADED WOODPECKER.—Uncommon summer visitant south in lower transition zone. A specimen (1087) taken near Eastend, April 30, 1920, by L. B. Potter. Two specimens from Cypress Lake (west of Eastend, Cypress Hills district) are considered referable to *M. e. erythrophthalmus* Oberholser, by P. A. Taverner.

408. *Asyndesmus lewisi*. LEWIS' WOODPECKER.—Uncommon visitant from the west. One specimen (525.2) taken at Herschel, September 23, 1914. Three taken in Qu'Appelle Valley by Geo. Lang (specimens examined) data lost. One reported seen near Eastend, September 19, 1915, by L. B. Potter.

412a. *Colaptes auratus borealis*. BOREAL FLICKER.—Flickers are common throughout the province, and in treeless areas are often found nesting in telegraph and telephone poles. Known also as Northern Flicker, Yellow-shafted Flicker, etc. Many examples of the so-called hybrid (between Red-shafted and "Yellow-shafted" Flickers) occur in extreme south-west, from Cypress Hills eastward.

413. *Colaptes cafer collaris*. RED-SHAFTED FLICKER.—A specimen (811) taken May 4, 1916, at Regina appears to be practically pure *C. c. collaris* (without fawn on gray throat). Two specimens from Cypress Hills have been referred

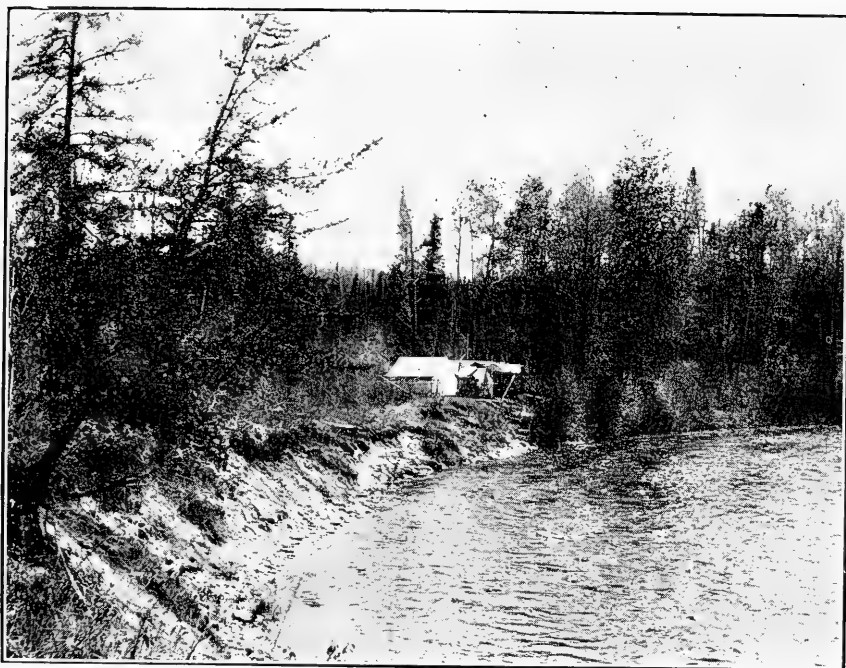

Collector's camp on Fir River (tributary to Red Deer River) near Hudson Bay
Junction.

(Canadian zone.)

Photo by H. H. MITCHELL
June, 1923.



North shore of Lake Athabaska, 6 miles northeast of Moose Island. Looking northward from an island. Beaver Mountains in the distance. Black spruce and canoe birch in foreground.

(Hudsonian zone.)

Photo by FRANCIS HARPER
August, 1920.

Courtesy of
U.S. Biol. Survey



An island just north of Beaver Lodge Island, Lake Athabaska. Looking west from the island to the Beaver Mountains, clothed with spruce, pine and birch. In foreground, black spruce and canoe birch.

(Hudsonian zone.)

Photo by FRANCIS HARPER,
August 15, 1920.

Courtesy of
U.S. Biol. Survey

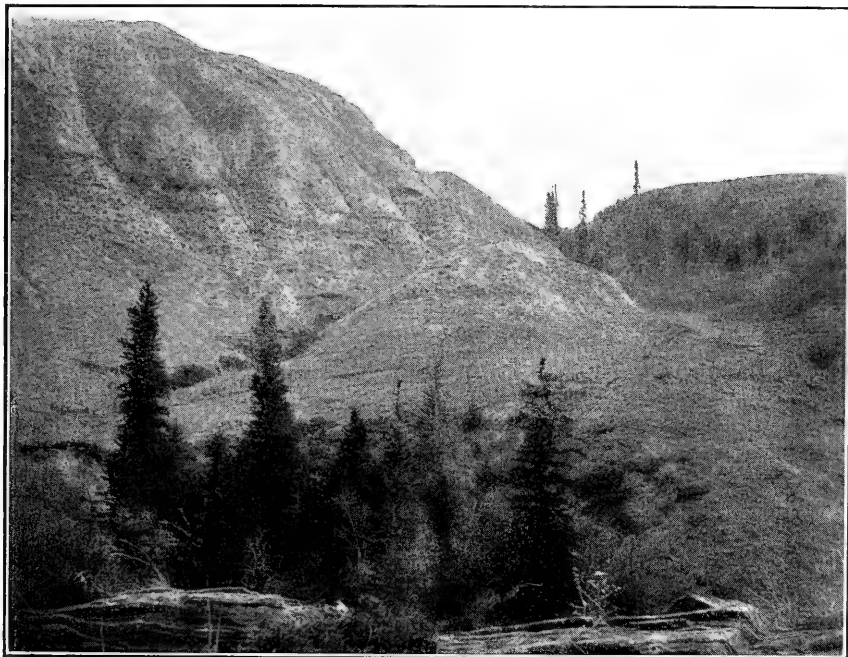

In the South Cypress Hills near Eastend.

(Transition zone.)

Photo by H. H. MITCHELL
May, 1915. []



Rapids on Red Deer River near Hudson Bay Junction.

(Canadian zone.)

Photo by H. H. MITCHELL
June, 1923.



Near Kutawagan Lake, south of Quill Lake. Figure pointing to nest of Marbled Godwit.

(Transition zone.)

Photo by P. A. TAVERNER
June, 1920.

to *C. cafer collaris* and are now in the Fleming collection, Toronto.

417. *Antrostomus vociferus vociferus*. WHIP-POOR-WILL.—Uncommon summer visitant to the south, occurring chiefly along Saskatchewan River from Prince Albert eastward. A specimen (992) from Winton (east of Prince Albert), July 21, 1919. Reported as heard at Kamsack, at Oxbow, and in the Qu'Appelle Valley.

[418. *Phalaenoptilus nuttalli*. POOR-WILL.—Rare or accidental south in transition zone. L. B. Potter, Eastend, writes: "The Poor-will appeared in the willows close to the house, uttering the 'poorwill' cry, in June, 1905." Reported seen at south end of Last Mountain Lake, by C. H. Young, 1920. Hypothetical.]

420. *Chordeiles virginianus virginianus*. NIGHTHAWK.—Common summer visitant as noted in Canadian zone, breeding in burnt-over areas about Big River and on sandy ground among open jackpine about Hudson Bay Junction. Also occurs through Hudsonian zone.

420c. *Chordeiles virginianus sennetti*. SENNETT'S NIGHTHAWK.—Fairly common summer visitant south in lower transition zone, noted breeding in Cypress Hills and Moose Mountain districts, also at Regina and Indian Head.

[423. *Chaetura pelagica*. CHEMNEY SWIFT.—Apparently occurs rarely south in transition zone. The most reliable information available on this species is from Geo. Lang, who writes: "I saw three on September 2, 1897, and found one dead on October 11, 1905, near Indian Head; these are the only records I have." Hypothetical.]

428. *Archilochus colubris*. RUBY-THROATED HUMMINGBIRD.—Fairly common summer visitant through the south, mostly so in eastern parts of transition and Canadian zones; probably occurs more sparingly through the north.

444. *Tyrannus tyrannus*. KINGBIRD.—Common summer visitant south in transition zone; occurs more sparingly northward.

447. *Tyrannus verticalis*. ARKANSAS KINGBIRD.—Fairly common summer visitant south-east in lower transition zone; less common westward and not noted north of Last Mountain Lake.

[452. *Myiarchus crinitus*. CRESTED FLYCATCHER.—Apparently of rare occurrence south-east in transition zone. Geo. Lang reports: "A pair found breeding near Indian Head, June 12, 1892. The nest in old hole of Woodpecker, contained a snake skin; the set of eggs are still in my possession." Hypothetical.]

456. *Sayornis phoebe*. PHOEBE.—Apparently uncommon summer visitant in the north; not noted, even as migrant, in the south. A specimen (761) from Reindeer River, June 30, 1914. One taken at Lake Athabaska, August 2, 1920, by U.S. Biol. Survey party, and reported at Lake Isle à la Crosse by Macoun.

457. *Sayornis saya*. SAY'S PHOEBE.—Fairly common summer visitant as noted south in lower transition zone, found breeding mostly in

Cypress Hills district, more sparingly eastward to Regina district.

459. *Nuttallornis borealis*. OLIVE-SIDED FLYCATCHER.—Fairly common summer visitant; several noted in Qu'Appelle Valley but not as breeding south in lower transition zone. Taken at Big River, Hudson Bay Junction and Lake Isle à la Crosse.

462. *Myiochanes richardsoni richardsoni*. WESTERN WOOD PEWEE.—Fairly common summer visitant, noted as most numerous in lower Canadian zone; found breeding at Big River and Hudson Bay Junction.

463. *Empidonax flaviventris*. YELLOW-BELLIED FLYCATCHER.—Apparently rare. One taken at Lake Athabaska, August 21, 1920, U.S. Biol. Survey, and a specimen (1236) taken at Lake Johnston, August 29, 1921.

466. *Empidonax trailli trailli*. TRAILL'S FLYCATCHER.—Apparently this form, as well as *E. t. alnorum*, occurs in the province. Specimens in the Victoria Memorial Museum, Ottawa, taken at Cypress Lake, May 31 and June 2 and 10, 1921, by P. A. Taverner, have been referred to this form.

466a. *Empidonax trailli alnorum*. ALDER FLYCATCHER.—Not common. Apparently of more northern range than *trailli*. Specimen (565) from Churchill River, June 6, 1914. Noted as fairly common at Hudson Bay Junction, 1923.

467. *Empidonax minimus*. LEAST FLYCATCHER.—Common summer visitant. Noted as breeding through the south, and probably so throughout the province.

469. *Empidonax wrighti*. WRIGHT'S FLYCATCHER.—Fairly common. Noted as breeding in Cypress Hills (northern slopes). Specimens also taken at Cypress Lake, May 31, June 2, 1921, by P. A. Taverner. These small Flycatchers, with the three or four listed above, are difficult to differentiate in life, their notes or "songs" being the best guide.

474a. *Otocoris alpestris arctica*. PALLID HORNED LARK.—Only available specimen record of this sub-species for the province is of birds taken at Indian Head, April 7, 1892, and referred to this form by P. A. Taverner; in the Victoria Memorial Museum, Ottawa.

474b. *Otocoris alpestris praticola*. PRAIRIE HORNED LARK.—Now apparently uncommon southeast in transition zone. A specimen taken at Regina, April 5, 1913, has been compared with a series of eastern birds and referred to this form by J. H. Fleming, Toronto.

474c. *Otocoris alpestris leucolæma*. DESERT HORNED LARK.—Common summer visitant south in transition zone, fewer northward; specimens from Cypress Hills district and from Big River. These Saskatchewan prairie birds will probably be recognized as *O. a. enthymia*, "Saskatchewan Horned Lark", of Oberholser, eventually. Besides the three forms here included, possibly *O. a. hoyti* will be found to occur in the province.

475. *Pica pica hudsonia*. AMERICAN MAGPIE.—Common resident south in lower transition zone, especially in Cypress Hills; numbers noted in parts of Qu'Appelle Valley and wooded areas to Quill Lake.

477. *Cyanocitta cristata*. BLUE JAY.—Fairly common as noted in lower Canadian zone. Found breeding in Moose Mountain and the Qu'Appelle Valley.

478. *Cyanocitta stelleri*. STELLER'S JAY.—A Steller's Jay was taken near Indian Head, May 24, 1923, by Geo. Lang. Specimen in his possession has been examined and is apparently referable to *C. s. annectens*.

484. *Perisoreus canadensis*. CANADA JAY.—Common resident from lower Canadian zone northward. Some winters numbers migrate south to Regina. Commonly known as "Whisky Jack".

486a. *Corvus corax principalis*. NORTHERN RAVEN.—Fairly common resident north in Canadian and Hudsonian zones; found breeding on Churchill River.

488. *Corvus brachyrhynchos*. AMERICAN CROW.—Common throughout most of the province; most abundant in Qu'Appelle Valley and Moose Mountain. Found nesting on and near the ground in treeless areas. The Crows of Saskatchewan do not show unmistakable differentiation from *C. b. brachyrhynchos*.

491. *Nucifraga columbiana*. CLARKE'S NUTCRACKER.—Uncommon visitant from the west. Specimen from Ravenscrag, Cypress Hills, September 19, 1919, taken by Spencer Pearse, who noted several on his ranch in that year.

494. *Dolichonyx oryzivorus*. BOBOLINK.—Not common summer visitant south in transition zone, occurring locally north to about Prince Albert.

495. *Molothrus ater*. COWBIRD.—Cowbirds are common summer visitants in transition and Canadian zones; probably less so in Hudsonian zone. Specimens from Cypress Hills district taken and referred to *M. a. artemisiæ*, by P. A. Taverner.

497. *Xanthocephalus xanthocephalus*. YELLOW-HEADED BLACKBIRD.—Common summer visitant south in transition zone. From Churchill River scarce into Hudsonian zone.

498. *Agelaius phoeniceus*. RED-WINGED BLACKBIRD.—Red-winged Blackbirds are mostly common throughout the province, breeding more abundantly through the south. Northern birds at least may prove to be referable to *A. p. arctolegus* Oberholser.

501.1. *Sturnella neglecta*. WESTERN MEADOWLARK.—Common summer visitant south in transition zone, mostly so on treeless prairies. Scarce northward. A pair found breeding at Hudson Bay Junction.

507. *Icterus galbula*. BALTIMORE ORIOLE.—Fairly common summer visitant south in lower transition zone, breeding mainly Moose Mountain to Moose Jaw districts. Scarce westward in Cypress Hills district.

[508. *Icterus bullocki*. BULLOCK'S ORIOLE.—No records available, but numbers taken or seen at Medicine Hat, Alber (less than 35 miles from the Saskatchewan boundary). It no doubt occurs in the Maple Creek or Cypress Hills district. Apparently this district marks the eastward limit of *bullocki* as well as the approximate westward limit of *galbula*. Hypothetical.]

509. *Euphagus carolinus*. RUSTY BLACKBIRD.—Fairly common as migrant south in transition zone; found breeding at Big River—8 pairs noted—and northward into Hudsonian zone.

510. *Euphagus cyanocephalus*. BREWER'S BLACKBIRD.—Common summer visitant, breeding through the south mostly in lower transition zone.

511b. *Quiscalus quiscula æneus*. BRONZED GRACKLE.—Common summer visitant, breeding through the south, and from Churchill River northward.

514. *Hesperiphona vespertina*. EVENING GROSBEAK.—Evening Grosbeaks are irregular and not usually common winter visitants in the south. Noted in Qu'Appelle Valley, at Indian Head, and at Prince Albert.

515. *Pinicola enucleator*. PINE GROSBEAK.—Pine Grosbeaks are usually common winter visitants through the south. Birds from the western part of the province at least may be referable to *P. e. alascensis*.

517. *Carpodacus purpureus purpureus*. PURPLE FINCH.—Fairly common summer visitant as noted in Canadian zone, breeding at Big River and Hudson Bay Junction. Observed only as migrant in lower transition zone.

521. *Loxia curvirostra minor*. AMERICAN CROSSBILL.—Common at times in migration through the south; no breeding records for the

province. Large flock at Regina in late October. Taken in June and July in Cypress Hills.

522. *Loxia leucoptera*. WHITE-WINGED CROSSBILL.—Not common. Five taken at Lake Athabaska, July 27, 1920, by U.S. Biol. Survey party. Specimens from Moosomin in March, Cypress Hills in July, and Regina in November.

524. *Leucosticte tephrocotis*. GRAY-CROWN-ED ROSY FINCH.—Uncommon winter visitant from the west. Specimens (1300-1304-1414) from East-end taken by L. B. Potter, November 26, 1921, and January 20, 1922. Mr. Potter has noted this species in that district for several years in small numbers and in flocks of about thirty individuals each. "Most winters a few are to be seen at Indian Head."—Geo. Lang.

527a. *Acanthis hornemanni exilipes*. HOARY REDPOLL.—Apparently rare. Specimen (307) from Fort Qu'Appelle, November 4, 1913.

528. *Acanthis linaria linaria*. COMMON REDPOLL.—Fairly common as winter visitant in the south, in lower Canadian zone and transition zone. Probably breeds in Hudsonian zone.

529. *Astragalinus tristis*. AMERICAN GOLD-FINCH.—Goldfinches are common summer visitants through the south, noted as less common in lower Canadian zone, as at Big River and Hudson Bay Junction; center of abundance along Qu'Appelle Valley. Birds of the lower transition zone, in the south-west at least, are no doubt referable to *A. t. pallidus*, Pale Goldfinch, but those of more northern and eastern occurrence are not, apparently, so well defined at present. Commonly called "Wild Canary".

533. *Spinus pinus*. PINE SISKIN.—Fairly common, mostly in fall migration, but noted at times during summer, through the south. Found breeding in pine trees on Experimental Farm, Indian Head, by Geo. Lang, also apparently breeds in Cypress Hills, but no nesting records available for the north.

Passer domesticus. HOUSE SPARROW.—An undesirable alien, first introduced from Europe (England?) to New York State in 1851-1852, and now spread practically over the whole of North America. Appears to have invaded Saskatchewan about 1898; now to be found throughout the province (even north to Lake Athabaska). Usually called "English" Sparrow.

534. *Plectrophenax nivalis*. SNOW BUNTING.—Common, but local, winter visitant; in transition zone mostly seen in early winter and early spring. Also called "Snowbird" and "Snowflake".

536. *Calcarius lapponicus*. LAPLAND LONGSPUR.—Fairly common transient visitant as noted in the south. It seems improbable that the form *C. l. alasensis* occurs in migration through this province.

537. *Calcarius pictus*. SMITH'S LONGSPUR.—Uncommon transient visitant as noted in the south. Specimen (234) Craven, October 1, 1913, taken by Buchanan. One taken at Lake Athabaska, August 7, 1920, by U.S. Biol. Survey party. Also known as "Painted Longspur".

538. *Calcarius ornatus*. CHESTNUT-COLORED LONGSPUR.—Common summer visitant south in transition zone, mainly in the lower transition zone.

539. *Rhynchophanes mccowni*. MCCOWN'S LONGSPUR.—Fairly common summer visitant locally through lower transition zone; a few noted breeding in Regina district some years.

540a. *Poœcetes gramineus confinis*. WESTERN VESPER SPARROW.—Common summer visitant through the south in transition zone, mainly in the lower transition zone. Scarce in the north.

542b. *Passerculus sandwichensis alaudinus*. WESTERN SAVANNAH SPARROW.—Savannah Sparrows noted as common summer visitants throughout the province. While the majority of specimens from at least western side of the province agree with *alaudinus*, birds from extreme north-east and from south in lower transition zone may be of other subspecific forms.

545. *Ammodramus bairdi*. BAIRD'S SPARROW.—Not common summer visitant except locally through the south in transition zone.

546a. *Ammodramus savannarum bimaculatus*. WESTERN GRASSHOPPER SPARROW.—Apparently rare and local. Recorded at Lake Johnston, 1922, by C. G. Harrold, as follows: "A male was taken on the lake-shore on May 16. This was the only example seen or heard." Mr. Harrold later sent the specimen to England.

548. *Passerherbulus lecontei*. LECONTE'S SPARROW.—Not common; probably breeds throughout the province. Specimens from Moose Mountain, Hudson Bay Junction and Churchill River.

549.1. *Passerherbulus nelsoni nelsoni*. NELSON'S SPARROW.—Not common summer visitant as noted south in transition zone—mainly south-east.

552a. *Chondestes grammacus strigatus*. WESTERN LARK SPARROW.—Uncommon south in lower transition zone; specimen (1415) taken near

Eastend, June 4, 1922, by L. B. Potter, who reports it of nearly regular occurrence in that district. Reported seen in Lake Johnston district, May, 1895, by Spreadborough.

553. *Zonotrichia querula*. HARRIS'S SPARROW.—Common transient visitant as noted through transition zone. Probably breeds in portion of Hudsonian zone, extreme north-east.

554. *Zonotrichia leucophrys leucophrys*. WHITE-CROWNED SPARROW.—Common summer visitant as noted breeding in Cypress Hills—northern slopes. Observed only as migrant elsewhere in lower transition zone.

554a. *Zonotrichia leucophrys gambeli*. GAMBEL'S WHITE-CROWNED SPARROW.—Not common; noted in Cypress Hills and at Lake Johnston. There is a specimen in the Fleming collection from Reindeer Lake, July 16, 1914. Five taken at Lake Athabaska, August 14, 1920, by U.S. Biol. Survey party.

558. *Zonotrichia albicollis*. WHITE-THROATED SPARROW.—Common summer visitant; breeds throughout the province, but mostly in Canadian zone; fewer northward and scarce as a breeder south in transition zone.

559. *Spizella monticola monticola*. TREE SPARROW.—Common in migration, especially in spring, through the south. Found breeding at Reindeer Lake, July, 1914. (Probably the Western Tree Sparrow, *S. m. ochracea*, occurs, at least in migration).

560. *Spizella passerina passerina*. CHIPPING SPARROW.—Common summer visitant in Canadian zone, apparently less so northward; also breeds sparingly in Moose Mountain and Cypress Hills. (Specimens taken at Lake Athabaska, August, 1920, are included in U.S. Biol. Survey list as *S. p. arizonæ*, Western Chipping Sparrow.)

561. *Spizella pallida*. CLAY-COLORED SPARROW.—Common summer visitant, breeding through the south mainly in transition zone, and more sparingly through the north.

562. *Spizella breweri*. BREWER'S SPARROW.—Uncommon and local south in lower transition zone. Specimen (993) taken in valley of Frenchman's River, Cypress Hills, June 18, 1919, where a few were evidently breeding in the sagebrush. One taken at Lake Johnston, May 16, 1922, by C. G. Harrold.

567. *Junco hyemalis hyemalis*. SLATE-COLORED JUNCO.—Common summer visitant in Canadian zone and northward, noted only as migrant south in transition zone.

567h. *Junco hyemalis mearnsi*. PINK-SIDED JUNCO.—Common summer visitant as noted breeding in the Cypress Hills, but mostly on the northern wooded slopes. (Birds of puzzling plumages suggesting other forms are seen about Regina in migrations.)

581. *Melospiza melodia melodia*. SONG SPARROW.—Song Sparrows are common and breed throughout the province. A pair taken at Reindeer River, June 28, 1914, are referred to this form by J. H. Fleming; it apparently breeds through Canadian and Hudsonian zones. Birds of the south, breeding at least in lower transition zone, appear to be referable to *M. m. juddi*, a subspecific form, however, that seems to be open to doubt.

583. *Melospiza lincolni lincolni*. LINCOLN'S SPARROW.—Not common as noted south in transition zone in migration. Specimens have been taken in the Cypress Hills, May 18; at Regina, September 29; at Big River (evidently breeding), June 17; and at Reindeer River, June 29.

584. *Melospiza georgiana*. SWAMP SPARROW.—Uncommon as summer visitant in the north and as migrant through the south. Specimen (763), Churchill River, June 6, 1914. One taken at Lake Athabaska, August 2, 1920, by U.S. Biological Survey party. One from Cabri Lake, September 10, 1920, is in the Victoria Memorial Museum, Ottawa.

585. *Passerella iliaca iliaca*. FOX SPARROW.—Uncommon through the south in migration; apparently breeds from upper Canadian zone through Hudsonian zone. Specimens from Ponteix, September 18, 1914, and Reindeer Lake, June 11, 1914.

588. *Pipilo maculatus arcticus*. ARCTIC TOWHEE.—Not common summer visitant. Breeds sparingly through the south, mostly in lower transition zone. (The eastern form, *P. m. erythrophthalmus*, has not been recorded in the province authentically.)

595. *Hedymeles ludovicianus*. ROSE-BREADED GROSBEEK.—Fairly common summer visitant, breeds all through the south and more sparingly northward.

596. *Hedymeles melanocephalus*. BLACK-HEADED GROSBEEK.—Uncommon summer visitant south in lower transition zone. Specimen (867) from Eastend, May 27, 1917. One taken at Lake Johnston, May 15, 1922, by C. G. Harrold. Reported eastward to Estevan.

598. *Passerina cyanea*. INDIGO BUNTING.—Rare visitant from the east; noted only south in transition zone. A male taken at Estevan by

D. L. Thorpe, May 28, 1893 (Seton, *Auk*, XXV, 1908, p. 454). Two reported seen at Indian Head in June, 1890, by Geo. Lang.

[599. *Passerina amoena*. LAZULI BUNTING.—May be a rare visitant from the west; reported only south in transition zone. Reported as follows: "One seen July 1 and 2, 1908, about the buildings on the ranch; it remained two days and was tame enough to allow of certain identification."—L. B. Potter, Eastend. "Two taken May 24, 1890; another May 26, 1892, at Indian Head."—Geo. Lang. Specimens not extant. Hypothetical.]

604. *Spiza americana*. DICKCISSEL.—Rare south in lower transition zone. Specimen (1485), a male, taken at Lake Johnston, 3 pairs seen, June 20, 1923, by H. McCrae. This species is also called "Black-throated Bunting".

605. *Calamospiza melanocorys*. LARK BUNTING.—Common summer visitant through the south in lower transition zone, especially so in Lake Johnston district. Scarce northward in upper transition zone.

607. *Piranga ludoviciana*. WESTERN TANAGER.—Not common; noted only in western part of Canadian zone. Specimens (1384-1413) taken at Big River, May 23, 1922.

[608. *Piranga erythromelas*. SCARLET TANAGER.—Apparently rare. This eastern species no doubt occurs, at least in extreme south-east. Geo. Lang writes: "Harvey found one dead after a snowstorm in late May, 1891, at Indian Head, which he mounted." Reported seen at Estevan and Moose Mountain. Hypothetical.]

611. *Progne subis subis*. PURPLE MARTIN.—Fairly common summer visitant locally. Found breeding in Moose Mountain and Prince Albert districts.

612. *Petrochelidon lunifrons lunifrons*. CLIFF SWALLOW.—Fairly common summer visitant, breeding more or less throughout the province.

613. *Hirundo erythrogastra*. BARN SWALLOW.—Common summer visitant through transition zone, breeding more sparingly northward; recorded at Lake Athabaska.

614. *Iridoprocne bicolor*. TREE SWALLOW.—Fairly common summer visitant locally, breeding throughout the province.

616. *Riparia riparia*. BANK SWALLOW.—Common summer visitant, breeding throughout the province in suitable localities.

[617. *Stelgidopteryx serripennis*. ROUGH-WINGED SWALLOW.—Probably occurs along or through extreme south, in lower transition zone. A pair seen near Wood Mountain in July, 1915, and another pair near Willowbunch, July, 1922, but identity not certain in either case. Hypothetical.]

618. *Bombycilla garrula*. BOHEMIAN WAXWING.—Usually fairly common as winter visitant through the south; probably breeds sparingly in upper Hudsonian zone.

619. *Bombycilla cedrorum*. CEDAR WAXWING.—Common summer visitant, breeding main-

ly in transition zone, more sparingly northward at least to upper Canadian zone.

621. *Lanius borealis*. NORTHERN SHRIKE.—Uncommon as noted in migration through the south; rarely seen in winter. Apparently breeds north in upper Hudsonian zone.

622a. *Lanius ludovicianus excubitorides*. WHITE-RUMPED SHRIKE.—Fairly common summer visitant in transition zone; noted breeding in Cypress Hills and more sparingly eastward.

624. *Vireosylva olivacea*. RED-EYED VIREO.—Common summer visitant, breeding throughout the province, but mainly through the south.

626. *Vireosylva philadelphia*. PHILADELPHIA VIREO.—Apparently rare. A specimen (116) taken at Indian Head by Geo. Lang, May 24, 1908. "One was secured by Dr. Bishop in the Maple creek timber on June 8, 1906."—A. C. Bent, in *Auk*, XXV, 1908, p. 32.

627. *Vireosylva gilva gilva*. WARBLING VIREO.—Fairly common summer visitant as noted south in transition zone. Two taken at Cypress Lake, 1921, by P. A. Taverner have been referred to the western form *V. g. swainsoni*.

[628. *Lanivireo flavifrons*. YELLOW-THROATED VIREO.—Possibly of rare or accidental occurrence south-east in lower transition zone. Reported taken at Moose Jaw by M. Christy, July 19, 1884, by Seton. Macoun, *Cal. Canadian Birds*. Hypothetical.]

629. *Lanivireo solitarius solitarius*. BLUE-HEADED VIREO.—Fairly common summer visitant through Canadian zone, especially so as noted at Big River and Hudson Bay Junction. Observed only as migrant in lower transition zone.

636. *Mniotilta varia*. BLACK-AND-WHITE WARBLER.—Fairly common in migrations through lower transition zone, apparently breeding northward in Canadian zone.

645. *Vermivora ruficapilla ruficapilla*. NASHVILLE WARBLER.—Apparently rare. Preble includes this species in *Athabaska-Mackenzie report*—*North American Fauna*, No. 27 in part as follows: "Richardson figured and described a specimen obtained at Cumberland House, May 15, 1827." "*Fauna Boreali-Americana*, II, p.220, 1831." Bent, on the authority of Bishop, states that a specimen was seen June 8, 1906, Maple Creek district, *Auk*, XXV, 1908, p. 33.

646. *Vermivora celata celata*. ORANGE-CROWNED WARBLER.—Fairly common summer visitant in parts of transition zone, notably so in Cypress Hills—northern and southern slopes. Found breeding also at west end of Qu'Appelle Valley, and recorded northward to Lake Athabaska.

647. *Vermivora peregrina*. TENNESSEE WARBLER.—Common as noted in spring migration at Big River. Occurs throughout the province, but apparently breeds mainly in Hudsonian zone.
650. *Dendroica tigrina*. CAPE MAY WARBLER.—Fairly common as noted in spring migration in lower Canadian zone; three specimens from Big River, May 19-23, 1922. Apparently rare migrant in lower transition zone. Recorded at Lake Athabaska.
652. *Dendroica aestiva aestiva*. YELLOW WARBLER.—Common summer visitant south in transition zone. (Probably this form also occurs throughout the province.) Specimens from Lake Isle à la Crosse, May 27, and Reindeer Lake, July 4, are referred to this form by J. H. Fleming, while one from Big River, May 30, he regards as suggesting *D. a. morcomi*, a sub-species described from middle west but not recognized. Other northern specimens taken at Lake Athabaska, August 6-10, are referred to *D. a. rubiginosa* in U.S. Biological Survey list, 1920.
655. *Dendroica coronata*. MYRTLE WARBLER.—Common as migrant south through transition zone; found breeding at Hudson Bay Junction and northward through Hudsonian zone.
656. *Dendroica auduboni auduboni*. AUDUBON'S WARBLER.—A western species only once recorded in the province as far as known. "Mr. Eastgate shot a female with food in its mouth, in a grove of pines in the Cypress Hills on June 28, 1906."—Bent, *Auk*, XXV, 1908, p. 33.
657. *Dendroica magnolia*. MAGNOLIA WARBLER.—Uncommon migrant as noted south in transition zone, but more numerous in Canadian zone. Specimens from Last Mountain Lake, May 24 and August 30, 1920; Big River, May 21, 1922; and Hudson Bay Junction, June 6, 1923.
659. *Dendroica pensylvanica*. CHESTNUT-SIDED WARBLER.—Uncommon as noted in migration south in transition zone; one taken at Valeport, May 30, 1916, but found fairly common and evidently breeding at Hudson Bay Junction; specimens taken May 26, June 14, 1923.
660. *Dendroica castanea*. BAY-BREASTED WARBLER.—Apparently uncommon, noted only as migrant through the south. One specimen (182) taken at Valeport, May 24, 1913, and one at Big River, May 25, 1922.
661. *Dendroica striata*. BLACK-POLL WARBLER.—Fairly common in migration through the south. Apparently breeds at least in upper Hudsonian zone.
662. *Dendroica fusca*. BLACKBURNIAN WARBLER.—Rare. Recording this species taken at Lake Johnston in 1922, C. G. Harrold writes: "A male was obtained on May 20. It's song betrayed its presence in a patch of Choke-cherry bushes." (The specimen was later sent to England.) Geo. Lang states: "It was noted at Indian Head and in the Qu'Appelle Valley during months of May in 1888, 1890, and 1895. Harvey had two males and one female in his collection, taken at Indian Head in May, 1901." One reported seen at Last Mountain Lake, 1920, by C. H. Young.
667. *Dendroica virens*. BLACK-THROATED GREEN WARBLER.—Not common in migrations as noted in transition zone. Specimens from Last Mountain Lake, 1920, and Big River, where it was apparently breeding on June 20, 1922.
672. *Dendroica palmarum palmarum*. PALM WARBLER.—Not common migrant as noted through the south. One taken at Valeport, May 13, 1913; two at Big River, May, 1922, and three at Lake Athabaska, 1920 (U.S. Biol. Survey).
674. *Seiurus aurocapillus*. OVEN-BIRD.—Fairly common summer visitant; occurs more or less throughout the province. Noted in Moose Mountain district, Qu'Appelle Valley, Cypress Hills and at Big River.
675. *Seiurus noveboracensis*. WATER-THRUSH.—The Water-Thrush occurs more or less commonly throughout the province; specimens from Beaver, Churchill and Reindeer Rivers have been referred to *S. n. noveboracensis*; others from Cypress Hills and Lake Athabaska have been referred to *S. n. notabilis*.
- [678. *Oporornis agilis*. CONNECTICUT WARBLER.—Probably occurs rarely at least in eastern Canadian zone. Recorded in the Duck Mountains, Manitoba, near Saskatchewan boundary, by Seton, 1884. Thought to have been seen at Hudson Bay Junction, 1923, but as it resembles the next species closely, identification was doubtful. Hypothetical.]
679. *Oporornis philadelphia*. MOURNING WARBLER.—Fairly common locally through the south. Several noted and evidently breeding at Big River, June, 1922, and at Hudson Bay Junction, June, 1923.
680. *Oporornis tolmiei*. MACGILLIVRAY'S WARBLER.—Common summer visitant. Found breeding in the Cypress Hills, southern and northern slopes; scarce eastward in lower transition zone. Also known as Tolmie Warbler. This species, like the Connecticut, resembles the Mourning Warbler.
- 681a. *Geothlypis trichas occidentalis*. WESTERN YELLOW-THROAT.—Common summer visitant through Cypress Hills district; less common eastward and through Qu'Appelle Valley.

A pair noted at Big River. Apparently the Maryland Yellow-throat is represented by this form in Saskatchewan.

683. *Icteria virens virens*. YELLOW-BREASTED CHAT.—Recorded only in the extreme south-west. A male specimen in the Victoria Memorial Museum, Ottawa, was taken at Cypress Lake, June 4, 1921, (another seen) by P. A. Taverner. L. B. Potter, Eastend, writes under date of July 10, 1922, in part: "... and I have discovered a pair of Chats, which are most certainly nesting just outside my east fence".

685. *Wilsonia pusilla pusilla*. WILSON'S WARBLER.—Common through the south in migration. Probably breeds through the north, mainly in Hudsonian zone, but no nesting records available.

686. *Wilsonia canadensis*. CANADIAN WARBLER.—Fairly common and apparently breeding at Hudson Bay Junction; observed as scarce in migrations south in lower transition zone.

687. *Setophaga ruticilla*. AMERICAN RED-START.—Fairly common summer visitant through the south. Less common northward, but apparently breeds throughout the province.

697. *Anthus rubescens*. AMERICAN PIPIT.—Fairly common transient visitant. Noted mostly in spring migration south in transition zone.

700. *Anthus spraguei*. SPRAGUE'S PIPIT.—Fairly common locally; noted as breeding mainly in central parts of transition zone. The "Skylark of the prairies".

[702. *Oreoscoptes montanus*. SAGE THRASHER.—Though nearest available record is from Montana, this species may be expected to occur at least in extreme south-west, along the boundary and south of the Frenchman River. Hypothetical.]

704. *Dumetella carolinensis*. CATBIRD.—Common summer visitant south in transition zone, mostly in lower transition zone. Not noted north of Prince Albert.

705. *Toxostoma rufum*. BROWN THRASHER.—Fairly common summer visitant. Found breeding through Qu'Appelle Valley and other wooded areas south in transition zone, mainly in lower transition zone.

715. *Salpinctes obsoletus obsoletus*. ROCK WREN.—Not common; noted, and found breeding, only in extreme south-west from Cypress Hills to Wood Mountain districts, in outcropping sandstone. Specimens (907-8) from near Ravensrag.

721a. *Troglodytes aëdon parkmani*. WESTERN HOUSE WREN.—Common summer visitant through transition zone, fewer northward. Noted as common at Big River but scarce at Hudson Bay Junction.

722. *Nannus hiemalis hiemalis*. WINTER WREN.—Uncommon; one specimen (1389) (of a pair seen); taken at Big River, June 10, 1922. Previously recorded as seen in the same district by Prof. J. S. Dexter, 1919. Noted as rare migrant south in transition zone.

724. *Cistothorus stellaris*. SHORT-BILLED MARSH WREN.—Not common, but local in transition zone, specimen (726) from Quill Lake (where several were found breeding), June 23, 1915.

725d. *Telmatodytes palustris iliacus*. PRAIRIE MARSH WREN.—Fairly common summer visitant, breeding in suitable places through transition zone and parts of lower Canadian zone. (A subspecies of the Long-billed Marsh Wren.)

726. *Certhia familiaris americana*. BROWN CREEPER.—Not common in migration south in transition zone; more numerous and evidently breeding at Big River in 1922. Two specimens (1063-1114) from south end of Last Mountain Lake, May 12-14, 1920. Two seen at Regina in spring migration, 1913-1923.

727. *Sitta carolinensis*. WHITE-BREASTED NUTHATCH.—This species occurs but sparingly through the south, noted mainly in transition zone. Specimens (375-723) from Prince Albert, March 23, 1914, and Regina, September 28, 1914. Also recorded in Cypress Hills, Qu'Appelle Valley and Moose Mountain. Saskatchewan birds show little indication of form *S. c. aculeata*.

728. *Sitta canadensis*. RED-BREASTED NUTHATCH.—Common in migration through prairies of lower transition zone. Apparently breeds mainly in Canadian zone. "One observed in winter south of Cumberland Lake on January 11."—A. Buchanan.

735a. *Penthestes atricapillus septentrionalis*. LONG-TAILED CHICKADEE.—Common, noted as resident at least in transition zone. Apparently breeds throughout the province.

740. *Penthestes hudsonicus hudsonicus*. HUDSONIAN CHICKADEE.—Not common resident from Prince Albert northward, breeding to northern boundary. Specimens taken at Lake Athabaska, Big River, Prince Albert and Hudson Bay Junction.

[748. *Regulus satrapa satrapa*. GOLDEN-CROWNED KINGLET.—Apparently rare. The nearest record is that of a male taken May 27, 1901, at west end of Lake Athabaska in Alberta—Preble, *Athabaska-Mackenzie Report*. This species no doubt occurs, at least in the north half of Saskatchewan. Hypothetical.]

749. *Regulus calendula calendula*. RUBY-CROWNED KINGLET.—Fairly common as migrant through lower transition zone, and common as found breeding at Big River and Hudson Bay

Junction. Recorded at Reindeer and Athabaska Lakes.

754. *Myadestes townsendi*. TOWNSEND'S SOLITAIRE.—Apparently rare or accidental visitant from the west. C. G. Harrold reports this bird from Lake Johnston: "A male of this species was taken on May 10, 1922. The bird was flycatching from a wire fence". The specimen was sent to England. One seen at Regina, September 30, 1923.—H. H. M.

756a. *Hylocichla fuscescens salicicola*. WILLOW THRUSH.—Common summer visitant, breeding south through transition zone; in Canadian zone found fairly common at Hudson Bay Junction and less so at Big River.

757. *Hylocichla aliciae aliciae*. GRAY-CHEEKED THRUSH.—Not common through the south in migration. A pair recorded on Churchill River, June 18. Probably breeds through Hudsonian zone.

758a. *Hylocichla ustulata swainsoni*. OLIVE-BACKED THRUSH.—Fairly common migrant south through transition zone, mainly through the lower transition zone. Recorded on Churchill River,

June 14. Probably breeds mostly through Canadian zone and northward.

759b. *Hylocichla guttata pallasi*. HERMIT THRUSH.—Not common in migration south in lower transition zone, but common and apparently breeding at Big River and Hudson Bay Junction. Recorded at Isle à la Crosse and Lake Athabaska.

761. *Planesticus migratorius migratorius*. AMERICAN ROBIN.—Common summer visitant, breeding more or less throughout the province. This "red-breasted" relative of the Thrushes shows, as far as Saskatchewan is concerned, but little indication of forms other than *P. m. migratorius*.

766. *Sialia sialis sialis*. BLUEBIRD.—Fairly common summer visitant locally through transition zone, found breeding in Cypress Hills and Moose Mountain and northward to Hudson Bay Junction.

768. *Sialia currucoides*. MOUNTAIN BLUEBIRD.—Fairly common summer visitant, breeding through the Cypress Hills district, less numerous eastward. Recorded at Regina and at Edam-Battleford district. Its range overlaps that of the above species, the Eastern Bluebird, *S. s. sialis*.

REFERENCE LIST OF HYPOTHETICAL SPECIES

Bittern, Least.....	106	Owl, Screech.....	110
Bunting, Lazuli.....	115	Oriole, Bullock's.....	112
Crane, Little Brown.....	106	Plover, Mountain.....	108
Duck, Greater Scaup.....	105	Poor-will.....	111
Flycatcher, Crested.....	111	Rail, Yellow.....	106
Goose, Blue.....	105	Swift, Chimney.....	111
Hawk, Cooper's.....	108	Swallow, Rough-winged.....	115
Jaeger, Parasitic.....	103	Tern, Caspian.....	104
Knot.....	107	Tanager, Scarlet.....	115
Kite, Swallow-tailed.....	108	Thrasher, Sage.....	117
Kinglet, Golden-crowned.....	117	Vireo, Yellow-throated.....	115
Loon, Pacific.....	103	Woodcock, American.....	106
Loon, Yellow-billed.....	103	Woodpecker, American Three-toed.....	110
Owl, American Barn.....	109	Warbler, Connecticut.....	116
Owl, Great Gray.....	109		



NOTES AND OBSERVATIONS

NOTE TO LIBRARIANS

The regular May issue was inadvertently marked "No. 6" instead of being marked "5".

LARGE NUMBERS OF MALLARDS REMAIN IN BUFFALO LAKE, ALBERTA, THROUGHOUT WINTER.—Approximately 2,000 Mallards have remained till this date, February 4th, 1924, in and around Buffalo Lake, Alberta, and from every indication intend to remain Canadians, if it is at all possible. On account of the drying up of the thousands of small sloughs and lakes in this part of Alberta the past season, all kinds of Ducks were forced to seek the larger lakes for resting and watering places. During October and November countless flocks of Mallards gathered at Buffalo Lake, and fed on the stubble of the wheat farms in that vicinity. When this lake froze over, many of the Mallards and all other varieties moved on south, but a number estimated at about 2,000 continued to feed on the bare fields, and spent the night in a hole in the ice about 35 feet across, and about a mile from shore. Even in the temperature of 36° below zero they were able to keep this space open, probably through their movements, and from the heat of their bodies. About the 20th of January several inches of snow fell, and the thermometer went down to 36° below zero. The Mallards were seen flying to the fields and returning before their usual time, and upon investigation it was found that they were unable to uncover the scattered heads of wheat, and were not procuring the necessary food. A few dead birds were found near the water hole, and they had evidently died from starvation, as their crops were empty. Coyotes and Snowy Owls were on the watch, and were seen to capture those that could not reach the water hole, after becoming chilled on the ice. This condition of affairs began to look serious and the Parks Branch of the Department of the Interior at Ottawa was notified, in the hope that some action would be taken to save the Mallards. The Department immediately appropriated \$500, which was to be used to feed the birds and to give the needed protection from pot hunters and other enemies. During the following week the weather became milder, straw and grain were scattered around the water hole, and the Mallards are now making themselves quite at home. On Sunday, the 3rd of February, the hole was visited, and at least 1,500 of the birds arose in a cloud, and, with the noise of thunder, left for their feeding grounds a few miles to the northwest of the lake. Fifteen dead ones were found in the water hole, all of which were in very poor condition. Mr. George

Cook, Guardian of the Buffalo Lake Sanctuary, and Frank Crossley, of the Alberta Provincial Police, have the matter in hand, and a sufficient amount of feed will be available for the Ducks from now on. One of the most gratifying incidents of the peculiar and unusual situation was the wholehearted way in which the sportsmen and citizens of the province generally offered aid and assistance to those who had the matter in charge.—FRANK L. FARLEY.

NOTES ON CROSSBILLS.—Current literature, at least any to which I have had access, contains little, if any, reference to the song of the Crossbill. Whether this is because few ornithologists have heard these birds in song, or whether their vocal efforts are as erratic as their other habits and do not always measure up to the standard, suffice it to say that their performance in Maine during the summer of 1922 seemed so outstanding that I would like, if possible, to put it on record so that others might enjoy with me the pleasures of that experience.

Where I live (London, Ontario), both White-winged and American Crossbills are irregular winter visitors, the latter being the commoner species. During years when they are common they occasionally stay well on into May or June and give us snatches of their song, which resembles somewhat, at that season of the year, a mixture of the songs of Goldfinch and Purple Finch. This is no doubt far from a perfect performance, as is the case with other migrants tuning up as they journey to the nesting grounds. The White-winged Crossbill I have never heard at London.

During 1922 it was my privilege to spend the month of July with a keen, bird-loving friend in the State of Maine. Among the trips we took to points of interest was one to the northern part of the state, our objective being "Troutdale Cabins", on Moxie Lake. The afternoon of our arrival, July 18th, we went for a walk to Mosquito Pond. On the way Crossbills were flying over, calling, and at last one alighted in a tree beside the trail and started to sing. Through our glasses we made it out to be a White-wing in the rosy plumage and my notes, made at the time, state that it was the finest bird song to which I had ever listened. It is rather difficult, perhaps unfair, to compare the song of one species of bird with that of another, and of course personal tastes may vary, but the impression made upon me at that time still remains most lasting, deepened, if anything, by the lapse of time.

The song began with a trill on one key, changing to one a little lower in pitch, then to one higher.

These three trills were followed by a series of chirps and throaty notes (so my pencil states), similar to those of a tame Canary, the only bird whose song this one might be said to resemble. The song continued with chirps, trills and warbles and seemed to last some minutes, although we did not actually time it.

During the three days of our stay Crossbills were in evidence most of the time and sang equally well on the wing or on the tip top of a spruce tree (usually a dead one), which seemed to be their favorite perch. All the singers that we were able to put the glass on proved to be White-wings in the rosy plumage, in fact we saw only two green ones all told. Those flying over, of course, were not always in sufficiently good light for us to identify them positively as to either species or plumage, but it is not unreasonable to suppose that the birds were all White-wings, as no American Crossbills were seen during the trip. My friend had seen plenty of them earlier in the summer on Mount Desert Island, near Bar Harbor, Maine, the White-wings being the absentees on that occasion. We never saw more than two or three of the birds together at one time, but they were continually flying around, calling or singing, which made an estimate of their total numbers more or less guesswork.

The following notes with reference to Crossbills at London may also be of interest.

The first is the taking of two specimens of Bendire's Crossbill on May 24th, 1892. This is a large form of the American which has been thrown out and reinstated again by the A.O.U. on different occasions. I believe it appears on their latest check-list.

The others are breeding notes. In 1902 two White-wings were shot a few miles from the city in an evergreen woods. Both were in the mottled plumage and it is presumed that they were young which had been bred there. The other record is more definite in that the nest and eggs were actually taken. This nest was found some two miles east of London on April 28th, 1909. It was in a maple tree and was situated some forty-five feet from the ground, being placed against the trunk of the tree. It was composed mainly of bark strips with some grasses and twigs and was lined with fine bark strips. It contained four eggs, three Crossbill's and one Cowbird's, and incubation had begun. There is unfortunately some doubt as to the species, but indications point to it being the American.—E. M. S. DALE.

Columbia forwarded to me, under date of December 6th, 1923, an aluminum band bearing the figure 21, but with no other inscription. This was taken from the leg of a Blue Grouse, shot on Raza Island, British Columbia, by Mr. L. A. Schibler, of Church House, who asked to be advised of its origin. It is obviously a home-made band, apparently cut out of a sheet of aluminum with scissors or tin shears. The figures are stamped in and show no abrasion.—J. A. MUNRO.

BIRDS MOBBING FELTING ON A FENCE-POST.—On August 6, 1923, several miles south of Ottawa, Ontario, seven Bluebirds, two Chipping Sparrows and one Kingbird were observed hovering around a fence-post. The excited "nose-dives" made by the Kingbird, especially, drew attention to a small dark object reposing on the top of the post. On investigating, I found a piece of machinery felting about one inch square and three inches long. At first glance, in size and color, the oily felt resembled a Short-tailed Shrew (*Blarina brevicauda*).—C. E. JOHNSON.

OCCURRENCE OF THE LEAST BITTERN IN MANITOBA.—On October 12th, 1923, Mrs. H. J. J. Smith, of Portage la Prairie, Manitoba, found in her yard a Least Bittern which had been injured by flying against the wires during the night. The bird was living when found, but died soon afterwards. It was taken for identification to Mr. Hamilton, the principal of the Collegiate Institute, and eventually was mentioned in the Winnipeg paper. I saw this report and wrote to Mr. Hamilton with a view to securing the bird for our museum. The skin had been preserved by one of the collegiate teachers and I was able to purchase it and have had it mounted and placed in our collection, at the Normal School, Brandon, Manitoba.

Owing to our not having received the bird in the flesh, it was impossible to make measurements which would be considered strictly accurate. The following are approximate: L. 13 inches; wing, $4\frac{3}{4}$ inches. The extent was not noted as it could not be even approximately judged from the skin. The plumage is that of the adult male.

While there are several records of this bird having been seen in Manitoba, so far as I know this is the only specimen taken in the province that has been preserved.—B. J. HALES.

Mr. Hales accompanied the above note by a photograph of the specimen in question. There can be absolutely no question as to identity.—P. A. T.

MYSTERY BANDS.—Mr. F. R. Butler, Secretary of the Game Conservation Board for British



CLASSIFIED NOTICES

"THE CONDOR" is a bi-monthly illustrated magazine of Western Ornithology—started in 1899 and now better than ever. Edited by Dr. Joseph Grinnell and published by The Cooper Ornithology Club. \$3.25 per year. *The Condor* is an essential to any student of American Birds. W. Lee Chambers, Business Manager, Eagle Rock, Drawer 123, Los Angeles, Cal.

L. C. Smith & Bro.

Typewriter

Ball bearings in every frictional part of the L. C. Smith insure long life, light touch and easy operation

Ottawa Typewriter Co. Limited

191 QUEEN ST., OTTAWA

Use the Classified Notices to a greater extent.

Eight Lines—One Insertion—One Dollar



Card Filing Systems for Naturalists

As makers of the Library Bureau line of Card Filing Devices in Canada, we are in a position to supply all Naturalists with cards and trays where they can readily index all their observations and notes

Lowe-Martin Ltd.
OTTAWA, CANADA

Printers of The Canadian Field-Naturalist

Publishers of the Autobiography of John Macoun, M.A.

The Crabtree Co.

Artists and
Designers

BLUEPRINTERS
ENGRAVERS
COMMERCIAL
PHOTOGRAPHERS
: PHOTO :
LITHOGRAPHERS

228 Albert Street
Ottawa, Ont.

COAL C. C. Ray Company Limited

BEST QUALITY LOWEST PRICES

46 Sparks St.—Phone Q. 461
OTTAWA

Geo. E. Preston & Sons MERCHANT TAILORS

*We make everything we sell and
guarantee everything we sell*

217-219 Rideau Street, Ottawa

Dr. Mark G. McElhinney

*Dentist to certain of the
cognoscenti*

252 LISGAR STREET, OTTAWA

Telephone Queen 2438

Kindly mention The Canadian Field-Naturalist to advertisers

Prices of Separates

Notes to Contributors, Etc.

Papers for publication should be addressed to the Editor, Mr. Harrison F. Lewis, Parks Branch, Ottawa, or to the appropriate Associate Editor.

Manuscript should be plainly written, typed if possible, on one side of the paper only, with wide spaces between the lines and ample margins. It is urged that special care be used that scientific names are legible, properly formed, and correctly spelled and capitalized.

Galley proof will be submitted to authors resident in Ottawa and proof of leading articles to any other author if requested when manuscript submitted. It is requested that it be corrected and returned to the Editor as quickly as possible.

Authors of leading articles are entitled to twenty-five copies of the number in which they appear, free of charge on application.

Separates of articles as they appear on the page, without any change of make-up will be supplied at the following rates:—

	25	50	100	200	300
1 page.....	\$2.00	\$2.25	\$2.50	\$2.75	\$3.00
2 ".....	3.00	3.25	3.75	4.00	4.25
3 ".....	3.50	3.75	4.00	4.25	4.50
4 ".....	3.50	3.75	4.00	4.25	4.50
5 ".....	4.50	4.75	5.00	5.25	5.50
6 ".....	4.50	4.75	5.00	5.25	5.50
7 ".....	6.00	6.25	6.50	6.75	7.00
8 ".....	6.00	6.25	6.50	6.75	7.00
9 ".....	7.50	8.00	8.75	10.25	11.75
10 ".....	7.50	8.00	8.75	10.25	11.75
Covers extra.....	3.00	3.00	3.00	4.00	5.00

If removal of matter on the pages non-pertinent to the article or changes of make-up are desired, or if insets or other extra work are necessary, special rates will be furnished on application to the Editor.

Applications for separates should be made to the Editor and must reach him not later than with the return of the corrected proof.

Rubber Stamps

FOR

Listing Your Specimens

The more consistent use of rubber stamps will materially assist you in cataloguing the collection of specimens you have spent so much time and trouble in securing. Let us help you.

CAPITAL RUBBER STAMP WORKS

175 NEPEAN STREET
OTTAWA, CANADA

Many More are Wanted on the Subscription Lists

The Membership Committee of The Ottawa Field-Naturalists' Club is making a special effort to increase the subscription list of *The Canadian Field-Naturalist* and we are asking every reader to assist in making the campaign the success it should be.

We would particularly urge the Secretary of each Affiliated Society to bring this matter up at EVERY meeting and secure as many subscribers as they possibly can to a Canadian Publication devoted to the study of Natural History in all its phases.

Use the blank below and forward it to the Treasurer.

CUT OFF HERE

MR. B. A. FAUVEL,
Treasurer, Ottawa Field-Naturalists' Club,
Mounted Police Headquarters,
Laroque Building,
Rideau and Dalhousie Sts.,
Ottawa, Canada.

I enclose One Dollar and Fifty Cents as my subscription to The Canadian Field-Naturalist for one year.

Name.....
(Mr., Mrs. or Miss)

Address.....

City and Province.....

Kindly mention *The Canadian Field-Naturalist* to advertisers

Affiliated Societies

NATURAL HISTORY SOCIETY OF MANITOBA 1923

Hon. Presidents: H. M. SPERCHLY, M.D.; W. G. SCOTT; *President:* PROF. V. W. JACKSON; *Vice-Presidents:* NORMAN CRIDDLE; J. J. GOLDEN; MRS. C. P. ANDERSON; PROF. C. H. O'DONOGHUE; PROF. F. W. BRODRICK; *General Secretary:* A. M. DAVIDSON, M.D., 6 Medical Arts Building; *Treasurer:* MISS HELEN R. CANNOM. **ORNITHOLOGICAL SECTION**—*Chairman:* A. G. LAWRENCE; *Secretary:* B. W. CARTWRIGHT; *Leaders:* H. M. SPERCHLY, M.D.; J. J. GOLDEN; C. E. KEIGHLEY; K. GRANT MCDUGAL; R. M. THOMAS; **ENTOMOLOGICAL SECTION**—*Chairman:* J. B. WALLIS, B.A.; *Secretary:* G. SHIRLEY BROOKS; *Leaders:* L. H. ROBERTS; A. V. MITCHENER, B.S.A.; J. D. SUFFIELD; J. D. DUTHIE. **BOTANICAL SECTION**—*Chairman:* C. W. LOWE, M.Sc.; *Secretary:* MRS. K. J. MCDUGAL; *Leaders:* JAMES COCKS; PROF. J. W. BRODRICK; DR. G. R. BISBY; H. F. ROBERTS, M.Sc.; **SUBSECTION—MYCOLOGY**—*Leader:* DR. R. G. BISBY; **GEOLOGICAL SECTION**—*Chairman:* PROF. R. C. WALLACE; *Secretary:* A. A. MCOUBREY; **SUBSECTION—PALAEOLOGY**—*Leader:* W. CUTLER.

THE HAMILTON BIRD PROTECTION SOCIETY (Incorporated)

Hon. President: MR. ADAM BROWN; *President:* MR. R. O. MERRIMAN; *1st Vice-President:* DR. H. G. ARNOTT; *2nd Vice-President:* MR. C. D. COOK; *Secretary-Treasurer:* MISS RUBY R. MILLS, Public Library, Hamilton; *Directors:* DR. H. G. ARNOTT; C. D. COOK; DR. J. A. DICKSON; MISS M. E. GRAHAM; MISS RUBY R. MILLS; M. HOLTON; M. JOHNSTON; MRS. F. E. MACLOGILIN; R. O. MERRIMAN.

NATURAL HISTORY SOCIETY OF BRITISH COLUMBIA, VICTORIA, B.C.

The Officers for the above Society for the year ending March 31st, 1923, are as follows:—*President:* W. N. KELLY; *1st Vice-President:* A. R. SHERWOOD; *2nd Vice-President:* C. C. PEMBERTON; *Secretary:* H. T. NATION; *Treasurer:* MISS S. M. THORNTON. *Committees:*—MISS C. G. FOX, MISS A. F. GARDINER, MISS I. CATHCART, WM. DOWNES, A. HALKETT. *Auditors:*—J. KEITH WILSON AND F. W. GODSAL. *Trustees:*—REV. R. CONNELL, DR. C. F. NEWCOMBE AND G. HARVEY.

ALBERTA NATURAL HISTORY SOCIETY

Hon. President: HON. GEO. HOADLEY; *Hon. Vice-President:* H. A. CRAIG; G. W. SMITH, M.P.P.; J. J. GAETZ; *President:* C. H. SNELL; *Vice-Presidents:* MRS. W. A. CASSELS; DR. HENRY GEORGE; *Secretary-Treasurer:* MRS. S. PAMELY, Red Deer; *Directors:* MRS. H. GEORGE, Red Deer; MRS. G. F. ROOT, Wetaskiwin; K. BOWMAN, Edmonton; F. S. CARR, Edmonton; D. MACKIE, Edmonton; W. A. CASSELS, Red Deer; S. PAMELY, Red Deer; C. G. S. CROSBY, Red Deer; W. F. HARRIS, Red Deer; H. R. ORAM, Red Deer. *Members qualified to answer enquiries:* *Birds:* MRS. W. A. CASSELS, Red Deer; DR. H. GEORGE, Red Deer; *Mammals:* DR. H. GEORGE, Red Deer; *Fishes:* F. C. WHITEHOUSE, Red Deer; *Flowers:* MRS. H. GEORGE, Red Deer; *Insects: Coleoptera,* F. C. CARR, 11050 123rd St., Edmonton; *Lepidoptera,* K. BOWMAN, 9914 115th St., Edmonton; *Odonata,* F. C. WHITEHOUSE, Red Deer.

The meetings of this Society are held in Red Deer on the last Friday of each month except during July and August and perhaps September. The annual meeting is held in Red Deer on the last Friday in November.

McILWRAITH ORNITHOLOGICAL CLUB, LONDON, ONT.

President: T. D. PATTERSON, 562 Waterloo Street; *Recording Secretary:* MRS. E. H. MCKONE, Worthy Road; *Corresponding Secretary and Treasurer:* E. M. S. DALE, 297 Hyman St.; *Members qualified to answer questions:* W. E. SAUNDERS, 240 Central Ave.; C. G. WATSON, 201 Ridout St. South; J. R. McLEOD, 365 Worthy Road; J. F. CALVERT, 461 Tecumseh Ave.; E. M. S. DALE, 297 Hyman St.

VANCOUVER NATURAL HISTORY SOCIETY

Hon. President: L. S. KLINCK, LL.D., Pres. University of B.C.; *President:* JOHN DAVIDSON, F. L. S., University of B.C.; *Vice-President:* FRED FERRY; *Hon. Secretary:* C. F. CONNOR, M.A., 3529-W. 2nd Ave., Vancouver, B.C.; *Hon. Treasurer:* A. H. BAIN, 2302 York St., Vancouver, B.C.

Fortnightly meetings in the University Buildings from September to April (inclusive). Semi-monthly excursions from May to August (inclusive).

PROVINCE OF QUEBEC SOCIETY FOR THE PROTECTION OF BIRDS

Hon. President: I. GAMMELL; *President:* L. MCI. TERRILL; *Vice-Presidents:* ALEX MACSWEEN, NAPIER SMITH, E. ARNOLD; *Hon. Corresponding Secretary:* W. S. HART, P.O. Box 1185, Montreal; *Hon. Recording Secretary:* MISS H. STONE; *Hon. Treasurer:* MISS M. ARMITAGE, 63 Arlington Ave., Westmount; *Directors:* MISS EDITH MORROW; MISS LOUISE MURPHY; MISS EMILY LUKE; MR. AND MRS. C. F. DALE; MRS. J. T. AYERS; MISS JEAN MCCONNELL; W. A. OSWALD; A. F. WINN; MR. AND MRS. WALLACE H. ROBB; W. G. WRIGHT. *Members qualified to answer questions:* L. MCI. TERRILL, 44 Stanley Ave., St. Lambert, Que.; NAPIER SMITH, Bank of Montreal, Magog, Que.; E. ARNOLD, 64 Durocher St., Montreal; W. A. OSWALD, 301 Wilson Ave., N.D.G., Montreal; C. N. ROBERTSON, c-o Ross Realty Co., Room 805, Lewis Bldg., St. John St., Montreal, Que.; DR. ARTHUR WILLEY, McGill University, Montreal; W. J. BROWN, 250 Oliver Ave., Westmount, Que.; MISS EDITH MORROW and MISS EMILY LUKE, c-o Secretary.

SOCIÉTÉ PROVANCHER D'HISTOIRE NATURELLE DU-CANADA

Bureau de direction pour 1923

Président: DOCTEUR S. GAUDREAU; *1er vice-président:* ABBE A. VACHON, M.A.; *2ème vice-président:* A.-R.-M. BOULTON; *Secrétaire-trésorier:* LOUIS-B. LAVOIE; *Chef de la section scientifique:* A.-A. GODBOUT; *Chef de la section de propagande éducationnelle:* DOCTEUR A. DERY; *Chef de la section de protection:* R. MEREDITH, N.P.; *Chef de la section d'information scientifique et pratique:* DOCTEUR J.-E. BERNIER; *Directeurs:* R.-F. LINDSAY; JOS. MATTE; G.-S. AHERN.

THE BRITISH COLUMBIA ORNITHOLOGISTS' UNION

Officers for 1923

Hon. President: HON. MINISTER OF AGRICULTURE, Victoria; *President:* FRANCIS KERMODE, Provincial Museum, Victoria; *Vice-President:* T. L. THACKER, Hope; *Secretary-Treasurer:* J. W. WINSON, Huntingdon; *Directors:* J. A. MUNRO, Okanagan Landing; DR. KELSO, Arrow Lakes; R. GLENDENING, Agassiz; K. RACEY, Vancouver; T. PEARSE, Courtenay; W. N. KELLY, Victoria.

THE TORONTO FIELD-NATURALISTS' CLUB

President: PROFESSOR R. B. THOMSON; *Vice-Presidents:* PROFESSOR E. M. WALKER, DR. A. COSENS, J. H. FLEMING; *Secretary:* W. F. GREGORY, 151 Ellsworth Ave., Toronto; *Treasurer:* F. H. BRIGDEN; *Honorary Librarian:* C. W. NASH; *Librarian:* DR. LYMAN B. JACKES. **BIRD GROUP**—*Chairman:* STUART THOMPSON; *Secretary:* JAMES BAILLIE. **FLOWER GROUP**—*Chairman:* DR. H. B. SFTON; *Secretary:* MISS J. G. WRIGHT, Ph.D.; **INSECT GROUP**—*Chairman:* PROFESSOR WALKER; *Secretary:* MISS NORMA FORD, Ph.D. **MAMMAL GROUP**—*Chairman:* J. R. DYMOND; *Secretary:* L. SNYDER. **REPTILE, FISH AND AMPHIBIAN GROUP**—*Chairman:* SHELLEY LOGIER; *Secretary:* T. B. KURATA. **PROGRAM COMMITTEE**—*Chairman:* DR. W. A. CLEMENS. **WILD LIFE PRESERVATION COMMITTEE**—*Chairman:* RUSSELL G. DINGMAN. **EDUCATIONAL COMMITTEE**—*Chairman:* TAYLOR STATTEN.

We would ask the Officers, and more particularly the Secretaries, of all the Affiliated Societies to assist us in our task of building up the circulation of this magazine. By securing every member as a subscriber we can truly make this magazine into one of the leading Natural History publications of America



FOR SALE

Back Numbers of The Ottawa Naturalist

The Club has for sale complete sets of its publications. Enquiries regarding price should be addressed to the Secretary of the Club, Dr. J. F. Wright, Geological Survey, Ottawa, Canada.

Any member having copies of the March, 1896 January, February, March and August, 1898, and December, 1900, issues of *The Ottawa Naturalist*, and who desires to dispose of the same, is requested to communicate with the Secretary.



Grant-Holden- Graham Limited

Outfitters to
Surveyors & Engineers

Manufacturers of
High-Grade Tents
Tarpaulins & Sleeping Bags

WRITE FOR CATALOGUES

147 Albert Street
OTTAWA

Fine Diamonds

Sterling Silver, Fine
Cut Glass, Electro-
Plated Ware

*The Store of
Moderate Prices*

C. A. Olmsted & Son

*Jewellers, Opticians, Watchmakers and
Engravers*

208 Sparks Street, Ottawa

Bird Houses

for
Blue Birds,
Tree
Swallows
and Wrens

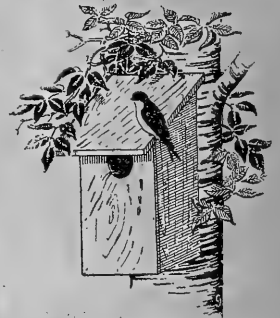

*Will add a
little touch of
beauty to any
surround-
ings — and
conserve our
native birds*

Model 1
made of Ruberoid
Round

Model 2 (shown)
made of Wood,
Square

\$1.00 Each **\$2.00 Each**
3 for \$5.00

Mailed C.O.D. or Express Collect
All remittances payable at par at Ottawa

PHILIP F. FORAN

147 Wilbrod St., OTTAWA

Kindly mention The Canadian Field-Naturalist to advertisers



THE CANADIAN FIELD-NATURALIST



PUBLISHED BY
OTTAWA FIELD-NATURALISTS' CLUB

ISSUED OCTOBER 16, 1924

Entered at the Ottawa Post Office as second-class matter

THE OTTAWA FIELD-NATURALISTS' CLUB

Patrons:

THEIR EXCELLENCIES THE GOVERNOR-GENERAL AND THE LADY BYNG OF VIMY

President: HOYES LLOYD.
 1st Vice-President: G. A. MILLER.
 Secretary: J. F. WRIGHT,
 (Geological Survey, Ottawa).
 2nd Vice-President: NORMAN CRIDDLE.
 Treasurer:
 B. A. FAUVEL,
 (Mounted Police Headquarters,
 Laroque Bldg., Rideau and Dalhousie Sts., Ottawa)

Additional Members of Council: W. T. MACOUN; MISS M. E. COWAN; C. M. STERNBERG; H. I. SMITH;
 F. W. WAUGH; P. A. TAVERNER; E. SAPIR; E. M. KINDLE; W. J. WINTENBERG; R. E. DELURY;
 ARTHUR GIBSON; M. O. MALTE; R. M. ANDERSON; H. GROH; MISS F. FYLES; C. B. HUTCHINGS;
 H. M. AMI; CLYDE L. PATCH; D. JENNESS; V. W. JACKSON; R. O. MERRIMAN; W. N. KELLY;
 C. H. SNELL; J. R. MCLEOD; JOHN DAVIDSON; L. MCL. TERRILL; R. MEREDITH; FRANCIS
 KERMODE; PROF. R. B. THOMSON; THE EDITOR.

Editor:

HARRISON F. LEWIS,
 Canadian National Parks Branch,
 Dept. of the Interior, Ottawa.

Associate Editors:

E. SAPIR	Anthropology	A. G. HUNTSMAN	Marine Biology
M. O. MALTE	Botany	P. A. TAVERNER	Ornithology
F. R. LATCHFORD	Conchology	E. M. KINDLE	Palaeontology
M. Y. WILLIAMS	Geology	R. M. ANDERSON	Zoology
ARTHUR GIBSON	Entomology	CLYDE L. PATCH	Herpetology

CONTENTS

	PAGE
Observations on the Habits of <i>Sphex procerus</i> in Manitoba. By Norman Criddle	121
Notes on the Canada Goose in Captivity. By Rev. Brother Wilfrid	124
List of Birds Recorded from the Island of Anticosti, Quebec. By Harrison F. Lewis. (Continued from Page 90)	125
The Home Life of the Columbian Ground Squirrel. By William T. Shaw	128
The Food Value of an Equisetum from the Lance Formation of Saskatchewan. By Prof. Edward W. Berry	131
Notes on the Spingidæ of Sault Ste. Marie, Ont. By W. H. A. Preece	132
Official Canadian Record of Bird-Banding Returns	133
Notes and Observations:—	
To Make the Detachable Funnel Trap for Bird Banding. By G. D. Sprot	136
Notes on Flickers' Roosts. By C. E. Johnson	137
A Red Squirrel's Christmas Dinner. By C. E. Johnson	137
Horned Larks Wintering in Alberta. By Frank L. Farley	137
Holboell's Grebe in Winter in Ontario. By W. E. Saunders	137
The First Ottawa Field-Naturalist. By F. R. Latchford	137
A Towhee in the Battle River Valley, Alberta. By C. H. Snell	138
Correspondence	138

THE CANADIAN FIELD-NATURALIST, lately THE OTTAWA NATURALIST, established thirty-seven years ago, "to publish the results of original research or investigation in all departments of natural history," is issued monthly, excepting for the months of June, July and August.

Papers, notes and photographs should be addressed to the Editor. Manuscript should be typewritten.

Subscriptions cover the current year, except those taken out during last quarter, when they will be applied on the following year, the remaining numbers of current year being sent free. Payments should be made to the Treasurer, Mr. B. A. Fauvel, Mounted Police Headquarters, Laroque Building, Ottawa. Price of this volume, \$1.50; single copies 20c each.

YES—

We Make Rucksacks

Seven different kinds—to suit almost every kind of work and for Field-Naturalists either of the two, De Luxe or Alpine, are suitable.

Woods' Rucks

*are the comfortable carrying kind made to fit—Order
from your sporting goods dealer*



WOODS MANUFACTURING CO.
OTTAWA

EXPLORATIONS in Western Canada

The Ottawa Field-Naturalists' Club has just published an interesting volume of over 300 pages, entitled:

Autobiography of John Macoun, M.A.

Canadian Explorer and Naturalist, Assistant Director and Naturalist to the Geological Survey of Canada—1831-1920.

This volume is an account of the life of this veteran naturalist. Agriculturists generally, in fact all interested in the development of Canada, will find this book of much interest and value.

The edition is limited. The price is \$3.00 with 15c added for bank exchange, if remittance is forwarded by personal cheque.

Applications for the volume should be made to

Mr. Arthur Gibson

Birks Building : Ottawa, Ont.

The Topley Co.

**Photographic Material
Scientific Apparatus
Eastman Kodaks**



**132 Sparks Street
OTTAWA**

Kindly mention The Canadian Field-Naturalist to advertisers

Lyman's Limited

(Established 1800)

MANUFACTURING CHEMISTS

Importers and Dealers in
CHEMICAL AND
ASSAY APPARATUS

344 St. Paul St. West, Montreal



GROW GOOD CROPS

SEEDS PLANTS BULBS

Our rigorous system of testing eliminates loss
and disappointment from your garden

Kenneth McDonald & Sons, Limited
Seed and Bulb Merchants

Market Square :: Ottawa, Ont

Ward's NATURAL SCIENCE ESTABLISHMENT

Rochester, New York, U.S.A.

Manufacturers of the genuine Schmitt boxes
exhibition cases and cabinets, also of the American
Entomological Company's insect pins.

Riker Mounts and botanical mounts always on
hand, also Riker botanical presses.

Send for our supply catalogue and other lists of
interest to collectors.

**Headquarters for Entomological Supplies
and Specimens**

Inspected Milk Ice Cream

Ottawa Dairy

Fresh Butter Buttermilk

THE Bank of Nova Scotia

Capital \$ 9,700,000
Reserve Fund and Divi-
dend Profits, over 18,000,000
Total Assets over 230,000,000

SEVENTEEN BRANCHES IN
OTTAWA AND HULL

W. A. Rankin, Ltd.

Hammocks
Refrigerators
Builders' Hardware

410-412 Bank Street, Ottawa

Phones—Queen 1023-1024

WHY NOT ADVERTISE
YOUR PRODUCTS IN

The
Canadian
Field-Naturalist

*The Leading Canadian
Natural History Publication*

WRITE FOR RATE CARD

ADVERTISING DEPARTMENT
THE CANADIAN FIELD-NATURALIST

175 Nepean Street

OTTAWA

Kindly mention The Canadian Field-Naturalist to advertisers

The Canadian Field-Naturalist

VOL. XXXVIII

OTTAWA, ONTARIO, SEPTEMBER, 1924

No. 7

OBSERVATIONS ON THE HABITS OF *SPHEX PROCERA* IN MANITOBA

By NORMAN CRIDDLE



AS INTERESTING objects for study the Hymenoptera probably rank above all other insect orders, and owing to the diversity of their habits they perhaps excel even some of the higher groups of animals such as birds. Much has been written concerning them, but vastly more remains to be told. Indeed their activities are all around us and their influences upon our daily life are manifested in innumerable ways.

It is not my intention here, however, to enlarge upon so general a subject, when there are already so many works available for reference. The writings of Henri Fabre, the Peckhams and, the Rauses in particular provide numerous fascinating studies. I propose instead to present a short paper on the life-history of *Sphex procera* Dahl. in Manitoba. This wasp has already been studied in Texas by Carl Hartman, and to a lesser extent by the Rauses, but there are gaps in its biography still to be filled and it is hoped that this paper will shed light upon them.

For the benefit of those not acquainted with *Sphex procera*, I may state that the insect is a large blackish wasp, very wiry in appearance and in shape long and slender, with an elongate thread-like waist which even the extremists in fashion could hardly imitate. This wasp is also long-legged and, when in company with others, often indulges in a dance-like motion produced by the combined action of legs and wings together. It rejoices in the hot sunshine and is partial to sandy situations.

On September 12, 1916, being in need of relaxation after some wearisome laboratory occupation, I set forth into the wilds in search of adventure. It was necessary for me to pass through a garden in my wanderings, and on the threshold I was brought to a stop by the following incident which eventually led to the writing of this paper. There at my feet a large wiry digger-wasp was busy in the not unfamiliar occupation of dragging a caterpillar many times her own size along the ground. The larva, to all appearances, was stiff and lifeless, and the wasp, grasping it behind the head partly carried and partly dragged it upon its back towards her lair. Exactly where the kill had taken place or what the distance covered by the hunter

with her game cannot be definitely stated but as the nearest food plant of the caterpillar, a cherry tree, was more than a hundred feet away it may be safely assumed that the final hunting scene had taken place at least that distance away from the home of the wasp. When I first met the *Sphex* with her prey, which proved to be a larva of *Smerinthus geminatus*, she had still fifty feet to travel to her nest, but in spite of various obstacles in her path, such as a rhubarb plant, she moved steadily onward towards her goal without hesitating in her direction and without once relaxing the hold upon her victim.

The *Sphex* moved directly towards her burrow, which she had already prepared for the reception of such game as this. In due course she arrived at her destination, but only to find another of her species in possession. The latter immediately darted at her, and the ensuing fight terminated in the hasty retreat of the intruder. The rightful owner of the caterpillar at once returned to her quarry and, after dragging it a little nearer to some holes clearly visible in the ground, left it nearby whilst she surveyed her surroundings, apparently having some doubt as to the exact situation of her lair. Becoming satisfied she grasped the larva and, straddling it in the customary manner, she made a circle with it around the entrance to her burrow. Then placing her burden near the entrance she entered the burrow, returning soon afterwards with a small stone. This operation was repeated until seven stones had been brought to the surface. Then followed various unsuccessful efforts to place the caterpillar in position for insertion into the burrow. This was at length accomplished by placing the larva in such a position that its head was as near as possible to the entrance. The wasp then entered the burrow backwards, dragging the caterpillar after her.

The horn-like tail of the larva had hardly vanished down the hole when the second wasp, already referred to, again appeared upon the scene. Looking eagerly about, as if to make sure that her rival was absent, she advanced towards the hole and ventured down it. On encountering the tail end of the caterpillar she at once rushed out in great excitement and, grabbing a stone, she hastily

dropped it into the hole and as quickly followed it with others. Soon all the available stones were blocking the entrance and then to complete the operation she speedily kicked sand over them. These wasps are impish at the best of times, but this one seemed particularly so as she strove to bury her sister alive. As I was speculating on the outcome the buried *Sphex* forced her way to the surface, rage being depicted in her every movement. The invader for a moment remained motionless with astonishment, and then literally took to her wings and fled with the owner of the burrow in hot pursuit. The chase, however, was of short duration and number one was soon again busy at work with her buried caterpillar.

It may have been the second wasp that had actually opened the burrow in the first place in preparation for using it herself. Whether the second wasp really knew, when she so hastily piled stones over the caterpillar, that she was also actually burying her rival can only be speculated upon. Her haste might lead one to believe this to be so, but I do not think it really was. It is probable that she was more concerned in using the larva later on for her own progeny. We will, however, avoid speculation and return to our first *Sphex*.

After chasing the intruder away she spent the next few minutes in again removing the stones and sand from the entrance of the burrow, carrying them in her jaws and placing them a few inches away. Having thus completed the excavation to her satisfaction she returned each stone to its position in the hole, making a low buzzing sound as she did so. Her manner in performing this work was very different from that of the second wasp; it was not merely a case of dropping the stones into the hole, but each was moved back and forth and steadily pressed into place in order to make it fit closely, the sand being used to fill up the spaces between. Nineteen stones were gathered in all, each slightly less than a quarter of an inch in width and irregular in shape, and arranged in this manner. Larger stones were tested but the difficulty in holding them with her jaws usually obliged the wasp to discard them. After the stones were in place they were covered with earth, the latter being kicked into place with the front legs after having first been loosened by means of the jaws, the whole operation being always accompanied by that half-angry buzz as if the wasp were taking vengeance on the soil because of its hardness.

The care with which the *Sphex* filled her burrow was equalled only by the thorough way in which she hid all traces of it. She not only obliterated all signs of the hole itself, but she also dug up the earth fully four inches in every direction from the

entrance of the burrow, so that it became quite impossible to distinguish the original hole. The wasp inspected her work many times and smoothed over or dug the soil a little more wherever it seemed necessary, but she did not, as others have reported, use either stick, leaf or moss to assist in hiding the hole. The whole operation described as I observed it took an hour and forty-three minutes, not including, of course, the original digging of the burrow or the caterpillar hunting.

Several other *Sphex* wasps of the same species were present in the vicinity, all busily working or dancing if there was nothing more important to do. When any of them drew near to our worker they were easily driven off, as if they realized that they were trespassing. Ants, too, frequently came near but although the wasp evidently had some fear of them the safety of her offspring overcame all other considerations, and, as the easiest means of ensuring safety, she took the ants by the middle and dropped them at some distance away. In most cases the ants seemed little the worse for this drastic treatment. Occasionally they were seen to be in a dazed condition showing that they had suffered somewhat in the process of removal.

On one occasion a large, hairy caterpillar blundered into the hole while the *Sphex* was digging and I really looked for something interesting as a result, but the wasp, after mistaking the caterpillar's head for a stone, showed no further interest other than a decided aversion to coming into contact with its bristly hairs.

On the following day I again visited the *Sphex*'s home. Soon after my arrival she appeared upon the scene and at once commenced to undo the work of yesterday by digging out the burrow. The disguised entrance so elaborately arranged on the previous day in no way misled her as to the exact location of the burrow, and, digging directly in, she removed the carefully placed stones and within a comparatively short time dragged forth the caterpillar. After examining it she seized it behind the head and, despite its inertness, thrust her sting twice into its thoracic segments. Having performed this operation she once more set to work to clean out the burrow. Taking advantage of her disappearance below ground, I removed the caterpillar and examined it carefully for signs of an egg but none was to be seen. I then placed it on the ground some distance away from the burrow and awaited results. The wasp continued to dig unconcernedly for some time and when ready for the caterpillar turned to secure it. She seemed considerably surprised at its absence and immediately commenced to circle around the burrow, increasing her distance from it with each revolution. In this way she soon discovered her

prey, which she then dragged back to the burrow. This was followed by a little more digging and the larva was once more buried out of sight. The wasp remained below with it for about three minutes while ovipositing and then returned to the surface. The work of filling in the hole was performed in the same careful way as before, twenty-three stones being used this time, some of which I had placed conveniently near. The *Sphex* then covered the stones with soil, packing it with her head and, having hidden all traces of her work by digging up the surrounding ground, departed from the spot.

The habit of burying a caterpillar one day with out depositing an egg, and of exhuming it the day following for that purpose, has not, to my knowledge, been previously observed, although Hartman reports digging up two caterpillars without eggs upon them. This habit needs to be verified, however, in view of the difficulty of identifying individual wasps. Judging from the habits of wasps of other genera this practice is not an unusual one, and it might indeed be suspected from the fact that burrows are often prepared several days before they are used.

I visited the spot on the following day and found a wasp, perhaps the same one, still present. She kicked the soil about from time to time and drove away intruders but made no effort to dig up the caterpillar. Several other females were at work close by. I saw three digging holes, two removing the soil by flying with it in their jaws, and the third by running with it, as in the case of the individual mentioned in my first notes. Each filled the opening with a few stones and concealed the entrance with material of such a condition and color that it merged into its surroundings perfectly so that no one would suspect the presence of a burrow in the neighborhood.

It was on the third afternoon that I witnessed another strange habit of these creatures. A smooth-skinned caterpillar had unwarily crawled onto the sand near to a burrowing *Sphex*. and eventually fell into the hole in which she was working. The wasp showed considerable astonishment at first, the astonishment giving place to anger followed by satisfaction at having so easily secured fresh meat for her larder. After a violent struggle she dragged the larva forth, and grabbing it behind the head lifted it onto its feet and twice inserted her powerful sting between its forelegs, and after altering her position slightly, again further back. This speedily had its effect and in a few moments the caterpillar became paralyzed, to remain fresh but incapable of escaping until

the larva of the wasp should be ready to feed upon it. A wonderful provision this for keeping meat fresh in hot weather and how simple in comparison with our elaborate systems of cold storage.

Having prepared her victim in the manner described, the *Sphex* ran with it twice around the entrance to her burrow, then, placing it nearby, she continued her digging. Much to my surprise she ultimately dragged from her burrow a large Sphingid caterpillar that had unquestionably been buried for some time, followed by a shiny white larva which was evidently one of her own kind that had been feeding upon the caterpillar. This last was placed among the stones. As she proceeded with her work it soon became evident that the wasp was considerably mystified by the presence of two caterpillars. First she would drag one a little way, and then the other. The Sphingid, too, had commenced to decay, and its juices proved far from pleasant to her. It was indeed quite amusing to watch her after handling this larva, rubbing her head in the sand and cleansing her antennae as if attempting to free them from the putrified matter. This cleansing process was repeated whenever she handled the caterpillar and she rested several times as if overcome from the effects.

In due course she modelled the burrow to her satisfaction and had the freshly killed larva in place and the Sphingid partly down. I believe the attempt to place both of the larvae in the burrow was due to the wasp's inability to distinguish between them or failure actually to recognize that there were two. The wasp had finished her work of cleaning out the surplus earth and had begun to lay the stones before she became aware that the Sphingid caterpillar was not in place. After hesitating for some time she ultimately dragged it from the burrow, carried it some distance away and abandoned it. The final task of filling in the hole was then resumed. Twice she flew away to rest, but, finally completing her work, she hid the burrow entrance by digging up the surrounding earth, and departed to return no more that afternoon.

The Sphingid caterpillar was left on the surface of the ground to be devoured by ants and the wasp larva for whom it was intended as food remained on the surface of the soil to die of hunger and exposure. One might ask whether this wasp was the mother of the larva thus left to perish or only an intruder into the nest of another, and finally, what would she have done had the second caterpillar not fallen upon her? These are questions for future investigators to solve. To me they remain a mystery.

NOTES ON THE CANADA GOOSE IN CAPTIVITY

By REV. BROTHER WILFRID,
Poultry Husbandman, La Trappe, Quebec.



IN 1903 I procured from Mr. Duval at Batiscan a couple of Canada Geese one year old. They did not lay in the following year, as these birds never lay until they are three years of age, a fact which is well known.

In 1905 seven eggs were laid, which proved to be unfertile. When the spring of 1906 brought a similar failure I concluded that the male was unsuitable for breeding purposes and in the fall of the same year I bought another from an old stock-raiser and hunter at Nicolet, Quebec; one that this hunter had used as a decoy for twenty years when hunting Geese. Naturally, this man had kept this bird a prisoner, fastened by one foot, in order to prevent its flying away with visitors of its kind. In fact the bird bore marks of this captivity and limped badly. This lameness was aggravated by age, with the result that last year the gander could no longer walk and forage for himself and finally died. When I bought him I was told that he had been raised by the seller himself and that this bird was fully twenty-five years old, the truth of which was corroborated by witnesses from Nicolet. The bird could not have been less than forty years of age when he died.

He was an example of perfection both in vitality and in colour and had all the qualities called for in a breeder.

The first spring that I mated this bird, that is, in 1907, the female laid two settings of six and seven eggs, respectively, giving me twelve goslings that rustled well for themselves.

A second setting was obtained in the following years on the occasions when I found it possible to remove the first setting. This is not always an easy matter as birds of this kind do not like to be disturbed during the course of reproduction.

I am inclined to consider it undesirable to secure double settings, as these birds, not unlike other animals for that matter, would rather follow the natural order of things.

One of the characteristics of the Canada Goose is certainly the care she takes in hiding herself from the inquisitive looks of all living creatures, when she is about to lay. In fact, one must follow her with field-glasses to discover her nesting site, which is generally among tangles of brush where nobody would be inclined to venture.

When the nest is made and the female begins to sit, the male shows real cunning and keeps away from his mate, sometimes at a very long distance, to make believe, as it were, that the nest was within the circle of his guard and to entice away any one that might be in search of it. At any rate he will let nobody approach the place without flapping his wings vigorously.

I never have been able to find the second nest. The eggs of the first setting were hatched either by hens or by an incubator. Incubation lasts thirty days.

The artificially reared goslings are perfectly tame; they will follow you everywhere from the time they are only a few days old.

They are very greedy and eat all the time when they are not on water, and, thanks to their exceptional voracity, they are, at the age of half a month, as large as chickens three months old and at six months it is difficult to distinguish them from the adults. Adults, however, eat very little. The pair which I bought in 1903 had each been carelessly pinioned to prevent them from flying: such an operation is nonsensical. The poor birds could not fly, however hard they tried. They seemed to me to protest against such an absurdity. It is much better to cut the tip off each wing. I was keeping these birds as an amateur, and I cut nothing, as I enjoyed seeing them take flight at migration time in the spring and fall. There is nothing so beautiful as when they soar into the air, gabbling and singing in their own way, flying around three or four miles, sometimes risking their lives; for more than once some hunter of the neighborhood would shoulder his gun to get one of them, but at second thought he would bring down his weapon and move on, saying, "They must be Brother Wilfrid's wild Geese."

The birds always came back home from their seasonal flight, sometimes after an absence of several days. At all other times the birds stayed within the boundaries of their park, placid and prim in their gait, except when troubled by some human visitor. Then they would put up a fight and chase the intruder.

I must complete the story of my flock by mentioning the fact that the female disappeared a few months ago and I lost all trace of her. It is possible that she longed for a change or wanted to impress on me the fact that she was of age, which indeed she was, being then twenty-one years old.

LIST OF BIRDS RECORDED FROM THE ISLAND OF ANTICOSTI, QUEBEC

By HARRISON F. LEWIS

(Continued from page 90)

105. *Nuttallornis borealis*. OLIVE-SIDED FLYCATCHER.—*Schmitt*: Summer. Rare. *Brooks*: Saw one September 3, 1919.
106. *Empidonax flaviventris*. YELLOW-BELLIED FLYCATCHER.—*Brewster*: Rather common in thickets of mountain maples about the edges and openings of the woods at Ellis Bay. *Schmitt*: Summer. Rather rare. *Brooks*: On September 8, 1919, saw a pair of adults with a brood of young at Ellis Bay. *Lewis*: Common in woods near Ellis Bay in June, 1922.
107. *Empidonax traillii alnorum*. ALDER FLYCATCHER.—*Schmitt*: Summer. Fairly common. *Lewis*: Fairly common near Ellis Bay in June, 1922. Several singing males were repeatedly observed in a bushy area east of the settlement.
108. *Empidonax minimus*. LEAST FLYCATCHER.—*Lewis*: On June 15, 1922, I saw a male Least Flycatcher, *chebec*-ing most vigorously, in trees not far from the head of the pier at Ellis Bay. It was very carefully observed with the aid of binoculars and its distinctive size and coloration were well seen. Although I had been at Ellis Bay since June 10 I had not previously observed this bird. Southerly winds (chiefly south-east) had prevailed for the twenty-four hours preceding this observation.
109. *Otocoris alpestris alpestris*. HORNED LARK.—*Schmitt*: Occurs in small flocks at the beginning of May. Much larger flocks in the fall migration, end of September, first of October. Fairly common. Some are seen after the end of March. Two wintered at English Bay in 1902-1903. *Dionne*: Fairly common spring and fall. *Lewis*: On June 10, 1922, I was shown in a cage at Ellis Bay a Horned Lark which I was told had been taken on the island.
110. *Cyanocitta cristata cristata*. BLUE JAY.—*Combes*: Recorded this species at West Point Light. *Schmitt*: Arrives in May, leaves in October. Common in certain years, rare in others.
111. *Perisoreus canadensis canadensis*. CANADA JAY.—*Verrill*: Common. Young ones full-grown shot July 15. *Brewster*: Abundant resident. *Schmitt*: Throughout the year. Common. *Dionne*: Very common. *Brooks*: Took ten specimens, which formed the basis of his description of *Perisoreus barbouri* as a new species. *Lewis*: Several observed at Ellis Bay, June 10-16, 1922.
112. *Corvus corax principalis*. NORTHERN RAVEN.—*Verrill*: Not very common. *Brewster*: Evenly distributed, but nowhere really abundant. *Combes*: Recorded this species without comment. *Schmitt*: Throughout the year. Fairly common. Young leave the nest early in July. *Dionne*: Fairly common. *Brooks*: Common about the shores of Ellis Bay.
113. *Corvus brachyrhynchos brachyrhynchos*. CROW.—*Verrill*: Very abundant. *Brewster*: Abundant. *Combes*: Recorded this species without comment. *Schmitt*: March-early November. Fairly common. In 1903, first arrivals March 8, bulk of species March 23. Some winter every year. *Dionne*: Fairly common. *Brooks*: Very abundant in the vicinity of Ellis Bay. *Lewis*: Common at Ellis Bay, June 10-16, 1922.
114. *Molothrus ater ater*. COWBIRD.—*Lewis*: On June 10, 1922, I was shown a male Cowbird in a cage at Ellis Bay. Mr. Martin-Zédé, Director of the island, told me that it had been captured in the residence of Senator Menier at Ellis Bay about a month prior to that time.
115. *Euphagus carolinus*. RUSTY BLACKBIRD.—*Schmitt*: Only in the fall migration, end of September-early November. Fairly common. In 1902, September 14-December 4. *Dionne*: Observed in small flocks.
116. *Quiscalus quiscula œneus*. BRONZED GRACKLE.—*Dionne*: Apparently rare.
- In a letter dated February 29, 1924, Mr. W. La Brie supplies the following information concerning his observations of this species on Anticosti: "The Bronzed Grackle which I mention in my observations on the birds of Anticosti was, beyond all doubt, an individual of that species, which is common here at Kamouraska in the spring.
- "I observed that bird on Anticosti in June, 1916, for the first time; it was alone and I was able to approach near enough to it to distinguish clearly the yellow color of the iris of the eye as well as the purplish iridescence of the neck and breast, which made me realize at once that the bird was indeed a Bronzed Grackle. Moreover, the bird uttered its cry, which is peculiar to this species, and with which I am very familiar.
- "In May, 1917, I again heard the voice of the bird in the woods near the 'Villa Menier' at Ellis Bay, but I was not able to see the bird."
117. *Pinicola enucleator leucura*. PINE GROSBEAK.—*Schmitt*: Throughout the year. Fairly common. *Dionne*: Fairly common.

118. *Carpodacus purpureus purpureus*. PURPLE FINCH.—*Brewster*: "We heard its rich song . . . in the lonely forests of Anticosti." *Lewis*: On June 10, 1922, I was shown Purple Finches in a cage at Ellis Bay and was told that they had been captured locally. On June 14, I observed two at liberty near Ellis Bay.

119. *Passer domesticus domesticus*. EUROPEAN HOUSE SPARROW.—*Schmitt*: A male and two females appeared at Ellis Bay in December, 1901. Captured the male and one female and made skins of them. The other disappeared some time later.

Mr. Martin-Zédé, Director of Anticosti, is prepared to take prompt action to suppress any invasion of the island by this species.

120. *Loxia leucoptera*. WHITE-WINGED CROSSBILL.—*Brewster*: Two pairs of adult birds with their young seen in one flock at Ellis Bay, July 24. *Schmitt*: Throughout the year. Fairly common. *Dionne*: Fairly common. *Taverner*: Two seen at Ellis Bay, July 13, 1915. *Brooks*: A single one seen at Ellis Bay on August 28, 1919.

121. *Astragalinus tristis tristis*. GOLD-FINCH.—*Dionne*: Apparently rare. *Brooks*: Saw a small flock on September 3 at Ellis Bay. *Lewis*: At Ellis Bay I saw two on June 14 and one on June 15.

122. *Spinus pinus*. PINE SISKIN.—*Brewster*: Found in flocks, July 24, in evergreen forests about Ellis Bay. *Schmitt*: Throughout the year. Fairly common. Found all winter in the forest. Young have left the nest by the end of July. *Brooks*: A large flock seen on September 3. *Lewis*: Three observed at Ellis Bay, June 14.

123. *Plectrophenax nivalis nivalis*. SNOW BUNTING.—*Schmitt*: At the time of its migrations. End of March, beginning of April. End of October—early November. Fairly common. *Dionne*: Common spring and fall.

124. *Calcarius lapponicus lapponicus*. LAPLAND LONGSPUR.—*Dionne*: Common. Presumably in migration only.

125. *Passerculus sandwichensis savanna*. SAVANNAH SPARROW.—*Verrill*: Common. Breeds. *Brewster*: Abundant. *Brooks*: Common at Ellis Bay. *Lewis*: Common at Ellis Bay in June, 1922.

126. *Zonotrichia leucophrys leucophrys*. WHITE-CROWNED SPARROW.—*Schmitt*: Summer. Rather rare. *Dionne*: Rather rare. *Lewis*: On June 10, 1922, I was shown White-crowned Sparrows in a cage at Ellis Bay and was told that they had been captured locally.

I doubt if this species remains on Anticosti to breed.

127. *Zonotrichia albicollis*. WHITE-THROATED SPARROW.—*Verrill*: Very common. *Brewster*: Abundant. *Schmitt*: May-October. Fairly common. *Dionne*: Very common. *Brooks*: Exceedingly abundant. *Lewis*: Very common at Ellis Bay in June, 1922.

128. *Spizella monticola monticola*. TREE SPARROW.—*Verrill*: Common. Breeds. *Dionne*: Rare.

Brewster, not finding the Tree Sparrow on Anticosti, suggested that *Verrill*, twenty years earlier, had mistaken Swamp Sparrows (not recorded by *Verrill*) for Tree Sparrows. In a letter dated January 26, 1924, Prof. *Verrill* says, concerning his field-diary, containing notes on his visit to Anticosti in 1861, "I find several entries of flocks of birds, seen but not identified. Most of them were recorded as sparrows, not near enough to be identified, but one shot, is recorded as the tree sparrow. Others, not named, may, of course, be the swamp sparrow."

I consider it not yet settled that the Tree Sparrow breeds on Anticosti; though it may do so to some extent.

129. *Spizella passerina passerina*. CHIP-PING SPARROW.—*Lewis*: Two males in song seen and carefully identified at Ellis Bay on June 14 and again on June 15, 1922.

Needless to say, I am thoroughly familiar with this species in the field.

130. *Junco hyemalis hyemalis*. SLATE-COLORED JUNCO.—*Verrill*: Common all summer. *Brewster*: Generally distributed on the shores and islands of the Gulf. *Schmitt*: May-October. Common. Found one in his shed, February 11, 1902, and kept it until spring. *Dionne*: Fairly common. *Brooks*: Astonishingly abundant during my stay at Ellis Bay. *Lewis*: Not common at Ellis Bay in June, 1922. Not more than two individuals recorded in one day.

131. *Melospiza melodia melodia*. SONG SPARROW.—*Dionne*: Very rare, only two seen. *Lewis*: A male in song observed at Ellis Bay on June 14 and 15, 1922.

132. *Melospiza lincolni lincolni*. LINCOLN'S SPARROW.—*Brooks*: A female taken September 6 in a small swamp, which was so boggy that I did not attempt to determine several other Sparrows that resembled Lincoln's Sparrows.

133. *Melospiza georgiana*. SWAMP SPARROW.—*Brewster*: Abundant. *Schmitt*: Summer. Rare. *Dionne*: Fairly common. *Brooks*: Apparently rare. One taken at Ellis Bay, September 5. *Lewis*: Rather common near Ellis Bay in June, 1922.

134. *Passerella iliaca iliaca*. FOX SPARROW.—*Verrill*: Common. Breeds. Two specimens

described as *P. obscura*, sp. nov. *Brewster*: Particularly abundant at Fox Bay. *Schmitt*: Summer. Rather rare. *Dionne*: Common. *Brooks*: Quite common. *Lewis*: Common at Ellis Bay.

135. *Hedymeles ludovicianus*. ROSE-BREADED GROSBEAK.—*Schmitt*: Summer, very rare.

Mr. Dionne assures me that this was included among the species of which he received one or more specimens from Schmitt for identification.

136. *Spiza americana*. DICKCISSEL.—*Dionne*: Accidental. Mr. La Brie found a specimen dead on the island. This specimen was examined by Dionne.

This specimen is now mounted and in Mr. La Brie's private collection, where I have seen it.

137. *Petrochelidon lunifrons lunifrons*.—CLIFF SWALLOW.—*Verrill*: Breeding in large numbers on the cliffs of Cape Eagle, at the entrance to Ellis Bay, July 15.

Apparently this colony no longer exists, as more recent visitors to Anticosti have sought for it in vain.

138. *Hirundo erythrogaster*. BARN SWALLOW.—*Schmitt*: Summer. Rare. Arrives in the first fortnight of May. *Dionne*: Observed rarely.

139. *Iridoprocne bicolor*. TREE SWALLOW.—*Verrill*: Common. Probably breeds. *Brewster*: Two seen at Fox Bay, July 9. *Schmitt*: Summer. Fairly common. Arrives in early May—leaves in August. Nest with young about to leave found June 15, 1902. *Dionne*: Fairly common. *Taverner*: Two seen at Ellis Bay, July 13, 1915. *Lewis*: Common at Ellis Bay in June, 1922.

140. *Riparia riparia*. BANK SWALLOW.—*Verrill*: Common.

141. *Bombycilla cedrorum*. CEDAR WAXWING.—*Schmitt*: Summer. Rather rare.

142. *Lanius borealis*. NORTHERN SHRIKE.—*Schmitt*: Summer. Rather rare. Some seen at the end of April, more common in fall. *Dionne*: Common.

143. *Vireosylva olivacea*. RED-EYED VIREO.—*Verrill*: Common.

144. *Mniotilta varia* BLACK AND WHITE WARBLER.—*Brewster*: A male heard singing at Fox Bay, July 9. One secured nearby on July 11. *Dionne*: Rather rare. *Brooks*: On September 3, 8, and 13 saw a single specimen each day. Saw two on September 12. *Lewis*: Rather common at Ellis Bay in June, 1922.

145. *Vermivora ruficapilla ruficapilla*. NASHVILLE WARBLER.—*Lewis*: Two individuals of this familiar species were observed at Ellis Bay on June 13, 1922.

146. *Vermivora peregrina*. TENNESSEE WARBLER.—*Brewster*: A male in song shot near Fox Bay, July 11. *Lewis*: At Ellis Bay in 1922 I saw two individuals of this species on June 14 and one on June 15.

147. *Compsothlypis americana pusilla*. NORTHERN PARULA WARBLER.—*Brewster*: A single male seen at Fox Bay, July 11.

148. *Dendroica aestiva aestiva*. YELLOW WARBLER.—*Verrill*: A few. *Brewster*: One of the most abundant of its family at Fox Bay. *Schmitt*: Summer. Rather rare. *Lewis*: Fairly common at Ellis Bay in June, 1922.

149. *Dendroica coronata coronata*. MYRTLE WARBLER.—*Schmitt*: Summer. Fairly common. *Dionne*: Common. *Brooks*: Saw several on September 3 and August 27. On September 10 a single individual was seen. *Lewis*: Fairly common at Ellis Bay in June, 1922.

150. *Dendroica magnolia*. MAGNOLIA WARBLER.—*Verrill*: Specimen taken at Ellis Bay, July 15. *Brewster*: More abundant than any other species of its family at Fox and Ellis Bays. *Schmitt*: Summer. Rather rare. *Dionne*: Common. *Lewis*: Common at Ellis Bay in June, 1922.

151. *Dendroica striata*. BLACK-POLL WARBLER.—*Brewster*: Fairly common. *Dionne*: Rather rare. *Brooks*: Saw a few on August 24 and 27. *Lewis*: Fairly common at Ellis Bay in June, 1922.

152. *Dendroica virens*. BLACK-THROATED GREEN WARBLER.—*Brewster*: Observed at Fox and Ellis Bays. Only 2 or 3 seen on Anticosti. *Dionne*: Three specimens seen. *Brooks*: Observed several on August 27 and September 5 and 6. *Lewis*: Common at Ellis Bay in June, 1922.

153. *Seiurus aurocapillus*. OVEN-BIRD.—*Verrill*: Specimens obtained at Ellis Bay, July 15. *Brewster*: A single pair observed at Ellis Bay, July 24. *Schmitt*: Summer. Rather rare. *Dionne*: Rather rare. *Lewis*: At Ellis Bay in 1922 I observed two of this species on June 13 and one on June 15.

154. *Seiurus noveboracensis noveboracensis*. WATER-THRUSH.—*Brooks*: saw several near Ellis Bay nearly every day from August 27 to September 8. *Lewis*: At Ellis Bay in 1922 I saw one on June 13 and three on June 14.

155. *Geothlypis trichas trichas*. MARYLAND YELLOW-THROAT.—*Verrill*: Common all summer. *Brewster*: Two seen at Fox Bay. One of them, a male, shot July 11. *Schmitt*: Summer. Fairly common. *Dionne*: Rather rare. *Brooks*: Saw only three; a pair September 1 and a single male September 5. *Lewis*: Common at Ellis Bay in June, 1922.

(Concluded in the October issue)

THE HOME LIFE OF THE COLUMBIAN GROUND SQUIRREL

By WILLIAM T. SHAW



ONE OF the most familiar summer animals of central and western Canada is the so-called gopher or ground squirrel. This animal has increased with favorable conditions of cultivated, grain-producing fields, until it has become an economic problem of great importance. The animal is a true ground squirrel belonging to a genus, *Citellus*, of wide range and abundant species in western North America. The kind given close consideration in this paper is the Columbian ground squirrel, (*Citellus columbianus columbianus*), (Fig. 1) of the Columbia Basin, an animal extending into British Columbia and Alberta from the south and west.

Though the appearance of ground squirrels during summer months is of common, every-day note, still the interest they excite in us is not fully developed until we start investigating their underground houses. Some time ago a most thorough investigation of the life of this animal was carried on by the writer at the Washington Experiment Station and the results as shown and recorded in this paper will present the home life of the interesting little rodent.

This work of investigation, which extended over a period of about five years, was most searching and during that period 163 dens were excavated in search for information on all phases of the life history, 22 of the excavations being made with a desire for direct information regarding its summer home life.

As a rule the underground houses of these animals are located on gently sloping hill sides, more commonly those facing the sun, though some dens are found on the northern exposures. The depth, texture and drainage of the soil are probably the most important factors in determining the location of the den. The squirrels seem to avoid stiff clay hill-tops and low flats even if the latter are wet only a part of the year. A fence row of snowberry shrubs (*Symphoricarpos*) is a very favorable place for a burrow. The snowberry stems in the center of the thicket are quite destitute of leaves for a foot or so up, then take on an abundant foliage, affording excellent shelter. Clumps of bushes conspicuous on north slopes, when snow is on the ground, are often a mark of the squirrel den. The two might well go together, as the squirrel throws out quantities of loose dirt, making a favorable place for plant development.

Locally there seem to be three intergrading types of summer dens; those in shallow soil, one foot to 18 inches in depth, for extending the feeding range;

those on the rimrock with 2½ feet of soil where young are frequently raised and those in deep soil where old squirrels commonly hibernate. These types consist of a series of radiating burrows very much interlaced near the center. From these are often found many short blinds, probably unfinished burrows for passing or turning places. There is no large excavated cavity. The only expansions found are those which usually occur at the intersection of burrows and these are not large, being sufficient only to accommodate the summer nest or the slightly larger brood nest. These nest cavities are typically arranged in a circle or quadrangle about a large central mass of earth which is not burrowed into to any extent. (Fig. 2). From this common center some burrows rise at an angle of 45 degrees. Others sometimes start deep and gradually rise until they are near the surface then continue radially for many feet, their function being to extend the area for safe pasture. Other burrows leading from the nests drop deep down into the lower parts of the den. The dens, though non-communicating, are often placed in colonies, the peripheral holes a rod or so apart.

PATHS.—When the colony of squirrels is well established, even early in the season and especially after the young have appeared, frequently trips from hole to hole soon wear paths in the grass. Ever watchful, the ground squirrel has learned to take no risks, and when crossing a den or going some distance, it almost invariably runs in a straight line between any two burrow entrances if they are at all in the desired direction. By June, paths a few inches wide lead from burrow to burrow, and radiate from the dens into the feeding grounds. A path 90 feet long was observed, leading between two dens, without intermediate holes. On August 7-9 many paths through the dead weeds or over the green grass and clover of the flat were noted leading from the roadside to a wheat field. These paths had holes here and there along the way to dodge into in case of danger. Another path studied led from a field of winter wheat to a den at the bottom of a hill and was 54 yards long.

THE ENTRANCE.—There are two distinct types of entrances to the burrows of the Columbian ground squirrel. One is small and round and not much if any larger than the burrow itself. There generally is no loose earth around it, all the dirt having been hauled below. In the other type the mouth of the burrow has been enlarged into a funnel-shaped opening sometimes several inches

across. Upon one side of it is a mound of earth thrown out by the squirrel. (Fig. 1).

The single entrance is sometimes converted into a double entrance which would have the advantage of greater safety in case of pursuit. These two entrances join into the same burrow a foot or so below the surface. A still further development of this type of hole has resulted in the formation of a protective entrance, in which the burrow terminates in four, five or more shallow troughs spreading out over the surface of the ground. (Fig. 3). This is undoubtedly a means of protection for the fleeing squirrel when closely pursued by an enemy. In most cases such protective entrances have no fresh dirt thrown about them, the dirt being hauled down through the burrow. These protective troughs are sometimes found on the mounds of loose earth cast out of a burrow. They are usually started about a month after the squirrel comes from hibernation. The number of entrances to a squirrel den is sometimes large. Careful count of the number of entrances to sixty dens gave an average of 11.16 entrances per den, the number varying from two entrances for a small den to 35 entrances for a large den.

THE DEPTH OF BURROWS.—The depth of the burrow is taken as the distance from the surface of the soil to the top of the burrow and is usually determined and limited by the sub-soil or by the hardpan, as they seldom go far into these harder strata. (Fig. 4). However, even in deep soil outlying burrows are sometimes shallow at the distal ends, probably because the soil is easier to dig nearer the surface. One large, open burrow was followed for 20 feet in a more or less straight line at an average depth of 4 feet. One burrow was found at a depth of 5 feet on a hardpan and another at a depth of 2 feet 3 inches. Sometimes outlying burrows will run more or less continuously in one direction for many feet. Usually they interlace towards the center of the den. Some of the very complicated dens show a great interlacing of burrows. One den was excavated where two burrows crossed so closely that there was not one inch of earth between them.

It is a matter of common observation that ground squirrels have the habit of returning to the surface for a cautious look after being chased into the den. This habit was noticed in young squirrels only 24 days old. This survey seems to be for the purpose of reconnoitering leisurely the situation from which it fled in haste. If forced to go down a second time, it remains there indefinitely. It is not surprising then to find a pocket in the side of the burrows where it can turn around without the necessity of going down to a nest

cavity or a point of intersection of burrows. Such pockets are usually within a few inches of the exit, especially in long radiating burrows.

THE SUMMER NEST. This type of nest is usually located at the juncture of burrows and is not elaborated. It generally consists of a little dead, dry wild grass matted down, though sometimes in spring it is roofed over, and it probably serves as a resting place for the squirrels during the day.

Some of these nests in undisturbed ground are located as near the surface as seven inches, probably for the heat they gain in early spring when the deeper soil is damp. Deeper nests probably serve for hot summer weather. Not infrequently these nest cells, as well as the cells of brood and hibernation nests, are empty suggesting that the nest material has been transferred to a more desirable location in the den. Such transfer was frequently observed among captive squirrels. The depths of different nests in a given den vary considerably, six nests in one den being located at depths of 18, 19, 22, 24, 30 and 31 inches respectively, or at an average depth of 24 inches. Observations made of nests in a burrow in deeper soil showed an average depth of 3 feet 2 inches, the depth to different nests varying from 1½ feet to 5 feet. Although the soil of this region is naturally provided against flooding by large numbers of earthworm burrows extending even as deep as eleven feet, the summer nests are frequently placed on the upper, drier side of the den to guard against the excess moisture.

THE DURABILITY OF DENS.—These dens are very durable, especially in clay soil. Very perfectly preserved burrows unused for at least eight years were exposed by street grading in Pullman. An excavation of a den equally old showed several open and other plugged burrows. The nose prints in the plugs were as distinct as if recently formed. This tends to show how easy it would be for them to reinhabit a territory if they were not held in check. In many cultivated fields, slight, broad elevations still remain, indicating the position of old squirrel dens. In periods when the squirrels are less disturbed they sometimes return and in a very short time open the entrances and transform these old dens into used ones.

A TYPICAL DEN.—Early in these investigations, a fairly large, fresh den located in a pasture above the high water mark on a sloping hill side, facing the northwest, was excavated for study (Fig. 2). The greatest depth of any burrow was two feet. The burrows dropped at an angle of about 45 degrees to this depth, where they met the clay sub-soil and seldom went much deeper. At intervals, especially at or near the intersections of these burrows, the tunnels were enlarged from the

average diameter of $3\frac{1}{2}$ inches to a diameter of from 7 to 10 inches but were not much increased in height though they were somewhat. The total length of burrows was 63 feet 8 inches.

Two of the nests found were old ones. One old nest was reconstructed and two new ones were found on the upper side of the den, which is significant from the view point of drainage. Other dens were excavated and similar conditions were found.

Owing to the comparatively short period of activity of this animal, it is natural that the breeding season should occur very soon after the squirrels come from hibernation. So prompt are they in this that the adult squirrels are out and rutting before the young of the previous season are up from hibernation.

THE BREEDING SEASON.—Breeding commences shortly after the adult females have appeared from hibernation and continues actively for a period of about three weeks, in conformity with the appearance of the young squirrels of the previous season. It is influenced by local conditions, such as those represented in north and south slopes, and, as in birds, is retarded by unfavorable weather conditions.

RELATIVE NUMBER OF MALES AND FEMALES.—It was desired to determine the relative number of males and females at large. This was done by taking a census between June 10 and July 10 of the year 1910, at the season when they would, in our judgment, be the most uniformly distributed as a species. The squirrels were collected by being shot in the fields at various times during the day. In all, 28 squirrels were taken. Of these, 17, or 60 per cent, were females and 11 were males. These figures are relatively the same as those given on a much larger scale by Foster, (1911, p. 2) *Bulletin of Washington Experiment Station*, in which he records 69 per cent of females to 31 per cent of males out of 545 squirrels examined.

RUTTING.—The rutting period is one of great activity for the squirrels. Then the colony is thrown into a state of the most intense animation, and what appears to be the most confused condition of the squirrel community manifests itself at this time.

PERIOD OF PREGNANCY.—The excitement of the rutting season has scarcely quieted down when the female begins to select a den suitable and secure, for nesting purposes. During the brief gestation period of 24 days she must do this and construct a nest for the reception of her very helpless young. For the first few days of this period she feeds quietly. Now by chance she may be observed carrying material for the nest and soon she becomes quite antagonistic towards other females. Her desire for seclusion seems to grow, especially during the two or three days before parturition, when she eats very little. After parturition the female takes on a gradual activity which grows more pronounced with the rapid development of the young, for it is necessary that she provide nourishment for them. This necessitates the constant gathering of food during the entire day. In 1911 this period, as determined by the presence of embryos and fetal scars, was found to extend between March 20 and April 14.

THE BROOD DEN AND ITS LOCATION. The brood den selected by the squirrels is very often found on a warm southern exposure, where the soil is shallower and drier, and on which the vegetation is more advanced. It is frequently chosen in some old uncultivated pasture or wild land and is simply an old summer den, a portion of which is used for the brood nest, often located 12 to 15 inches below the surface. The excavation for the nest, about 9 by 9 by 8 inches, is usually made at the intersection of burrows, though sometimes greater privacy is secured by plugging one of its entrances. Communication burrows from these nests frequently drop down to deeper parts of the den.

(Concluded in the October issue)

NOTE.—*The Canadian-Field Naturalist* is again fortunate in being able to present its readers with illustrations of varied interest. Those which appear in this number are published through the kind assistance of Messrs J. H. Fleming, W. E. Saunders and P. A. Taverner, the Geological Survey of Canada and the Canadian National Parks Branch.—EDITOR.



FIG. 1.—The Columbian ground squirrel at the entrance of a burrow leading to its underground home. These animals, when frightened into their den, have the habit of returning in a few moments to reconnoiter the situation from which they may have fled in haste.

Photo from life by WILLIAM T. SHAW

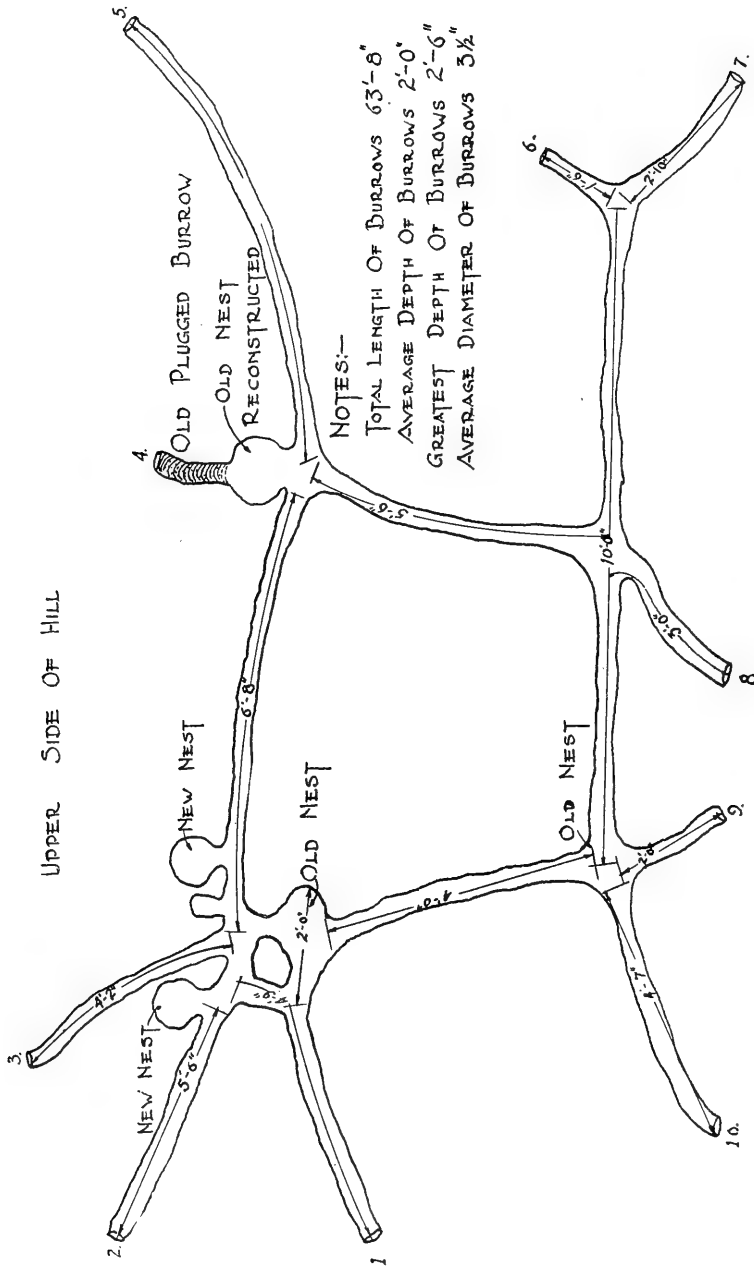

FIG. 2.—In sketch, the den of this ground squirrel shows a series of burrows and small nest chambers. This sketch shows in an interesting way that the animal appreciates the danger from flooding and has placed his nests on the high side of the den. (Original.)



FIG. 3.—Having been pursued for ages by enemies such as hawks and coyotes, the squirrel has learned to provide his burrow entrances with safety devices in some form or other, one of which is shown in this illustration as a series of radiating troughs all leading to the burrow mouth. It is evident that a burrow mouth of this nature would be much easier found in times of great haste than a small round hole.

Photo by WILLIAM T. SHAW

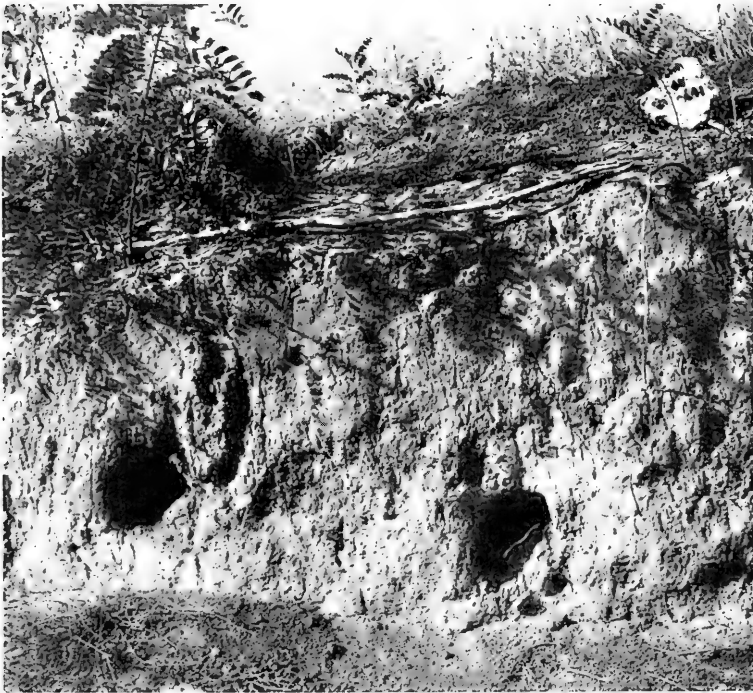

FIG. 4.—As a rule the depth of the burrows is determined by some hard, underlying stratum into which they do not like to dig. The lighter lower stratum here shown is of a hard, gritty, slightly cemented material.

Photo by WILLIAM T. SHAW

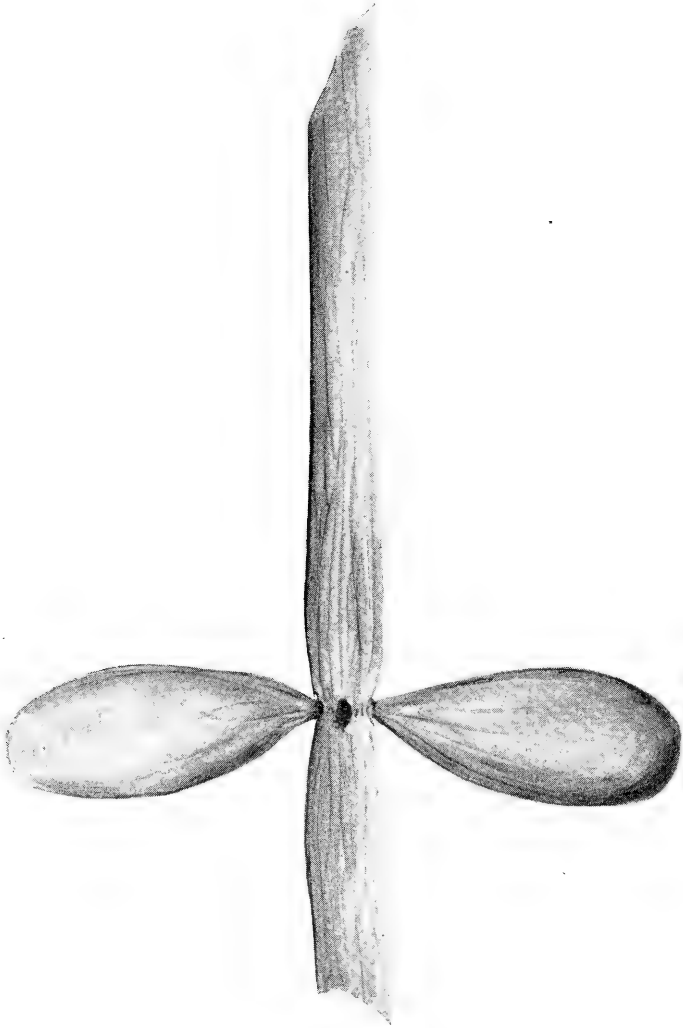

FIG. 1.—*Equisetum arcticum* Heer, a fossil plant which probably figured in the Dinosaur bill of fare.

THE FOOD VALUE OF AN *EQUISETUM* FROM THE LANCE FORMATION OF SASKATCHEWAN*

By PROFESSOR EDWARD W. BERRY
of The Johns Hopkins Institute



IT MAY well be doubted if it is ordinarily possible, in the absence of anatomical characters, to distinguish between most fossil species of *Equisetum*, and the literature of systematic paleobotany contains a very large number of so-called species based on fragments of stems or rhizomes. Where these have a stratigraphic value they are doubtless justified, on the well known principle that analysis should precede synthesis. Where, however, a variety of so-called fossil species have been described from a similar or identical geological horizon, it may be an advantage, at least from the botanical standpoint, to consider many such illy-characterized fragments that have been described, as representing a single botanical species. The justification for this is the well known extensive geographical range of most of the existing species of *Equisetum*.

The late Oswald Heer described *Equisetum arcticum* from the Tertiary of Spitzbergen in 1868 and subsequently identified somewhat doubtful remains from Grinnell Land as the same species, which has also been recorded by Penhallow from Red Deer River, and possibly also from Porcupine Creek and Great Valley in Canada. A pronounced feature of the Spitzbergen material was the numerous and large tubers on the rhizomes. These are well shown in Heer's second contribution to the fossil flora of Spitzbergen.†

During the summer of 1921, C. M. Sternberg, working for the Geological Survey, collected what appears to be this same species of *Equisetum* from an exposure on Rocky Creek, Saskatchewan (Sec. 15, Township 1, Range 5, West of 3). These have the largest tubers that I have ever seen on an equisetum—they are bigger than good-sized lima beans, and as large as some of the tubers which, in the uplands of Bolivia and Peru, are considered sufficiently good potatoes to warrant their cultivation and marketing.

The tubers of *Equisetum arcticum* are borne in clusters at the nodes of the rhizomes or underground stems, and one specimen from Rocky Creek shows a verticil of three of these at a single node. Heer figures four somewhat smaller tubers at a single node in one specimen from Spitzbergen. The sandy clays of the Lance formation are packed

with these tubers at the outcrop on Rocky Creek. They are flask-shaped and run up to 4 centimeters in length by nearly 2 centimeters in maximum diameter in the somewhat flattened condition in which they are preserved.

The most interesting feature in connection with their occurrence in Saskatchewan is their association in a series of "somber" clays and sandstones, which Sternberg calls the Lance formation, with dinosaurian remains. The collector mentions only the genus *Triceratops* as in actual association with fossil plants, but speaks of Dinosaurian remains as very common throughout these beds in this section, and as the other herbivorous forms were probably not far away when *Triceratops* was around, it occurred to me at once that here we have a promising article of diet on the Dinosaurian bill of fare.

It has always been a subject for speculation as to what the herbivorous dinosaurs fed on, and although some seem to have been well fitted by nature for browsing, others, like *Trachodon* and its allies, would seemingly have found it difficult or impossible to have availed themselves of hard or coarse food such as leaves or grasses. Other students have indulged in speculation regarding the few calories in such types of food and have compared this with the great bulk of a large number of the dinosaurs, and have sought to calculate the prodigious amounts of such low-grade food that an individual would consume.

Equisetums are gregarious plants which would probably have been present on the Lance river flats in great abundance, their rhizomes would ramify near the surface of the mud or sand, and if they formed tubers as abundantly as the fossils appear to indicate, they would seem to offer a highly concentrated food. These tubers contained a percentage of starch as high as, or even higher than, that contained by the modern potato, and although all animals do not thrive on a starch diet, some, such as hogs, can live almost wholly on a starch diet and transform it into fats, and there is no legitimate basis for thinking that dinosaurs might not do the same.

I am reproducing an illustration of a specimen of the Saskatchewan *Equisetum*, natural size, to show the size of its tubers, and there follows the synonymy of *Equisetum arcticum*, in which I have included a number of supposedly different, named forms from the Laramie, Hanna, and Fort Union formations, that appear to me to represent the

*Published by permission of the Director of the Geological Survey of Canada.

†Heer, O., *Kgl. Svenska Vetensk.-Akad. Handl.*, Bd. 8, No. 7, pl. 1, 1870.

same species, or closely related forms of not over-good standing.

Equisetum arcticum Heer, *Fl. Foss. Arct.*, Bd. 1, p. 156, pl. 29, figs. 8, 9e, f, 1868. Bd. 2, p. 31, pl. 1, figs. 1-15; pl. 2, figs. 1-4, 1870. (?) Bd. 5, Abt. 1, p. 19, pl. 1, fig. 1a, 1878.

Penhallow, *Trans. Roy. Soc. Canada*, 2nd ser., vol. 8, sec. 4, p. 49, 1902. *Rept. Tert. Plants Brit. Col.*, p. 53, 1908.

Physagena Parlatorii Dawson (not Heer), *Rept. Geol. & Res. 49th Parallel*, App. A, p. 329, pl. 16, figs. 3, 4, 1875.

Equisetum root, Dawson, *Trans. Roy. Soc. Canada*, vol. 4, sec. 4, p. 22, pl. 1, fig. 2, 1887.

Equisetum Parlatorii Penhallow (not Schimper) *Rept. Tert. Plants Brit. Col.*, p. 54, 1908.

Equisetum Haydenii Lesquereux, *Ann. Rept. U.S. Geol. & Geogr. Surv. Terr.*, p. 284, 1871 (1872). *Tertiary Flora*, p. 67, pl. 6, figs. 2-4, 1878.

Equisetum lævigatum Lesquereux (not Al. Braun) *U.S. Geol. & Geogr. Surv. Terr.*, *Ann. Rept. for 1873*, p. 395, 1874. *Tertiary Flora*, p. 68, pl. 6, figs. 6, 7, 1878.

Equisetum perlævigatum Cockerell, *West. Ann. Sci.*, vol. 6, p. 154, 1889.

NOTES ON THE SPHINGIDÆ OF SAULT STE. MARIE, ONTARIO

By W. H. A. PREECE



FOR MUCH of the information utilised in the preparation of the following notes I am indebted to Mr. Arch. Nicholls, who has collected in this vicinity for the last eight years. My own records cover 1923 only.

The total number of species so far recorded here is only sixteen and comparatively few of these can be regarded as common. Two species not previously recorded were taken here this year (1923), namely, *Darapsa pholus*, and *Proserpinus flavofasciata*. *Celerio lineata* and *Celerio intermedia*, the latter usually one of the most abundant species, were the only previously recorded species not taken in 1923.

Ceratomia undulosa Wlk. Quite the commonest species here. All specimens were taken at light, with one exception, which was found resting on a tree during the day. First taken, June 12th; last, July 6th.

Sphinx kalmix A. & S.—Five records 1923, only one previous record. All taken at light, first June 13th; last June 24th.

Sphinx gordius Cram.—Four records 1923; a few are recorded yearly. All taken at light, first June 25th; last, July 6th.....

Sphinx drupiferarium A. & S.—One record; taken at light, June 24th; two previous records.

Smerinthus cerisyi Kirby.—Common, all specimens taken at light, first taken June 12th; last, June 28th.

Smerinthus jamaicensis Dru.—Fairly common, all specimens taken at light, first taken June 10th; last July 17.

Paonias excaetata A. & S.—Not common, all specimens taken at light, first June 18, last July 4.

Paonias myops A. & S.—Three records 1923, June 15 and 24, and July 1. Twice recorded in previous years.

Pachysphinx modesta Harris—Fairly common, all specimens taken at light, first taken June 12, last July 13. The local form is very fine and appears to be considerably darker than the typical one.

Hæmorrhagia thysbe Fabr. (Form *cimbiciformis* Steph.).—Quite common, first taken June 10, last July 1. Appears to favour choke-cherry blossoms.

Hæmorrhagia diffinis Boisd., var. *æthra* Stkr.—Common, first taken June 9, a number were seen up until the early part of July but, owing to their battered condition, none were taken after June 12. A newly emerged specimen, however, was taken on August 12, which tends to show that this species is partially double-brooded here. Most specimens were taken at the blossoms of blueberry and pin-cherry, a few at wild strawberry.

Darapsa pholus Cram.—One taken at light, July 4. No previous record.

Amphion nesus Cram.—Two specimens taken, one on the wing, late in the afternoon of June 10, the other inside a shop window in the morning of June 19. One previous record.

Proserpinus flavofasciata Wlk.—Two specimens taken, one in a sphagnum swamp, May 27, the other inside a freight-shed, June 9. No previous record.

Celerio lineata Fabr.—Not recorded 1923. So far as is known, only one specimen has been taken here, which is in Mr. Nicholls' collection.

Celerio intermedia Kirby.—Not recorded 1923; usually one of the most abundant species.

OFFICIAL CANADIAN RECORD OF BIRD-BANDING RETURNS**(Continued from page 93)*

BLACK DUCK, No. 101,155, banded by H. S. Osler, at Lake Scugog, Ontario, on August 20, 1922, repeated until September 5, 1922, and was shot at Caesarea, Lake Scugog, Ontario, on October 28, 1923.

BLACK DUCK, No. 101,163, banded by H. S. Osler, at Lake Scugog, Ontario, on August 21, 1922, was recaptured at the same station on October 10, 1922, and was killed at Lake Scugog, Ontario, on September 11, 1923.

BLACK DUCK, No. 101,165, banded by H. S. Osler, at Lake Scugog, Ontario, on August 21, 1922, was killed at Reeds Egg Island, off Brant Beach, in Barnegat Bay, New Jersey, on December 8, 1923.

MALLARD, No. 101,180, banded by H. S. Osler, at Lake Scugog, Ontario, on August 22, 1922, was shot near Orillia, Ontario, on September 2, 1922.

BLACK DUCK, No. 101,184, banded by H. S. Osler, at Lake Scugog, Ontario, on August 23, 1922, was shot on the marshes above Saginaw, Michigan, on November 6, 1922.

BLACK DUCK, No. 101,189, banded by H. S. Osler, at Lake Scugog, Ontario, on August 23, 1922, was killed at a place ten miles northwest of Peterboro, Ontario—date not given, but reported on January 31, 1923.

BLACK DUCK, No. 101,196, banded by H. S. Osler, at Lake Scugog, Ontario, on August 24, 1922, was killed near Dollis Creek, on the Gulf of Mexico, Florida, on December 4, 1922.

BLACK DUCK, No. 101,226, banded by H. S. Osler, at Lake Scugog, Ontario, on August 26, 1922, was killed at Quimby, Virginia, on January 11, 1923.

BLACK DUCK, No. 101,233, banded by H. S. Osler, at Lake Scugog, Ontario, on August 27, 1922, was killed at Bayou Biloxi, St. Bernard Parish, Louisiana, on December 3, 1922.

BLACK DUCK, No. 101,245, banded by H. S. Osler, at Lake Scugog, Ontario, on August 28, 1922, was killed at Reelfoot Lake, Tennessee, on December 19, 1922.

BLACK DUCK, No. 101,256, banded by H. S. Osler, at Lake Scugog, Ontario, on August 29, 1922, was killed about seven miles northeast of Ocracoke Island, North Carolina, on November 7, 1923.

MALLARD, No. 101,258, banded by H. S. Osler, at Lake Scugog, Ontario, on August 29, 1922, was recaptured on September 7, 1922, and killed at the same place on October 10, 1922.

BLACK DUCK, No. 101,283, banded by H. S. Osler, at Lake Scugog, Ontario, on August 31,

1922, was killed about four miles southeast of Houma, Louisiana, on December 14, 1922.

BLACK DUCK, No. 101,287, banded by H. S. Osler, at Lake Scugog, Ontario, on August 31, 1922, was killed near Wachapreague, Virginia, on November 25, 1923.

BLACK DUCK, No. 101,293, banded by H. S. Osler, at Lake Scugog, Ontario, on September 1, 1922, was killed at Grape Vine Point, near the mouth of the Bohemia River, Cecil County, Maryland, on December 23, 1922.

BLACK DUCK, No. 101,300, banded by H. S. Osler, at Lake Scugog, Ontario, on September 1, 1922, was killed at Sweet Hall, Virginia, on December 5, 1922.

FLORIDA GALLINULE, No. 207,513, banded by H. S. Osler, at Lake Scugog, Ontario, on September 3, 1922, was shot at Rice Lake, Ontario, on September 18, 1923.

BLACK DUCK, No. 207,521, banded by H. S. Osler, at Lake Scugog, Ontario, on September 4, 1922, was shot at Kent Island, Maryland, on January 25, 1923.

BLACK DUCK, No. 207,529, banded by H. S. Osler, at Lake Scugog, Ontario, on September 5, 1922, was killed in a marsh near Odessa, Delaware, during the latter part of January, 1923.

BLACK DUCK, No. 207,530, banded by H. S. Osler, at Lake Scugog, Ontario, on September 6, 1922, was caught in a steel trap on the marsh of Chester, Kent County, Maryland, on January 11, 1923.

BLACK DUCK, No. 207,531, banded by H. S. Osler, at Lake Scugog, Ontario, on September 6, 1922, was "caught" at a marsh near Barley's Island Bay, Currituck County, North Carolina, on December 21, 1922.

BLUE-WINGED TEAL, No. 207,557, banded by H. S. Osler, at Lake Scugog, Ontario, on September 13, 1922, was recaptured at the same station on September 30, 1922, and shot at Noonan, North Dakota—no date given, but reported on October 17, 1923.

BLUE-WINGED TEAL, No. 207,585, banded by H. S. Osler, at Lake Scugog, Ontario, on September 14, 1922, was shot at Port Lambton, Ontario, on September 20, 1923.

MALLARD, No. 207,624, banded by H. S. Osler, at Lake Scugog, Ontario, on September 17, 1922, was shot on the south shore of Lake Poygan, Wisconsin, on October 19, 1923.

BLACK DUCK, No. 207,643, banded by H. S. Osler, at Lake Scugog, Ontario, on September 19, 1922, was recaptured at the same station on September 25, 1922, and was killed at Agamaski, James Bay, on August 8, 1923.

*Published by authority of the Canadian National Parks Branch, Department of the Interior, Canada.

BLACK DUCK, No. 207,653, banded by H. S. Osler, at Lake Scugog, Ontario, on September 19, 1922, was killed in Cape May County, New Jersey, on October 24, 1923.

BLACK DUCK, No. 207,657, banded by H. S. Osler, at Lake Scugog, Ontario, on September 19, 1922, was shot on the Trent River, six miles south of Campbellford, Ontario, on October 6, 1923.

BLACK DUCK, No. 207,665, banded by H. S. Osler, at Lake Scugog, Ontario, on September 19, 1922, was killed in Section 35, Riley Township, Sandusky County, Ohio, about December 21, 1922.

BLACK DUCK, No. 207,666, banded by H. S. Osler, at Lake Scugog, Ontario, on September 19, 1922, was killed off the shore of Franklin City, Virginia, on January 23, 1923.

BLACK DUCK, No. 207,667, banded by H. S. Osler, at Lake Scugog, Ontario, on September 19, 1922, was shot in the waters of Chincoteague, eastern shore of Virginia, on January 18, 1923.

BLUE-WINGED TEAL, No. 207,674, banded by H. S. Osler, at Lake Scugog, Ontario, on September 20, 1922, was shot at West Point, Nebraska, on October 19, 1923.

BLUE-WINGED TEAL, No. 207,724, banded by H. S. Osler, at Lake Scugog, Ontario, on September 20, 1922, was killed at the same place on October 21, 1922.

BLUE-WINGED TEAL, No. 207,734, banded by H. S. Osler, at Lake Scugog, Ontario, on September 20, 1922, was shot on Lake St. Louis, thirty-five miles from Montreal, Quebec, on September 6, 1923.

BLUE-WINGED TEAL, No. 207,735, banded by H. S. Osler, at Lake Scugog, Ontario, on September 20, 1922, was killed near Garretson, South Dakota—no date given, but reported on October 17, 1923.

BLACK DUCK, No. 207,738, banded by H. S. Osler, at Lake Scugog, Ontario, on September 21, 1922, was killed at Green Creek, New Jersey, on October 18, 1922.

BLACK DUCK, No. 207,741, banded by H. S. Osler, at Lake Scugog, Ontario, on September 21, 1922, was killed at the same place on October 10, 1922.

BLACK DUCK, No. 207,747, banded by H. S. Osler, at Lake Scugog, Ontario, on September 21, 1922, was shot at Hay Bay, Lennox County, Ontario, on October 19, 1922.

BLACK DUCK, No. 207,755, banded by H. S. Osler, at Lake Scugog, Ontario, on September 22, 1922, was killed on the marshes of Dorchester County, Maryland, on December 21, 1922.

BLACK DUCK, No. 207,757, banded by H. S. Osler, at Lake Scugog, Ontario, on September 22, 1922, was killed on the Shenango River at And-

over, Ohio—no date given, but reported on December 3, 1923.

BLACK DUCK, No. 207,762, banded by H. S. Osler, at Lake Scugog, Ontario, on September 22, 1922, was killed at Bayou Meto, Arkansas County, Arkansas, on November 23, 1922.

BLACK DUCK, No. 207,767, banded by H. S. Osler, at Lake Scugog, Ontario, on September 22, 1922, was killed at Cedar Island Beach, Virginia, on December 15, 1922.

BLACK DUCK, No. 207,772, banded by H. S. Osler, at Lake Scugog, Ontario, on September 22, 1922, was killed at Port Rowan, Ontario, on November 24, 1922.

BLACK DUCK, No. 207,774, banded by H. S. Osler, at Lake Scugog, Ontario, on September 22, 1922, was killed at the same place on October 22, 1922.

BLACK DUCK, No. 207,788, banded by H. S. Osler, at Lake Scugog, Ontario, on September 23, 1922, was killed on the Ocklocknee River, Florida, about January 25, 1923.

BLACK DUCK, No. 207,790, banded by H. S. Osler, at Lake Scugog, Ontario, on September 23, 1922, was killed near Artificial Island, Salem County, New Jersey, on December 12, 1922.

BLACK DUCK, No. 207,791, banded by H. S. Osler, at Lake Scugog, Ontario, on September 23, 1922, was shot at the mouth of the South Santee River, South Carolina, on January 11, 1923.

BLACK DUCK, No. 207,793, banded by H. S. Osler, at Lake Scugog, Ontario, on September 23, 1922, was shot near Georgetown, South Carolina, on December 18, 1923.

BLACK DUCK, No. 37,410 (A.B.B.A.), banded by H. S. Osler, at Lake Scugog, Ontario, on September 24, 1922, was killed on the Delaware River, off Elsinboro, above Alloway Creek, New Jersey, on January 22, 1923.

BLACK DUCK, No. 37,406 (A.B.B.A.), banded by H. S. Osler, at Lake Scugog, Ontario, on September 24, 1922, was shot at the Santee Club Preserve, South Santee River, South Carolina, on December 18, 1922.

MALLARD, No. 37,425 (A.B.B.A.), banded by H. S. Osler, at Lake Scugog, Ontario, on September 25, 1922, was killed at the same place on October 16, 1922.

BLACK DUCK, No. 37,433 (A.B.B.A.), banded by H. S. Osler, at Lake Scugog, Ontario, on September 25, 1922, was killed at Hog Island, Virginia, on November 10, 1922.

BLACK DUCK, No. 37,440 (A.B.B.A.), banded by H. S. Osler, at Lake Scugog, Ontario, on September 25, 1922, was killed at Quiver Creek, near Havana, Illinois, on November 30, 1922.

BLACK DUCK, No. 37,443 (A.B.B.A.), banded by H. S. Osler, at Lake Scugog, Ontario, on Sep-

tember 25, 1922, was killed about seven miles northwest of Onancock, Virginia, on November 3, 1922.

BLACK DUCK, No. 37,455 (A.B.B.A.), banded by H. S. Osler, at Lake Scugog, Ontario, on September 26, 1922, was killed at Pecan, Mississippi, two miles from Mississippi Sound, on December 27, 1922.

BLACK DUCK, No. 37,465 (A.B.B.A.), banded by H. S. Osler, at Lake Scugog, Ontario, on September 26, 1922, was killed on Sipsev River Swamp, Tuscaloosa County, Alabama, on January 16, 1923.

BLACK DUCK, No. 37,469 (A.B.B.A.), banded by H. S. Osler, at Lake Scugog, Ontario, on September 26, 1922, was killed at Deals Island, Somerset County, Maryland—no date given, but reported on February 20, 1923.

BLACK DUCK, No. 37,470 (A.B.B.A.), banded by H. S. Osler, at Lake Scugog, Ontario, on September 26, 1922, was killed near the Ohio River, Clermont County, Ohio, about December 1, 1922.

BLACK DUCK, No. 37,474 (A.B.B.A.), banded by H. S. Osler, at Lake Scugog, Ontario, on September 26, 1922, was recaptured several times at the same station until October 11, 1922, and was killed at a place seven miles from where it was banded, on October 27, 1922.

BLACK DUCK, No. 37,475 (A.B.B.A.), banded by H. S. Osler, at Lake Scugog, Ontario, on September 26, 1922, was killed on Chicamuxen Creek, Charles County, Maryland, thirty-five miles from Washington, D.C., on January 22, 1923.

BLACK DUCK, No. 37,482 (A.B.B.A.), banded by H. S. Osler, at Lake Scugog, Ontario, on September 26, 1922, was killed at the same place on October 15, 1922.

BLACK DUCK, No. 37,486 (A.B.B.A.), banded by H. S. Osler, at Lake Scugog, Ontario, on September 26, 1922, was killed at Corson's Inlet, Strathmere, New Jersey, on December 20, 1922.

BLACK DUCK, No. 37,498 (A.B.B.A.), banded by H. S. Osler, at Lake Scugog, Ontario, on September 27, 1922, was found dead on the mainland shore of Great South Bay, at Speonk, Long Island, New York, about December 24, 1922.

BLACK DUCK, No. 207,902, banded by H. S. Osler, at Lake Scugog, Ontario, on September 27, 1922, was shot at Kent Island, Maryland, on January 25, 1923.

BLACK DUCK, No. 207,906, banded by H. S. Osler, at Lake Scugog, Ontario, on September 27, 1922, was killed at Hog Island Bay, Accomack County, Virginia, on December 7, 1922.

BLACK DUCK, No. 207,907, banded by H. S. Osler, at Lake Scugog, Ontario, on September 27, 1922, was shot at Rondeau Bay, Ontario, on November 8, 1923.

BLACK DUCK, No. 207,925, banded by H. S. Osler, at Lake Scugog, Ontario, on September 28, 1922, was captured at Lower Peach Tree, Alabama—date not given, but reported on January 29, 1923.

BLACK DUCK, No. 207,927, banded by H. S. Osler, at Lake Scugog, Ontario, on September 28, 1922, was accidentally caught in a muskrat trap, near Woodland Beach, nine miles from Smyrna, Delaware—date not given, but reported on January 26, 1923.

BLACK DUCK, No. 207,929, banded by H. S. Osler, at Lake Scugog, Ontario, on September 28, 1922, was recaptured at the same station on October 20, 1922, and was killed on the Kalamazoo River, about eighteen miles southeast of Saugatuck, Michigan, about December 9, 1922.

BLACK DUCK, No. 207,935, banded by H. S. Osler, at Lake Scugog, Ontario, on September 29, 1922, was killed at the Currituck Shooting Club, North Carolina, on December 21, 1922.

BLACK DUCK, No. 207,943, banded by H. S. Osler, at Lake Scugog, Ontario, on September 30, 1922, was killed on the Potomac Creek, Virginia, on November 10, 1922.

BLACK DUCK, No. 207,946, banded by H. S. Osler, at Lake Scugog, Ontario, on September 30, 1922, was killed at Muscamoot Bay, Michigan, on November 23, 1922.

BLACK DUCK, No. 207,940, banded by H. S. Osler, at Lake Scugog, Ontario, on September 30, 1922, was killed at Tar Bay, Maryland, on November 21, 1922.

BLACK DUCK, No. 207,954, banded by H. S. Osler, at Lake Scugog, Ontario, on October 1, 1922, was caught in a trap at Cut Off, Louisiana, on January 10, 1923.

BLACK DUCK, No. 207,962, banded by H. S. Osler, at Lake Scugog, Ontario, on October 1, 1922, was shot in a marsh of Mitchell's Bay, Kent County, Ontario, on November 17, 1923.

PINTAIL, No. 207,964, banded by H. S. Osler, at Lake Scugog, Ontario, on October 1, 1922, was killed at the same place on October 20, 1922.

ROBIN, No. 104,491, banded by R. W. Tufts, at Wolfville, Nova Scotia, on October 2, 1922, was found dead within one hundred yards of the place where it was liberated, on November 6, 1922. This bird appeared sick when banded, and apparently died shortly afterwards.

BLACK DUCK, No. 207,978, banded by H. S. Osler, at Lake Scugog, Ontario, on October 2, 1922, was killed at the same place on October 10, 1922.

(To be continued)

NOTES AND OBSERVATIONS

under here when completed).

Cut the wire away through the arch, this gives the main entrance.

Take a piece of wire netting about 12''x20'' and cut roughly as Fig. 3. Bend up the edges along the dotted lines and press sides together to form Fig. 4. (This must be done to suit your special requirements. I find a useful size for Jays and smaller birds is an opening at the small end of the funnel of 3''x3''. This size requires no altering nor projecting wires.)

Place your arch over the large end of the funnel and tack on along the inner edge of the funnel. This now fits in against its fellow arch at C., Fig. 1, and can be removed when desired.

Cut away an opening 4'' high by 3'' wide at D., Fig. 1, 2'' or 3'' away from the corner. Keep a collecting box covering this opening at all times.

NOTES IN CONNECTION WITH THIS TRAP

I have experimented with a great many traps during the last eight months, trying them out under all possible conditions, and I find that under the conditions prevailing here, Mill Bay, Vancouver Island, I am unable to get sufficient repeats with resident species to satisfy me, with either the Sieve Trap (drop-trap) or the Government Sparrow Trap, because the former 'slams' and makes certain species highly nervous, whilst the latter with its fixed funnel never becomes popular as a regular feeding platform. The Detachable Funnel Trap, however, allows birds to feed in and out of it through the entrance whenever the trapper so desires, which is very necessary in regaining the confidence of over-trapped or very shy species. Birds caught in this trap are never so nervous or 'jumpy' in going under the arch, as a drop-trap repeat is when re-entering the drop-trap. I also find that the drop-trap will often spoil certain species from entering any other traps unless hard pressed for food, but after feeding unmolested for a few days in the Detachable Funnel Trap they seem to regain confidence and repeat fairly steadily if a little judgment be used on the part of the trapper in handling the funnel.

I also found the Government Sparrow Trap too high, causing unnecessary bad bruising, also too narrow, and with the funnel at the end instead of the side, it makes two funnels necessary when one should do, as well as requiring projecting wires. Neither of the latter are necessary as far as I have experienced, with the Detachable Funnel Trap, nor need the size of the opening be altered, for I have caught Quail, Jays, and Sparrows equally well without to my knowledge having lost a bird, and I have often, on purpose, given them all chances to find their way out. For larger birds than Sparrows I advise pegging down the corners with forked sticks or tacking the bottom edges of two opposite sides to light poles.

This trap may be used as a 'slam' trap by placing a wire

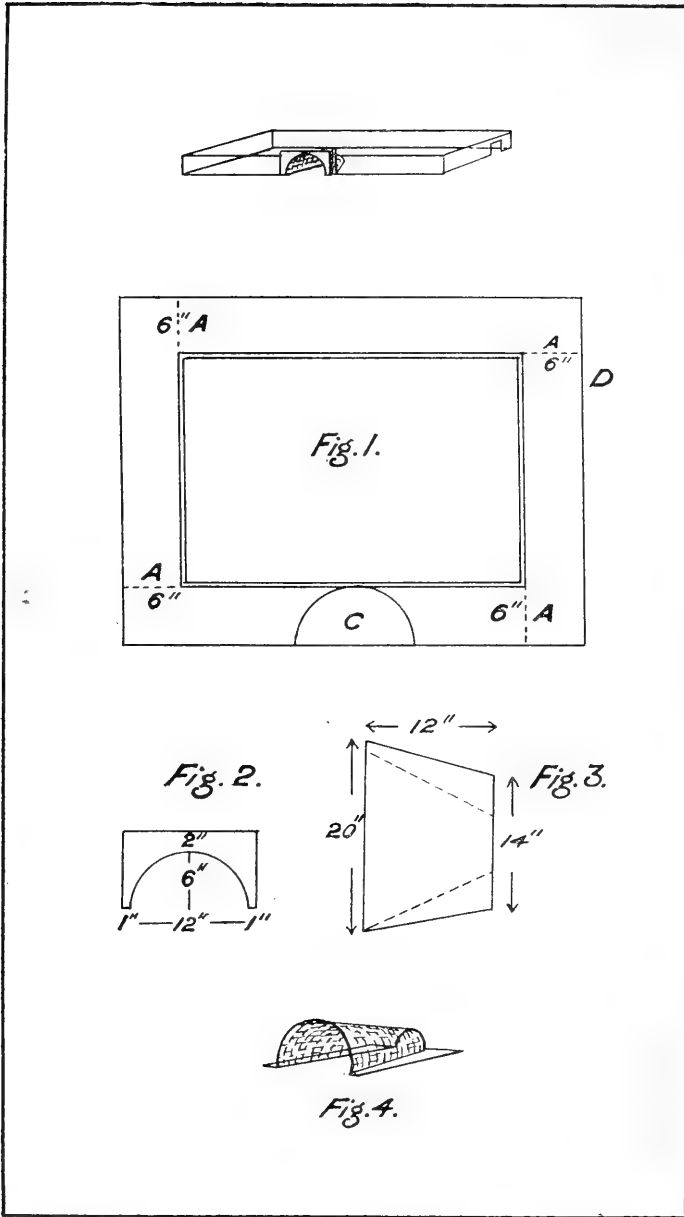

TO MAKE THE DETACHABLE FUNNEL TRAP FOR BIRD BANDING.—Take a piece of 1/2'' wire netting 4'x3'. Cut down the dotted lines AAAA Fig. 1. Fold along the double lines, Fig. 1. Overlap the corners to give double strength.

Take 2 pieces of 1/2'' board 14''x8''. Tack one on top of the other and cut out of both a half circle as Fig. 2. Separate them and tack one to the trap at C., Fig. 1. (Do not tack the wire to the inner edge of arch as the funnel has to pass

door in place of the funnel to drop at the pull of a string, but if repeats are desired it does not give good results, only frightening them. The wooden arch is not absolutely necessary, a square or triangular one may be just as good and perhaps easier for some people to make, but I strongly advise it be made of wood, and not all wire. It serves as a perch and is an obvious guide to the entrance. If birds get stale, I raise the whole trap 4"-6" up by stones at the corners and leave it so for 2 or 3 days, feeding heavily under and around it.

I am careful to remove the funnel every time I may be away for over an hour.

When working it steadily I remove the funnel in any case at dark, allowing birds an hour or more in the mornings to feed unmolested. I replace the funnel about 8 a.m. till noon, removing it again till about 4 p.m., replacing it until dark. After a week or so I reverse the order of things.

I get my best results with the *back* of the trap against bushes at the edge of some clump. If the front faces the bushes, captured birds running up and down this side, which they do, are quite likely to find the exit. I keep the collecting box always in position and birds run in on my approach saving unnecessary dashing around.

I always carry a cover and lay it over the trap if birds are wild. The whole trap is simple, as well as easily, cheaply, and quickly made and the best I have used yet for resident repeats.

I hope, with several of these traps, to be able to keep up an interesting record of repeats, and also to do away with drop traps, box traps, and other nerve shockers for seed eating species. I have but a few birds here and I like to make the most of them. For hurrying migrants a drop-trap and others may be necessary as well, though I missed few migrants (seed-eaters) as far as I know with this trap, examinations during the daytime find my few visitors nearly all carrying bands, and being fresh shiny bands at that I think they were all christened at this station.—G. D. SPROT.

NOTE ON FLICKERS' ROOSTS.—For five nights in succession a juvenile Flicker roosted in a niche beneath the eave on the gable-end of a residence on Cameron St., Ottawa South. Each evening at dusk the bird was observed as it climbed the stucco wall to its roost, August 13-17, 1923.

Another Flicker, an adult male, under observation for the greater part of two weeks, and later banded, was using a shallow depression in the side of a decayed fence-post, Ottawa, May 6-17, 1923.—C. E. JOHNSON.

A RED SQUIRREL'S CHRISTMAS DINNER.—While taking part in the Ottawa Field-Naturalists' Club Bird Census of December, 1922, I found a Red Squirrel perched on a rail fence and tearing the papery husk from a ground cherry. His many trips over well-beaten snow-trails to a pile of short logs near by revealed his cache beneath. On the snow, around the fence, was strewn a pint of the husks, some of which were collected and kindly identified by Dr. M. O. Malte as those of *Physalis pubescens*.—C. E. JOHNSON.

HORNED LARKS WINTERING IN ALBERTA.—On the 30th of January, 1924, while motoring between Camrose and Monitor, I observed two pairs of Horned Larks feeding along the road. One pair was about ten miles south of the Big Bend of the Battle River, while the second pair was about 40 miles farther south-east. They appeared in the best of condition and had evidently remained in this latitude on account of the extremely mild winter, and the freedom from snow covering the prairie. It was impossible to tell whether they

were of the type form or of one of the sub-species, but the characteristic pink coloring was very prominent. The fact that the birds were paired is worthy of note. In more southern localities where these birds winter they are generally seen in flocks. This is the first record that I have of these birds wintering this far north, although it is possible that a few remain the entire winter in southern Alberta, especially when the winters are such as the present.—FRANK L. FARLEY.

HOLBOELL'S GREBE IN WINTER IN ONTARIO.—Once in a while the attention of some one is attracted by a large bird in the back yard or on the farm in the cold winter months, the bird being unable to fly; and frequently it turns out that the stranger is the Holboell's or Red-necked Grebe. The present winter (1923-4) has produced two such records, one at Guelph, when the bird was picked up on Essex St., near the river, on February 20 and came into possession of H. Howitt, and the other reported from near Ripley, which is within eighty miles of Guelph, on February 12th. Both birds were alive when found, but refused food and died in a few days.

There is in my collection a bird of this species which was shot near London on January 18, 1910, and Mr. W. D. Hobson has another which was brought to him on February 20, 1901, the exact day of the month for the Guelph bird of this winter.

The smaller Grebes seem to escape from this sort of semi-suicide, but the Red-throated Loon may suffer from the same cause, as I had one brought to me in November, 1898, which had been caught in a strawberry patch near London.

The fact that these birds are unable to rise from the land places them under an enormous handicap, when, by accident or otherwise, they alight at any considerable distance from the water, but just why they should attempt considerable flights in midwinter and thus get caught, is not easy to surmise. Both species are rare on the rivers, and the lakes are not frozen over this winter, whatever may be the case in other winters. Of course it is always possible that the birds may have been living on a river which has offered them a constantly diminishing area of open water, and that doubtless is the reason why some of them fly in midwinter, but when flight is necessitated, they *should* be able to reach one of the larger lakes, with which this part of Ontario is almost surrounded.—W. E. SAUNDERS.

THE FIRST OTTAWA FIELD-NATURALIST.—Three centuries ago, late in July, 1623, several parties of Hurons at intervals of a few days passed upward over the portage by the Falls of the Chaudiere,

on what was then often called La Riviere des Prairies, a name still retained by a branch of the Ottawa at Montreal. Dispersed among the Indians were three followers of that great nature lover, St. Francis of Assisi—Fathers Joseph le Caron and Nicholas Viel, and Brother Gabriel Sagard-Theodat, with eleven Frenchmen furnished by Champlain and two *donnés*—all on their way to the Huron Mission begun by Le Caron in 1615.

Sagard, as he is commonly called, was the chronicler of the expedition. His *Grand Voyage au Pays des Hurons* is a fascinating story. It was published in 1632, the year in which the first white man to ascend the Ottawa, "*Le Truchement*" Etienne Brulé, met his death among the savages, many of whom he is said to have warmly but unwisely loved.

In his book, Sagard relates that in passing the Falls—"the most admirable, dangerous and terrifying of all he had seen"—he noticed that the rocks were covered with what seemed to be small stone snails (*petits limas en pierre*). "I am," he says, "unable to account for this, unless it is owing to the nature of the stone itself, or that the result has been produced by mist from the falling waters." His uncertainty as to the origin of fossils, abounding now as then in the vicinity, is not surprising in view of the state of natural science at the time. Da Vinci's conjectures were doubtless unknown to him; and John Ray and Martin Lister's correct theories as to the origin of fossils were not advanced until half a century afterward. Sagard mentions also that he found "at this place"—along the portage, no doubt—"plants of a scarlet lily which had but two flowers on each stalk." It differed, he observes, from a martagon or turk's-cap lily, "not found in the Huron country", which he had seen "in Canada", a name then restricted to the settlements on the St. Lawrence.

The lily noticed by Sagard at the Chaudiere is known botanically as *Lilium philadelphicum*, and locally as the wild orange lily. It has persisted there since Sagard's time, but, like the Falls¹ themselves, especially those of the Petite Chaudiere, has almost disappeared before the advance of industrialism. A few plants may still be found among the red cedars south of the Aylmer Road, and on Lemieux Island; and it abounds on thin

soil over limestone along the Canadian Pacific Railway west of Stittville.

The lily seen by Sagard "in Canada" was the indigenous *L. canadense*. It grows, or did grow abundantly thirty years ago, in the vicinity of Quebec, on the mainland and on the island of Orleans. Frequently attaining a height of more than five feet, it is in the estimation of many the most beautiful of all our native flowers.

Champlain had previously (1613) noted the occurrence of the red cedar on the islands at Les Chats; but Sagard is better entitled to be considered the first Ottawa Field-Naturalist.

—F. R. LATCHFORD.

There were two "falls" and two "kettles", the big and the little. While the former could be seen from the canoes as they came up to the "port" or landing—the "Summer Landing" was within a hundred yards of the present bridge, and all the "ports" were on the Quebec side—it was by the little falls and *Chaudiere* that the portage route passed. When the waters were in flood, the "port" was at the mouth of the gorge opposite the foot of Lyon Street or even as far down as where the Eddy Sulphite Mill now stands. The water was always taken again near the east end of the present viaduct across Brewery Creek. The "Second Portage of the *Chaudiere*," mentioned by Alexander Henry and others, was at the next rapids, now known as the "Little Chaudiere". I have not been on this portage for many years, but in my boyhood it was a well-defined trail. From the hidden mouth of Squaw Bay at its foot, the Iroquois, according to tradition, were wont to sally forth in force upon passing Hurons and Algonquins who, seeking to escape by paddling out from the shore, were often caught in the smooth but treacherous "draw" and swept to certain death in one or other of the cold, yet boiling, cauldrons below. The true Little Chaudiere should not be confounded with the rapids of that name. It is shown in its proper place on several of the old maps.

A TOWHEE IN THE BATTLE RIVER VALLEY, ALBERTA.—On August 4, 1923, while working along the steep valley of the Battle River in Alberta in Township 47-6-4, I was surprised to hear and see a Towhee—evidently a male in good plumage. I watched it for some minutes through the telescope of a small level that I was using and was near enough to see its bright red eyes. I have seen the Towhee in the Frenchman Valley in southern Saskatchewan, but I did not know that it ranged as far north as the Battle River.—C. H. SNELL.

NOTE.—P. A. Taverner (*Birds of the Red Deer River, Alberta, Auk*, XXXVI, 1919, pp. 257-258) reports that in descending the river in 1919 the first Spotted Towhee (*Pipilo maculatus*) was seen in Township 34, almost exactly Lat. 52° north, where the first definitely arid conditions prevailed. It is seen that Mr. Snell's record adds a considerable northern extension of range to this.—P. A. T

CORRESPONDENCE

EDITOR, *The Canadian Field-Naturalist*,
Ottawa, Ont.

Dear Sir:—

May I add a few words to the controversy aroused by J. A. Munro's article, *The Necessity for*

Vermin Control on Bird Sanctuaries, and your Editorial on that subject, both of which appeared in the November, 1923, number of your magazine.

Some statements regarding the prevalence of certain predatory birds in Great Britain have

appeared from several pens. These statements require correction, or at least amendment. I have had a good many years of intimate acquaintance with game preserves and preserving in Great Britain, and I believe that I am competent to correct some impressions which have no doubt been created.

Certain correspondents would have us believe that Great Britain is one vast Game Preserve, wherein all vermin is systematically destroyed. This, of course, is absurd. I very much doubt if game is preserved over more than a fifth of the country; indeed, I consider this a generous estimate. To cite a few examples of the non-preserved areas, little or no preserving is carried on in the Midlands, which are devoted to Fox-hunting, in the vast areas in Scotland, set aside as deer forests, in the Welsh mountains, on Ex-moor and Dartmoor in the West Country or on the Downlands of the South. Plenty of suitable strongholds for predators, one would imagine, though as I will show later these strongholds have proved inadequate as preservers of most of the British species of predatory birds.

The next impression created is that there are and have been but two species of predators in Great Britain, namely, the Crow and the Sparrow-hawk and that these, despite the eternal war waged upon them, are everywhere abundant; therefore, it is inferred, no matter what is done in Canada it would be impossible to exterminate the Canadian predators. This seems to me to be taking the exception and calling it the rule. There are, or perhaps it would be more correct to say have been, some sixteen British species rightly or wrongly, several of them certainly wrongly, regarded as vermin and treated as such: of these the Carrion Crow and Sparrow-hawk alone survive to any appreciable extent; the remainder have been exterminated or placed in grave danger of extermination by the gamekeeper-collector combination. The other fourteen species to which I refer are:—Raven, *Corvus corax* Linn.; Short-eared Owl, *Asio accipitrinus* Pall.; Marsh Harrier, *Circus æruginosus* Linn.; Hen Harrier, *C. cyaneus* Linn.; Montagu's Harrier, *C. cineraceus* Mont.; Common Buzzard, *Buteo vulgaris* Leach.; Rough-legged Buzzard, *B. lagopus* J. F. Gmelin; Golden Eagle, *Aquila chrysaetus* Linn.; White-tailed Eagle *Haliaeetus albicilla* Linn.; Kite, *Milvus iclinus* Savigny; Honey Buzzard, *Pernis apivorus* Linn.; Peregrine Falcon, *Falco peregrinus* Tunst.; Hobby *F. subbuteo* Linn.; Osprey, *Pandion haliaetus* Linn.

Before proceeding further I may say that I ascribe the fact of the Sparrow-hawk and the Carrion Crow still existing in Great Britain in fair numbers (I do not consider either species abund-

ant) to their undesirability from the collector's point of view almost as much as to their having large areas over which they can roam with a considerable measure of immunity from "keepers".

"Game-farm" is a term which several correspondents seem to have employed when referring to what would more correctly be termed a Game preserve, though even at that it is a pretty futile comparison when applied to a Bird Sanctuary. In Great Britain a game-farm consists of pens similar to chicken-runs, which are wired at the top as well as at the sides; consequently, winged predators are amongst the very least of the game-farmer's worries. The business of the game-farmer consists of supplying eggs and young birds, principally pheasants, to the owners and tenants of preserves.

A game preserve may be described briefly as an area which by artificial stocking and feeding is caused to carry possibly some fifty times as many head of game as would exist upon it under normal circumstances and natural conditions. This "artificial" stock which is placed on the preserve each summer, forms the bulk of the "bag" in the ensuing fall and winter.

Surely it is preposterous to compare a Bird Sanctuary with either a game-farm or a game preserve; I can only conclude that those who have made such comparisons have done so through lack of first-hand knowledge of the conditions and misunderstanding of the real meanings of the terms.

After perusal of the correspondence so far published, it seems very evident that the lack of agreement amongst the participants in the controversy is not due merely to difference of opinion on a question of policy in the administration of Bird Sanctuaries, but also and rather to a difference of understanding as to the essential reasons and purposes on account of and in pursuit of which such sanctuaries have been established. In view of this it is not my intention to enter into this controversy since, until these reasons and purposes are definitely established, it hardly seems possible to discuss questions of policy intelligently.

May I suggest, Mr. Editor, that you tabulate your understanding of the reasons and purposes alluded to. The criticisms, suggestions, etc., which would doubtless ensue, might help to clear the air.

Yours very truly,

W. H. A. PREECE.

Sault Ste. Marie, Ont.,

April 17, 1924.

NOTE:—The information requested in the final paragraph of our correspondent's letter has already been published in an Editorial on the subject of "Bird Sanctuaries" which appeared in *The Canadian Field-Naturalist* for November, 1923, pages 149-150.—Editor.

EDITOR, *The Canadian Field-Naturalist*,
Ottawa, Ont.
Sir:—

The reference to the late Dr. Brodie of Toronto in the April number of *The Canadian Field-Naturalist* reminds me that about forty years ago I had some correspondence with him and, being in Toronto soon afterwards, called to see him. In the course of an interesting talk on natural history subjects, he took me out to the yard behind his dental office and showed me a collection of live rattlesnakes which he was keeping in barrels sunk in the ground to about three-quarters of their depth. He put his arm down into one of the barrels among the snakes in a way that made my flesh creep, but he assured me that so long as he was careful to keep his hand behind a snake's head, there was no danger of its striking. He also explained that, although the barrels were open at the top, there was no possibility of the snakes being able to climb out. No doubt he was right; but what an amount of confidence in his judgment his neighbours must have felt that they did not register a most vigorous protest against his being permitted to keep the snakes in such an exposed place in a crowded quarter of a large city. As I recall, there were several people about when the snakes were shown to me, but none of them seemed at all concerned.—W. L. SCOTT.

Ottawa, Ont.
April 17, 1924

NOTE.—A rattlesnake will seldom strike except to secure living rodents for food or to defend itself when accidentally or intentionally injured. Nevertheless a person who handles one in full vigor is supremely foolhardy, for, although the bite of a rattlesnake does not usually prove fatal, it is an extremely serious proposition.—C. L. P.

EDITOR, *The Canadian Field-Naturalist*,
Ottawa, Ont.
Sir:—

In the May number of *The Canadian Field-Naturalist*, Mr. E. M. S. Dale states that current literature contains little if any reference to the song of the White-winged Crossbill. To his ear it is the finest bird song to which he had ever listened. This opinion corresponds rather closely to my own.

When the beautiful glades of caribou moss become a blaze of glory with orchis and butterwort in Labrador and in the James Bay region, the clean, transparent air vibrates all day long with the melody of hundreds of songsters. Among them all four birds in particular have always made particular appeal to me.

The White-throated Sparrow exchanges greetings of hearty optimism with his neighbors of the

bush. The Hermit Thrush in a voice of spiritual ecstasy invites us to join him in elevation of our thoughts. The Water Wagtail gives ringing welcome to the morning sunshine, but the Cross-bills have above all other birds the sweetest tones of harmony with life and its living.

A few years ago Doubleday Page & Co. published a book for me entitled "A Surgeon's Philo-sophy". It is now out of print because nobody cared to read it, but in this volume I write of the song of the "Red Cross-bill". It was probably the White-winged Cross-bill in rosy plumage, but I would about as soon shoot a baby in the cradle as to kill one of them for purposes of exact identification. What I wrote on Page 215 of the book was this:

"The unnatural character of much of our high culture music produces an artificial taste which dulls the sensibilities against appreciation of real music. I have often called the attention of a companion who was humming some refrain from Debussy or from Wagner to a bird like the Red Cross-bill that was singing near at hand. My friend would stop for a moment and exclaim, "Yes, fine!"—and then go on humming his Debussy or Wagner again while the Red Cross-bill was still singing. That was an impious interruption of Jehovah who was speaking to us at that moment straight out of his great heart from his own wonderful throne! I have never made any comments when my friends have done this, but away down deep there was a feeling of pity—a feeling of shame for the misdeeds of culture.

"The song of the Red Cross-bill is the inspired voice of comradeship—a clear song of vibrant cheer from the roads of his merry flock among the very tip tops of dark pointed firs. From the fragrant resin of their cones he abstracts a spicy virility which accords with the sprightly vigor of his manner and presence. High winds, high sun; these he braves with a choice that belongs to his nature, yet he cares not a bit for lowering cloud nor driving rain so long as companions are near."
—ROBERT T. MORRIS.

114 E. 54th St., New York, N.Y.
June 24, 1924.

We think this correspondent makes the common mistake of attempting to compare unlike and incomparable things. Bird songs are not music in the musician's meaning of the term, though we may call them music as a figure of speech or in lieu of another word of designation. This statement is not derogatory to either bird songs or human music. Both are admirable in their separate ways, but those ways are too far apart for a just comparison.
—ORNITHOLOGICAL EDITOR.

Sweet Canada

Eleven Bird Songs and a Round
by

Louise Murphy

Author of "A Little Book of Bird Songs,
Rhymes and Tunes for Tiny Tots"

PRICE \$1.00

Longmans, Green & Co.
210 Victoria Street, Toronto

L. C. Smith & Bro.

Typewriter

*Ball bearings in every frictional part of
the L. C. Smith insure long life, light
touch and easy operation*

Ottawa Typewriter Co. Limited
191 QUEEN ST., OTTAWA

The Crabtree Co.

Artists and
Designers

BLUEPRINTERS
ENGRAVERS
COMMERCIAL
PHOTOGRAPHERS
: PHOTO :
LITHOGRAPHERS

228 Albert Street
Ottawa, Ont.



Card Filing Systems for Naturalists

As makers of the Library
Bureau line of Card Filing
Devices in Canada, we are
in a position to supply all
Naturalists with cards and
trays where they can read-
ily index all their observa-
tions and notes

Lowe-Martin Ltd.
OTTAWA, CANADA

*Printers of The Canadian Field-Naturalist
Publishers of the Autobiography of John Macoun, M.A.*

COAL C. C. Ray Company Limited

BEST QUALITY LOWEST PRICES

46 Sparks St.—Phone Q. 461
OTTAWA

Geo. E. Preston & Sons MERCHANT TAILORS

*We make everything we sell and
guarantee everything we sell*

217-219 Rideau Street, Ottawa

Dr. Mark G. McElhinney
*Dentist to certain of the
cognoscenti*

252 LISGAR STREET, OTTAWA
Telephone Queen 2438

Kindly mention The Canadian Field-Naturalist to advertisers

Prices of Separates

Notes to Contributors, Etc.

Papers for publication should be addressed to the Editor, Mr. Harrison F. Lewis, Parks Branch, Ottawa, or to the appropriate Associate Editor.

Manuscript should be plainly written, typed if possible, on one side of the paper only, with wide spaces between the lines and ample margins. It is urged that special care be used that scientific names are legible, properly formed, and correctly spelled and capitalized.

Galley proof will be submitted to authors resident in Ottawa and proof of leading articles to any other author if requested when manuscript submitted. It is requested that it be corrected and returned to the Editor as quickly as possible.

Authors of leading articles are entitled to twenty-five copies of the number in which they appear, free of charge on application.

Separates of articles as they appear on the page, without any change of make-up will be supplied at the following rates:—

	25	50	100	200	300
1 page.....	\$2.00	\$2.25	\$2.50	\$2.75	\$3.00
2 ".....	3.00	3.25	3.75	4.00	4.25
3 ".....	3.50	3.75	4.00	4.25	4.50
4 ".....	3.50	3.75	4.00	4.25	4.50
5 ".....	4.50	4.75	5.00	5.25	5.50
6 ".....	4.50	4.75	5.00	5.25	5.50
7 ".....	6.00	6.25	6.50	6.75	7.00
8 ".....	6.00	6.25	6.50	6.75	7.00
9 ".....	7.50	8.00	8.75	10.25	11.75
10 ".....	7.50	8.00	8.75	10.25	11.75
Covers extra.....	3.00	3.00	3.00	4.00	5.00

If removal of matter on the pages non-pertinent to the article or changes of make-up are desired, or if insets or other extra work are necessary, special rates will be furnished on application to the Editor.

Applications for separates should be made to the Editor and must reach him not later than with the return of the corrected proof.

Rubber Stamps

FOR

Listing Your Specimens

The more consistent use of rubber stamps will materially assist you in cataloguing the collection of specimens you have spent so much time and trouble in securing. Let us help you.

CAPITAL RUBBER STAMP WORKS

175 NEPEAN STREET
OTTAWA, CANADA

Many More are Wanted on the Subscription Lists

The Membership Committee of The Ottawa Field-Naturalists' Club is making a special effort to increase the subscription list of *The Canadian Field-Naturalist* and we are asking every reader to assist in making the campaign the success it should be.

We would particularly urge the Secretary of each Affiliated Society to bring this matter up at EVERY meeting and secure as many subscribers as they possibly can to a Canadian Publication devoted to the study of Natural History in all its phases.

Use the blank below and forward it to the Treasurer.

CUT OFF HERE

MR. B. A. FAUVEL,
Treasurer, Ottawa Field-Naturalists' Club,
Mounted Police Headquarters,
Laroque Building,
Rideau and Dalhousie Sts.,
Ottawa, Canada.

I enclose One Dollar and Fifty Cents as my subscription to The Canadian Field-Naturalist for one year.

Name.....
(Mr., Mrs. or Miss)

Address.....

City and Province.....

Kindly mention *The Canadian Field-Naturalist* to advertisers

Affiliated Societies

NATURAL HISTORY SOCIETY OF MANITOBA 1924

Hon. President: V. W. JACKSON; *President:* J. J. GOLDEN; *Vice-Presidents:* H. M. SPEECHLY, A. M. DAVIDSON, A. G. LAWRENCE, NORMAN CRIDDLE; *Mrs. C. E. BASTIN, Mrs. C. P. ANDERSON;* *General Secretary:* A. A. MCCOUBREY, 307 C.P.R. Depot, Winnipeg, Man.; *Executive Secretary:* R. M. THOMAS; *Treasurer:* MISS HELEN R. CANNOM; **ORNITHOLOGICAL SECTION:**—*Chairman:* B. W. CARTWRIGHT; *Secretary:* C. L. BROLEY. **ENTOMOLOGICAL SECTION:**—*Chairman:* A. V. MITCHENER; *Secretary:* A. SHIRLEY BROOKS. **BOTANICAL SECTION:**—*Chairman:* C. W. LOWE; *Secretary:* MISS GRACE CAMERON. **GEOLOGICAL SECTION:**—*Chairman:* A. A. MCCOUBREY; *Secretary:* J. M. BENSON.

THE HAMILTON BIRD PROTECTION SOCIETY (Incorporated)

Hon. President: MR. ADAM BROWN; *President:* MR. R. O. MERRIMAN; *1st Vice-President:* DR. H. G. ARNOTT; *2nd Vice-President:* MR. C. D. COOK; *Secretary-Treasurer:* MISS RUBY R. MILLS, Public Library, Hamilton; *Directors:* DR. H. G. ARNOTT; C. D. COOK; DR. J. A. DICKSON; MISS M. E. GRAM; MISS RUBY R. MILLS; M. HOLTON; M. JOHNSTON; MRS. F. E. MACLOGHLIN; R. O. MERRIMAN.

NATURAL HISTORY SOCIETY OF BRITISH COLUMBIA, VICTORIA, B.C.

The officers for the above Society for the year ending March 31st, 1923, are as follows:—

President: W. N. KELLY; *1st Vice-President:* A. R. SHEERWOOD; *2nd Vice-President:* C. C. PEMBERTON; *Secretary:* H. T. NATION 2380 Windsor Road, Victoria, B.C. *Treasurer:* MISS S. M. THORNTON; *Committee:*—MISS C. G. FOX, MISS A. F. GARDNER, MISS L. CATHCART, WM. DOWNES, A. HALKETT. *Auditors:*—J. KEITH WILSON AND F. W. GODSAL. *Trustees:*—REV. R. CONNELL, DR. C. F. NEWCOMBE AND G. HARVEY.

ALBERTA NATURAL HISTORY SOCIETY

Hon. President: DR. H. Y. GEORGE, Victoria B.C.; *Hon. Vice-President:* MR. J. J. GAETZ, Red Deer; *President:* MR. C. H. SNELL, Red Deer; *1st Vice-President:* MR. G. C. S. CROSBY, Red Deer; *2nd Vice-President:* MRS. W. A. CASSELS, Red Deer; *Hon. Sec.-Treas.*: MRS. S. PAMELY, Red Deer; *Directors:* MRS. G. C. S. CROSBY, MISS E. C. IRVING, MR. W. A. CASSELS AND MR. S. PAMELY, Red Deer, MRS. G. F. ROOT, Wetaskiwin, MR. K. BOWMAN, Edmonton, MR. B. LAWTON, Edmonton, MR. T. RANDALL, Castor, MR. F. L. FARLEY, Camrose, MR. W. C. MCCALLA, Bremner, and MR. D. M. SINCLAIR, Peace River.

The meetings of this Society are held in Red Deer on the last Friday of each month except during July and August and perhaps September. The annual meeting is held in Red Deer on the last Friday in November.

McILWRAITH ORNITHOLOGICAL CLUB, LONDON, ONT.

President: T. D. PATTERSON, 562 Waterloo Street; *Recording Secretary:* MRS. E. H. MCKONE, Worthey Road; *Corresponding Secretary and Treasurer:* E. M. S. DALE, 297 Hyman St.; *Members qualified to answer questions:* W. E. SAUNDERS, 240 Central Ave.; C. G. WATSON, 201 Ridout St. South; J. R. McLEOD, 355 Wortley Road; J. F. CALVERT, 461 Tecumseh Ave.; E. M. S. DALE, 297 Hyman St.

VANCOUVER NATURAL HISTORY SOCIETY

Hon. President: L. S. KLINCK, L.L.D., Pres. University of B.C.; *President:* JOHN DAVIDSON, F.L.S., University of B.C.; *Vice-President:* FRED PERRY; *Hon. Secretary:* C. F. CONNOR, M.A., 3529-W. 2nd Ave., Vancouver, B.C.; *Hon. Treasurer:* A. H. BAIN, 2302 York St., Vancouver, B.C.

Fortnightly meetings in the University Buildings from September to April (inclusive). Semi-monthly excursions from May to August (inclusive).

PROVINCE OF QUEBEC SOCIETY FOR THE PROTECTION OF BIRDS

Hon. President: I. GAMMELL; *President:* L. MCI. TERRILL; *Vice-Presidents:* ALEX MACSWEEN, NAPIER SMITH, E. ARNOLD; *Hon. Corresponding Secretary:* W. S. HART, P.O. Box 1185, Montreal; *Hon. Recording Secretary:* MISS H. STONE; *Hon. Treasurer:* MISS M. ARMITAGE, 63 Arlington Ave., Westmount; *Directors:* MISS EDITH MORROW; MISS LOUISE MURPHY; MISS EMILY LUKE; MR. AND MRS. C. F. DALE; MRS. J. T. AYERS; MISS JEAN MCCONNELL; W. A. OSWALD; A. F. WINN; MR. AND MRS. WALLACE H. ROBB; W. G. WRIGHT. *Members qualified to answer questions:* L. MCI. TERRILL, 44 Stanley Ave., St. Lambert, Que.; NAPIER SMITH, Bank of Montreal, Magog, Que.; E. ARNOLD, 64 Durocher St., Montreal; W. A. OSWALD, 301 Wilson Ave., N.D.G., Montreal; C. N. ROBERTSON, c-o Ross Realty Co., Room 805, Lewis Bldg., St. John St., Montreal, Que.; DR. ARTHUR WILLEY, McGill University, Montreal; W. J. BROWN, 250 Oliver Ave., Westmount, Que.; MISS EDITH MORROW AND MISS EMILY LUKE, c-o Secretary.

SOCIÉTÉ PROVANCHER D'HISTOIRE NATURELLE DU CANADA Bureau de direction pour 1923

Président: DOCTEUR S. GAUDREAU; *1er vice-président:* ABBE A. VACHON, M.A.; *2ème vice-président:* A.-R.-M. BOULTON; *Secrétaire-trésorier:* LOUIS-B. LAVOIE; *Chef de la section scientifique:* A.-A. GOUBOUT; *Chef de la section de propagande éducationnelle:* DOCTEUR A. DERY; *Chef de la section de protection:* R. MEREDITH, N.P.; *Chef de la section d'information scientifique et pratique:* DOCTEUR J.-E. BERNIER; *Directeurs:* R.-F. LINDSAY; JOS. MATTE; G.-S. AHERN.

THE BRITISH COLUMBIA ORNITHOLOGISTS' UNION Officers for 1923

Hon. President: HON. MINISTER OF AGRICULTURE, Victoria; *President:* FRANCIS KERMODE, Provincial Museum, Victoria; *Vice-President:* T. L. THACKER, Hope; *Secretary-Treasurer:* J. W. WINSON, Huntingdon; *Directors:* J. A. MUNRO, Okanagan Landing; DR. KELSO, Arrow Lakes; R. GLENDENING, Agassiz; K. RACBY, Vancouver; T. PEARSE, Courtenay; W. N. KELLY, Victoria.

THE TORONTO FIELD-NATURALISTS' CLUB

President: PROFESSOR R. B. THOMSON; *Vice-Presidents:* PROFESSOR E. M. WALKER, DR. A. COSENS, J. H. FLEMING; *Secretary:* W. F. GREGORY, 151 Ellsworth Ave., Toronto; *Treasurer:* F. H. BRIDGEN; *Honorary Librarian:* C. W. NASH; *Librarian:* DR. LYMAN B. JACKES. **BIRD GROUP:**—*Chairman:* STUART THOMPSON; *Secretary:* JAMES BAILLIE. **FLOWER GROUP:**—*Chairman:* DR. H. B. SIFTON; *Secretary:* MISS J. G. WRIGHT, Ph.D.; **INSECT GROUP:**—*Chairman:* PROFESSOR WALKER; *Secretary:* MISS NORMA FORD, Ph.D. **MAMMAL GROUP:**—*Chairman:* J. R. DYMOND; *Secretary:* L. SNYDER. **REPTILE, FISH AND AMPHIBIAN GROUP:**—*Chairman:* SHILLEY LOGIER; *Secretary:* T. B. KURATA. **PROGRAM COMMITTEE:**—*Chairman:* DR. W. A. CLEMENS. **WILD LIFE PRESERVATION COMMITTEE:**—*Chairman:* RUSSELL G. DINGMAN. **EDUCATIONAL COMMITTEE:**—*Chairman:* TAYLOR STATEN.

We would ask the Officers, and more particularly the Secretaries, of all the Affiliated Societies to assist us in our task of building up the circulation of this magazine. By securing every member as a subscriber we can truly make this magazine into one of the leading Natural History publications of America.



FOR SALE

Back Numbers of The Ottawa Naturalist

The Club has for sale complete sets of its publications. Enquiries regarding price should be addressed to the Secretary of the Club, Dr. J. F. Wright, Geological Survey, Ottawa, Canada.

Any member having copies of the March, 1896, January, February, March and August, 1898, and December, 1900, issues of *The Ottawa Naturalist*, and who desires to dispose of the same, is requested to communicate with the Secretary.



Grant-Holden- Graham Limited

**Outfitters to
Surveyors & Engineers**

Manufacturers of
**High-Grade Tents
Tarpaulins & Sleeping Bags**

WRITE FOR CATALOGUES

**147 Albert Street
OTTAWA**

Fine Diamonds

Sterling Silver, Fine
Cut Glass, Electro-
Plated Ware

*The Store of
Moderate Prices*

C. A. Olmsted & Son

*Jewellers, Opticians, Watchmakers and
Engravers*

208 Sparks Street, Ottawa



*Publishing
for Naturalists*



**Book Publishing
Pamphlets, Booklets
and all kinds of Publicity
for Lovers of
Outdoor Study**

**The Graphic Advertisers
175 Nepean Street
Ottawa**

Kindly mention The Canadian Field-Naturalist to advertisers

35,343



THE CANADIAN FIELD-NATURALIST



PUBLISHED BY
OTTAWA FIELD-NATURALISTS' CLUB

ISSUED NOVEMBER 6, 1924

Entered at the Ottawa Post Office as second-class matter

THE OTTAWA FIELD-NATURALISTS' CLUB

Patrons:

THEIR EXCELLENCIES THE GOVERNOR-GENERAL AND THE LADY BYNG OF VIMY

President: HOYES LLOYD.
1st Vice-President: G. A. MILLER.
Secretary: J. F. WRIGHT, (Geological Survey, Ottawa).
2nd Vice-President: NORMAN CRIDDLE.
Hon. Treasurer: B. A. FAUVEL, 321 McLeod St. Ottawa, Ont.

Additional Members of Council: W. T. MACOUN; MISS M. E. COWAN; C. M. STERNBERG; H. I. SMITH; F. W. WAUGH; P. A. TAVERNER; E. SAPIR; E. M. KINDLE; W. J. WINTENBERG; R. E. DELURY; ARTHUR GIBSON; M. O. MALTE; R. M. ANDERSON; H. GROH; MISS F. FYLES; C. B. HUTCHINGS; H. M. AMI; CLYDE L. PATCH; D. JENNESS; V. W. JACKSON; R. O. MERRIMAN; W. N. KELLY; C. H. SNELL; J. R. MCLEOD; JOHN DAVIDSON; L. MCI. TERRILL; R. MEREDITH; FRANCIS KERMODE; PROF. R. B. THOMSON; THE EDITOR.

Editor:

HARRISON F. LEWIS,
 Canadian National Parks Branch,
 Dept. of the Interior, Ottawa.

Associate Editors:

E. SAPIR.....	<i>Anthropology</i>	A. G. HUNTSMAN.....	<i>Marine Biology</i>
M. O. MALTE.....	<i>Botany</i>	P. A. TAVERNER.....	<i>Ornithology</i>
F. R. LATCHFORD.....	<i>Conchology</i>	E. M. KINDLE.....	<i>Palaeontology</i>
M. Y. WILLIAMS.....	<i>Geology</i>	R. M. ANDERSON.....	<i>Zoology</i>
ARTHUR GIBSON.....	<i>Entomology</i>	CLYDE L. PATCH.....	<i>Herpetology</i>

CONTENTS

	PAGE
A Preliminary Report on the Destruction of Birds at Lighthouses on the Coast of British Columbia. By J. A. Munro.....	141
List of Birds Recorded from the Island of Anticosti, Quebec. By Harrison F. Lewis.....	146
Miscellaneous Bird Notes from Southern Vancouver Island, 1923. By J. A. Munro.....	147
A New Genus and a New Species of Gastropod from the Upper Ordovician of British Columbia. By Alice E. Wilson.....	150
The Home Life of the Columbian Ground Squirrel. By William T. Shaw.....	151
Official Canadian Record of Bird-Banding Returns.....	154
Notes and Observations:—	
Marine Investigations on the West Coast of Vancouver Island, 1909. By John Macoun.....	157
Lesser Snow Geese. By K. Racey.....	158
Notes on Gray Squirrel in New Brunswick. By Susan K. Squires.....	158
Salamanders Lost, Strayed or? By H. Groh.....	159
Notes on Robins Wintering in British Columbia. By F. C. Whitehouse.....	159
The Exhibition of Wild Life Photographs. By Clyde L. Patch.....	159
Editor's Note.....	160
Book Review:—	
Research Methods in the Study of Forest Environment. By Carlos G. Bates and Raphael Zon.....	160
Publications Received.....	160

THE CANADIAN FIELD-NATURALIST, lately THE OTTAWA NATURALIST, established thirty-seven years ago, "to publish the results of original research or investigation in all departments of natural history," is issued monthly, excepting for the months of June, July and August.

Papers, notes and photographs should be addressed to the Editor. Manuscript should be typewritten.

Subscriptions cover the current year, except those taken out during last quarter, when they will be applied on the following year, the remaining numbers of current year being sent free. Payments should be made to the Hon. Treasurer, Mr. B. A. Fauvel, 321 McLeod St. Ottawa. Price of this volume, \$1.50; single copies 20c each.

YES—

We Make Rucksacks

Seven different kinds—to suit almost every kind of work and for Field-Naturalists either of the two, De Luxe or Alpine, are suitable.

Woods' Rucks

are the comfortable carrying kind made to fit—Order from your sporting goods dealer

of 50

WOODS MANUFACTURING CO.
OTTAWA

***EXPLORATIONS
in Western Canada***

The Ottawa Field-Naturalists' Club has just published an interesting volume of over 300 pages, entitled:

***Autobiography of
John Macoun, M.A.***

Canadian Explorer and Naturalist, Assistant Director and Naturalist to the Geological Survey of Canada—1831-1920.

This volume is an account of the life of this veteran naturalist. Agriculturists generally, in fact all interested in the development of Canada, will find this book of much interest and value.

The edition is limited. The price is \$3.00 with 15c added for bank exchange, if remittance is forwarded by personal cheque.

Applications for the volume should be made to

Mr. Arthur Gibson
Birks Building : Ottawa, Ont.

**The
Topley Co.**

**Photographic Material
Scientific Apparatus
Eastman Kodaks**



**132 Sparks Street
OTTAWA**

Kindly mention The Canadian Field-Naturalist to advertisers

Lyman's Limited

(Established 1800)

MANUFACTURING CHEMISTS

Importers and Dealers in
CHEMICAL AND
ASSAY APPARATUS

344 St. Paul St. West, Montreal



GROW GOOD CROPS

SEEDS PLANTS BULBS

Our rigorous system of testing eliminates loss
and disappointment from your garden

Kenneth McDonald & Sons, Limited
Seed and Bulb Merchants

Market Square :: Ottawa, Ont

Ward's NATURAL SCIENCE ESTABLISHMENT

Rochester, New York, U.S.A.

Manufacturers of the genuine Schmitt boxes
exhibition cases and cabinets, also of the American
Entomological Company's insect pins.

Riker Mounts and botanical mounts always on
hand, also Riker botanical presses.

Send for our supply catalogue and other lists of
interest to collectors.

**Headquarters for Entomological Supplies
and Specimens**

Inspected Milk

Ice Cream

"Ottawa Dairy"

Fresh Butter

Buttermilk

THE Bank of Nova Scotia

Capital \$ 10,000,000

Reserve Fund 19,500,000

Total Assets over 237,000,000

FIFTEEN BRANCHES IN
OTTAWA AND HULL

W. A. Rankin, Ltd.

Hammocks

Refrigerators

Builders' Hardware

410-412 Bank Street, Ottawa

Phones—Queen 1023-1024

WHY NOT ADVERTISE
YOUR PRODUCTS IN

The Canadian Field-Naturalist

*The Leading Canadian
Natural History Publication*

WRITE FOR RATE CARD

ADVERTISING DEPARTMENT
THE CANADIAN FIELD-NATURALIST

175 Nepean Street

OTTAWA

Kindly mention The Canadian Field-Naturalist to advertisers

The Canadian Field-Naturalist

VOL. XXXVIII

OTTAWA, ONTARIO, OCTOBER, 1924

No. 8

A PRELIMINARY REPORT ON THE DESTRUCTION OF BIRDS AT LIGHTHOUSES ON THE COAST OF BRITISH COLUMBIA

By J. A. MUNRO



WITHIN recent years there has been considerable discussion amongst bird protectionists regarding the destruction of migrating birds at lighthouses on the Canadian coasts; whether such destruction was serious or slight; under what weather conditions and by what means birds are usually killed, and whether preventive measures should be undertaken by the Dominion Government.

As a first step towards dealing with the question of control it appeared desirable to establish the extent of the destruction and to clear up, as far as possible, the more controversial points. Accordingly I was instructed by the Commissioner of Canadian National Parks to obtain whatever data were available in reference to conditions on the British Columbia Coast. With this object in view a questionnaire was forwarded to all resident light-keepers. Information was requested on thirteen points, as follows:

1. Give details in regard to the light in your charge—whether it is a fixed or a revolving light and whether there is a resident lightkeeper?
2. Give location of your lighthouse; the elevation and whether situated on an island or on the mainland?
3. Are birds ever killed at the lighthouse?
4. If so, give estimates concerning the number of birds found dead.
5. At what season of the year is such mortality greatest?
6. During what kind of weather is the greatest mortality noted? At what time? Stormy nights? Clear nights? Thick, foggy nights? Daytime?
7. Does the destruction of the birds seem due to their flying violently against the glass or do they become confused and fly around and against the glass until they become exhausted and fall to the ground?
8. Are there more dead birds on one particular side of the lighthouse than on the other sides?
9. Have you noticed any marks of injury on such birds as you have picked up about the lighthouse? If so, state nature of injury.
10. Is there a railing around your lighthouse, or any support upon which birds might rest?

11. Name as many birds as you can which have been found dead at your lighthouse. If you do not know them by name—were they sea-fowl or land birds, or both?

12. Is the number of birds killed at lighthouse stations increasing or decreasing?

13. Do you consider that any means could be employed to reduce the mortality? If so, state the particulars.

In due course all the questionnaires, forty-five in number, were returned. The answers to the various questions have been carefully studied and a summary of the information obtained is submitted herewith.

The reader, when analyzing this summary, should bear in mind that it is based on casual observations, which, in all probability, were not considered of much importance at the time they were made, and, consequently—human memory not being infallible—due allowance should be made for a margin of error.

Light stations are referred to in the sequence adopted in the "List of Lights and Fog Signals of the Dominion of Canada on the Pacific Coast and Rivers and Lakes of British Columbia", published by the Department of Marine. From the same publication is taken the information submitted regarding equipment, elevations, and location of lights.

QUATSINO STATION, situated on an island in Quatsino Sound, has a fixed light at an elevation of 89 feet. The officer in charge, on duty since June 16th, 1922, reports that no birds have been killed during his term of residence, although pieces of down have been found adhering to the glass in front of the light.

NOOTKA STATION, on San Rafael Island in Nootka Sound, has a 15-second occulting light at an elevation of 108 feet. The attendant reports that three casualties have occurred during the past three years—two land birds and one sea bird. These were found after foggy nights in the summer and were killed by flying against the glass.

ESTEVAN POINT STATION, on the southwestern extremity of Estevan Point, south of Nootka Sound, is a 10-second group-flashing light at an elevation of 125 feet, with a radius of seven-

teen miles in clear weather. The lightkeeper reports that heavy casualties occur on stormy nights during the spring and fall migrations. The victims are chiefly Geese, Brant and Ducks, and the number of birds found dead is estimated at "a barrel a night for three nights". This station is equipped with wireless apparatus and the destruction of birds is said to be due to their flying against the masts, guy wires and the lighthouse itself.

LENNARD ISLAND STATION, on Lennard Island in Clayquot Sound, is equipped with an 85 mm. flashing vapour light, at an elevation of 115 feet. The present attendant has been on duty since October, 1922, and reports that only one bird has been killed since that date. This was a Mallard Duck, picked up after a stormy, misty night.

CAPE BEALE STATION, at the entrance to Barkley Sound, is equipped with revolving oil lamps and reflectors at an elevation of 190 feet. The lightkeeper reports that no birds have been killed since he was transferred to the station in August, 1922, a condition he ascribes to the low power of the light—half of which is coloured red—and to the close proximity of the powerful Pachena Light.

PACHENA STATION, situated on Vancouver Island, nine miles south of Barkley Sound, has a powerful group flashing light of 180,000 candle power, at an elevation of 200 feet. The lightkeeper reports that numerous land birds and a few sea-birds are killed at this light, the majority through hitting the lantern and the remainder from exhaustion, which I presume is due to flying continuously around the light. Some of the dead birds were noted to have damaged heads.

The period of August, September and October is the season during which the greatest mortality occurs; thick, foggy nights are reported as being the most destructive, while some casualties also occur on stormy nights.

The lightkeeper is of the opinion that the number of birds killed at this station is increasing. He considers that the mortality would be reduced if a six-inch wind-break was built around the lighthouse platform—a structure which would not interfere with the light. His idea is that birds, when stunned by flying against the glass, would drop to the platform and there remain until recuperated—without a wind-break such birds are usually carried away by the force of the wind.

CARMANAH STATION, on a mainland point of Vancouver Island about 12 miles south of Cloose, is a 3-second flashing light at an elevation of 173 feet. The attendant states that "two or three dozen birds", chiefly Sparrows, are killed annually during the autumn migration on thick, foggy

nights. Their destruction is said to be due to their flying violently against the glass.

SHERINGHAM POINT STATION, situated on the mainland of Vancouver Island near the mouth of the Jordan River, is equipped with a group-flashing light at an elevation of 90 feet. The lightkeeper reports no casualties.

RACE ROCKS STATION is a lighthouse of the old tower type, built of solid masonry by the Imperial Government in 1860. The light is a 10-second flash at an elevation of 118 feet. The tower is situated on Great Race Rock, an island of approximately one acre, in the Strait of Juan de Fuca, nine miles south of Victoria.

It is reported that about two dozen birds are killed in the course of the year through flying violently against the glass. The greatest mortality is said to occur during very dark nights in the autumn and "broken beaks" is given as the injury noted on the dead birds, some of which are identified as Northern Phalarope, Rusty Song Sparrow, and "Wild Canaries". It is also stated that more dead birds are found on the north side of the lighthouse than on any other side. The lightkeeper has no suggestion to offer regarding methods that might be employed to reduce the mortality.

I visited this station on November 23rd, 1923, and found the remains of several Shearwaters and Murrelets which had recently been killed. Unfortunately the bodies had been partly eaten by the lightkeeper's dog, so it was impossible to obtain any information from these specimens. A few days later an Ancient Murrelet was found dead beside the tower and sent to me in the flesh. Examination of the body showed a bruised area on the breast, but no other injuries.

FISGARD STATION, at the entrance of Esquimalt Harbour, is equipped with a fixed white light with red sector at an elevation of 67 feet. No casualties are reported from this station.

TRIAL ISLAND STATION, close to Shoal Bay, Victoria, has a group flashing light at an elevation of 85 feet. The officer in charge states, "Birds are never killed around our lighthouse".

FIDDLE REEF STATION, on a reef close to Discovery Island, near Victoria, has a stationary light at 30 feet elevation. It is reported that no birds are killed at this station.

DISCOVERY ISLAND STATION, is equipped with a white occulting light at an elevation of 91 feet. The lightkeeper reports that no birds have been killed during the seventeen years of his residence.

SATURNA ISLAND STATION, on East point of Saturna Island, is equipped with a fixed and group flashing light at an elevation of 125 feet. The officer in charge reports that two birds, a

Grebe and a Merganser, have been killed during the past two years.

PORTLOCK POINT STATION, situated on the northern extremity of Prevost Island, is equipped with a fixed light at an elevation of 55 feet. The lightkeeper reports that no birds are killed at this station.

BARE POINT STATION, on extremity of point in Chemainus Bay, is equipped with a white fixed light at an elevation of 36 feet. It is said that no birds are killed at this light.

PORLIER PASS STATION, at the north end of Galiano Island, has two fixed lights, one on Race Point, elevation 21 feet, and one on Virago Point at an elevation of 32 feet. The lightkeeper reports that sometimes over one hundred birds are found dead at these lights and that the mortality is greatest in the autumn. A few birds are killed in the daytime during stormy weather, but the majority during dark, stormy nights.

The casualties are entirely small land birds, "pretty little fellows". They "become confused as they fly around and round" and, presumably, are killed by flying against the glass, as "broken necks" is stated to be the injury noted on the dead birds.

POINT ATKINSON STATION is situated on the mainland, near North Vancouver. The light is described as a revolving vapour flash, giving twenty-four flashes per minute. The officer in charge reports that an average of twenty-five birds are killed annually, usually during nights of strong south-east wind accompanied by rain. He states that the birds are killed through flying against the glass and remarks that he has several times picked birds off the glass and carried them out of the range of the light, to which they immediately returned when released. He is of the opinion that no means could be successfully employed to reduce the mortality. The birds found dead are described as "mostly small birds resembling the wild canary with long pointed beak—insect eaters".

PROSPECT POINT STATION, under bluff at Prospect Point, First Narrows, Burrard Inlet, has a white light with red sector, occulting 9 seconds, at an elevation of 28 feet. The lightkeeper states, "I have been in charge for twenty-four years and there has only been one dead bird found that was killed by flying against the lantern, a loon on a stormy night".

FIRST NARROWS STATION, at the mouth of the Capilano River, is furnished with a kerosene lamp using a Mammoth Duplex Burner occulting six seconds; the elevation is 20 feet. It is reported that no birds are killed at this station.

BROCKTON POINT STATION, on the First Narrows, near Vancouver, is furnished with a low

power occulting vapour light at 25 feet elevation. The lightkeeper reports that no birds have been killed during his twenty-four years' attendance.

ENTRANCE ISLAND STATION, on an island in north entrance to Nanaimo Harbour, is furnished with a fixed and flashing diamond vapour light, at an elevation of 65 feet. No birds are killed at this station.

MERRY ISLAND STATION, situated at the south-east entrance to Welcome Pass, has a fixed light at an elevation of 57 feet. The lightkeeper reports no casualties.

BALLENAS ISLAND STATION, on north point of North Ballenas Island, north of Nanoose Bay, has a fixed and group flashing light at an elevation of 70 feet. It is stated that no birds are killed at this light.

SISTERS STATION, on rock, west of Lasqueti Island, has a group flashing light at an elevation of 46 feet. In reference to this light the officer stationed at Pachena writes as follows:

"At the Sisters Lighthouse I used to go up to the tower with a box and pick the birds off the platform and fill the box and let them go in the morning. Calm, foggy nights in September and October are the worst. Birds include canaries, sparrows, sea pigeon, and a bird that looks like a paroquet, nearly all red". (Male Pine Grosbeak?)

The officer at Cape Beale Light writes: "Whilst on Sisters Rocks there were two migrations, but no birds killed in either. These birds fluttered round the lantern for two nights on each occasion. They were, I think, of the canary family, being colored in yellow and black".

The lightkeeper now in charge reports that two Ducks have been found dead during the past twelve months. These were killed on clear autumn nights by flying violently against the building.

YELLOW ISLAND STATION, situated on a small rocky island near the east end of Denman Island, is equipped with a 6-second flashing light at an elevation of 83 feet and a fixed white light at an elevation of 48 feet. The lightkeeper reports that one Gull and one Grebe have been killed during the past seventeen months.

CAPE MUDGE STATION is situated on Valdez Island, south of Campbell River, and the flashing light is at an elevation of 57 feet above high water.

It is reported that twenty to thirty sea-fowl are killed annually, through striking the glass on stormy or foggy nights during the fall and winter.

This report also states that some of the birds which strike the glass are only temporarily disabled and recover upon being put in the water; that more birds are found on the south side of the building, and that the number of casualties is

decreasing.

PULTENEY POINT STATION, situated on Malcolm Island, in Queen Charlotte Strait, north of Alert Bay, is equipped with a fixed light at an elevation of 38 feet. According to the light-keeper's report, three birds have been injured, during the past ten years, by flying against the glass during thick fog. Two of these were Petrels, the third was not identified.

SCARLETT POINT STATION, on Balaklava Island at the entrance to Christie Passage, is equipped with a fixed light at an elevation of 90 feet. The attendant states that no birds are killed at this station.

PINE ISLAND STATION, situated on Pine Island in the entrance to Queen Charlotte Strait, is equipped with a light which shows two flashes every 10 seconds; the elevation is 80 feet. The lightkeeper estimates the yearly casualties at fifty. These are chiefly Crows, Sparrows, Woodpeckers and Robins. The greatest mortality is reported as occurring in summer and autumn during stormy weather with a south-east wind, and birds are killed in the daytime as well as at night. The dead birds, which are said to have the neck broken, are found chiefly on the north-west side of the building. The number of birds killed is thought to be decreasing.

The lightkeeper expresses the opinion that no means could be employed to lessen the mortality, as the casualties take place during heavy gales. He reports that the birds inhabiting the island are: Golden Eagle, Bald Eagle, Hawks, Snowy Owl, Sparrows, Robin, Woodpeckers, Humming-bird, Wild Pigeon, Wild Canaries, Snipe, Puffin, Mallard, Whistlers, Black Duck (Scoter), Sawbill, and remarks that: "The most of the destruction of birds on this Island is caused by Hawks and Eagles. In fact, the Hawks have killed 6 of our Chickens and an Eagle tried to fly away with our dog. It tore one of the dog's eyes out. The Hawk only sucks the blood out of the birds and leaves the carcass. The Eagles will tackle anything. While watching them I have seen them swoop down and seize a salmon weighing anything from 20 to 30 lbs. Not once have I witnessed the above, but on several occasions." "N.B. I wrote the above thinking it might be of some interest to you. If you should like any special information I would be only too glad to give it if it is in my power."

A later report from this station dated September 28th, 1923, refers to twenty-three sea-birds of two species which were picked up on the platform after a stormy night accompanied by heavy rain. The descriptions given of these birds seem to fit the Rhinoceros Auklet and Sooty Shearwater.

EGG ISLAND STATION, on the summit of a small islet on the west side of Egg Island, which is in Queen Charlotte Sound, has a revolving light at an elevation of 85 feet, flashing every 30 seconds. The attendant reports that he has "collected as many as two pails full of dead birds, mostly land birds". The majority of these were killed through contact with the glass; the heads were noted as being badly mutilated. The greatest mortality is said to occur on dark nights during the spring and autumn migrations. It is stated that the largest number of dead birds are found on the south side of the building during the spring and on the north side during the fall.

ADDENBROOKE STATION, on west point of Addenbrooke Island, Fitzhugh Sound, is furnished with a fixed light at an elevation of 81 feet. The lightkeeper reports that no dead birds have been found during her two years' residence.

POINTER ISLAND STATION, situated on the south-east end of Pointer Island—a small rocky island of approximately two acres, two hundred yards off shore at the entrance to Lama Passage, near Bella Bella—is equipped with a fixed light of the third class at an elevation of 42 feet. The lightkeeper states that birds are rarely killed and only during thick, snowy nights in the winter. In this connection he writes as follows:

"I have received your Questionnaire re destruction of birds at lighthouses. In reply I must say that I have been living at this light station for over 23 years. In that length of time not over one dozen birds have been attracted by the light. They were of the following varieties: 4 or 5 Plover, 4 or 5 Petrel, 1 small Owl and one small Sea-bird (Puffin?). Of these only the owl was killed. The others, although striking the glass with force, were not even stunned, but sat on the platform surrounding the lamp, blinking stupidly at the light until I went over and picked them up, which I did at once, to prevent them fouling the roofs, from which we collect our drinking water. It was my practice to take them down to the ground, away from the rays of the light, when, on being released, they at once flew away. The birds struck the light on thick snowy nights in Winter, never in fog and never in Summer. They always came down the wind, sometimes from the North and sometimes from the South-west, but always from the quarter from which the wind was blowing. Seagulls often approach the light in thick weather, but never strike, being always able to save themselves by swerving aside. No birds have struck the light recently, the last that I remember was four years ago."

DRYAD POINT STATION, situated on Cape Carpenter, near Bella Bella, is equipped with a

fixed white light at an elevation of 50 feet. It is reported that no birds are killed at this station.

IVORY ISLAND STATION is situated on an island, approximately one and a half miles long by one mile wide. This station is equipped with a number two duplex burner, a fixed light of low power at an elevation of 66 feet. The lightkeeper reports that no dead birds have been found during his five years' residence. On the back of his report appears the following: "Quite a number of birds call and stay here awhile, the first is the Hedge Sparrow, then another bunch comes—they are a little bigger, they have yellow feathers round their neck and then comes Mr. Robin, the best of them all. There are some small birds, which stay all winter. We have the crows and eagles here all the time. I have only seen one grouse since I have been here. A pair of Herons nest here on the Island, and have their young every year. No birds get killed here as we are pretty near the mainland and there are lots of Islands all round. Deer, also, come now and again."

LAWYER ISLANDS STATION, situated on the summit of the northernmost island of the group, is furnished with a group flashing light at an elevation of 126 feet. There is the usual railing about the structure and the lightkeeper, who has been on duty for seventeen months, states that he has observed a few land birds resting thereon during the early autumn, but no dead birds have been found.

HOLLAND ROCK STATION, situated on a small, bare island, eight miles south of Prince Rupert, has a fixed light of the fourth order at an elevation of 45 feet. The lightkeeper reports that during his eight months' residence he has found no dead birds.

LUCY ISLAND STATION, on the north-east extremity of East Lucy Island, is equipped with a white occulting light. It is reported that no birds are found dead at this station.

GREEN ISLAND STATION is situated on Green Island, twelve miles west of Port Simpson. The powerful light flashes $\frac{3}{4}$ seconds and is eclipsed $4\frac{3}{4}$ seconds: the elevation is 81 feet. There is a two-tier guard railing below the light.

The lightkeeper reports that in the spring and fall birds are frequently killed during nights of high wind accompanied by rain. There are few casualties on clear nights and none on thick, foggy nights or during the day time. The greatest number found dead at one time is estimated at 200; this was in October, 1921, but there has been no great mortality since that date. The

species include Goose, Duck, Auk, Murrelet, Warblers, Sparrows, Robins, Snipe and Grebe. Regarding the cause of destruction the lightkeeper states that: "The birds are blown against the glass. *During moderate winds they circle the light for hours without casualty and resume their journey at dawn without apparent exhaustion.*" Dead birds are not found on any particular side of the building and this is ascribed to the fact that the wind carried the birds away after they had been killed or stunned.

Injuries noted are, broken necks, broken wings, eyes knocked out, and badly bruised breasts, and it is stated that "many birds that are merely stunned I bring indoors and release in daylight after they have recovered."

In reference to the question of reducing the mortality the lightkeeper states: "My observations go to show that the mortality here is caused by the strong winds at migration time. Additional perches would help by inducing the birds to perch instead of circling." He goes on to say that:

"On one occasion, in Spring, 1919, I found all available space for perching, around the cupola, on the bars that tie the chimney, and the chimney itself fully occupied by birds, and in addition there were many on the platform of the lantern. Many more birds were circling round. The night was stormy, with rain, and there was a heavy toll taken before dawn permitted the birds to resume their journey. The birds were of several species, and did not appear frightened when I walked among them. As it was my first experience with bird migration at close range, I picked several of the birds off the rail and examined them. They acted much as chickens act if picked off the perch at night and several of them cuddled down to sleep again when I restored them to the rail. A few others flew to another part of the railing. The birds appeared to be tired, but by no means exhausted, and I noticed that of all the birds that had encircled the light all night not one lighted on the ground to breakfast, and at daylight Green Island's feathered visitors had all departed, except those that were casualties.

"This was the only time the perching facilities had appeared to be inadequate.

"Many hundreds of snipe stay with us throughout the winter, and in misty weather they often rise and circle the light all night, and resume feeding at dawn. Odd ones often are killed throughout the winter months, but they do not rise in flocks to circle if the wind is strong."

LIST OF BIRDS RECORDED FROM THE ISLAND OF ANTICOSTI, QUEBEC

By HARRISON F. LEWIS

(Concluded from page 127)

156. *Wilsonia pusilla pusilla*. WILSON'S WARBLER.—*Brewster*: Adults seen feeding newly-fledged young at Ellis Bay. *Schmitt*: Summer. Rather rare. *Brooks*: Saw them only on August 24, when they were common back of the settlement at Ellis Bay. *Lewis*: Common at Ellis Bay in June, 1922.

157. *Wilsonia canadensis*. CANADA WARBLER.—*Dionne*: Rare, only two observed.

In a letter dated January 11, 1924, Mr. Willie La Brie has kindly furnished me with the following details concerning the observations, made by him, upon which *Dionne*'s record, quoted above, was based: "I found a pair of these birds, male and female, during the summer of 1917. I saw this pair several times, and I believed that they nested there, for I saw the female in June carrying fibrous material in her beak. I saw the same pair again in July at the same place, apparently much distressed at my presence, causing me to believe that their nest must be near. I saw only this pair.

158. *Setophaga ruticilla*. REDSTART.—*Verrill*: Very common. Young just able to fly seen July 18. *Brewster*: Several seen at Fox Bay. Common at Ellis Bay in hardwood timber and mixed growth a little back from the shore. *Schmitt*: Summer. Rather rare. *Dionne*: Fairly common. *Brooks*: Noted a considerable number at Ellis Bay until the night of September 9, when there was a migration. After that saw but one—on September 13. *Lewis*: Very common at Ellis Bay in June, 1922.

159. *Anthus rubescens*. PIPIT.—*Schmitt*: May-September. Fairly common. *Dionne*: Common, especially in autumn. *Brooks*: At Ellis Bay saw a flock of 30 on September 11 and a flock of 50 on September 13.

160. *Mimus polyglottos polyglottos*. MOCKINGBIRD.—*Schmitt*: A single specimen, captured at English Bay, August 8, 1902.

Mr. *Dionne* informs me that this specimen was submitted to him for identification.

161. *Nannus hiemalis hiemalis*. WINTER WREN.—*Verrill*: A small Wren, apparently of this species, seen at South-west Point in July. *Schmitt*: Summer. Rather rare. *Dionne*: Fairly common. *Brooks*: One seen at Ellis Bay, September 3 and 4. *Lewis*: Fairly common at Ellis Bay in June, 1922.

162. *Sitta canadensis*. RED-BREASTED NUTHATCH.—*Verrill*: Common. *Dionne*: Common. *Brooks*: Common at Ellis Bay. *Lewis*: Two observed at Ellis Bay on June 14 and again on June 15, 1922.

163. *Penthestes atricapillus atricapillus*. CHICKADEE.—*Verrill*: Very common. *Schmitt*: Throughout the year. Common. *Dionne*: Common. *Brooks*: Common.

164. *Penthestes hudsonicus littoralis*. ACADIAN CHICKADEE.—*Dionne*: Common. *Brooks*: Quite common. Specimens secured by him were referred to *P. h. nigricans* Townsend, Labrador Chickadee. *Lewis*: One observed at Ellis Bay on June 14, 1922.

Possibly all representatives of this species on Anticosti are *nigricans*, not *littoralis*, but *nigricans* has not yet been recognized in any supplement to the A.O.U. 'Check-List'.

165. *Regulus satrapa satrapa*. GOLDEN-CROWNED KINGLET.—*Schmitt*: May. September. Rather rare.

166. *Regulus calendula calendula*. RUBY-CROWNED KINGLET.—*Brewster*: A female seen at Fox Bay, July 11. *Schmitt*: May-September. Rare. *Dionne*: Common. *Lewis*: Not common at Ellis Bay in June, 1922.

167. *Hylocichla fuscescens fuscescens*. VEERY.—*Brewster*: A pair seen very distinctly and positively identified at Ellis Bay, July 24. Not taken. Judged by their actions to have a brood of young near. *Schmitt*: Summer. Fairly common.

Mr. *Dionne* assures me that one or more specimens of this species were submitted to him by *Schmitt* for identification.

168. *Hylocichla ustulata swainsoni*. OLIVE-BACKED THRUSH.—*Verrill*: Very common. *Brewster*: An adult female collected at Fox Bay, July 11, 1881. *Schmitt*: Summer. Common. Many found dead at West Point light, October 3, 1902. *Brooks*: A male seen and taken on September 3. *Lewis*: Common at Ellis Bay in June, 1922.

169. *Hylocichla guttata pallasii*. HERMIT THRUSH.—*Verrill*: Common. *Brewster*: Abundant. *Schmitt*: Summer. Rather rare. *Dionne*: Common. *Brooks*: An immature bird was taken at Ellis Bay on September 6. *Lewis*: Two observed at Ellis Bay on June 13, 1922.

170. *Planesticus migratorius migratorius*. ROBIN.—*Verrill*: Not common. Seen chiefly at Ellis Bay. *Brewster*: Common at almost every point where our vessel touched. Fully-fledged young seen at Ellis Bay, July 24, 1881. *Combes*: Common in all the island. *Schmitt*: March or April to end of September. Common. First arrival in 1902, March 10. Young left nest July 15, 1902. By September 26, 1902, no Robins

remained on the Island. First arrival in 1904, April 25. *Dionne*: Common. *Brooks*: Quite common about Ellis Bay. *Lewis*: Abundant at Ellis Bay in June, 1922.

[HYPOTHETICAL. *Oenanthe oenanthe leucorhoa*. GREENLAND WHEATEAR.—Mr. Willie La Brie, in a letter dated January 11, 1924, states concerning this species as follows: "I noticed an individual of this species for the first time at the end of April, 1913. This bird first drew my attention by its strange manner of taking flight. It appeared to turn a somersault in taking flight, somewhat as does sometimes a bird which has been shot, but not instantly killed. I thought it was wounded, but as I was able to observe it for three or four days, I quickly perceived that it was actually a Greenland Wheatear and that the strange manner of its taking flight was really a distinctive trait which would aid in recognizing this species. As this was in the spring the color appeared to me to be the same as that of the engraving which appears in "Birds of Eastern North America" by Chester A. Reed. The habits of this bird appeared to me similar to those of the Horned Lark and the Lapland Longspur, with which it was associated. It was in the fields near the houses at Rentilly Farm, where the Horned Lark and the Lapland Longspur are always common in the spring, that I saw this species." In a later letter, dated February 13, 1924, Mr. La Brie adds: "I used the word somersault, but it was so in appearance only. The bird, on taking flight, raises its tail very high as if it would flap it over on its back, meanwhile lowering its head, which resembles a somersault, but is not one. In *Nature Neighbors*, Vol. VI, page 762, Mr. Saunders writes, "From early spring onward, the Wheatear is to be seen jerking its white tail as it flits along, uttering its sharp "chack chack," on open marshes, moors, and uncultivated places." I think that this writer intended to allude to this bird's manner of taking flight.

"When I observed this bird for the first time, I did not think that my observations would be useful to any one, or I would have made more detailed observations.

"If Mr. Dionne did not include this species in the paper that he published, it was because he forgot it, or perhaps it was I who forgot to include it in the notes that I furnished him."

Personally, I believe Mr. La Brie's identification and record of this species to be correct. But the record was not included by Mr. Dionne, in his list of Anticosti birds, based on La Brie's field-work; the species is rare and of uncertain status in North America; and detailed notes of appearance, written at the time are not available. Therefore it seems best to record this species as hypothetical until further evidence is at hand.]

171. *Sialia sialis sialis*. BLUEBIRD.—
Schmitt: Summer. Rather rare.

MISCELLANEOUS BIRD NOTES FROM SOUTHERN VANCOUVER ISLAND, 1923

By J. A. MUNRO

THE COMPARATIVE scarcity of literature relating to the bird-life of southern Vancouver Island is my reason for submitting the following meagre notes, obtained at irregular intervals during a busy year. As I am a newcomer to this district and unfamiliar with local conditions, these observations have been of personal interest, an interest no doubt stimulated by the fact of their having reference largely to birds which hitherto I had met rarely or not at all, or else encountered under totally different conditions. Personal interest, so I am told, is a fairly reliable standard by which to judge the value of casual observations on the distribution and life histories of birds; therefore, it may be, these notes will prove of interest to others.

Brachyramphus marmoratus. MARBLED MURRELET.—Fairly common on Cowichan Lake, twenty

ADDENDA.—The following titles should be added to those contained in the Bibliography which was published with the first instalment of this list. In this connection I am indebted to Mr. J. H. Fleming, who corresponded with me concerning them and kindly lent me his copy of one of them.

Verrill, A. E.—Description of a Species of *Passerella*, supposed to be new, from Anticosti. *Proc. Boston Soc. Nat. Hist.*, Vol. IX, pp. 143-146. Boston, 1865. Description of *Passerella obscura*.

Rowan, John J.—The Emigrant and Sportsman in Canada. London: Edward Stanford, 55, Charing Cross, S.W., 1876. Chapter VIII is devoted to Anticosti, the greater part of it being abridged from a description published by the same writer about ten years earlier, in the *Field* newspaper. This book lists 37 species of birds as being found in Anticosti, and states that, except the Brant, they all breed there. Species thus given by Rowan which are not included in this present list are: Black-throated Loon, Blue-winged Teal, Buffle-head, Ruffed Grouse and Pileated Woodpecker. It seems almost certain that this record of the Ruffed Grouse, at least, must be in error, and as various evident errors are to be found in other ornithological records in this book, and as all these records are given without any supporting details, I am unable to accept any of them as correct, though some of them may be so.

In correspondence Mr. Fleming has also furnished the following interesting information:

"My copy of 'Notes on the Natural History of Anticosti' by A. E. Verrill, is paged 132-151 (birds 137-145), you give the paging as 137-143 and the date 1865, my copy is dated 1862 . . ."

"Ridgway, *B.N. & M.A.*, Vol. I, under Fox Sparrow, quotes the date as December 1862, my copy is dated October, 1862, and paged as in the *Proceedings*, not as a separate, but at the end is an errata slip which says, 'The extra copies of the preceding paper having been printed, by mistake, before the final proofs had been returned, the following errors should be corrected.' My copy is the one actually reviewed in the *Ibis* in October, 1863 . . ."

miles from the sea, on November 23th, 1923. They were in pairs, as is usual, and difficult to approach, more so than is generally the case when on salt water. Mr. George Buchanan Simpson, a resident of the district for the past ten years, stated that Marbled Murrelets wintered regularly on the lake and had also been noted, during the months of May or June, flying through a timbered draw some distance from the lake shore. To find this species inhabiting fresh-water lakes I believe to be unusual, and it would be of interest to discover the nature of their food under these conditions. Those under observation on Cowichan Lake were diving, and apparently feeding, in deep water, some distance out from shore.

The only other record I have of their occurrence on fresh water was obtained at Henderson Lake, Vancouver Island, where several birds were seen on November 10th, 1922. This did not seem

particularly worthy of note, however, as Henderson Lake is only a short distance from the sea, and various sea-birds, and also seals, wandered to the upper end of the Lake.

Stercorarius pomarinus. POMARINE JAEGER.—A Jaeger of this species, picked up in a dying condition at Shoal Bay, Victoria, by Mr. Clement Kauffman, was brought to me in the flesh. This specimen is an immature male in the intermediate phase.

Larus glaucescens. GLAUCOUS-WINGED GULL.—During the mild winter of 1923-24, large flocks of Glaucous-winged Gulls—attracted by the ploughing operations then in progress—visited the fields in the Saanich Peninsula and Metchosin District. While I was driving through the country during December, Gulls were always in evidence, flying over the fields, walking across ploughed land or standing on the shores of the winter ponds which had formed on low-lying meadows. After five weeks absence I returned in mid-February to find even more birds in the fields, and at the time of writing, March 6th, 1924, there has been no apparent decrease in their numbers. At least ninety-five per cent are birds in fully adult plumage.

Every fresh ploughing observed, during frequent trips through the Saanich District, was occupied by Gulls, and I did not encounter a farmer ploughing without a flock in attendance. Fearless in their eager search for what insect-food might be turned up, they followed close behind the plough, scrambling over each newly turned furrow. The gleanings quickly done, a number would rise suddenly, circle over the ploughman, and drop again on fresh ground, while, from further in the rear, came others to alight upon the widening space between the foremost birds and the slow-moving team drawing the plough.

The sight of a human being walking over a field frequently attracted passing birds to circle overhead. Chinese gardeners, cultivating their vegetable gardens by hand, were often attended by a band of tame Gulls. In one such garden, where three Chinese were hoeing, I counted 81 birds spread out in a long straggling line and indifferent to the presence of the gardeners working ten yards away.

A flock of, say, one hundred large Gulls concentrated on a single field, and systematically combing every foot of earth turned over by the plough, must destroy a large number of noxious insects in the pupal and larval stages. No ploughing escapes their attention and as this habit is not peculiar to the Gulls of Vancouver Island—the same has been observed frequently in the Fraser Valley—their value from an agricultural standpoint is of sufficient importance for consideration

by those who advocate removal of the protection now afforded this species under the Migratory Birds Convention.

Larus philadelphia. BONAPARTE'S GULL.—A flock of yearling Bonaparte's Gulls, estimated to number fifty, was noted on the sea beach near Courtenay on June 22nd, 1923. Several were teasing a Bald Eagle that stood perfectly motionless upon his perch on a tall pile in the water, while the Gulls swooped repeatedly close over his head.

Xema sabini. SABINE'S GULL.—On October 20th, 1923, at Whiffin Spit, Sooke Harbour, I picked up an adult male Sabine's Gull in winter plumage. The bird had evidently been killed through contact with crude oil, as a thick deposit of this substance adhered to the feathers between the shoulders. It was possible, however, to clean and preserve the specimen, which is now in my collection.

Puffinus griseus. SOOTY SHEARWATER.—On May 22nd, 1923, a friend living at Shoal Bay, Victoria, advised me that he had picked up four Shearwaters on the beach. The same evening we made a further search and found six others, half buried in the drifted kelp and rubbish on the beach. A careful examination of four specimens, which were fresh enough to preserve, did not reveal the cause of death. All were fat and apparently in healthy condition. They had not been shot, or killed through contact with oil.

Aix sponsa. WOOD DUCK.—Report received last autumn from Somenos Lake and other local points indicate that the Wood Duck, never particularly common on Vancouver Island, is showing a slight increase due, possibly, to the protection afforded during the past six years.

Marila collaris. RING-NECKED DUCK.—A flock of seven seen on Cowichan Lake, November 28th to December 1st, 1923, and subsequently reported by Mr. G. Buchanan Simpson.

Stomach contents of one male and one female taken on December 11th, at Cowichan Lake, are as follows: 3 Odonata nymphs (sp.), 1 Chrysomelid beetle (*Donacia proxima*), 14 small bivalves (*Pisidium variabile*), approximately 30 seeds of Yellow pond-lily (*Nymphaea*), and root stalks of horsetail (*Equisetum palustre*).

Histrionicus histrionicus pacificus. WESTERN HARLEQUIN DUCK.—The Island coast between Oyster River and Campbell River has been noted as a favorite resort for drake Harlequins during the summer months. At the former point on June 22nd, 1923, two flocks were under observation, one numbering 66 and the other 26. The smaller flock, when first seen, was resting on a gravel bar lying across the river's mouth; the larger flock on the sea a hundred yards from shore.

Later these birds swam to the beach, in small detachments, and rested on the shingle close to the water's edge. The swimming birds occasionally voiced a rather plaintive call when approaching the shore but those on land were silent. I stalked this flock carefully and was able to approach within ninety yards without disturbing them and observed that all were drakes in full breeding dress.

Later in the evening, when the birds had commenced feeding close to shore, I lay concealed in a depression in the beach while my companion made a wide detour to come out on the shore beyond them with the object of driving a portion of the flock towards me. This plan was successful and a flock of twelve worked slowly along shore in my direction, feeding as they came. In diving they disappeared simultaneously and emerged together.

It has been noted that other species of diving ducks, when feeding in bands of this size, do not as a rule submerge together, but at short intervals, so that generally some birds are always on the surface. Even when all are below together, there may be only a few seconds interval between the dive of the last bird and the re-appearance of the bird that submerged first. This habit, probably not a conscious manoeuvre, tends to protect the flock from enemies.

In the case of the twelve Harlequins under observation it would have been possible, when all were below the surface, to rush to the water's edge and "brown" the flock when it emerged. They were not shot at, however, but at my sudden appearance on the beach, swam a short distance out to sea, with necks outstretched, and then rose in a body.

North of Oyster River, on the following day, other smaller flocks were seen from the Island Highway. A particularly fine view was obtained of eight drakes and four ducks clustered on a small rounded boulder, forty yards from shore.

Branta canadensis minima. CACKLING GOOSE.—On November 28th, 1923, while I was travelling along the side of a wooded mountain above Cowichan Lake, a male Cackling Goose rose from behind a clump of madronas and was secured as it flew through the open woods. Examination of the stomach contents showed the bird had been feeding on Kinnikinnik berries (*Arctostaphylos uva-ursi*), and the terminal twigs of club-moss (*Selaginella wallacei*). The entire length of the gullet was filled with the latter material.

Arquatella maritima. PURPLE SANDPIPER.—Two Purple Sandpipers were noted on November 20th, 1923, on a rocky point in Shoal Bay, Victoria. It may be stated that I examined these birds for ten minutes or longer from a distance of twenty

feet, also that I am familiar with the appearance of this Sandpiper in life. In all probability these were *couesi*, as to this race has been referred a series of specimens collected on Graham Island, British Columbia.

Actitis macularia. SPOTTED SANDPIPER.—As this species is rarely encountered in British Columbia during the winter months it is considered advisable to record that one was noted at Sooke Harbour on December 10th, 1923. Other winter records for this Province are: Chilliwack, December 3rd, 1895 (Brooks), and Oyster River, February 14th, 1921 (Munro).

Arenaria melanocephala. BLACK TURNSTONE.—While it was known that this species winters regularly at various points on the coast of Vancouver Island, it gave me considerable pleasure to find them within the city limits of Oak Bay. This was at Shoal Bay on January 1st, 1924, when six birds, conspicuously black and white in flight, came twisting in from the sea and alighted on the rocks at my feet. There, standing motionless with the contrasting black and white no longer visible, they might have passed for slight projections on the rock, so close was the harmony.

Columba fasciata fasciata. BAND-TAILED PIGEON.—On June 9th, 1923, I had occasion to investigate a report that Band-tailed Pigeons were causing damage to sprouted wheat on a small bush farm in the Sooke District. The farm in question was found to include a portion of a large beaver meadow—one of the few open areas in this heavily wooded region—the balance comprising rough timbered hillside, and a wooded ravine through which flows a small stream. About eight acres of the meadow had been seeded to wheat and oats—by hand—and as always is the case with this method of sowing, a large percentage of the seed was on the surface. This exposed seed had germinated.

Pigeons commenced feeding on the wheat field shortly after my arrival, so, in order to study them at close quarters—for they are invariably wild when in the open—I made a careful stalk through the wooded ravine and reached, unobserved, a suitable hiding-place at the edge of the field. From this position it was seen that 53 Pigeons were feeding. Usually in flocks of this size, small detachments from the rear keep flying over the main flock to alight in front of the foremost birds, but on this particular day the birds kept their formation—an undulating blue ribbon—and slowly moved across the field in my direction until a scant sixty yards distant, when they suddenly arose, circled several times, and then dropped on another part of the field—there to spread out immediately and commence feeding as before. From several dead trees amongst the

green timber behind me came other birds, singly as a rule, and joined the feeding band. Close observation with binoculars showed that only sur-

face seed was being taken, the young plants from buried seed were not pulled up.

(Concluded in November issue)

A NEW GENUS AND A NEW SPECIES OF GASTROPOD FROM THE UPPER ORDOVICIAN OF BRITISH COLUMBIA*

By ALICE E. WILSON

DURING the field work of 1922, Mr. J. R. Marshall, of the Canadian Geological Survey, found a considerable thickness of Upper Ordovician rocks at a new locality in the Kananaskis-Palliser area of the Rocky Mountains near the Palliser Pass. These rocks have yielded a new genus of gastropod. As long ago as 1886 in sections near Golden, B.C., about 75 miles northwest of this locality, R. G. McConnell noted* a series of dolomites and quartzites which he termed "Halysites" beds. He assigned the Graptolite beds below them to the Cambro-Silurian—the Ordovician of later authors—and the "Halysites" beds to the Silurian because of the presence of Halysites, known then only from the Silurian. Walcott† later referred the coral beds of the Beaverfoot Range to the "Silurian?", introducing for them the name Beaverfoot formation. Burling‡ confines the term "Beaverfoot" to the Richmond portion of the Ordovician of the Beaverfoot Range. Both these localities are north and west of the Palliser Pass exposures, and until further work is done upon the fauna they cannot all be definitely correlated with the Halysites beds of the Palliser Pass locality. Detailed study of the fauna from Palliser Pass shows that the Halysites beds of this section belong to the Richmond fauna of the Upper Ordovician. The two gastropods here described are from these beds.

Family EUOMPHALIDÆ de Koninck

Palliseria gen. nov.

Shell with a rapidly enlarging sinistral whorl and a depressed turbinate spire, a deep open umbilicus, and whorls ornamented by several carinæ and cross striations.

The genus is like *Maclurina* in its sinistral whorl, but is without an operculum so far as is known. It differs from *Maclurina* essentially in its turbinate spire and in its ornamentation, in both of which respects it more closely resembles some members of the Trochoturbinidæ. (See Pl. I, fig. 1, 2., Pl. II, fig. 1, 2).

Palliseria robusta n. sp.

Pl. I, fig. 1, 2, Pl. II, fig. 1, 2.

Large robust turbinate shell, largest specimen

though incomplete measuring $3\frac{1}{2}$ inches across and $2\frac{1}{4}$ inches high Umbilicus open and deep, extending to the apex of the shell, five or six rapidly enlarging whorls, closely coiled, highly ornamented by the various carinæ of the whorls and by growth lines. There is a gradual evolution in the shape of the whorl from the nepionic to the gerontic stage. In the early stages the whorl is narrow and deep, the margin of the umbilicus being sharply defined, the other carinæ are only faintly indicated or not yet developed. As the shell grows its proportions become more robust, the whorl increases in thickness more rapidly than in depth, each whorl impressing itself upon the succeeding whorl. The carinæ of the gerontic stage are well defined. In the section of the last whorl preserved there are six outstanding angles formed by the carinæ. The preceding whorl is impressed broadly and deeply, producing two angles on the outline of the whorl, one at the umbilicus, one a sharply defined shoulder at the suture line. Exposed top of whorl evenly convex. The outside of the whorl presents a broad, flat band-like surface, limited above by a rounded carina and below by a more sharply defined one. The band and its limiting carinæ are only evident in the later stages. The fifth angle on the section

of the whorl is the acute margin of the umbilicus. The umbilical margin of each whorl is free from the surface of the following whorl and projects into the umbilicus in a most striking manner. In addition to this there is a sixth carina entirely within the umbilicus, between the margin



Fig. 1.—*Palliseria robusta* n. sp. Diagrammatic outline of the last whorl showing the various carina. (Nat. size)

and the suture along the line of contact with the preceding whorl. This carina is pointed slightly inward and downward toward the umbilical margin.

Growth lines, after a very slight backward inclination from the suture line, pass forward with

*Published with the permission of the Director, Geological Survey, Canada.

†*Geol. Surv. Can. Ann. Rept.*, 1886, pp. 15d, 21D.

‡*Misc. Coll. Smithsonian Inst.*, vol. 67, no. 8., p. 463, 1923.

§*Geol. Mag.*, vol. 59, no. 700, p. 453.

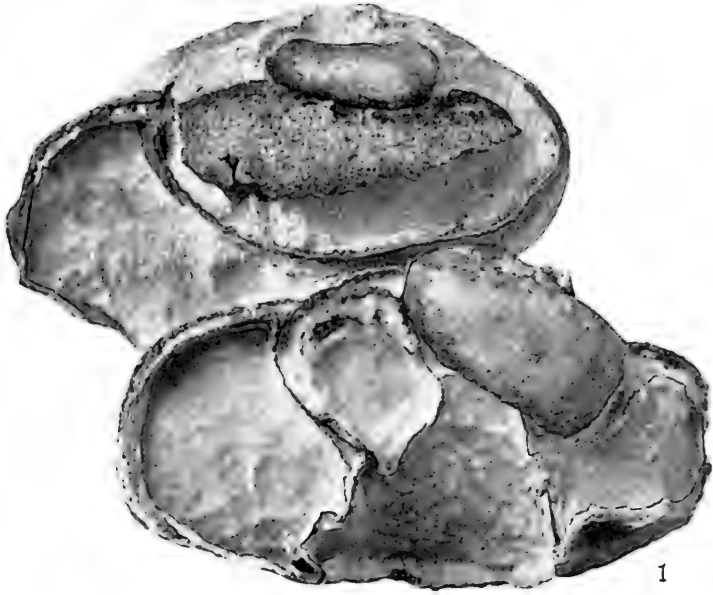

FIGURES NATURAL SIZE
PLATE I.

Fig. 1.—*Palliseria robusta* gen. nov. Natural sections of two specimens, the lower one showing the six angles of the section, and the umbilical ridge projecting into the umbilicus. The upper specimen is at an angle.
Fig. 2.—The same, seen from the opposite side, showing the broad, flattened band-like area on the last whorl, and the surface markings across it and on the under side.



PLATE II.
FIGURES NATURAL SIZE

- Fig. 1.*—*Palliseria robusta*. The same specimen showing the growth lines on the upper surface of the upper shell.
Fig. 2.—The same, from below, showing the piled up growth lines on the umbilical ridge.
Fig. 3.—*Lophospira occidentalis*. n. sp. Showing the general shape and natural section of the last whorl. a little foreshortened.

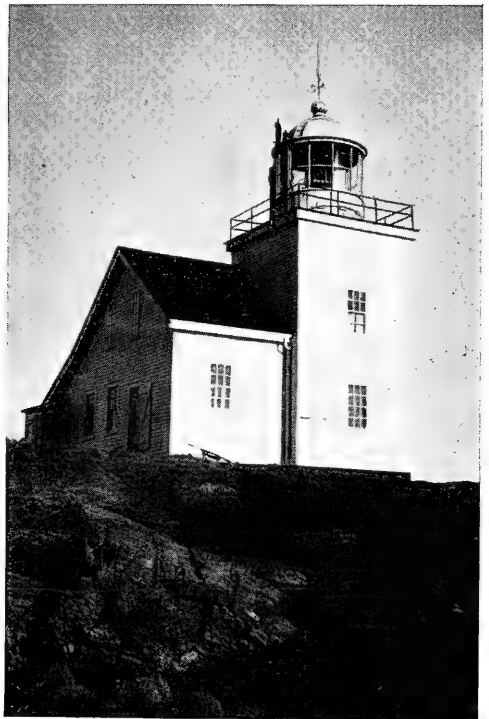

FIGURE 1.

Pachena Station, on west coast of Vancouver Island, British Columbia. This station is equipped with a powerful group-flashing light at an elevation of 200 feet above sea level. A large number of land-birds and a few sea birds are killed at this light during the autumn migration.

FIG. 2

Green Island Station, twelve miles west of Port Simpson, British Columbia. The powerful flashing light at this station at an elevation of 81 feet above sea level is responsible for numerous casualties.



LIGHTHOUSES ON THE COAST OF BRITISH COLUMBIA

Illustrations accompanying "A Preliminary Report on the Destruction of Birds at Lighthouses on the Coast of British Columbia", by J. A. Munro. Pages 141-145.



Fig. 5.—Young Columbian ground squirrels, one day old. Very young squirrels resemble young field mice; they are quite imperfect, being blind, toothless and hairless; but develop very rapidly, even doubling their original weight in five days.



Fig. 6.—Here is represented a nest of young wild Columbian ground squirrels at about 25 to 30 days old, at or a few days before the time when they are ready to leave the home den. Their early development is very prompt, in keeping with the short summer life of activity as lived by this species.

a sigmoid curve to the top of the flattened band area, across the band they incline backward at a gentle angle, crossing the lower carina, where they again curve slightly forward; at the umbilicus margin they turn sharply back and pile upon one another, making a ridge around the umbilicus. This ridge, as stated above, is not confined to the last whorl but projects into the umbilicus from the base of each whorl. The growth lines again curve slightly forward until they meet the sixth carina where they again pile up; from here they incline slightly forward to the point of contact with the whorl above.

Shell substance very thick, composed of three layers, the inner and outer layer apparently similar and much stronger than the intermediate one, which appears to have been more porous. Its place is generally filled by the matrix; where it is partially preserved it is more or less granular.

Horizon and Locality. Upper Ordovician, Palliser Pass, Rocky Mountains, B.C., collected by J. R. Marshall.

Lophospira occidentalis n. sp.

Pl. II, fig. 3.

Greatest width 17 mm., greatest length 19 mm. Five whorls, that at the apex but partially preserved. Each whorl sharply defined by a prominent carina, a little less than a third above the contact of the whorl with the succeeding one. Slightly convex below the carina, giving each whorl the aspect of overhanging the succeeding one. The final whorl shows that the convexity becomes somewhat flattened towards the narrow umbilicus. Above the carina the whorl slope is flat except for the slight unevenness produced by the band on the carina. Upon reaching the overhanging por-

tion of the carina of the whorl above, the upper portion rounds in toward the suture, leaving a narrow flattened area below the carina of the whorl above. Whorl nearly quadrate in section, the upper edge being rather shorter than the other sides and the angles more rounded. Edge of umbilicus not exposed.

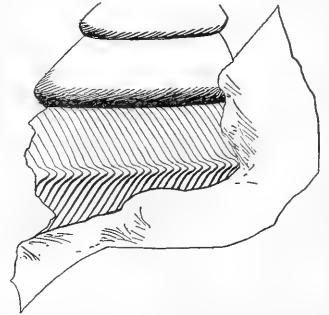

Fig. 2.—*Lophospira occidentalis* n. sp. Restoration of the growth lines on a portion of a whorl. $\times 2\frac{1}{2}$.

The ornamentation is preserved only on one small section, but it shows the notched lip of *Lophospira* and the lines of growth sweeping back toward the band both above and below the carina. Of the Upper Ordovician species described *L. occidentalis* seems most nearly to resemble *L. tropidophora* in general outline, but it differs from it in having more whorls and consequently narrower ones in the same sized shell, and in having the lower portion of the lip rounded rather than projecting, with the consequent difference in the section of the whorl. The same differences are more pronounced between *L. occidentalis* and *L. perlamellosa* and its tendency to have a convex rather than a concave slope above and below the carina differentiates it from most other species of the genus.

Horizon and Locality. Upper Ordovician, on the slope east of Palliser Pass, Rocky Mountains, B.C. Collected by J. R. Marshall.

THE HOME LIFE OF THE COLUMBIAN GROUND SQUIRREL

By WILLIAM T. SHAW

(Concluded from page 130)

THE NEST.—The nest is large and bulky and made of dead wild grass or straw leaves, usually the material at hand. The outer portion is of coarser material and the lining of the nest is made of very finely shredded grass blades. This fineness is due not altogether to selection, but rather to the nest material having been shredded by the squirrel. These linings are very dry, soft and warm, quite a fit cradle blanket for any little squirrel. At first the brood nest is arched over, but when the young are nearly grown, they break it down completely and lie on top of it. (Fig. 6.)

Squirrels are very industrious when building their nest. When once they start they make repeated trips in rapid succession, seeming to delay for nothing. They appear to roll the nest

material with a quick motion of the front paws, packing it back to the grasp of their teeth alternately on either side of the mouth, so that no loose ends will interfere when they get into the burrow. Five of these brood nests were excavated and studied with care.

THE USE OF DENS BY SEXES DURING THE RUTTING SEASON.—The rutting season is one of great confusion among the squirrels. From March 8, 1915, when rutting was first noticed on the north slope, until March 22, at which time it was about over for the season, excavation investigations carried on showed that the sexes were found indiscriminately in the same dens. Ten of twelve dens treated with gas contained both sexes. The same condition was recorded on March 7,

1914, though another den treated and excavated on that date showed only one sex.

THE USE OF DENS BY SEXES DURING THE GESTATION SEASON.—During this time of den selection and nest making, the male squirrel is not allowed near the den. He shows no interest in the life history of the species after the mating has taken place. Indeed, the antagonism shown by the female toward the male and the fact of these squirrels being cannibalistic would lead us to believe that his presence in the den would be not only undesirable, but dangerous to the growing young. That the sexes remain isolated at this season in the matter of den occupation is shown by the fact that of 3 dens excavated for gassed squirrels on March 23, 24 and 26, one male and two females were found living each in a separate den.

THE USE OF DENS BY SEXES DURING BROODING SEASON.—Roughly speaking, the brooding season extends from about the 15th of April until the 10th of May and is a time of segregation, for now the helpless young are in the dens.

On April 28, two males were taken in one den. Nearby, two females were taken, each from a separate den. This was at a time when the young were in the nest, and before they had appeared above ground. The following year, on May 4, four females were taken in as many dens. These dens were completely excavated and no males found in them. The next year, however, an observation was made on May 10, in which a den containing a brood nest was excavated and found to contain one male, one female and five young. It must be noted here, however, that this occurrence of a male squirrel in a den with young may have been due to his having been surprised and compelled to take refuge there, and to the fact that the young were now running about. In no other instance, during the six years of this investigation, has a male squirrel been found in a den with a brood nest and young.

THE YOUNG.—The young are quite undeveloped when born but undergo a most remarkable and rapid growth. (Fig. 5.) About two months after the squirrels have come from hibernation and about 30 days after their birth the little brood make exit to the open world. (Fig. 6.) We believe from observations made with the captive squirrels they probably begin to move about in the den two or three days before showing themselves, or during the time of the opening of their eyes. On the morning of their appearance they look like a small bunch of downy precocious birds, all huddled about the little round entrance. When approached, they crowd about this diminutive squirrel door in curious wonderment, all in a compact furry ball, ready to scramble precipitately.

At the warning whistle of the mother they disappear like a flash, but the instinct of *Citellus* curiosity impels them to peep again for another look at the stranger; sometimes giving the call note just as would an adult. At first they appear at one entrance only, which can be told by its dust appearance, made so by the many little claws scratching about. This is the opening of a burrow leading rather directly to the nest. This behavior continues for a day or so, and then they appear scattered in their den, slyly looking from the doors of as many burrows as there are pairs of sharp black eyes. Then, after a little more brooding by the mother in attempting to protect them from their enemies, and a day or two of play and tussle on the mounds of dooryard earth, they scatter indiscriminately over their slope, wherever dens and burrows exist, for this is the beginning of their local migration.

NUMBER OF LITTERS PER YEAR.—Regarding the number of litters raised each year there has been considerable controversy. Appearing so abundantly and spontaneously from the brood nests, they are apt to give the casual observer the idea that they are more prolific than they really are. Moreover, we have been accustomed to compare the smaller rodents, for lack of exact knowledge, with related species, and being familiar with the better known rabbit and the remarkably precocious and prolific Guinea pig, have hastily concluded that the squirrel is likewise prolific. Our investigations have shown that, beyond a doubt, for this locality there is, and can be, but one brood per annum. It could not be otherwise, for the active season of the squirrels is not much more than five months. Over two months of this period is taken before the squirrels can mate, reproduce, and develop the young sufficiently to make it safe for them to expose themselves to the dangers of the open fields. This leaves but a comparatively brief space of time, three months, during which period the somewhat exhausted females, to say nothing of the maturing young, must make provision for an approaching period of adversity and subsequent aestivation and hibernation. It is further known that the growth of the young is arrested during this first summer, and taken up in the following spring. These facts prohibit the possibility of a second brood; and also the likelihood of the still more extreme assertion that the young females of a first brood were breeding during the summer in which they were born. The young females do breed, however, the following spring, which would be at the age of about eleven months. The data gathered in the investigation will bear out these statements. In the case of a litter which was bred under wild conditions, we have a fair illustration of the regular

sequence of events. The wild squirrels appeared from hibernation on February 19, 1914, and were rutting on March 7. On April 1, young were born. These young, although reared in captivity, were well cared for and developed normally, but did not come out into the daylight until April 30. So, two months and more have passed out of the five or six months, at most, of the active life of the squirrels and the young are not yet weaned. Were the female to breed again, immediately, which she does not do, her second litter would have but one month instead of three, during the most adverse season, in which to prepare for aestivation. The facts are that these of the first brood go into aestivation before reaching maturity, finishing their growth the following year.

These and still other factors may enter into the problem as a further hindrance to the production of a second litter. One of these factors is found in the sexually impotent males, which became so after the brief rutting season had passed, and remained so throughout the active season, a fact which precludes the possibility of a second litter.

That there is a regular order of events through the active season of the squirrel is further shown by the case of squirrels in captivity. The litter was born on May 12, 1911, six weeks later than normal. The young did not go into hibernation until September 28, nearly six weeks later than the wild squirrels. These same squirrels had aestivated the next year by July 31, however, going in at the usual time for the species. One of them appeared from hibernation at the usual time, March 21, 1923.

It has been argued that the females are bred in the fall before going into hibernation. This has been disproved many times by observing the females in captivity. They do not breed unless allowed with the males in the spring, though they have run with them the previous autumn. This is shown in the case of the males and females permitted to run together all summer and later to hibernate together. The following spring they were separated as they came from hibernation, and as a result it was found they had not bred.

THE NUMBER OF LITTERS DURING THE LIFE-TIME.—In regard to this question, we can only infer that there is one litter per season from the time the squirrel is one year old until she has run her course. That this is the case would seem true, owing to the fact that almost never was a squirrel found which had not bred during the season. Only once, in all the investigation, was such a

squirrel found.

AVERAGE NUMBER OF YOUNG PER LITTER AS SHOWN BY EMBRYOS.—For the determination of this point 176 dissections of female squirrels were made. Of these, 56 bore embryos, the smallest number being 2 and the largest being 7. The average number for the 56 was 5.4 embryos.

AVERAGE NUMBER OF YOUNG PER LITTER AS SHOWN BY FETAL SCARS.—As in the case of other Rodentia, the placentation is discoidal, resulting in the formation of a congested spot on the wall of the uterus at the time of the birth of the young. This dark spot remains some weeks after the birth of the young, and may be looked for in determining the number of young per litter after parturition. At least two cases in the citellary, and a female taken with her brood on May 4, 1912, showed the number of the litter and the number of fetal scars to coincide exactly. That these scars remained distinct for several weeks, e.g., 88 days, made them of value as an indicator. Using the fetal scars as an index, twenty-one squirrels were examined. The smallest number of fetal scars was 2 and the largest 10. The average of the 21 was 5.09 scars.

DESTRUCTION OF YOUNG BY MOTHER.—That the reduction of the number of the litter may be effected by the cannibalistic instinct of the mother is possible, although no direct evidence has been obtained. One of the seven squirrels in a captive litter disappeared when they were fifteen days old.

RELATION OF AGE AND MATURITY TO SIZE OF LITTER.—That the size of the litter would appear but slightly affected by the age and maturity of the female would seem the case by examining data compiled from squirrels taken in March, April and May, 1911, showing that, out of 64 pregnant females examined, 24 above the average weight had a litter average of 5.32.

The heaviest squirrel weighed 536 grams.

The lightest squirrel weighed 228 grams.

RELATION OF AGE TO TIME OF BREEDING.—That the mature females would breed before the younger ones, we would naturally infer from the fact that they appear from hibernation first. Careful dissection of five females showed the adult females about three days in advance of the immature.

This, in brief, is an account of the home life of the Columbian ground squirrel, strangely modified by its environment. That other phases of its cycle have shown phenomena of equal interest would lead one to believe that many small mammals of obscure habit have lives of unusual interest.



OFFICIAL CANADIAN RECORD OF BIRD-BANDING RETURNS**(Continued from page 135)*

- BLACK DUCK, No. 207,980, banded by H. S. Osler, at Lake Scugog, Ontario, on October 2, 1922, was shot at Go-Home Bay, Georgian Bay, Ontario, on November 15, 1922.
- BLACK DUCK, No. 207,991, banded by H. S. Osler, at Lake Scugog, Ontario, on October 3, 1922, was killed within one mile of the trap on November 6, 1922.
- BLACK DUCK, No. 207,994, banded by H. S. Osler, at Lake Scugog, Ontario, on October 3, 1922, was shot in a marsh on Lake Erie, between Detroit and Monroe, Michigan, on December 1, 1922.
- BLACK DUCK, No. 228,406, banded by H. S. Osler, at Lake Scugog, Ontario, on October 6, 1922, was caught in a muskrat trap in the marshes along the James River, Virginia, about January 30, 1923.
- BLACK DUCK, No. 228,411, banded by H. S. Osler, at Lake Scugog, Ontario, on October 7, 1922, was caught in a muskrat trap in New Castle County, Delaware, on December 15, 1923.
- BLACK DUCK, No. 228,412, banded by H. S. Osler, at Lake Scugog, Ontario, on October 7, 1922, was killed at a point five miles west of Snow Lake, Desha County, Arkansas, on December 12, 1922.
- BLACK DUCK, No. 228,421, banded by H. S. Osler, at Lake Scugog, Ontario, on October 7, 1922, was killed on the Upper Chester River, Kennedyville, Maryland, on January 10, 1923.
- BLACK DUCK, No. 228,429, banded by H. S. Osler, at Lake Scugog, Ontario, on October 7, 1922, was killed at the same place on October 15, 1922.
- BLACK DUCK, No. 228,434, banded by H. S. Osler, at Lake Scugog, Ontario, on October 7, 1922, was killed at Gillette, Arkansas, on January 22, 1923.
- BLACK DUCK, No. 228,436, banded by H. S. Osler, at Lake Scugog, Ontario, on October 7, 1922, was shot twelve miles east of Belleville, Ontario, at the east end of Big Island, on the Bay of Quinte, on November 7, 1922.
- BLACK DUCK, No. 228,440, banded by H. S. Osler, at Lake Scugog, Ontario, on October 7, 1922, was killed at the same place on October 20, 1922.
- BLACK DUCK, No. 228,450, banded by H. S. Osler, at Lake Scugog, Ontario, on October 8, 1922, was killed at Big Spring, Kentucky, on January 2, 1923.
- BLACK DUCK, No. 228,454, banded by H. S. Osler, at Lake Scugog, Ontario, on October 8, 1922, was killed in Jackson County, close to Matagorda Bay, Texas, on January 1, 1923.
- BLACK DUCK, No. 228,456, banded by H. S. Osler, at Lake Scugog, Ontario, on October 8, 1922, was killed at Hog Island Bay, Northampton County, Virginia, on December 28, 1922.
- BLACK DUCK, No. 228,457, banded by H. S. Osler, at Lake Scugog, Ontario, on October 8, 1922, was killed on the Nanticoke River, Dorchester County, Maryland, on January 6, 1923.
- BLACK DUCK, No. 228,458, banded by H. S. Osler, at Lake Scugog, Ontario, on October 8, 1922, was killed at Stevenson, Alabama, on December 29, 1922.
- BLACK DUCK, No. 228,461, banded by H. S. Osler, at Lake Scugog, Ontario, on October 8, 1922, was shot on the Canadian Marsh, by a resident of Detroit, Michigan, on November 20, 1922.
- BLACK DUCK, No. 228,470, banded by H. S. Osler, at Lake Scugog, Ontario, on October 8, 1922, was killed at the same place on October 20, 1922.
- BLACK DUCK, No. 228,471, banded by H. S. Osler, at Lake Scugog, Ontario, on October 8, 1922, was killed near Fort Mott, New Jersey, on December 28, 1922.
- BLACK DUCK, No. 228,480, banded by H. S. Osler, at Lake Scugog, Ontario, on October 8, 1922, was killed at the same place on October 15, 1922.
- BLACK DUCK, No. 228,485, banded by H. S. Osler, at Lake Scugog, Ontario, on October 8, 1922, was shot on Gull Lake, 49°45' N., 76°45' W. Waswanipi River, Quebec, during the first part of May, 1923.
- BLACK DUCK, No. 228,487, banded by H. S. Osler, at Lake Scugog, Ontario, on October 8, 1922, was killed at the same place on October 20, 1922.
- BLACK DUCK, No. 228,500, banded by H. S. Osler, at Lake Scugog, Ontario, on October 10, 1922, was shot twelve miles east of Belleville, Ontario, at the east end of Big Island, on the Bay of Quinte, on November 13, 1922.
- BLUE-WINGED TEAL, No. 228,501, banded by H. S. Osler, at Lake Scugog, Ontario, on October 10, 1922, was shot at Forman, North Dakota, on September 30, 1923.
- BLACK DUCK, No. 228,502, banded by H. S. Osler, at Lake Scugog, Ontario, on October 10, 1922, was shot on the shores of South Carolina, one mile from Savannah, Georgia—no date given.
- BLACK DUCK, No. 228,519, banded by H. S. Osler, at Lake Scugog, Ontario, on October 10, 1922, was shot one mile above Catskill, on the Hudson River, New York, on October 16, 1922.
- BLACK DUCK, No. 228,533, banded by H. S. Osler, at Lake Scugog, Ontario, on October 13, 1922, was killed on Lac au Sable, about twenty miles east of Obijuan, on the head waters of the St. Maurice River, Quebec, on March 3, 1923. (Date of return appears improbable.—Ed.)
- BLACK DUCK, No. 228,537, banded by H. S. Osler, at Lake Scugog, Ontario, on October 13, 1922, was killed on the south fork of the Halston River, in Smyth County, Virginia, during the month of November, 1922.
- BLACK DUCK, No. 228,541, banded by H. S. Osler, at Lake Scugog, Ontario, on October 13, 1922, was killed at Thirty Thousand Islands, Ontario, during the month of October, 1922.
- SLATE-COLORED JUNCO, No. 26,411, banded by B. W. Cartwright, at Sturgeon Creek, Manitoba (three miles west of the limits of Winnipeg), on October 15, 1922, was found dead at the same place, on October 19, 1922.
- BLACK DUCK, No. 228,555, banded by H. S. Osler, at Lake Scugog, Ontario, on October 16, 1922, was killed on the marshes adjoining Lake

*Published by authority of the Canadian National Parks Branch, Department of the Interior, Canada.

Erie, in Ottawa County, thirty miles east of Toledo, Ohio, on November 30, 1922.

BLACK DUCK, No. 228,566, banded by H. S. Osler, at Lake Scugog, Ontario, on October 16, 1922, was killed in Bogue Sound, Carteret County, North Carolina, on January 1, 1923.

BLACK DUCK, No. 228,567, banded by H. S. Osler, at Lake Scugog, Ontario, on October 20, 1922, was killed within one mile of the trap, on November 6, 1922.

BLACK DUCK, No. 228,582, banded by H. S. Osler, at Lake Scugog, Ontario, on October 20, 1922, was shot at Savannah, Georgia, about December 4, 1922.

BLACK DUCK, No. 228,598, banded by H. S. Osler, at Lake Scugog, Ontario, on October 20, 1922, was killed at Lake Scugog, Ontario, on October 25, 1922.

BLACK DUCK, No. 228,604, banded by H. S. Osler, at Lake Scugog, Ontario, on October 21, 1922, was killed within one mile of the trap, on November 6, 1922.

BLACK DUCK, No. 228,608, banded by H. S. Osler, at Lake Scugog, Ontario, on October 21, 1922, was killed at McCuller's Mill Pond, Burke County, Georgia, twelve miles from Waynesboro, Georgia, about November 30, 1922.

BLACK DUCK, No. 228,609, banded by H. S. Osler, at Lake Scugog, Ontario, on October 21, 1922, was killed at Fredericksburg, Virginia—no date given, but reported on January 3, 1924.

BLACK DUCK, No. 228,623, banded by H. S. Osler, at Lake Scugog, Ontario, on October 21, 1922, was killed at Reydel, about forty miles south of Pine Bluff, Arkansas, on December 23, 1922.

BLACK DUCK, No. 228,647, banded by H. S. Osler, at Lake Scugog, Ontario, on October 29, 1922, was killed forty miles from Fredericksburg, Virginia, on December 3, 1923.

BLACK DUCK, No. 228,670, banded by H. S. Osler, at Lake Scugog, Ontario, on November 6, 1922, was recaptured at the same station on November 10, and 11, 1922, and was killed on the Grand River, five miles from where it empties into Lake Erie, on November 25, 1922.

BLACK DUCK, No. 228,674, banded by H. S. Osler, at Lake Scugog, Ontario, on November 10, 1922, was shot at Bainbridge, New York, on October 27, 1923.

MALLARD, No. 1,402, banded by Miss Gussie Innes, at Kinalmeaky Farm, Headingly, Manitoba, on November 11, 1922, was shot at Matlock, Manitoba, on October 31, 1923.

BLACK DUCK, No. 228,678, banded by H. S. Osler, at Lake Scugog, Ontario, on November 11, 1922, was shot on the east shore of Lake St. Clair, near Mitchell's Bay, Ontario, on December 6, 1923.

BLACK DUCK, No. 228,680, banded by H. S. Osler, at Lake Scugog, Ontario, on November 11, 1922, was killed at Gray Court, South Carolina, on December 7, 1922.

BLACK DUCK, No. 228,692, banded by H. S. Osler, at Lake Scugog, Ontario, on November 13, 1922, was shot at Pine Brook, on the Passaic River, New Jersey, about December 11, 1922.

BLACK DUCK, No. 228,699, banded by H. S. Osler, at Lake Scugog, Ontario, on November 16, 1922, was shot on Lake Ontario, at Point Breese, Orleans County, New York, on November 20, 1922.

MALLARD, No. 230,074, banded by F. C. Lincoln, at the Sanganois Club, Browning, Illinois

on November 16, 1922, was shot at Portage la Prairie, Manitoba, on October 15, 1923.

BLACK DUCK, No. 202,502, banded by H. S. Osler, at Lake Scugog, Ontario, on November 18, 1922, was shot in Port Rowan Bay, Ontario, on November 30, 1923.

MALLARD, No. 230,541, banded by F. C. Lincoln, at the Sanganois Club, Browning, Illinois, on November 22, 1922, was shot near Eyebrow, Saskatchewan, on September 15, 1923.

BALD EAGLE (Species?), No. 202,114, banded by Herman Battersby, at Oak Lake, Manitoba, on November 23, 1922, was killed on the banks of the Souris River, two miles west of the town of Hartney, Manitoba, on November 24, 1922.

MALLARD, No. 230,651, banded by F. C. Lincoln, at the Sanganois Club, Browning, Illinois, on November 24, 1922, was shot at Red Earth, Saskatchewan, one hundred miles in a straight line from The Pas, Manitoba, on October 2, 1923.

MALLARD, No. 230,726, banded by F. C. Lincoln, at the Sanganois Club, Browning, Illinois, on November 24, 1922, was killed at Carmel, Saskatchewan, on October 15, 1923.

MALLARD, No. 230,764, banded by F. C. Lincoln, at Browning, Illinois, on November 24, 1922, was shot at Englefield, Saskatchewan—no date given, but reported on November 20, 1923.

MALLARD, No. 230,999, banded by F. C. Lincoln, at Browning, Illinois, on November 28, 1922, was killed in the vicinity of Wainwright, Alberta, on September 15, 1923.

MALLARD, No. 231,030, banded by F. C. Lincoln, at the Sanganois Club, Browning, Illinois, on November 28, 1922, was killed at the north end of Burnt Wood Lake, Saskatchewan, on May 12, 1923.

MALLARD, No. 231,048, banded by F. C. Lincoln, at the Sanganois Club, Browning, Illinois, on November 28, 1922, was shot thirty miles east of Edmonton, Alberta, on September 15, 1923.

MALLARD, No. 231,284, banded by F. C. Lincoln, at the Sanganois Club, Browning, Illinois, on December 5, 1922, was killed in the vicinity of Cupar, Saskatchewan, on October 17, 1923.

MALLARD, No. 231,302, banded by F. C. Lincoln, at the Sanganois Club, Browning, Illinois, on December 5, 1922, was shot ten miles north of The Pas, Manitoba, on October 6, 1923.

GREEN-WINGED TEAL, No. 504,440, banded by E. A. McIlhenny, at Avery Island, Louisiana, on December 27, 1922, was killed at Lethbridge, Alberta, on September 1, 1923.

SONG SPARROW, No. 12,045, adult, banded by Ralph E. DeLury, at 330 Fairmont Avenue, Ottawa, Ontario, on April 1, 1922, repeated on April 5, 1922, returned to the same station on April 27, 1923, and repeated on May 10, May 13, and May 25, 1923. This bird screeched when taken and bit the fingers savagely.

SONG SPARROW, No. 12,047, adult male, banded by Ralph E. DeLury, at 330 Fairmont Avenue, Ottawa, Ontario, on April 1, 1922, repeated at the same station on July 9, 1922.

SONG SPARROW, No. 12,053, adult female, banded by Ralph E. DeLury, at 330 Fairmont Avenue, Ottawa, Ontario, on April 11, 1922, repeated several times at the same station until June 28, 1922.

SLATE-COLOURED JUNCO, No. 12,055, adult male, banded by Ralph E. DeLury, at 330 Fairmont Avenue, Ottawa, Ontario, on May 3,

- 1922, was re-caught at the same station on May 4, 1922.
- WHITE-THROATED SPARROW, No. 26,802, adult male, banded by Ralph E. DeLury, at 330 Fairmont Avenue, Ottawa, Ontario, on May 6, 1922, fed about the trap from which it was banded for a week before and after banding.
- CHIPPING SPARROW, No. 26,813, adult female, banded by Ralph E. DeLury, at 330 Fairmont Avenue, Ottawa, Ontario, on June 24, 1922, was re-caught at the same station on July 24, 1922. This bird fed about a trap in front of Mr. DeLury's house during the month of July.
- ROBIN, No. 104,127, adult female, banded by Hoyes Lloyd, at 406 Queen Street, Ottawa, Ontario, on July 1, 1922, returned to the same trap on April 26, 1923, and was seen every day or so in the same locality until May 1, 1923.
- CHIPPING SPARROW, No. 26,825, adult male, banded by Ralph E. DeLury, at 330 Fairmont Avenue, Ottawa, Ontario, on July 24, 1922, was re-caught at the same station on July 30, 1922, returned to the same place, but to a different trap, on May 12, 1923, and repeated several times at the same station until July 24, 1923.
- SONG SPARROW, No. 26,828, adult male, banded by Ralph E. DeLury, at 330 Fairmont Avenue, Ottawa, Ontario, on July 30, 1922, was re-caught at the same station on August 22, 1922.
- SONG SPARROW, No. 26,829, adult female, banded by Ralph E. DeLury, at 330 Fairmont Avenue, Ottawa, Ontario, on August 6, 1922, was re-caught at the same station on August 19, and August 26, 1922, returned to the same station on April 29, 1923, and repeated on May 13, and May 17, 1923.
- SONG SPARROW, No. 26,716, banded by K. Grant McDougal, on Lot 50, East Kildonan Road, Winnipeg, Manitoba, on September 7, 1922, repeated at the same station on September 24, 1922.
- WHITE-THROATED SPARROW, No. 26,720, adult, banded by K. Grant McDougal, on Lot 50, East Kildonan Road, Winnipeg, Manitoba, on September 9, 1922, repeated at the same station on September 11, 1922.
- SONG SPARROW, No. 26,731, adult, banded by K. Grant McDougal, on Lot 50, East Kildonan Road, Winnipeg, Manitoba, on September 18, 1922, repeated at the same station on September 25, 1922.
- WHITE-THROATED SPARROW, No. 26,741, adult, banded by K. Grant McDougal, on Lot 50, East Kildonan Road, Winnipeg, Manitoba, on September 19, 1922, repeated several times at the same station until September 28, 1922.
- SLATE-COLOURED JUNCO, No. 26,431, adult male, banded by K. Grant McDougal, at Lot 50 East Kildonan Road, Winnipeg, Manitoba, on October 5, 1922, repeated at the same station on October 7, 1922.
- SLATE-COLOURED JUNCO, No. 26,439, adult male, banded by K. Grant McDougal, on Lot 50, East Kildonan Road, Winnipeg, Manitoba, on October 15, 1922, repeated at the same station on October 17, 1922.
- FOX SPARROW, No. 28,135, adult, banded by K. Grant McDougal, on Lot 50, East Kildonan Road, Winnipeg, Manitoba, on October 15, 1922, repeated at the same station on October 16, 1922.
- SLATE-COLOURED JUNCO, No. 26,444, adult male, banded by K. Grant McDougal, on Lot 50, East Kildonan Road, Winnipeg, Manitoba, on November 4, 1922, repeated at the same station until November 12, 1922.
- SLATE-COLOURED JUNCO, No. 26,445, adult male, banded by K. Grant McDougal, on Lot 50, East Kildonan Road, Winnipeg, Manitoba, on November 4, 1922, repeated twice at the same station on November 5, 1922.
- SLATE-COLOURED JUNCO, No. 26,447, adult male, banded by K. Grant McDougal, on Lot 50, East Kildonan Road, Winnipeg, Manitoba, on November 5, 1922, repeated at the same station several times until November 11, 1922.
- RING-NECKED DUCK, No. 101,735, banded by E. A. McIlhenny, at Belle Isle Lake, Louisiana, on February 21, 1922, was found dead in a muskrat trap, in Tp. 59, R. 16, W. 3rd M., on the south shore of Meadow Lake, Saskatchewan, during the early part of May, 1923.
- MALLARD DUCK, No. 102,090, banded by L. V. Walton, at Cuiivre Island, Missouri, on February 21, 1922, was shot at Tangleflags, Saskatchewan, on November 16, 1923.
- PINTAIL DUCK, No. 102,812, banded by F. C. Lincoln, at the Sanganois Club, Browning, Illinois, on March 13, 1922, was shot on Great Slave Lake, near Resolution, Northwest Territories, during the month of September, 1923.
- BLUE-WINGED TEAL, No. 207,702, banded by H. S. Osler, at Lake Scugog, Ontario, on September 20, 1922, was killed in the Black Lake Bottoms, Kentucky, on April 20, 1924.
- BLUE-WINGED TEAL, No. 207,718, banded by H. S. Osler, at Lake Scugog, Ontario, on September 20, 1922, was killed near Cranks, Harlan County, Kentucky, about April 28, 1924.
- BLACK DUCK, No. 207,901, banded by H. S. Osler at Lake Scugog, Ontario, on September 27, 1922, was shot at Bennett's Cove, Presque Isle Bay, on the north shore of Lake Ontario midway between Coburg and Belleville, during the last week of November, 1922.
- BLACK DUCK, No. 207,910, banded by H. S. Osler, at Lake Scugog, Ontario, on September 27, 1922, was killed four miles north of Ocean City, Maryland, on January 4, 1924.
- WHITE-THROATED SPARROW, No. 26,737, adult, banded by K. Grant McDougal, on Lot 50, East Kildonan Road, Winnipeg, Manitoba, on September 19, 1922, repeated at the same station on September 20, 1922, and September 22, 1922. On September 22nd the bird was found to have a broken leg, and it died on this day.
- BLACK DUCK, No. 207,934, banded by H. S. Osler, at Lake Scugog, Ontario, on September 29, 1922, was killed in Ponds Creek, at the head of Chesapeake Bay, Maryland, on January 27, 1924.
- BLACK DUCK, No. 228,447, banded by H. S. Osler, at Lake Scugog, Ontario, on October 8, 1922, was killed at Golden Hill, Maryland, on March 2, 1924.
- BLACK DUCK, No. 228,562, banded by H. S. Osler, at Lake Scugog, Ontario, on October 16, 1922, was killed in the same vicinity on the day on which it was banded.
- BLACK DUCK, No. 228,011, banded by Jos. Pulitzer, at Spring River Pond, Hancock County, Maine, on October 31, 1922, was killed at Wedgeport, Yarmouth Co., Nova Scotia, on January 18, 1924.
- MALLARD DUCK, No. 230,293, banded by F. C. Lincoln, at Browning, Illinois, on November

20, 1922, was killed on Gull Rock Lake, in the District of Patricia, Ontario, on April 23, 1924.

BLUE-WINGED TEAL, No. 504,165, banded by E. A. McIlhenny, at Avery Island, Missouri, on November 23, 1922, was shot on the east side of Lake Manitoba, seventy-five miles north of

Winnipeg, Manitoba, on September 16, 1923.

MALLARD, No. 230,885, banded by F. C. Lincoln, at Browning, Illinois, on November 26, 1922, was shot at Richardson's Lake (known as Jack Fish Lake), about thirty miles south of Fort Chipewyan, Alberta, about September 26, 1923.

(To be continued)

NOTES AND OBSERVATIONS

MARINE INVESTIGATIONS ON THE WEST COAST OF VANCOUVER ISLAND, 1909.—The Biological Station at the head of Departure Bay was established in the spring of 1908 and the Rev. G. Taylor, one of our fellows, was placed in charge. That summer the writer was on Vancouver Island collecting Natural History specimens, and two months were spent at the station. The writer had suggested in spring that Mr. C. H. Young should come out late in summer and attempt to prepare specimens of star-fishes and crabs for the National Museum. He came and our success was so apparent that permission was granted for the writer, Mr. C. H. Young and Mr. W. Spreadborough to spend the summer of 1909 on the west coast of Vancouver Island and make collections of the Marine fauna and flora.

We reached Ucluelet on the west side of Barclay Sound on May 3, 1909, and, having been offered a fine new house by Mr. Sutton, we moved in and established ourselves at once. Our residence was about two miles up Ucluelet Inlet, which extended about four miles farther to the west. Collections were made along the whole coast of the Inlet and on the outside of the Peninsula and for about 16 miles amongst the islands towards Toquart.

Besides the shore collecting, dredging was carried on by the aid of a motor launch and many fine things were secured at depths ranging from 5 to 30 fathoms. On the outer coast and the shores of all the islands, collecting was very difficult, owing to the wonderful growth of seaweed, the slippery and jagged rocks, and, not infrequently, the heavy swell from the Pacific Ocean, which never wholly ceased.

Being on the exposed coast the tides were very regular; and we soon found that the afternoon tide was never low, and that the low tides to suit were between 3 a.m. and 9 a.m. On this account our work every alternate week commenced at 4 a.m. To get out of the inlet we had two miles to row and if we went outside we had to cross the inlet and force our way through almost impassable undergrowth to the outer coast.

The whole coast outside the Inlet was lined with kelp, the belt being from 50 to 200 yards in width. Between the shore and the kelp line was the part laid bare at low tide and in this were boulders, ledges, and pools, all covered by a most luxuriant growth of seaweed. As usual, *Fucus* of numerous

varieties covered the rocks down to half tide. Below that to the line of the kelp below low water were various species of *Alaria*, *Agarum*, *Costaria*, *Laminaria*, *Lessonia*, *Postilosia* and *Egeria*; these, with multitudes of smaller species, hung from rocks and stones and made a slippery floor that covered everything and was a complete shelter for all kinds of marine life. The kelp belt consisted of *Macrocystis pyrifera* and *Nereocystis Luetkiana*. The former extended inwards to almost extreme low water, while the latter formed the outer fringe. No doubt many animals found shelter in this belt, but we were unable to see to any considerable depth, owing to the color of the water.

Mr. Young and Mr. Spreadborough soon learned the hiding places of crabs and their allies, and four hours' collecting gave them material to work on for the remainder of the day, which often did not end until dark. My work was chiefly collecting seaweeds and marine life, seldom below half tide. Our collections were sorted out and each member of the party did his own special work. Mr. Spreadborough prepared the alcoholic and formaline specimens. Mr. Young prepared the crabs and star-fishes, while I mounted sea-weeds, took charge of the shells and collected land plants.

Every alternate week dredging was done, either at the mouth of the Inlet, or amongst the islands towards Toquart. Many valuable specimens were obtained in this way and we learned the character of the bottom. Dredging had to be done early in the morning, as the Pacific swell became too great when the forenoon waned. Decapods, fish and shells were the chief results obtained in this way.

The only drawback we had was the change in the color of the sea-water. Towards the last of June the water became milky and from that time forward we ceased to collect from pools. This condition remained with us for the remainder of the season, but was not so bad late in August. The whalers told us that at first it was only about five miles from shore; but it kept extending outward, and by the middle of August was over 30 miles from shore.—JOHN MACOUN.

NOTE—Professor Macoun in no way better showed his enthusiasm in collecting and the broadness of his interests than in undertaking in 1908 and later the collection of marine animals. The results of his labours and of those of his collabor-

ators have been of very considerable value in extending our knowledge of marine forms. The material collected has been only in part worked up, but has figured prominently in Dr. Fraser's publications on Hydroids, in those of Drs. Dall and Bartsch on Mollusks, and in our own on Ascidians. We were so fortunate as to visit Professor Macoun at Ucluelet in 1909, and have still a vivid recollection of his activity, his kindness, and of his conversation, so stimulating to a young man.

He has well described the interesting conditions at Ucluelet, but we might add a few personal observations. The heavy rainfall of that coast was well shown during our stay, the sun rarely being visible, and the clouds always in evidence around the mountain behind the village, and lowering daily to give one or more showers. It was stated that the stumps removed in clearing land could with difficulty be burned, and were more usually piled up or overturned into the sea. Rotting of wood must proceed but slowly, as we found in one case three generations of trees growing one on top of another, the two lowermost of course fallen, but their stumps still in evidence. All of the trees would be considered large.

The fauna of the intertidal zone was found to be wonderfully rich on the shore exposed to the open Pacific, and well repaid the struggle through wet forest and thickets that was necessary to reach it. It would seem that the uniformity in temperature, ensured by the ocean influence and by the clouds serving as a shield from the sun, had permitted many sensitive forms to succeed in situations where they were exposed twice daily to the air. The comparative protection from the direct rays of the sun that the clouds afforded was doubtless also a factor, as so many of the marine animals are killed by exposure to direct sunlight. Professor Macoun and his assistants were lavish in help to enable us during our short stay to explore the neighbouring shores and obtain a large series of the Ascidians or sea-squirts of that district, which formed the main objective of our trip to Ucluelet and which were found growing in great luxuriance. —A. G. H.

LESSER SNOW GESE.—On February 9, 1924, I had the opportunity of closely observing these birds at Terranova, Lulu Island, B.C. The five-foot low tide was about 4.45 p.m. From the dyke, great flocks of Geese could be seen feeding along the mud flats, the white patches of birds showing up in sharp contrast to the gray and dark brown of mud and sedge roots. As I approached, the Geese arose with harsh raucous honking and a roar of wings, like distant thunder. Turning and twisting, they flew in great masses about a quarter

of a mile farther on, alighting and beginning to feed once more.

A Swan was noticed flying along the foreshore, and later I saw it feeding on the flats. It allowed me to approach within about two hundred yards of it, and then, uttering several peculiar harsh cries, and with loud flapping of wings, it arose and flew over to join a flock of Geese feeding farther along the shore.

It was a beautiful sight to view these birds flying by in flocks of from three or four to many hundreds, the black wing tips contrasting sharply with the pure white of the rest of their plumage. Sometimes they flew in V-formation, sometimes in long lines, sweeping over the water, and at other times in cloud-like masses.

I investigated the stomach contents of five of these Snow Geese. One contained a large quantity of tule roots and some fine gravel, the four others were almost empty except for fine gravel and a few of the same roots. Four were fat and the fifth, a male bird, was thin.

I understand from old hunters that in years gone by the Snow Geese used to feed at night in the fields of Lulu Island, but now they no longer do this, but content themselves with feeding on sedge roots along the foreshore at low tide.

This winter the Lesser Snow Geese have been more numerous than usual and appear to confine themselves entirely to the tide flats lying to the north of Lulu and Sea Islands.

On the afternoon of February 16, in company with Dr. M. Y. Williams, I visited the flats and it was not until about 4 p.m. that the Geese put in an appearance. When they came drifting along in countless numbers from the direction of the Sea Island foreshore. The tide was about half out and they flew up and down the shore, then finally settled on the flats near the Stevenson breakwater. —K. RACEY.

NOTES ON GRAY SQUIRREL IN NEW BRUNSWICK. —As far as I can learn, the gray squirrel is not a native of New Brunswick. I have asked those who should know, such as the Chief Forester and others, if they ever saw a gray squirrel in our New Brunswick woods and in each case was answered in the negative.

It seems as if they have been coming here* for several years, probably on the train. One of our city school teachers told me that she saw one six or seven years ago and I believe she knew what she was talking about, although her statement was scoffed at by others. Two years ago last October I saw one myself. Of course, I was curious to know where it came from. Later I learned that four had arrived in the city in a carload of grain from some point in Ontario. I doubt if any of

*Fredericton, N.B.

these four survived, as three or four were seen some weeks later at the local taxidermist's. He said that they had been shot in the woods near the city.

One that has been wintering here was seen first about the middle of last August, and two others were seen in other parts of the city. The one on our property was very wild at first and will hardly sit still to be looked at, even yet. This seems very strange to one who has been accustomed only to the impudent red squirrel.

When he first came, he fed on the butternuts that had been left on the ground the previous fall. Nuts were very scarce last fall, I could not find more than half a bushel, under about a dozen trees, but these I collected and placed under a large butternut in front of the house, so the squirrel would be forced to come where I could watch him. After he had eaten or carried away all of the fresh nuts, I carried out dry ones from the house.

Early in the fall, he would come to the tree, two or three times a day, eat three nuts each time, wash his hands and face and then go back to his nest. As the weather grew colder, he came only once a day and sometimes skipped a day, but when he did come he would eat as many as seven nuts without stopping. About Christmas, he stopped coming and lived on the food he had stored until the first of March.

I do not know enough about gray squirrels to know what kind he is. I should judge he is about eighteen or twenty inches long, about half of which length is a beautiful tail. When he came his feet and face were a reddish brown but when he got his winter coat of fur, his feet became clear gray and his face almost the same. The rest of his body is a beautiful, clear gray.

The red squirrels declared war on him at sight but he would not fight with them, although so much larger. He would dodge them and run away. I have been wondering if I could tame him but am doubtful, as he is so extremely wild.—SUSAN K. SQUIRES, (MRS. NATHAN C. SQUIRES).

SALAMANDERS LOST, STRAYED OR ?.—On the morning of April 19, 1924, I found a half-dozen salamanders, *Amblystoma jeffersonianum*, five or six inches in length, scattered about within a few rods, and mostly close together, on the new Government driveway where it passes through the woods at the rear of the Lady Grey hospital, Ottawa. Most of them had been crushed or crippled by passing automobiles, but some, even though injured severely, wriggled their tails when disturbed. One which was apparently unharmed, except for a coating of sand adhering to it, was scarcely livelier than the rest. The query which suggested itself was this: Was this some gregarious

and unseasonable migration that our zoological friends would be glad to have on record, or did some prowler in the woods find them under a log or logs, and lose or leave them in this unseemly place? The latter explanation seemed a plausible one until on May 1, another specimen, also freshly crushed by traffic, was found a little farther along the driveway; and on May 6 still another, dead, was found on a street close to the same woods and driveway. On each occasion rain had preceded their appearance, and earthworms also were strewn about in abundance.—H. GROH.

NOTES ON ROBINS WINTERING IN BRITISH COLUMBIA.—At Nelson all through this winter (1923-24) the very extraordinary sight of Robins perched in the trees could be seen. If it were only a case of one or two of these birds wintering north, it might be attributable to injury, and to unwillingness, or inability of the part of the birds to make the southern flight, but I counted on one occasion as many as fourteen in one flock, and there is not a doubt that the unusual course was premeditated. Some local bird observers attributed the matter to the fact that the mountain ash trees were loaded with berries—which was true; and others to foreknowledge on the part of the birds that the winter would be a very mild one—which, mercifully, it was. The behaviour of the birds was sluggish; they fed around quietly with their feathers fluffed out. I heard one on a sunny day essay a little song, but it was only half-hearted and *pp.*, as if he appreciated the fact that there was something irregular in the whole proceeding.—F. C. WHITEHOUSE.

THE EXHIBITION OF WILD LIFE PHOTOGRAPHS.—As previously noted in *The Canadian Field-Naturalist*, the collection of Wild Life photographs assembled by the Ottawa Field-Naturalists' Club and affiliated societies was exhibited in Quebec under the auspices of the Provancher Society of Natural History of Canada.

Owing to the interest created by the collection on this occasion, a second request was received for the loan of the pictures for exhibition in Quebec during National Week, June twenty-fourth to July first, organized by the Municipal Commission of the Quebec Provincial Exposition.

Unfortunately only 135 pictures were available for lending, as the balance of the original ensemble had been returned to the respective owners.

The Secretary of the Exposition reported as follows regarding the showing of the Wild Life pictures. "We made a beautiful display of what you sent us. More than 20,000 persons had the opportunity of seeing, admiring and studying the

collection of photographs, which was very valuable to us in the whole of our programme."—CLYDE L. PATCH, *Chairman, Wild Life Photographic Exhibitions Committee.*

NOTE.—The extra expense incurred in connection with the illustrations in this issue of *The*

Canadian Field-Naturalist has been met by Prof. William T. Shaw, the Geological Survey of Canada, and the Canadian National Parks Branch, to each and all of whom our thanks are tendered. We wish also to acknowledge with thanks our obligation to our printers for material reductions in the prices charged for special glazed paper for illustrations in this and the preceding issue.—EDITOR.

BOOK REVIEW

RESEARCH METHODS IN THE STUDY OF FOREST ENVIRONMENT. *By Carlos G. Bates and Raphael Zon. U.S. Dept. Agriculture Bulletin No. 1059.*

Ecology, which, in its early days, was largely observational and entirely qualitative, has now become definitely quantitative in its aims, and as a result the selection and use of instruments of precision for measuring the various factors of the environment is a matter of paramount importance in ecological work. In this bulletin the authors

describe the various instruments which are available for the measurement of the factors of terrestrial habitats, with special emphasis on those of the greatest service in forest investigations, and give instructions and precautions as to their use. In addition to this the various ecological factors and their interrelationships are discussed in a careful yet lucid manner. The statement that "A great deal more is to be learned as to the requirements of different species by closer observation of individuals" is true not only in ecology but also in natural history in general.—A. B. K.

PUBLICATIONS RECEIVED

Rivista Italiana di Ornitologia. Messina, 1924.
The Prouancher Society of Natural History of Canada. Annual Report, 1923. Quebec, P.Q.
Bulletin de la Ligue Francaise pour la Protection des Oiseaux. Triezième Année. Nos. 2-3—Février-Mars, 1924. Paris.
Bulletin de la Ligue Francaise pour la Protection des Oiseaux. Triezième Année. No. 4—April, 1924. Paris.
Bulletin de la Ligue Francaise pour la Protection des Oiseaux. Triezième Année. No. 5—Mai, 1924. Paris.
Bulletin de la Ligue Francaise pour la Protection des Oiseaux. Triezième Année. Nos. 7-8—Juillet-Aout, 1924. Paris.
Bulletin de la Ligue Francaise pour la Protection des Oiseaux. Triezième Année. Nos. 7-8—Juillet-Aout, 1924. Paris.
Le Gerfaut, 1924, Fascicule I-II. Bruxelles, Belgique.
Report of the Director of Forestry for the Fiscal Year ended March 31, 1923. Ottawa, 1924.
Hemlock. Tree Pamphlet No. 4. Forestry Branch, Department of the Interior. Ottawa, 1923.
Western Hemlock. Tree Pamphlet No. 5. Forestry Branch, Department of the Interior. Ottawa, 1924.
Red Pine. Tree Pamphlet No. 6. Forestry Branch, Department of the Interior. Ottawa, 1924.
The Preservative Treatment of Fence-Posts. Circular No. 16. Forestry Branch, Department of the Interior. Ottawa, 1924.
Pulping Qualities of Fire-killed Wood. Bulletin No. 76. Forestry Branch, Department of the Interior. Ottawa, 1924.
The Influence of certain Ductless Gland Substances on the Growth of Plant Tissues, by Professor Robert A. Budington, Oberlin College Laboratory Bulletin No. 37. Oberlin, 1919.
Journal of Scientific Transactions. British Association for the Advancement of Science. Toronto, 1924.
Construction and Control in Animal Life, by Professor F. W. Gamble, D.Sc., F.R.S. Toronto, 1924.
Breeding, Feeding, and Other Life Habits of Meadow Mice (Microtus), by Vernon Bailey. Reprinted from *Journal of Agricultural Research*, Vol. XXVII, No. 8. Washington, D.C., February 23, 1924.
Summary Report, 1923, Part A. of the Geological Survey of Canada. Ottawa, 1924.
Cochihalla Area, British Columbia, by C. E. Cairnes. Memoir 139. Geological Survey. Ottawa, 1924.
Report of the Canadian Arctic Expedition 1913-18. Volume XI: Geology and Geography. Part A.: The Geology of the Arctic Coast of Canada, west of the Kent Peninsula, by J. J. O'Neill. Part B.: Geographical Notes on the Arctic Coast of Canada, by Kenneth G. Chipman and John R. Cox. Ottawa, 1924.

The Geographic Setting of Chengtu, by Professor George D. Hubbard, Oberlin College. Laboratory Bulletin No. 34. Oberlin, 1923.

1. *The Antimony Mines of Shiu Chow, China.* 2. *The Antimony Ores of Shiu Chow, China.* 3. *Concretions in Lake Deposits, Elgria, Ohio.* By Professor George D. Hubbard, Oberlin College. Laboratory Bulletin No. 35. Oberlin, 1922-23.

Dimensions of the Cincinnati Anticline, by Professor George D. Hubbard, Oberlin College. Laboratory Bulletin No. 38. Oberlin, 1893.

1. *Amphibian Footprints from the Mississippian of Virginia.* 2. *Dinichthys Intermedius Newberry from the Huron Shale.* By E. B. Branson, Oberlin College. Laboratory Bulletin No. 41. Oberlin, 1908-10.

Materialization along the Dikes of Southern Vermont, by Harriet G. Bray and Alden H. Emery, Oberlin College, Oberlin, Ohio. Laboratory Bulletin No. 33. Oberlin, 1923.

Chromatic Emulsions, by Harry N. Holmes and Don. H. Cameron, Oberlin College. Laboratory Bulletin No. 32. Oberlin, 1922.

Cellulose Nitrate as an Emulsifying Agent, by Harry N. Holmes and Don. H. Cameron, Oberlin College. Laboratory Bulletin No. 39. Oberlin, 1922.

A Movement to Develop Research in Colloid Chemistry, by Harry N. Holmes, Oberlin College. Laboratory Bulletin No. 40. Oberlin, 1919.

Thirty-fourth Annual Archaeological Report, 1923, by Dr. R. B. Orr, being part of Appendix to the Report of the Minister of Education, Ontario, Toronto, 1924.

A Chapter in American Education. Rensselaer Polytechnic Institute, 1824-1924, by Ray Palmer Baker, Ph.D. New York. Charles Scribner's Sons, 1924.

Boletín Oficial de la Secretaria de Agricultura y Fomento. Mexico, 1923.

Monthly Record of Meteorological Observations in the Dominion of Canada, and the Colonies of Bermuda and Newfoundland. November, 1923. Issued by the Meteorological Service of Canada. Ottawa, 1924.

Ford News, Vol. 6, No. 4. Ford, Ontario.
Monthly Weather Map, Meteorological Service, Dominion of Canada. August, 1924.

Report of the Provincial Museum of Natural History for the year 1923. Victoria, B.C., 1924.

Animal Life in the Yosemite: An Account of the Mammals, Birds, Reptiles, and Amphibians in a Cross-section of the Sierra Nevada, by Joseph Grinnell and Tracy Irwin Storer. Berkeley, California, 1924.

Sweet Canada

Eleven Bird Songs and a Round
by

Louise Murphy

Author of "A Little Book of Bird Songs,
Rhymes and Tunes for Tiny Tots"

PRICE \$1.00

Longmans, Green & Co.
210 Victoria Street, Toronto

L. C. Smith & Bro.

Typewriter

*Ball bearings in every frictional part of
the L. C. Smith insure long life, light
touch and easy operation*

Ottawa Typewriter Co. Limited
191 QUEEN ST., OTTAWA



Card Filing Systems for Naturalists

As makers of the Library Bureau line of Card Filing Devices in Canada, we are in a position to supply all Naturalists with cards and trays where they can readily index all their observations and notes

Lowe-Martin Ltd.
OTTAWA, CANADA

*Printers of The Canadian Field-Naturalist
Publishers of the Autobiography of John Macoun, M.A*

The Crabtree Co.

Artists and
Designers

BLUEPRINTERS
ENGRAVERS
COMMERCIAL
PHOTOGRAPHERS
: PHOTO :
LITHOGRAPHERS

228 Albert Street
Ottawa, Ont.

COAL C. C. Ray Company

Limited

BEST QUALITY LOWEST PRICES

46 Sparks St.—Phone Q. 461
OTTAWA

Geo. E. Preston & Sons

MERCHANT TAILORS

*We make everything we sell and
guarantee everything we sell*

217-219 Rideau Street, Ottawa

Dr. Mark G. McElhinney

*Dentist to certain of the
cognoscenti*

252 LISGAR STREET, OTTAWA
Telephone Queen 2438

Kindly mention The Canadian Field-Naturalist to advertisers

Prices of Separates

Notes to Contributors, Etc.

Papers for publication should be addressed to the Editor, Mr. Harrison F. Lewis, Parks Branch, Ottawa, or to the appropriate Associate Editor.

Manuscript should be plainly written, typed if possible, on one side of the paper only, with wide spaces between the lines and ample margins. It is urged that special care be used that scientific names are legible, properly formed, and correctly spelled and capitalized.

Galley proof will be submitted to authors resident in Ottawa and proof of leading articles to any other author if requested when manuscript submitted. It is requested that it be corrected and returned to the Editor as quickly as possible.

Authors of leading articles are entitled to twenty-five copies of the number in which they appear, free of charge on application.

Separates of articles as they appear on the page, without any change of make-up will be supplied at the following rates:—

	25	50	100	200	300
1 page.....	\$2.00	\$2.25	\$2.50	\$2.75	\$3.00
2 ".....	3.00	3.25	3.75	4.00	4.25
3 ".....	3.50	3.75	4.00	4.25	4.50
4 ".....	3.50	3.75	4.00	4.25	4.50
5 ".....	4.50	4.75	5.00	5.25	5.50
6 ".....	4.50	4.75	5.00	5.25	5.50
7 ".....	6.00	6.25	6.50	6.75	7.00
8 ".....	6.00	6.25	6.50	6.75	7.00
9 ".....	7.50	8.00	8.75	10.25	11.75
10 ".....	7.50	8.00	8.75	10.25	11.75
Covers extra.....	3.00	3.00	3.00	4.00	5.00

If removal of matter on the pages non-pertinent to the article or changes of make-up are desired, or if insets or other extra work are necessary, special rates will be furnished on application to the Editor.

Applications for separates should be made to the Editor and must reach him not later than with the return of the corrected proof.

Rubber Stamps

FOR

Listing Your Specimens

The more consistent use of rubber stamps will materially assist you in cataloguing the collection of specimens you have spent so much time and trouble in securing. Let us help you.

CAPITAL RUBBER STAMP WORKS

175 NEPEAN STREET
OTTAWA, CANADA

Many More are Wanted on the Subscription Lists

The Membership Committee of The Ottawa Field-Naturalists' Club is making a special effort to increase the subscription list of *The Canadian Field-Naturalist* and we are asking every reader to assist in making the campaign the success it should be.

We would particularly urge the Secretary of each Affiliated Society to bring this matter up at EVERY meeting and secure as many subscribers as they possibly can to a Canadian Publication devoted to the study of Natural History in all its phases.

Use the blank below and forward it to the Treasurer.

————— CUT OFF HERE —————

MR. B. A. FAUVEL,
Treasurer, Ottawa Field-Naturalists' Club,
Mounted Police Headquarters,
Laroque Building,
Rideau and Dalhousie Sts.,
Ottawa, Canada.

I enclose One Dollar and Fifty Cents as my subscription to The Canadian Field-Naturalist for one year.

Name.....
(Mr., Mrs. or Miss)

Address.....

City and Province.....

Kindly mention *The Canadian Field-Naturalist* to advertisers

Affiliated Societies

NATURAL HISTORY SOCIETY OF MANITOBA 1924

Hon. President: V. W. JACKSON; *President:* J. J. GOLDEN; *Vice-Presidents:* H. M. SPEECHLY, A. M. DAVIDSON, A. G. LAWRENCE, NORMAN CRIDDLE; *Mrs. C. E. BASTIN, Mrs. C. P. ANDERSON; General Secretary:* A. A. MCCOUBREY, 307 C.P.R. Depot, Winnipeg, Man.; *Executive Secretary:* R. M. THOMAS; *Treasurer:* MISS HELEN R. CANNOM; **ORNITHOLOGICAL SECTION:**—*Chairman:* B. W. CARTWRIGHT; *Secretary:* C. L. BROLEY. **ENTOMOLOGICAL SECTION:**—*Chairman:* A. V. MITCHENER; *Secretary:* A. SHIRLEY BROOKS. **BOTANICAL SECTION:**—*Chairman:* C. W. LOWE; *Secretary:* MISS GRACE CAMERON. **GEOLOGICAL SECTION:**—*Chairman:* A. A. MCCOUBREY; *Secretary:* J. M. BENSON.

THE HAMILTON BIRD PROTECTION SOCIETY (Incorporated)

Hon. President: MR. ADAM BROWN; *President:* MR. R. O. MERRIMAN; *1st Vice-President:* DR. H. G. ARNOTT; *2nd Vice-President:* MR. C. D. COOK; *Secretary-Treasurer:* MISS RUBY R. MILLS, Public Library, Hamilton; *Directors:* DR. H. G. ARNOTT; C. D. COOK; DR. J. A. DICKSON; MISS M. E. GRAHAM; MISS RUBY R. MILLS; M. HOLTON; M. JOHNSTON; MRS. F. E. MACLOGHLIN; R. O. MERRIMAN.

NATURAL HISTORY SOCIETY OF BRITISH COLUMBIA, VICTORIA, B.C.

The officers for the above Society for the year ending March 31st, 1923, are as follows:—

President: W. N. KELLY; *1st Vice-President:* A. R. SHERWOOD; *2nd Vice-President:* C. C. PEMBERTON; *Secretary:* H. T. NATION 2380 Windsor Road, Victoria, B.C. *Treasurer:* MISS S. M. THORNTON; *Committee:*—MISS C. G. FOX, MISS A. F. GARDINER, MISS I. CATCHART, WM. DOWNS, A. HALKETT. *Auditors:*—J. KEITH WILSON AND F. W. GODSAL. *Trustees:*—REV. R. CONNELL, DR. C. F. NEWCOMBE AND G. HARVEY.

ALBERTA NATURAL HISTORY SOCIETY

Hon. President: DR. HY. GEORGE, Victoria B.C.; *Hon. Vice-President:* MR. J. J. GAETZ, Red Deer; *President:* MR. C. H. SNELL, Red Deer; *1st Vice-President:* MR. G. C. S. CROSBY, Red Deer; *2nd Vice-President:* MRS. W. A. CASSELS, Red Deer; *Hon. Sec.-Treas.*: MRS. S. PAMELY, Red Deer; *Directors:* MRS. G. C. S. CROSBY, MISS E. C. IRVING, MR. W. A. CASSELS AND MR. S. PAMELY, Red Deer, MRS. G. F. ROOT, Wetaskiwin, MR. K. BOWMAN, Edmonton, MR. B. LAWTON, Edmonton, MR. T. RANDALL, Castor, MR. F. L. FARLEY, Camrose, MR. W. C. MCCALLA, Bremner, and MR. D. M. SINCLAIR, Peace River.

The meetings of this Society are held in Red Deer on the last Friday of each month except during July and August and perhaps September. The annual meeting is held in Red Deer on the last Friday in November.

McILWRAITH ORNITHOLOGICAL CLUB, LONDON, ONT.

President: T. D. PATTERSON, 562 Waterloo Street; *Recording Secretary:* MRS. E. H. MCKONE, Worthy Road; *Corresponding Secretary and Treasurer:* E. M. S. DALE, 297 Hyman St.; *Members qualified to answer questions:* W. E. SAUNDERS, 240 Central Ave.; C. G. WATSON, 201 Ridout St. South; J. R. McLEOD, 355 Worthy Road; J. F. CALVERT, 461 Tecumseh Ave.; E. M. S. DALE, 297 Hyman St.

VANCOUVER NATURAL HISTORY SOCIETY

Hon. President: L. S. KLINCK, L.L.D., Pres. University of B.C.; *President:* JOHN DAVIDSON, F.L.S., University of B.C.; *Vice-President:* FRED PERRY; *Hon. Secretary:* C. F. CONNOR, M.A., 3523-W. 2nd Ave., Vancouver, B.C.; *Hon. Treasurer:* A. H. BAIN, 2302 York St., Vancouver, B.C.

Fortnightly meetings in the University Buildings from September to April (inclusive). Semi-monthly excursions from May to August (inclusive).

PROVINCE OF QUEBEC SOCIETY FOR THE PROTECTION OF BIRDS

Hon. President: I. GAMMELL; *President:* L. MCI. TERRILL; *Vice-Presidents:* ALEX MACSWEEN, NAPIER SMITH, E. ARNOLD; *Hon. Corresponding Secretary:* W. S. HART, P.O. Box 1185, Montreal; *Hon. Recording Secretary:* MISS H. STONE; *Hon. Treasurer:* MISS M. ARMITAGE, 63 Arlington Ave., Westmont; *Directors:* MISS EDITH MORROW; MISS LOUISE MURPHY; MISS EMILY LUKE; MR. AND MRS. C. F. DALE; MRS. J. T. AYERS; MISS JEAN MCCONNELL; W. A. OSWALD; A. F. WINN; MR. AND MRS. WALLACE H. ROBB; W. G. WRIGHT. *Members qualified to answer questions:* L. MCI. TERRILL, 44 Stanley Ave., St. Lambert, Que.; NAPIER SMITH, Bank of Montreal, Magog, Que.; E. ARNOLD, 64 Durocher St., Montreal; W. A. OSWALD, 301 Wilson Ave., N.D.G., Montreal; C. N. ROBERTSON, c/o Ross Realty Co., Room 805, Lewis Bldg., St. John St., Montreal, Que.; DR. ARTHUR WILLEY, McGill University, Montreal; W. J. BROWN, 250 Oliver Ave., Westmont, Que.; MISS EDITH MORROW AND MISS EMILY LUKE, c/o Secretary.

SOCIÉTÉ PROVANCHER D'HISTOIRE NATURELLE DU CANADA Bureau de direction pour 1923

Président: DOCTEUR S. GAUDREAU; *1er vice-président:* ABBE A. VACHON, M.A.; *2ème vice-président:* A.-R.-M. BOULTON; *Secrétaire-trésorier:* LOUIS-B. LAVOIE; *Chef de la section scientifique:* A.-A. GOBOUT; *Chef de la section de propagande éducationnelle:* DOCTEUR A. DERY; *Chef de la section de protection:* R. MEREDITH, N.P.; *Chef de la section d'information scientifique et pratique:* DOCTEUR J.-E. BERNIER; *Directeurs:* R.-F. LINDSAY; JOS. MATTE; G.-S. AHERN.

THE BRITISH COLUMBIA ORNITHOLOGISTS' UNION Officers for 1923

Hon. President: HON. MINISTER OF AGRICULTURE, Victoria; *President:* FRANCIS KERMODE, Provincial Museum, Victoria; *Vice-President:* T. L. THACKER, Hope; *Secretary-Treasurer:* J. W. WINSON, Huntingdon; *Directors:* J. A. MUNRO, Okanagan Landing; DR. KELSO, Arrow Lakes; R. GLENDENING, Agassiz; K. RACEY, Vancouver; T. PEARSE, Courtenay; W. N. KELLY, Victoria.

THE TORONTO FIELD-NATURALISTS' CLUB

President: PROFESSOR R. B. THOMSON; *Vice-Presidents:* PROFESSOR E. M. WALKER, DR. A. COSENS, J. H. FLEMING; *Secretary:* W. F. GREGORY, 151 Ellsworth Ave., Toronto; *Treasurer:* F. H. BRIDGEN; *Honorary Librarian:* C. W. NASH; *Librarian:* DR. LYMAN B. JACKES. **BIRD GROUP:**—*Chairman:* STUART THOMPSON; *Secretary:* JAMES BAILLIE. **FLOWER GROUP:**—*Chairman:* DR. H. B. SIFTON; *Secretary:* MISS J. G. WRIGHT, PH.D.; **INSECT GROUP:**—*Chairman:* PROFESSOR WALKER; *Secretary:* MISS NORMA FORD, PH.D. **MAMMAL GROUP:**—*Chairman:* J. R. DYMOND; *Secretary:* L. SNYDER. **REPTILE, FISH AND AMPHIBIAN GROUP:**—*Chairman:* SHILEY LOGIER; *Secretary:* T. B. KURATA. **PROGRAM COMMITTEE:**—*Chairman:* DR. W. A. CLEMENS. **WILD LIFE PRESERVATION COMMITTEE:**—*Chairman:* RUSSELL G. DINGMAN. **EDUCATIONAL COMMITTEE:**—*Chairman:* TAYLOR STATTON.

We would ask the Officers, and more particularly the Secretaries, of all the Affiliated Societies to assist us in our task of building up the circulation of this magazine. By securing every member as a subscriber we can truly make this magazine into one of the leading Natural History publications of America.



FOR SALE

Back Numbers of The Ottawa Naturalist

The Club has for sale complete sets of its publications. Enquiries regarding price should be addressed to the Secretary of the Club, Dr. J. F. Wright, Geological Survey, Ottawa, Canada.

Any member having copies of the March, 1896, January, February, March and August, 1898, and December, 1900, issues of *The Ottawa Naturalist*, and who desires to dispose of the same, is requested to communicate with the Secretary.



Grant-Holden- Graham Limited

Outfitters to
Surveyors & Engineers

Manufacturers of
High-Grade Tents
Tarpaulins & Sleeping Bags

WRITE FOR CATALOGUES

147 Albert Street
OTTAWA

Fine Diamonds

Sterling Silver, Fine
Cut Glass, Electro-
Plated Ware

*The Store of
Moderate Prices*

C. A. Olmsted & Son

*Jewellers, Opticians, Watchmakers and
Engravers*

208 Sparks Street, Ottawa



*Publishing
for Naturalists*



Book Publishing
Pamphlets, Booklets
and all kinds of Publicity
for Lovers of
Outdoor Study

The Graphic Advertisers
175 Nepean Street
Ottawa

Kindly mention *The Canadian Field-Naturalist* to advertisers



THE CANADIAN FIELD-NATURALIST



PUBLISHED BY
OTTAWA FIELD-NATURALISTS' CLUB

ISSUED NOVEMBER 28, 1924

Entered at the Ottawa Post Office as second-class matter

THE OTTAWA FIELD-NATURALISTS' CLUB

Patrons:

THEIR EXCELLENCIES THE GOVERNOR-GENERAL AND THE LADY BYNG OF VIMY

President: HOYES LLOYD.

1st Vice-President: G. A. MILLER.

2nd Vice-President: NORMAN CRIDDLE.

Secretary:

Hon. Treasurer:

J. F. WRIGHT,

B. A. FAUVEL,

(Geological Survey, Ottawa).

321 McLeod St.

Ottawa, Ont.

Additional Members of Council: W. T. MACOON; MISS M. E. COWAN; C. M. STERNBERG; H. I. SMITH; F. W. WAUGH; P. A. TAVERNER; E. SAPIR; E. M. KINDLE; W. J. WINTENBERG; R. E. DELURY; ARTHUR GIBSON; M. O. MALTE; R. M. ANDERSON; H. GROH; MISS F. FYLES; C. B. HUTCHINGS; H. M. AMI; CLYDE L. PATCH; D. JENNESS; V. W. JACKSON; R. O. MERRIMAN; W. N. KELLY; C. H. SNELL; J. R. MCLEOD; JOHN DAVIDSON; L. MCL. TERRILL; R. MEREDITH; FRANCIS KERMODE; PROF. R. B. THOMSON; THE EDITOR.

Editor:

HARRISON F. LEWIS,
Canadian National Parks Branch,
Dept. of the Interior, Ottawa.

Associate Editors:

E. SAPIR	Anthropology	A. G. HUNTSMAN	Marine Biology
M. O. MALTE	Botany	P. A. TAVERNER	Ornithology
F. R. LATCHFORD	Conchology	E. M. KINDLE	Palaeontology
M. Y. WILLIAMS	Geology	R. M. ANDERSON	Zoology
ARTHUR GIBSON	Entomology	CLYDE L. PATCH	Herpetology

CONTENTS

	PAGE
A Biological Excursion to Anticosti Island. By Frits Johansen	161
Notes on Bell's Painted Turtles (<i>Chrysemys marginata bellii</i>) in British Columbia. By T. L. Thacker	164
Eagle Snaring Among the Bellacoola Indians. By Harlan I. Smith	167
The National Aspect of Game Conservation. By Harrison F. Lewis	168
Notes on the Catocalinæ of Sault Ste. Marie, Ont. By W. H. A. Preece	170
A Preliminary Report on the Destruction of Birds at Lighthouses on the Coast of British Columbia. By J. A. Munro (Concluded)	171
Miscellaneous Bird Notes from Southern Vancouver Island, 1923. By J. A. Munro (Concluded)	175
Official Canadian Record of Bird-Banding Returns	177
In Memoriam—Edward J. Whittaker. By E. M. K.	179
Notes and Observations:—	
Notes on the Measurements and Soft Parts of Three Trumpeter Swans <i>Cygnus buccinator</i> . By J. A. Munro	179
▲ Northern Records of the Wild Strawberry in the Mackenzie River Basin. By William H. Kelly	180
Field Sparrow and Towhee at Christie Lake, Ontario. By Hoyes Lloyd	180
Late Freezing of the Mackenzie River. By E. M. Kindle	180
Annual Meeting, Ottawa Field-Naturalists' Club. By J. F. Wright	180
Canadian Field-Naturalist Publication Fund. By P. A. Taverner	181
Editor's Notes	182
Book Review:—	
Twenty-Fourth Annual Archæological Report, 1923. By W. J. W.	182
Publications Received	182

THE CANADIAN FIELD-NATURALIST, lately THE OTTAWA NATURALIST, established thirty-seven years ago, "to publish the results of original research or investigation in all departments of natural history," is issued monthly, excepting for the months of June, July and August.

Papers, notes and photographs should be addressed to the Editor. Manuscript should be typewritten.

Subscriptions cover the current year, except those taken out during last quarter, when they will be applied on the following year, the remaining numbers of current year being sent free. Payments should be made to the Hon. Treasurer, Mr. B. A. Fauvel, 321 McLeod St. Ottawa. Price of this volume, \$1.50; single copies 20c each.

The Canadian Field-Naturalist

VOL. XXXVIII

OTTAWA, ONTARIO, NOVEMBER, 1924.

No. 9

A BIOLOGICAL EXCURSION TO ANTICOSTI ISLAND

By FRITS JOHANSEN

DURING the end of July and the first half of August, 1923, I spent a couple of weeks on Anticosti Island, in the Gulf of St. Lawrence, for the sake of marine and freshwater investigations. Apart from a four days' sailing all around the island in the guards' boat with a stop-over for half a day at Fox Bay, on the north-east end of the island, I stayed at Ellis Bay, exploring the west end of the island.

No freshwater Isopods were found, but woodlice (Oniscidæ) were common all over the island, under stones, in decayed trees, etc., and I kept a female with eggs from Ellis Bay, August 1, which has been identified by Mr. C. R. Shoemaker of the U.S. National Museum as *Porcellio scaber* Latr. Apparently this is the first definite record of terrestrial Isopods from this island.

The only freshwater Amphipods recorded from the island so far are *Gammarus limnæus* Smith, listed by Dr. J. Schmitt, in his "Monographie de l'Île d'Anticosti", Paris, 1904, p. 256, from both the east (Fox Bay) and west (Baie St. Clair and Ellis Bay) ends of the island. These specimens

from the west end of the island (Cape Ruisseaux and Lake St. George) are found both in the local museum at Ellis Bay (Port Menier), where I saw them and retained a couple for the Ottawa Museum, and in the U.S. National Museum, they having been identified for Dr. Schmitt by Mr. S. J. Holmes of Washington, D.C., and now re-examined by Mr. C. R. Shoemaker (letter of April 5, 1924). On August 31, 1923, I also collected a specimen of *G. limnæus* in Lake St. George (Gamache Lake); and on August 10, 1923, a couple in Lake Princeton, in the interior of the west end of the island. But I obtained other freshwater Amphipods too, in 1923.

Thus on July 30 I walked up along the Gamache River, from its outlet in Ellis Bay to the place where it is dammed up by a large rotating water-wheel, which supplies the Chateau Menier with fresh water. In the streaming water, just below this water-wheel (which was moving at the time of my visit) I noticed aquatic insects and schools of small brook-trout, and coming down with the current were a number of freshwater Amphipods,



Outlet of Gamache River into Lake St. George, Anticosti Island, P.Q., August 3, 1923.
(Seen from north end of the lake)

Photo by F. Johansen



Lake St. George, Anticosti Island, P.Q., August 3, 1923. (Seen from south-east end, looking north)

Photo by F. Johansen

which I was able to secure in the deeper pools of the channel of the river, where the water was more quiet, as they attached themselves to the scattered, submerged vegetation there. These Amphipods have been kindly identified by Mr. C. R. Shoemaker of the U.S. National Museum, as probably *Gammarus fasciatus* Say, hitherto not recorded from this island. I noticed at the time of capture that, because of their smaller size, the red-brown lining of the metamers, etc., they did not look like *G. limnæus*, but rather like the freshwater Amphipods I collected last summer on Prince Edward Island (see *The Canadian Field-Naturalist* for December, 1922, p. 178).

On August 3 I walked all around Gamache Lake (Lake St. George), which is an artificial widening of Gamache River, caused by the damming up and the locks placed in this river just north of the settlement at Ellis Bay, about 20 years ago, for the sake of lumbering. Now the lumber-cutting, floating, and export has been abandoned and practically no water comes through these locks from Lake St. George down the artificial ditch (St. George's Channel) to the pulp mill at Port Menier; but it is allowed to follow the original brook-bed (Gamache River) down to the sea, except for what is diverted to the chateau by the above-mentioned waterwheel and pipes placed astride the river near its outlet (see Bayfield's detail-map, 1828, of Ellis Bay, "Plans in the Gulf of St. Lawrence", No. 308, Brit. Admiralty). Gamache Lake (Lake St. George) has, in the course of time, developed a rich vegetation around

and in it, as will be seen from the photograph I took of it, and is shallow, though quite extensive. At the time of my visit it was much dried up along the margin, exposing sand-bars, mud-flats, or the level limestone-floor (bed-rock), so that it was not difficult to walk all around it. The woods, which formerly practically surrounded it, are now found only along its north side; along its east side they have been replaced by a shrubbery of alder, etc., and along its south and west sides by grass-swamps or agricultural fields, etc. The shores of the lake are everywhere low and consist of loose material (gravel, sand, clay, etc.); at the east end is a peat deposit, formerly used, and at the north-west end is much cleared land, owing to the model-farm being situated here. Gamache River falls into the lake on its north side and leaves it again at its south-west end; at both places in the form of a sluggish brook.

Out in the lake and along its margin still stand the remains of the earlier lumber industry, in the form of platforms, piers or shacks, etc.; and particularly in the bights along its south shore are washed-up logs, not needed any more now.

In one of these bights with *Juncus* vegetation on the south side of this lake I collected among the bottom deposits of saw-dust, mosses, etc., or from the underside of smaller pieces of wood, stones, etc., a number of invertebrates, snails (*Lymnæa*); Oligochaete worms; small, pale leeches* with young (identified by Prof. J. P.

*First record for the island.

Moore of Philadelphia as *Helobdella stagnalis*); yellow-green Sponges (*Spongilla*); aquatic insects, etc., and also samples of the tadpoles and sticklebacks so common here. Most interesting to me was however the finding of a great many freshwater Amphipods (*Hyalella azteca*) here; and I collected a number of them, both females with eggs and other adults, besides young ones. This is the first record of this species from Anticosti Island.

On August 10 I accompanied the party of Senator Gaston Menier on an excursion to the (supposed) largest lake in the interior of the island (Lake Simonne), and on the way back I got off the train and went down to Lake Princeton, which lies about half way between the north and south shores of the island, about eight miles north-east of Ellis Bay. We remained only half an hour at Lake Simonne.

Both Lake Simonne and Lake Princeton are beautiful bodies of water, all surrounded by the woods, except where the latter have been cleared for the purpose of laying the railroad-track and the resulting lumber-cutting, along the north side of Lake Simonne and along the west side of Lake Princeton. Lake Simonne has a small, heavily wooded island in it; but the banks surrounding Lake Princeton are higher, except at its north and south ends, where a brook comes in and runs out in grass-swamps. Both lakes have extensive and shallow marginal water (though they are said to be deep in the middle); and dry up very much here, so that the mudflats and limestone bed-rock

floor forming their bottom are exposed all around.

I took a picture of Lake Princeton from its west shore, looking north, which shows well these characteristics of the natural lakes on Anticosti Island, namely, the woods surrounding them, the extensive exposure of the limestone "beach" all around, owing to drainage and evaporation during the summer; their clear water and the general lack of aquatic plants, apart from bights with more muddy bottom and the places where brooks come in or run out. Upon the east shore of the lake will be seen, in the photograph, a burned-over part of the forest; and the wooded point to the left separates the bight south-west of it from the north end of the lake.

This bight had a vegetation of high *Juncus*, and a bottom of deep mud mixed with empty shells of small Molluscs (*Lymnaea*, *Planorbis*, *Physa*, *Sphaerium* and *Pisidium*). Large freshwater clams (*Anodonta marginata*) were also common here, as well as in Lake Simonne; often with a freshwater-sponge (*Spongilla*) spreading over the umbo.

I secured here also, attached to moss or small pieces of wood, Oligochaete worms, and both adults and young of the same species of freshwater Amphipods (*Hyalella azteca*), which I had collected a week before in Lake St. George. The bight was the favorite resort for great schools of Killifish (*Fundulus diaphanus*†) of all sizes from the fry to adults, which were continually jumping up in the water, after the manner of small trout, to catch

†Identified by Prof. P. Cox of Fredericton, N.B.



North end of Lake Princeton, Anticosti Island, P.Q., August 10, 1923. (Seen from west bank)

Photo by F. Johansen

the swarms of gnats, Ephemeroidea and Trichoptera, flying above. A stickleback (*Gasterosteus alkinsi*†) was also secured here.

While fresh bear-tracks were seen in the mud flats surrounding these lakes that I visited on Anticosti Island, and the red deer was often seen coming out to them for drinking, their lack of bird-life was most conspicuous. No waders, Grebes or Loons, etc., hardly a song-bird in the bush or woods nearby; and only an occasional Eagle sailing through the sky far above, or a couple of Gulls circling over them. Lake St. George is a little more enlivened by the presence of noisy Terns, which may nest upon the abandoned platforms out in the lake; but the silence of the inland country upon this island is most oppressive. It is probably different in the spring, when the northward migration of the birds take place; and the wealth of fishes (*Fundulus*) and invertebrates in these lakes cannot fail to attract their attention and make them linger for a while on Anticosti Island.

It is not my intention, in this article about the freshwater Amphipods of Anticosti Island, to write as fully as I could about all that I saw there during a two weeks "holiday". The freshwater invertebrates which I collected have only been partly identified yet, and I intend to write later an account of the fishes of this island, based upon the many specimens I collected. I also collected a number of insects (particularly bees), etc., which have been presented to the National Collection here in Ottawa and will be identified in the course of time, and a number of marine invertebrates, for a description of the fauna in shore-waters around the island.

As the late Prof. J. Macoun has done the botanical collecting upon the island so wonderfully well,

†Identified by Prof. P. Cox of Fredericton, N.B.

I collected only an occasional plant, particularly things (aquatic forms) which he perhaps did not secure. Among them are *Chara foetida* from the merging of Gamache River into the north end of Lake St. George, and *Chara fragilis* from pools in the bed of Fox River, on the east end of the island, August 6, both submerged plants, and typical for calcareous bottom; they have been kindly identified for me by Dr. M. A. Howe of the New York Botanical Garden.

My observations on the birds upon the island will be found in Mr. H. F. Lewis' account of the Avifauna of Anticosti appearing in this volume of *The Canadian Field-Naturalist*; and Mr. Bryant Walker, of Detroit, has kindly identified the freshwater Molluscs I collected there. So there will be further notes or articles about the freshwater fauna of this island.

But we already have now the first records of several lower animals from this island, and it is ample reward for my two weeks' efforts last summer to know that the only representative collections of fishes and terrestrial invertebrates from this island are now found in the small, local museum at Ellis Bay and in the National collections here in Ottawa.

I take this opportunity to express my appreciation for the many courtesies and the kind assistance shown me by the Administration of Anticosti Island during my stay there last summer, which enabled me to accomplish my purpose so well. It is only as we gradually find out what this island exactly contains of wild life that we understand that Anticosti Island is one of the very few extensive, real sanctuaries in southern Canada, if not the only one, and that we owe a debt of gratitude to the late Mr. Menier and to his brother, the present owner of the island, for having preserved it as such for the last thirty years.

NOTES ON BELL'S PAINTED TURTLES (*Chrysemys marginata bellii*) IN BRITISH COLUMBIA

By T. L. THACKER

DISTRIBUTION. Bell's Turtles appear to be plentiful in suitable places in the whole of the Okanagan Valley, from the Boundary as far as the south end of Okanagan Lake. From there northwards they are not so plentiful, but have been met with at the north end of the lake. I have been able to get no definite information as to whether their range extends further north, but I have heard a rumor that they occur somewhere about Kamloops or Nicola. I have never heard of them up the North and South Thompson Rivers, nor do they appear to be known on the main Thompson River below

Kamloops, nor in the Fraser Valley. A correspondent in the Cariboo has not heard of them.

Their distribution may at one time have been more extensive, for near Yale, some years ago, several stones carved in the shape of tortoises were dug up, and one has recently been found near Lillooet.

Turtles occur in the Columbia Valley near both Grand Forks and, I believe, Cranbrook. They are probably the same species. In the Southern Okanagan, I had trustworthy information that they occur above Elkhorn Lake at an elevation of over 3500 feet, and this is corroborated by Mr.

Latimer, C.E., who says he has seen them high up on the Naramata road, which goes eastward into the valley of the Kettle River.

While they may occur in the lower part of the Similkameen Valley, they are not known near Princeton nor on the Tulameen River.

According to Mr. C. F. Kaufmann, of Victoria, turtles also occur at Turtle Lake, between Nanaimo and Alberni on Vancouver Island, but those existing in Beacon Hill Park and Langford Lake near Victoria are supposed by him to have been introduced; Dr. C. F. Newcombe, however, states that he was told by Dr. Maynard, one of the early residents of Victoria, of turtles frequenting a stream which flowed near what is now Yates Street.

HABITS. In the spring of 1922 (a late spring) the first turtles were seen at Vaseaux Lake, South Okanagan, on the 22nd of April, but in other years they may appear a week or two earlier. Very shortly after this, turtles were moving freely about the shore, as was evident from the tracks left upon the sandy beach; and on the 29th of April they were travelling across a ridge about a hundred feet high between a pond, lying in a hollow a quarter of a mile away from the lake, and the main lake. Almost any morning from then on, the tracks of turtles could be seen in the dust of the road which here passes along the ridge.

Lakes and ponds are found in the neighbourhood almost in any direction and at greatly varying elevations, but in many of the lakes which we examined closely we did not see any tortoises; in others they were extremely plentiful, and it seems that a good deal of migration takes place between the lakes which they occupy, but for some reason they confine themselves to certain routes and so are not met with in similar lakes near at hand, which to every appearance would be suitable habitats.

A closer study of their local distribution would, we believe, raise some interesting problems.

MOULTING. Many of the specimens we obtained seemed not to have finished completely what we assume must be an annual moult of the top layer of the carapace. This flakes off in thin chitinous sheets, and we noticed that the sheets of the marginal shields nearest the nuchal shield, on the left side, remain longest attached.

The brightness of the outer coverings of these turtles, and their clean and polished smoothness, when compared with the snapper (*Chelydra serpentina*), might lead one to the conclusion that this species casts off the outer "skin" of its carapace a great deal more often. Whether this takes place during the time that the turtle is buried in the mud, or immediately it regains the water, we do not know, but quite a number of these thin

sheets were found in an undamaged condition on the sand of the lake bottom. Since good-sized waves often break on the shores of the lake, it seems unlikely that such delicate objects could have been long in the water and still remain, as we found them, entirely unabraded.

SIZE. We may note that Mr. E. Thompson Seton, in *The Ottawa Naturalist* for November, 1918, states that in Manitoba this species may be "recognized by its size (about 4½ inches along the back)", but at Vaseaux Lake there were many twice as long as this, and a few even longer.

SEX. As far as we were able to tell without dissecting, there is little in their appearance by which to distinguish the sexes; but from the fact that one gentleman insisted that there were two kinds of turtles here—the one distinguished from the other by being yellower and of much greater pugnacity, "showing fight upon every occasion when poked at", and from our own observations that there appeared to be some specimens with lighter-coloured shells, considerably flatter and less convex in transverse section, and that none of this kind were found making nests or depositing eggs, we think that these lighter-coloured ones with the flattened carapaces were males.

BREEDING AND REPRODUCTION. Very little was learned about their mating. On one occasion, May 11th, we recorded a large individual acting in a peculiar way in the water with two smaller ones, and a friend reported that he saw one chasing others in a pond at Osoyoos on May 10th.

One female which we examined on the 29th of April contained a mass of eggs (all without shells) the largest of which was about three-quarters of an inch in diameter, the two next about half an inch, and the rest smaller down to minute specks. There were at least a hundred eggs in the whole mass.

The first nest was found on the last day of May. A diagram is submitted showing a section of this nest, which was in coarse sand about fifteen feet above the water near the northern end of a pond in a deep hollow. The sun fell full upon the spot. The sand here was fairly loose, being much trampled by cattle during the spring. The hole had been made in slightly sloping ground, and the sand dug out had been placed at the lower end in the form of a small mound, which showed plainly that it had been scooped up in "handfuls" by the tortoise—at any rate the upper part of it—from the depth of the hole.

The total depth from the top of the mound to the bottom of the hole was seven and a half inches, and it is obvious from the diagram that the turtle in this instance had practically sunk her whole body below the natural surface of the slope before starting to scoop out what we may term the

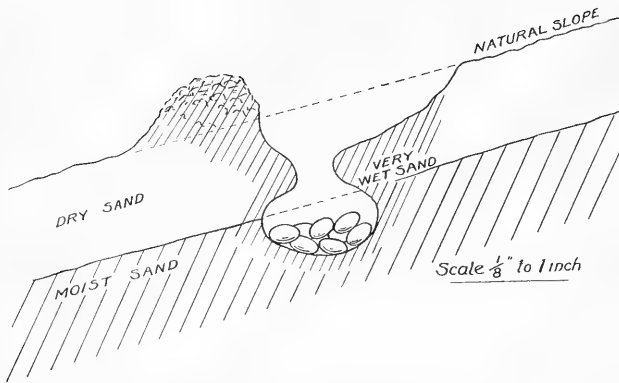

Diagram showing transverse section of nest of Bell's Painted Turtle

"neck of the bottle" and the nest-hole itself. It would have been impossible for the hole to have been dug so deep had she not first buried herself as far as the "neck".

When we found her, she was lying with her head up the slope, and directly she moved away we noticed that all the newly excavated sand was quite wet, and the neck of the hole was also wet, smoothly rounded so that it was sufficiently solid to stay in place and did not fall on the eggs. The undisturbed sand away from the hole was dry to a depth of four or five inches; only the sand from the lowest part of the nest-hole would naturally have been at all moist, and none of it would have been moist enough to cohere sufficiently to form the overhanging portion had not the turtle itself supplied the necessary moisture.

When the turtle left, the eggs were plainly visible in the hole; and when it was excavated we found five eggs in the bottom layer, two more resting above these. The largest number of eggs taken from any nest was thirteen, and these completely filled the hole, some of them lying as a third layer.

Some nests were filled with sand on top of the eggs, but none that we saw had been entirely closed, though it is quite possible that this may regularly be done.

Our endeavours to determine the period of incubation were inconclusive, nor was anyone able to tell us definitely when the eggs usually hatch. The following facts give us some data: Late in March, 1922, Mrs. Jukes, of Penticton, saw a nest which had been exposed during the construction of the new railway, and from it were taken several young ones, some of them just breaking out of the shell. It is said that at this time the frost was still in the ground immediately beneath the nest. A record of the hatching of eggs in the spring was also given me by Mr. Val Haynes, of Osoyoos, who stated that a Chinaman in his employ was, a few

years back, clearing out the hearth in a smoke-house in the month of April, when he found several small turtles, less than a fifty-cent piece in size, one of which Mrs. Haynes kept alive for ten days.

Though all our party kept a good look-out for newly-hatched specimens, we did not succeed in finding any until the 2nd of June (two days after we had found the first nest), and up to the middle of the month we saw only one other.

From this we are inclined to conclude that the eggs that are laid from the beginning of June onwards hatch the same season; but

it may be a fair assumption that eggs that are laid too late in the year to get the necessary conditions of temperature and moisture to hatch out that season may survive—or at any rate, some of them—over the winter and hatch the following spring.

If this is not the case, it would seem that incubation must extend over more than twelve months, for we found practically no young ones before we left the district in the middle of June.

FOOD. Inside one female, which had been crushed by a car, we found one insect larva and what was probably the remains of another. The larva seemed to be that of a caddis fly, for parts of what may have been its case were mixed with it. Lower in the intestine were masses of vegetable matter, which had been cut in lengths of about half an inch; most of this we easily recognised as the young tips of tules (*Scirpus lacustris occidentalis*), for they retained their shape and structure exactly. Under the low power of a microscope this was plainly established. We also noticed in one pond that the young growth of tules in deep water had been eaten off, presumably by turtles.

Mr. Vincent Green, of Osoyoos, states that a neighbour of his declares that the turtles pull down young Geese below the water by their legs; if this is so (and not a memory of the snapping turtle) the good reputation given them by Mr. Thompson Seton in Manitoba must be attributed to the small size that they attain in that province.

From Mr. De B. Green we learned that they are omnivorous and regularly clean out cooking-pots set to soak in the water at Elkhorn Lake. We ourselves succeeded in keeping quite a number in good condition for some weeks in a small pen in shallow water. We fed them upon shoots of the tules, water-weed of several kinds, and small pieces of bacon, as well as the scrapings of the

porridge pot, and it surprised us to find what a quantity of these delicacies disappeared.

Mr. Schoonover, of Vaseaux Lake, further told us that the turtles annoy fishermen by nibbling at their baits and, if caught, are very troublesome to get off the hook.

ENEMIES. The eggs, without doubt, are often destroyed; horses roll frequently in certain places where they are deposited, and cattle trample the sand as well. Predatory animals such as weasels take their toll; snakes also and crows probably destroy many eggs where the holes are not properly closed by the female, or naturally filled up by the sand drifting or drying out and falling in upon the eggs.

Many young turtles, too, must be destroyed before they even reach the water, and there, as well, the larger fishes probably eat their share. We collected a few bigger turtles with their shells badly damaged, and one which had lost part of a leg.

In conclusion, we may tell that an acquaintance of the writer, of whom enquiries were being made, offered to question his wife, whose mother was an Indian woman, as to the knowledge which the natives possess of the habits of the turtles. Some

days later—we believe in all innocence—he retailed the following information. (We might, however, suspect an experiment upon the credulity of his questioner.)

The old Indian woman had told her daughter that the eggs were laid in June, and that the male turtle attended at the ceremony and fertilised them after the manner of the male salmon; that they did not hatch until the following June, and that the female returned at the right time to assist her offspring to see the light of day. She further went on to relate that on one occasion she had discovered a nest of young turtles emerging from the shell, but was surprised that the mother was not present. She had picked one up to examine it more closely, and had turned aside with it in her hand. On looking round she saw the mother turtle with the remaining young ones, moving rapidly about from one to another in what appeared a state of great distress. Realising at once what was amiss, she gently laid down beside its parent the one she held in her hand, and the mother turtle immediately recognised it, gathered up her brood and made off as fast as possible to the lake near by.

Thus joyously is the humble student of Nature entertained in his pursuit of knowledge.

EAGLE SNARING AMONG THE BELLACOOOLA INDIANS

By HARLAN I. SMITH



THE FOLLOWING account of Eagle snaring among the Bellacoola Indians was secured by means of Chinook jargon from Captain Schooner, an old Bellacoola Indian, June 26, 1923. It has been translated and arranged. Captain Schooner has since died.

A snare, called *Sticlöse* in Bellacoola, was used for taking Eagles, and was specified as being an Eagle snare. The hunter, when operating this snare, sat concealed in a little house or blind. This was made of two poles, of any kind of wood, about six feet long and two inches in diameter, placed parallel and horizontally, and tied at the ends to upright stakes about four feet from the ground, the rear pole being a little lower than the front. Similar horizontal poles tied at the ends to the uprights closed in the front and ends. The back was left without them. Bark of red cedar was put on top to keep off the rain. The entire structure was well hidden with material to match that at which it was built—evergreens, cottonwood branches, or grass, but moss was not used. Stumps were sometimes used. The blind was not made in the day time, but just before dark, when there were no Eagles about. It might take two days to make such a blind, and it was repeatedly used by the hunter and his friends or

young men, each hunter supplying his own snare.

The snare, made of a three-strand cord of nettle fibre, was hung in the notched or split end of a pole, and the line run straight back along the pole about fifteen to eighteen inches and tied with a single knot. The sliding loop was slid back to this place, leaving one string of the snare hanging down. The line was then run back and tied about four feet from the end. The pole was long and light, never heavy, carefully made and well rounded. It was made of red cedar because that is light, never of other wood. The pole was manipulated from the little house, the snare-bearing end being projected between the poles in front while the butt might project out through the rear where there was only the horizontal pole at the top, which held up the lower edge of the roof. The places selected for snaring Eagles were sandy points, not rock noses, projecting into the river near a creek mouth up which salmon run, and where the water made a noise so the Eagles could not hear the hidden hunter moving. Fresh coho salmon was used for bait, placed ten to twelve feet from the blind. It was threaded through with twisted red cedar twig and tied to the top of a stake driven in the beach in such a way that both withe and stake were hidden. One or more

Eagles would come and sit on the sandy point to eat fish. Eagles are not good in summer, but just before winter they are fat. When about to eat fish an Eagle is cautious and it starts slowly. It eats slowly and watches. It often looks back between its legs.

The hunter went to his blind early in the morning, about half an hour before sunrise. When at last an Eagle was eating the bait, the hunter had the handle of the snare held close so that the near end of the snare was among the horizontal poles of the house front. He moved cautiously and slowly, watching the Eagle's eyes. An Eagle gets so it does not see well when it eats and does not look sharply. Then the hunter slowly and carefully puts out the pole as quietly as possible, the noise of the river helping to drown any noise he may make. The Eagle may see the nettle cord but its attention is attracted by the bait. It puts its head down to tear the bait and the hunter pulls up the pole. When he pulled back or the Eagle flew forward, the snare came out of the notch in the end of the handle and closed up on the Eagle's neck. The hunter quickly pulled the pole in until the Eagle's head came in between the crossbars of the house front. These being tight

above and below prevented the Eagle from reaching the hunter with his talons and wings. Taking the bird by the head, he wrung its neck. Then releasing the snare and dropping the bird on the outside of the bars he took it in under the lower bar of the blind, re-arranged the snare and waited for an opportunity to take another Eagle. In this way he possibly got five in one day.

The Eagle meat was eaten; the down, called spook, was highly regarded for use on some ceremonial paraphernalia and some or all dancers; the large white tail feathers were used; the tails were used for spring salmon charms; and the large wing feathers were used for feathering the sort of imitation spears, called Seekclayak, used in a game. A spring salmon charm was made by tying an Eagle tail on a pole about ten feet long. Eagle down was also put on the pole. The first spring salmon caught in a trap at a fish dam was tied to the stake. One or two of these were set up, each by tying it to a stake driven in the river bottom, in a still part of the river. They were kept there a number of nights. If put in swift water the salmon might be washed away. All the spring salmon, according to Bellacoola Indian belief, thought well of this procedure.

THE NATIONAL ASPECT OF GAME CONSERVATION*

By HARRISON F. LEWIS



AS A CONFERENCE of truly national character, whose members have assembled from all sections of the Dominion, we may well give our attention for a few minutes to a consideration of the national aspect of game conservation. Without special consideration of the subject, we are apt to become so engrossed with the local aspects of the problems with which each of us is called upon to struggle that we lose sight, to a certain extent, of the national character of many of the interests involved. Canada, as a nation, is a Unit, and whatever benefits any part of that Unit benefits the whole. Success in any phase of game conservation in one province is certain to have its beneficial effect in neighboring provinces and throughout the country.

For special reasons wild game conservation can be viewed with benefit from the national standpoint. One of these reasons is the fact of the great mobility of wild game. Many birds on their migrations pass from province to province; some breed in one province and pass the entire winter season in another. The desirability of national

and even international protection of such species has resulted in the adoption of the Migratory Birds Convention and the passage of its enabling act. Many game mammals also have more or less regular habits of migration. It is well known that the caribou of northern Canada migrate long distances in great herds. The movements of the marten have often been the subject of discussion and the moose is believed to be changing its range as conditions alter. Thus the protection or non-protection of a game bird or animal in one province may have a distinct effect upon the abundance of that bird or animal in the neighboring provinces.

The natural mobility of game also permits of its artificial introduction into regions where it was naturally wanting or had been extirpated. White-tailed Deer have been introduced into Nova Scotia and the Island of Anticosti, where they have been distinctly successful. The European Hare has been accidentally introduced into southern Ontario. Quail or Bob-white are frequently introduced into areas where their numbers have been depleted through over-hunting. The Hungarian or European Gray Partridge, successfully introduced in Alberta, has spread into Saskatchewan. Through such introductions the game supply in

*Address delivered at the conference of federal and provincial game officials, Ottawa, Ontario, February 7, 1924.

one province may be increased from the stock in another province.

Furthermore, it is not the game alone which is mobile and, to a certain extent, inter-provincial. The people who must conserve the game and from some of whom the game must be protected also move about from province to province to a large and increasing extent. Those provinces which, like the western provinces, receive large accessions of population from elsewhere are interested in seeing that their new settlers are game conservationists. A satisfactory popular interest in conservation, upon which the best results are dependent, can be secured only through nation-wide educational efforts. Fortunately efforts of this kind are already being put forth, and results are becoming increasingly apparent.

It is to be remembered also that Canada's great northern game area, including the Northwest Territories and the Yukon Territory, is the property of the entire nation, and that all Canada is therefore interested in its development and control. Game is one of the great assets of this region, and, if properly conserved, it will always be among its major assets.

In some cases, as in the protection of migratory birds and of antelope, questions of game conservation are of an international character and involve dealings with other powers. In such instances, of course, the Canadian interests involved must be safeguarded by national action.

It was observed again and again by all who were present at the conference in December, 1922, that a surprisingly large number of problems relating to important details of administration in the several provinces were nearly or quite identical. It was also found that through a national conference, bringing together from all the provinces those officials who were accustomed to dealing regularly with these problems at first-hand, the problems in their provincial aspects could be co-ordinated, and a nation-wide view could be obtained, to the benefit of all who participated. I believe that the holding of a second conference of that nature will bring a renewal of benefits of this kind and that the truly national character of many of the problems involved will be still more clearly revealed.

Even where actions or conditions in one province do not directly affect conditions in other provinces they have a very marked indirect effect, because, through the medium of the press and, more recently, the radio, news concerning changes in game laws or in the abundance of game in any province is soon known throughout Canada, thus producing nation-wide re-actions.

As indicating what this conference may accomplish I shall briefly report the results of the

resolutions passed by the first conference.

A. Action concerning the following resolutions could be taken only by the provinces themselves.

1. Resolution concerning prohibition of sale of game birds and mammals, except fur-bearers.

2. Resolution approving of the principle of all provinces requiring permits allowing wild life to be shot, and requiring returns on these permits.

3. Game license fee charged a non-resident British subject to be lower than that charged an alien non-resident by any province.

B. The following resolutions involved co-operation with the United States. They have been discussed with the United States' authorities, who considered it inadvisable to take action concerning any of them at present.

1. Resolution urging the adoption of a daily and season bag limit in Canada and the United States covering migratory birds.

2. Resolution proposing absolute protection for the Harlequin Duck.

3. Resolution respecting a permanent close season for the Golden and Black-bellied Plover.

4. Resolution respecting negotiations for the inclusion of Murres, Auks, Auklets, and Puffins in the game bird list under the Treaty.

C. A Resolution urging the Department of Indian Affairs to continue to instruct Indians in the observation of Provincial and Federal Game Laws. This has been referred to the Department of Indian Affairs.

D. A Resolution respecting protection of great marine mammals has been referred to Dr. E. E. Prince, Chairman of the Biological Board.

E. As a result of a resolution respecting a proposed Act covering the interprovincial shipment of game, a draft of such an Act has been prepared and will be submitted to this conference for discussion.

F. Resolutions requiring independent action by the Dominion authorities have resulted as follows:

1. A Resolution respecting the Department of the Interior and an active educational campaign in co-operation with the various Provinces and Territories.

ACTION: Pamphlets on *Attracting Birds with Food and Water* and *Hints for Hunters* have been published. These, together with pamphlets previously published, such as *Bird-Houses and Their Occupants* and *Lessons in Bird Protection* are being distributed by tens of thousands. The total of pamphlets on protection and conservation of wild life distributed by the Wild Life Division of the Canadian National Parks Branch in 1923 is more than 75,000.

Eight cartoons on wild life conservation are being prepared for distribution and samples of

some of them are now before you.

2. A Resolution respecting protection of the Eider Duck in the Gulf of St. Lawrence and in the Maritime Provinces, and in the adjacent States of the United States.

ACTION: The close season for the Eider Duck in the Gulf of St. Lawrence and in the Maritime Provinces was extended by Regulation under the Migratory Birds Convention Act until January 31, 1924.

3. A Resolution respecting restriction of sink boxes in Tabusintac Lagoon, New Brunswick.

ACTION: Regulations respecting sink boxes in Tabusintac Lagoon were included in the amendment to the Regulations under the Migratory Birds Convention Act in 1923.

NOTES ON THE CATOCALINÆ OF SAULT STE. MARIE, ONTARIO

By W. H. A. PREECE

IT IS improbable that the species here dealt with are all that occur in this vicinity, as prior to this year Mr. Arch. Nicholls, the only other local collector, had never been able to devote much time to collecting. It is hoped therefore, that these notes may be of service to future workers in this group.

Careful notes were made of the positions assumed by the various species encountered, the actual attitude in which they rested, the kind of tree upon which they were found, etc. This information together with the method of capture proved to be most successful is included in the notes on the different species.

The year referred to in the following notes is 1923.

Catocala relicta Wlkr.

This is the commonest species occurring here. Some fifty specimens were taken or examined this year. First taken August 15, last observed October 3. Invariably found resting on young poplars with the head pointing upwards and frequently touching the underside of a branch, at a height of from five to seven feet from the ground. This species is not so difficult to remove from the tree as most; it is best taken by placing the killing-bottle beneath it and scraping it in with the lid, though no time must be lost in the operation. The form most frequent here approximates to *bianca* Edw., rather than the typical one and about fifteen per cent have very little light marking on the fore-wings and appear to be considerably darker than the typical *bianca*.

Catocala concumbens Wlkr.

Not so abundant as *relicta* but by no means uncommon. First taken August 11, last Septem-

ber 9. This species is rather erratic in its habits, resting on fence-posts, telegraph-poles and dead cedar stumps, head pointing down, and usually about four feet from the ground. The safest method of capture was found to be to place the mouth of the killing-bottle over the specimen, blocking the avenues of escape with the hands and retaining that position until the moth became stupefied. This is possibly the easiest species to capture but is by no means the sluggish that its trivial name might lead one to suppose.

4. A Resolution respecting Mergansers, Loons, and Great Black-backed Gulls in certain counties in the Province of Quebec.

ACTION: An amendment to the Regulations under the Migratory Birds Convention Act, dealing with these birds in Quebec, was, by agreement with the authorities of that Province, made a part of the Regulations in 1923.

The importance of the national aspect of our problems of game conservation is, therefore, apparent. While each one of us has a part of the work to perform, and while at times we may seem more or less isolated, yet in a representative gathering of this nature the national point of view may well find expression.

Catocala unijuga Wlkr.

Not uncommon but more often seen than taken. First taken August 11, last August 29. Likes a high perch on an old poplar; none were seen that could be taken without climbing. Usually by the time one has ascended to about half way, off goes the moth. All seen were resting head up and consequently if it is possible to get within range, the method employed in taking *relicta* is best. If, however, the specimen can be reached with the net from the ground and a clear sweep can be obtained, it is probably best to attempt to capture in that way as it is so rarely possible to get within "bottling distance" by climbing, the slightest jar or shake being sufficient to scare these moths off their perch.

Catocala briseis Edw.

Never common, only one or two specimens being taken each year. One was taken this year on August 29. It was resting head downward on a young poplar, about two feet from the ground. The method of capture employed was as suggested for *concumbens*.

Catocala parta Guen.

One record only, a specimen taken by Mr. A. Nicholls, August 23, 1921.

Catocala ultronia Hub.

Not uncommon; quite a number were seen, invariably at a sufficient height from the ground to necessitate climbing. This was far the most elusive species to contend with and I must confess to defeat in each and every encounter. Mr. Nicholls obtained one specimen which was in reach of his net and which he swept from the tree. Specimens were observed from August 11 to August 29, all resting head downward on old poplars.

Catocala cerogama Guen.

In eight years collecting here Mr. Nicholls has taken three specimens only, one of them this year on August 29. It was resting head upward on a dead poplar about five feet from the ground.

Catocala blandula Hulst.

Twice recorded this year. Mr. Nicholls took one at rest on a railway car at Franz on July 22 and I took the other here on August 11 resting head upward on an old poplar about seven feet from the ground. There is no record of this species having occurred here prior to this year.

A PRELIMINARY REPORT ON THE DESTRUCTION OF BIRDS AT LIGHTHOUSES ON THE COAST OF BRITISH COLUMBIA

By J. A. MUNRO

(Concluded from page 145)

TRIPLE ISLAND STATION is situated on the north-easterly rock of the Triple Islets group. This station is equipped with a light which shows a double flash every eight seconds; the elevation is 97 feet.

A former lightkeeper reports that birds are killed at this light chiefly on hazy or misty, rainy nights, occasionally on clear nights and thick, foggy nights. An estimate is not given of the number of birds killed. The cause of destruction is said to be from flying violently against the glass or against the white building upon which the light is reflected. Marks of injury noted were broken necks and broken wings. The species recorded are Sparrows, Thrushes and other land birds, Rails, Snipe, Petrel, Murres, Murrelets, one Brant and an occasional Duck.

A further report from this Station indicates a serious destruction of land birds during the spring migration. It is stated that "about three thousand" birds were killed in 1923, chiefly during the month of May. These are said to have been "mostly grey birds, many canaries, a few robins and linnets". This destruction occurred on misty, foggy and rainy nights, and was due to the birds flying violently against the glass on the lee side of the tower.

MASSET INLET STATION, on Graham

Island, at entrance to Masset Inlet, has a fixed light at an elevation of 63 feet. It is reported that one bird has been found dead during the past eight years.

LANGARA STATION, on Langara Island, of the Queen Charlotte Islands group, is equipped with a high power five-second flash light at an elevation of 160 feet. The lightkeeper reports that three birds have been killed during the past three years. These were Petrels, and in each case were killed by flying against the glass.

CAPE ST. JAMES STATION is on St. James Island, which lies near the south end of Kunghit Island. The light is a 55 mm. five-second flash, 310 feet above high water.

The officer in charge states that from three to fifteen birds, both sea-birds and land birds, are killed nightly from early spring until late fall. The time is given as from 8 p.m. until daylight, during stormy nights and clear nights, but not on thick, foggy nights. Destruction is said to be due both to striking the glass and tower and to exhaustion from flying around the light. Injuries noted are crushed bills, broken wings and legs. The number of birds killed is said to be approximately the same from year to year.

TABLES SHOWING TYPE OF LIGHT, LOCATION AND YEARLY CASUALTIES

EXPLANATION OF ABBREVIATIONS

F. FIXED—a continuous steady light.

Fl. FLASHING—showing single flashes.

Gp. Fl. GROUP FLASHING—showing groups of two or more flashes in succession, separated by eclipses, followed by a longer eclipse.

F. and Fl. FIXED AND FLASHING—fixed light, varied by single white or colored flashes, which may be preceded and followed by short eclipses.

Rev. REVOLVING—light gradually increasing to full effect then decreasing to eclipse.

Occ. OCCULTING—a steady light suddenly and totally eclipsed.

Light Station	Location	Character of Light	Height in feet above High Water Mark	Estimated number of birds killed annually	Kind of Weather showing greater mortality	Class of Birds Killed—Land Birds, Sea Birds	Remarks
1. Quatsino	On S.E. end of Entrance Island Quatsino Sound.	F.	89	None			Officer reporting has been on duty 6 months.
2. Nootka	On summit of San Rafael Island just inside of Yuquot Pt., Friendly Cove, Nootka Sound.	occ. 15 secs.	108	1	Foggy nights. Summer.	Both	2 land birds and one sea bird in three years.
3. Estevan Point	S.W. extremity of Estevan Pt., V.I.	Gp. Fl. 10 secs.	125	Large number	Stormy nights Spring & Fall	Sea Birds	
4. Lennard Island	On S.W. point of Island, W. Coast, V.I.	Fl. 11½ secs.	115	1	Stormy misty night.		Officer reporting has been on duty five months—1 Mallard found dead.
5. Cape Beale	S.E. point of entrance to Barkley Sound	Rev. 30 secs.	178	None			Officer reporting has been on duty four months.
6. Pachena	On Pachena Pt., West Coast, V.I.	Gp. Fl. 7½ secs.	200	Large number	Thick foggy nights; Aug. to October	Chiefly land birds	Officer is of opinion that destruction is increasing—has had experience at three lights.
7. Carmanah	On point 3 miles from Bonilla Pt., West Coast V.I.	Fl.	173	30	Thick foggy nights. Autumn	Land birds	
8. Sheringham Point	On Sheringham Pt., West Coast, V.I.	Gp. Fl. 7½ Secs.	72	None			
9. Race Rocks	Great Race Rock in Juan de Fuca Strait	Fl. 10 secs.	118	24	Dark nights autumn	Both	
10. Fisgard	On Fisgard Island, west side of entrance to Esquimalt Harbour	F. white, red sector.	67	None			
11. Berens Island	West side of entrance to Victoria Harbour	occ. 20 secs.	44	None			
12. Trial Islands	On S.W. side of southernmost Island near Victoria	Gp. Fl. 10 secs.	85	None			
13. Fiddle Reef	Near Victoria	F. white red sector	30	None			
14. Discovery Island	On extremity of Island in Haro Strait	Occ. 15 secs.	91	None			
15. Saturna Island	On N.E. point of Island, Georgia Strait	F. Gp. Fl. 24 secs.	125	1		Both	
16. Portlock Point	On N.E. extremity of Prevost Island, Georgia Strait	F. white, red sector	72	None			
17. Active Pass	On Georgian Pt., Mayne Island, Georgia Strait	occ. 10 secs.	55	None			
18. Bare Pt.	On extremity of point. Chemainus Bay	F.	36	None			
19. Porlier Pass	On Race Pt. on Virago Pt., Galiano Island	F. F.	21-32	Large number	Dark stormy nights, autumn	Land birds	
20. Point Atkinson	N. point of entrance to Burrard Inlet	Gp. Fl. 5 secs.	108	25	Stormy nights accompanied by rain	Land birds	
21. Prospect Pt.	First Narrows, Burrard Inlet	Occ. 9 secs. White, red sector	28				1 casualty during 24 year

Light Station	Location	Character of Light	Height in feet above High Water Mark	Estimated number of birds killed annually	Kind of Weather showing greater mortality	Class of Birds Killed — Land Birds, Sea Birds	Remarks
22. First Narrows	N. shore of W. entrance to First Narrows	Occ. 6 secs.	25	None			
23. Brockton Point	Entrance to Vancouver Harbour	F., Red, white sector	40	None			
24. Entrance Island	On island northern approach to Nanaimo	F. & Fl. 5 secs.	65	None			
25. Merry Island	S.E. extremity of island, S.E. entrance to Welcome Pass	F.	57	None			
26. Ballenas Islands	On N. point of North Ballenas Island	F. and Gp. Fl. 18 secs.	70	None			
27. Sisters	On easterly and largest Sisters rock, Georgia Strait	Gp. Fl. 10 secs.	46	Large number	Calm foggy nights, autumn	Both	Chiefly land birds.
28. Yellow Island	On eastern extremity of Island.	Fl. 6 secs.	83	2			2 casualties in 17 months.
29. Cape Mudge	On Valdez Island	Fl. 5 secs.	57	25	Stormy and foggy nights, winter	Sea birds	Casualties said to be decreasing
30. Pulteney Point	Extremity of Point on Malcolm Island	F.	38				3 casualties in 10 years.
31. Scarlett Pt.	On point at entrance to Christie Pass	F.	90	None			
32. Pine Island	S.W. point of Island	Fl. 10 secs.	80	50	Stormy weather night & day	Land birds	
33. Egg Island	Summit of small Islet, west side of island	Rev. 30 secs.	85	Large number	Dark nights spring & fall	Land birds	
34. Addenbroke	West point Island, Fitzhugh Sound	F.	81	None			
35. Pointer Island	S.E. end of island, S. of E. entrance to Lama Passage	F.	42				1 bird killed in 23 years.
36. Dryad Pt.	N. entrance, Main Passage, Seaforth channel	F., white red sector	38	None			
37. Ivory Island	Surf Pt., Milbrook Sd.	F.	66	None			
38. Lawyer Islands	14 miles from Prince Rupert on summit of northernmost island at its N.W. end	F. Gp. Fl. 24 secs.	126	None			
39. Holland Island	Near Prince Rupert	F.	45	None			
40. Lucy Island	On N.E. extremity of E. Lucy Island	F.	65	None			
41. Green Island	On S.W. point of island, 12 miles west Pt. Simpson	Fl. 5½ secs.	81	Large numbers	Nights of wind accompanied by rain	Both	200 in one night.
42. Triple Island	On the N.E. rock of the Triple Islets Group	Fl. 8 secs.	97	Large numbers	Misty, rainy, nights	Both	
43. Cape St. James	South of Kunghit Island	Fl. 5 secs.	310	1200	Stormy nights clear nights	Both	
44. Masset Inlet	West extremity of Entry Point	F.	63				One casualty in 8 years.
45. Langara	On Langara Island	Fl. 5 secs.	160			Sea birds	

LIST OF DEAD BIRDS IDENTIFIED BY LIGHTKEEPERS

It would appear from the following list of dead birds, identified or described by the lightkeepers, that the relative number of casualties amongst the land birds and sea-birds is about equal. But this is not the case. With two exceptions (Cape Mudge and Estevan Point), all reports indicate a much higher proportion of land birds and it may be stated that the sea birds listed below are chiefly records of single birds:

<i>Species</i>	<i>No. of times recorded</i>
Grebe.....	2
Petrel.....	3
Pigeon Guillemot.....	1
Murre.....	1
Auk (Murre?).....	1
Murrelet.....	3
Puffin.....	1
Rhinoceros Auklet.....	1
Gull.....	1
Sooty Shearwater.....	2
Merganser.....	1
Duck.....	3
Goose.....	2
Brant.....	2
Rail.....	1
Northern Phalarope.....	1
Sandpiper.....	1
Snipe (Sandpiper?).....	2
Plover.....	1
Hawk.....	1
Owl.....	1
Woodpecker.....	1
Crow.....	1
Redpoll.....	1
Pine Siskin.....	2
Pine Grosbeak.....	1
Sparrow.....	4
White-crowned Sparrow.....	1
Golden-crowned Sparrow.....	1
Song Sparrow.....	1
Warbler.....	7
Thrush.....	1
Robin.....	3

SUMMARY AND CONCLUSION

Destruction of birds at lighthouses on the British Columbia Coast is believed to be confined to the following stations, viz.: Estevan Point, Pachena, Porlier Pass, Sisters Rock, Egg Island, Green Island, Pine Island, Triple Island, Cape St. James, Cape Mudge, Carmanah, Point Atkinson and Race Rocks; the casualties at the last four lights being merely nominal. Casualties at other stations, from which reports have been received, are so rare they may be considered accidental. As some reports do not give an estimate of the yearly mortality, merely stating that a large



FIGURE 3—Map of British Columbia showing location of the lighthouses which are destructive of bird-life

- Stations where serious destructions occur.
- Stations where destruction is slight.
- 3. Estevan Point. 19. Porlier Pass. 33. Egg Island.
- 6. Pachena. 20. Pt. Atkinson. 41. Green Island.
- 7. Carmanah. 27. Sisters. 42. Triple Island.
- 9. Race Rocks. 29. Cape Mudge. 43. Cape St. James.
- 32. Pine Island.

number of birds are killed or "two pails full have been picked up in one day", etc., it is not possible to submit figures regarding the total number of birds killed annually on the entire Coast. In all probability, however, the average number of birds either killed or stunned exceeds 6,000 annually. The destruction is said to be increasing at Pachena, the same from year to year at Cape St. James and Race Rocks, and decreasing at Pine Island, Cape Mudge and Porlier Pass. From a study of the reports it is gathered that a large number of birds which are picked up by the lightkeepers afterwards recuperate sufficiently to fly away and these may eventually recover from their injuries. Although several reports state that some birds die from exhaustion due to flying around the light, the concensus is that the majority are killed through striking violently against the glass or the tower. Apparently the greatest mortality occurs on dark, stormy nights during the autumn migration. Several reports specify nights of high wind accompanied by rain as the most dangerous—a condition that would be described merely as "stormy" by the majority of observers.

That more destruction takes place during the autumn migration than during the spring migration may be accounted for in part by the fact that young birds on their maiden voyages form a large percentage of the migrating flocks in the autumn, and it is thought probable that young birds are more liable to disaster than are adults. Another factor conducive to heavy mortality in the autumn is the less favorable weather conditions at that season as compared with the spring.

A study of the data collected indicates two factors chiefly responsible for the destruction of birds at lighthouses, namely, the geographical position of the station, and the power of the light. The type of light would seem to make little difference, for fixed lights, single flashing, and group-flashing lights are equally destructive under certain conditions. Neither has the elevation of the light above sea level much bearing on the question for the lights at which serious destruction occur vary from 21 to 310 feet in height.

The report submitted by Mr. John Moran,

lightkeeper at Green Island Station, is considered of particular value. His opinions would appear to be formed on careful observation, prompted by an interest in bird study which he is known to possess. His statement to the effect that birds may circle the light for hours, during light winds, without damaging themselves, is supported by that of a former lightkeeper at Sisters Rock, and, assuming the correctness of these observations, the building of additional perching places, on lighthouses where there is serious destruction, would appear to be justified. Installing canvas wind-breaks on the platform railings as an additional protection might also be considered. The idea of a windbreak is to afford shelter to the birds which fall to the platform after being stunned through flying against the glass. It is reasonable to believe that without such protection many temporarily disabled birds would be blown away, either out to sea where, if land birds, they would drown, or on to the land to be eaten eventually by their natural enemies.

MISCELLANEOUS BIRD NOTES FROM SOUTHERN VANCOUVER ISLAND, 1923

By J. A. MUNRO

(Concluded from page 150)

Rain had been falling all morning and towards eleven o'clock the downpour increased. Possibly for this reason the flock left suddenly about 11.15 and flew into some tall firs on a rocky hillside near the edge of the meadow and many individuals perched on branches that were directly exposed to the rain. No sound had come from the feeding birds, but, once in the trees, the loud cooing note was given repeatedly.

Two hours later, twenty-five birds alighted in a tall dead cedar and no doubt would have flown to the wheat field had I not shot two out of the flock. These proved to be male and female in breeding condition. In the crop of the male were found 321 wheat kernels; the crop of the female contained 89, the stomach 50 wheat kernels and 1 oat kernel. All these seeds were swollen, many sprouted, and 27 kernels were attached root stalks averaging one inch in length. Forty-one pebbles were found in the gizzard of the female and thirty-five in the male, the majority being attractive pieces of pink and white water-worn quartz, none greater in bulk than a grain of wheat. With the exception of five pieces, all are light in colour. This would seem to indicate that pebbles are selected and not picked up hap-hazard. I do not mean to suggest that Band-tailed Pigeons exercise aesthetic discrimination in the choice of pebbles, but I do think it probable that light-

coloured pebbles attract their attention—that their choice happens to please the human eye is merely accident.

To determine how the destruction of surface seed would affect a stand of wheat, I visited this farm again four weeks later. It was noted that exposed seeds had produced vigorous plants averaging six inches in height, and that the crop was thin in comparison with an adjoining oat crop which had not been molested by the Pigeons to any extent. This might be accounted for in part by a difference in soil favouring the oat-field but there can be little doubt that, by removing much of the exposed seed, Pigeons were largely responsible.

Pigeons remained later than usual in the autumn of 1923, perhaps because of the heavy crop of acorns. During the last week of September many birds congregated in the oak woods near Cedar Hill, the last flock being noted on September 28th. The crop of an immature male taken on September 22nd contained 8 whole acorns and in the stomach was found another, partly digested, and eight dogwood seeds (*Cornus nuttallii*).

Accipiter velox. SHARP-SHINNED HAWK.—I have at hand a series of twelve Sharp-shinned Hawks from the Victoria region, as follows: 1 adult male, March 22nd, 1922; 3 immature males, November 1st, 1922, January 15th, 1923, and November

26th, 1923; 7 adult females, March 23rd, 1922, March 24th, 1922, March 25th, 1922, November 1st, 1922, July 28th, 1923, February 26th, 1924, March 2nd, 1924; 1 immature female, November 1st, 1922. The female taken July 28th, 1923, is in a state of moult from the immature plumage to the adult, while the majority of the others are in fresh unfaded plumage. It is also considered that all these birds are migrants, presumably from the north-west coast.

A study of this series, together with one breeding female from the same region, and comparable material from the interior would seem to indicate the existence of a north-western form of the Sharp-shinned Hawk (as suggested by Swarth*) characterized by darker and richer colouration of the underparts and tibia. This is apparent in adults of both sexes and immature males. The only immature female available is of the pale form.

Asio wilsonianus. LONG-EARED OWL.—Notably less common than in the interior of British Columbia. Eight have been trapped at the Cedar Hill Pheasant Farm during the past three years.

Otus asio. SCREECH OWL.—In my collection is a series of thirteen Screech Owls, (taken in the Victoria region during the months of January, February, March and April), which have been identified as *kennicotti*. Of these, seven are in the gray phase and six in the brown phase. Within the past two years I have examined eight other specimens in the flesh, all of which were gray birds. Apparently this is the commoner type locally, although Ridgway†, in his description of *kennicotti* mentions that the gray phase is relatively rare. Gray birds are fairly uniform in color on the underparts but show considerable individual variation in the depth of color on upper parts. A color variation is noticeable also on the upper parts of brown birds, and in addition to this, there is some degree of difference in the shades of tawny which suffuse the under parts.

Nine stomachs were examined from specimens taken in the Victoria region on the following dates: March 21st, 1922, March 25th, 1922, April 26th, 1922, February 24th, 1924, March 10th, 1924, March 18th, 1924, March 21st, 1924, March 24th, 1924. These contained insect remains only. Three stomachs held respectively 60, 65 and 80 cutworms (*Noctuidæ*), five others contained fragments of elytra and tarsi of ground beetles (*Carididæ*).

Glaucidium gnoma. PYGMY OWL.—A Pygmy Owl shot at Cowichan Lake at 8.30 p.m. on June 20th, 1923, had in its stomach the remains of a

nestling Russet-backed Thrush. It is known that the Pygmy Owl is an inveterate enemy of small birds but this is the first evidence of nest-robbing that has come to my notice.

Asyndesmus lewisi. LEWIS' WOODPECKER.—A common summer resident of local distribution. Two winter records as follows: William Head, November 23rd, 1923. Oak Bay, January 5th, 1924.

Empidonax difficilis difficilis. WESTERN FLY-CATCHER.—As illustrating the ready acceptance of unusual, man-made, nesting sites by certain species of Flycatchers, I would cite the following example, which may be unique. Several times during the first two weeks of August, 1921, I noticed a Western Flycatcher in a certain large apple tree, growing close to the veranda of a suburban bungalow. From the bird's actions it was obvious she was nesting, but close scrutiny of the surroundings failed to reveal the nest. I called for assistance in my search and we studied the situation from every angle, while the Flycatcher lamented at arm's length. The search was continued at odd moments over a period of two weeks until August 14th, when, by accident, I discovered the mossy nest, containing two fledglings, on top of an electric-light meter just above the front door of the bungalow and about eight feet distant from the nearest limb of the apple tree—plainly visible to anyone who had not settled ideas as to where a Western Flycatcher should nest.

Cyanocitta stelleri stelleri. STELLER'S JAY.—Little is known regarding the erratic migratory movements of this Jay. During some winters it is abundant, in others comparatively scarce. Throughout the winter of 1922-23, Jays were very plentiful in the Victoria district—approximately 200 were caught in Quail traps by Provincial Game Officers. The following winter, with traps set on the same ground, only seven were taken and a scarcity of Jays was noted on many parts of the Island. Mr. G. D. Sprot, Cobble Hill, is banding Jays whenever possible and could this work be carried on systematically by a number of observers something might be learned of the seasonal movements of this interesting species.

Tachycineta thalassina lepida. NORTHERN VIOLET-GREEN SWALLOW.—In the interior of British Columbia this Swallow usually nests in rock crevices, rarely, if ever, about buildings, while on Vancouver Island they do so commonly. Natural cavities in trees or old Woodpeckers' holes are also used, in fact, locally, this species in its breeding habits closely resembles the Tree Swallow, which is scarce on Vancouver Island.

Vireo huttoni. HUTTON'S VIREO.—Comparatively rare. A male taken at Cowichan Lake on November 29th, 1923, was associated with Sitka

*Swarth, *Birds and Mammals of the 1909 Alexander Alaska Expedition*, pp. 60-61.

†Ridgway, *Bulletin 50*, Vol. 6, p. 698.

Kinglets and Chestnut-backed Chickadees. Lacking comparable material, and in view of Grinnell's remarks on the status of *obscurus**, I have not attempted subspecific identification.

Thryomanes bewicki calophonus. SEATTLE WREN.—The fact that this Wren nests readily in bird houses may be worth recording for the information of bird-house enthusiasts.

*Grinnell, *The Condor*, Vol. 24, p. 32.

OFFICIAL CANADIAN RECORD OF BIRD-BANDING RETURNS*

(Continued from page 157)

BLACK DUCK, No. 36,929 A.B.B.A., banded by H. S. Osler, at Lake Scugog, Ontario, on October 17, 1918, was re-caught at the same station on October 26, 1918.

JUNCO, No. 50,682 A.B.B.A., adult, banded by R. O. Merriman, at 96 West Second Street, Hamilton, Ontario, on October 26, 1920, was re-caught in another trap in the same locality, on January 25, 1921.

BLACK DUCK, No. 5,182, banded by H. S. Osler, at Lake Scugog, Ontario, on September 15, 1921, was shot at Long Point, Port Rowan, Ontario—no date given, but reported on February 28, 1924.

BLACK DUCK, No. 4,799, banded by H. S. Osler, at Lake Scugog, Ontario, on September 24, 1921, was killed in Muhlenburg County, Kentucky, four miles from McNary, Kentucky, on December 23, 1923.

WHITE-BREASTED NUTHATCH, No. 26,844, adult male, banded by Ralph E. DeLury, at 330 Fairmont Avenue, Ottawa, Ontario, on January 11, 1923, was re-caught several times at the same station until March 18, 1923, repeated on September 22, 1923, and several times after that date until December 30, 1923.

SLATE-COLOURED JUNCO, No. 30,861 banded by R. W. Tufts, at Wolfville, Nova Scotia, on February 6, 1923, repeated several times at the same station until March 26, 1923.

WHITE-BREASTED NUTHATCH, No. 26,845, adult female, banded by Ralph E. DeLury, at 330 Fairmont Avenue, Ottawa, Ontario, on February 15, 1923, repeated several times at the same station until March 27, 1923.

DOWNY WOODPECKER, No. 15,836, adult male, banded by Ralph E. DeLury, at 330 Fairmont Avenue, Ottawa, Ontario, on February 18, 1923, was re-caught several times at the same station until February 19, 1924.

CHICKADEE, No. 36,566, adult, banded by Adolf L. Holm, at Otto, Manitoba, on March 21, 1923, repeated at the same station on March 31, 1923.

SONG SPARROW, No. 51,029, banded by Willis H. Ropes, at Danvers, Massachusetts, on March 24, 1923, was caught and released at Weymouth, Digby County, Nova Scotia, during the month of June, 1923.

FOX SPARROW, No. 13,600, banded by R. W. Tufts, at Wolfville, Nova Scotia, on March 27,

Regulus calendula grinnelli. SITKA KINGLET.—An abundant resident. Found commonly at Cowichan Lake on November 30th, 1924, associated with Chestnut-backed Chickadees. I am informed by Mr. G. D. Sprot that Ruby-crests winter regularly at Mill Bay. A male taken on the above date is noticeably darker in colour and can readily be distinguished from Okanagan specimens which have been referred to this race by Oberholser.

1923, was retaken in the same trap, on March 28, 1923.

SONG SPARROW, No. 30,863, banded by R. W. Tufts, at Wolfville, Nova Scotia, on March 28, 1923, was retaken in the same trap, on April 2, 1923.

SLATE-COLOURED JUNCO, No. 30,864, banded by R. W. Tufts, at Wolfville, Nova Scotia, on March 28, 1923, was retaken in the same trap, on April 2, 1923.

CHICKADEE, No. 36,569, adult, banded by Adolf L. Holm, at Otto, Manitoba, on April 7, 1923, repeated several times at the same station until February 17, 1924.

SONG SPARROW, No. 26,849, adult, banded by Ralph E. DeLury, at 330 Fairmont Avenue, Ottawa, Ontario, on April 8, 1923, repeated at the same station on April 10, 1923.

ROBIN, No. 18,931, adult male, banded by Ralph E. DeLury, at 330 Fairmont Avenue, Ottawa, Ontario, on April 14, 1923, was re-caught in the same trap, on April 16, 1923.

ROBIN, No. 18,933, adult male, banded by Ralph E. DeLury, at 330 Fairmont Avenue, Ottawa, Ontario, on April 18, 1923, repeated at the same station on April 25, 1923, and on August 10, 1923.

ROBIN, No. 15,182, banded by Howard F. Cant, at Galt, Ontario, on April 21, 1923, repeated at the same station, on May 19, 1923.

SLATE-COLOURED JUNCO, No. 35,156, banded by K. Grant McDougal, at East Kildonan, Manitoba, on April 22, 1923, repeated at the same station several times until April 27, 1923.

SLATE-COLOURED JUNCO, No. 35,160, banded by K. Grant McDougal, at East Kildonan, Manitoba, on April 22, 1923, repeated at the same station until April 26, 1923.

SONG SPARROW, No. 52,357, adult, banded by Ralph E. DeLury, at 330 Fairmont Avenue, Ottawa, Ontario, on April 22, 1923, was re-caught in a different trap at the same station on May 13, 1923.

SLATE-COLOURED JUNCO, No. 35,165, banded by K. Grant McDougal, at East Kildonan, Manitoba, on April 23, 1923, repeated at the same station on April 24, 1923.

SLATE-COLOURED JUNCO, No. 35,166, banded by K. Grant McDougal, at East Kildonan, Manitoba, on April 23, 1923, repeated at the same station twice on April 27, 1923.

SLATE-COLOURED JUNCO, No. 35,180, banded by K. Grant McDougal, at East Kildonan,

*Published by authority of the Canadian National Parks Branch, Department of the Interior, Canada.

Manitoba, on April 25, 1923, repeated at the same station on April 26, 1923.

SONG SPARROW, No. 52,358, adult, banded by Ralph E. DeLury, at 330 Fairmont Avenue, Ottawa, Ontario, on April 25, 1923, was re-caught in a different trap at the same station, on April 27, 1923.

SLATE-COLOURED JUNCO, No. 35,182, banded by K. Grant McDougal, at East Kildonan, Manitoba, on April 26, 1923, repeated at the same station on April 27, 1923.

ROBIN, No. 18,934, adult female, banded by Ralph E. DeLury, at 330 Fairmont Avenue, Ottawa, Ontario, on April 27, 1923, repeated several times at the same station in different traps until July 6, 1923, and again on October 6, 1923.

DOWNY WOODPECKER, No. 15,838, adult female, banded by Ralph E. DeLury, at 330 Fairmont Avenue, Ottawa, Ontario, on April 29, 1923, repeated several times at the same station until May 5, 1923.

SONG SPARROW, No. 527359, adult, banded by Ralph E. DeLury, at 330 Fairmont Avenue, Ottawa, Ontario, on April 30, 1923, repeated several times in different traps at the same station until July 29, 1923.

SONG SPARROW, No. 65,772, adult, banded by W. E. Hurlburt, at 71 Alexandra Boulevard, North Toronto, Ontario, on April 30, 1923, returned to the same station on April 9, 1924, and repeated several times at the same station until June 7, 1924.

SONG SPARROW, No. 34,943, banded by Mrs. W. B. Perley, at Ojibway, Essex County, Ontario, on May 2, 1923, repeated several times at the same station until May 30, 1923.

SONG SPARROW, No. 52,360, adult, banded by Ralph E. DeLury, at 330 Fairmont Avenue, Ottawa, Ontario, on May 6, 1923, repeated at the same station in a different trap on May 29, 1923.

SONG SPARROW, No. 64,021, adult, banded by K. Grant McDougal, at East Kildonan, Manitoba, on May 6, 1923, repeated on May 15, 1923, returned to the same station on April 27, 1924, and repeated there on June 9, 1924.

WHITE-THROATED SPARROW, No. 54,796, banded by Mrs. W. B. Perley, at Ojibway, Essex County, Ontario, on May 8, 1923, repeated at the same station on May 12 and 13, 1923.

WHITE-THROATED SPARROW, No. 54,798, banded by Mrs. W. B. Perley, at Ojibway, Essex County, Ontario, on May 8, 1923, repeated at the same station on May 9, and several times on May 11, 1923.

WHITE-THROATED SPARROW, No. 54,799, banded by Mrs. W. B. Perley, at Ojibway, Essex County, Ontario, on May 8, 1923, repeated several times at the same station until May 16, 1923.

WHITE-THROATED SPARROW, No. 54,800, banded by Mrs. W. B. Perley, at Ojibway, Essex County, Ontario, on May 8, 1923, repeated several times at the same station until May 18, 1923.

WHITE-THROATED SPARROW, No. 54,801, banded by Mrs. W. B. Perley, at Ojibway, Essex County, Ontario, on May 8, 1923, repeated several times at the same station until May 11, 1923.

WHITE-THROATED SPARROW, No. 42,786, banded by Mrs. W. B. Perley, at Ojibway, Essex County, Ontario, on May 9, 1923, repeated at the same station on May 12, 1923.

WHITE-THROATED SPARROW, No. 54,802, banded by Mrs. W. B. Perley, at Ojibway, Essex

County, Ontario, on May 9, 1923, repeated at the same station on May 12, 1923.

WHITE-THROATED SPARROW, No. 54,805, banded by Mrs. W. B. Perley, at Ojibway, Essex County, Ontario, on May 9, 1923, repeated at the same station on May 11, 1923.

CHIPPING SPARROW, No. 52,363, adult, banded by Ralph E. DeLury, at 330 Fairmont Avenue, Ottawa, Ontario, on May 12, 1923, repeated in a different trap at the same station on May 14, 1923.

CHIPPING SPARROW, No. 52,364, adult, banded by Ralph E. DeLury, at 330 Fairmont Avenue, Ottawa, Ontario, on May 12, 1923, repeated several times at the same station in different traps until June 3, 1923.

CHIPPING SPARROW, No. 52,365, adult, banded by Ralph E. DeLury, at 330 Fairmont Avenue, Ottawa, Ontario, on May 15, 1923, repeated several times in different traps at the same station, until May 31, 1923.

SONG SPARROW, No. 52,366, adult, banded by Ralph E. DeLury, at 330 Fairmont Avenue, Ottawa, Ontario, on May 20, 1923, repeated in different traps at the same station on that day, and on May 23, 1923.

HOUSE WREN, No. 21,133, banded by Howard F. Cant, at Galt, Ontario, on May 21, 1923, repeated at the same station on June 9, 1923.

HOUSE WREN, No. 36,575, banded by A. L. Holm, at Otto, Manitoba, on May 26, 1923, repeated at a bird house five feet west of the one at which it was banded, on June 4, 1923.

HOUSE WREN, No. 36,576, banded by A. L. Holm, at Otto, Manitoba, on May 27, 1923, repeated at a bird house a few feet north of the one at which it was banded, on June 28, 1923.

TREE SWALLOW, No. 58,592, banded by H. Battersby, at Oak Lake, Manitoba, on May 27, 1923, returned to the same bird box, on May 10, 1924.

BARN SWALLOW, No. 54,769, banded by Reuben Lloyd, at Davidson, Saskatchewan, on May 27, 1923, was re-captured at the same station on June 28, 1924, and built its nest in the same building in which it built in 1923.

HOUSE WREN, No. 21,135, banded by Howard F. Cant, at Galt, Ontario, on May 29, 1923, repeated at the same station on June 10, 1923.

FLICKER, No. 111,133, adult male, banded by Adolf L. Holm, at Otto, Manitoba, on May 29, 1923, repeated on June 3, 1923, and returned to the same nesting hole on May 13, 1924.

HOUSE WREN, No. 36,577, banded by A. L. Holm, at Otto, Manitoba, on May 31, 1923, repeated at the same place on June 3 and 4, 1923.

HOUSE WREN, No. 36,579, banded by A. L. Holm, at Otto, Manitoba, on June 1, 1923, repeated at the same place on June 4 and 7, 1923.

SONG SPARROW, No. 52,368, adult, banded by Ralph E. DeLury, at 330 Fairmont Avenue, Ottawa, Ontario, on June 2, 1923, repeated at the same station on June 3, 1923.

TREE SWALLOW, No. 36,580, adult, banded by Adolf L. Holm, at Otto, Manitoba, on June 3, 1923, was re-captured at a place one-half mile from where it was banded, on July 8, 1923.

SONG SPARROW, No. 52,369, adult, banded by Ralph E. DeLury, at 330 Fairmont Avenue, Ottawa, Ontario, on June 3, 1923, repeated at the same station on August 4, 1923.

TREE SWALLOW, No. 36,581, banded by A. L. Holm. at Otto, Manitoba, on June 4, 1923, repeated at the same station on June 5, 1923.

FLICKER, No. 110,136, male, banded by

Dan Patton, at Midnapore, Alberta, on June 7, 1923, returned to the same station on April 15, 1924. It mated with the same female and nested in the same place as it did in 1923.

IN MEMORIAM

Edward J. Whittaker

Born November 12, 1891

Died September 14, 1924

Through the death of Edward J. Whittaker on the 14th of September, the Geological Survey of Canada has lost one of its most promising younger members. The deplorable accident which closed a scientific career just at its beginning occurred while Mr. Whittaker was enjoying a holiday with his wife and friends among the Gatineau hills a few miles from Ottawa.

Edward J. Whittaker was born November 12, 1891, at Toronto, Ontario, the son of John W. and Mary Whittaker, née Mary Somerville. He was married in 1916 to Miss Winnifred Robertson. His mother and wife survive him.

Mr. Whittaker was a graduate of Toronto University, where he received the M.A. degree in 1913. He became a member of the Geological Survey of Canada in 1913. Leave of absence was granted him in 1922 to complete his university training at Yale University. The thesis undertaken during his residence at Yale was nearly completed at the time of his death. Mr. Whittaker was a member of The Ottawa Field-Naturalists' Club and of the Palæontological Society of America.

Field work with various members of the Geological Survey staff during his college vacations had given him an unusually extended acquaintance with many of the problems dealt with in survey work. Mr. Whittaker's work for the Survey included several seasons in the Mackenzie River basin, a season in southern Alberta, and work in various parts of Eastern Canada. His published

work includes papers in *The Canadian Field-Naturalist*, *Nautilus*, and the *Summary Reports of the Geological Survey of Canada*, and other scientific publications. Mr. Whittaker will be remembered by readers of *The Naturalist* as an occasional contributor to its pages. Naturalists interested in freshwater shells will find his illustrated paper, *Bulletin 33, Geological Survey of Canada*, on the molluscan fauna of the marl bed near Ottawa of permanent value.

It was the writer's good fortune to be closely associated with Mr. Whittaker both in the field and in the office for a decade. The wide variety of problems which were taken up during that period always enlisted his enthusiastic interest and energetic co-operation. The cheerful optimism which was the keynote of Whittaker's disposition had won for him a host of friends. He had never learned the meaning of the word "can't". The discomfort, difficulty, or hazard of any piece of work was never a deterrent to him if it needed to be done. Whether the work was taking bottom samples from Ontario lakes in mid-winter, crossing the widest part of Lake Ontario in a small and antiquated launch, or threading the rapids of unexplored rivers, Whittaker did it cheerfully as part of the day's work, worthy of no more serious comment than a jest.

Such men are very rare and it is with a feeling of deep personal loss that the writer records that Fate has written *finis* so early in a career that promised so much for Science.—E. M. K.

NOTES AND OBSERVATIONS

NOTES ON THE MEASUREMENTS AND SOFT PARTS OF THREE TRUMPETER SWANS, *Cygnus buccinator*.—In view of the scarcity of Trumpeter Swans in collections it would seem desirable to publish the following notes relating to three specimens taken in British Columbia during recent years. The two adults referred to are in the Brewster-Sanford collection in the American Museum of Natural History, New York; the immature ♀ is in the writer's collection at Victoria, British Columbia.

Adult ♂—British Columbia, April 2nd, 1918.

Weight 26¼ lbs.; tail feathers 22; bill black; roof of mouth lavender, shading to green on outer margins; lamellæ dark flesh, base salmon red; tarsus olivaceous black, darker at joints; toes and webs black; iris fuscous black.

Adult ♀—British Columbia, April 2nd, 1918. Weight 22¾ lbs.; tail feathers 22; colors of soft parts as above.

The stomach and gullet of each specimen contained seeds of sago pondweed, *Potamogeton pectinatus*.

Immature ♀—British Columbia, January 7th, 1924. Weight 17 lbs.; tail feathers 22; bill dull black, clouded with purplish-vinaceous, above and below nostril; tarsus and toes nearest to honey yellow, darker at joints; webs deep mouse gray, becoming brighter and merging into honey yellow near angle formed by toes; claws mouse gray.

MEASUREMENTS IN MILLIMETERS FROM SPECIMENS
IN FLESH

	Length	Wing	Tail	Tarsus	Middle Toe and Claw	Culmen	Anterior Angle Eye to Posterior Nostril	Anterior Angle Eye to Tip Bill	Height of Bill at Base	Maximum Width of Bill
Ad. ♂	1555	615	175	117	195	118	73	141	44	38
Ad. ♀	1500	610	170	116	177	115	74	144	44	37
Im. ♀	1395	590	174	115	179	112	70	136	45	33

—J. A. MUNRO.

a NORTHERN RECORDS OF THE WILD STRAWBERRY IN THE MACKENZIE RIVER BASIN.—During the summer of 1923, a geological survey party had occasion to ascend the valley of the Dahadinni River, a western tributary of the Mackenzie, which joins the latter about lat. 64°N. When the party was about 15 miles up the river, several patches of the wild strawberry were noticed. These grew on the flats of the river.

In the *Geogr. Review*, Vol. 10, 1920, p. 395, Dr. Kindle says:

"The wild strawberry is abundant along the Mackenzie as far north as Simpson, at the mouth of the Liard, which appears to be near the northern limit of its range."

I am informed, however, that the National Herbarium of Canada has a record of strawberries collected by Bell from the west shore of Great Slave Lake. This puts the limit at least 150 miles farther north.

Other berries met with were raspberries, a blueberry, black currants, and red currants. These latter two were found on the west shore of what is called Whitefish Lake about lat. 65°30' N. This is one of several lakes drained by Brackett River (Willow River on old maps), which flows into Great Bear River, about 10 miles east of Fort Norman.—WILLIAM H. KELLY.

FIELD SPARROW AND TOWHEE AT CHRISTIE LAKE, ONTARIO.—Christie Lake lies in the south-western corner of Lanark County, some twelve miles south-west of Perth. In connection with these occurrences it is of interest to observe as well that it is almost equidistant from Arnprior and Kingston, Ontario, being 39.5 miles north of

Kingston. Mr. James White in "Altitudes in Canada" gives the altitude of the lake as 542 feet above mean sea-level, whereas Lake Ontario (1871-1899) is given as 245.8 feet, and the Central Station at Ottawa, as 213.7 feet. I spent July 22nd and 23rd, 1923, and July 25-28, 1924, in bird instruction work at a boys' camp located there. On July 22, 1923, I was out at 4.15 a.m. on my first real bird walk in this very attractive locality, which, with its rocky winding roads, reminded me strongly of the days at Sulphide, Ontario, just about forty miles to the westward. A pleasant surprise awaited me, for the song of the Field Sparrow came to me clearly on the fresh morning air. There were two singing males found, and, as though to mark Christie Lake definitely as more southern than Ottawa, a pair of Towhees was discovered at the same spot. Additional confirmation of a southern influence reaching this locality was found in the fact that the Black Squirrel was fairly common, and that the red juniper occurred. In the course of my 1924 visit the Towhees were found again, and, while I believe the Field Sparrow's Song was heard in the distance, I am not positive of this species for this year.

Both the Towhee and the Field Sparrow are rare and irregular at Ottawa, although W. E. Saunders records the Field Sparrow from Kazubazua, Quebec, forty miles north of the city, and I have heard has evidence of the occurrence of the Towhee at River Desert, near Maniwaki, Quebec, sixty-seven miles to the north of the capital.—HOYES LLOYD.

LATE FREEZING OF MACKENZIE RIVER—A letter recently received by one of the associate editors from Mr. T. W. Harris, who has resided for many years at Simpson, on the Mackenzie River, states that "We had a late fall; the Mackenzie did not freeze till December 3rd, which has rarely happened. At the moment of writing (January 21st, 1924) the thermometer stands at 5 below zero, which is mild for this time of year."—E. M. KINDLE.

ANNUAL MEETING, OTTAWA FIELD-NATURALISTS' CLUB.—The Annual Meeting of the Ottawa Field-Naturalists' Club was held in the lecture amphitheatre of Victoria Memorial Museum on Saturday evening, December 8th, 1923. President Lloyd presided and in opening the meeting briefly outlined the activities of the Club during the past year, and gave a summary of the aims of the Club

during the coming year.

Article VI of the Constitution was changed and approved so that Presidents of affiliated societies are now ex-officio members of Council. The reports of Council and of the Treasurer were read and accepted.

The following officers and members of Council were elected: President, Mr. Hoyes Lloyd; 1st Vice-Pres., Mr. G. A. Miller; 2nd Vice-Pres., Mr. Norman Criddle; Secretary, Dr. J. F. Wright; Treasurer, Mr. B. A. Fauvel; Council: W. T. Macoun, Miss M. E. Cowan, C. M. Sternberg, H. I. Smith, F. W. Waugh, P. A. Taverner, E. Sapir, E. M. Kindle, W. J. Wintemberg, R. E. DeLury, Arthur Gibson, M. O. Malte, R. M. Anderson, C. B. Hutchings, C. L. Patch, H. Groh, Dr. H. M. Ami, D. Jenness, Miss Fyles, H. F. Lewis.

Following the business meeting, Mr. Frank Morris of Peterborough delivered an address on "Hudson, the Naturalist". This address has been published in the February and March *Naturalists*. —J. F. WRIGHT, *Secretary*.

CANADIAN FIELD-NATURALIST PUBLICATION FUND.—The Ottawa Field-Naturalists' Club has been notified by the Department of Education, Province of Ontario, that the Club's usual grant of two hundred dollars was not voted for the fiscal year of the Province, November 1, 1924—October 31, 1925. The Club has been in receipt of an annual grant from this Department of the provincial Government since 1898, and it is the feeling of the present members of Council that very ample return has been made to the people of Ontario, through the publication of *The Ottawa Naturalist* and, subsequently, of *The Canadian Field-Naturalist*, through public lectures, and by instruction given the pupils of the Normal School, Ottawa. The original note concerning the grant will be found in *The Ottawa Naturalist*, Vol. XII, 1898-9, pp. 8-9. The Hon. G. W. Ross was then Minister of Education, and the name of Dr. S. P. May, then Inspector of Mechanics' Institutes and Libraries, is mentioned in this connection.

The withdrawal of the financial support of the Province of Ontario may be serious to the well-being of the Club and *The Canadian Field-Naturalist* unless every member takes the question to heart and makes an urgent endeavor to meet the situation.

The publication of *The Canadian Field-Naturalist* for one year, including nine issues of eight hundred copies each, costs fourteen hundred fifty dollars. A single volume of nine numbers costs one-eight hundredth of this sum, or one dollar, eighty-one cents. Moreover, the entire eight hundred copies are not sold. The number of

copies of an issue which are sold is at present only about 575. The remaining 225 copies are required to supply twenty-five free copies to each author of a leading article and to maintain a moderate reserve. It thus appears that, dividing the cost of publication equally among the present 575 paid subscriptions, the fair share of the cost which must be apportioned to each of them is two dollars, fifty two-cents, or one dollar, two cents, more than is received from the subscriber! This deficit has hitherto been met by The Ottawa Field-Naturalists' Club, with the assistance of the provincial grant which is now withdrawn. *The Canadian Field-Naturalist* will suffer in size and quality unless other means are taken to make up for this withdrawal. Increase in the number of subscribers is of fundamental importance, as ultimate relief can be expected only from that source. But in the present emergency quicker means of raising funds are necessary. One affiliated organization, The Province of Quebec Society for the Protection of Birds, has already this year given substantial help by making a cash contribution of \$125.00 to the *Naturalist*. Other cash donations have been received from individuals who are aware of our need and of the importance of the *Naturalist* to Canada. Such contributions, which are in addition to assistance received to meet the cost of special paper and cuts for illustrations, will form the nucleus of a special "Publication Fund", which is now open for additional donations. This fund will be used to help in the publication of our magazine, thus keeping in existence a Canadian Natural History periodical. This is an opportunity for every subscriber and every affiliated organization to help, either by a donation, or by bringing the matter to the attention of others who may be interested. Your aid is solicited.

Subscriptions should be sent to the Treasurer, Mr. B. A. Fauvel, Mounted Police Headquarters, Laroque Building, Ottawa.

Cash contributions already received this year are listed below.

CANADIAN FIELD-NATURALIST PUBLICATION FUND

The Province of Quebec Society for the	
Protection of Birds.	\$125.00
Dr. M. O. Malte, Ottawa.	30.00
Frits Johansen, Ottawa.	10.00
R. Meredith, Quebec.	10.00
Col. Wm. Wood, Quebec.	5.00
D. Jenness, Ottawa.	50.00
<hr/>	
Total received.	\$230.00

P. A. TAVERNER,
Chairman, Publications Committee.

NOTE.—*The Canadian Field-Naturalist* for 1924 has been much improved by the generous donation of cuts and special paper upon which to print illustrations. Some of these donations have been by authors, and others by those who have a friendly interest in the success of the paper. Credit has been given to all who have assisted in the number of the paper they have helped improve, but in view of the opening of the special *Canadian Field-Naturalist* publication fund it seems desirable to recapitulate and give a list of those who have helped by providing illustrations and paper, for some have given so generously in this way that their donation to the special fund must be affected. In some instances cuts have been furnished, and the cash value of the donation is not exactly known.

W. J. Brown, (Estimated)	\$15.00
Frits Johansen "	47.00
R. E. DeLury "	22.50
Ira Cornwall "	5.00
Canadian National Parks Branch (Est.)..	9.00
P. A. Taverner (Estimated) ..	20.50
Victoria Memorial Museum (Estimated) .	3.00
Geological Survey "	19.00
J. H. Fleming	10.00
W. E. Saunders	10.00
William T. Shaw (Estimated)	24.00
The Publishers of the <i>C.F.-N.</i>	12.00

—EDITOR.

NOTE.—*The Canadian Field-Naturalist* is indebted to Mr. Frits Johansen, the Canadian National Parks Branch and the Geological Survey of Canada for the illustrations which appear in this issue.—EDITOR.

BOOK REVIEW

TWENTY-FOURTH ANNUAL ARCHÆOLOGICAL REPORT, 1923, by Dr. R. B. Orr, being part of *Appendix to the Report of the Minister of Education, Ontario, Toronto, 1924, pp. 141.*

This report is a continuation of the Annual Archæological Reports, which were issued by the late Dr. David Boyle, curator of the archæological section of the Canadian Institute, 1886-1893, and later (1894-1909) Superintendent of the Provincial Museum. This is the twelfth report issued by Dr. Orr. The articles of a purely archæological nature are as follows: *Primitive Cultures in the State of Maine*, by W. K. Moorehead; *Effigy Pipes in Stone (Sixth Paper)*, by Col. George E. Laidlaw; *Unusual Stone Artifacts from Ontario*, by W. J. Wintenberg; *Prehistoric Iroquoian Culture*, by G. E. Rhoades; *Exploration of the Ossuary Burial of the Huron Nation, Simcoe County*, by J. Hugh Hammond; and *Regional Notes on Specimens of Primitive Copper Craft*, by Frank Eames. Under

"New Accessions to the Museum", some of the more important accessions to the Museum during the year are described and illustrated. We would suggest that in future issues the illustrations be designated by serial numbers instead of by the catalogue numbers of the specimens, which are too unwieldy for direct reference. Other articles in the report are: *The Crees of New Ontario*, by R. B. O.; *When the Crees Moved West*, by Chief Buffalo Child Long Lance; *The Unweiling of Memorials in Huronia; Where Champlain Lost His Way*, by W. S. Herrington; *The Indian Tribes on the St. Lawrence at the Time of the Arrival of the French* (from *Histoire de la Colonie Française en Canada*), by Abbé Faillon (Villemarie, 1865), Tome I, pp. 524-533), translated by Prof. John Squair; and *The Jemez Indians*, by Albert B. Reagan. The report concludes with an obituary of the Rev. Dean Harris, who has done so much to create and keep alive an interest in archæological and historical matters in Ontario.—W. J. W.

PUBLICATIONS RECEIVED

The Magnetic Mechanical Analysis of Manganese Steel by Sir Robert Hadfield, F.R.S., and Messrs. S. R. Williams and I. S. Bowen. Oberlin College. Laboratory Bulletin No. 36. Oberlin, 1920.

Reptile Lore of the Northern Indians by Frank G. Speck. Reprinted from *American Journal of Folk-Lore*, Vol. 36, No. 141, July-September, 1923.

A Note on the Breeding Habits of Sceloporus by F. G. Speck. *Copeia*, Number One Twenty-Eight, for March 31st, 1924.

Some Remarks on Birds by Dr. George T. McKeough, with *A List of the Birds of the County of Kent* by Dr. G. T. McKeough and J. H. Smith, I.P.S. Kent Historical Society, Papers and Addresses. Vol. 6, 1924. Pages 49-74.

Aiming a Camera at a Wild Mountain Goat by William T. Shaw. Reprinted from *Natural History*, Vol. XXIV, No. 3, 1924, pp. 381-37.

Monthly Record of Meteorological Observations in the Dominion of Canada, and the Colonies of Bermuda and Newfoundland. April, May, June and July, 1923. Issued by the Meteorological Service of Canada. Ottawa, 1924.

Lichens Collected on the North-Coast of Greenland By the Late Dr. Th. Wulff by B. Lyngé. Copenhagen, 1923.

The Vegetation of the North-Coast of Greenland Based Upon the Late Dr. Th. Wulff's Collections and Observations by C. H. Ostenfeld. Copenhagen, 1923.

Some Mosses from N.W. Greenland (Wolstenholme Sound and Inglefield Gulf) and Mosses Collected on the North Coast of Greenland by the Late Dr. Th. Wulff by Aug. Hesselbo. Copenhagen, 1923.

Flowering Plants and Ferns from Wolstenholme Sound (ca. 76°30' N. Lat.), and Two Plant Lists from Inglefield Gulf and Inglefield Land (77°25' and 79°10' N. Lat.), N.W. Greenland by C. H. Ostenfeld. Copenhagen, 1923.

Critical Notes on the Taxonomy and Nomenclature of Some Flowering Plants from Northern Greenland by C. H. Ostenfeld. Copenhagen, 1923.

Dr. Thorild Wulff's Plankton-Collections in the Waters West of Greenland. Metazoa by P. Jespersen. Copenhagen, 1923.

Dr. Thorild Wulff's Hydrographical Investigations in the Waters West of Greenland. Report Worked Out by Martin Knudsen in August, 1918. Copenhagen, 1923.

La Science Moderne. Numéro 3. Mars, 1924. Paris, France.

Lyman's Limited

(Established 1800)

MANUFACTURING CHEMISTS

*Importers and Dealers in
CHEMICAL AND
ASSAY APPARATUS*

344 St. Paul St. West, Montreal



**GROW
GOOD
CROPS**

SEEDS PLANTS BULBS

Our rigorous system of testing eliminates loss
and disappointment from your garden

Kenneth McDonald & Sons, Limited

Seed and Bulb Merchants

Market Square :: Ottawa, Ont

The Topley Co.

**Photographic Material
Scientific Apparatus
Eastman Kodaks**



**132 Sparks Street
OTTAWA**

Ward's NATURAL SCIENCE ESTABLISHMENT

Rochester, New York, U.S.A.

Manufacturers of the genuine Schmitt boxes
exhibition cases and cabinets, also of the American
Entomological Company's insect pins.

Riker Mounts and botanical mounts always on
hand, also Riker botanical presses.

Send for our supply catalogue and other lists of
interest to collectors.

**Headquarters for Entomological Supplies
and Specimens**

THE

Bank of Nova Scotia

Capital.....\$ 10,000,000

Reserve Fund..... 19,500,000

Total Assets over..... 237,000,000

**FIFTEEN BRANCHES IN
OTTAWA AND HULL**

Inspected Milk Ice Cream

Ottawa Dairy

Fresh Butter Buttermilk

W. A. Rankin, Ltd.

**Hammocks
Refrigerators
Builders' Hardware**

410-412 Bank Street, Ottawa

Phones—Queen 1023-1024

Kindly mention The Canadian Field-Naturalist to advertisers

Sweet Canada

Eleven Bird Songs and a Round

by

Louise Murphy

Author of "A Little Book of Bird Songs,
Rhymes and Tunes for Tiny Tots"

PRICE \$1.00

Longmans, Green & Co.
210 Victoria Street, Toronto

L. C. Smith & Bro.

Typewriter

*Ball bearings in every frictional part of
the L. C. Smith insure long life, light
touch and easy operation*

Ottawa Typewriter Co. Limited

191 QUEEN ST., OTTAWA



Card Filing Systems for Naturalists

As makers of the Library Bureau line of Card Filing Devices in Canada, we are in a position to supply all Naturalists with cards and trays where they can readily index all their observations and notes

Lowe-Martin Ltd.
OTTAWA, CANADA

Printers of The Canadian Field-Naturalist

Publishers of the Autobiography of John Macoun, M.A.

The Crabtree Co.

Artists and
Designers

BLUEPRINTERS
ENGRAVERS
COMMERCIAL
PHOTOGRAPHERS
: PHOTO :
LITHOGRAPHERS

228 Albert Street
Ottawa, Ont.

COAL C. C. Ray Company
Limited

BEST QUALITY · LOWEST PRICES

46 Sparks St.—Phone Q. 461
OTTAWA

Geo. E. Preston & Sons
MERCHANT TAILORS

*We make everything we sell and
guarantee everything we sell*

217-219 Rideau Street, Ottawa

Dr. Mark G. McElhinney

*Dentist to certain of the
cognoscenti*

252 LISGAR STREET, OTTAWA
Telephone Queen 2438

Kindly mention The Canadian Field-Naturalist to advertisers

Affiliated Societies

NATURAL HISTORY SOCIETY OF MANITOBA 1924

Hon. President: V. W. JACKSON; *President:* J. J. GOLDEN; *Vice-Presidents:* H. M. SPEECHLY, A. M. DAVIDSON, A. G. LAWRENCE, NORMAN CRIDDLE; *MRS. C. E. BASTIN, MRS. C. P. ANDERSON; General Secretary:* A. A. MCCOUBREY, 307 C.P.R. Depot, Winnipeg, Man.; *Executive Secretary:* R. M. THOMAS; *Treasurer:* MISS HELEN R. CANNOM; **ORNITHOLOGICAL SECTION:—Chairman:** B. W. CARTWRIGHT; *Secretary:* C. L. BROLEY. **ENTOMOLOGICAL SECTION:—Chairman:** A. V. MITCHENER; *Secretary:* A. SHIRLEY BROOKS. **BOTANICAL SECTION:—Chairman:** C. W. LOWE; *Secretary:* MISS GRACE CAMERON. **GEOLOGICAL SECTION:—Chairman:** A. A. MCCOUBREY; *Secretary:* J. M. BENSON.

THE HAMILTON BIRD PROTECTION SOCIETY (Incorporated)

Hon. President: MR. ADAM BROWN; *President:* MR. R. O. MERRIMAN; *1st Vice-President:* DR. H. G. ARNOTT; *2nd Vice-President:* MR. C. D. COOK; *Secretary-Treasurer:* MISS RUBY R. MILLS, Public Library, Hamilton; *Directors:* DR. H. G. ARNOTT; C. D. COOK; DR. J. A. DICKSON; MISS M. E. GRAMM; MISS RUBY R. MILLS; M. HOLTON; M. JOHNSTON; MRS. F. E. MACLOGHLIN; R. O. MERRIMAN.

NATURAL HISTORY SOCIETY OF BRITISH COLUMBIA, VICTORIA, B.C.

The officers for the above Society for the year ending March 31st, 1923, are as follows:—

President: W. N. KELLY; *1st Vice-President:* A. R. SHERWOOD; *2nd Vice-President:* C. C. PEMBERTON; *Secretary:* H. T. NATION 2380 Windsor Road, Victoria, B.C. *Treasurer:* MISS S. M. THORNTON; *Committee:*—MISS C. G. FOX, MISS A. F. GARDINER, MISS I. CATHCART, WM. DOWNS, A. HALKETT. *Auditors:*—J. KRITH WILSON and F. W. GODSAL. *Trustees:*—REV. R. CONNELL, DR. C. F. NEWCOMBE and G. HARVEY.

ALBERTA NATURAL HISTORY SOCIETY

Hon. President: DR. H. Y. GEORGE, Victoria B.C.; *Hon. Vice-President:* MR. J. J. GAETZ, Red Deer; *President:* MR. C. H. SNELL, Red Deer; *1st Vice-President:* MR. G. C. S. CROSBY, Red Deer; *2nd Vice-President:* MRS. W. A. CASSELS, Red Deer; *Hon. Sec.-Treas.* MRS. S. PAMELY, Red Deer; *Directors:* MRS. G. C. S. CROSBY, MISS E. C. IRVING, MR. W. A. CASSELS and MR. S. PAMELY, Red Deer, MRS. G. F. ROOT, Wetaskiwin, MR. K. BOWMAN, Edmonton, MR. B. LAWTON, Edmonton, MR. T. RANDALL, Castor, MR. F. L. FARLEY, Camrose, MR. W. C. MCCALLA, Bremner, and MR. D. M. SINCLAIR, Peace River.

The meetings of this Society are held in Red Deer on the last Friday of each month except during July and August and perhaps September. The annual meeting is held in Red Deer on the last Friday in November.

McILWRAITH ORNITHOLOGICAL CLUB, LONDON, ONT.

President: T. D. PATTERSON, 562 Waterloo Street; *Recording Secretary:* MRS. E. H. MCKONE, Worthey Road; *Corresponding Secretary and Treasurer:* E. M. S. DALE, 297 Hyman St.; *Members qualified to answer questions:* W. E. SAUNDERS, 240 Central Ave.; C. G. WATSON, 201 Ridout St. South; J. R. MCLEOD, 355 Wortley Road; J. F. CALVERT, 461 Tecumseh Ave.; E. M. S. DALE, 297 Hyman St.

VANCOUVER NATURAL HISTORY SOCIETY

Hon. President: L. S. KLINCK, L.L.D., Pres. University of B.C.; *President:* JOHN DAVIDSON, F.L.S., University of B.C.; *Vice-President:* FRED PERRY; *Hon. Secretary:* C. F. CONNOR, M.A., 3529-W. 2nd Ave., Vancouver, B.C.; *Hon. Treasurer:* A. H. BAIN, 2302 York St., Vancouver, B.C.

Fortnightly meetings in the University Buildings from September to April (inclusive). Semi-monthly excursions from May to August (inclusive).

PROVINCE OF QUEBEC SOCIETY FOR THE PROTECTION OF BIRDS

Hon. President: I. GAMMELL; *President:* L. MCI. TERRILL; *Vice-Presidents:* NAPIER SMITH, E. ARNOLD, W. A. OSWALD; *Hon. Corresponding Secretary and Acting Treasurer:* W. S. HART, P.O. Box 1185, Montreal; *Hon. Recording Secretary:* MISS H. STONE; *Curator:* MISS E. G. LUKE; *Committee:* MISS M. ARMITAGE, MISS E. BENNETT; W. J. BROWN; MR. AND MRS. C. F. DALE; H. A. C. JACKSON; MISS E. MORROW; MISS L. MURPHY; A. MACSWEEN; MISS H. MCLACHLAN; L. MCI. SPACKMAN; MRS. W. W. WALKER; DR. ARTHUR WILLEY; W. H. ROBB; *Members qualified to answer questions:* L. MCI. TERRILL, 44 Stanley Ave., St. Lambert, Que.; NAPIER SMITH, Bank of Montreal, Magog, Que., E. ARNOLD, 64 Durocher St., Montreal; W. A. OSWALD, 301 Wilson Ave., N.D.G., Montreal; C. N. ROBERTSON, c-o Ross Realty Co., Room 805, Lewis Bldg., St. John St., Montreal, Que.; DR. ARTHUR WILLEY, McGill University, Montreal; W. J. BROWN, 250 Oliver Ave., Westmount, Que.; MISS EDITH MORROW and MISS EMILY LUKE, c-o Secretary.

SOCIÉTÉ PROVANCHER D'HISTOIRE NATURELLE DU CANADA Bureau de direction pour 1923

Président: DOCTEUR S. GAUDREAU; *1er vice-président:* ABBE A. VACHON, M.A.; *2ème vice-président:* A.-R.-M. BOULTON; *Secrétaire-trésorier:* LOUIS-B. LAVOIE; *Chef de la section scientifique:* A.-A. GOUBOUT; *Chef de la section de propagande éducationnelle:* DOCTEUR A. DERY; *Chef de la section de protection:* R. MEREDITH, N.P.; *Chef de la section d'information scientifique et pratique:* DOCTEUR J.-E. BERNIER; *Directeurs:* R.-F. LINDSAY; JOS. MATTE; G.-S. AHERN.

THE BRITISH COLUMBIA ORNITHOLOGISTS' UNION Officers for 1923

Hon. President: HON. MINISTER OF AGRICULTURE, Victoria; *President:* FRANCIS KERMODE, Provincial Museum, Victoria; *Vice-President:* T. L. THACKER, Hope; *Secretary-Treasurer:* J. W. WINSTON, Huntingdon; *Directors:* J. A. MUNRO, Okanagan Landing; DR. KELSO, Arrow Lakes; R. GLENDENING, Agassiz; K. RACEY, Vancouver; T. PEARSE, Courtenay; W. N. KELLY, Victoria.

THE TORONTO FIELD-NATURALISTS' CLUB

President: PROFESSOR R. B. THOMSON; *Vice-Presidents:* PROFESSOR E. M. WALKER, DR. A. COSENS, J. H. FLEMING; *Secretary:* W. F. GREGORY, 151 Ellsworth Ave., Toronto; *Treasurer:* F. H. BRIDGEN; *Honorary Librarian:* C. W. NASH; *Librarian:* DR. LYMAN B. JACKES. **BIRD GROUP:—Chairman:** STUART THOMPSON; *Secretary:* JAMES BAILLIE. **FLOWER GROUP:—Chairman:** DR. H. B. SIFTON; *Secretary:* MISS J. G. WRIGHT, Ph.D.; **INSECT GROUP:—Chairman:** PROFESSOR WALKER; *Secretary:* MISS NORMA FORD, Ph.D. **MAMMAL GROUP:—Chairman:** J. R. DYMOND; *Secretary:* L. SNYDER. **REPTILE, FISH and AMPHIBIAN GROUP:—Chairman:** SHILLEY LOGIER; *Secretary:* T. B. KURATA. **PROGRAM COMMITTEE:—Chairman:** DR. W. A. CLEMENS. **WILD LIFE PRESERVATION COMMITTEE:—Chairman:** RUSSELL G. DINGMAN. **EDUCATIONAL COMMITTEE:—Chairman:** TAYLOR STATEN.

We would ask the Officers, and more particularly the Secretaries, of all the Affiliated Societies to assist us in our task of building up the circulation of this magazine. By securing every member as a subscriber we can truly make this magazine into one of the leading Natural History publications of America.



FOR SALE

Back Numbers of The Ottawa Naturalist

The Club has for sale complete sets of its publications. Enquiries regarding price should be addressed to the Secretary of the Club, Dr. J. F. Wright, Geological Survey, Ottawa, Canada.

Any member having copies of the March, 1896, January, February, March and August, 1898, and December, 1900, issues of *The Ottawa Naturalist*, and who desires to dispose of the same, is requested to communicate with the Secretary.



Grant-Holden- Graham Limited

Outfitters to Surveyors & Engineers

Manufacturers of
High-Grade Tents

Tarpaulins & Sleeping Bags

WRITE FOR CATALOGUES

147 Albert Street
OTTAWA

Fine Diamonds

Sterling Silver, Fine Cut Glass, Electro- Plated Ware

*The Store of
Moderate Prices*

C. A. Olmsted & Son

*Jewellers, Opticians, Watchmakers and
Engravers*

208 Sparks Street, Ottawa

Prices of Separates

Notes to Contributors, Etc.

Papers for publication should be addressed to the Editor, Mr. Harrison F. Lewis, Parks Branch, Ottawa, or to the appropriate Associate Editor.

Manuscript should be plainly written, typed if possible, on one side of the paper only, with wide spaces between the lines and ample margins. It is urged that special care be used that scientific names are legible, properly formed, and correctly spelled and capitalized.

Galley proof will be submitted to authors resident in Ottawa and proof of leading articles to any other author if requested when manuscript submitted. It is requested that it be corrected and returned to the Editor as quickly as possible.

Authors of leading articles are entitled to twenty-five copies of the number in which they appear, free of charge on application.

Separates of articles as they appear on the page, without any change of make-up will be supplied at the following rates:—

	25	50	100	200	300
1 page.....	\$2.00	\$2.25	\$2.50	\$2.75	\$3.00
2 ".....	3.00	3.25	3.75	4.00	4.25
3 ".....	3.50	3.75	4.00	4.25	4.50
4 ".....	3.50	3.75	4.00	4.25	4.50
5 ".....	4.50	4.75	5.00	5.25	5.50
6 ".....	4.50	4.75	5.00	5.25	5.50
7 ".....	6.00	6.25	6.50	6.75	7.00
8 ".....	6.00	6.25	6.50	6.75	7.00
9 ".....	7.50	8.00	8.75	10.25	11.75
10 ".....	7.50	8.00	8.75	10.25	11.75
Covers extra.....	3.00	3.00	3.00	4.00	5.00

If removal of matter on the pages non-pertinent to the article or changes of make-up are desired, or if insets or other extra work are necessary, special rates will be furnished on application to the Editor.

Applications for separates should be made to the Editor and must reach him not later than with the return of the corrected proof.

Kindly mention The Canadian Field-Naturalist to advertisers

35,343 JAN 26 1925

VOL. XXXVIII, No. 10

DECEMBER, 1924



THE CANADIAN
FIELD-NATURALIST



OTTAWA FIELD-NATURALISTS' CLUB

ISSUED JANUARY 24, 1925

Entered at the Ottawa Post Office as second-class matter

THE OTTAWA FIELD-NATURALISTS' CLUB

Patrons:

THEIR EXCELLENCIES THE GOVERNOR-GENERAL AND THE LADY BYNG OF VIMY

President: HOYES LLOYD.

1st Vice-President: G. A. MILLER

Secretary:

J. F. WRIGHT
(Geological Survey, Ottawa).

2nd Vice-President: NORMAN CRIDDLE.

Hon. Treasurer:

B. A. FAUVEL,
321 McLeod St.
Ottawa, Ont.

Additional Members of Council: W. T. MACOUN; MISS M. E. COWAN; C. M. STERNBERG; H. I. SMITH; F. W. WAUGH; P. A. TAVERNER; E. SAPIR; E. M. KINDLE; W. J. WINTENBERG; R. E. DELURY; ARTHUR GIBSON; M. O. MALTE; R. M. ANDERSON; H. GROH; MISS F. FYLES; C. B. HUTCHINGS; H. M. AMI; CLYDE L. PATCH; D. JENNESS; V. W. JACKSON; R. O. MERRIMAN; W. N. KELLY; C. H. SNELL; J. R. MCLEOD; JOHN DAVIDSON; L. MCL. TERRILL; R. MEREDITH; FRANCIS KERMODE; PROF. R. B. THOMSON; THE EDITOR.

Editor:

HARRISON F. LEWIS,
Canadian National Parks Branch,
Dept. of the Interior, Ottawa.

Associate Editors:

E. SAPIR.....	Anthropology	A. G. HUNTSMAN.....	Marine Biology
M. O. MALTE.....	Botany	P. A. TAVERNER.....	Ornithology
F. R. LATCHFORD.....	Conchology	E. M. KINDLE.....	Palaeontology
M. Y. WILLIAMS.....	Geology	R. M. ANDERSON.....	Zoology
ARTHUR GIBSON.....	Entomology	CLYDE L. PATCH.....	Herpetology

CONTENTS

	PAGE
An Exploration into the Northern Plains North and East of Great Slave Lake, Including the Source of the Coppermine River. By G. H. Blanchet, F.R.G.S.	183
Notes on Some Game Birds in the County of Kent, Ontario, Season of 1924. By George T. McKeough	187
Finding Range for Canada's Buffalo. By Maxwell Graham.	189
Official Canadian Record of Bird-Banding Returns.	190
In Memoriam:—	
Charles Frederick Newcombe, M.D.	191
William Daily Hobson.	192
Notes and Observations:—	
On a New Case of Commensalism Between Echinoderm and Annelid. By Edith Berkeley	193
Display of the Killdeer Plover. By Theed Pearse.	193
An Old Breeding Record for the Herring Gull at Lac des Iles, Labelle County, Quebec. By Hoyes Lloyd.	193
A Fulmar at Arnprior, Ontario. By Hoyes Lloyd.	194
A North-eastern Colony of Purple Martins. By D. A. Dery.	194
The White-fronted Goose in the Province of Quebec. By D. A. Dery.	194
Reprints from Our Pages. By Hoyes Lloyd.	194
Editor's Notes.	194
Canadian Field-Naturalist Publication Fund.	194
Index to Vol. XXXVIII.	195

THE CANADIAN FIELD-NATURALIST, lately THE OTTAWA NATURALIST, established thirty-seven years ago, "to publish the results of original research or investigation in all departments of natural history," is issued monthly, excepting for the months of June, July and August.

Papers, notes and photographs should be addressed to the Editor. Manuscript should be typewritten.

Subscriptions cover the current year, except those taken out during last quarter, when they will be applied on the following year, the remaining numbers of current year being sent free. Payments should be made to the Hon. Treasurer, Mr. B. A. Fauvel, 321 McLeod St. Ottawa. Price of this volume, \$1.50; single copies 20c each.

YES—

We Make Rucksacks

Seven different kinds—to suit almost every kind of work and for Field-Naturalists either of the two, De Luxe or Alpine, are suitable.

Woods' Rucks

*are the comfortable carrying kind made to fit—Order
from your sporting goods dealer*

es 50

WOODS MANUFACTURING CO.
OTTAWA

EXPLORATIONS in Western Canada

The Ottawa Field-Naturalists' Club has just published an interesting volume of over 300 pages, entitled:

Autobiography of John Macoun, M.A.

Canadian Explorer and Naturalist, Assistant Director and Naturalist to the Geological Survey of Canada—1831-1920.

This volume is an account of the life of this veteran naturalist. Agriculturists generally, in fact all interested in the development of Canada, will find this book of much interest and value.

The edition is limited. The price is \$3.00 with 15c added for bank exchange, if remittance is forwarded by personal cheque.

Applications for the volume should be made to

Mr. Arthur Gibson
Birks Building : Ottawa, Ont.

WHY NOT ADVERTISE
YOUR PRODUCTS IN

The Canadian Field-Naturalist

*The Leading Canadian
Natural History Publication*

WRITE FOR RATE CARD

ADVERTISING DEPARTMENT
THE CANADIAN FIELD-NATURALIST

175 Nepean Street

OTTAWA

Kindly mention The Canadian Field-Naturalist to advertisers

Lyman's Limited

(Established 1800)

MANUFACTURING CHEMISTS

Importers and Dealers in
CHEMICAL AND
ASSAY APPARATUS

344 St. Paul St. West, Montreal



GROW GOOD CROPS

SEEDS PLANTS BULBS

Our rigorous system of testing eliminates loss
and disappointment from your garden

Kenneth McDonald & Sons, Limited
Seed and Bulb Merchants

Market Square :: Ottawa, Ont

Ward's NATURAL SCIENCE ESTABLISHMENT

Rochester, New York, U.S.A.

Manufacturers of the genuine Schmitt boxes
exhibition cases and cabinets, also of the American
Entomological Company's insect pins.

Riker Mounts and botanical mounts always on
hand, also Riker botanical presses.

Send for our supply catalogue and other lists of
interest to collectors.

Headquarters for Entomological Supplies
and Specimens

The Topley Co.

Photographic Material
Scientific Apparatus
Eastman Kodaks



132 Sparks Street
OTTAWA

THE Bank of Nova Scotia

Capital \$ 10,000,000
Reserve Fund 19,500,000
Total Assets over 237,000,000

FIFTEEN BRANCHES IN
OTTAWA AND HULL

Inspected Milk Ice Cream

Ottawa Dairies

Fresh Butter Buttermilk

W. A. Rankin, Ltd.

Hammocks
Refrigerators
Builders' Hardware

410-412 Bank Street, Ottawa

Phones—Queen 1023-1024

Kindly mention *The Canadian Field-Naturalist* to advertisers

The Canadian Field-Naturalist

VOL. XXXVIII

OTTAWA, ONTARIO, DECEMBER, 1924

No. 10

AN EXPLORATION INTO THE NORTHERN PLAINS NORTH AND EAST OF GREAT SLAVE LAKE, INCLUDING THE SOURCE OF THE COPPERMINE RIVER

By G. H. BLANCHET, F.R.G.S.
of the Topographical Survey of Canada



HERE has been a growing interest in recent years in the great unknown stretches of Northern Canada. Discoveries of oil, minerals, timber, pulpwood and waterpowers have been drawing industry into the north from Labrador to the Mackenzie basin. Developments in transportation—land, water and air—have given interest to districts formerly considered inaccessible. It is natural, therefore, in the course of investigating our outlying districts for new resources, that attention should be directed to that great block of country, described as the "Sub-Arctic Barren Lands".

It is interesting to note here some remarks made by Mr. G. M. Dawson, in a paper read before the Ottawa Field-Naturalists' Club some forty years ago. He said: "Fortunately or unfortunately, as we may happen to regard it, the tendency of our time is all in the direction of laying bare to inspection and open to exploitation all parts, however remote, of this small world in which we live. It is, therefore, rather from the point of view of utility than any other that an appeal must be made to the public or the government for further extension of explorations, and my main purpose in addressing you is to make such appeal and to show cause, if possible, for the exploration of such considerable portions of Canada as still remain almost or altogether unmapped." He goes on to call attention to the lack of proper authorities for much of the topographical information on the outlying districts of the country, making the maps often of little service. He also makes the point that should the exploration of an area reveal no resource of value the work will not have been wasted as the sign "no thoroughfare" may be marked authoritatively on it.

In the period which has elapsed since this paper was read, much development has taken place in portions of northern and western Canada to which Mr. Dawson called attention, and there has also been a great extension of surveys to meet it, particularly by the Topographical Survey of Canada, but large areas still exist of which there is only the vaguest knowledge, often based on questionable authority.

LOCATION AND EXTENT OF THE SUB-ARCTIC REGIONS.

If lines were drawn from the east end of Lake Athabaska, northwesterly to the mouth of Mackenzie River and easterly to Fort Nelson on Hudson Bay, the figure included between them and tidewater would be roughly that to which the term "Sub-Arctics" is applied. It has an area of about 650,000 square miles, one-sixth of the Dominion. Due to the influence of the mountains on the west and of Hudson Bay on the east, climatic zones in western Canada take a northwesterly course. For the purpose of illustration, if the area were turned on its northwesterly axis until it stood upright it would nearly duplicate conditions found in a high mountain—the wooded base with timbered valleys extending up the slope, the dwindling forests terminating at the timber line, the bare higher regions crowned by the ice cap with glaciers descending from it—all are represented here and in the same sequence.

The conditions existing at the base and the summit—the forested country and the ice cap—are well known, but the intermediate region has received little study. Much of this country is accessible, and, though its climate is severe, with exaggerated extremes, it would not prohibit development if resources of sufficient value were discovered.

EXPLORATION AND TRAVEL IN THE PAST.

The first exploration into the country was made by Samuel Hearne, in 1770-71, when he made a spectacular journey into the then unknown interior, in company with a band of Indians making war against the Eskimos. His journey touched recognizable features at certain points, of which the Arctic coast at the mouth of Coppermine River and Great Slave Lake, his farthest west, were the most important. During the first half of the last century expeditions by Franklin, Back, Simpson and Dease crossed the northern portion of the area, using its waterways to reach their objective—the Arctic coast. However, though the exploration of the interior was of a secondary nature on these trips, the information which they obtained gave

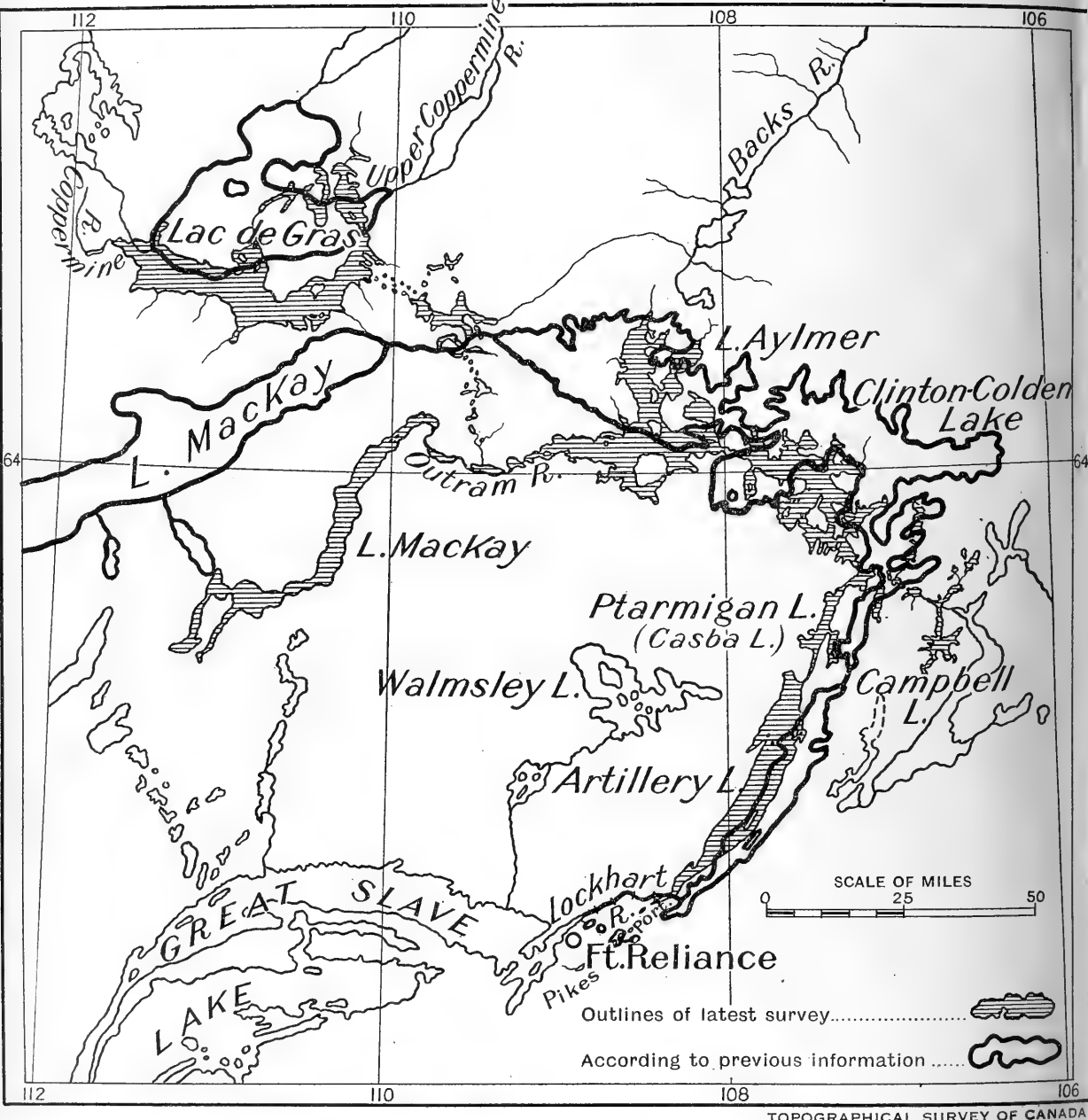

FIGURE 1.—COMPARATIVE MAP

Showing the Waterways, north and east of Great Slave Lake, as they were previously mapped and as now surveyed.

the form to features of the country which furnishes the map of to-day. Little has been added or corrected, nor has much been done to verify their estimates of conditions obtaining there or to consider them in the light of development of the country to the south and the general developments of the last century.

In more recent years the southern portion of

the area was investigated along the lines of several exploration routes extending from the interior to Hudson Bay. There has also been a certain amount of information supplied by travellers who have entered and explored the country in a private capacity and by official patrols made by the R.C.M.P.

It may be taken, therefore, that something is



FIGURE 2.—WHITE WOLF PUPS

Taken at Talthelei, July first. They are from a litter of five and are about two weeks old.

known of the main physical features and that we have a collection of reports on the character of the country made at widely different times and seasons. However, there is a certain vagueness in the minds of most people as to the real nature of our vast hinterland areas grouped under the name of "Sub-Arctic Barren Lands". Both these terms suggest country of a most forbidding character, and call up pictures of rock and ice and desolate plains. Unfortunately the narratives of explorers and travellers who have penetrated these regions are concerned with incidents of travel rather than with presenting clear pictures of the country. The impressions left on the minds of the observers have been coloured strongly by the conditions under which they had been living,

often those of an accidental nature. It must also be borne in mind that in so vast a region a variety of conditions prevails, which makes it inadvisable to generalize too broadly. But here as elsewhere cause and effect are fundamental laws, and the type will be found to be the result of certain definite conditions.

The observer entering the Barren Lands should maintain an open mind, recording the various conditions met with, but reserving his judgment until, as the topography, soil and geology are studied, and the physical history of the country is considered, the resultant conditions become clear.

ENTRY INTO THE "BARREN LANDS" BY THE GREAT SLAVE ROUTE.

At Great Slave Lake the highway to the north by way of the Mackenzie system forks. To the westward lies the route to the Arctic, by way of the Mackenzie River, which approaches and flows through the Rocky Mountains and maintains in its valley conditions characteristic of the Alberta plateau to the south. Proceeding north and east from the lake one passes abruptly from conditions of the Alberta plateau, through those classed as Hudsonian, and into the treeless plains of the north. There is, here, a most sharply drawn natural boundary, which is rendered remarkable from the fact that on the same lake such different conditions prevail. Great Slave Lake offers an unusually interesting route into these regions, both in the comparatively easy conditions of travel and in features peculiar to itself. Successively, you pass through the Slave delta with its heavy growth of timber, the rocky archipelago,

with its intricate channels and the variety in the form and arrangement of its islands, and, opening from these, the easterly portion of the lake, with its massive enclosing hills on the north and remarkable mural cliffs on the south.

The Narrows of Talthelei might be said to be the point at which the ordinary life of the country ends and from which all trails lead off into a country only hazily known. For the Indians travelling beyond here life may only be maintained by their skill in living off the country, and to-day, as before the coming of the white man, the non-arrival of the caribou or the failure of the fisheries means starvation. A generation ago the Yellowknives, Dogribs, and Slave Indians from Great Slave Lake spent most of the year in the so-called

Barren Lands, and their trading was chiefly caribou meat and skins. Gradually conditions changed. They found it easier to trap and trade furs and to support themselves on the fisheries of the lake, supplemented by trade goods. In this change they lost their roving characteristics. The long expeditions after the muskox and caribou, which formerly took them nearly to the Arctic coast, have been reduced to short trips in the fall to meet the caribou, during which they seldom leave the last woods. Life has become for them simpler and more secure, but the change has been accompanied by a certain physical and moral decay. They lack the courage to attempt a long and difficult trip and the stamina to accomplish it.

GENERAL SITUATION IN THE INTERIOR COUNTRY.
 The great interior plateau, which has an elevation of about 700 feet above Great Slave Lake, approaches to within a few miles of it and the descent is abrupt and of very rugged character. When leaving the lake, therefore, to travel north or east one is immediately confronted by this barrier. Due to the hardness of the rock the streams discharging from the interior have been unable to cut channels but tumble over the escarpment in a succession of cascades and falls. This situation has also forced drainage northward in many places from comparatively near the lake. The accumulated drainage has gathered into a series of great shallow depressions lying in an east and west direction and immediately to the south

of the Arctic-Mackenzie height of land. The drainage through them is easterly, finally swinging south and southwest and entering the east end of Great Slave Lake by Lockhart River. This river follows the valley which is the continuation of the great transverse valley of the lake but, in spite of this natural valley and the tremendous erosive action of its waters, its discharge being over 20,000 cubic feet per second, its course is a succession of rapids and falls. The importance of the interior waterways may be appreciated when we consider their extent and their situation, close to the height of land, thereby giving access to waters flowing easterly to Hudson Bay and northerly to the Arctic. They form an important highway for patrol, investigation and development of the vast areas lying to the north and east of Great Slave Lake. The two chief difficulties which have had to be overcome by those entering the country were the ascent to the interior plateau and the fuel supply when travelling through it, for most of the country is destitute of timber.

THE CLIMB FROM THE LAKE TO THE INTERIOR PLATEAU.

In the past attempts have been made at several points to ascend rivers flowing into Great Slave Lake and, though the interior lakes were reached, the journey entailed great hardships and supplies had to be cut down to absolute essentials. The Indians never use the Rivers but follow portage



FIGURE 3.—YOUNG FOXES, THREE CROSS AND ONE RED
 Taken on the north shore of Great Slave Lake. Though nervous, they became quite tame and were very playful.

routes, taking advantage of chains of lakes. Although there are several of these, there is only one practicable for heavy loads, namely, that first noted by Warburton Pike in 1890 and to which his name has been applied. It unites Great Slave Lake with Artillery Lake, the first of the great lake series. The distance between them is 24 miles and includes ten small lakes. The only difficult portage is the first, by which the climb out of the valley is made by a sandy glacial spill-way. It may be said that anything that can be man-handled can be taken over the portage.

Entering the interior, the impression of isolation from familiar things which the east end of the lake produces becomes intensified. The struggle for existence becomes more and more apparent in the plant and animal life. The less sturdy types are one by one eliminated, perhaps to re-appear at some more advanced point, especially favourably situated, but thereby only drawing attention to the fact that they may not normally live there. At first the changes are gradual, conforming with the variations in the character of the country, but, as the Barren Lands are approached, one sees in rapid succession the last birch, the last Robin and the last sign of the animals whose home is in the timber. Finally the elimination reaches a point of stability. The stragglers disappear, and the fauna and flora natural to sub-Arctic conditions prevail with some uniformity.

The natural ruggedness of the border of the plateau has been accentuated by the erosion of its drift-filled valleys, and a condition has been produced of open, rocky hills, covered with boulders and sometimes approaching buttes, and of irregularly disposed valleys containing many lakes. In the shelter of the valleys trees still reach fair development, but in the exposure of the hill tops only the most hardy varieties survive in stunted form. However, as the forests dwindle, their

place is taken by a variety of mosses, lichens and shrubs which, to a large extent, relieve the country from any appearance of barrenness.

An illustration of the immediate response of the vegetation to favourable conditions may be witnessed in the lower valley of Lockhart River. An extensive sandy plain formed in this portion of the valley in glacial times, through which the river has cut a new valley some six hundred feet deep, reaching bed rock. In the valley frost comes out early and there is protection from the wind, permitting a growth of vegetation remarkable both in variety and development as compared with that of the surrounding country. Lockhart River was examined for some distance from the lake to verify the reports of its spectacular waterfalls and the general situation as to navigability. It was not necessary to travel far to realize the impossibility of attempting to bring any craft through its succession of rapids, cascades and falls. Here is a powerful river constrained to flow through a narrow, unyielding, rocky valley and making a big drop in a comparatively short distance. The drop is distributed in four large falls and almost innumerable rapids and cascades which keep its course broken by white water. Parry Falls are the most striking. They had been estimated by Back to be four hundred feet high and the most spectacular he had seen in his travels in many parts of the world. Actually they have a drop of about one hundred feet, and they justify their reputed wildness. It would be impossible to imagine a more imposing effect of powerfully driven water forcing its way through a torn and broken rocky chasm. From the portion of the river seen it was decided that as a power proposition it is almost unrivalled, but it is unnavigable.

(Continued in the January issue)

NOTES ON SOME GAME BIRDS IN THE COUNTY OF KENT, ONTARIO, SEASON OF 1924

By **GEORGE T. McKEOUGH**



THE TOPOGRAPHY of the County of Kent and its place on the map make it a favorite domicile for many varieties of birds. Besides, we are in the line of a great migration and, during that period of passage, an auspicious pausing place for many migrants, both land birds and shore birds and other water fowl. We are partly embraced by two links of the great chain of lakes, and here and there, contiguous to the lakes, are acres of marsh lands with wild rice and celery beds, rushes and grasses

interminable, intersected with sluggish streams and placid, lonely pools, ideal rendezvous for many species of water fowl.

Golden Plover were at one time very abundant during fall migration. Mr. E. W. Sandys, in *Outing*, December, 1897, writes that on October 15th of that year there were hundreds of them scattered over the fields near Mitchell's Bay, Lake St. Clair, a regular tornado at times. Eleven dropped to the two barrels of his gun on the initial firing and more and more followed. He also

obtained 40 Snipe that day and concludes his article by stating that it was a rare good day's shooting when he had so many birds he was ashamed to kill more. Since that carnage, this fine game bird gradually diminished in numbers each season and for many years one looked in vain for one in their old forage grounds. Last autumn (1923) I wrote a series of articles for a local paper on water fowl and, during August and September, frequented almost daily the lake shores and adjacent fields of the county. Numerous species were observed: Spotted, Solitary, Red-backed, White-rumped, Semi-palmated and Least Sandpipers, Sanderlings, a few Upland Plover, Killdeer, Semi-palmated and Piping Plover, Turnstones, Dowitchers, Willets, Greater and Lesser Yellow-legs, Hudsonian Curlew, Jack Snipes, and Black-bellied Plover, but no Golden Plover; but on the 30th of September this year (1924) they returned to their old resorts in the township of Dover near Lake St. Clair. Their numbers were estimated at between five and six hundred and they have been seen in lesser numbers since, and a few have been shot to my knowledge, the absence of the hind toe confirming the diagnosis.

Another of our popular game birds which was almost exterminated, the Quail, or Bob-White, more precious and valuable, however, to farm life than to the epicure or sportsman, is making our fields reverberate again with its melodious and plaintive call, *bob, bob-white*; scarcely a day has passed this summer that one or more have not been seen or heard, and as I write these notes, a bevy of fifteen to twenty run across our lawn. Thanks to a more universal knowledge—broadcasted largely by the teachers of our public schools—of their immense importance to our agriculturists, it is doubtful if they will ever become so near extinct as they were a few years ago. The farmers have learned that they are one of their very best friends of infinite service and enormous utility in the production of profitable crops, and, even if legislators grant sportsmen certain privileges, they will be up against "no shooting permitted on these premises". Furthermore, the farmers' wives and daughters, living amid nature with all her subtle suggestiveness, have learned to love beauty and, with the advent of more serviceable utilities in the home, they have greater leisure to devote to beautifying and making attractive their gardens and premises and in this respect nothing can emulate trees, flowers and their bird consorts and no birds are more winsome, alluring and lovable about farm abodes than Quail.

Mr. W. D. Elliott, of High River, Alberta, in an interesting article in *Rod and Gun*, October, 1924, states that in 1908 the local sportsmen in Alberta, assisted by the Alberta government, imported 300 pairs of Partridges from Hungary; after these birds were liberated, little was heard of them for many years, but since 1917 they have increased at a rapid rate until to-day there is a covey to almost every field and they are the premier resident game bird of Alberta. In 1914 the Hon. Dr. Reaume, then Minister of Public Works for Ontario, imported a number of these

birds, and some were distributed in the county of Kent. I obtained three pairs. They were fed bountifully and every effort was made to subdue their restlessness, but it was of no avail and in the following spring they were released and soon disappeared. They were not observed and nothing was heard of them until late that autumn, when a small covey returned and remained for some time. They continued to return every autumn for several years, when they disappeared altogether for three or four years. Last fall they again returned, a covey of twenty or more, and remained in our ravines and meadows for two months and were not nearly as wild as formerly. We have not seen any as yet this fall, but they have been reported in other parts of the county. Our gardener, an Englishman and familiar with English country life, maintains they are similar to the English Partridge, and Mr. Elliott, in his article, states that he is assured by those who should know that they are the same bird.

That splendid game bird, the Wilson's Snipe, which at one time was so abundant with us, and was shot with little compunction, as it did not take up a permanent residence here, has either acquired another migrating route or has diminished greatly in numbers, for they are almost a curiosity now and usually give rise to some happy exclamatory expression when noted.

The Woodcock, however, which was a *rara avis* for many years is apparently increasing in numbers. A pair nested in one of my gullies and another nest was found in a neighbour's marshy meadows, but the northern section of the county, in the neighbourhood of the Snye Ecarté River, has always contained their favorite feeding and nesting grounds, and reports from there indicate that they are multiplying slowly.

The old familiar drumming of the Ruffed Grouse was occasionally heard during the spring and summer in the southern part of the township of Orford and some were shot during the short open season for them. The palate, however, of very few fastidious epicures would be gratified by such a delicacy.

Another game bird becoming plentiful in the southern portion of the county is the English Pheasant, and nothing gives one a pleasanter thrill than suddenly and unexpectedly to arouse one of these beautiful birds in a walk through rural regions. Very few days of the past summer went by without either flushing them or hearing their characteristic call. Independent of their aesthetic interest and paramount rank in the bird kingdom they are pre-eminently useful in consuming weed seeds and weeds are flourishing beyond compare with any other vegetation in this luxuriant agricultural neighbourhood. Mr. Goldworthy, our park superintendent (Rond Eau), deserves much praise for liberating, distributing and subsequently looking out for several of these birds. These, together with those that the late Mr. William Chaplin, of St. Catherines, sent us, which, after being confined for some time, were also set free, have multiplied largely and become the extensive colony that inhabits the fields adjacent to Lake Erie. Last summer a pair built their nest in one of my neighbour's fields, fourteen eggs were laid and thirteen were hatched. Although the nest was cautiously inspected daily, the young birds were never seen, for, as soon as they left their shells, they disappeared.

FINDING RANGE FOR CANADA'S BUFFALO*

By MAXWELL GRAHAM



ANADA'S herd of Buffalo at Wainwright Park is outgrowing its accommodation. The number has increased to a point where there is insufficient pasture and forage, and new areas must be provided for the overflow. It is proposed to ship annually from one to two thousand of the young buffalo from Wainwright Park to the new Wood Buffalo Park near Fort Smith, N.W.T.

The park at Fort Smith already contains buffalo which from time immemorial have thrived there and the bison transferred from Wainwright will be placed on one or two selected locations in the southern range of the Wood Buffalo Park, where they will meet with and come under the protection and leadership of adult wild bison in those areas. Otherwise they would be defenceless against predatory animals such as wolves.

The first shipment will consist of stock from last season's calf crop in sex proportion of one male to five females; later shipments, navigation permitting, will include two-year-old heifers but no males of any age. It is hoped that some 2000 young stock as above described will be thus transported by rail and water during the coming season. The cost of shipping adult bison, as an alternative, would be prohibitive, since they would have to be crated and other precautions taken.

Objection may be made that plains bison should not be allowed to mingle and breed with the only known sub-species of their race on this continent, the wood-bison, but the theory advanced as to the so-called wood-bison being a sub-species has recently been considered doubtful. As stated in the writer's report, *Observations in the Wood Buffalo Park*, published by the Department of the Interior in 1922:

"Our wood buffalo has been classified as a sub-species of the American bison and is referred to as *B. c.* (*Bison bison athabascæ*, but whatever differences there are between it and the buffalo of the plains are largely owing to environment."

To those who believe that Rhoads, in 1897, was, and has since been, justified in describing our northern bison as a sub-species under the name *Bison bison athabascæ*, the following information should be welcome. The specimen on which Rhoads based his contention was an adult bull bison, taken by Indians 50 miles south of Fort Resolution, in March, 1892, the mounted specimen being now at the Victoria Memorial Museum. Study of the map will show that 50 miles south of Resolution lies in the northern portion of the northern range of wood-bison. This northern

range is bounded on the north by the Nyarling River and its north branch; on the east by the Little Buffalo River; on the south by the upper reaches of this river and the Caribou Mountains; on the west by Buffalo Lake. This northern range, like the southern range, is self-contained as a sanctuary for bison, having its own seasonal feeding areas. The important point, also, in connection with this northern range is that not only does it contain bison estimated at 500 but, according to Doctor Charles Camsell and others, the bison inhabiting this area never enter the southern range nor do those in the southern range at any time enter the northern range, presumably owing largely to physical conditions, such as swamps and extensive muskgs. Quoting from Dr. Camsell's report of November 21st, 1916:

"The wood buffalo of northern Alberta and the adjacent portion of the North West Territories are in *two separate bands* occupying *two distinct ranges*, and there does not seem to be at present or within recent years *any migration of buffalo from one range to the other.*"

Since it is into the southern range only that it is proposed to introduce plains bison from the Wainwright Park, in which range some 1000 wood-bison are at present established, those bison indigenous to the northern range, one of which was the type taken as representative of Rhoads' sub-species, will remain inviolate so far as admixture with the introduced bison is concerned.

A definite decision as to the action to be taken regarding the first shipment will shortly be rendered. The preliminary work will be done by the Canadian National Parks Branch. This consists of segregation, corralling and placing on cars at Wainwright of selected young stock, while the work of the Northwest Territories Branch will consist of shipping the animals to Waterways, via Edmonton, transshipping at Waterways to a barge on the river, and thence by water to either Peace Point or LaButte in the Wood Buffalo Park.

If the project above dealt with is successfully carried out, the introduced plains bison, under the leadership and protection of the adult wild ones now in the southern range of the Wood Buffalo Park, should so multiply that a future source of food supply may be assured to the natives in surrounding districts. While in the immediate future this project holds out a promise of re-stocking vast areas suitable for the propagation of bison, at comparatively little cost, it will also be the means of saving for posterity the calf crop at the Wainwright Park for 1922-23 and succeeding years, which otherwise cannot, apparently, be saved.

*Published by authority of the Director, North-West Territories Branch, Department of the Interior, Canada.

OFFICIAL CANADIAN RECORD OF BIRD-BANDING RETURNS**(Continued from page 179)*

LOON, No. 5,481, immature, banded by R. W. Tufts, at Albany, on Trout Lake, Annapolis County, Nova Scotia, on June 23, 1923, was caught in a net and drowned in Gold River, Lunenburg County, Nova Scotia—no date given, but reported on October 27, 1923.

COMMON MURRE, No. 204,667, adult, banded by Harrison F. Lewis, at St. Mary's Islands, Saguenay County, Quebec, (Canadian Labrador), on July 24, 1923, was found dead in the same crack in the rock in which it was banded on August 12, 1924. The bird was probably killed three weeks before by a dog.

COMMON MURRE, No. 204,668, adult, banded by Harrison F. Lewis, at St. Mary's Islands, Saguenay County, Quebec, (Canadian Labrador), on July 24, 1923, was found dead in the same crack in the rock in which it was banded on August 12, 1924. The bird was probably killed three weeks before by a dog.

COMMON MURRE, No. 204,716, adult, banded by Harrison F. Lewis, at St. Mary's Islands, Saguenay County, Quebec, (Canadian Labrador), on July 24, 1923, was found dead near the crack in the rock in which it was banded, about July 28, 1924. The bird was probably killed one week before by a dog.

GREAT BLACK-BACKED GULL, No. 5,584, partly fledged young, banded by Harrison F. Lewis, on an islet near Fog Island, Saguenay County, Quebec, (Canadian Labrador), on July 13, 1923, was caught on a fish hook at Point-du-Loup, Magdalen Islands, Quebec, about September 20, 1923.

GREAT BLACK-BACKED GULL, No. 204,706, partly fledged young, banded by Harrison F. Lewis, at St. Mary's Islands, Saguenay County, Quebec, (Canadian Labrador), on July 21, 1923, was caught in a fish net at Cove Head Bay, Queen's County, Prince Edward Island—no date given, but reported on October 17, 1923.

HERRING GULL, No. 231,893, banded by F. C. Lincoln, at Hat Island, twelve miles north-east of St. James, Michigan, on July 22, 1923, was killed in the St. Lawrence River at the eastern end of Montreal, Quebec, on September 9, 1923.

HERRING GULL, No. 236,807, banded by F. C. Lincoln, at Hat Island, near St. James, Michigan, on July 22, 1923, was found dead on the north shore of Lake Ontario, near Toronto, Ontario, on September 10, 1923.

HERRING GULL, No. 236,993, banded by F. C. Lincoln, at St. James, Michigan on July 25, 1923, was caught in an Indian's trap at a place about ten miles north of Gull Bay Outpost, Lake Nipigon, Ontario, on November 7, 1923.

HERRING GULL, No. 209,565, young, banded by Wm. M. Duval, at Bonaventure Island, Gaspé County, Quebec, on July 28, 1923, was captured at Lavallette Beach, New Jersey, on November 22, 1923.

HERRING GULL, No. 209,571, young, banded by Wm. M. Duval, at Bonaventure Island, Gaspé County, Quebec, on July 30, 1923, was found at Raritan Bay, Keansburg, New Jersey, on October 3, 1923.

COMMON CORMORANT, No. 204,741, partly fledged nestling, banded by Harrison F. Lewis, at one mile east of Cape Whittle, Saguenay County, Quebec, on July 17, 1923, was shot at Kegashka (about twenty-five miles east of Natashquan), Saguenay County, Quebec, on January 14, 1924.

DOUBLE-CRESTED CORMORANT, No. 232,048, young, banded by Reuben Lloyd, at Last Mountain Lake, Saskatchewan, on July 1, 1923, was shot at a place six miles north-east of Granville, McHenry County, North Dakota, on October 14, 1923.

DOUBLE-CRESTED CORMORANT, No. 204,756, downy nestling, banded by Harrison F. Lewis, on an islet near Fog Island, Saguenay County, Quebec, (Canadian Labrador), on July 13, 1923, was caught and found dead in a pound net at a place five miles north of Cape Hatteras, North Carolina, on October 18, 1923.

MALLARD, No. 200,355, female, banded by L. V. Walton, at Cuivre Island, Missouri, on January 11, 1923, was killed about five miles north of Cross Lake Post of Hudson's Bay Company, which is about one hundred miles almost due north of Lake Winnipeg, Manitoba—no date given, but reported on July 17, 1923.

MALLARD, No. 200,385, banded by Jos. Pulitzer, at Cuivre Island, Missouri, on January 11, 1923, was shot at a place three miles west of Saltcoats, Saskatchewan, on October 27, 1923.

MALLARD, No. 200,417, female, banded by L. V. Walton, at Cuivre Island, Missouri, on January 12, 1923, was shot at Sled Lake, Saskatchewan, in Tp. 63, R. 10, W. 3rd M., during the spring of 1923.

MALLARD, No. 200,494, banded by Jos. Pulitzer, at Cuivre Island, Missouri, on January 13, 1923, was shot at a place eighteen miles north of Oak Lake, Manitoba, on October 26, 1923.

MALLARD, No. 101,924, banded by L. V. Walton, at Cuivre Island, Missouri, on January 15, 1923, was shot at a place forty miles north of Mine Centre, Ontario, about the middle of November, 1923.

MALLARD, No. 200,534, banded by L. V. Walton, at Cuivre Island, Missouri, on January 16, 1923, was killed in a rat trap at a place twenty miles southwest of The Pas, Manitoba, near the Saskatchewan River, on May 1, 1924.

MALLARD, No. 203,305, female, banded by John Broecker, at Portage des Sioux, Missouri, on January 22, 1923, was caught in a trap, at a point sixty miles east of The Pas, Manitoba, on the Saskatchewan River, on April 29, 1923.

MALLARD, No. 205,131, female, banded by Jos. Pulitzer, at Cuivre Island, Missouri, on January 25, 1923, was shot at a place four miles south-east of Spy Hill, Saskatchewan, on November 15, 1923.

MALLARD, No. 205,196, female, banded by L. V. Walton, at Cuivre Island, Missouri, on January 28, 1923, was shot at Lake Mamawi, about fifteen miles south of Chipewyan, Northwest Territories, on August 29, 1923.

MALLARD, No. 205,230, banded by L. V. Walton, at Cuivre Island, Missouri, on January

*Published by authority of the Canadian National Parks Branch, Department of the Interior, Canada.

28, 1923, was shot at Long Lake, Straszbourg, Saskatchewan, on September 28, 1923.

MALLARD, No. 102,186, banded by Allen Green, at Oakville, Iowa, on January 30, 1923, was killed at Regina Beach, Saskatchewan, on November 2, 1923.

MALLARD, No. 203,758, banded by John Broeker, at Portage des Sioux, Missouri, on February 4, 1923, was killed at Herbert, Saskatchewan, on October 13, 1923.

MALLARD, No. 205,291, female, banded by Jos. Pulitzer, at Cuivre Island, Missouri, on February 7, 1923, was shot at a place nine miles south of Indian Head, Saskatchewan, on November 3, 1923.

MALLARD, No. 203,443, male, banded by John Baker, at Portage des Sioux, Missouri, on February 8, 1923, was killed in Northern Saskatchewan, at a place about one hundred miles northwest of Battleford, Saskatchewan, on May 12, 1924.

MALLARD, No. 203,446, female, banded by Joseph Pulitzer, at Portage des Sioux, Missouri, on February 8, 1923, was killed at the Oak Lake Country Club, eighty miles west of Winnipeg, Manitoba, during the latter part of October, 1923.

MALLARD, No. 205,378, banded by L. V. Walton, at Cuivre Island, Missouri, on February

23, 1923, was shot at Allan, Saskatchewan, on September 17, 1923.

MALLARD, No. 205,437, banded by L. V. Walton, at Cuivre Island, Missouri, on February 24, 1923, was shot in Tp. 32, Sec. 27, R. 1, W. 4th M., Alberta, on November 3, 1923.

MALLARD, No. 205,440, female, banded by Jos. Pulitzer, at Cuivre Island, Missouri, on February 24, 1923, was shot at Kipling, Saskatchewan—no date given, but reported on October 22, 1923.

MALLARD, No. 205,544, banded by L. V. Walton, at Cuivre Island, Missouri, on March 1, 1923, was shot at a place twenty miles south-west of Unity, Saskatchewan, about October 25, 1923.

MALLARD, No. 205,545, female, banded by L. V. Walton, at Cuivre Island, Missouri, on March 1, 1923, was shot at a place six miles south of Springside, Saskatchewan, on October 10, 1923.

MALLARD, No. 205,603, female, banded by L. V. Walton, at Cuivre Island, Missouri, on March 4, 1923, was killed at Spy Hill, Saskatchewan, about October 17, 1923.

MALLARD, No. 205,640, female, banded by Jos. Pulitzer, at Cuivre Island, Missouri, on March 8, 1923, was shot at a place about eighteen miles north of Portage la Prairie, Manitoba, on October 20, 1923.

(Continued in January issue)

IN MEMORIAM

CHARLES FREDERICK NEWCOMBE, M.D.

Died at Victoria, B.C., October 19, 1924

In the death of Dr. C. F. Newcombe, British Columbia has lost its most distinguished naturalist. There is not, I make bold to say, a working student in the field of nature in the province who, if he ever came into contact with him, and few had not, does not feel the poorer to-day. Certainly in Victoria he placed us under the greatest obligations to him by his ever-ready help in the unravelling of the problems we met. As one who knew him well and received many kindnesses from him, I wish to record not only my own impressions, but also something of his services to science.

I first met him at a session of the Natural History Society of British Columbia, in their rooms at Victoria. A short, spare man, with the complexion of one who was much in the open-air, and keen alert blue eyes, his personality breathed interest and sympathy. On hearing that my interests were geological and botanical, he was greatly pleased. His own reputation as a botanist was no mean one, and he was in close correspondence with men of international repute who valued to the full his careful judgment. To me, therefore, his interest in what I was doing was a great encouragement, and over and over again he rendered me his invaluable aid. His interest in geology was largely palaeontological. He was, if I mistake not, the first collector of the fauna of

the Sooke and Carmanah Tertiary beds and on his material Dr. Merriam based his monograph of 1896 on *Two Tertiary Faunas from the Rocks of Southern Vancouver Island*. The procuring of these fossils was no easy task in those days before the era of gasoline launches and motor stages; some of the places could be reached only by small boat. He made a further contribution to the geology of the island by the publication in the *Ottawa Naturalist* of November, 1914, of an article on *Pleistocene Raised Beaches at Victoria, B.C.* This article crystallised the knowledge of the evidences known at that time and gave an impetus to further study both on his own part and on that of others, with the result that new localities have been added to those he there enumerates and additional fossil remains have been recorded. Illustrating his interest in palaeontological geology, there lies before me a letter he wrote me on October 23, 1916. It contains an outline of an evening's lecture scheme at a Natural History Society's meeting, dealing with the fossil mammal of the Sooke beds, then known by a single tooth and identified with Marsh's *Desmostylus hesperus*, but, since the finding of a second tooth, named by Dr. O. P. Hay *Cornwallius sookensis*. Of the three short lectures to be delivered, the first, on the tooth and its faunal relations, was in due course delivered by himself and was an excellent example of his width of knowledge and keenness of spirit.

Thirty years ago he took an active part in the promotion of the pursuit of marine biology, and, although other interests came to crowd the study out, he never lost touch with his old science. To the end he was as interested as ever in the shells of the coast and, I believe, had latterly been spending much time over his large and representative collection. Last year, during a visit of Dr. O'Donoghue, of the University of Manitoba, he invited me to be one of a dredging party operating off Brothie Ledge, and among us none was more enthusiastic over our finds than he. I remember as we were gathered on the wharf before going on board an elderly man came up and hailed him, and the two were soon in the flood of reminiscence. He had in earlier days taken Dr. Newcombe about the waters of San Juan Harbour on one of his exploratory trips.

There is no doubt that Dr. Newcombe's best-known work was done in the field of anthropology. Mr. Kermode, Curator of the Museum at Victoria, to whom I am greatly indebted for the use of his material and for his personal information, tells in his notes of his old friend's life how he accompanied the Doctor on his first visit to the Queen Charlotte Islands in 1895. Around the shores of these islands, then practically unknown scientifically, they went in open rowboats. The very wildness of the region made it an attractive one to the student of primitive races, hardly touched by civilization, as well as for the field-naturalist. Dr. Newcombe now began a thorough investigation of the manners and customs of the tribes of the northwest coast and as a result he became widely known as a working anthropologist. He did remarkable work for the Provincial Museum and he had the pleasure of seeing the fruits of his labor in the admirable Anthropological Department opened a year or two ago, in which the life habits of the aborigines are enshrined. The appreciation in which he was held by men of first rank is shown by the fact that he was invited in 1905 to superintend the arrangement of the Indian collection in the Northwest Hall of the Field Museum at Chicago.

Among the duties which came to him was one which showed his breadth of interest and his adventurous spirit. The Fisheries' Board of Canada asked him to report on the life-history of the sea-lions. These animals are found on the sea-girt islets off the shores of Vancouver and Queen Charlotte Islands, little more than projecting rocks amid the Pacific breakers. Of necessity the work was dangerous, for only small boats could be used to make the landings. Those who have been up the west coast will appreciate what that means. Later, as a result of his work,

he acted as one of the Commission appointed by the Biological Board to report on the sea-lions in relation to the salmon.

It is to be regretted that his busy life did not permit him to publish more, for few men knew the coast as he. In addition to the article I have already spoken of, he compiled the *Guide Book to the Anthropological Collection of 1909*. Then, in 1914, he published *The First Circumnavigation of Vancouver Island*, an interesting and readable summary of the established facts. Last year he edited for the Archives Department of the Province *Menzie's Journal of Vancouver's Voyages* with a *Botanical and Ethnological Index*. He also wrote a short account of the Indian Petroglyphs of the British Columbia Coast.

One of the most modest and unobtrusive of men, he never seemed happier than when helping some younger man, either from the stores of his own experience or from his large and extensive library of natural history. On a journey into the country he was a delightful companion. Everything was full of matter for observation. One of the last letters he received related to the identification of a fern new to this locality, and I am told that, ill as he was, his pleasure at the receipt was as great as ever. He died in harness, as he himself would have wished, with his powers of mind unimpaired. Physically he was wonderfully active for his years; he had just returned from one of his northern journeys when he fell ill. Of late deafness had made attendance at meetings irksome, so that he had dropped out of public relations to some extent. The visit of the British Association delegation to the coast was a great delight to him, enabling him to renew many old acquaintances and exhibit to them the treasures in the collecting of which he had played so large a part.

Born in Newcastle-on-Tyne, he had attained the age of 73 years, thirty-five of which were spent on the Pacific Coast where, in Victoria, he made his home.—R. C.

WILLIAM DAILY HOBSON

Died October 10, 1924

On October 10th, 1924, William Daily Hobson passed away. Mr. Hobson was in his seventieth year and had spent nearly all of the latter half of his life in Woodstock, Ontario, which city he has served as Mayor. He was an ornithologist and botanist of standing, very careful in his identifications and a keen hunter of the beautiful and interesting in nature, though he rarely carried a gun. In earlier years he made a collection of birds and these are still in the possession of Mrs. Hobson. The main outstanding rarity that he

took was a specimen of the White-eyed Vireo, now in the writer's collection. He had also local specimens of the Great Gray Owl and the Canada Jay, both of which are exceedingly rare in the district.

During the last ten years his attention had been turned more particularly to botany and he made many paintings of our native orchids and other beautiful wild flowers.

Mr. Hobson was widely known through the province as a lecturer on birds, in which capacity

he was a very useful citizen. His early life was largely spent in the mining districts of the West, and he had many interesting tales of the wild life of those days.

He is survived by his wife, who was Catherine Cawson before her marriage.

Mr. Hobson will be missed particularly by the members of the McIlwraith Ornithological Club, of London, with whom he was a welcome guest nearly every winter, and whose members held him in high regard.—W. E. S.

NOTES AND OBSERVATIONS

ON A NEW CASE OF COMMENSALISM BETWEEN ECHINODERM AND ANNELID.—(From the Biological Station, Nanaimo, B.C.)—Commensalism between Echinoderms and Polychætes is not uncommon. In the neighbourhood of Nanaimo the Polynoid *Halosydna pulchra* is found commensal with the Holothurian *Stichopus californica* and with *Solaster stimpsoni*, *Pteraster tessalatus* and other species of starfish; *Halosydna fragilis* is commensal with *Evasterias troschelii*, *Orthasterias leptolena*, *Orthasterias columbiana* and other starfishes; and a species of *Myzostoma* is very common with the local Crinoids.

No case of commensalism of Polychæte with a Synaptid has, however, been described from this locality nor, indeed, elsewhere, so far as I have been able to ascertain from a consultation of the literature at my disposal. A recent observation of such a case seems, therefore, worth recording.

In 1923 I described a new species of Polynoid under the name *Malmgrenia nigralba* (*Contributions to Canadian Biology, New Series*, Vol. 1, p. 213). The description was based on a few specimens collected at very low tide mark on a sand bed in a lagoon in the vicinity of the Biological Station. In spite of frequent searches in the same place at low tides during the Spring of this year I failed to find another specimen of the species, nor had I better luck elsewhere. Later in the year, whilst digging for *Leptosynapta inhzereus* at a considerably higher level of the lagoon the explanation was found. This Synaptid lives in almost vertical burrows in coarse gravelly sand. Within some 20 per cent of the burrows excavated the Polynoid *Malmgrenia nigralba* was found. The occurrence was far too frequent to be accidental and there is no doubt it represents a true case of commensalism. The few individual Polynoids originally found free-living had in all probability been washed out of destroyed Synaptid burrows.—EDITH BERKELEY.

Note—Since the foregoing note was written I have found a reference, in Fauvel's recently published volume on the Polychæte in the *Faune de France*, to a Polynoid, classified as *Harmothoe*

lunulata, var. *Synapta*, which is found commensal with Synaptids on the north and west coasts of France.—E. B.

DISPLAY OF THE KILLDEER PLOVER.—The habit of the Killdeer Plover of feigning injury to draw off intruders is well known, but the actions of one of a pair that came under my notice this month seemed to raise a very interesting question as to the possible relationship of such actions to sexual display.

The Killdeer Plover is found practically the year through in the Comox Valley, Vancouver Island; isolated pairs breeding, particularly on the reclaimed delta land. A pair evidently had their nest on a ridge adjoining a slough there, as at my approach, one bird at once started the usual commotion, soon to be joined by the mate. As soon as the danger zone was passed the latter bird left (returning presumably to the nest as I did not see it again until returning over the same ground); the male continued flying around and, when I sat down, he alighted and kept running around a few yards away, calling frequently with the usual note and every now and then settling down as though on a nest, sometimes calling when so sitting. On two occasions that I saw, on getting up he ran a short distance and then went through what looked like a sexual display, crouching on the ground and leaning towards one side with wings lowered and then opening the tail in fan shape over the back so that the cinnamon tail coverts came conspicuously into view, at the same time uttering a trilling note.

The bird could not have been so acting to entice me away from the nest as this must have been over fifty yards away (judging from the actions of the two birds); furthermore, the bird was between me and the nest and, had I followed it when displaying, I should have been going in the direction of the nest.—THEED PEARSE.

AN OLD BREEDING RECORD FOR THE HERRING GULL AT LAC DES ILES, LABELLE COUNTY, QUEBEC.—Following the publication of "The Birds of

Ottawa, 1923", Mr. F. W. Warwick, B.Sc., formerly of Buckingham, Quebec, but now of Galt, Ontario, has acquainted me with a breeding record for the Herring Gull in the locality given in the title. He has in his collection two eggs taken from a nest on a small rocky islet situated about the middle of the lake, the respective dates being May 13th and 15th, 1900. The nest was of moss, sticks, and grass and was placed in a corner of rock. During three days spent at the lake, only three Gulls were seen. Mr. Warwick was familiar with the species from twenty years' residence, 1850-70, at Southend, Essex, England, "being at that time also a lover of birds".

The measurements of the eggs as given by the collector, Mr. Warwick, are: 2.98 x 1.90 and 3.13 x 1.98. The locality where this nesting occurred is about seventy-one miles almost due north of Ottawa, and hence outside the defined "Ottawa District". Nevertheless it is of interest to the student of the birds of our vicinity, and no doubt the species once nested even much nearer the capital than this.—HOYES LLOYD.

A FULMAR AT ARNPRIOR, ONTARIO.—Mr. A. L. Gormley, of Arnprior, reports in *The Auk*, XLI, 1924, pp. 470-1, the capture of a specimen of *Fulmaris glacialis glacialis* at the mouth of the Madawaska River, where it empties into Lac des Chats. This is near Arnprior, and, as shown by the map, the spot mentioned is thirty-one and a half miles almost due west of Ottawa, just outside the thirty mile radius defining the "Ottawa District". Mr. Gormley is certainly to be congratulated upon his rare find and upon securing the specimen for the Canadian National Museum. Truly ornithology is full of surprises.—HOYES LLOYD.

A NORTH-EASTERN COLONY OF PURPLE MARTINS.—At the suggestion of The Provancher Society of Natural History of Canada, Rev. Father Bois, a bird-lover, had some forty bird-houses erected at Ste. Anne de la Pocatiere, Kamouraska County, Quebec. In 1924 four of these bird-houses were occupied by Purple Martins, about forty-five in number. I identified them on the occasion of a visit to the locality in the last week of July, 1924. Ste. Anne de la Pocatiere is in latitude 47°23' N., longitude 70°2' E. from Greenwich.—D. A. DERY.

THE WHITE-FRONTED GOOSE IN THE PROVINCE OF QUEBEC.—A White-fronted Goose (*Anser albifrons* subsp.?) was killed at Cap St. Ignace, Montmagny Co., P.Q., among a flock of Canada Geese, in the week of October 15, 1924. The bird was sent to the market in Quebec, where I purchased it. It is now being prepared for permanent

preservation by Mr. C. E. Dionne, of Laval University, Quebec. It will be donated to the "Provancher" collection. Owing to the condition of the specimen, the sex could not be definitely ascertained, but it is presumed that the bird is an adult male, as the white area on the forehead is large and the white is very pure.

The only known previous record of the taking of this species in the Province of Quebec is that of one killed in the autumn of 1870 at Lake Jacques Cartier, and preserved in the Museum of Laval University. (See Dionne, *Les Oiseaux de la Province de Quebec*, page 111.) Wintle reports having seen three at Lake St. Louis, near Montreal.—D. A. DERY.

REPRINTS FROM OUR PAGES.—It is interesting to observe that the Canadian National Parks Branch of the Department of the Interior has made use of two articles which appeared in *The Canadian Field-Naturalist* by reprinting them. The first article to be reprinted was "Bird Houses and Their Occupants," by P. A. Taverner. There have been three editions in English of this reprint and two in French, the total number of copies amounting to two hundred and fifteen thousand. The later editions have been on very fine tinted paper, bound in pamphlet form, with the picture of Mr. P. A. Taverner's Purple Martin house on the cover. The next paper to be reprinted from *The Naturalist* was the article entitled "The Pileated Woodpecker," by J. A. Munro. This is illustrated with a cut of the Pileated Woodpecker by Major Allan Brooks, and the edition of the separate amounts to thirty thousand copies.—HOYES LLOYD.

NOTE—Illustrations in this issue were provided by Topographical Surveys, Department of the Interior, Canada, to whom we express our obligation

We are also indebted to Lowe-Martin Ltd. and The Graphic Advertisers for donating to the use of the magazine their paid advertising space in the November and December issues, thus enabling us to publish two extra pages of printed matter in each issue.—Editor.

CANADIAN FIELD-NATURALIST PUBLICATION FUND
Statement of Receipts

Previously acknowledged.	\$230 00
Dr. E. M. Kindle.	10 00
G. A. Miller.	10 00
H. F. Lewis.	5 00
C. Goodrich.	5 00
Total.	\$260 00

INDEX TO VOLUME XXXVIII

- Acanthis hornemannii exilipes* . . . 113
linaria linaria . . . 113
 Accipiter . . . 36
Accipiter cooperi . . . 108
 velox . . . 89, 108, 175
Acer spicatum . . . 80
Actitis macularia . . . 75, 107, 149
 Adam and Eve . . . 62
 Adder's Mouth, Green . . . 61
 White . . . 62
Adiantum pedatum var. *aleuticum*
 Admiral, Red . . . 83
 White . . . 83
Adocus . . . 68
Aechmophorus occidentalis . . . 103
Æsculus . . . 66
 antiquus . . . 69
 Agarum . . . 157
Agelaius phoeniceus . . . 112
 phoeniceus arctolegus . . . 112
Aglais antiopa . . . 83
 milberti . . . 83
Aiz sponsa . . . 104, 148
 Alaria . . . 157
 Albatross . . . 97
Alca lorda . . . 45
Alces americanus . . . 27
 Alga, Freshwater . . . 40
 Alga-mould . . . 7
Alle alle . . . 45
Amblystoma jeffersonianum . . . 159
Ambystoma tigrinum . . . 81
Amelanchier canadensis . . . 78
Ammodramus bairdi . . . 113
 caudacutus . . . 10
 savannarum australis . . . 10
 savannarum bimaculatus . . . 113
Amphion nesusus . . . 132
Am. nias . . . 161, 162, 163
Anaptychyrhynchus . . . 104
 rubripes . . . 72, 104
 Anderson, Rudolph Martin, ar-
 ticle by . . . 27
 Annelid . . . 193
Anodonta marginata . . . 163
Anser albifrons . . . 105, 194
 Antelope . . . 169
Anthus rubescens . . . 15, 117, 146
 spraguei . . . 117
Antrostomus vociferus vociferus . . . 111
 Aphis . . . 20
Aplectrum hyemale . . . 62
Apocynum androsaemifolium . . . 80
Apomotis cyanellus . . . 85
Aquila chrysaëtos . . . 89, 109, 139
Aquila canadensis . . . 86
Aralia coloradensis . . . 69
 Arches, Pink . . . 83
Archibuteo ferrugineus . . . 109
 lagopus sancti-johannis . . . 89, 109
Archilochus colubris . . . 90, 111
 Arctic, The . . . 82
Arctostaphylos uva-ursi . . . 149
Ardea herodias . . . 106
 herodias herodias . . . 74
 herodias treganzai . . . 106
Arenaria interpres morinella . . . 75, 108
 melanocephala . . . 149
Arquatella maritima . . . 149
 maritima couesi . . . 149
 Ascidian . . . 158
Asio accipitrinus . . . 139
 flammeus . . . 89, 109
 wilsonianus . . . 109, 176
Aspiderites . . . 68
Asplenium platyneuron . . . 50
 Trichomanes . . . 50, 51
 Aster . . . 82
Aster puniceus . . . 82
Astragalus tristis . . . 113
 tristis pallidus . . . 113
 tristis tristis . . . 126
Asur atricapillus atricapillus . . . 89, 109
Asyndesmus lewisi . . . 110, 176
Athyrium angustum var. *etatus* . . . 50
 Auk . . . 145, 169, 174
 Great . . . 58
 Razor-billed . . . 45
 Auklet . . . 169
 Rhinoceros . . . 144, 174
 Avocet, American . . . 106
 Azolotes . . . 81
Baena . . . 68
 Bailey, Alfred M., review of
 article by . . . 39
Balanus . . . 42
 cariosus . . . 41, 42
 crenatus . . . 43
 rostratus . . . 42, 43
 Baldpate . . . 104
 Baltimore, The . . . 83
 Barnacle . . . 41, 42
Bartramia longicauda . . . 107
Basilarchia archippus . . . 83
 arthemis . . . 83
Basilemys . . . 68
 Bat . . . 58, 76, 95
 Brown . . . 76
 Bates, Carlos G., review of his
 "Research Methods in the
 Study of Forest Environ-
 ment" . . . 160
Batrachia . . . 68
 Bauer, Miss, article by . . . 17
 Baxter, Donald, article by . . . 17
 Bear . . . 71
 Beauty, Camberwell . . . 83
 Beaver . . . 70, 71, 72
 Beech . . . 35
 Beetle, Chrysomelid . . . 148
 Ground . . . 176
 Bent, Arthur Cleveland, review
 of his "Life Histories of
 North American Petrels
 and Pelicans and Their
 Allies" and his "Life His-
 tories of North American
 Wild Fowl" . . . 96
Bernicia canadensis . . . 74
 Berry, Edward W., article by . . . 131
 Berry, S. Stillman, review of
 article by . . . 19
 Biological Excursion to Anti-
 cost Island, A . . . 161
 Birch . . . 187
 Birds of Ottawa, The . . . 10
 Birds of Saskatchewan . . . 101
 Bison . . . 189
Bison bison athabascæ . . . 189
 Bittern . . . 32, 74, 87
 American . . . 106
 Least . . . 10, 106, 118, 120
 Black-billed Cuckoo in Mani-
 toba, The . . . 64
 Blackbird, Brewer's . . . 20, 112
 Red-winged . . . 112
 Rusty . . . 20, 112, 125
 Yellow-headed . . . 20, 112
Blarina brevicauda . . . 120
 Blueberry . . . 180
 Bluebird 16, 17, 21, 39, 58, 118, 120, 147
 Eastern . . . 118
 Mountain . . . 118
 Bobolink . . . 112
 Bob-white . . . 168, 188
Bonasa umbellus togata . . . 108
Bombicilla cedrorum . . . 12, 115, 127
 garrula . . . 12, 115
Bos bison athabascæ . . . 189
Botaurus lentiginosus . . . 74, 106
Botrychium obliquum var. *onei-*
dense . . . 50
 simplex . . . 50
 virginianum . . . 50
 virginianum var. *europæum*
 . . . 50
 Bowles, J. Hooper, review of
 article by . . . 20
Brachyramphus marmoratus . . . 147
Branchinecta . . . 2, 3
 paludosa . . . 1
 Brant . . . 74, 142, 147, 171, 174
Branta bernicla glaucogastra . . . 74
 canadensis . . . 74
 canadensis canadensis . . . 74, 105
 canadensis hutchinsi . . . 105
 canadensis minima . . . 149
 British Association, The Toronto
 Meeting of The . . . 95
 Brooks, Allan, review of articles
 by . . . 19, 20
 Brook-trout . . . 161
 Brown, Roland, article by . . . 17
Bubo virginianus . . . 110
 virginianus pallascens . . . 110
 virginianus subarcticus . . . 110
 Buffalo . . . 189
 Buffle-head . . . 19, 105, 147
 Bunting, Black-throated . . . 115
 Indigo . . . 11, 21, 24, 114
 Lark . . . 115
 Lazuli . . . 115, 118
 Snow . . . 10, 17, 113, 126
Buteo borealis . . . 109
 borealis borealis . . . 89
 borealis calurus . . . 109
 borealis krideri . . . 109
 lagopus . . . 139
 platypterus platypterus . . . 109
 swainsoni . . . 109
 wulgaris . . . 139
 Butterfly . . . 82, 83
 Hunter's . . . 83
 Butterwort . . . 140
 Buzzard . . . 35
 Common . . . 139
 Honey . . . 139
 Rough-legged . . . 139
 Turkey . . . 76
Calamospiza melanocorys . . . 115
Calcarius lapponicus . . . 113
 lapponicus alascensis . . . 113
 lapponicus lapponicus . . . 10, 126
 ornatus . . . 113
 pictus . . . 113
Calidris canutus . . . 16, 74, 107
 Calopogon . . . 87
Calopogon pulchellus . . . 87
Calypto . . . 61, 62, 86
 bulbosa . . . 61
 Camptolaimus . . . 44
Camptorhynchus labradorius . . . 73
Camptopus . . . 50
 rhizophyllus . . . 50
Canachites canadensis . . . 108
 canadensis canace . . . 108
 Canada Goose at Home, The . . . 70
 Canary . . . 120, 143, 171
 Wild . . . 113, 142, 143, 144
 Canvasback . . . 105
 Cardinal . . . 11, 17, 18
Cardinalis cardinalis . . . 18
 cardinalis cardinalis . . . 11
 cardinalis cardinalis . . . 43
Cardium corbis . . . 176
Caribidae . . . 168, 185, 186
 Caribou . . . 168, 185, 186
 Barren Ground . . . 29
Carpodacus purpureus purpureus
 . . . 112, 126
Carterocephalus palaemon . . . 82
 Catbird . . . 15, 39, 117
Cathartes aura septentrionalis . . . 108
Catocala blandula . . . 170
 briseis . . . 171
 cerogama . . . 170
 concombens . . . 171
 parla . . . 170
 relicta . . . 171
 ultronia . . . 170
 umjuga . . . 170
 Catocalinæ . . . 170
Catoptrophorus semipalmatus in-
ornatus . . . 107
 Cedar . . . 80
 Red . . . 132
Celero intermedia . . . 132
 lineata . . . 132
Centrocercus urophasianus . . . 108
Cepphus grylle . . . 45
Ceratomia undulosa . . . 132
Certhieis sparveria sparveria . . . 89, 109
 15, 87, 117
Certhia familiaris americana . . . 110
Ceryle alcyon . . . 90
 alcyon alcyon . . . 90, 111
Chaetura pelagica . . . 68
Champsosaurus . . . 164
Chara foetida . . . 164
 fragilis . . . 164
Charadrius melodus . . . 75, 108
 semipalmatus . . . 75, 108
Chattonella albeola . . . 105
 Chat, Yellow-breasted . . . 117
Chauliastmus streperus . . . 72, 104
 Checker-spot, Harris' . . . 83
Chelydra serpentina . . . 165

INDEX—Continued

- Chen caerulescens*..... 105
hyperboreus hyperboreus..... 105
hyperboreus nivalis..... 73, 105
rossi..... 105
Chenopodium..... 17
Cherry, Ground..... 137
Chickadee..... 15, 17, 18, 60, 146, 177
 Acadian..... 146
 Black-capped..... 17, 18
 Chestnut-backed..... 16, 177
 Hudsonian..... 16, 117
 Labrador..... 146
 Long-tailed..... 117
Chicken, Prairie..... 108
Chimæroid..... 64
Chlidonias nigra surinamensis..... 104
Chondestes grammacus strigatus..... 113
Chordeiles virginianus sennetti..... 111
 virginianus virginianus..... 90, 111
Chrysemys marginata bellii..... 164
Chrysodomus tabulatus..... 43
Chthamalus dalli..... 42
Cinclus mexicana unicolor..... 48
Cinquefoil, Three-toothed..... 51
Circus aeruginosus..... 139
 cineraceus..... 139
 cyaneus..... 139
 hudsonius..... 89, 108
Cirripedia..... 41
Cistothorus stellaris..... 15, 117
Citellus..... 128, 152
 columbianus columbianus..... 128
Cladocera..... 1
Cladodactyla miniata..... 56
Clam, Freshwater..... 163
Clam-shrimp..... 1, 4, 7, 8
Clangula hyemalis..... 73, 105
Clark, Hubert Lyman, article by..... 54
Cloak, Mourning..... 83
Club-moss..... 149
Coccyzus erythrophthalmus..... 90, 110
Cock-of-the-Woods..... 110
Colaptes auratus borealis..... 90, 110
 cafer collaris..... 110, 111
Columbia fasciata fasciata..... 149
Columbine, Wild..... 86
Colymbus auritus..... 44, 103
 holoelli..... 103
 nigricollis californicus..... 103
Coyote..... 119
Comeau, Napoleon A., obituary of..... 29
Comma, Green..... 83
 The Grey..... 83
Compeloma producta..... 69
Compsothlypis americana pusilla..... 13, 87, 127
Concentration of Migratory Birds at Sault Ste. Marie, Ontario, in the Spring, The..... 9
Condor, The, review of..... 19, 39
Conference of Provincial and Federal Officials..... 95
Cook, C. D., article by..... 17
Cook, Mrs. C. D., article by..... 17
Coot..... 74
 American..... 106
Copepod..... 1, 4, 7
Copper, American..... 82
 Bronze..... 82
 Least..... 82
Corallorhiza maculata..... 62, 87
Coral Root..... 62
Cormorant..... 72
 Common..... 190
 Double-crested..... 72, 104, 190
Cornus nuttallii..... 175
Cornwall, Ira E., article by..... 41
Cornwallius sookensis..... 191
Corpolithes..... 69
Corvus brachyrhynchos..... 112
 brachyrhynchos brachyrhynchus..... 112, 125
 corax..... 139
 corax principalis..... 112, 125
Corydalis, Pale..... 51
Corydalis sempervirens..... 51
Coslaria..... 157
Colurnicops noveboracensis..... 106
Colurniculus passerinus..... 10
Cowbird..... 15, 16, 36, 58, 112, 120, 125
Cox, Philip, article by..... 85
Crab..... 43, 157
Crane, Little Brown..... 106, 118
 Sandhill..... 106
 Whooping..... 106
Creeper, Brown..... 15, 17, 87, 117
Creeper, Virginia..... 18
Cridle, Norman, article by..... 121
Crinoid..... 193
Crocethia alba..... 75, 107
Crocodylia..... 68
Crocodylus..... 68
Crossbill..... 20, 37, 119, 120, 140
 American..... 112, 119, 120
 Bendire's..... 120
 Red..... 140
 White-winged..... 140
 87, 113, 119, 120, 126, 140
Crow, 9, 17, 18, 31, 32, 33, 34, 35, 36, 59, 60, 64, 125, 139, 144, 145, 167, 174
 American..... 112
 Carrion..... 139
Crustacean..... 1
Cryptolaux acadica..... 110
 acadica acadica..... 90
 funerea richardsoni..... 109
Cuckoo, Black-billed..... 17, 64, 65, 78, 90
 Yellow-billed..... 10
Cucumaria..... 54, 56, 57
Cucumaria..... 54, 57
 californica..... 54
 chronohelmt...... 55, 57
 lissoplata..... 55, 57
 lubrica..... 55, 57
 miniata..... 56
 piperata..... 56
 populifer..... 56
 populifera..... 55, 56, 57
 trachyplata..... 55, 56
 vegæ..... 57
Curlew, Eskimo..... 75
 Hudsonian..... 75, 188
 Long-billed..... 108
Currant, Black..... 180
 Red..... 180
Cutworm..... 176
Cyanocitta cristata..... 112
 cristata cristata..... 125
 stelleri..... 112
 stelleri annectens..... 112
 stelleri stelleri..... 176
Cyclodius gigas..... 47
Cyclostome..... 64
Cygnus buccinator..... 105, 179
 columbianus..... 105
Cypripedium..... 62
 arietinum..... 61, 87
 hirsutum..... 62, 87
 passerinum..... 62
Dafila acuta..... 73
 acuta tzitzihoa..... 16, 73, 104
Dale, E. M. S., article by..... 16
Danaus archippus..... 82
Darapsa pchelus..... 132
Dean's Bibliography of Fishes..... 63
Deer..... 28, 145
 Red..... 164
 White-tailed..... 28, 168
DeLury, Ralph E., article by..... 21
Dendroica aestiva aestiva..... 13, 116, 127
 aestiva morcomi..... 116
 aestiva rubiginosa..... 116
 auduboni auduboni..... 116
 caerulescens caerulescens..... 13
 castanea..... 14, 116
 cerulea..... 13
 cornata..... 13, 116
 coronata coronata..... 127
 discolor..... 58
 fusca..... 14, 116
 magnolia..... 13, 116, 127
 palmarum hypochrysea..... 14
 palmarum palmarum..... 14, 116
 penysylvanica..... 14, 116
 striata..... 14, 116, 127
 tigrina..... 13, 116
 vigorsi..... 14
 virens..... 14, 116, 127
Desmostylus hesperus..... 191
Diatom, Freshwater..... 40
Dickcissel..... 11, 44, 115, 127
Dictamnus fraxinella..... 77, 78
Digger-wasp..... 121
Dinosaur..... 67, 68, 69, 131
Dinosauria..... 68
Dipper..... 48, 49, 50
Dog, Water..... 82
Dogbane, Spreading..... 80
Dogwood..... 175
Dolichonyx oryzivorus..... 112
Donacia proxima..... 148
Dove, Mourning..... 10, 89, 108
Dovekie..... 45
Dowitcher..... 107, 188
 Long-billed..... 107
Dryobates pubescens..... 110
 pubescens medianus..... 90
 pubescens nelsoni..... 110
 villusus..... 90
 villosus leucomelas..... 110
Dryopteris..... 50
Dubois, A. D., review of article by..... 20
Luck, 31, 34, 59, 71, 73, 78, 87, 89, 91, 142, 143, 145, 171, 174
 Black..... 72, 84, 92, 93, 104, 133, 134, 135, 144, 154, 155, 156, 177
 Eider..... 170
 Greater Scaup..... 105, 118
 Harlequin..... 73, 169
 Labrador..... 58, 73
 Lesser Scaup..... 73, 105
 Mallard..... 78, 142, 156
 Old-squaw..... 105
 Pin-tail..... 73, 90, 156
 Ring-necked..... 73, 93, 96, 105, 148, 156
 Ruddy..... 105
 Scaup..... 73
 Teal..... 76
 Western Harlequin..... 148, 149
 Wood..... 91, 104, 148
Dumetella carolinensis..... 15, 117
Eagle..... 35, 60, 144, 145, 164, 167, 168
 Bald..... 144, 148, 155
 Golden..... 89, 109, 139, 144
 Kamchatka Sea..... 20
 Northern Bald..... 89, 109
 White-tailed..... 139
Eagle Snaring among the Bella-coola Indians..... 167
Echinoderm..... 193
Ectopistes migratorius..... 89, 108
Eel..... 63
Eider..... 73
 King..... 73
 Northern..... 73
Egeria..... 157
Elanoides forficatus..... 108
Elfin, Brown..... 82
Empidonax difficilis difficilis..... 176
 flaviventris..... 111, 125
 minimus..... 111, 125
 trailli anorum..... 111, 125
 trailli trailli..... 111
 wrighti..... 111
Enodia portlandia..... 83
Entomotraca..... 7
Ephemeroid..... 164
Epipactis, Broad-leaved..... 62
Epipactis..... 87, 88
 latifolia..... 62
 pubescens..... 61, 88
 viridiflora..... 62
Eptesicus fuscus fuscus..... 95
Equisetum..... 131
Equisetum..... 132
 arcticum..... 69, 131, 132
 Haydeni..... 132
 laevigatum..... 132
 palustre..... 148
 Parlatorii..... 132
 perlaevigatum..... 132
Ereunetes pusillus..... 75, 107
Erimaturax jamaicensis..... 105
Eubranchipus..... 2, 3
 gelidus..... 1, 3, 4, 5, 6, 7, 8
Euomphalidae..... 150
Euphagus carolinus..... 112, 125
 cyanocephalus..... 112
Euphrydas phaëton..... 83

INDEX—Continued

Euphyllopoda	7, 8	<i>Gavia adamsi</i>	103	<i>Habenaria Andrewsii</i>	61
Euphyllopods, Further Notes on Canadian	1	<i>immer</i>	44, 103	<i>blephariglottis</i>	51, 61, 87
<i>Eupomotis auritus</i>	86	<i>pacifica</i>	103	<i>blephariglottis</i> var. <i>holo-</i>	
<i>Eurymus pholidice</i>	83	<i>Gavia stellata</i>	44, 103	<i>petala</i>	61, 87, 88
<i>Evasterias troschelii</i>	193	<i>Geothlypis trichas occidentalis</i>	116	<i>bracteata</i>	86
Exhibition of Wild Life Photographs, The	159	<i>trichas trichas</i>	15, 127	<i>dilatata</i>	86
Exploration into the Northern Plains North and East of Great Slave Lake, Including the Source of the Coppermine River, An.	183	<i>Gerrhonotus</i>	47	<i>dilatata</i> var. <i>media</i>	61, 88
Eye, Pearly	83	<i>scincicauda scincicauda</i>	47	<i>flava</i>	61
		<i>scincicauda webbiti</i>	47	<i>Hookeri</i>	86
		Gilbert, Charles H., review of article by	20	<i>hyperborea</i>	88
		<i>Glauucidium gnoma</i>	176	<i>macrophylla</i>	87
		<i>Glauconella clangula americana</i>	73, 105	<i>orbiculata</i>	87
		<i>islandica</i>	73	<i>Habrosyne scripta</i>	83
		Godwit, Hudsonian	107	<i>Haemorrhagia diffinis</i> , var. <i>aethra</i>	132
		Marbled	107	<i>thysbe</i> (Form <i>cimbiciformis</i>)	132
		Golden-eye	17, 73	Hairstreak	82
		American	17, 73, 105	Acadian	82
		Barrow's	73	Striped	82
		Goldfinch	17, 18, 119, 126	<i>Haliæetus albicilla</i>	139
		American	113	<i>leucocephalus alascanus</i>	89, 109
		Pale	113	<i>Halosydna fragilis</i>	193
		<i>Goodyera</i>	88	<i>pulchra</i>	193
		Goose	27, 142, 145, 166, 174	Hare, European	168
		Blue	105, 118	<i>Harmothae tumulata</i> , var. <i>Syn-</i>	
		Cackling	149	<i>aptae</i>	193
		Canada	44, 59, 70, 71, 72, 74, 90, 91, 105, 124, 194	<i>Harporhynchus cinereus</i>	15
		Greater Snow	73, 105	Harrier	35
		Grey	78	Hen	139
		Hutchins'	105	Marsh	139
		Lesser Snow	105, 158	Montagu's	139
		Ross's Snow	105	Hawk	8, 17, 31, 32, 35, 36, 59, 60, 102, 144, 174
		Snow	74	American Rough-legged	109
		White-fronted	44, 74, 105, 194	American Sparrow	109
		Gopher	123	Broad-winged	109
		Goshawk	8, 89, 109	Cooper's	32, 108, 118
		American	8	Duck	37, 89, 109
		Gnat	10, 164	Ferruginous Rough-legged	109
		Gnatcatcher, Blue-gray	16	Fish	109
		Grackle	52	Marsh	34, 89, 108
		Bronzed	17, 18, 36, 64, 112, 125	Pigeon	89, 109
		Grasshopper	24	Red-tailed	89, 109
		Grebe	137, 143, 145, 164, 174	Rough-legged	89
		Eared	103	Sharp shinned	32, 33, 60, 89, 108, 175, 176
		Holboell's	31, 103, 137	Sparrow	17, 32, 89
		Horned	44, 103	Swainson's	109
		Pied-billed	103	Western Red-tailed	109
		Red-necked	137	<i>Hedymeles ludovicianus</i>	11, 114, 127
		Western	31, 103	<i>melanocephalus</i>	114
		Grinnell, J., review of article by	20	Helleborine	62, 63
		Grosbeak, American Pine	20	<i>Hellobella stagnalis</i>	163
		Black-headed	114	Hen, Heath	34
		Evening	18, 36, 112	Prairie	108
		Pine, 17, 18, 36, 112, 125, 143, 174		Henderson, A. D., articles by	8, 70
		Queen Charlotte	20	<i>Heodes epixanthe</i>	82
		Rose-breasted	11, 114, 127	<i>hypophlæas</i>	82
		Grouse	32, 145	<i>thoe</i>	82
		Blue	120	Heron	33, 87, 145
		Canada Ruffed	108	Black-crowned Night	106
		Pinnated	108	Great Blue	74, 106
		Prairie Sharp-tailed	108	Herring	43
		Ruffed	17, 18, 40, 77, 147, 188	<i>Hesperiphona vespertina</i>	112
		Sage	108	<i>Hirundo erythrogastra</i>	12, 115, 127
		Spruce	77, 108	<i>Histrionicus histrionicus histrionicus</i>	73
		<i>Grus americana</i>	106	<i>histrionicus pacificus</i>	148
		<i>canadensis</i>	106	Hobby	139
		<i>mexicana</i>	106	Hobson, William Daily, obituary of	192
		Guillemot, Black	45	<i>Holothuria inhaerens</i>	54
		Pigeon	174	Holothurian	54, 55, 193
		Gull	20, 34, 36, 84, 91, 143, 164, 174	Home Life of the Columbian Ground Squirrel, The	128, 151
		Bonaparte's	46, 104, 148	Horsetail	148
		California	103	Hummingbird	144
		Franklin's	103	Ruby-throated	90, 94, 111
		Glaucous	20, 45	<i>Hyalella azteca</i>	163
		Glaucous-winged	93, 148	<i>Hydrobates pelagicus</i>	46
		Great Black-backed	45, 92, 170, 190	Hydroid	158
		Herring	17, 18, 45, 103, 190, 193, 194	<i>Hylocichla aliciae aliciae</i>	16, 118
		Iceland	45	<i>aliciae bicknelli</i>	16
		Ivory	45	<i>fuscescens fuscescens</i>	16, 146
		Ring-billed	17, 45, 103	<i>fuscescens salicicola</i>	118
		Sabine's	104, 148	<i>guttata pallasi</i>	16, 118, 146
		Sea	144	<i>mustelina</i>	16
		Short-billed	103	<i>ustulata swainsoni</i>	16, 118, 146
		Western	20, 34, 86	Hymenoptera	121
		Gyr Falcon	109		
		Black	89		
		Gray	109		
		White	20, 89, 109		
Gadwall	72, 93, 104				
<i>Gallinago delicata</i>	74, 106				
<i>Gallinula chloropus cackinnans</i>	74				
Gallinule	92				
Florida	74, 133				
<i>Gammurus fasciatus</i>	162				
<i>limnaeus</i>	161, 162				
Gannet	44, 46, 93, 96				
Ganoid	64				
Garpike	66				
<i>Gasterosteus atkinsi</i>	164				
Gastropod	150				

INDEX—Continued

- Icteria virens virens* 117
Icterus bullocki 112
gabula 112
Iguanatus 68
Incisalia angustus 82
 Indian, Menomini 40
 Northern 40
 Infusoria 7
 Intelligence Behaviour in Lizards 47
Iridoprocne bicolor 12, 115, 127
 Isopod 161
 Ivy, Ground 83
Izobrychus exilis 106
- Jack, Whisky 112
 Jaeger, Long-tailed 45
 Parasitic 45, 103, 118
 Pomarine 103, 148
 Jay 44, 136
 Blue 17, 18, 39, 112, 125
 Canada 112, 125, 193
 Steller's 112, 176
 Johansen, Frits, articles by 1, 161
 Johnstone, M., article by 17
 Junco 17
 Pink-sided 103, 114
 Slate-colored 11, 92, 114, 126, 154, 155, 156, 177, 178
Junco hyemalis hyemalis 11, 114, 126
hyemalis mearnsi 114
Juncus 162, 163
 Juneberry 78
 Juniper 58
- Kabara-goya 47
 Killdeer 75, 108, 188
 Killer Whales at Green Island
 Lighthouse 84
 Killifish 163
 Kingbird 90, 111, 120
 Arkansas 111
 Kingfisher 49
 Belted 17, 90, 110
 Kinglet, Golden-crowned 16, 17, 21, 24, 87, 117, 118, 146
 Ruby-crowned 16, 117, 146
 Sitka 177
 Kingston, Lois R., article by 13
 Kinnikinnik 149
 Kite 35, 139
 Swallow-tailed 108, 118
 Kittiwake 45
 Knot 74, 107, 118
- Lacerta ocellatus* 47
 Ladies' Tresses, Hooded 62
 Nodding 61, 88
 Slender 87
 Lady, Painted 83
 Lady's Slipper, Ram's Head 61, 87
 Showy 62, 87
Lagopus lagopus lagopus 88, 108
rupestris rupestris 89
Laminaria 157
Lanius borealis 12, 115, 127
 ludovicianus excubitorides 115
 ludovicianus migrans 12
Lanius flavifrons 13, 115
solitarius solitarius 13, 115
Laportea canadensis 80
 Laridae 20
 Lark, Desert Horned 112
 Horned 17, 125, 137, 147
 Pallid Horned 111
 Prairie Horned 111
 Saskatchewan Horned 112
Larus argentatus 45, 103
 brachyrhynchus 103
 californicus 103
 delawarensis 45, 103
 franklini 103
 glaucescens 148
 hyperboreus 45
- Larus leucopterus* 45
 marinus 45
 philadelphia 46, 104, 148
Laurus 69
 Leech 162
Lehma 66
 scutala 69
Lepidosteus occidentales 68
Leptosynapta inhaerens 54, 193
Lessonia 157
Leucosticte tephrocotis 113
 Lewis, Harrison F., articles by 43, 72, 88, 125, 146, 168
Lilium canadense 138
 philadelphicum 138
 Lily, Scarlet 138
 Turk's-cap 138
 Wild Orange 138
Limentis sibylla 83
Limnetis 7
 brachyurus 6
 gouldi 1, 4, 6, 7
Limnodromus griseus griseus 107
 griseus scolopaceus 107
Limosa fedoa 107
 haemastica 107
 Limpet 43
 Linnæus 171
Liparis Loeseli 62
- List of Birds Recorded from the
 Island of Anticosti, Que-
 bec 43, 72, 88, 125, 146
Listera auriculata 61
 Lizard 47, 81, 82
 Alligator 47
 Eyed 47
 Plated 47
 Lloyd, Hoyes, articles by 10, 17
Lobipes lobatus 74, 106
 Longspur, Chestnut-collared 10, 113
 Lapland 10, 113, 126, 147
 McCown's 113
 Painted 113
 Smith's 113
 Loon 44, 60, 143, 164, 170, 190
 Black-throated 103, 118, 147
 Common 39, 103
 Pacific 103, 118
 Red-throated 44, 103, 137
 Yellow-billed 39, 103
Lophodytes cucullatus 72, 104
Lophospira 151
 occidentalis 151
 perlamellusa 151
 tropidophora 151
Loxia curvirostra minor 112
 leucoptera 87, 113, 126
Lymnaea 162, 163
- MacLoughlin, Mrs. F. E., article
 by 17
 Maclurina 150
Macrocyttis pyrifera 157
 Magpie 19, 34, 36
 American 112
Malapterurus 63
Malaxia monophyllos 62
 unifolia 61, 62
 Malcolm, Miss, article by 17
 Mallard 93, 104, 119, 133, 134, 144, 155, 157, 190, 191
Malmgrenia nigralba 193
Malapterurus 63
 Man, Prehistoric 77
 Maple, Mountain 80
Mareca americana 104
Marila affinis 73, 105
 americana 73, 105
 collaris 73, 105, 148
 marila 73, 105
 valisineria 105
 Martagon 138
 Marten 168
 Martin, Purple 12, 115, 194
 McKeough, George T., article by 187
 McMillan, G. O., article by 17
 McQueston, C., article by 17
 Meadowlark 58
 Western 39, 112
- Melanerpes erythrocephalus* 110
 *erythrocephalus erythrop-
 thalmus* 110
Melospiza georgiana 11, 114, 126
 lincolni lincolni 11, 114, 126
 melodia juddi 114
 melodia melodia 11, 114, 126
Melitæa harrisi 83
 Merganser 18, 72, 143, 170, 174
 American 19, 96, 104
 Hooded 72, 104
 Red-breasted 72, 104
Mergus americanus 72, 104
 serrator 72, 104
 Merlin, Richardson's 109
Merula migratoria 38
Micropalama himantopus 107
Microstylis ophioglossoides 61
Microtus 37
 Mills, Miss, article by 17
Milvus icimus 139
Mimus polyglottos polyglottos 146
 Miner, Jack, review of his "Jack
 Miner and the Birds" 59
 Miscellaneous Bird Notes from
 Southern Vancouver Is-
 land, 1923 147, 175
 Mitchell, H. Hedley, article by 101
Mniotilta varia 13, 115, 127
 Moccasin Flower, White 62
 Mockingbird 146
 Mollusk 158, 163
Molothrus ater 112
 ater artemisiae 112
 ater ater 125
 Monarch 82
 Monitor 47
 Monster, Gila 47
 Moose 27, 28, 168
 Moran, J., article by 84
Moris bassana 46
 Morris, Frank, article by 24, 51
 Moss, Caribou 140
 Mouse, Lemming 37
 Pine 37
 Red-backed 37
 Mousley, Henry, articles by, 61, 82, 86
 Mudpuppy 81
 Munro, J. A., articles by 48, 141, 147, 171, 175
 Munro, J. A., review of article by 20
 Murre 20, 34, 45, 169, 171, 174
 Common 190
 Murrelet 142, 145, 171
 Ancient 142
 Marbled 147
 Musk-ox 29, 186
 Muskrat 17
 Mussel 42
Myadestes townsendi 118
Myiarchus crinitus 111
*Myiochanes richardsoni richard-
 soni* 111
Myladephus bipartitus 68
Myotis lucifugus 76, 95
Mytella polymerus 42
Mytilus edulis 42
 Myzostoma 193
- Nannus hiemalis hiemalis* 15, 117, 146
 National Aspect of Game Con-
 servation, The 168
Necturus 81
 maculosus 81
Nepeta glechoma 83
Nereocystis Luetkiana 157
 Nesting Habits of the American
 Goshawk 8
Nettion carolinense 72, 104
 Nettle, Slender 80
 Wood 80
 New and Rare Records of Cer-
 tain Freshwater Fishes in
 Canada 85
 New Genus and a New Species of
 Gastropod from the Upper
 Ordovician of British Colum-
 bia, A 150
 Newcombe, Charles Frederick,
 M.D., obituary of 191

INDEX—Continued

Nighthawk.....	90, 93, 111	Ottawa Field-Naturalists' Club,		Pewee, Western Wood.....	32, 111
Sennett's.....	111	Annual Meeting.....	180	<i>Phalacrocorax auritus</i>	104
Noctua.....	83	<i>Otus asio</i>	110, 176	<i>auritus auritus</i>	72
Noctuidae.....	176	<i>Otus asio kenneicotti</i>	176	<i>carbo</i>	72
Notes on Some Game Birds in		Oven-bird.....	14, 116, 127	<i>Phalaenoptilus nuttalli</i>	111
the County of Kent, Ont-		Qwl, 8, 9, 31, 32, 35, 36, 59, 60, 144, 174		Phalarope, Northern.....	
ario, Season of 1924.....	187	American Barn.....	109, 118	Red.....	74, 106, 109, 142, 174
Notes on the Canada Goose in		Arctic Horned.....	110	Wilson's.....	74, 106
Captivity.....	124	Barred.....	90	<i>Phalaropus fulicarius</i>	74, 106
Notes on the Catcoline of Sault		Burrowing.....	110	Pheasant, English.....	188
Ste. Marie, Ontario.....	170	Great Gray.....	109, 118, 193	<i>Phlebotomus pileatus abieticola</i>	110
Notes on the Lance Formation		Great Horned.....	8, 9, 32, 33, 110	Phoebe.....	94, 111
of Southern Saskatchewan.....	66	Hawk.....	90	Say's.....	103, 111
Notes on the Relation of the		Long-eared.....	109, 176	<i>Phragmites</i>	69
Dipper (<i>Cinclus mexicana</i>		Pygmy.....	176	<i>Phrynosoma blainvilliei</i>	47
<i>unicolor</i>) to Fishing In-		Richardson's.....	90, 109	Phyllopod.....	1
terests in British Columbia		Saw-whet.....	90, 110	Phyllopod-nauplii.....	2
and Alberta.....	48	Screech.....	17, 18, 31, 35, 58, 60,	<i>Physa</i>	163
Notes on the Sphingidae of Sault		Short-eared.....	110, 118, 176	<i>Physagenia Parlatorii</i>	132
Ste. Marie, Ontario.....	132	Snowy.....	90, 110, 119, 144	<i>Physalis pubescens</i>	137
<i>Nucifraga columbiana</i>	112	<i>Oxyechus vociferus</i>	108	<i>Pica pica hudsonica</i>	112
<i>Numenius americanus</i>	108	<i>vociferus vociferus</i>	75	<i>Picoides americanus</i>	110
<i>borealis</i>	75			<i>americanus americanus</i>	90
<i>hudsonicus</i>	75			<i>americanus fasciatus</i>	110
Nutcracker, Clarke's.....	112			<i>arcticus</i>	90, 110
Nuthatch, Red-breasted.....				Pigeon, Band-tailed.....	149, 175
.....15, 17, 18, 117, 146				Passenger.....	89, 108
White-breasted.....		<i>Pachysphinx modesta</i>	132	Sea.....	143
.....15, 17, 18, 21, 24, 117, 177		<i>Pagophila alba</i>	45	Wild.....	144
<i>Nuttallornis borealis</i>	87, 111, 125	<i>Paliurus</i>	69	<i>Pintcola enucleator</i>	112
<i>Nyctea nyctea</i>	90, 110	<i>Paliurus pulcherrium</i>	69	<i>enucleator ascensis</i>	112
<i>Nycticorax nycticorax naevius</i>	106	Palliseria	150	<i>enucleator carlottae</i>	20
<i>Nymphæa</i>	148	<i>robusta</i>	150	<i>enucleator leucura</i>	125
		<i>Pandion haliaëtus</i>	139	Pintail.....	93, 135
		<i>haliaëtus carolinensis</i>	89, 109	American.....	73, 104
		<i>Paonias excaetata</i>	132	<i>Pipilo erythrophthalmus erythro-</i>	
		<i>Parus rufescens</i>	16	<i>phthalmus</i>	11
		<i>Papilio cressphontes</i>	77	<i>maculatus</i>	138
		<i>glaucus canadensis</i>	82	<i>maculatus arcticus</i>	114
		<i>Pappichys</i>	68	<i>maculatus erythrophthalmus</i>	114
		Parrot, Kea.....	19	Pipit.....	15, 146
		Partridge.....	188	American.....	117
		Canada Spruce.....	108	Sprague's.....	117
		English.....	188	<i>Piranga erythromelas</i>	11, 115
		European Gray.....	168	<i>ludoviciana</i>	115
		Hudsonian Spruce.....	108	<i>Pisces</i>	68
		Hungarian.....	108, 168	<i>Pisidium</i>	163
		White.....	108	<i>variable</i>	148
		<i>Parus rufescens</i>	16	<i>Pisobia bairdi</i>	107
		<i>Passer domesticus</i>	10, 113	<i>fuscicollis</i>	74, 106
		<i>domesticus domesticus</i>	126	<i>maculata</i>	74, 106
		<i>Passerculus sandwichensis alaud-</i>		<i>minutilla</i>	74, 106
		<i>inus</i>	113	Pittman, H. H., article by.....	64
		<i>sandwichensis savanna</i>	10, 126	<i>Pitymys pinetorum scalopsoides</i>	37
		<i>Passerella</i>	147	<i>Planesticus migratorius</i>	38
		<i>Passerella iliaca iliaca</i>	11, 114, 126	<i>migratorius migratorius</i>	
		<i>obscura</i>	127, 147	16, 118, 146
		<i>Passerherbulus caudacutus</i>	10	<i>Planorbis</i>	163
		<i>lecontei</i>	113	Plant, Gas.....	78
		<i>nelsoni nelsoni</i>	10, 113	Plantain, Downy Rattlesnake.....	61, 88
		<i>Passerina amoena</i>	115	Rattle-snake.....	87, 88
		<i>cyanea</i>	11, 114	<i>Platacodon</i>	68
		Patch, Clyde L., articles by.....	18, 81	<i>Platanus</i>	69
		<i>Pecten hastatus</i>	43	<i>aceroides latifolia</i>	69
		<i>Pediactetes phasianellus campes-</i>		<i>guillelmae heerii</i>	69
		<i>tris</i>	108	<i>nobilis</i>	69
		<i>phasianellus phasianellus</i>	108	<i>Plectrophenax nivalis</i>	113
		<i>Pelecanus erythrorhynchus</i>	104	<i>nivalis nivalis</i>	10, 126
		Pelican, White.....	92, 104	Plover.....	144, 174
		<i>Pelidna alpina sakhalina</i>	107	American Black-bellied.....	75, 108
		<i>Pentacta frondosa</i>	54	American Golden.....	108
		<i>piperata</i>	56	Black-bellied.....	169, 188
		<i>populifer</i>	56	Golden.....	75, 169, 187, 188
		<i>Penikestes atricapillus atricapil-</i>		Killdeer.....	193
		<i>lus</i>	15, 146	Mountain.....	108, 118
		<i>atricapillus septentrionalis</i>	117	Piping.....	75, 108, 188
		<i>hudsonicus hudsonicus</i>	16, 117	Semipalmated.....	75, 108, 188
		<i>hudsonicus littoralis</i>	146	Upland.....	107, 188
		<i>hudsonicus nigricans</i>	146	<i>Pluvialis dominica dominica</i>	75, 108
		<i>Perdix perdix</i>	108	<i>Podasocys montanus</i>	108
		<i>Periene oregonensis</i>	43	<i>Podilymbus podiceps</i>	103
		<i>Perisoreus barbouri</i>	44, 125	Pogonia.....	87
		<i>canadensis</i>	44, 112	<i>Pogonia ophioglossoides</i>	87
		<i>canadensis canadensis</i>	125	<i>Poliopitila caerulea</i>	16
		<i>Pernis apivorus</i>	139	Polychaete.....	193
		<i>Peromyscus</i>	37	<i>Polyclados miniata</i>	56
		Petrel.....	144, 171, 174	<i>Polygona</i>	83
		Leach's.....	46	<i>faunus</i>	83
		Storm.....	46	<i>interrogationis</i>	83
		Wilson's.....	46	<i>progne</i>	83
		<i>Petrochelidon lunifrons lunifrons</i>		<i>satyrus</i>	83
		12, 115, 127	<i>Polygonum</i>	11

INDEX—Continued

- Polynoid..... 193
Polydorn virginianum forma
bipinnatifidum..... 51
vulgare..... 51
Polypody, Common..... 51
Polystichum Braunii..... 51
Pond-Lily, Yellow..... 148
Pondweed, Sago..... 179
Poaetes gramineus confinis..... 113
gramineus gramineus..... 10
Poor-will..... 111
Populus speciosa..... 69
Porcellio scaber..... 161
Porzana carolina..... 74, 106
Postilosa..... 157
Potamogeton pectinatus..... 179
Potentilla tridentata..... 51
Preliminary Report on the Des-
truction of Birds at Light-
houses on the Coast of
British Columbia, A..... 141
Preece, W. H. A., articles by.....
9, 132, 138, 170
Progne subis subis..... 12, 115
Prosecutions..... 90
Prosopernis flavofasciata..... 132
Psaltriparus minimus..... 94
Psolus chitonoides..... 57
Ptarmigan..... 44
Rock..... 88, 89
Willow..... 88, 89, 108
Pteraster tessalatus..... 193
Publication Fund, Canadian
Field-Naturalist..... 181, 194
Publications Received..... 97, 160, 182
Puffin..... 44, 144, 169, 174
Puffinus griseus..... 46, 148
Purple, Banded..... 83
Purpura crispata..... 43
Putty-root..... 62
Quail..... 136, 168, 176, 188
Querquedula cyanoptera..... 104
discors..... 73, 104
Quiscalus quiscula aeneus..... 112, 125
Rail..... 171, 174
Sora..... 106
Virginia..... 106
Yellow..... 106, 118
Rallus virginianus..... 106
Range of the Moose Extending
Northward..... 27
Raspberry..... 180
Rattlesnake..... 140
Raven..... 139
Northern..... 112, 125
Recurvirostra americana..... 106
Red Eye, Little..... 85
Redhead..... 73, 105
Redpoll..... 17, 18, 174
Common..... 113
Hoary..... 113
Redstart..... 15, 146
American..... 117
Regulus calendula calendula..... 16, 117, 146
calendula grinnelli..... 177
satrapa satrapa..... 16, 87, 117, 146
Reptilia..... 68
Rhopalocera..... 82
Rhynchocephalia..... 68
Rhynchophanes mecoweni..... 113
Riparia riparia..... 12, 115, 127
Rissa tridactyla tridactyla..... 45
Robin, 16, 17, 18, 20, 21, 38, 39, 49, 91,
92, 93, 135, 144, 145, 146, 156,
159, 171, 174, 177, 178, 187
American..... 118
Root, Coral..... 87
Rubicola minor..... 74, 106
Salamander..... 159
Tiger..... 81, 82
Salmon..... 30, 48, 49, 144, 167, 168, 192
Cohoe..... 167
Dog..... 49
Sock-eye..... 49
Salpinctes obsoletus obsoletus..... 117
Sanderling..... 75, 107, 188
Sandpiper..... 91, 174
Baird's..... 107
Buff-breasted..... 107
Least..... 74, 107, 188
Pectoral..... 74, 107
Purple..... 149
Red-backed..... 107, 188
Semipalmated..... 75, 107, 188
Solitary..... 75, 107, 188
Spotted..... 75, 107, 149, 188
Stilt..... 107
Western Solitary..... 107
White-rumped..... 74, 107, 188
Sapindus affinis..... 69
Sapsucker, Yellow-bellied..... 90, 110
Saunders, W. E., article by..... 26
Sauria..... 68
Sawbill..... 144
Sayornis phoebe..... 111
saya..... 111
Scapherpeton
lectum..... 68
Scap, Greater..... 97
Lesser..... 97
Scirpus
lacustris occidentalis..... 166
Scoter..... 73, 144
Surf..... 73, 105
White-winged..... 73, 105
Scotiaplex nebulosa nebulosa..... 109
Seal, Hair..... 84, 85
Sea-lion..... 85, 192
Sea-squirt..... 158
Sea-weed..... 157
Seiurus aurocapillus..... 14, 116, 127
noveboracensis..... 116
noveboracensis notabilis..... 14, 116
noveboracensis noveboracen-
sis..... 14, 116, 127
Selaginella wallacei..... 149
Serapias Helleborine..... 62, 63
Setopaga rutilica..... 15, 117, 146
Shaw, William T., article by..... 128, 151
Shearwater..... 142
Sooty..... 46, 144, 148, 174
Shoveller..... 104
Shrew, Short-tailed..... 120
Smoky..... 37
Shrike..... 59
Migrant..... 12, 58
Northern..... 12, 18, 115, 127
White-rumped..... 115
Sialia currucoides..... 118
sialis sialis..... 16, 118, 147
Siskin, Pine..... 18, 113, 126, 174
Sitta canadensis..... 15, 117, 146
carolinensis..... 117
carolinensis aculeata..... 117
carolinensis carolinensis..... 15
Skink, Giant..... 47
Skinner, M. P., review of article
by..... 19
Skipper..... 82
The Chequered..... 82
Skunk..... 35
Smerinthus cerysi..... 132
geminatus..... 121
jamaicensis..... 132
Smith, Harlan I., article by..... 167
Smith, Huron H., review of his
"Ethnobotany of the
Menomini Indians"..... 78
Smith, Miss, article by..... 17
Snail..... 138, 162
Snake..... 35, 40
Butler's Garter..... 40
Glass..... 47
Snapper..... 165
Snipe..... 144, 145, 171, 174, 188
Jack..... 188
Wilson's..... 74, 106, 188
Snowberry..... 128
Snowbird..... 10, 113
Snowflake..... 193
Solaster stimpsoni..... 118
Solitaire, Townsend's..... 73
Somataria mollissima borealis..... 73
mollissima dresseri..... 73
spectabilis..... 73
Some Experiences in Bird-Band-
ing..... 21
Some Holothurians from British
Columbia..... 54
Some Littoral Barnacles from
William Head, British Col-
umbia..... 41
Sora..... 74
Sparganium stygium..... 69
Sparrow..... 33, 126, 136, 142, 143, 144,
145, 171, 174
Baird's..... 113
Brewer's..... 114
Chipping..... 11, 21, 24, 114, 120, 126, 156, 178
Clay-colored..... 10, 114
English..... 33, 36, 113
European House..... 126
Field..... 11, 180
Fox..... 11, 114, 126, 147, 156, 177
Gambel's White-crowned..... 114
Golden-crowned..... 174
Grasshopper..... 10
Harris..... 10, 114
Hedge..... 145
House..... 10, 38, 113
Leconte's..... 113
Lincoln's..... 11, 21, 114, 126
Nelson's..... 10, 113
Rusty Song..... 142
Savannah..... 10, 126
Sharp-tailed..... 10
Song, 11, 17, 21, 39, 92, 114, 126,
155, 156, 174, 177, 178
Swamp..... 11, 114, 126
Tree..... 11, 17, 114, 126
Vesper..... 10
Western Chipping..... 114
Western Grasshopper..... 113
Western Lark..... 113
Western Savannah..... 113
Western Tree..... 114
Western Vesper..... 113
White-crowned, 11, 114, 126, 174
White-throated..... 11, 92, 114, 126, 140, 156, 178
Sparrow-hawk..... 139
Spatula clypeata..... 104
Speck, Frank G., article by..... 47
Speck, Frank G., review of his
"Bird-Lore of the North-
ern Indians"..... 60
Spectylo cunicularia hypogæa..... 110
Sphaerium..... 163
Spher..... 121, 122, 123
procera..... 121
Sphingid..... 123
Sphingidae..... 132
Sphinx drupiferarium..... 132
gordius..... 132
kalmia..... 132
Sphyrapicus varius..... 110
varius varius..... 90
Spidodola scutata..... 69
Spinus pinus..... 113, 126
Spiranthes cernua..... 61, 88
cernua var. ochroleuca..... 88
gracilis..... 87
Romanzoffiana..... 62
Spiza americana..... 11, 115, 127
Spizella breweri..... 114
monticola monticola..... 11, 114, 126
monticola ochracea..... 114
pallida..... 114
passerina arizonæ..... 114
passerina passerina..... 11, 114, 126
pustilla pustilla..... 50
Spleenwort, Ebony..... 50, 51
Maidenhair..... 50, 51
Sponge..... 163
Spongilla..... 163
Squatrola squatarola cynosuæ.....
16, 75, 108
Squirrel..... 32, 34, 35, 36
Black..... 180
Columbian Ground..... 153
128, 129, 130, 151, 152, 153
Gray..... 158, 159
Ground..... 128
Red..... 137, 159
Star-fish..... 157, 193
Starling..... 58
Statement, Financial, Ottawa
Field-Naturalists' Club,
1922-23..... 19

INDEX—Continued

- Statement, Receipts and Disbursements, Ottawa Field-Naturalists' Club, 1922-23 19
- Statement Trust Funds Committee 96
- Steganopus tricolor* 74, 106
- Stelgidopteryx serripennis* 12, 115
- Stercorarius longicaudus* 45
- parasiticus* 45, 103
- pomarinus* 103, 148
- Sterna caspia imperator* 104
- forsteri* 104
- hirundo* 46, 104
- paradisaea* 104
- Sternberg, Charles M., article by 66
- Stewart, D. A., article by 81
- Stichopus badinotus* 55
- californica* 193
- Stickleback 163, 164
- Strawberry, Wild 180
- Strix varia varia* 90
- Strymon acadica* 82
- liparops* 82
- Sturnella neglecta* 112
- Sturnus vulgaris* 58
- Subscribers, List of 97
- Sulphur, Clouded 83
- Sun-fish, Green 85, 86
- Long-eared 86
- Surnia ulula caparoch* 90, 110
- Swallow, Bank 12, 115, 127
- Barn 12, 115, 127, 178
- Cliff 12, 115, 127
- Northern Violet-green 176
- Rough-winged 12, 115, 118
- Tree 12, 21, 92, 93, 115, 127, 176, 178, 179
- Swallowtail, Giant 77, 78
- Tiger 82
- Swan, Mute 27
- Trumpeter 57, 58, 105, 179
- Whistling 26, 27, 74, 105
- Swift, Chimney 90, 111, 118
- Symphoricarpos* 128
- Synaptid 193
- Synaptomys fatuus* 37
- Tachycineta thalassina lepida* 176
- Tadpole-shrimp 6
- Tanager, Scarlet 10, 11, 115, 118
- Western 103, 115
- Taverner, P. A., review of article by 20
- Teal, Blue-winged 73, 92, 93, 104, 133, 134, 147, 156, 157
- Cinnamon 104
- Green-winged 72, 93, 97, 104, 155
- Telmatodytes palustris iliacus* 117
- palustris palustris* 15
- Tern 164
- Arctic 46, 104
- Black 104
- Caspian 104, 118
- Common 46, 104
- Forster's 104
- Thacker, T. L., article by 164
- Thalassogeron chrysostomus culminatus* 97
- Thamnophis* 35
- Thelypteris* 50
- spinulosa* var. *americana* 51
- Theselosaurus neglectus* 68
- Theselus* 68
- Thespesius* 67, 68, 69
- annectens* 68
- Thompson, Stuart L., article by 17
- Thrasher, Brown 15, 21, 117
- Sage 117, 118
- San Lucas 15
- Thrush 171
- Cinereous 15
- Gray-cheeked 16, 118
- Hermit 16, 118, 140, 146
- Olive-backed 16, 118, 146
- Russet-backed 176
- Varied 89
- Willow 118
- Wood 10, 118
- Thryomanes bewicki calophonus* 177
- Thuja occidentalis* 80
- Tiger Salamander at Ninette, Manitoba, The 81
- Tiliqua scincoides* 47
- Tip, The Violet 83
- Tipularia discolor* 62
- Tit, Least Bush 94
- Toad, Horned 47
- Tortoise-shell, The American 83
- Totanus flavipes* 75, 107
- melanoleucus* 75, 107
- Towhee 10, 11, 138, 180
- Arctic 114
- Spotted 138
- Townsend, Charles Wendell, review of his "Beach Grass" 60
- Toxostoma rufum* 15, 117
- Trachodon 131
- Trap, Detachable Funnel 136, 137
- Trapa borealis?* 69
- Triceratops* 67, 68, 69, 131
- prorsus?* 68
- Trichoptera 164
- Tringa solitaria cinnamompa solitaria solitaria* 75, 107
- Trochoturbinidae 150
- Troglodytes aedon aedon aedon parkmani* 15
- Trout 48, 49
- Cut-throat 48, 49
- Tryngites subruficollis* 107
- Tule 166
- Turdus migratorius* 38
- Turnstone 188
- Black 149
- Ruddy 75, 108
- Turtle 66, 68
- Bell's Painted 164, 165, 166, 167
- Snapping 166
- Tustudines* 68
- Twayblade, Auricled 61
- Loesel's 62
- Tympanuchus americanus americanus* 108
- Tyrannus tyrannus* 90, 111, 111
- verticalis* 111
- Tyto alba pratincola* 109
- Unio danae* 69
- Uria lomvia* 45
- troille troille* 45
- Urtica gracilis* 80
- Vanessa atalanta* 83
- cardui* 83
- virginensis* 83
- Van Rossem, A. J., review of article by 39
- Varanus salvator* 47
- Veery 16, 146
- Vermivora celata celata* 13, 115
- peregrina* 13, 116, 127
- ruficapilla ruficapilla* 13, 115, 127
- Viceroy, The 83
- Vireo, Anthony 20
- Blue-headed 13, 115
- Hutton's 176
- Least 13
- Philadelphia 12, 115
- Red-eyed 12, 115, 127
- Warbling 12, 13, 115
- White-eyed 193
- Yellow-throated 10, 13, 115, 118
- Vireo gilvus* 13
- huttoni* 176
- huttoni huttoni* 20
- huttoni insularis* 20
- huttoni obscurus* 20, 177
- pusillus* 13
- Vireosylva gilva gilva* 12, 115
- gilva swainsoni* 115
- olivacea* 12, 115, 127
- philadelphia* 12, 115
- Vulture 35
- Turkey 76, 108
- Wagtail, Water 140
- Walker, Ernest P., review of article by 19
- Warbler 145, 174
- Audubon's 116
- Bay-breasted 14, 116
- Black and White 13, 115, 127
- Blackburnian 14, 116
- Black-poll 14, 93, 116, 127
- Black-throated Blue 13
- Black-throated Green 14, 116, 127
- Canada 15, 146
- Canadian 117
- Cape May 13, 116
- Cerulean 13, 14
- Chestnut-sided 14, 116
- Connecticut 14, 116, 118
- Golden-winged 10
- Kentucky 14
- Macgillivray's 116
- Magnolia 13, 116, 127
- Mourning 15, 116
- Myrtle 13, 18, 38, 116, 127
- Nashville 13, 115, 127
- Northern Parula 13, 87, 127
- Orange-crowned 10, 13, 115
- Palm 14, 116
- Pine 14
- Prairie 58
- Tennessee 13, 116, 127
- Tolmie 116
- Wilson's 15, 117, 146
- Yellow 13, 116, 127
- Yellow Palm 14
- Wasp 121, 122, 123
- Water-Thrush 14, 116, 127
- Louisiana 37
- Northern 37
- Waxwing, Bohemian 12, 115
- Cedar 12, 115, 127
- Weasel 31, 32, 64
- Whale, Killer 84
- Wheatear, Greenland 147
- W. H. Hudson, The Naturalist, (1841-1922) 24, 51
- Whip-poor-will 111
- Whistler 144
- Whistling Swans in Ontario 26
- Whittaker, Edward J., obituary of 179
- Widgeon, American 104
- Wilfrid, Rev. Brother, article by 124
- Willet 188
- Western 107
- Willey, A., article by 63
- Wilson, Alice E., article by 150
- Wilsonia canadensis* 15, 117, 146
- pusilla* 15, 117, 146
- Wolf 28, 185
- Wood-bison 189
- Wood-buffalo 189
- Woodcock 10, 74, 188
- American 106, 118
- Woodlice 161
- Woodpecker 58, 111, 144, 174, 176
- American Three-toed 110, 118
- Arctic Three-toed 37, 90, 110
- Downy 17, 18, 21, 24, 90, 110, 177, 178
- Hairy 17, 18, 24, 90
- Lewis's 39, 110, 176
- Nelson's Downy 110
- Northern Hairy 110
- Northern Pileated 110
- Pileated 147, 194
- Red-bellied 10, 37
- Red-headed 10, 110
- Three-toed 90
- Woodsia, Rusty 51
- Woodsia ilvensis* 51
- Worm, Oligochaete 162, 163
- Wren 50
- Bewick's 94
- House 15, 21, 35, 92, 94, 178
- Long-billed Marsh 15, 117

INDEX—Concluded

Wren, Prairie Marsh.....	117	<i>Xanthocephalus xanthocephalus</i>	112	<i>Zenaidura macroura carolinensis</i>	89, 108
Rock.....	117	<i>Xema sabini</i>	104, 148	Zon, Raphael, review of his "Research Methods in the Study of Forest Environ- ment".....	160
Seattle.....	177			<i>Zonotrichia albicollis</i>	11, 114, 126
Short-billed Marsh.....	15, 117			<i>leucophrys gambeli</i>	114
Western House.....	117			<i>leucophrys leucophrys</i>	11, 114, 126
Winter.....	15, 94, 117, 146			<i>querula</i>	114
		Yellow-legs, Greater.....	75, 107, 188		
		Lesser.....	107, 188		
		Yellow-throat, Maryland.....	15, 117, 127		
		Western.....	116		



Sweet Canada

Eleven Bird Songs and a Round

by

Louise Murphy

Author of "A Little Book of Bird Songs,
Hymes and Tunes for Tiny Tots"

PRICE \$1.00

Longmans, Green & Co.

210 Victoria Street, Toronto

L. C. Smith & Bro.

Typewriter

*Ball bearings in every frictional part of
the L. C. Smith insure long life, light
touch and easy operation*

Ottawa Typewriter Co. Limited

191 QUEEN ST., OTTAWA



Card Filing Systems for Naturalists

As makers of the Library Bureau line of Card Filing Devices in Canada, we are in a position to supply all Naturalists with cards and trays where they can readily index all their observations and notes

Lowe-Martin Ltd.

OTTAWA, CANADA

Printers of The Canadian Field-Naturalist

Publishers of the Autobiography of John Macoun, M.A.

The Crabtree Co.

Artists and
Designers

BLUEPRINTERS

ENGRAVERS

COMMERCIAL

PHOTOGRAPHERS

: PHOTO :

LITHOGRAPHERS

228 Albert Street

Ottawa, Ont.

COAL C. C. Ray Company

Limited

BEST QUALITY LOWEST PRICES

46 Sparks St.—Phone Q. 461

OTTAWA

Geo. E. Preston & Sons

MERCHANT TAILORS

*We make everything we sell and
guarantee everything we sell*

217-219 Rideau Street, Ottawa

Dr. Mark G. McElhinney

*Dentist to certain of the
cognoscenti*

252 LISGAR STREET, OTTAWA

Telephone Queen 2438

Kindly mention The Canadian Field-Naturalist to advertisers



*Publishing
for Naturalists*



**Book Publishing
Pamphlets, Booklets
and all kinds of Publicity
for Lovers of
Outdoor Study**

The Graphic Advertisers
175 Nepean Street
Ottawa

Rubber Stamps
— FOR —
Listing Your Specimens

*The more consistent use of
rubber stamps will materially
assist you in cataloguing the
collection of specimens you
have spent so much time and
trouble in securing. Let us
help you.*

**CAPITAL RUBBER STAMP
WORKS**
175 NEPEAN STREET
OTTAWA, CANADA

**Many More are
Wanted on the
Subscription
Lists**

The Membership Committee of The Ottawa Field-Naturalists' Club is making a special effort to increase the subscription list of *The Canadian Field-Naturalist* and we are asking every reader to assist in making the campaign the success it should be.

We would particularly urge the Secretary of each Affiliated Society to bring this matter up at EVERY meeting and secure as many subscribers as they possibly can to a Canadian Publication devoted to the study of Natural History in all its phases.

Use the blank below and forward it to the Treasurer.

————— CUT OFF HERE —————

MR. B. A. FAUVEL,
Treasurer, Ottawa Field-Naturalists' Club,
Mounted Police Headquarters,
Laroque Building,
Rideau and Dalhousie Sts.,
Ottawa, Canada.

*I enclose One Dollar and Fifty Cents
as my subscription to The Canadian
Field-Naturalist for one year.*

Name.....
(Mr., Mrs. or Miss)

Address.....

City and Province.....

Kindly mention The Canadian Field-Naturalist to advertisers

Affiliated Societies

NATURAL HISTORY SOCIETY OF MANITOBA 1924

Hon. President: V. W. JACKSON; *President:* J. J. GOLDEN; *Vice-Presidents:* H. M. SPEECHLY, A. M. DAVIDSON, A. G. LAWRENCE, NORMAN CRIDDLE; *Mrs. C. E. BASTIN, Mrs. C. P. ANDERSON; General Secretary:* A. A. MCCOUBREY, 307 C.P.R. Depot, Winnipeg, Man.; *Executive Secretary:* R. M. THOMAS; *Treasurer:* MISS HELEN R. CANNON; **ORNITHOLOGICAL SECTION:**—*Chairman:* B. W. CARTWRIGHT; *Secretary:* C. L. BROLEY. **ENTOMOLOGICAL SECTION:**—*Chairman:* A. V. MITCHENER; *Secretary:* A. SHIRLEY BROOKS. **BOTANICAL SECTION:**—*Chairman:* C. W. LOWE; *Secretary:* MISS GRACE CAMERON. **GEOLOGICAL SECTION:**—*Chairman:* A. A. MCCOUBREY; *Secretary:* J. M. BENSON.

THE HAMILTON BIRD PROTECTION SOCIETY (Incorporated)

Hon. President: MR. ADAM BROWN; *President:* MR. R. O. MERRIMAN; *1st Vice-President:* DR. H. G. ARNOTT; *2nd Vice-President:* MR. C. D. COOK; *Secretary-Treasurer:* MISS RUBY R. MILLS, Public Library, Hamilton; *Directors:* DR. H. G. ARNOTT; C. D. COOK; DR. J. A. DICKSON; MISS M. E. GRAHAM; MISS RUBY R. MILLS; M. HOLTON; M. JOHNSTON; MRS. F. E. MACLOGHLIN; R. O. MERRIMAN.

NATURAL HISTORY SOCIETY OF BRITISH COLUMBIA, VICTORIA, B.C.

The officers for the above Society for the year ending March 31st, 1923, are as follows:—
President: W. N. KELLY; *1st Vice-President:* A. R. SHERWOOD; *2nd Vice-President:* C. C. PEMBERTON; *Secretary:* H. T. NATION 2380 Windsor Road, Victoria, B.C. *Treasurer:* MISS S. M. THORNTON; *Committee:*—MISS G. F. FOX, MISS A. F. GARDNER, MISS I. CATHCART, WM. DOWNES, A. HALKETT. *Auditors:*—J. KEITH WILSON AND F. W. GODSAL. *Trustees:*—REV. R. CONNELL, DR. C. F. NEWCOMBE AND G. HARVEY.

ALBERTA NATURAL HISTORY SOCIETY

Hon. President: DR. HY. GEORGE, Victoria B.C.; *Hon. Vice-President:* MR. J. J. GAETZ, Red Deer; *President:* MR. C. H. SNELL, Red Deer; *1st Vice-President:* MR. G. C. S. CROSBY, Red Deer; *2nd Vice-President:* MRS. W. A. CASSELS, Red Deer; *Hon. Sec.-Treas.* MRS. S. PAMELY, Red Deer; *Directors:* MRS. G. C. S. CROSBY, MISS E. C. IRVING, MR. W. A. CASSELS AND MR. S. PAMELY, Red Deer, MRS. G. F. ROOT, Wetaskiwin, MR. K. BOWMAN, Edmonton, MR. B. LAWTON, Edmonton, MR. T. RANDALL, Castor, MR. F. L. FARLEY, Camrose, MR. W. C. MCCALLA, Bremner, and MR. D. M. SINCLAIR, Peace River.

The meetings of this Society are held in Red Deer on the last Friday of each month except during July and August and perhaps September. The annual meeting is held in Red Deer on the last Friday in November.

McILWRAITH ORNITHOLOGICAL CLUB, LONDON, ONT.

President: T. D. PATTERSON, 562 Waterloo Street; *Recording Secretary:* MRS. E. H. MCKONE, Worthey Road; *Corresponding Secretary and Treasurer:* E. M. S. DALE, 297 Hyman St.; *Members qualified to answer questions:* W. E. SAUNDERS, 240 Central Ave.; C. G. WATSON, 201 Ridout St. South; J. R. MCLEOD, 355 Wortley Road; J. F. CALVERT, 461 Tecumseh Ave.; E. M. S. DALE, 297 Hyman St.

VANCOUVER NATURAL HISTORY SOCIETY

Hon. President: L. S. KLINCK, L.L.D., Pres. University of B.C.; *President:* JOHN DAVIDSON, F.L.S., University of R.C.; *Vice-President:* FRED PERRY; *Hon. Secretary:* C. F. CONNOR, M.A., 3529-W. 2nd Ave., Vancouver, B.C.; *Hon. Treasurer:* A. H. BAIN, 2302 York St., Vancouver, B.C.

Fortnightly meetings in the University Buildings from September to April (inclusive). Semi-monthly excursions from May to August (inclusive).

PROVINCE OF QUEBEC SOCIETY FOR THE PROTECTION OF BIRDS

Hon. President: I. GAMMELL; *President:* L. MCI. TERRILL; *Vice-Presidents:* NAPIER SMITH, E. ARNOLD, W. A. OSWALD; *Hon. Corresponding Secretary and Acting Treasurer:* W. S. HART, P.O. Box 1185, Montreal; *Hon. Recording Secretary:* MISS H. STONE; *Curator:* MISS E. G. LUKE; *Committee:* MISS M. ARMITAGE, MISS E. BENNETT; W. J. BROWN; MR. AND MRS. C. F. DALE; H. A. C. JACKSON; MISS E. MORROW; MISS L. MURPHY; A. MACSWEEN; MISS H. MCLACHLAN; L. MCI. SPACKMAN; MRS. W. W. WALKER; DR. ARTHUR WILLEY; W. H. ROBB; *Members qualified to answer questions:* L. MCI. TERRILL, 44 Stanley Ave., St. Lambert, Que.; NAPIER SMITH, Bank of Montreal, Magog, Que.; E. ARNOLD, 64 Durocher St., Montreal; W. A. OSWALD, 301 Wilson Ave., N.D.G., Montreal; C. N. ROBERTSON, c-o Ross Realty Co., Room 305, Lewis Bldg., St. John St., Montreal, Que.; DR. ARTHUR WILLEY, McGill University, Montreal; W. J. BROWN, 250 Oliver Ave., Westmount, Que.; MISS EDITH MORROW AND MISS EMILY LUKE, c-o Secretary.

SOCIÉTÉ PROVANCHER D'HISTOIRE NATURELLE DU CANADA Bureau de direction pour 1923

President: DOCTEUR S. GAUDREAU; *1er vice-président:* ABBE A. VACHON, M.A.; *2ème vice-président:* A.-R.-M. BOULTON; *Secrétaire-trésorier:* LOUIS-B. LAVOIE; *Chef de la section scientifique:* A.-A. GOUBOUT; *Chef de la section de propagande éducationnelle:* DOCTEUR A. DERY; *Chef de la section de protection:* R. MEREDITH, N.P.; *Chef de la section d'information scientifique et pratique:* DOCTEUR J.-E. BERNIER; *Directeurs:* R.-F. LINDSAY; JOS. MATTE; G.-S. AHERN.

THE BRITISH COLUMBIA ORNITHOLO- GISTS' UNION Officers for 1923

Hon. President: HON. MINISTER OF AGRICULTURE, Victoria; *President:* FRANCIS KERMODE, Provincial Museum, Victoria; *Vice-President:* T. L. THACKER, Hope; *Secretary-Treasurer:* J. W. WINSON, Huntingdon; *Directors:* J. A. MUNRO, Okanagan Landing; DR. KELSO, Arrow Lakes; R. GLENDENING, Agassiz; K. RACEY, Vancouver; T. PEARSE, Courtenay; W. N. KELLY, Victoria.

THE TORONTO FIELD-NATURALISTS' CLUB

President: PROFESSOR R. B. THOMPSON; *Vice-Presidents:* PROFESSOR E. M. WALKER, DR. A. COSENS, J. H. FLEMING; *Secretary:* W. F. GREGORY, 151 Ellsworth Ave., Toronto; *Treasurer:* F. H. BRIDGEN; *Honorary Librarian:* C. W. NASH; *Librarian:* DR. LYMAN B. JACKES. **BIRD GROUP:**—*Chairman:* STUART THOMPSON; *Secretary:* JAMES BAILLIE. **FLOWER GROUP:**—*Chairman:* DR. H. B. SIFTON; *Secretary:* MISS J. G. WRIGHT, Ph.D.; **INSECT GROUP:**—*Chairman:* PROFESSOR WALKER; *Secretary:* MISS NORMA FORD, Ph.D. **MAMMAL GROUP:**—*Chairman:* J. R. DYMOND; *Secretary:* L. SNYDER. **REPTILE, FISH AND AMPHIBIAN GROUP:**—*Chairman:* SHILLEY LOGIER; *Secretary:* T. B. KURATA. **PROGRAM COMMITTEE:**—*Chairman:* DR. W. A. CLEMENS; **WILD LIFE PRESERVATION COMMITTEE:**—*Chairman:* RUSSELL G. DINGMAN. **EDUCATIONAL COMMITTEE:**—*Chairman:* TAYLOR STATTON.

We would ask the Officers, and more particularly the Secretaries, of all the Affiliated Societies to assist us in our task of building up the circulation of this magazine. By securing every member as a subscriber we can truly make this magazine into one of the leading Natural History publications of America.



FOR SALE

Back Numbers of The Ottawa Naturalist

The Club has for sale complete sets of its publications. Enquiries regarding price should be addressed to the Secretary of the Club, Dr. J. F. Wright, Geological Survey, Ottawa, Canada.

Any member having copies of the March, 1896, January, February, March and August, 1898, and December, 1900, issues of *The Ottawa Naturalist*, and who desires to dispose of the same, is requested to communicate with the Secretary.



Grant-Holden- Graham Limited

Outfitters to Surveyors & Engineers

Manufacturers of

High-Grade Tents

Tarpaulins & Sleeping Bags

WRITE FOR CATALOGUES

147 Albert Street

OTTAWA

Fine Diamonds

Sterling Silver, Fine Cut Glass, Electro- Plated Ware

*The Store of
Moderate Prices*

C. A. Olmsted & Son

*Jewellers, Opticians, Watchmakers and
Engravers*

208 Sparks Street, Ottawa

Prices of Separates

Notes to Contributors, Etc.

Papers for publication should be addressed to the Editor, Mr. Harrison F. Lewis, Parks Branch, Ottawa, or to the appropriate Associate Editor.

Manuscript should be plainly written, typed if possible, on one side of the paper only, with wide spaces between the lines and ample margins. It is urged that special care be used that scientific names are legible, properly formed, and correctly spelled and capitalized.

Galley proof will be submitted to authors resident in Ottawa and proof of leading articles to any other author if requested when manuscript submitted. It is requested that it be corrected and returned to the Editor as quickly as possible.

Authors of leading articles are entitled to twenty-five copies of the number in which they appear, free of charge on application.

Separates of articles as they appear on the page, without any change of make-up will be supplied at the following rates:—

	25	50	100	200	300
1 page.....	\$2.00	\$2.25	\$2.50	\$2.75	\$3.00
2 ".....	3.00	3.25	3.75	4.00	4.25
3 ".....	3.50	3.75	4.00	4.25	4.50
4 ".....	3.50	3.75	4.00	4.25	4.50
5 ".....	4.50	4.75	5.00	5.25	5.50
6 ".....	4.50	4.75	5.00	5.25	5.50
7 ".....	6.00	6.25	6.50	6.75	7.00
8 ".....	6.00	6.25	6.50	6.75	7.00
9 ".....	7.50	8.00	8.75	10.25	11.75
10 ".....	7.50	8.00	8.75	10.25	11.75
Covers extra.....	3.00	3.00	3.00	4.00	5.00

If removal of matter on the pages non-pertinent to the article or changes of make-up are desired, or if insets or other extra work are necessary, special rates will be furnished on application to the Editor.

Applications for separates should be made to the Editor and must reach him not later than with the return of the corrected proof.

Kindly mention *The Canadian Field-Naturalist* to advertisers



ERNST MAYR LIBRARY



3 2044 110 350 253

Date Due

~~JUN 28 1990~~

~~APR 5 1994~~

Date Due

49

